

# The Wireless 6<sup>d</sup> Constructor

RADIO CONSULTANT-IN-CHIEF CAPT. P. PECKERSLEY M.I.E.E.

Vol. XIII.

NOVEMBER, 1931.

No. 61.

*All the World on One Dial!*

**The "I.E." THREE**

**DESIGNED BY VICTOR KING**

THIS SET  
INCORPORATES A COM-  
PLETELY NEW SYSTEM  
OF TUNING. IT PROVIDES  
LOUD-SPEAKER PROGRAMMES  
FROM BRITISH STATIONS, OR  
FROM THE OTHER SIDE OF  
THE WORLD, WITH JUST  
THE ONE TUNING  
CONTROL.





# The **NEW** **LEWCOS** BAND PASS FILTER



**PRICE**  
**12/-**  
(Screen 2/6  
Extra.)

Perfect selectivity—the aim of all radio enthusiasts—can at last be achieved!

**The New Lewcos Band Pass Filter**, the product of exhaustive experiments in our Laboratories, gives maximum efficiency on both wave-length ranges (235/550 and 1000/2000). This has been obtained by the production of a Filter which is capable of giving a steep-sided and flat-topped response curve—ideal for super-selectivity and quality performance.

Try this new Lewcos component in your set; you will be astounded at the results.

Send for fully descriptive leaflet, Reference R.73.



**LEWCOS RADIO PRODUCTS FOR BETTER RECEPTION**

THE LONDON ELECTRIC WIRE COMPANY AND SMITHS LIMITED, CHURCH ROAD, LEYTON, LONDON, E.10



# ANNOUNCING THE NEW RANGE OF J.B. PRECISION INSTRUMENTS

**J.B. ENCLOSED GANG** ('0005). Extremely rigid. Totally enclosed. Units matched within 1% and fitted with '0001 "trimmers." Mounts on side or base. 2-gang, 20/-; 3-gang, 29/6.

**BASEBOARD DRUM DIAL** for use with above and all other ganged condensers, 4-inch Drum. Ratio 16:1. Oxidised silver or bronze panel plates. 7/6.

**TYPE R.M. SCREENED 2-GANG CONDENSER** ('0005). Used in "Radio for the Million" V3 Kit Set. Complete with Disc Drive and Panel Plate. 22/-.

**POPULAR.** Extra-heavy gauge brass vanes. Nickel-plated frames. High-grade ebonite insulation. Slow-Motion Type (35/1) as illustrated, with 3-inch dial, 8/6. Plain Type, 6/-; 4-inch Dial, 1/6 extra.

**TYPE U.20 2-GANG**, for use with "Square Peak" Coils. Complete with Illuminated Wavelength-calibrated Disc Drive. 24/-.

Type U.30 3-Gang, 34/6.

**BASEBOARD TRIMMING CONDENSER.** Ebonite Base. Mica insulation. '00005 and '0001 1/- each.

**GANG COUPLING DEVICE.** Gangs two condensers while insulating rotors. 9d.

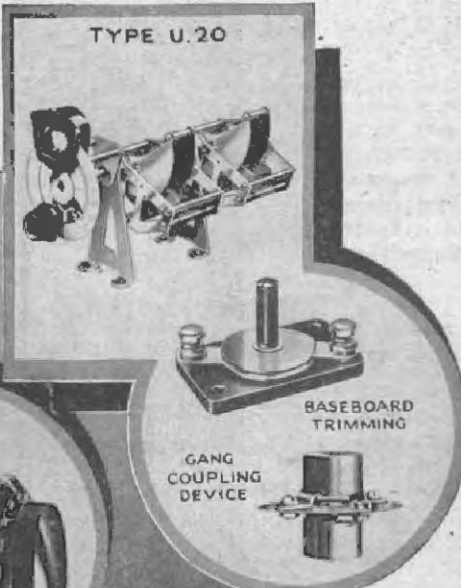
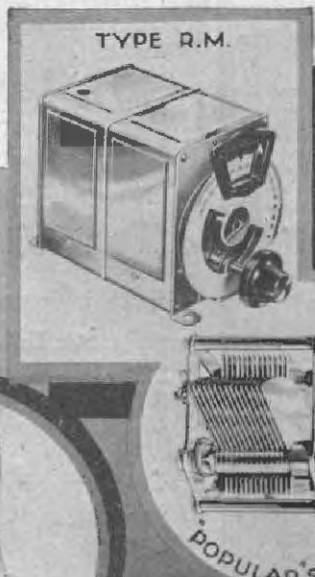
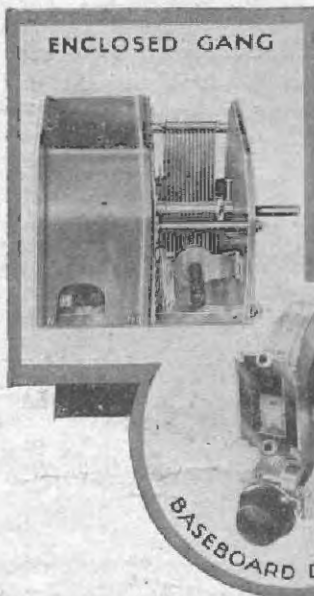

For J.B., years of specialisation have been years of progress. J.B. have gone on from success to success, making tuning still simpler and still more accurate.

J.B. design ensures electrical and mechanical perfection. J.B. precision results in unfailing accuracy and balance. J.B. workmanship and J.B. materials perfect a range of Precision Instruments scientifically designed by practical engineers.

For particulars of other J.B. lines write for the new catalogue.

PRECISION INSTRUMENTS



# Improve your Receiver's performance

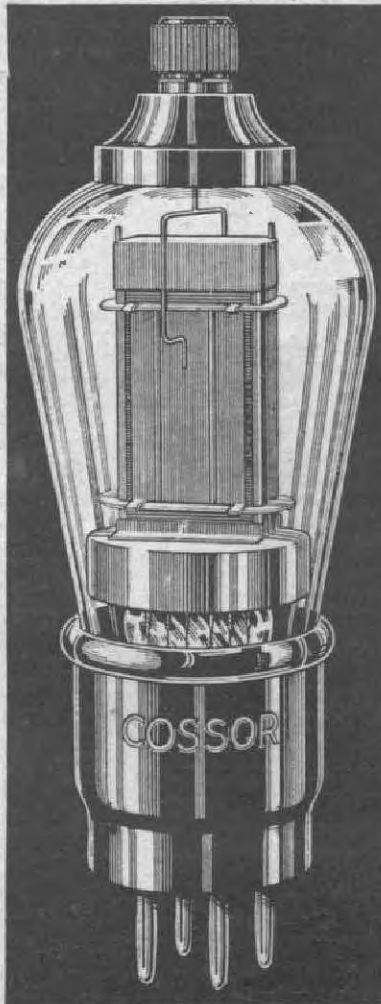

**COSSOR**

**215 S.G.**

Cossor 215 S.G. 2 volts, .15 amp. Impedance 300,000. Amplification Factor 330. Mutual conductance 1.1 m.a./v. Normal Working Anode Volts 120. Positive Voltage on Screen, 60-80.

Price • **20/=**

**COSSOR**

**220 S.G.**

Cossor 220 S.G. 2 volts, .2 amp. Impedance 200,000. Amplification Factor 320. Mutual Conductance 1.6 m.a./v. Normal Working Anode Volts 120. Positive Voltage on Screen, 60-80.

Price • **20/=**

**T**HE performance of any Screened Grid Receiver can be materially improved by fitting a Cossor Screened Grid Valve.

This is because of the substantial increase in effective amplification which these valves permit. Due to their abnormally low inter-electrode capacity, which has been reduced to the order of .001 micro-micro-farads — lower than that of any other S.G. Valve on the market—Cossor Screened Grid Valves permit an exceptionally high stage gain.

As a result of their outstanding efficiency the use of Cossor Screened Grid Valves in any S.G. Receiver ensures a marked improvement in range and selectivity.

Cossor Screened Grid Valves are obtainable from your Radio Retailer in types to suit all Battery operated and A.C. Mains Receivers.

Full technical details of all types of Cossor Screened Grid Valves are given in Folder L.36. — write for a copy, it will be sent post free.

# COSSOR

## SCREENED GRID VALVES



# The WIRELESS CONSTRUCTOR

Published by the Amalgamated Press, Ltd., Fleetway House,  
Farringdon Street, London, E.C.4.



## THE EDITOR'S CHAT



Everything points to this being a wonderfully good winter for reception, but although the wave-length situation needs watching our latest set gives you plenty of alternative programmes.

**M**OST of my readers have seen in the newspapers lately references to the possibility of ether congestion this winter unless something is done, and done quickly, to forestall the approaching crisis.

### B.B.C. Concessions

For some time past the B.B.C. has been aware of the possible danger, and recently Mr. Noel Ashbridge—the B.B.C.'s Chief Engineer—went to Brussels to meet various Continental broadcasting authorities with a view to making some readjustment of the Prague Plan, thus to avert the winter menace of the congested ether.

But it appears that the Continental authorities are rather apathetic, and they said, more or less on these lines: "Oh, let's wait until the Madrid Conference in 1932."

Despite the fact that Mr. Ashbridge was authorised by the B.B.C. to make concessions in the matter of British wave-lengths—for example, Mr. Ashbridge was empowered to give up the common British wave-length, and, I believe, the wave-length of 356.4; and although he impressed on his colleagues on the Continent the seriousness of the situation—he had to return without having brought his mission to a successful conclusion.

### A New Scheme

It is now understood that the B.B.C. has prepared a new scheme with the idea of economising in wave-lengths. The idea is that the National programmes should all be broadcast on a common wave-length, except from Daventry 5XX.

If such a scheme were put into practice it would mean that London National, Northern National, and eventually Scottish and Western

National transmitters would all use the same wave-length.

Is this scheme practicable?

Many experts think not, including Captain P. P. Eckersley, the late Chief Engineer of the B.B.C. and now our Chief Radio Consultant.

Capt. Eckersley points out that if you put all the Nationals on the same wave-length you get very large mush areas. That is to say, areas where reception is blurred.

Captain Eckersley points out, also, that when the Regional Scheme was being discussed the same idea was suggested, but was definitely abandoned as impracticable.

### A GUILTY CONSCIENCE ?



*She is reading the warning to "pirates" exhibited in a London post-office, and it is certainly making her do some hard thinking!*

Whatever the result of the B.B.C.'s endeavour to get the situation cleared up in time, one thing is clear, and that is that the present 9-kilocycle

separation between wave-lengths is not sufficient, and the B.B.C.'s offer still holds good to this effect: that if the gap is increased the B.B.C. is prepared to give up one or two of the nine British exclusive wave-lengths, providing other countries will make some contribution also.

### The "I.E." Three

You will be able to read in this issue full details for constructing the "I.E." Three. I think you will agree that this is an unusually interesting set, for with it you can receive ordinary broadcasting and short waves just as any ordinary receiver is capable of handling long and medium broadcast waves.

By using the Extenser you will observe it is not necessary to change coils to go down to the short waves, nor is it necessary to incorporate a wave-change switch on the panel. All you do is turn the Extenser tuning control to a different set of dial readings.

At one minute you can listen to the local station, and the next—by a twist of the hand—you can go right over to an American short-wave transmission, or perhaps to an Empire short-waver thousands of miles away.

### Don't be Satisfied with Europe

In short, you need no longer be limited to your own Continent, and that is why you may interpret the initials as "Imperial Extenser." The set really speaks for itself, and there's no need for me to indulge in a detailed explanation here of its possibilities.

Readers of the "Wireless Constructor" know a good thing when they see it, and I am confident that they will be quick to appreciate the many fine points about the "I.E." Three.



# POWER FROM LOW VOLTAGE MAINS

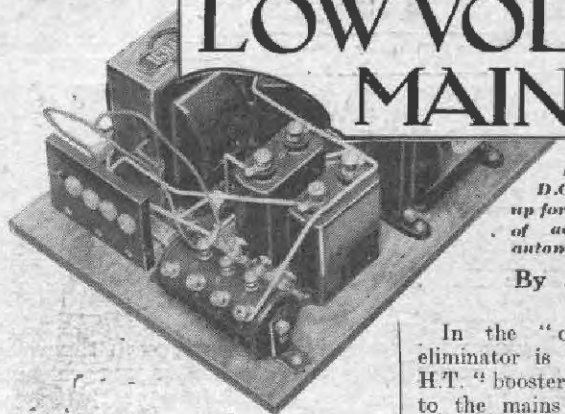

*How users of low-voltage D.C. mains can boost them up for H.T. purposes by means of accumulators which are automatically kept charged.*

By J. PEERS.

**T**HE owner of a radio receiver who has a mains supply of 100-110 volts D.C. (a figure still in use in several districts), and who is desirous of using a mains unit, finds himself very restricted as regards quality of reproduction at least.

This is due to the fact that the maximum output available from the eliminator is probably only 75-80 volts, a value too low to work the output stage satisfactorily where a power or super-power valve is used. In this article a system is described which costs comparatively little, and has proved very successful in actual practice.

## A 4-Point Change-Over

The main point of the system is the use of a "booster" battery of H.T. accumulators, which is connected in series with the mains unit output to feed the receiver when in use, and which is automatically kept fully charged when the set is switched off. The same switch also provides for a similar automatic charging of the L.T. battery.

The illustration shows the diagram of connections, a 4-pole switch having three positions—"off," "on," and "charge." In the "off" position the L.T. and H.T. is isolated from the set, and the eliminator is disconnected from the mains.

## H.T. and Charging

In the "on" position the 50-volt booster battery, consisting of, say, five Exide W.H.10 units, is connected in series with the mains unit, giving a total of 135 volts to the power valve. The intermediate tapplings of the eliminator feed the S.G. and detector valves, and the L.T. accumulator heats the filaments.

In the "charge" position the eliminator is switched off, and the H.T. "booster" battery is connected to the mains through a resistance for charging, and the L.T. accumulator is similarly connected through a lamp which passes the necessary charging current.

## A Typical Case

The successful working of the system depends mainly on finding a suitable value for the charging resistance and lamp which will put just enough "juice" into the batteries to make up for the current taken out during use.

a value of 3,000 ohms, which passes a charging current of about 15 m.a.

The switch is transferred to the "charge" position when the receiver is not in use during the day, and put in the "off" position at night only.

## The Booster Battery

A 15-watt lamp similarly refreshes the L.T. battery. The values of resistance and lamp must necessarily be arbitrary by reason of the varying periods of use. However, in this particular case a test taken every month over a period of several months has shown that both batteries keep well charged.

A diagram showing the general principles only is given, as for different sets the values of resistance and size of lamp must necessarily be modified to suit the needs of various receivers.

In the case of the installation now in use the "booster" battery, charging resistance, and L.T. lamp, are neatly and inconspicuously stowed away in the loud-speaker cabinet, which also carries the master switch.

## Absolutely "Trouble-Free"

This is mounted below the fret in front, the eliminator being fixed inside the metal case of the receiver.

The installation has proved entirely

## A SUCCESSFUL BATTERY-MAINS COMBINATION

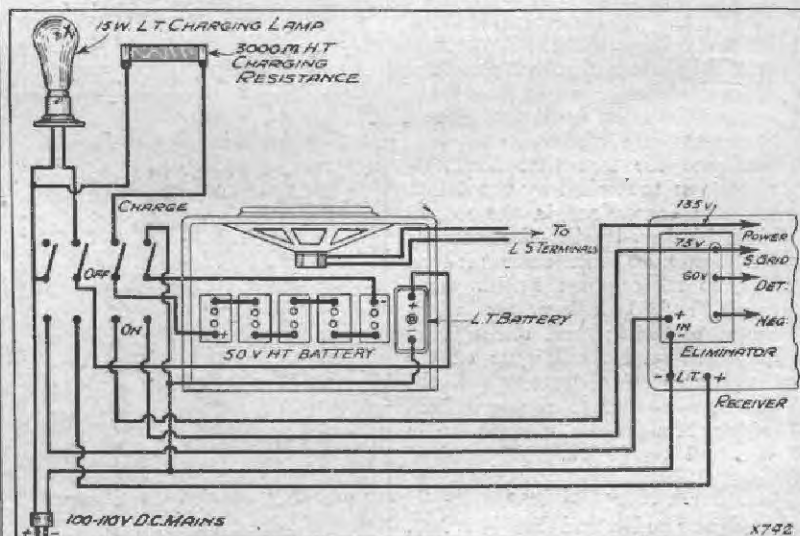

The complete circuit in which a "booster" battery is used in conjunction with a low-voltage D.C. supply.

A typical case, which has been in successful operation for several months, is a three-valve set taking about 10 m.a. in the output stage, which is used consistently for about five to six hours a day. The H.T. charging resistance has been fixed at

successful, and absolutely fool-proof and trouble-free. The background noise is negligible, and the performance of the set as regards quality of reproduction and distance-getting powers is all that can be desired by even the fastidious listener.



# THE "I.E." THREE

By VICTOR KING

*A three-valve version of an entirely new principle in radio receiver technique. The "I.E." Three single tuning dial covers the whole world of broadcasting, although the receiver is extremely easy to assemble and embodies no intricate mechanism or involved wiring.*

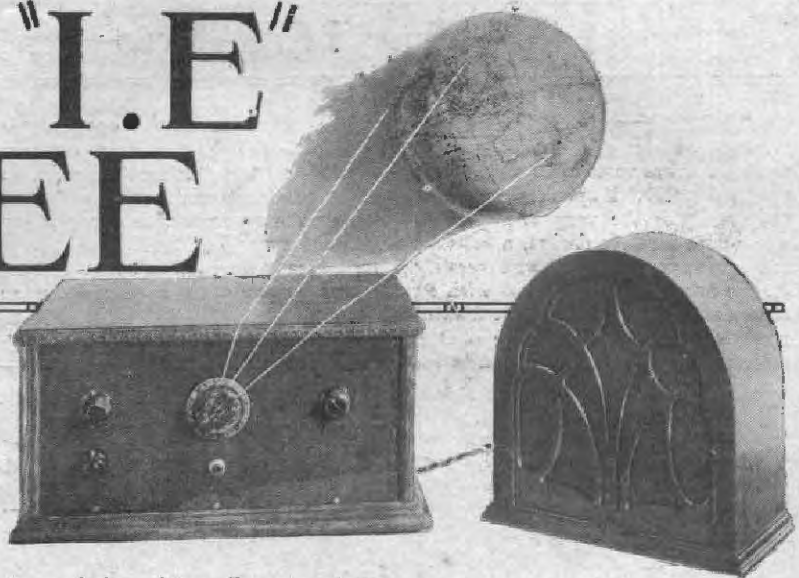

**H**AVE you ever tried your hand at short-wave reception? Or have you in the past been frightened off it because of the inconvenience of having a separate set for the purpose, or on account of the inevitable "swopping about" with the circuit of your ordinary broadcast set needed to make it suitable for short waves?

## A Worth-While "Band"

Perhaps you haven't realised before that in giving short waves the "go by" you have been missing more than a hundred really worth-while

transmissions from all parts of the world on a wave-band where heterodyne interference is almost unknown.

Well, now is the time—the period immediately after the Radio Show—when we *all* turn our attentions to a new set for the coming dark evenings, and *now* is the time when you can actually build, and no longer dream of, the set that will enable you to hear programmes from all over the world on an ordinary broadcast set in much the same way as you now listen to the continentals.

One-dial tuning, no wave-change

switching, and signals from all over the world simply "swarming" down your aerial, waiting for you to set the Extenser dial at the magic figures that will let them in! Such are the remarkable features of the "I.E." Three.

## Mediums as Well

It is not a short-waver any more than—in a sense—it is a broadcast set. It is a remarkably efficient combination of the two. It is, as a matter of fact, the very set that we have dreamed about for years, but which has never before been possible on account of all sorts of technical snags which have only been removed by the introduction of Extenser tuning.

Sounds good, doesn't it?

You can take it from me, it is good. In fact, it is one of the most fascinating receivers I have ever handled.

Just try and imagine a set with which you can tune in the London Regional at, say, 150 degrees, the Northern Regional at 175 degrees, and then, with a "spot" of reaction, New York at 45 degrees, and perhaps Sydney at 47 degrees!

## Fully Extensured

No wave-change switching, no coil changing, no circuit "swopping." Just a "swish" of the tuning dial and you leave your locals and the continentals and can select your programmes from stations in all parts of the world.

And if you can imagine all that, then you've got a jolly good idea of

## ALL SET FOR A WORLD TOUR

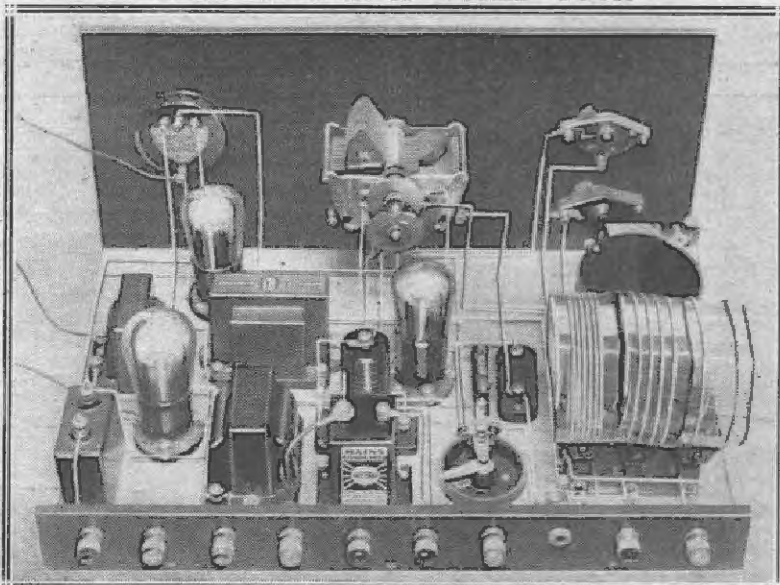

*Plug-in short-wave coils are used, but these do not have to be changed for ordinary broadcasting. One full rotation of the single tuning dial and you tune through both normal and short-wave stations.*



## The "I.E." Three—continued

the "I.E." Three. "I.E." stands for "Imperial Extensar." It also happens to be an abbreviation of "that is"—that is . . . if you want a set that really is the very last word in up-to-date receiver design, a set that will give you volume and quality on the broadcast band, a set with an absolutely *unlimited* range for distant reception; in fact, the set of the moment, then get a kit of parts for the "I.E." Three!

### On Long Waves

As for the long-wavers—well, if you want to hear those you can do so simply by plugging in a set of long-wave coils in the short-wave coil holders. But I'm very doubtful whether you will want to hear the long-wavers when once you have experienced the fascination of short-wave ether-searching. I've got a feeling that you will spend most of your time with the Extensar dial between 0 and 100 degrees with the short-wave coils in circuit.

Before I settle down to give you details of the construction of this set, I'm just going to mention the uses of the three small knobs on the panel, because I don't want you to imagine that the "I.E." Three is difficult to operate.

The upper knob on the left-hand side is the reaction control, and the one immediately below it is a station selector, which is only in circuit when the set is on broadcast wave-lengths. I shall have more to say about that later on.

The other knob—the one on the right of the panel—is a volume control of the "fader" type. In other words, it enables the set to be changed over from radio to pick-up without switching, and all that it is necessary to do when you want gramophone music instead of radio is to

forward three-valve—take my advice and choose from among the makes given in the list of components. Remember that the finished set has got to amplify signals from thousands of miles away, and that, in consequence, it is more important even than in the case of an ordinary

### A HUNDRED NEW ALTERNATIVE PROGRAMMES

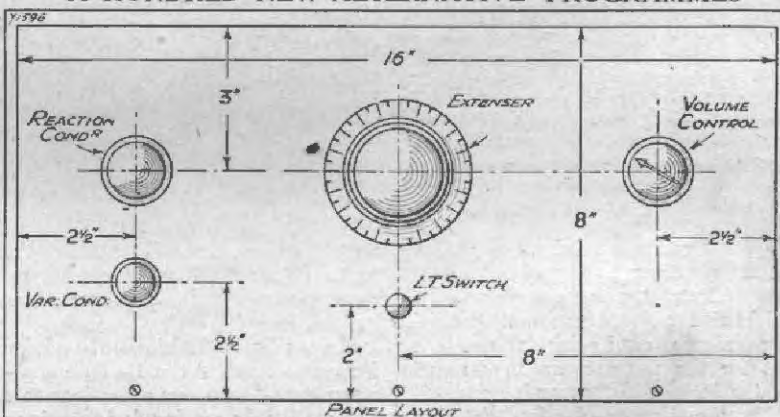

The controls of the "I.E." Three are quite straightforward, and if you can tune an ordinary radio set it is quite certain you'll be able to bring in the scores of short-wave stations on the "I.E."

turn the fader control right round. The pick-up can be left permanently connected to the plug, which need not be removed from the jack on the terminal strip at the back of the set.

### Inexpensive to Build

Now, as to parts—the total cost of which, by the way, will be precious little more than for any other straight-

broadcast receiver to select your parts with care.

In the ordinary way it would hardly be necessary to enter into details regarding the construction of the set, because most of you regular CONSTRUCTOR readers know as well as I do the general procedure when building, and can work unaided from the back-of-panel

### YOUR SHOPPING LIST FOR THE "I.E." THREE

- |  |  |   |
|--|--|---|
| 1 Panel, 16 in. × 8 in. × $\frac{1}{16}$ in. (Wearite, Permcoul, Becol, Red Seal, Goltone).  | 3 Baseboard-fixing plug-in coil mounts (Lotus, Igranie, Bulgin, Red Diamond, Wearite).   | 2 L.F. transformers of fairly low ratio (R.I. General-Purpose, Lotus, Telsen, Igranie, Mullard, Leweos, Lissen, Varley, R.I., Ferranti, Graham Farish). |
| 1 Cabinet for above panel size, with baseboard 10 in. deep (Camco, Pickett, Gilbert, Osborn).  | 3 Sprung-type valve holders (Telsen, Wearite, Lotus, Bulgin, W.B. Graham Farish, Burlington).  | 1 L.F. output choke (Ferranti, Igranie, Varley, R.I., Wearite, Bulgin, Lissen, Graham Farish).  |
| 1 0005-mfd. Extensar with slow-motion drive. Note that slow-motion drive for this particular set is essential. (Wavemaster, Cyldon, Formo, J.B.) | 1 0003-mfd. fixed condenser (Dubilier, Telsen, Mullard, T.C.C., Igranie, Graham Farish, Lissen, Ediswan).  | 1 P.V.1 coil and one P.J.2 (Leweos, R.I., Parex, Peto-Scott, Formo, Wearite, Goltone).  |
| 1 00075-mfd. "Brookmans" type solid-dielectric variable condenser (Ready Radio, Polar).  | 1 Grid-leak holder (Wearite, Graham Farish, Telsen, Varley, Watmel, Ediswan, Igranie, Lissen, Mullard).  | 1 25,000-ohm "Spaghetti" resistance (Telsen, Ready Radio, Bulgin, Varley, Igranie, Magnum, Leweos).   |
| 1 L.T. on-off switch (Telsen, Ready Radio, Bulgin, Junit, Goltone, Lotus, Igranie, Wearite, Graham Farish).                                      | 1 2-megohm grid leak (Dubilier, etc.).   | 1 Pick-up jack and plug (Bulgin, Igranie, Lotus).   |
| 1 1-megohm fader-type volume control. This enables the set to be changed over from radio to pick-up without switching. (Magnum, A.E.D.)          | 1 400-ohm baseboard-mounting potentiometer (Sovereign, Igranie, Lissen).   | 9 Engraved-type terminals (Belling & Lee, Eelex, Igranie, Clix). Strip of ebonite, 16 in. × 2 in., for terminal strip.                                  |
|  | 1 H.F. choke. This must be of the universal type suitable for all waves from 20 to 2,000 metres. (Leweos, R.I., Varley, Wearite, Graham Farish, Peto-Scott, Sovereign, Ready Radio.) | 3 Wander plugs for G.B. leads (Igranie, Eelex, Belling & Lee, Clix).  |
|  | 2 2-mfd. condensers (Formo, T.C.C., Dubilier, Mullard, Igranie, Helsby, Telsen, Lissen, Ferranti).   | Glazite, Lacoline, Quickwire, for wiring.   |
|  |  | Flex, screws, etc.  |

## The "I.E." Three—continued

diagram. But among the ever-increasing number of WIRELESS CONSTRUCTOR readers there are no doubt many newcomers who may never before have tackled the construction of a receiver.

So, as this is something of a special set, I'm going to deal with the construction in detail for the benefit of the newcomers; and those of you who are old hands at the game, well, just carry on from the back-of-panel diagram and I shall have some more to say to you a little later on when dealing with the operation of the set.

### No "Snags" Whatever

Even those who haven't previously tackled the construction of a set can tackle this one with the almost certain knowledge that it will work when you have finished it. It's a very simple set to make, and you begin by taking the panel and marking it out in accordance with the diagram, on which all the dimensions are shown.

In order to keep the front of the panel free from scratches, the drilling centres should be marked out on the back, in which case it is necessary to remember that the dimensions shown in the front-of-panel diagram become reversed; that is to say, the left becomes the right, and vice versa.

When all your centres have been correctly marked, the actual drilling will not take you very long, and when this is done the panel can be screwed to the edge of the baseboard.

You can now proceed to fix the five components on the panel, after which the baseboard components and the terminal strip can be secured. The disposition of the parts on the baseboard is rather an important point, and you should endeavour to follow the original as closely as possible.

### Fixing the Components

In this connection the positions can quite easily be determined by reference to the scale given on the back-of-panel diagram. You just take a pair of dividers—or a piece of paper will do—and measure the distance between the edge of the baseboard and a particular component, or between one component and another, and then hold the dividers or the piece of paper against the scale, which will give you the distance in inches.

The next job, having screwed the components down, is to wire the set up in accordance with the wiring diagram. That doesn't mean to say

that you have got to get every angle the same as in the original set. As a matter of fact, the set will work equally well if you make all the connections absolutely from point to point. The only thing is that it won't look quite so nice, which after all is not very important.

In order not to leave out any connections, you will find it best to mark each one off as you make it on the back-of-panel diagram. You can then see at a glance those which have been done and those which have still to be done.

With regard to the P.J.2 coil, you will notice that one end of the winding is joined to the .00075 condenser on the panel. The other end is joined to a length of No. 22 or 24 D.S.C. wire which passes twice round the centre winding on the P.V.1 coil unit, and

ends up at terminal Z on the same coil unit.

### A Coil "Adjustment"

This P.V.1 coil unit, by the way, requires a slight modification in regard to grid-coil turn numbers. This is on account of the fact that on the medium broadcast band the short-wave grid coil is in series with the P.V.1 grid coil, which, of course, slightly alters the wave-band over which the set is required to tune.

To put the matter right, just take 12 turns off the centre-winding of the P.V.1 coil unit. It doesn't very much matter which end you take the turns off, so that you can choose the end that happens to be the most convenient. When you have taken off the necessary turn numbers, the end of the wire should be fixed once again to the

### PLENTY OF POWER AVAILABLE

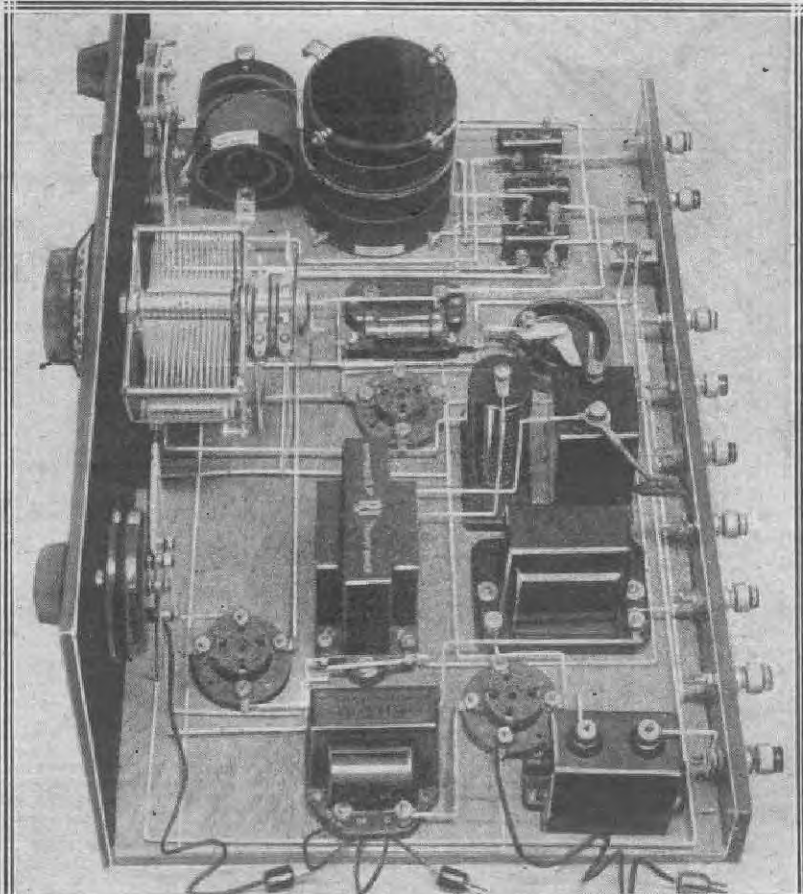

The "I.E." will give you an enormous output and you'll be able to operate any size speaker on many of the programmes. America, and perhaps even Australia, will at times fill the room like a home station.



## The "I.E." Three—continued

terminal from which you commenced to make the alteration.

Otherwise I think I've said all that need be said regarding the construc-

tion, so now I will carry straight on with the operating procedure.

First of all study the operating panel given elsewhere in the article

(which should be cut out and pasted to the inside of the set cabinet for future reference) for information, regarding coils, valves, H.T. voltages, etc.

### NOTHING NEW FOR YOU TO DO

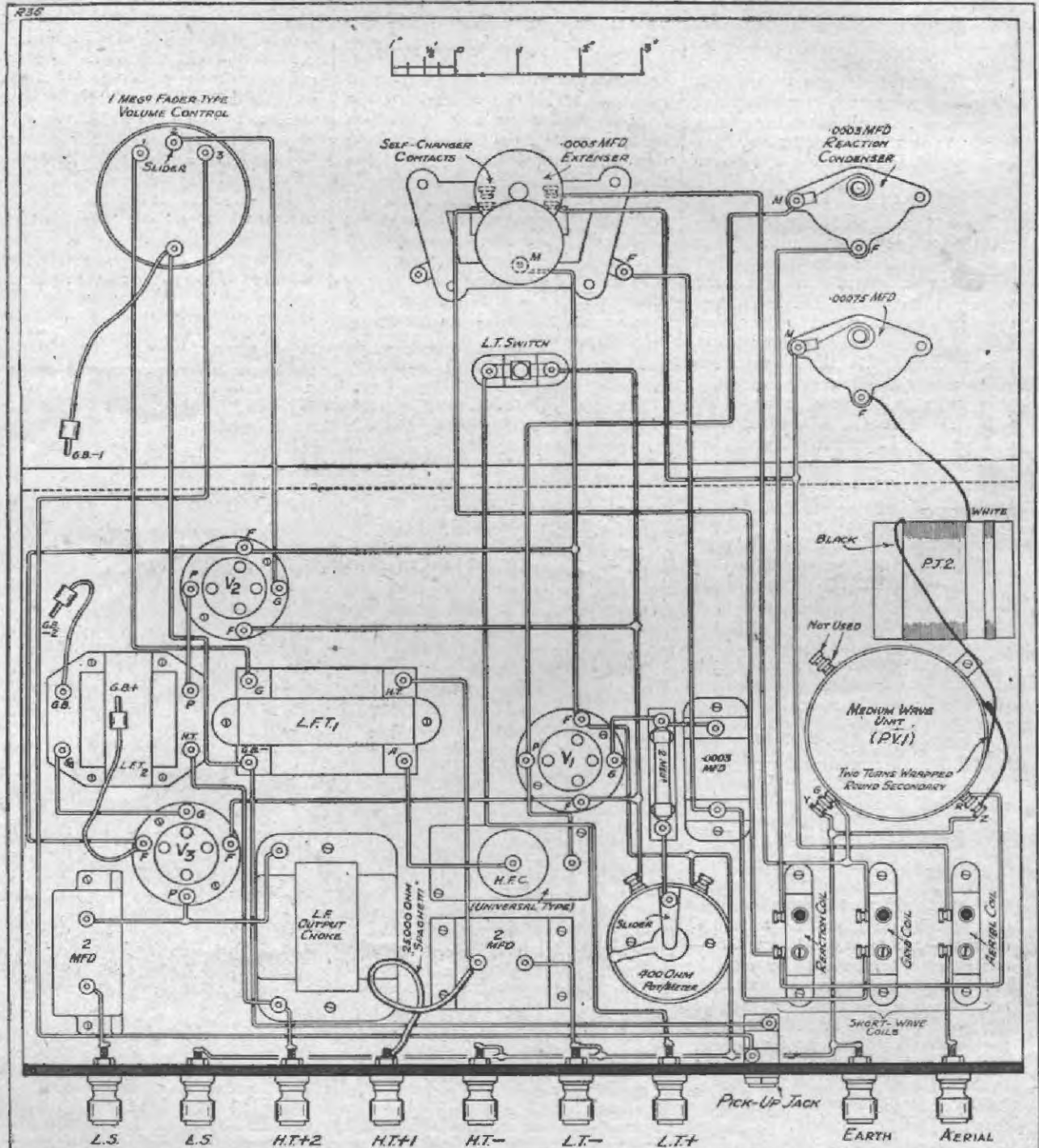

Despite its completely original design, you can see the "I.E." Three is entirely orthodox in assembly.

## The "I.E." Three—continued

When these matters have been attended to, and when the aerial and earth and loud-speaker leads have been joined up to the appropriate terminals, the set can be switched on.

the use of reaction, and that is that the set must never be in an oscillating condition when you are anywhere near the setting of the local station. If it is you will be likely to cause

### ACCESSORIES WE CAN RECOMMEND FOR THE "I.E." THREE.

**Valves.** 1 H.L. or special detector type, 1 L.F., and 1 small-power or power valve. (Osram, Mullard, Mazda, Eta, Tungram, Dario, Cosmor, Six-Sixty, Lissen, Fotos.)

**Coils.** Short waves: Plug-in type (see Operating Box). (Igranic, Atlas). Long waves: Plug-in type (see Operating Box). (Lowcos, Lissen, Igranic).

**Batteries.** 120- or 150-volt H.T. battery and a 9- or 18-volt unit for grid bias. (Ever Ready, Magnet, Columbia, Pertrix, Ediswan, Lissen, Drydex).

**Accumulator.** Voltage to suit valves chosen. (Exide, Ediswan, Lissen, Pertrix, G.E.C.).

**Loud Speakers.** (Undy, B.T.H., Mullard, Ampliou, Celestion, Blue Spot, Graham-Farish, W.B.).

100 degrees. On this band the set should always be operated in an oscillating condition when searching for distant stations, and when you hear a howl, then reaction should be slackened off until you hear the transmissions intelligibly.

### "Slow-Motion" Essential

But in order to achieve successful results on the short waves it is absolutely essential for the Extenser to be rotated very, very slowly. If you tune in this manner, and adjust the slider of the potentiometer on the baseboard until the set changes into the oscillating condition when you adjust the reaction condenser with nothing more than a gentle rushing sound, then you should not have any difficulty in picking up the distant short-wavers.

## THE "WIRELESS CONSTRUCTOR" "I.E." THREE RECEIVER

Circuit : Det. and 2 L.F. (automatic change from short to medium waves).

### VALVES.

1st (nearest coils) : H.F. or special det. type.  
2nd (nearest panel) : L.F. type.  
3rd : Small power or power type.

### COILS.

For Long Waves.  
Holder nearest end of baseboard No. 100 or 150; centre holder No. 200 or 250; remaining holder No. 100 or 150.

### For Short Waves.

Approx. Wave-range	Aerial Coil	Grid Coil	Reac. Coil
	No.	No.	No.
24 to 50 metres	2	4	6
40 to 80 metres	2 or 4	6	6 or 8

NOTE.—Medium-wave coils are in set.

### VOLTAGES.

L.T. : 2, 4 or 6 volts, to suit valves.  
H.T.+1 : 30 to 70 volts.  
H.T.+2 : 120 to 150 volts.  
G.B.—1 : 1 to 3 volts.  
G.B.—2 : 5 to 15 volts, depending upon valve in output stage (see maker's instructions).

### ADJUSTMENTS.

**POTENTIOMETER :** Adjust slider to position which gives smooth reaction control.

**SELECTIVITY (Medium wave-band) :** Increase, or reduce, according to local requirements, number of turns wrapped round the P.V.1 coil (this is the coil mounted vertically).

### OPERATION.

Tune with centre knob. Normally, a two-figure reading indicates a short-wave station, and three-figure numbers give stations on medium broadcast band. When long-wave coils are in circuit, a two-figure reading indicates stations on this band.

Upper left-hand knob controls reaction.

Lower left-hand knob is station selector. It should be adjusted for every setting of Extenser dial on medium waves only.

Right-hand knob is fader-type volume control, which not only controls volume, but switches set over from radio to gramophone (jack for pick-up is at back of set).

Set is switched on and off by small knob below Extenser dial.

In order to hear the local station, which should give you an idea of whether the set is working correctly, tune with the Extenser between 100 and 200 degrees. When you hear the transmission, which, by the way, should be possible with reaction set at zero (plates all out), turn the station selector until you get loudest results.

Mind you don't get caught out with the fader volume control! Remember that this *must* be over on the radio side before you can hear any broadcasting.

### Searching for Foreigners

When tuning in a distant station on the broadcast band, especially if you are a newcomer to radio, there is not very much harm in searching for a carrier-wave, or, if you like, a howl, with the set actually oscillating. Until you become familiar with a set this greatly simplifies searching, for when you hear a howl all that you have to do is to decrease the reaction condenser until you hear speech or music.

But there is one very important thing to remember in connection with

severe interference to your neighbours.

When you have tuned in a distant transmission on the broadcast band the station selector should be adjusted for loudest results.

To change the receiver over to short waves, and by short waves I mean the very short waves between about 24 and 50 metres, you simply tune with the Extenser between 0 and

## YOUR PASSPORT FOR THE WORLD TOUR

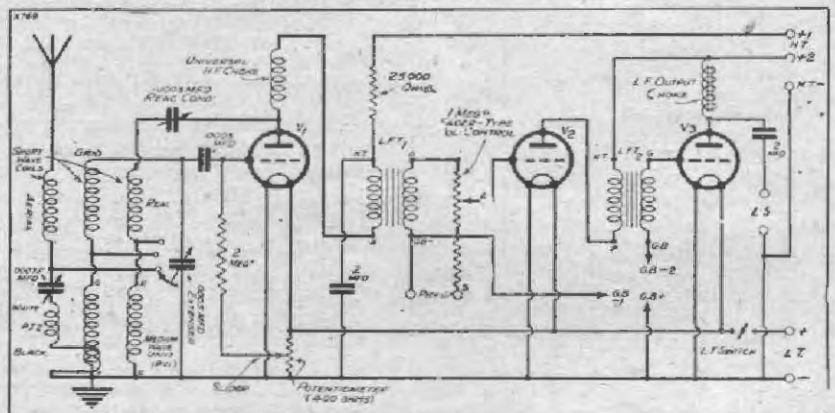

There are no snags, the circuit is a thoroughly tried and tested one, and is far removed from being a "freak" in any one way.



# QUEER QUERIES



Some suggestions about unusual radio faults that may help you towards better reception.

By P. R. BIRD.

## Checking Distortion on a Cheap Milliammeter

A SHEFFIELD quality enthusiast was recently troubled to discover that an expensive milliammeter connected in the plate circuit of the last valve would not show up distortion so well or so quickly as the quite cheap instrument which he had been using before. This is a little peculiarity of behaviour which is apt to be misleading.

The trouble is, of course, that a really expensive milliammeter is "dead beat," while the cheaper kinds flicker and flutter on the smallest provocation.

These cheaper and less efficient instruments are not so good for rapidly reading off the number of milliamps. flowing, because they take such a long time to "come to rest." But, as a matter of fact, they are much better for indicating distortion, the needle being agitated by the first sign of it.

So, if you are getting a milliammeter to instal permanently in the plate lead to the last valve, as a check on overloading, it is not a bad plan to get a cheap and lively one, and save cash!

## Probing a "Paratune"

Writing from Derbyshire a reader wants to know why it is necessary to probe his "Paratune" coil to get maximum strength from distant stations?

Quite by accident he discovered that on pushing the travelling blade of the Paratune coil hard up against the turns of wire with a lead pencil enabled him to bring in Fécamp at twice the strength with which this station was received when the pencil was removed.

Being of an inquisitive turn of mind he tried this pencil probing on other stations, and although on most of

them—particularly the locals and stronger stations—no difference whatever was noticeable, there was nevertheless a marked improvement in most of the foreigners at the bottom end of the tuning range.

## Improved Results

Nurnberg, the German, was doubled in strength, and Cork was greatly improved; but, curiously enough, Dublin—receivable at about the same strength as Cork—was not susceptible to a "pencilled" improvement in this way.

.....  
 \* \* \* \* \*  
**HOW IS YOUR SET BEHAVING NOW?**  
 \* \* \* \* \*  
 If you are troubled by a radio problem, remember that the "Wireless Constructor" Technical Queries Department is fully equipped to help you.  
 Full details of the service, including scale of charges, can be obtained on application to the Technical Queries Department, "Wireless Constructor," Fleetway House, Farringdon Street, London, E.C.4.  
 SEND A POSTCARD, on receipt of which the necessary application form will be sent by return.  
 LONDON READERS, PLEASE NOTE. Application should not be made by telephone, or in person at Fleetway House or Tallis House.  
 \* \* \* \* \*

The fact that the phenomenon was observed only at one end of the tuning range indicated that contact there was less effective than over the rest of the coil.

It was suggested that the component should be partially dissembled, and the spring, which had evidently been weakened, should be improved by its being carefully bent over in such a direction that its pressure on the turns of wire was somewhat greater than formerly.

Sure enough, this did the trick.

What had been happening was that fair contact was being made over most of the coil. But its lower end, due possibly to some slight discrepancy in manufacture, was resting too lightly on the turns for good contact.

The slight increase of tension caused by re-bending the spring was all that was required to cure the trouble.

## Duplicated Terminals on Reaction Condensers

A correspondent who lives at Garston, Liverpool, suggests—probably with truth!—that I might save a lot of bad language being used if I warn wireless constructors of the "reaction condenser snag." The results from his last set had been too disappointing for anything, and he started suspecting different components and wires on the set before he discovered that he had struck the old snag of duplicating terminals.

His reaction condenser was an ordinary one, but with three terminals on it, one for the moving vanes and two for the single set of fixed vanes. (It was not a differential reaction condenser, remember.)

And not noticing what he was doing he had taken one connection to one side of the fixed vanes, and the other connection (which, of course, should have gone to the moving vanes) to the other side of the fixed vanes, so that really the reaction condenser was not working at all!

Of course, it was but the work of a moment to put it right, but although the snag has been pointed out before it is very easy to fall into, and is mentioned here again just as a reminder.

## THOSE PARALLEL WIRES

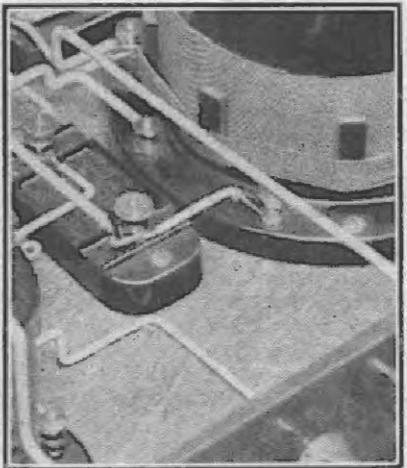

Remember that when two wires must run parallel to one another they should be spaced well apart, and wires which cross near other wires should do so at right angles, to keep the capacity effects between them as low as possible.



# SEEN AT THE SHOW

**T**HERE were hosts of things to attract the eye and tickle the fancy at this year's Radio Exhibition, but everyone was talking about the amazing displays of valves, new and old, that were provided by the various valve firms.

Every possible requirement was catered for, and a host of new valves made their bow to the public during those eight days.

Not content with the famous A.C./S.G. valve, for instance, the Mazda valve people introduced another indirectly-heated S.G. type for A.C. mains.

This is the A.C./S.2, a particularly fine valve having the surprising characteristics of 600,000 ohms impedance and a magnification factor of something like 3,000. The inter-electrode capacity is exceedingly low, so that quite a large portion of this magnification is a practical one in a carefully designed amplifier.

### For the "D.C." Man

The D.C. mains user has also been well catered for by the same firm, for in addition to the .5-amp. class of indirectly-heated D.C. valves there are now available some .1-amp. types.

The range is not quite completed, but when it is it will include the S.G., D.C.3/H.L., D.C.2/P., and D.C.2/Pen. These have heater voltages of 30, 30, 40 and 40 volts respectively.

Coming to battery valves, we have two new Mazda 2-volt S.G.'s—the S.215A. and S.215B., and a couple of new pentodes. These are the Pen.220 and Pen.220A.

The former has a .2-amp. filament and the extraordinarily low anode current consumption of 3 milliamps at 120 volts, increasing to 5 milliamps at 150 volts. At this figure it is possible to obtain about 370 milliwatts undistorted output.

The larger valve of the two—the Pen.220A.—takes 18 milliamps at 150 volts, and supplies nearly 1,000

*Many new valves made their appearance at Olympia during the National Radio Exhibition. Here is a brief description of some of the most outstanding types.*

By G. W. EVANS.

milliwatts (900 to be exact), while at a lower voltage (120) 600 milliwatts are available, and only 12 milliamps are consumed.

Mullard pentodes made a fine show at Olympia, several new ones being

### A POPULAR PAIR



*Miss Pat Paterson, the radio artiste, with the giant Mullard valve which was a feature of the Radio Exhibition at Olympia last month.*

added to our old favourites. These were the P.M.24C. and P.M.24D., even "larger" valves than the P.M.24A. and 24B.

Then the Pen.4V. made its debut. This is an indirectly-heated pentode for A.C. operation, and has a slope of 3 milliamps per volt.

### Variable-Mu "Tubes"

The variable-mu S.G. valves also created a great deal of interest. We must not forget the P.M.202, a 2-volter of wonderful characteristics for output purposes, while new A.C. mains valves have also been introduced.

We have mentioned the Pen.4V., but in addition to this we have the 904V., a detector of great sensitivity, with an amplification factor of 85-90, and an impedance of under 20,000 ohms.

New S.G. valves played a big part in the Cossor display, including an S.G. H.F. pentode—the M.S./Pen.A. Then there are mains S.G. valves for high or low amplification, called respectively the M.S.G./H.A. and M.S.G./L.A.

The new Cossor mains pentode is a valve to be reckoned with. It has a mutual conductance of 4, and is a highly efficient valve.

### Better Battery Valves

But this does not finish the Cossor range of A.C. valves, for in addition we have the 41M.P. and the 41M.X.P., having the remarkable mutual conductance of 7.5.

Battery valves, too, have been given considerable attention, and the metalised S.G. and detector valves created considerable interest. They are exceedingly good valves, and the metallic coating is a valuable aid to screening.

The S.22, an Osram screen-grid valve, is worthy of note, as also is its brother the S.21. The first has a



## Seen at the Show—continued

steep slope, and the second a long grid swing and somewhat lower mutual conductance. The impedance is the same in both cases.

### Many Improvements

Since last Show the L.P.2 and the P.2 valves have made their appearance, having slopes of little under 4, while a new pentode—the P.T.2—is worth careful consideration.

The famous P.X.4 has been greatly improved, its maximum anode voltage having been increased to 250 volts and the slope increased to 6. The valve is now capable of providing an undistorted output of considerable magnitude, as the power dissipation is round about 12 watts.

The A.C. mains M.P.T.4 is a new pentode of the indirectly-heated variety, and the P.T.4 is a directly-heated type that should have a ready sale. The former has a slope of round about 3, and the latter a slightly less steep characteristic of 2.2.

Naturally, the Osram D.C. valves were well to the fore, these having the useful heater consumption of .25 amp. at 16 volts. These consist of the D.S., D.H., and D.L., and have been used in the WIRELESS CONSTRUCTOR mains set described this month.

More Eta valves are on the way, I hear, for the famous range of two-volters is to have three new valves added to it, and a fresh rectifier for A.C. sets is also contemplated.

### A New Rectifier

The latter is a full-wave rectifying valve, with a 4-volt filament taking .7 amp. and providing 50 milliamps at 300 volts. It should prove an exceedingly useful valve, and will be known as the D.3-50B.

The three new two-volters are all welcome, and consist of a couple of H.F.-detector valves and a super-power. The H.F. valves (B.Y.2020 and B.Y.1210) have impedances of 20,000 and 10,000 ohms, and, of course, the really sane system of nomenclature adopted by the Electrical Trading Association, Ltd., is employed.

This gives the characteristics of the valves at a glance, and we see that they have amplification factors of 20 and 12. The mutual conductances are not high, therefore, but they are useful, and the valves should meet with general success.

The third of the two-volters is the B.X.604, and is a .2-amp. filament output valve with an impedance of 4,000 ohms and an amplification factor of 6. In all cases the recommended maximum H.T. voltage is 150 volts, and the prices will be 7s., 7s. and 8s. respectively for the two-volters, and 12s. 6d. for the A.C. rectifier.

### To Be Released Shortly

The release of these valves, I understand, is imminent, and they may even be available before these words are in print.

I have recently received for test a batch of A.C. and 2-volt Tungstam barium valves. Without going into details of the tests and how each valve

### PLENTY OF PUNCH



Putting the giant valves in the B.B.C. relay amplifier at Olympia. It fed about 400 loud speakers.

behaved "itself" it will be sufficient to say that they are all excellent. In fact, I am using one of the A.C. general-purpose valves (A.G.4100) in a super-het. I have working at home.

### For the Output Stage

But especially outstanding among these valves is the P.460, which has characteristics like the Osram P.X.4. It is a remarkable valve, and has an A.C. output of something like 2 watts.

For the information of those unfamiliar with this make of valve the

following details may be useful. The two-volters are arranged as follow: H.210, P.D.220 (special det.), L.210 (det. or L.F.), P.215 and P.220 (power), and S.P.230 (super-power).

Among the A.C. types the following are most valuable: A.8.4100 (metalised screened-grid valve), A.G.4100 (det. or L.F.), P.460 (directly-heated super-power valve).

### NEXT MONTH.

We are presenting a unique 2-valve set design for home-constructors in the December issue.

On Sale Nov. 14th. Price 6d.

\*\*\*\*\*  
 \* SAFEGUARDING \*  
 \* YOUR VALVES \*  
 \* A useful tip for prolonging the \*  
 \* lives of "wobbly" ones. \*  
 \*\*\*\*\*

OCCASIONALLY, owing to faulty handling or to some other cause, the bulb of a valve comes loose in its seating, and whilst still retaining electrical connection with its pins it can be moved about within its base.

Have you any "Swivel-necks" in your collection of valves? If so, try this little dodge and make them all "Rubber-necks"!

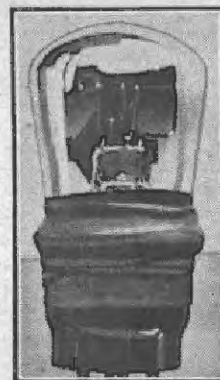

A valve in this condition is naturally one which is on the broad road to oblivion. However, much can be done to put matters right by the very simple procedure of wrapping several turns of rubber tape around the junction between valve bulb and valve base, as indicated in the accompanying illustration.

# The D.C. "ACE"

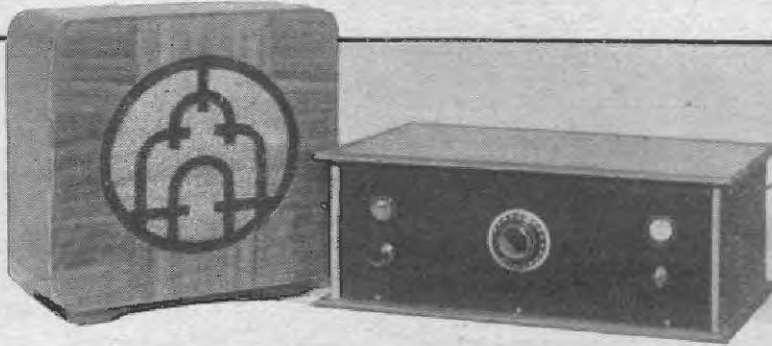

WHEN introducing an all-from-the-mains receiver in these times of National economy—especially an outfit intended for D.C. mains—it seems to be very desirable to get down straight away to the question of upkeep costs.

### Inexpensive Running

And those of you who have previously been under the impression that a D.C. outfit was an expensive proposition to run should prepare for a shock! For, taking the cost of power as 6d. a unit, which is rather more than the average figure, the "D.C." Ace can be maintained for an all-in figure of something less than half-a-crown a month. And that is assuming that the set will be in use for four hours a day on every day of the week!

Can you run your battery set for less than 8d. a week? More likely to be a shilling or one shilling and threepence, isn't it?

So much for point number one.

Then what about safety? As a close relation of mine once asked me when I had installed an all-mains set, "Is it likely to blow up?" The "D.C." Ace—or, for that matter, any other well-designed mains set—is about as likely to "blow up" as an electric torch!

### No Danger

As in the case of all electric gear, there are, of course, certain precautions to be observed. But providing you don't deliberately ask for trouble by tinkering about inside the set with the mains switched on, the chances of

By G. T. KELSEY.

*This is the first set of its kind we have ever published! A two-valver giving three-valve results would be remarkable enough, but, in addition, this one has no batteries at all and no wave-change switching! Don't miss reading all about it.*

getting a shock are very remote—in fact, are well-nigh impossible.

So that if you are on D.C. mains, and decide to try your hand at this

latest all-mains design, you can do so with the comforting thought that when you have finished it, not only will it be safe enough for anyone in the household to handle, but also that it will actually be cheaper to run than an ordinary battery-operated receiver.

But now for the biggest plum of all. The "D.C." Ace, although to all appearances only a two-valver, is equal in performance to many of the "threes" I've heard of the ordinary battery-operated variety! Not only is it sensitive and selective, but it is

### IT USES THE VERY LATEST VALVES

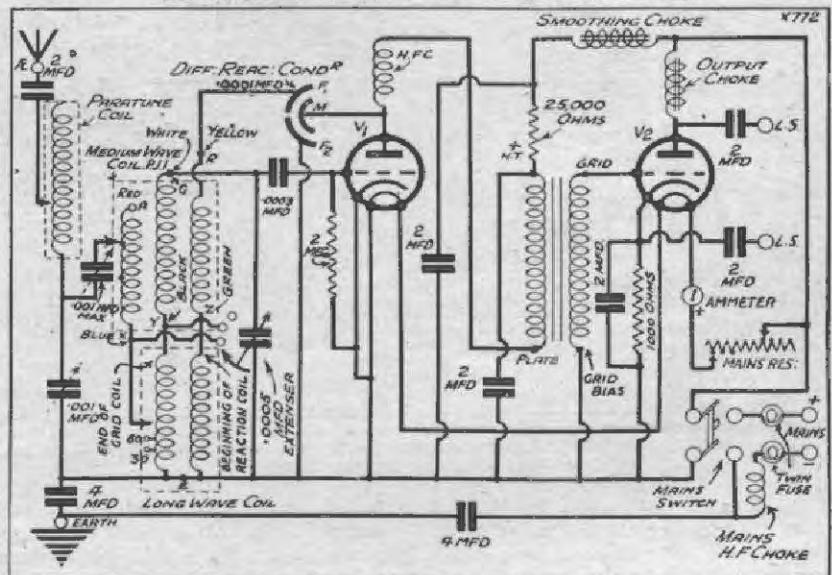

Many points of real interest will be obvious from a study of the circuit. Note that the high-efficiency indirectly-heated D.C. valves are wired in series with one another, and with an ammeter which is mounted on the panel.



## The D.C. "Ace"—continued

capable of giving an output from the local stations sufficient to work a moving-coil loud speaker.

### Outstanding Features

Selectivity, sensitivity, superb quality, and ample volume for all normal domestic purposes—such are

wave-change switches and no coils to change.

Without a doubt, the designing of an all-mains set for D.C. mains has in the past been something of a ticklish problem. But now that the valve manufacturers have at last concentrated upon the production of valves

set to and build yourself a "D.C." Ace!

### No Batteries At All

Do not consider it beyond your set-making capabilities just because it happens to be a mains receiver. It's as simple to make as any ordinary battery-operated outfit, and the great advantage is that when you have finished it you can fit it up and forget about it.

Everything necessary for its operation—H.T., L.T., and G.B.—is obtained from the mains, so that once it is installed, even though the initial outlay is heavier than for a battery-operated set, you can count on absolutely trouble-free radio. Nothing short of a breakdown at the power station is likely to interfere with your programmes if you build yourself a "D.C." Ace.

### The Coils Employed

A complete list of the parts required for this set, showing the makes used in the original receiver, together with the WIRELESS CONSTRUCTOR'S recommended alternatives, is given elsewhere in the article, so that there is hardly any need to say anything further in this respect.

But before you can proceed very far with the construction you will require details of the special coils employed, so it would perhaps be as well to deal with these first of all.

The P.J.1 coil, which can be obtained commercially if you would prefer not to make it yourself, consists of three windings of No. 30 D.S.C. on a former 2 in. in diameter and 3 in. long. The first winding, which is the aerial winding, should be commenced about  $\frac{3}{8}$  in. from one end of the former, and consists of 9 turns, with tappings at the fourth and sixth turns.

### Winding Details

The second winding, which is the grid winding, should commence about  $\frac{3}{8}$  in. away from the end of the first coil, and consists of a straightforward winding of 64 turns.

This time leave a space of about  $\frac{1}{2}$  in., and then wind on a further 34 turns for reaction. All these windings should be in the same direction.

In order to simplify connecting up, the ends of the windings on this P.J.1 coil should be marked with the following distinctive colours, which

### STRIKING SIMPLICITY FOR A MAINS SET

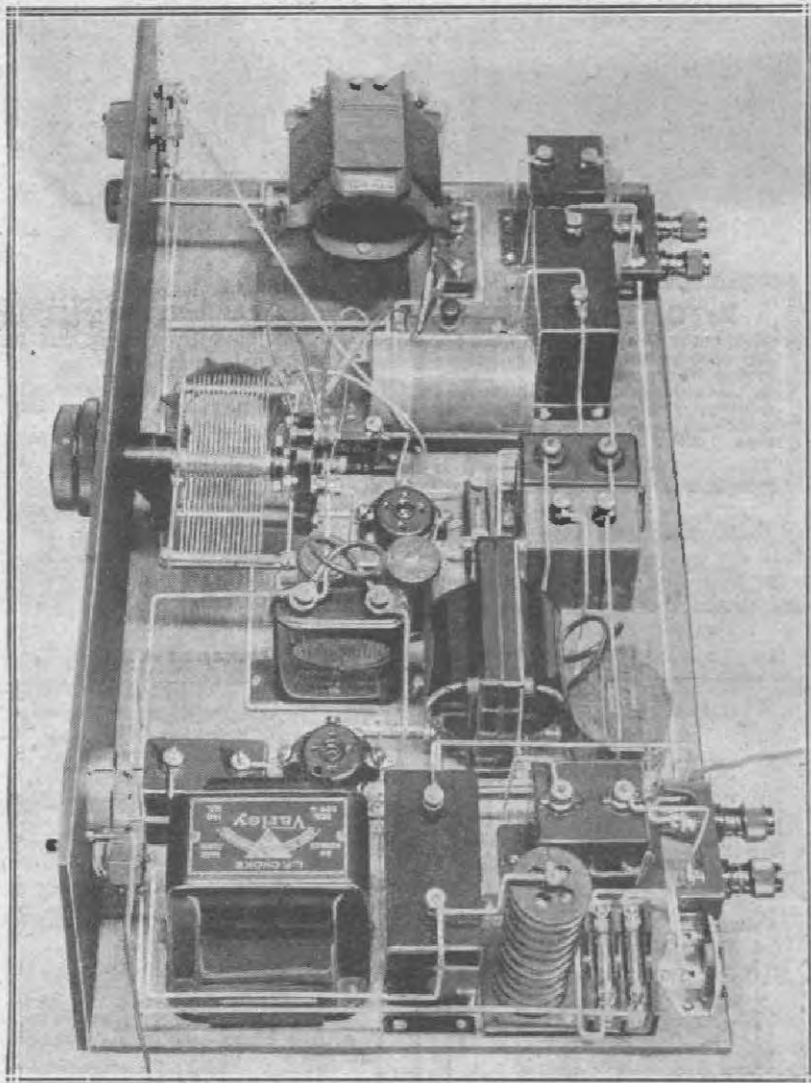

When seen from the "smoothing" end a mains set is generally a mass of big condensers and chokes, but this one attains perfectly hum-free reception with quite a moderate demand on your pocket.

the outstanding features of this newest-in-mains-sets design. And to crown all that, the set is a dual-ranger; that is to say, it covers both medium- and long-wave stations, even despite the fact that there are no

specially for this purpose—and remarkably efficient valves they have turned out to be—well, I'll say no more other than that if you are on D.C. mains which are rated anywhere between 200 and 250 volts, you should

## The D.C. "Ace"—continued

correspond with those given on the back-of-panel diagram. Start of aerial winding red, end of aerial winding blue; start of grid winding white, end of grid winding black; start of reaction winding green, end of reaction winding yellow.

There is nothing very difficult in the construction of the long-wave coil, for a coil quoit is used for the former, and the windings are put on hank fashion. Again, the wire used is No. 30 D.S.C., and when you have fixed one end to the quoit wind on 60 turns for the reaction coil.

### The Tapping Points

At this point bring out a tapping—which should be marked "E"—wrap a piece of Empire cloth (or paper will do) over the top of the first winding, and then continue with a further 150 turns, making tappings at 30 and 60 turns from the tapping marked "E." The 150-turn winding is the grid coil.

When your coils are completed you can then carry on with the construction of the set, which, with the aid of the back-of-panel diagram, you will not find to be a particularly difficult job. Follow the original as closely as possible when spacing out the components.

When you have fixed the control knobs to the components which are mounted on the panel, just put a blob of sealing wax over any knob's grub-screw that protrudes sufficiently far for the fingers to touch it. (This

been made, and those which have still to be made.

When the set is completed and you feel quite certain that the wiring of your version corresponds in every respect with the wiring diagram, place

### NO WAVE-CHANGING TO WORRY ABOUT

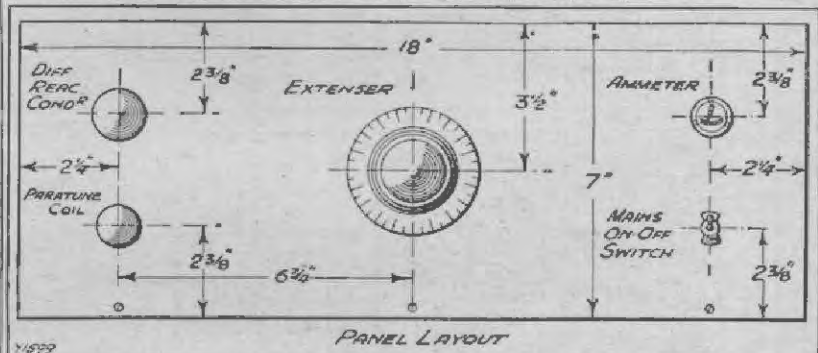

The controls are self-explanatory, and virtually all the operation is centred in the Extenser. The secondary adjustments of differential reaction and Paratune will, however, turn the set into an amazing distance-getter.

is just a precautionary measure in case the positive side of your mains happens to be earthed.)

Be careful not to make any wrong connections or omissions when wiring up, and mark off each lead on the wiring diagram as you make it on your set. You will then be able to tell at a glance the connections which have

an Osram D.H. valve in the first valve holder (the one nearest the coils), an Osram D.L. valve in the second position, and then slide the set into the cabinet, bringing out to the rear the two leads marked "to mains resistance."

One of these leads (it doesn't matter which one) should be joined to the

### NUMBERS OF POINTS OF SPECIAL INTEREST

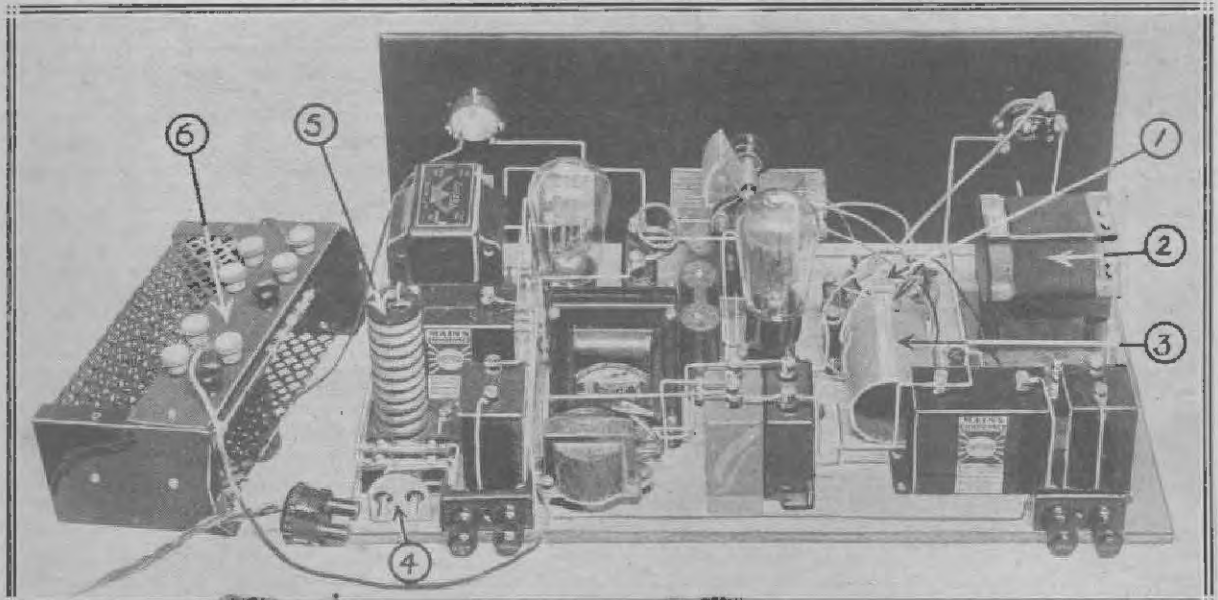

The design of the D.C. "Ace" is quite out of the ordinary. The long-wave coil is wound on a coil quoit (1), and at (2) and (3) are shown respectively the Paratune coil and the P.J.I. A special safety mains-plug is indicated at (4). The mains H.F. choke is depicted at (5), while at (6) we have the special resistance that is mounted on the back of the cabinet.



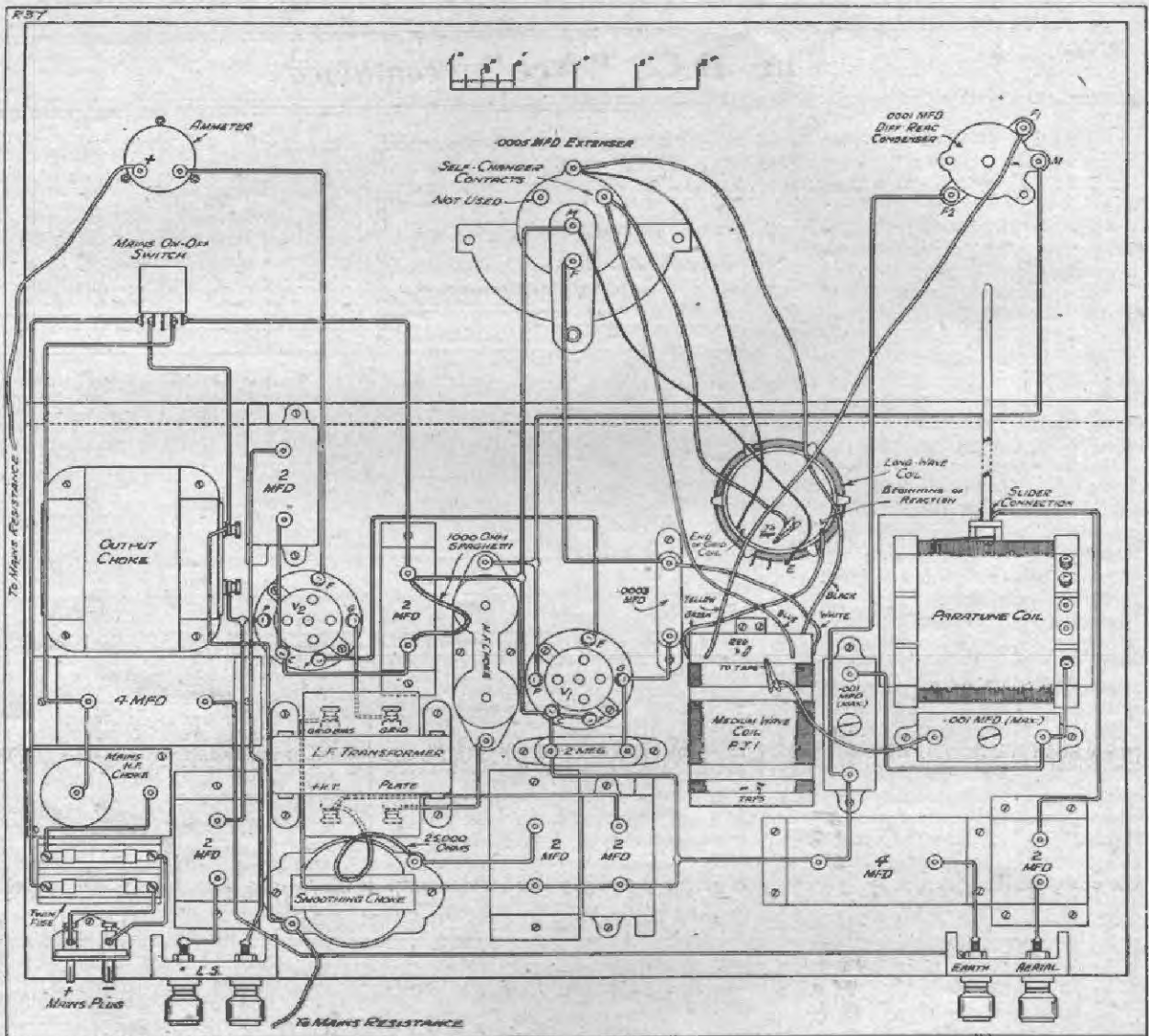

**THE PARTS FOR THE D.C. "ACE"**

- |  |  |   |
|--|--|---|
| <p>1 Panel, 18 in. x 7 in. x 1/8 in. (Peto-Scott, Fernicol, Goltone, Wearite, Becol).</p> <p>1 Cabinet for above panel size, with baseboard 10 in. deep (Peto-Scott, Cameo, Pickett, Osborn, Gilbert).</p> <p>1 0005-mfd. Extenser (Formo, J.B., Cyldon, Wavemaster).</p> <p>1 0001-mfd. differential reaction condenser (Ready Radio, Lotus, Telsen, J.B., Formo, Igranie, Polar, Cyldon, Burton).</p> <p>1 0 to 5 ammeter (Bulgin).</p> <p>1 Mains-type switch (Bulgin, Igranie).</p> <p>1 Paratune unit (Wearite, Ready Radio).</p> <p>1 P.J.1 coil unit (R.I., Peto-Scott, Wearite, Formo, Ready Radio Parex, Melbourne, Goltone).</p> <p>2 001-mfd. max. compression-type condensers (Formo, Sovereign, Goltone, Lewcos, R.I., Lissen, Telsen).</p> <p>1 Coil quoit (Peto-Scott, Wearite, Sovereign, A.E.D.).</p> | <p>2 Five-pin valve holders (Burton, W.B., Telsen, Lotus, Wearite, Bulgin, Magnum).</p> <p>1 0003-mfd. fixed condenser (T.C.C., Telsen, Mullard, Dubilier, Igranie, Graham Farish, Ferranti, Ediswan).</p> <p>1 H.F. choke (Telsen, Ready Radio, Lewcos, R.I., Varley, Lotus, Lissen, Wearite, Magnum, Sovereign, Peto-Scott, Parex).</p> <p>1 2-megohm grid leak and holder (Ferranti, Graham Farish, Igranie, Mullard, Ediswan, Telsen, Varley, Watmel).</p> <p>6 2-mfd. condensers (Ferranti, T.C.C., Formo, Dubilier, Heisby, Mullard, Lissen, Telsen).</p> <p>2 4-mfd. condensers (Formo, etc.).</p> <p>1 L.F. transformer (Ferranti A.F.3, R.I., Mullard, Telsen, Igranie, Lotus, Lewcos, Lissen, Varley).</p> <p>1 L.F. output choke (Varley, R.I., Igranie, Bulgin, Wearite, Graham Farish, Lissen, Ferranti).</p> | <p>1 L.F. smoothing choke (Igranie Midget, Varley, R.I., Wearite, Bulgin, Lotus, Ferranti, Lissen).</p> <p>1 Mains-type H.F. choke to carry 25 amp. (Wearite).</p> <p>1 Twin-fuse unit (Bulgin).</p> <p>1 Mains plug and socket, baseboard-mounting type (Bulgin).</p> <p>1 1,000-ohm "Spaghetti" resistance (Magnum, Bulgin, Telsen, Igranie, Varley, Ready Radio, Lewcos, Sovereign).</p> <p>1 25,000-ohm "Spaghetti" resistance (Lewcos, Goltone, Telsen, etc.).</p> <p>2 2-terminal blocks (Belling &amp; Lee, Junit).</p> <p>4 Engraved-type terminals (Belling &amp; Lee, Igranie, Eelex, Clix, Goltone, etc.).</p> <p>Glazite, Lacoline, Quickwire.</p> <p>1 D.C. 25-amp. mains resistance (Bulgin).</p> <p>Crocodile elips (Goltone, Graham Farish) Flex, screws.</p> |
|--|--|---|

## The D.C. "Ace"—continued

### THE "WIRELESS CONSTRUCTOR" D.C. "ACE"

Circuit: All-from-the-mains (D.C.) det. and 1 L.F.

#### ADJUSTMENTS.

1. Compression-type condensers near Paratune coil (the coil with slider) should be adjusted for best results in your particular locality.
2. Tap for best results on medium-wave coil (P.J.I) should be found by varying position of clip.
3. Tap for best results on long-wave coil (coil quit) should be found by varying position of clip.

#### VALVES

V<sub>1</sub>: D.C. indirectly-heated detector valve.  
V<sub>2</sub>: D.C. indirectly-heated L.F. valve.

**WARNING.**—No adjustments must be made to clip positions until mains have been switched off.

#### OPERATION.

Tune with central dial, and when station has been found adjust Paratune control (medium waves only) for loudest results.  
On long waves (three-figure readings on central dial), Paratune adjustment should be set, and left, at position which eliminates any "break through" from local station on long waves.  
Top left-hand dial is reaction control.  
Paratune adjustment is knob below this.  
Set is switched on and off by the lower control on the right of panel.

necessary to vary the positions of the clips in order to determine which give the best results. But in this case alteration of the tapping-clip positions can—in fact, *must*—be done with the mains switched off.

Every time you adjust the Extenser to a different setting over its two-figure range the slider of the Paratune coil also should be adjusted.

On long waves, in other words, when the Extenser is at a three-figure reading, the Paratune adjustment should be set at the position where it eliminates any "break-through" from the local station, and should not then be touched again.

terminal on the mains resistance marked "2," and the other to the terminal corresponding, or most nearly corresponding, with the voltage of your local supply. (This mains resistance, by the way, should be screwed to the back of the cabinet.)

You can now connect up the aerial and earth, the loud speaker, and finally the mains plug, after which the set can be switched on. The moment the set is switched on, the needle of the ammeter on the front of the panel should go up to .25 amp., although you will not be able to hear anything for half a minute or so until the valves have warmed up.

#### ACCESSORIES

Valves, 1 Detector and 1 L.F. valve (indirectly heated). Those used in set were Osram D.C. valves, D.H. and D.L.  
Loud Speaker. (Mullard, Celestion, Undy, B.T.H., Blue Spot, Amphon).

If the needle does not go up to .25 when you switch on, then you have most likely got the mains connected round the wrong way, and the mains plug should be taken out and reversed.

The only time when you need to make adjustments inside the set *with* the mains switched on is when you are determining the best settings of the two compression condensers near the Paratune coil. Even then there is no need to put your hand inside, because the knobs are grooved so that they can be adjusted with a wooden "screwdriver."

You will notice that there are tappings on both the P.J.I coil and the long-wave coil quit, and it will be

### WHEN THE WIRING IS FINISHED

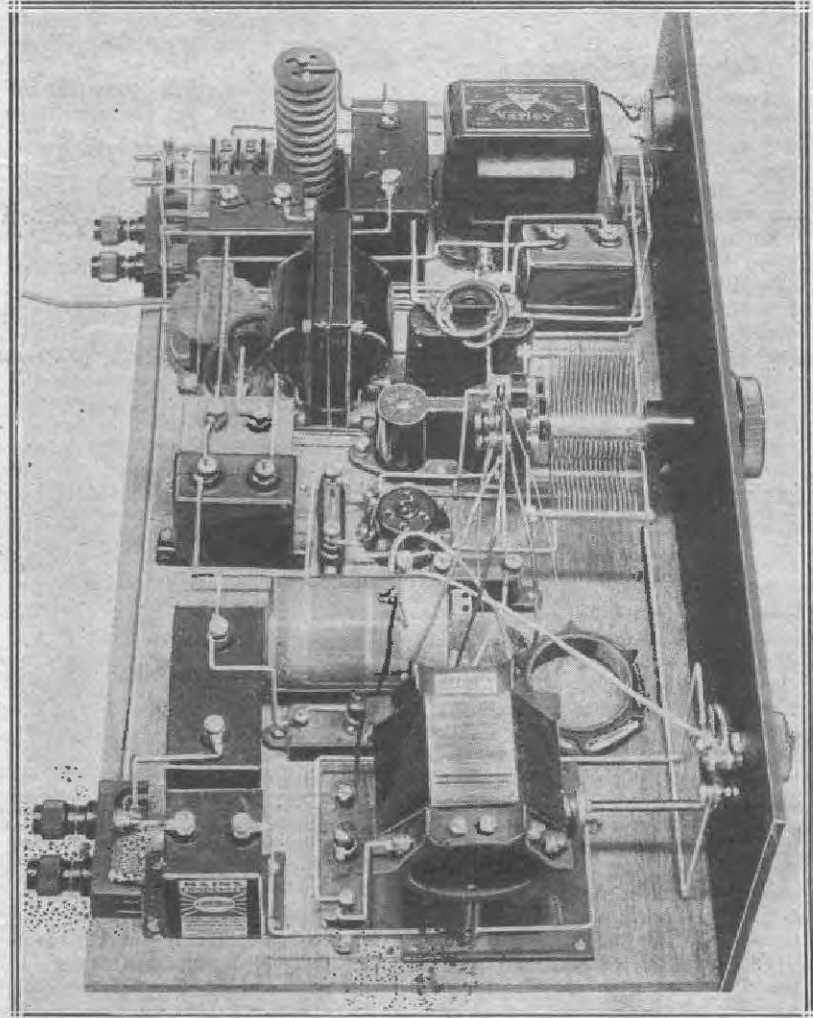

Check over the wiring carefully after you have made the final connection.



# AN "INTER-SPAG" UNIT

*Details of how to make an extremely simple, but very useful, gadget that enables Spaghetti resistances to be rapidly changed for experimental purposes.*

By A. S. CLARK.

A NODE resistances, and resistances of similar type, were a short while ago more or less universally of the wire-wound, clip-in, or interchangeable kind. But at the present time the recently introduced Spaghetti resistances are very popular and are fast becoming more widely used alternatives.

## Concerning Construction

So far as the wire-wound part of the business is concerned, there is quite a similarity. Spaghetti resistances, which in simple form have been used in the electrical trade for a long while, are constructed as follows:

On a thin core, which is usually made of a kind of asbestos string, a spaced winding of bare resistance wire is wound. The result is a thin, flexible resistance element that has a definite resistance per inch.

The actual number of ohms per inch will, of course, depend upon the closeness of the winding and also upon the particular resistance wire used. That is why the resistance of the "Spag" is not always proportional to the same multiple per inch.

## A Quick Change-Over

When the resistance element has been cut to the necessary lengths it is encased in a form of thick insulating tubing and secured at either end to a tag connector. The older type of wire-wound resistance is wound on a rigid former, and may have more than one layer, but is not really so very different in its winding from a Spaghetti resistance.

Where the two resistances do differ is in regard to the method in which they are mounted. And it is in this connection we find what is perhaps the only advantage of the older type over the new flexible resistances.

The tubular resistances have a holder with two metal uprights between which the resistance itself is clamped. The value of the resistance

can thus be changed in a moment without touching the set's wiring.

The Spaghetti, on the other hand, is intended for connecting directly into circuit—and, indeed, this is where it scores so much. The space taken up by a holder is saved, and the two wires that would normally go to it are obviated, the Spaghetti actually acting as a connection as well as a resistance.

But there are times when the only way to find the best value resistance

## "VERY LITTLE TO IT"

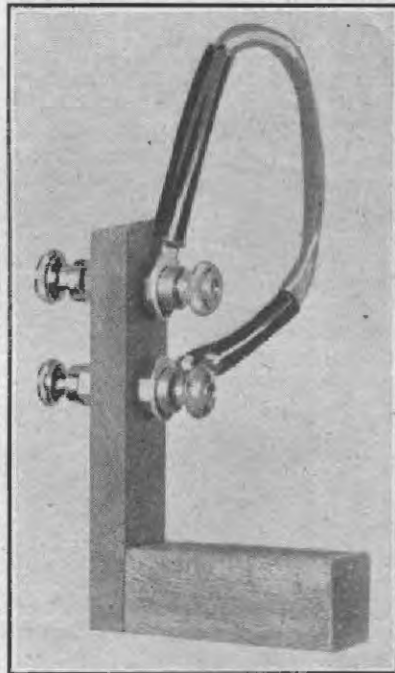

*One end of the double terminals is used for wiring up the holder into the receiver, and the other for making connection to the Spaghetti resistance itself.*

is by experiment, and other times when it is desirable to provide a means of rapidly changing a resistance.

This is where the "Inter-Spag" unit comes into its own, for it enables you to change round the Spaghetts

very easily. What is more, it is probably the simplest gadget to make that has ever been described.

You could almost make it from memory after just one glance at the accompanying photograph. Still, I will not leave the construction quite so briefly as that.

## Few Parts Required

The unit consists of a piece of upright ebonite about  $\frac{1}{2}$  in. wide and 3 in. high. This is screwed at one end to a block of wood the actual size of which is quite immaterial, as it is only for the purpose of securing the unit to the baseboard.

Fixed in the upright piece of ebonite there are two double ended terminals. To make these you will require a short length of four B.A. threaded brass rod, four nuts to fit it, and also four terminal screws.

The brass rod you cut into two pieces 1 to  $1\frac{1}{2}$  in. long. These are then passed through holes in the ebonite and secured with the nuts, so that they project an equal distance either side of the ebonite. One nut goes on each side.

## Using the Unit

And when you have put the terminal nuts in place the job is completed. Now for the method of using it, which is also just about as clear as it could possibly be from the photograph.

The two points in the set across which it is desired to have the resistance are wired to the terminals on one side the ebonite strip, just as any ordinary component would be wired up. Across the other two terminals is arranged the Spaghetti resistance itself, and it will be immediately apparent how this can be quickly changed.

There is a further refinement that you can add, in the form of another plain terminal underneath the other two, which will make it possible for you to connect two resistances in series so as to obtain values other than those that you have on hand. The method of connecting up the Spaghetts in this case would be as follows:

## Spaghetts in Series

Connect one end of one Spaghetti to the top terminal and one end of the other Spaghetti to the second terminal. The two unconnected ends of the two Spaghetts are then both placed under the third or bottom terminal.

You will be surprised at the number of cases in which this unit can prove useful.



### Ealex Adaptor

**W**e have had the opportunity of trying out one of the Ealex short-wave units. This unit comprises a single-valve reaction circuit with a plug-in type inductance of bare tinned copper wire, covering a wave-band of 16-60 metres when tuned

### FOR THE SHORT WAVES

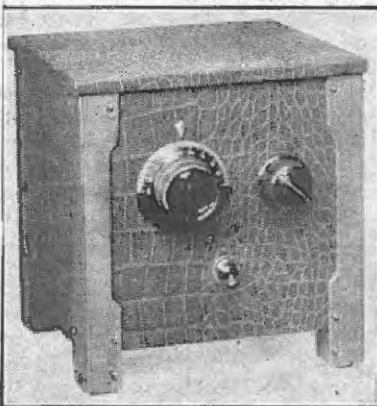

The "Ealex" short-wave adaptor is designed for use with broadcast receivers having one or more H.F. stages. It immediately converts the set into a short-wave super-heterodyne.

by a 00025-mfd. variable condenser. The adaptor is designed to function as a combined first detector-oscillator, and in operation is coupled up to any broadcast receiver having one or more stages of high-frequency amplification.

The receiver then becomes a short-wave super-heterodyne.

The maker's recommend setting the tuning of the broadcast set to a wave length of approximately 1,100-

metres, since, they state, this particular wave-length is free from long-wave interference.

The circuit of the unit is much the same as that of a conventional one-valve short-wave receiver, the aerial and grid circuits being adjusted with the aid of tapping clips. The anode circuit of the adaptor is connected first of all to a special short-wave H.F. choke so that the "mixer" valve can be made to oscillate freely at the required beat frequency. The "output" end of this short-wave choke is joined to a fixed condenser and to a long-wave choke.

Thus the incoming signals are passed via the fixed condenser to the aerial terminal of the broadcast receiver and are then amplified by the high-frequency stage or stages on the well-known super-heterodyne principle.

In use the adaptor is maintained in a mild state of oscillation by means of the reaction control provided, and the tuning dial is slowly rotated until the required signals are heard. The detector-oscillator valve is not critical, an "HL" type being satisfactory, and the H.T. voltage need be only sufficient to produce oscillation.

We tested the unit in conjunction with a two screened-grid fully-shielded four-valve receiver and Moscow (Trades Union) came in at good loud-speaker strength. Two unidentified American transmissions (fading was bad), a number of C.W. Morse stations, and Rome were also received on the speaker.

The price of the adaptor is £3, and the makers are Messrs. J. J. Eastick & Sons, Ealex House, 118, Bunhill Row, London, E.C.1.

### A Ferranti Choke

One of the latest Ferranti products is the type B.8 choke. It is intended for use in output filter circuits or as a mains unit smoothing choke. As is usual with this firm's components, the finish is excellent and the choke comes fully up to the high standard that one associates with the name Ferranti.

The nominal inductance rating is 17 henries, and the maximum permissible current is 45 milliamps. Retailing at the extremely moderate price of 7s., this choke may be regarded as a value-for-money product.

The makers are Ferranti, Ltd., Hollinwood, Lancashire.

### "Vicegrip" Wander Plugs

The average wander plug rarely seems to fit "snugly" into the tapping sockets on the H.T. battery.

### A GOOD CHOKE



The Ferranti B.8 choke which, retailing at the very moderate price of 7s., is excellent value for money.



## As We Find Them—continued

You so frequently have to adjust matters with the aid of a penknife, otherwise unpleasant crackling noises make themselves heard in the speaker.

Messrs. Lectro Linx, Ltd., have sent us samples of their "Vicegrip" wander plugs, and we can bear out the makers' claims regarding their gripping properties. They are excellent little plugs, and can be obtained in either red or black (engraved) at 1½d. each.

### Dux Transformer

Messrs. Radio Instruments, Ltd., Purley Way, Croydon, have produced a transformer retailing at a price which should place it within reach of the most limited purse.

In the case of this particular transformer the core is built up from an iron having extremely low losses and high permeability, and the windings are split up into three sections upon bakelite bobbins, this procedure reducing the mechanical stresses on the fine wire and thus minimising the risk of breakdown. The instrument is enclosed in a maroon-coloured case of bakelite.

The primary winding has a nominal inductance value of 30 henries, and this figure is maintained when the D.C. in the anode circuit approximates to the current taken by the average detector valve of the "H.F." type.

The maximum permissible anode current is 5 m.a., and the primary D.C. resistance is 1,200 ohms. The primary-secondary turns ratio is 1-3.5. Retailing at the very moderate figure of 6s. 9d., this transformer should achieve a well-deserved popularity, particularly in view of the highly satisfactory low-note response obtainable.

### Wearite Frame Aerial

We have recently tested one of the Wearite dual-range frame aerials,

### A WELL-MADE CONDENSER

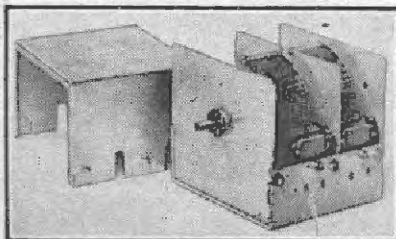

One of the latest Utility ganged condensers. Trimmers are provided to ensure accurate matching of the sections.

### ATTRACTIVELY FINISHED

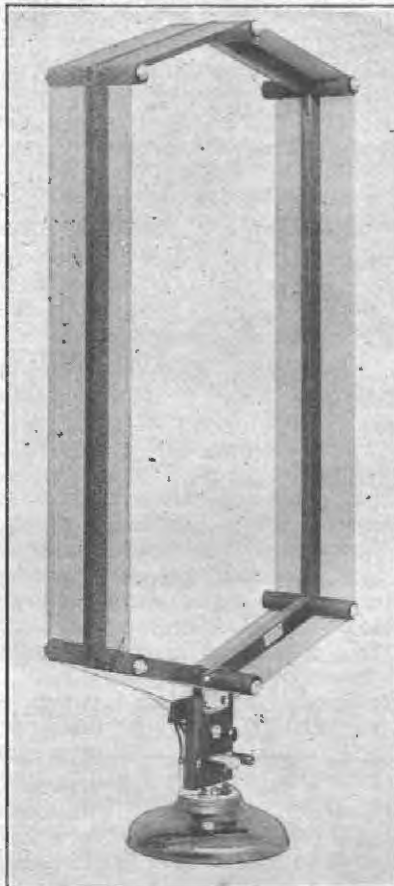

The Wearite frame is suitable for both long and medium waves and the windings are centre-tapped.

manufactured by Messrs. Wright & Weaire, Ltd., 740, High Road, Tottenham, N.17.

The Wearite frame is an attractive proposition, the construction being both electrically and mechanically sound.

The windings consist of 9/40 gauge green silk-covered wire wound upon ebonite spacers, and the amount of metal used in the frame is the smallest possible consistent with mechanical strength.

The long-wave turns are permanently in circuit, the medium-wave windings being in parallel with them for medium-wave reception. A three-point wave-change switch on the connecting strip enables the medium-wave turns to be included in circuit or excluded as desired. The frame rotates freely upon its base.

The medium- and long-wave ranges are approximately 180-598 metres and 800-2,300 metres respectively

when the windings are tuned with a good 0.0005-mfd. condenser.

This frame aerial is a thoroughly workmanlike job and the price in either polished oak or mahogany is 32s. 6d.

### Camco Cabinets

In our issue of last month, page 281, we gave details of the very attractive "Melodee" loud-speaker cabinet made by Messrs. Carrington's. It should be noted, however, that the inside dimensions of the larger model are 15½ in. by 15½ in. by 10½ in. deep and not as stated in the October issue.

### Utility Condensers

The modern requirements of high selectivity combined with simple control have increased the demand for first-class ganged condenser units.

The designers of "Utility" components have produced a fine range of ganged condensers which are supplied either semi-screened or totally screened. Accuracy in matching is ensured by the use of trimmers, and the ball-bearing centre spindle provides a smooth movement free from any trace of stickiness. These condensers are extremely well-made, and the price of the two-gang, fully screened unit is 22s. 6d. The makers are Messrs. Wilkins & Wright, Ltd., Holyhead Road, Birmingham.

### EFFICIENCY WITH ECONOMY

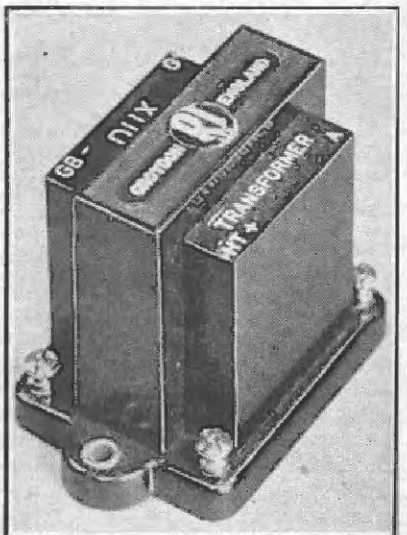

Although the price of this R.I. transformer is only 6s. 9d., the primary inductance is 30 henries.



# MAKING A RADIO CABINET

If you saw the "Wireless Constructor" Stand at Olympia you probably noticed the very handsome cabinet containing the "Exhibition" Four. Here are the full details for constructing this fine piece of furniture.

By the RESEARCH and CONSTRUCTION DEPARTMENT.

THE construction of the cabinet for the "Exhibition" Four—the set which was described in the last issue of the WIRELESS CONSTRUCTOR, and which those of you who were fortunate enough to get to the Show will have had an opportunity of examining—is not nearly so difficult as it might at first appear.

## FOR COMFORTABLE CONTROL

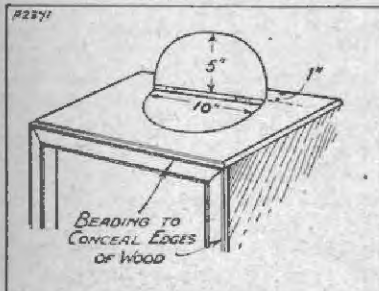

Fig. 1. The easily-made aperture at the top enables you to rest your arm while tuning, as shown in the photograph above.

We ourselves do not by any means fall into the category of skilled carpenters (we are much too concerned with CONSTRUCTOR research!), and yet the identical cabinet that you saw at the Show, the cabinet which has housed the set in all the published illustrations, was turned out in our department. And, might we add, mighty proud we are of it, too!

## A Handsome Job

If we can turn out a handsome job—may we, with all due modesty, call it such?—with nothing more than the ordinary everyday tools such as a saw, a small plane, a drill, etc., well,

so can you. Who knows, if you haven't previously tried your hand at carpentering, but that you may be a budding genius at the game!

Anyhow, without any further ado, let us tell you how we turned out our cabinet, then perhaps you will be more inclined to believe us when we say that you, too, can build a cabinet every bit as good, and probably even better, than the one which adorned the WIRELESS CONSTRUCTOR stand at Olympia.

## The Materials Employed

First of all, a few words as to the materials required. The legs—the set of which can be obtained from one of Hobby's places, or from almost any woodwork shop—are of the Jacobean style, and measure  $11\frac{1}{2}$  in. high overall. These are held together by lengths of  $1\frac{1}{2}$  in. by 1 in. ready-planed oak battening, the approximate total length of which you will easily be able to calculate from the dimensioned photograph accompanying this article.

This photograph, as a matter of fact, will also enable you to determine the amount of  $\frac{1}{4}$ -in. oak-faced

## BRACED BY BRACKETS

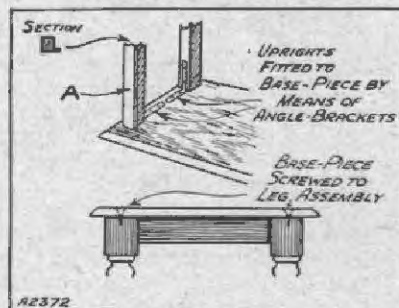

Fig. 2. Strong, rigid joints are a feature of the construction, and the method of supporting the uprights by angle-brackets is clearly shown above.

plywood that is required for the sides and top, and, if you decide not to have a glass front as in the original, for the front as well.

In addition to the materials mentioned above, you will also require a piece of  $\frac{1}{2}$ -in. planed oak to form the base-piece; a 5-ft. length of oak beading (see section of upright A in Fig. 2), approximately 1 in. square, to form the front uprights and the

## NEATLY CORNERED

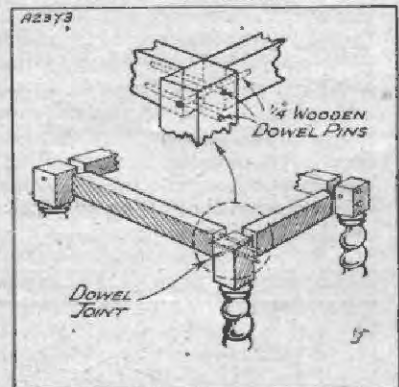

Fig. 3. The dowel joints are not at all difficult if you follow the instructions given.

cross-piece at the top; a 5-ft. length of planed oak, 1 in. square, to form the uprights and cross-piece at the back; four fairly substantial right-angle brackets; a quantity of ordinary ornamental beading to suit your own particular taste, and a length of  $\frac{1}{4}$ -in. dowelling rod.

## Fitting the Legs

And when you have got all that, and a good quantity of wood screws, then take off your coat and prepare for work!

The "work" commences with the assembly of the "stool" on to which the cabinet proper is built. First of all cut from the  $1\frac{1}{2}$  in. by 1 in. oak battening two pieces  $11\frac{1}{2}$  in. long and two  $7\frac{1}{2}$  in. long, and after having made quite certain that the legs are all the same length, join them as shown in Fig. 3.

These dowel joints, as they are called, are made by drilling holes,



## Making a Radio Cabinet—continued

first right through the legs, and then, in the correct positions, into the ends of the cross-pieces for a depth of about 2 in. The diameter of these holes should be about  $\frac{1}{4}$  in., so that when you knock the  $\frac{1}{4}$ -in. dowelling rods through them to make the joints the rods form a tight push-fit.

Do not forget, by the way, before you knock the dowelling rods in to give them a coat of glue.

### The Base-Piece

There is no need to be alarmed if when the leg assembly is finished the whole thing seems a bit rickety, because that is all put right when the base-piece is fitted in the manner shown in the lower half of Fig. 2. The fitting of this base-piece, which is the next part of the procedure, should be carried out in such a way that  $\frac{3}{8}$  in. of the top of the back legs is not covered. The ledge thus formed supports the set's baseboard, which is also, of course, the back of the cabinet.

Next comes the cutting and fitting of the uprights to the base-piece,

### THE FINISHING TOUCHES

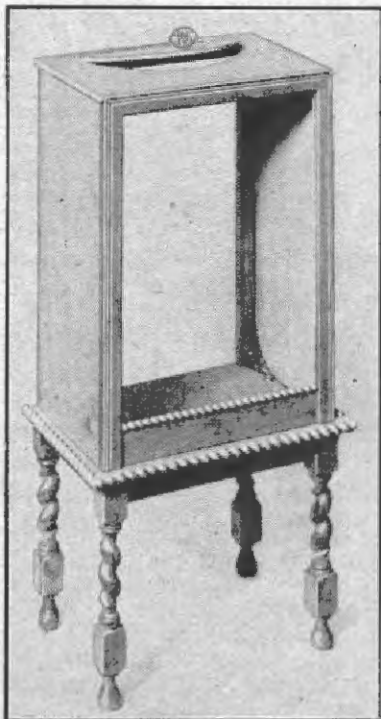

The original cabinet had a glass front panel, so that the works were always visible. But you can use a wooden panel if you prefer it.

which is done by means of the angle-brackets, as shown in the upper half of Fig. 2. Before these uprights are actually screwed into position it is best to join the two front ones and the two back ones at the top by means of the cross-pieces, so that you have two three-sided frames.

It doesn't very much matter how you join the uprights to the cross-piece at the back, since the joints will not be seen. But at the front, which is visible, there is nothing that looks quite so nice as mitred joints.

### Those Neat Corners

In case you are not quite certain of what is meant by a mitred joint, have a look at a picture frame. You will see that the sides are cut at the corners at an angle of forty-five degrees, and that is what is wanted in this case. When you have cut the two pieces of wood so that when the angular edges are held together they form a right-angle, they can be held in position by means of a small strip of metal screwed on at the back.

At this stage the cabinet begins to look something like a cabinet, especially when the side-pieces of the  $\frac{1}{4}$ -in. oak-faced plywood are fitted, which is the next job. These side-pieces, by the way, although requiring to be flush with the back edge of the back supports, should only be brought to within about  $\frac{1}{4}$  in. of the front edge of the front supports, so that a strip of  $\frac{1}{4}$ -in. beading can be used to hide the edge of the wood.

The best way in which to secure these side-pieces to the upright supports is by means of small gim-pins, which can ultimately be knocked below the surface of the wood, the resulting holes being filled with plastic wood.

### Cutting Out the Lid

The oak-faced plywood for form the top should be cut to such a size that it is flush with the sides and back, but  $\frac{1}{4}$  in. short of the front edge of the top cross-piece, so that here, again, the edge of the wood can be hidden by means of a strip of beading.

This beading-to-hide-the-edge idea may not be in keeping with the highest ideals of cabinet-making, but at least it looks all right, and, what is of even greater importance, it is easy to carry out.

Before the top piece can be fitted it is, of course, necessary to cut the

hole for the lid. The shape and size and exact position for this opening can be obtained from the dimensioned drawing shown in Fig. 1, and if you are very careful when cutting the centre piece out (you will find a fret-saw best for the job) the piece thus removed can be used for the hinged lid.

### ALL THE DETAILS

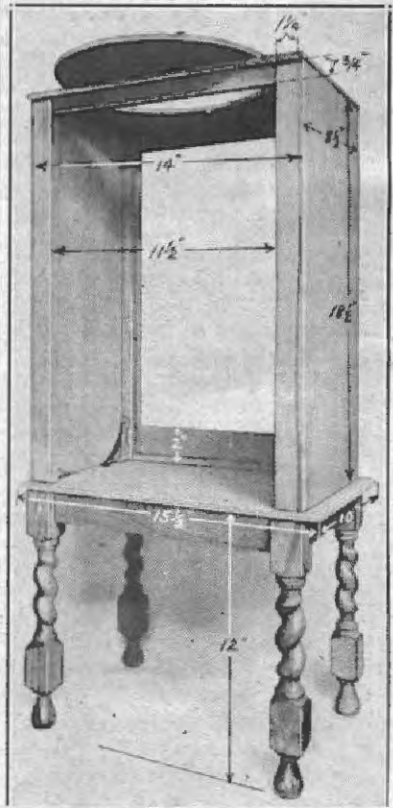

Here is the whole story of the dimensions, told in figures that were marked on an actual photograph. Note the corner-bracket that is visible.

There has so far been nothing very difficult in the construction of the cabinet, has there? Well, apart from the fitting of the glass front (or the wooden panel if you prefer not to use glass), and the 2-in. wooden strip along the bottom of the front framework, the cabinet is finished! Finished, that is, with the exception of whatever ornamental beading you choose to put on.

As for staining and polishing, unless you have previously tried your hand at french-polishing we do not advise you to tackle that part of the business, for it will not cost much to have it done professionally.

# WITH PICK-UP *and* SPEAKER



By  
A. JOHNSON-RANDALL

*Inserting a pick-up in the "Extenser" Five—Pentode output circuits and de-coupling.*

**I** EXPECT those of you who have built the "Extenser" Five will be keen to fit a switch for changing over to pick-up, thus converting the set into a radio-gram. The modification is quite simple. First of all, you must remove the wire which goes from one terminal of the '0003-mfd. grid condenser to the grid terminal of the valve holder  $V_3$  (see diagram, page 220, September issue). Don't touch the lead from the terminal on the '0003-mfd. condenser to the grid leak. This should remain as before.

## Keep Leads Short

Now you must fit two extra terminals to the terminal strip on the baseboard and also a single-pole change-over switch (one of the push-pull type). Unfortunately, there isn't much room if you have already completed the set, but a little ingenuity will soon solve the difficulty. Whatever you do, keep the leads short.

Next, join the grid (G) terminal of the valve holder  $V_3$  to the common terminal (spindle) of the change-over switch.

## Controlling Volume

Connect one of the remaining terminals on the switch to the terminal on the grid condenser from which you previously removed the lead. Join the other terminal on the switch to one of the two extra terminals on the terminal strip. Connect the second terminal to a length of flexible for grid bias  $-3$ . The grid-bias voltage required will be about  $1\frac{1}{2}$  volts. The pick-up leads are connected to the two new terminals on the strip and your "Ex-

tenser" Five has now become a radio-gram.

I advise you to use a volume control across the pick-up so that you do not overload the first valve. The connections require only a slight alteration. The two outside terminals on the volume control normally go to the two ends of the resistance element

goes to the change-over switch and thence to the grid of  $V_3$ .

One of the other terminals on the volume control is connected to the remaining pick-up terminal on the strip.

## A Pentode Query

By the way, one of my readers wrote in to me the other day with a little moan about his pentode valve. He said that he made up a two-valve amplifier with a fairly high-mag. stage of transformer coupling, which worked quite well with an ordinary output valve, but unfortunately did not give him sufficient volume on his pick-up, so he decided to use a pentode in order to obtain more mag. He is now unhappy because he finds that not only is his amplifier a trifle unstable, but the pentode gives him "screechy" reproduction.

This reader sent me a rough sketch of his circuit, and I noticed two things. In the first case there is no de-coupling to the priming grid of the pentode, and I suggest he inserts a 1,000-ohm resistance in series with the priming grid, together with a 2-mfd. condenser to earth.

## Suitable Output Essential

Secondly, his output circuit is incorrectly arranged. The impedance of a pentode valve is very high, and it is essential to use either a suitable pentode output transformer or choke output having a high inductance choke.

Provided these precautions are taken there is no reason why a pentode valve should not give excellent reproduction and magnification.

A metallised detector valve is sometimes an aid to stable working.

## THE "EXTENSER" FIVE

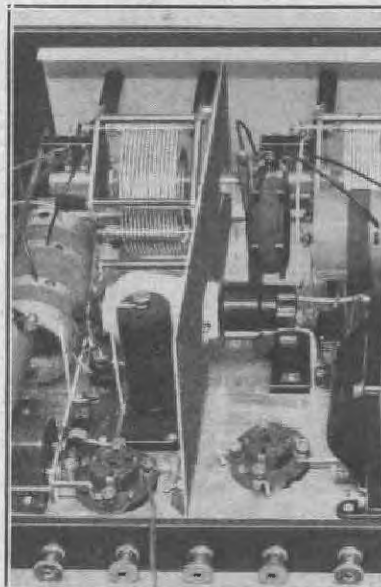

*By slightly rearranging the wiring of the detector portion of the "Extenser" Five it is an easy matter to insert a pick-up switch.*

and these terminals are connected to the two pick-up leads.

The centre terminal on the volume control (the slider) is joined to the terminal on the terminal strip which





# ROUND *the* DIALS

*Practical notes on what stations to look for and how to get the foreigners that are coming over well.*

**A**LL the Continental long-wave stations seem to be starting the season in very fine form. At the moment of writing, Warsaw—which had been criticised as not coming up to the expectations of its enormous power (158 kw.)—has been phenomenally vigorous, and interesting tests are being carried out by Vienna.

In the south of England this station, the new Radio-Paris, Oslo, Motala, and Kalundborg have all been arriving at a strength that augurs well for our alternative winter entertainment.

### Gingering Up Daventry

Since last month's notes on the possibility of Britain's long-wave station at Daventry being "gingered up" in power and brought right into line with its rivals, there have been many rumours as to the B.B.C.'s intentions. No official details have

been given, but the need for the scheme is daily becoming more obvious.

It is to be hoped that the B.B.C. will soon make 5 X X once again the leader of the long-wave stations.

### Daylight Reception

On the medium waves, Toulouse has been coming over in daylight in the London district with almost as much power as the Midland Regional. But the programme quality has been somewhat inferior owing to heterodynes, apparently owing to the station's inability to keep accurately to its allotted wave length.

The Italians, too, led by Rome and ably seconded by Milan and Turin, have found their way to the North latitude with a punch like their own Carnera. Algiers also has been doing well, and, in fact, the whole of the Mediterranean seems to have been putting over a barrage round the south of England during the last few weeks.

Apart from the tests by Cosky Brod (Prague) and Radio-Paris, I have not come across any really interesting items from new transmitters, but it is known that quite a number of new stations hope to have their tests between now and the end of the year, so that almost any night there is a possibility of coming across something good and unexpected.

### Polish Radio Circle

One old friend to which I can commend you is Katowice, Poland, on 408 metres. I am glad to see that this station is still continuing its "radio circle" on Wednesday and Friday evenings, and English names and addresses can often be heard, the language used for this being French.

The charming informality of this Polish radio circle was, I think, the subject of a note of mine to you some few months ago. Any long-distance listener with a good set who wants the pleasure of hearing his own name from a foreign station should make a point of writing to Katowice.

### Informal Charm

Even if he is not familiar with the French language, the informal charm of the announcer's manner, his laugh, his asides, and his own evident enjoyment of the radio circle, make this quite a memorable feature!

Another station that asks for letters from this country is Moscow, on 1,304 metres, but although I have not written to Moscow in reply to their spoken invitation, there is an air of propaganda about it that is entirely absent from the engaging invitation extended by Katowice.

**T**HE Extenser system of simplified tuning without wave-change switching was first introduced to the world in the WIRELESS CONSTRUCTOR, so readers of this journal will be specially interested in the news that yet another condenser firm is now marketing Extensers.

This is Jackson Bros.—a name so familiar to every constructor that it is hardly necessary to say that the "J.B." Extenser is a fine piece of work. It is supplied complete with an illuminated disc-drive for 14s. 6d.

### Using the Mains

The Westinghouse Brake and Saxby Signal Co., Ltd., inform us that an entirely new rectifier, the H.T.8, is now available. The smoothed output is 250 volts at 60 milliamps.

Customers of Burne-Jones & Co.,

\*\*\*\*\*  
 \* **POINTS FOR** \*  
 \* **PURCHASERS** \*  
 \* *Interesting details from manufac-* \*  
 \* *turers about recent trade activities.* \*  
 \*\*\*\*\*

Ltd., will be interested to hear that this firm has secured the contract for a wireless installation at the Institute for the Blind in Tottenham Court Road, London, W. It is an all-mains equipment of special design, and provides alternative programmes in twelve workshops for the entertainment of the blind craftsmen.

### A Good Transformer

Before continuing with this month's news we must revert for a moment to the Radio Instruments L.F. transformer which was mentioned in the

review of the Radio Exhibition in last month's WIRELESS CONSTRUCTOR.

In the description on page 339 the "Parafec" transformer was referred to as "weighing only 3½ oz., with an inductance in the primary of 18 henries." This latter figure was, of course, an error, as the primary inductance is actually 80 henries, not 18 as stated!

### The "Chassikit" Set

Kit sets emanating from the valve manufacturers seem to be coming into favour more firmly than ever. The latest is the Six-Sixty "Chassikit," employing three-gang band-pass tuning for an S.G., det. and pentode.

Full details will be sent to any reader of the WIRELESS CONSTRUCTOR on application to the firm at Six-Sixty House, 17-18, Rathbone Place, Oxford Street, London, W.1.

# FROM METRES TO INCHES

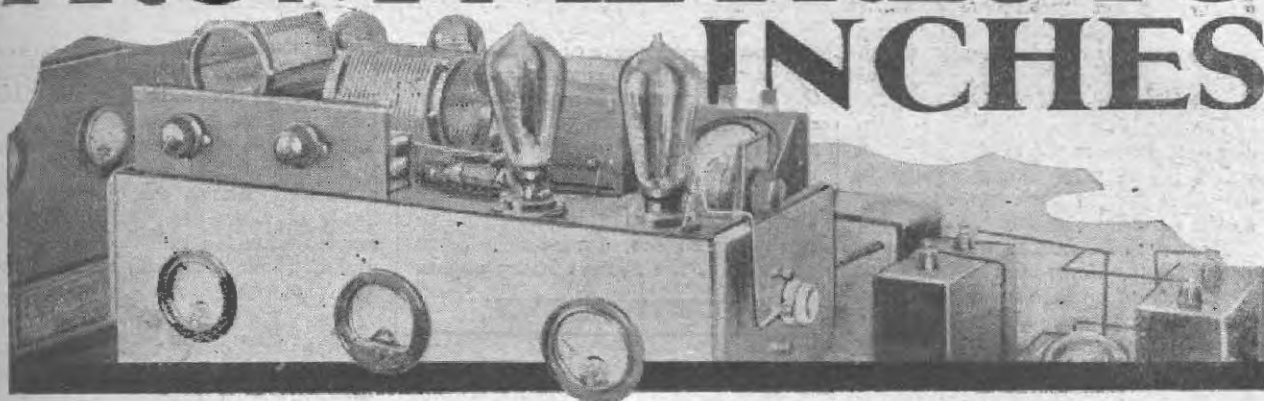

**T**HE future of wireless is becoming more and more bound up with the use of short waves.

In the early days waves were measured in thousands of metres. When broadcasting came in it exploited the wave-band between 200 and 500 metres, though the amateurs soon started to work on transmissions well below the 100-metre mark.

## Tiny Power Used

Then came the Beam working on 15 metres, and now we have reached the point where metres are being replaced by inches as the standard of measurement.

One of the most interesting events of the year in this connection is the recent transmission of speech and "facsimile," or printed messages across the English Channel on a wave-length of 18 centimetres—or a little more than 7 in.

All this was accomplished by waves transmitted and received on aerials round about 1 in. in length, backed by spherical reflectors to increase the directional effect.

The amount of power used to transmit the signals across 21 miles of space was barely half a watt. One must remember that it takes forty times this amount to light the kind of electric lamp one uses in a hall or passageway.

## A New Oscillator

We are at present on the threshold of a new era of ultra-short-wave radio. Senatore Marconi is already experimenting with wireless waves less than 2 in. in length. The micro-wave is, in fact, a new focus of interest.

It has been rendered possible by the discovery of a new method of

## By CARDEN SHIEL'S.

*Radio engineers the world over are making use of shorter and shorter wave-lengths. They are now experimenting with such high frequencies that the waves have to be measured in inches instead of metres. In this article the author deals with the latest development in this direction.*

producing oscillations, of the order of two thousand million per second, by means of an improved thermionic valve.

## The Usual Method

In the ordinary way, high-frequency oscillations are generated by means of a valve with magnetic or capacitative coupling between the plate and the grid circuits, so that energy is fed back from the output

## TUNED TO 18 CENTIMETRES

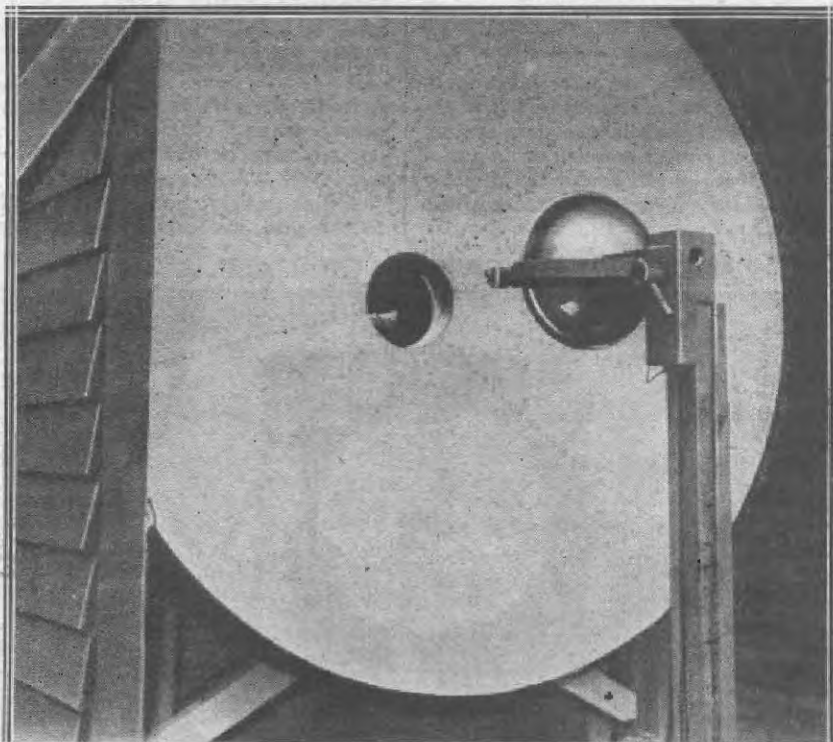

*This is the Dover transmitter used in the recent cross-Channel experiments. The radiated waves, only 18 cm.'s long, are thrown out across the Channel in a narrow beam by the giant 10-ft. reflector seen above.*



## From Metres to Inches—continued

to the input at a frequency which depends upon the tuning of an external circuit.

The resulting oscillations are actually derived from the electron stream, which passes from filament to plate in pulses having the same frequency as the external tuned circuit.

By contrast, in the new type of generator the electron stream is made to vibrate to and fro inside the bulb, and the frequency of the generated wave is determined partly by the rapidity of the electron movements and partly by the natural frequency of a short piece of wire directly attached to one of the electrodes of the valve.

If the electron stream passed, as usual, to an external circuit containing inductance coils and condensers, it would be impossible to tune down to the required wavelength.

### Novel Tuned Circuit

The inductance of a single turn of wire barely 1 in. in diameter is much too "heavy" for the frequency required. Similarly, any ordinary kind of tuning condenser would "swamp" a circuit designed to carry micro-waves.

It is true that the micro-rays must be fed into and sustained by a "working circuit," but in the new system the tuned circuit consists of an aerial an inch in length connected directly to one of the internal electrodes of the valve.

Even a short piece of straight wire possesses a certain inductance, and the amount present in a piece roughly an inch long is found to be sufficient to tune to the frequency of the micro-ray.

The capacity necessary to complete the tuning is found in the capacity of the same piece of wire relative to earth or to the nearest bulky object.

### HOW IT WORKS

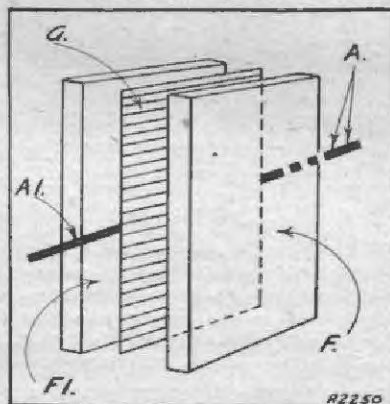

With the help of this diagram and the description given in the text you should have no difficulty in understanding how these ultra-short waves are produced. In fact, you will probably wonder why it was not thought of before!

Actually the wire acts as an ordinary quarter-wave "plain" aerial having no inductive or capacitive "loading."

A high positive potential is applied to the grid instead of to the plate

of a three-electrode valve. The plate is either left at the same potential as the filament, or else made more negative.

With this arrangement the electrons liberated from the filament are attracted towards the charged grid. Some of them, are "trapped," and are fed from the grid to a short-wire aerial, which is directly connected to it.

### Electrons Reverse

The bulk of the electrons, however, pass through the meshes of the grid, owing to their momentum. As soon as they reach the other side they find they have overshot the mark, since they are now travelling against the attraction of the positive charge on the grid.

Further movement in the forward direction is accordingly checked, and the electron stream "reverses" back towards the highly positive grid. Here, again, some of the electrons are "caught" and fed to the aerial.

The remainder are carried through for a short distance, until the positive charge on the grid again makes its presence felt. In this way an internal oscillation of the electron stream is set up and maintained at an extraordinarily rapid rate. Those electrons that are "trapped" by the grid flow directly into the short-wire aerial to supply the power necessary for radiation.

### Use of Two Filaments

This principle has recently been further developed by causing the electron streams from two separate filaments to interact with each other and with a common grid carrying a high-positive potential.

The arrangement is illustrated diagrammatically in the figure, where two plane surfaces,  $F$  and  $F_1$ , are heated so that each emits an electron stream. Midway between the two surfaces is a "control" electrode or grid-mesh marked  $G$ . The short-wave aerial  $A, A$ , consists of two short pieces of wire connected directly to each side of the grid.

For the sake of clearness, the H.T. and L.T. sources are not shown, though it is important to connect H.T. tapping to the centre of the grid  $G$ , where it will be at a nodal point on the aerial circuit formed by the wires  $A, A$ , and the grid.

### ACROSS THE CHANNEL ON HALF A WATT

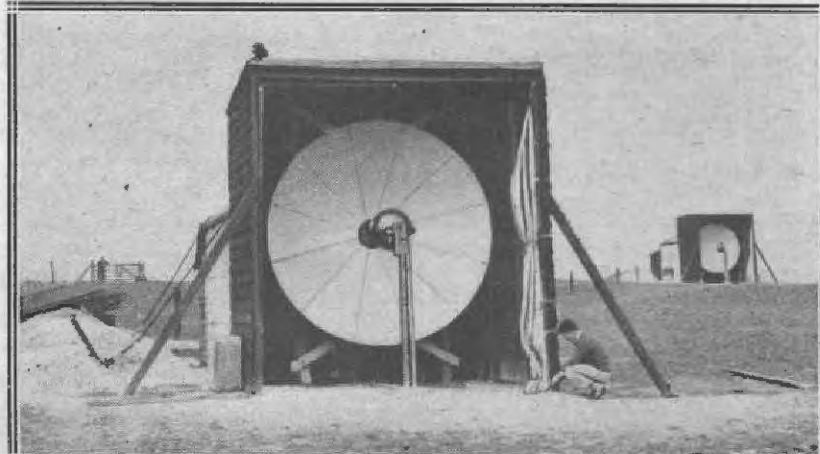

This is the short-wave transmitter at Dover used in the cross-channel tests. These illuminating experiments have caused quite a stir in the radio world. The receiver can be seen in the background.

# READY RADIO TESTED KITS

## THE "I.E." THREE

	£	s.	d.
1 Ebonite panel, 16 in. x 8 in. x 1/4 in., drilled to specification	5	6	
1 "Lander" cabinet, with 10-in. baseboard	1	3	0
1 "Wavemaster" Extenser, '0003, with slow-motion drive	15	6	
1 ReadRad '0003 Brookmans condenser	3	6	
1 ReadRad '00075 Brookmans condenser	3	6	
1 A.E.D. Fader-type volume control	10	6	
3 "Junit" valve holders	2	0	
1 T.C.C. '0003 fixed condenser, type 34	1	6	
1 ReadRad on/off switch	1	10	
3 Lotus single-coil holders	2	0	
1 ReadRad 2-meg. grid leak and holder	1	4	
2 T.C.C. 2-mfd. condensers, type 50	7	8	
1 R.I. General Purpose L.F. transformer	10	0	
1 Lotus L.F. transformer (No. 1)	5	6	
1 ReadRad Standard H.F. choke	4	0	
1 R.I. General Purpose L.F. Choke	12	6	
1 Lewcos 25,000-ohm Spaghetti resistance	1	0	
1 ReadRad 400-ohm baseboard-mounting potentiometer	2	9	
1 P.V.1 coil unit	3	0	
1 P.J.2 coil unit	2	0	
1 Ebonite terminal strip, 16 in. x 2 in., drilled to specification	1	0	
9 Belling-Lee indicating terminals, type "R"	2	3	
1 Lotus pick-up Jack, No. J.K.1	2	0	
1 Lotus Plug, J.K.1	2	0	
1 Packet "Junitinx"	2	6	
3 Belling-Lee wander plugs	6	6	
1 Lewcos plug-in coils, Nos. 100, 150, 200	13	6	
1 Set Atlas S.W. coils, 2, 4, 6, 9	10	0	
3 Mullard valves, as specified (P.M.r.H.F., P.M.r.L.F., P.M.c.)	1	7	6
Flex, screws, etc.			6
<b>Total (including Valves and Cabinet)</b>	<b>£9</b>	<b>1</b>	<b>6</b>

**KIT "A"** (less Valves and Cabinet) **£6:11:0**

or 12 monthly instalments of 12/-

**KIT "B"** (with Valves, less Cabinet) **£7:18:6**

or 12 monthly instalments of 14/6

**KIT "C"** (with Valves and Cabinet) **£9:1:6**

or 12 monthly instalments of 16/9

Completely assembled Receiver, Aerial tested, Royalties Paid **£10:11:6**

or 12 monthly payments of 19/6

## THE "AMPLITONE"

	£	s.	d.
1 Ebonite panel, 8 in. x 4 1/2 in. x 1/4 in., drilled to specification	1	0	
1 Terminal strip, 8 in. x 1 1/2 in., drilled to specification			3
8 Belling-Lee indicating terminals, type R	2	0	
1 Junit valve holder, horizontal mounting	1	3	
1 Sovereign 50,000-ohm potentiometer	4	6	
1 ReadRad on/off switch	1	10	
1 R.I. General Purpose L.F. transformer	10	0	
1 Lotus output choke	12	6	
2 T.C.C. 2-mfd. condensers, type 50	7	8	
1 T.C.C. '01 condenser, flat S type	2	0	
1 Packet "Junitinx" for wiring	2	0	
2 Belling-Lee wander plugs	6	6	
1 Mullard P.M.252 valve	13	6	
Screws, flex, etc.			6
<b>Total (including Valve)</b>	<b>£3</b>	<b>1</b>	<b>6</b>

**KIT "A"** (less Valve) **£2:8:0**

or 6 monthly payments of 8/6

**KIT "B"** (with Valve) **£3:1:6**

or 6 monthly payments of 10/6

**If you do not need the complete kit, you can buy any of the parts you require separately.**

**TO INLAND CUSTOMERS**—Your goods are despatched Post Free or Carriage Paid.

**TO OVERSEAS CUSTOMERS**—Everything Radio can be supplied against cash. In case of doubt regarding the value of your order, a deposit of one-third of the approximate value will be accepted and the balance collected by our Agent upon the delivery of the goods. All goods are carefully packed for export and insured. All charges forward.

Every Ready Radio Kit is composed of chosen components which have been tested and passed before despatch under the supervision of Mr. G. P. Kendall, B.Sc., who has joined the staff of Ready Radio as Chief Engineer. For many years the well-known Chief of Research for "Popular Wireless" and "Modern Wireless," he is the designer of many famous sets.

In the event of difficulties with your set, Mr. Kendall's wide experience is at your service. By building your receiver with a Ready Radio Tested Kit you are consequently assured of the finest possible results obtainable from the circuit of your choice.

## ORDER FORM To READY RADIO, Ltd., Eastnor House, Blackheath, S.E.3

**CASH ORDER.** Please despatch to me at once the goods specified for which I enclose payment in full of **£**.....

Name.....

**C.O.D. ORDER.** Please despatch to me at once goods specified for which I will pay in full the sum of **£**.....

Address.....

**EASY PAYMENT ORDER.** Please despatch my Easy Payment Order for the goods specified for which I enclose first deposit of **£**.....

Kit Required.....

# Ready Radio

READY RADIO, LTD., EASTNOR HOUSE, BLACKHEATH, S.E.3. Lea Green 5678. Showrooms, 159, BOROUGH HIGH ST., S.E.1. Hop 3000. Grams: Readrad, Sedist.



# PICK-UP HINTS and TIPS



Interesting notes on various practical aspects of radio-gram reproduction.

By A. BOSWELL.

THE number of different makes of pick-up on the market is still rapidly increasing, and it is, of course, becoming increasingly difficult to make one's choice.

A demonstration is the only way of getting anything like a reliable idea of the merits or demerits of any particular make. Curves will help, but there is nothing like hearing the instrument before you finally decide to take it.

Curves can be misleading, but they are not even available nearly often enough. Every pick-up should have its curve, or "pedigree," in the box. It would help the prospective purchaser quite a lot.

### Choose a Good Make

But perhaps—in some cases—it would not help the manufacturer, for, I am ashamed to say it, even in these enlightened days of radio there are still some doubtful pick-ups being sold. I use the word "doubtful" in the sense that they are not of so high a standard as they should be, and as their published descriptions lead one to expect. They operate, of course, but their curves (which are not made public) are lamentable examples of peakiness.

Therefore, then, I repeat, hear your pick-up before purchasing, though if you obtain one from a really reputable and well-known manufacturer you certainly will not be sold a "pup."

### Cleaning Records

Do you ever use those dust pads for keeping your records free from dirt? If so, have you noticed how essential it is as a rule to stroke the disc slowly and very lightly, or else you are liable to end up with more dust than you started with?

The reason is that a gramophone record is easily charged with static electricity (like a stick of sealing-wax, or glass rod, when rubbed with a dry cloth), and in this condition readily attracts particles of dust floating about in the air.

A soft brush is usually more successful as a dust remover than the felt pad.

### TRY THESE

RECORDS WORTH HEARING.		
	Vocal.	
	The Diver.	
Norman Allin	Good-bye.	Columbia
Benjamin Gishi		H.M.V.
	Orchestral.	
	Holiday Hits.	
New Mayfair Orchestra	The Bartered Bride.	H.M.V.
Symphony Orchestra	Down Memory Lane.	H.M.V.
J. H. Squire	Celeste Octet	Columbia
	Organ.	
	Englandia.	
Reginald Foot		Columbia
	Dance.	
	Bolero.	
Jack Payne	Let Love Take Care of You.	Columbia
Jack Payne		Columbia
	Vaudeville.	
	Oh, Sailor, Behave.	
Gracie Fields	Oh, Mr. Porter!	H.M.V.
Norah Blaney		Columbia

Have you ever tried running two pick-ups—or a pick-up and sound box—together on a record? With careful wangling and paralleled or series connected pick-ups one can get quite an interesting "stereoscopic" effect from a record.

The scheme is only applicable in a satisfactory manner to dance or orchestral records, and is quite simply obtained if you can so track the pick-ups that the needles will run within, say, one inch of each other.

By volume controlling the second pick-up the echo effect which is obtained can be adjusted in its intensity with very pleasing results.

The echo is generated, of course, by the fact that the second pick-up gives the music of the first one a short time after. By varying the distance between the needles the time period between "original" and "echo" can be varied, and on many orchestral recordings quite a concert hall "atmosphere" can be achieved.

The two pick-ups are started off together in the same groove, and if they happen to run in different grooves the result is musical chaos.

### "Mixing" Music

Have you ever tried "mixing" your radio with gramophone music? It is quite useful sometimes, and incidental gramophone music played faintly as the background of a recitation or speech sometimes has a very pleasing effect.

Of course, such mixing has to be done with circumspection or the effect will be merely ludicrous, and whereas a faint cinema organ or light orchestral backing for light speeches may increase their entertainment value, such an accompaniment to a political broadcast might be totally out of place.

The background idea can easily be carried too far, but on occasion the musical accompaniment will greatly add to the pleasure of listening.

### How Many Valves?

How many valves are required for pick-up reproduction? That is a question I often have addressed to me. It is not easy to answer conclusively, because it all depends how loud you want the reproduction to be and what battery or mains power you have available.

It should be possible, however, to obtain quite adequate "ordinary-living-room" results with two valves, provided that a sensitive pick-up is employed.

### Sensitive Pick-Ups

Many makes now give a peak voltage of up to two volts, and these, including the H.M.V., B.T.-H., and similar sensitive types, will give excellent results with two stages.

Naturally three are better, and give one more latitude in choice of pick-up and also in range of volume. I always use three stages (using the detector as the first), and for a really adequate factor of safety for moving-coil reproduction I should say three are essential.

With three valves you can always cut the volume down, but with two you cannot put it up should you desire louder results.



By A. S. CLARK.

**P**LENTY of bass and as much high-stuff as one can possibly wheedle out of the set and speaker do not necessarily constitute the most desirable reproduction. Quite often one hears the remark: "What a pleasing tone your loud speaker's got," applied in cases where bass and treble are more noticeable by their absence than their presence!

### "Balance" Essential

Without entering into an argument as to whether one should go all-out for the most technically correct reproduction or for the most pleasant-sounding, it can be stated that there are two very definite things upon which the question of a pleasing tone depends.

First of these is balance. A correct equilibrium of high and low frequencies must be obtained. If you have too much bass you will get a battery-of-native-tom-toms effect, while too much "top" will give you an annoying shrillness.

The human factor enters very largely into the second point, for it concerns the differences of opinion that exist as to what is a proper balance of "top" to "bottom." To please everybody it is necessary to be able to vary the tone to suit the individual.

### Tone Control

Bearing these two items in mind, it is easy to appreciate that to take advantage of a tone control it is not necessary to have a super set working the last word in moving-coil speakers. In fact, a tone control is most useful with a set that over-emphasises certain frequencies or is completely lacking in others.

The best place for such a tone control is not "stuck on" the outside

*Here is a unit which will give you loud-speaker results from your single-valve, or if you have a two-valve set will improve your "loud speaking" out of all recognition. Not only does it increase volume, but it enables you to adjust the tone of reproduction to a nicety.*

of a set, but actually incorporated in it. The tone control of the "Amplitone" single-valve amplifier is therefore arranged as part and parcel of the complete assembly.

So not only will the amplifier give you "bags" more volume, but at the same time it will enable you to alter the tone of reproduction at will. With it you will be able to suit your

output to any speaker that you desire to connect up, and, what is more, you will be able to suit the speaker to the tastes of any individual who may be listening.

### Amplifying the Output

It is equally suitable for use after a single-valve or after a two-valve, providing, of course, that the latter does not employ a pentode output valve. Following a one-valve receiver it will give you many programmes on the speaker, while after a two-valve set it will give you many more stations at loud-speaker strength and increase the power of those that already come in on the speaker.

Tone is controlled by altering the amount of high response in relation

### QUALITY IS PERFECT FROM THIS CIRCUIT

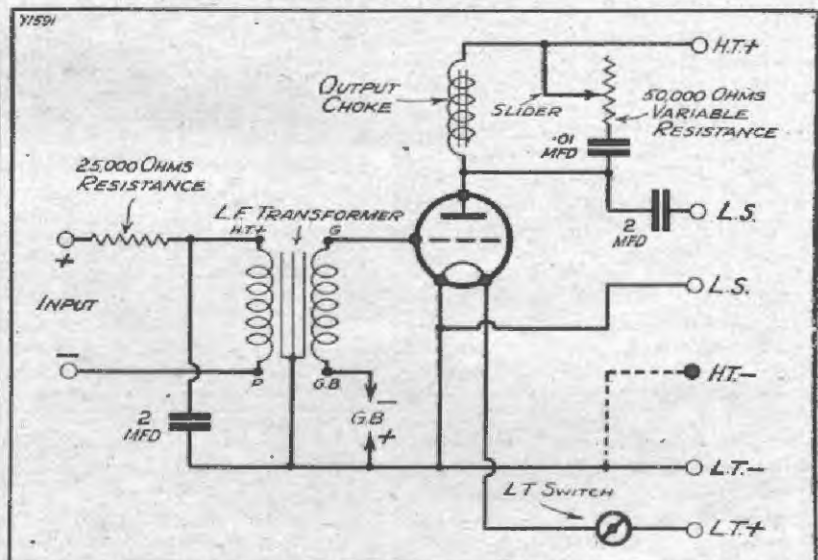

Precautions against instability, coupled with the special tone control across the output choke, enable you to obtain your ideal of reproduction with the "Amplitone," the circuit of which is laid bare by this simple circuit diagram.



## The "Amplitone"—continued

to the low "stuff." This is carried out with a single knob on the panel of the amplifier—as you turn it to the right the reproduction becomes more rich in bass; or, if you prefer it, less high-pitched.

Any "balance" that you desire can be obtained by just twisting this one control. The control itself is actually a variable resistance, but

the work of removing the undesired top is carried out by a capacity by-passing effect.

The circuit diagram will help to make this quite clear. Across the output choke you will see a fixed condenser and a variable resistance connected in series. These two components constitute the tone control.

### A PAIR OF PLIERS, A FEW WIRES AND IT'S DONE

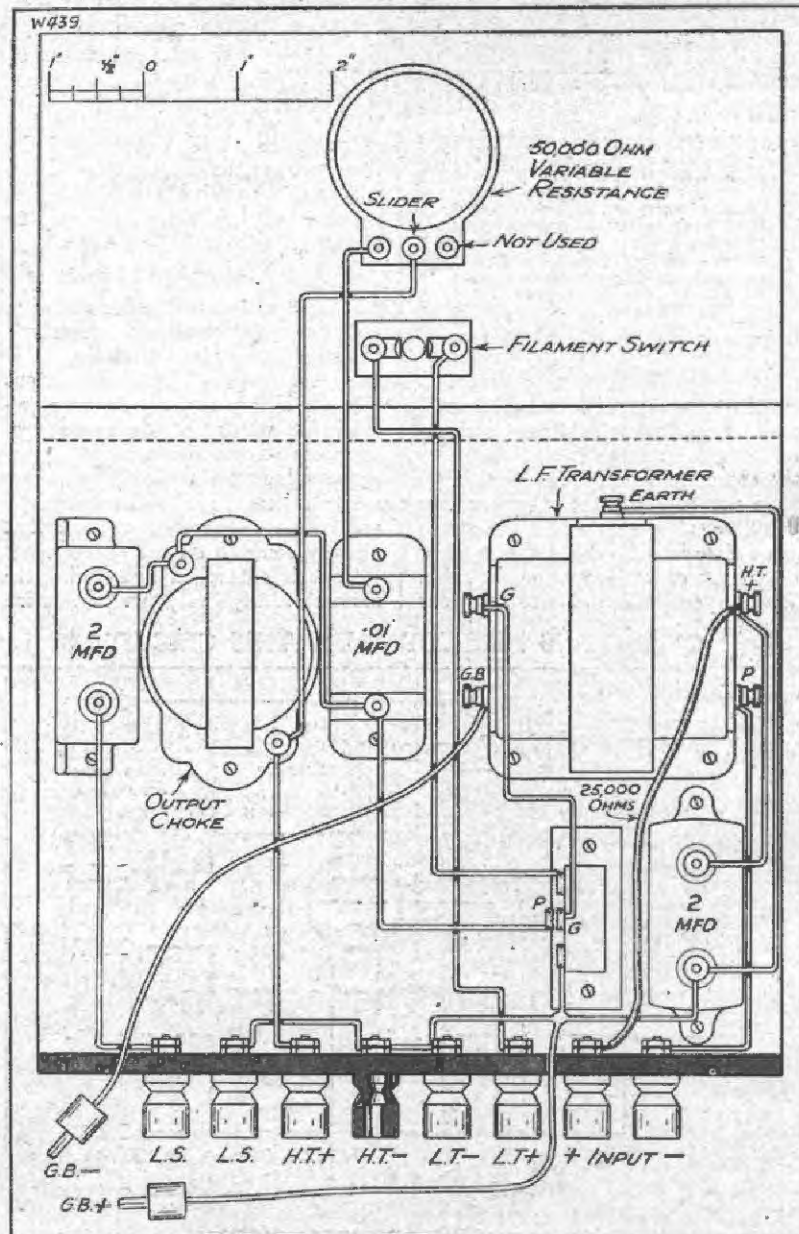

The "little black chap" amongst the terminals does not have to be connected up if you use the same batteries for the amplifier as are employed for the receiver preceding it. Otherwise it would be joined up the same as any other H.T. -terminal.

The job of the condenser is to by-pass the higher frequencies, and the job of the variable resistance is to control the effective amount of by-pass obtained. For purposes of explanation the condenser can be considered as a resistance, when it becomes quite obvious that the lower the value of the variable resistance the more effect the fixed "resistance" of the condenser will have.

### By-Passing the "High Stuff"

You can thus see that when the variable resistance is at maximum the total resistance is so large that no apparent by-passing takes place. As the resistance is reduced, the condenser has more and more effect, until, with the resistance at zero, the condenser is to all intents and purposes connected directly across the choke.

While we are looking at the circuit there is another point that I should like to call your attention to. It is the resistance and by-pass condenser connected up to the primary of the L.F. transformer.

These two components act as a de-coupler in the same way as similar components are often connected in the plate circuit of the detector valve of a multi-valve receiver. With a single-valver they would not be present in the set itself, and so are very desirable.

With a two-valver this de-coupling arrangement comes in the plate circuit of the first "L.F.," where it serves to make all possibility of L.F. instability a back number. That is a point well worth noting, because it so often happens that when an extra L.F. valve is added to a receiver much trouble is caused by a tendency to howl, if not by actual whistling.

The earthing of the core of the L.F. transformer also helps, so that everything is absolutely stable.

### A Point to Remember

The last item to refer to in connection with the circuit is the dotted lead between L.T. negative and H.T. negative. In most cases this wire will not be in use. The H.T. negative terminal and connection to it are included for use only if separate H.T. or L.T. (or both) is employed for the amplifier.

When you use the same supply for the "Amplitone" as for the set (no matter whether it be battery or

# TELSEN TRANSFORMERS & CHOKES

## TELSEN L.F. & OUTPUT TRANSFORMERS

Telsen transformers have achieved fame in the radio world on account of the high standard of their quality and performance. Designed and built on the soundest engineering principles, these robust, full-size transformers will give not only efficient but enduring service.

### TELSEN L.F. TRANSFORMERS

- Telsen "Ace" Transformer, Ratios 3-1, 5-1 . . . . . Price 5/6
- Telsen "Radiogrand" Transformer, Ratios 3-1, 5-1 . . . . . Price 8/6
- Telsen "Radiogrand" 7-1 Super Ratio Transformer . . . . . Price 12/6
- Telsen Intervalve Transformer, Ratio 1.75-1 . . . . . Price 12/6

### TELSEN OUTPUT TRANSFORMERS

Telsen Multi-Ratio Output Transformer, giving three Ratios of 9-1, 15-1, 22.5-1 . . . . . Price 12/6

Telsen Output Transformer, Ratio 1-1 . . . . . Price 12/6

Telsen Pentode Output Transformer . . . . . Price 12/6

### TELSEN L.F. CHOKES

Telsen L.F. Intervalve Coupling Choke, 40, 100, and 125 henrys . . . . . Price 5/-

### TELSEN OUTPUT CHOKES

- Telsen Output Choke (Plain), 20 henrys . . . . . Price 8/-
- Telsen Output Choke (Tapped), 20 henrys . . . . . Price 8/6
- Telsen Heavy Duty Power Grid L.F. Choke, 40 henrys . . . . . Price 8/-

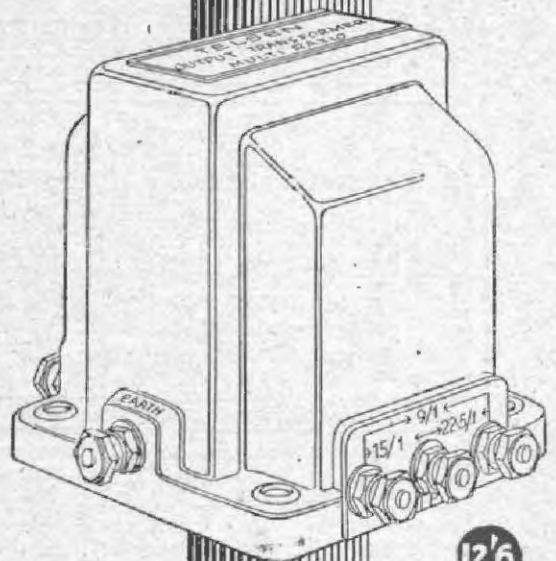

# TELSEN

ALL-BRITISH  
RADIO COMPONENTS

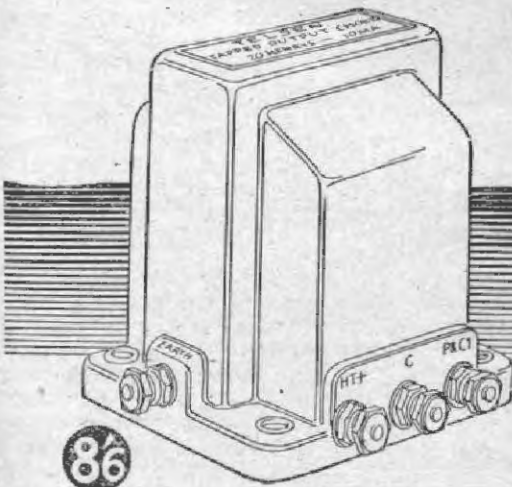
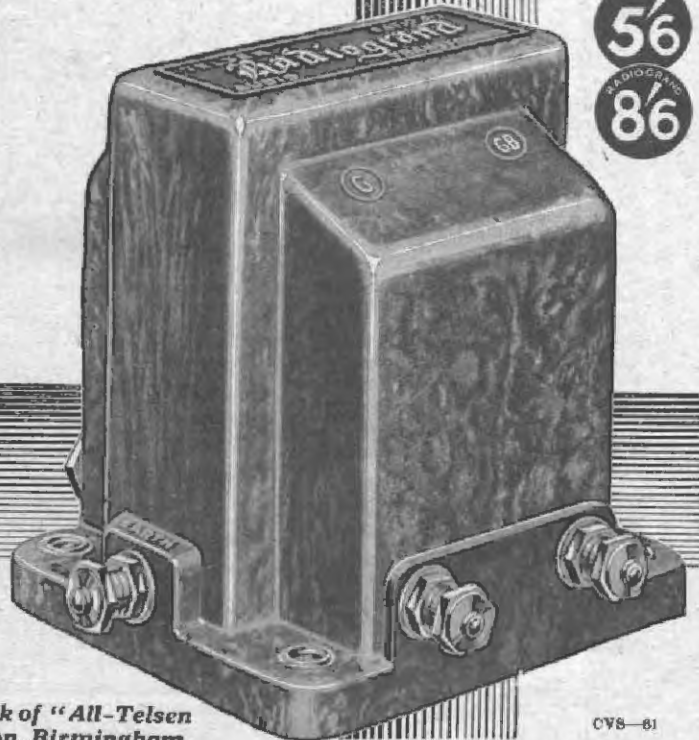

Send for the "Telsen Radio Catalogue" and book of "All-Telsen Circuits" to—The Telsen Electric Co., Ltd., Aston, Birmingham.



## The "Amplitone"—continued

mains supply), the L.T. will already be connected to H.T. inside the receiver. This H.T. negative connection is therefore unnecessary.

In such cases never connect a wire

'04 condenser, and you will want an explanation for this before purchasing the parts. This condenser is part of the tone-control scheme, and the larger one will naturally give a bigger by-pass

other is desirable if you wish to suit all and any valve.

For instance, it makes possible the use of a pentode valve in the "Amplitone" quite a practicable proposition providing that the unit is to be used only after a single-valve set. Incidentally, with a pentode in use the range of tone control is really remarkable, making it possible to adjust from an almost piercing high-pitched tone down to a really "woofley" one.

### "Resistance" Connections

As already mentioned, the way the original unit was wired the control gave most bass when turned to the right or clockwise. To get the same effect you must see that the variable resistance is wired as in the wiring diagram, namely, so that the resistance is at a minimum when the knob is turned to the right.

Naturally it does not matter which way the control works, but if the point was not mentioned you might be led to wonder if something was

### "SIMPLICITY IS THE BEST PROPERTY"—

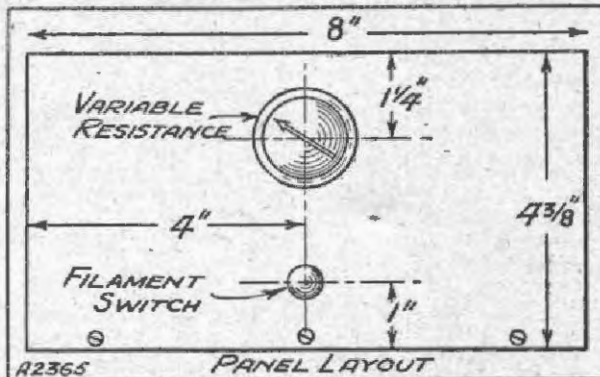

—and "Patience is a virtue," but you won't need any when making the "Amplitone," for the whole of its construction, like drilling the panel, is as simple as you could wish.

to the H.T. negative of the amplifier, because should it so happen that H.T. negative goes to L.T. positive in your receiver (and this is sometimes the case), the L.T. would be shorted because both sides of it would be joined up to H.T. —

From the practical diagrams you will see that compactness is one of the main features of the unit. To aid this compact effect, and at the same time to avoid the use of an unnecessary large panel, the valve has been given a similar type of valve holder to that so often used for S.G. valves in H.F. stages, in which the valve lies horizontally.

### A "Dinky" Outfit

The panel and baseboard are not of a standard size, as no standard cabinets are small enough for our purpose. If therefore you wish to encase the unit in a cabinet you will have to knock one up for yourself, unless you have one made specially for you. Anyway, the former is not difficult and the latter not very expensive, so it's up to you.

If 9 volts grid bias is sufficient for the valve you use, and a cabinet is employed, you will find room to tuck the G.B. away inside just above the terminal strip. Should you have to use a larger battery than that, then bore a hole in the back of the cabinet and bring the two flex leads through to the grid-bias battery.

In the list of components you will find that a '01 fixed condenser is specified, with the alternative of a

effect with the resistance at zero than will the smaller one.

It is thus simply a matter of how much control you need. The '01 will usually give ample control, but the

### IT DOESN'T TAKE IT LYING DOWN!

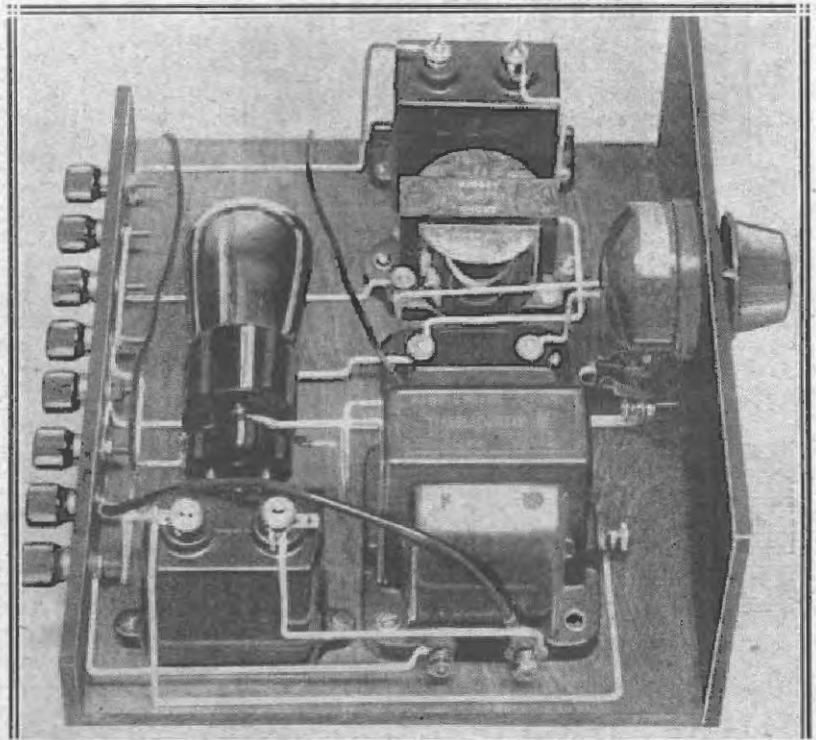

The valve is arranged horizontally, but it certainly stands up for itself, and makes its presence felt by dealing out as much punch as you can take, and yet the tone is adjustable to just the right pitch.

TO BE COMPLETED IN ABOUT 32 WEEKLY PARTS

**A NEW  
WORK WRITTEN  
BY EXPERTS**

# NEWNES PRACTICAL ELECTRICAL ENGINEERING

Here is a splendid work which, when completed, will be worth pounds to every reader of the "Wireless Constructor." It is packed full of practical information on every branch of modern wireless practice, and on the wider subject of electricity as applied to everyday life. It shows the approved methods of wiring a house for lighting, heating and power, how to instal a private generating plant, how to re-wind a motor, how to instal and keep in good repair all kinds of electrical accessories

**Would not this knowledge be worth many pounds to you?**

**HERE IS AN OUTLINE OF THE WORK—**

**WIRELESS FOR THE PRACTICAL MAN**

Trouble Shooting in Wireless Sets.  
Some Standard Wireless Circuits.  
Practical Notes on—  
Battery Charging.  
Loudspeakers.  
Low Frequency Transformers.  
High Frequency Transformers.  
Variable Condensers.  
Fixed Condensers.  
Coils and Inductances.

Trickle Chargers.  
Remote Control.  
H.T. Units.  
Types of Valves and Their Uses.  
Cases and Cabinets.  
Erection of Aerials.  
Wiring a House for Wireless.  
Testing of Wireless Components.  
Radio Gramophones.

**INSTALLATION WORK**

Electric Wiring Systems—Conduit,  
Lead-Sheathed Surface System,  
Other Surface Systems.  
Planning a Wiring Circuit.  
Installation Accessories.  
Domestic Power Apparatus and  
Control.  
Inspecting and Testing an Instal-  
lation.  
Office Lighting and Wiring.

Maintenance Notes for the Instal-  
lation Engineer.  
Shop Lighting and Wiring.  
Theatre Lighting and Wiring.  
Restaurant and Hotel Lighting  
and Wiring.  
Factory Wiring for A.C. Motors.  
Factory Wiring for D.C. Motors.  
Private Generating Plant.

**PRACTICAL NOTES ON**

Accumulator Charging.  
Accumulator Repair.  
Primary Batteries.  
Bells and Indicators.  
Burglar Alarms.  
House Telephones.  
Sound Film Apparatus.  
Dynamos.

Motors.  
Switchgear.  
Instruments and Motors.  
Transformers.  
Electric Lifts.  
Electric Cranes.  
Electromagnets.

**UPKEEP, FAULTS AND REPAIRS FOR**

Electric Signs.  
Electric Radiators.  
Electric Suction Cleaners.  
Electric Hairdressing Appliances.  
Electric Fans.  
Electric Tools.

Electric Washing Machines.  
Electric Water Heaters.  
Electric Cloaks.  
Electric Cooking Accessories.  
Electric Dimmers.  
Electric Time Switches.

**ELECTRICITY IN INDUSTRY**

Electro Medical Apparatus.  
Electroplating.  
X-Ray Apparatus.

Electric Welding.  
Electric Furnaces.  
Electric Traction, Etc.

**14 WIRING DIAGRAMS  
PRINTED IN 2 COLOURS  
GIVEN IN PART 1.**



**A FEW OF THE CONTRIBUTORS**

- Sir John Ambrose Fleming, M.A., D.Sc., F.R.S.
- Col. R. E. Crompton, C.B., M.I.E.E., R.E., M.Inst.C.E.
- Sir Richard Tetley Glazebrook, K.C.B.
- Col. Sir Thomas F. Purves, M.I.E.E.
- Dr. S. Parker Smith
- W. M. Thornton, O.B.E., D.Sc., D.Eng., M.I.E.E.
- Miles Walker, D.Sc., M.I.E.E.
- Lt.-Col. Kenelm Edgcumb, M.I.E.E.
- A. T. Dover, M.I.E.E.
- A. E. Watkins, M.I.Rad.E.

**WHY YOU SHOULD BUY THIS WORK**

- (a) Because you will find in it many practical hints and tips on the installing, construction and repair of wireless. Many money-making ideas!
- (b) If you are an expert on wireless matters you will find that a knowledge of the other branches of electrical engineering is both useful and valuable in your work.
- (c) Because when this work is completed you will find it is worth to you many times what it has cost, as it will provide an ever-ready source of reference on any practical point which may arise in connection with electrical engineering and wireless practice.

**ORDER YOUR COPY TO-DAY**

**PART 1  
ON SALE  
TO-DAY**

Of all Newsagents and Bookstalls, or 1s. 2d. post free from  
**GEORGE NEWNES, Ltd., 8/11, Southampton St., Strand, W.C.2**

**ONE  
SHILLING  
WEEKLY**



## The "Amplitone"—continued

wrong should your control turn out to work the other way round.

When an ordinary valve is used in the "Amplitone," whether it be power or super-power, do not have too low an impedance one, as the most effective range of control is obtained with higher impedance valves. That is why a pentode proves so effective.

### Using a Pentode

Should you use a pentode, you must make an extra connection from the terminal on its side to the H.T. battery, giving it the same voltage, or nearly so, as the H.T. plus on the unit. Whatever valve you use it is desirable to have one of the same L.T. voltage as those in use in the receiver.

Then you just run leads from the set battery terminals to the correct ones on the unit (remembering the notes about H.T. —), connect up the

loud speaker to its terminals, and also the input, and away you go. The H.T. — terminal is shown in black on the wiring diagram to emphasise that it does not usually have to be connected up.

to be on the high-tension side of the anode circuit of the last valve in the set. This means that the input terminal on the unit nearest to the end of the terminal strip goes to the L.S. or 'phone terminal on the

### YOUR SHOPPING LIST FOR THE "AMPLITONE"

- |  |  |
|--|--|
| 1 Ebonite panel, 8 × 4½ in. (Goltone, Peto-Scott, Permoat, Wearite).           | 1 L.F. transformer of medium ratio (Telsen, Igranic, Lotus, Lewcos, Varley, R.I.).   |
| 1 Cabinet (see text).  | 1 Output choke (Igranic, Bulgin, Telsen, Atlas, Lotus, R.I.).                        |
| 1 Terminal strip, 8 × 1½ in.   | 2 2-mfd. fixed condensers (T.C.C., Dubilier, Telsen, Igranic, Ferranti, Peto-Scott). |
| 8 Indicating terminals (Belling & Lee, Clix, Igranic, Bulgin, Ealex).          | 1 01- or 04-mfd. (see text) fixed condenser (Dubilier, Ready Radio, T.C.C.).         |
| 1 Valve holder for horizontal mounting of valve (Parex, or Bulgin).            | 2 Battery plugs (Ealex, Belling & Lee, Clix).  |
| 1 50,000-ohm, 3-terminal volume control (Sovereign, Igranic, Magnum, Wearite). | Glazite, Lacolite, Quickwire.  |
| 1 L.T. "on-off" switch (Telsen, Goltone, Ready Radio, Lotus, Bulgin).          | Flex, screws, etc.   |

There is a right and wrong way of connecting up the input, because of the de-coupling resistance which has

receiver that is marked negative.

If there is an output filter on the receiver and the L.S. terminals are not marked, trace out which of them is joined to the plate of the last valve and connect this up to the end terminals just mentioned. The H.T. supply to the receiver does not have to be touched in any way.

Unless the potentiometer that you use as a variable resistance is of the graduated type you will find that most of the controlling occurs at one place, and is not evenly distributed over the whole movement of the tone control. This is as it should be, and you will not find it so confined that there is any difficulty in making nice degrees of adjustment.

### "Switching Off"

Probably the effect of the control on speech will be most surprising to you, and you will find it quite fascinating to adjust tone to suit the item being received.

And now just a caution before finishing off. You are no doubt by now quite used to remembering to switch your set off before you go to bed, and so avoiding having to turn out of the warm when your memory gives you a jerk; but you must now remember the "Amplitone" L.T. switch as well.

If you switch off the set there can be no sound from the speaker to warn you that the amplifier is still "on." Whenever you push one L.T. switch in, you must also push the other one in.

### YOUR "AMPLITONE" SHOULD BE LIKE OUR OWN

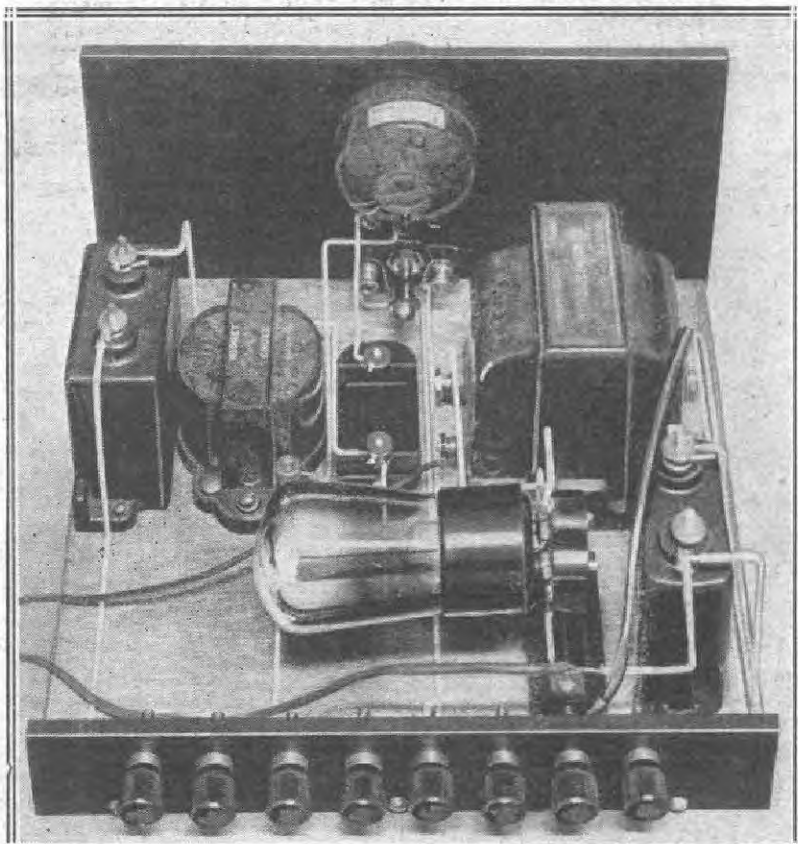

Even if some of your component makes are different from those of the original model, you can stick to this layout and arrangement, and thus ensure the same excellent results.

# -the newest in Radio SIX-SIXTY CHASSIKIT

Has created most extraordinary interest at the National Radio Exhibition, Olympia.



A prominent journal says: "A production which combines the advantages both of the complete factory-built receiver and the home constructor's kit, with the attendant freedom of choice in cabinet style . . . undoubtedly very successful . . . a wonderful show on the Stand."

AND FITTED WITH THE FAMOUS **SIX-SIXTY (B.V.A.) Valves**

**£6-17-6**

Complete Chassikit. 3-gang improved band-pass tuning, with 2-volt battery valves, S.G.-Det. (both metallised)-PENTODE output. II with A.C. Valves, £7. 0s. 6d. Cabinets from 10/6 to 12 gns.

Get the **FREE** folder—**YOU WILL BE GLAD**—**COUPON**

To Six-Sixty Radio Co. Ltd., Makers of the famous Six-Sixty (B.V.A.) Valves,  
Six-Sixty House,  
17/18 Rathbone Pl., Oxford St., London, W.1.  
Please send me **FREE** and **POST FREE** the  
Chassikit illustrated and descriptive Folder.

NAME \_\_\_\_\_  
ADDRESS \_\_\_\_\_

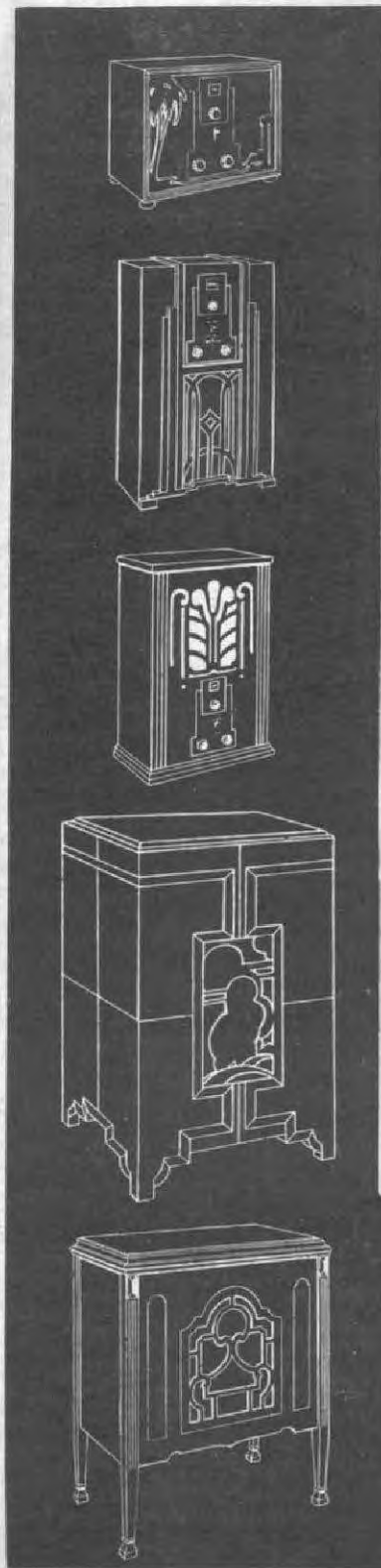





# A PRACTICAL MAN'S CORNER

In this section, which is of special interest to the self-builder, many valuable hints on construction and on the handling of tools are given.

By R. W. HALLOWS, M.A.

**T**HOUGH neat shields for screened-grid valves in sensitive circuits can now be bought very cheaply, there are many constructors who like to make everything they possibly can themselves. These will appreciate the idea illustrated in Fig. 1, which shows a type of shield that anyone can turn out.

It is also a useful pattern for test purposes if you want to see before

## AN S.G. SHIELD

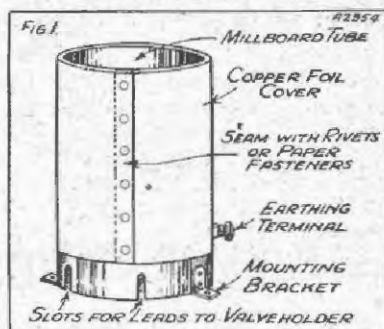

For those constructors who prefer to make their own gadgets, here is a very useful S.G. valve shield which can be made up quite easily. It consists of a cardboard tube, covered with copper foil, which is provided with an earthing terminal.

purchasing a shield whether screening an S.G. valve does effect an improvement. The foundation is nothing more than a short piece of millboard tube, which used to have such a large sale for making the formers of solenoid tuning coils. From 2 in. to 2½ in. is about the inside diameter required; the exact measurement will depend upon the type of valve holder in use.

### Foil-Covered Cardboard

The tube is covered from the top down to about ¼ in. from the bottom with a strip of copper foil whose seam

is fastened with small rivets, or even with paper fasteners. Failing copper foil, ordinary tin foil may be used in an emergency, and this can be stuck on to the outside of the tube with some strong adhesive.

At the bottom of the tube four narrow slits are cut each about ¼ in. in height. These are to allow the leads to the valve holder to pass.

The tubular shield may simply be slipped over the valve in its holder, or it may be fixed in position by means of little meccano angle-brackets.

The screening is made still more effective if a lid is made in the following way.

### Making the Top

Take a piece of tube whose internal diameter is such that it will just slip over the first. Cut off a piece about ¾ in. in length. Now cut out a disc from stout cardboard, its diameter being the same as the external diameter of the tube.

Cut a hole in the middle of this that will just comfortably pass the anode terminal, and glue this to the short piece of tube as seen in Fig. 2. Now cover the tubular portion with a strip of copper foil or tin foil and cut out a disc to cover the top. When a lid is used the total height of the screening tube plus the lid should be such that the plate terminal of the valve just protrudes.

### Metallic Contact

The tin foil encircling the tubular portion of the lid should be turned up a little round the lower edge so that it will make contact with the metal covering of the main part of the screen. The screen itself must, of course, be earthed. A very convenient way of doing this is to provide a small terminal, as seen in Fig. 1.

One of the handiest little saws that the constructional enthusiast can possess is that illustrated in Fig. 3. These saws, though surprisingly inexpensive, have a multitude of uses. The saw consists of a metal frame of U-section fitted into a ferruled wooden handle.

### Blade Changing

The far end of the frame is turned upwards to form a kind of hook. Near its end is a bolt with a wing-nut passing through both arms of the narrow U formed by the frame and close to the ferrule there is a fixed pin. The shape of the blades is shown in the drawing. To remove a blade, simply loosen the wing-nut and pull out the end of the blade nearer to it.

### PUTTING THE LID ON

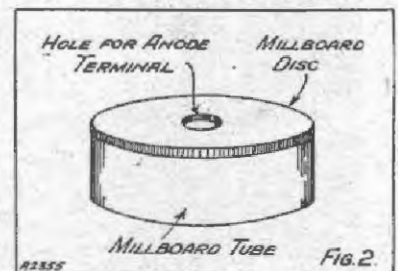

This is the lid of the gadget shown in the previous diagram. It fits snugly over the top and the anode terminal of the screened-grid valve protrudes through the central hole.

It comes out as if on a hinge, pivoting on the pin until it is at an angle of about 45 degrees to the holder. It can then be pulled right out. To insert another blade, begin by putting the corner near the notch marked X in the drawing into the division of the frame and slide the blade down towards the handle until the notch X engages with the pin.

## A Practical Man's Corner—continued

The blade then goes in quite easily, the notch Y coming round the bolt of the wing-nut. Tighten the wing-nut and the blade is secure. Blades of three different kinds are available. There is first a stout wavy-edged hacksaw blade meant particularly for iron or other hard metals.

Next comes a hacksaw suitable for ebonite or softer metals and, lastly, there is a blade whose use converts

### A "FLEXIBLE" SAW

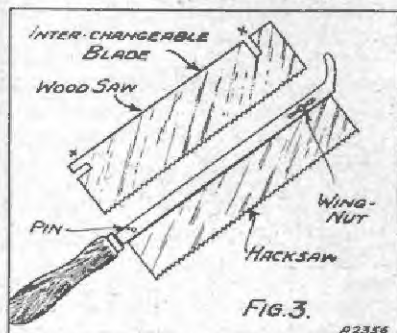

A saw with interchangeable blades is a very handy tool to possess. It enables you to use the right type of blade for any particular job.

the tool into a small tenon saw for wood. This tool is particularly handy to use. The work should be held in the vice.

The right hand, then, of course, grasps the wooden handle whilst the hook at the end of the frame takes the thumb of the left hand. Sawing thus becomes easy owing to the amount of "beef" that you can put into the work by using both hands.

### Suits Most Jobs

Armed with a tool of this kind you have all that you require in the way of saws for the majority of jobs that come the way of the constructor of wireless apparatus. The stout hacksaw blade will tackle any metal job that is likely to crop up in the constructor's workshop; the medium blade is ideal for brass, nickel, German silver, or ebonite, and the wood saw is exceedingly handy for the making of wireless cabinets.

Naturally, you cannot cut out the sides, ends and lids of cabinets with this tool, but as likely as not you will get the big sawing jobs done for you by the man from whom you buy the wood.

Though most of us prefer very rightly to use British-made com-

ponents, it is bound to happen at times that we come across one of foreign make. The letters B.A., by which we call the screws and nuts of various sizes with which we are most familiar, stand for British Association. Our makers use these, but foreigners do not. They usually employ screws and nuts which are of metric sizes.

There are few certainties in wireless, but one of them is that if you have a foreign component to fit in you will inevitably lose one or more of its terminal nuts. You will then find that a search in your box of odd B.A. nuts produces nothing that is a good fit.

### Packing with Washers

There are two possible courses open. The first, which I do not recommend, is to run a B.A. die down the shank of the offending terminal. If you try this the odds are strongly in favour of your stripping the thread altogether. The second method is to find a B.A. nut that will go on for a turn or two before it jams and refuses to be tightened any farther.

Put on your lead and then use sufficient washers to leave just a few threads of the screw exposed. You can then tighten all down with the B.A. nut. If the terminal is very long this may appear to want an unconscionable number of flat washers.

Look through that odd drawer of yours again and you will probably find that you have got quite a number of spacing washers that are used in the construction of variable condensers. Put an ordinary flat washer immediately on top of the lead. Follow this with as many of the condenser washers as may be required, put a flat washer (or two if need be) on top of them, and then tighten up the nut.

### Baffle Fixing

Owing to the numerous low-priced moving-coil loud-speaker units available this year, of both the permanent-magnet and the electro-magnet types, there is sure to be a boom in the home construction of moving-coil loud speakers. The business is exceedingly simple, since once you have the driving unit with its cone and chassis all that you need is a vertical baffle-board, with a hole of the correct size cut in the

middle of it, fixed to a horizontal base.

If you can find a corner where this arrangement will be sufficiently out of sight not to be an offence to the eye I would recommend it in preference to any kind of cabinet, for the quality of reproduction is better owing to the absence of boominess due to cabinet resonance.

### Useful Speaker "Table"

If, though, the baffle-board is of reasonable size (it should be, if possible, not less than 2 ft. 6 in. square), you will require something upon which to stand the driving unit in order to bring it up to the proper height. For this purpose you will find very convenient a little table of solid construction made on the lines of the one illustrated in Fig. 4.

Use good, stout wood such as 1-in. deal; 6 in. by 6 in. is a useful size for the top of the table. The height of the two battens which form the supports will depend upon the size of the baffle-board and of the driving unit itself.

There is no need to make exact measurements, for once the driving unit has been bolted to the top of the stand you can centre up the mouth of the cone with the hole in the baffle-board by placing pieces of wood under the stand until the desired result is achieved.

You can then fix the stand and the pieces of wood which act as packing

### FOR MOUNTING "MOVING COILS"

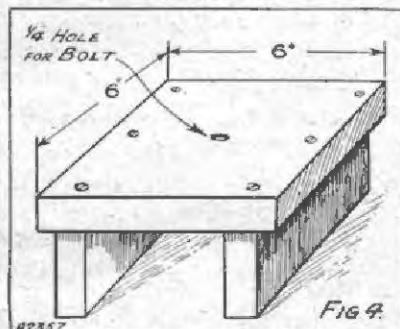

With the increased popularity of moving-coil loud speakers many constructors will undoubtedly find this wooden stand extremely useful. It is for supporting the unit behind a baffle board.

firmly to the baseboard by drilling a  $\frac{1}{2}$ -in. hole through the top of the stand and the packing pieces and using a long  $\frac{1}{2}$ -in. or  $\frac{3}{8}$ -in. bolt.





"ROTTEN time of the year this," snarled the Professor, as we sat smoking in his den at the "Microfarads."

"Why, my good idiot," I roared, "it's the best of all times. Foreign stations are simply rolling in. Last night I got Vzsmyl, and Nastikoff, and Lwow, and dozens of others on the loud speaker."

"Oh, wireless is all right." "Then what are you grumbling about. Does anything else matter?" The Professor grunted.

**Everybody's Ailment**

"Ah, ha," I cried, "I've got it!" And, seizing the morning paper, I ran through the advertisements. "Are you suffering from loss of appetite?" I read. "Have you pains in the back? Do your feet ache? Are you uncomfortable after meals? In fact, does every picture tell a story, so to speak? What you want is a bottle of—"

"No, no, no. My health's splendid. What I'm suffering from is simply that I am jolly hard up."

"Only that?" I exclaimed. "Why, all the best men always are. Still, we can soon set your financial position right. Let's do a little thinking."

The upshot of our deliberations was that the Professor should give a lecture in about three weeks' time at the Mudbury Wallow Town Hall. The subject he wanted to choose was "Adiabatic Permutations in Metaglobolised Tuned Circuits," or something of that kind; but I persuaded him to select instead: "Wireless Freaks and Oddities."

**The First Stage**

I was careful to explain that there was nothing *personal* about my suggestion. When we had decided upon the subject I undertook to go round and beat up a good audience for him.

My first visit was to Primpleson, who listened most sympathetically.

"Of course, you'll come?" I asked. "My dear fellow, I am absolutely desolated but that is the only single night between now and the end of the year when I have an engagement

which I simply cannot break. Frightfully hard luck, isn't it?"

"Rotten," I said. "You see, the date hasn't been fixed yet."

Primpleson collapsed like a pricked bladder and promised that nothing should keep him away. "Never," he

**THAT'S THE TICKET**



"Primpleson's eyebrows shot up."

said, making conversation, "can I cease to marvel at the wonder of broadcasting. Why, my licence gives me a season ticket to the concerts of Europe for a paltry ten shillings a year."

"I can beat that," I said.

"Beat that?"

"Mmmmm."

"What on earth do you mean?"

"Well, I have a perpetual ticket for all the entertainments of England, which cost me threepence."

Primpleson's eyebrows shot up towards the place where the per-

**A REFEREE'S RIGHTS**



"... and duly counted out the prostrate Primpleson."

manent waves used to begin before he began to get thin on the top.

"What on earth are you talking about?" he asked.

From my pocket I produced a small red disc of ivory, or some such material, and handed it to him. Upon it, surrounded by a laurel wreath kind of thing, he read the magic words "Committee."

"I bought it some time ago from

Pobblesworth, the stationer," I explained with a smile, and it works like a charm. You simply show it at the doors at concerts or exhibitions, or amateur theatricals, or even at the gates of race meetings, and unless your luck is dead out you can walk straight in with all the fellows touching their hats to you. To think of a thing like that," I said modestly, "one must, of course, have what is known as brains."

"Then who told you about it?" cooed Primpleson.

I will draw a veil over the little scene that followed. Sufficeth it to say that after some minutes I drew from another pocket my alternative badge, which is marked "Referee," put this on, and duly counted out the prostrate Primpleson.

"It's a novel idea of yours," said Tootle next time I met him. "That badge thing, I mean. Primpleson was telling me about it."

"Silly ass!" I cried, and I swore him to secrecy. "Now don't you go telling everybody, or it will get all over the place."

**A Lady Enthusiast**

During the next two or three days I was congratulated by practically everyone I met. It began really to be rather embarrassing. However, the novelty seemed to wear off in time, and people soon found something else to talk about.

I have often told you about Miss Worple, the rather intense lady member of the Mudbury Wallow Wireless Club. Possibly, though, you do not realise that most of the high-brow poetry broadcast from the B.B.C. studios is written by her under one of her many pen names.

Miss Worple's brow is so high that she has to use a step-ladder in order to put on her hat. This is the kind of thing she gets off her chest when she is really in good form:

Oh, the beautiful purple trees,  
Dancing under the square, pink moon.

Trees,

CHALLENGING  
 INTERESTING  
 HELPFUL  
 CRITICAL  
 SCATHING  
 TRENCHANT  
 CONSTRUCTIVE  
 ENTERTAINING  
 FORCEFUL  
 EXPERT  
 UNIQUE  
 VIGOROUS  
 BLUNT  
 VIRILE  
 LIVE  
 OUTSPOKEN  
 PROVOCATIVE  
 FRANK  
 BRIGHT  
 USEFUL  
 TOPICAL  
 INTRIGUING  
 INSTRUCTIVE  
 CHALLENGING

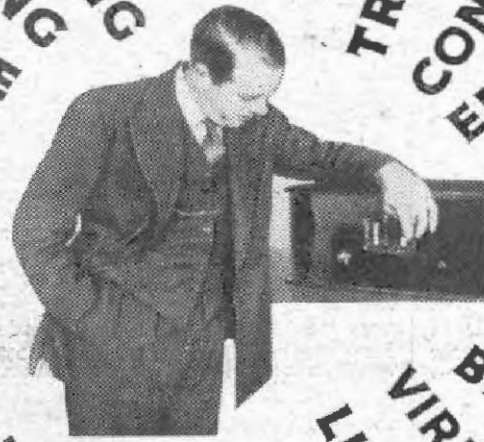

Read Capt.P.P.  
**Eckersley's**  
**Radio Feature**

World-famous as one of the  
 pioneers of broadcasting,  
 both with the Marconi Co.  
 and the B.B.C., Captain P. P.  
 Eckersley is now Wireless  
 Editor of *The Daily Mail*.

every Wednesday in the

**DAILY MAIL**



## In Lighter Vein—continued

Like hearth-brushes standing on end,

Living aerial poles.

What is your message for me?

Beautiful purple trees.

And so on and so on. People simply eat it by the yard.

Miss Worpel was one of my hardest cases whilst I was going round doing the beating up. The Professor, she told me, didn't come to her poetry readings, and she jolly well didn't see why she should come to his lecture. I was able at length to persuade her by promising that she should sit next to Captain Buckett, our oldest but most eligible bachelor.

### Officials All

When the great night arrived I was early on the scene, for the Professor had asked me to see to the seating arrangements, and had, of course, given me permission to wear my badge. An imported commissionaire was at the door. I pointed to the badge. He sprang smartly to attention with a waggly salute and I passed in.

### GOOD "BY-PASSING"!



"They all showed something to the rather surprised commissionaire and walked in."

Having taken a look round to see that all was well inside, I stationed myself in the vestibule in order to greet people as they arrived and to direct them to their places. First came Mr. Spoooper from the garage, with his wife and their family of nine. They all showed something to the rather surprised commissionaire and walked in.

Mr. Spoooper, I found on examination, was labelled "Steward" and his wife "Press." (As Mrs. Spoooper is large and forbidding, and as we are all perfect gentlemen in Mudbury Wallow, I can assure you that nobody accepted the invitation.) The children, down to the tiniest tot, bore "Messenger" badges.

Fresh arrivals followed thick and fast, almost everyone turning out to be connected with the Press or the

Ambulance Brigade. All the rest were labelled "Programme Seller," except Sir K. N. Pepper, who had the effrontery to wear a badge lettered, "Inspector of Entertainments." A pretty good idea that, though. I have made a note of it.

### No Results

When everyone was seated, I floated round to the box office to ask how the receipts were going. Tootle, who was in charge, informed me that though it was a case of standing room only, not a single soul had paid for admission. That would have been a face to most organisers, but we Wayfarers are full of resource.

The lecture on the whole was a great success, though the Professor did not exactly stick to the point. But there was enthusiasm from the very start when the Professor made his appearance in Mrs. Goop's most dazzling suit of beach pyjamas, which he had donned in an absent-minded moment instead of his evening togs.

At length, amidst rousing applause, the Professor sat down, wiping his fevered brow. Sir K. N. Pepper then rose to move a vote of thanks, clearly intending to do so at some length, as is the way of chairmen. Luckily, though, he observed that one of his shoe laces was undone. He stooped down to set matters right, two brace buttons hit the ceiling with resounding smacks, and Sir K. N. Pepper sat down hastily.

### Success at Last

The audience was shuffling about for its hats and things when I leapt on to the platform and banged the chairman's bell.

"My friends," I said, "it has indeed been a pleasure to the Professor and myself to see so many of you present this evening in an official capacity. Never, I imagine, has a lecture been so thoroughly staffed as this one.

"The remarkable point is that the committee is so small, consisting as it does"—and here I fingered my badge—"of Professor Goop, myself, and Mr. Tootle in the box office. By your loud applause you have signified that you are thoroughly enjoying yourselves here. We wish you to go on enjoying yourselves, and we have, therefore, arranged to lock all the exit doors!

"Lest you should lose an instant of

your pleasure they will remain locked until mid-day to-morrow. Anyone, though, who has urgent private business will be emitted, as opposed to admitted, upon payment of half a guinea."

It worked like a charm. A movement to rush the doors was quelled instantly by my appearance with the fire hose. Before midnight we col-

### A "HOWLING" SUCCESS



"... in Mrs. Goop's most dazzling suit of beach pyjamas ..."

lected £271 16s. 4d. in cash, and seventeen watches from those who had left their purses on the piano. On a fifty-fifty basis, both the Professor and I did quite well. A few more lectures by him and I shall be taking a grouse moor next summer.

\*\*\*\*\*  
**THE "KELSEY" ADAPTOR**  
 New York heard immediately on connecting 'up'.  
 \*\*\*\*\*

Sir,—Having recently decided to take up short-wave work, I have just built the "Kelsey" Adaptor described in your February issue this year. I completed it last night at about 9 p.m., and before a quarter past was listening to New York. It was the second telephony station that I picked up; the strength was good, but it faded often and badly.

It is only the second time I have operated a short-wave set, and I had only a plain dial to tune with. Nevertheless, I picked up six or seven other telephony stations, none of which I have yet identified.

I was using the unit coupled to two transformer stages of L.F., and New York was at times at moderate loud-speaker strength.

Beyond differences in the makers of the components, the only ways I departed from specification were in using a 25,000-ohm potentiometer and a larger baseboard.

Yours faithfully,

J. F. BOURDILLON

Headington, Oxford.



### Sir John Travels

**P**IONEERS of British broadcasting were amazed this summer to be told that Sir John Reith had spent about six weeks in visiting America and another month in Central Europe. How different from the old days!

Then the Director-General took no holidays at all, not even Sunday. The senior staff are reported to be particularly pleased at what they regard as an unprecedented sign of confidence in their capacity to "carry on."

Incidentally, the Chairman of the Board of Governors (in this case Mr. Whitley) has been provided with, and has accepted, an excellent opportunity for learning something about the business and practice of broadcasting, for which he is the chief public trustee.

### Mrs. Snowden

After more than four years' service as Governor of the B.B.C., Mrs. Philip Snowden has at last made her real microphone debut. In the talk which she gave introducing the new series of morning household talks, Mrs. Snowden proved she has first-class ability at the microphone.

Some of her friends were apprehensive lest the very excellence of her platform manner might be an obstacle at Savoy Hill. But Mrs. Snowden had taken care to adapt her technique. She said afterwards that she was nervous; if so, she did not show it; also, if so, she is bound to do better with every appearance before the microphone.

I suggest seriously to the B.B.C. that Mrs. Snowden should be put on the air at least once a month. What better exponent and interpreter could be found of B.B.C. policy?

# SAVOY HILL —NEWS—

*Sir John Travels—Mrs. Snowden—Economy at Savoy Hill  
—Mr. Churchill Declines—Those Ultra-Short Waves—Dr.  
Boult's Future—New Hood—Broadcasting House.*

### Economy at Savoy Hill

I have been investigating the various measures which have been adopted by the B.B.C. to enable it to meet present and prospective Treasury demands. No essential service has so far been endangered.

Of course, the immediate requirements of the Treasury from the funds of broadcasting are much less considerable than was recommended by the May Committee, which made the mistake of assessing what should be spent on the broadcasting service from evidence provided by a Post Office official without reference to the B.B.C.

There is, however, a danger constantly growing more acute, that those at Savoy Hill who are die-hard centralisers will exploit the present

situation to make another and perhaps decisive attack on Regional organisation.

I trust that these attacks, if they develop, will be promptly frustrated. I warn the B.B.C. that a great deal of its goodwill and much of the basis of its attenuated revenue is due to the activities of B.B.C. people outside London, particularly in the North of England.

### Mr. Churchill Declines

It seems to me a great pity that Mr. Winston Churchill has declined the invitation of the B.B.C. to take part in a world dictatorship series, which is being opened by Mr. H. G. Wells. I understand that Mr. Churchill is so anxious about India and tariffs that he could find no time for a

### HOW ULTRA-SHORT WAVES AID THE DOCTORS

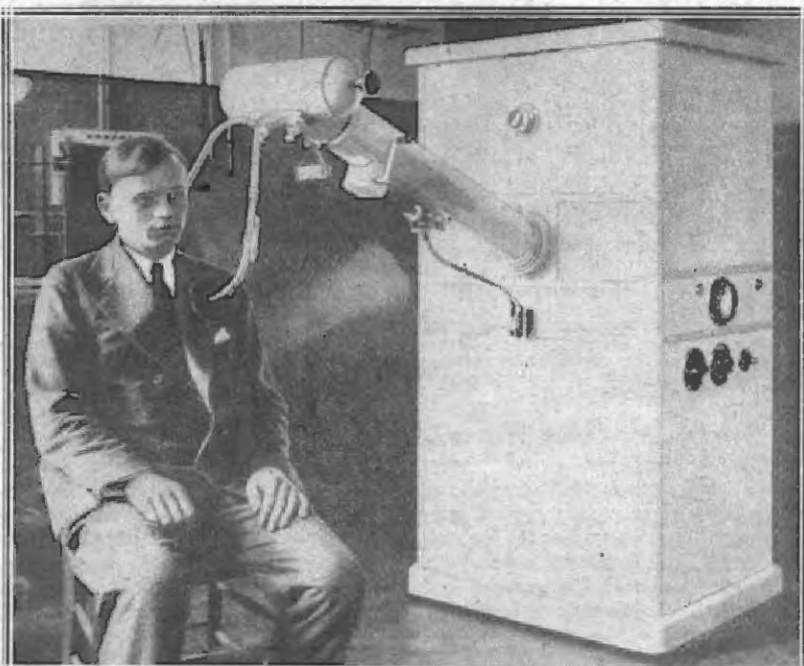

*This diathermic apparatus is used for treating patients at a large German hospital. It is virtually a radio transmitter which radiates extremely short waves, and is invaluable for giving high-frequency treatment to the internal organs.*



## Savoy Hill News—continued

theoretical exercise on World Dictatorship.

His absence greatly weakens the series, which may "tail off" without him. Well, I hope the B.B.C. will not neglect Mr. Churchill, until they get him as keen on broadcasting as is Mr. Wells.

If Mr. Churchill withdraws temporarily from party politics, as is possible, the B.B.C. should pursue him relentlessly. He has just the type of mentality and dynamic imagination that the microphone needs and transmits so admirably.

revolution in broadcasting. Consider what it means.

If the experiments are conclusive, and if they can be interpreted economically, it means that this country, as well as the Continent, will be permanently released from the bondage of wave-length limitation. It means positively that there will be almost an unlimited number of ether channels undisturbed and available for broadcasting.

Thus one of the chief reasons for the retention of the broadcasting monopoly in this country would

optimistic basis, it would be 1935 before the new dispensation could become effective.

Curiously enough, that is the year in which there will be set up the next Parliamentary Committee to advise the Government of the day on the constitution of the authority which will take over from the B.B.C. at the end of 1936.

### Dr. Boulton's Future

I have already expressed anxiety lest through some maladroitness the B.B.C. should lose the services of Dr. Adrian Boulton. I am still not altogether happy about the future in this respect. Dr. Boulton has done wonders both in administration and in conducting.

He has realised, quite rightly, that he must continue to do most of the conducting of the new orchestra if it is to make the steady progress in artistic achievement at which he aims. He realises also that he must retain administrative control.

But although he is now ably seconded on the administrative side, he is not quite invulnerable. I would feel happier about the future of the B.B.C. if I knew that Dr. Boulton was being given a freer hand.

### New Blood

My study of the programmes has been fairly continuous over the past seven years, nor do I think I could be fairly accused of lack of understanding. But I am bound now and then to sound warnings, and here is one.

There is too much of a "closed circuit" among those regularly engaged in the lighter entertainment side of broadcasting. I do not suggest that these people are deficient in talent; on the contrary, I believe they show an admirable consistency of performance.

It is not this, but rather the feeling that Savoy Hill believes it has encompassed all the available talent for its purpose, and almost denies the possibility of recruitment. This is what is wrong.

New blood should flow continuously without imperilling established talent.

### Broadcasting House

The new headquarters in Portland Place are now about half occupied. The move from Savoy Hill will be completed before Christmas.

### A NOVEL WEAPON FOR U.S.A. CAVALRYMEN

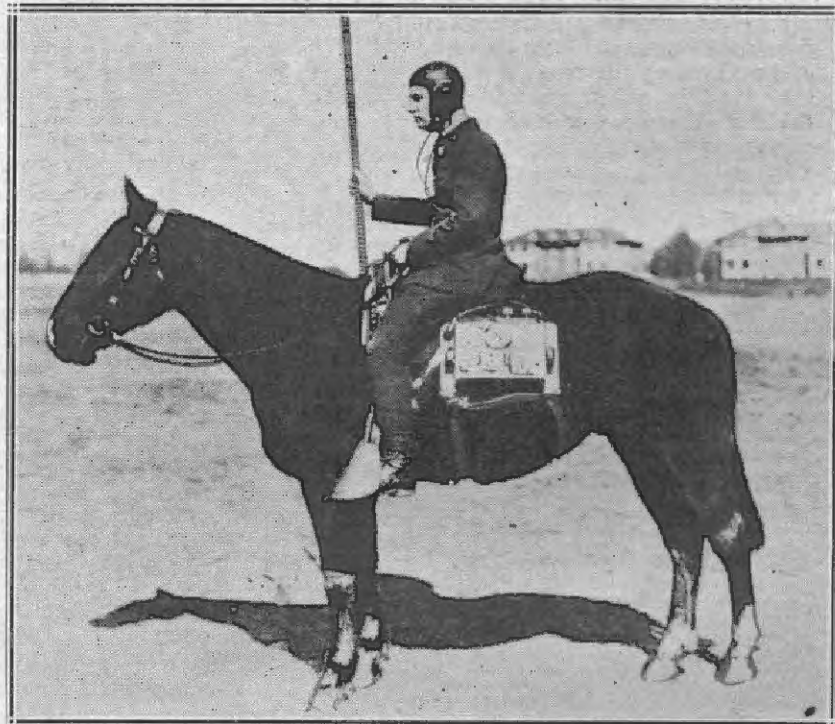

Radio for cavalrymen is the latest stunt in the U.S.A. The wireless set can be seen fixed to the saddle, while the horseman carries the aerial round his lance. It is claimed that by this means greater effectiveness in manoeuvres is obtained.

### Those Ultra-Short Waves

The implications of the recent B.B.C. admission that experiments with ultra-short waves are in active progress do not appear to be fully realised. The Germans, who started their experiments a few months ahead of the B.B.C., are reported as having attained remarkable results.

Although there are no official reports to justify these claims, my impression is that the ultra-short wave is destined to work a real

evaporate overnight. Also, it would be feasible to have broadcasting stations in every centre of any importance at all.

Of course, such a development cannot come about at once. I understand that two years must elapse before the present experiment can give any conclusive and compelling result.

This is just as well, because such a revolutionary change in the method of distribution would require far-reaching modifications in the instruments of reception. On the most

# THE long-life BATTERY



'C'  
TYPE. L.T. BATTERIES FOR WIRELESS

The Exide "C" Battery for low tension is the battery for big sets and greedy valves. This battery is famous for its strong construction—robust Exide long life plates—patented separators to prevent shorting—strong leak-proof containers of celluloid or glass. It is a very *convenient* battery—fitted with the new Exide identification slip to

prevent mistakes during recharging—terminals of different colour and shape distinguishable even in the dark. Thus the way of the listener-in is made smoother still by Exide. If your set makes such a demand on L.T. current that recharging must be frequent, you cannot do better than fit an Exide "C" Type Battery.

## Exide

Reduced prices per 2-volt cell: CZ2-20 amp. hrs. 9/-. CZ4-40 amp. hrs. 13/-  
CZ6-60 amp. hrs. 17/-. Other sizes up to 120 amp. hrs.

From Exide Service Stations or any reputable dealer.

Exide Service Stations give service on every make of battery.

Exide Batteries, Clifton Junction, near Manchester. Branches at London, Manchester, Birmingham, Bristol, Glasgow, Dublin and Belfast



# THE MONTH ON SHORT-WAVES



FROM observations I have made during the last month there is every indication that the coming "dark-evening" season is going to be the best ever for the short-wave enthusiast.

It isn't so much that conditions are likely to be any better than in previous winters—the chances are that they may even be worse!—but the number of really worth-while transmissions receivable between about 15 and 70 metres is going up by leaps and bounds.

I know, from my correspondence, that there are a great number of CONSTRUCTOR readers who revel in knob-twiddling on short waves, but I think it is time that something was done now that the "good" days are ahead to promote a spirit of competition.

### Honourable Mention

So, beginning with this month, every month in my notes I'm going

to give details of a station I have heard, the reception of which I consider to be something of an achievement, and if you manage to log it I want you to let me know.

**THIS MONTH'S "H.M." STATION**

Location: Tegucigalpa (Honduras).  
 Call-sign: H R B.  
 Wave-length: 48.02 metres (just below the higher-wave W 6 X K on 48.96 metres).  
 Time of transmission: 12 to 5 a.m. G.M.T. daily.  
 Interval signal: Three "cuckoos."

And when you write in, please give details as to when you heard it, what you heard, and how it came over.

I'm afraid there is no prize attached to this offer (we must, at all costs, maintain our amateur status!), but those who on the basis of results do the best will receive Honourable Mention in these columns. So now

see what you can do this month towards becoming a WIRELESS CONSTRUCTOR H.M.

Apropos my reference last month to a station in Buenos Aires which I believed to be L S O R, I am indebted to T. A. C. (of London, S.W.16) for confirmation of this. Many thanks, T. A. C., for your interesting letter.

I'm sorry I can't reciprocate by giving you the identity of "Malachi" on 28 metres. It is certainly a new one on me, but perhaps some other readers can throw light on the subject. Anybody heard him?

To conclude this month, I want to give you a few additions for your short-wave note-book.

CTIAA is now confining his short-wave activities to one night a week. He can be heard only on Thursday evenings on his old wave of 42.9 metres, and henceforth will announce in five languages—Portuguese, German, Italian, French and English.

### Lisbon and Jo'burg

"Radio Lisboa," a privately-owned transmitter at Lisbon, is doing a short-wave transmission on 42.19 metres on Mondays, Wednesdays and Saturdays. The call-sign, which is the name of the station, is repeated in English, French, German and Spanish.

Johannesburg is now on the air with a short-waver on 49.4 metres. Transmissions may be heard from 5 to 8.30 p.m. G.M.T.

G. T. K.

SELECTIVITY, selectivity, selectivity—that is the war cry at the present. A set must be selective, whether it is the humblest of crystal receivers or the most magnificent of side-band-scoring Stenodes.

When it comes to simple sets of the det. and L.F. type with one tuned circuit, the problem is complicated by the fact that to a large extent what we gain on the swings of selectivity, we lose on the roundabouts of volume. But I'm not so sure that we are on the right track.

### Volume and Selectivity

Take a simple aperiodic aerial tap scheme. We know that the larger our aerial the less the selectivity, and we also know that the lower our tap the greater the selectivity. In other words, the smaller our aerial the larger the tap we can use.

Going a step farther; the smaller our aerial the less our volume, but the bigger our tap the greater our volume. So which is the better in the end?

\*\*\*\*\*  
 \*\* "ON THE GRID" \*\*  
 \*\*\*\*\*

Put more simply, I think we might find that a small aerial and practically direct coupling would give better results than the more usual large aerial and small tap. So one of these days I am going to make some extensive measurements, and see if I cannot confound present ideas on the subject.

It really is surprising how many people in these enlightened times try to use the reaction condenser as though it were a volume control. Although in many circuits the reaction adjustment is to all intents and purposes nothing to do with the tuning, in many more an adjustment of reaction requires a further slight tuning alteration.

Here is a tip for wood-workers. We have all discovered how difficult it is

to join two pieces of wood at a picture-frame corner—"mitring" is the correct term, I believe.

Attempts at this usually result—at least where I am concerned they do—in a miniature ravine being formed diagonally across the corner of the frame. Perhaps I should have said that where I am concerned they used to result in the geographical formation I have mentioned, for I have now found the way of doing the job.

### For the Wood-worker

Lay the two pieces of wood over one another at the ends where they have to be joined. See that they make a proper right-angle, pack up the top one so that it is nice and solid, and then clamp the two down to a bench.

All you now have to do is to take your saw in your right hand and saw straight through both pieces together at the corner. I guarantee that they will then fit up as well as a shell fits a gun!

A. S. C.

# LOTUS COMPONENTS ARE SPECIFIED for RELIABILITY in THE "I.E." THREE described in this issue

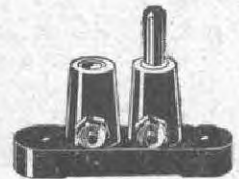
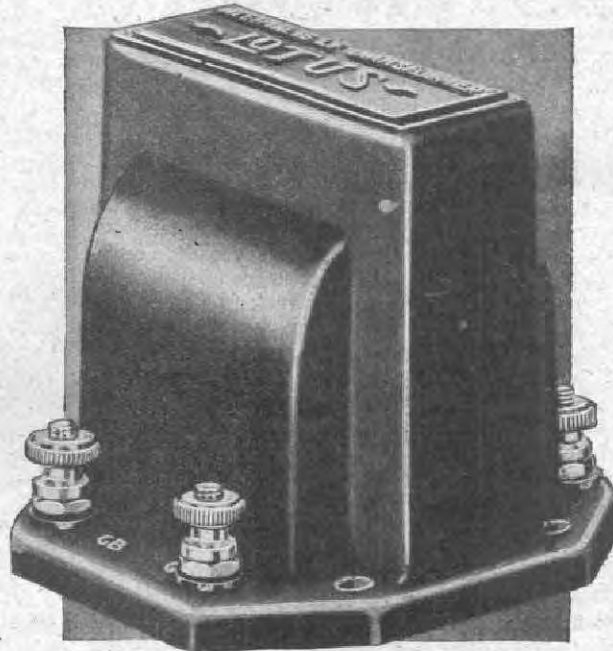

The LOTUS Coil Block with terminals... 8d.

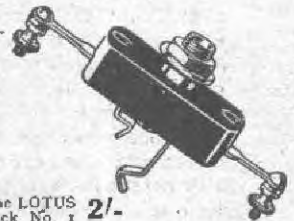

The LOTUS Jack No. 1 2/-  
Jack Plug 2/-

The new LOTUS Audio Transformer No. 1. An inexpensive instrument for the home constructor. It is remarkably efficient and has a good straight-line amplification curve. In two ratios, 3-1 and 5-1 ... .. 5/6



The LOTUS Anti-Microphonic 4-pin Valve Holder. With or without terminals 1/-



The LOTUS Battery Switch ... .. 1/6

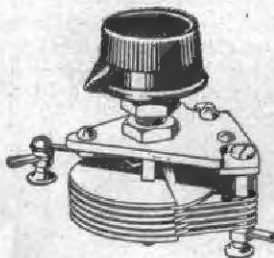

The LOTUS Reaction Condenser, '000134 4/- and '00034 ... 4/-

LOTUS RADIO LTD.,  
MILL LANE, LIVERPOOL.

Famous from the earliest days of broadcasting, LOTUS Components have always enjoyed the esteem of the radio constructor. This year many new lines have been born from the LOTUS Research Laboratories. Designed by the genius of J. Slegger, and manufactured with the unequalled resources of the Lotus Works and experience, they are miracles of efficiency and value.

In no case has quality been sacrificed for price. Nevertheless, through highly intensified production, they are within the reach of every pocket.

That is why all the leading radio designers specify and use them. They know from actual experience that LOTUS Components are reliable and will ensure the high efficiency they themselves have achieved.

Follow the experts' lead; insist on LOTUS Components. When you build the "I.E." THREE, described in this number, be sure to ask your dealer for one LOTUS Audio Transformer No. 1, three LOTUS Anti-Microphonic Valve Holders, one LOTUS Battery Switch, one LOTUS Reaction Condenser, three LOTUS Coil Blocks, and one LOTUS No. 1 Jack and Plug. Write or ask for your copy of the new LOTUS Component Catalogue; every home constructor should have one.

MANCHESTER RADIO EXHIBITION  
STAND NUMBER 42  
Oct. 7th to 17th

# LOTUS

RADIO COMPONENTS





# IS HOME- CONSTRUCTION WORTH WHILE?

*A trenchant article of a vitally informative character.*

By VICTOR KING.

**T**HERE are many readers to whom the question constituting the title of this article will appear absurd. But there must be also quite a few who have their doubts as to the "worth-whileness" of "rolling your own."

And they cannot be blamed for that, inasmuch as the prices of commercial sets have fallen considerably during the past few years owing to a more scientific application of mass-production methods in the industry.

## A True Comparison

But it is worth noting that the prices of components have followed suit, and a comparison between the figures given in the advertisement pages of the WIRELESS CONSTRUCTOR two or three years ago and those of to-day reveals that the price falls here in cases been almost precipitous.

It is of little use choosing at random one particular make of set and setting the cost of this against that of a similar home-assembled job. Such is not a true comparison. You must first ascertain the quality of the component parts used in the commercial set, and that you will find difficult to do.

## A Question of Cost

Generally speaking, the components of commercial sets are of very medium quality, although there are exceptions—in some cases a very high standard is reached, but extremely seldom with moderately-priced outfits. At the other extreme there is only one word that adequately describes the quality of parts in some of the cheaper sets, and that is "junk."

There is such a big case to be made out for the home-assembled outfit that I hardly know where to start,

although I do not think I can do better than to stick to finances for a bit, as at the time of writing this topic is very much in the air.

Supposing, for the sake of example, there were in existence a commercial set and a constructor's design that were similar in every way?

## Factory Facts

The constructor completes his outfit from a kit of unassembled components. He has to drill the panel, screw this to the baseboard, fix a panel strip and wire up. Finally, he has to carry out a fairly simple task of testing.

That doesn't, on paper, look a very formidable list of operations; but whatever the labour involved, the man who buys a complete set has to pay approximately twice as much

as would be needed to buy the components.

Actually, a works manager regards the assembly of the set and the testing as major operations, as they call for skilled labour—particularly the testing. The wiring is done step by step, and is facilitated by the adoption of a special layout designed specifically with a view to easy connections. Nevertheless, the task takes time and many "hands" have to be employed to carry it out.

## Discounting the Discounts

The cost of all this is as real a cost as the cost of the materials, and it may exceed this latter.

Remember that the trade discounts have to be paid on every manufacturing process, and it is obvious that

## WHERE CONSTRUCTORS SCORE HEAVILY

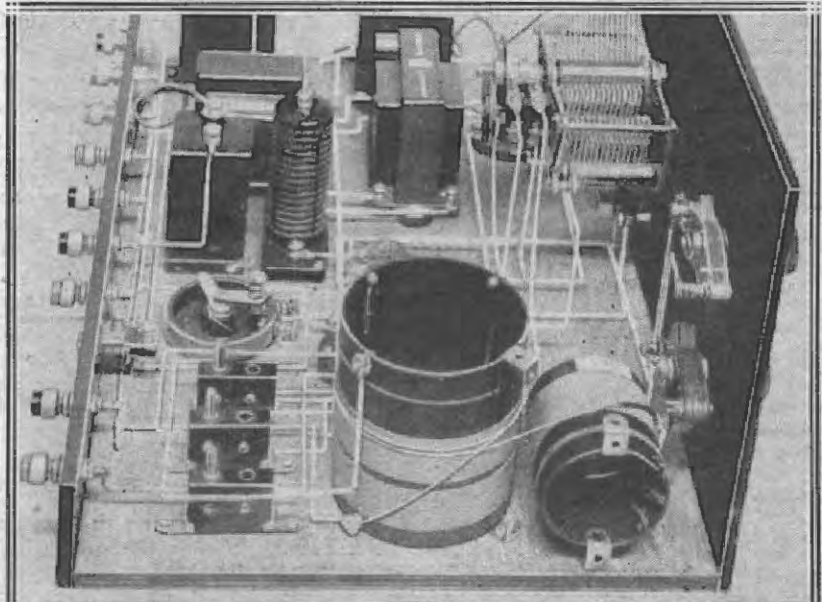

*A back-of-panel view of a home-constructor design that is entirely original in conception. It is the "I.E." Three, which is fully described in other pages in this issue. The radio trade is as yet unable to offer a commercial set embodying a similar scheme.*

# £6·6·0!

An astounding  
Olympia Success —

## ZONOPHONE Home Constructors KIT SET



### Seven Points of vital importance

- 1 Self-contained Loud-Speaker.
- 2 Band-Pass Tuning and Pentode Output giving astonishing selectivity and power.
- 3 Economical Battery consumption.
- 4 Full Broadcast range and easy operation.
- 5 Entirely new and simple colour-coded assembly without soldering.
- 6 Fixed Pick-up Sockets.
- 7 Compact Walnut Cabinet.

## ● And ZONOPHONE BATTERIES

HIGHEST EFFICIENCY

GREATEST ECONOMY

### THE ZONOPHONE PICK-UP

The finest Pick-up value in the world



Output 1½ Volts  
Weight 130 grs.

15/-

- |                                     |      |
|-------------------------------------|------|
| High Tension                        | 14/- |
| (108 v. Standard Capacity)          |      |
| Grid Bias (9 v. Standard Capacity)  | 1/6  |
| Low Tension                         |      |
| GLASS Accumulators, Mass Plate Type |      |
| Size 1 . . . 20 amp. hour           | 4/6  |
| Size 2 . . . 45 " " "               | 8/6  |

*These Prices do not apply in the Irish Free State*



## Is Home-Construction Worth While?

the more of these that can be cut out the greater is the saving to the consumer.

In actual fact, the discrepancy between factory and retail prices is often vastly greater than is realised by the purchaser. I can give you a very striking instance, and I assure you that it is perfectly true.

A friend of mine, who is the managing director of a big electrical manufacturing concern, once showed me a piece of apparatus which he said was produced by his factory.

"But it has 'So-and-so's' trademark on it," I pointed out, thinking he had made a mistake, for the trade-

ron advertiser, by the way) which has a cone loud speaker built in it that one factory sells to another factory at less than four shillings.

### Big Advantages

Then, again, there is a quite well-known commercial set embodying an L.F. transformer that has a wholesale value of less than two shillings. But for all that the set retails at a figure well above the cost of a de luxe constructor outfit.

The constructor has this one big advantage: All the parts for his receiver are individual items that have to reach a fairly high general

market that are not reasonably good, while some reach extremely high standards of efficiency.

But it would be unfair to the industry if I gave you the impression that commercial sets are, as a whole, built up from "sub-standard" parts. They are not. But just compare prices.

A really good all-mains radio-gram four may catalogue at anything up to £70. Just think what you could build for that figure! But perhaps you do not feel you could tackle such an instrument. Then take a battery-driven three of simple design. The cheapest one of good make I can find in a comprehensive list I have before me as I write is £12 12s.

I hardly need to point out that you could assemble a most de-luxe four-valver for that.

### That "Assembling" Bogey

There are many other ways in which a constructor gains over the buyer of a complete set, and it may be expedient for the sake of new readers to deal with these, too, in some future issue.

In the meantime I will conclude with a few remarks concerning the extension of the home-construction principle to the component parts of a set.

There are those who see fit to sneer at the home constructor, and say that nowadays all he has to do is to *assemble* and not *construct*. But the "screwing down of components and wiring them up" is, as I have already pointed out, a major operation as viewed by the factory, so it cannot lightly be dismissed by the layman as though it were "jig-saw."

It takes time and the application of an alert brain to assemble a set properly.

### A Fact to Remember

I firmly believe that it is only the man who has just a little keener brain-power than his fellows who is in the first instance attracted by home construction!

And I am not intending this as a fulsome compliment to WIRELESS CONSTRUCTOR readers, but record it as a fact. In my opinion, if a fellow *thinks* about set construction, that is good *prima facie* evidence that he has at least a modicum of the needed grey matter for the not very difficult task that lies before him.

### UP-TO-THE-MINUTE DESIGNS

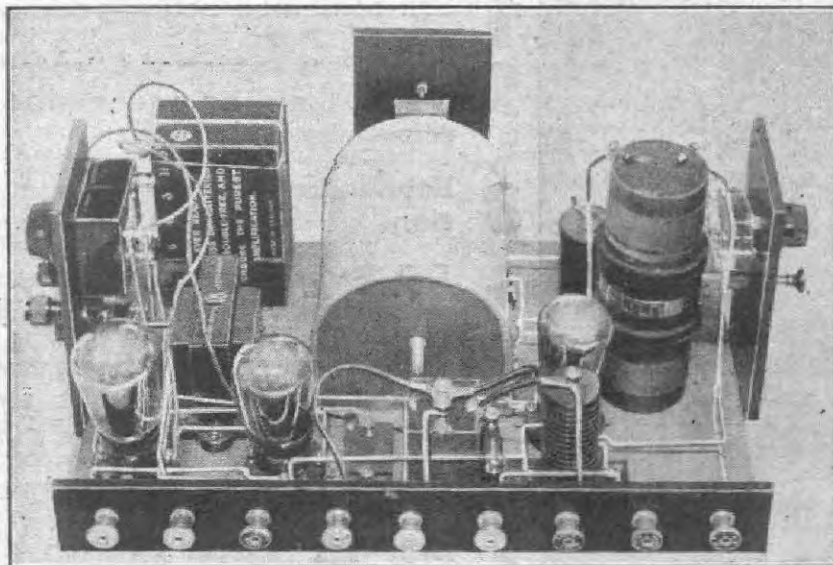

Frequently new principles are first popularised in home-constructor sets. For example, above is a photo of a band-pass set which was detailed in the "Wireless Constructor" quite a long time ago.

mark was of another and even bigger company.

"Oh, yes," he explained, "we make all these gadgets for them."

### First Costs

"You make 'em, sell 'em to these people, and they sell them to the factors, and they pass them on to the retailers, and they vend them to the public, eh? What do you get for them?"

"Fifteen shillings each," he said.

"And what do they retail at?"

"Five guineas."

Can you believe it? Well, to press the point home, I know a portable set (not a product of a WIRELESS CONSTRUCTOR

standard of efficiency, otherwise they would never survive the keen competition that exists in the sale of such.

A fixed condenser built into a tightly-sealed-up case of a commercial set can be a rough sandwich of foil and not-too-good paper, but a fixed condenser sold separately is always liable to be given those simple but effective tests known to constructors, and its merits or demerits mooted abroad.

Also, when you buy disjointed radio parts it is not difficult to make comparisons by "swopping makes."

All this is realised by the manufacturer, with the result that there are mighty few components on the

# TELSEN RADIO COMPONENTS



6<sup>d</sup>

**TELSEN VALVE HOLDERS.**  
(Prov. Pat. No. 20286/30).

The Telsen four and five-pin valve holders embody patent metal spring contacts, which are designed to provide the most efficient contact with split and non-split valve legs, and are extended in one piece to form soldering lugs. Low capacity and self-leakage.

Telsen 4-pin Valve Holder .. Price 8d.  
Telsen 5-pin Valve Holder .. Price 8d.



From 16

**TELSEN MANSBRIDGE TYPE CONDENSERS.**

Telsen have installed the most advanced plant in the world for the manufacture of Mansbridge Type Condensers. Only genuine Mansbridge foil paper and the finest linen tissue are employed. Post Office standards of insulation are adopted throughout. The following values are guaranteed within 5 per cent:

Cap. mfd.	500 Volt Test. Price	1,000 Volt Test. Price
.01	1/6	2/6
.04	1/9	2/6
.1	2/-	2/9
.25	2/-	3/-
.5	2/3	3/3
1.0	2/3	3/6
2.0	3/-	5/-



5-

**TELSEN BINOCULAR H.F. CHOKE.**

Hailed unanimously by the leading experts as the perfect H.F. Choke. The Telsen Binocular Choke is called for wherever highest efficiency is desired. Especially in H.F. amplification is the performance of the Choke of supreme importance.

Its highest inductance (180,000 micro-henrys) and exceptionally low self capacity (0.00002 microfarad) ensure a very high impedance at all wavelengths, and its excellent efficiency curve is free from parasitic resonances. These qualities, together with the restricted field due to the binocular formation, make it the ideal Choke for a high-class circuit ... Price 5/-



56

**TELSEN LOUD-SPEAKER UNIT.**

The Telsen Loud-speaker Unit is pleasing to the most sensitive ear. The deep notes of the bass, the brilliance of the soprano, and the crispness of the treble are clearly reproduced without any distortion.

It employs robust steel magnets, and the detachable cone which carries the cone is fitted with cone washers and clutch. The entire unit is enclosed in a beautifully moulded bakelite dust cover. Price 5/6

## TELSEN ALL-BRITISH RADIO COMPONENTS

Also include:—

H.F. Chokes	from 2/-
Transformers	.. 5/6
Output Chokes	.. 8/-
Power Grid Chokes	.. 8/-
L.F. Coupling Chokes	.. 5/-
Slow Motion Dial	.. 2/6
Mica Condenser	.. 6d.
Pre-set Condenser	.. 2/6
Variable Condenser	.. 4/6
Spaghetti Resistances	from 6d.
Loud-Speaker Chassis	.. 5/8
Pipe Holder	.. 6d.
Grid-Leak Holder	.. 6d.

Send for the "Telsen Radio Catalogue" and book of "All-Telsen Circuits" to: The Telsen Electric Co., Ltd., Aston, Birmingham.

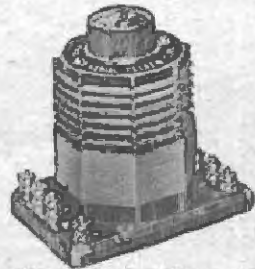

76

**THE TELSEN AERIAL COIL**

is the latest development in Dual Range Aerial Coil Design. It incorporates a variable series condenser which can be set to give any desired degree of selectivity, making the coil suitable for ALL districts. This adjustment also acts as an excellent volume control. The wave-band change is effected by means of a three-point switch. A reaction winding is included. Price 7/6 each.

**TELSEN DUAL-RANGE H.F. COIL AND TRANSFORMER.**

This coil is designed for H.F. amplification in conjunction with screened-grid valves. It can be connected as a Tuned Grid or Tuned Anode Coil, or alternatively as an H.F. Transformer. This Coil also makes a highly efficient aerial coil where the adjustable selectivity feature is not required. Reaction winding is incorporated. When used as an H.F. Transformer the wave change is effected by means of a 2-pole switch. Price 5/6 each.



9<sup>d</sup>

**TELSEN GRID LEAKS.**

Telsen Grid Leaks are absolutely silent and non-microphonic, and practically unbreakable. They cannot be burnt out and are unaffected by atmospheric changes. Telsen Grid Leaks are not wire wound and therefore there are no capacity effects. Their value is not affected by variation in the applied voltage.

Made in capacities ranging from 4.5 megohms Price 9d.



2/-

**TELSEN BAKELITE DIELECTRIC CONDENSERS.**

These Condensers are of a new type and of exceptionally compact dimensions. The moving vane, which are interleaved with finest quality bakelite, are keyed on to the spindle so that they cannot be pushed out of line, and there is a definite stop at each end of the travel. The connection to rotor is made by means of a phosphor-bronze digital so that there is no cracking due to rubbing contacts. The connection to the stator vane is absolutely positive—a very important point.

Telsen Bakelite Dielectric Differential Condenser	Made in capacities of 0003, 00015, 0001	Price 2/-
Telsen Bakelite Dielectric Reaction Condenser	Made in capacities of 0003, 00015, 0001	Price 2/-
Made in capacities of 00075, 0005		Price 2/6
Telsen Bakelite Dielectric Tuning Condenser	Made in capacities of 0005, 0003	Price 2/-



From 1/-

**TELSEN PUSH-PULL SWITCHES.**  
(Prov. Pat. No. 14125/31.)

The Telsen Push-Pull Switches employ a proper electrical knife switch contact and are soundly constructed on engineering principles. The centre plunger is wedge-shaped, so that as it is pulled out it forces the inner fixed contacts outwards, tightly gripping the moving contacts. There is no fear of cracking with Telsen Push-Pull Switches. Their low self-capacity makes them suitable for use in H.F. circuits.

**Telsen Push-Pull Switches—**

Two-point	Price 1/-
Three-point	Price 1/3
Four-point (2 pole)	Price 1/6





By C. W. R.

*Round-the-room aeriels are very popular, and also very effective, so these practical and well-tried ideas for making them still more efficient should prove very welcome.*

**M**y first practical experience with loop aeriels was at a time when I was exclusively a crystal user, and as such was exploring every means to increase the efficiency of my aerial system.

I shall not forget easily the very pleasant surprise I had at the first attempts!

**Looping the Loop**

A loop aerial is merely a frame aerial expanded in its linear dimensions and reduced to one turn of wire instead of several.

The principle of its action is precisely the same, namely, the utilisation of the phase-difference existing at any given instant at different points of the wave in the direction of travel. It needs no earth connection of any kind.

**A SIMPLE CIRCUIT**

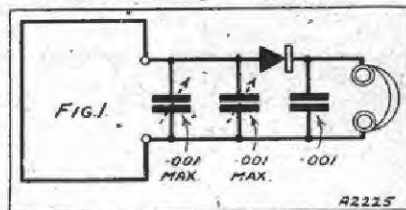

*A loop type of indoor aerial enables very strong reception even with such a straightforward hook-up as this.*

As its linear dimensions are increased so does the phase difference existing at its opposite sides increase, until, within the limits of an ordinary room, it becomes available for crystal reception at quite considerable distances from a Regional station.

I may mention that at about 24 miles I have had quite good reception from Brookmans Park on a loop about

12½ ft. by 9 ft. Owing to the attenuation of the shorter wave at this distance the National transmission is more difficult, but at lesser ranges this disparity tends to disappear.

What, then, does the loop aerial offer?

- (1) Stronger reception than that given by an aerial of the normal type occupying similar space.
- (2) Superior selectivity for two reasons: firstly, on account of its own inherent selectivity; and, secondly, by reason of its directional properties.
- (3) It requires no earth connection of any kind and hence it is equally suitable for erection in an upper or in a lower room.
- (4) It is rather less susceptible to interference by atmospherics than is the usual type of aerial and also to any damped-wave telegraphy (spark).

**Some Practical Directions**

Seeing that the crystal user will depend exclusively on his Regional station for his radio programmes, the directional effects of his loop will be a positive advantage.

Now a few practical directions. I find twin electric-bell flex is the best wire to use for a loop aerial indoors. It is electrically efficient for such a purpose, pleasing in appearance and easy to handle. Also the colour of the insulation can be chosen to match its location.

If this wire be used, the two stranded wires which form it are to be considered as one wire and should be soldered together at each of the end terminals.

To erect the loop proceed as follows: Ascertain the direction of the station

to be received, using a map and compass if necessary.

Decide at which end of the room the receiver is to be placed. (It does not matter at all at what point the loop is broken for the connection of the receiver).

**Quite Inconspicuous**

Take the wire from the receiver up the wall and across the ceiling in the direction of the transmitting station and down the opposite wall, then under the carpet, rugs, or whatever the floor covering may be, and back to the receiver.

Let the loop so formed be as large as the room will accommodate in the requisite direction, but it is as well to space the wire from the walls where possible by about ½ in., and to avoid proximity to large metal objects and mirrors.

Obviously, for merely testing purposes the lower wire can be simply laid on the floor. But if objection be taken to the appearance of a wire across the ceiling as a permanent fixture, with another one under the carpet, it is quite possible to deflect

**INDUCTIVELY COUPLED**

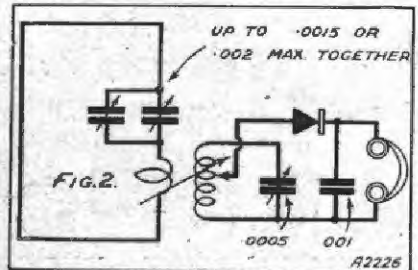

*This arrangement is more selective than that of Fig. 1, very loose coupling by means of one turn of wire being used.*

both the upper and lower wires so that they pass round the contour of the room; the upper going round the picture rail and the lower being taken round the wainscot.

My own loop is erected in this way and is, for the most part, invisible.

**Compression Condensers**

What is still more important is that no appreciable loss of efficiency resulted from this procedure in the case of two such aeriels which I tried.

Suppose the loop is to measure some 12 ft. or 14 ft. long by 9 ft. or 10 ft. high. A variable condenser of fairly high capacity will be needed to tune it to, say, 360 metres; something between .001 mfd. and .002 mfd. This high value need not disturb you in the least, because it happens that, in the case of a loop used for crystal reception, a high ratio of capacity to



and only  
then... **O.K.!**

**W**HEN you buy a condenser you have to buy in good faith—to take much for granted—its capacity and working voltage. Then make sure you buy the condenser that has prestige and a reputation to maintain . . . . . buy T.C.C.!

Because of that high reputation, no T.C.C. can possibly find its way to you until, after repeated tests, we find it "O.K." Thus we maintain our reputation—and thus you are assured of a condenser of unquestionable accuracy and downright reliability.

**T.C.C.**  
**CONDENSERS**

TELEGRAPH CONDENSER CO., LTD., N. ACTON, W.3.

8928

# AMPLION MOVING COILS for Home Constructors

**N**OW no home constructors need be without the very finest reproductive equipment, with **AMPLION** Moving Coil units at such modest figures. These super-sensitive units will make a world of difference to your results on any circuit; there are many handsome cabinet models, or you can easily fit one to your existing cabinet.



**MC6**

UNIT, complete with Transformer,

**67/6**

**D.C. ENERGISED MODEL (E.M. 644)**

**A** MOST efficient unit for D.C. Voltages: 100/110, 200/240, very suitable for inclusion in A.C. sets. Full details of alternative methods of operation supplied with each model

UNIT ONLY **29/6**

UNIT WITH matching transformer **42/-**

The fact that this famous Amplion M.C.6 Unit is a "best seller" is proof that it represents the finest value and greatest efficiency among small permanent-magnet moving coil speakers. Its reproduction and sensitivity are really remarkable, and it will handle without distortion adequate volume for all normal requirements. The universal transformer which is fitted enables the speaker to be correctly matched to either Power, Super Power or Pentode output from standard British 2, 3 or 4 valve receivers, and provision is made for push-pull

**M.C.9 UNIT**

**THIS** is a permanent magnet type but larger and more powerful than the M.C.6. A matching transformer can be supplied at an extra cost of 15/-

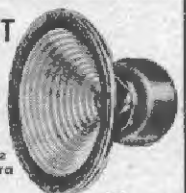

**M.C.9 UNIT ONLY £6**

(or on deferred terms)

GRAHAM AMPLION LTD., 26, Savile Row, W.1

## EFFICIENT INDOOR AERIALS—continued

inductance is quite permissible and gives excellent results.

Two of those handy little compression variable condensers, with capacity maxima of .001 mfd. each, connected in parallel will serve perfectly, and a switching arrangement to cut one out at will would enable an instantaneous change to be made from the Regional to the National wavelength.

### Circuit Simplicity

If a more refined adjustment be desired, a vane condenser of the usual pattern can be used in parallel with one of the compression type.

The circuit is thus of the simplest possible type (Fig. 1).

planation, but it should be remarked that, as the loop is a tuned circuit, the coupling between it and the coil can be very weak.

One turn of the loop around the coupled coil will be sufficient generally if the wire is as close as possible to it—two or three turns about 3 in. in diameter will be enough if the two are about  $\frac{1}{2}$  in. to 1 in. apart.

### Fine for Local Reception

Recently I have taken to receiving Brookmans Park on a loop aerial as described, inductively linked to a 3-valve resistance-capacity-coupled receiver and a high-grade speaker mounted in a large cabinet. The quality is really beautiful, and up to the present I have experienced not the slightest trace of interference from Mühlacker, which used to come in at times on another aerial.

The transference of the "family

## MAKING THEIR OWN HOME TALKIES



We are all now quite used to the idea of making records at home, but apparatus by which amateurs can make their own talkies was introduced for the first time at the Radio Exhibition. Here we see a stage in the experimentation to produce a home talkie outfit.

It may be found that the intrinsic selectivity of the loop is sufficient to separate the two transmissions, but if it is not, and one still remains faintly audible through the other, we have more than one method available to meet the difficulty.

For instance, we can use a coupling which is wholly inductive between the loop circuit and a closed circuit of the usual type (Fig. 2).

This figure needs no further ex-

set" to a loop aerial put up in any room where required, and thus free from the "anchorage" of an earth lead, will liberate the outdoor aerial and "earth" for the use of the experimenter for, say, the long or the very short waves, and will also remove the need for long loud-speaker extension wires.

Quality will probably be better, and interference noticeably less. Give the system a trial.

\*\*\*\*\*  
\* "A PAT ON THE BACK" \*  
\*\*\*\*\*

Sir,—Please give the designer of your "Kelsey Adaptor" a "pat on the back" from a satisfied reader. When I mention that mine was made up from the junk box and that within a very few minutes of connecting it up I received America, and listened, with very occasional fading, for about one and a half hours, I think it's worth telling you of, for the benefit of any other novice who may be considering making the unit. It is very useful and easily connected up by the man whose sole set is the family's set, which can only be utilised at odd times. (I'm not a late sit-up-all-night "bird.")

### After a Thunderstorm

Although I did not actually get the call-sign of the American (New York station), I think the announcer said "W G Y" (perhaps relaying W G Y), but didn't get it quite clear. I suppose it is a peculiarity of short waves, but I was able to try out the unit immediately after a rather severe thunderstorm about three weeks ago, when the family had switched off for safety, so I rigged up a few feet of indoor aerial, about 8.30 p.m., and the freedom from atmospherics I imagine was exceptional, judging by the bad short-wave reports I read about that time.

I heard the time given, 4 o'clock E.S.T., a musical trio, usual S.O.S.'s, Wall Street prices, etc. I've received Berlin, Moscow and Rome since, all on the L.S., besides lots of Morse stations.

### No Soldering Used

May I say that there is not a soldered joint in my unit, and perhaps I can pass on a wrinkle to others who do not solder, and that is to use a small hammer to flatten all round wire before being screwed under terminals. Any cross joints (where no terminals are available), I use "Gripsco" screw-down links, which for all purposes, especially hook-ups, are exceptionally firm and handy. Can be used over and over again, and I always keep a dozen or so by me.

Thanking you for all the wrinkles and dodges in your wonderful monthly "tanner's" worth.

Yours truly,

"DURNOVARIAN."

London, W.4.



**ASTOUNDING RESULTS WITH "WEARITE" COILS**

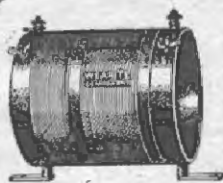

**"POP-VOX" SENIOR COILS**  
 Wonderful results will be obtained if you use these coils. Made exactly to published specification, they are specified by the "Wireless Constructor" for the "I.E." Three.  
 Price per set of 2 coils, P.V.1 and P.V.2, 7/6

Write for free illustrated list and leaflet.

**"WEARITE" PARATONE COIL**  
 Highly selective and very sensitive. It is approved by "Wireless Constructor," and is specified for the D.C. "Ace." Make certain of getting the best results. Price, 10/6

**"WEARITE" EARTH TUBE**  
 The finest earth tube obtainable. Improves reception and selectivity. The earth wire is connected to the tube by a unique feature, only obtainable with "Wearite." Price 3/6

**WEARITE COMPONENTS**

Wright & Wenire, Ltd., 740 High Road, Tottenham, N.17. Phone: Tottenham 3847/8/9

**SPECIFIED FOR THE "I.E." THREE AND THE "AMPLITONE"**



**MAGNUM VOLUME CONTROL**

50,000 ohms, 3-terminal type, specified for the "Amplitone." Price 5/-



**MAGNUM FADER TYPE VOLUME CONTROL**  
 1 meg., as specified for "I.E." 3. Price 10/-

The "I.E." 3, "Amplitone," D.C. "Ace," and all "Wireless Constructor" sets, can be supplied as constructional kits, ready wired and tested, or parts separately.

Full range of lists, including a list of short-wave stations and booklet on the "Stenode." Free on request.

**BURNE-JONES & CO. LTD.**

"MAGNUM HOUSE," 296, BOROUGH HIGH STREET, LONDON, S.E.1.

Telephone: Hop 6257 and 6258.

Scottish Agent: Mr. Ross Wallace, 54, Gordon Street, Glasgow, C.1.

**100% BRITISH MADE**

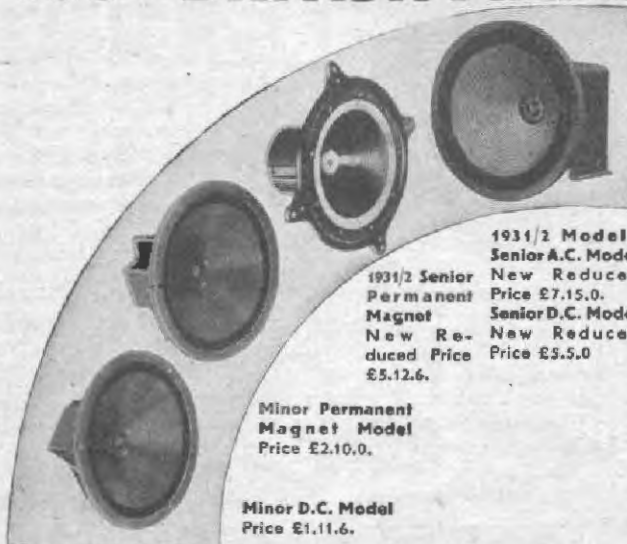

1931/2 Models. Senior A.C. Model

New Reduced Price £7.15.0.

1931/2 Senior Permanent Magnet New Reduced Price £5.12.6.

Senior D.C. Model New Reduced Price £3.5.0

Minor Permanent Magnet Model Price £2.10.0.

Minor D.C. Model Price £1.11.6.

**-and it costs less**

If you must have the best possible reproduction it means a B.T.H. R.K. There are many new models available now. In the R.K. range, from the "Minors" at 31/6 (field excited model) and 50/- (permanent magnet) to the Senior A.C. R.K. at £7:15:0, there is a model specially suited to your requirements.

Ask your dealer for a demonstration and full particulars.

**GREENWICH TIME FROM THE MAINS**



Have you seen the Ediswan A.C. Mains Electric Clock? Ask your radio dealer. Prices from 49/-

**B.T.H.**



**MOVING COIL REPRODUCER**

**EDISWAN RADIO**



THE EDISON SWAN ELECTRIC CO. LTD.

Radio Division: 155 Charing Cross Road, London, W.C.2

W.177



# OUR NEWS BULLETIN

### A Rival for 5XX

News is to hand that the Free State Government has made up its mind to erect a central high-power broadcasting station on a site at Moydrum, near Athlone. Work will shortly commence, and when the station is complete it is reckoned that the cost will be at least £70,000, and will equal Daventry 5XX in power and importance.

### Jack's Little Corner

The B.B.C. will probably have to engage some more librarians if they're not careful. In the music library at Savoy Hill it is said there are 40,000

vocal scores and more than 10,000 complete orchestral scores.

The Military Band section of the library holds about 2,000 complete works, while Jack Payne has his own little library containing about 3,500 complete sets of dance tunes.

### Pressing Forward

Despite the B.B.C.'s economy offer to the Government, I understand that work on the new Regional station near Falkirk, in Scotland, will not be interrupted. Nor will the work be interrupted on the West Regional station near Minehead. Reconstruction will also continue in connection with the Belfast station.

### The Axe

Savoy Hill has its own economy problems, like everybody else, and I hear the Governors have been meeting recently and working out ways in which to save money. It seems that

radio artistes' fees will in some way suffer a reduction, while salaries and bonuses are definitely going to feel the axe.

### No Christmas Present

In past years the B.B.C. has been accustomed to pay staff bonuses at Christmas; this year, however, I understand no bonuses will be paid at all, and this will be equivalent to a 2 or 3 per cent cut in salaries.

### Olympian Orders

As we go to press we hear that orders for £250,000 have already been given at Olympia. During the first two days 38,592 people visited the Exhibition. This is an increase of 8,011 on the first two days of last year. On the first Saturday, 28,694 people visited Olympia—a number equalling two days' visitors for last year.

### Better Business

The dance floor at Olympia has been very successful this year, and on the first Saturday of the Exhibition I calculated there were at least 200 couples on the floor.

As far as statistics are available as we go to press, it seems there is a general average increase of about (Continued on page 58.)

## THREE FINE CONDENSERS

Each designed to accurately and faithfully serve the circuit they are placed in. Polar Condensers produce the maximum pleasure from every receiver.



#### POLAR No. 4

A Direct Drive tuning condenser. Ball-bearing action. Aluminium vanes and end plates. Bonded rotors. Rigid construction with four brass pillars.

·0003 ·0005 ·00035

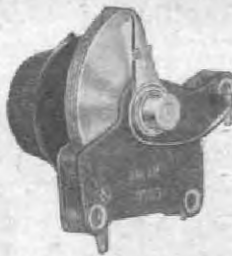

#### POLAR No. 2

Combines both Fast and Slow motion, for quick and accurate tuning. Sturdy construction of aluminium and brass pillars. Bonded rotors. Ball bearings.

·0003 ·0005 ·00035

THE "COMPAX." A solid di-electric condenser specially designed for either Tuning or Reaction. Very compact. Bonded rotor vanes, silent and smooth action; one-hole firing.

·0003, ·00015, ·0001, ·00005 - 2/6; ·0005, 2/9

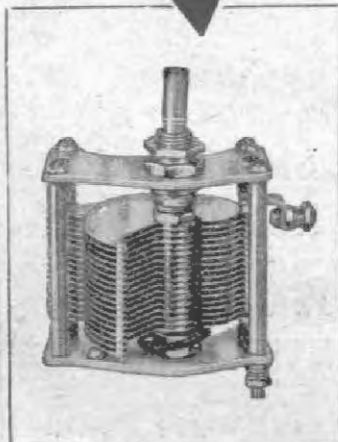

# POLAR CONDENSERS

Illustrated Catalogue Free.

# A COMPLETE RANGE OF FUSES for EVERY REQUIREMENT

## TECHNICAL REASONS

A fuse in a mains lead is a totally different proposition from a fuse in a H.T. or G.B. lead. In the mains lead it is unsound to use a lower rating than 1 amp, because the mere switching on and off of current creates a surge which might easily blow a fuse of lower rating. Further, in a mains lead fuses should always be more than 1 in. long to make arcing impossible. In H.T. and G.B. leads and rectifier circuits, on the other hand, it is unnecessary for fuses to go beyond 1/2 amp, even with multi-valve sets. Nor need they be longer than 1/2 in., even with a powerful H.T. supply. H.T. fuses should be kept as short as possible, for the fine high-resistance wire is liable to act as a coupling between the circuits and to set up "motor-boating" if too long.

That is why Belling-Lee now make their fuses in two lengths: H.T. ratings, 60 m/a., 150 m/a., and 1/2 amp, 1/2 in. long; mains ratings, 1, 2, and 3 amp, 1 1/2 in. long.

Spare fuses of all ratings are sold at 6d. each.

**BELLING-LEE**  
FOR EVERY RADIO CONNECTION

Advt. of Belling & Lee, Ltd., Queensway, Ponders End, Mid.

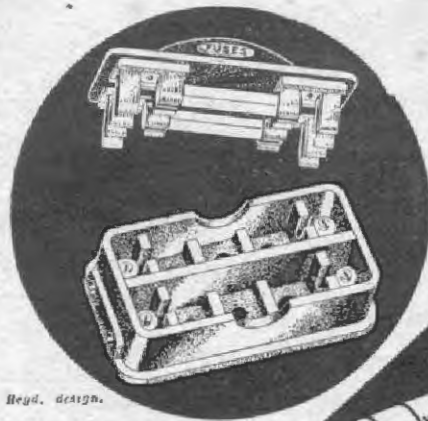

Regd. design.

**TWIN BASEBOARD FUSEHOLDER**, with two 1 amp. fuses for mains leads (illustrated above) .. 3/6  
**WANDERFUSE**, combined wander plug and fuse, with 60m/a. fuse 1/6  
**FLEXIBLE LEAD FUSEHOLDER**, short type, with 1/2-amp. fuse .. 1/- (Longer type with mains fuse, 1/-).  
**SINGLE BASEBOARD FUSEHOLDER**, with 1/2-amp. fuse. The best method of mounting a fuse inside a set or mains unit .. .. 1/3

Dealers will exchange fuses for other ratings at the time of purchasing any Belling-Lee Fuseholders.

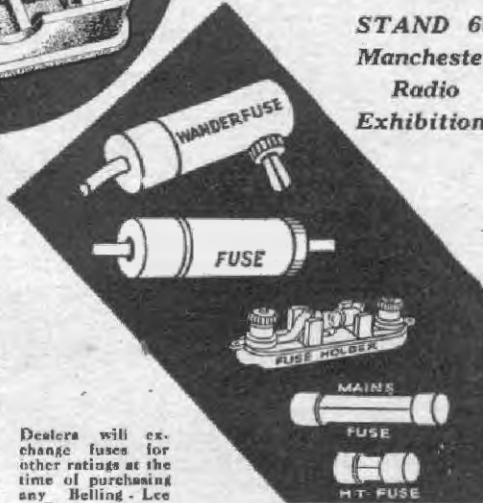

**STAND 69**  
Manchester  
Radio  
Exhibition.

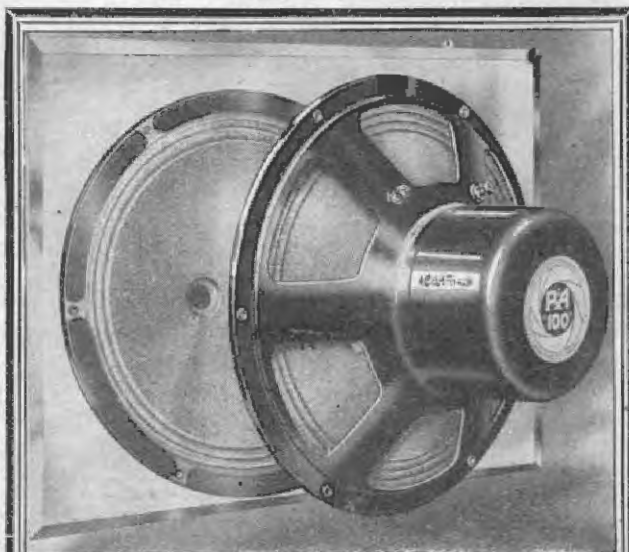

For sheer quality of reproduction the R. & A. "100" stands supreme. Its sensitivity is such that it gives perfect results from small receivers, yet is capable of handling large inputs without distress. Ask your dealer to give a demonstration; compare it with any other speaker at any price, and you will realise there is none to equal it.

The R. & A. "100" Multi-ratio Output Transformer, to suit all power valves, is recommended for use with this Reproducer. Price 12/6.

Descriptive Illustrated Leaflet sent post free on request.

**REPRODUCERS & AMPLIFIERS, LTD.,**  
Frederick St., Wolverhampton.

**45/-**



## High-Grade RADIO GRAMOPHONE CABINET

of exclusive modern design, hand-made and polished on Queen Anne legs.

Figured Oak - - - - - £5 : 5 : 0  
 Figured Walnut or Mahogany £5 : 10 : 6  
*Carriage Paid.*

### THE ACME OF CRAFTSMANSHIP

Radio-Gram Cabinets from £3 : 19 : 6 to £21  
 Wireless Cabinets - - - - - from £2

Photographs and 30-page illustrated Catalogue free.

Cabinets made to order a speciality. Furniture at Maker's prices.

**GILBERT, CABINET MAKER, SWINDON.**

Estimates free.

Estd. 1866.

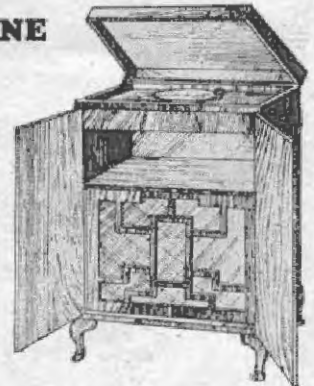

## LOW-TENSION TRANSFORMER 9/-

Here is the ideal model for running two A.C. Valves and one 4-v. Power Valve or three A.C. Valves. Output 4 volts 3 amps. Cheap and thoroughly efficient.

No. 723.



Other Heayberd Transformers in this series are as follow :

- No. 727, 4 v 5 amps. - 12/6
- No. 731, 4 v. 10 amps. - 22/6
- No. 721, 0·8 v. 4 amps. - 12/6

Send 3d. stamps for full lists of Transformers, circuit diagrams, etc



10, Finsbury Street, LONDON, E.C.2.



**OUR NEWS BULLETIN**

—continued from page 56

35 per cent in business all round the Exhibition compared with last year.

**We Sold Out!**

Certainly the WIRELESS CONSTRUCTOR has nothing to grumble at! On the fourth day of the Exhibition the Exhibition Number of this journal was sold out, 900 copies being disposed of in a few hours. However, the printers quickly got busy and a reprint soon enabled our salesmen at the stall to cope with the ever-increasing demand.

**Too Much Mush?**

The B.B.C.'s revival of the old suggestion in connection with the Regional Scheme that National programmes (except 5 X X) should all be broadcast on the same wave-length has aroused considerable criticism. Of course, it would mean an economy in wave-lengths, but, as Captain Eckersley pointed out the other day, mush areas would undoubtedly develop, and listeners situated at equal distances between two stations would probably find that all they would

receive would be a medley of two programmes.

**An Old Idea**

Captain Eckersley told me the other day that this idea of using a common wave-length was old history, for it was first propounded when the Regional Scheme was outlined nine years ago. Of course, the idea was abandoned as impractical, and it is strange to find the B.B.C. trying to re-hash this old idea in these progressive days.

**The Moonlight Flit**

The migration from Savoy Hill, Strand, to Broadcasting House, Portland Place, has already started, but, of course, it will be some months before the final moving-in arrangements have been completed.

**Rugby's Ten-Footer**

One of the exhibits at the Faraday Exhibition at the Albert Hall, Kensington, which attracted a good deal of attention was the British radio valve 10 ft. high. This is reported to be the largest valve ever made, and cost more than £1,000. I understand it will be used in future in connection with transatlantic wireless communication from Rugby.

**Metro-Vick Does the-Trick!**

Metropolitan-Vickers Electrical Company was responsible for its construction. The valve uses a filament current of about 5,000 times that of an ordinary broadcast receiving valve, and is capable of operating the mains transmitter at Rugby in a way which will dispense with a bank of 50 high-power valves.

**Combing the Pirates**

The General Post Office is getting definitely restive about the number of wireless pirates. It is reckoned that there are 400,000 in London alone. It has been proved that in the London postal area the number of wireless licences purchased totals 662,000, and investigations have shown that a much larger number of licences should have been taken out.

The Post Office state that unless an improvement takes place further investigations will be put in hand and areas will be thoroughly well combed by the G.P.O. wireless detectives.

**The Evil-Doers**

Figures show that since the British Broadcasting Corporation came into existence there have been over 6,000 prosecutions in connection with the

(Continued on page 60.)



**I'M "IT"!**

Birmingham.  
Sept. 27th, 1931.

Dear Sirs,

Perhaps you will remember the "Constant Square Peak Coil" you dispatched to Birmingham a little while back . . . Well I'm it.

I'm now installed in a very good old 3-valve set, and it seems I was the only one necessary to make the set selective and give tone. I've succeeded through sheer ability, for the individual who moves the dials granted me satisfaction to his wife last night, and said I had saved him buying a new set, and that I responded gamely to his every wish. He said I was a real acquisition, whatever that may mean.

Of course, I am new blood in old company, but we work well together as a team and find the loud speaker many languages to unravel.

Your obedient servant,  
C.S.P.C.

The Varley Co.

The above is one of the many letters that reach us daily from users of the "Square Peak" Coil.



"SQUARE PEAK" COIL  
(Regd. Trade Mark)

New model without switch for use with Extensers. Specified in the "Wireless Constructor" "Exhibition" Four.

Gives 9 kilocycle separation over the whole of both wave-bands. Needs no screening.

**READY NOW!**

List No. B.P.7.

**15/-**

**Varley**

## Run your radio FROM YOUR MAINS

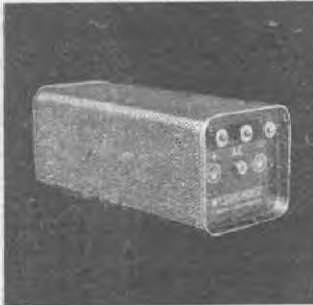

The H.T.S. has an output of 250 volts, 60 milliamps (after smoothing). Price 21/- Other H.T. types are from 12/6.

IF you have electricity in your house, use it for running your radio set. It is cheap, reliable and available by the touch of a switch. Battery-operated sets can easily be converted to mains-operated by a Westinghouse Metal Rectifier and a few other components. Complete information for building eliminators for existing and new sets is contained in the new edition of our 36-page booklet, "The All-Metal Way, 1932." We shall

be pleased to send you a copy on receipt of the coupon with 3d. in stamps.

## WESTINGHOUSE Metal Rectifiers

The Westinghouse Brake & Saxby Signal Co., Ltd., York Road, King's Cross, London, N.1. Phone: North 2475.

### COUPON

PUBLICITY MANAGER, W.B. & S.S. Co., Ltd., 82, York Road, King's Cross, London, N.1.

I enclose 3d. in stamps, for which please send me "The All-Metal Way, 1932."

NAME.....

ADDRESS.....

W.C. 11/31.

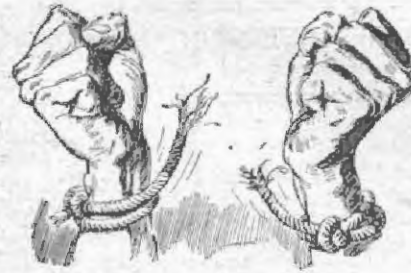

## Break Those Bonds

Don't be a slave to circumstances all your life. Break loose. All around you are people with no more intelligence than yourself who have climbed out of the routine class and

are occupying good positions because they availed themselves of specialized training.

Waiting for you at this moment is a bigger and better position. You can have it as soon as you have secured the training that will qualify you for it. And you can get that training in the spare time that you now let go to waste.

No matter where you live, the International Correspondence Schools will come to you. No matter what your handicaps, or how small your means, we have a plan to meet your circumstances.

For forty years the International Correspondence Schools have been helping men to get ahead in business and in life. They will help you, too, if you will only make the start.

We have nearly 400 Standard Courses, including many in the following subjects:

- |                              |                               |                       |
|------------------------------|-------------------------------|-----------------------|
| Accountancy and Book-keeping | Engineering, all branches     | Salesmanship          |
| Advertising                  | French and Spanish            | Scientific Management |
| Architecture and Building    | General Education             | Secretarial           |
| Chemistry                    | Insurance                     | Shorthand-Typewriting |
| Commercial Art               | Plumbing                      | Showcard Writing      |
| Commercial Training          | Railway Equipment and Running | Textiles              |
| Draughtsmanship              |                               | Window Dressing       |
|                              |                               | Wireless Engineering  |
|                              |                               | Woodworking           |

ALL EXAMINATIONS—Commercial, Technical, Matriculation and Civil Services  
Write to-day for free Booklet containing full information regarding the Courses in which you are most interested.

International Correspondence Schools, Ltd.  
172, International Buildings, Kingsway, London, W.C.2.

## Again Specified

### IGRANIC COMPONENTS

IGRANIC Components have again been recommended for use in conjunction with sets published in this issue. Such recommendations once more serve to prove that IGRANIC have always set the high standard of radio reliability.

### IGRANIC MIDGET CHOKE

(Type C 20)  
PRICE  
8/6

Specified for the "AMPLITONE" and THE D.C. "ACE"

If you cannot obtain Igranic Components locally, write Dept. J. 1152. We will supply C.O.D.

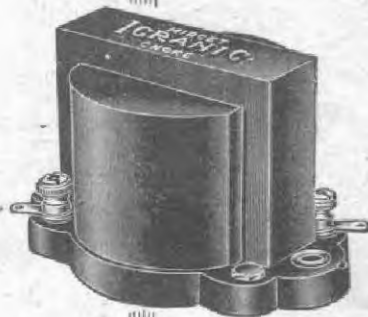

## Exciting School and Adventure Tales

This is the favourite gift book for boys—a wonder book of exciting tales of school life, mystery and adventure. It is lavishly illustrated with remarkable black and white drawings and also contains beautiful colour plates. The boy who has the BRITISH BOYS ANNUAL will have a book that he will want to read again and again. If you want a gift that cannot fail to please—make sure you get the

**BRITISH BOY'S ANNUAL** Now on Sale, 5/-

**OUR NEWS BULLETIN**

—continued from page 58

use of unlicensed wireless sets. In London, from August, 1930, to July, 1931, there were 269 prosecutions and 268 convictions; but it is pointed out that these figures do not show all the cases that might have been brought forward.

**Stamping It Out**

Post Office warnings are now going to be stuck up all over the country, so when you go and buy a postage stamp look out for the warning which says: "Is your wireless set licensed?"

Although we don't imagine for one moment that our readers need notifying, perhaps it would not be out of place here to mention the fact that a wireless licence costs 10s. a year, and can be obtained at any post office which issues money orders.

**Cancelled Concerts**

Sir Hamilton Harty, the famous conductor, has decided to cancel his projected season of London concerts with the Hallé Orchestra. In a letter to the "Daily Telegraph" recently

he pointed out that his reason was purely economic. Sir Hamilton Harty further maintains that the B.B.C. is not justified in entering into competition with private interests by means of giving public concerts financed by public money.

**L.S.O. and £.S.D.**

In his letter Sir Hamilton said: "I also agree that the work accomplished by the B.B.C. Orchestra could be undertaken by other orchestras, such as the L.S.O., or the Hallé, with at least as good musical results, and with much advantage to the financial well-being of these organisations and others, and probably a considerable saving in the sums now being expended under the B.B.C.'s present system."

**The Salary Question**

Many people will agree with Sir Hamilton, for it does seem silly that the B.B.C. should spend £100,000 a year on organising and running what is admittedly the finest orchestra in the world when, by negotiations and financial arrangement, the same sort of orchestra could be got together when necessary by enlisting the temporary services of other famous orchestras.

**The Balance Sheet**

Another writer in the "Daily Telegraph" makes pertinent reference to the latest revenue account afforded by the B.B.C. Year Book for 1931. The "Daily Telegraph" correspondent points out that on the debit side of the Balance Sheet the items are lumped together in such large groups that it is quite impossible for the taxpayer to tell how much is actually paid for each head. He goes on to point out that the largest item, programme expenditure, totals £548,676 2s. 8d., which he understands was increased last year to no less than £580,303.

**Too Vague**

"One might have expected some informative divisions of this amount," writes this correspondent, "but all the B.B.C. does is to announce in an airy way that the item includes payment of artistes, orchestras, new royalties, performing rights and simultaneous broadcast telephone system, salaries and expenses of broadcast staff. Sir Hamilton Harty, a year ago, estimated an amount less than a fifth of this enormous sum as being in his view what the B.B.C. probably spends on its orchestras."

**Building a Radiogram!**

**— select your Pick-up from this Range**

If you want brilliant reproduction—sparkling treble, ample bass, crystal clear middle register—you must have a B.T.H. Pick-up. Whichever model you select—the "Minor" at 27/6 or the "Senior" at 45/-—you are getting a product of the engineering skill which has made the B.T.H. Pick-up the recognised choice of radiogram experts. Ask to hear one at your dealer's.



Minor Pick-up



Senior Pick-up



"Minor" B.T.H. Pick-up and Tone Arm. Price complete **27/6**

"Senior" B.T.H. Pick-up and Tone Arm. Price **45/-**

"Senior" B.T.H. Pick-up only with adaptors. Price **27/6**

**EDISWAN RADIO**



**PICK-UP**  
and **TONE ARM**



THE EDISON SWAN ELECTRIC CO. LTD.  
Radio Division:  
155 Charing Cross Road, London, W.C.2  
Showrooms in all the Principal Towns

W.167





**A**MERICA is the only country in the world where really strict control of all broadcasting stations, amateur and professional, is kept by its own authorities; but as there are some 650 commercial broadcasting stations alone, and thousands of amateur stations, this strict control is really needed!

#### "Police" Stations

There are springing up all over the country a number of "monitoring" stations, which occasionally transmit signals on fixed wave-lengths so that broadcast stations can take these as a standard; and when not engaged in transmitting they keep a rigorous check on transmitters.

They make a note of any change of wave-length, of any apparent under- or over-modulation and, in the case of commercial stations which transmit Morse code, a check is kept on the "purity" of the note giving the dots and dashes.

There is a big monitoring station run by the Department of Commerce at Hingham, Mass., and this is the first of ten new radio police stations which are to be opened.

#### "Long-Armed Sam!"

Not only does Hingham watch American broadcasting, but, at the request of several other authorities, including the B.B.C., a check is kept on reception of distant stations. As a matter of fact, at Hingham there is a special log record of 5 S W, our short-wave transmitter at Chelmsford. At any time Hingham can tell what deviation Chelmsford makes from its proper wave-length of 25.53 metres, and can give an account of the audibility, amount of hetero-

*America is going ahead with plans for a number of new "monitoring" or "watching" stations to keep a check on offending broadcasters. Hingham, the ether policeman here described, also keeps a watchful eye on the behaviour of our own short-wave transmitters.*

#### From a Correspondent.

dying and fading. A very strict watch is kept on amateur stations, and in a few cases the licences of a number of American amateurs have been cancelled because they did not transmit on their proper wave-lengths.

The apparatus at Hingham somewhat resembles the wave-length checking receivers (mostly super-heterodyning) used by the B.B.C. at the Tatsfield testing station. Hingham station is in a separate building devoted entirely to this radio ether policeman work, and the 150-ft. aerial is a local landmark.

#### Warming the Waves!

The inside of the wave-length checking room is kept at a constant temperature by means of a special heating system, so that the sets operate under constant conditions so far as is

#### KNOWN THE WORLD OVER

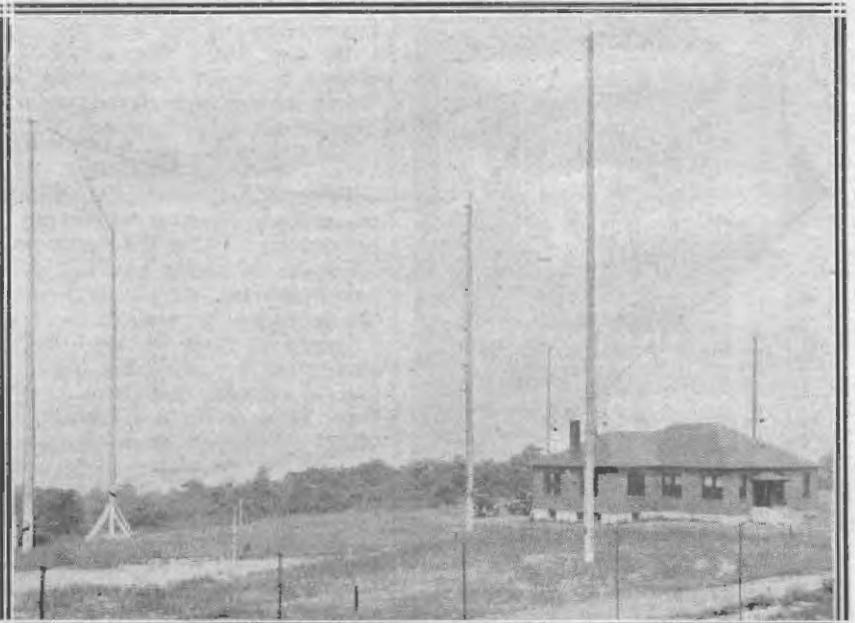

*This is a view of one of the KDKA (Pittsburg) experimental aeriels. This station has been transmitting regularly for over ten years and claims to be the oldest broadcasting station in the world.*

# MAKE YOUR SET UNIVERSAL



## EELEX SHORT WAVE CONVERTOR

A remarkable invention that converts your set into an "all-station receiver." Enables your existing set to be used on the ultra short-wave bands. It is an indispensable addition giving you the choice of a wide range of programmes. Housed in leather cloth covered "Byldurone" cabinet with nickel corners, it has a pleasing appearance. It covers the 16-60-metre band. Price 60s. An additional coil for the 140-190-metre wave-band is available at 5s.

## BYLDURONE

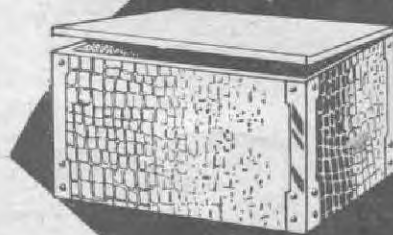

## CABINETS

As used and recommended to constructors for the Mullard V.3, Set in "Radio for the Million," Super 60, Century Super, and many other sets. Anyone can construct these cabinets. All that is required is a saw, screwdriver, "Byldurone" corner-pieces, and a supply of s-ply wood.

Write for list L.2.

## J. J. EASTICK & SONS,

EELEX HOUSE,

118, BUNHILL ROW, LONDON, E.C.1.

Phone: METROPOLITAN 0314/5/6.

## UNCLE SAM'S RADIO SLEUTH

—continued from page 61

physically possible. Two receivers are used, and these are rigged up in typical American fashion on metal panels with the frequency-testing equipment between the two sets.

The first receiver tunes from 200 up to 3,000 metres, and is a real long-range job, having four H.F. stages and three L.F. stages, two of which are resistance coupled. A large frame aerial at the side of the receiver frame is used when, for any reason, there is local interference on the station which makes the directional properties of a frame handy.

### The "Short-Wave" Set

The long outdoor aerial is normally used. It is interesting to note that sets of plug-in coils are used to cover the wave-length range.

The other receiver tunes from 200 metres down to 10 metres or thereabouts, and this is used with a vertical aerial made of copper tubing. This aerial hangs down parallel with the 58-ft. pole supporting the broadcast-band aerial, and it is supported away from the pole on stand-off type insulators.

The short-wave receiver is an interesting job, because elaborate precautions have been taken to make it very stable in working so that there is no difficulty in getting a constant signal for frequency tests.

It has three screen-grid H.F. stages, a detector and three L.F. stages in the same arrangement as used for the broadcast-band set.

### Crystal Control

On top of each receiver panel stands an indicator speaker which can be switched in so that the operators at Hingham can form an idea of the modulation and get an aural idea of the audibility and quality.

Quartz crystals are used for frequency testing, and in the metal rack placed between the two receivers there is a small A.C.-heated oven which, controlled by a thermostat, governs the temperature of the crystal to well within  $\pm 1$  of 1 degree C. This crystal is ground for a frequency of 30,000 cycles, and by means of harmonic selector circuits this can lock with the testing apparatus tuned to various frequencies.

### Electrically Heated

The crystal is in a box with alternate layers of felt and aluminium

between the crystal itself and the outside of the box. The box, by the way, is a heavy aluminium casting.

This is placed in the centre of the electric "oven," which is heated by two current sources. One keeps the temperature fairly high and as near as possible at a constant level, while the other is controlled by the thermostat and only comes into action when needed.

There is a heat indicator and a meter showing the heterodyne frequency.

### A Careful Check

In this way the operators get a visual indication of the exact heat, and they check up also by wearing 'phones and listening in.

Generally speaking it is only a matter of a few minutes to tune-in a station on either the "B" receiver (for the broadcast band) or the "C" receiver for the short waves, and to switch on the heterodyne arrangement and frequency checker. The complete log of any station can be made up in five minutes.

Several requests have been received by Hingham to check foreign stations which, although separated by thousands of miles, are reported to be interfering with each other.

## NEW H.F. CHOKE ADVANTAGEOUS IN ALL "STRAIGHT" AND "SUPER" CIRCUITS.

### The "KINVA" SCREENED H.F. CHOKE

THE LATEST ADDITION TO MODERN SCREENING PRACTICE. ASSISTS STABILITY. CHOKES EFFICIENTLY. HELPS COMPACT "LAYOUT."

INCORPORATES MULTI-SLOT LOW CAPACITY COIL OF HIGH INDUCTANCE, UNIFORMLY EFFECTIVE UP TO 3,000 METRES. ABSOLUTELY FIELDLESS.

NO OTHER CHOKE offers you all these points and it's a high-class job at a low price.

In stock at most Dealers. If any difficulty in obtaining, refuse substitutes, and write direct to:

SOLE MANUFACTURERS: POSTLETHWAITE BROS., KINVER, Nr. STOURBRIDGE.

## USED IN THE BEST SETS

## BECOL EBONITE

GUARANTEED AND READY FOR USE USE THE FAMOUS LOW-LOSS FORMER-TESTED

APPLY FOR PRICE LIST

SOLE MAKERS:

THE BRITISH EBONITE CO., LTD., HANWELL, W.7.

**WIRING WRINKLES**

*A practical article for the constructor.*

By H. R. W.

It happens not infrequently that one wants to lengthen a flex lead which is a few inches too short. For one reason or another it would be quicker and more convenient to make a joint than to fit up an entirely new lead.

There is a right way and many wrong ways of making joints in flex, but if you want to make a really good job I can strongly recommend the method illustrated in Fig. 1. Begin by baring about an inch of each of the pieces of flex. Unstrand the exposed wires.

**Separate the Strands**

Many people go wrong by twisting up the wires of each lead into a tight pigtail at its point. A far better joint is made if they are unstranded as seen at Fig. 1A. Lay the two ends across one another and twist them up tightly as shown in Fig. 1B. It is best now to apply a little flux—resin for preference—and to solder the wires as seen at Fig. 1C.

If, though, you are in a hurry or do not care about soldering, you can omit this part of the process so long as you have twisted the wires really tightly together. Lastly, take a narrow piece of insulating tape or

**MAKING A TWIST**

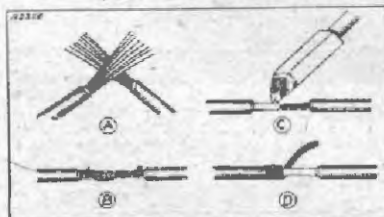

Fig. 1. A good way of jointing flexible wires.

ordinary sticking plaster, and with it wrap the exposed wires closely and tightly.

The best width of tape or plaster to use is about 1/4 in. You cannot buy this, but you can easily split 1/2-in. material by making a small cut in the end with a pair of scissors and then tearing down. Ordinary sticking plaster, by the way, is a very good insulator, since its sticky surface consists largely of rubber.

A "T" joint in flex is best made in very much the same way. In the main portion bare a length of about

an inch and separate the strands a little. Bare about one inch of the branching piece, and separate its strands also. Twist the two pieces tightly together and proceed in the way already described.

**An Even Better Way**

A still better "T" joint is made by dividing the strands of the branch piece into two approximately equal groups, separating the strands of the main piece in the same way and passing those of the branch piece through the loop thus formed. You then twist one-half of the strands of the branching piece round those of the main piece to the right, and the other half of the strands of the branching piece round those of the main piece

**A "T" JOINT**

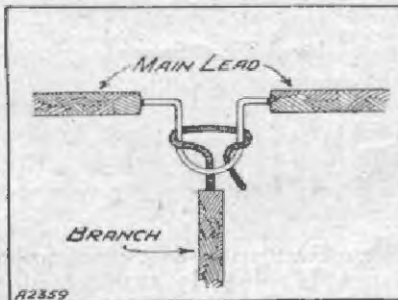

Fig. 2. A knotting scheme that will "take some beating."

to the left. After this, solder if possible and wrap as before.

For quick, temporary joints, whether straight or "T," in flex, there is nothing to beat the knotting method. For straight joints, bare about 1 1/2 in. of each lead and tie them together in a tight knot. Fig. 2 shows the right knot used for a "T" joint. Again about an inch and a half of each lead must be bared.

**A Useful Knot**

With the bared portion of the main lead make a loop as shown in Fig. 2. Pass the bared end of the branch under, over, round behind, over again, and then under. Pull tight, cover with tape, and there you are. If you solder these knotted joints subsequently you can rely on them to last almost for ever and to be capable of withstanding considerable pulling strains.

**FREE**

With next month's issue of the "WIRELESS CONSTRUCTOR" a magnificent book of "77 SELECTED CIRCUITS"

Out Nov. 14th. Usual Price

**MAKE SURE that your EXTENSER has this patent SILVER-GOLD AUTOMATIC WAVE SWITCH**

**14/6**



**ONLY FORMO**  
ARTHUR PREEN & CO. LTD.

**MAKE IT**

The Formo design and construction of the Extenser Condenser incorporates features of special importance for the experienced constructor, who desires to choose the best components available. The slow- and fast-motion dials give a silky smoothness essential for the tuning of close stations, whilst the special type of wave-switch is fitted with silver-gold contacts ensuring perfect electrical continuity. Tested to 200 volts before despatch and guaranteed exactly to specification.

0-100 covers 230-530 metres.  
0-200 covers 1000-2000 metres.  
Complete Catalogue from:  
**ARTHUR PREEN & CO. LTD.,**  
Golden Square, Piccadilly Circus, London, W.1.  
- Crown Works, Southampton.

**YOU CAN USE YOUR SPARE TIME TO START A MAIL ORDER BUSINESS**  
that quickly brings you a full-time income. Few pounds capital only needed; no samples or outfits to buy. No rent, rates or canvassing. New method makes success certain.  
Send to-day for Booklet.  
**BUSINESS SERVICE INSTITUTE**  
(Dept. 318), 6, Carmelite Street, E.C.4.

**Radio Furniture De Luxe! PICKETTS**  
Will delight you! Individually made; not mass produced. (Used by famous experts, B.B.C.) Advantages also of **PIANO TONE!** Baffle chamber, pure, mellow tone that thrills. Reduced prices: 25/- to £10 cash—or 10/- monthly. Photographs **FREE!**  
**PICKETTS Piano-Tone Cabinets**  
Works, 43 W., Albion Road, Boxley Heath.

**PLEASE be sure to mention "Wireless Constructor" when communicating with Advertisers THANKS!**



# CLIX CONSTRUCTOR'S KIT



Contents: — 2 Spade Terminals, engraved L.T.; 2 Plugs and Sockets (A and E); 7 Terminals, H.T., L.T., L.S., 6 Wander Plugs, H.T. and G.B.  
Value 3/5  
PRICE

3/-

Buy a Clix Kit for your next set and save fivepence.



CLIX PANEL TERMINAL

Obtainable from your dealer. If any difficulty, order direct. Folder "C" on request.

**Cheapest PERFECT Contact**

Lectro Lins, Ltd., 254 Vauxhall Bridge Road, S.W.1

## PAREX

Products PAR-EXcellence

are used and recommended for

THE "I.E." THREE

P.V. COILS - - - per pair 8/6  
EBONITE PANEL, 16" x 8", pol. and drilled 7/-  
REACTION CONDENSER - - - 4/-  
H.F. CHOKE - - - 3/6

THE D.C. "ACE"

P.J.1 COIL - - - 2/6  
PARATONE COIL - - - 10/6  
EBONITE PANEL, 18" x 7", pol. and drilled 8/-  
QUOIF COIL - - 2/6 H.F. CHOKE - 3/6  
DIFF. REACTION CONDENSER - 4/6

THE "AMPLITONE"

EBONITE PANEL, 8" x 4", pol. and drilled 2/-  
S.G. VALVE HOLDER - - - 1/6

SPAGHETTI RESISTANCES, ALL SIZES.  
SCREENS AND COILS OUR SPECIALITY.

Unconditional Guarantee of Satisfaction.

E. PAROUSSI 10, Featherstone Buildings,  
High Holborn, London, W.C.1  
Phone: Chancery 7010

ALL APPLICATIONS for ADVERTISING SPACE in "WIRELESS CONSTRUCTOR" must be made to the Sole Advertising Agents, JOHN H. LILE, LTD., 4, LUDGATE CIRCUS, LONDON, E.C.4.

### EASY CONNECTIONS

How to make spring terminals.

FOR making sure and permanent contacts there are few devices to beat the screw-down terminal, although soldering, without any "dry" joints at all, is the ideal. Some connections, however, must be detachable, such as those of the batteries and, perhaps, the headphones.

The experimenter, too, concerned with trying out different circuit arrangements and continually altering the wiring, finds it best to use terminals of a sort, and the screw-down pattern is not always the most convenient.

### Real Time Savers

Spring terminals, on the other hand, are admirable for making quick connections, and it is not difficult to adapt the ordinary telephone terminal so that it has a spring grip. This grip, although entirely satisfactory for such detachable connections as have been mentioned, is not to be recommended for the more permanent wiring elsewhere in the set.

An easy way of making spring terminals is shown in the accompanying illustration. Here a standard 2 B.A. telephone terminal forms the starting point. The only additional parts required are a short length of brass tube, a flat washer, and a short length of coiled wire spring—items which are sure to be found in the scrap-box.

The tube should be of such an internal diameter that it will just slide easily over the body of the terminal. If the terminal is a trifle too large, put it in the chuck of the drill brace, put the brace in the vice, and file the terminal down to size, spinning it as fast and as evenly as you can.

### Easy to Make

Next you must drill the hole in the tube diametrically through both walls. Locate the hole so that its centre is just below the lower edge of the hole in the terminal when the latter

is set in a panel with the tube over it. After this the tube may be cut to length, a trifle longer than the body of the terminal.

### Good "Grippers"

You are now ready to assemble the spring terminal. Fix the terminal in its place on the panel, slip on the tube, place a flat washer on the top, then the spring, and finally screw in the head bolt.

Tighten it down far enough to press firmly on the spring, but not so far that its lower end blocks the hole in the terminal.

Finally, lift the tube against the spring, slip in a telephone tag or a piece of wire, let go of the tube, and then try and pull out the wire. You

### THE COMPONENT PARTS

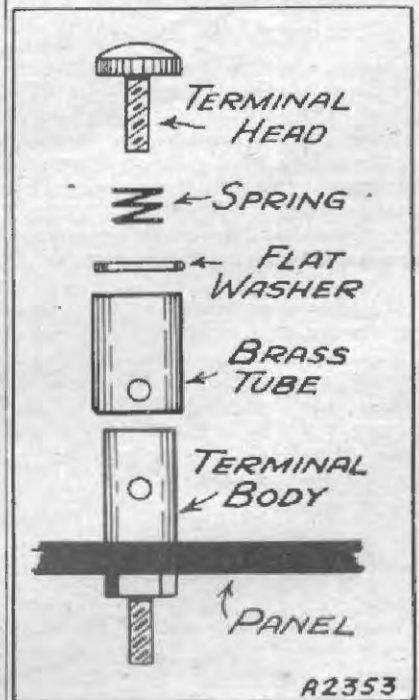

will be surprised to find how firmly it is gripped.

If you wish to put more than one wire or tag in the terminal, you can arrange for this by enlarging the holes in the terminal and the tube up to the limit allowed by the size of the terminal.

A.V.D.H.

## There's no substitute for cyldon

**CYLDON EXTENSER**  
Type EX5. Fitted with a perfectly timed, adjustable wave-change switch and noiseless brush wipe contacts. 4' Bakelite, 360° Dial 1/6 extra.

12/6

**CYLDON SLOW MOTION EXTENSER**  
Type EX5V. Fitted with wedge drive, disc type, Slow-motion Control. Hair-line sight. 5 to 1 reduction. Perfectly timed Extenser wavechange switch.

16/6

**CYLDON SLOW MOTION DIAL**  
New wedge friction drive. 9:1 ratio, non-slip, rotation in same direction as condenser, illuminated scale, hair-line sight. Sector vision.

7/6

SYDNEY S. BIRD & SONS LTD.  
CYLDON WORKS,  
SARNESFIELD ROAD, ENFIELD

\*\*\*\*\*  
**DO YOUR RECORDS  
 RUN TRUE ?**  
 By J. H. T. ROBERTS, D.Sc.  
 Formerly Research Chief,  
 Columbia Graphophone Co., Ltd.  
 \*\*\*\*\*

In some notes in "Popular Wireless" a short time back I was talking about records being off-centre and emitting a peculiar wailing sound when played. Readers have asked me various questions about this—how it arises, how to cure it, and why it becomes more noticeable towards the end of the record.

**That Wailing Tone**

So I thought it might interest you if I told you something further about this particular record defect.

When the record gives this wailing sound you will find, if you look at the sound-box in the direction along the tone-arm, that the sound-box is oscillating left-and-right, and the up-and-down wailing coincides with these left-and-right movements which, in turn, coincide with the revolutions of the record.

This means that the circles of the sound grooves are not concentric with the hole in the centre of the record. The wailing effect is particularly noticeable on a note which, in the original recording, has been maintained constant during several revolutions of the record; for example, a singer's top note at the conclusion of a vocal selection will be completely ruined if the record is much off-centre.

**How It Arises**

To see how these fluctuations arise let us consider a single note, say, the note produced by a violin string and having a frequency of 500 vibrations per second—which is roughly the upper "c" of the pianoforte. This means that when the record is correctly centred the waves in the sound track are passing under the needle at the rate of 500 per second.

Now let us suppose that the record is  $\frac{1}{8}$  in. off-centre, that is to say, the centre of the hole is  $\frac{1}{8}$  in. away from the true centre of the circles of the sound grooves. The result is that when the part of a sound circle which is farthest away from the centre hole comes round under the needle, the needle is  $\frac{1}{8}$  in. farther away from the turntable centre than it should be, and when the part of the sound circle nearest to the centre hole comes round under the needle, the needle is  $\frac{1}{8}$  in.

(Please turn to page 66.)

**It's So Easy**

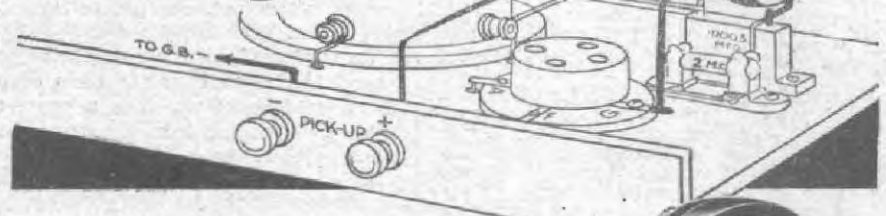

You need not hesitate to connect a pick-up to your set. By using a Bulgin Rotary Change-over Switch it is child's play. Just break the lead between grid condenser and grid of detector valve. Connect centre point of switch to grid connection of valve holder. Connect outer terminals to grid condenser and pick-up and terminal respectively. The minus pick-up terminal is connected to minus  $1\frac{1}{2}$  volts grid bias. You can leave the pick-up permanently connected, and have radio or gramophone music at will.

Send 2d. postage for the new 75-pp. Bulgin illustrated Catalogue and Manual, which also details the New Bulgin Technical Service.

**A. F. BULGIN & CO., LTD.,**  
 ABBEY ROAD, BARKING, ESSEX.  
 Telephones: GRANGEWOOD 3266 & 3267.

London Showrooms:  
 9, 10, 11, Corsitor Street, Chancery Lane, E.C.4.  
 Telephone: HOLBORN 2072.

**ROTARY  
 CHANGE-OVER  
 SWITCH.**

A single-pole switch suitable for use on radio-gramophone, etc. Engraved Bakelite indicating frame.  
 List No. S.86.



**24**



**CIRCUITS**  
 Our 1932 Radio Catalogue contains original and interesting diagrams for two-, three- and four-valve circuits. Every serious constructor should send for his copy which will be mailed free by return of post.

The Benjamin Electric Ltd.,  
 Trafalgar Road, Tottenham, N.17.  
 Tottenham 1300.

**BENJAMIN**

Make  
**The DAILY SKETCH**  
 YOUR Picture Paper.

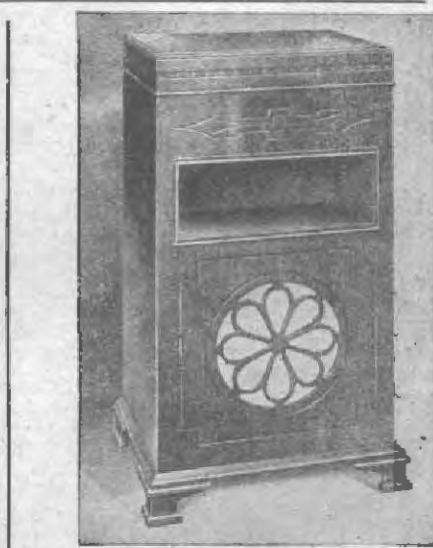

**WORTHY OF THE FINEST SET—**  
**£5.10.0**

The Camco "Waverley" Radio-Cabinet Cabinet is appealing tremendously to the Public. A beautifully finished and handsome piece of furniture, it represents astonishing value at its low cost of only £5.10s. There are two models, Junior and Senior, and in each ample space is provided for batteries, etc., and clearance allowed for gramophone motor. Write now for the 24-page Camco Radio Cabinet Catalogue, giving full details of Camco's fine range. Works: S. Cookson

**CARRINGTON MFG. CO., LTD., 21, Hatton Gdn., London, E.C.1.**  
 Tel.: HOLBORN 5302.  
 Works: S. Cookson

NAME.....  
 ADDRESS.....  
 W.C.7.

# YOUR SET WILL LOOK BETTER IN THE 1932 VOXKIT CABINET

## THE NEW FASHION



Front Panel drilled FREE to your specification.

VOXKIT 1932 CONSOLE (Radio only). Another attractive addition to the famous Voxkit range. Accommodates the largest home-built receiver and bulkiest speaker, mains or battery supply. Dimensions: 37 in. high by 22 in. wide by 15½ in. Panel, 18 by 7 in. Baseboard, 18 by 12 in. Speaker Compartment, 18 in. wide by 14 in. high by 12 in. deep. Front panel, 12½ in. In hand French-polished oak.

Cash Price

**£3-15-0**

or 12 monthly payments of 6/11

Delivered Free England & Wales.

Full details of Pilot Authors' Kits for this month's Sets free on request.

# PETO - SCOTT

PETO-SCOTT CO. LTD. 77, City Road, London, E.C.1; Clerkenwell 9406. 62, High Holborn, London, W.C.1. Chancery 8266.

## SOLVE ALL H.T. TROUBLES

Per doz.	No. 1.	No. 2.
Jars (waxed)	13	15
Sacs	12	15
Zincs	10	11
Rubber Bands(25)	4	4
Terminals	8	10

Trade Supplied.



### LONG LIFE : SILENT : ECONOMICAL

Sample doz. (18 volts), complete with bands and electrolyte. No. 1, 41. No. 2, 5/-. Post 9d. terminals extra. No. 3, with terminals, 7/6 (10,000 milli-amps), sample unit 6d. Orders 10/- carr. paid. New illustrated catalogue post free.

Bargain List of Receivers, FREE Amplifiers and Components C. TAYLOR, 57, Studley Road, Stockwell, London.



WRITE NOW FOR THIS FREE LITERATURE  
**BAUBOY**

## YOUR MOVING COIL SPEAKER!

42 pages of valuable information on how to secure REALISTIC REPRODUCTION.

**BAKER'S 'Selhurst'**  
RADIO

CROYDON - SURREY.  
PHONE - CROYDON 1018.



The Picture Paper with the MOST NEWS—

**SUNDAY GRAPHIC**  
and SUNDAY NEWS.

## DO YOUR RECORDS RUN TRUE?

—continued from page 65

nearer to the turntable centre than it should be.

So we have two points on the same sound circle (at opposite ends of a diameter), one of which is a quarter of an inch farther from the centre of rotation than the other.

### Proportional to the Radius

Now the actual velocity (the "linear" velocity as it is called) of a point on the record when the record is rotating at uniform angular speed will be proportional to the radius at the point—that is, to the distance from the point to the centre of rotation.

You will see that, in the case we have supposed, there is one part of the record where the radius of rotation is a quarter of an inch greater than at the diametrically opposite part. Let us now suppose that the needle is at an average distance of 5 in. away from the centre of the record.

Then at one moment the needle will be 5½ in. from the centre of rotation, whilst when the record has turned one half a revolution the needle will be 4½ in. from the centre of rotation.

The number of waves per second (assuming a constant note, of course) which pass under the needle in the former case will bear the relation to the number per second which pass under the needle in the latter case of 5½ to 4½, that is, 41 to 39, or approximately 5 per cent difference.

So if the note in question has a true frequency of 500 per second we shall have not a constant note of that frequency, but a note which rises and falls between a frequency of approximately 512 and one of 488 vibrations per second. It is this rising and falling which causes the wailing effect referred to.

### Why It Became Worse

Now let us see why the effect increases towards the end of the record. Suppose at the end of the selection the needle is at an average distance of 2 in. from the centre, then the maximum and minimum distances will be 2½ in. and 1½ in., which bear the ratio to one another of 17 to 15; that is, about 12 per cent difference.

The result is that a 500 frequency note will vary in reproduction between approximately 530 and 470 vibrations per second, which is much greater

than in the first case when the needle was 5 in. away from the centre.

So you see that although the degree of eccentricity or off-centre remains the same, its effect upon the reproduction increases as the needle travels towards the centre of the record.

For simplicity I have been calculating the effect on the assumption that the record is off-centre to the extent of ¼ in., but this is much greater than would actually happen in practice. The maximum amount of off-centre allowable in the inspection tests of a good record manufacturing concern would be 5 to 10 mils (one mil equals 1,000th in.).

### What the Ear Will Stand

It is easy to show by simple calculation that this is about the maximum off-centre swing allowable, although the amount has no doubt been discovered by experience. We can show it in this way.

Taking the position of the needle nearest to the centre—that is, the worst condition—as being, say, 1½ in. (equivalent to 3 in. diameter label-space) and the off-centre as the maximum amount of 10 mils—that is, 1/100 of an inch—this gives a ratio of velocities of 1½ in. minus 1/100 in. to 1½ in. plus 1/100 in., or 151/100 in. to 149/100 in.—that is, 151/149, or roughly 1½ per cent variation.

Now it has been found in experimental psychological laboratory experiments that a variation of 1 per cent in the number of vibrations in a musical note can be detected by a good musical ear, whilst a variation of 2 per cent begins to be objectionable to the ordinary ear.

### The Maximum Permissible

You will see, then, from the above simple calculation that an amount of off-centre of 100th in. is about the maximum permissible, both as found by calculation and as confirmed by experience.

A few years ago you would sometimes get hold of a record which was terribly off-centre, but record manufacturing methods have been so much improved that it is nowadays very rare to get a really bad record.

I have often been asked whether it is possible to cure a record which is off-centre, but I am afraid I cannot recommend any dodge which is really satisfactory. Sometimes it is possible to block up the centre hole with some type of hardening cement or similar substance and then to re-drill the hole, but I never recommend anything of this kind, because you are almost certain to make the off-centre worse than it was when you started.



\*\*\*\*\*  
 \* **THE RADIO DOCTOR** \*  
 \* From a Correspondent. \*  
 \*\*\*\*\*

**I**n the country of the blind the one-eyed man is king. So I, a humble pioneer in the art of knob twiddling, found myself in the position of honorary radio doctor to the countryside. No sinecure, involving as it did journeys of many miles, the erection of aerials, and construction and maintenance of sets for new aspirants.

#### A Run-Down Accumulator

The humble tiller of the soil has much native shrewdness, not extending to radio. Confronted with a run-down accumulator, the irate owner exclaims: "I thought you said it would last for years." Well, so I had, but in quite a different sense. As a peace offering, I undertake to give it a fresh charge.

One old friend writes laboriously in a small notebook, L.T. + (red), L.T. - (black). Alas, for the best-laid schemes! When I answer his S.O.S., he has mixed up L.T. with H.T. Another of my clientele, an elderly lady, had a most unfortunate habit of dropping the L.T. leads on the H.T. battery.

Every few months she sent for three new valves at £2 5s., till I moved the battery out of reach and fitted an L.T. on-off switch. Even then she managed one final disaster before settling down in peace, by dropping the household hammer in a strenuous effort to hang a pair of 'phones above the set.

A year or two ago WIRELESS CONSTRUCTOR published a photo of a weird home-made "Family" Four receiver. It was a perfect gem compared with some I have visited.

#### Panels Boiled in Wax!

When the rural family took to set construction the result had to be seen to be believed. My first experience was with an S.T.100. The panel was the lid of a soap box, boiled in candle-wax. Its condensers were home assembled, and the vanes exchanged kindly greetings in passing.

Its sole performance was a magnificent imitation of a waterfall, accompanied by a monotonous howl in the bass clef. A thrifty soul, inspired by an article in WIRELESS CONSTRUCTOR on reflex sets, had got all the gadgets on a 6 in. by 6 in. panel.

There never can have been a better rendering of a full choir of bluebottles.

I couldn't blame him; I never had much luck with the wretched things myself.

There is such a thing as being too helpful. Quite recently a set arrived for repair, with a 6-in. former containing long, medium, and reaction windings. The broken end of the reaction coil was pushed into a hole in the former, while the loose end had been bared and neatly attached to the aerial lead.

Not until I had removed the works and gone over the whole of the windings could I find the fault. When I did—well, words failed me. I have just replaced a burnt-out transformer in a set; from memory I should date it about 1924. Surely a *rara avis*, for in those days transformers were delicate creatures, rarely surviving the first year.

#### Still a Few Left

Calls on my time in these days are few, for the modern set, like the motor cycle, is nothing if not reliable, but there are still a few hardy ancients staggering gallantly on. Town dwellers cannot realise the tedium of the long winter nights to a community for the most part little given to reading.

The genuine gratitude of the older

folk, and their sheer delight in the magical world of broadcasting, have been an ample reward for the few hours spent in bringing this new source of happiness to their homes.

#### RECORD APPEAL!



An attractive demonstration of home-recording at Olympia.

## An addition to a famous range of DUBILIER CONDENSERS

... a 4 mfd.  
 type BB



#### PRICES:

Type BB  
 1 mfd. 2/6, 2 mfd. 3/6,  
 4 mfd. 6/3

(Working Voltage 200 D.C.  
 Tested at 400 V.D.C.)

With the addition of this new 4 mfd. model the need for paper condensers suitable for wireless receivers can now be met from the range of Type BB Dubilier Condensers.

This range of Condensers has already been used by many thousands of constructors of wireless receivers with entire satisfaction. They are built with all that precision which ensures unflinching reliability in any Condenser bearing the name Dubilier.

**DUBILIER**  
 CONDENSER CO. (1925) LTD.  
 DUCON WORKS, VICTORIA ROAD, N. ACTON, LONDON, W.3.

\*\*\*\*\*  
**THE ORIGIN OF THE MORSE CODE**  
 \*\*\*\*\*

Few present-day listeners are sufficiently interested in the Morse code to take the trouble to learn it. Perhaps, too, they are wise in their generation, for the mastering of Morse necessitates the expenditure of no little time and mental energy.

The Morse code is universally used and understood. It is, also, getting well on towards its centenary, and perhaps the surprising fact about it is that it has never been superseded to any extent by any other system. Nowadays, a large proportion of commercial wireless traffic is conducted through the agency of Morse, and particularly through more or less mechanical systems whereby the code is transmitted at very high speeds.

**The Old Visual Method**

Before Samuel F. B. Morse brought out his famous code, comprising a combination of two sounds varying in duration, crude telegraphic messages were transmitted and received by means of needle instruments, the deflections of one or more needles to one side or the other of an instrument dial making up a code of readable signals.

Morse, however, who started out in life not as a scientist but as a portrait and scenic painter, gave to the world a new telegraphic instrument—his famous "Sounder"—in which a bar was attracted to and released by an electro-magnet.

It was the noises which this alternate attraction and liberation of the movable bar gave rise to which stirred up in the mind of its inventor the idea

of constructing a code based on sound instead of on sight.

It is, indeed, a tribute to Morse's ingenuity that the Morse code of the present day is so little altered from the original code. Morse's code was subjected to International revision in 1851, since which time it has remained unchanged.

**AN EARLY "SOUNDER"**

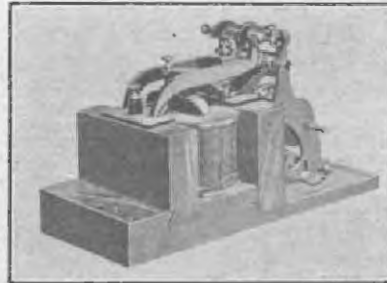

From 1851 until the present day the original Morse sounder has changed but little.

**NEXT MONTH!**

The December "Wireless Constructor," now being prepared, is our **GREAT GIFT NUMBER.**

Don't fail to order your copy, for every reader will be presented with a book of **77 SELECTED CIRCUITS FREE!**

All Tested! All Reliable!  
 All the Latest!

**ORDER NOW. USUAL PRICE.**

**THE DECEMBER "WIRELESS CONSTRUCTOR"**

\*\*\*\*\*  
**THE BOOK ALL WIRELESS ENTHUSIASTS NEED**  
*A Remarkable Enterprise in Modern Publishing.*  
 \*\*\*\*\*

RADIO enthusiasts must certainly be regarded as among the intelligent section of the community. To be a wireless constructor presupposes some degree of hard thinking and scientific knowledge, and these qualities are certainly not possible to any but people with a greater share than usual of brain power. The wireless expert is necessarily a man who thinks, and one who thinks is always desirous of increasing knowledge. What more irritating than to come across something new and not be able to find out quickly the how and why of it. This applies particularly to the many new words that come into use to express new ideas not only in wireless, but in all the sciences as well as in other departments of life.

The language grows by leaps and bounds; new words crop up in our technical journals and in our daily newspapers, and often we wonder what they mean. We turn to the dictionary, but fail to find the word, for it has been invented or come into use since the dictionary was compiled some years ago. In other words, when we want to be up to date we find the dictionary out of date.

But we need not be distressed or hopeless. This need that arises from the constant flow of new words into the language has been met, and The Universal English Dictionary which is about to be published brings the vocabulary of English right up to 1931. It is a great work, scholarly and yet popular, valuable and yet inexpensive, and it is an absolute necessity for the thinking man and woman, be they young or old, rich or poor, student or expert.

This great new dictionary is edited by Mr. Henry Cecil Wyld, B.Litt., M.A., the Merton Professor of English Language and Literature in the University of Oxford, one of the greatest living experts in English; and its Managing Editor, responsible for its production and form, is Mr. J. A. Hamerton, Editor of The Universal Encyclopedia and a score of other standard works. These names guarantee the excellence of the dictionary.

New works of this kind are generally very expensive, far too costly for the ordinary man or woman, but The Universal English Dictionary will be brought within reach of all, even of boys and girls. It is to be issued in 52 weekly parts at sixpence each; that is, for less than a penny a day. The first part is on sale at all newsagents and bookstalls to-day, and you should go at once and place an order so as not to be disappointed by delay.

The Universal English Dictionary is a work that you must have. It is a real book of knowledge, but at the same time it is a book of absorbing interest, for not only does it give the pronunciations and meanings of nearly 100,000 words in the English language, but it tells also their life stories, explaining how they came onto our language and what their past history has been. Although many people do not know it, the history of words is one of the most fascinating of all studies.

You really need to see this dictionary to appreciate it, so be sure to get the first part, and you will certainly take the succeeding parts.

**INDEX TO ADVERTISERS**

	PAGE
British Blue Spot Co., Ltd.	Cover iii
British Zonophone Co., Ltd.	49
Belling & Lee, Ltd.	57
Burne-Jones & Co., Ltd.	56
Bulgin, A. F., & Co., Ltd.	55
British Ebonite Co., Ltd.	62
Baker's (Selhurst) Radio	66
Benjamin Electric Co., Ltd.	65
Bird, Sydney S., & Sons, Ltd.	64
Business Service Institute	63
British Boys' Annual	59
Cosser, A. C., Ltd.	4
Carrington Manig. Co., Ltd.	65
"Daily Mail"	41
Dubilier Condenser Co. (1928), Ltd.	67

	PAGE
Edison-Swan Electric Co., Ltd.	Cover iv, 55 & 60
Exide Batteries	45
Eastick, J. J., & Sons	62
Ferranti, Ltd.	1
Forno Co.	63
Graham Ampion, Ltd.	53
Gilbert Cabinets	57
Haybeard, F. C., & Co.	57
International Correa. Schools, Ltd.	59
Igramic Electric, Ltd.	59
Jackson Bros	3
London Electric Wire Co. & Smiths, Ltd.	Cover ii
Lotus Radio, Ltd.	47
Leetro-Linx, Ltd.	64
Newnes, Geo., Ltd.	35
Postlethwaite Bros.	62
Peto-Scott Co., Ltd.	66
Paroussi, E.	64

	PAGE
Pickett's Cabinet Works	63
Ready Radio, Ltd.	29
Reproducers and Amplifiers, Ltd.	57
Six-Sixty Radio Co., Ltd.	37
Teleon Electric, Ltd.	33 & 51
Telegraph Condenser Co., Ltd.	53
Taylor, C.	40
Universal English Dictionary	2
Varley Products	58
Wingrove & Rogers, Ltd.	56
Wright & Weairs, Ltd.	55
Westinghouse Brake & Saxby Signal Co., Ltd.	50

All communications concerning advertising in "Wireless Constructor" must be made to John H. Lide, Ltd., 4, Ludgate Circus, London, E.C.4. Telephone: City 7261.

# CONTENTS

	Page		Page
The Editor's Chat .....	5	A Practical Man's Corner .....	38
Power from Low-Voltage Mains .....	6	In Lighter Vein .....	40
The "I.E." Three .....	7	Savoy Hill News .....	43
Queer Queries .....	12	The Month on Short Waves .....	46
Seen at the Show .....	13	"On the Grid" .....	46
The D.C. "Ace" .....	15	Is Home Construction Worth While? .....	48
An "Inter-Spag" Unit .....	20	Efficient Indoor Aerials .....	52
As We Find Them .....	21	"A Pat on the Back" .....	54
Making a Radio Cabinet .....	23	Our News Bulletin .....	56
With Pick-up and Speaker .....	25	Uncle Sam's Radio Sleuth .....	61
Round the Dials .....	26	Wiring Wrinkles .....	63
Points for Purchasers .....	26	Easy Connections .....	64
From Metres to Inches .....	27	Do Your Records Run True? .....	65
Pick-up Hints and Tips .....	30	The Radio Doctor .....	67
The "Amplitone" .....	31	The Origin of the Morse Code .....	68

*As some of the arrangements and specialties described in this Journal may be the subject of Letters Patent, the amateur and trader will be well advised to obtain the permission of the patentees to use the patents before doing so.*

**Chief Radio Consultant:**  
**Capt. P. P. ECKERSLEY, M.I.E.E.**

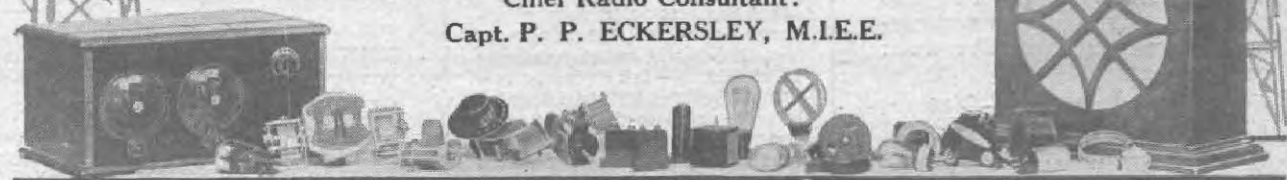

## FERRANTI CONDENSERS AND RESISTANCES

### FOR POWER SUPPLY UNITS

Most constructors will agree that to provide a Receiver with H.T. power from a dry battery or accumulator, if A.C. Mains are available, is like lighting the house with candles. It's out of date.

If your Set depends on batteries for its power—power that should be ample, constant and silent—and from batteries it seldom is—you will derive lasting satisfaction from a High Tension Power Supply Unit.

In the construction of such a Unit it is of great importance to use components that can be depended upon to stand up to the severe conditions imposed.

As is to be expected, inferior components give inferior service, and are liable to break down under the electrical stresses set up, with possibly serious results to the Receiver and the components of which it is constructed.

Therefore do not take unnecessary risks. Employ components designed with knowledge of the conditions they have to deal with, and built by Engineers with nearly 50 years' electrical experience behind them.

**FIXED CONDENSERS** for smoothing.  
**RESISTANCES** for voltage dropping.  
**CHOKES** and **MAINS TRANSFORMERS**.

FERRANTI issue free **CHARTS** for the construction of H.T. Power Supply Units to meet all conditions. A copy will be forwarded on request accompanied by H.d. stamp.

**WHATEVER YOU DO:** put in reliable components. It pays, on the Mains.

# FERRANTI

FERRANTI LTD. Head Office & Works: Hollinwood, Lancs. London: Bush House, Aldwych, W.C.2





# At Last—A NEW Dictionary for EVERY Home within the reach of EVERY Purse!

The ONLY Dictionary Entirely Written Since the War

HERE is the *only* important English Dictionary which has been entirely compiled since the war. The UNIVERSAL ENGLISH DICTIONARY takes each word in the English language and tells you what part of speech it is, how to pronounce it, how it came into English, its different shades of meaning, how it is used in typical phrases of everyday speech, and so on.

This dictionary has taken over eight years to prepare, and it is to be sold in 52 weekly parts at sixpence a part. For less than a penny a day this monumental and authoritative work can be yours!

Everyone every day—Mother, Father and boys and girls of school age—needs a good dictionary. In every home in the land, in every walk of life it is essential. The UNIVERSAL ENGLISH DICTIONARY is more than a *good* Dictionary—it is the *only* dictionary of its kind. It is much more complete than the average desk dictionary, yet its form, a single

## THE UNIVERSAL ENGLISH DICTIONARY

Edited by

H. C. WYLD

Merton Professor of English  
Language and Literature,  
Oxford.

Nearly

### 100,000 Words

defined in clear and simple language—over 300,000 shades of meaning clearly and interestingly differentiated—full etymologies—Pronunciations simply indicated for the man-in-the-street and phonetically indicated for the scholar—Hundreds of thousands of quotations illustrating phrases, modern usages and idioms—A book for every home, every school, every library and every office.

large-page volume is vastly more convenient than the many volumed, chiefly American dictionaries, which are really only necessary to the student. The cost of these really *big* dictionaries is far beyond the reach of most private libraries. The UNIVERSAL is within the reach of all, for by the method of publishing in weekly parts, its cost, binding included, is little more than the price of a daily paper for one year.

The value of such a work increases year by year. With the UNIVERSAL in your home your children have at hand a ready answer to almost every question. They will grow up equipped with a true knowledge and understanding of their most precious heritage—the English language.

And to that ever-growing band of "Crossword" enthusiasts the UNIVERSAL ENGLISH DICTIONARY will give added zest to their hobby and the certainty of quicker solutions!



Sixpenny  
Weekly  
Parts!

Every  
Thursday

Complete in  
ONE Volume!

This ingenious Self Binding Case is available to subscribers to the UNIVERSAL ENGLISH DICTIONARY at a much REDUCED PRICE. The complete work can, by this means, be built up week by week, each part being bound in it as it is published. Full particulars of this remarkable offer will be found in Part 1.

# THE UNIVERSAL ENGLISH DICTIONARY

Part 1 Now On Sale—Buy Your Copy TO-DAY! **6<sup>D.</sup>**

A pleasure to look at ...  
A joy to listen to!



BRITISH MADE THROUGHOUT.

*Illustrated above on the left is the*  
**BLUE SPOT SPEAKER** (in-  
ductor type) 100D in Oak.  
Price complete **63/-**

*Illustrated above on the right is the*  
**BLUE SPOT SPEAKER 44R**  
also in Oak. Price complete **52/6**

*Write for catalogue W.C.10 showing complete  
range of speakers.*

**A**REN'T they beautiful—these new BLUE SPOT Loud Speakers with their graceful lines, delightful proportions and lovely graining of fine quality woods. They will enhance any room, harmonise with any furniture.

And the beauty of their appearance is reflected in the beauty of their tone, the faultlessness of their reproduction. Harshness is a word meaningless in their presence, distortion and blurring are unknown to them. Their reproduction is life-like, unbelievably, astonishingly life-like. They make listening-in a pleasure—even the most exacting critic will admit their perfection.

Your dealer is proud to sell these speakers. He will demonstrate them with pleasure. Ask him to do so to-day.

Ask to hear the New BLUE SPOT RECEIVERS  
—a triumph of modern technical skill. Ask for descriptive leaflet.



Regd. Nos. 515639 & 516180.

**THE BRITISH BLUE SPOT COMPANY LTD.**

BLUE SPOT HOUSE, 94/96 ROSOMAN ST. ROSEBERY AV., LONDON, E.C.

Telephone: Clerkenwell 3570. Telegrams: "Bluospot, Isling, London."  
Distributors for Northern England, Scotland and North Wales: H. C. RAWSON (Sheffield and London) Ltd., 100, London Road, Sheffield; 22, St. Mary's Parsonage, Manchester; 183, George Street, Glasgow.

clulcbomas