

# *The* **Wireless** 6<sup>d</sup> **Constructor**

RADIO CONSULTANT-IN-CHIEF CAPT. P. PECKERSLEY M.I.E.E.

Vol. XII.

MAY, 1931.

No. 55.

## HEAR THIS ON THE "KILOTRAP"!

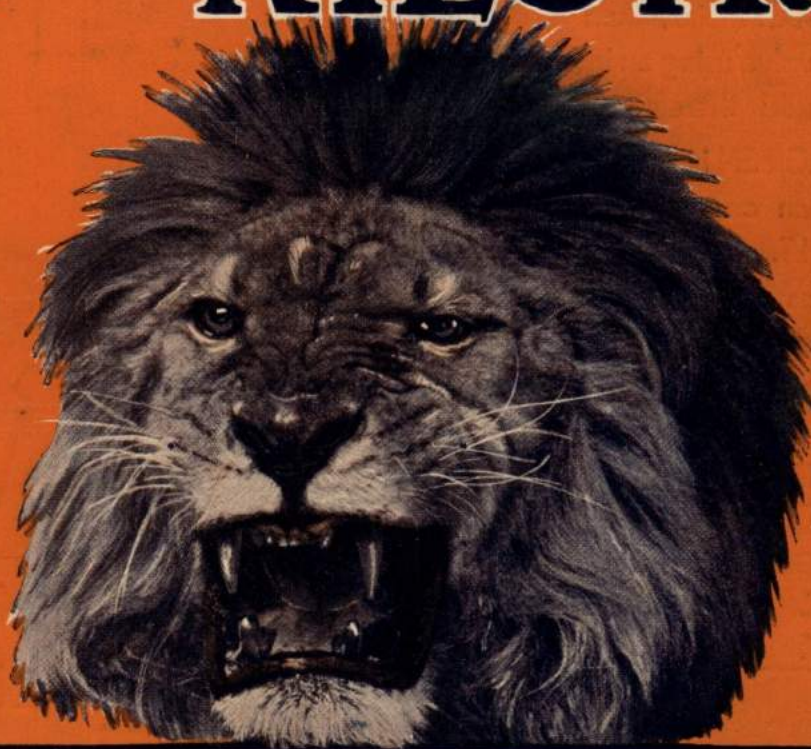

WHAT YOU WILL FIND IN THIS NUMBER:

FULL DETAILS OF OUR SPECIAL NAIROBI SHORT-WAVE TESTS  
MORE ABOUT THE "EXTENSER"—BY VICTOR KING  
A COMPLETE DESCRIPTION OF THE "EXTENSER" THREE

*For large volume*

**WITHOUT HUM  
or DISTORTION**

In A.C. mains Sets where the output valve—whether triode or pentode—is directly heated by A.C. mains, hum is difficult to eliminate. A valve using an indirectly heated cathode should therefore be employed. The Mazda AC/PEN is a high power Pentode capable of an enormous output with only 250 volts H.T. Its characteristics ensure excellent bass response and brilliant high notes and a detector can fully load it without an intermediate stage and complete freedom from hum is assured.

**THE  
AMAZING**

**MAZDA  
RADIO  
VALVES**

**CHARACTERISTICS**

TYPE	Fil. Volts	Fil. Amps.	Max H.T. Volts	Amp. Factor	Anode Resistance (ohms.)	Mutual cond. m A/V	PRICE
AC/SG	4	1.0 approx.	200	1200	—	—	25/—
AC/HL	4	1.0 "	200	35	11700	3.0	15/—
AC/P	4	1.0 "	200	10	2650	3.75	17/6
AC/P 1	4	1.0 "	200	5	2000	2.5	17/6
AC/Pen	4	1.0 "	250	—	—	2.5	27/6



THE EDISON SWAN ELECTRIC CO., LTD.  
*Incorporating the Wiring Supplies, Lighting Engineering  
and Radio Business of the British Thomson-Houston Co., Ltd.*

Radio Division Showrooms:  
155 Charing Cross Road, London, W.C.2  
*Showrooms in all the Principal Towns.*

**EDISWAN**

# CONTENTS

	Page		Page
The Editor's Chat . . . . .	3	Points for Purchasers . . . . .	30
Using the "Kilotrapp" Coils . . . . .	4	A Practical Man's Corner . . . . .	31
Listen to Nairobi . . . . .	5	A New Range of Valves . . . . .	33
More About the "Extenser" . . . . .	9	With Pick-Up and Speaker . . . . .	36
Queer Queries . . . . .	12	In Lighter Vein . . . . .	39
Savoy Hill News . . . . .	13	The "Kilotrapp" Broadcast Coils . . . . .	42
As We Find Them . . . . .	15	"On the Grid" . . . . .	44
The "Plus-Stage" Two . . . . .	17	Our News Bulletin . . . . .	46
A Visit to Muhlacker . . . . .	21	Pick-Up Hints and Tips . . . . .	52
The "Extenser" Three . . . . .	23	Telling the World . . . . .	56
Round the Dials . . . . .	30		

*As some of the arrangements and specialities described in this Journal may be the subject of Letters Patent, the amateur and trader will be well advised to obtain the permission of the patentees to use the patents before doing so.*

**Chief Radio Consultant:**  
**Capt. P. P. ECKERSLEY, M.I.E.E.**

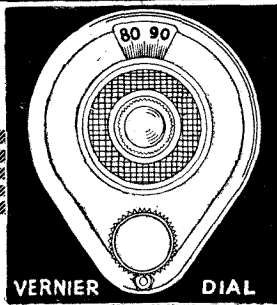
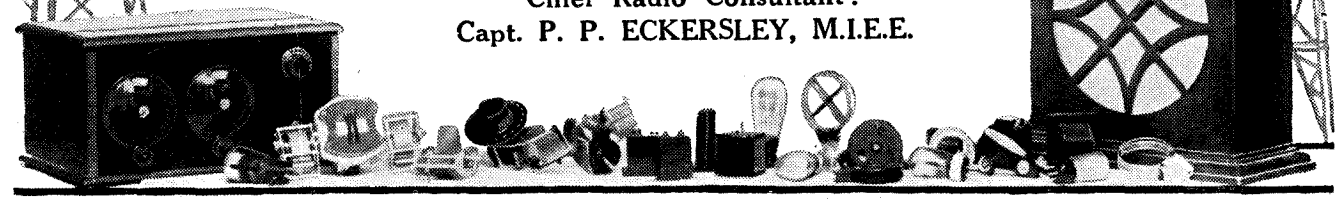

**VERNIER DIAL**  
 Wonderfully smooth action and fractional accuracy makes tuning of close stations a simple operation. Price 3/-.  
 ■■■■■

**Build and Replace with**  
**FORMO**  
 ARTHUR PREEN & CO. LTD.

**THE COMPONENTS SPECIFIED FOR PERFORMANCE**

Select Formo Radio Components and you are always certain of the best results that your set is designed to give. Sold by all Radio Dealers.

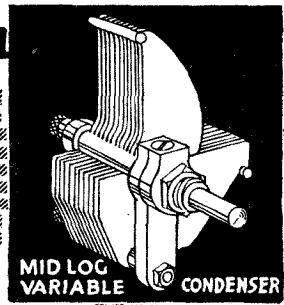

**MID LOG VARIABLE CONDENSER**  
 The enclosed and protected pigtail within the shaft ensures high performance and low loss. In 4 capacities. Price 4/6.  
 ■■■■■

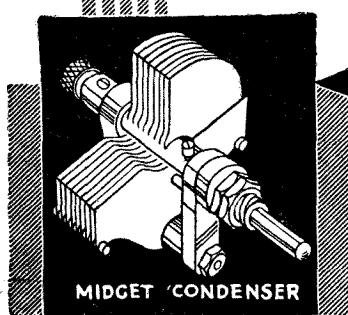

**MIDGET CONDENSER**  
 Compact, noiseless and silky action. Concealed internal pigtail. For all reaction circuits. Price 2/9. With knurled knob and pointer, 3/3.  
 ■■■■■

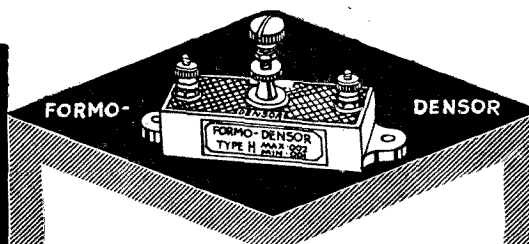

This well-known product is the finest on the market. Sold in 1,000's a week. Price 1/6.

Catalogues sent on request from:  
**ARTHUR PREEN & CO.**  
 Golden Square, Piccadilly Circus, W.1  
 FACTORY: Crown Works, Southampton.

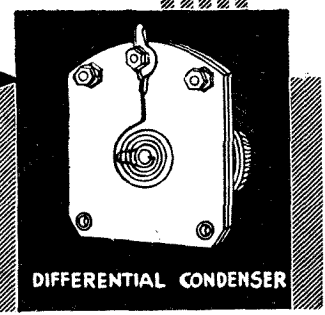

**DIFFERENTIAL CONDENSER**  
 Compact, no metal end plates. A perfectly designed condenser with high performance and lasting reliability. Price 3/9.  
 ■■■■■

Simple facts for Valve Users No. 1.

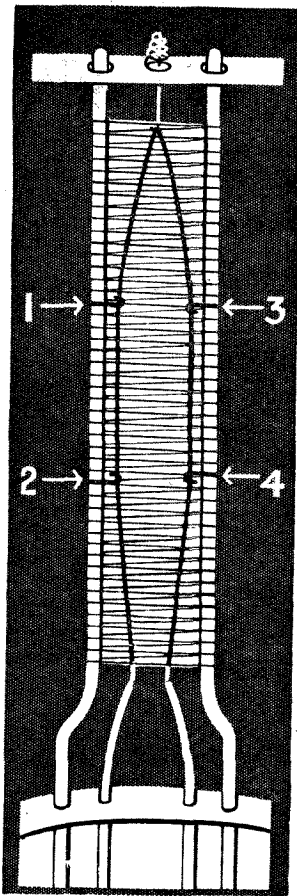

**Over 50 types of Cossor Valves are available from any Wireless Shop to suit all 2, 4, and 6 volt Battery operated and A.C. Mains Receivers**

# Why Cossor Valves are non-microphonic

**M**ICROPHONIC (or ringing) noises in a valve are usually due to filament vibrations. It is normal practice to suspend the filament in an inverted V formation with a spring hook at its upper extremity to counteract expansion due to heat. Naturally—because it is taut—such a filament is very prone to vibrate.

Cossor engineers have definitely solved the problem of microphonic noises by evolving the 7-point filament suspension system shown here. You will notice the four insulated hooks which secure the filament in position and instantly damp out any tendency to vibration. Incidentally, the Cossor Insulated Bridge Construction ensures a much higher standard of accuracy in assembly—thereby permitting greater uniformity of characteristics and a finer all-round performance.

# COSSOR

A. C. Cossor, Ltd., Highbury  
Grove, London, N.5.

♥ 8080

# The WIRELESS CONSTRUCTOR

Published by the Amalgamated Press, Ltd., Fleetway House, Farringdon Street, London, E.C.4.

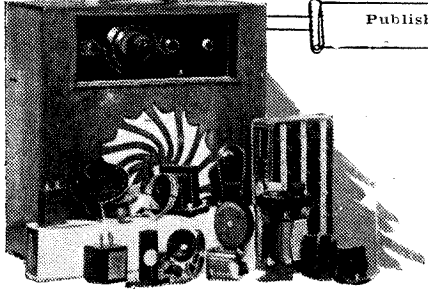

## THE EDITOR'S CHAT

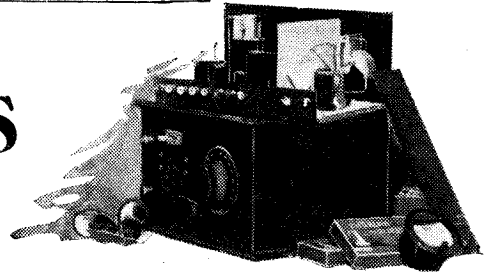

A few words about two of the "Wireless Constructor's" activities that are occasioning the widest possible interest—the wonderful "Extenser" system and the special Nairobi short-wave test.

READERS will be interested to learn that the radio trade has evinced very great interest in the "Extenser"—details of which appeared exclusively and for the first time in last month's issue of the WIRELESS CONSTRUCTOR.

Leading radio manufacturers who have examined and tested "Extenser" models in our laboratory are unanimous in their praise, and in agreeing that the "Extenser" represents a very important development in the technique of simpler radio reception.

### Standardising "Extensers"

Because of its obvious advantages and the possibilities of its wide application, we are determined that the "Extenser" shall not begin its commercial career haphazardly, and consequently we are recommending a few broad principles, in connection with the design of the "Extenser" condenser, which we feel will be of benefit to manufacturers, and which we feel confident they will appreciate and adhere to.

Nevertheless, we wish to emphasise the fact that we in no way wish to cramp the individuality of various makers as regards detail, etc.

For example, readers will note the special article in this issue, in which Mr. Victor King describes a method of dial marking which we recommend as essential if confusion is to be avoided; but we do not request manufacturers to conform to any specific size or form of dial.

### Retaining Individuality

Standardisation can be overdone. Up to a point, however, conformity—as in the instance we have described—to a specific principle can be of tremendous importance; but as to the size and form of "Extenser" con-

densers, these two aspects of the design can be altered in accordance with the individual ideas of manufacturers.

### Our Nairobi Broadcast

Readers will also find in this issue the final details about the Nairobi special broadcast we have arranged. We are hoping that the "Kilotrap" receiver, described in our last issue, will have been successfully built by now by thousands of readers, and that the hints on picking up Nairobi's broadcast with this set will enable the special broadcast on April 20th to be heard by all who have constructed the set, and all the friends who will doubtless be invited to make up listening parties that evening.

on the whole, extremely satisfactory.

We can only conclude by hoping that you will have good luck on the 20th, and that those of you who have friends or relations in Kenya Colony will be able to enjoy the unique experience of hearing them broadcast their greetings to their folks in this country.

### Will They Roar?

And for those who will not be expecting to hear a familiar voice that night—well, we only hope that the lions will be sure to oblige when they come within range of the microphones which will be placed near one of their favourite drinking pools.

### SENDING A TELEGRAM FROM THE AIR

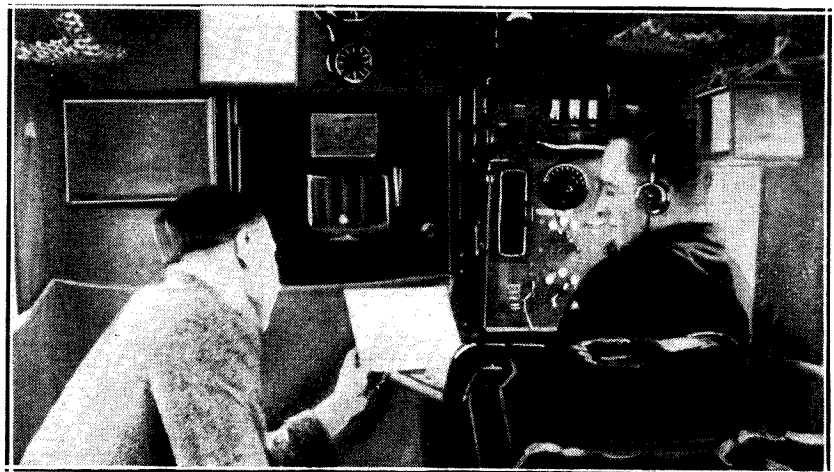

On one of the continental passenger air lines a new service has been inaugurated by which travellers may send private telegrams to any part of the world, via the aeroplane's radio installation.

A member of the staff of the WIRELESS CONSTRUCTOR has been of late listening regularly to Nairobi broadcasts with a "Kilotrap" set, and reports that reception has been,

The great and burning question on the 20th will be: "Will they roar?" If they don't, then they are not the sort of lions we want in a British Colony!

# USING THE "KILOTRAP" COILS

A selection of efficient short-wave circuits making use of the special short-wave coils designed by the Research Department and described last month. These are the coils employed in the "Kilotrap" receiver.

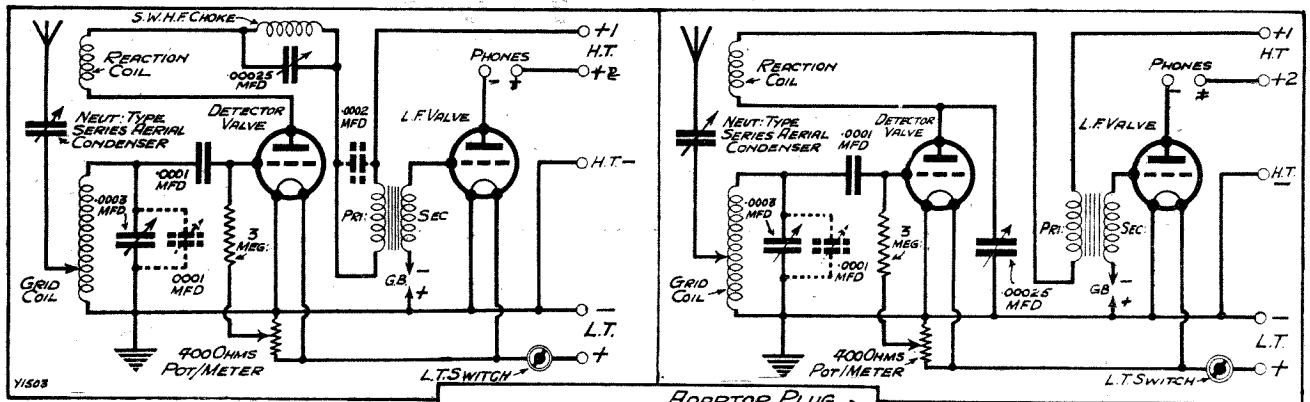

The first circuit, shown above, is an efficient two-valve arrangement in which reaction is controlled by means of a variable condenser across the H.F. choke in series with the reaction coil. The fixed condenser, shown by broken lines, across

The two-condenser tuning scheme shown in all these circuits greatly facilitates operation. The larger of the two should be regarded as a wave-length adjuster, whereas the actual tuning should be done with the smaller of the two. If you prefer to use a single condenser it should have a maximum capacity of not more than .00035 mfd.

the primary of the L.F. transformer, will only be necessary if the set cannot be made to oscillate.

For those readers who are keen on the adaptor system of short-wave reception, the circuit in the centre of the page will be of particular interest. This is an interesting variation of the "Kelsey"

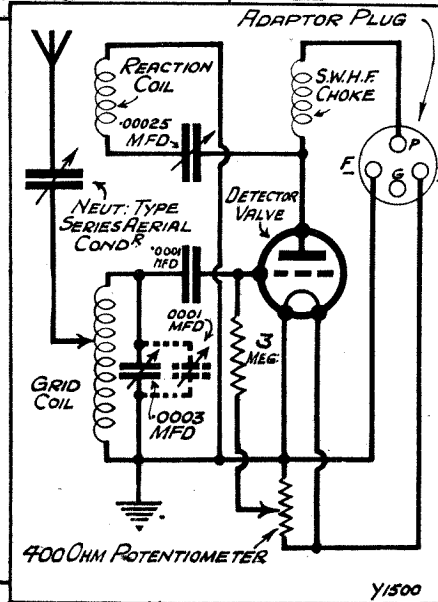

Adaptor showing how the "Kilotrap" coil can be introduced. The adaptor plug takes the place of the detector valve in your present set, and the detector valve from your set is placed in the adaptor.

**IF YOUR CIRCUIT WILL NOT OSCILLATE, TRY—**

- (a) Reversing leads to reaction coil.
  - (b) Variation of series aerial condenser.
  - (c) Increase of H.T. voltage on detector valve, and
  - (d) Another valve in detector position.
- NOTE.—For "ploppy" reaction or overlap troubles, try varying the position of the potentiometer slider.

The circuit on the right at the top of the page is similar in many respects to the first arrangement. The essential difference is in the reaction arrangements, where oscillation is controlled by a variable condenser joined between the plate of the detector valve and L.T. minus. This condenser must be of the low minimum type.

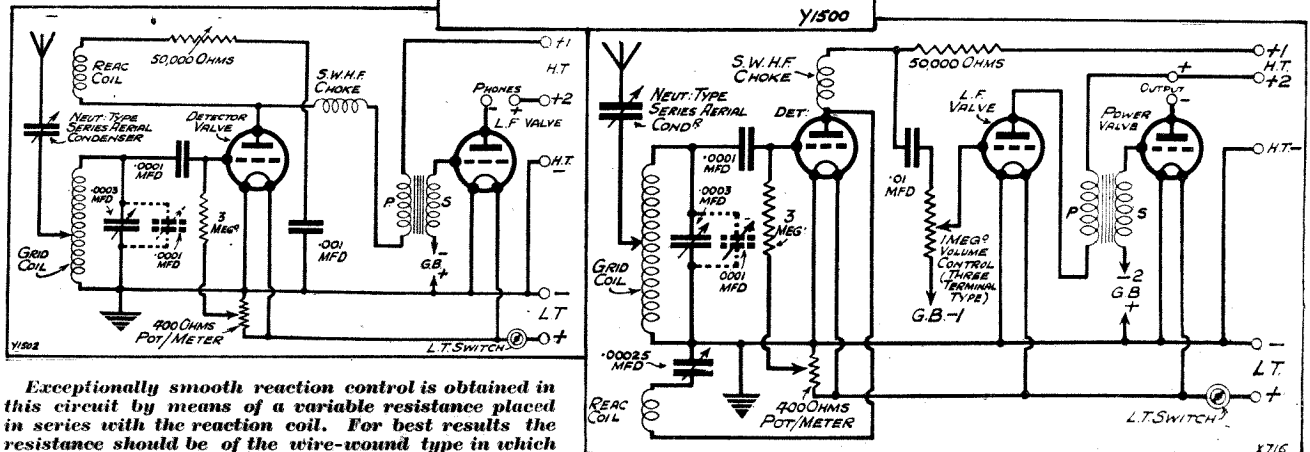

Exceptionally smooth reaction control is obtained in this circuit by means of a variable resistance placed in series with the reaction coil. For best results the resistance should be of the wire-wound type in which variation of resistance is obtained by means of a slider arm. One of the ordinary wire-wound three-terminal type potentiometers can be used quite satisfactorily if one of the terminals is ignored, the connections being taken to one end of the winding and to the slider arm. A resistance-controlled reaction circuit such as this is usually particularly free from hand-capacity effects.

For successful results the tuning condensers in all these circuits must be of the slow-motion type, or ordinary type fitted with vernier drive.

In this arrangement, which most of you will recognise as a Reinartz circuit, the components required are all of a perfectly standard type. Many of the modern commercial H.F. chokes intended for use on the medium and long wave-lengths will function quite satisfactorily on short waves. There are some, however, which are definitely unsuitable for short waves, and if you do not possess a suitable H.F. choke you can quite easily make one by winding 75 turns of No. 30 D.S.C. wire on a 1-in. diameter former. A choke made in this way would be suitable for any of the circuits shown on this page.



*One of the most romantic broadcasts that has ever been attempted will take place on April 20th, when a special programme will be transmitted by the Nairobi short-wave station to readers of the "Wireless Constructor." Here are full details of this unique broadcast.*

For the first time in the history of British broadcasting an attempt is shortly to be made to broadcast the roar of "real live lions" from the jungle of Kenya Colony.

This is to be part of the special Empire broadcast arranged by the WIRELESS CONSTRUCTOR, in conjunction with the British East African Broadcasting Company, to take place from the world-famous short-wave station 7 L O on the evening of April 20th.

### Kenya Colony Calling

In addition to the "performing lions," part of the time is to be devoted to personal greetings from Kenya Colonists to friends and relations in Great Britain. The whole programme promises to be one of outstanding interest, and every reader of the WIRELESS CONSTRUCTOR in possession of a short-wave receiver or adaptor can—in fact, we hope will—take part

in the first organised attempt to establish closer radio contact between Kenya and the Mother Country.

The success of this unusually interesting effort is, we feel, very largely

### HEAR THEM ON THIS

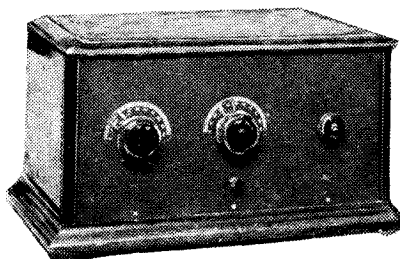

*You will find the lions broadcasting from Nairobi with the "Kilotrap's" right-hand condenser dial at 80 and the left-hand one at about 73.*

dependent upon the co-operation of every CONSTRUCTOR reader who has a receiver that will tune down to 49.5 metres, because the programme has been arranged for his special benefit.

As was mentioned in our last issue,

the test was originally intended to enable all builders of the "Kilotrap" short-wave receiver (fully described in the last issue) to test the capabilities of the set on a known transmission from a station thousands of miles away.

### B.B.C. May Re-Broadcast

But the highly interesting nature of the programme (coupled with the fact that it is the first organised link between Great Britain and Kenya) renders the broadcast of particular interest not only to "Kilotrap" fans, but to every single reader who is at all interested in short-wave reception.

Although at the time of going to press we are unable to make a definite statement, it is hoped if conditions are entirely favourable that the B.B.C. will attempt to relay part of the programme for the benefit of the great public unable to receive the transmission direct on short waves.

This, of course, will depend upon



*Ancient and Modern—The masts and buildings of the modern radio station look peculiarly incongruous in the background of this typical African scene.*

## Listen to Nairobi—continued

the conditions prevailing at the time, because even if, as we fully anticipate from our tests already made, Nairobi is received at comfortable phone strength, it may still not be up to a sufficiently high standard of reliability to enable the B.B.C. to make a successful relay. In this connection we can only hope that the evening of April 20th will turn out to be one of the best that has ever been known for reception on 49.5 metres!

### Our Own Tests

And now perhaps we ought to tell you something of our preliminary tests with Nairobi, and the best way in which to find 7 L O on the dial. You will find elsewhere in the article full details of the daily schedules on

49.5 metres from 7 L O, which means to say that you will have an opportunity of locating the dial reading before the special transmission takes place, and with the details that we are about to give you we do not anticipate that you will have very much difficulty in forming yourself into one of the vital links in this inter-imperial chain.

We are hoping that every reader of the WIRELESS CONSTRUCTOR who receives the whole, or even only part, of the transmission will let us know of their results, mentioning, of course, the receiver in use. If only conditions hold out as they are at the time of writing we are fully expecting a record mail during the week commencing April 20th!

The finding of the setting for 7 L O

for all those readers who have built a "Kilotrap" will be a comparatively simple matter, because all our tests with Nairobi have been carried out on the original model of this receiver, and, in consequence, if yours is a reasonably accurate copy of the published version we need only tell you the dial readings and we do not imagine that you will have to do much searching.

### How to Get Him

The wave-length adjuster (the right-hand dial) should be set at 80 degrees, and, with this so adjusted, Nairobi tunes in on the original version at 73 degrees on the actual tuning con-

### ACROSS TWO CONTINENTS

**THE SPECIAL "WIRELESS CONSTRUCTOR" BROADCAST.**

Date: April 20th, 1931.

Time: 8 p.m. to 9 p.m.

B.S.T. (7-8 G.M.T.).

Power . . . . . 2 kw.

Call-sign . . . . . 7 L O

Wave-length

49.5 metres

**OFFICIAL DAILY SCHEDULES FROM 7 L O ON 49.5 METRES**

Sunday 4.30-7.0 p.m.

Monday 4.0-7.30 p.m.

Tuesday 4.30-7.30 p.m.

Wednesday 4.0-7.30 p.m.

Thursday 4.30-7.30 p.m.

Friday 4.0-7.30 p.m.

Saturday 4.30-8.30 p.m.

Above times are G.M.T.

(Add one hour for Summer Time.)

X723

Across two Continents Nairobi will speak to "Wireless Constructor" readers on April 20th, sending messages from Kenya Colonists to their friends in Britain. The longitudinal difference between Kenya and Great Britain is two hours, as is shown in this map. On account of British Summer Time one hour must be added to Greenwich Time for listeners in the British Isles.

### HELPFUL HINTS ON HOW TO HEAR THE LIONS.

Use as tight aerial coupling as possible, and if necessary increase the H.T. voltage on the detector valve up to 100 or more volts in order to make the set oscillate.

The tighter the aerial coupling, the louder the signals, providing it is still found possible to make the set oscillate satisfactorily.

Make quite certain that your earth connection is in good order, so as to reduce hand-capacity effects to a minimum.

Smooth reaction control is vitally important. Satisfactory reception of 7 L O (Nairobi) is only possible when the set goes into oscillation without the slightest trace of "ploppiness" or overlap. To obtain smooth reaction control try:

- (a) Variation of the H.T. voltage on the detector valve.
- (b) Variation of the position of the slider on the grid-leak potentiometer. (If your set does not employ a potentiometer, you would be wise to fit one.)
- (c) Higher value grid leak, up to 4 or 5 megs.
- (d) Different valve in detector position.
- (e) Alteration of aerial coupling.

If your set produces a low growl just as it goes into the oscillating condition, try connecting a .5- or 1-megohm grid leak across the secondary of one or other of the L.F. transformers in the set.

Use a good slow-motion condenser, or vernier dial, and be sure to turn it very, very slowly, and finally—

Do not forget the time and date—8 p.m. B.S.T. on the evening of Monday, April 20th.

denser. This latter setting may vary as much as 10 or 20 degrees, depending upon the degree of aerial coupling in use, but it is fairly safe to say that in every case 7 L O will be tuned in with the wave-length adjuster set at 80 degrees; and as the actual tuning condenser only covers a very narrow band of wave-lengths, the difficulty of finding 7 L O should not be a particularly great one.



## Listen to Nairobi—continued

For the benefit of readers who will be using short-wave sets other than the "Kilotrap," the best way of finding the setting for Nairobi is to go by powerful transmissions which take place on either side of 49.5 metres.

At 50 metres, for instance, there is the terrifically powerful transmission from the Trade Union station at Moscow. This station can be recognised by the frequent announcements in English, but quite apart from this the station can be quite easily identified on account of the almost unbearable hum which accompanies its transmissions.

### Marked by Moscow

Immediately below this—a matter of a degree or so away—comes a very strong German short-wave station. This latter station does not seem to work to any regular schedule, but for all that it is quite often on the air. Moscow, we might add, is almost always on, and for purposes of calibration, even if for nothing else, is quite useful.

Nairobi, on 49.5 metres, is a degree or so below the powerful German station, and it is not difficult to find when once you have located the two transmissions to which we have referred. The announcements from 7 L O are, of course, in English, and the station is easily identified by the typically English programmes that are radiated—orchestral items, piano-forte concertos, songs, gramophone records, and so on.

### A TYPICAL

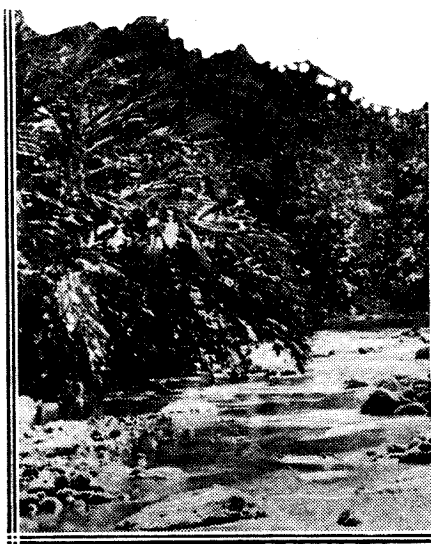

Where cooling streams leave the parched surface of the earth

### WHERE WEST MEETS EAST

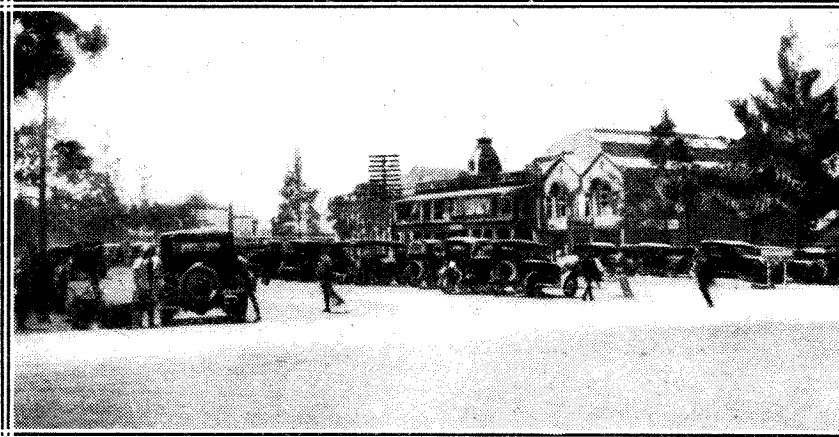

Quite a western effect is given by this view of a fashionable part of Nairobi—South Avenue.

On the other side of Nairobi—that is to say, below 49.5 metres—there is W S X K, on 48.86 metres—a transmission that is received quite well at times in this country; and H R B, at Tegucigalpa (Honduras), on 48.62

metres, which can often be heard at quite good phone strength after about 1.30 a.m. G.M.T.

### Those French Amateurs

Below these two stations you will find a band literally alive with French amateurs, who are easily identified by, alas, in many cases, the atrocious quality of their telephony transmissions. These transmissions are supposed to be on 45 metres, but unless the Research Department wave-meter plays tricks just at this particular setting we have our doubts!

Anyway, from these details you should not have much difficulty in locating fairly accurately the setting for the all-important wave-length of

### AFRICAN SCENE

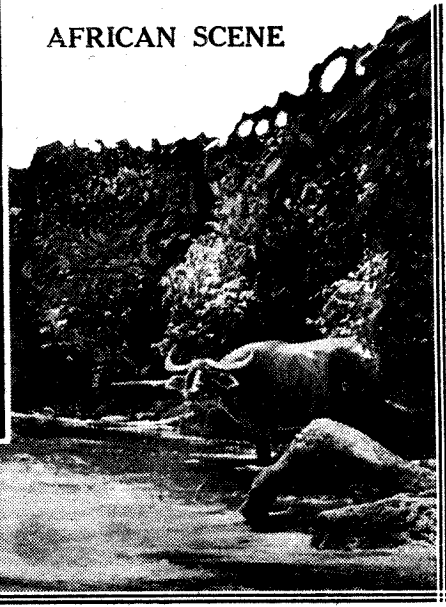

#### OPERATING THE "KILOTRAP"

In our preliminary tests with Nairobi the best results have been obtained from the "Kilotrap" by joining the clip from the series aerial condenser to the end turn on the right of the grid coil looking at the set from the back. With it thus connected, and with the actual series aerial condenser set at about three-quarters of its full capacity, we found it necessary to use 120 volts on H.T. + 1 in order to obtain satisfactory reaction control.

You will probably find it necessary to vary the position of the potentiometer slider in order to obtain dead smooth reaction control. For best results the slider should be placed as near to the positive end (the end nearest the terminal strip) as is consistent with smooth reaction control.

The easiest way to find a station on short waves is to search with the set in an oscillating condition. When you find a carrier-wave, or in less technical language, a howl, the reaction control should be moved very slowly to the left until the set just stops oscillating, and then with possible slight readjustment of the tuning condenser you should hear signals.

#### "KILOTRAP" CALIBRATION

Wave-length (metres)	Dial reading (wave-length adjuster)
63	100
50	85
43.4	70
31	50
25.53	30
21.7	15
19.56	10

## Listen to Nairobi—continued

### DOWN IN THE NATIVE QUARTER



Part of the native section of Nairobi, whose broadcasting station, 7 L O, has earned world-wide fame.

49.5 metres providing your set will tune up to this wave-length. If your set employs plug-in short-wave coils, a six-turn coil will in most cases enable you to tune well beyond 50 metres with a .00025- or .0003-mfd. tuning condenser.

#### How Loud Will He Be?

With regard to the strength of 7 L O, you must not expect a signal up to the standard of, say, for instance, W 2 X A F—the American station that relays W G Y on 31.48 metres—because after about 10 p.m. G.M.T.

this station can be heard with the "Kilotrap" at loud-speaker strength. Comparatively, 7 L O is weak, but, even so, if you make careful use of reaction you will find it possible to receive Nairobi at quite moderate 'phone strength. Sufficiently loud, at all events, to enable you to participate in this special programme satisfactorily.

As is the case with all really long-distance short-wavers, the strength of signals from Nairobi varies quite a lot from one night to another. One evening you may hear 7 L O's announcer telling you that "This is

Nairobi, 'Keen-ya,' on 49.5 metres," at excellent strength, whereas possibly on the very next night you may find it impossible to follow speech clearly.

But, even so, during our preliminary tests we have been very lucky with conditions, and signals have rarely been weak to the extent of being unintelligible, so that there is every possibility of the WIRELESS CONSTRUCTOR broadcast being a great success.

#### Look Out For Your Pals!

If you want to hear, for the first time in history, the roar of lions from Central Africa, or if you have any friends or relations in Kenya, who quite possibly may have a personal greeting to send you, be sure to listen to Nairobi between 8 and 9 p.m. on the evening of April 20th.

The WIRELESS CONSTRUCTOR Research Department will be listening on the original "Kilotrap," and arrangements are also being made by us for the signals to be picked up at loud-speaker strength on an elaborate super-heterodyne receiver so that if conditions are favourable a gramophone record can be made of the most interesting parts of the programme.

### ON THE OUTSKIRTS OF THE AFRICAN JUNGLE

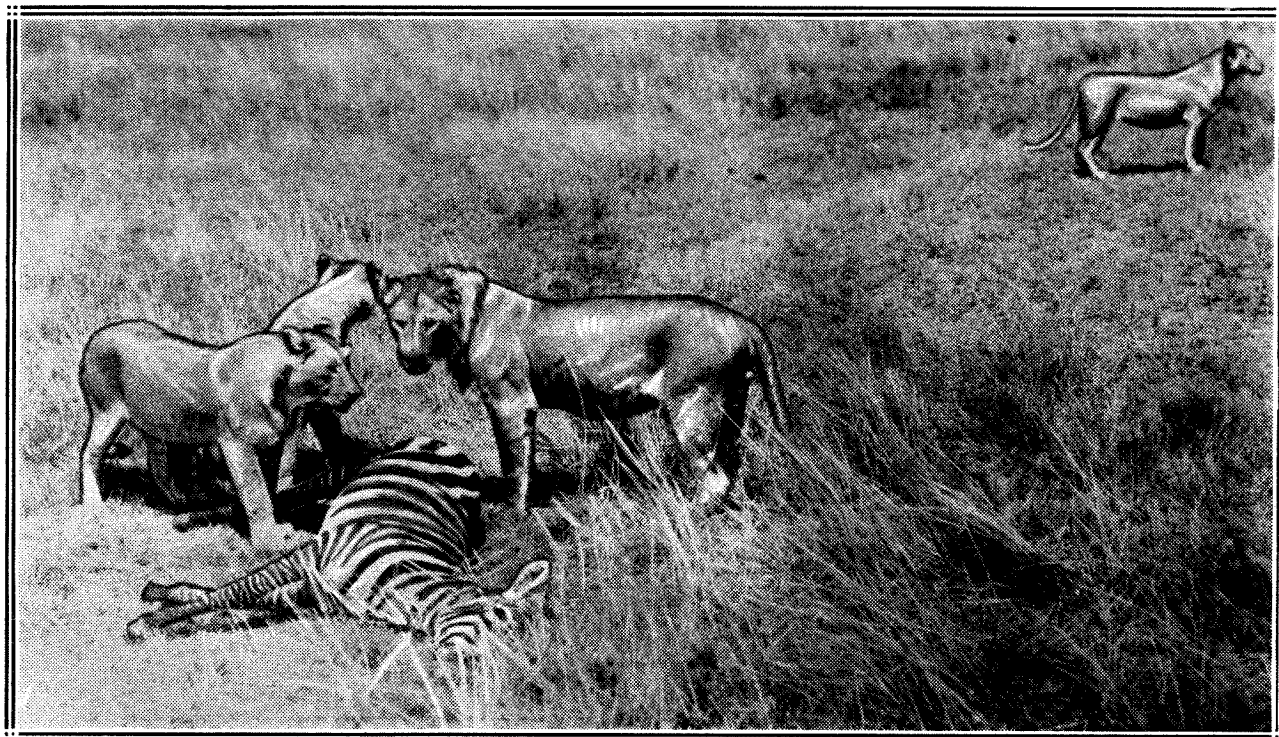

A "family group" of lions and lionesses pleased over their success in a hunt on the African veldt.

# MORE ABOUT THE "EXTENSER"

BY VICTOR KING

*Some further important details concerning the "Wireless Constructor's" new tuning component in which some hitherto unchronicled advantages are pointed out.*



**D**URING the course of the next few weeks the final arrangements for the manufacture of WIRELESS CONSTRUCTOR Extenser condensers by the tens of thousands will be complete. Several of the leading manufacturers have fashioned their models and are at the time of writing busily engaged in setting their machines for large-scale production.

### "Important Contribution"

The Extenser can be manufactured on existing machines, but it necessitates the making of new tools costing hundreds of pounds. I mention this to illustrate the seriousness with which the trade are viewing this new component. They do not regard it as a mere novelty—here to-day and gone to-morrow—but as an important contribution to radio progress.

It is because of this that the Editor has asked me to place on record certain recommended details of design in order that there shall be no initial confusion.

I want to make it clear that these are only recommendations, and that the last thing we want to do is to impose too rigid a standardisation on the making of commercial Extensers. We feel that it will be to the benefit of manufacturers if they are permitted

### WHAT THE EXTENSER DOES

- (1) Simplifies set construction.
- (2) Simplifies set operation.
- (3) Increases receiver efficiency.
- (4) Eliminates wave-change switches.
- (5) Enables one set of dial readings to cover both long and ordinary waves.
- (6) Makes dial readings logical and definite instead of merely arbitrary.

ample scope for the expression of their own individualities so long as their main ideas conform to certain general principles of design.

But I fancy that, in regard to the marking of Extenser dials, it will be

extremely desirable to retain complete uniformity, and I hope every Extenser will be "dialled" in accordance with the suggestions embodied in the following paragraphs.

There are existing dials which could be used with the Extenser, but it is widely felt that a new dial is almost essential. The WIRELESS CONSTRUCTOR agrees with this and suggests that it should be engraved 99-0-200 in the manner illustrated by one of the accompanying diagrams.

### Perfectly Progressive

If this is done the Extenser assumes yet one more virtue, and one that is so obvious that it hardly needs a detailed explanation. In short, while the numbers are perfectly progressive for all the medium and long wave-lengths, the two-figure numbers can stand for the medium waves (which are themselves three-figured—261, 525, etc.) and the three-figure numbers, 100-200, for the long waves (which are all four-figured—1,554 metres, 1,800 metres, etc.).

So as you automatically and almost unconsciously go from medium- to

FROM 200 to 2,000 METRES ON ONE DIAL

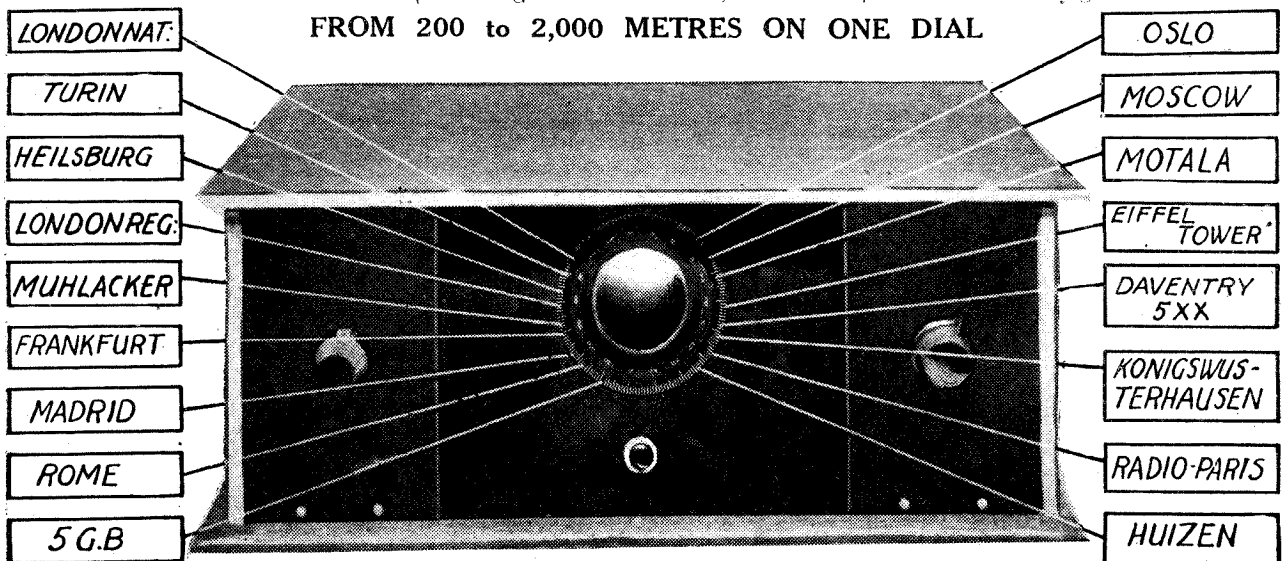

The dial is numbered from 0 to 200, and you get the medium-wave stations on the readings up to 99, and from 101 to 200 are situated the long-wave stations. So, you see, the dial readings of the "Extenser" are really logical and do mean something instead of being purely arbitrary.

## More About the "Extenser"—continued

long-wave tuning as you sweep about with your Extenser, you run into dial readings having an extra figure, hundreds instead of tens, and thus make station-searching vastly easier.

Let me repeat it; it seems worth rubbing in. The tens stand for the medium waves and the hundreds for long waves. So beautifully logical, isn't it?

### Logical Tuning

The zero dial reading stands for zero on both medium and long waves. When you turn the dial to the right you run up the medium wave-lengths, and that is exactly what you do at the present time with ordinary tuning condensers. But with the Extenser you can turn the dial to the left and run up the long wave-lengths.

It doesn't matter a scrap whether or not a definite stop position is arranged at the 200 dial reading, which represents the point of maximum capacity—arbitrarily for the long waves, but, theoretically, for both bands.

Some manufacturers favour a continuous and unrestricted rotation, while others prefer to have the stop. That is a detail that can easily be left to the individual concern, though I, personally, like the stop if only for

same general plan as indicated in the other diagram. Some existing drum-driven condensers have their readings running upwards, while others are the other way round. I do think, however, that Extensers should retain the same general scheme through all the different makes.

Now a word or two about the Extenser "self-changer." It would be a distinct advantage from at least one point of view if the one scheme of switching in sets could be made absolutely uniform—it would enable Extensers to be just a wee bit simpler.

But it would not be wise to impose any initial restrictions on the use of the component, or to allow it to restrict freedom in set design. Therefore, we are recommending that four-point switching should be aimed at in all models.

### Readily Adaptable

One firm has evolved a method whereby Extensers can readily be adapted to any type of switching, from straightforward two-, three- or four-point "shorts" up to multi-pole double-throw varieties.

And it is interesting to note that another firm has patented two systems of carrying out Extenser "self-changing." And that reminds me—

tenser—and, no doubt, for many other articles that are manufactured—it definitely is not as good as it might be for commercial Extensers.

### Amazing Ingenuity

But you will soon be able to see for yourselves exactly how the different firms will deal with this particular detail, and will, no doubt, be amazed at the ingenuity employed to ensure efficient actions.

### "EXTENSER" DRUM DRIVE

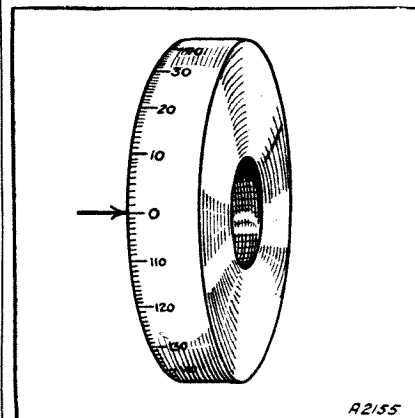

How the readings will appear on an Extenser drum drive.

That reminds me of something else. Some manufacturers were at first troubled by the necessarily long fixed vanes in the Extenser; and this, despite their three-point suspension. You see, it is easy enough for a constructor to trim up the vanes of a home-made Extenser, but manufacturers aim at the simplest possible assembly, and the less individual "wangling" that has to be done during the assembly the better.

### Some Minor Points

In one or two instances the vanes are being made thicker than usual, and in others they are being made smaller and slightly more numerous. In yet other cases, I believe, thin bakelite washers, about the size of a penny, are being inserted between the vanes at the centre to ensure that the vanes do not scrape or vibrate.

A small amount of "solid dielectric" so employed will have no appreciable effect on the component, and constructors need not fear that this is a weakness in design. On the contrary, I trust that they will realise that this and other expedients are adopted only after reference to the WIRELESS CONSTRUCTOR Research Dept. and in

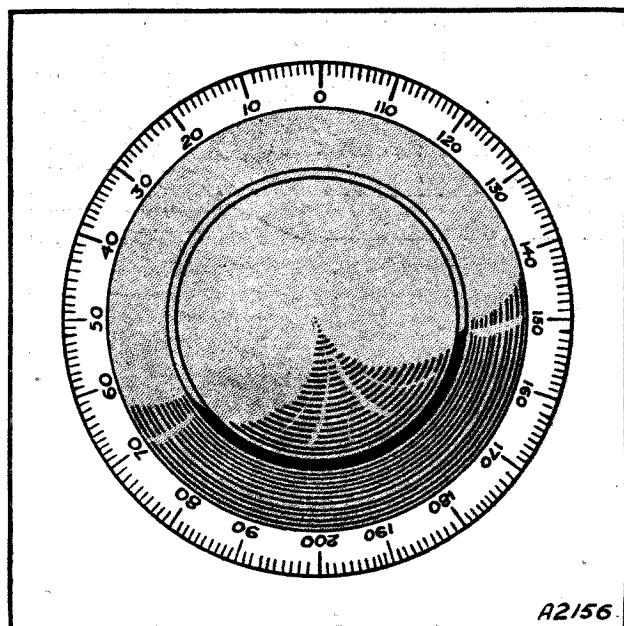

A clear illustration of the recommended dial-marking for Extenser condensers. The two-figure numbers will indicate the medium wave-lengths, and the three-figure numbers the long-wave stations. Thus you can tell at a glance which band you are working on.

the reason that it would make it easier for a blind person to locate his dial bearings.

In the case of drum drives, the readings should, I think, follow the

the switching scheme embodied in our original model is not the best possible by far.

Although being excellent for the home-constructed version of the Ex-

## More About the "Extenser"—continued

order to keep prices down to the very lowest levels.

I feel that I must take this opportunity of telling you something more about the Extenser's reception by the trade. I've held this back in order to get the above vitally important points prominently placed.

### "A Very Big Thing"

They form the strictly business part of my article! As I have already explained, and I am convinced you must all by now fully realise, the Extenser is a very big thing and is as far removed from being a "toy" or a "stunt" as is an L.F. transformer from a child's tin train.

It is going to mean hundreds of thousands of pounds in new trade for the radio industry, and, very soon, simpler and better sets for everybody. One factory alone is already taking on dozens of new men and thus materially assisting in the reduction of unemployment.

### Unanimous Approval

I am not going to repeat all the enthusiastic things that have been said by the various interested manufacturers; in any case, there wouldn't be room for that, and much of it would be mere repetition. But when I tell you that there has been complete unanimity, those of you who know how "case-hardened" are some who are associated with the making of radio gear, and how necessarily conservative are others, you will gather that the Extenser is indeed regarded as an attractive proposition!

And we have had all sorts come round to examine and criticise our original models. There have been managing directors with no technical knowledge, and works managers and chief technicians who know all there is to be known about the design of wireless gear.

### No Snags

And you can be sure that sales managers and sales organisers have been sent along to gauge the selling possibilities of this new article of ours.

I feel mighty proud that I was allowed to be present on the occasion of a few of these visits, for I fancy it is the first time in the history of radio that any radio journal has been able to introduce to the industry a new

component having such extraordinary potentialities.

Usually there are "snags" in all new inventions. The best of them generally give you benefits only at the price of certain fundamental disadvantages. The screen-grid valve, for instance, is greedier with H.T. than the ordinary H.F. valve, and it generally necessitates more complicated screening than the "neut."

But the Extenser is all advantages, and the more you think about it the better it seems to become. You look for snags, only to find more attractions!

and cease to be merely arbitrary and almost meaningless numbers.

If you do not want to bother about the readings, you merely twist the dial until you get the long or medium station you wish to hear, simply by reference to the sounds it produces. Or you can find it by reference to the one calibration curve or table. On the other hand, you can tell at a glance simply by looking at the numbers which wave-band you are ranging through.

Well, that is all for the time being, but I have the feeling that the Extenser has some further surprises in

### AN EXTENSER IN A CRYSTAL SET



*You can use an Extenser even in a crystal set with very great advantage. Indeed, its application to the simplest of all existing set types emphasises its own marvellous qualities of simplification.*

### "Real Sense"

That business of the dial is a very good case in point. One of our most prominent condenser makers raised what he first thought to be a criticism. He said that the Extenser would mean a complicated system of dial readings.

But when we explained the system of markings shown in the accompanying diagram he was delighted. And it was he who first expressed in words the fact that the Extenser is the first device to give real sense to dial readings; for dial readings do become beautifully vital with the Extenser

store for us! And, if I am not much mistaken, there won't be many sets at future radio exhibitions that haven't got Extensers incorporated in them.

Watch the  
**"WIRELESS  
 CONSTRUCTOR"**

**For Future Important  
 Extenser Developments.**

# QUEER QUERIES



Some suggestions about unusual radio faults that may help you towards better reception.

By P. R. BIRD.

PROBABLY everybody connected with practical wireless work knows that foolish feeling which results from laying the blame of a fault on to the wrong part of the set. We have all done it, and probably every one of us will do it again some day!

I remember once being present at a very funny scene when a certain famous radio man called aloud upon all his gods to witness the scandalous and sinful action of an H.T. battery-maker who had sent him a 100-volt battery that read only 50-odd volts. "The gross carelessness!" he shouted. "The rotten junk they swing on the public!" And so on, with a loud voice and flashing eye.

And then somebody gently reached for another voltmeter, and this showed the battery in question to be right up to standard! And we all manfully tried not to laugh. (And failed, of course! Very painful!)

I mention this case because several readers have recently been in trouble with testing instruments which gave misleading results. In one very unusual case the expensive milliammeter in question was in perfect order, but tests were being carried out near a set in action, and the readings were all thrown out because the instrument was placed too near to the large and powerful magnets of a moving-coil loud speaker!

As phones and loud speakers are often used as testing instruments, special care should be taken that when these are used they are in good order. Otherwise even a simple fault may prove a baffling mystery for a time, until the true delinquent is discovered.

## The Pop-Gun

A cheery Sheffield soul who connected up a two-transformer, det. and 2 L.F. set calls the result a Pop-gun! "When I feel down in the mouth," he

writes, "I pop the switch on, and immediately 'pop-pop-pop-pop-pop' goes the set, like a dirt-track rider, all out."

Having scouted round amongst his wireless friends, and astonished them

### HOW'S THE SET GOING?

If you are puzzled by a radio problem remember that the "Wireless Constructor" Technical Queries Department is fully equipped to help you.

Full details of the service, including scale of charges, can be obtained on application to the Technical Queries Department, "Wireless Constructor," Fleetway House, Farringdon Street, London, E.C.4.

SEND A POSTCARD, on receipt of which the necessary application form will be sent by return.

LONDON READERS, PLEASE NOTE. Application should not be made by telephone, or in person at Fleetway House or Tallis House.

one and all with his "pop-gun," he learns that the consensus of opinion is that he needs some de-coupling. Where should he put this, and how?

In nearly all such cases the detector stage is the one to doctor, and this is done by breaking the lead from the first L.F. transformer primary to H.T.+, and inserting a resistance (20,000 ohms or so) in it.

Now all that is needed is a large fixed condenser, 1 or 2 mfd. at least, connected as follows:

One side to the junction between the new resistance and the L.F. transformer primary. The other side of the large condenser to L.T.—, H.T.—, or to any convenient point on the set's wiring that goes to these places.

When these simple alterations have been carried out the detector is de-coupled. And the pop-gun should at once behave like a respectable set, and not like a machine-gun in action.

## That Working Voltage

"Another thing I grumble at," says a canny North of England reader in a letter-ful of trouble, "is having to buy '500-volt' condensers when my mains are only 240 volts. Surely a condenser tested at 250 volts would give a good safety margin? In ordinary business there is not all that discrepancy between the requirement and the recommendation."

Although I am not quite sure of what is meant by this last statement, I am quite sure that this reader is taking up a wrong attitude.

This question of condenser breakdown and safe test-voltages has been thoroughly investigated, and even on D.C. a condenser used for safety purposes should be tested at *double* the mains voltage.

For A.C. the recommendation is that three times the mains voltage should be employed as a test voltage. There is a technical reason for this, but quite apart from the technicalities it should be obvious that when responsible bodies like the I.E.E. recommend certain safeguards it is folly for the inexperienced to ignore that recommendation.

So if the designer of a set says "use a condenser tested at 500 volts," don't be put off with one of the "this-will-do" type. Insist on one which comes up to specification.

## A TIP FOR DRILLING

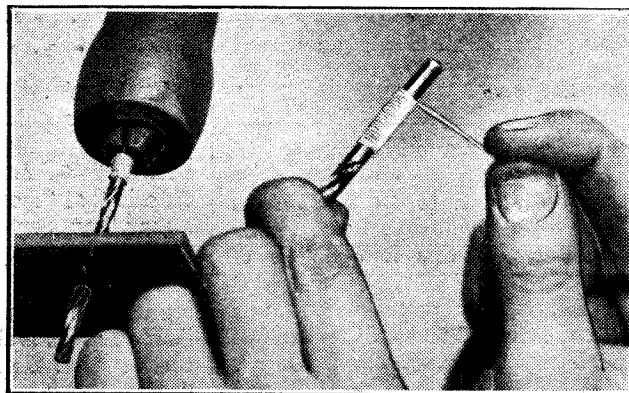

When using a carpenter's brace which won't "bite down" on a small drill, a winding of wire round the drill's shank, as shown, will enable it to be held firmly.



*Fewer Sopranos—Return of Paul Robeson—The B.B.C. Symphony Orchestra for America?—B.B.C. to Lose Harold Nicolson—Regional Changes—Mr. Ashbridge's Success—The Governor Stakes—Broadcasting House—Sir John Reith for America?—Return of B.B.C. Chairman.*

**Fewer Sopranos**

THE B.B.C. has at last decided to reduce the number of sopranos in the programmes. Apart from the fact that both for transmission and reception the soprano is the most difficult voice, there has been the chronic trouble of wobble which seems to afflict this kind of voice worst. Credit for the reform must be given personally to Mr. Roger Eckersley, who has had a long and difficult job convincing the Music Department that he was right.

**Return of Paul Robeson**

Paul Robeson is coming over from the States again in May, and the B.B.C. is hot on his track for two special broadcasts, one National and one Regional. The former will be a recital with piano on a Sunday afternoon and the latter probably a recital with full orchestra on a week-day.

This will be very welcome news to vast numbers of listeners who have a warm place in their hearts for this great artiste. Paul Robeson is one of the most popular B.B.C. "turns."

**The B.B.C. Symphony Orchestra for America?**

There have been inquiries from several sources as to whether the B.B.C. would allow its new orchestra to tour in the United States. At least three of the leading agents are interested. There seems no doubt that it would be a "good thing" financially.

Also, of course, a visit of this kind would be a great advertisement for the B.B.C. as well as for British prestige and enterprise. The snag is that it would be very difficult to spare the

orchestra from the programmes for the time such a tour would require.

Anyway, it will not be undertaken earlier than the season 1932-33, by which time the B.B.C. will have settled into its new home in Portland Place.

**B.B.C. to Lose Harold Nicolson**

The Hon. Harold Nicolson, who two years ago took over from Mr. Gerald Barry the weekly London gossip talk, is about to relinquish broadcasting in favour of politics, which has always been his main interest since he left the Diplomatic Service.

Mr. Nicolson will be hard to replace. He accepted an unusually difficult succession when he followed Mr. Gerald Barry. But he soon made a host of friends, and became a big feature of broadcasting. He was as brilliant and versatile as his predecessor; and although he had several compensating qualities, perhaps his

only disadvantage, in comparison with Mr. Barry, was a certain lack of robustness.

Now that Mr. Nicolson is giving up his broadcasting work many people will hope that Mr. Gerald Barry may be induced to resume; and if not he, then Mr. J. C. Squire, or Mr. Shanks, the poet.

**Regional Changes**

Those who are closest in touch with the international situation, so far as it affects broadcasting, make no secret of their opinion that the B.B.C. Regional scheme, as originally designed, is bound to be altered radically before it is completed.

Interference between adjacent high-power stations has become a matter of serious anxiety. I would venture to prophesy confidently that before long the B.B.C. will be only too glad to give up some of its wave-lengths in

**CONSTRUCTORS OF THE FUTURE**



*A scene just before an important City broadcast, when intense interest in the apparatus to be used was shown by a party of schoolboys.*

## Savoy Hill News—continued

return for a more restricted but quieter stretch of ether.

When this happens there will have to be a revision of the distribution of channels in this country. But no definite scheme has been worked out.

### Mr. Ashbridge's Success

Mr. Noel Ashbridge succeeded Captain Eckersley as Chief Engineer of the B.B.C. about two years ago. In this time the new "Chief" more than "made good," and is a great credit to his former leader and friend, Captain "P.P."

Mr. Ashbridge has gone about his

### IT KNOCKS OUT "X's"



*That it will eliminate statics or X's is the startling claim of this young inventor for his home-made apparatus. He lives in America.*

task quietly, efficiently and unostentatiously. But the engineering branch of the B.B.C. goes steadily on from achievement to achievement. There will be some honours for B.B.C. staff at the end of the licence in 1935, and I would bank on Mr. Ashbridge getting recognition in addition to Sir John Reith, who, if he is still there, may be made a baronet.

### The Governor Stakes

Betting is brisk on the chances of candidates for the new Board of Governors of the B.B.C., which takes office on January 1st. Mr. Whitley, the Chairman, is safe for the full period of the licence. Mrs. Philip Snowden is the other certainty among the present Governors.

It is not known whether Lord Gainford would care to stay on. He has held responsible office in the B.B.C. since 1922, and might reasonably claim the right to a rest from this branch of the public service. Nor is anything public about the intentions of Sir Gordon Nairne and Dr. Rendall.

In the event of there being no retirements, the Government will be urged to add two members to the Board, in accordance with one of the suggestions of Lord Crawford's Committee of 1925. In this case there will be keen competition. The following are present favourites, in the order named: Captain Ian Fraser, Dr. H. R. L. Sheppard, Sir Harry Brittain, Col. Moore-Brabazon, Mr. C. B. Cochran, and Sir Hugh Robertson.

### Broadcasting House

A cross-section illustration of Broadcasting House recently pub-

lished in an illustrated weekly caused a good deal of interest, not least because of the comparatively tremendous size of the office reserved for the Director-General, which looked to be bigger than all the studios except one.

Apparently something was wrong with the proportions of the illustration, because I am told at Savoy Hill that the office of the Director-General will be not nearly as big as represented. For the rest the studios rightly have pride of place, and offices are put here and there where corners can be found.

The B.B.C. is more than pleased with the progress of the building; certainly some parts of the staff will begin the move over by the end of

June. The only big disappointment encountered in the course of the erection was the discovery that the water emerging from the artesian well was too soft for use in the boilers. Therefore, the sinking of the shaft was a waste. But as all the experts were confounded the B.B.C. can hardly be blamed.

### Sir John Reith for America?

There is a persistent rumour, both in American newspapers and in British wireless circles, that Sir John Reith is about to pay a very important visit to the United States and Canada. Sir John has a host of friends in the States, where during the latter part of the War, after being seriously wounded at the Front, Sir John was the chief British agent for munitions, and had a small army of several thousands of inspectors, officials and assistants under him.

No doubt he will broadcast from New York. When he goes across the border into Canada, Sir John can be counted on to have something to say about the Canadian broadcasting situation.

### Return of B.B.C. Chairman

It is believed that with a slight overlap the departure of Sir John Reith for America will coincide with the return from India to England of the Chairman of the B.B.C., Mr. J. H. Whitley. Since his appointment to succeed Lord Clarendon a year ago, Mr. Whitley has not had much chance to get down to his new job.

The completion of his work as Chairman of the Indian Labour Commission has claimed most of his time and energy in the interval that has elapsed since his appointment to the B.B.C. by the Prime Minister. But when he gets back from India he will throw himself wholeheartedly into the complexities of broadcasting, and I would not be surprised to see, during the absence of the Director-General, a regime of executive-chairmanship, with the assistance of Admiral Carpendale.

It is believed that Mr. Whitley intends to make a practice of coming to the microphone periodically in order to explain B.B.C. policy and take listeners more into confidence than has ever been done in the past.



# AS WE FIND THEM



## A General-Purpose Transformer

**T**RANSFORMER design has improved greatly during the past year or so. It is now possible to obtain a really high quality instrument capable of giving a good proportion of the bass notes and excellent amplification for half a guinea. Of course, these transformers do not give quite the same performance as the more expensive ones which their makers list. This could not be done at the price, but

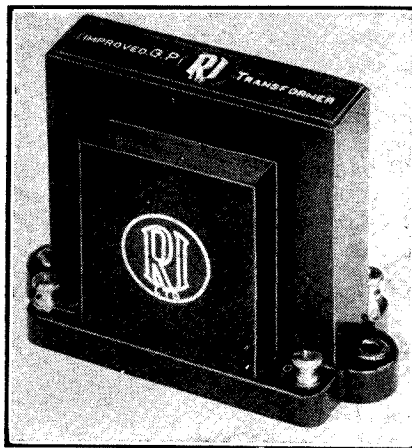

*The R.I. general-purpose transformer has a primary inductance of 35-40 henries, and is excellent value for money.*

those whose pockets will not run to the higher-priced models need not worry. They will not be disappointed at the results obtainable from the less expensive types provided they go to one of the well-known manufacturers. The latest transformer which comes within this category is the one made by Messrs. Radio Instruments, Ltd., Purley Way, Croydon.

The core used in this instrument is not of the nickel-alloy kind, and in

consequence the transformer is somewhat large, although by no means unduly so. For instance, there will be more than ample space for it in any ordinary WIRELESS CONSTRUCTOR design.

The primary winding gives an inductance value of 35-40 henries, and currents up to 5 milliamps. may be passed without danger of saturation. This feature permits the use of a valve of medium impedance (provided it is properly biased), with a consequent improvement in quality on the lower frequencies. The turns ratio is 3.5-1, and the weight is 1 lb. 2 oz.

The transformer is enclosed in a neat bakelite case, and is excellent value at 10s. 6d.

## Eelex Earth Bowl

The importance of a good earth has often been stressed in this journal, and it is an accepted fact that an efficient buried earth is second to none.

One of the main troubles is that of ensuring satisfactory contact with the soil. Moreover, many listeners have some difficulty in making soldered joints to sheets of metal owing to the rapid dissipation of heat. There is no doubt that it is a skilled job of work.

Messrs. J. J. Eastick & Sons, 118, Bunhill Row, London, E.C.1, have, however, solved both of these troubles with their "earth bowl." The shape of the device is such that it beds well down into the soil and presents an adequate area of contact. Moisture percolates through, and is retained for the maximum length of time by the

"bowl" shape, while a stout earth lead is supplied ready soldered to the device, the joint being protected from electrolytic action by a covering of black substance.

Thus, properly buried, the Eelex earth bowl should provide a thoroughly efficient earth for broadcast reception.

## Heyberd Block Condensers

Messrs. F. C. Heyberd & Co., 10, Finsbury Street, London, E.C.2, have submitted for test one of their large block condensers designed for use with H.T. eliminators.

These condensers are rated at 800 volts D.C., and may be employed with units which incorporate metal or valve rectifiers. There is a common negative terminal and six others which are connected internally to various condensers embodied in the block, the capacities being 4, 4, 4, 1, 1, 1 mfd. The unit eliminates the use of six separate condensers, saves space and makes for neatness in wiring. The price is 17s.

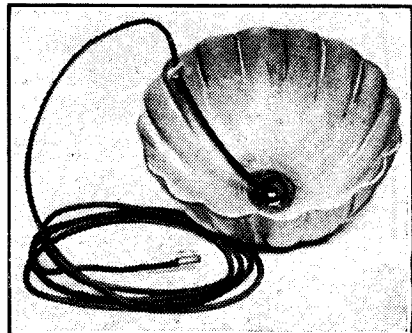

*The Eelex earth bowl is designed to ensure good contact with the soil, and a substantial insulated lead is soldered to the centre point of the bowl.*

## As We Find Them—continued

### Testing Prods

Messrs. J. J. Eastick & Sons have also sent us two of their latest spring-loaded testing prods. They are coloured red and black respectively, and in appearance resemble pencils of the propelling type. A half turn of the top of the insulated handle causes the metal needle to emerge from the end. We consider these prods to be most useful for general test work.

### The W.B. Loud Speaker

We have recently tested one of the W.B. permanent-magnet moving-coil loud speakers type P.M.2. This

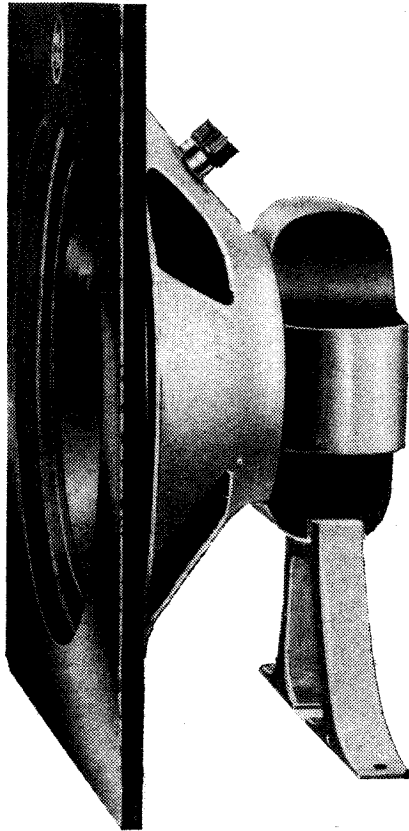

*The W.B. permanent-magnet moving-coil loud speaker has a low-resistance coil and requires a step-down output transformer. The speaker was found to be sensitive and the response over the musical range very good.*

model is the smaller of the two which this firm markets, the larger one having more substantial magnets. Having already tried one of these and been favourably impressed by the excellence of the reproduction and high sensitivity, we were naturally interested in the smaller model.

Apart from the size of the magnets, there did not appear to be any appreciable external differences. On test we found the response over the musical range to be very good indeed

Tested at 500 volts, the insulation of the various samples sent in was found to be infinity, and this figure held good after they had been immersed in water for over two hours.

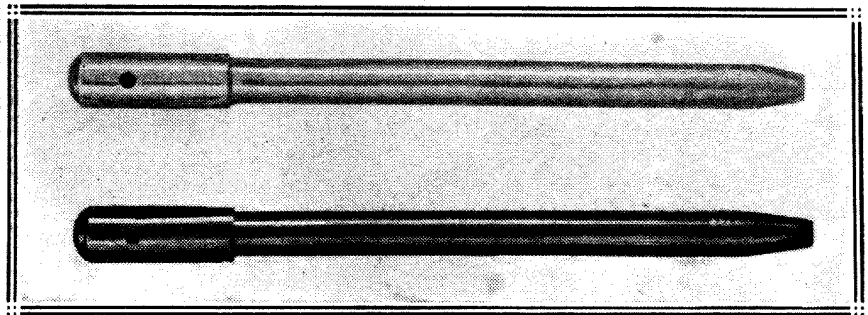

*The Eetex testing prods. A half-turn of the top of the insulating tube causes the testing needle to emerge from the end. In practice, the prods are used in conjunction with two flexible leads and a dry cell, or with some form of indicating device such as a pair of 'phones or a voltmeter.*

when used in conjunction with our standard amplifier and a Columbia "gliding tone" record. There were no unpleasant resonances, and the sensitivity was high.

The magnet system is of cobalt steel, and is evidently very efficient.

The W.B. P.M.2 speaker retails at £4 10s., a suitable double-ratio step-down transformer being supplied for 15s. extra.

Incidentally, it is essential to use an output transformer, since the standard coil winding is of low-resistance.

The permanent-magnet models require no mains or batteries for their operation, and, in consequence, can be employed with any set having a well-designed L.F. side and a super-power valve in the output stage. The makers are Messrs. Whiteley Electrical Radio Co., Nottingham Road, Mansfield.

### Fixed Condensers

Messrs. The Telegraph Condenser Co., Ltd., Wales Farm Road, North Acton, W.3, have recently produced a new type (type M) mica condenser.

These condensers are of very compact construction, and the internals are completely enclosed in bakelite mouldings.

They are designed so that they can be either suspended directly across the wiring or screwed down to the baseboard in the usual manner.

The condensers are moderately priced—i.e. values from '00005-'0005 mfd. are 1s., those ranging from '001-'004 mfd. are 1s. 4d., and the '01 mfd. is 2s. 3d.

### Clix Connectors

Messrs. Lectro Linx., Ltd., 254, Vauxhall Bridge Road, London, S.W.1, are continually devising new gadgets in the way of special terminal connectors, wander plugs, etc.

Their latest is a "non-short" accumulator connector, which provides a speedy plug and socket L.T. connection. The terminal tag is lead-coated to prevent corrosion, and the accumulator leads can be rapidly connected or disconnected by inserting or withdrawing the insulated sockets, which fit on to the solid pin tags. The price of these connectors is 3d. each, and the insulated portions are coloured red and black.

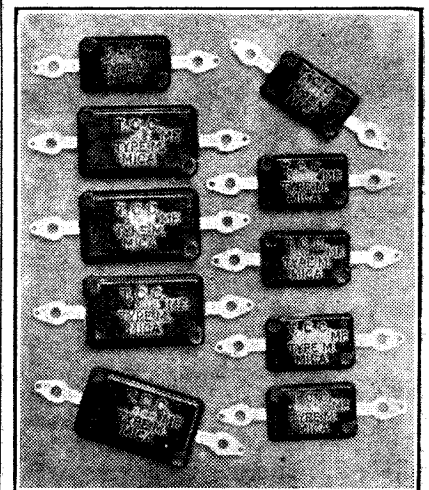

*A group of the latest T.C.C. fixed condensers which can be either suspended directly across the wiring of the set or screwed to the baseboard in the usual way.*

# THE "PLUS-STAGE" TWO

Designed and  
Described by the  
Research Dept.

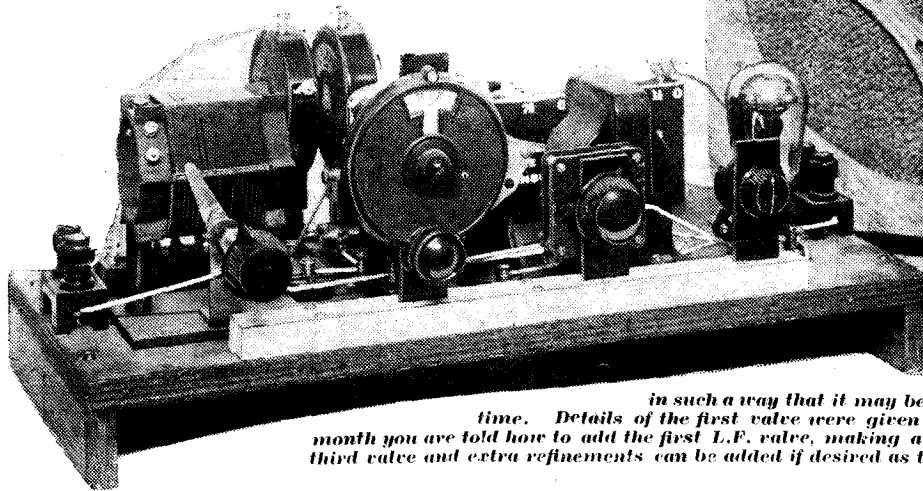

*Here is a new type of receiver which is built section by section, and is designed in such a way that it may be used as a complete set the whole time. Details of the first valve were given in the March number, and this month you are told how to add the first L.F. valve, making a fine loud-speaker set to which a third valve and extra refinements can be added if desired as the details appear in later issues.*

THOSE who made up the "Plus-Stage" One when it appeared recently have probably been waiting very impatiently for this issue. The "Plus-Stage" Two was to have appeared last month, but unfortunately was crowded out; still, those who were eagerly awaiting the details will no doubt admit that they had something of great interest to read about last month in the introduction of the "Extenser" system.

### Adding an L.F. Stage

For the benefit of new readers we must explain what the "Plus-Stage" series of sets is. Mainly, the idea is a progressive scheme which enables an efficient three-valve set to be built up stage by stage.

The receiver is quite complete in its various stages, so that it can be used the whole time; the various stages being added as they are published, or when funds permit.

There is also the advantage that each stage may be made to work perfectly before the next is added, thus ensuring that the receiver when complete will operate with maximum efficiency.

The "Plus-Stage" One has already been fully described in the March issue of the WIRELESS CONSTRUCTOR. It constitutes a highly efficient and selective, though simple, single-valver.

The circuit arrangement of the

single-valve part is shown in dotted lines in the theoretical circuit, the solid lines indicating the section which is added this month. The pictorial circuit diagram to the right of the theoretical circuit also illustrates the section added this month.

When you have completed these additions the set becomes the "Plus-Stage" Two, which is a complete detector and one low-frequency valve loud-speaker receiver. The components which are to be added constitute a complete transformer-coupled L.F. stage.

Before considering the connections

we will describe the components themselves. They are three in number and are listed below the circuit diagrams.

The makes mentioned first are those we have used in the original set, and those which follow are suitable alternatives. First of all, with regard to the low-frequency transformer.

### Transformer Coupled

Any ordinary L.F. transformer can be used for the two-valve arrangement, but you must not forget that another L.F. stage has later to be added. For this reason it is very desirable to use

INEXPENSIVE, EFFICIENT

AND SIMPLE

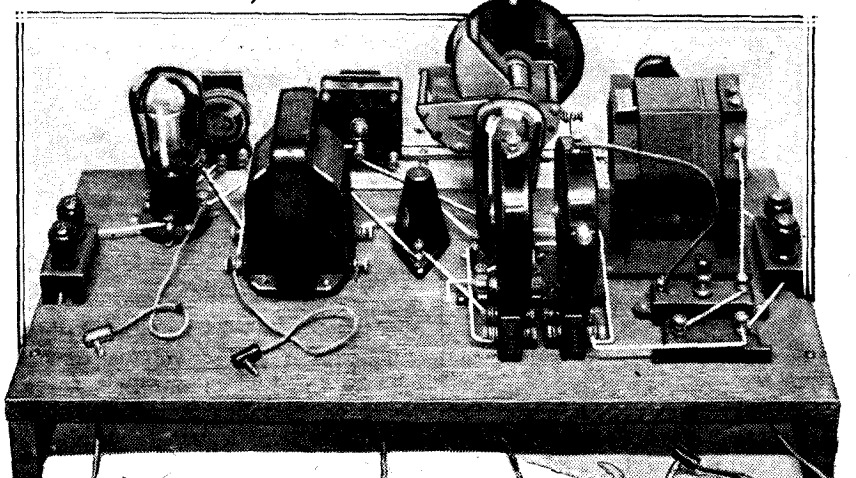

*This is how the set looks from the back now that the first L.F. stage has been added. The appearance from the front can be gathered from the view in the heading.*

## The "Plus-Stage" Two—continued

a low or medium ratio, certainly not more than 5-1. A high ratio such as 7-1 would be very likely to cause trouble from L.F. instability when the third stage is added to the receiver.

The volume control may have a value between .5 and 2 megohms. It does not matter what the value is so long as it comes within these limits. This is specially mentioned

holder almost any kind will do, although, of course, there would be no point in having one of the five-pin holders.

If you study the circuit diagrams you will see that the telephones that were used in the one-valver are now replaced by the primary of the L.F. transformer. The transformer secondary has the ends of the volume control

a real loud-speaker set capable of giving good volume.

The flex lead which was previously used for H.T. + is now termed H.T. + 2. It does not serve the detector valve now, the H.T. for this being obtained via a new flex lead H.T. + 1.

Getting down to practical details, you will see that the one extra control

### MAKING THE "PLUS-STAGE" ONE—

This special combination diagram shows very clearly the progress of the "Plus-Stage" receiver. Immediately below, in dotted lines, you see the first stage, namely the detector arrangement, whilst the first L.F. stage is seen to the right, added in solid lines.

### THE FIRST L.F. STAGE:—

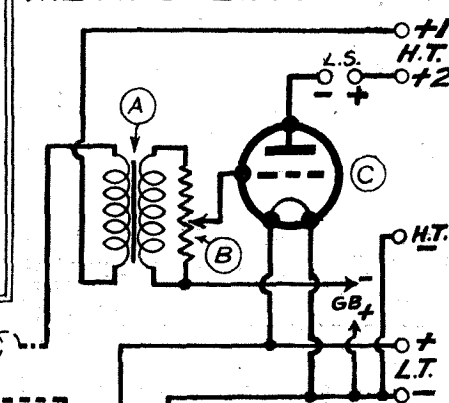

### —INTO THE "PLUS-STAGE" TWO

The pictorial diagram is of the L.F. stage, details for adding which are given in the article. The letters against the components correspond with those in the theoretical circuit diagram and thus enable easy comparison. Right at the bottom you will find the three new components listed, together with the names of suitable makes.

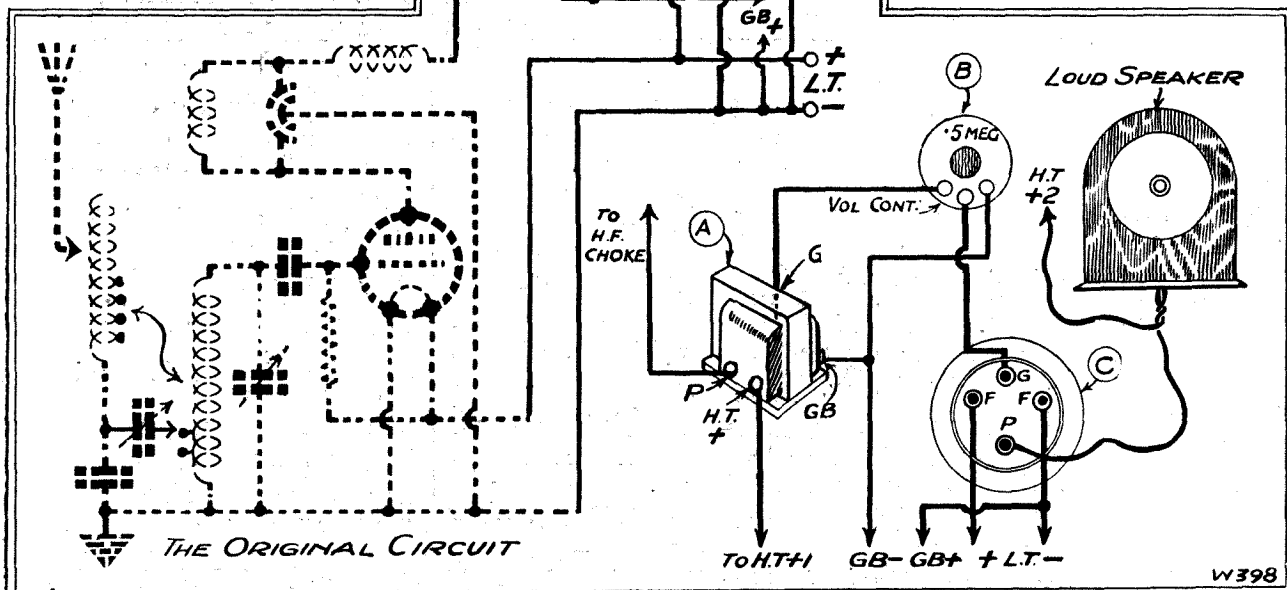

because the value obtainable is often determined by the make chosen.

The control must be of the potentiometer type, namely, the type which has three terminals; one being joined to a slider or other variable contact, and the remaining two terminals connected to the ends of the resistance element.

### An Easy Change-Over

Do not use a two-terminal resistance as volume control, because in certain circumstances it is quite likely to upset the quality of reproduction.

No special comment need be made about the valve holder, the third component. So long as it is a valve

### FOR WHICH YOU WILL REQUIRE

- 1 L.F. transformer, not high ratio (Lissen Super, or Telsen, Varley, Igranic, Ferranti, R.I., Lotus, Mullard, Lewcos, etc.).
- 1 Sprung-type valve holder (W.B., or Telsen, Igranic, Benjamin, Clix, Lotus, Lissen, Formo, etc.).
- 1 5 to 2-megohm 3-terminal type volume control (Igranic, or Lissen, Gambrell, Sovereign, Varley, Centralab, etc.).

connected across it, and one of these also goes to a grid-bias negative tap.

The slider of the volume control goes to the grid of our new valve, the plate of which is joined to the negative output terminal. Incidentally, the output terminals are labelled L.S. on the new wiring diagram to emphasise that the set now becomes

that we add, the volume control, has to be mounted on a strip of ebonite like the variable condensers. A piece the same size as that used for the reaction condenser will do quite well, namely, 1 in. by 3 in., and the hole should be drilled at the same height as that for the reaction condenser. This, you will remember, is 2½ in. from the bottom of the strip of ebonite.

### Volume Control Connections

Having mounted the volume control on the ebonite, the latter can be put into place between the two strips of wood. Incidentally, it should be mentioned here that the terminals

## The "Plus-Stage" Two—continued

of the volume control are arranged to be at the bottom.

If you use the same volume control as we did, or one with similar connections, and mount it upside down, you may find that it works backwards when wired up. You will then have to turn it in an anti-clockwise direction to increase volume.

### Your Old Wiring

Screw the transformer and valve holder to the baseboard in the positions shown in the wiring diagram. These positions are chosen so that the other components that are to be added later will fit in nicely.

Now with regard to the wiring. There is only one connection to be broken, and it should be removed before you commence to put on the new wires. It is the connection running from the H.F. choke to the output or L.S. negative terminal.

Having removed this altogether you can proceed with the new connections. These are very clearly indicated on the wiring diagram by full black lines, the old wiring being shown as double lines.

There are ten leads altogether to be put on, three of which are flex leads. You will notice that the lead running from one filament contact of the new valve holder to one end of the 2-megohm grid leak is run underneath the baseboard, being taken through the latter via two small holes.

### Easy Additions

This makes it possible for this lead to have a direct run underneath the transformer, which would not be possible if it were above the baseboard. The flex lead marked H.T. +1 also passes through a hole in the baseboard and comes out underneath it like the other battery leads.

As soon as you have completed the wiring you will no doubt be anxious to try out the extra stage. Unless you still wish to use the set with telephones there are several fresh accessories to purchase.

Before going on to deal with them we will consider the case when telephones are still to be used. Here a new valve and a grid-bias battery will be necessary.

The valve should have the same voltage rating as the detector, and be of the L.F. type. A 9-volt G.B. battery will be suitable and most likely 3 or 4½ volts will prove sufficient.

The 60-volt H.T. battery which we advised for the "Plus-Stage" One will be ample. H.T. + 2 should be plugged into the maximum positive tap and H.T. + 1 into the voltage that has been found most suitable for the detector.

If you have been using 60 volts with the detector, plug the H.T. + 1 into the tapping next to that in which the H.T. + 2 plug is inserted. The use of telephones on the two valves has been mentioned because even if a loud speaker is going to be used you may want to try out the two valves before your loud speaker arrives.

The grid bias and L.F. valve will be required in any case, although this

type of valve is not wanted when a loud speaker is to be used, until the third stage of the receiver is added.

For loud-speaker work on the two valves you will require a power valve, one or two 9-volt G.B. batteries (according to the power valve to be used), and a loud speaker. The latter may conveniently be of the ordinary cone type.

### The Loud Speaker

Whilst the final three-valve arrangement will be capable of working a moving-coil speaker, the two valves will hardly do this satisfactorily, and, in any case, an ordinary cone speaker is more likely better to meet

### JUST THREE COMPONENTS TO BE ADDED

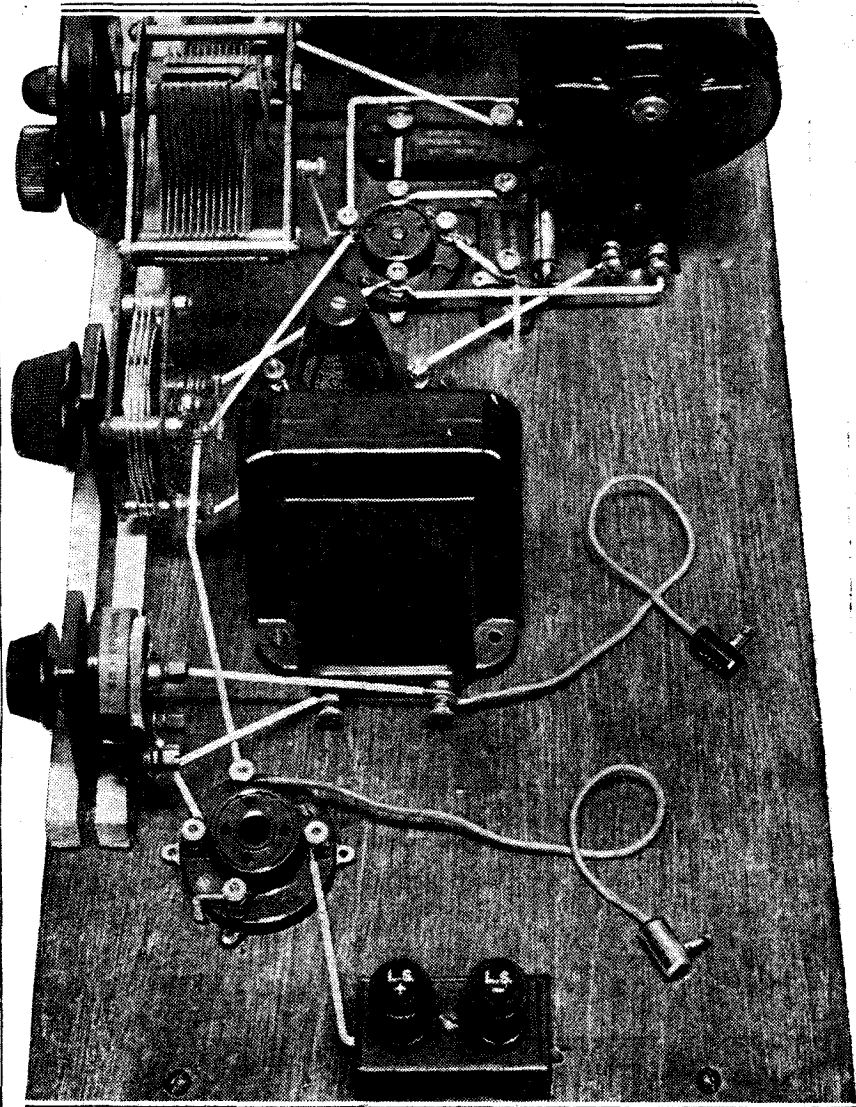

The addition of the first L.F. stage consists of wiring-up a valve holder, transformer and volume control. It will not take you many minutes, and you can see nearly all the new leads required in this photograph.

## The "Plus-Stage" Two—continued

the requirements of the constructor of this receiver.

### The H.T. Needed

It will be necessary for you to decide whether to purchase a small power valve or a super-power valve. If you will require only small volume at all times, and/or (as all official forms will have it) the H.T. supply is to be from dry batteries, a small power valve should be used. Otherwise a super-power valve is to be desired.

Of course, for loud-speaker work, 60 volts H.T. (the value we advised for the "Plus-Stage" One) will not be sufficient. At least 100 volts will be

required, but the maker's details are more or less certain to give this information. If you need more than 9 volts, join the two 9-volt batteries in series in the same way as we have just described for the H.T. batteries.

Normally, you will need three extra wander plugs, but if you have to join two grid-bias batteries together, as just described, you will want two more for the extra connections. Similarly, another couple will be required if you desire to join two 60-volt H.T. batteries together.

Thus the number of battery plugs will be three, five, or seven, according to circumstances. Those seen in the

about the extra accessories. The operation of the receiver will be just the same as before so far as tuning is concerned.

### Setting the Volume Control

Normally the volume control should only be used for local stations, or on transmissions that do not require the use of reaction. In view of this you should always have the volume control set for maximum volume whenever reaction is in use, unless you wish to use a little reaction for the sole purpose of sharpening up tuning a little.

The receiver is still turned on and off in the same way as described for the

### EXTENDING THE SET FROM ONE VALVE TO TWO

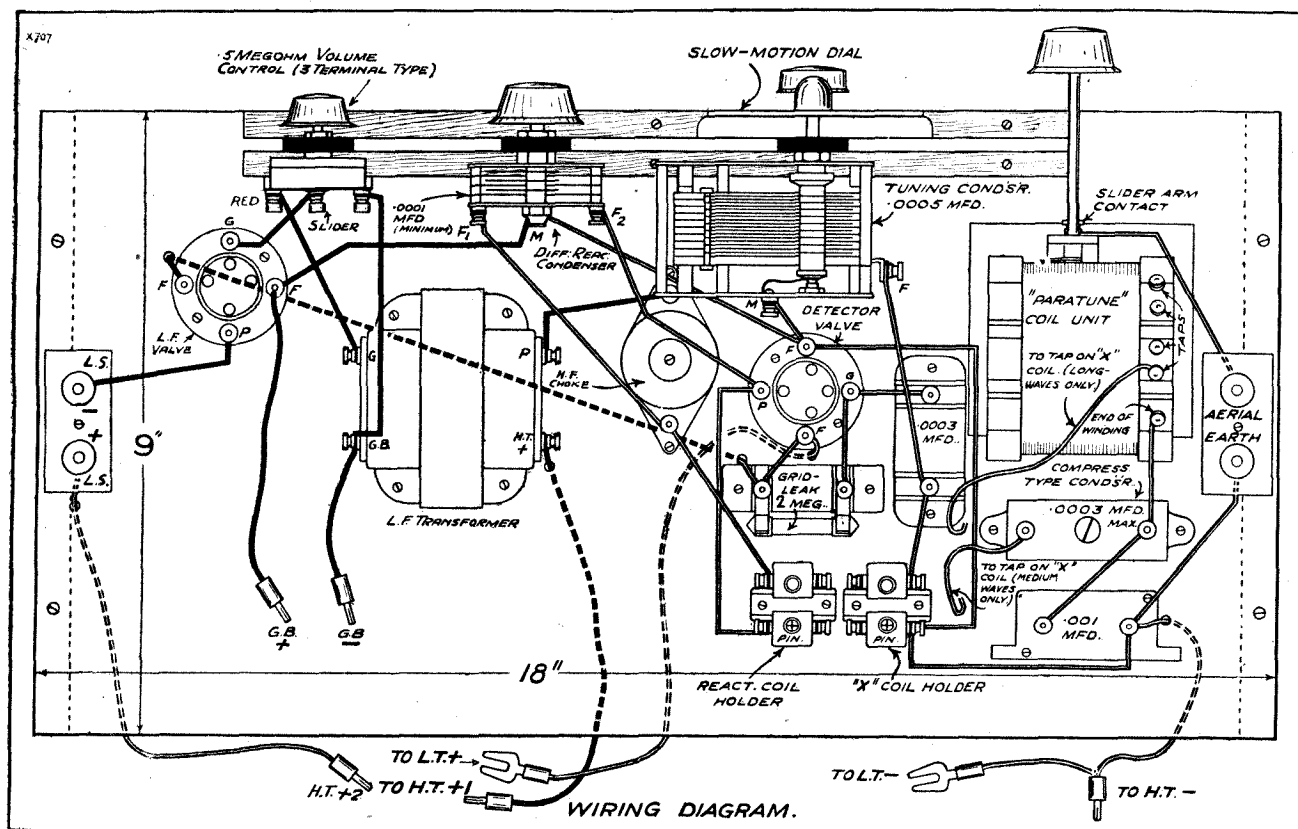

Without doubt you have been able to hear very many stations on the 'phones with your "Plus-Stage" One receiver, and all you have to do to hear most of them on the loud speaker is to convert your one-valve to the "Plus-Stage" Two by adding three components and the leads shown solid in this diagram.

required, and preferably 120. The latter is easily obtained by connecting another 60-volt battery in series with your present one. To do this you simply connect the negative of one to the positive of the other, the remaining positive and negative being treated as the ends of an ordinary 120-volt battery.

We cannot tell you what value of G.B. to use as this depends on the

photographs are very convenient, because the flex goes in at right angles to the split metal part.

These plugs are Clix, but any other good make of plug may be used, such as Belling-Lee, Eelex, Igranic, etc. See that your battery plugs make good contacts in their sockets, as damage to valves results from plugs coming out while the set is working.

That tells you all you need to know

single stage. The addition of the L.T. switch will be described with the "Plus-Stage" Three details.

The details of the addition of the third stage, or the second L.F. valve, we hope to give next month. You will then be able to bring many of the distant stations, which come in faintly on the loud speaker with the "Plus-Stage" Two, up to good speaker strength.

# A VISIT TO MÜHLACKER

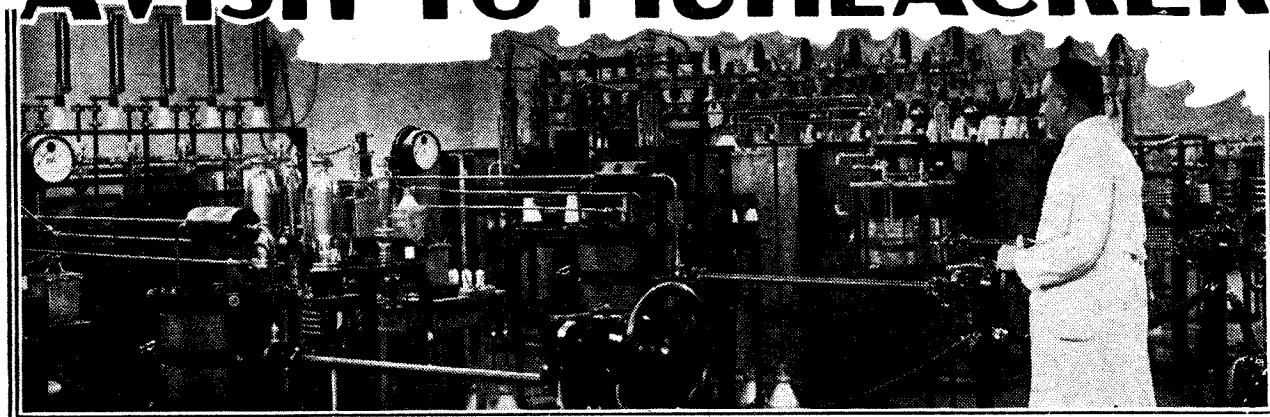

It is all very well asking a woman to describe Germany's first high-power station, I shall probably be hearing that I have worried too much about the decoration scheme and too little about the valves, but after listening to a very kind and attentive engineer for an hour or so, and even touching some of those glistening tubes and copper ropes, I find that I know all about it.

Now let me think. Yes, I know now! Germany has been having a very bad time of it lately. All the neighbours have been building huge big stations right bang on the borders and the poor German listeners have been paying their twenty-four shillings a year to a station they could not hear.

## Helping the Listeners

In some parts it was worse than in others, so that the German Post Office (funny it should worry about anything else except stamps and letters) decided to build a whole network of high-power stations to let the poor listeners get their local stations on crystals or simple valve sets (so the engineer told me), instead of having to listen to foreigners.

That horrible black corner of Germany called the Black Forest was having the worst time of it, so that the first high-power station was opened midway between Karlsruhe, the capital of the Republic of Baden (near to Baden-Baden), and the capital of Württemberg, Stuttgart.

The old Stuttgart station we all used to listen to has been closed down, wrapped up and kept in reserve in case of any breakdowns. Mühlacker, the name of a railway station where nearly all the express trains stop, is now the name of Germany's first high-power station as well. I find that broadcasting transmitters nowa-

## By NEVENKA UGRINIC

*A description of Germany's first high-power broadcaster by a German girl. She might not be a radio expert, but you'll agree that she can use her eyes—and her pen—to good effect!*

days are usually far from what we call civilisation, meaning big towns; but Mühlacker is an exception.

## Plenty of Climbing

After climbing up a stiff hill from the station, I found that I had to walk all the way down again on the other side, and then climb up an even steeper hill the other side to get to the station. A fine fence has been put right round the grounds, and one has to ring a bell at the gate and wait till a man comes to open, otherwise a nasty big dog tries to taste your legs, and you all know how very bad for silk stockings that is, because they don't grow again like the leg.

The two masts holding the aerial are of wooden trellis-work, and 100

metres high. I tried to climb one, but found everybody watching me from below, so that I gave it up and promised to come back in a gym. suit the next time and race one of the engineers up the other tower.

He told me he did that for daily exercise, anyway, but I don't quite believe him. The aerial is of the cage type, and is formed of five wires.

The whole is 85 metres long and hangs straight down from the centre of the rope slung from the tops of the towers. In fact, they told me it was a vertical aerial, and that for the wave used this was the best type, also that the wooden masts were far better than steel ones, as the steel ones swallow up a lot of the energy radiated from the aerial.

## Below the Aerial

At the foot of the aerial there is a small house. I looked in, and was told it contained the aerial tuning circuit and the capacity coupling for the feeder line on to the aerial.

## WHERE THOSE POWERFUL IMPULSES ORIGINATE

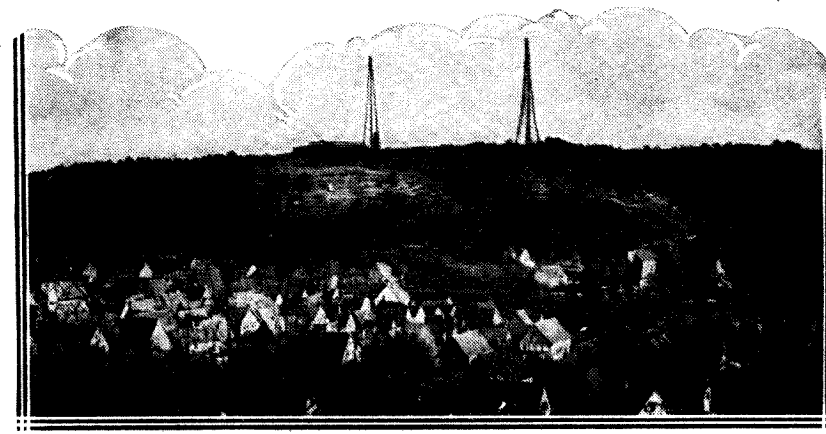

*The masts of Mühlacker are erected just outside the town, but, as our contributor discovered, they are not as easily reached as might be suggested by this photo.*

## A Visit to Mühlacker—continued

They call the nice little house the feeder house; I would have liked it for summer tea-parties. We walked back to the transmitter house under a double feeder line 200 metres long.

The transmitter house itself seems rather a waste of space. A huge hall half empty, with some big, heavy machines at one end and a lot of switches along the one wall, then a small room full of wires, and then a smaller hall packed with coils and valves. And only two dear little apartments for the poor engineers.

### A Nice Young Man

The others have to go all the way to Mühlacker to get home. I rather liked the cosy little office, where a very nice young man (I found out later on that he was the man in charge) said all kinds of nice things about the way I spoke of his transmitter, as if I knew all about it. Well, and perhaps I really do. It isn't so very difficult after all.

The big machine hall contains the equipment that supplies the transmitter with all the different types of power necessary. One huge, big dynamo gives the valves 10,000 volts of anode voltage, and should it break down there is a large bank of rectifying valves ready to take over the work.

I rather liked the idea of having left so much space just in case it would be

found necessary to increase the power of the station. It has 75 kilowatts in its aerial now, and this can be increased to 150 kilowatts with very little trouble.

after switching them all on, just needed to sit and watch.

Downstairs in the cellar I was shown a piece of apparatus which made hot-water, but I found out later

### JUST A BIT OF THE GEAR USED!

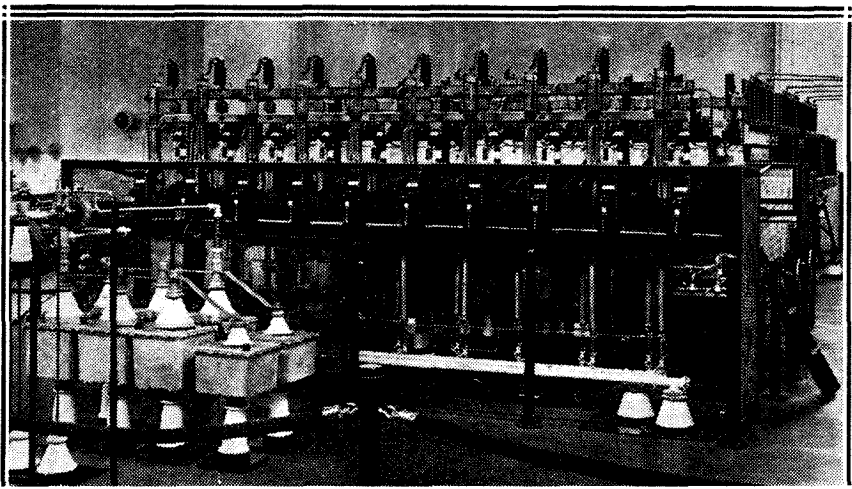

Here is a bank of the huge water-cooled valves used to generate the colossal radio energy.

The big German firm, Telefunken, seems to build all its transmitters more or less alike. There is just a bar between you and the high tension on all those shining rods and coils.

The engineer told me that the whole transmitter worked more or less automatically. The man at the desk behind the semi-circle of controls,

that the nice man (I think him horrid now) was pulling my leg, and that the thing really was the artificial aerial used when the transmitter was undergoing tests of any kind, and when the energy otherwise supplied to the real aerial was passed over resistances, these being cooled by water; so, after all, it does make hot-water in a kind of secondary way.

### WOULD YOU LIKE TO HANDLE THESE?

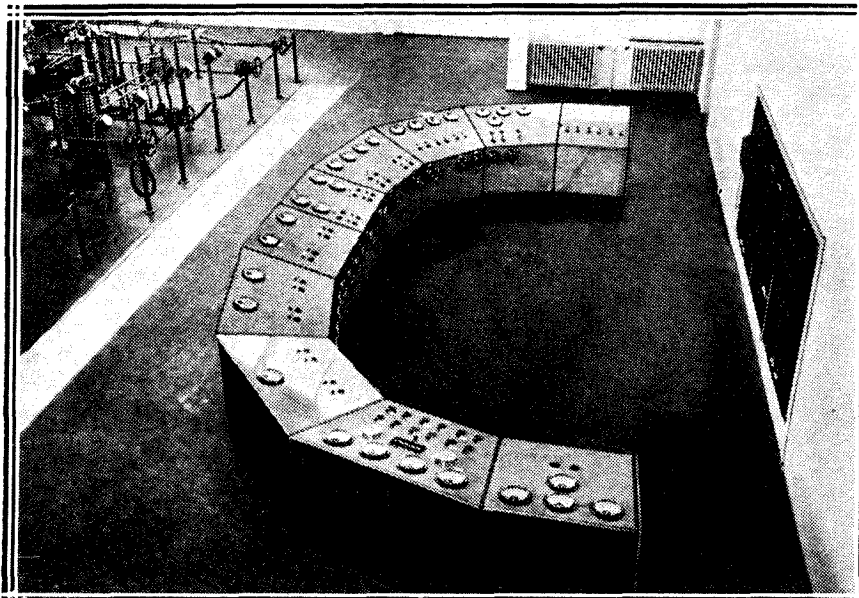

The great station can be completely controlled from these desks. It is far from being a "one-knob" outfit, as you can see!

### "DX" Switching

Another room in the cellar immediately beneath the semi-circle of controls upstairs contained a whole series of switches with chains running up through the ceiling. I found out that though the man turned the handles upstairs, the actual switching was done down here, being controlled by him from above.

The programmes still come from Stuttgart and Frankfurt and Karlsruhe, and the station really belongs to the Südfunk, Stuttgart's enterprising broadcasting company. You know, the people who did the first transatlantic relays and let Schmeling speak to his mother at Berlin via the broadcaster, and who link up Toulouse and Barcelona and their own station, and just have a nice talk all about everything and some music to make it go, and let the listeners listen in. Oh! that was a bad one.



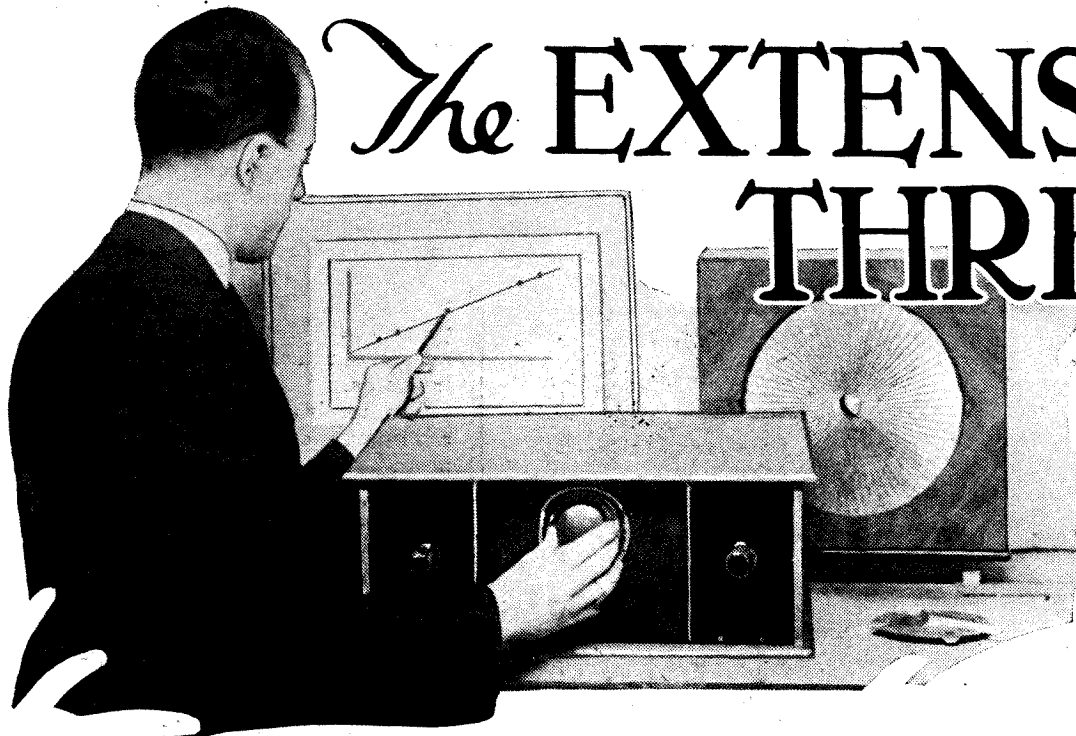

# The EXTENSER THREE

Designed and Described by the "Wireless Constructor" Research Dept.

**I**F you were asked what was the best all-round type of receiver, what would your answer be? By type is meant the number of valves and the method in which they are employed.

Most of you would probably plump for the particular kind of set that you use yourself. That is, unless you are using a smaller or different sort of set from your ideal, simply for reasons connected with expense.

### Most Popular Set

We have heard all classes of sets, from crystal and one valve to super-hets, acclaimed as the best sort to use. Generally good reasons for the statements are given, but as

*A powerful three-valver in which you can use conventional tuning controls and have a first-class long-distance loud-speaker set. But this inexpensive, easy-to-build outfit can be fitted with a "Wireless Constructor" Extenser, and thus assume tremendous advantages over any other "three" in existence.*

a rule these reasons resolve themselves into a matter of the particular desires of the individual so far as results are concerned.

Therein lies the reason for our publishing many designs of sets. Unfortunately, one receiver cannot be made to suit all circumstances, so

we have to endeavour to publish a sufficient variety of receivers that everyone can find something ideal for their own purpose.

We think we can say with perfect truth, and without having recourse to a public ballot, that the three-valver is the most popular receiver. And of three-valvers there need be no hesitation in affirming that the Det. and 2 L.F. type is the most common.

### Simple to Operate

One does not have to search far for the reasons for this. In the first place it is simple to operate, without being in any sense a local station receiver only.

Secondly, it is really powerful.

## HERE IS YOUR "EXTENSER" THREE SHOPPING LIST

- |   |  |   |
|---|--|---|
| <ul style="list-style-type: none"> <li>1 Ebonite panel, 9 in. × 7 in. (Peto-Scott, or Goltone, Parex, Lissen, etc.).</li> <li>1 Metal panel, 10 in. × 7 in. (Parex, or Ready Radio, Wearite, Keystone, Magnum, etc.).</li> <li>1 Cabinet to take panel 18 in. × 7 in., with 10-in. baseboard (Camco, or Pickett, Lock, Osborn, Gilbert, Kay, etc.).</li> <li>1 '0005-mfd. Extenser (see text).</li> <li>1 '0001-mfd. differential reaction condenser (Ready Radio, or Lotus, J.B., Dubilier, Cyldon, Igranic, Ormond, etc.).</li> <li>1 5 to 2-megohm maximum three-terminal type volume control (Gambrell, or Igranic, Varley, Lissen, Wearite, Sovereign, Centralab, etc.).</li> <li>1 "P.W." and "M.W." dual-range coil (R.I., or Formo, Wearite, Ready Radio, Goltone, Keystone, Magnum, Tunewell, Parex, etc.).</li> </ul> | <ul style="list-style-type: none"> <li>1 '0003 fixed condenser (Dubilier, or Telsen, Lissen, Ferranti, Ready Radio, Ediswan, T.C.C., Graham-Farish, Watmel, Mullard, etc.).</li> <li>1 '001 fixed condenser (Telsen, etc.).</li> <li>2 2-mfd. fixed condensers (T.C.C. and Lissen, or Ferranti, Igranic, Formo, Dubilier, Mullard, etc.).</li> <li>1 '0003-mfd. maximum compression-type condenser (Formo, or Polar, R.I., Lewcos, Lissen, etc.).</li> <li>1 2-megohm grid leak and holder (Graham-Farish, or Ediswan, Telsen, Igranic, Ferranti, Dubilier, etc.).</li> <li>1 25,000-ohm Spaghetti resistance (Magnum, or Lewcos, Ready Radio, Bulgin, Keystone, Sovereign, etc.).</li> <li>1 L.T. "on-off" switch (W.B., or Igranic, Lotus, Ready Radio, Bulgin, Benjamin, Lissen, Red Diamond, Magnum, Keystone, Goltone, Wearite, Junif, etc.).</li> <li>1 "Conradyne" coil (Parex, or</li> </ul> | <ul style="list-style-type: none"> <li>Magnum, Ready Radio, Wearite, Goltone, etc.).</li> <li>1 H.F. choke (Ready Radio, or Lewcos, Telsen, R.I., Keystone, Wearite, Varley, Magnum, Dubilier, Lotus, Igranic, Parex, Watmel, Sovereign, etc.).</li> <li>2 L.F. transformers (R.I. General Purpose and Igranic Midget, or other good pair chosen from such makes as Ferranti, Telsen, Lissen, Varley, Lotus, Lewcos, Mullard, etc.).</li> <li>1 L.F. output choke (Varley, or Atlas, Igranic, Lissen, R.I., Ferranti, Wearite, Magnum, etc.).</li> <li>3 Sprung valve holders (Telsen, or Lotus, Benjamin, Clix, Igranic, W.B., Lissen, Dario, Bulgin, Formo, etc.).</li> <li>1 Terminal strip, 18 in. × 2 in.</li> <li>9 Insulating terminals (Belling-Lee, or Ealex, Clix, Igranic, etc.).</li> <li>G.B. plugs (Clix, or Belling &amp; Lee, etc.).</li> <li>Copper foil, wires, screws, etc.</li> </ul> |
|---|--|---|

## The "Extenser" Three—continued

Not only is full moving-coil speaker strength obtainable from the local station, but many foreigners are receivable, without difficulty, at good volume on the loud speaker.

work from ordinary-size dry H.T. batteries if necessary.

Ease of construction is not such an important point as those mentioned already. Nevertheless, it is a con-

The points covered are merely the most noteworthy and outstanding. There are, of course, many others which will immediately suggest themselves to the minds of readers.

Sufficient has been said to show why we consider it highly desirable to present a three-valve "Extenser" set early in the history of this unique invention.

The receiver has all the normal advantages of a Det. and 2 L.F. arrangement, plus many more which cannot be obtained with ordinary schemes. They are made possible by the Extenser system of tuning.

Before going on to deal with the set, its circuit and advantages, there is one point which is worthy of special mention. It concerns the majority of the components employed.

### HOW YOU CAN FIT A PICK-UP

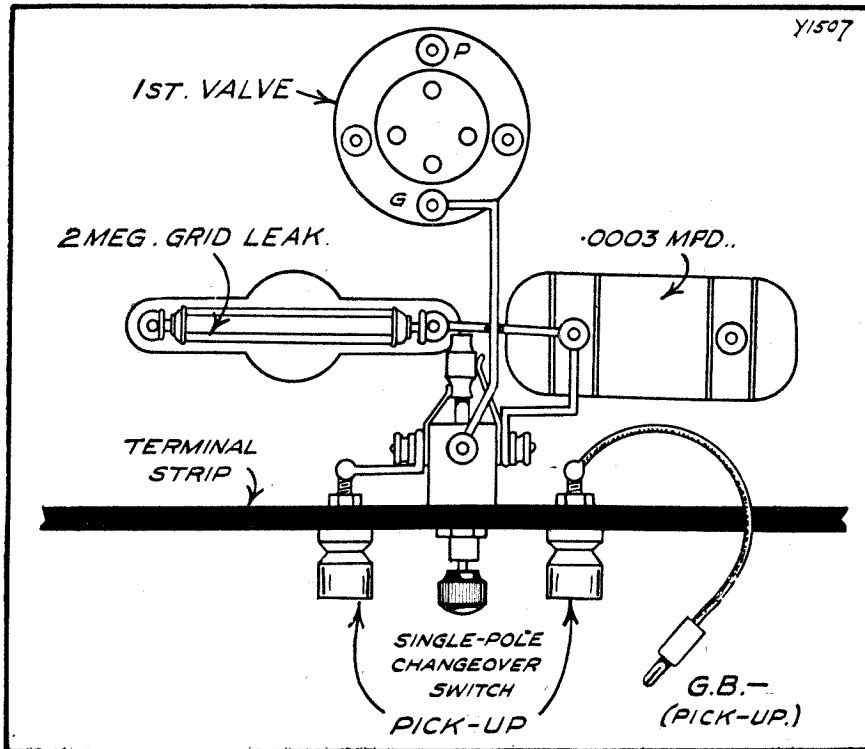

You can easily fit pick-up switching to your "Extenser" Three, as shown in the above diagram.

Then there is the all-important question of first expense and running costs. These need not be high, and such a set can be arranged to

consideration which carries much weight with many people, particularly those who have not had previous experience of set building.

### Standard Parts

Special steps have been taken to keep these quite ordinary, and of types which constructors are likely to have on hand. We realise that there will be many readers going over to the Extenser system who are desirous of using as many as possible of the parts in their present sets, or who wish to use up spare components on hand.

You will therefore be interested to note that most likely the Extenser will be the only important item that you need. The other components, such as the dual-range coil, being more or less of a standard nature nowadays, or, at least, stocked by all the radio stores worthy of the name.

### "EXTENSER" SETS ARE REVOLUTIONARY IN THEIR SIMPLICITY

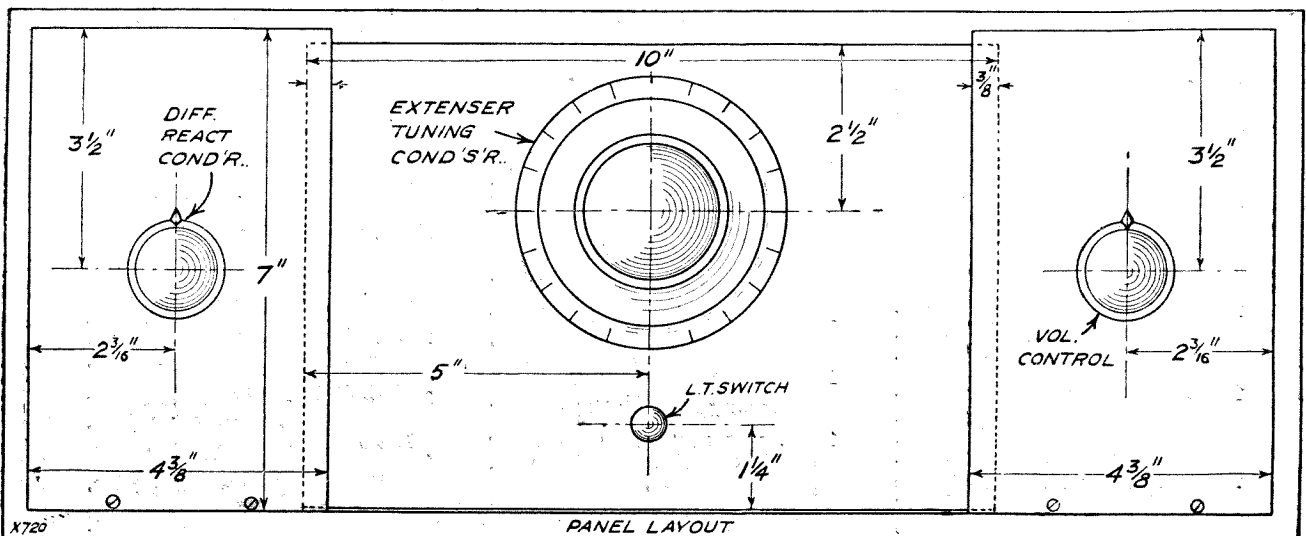

Only the one station-selecting dial for both medium- and long-wave stations—no wave-change switch—no confusion in dial readings—simpler and more efficient construction.

## The "Extenser" Three—continued

With regard to the Extenser. Before long quite a number of makes of these will be on the market.

Those, however, who like working with metal instruments, and prefer to make their own Extensers, will find very comprehensive practical details in last month's issue of the WIRELESS CONSTRUCTOR.

### Extreme Simplicity

One of the things already mentioned as being an attribute of the three-valve arrangement is ease of control. This is even more so with the "Extenser" Three, for simplicity of operation is one of the biggest points of the Extenser system.

If you glance at the front-of-panel diagram you will see that there are only four controls on it. There is the Extenser in the centre, with the L.T. switch just below, and the reaction condenser to their left and volume control to the right of them.

Another point which will strike you is the special arrangement of the panel in three sections, the middle one being sloping backwards from the bottom to the top. This

### ENTIRELY NEW THEORETICAL CIRCUIT

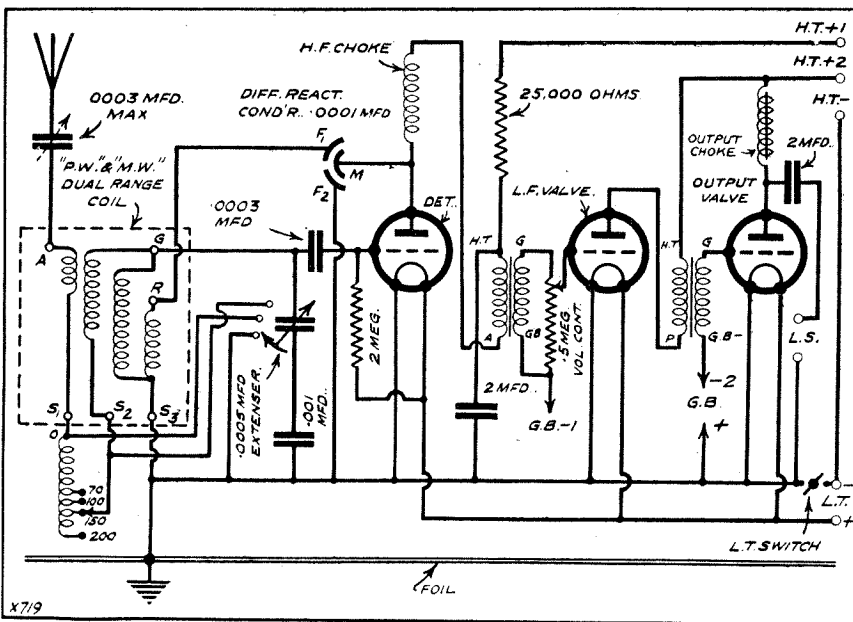

The use of an Extenser necessitates a new radio symbol, and adds new interest to theoretical circuits. Note how fundamentally simple the device is from all points of view.

lends an extremely distinctive appearance to the receiver as well as enabling adjustments of the

Extenser to be carried out in comfort.

Of course, should you prefer not to

### A NEW ERA IN SET DESIGN AND CONSTRUCTION

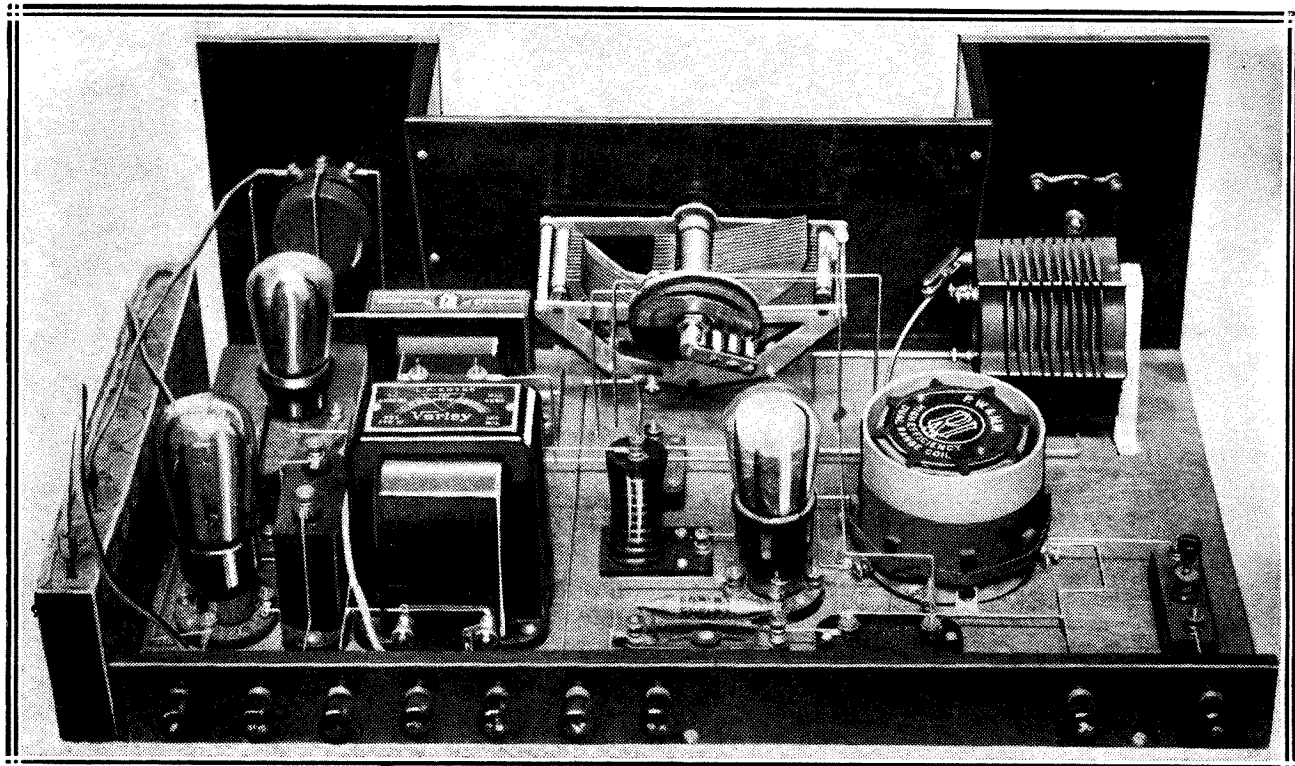

It won't be long before the "Extenser" Three will be regarded as the precursor of a completely new epoch in set making. The Extenser system is so full of advantages, and so free from "snags," that its universal adoption is inevitable.

## The "Extenser" Three—continued

arrange your panel in this manner, you will not affect the operation at all by using an ordinary vertical panel arrangement. In this case you simply order a plain 18 in. by 7 in. panel.

### Unusual Symbol

Now, just take a glance at the circuit diagram. You will see a somewhat unusual symbol for the variable condenser. This is the theoretical hieroglyphic which we introduced

last month to represent an Extenser.

There are two connections to the special tuning part of the Extenser, one to moving vanes and one to the fixed. The three separate contacts are those of the Extenser switch, which takes the place of the ordinary wave-change switch.

These three contacts are all joined together with the moving vanes in a certain position, by the switch arm

which is also in contact with the moving vanes. This arm is represented by the short, curved arrow.

### Dual-Range Coil

The dual-range coil employed, which is of the "P.W." and "M.W." type, is arranged on long waves in quite a different manner from usual. In principle the scheme consists of the grid and filament circuit of the detector valve, together with its

## JUST THE SET YOU HAVE BEEN WAITING FOR

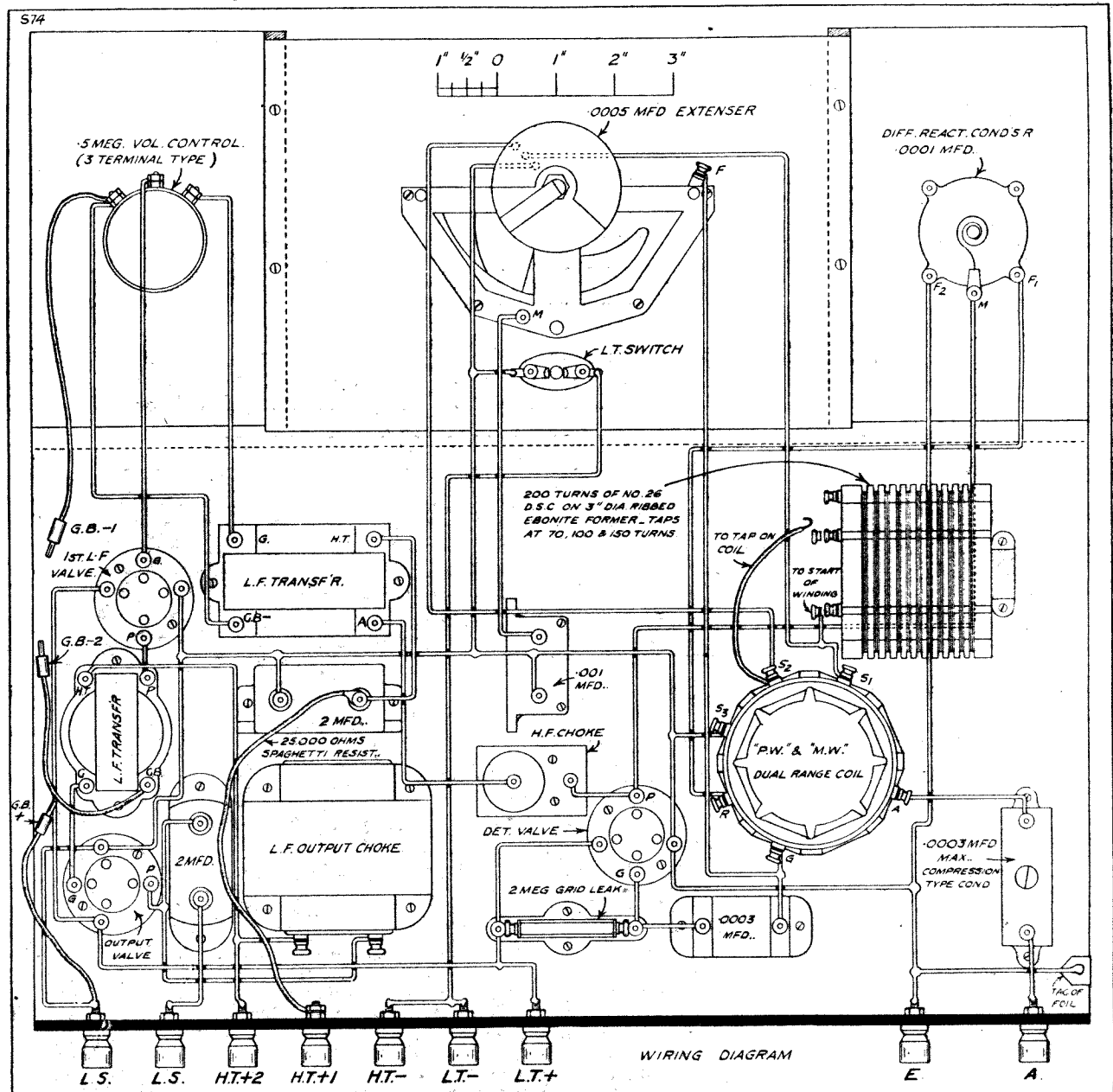

The "Extenser" Three is selective, its distance-piercing qualities are of a very high order, and altogether it makes the best possible use of three valves. In constructing your receiver from this wiring diagram be careful that you get the wires to run exactly as shown. We are employing a very definite type of diagram so that you can see exactly how the connections are made, even to the extent of their relative positions where they cross over one another.

## The "Extenser" Three—*continued*

tuning condenser, being tapped across only a part of the total inductance, which is directly coupled to the aerial via the series aerial condenser of the compression type.

This arrangement, whilst being as already mentioned quite unusual, is nevertheless extremely efficient, and gives excellent volume on long-wave stations. The .001 fixed condenser in series with the Extenser is also rather unusual.

### PLACING THE PANEL

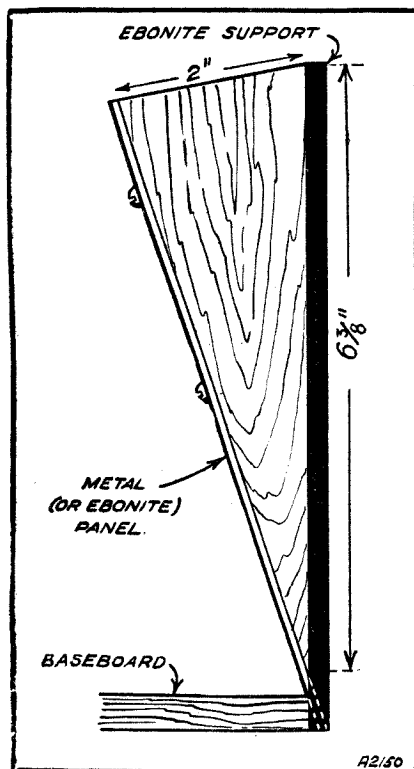

Showing how the ingeniously and attractively arranged panel is fitted.

This has been incorporated so that the readings of the long-wave stations will be kept somewhere about normal for this coil. This is its only function, and on the medium waves it is cut out of circuit.

### Standard L.F. Side

The remainder of the circuit is built along standard lines. The two transformer-coupled L.F. stages give a tremendous mag., and, consequently, the number of stations that come in at loud-speaker strength, and the ease with which the Extenser makes them tunable, combine to offer you a set such as you have never before handled.

The first part of the constructional work consists of preparing the panel. In the list of components you will see that a metal panel is specified for the sloping part.

### The Sloping Panel

You can, if you like, use a piece of ebonite for this section, but if you do you will have to trim the front edge of the baseboard where the sloping panel touches it. There is a special sectional diagram showing how the metal panel is assembled.

The metal panel and the front ebonite supports are both screwed to wedge-shaped pieces of wood. At the

bottom the ebonite supports overlap the metal panel for the thickness of the wooden wedges, which should be  $\frac{3}{8}$  in.

To enable the metal to go close up to the wedge it is therefore necessary to file the inside bottom edge of the ebonite for  $\frac{3}{8}$  in. to allow the metal to fit in. The amount to be filed is easily seen from the sketch.

### If Ebonite is Used

If you use ebonite throughout you should obtain a 21 in. by 7 in. panel, and cut from it the necessary sized pieces. Assemble in just the same way, but trim the top front edge of

### STABLE L.F. STAGES

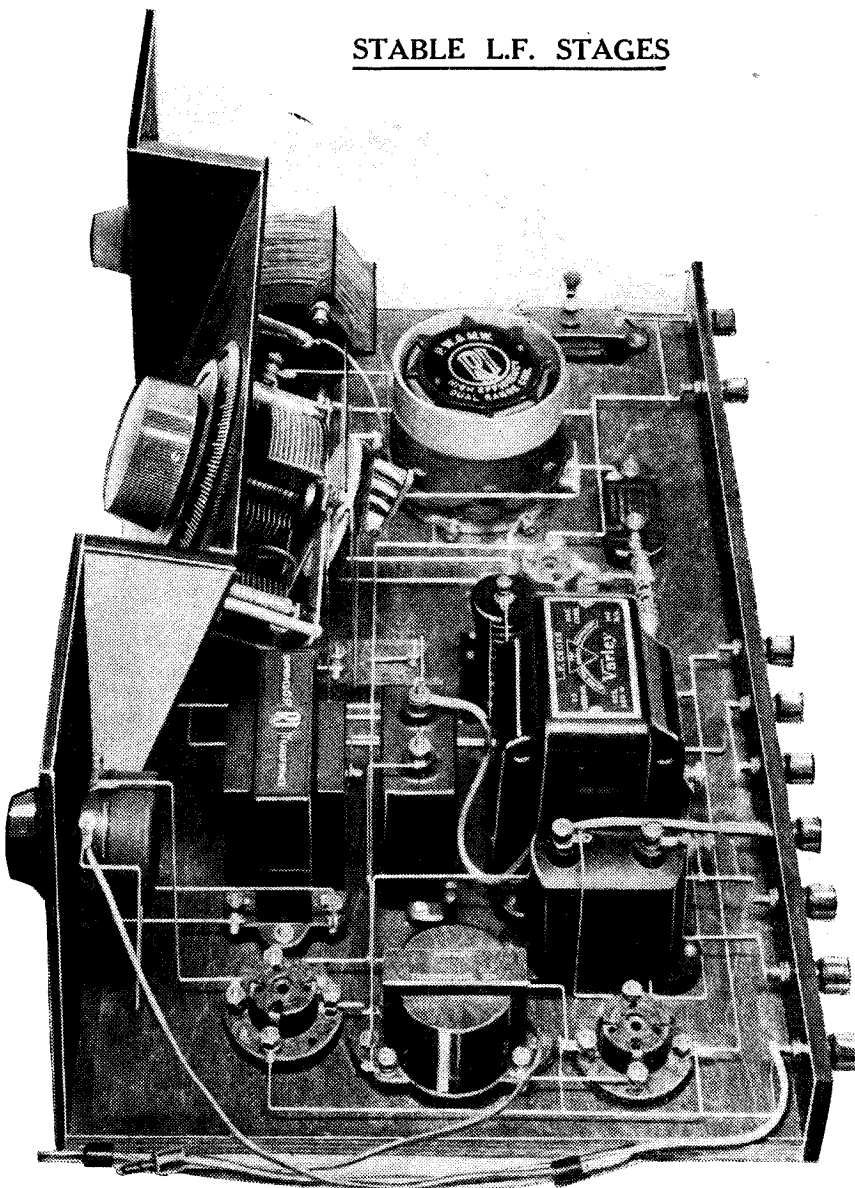

Although high magnification has been achieved, the design of the L.F. section is such that complete stability results.

## The "Extenser" Three—continued

the baseboard to allow for the extra thickness of the ebonite over the metal.

With metal, the ebonite supports are cut from the 9 in. by 7 in. panel. The metal panel in the original set was given a coat of black enamel to make it resemble ebonite. This coating also serves to prevent shocks being obtained from the panel should it become live when used with a D.C. H.T. mains unit.

### Last—But Not Least

After attaching the panel to the baseboard, and also the terminal strip with the terminals in place, you can

mount the components on the baseboard and on the panel, with the exception of the Extenser. Before this is fixed in place the L.T. switch should be wired up, otherwise due to the sloping panel you may find it a little difficult to get at the switch.

When the switch is wired, put the Extenser in position, and proceed to complete the wiring. There is nothing difficult about this, and it is merely a matter of carefully following the wiring diagram.

At the bottom right-hand corner of the baseboard you will see a wire joined to a tag. This is fixed to a piece of copper foil which covers the

whole of the underside of the baseboard.

It is best to fix this in place before the panel is attached to the baseboard. The earthing tag can easily be a part of the actual foil projecting from the main section and bent round the edge of the baseboard.

For the benefit of those who would like to get the set made up and working before obtaining the Extenser, and to fit this later, we give another diagram of the wiring. This diagram shows an ordinary condenser in use with a wave-change switch on the ebonite strip.

### Powerful L.F. Stages

The switch has been placed on the terminal strip so that the panel appearance is not spoilt by an unnecessary hole when the Extenser is fitted. Incidentally, this extra diagram serves as a good illustration of the simplification produced by the Extenser.

To enable you to compare the wiring of the two diagrams they have both been made exactly the same size. It is thus an easy matter to note the wiring changes by tracing the sectional drawing and placing the tracing over the complete wiring diagram.

The receiver has a powerful L.F. circuit, and is very suitable for use with a gramophone pick-up. Pick-up switching has not been included in the main design, because we realise that it is not everyone who will want it.

We have prepared a special small diagram which shows the necessary connections for a pick-up switch. Two terminals and a single-pole change-over switch of the push-pull type are mounted on the terminal strip near to the detector valve's grid leak and grid condenser.

### The Volume Control

There is a volume control on the L.F. side of the receiver, and this will be in circuit when using a pick-up. It is, however, possible for a sensitive pick-up to overload the detector valve, and the volume control on the set will naturally not prevent such detector overloading.

For this reason it is desirable to connect a three-terminal type of volume control across the pick-up. This can conveniently be placed at the pick-up end of the leads, where it

### THE ALTERNATIVE SCHEME

*Here are illustrated the alternative layout and wiring for an ordinary tuning condenser and wave-change switch. We suggest that if "Extensers" are not available by the time this issue of the "Wireless Constructor" is published, and if you do not feel you can make one yourself from the full details given in the last issue, you should use the conventional components, which you will probably have in hand, for the time being, and change over to the "Extenser" system at some future date. This change-over will be extremely simple, as you can see by comparing this diagram with that showing the complete set.*

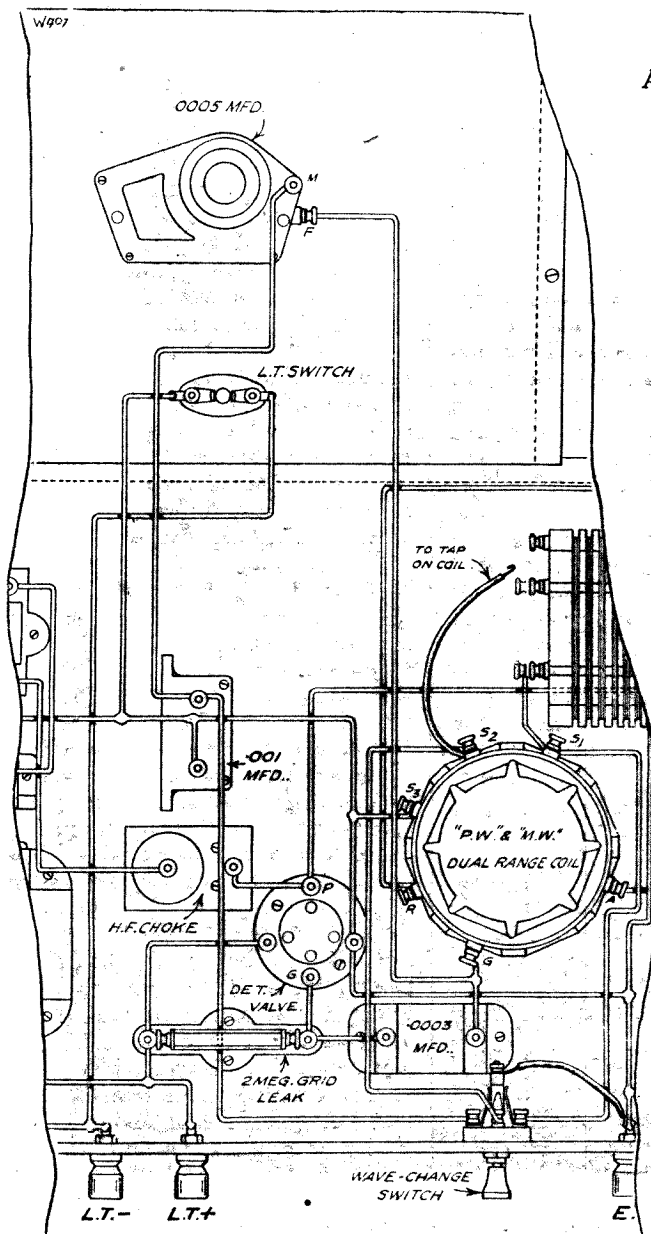

## The "Extenser" Three—continued

### THE "WIRELESS CONSTRUCTOR" "EXTENSER" THREE

Circuit: Det. and 2 L.F. arrangement employing Extenser system of tuning.

#### VALVES.

1st (nearest coil): Special detector or H.F. type.  
2nd (near panel): L.F. type.  
3rd: Power or super-power type.

#### VOLTAGES.

L.T.: 2, 4 or 6 volts, according to rating of valves used.  
H.T. + 1: Between 40 and 60. Use value that gives smooth reaction control.  
H.T. + 2: 100 to 120 or 150. Maximum voltage depends on valve rating.  
C.B.—1: 1½ to 4½ volts. Adjust for best results.  
C.B.—2: Adjust by data given by makers of power valve.

#### OPERATION.

All tuning is carried out on centre dial, which covers both medium and long wave-bands. Knob immediately below tuning dial switches set on when pulled out (off when pushed in). Right-hand knob controls volume. Left-hand knob controls reaction. Turn to right to increase.

#### NOTES.

Normally the flex lead to the tapped coil from the dual-range coil will be on 150. Try other taps to see whether they give better results. Adjust compression-type condenser for desirable degree of selectivity on long waves. Keep as near maximum as this will permit.

to join four points together instead of three in the usual way.

The fourth point is provided by a flex lead connected to the plunger that joins the three springs together. The switch used must have three springs and not be of the type which has two springs, the third contact being provided by a connection to the sliding part of the plunger.

The grid-bias battery should be attached to the side of the cabinet. Details of the other batteries and accessories are given in the operating chart.

This chart also tells you all about operating the receiver, so there is no more to be said here, except to wish you good luck with the receiver.

will be at hand to adjust the volume for any record that is put on.

The plain coil wound on a ribbed former is for the purpose of preventing medium-wave interference taking place on the long-wave band. A standard sort of ribbed former is employed with the slots about  $\frac{1}{16}$  in. wide and  $\frac{1}{8}$  in. apart.

#### The Coil Windings

Details so far as gauge of wire and number of turns are given for this coil on the diagram. It is wound in the same direction throughout, there being 20 turns in each slot.

When one lot of 20 turns have been put on, just pass to the next slot and wind on the next 20 in the same direction. If you prefer, you can purchase this coil ready-made. It is known as a Contradyne coil.

#### Extra Components if Extenser is Not Used.

- 1 .0005-mfd. variable condenser and dial (Polar, or other good make).
- 1 Three-spring type wave-change switch, see text (Wearite, etc.).

#### Extra Components for Pick-up Switching.

- 1 Single-pole push-pull change-over switch (Red Diamond, etc.).
- 2 Indicating terminals (Belling-Lee, etc.).

There are two wires passing under this coil, but they are not connected to it in any way. They both run to the reaction condenser, one going to the moving vanes and one to the  $F_2$  fixed vanes.

While on the question of components there is one point to be

mentioned about the wave-change switch if one is used. This is arranged

### VERY LOUD LONG-WAVERS

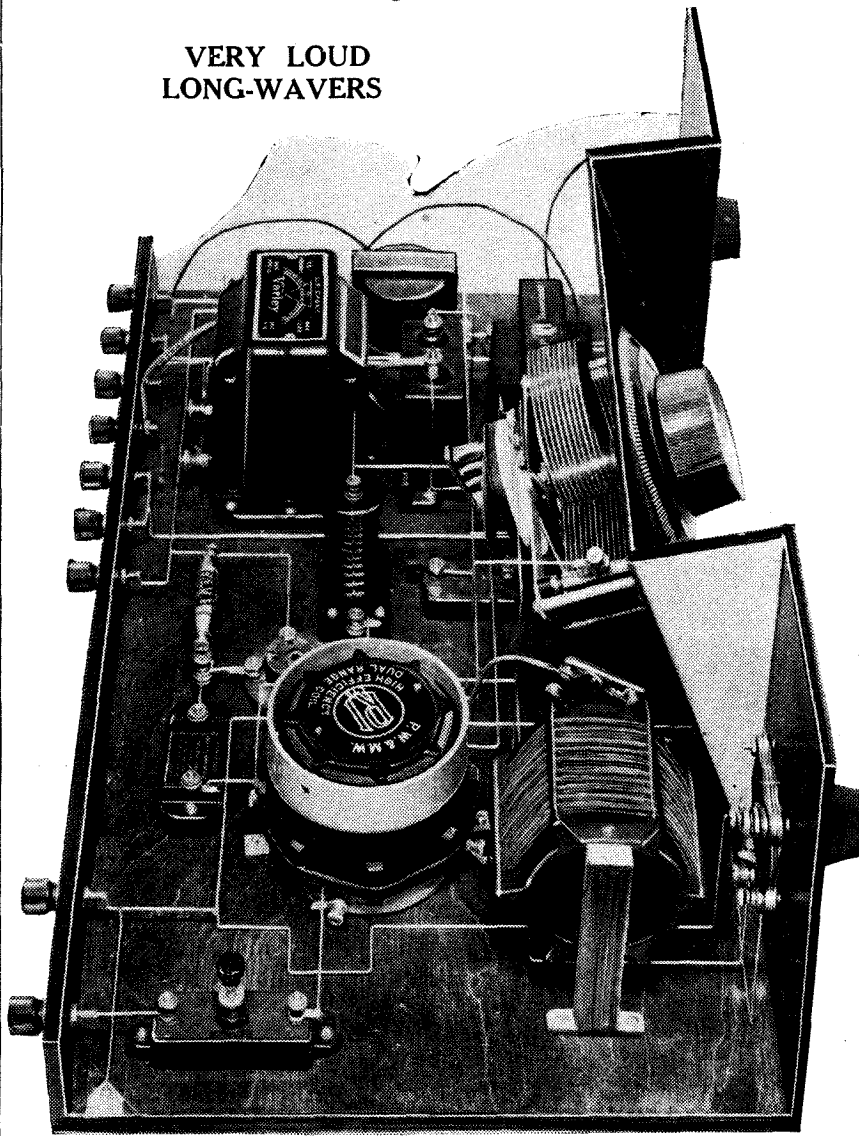

By using a "P.W." and "M.W." dual-range coil in combination with a Contradyne coil the long-wavers come in with exceptional volume, and free from the jamming of medium waves "breaking through."



# ROUND the DIALS

*Some practical notes on what stations to look for and how to get the foreigners that are coming over well.*

A COUPLE of years ago a great many people who ought to have known better were saying that long-distance listening was a fast-dying craze. They thought that more and more people would turn to purely "local" listening, and that foreign stations were not worth tuning-in. They were wrong!

The fact is that nowadays *increasing* numbers of listeners turn to the Continent for their programmes, and the Continental stations respond right nobly to the demand!

During the past month reception on the medium wave-band often seemed too good to be true. One really tremendous station has been Bordeaux Lafayette, on 304 metres, the strength on many evenings with just a little reaction being like a "local."

Another very fine programme which is worth looking for is Lyons La Doua, on 466 metres; and one evening I was enjoying a fine band from this station—at least, I *thought* it was Lyons—when he announced himself as Zurich! (Only a couple of degrees lower on the dial, and just about as strong as Lyons, this station appears to have been gingered up during the recent re-organisation of Swiss broadcasting.)

On the long waves, Warsaw, 1,411 metres, has been strong and steady, but there is a terrible lot of talk from this station which makes him a dull companion. Moscow, too, on 1,304 metres, has had far too much to say; but Kalundborg, on 1,153 metres, is always inclined to gaiety, and his gramophone records are the star turn at the lower end of the dial.

How do you find the new North Regional now coming on the air from Moorside Edge? My first impressions are that it is going to be far stronger in the London area than we might have expected, and will prove as convenient an alternative as the Midland Regional.

As the Midland Regional will ultimately have to take Glasgow's wave-length of 398.9 metres, I have often tuned for Glasgow lately, and can generally raise him quite easily. (Some Londoners complain that Glasgow is one of the hardest stations to get, and often eludes a good four-valve set situated south of the Thames. But, using an "A.C. Paratune," I find Glasgow comparatively easy; in fact, all the British stations can be pulled in on that set without much bother.)

Ankara, the long-wave Turkish station, to which is allotted 1,961 metres, appears to be "sitting" just below 5 X X, and cannot be heard when the latter is working. As it usually closes long before midnight, this means that Ankara is an extremely difficult station to pick up at present.

F. F. C.

\*\*\*\*\*  
 \* **POINTS FOR PURCHASERS** \*  
 \* *Some interesting details from manufacturers about recent trade activities.* \*  
 \*\*\*\*\*

**New Ferranti Transformer**  
 WE are informed by Ferranti, Ltd., that their type A.F.8 L.F. transformer—which is listed at 11s. 6d.—deals with the lower musical frequencies remarkably well, considering its low price. The

cut-off at 50 cycles is less than 50 per cent, and when it is remembered that many higher-priced transformers fall off much more sharply than this the merit of the design is apparent.

By the way, contrary to the usual Ferranti practice, this transformer does *not* incorporate a fixed condenser. So, when used to follow a detector in a circuit not employing differential reaction, a .0003-mfd. fixed condenser may be needed across its primary terminals.

### Trade Items

The Stenode Radiostat is being produced in commercial form by Radio Instruments, Ltd., Purley Way, Croydon.

### Inductor Loud Speakers

Messrs. A. Brodersen, of 11, Northampton Square, E.C.1, the distributors of the original N. & K. Inductor loud speaker, announce that in future they will issue a certificate of guarantee available for 12 months for every N. & K. speaker distributed by them.

**NEXT MONTH**  
 THE JUNE ISSUE OF THE  
**"WIRELESS CONSTRUCTOR"**  
 WILL BE ON SALE MAY 15th.  
**ORDER YOUR COPY NOW**

If any mechanical defect should occur during that period a replacement will be made upon production of the certificate to the dealer who affected the sale.

Purchasers are requested to make sure that they obtain a certificate, and that the red and green licence marks, which on no account must be removed, are attached to the speaker. Replacement cannot be effected unless these conditions are conformed with.

### A Permanent-Magnet L.S.

The new W.B. permanent magnet loud speaker is well illustrated and described in a leaflet now available. There is a wide demand for this class of speaker, because "when it's bought it's bought!" There are no running costs whatever, no connections to the mains, etc., and if—as in this case—the original cost is low, it is an extremely attractive proposition.

Full details can be obtained by any WIRELESS CONSTRUCTOR reader from Whiteley Electrical Radio Co., Ltd., Radio Works, Nottingham Road, Mansfield, Notts.



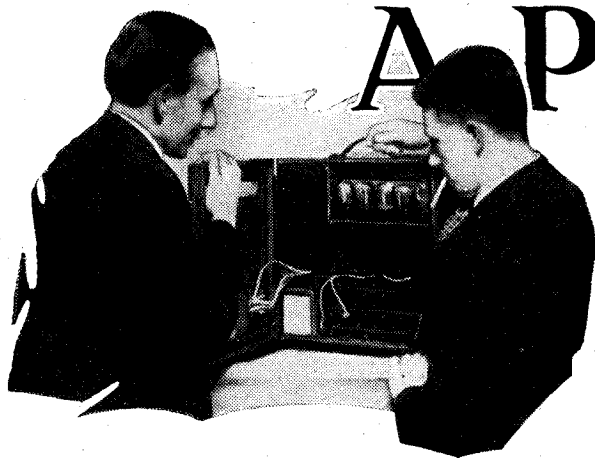

# A PRACTICAL MAN'S CORNER

*An invaluable section for the home constructor.*

By R. W. HALLOWS.

## Woods for Cabinets

**I** ALWAYS think that for a cabinet base-piece and the back any kind of wood will do, for what the eye does not see the heart does not grieve. Bass wood or deal without knots are as good as anything; or plain unveneered three-ply may be used.

For the sides and lid you can employ three-ply with a veneer of oak, mahogany, teak or some other ornamental wood, or if you like you can make the whole cabinet of plain white wood and afterwards cover it with one of the wonderfully convincing veneer papers sold by the makers of the corner-pieces.

Some of these imitate with surprising faithfulness various fancy woods, whilst others even reproduce a very good crocodile-skin effect. These

## FOR YOUR FRAME

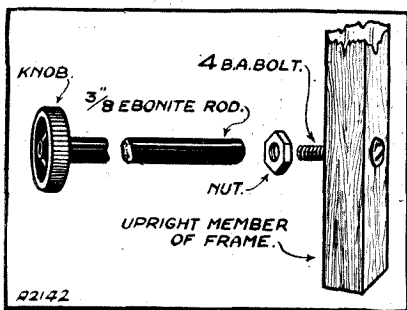

Fig. 1. How to fix a handle to a frame aerial so that you can turn it without having to touch the wires.

veneer papers are simply cut to size and glued on to the lid and sides. If they are used and the cabinet is made of white wood the total cost is a little more than a matter of pence, even for a cabinet to take a five-valve set. Despite this the resulting job is one that is thoroughly pleasing to the eye.

## A Frame Handle

Most frame aerials that I come across have one defect; or, at any

rate, I consider it a defect. They lack a suitable handle for moving them in the required direction. This means that you have to get hold of one of the arms, and as likely as not your fingers come in contact with the windings.

Touching the windings entirely alters the tuning, and it is certainly not good for the wires to be constantly handled. A tip that I use with my own frames may be found handy by readers. As near as possible to the bottom of the vertical member a 4 B.A. clearance hole is drilled right through. Through this is passed a 4 B.A. bolt about an inch in length. A 6-in. length of round ebonite rod is cut off. In each end a 4 B.A. tapped hole is made and a thread is cut with a tap. The bolt is passed through the vertical member of the frame, is locked with a nut, and the ebonite rod is screwed tightly on to it.

A piece of studding is screwed into the tapped hole at the other end of the rod and locked with a thin 4 B.A. nut. The protruding part of the studding should be a little more than a quarter of an inch in length. On to this screw a small knob tapped 4 B.A. (Fig. 1.)

You will probably find one in your junk box on some ancient component that has long since passed out of use. Or if you have not one you will be able to purchase one for a penny or so from a wireless shop. These handles look well, and they certainly add to one's pleasure when using a frame.

## Another Addition

Another addition to the frame which greatly adds to the interest of using it is a pointer and a compass scale. The pointer, which is fixed to the pivot, can be made from sheet brass. The compass scale takes the form of a celluloid ring mounted on

the stand. This can be marked off either in figures (0-360 for North, 90 for East, 180 for South and 270 for West) or according to the conventional compass markings, N., N.N.E., N.E., and so on.

The stand itself must, of course, be orientated by means of a compass to begin with. Remember when you are doing this not to bring the compass too near the set or the loud speaker, or you may obtain some queer readings from it, owing to magnetic effects.

A scale of this kind greatly helps the identification of stations, for owing to the directional properties of your aerial you know approximately from which direction a particular set of signals is coming.

## Centre Finding

Some time ago I described methods of finding the centre in small pieces of round work, but I will give these again for the benefit of new readers—and for old ones who have forgotten the hints. The simplest way is this.

Having tried up the end, hold the work in the fingers of your left

## AN L.T. FUSE

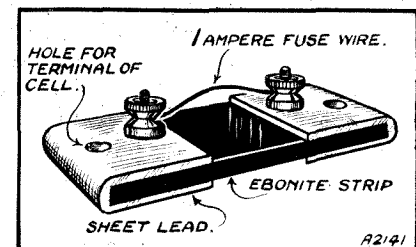

Fig. 2. An easily-made fuse for an accumulator.

hand, and with the right hold a sharply pointed pencil. Put the point of the pencil where you guess the centre to be.

Hold it there and turn the work gently to and fro with the fingers of the left hand. You will be able to see at once if the point of the pencil

## A Practical Man's Corner—continued

is a little off centre. Move the pencil in whichever direction is indicated for making the necessary correction, and rotate again.

In a matter of seconds you will have located the centre as near as makes no matter. Press the point hard into the ebonite, centre-punch, and there you are.

Another method, which is really an elaboration of the same thing, is to fix up the hand-drill horizontally in the vice and to mount the work in its chuck. Spin it by turning the hand-drill with the left hand and you won't have much difficulty in putting the point of the pencil or the scriber on the exact centre.

### Safeguarding the Accumulator

Most of us nowadays fit fuses for our high-tension batteries, but too often the accumulator is not safeguarded in the same way. Shorts in the filament circuit do not often occur it is true, but when they do their results are often pretty serious, for an accumulator of, say, 60 ampere-hours capacity can deliver something like a couple of hundred amperes for a second or two.

This is actually the load that comes the way of the starting batteries of bigish cars, but it is far more than is good for the health of the kind of battery that we use for wireless work. Also, 200 amperes at 6 volts is 1.2 kilowatts, which is quite enough to do damage outside the battery!

Fig. 2 illustrates a simple and quite effective way of providing low-tension accumulator fuses. Remove the lead strip connecting one cell with its next-door neighbour, and cut out a piece of  $\frac{1}{4}$ -in. ebonite of the same size.

With tin shears cut two strips of sheet lead of the same width as the ebonite, and each about 4 in. in length. Fit them to the ends of the ebonite piece as shown in Fig. 2.

### A Simple Scheme

Using the original lead connector as a template, drill holes right through the lead and the ebonite for the terminals of the cells. Now take a pair of brass terminals and mount these as shown in the drawing by drilling 4 B.A. clearance holes through lead and ebonite.

Grease them well with petroleum jelly before mounting. From any electrical shop you can obtain a supply of 1-ampere fuse wire. Connect the

terminals together by means of a short piece of this, greasing the wire before you screw it down.

The accumulator is now perfectly safe, for the fuse will blow at once should a short-circuit impose an excessive load. One-ampere fuse wire will be sufficient to carry the current for any ordinary set, though should you be using a large number of valves requiring a heavy filament current you can substitute 2-ampere fuse wire.

A fuse made in this way will remain in good condition for a long time, but it is a wise precaution to renew the wire whenever the accumulator comes back from the charging station. Should yours be a single-cell 2-volt accumulator the same device can be used.

In this case use one of the end holes for fixing it to, say, the positive terminal of the cell, and in the other mount an additional terminal to which the set connection is made.

### Testing Prods

Amongst the ingenious gadgets that have been devised in the last few months none is more useful to the wireless man than the prod which is intended for attachment to the leads of the voltmeter or any other measuring instrument. One ex-

### INGENIOUS GADGET

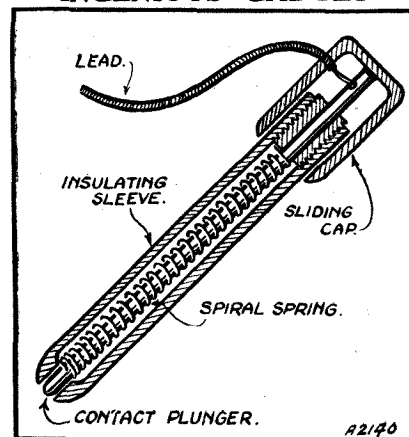

Fig. 3. Illustrates the construction of one of the spring prods.

cellent type (the Ealex) is illustrated in section in Fig. 3, and its construction is worth a few moments attention.

Firmly fixed to the sliding cap at the top is a contact plunger rod which passes through an insulating sleeve some 4 in. in length. A spiral spring surrounding the plunger draws its point normally up within the sleeve and out of harm's way.

### Perfectly Safe

A slight pressure on the cap causes the point of the plunger to protrude and the gadget is provided with a device which enables the plunger to be locked in this position if desired. The lead from the measuring instrument is connected by means of an ordinary screw-down fixing to the plunger at a point within the sliding cap.

Now you will see at once how exceedingly useful it is to have a pair of these prods and to keep them connected up to the leads of whatever instrument you use for making voltage or current measurements for the purpose of fault-finding.

Is filament current reaching the legs of number three valve in the set? To get at those legs might in the ordinary way be a difficult business, with a risk of causing various short-circuits. With the prods, though, you need have no fears.

With their points inside the insulating sleeves you can pass them down through the worst cat's-cradle of connecting wires until the legs of the valve holder are reached. Then a slight pressure on the cap of each prod causes the plunger to emerge and to make contact.

You can see in a moment whether all is well with that valve holder or otherwise. I have mentioned a simple case. There are many others far less so when one is engaged in pursuing an elusive fault in a set of complicated design and intricate wiring. Having had a pair in use for some time now I am very much a pro-prod man.

### Valve Caps

Recently I have come across a larger number of loose valve caps than has come my way for several years.

This is a defect of the kind which demands immediate action or bad trouble will ensue. If you notice the slightest loosening of a valve cap, fix it firmly in place without delay by means of Chatterton's compound or one of the cements that you can buy at any ironmongers which are meant for mending broken china. Chatterton's compound, by the way, is very easily reduced to a liquid state, in which it can be poured in at a convenient crevice.

# A NEW RANGE OF VALVES

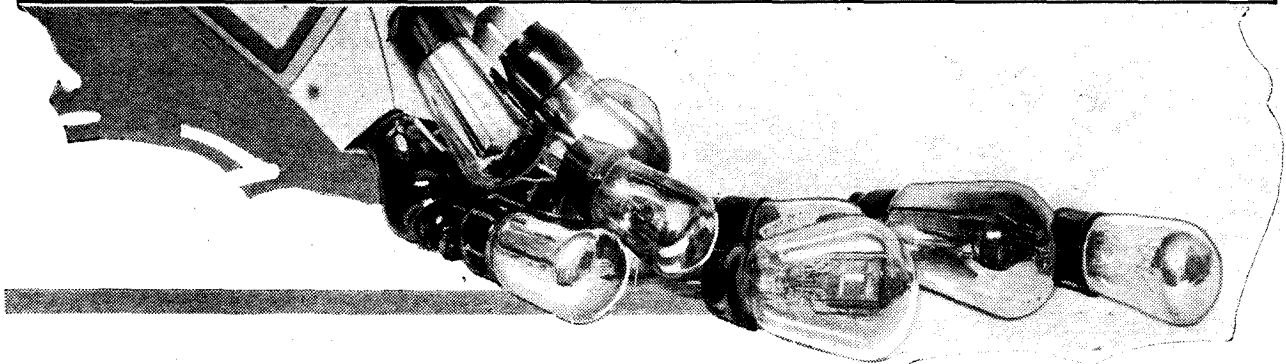

**Y**ou probably noticed in the last issue of the WIRELESS CONSTRUCTOR an advertisement relating to a new series of valves that has been placed on the British market. These valves go under the name of "Eta," and I expect you have wondered why we did not mention them in the editorial columns.

The reason is not far to seek. We have been engaged on tests with these valves, and as there are about seventeen of them it takes some time before one can voice one's opinion.

We have not space to go into the details of our tests here, but we can say that the valves passed very creditably.

Let us consider the various Eta valves that are available. We have two main classes, the 2-volt battery type and the A.C. mains variety. The former consists of a screened-grid, two H.F., Det., L.F., power and super-power—seven valves in all.

## The Designation Scheme

But one of the most striking things about them is that the firm responsible (The Electrical Trading Association, Ltd.) have adopted a classification put forward in this journal over two years ago. It is that the figures denoting the valve should tell you at a glance the two most important characteristics of that valve, namely, the impedance and the magnification factor.

And, if I remember rightly, impedance was placed first and mag. factor second. Thus a valve with impedance of 10,000 ohms and mag. of 15 would have the figures 1015 after its prefix letter.

The "Eta" valves go the other way about it. They put mag. first and impedance second. Thus we have the

*During the past few weeks large numbers of new valves have appeared on the market, including two completely new series which are discussed below.*

**By G. W. EVANS.**

battery H.F. valve, with 2,300 ohms impedance and mag. factor of 20, denoted as BY2023; the L.F. valve is BW1304 (13 and 4,000 ohms impedance); the S.G. valve has a plain number (6), and is denoted by BY6.

Now let us see the full range. The

filament amperage of the battery valves (2-volters all) ranges from 0.12 to 0.32, the latter being for the power and super-power valves. The maximum H.T. voltage in each case is 150 volts, and the characteristics are taken (as usual) at 100 volts H.T. and zero grid bias.

## Values Indicated

The designation of each valve provides us with the magnification factor and the impedance in the nearest round figures, so there is no need to

## A RADIO "RESERVOIR"

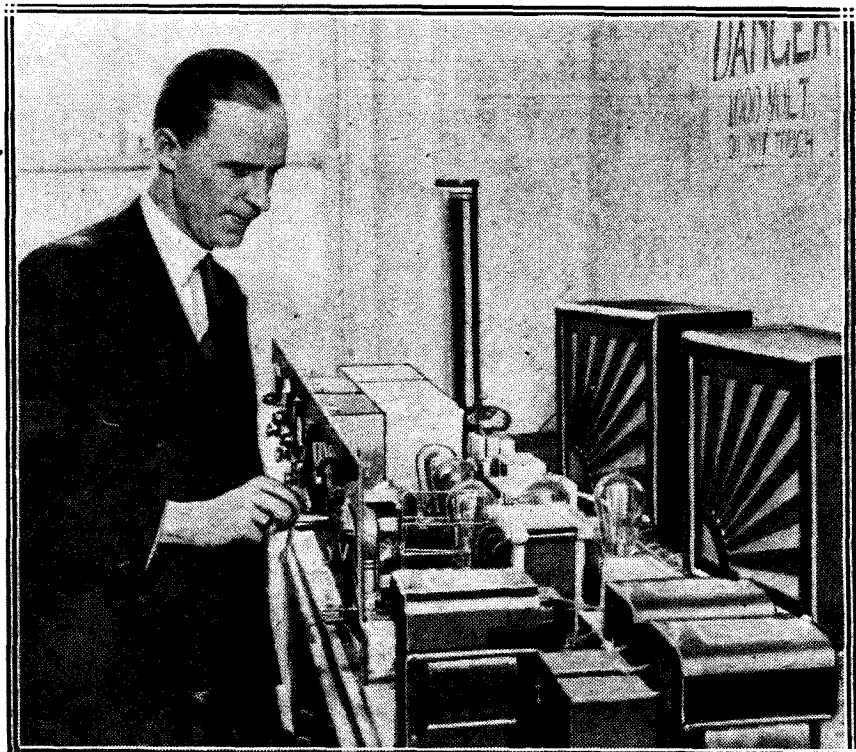

Radio programmes "on tap" from a central "supply" can be obtained at Bowes Park, N. Here is the giant set and amplifier which provides the subscribers with their programmes at 1s. 6d. per week (plus P.O. licence).

## A New Range of Valves—*continued*

discuss these further than to provide the actual list of valves.

The S.G. is the BY6 (300,000 ohms and 300); H.F., BY2023 (20 and 23,000); H.F., BY1814 (18 and 14,000); H.F. or Det., BY2010 (20 and 10,000); L.F., BW1304 (13 and 4,000); super-power, BW303 (given in exact figures this is actually 3 and 2,700); and, finally, BW602, power valve, with mag. of 6.5 and impedance of 1,900 ohms.

### The A.C. Range

Of the A.C. valves six are indirectly heated and three are directly heated. The nomenclature is similar to the battery types. S.G.'s are DW2 and DW6, having impedances of 200,000 and 800,000 ohms, and amplification factors of 240 and 1,000 respectively. Heater voltage throughout the A.C. valves is 4 volts, and the amperage 1 amp. for indirectly-heated valves and the peculiar figures of 0.15, 0.23, and 1.05 for the directly-heated types. The largest of these is capable of handling an undistorted output of 1,600 milli-watts.

The valves for A.C., in addition to the two S.G.'s, are as follow: DW4023, DW1508, DW704, DW1003 (indirectly heated); and DX502, DW702, and DW302 (directly heated).

Finally, we have a full-wave rectifier with 4-volt filament and taking a maximum anode pressure of 350 volts, delivering 80 milliamps. at that pressure.

The prices of the valves are not very low, though they are slightly lower than the "ring" valves. Two-volters are 7s. for ordinary, 8s. and 10s. for L.F. and power valves, and the S.G. is 17s. 6d. Indirectly-heated A.C. valves vary from 11s. 6d. to 19s. 6d., and the directly-heated types are 11s. 6d. Fifteen shillings cover the cost of the rectifier.

And now I must just mention a very different type of valve, ranking among super-powers—the Mazda PP5/400. This is a new output valve of colossal proportions. The anode is built on very generous lines, with the result that although it dissipates 25 watts the valve only gets mildly hot. The impedance is 1,500 ohms, and the amplification factor 9.

### Some "Bottle"

The undistorted output is 5 watts at 400 volts anode potential, and 83 milliamps. Truly a big bottle! The filament is of the very dull-emitter type, and is, of course, designed for use with direct A.C. It takes 2 amps. at 4 volts.

This valve is obviously not one for battery drive, or even small mains receivers, but it is a very useful valve for largish receivers, using moving-coil or inductor loud speakers. The grid swing is not large, but that is hardly necessary with the impressive amplification factor possessed by this valve. The grid bias for full anode voltage is 32 volts.

### NEXT MONTH

#### Adding an "Extenser" to Your Set

On Sale May 15th. Price 6d.

With automatic bias this figure is just about obtained by the use of an ordinary 400-ohm potentiometer as biasing resistance—a very simple and useful arrangement, for this resistance has to carry the 80 odd milliamps. of anode current.

And now, in closing, let me remind you of the special test arranged by the WIRELESS CONSTRUCTOR for short-wave enthusiasts. I refer to the Nairobi programme on April 20th. Look to your sets, and pick out, borrow, or otherwise obtain the very best detectors you can.

It rests with your detector valve, so don't use anything but the best you can get. A good, sensitive, smooth, oscillator is what you want—usually an H.F. or special det. valve having an impedance of from 12,000 to 20,000 ohms. Perfect reaction is essential, so buck to and get your set absolutely ready—and good luck!

### Two Excellent Detectors

Oh! I forgot! There are a couple of new valves that may help you a great deal—the Mullard P.M.1H.L. and the P.M.2D.X. These are excellent detectors, the latter being specially designed for that purpose.

Two-volters, they take the usual .1-amp. filament current and are excellent valves. The former has an impedance of 18,500 ohms, and an amplification factor of 28, and the latter is an improved model of the old 2-volt special detector.

The impedance in this case is 10,000 ohms, and the amplification factor 17, making it an ideal short-wave detector.

### REGULATING RUGBY'S RADIO

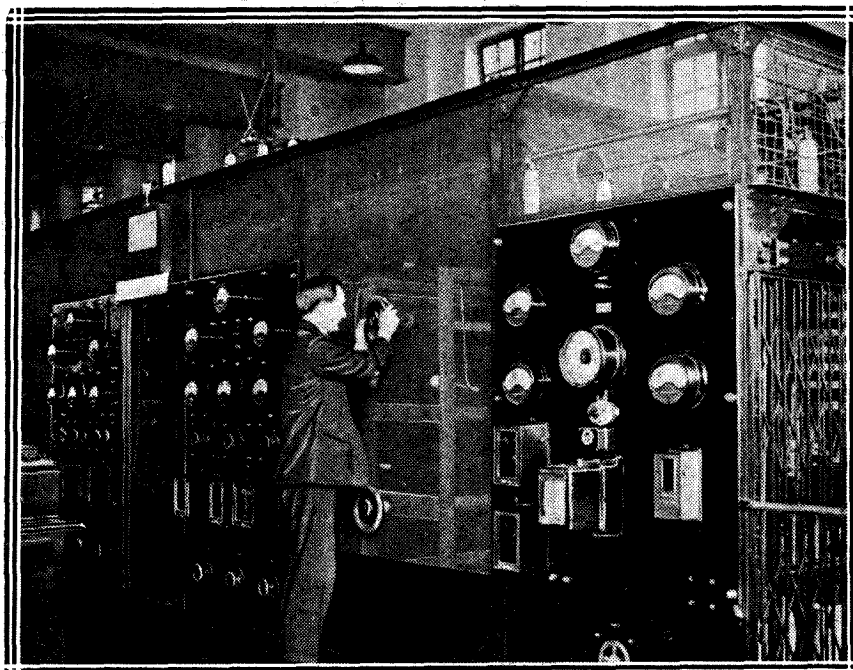

Adjusting one of the controls in the Rugby super-station which carries out world-wide communication on all sorts of wave-lengths.

# THE SPLIT SECOND THAT ADDS MONTHS TO BATTERY LIFE



*"Time Factor" is considered by Lissen of such importance to the Secret Process that every operation is controlled with laboratory precision*



ORDINARY mixing of standard battery chemicals will set up a flow of electric current—current good enough, perhaps, to ring a bell or light a bulb. But in radio every flaw is magnified, every fault amplified, the slightest current variation reflected harshly by the delicate receiving valves. That is why the actual factory methods employed in making a battery are so important—that is why such a difference is noticeable immediately a Lissen Battery is introduced into the receiver.

In the Lissen Battery Factory, precise laboratory methods are used. The quantities of the various chemical constituents of the Lissen Secret Formula are controlled with microscopic accuracy. Their purity is ensured by analytical test; their thorough and complete admixture supervised at every stage.

*And here enters the time factor.* Appreciation of the importance of this time factor makes all the difference between an ordinary battery with an ordinary battery's life, and a Lissen Battery with a Lissen Battery's life! In some parts of the Lissen Secret Process the time factor is considered by Lissen of such vital importance that the operations are controlled on a rigorous time-schedule.

The effect of the time-controlled process is shown in the fine response of the battery when the cells are called upon for heavy output over long periods. Then you will find the unique Lissen production methods have put a reserve of chemical activity into the Lissen cells which meet any and every demand for high-tension power. The current always flows steadily and at high pressure—the cells **RESIST VOLT DROP WITH A STUBBORNNESS UNKNOWN IN ANY OTHER BATTERY. AND THE LISSEN BATTERY GAINS MONTHS OF EXTRA LIFE.**



**LISSEN BATTERIES  
ARE WORTH THEIR  
PRICE!**

**60 VOLT  
7/11  
100VOLT  
12/11**

LISSEN LIMITED, Worplesdon Road, Isleworth, Middlesex.

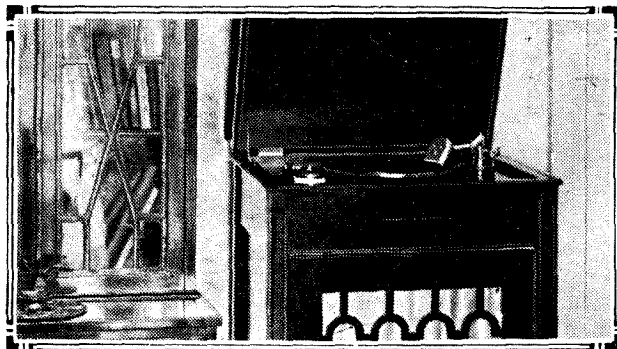

# WITH PICK-UP AND SPEAKER

*A fine electric motor.—The new model Marconiphone pick-up.*

Conducted by A. JOHNSON-RANDALL.

JUST lately there seems to have been a sudden outbreak of L.F. troubles.

I am afraid that it is partly due to the increasing popularity of mains units, coupled with the use of modern

## QUITE SILENT

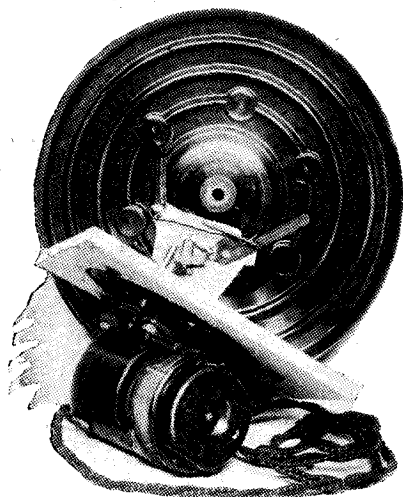

*The Dicht induction motor.*

transformers and endeavours to obtain too much magnification.

Mains units can produce very serious back-coupling effects, and many listeners when they are purchasing do not choose a unit capable of giving a big enough current output.

They get hold of a small mains unit and then connect it to a radio-gram receiver having a super-power valve, and probably an S.G. H.F. stage. Of course, the poor mains unit is hopelessly overloaded, and the receiver doesn't work properly.

## Safe Designs

If you make up one of the WIRELESS CONSTRUCTOR designs there is no need to worry, because these supply adequate current for a four- or five-valve set; but if you intend to get a commercial mains unit, then purchase the biggest one you can afford.

It is unwise to economise on this point. Very often the unit will have to be put aside in the end and a larger one obtained.

Small units are quite satisfactory with small sets, but a modern four-valve receiver may take 25 milliamps. or more. It depends largely upon the output valve, but my experience is that the present-day listener is after quality, and to get this he uses a super-power valve in the last valve holder. But what is the good of having a super-power valve if the mains unit or H.T. batteries cannot supply its needs?

If your gramophone amplifier is giving trouble, make sure that your H.T. supply is O.K., and see that your valves are adequately de coupled.

## The A.E.D. on Test

Last month I mentioned that we had received one of the new A.E.D. pick-ups for test. It is certainly a nicely finished job, and the following points are among its salient features:

- (1) A stop so that the pick-up cannot travel beyond the centre of the record.
- (2) An earth terminal for the tone-arm.
- (3) A refinement to facilitate needle changing. The pick-up can be rotated through an angle of 180 degrees.
- (4) An adjustable rest is provided for the tone-arm when not in use.

A template is provided with each pick-up, and it is a simple matter to get it tracked up correctly.

The provision for earthing the tone-arm reminds me that pick-up enthusiasts sometimes forget to do this. It is, of course, not essential, but it does reduce the chances of L.F. instability, which are only too frequent when transformer-coupling is used.

## Very Sensitive

On test we found the pick-up to be very sensitive, and a volume control is required in order to prevent the first valve from overloading, assuming this valve to be of the "H.F." or medium impedance L.F. type biased at  $-1\frac{1}{2}$  or  $-3$  volts.

We could find little amiss with the reproduction, the response over the musical scale being very good, with no unpleasant resonances.

Needle scratch is not excessive, even without the volume control.

The armature is only slightly damped, a factor which reduces wear on the record to a minimum, but there is a fair amount of chatter when the pick-up is used with loud-tone needles, as recommended by the makers.

*(Other new radio-gram items are described on page 54).*

## THE IMPROVED MARCONIPHONE PICK-UP

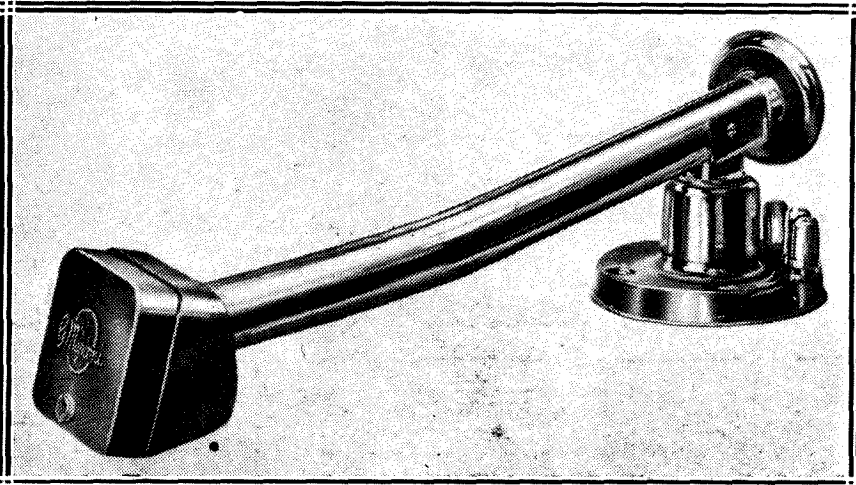

*It retains its original technical characteristics, but is improved in detail.*

# For 100% Efficiency

## Build with a "Ready Radio" Guaranteed Kit

**YOU CAN BUY ANY RADIO EQUIPMENT FROM READY RADIO BY EASY PAYMENTS**

### 1931 OSRAM "MUSIC MAGNET" FOUR

2 S.G. Valves, Det. and 1 L.F. One-knob control. Complete Kit of Parts with valves, oak cabinet and instructions, £11/15/0, or 12 monthly payments of 21/6.

### 1931 MULLARD "ORGOLA" FOUR

2 S.G. Valves, Power Grid, Detector and Pentode. Complete Kit of Parts with valves and cabinet, £13/12/6, or 12 monthly payments of 25/-.

*Send for Ready Radio Catalogue: A complete encyclopedia of all modern Sets, Speakers, Equipment, Components and Accessories, including everything needed by the set-builder. Price 1/-, post free.*

**TO OVERSEAS CUSTOMERS**

All your goods are very carefully packed for export and insured, all charges forward.

Ready Radio hold colossal stocks of radio sets, equipment and components. Your order can be supplied from stock. There is no need for you to suffer the inconvenience of delay; you need not accept substitutes—if you send your order to Ready Radio you know that you will get what you order—immediately—and that everything you order will be new and in perfect condition.

### THE "EXTENSER" 3

Complete Kits supplied on EASY

MONTHLY PAYMENTS or

CASH ON DELIVERY or

CASH WITH ORDER

Complete Price List on Application

### CONVERTING THE "PLUS-STAGE" ONE TO THE "PLUS-STAGE" TWO

CONVERSION KIT:

- 1 Telsen "Ace" Transformer, ratio 3-1 .. 8 6
- 1 Telsen 4-pin Valve Holder .. 1 0
- 1 Igranac ½-meg. Volume Control 6 0
- 1 Mullard Power Valve .. 10 6
- Flex, Wire, Plugs, etc. .. 1 0

Total (including valve) .. £1 7 0

KIT "A" (less valve) 16/6

KIT "B" (including valve) £1:7:0

**YOU CAN BUY YOUR NEW SET FROM**

**READY RADIO ALREADY ASSEMBLED**

**OR AS A COMPLETE KIT**

**of GUARANTEED COMPONENTS**

### 1931 MULLARD "ORGOLA" THREE

Screen Grid, Detector, Pentode. Complete Kit of Parts with valves and cabinet, £8/0/0, or 12 monthly payments of 14/8.

### COSSOR "EMPIRE MELODY MAKER"

Powerful Long Range Screen Grid Receiver. Complete Kit of Parts with valves and cabinet, £6/17/6, or 12 monthly payments of 12/7.

"AMPLION" and "CELESTION" and other leading makes of loud speakers. Large stocks of all models for cash or monthly payments.

**TO INLAND CUSTOMERS**

Your goods are dispatched post free or carriage paid.

**Cash or Easy Payments**

**Ready Radio**  
R.R. LTD.  
159, BOROUGH HIGH STREET,  
LONDON BRIDGE, S.E.1.  
Telephone: Hop 5555 (Private Exchange) Telegrams: READIRAD, SEDIST.

**Immediate Dispatch**

# These LEWCOS RADIO PRODUCTS

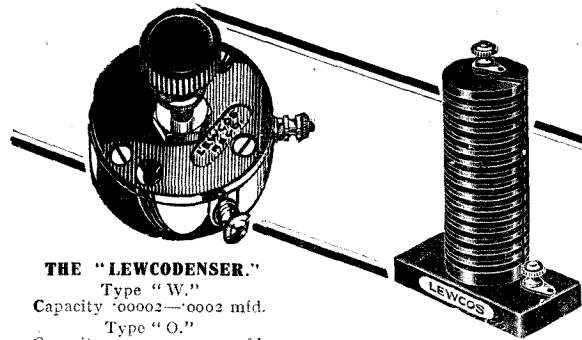

**THE "LEWCODENSER"**  
 Type "W."  
 Capacity .00002—.0002 mfd.  
 Type "O."  
 Capacity .00015—.0001 mfd.  
 Price 2/3  
 Write for fully descriptive leaflet  
 Ref. R.60.

**THE LEWCOS H.F. CHOKE**  
 is specially constructed to eliminate self-oscillation. Price 7/9  
 Write for fully descriptive leaflet. Ref. R.33.

We respectfully request the public to order through their local radio dealer as we only supply direct to the trade.



Many of the most successful receivers in the past depended in a large measure on the superlative qualities of LEWCOS Radio Products.

You will find that the LEWCOS components illustrated on the left will improve your receiver to an astonishing degree. "Perfection in every detail" is the keynote of the LEWCOS factory where these components are made.

## AND A LEWCOS SPAGHETTI RESISTANCE

(25,000 Ohms—Price 1/6)  
 ARE SPECIFIED FOR THE  
 "EXTENSER" 3 RECEIVER  
 DESCRIBED IN THIS  
 ISSUE

**LEWCOS RADIO PRODUCTS FOR BETTER RECEPTION**

THE LONDON ELECTRIC WIRE COMPANY AND SMITHS LIMITED, CHURCH ROAD, LEYTON, LONDON. E.10

A Genuine

# MAGNAVOX

Moving Coil Speaker  
 for **57'6**

Birthday of the  
**LITTLE GIANT**

Now you can buy a genuine Magnavox moving coil speaker for 57'6. The new Little Giant embodies all the latest developments in moving coil speaker construction and gives the same perfect performance and response which can only be secured with a genuine Magnavox unit. Your dealer will demonstrate this wonderful new model and you will not be satisfied until you have one. Remember that Magnavox originated the moving coil speaker.

MODEL 230	6-12 volts D.C.	£2 17 6
" 130	110-130 "	" £2 17 6
" 151	180-300 "	" £2 17 6
" 420	105-120 " A.C.	£5 10 0
" 424	220-240 "	" £5 10 0

WRITE FOR THE NEW FOLDER—THE MAGNAVOX FAMILY

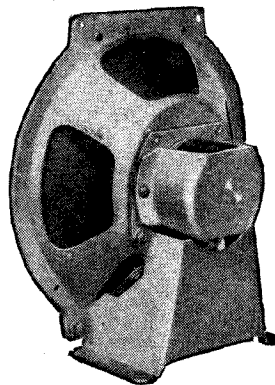

**THE ROTHERMEL CORPORATION LTD.,**  
 24, Maddox Street, London, W.1.

'Phone: MAYFAIR 0578/9

Continental Sales Office:  
 27, QUAI DU COMMERCE, BRUSSELS, BELGIUM.

## A NEW CONDENSER

HYDRA, greatest of Condenser makers, have produced a new condenser, the new Hydra "Zenith" type which embodies characteristics far in advance of any other Condenser available.

Take advantage, therefore, of Hydra's research work and insist on the new type condenser. Your dealer carries a stock.

The new  
**HYDRA "ZENITH" TYPE**

**LOUIS HOLZMAN, Ltd.**

37, Newman Street, London, W.1

Telephone: Museum 2641



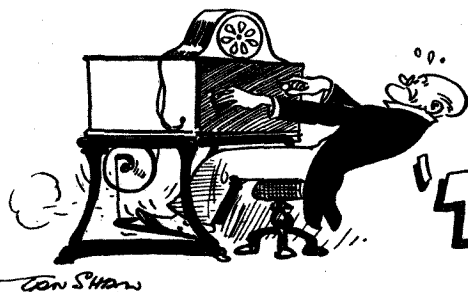

# In Lighter Vein

## PROF. GOOP'S

# 'TREADMILL SIX'

BY "Wireless Wayfarer"

IT is some time since Professor Goop gave the world one of his epoch-making receiving sets, but that does not mean that the great mind has been inactive. Quite the contrary. During the past few months he has produced a whole host of stupendous inventions, each of which is certain to revolutionise something or other.

Laundries, for instance, are simply bound to adopt his new labour-saving automatic button-cracker, which pulverises every button on a shirt in less than a fifth of a second as against the two minutes twenty-five seconds usually required to perform this operation by hand. No up-to-date laundry could possibly afford to be without it.

### Self-Charging L.T.

And what of his new motor-car gear box fitted with rubber cog-wheels which completely prevents noisy changes? Or, perhaps, the most ingenious of all, his self-charging wireless accumulator? Under the old method, which will shortly be obsolete, the low-tension circuit was most inefficiently wired.

### STUPENDOUS!

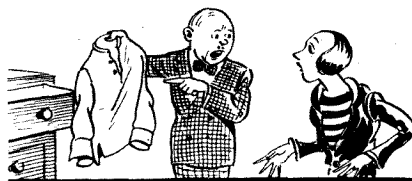

The Goop machine pulverises every button on a shirt.

Electrons leaving the negative terminal of the accumulator were led via the low-tension busbars through the filaments of the valves and then, if you please, to the positive terminal of the accumulator, where they found nice fat positive ions with whom they joined up and immediately retired from business.

Under Professor Goop's novel system, electrons are given no chance of shirking like this. Instead, they are brought back to the *negative* terminal,

All about the famous (sic) scientist's latest and very greatest invention.

and here a very interesting process occurs.

All intelligent people, and even possibly you, dear reader, know that the repulsion exercised by one electron upon another is one of the mightiest forces in nature. When, then, the electrons that have passed through the filaments of the valves try to elbow their way on to the negative terminal, they get such a kick in the neck from electrons already there that they are hustled off round through the filaments again before they have even time to wonder what has hit them.

I should, perhaps, have explained that the return wire from the filament circuit is led down towards the positive terminal, so that electrons think that they are going to the place where they will be pensioned off. Just before they reach it, however, the lead makes a sharp bend to the negative terminal; but they are then travelling so fast that even if they put on the brakes they reach it by skidding.

### Something Different

These are a few of the Professor's inventions. Important as they are, they will, however, not create quite the same amount of stir as the wonderful receiving set which it is now my privilege to describe in full detail to you.

Though my description of the circuit will make everything pretty plain sailing, I may mention that a blue print is available, which may be obtained absolutely free of charge from me provided that sufficient money is enclosed with the application. Cheques should be made payable to me, and crossed "Overdrawn Account No. 6." •

The new set is the "Treadmill" Six, which opens an entirely new

vista in wireless reception. Let us think for a moment. To make matters easier, I will do the thinking while you go through the motions.

What has always been the fattest fly in the ointment of wireless reception? Don't all speak at once. What did you say, sir? High-tension supply? Quite right, sir. You can go up three places. If only we had unlimited volts; if only we did not need to think about the milliamps., what a time we should have. I don't want to draw an exaggerated picture, but, honestly, if these things were ours we could even obtain pure and undistorted reception from our local B.B.C. station.

### Wet or Dry?

What happens if we use batteries? Dry batteries cost money, and many a fond father is this day sticking wander plugs into what ought to have been a new pair of pants for little Willie. Dry batteries are full of atmospheric,

### MISSPENT MONEY!

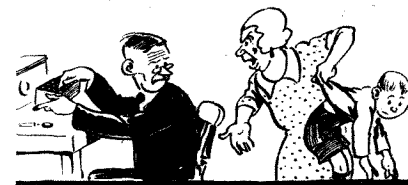

A new pair of pants for little Willie.

and no dealer will give more than half-price for them when they are run-down. Wet batteries are wet, though dry batteries are not dry. Those who have been to America tell me that it is just the same with countries.

Mains units are splendid things, since if you are lucky they enable the set to run slap off the lighting mains. I must be one of the unlucky ones, for they won't work in my house; or is it, perhaps, because mine are gas mains?

With one magnificent stroke Professor Goop has eliminated both the battery and the eliminator. Volts and current galore will henceforth be available to everyone.

The circuits of this wonderful six-valver are perfectly simple and

## In Lighter Vein—continued

straightforward. Incoming oscillations are amplified at high frequency by a special screen-grid valve containing two plates. The output from the first of these, which contains all atmospheric, heterodynes and flashing-sign noises, is taken straight to earth and decently buried.

The other plate is connected to the primary of a Boozelhein steriliser, where the output is washed, disinfected, and cooled to a temperature of 98.4 degrees Fahrenheit.

### All In Esperanto

The secondary feeds the grid of the first detector, which functions in the ordinary way as a naughty-dyne converter, transforming Russian, Japanese, and other foreign languages, as well as the Standard English of the B.B.C. announcers, into Esperanto.

In the intermediate-frequency stages, of which there are two, impulses, still in Esperanto, are further amplified, and the second detector converts them into English in a manner so familiar to all. Between the second detector and the output valve is a particularly interesting device of an entirely original character.

### FOR TOPICAL TALKERS



For restoring and eliminating aspirates.

This is Professor Goop's "H" corrector, which restores dropped "H's" or eliminates those which have crept in where they should not be. It is felt that this will be welcomed by politicians, newly-created peers, and other brands of topical talkers. All this is pretty good, you will admit.

### Treadling Out Volts

But the really jammy part of the set is to be found in its high-tension supply arrangements. The cabinet itself is mounted upon a sewing machine stand, beneath which is fixed a generator capable of supplying oodles of current at a thousand volts, provided, of course, that you treadle hard enough. Operating the set is as easy as playing the harmonium, and very much more pleasant. Let me

describe, for example, precisely how the London National is tuned in.

Anticipating stern work ahead, the enthusiast may remove his coat, waistcoat, collar and tie before seating himself at the controls. This, however, is purely a matter of personal preference. His left hand grasps the single tuning knob, his right hand is upon the grid-bias regulator for the L.F. valves, and his tootsies are planted firmly upon the treadles. Having taken a deep breath, he gets to work, remembering that the harder he works the higher will be the voltage and therefore the better the quality.

### Making a Start

It is as well, though, to go easily until you have got your second wind. The operator, therefore, aims at about 250 volts to start with, and sets the grid bias accordingly. He now tunes in the London National, being probably rewarded by a series of raucous noises which show, even though the volume from the loud speaker is quite small, that the set is being overloaded owing to the B.B.C.'s quaint fashion for deep modulation.

Now is the operator's time to pull up his socks, particularly if a nice peaky piano passage is in progress. Faster and faster he treadles until his flying feet become almost an indistinguishable blur. Up go the plate volts and his trusty right hand is meantime increasing the grid bias.

### A Sign of Quality

Experiments have shown that at a range of fifty miles it is perfectly possible to obtain undistorted reproduction from the London National or the London Regional with a high-tension voltage of 1,000 and a negative grid bias of the order of 400 volts.

Not the least of the advantages of the "Treadmill" Six is that it provides its owner with plenty of healthy exercise. In the past, owing to the little use that they made of their lower limbs, wireless men have been easily distinguishable by their thin calves.

Other signs, of course, are the 'phone-flattened ear and the clutching hands adapted for grasping knobs. The wireless enthusiast of the future, now that Professor Goop has given him the priceless boon of the "Treadmill" Six, will be recognisable at

once by his finely developed calves. In fact, we shall probably be saying

### LOOK AT HIS LEGS!



"That fellow can't care much about quality."

about this time next year: "That fellow cannot care much about quality; just look at his scraggy legs!"

\*\*\*\*\*  
**WATER-TAP CHARGING**  
 A cheap and simple way of charging small accumulators, when there is no objection on the part of the water supply company, is by means of a water motor.  
 \*\*\*\*\*

FEW listeners in out-of-the-way districts realise that a small water motor and dynamo will keep their wireless accumulator fully charged, even using four valves for six or seven hours a day.

The plant need not be expensive. A small 1/2-h.p. water motor costs about twenty-five shillings. If the bearings are plain cast iron, drill the holes a little larger and tap in a piece of brass tube at each end for the axle to run in.

Also see that the couplings between rotor and axle and pulley-wheel flange and axle are bored right through the axle and secured with bolts and nuts. Do not rely on the usual form of coupling, a screw pressing on the axle, as this is liable to loosen with the vibration and lead to endless annoyance.

### Little Attention Required

With modern low-consumption valves the lightest form of motor-cycle dynamo is quite satisfactory. A small dynamo, such as the Lucas E3, can be purchased second-hand from one of the firms dealing in motor-cycle spares for about thirty shillings, and will run continuously without any attention except very occasionally to grease the ball-bearings as a precaution against rust and wear.

# TELSEN

## COMPONENTS

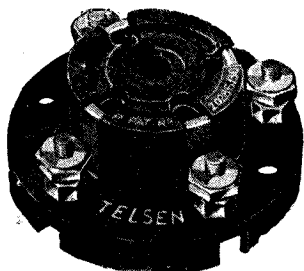

**Telsen Four-Pin Valve Holders**  
Price 1/- each.

**Telsen Valve Holders.**  
Pro. Pat. No. 20286/30.  
An entirely new design in Valve Holders, embodying patent metal spring contacts, which are designed to provide the most efficient contact with the valve legs, whether split or non-split. Low capacity, self locating, supplied with patent soldering tags and hexagon terminal nuts.

**Telsen Five-Pin Valve Holders.** Price 1/3 each.

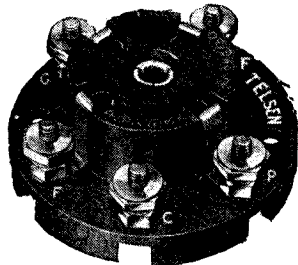

**Telsen Grid Leaks.**  
Absolutely silent and non-microphonic, practically unbreakable, cannot be burnt out, and are unaffected by atmospheric changes. Not being wire wound, there are no capacity effects. Made in capacities: 1, 1.2, 3, 4, and 5 megohms. Price 1/- each.

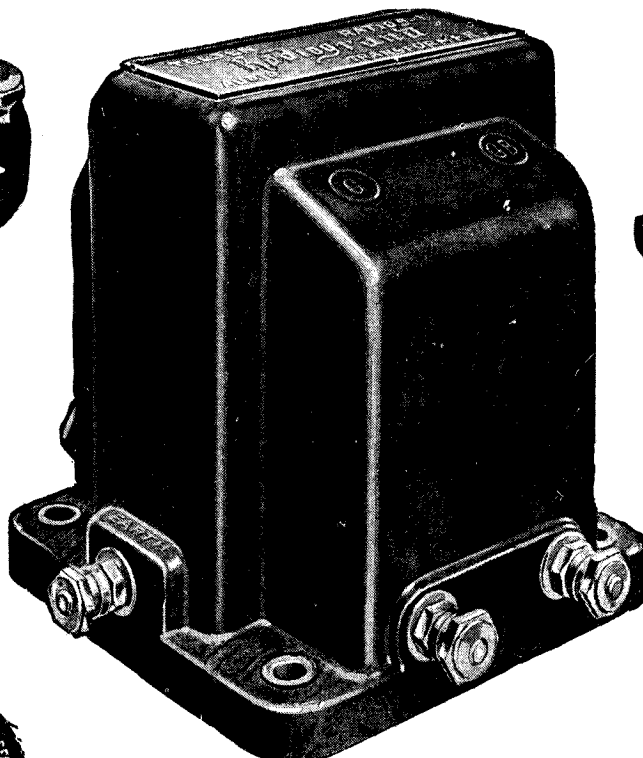

**TELSEN L.F. TRANSFORMERS**

"ACE" - - - - -	Ratios 3-1 & 5-1	8 6
"RADIOGRAND" - - -	3-1 & 5-1	12 6
"RADIOGRAND" - - -	Super Ratio 7-1	17 6

**Every TELSEN Component has the same end in view—to pass on to you the full perfection of the original sound—to establish in every receiver fixed points where there is no possibility of error—to enable the constructor to build his set on foundations which he need never call in question—in other words, when you fit TELSEN COMPONENTS ...**

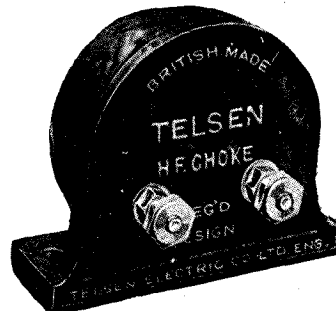

**Telsen H.F. Chokes.** Designed to cover the whole waveband range from 18 to 4,000 metres, extremely low self capacity, shrouded in genuine bakelite. Inductance, 150,000 microhenries; resistance, 400 ohms.  
Price 2/6 each.

**Telsen Fixed (Mica) Condensers.** Shrouded in genuine bakelite, made in capacities up to .002 mfd. Pro. Pat. No. 20287/30. .0003 supplied complete with patent grid-leak clips, to facilitate series or parallel connection. Can be mounted upright or flat. Tested on 500 volts.  
Price 1/- each.

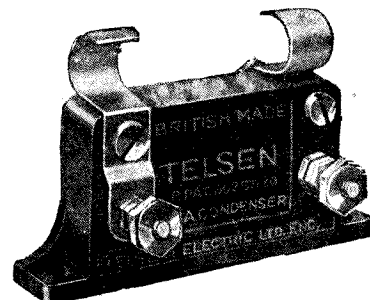

**WHAT THE MIKE TELLS TO**

**TELSEN - TELSEN TELLS TO YOU**

## THE "KILOTRAP" BROADCAST COILS

*With these coils, the "Kilotrap" short-wave receiver or any set which makes use of the "Wireless Constructor" standard short-wave coil may be used on either the medium or long waves.*

THE "Kilotrap" short-wave coils (as used by Mr. Kelsey in the "Kilotrap," a very special two-valve short-wave set described in the WIRELESS CONSTRUCTOR last month) are already well to the fore in matters short-wave.

On another page you will find a selection of alternative short-wave circuits with which these coils can be

### FOR MEDIUM WAVES

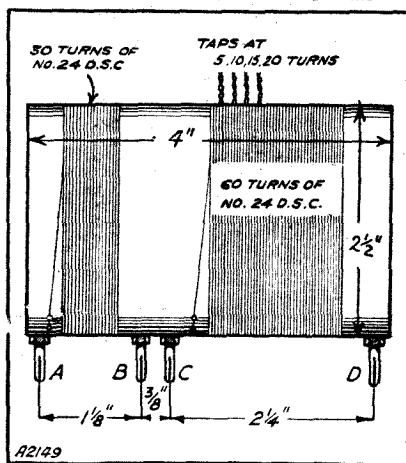

The medium-wave coil is extremely simple to make.

used. But, as you were told last month, sets using these coils can be so arranged that they may be used on broadcast waves as well.

On such sets all that has to be done to go over to medium or long broadcast wave-bands is to pull out the short-wave coil and plug in the applicable broadcast coil.

There are two broadcast coils, one for medium waves and one for long. They are both fully illustrated on this page.

### Not Many Parts Needed

First of all, the materials required: Two formers are needed, one being of the plain type and one having ribs.

The plain former should be 2½ in. in diameter, and the ribbed one 2½ in. to the outside of the ribs. Pirtoid tubing will do fine for the plain former, and the other one should be of ebonite.

You will also require eight split-pins with nuts for holding in position. These may be ordinary valve pins.

The wire for winding the coils is 24 D.S.C. in the case of the medium-wave one and 26 D.S.C. for the long-wave coil. The wire is usually sold in ¼ lb. reels, and although you will not use a quarter of a pound for either coil, the wire is bound to come in useful at a later date.

The diagrams will enable you to follow the construction without difficulty. The pins have to be fitted at the same distances apart in both coils, and you will find the measurements given.

Start winding the medium-wave coil at A. It does not matter in which way you wind so long as both windings are in the same direction.

### Putting on the Windings

The distance from the pin A that the winding is commenced is not important; a rough idea of this measurement, however, can be obtained from the photograph of the coils. Finish this winding of 30 turns at the pin B.

The second winding is started at C and should be wound as though it were a continuation of the first. There are four taps to be made—at the 5th, 10th, 15th and 20th turns, and the winding is finished off at pin D.

Before you can start the long-wave coil a number of slots have to be made in the ribs. These can be cut by means of a flat file about ¼ in. thick,

although the easier method is to use a fretsaw.

The positions of the slots are quite clear in the diagram. The connections to the pins and the direction of winding for this coil are just the same as for the medium-wave coil.

The reaction slots—namely, the two between the pins A and B—have 40 turns in each, and the other slots all

### SLOTS FOR LONG WAVES

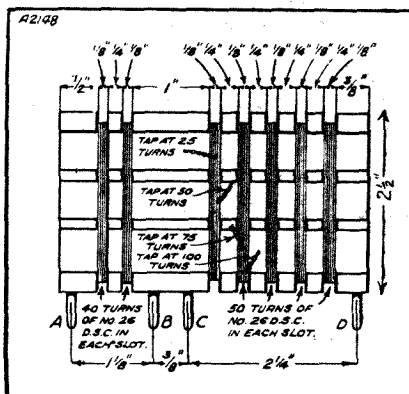

The slots in which the long-wave windings are wound are cut or filed in the ribs of the ebonite former.

have 50 turns in them. When the right number of turns has been put in one slot, pass on to the next and continue winding in the same direction.

In the case of this coil the taps have to be made at 25, 50, 75 and 100 turns.

When in use, the clip which in the case of short waves was joined to one of the turns is taken to one of the taps. Choose the highest number tapping consistent with sufficient selectivity.

Naturally, no details of the mount for these coils is given, as this was described in last month's issue, where it can be referred to if necessary.

### HOW THE FINISHED COILS LOOK

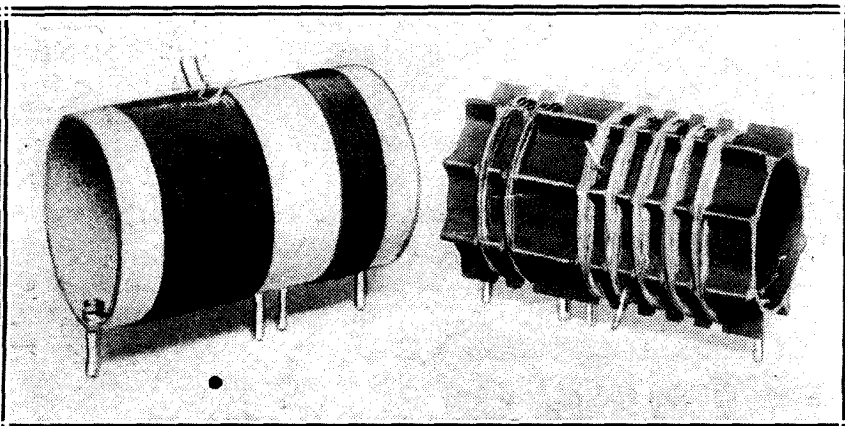

The one on the left, which is wound on a plain former, is for the medium wave-band. The long-wave coil (right) makes use of a slotted ribbed former.



**SMOOTH  
RELIABLE  
RIPPLE-FREE POWER**

**E**XPERTS the world over know that any battery eliminator or all-electric set is the better for using Dubilier Paper Condensers. There are numerous types to suit every requirement.

A broken-down Condenser may cause damage to valves and other apparatus. Dubilier Condensers will never let you down if you use the correct type—their factor of safety is too great.

*Write for our Latest Catalogue.*

**DUBILIER  
CONDENSERS**

DUBILIER CONDENSER Co. (1925) Ltd.,  
Ducon Works, Victoria Road, N. Acton, London, W.3.



ETA Valves have arrived! Quality valves in every respect, they are manufactured with the greatest care and tested again and again before they leave our works.

ETA Valves are sold at a price that will place them high in the esteem of radio-lovers. For purity of tone, dependable efficiency and low current consumption fit ETA Valves. They more than justify their claim of being "the best between aerial and earth." Prices from 7/-

Ask your Radio dealer for particulars of the ETA Valve to suit your set.

**ETA  
VALVES**

THE ELECTRICAL TRADING ASSOCIATION LIMITED,  
ALDWYCH HOUSE, ALDWYCH, W.C.2.

Telegrams: Eltradax, Estrand, London.

Telephone: Holborn 8139.



*A low-voltage grid-bias cell—An enterprising firm—Interesting tests with aeriels.*

**C**ERTAIN little radio items can be very puzzling—until they are explained. A good instance of what I mean by this learned remark is the 9-volt grid-bias cell that is so often recommended for use with 2-volt S.G. valves.

One could even be driven into thinking that perhaps it might be simply a run-down cell of the 1½-volt fraternity. But, on second thoughts, involving the repute of the manufacturers, the idea of such a “cell” has to be turned down.

A series resistance scheme would not be of any use—for, as we all know, G.B. batteries have strict instructions not to let any current pass. What, then, is the solution of the puzzle?

It is simple enough. A metal which is less electro positive in relation to carbon than zinc is employed. Actually, I understand the metal is lead, which produces just the potential difference that is required. Otherwise the construction is more or less normal.

### Those Needle Kicks

**T**ALKING—(I beg your pardon). Writing about grid-bias cells reminds me of a warning I want to pass on to fellow listeners. It concerns the adjustment of grid-bias by noting the amount of kick the milliammeter needle gives on loud passages.

We are usually told to increase the bias if the needle kicks d——. (Just a minute, I'll have to work it out. I always do!) That's it, when the needle kicks down, and vice versa. But unless the meter is very good, or one's eyesight is ultra-rapid, it is usually impossible to decide whether the needle is kicking upwards or downwards, due to its back swing.

Consequently one has to adopt the practice of trying a little more or a little less bias and noting which seems

to calm the needle down more. But as the bias is increased the current goes down, and the kick may look smaller when overloading is worse!

So remember that it is the ratio of kick to steady current that counts. You will then quickly arrive at the correct value, which may otherwise prove somewhat elusive.

### Enterprise

**L**AST month I mentioned that it was high time manufacturers of components gave us a combined reaction condenser and volume con-

### THE WORLD'S YOUNGEST ANNOUNCER



*There is quite an amount of speculation as to the appearance of announcers, and we all have our favourites. This young girl (she is only thirteen), who claims to be the youngest regular announcer in the world, has held this position at her father's station in the United States for over a year.*

trol. Since writing that note I have learnt that one enterprising firm has already obtained a patent for such a device and intends to manufacture it in quantity.

At present I do not know when they will be available, nor have I any details of their design, but as soon as I can lay my hands upon one you may be sure it will quickly find a place on my pet set.

### About Aeriels

**N**OW a word about aeriels. You may be surprised to learn that my home aerial consists of 30 ft. of 24 D.C.C. wire. I do not use a “Moor-side Edge” type aerial and an outfit looking like a talkie installation, for the simple reason I like to get a line on radio from the point of view of the “man-in-the-street.” Forgive me for using this term, but it gets over so nicely just what I mean.

Anyhow, what I want to tell you is, it seems possible that indoor aeriels may not be quite so efficient as is usually supposed. Comparisons between my aerial and a frame with 2-ft. sides show the latter to be miles ahead as a pick-up of radio energy.

### It Should Be!

**D**ID you say you would not have thought it? Well, neither would I! Now a scheme is germinating at the back of my mind to wind a large “frame” of two or so turns round one wall of my den, and to see how good that is.

By the laws of proportion it should be excellent. “Ah!” you remark, “what about directional effects?” But that has not missed my mind. I may have one on each of two walls at right angles, or even a combination of two such loops.

The idea is as yet untried by me, but possibly some of you have already experimented with it. If so, it would be interesting to know what results you obtained.

A. S. C.

# EXTENSER

**A**LWAYS first with progressive Condenser design we announce the CYLDON "Extenser" which will become available to the Radio public on May 1st. Embodying exclusive CYLDON features: Cone bearings; vastly improved insulation over anything yet used in condenser design; straight through spindle; improved one-hole mounting which makes it impossible to loosen the end bearing when fixing to the panel; complete rotation through 360° either way; brush collector contact (superceding

the pigtail) with provision for soldering direct to collector if required; commutator switching system; self-cleaning contacts and phosphor-bronze brushes; plus CYLDON quality and the CYLDON 5 years guarantee. The CYLDON "Extenser" is a complete unit that will readily gang with other CYLDON "Extensers," being as simple to mount, connect and operate as the ordinary old-fashioned type of condenser. **WAIT FOR THE CYLDON "EXTENSER."**

SYDNEY S. BIRD & SONS LTD. CYLDON WORKS, SARNESFIELD ROAD, ENFIELD, MIDDX. Phone Enfield 2071/2



S.F.B. **FIVE YEARS GUARANTEE**

## *Smiler BUNN* *Again!*

Supported by his old crony, Lord Fortworth, and his inimitable Chinese servant, Sing, Mr. Bunn acts with chivalrous courage on behalf of a beautiful heiress whose happiness is over-shadowed by the activities of a ruthless gang. This absorbing and exhilarating story—a swift procession of thrills and surprises—will delight all readers. Do not miss

**“Smiler BUNN and the VENOM TERROR”**  
By **BERTRAM ATKEY**

It begins in the May issue of

# CORNER Magazine

At all Newsagents, etc.

Now on Sale - - 7d.



*Death moved beyond the door.  
Tense and silent they waited.*



### Charges Against the B.B.C.

ONE of the recent campaigns conducted against the B.B.C. by a morning newspaper was successful enough in getting the whole matter discussed in the House of Lords.

The campaign led up to charges against the B.B.C.—charges, in fact, of political bias and inefficiency. The political bias was due, of course, to the fact that the B.B.C. recently allowed a Communist to broadcast a talk on the Soviet Five Year Plan.

When the matter reached the House of Lords it was the Earl of Radnor who declared that there had been instances recently which indicated that there was a tendency on the part of those in charge of the B.B.C. to try to educate the people of this country towards Socialism, and even towards Communism.

### Russian Official Broadcasts

The noble lord went on to condemn broadcast publicity of a ballot scheme and discussions on Russia. "I am informed," he said, "that Mr. Maurice Dobb (the gentleman who broadcast the talk on Russia) is in effect a paid official of the Russian Government.

"Either there is political bias within the B.B.C. organisation," he went on, "or there is such a degree of inefficiency in the supervision of the programmes that those who are interested politically against the welfare of this country are enabled to slip past the watch dogs."

### Not Substantiated

We won't quote any more of the charges made against the B.B.C., because, as our readers probably know, they all fell through; and, in fact, those who made them probably wished they hadn't, because there

was not one iota of proof to substantiate the charge that the B.B.C. was politically biased.

In fact, Lord Ponsonby, in the House of Lords, referred to the charge as "a steam hammer which had been used to crack a nut, and when opened the nut was found to contain no kernel."

### Too Much Discretion

The "Evening Standard" reported that the view of the House of Lords was entirely with Lord Gainford in his calm defence of the B.B.C. policy. "Obviously a daily programme addressed to 17,000,000 listeners must," says the "Evening Standard," "on occasion rouse the angry passions of a certain section of the community."

We agree with the "Evening Standard" when it says that it is not the B.B.C.'s indiscretion which is to blame, but its absurd discretion.

It is true that controversial matter is the bugbear of every B.B.C. official, with the inevitable result that the B.B.C.'s programmes, although quite sincere, are far, far too frequently dull.

### Our Efficient B.B.C.

The Earl of Crawford, by the way, also had a few words to say in defence

(Continued on page 48.)

# LOTUS CONDENSERS

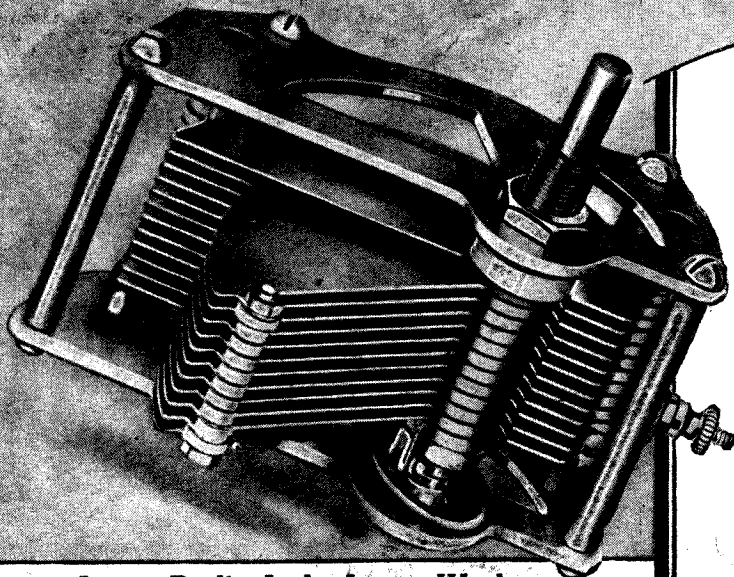

Lotus Radio Ltd., Lotus Works,  
Mill Lane, Liverpool.

When making your "Plus-Stage" One into a "Plus-Stage" Two, remember that a '0005 Lotus Variable Logarithmic Condenser, Price 5/9, was specified in the "Plus-Stage" One in the March issue of the "Wireless Constructor." Make sure you have this Condenser in your set—it will make all the difference to its performance.

In other capacities:—

'0003 .. 5/6	'00035 .. 5/7
'00025 .. 5/3	'00015 .. 5/-

Also Differential Condensers from 5/3, Reaction Condensers from 4/9, and Drum Dial for Ganged Condensers:—

With one '0005 Condenser	15/3
" two " " "	22/-
" three " " "	28/9

From every Wireless Dealer.



**MAKE YOURS A MAINS SET FOR LESS THAN £3**

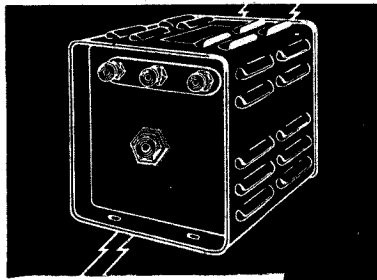

If your house is supplied with alternating current, as little as £2 15 0 will enable you to run your radio set from the mains—less than you would spend on dry batteries alone during the course of a year. As you know, a rectifier is necessary when employing alternating current to run a wireless set. Of the many types of rectifier obtainable, none can claim so many virtues as the "Westinghouse." It is all-metal—substantial—compact—never needs attention—and its life is so prolonged we haven't yet been able to determine its limit. The H.T.5, priced at 15/-, is a particularly popular style. Most good radio-dealers sell Westinghouse Rectifiers, but if you find any difficulty in obtaining the Rectifier, or advice as to the most suitable unit for your particular purpose, write to us and we will give you the name of your nearest stockist.

**WESTINGHOUSE**

**METAL RECTIFIERS**

The Westinghouse Brake & Saxby Signal Co., Ltd., 82, York Road, King's Cross, London, N.1. Telephone: North 2415.

*A Wonderful Book for FILM FANS!*



**OVER 500 Biographies of Famous FILM STARS**

**EIGHT Full Page PORTRAIT PLATES of Well-known Stars**

*Scenes and Casts of this Year's Best Pictures*

**PICTURE SHOW WHO'S WHO ON THE SCREEN**

On Sale Everywhere . . . . . 6<sup>d</sup>.

# THE FOUNDATION OF A GOOD SET—A GOOD EARTH

The new Wearite Earth Tube gives perfect earth contact and is provided with a most ingenious device by which a perfect and lasting soldered joint is obtained just by striking a match! Every listener who has attempted to make a good soldered joint out-of-doors will appreciate this special Wearite feature. Made of solid drawn copper of substantial thickness and fitted with cast-iron driving head. Price, only 3/6

Send for descriptive leaflet.

## WEARITE COMPONENTS

WRIGHT & WEAIRE, Ltd., 740, High Rd., Tottenham, N.17  
Telephone: TOTTENHAM 3847.

**CHEAPER ELECTRIC RADIO**  
by



Write for FREE Art Booklet, with Colour Supplement, "Cheaper Electric Radio by Regentone." REGENTONE LIMITED, Regentone House, 21, Bartlett's Bldgs., London, E.C.4 Telephone: Central 8745 (5 lines). Irish Free State Distributors: Kelly and Shiel, Ltd., 47, Fleet Street, Dublin

## HOUSE YOUR PORTABLE IN



THE **CAMCO** CASEWORK "RIVERSIDE"

You must have a good cabinet for your portable. The Cameo "Riverside" is strong and well built and yet is handsome and attractive. Covered in good quality blue leatherette. Inner frame, baseboard, etc. As used by leading manufacturers. With polished wood panel, 14 in. x 6 1/2 in., 45/-

Send Coupon for free Catalogue to:  
**CARRINGTON Mfg., Co., Ltd.,**  
24, Hatton Garden, LONDON, E.C. 1.  
(Phone: Holb. 8202), (Works: S. Croydon)

Name.....  
Address.....  
W.C.2

**OUR NEWS BULLETIN**

—continued from page 46

of the B.B.C. He said: "I don't know whether Lord Radnor has studied the broadcast system of America. It is deplorable, it is grotesque, laughable, compared with the efficiency of our broadcasting here.

Those who so lightheartedly attacked the B.B.C. should compare our situation with what prevails elsewhere. I have no hesitation in saying that there are few countries in which broadcasting is more efficient than in our own."

**Two Significant Items**

It also came out in this debate in the House of Lords that the B.B.C. last year received 54,000 letters commending the programmes, and only 3,492 were adversely critical.

It also appears the B.B.C. feels a grievance at the amount of money paid to the Government out of that received for licences. Last year this amounted to £441,000.

The B.B.C. has some reason to feel a grievance, as readers of the WIRELESS CONSTRUCTOR will agree.

**More Interference Ahead**

As we go to press we understand that the preliminary tests of the new North Regional station are proving very satisfactory, and that before the end of the present month the station should be on the air for short periods.

Readers will remember that the North Regional wave-length of 479.2

**Interested in the Foreigners?**

They are coming over with a punch, aren't they? And if you get some you don't recognise, you ought to read

**THE WORLD'S PROGRAMMES**

—a feature that is simply invaluable to the "Distance" Man!—in the April

**"MODERN WIRELESS"**

Now On Sale 1/- Get Yours Now!

metres will be taken from the Midland Regional, the latter using 399 metres for a short time at any rate.

One writer in the Press has pointed out that this looks like trouble from the new Swiss station at Sottens, which has a wave-length of 403

metres—that is, unless the Midland Regional pushes out a few extra kilowatts.

Budapest seems to be coming over well these days; and so it ought, for this station uses a power of 23 kw. Brussels, Nol., although coming over well, is not using anything like its full power; but the programmes from both these stations are well above the average, and if you haven't tuned them in lately, have a shot at them.

Milan will shortly be working on the same power as Brussels, but as there is a separation of 8 metres it is not likely that there will be any serious interference.

**Who's Who**

There was quite a fuss in the papers the other day about the identity of Alexander and Mose, and eventually it transpired that Mose is no other than Mr. Billy Bennett, who is well known to probably thousands of our readers as "Billy Bennett—Almost a Gentleman."

Alexander is Mr. James Carew, the well-known actor who was the husband of the late Dame Ellen Terry.

Although officials at the B.B.C. were sworn to secrecy, the identity

(Continued on page 50.)

**MAGNUM PRODUCTS**

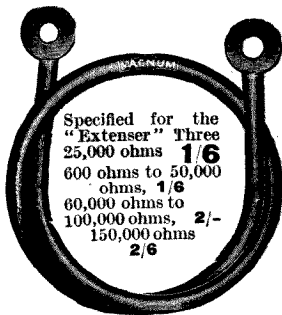

Specified for the "Extenser" Three  
25,000 ohms 1/6  
600 ohms to 50,000 ohms, 1/6  
60,000 ohms to 100,000 ohms, 2/-  
150,000 ohms 2/6

**SPAGHETTI WIRE-WOUND RESISTANCES**

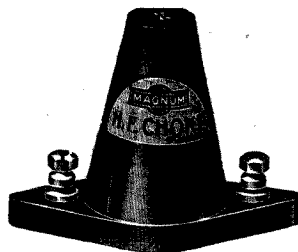

**MAGNUM H.F. CHOKE**

Specified for the "Plus-Stage" Two, and many other high-grade sets. 7/6

"Wireless Constructor" sets can be supplied ready wired and tested or as constructional kits. Lists, including particulars of the Magnum "Band Pass" Four A.C. Mains Set, and "Universal Three" Short-Waver, etc., Free on request.

**BURNE-JONES & CO., LTD.**

"MAGNUM" HOUSE, 296, BOROUGH HIGH ST., LONDON, S.E.1.

Telephones: Hop 6257 & 6258.

SCOTTISH AGENT: Mr. ROSS WALLACE, 54, Gordon St., GLASGOW.

**High-Grade RADIO GRAMOPHONE CABINET**

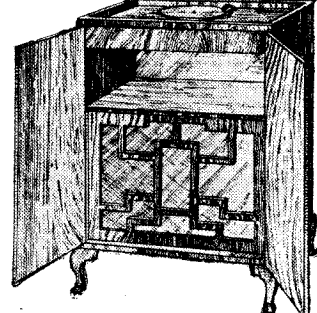

of exclusive modern design, hand-made and polished on Queen Anne legs.

Figured Oak - - - - - £5 : 19 : 6

Figured Walnut or Mahogany £6 : 17 : 6

Carriage paid.

**THE ACME OF CRAFTSMANSHIP**

Radio-Gram. Cabinets from £3 : 19 : 6 to £21

Wireless Cabinets - - - - - from £2

Photographs and 30-page illustrated catalogue free.

Cabinets made to order a speciality.

Furniture at Maker's prices.

**GILBERT, CABINET MAKER, SWINDON.**

Estimates free.

Estd. 1866.

**DUPLEX TRANSFORMER**

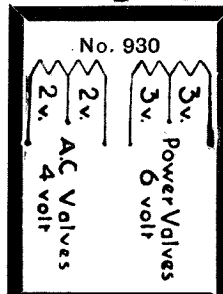

Designed for the dual purpose of indirectly heating the filaments of two, three, or four A.C. Valves and directly heating the filaments of Power Valves, the Heayberd No. 930 Duplex Transformer is unequalled in the L.T. class. With the use of the Heayberd M.1 Rectifier it is possible to charge 2-, 4- and 6-volt accumulators. No less than seven different A.C. voltage tappings are available, viz.: 2, 3, 4, 5, 6, 8 and 10 volts. Accurate and steady voltage delivery. This is a model capable of almost limitless usage.

Send 3d. stamps for Heayberd Lists showing all the new Models with full information and diagrams on how to use them.



10, Finsbury St., LONDON, E.C.2.

Tel.: MET. 7516

**A NEW W.B.  
PERMANENT MAGNET  
MOVING-COIL SPEAKER  
FOR £4-10-0**

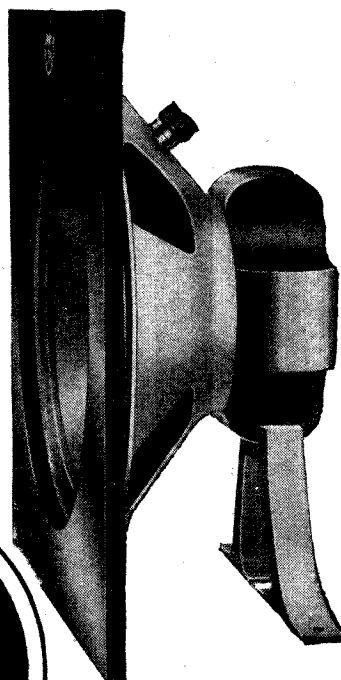

So sensitive that any 2- or 3-valve set will drive it—no mains or batteries needed.

Identical with the very successful model introduced earlier this season—only the Darwin Sheffield-made Cobalt-Steel Magnet is not quite so massive.

Hear this new W.B. Moving-Coil Speaker at your dealer's. Ask him for the free colour folder or write to us direct.

*The standard model has a low resistance winding. A multi-ratio step-down transformer must be used between set and speaker, suitable ratios for the average valve set being between 15 and 25/1.*

*Made by the Makers of the famous W.B. Cone Speakers, Switches and Valveholders.*

Type P.M.2. chassis completely assembled with 11½ in. x 11 in. baffle board.

**£4 : 10 : 0**

A double-ratio step-down transformer can be supplied attached to the Speaker for 15/- extra.

*Whiteley Electrical Radio Co., Ltd., Radio Works, Nottingham Road, Mansfield, Notts. Irish Free State Distributors: Kelly & Shiel, Ltd., 47, Fleet St., Dublin*

**THE WORLD'S PROGRAMMES**

All who are interested in the reception of distant stations should make a point of purchasing

**“MODERN WIRELESS”**

in which appears a special section especially devoted to this particularly fascinating aspect of radio. In it you will find all the latest news and views about those distant programmes, and a mass of interesting information including technical tips and hints on how to handle sets for best DX results.

**ON SALE EVERY MONTH**

**PRICE 1/-**



**OHMITE**  
Anode Resistances.  
All values, 100 ohms  
to 500,000 ohms.

**2/3** each

Ohmite and Megite Resistances are constant in value, of negligible self capacity and non inductive. Dead silent and always reliable, they

provide the most effective resistance on the market, giving the full range of values required. Supplied with vertical or upright holders of superior brown bakelite construction 6d. extra. Graham Farish components carry a written guarantee of accuracy.

Ask your dealer to obtain, or write direct to

**GRAHAM FARISH**

LIMITED. BROMLEY, KENT

**MEGITE**  
Grid Leak. All values,  
1 megohm to 5 meg-  
ohms.

**2/-** each

**OUR NEWS BULLETIN**

—continued from page 48.

of Mr. Bennett eventually leaked out.

It is really extraordinary, talking of secrecy at the B.B.C., how well the identity of Mr. A. J. Alan has been kept. We met him recently, but were sworn to secrecy also, and therefore cannot impart the solution to the great mystery to readers of the WIRELESS CONSTRUCTOR.

However, Mr. A. J. Alan in private life is a well-known Foreign Office official, and we were privileged a few months ago to listen to a reading of one of his new stories, and, believe us, in private life Mr. Alan reads just as attractively and humorously as he does before the microphone.

**Football League and Mike**

It is understood that members of the Football League are now taking steps with a view to passing a resolution prohibiting the broadcasting of football matches next season. According to the "News Chronicle," it has been pointed out that where towns possess two teams, the supporters of one will not go to see the other play when an away game in which the favourites are taking part is being broadcast, with the result that attendances have been smaller.

**"Health Ban on Radio"**

A doctor writing in the "Daily Express" maintains that for the man of business whose working hours give full employment for the brain, one of the most unprofitable hobbies to yield to is the fascination of radio.

This doctor maintains that wireless undoubtedly tends to lead to lack of exercise, and that many valuable minutes, or even hours, that might be far more profitably spent, so far as health is concerned, are passed in the depths of a comfortable armchair when listening-in.

Well, well, well! What will doctors suggest next?

**A Grand Old Man**

Professor Sir John Ambrose Fleming, the inventor of the thermionic valve, was presented the other day at the Imperial College of Science with the Duddell Medal of the Physical Society—the highest honour that the Society can bestow.

It is rather like the irony of fate that Sir John, whose invention has enabled so many millions of people to enhance the pleasure of listening-

in, should himself suffer from deafness; but, despite this drawback, his dynamic personality and his tremendous intellectual energy have not been minimised, and to-day, although at least eighty years of age, he is as energetic and as interested in science as many a colleague half his age.

**"Wind Up"**

The postponement of the "Krassin Saves Italia" play was rather farcical, for it appears the B.B.C. got the "wind up," as it was alleged the play contained a lot of Soviet propaganda.

This is another instance of the B.B.C.'s discretion running away with it. How we do hope that some day the B.B.C. will be indiscreet—or, if not indiscreet, at least a little adventuresome. "Krassin Saves Italia" was a jolly good idea for a play, as it was based on actual fact, and just because one or two speeches contained red propaganda it was assumed that it would be dangerous for people to listen to it.

Well, our sympathies are with Cecil Lewis, the translator and producer. It seems he has had a lot of work for nothing!

\*\*\*\*\*  
\* **THE** \*  
\* **"KELSEY" ADAPTOR** \*  
\* *Reader Gets America "Any* \*  
\* *Night."* \*  
\*\*\*\*\*

Sir,—May I have the pleasure of thanking you for your wonderful "Kelsey" adaptor, which is proving itself every night to be a real short-wave adaptor, for I can log any night K D K A and W G Y. Radio Roma and Berlin are on all day, and enough Morse to blow your head off.

I see that G. T. Kelsey gives us a new wave-band to try using another coil, but here is an idea for those who would like to try it.

Wind on the coil former the 8 turns for the grid and the 10 turns for reaction and fix this in the same way as before, then take a flex lead from the plate of the valve to the end of reaction coil with a clip on the end of the flex so as to go up or down the coil. Then take another flex lead from the potmeter, with another clip on it, and clip this on to the grid coil, either at the fourth or eighth turn for the wave-length wanted; the same with the reaction fifth or tenth turn.

All the luck in the world,

Yours truly,

W. SMITH.

Motherwell.

# 64 Page Motoring Handbook **FREE**

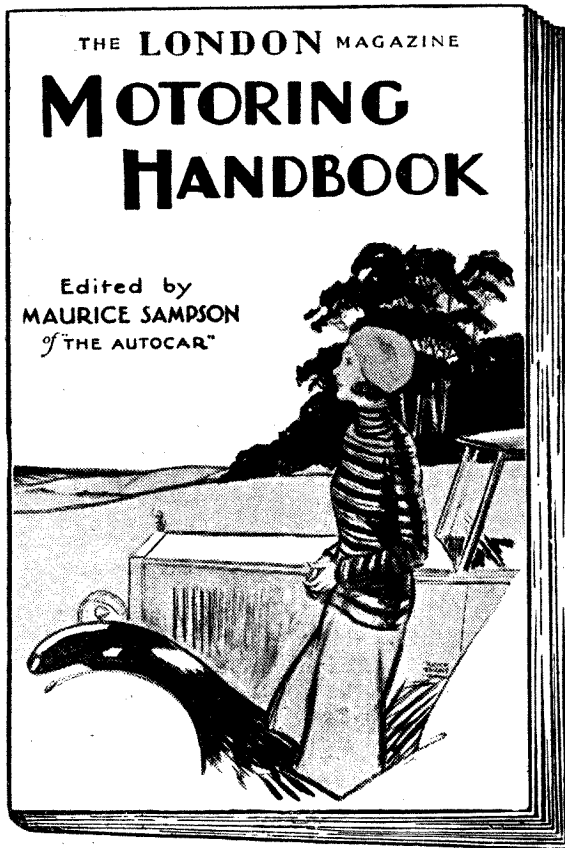

Every user of the road will welcome this invaluable motoring handbook. Edited by Mr. Maurice Sampson of "The Autocar," it is a veritable mine of useful information. Sixty-four pages of advice and hints from acknowledged experts, five road maps printed in two colours and numerous black-and-white illustrations amplifying the text. Such is the LONDON MAGAZINE MOTORING HANDBOOK, a copy of which is presented FREE with the MAY Number of this splendid magazine. A few of the contents, listed below, will give you some idea of the utility of this amazing gift.

**MOTORISTS and INSURANCE  
RUNNING-IN the NEW CAR  
DO's and DON'T's for DRIVERS  
BATTERIES and their BURDENS  
CAUSE and PREVENTION of FIRE  
TOURS in DEVON, NORTH WALES, etc.  
TYRES—BRAKES—IGNITION  
Useful TOOLS for CAR and GARAGE  
MOTORISTS AND THE LAW**

Apart from the free gift, which is alone worth far more than the price of the magazine, there is the usual programme of fiction—the finest work of the best-known writers—articles, interesting, amusing and splendidly illustrated, and many other fascinating features. Don't miss this bumper issue of

## The NEW LONDON Magazine

*For MAY - On Sale Everywhere - 6d.*

Specified  
for the  
"EXTENSER"  
THREE  
IGRANIC  
MIDGET  
TRANSFORMER

A small transformer with  
a BIG Performance

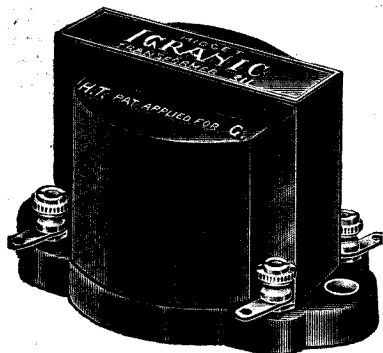

PRICE 10/6

IGRANIC  
"MEGOSTAT"  
Volume Control

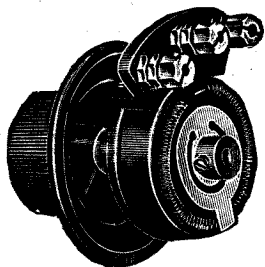

PRICE  
6/-

If you are unable to  
obtain Igranic com-  
ponents locally, write  
direct to us to Dept.  
J.1123.



# PICK-UP HINTS and TIPS

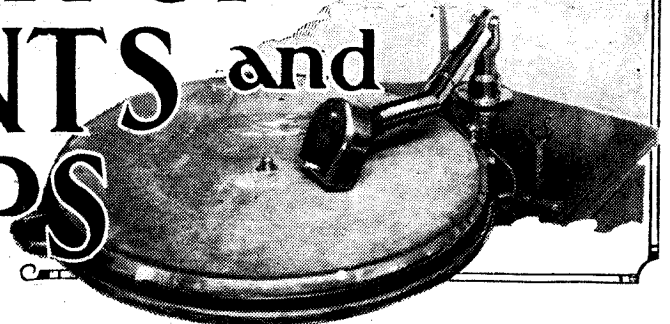

Interesting notes on various practical aspects of radio-gram reproduction.

By A. BOSWELL.

IN this section of the WIRELESS CONSTRUCTOR from time to time I want to give some miscellaneous hints that may help readers to get the best out of their radio-grams.

Too many such outfits are spoiled because one or two little things are forgotten. For instance, long pick-up leads are always liable to cause trouble. Keep them as short as you can if you want to get the very finest reproduction.

### The Volume Control

Another point is the position of the volume control; many sets have the usual potentiometer volume control in the first L.F. stage, but if you are switching your pick-up in the detector stage you really need another control—to control the input.

Otherwise, if the pick-up is a sensitive one you stand quite a good chance of overloading the first valve on specially loud passages. A volume control across the pick-up enables you to prevent this, and incidentally gives you the best general control possible.

### Keep the Lid On

A minor point that is worth while watching is the type of lid used to enclose the pick-up while it is playing. If care is not taken to suppress the direct noise caused by the vibration of the needle, you may find a peculiarly distracting edge or roughness superimposed on the reproduction.

This noise is not due to distortion, and careful examination will prove that it does not emanate from the loud speaker, but comes direct from the pick-up. It sounds like the distortion caused by overloading, and the only way to avoid it is to enclose the pick-up in a sufficiently sound-tight chamber.

Not all pick-ups do it badly, but I have not come across a perfectly

silent one. The sensitive, highly-damped pick-ups seem to be the worst offenders, though this "chatter" does not necessarily mean that they are in any way inefficient or inaccurate in their response.

I am often asked if it is possible to cut out the scratch of record reproduction "like the B.B.C. do." Yes and no! I do not know what circuits

### TRY THESE

#### SUGGESTED TEST RECORDS

	Vocal.		
The Menin Gate	Peter Dawson	H.M.V.	
Mr. Potter Waxes	Gillie Potter	Columbia.	
Historical			
High Water	Paul Robeson	H.M.V.	
	Brass Instruments.		
Memories of Sullivan	Jack Hylton	H.M.V.	
Eniale Blues	Boyd Senter	Parlophone	
	Piano Records.		
Hungarian Rhapsody No. 6	Lenitzki	H.M.V.	
Scherzo No. 3 (Chopin)	"	H.M.V.	
	Orchestral.		
Midsummer Night's Dream	Berlin State Opera	H.M.V.	
Intermezzo (Cavalleria Rusticana)	Sir Henry Wood and Orchestra	Columbia.	
	Cinema Organ.		
Rhapsody in Blue	Quentin Maclean	Columbia.	
Hungarian Rhapsody No. 2	"	Columbia.	
	Grand Organ.		
Largo (Handel)	Cunningham	H.M.V.	
Scherzo	"	H.M.V.	

they use, and I doubt whether quite the same probably elaborate system of scratch filtering could be successfully applied by the average constructor. But there are methods of attenuating the scratch, and a useful article on the subject has just been published in our contemporary "Modern Wireless."

The question of whether or no it is an advantage to cut down scratch is a moot one, and one that you

(Continued on page 53.)

**PICK-UP HINTS AND TIPS**

—continued from page 52

must answer for yourself, bearing in mind the fact that scratch removal means attenuation of the higher frequencies and consequent loss of brilliance.

A gradual control of attenuation can be carried out, however, with quite simple apparatus, as the article I have referred to (The "M.W." "Hi-Tone Control") explains. In many cases a .0003-mfd. condenser across the pick-up helps, but it may cause a peculiar sort of "tuning," and if quality seems to suffer try a .25-meg. resistance across as well.

Another scheme is to use a .5-meg. variable resistance in series with a .001-mfd. condenser across the pick-up.

**Quite Easily Chosen**

Test records are not really difficult to choose, as many correspondents seem to think. They must be of good make, however, and should bring out clearly those particular instruments the reproduction of which you want to judge on your set.

For instance, if you want to test your set on high frequencies, for brilliance or pick-up reproduction, one of Boyd Senter's clarinet solos (with piano and guitar accompaniment) will be ideal.

These are Parlophones, and I suggest such items as "Enial Blues" or "Wabash Blues."

Musically they may not be everybody's choice, but some very fine clarinet notes are provided, and as this instrument is rich in high harmonics any "smoothing" or splitting of the notes will soon show up. The guitar accompaniment is also very valuable.

Jack Payne's Columbia recordings are also most useful, for here one can compare the "canned" version with the original. "Sittin' on a Five-Barred Gate" is a good one to try your set on. And so is Jack Hylton's "The King's Horses" (H.M.V.). This latter band is particularly good in the brass.

**A WELL-KNOWN J.B. CONDENSER**

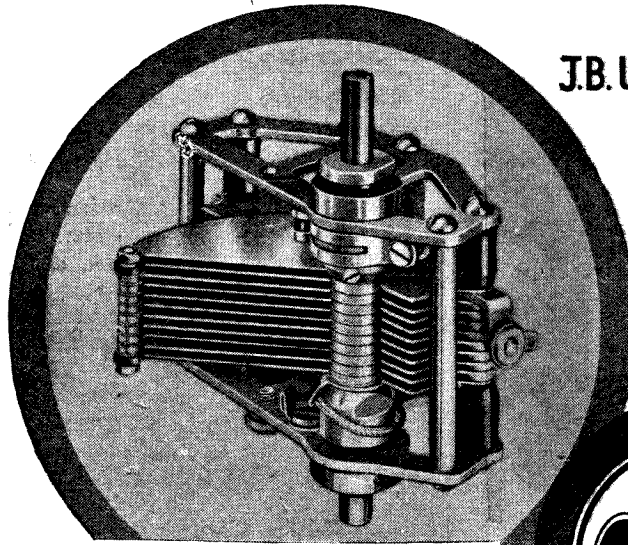

**J.B. UNIVERSAL LOG**



A special feature of the J.B. Universal Log Condenser is its adaptability. It can be ganged; it can be mounted with either end next the panel; or screwed to the baseboard; it can be mounted either left- or right-hand. Extremely low-loss yet rigid construction. Frame and vanes of extra hard brass; one-hole fixing. Takes any panel up to 1/2". Pigtail connection to rotor.

**PRECISION INSTRUMENTS**

	PRICES:		
.0005	9/6	.0003	9/-
.00025	8/9	.00015	8/9
4" J.B. Bakelite Dials, Black, 1/6 extra; Mahogany, 2/- extra.			

Advertisement of Jackson Bros., 72, St. Thomas Street, London, S.E.1. Telephone: Hop 1337.

**RADIO & POWER SWITCHES**

**LYONS "B.A.T." "Q.M.B." SWITCHES ARE THOROUGHLY RELIABLE**

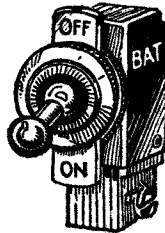

Latest model illustrated. Easily breaks 3 amps. at 250 volts. Q.M.B. action. Indicating. Live parts are insulated from lever. One hole fixing. Nickel finish. Small. Neat. Guaranteed fully.

- No. 728 with Soldering Tags .. 2/- each
- No. 730 with Screw Terminals 2/3 each
- No. 729, 2-way Type .. .. 2/6 each
- No. R.671, S.P. 4-way .. .. 3/9 each
- No. 156, D.P. Model, 5 Amp. .. 3/6 each
- No. D.55, D.P.D.T. Model .. 5/3 each

**MANY OTHER TYPES.**

Send for Free Booklet "Switches for Radio and Power," with 20 new circuits.

**CLAUDE LYONS LTD.**

76, OLDHALL ST., LIVERPOOL  
40, BUCKINGHAM GATE, S.W.1

**PROUD OF YOUR SET?**

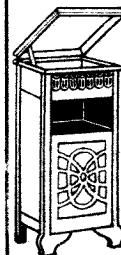

You will be when it is contained in a "Castle Royal" cabinet! Constructed of finest grained oak, and highly French polished, this cabinet is a fine piece of furniture designed to accommodate a complete radio-gramophone outfit

**Model No. 1** (as illustration)

£4 10 0 Carr. paid.

**Model No. 2**, with framed doors, £5 10 0 Carr. paid.

Deposit on packing cases 7/6 extra. Case returnable and money refunded at once. Satisfaction, or money returned. Illustrated folder free on request.

**HERBERT ELLAMS**  
274, DEANS GATE, MANCHESTER

**SAY SIX-SIXTY**

Write for FREE BOOKLET giving full details of the whole Six-Sixty range.

THE POWER UNIT THAT SUPPLIES THOSE EXTRA VOLTS—SAY SIX-SIXTY FOR 200 VOLTS H.T. Automatic Grid Bias, too, safeguarding your valves. Replaces existing batteries in a moment—takes no more room. Price £6 : 6 : 0. An extra winding for L.T. enables you to use the unit at any time as a complete mains-drive for A.C. Valves.

Six-Sixty Radio Co., Ltd., Six-Sixty House, 17/18, Rathbone Place, Oxford Street, London, W.1. Tel.: Museum 6116-7.

**PUT  
YOUR SET  
IN THE  
VOXKIT**

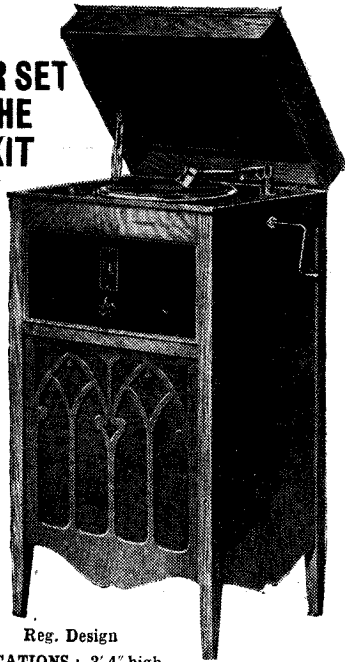

Reg. Design

**SPECIFICATIONS:** 3'4" high x 1'10" wide x 1'5" deep. Panel size, 18" x 8". Base-board depth 14". Loud-speaker compartment suitable for Double Linen Diaphragm or Moving-Coil Speakers, 17 1/2" x 17" x 14". In hand French-polished Oak; removable back; lift-up lid; and silk-covered fret.

CASH PRICE

**63/-**

or 6 monthly payments of 11/-

**PETO-SCOTT CO. LTD.**

77, CITY ROAD, LONDON, E.C.1.  
62, HIGH HOLBORN, W.C.1.

## Engineers' Guide

containing the widest choice of engineering courses in the world

Qualify for a well-paid post in Engineering by studying at home with The T.I.G.B. Become an A.M.I.C.E., A.M.I.Mech.E., A.M.I.E.E., etc. Training until Successful is Guaranteed. WRITE NOW for "The Engineer's Guide to Success," stating the branch, post or qualification that interests you, to

**THE TECHNOLOGICAL INSTITUTE OF GT. BRIT.,**

21, Temple Bar House, London, E.C.4 (Founded 1917; 17,000 Successes).



**Free!**  
128 PAGES

**To Success**

## PAREX

SCREENS as recommended for the COILS, ETC.

**"EXTENSER" THREE**

"P.W." & "M.W." DUAL COILS

APPROVED BY 12/6 "P.W." each

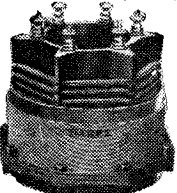

Each coil tested and calibrated on actual broadcasting. Delivery by return.  
Ebonite Panel, 9" x 7", 4/6.  
Terminal strip, 18" x 2", 3/6.  
Metal Panel, 10" x 7", 3/6.  
All drilled to specification.  
Differential Cond., 4/6.  
H.F. Choke, 3/6.  
Copper Foil, 18" x 12", 3/6.

**E. PAROUSSI** 10, Featherstone Buildings, High Holborn, London, W.C.1  
Phone: Chancery 7010

PLEASE be sure to mention "Wireless Constructor" when communicating with Advertisers. Thanks!

## WITH PICK-UP AND SPEAKER

—continued from page 36

While on this subject of new pick-ups it is interesting to note that the Marconiphone Co. are supplying a new model known as No. 10.

We are informed that the instrument retains the same electrical characteristics as the old one, and that the performance is unaltered. The Marconiphone pick-up, as readers probably know, is one of the most sensitive on the market.

The changes are merely in the nature of refinements; for example, quick-grip spring terminals are now fitted, and the moulded base is larger and more robust. The instrument, instead of being black, is now brown in colour, and the price is as before, viz., 3 guineas.

### First-Class Electric Motor

Messrs. Claude Lyons, Ltd., 40, Buckingham Gate, S.W.1, have sent us one of the "Diehl" electric gramophone motors which they are handling in this country. The motor is of the induction type and is of American origin.

It retails at 4 guineas, and should be of interest to those who are contemplating the construction of amplifiers or radio-gram receivers for operating from A.C. mains.

The turntable is a beautiful moulding of bakelite, and the main driving shaft is driven by worm and worm wheel, a cork clutch being fitted to prevent any accidental damage to the gears.

There is a speed regulator and an automatic on-off switch. The motor contains no brushes, and needs practically no attention.

Messrs. Claude Lyons state that each motor is guaranteed for a year.

The current consumption is rated at 18 watts.

We found the motor to be mechanically silent in operation, and in addition there was no hum or other interference when the radio-gram equipment was working.

### A MAGNIFICENT RADIO MAGAZINE

Make a point of glancing through a copy of "MODERN WIRELESS" some time. We are sure you will then buy it.

Every Month. Price One Shilling.

## A NEW BELLING-LEE SPADE TERMINAL for

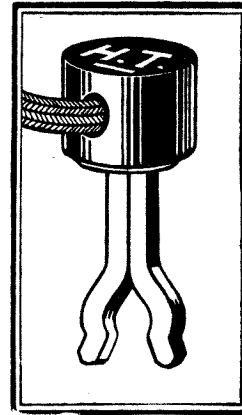

**2<sup>D</sup>.**

All British. Handles permanently engraved. Side-entry—the whole flex gripped, copper, rubber and fray.

Patent Nos.: 329465 & 12423/30

Use it for neat and permanent connections to receiver terminals, tapped coils, L.T. accumulators, etc.—for hook-ups, clipped on to any screw or wire!

The new Belling-Lee Spade Terminal clips on to any terminal stem and makes good contact with its powerful spring prongs. Connecting up becomes a one-hand job.

See it at your dealer's.

**BELLING-LEE**  
FOR EVERY RADIO CONNECTION

Advt. of Belling & Lee, Ltd., Queensway Wks., Ponders End, Middlesex.

### Radio Furniture De Luxe!

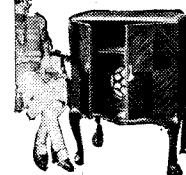

To house your Set or Radio-Gram—the sort people desire to possess and keep. (Used by famous Experts, B.B.C.) Advantages also of **PIANO TONE!** Baffle chamber, rich mellow tone that thrills. Why risk cheap, drummy Cabinet noises? £4 to £15. Piano finish. 7 days' Approval. (Cash or deferred.) Lists **FREE!** PICKETTS Radio Furniture (C.W.), Albion Rd., Bexleyheath.

## QUIS?

If you had to devise an experiment to show quantitatively how a sprung valveholder damped out vibration which a solid holder transmitted to the valve, how would you set about it? There are no prizes, but as a test for your ingenuity you might care to sketch out an idea and then write to us for a little booklet, "The Elimination of Pong," which describes how a well-known scientist set about the job—and what he found.

**THE BENJAMIN ELECTRIC LTD.,**  
Tariff Road, Tottenham, N.17

**BENJAMIN**



\*\*\*\*\*  
**THE "KELSEY"**  
**ADAPTOR**  
 \*\*\*\*\*

Sir,—For some months past I have endeavoured to adapt my wireless set (Det. and 2 L.F.) to the ultra-short waves with little success. I was troubled by very bad "hand-capacity" and in the end gave up the short waves as a bad job.

Well, in the February issue of the WIRELESS CONSTRUCTOR I read with interest the article introducing the "Kelsey" Adaptor. To cut a long story short, I decided to build it, and I must say results are simply amazing.

**Picked from the Log**

Here are some of the principal stations I have received during the last fortnight.

	Metres
Schenectady (W 2 X A D) ..	19-56
Pittsburg East (W 8 X K) ..	25-25
W 3 X A L (Bound Brook, N.J.) ..	49-18
W 8 X K (Pittsburg East) ..	48-86
Saigon (China) ..	49
Buenos Aires (L S X) ..	28-98
Zeesen ..	31-38
Rome ..	25-4
Vatican City ..	50-26
Philadelphia (Pa.) (W 3 X A V)	49-5
Chicago (W 9 X F) ..	49-83
Richmond Hill (N.Y.) (W 2 X E)	49-02
W 2 X A F ..	31-48
G 5 S W ..	25-53

The majority of these stations have given from time to time quite good L.S. reception. W 3 X A L (49-18 metres) generally gives excellent reception on L.S. between 10 and 11 p.m. G.M.T. This station suffers badly from fading on some nights, but on the whole is very reliable. W 8 X K (25-25 metres) gives good headphone signals from 5 p.m. onwards; on some evenings it fades out at about 7 p.m. Enormous L.S. signals are given by Rome, 25-4; Zeesen, 31-38; Vatican City, 50-26 metres.

**A Real Boon**

I always thought that short-wave work required an elaborate set costing many pounds, but now I have an entirely different view. The "Kelsey" Adaptor is a real boon to those who, like myself, want an efficient instrument at a small outlay.

The set is amazingly easy to handle, and is entirely free from hand-capacity. I find no difficulty in tuning whatever.

Wishing the WIRELESS CONSTRUCTOR every success,

Yours faithfully,  
 Southampton. DENIS STEVENS.

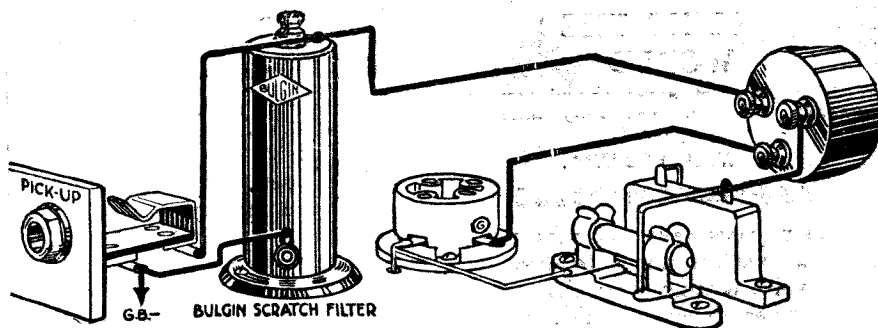

**MAKE A GOOD JOB OF IT!**

To connect a pick-up properly you need Bulgin components.

Think of the convenience of having the pick-up leads permanently connected at the back of the set, while a change-over switch on the panel enables the set to be used as either a radio receiver or gramophone amplifier. The above diagram shows how simply this is carried out with Bulgin components. In this case an efficient scratch filter is incorporated, greatly enhancing the quality of reproduction.

**Single Circuit Jack.**

A miniature jack which only projects 1" behind the panel.  
 J2, with tags 1/-  
 J3, with terminals 1/3

**Scratch Filter Choke.**

Choke and condenser for reducing needle-scratch and extraneous noises.  
 Type LF8 7/6

**Rotary Change-over Switch.**

All-enclosed, snap action, highest quality bakelite, with indicating frame grained "Radio" and "Gramo" and Type S86, 2/-

Write for 60 pp. catalogue and manual  
 Enclose 2d. postage.

**A. F. BULGIN & CO. LTD.**

9, 10, 11, Cursitor Street, Chancery Lane, LONDON, E.C.4.

Phones: Holborn 1072 & 2072.



**IS YOUR SPEAKER MATCHED TO YOUR OUTPUT VALVE?**

Make your Speaker better still—strengthen the bass, get greater volume without distortion and protect the windings—with a Varley Impedance Matching Output Transformer.

Two Models, giving a wide choice of ratios, and enabling you to match any speaker and valve exactly.

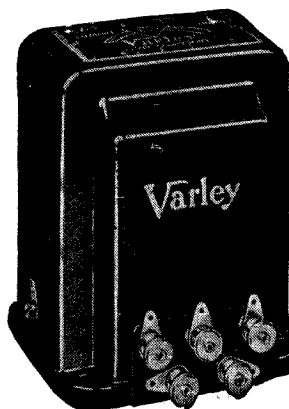

**VARLEY IMPEDANCE MATCHING OUTPUT TRANSFORMERS.**

Type D.P.20. 5 ratio (for high impedance speakers), 22/6

Type D.P.14. 6 ratio (for low impedance speakers), 22/6

Write for Section D of the Varley Catalogue for full particulars of all Varley Output Transformers and Chokes.

**Varley**

Advertisement of Oliver Pell Control, Ltd., Kingsway House, 103, Kingsway, London, W.C.2. Telephone: Holborn 5303.

**EELEX**

**TEST YOUR SET WITH SAFETY**

with EELEX Testing Prods, 3/6 per pair

Eelox testing prods have now been improved. Ball points have been fitted to the existing pointed prods for greater ease in use. Recommended by all Wireless papers. The ideal testing instrument for the wireless enthusiast eliminating all danger of shock, burnt-out valves or displaced wires. Write for List Y86.

J. J. EASTICK & SONS, Eelox House, 118, Bunhill Row, E.C.1. Phone: MET. 0314/5/6.

**SOLVE ALL H.T. TROUBLES**

**WET BATTERIES TAYLEX SELF GENERATING**

Per doz.	No. 1.	No. 2.
	s.d.	s.d.
Jars (waxed)	1 3 1	6
Sacs	1 2 1	9
Zincs	10	11
Rubber Bands (24)	4	4
Terminals	8	10

Trade Supplied.

**LONG LIFE : SILENT : ECONOMICAL**

Sample doz. (18 volts), complete with bands and electrolyte. No. 1, 4/1; No. 2, 5/-; post 9d.; terminals extra. No. 3, with terminals, 7/6 (10,000 milli-amps), sample unit 6d. Orders 10/- carr. paid. New illustrated catalogue post free. Bargain List of Receivers, FREE Amplifiers and Components.

C. TAYLOR, 57, Studley Road, Stockwell, London.

Make  
**The DAILY SKETCH**  
 YOUR Picture Paper

\*\*\*\*\*  
**TELLING THE WORLD**  
*An account of some experiences many of you, too, may have encountered.*  
 By **W. R. FLOWER.**  
 \*\*\*\*\*

A FEW years ago listeners used at various times to hear a voice coming from their loud speakers or 'phones which said: "Don't do it, please don't do it!"

In those days the oscillation fiend made his presence felt, and heard, in nearly every part of the country. And, as most of us know, the reason he was asked not to do it was because an oscillating receiver causes interference with other receivers over quite large distances.

Nowadays we listeners can, for the most part, listen in comfort without having our reception spoilt by squeals, shrieks and grunts. The oscillator has nearly died out and has left off "telling the world" that he has a radio set, and we are very glad that he has done so.

**The Modern Pest**

But there is another pest in the radio world, and although his activities are more local than were those of the oscillator, yet he seems determined to "tell the world" that he is about. I ran across one of these gentry a week or so ago.

He came to my place on a small matter of business at a time when I was enjoying a spot of orchestral music on the radio. His first words on entering the room where I lolled back in an armchair, listening to soft music from Frank Westfield's orchestra, were: "Hallo, what's wrong with the wireless. Battery run down?"

On my replying in the negative, he

went on: "You don't call *that* a wireless set, do you? You want to come round and hear mine. Talk about having the band right in the room with you—why, bless me, man, you'd imagine the performers were right there!"

Later I went around to his place to hear this radio wonder. The front door of his house was opened in response to my ring, and for a moment I stood aghast; could I ever believe that the raucous blare that greeted me was coming from a radio set? I entered; I stood and looked in horror at a huge horn from which

When I had calmed him down somewhat I talked long and earnestly to him on the subject of good radio reproduction. Finally, I fetched a good cone speaker and a volume control, and fitted both to his set.

**Music at Last**

I left that man listening to what he had never heard from his set before—music; and if I know anything about it I have earned the heartfelt thanks of his neighbours.

There are lots of these people about, people who seem determined to let the world know that they possess a radio set, and who boast that you can hear their set a mile away. They upset their neighbours quite as much as did the oscillator, and whereas these gentry kept their activities quiet, the noise fiend boasts about the horrible row he kicks up and glories in doing it.

So, then, if you who are reading this happen to know some of these noise fiends, tell them to remember that there are others besides themselves.

**A Little Advice**

If they think that radio is just a matter of mere volume, then they are badly off the mark. My advice to them is that they get someone who has a receiver that is treated properly in the matter of anode voltages and grid bias, which operates a cone or moving-coil type of loud speaker, and which is fitted with a volume control, who understands how to handle the set so as to get the best out of it, to demonstrate his apparatus to them.

Unless there is something radically wrong with their ears they will then go home and set to work to make their receivers as nearly like the one they have just heard as they can.

**LOOK OUT**  
 for the Special  
**FOUR-VALVE PORTABLE**  
 to be fully described in the June  
**"WIRELESS CONSTRUCTOR"**  
**NEXT MONTH**  
 On Sale May 15th. Price 6d.

were emitted sounds reminiscent of the steam hurdy-gurdies one meets at a fair.

"What do you think of that?" queried the owner of the noise.

"Awful," I managed to gasp. "Good heavens, what on earth is it?"

"Awful? What is it?" spluttered the owner. "Why, Great Scott, I'll bet you've never heard a wireless set like that before in your life!"

I shuddered and agreed, thankfully, that I had not.

**INDEX TO ADVERTISERS**

Belling & Leo, Ltd. . . . .	PAGE 54
Benjamin Electric, Ltd. . . . .	54
Bird, Sydney S., & Sons, Ltd. . . . .	45
British Blue Spot Co., Ltd. . . . .	Cover iii
Bulgin, A. F., & Co., Ltd. . . . .	55
Burne-Jones & Co., Ltd. . . . .	48
Carrington Mfg. Co., Ltd. . . . .	47
Cossor, A. C., Ltd. . . . .	2
"Corner Magazine" . . . . .	45
Dubilier Condenser Co. (1925), Ltd. . . . .	43
Eastick, J. J., & Sons . . . . .	55
Edison Swan Electric Co., Ltd. . . . .	Cover ii
"Eta" Valves . . . . .	43
Ellams, Herbert . . . . .	53

Formo Co. . . . .	PAGE 1
Gilbert, J. C. (Cabinets) . . . . .	48
Graham Farish, Ltd. . . . .	50
Hayberd, F. C., & Co. . . . .	48
Holzman, Louis . . . . .	38
Igranic Electric Co., Ltd. . . . .	52
Jackson Bros. . . . .	53
Lissen, Ltd. . . . .	35
London Electric Wire Co. & Smiths, Ltd. . . . .	38
Lotus Radio, Ltd. . . . .	46
"London Magazine" . . . . .	51
Lyons, Claude, Ltd. . . . .	53
"Modern Wireless" . . . . .	49
Parocsi, E. . . . .	54
Peto-Scott Co., Ltd. . . . .	54
Pickett's Cabinet Works . . . . .	54
"Picture Show" Who's Who . . . . .	47

Radio Instruments, Ltd. . . . .	PAGE Cover iv
Ready Radio . . . . .	37
Regentone, Ltd. . . . .	47
Rothermel Corporation, Ltd. . . . .	38
Six-Sixty Radio Co., Ltd. . . . .	53
Taylor, C. . . . .	55
Technological Institute of Gt. Britain . . . . .	54
Telsen Electric Co., Ltd. . . . .	41
Varley Products . . . . .	55
Westinghouse Brake & Saxby Signal Co., Ltd. . . . .	47
Whiteley Electrical Radio Co., Ltd. . . . .	49
Wright & Weaire, Ltd. . . . .	47

All communications concerning advertising in "Wireless Constructor" must be made to John H. Lile, Ltd., 4, Ludgate Circus, London, E.C.4. Telephone: City 7261.

# If you don't want to BUILD your own speaker

THOUSANDS of wireless enthusiasts are quite capable of building their own loud speakers. But it is not everybody who is willing to take the necessary trouble. And why should they when they know that they can have at their service the most highly perfected speaker in the country.

Blue Spot have a complete range of "ready made" speakers embodying their famous driving movements. It is admitted that no higher standard than Blue Spot exists. It would therefore be mere surplusage to pile up adjectives about "tone" and "volume."

One may add quite simply that the appearance and workmanship of the cabinets are worthy of the unit inside and that the price is moderate enough to satisfy the pockets of all who appreciate quality.

Your dealer will be proud to show you a Blue Spot Speaker and to demonstrate its capabilities.

## 71 R

This model has a most attractive appearance and is well built and beautifully finished. It can handle enormous volumes without distortion.

Price complete  
(14" high x 18½"  
wide x 7" deep) **95/-**

### THE BRITISH BLUE SPOT COMPANY LTD.

BLUE SPOT HOUSE, 94-96, ROSOMAN STREET, ROSEBERY AVENUE, LONDON, E.C.1  
Telephone: Clerkenwell 3570. Telegrams: "Bluspot, Isling, London"

Distributors for Northern England, Scotland and North Wales:  
H. C. RAWSON (Sheffield and London) LTD., 100 London Road, Sheffield; 22 St. Mary's Parsonage, Manchester; 183 George Street, Glasgow.

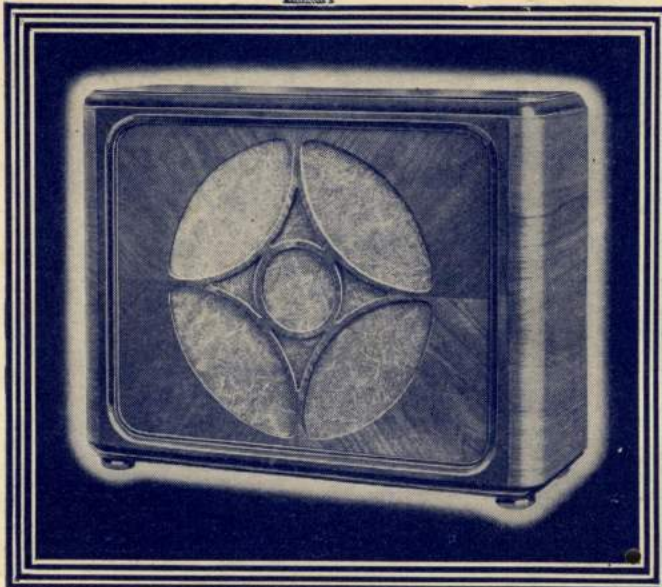



# SCORE AGAIN

with a new, improved model of the  
P.W. and M.W.

## SELECTOR COIL

Here is the latest and best production of the "P.W.," "M.W." and "Constructor" coil made and perfected by R.I. to a degree of amazing efficiency and finished excellence. The thousands of satisfied users of the R.I. Dual Range Coil will find that it has paid them to wait for the R.I. Selector Coil, which is certainly a wonderful job, built of bakelite and fitted with an engraved scale—a new and essential feature showing the exact position of the tapings. This is indispensable for easy operation of your set.

The obvious thoroughness in design and manufacture, and the exactitude of this latest R.I. component, clearly pre-determine that the results, claimed by the designers of the coil, will be positively attained by using the R.I. model with the engraved dial.



The R.I. Selector Coil, made to the exact specification of the designers and laboratory tested to ensure highest efficiency. Bakelite moulded former wound with finest double silk wire. One hole fixing.

12/6

and for Specified Highest Efficiency these R.I. Components excel



The Famous



### DUAL RANGE COIL

The amazing perfection of the R.I. Dual Range Coil and its immense success is due to the most highly critical laboratory tests, including the wavemeter and inductance bridge, and a special apparatus answering to all "P.W." and "M.W." published circuits in which the coil is specified.

12/6

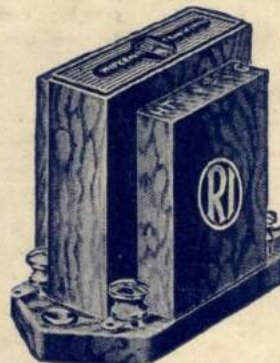

### The HYPERMITE Nikalloy Transformer

The use of the "Hypermite" ensures getting the best bass notes and the highest treble of which any speaker is capable. It is a marvel for its weight and size, and absolutely indispensable in compact set assembly. Primary inductance over 50 henries. Ratio 3½ to 1.

12/6



### The Improved G.P. L.F. TRANSFORMER

This improved model of the famous G.P. Transformer when employed in conjunction with the "Hypermite" definitely gives higher amplification and purer reproduction than any other combination of transformers at the price. Ratio 3½ to 1. Primary inductance 35.40 henries.

10/6

**PURCHASE R.I. THEY'RE BEST AND COST NO MORE**

Radio Instruments Ltd., Madrigal Works, Purley Way, Croydon.

Phone: Thornton Heath 3211.

Printed and published on the 15th of each month by the Proprietors, The Amalgamated Press, Ltd., The Fleetway House, Farringdon Street, London, E.C.4. Advertisement Offices only: Messrs. J. H. Lile, Ltd., 4, Ludgate Circus, London, E.C.4. Registered for transmission by Canadian Magazine Post. Subscription rates: Inland and Abroad, 8/6 per annum. Canada only, 7/6 per annum. Sole Agents for South Africa: Central News Agency, Ltd. Sole Agents for Australia and New Zealand: Messrs. Gordon & Gotch, Ltd. S.L.