

The Wireless Constructor

6^D
MONTHLY



Vol. III. DECEMBER, 1926 No. 2

READER DESCRIBES

HIS WINNING RECEIVER IN
NEW YORK INTERNATIONAL
SET COMPETITION



Full Constructional Details

IN THIS ISSUE



Ask Your Dealer These Questions

IS THE FILAMENT UNBREAKABLE? **YES!**
 except by the very roughest handling - - - - ?
 Since the life of the valve you purchase is only as long as the life of its filament, you want to be protected against loss due to accidents.

DOES THE FILAMENT OPERATE AT AN EXTREMELY LOW TEMPERATURE? **YES!**
 so that its life is vastly increased - - - - ?
 The extent of a filament's electrical life is governed by the operating temperature. You are assured of long useful life from your valves when the filament temperature is so low that no sign of glow can be discerned.

IS THE EMISSION SURFACE OF THE FILAMENT GENEROUS and up to 5½? **YES!**
 times that of an ordinary filament - - - - ?
 The more copious the emission from the filament of a valve the better the results and the greater the control range, particularly when that emission is secured from an economical input.

DOES THE FILAMENT CONSUME ONLY ONE TENTH AMPERE giving? **YES!**
 greater life to each accumulator charge - - - - ?
 You want to be relieved of the burden of accumulator recharging as much as possible without impairing the efficiency of your receiver. With a consumption of only one-tenth ampere as few as 3 rechargings of your accumulator will carry you through the whole winter.

DOES THIS VALVE USE THE SAME H. T. CURRENT as ordinary valves for? **YES!**
 the same operation - - - - ?
 Greatly increased emission does not indicate increased H.T. consumption. The H.T. current is the same, but the volume is vastly increased, enabling you to have a large reserve of power.

The only valves that can satisfy all these questions are **MULLARD P.M. VALVES** with the wonderful Mullard P.M. Filament.

Get them from your radio dealer.



<i>For 4-volt accumulator or 3 dry cells</i>	
THE P.M. 3 (General Purpose) 0.1 amp.	14/-
THE P.M. 4 (Power) 0.1 amp.	18/6
<i>For 6-volt accumulator or 4 dry cells</i>	
THE P.M. 5 (General Purpose) 0.1 amp.	18 6
THE P.M. 6. (Power) 0.1 amp.	18/6
<i>For 2-volt accumulator</i>	
THE P.M. 1 H.F. 0.1 amp.	14/-
THE P.M. 1 L.F. 0.1 amp.	14/-
THE P.M. 2 (Power) 0.15 amp.	18 6

These prices do not apply in Irish Free State.

British Made
 in a
British Factory

Mullard

THE MASTER VALVE

The WIRELESS CONSTRUCTOR

Vol. III. No. 2.

CONTENTS

DECEMBER.

<p>The "All-British Six" 85 By H. E. HASSALL. Music Via the Ether 93 By JACK HYLTON. Making Use of Your Supply Mains .. 95 By J. H. REYNER, B.Sc.(Hons.), A.M.I.E.E. Choice of Programmes Made Easy .. 97 By STANLEY G. RATTEE, M.I.R.E. Mr. Scott-Taggart Enters Valve Business Getting the Best from the "Spanspace Three" 107 By G. P. KENDALL, B.Sc. A "Throttle-Controlled" Single-Valve Set 111 By L. H. THOMAS. Improving Your Short-Wave Set .. 117 By A. V. D. HORT, B.A.</p>	<p>Helpful Hints for the American Season 121 Things Every Operator Should Know 125 By G. P. KENDALL, B.Sc. How Wireless Components Are Made 129 By CAPT. JACK FROST, M.I.R.E. Watch Your Batteries! 133 By A. S. CLARK. How to Beautify Your Loud-Speaker 137 By ERN SHAW. A Flexible Crystal Set 144 By G. T. KELSEY. Notes and Jottings 155 Do We Need Reaction? 161 By D. J. S. HARTT, B.Sc. Practical Workshop Hints 165 Apparatus Tested 173</p>
--	--



All enquiries for Lewcos Radio Products should be made to your local dealer.

TABLE 1			TABLE 2			
Coil	Inductance in microhenries	Self-capacity in micro-microfarads	Coil	Parallel capacity in micro-microfarads	Wave-lengths in metres	Effective resistance in ohms.
35	61	15	35	300	264	2.8
40	90	15	40	"	318	2.9
50	150	9	50	"	406	3.3
60	200	13	60	"	472	4.4
75	295	12	75	"	573	5.3
100	540	11	100	"	774	6.6
150	1,410	12	150	"	1,250	15.8
200	2,220	17	200	"	1,580	19.7
250	3,070	17	250	"	1,860	24.9
300	4,800	14	300	"	2,320	28.2

Results of in² dependent H.F. tests made by the N.P.L.

Here are the figures — judge for yourself!

The National Physical Laboratory figures fully bear out our claim that the LEWCOS Coil is the most efficient produced. In the design of radio inductances, the smaller the R/L value for any circuit, the greater is the selectivity and the signal strength. This fact has predominated over all other considerations in producing Lewcos Inductance Coils with the



result that we can publish without fear the R/L values for LEWCOS Inductance Coils as obtained from the N.P.L. measurements together with the wave length at which measurement was made. LEWCOS Coils make all the difference in reception. Ask your wireless dealer to demonstrate the Lewcos Coil on his set. Descriptive leaflet gladly sent on application.

LEWCOS Inductance COIL

The LONDON ELECTRIC WIRE COMPANY and SMITHS, LIMITED
 Phone: Clerkenwell 1288 Playhouse Yard, Golden Lane, London, E.C.1 Telegrams: Electric, London

DYNAMIC CURVES

IT'S THE CURVE THAT COUNTS!

Every operating merit of a valve, except its life, shows up in its characteristic curves provided the right ones are chosen. Every S.T. valve is designed to give the right *Dynamic* curve.

An ordinary or *static* curve (see broken line) is taken with a fixed anode voltage while the S.T. Dynamic curve (thick line) takes into consideration the fact that as the grid voltage falls or rises so the anode voltage increases and decreases—due to the output impedance (e.g., loudspeaker, transformer or resistance). Judging a valve by its ordinary curve is like estimating the speed of a racing car while it is stationary.

The Dynamic curve given is that of the S.T. 63 Super Power Valve. See how dead straight it is over a very wide grid voltage range and you will feel that this loudspeaker valve can justifiably be called "The Valve with the Golden Voice."

S.T.—The Valve with the Right Dynamic Curve

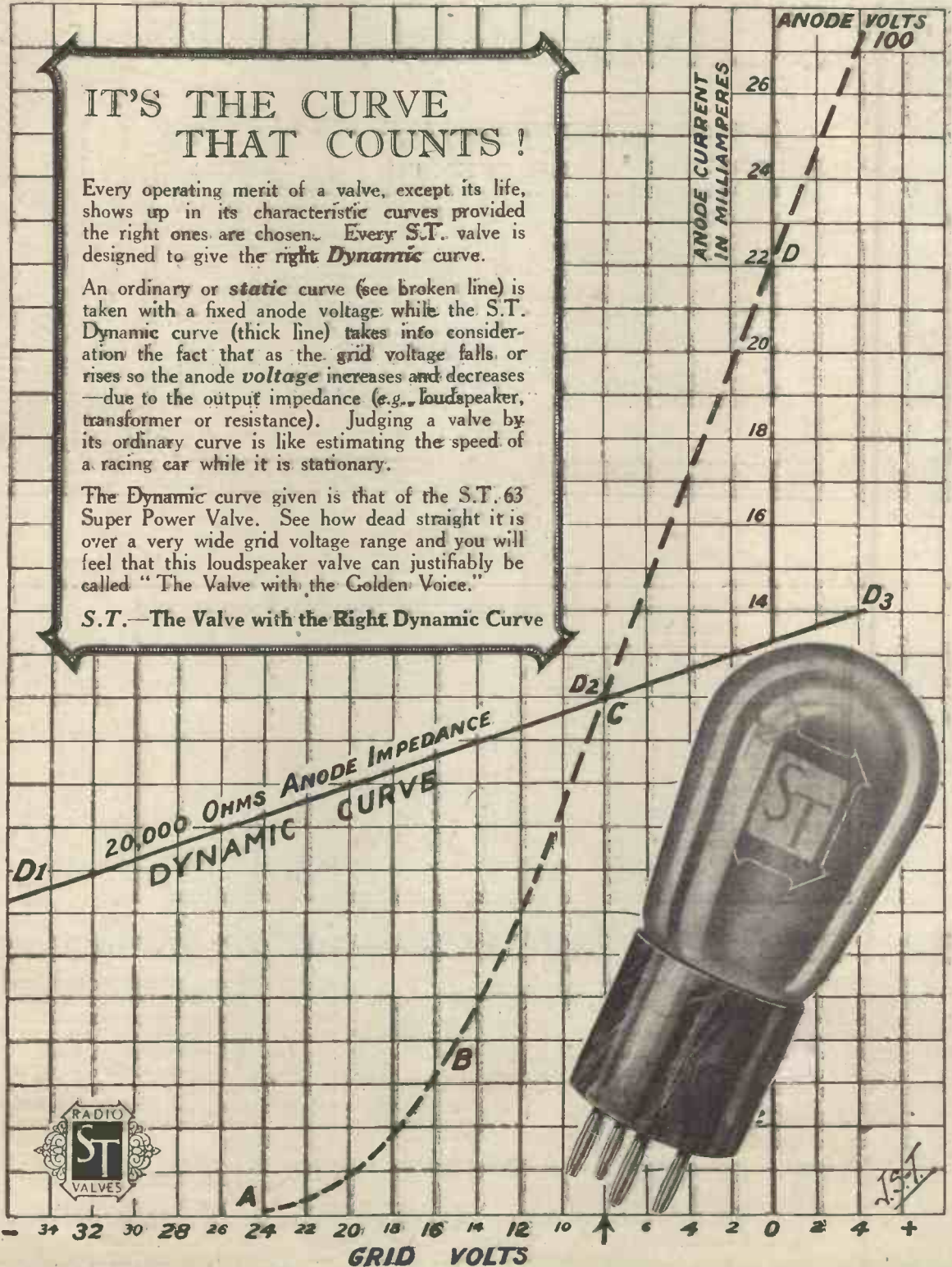

Advt. of S.T., 2, Melbourne Place, W.C.2.



Published by Radio Press, Ltd., Bush House, Strand, W.C.2. 'Phone : City 9911.

THE "ALL-BRITISH SIX"

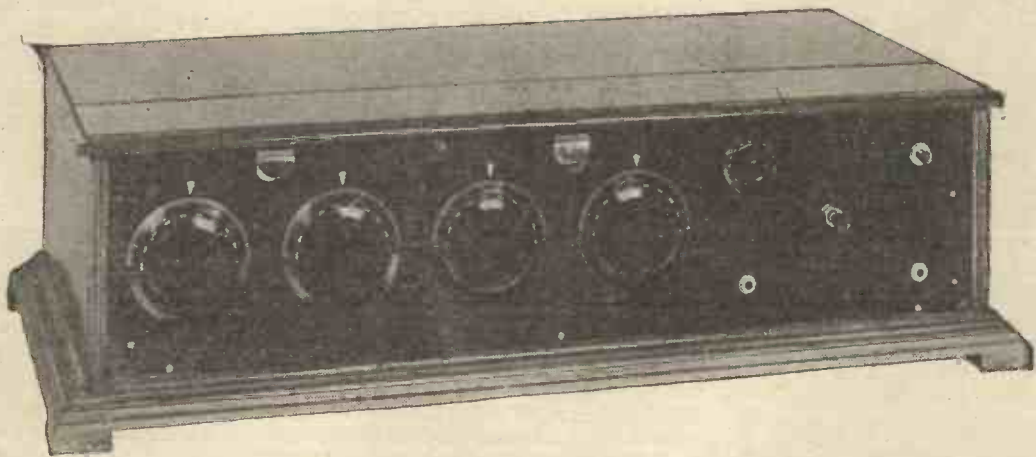

EUROPEAN CHAMPIONSHIP SET IN NEW YORK

Described by H. E. HASSALL, the "Wireless Constructor" reader who built the set.

THE "ALL-BRITISH SIX" was entered for competition in the Multi-Valve Class of the International Amateur Set Building Contest at the Radio World's Fair in New York, and was awarded the Third Prize in this Open Competition—the First and Second Prizes being gained by American receivers.

A receiver, to compete successfully in America, needs selectivity of a very high order. Around New York, for example, there are over 65 Broadcasting Stations in operation. In the October issue of "Radio News," our American contemporary, the following opinion was expressed: "A European Set could not perform in the United States at all, because it would, very likely, not tune sharp-enough."

The "All-British Six" uses the circuit of the famous "Elstree Six," modified to allow of the use of screened H.F. Transformers. This modification was made necessary by the extreme selectivity required.

Mr. H. E. Hassall, one of our readers, who constructed and entered the "All-British Six" for the New York Competition, describes in his own words the design and construction of the Set. Full details are given, and the usual blueprints may be obtained, so that our readers may make up similar sets, and realise from their own experience the high performance of which the "All-British Six" is capable.

The "All-British Six"

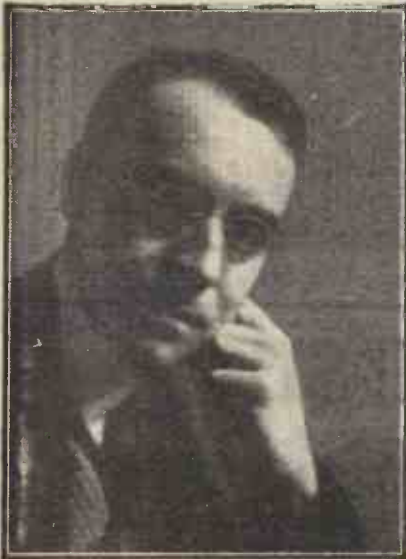

A recent portrait of Mr. H. E. Hassall

THE UNITED STATES has had the advantage of a long start in the race for radio supremacy. Whilst it would be unwise to postulate on any subject connected with radio, one is, I think, on common ground in stating that their pre-eminence in the field of high-frequency design has been universally admitted. Bearing this in mind it will follow that possibly the most exacting and severe test of the capabilities of a multi-valve high-frequency receiver is to place it in open competition with the latest American designs at the Annual Radio World's Fair in New York.

Although the set I am about to describe did not gain the premier prize—this was awarded to a seven-valve super-heterodyne, and second prize to another American receiver, particulars of which at the time of writing are not available—the "All-

British Six" was placed third in the Multi-Valve Competition open to the world.

Requirements of Design

Practically all American sets are designed for the fixed broadcast band (U.S.) of 250-550 metres. As the "All-British Six" will tune over all wavelengths, readers will realise its labours, in comparison with an American receiver, under the disadvantage of having to provide plug-in transformers, sockets, etc., for this unlimited wavelength range, thereby

in *Modern Wireless* (Vol. 6, Nos. 1 and 2). Those who wish to acquaint themselves with the *raison d'être* of this extremely efficient circuit are advised to refer to the articles in question.

Modifications

According to the latest lists, over sixty-five broadcasting stations are operating in the city and neighbourhood of New York. With these conditions in mind, it was felt that a cardinal point in the design of the set was high selectivity. It is a

TEST REPORT

The receiver was tested on an aerial 60ft. long and 20ft. high at a distance of about 12 miles from the London station. The following stations, for which the dial readings are given, were tuned in on the loud-speaker, no telephones being employed. Many other stations were heard, but only those which were clearly received and identified are given.

Station	Dial Reading	Station	Dial Reading	Station	Dial Reading
Kiel	59	Cardiff	93	Frankfort	140
Cassel	70	German*	96	Birmingham	141
Dortmund	74	London	102	Brussels	143
Gothenburg	75	Manchester	107	Munich	144
Bradford	82	Oslo	108	Aberdeen	148
Dundee	84	Bournemouth	110	Berlin (Voxhaus)	150
Barcelona	86	Dublin	114	Zurich	156
Nottingham	87	Newcastle	115	Rosenhügel (Austria)	161
Edinburgh	88	Munich	117	Berlin (M.P.)	170
Liverpool	89	Glasgow	122	Radio Wien (Vienna)	176
Copenhagen	91	Berne	128		
San Sebastian	92	Barcelona	135		

* The reception of this unidentified German station, located between London and Cardiff, points to the very high selectivity obtainable with the receiver. The programme was clearly received though the station could not be identified, except in nationality.

In a further test at a distance of one mile from the London Station, Cardiff was received on the loud-speaker at approximately twice the strength of London at the same setting.

setting up slight losses as compared with the American receiver with its fixed transformers and short direct wiring.

Circuit

The theoretical diagram is shown in Fig. 1. It is based, as experienced experimenters will recognise, on the "Elstree Six" circuit, a full description of which has already appeared

fairly simple matter to design a transformer to give "knife-edge" selectivity, if one is prepared to sacrifice a little as regards quality in reproduction. The problem was to combine the two ideals, plus the highest degree of sensitivity.

Special Transformers

A great deal of time was spent in experimenting with different types of

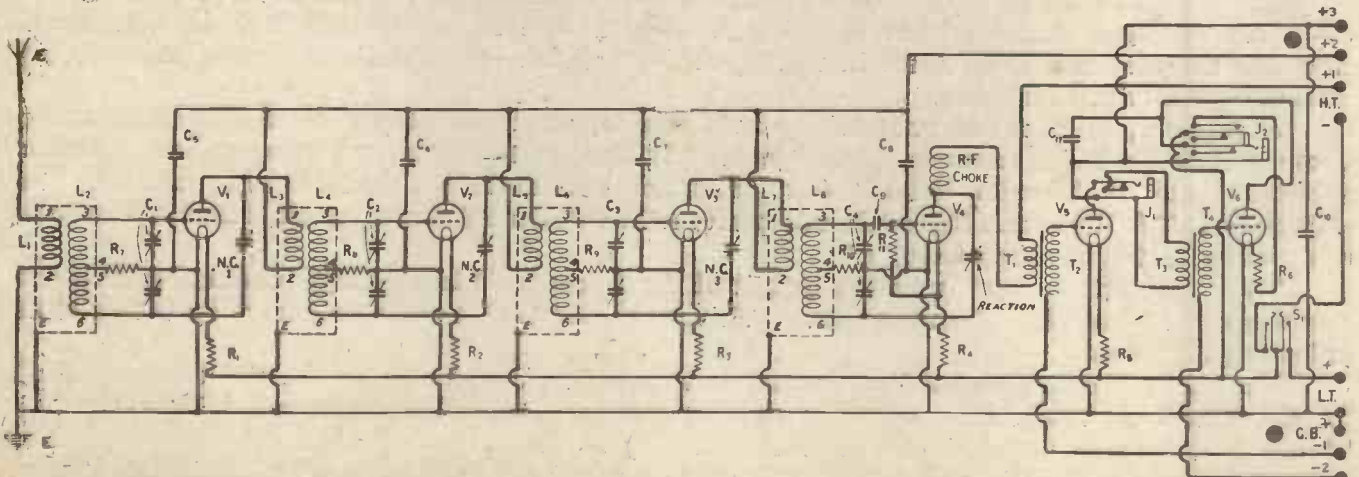

Fig. 1.—The panel light wiring and switch are omitted from the circuit diagram in order to avoid complication. The values of components will be found in Fig. 3.

FULL DETAILS FOR CONSTRUCTION

H.F. transformers before the ideal was achieved. The special H.F. transformers finally used are the subject of a provisional patent covering a device that nullifies the capacity

ference of the type set up by electric trams, dynamos, etc.

Those unfortunate persons who reside in the shadow of a broadcasting station may still pick up signals on

BUILD THIS SET WITH—

- One ebonite panel, 30 in. by 7 in. by $\frac{1}{4}$ in.
- Two ebonite strips, 9 in. by $1\frac{1}{2}$ in. and 3 in. by $1\frac{1}{2}$ in.
- One cabinet to suit, with baseboard, 13 in. deep. (Peto-Scott Co., Ltd.)
- Two panel brackets.
- Four "Cyldon" .0005 dual variable condensers, with 4 in. dials. (S. S. Bird.)
- Four standard coil screens and bases.
- Four special H.F. transformers. (Peto-Scott Co., Ltd.)
- Three baseboard neutralising condensers.
- One panel neutralising condenser. (Peto-Scott Co., Ltd.)
- Six anti-microphonic valve holders. (Benjamin Electric Co.)
- Six fixed condensers, .002, type 600A. (Dubilier.)
- One H.F. Choke. (Lissen, Ltd.)

- Four 100,000-ohm resistances and mounts. (Varley Magnet Co.)
- Six "Temprytes" and mounts (value to suit valves used). (S. S. Bird.)
- One L.F. Transformer A.F.3. (Ferranti, Ltd.)
- One L.F. Transformer, multi-ratio. (Radio Instruments, Ltd.)
- One .00025 fixed condenser and 2-megohm leak. (T.C.C.)
- One double contact on-and-off switch. (Wright & Weaire.)
- One single closed jack and one single closed circuit filament control jack. (Ashley Wireless Telephone Co., Ltd.)
- Four "Decko" dial indicators. (A. F. Bulgin & Co.)
- Eleven terminals.
- One on-and-off push-pull switch and two panel lights. (A. F. Bulgin & Co.)
- Glazite, screws, etc.

Approximate Cost £25

between the primary and secondary windings. Each stage was screened, the metal shields and bases being of the orthodox kind designed by Mr. J. H. Revner at the Elstree Labora-

tory. A possible remedy is to line the cabinet and panel with metal, being careful, of course, to earth the metal screen and insulate points where necessary.

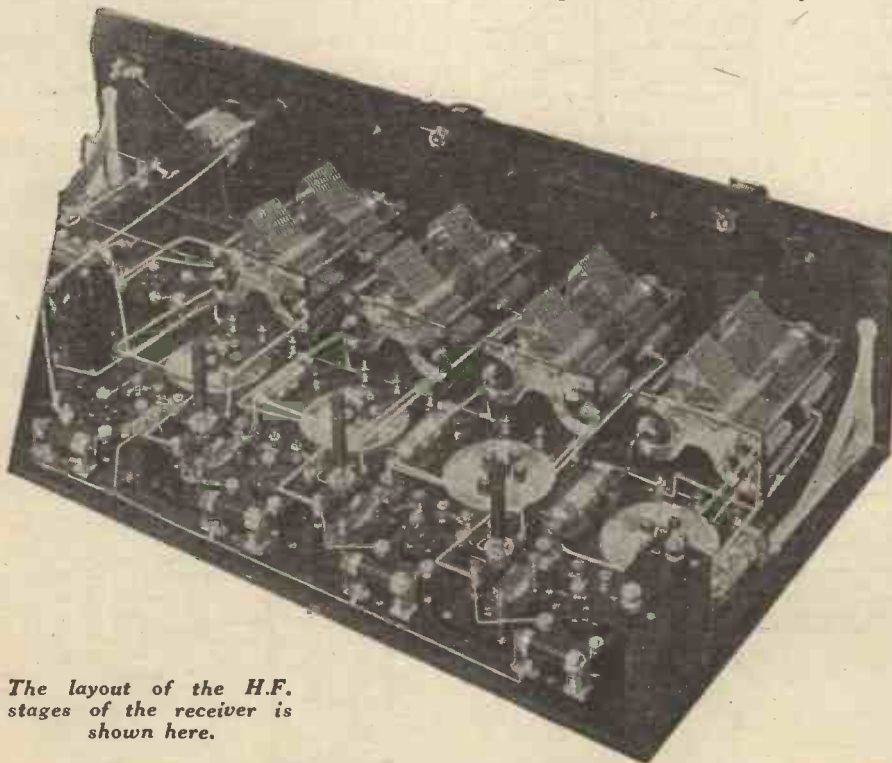

The layout of the H.F. stages of the receiver is shown here.

tories. The screening makes possible a compact layout, improves selectivity and gives greater stability. It will also be found of great help in eliminating trouble from local inter-

The Detector

Another modification from the fundamental circuit is grid rectification in place of the detector working on the bottom bend of the curve. The

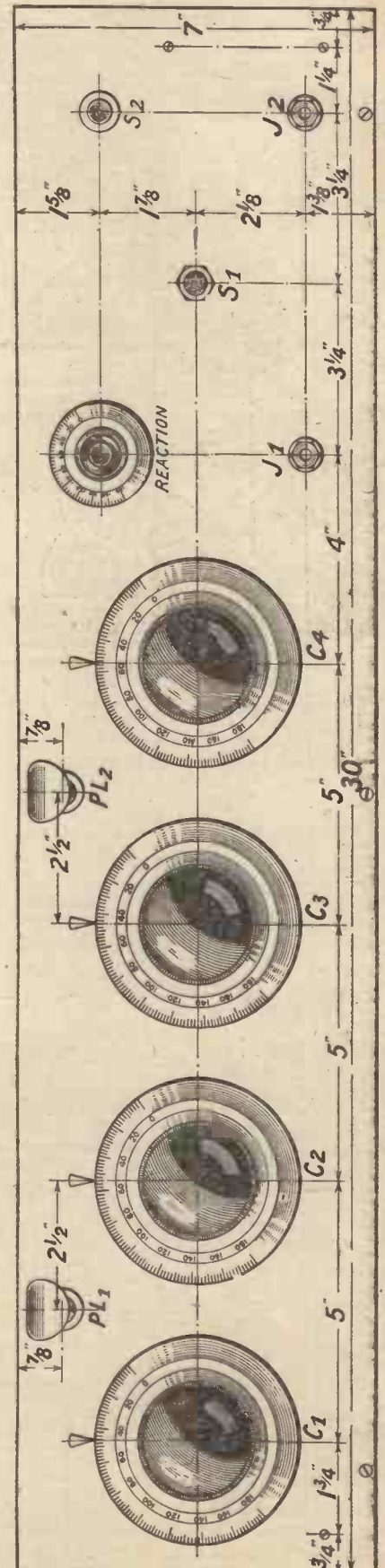

Fig. 2.—Blueprint No. C 1069A is obtainable free with the coupon in this issue.

The "All-British Six"

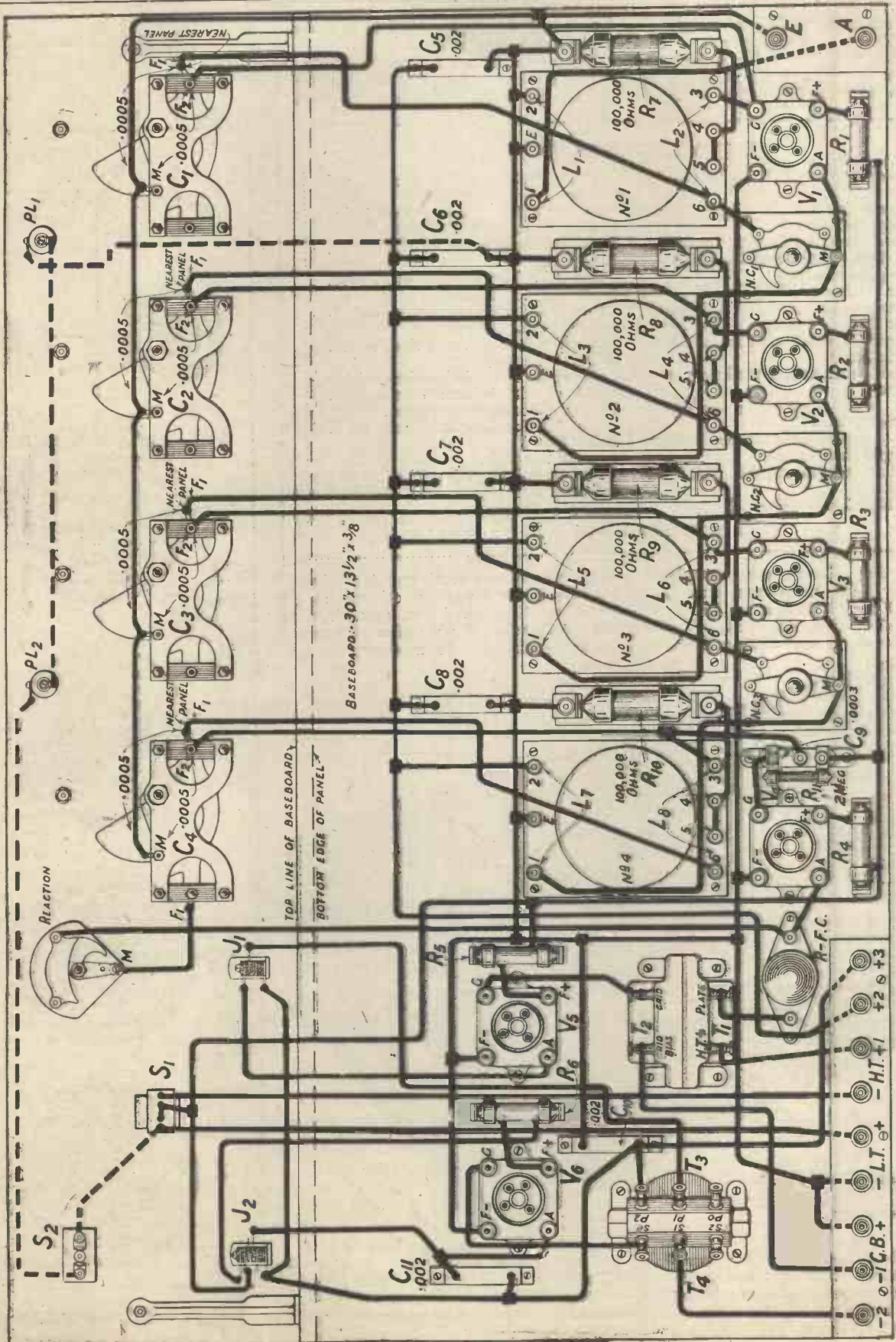

Fig. 3.—The connections from terminals 6 of the coil bases to the variable condensers shown across the screens for the sake of clearness are actually placed beside the wires from terminals 3 on the right of each base. The wiring to the panel lights is shown dotted. Blueprint No. C1069 B is obtainable free by using the coupon in this issue.

You Can Build It Too

latter method gives slightly better quality, provided the proper values of high-tension and grid bias are used, but in actual practice many experimenters do not obtain good results, simply through inexperience in working this method of detection. The grid condenser, C_g , has three terminals; by taking the lead from the end terminal, positive bias on the detector grid gives excellent rectification. It is difficult to detect aurally any difference in the quality of tone as compared with anode rectification, and the method also gives increased sensitivity. When receiving strong signals, such as those from the local station, constructors may try the effect of substituting a smaller value grid leak, say 1 or $\frac{1}{2}$ megohm.

L.F. Amplification

The first stage low-frequency transformer is a Ferranti A.F.3. The inductance of the primary winding is 80 henries, and with a detector valve of high impedance (average impedance 25,000 to 30,000 ohms) an overall amplification of about 70 is obtained, with good quality. The second stage transformer is an R.I. and a ratio of 1½-1 will be found to sustain the excellent tonal quality together with good amplification. If the signal received is very weak, the more usual ratios of 4-1 or 6-1 may be used with increased step-up. The actual connections shown in the diagram, i.e., ratio 1½-1, were found to give satisfactory amplification when

thereby economising space and simplifying control. The on-and-off switch fitted on the panel is of the double-

of the family. It is sad, but true, that after a few days, when the effervescence of novelty has subsided, any

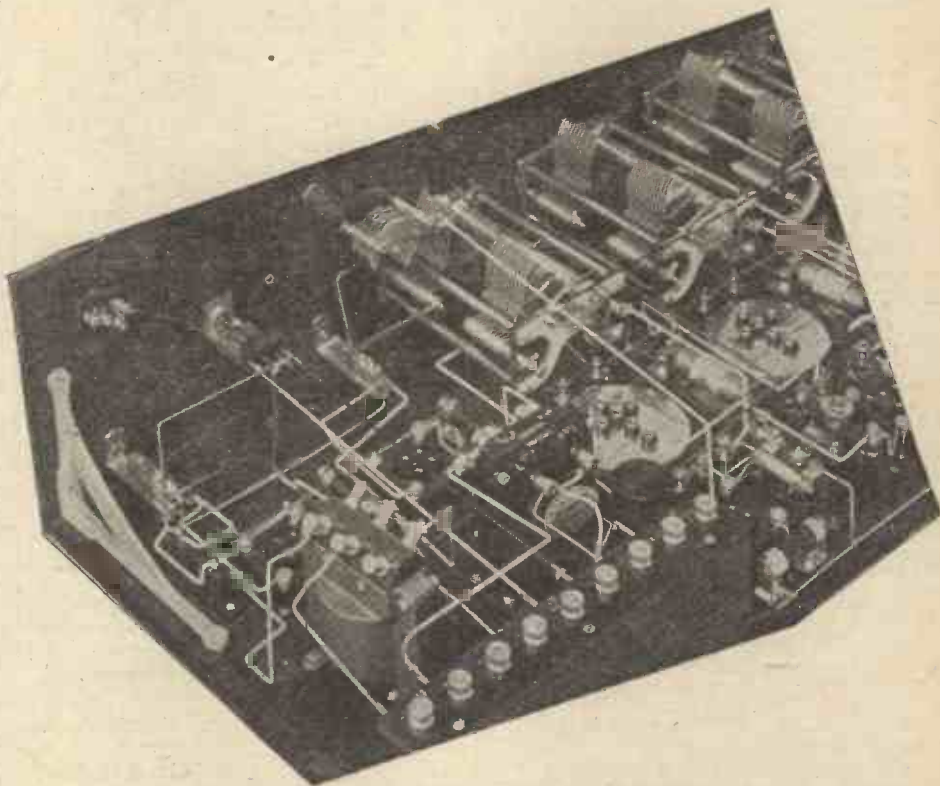

Tappings on the multi-ratio transformer should be chosen to suit individual requirements.

WIRING IN WORDS.

All directions are given as viewing the set from the back.

Join aerial terminal to terminal 1 of No. 1 coil base.

Join earth terminal to one side of R7, to E and terminal 2 of No. 1 coil base, to one side of C5, C6, C7, C8, and C10, to E of Nos. 2, 3, and 4 coil bases, to one side of R8, R9, and R10, to one filament contact of V1, V2, V3, V4, V5, and V6 valve holders, to moving vanes of C1, C2, C3 and C4, and to L.T.—and G.B. + terminals.

Join together the remaining sides of C5, C6, C7 and C8, also terminals 2 of Nos. 2, 3 and 4 coil bases, and continue to H.T. + 2 terminal.

Join terminal 3 of No. 1 coil base to G contact of V1, and to F2 contact of variable condenser C1.

Join terminal 3 of No. 2 coil base to G contact of V2, and to F2 contact of variable condenser C2.

Join terminal 3 of No. 3 coil base to G contact of V3, and to F2 contact of variable condenser C3.

Join terminal 3 of No. 4 coil base to centre terminal of C9, also to F2 contact of variable condenser C4.

Join common terminal of C9 and R11 to G contact of valve holder V4.

Join together terminals 5 and 4 on Nos. 1, 2, 3, and 4 coil bases and continue to remaining sides of R7, R8, R9, and R10 respectively.

Join terminal 6 of No. 1 coil base to fixed plates of N.C.1, and to F1 contact of C1.

Join terminal 6 of No. 2 coil base to fixed plates of N.C.2, and to F1 contact of C2.

Join terminal 6 of No. 3 coil base to fixed plates of N.C.3, and to F1 contact of C3.

Join terminal 6 of No. 4 coil base to F1 of C4, and to moving plates of reaction condenser.

Join terminal 1 on No. 2 coil base to moving vanes of N.C.1, and to A contact of V1.

Join terminal 1 on No. 3 coil base to moving vanes of N.C.2, and to A contact of V2.

Join terminal 1 of No. 4 coil base to moving vanes of N.C.3 and A contact of V3.

Join remaining filament contacts on V1, V2, V3, V4, V5, and V6 to one side of fixed resistors R1, R2, R3, R4, R5, and R6.

Join together the remaining sides of fixed resistors R1, R2, R3, R4, and R5, and continue to both centre contacts of Switch S1, also to one contact from top on left side of Jack 2, and to free end of leak R11.

Join top contact of Jack 2 to remaining side of R6.

Join A contact of V4 to one side of R.F. choke, also to fixed vanes of reaction condenser.

Join other side of R.F. choke to "Plate" terminal of L.F. transformer T1 T2.

Join "H.T. + " terminal of T1 T2 to H.T. + 1 terminal.

Join "Grid" terminal of T1 T2 to G contact of V5.

Join "Grid Bias" terminal of T1 T2 to G.B. — 1 terminal.

Join A contact of V5 to top contact of Jack 1.

Join middle contact on Jack 1 to P1 terminal of L.F. transformer T3 T4.

Join bottom contact of Jack 1 to bottom contact of Jack 2, to one side of C11, to remaining side of C10, to P2 terminal of T3 T4, and to H.T. + 3 terminal.

Join A contact of V6 to remaining side of C11, and to lower right contact of Jack 2.

Join G contact of V6 to terminal SO of T3 T4.

Join S1 terminal of T3 T4 to G.B. — 2 terminal.

Join L.T. + terminal to left contact of Switch S1.

Join H.T. — terminal to right contact of Switch S1.

Join "Grid" terminal of T1 T2 to G contact of V5.

Join "Grid Bias" terminal of T1 T2 to G.B. — 1 terminal.

Join A contact of V5 to top contact of Jack 1.

Join middle contact on Jack 1 to P1 terminal of L.F. transformer T3 T4.

Join bottom contact of Jack 1 to bottom contact of Jack 2, to one side of C11, to remaining side of C10, to P2 terminal of T3 T4, and to H.T. + 3 terminal.

Join A contact of V6 to remaining side of C11, and to lower right contact of Jack 2.

Join G contact of V6 to terminal SO of T3 T4.

Join S1 terminal of T3 T4 to G.B. — 2 terminal.

Join L.T. + terminal to left contact of Switch S1.

Join H.T. — terminal to right contact of Switch S1.

The following connections should be made if the panel lights are included.

Join left contact of Switch S1 to right contact of Switch S2.

Join left contact of Switch S2 to outer contact of PL2 bulb holder.

Join inner contact of PL2 to inner contact of PL1.

Join outer contact of PL1 to earthed side of C6 (i.e., to L.T. negative).

the last stage was used. As a matter of fact, the majority of stations were received on the loud-speaker, using only the first L.F. stage.

Filament Control

Fixed resistors (4-ohm for 6-volt valves) are used for each valve,

pole push-pull type, which simultaneously cuts off both the low-tension and the high-tension batteries.

Panel Lights

The arrival of a new wireless receiver in the household causes wonder and much interest to certain members

old corner of the room is considered suitable as a resting place by the powers-that-be.

My receiver reposes in a dark corner, and a similar state of affairs appears to be the rule in many houses I have visited. The dial lights will be found very helpful in these circum-

THE "ALL-BRITISH SIX"—continued

stances. Ordinary flash-lamp bulbs are used, and it should be noted that they are connected across the 6-volt L.T. battery in series, taking only half the amount of current as compared with 6-volt lamps connected in the more usual parallel method. A switch is provided to extinguish the lights when tuning is finished.

They are much appreciated by the feminine element. Here is a story apropos of this. In response to the invitation of a charming visitor, whose age I suppose was between 20

stituted, but if results equal to the original design be desired, the H.F. transformers specified should be used.

Construction

It is suggested that first of all the components be secured to the base-board in accordance with the wiring diagram (Fig. 3). At first glance the wiring may appear complicated, but if one stage is completed at a time, it will be found no more difficult than a two- or three-valve set. It is advis-

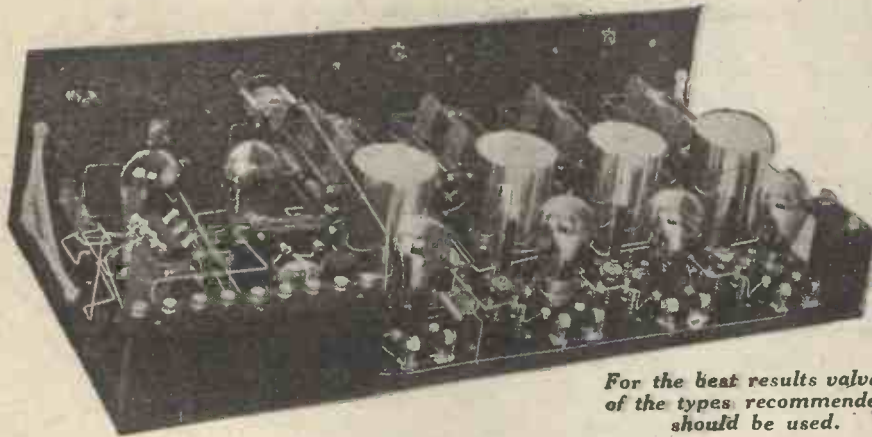

For the best results valves of the types recommended should be used.

and 40, I had gone to some length in explaining the high-frequency side of the receiver, and then tried to show how the L.F. side operated. At the end of the discourse I paused for comment. "Most interesting," she smiled; "but what dinky little dash lamps you've got!"

The lights can, of course, be omitted, it is hardly necessary to add, without affecting the performance of the receiver.

Components

A list of the actual components used is given in the table accompanying this article. Other components of similar quality and performance may be sub-

able to wire the filament circuits first, and it is absolutely necessary that the fixed condensers and long wiring reposing under the dual condensers be soldered before the panel is screwed to the baseboard. In fact, it is strongly advised that the whole of the base-board wiring be completed first. The panel may then be drilled, the condensers, etc., fitted, and the final wiring completed.

Follow the Layout

The transformer bases are so arranged that the grid wires are extremely short. A note of warning

(Continued on p. 178.)

NEWS IN ADVERTISEMENTS

Messrs. Finston Manufacturing Co., Ltd., are announcing the Finston Screened Coils.

The Blackadda Radio Building System is advertised by Messrs. The Blackadda Radio Co., Ltd.

A new series of super low-loss coils is being produced by Messrs. Radiax, Ltd.

Readers are invited to send to Messrs. Smith, Farmer & Co., for an illustrated brochure dealing with the "Flor" H.T. battery.

The full range of Cyldon Gang-Condensers is featured in the advertisement of Messrs. Sydney S. Bird & Sons.

Messrs. The Carborundum Co., Ltd., are announcing a new product—the Carborundum Stabilising Detector Unit.

In the series of advertisements featuring the range of S.T. Valves, Messrs. S. T., Ltd., the manufacturers, offer to advise readers as to the types most suitable for their receivers.

The new Igranic Triple-Gang Condenser is the subject of an announcement issued by Messrs. Igranic Electric Co., Ltd.

"One hundred guineas for a name" is being offered by Messrs. C. A. Vandervell & Co., Ltd.

Messrs. Falk, Stadelmann & Co., Ltd., are featuring the Efesca "Centadyne" Screened Coils.

The C. E. Precision Floating valve holder is being marketed by Messrs. C. Ede & Co., Ltd.

An interesting advertisement to all music-lovers is published by Messrs. Ferranti, Ltd.

Messrs. Dubilier Condenser Co., Ltd., are announcing the Dubilier Univane Condenser.

THE EXPERT

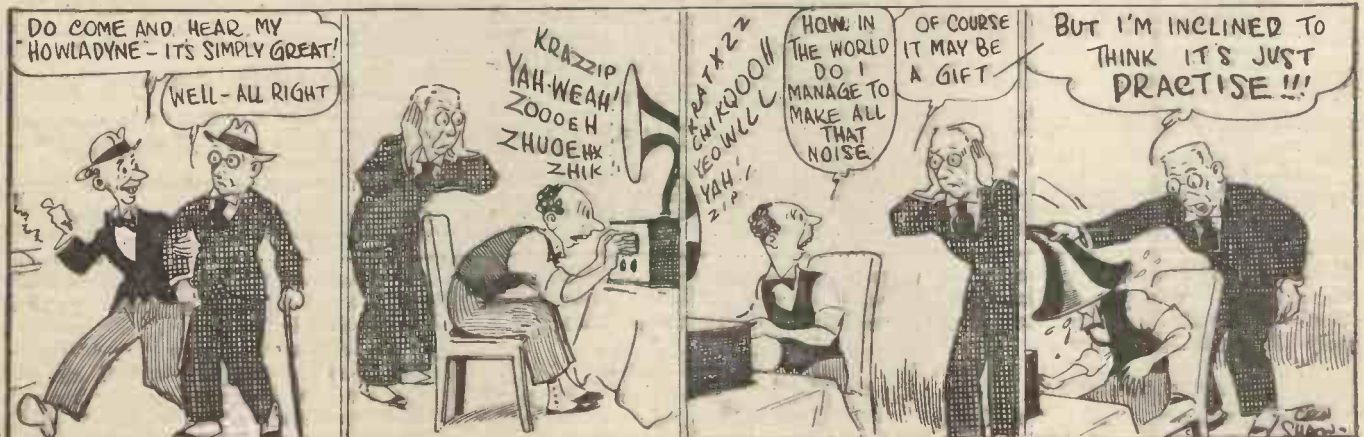

MUSIC VIA THE ETHER

A Critical Study in Sound Reproduction

By JACK HYLTON

What instrument is most faithfully reproduced for the listener? Should the broadcasting of some sounds not be attempted? From the musician's point of view the well-known conductor who writes this article offers his own criticisms of the transmission of the musical items in the programmes.



AT a friend's house the other night I enjoyed a pleasure which I do not often attain owing to the fact that I am usually working in the evenings. I spent a quiet hour listening to radio music.

Conversation turned upon the remarkable manner in which some notes and instruments are transmitted by radio and reproduced with extraordinary fidelity, whilst others bear but a small resemblance to the original sounds. A few of the same friends suggested that the views I then expressed on the matter, purely from the point of view of a musician and without any pretence to any knowledge of the technicalities of radio, might be of more general interest, which is the only apology I make for this article.

The Human Voice

It is common practice among many listeners to test the quality of reception in their loud-speaker or telephones by means of the announcer's voice. When a new arrangement of circuit is made they say: "Wait until we hear the announcer. Then we'll decide how we think it is coming through." The reason for this, presumably, is that the majority of folk are more accustomed to hearing the spoken voice and consequently can compare its variations more easily than anything else. But because they hear the voice well they assume that the reception of music generally is also good, a hasty conclusion which I suggest is frequently unwarranted. Unless a person's ear is trained in the comparison of musical sounds, his judgments are likely to be faulty,

although his appraisal of the human voice is usually minute and accurate.

A Better Test

In testing reception, therefore, it is not advisable to follow the widespread practice of basing judgment upon the reproduction of the announcer's voice. To begin with, this gentleman is an expert elocutionist, and few other speakers into the microphone are likely to do so with equal skill and facility. It is better to found one's opinion upon the quality of reproduction of an instrument of easily-recognised and familiar tone, one which will traverse the whole or the best part of the musical scale. For this purpose no instrument is better than the piano. Many listeners maintain that one of the best instruments for transmission by wireless is the 'cello, and whilst this is doubtless so, I am of opinion that, granted a really good receiver, first place goes to the piano.

Faithful Reproduction

I was curious enough, some time ago, to listen to the transmissions of the "mystery pianist" at 2LO, a little stunt which the B.B.C. officials

Accordingly, in making comparisons between receiving sets, amplifiers, loud-speakers or other ingredients in the wireless pie of which, technically speaking, I confess to knowing nothing, I would prefer to make my comparisons by noting the results on a good pianoforte transmission.

Low Notes

Speaking generally, the brass instruments such as the trumpet and trombone do not reach my ears by radio in their true colours, whilst the drums are decidedly unnatural. I am told that this is due definitely to the inability of many amplifiers to deal with notes which are low in pitch, and it is a great pity that this defect cannot be remedied, because one of the essential features of our modern symphonic syncopated music is the continuous rhythm provided principally by the drums, banjos and the left hand of the pianist. This undercurrent of rhythm is low in pitch, and thus it frequently happens that radio dance music is almost useless for dancing purposes owing to the partial suppression of this vital rhythm.

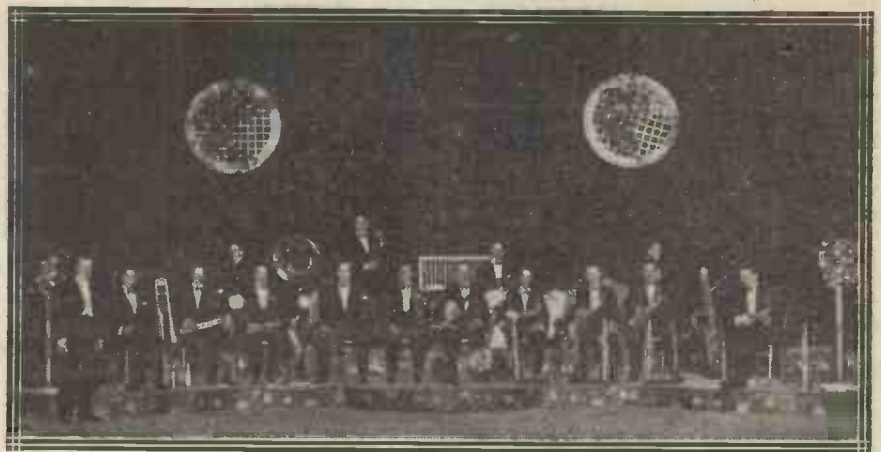

Jack Hylton's band must be familiar to all listener

arranged very cleverly. I remember distinctly standing before a loud-speaker almost hypnotised by the perfect fidelity of reproduction.

Orchestral Broadcast

In listening to violin and 'cello solos I have noticed that a peculiar

Music Via the Ether—continued

prominence is often given to the open notes, causing a certain uneven effect which I am quite at a loss to explain. The saxophone suffers also, and all its notes are not reproduced with com-

plete fidelity. But it is when we come to orchestral transmissions that the ear of the true musician is pained the most.

Is it the Microphone?

songs transmitted by radio are not heard distinctly is not to be found in the apparatus itself or in bad articulation on the part of the singer. The words of several radio artistes, powers-that-be at Savoy Hill have laid down the law in this respect I know not, but the last singing I heard by wireless was singularly free from this tiresome fault.

Noises

It is when we talk about the attempted transmissions of plays, sketches, adventures of Territorials in France and so on that our criticisms tend to become harsh. I listened to one of these things with my friends the other night, and although I succeeded in recognising a cat-like howl followed by a bang on the drum as an exploding shell, the best part of it was utterly unintelligible. All the other weird noises, which varied from slight scrapings to effects which a clumsy person or the proverbial bull might make in a china shop, strained my imagination too much to suggest their real identity.

All this may be due to excessive stupidity on my part, and I may be alone in the view that the transmission of sketches and plays by radio is not a success at the present time. It is not fair to leave the listener in doubt as to the interpretation of these noises, or to require of him so much guessing as to the purport of things. And it is certainly unfair to the actor who nearly always depends for his effects upon something more than his voice. The proper enjoyment of plays via the ether must wait, I fancy, until television can supplement the loud-speaker.



A historic event on the terrace of the House of Commons—the return of Sir Alan Cobham from his Australian flight. The broadcasting microphones may be seen on the table.

such as Miss Mavis Bennett, for instance, have always been crystal-clear whenever I have had the pleasure of hearing them by radio. More often than not the poor singer is almost drowned by the accompaniment.

If I were standing in the studio I might not think the accompaniment too loud, and there it is probably correct. But as it comes over the wireless it frequently bears a wrong

Experiments at Washington, D.C., have shown that weather forecast maps can now be transmitted to ships at sea by a process akin to wireless photography.



relationship to the singer's voice. This matter, again, is one which the B.B.C. engineers would do well to investigate a little more closely if they desire to improve the quality of their programmes.

The only other comment I can make upon wireless transmissions of the voice, and this I do with some pleasure, is that eighteen months ago I heard several singers by radio whose renderings were spoiled completely by an annoying vibrato. Whether the

Singers

Amongst the singers that one hears by wireless there appear no greater differences than are usually observed on the ordinary stage. Some are good, some distressingly bad. I am convinced, however, that the principal reason why the words of so many

The Next Issue of
**“THE WIRELESS
 CONSTRUCTOR”**
 will be a
CHRISTMAS DOUBLE NUMBER.
Order Early. Price 6d. as usual

Making Use of Your Supply Mains

By J. H. REYNER, B.Sc. (Hons.), A.C.G.I., D.I.C., A.M.I.E.E.

Do you take advantage of the electric supply mains for charging your batteries or running your set direct? Developments in the electricity supply system all over the country are to be expected within the next few years, and apparatus is now available for applying the mains to wireless. Mr. Reyner discusses here the various methods of application in an article which cannot fail to appeal to all who wish to have a clear understanding of modern practice in this field.

ALTHOUGH there must be many readers who are not fortunate enough to possess electric light, yet there are a large number who are connected with some supply or other, and with the prominence which is being given to the whole question of electrical supply at the moment, there is no doubt that future development in this direction will be extensive. There are many ways in which this electrical supply may be turned to good account in connection with wireless receivers.

Energy Required

A wireless receiver requires in general three sources of electrical supply. First of all, we have the low-tension supply for lighting the filaments of the valves, this being known in America as the "A" battery. Secondly, we have the high-tension or "B" battery which has to supply a voltage of up to 120 volts or more, but only a comparatively small current of a few milliamps. Finally, with most modern receivers, we have the



A charging unit of a type designed for heavy currents, suitable for charging several accumulators.

grid bias or "C" battery, which is necessary in order to ensure that the low-frequency valves are operating at the correct grid potential to avoid distortion.

Batteries

These sources of supply are in general obtained from batteries. In

the majority of cases accumulators are used for the low tension, owing to the fairly heavy current demand, although with low-consumption valves large wet cells, or even dry cells, may be used in certain cases. The high-tension supply is generally in the form of dry batteries, but these have to be carefully designed in order to withstand the fairly heavy demand made on them

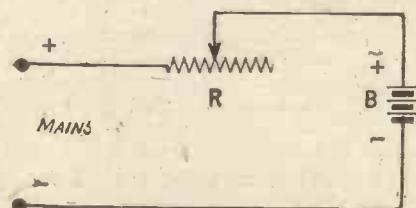

Fig. 1.—When charging from D.C. mains, the variable resistance R is used to control the current passed through the battery B .

by the anode current of the several valves, particularly in the case of a multi-valve receiver. In fact, the demand with the average three- to five-valve receiver is between 10 to 20 milliamps, which is much too heavy a load for the small type of dry cell which was originally employed for high-tension batteries, and there has been a gradual increase in the size and robustness of dry cells for high-tension supply in order to obtain a reasonably satisfactory life from these batteries.

H.T. Accumulators

Even so, however, these difficulties in the way of satisfactory supply are such that manufacturers have recently turned their attention in the direction of high-tension accumulators, which can be recharged when they are exhausted. There are several difficulties in the way of production of satisfactory accumulator units, but these have now largely been overcome, and the few remaining difficulties will ultimately, no doubt, be completely removed. It is not proposed, however, to dwell more on this aspect of the question at the present time.

Grid Bias

The C battery, or grid-bias battery, is required merely to provide a polarising potential, and the actual current to be taken is negligible, since the purpose of the battery is to maintain the grid at a negative potential, and no appreciable currents will flow under such conditions. The requirements of a grid-bias battery, therefore, are that it shall have what is known as a very long "shelf" life, so that it can maintain its potential without supplying any current for a very long period without deterioration.

Using the Mains

Now there are several ways in which the electric light mains may be utilised in connection with these three sources of supply. In the case of the filament supply, we can first supply the valves themselves direct from the mains. Whether or not such an arrangement is satisfactory is a matter of conditions, and we will go into this shortly.

Secondly, we can supply the receiver with an accumulator and charge this



A charging unit for use on A.C. mains, which uses chemical rectification and gives a low or moderate output current.

accumulator as required, utilising the mains as a source of supply. This obviates the necessity for transporting the accumulator to the local charging station, although in many cases arrangements are made by enterprising firms to collect and re-deliver accumulators as part of the charging service.

Making Use of Your Supply Mains—continued

On the high-tension side we have again the two alternatives—first, of supplying the high-tension voltage direct from the mains; or, secondly, of utilising the mains to charge a high-tension accumulator if such is used. The question of the grid-bias battery is not of very much importance. The price of such a battery is small, and it usually lasts a considerable time, so

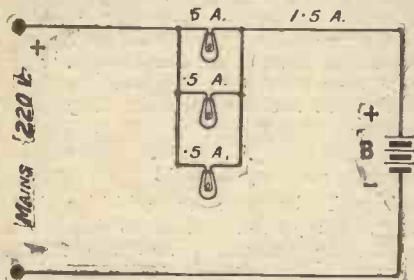

Fig. 2.—By inserting suitable lamps in parallel the required current may be passed through the battery on charge.

that it is hardly worth going to any trouble to arrange for the grid-bias voltage to be supplied from the mains.

D.C. Mains

It is proposed in this article to review generally some of the methods which have been or can be adopted in order to make use of the electric light mains in the various ways which have just been outlined. In all these problems we have two aspects to consider, depending upon the type of electrical supply. In some cases the supply is what is known technically as Direct Current, in which case the polarity of the mains is always constant. Thus we have a negative main and a positive main, just as in the case of a battery, and in any circuit connected across the mains the current will always flow in the same direction.

A.C. Mains

In the other case we have what is known as Alternating Current mains. In this case the polarity of the mains is continually varying. At one instant there is no voltage across the mains at all. The voltage then rises rapidly to a maximum or peak value, after which it falls again to zero. It then rises to a maximum value in the opposite direction, after which it falls to zero again. Now this periodic reversal of the polarity occurs a large number of times in every second; one of the most common frequencies as it is called, or number of times in which this reversal takes place, is fifty per second. There are supplies on which the frequency is different, values ranging from 25 up to 100 being in force in various parts of the country.

Owing to this comparatively rapid fluctuation (although it should be noted that this is very slow indeed compared with the fluctuation of the

current in a wireless receiver) it is possible to utilise such a source of supply for the lighting of lamps without an appreciable flicker, and as far as the results are concerned there is little to indicate whether the source of supply is D.C. or A.C. It is necessary, however, to find out which type of supply is in force before any arrangements can be made to utilise them for wireless purposes.

Accumulator Charging

Let us consider first of all the case of charging accumulators on the electric light mains. If the supply is direct-current, or D.C., the problem is fairly simple. Consider the case of charging a 6-volt low-tension battery. The voltage of the mains is probably between 100 and 200 volts. If the mains were connected directly across a 6-volt accumulator, the effect would be practically the same as a short circuit, a very large current would flow, and even if the accumulator were not damaged, as it probably would be, the fuse in the electric lighting circuit would blow.

Current Regulation

We must interpose, therefore, some arrangement in order to cut down the current to a reasonable value, and reduce the voltage actually applied across the accumulator, and so cut down the current actually flowing through the circuit. The simplest way of doing this is by the insertion of a resistance in series with the mains.

high, then the charging current will be small, and vice versa.

Suitable Resistances

The actual type of resistance utilised depends again on the circumstances. Where it is only desired to charge at a comparatively small rate of, say, 1 or 2 amperes, it is customary to utilise carbon-filament lamps. These lamps carry a fairly heavy current, and if two or three such lamps are placed in parallel, as in Fig. 2, then the total current passed by the circuit will be the sum of the currents through the individual lamps. To take a concrete example; if we have 220-volt mains, then we may choose three 220-volt 25 candle-power carbon-filament lamps, each of which will pass about 0.5 of an ampere. The net charging current through the accumulator will thus be of the order of 1.5 of an ampere.

The actual voltage of the accumulator is so small compared with the voltage of the mains that it does not enter into the calculations to any appreciable extent. If larger charging currents are required, then either more or bigger lamps, or a combination of both, must be used, or alternatively, resistances constructed of heavy-gauge resistance wire may be used.

High-Tension Charging

Considering now the question of high-tension accumulators, provided

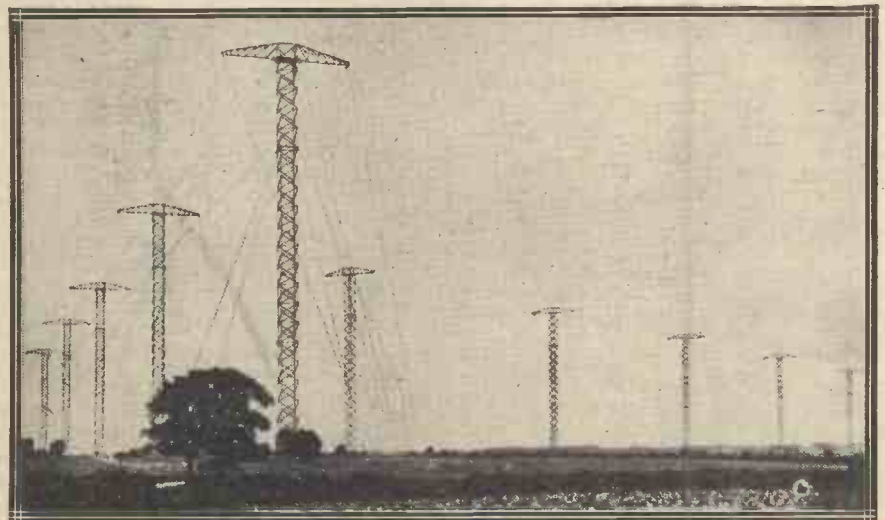

The beam station at Bodmin, Cornwall, for communication with Canada (left line of masts) and South Africa (right line of masts).

Fig. 1 shows such an arrangement. The current flowing through the resistance and the battery in series causes the voltage to drop across the resistance itself, and by a suitable choice of the resistance the required current can be passed through the accumulator. If the resistance is fairly

that the voltage of the mains is higher than that of the accumulator to be charged, we can utilise the same principle. That is to say, we can connect the mains directly across the accumulator, making sure, of course, that the polarity is in the correct direction, and

(Continued on page 178).

CHOICE OF PROGRAMMES MADE EASY

By STANLEY G. RATTEE, M.I.R.E

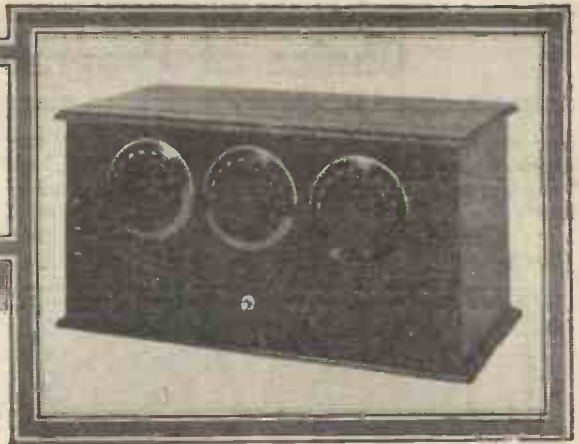

Have you yet explored the "Ether of Europe"? If not, here is a set which will enable you to do so with ease. Probably you have many of the components by you and you will not need to go to great expense for the rest.

ONE of the chief desires of the present-day listener is to provide himself with a receiver which will enable him to listen with comfort to a programme other than that emanating from the local station.

It order to do this it must of course be appreciated that two of the most important essentials in a receiver are sensitivity and selectivity, and confining our arguments to small sets, these two essentials are not easy to combine in receivers of modest price.

Number of Valves

It is true that with certain types of single-valve sets it is possible to tune in other stations, but usually the

attended with consistent success is best attempted with a receiver employing at least one stage of high-frequency amplification, when it will be found that the reaction adjustments are rarely as critical as those of a single-valve set, while generally the selectivity is greater.

Modern Requirements

The modern standards of sensitivity and selectivity are greatly in advance of those which were obtaining, say, twelve months ago, and the object in designing the present two-valve set has been to produce a receiver which, though up to present-day standard, is nevertheless moderate in its de-

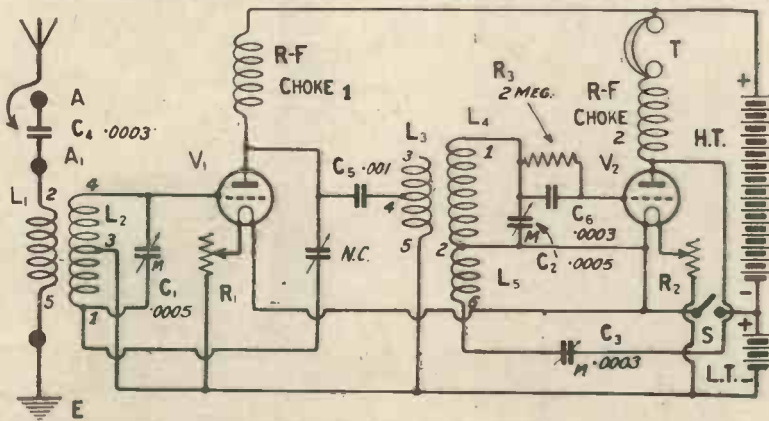

Fig. 1.—The condensers C1 and C2 are the tuning controls, while C3 is for reaction.

operation is a rather tedious one, while the set itself is adjusted so near to the oscillation point that in many cases distortion results. For all ordinary purposes where distance work is concerned the conventional single-valve set should be regarded as not quite good enough when used in the hands of the average listener, and should therefore be left to those listeners who have more operating experience or should be left alone until some circuit is devised which will be a considerable improvement upon those at present existing, even as a good many of them—undoubtedly are.

Distance work which is likely to be

mand upon the pocket of the builder. Such is the purpose of the set under review, while in practice it does exactly what is expected of it, namely, a number of programmes are available to the listener, thus enabling him to make his choice.

RESULTS OBTAINED

As to actual results, the receiver has been used for some time in the South London district, and during the transmission of the local station a number of British and Continental stations have been identified. Among these may be mentioned: Birmingham, Newcastle, Bournemouth, Glasgow,

WHAT YOU WILL NEED

- Two .0005 S.L.F. variable condensers (Jackson Bros.).
 - One .0003 square law condenser (Jackson Bros.).
 - Two valve holders ("Etherplus").
 - One aerial coil and base (Collinson Precision Screw Co., Ltd.).
 - One standard split primary H.F. transformer with reaction and base (Bowyer Lowe; Burne-Jones; Collinson; Efesca; Lewcos; Peto-Scott).
 - One ebonite panel, measuring 16 in. by 8 in. by 1/4 in. (Ebonart).
 - Two baseboard mounting filament resistances (A. F. Bulgin & Co.).
 - Cabinet and baseboard 7 ins. deep (Camco).
 - One neutralising condenser, baseboard mounting (Peto-Scott Co., Ltd.).
 - One .0003 grid condenser (Dubilier Condenser Co., Ltd.).
 - One 2 megohm grid leak (Dubilier Condenser Co., Ltd.).
 - One .001 fixed condenser (Dubilier Condenser Co., Ltd.).
 - One .0003 fixed condenser (Dubilier Condenser Co., Ltd.).
 - One "On-off" switch (Igranic Electric, Ltd.).
 - Two H.F. chokes (Beard & Fitch, Ltd.).
 - Pair right-angle brackets (Burne-Jones & Co., Ltd.).
 - Nine terminals marked "Aerial," "Aerial 1," "Earth," "Phones+," "Phones-," "L.T.+", "L.T.-," "H.T.-," "H.T.+", (Belling & Lee, Ltd.).
 - Strip of ebonite measuring 4 in. by 2 in. by 1/4 in. (Ebonart).
 - Quantity No. 16 Glazite connecting wire, wood screws, etc.
- Approximate cost £6 10s.

Radio - Belgique, Radio - Barcelona, Leipzig, Hamburg, Radio - Milan, Radio - Toulouse, Frankfurt and Munster.

Though it has not been attempted to receive all these stations during one evening, never yet has the receiver failed to bring in the station it was desired to hear. Further, owing to the modesty of the Continental stations in announcing their identity, it is doubtful whether one would be able actually to identify by name more

Choice of Programmes Made Easy—continued

than one or two or three even during hours of listening, so rarely do the "Continental" announce their name.

Constructional Design

As to the receiver itself, it is so

ing to carry the various controls, the aerial, earth and 'phone terminals; the baseboard being used for the remainder of the components permits of everything being enclosed within the cabinet.

and then only a few degrees at a time.

The Circuit Used

One of the drawings accompanying this article shows the theoretical circuit used in the set under this review, and it will be seen from this that in series with the aerial coil L_1 a .0003 condenser is included. The terminal arrangement of the receiver allows the condenser to be used or not as desired, and it will probably be found that with some aerials, including the condenser will give better results than without it, while with other aerials the reverse will hold good.

The Coils

The coils L_1 and L_2 are wound upon the same former, which is fitted with six pins for sliding into the standard screen coil base. The actual coil unit is the same as that used in the same position in the "Spanspace Three," described in the November issue of THE WIRELESS CONSTRUCTOR, and should readers care to wind their own coils, details as to turn numbers are given in that journal; this coil may, of course, be purchased ready wound if preferred. The coils L_2 and L_3 are

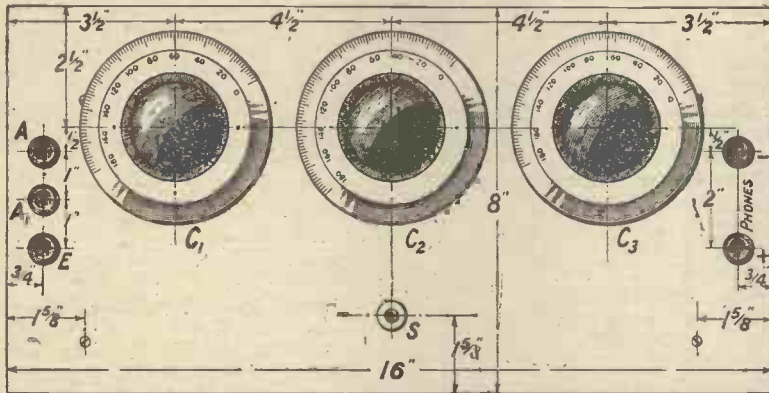
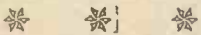

Fig. 2.—Dimensions for drilling the panel may be taken from this diagram. Blueprint No. C1070 A.

designed as to enable the desired degree of selectivity to be obtained, together with sensitivity and stability, without the use of screens. The high-frequency circuit is of the neutralised

Apart from the three dials on the front of the panel, there will also be seen, immediately below the centre dial, an "on-off" switch for controlling the L.T. supply for the valve



The neutralising condenser on the right is set when the receiver is first tested. Reaction is controlled by the variable condenser seen on the left in this photograph.

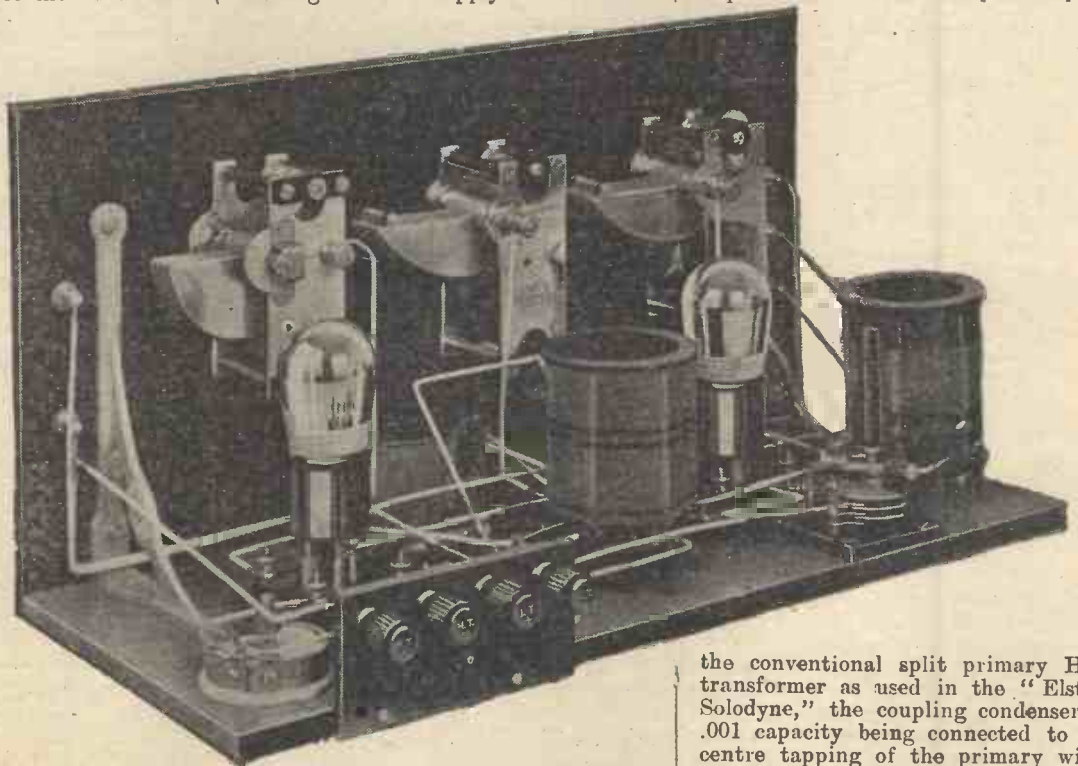

type, while the aerial circuit is inductively coupled in accordance with modern practice.

As to constructional design, it may be gathered from the photographs that the popular method of utilising an upright panel and baseboard has been adopted, the panel merely serv-

ing the filament. As regards the three dials, the first two are used for tuning purposes, while the third is merely for controlling the reaction effect. In practice, most of the operating is performed with the first two dials, the reaction adjustment not often requiring to be altered when once adjusted,

the conventional split primary H.F. transformer as used in the "Elstree Solodyne," the coupling condenser of .001 capacity being connected to the centre tapping of the primary winding, namely, No. 4 on the base. Wound on the bottom end of the former is a reaction coil which is part and parcel of the H.F. transformer and is connected between No. 2 and 6 of the base.

Reaction Condenser

The .0003 variable condenser connected between the anode of the

Choice of Programmes Made Easy—continued

second valve and the lower end of the reaction winding gives a smooth control of reaction without appreciably affecting the tuning of the receiver. Indeed, the adjustment may be made so fine that though set for stability loud signals will cause the set to pass in and out of self-oscillation as the signals start and stop in their transmission.

Components and Materials

Before starting upon any endeavour to build a receiver as illustrated, it is suggested that the materials and components given elsewhere be collected together. Following upon the names of these components, their trade mark or manufacturer is given,

and though, of course, other suitable makes will be found among the advertisement pages, the actual values where stated should be strictly adhered to. In regard to the H.F. transformer, a few alternative makes are suggested. The alternatives suggested allow of the illustrated lay-out being used, and should the reader decide to use still other makes, then care must be taken to see that sufficient clearance is given for the valves to vibrate within their holders.

Arranging the Components

In view of the fact that the coils used do not employ screens, it is essential that the lay-out illustrated should be copied with care, otherwise there

may be some difficulty in obtaining either selectivity or stability over the whole tuning range of the condenser. Another point worthy of remembering is that when mounting the components upon the baseboard care must be taken to ensure that sufficient room is allowed to enable the valves to vibrate clear of the variable condensers. The best way of making sure of this fact is to insert the valves in the holders and then to ascertain the best positions by moving them about upon the baseboard.

Wiring Tips

The wiring-up of the components will not be found a difficult business, neither will it occupy many hours,

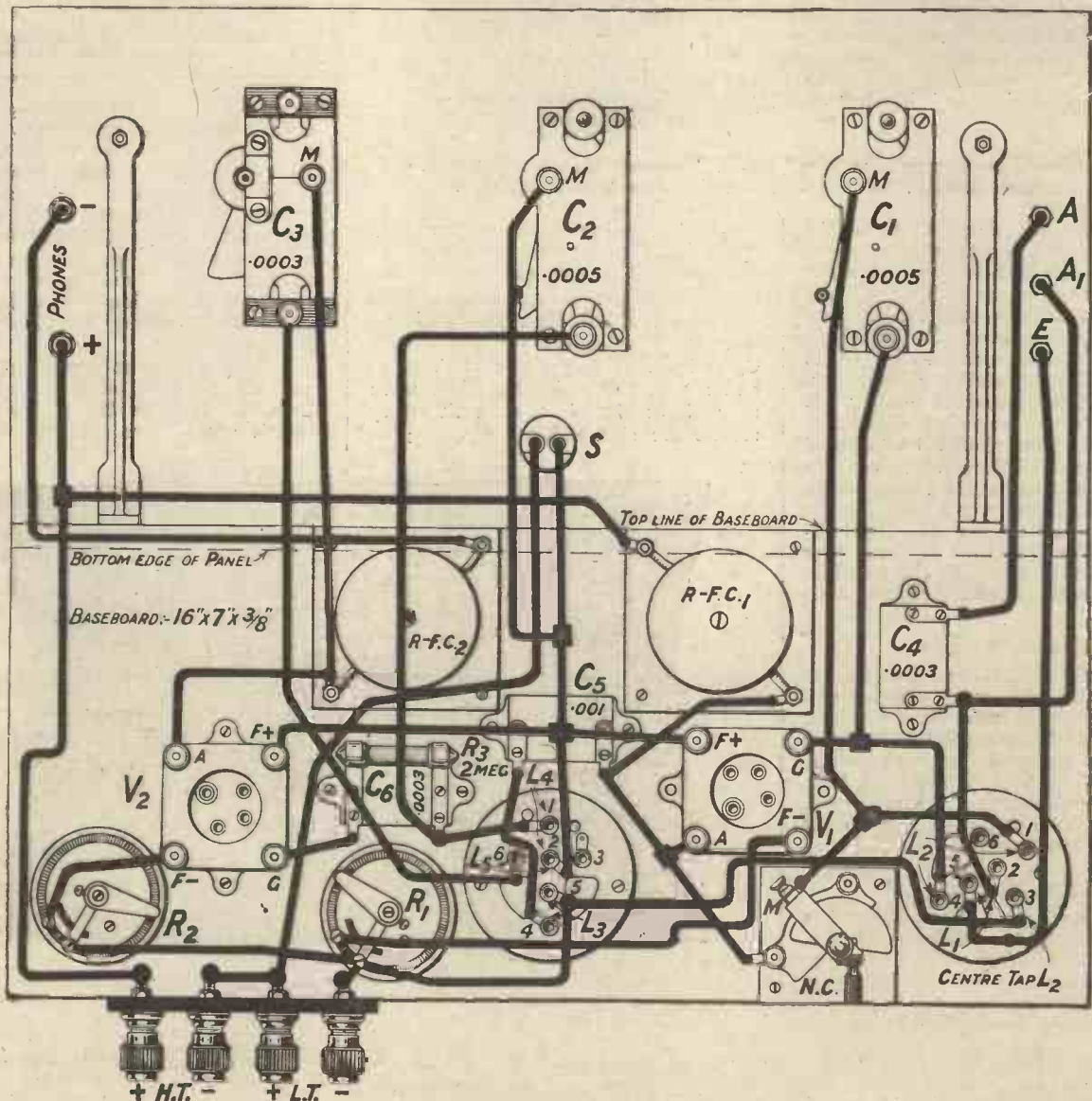
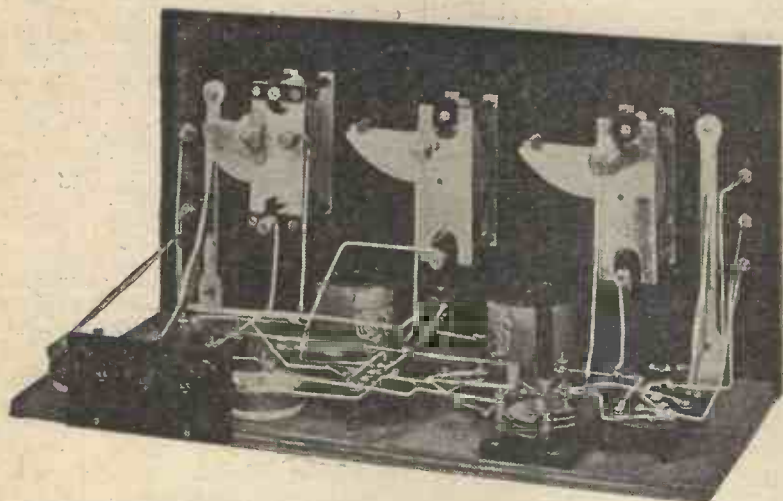

Fig. 3.—The layout given should be carefully followed in order to obtain the best performance from the receiver. Blueprint No. C1070 B is also obtainable.

Choice of Programmes Made Easy—continued

since only two valves are involved. There are one or two points which will be found useful in speeding up the work, as, for instance, along the

Commencing with the condensers all set to a zero reading, slowly turn C_1 and C_2 one or two degrees at a time until the local station is tuned in to



Wires should be attached to the "on-off" switch before fixing it in position, as it will otherwise be somewhat inaccessible later on.

edge of the baseboard next to the panel there are two wires, one going to each of the high-frequency chokes. To facilitate the easy making of these connections it is best to solder these leads before screwing the panel in position, leaving sufficient length to complete the remaining connections. Similarly, the connections to the "on-off" switch are somewhat difficult of access, and these should be fastened to the switch before screwing the panel in position, again remembering to leave plenty of spare wire for the remaining connections of the component. The remainder of the wiring may be carried out with the panel in position, and should present no difficulty.

Valves to Use

Valves of the 2-, 4- and 6-volt types may be used with equal success, and the best results have been obtained with valves of the special H.F. type. General-purpose types may, of course, be used if desired, but special high impedance valves are to be preferred, working with an anode voltage of something like 80 volts.

Neutralising the Set

After the wiring of the receiver has been checked and found to be correct, turn the "on-off" switch to the "off" position, turn the filament rheostats so that the whole of the resistances are in circuit, and connect both the L.T. and H.T. batteries. Connect the 'phones, insert the valves, connect the aerial and earth (the aerial to either terminal for the time being) and light the valves to a suitable degree of brilliancy.

its loudest volume, whereupon turn out the H.F. valve by means of its rheostat and adjust the neutralising condenser so that no signs of the local station are heard, irrespective of any amount of retuning performed with C_1 and C_2 . Re-light the H.F. valve and retune to the local station, when it will be found that satisfactory results are obtained.

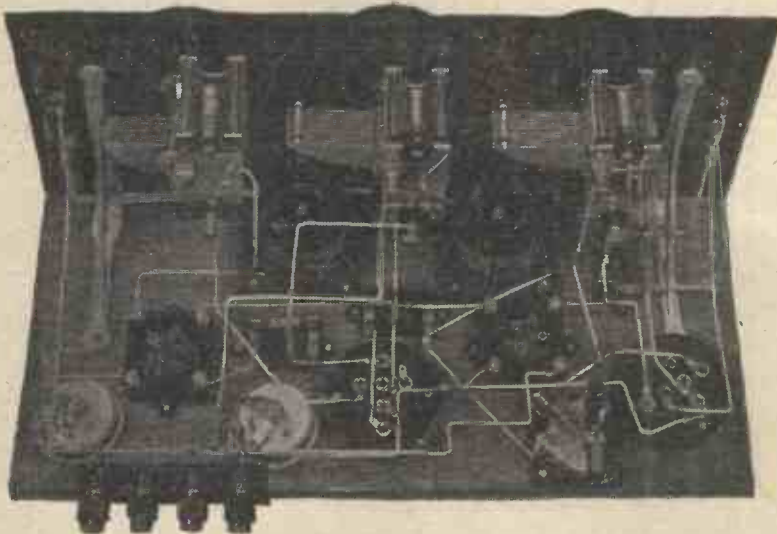

Note carefully the relative positions of the coil bases and other components.

Operating the Set

By slowly turning the condensers C_1 and C_2 together the signals from the local station will quickly disappear, and the turning of the condensers should be continued at such relative

WIRING IN WORDS

Join phones - to one side of R-F.C.2.
Join phones + to one side of R-F.C.1, and H.T. +.
Join remaining side of R-F.C.1 to one side of C_5 ; same side of C_5 to A of V_1 ; A of V_1 to fixed plates of N.C.
Join moving plates of C_2 to one side of S, to F+ of V_1 , F+ of V_2 and contact 2 of L_3 .
Join fixed plates of C_1 to G. of V_1 and contact 4 of L_2 .
Join A to one side of C_4 .
Join A1 to other side of C_4 ; same side of C_4 to contact 2 of L_1 .
Join moving plates of C_1 to moving plates of N.C., and contact 1 of L_2 .
Join one side of R_2 to L.T. -; L.T. - to one side of R_1 ; same side of R_1 to contact 5 of L_3 ; contact 5 of L_3 to contact 3 of L_2 .
Join E to contact 5 of L_1 .
Join remaining side of R_1 to F - of V_1 .
Join G of V_2 to one side of C_6 .
Join F - of V_2 to remaining side of R_2 .
Join moving plates of C_3 to remaining side of R-F.C.2; same side of R-F.C.2 to A of V_2 .
Join fixed plates of C_3 to contact 6 of L_5 .
Join remaining side of S to L.T. +; L.T. + to H.T. -.
Join fixed plates of C_2 to remaining side of C_6 and same side of C_6 to contact 1 of L_4 .

speeds that the two circuits $L_2 C_1$ and $L_4 C_2$ are always in tune (as evidenced by a slight breathing sound in the 'phones) until a distant station is picked up. Upon the station being properly tuned in, the aerial should be connected to the other terminal and the C_1 condenser again adjusted for the best results, noting whether or not there is any improvement on including or excluding the .0003 series condenser.

It will probably be found that when receiving stations using wavelengths above 400 metres better results as regards volume are obtained without

the condenser, though the selectivity is not so good. On the other hand, it may be found that when receiving stations working below 400 metres the best results are obtained with the con-

Continued on p. 170.



Treasures which crumbled at a touch

NOT so long ago the whole world was thrilled with the accounts of the exquisite treasures being exposed to the light of day at Luxor. Superb jewels worth a king's ransom—marvellous carvings typical of the splendour of the Pharaohs—georgous sepulchral furniture—and most wonderful of all, tapestries and draperies which, until they were moved, retained the beauty and freshness of the day they were woven.

But—whilst the jewels, the carvings and the furniture have now been added to the museums—the fabrics and the tapestries have gone for ever. Their delicate, gossamer-like threads could not withstand even the most careful handling. After thirty centuries, the fibres had lost their pliability—at a touch they shivered into a thousand fragments.

This tragedy of crumbling treasures affords a striking parallel for wireless enthusiasts. Once the filament of a valve is crystallised

with age it is liable to become fractured at the slightest blow. Even the ordinary wear and tear of everyday use will shorten its life. Now, however, a filament has been discovered which—because it operates almost without heat—permanently retains its pliability. Age cannot affect it. Even after several thousand hours of use its electronic emission is as prolific as ever. This Kalenised filament is one of two vital improvements introduced by Cossor this season. The other is Co-axial Mounting—a system of construction acknowledged to be one of the greatest steps forward in valve design for several years. Ask your Dealer to-day for our latest Folder describing the many exclusive features of these new valves.

Read about their amazing economy—their greater sensitivity and improved tone, but above all, their guaranteed uniformity of performance. Never before have such remarkable valves been available.

The new Cossor Point One

With Black Band. An ideal supersensitive Detector. Consumption '1 amp. at 1.8 volts **14/-**

The new Cossor Point One

With Red Band. Pre-eminent among H.F. valves. Consumption '1 amp. at 1.8 volts **14/-**

The new Cossor Stentor Two

With Green Band. For Power Valve use—ideal for Super Sets. Consumption '15 amp. at 1.8 volts **18/6**

Cossor Valves

A good Circuit deserves
IGRANIC COMPONENTS



**IGRANIC Centre Tapped
"XLLOS" (Extra Low Loss)
COILS.**

Igranic Centre Tapped "XLLOS" Coils are particularly suitable for modern neutrodyne circuits.

Igranic Centre Tapped "XLLOS" Coils actually contain two separate inductances which may be used separately or may be joined in series to form a single coil from which a centre tapping may be taken.

Five sizes giving wavelengths of approximately 110 to 3,500 metres.

No. 1, 7/-	No. 4, 9/3
No. 2, 7/6	No. 5, 10/6
No. 3, 8/3	
Mounting Base, 4/6.	

Send for full particulars.

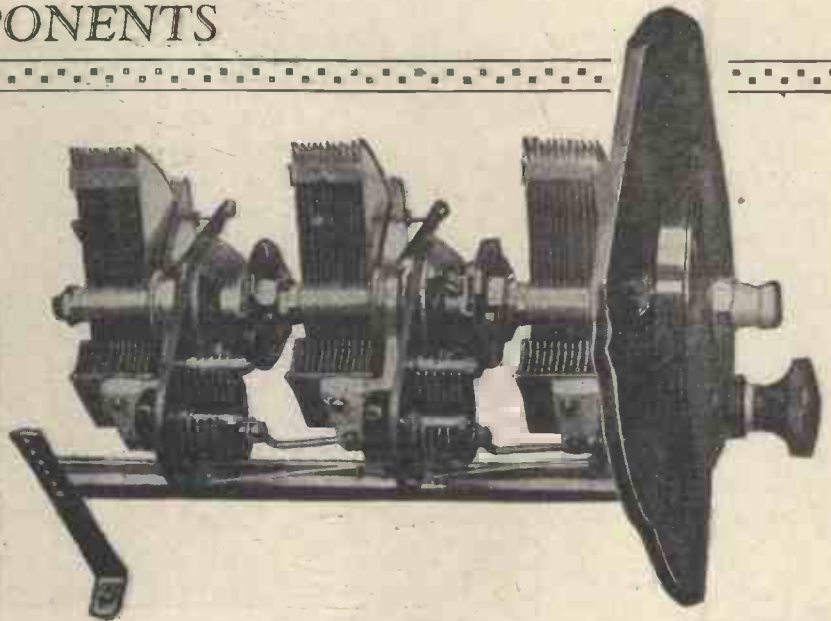

The Triple Gang
problem solved!

THE new Igranic Triple Gang Condenser successfully overcomes the difficulties of tuning three circuits with a single control. Two miniature condensers are incorporated in easily accessible positions so that each circuit can be exactly equalised, after which all tuning is effected through the main control knob.

The Igranic method of equalising the three circuits does not necessitate altering the relative settings of the three main condensers, and the wavelength variation for a given movement is the same in each condenser, thus preserving the accurate square law characteristic of the Igranic Triple Gang Condenser over its whole range.

The Igranic Triple Gang Condenser is unique. It makes the tuning of the "Solodyne" as simple as a single valve receiver.

PRICE.....£3 15s. 0d.

PRICE, without equalising condensers but with adjustable couplings£3 10s. 0d.

Igranic Triple Gang Condensers are built up from three Igranic-Pacent .0005 mfd. Square Law Condensers. The whole construction is particularly robust; losses and minimum capacity are negligible and the movement is extremely smooth.

The Igranic Indigraph Vernier Knob and Dial is particularly recommended for tuning.

PRICE.....7s. 6d.

SEND FOR THE NEW IGRANIC CATALOGUE * (J.151.)

IGRANIC ELECTRIC CO. LTD. 149, Queen Victoria St., LONDON.
Works: Elstow Road, BEDFORD.



HEAD OF RADIO PRESS RETIRES

Mr. Scott-Taggart's Decision to Enter Valve Business

Will Probably Continue to Write

IT will, no doubt, come as a great surprise to readers of THE WIRELESS CONSTRUCTOR to hear that Mr. John Scott-Taggart, F.Inst.P., A.M.I.E.E., the founder and head of the great Radio Press organisation, has retired in order to enter the valve business.

To those who know him, the step which he has now taken is not altogether surprising. His whole technical life has been devoted to a study of the manufacture and use of the valve. Behind the scenes he has done a great deal to assist the radio industry and valve industry, and it is only logical for him to market a series of valves bearing his name, which will carry with them a reputation which has always belonged to one who has devoted the whole of his interest to this section of radio.

It is probably news to a large number of readers of THE WIRELESS CONSTRUCTOR that Mr. John Scott-Taggart has already been a valve manufacturer. The present time is an appropriate one to review what must be one of the most interesting and unusual careers.

Early Days

Before the war, Mr. Scott-Taggart was a keen amateur, and 13 years ago he was writing articles, although only at school. He had one of the relatively few transmitting stations in those days, and possessed the call sign LUX.

During the war, Mr. Scott-Taggart served from 1914 to 1919, first in the Seaforth Highlanders and later in the Royal Engineers. Enlisting as a private, he rapidly was promoted to Ser-

geant-Instructor of Signalling. He was later promoted in the field to commissioned rank, and was first in the results of every examination on valves held at the General Headquarters in France.

Pioneer Work on Valves

As a wireless officer in the Royal Engineers, he took part in fighting on Vimy Ridge in April, 1917, and was one of the very first to use valve transmitters in warfare. Later in the year, he became an Instructor at the 1st Army Signal School, giving courses of lectures on the valve. Although he had been engaged in active service, Mr. Scott-Taggart had written articles for *The Wireless World* in 1917, and later in the year he wrote the first article dealing in a comprehensive manner with the characteristic curves of valves. This article was entitled,

Mr. Scott-Taggart Enters Valve Business

"On Characteristic Curves and their Use in Radio Telegraphy and Telephony," and was also published in *The Wireless World*.

Although investigators in the services had, no doubt, similar information, Mr. Scott-Taggart had to investigate the whole question of characteristic curves from the beginning, and carried out a very laborious set of measurements, which formed the basis of what is one of the first real published analyses of "families" of valve curves.

Wireless Proves Its Worth

At the beginning of 1918, Mr. John Scott-Taggart joined the 55th Division, just before the battles of Festubert and Givenchy, in the La Bassée sector. On April 9, 1918, a fierce attack was made along the whole British front, and due to a flanking movement the original site of the 55th divisional headquarters was actually captured, while the front remained substantially unaltered.

The whole of the communications of the division were broken by shell fire, and the direction of operations was carried out entirely by the wireless system, which extended to the front line trenches. For work on this occasion, Mr. John Scott-Taggart was mentioned in despatches.

The part played by wireless in this division may be judged from the fact that the wireless section under his command possessed the highest percentage of decorations for gallantry of any wireless section in the British Army. Later in the year, during the final fighting, Mr. John Scott-Taggart was awarded the Military Cross for "gallantry in maintaining wireless communications under fire."

Continuous Experiment

Although not enjoying the advantages of a more sheltered technical post, Mr. John Scott-Taggart maintained the closest technical interest in valve work, and carried out much experimental work during rest periods. He also continued to write articles for the technical Press, which disclosed for the first time the great usefulness of the three-electrode valve. Professor Fleming, in his book on the valve, quoted large extracts from these articles, and in his Preface paid a very generous tribute to the original author.

During this period, Mr. Scott-Taggart developed a valve attachment for trench work which eliminated the

high-tension battery, and at the time of the Armistice, according to the statement of Colonel Trew, who was the officer in charge of wireless of the B.E.F., this valve attachment was to be fitted to all trench sets.



A frame aerial set in use in the recent Army training operations.

A Standard Text-Book

Immediately after the war, Mr. John Scott-Taggart completed a book entitled, "Thermionic Tubes in Radio Telegraphy and Telephony." It is, to-day, the standard text-book on the



Army manoeuvres have been carried out in Germany this year and a German mobile wireless station is shown in this photograph.

valve, and is easily the largest book on the subject.

In 1919, Mr. Scott-Taggart took charge of valve manufacture at the lamp works of The Edison Swan Electric Company, Limited. His work was principally the manufacture of different types of valves for the

Government, and in view of the very strict specifications and the fact that every valve was rigidly tested by the Government Departments concerned, it proved an excellent training in a particularly difficult process of manufacture. It is interesting to note that the first valves specifically designed for amateur use were designed by Mr. Scott-Taggart, and were called E.S.2 and E.S.4 valves. These were different from the standard service type of valve, which was then the only one readily available to the British public.

Wide Experience

Mr. Scott-Taggart left the Edison Swan works to join the Radio Communication Co., Ltd., which, as readers may know, carries on a big business in ship wireless installations with activities in this country as regards general wireless work which are only second to the Marconi Co. Mr. Scott-Taggart became head of the department dealing with inventions and patents, and was next in seniority to the chief engineer.

He held this position for several years, and during this time acted as patent adviser to the Mullard Radio Valve Co., Ltd., and in fact prepared the original defence in the patent lawsuit which that company had with the Marconi Co., which finally resulted in the House of Lords' decision for the Mullard Co.

The Negatron

It was during his stay with the Radio Communication Co. that Mr. Scott-Taggart's invention, the Negatron valve, was adopted for use in continuous wave reception on dozens of liners, which to-day receive their news bulletins on this ingenious valve which gives a negative resistance effect. This valve, like many of Mr. Scott-Taggart's principal inventions, has no application to broadcasting, but has valuable uses in "commercial" wireless.

Distinctions

Mr. Scott-Taggart is a Fellow of the Institute of Physics, and at the time of his election was the youngest to have achieved that distinction, which is one of the highest professional diplomas in physics. He is also an Associate Member of the Institution of Electrical Engineers, besides holding similar membership in the French, Belgian and American Institutions of Electrical Engineers. Many of his writings, including text-books on the

(Concluded on page 143.)

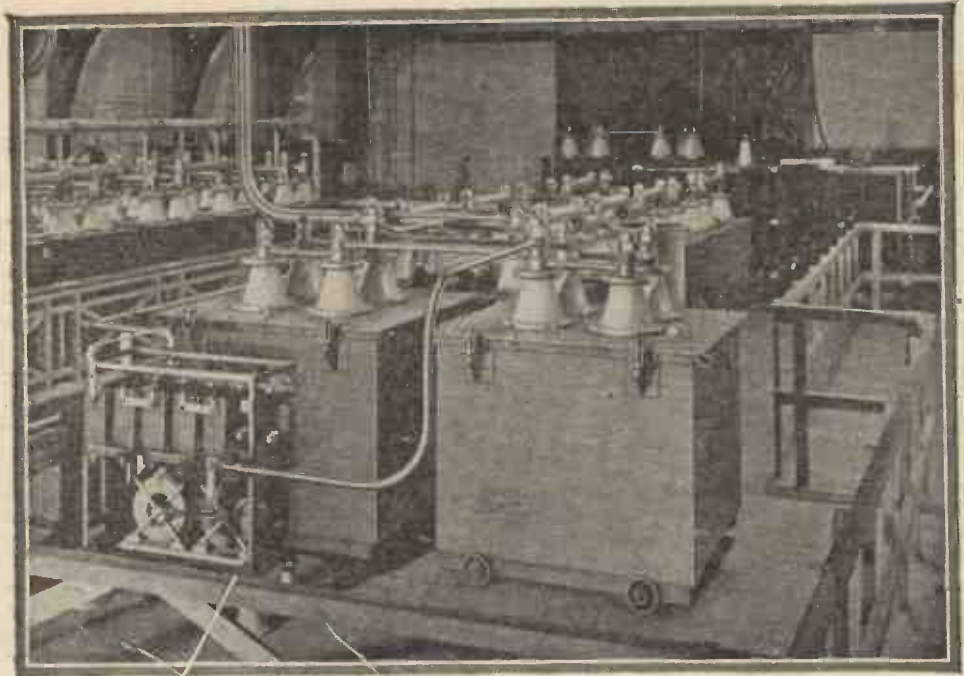

Specify Dubilier!

Sixteen years ago we commenced manufacturing wireless condensers. In those days, electrical condensers certainly existed, but they were totally unsuitable for wireless purposes. Accordingly we made a minute study of the subject, and as a result of careful observation over long periods, we were enabled to design condensers in which hysteresis losses, insulation leakage, and numerous other factors, opposed to condenser efficiency were either reduced to the minimum or eliminated completely. The small, hermetically sealed groups of mica and metal plates which form the essential units of the familiar 600 Type condensers are the direct outcome of these observations. They represent the very high standard of electrical efficiency to which modern science has brought the condenser, and it is interesting to note that these identical units grouped in their tens of thousands, make up the Condenser Banks of the world's principal wireless stations. In the Condenser equipment of the Government Radio Station at Rugby, of which we show a view above, there

are in each of the large "tanks" over half a million of such mica and metal plates grouped into hundreds of condenser units.

Each of the many millions of plates was individually selected and tested before being collected into groups, and each group was again subjected to frequent and stringent tests during the successive stages of assembly.

This ritual of tests, tests, and more tests is observed in the case of every single product bearing the Dubilier name. Our long experience has taught us that if we are to make condensers which will be satisfactory in service whether they are designed for High Power Stations or for Broadcast Receivers, we must take precautions to eliminate every possible cause of failure. As Condenser Specialists we know these precautions to be not only desirable, but essential.

Governments and Manufacturers of Broadcast Receivers all over the world, agreeing with us in this matter specify Dubilier.

Are there Dubilier Condensers in your Set?



Specify—



ADVERT. OF THE DUBILIER CONDENSER CO. (1925) LTD.,
 DUCON WORKS, VICTORIA ROAD, NORTH ACTON, W.3.
 TELEPHONE: CHISWICK 2241-2-3.

E.P.S. 238

Finston SCREEN COILS

Made to "Radio Press" Specifications and fully guaranteed.

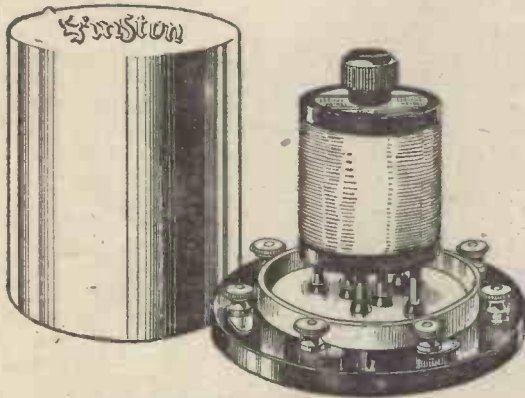

"FINSTON" SCREEN COILS.
Obtainable from most Dealers.

Stranded wire is used thereby giving maximum inductivity from high-frequency currents.

Pins on base are surrounded by Bakelite bushes to prevent leakage on metal shield.

Pins on coil moulded in and all connections soldered.

Series No.	Type of Coil.	Price.
		Metres. Each
No. S.C. 1	SPLIT PRIMARY AERIAL COIL	250/550 5/6
No. S.C. 2	SPLIT PRIMARY AERIAL COIL	1,000/2,000 5/6
No. S.C. 3	SPLIT PRIMARY H.F. TRANSFORMERS	250/550 7/6
No. S.C. 4	SPLIT PRIMARY H.F. TRANSFORMERS	1,000/2,000 7/6
No. S.C. 5	SPLIT SECONDARY H.F. TRANSFORMERS	250/550 7/6
No. S.C. 6	SPLIT SECONDARY H.F. TRANSFORMERS	1,000/2,000 11/-
No. S.C. 7	REINARTZ COILS	250/550 7/6
No. S.C. 8	REINARTZ COILS	1,000/2,000 11/-
No. S.B. 9	SCREEN COMPLETE, with 6-pin base	9/-

SPECIAL NOTICE TO THE TRADE.

Add Finston "Screen Coils" to our range of components which you stock; they are continually being asked for by the public. You can guarantee your customers prompt delivery of these new lines. Write for full details and trade terms.

FINSTON MANUFACTURING CO., LTD.

45, Horseferry Road, London, S.W.1.

Telephone : VICTORIA 1644.

Telegrams : Wyrfinston, Sowest.

Parra Ad.

You can construct this
or this with equal ease

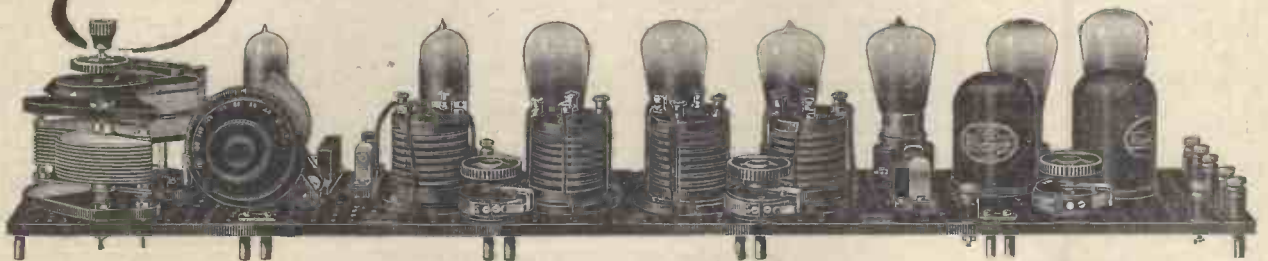
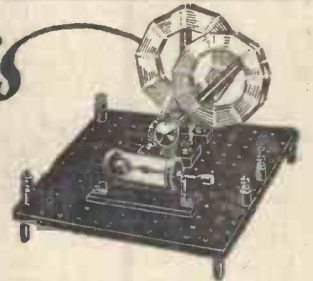

If you adopt
No Technical
Knowledge Required.

BLACKADDA RADIO CO., LTD.
SADLER GATE,
DERBY.

'Phone : Derby, 1820. 'Grams : "Blackadda, Derby."

Results from Blackadda sets are equal to any on the market. If your local dealer is unable to supply, we will forward direct on receipt of remittance or C.O.D.

BLACKADDA

RADIO BUILDING SYSTEM

The enthusiast can start with a simple set and gradually build up to the multi-valve receiver without tools, soldering or waste as all parts are interchangeable, he is also enabled to keep up to date with all improvements and developments.

FAILURE IMPOSSIBLE

The Blackadda system has revolutionised wireless construction and we publish service sheets describing various new circuits which can be easily understood and followed.

The Blackadda circuit book containing a fund of Wireless information and illustrations and details of over fifty up-to-date circuits is available. Price 1/-.

GETTING THE BEST FROM THE "SPANSPACE THREE"

Valves to Use and Hints on Operating

By G. P. KENDALL, B.Sc.

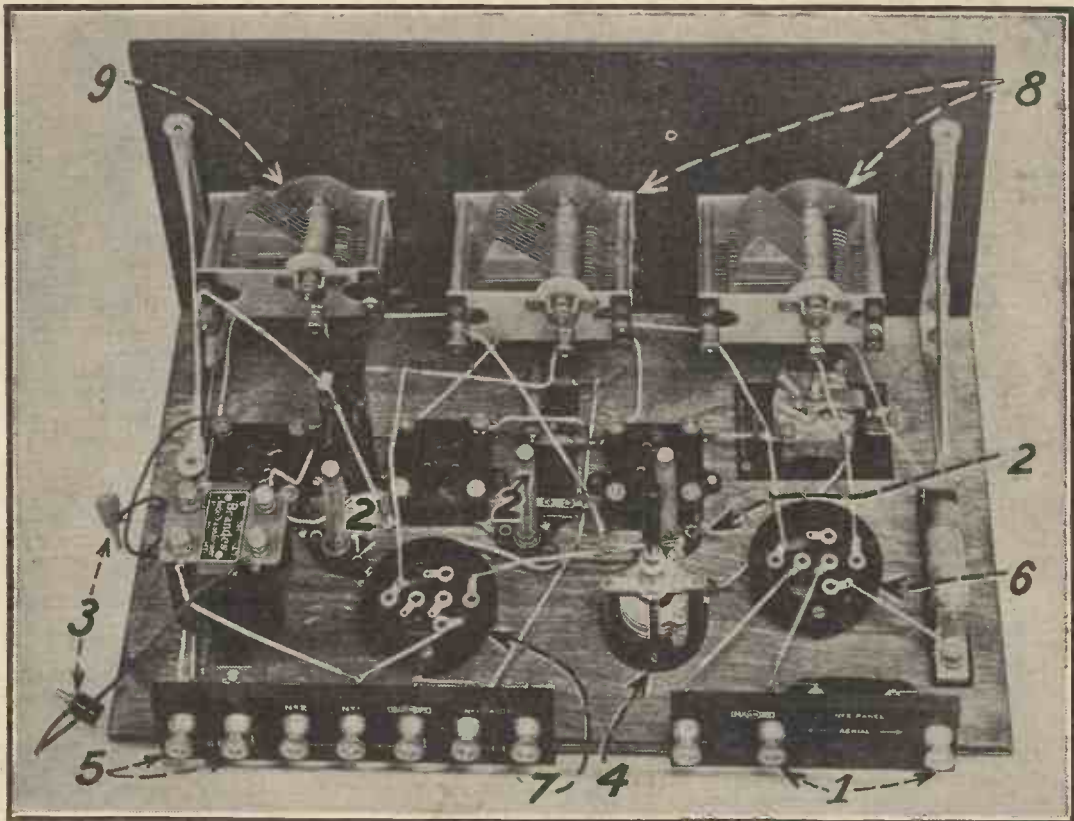

NOTE THESE POINTS

1. Attach aerial lead to one or other of these terminals, whichever is found best by experiment.
2. Insert fixed resistors here to suit the valves used.
3. Plug in to grid-bias battery here.
4. Set neutralising condenser on first testing and leave set.
5. Connect telephones or loud-speaker to these terminals.
6. Insert aerial coil here.
7. Insert anode coil here.
8. These condensers have approximately matched dial readings.
9. Adjust this reaction condenser for volume required.

I HAVE not found the "Spanspace Three" to be at all critical as to the types of valves employed, but possibly a little further information as to those which have been used and the results obtained will be useful.

The Power Type

One of the first types of valves to be tried in the first or H.F. stage was one of the fairly low impedance power valves which at one time were used so largely as H.F. amplifiers. All those which I tried were all of the 5-volt 1/4-ampere type, and results were certainly quite pleasing. Signals were not so loud as with other types, which

will be discussed in a moment, but the operation of neutralising was particularly easy, and the reaction control from the succeeding valve was particularly smooth and pleasant. With a valve of this general type, that is to say, low impedance power valve type, results may be expected to be quite good, but sensitivity and also selectivity will not be quite up to the standard which is possible with a really well-chosen valve.

Better Results

The actual difference which different types of valves make, so long as they are reasonably suitable, is much less great in the "Spanspace Three" than

in many receivers which I have tried, but there is a distinct improvement to be obtained by the use of the special high-impedance high amplification factor valves which are now so largely used for H.F. work. These valves are mostly of the dull-emitter type, taking a very moderate amount of filament current, and for the most part incorporating the large grid and plate which we are accustomed to associate solely with power valves. Many of these valves have an impedance of the order of 15,000 to 20,000 ohms or even more, and it will be found that a distinct improvement in both selectivity

(Continued on page 109)

SIX COUNTRIES ON ONE VALVE!



Extract from "Radidea's" article in the "Manchester Evening Chronicle," September 30th, 1926.

"During the week-end I have been testing one of the new BENJAMIN SP. 55 Valves, this being a 6-volt power valve.

It has an anode impedance of 3,500 ohms, an amplification factor of 6, with short-path construction and dull-emitter filament.

I used the new reflex unit, which is described in the forthcoming new edition of the "Wireless Guide," and obtained a volume equal to any two-valve set employing a detector and one stage of L.F.

This unit was connected to the new Chronicle Crystal Set, giving full loud-speaker volume from MANCHESTER; in fact, too loud for an ordinary sitting-room.

I started off with HILVERSUM on Sunday, tuning in the morning service at 9.45, followed by HAMBURG at 11 a.m. giving a lesson in some other language.

FRANKFURT was tuned in at noon, and I listened to a most excellent concert for nearly one hour, and immediately the MANCHESTER Station closed at 6 p.m. I tuned in COPENHAGEN, giving the time signal and chimes.

At the close of the Manchester transmission I tuned in DUBLIN, followed by BRESLAU UNION RADIO, MADRID, and the lady giving the late news from ROME. The church service from NEWCASTLE was heard distinctly and I logged 22 amateur transmitters during the day.

DAVENTRY was at good loud-speaker strength, and the transmission from PARIS, Eiffel Tower, was good 'phone strength.

As I pointed out a few weeks ago, this type of valve is

the finest in the world for a reflex set, giving full volume with a beautiful quality."

- S.P. 18 RED - 14/- Fil. Volts 1'6, Amps. '3
- S.P. 18 GREEN 14/- Fil. Volts 1'6, Amps. '3
- S.P. 18 BLUE- 14/- Fil. Volts 1'6, Amps. '09
- D.E. 55 - 18/6 Fil. Volts 5'5, Amps. '09
- S.P. 55 BLUE- 18/6 Fil. Volts 5'5, Amps. '09
- S.P. 55 RED - 22/6 Fil. Volts 5'5, Amps. '25

THE BENJAMIN ELECTRIC LTD.,
Brantwood Works, Tottenham, London, N.17

BENJAMIN VALVES (SHORTPATH)



GETTING THE BEST FROM THE "SPANSACE THREE."

Continued from page 107.

vity and sensitivity will be obtained by their use, although a little greater care will be needed in making the neutralising adjustment.

Bright Emitters

Bright emitters can be used in the "Spanspace Three," and quite good results have been obtained with them. By choosing bright emitters which correspond fairly closely in their characteristics to those of the special high amplification valves mentioned, quite good selectivity can be obtained; but since bright emitters of this kind do not as a rule possess the desirable high amplification factor, signal strength will again not be quite so good as with the special H.F. valve referred to.

The Detector

The type of valve used as a detector is largely governed by the requirement of smooth reaction control, and for this reason one of the special H.F. valves is again very desirable. From the point of view of sensitivity and selectivity, also, such a valve is desirable in the second socket, but it has one drawback, that for the greatest possible purity of reproduction

from the local station it is, not quite ideal. Such valves have rather a high impedance for this purpose, and if the set is to be used much for loud-speaker results, from the local stations for purely family purposes, I would recommend that one of the ordinary type of low-impedance power valves be substituted when the set is used for the local programme.

Selectivity Adjustments

I think it will interest the more advanced users of this set to understand how it is possible to alter the relative degrees of signal strength and selectivity in the "Spanspace Three," and I will describe how it can be done. In the first place it will be noticed that in the aerial circuit there is a coil Ll of 20 turns, which is normally used in series with a fixed condenser. Now, the size of this winding has a very great influence upon the amount of selectivity and the degree of signal strength which will be obtained. In general, the larger the coil the greater the signal strength up to a certain point. This point is that at which so much wire is used upon this coil that the aerial circuit is brought actually into tune with the secondary circuit, whereupon tuning is liable to become flat. Up to this point, signal strength increases, but selectivity becomes poor.

It is therefore interesting to try the effect of pulling off a few turns from this winding if you find it difficult to

eliminate a powerful local station. Similarly, if you want to obtain the very loudest possible results from one particular station near the upper end of the wavelength scale, you might try the effect of putting on, say, another five turns.

H.T. Tapping Point

The position of the tapping for the H.T. connection upon the tuned anode coil is rather an important factor in deciding the performance of the set, and general rules can be laid down here. In general, then, the nearer this tapping point is to the anode end of the coil, the greater will be the selectivity, but the poorer the signal strength. At present, it will be remembered, this tapping point is located at two-thirds of the way from the anode end of the coil to the opposite extremity, and this is quite a good average position. Bringing it along to, say, the middle of the coil, will produce a not very serious loss of signal strength and a distinctly perceptible improvement in selectivity.

This experiment is quite easy to try, and will be found of special interest to those who have a powerful nearby transmitter to contend with.

Effect on Reaction

It must be remembered that the effect of shifting this tapping point about is to vary the amount of the coil which is used as a reaction wind-
(Continued on page 176.)

Over 4 years ago

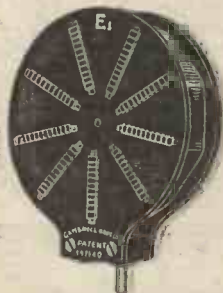

GAMBRELL

Coils established themselves as "Efficiency" coils, and they still retain the fullest confidence of technical experts and the general radio public.

SIZES	a/2	a	A	B	C	D	E	F	G	H	I	J
PR CES	4/10	4/10	5/-	5/3	5/6	5/9	6/3	6/9	7/9	8/6	10/-	12/6, 14/-, 17/6
Number of Turns	18	25	30	40	50	75	100	150	200	300	500	750 1000 1500

CENTRE TAPPED COILS.

All Gambrell Coils can now be supplied centre tapped, 6d. extra for each coil.

NEUTROVERNIA CONDENSER.

Baseboard Mounts for the "Gambrell Neutrovernia" can now be obtained, price 6d. each.

WRITE FOR DESCRIPTIVE FOLDERS AND LEAFLETS OF ALL GAMBRELL APPARATUS.

GAMBRELL BROTHERS LTD.
76, VICTORIA STREET, LONDON, S.W.1.

Parrs Ad.

SAFE AND SURE

EDDYSTONE

SAFETY LEAD-IN.
(PRO. PAT.)

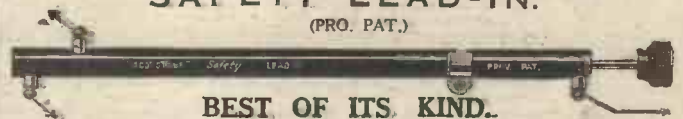

BEST OF ITS KIND.

- ☛ All contacts are positive and enclosed.
- ☛ It is operated in comfort from inside.
- ☛ Push the knob in and your set is isolated, with the aerial joined directly to earth.
- ☛ Pull out, and the aerial lead is brought through to the set ready for use.
- ☛ Easy to fix—nothing to go wrong.

"SLEEP AND FORGET."

Price 3/6 complete.

LENGTH 10 inches OVERALL.

"EDDYSTONE" ABSORBOS.

Pat. No. 9618.



Your set should have them. They take up all outside shock, thus giving longer valve life. Prevent microphonic noises, and stop entirely any strange leakage to earth, ensure greater efficiency. They prevent marking or scratching the furniture. Easy to fix. Mount your cabinet on them to-day.

Price 2/3 per set of 4.

Obtainable from all high class dealers. If any difficulty write direct to the manufacturers.



Send for a copy of our latest complete catalogue of "EDDYSTONE" radio products.

STRATTON & CO., LTD.

Balmoral Works, Birmingham.

IMPROVED C.A.V. 1927 MODEL

H.T. ACCUMULATOR

EXPERIENCE in manufacturing Accumulators for the past 35 years has gone towards perfecting our IMPROVED 1927 model H. T. Accumulator, the exclusive features of which are as follow:—

1. **LONG RETENTION OF CHARGE.**
This is a super-charged battery, it being given several cycles of charge and discharge during the initial charging process. By this method retention of charge over a long period is obtained.
2. **NO INTERCELL CURRENT LEAKAGE.**
Owing to high terminal voltages it is very important that inter-cell current leakage is prevented. This is effectually overcome by each cell being air spaced from neighbouring cells, and securely held at the base, providing a maximum surface leakage of 9". This is a decided improvement in design compared with accumulators of block construction.
3. **NON-CORROSIVE TERMINALS.**
Specially designed non-corrosive terminals are fitted.
4. **CONVENIENCE IN SERVICE.**
When delivered every accumulator is **READY FOR IMMEDIATE USE.** There is no filling with acid or charging to be done. A distilled water-filler having an $\frac{1}{4}$ " diameter stem is supplied free for topping up after evaporation. A special spring clip is also provided with which tappings can be taken at any 2-volt intervals. Special end terminals are fitted suitable for taking standard wander plugs, or for flex connections. Fitted in wood case with handle it is perfectly portable.
5. **CHARGING.**
These batteries can be charged at home from Public Electricity Supply, where other convenient facilities are not available, and any advice is gladly given by us when any difficulty exists.

COMPETITION OPEN TO USERS OF THIS ACCUMULATOR.

Owing to the various special features of our H. T. Accumulator we desire to give it a distinctive name, and invite suggestions. Prizes will be awarded as follows:—

FIRST PRIZE - - 75 GUINEAS
TO THE ENTRANT OF NAME ADJUDGED THE BEST

SECOND PRIZE - 25 GUINEAS
TO THE TRADER FROM WHOM THE FIRST PRIZE WINNER PURCHASED HIS ACCUMULATOR

1. The name must be original and preferably indicate one or more special features of the accumulator.
2. To assist competitors the special features of this accumulator enumerated above should be read carefully.
3. The envelope in which your suggestion is forwarded must be addressed "NAME COMPETITION, C. A. VANDERVELL & CO., LTD., ACTON VALE, W.3."
4. Competitor's name and address must be stated, together with the name and address of the Wireless Dealer (if any) from whom the battery is purchased.
5. State the serial number quoted on the label attached to the inside of the accumulator lid. (All owners of 1927 improved types are eligible to compete, provided the serial number of their accumulator is higher than G. 16300. Entries are restricted to one for each accumulator.)
6. The names of prize winners will be advertised in a January issue of this journal.
7. No employee of Messrs. C. A. Vandervell or their associated Companies or Agents or Agents' employees are eligible to compete.
8. The Company's decision as to the prize winners will be final, and no correspondence can be entered into regarding same.
9. The last date for entrance is December 31st.

SALES DEPOTS.

BIRMINGHAM.—Great Hampton Street. LONDON.—90, High Street, Camden Town, N.W.1.
BRISTOL.—7-29, Temple Street. MANCHESTER.—191-3 and 47, Deansgate, N.W.1.
DUBLIN.—Taylor Bros., 41, Middle Abbey St. NEWCASTLE.—on TYNE.—68, St. Mary Place.
GLASGOW.—227-229, St. George's Road.
LEEDS.—117, Park Lane.
LONDON.—224, Shaftesbury Avenue, W.C.2.

Also supplied by all C.A.V. Service Stations and recognised Wireless Dealers.
Write for copy of C.A.V. Illustrated Radio Catalogue.

C.A.V. Vandervell & Co. Ltd.
ACTON, LONDON, W. 3

Telephone: Chiswick 3801.
(Private Branch Exchange)

Telegram: "Vanteria, Act, London."

100 Guineas for a Name!

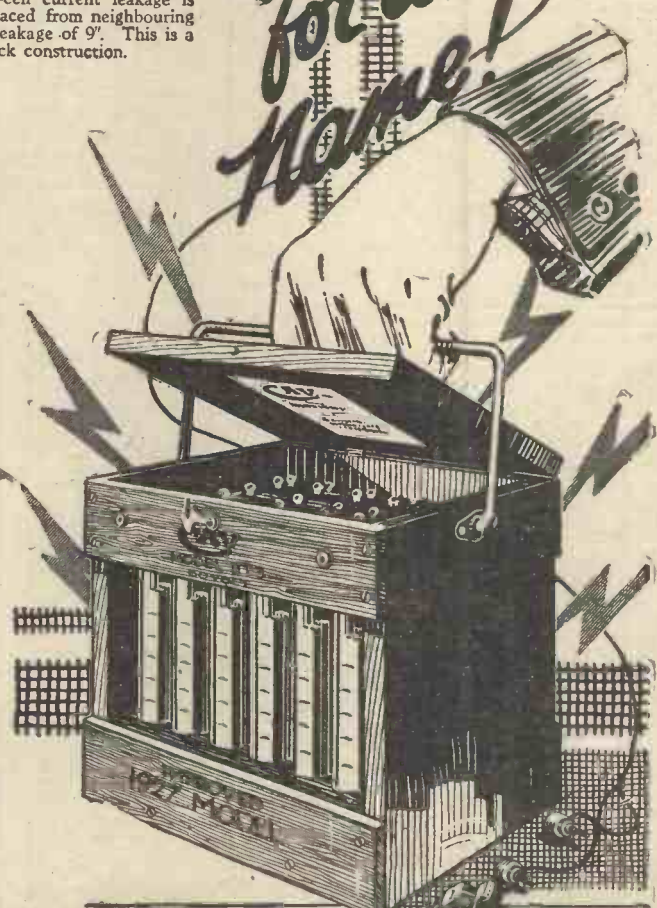

MODEL H.T. 3 **60** SUPPLIED READY FOR USE, NO FILLING WITH ACID, NO CHARGING

Dimensions 8 1/2" x 7" x 7 1/2" High
Weight Charged 16 1/2 lbs - Dry 13 1/2 lbs

ALSO SUPPLIED IN 30 & 90 VOLTS
MODEL H.T. 4 - 30 VOLTS . . . 30/6
MODEL H.T. 5 - 90 VOLTS . . . 90/6



A "THROTTLE-CONTROLLED" SINGLE-VALVE SET

By L. H. THOMAS

Selectivity being an essential feature of modern receivers, something more is called for in the design of even the simplest valve set. The method of reaction control used in this single-valve set will commend itself to the constructor who wants a set easy to handle and sensitive in operation.

THE definition of "a good single-valve receiver" used to be, in the minds of many, "one that is fairly selective, and gives good 'phone strength on the local station." Others, generally regarded as optimists, hoped to receive a few foreign stations on their "good single-valve set"; while there were even some who averred that nothing "worth having" could be received without the addition of one or two stages of low-frequency amplification.

Modern Requirements

Times have changed rapidly, however, and the average person now re-

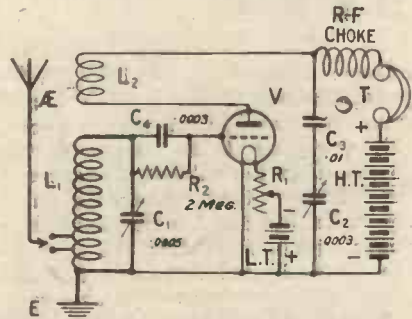

Fig. 1.—An on-off switch, not shown in this diagram, is inserted between L.T. negative and the rheostat R1.

quires much more from a single valve than he would ever have expected before. The chief point is that a single-valve receiver nowadays is worth no consideration at all unless it possesses a really high degree of selectivity. The other requirements are, of course, reasonable sensitivity, ease of operation and consistency in performance.

The second of these requirements, i.e., ease of operation, is apparently overlooked by many and misunderstood by most. The chief consideration making for a real "pleasure-to-handle" set is a really efficient reaction control. It must not alter the wavelength at all, and it must not be "ploppy" or irregular; it must act more or less evenly over the whole of the main tuning scale, and must not need much alteration when the tuning coils are changed for the purpose of covering a different wave-band.

TEST REPORT

The stations actually received on headphones with the receiver to be described were:—

- | | |
|----------------|-----------------|
| Elberfeld. | Dublin. |
| Brussels. | Newcastle. |
| Toulouse. | Münster. |
| Dortmund. | Glasgow. |
| Hull. | Rome. |
| Cardiff. | Belfast. |
| London. | Stuttgart. |
| Manchester. | Radio Catalaña. |
| Bournemouth. | Birmingham. |
| Radio-Iberica. | Aberdeen. |
| Hamburg. | |

As regards selectivity, Cardiff suffered slightly from interference by 2LO, at a distance of six miles from the latter station, but Bournemouth could be received quite clearly.

than the others. This method was that now generally known as "throttle control," and is the system made use of in the receiver which is the subject of this article.

Circuit

Reference to the circuit diagram will show that the circuit is quite "straight"; L₂ is coupled to the reaction coil L₃, and this coupling is fixed. The aerial is auto-coupled, an "X" coil being used for L₁. The condenser C₁ tunes the whole of the coil L₁, and C₂ is the reaction control. The latter is connected across the telephones and the high-tension battery, thus acting as a variable by-pass for the high-frequency current flowing in this circuit. A high-frequency choke has, it will be noticed, been inserted between the telephones and the

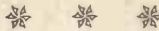

The "X" coil is placed in the nearer of the two coil holders, with a lead from the aerial terminal to the tapping on the coil.

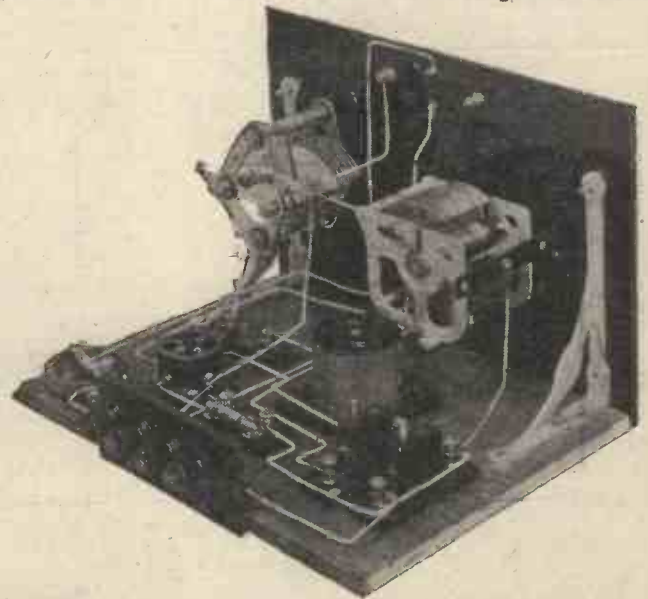
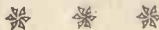

Reaction Control

Some time ago the writer made up a receiver simply for the purpose of finding the best possible form of reaction control. It was then found that, although there were at least three means of controlling reaction without varying the tuning of the secondary and primary circuits, one of these was much better in operation

reaction coil. In some cases the set will operate perfectly without this, but there is a tendency for the self-capacity of the telephones, cords, etc., to act as a by-pass condenser of sufficient size to keep the receiver in a state of oscillation without any other form of reaction control being used, and the H.F. choke is used to ensure that the only path for the H.F. currents is via the reaction condenser C₂.

A "Throttle-Controlled" Single-Valve Set—continued

BUILD THIS SET WITH

- One "Radion" panel, 12 ins. by 8 ins. by $\frac{1}{8}$ in. (American Hard Rubber Co.)
 - One cabinet to suit, with loose baseboard $8\frac{1}{2}$ in. deep and one pair of brackets. (Carrington Manufacturing Co., Ltd.)
 - One "Di-Kast" .0005 variable condenser. (Cleartron Radio Ltd.)
 - One slow-motion dial. (Cleartron Radio, Ltd.)
 - One "Eddystone" .0003 low-loss variable condenser. (Stratton & Co.)
 - One "Aermonic" low-capacity baseboard mounting valve-holder. (A. F. Bulgin & Co.)
 - One .01 fixed condenser, one .0003 fixed condenser, and one 2 megohm "Dumetohm" leak. (Dubilier Condenser Co. (1925), Ltd.)
 - One H.F. choke. (Beard & Fitch.)
 - Two baseboard mounting coil sockets. (Beard & Fitch.)
 - One baseboard mounting rheostat, 30 ohms. (Lissen, Ltd.)
 - One "Frost" toggle switch. (Rothermel Radio Corporation)
 - Terminals engraved: Aerial, Earth, L.T.—, L.T.+, H.T.—, H.T.+, Phones— and Phones+. (Belling & Lee, Ltd.)
 - Quantity of Glazite for wiring up, also small brass bolts, wood screws, etc.
- Approximate Cost: £4 10 0

Easy Tuning

The variable condenser C_2 acts as a perfect control of the degree of oscillation, without having the slightest

readjust C_1 , even by the very slightest amount. The function of the fixed condenser C_3 , connected in series with C_2 , will be explained later.

Construction

The best method of construction for this receiver will be found to be as

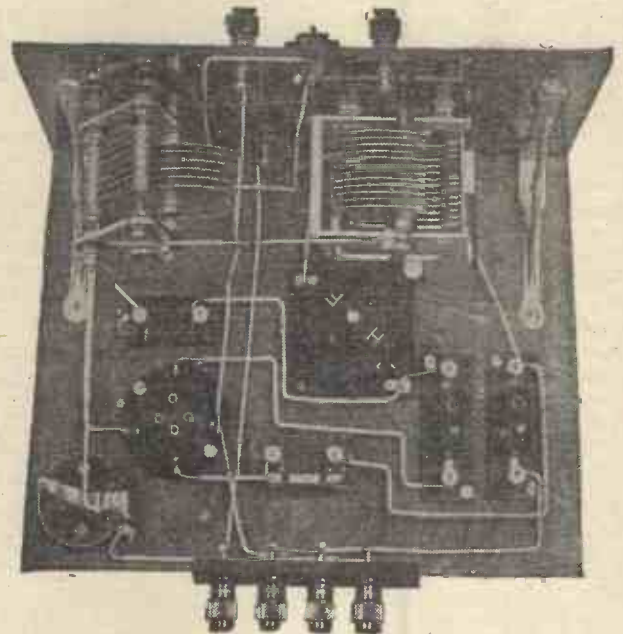

This view of the set will be of material assistance to the constructor in making the necessary connections.



A list of the actual components used in the author's own receiver accompanies this article. It is, of course,

follows: First of all, carefully fit the panel brackets to the baseboard, and secure the panel in the usual manner, this operation being done with the baseboard in the cabinet, to ensure a perfect fit. Then remove the panel again, drill it for the necessary components (drilling centres are given in the front-of-panel diagram, Fig. 2). Mount the necessary components upon the baseboard and wire them up, lastly affixing the panel components and completing the wiring after the panel has been placed in position and finally secured.

No dial has been used on the reaction condenser; this is not necessary and only complicates the appearance of the panel. Also one always adjusts this control by "sense" and not by merely setting it to a pre-arranged value.

A Safety Device

It will be seen that the reaction condenser (in series with the fixed condenser C_3) is connected across the H.F. choke, the H.T. battery and the 'phones. Thus it is clear that, were it not for the fixed condenser, any minute leaks across the variable, such as might be caused by an accumulation of dust on the plates, might cause a leakage of current from the H.T. battery through the 'phones, resulting in

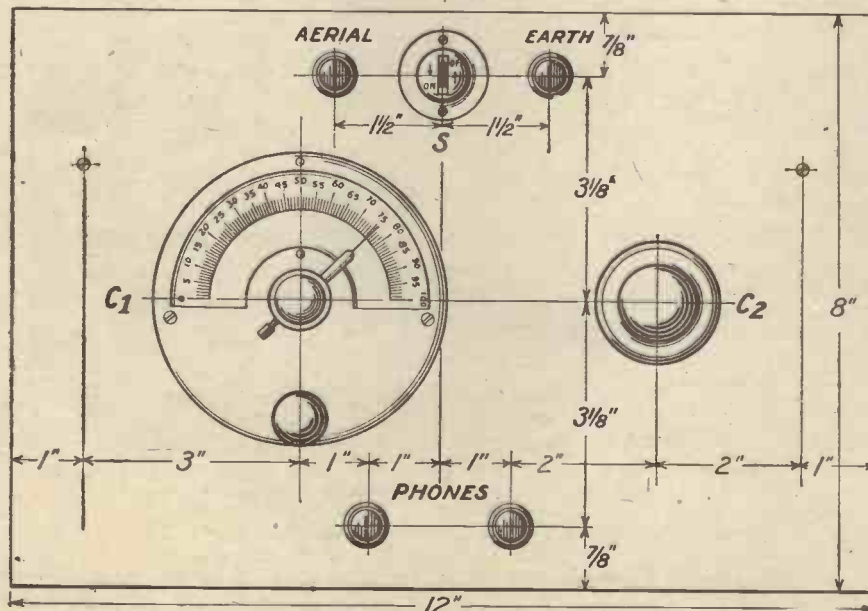

Fig. 2.—The slow-motion dial adds considerably to the ease of operation of the set. Blueprint No. C1071 A is also obtainable.

effect upon the setting of C_1 . That is to say, when a station has been carefully tuned in on C_1 with the set well below the point of oscillation, it can be carefully brought up to this point simply by increasing the setting of C_2 , and there will be no need to

not necessary to adhere strictly to this, although it will probably be found inadvisable to make any very drastic changes. In particular, the lay-out of the components upon the baseboard should not be altered.

A Perfect Accumulator for 6/-

ENDURO



By Appointment

Users of both dull and bright Emitter Valves are welcoming this really efficient accumulator, having in mind particularly its very moderate cost. Assembled in an attractive glass container, with a capacity of 10 ampere hours (at the 20-hour rate of discharge) the 5 plates of the "HART" 2-Volt "Enduro" Cell are designed specifically to give steady discharge and long life—both of which essential features they embody in a marked degree.

Discard your dry batteries from to-day. The "HART" "Enduro" Cell will give you better results, at less cost.



THE "HART" ENDURO 2-VOLT ACCUMULATOR

HART

THE BATTERY OF QUALITY

Write to Dept. W.C.3 for illustrated leaflets and full particulars.

HART ACCUMULATOR Co., Ltd., STRATFORD, LONDON, E.15

A "Throttle-Controlled" Single-Valve Set—continued

terrible noises when the knob of the reaction control was rotated. The fixed condenser of .01 capacity serves to

being the enormous effect upon the tuning of the aerial circuit caused by a slight variation in the coupling.

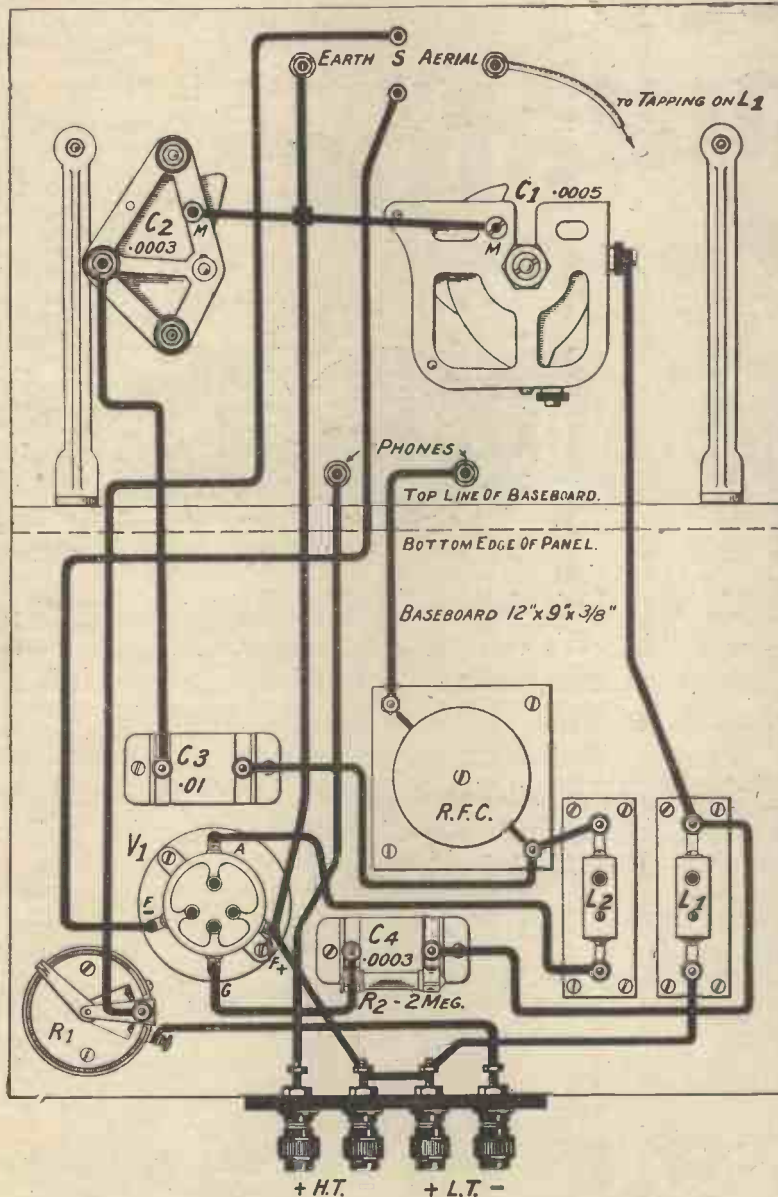

Fig. 3.—This diagram should be studied in conjunction with the wiring instructions given on this page. Blueprint No. C1071 B.

keep the H.T. potential off the plates of the reaction condenser, without appreciably altering the capacity.

The advantage of using this "throttle control" for reaction well repays the constructor for the use of a second variable condenser. With the circuit used, the degree of oscillation could, of course, be conveniently controlled by varying the coupling between L_1 and L_2 . Swinging-coil reaction is, however, less convenient for more reasons than one, chief of these

Testing

Having completed the wiring, and thoroughly checked it over, the usual preliminary tests should be carried out. Insert the valve (one of the 6-volt, .25 ampere type was used by the writer), and connect up a low value of high-tension (say $4\frac{1}{2}$ or 6 volts). If the valve lights, disconnect the H.T. immediately and look over the wiring again. If it does not, connect the low-tension battery and plug in the full value of H.T. (about 35 volts should give good results).

Operation

Set the filament rheostat (on the baseboard) about three-quarters in and close the filament circuit by means of the switch on the panel. Insert a No. 50 "X" coil or its equivalent in the L_1 socket, a No. 35 or 50 coil in the L_2 socket, and connect the aerial tap to one of the tappings on the "X" coil. With the reaction condenser set at its minimum position, rotate C_1 slowly until the local station is heard; headphones should, of course, be used, although sufficient volume to work a small loud-speaker may be obtained if the set is operated within a few miles of a main station.

Now de-tune slightly from the "local" and cautiously increase the

WIRING IN WORDS

All directions are given as viewing the set from the back.

Join fixed vanes of variable condenser C_1 to one side of L_1 coil holder and to one side of fixed condenser C_4 and leak R_2 .

Join other side of L_1 coil holder to L.T. + terminal, also to H.T. - terminal, one filament contact of valve holder, moving vanes of both variable condensers and earth terminal.

Join remaining contact of C_4 and R_2 to grid contact of valve holder.

Join remaining filament contact of valve holder to lower contact of switch S .

Join top contact of switch S to one side of rheostat R_1 .

Join other side of R_1 to L.T. - terminals. Join H.T. + terminal to one telephone terminal.

Join other telephone terminal to one side of R.F. choke.

Join other side of R.F. choke to one side of L_2 coil holder and to one side of fixed condenser C_3 .

Join other side of C_3 to fixed vanes of variable condenser C_2 .

Join remaining side of L_2 coil holder to anode contact of valve holder.

setting of the reaction condenser. At about 90 degrees on the scale the set should slide slowly into oscillation, this state being evidenced by a gentle hiss or rushing noise. Turn the dial back until the set is working just below this point, and with the hand kept on the knob of the reaction condenser, in readiness to reduce its value should the set start oscillating, search round the scale of C_1 . Quite half a dozen stations should be tuned in quite easily at 8 p.m. or thereabouts on an average evening. The two controls will be found very easy to handle, and the reaction condenser will hardly have to be touched while the other dial is being swung round. Should any "overlap" exist, alteration in the H.T. and L.T. values, or possibly of the grid-leak, will nearly always cure it.

EFESCA

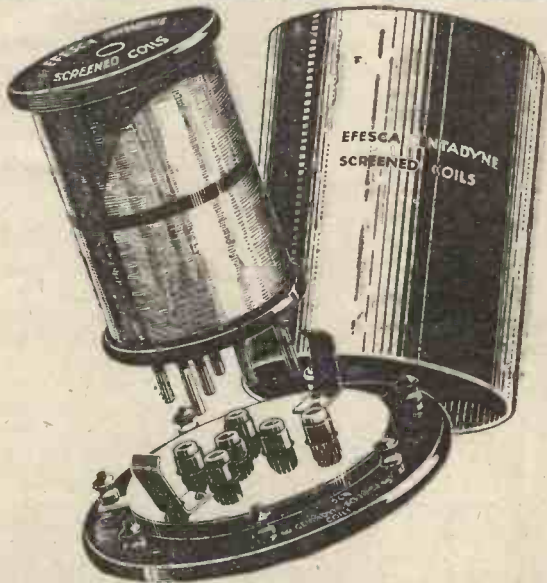

"CENTADYNE" Screened Coils

FOR NEUTRALISED CIRCUITS

Made to Elstree Laboratories specification and officially approved.
SUITABLE for all star and other circuits described in "Modern Wireless," "Wireless Constructor," and "Wireless" employing 6-pin standard coils.

PRICES

	Coils with 6-pin plugs, 250 to 550 metres.	1,000 to 2,000 metres.
Aerial Coils, split primary ...	4/6	4/6 each.
H.F. Transformer, split primary and optional reaction ...	7/6	7/6 each.
H.F. Transformers, split secondary ...	7/6	7/6 each.
Reinartz Coils ...	7/6	10/- each.
Copper Screen with 6-pin base 15/- each. Unshielded 6-pin base for standard Coils when used without screen 4/- each.		

From all wireless dealers.

Ask your retailer, or write for catalogue 573/1 of Efesca Components and circuits employing them.

FALK STADELMANN & CO., LTD.

83/93, Farringdon Road, LONDON, E.C.1.
and at Glasgow, Manchester, Birmingham, Newcastle and Dublin.



Efesca £200 Popularity Competition closes 31st Dec. Have you entered?

WESTON Instruments for Economy & Efficiency

PROTECT your valves and secure the best results of which your set is capable, by correct adjustment of Filament, Plate and Grid Voltage.

Open circuit tests are useless! Test under normal working conditions with the reliable high resistance.



WESTON Pin Jack Voltmeter plugged into High-Range Stand

Range: 6V and range 200V (750 and 25,000 ohms resistance).

£2:10:0

WESTON ELECTRICAL INSTRUMENT CO., LTD.
15, Great Saffron Hill, London, E.C.1.

Telephone: Holborn 2029.

Telegrams: "Pivoted, Smith, London."

65

Our latest production, the C.E. PRECISION FLOATING VALVE-HOLDER



shows great improvements upon others.

By its use the distortion due to vibrations transmitted to valve filaments is entirely eliminated and a receiver fitted with it acquires a perfectly clear background which facilitates the reception of distant stations.

Of very low capacity and entirely non-microphonic the C.E. PRECISION FLOATING VALVE-HOLDER is ideal for its purpose.

Made from Bakelite and fitted with soldering tags and terminals.

Price 2/3 each.

There are also the well-known C.E. PRECISION RHEOSTATS AND POTENTIOMETERS. Perfectly smooth and silent in action, Bakelite Formers, Silvered Dials, fitted with soldering tags and terminals. Always specify C.E. PRECISION.

7 & 15 Ohms. - 2/9 each.

30 & 50 Ohms. - 3/- "

Dual Rheostats &

Potentiometers 3/9 "

FOR UTMOST
C.E. PRECISION
EFFICIENCY

C. EDE & CO., LTD., BYFLEET, SURREY

Telephone: Byfleet 226.

Telegrams: "Ceprecise, Byfleet."



Duo-triangular filament suspension

The NEW



"GLOWLESS" VALVES



Longer Life!

WHEN a piece of red hot iron is dipped in cold water it suddenly contracts and becomes hard and brittle. With one or two notable exceptions, this tendency to become brittle is shown by all metals with high melting points, and is dependent, among other things, on the rate of heating or cooling.

Now take the case of Radio Valves. The filament in the ordinary valve on the market to-day has to be heated to incandescence to produce the requisite electronic emission, and owing to its remarkably small dimensions the rate of heating and cooling is very rapid, a process which quickly produces brittleness, and eventually tendency to fracture.

With the new Six-Sixty Point One Valves, there is absolutely no "glow" whatever from the filament when operating at the rated voltage—in fact there are no valves on the market to-day that can boast of a longer life because there are no valves that operate at a lower temperature.

In addition, every advantage of the special Six-Sixty filament—which requires barely .1 amp. to ensure the best results—is utilised to the highest degree possible by our Duo-Triangular system of Suspension to produce the perfect valve.

It is interesting to note that Messrs. A. J. Stevens & Co., (1914) Ltd. have decided, after exacting and exhaustive tests, to standardise Six-Sixty Valves in their famous "Symphony" Range of Receivers.



S.S. 2A., H.F. and L.F.
D.E., 1.8 volts, .1 amp.,
H.F., L.F. & Detector 14/-

S.S. 10.
D.E., 2 volts, .15 amp.
Power Amplifier 18/6

S.S. 7.
D.E., 3.7 volts, .1 amp.,
Power Amplifier 18/6

S.S. 8.
D.E., 3-4 volts, .1 amp.,
General Purpose 14/-

These Prices do not apply in the Irish Free State.

DESCRIPTIONAL
LEAFLET S.S. 9-26
WITH PARTICULARS
OF COMPLETE RANGE,
FREE ON APPLICATION.

SIX-SIXTY VALVES
Better by Six Times Sixty

The Electron Co., Ltd., Triumph House, 189, Regent Street, London, W.1.

IMPROVING YOUR SHORT-WAVE SET

By A. V. D. HORT, B.A.

There is every sign that short-wave reception is becoming increasingly popular amongst listeners. Short-wave sets possess certain peculiarities in operation, and some useful hints are given here to assist you to get better results.

ALTHOUGH nowadays there is in reality no time of the year which is useless for short-wave reception, with the coming of the longer hours of darkness the useful periods available to the listener are greatly increased. Those who have during the summer heard only the weakest of signals, if any at all, from such stations as KDKA and WGY, will by now have found that these transmissions come in at greater strength every night. While it is rather exceptional in the summer to be able to pick up these far-distant short-wave telephony stations at good enough strength to enable the programmes to be really clearly heard, in the winter it is quite often possible to hear everything distinctly and to get the full enjoyment from the items transmitted.

A Popular Set

Judging from the reports which have been received, quite a number of our readers have made up the "Australia on Two Valves" set, which appeared in the August issue of THE WIRELESS CONSTRUCTOR. Some of the appreciative letters will be found on another page in this issue.

Adding an L.F. Stage

A set such as that mentioned fulfils the requirements of the average short-

frequency amplifier. For ordinary listening on telephones this will make many signals uncomfortably loud, but it will often enable telephony transmissions, such as those mentioned already, to be heard at good strength on the loud-speaker.

Fading

A peculiarity which often occurs in the reception of short-wave telephony, especially from stations at a distance, is the phenomenon of fading. On some nights this may not be noticeable, the signal strength being quite steady. At other times the signals will vary from practical inaudibility up to full telephone strength within a short space of time, the signal strength continuously rising and falling.

This phenomenon may lead those who are not acquainted with it to suspect a fault in the set or its accessories, whereas, of course, no alterations made there can effect a cure. It will be as well, however, to make sure that there is no fault at the receiving end giving rise to a somewhat similar effect.

Sharp Tuning

Owing to the sharp tuning necessary on the short waves, very slight variations in the inductance or capacity of the tuned circuits will suffice to upset

as the aerial swings backwards and forwards.

Aerial Swing

This fault can usually be distinguished from the true fading effect, because the aerial swing will normally produce much quicker and more regular variations in signal strength. A simple test may also be applied if the aerial is suspected. A strong signal should be tuned in, and the aerial disconnected from the set. By slight re-tuning it will be possible to hear the station still, though, of course, more weakly. If the signals are now steady, while connecting the aerial again produces the swing, the aerial is obviously to blame.

It will also be noticed, if the aerial wire is swinging, that all signals are more or less equally affected, whereas the fading phenomenon is much more noticeable on the transmissions from more distant sources.

Howling

Another trouble which sometimes occurs in short-wave receivers is howling just as the set goes into and out of oscillation. This may be cured by adjusting the value of the grid-leak of the detector valve, usually by increasing its value well above the normal 2 megohms. An unsuitable H.F. choke, when a "parallel feed" circuit is employed, may also give rise to this howling. Chokes of various turn numbers should be tried, though the exact number required is not usually critical, about 100 turns being suitable for the band of wavelengths from 30 up to 100 metres.

Another Remedy

One or other of these alterations will usually be effective, if the detector valve is being used alone. If, however, a transformer-coupled low-frequency amplifying valve follows the detector, the howl may still persist. Under these circumstances a variable high resistance, such as a variable grid-leak, should be connected across the secondary of the low-frequency transformer. In order not to reduce signal strength more than is necessary, this resistance should be set to a value no lower than that required to eliminate the howl. A further advantage of the inclusion of the resistance will be that "mush" and other noises will be appreciably diminished in intensity, without a corresponding reduction in signal strength.



Mr. Eric Megau, using the call sign GX-6MU, was in short-wave communication with Ulster throughout a recent voyage to America.

wave enthusiast. The set, it will be remembered, consists of a detector valve with tuning coils of the low-loss type and the "Reinartz" form of reaction, a choke-coupled low-frequency valve following. It is a very simple matter to add to the set a second low-

the tuning. Swinging of the aerial wire will give a very fair imitation of the "fading" phenomenon. This effect will be particularly noticeable if the aerial runs close to surrounding objects, such as trees or buildings, signals appearing to "come and go"

EXPERTS IN RADIO ACOUSTICS SINCE 1908

TWO NEW CONE SPEAKERS

THE Ellipticon has been described as "the best loudspeaker on the market" by one who is fully qualified to judge, and who has no personal interest in our success. And we honestly consider that it is one of the best instruments we have ever turned out. The Tablecone, too, can really be said to be superior to similarly priced Cones.



THE ELLIPTICON

(Registered Trade Mark)

The new Brandes Cone. Undoubtedly the best loudspeaker produced, it brings tone of great depth and sweetness. The cone has a large vibrating area and a driving unit of special design. The magnets in the unit are unusually large. There is no diaphragm but a small arma-

ture which, actuated on the "push-pull" principle, reacts to the faintest impulse. The specially designed cabinet "reflects" the sound in rich and mellowed tones.

Height ..	13½ ins.	£5 10
Depth ..	7½ ins.	
Width ..	10½ ins.	

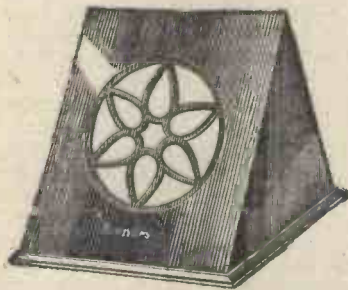

THE TABLECONE

Attractive cabinet of unique design, finished in dark walnut. The cone unit is fitted with a large magnet and the circular diaphragm has an extremely sensitive driving unit which provides plenty of volume with unblemished tone.

Supplied complete with cord connection. It has a genuine claim to be superior to any similarly priced cone speaker.

Height ..	10 ins.	£2 15
Depth (at base) ..	11½ ins.	
Breadth ..	9½ ins.	

Brandes

From any reputable Dealer.

BRANDES LIMITED • 296 REGENT ST. • W.1

62

IMPROVING YOUR SHORT-WAVE SET—continued

Valves

While quite good results may be obtained with a general purpose valve as detector, a special valve may be expected to give a considerable improvement. Valves with a moderate or high-impedance, such as those designed for resistance-capacity coupling, will function well as detectors, giving in addition that smooth control of reaction which is essential for successful short-wave reception.

Small power valves of low-impedance may be tried, but it will probably be found that reaction tends to be "poppy" when they are used. The number of turns required on the reaction winding to give a smooth control will also be less than that needed with the former type of valve.

Smooth Reaction Essential.

It should be borne in mind that until a smooth control of reaction has been obtained, with no sign of howling as the set goes into and out of oscillation, it will be practically impossible to tune in distant stations to their full strength; weak signals, too, may very easily be missed altogether. While searching it will be found an advantage to apply only 30 or 40 volts, or even less, to the anode of the detector valve. The lowest value which will give smooth and continuous oscillation over the tuning range should be chosen. When a signal has been located in this way, it may be increased in strength by increasing the detector anode voltage, and decreasing the reaction setting, in order to keep the set just oscillating for continuous waves, or just clear of oscillation for telephony.

"Dead Spots"

The size of the aerial coil, assuming that this is of the loose-coupled untuned type, often has a considerable bearing on the smoothness or otherwise of reaction. In the neighbourhood of "dead spots" in the tuning range, where more than the normal amount of reaction is required to make the set oscillate, this latter control is liable to be "poppy."

Remedies

This trouble can be cured by loosening the aerial coupling, or, alternatively, by inserting in series with the aerial coil a small fixed condenser of, say, .0001 capacity. If there is more than one dead spot, it is convenient to use a variable series condenser, with maximum capacity of .0005. The best signal strength can then be obtained at those settings at which the set oscillates readily by using a large value of series capacity. When working near a dead spot the capacity should be decreased till the set goes smoothly into and out of oscillation at this point.

BEST IN ALL EUROPE!

THE "ALL-BRITISH SIX"

Details of the phenomenal results obtained on this receiver, which recently gained the highest award for any European entry in the International Exhibition held in New York, appear in this issue.

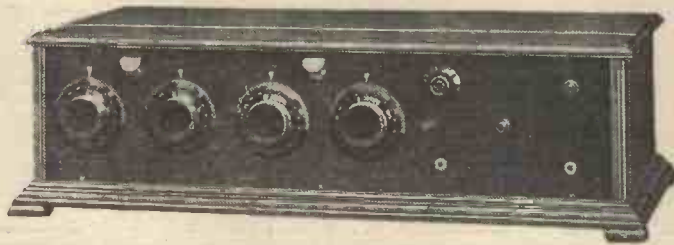

Set of Copex "O.C." type Coils 250/550 M. with screens and bases, and Blue Print, showing conversion details to enable you to convert your existing "Elstree Six" to the "All-British" circuit .. £5 2 0
 Complete kit of components for the "All-British Six" including Copex "O.C." type Screened Coils for 250/550 M. and Blue Prints for layout and wiring—these blue prints are autographed by Mr. H. E. Hassall .. £20 1 6
 "Red Triangle" polished Ebonite Panel 30 in. x 7 in. x 1 in. drilled .. 15 6
 Polished Mahogany Cabinet, asillus, £3 3 0

THE PETO-SCOTT CO., LTD., CHOSEN BY MR. H. E. HASSALL TO BUILD "ALL-BRITISH SIX" SETS.

REALISING the enormous demand there will be for the "All-British Six" and also that the assembly and wiring of this particular circuit call for scrupulous care in order to ensure the best results, Mr. H. E. Hassall has requested us to make up these instruments. We have submitted a sample to him and he informs us that this Receiver gives even better results than those obtained on the original model which he entered for the International Exhibition in New York.

There is thus a fine opportunity for you to obtain immediately a Set which we definitely state is the best 6-valve receiver in the whole world.

Each of these sets will be submitted to the designer for his approval before being released for sale, and in order to safeguard buyers, a certificate autographed by Mr. Hassall will be given with each instrument sold by us.

FINISHED INSTRUMENT,

Tested by Capt. R. W. Tingey, A.M.I.R.E. (late of Radio Press Research Laboratories). Approved by Mr. H. E. Hassall.

(This Set may be inspected at any of our Branches).

£35 10s. (Royalty Paid).

COPEX "O.C." COILS—with the patented feature— ARE ESSENTIAL TO THE SUCCESS OF THIS CIRCUIT.



COPEX "O.C." type Screened Coils embody a special patented feature, which makes them far superior to other types of screened coils. The chief advantages gained by the use of Copex "O. C." coils are:—

- (1) Oscillation is rendered perfectly under control.
- (2) Higher amplification is obtained.
- (3) All Copex Coils and Transformers are matched within one metre, this accuracy being attained by testing against a Quartz Oscillator.

Here are the prices:—

- Copex "O. C." type Split Secondary Transformer 250/550 M. 10 6
- Ditto, 1000/2000 M. 14 6
- Copex "O. C." type Split Primary Transformer 250/550 M. 10 6
- Ditto 1000/2000 M. 10 6
- All Copex Coils for B.B.C. Wave Lengths are wound with Litz Wire.

AS the Originators and Patentees of the Interchangeable Coil Screen, we have used our utmost endeavours to make the Copex Copper Coil Screens superior to all imitations now on the market. The salient features of these Screens are as follows:—

- (1) High grade copper is used for the screen—other metals cannot give the same degree of efficiency.
 - (2) Copex Screens are sprung on to the copper base, and may be revolved on the base, thus giving perfect electrical and self-cleaning contact.
 - (3) Copex Bases are cut from the best quality ebonite and highly polished.
 - (4) The lacquered finish of the Screens prevents tarnishing.
- Copex Copper Screen and interchangeable 6 pin base (Patent No. 259,459) 15 0



When a complete Kit of Components is ordered, a Marconi Royalty of 12/6 per Valve Holder is payable and should be remitted with order.

PETO-SCOTT CO., LTD.

Registered Office, Mail Order and Showroom:

77, CITY ROAD, LONDON, E.C.1

Branches:

LONDON: 62, High Holborn, W.C.1 WALTHAMSTOW: 230, Wood St.
 PLYMOUTH: 4, Bank of England Pl. LIVERPOOL: 4, Manchester St.

The PILOT MANUAL, contains illustrated details of a number of up-to-date sets which we thoroughly recommend. Much useful information on soldering, assembling, testing, etc., is also included. 3d. Post free



THE PILOT MANUAL

P.S. 6082

Full details of Copex Coils and Screens appear in the Copex Folder "W. R." Send a 2d. stamp for a copy today.

In replying to advertisers, please mention THE WIRELESS CONSTRUCTOR.

THE OPENING BARS OF THE OVERTURE TO TANNHAUSER
 ARE A GOOD TEST OF THE QUALITY OF AN AUDIO FREQUENCY TRANSFORMER



In the upper lines of music the size of each note is strictly proportional to the amplification obtained with the Ferranti AF3 Transformer. The "nearly perfect" amplification as shown by curve II below enables this transformer to reproduce all notes in true tone.

In the lower lines of music the size of each note is strictly proportional to the amplification obtained with the transformer, curve IV below. It will be noted that the amplification is inferior and inconstant, with the result that some notes are almost lost and others distorted.



FOR TRUTH IN MUSIC USE



AF 3



25/-

Ask your Dealer for Leaflet W-401

FERRANTI Ltd.
 HOLLINWOOD, LANCASHIRE.

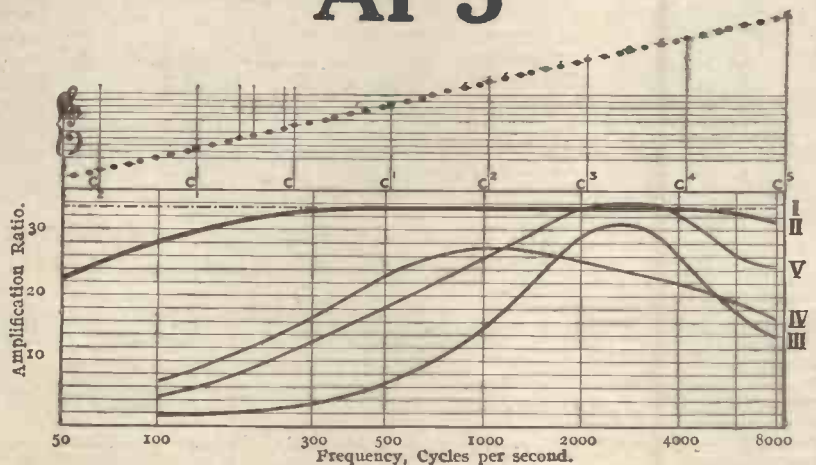

HELPFUL HINTS FOR THE AMERICAN SEASON



NOW that we are in the thick of things once more it behoves the earnest wireless man to leave no knob unturned in order to get the very best out of himself, his friends and his set. During the summer many people pack up their wireless sets in lavender and moth balls and lay them tenderly away in cupboards and chests. Such folk are seriously handicapped when the long dark nights are with us once more, not only by the sneezing which is apt to be produced by the moth balls and the difficulty of picking little chunks of lavender out of the condenser vanes, but also by the fact that their consciences are thoroughly out of training for serious long-distance work. It is largely for this reason that the reception of American broadcasting in this country seldom becomes really widespread until about Christmas time. The only people who do thoroughly well during the earlier part of the autumn are fishermen, whose consciences are always properly under control. Another great advantage which they have is that their fingers do not become stiff and unused to turning knobs during the radio close season, for the work which they put in with their reels serves to keep both digits and wrists in a fine state of suppleness.

Excelsior!

Let us consider without further delay how the wireless man should tackle the problem of squeezing the utmost drop of joy from the coming



The double Gooby knot.

winter. First of all, I think he should attend to his aerial. A glance at curves A, B and C in Fig. 1 will show in a moment the far-reaching effects produced by giving proper attention to the aerial. Curve A shows the signal strength in microvolts per millibar given by the old aerial; the effect of a thorough renovation is shown in curve B; whilst curve C shows the extraordinary all-round improvement that results from hewing down the old

aerial and erecting in its stead a new one that is loftier and designed on more scientific lines. The first valuable hint that I will give you concerns the suspension of the aerial itself. So-called experts have in the

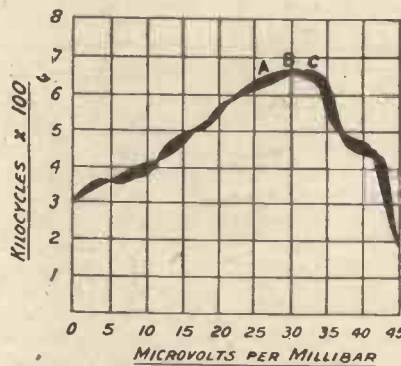

CURVE A..... WITH OLD AERIAL
CURVE B..... WITH OLD AERIAL RENOVATED
CURVE C..... WITH NEW AERIAL

Fig. 1.—These curves show the amazing improvement brought about by spending time (in hours), trouble (in foot-pounds) and money (in Fisher-pounds) on the aerial.

past terribly handicapped the enthusiast by recommending him to use wire instead of rope for the purpose. The reason that they give in their folly is that rope lengthens as it dries and shortens under the effects of moisture, whilst wire remains unaffected.

High or Low Tension?

This is all very well so far as it goes, but it entirely overlooks the desirability of keeping the aerial wires themselves in a limber condition. Where rope is used, they sag on one day like the strings of the tennis racquet that you thoughtlessly left out one night last summer, whilst on the next they become so taut that it is almost possible to play a tune upon them. This treatment greatly increases their power of dealing effectively with oscillating impulses, keeping them always thoroughly up to the mark. Further, if a rope breaks, the clothesline can always be borrowed for repairs when your better half is not looking, whilst the man who uses wire finds himself in a hopeless predicament when faced by a similar catastrophe.

A Knotty Problem

It is most important that the supporting ropes should be properly

secured to the insulators. Various knots have been recommended from time to time for the purpose, but none of these is a patch upon the double Gooby, which a little practice in the train with the ends of your necktie will enable you to make as skilfully as any old hand. Whilst you are so engaged it is always as well to whistle a hornpipe or to sing a sea shanty, in order to get the right atmosphere. Here are the simple directions, which you will have no difficulty at all in following:—

Pass the end through the insulator, take two turns from right to left and two from left to right round the standing part, make two and a half half-hitches, lay the end over the standing part, pass it twice under the reef and through the bight, take the end through the insulator round the standing part, up through the bight and down again, make a double granny backwards, taking the end through the bight round the standing part and over itself; three further turns in alternate directions, a couple of timber hitches and a bowline complete the work, which may be finished off by applying a pint of liquid to the inside of the tier.

In addition to its exceedingly neat appearance the double Gooby knot possesses the inestimable advantage of never coming undone unless it is not wanted to do so.

You Ought To Do This

I do not recommend the use of porcelain or ebonite insulators, which

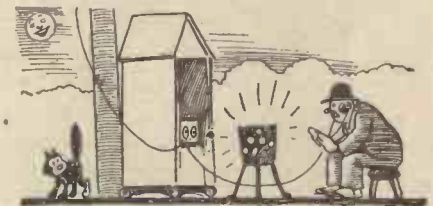

In this the wireless set may be housed . . .

are far too brittle for general use. Metal insulators will be found far more durable. It is, of course, most important that the mast should be high enough to raise the free end of the wire above the house end. If you have not already achieved this desirable state of affairs you should take steps forthwith to secure it. Should there be difficulty in increasing the

TRIX

SIX-POINT SCREENED COILS

SIX points of connection and Six points of superiority.

- Bigger magnetic coupling.
- Special low-loss base. Patent No. 245878.
- Best quality ebonite former and ends, and screen of lacquered oxidised copper.

These coils and screens are made to the Standard Radio Press specifications and are essential for best results in any set using screened Coils.

Special 6-pin base and pure Copper Screen. No 348 - 12/6
 H.F. Transformer, Split Primary 250 550 m. - 10/-
 Aerial Coil to suit - 5/6
 H.F. Transformer, Split Secondary 10/-

Use these TRIX-SIX Coils in the All British Six described in this issue. Complete set 44 10 0

We can deliver immediately. Send for latest Catalogue C 12 of other fixed parts.

ERIC J. LEVER, 33, Clerkenwell Green, London, E.C.1.

Phone: Clerk. 3014/5.

Branches: Birmingham, Liverpool, Halifax, Glasgow

"THE ALL BRITISH SIX"

Genuine Ebonite Panels and Terminal Strips, drilled and engraved in 1/2" thick as described in this issue.

POLISHED OR MATT. PRICE 18/6 THE SET. Carriage Paid. Trade supplied.

S. Marks & Sons, Ltd. 7-8, Carthusian St. LONDON E.C.1.

DECKOREM DIALITE
 USED IN THE
 "ALL-BRITISH SIX"
 PRICE 2/6 EACH.
 NEW CATALOGUES ON APPLICATION.
 OBTAINABLE FROM ALL DEALERS OR
A.F. BULGIN & CO.
 9-11, QUARITOR STREET
 TEL. NOLDBORN 2072 CHANCERY LANE E.C.4. WORKS CHESHAM
 TRADE MARK

HELPFUL HINTS FOR THE AMERICAN SEASON

—continued

height of the mast, this may be overcome by slightly lowering the house, which can be accomplished by means of mining operations beneath the foundations. This is a course that I am rather inclined to recommend, since it enables the enthusiast to make sure that his earth plate is deeply buried. Another method is to remove



... introduce a small colony of rabbits.

the top storey. If, however, it is felt that this would spoil the look of the house, an alternative is to reduce the height of the ceilings on each floor to 4 ft. 6 in. or thereabouts.

Yet another method of ensuring that the free end is higher than the other, where a lofty mast cannot be erected, is to install at the foot of the pole one of those little wheeled huts which are so frequently seen in the devastated areas of our great cities when road-smashing operations are in progress. In this the wireless set may be housed, the necessary warmth being supplied by a coke-filled bucket with holes in it placed outside the door.

"Burying" Your Earth

The most satisfactory way of obtaining a good earth without the performance of manual labour is to introduce on to the tennis lawn a small colony of rabbits. Left to themselves, these little creatures, who really seem to enjoy working, will be found to have made respectable progress towards the bowels of the earth in a remarkably short time. Obtain now a pound of mercury and solder the end of the earth wire to it. Pour the mercury into the largest hole, paying out the wire as it trickles down, and the thing is done. Should difficulty by any chance be experienced in making the soldered joint, the hole should be filled to the brim with mercury, the end of the earth wire being merely immersed in the metal.

Clear Out The !

We are now ready to tackle the receiving set itself. The first process is to remove from coils, condensers and so on any nests of birds, bats, mice or other of Nature's children that may have accumulated in them during the summer months. The inhabitants of the nests are best disposed of by shutting the cat into the cabinet over night, care being taken to switch off both high- and low-tension batteries before pussy is introduced. In crystal receivers the catwhisker should first

be removed for fear of hurting feline feelings. The tools recommended for use on the next day for extracting the now empty homes are a corkscrew, a button-hook, a pitchfork, a case-opener and a selection of the mining instruments used by dentists. Having armed yourself with these, get down to it and let the work go forward with a will. Be careful to remove every particle of the debris, bearing in mind the old proverb about the last straw.

Gentle Persuasion

Owing to their long period of idleness during the summer and early autumn months, the electrons in your valve filaments will probably become quite stiff in the joints. They can be thoroughly awakened from their torpid state by connecting the filament legs of each valve in turn for a few minutes to the terminals of the high-tension battery. Should a blue light appear within the bulb it is a sure sign that they are getting really busy. If it is found that the moving vanes of condensers have become fixed after their prolonged spell of inaction, they should be gently loosened by applying a monkey wrench to the knobs. Where this fails, a little persuasion with a coke hammer often works wonders. Flexible leads that have become stiff should be gently



... a little persuasion with a coke hammer ...

massaged for two or three hours a day. If, as not infrequently happens, the loud-speaker is a little hoarse when it is first brought into commission again, a careful search for cigarette ends should be made in its trumpet.

For Your Own Guidance

When all these precautions have been taken, the set may be regarded as perfectly ready for long-distance work. It only remains to take the creases out of one's conscience. This is most easily done by providing oneself with a long bow and drawing it at least a dozen times a day, until the process becomes almost second nature. Excellent long bows can usually be picked up second-hand for a mere song from retired politicians, reformed golfers, ex-big game hunters or sea-sick American tourists. In choosing a long bow, always be careful to see that it is provided with two strings and that it shows no tendency to overshoot the mark.

CARBORUNDUM STABILISING DETECTOR UNIT

Banishes
Detector
Troubles

ENSURES
**GREATER SENSITIVITY
INCREASED SELECTIVITY
CRYSTAL CLEAR TONES**

Stable
and
Permanent

There is no denying the pure, true tone quality of crystal reception, and it is now possible to get such reception on any set without the fuss and trouble of a nervous cat's-whisker jumping off the sensitive spot.

The Carborundum Stabilising Detector Unit has revolutionised crystal reception. It is built around the fixed permanent Carborundum Detector—no cat's-whisker—no adjustments—retains its sensitivity and simply cannot burn out.

The Stabiliser gives you a resistance-controlling feature through which the Detector can be made to match the circuit impedance—think what this means on reflex sets.

For the reception of tones of natural quality equip your set with the Carborundum Stabilising Detector Unit, which is the only really permanent detector and the only perfect detector for crystal and reflex receivers.

PRICES, INCLUDING POSTAGE:—

- No. 32. Carborundum Stabilising Detector Unit, complete with No. 30 Detector,
but without Dry Cell - - - - - 12/6
Ever Ready Dry Cell, U.W.S. (Price Extra, 5d.)
No. 30. Carborundum Detector - - - - - 5/-

SEND FOR DESCRIPTIVE FOLDER W7 to—

THE
CARBORUNDUM
COMPANY, LIMITED,
TRAFFORD PARK,
MANCHESTER.

British
Made

One Hole
Fixing

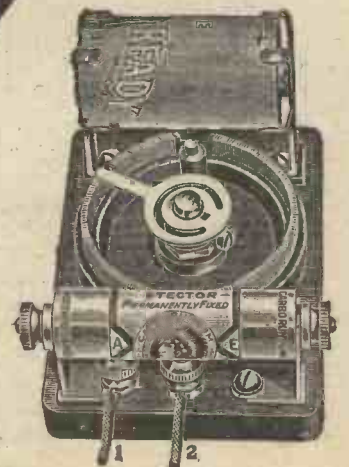
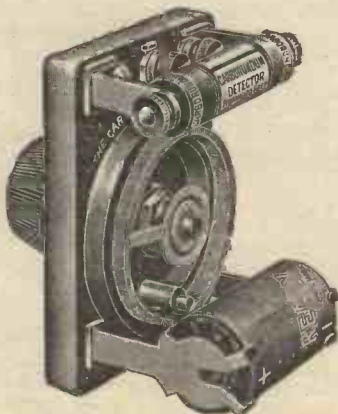

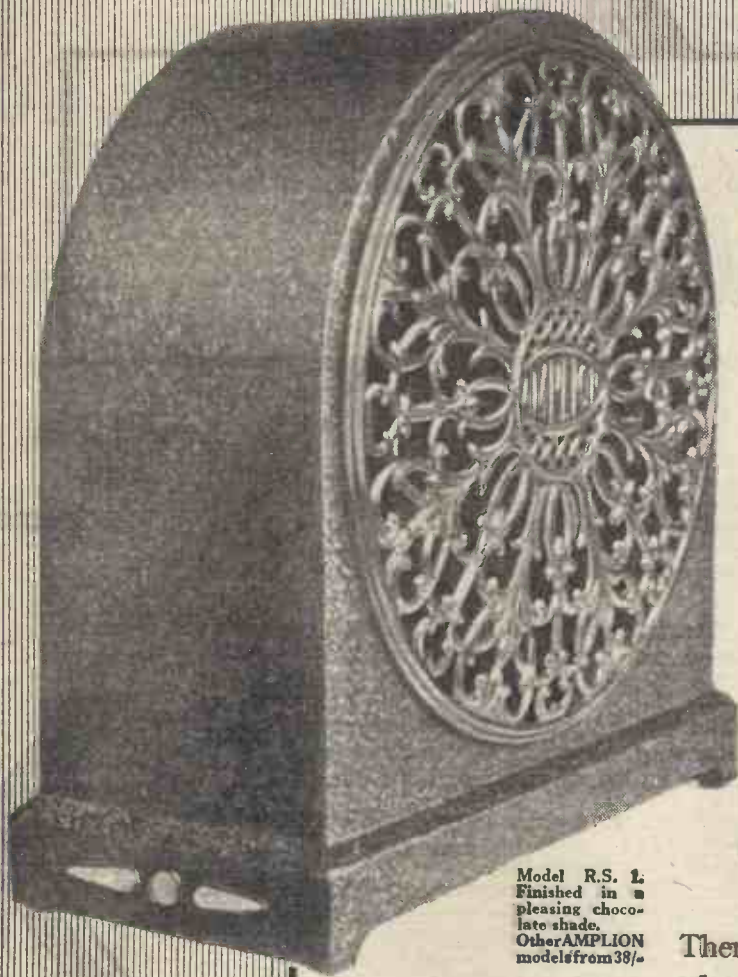

Model R.S. 1.
Finished in a
pleasing choco-
late shade.
Other AMPLION
models from 38/6

Radiolux AMPLION

The
Natural
Tone
Loud
Speaker

£6/10/-

There are many good points about the RADIOLUX AMPLION, but perhaps none is more striking than the quality of natural reproduction which it possesses to a remarkable degree.

AMPLION

The World's Standard Wireless Loud Speaker

Ask your
Dealer
for particulars
of the new
AMPLION
Radio
Valves

Announcement of Alfred Graham & Co. (A. Graham), 25, Savile Row, London, W.1.



THINGS EVERY OPERATOR SHOULD KNOW

By G. P. KENDALL, B.Sc.

Continuing his series of articles on operating, the first of which appeared in the October issue of "The Wireless Constructor," Mr. Kendall describes the best way to tune and roughly calibrate sets which have three or more tuning dials.

IN concluding the last article of this series, I gave a method for searching with a two-dial receiver which could be used upon an entirely new and unfamiliar receiver by any one entirely unskilled as an operator. This method was to cover all possible combinations of the readings of the two dials by the logical process of advancing one of them a degree or perhaps two degrees at a time, at the same time rapidly swinging the other condenser throughout its whole scale. This method, it will be remembered, was given as an alternative to the quicker and better one employed by the more skilled operator of revolving the two dials in unison in such a way that the two circuits are maintained in tune with each other, this method being, of course, one which takes a certain amount of learning.

A More Difficult Case

When we come to a three-dial receiver, the position is somewhat different, and we no longer have a choice of methods as we had in the case of a two-dial set. If one possessed three hands it might be possible to learn to revolve the three dials simultaneously in such a way that the circuits were maintained in tune with each other, but since one has to make shift with two it is necessary to seek about for some alternative method of search.

The best method to adopt will depend upon the particular type of three-dial receiver which is being used, and here I must digress a moment to explain the difference between the older types of three-dial sets and the more modern ones.

The Older Sets

In the older types of set it was no uncommon thing to find that the reading for any given station would be quite different upon each of the three dials, the three tuned circuits being quite differently constituted. In a case like this, only somewhat laborious methods of searching are possible, unless a wavermeter can be used. The best thing to do in a case like this is really to endeavour to calibrate the receiver over the whole of the dials, by picking up stations of known wave-

lengths and drawing calibration charts for each dial.

Until calibration charts have been prepared, the only thing to do is to adopt a very laborious method of searching which will serve to enable one to try each of the possible combinations of the dial readings until the desired station is picked up. This may seem a very tiresome process, but there is no alternative, since mere haphazard twisting of the dials is very unlikely to lead to any other result than the picking up of the local station.

A Laborious Process

What is required is an extension of the method outlined for the two-dial set, and the procedure is something like this: Set Number One dial to, say, zero. Set Number Two dial to zero

until all possible combinations of the three dials have been covered, in steps of two degrees at a time, and if a sufficient number of stations has been picked up of known wavelengths, it will enable a general idea of the calibrations of the circuits to be obtained, so that the searching for any given station will in future be limited to a much smaller portion of each dial. As a matter of fact, once this has been done, any given station can usually be located upon a range of, say, ten degrees of each dial, and it does not take long to cover all the possible alternatives within these limits, so that the method is not, in actual practice, so laborious as it sounds.

The Modern Types

Turning now to the more modern

THIS DIAL APPROXIMATES IN READING TO THE OTHERS

THESE DIALS READ THE SAME



"In the more modern types of receivers . . . at least two of the dials give . . . matched readings." The "Elstree Six," of which the front panel is shown here, is an example of this practice.

and swing Number Three dial slowly throughout its full scale and back again. Now advance Number Two dial to two degrees, and again swing Number Three dial throughout its full scale. Advance Number Two dial to 4 degrees, and again swing Number Three, proceeding this way until all possible combinations of Numbers Two and Three dials have been covered with Number One dial set to zero. If the desired station has not been picked up, advance Number One dial two degrees, leave it thus set, and repeat the process with Numbers Two and Three.

Preliminary Calibration

If this method is persevered with

types of receivers, it will usually be found that in these sets at least two of the dials give what are called matched readings; that is to say, for any given station at least two of the dials will read approximately the same. In many sets, even, all three dials will read the same to a rough approximation, and searching becomes exceedingly simple.

In most of the better class American factory-built receivers of the three-dial type, for example, the readings are all fairly accurately matched, and to search for a distant station all that one does is to set each dial to, say, 20 degrees, listen a moment, set them all to 21 degrees, listen again, and so on, until the desired station is picked up.

THINGS EVERY OPERATOR SHOULD KNOW—continued

An Easier Process

Home-built receivers do not as a rule give such closely matched readings, but an approximation usually exists which is of the greatest service in searching. In some sets, for example, it will be found that the middle and

actual degree of matching of the two right-hand dials, and then when searching one can set these dials forward or back a degree at a time, preserving the relative difference which has been discovered, and at each movement swinging the third dial

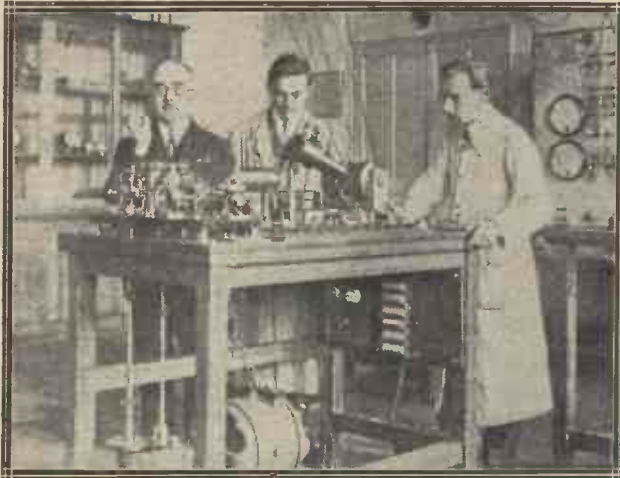

M. Edouard Belin (left) recently gave successful demonstrations of his system of television before the French Convention at Lyons.



right-hand dials give quite closely matched readings, whereas the left-hand dial is a little way out. In such a case all that one has to do is to pick up just one station, and discover the

throughout its scale, until the wished-for station is found.

How It Is Done

In most of the latest receivers it

will be found that all three dials are roughly matched, and preserve their slight relative differences practically unchanged over the whole of the tuning range. In a case like this searching becomes very simple, and all one needs to do is to find out the actual discrepancy between the three dials on any given station, and then set them all backwards or forwards a degree at a time, maintaining the same relative differences. In this way stations will be quite readily picked up, and slight final variations made after the signals have been found.

As a matter of fact, on a set of this type it is usually possible to secure a higher degree of matching still by the simple expedient of tuning in a given station, then slacking off the condenser dials upon their spindles, and resetting them without moving the rotors of the condensers to an identical reading in each case. With the corrected square-law type of condenser this crude system of matching proves surprisingly effective.

"DRAWING ROOM FIVE"

An up-to-date receiver of attractive design is described by

John Underdown in
'MODERN WIRELESS'

November Issue.

NOW ON SALE - Price 1/-



CONSTRUCT THE
ALL-BRITISH SIX

AS DESCRIBED IN THIS ISSUE.

This Set can be supplied ready wired and tested, or the Components separately as desired.

Send stamp for List dealing with this and other Radio Press Sets, including:—

- | | |
|-------------------|----------------------|
| THE ELSTREE SIX | THE ELSTREE SOLODYNE |
| THE MEWFLEX THREE | THE NIGHT HAWK |
| THE DISTAFLEX TWO | THE SPAN SPACE 3 |

etc., etc.

We specialise in Components for Sets described in all Radio Press Publications.



MAGNUM RESISTORS

are suitable for

- "ALL-BRITISH SIX,"
- "ELSTREE SOLODYNE,"
- "NIGHT HAWK,"

and all Modern Receivers.

Price:	s. d.	Size:
Resistor on base ...	2 6	Overall size of base, 2 1/2 in. by 1/2 in.
Resistor only ...	1 9	Overall height, 1 1/2 in.
Shorting Plug ...	1 0	

BURNE-JONES & CO., Ltd.

Manufacturing Radio Engineers,

Magnum House,

296, BOROUGH HIGH ST., LONDON, S.E.1.

Telephone: Hop 8257. Telegrams: "Burjomag, Sedlist, London."
Cables: "Burjomag, London."

BAKELITE

GRAHAM-FARISH

Upright or Flat

Series or Parallel

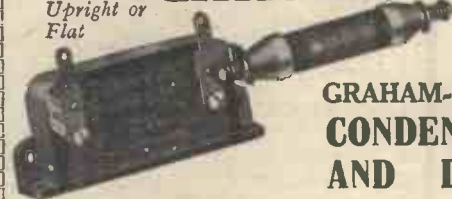

GRAHAM-FARISH CONDENSERS AND LEAKS

- can be attached in series or parallel
- are issued with a written guarantee
- can be mounted upright or flat
- are cased in solid Bakelite
- are the best money can buy

PRICES:

- Condensers, '0001-'002 - - 1/-
- Condensers, '003-'01 - - 1/6
- Grid Leaks, all sizes - - 1/3
- Combined '0033 and 2 meg. - 2/-

For the ALL BRITISH SIX

Set of Condensers and Leaks, comprising:

- 4 100,000 ohm Resistances - - -
 - 6 '002 Fixed Condensers - - -
 - 1 Combined Grid Condenser & Leak - - -
- 13/-**
PRICE

Catalogue on request. Dealers write for terms.

GRAHAM-FARISH MFG. CO.

17, MASONS HILL, BROMLEY, KENT.

YOU will have no difficulty in finding "THE DAILY CHRONICLE" Wireless Programme!

THIS IS A SPECIMEN.

TO-DAY'S WIRELESS PROGRAMMES.

LONDON (ELO): 365 Metres.
8.20-Time from Greenwich. Camille Costantini's Orchestra. From Restaurant Frascati.
8.30-Boboko. Mr. Gerald Gould and Miss Mary Somerville. Reader and Writing.
8.45-Time from Greenwich. Ethel M. Bennett. Women Doctors Through the Centuries.

9.15-Organ Recital by Reginald Foot, relayed from New Gallery Cinema.
9.15-Children.
9.15-Radio Doctor.
9.30-News.
9.40-News from the Royal Horticultural Society.
9.50-Weather and News. Dr. G. C. Simpson. Transfer storms.
10.00-Music.
10.15-Mrs. Neville Chamberlain. Tuberculosis - A Preventable Disease.

8.30-The Passing Mr. Jerome K. of the Third Floor Back, an idle fancy by Jerome K. Jerome, arranged for broadcasting and presented by R. E. Jeffrey. Cast includes Bonus Bert, Lillie Harrison, Irene Booth, Constance Pollard, Annie Edmund, Antoin Pearson, Amy Brandon-Thomas, Edmund Keane, Michael Hogan, Bester Abbas, Philip Wade and Ion Swinley.
9.30-Olive Lodge. Atoms and Worlds - The Atom of Electricity.
9.45-Maurice Cole (piano). Beethoven.
10.00-Time from Greenwich. Weather and News. Local Announcements.
10.15-Philharmonic Piano Quartet. Charles Kelly (piano). Paul Beeld (violin). Frank Weston (viola). John C. Beck (cello).
10.45-The Impresso. Narrative Poetry by Bret Hartley. Read by Richard Clowesley Baxendale.

BOURNEMOUTH (BBM): 356 Metres.
3.15-Miss Widlake. The Beginning of Personal Surprises. 4.45-Wireless String Orchestra, conducted by Capt. W. A. Featherston, with Ben Bramhall (baritone). 5.35-Children. 6.45-Bible Lessons, conducted by Reginald B. Mount, with Evelyn Frost (contralto).
7.00-Children.
7.15-The Station Pianoforte Quartet. Leader, Mrs. A. Cantell, relayed from the Birmingham "Weekly Post" Wireless Exhibition. 8.5-Mrs. J. Krone. Jones. Dr. Johnson and Home Might Have Homax. Children. 8.45-Local Picture.
8.55-Barnes. Conducted by Paul Simpson. 9.55-Children.
10.15-Weather and News. 10.15-11.00-Verities. Janet Joyce, with Grand Hotel, at the Piano. Robert Pitt and Langton Marks entertainers.

BIRMINGHAM (BIT): 479 Metres.
3.15-The Station Pianoforte Quartet. Leader, Mrs. A. Cantell, relayed from the Birmingham "Weekly Post" Wireless Exhibition. 4.5-Mrs. J. Krone. Jones. Dr. Johnson and Home Might Have Homax. Children. 8.45-Local Picture.
8.55-Barnes. Conducted by Paul Simpson. 9.55-Children.
10.15-Weather and News. 10.15-11.00-Verities. Janet Joyce, with Grand Hotel, at the Piano. Robert Pitt and Langton Marks entertainers.

WHO'S WHO.

Mr. Jerome Klapsa Jerome, a radio version of whose "The Passing of the Third Floor Back" will be broadcast at 8.30 tonight, has in his day played many parts - including a few as actor. He has also been schoolmaster, journalist and editor. He established his reputation as a humorist with "Three Men in a Boat," and as a more serious novelist with "Paul Kelter." Showing distant kinship with "David Copperfield," it also bears resemblance in that it is the author's "favourite child."

"The Passing of the Third Floor Back" provided Sir J. Forbes-Robertson with one of his most successful parts, "The Stranger" - to be played tonight by Mr. Ion Swinley.

Miss Irene Rooke, the "Miss Rita" of the play, after graduating with the Ben Greet Company, made her first London appearance in 1927 as Opelia in the Hallel of Mr. Gordon Craig. She was a leading member of Miss Horniman's company at the Gaiety, Manchester, and since then has made regular appearances in the West-end theatres.

Dr. G. C. Simpson, who speaks on "Thunderstorms" at 7.10, has been director of the Meteorological Office since 1920.

DAVENTRY (DAX): 1,600 Metres.
11.00 a.m. - The Signal and Weather.
11.15-11.30 - Radio Quartet and Margaret Parry (contralto).
11.30-11.45 - Programmes. 8.5. from London.
11.45-12.00 - The Signal and Weather.
12.00-12.15 - The Signal and Weather.
12.15-12.30 - The Signal and Weather.
12.30-12.45 - The Signal and Weather.
12.45-1.00 - The Signal and Weather.

FOREIGN STATIONS.

Station	Frequency	Time	Notes
London	200	11.15	Signal and Weather
London	200	11.30	Signal and Weather
London	200	11.45	Signal and Weather
London	200	12.00	Signal and Weather
London	200	12.15	Signal and Weather
London	200	12.30	Signal and Weather
London	200	12.45	Signal and Weather
London	200	1.00	Signal and Weather

CARDIFF (SWA): 355 Metres.

3.15-Schools. Mr. Isaac J. Williams. The Arts and Crafts. 1.40-(Station Trio) Frank Thomas, violin. Frank Whitall, violoncello, and Vera McGowan Thomas, pianoforte. 4.45-Mr. J. Kyrie Fletcher. The Land of Arthur. 8.45-Mrs. P. K. Thomas. Man and His Past. (1) The Old Stone Age. (2) The New Stone Age. 8.55-Vire Le France! The National Orchestra, conducted by Warwick Braithwaite, with Kasia Winter, soprano. 10.15-11.00-Franco. An Episode of the Franco-German War, by John G. Wallis. Franco. Cast includes John G. Wallis. Franco. Cast includes John G. Wallis. Franco. Cast includes John G. Wallis.

Miss Irene Rooke. (1) "The Stranger". (2) "The Stranger". (3) "The Stranger". (4) "The Stranger".

THINGS WORTH LISTENING FOR FROM NORTHERN STATIONS.

GLASGOW (GGC): 422 Metres.
8.8-National Broadcasting Conference relayed from the Melburn Galleries, Glasgow. Speakers: Sir John Gilmour, M.P., Secretary of State for Scotland; Sir Walford Davies, and Vice-roy of the British Empire, Sir Walford Davies. Discussion on "The Home and Foreign Trade of Great Britain".

MANCHESTER (2ZY): 378 Metres.
10.15-12.00-George Formosa. A comedy by James Roden. Cast includes: W. E. Dickson. Louis Rogers and Hyde Metcalf. The 1924 dramatic season in one act by Adam Goussis. Wynn Easton. The 1924 dramatic season in one act by Adam Goussis. Wynn Easton. The 1924 dramatic season in one act by Adam Goussis. Wynn Easton.

HULL (GKH): 335 Metres.
9.30 a.m. 11.15 a.m. - Doremore of Welcome on the 11.15. The Prince of Wales on his visit to Hull.

NOTTINGHAM (5 NG): 323 Metres.
8.8-Third Concert of the Community Singing Society, relayed from the Albert Hall. Artists: Gladys Adams, soloist; Harold Williams (baritone) and John Barry (soprano). The Nottingham Philharmonic Society, conducted by William Turner. Accompanists: Michael Hodgkinson and Alfred E. Jess.

SUCCESS RADIO PRODUCTS

For perfect Radio Reception



SUCCESS SUPER CHOKES

List No. 113
High Impedance Value.
Price 18/6

"SUCCESS" SUPER TAPPED CHOKE (4 Tappings)
List No. 132 Price 22/6

"SUCCESS" H.F. CHOKE
List No. 126 Price 10/6

"SUCCESS" STANDARD L.F. CHOKE
List No. 111 Price 10/6

Instruments that can only be designed and manufactured by Super-Radio Engineers.

Manufactured by
BEARD & FITCH, LTD.
34-36, Aylesbury St.,
London, E.C.1.



To be found on Page 2 of "THE DAILY CHRONICLE" Every Day.

UNPRECEDENTED CLAIMS

Equals Outdoor. Gets More Stations. Fixed in 15 Minutes. Practically Invisible. GUARANTEED.



RECEPCO NORMAL INDOOR AERIAL Complete With 150' AERIAL & EARTH WIRE

3/ Complete

COUPON QUESTIONS AND ANSWERS.

This Coupon must be accompanied with a 2/6 P.O. and Stamped Addressed Envelope.

"Wireless Constructor," DECEMBER 1926.

Certain contact for 1d.



Cut down your wireless losses and ensure certain and perfect contact by using NEWEY SNAP TERMINALS. THE TERMINAL WITH 1000 USES. You can now buy Newey Snap Terminals, Studs, Adapters, Phone Connectors, Multiple Connectors, etc., for 1d. each (nickel plated 1 1/2d.), a trifling sum for such additional convenience and assurance of perfect contact.

Experimental sets in Boxes, Brass, 1/6 each. Nickel plated, 2/6 each.

Ask your dealer for the Newey Catalogue of Radio Components; if you have any difficulty write direct.

Sole Distributors - **PETTIGREW & MERRIMAN (13 5) LTD., PHONOS HOUSE,** 2 & 4, Bucknall Street, New Oxford Street, LONDON, W.C.2
Telephone - GUYARD 4246-49
Telegrams - MERRIGRO, Westcent, London.

Newey SNAP TERMINALS

In replying to advertisers, please mention THE WIRELESS CONSTRUCTOR.

SUPER POWER



THIS is the valve with the golden voice. The very long straight Dynamic curve of the S.T. 63 and its low mean differential A.C. resistance enables it to handle the strongest signals without a trace of distortion. Try it in your last valve holder and this leader of the super power class will give a richness of tone which you have never before achieved.

The S.T. 63 is not merely intended for demonstrations, but also for exquisite reproduction in your own drawing room. The sudden glorious high notes of a soprano or the rich low notes of the organ often cause an increase of 1,000% in the "grid voltage swing" of your valve and the ordinary power valve, perfectly competent to handle music of average strength, fails ignominiously. The S.T. 63, however, cannot "blast," but responds lightly and faithfully to every fluctuation in the music and gives that sense of reality which brings the artist to your own fireside.

Type S.T. 63 Price 22/6. S.T., Ltd., 2, Melbourn Place, W.C.2.



HITCH YOUR AERIAL TO A "STAR"!

We supply all RADIO PRESS "STAR" SETS either as finished Receivers or in parts for home-assembly



A Typical "Pilot" Receiver.

Every finished instrument bears the signature of Capt. W. R. TINGEY, A.M.I.R.E. (late of Radio Press Research Laboratories), who is now in charge of our Test Department.

Prices of "Star" Sets:

"Elstree Solodyne."		"Night Hawk."	
Finished Instrument, royalty paid	27 7 6	Finished Instrument, royalty paid	23 1 3
Set of Copex Screened Coils, 250/550m	3 11 0	Set of Keystone Fieldless Coils and bases 250 to 500 m.	2 2 0
Other parts required	10 17 6	Other parts required	9 8 3
Black Ebonite Panel, matted and drilled	11 6	Panel, matted and drilled	8 6
Mahogany Panel, matted and drilled	18 6	Polished Mahogany Cabinet	3 0 0
Polished Mahogany Cabinet	4 5 0		

"Mewflex Three."

Finished Instrument, royalty paid	26 3 6
Set of Copex Screened Coils, 250/550m	3 15 0
Other parts required	10 3 0
Panel, matted and drilled	14 6
Polished Mahogany Cabinet	4 5 0

For Prices and Particulars of the "All British Six" see page 119

If a complete set of parts is ordered, Marconi Royalties at the rate of 12/6 per valve holder must be remitted with order.

Improve your Set with "KEYSTONE" Guaranteed Components.

"Keystone" Neutralising Condensers.

Designed to suit the capacities of all types of valves. Beware of imitations which, owing to incorrect design, may not neutralise your valves properly.

For board mounting 5/-
For panel mounting 6/3



Balancing Condensers.

Similar in design to the above, but having two sets of fixed plates instead of one

7/6

"Keystone" Fixed Resistors.

Our latest product. Available in the following types:—

No. 4 for .25 amp. valves with 6 v. accumulator.

No. 17 for .06 amp. valves with 4 v. accumulator.

Price, complete with base, each 2/6

The PILOT MANUAL contains illustrated details of many up-to-date sets. Also information on soldering, assembling, testing, &c. Post free 3d.

PETO-SCOTT Co., Ltd., 77, City Road, E.C.1.

Branches: 62, High Holborn, London, W.C.1. WALTHAMSTOW—230, Wood St. PLYMOUTH—Bank of England Place. LIVERPOOL—4, Manchester St.

P.S. 6082.

HOW WIRELESS COMPONENTS ARE MADE

No. 1.

The Making of the Receiving Valve

By Captain JACK FROST, M.I.R.E.

Many of our readers must from time to time have wondered how various processes in the manufacture of wireless apparatus are carried out. Under the above heading Capt. Frost is contributing a series of articles to "The Wireless Constructor" explaining in simple language the "mysteries" of the factory.

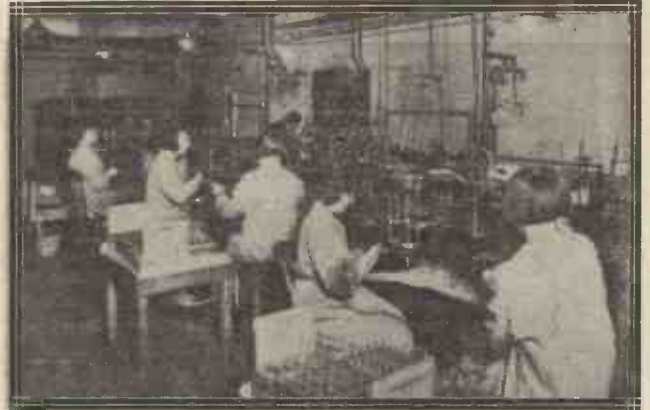

A general view of the assembling room in a valve factory.

DURING the past four years I have given a number of talks during the children's hour from 2LO, explaining in simple language technical points about wireless reception and broadcasting. The adults, I found, were as much interested as the children, and accordingly talks were broadcast at 7.40 p.m. weekly during the summer of 1925, the subject being the way in which wireless components are made. This aroused general interest, and the following series of articles is the outcome.

A Mysterious Science

Science has made great strides in all its branches, and particularly does this apply to the science of wireless, both in broadcasting through the

simple a way as possible some of my very limited knowledge, with the hope that it may assist you towards the understanding of and interest in your own apparatus.

Many components which we use and know so well by name are really mysteries to us, because they are too complicated for us to make, and we must not pry into their interior in case we damage them—replacements are expensive.

valve amplifiers for crystal sets. How many of you have ever seen valves being made? They are not the sort of thing that you would make yourself, because that would be far, far too hard a thing to do. I was very fortunate the other day in being able to see valves being made by one of the companies who make large numbers of them—possibly you are using some of those very valves now. First of all, at the bottom of your valve, you have what is called the "foot" of the valve. This, in the particular type of valve which I saw being made, was of glass. It is that little glass tube which holds the supports for the things inside the bulb of the valve, which are called the anode, the filament and the grid. Let me describe it to you exactly as I saw it.

Making the "Foot"

A girl was at a machine, cutting off sections of a long glass tube; each section was to become the foot of a valve. Then the little glass sections were passed in a box to another girl, who put them into what is called the "dolly." This "dolly" is, really an iron arrangement with a hole in the centre, which holds the little piece of glass tubing. All the time that it holds it, it turns round and round. This "dolly" is mounted on to a circular machine, which also has five other "dollies" mounted on it in the same way, and they all turn round, each one having a piece of glass tubing fixed to it.

Shaping

As the machine works electrically, so are the "dollies" put first of all into a gas flame of a certain heat, which softens the top of the little glass tube. Then the machine turns, and a higher gas flame softens the glass still further, and so on until a little finger made of steel comes down and



Here is the machine which shapes the "foot" of the valve. A completed "foot" is to be seen in the tray of the machine.

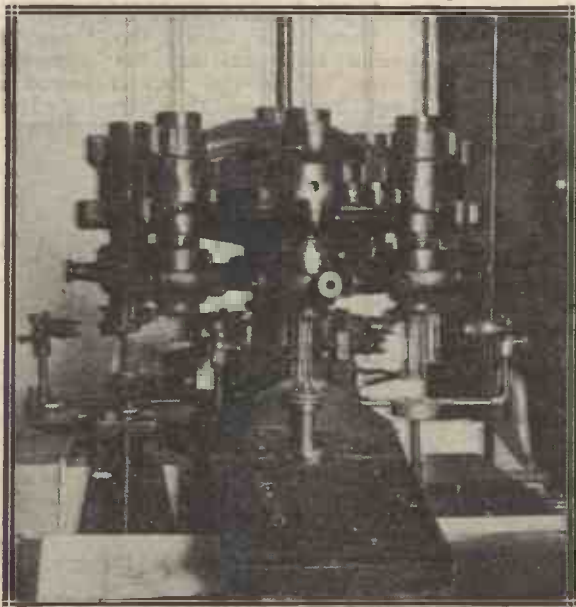
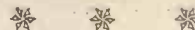

medium of the ether and in the reception of broadcast transmission. We are, as yet, but paddling on the sea-shore of an unknown ocean, for so little is known of the ether; even the scientist himself will admit that. We are all children in our knowledge of this subject, and this fact is impressed upon us when we meditate upon the enchanting and mysterious ether which we are using. I can, therefore, only endeavour to pass on to you in as

It may be interesting for us to learn how they are made by the people who make them in quantities. The valve is one of the most popular components, and one of the greatest mysteries, too. Let us consider this first of all.

Valves

How many of you are using valves in your receiving sets? Some are using valve-sets, and some are using

How Wireless Components are Made—continued

presses on to the revolving piece of softened glass in its "dolly" and turns the glass edge of the tube over, making what is called a "flange." This is the flange which later on fits

length, and not at the end. When it is soft, two little hammers come up and bang together, with the soft glass between them. When they bang together the soft glass is in this way

very quickly in the cold air it would crack. The annealer prevents this, and passes the glass slowly through the different temperatures of the oven until it has gradually cooled down. The annealer is made of copper, because copper cools slowly. The foot, as it is now, has four copper wires sticking out of the bottom of it, and above it the four supports of the electrodes. If the valve maker were then to make the valve without examining the foot, what is called "strain" might occur where the glass has been squeezed together around the wires, and a crack might possibly result which would cause a short circuit in the foot of the valve when used in your set.

The foot, then, has to be examined, and this is the way in which it is done. What is called a "Strain Viewer" is used. This looks like a large box with a little telescope sticking out of one end of it. An electric lamp is at the other end, and reflects its light into mirrors at different angles. These rays of light are thrown into the eye-piece of the little telescope. When you look into this telescope you see a mauve-coloured light. The foot of the valve is put into the box in the line of sight of the eye-piece. If the glass, in being squeezed around the copper wires, has been strained, then all sorts of colours show in the glass. If no strain exists, then only one colour appears.

If strain is found, then back the valve foot goes into the annealing oven. Again the glass is heated to red heat, and then carefully and

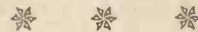
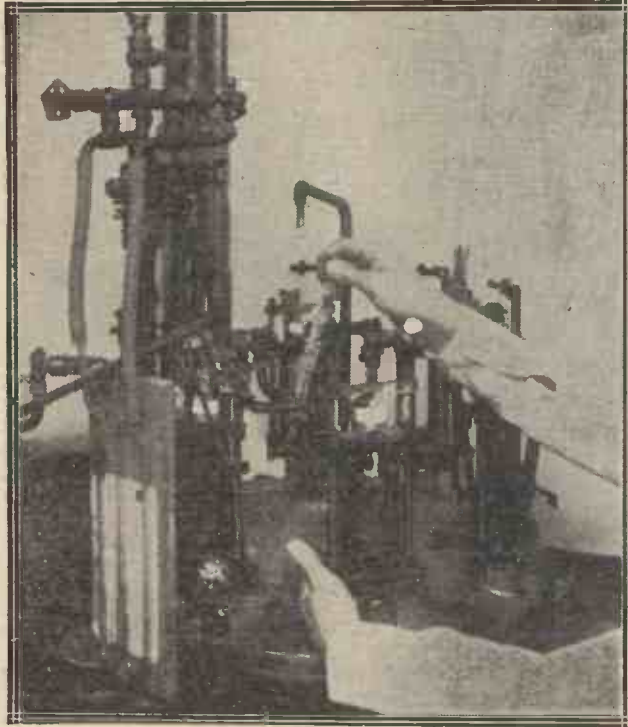

This photograph illustrates the fitting of the supports for the electrodes in the "pinch" of the valve. The "foot" will be recognised at a further stage of development.



into the bottom of the glass end of the valve. Then I saw a really wonderful process called "welding," where short lengths of copper wire are welded on to pieces of platinum and on to little metal supports, which will later hold the three essentials of the valve—the filament, the anode, and the grid.

Welding

This welding process is carried out in what is called a non-oxidising flame, so that no insulating substance can be formed in the process. If any were formed, a great deal of the correct working of the valve would be impaired. Different-sized pieces of platinum are welded for the grid, the anode, and the filament. Girls do this, and it is very delicate work, because each little piece of platinum is very, very small.

Assembling

The next process is the fixing of these welded wires and supports to the glass foot of the valve. Another machine, like the first, with five "dollies" is used for this. First of all the little glass foot of the valve is fixed into a "dolly," and a girl lays the copper wires, which are later to form the contact to the legs of the valve, into the foot. Then the "dollies" turn round and round, and pass through gas flames, which get hotter and hotter, until the glass is soft—this time at the centre of its

moulded tightly around the copper wires.

Annealing the Glass

The foot of the valve with the copper

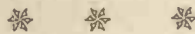
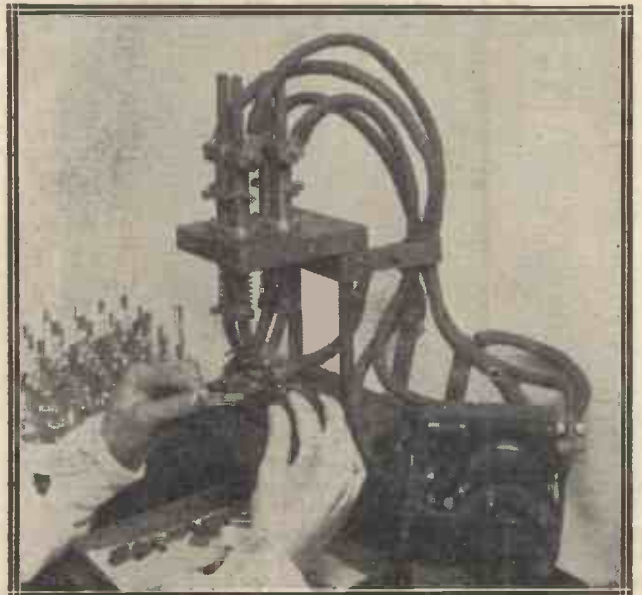

The arc welding apparatus which is used for mounting the electrodes on their supports.

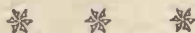

wires fixed to it is then put into what is called an "annealer." This is really an oven with a revolving stand fixed to it. The stand holds the glass foot of the valve with its wires fixed to it, which is still very hot and quite soft. If the glass were to cool down

gradually cooled down. This takes away the strain. The light used in this strain viewer is called "polarised light."

The Electrodes

Let us leave the making of the foot

HOW WIRELESS COMPONENTS ARE MADE—concluded

of the valve for a moment, and talk about the making of the various electrodes, as they are called—the grid, the anode, and the filament. There are two sorts of filaments to valves. One is the dull emitter type of filament, and the other the bright emitter. The dull emitter was the first that I saw being made. A coil of very fine wire, as fine as a hair, was passed through a little holder on to a little machine whose action was very much like the action of a rifle. In front of this machine was a tiny arm, which regulated the length of each piece of wire passing into the machine. Then, suddenly, there was a click, as a strong catch was released and a striker in the machine hit the thin thread of wire, fixing to it a tiny V-shaped piece of metal. This process is called "tabbing." These tabs are fixed so that the filament can be easily attached to its supports on the foot of the valve.

Completed Filaments

The filament wire is cut by the help of a gauge to its correct length, and then carefully examined by an examiner with another gauge. So that these tiny pieces of wire with the tabs attached may not be lost, they all have to be carefully mounted in trays for fixing at a later date to the filament supports. The bright emitter filaments are just cut out to their proper lengths, and are ready for fixing without any tabs being affixed to the filament supports.

Forming the Grid

The making of a grid of a valve is an interesting process. The wire of which the grid is to be made is formed into a spiral for the spiral-shaped filaments, and then is later on mounted to the support upon the foot of the valve, by electric welding. The spiral is made in a continuous length, and then cut out into its correct lengths later on. Another type of grid is wound by hand. What is called a "pitch" is used for this, this giving the exact distance between each band of the wires in the grid. When this winding is done by machinery the "pitch" is, of course, unnecessary, because a machine can work so much more accurately than the human hand. The making of the foot of the valve is simple. It is cut out, the edges are turned over, and then it is welded to its support by the electric process.

In the next article we shall see how these various parts are assembled and tested, and how the valve obtains its vacuum and is prepared for use.

The three photographs of valve manufacturing apparatus which accompany this article are reproduced by courtesy of the General Electric Co., illustrating the making of Osram valves at their works.

EXPERTS IN RADIO ACOUSTICS SINCE 1908

IS THIS WHAT YOU'RE LOOKING FOR ?

TESTING the new 2-valve receiver at our Works at Slough, on a standard P.M.G. aerial, we tuned in the two Paris stations, London, Daventry, Bournemouth, Birmingham and Newcastle on the loudspeaker. This despite bad screening set up by a large power station not more than 50 yards from the vicinity of the laboratory. We were testing on 66 volts only. You can expect even better from the 3-valve Brandeset.

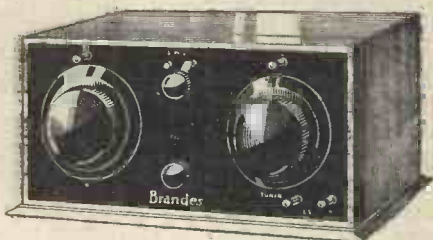

THE BRANDESET II.

The new Brandes 2-valve set features simplicity of control and ingenious compactness. Condenser dial, filament rheostat, reaction dial and "throw-over" switch for long or short wave tuning complete the panel controls. Straight line frequency condenser tuning and grid-bias is employed. The standard coil is suitable for Daventry and no "plug-in" coils need be purchased. The L.T., H.T., and grid-bias leads are plated into one cable from rear of set.

£6 10

(Exclusive of Marconi Royalty and Accessories.)



THE BRANDESET III.

The new Brandes 3-valve receiver employs the same ingenious characteristics as the Brandeset II, except that an extra stage of Audio Frequency is employed. It has straight line frequency condenser tuning, grid-bias, and is adapted to long and short wave tuning. Both receivers give most excellent loudspeaker reproduction on a number of stations, and are specially designed for this purpose.

£8 10

(Exclusive of Marconi Royalty and Accessories.)

Brandes

From any reputable Dealer.

BRANDES LIMITED · 296 REGENT ST. · W.1

And they say that the camera cannot lie!

HERE is another fallacy blown sky high. The camera can—and often does—lie. It all depends on the lens. Sometimes the lens has not been corrected for astigmatism and the edges of the pictures are awry. Buildings appear as if they are tumbling down. The young gentleman with the saxophone in the lower photograph would hardly be recognised by his own mother. It is a case of distortion made visible to the eye.

A good lens is proof against distortion because it is scientifically corrected against astigmatism. It projects all parts of the image equally. In exactly the same way a really good Transformer, such as the Eureka, is scientifically corrected against distortion. It must amplify all the notes in the harmonic scale evenly—it cannot emphasize some at the expense of others. Just as a corrected lens will reproduce a perfectly life-like image of the saxophone player, so the Eureka Transformer will recreate exactly the characteristic flute-like notes from his instrument. You will hear him as naturally as if you were in the studio.

Because a good lens costs more than a cheap one, so the Eureka naturally costs more than an inferior Transformer. It costs much more to produce. In every Concert Grand, for example, there are no less than 3 miles of copper wire. But in designing the Eureka we aimed high. We set aside the question of expense, believing that most people took a pride in the quality of their Radio Music. And our policy has been a wise one.

The Eureka to-day occupies a unique position in the Transformer field. Everywhere it is recognised as setting an extremely high standard of reproduction. We are justifiably proud of its good name. When building your next Set remember the only thing that counts to-day is *quality* of tone. The rich mellow tones of a Eureka-equipped Set make radio really worth while.



Makers also of the Eureka Orthocyclic Condenser.



Types and Prices—

- Eureka Concert Grand**
A superb L. F. Transformer hermetically enclosed in a coppered steel case proof against atmospheric influences. Fully guaranteed
No. 1 25/-
No. 2 21/-
- Eureka Reflex**
For reflex work a special Eureka is available. Gives an exceptional volume of mellow clear tone. Fully guaranteed 15/-
- Eureka Baby Grand**
For those who cannot afford the necessarily higher price of the larger Concert Grand we have introduced the Baby Grand. Fully up to the same high standards of workmanship and carrying the same generous guarantee. Fully guaranteed
No. 1 15/-
No. 2 15/-
- Eureka L.F. Choke Unit**
The L. F. Choke method of amplification is gaining in popular favour amongst seasoned experimenters. The Eureka Choke Unit, incorporating grid leak and condenser, is the finest instrument of its type. Fully guaranteed 25/-

Re-creates the **EUREKA** Living Artiste

Portable Utilities Co., Ltd., Fisher St., W.C.1. Sole Manufacturers of Eureka Radio Products

Gilbert Ad. 6204

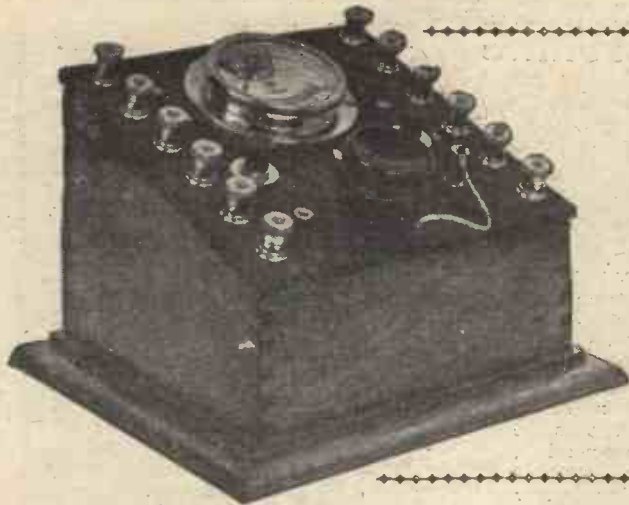

The completed unit is of handsome appearance.

WIRELESS for the amateur is becoming more and more a precise science, and therefore one will nearly always find at least one meter in the possession of the average amateur. It is, however, a rather tedious and uninteresting business connecting a loose meter across the batteries, which probably are in awkward positions for this operation.

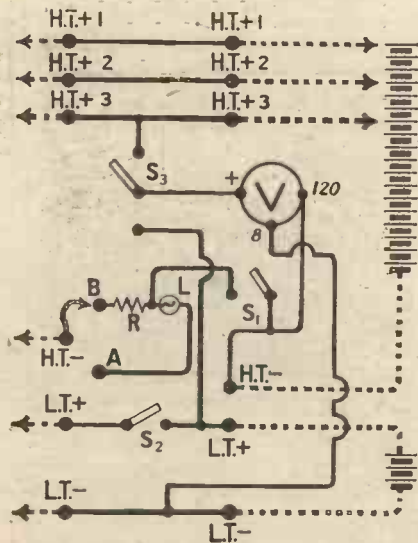

Fig. 1.—The dotted lines indicate the connections outside the unit, those on the left going to the receiver.

A Handy Unit

The unit described here is designed so that it is permanently in circuit with the batteries, and may be placed alongside the set, where, since it has an attractive appearance it will not look out of place. A double reading voltmeter is used, and by means of the change-over switch, seen just below the meter, the desired range may be connected across the appropriate battery. On and off switches are incor-

WATCH YOUR BATTERIES!

By A. S. CLARK.

A useful meter unit, for attachment to any set, which will enable you to check accurately the condition of your high- and low-tension batteries. The unit also incorporates a safety fuse or current limiter in the high-tension circuit.

porated for both high-tension and low-tension, making it possible to make alterations in the set without fear of accidents and without having to touch the battery connections.

It is also possible to connect either a fuse, in the form of a flash-lamp bulb or a high resistance, in circuit with the H.T. battery. This will prevent accidents should the H.T. leads be accidentally connected across the L.T. terminals of the set.

Components

A list of the components required to build the unit will be found accompanying this article. The names of the manufacturers of the components actually employed are given, but it is not absolutely necessary to keep to

BUILD THIS UNIT WITH

- One ebonite panel 6 in. by 6 in. by 1/4 in.
- Suitable sloping cabinet. (Pickett Bros.)
- One double reading high resistance voltmeter, 0-8 and 0-120 volts. (A. H. Hunt, Ltd.)
- One change-over switch, one-hole fixing. (Wilkins & Wright, Ltd.)
- Two push-pull on and off switches. (A. F. Bulgin & Co.)
- One flash-lamp bulb holder. (A. F. Bulgin & Co.)
- One clip-in resistance, not less than 12,000 ohms. (L. McMichael, Ltd.)
- One Clix plug and two Clix sockets. (Autoveyors, Ltd.)
- 12 terminals.
- Glazite and a short length of flex.
- Radio Press panel transfers.
- Approximate cost £2 10s.

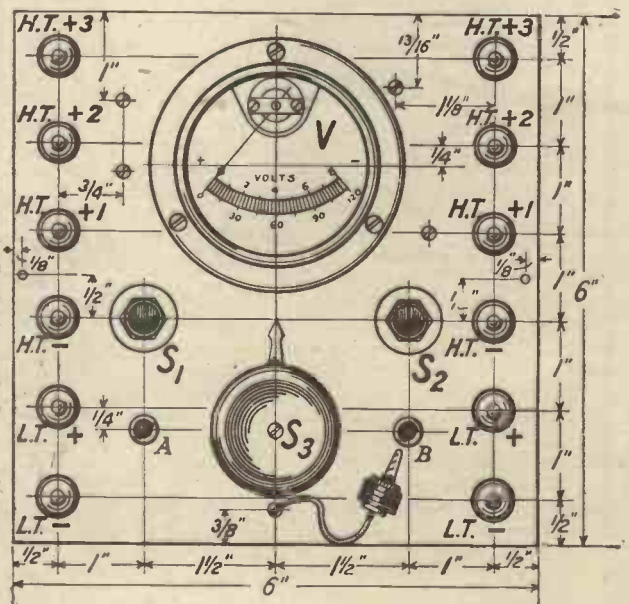

Fig. 2.—With the aid of this drilling diagram the panel may be marked out.

these provided that discrimination is used in choosing other makes.

The Meter

With reference to the meter, this need not be a very expensive one. The

particular make listed is retailed at twenty-seven shillings. There is one point, however, about the meter, which is very important, and that is that it should have a high resistance, as otherwise harm may be done to the

S. L. F.

FOR PERFECT TUNING

TRUE TUNING S.L.F.

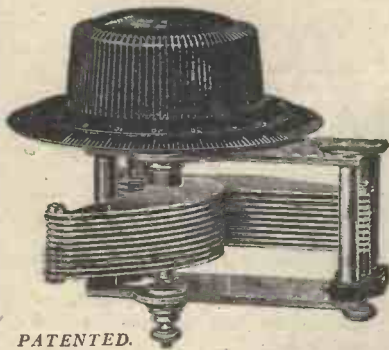

PATENTED.

The New J.B., S.L.F. Condenser is made on lines similar to our Low Loss type (Pat. No. 241,805). In addition, its many excellent new features include Special Bearings Top and Bottom which eliminate springs. Side and End play in the centre spindle is impossible. The Top Bearing is of large diameter and friction-lined, which ensures an absolutely smooth movement. The brass vanes are supported at tips to ensure accurate spacing. End plates are highly polished, and all fittings are heavily nickel-plated. Fitted with 1/4 in. shaft, sold complete with 4 in. Dial and is more compact than most S.L.F. Condensers.

RETAIL PRICES.

.005 mfd.	- - - - -	11/6
.00035 mfd.	- - - - -	10/6
.00025 mfd.	- - - - -	10/-

The New J.B. .0005 Dual Gang Control Condenser, complete with 4 in. Bakelite Dial, for the "Monodial" - - - - - **£1 13 0**



The New J.B. "TRUE TUNING S.L.F." is the latest development in SLOW MOTION CONDENSER design.

The Vanes are designed on a new principle—developed to fall in line with the latest method (Geneva Plan) of allotting wavelengths to transmitting stations—a principle which gives the most even spacing of stations possible, obviating any crowding at the upper end of the scale, and marking the new J.B. TRUE TUNING S.L.F. as the Condenser of the future.

This new model is provided with a Double Reduction friction drive giving a ratio of 60 - 1. The friction surfaces are all metal, engaging with a vice-like grip, which prevents all possibility of slip.

The use of Ball Bearings cuts down friction to an absolute minimum, permitting a wonderfully smooth control, and obviating the disadvantages of "static" friction so usual in the ordinary type of condenser. A noticeable feature is the complete absence of backlash. A coarse and fine movement can be obtained, i.e., the body of the condenser can be moved independently of the friction device for quick search.

One hole fixing, specially designed for rigid mounting, this new model combines all the excellent features of the ordinary J.B., S.L.F.

RETAIL PRICES.

.005 mfd.	- - - - -	16/6
.00035 mfd.	- - - - -	15/6
.00025 mfd.	- - - - -	15/-

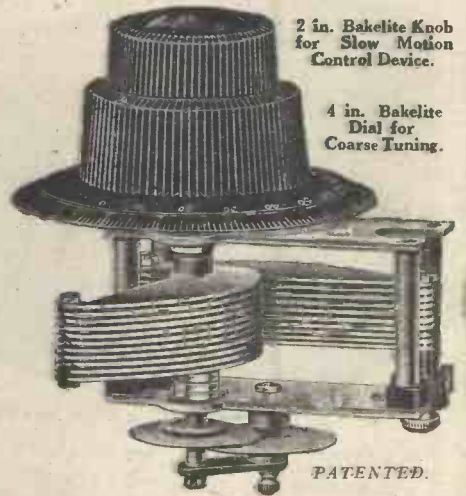

2 in. Bakelite Knob for Slow Motion Control Device.

4 in. Bakelite Dial for Coarse Tuning.

PATENTED.

JACKSON BROS.
8, POLAND ST- OXFORD ST
LONDON - W. 1
(First Floor)
Telephone: GER. RARD 7414



look for it

The name "Wearite" on any component assures all-British work from design to assembly. Here is just one of the complete "Wearite" range—specially made for first-class construction at a moderate price. Write for descriptive folder of all Wireless parts.

Illustration shows "Wearite" Anti-Microphonic Low Loss Valve Socket. (Pat. applied for) L.A.S. 5, 2'6.

WEARITE
COMPONENTS

Lancashire Agent:
Alexander Scandlers,
1 B, Cooper Street,
Manchester.
Glasgow Agent:
C. G. Tideman,
47, Garrick Street,
C.2, Glasgow.

WRIGHT & WEAIRE, LTD.,
740, High Rd., Tottenham, London, N. 17
Telephone: Tottenham 3132. Telegrams: Inland, "Wrightsea, Tottenham, London." Foreign, "Wrightsea, London." 186-3



be sure you get a reliable

CONDENSER

Although the standard of quality has been raised prices are very reasonable. Capacities stocked are from .00011 mfd. to 10 mfd. 1 mfd. 2/9; 2 mfd., 3/9; 4 mfd., 6/-; etc., etc.

Hydra Condensers operate perfectly at all voltages up to 700 D.C. Guaranteed precise within 5 to 10 per cent. of their rated capacity and to maintain rated capacity through all variations in temperature. From all good dealers.

Louis Holzman
109 KINGSWAY, LONDON, W.C. 2

Watch Your Batteries!—continued

H.T. cells. The instrument used should preferably be of the moving coil type, though it is possible to obtain

WIRING IN WORDS

All directions are given as viewing the panel from below. L = Left Side. R = Right Side.

Join H.T. + 3 (L) to H.T. + 3 (R) and also to right contact of change-over switch.

Join H.T. + 2 (L) to H.T. + 2 (R).

Join H.T. + 1 (L) to H.T. + 1 (R).

Join H.T. - 1 (R) to 120-volt terminal of voltmeter, and to one contact of right switch.

Join other contact of right switch to one side of flash-lamp bulb holder and one side of resistance holder.

Join other side of flash-lamp bulb holder to right Clix socket.

Join other side of resistance holder to left Clix socket.

Join positive terminal of voltmeter to centre contact of change-over switch.

Join L.T. + (L) to one contact of left switch.

Join other side of left switch to left contact of change-over switch, and to L.T. + (R).

Join L.T. - (L) to L.T. - (R), and to 8-volt terminal of voltmeter.

Join a flex lead to H.T. - (L), pass the free end through the panel and attach a Clix plug.

satisfactory instruments of the moving iron type.

Construction

Having collected together all the components required, the construction may be undertaken. This is not difficult, and will not take very much time, provided that attention is paid to the instructions and diagrams.

Drilling

Mark out the panel in accordance with the drilling diagram of Fig. 2.

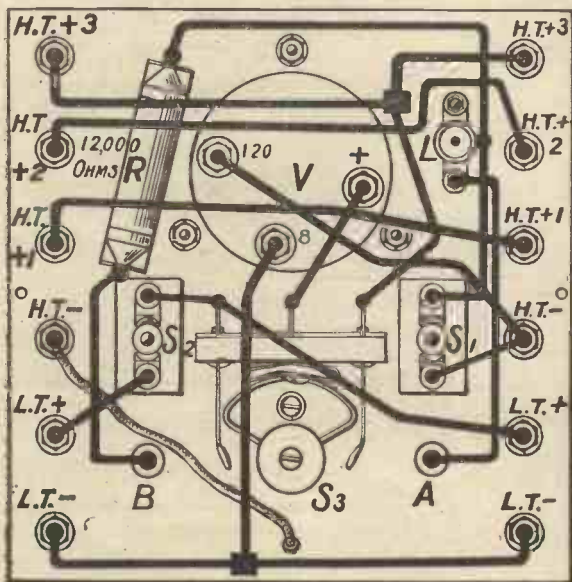

The large hole for the meter is best cut out with a fret-saw.

The next step is to mount the components. This should present no difficulty. Now all points to which wires have to be soldered should be cleaned and well tinned.

Connecting Up

When the unit is completed, it should be connected up as indicated in Fig. 3. The low-tension is switched

lamp bulb will carry more current than that required to burn out the valves. When the high-resistance is in circuit, a higher H.T. voltage than



The resistance in the high-tension circuit fits in the clips on the left, the flash-lamp socket being on the right.

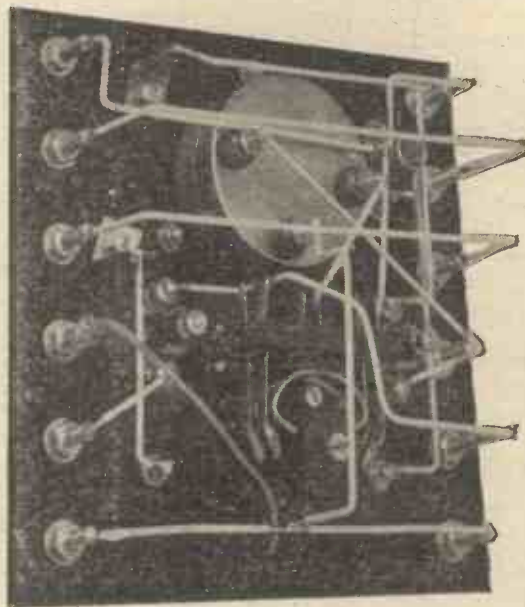
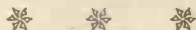

on by pulling out the right-hand push-pull switch (S₂), and the high-tension by pulling out the left-hand switch (S₁). By placing the Clix plug in the left-

usual may be required to compensate for the voltage drop across it.

Readings

When the change-over switch (S₂) is placed to the right, the voltage of the accumulator is read, and when over to the left the highest H.T. voltage is read. Both these readings should, of course, be taken while the set is working, so that the batteries will be under load.

Testing Intermediate Cells

If it is desired to take readings of any intermediate cells of the H.T. battery, the leads which are connected to H.T. + 3 and H.T. - should be connected across the intermediate tapings of the H.T. battery. The lead to the H.T. - terminal will, of course, be taken to the tapping with the lower value marked against it.

The H.T. on and off switch should be in the "on" position when these readings are taken, since no readings can be taken with it off. Also, the Clix plug should be in the A socket, since the inclusion of the limiting resistance in circuit would prevent a true reading from being obtained.

It may be noted that the unit may be connected either way round with respect to the batteries and the set; that is to say, the set and batteries may be connected to the left- and right-hand terminal respectively, or the other way round.

Fig. 3.—The wiring diagram should be carefully followed.

hand socket (A) the fuse is brought into circuit, and by placing it into the right-hand socket (B), the resistance is in circuit. This is for use when one or two valves of the .06 ampere type are employed. The fuse would be unsuitable in this case, since the flash-

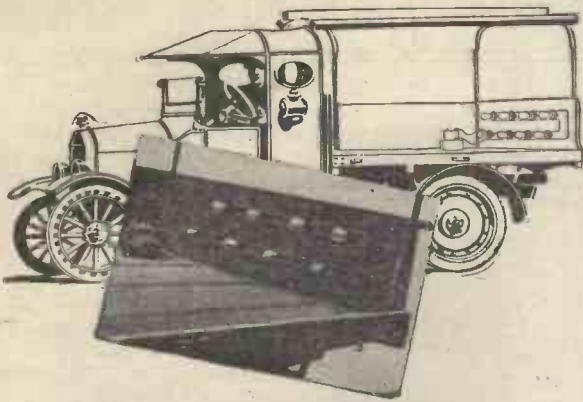

Here's Proof that
the 'LOTUS' Survives
Shock and is
anti-microphonic

EIGHT Lotus Valve Holders fitted with large power valves and fixed to tailboard of a Ford motor lorry, driven over rough roads for 30 miles, survived the test

At the finish each spring was as it started — perfect. No damage or looseness at the connection of leg socket and spring — no valve became loose from the holder. Both were electrically perfect all the way.

That is why we guarantee the security of Lotus Valve Holders against shocks and vibration.

Fit the 'Lotus' to your set and protect your valves.

From all Radio Dealers.

Prices :
Combina-
tion Grid
Leak and
Valve
Holder

3/9

VALVE
HOLDER
With
Terminals

2/6

VALVE
HOLDER
Without
Terminals

2/3



Pat. No. 256838.

Made from best bakelite moulding with springs of nickel silver and phosphor bronze valve sockets.

GARNETT, WHITELEY & CO., LTD.,
Lotus Works, Broadgreen Rd., Liverpool.
Makers of the famous "Lotus" Vernier Coil Holder.

CLIX

NICKEL PLATED FITMENTS



CLIX WANDER PLUGS

with patented helical spring plug, ensuring perfect contact in all types of H.T. Batteries. Red or black insulator.

2d. each.

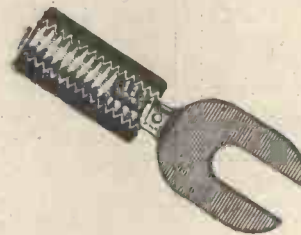

CLIX SPADE TERMINALS

for use where terminals are already fixed. Prevents breaking or twisting of wire. Red or black insulator.

2d. each.

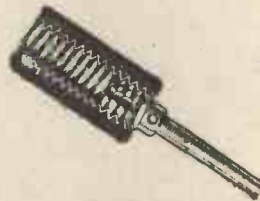

CLIX PIN TERMINALS

A most convenient tag for general use, supplied with red or black insulator.

2d. each.

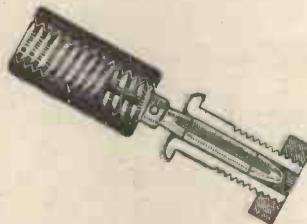

CLIX PARALLEL PLUGS

with resilient fitting, having extraordinary radial expansion and compression. Red or black insulator.

Plugs 2d. Sockets 1d.

ALL THE ABOVE FITTED WITH PATENTED
BRIDGE WIRING CHANNEL.

CLIX TAPER and ACCESSORIES

Clix Plug Sockets - - - 2d. each.

Clix Taper Adapters - - - 1½d. each.

Insulators in six colours ½d. each.

Bushes in six colours
½d. per pair.

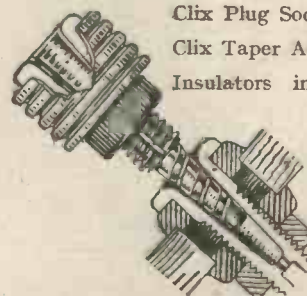

A unique connector, uni-
versally applicable, The
most handy wireless
gadget ever invented.
Terminals eliminated,
tight connections ensured.

AUTOVEYORS LTD.

84, VICTORIA ST., WESTMINSTER, S.W.1.

Phone : Victoria 309. Telegrams : "Autoveyer, Sovesl, London."

How to Beautify Your Loud-Speaker

A FASCINATING JOB
FOR THE WINTER EVENINGS.

By ERN SHAW.

Describing how anyone may with very little trouble or expense apply a most attractive form of decoration to the horn of a loud-speaker.



The lacquer work is in keeping with the dark background of the horn.

brown finish of the horn is an admirable substitute.

The design should first be traced on to the surface to be decorated, or drawn freehand with pointed chalk. The designs given with this article can be traced on to tissue paper, the reverse side of which should then be rubbed over with chalk.

Place each portion of the design in the correct position and go over the lines with a sharp pencil, using the design of Fig. 10 as a guide.

Of course, in the case of a very small loud-speaker, some of the con-

MOST manufacturers of loud-speakers have endeavoured to supplement the efficiency of their products by artistic designs. A variety of types has been adopted which are, in the majority of cases, graceful in form. Few, however, have incorporated pictorial design, and as the loud-speaker has become part of the drawing-room "furniture," this seems to leave scope for improvement.

Lacquer Work

Probably the main reason has been the difficulty of creating a standard pattern or colour scheme which could be universally adaptable, but the writer recently made an experiment, the result of which seems to solve the problem, the solution being Chinese lacquer work, which with a little practice and for but a small outlay would enable many of our readers, during the winter evenings, to add considerable beauty and value to their loud-speakers.

The writer's model is a 22-inch Amplion "Concert Grand," with a black matt finish, but the method explained could be successfully followed on almost any standard model.

Materials Required

First of all the materials required are few and inexpensive, being as follows: — Two or three "pencil" brushes; four small tubes of oil colour, viz., black, burnt sienna, chrome, and vermilion; glass tubes of Winsor & Newton's bronze powders, viz., brilliant citron, gold, bright green and silver. Also a bottle of lacquer medium and a bottle of raising paste. There are sufficient materials here to decorate several instruments.

Making the Design

In the case of loud-speakers, it is

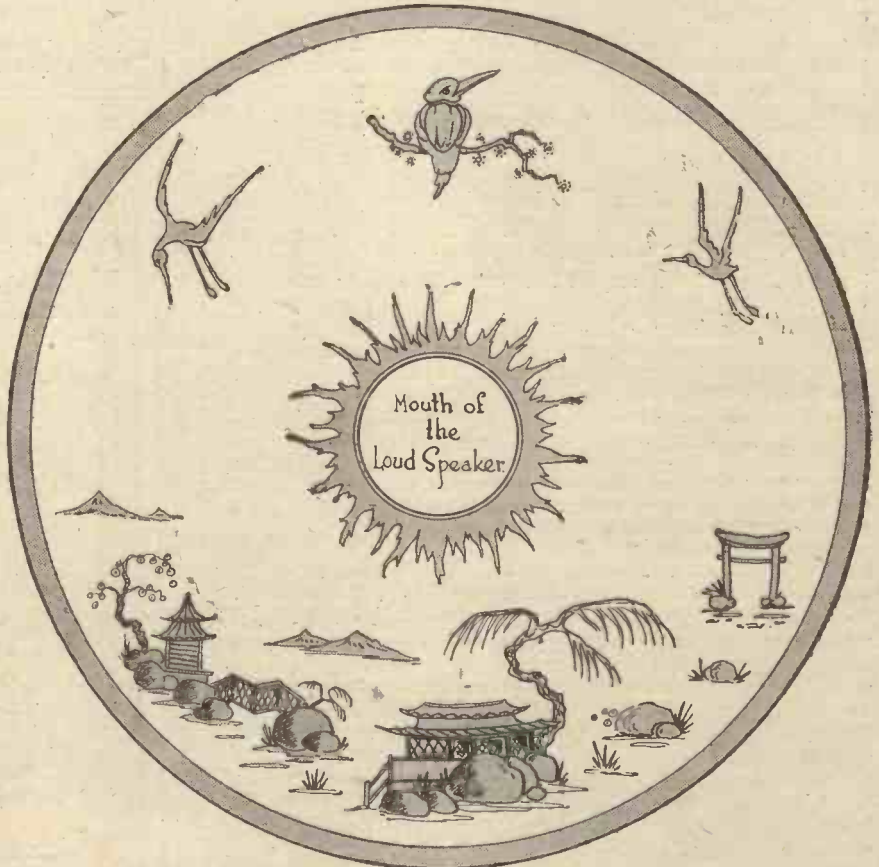
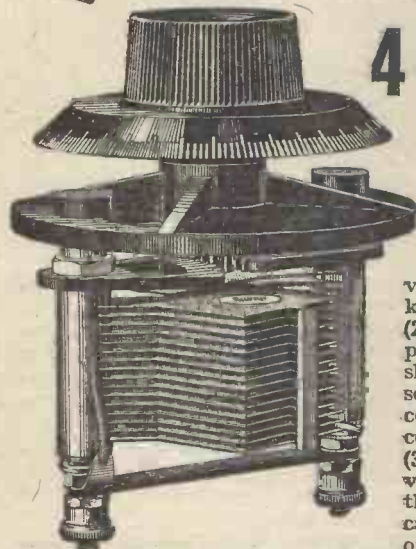

Fig. 10.—This drawing shows how a complete design may be made up from drawings similar to those on page 139.

not necessary to prepare first of all a lacquer ground, as the usual black or conventional objects could be left out. It is a mistake to overcrowd the surface

THE Newey "4 Point" Condenser



4 Revolutionary Points.

(1). **NO HAND CAPACITY:**—The Bakelite mounting plate is specially designed to minimise self-capacity, eliminate di-electric losses, and isolate the vanes from the control knob.

(2). **ZERO LOSS:**—All plates are bonded into a slotted equaliser bar to secure true zero loss conditions. No rubbing contact is employed.

(3). **360° CONTROL:**—No vernier is necessary since the condenser drive is calibrated over a range of 360°.

(4). **NEGLECTIBLE ZERO CAPACITY:**—The capacity at Zero reading as certified by the National Physical Laboratory gives only .00003 mfd.

The complete condenser operates on the Square Law principle, is beautifully finished and made by all-British Labour in all-British Factories from the finest available materials.

Price, complete with knob and dial, .0005 mfd. 17/6
.0003 mfd. 15/-

What the Wireless Technical Press thinks of the Newey 4-Point Condenser.

"Amateur Wireless." "In construction it is of the ultra low-loss type, and in this respect it is one of the finest examples we have seen."

"The Broadcaster." "A noticeable feature is the high-class workmanship throughout, and that all rubbing contacts from vanes to connecting terminals are avoided by the use of soldered flexible wire connections."

"On test we found the maximum capacity very close to the nominal (.0005 mfd.), while the minimum was lower than that of the usual vane type of condenser. Tested in critical oscillating circuits, no losses were apparent, while on practical test in a valve receiver tuning the aerial inductance, the actual performance was highly satisfactory."

THE NEWAY VERNIER COIL HOLDER.

A perfectly constructed coil holder, designed for Back-of-Panel One-hole fixing, and in addition provided with lugs for fixing in any position on panel. Bakelite moulding throughout. Worm geared by means of metal segment and worm, and fitted with patent stop plate to prevent over-winding in extreme positions—gearing ratio 8-1 giving fine critical tuning and permitting the use of the heaviest coil.

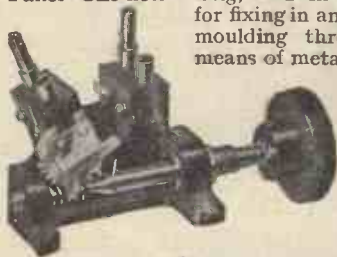

Price - - 7/6

PETTIGREW & MERRIMAN (1925) Ltd., PHONOS HOUSE, 2 & 4, Bucknall Street, New Oxford Street, London, W.C.2.

Telephone: Gerrard 4248-49. Telegrams: Merrigrew, Westcent, London.

"Silvertown" WIRELESS ACCESSORIES

Quality guaranteed by over 50 years' electrical manufacturing experience.

SILVERTOWN WIRELESS ACCESSORIES INCLUDE

- Condensers (All Types)
- Crystal Holders
- Dials and Knobs
- Earth Plates
- Inductance Switches (10-way, etc.)
- Insulators ("Everdry," "Featherweight," Cone lead-in, Window Pane, etc.)
- Potentiometers
- Rheostats, Filament (One-hole fixing, etc.)
- "Silvertown" Loud-Speakers
- Testing Buzzers
- Transformers (All Types)
- Valve Holders, Anti-Microphonic
- Verniometers, etc., etc.



B. 500. INTERVAL TRANSFORMER.

Guaranteed for 12 months. Price 21/- each. This Transformer has been adopted by leading Manufacturers of Wireless Receiving Sets and discriminating amateurs in all parts of the world. Excellent results have been obtained on tests carried out by the National Physical Laboratory. Copy of the curve can be had on application.

THE SILVERTOWN COMPANY, 106, CANNON STREET, LONDON, E.C.4.

Works: Silvertown, E.16.

BELFAST. GLASGOW. NEWCASTLE-ON-TYNE.
BIRMINGHAM. LEEDS. PORTSMOUTH.
BRISTOL. LIVERPOOL. PORTSMOUTH.
CARDIFF. LONDON. PORTSMOUTH.
DUBLIN. MANCHESTER. SHEFFIELD.



The "Eelex" Multiple Connector

Price 5/6 Complete.

Non-reversible, detachable name plates, built with Eelex standardised Plugs and Sockets. All parts are standard, detachable and interchangeable. Coloured flexibles can be supplied in the following colours: red, blue, green, yellow, black, white and maroon at 1½d. per yard. If at any time sets change so that multiple connectors are no longer required; then the parts can be put to other uses. It will pay you to adopt the Eelex Standardised system of Connections.

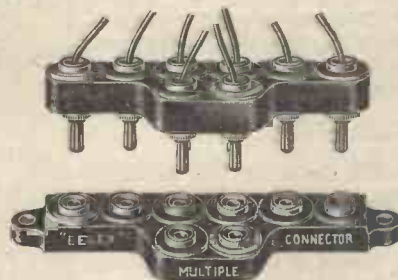

Send to-day for the Free EELEX List W.C.3

J. J. EASTICK & SONS

Eelex House, 118 Buryhill Row.

Phone: Clerkenwell 9282-9283.

Branches and Trunks of Trees

should be put in first with the **RAISING PASTE**. Make leaves as delicately pointed as possible when painting in with **LACQUER MEDIUM**.

The shaded portions on the roof should be touched in with **Vermilion**.

Rocks and other solid objects may be shaded with burnt sienna thinned with Turps

Markings on Buildings are made with black oil colour — using a fine sable brush.

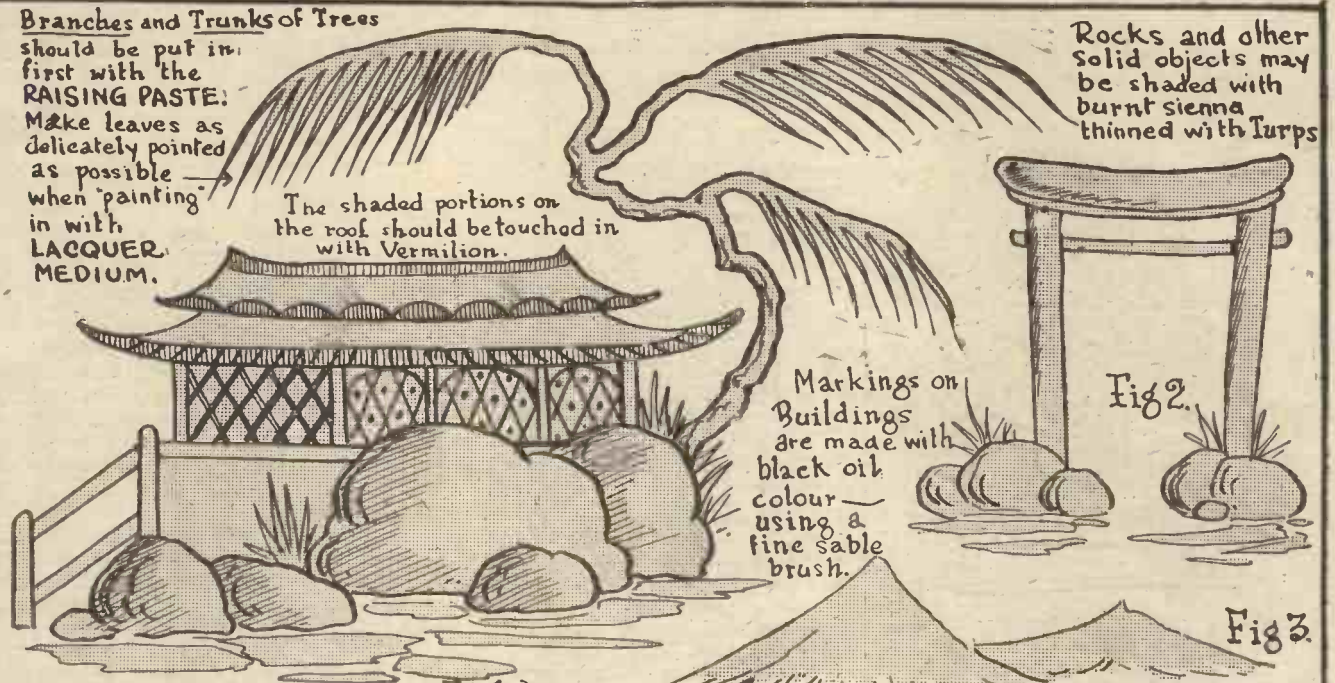

Fig 1.

Fig 2.

Fig 3.

In making mountains — paint in thinly with **LACQUER MEDIUM** — and carefully wipe off the base with finger or cloth. This — when dusted with the silver powder — will give a vignette effect.

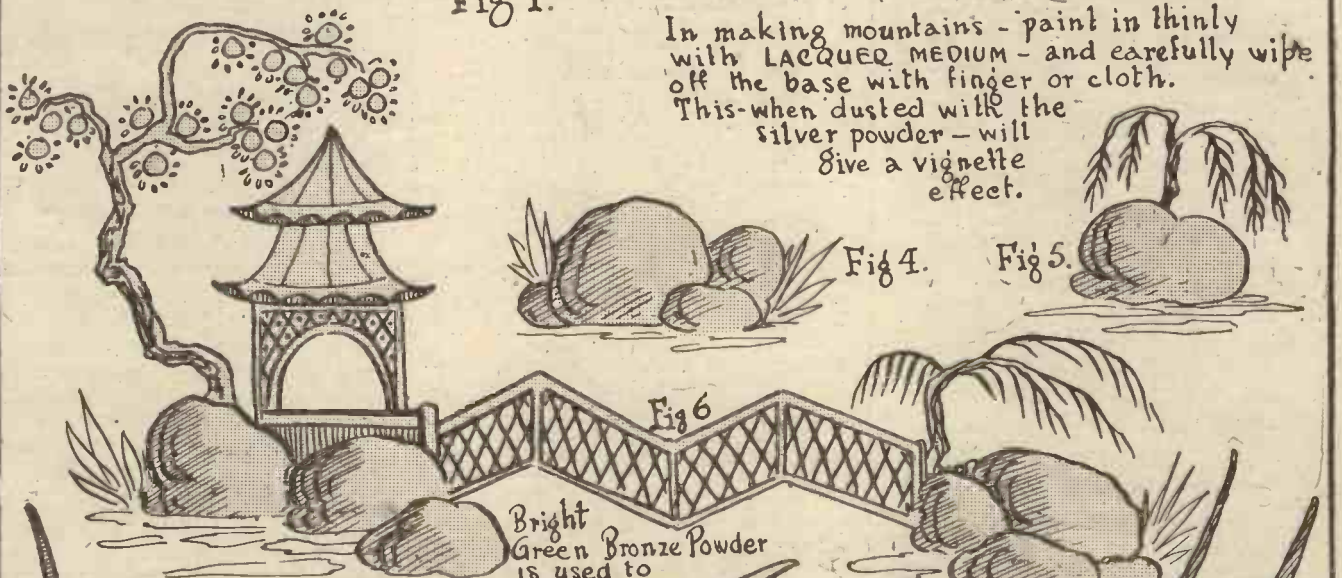

Fig 4.

Fig 5.

Fig 6.

Fig 7.

Fig 8.

Fig 9.

Bright Green Bronze Powder is used to indicate water.

The birds — after gilding — should be shaded with Burnt Sienna, marked with black paint and the shaded portions tipped with Vermilion.

Figs. 1-9.—These drawings may be copied or traced, and transferred to the loud-speaker horn.

Ashley Radio JACKS

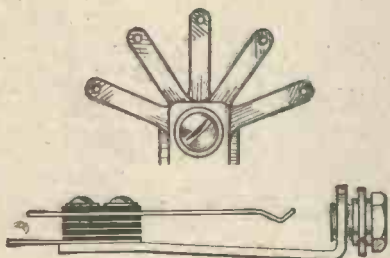

are made of nickel silver springs, with pure silver contact, and Bakelite insulation throughout. Tags are tinned and spread fan wise for easy soldering.

Jack No. 1. Single Circuit (open) **1/3** Jack No. 2. Single Circuit (closed) **1/6**

Jack No. 3. Double Circuit **1/9** Jack No. 4. Filament Single Control **1/9**

Jack No. 5. Filament Double Control **2/3**

TELEPHONE PLUG, 1/6

CLARITONE LOUD SPEAKERS

Senior Model, 2,000 ohms. W. 265
120 ohms. W. 266
£5 0 0.

Junior Model, 2,000 ohms. W. 267
120 ohms. W. 268
£2 15 0.

CLARITONE HEADPHONES
W. 216. **20/-**

ASHLEY WIRELESS TELEPHONE Co. Ltd.

17, Finch Place,
London Road,
LIVERPOOL.



HOW TO BEAUTIFY YOUR LOUD-SPEAKER—continued.

to be decorated. The width of the strip on the rim of the horn is determined by the size of the loud-speaker, but from $\frac{1}{2}$ in. to $\frac{3}{4}$ in. is wide enough. To prevent soiling, this should be left until last.

The hole deep in the mouthpiece can be camouflaged to represent a rising sun. This need not be traced, so long as the centre of the design, Fig. 10, is used as a reference.

Applying the Powder

The lacquer medium is a substance which, shortly after a thin application, becomes "tacky" or sticky. The metallic powders are then dusted, not rubbed on, with a dry brush or a soft, clean cloth. Allow sufficient time to dry before wiping away the superfluous powder.

When working on black it is advisable to mix a little chrome oil colour with the medium; this will enable you to see clearly where it has been applied.

Do not attempt to complete the whole of the design in medium before putting on the powders, or in the earlier part of the work the medium would be too dry to grip the powders. Do one little group of objects at a time.

The Method in Detail

If the execution of Fig. 1 be now explained, the method can be followed throughout the job.

After tracing the design, take the raising paste and with a brush apply it to the branches and trunk of the tree, the roof of the pagoda, and the rocks. A narrow space should be left between each of the latter. Do not put the paste on too thick or it will look clumsy; it is also apt to chip. Treat the roofs, rocks and trees in the other portion of the design in the same way, letting the paste dry slowly.

This is the usual method, but if this seems to be too much trouble to the amateur, the rocks only need be raised, and this can be done effectively, as in the case of the writer's loud-speaker, with ordinary letter sealing-wax.

Lacquering

Next comes the application of the lacquer medium. Dealing with Fig. 1, first paint in the trunk of the tree; then add the leaves, using a fine brush and taking care to get the leaves delicately pointed. Then proceed with the pagoda and rail. Now cover the rocks, overlapping the raised portion slightly.

When the medium is "tacky," dust on the gold metallic powder, using plenty, the surplus being shaken into a saucer. If any part has not taken the powder well, apply a little more

medium and powder again. When all the loose gold powder is cleared off, "paint" in the mountains, finishing these with silver powder.

Lastly, paint the water with medium and dust with bright green powder.

Use brilliant citron for the birds, except the beaks and legs, for which employ gold. How to apply the finishing touches to these and other objects is explained below. Brilliant citron will also look effective on the rim of the loud-speaker.

Shading

Having covered the different portions of the design with the metallic powders, you now proceed to "shade" the objects, i.e., trees, rocks, etc., and this must be done very carefully. In lacquer work it is conventional always to shade the left side of an object.

Take a little burnt sienna with a tinge of chrome and mix with a drop of turpentine. Don't use the brush too full. With a few deft touches



The materials shown here will suffice to decorate more than one loud-speaker.

model the roof and supports of the pagoda, the trunks and branches of the trees, and the rocks. Then, with a small brush and using black paint, outline the details of the building, etc. (see Fig. 1).

Little touches of vermilion, in the parts indicated by shading, will strengthen the effect. The "flowers" on the tree in Fig. 6 might also be dotted with vermilion. The shaded portions of the birds, Figs. 7, 8 and 9, need a touch of the same colour.

Cleaning-up

Twenty-four hours after the work has been completed carefully test to make sure that the touches of oil colour are dry, and if so, the whole of the work may be sponged with clean water to remove superfluous powder.

The result, if the work is done well, will amply repay the trouble, and will greatly enhance the pleasure of listening to the programmes.

It should be added that the foregoing instructions are open to criticism by the expert in lacquer work, but the writer's object has been to simplify the method, so that the average reader may be able to provide a striking effect with the minimum of effort.

A NEW AND BETTER TRANSFORMER

is sweeping the country

Guaranteed for
12
Months.

8/6

Turns Ratio
3 to 1
Resistance
Ratio 4 to 1



The heart of your amplifier is your transformer. Now LISSEN gives you a transformer which surpasses anything ever before available—users everywhere are learning that it is no longer necessary to pay a high price to get a high grade transformer. This new LISSEN is being tried and tested under all conceivable conditions everywhere—it is being enthusiastically and largely bought by the trade for their own made-up sets.

Throughout the whole range of audible frequencies this new LISSEN transformer amplifies fully every note, every harmonic, every overtone. That means realistic reproduction. In the purity and power of volume the results are remarkable. You will appreciate at once the clearer tones and greater volume.

Expensively made in all its details. Traders at the recent Exhibition at Olympia, asked to name the price at which they thought they could sell it, invariably named a price close to £1. Many said 25/- and many even more than that.

Tested by a Trade Paper

A well-known trade paper reviewing its performance says:—
"It is infinitely better than the average transformer around this price. In strength it was only slightly below our standard, which is 4 to 1."

You can rely that this standard was an expensive transformer and the new LISSEN was said to be nearly as good for volume. Nothing was said about purity, and we know that for PURITY AND POWER the new LISSEN Transformer is equal to the very best transformer made. It is due to our new direct-to-dealer-distribution policy which cuts out all wholesale profits that we are able to sell this splendid new transformer at the unprecedented price of 8/6.

Test it for 7 days—if you are not satisfied take it back to your dealer or send it back to us. Use it for 1, 2 or 3 stages L.F. It is suitable for all circuits and all valves you will want to use. Compare it against any for tone purity and power. You can get it at your dealer's or send remittance direct to factory if any difficulty. Include no postage if you send direct, but please mention dealer's name and address.

N.B.—So good is this new Lissen that we have unhesitatingly withdrawn all our own previous high priced transformers.

**LISSEN LTD., Lissenium Works,
26-30, FRIARS LANE, RICHMOND, SURREY**

Managing Director: T. N. COLE.

L83

THE DUBILIER "UNIVANE" CONDENSER

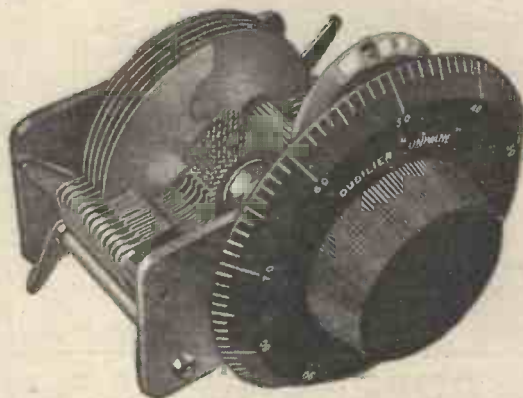

Patent No. 247365

IF YOU VALUE FINE TUNING USE A UNIVANE

Did you examine the big working model of the Univane at the Radio Exhibition?

If so you will agree that the problem of ultra-fine tuning has been solved once for all.

The Univane gives the equivalent of a continuous vernier adjustment between minimum capacity and a maximum of 0.0005 mfd.

By a highly ingenious gearing, rotation of the scale moves *one plate at a time*, adding it to or subtracting it from those already in opposition.

Figures appearing on a small auxiliary dial indicate the number of plates in opposition and enable you to make a permanent log of every station heard.

The Univane is in no sense a condenser for "special" circuits; it is intended for use on every occasion where the ordinary variable is employed.

The action is smooth and silken, and the workmanship and finish are of Dubilier standard.

Price

25/-



ADVERT. OF THE DUBILIER CONDENSER CO. (1925), LTD., DUCON WORKS, VICTORIA ROAD, N. ACTON, W.3.

E.P.S.231



RECUPERATING AGENT
in the
HELLESEN
DRY BATTERIES

Foresight!

Five years ago the manufacturers of Helleesen dry Batteries realised that specialisation was necessary in Wireless types if the needs of to-day were to be efficiently and economically met.

A longer life to meet the long and frequent periods of use which you demand to-day without sacrificing in the slightest the smooth uniform supply which has made Helleesen Dry Batteries known as the *Best in the World*.

60 volt "WIRIN" 12/6
99 volt "WIRUP" 21/-

POSTAGE EXTRA.

All types, voltages, etc., in Double and Treble capacities for H.T. and L.T. Supply. Ask your dealer for the type to suit your set and get the maximum service or write us for full particulars.

Obtainable at all Radio, Electrical and General Stores, Harrods, Selfridge's, etc., or direct from

A. H. HUNT LTD., DEPT 15 CROYDON, SURREY

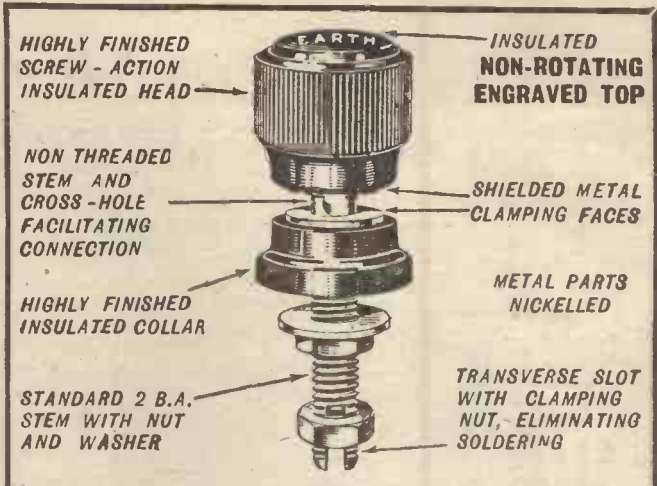

Beautifully finished genuine bakelite and engraved with 28 different letterings.
STANDARD MODEL, 9d. each. POPULAR METAL MODEL, 6d. each

DIAL INDICATORS, 6d. each. **REACTION** One-hole fixing, 8 different letterings.

Solid cast metal with white polished letters on a black background.

BELLING-LEE
PANEL FITTINGS

Advertisement of Belling & Lee Ltd.
Queensway Works, Ponders End, Middlesex

The Bretwood Straight Line Frequency CONDENSER



has ALL the essentials of a REAL Low Loss, Slow Motion, Straight Line Frequency Condenser.

LOW LOSS Losses minimised, the supports being two only and with very small area surface.

STRAIGHT LINE FREQUENCY. Fixed and moving plates specially designed to give this.

VERNIER. Noiseless adjustment with a reduction of 40 to 1. Dial giving 360 degrees registering in all 3,600 degrees.

CONSTANT. Constancy is obtained by rigid construction. All wear is automatically taken up through conical and ball thrust bearings.

CALIBRATION OF Vernier. Calibration over the whole Vernier is given by the automatic indication of numbers and degrees.

HAND and Body Capacities. These are completely eliminated by insulation and the special setting of vanes.

PRICES	
.0005	17/6
.0003	14/9

HIGH CLASS WORKMANSHIP AND FINISH. All parts guaranteed dead true to within one thousandth of an inch. Easy to mount and connect.

The Bretwood Auto-Audio Frequency AMPLIFIER



There is nothing better than public opinion to prove the popularity and efficiency of any component.

We hold numerous letters from those who have tested and confirmed our statements that the Bretwood Amplifier does give you distortionless reproduction.

Prove this statement yourself. Send for one on 10 days' trial. We guarantee to refund money if you are not satisfied.

PRICE 20/-

Obtainable from all dealers or direct from Sole Manufacturers:
BRETWOOD LTD., 12, LONDON MEWS, MAPLE STREET, LONDON, W.1.

Mr. Scott-Taggart Enters Valve Business

(Concluded from page 104)

valve, have been published in foreign countries, and he is an honorary member of the German Radio Society.

Mr. Scott-Taggart has lectured before the British Association, and at one time devoted considerable attention to the fostering of the Radio Society movement. He was a member of the Council of the Radio Society of Great Britain and president of several Radio Societies.

Radio Press, Ltd.

In 1922 Mr. Scott-Taggart established Radio Press, Ltd., as a radio publishing organisation, and has built up the business to its present successful state. Those who have worked with him have been greatly influenced by his enthusiastic aim at technical accuracy in the articles and efficiency in the receiver designs published.

The slightest error in one of his papers has always been followed by what has almost amounted to a court of inquiry to see exactly how the error arose. With regard to the receiver designs, he leaves behind a tradition of seeing that every set is put to exhaustive test and reaches a very high standard before a description is published.

Founding Elstree

It is partly on this account that he conceived the idea, most unusual for a publishing firm, of establishing special laboratories where apparatus could be put through exhaustive tests and new ideas and designs tried out. The result was the Elstree Laboratories. Mr. Scott-Taggart has amply justified his views on the sound design of receiving apparatus by the production of such receivers as the "Elstree Six," "Solodyne," "Elstreflex," "Magio Five," and other leading designs emanating from the Elstree Laboratories.

The New Company

It is not illogical that Mr. Scott-Taggart should desire to enter the valve business. He possesses all the necessary qualifications for success in this branch of work. We feel convinced that he would not have taken this step unless he were wholeheartedly confident of the product his company is to produce. He is probably the only person in this country who has acquired a wide reputation as an expert on the use of valves as well as

their manufacture. The average valve maker is rather inclined to look upon a valve as a form of lamp, and rather to ignore the suiting of the valve to the circuit in which it is to be employed. The use of proper valves for certain purposes is a comparatively recent development, and no doubt Mr. Scott-Taggart's unique experience of modern receiver designs will be an important factor in his new activities.

The Future

On the technical side of Radio Press, Ltd., there are able engineers who will take Mr. Scott-Taggart's place, and the existing traditions will be carried on exactly as before. We have made arrangements whereby we shall from time to time publish articles from Mr. Scott-Taggart's pen, and we are sure that readers will join with us in wishing him every success in his new sphere of activities.

A New Appointment

Some twelve months ago Mr. Scott-Taggart resigned the managing directorship of Radio Press, Ltd., so the actual management of the business remains, as heretofore, in the hands of Mr. Robert A. Lodge, A.S.A.A. Mr. J. H. Reyner, B.Sc., A.M.I.E.E., has been appointed technical manager of the company—an appointment which, we feel sure, will meet with satisfaction in every quarter.

This will help you

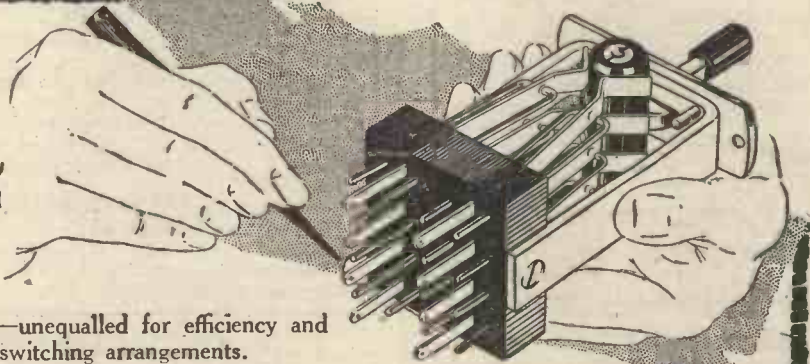

USE T.M.C. Low Capacity Keys—unequalled for efficiency and adaptability to many and varied switching arrangements.

Try them for your Remote Control.

Multi-valve—Series-parallel—and Battery switching.

Change over from Headset to Loud Speaker, etc.

They combine a smooth, free action with a positive lock in each position. Contact is made on non-oxysiding "gold-silver" points, and the actual movement is so small that it is practically impossible for the moving parts to lose their relative adjustment.

The live springs and contact arms are heavily insulated from the frame and have their lower ends tinned to facilitate soldering.

Escutcheon plates and levers are finished in bright nickel plate or polished and lacquered brass, to choice.

Ask for the new T.M.C. Catalogue at your local Wireless Shop—or we will send a copy free on request. Please mention the name of your usual dealer.

TMC Low Capacity Keys

MADE IN THREE MODELS.

- No. 1. 12 point, 3 position .. 7/-
- No. 2. 6 point, 2 position .. 6/-
- No. 3. 24 point, 3 position .. 15/6

These prices do not apply to the Irish Free State.
Packed in attractive black, red and yellow labelled cartons.

Telephone Manufacturing Co. Ltd.

"HOLLINGSWORTH WORKS, WEST DULWICH S.E. 21"

Phones: Sydenham 2460/1. Telegrams: "Bubastis, Dulcrox, London."

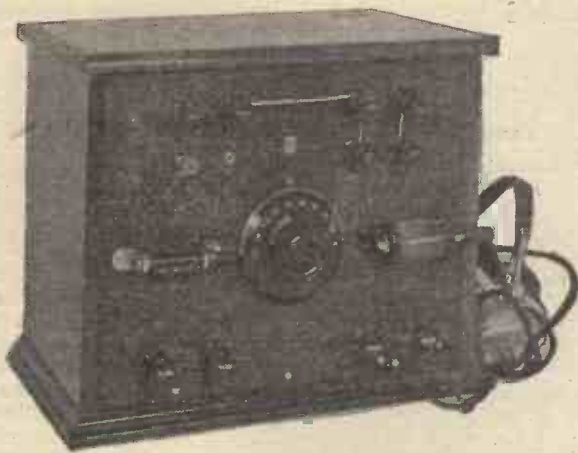

A FLEXIBLE CRYSTAL SET

By GEORGE T. KELSEY

Opinions differ widely about the relative efficiency of crystal circuit arrangements. This set will enable you to test one detector against another, use series aerial tuning if you wish to, and find the best settings for crystal and aerial on the local station's transmission. Daventry is, of course, provided for too.

TO define a crystal receiver as flexible is apt to convey to many that the operation of such a set is no easy matter; yet, in view of the many different conditions under which a published design is likely to be used, it would seem reasonable to suppose that a certain degree of flexibility would be a desirable feature in order to obtain the best results. If it is a matter of probable improvement of signal strength, it would seem worth while to go to the little extra

Daventry, which is normally fairly weak in the district in which the receiver was tried, seemed to be just slightly above the average strength.

WHAT YOU WILL NEED

- One "Becol" panel, 10 in. by 8 in. by 1/4 in. (British Ebonite Co., Ltd.).
- One cabinet to take the above, and base-board, 5 1/2 ins. deep. (Aircraft Cabinet Co.).
- One micrometer crystal detector. (Burndept Ltd.).
- One "Crystastat" semi-permanent detector. (Neutron, Ltd.).
- One .0003 square-law low-loss condenser. (Ormond Eng. Co., Ltd.).
- One "Becol" former, 3 in. long. (British Ebonite Co., Ltd.).
- Two Clix sockets and one Clix plug. (Autoveyors, Ltd.).
- Ten Belling-Lee terminals marked "Aerial," "Aerial 2," "Earth," four "Phones," and three blank. (Belling & Lee, Ltd.).
- Two spring clips. (Burndept Ltd.).
- 1/4 lb. No. 6 enamelled wire.
- 1/4 lb. No. 26 d.c.c. wire.
- Glazite and flex for wiring.
- Approximate cost, £1 5s.

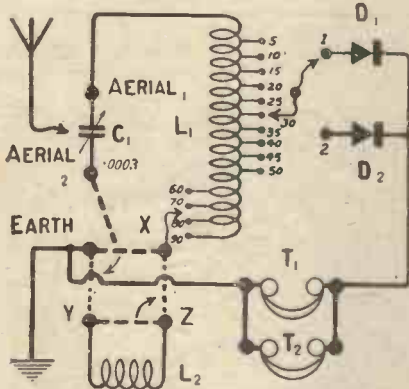

Fig. 1.—The tapped coil for the lower broadcast band allows of reasonably fine adjustments for the best signal strength.

trouble in manipulating such a receiver.

In this article it is intended to give the full structural details of the crystal receiver illustrated, which allows one of two different circuit arrangements to be tried.

Results

As to results, the receiver has given very good signal strength from the London station at a distance of ten miles on two pairs of telephones, using an average outdoor aerial. It was found on test that slightly louder signals were obtained when using a series tuning condenser.

coil. For this the ribbed ebonite former and a quarter pound of No. 26 enamelled wire will be required. Drill two small holes about half an inch from one end of the former, and secure through these one end of the wire, leaving four or five inches for connecting purposes. Now wind on five turns and make a tapping.

Method of Tapping

This can be done by twisting a loop in the wire, or, for those who prefer to solder, by raising the turn which is to be tapped by means of a small piece of match-stick.

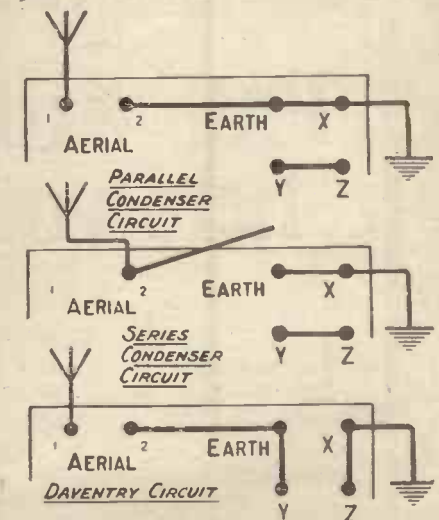

Fig. 2.—Showing how the shorting links may be used to obtain various circuit arrangements in the simplest possible manner.

Having decided the method by which it is intended to tap the coil, make the first tapping, and proceed to wind on forty-five turns, making a tapping at every five turns. These ten connections are mainly for tapping the crystal, but they can also be used in tuning. There should now be fifty turns of wire on the former, and to

Series or Parallel?

There are various opinions as to whether a series or parallel tuning condenser is best, and so, in the present receiver, a simple switching arrangement is incorporated in order that both may be tried. Further, the local coil is so constructed that the effect of tapping the crystal across only part of the inductance can be tested. The Daventry coil, which is home constructed, can be brought into circuit simply by changing the positions of the shorting strips between the terminals marked "Earth," "X," "Y," and "Z."

The "Short-Wave" Coil

It will be best to commence the construction of the receiver with the coils, making first of all the "local"

Details of The New S.T. Valves

Designed by
JOHN SCOTT-TAGGART,
F.Inst.P., A.M.I.E.E.,
and covered by numerous patents.

S.T.
Limited,



2,
Melbourne
Place,
LONDON,
W.C.2.



Built like the Pyramids—to last

In replying to advertisers, please mention THE WIRELESS CONSTRUCTOR.

Scott-Taggart makes them

THE S.T. valves described in these pages have been manufactured in England by, and to the specification of, John Scott-Taggart, M.C., F.Inst.P., A.M.I.E.E., whose name is probably more familiar than that of any other expert on the valve.

Before entering the valve manufacturing industry, Mr. Scott-Taggart was the head of the group of wireless periodicals which included *Modern Wireless*, *Wireless*, and *The Wireless Constructor*. In addition, he was the founder and head of the Elstree radio research and test laboratories, where part of the work consisted in the critical testing of valves, sets and components of the leading manufacturers in this country. Before these activities, Mr. Scott-Taggart was in charge of the manufacture of valves made for the British Government.

Mr. Scott-Taggart is the author of the leading text-books on the valve, his *Thermionic Tubes in Radio Telegraphy and Telephony* being the standard and most comprehensive work on this subject. In addition, his books, *Elementary Textbook on Wireless Vacuum Tubes*, *Practical Wireless Valve Circuits*, *More Practical Valve Circuits*, *Radio Valves and How to Use Them* have helped in no small measure the present generation of valve users. More than half a million of his books have been sold, excluding foreign translations, indicating to some extent the confidence of the wireless public in his work, his judgment, and his knowledge and experience.

More than fifty patents, all concerned with valves, stand in his name, some proof of the inventive genius of one whose whole technical life has been concerned entirely with this branch of radio.



JOHN SCOTT-TAGGART,
F.Inst.P., A.M.I.E.E.

Having already firmly established the design and processes of manufacture, Mr. Scott-Taggart (whose initials S.T. give the valves their name) determined, in spite of the laborious work involved, to see that each and every valve sent out by S.T. Ltd. should be tested by electrical measurements and on actual signals under his own supervision. Each valve box has a space on it where Mr. Scott-Taggart personally initials a test certificate for the valve inside. The firm of S.T. Ltd. and its Managing Director feel that valves should not be regarded as a kind of lamp or as so much merchandise. They feel that the manufacture and testing of valves require the undiluted attention of those who have devoted their lives to this industry and have no subsidiary interests.

However casually one may regard a valve, the fact remains that no two makers' valves are the same. Outwardly and in actual operation the S.T. valve is robust, highly efficient and foolproof. A child can buy one and fit it in the family set. But inside that glass bulb all the ingenuity of modern science, the precision of specially designed machinery and painstaking care in testing have contributed to make a valve which stands out head and shoulders above others.

In the early stages, the designer of the S.T. valve refused to proceed unless he was entirely unhampered and able to use any invention he desired. As a result, S.T. Ltd. are operating under all the leading patents which have contributed to the advancement of the valve. Nothing has been sacrificed in design through inability to use some invention essential to achieve the best results.

Reasons why you'll prefer S.T. Valves

(1) *The Name behind them*

They bear the imprint of John Scott-Taggart and all that this name has come to mean in the valve world.

(2) *Possess the right Dynamic curves*

They are designed and tested on the basis of Dynamic characteristic curves. The common method is to have regard only to the static or ordinary curve. The ordinary curve, while valuable for some purposes, ignores working conditions, since it is taken with a fixed anode voltage. Every valve in a wireless receiver has, however, a constantly fluctuating anode voltage which, when the grid is made more positive, becomes less than the H.T. voltage, while when the grid is more negative, the anode voltage rises to a value higher than that of the H.T. battery. This is due to the variation in current through the impedance always in the anode circuit of the valve. This impedance may, for example, be an H.F. or L.F. transformer, a choke, a resistance or a loudspeaker.

This phenomenon is generally overlooked by both manufacturers and many valve users. Every type of S.T. valve, however, is designed to give the right

Advt. of S. T. Ltd., 2, Melbourne Place, W.C.2.

Dynamic curve which represents the conditions with the impedance in circuit. The valve, moreover, is tested dynamically, i.e., under operating conditions.

(3) *It is their curves that count*

All the operating merits of a valve, whatever the type may be, are reflected in the characteristic curves of the valve—provided, of course, that the right curves are taken. The effect of electron emission, the shape, sizes and spacing of electrodes, for example, all produce an effect on efficiency which is noticeable in the characteristic curves of the valve. That is why S.T. Ltd. lay so much store by the curves of their valves. Anyone can claim perfection and this or that merit, but in the end the curves show defects or merits. The Dynamic curve of a valve cannot lie. It's the curve that counts!

(4) *Like the Pyramids, they last*

However good a valve may work and however good a curve it may have, this is no consolation if the valve only lasts a few days or a few weeks. This brings us to what many people regard as the most important factor—the life of the valve. About 50 per cent. of the valves sold use

thoria in their filaments and often the power of emitting electrons seriously falls off. The valve remains alight, but the emission falls below the safe limit and signals become—to many—unaccountably weak, and distortion also arises. The S.T. valve has a *torodium* filament and has a very long and useful life. If you buy your valves on the basis of the length of service they give, you will always choose S.T.'s, for they are built like the Pyramids—to last.

(5) *The Torodium filament*

The secret of the long life of the S.T. valve lies first in the filament and secondly in the vacuum. The filament is made of torodium, a recently invented alloy of precious metals which gives off, when heated, a copious stream of electrons. This power of emitting a generous supply of electrons remains throughout the life of the valve, and, moreover, breakages through the brittleness of the filament are unknown, as even after being used for a long period it retains a strength and pliability comparable to that of a steel cable. The life is also largely attributable to the fact that the torodium filament

operates at so very low a temperature that it gives no visible glow.

(6) *Extremely high vacuum due to the Barguet process*

The vacuum in a valve is a feature which greatly influences not merely the initial operation of the valve, but also its life. After a time, there is a tendency for gases absorbed or "occluded" by the metal electrodes in the valve to leak out into the space in the bulb and partially spoil the vacuum. It has been proved beyond question that the slightest traces of oxygen, water vapour and other gases greatly affect the electron emission and the life of the filament. In the case of S.T. valves, the electrodes are heated to a very high temperature to drive out every particle of gas. These gases are then withdrawn from the bulb by the Barguet process of evacuation, which produces the highest vacuum known to science. This high vacuum is retained, and is a potent factor in giving the S.T. valve a long and efficient useful life.

(7) *Economical, as they take very little current*

Economy in upkeep is a vital factor in the choice of a valve. Hence the great popularity of dull-emitter valves. Many so-called dull-emitters are, however, very extravagant in current consumption in comparison with the S.T. valves, which only take 0.1 ampere in most cases and 0.15 ampere in the case of one of the power valves. Work out how much this saves you in the cost of accumulator charging and the fatigue of carrying accumulators to be charged. The smallest increase above these figures means greater cost and trouble.

(8) *Not critical to work*

One of the most delightful features of the S.T. valve is the fact that it is not critical to work. You can, in fact, be careless. For example, the torodium filament will work efficiently with or without a rheostat or resistor. Many valves are very critical on filament voltage, but the 6 volt S.T., for example, will work off any

voltage between about 4.5 and 6 volts. Some valves only work at their best when the accumulator is absolutely fully charged, and signals "go off" after a time. The S.T. valve, however, will continue at work until the accumulator runs down.

(9) *Non-microphonic and robust*

The S.T. valve is non-microphonic. You can tap it with impunity. It is very strongly made. Built like a chronometer for accuracy and uniformity, it is yet robust. Each electrode is supported in several places to give strength.

(10) *Every valve certified O.K. by John Scott-Taggart*

Every valve is tested under Mr. Scott-Taggart's supervision and every carton is personally initialled by him to certify the satisfactory characteristic of the valve. The valves are uniform and every one is a "picked" valve. Any valve not coming up to the required standard is destroyed.

Specifications and Characteristic Curves

(The curves given are static curves to serve as some comparison with other valves. Dynamic curves are obtainable on application)

VALVES FOR 2-VOLT BATTERIES

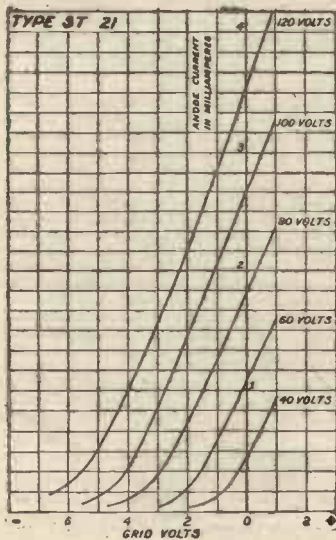

S.T. 21

H.F.

Filament 1.8 volts.
" 0.1 amp.
Anode 40-120 volts.
Impedance 26,000 ohms.
Amplification 16.

An excellent valve for H.F. amplification and resistance capacity coupling. It is also to be recommended as a detector valve.

Price 14/-

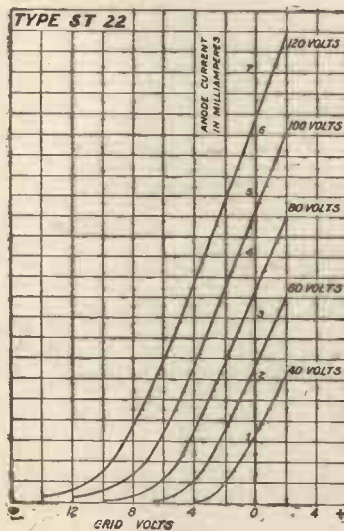

S.T. 22

L.F.

Filament 1.8 volts.
" 0.1 amp.
Anode 40-120 volts.
Impedance 16,000 ohms.
Amplification 10.

This valve is for the first stage of a low frequency amplifier and will give undistorted reproduction. It may also be used for H.F. amplification, especially in neutrodyne circuits, and for detection.

Price 14/-

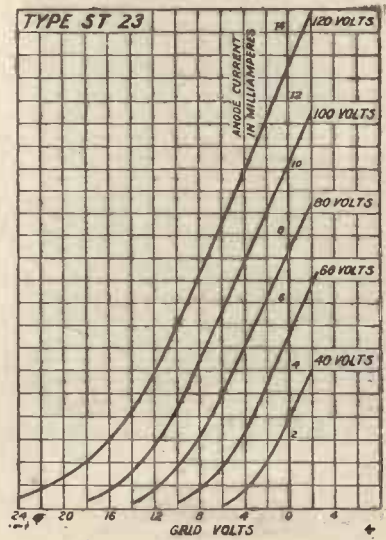

S.T. 23

POWER

Filament 1.8 volts.
" 0.15 amp.
Anode 80-120 volts.
Impedance 6,000 ohms.
Amplification 6.

A magnificent 2 volt power valve giving superb reproduction when used as the last valve of a set when a loudspeaker is employed. Note its low impedance and the high amplification factor for such a valve.

Price 18/6

Advt. of S. T. Ltd., 2, Melbourne Place, W.C.2.

VALVES FOR 4-VOLT BATTERIES.

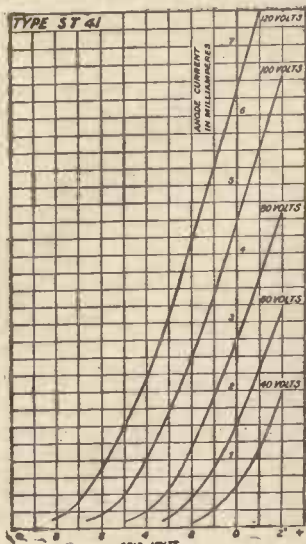

S.T. 41

H.F.

Filament 3.7 volts.
0.1 amp.
Anode 40-120 volts.
Impedance 16,000 ohms.
Amplification 13.

This is an efficient H.F. valve more particularly designed for heurodyne circuits. It brings in the distant stations with ease. This valve may be used as the first L.F. and as the detector valve. It is the valve for resistance capacity coupling.

Price 14/-

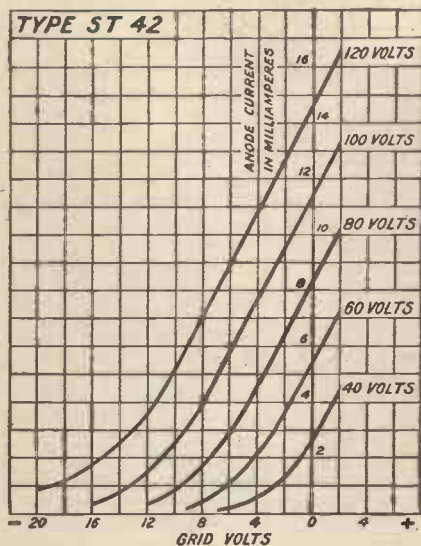

S.T. 42

POWER

Filament 3.8 volts.
0.1 amp.
Anode 40-120 volts.
Impedance 6,000 ohms.
Amplification 6.

An excellent power amplifier recommended for first and also the second stage of L.F. although the S.T. 43 is the ideal loudspeaker valve in the 4 volt class.

Price 18/6

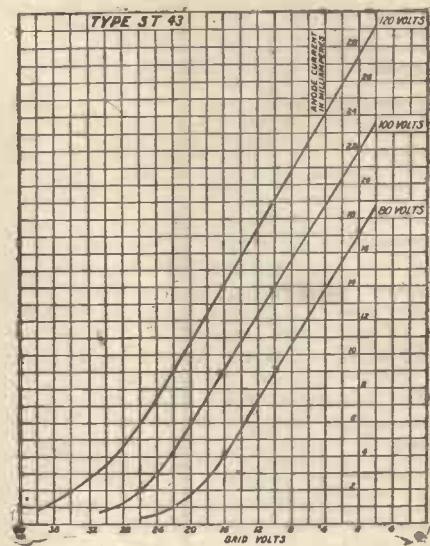

S.T. 43

SUPER POWER

Filament 3.8 volts.
.25 amp.
Anode 120 volts.
Impedance 4,000 ohms.
Amplification 3.33

This valve is the only standard 4-volt valve in the super-power class, hitherto confined to 6 volt valves. It is "the valve with the golden voice" and is capable of great volume and exceptional purity of tone.

Price 22/6

VALVES FOR 6-VOLT BATTERIES.

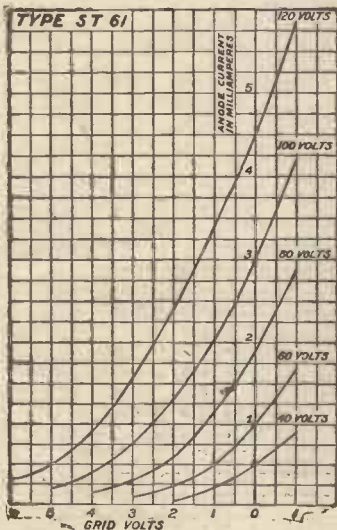

S.T. 61

H.F.

Filament 5.6 volts.
0.1 amp.
Anode 50-120 volts.
Impedance 20,000 ohms.
Amplification 20.

This efficient H.F. valve is particularly to be recommended for all neutrodyne types of circuit, while it may also be used for resistance capacity coupling. It makes an excellent detector.

Price 18/6

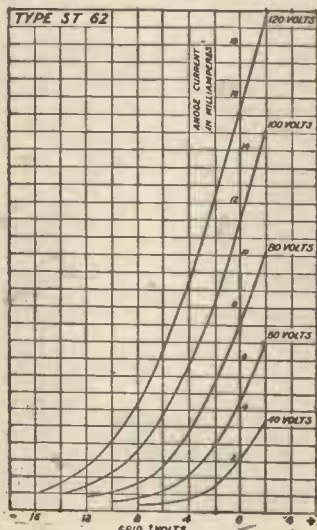

S.T. 62

POWER

Filament 5.6 volts.
0.1 amp.
Anode 80-120 volts.
Impedance 6,000 ohms.
Amplification 8.3

This power valve is the best of its class and makes a good first and second L.F. valve. It is intended especially as a good all-round power valve.

Price 18/6

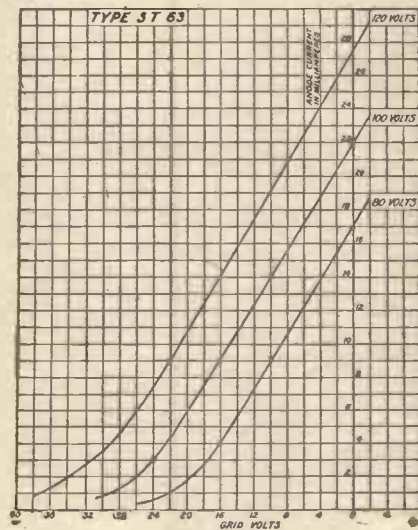

S.T. 63

SUPER POWER

Filament 5.6 volts.
.25 amp.
Anode 120 volts.
Impedance 4,000 ohms.
Amplification 3.33

This is "the valve with the golden voice." It is an entirely new class of valve having very long dead-straight dynamic curve giving exquisitely pure loudspeaker reproduction.

Price 22/6

GENERAL NOTES.—S.T. valves operate at the lowest temperature of any valve made. Do not assume that because you cannot see the filament alight that the valve is not working. Any of the valves will work directly off an accumulator or with a rheostat or fixed resistor. Under no circumstances should a valve be worked with a rheostat off a battery of higher than the rated voltage, e.g., do not work an S.T. 23 off a 6 volt accumulator through a rheostat. No responsibility can be taken for valves spoilt by over-running—so liable to occur in such cases. Where it is desired to work, say, a 2 volt valve from a 6 volt battery (an undesirable practice) a fixed resistor should be used and suitable values (and the resistors themselves, if desired) will be supplied on application. A rheostat or fixed resistor may always be used with, say, a 2 volt valve when working off a 2 volt accumulator, but neither is essential. The life of the valve will be increased if the filament current is kept as low as is consistent with good results.

The valves used for L.F. amplification should always be operated with a grid bias battery which should be variable, and give not less than a maximum of 9 volts. The S.T. 43 and S.T. 63 valves require a grid bias battery giving up to 18 volts.

Note that both the S.T. 41 and S.T. 61 valves, though marked H.F., may be used as general purpose valves. The marking of the valves H.F. and L.F. is adhered to, although this arbitrary labelling is really inaccurate, as the valves can often be used for different purposes. We shall always be happy to give individual customers advice on the choice of valves. A high-tension battery of 120-volts will be found the most useful.

Advt. of S. T. Ltd., 2, Melbourne Place, W.C.2.

A Flexible Crystal Set—continued

complete the coil it only remains to wind on forty more turns, making provision for connections at sixty, seventy, eighty, and the end of winding, which should be finished off through a small hole drilled in one of the ribs of the former.

terminals are provided for telephones, so that two sets of telephones can be attached without any difficulty.

Drawings

Full details of the panel layout can be obtained from the dimensioned

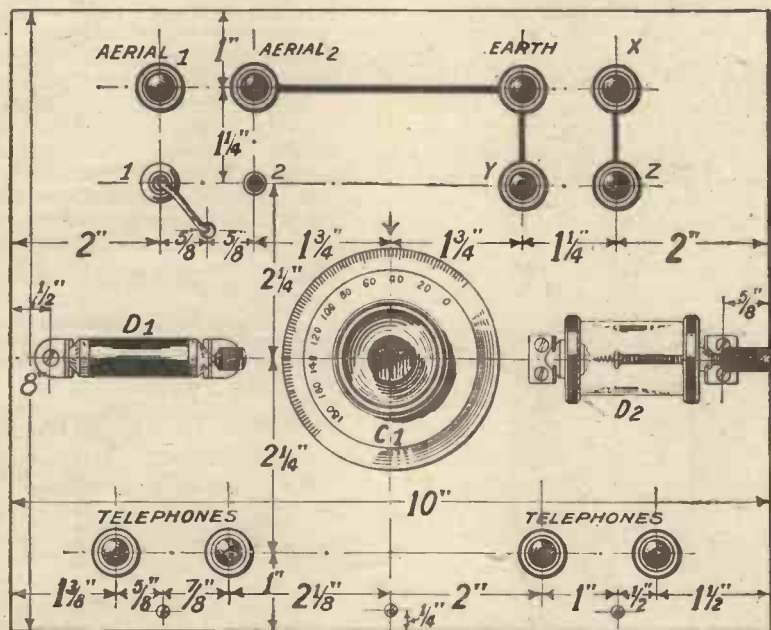

Fig. 3.—The layout is attractive in appearance. Dimensions may be taken from this diagram. Blueprint No. C. 1072 A.

If the connecting points on the coil have been made by using matth-sticks, the enamel should be scraped off the wire where it passes over the wood, and a short length of wire soldered to each one to enable the clip connector to be used. In either case, the enamel will, of course, have to be removed at the points at which it is desired to make connections.

The Daventry Coil

The Daventry coil is a much more simple affair, consisting of 130 turns of No. 26 d.c.c. wire wound round any convenient former, 3 in. in diameter. An ordinary jug or tin of the required diameter will suit admirably for this purpose. When the winding is completed, it is slipped off its former, and made secure with a binding of Empire cloth.

Constructing the Set

The construction of the actual receiver now remains to be done. This is by no means a difficult job, and the use of special terminals greatly simplifies the wiring, in that very few soldered connections are required. The receiver is fitted with two crystal detectors, one of the semi-permanent variety and one of the catwhisker type. The employment of two detectors in this fashion will be found of great use in practice. Two pairs of

drawing accompanying this article. Do not, of course, mount the panel on the front of the baseboard until the former has been drilled.

WIRING IN WORDS.

All directions are given as viewing the Set from the back.

Join Aerial 1 terminal to fixed vanes of variable Condenser C1, and to right end of L1 coil winding.

Join Aerial 2 terminal to moving vanes of variable condenser.

Join No. 1 Clix Socket to one side of permanent detector.

Join other side of permanent detector to one of right-hand pair of telephone terminals, one of left-hand pair of telephone terminals and one side of catwhisker detector.

Join other side of catwhisker detector to No. 2 Clix Socket.

Join Earth terminal to remaining two telephone terminals.

Join terminal Z to one end of Daventry Coil L2 and terminal Y to the other end.

Join a flex lead to terminal X and fit the free end with a spring clip.

Join a Clix plug to the end of a flex lead, pass the free end out through the panel and fit a Clix plug.

Fit a wire shorting link between Aerial 2 and Earth terminals. Also attach wire links to terminals X and Y, long enough to connect with Earth and Z terminals.

crystal brackets before securing in position the variable condenser.

Mounting the Coils

The method of mounting the Daventry coil is simple, a piece of wood being screwed to the baseboard to hold the coil in position.

A little more care is necessary, however, when mounting the "local" coil. This can be fixed in position by means of small brass angle brackets screwed to the former in any suitable manner. Perhaps a description of the method



The method of securing the Daventry coil is to clamp it to the baseboard by means of a screw through a strip of wood.

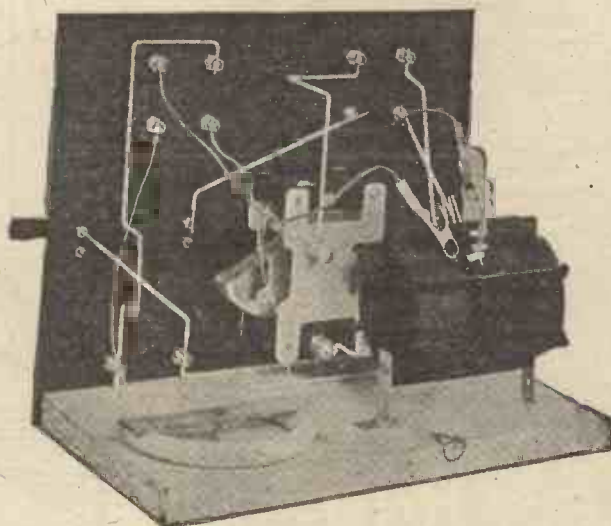
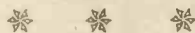

The panel when drilled is secured to the baseboard by means of three screws, after which the components can be mounted. In constructing the original receiver it was found much easier to mount the terminals and

used when constructing the original will be of interest. A small hole was drilled in each end of the former at the base of one of the ribs, and a screw was found which could just be screwed in, so cutting a thread in the compara-



**SILENT
CONSTANT
ROBUST**

It is personal experience that counts ; special sets and other people's experience are certainly of interest, but your own experience on the set that you have built, are building, or intend building is the one satisfactory test for a wire-wound resistance.

Uniformity in value, silence in operation, mechanical strength and purity of tone. Surely you are the best judge of these characteristics.

The Mullard standard of production allows one result and one only. Complete satisfaction, however severe the test.

Mullard EVER-REST Wire Wound Anode Resistance (80,000 and 100,000 ohms) 5/-
Complete with Holder 6/6

Other Values to Specification.

Mullard Grid Leaks and Condensers, Type Grid B 0.5 to 5.0 megohms .. 2/6
Type Grid B, combined with .0003 mfd. Condenser Type MA .. 5/-
Type MA Condenser .0001 to .0009 mfd. 2/6
Type MB Condenser .001 to .01 mfd. .. 3/-
Leaflet W. free on request.

**Mullard
EVER-REST**

WIRE WOUND ANODE RESISTANCE

The MULLARD WIRELESS SERVICE Co., Ltd.
Mullard House, Denmark St., London, W.C.2

A FLEXIBLE CRYSTAL SET—continued

tively soft ebonite. Be very careful if using this method of tapping, however, as rough treatment may cause the ebonite to crack. While on the subject, it would be as well to mention that the rib selected should be the one which allows the tapping points to be uppermost.

The Wiring

The wiring, which is given in words as well as in the back of panel diagram, calls for no particular comment, and with this finished there is but one thing to do before the receiver is tested. This is to provide suitable shorting strips on the terminals. It will have been noticed in the constructional work that the terminals marked "Earth", "X", "Y" and "Z" form the corners of a square. This is to enable the same shorting

strips to be used in different positions between the terminals concerned. Reference to Fig. 2 will show where the shorting strips are required.

The First Test

Connect first the aerial to the top left-hand terminal, place in position a shorting strip between "Aerial 2" and "Earth," and also a shorting strip between "Earth" and "X." Next connect the earth to terminal "Aerial 2," "Earth," or "X," whichever is most convenient. Place the Olix plug into the socket marked 1 (the semi-permanent detector), and attach a pair of telephones to either of the two lower pairs of terminals. All that remains now, prior to listening for signals, is the fixing of the clips on the coil.

(Continued on page 157).

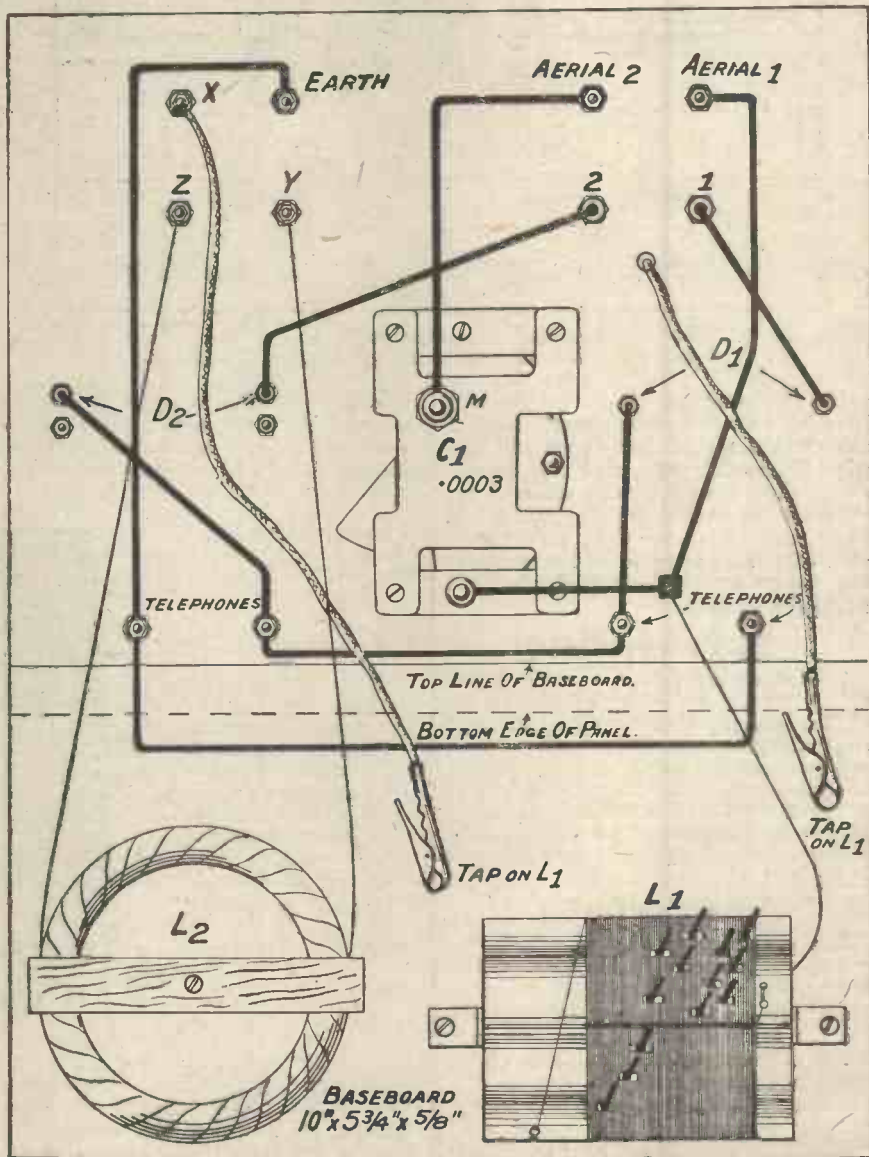

Fig. 4.—The flexible lead on the right in this diagram carries a Clix plug on the front of the panel. Blueprint No. C. 1072 B.

THIS IS THE VERNI-NOB!

PRICE

6d.

From all dealers.
By post, 7½d.

The Verni-Nob does all the work of a Vernier attachment or Vernier dial and increases the selectivity of your set.

Positive drive. No backlash. 10 to 1 reduction with 3" dial. 16 to 1 reduction with 4" dial. Over 8,000 were sold during the Wireless Exhibition at Olympia.

Fitted in a few moments.



THE M.A.P. Company,
246, Gt. Lister Street,
BIRMINGHAM.

STANDARD SCREENS & COILS

THE SOVEREIGN

12/6

Screen and Base.
Post Free.

BBETTER and Cheaper. The "Sovereign" screen and base now comes to prove that a better quality component can be used in circuits employing the standard screening method, whilst effecting a considerable economy in outlay.

The Screen, constructed of aluminium and highly finished in bronze lacquer, is mounted on a best quality ebonite base provided with the terminals, tags and numbers, according to the specification published in MODERN WIRELESS.

DEALERS—Send to-day for terms of this quick-selling line.

J.R. WIRELESS CO.

6 & 8, ROSEBERY AVENUE, E.C.1.

Better be safe

than
sorry!

Q See
that your
**Battery
Eliminator
employs
T. C. C.
Condensers**



MOST Battery Eliminators contain Condensers which have to stand up to the full voltage of the mains. The mains supply is often as high as 250 Volts A.C., and ordinary condensers tested to 300 volts cannot be guaranteed to stand up to this pressure for a long period.

Therefore, for safety's sake, use—or see that your Battery Eliminator utilizes—the special

T.C.C. High-voltage Condensers. Built and tested to withstand 600 volts, the T.C.C., having been used on domestic lighting supply for a number of years, is perfectly safe and absolutely reliable. For behind it are twenty brimming years of experience in Condenser-making—years during which millions of Condensers, from large 4-ton Power models (consistently used by the G.P.O., Admiralty, War Office and Cable Companies), to the famous little green 1½-ounce Wireless Condensers have been used. In the name of safety, could there be a better choice for a Battery Eliminator than T.C.C.?

Q

T.C.C. 600 volt D.C. Test Mansbridge Condensers for Battery Eliminators come in capacities of 5, 1, 2, 4, 5, 8 and 10 mfd.

T.C.C. Condensers
(Tested & Guaranteed)
for Battery Eliminators

Adv. Telegraph Condenser Co., Ltd., N. Acton, W.3.

G.A. 6084.

EXPERTS IN RADIO ACOUSTICS SINCE 1908

JUST TO REMIND YOU

WHEN you're wanting "pukka" telephones for long range work, don't forget that Brandes Matched Tone are still far and away the best. And if you are building, the 1st and 2nd stage Brandes Transformers are admirably efficient. Look at the prices!



AUDIO TRANSFORMERS

The Brandes 1st stage Transformer has a high voltage amplification ratio of 15. This, together with a straight line amplification curve, means that the amplification is constant over a wide band of frequencies, thus eliminating resonance.

Ratio 1-5 (black case).

The 1-3 Transformer amplifies over speech, pianoforte and harmonic ranges equally well. Mechanically protected and shielded against interaction. Terminals and outside soldering tags.

Ratio 1-3 (brown case)

17/6



MATCHED TONE HEADPHONES

The whole secret of Matched Tone is that one receiver refuses to have any quarrel with its twin. Ably schooled in these generous sentiments by our specially erected Matched Tone apparatus, their

synchronised effort discovers greater sensitivity and volume and truer tone. There is no possibility of the sound from one earpiece being half a tone lower than its mate.

20/-

Brandes

From any Reputable Dealer

BRANDES LIMITED - 296 REGENT ST., W.1

63

The "FIVE FIFTEEN"

A New Coil for the Daventry Range

THE "Five Fifteen" receiver, which was described by Mr. J. H. Reyner in the July issue of THE WIRELESS CONSTRUCTOR, has proved a very popular receiver on account of the ease of construction and the excellent results which can be obtained with very little trouble.

Hitherto, however, the reception has been principally confined to the lower waveband owing to the fact that the first tuned-anode circuit incorporated a General-Radio coil which was only made for the 200- to 600-metre waveband.

Efficient New Coils

Those readers who wished to receive Daventry, therefore, were forced to obtain the blank former and wind



The interchangeable low-loss split coils are of the type shown in this photograph.

their own coil for the long waves. This trouble has now been satisfactorily overcome by the production of a special Daventry coil to suit the "Five Fifteen" receiver. The coil is wound in three layers, the layers themselves being insulated with waxed paper, and by this construction a coil having a low ratio of resistance to inductance with consequent sharp tuning is obtained.

Where to Obtain Them

Those readers who have constructed the "Five Fifteen" and who have encountered this difficulty may now obtain this Daventry coil direct from Messrs. Claude Lyons, the Concessionaires of General Radio of America, or through their usual dealers.

TWIN CONDENSERS

For the ALL-BRITISH SIX

described in this issue.

NOTE THE VERY LOW PRICES.

LOW LOSS STRAIGHT LINE WAVE-LENGTH (SQUARE LAW).

Slow motion friction control movement with the ideal ratio of 55 to 1. Fitted with ball bearings to ensure smooth action. Rigid construction: moving vanes connected to heavily nickelled and polished brass end-plates. Negligible losses. Fixed vanes supported on best quality ebonite strips. No gears—absolutely silent action on shortest wave-lengths. The ratio is high enough for finest tuning: low enough for easy searching: direct drive used for rough setting. Terminals and soldering tags for connections. An ideal condenser for tuning two circuits simultaneously when stations referred to under the wavelength description. ONE-hole fixing. Complete with 3" knob and dial and slow motion dial.

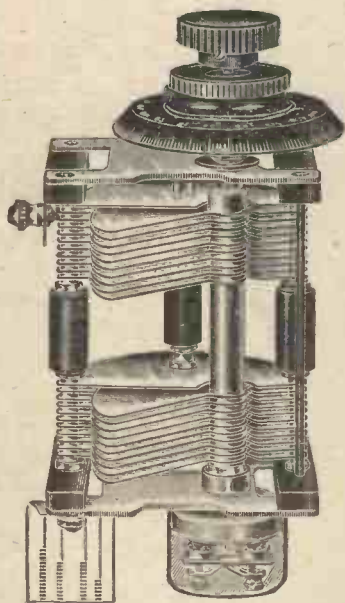

.0005
(as illustrated)

23/-

Other capacities :-

.00025
19/-

.0003
21/-

Patent applied for.

Registered Design No. 719828.

LOW LOSS SQUARE LAW.

This Condenser was primarily designed for the purpose of tuning the anode circuits of two succeeding Radio Frequency Amplifiers when used in conjunction with matched coils or Radio Frequency Transformers. The centre lower terminal is connected to part of the circuit common to both amplifying stages usually positive High Tension, whilst the remaining two terminals are connected to the two anodes respectively. When used in this manner each circuit is tuned with its own .00025 mfd. condenser operated by one control knob. When used for tuning one circuit only, similar to a standard type variable, one of two methods of connection may be employed: If the centre lower terminal be ignored, and the upper and lower plate terminals be used, a variable condenser having a maximum capacity of .000125 mfd. is the result. Should a variable condenser having a maximum capacity of .0005 mfd. be required, use the centre lower terminal and the upper and lower plate terminals as one by bridging them with a connecting wire. Usual fine Ormond finish and ONE-hole fixing.

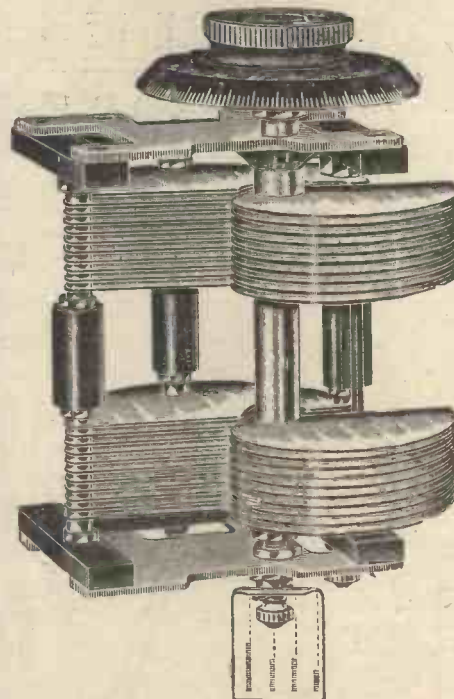

.0005
(as illustrated)

16/-

Other capacities :-

.00025
12/-

.0003
14/-

Ormond Condensers
are used by
Radio Press.



Write for a copy of
the new 1926/27
Ormond Catalogue.

199-205, PENTONVILLE ROAD, KING'S CROSS, LONDON, N.1

Telephone : Clerkenwell 9344-5-6

Telegrams : "Ormondengi, Kingcross"

FACTORIES: WHISKIN STREET AND HARDWICK STREET, CLERKENWELL, E.C.1
Continental Agents: Messrs. PETTIGREW & MERRIMAN Ltd., "Phonos House," 2 and 4, Bucknall Street, New Oxford Street, W.C.1

POINTED FACTS

- (1) *The use of super efficient vacuum pumps gives CLEARTRON Valves a remarkable degree of vacuum.*
- (2) *Special thoriated filaments of an unusual strength and durability, a patent anode and a path developed on a unique theory bring Long Life and an increase of 40 or 50 per cent. in electronic emission.*
- (3) *CLEARTRON construction ensures resonant and non-microphonic volume with operatic purity of tone.*
- (4) *They have behind them the knowledge and experience of CLEARTRON'S English and American Research Laboratories, and*
- (5) *They are genuinely protected by the IRONCLAD GUARANTEE.*

CLEARTRON RADIO LTD

1, CHARING CROSS, LONDON, S.W.1.

Works:

Birmingham.

Phone:
Regent 2231

Grams &
"Cleartron,
Westrand,
London."



14/-

18/6

Ask for

CLEARTRON

HI-VAC

1926 - 1927 NEW MODEL

VALVES

C.T. 65

THOSE who wind their own coils may sometimes be puzzled to know which way round to connect the ends of the tuning and reaction coils in, for example, a single-valve set with magnetic reaction. It is a nuisance to have to try first one method of connection and then the other, especially if this involves any soldering work. The rule, as a matter of fact, is quite easy to remember, and Fig. 1 illustrates it further. Supposing that the two coils are wound in the same direction, then *opposite* ends of the coil should go to grid and anode respectively. That is to say, the connections for solenoid windings on one former will be as in Fig. 1. With multi-layer coils, if the inner end of one goes to the grid, then the outer end of the other will be taken to the anode, and *vice versa*, assuming, of course, that the coils are coupled together with the direction of their windings the same.

IT appears from research work carried out recently that many of the things which one has in the past been supposed to beware of in the treatment of valves are really the best from the point of view of valve life. For instance, it has been usual to recommend that valve filaments be turned on slowly by means of variable resistances. Now it appears that it is much better to switch on the full voltage

NOTES AND JOTTINGS

direct across the filament. Again, running the filament below the manufacturer's rating has been thought to be a sure method of prolonging the useful life of a valve. It transpires,

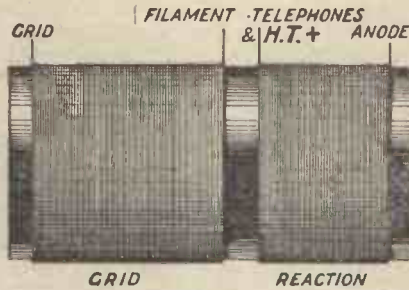

Fig. 1.—Showing the correct method of connecting the grid and reaction coils to obtain a reaction effect, both windings going in the same direction.

however, that this practice, too, is to be deprecated, and that the valve may be expected to last longest if it is run at the actual filament rating given by the manufacturer. Overrunning of

the filament must, of course, be avoided, since this does quite definite damage. It should be noted that these points apply to valves of the dull-emitter type. The data at present available are too incomplete to allow one to lay down definite rules, but the theory is doubtless interesting to all valve users.

ANOTHER instance of supposed rough treatment, now stated to be good practice, may also come as a surprise to many. Careful valve users are accustomed to switch off their valves before removing them from the holders. It is now asserted that this practice is liable to result in damage to the filament, since it is in a comparatively brittle condition when cold. On the other hand, when the filament is glowing it is much more elastic. Consequently, if a valve is removed from its holder without switching off the filament supply, there will be little risk of damage to the filament from the slight shock which usually occurs as the valve legs are withdrawn from close-fitting sockets.

It appears, therefore, that the most convenient practices are also those to be recommended for long valve life. Anyone who is thoroughly accustomed to the handling of valves will do well, however, to take out the H.T. positive plug before changing valves in their holders.

Bowyer-Lowe

This Mark on Wireless Components is your Guarantee

PIONEERS of WIRELESS RECEPTION

BOWYER-LOWE are amongst the first manufacturers of Wireless Components. Since the days when wireless and its possibilities were but vaguely realised, Bowyer-Lowe have experimented unceasingly, and the components bearing the Bowyer-Lowe name-plate are backed by unlimited knowledge and research.

The "Popular" Condenser has proved the significance of this experience—hundreds of amateurs and experts write their appreciation of its excellent performance.

Designed without freaks or frills, the Bowyer-Lowe Popular Condenser is, by its designing, inexpensive to produce, and you may secure the razor edge tuning this instrument provides, at a trifling cost.

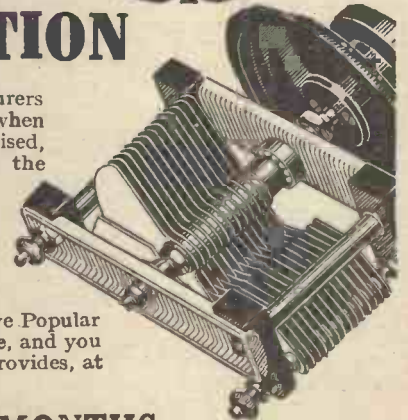

GUARANTEED FOR TWELVE MONTHS

Buy a POPULAR To-day—
SEND YOUR CONGRATULATIONS TO-MORROW!



·0003 M.F.
10'
·0005 M.F.
10'6

ANNOUNCEMENT BY THE BOWYER-LOWE CO. LTD. LETCHWORTH HEARTS

At last an Accumulator which can be charged quickly but discharged slowly

AFTER successfully solving the problem of the H.T. Accumulator, Oldham now presents in the new O.V.D. a slow discharge Accumulator incorporating entirely new principles of construction. With the growing popularity of Dull Emitter Valves

there has been an incessant demand for a small accumulator suitable for use with two- and three-valve sets, capable of holding its charge over long periods without sulphation. Read below and see how, in the new O.V.D., Oldham has now overcome every previous obstacle.

ON the introduction of the Dull Emitter Valve, a new problem began to loom on the horizon for the accumulator manufacturer. With the valve-maker producing valves of almost negligible consumption it became increasingly obvious that old ideas had to be swept overboard. The old idea was that an accumulator should last the average valve set anything from a week to a fortnight and should then be recharged. That was alright with bright emitters consuming .75 amp. each, but when consumption was dropped to one tenth of an ampere at 2 volts, a new kind of accumulator became necessary. An accumulator which would hold its charge for weeks on end without the necessity of recharging.

Oldham solves the problem of re-charging

Here, then, was the problem — how should it be solved? One way would be to increase the thickness of the plates. But this introduces another difficulty — the difficulty of recharging. Obviously a thick plate will hold its charge for many weeks. It won't buckle and it is reasonably free from the risk of sulphation. But it cannot easily be recharged. It must be charged slowly and for a long period on end. Compare the thick plate if you like to a thick mass of absorbent material dipped in liquid. It will take a long time for moisture to penetrate to its inmost recesses, but cut it in strips and the liquid can take effect at once. That was exactly what Oldham did. The new Oldham O.V.D. plate is the equivalent of a thick plate made up of laminations. Electrolyte can penetrate completely through the plate and get to work upon its several surfaces. So the new O.V.D., therefore, incorporates every advantage of a thick plate with none of its disadvantages. It can be charged



quickly — that is to say, at the normal accumulator charging rate. There is no fear that it can be damaged during charging. And it will readily take up its charge.

A plate that cannot buckle or sulphate

The new O.V.D. plate, owing to its exceptionally rigid girder-like construction, cannot buckle. Nor can it sulphate even if left for months without being recharged. Owing to the internal construction of the stout glass cell no separators are necessary.

The new O.V.D. supplied charged ready for use

This new Accumulator is supplied "dry charged." This means that it has already been charged at the factory. Merely add acid and wait for a short while for the cell to get active and it can be used at once. Think how this will benefit you. No long first charge to delay you. The O.V.D. can come straight off the dealer's shelf to your home and within an hour can be delivering its stored-up energy.

Every O.V.D. made under the Special Activation Process

The famous Special Activation Process which has made the name Oldham a household word for reliable accumulators is used in the O.V.D. Its Laminode Plates are manufactured under the same conditions as other Oldham plates. As a result the same high standard of efficiency is available. At the low price of 5/6 the new O.V.D. offers remarkable value. Its stout clear-glass container — rugged enough to withstand even the hardest knocks — its coloured terminals of generous size — and its non-splash vent cap bespeak the quality product. Ask your Dealer about it to-day.

Type O.V.D.

2 volts — for use with Dull Emitter Valves. Fitted with the new Laminode Plate. Dimensions 6 ins. by 3 ins. by 2½ ins. 10 amp. hours.

5/6

Oldham & Son, Ltd., Denton, Manchester

London Office and Service — 6, Eccleston Place, S.W.1

Phone: Sloane 2701



Makers of the Oldham H.T. Accumulator, famous for its expanding bookcase principles of construction.

Gilbert Ad. 6070.

A Flexible Crystal Set—continued from page 150

The Clips

Place first the clips from the crystal detector on the first tapping (start of

place the earth clip on the 40-turn tapping and repeat the tuning process. If still no signals are heard, continue to

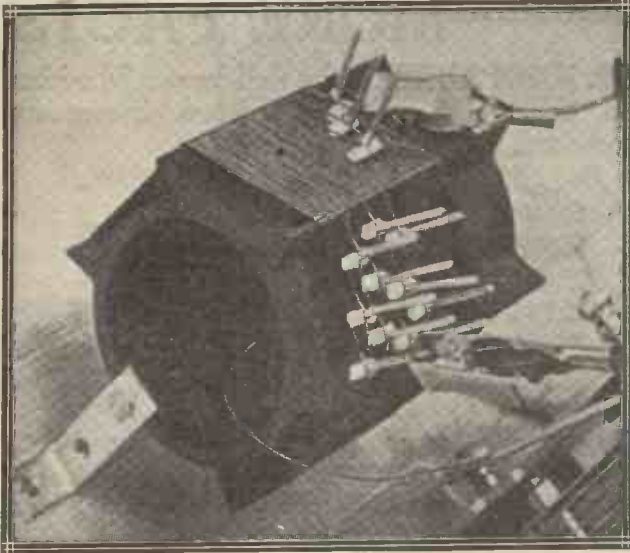

* * *

The short lengths of match-stick inserted under the tapping points simplify the operation of soldering on the thicker tags of wire.

* * *

winding), and place the remaining clip on the 50-turn tapping. Now rotate the variable condenser slowly from zero to 180 degrees until signals are heard. If no results are obtained,

vary the earth tap either above or below the 50-turn tapping.

When the local station has been tuned in, try the effect of tapping the crystal; in other words, vary the posi-

tion of the clip which is connected to the crystal detector. To try the cat-whisker detector, it is only necessary to alter the position of the Clix plug from socket 1 to socket 2.

Series Condenser Circuit

The next circuit calls for the removal of the shorting strip between "Aerial 2" and "Earth." For this arrangement connect the aerial to "Aerial 2" and earth to "Earth," leaving in position the shorting strip between "Earth" and "X." Place the earth clip for this circuit on the 80-turn tapping and tune as before with the variable condenser. If the local station is not heard, vary the earth clip either above or below the 80-turn mark, tuning from zero to 180 degrees at each point to which the clip is attached.

Reception of Daventry

Follow the "shorting strip guide" given in the diagram, and try reception of the high-power station, that is, of course, if you are within range of this station. It should be mentioned in connection with Daventry that a series condenser should not be used when receiving this station, as otherwise a considerable drop in signal strength may result.



One quarter over actual size.

PRICE
4/6

For the "ALL BRITISH SIX" Set described in this issue, use "Utility" Double Condensers for best results. Price: .0005 Double £2 2 0, Fitted with Patent Variable Coupling and "Utility" 70-x Ratio Micro Dial.

Utility

GUARANTEED

COMPONENTS

The Push-Pull Switch

is designed and made with the same care and accuracy to detail that distinguishes all "Utility" Guaranteed Components. Its extremely low capacity, smooth action and perfect contact ensure best results. One hole fixing, two-pole change over. To obtain the greatest possible efficiency use "Utility" Components—you can obtain them from your local dealer. If he cannot supply, send for Catalogue.

*Insist upon "Utility" No-Capacity
Change over Switch, Micro-Dial,
Jack and Plug, Low Loss Condenser.*

WILKINS & WRIGHT LTD
KENYON ST. *Utility* BIRMINGHAM
WORKS

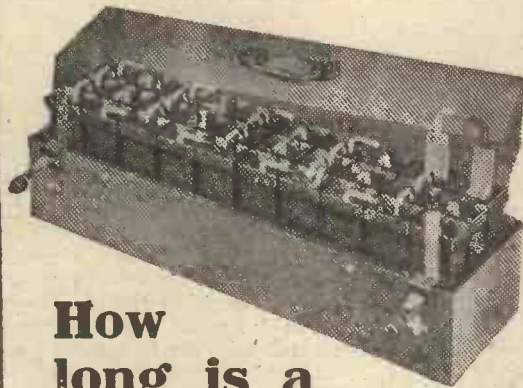

How long is a piece of string?

When you buy an H.T. Accumulator—and one day you're going to; nobody can stick for ever the continual cost and dissatisfaction of dry cells—buy capacity. Buy watt-hours. Buy energy. Buy a P. & R. H.T. Buy power. Never buy "volts," which only represent pressure, whatever the current may be.

To quote the price of an H.T. Accumulator as "so much a volt" is like offering to sell treacle at so much a yard; like asking how long is a piece of string. It doesn't mean anything.

It's power you want. In the P. & R. H.T. you get it; 180 watt-hours of it in the 60-volt battery. You get lots more well-worth-having things in the P. & R. H.T. For instance: you can't reverse the plates. There's no surface leakage and, consequently, no self discharge. Every part is accessible for examination or repair.

There's a whole host of good reasons why a P. & R. should be your choice. To know them all send a postcard for the free book, "The Technics of the H.T. Accumulator," to Peto & Radford, 50, Grosvenor Gardens, S.W.1.

P AND R
PETO & RADFORD
ACCUMULATORS
The beginning and the end in
POWER

H.T.1.

WE GUARANTEE—

To make every home constructed model operate as efficiently as our standard models, providing our schedule and charts have been adhered to.
 Write for particulars of our Home Constructors' service after purchase Department.

MORE FACTS

MR. JOHN ANSELL, the well-known Musician and Conductor of the Wireless-Symphony Orchestra, writes:

Gentlemen,—I am frankly delighted with my "CURTIS" double-circuit Super Heterodyne "eight" incorporating a "CURTIS" cabinet loud-speaker. As a conductor and critical musician, possibly I expect more from a wireless receiving set than the average listener. It may interest you, therefore, to have my assurance that the volume and quality of tone are indeed a revelation to me, whilst the wonderful selectivity of my "CURTIS" set is proving most valuable. The taste and exquisite finish of your "WINDSOR" cabinet model have already evoked the admiration of my many musical friends.
 As advised by you, I am using "HART" Accumulators for both my Low and High Tension supply, and these are functioning admirably.—Yours faithfully,

JOHN ANSELL.

Then Build your own Curtis Super-Set. HOME CONSTRUCTORS' TREATISE contains:—
 1. Circuit Diagrams. 2. Simplified Lay-out and Wiring Diagrams. 3. Instructions for operation. 4. Schedule of Components. Price 2/6.

... I have at last found a combination that has made my set as near perfect as it is possible to get one. They are as follows: 1st and 2nd Stages of High Frequency "Mullard" P.M. 5¹ Detector "Osram" D.E.5, 1st Low Frequency "Fellows" F.E.R.1. Second Stage "B.T.H." B.4.

For sensitiveness, selectivity, and volume I am willing to back my set against all comers. I use 120 volts (all out) Loud Speaker Battery, about 40 volts H.T. and 4½ grid bias, with Amplion Dragon Loud Speaker.

The Duodyne ought to be pushed. With the combination of Valves I have mentioned, it is second to none and is the Receiver de luxe. I am willing to demonstrate my set to any interested party.

This set puts all the —dynes and Straight — in the shade. I don't wish to teach you your job, but the efficiency of your set only needs to be brought before the Radio fans to ensure a thumping sale.—Congratulations from

C. A. T., Pontefract, Yorks.

... I have now constructed the set, and am more than pleased with it, both as a "distance-getter" and also for the purity of reproduction, even with stations 1,000 miles and more away, and although I have only been operating the set two days, I have already logged over a dozen stations, all at full loud-speaker strength, and I am consequently recommending my many friends interested in radio, to build a "Duodyne."

I may say that this is about the thirtieth set I have built, and it is by a long way the best I have heard so far.

T. W., Margate.

Then Build your own Duodyne. HOME CONSTRUCTORS' TREATISE, price 2/6, contains:—

1. Circuit Diagrams for 3 and 5 valves.
2. Lay-out and Wiring Charts.
3. Instructions for Operation.
4. Schedule of Components.

N.B.—USE CURTIS AUDIO FREQUENCY TRANSFORMERS AND OTHER COMPONENTS. AS FITTED IN ALL CURTIS DUODYNE MODELS AND GET THE BEST RESULTS

PETER CURTIS, LTD.

11, RED LION SQUARE, LONDON, W.C.1

PHONE: CHANCERY 7543. TELEGRAMS: PARACURTEX, HOLB. MANCHESTER Phone—Central 5095 312, DEANSGATE

A USEFUL C.A.T. UNIT

IT is not always desirable to fit a constant aerial tuning condenser in a receiver. Some experimenters or constructors may, as a matter of fact, prefer to work without incorporating this feature in their design. On the other hand, it is very useful from many points of view, one advantage being that it renders aerial tuning practically constant. This enables one to log the various stations on a certain receiver, and these readings will apply with fair exactitude when the receiver is used on any aerial in any locality. Thus it is possible to give dial readings from the aerial tuning condenser, stating the degrees on which various stations are to be received. This is distinctly helpful for operating purposes.

An Independent Unit

A useful unit may be made up as described in this article, entirely independent of the receiver. It may be screwed to the experimental bench or attached to the wall near the receiver, or mounted independently upon or in the cabinet of the receiver. Very little material is required for construction.

Materials

One clip-in condenser .0001 (with clips).

One miniature S.P.D.T. knife switch.
Two terminals.
One piece of ebonite, for base.

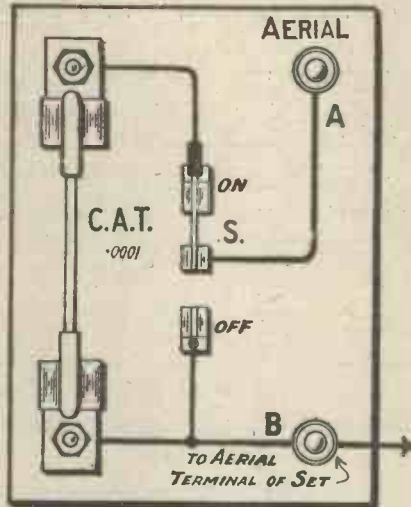

Fig. 1.—This diagram shows the circuit arrangement and the constructional work involved.

Construction

The constructional work entailed is

simple. Mount upon the ebonite base the fixed condenser clips, the knife switch, and the two terminals A and B. Two 4 B.A. screws are used, as shown in Fig. 1, to secure the clips. The base piece may be raised upon small side fillets in order to give clearance for the nuts and wire connections underneath, or alternatively the wiring may be carried out on the upper surface of the base, the terminal screws, etc., being countersunk on the under-side of the base. In this instance no fillets are required.

Connections

The connections of the unit are shown in Fig. 1. A wire is taken from terminal A to the centre connection of the switch, and from terminal B to the "off" connection of the switch, and from this point to one side of the clip-in condenser. The "on" connection of the switch is taken to the remaining side of the fixed condenser.

The Unit In Use

When the switch is in the "on" position with the aerial connected to terminal A, a flex lead being taken from terminal B to the existing aerial terminal of the set, the constant aerial tuning condenser is in circuit. To cut this condenser out of circuit it is only necessary to place the switch in the "off" position.

H. B.

A word from Professor Low

"There seems no end to their utility, and I have seldom come across apparatus so capable of hard use without requiring any attention whatever. They are excellent in every way."

(Signed) A. M. LOW.

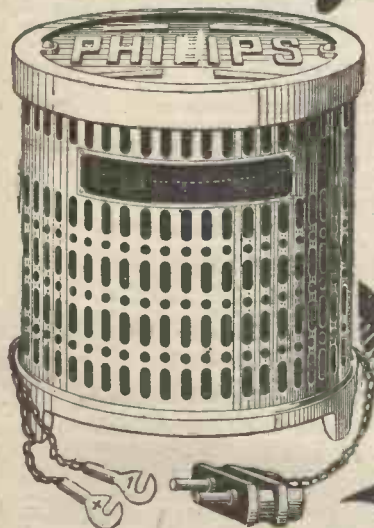

PHILIPS PECTIFIER
CHARGES RADIO BATTERIES SILENTLY AND CLEANLY, AUTOMATICALLY REGULATING THE CURRENT SUPPLY. IT NEEDS NO ATTENTION. JUST A PLUG TO BE INSERTED IN AN ELECTRIC LAMP SOCKET, THE WIRES TO BE CONNECTED TO THE BATTERY, AND THE WHOLE OUTFIT CAN BE FORGOTTEN.
Price Complete **£4.15.0**



PHILIPS H.T. SUPPLY UNIT
GIVES AN UNLIMITED AND STEADY FLOW OF CURRENT THAT WILL OPERATE A SET OF ANY SIZE AT A COST THAT IS ALMOST NEGLIGIBLE, WHILE IN ACTION IT IS PERFECTLY CLEAN AND SILENT.

Price Complete **£7.10.0**

Both Units are suitable for alternating current only.

Advt: Philips Lamps, Ltd., Philips House, 145, Charing Cross Rd., London, W.C.2.

In replying to advertisers, please mention THE WIRELESS CONSTRUCTOR.

Two interesting receivers published in Issue Now on Sale

THE "DRAWING ROOM FIVE." The set described by John Underdown has been designed with the object of giving good all-round results. It will give excellent reproduction from the local station and very good loud-speaker signals on many British and Continental stations. As will be seen from the accompanying illustration, the L.F. Coupling is by the resistance-capacity method. A volume control is provided which enables very loud signals to be adjusted to the strength required.

A "PUSH-PULL THREE." This receiver, incorporating the push-pull method of amplification, has been specially designed for those home constructors who, possessing a number of general purpose valves, desire to obtain power valve results without purchasing special L.F. Power Valves. Mr. Stanley G. Rattee is the author.

BUY YOUR COPY TO-DAY

1/-
MONTHLY

**MODERN
WIRELESS**

Obtainable from all Newsagents, Booksellers or Bookstalls, or direct from the Publishers, Radio Press, Ltd., Bush House, Strand, London, W.C.2. Subscription Rates 15/- per annum (13/6 per annum Canada and Newfoundland). Lesser periods *pro rata*.

Contents of this issue also include:

- Some Further Notes on the "Solodyne"
- The "Elstree Six" (Further Hints on Operation, etc.)
- Day and Night Effects
By G. P. Kendall, B.Sc.
- What Jack Shall I Need?
By A. V. D. Hort, B.A.
- Neatness and Efficiency (A Crystal Set)
By H. Bramford.
- Hints for the Short-Wave Novice
By L. H. Thomas (6 QB.)
- Points about Battery-Eliminators
By J. H. Reyner, B.Sc. (Hons.), A.M.I.E.E.

The top reproduction of a photograph shows the back-of-panel view of the "Drawing Room Five," while the neat baseboard lay-out of the "Push-Pull Three" is conveyed by the lower illustration.

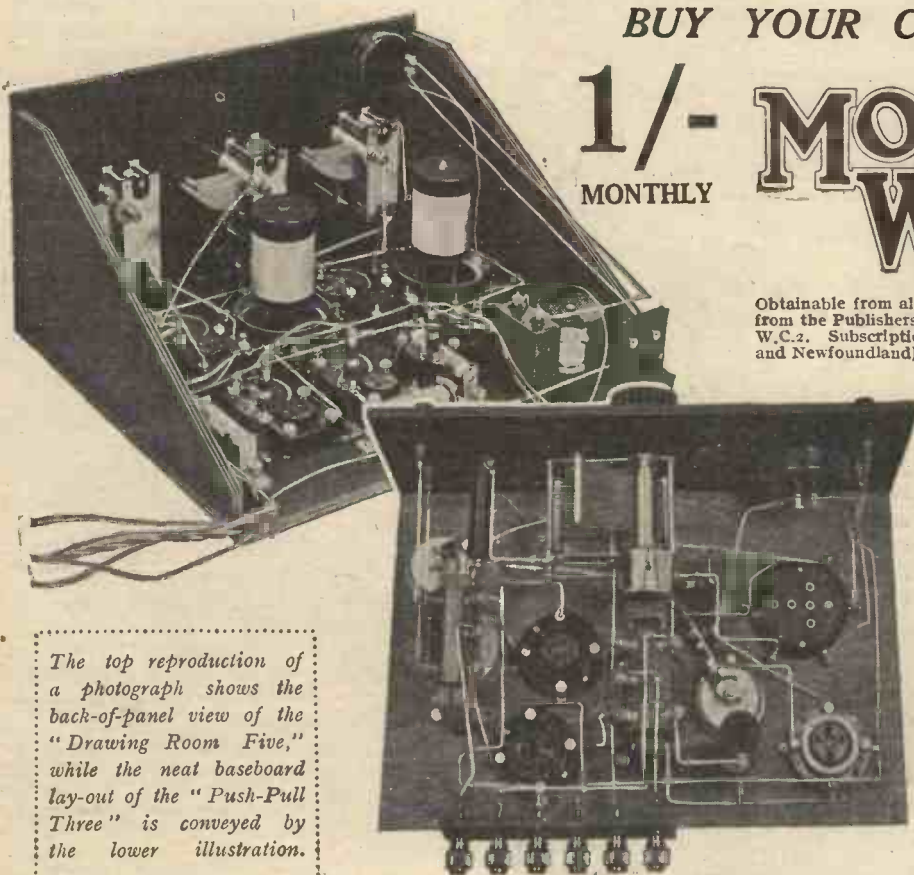

This magazine published "The Elstree Six"

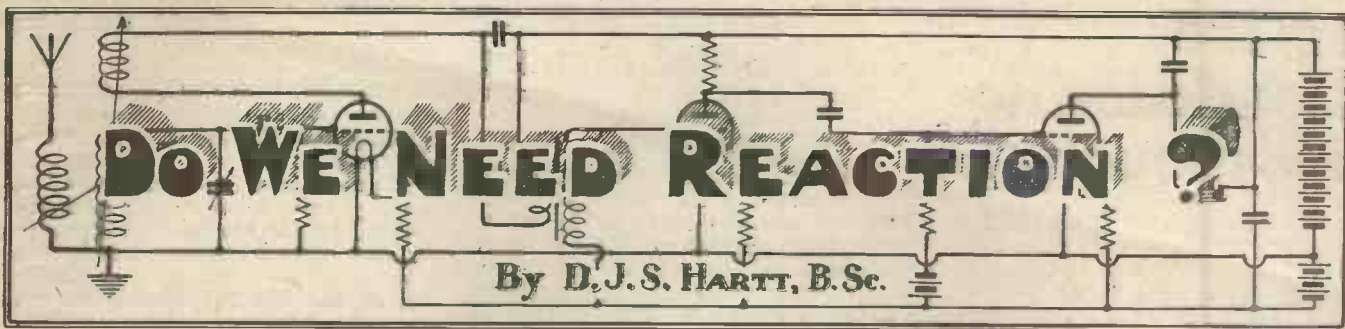

When reaction leads to radiation, we can certainly do without it. It is a great help to reception in many ways, provided that it is properly applied. Some would like to abolish reaction, but read this article and see what you think.

WE read such a lot nowadays about the harmful effects of the injudicious use of reaction that one is prompted to ask whether we could abolish reaction altogether in our sets. Such a state of affairs would be truly ideal from one point of view, as any listener will grant who has had occasion to try to tune in a foreign station when his local B.B.C. station has closed down for the night. At one time we could do quite well without reaction on to the aerial, but despite the fact that many of the circuits in common use at that time were popularly supposed to be non-radiating, experience proved this not to be the case, and many a listener was exciting his aerial unconsciously.

Some Typical Circuits

Let us, then, consider a few typical circuits and assume that the usual means of adding and controlling reaction has been entirely removed, and that no reaction effects are possible. Most of us have had experience of such circuits with the normal reaction control set temporarily at zero, so we shall be in a favourable position to discuss their capabilities under the conditions in question.

Advantage of Reaction

Take first the simple single-valve detector; if this is provided with a means of obtaining smoothly controlled reaction we can, under good conditions, do most remarkable things with such simple equipment. Not a few of you, I expect, have even heard America broadcasting, both on the short and the long wavelengths, with only a detector valve and reaction on the aerial. Even under normal conditions in the country, one can usually hear about a dozen British and Continental stations at night, using only a single valve.

A Reactionless Circuit

Now consider that the means of obtaining reaction has been removed entirely and no alteration made to the rest of the circuit. What will the set do now? Well, it is safe to say that its capabilities for distant reception have been almost entirely restricted to the reception of telephony stations within a 50-mile radius. You may, on some occasions,

be able to hear stations more distant than these, but they will be very rare.

Reduction of Signal Strength

Signal strength will be reduced correspondingly, though there may be a considerable improvement in the quality, especially if you are in the habit of working a single-valve reaction set well up to the limit before it bursts into oscillation.

You may inquire whether it may be possible, after the means of producing reaction has been removed, to alter the circuit so that there will be an improvement on these results. Slight improvements may possibly be effected, but in general the results will not be radically different from those just described.

The Question of Selectivity

Another important difference which will be noted is the very marked reduction in selectivity. Whereas



The operator of the amateur station, 5VG, has recently been doing good work on short waves with a radio-equipped car.

previously the local station was restricted to, say, about 10 or 15 degrees on the dial, you cannot now reduce it to the same limits of audibility by a movement of 40 or 60 degrees.

It is fairly obvious, then, that if the one-valve set is to retain its present great popularity, we cannot very well, at the present state of the art, do away altogether with the use of reaction.

The Howling Problem

The single-valve set is, for obvious reasons, probably the most popular of all valve receivers, and it also is perhaps the worst offender as regards interference, if the reaction control is poor or is badly operated. It would thus seem that the remedy for much of the "howling" which is so general at present lies not so much in any attempt to prohibit the use of reaction on the aerial (which would probably prove futile at this stage), or even in some radical change of design, but more in the direction of improvement of the method of producing reaction and the ease of controlling it, and also in the education of the "one-valve" fraternity in the handling of their receivers. There are probably some single-valve users reading this article, some perhaps of the "don't-care" class, others of the "can't help it" but "would avoid it if they could" category, and perhaps even some of the "blissfully ignorant" type.

I know that appeals to listeners to avoid the abuse of reaction, which leads to so much trouble, are not very successful, for the nuisance seems to continue practically unabated. I am of opinion, however, that an extensive campaign of local lectures and, more important still, actual demonstrations of the correct handling of such receivers, would do far more good.

Reaction and Multi-valve Sets

What has been said of single-valve sets applies almost as much to two- and some three-valve receivers. In the case of multi-valve sets, however, employing more than three valves, there is much more scope for the abolition of reaction, and indeed in many of the designs we do not incorporate deliberate reaction at all, but take steps to nullify the effects of the inherent reaction in order to make the circuit perfectly stable.

Before Broadcasting was thought of

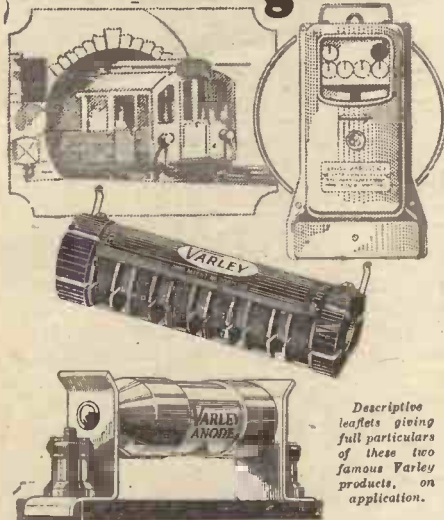

Descriptive leaflets giving full particulars of these two famous Varley products, on application.

THE VARLEY MAGNET COMPANY

were specialising in the design and construction of every form of intricate coil winding. In scores of the biggest electrical undertakings in the country—among them the Electric Railway Systems of Great Britain—the Varley winding has enabled automatic electrical devices of every kind to be brought to their present state of perfection.

With the growth of Broadcasting, the Varley Magnet Company, realising that their long and successful experience in coil winding design and construction gave them advantages possessed by no other firm in the country, produced, firstly, the Varley Bi-Duplex Anode Resistance, and, secondly, the Varley Multi-cellular H.F. Choke, both wire-wound on the famous Bi-Duplex system and both infinitely superior to any similar products on the market to-day.

What has happened in the Electrical world is now taking place in the Radio world proper. Varley components are used by *the* biggest institutions in the country to ensure that the public shall get the benefit of real purity of tone, and constancy of perfect reception.

Varley components are stocked by all the best Wireless Traders in the country.

We are in the position to supply both Varley Bi-Duplex Anode Resistances— all standard sizes—and also Varley Multi-cellular H.F. Chokes immediately on receipt of order. If you have difficulty in obtaining our products, send us the name of your dealer (we will refund postage), and your letter will have our immediate attention.



THE VARLEY MAGNET CO.,
(Proprietors: Oliver Fell Control Ltd.)
Granville House, Arundel St., London, W.C.2.
Telephone: City 3393.

DO WE NEED REACTION?—concluded

Neutralisation

Take the modern neutralised circuits, for instance. Here we introduce a negative effect to counteract the effect produced by the inter-electrode capacities of the valves and other stray couplings and capacities. In some sets no deliberate reaction is introduced, nor is it at all necessary, the circuits being adequately sensitive and selective without it. In other receivers we do introduce reaction, but only in the circuits of the detector valve, and on account of the fundamental design of the circuit the aerial cannot be excited by abuse of this control once the high-frequency portion of the receiver has been correctly adjusted.

Future Design

The trend of modern design is all for simplification wherever possible, and since reaction invariably needs an extra control, it is quite conceivable that ultimately it may be completely abolished or perhaps incorporated in such a manner that the control is automatic and varies correctly according to the setting of the tuning condenser.

spoiling the fidelity of the reproduction.

High-frequency amplification is scarcely ever necessary for such receivers, so there will not necessarily be any inherent reaction effects, and energising the aerial is practically impossible. The last winter has not been characterised by good or even normal conditions for distant reception, and though this has been disappointing to a good many people, it may have been a blessing in disguise, for I should imagine that the bad conditions have certainly tended to make more popular the type of set I have just mentioned.

A Good Start in Wireless

A good many people have come to me for advice on the installation of their first wireless set, and they invariably want something which will give them, say, 2LO and 5XX and a few other British and Continental stations on the loud-speaker. After having had the pros and cons of the case pointed out to them, they are generally still insistent, and since they do not, in the majority of cases, want to spend more than about £20 for the complete installation, recourse has to be had to reaction to increase the sensitivity of the set.

Invariably, however, these people settle down in time to listen to their local station or 5XX, and they discover that the quality given by their equipment is perhaps not all they desire. It is only then that your well-meant advice in the first place comes home to them, and they want their sets modified.

Abolishing Reaction

We thus see that there must be many listeners with equipment inadequate for picking up distant stations sufficiently well to enable them to enjoy these programmes, who could, if they cared to, relinquish altogether their evenings spent listening to heterodynes, Morse, squeals, and atmospheric, interspersed occasionally with a burst of speech or music, and settle down to listen to and be contented with their local station. In all these cases reaction could probably be abolished entirely, and both these listeners and others would be the better for it.

The greatest barriers to the complete abolition of reaction are the one- and two-valve sets, particularly the former. For the present, it does not seem possible to do away with reaction here or sensibly lessen its evil effects, at any rate in a short time, unless some such methods as previously indicated are adopted, or the bolder step taken of discouraging the use of single-valve sets, which I believe, finds favour in America, and encouraging the use of more valves.

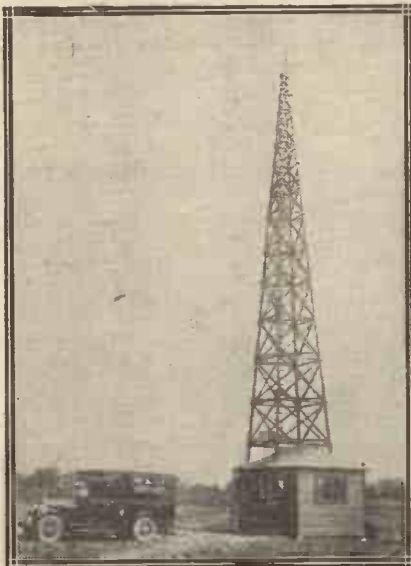

Radio Beacon towers are being erected in the United States of America as aids to air navigation.

Reaction and Quality

One thing is practically certain, there is no necessity whatever for the use of reaction in sets employed as, shall we say, "wireless gramophones," that is, solely for loud-speaker reception of the local station up to about 20 or 30 miles or for Daventry. Good volume, consistent with adequate purity of reproduction, is the main requirement for such sets, and the inclusion of reaction is only a serious temptation to use it excessively to get still more volume, thereby perhaps



Choose your programme— these Eureka Ortho-cyclics will find the Station

AT last here is a variable Condenser which makes station hunting a pleasure. The Eureka Ortho-cyclic utilises new principles of tuning. The old idea of crowded wavelengths jostling each other at one end of the dial has gone for ever. In the Eureka one degree on its 100° dial covers one Geneva wavelength of 10 kilocycles separation, irrespective of its position. The first fifteen degrees on the dial covers fifteen wavelengths precisely—no more and no less. Whereas this same movement with an ordinary Condenser would cover no less than 51 possible wavelengths. And the second fifteen degrees on the Eureka Ortho-cyclic still covers only fifteen wavelengths—and

so on right through the dial one degree equals one wavelength. As evenly, in fact, as the rungs of a ladder.

This is the kind of tuning you have always longed for. Now you can get razor sharp selectivity at small cost. The new Geneva wavelength plan makes ortho-cyclic principles of tuning essential. The ether is being divided into wavelengths of 10 kilo-cycles separation. That is to say, using a Eureka Ortho-cyclic Condenser there can never be more than one station to any degree on the dial. It will be impossible with a sensitive Set equipped with Eureka Ortho-cyclics to hear two stations at the same time. See this all-metal, low loss, Condenser at your Dealer's to-day—you will be amazed at its low price for such a beautifully constructed instrument.

Six exclusive Eureka features:

1. Compact design permits a panel depth of only 2 inches.
2. Ball bearings throughout ensure velvet-smooth action.
3. One-hole or three-hole mounting as desired.
4. Electrical losses so low as to be negligible.
5. Earthed rotor ensures stable reception.
6. Permanent contact guarantees continuous silent performance.

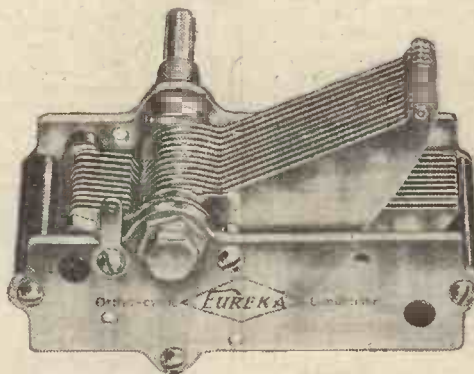

Prices:

·0005 mfd. - 15/6
·0003 mfd. - 14/6

Slow Motion Dial.

Engraved 0 to 100, right to left, for kilo-cycles, and 0 to 100, left to right, for wave-lengths. Beautifully constructed in metal throughout to fit all Condensers, including the Eureka Ortho-cyclic, with 1/4-inch shafts. Easily fixed to set. Price 4/6

EUREKA ORTHO-CYCLIC CONDENSER

Advt. Portable Utilities Co., Ltd., Fisher St., W.C.1

Gilbert Ad. 6204.

In replying to advertisers, please mention THE WIRELESS CONSTRUCTOR.

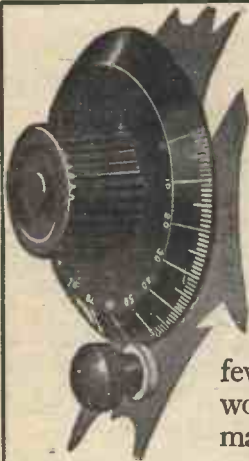

The ORIGINAL
"MIDGET"

An inexpensive friction tuning device giving excellent results.

The "Midget" can easily be fitted to all sets in a few moments, and it will work equally as well as many higher priced vernier controls.

Complete with full instructions for fixing.

9d. Each.

All metal parts heavily nickel-plated, highly polished Bakelite knob and best quality rubber washer. It is self-adjusting and will add 100% efficiency to your set.

Full particulars of other radio products upon request. "Belden" Battery Cords, plain or fused; 5, 6, or 7 way. Frame aerial wire, enamelled and new braided type. Headphone and Loud Speaker Cords. Terminals, insulator hooks, etc. Trade enquiries invited.

THE STANDARD INSULATOR Co., Ltd.,
Winsley House, Wells Street, Oxford Street, LONDON, W.1.
Phone: Museum 5978 and 7571.

NOTE THIS THUMB GRIP
Moulded into the bakelite base of Finston Lo-Loss Coils.

No fear of damaging windings when plugging in or pulling out.

PRICES: No. 25 1/8. No. 35 2/-.
No. 75 2/8. No. 100 2/8. No. 150 3/4.
No. 175 3/3. No. 200 3/3. No. 250 3/6.
No. 300 4/-.

Manufactured under De Forrest and O'Keefe patents.

Obtainable from all Dealers.

Write for free Illustrated Leaflet of all our Components.

FINSTON, MFG. CO., LTD.,
45 Horseferry Road, London, S.W.1

Parr's Ad.

"CABINETS OF DISTINCTION"

Soundly constructed in Solid Oak or Mahogany. Best hand polish finish. Send for illustrated list giving full range and prices of cabinets for "The All-British Six" and 2-wire set as described in this issue.



TYPE A/G MAHOGANY.

"Panels of Distinction" also supplied. Trade enquiries invited.

W. & T. LOCK, ST. PETER'S WORKS, BATH

If coils were this size the "Lotus" would hold them securely

Patent No. 244,251

The Moving Block Cannot Fall

The vernier movement comprises three sets of enclosed precision machine-cut gears, and reduces the speed of the moving block by eight times. Side plates, coil blocks and knobs in artistic bakelite mouldings. All metal parts heavily nickel plated. Made for left as well as right hand.

LOTUS
VERNIER
COIL HOLDERS

PRICES:
Two Types:
For outside panel mounting:
Two-way .. 7/-
Three-ways .. 10/6
For inside baseboard mounting, with 6-in. handle:
Two-way .. 8/-
Three-way .. 12/6

Made by the makers of the famous Lotus Buoyancy Valve Holder.

GARNETT, WHITELEY & CO., LTD.
Lotus Works, Broadgreen Rd., Liverpool.

A SENSATION AT OLYMPIA EXHIBITION
CHEAPER THAN USING THE MAINS

Eliminators Eliminated by
WESTAM
EVERLASTING
H.T. ACCUMULATORS
Requires re-charging twice a year only
6d. a Volt. 2 Amps.
ENTIRELY BRITISH.
FULLY GUARANTEED.

60 Volt Model - 30/-
also 20, 30, 90, 100 & 120 volts.
SCRAP YOUR DRY BATTERY.
Catalogue and spare parts list from your dealer, or
WESTAM ACCUMULATORS,
CLEMENTS ROAD, LONDON, E.C.8.

Pat. No. 1093626

Superfine Quality Only! NO 'SECOND' QUALITY

WE DO NOT MANUFACTURE LOW GRADE MATERIAL

from good dealers

Superfine Quality
Trelleborgs
GUARANTEED
GENUINE EBONITE

120000 VOLTS PER M/M
National Physical Lab. Report

Size Thickness Finish
18

PRICES

THICKNESS.	HIGHLY POLISHED.	MATT.	STANDARD GLOSSY.	MAHOGANY.
1/4 in.	Per sq. in. 1d.	.9d.	.8d.	1.1/3d.
1/2 in.	Per sq. in. .75d.	.66d.	.6d.	1d.

Address Trade Enquiries only to:—P. C. MICHELL, Managing Director.
TRELLEBORGS EBONITE WORKS Ltd., AUDREY HOUSE, ELY PLACE, E.C.1

PRACTICAL WORKSHOP HINTS FOR THE HOME CONSTRUCTOR

*Useful Gauges—What the Bench Drill can do—Erinoid and Ivorine
—Two Useful Tools—For Fixed Resistors—Improving a Potentiometer*



USEFUL GAUGES

THE constructor who does not already possess a set of gauges of various kinds will find that he can save himself a great deal of time and trouble by spending a spare hour or two in making up a set in his own workshop. One of the most useful is a plate showing the sizes of the holes made by the various drills which make up his stock. For this we need a piece

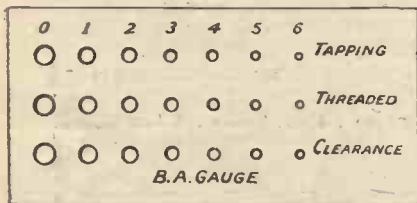

Fig. 1.—A gauge plate of this type should not take long to make, and it is a useful accessory in the workshop.

of 1/4-inch sheet brass, whose size will depend upon the number of drills in the tool box. In it make a hole for each of your drills, beginning with the smallest and continuing with one after another in order of size. The Morse number or the inch-fraction size of the drill should be scratched with a scribe against each hole made. With the help of this gauge you will have no difficulty in discovering just which of your drills is best suited for making a hole to pass any terminal, rod, spindle, bush or wire. Another exceedingly handy gauge is that devoted to the B.A. sizes. A good type is seen in Fig. 1. For each size for which you possess drills and taps three holes are made. The top one is made with the tapping size drill, the middle one is threaded, and the lower one is clearance size. With this gauge you can tell in a moment whether a screw is B.A., and, if so, what its size is, by trying it in the threaded holes. There is no need to memorise either the tapping or the clearance sizes for B.A. screws and studding, since by trying drills in the appropriate holes in the plate you can discover at once the correct sizes to use.

A Depth Gauge

Fig. 2 shows a delightfully simple gauge which can be used for measuring the depth of a hole that has been drilled. It consists of nothing more than a fine knitting needle pushed through a small square of indiarubber about a quarter of an inch in thickness. To use this gauge, bring the rubber down close to the point, then thrust the needle into the hole. The rubber will slide up the needle as it

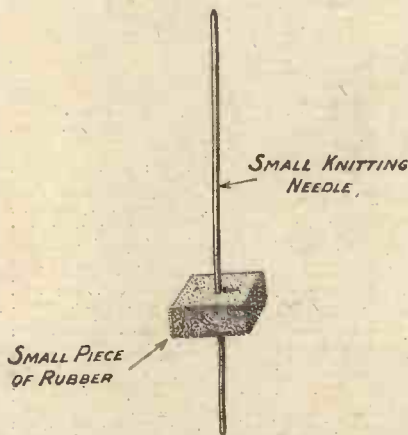

Fig. 2.—The construction of this simple depth gauge is self-explanatory.

descends, and when the gauge is withdrawn the measurement of the portion below the rubber will enable you to ascertain the depth of the hole.



WHAT THE BENCH DRILL CAN DO

A WONDERFUL number of jobs which really ought to be done on a lathe can be performed in an emergency with the help of a bench drill. One of these came my way the other day when I was staying with a friend who wished to substitute capacity reaction for the existing magnetic arrangement with swinging coils in his receiving set. He did not possess the necessary high-frequency choke,

but as he had a bench drill and a piece of 1/4-in. round ebonite rod, we resolved to see what could be done in the way of making one at home.

The first process was to trim up the ends of the rod and to find the centre of one of them. This last task was accomplished successfully by the familiar method of scribing a number of cross lines, which leaves so little to guess work that it is possible with a little care to make a punch mark at almost exactly the right point. This done, we drilled and tapped a 4B.A.

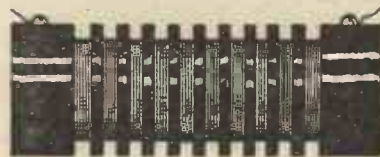

Fig. 3.—This type of H.F. choke former can be made quite satisfactorily with a bench drill as a "lathe."

hole into which we screwed a valve leg to enable the work to be fixed into the chuck of the drill. By spinning it in the drill we located the centre of the other end without difficulty. Here a punch mark was made, afterwards enlarged into a small hollow with the point of a drill. Next a centre point was placed in the hole of the drill table, its tip being lubricated with oil. The valve leg screwed into the rod was fixed tightly in the chuck and the work was turned down on to the centre. Since no lathe tools were available for cutting the necessary grooves, we made use of the edge of a small file. One of us supplied the motive power by turning the crank, whilst the other held the edge of the file against the rotating rod.

Making the Cuts

Working in this way we found it surprisingly easy to cut the ten notches that we decided to have in the former. The file clogged up rather quickly, but it was soon cleaned with a wire brush. I am not going to say that the notches were all exactly 1/4-in. wide, as we had planned that they should be, that all were of the same depth or that



IN the Brown H.Q. model are to be found a beauty of outline and perfect balance rarely seen in a Loud Speaker, with tonal purity and astonishing volume such as the most discerning could not wish to better. Standing twenty inches in height and in resistances of 2,000 or 4,000 ohms. £6

The Mouthpiece of the Ether

Before you buy a Loud Speaker ask these questions: is it pure in tone?—is its volume adequate?—will it reproduce evenly and accurately, music and speech alike?—will it still retain these qualities after years of use? If the Loud Speaker you buy fails in any one of these respects, you have not made the wisest choice possible to you. For in one of the nine Brown models there is an instrument to suit your pocket, which conforms with every requirement of the perfect Loud Speaker, and which will render you the

same faithful service years after, as on the day you bought it.

We do not make extravagant claims for the Brown—it is not necessary. An instrument which has risen in a few years from a small "local" sale to World-wide fame; which has found its way into the homes of people of every nationality; and whose name has come to be universally regarded as a veritable synonym for perfect Radio reproduction—a Loud Speaker with such a record of achievement behind it surely needs no further recommendation.

Brown

S. G. BROWN, LTD., Western Avenue, North Acton, W.3

Retail Showrooms: 19, Mortimer Street, W.1; 15, Moorfields, Liverpool; 67, High Street, Southampton.

Wholesale Depots:—2, Lansdown Place West, Bath; 120, Wellington St., Glasgow; 5-7, Godwin St., Bradford;

Cross House, Westgate Road, Newcastle; Howard S. Cooke & Co., 59, Caroline St., Birmingham.

N. Ireland: Robert Garmany, Union Chambers, 1, Union St., Belfast.

Q

In addition to the H.Q. there are eight other Brown Loud Speakers—a type for everyone from 30/- to £15 15 0.

PEERLESS
FIXED RESISTOR



1/3

USE IT IN THE
ALL-BRITISH
SIX

described in this issue.

YOU can see from the illustration what a neat job this "Peerless" Fixed Resistor is. The base is solid insulation and the former a strong impregnated material that atmospheric conditions will not affect. The wire is wound evenly and firmly and terminals and soldering tags are fitted. One hole fixing. A very thoroughly assembled and finely finished unit in all.

OTHER BEDFORD PRODUCTS.

- "Peerless" Dual Rheostat, 3/9
For bright and dull emitter valves
- "Peerless" Junior Rheostat
6, 15 or 30 ohms
(already over 1/4 a million sold) 2/6
- "Peerless" Resicon Variable Condenser
A strong, precision instrument
from 15/- to 18/-
Dial and Vernier 2/6 extra
- "Peerless" Master Switch 2/9
For High and Low Tension
- "Peerless" Valve Switch 3/-

From all good dealers or direct.

BEDFORD ELECTRICAL & RADIO CO. LTD.
22 CAMPBELL RD. BEDFORD

WORKSHOP HINTS—continued

less than a quarter of an inch in depth from back to teeth, and a fine one very like those used in fretsaws. Either of these will cut ebonite or brass and any other metal used in wireless construction with the greatest ease.

The coarser blades are useful for roughing out panels of various sizes, whilst the fine ones can be used for a variety of jobs which are quite outside the scope of the ordinary hacksaw. With them, for example, you will have little difficulty in making your own valve pins or wander plugs from 1/8-inch round brass rod, which can be split quite easily. If you do not possess a fine hacksaw of this kind I would recommend you to purchase one without delay, for you will be surprised to find for how many jobs it comes in useful and what fine work can be done with its help. Fig. 4 shows a typical coping saw.

A Screwdriver Fitting

I have mentioned before the usefulness from the constructor's point of view of the spiral ratchet screwdriver whose use saves an immense amount of time when one is making (or dismantling) any kind of wireless apparatus. Those who possess these handy tools do not always realise how many useful attachments for them are obtainable. Did you know, for instance, that you could purchase a countersink, a B.A. box spanner or



Fig. 5.—A useful screwholder for ratchet screwdrivers.

drills from 1/16-inch to 11/64-inch for use with them? You can do so from any tool shop which stocks the screwdrivers themselves, where you can also obtain a rimer which will enlarge holes from 1/8-inch to 1/4-inch, and a particularly handy wire bender. One of the most useful attachments for the spiral ratchet screwdriver that I know is the screwholder seen in Fig. 5. The drawing is self-explanatory, and readers will realise what a wonderfully useful fitment this is when it comes to inserting screws in those awkward places which cannot be dealt with in the ordinary way.

FOR FIXED RESISTORS

I DESCRIBED recently a method of making fixed resistors for dull-emitter valves by winding Eureka wire of suitable gauge upon formers of round ebonite rod threaded by means of a Whitworth die. Though the process of putting a thread on to round

rod is really a very simple one, even for the inexperienced, some constructors rather shy at it. Another objection urged by some of them to the method is that they do not keep 3/8-inch round ebonite rod in their workshop stocks, having little general use for it. During the last few days I have made up a set of resistors, whose

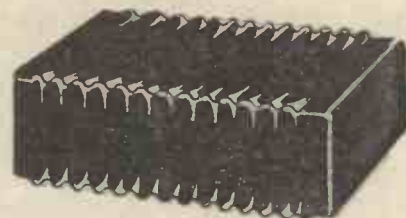

Fig. 6.—To make a resistor former the edges of a square section ebonite rod are notched with a die.

formers are so easily turned out in the home workshop that the veriest beginner will have no difficulty in making them for himself.

Instead of round rod, a square former was used, cut from a piece of sheet ebonite. This is slightly chamfered off at one end in order to make it easy to start the die. When the rod is placed in the vice the die can be run on without the least trouble; it does not, of course, put on a full thread, but merely makes notches at the corners of the former. These, however, are amply sufficient to hold the windings securely in position. Either a 1/4-inch or a 3/8-inch die may be used; if the first size is chosen, trim up the former until it measures a quarter of an inch diagonally, whilst the diagonal measurement must be 3/8-inch for the larger die.



IMPROVING A POTENTIOMETER

WITH the return to popularity of anode bend rectification, the potentiometer is coming once again into general use, not for its old evil purpose of regulating the damping introduced into otherwise unruly H.F. circuits to keep them in order, but to adjust the grid potential of the detector valve to the most suitable figure for effective rectification. When used in this position it is most desirable that the contact of the potentiometer should be smooth and velvety; otherwise devastating noises will be produced in the telephones or loud-speaker when its knob is turned.

Most of us have lying about in our odds-and-ends boxes old potentiometers which were discarded when we became converts to the neutrodyne circuit. The fault with these instruments, and with not a few of those on the market today, is usually that the contact is too harsh. It feels unpleasant when we





Your Transformer must be right!

YOUR valves may be of the right impedance, your condensers low in loss, your plate voltage right, but if you have a poor transformer you *must* have distortion, poor volume, and worse reproduction.

Put an Ericsson Tested Transformer on your baseboard and the difference will astonish you. Distortion disappears, volume swells and clarity and purity takes the place of discordant muffling and harshness.

Ericsson Tested Transformers are designed along careful tone value lines and are guaranteed distortion free. Replace your present Transformers with Ericsson Tested—you'll transform your set.

Two ratios, one price. 1:2, 1:4

17/6

On Sale at all good dealers.
Write to-day for full particulars.

ERICSSON TELEPHONES LTD.,
67/73, Kingsway, London, W.C.2.



TESTED
TRANSFORMERS

QUALITY RHEOSTATS previously 4/-—NOW 2/6

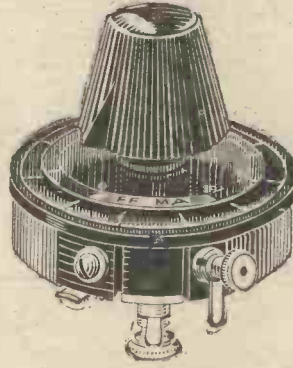

LISSEN quality—look how they are made—the wires cannot shift and short—the contact brush rides firmly yet smoothly—the heat-resisting former cannot soften—there are accessible terminals—and the combined knob and pointer will fit flush with the neat photo-engraved dial when mounted. Lastly note the irresistible appeal of the price, made possible by our big production programme backed by our new direct-to-dealer distribution policy which cuts out all wholesale profits.

EVERY RHEOSTAT AND POTENTIOMETER LISSEN ONE HOLE FIXING, OF COURSE.

LISSEN 7 ohms Rheostat	previously 4/-	NOW 2/6.
" 35 " " " " " " " " " "	4/-	" 2/6.
" Dual " " " " " " " " " "	6/-	" 4/6.
" Potentiometer 400 ohms	4/6	" 2/6.

Before you buy any wire rheostat or potentiometer, first see a LISSEN and compare it.

DELIVERS ALL STORED-UP ENERGY | DOUBLE PURPOSE VALVE HOLDER



Use LISSEN FIXED MICA CONDENSERS—made with scrupulous care—accurate to 5 per cent—THEY NEVER LEAK—THEY NEVER VARY—THEY DELIVER ALL THEIR STORED-UP ENERGY, ALL THE TIME.

Capacities .0001 to .001 1/- each (reduced price). Capacities .002 to .006 1/6 each (reduced price). (One pair grid leak clips included free with each .0003 and .0002 capacity).

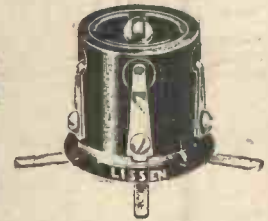

Bend back springs for baseboard mounting—or put through panel for panel mounting—low loss, low capacity, meaning clearer, better signals.

LISSEN VALVE HOLDER, previously 1/8, NOW 1/- each.

LISSEN GRID LEAKS—AN ACTUAL TEST



A case of LISSEN FIXED GRID LEAKS was left on the roof of the LISSEN Factory—they were soaked by rain, they were baked by the sun—then they were handed over to the LISSEN research department and carefully tested. In every grid leak the resistance was found unvaried and true to the market value. All capacities, previously 1/8, now 1/- each.

REAL RADIO SWITCHES

There is a LISSEN switch for every switching need. Your dealer has them all, or, if any difficulty, send direct.

- LISSEN 2-way switch, previously 2/9, NOW 1/6.
- " Series - parallel switch, previously 3/9, NOW 2/6.
- " Double Pole Double Throw, previously 4/-, NOW 2/6.
- " Key Switch, previously 2/6, NOW 1/6.

Important to the Trade! Retailers who have not already been notified of our new direct-from-factory-to-dealer distributing policy should in their own interests communicate with us without delay. All orders must now be sent to us at Richmond and not to usual factor.

LISSEN LTD., LISSENIUM WORKS,
26-30, Friars Lane, RICHMOND, SURREY.
Managing Director: T. N. Cole. L 75.

THE NEW LOTUS JACKS & PLUGS

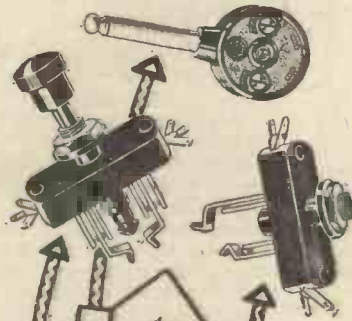

LOTUS JACK PLUGS
 Designed for use with Lotus Jacks. Bakelite from mouldings and Dicksel. To fit, the slots are placed in the position of the flipped terminals by a screw can. **PRICE: 2/-**

LOTUS JACK SWITCHES
 This push pull switch is designed to occupy the minimum space, being only 1 1/2 in. deep. Of the finest Bakelite, it has nickel silver springs and contacts of pure silver. Soldering contacts can be made to suit any wiring. **PRICES:**
 No. 9 as illus. 4/-
 Others from ... 2/9

LOTUS JACKS
 Designed to take up the least space, the depth back of panel being 1 1/2 in. Made from the best Bakelite and nickel silver springs and pure silver contacts. One hole fitting. Soldering contacts can be brought into any position. **PRICES:**
 No. 3 as illus. 2/6
 Others from 2/- to 3/-

The name 'LOTUS' is your guarantee of sound results and solid satisfaction.

From all Radio Dealers.

LOTUS

JACKS·SWITCHES·PLUGS

Made by the makers of the famed 'LOTUS' Vernier Coil Holders and 'LOTUS' Buoyancy Valve Holders.

Garnett, Whiteley & Co., Ltd.
 Lotus Works,
 Broadgreen Road, Liverpool.

WORKSHOP HINTS—continued

turn the knob, and a hateful grating sound is produced as the arm travels over the windings. The simple tip shown in Fig. 7 will enable any constructor to improve an old potentiometer, giving it that smooth silky action which is so much to be desired. Remove the old straight arm and re-

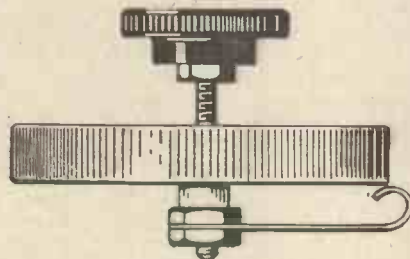

Fig. 7.—A potentiometer may sometimes be improved by bending the contact arm as shown here.

place it with one of the shape shown in the drawing. The new arm may be made either from German silver or from thin springy sheet brass. The pressure of the arm upon the windings is easily regulated by adjusting the curved portion with a pair of pliers. Jumpiness or noisiness in a potentiometer is often caused by the fact that the lower edge of the former which holds the winding is not quite level. With an arm made on the lines suggested any inequalities are taken up by the curved springy portion and contact is always quite even.

CHOICE OF PROGRAMMES MADE EASY

(Concluded from page 100)

denser in circuit; the actual condition of affairs is, however, dependent upon individual aeriols, and both connections should be tried in all cases.

Reaction Adjustment

When a weak station has been tuned in to the best of the operator's ability, the reaction condenser should be slowly increased in its reading, whereupon it will be found that signals will increase in strength until a position of the dial of the reaction condenser is found where a slight rushing sound begins. This sound indicates that the oscillation point is being reached, and upon turning the condenser still further the signals will become distorted. After some little practice in the handling of the receiver, it will be found possible to keep the receiver just off self-oscillation, and consequently in its most sensitive condition throughout the whole tuning range, when the reception of the distant stations will be found a relatively simple business.

SOLDERING ABOLISHED

THE SUPER TERMINAL

FOR PERFECT CONTACT

BY USING TIXIT TERMINALS AND COUPLERS

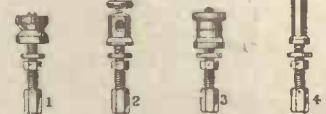

Brass: 2½d; Nickel: 3½d each, COMPLETE
 Simple and effective. Insert the wire through the base into the hole in the stem of the terminal, tighten up the lock nut and perfect contact results. NO soldering required. Wire 16G. 3d., Coil, 8 ft.



8⁰ DOZ TIXIT COUPLERS
 For connecting Junction Wires without Soldering. All Dealers or direct orders over 2/6 post free.

DESCRIPTIVE PAMPHLET SENT ON REQUEST
L. H. REID & CO.
 32, VICTORIA ST. LONDON, S.W.1

CABINETS!
 for every Constructor.
 "Dawlow" Model from 30/-
 "Elstree Solodyne" } from 45/-
 "Night Hawk" }
 "Drawing Room Five"
 ON APPROVAL.
 Estimates and LISTS—PER RETURN!
BUREAU.
 3 gns. to 6 gns.
PICKETT'S CABINET (W Cr.) WORKS, Bexleyheath.

WIRELESS
 Capable, trustworthy men with spare time who wish to substantially increase income required where we are not fully represented. Applicants must have practical knowledge of installation of Set and Aerial, be a Householder or live with parents, and be able to give references; state age and experience. Address Dept. 22, **GENERAL RADIO COMPANY LIMITED, Radio House Regent Street, LONDON, W.1.**

REPAIRS

By specialists skilled in every form of accurate and intricate coil windings.
Headphones, Loud Speakers and Transformers rewound, remagnetised, and reconditioned **EQUAL TO NEW**
 Owing to the rapid growth of business in our REPAIRS Department, we regret that we find it temporarily impossible to maintain our 24-hours service. Pending extension and reorganisation, a delay of a few days may be unavoidable.

VARLEY Magnet Co.
 Coil Dept.:
 Woolwich,
 S.E.18.

 Proprietors:
 Oliver Pell
 Control Ltd.

WET H.T. BATTERIES
 British made (round or square) Leclanche Glass Jars, 2 1/2 x 1 1/2 x 1 1/2; for wet H.T. Units. Waxed, 1/3 doz., plain, 1/- doz. Zincs, 1/- doz. Grade 1 Sacs, 1/8 doz. Grade 2 Sacs, 1/3 doz. Carriage and packing extra. **Eton Glass Battery Co., 46 St. Mary's Rd., Leyton, E.10**

Want a better Set?
 YOU can have one and listen while you pay! We supply any Radio Press Set on a system of easy payments. Our technical advice is yours for the asking. Send for Catalogue "W" to:
New Times SALES CO., 77, CITY ROAD, E.C.1.

Complete Wireless Equipment by Post



YOU have decided to build a wireless set, possibly one described in these pages. Good! Let us help you. You probably find that you require at least ten different components and you either call on your local dealer, to find that he has less than 50% of what you require in stock, or you prepare to write to ten different manufacturers and hope that they will all give your letter immediate attention. How much easier would it not be for you to write direct to us? We carry stocks of all components and accessories for sets described in this and in all other wireless publications. You will save yourself time and money, and you can be sure that we shall dispatch the goods immediately on receipt of your order. We have a highly organised and efficient Mail Order Department, and all goods dispatched by us are **guaranteed safe delivery.**

This advertisement is backed by 30 years' experience.

Economic Electric Ltd 10, FITZROY Sq. LONDON W.1.

£300 A YEAR FOR YOUR SPARE TIME!

Wonderful New Invention YOU can Make and Sell under My Patent!

REALLY, genuinely, you can make at home and in your spare time a sum of extra money up to £300 per year. The work is of fascinating interest. It will open up to you new ideas, new vistas of money-making; provide many of those luxuries and necessities which you have so long wished for, and give you occupation just at those hours when time is apt to hang heavily on the hands.

to manufacture under my Royal Letters Patent, in order to ensure unrestricted marketing. Let me hear from you NOW before somebody else is granted the licence and the extra income that can so easily become yours.

Simply fill in and forward the coupon below and, by return of post, I will send you every part-



Others are doing this by working my enormously successful patents. Why not you? It costs you nothing to write for full particulars, and you can then see for yourself exactly what you can do.

My patents are in very great demand in the field of wireless and electricity—so much so that

I GUARANTEE

your profits, and further guarantee to protect you against any infringement or interference with your market. Only one person in 50,000 of the population is allowed

IN THE COMFORT OF YOUR OWN HOME YOU CAN DOUBLE YOUR INCOME. The work is a delight. You can keep at it just as long as you like each day or week. No "plant" or machinery is needed. A spare-room or even the kitchen table can serve as your profit-making "factory"—and the children can help too!

particular with which you may wish to be acquainted. It is those who seize opportunities who succeed. Take this opportunity NOW.

"MAKE-MONEY-AT-HOME,"

COUPON.
To THE ENGLAND-RICHARDS CO.,
12K, King's Lynn, Norfolk.

Sirs,—Please send me at once, and FREE, full details as to how I can Make Money at Home in my spare time. I enclose 2d. stamps for postage.

Print your name and address boldly in capital letters on a plain sheet of paper and pin this coupon to it.
Wireless Constructor, 15/12/26.

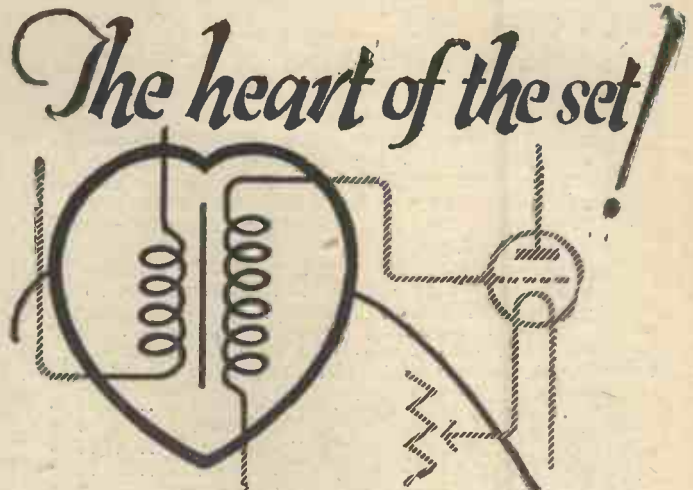

Guaranteed to magnify without distortion and to reproduce with perfect purity both speech and music, the Britimax super is the heart of the set. It has given unfailing satisfaction in all tests to which amateurs and experts have subjected it.

Britimax SUPER TRANSFORMER



18'6

In two models. Ratio 3:1 and 5:1

From all dealers or direct from:
BRITISH GENERAL MANUFACTURING CO. LTD.,
Radio Works, Tyrwhitt Road, BROCKLEY S.E.4

As used in the MONODIAL described in "Wireless" Oct. 30.

"THE inductances used have an extremely low self-capacity so that the 200- to 600-metre band is covered by a movement of about 90 degrees on the dial and it is possible to proportion the coils so that the whole of this waveband comes approximately above the critical point on the dial below which there is any risk of the matching not holding good.

Another effect of reducing the size of the inductances is to reduce their H.F. resistance and so produce an increase in efficiency."

COMPLETE COIL KITS

to standard specification (long wave and short wave coils) are included in the following prices:



- The Monodial .. £2 10 0
- The Elstreflex .. £2 9 0
- The Mewflex .. £4 14 6
- The Distaflex Two.. £4 14 6
- The Magic Five .. £4 7 6
- The Elstree Solodyne £4 9 6
- The Four for Range and Selectivity .. £3 4 0
- The Screened Coil Three .. £2 17 0
- A Three-Valve Trap Receiver .. £1 13 6

Send postcard for full particulars of Colvern Proved Products

- Copper Screen with Standard 6-pin Base .. 8/6
- Screen complete with Base & unwound Coil .. 12/6
- Former & Base, unwound .. 5/-
- Former only .. 4/-
- Base .. 1/6

COLLINSON PRECISION SCREW CO., LTD.,

Provost Works, Macdonald Road, Walthamstow, LONDON, E.17.

Telephone—Walthamstow 532.

ALSO AT 150, KING'S CROSS ROAD, W.C.1



STEEL PLATE ACCUMULATORS FOR HIGH TENSION

Only 1/- per volt.

Absolutely Noiseless.
No Acid. No Fumes.
Last a Lifetime.

BATTERIES, LTD., REDDITCH
LONDON OFFICE—220, Shaftesbury Avenue, W.C.2.

THE FINEST VALVE CONTROL
Can be assured by using only the

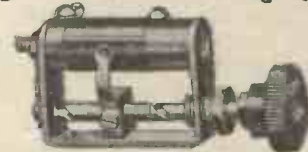

Resistance, 6, 13 or 30 ohms 2s. 6d.

Potentiometer, 300 ohms 3s. 6d.

NEW T.C.B. GUARANTEED RESISTANCE

Smooth and dead silent in operation; positive stops for "Off" and "Full On" positions; a travel from "Off" to "On" in two turns of the knob, easy to fit; occupies minimum panel space. Every one carries our written guarantee to replace if slightest defect found within 3 months of date of purchase

Of all dealers or direct post free from Sole Manufacturers—

Wavio Ltd

If ordering direct state whether one or two hole fixing is desired.

SPEEDWELL WORKS, QUEEN STREET, HITCHIN

The "BULLPHONE" Nightingale



Will not overload from 2 to 10 valves

ACCLAIMED THE WONDER SPEAKER OF THE WORLD

The pure, rich tone of the Bullphone is true to its name — the "Nightingale."

5/- deposit and 12 monthly payments of 5/- or 60/- cash.

Individually tested and guaranteed to be superior to any other Loud Speaker, regardless of price, for finish, purity and strength of tone and value. Cash Price 60/-, post free, United Kingdom.

Apply through your local dealer or send direct to us. Deposit returned if not highly satisfactory.

CLEAR TONE GREAT VOLUME

Specification:

Height 21 ins. Bell Mouth 14 ins. Nickel Arm and Stand. Black crystal bell head, as photo. Also deluxe model, mahogany finish bell, same size, 65/- cash or 10/- deposit. List free.

W. BULLEN 38, HOLYWELL LANE, LONDON—E.C.2.

ARTCRAFT "Popular Type" CABINETS

The design and construction of "Artcraft" Cabinets has won the approval of leading constructors and of the "technical press" in general.

Xmas will soon be here. Have your set in a handsome cabinet before the festive season arrives.

FREE GIFT.

This year we are giving to all who purchase an Artcraft Cabinet listed at 10/- or over an exceptionally nice Ever-pointed pencil, ever-ready to record the stations you log or to make any notes re engagements, &c.

NO INCREASE IN PRICES OF "ARTCRAFT" CABINETS.

We have consistently advertised Artcraft Cabinets at the prices listed below.

Sizes and Prices of "Artcraft Popular Type" Cabinets. Supplied in Oak or Mahogany.

Panel Size Depth.	Price in Oak.	Price in Mahogany.
9 x 6 x 6	6/0	10/0
10 x 6 x 6	8/0	12/0
12 x 10 x 8	12/0	16/0
14 x 10 x 8	14/0	19/0
16 x 8 x 8	14/0	19/0
18 x 12 x 9	21/0	29/0

Baseboards Free. Hinged Lids 1/6 extra.

TO RECEIVE YOUR FREE GIFT.

Send your order between November 15th and December 25th.

Radion-Resiston or Ebonart Panels can be supplied with all our Cabinets.

THE ARTCRAFT CO., 156, CHERRY ORCHARD ROAD, CROYDON.

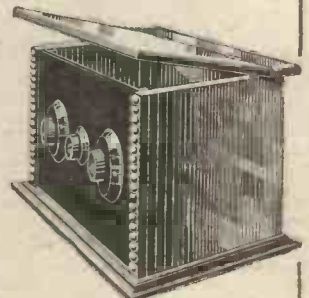

CARRIAGE PAID England and Wales.

ILLUSTRATED CATALOGUE POST FREE.



Apparatus tested

For "The Wireless Constructor" at our Elstree Laboratories.

Plugs and Jacks

WE have received several of their plugs and jacks from Messrs. Bowyer-Lowe Co., Ltd., for test.

The jacks are constructed on the girder principle, and the soldering tags to the spring contacts are set to either side so as to facilitate soldering connections to them. An excellent feature is applied in the method of fixing, which is of the usual one-hole type. The bush itself is fixed, and a nut is employed to fasten this component on the panel. This obviates the need for

period, and will stand up to rougher treatment than normal.

We have had the battery in intermittent use for over two months. During the majority of the time it was used for about two hours a week, at the end of which it was put on a steady discharge at a current of 1.5 amperes, and was found to give well over its rated capacity.

There was an entire absence of any sediment at the bottom of the cells, and as far as can be seen, the battery should give excellent service under rough conditions.

metres, and two dials are provided, the main dial being divided in 50-metre divisions, and the smaller dial, which is geared to the main dial and actuated by the operating knob itself, is divided into metre divisions. It is claimed that this instrument is accurate within one metre, and when checked against our standard instrument the largest discrepancy obtained was .67 of a metre.

The instrument is so designed that a variation in high-tension potential of five volts either side of the recommended value will not affect the calibration.

We can thoroughly recommend this wavemeter. It is simple to use, gives accurate results, and the workmanship of the whole instrument is exceedingly good.

Low-Loss Coil Former

WE have received a loss-loss coil former from Messrs. the Jewel Pen Co., for test and report.

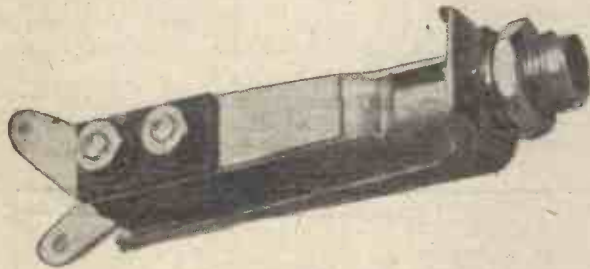

* * *

The method of securing Messrs. Bowyer - Lowe's jacks to the panel is worthy of note.

* * *

any special spacing washers, and makes sure that the reach of the plug be correctly set, no matter what thickness of panel is employed.

The jacks are robustly constructed and are efficient in use, while the insulation between adjacent contacts was found to be infinity.

The plug for use with these jacks is constructed throughout of brass as regards the metal portion, while the fixing screws provided allow either of round tags or flexible wire being fastened.

We can recommend these plugs and jacks for all wireless purposes.

L.T. Accumulator

A SAMPLE of their Acton glass case accumulator has been submitted by Messrs. C. A. Vandervelt and Co. The unit supplied was a 6-volt 48-ampere hour battery, each of the cells being provided with a glass container. The three cells were mounted in a stout carrying case provided with a leather strap.

No separators were provided between the plates, the glass of the cells being moulded to keep the plates apart. By this construction it is claimed that any undue internal resistance in the battery is completely eliminated, that the battery will maintain its charge even when it is not used for some

Emerald Wavemeter

WE have received an Emerald Wavemeter for test and report from Messrs. Heath and Co., Ltd., of New Eltham.

This instrument is housed in a handsome mahogany box, clearly marked terminals being provided for connecting the batteries. The valve, which is carried within the wavemeter

* * *

The dial of the Emerald wavemeter is marked in steps of 50 metres, with a smaller graduated dial for readings to one metre.

* * *



itself, is sunk below the panel so as to protect it from injury. The range of this instrument is from 200 to 600

This former is of the skeleton type, and consists of three ebonite rings to which four lengths of threaded rods

Apparatus Tested—continued

are fitted. The four ends of these threaded rods carry strips of ebonite, which are threaded so as to allow the windings of the coil to be spaced. Two plugs and sockets are provided, one to each end of the former, for mounting purposes. By this means it is possible

provided to enable connections to be made with the winding.

This former is well constructed and strongly made, being able to stand up to a considerable amount of rough usage, and can be recommended for use.

their well-known components, a different terminal arrangement, however, being provided.

Instead of this component being provided with only two terminals, three are provided, which in conjunction with their grid-leak clips enables

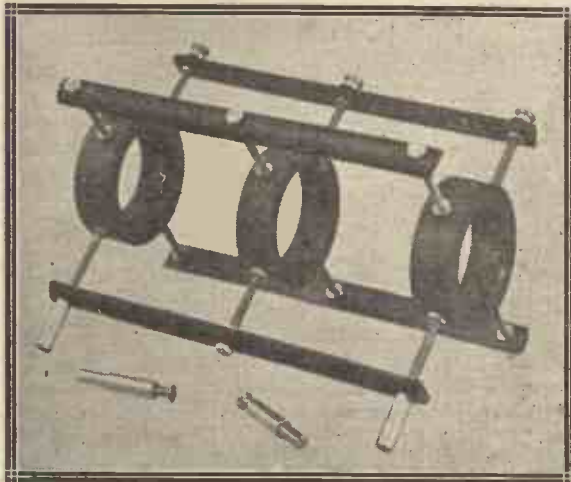

* * *

The low-loss coil former, submitted for test by the Jewel Pen Co., may be arranged to plug into its place in a receiver

* * *

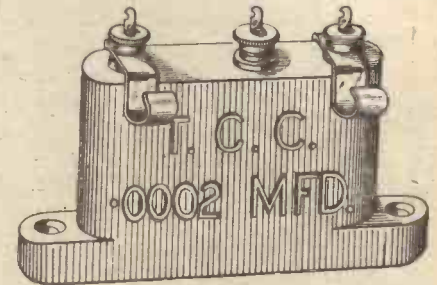

The grid-leak clips on the T.C.C. condenser are detachable.

it to be used either for series or parallel arrangement of the grid leak. Each condenser is accompanied by an explanatory leaflet showing how the desired connections can be obtained.

Rated at a capacity of .0002, its actual value was found to be .000193, giving an accuracy within less than 5 per cent.

The arrangement provided widens the scope of this component which can, apart from its general utility, be recommended for its accuracy.

to wind different coils for different purposes, and to change them as desired, an advantage over the usual low-loss former, which is generally a fixture in the set in which it is used. Three terminals and soldering tags are

Grid Condenser

WE have received a grid condenser for test from Messrs. The Telegraph Condenser Co., Ltd.

This is similar in construction to

THE NEW SERIES OF SUPER LOW-LOSS COILS

A type is made for all best circuits. Get the special list. These are perfectly made and finished and accurately calibrated and matched. A guaranteed Radiax proposition.

SPLIT SINGLE COILS

for anode tuning and a variety of purposes.

150/400	6/8
300/600	6/9
600/1200	8/-
1200/3000	9/-

Three-leg base, 2/3

TRANSFORMER with split primary or secondary.

150/400	10/6
300/600	10/6
600/2200	11/-
1200/3000	12/6

Six-leg base, 2/6



S. L. F. CONDENSER

Real Low Loss, Smooth movement, perfect finish. A thoroughly reliable component, with dial as shown.

Single .0003	10/8
.. .0005	11/8

Double for Elstree Six, etc., .0005 17/-

GEARED COIL-HOLDER

Another new Radiax line of wonderful value. Beautifully made and finished. Smooth working and free from backlash.

Cat. No. 865 4/-

SUPER-HETERODYNE KIT

The Super-Het. is probably the best Super Set. Its selectivity and range are undoubted and it avoids the difficulties of straight H.F. Stages. Our new Low Loss Components, Oscillators, etc., enable a Super-Het. Set to be assembled as easily as the simplest straight circuit.

6-valve Kit comprising filter transformer with condensers, 3 I.F. transformers with condensers, oscillator transformer, and coupler.

£3 : 10 : 6.

H. F. CHOKE

Low self-capacity type. The successful control of reaction depends upon the Choke coil used. To build a first-class choke is by no means the simple task one might imagine, and much costly and experimental work has preceded the production of the Radiax choke, which is perfect for modern neutrodyne circuits.

Up to 150 metres .. 7/6

150/4000 metres .. 8/-

GET OUR LIST of newest Low Loss Components.



RADIAX LTD.,

44, ACCESSORY HOUSE, PALMER PLACE, HOLLOWAY, LONDON, N.7.

Farr's Ad.

RADIAX COILS
Exceed in efficiency all ordinary types.
The standard Low Loss coil is the most efficient form of all the plug-in coils, nothing but wire and air.
No. 25 1/3 No. 100 2/6
35 1/8 150 3/-
50 1/8 200 3/6
75 2/- 250 4/-

THE D.X. COIL
For distance work gives an auto-coupled circuit without altering your set. Permits a variety of aerial tuning circuits; enables neutralising on anode circuits; makes the poor set good, and the good set a "super." Everyone needs these coils, which positively add selectivity and range.
No. 35 3/- No. 150 5/6
50 3/8 200 6/-
75 4/-

Set of 5 21/-
Free chart of circuits with each purchase.

FINSTON Fixed Condensers
This season's improved model is worthy of replacing any you may have in your set.
Ruby Mica and Copper Foil, Bakelite moulding. Quality Terminals and Sensible Soldering Tags.
Prices:
'0001-2-3-4-5-6 and 001 1/- each
'002-3-4-5 and '006 1/9 each
Get them from your Dealer and write us for Complete Illustrated Folder of all Finston Components.
FINSTON MFG. CO., LTD.
5 Horseferry Road, London, S.W.1.

"FLOR" — FOR BETTER RESULTS.
9^d. per volt. The World's finest H.T. Accumulator
OUTSTANDING FEATURES
60v—£2 12 6 ECONOMICAL
80v—£3 6 8 RELIABLE SERVICE
120v—£4 10 0 CONSTANT VOLTAGE
In handsome Oak Cabinets with carrying handle. PURITY OF TONE
Send to-day for illustrated Brochure dealing with "Flor" H.T. Accumulators.
Smith Farmer & Co. 6, Broad St. Place, E.C.2.
Dealers send at once for generous trade terms.

Still further triumphs for CYLDON CONDENSERS

THE "CYLDON" GROUNDED ROTOR SQUARE LAW DUAL CONDENSER

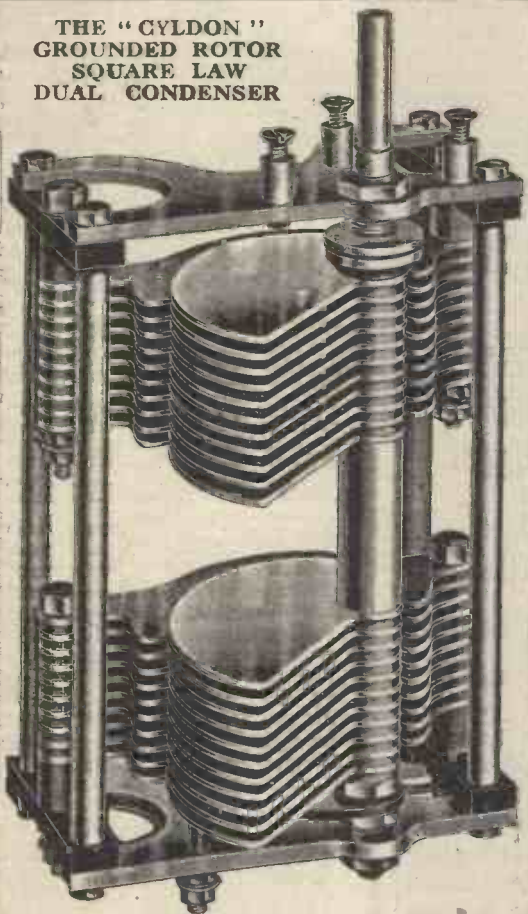

SPECIFICATION.
ENDPLATES 4-in. Aluminium, highly polished.
FIXING 3-screw for 4-in. or 3/16-in. panels (drilling template supplied).
BEARINGS Top: Bronze, 1-in. long, with 1-in. dia. thrust face. Bottom: Steel Ball in Cone Bearing.
SPINDLE 1/4-in. dia. plain, Nickel Chrome Steel, ground to limits of .00025 of one inch.
VANES Hard Rolled Aluminium, 20 S.W.G. The two sets of moving Vanes on one spindle.
INSULATION "Radion" outside electrostatic field.
CONNECTION Phosphor Bronze Pigtail from rotor to frame terminal.

GUARANTEED UNCONDITIONALLY.

Each Condenser individually tested both Electrically and Mechanically and each section accurately matched.
 Condenser, .0005 mfd. capacity, each section with 4-in. Knob Dial each **27/6**
 Without Dial, 25/6 each.
 Condenser, .0003 mfd. capacity, each section with 4-in. Knob Dial each **25/0**
 Without Dial, 23/- each.

1. Premier Award. Mr. R. Waldo Emerson, who was awarded the International Gold Medal for 1926 by the Amsterdam Radio Society for his "Elstree Six," has written us saying that his success was due "in great measure" to his use of "CYLDON" Condensers.

2. Second Prize. Radio World's Fair, New York, September, 1926. 2nd Prize awarded in senior section of the Junior Competition for a "Mewflex" Receiver fitted with "CYLDON" Condensers.

3. Second Prize. At the Chicago Exhibition, 1926, the 2nd prize was awarded to a "Mewflex" Receiver fitted with "CYLDON" Condensers.

4. Third Prize. Radio World's Fair, New York, September, 1926. 3rd Prize awarded in the multi-Valve Class in the International Competition for the "All British" Set. "CYLDON" Condensers and Temprytes were fitted.

The above competitions were open to the world—including American and European receivers. Verb. sap.

Three Popular "CYLDON" Condensers

Triple-gang Condenser	Price £3 10 0 without dial.
2-gang Condenser	£2 10 0 " "
4-gang Condenser	£4 10 0 " "

Get full particulars of all "CYLDON" Products from your dealer or write direct to the makers. Other "CYLDON" Condensers comprise Square Law, Square Law Dual Pattern, and the S.L.F. model 4-in. Knob Dial, supplied free with Square Law and Dual Models, and 2/- extra with S.L.F. or 2, 3, and 4-gang models.

And then there is the—

CYLDON WAVEMETER

—it identifies unknown stations and makes searching and testing out simplicity itself.

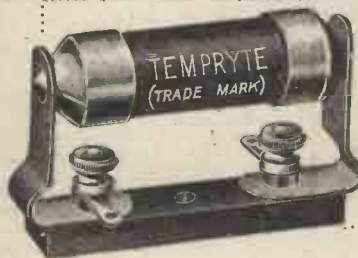

CYLDON TEMPRYTES

The best means of valve control. British-Made and delivered from stock immediately. Can be supplied in correct resistance for ANY Valve. State resistance (ohms) required, when buying, or be sure to give name of Valve and voltage of Accumulator supplying current to the Valve.

"CYLDON" Temprytes	each 2/6
Holder mountings	each 1/6

CYLDON

(pronounced SIL-DON)

SYDNEY S. BIRD & SONS,
 "Cyldon" Works, Sarnesfield Road,
 ENFIELD TOWN, MIDDLESEX.
 Telephone: Enfield 0672.

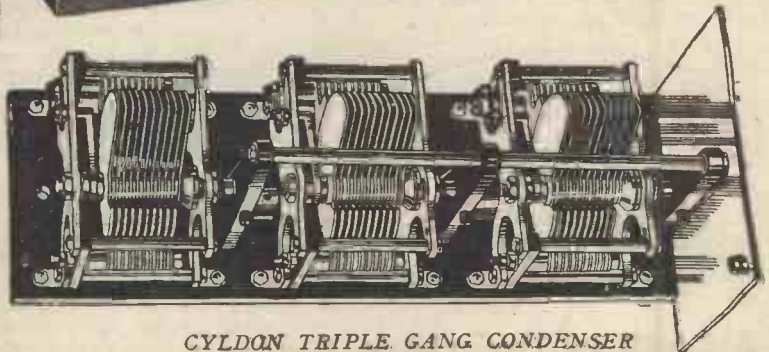

CYLDON TRIPLE GANG CONDENSER

The TANGENT
TOUCHTONE
 Loudspeaker

STANDS IN A CLASS OF ITS OWN FOR DISTINCTION OF DESIGN AND CONSTRUCTION.



DESIGNED on quite new and original acoustic lines this Loudspeaker produces the lowest as well as the highest notes in perfectly natural form.

Its design does not permit comparison with ordinary Loudspeakers which do not always add to the beauty of a room. The "Touchtone" is attractively finished with that subdued distinction so pleasing to people of good taste. It has no visible trumpet and is not in any way a scientific looking instrument. The artistic proportions and appearance of the "Touchtone" lends to its inclusion in any room.

Price in Oak - - - £6-6-0
 Mahogany - - - £7-0-0

Write for full illustrated leaflet giving all particulars.



LONDON: 25 Victoria Street, S.W.1.
 NEWCASTLE/TYNE: TANGENT House, Blakett Street.

GENT & CO. Ltd., Faraday Works, LEICESTER.

GETTING THE BEST FROM THE "SPANSACE THREE"

—continued from page 109

ing by means of the reaction condenser C5, and you must be prepared to have to use quite different values of this condenser when the tapping point is altered. As the tapping point approaches the anode end of the coil you will find that smaller and smaller values of this condenser are needed, so that finally when you reach the middle point of the coil it is quite possible that the setting may be quite near the oscillation point even when the variable condenser is set to its minimum value.

ELSTREE
 "SOLODYNE"

Successful in
 Chicago Competition

We hear that Radlo Press Star Sets have again been successful in America. From information so far to hand, we gather that a "Solodyne" receiver, constructed by Mr. Anspach, of Dartford, Kent, has won a first prize at Chicago. The "Mewflex" receiver, constructed by J. A. E. Black, the thirteen-year-old competitor, who was successful in securing an award in the New York Radio World's Fair, was awarded a prize at Chicago also.

 * HAVE YOU TRIED THIS? *

EXPERIMENTS in the placing of a loud-speaker in different positions in a room are always interesting, because of the varying "echo" and other effects which are obtained, improving or detracting from the quality of the reproduction. One such experiment which is worth a trial, particularly with the hornless type of instrument, is to suspend it from the ceiling. A certain amount of "roundness" is often imparted to the tone of a loud-speaker when it stands on a table. In some cases this may even produce a muffling effect, whereas when the loud-speaker is suspended in mid-air its own natural tone will be heard.



Columbia

DRY BATTERIES FOR CONTINUOUS AND EVEN DISCHARGE

USE Columbia for every radio battery purpose. Unlike your ordinary batteries, their current drains evenly and eliminates hum and distortion. Then again the voltage drops gradually which prevents a sudden fall in reception volume. Columbia Dry Batteries are designed to discharge the greater part of their useful energy before their voltage drops to approximately .8 volts.



Send for our free instruction books "How to get the most out of your radio batteries" and "Choosing and using the right radio batteries." It is astonishing what will result in economy of operation and improved quality of reception when you have definite knowledge as to the correct use of your radio batteries.

J. R. MORRIS,
 15-19, KINGSWAY, LONDON, W.C.

Telegrams: Colcarprod, London. Telephone: Gerrard 3038.

Scottish Representative: John T. Cartwright, 3, Cadogan Street, Glasgow.

CREATING A NEW RADIO VOGUE

Have you started to build the MONODIAL? The popular Radio Press Star Single Dial Receiver. This week's issue of WIRELESS contains a very detailed account of the author's success on the long waves. Purchase a copy to-day to read about the popularity of the MONODIAL for yourself.

The design of the MONODIAL is so planned that every reader of WIRELESS will have no difficulty whatsoever in duplicating the published results. You will find it supremely easy to control and on points of selectivity and range it will realise all your ambitions. Buy your copy to-day, build the "Monodial" and enjoy for yourself the delight of running through the full tuning range of the gang-condenser. It's an experience which will make you a Monodial enthusiast.

THE MONODIAL

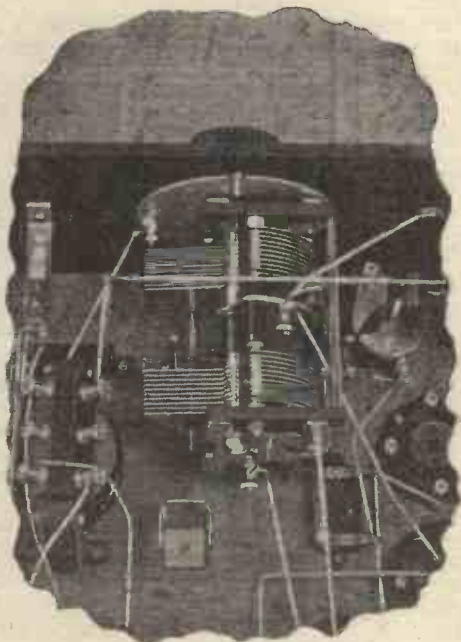

This photograph shows the double gang-condenser which simultaneously tunes the aerial and high-frequency circuits of the Monodial.

The contents of this issue (November 13th) also includes:

WHAT DO WE GAIN BY LOW-LOSS?

By Capt. H. J. Round, M.C., M.I.E.E.

**KEEPING LISTENERS' INTEREST:
WHY GREAT ARTISTS CANNOT
BROADCAST**

By Dame Clara Butt.

**THE "MINIMINE" SUPERHETERO-
DYNE**

By Stanley G. Rattee, M.I.R.E.

Place a standing order with your newsagent to deliver Wireless from this week's number. More news about the Monodial in subsequent issues.

WIRELESS
INCORPORATING
WIRELESS WEEKLY **2^D**
WEEKLY

Obtainable from all Newsagents, Bookstalls, and Booksellers, or direct from the Publishers, Radio Press, Ltd., Bush House, Strand, London, W.C.2. Subscription rates, 13/- per annum throughout the world.

Buy "Wireless" on the way home



Panel Talks: No. 3.

How to safeguard your Set against Panel leakage

WHEN you buy a panel, what assurance have you that it will not, by surface leakage, nullify the many hours you spend in building your Set? How can you tell that it will not allow those vital signals to escape before they have reached the telephones or the loud speaker? Or perhaps you have already built a set, and are unable to account for a noticeable weakness in signal strength?

Apart from elaborate electrical tests there is only one protection against such defects—it is the "hallmark" which every panel of the American Hard Rubber Co. (Britain) Ltd. bears. The twin names, Radion and Resiston, are your insurance against surface leakage and all other panel ills.

In Resiston—brother panel to the world-famous Radion—is available, at a little lower price, a panel of superior qualities. The high-grade of hard rubber—the finest insulation material known to Science—used entirely in the manufacture of Resiston, ensures a panel which is free from the bugbear of surface leakage, which is perfect in insulation, which has a low dielectric constant, is permanent in its colour and of great strength.

Don't buy your panel in the dark! There is one great safeguard against all ebonite troubles—it is the word 'Resiston.' Say it to your Wireless Dealer.

Resiston comes in 17 stock sizes in Black or Mahogany-grained finish. Each panel is protected by its own stout manilla envelope—your safeguard.



American Hard Rubber Co. Ltd., 13a, Fore St., E.C.2
G.A. 6080.

THE "ALL-BRITISH SIX"

—continued from page 92

should be directed to those experimenters who try to alter "lay-outs" without possessing the requisite knowledge. Sometimes they are lucky, but more often the performance of the "improved" receiver is the antithesis of that obtained by the designer.

The operation of wiring-up having been completed—and it is advisable to expend a good deal of care on this—the whole of the connections should be carefully checked against the wiring diagram.

Valves to Use

In the H.F. and detector sockets valves of high impedance should be used. The first L.F. valve may be a small power valve of low impedance, and the last valve may be a valve of a lower impedance than the first for full volume.

Testing Out

Insert the valves and connect the low-tension leads to the proper terminals. The valves should light up. If all is well here, disconnect the L.T. leads and place them across the high-tension negative and positive terminals. The valves should not light. If they do, there is obviously a wrong connection, and this should be remedied.

Sufficient details and diagrams are included in this article to enable readers to construct the "All-British Six." Further notes on the operation of the receiver will appear in the next issue of THE WIRELESS CONSTRUCTOR.

H. H. Hoosall

MAKING USE OF YOUR SUPPLY MAINS—continued from page 96

then by inserting a suitable resistance in series we can adjust the charging current to any value we choose, a value of 50 or 100 milliamperes being usual. A resistance, therefore, of 100 or 200 ohms capable of carrying 0.1 of an ampere is all that is necessary in this case, and it will be appreciated that such resistances are a standard product.

In a further article the problem of charging accumulators from A.C. mains will be dealt with, and also the kindred questions of supplying low-tension and high-tension current direct from the mains.

ACCUMULATORS ON EASY PAYMENTS

High Tension Accumulators built up from 20 Volt sec ions (15/- each). Example: 60 Volt H.T. 45/- CASH or 12/6 DOWN and 6 monthly payments of 6/-. Carriage Paid. Satisfaction or money back. Write for Lists to DEPT. 13, COVENTRY DIRECT SUPPLIES LIMITED, 23, Warwick Row, COVENTRY. Any Wireless Goods supplied on easy payments.

TRADE MARK FINEST QUALITY RED DIAMOND RADIO COMPONENTS

REGISTERED EVERY COMPONENT IS PERFECT.

R.D. 40 Perm. Detector, 2/- each. Also in Red Mottled (R.D. 40A), 3/-



Of all High-class Radio Dealers or Sole Makers: JEWEL PEN CO., LTD., Radio Dept. 41, 21/2, Gt. Sutton St., E.C.1.

EBONITE BUSHES

FOR MOUNTING ON WOOD. PERFECT INSULATION.

Orders under 1/- send 1/4d. Postage. Two required for each hole.

NUMBER	0	1	2	3	4	5	6
Hole in Bush	6BA, 4BA, 2BA,	1/4",	5/16",	3/8",	7/16"		
Price each	1d.	1d.	1 1/2d.	2d.	2d.	2d.	2d.

DAREX RADIO CO., Waldram Rd., Forest Hill, London, S.E.23. TRADE SUPPLIED.

WIRELESS WAREHOUSE

Buy your Wireless parts direct from the Warehouse at Warehouse prices. Every known component in stock. Write NOW for list.



BUSH HOUSE 35, Shudehill, MANCHESTER

A HOME FOR YOUR WIRELESS SET

OUR STANDARD CABINETS

are DUSTPROOF and house the whole apparatus, leaving no parts to be interfered with. Made on mass production lines, hence the low price. Provision is made to take panels from 16 by 7 up to 30 by 18 in.



Special Cabinets for the ELSTREE SOLODYNE, NIGHT HAWK, etc., now ready. Write for free particulars.

MAKERIMPORT Co. Dept. 20, 50a, Lord Street, LIVERPOOL.

WE TRUST YOU

Wireless for everyone. Our great Bargain List is Free. Easy Payments. WORLDS' WIRELESS STORES, WALLINGTON.

EVERY LOUDSPEAKER

DESERVES MULLARD MASTER VALVES

— Ask for — Mullard P. M. Power Valves.

A mile of wire

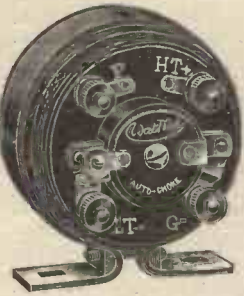

wound the Watmel way

The special windings of the Watmel Auto-Choke are done by expensive and absolutely up-to-date machines which lay the wire exactly parallel and interweave cotton strands between each layer. Cotton acts as binder, and insures perfect insulation. Get to know the other reasons for the fine amplification and natural-sounding reproduction possible only with the



AUTO-CHOKE

PRICE 18/6

From your dealer or direct from—
THE WATMEL WIRELESS CO., LTD.
 332a, Goswell Road, London, E.C.1.
 Telephone: Clerkenwell 7990.

Lancs., Yorks. and Cheshire Representative,
 Mr. J. B. Levee, 23, Hartley St., Levenshulme
 Manchester. Telephone: 478 Heston Moor.

Valves Repaired

AS GOOD AS NEW!!

HALF LIST PRICE

Except Weeco, S.P.'s, and low capacity types. Minimum D.E. Current 0-15 amps when repaired.

ALL BRIGHT & DULL EMITTERS Listed at less than 10/-
 MINIMUM CHARGE - 5/-
VALCO LTD., Dept. C., Tabor Grove Wimbleton, S.W.

STERLING RECEIVERS

SENSATIONAL OFFER!

Having purchased a large number of Sterling 2 Valve Loud Speaker Sets, we are offering them to the public on unprecedented terms. A genuine Sterling 2 Valve Loud Speaker Set complete, ready for immediate use with D.E. '06 Valves, H.E. and L.T. accumulator, Ariel Equipment and one of our World Famed De Luxe Excellent Loud Speakers. Price £15 15s. 0d., royalties paid. Terms 15/- Deposit and 15/- Monthly Payments of 20/-.

Send for one of these Superb sets at once as the number for sale is limited, and when sold cannot be repeated under double the price.

Free Catalogue on Application
The Wireless Distributing Co., Ltd., (Dept. A.C.),
 Wireless House, Stoke Newington, N.16



THE WIRELESS DOCTOR

will call (London and Home Counties) and put you right, if your set is troublesome. No cure, no charge. Sets installed, maintained and brought up to date. Ectree Soliholme demonstrated.

ALEXANDER BLACK,
 2a, Woodville Grove, N. 16. Clissold 9887.

MAKE SCREENED COILS AT HOYE!

COPPER FOL, 4 1/2 in. x 60 in., 3/- piece; D.S.C. Wire, 30 Gauge, 2/9 Reel (Double Silk covered) postage 6d. Ample to make the three screened coils to Mr. Reyners's specification. Details how to make the 6-formers for a few pence, to all my customers, free. **C. WALKER,** 110, Thornhill Rd., Handsworth, Birmingham.

2-VALVE AMPLIFIER 3/-

1-Valve Amplifier 20/-, as new. Valves, D.E. '06 7/-, Headphones 8/6 pair. New 4-Volt Accumulator 13/-, New 60-Volt H.T., guaranteed, 7/-. 2-Valve All Stn. Set, 24. Approval willingly. Write for free bargain list.
C. Taylor, 57, Studley Road, Stockwell, London.

VALVES FOR THE "DISTAFLEX TWO"

THE following valves, suitable for use in the "Distaflex Two," the Radio Press Star Set described in the October issue of THE WIRELESS CONSTRUCTOR, may be added to the list given on page 25 of the last issue of this journal:—

MANUFACTURER.	VALVE TYPE.
S.T., Ltd.	S.T.42
	S.T.43
	S.T.62
	S.T.63
Electron Co., Ltd.	S.S. 7
	S.S.10

It should be noted that practically any valves of low impedance may be employed in the "Distaflex Two," small-power valves being recommended for the proper handling of the large volume obtainable.

"SEEN AT THE SHOW"

WE regret that the superheterodyne attachment illustrated in the photograph reproduced herewith, which appeared on page 30 of the November issue of THE WIRELESS CONSTRUCTOR, was incorrectly

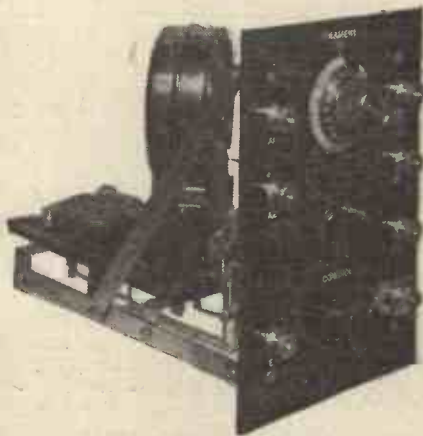

A superheterodyne attachment produced by Messrs. Igranic Electric Co., Ltd.

stated to be a production of Messrs. Gambrell Bros., Ltd.

The correct description is given with the photograph on this page, and it will be seen that the manufacturers of the apparatus in question are Messrs. Igranic Electric Co., Ltd.

VARIABLE CONDENSERS FOR THE "NIGHT HAWK."

WE are informed by Messrs. Portable Utilities Co., Ltd.; that the "Eureka" S.L.F. condensers used in the "Night Hawk" receivers are made both in clockwise and anti-clockwise types. Readers who are building the set and who obtain a drilled panel should specify the type originally used.

THE WIRELESS CONSTRUCTOR SOLDERING SUPERSEDED "KRISCROS" CONNECTORS



Prices from 1/- per doz. Send for List. KRISCROS COMPANY, 50, GRAY'S INN ROAD, LONDON, W.C.1

AERMONIC 1/9 DON'T PAY MORE

Anti-phonc. Lowest Capacity. Lowest price—best value. The new design enables us to sell at less than other makes and puts Aermonic "miles-in front."



Aermonic Holder - 1/9

Other makes are not so fine, if 'can't obtain' drop us a line

List of Aermonic Specialties Free.

JAMES CHRISTIE & SONS, LTD.,
 246, WEST STREET, SHEFFIELD.

London Agents: A. F. BULGIN & Co., 10, Curator St., London, E.C.4

THE ALL-BRITISH SIX BUILT FOR 15/-

We construct the above or any other Radio Press set, exactly as specified, at the price of the components plus 2/6 per valve only. First-class workmanship. Every set guaranteed.

London Radio Supply Company, 11, Oat Lane, London, E.C.2. Phone: City 1977.

CABINETS

In this issue:

THE ALL-BRITISH SIX (SPECIAL).

Oak 45/-. Mahogany 50/-.

Baseboard and carriage included.

Paragon Panels supplied, drilled and engraved.

Enquiries for all Cabinets to:—

H. CATTERMOLE, 227, Anlaby Rd., Hull



A Better Adhesive for Home Repairs

The new super-adhesive for all repairs of broken china, glassware, etc. Durofix makes a repair of great strength and durability. China and glassware repaired with it can be put into hot water and hot ovens with perfect safety. Try it. In 6d. and 1/- tubes from Ironmongers, etc.

RAWLPLUG

DUROFIX

LIQUID PORCELAIN
 Unique preparation for top, door, lin. br., etc. Gives glossy white finish, like real porcelain. In tins, 1/6 and 2/6 each.

DUROLUSTRE
 The super-lacquar that prevents tarnish to all polished metal goods. Sold in tins, 1/6 and 2/6 each.

THE RAWLPLUG CO., LTD.
 RAWLPLUG HOUSE, CROMWELL RD., LONDON, S.W. 7.

INDEX TO ADVERTISERS.

	PAGE		PAGE		PAGE
American Hard Rubber Co. ...	178	Ede (C.) & Co., Ltd. ...	115	Oldham & Son, Ltd. ...	156
Aircraft Company (The) ...	172	Electron Co., Ltd. ...	116	Ormond Engineering Co., Ltd. ...	153
Ashley Wireless Telephone Co., Ltd. ...	140	England-Richards Co. ...	171	Peto & Radford ...	158
Autoveyors, Ltd. ...	136	Eton Glass Battery Co. ...	170	Peto-Scott Co., Ltd. ...	119, 128
Batteries, Ltd. ...	174	Falk, Stadelmann & Co., Ltd. ...	115	Pettigrew & Merriman (1925), Ltd., ...	127, 138
Beard & Fitch ...	127	Ferranti, Ltd. ...	120	Phillips Lamps ...	159
Bedford Electrical & Radio Co., Ltd. ...	168	Finston Mfg. Co., Ltd. ...	106, 164, 174	Picketts Cabinet Works ...	170
Belling & Lee, Ltd. ...	142	Formo Co. ...	180	Portable Utilities Co., Ltd. ...	132, 163
Benjamin Electric Co. ...	108	Gambrell Bros., Ltd. ...	109	Radiax, Ltd. ...	174
Bird (Sydney S.) ...	175	Garnett, Whiteley & Co., Ltd., ...	136, 164, 170	Radio Instruments, Ltd. ...	Cover iv
Black (A.) ...	179	General Radio Co., Ltd. ...	170	Radio Reception Co. ...	127
Blackadda Radio Co. ...	106	Gent & Co., Ltd. ...	176	Rawplug Co., Ltd. ...	179
Bowyer-Lowe Co., Ltd. ...	155	Graham (Alfred) & Co. ...	124	Raymond (K.) ...	166
Brandes, Ltd. ...	118, 131, 152	Graham-Farish Mfg. Co. ...	126	Reid (L. H.) & Co. ...	170
Bretwood, Ltd. ...	142	Hart Accumulator Co., Ltd. ...	113	Silvertown Co., The ...	138
British General Mfg. Co., Ltd. ...	171	Holzman (Louis) ...	134	Smith Farmer & Co. ...	174
British L.M. Ericsson Mfg. Co. ...	169	Hunt (A. H.), Ltd. ...	142	Standard Insulator Co., Ltd. ...	164
Brown (S. G.), Ltd. ...	167	Igranio Electric Co., Ltd. ...	102	Stratton & Co. ...	109
Bulgin (A. F.) & Co. ...	122	Jackson Bros. ...	134	S.T., Ltd. ...	86, 128, 145, 146, 147, 148, 160
Bullen (W.) ...	172	Jewel Pen Co. ...	178	Taylor (C.) ...	178
Burne-Jones & Co., Ltd. ...	126	J.R. Wireless Co. ...	151	Telegraph Condenser Co., Ltd. ...	151
Bush House ...	178	Kriscore Co. ...	179	Telephone Mfg. Co., Ltd. ...	143
Carborundum (The) Co., Ltd. ...	123	Lever (Erio J.) ...	122	Tralleborg's Ebonite Works ...	164
Carrington Mfg. Co., Ltd. ...	180	Lisson, Ltd. ...	141, 169	Valco, Ltd. ...	179
Cattormole (H.) ...	178	Lock (W. & T.) & Co. ...	164	Vandervell (C. A.) & Co., Ltd. ...	110
Christie (Jas.) & Son ...	179	London Electric Wire Co. and Smiths, Ltd. ...	85	Varley Magnet Co. ...	162, 170
Cleartron Radio, Ltd. ...	154	London Radio Supply Co., Ltd. ...	179	Walker (C.) ...	179
Collinson Precision Screw Co. ...	172	Makerimport Co. ...	178	Watmel Wireless Co., Ltd. ...	179
Cossor (A. C.), Ltd. ...	101	M.A.P. Co. ...	151	Wavio, Ltd. ...	172
Coventry Direct Supplies, Ltd. ...	179	Marks (S.) & Sons, Ltd. ...	122	Westam Accumulator Co. ...	164
Curtis (Peter), Ltd. ...	158	Morris (J. R.) ...	176	Weston Elec. Instrument Co. ...	115
"Daily Chronicle" ...	127	Mullard Wireless Serv. Co., Ltd. ...	150, 179	Wilkins & Wright, Ltd. ...	157
Darox Radio Co. ...	178	New Times Sales Co. ...	170	Wireless Distributing Co. ...	178
Dubilier Condenser Co. (1925), Ltd., ...	105, 141			Wolf (M. & A.) ...	180
Eastick (J. J.) & Sons ...	138			World's Wireless Stores ...	122
Economic Electric, Ltd. ...	171			Wright & Weaire ...	134

FORMO

ULTRA LOW LOSS
Straight Line Frequency
Condenser.

Cone Bearings. Braced Vanes. Positive Collector. A Real Precision job.
Condenser only .0003μF.—.0005μF. 9/-
Condenser with plain Dial 10/8
Standard 1/2" Dia. Shaft.

New Vernier Logging Dial. 9/-
No Backlash. Reduction Ratio 16-1.
Can be used on any Condenser with 1/2" spindle.

THE FORMO COMPANY,
Crown Works, Cricklewood, N.W.2.
Phone: Hamp. 1787.
Manchester: Mr. J. B. Levee, 23, Hartley Street, Levenshulme.
Phone: Heaton Moor 475.



CONDENSER
9/-
VERNIER DIAL
8/-

ETHERPLUS + New Model TRANSFORMER
EXQUISITE PURITY.

The tonal quality and volume of our "Concerto" Transformer equal, at a competitive price, the most expensive instruments

12/6 each

No. W 61F. ratio 1 : 5
No. W 62F. ratio 1 : 2.5

From all dealers or from
M. & A. WOLFF,
9-15, WHITECROSS STREET,
LONDON, E.C.1.



ETHERPLUS

CUT THIS OUT FOR CABINETS

and post to us for **FREE** list illustrating Cabinets as shown in "Wireless Constructor," etc., etc.

NAME.....
ADDRESS.....

(Write in block letters please.)
CARRINGTON MFG. CO., Ltd.
18/20, Normans Buildings,
Mitchell St., Central St., E.C.1
Trade enquiries especially invited.
Telephone: Clerkenwell 6903.



FREE BLUEPRINT SERVICE

COUPON

Wireless Constructor. Vol. III. No. 2. Dec., 1926.

This coupon entitles the reader to one free panel blueprint of any set described in the above issue, and must accompany each postal application.



Sources of supply

"THE WIRELESS DEALER and Radio Trade Journal" contains two important guides to sources of supply—Index to Advertisers and The Buyer's Guide. The first will refer to advertisements in the issue, while the second will direct you to the manufacturers of any particular product which you may require to order. These two guides compose an important fund of information.

Commence your subscription with the November issue—it is rather an import-

ant one for the retail section of the Trade. It contains a detailed and profusely illustrated "Stand to Stand" Review of the Manchester Exhibition, giving special prominence to popular lines. "What the Manufacturers are Doing" and "What the Wireless Journals are Doing"—both widely-read regular features—are of particular interest in this number.

Make a note to post your application to-day.

SUBSCRIPTION RATES:

7/6 per annum (abroad 10/-). Available to the Trade only. Trade card or business heading should accompany every subscription to the SALES MANAGER, Radio Press, Ltd., Bush House, Strand, London, W.C.2.

The **Wireless Dealer**
AND
Radio Trade Journal



The Tide of the Present

Shouting the slogan "Economy and Simplicity" as the tide of modern progress bears us farther and farther from all that these terms truly represent, we deafen ourselves to their real meaning. In our efforts to reach the state from which we sprang, we merely become involved in further complications and yet we are satisfied that the tide of the present is definitely set for the happy condition of simple and economical existence.

Wireless to-day is perhaps considered, in a broad sense, supreme as an illustration of these two qualities, yet few people have succeeded in reducing its complexities. Only R. I. could produce the Retroactive Tuner, which, for the first time, gave the constructor the means of easy and efficient tuning. Now this unit is universally recognised as the most simple and economical method of tuning. Simple because it ensures that correct aerial reaction is used over the whole range of wave lengths covered, 175-4000 metres, and economical because it supersedes the usual multiplicity of coils, which together with coil holder to cover the same range cost appreciably more than the Retroactive Tuner.

Next time you have difficulty in selecting the station you want, remember the R. I. Retroactive Tuner, the unit that applies the principles of the future to the design of the present.

Price: One Pound Nineteen and Sixpence.

R. I. Ltd., 12 Hyde Street, New Oxford Street, London, W. C. 1



Published by RADIO PRESS, LIMITED, Bush House, Strand, London, W.C.2, on the 15th of each month, and Printed for them by THE AVENUE PRESS (L. Upcott Gill & Son, Ltd.), 55-57, Drury Lane, London, W.C.2. Address for Subscriptions and Editorial Communications:—Bush House, Strand, W.C.2. Address for Advertisements:—Advertisement Manager, THE WIRELESS CONSTRUCTOR, Bush House, Strand, W.C.2. Phone: City 9911. Registered as a magazine for transmission by Canadian Magazine Post. Subscription rates U.K. and abroad:—8s. 6d. per annum, 4s. 3d. for six months; Canada, 7s. 6d. per annum, 3s. 9d. for six months. Sole Agents for Australasia:—GORDON & GORCH (Australasia), LTD. For South Africa:—CENTRAL NEWS AGENCY, LTD. American Agents:—INTERNATIONAL NEWS Co., New York. Canadian Agents:—THE AMERICAN NEWS Co., LTD., 1850 IMPERIAL NEWS Co., LTD.