

OCTOBER 1969 2s 6d

tape recorder

THE SYNTHESIS OF MUSICAL
INSTRUMENT TONE

INSIDE EMI

REVIEWS OF UHER 1000
PILOT AND
FICORD 800/850
CAPACITOR MICROPHONES

AUTOMATIC TAPE
TRANSPORT CONTROL

SONY TC260 SERVICING

A HISTORY OF STUDIO
RECORDING EQUIPMENT

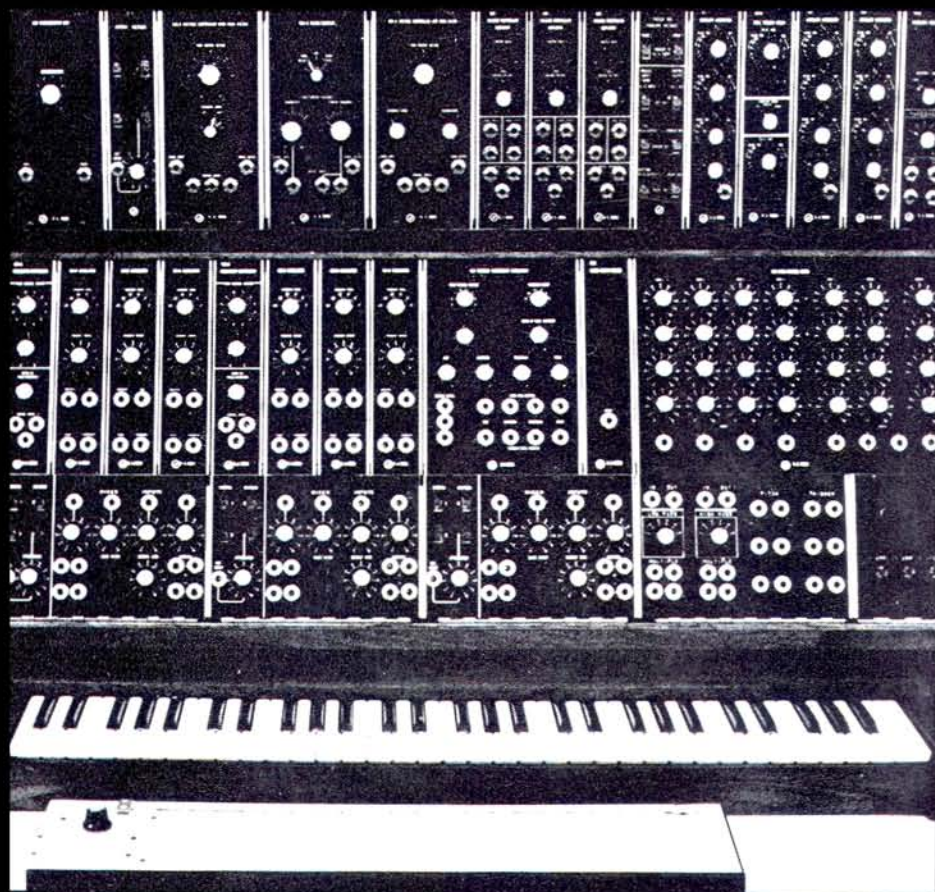



Two brilliant new additions to the Beocord range

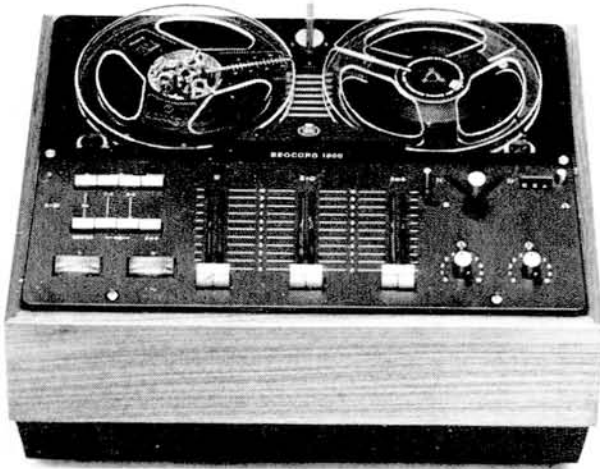

BEOCORD 1800



BEOCORD 2400

Made by Bang & Olufsen for those who consider design and quality before price.

Whether you prefer to centre your High fidelity system around a separate amplifier, or to base it on an amplifier integrated into one of the audio units, your needs for a tape recorder to complete your system can be satisfied by choosing one of these new Beocords. Both machines exceed the minimum requirements for DIN 45,500, and have operational facilities comprehensive enough to attract the semi-professional as well as the domestic user. These include a 3 digit tape counter with push button

The Beocord 1800 – designed for use with a High Fidelity amplifier such as the Beolab 5000 or Beomaster 1400.

Available in 2 versions: (a) $\frac{1}{2}$ track record and replay with extra switched $\frac{1}{4}$ track replay head, (b) $\frac{1}{4}$ track record and replay only. Sockets duplicated in DIN and phono type to simplify connection. Special amplifier and volume control for output to headphone sockets.

reset. Foil operated auto stop plus thyristor controlled photo-stop for end of tape, tape break or programme scanning. Push button selection of A-B monitoring, sound on sound, echo, syncroplay, mono left, mono right, mixed mono or stereo play. New hyperbolically ground tape heads with special patented machining give greatly improved contact between tape and tape head and less friction and noise during operation, resulting in less wear to tapes and tape heads.

The Beocord 2400 – complete with its own stereo amplifier section giving 2 x 10 watts RMS output. $\frac{1}{4}$ track record and replay. 4 dual channel inputs in mixer section including a magnetic P.U. input. Bass, treble and split channel volume controls. Switched output for 2 pairs of speakers. The amplifier may be operated independent of the motor.

As we want people who choose B & O to receive really good service, every effort has been made to appoint only dealers of the highest ability and integrity and this policy may necessarily limit the number in your town or city. So write today for the name and address of your nearest dealer and for further information about the B & O range to:—

Bang & Olufsen U.K. Limited. Eastbrook Road, Gloucester. Telephone: 0452 21591

London Showrooms: 70/71 Welbeck Street, London, W.1. Telephone: 01-486 2144.

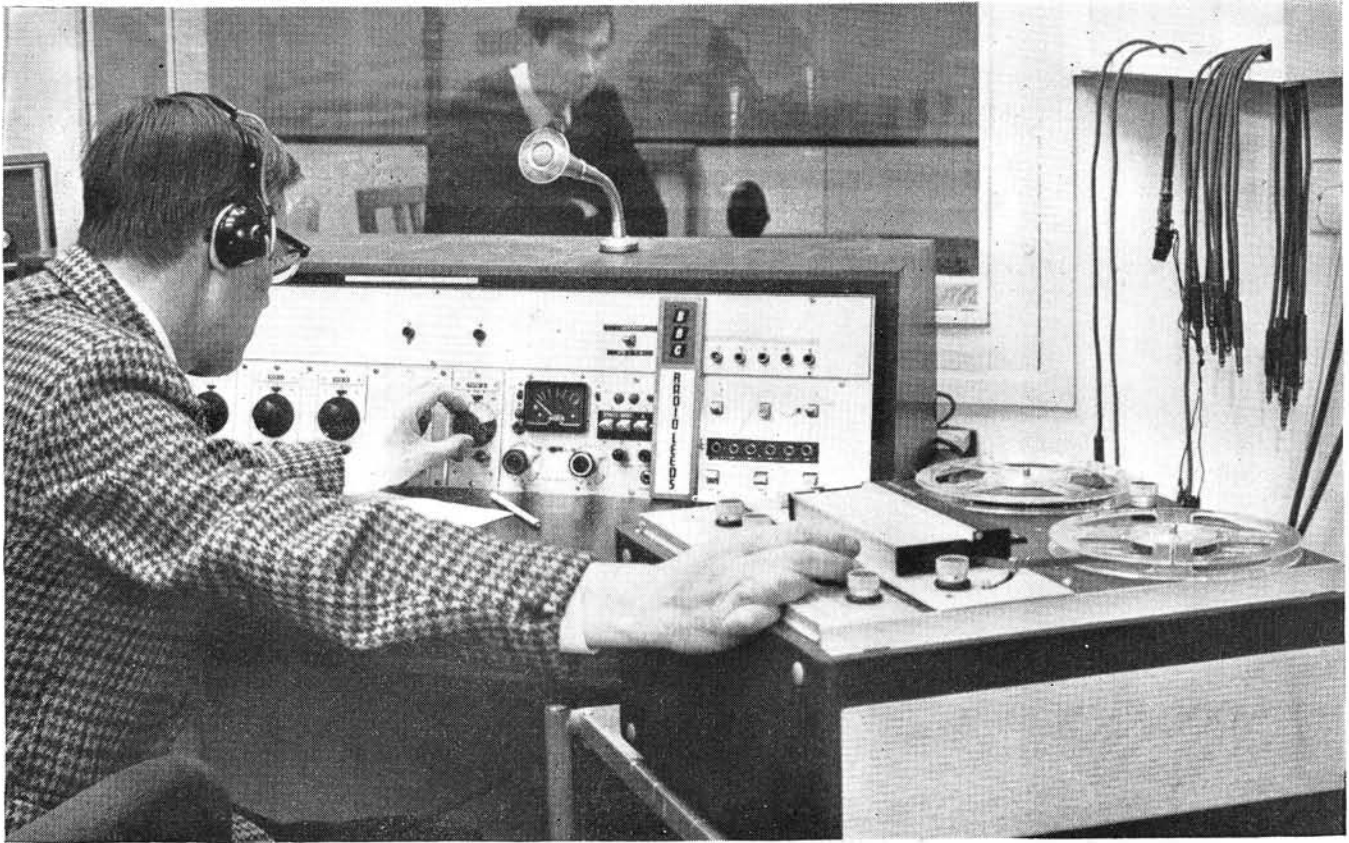

Radio Leeds: Where a tape recorder must be good and reliable you'll find a Ferrograph.

In a radio station, the tape recorder is in constant use. Technical performance is all-important; absolute dependability and split-second control are essential. So Radio Leeds uses the Ferrograph Series 7 tape recorder.

Ferrograph Series 7 recorders are British-made, available in Mono and Stereo, with and without end amplifiers, in two versions: in elegant hardwood case, or in grey vinyl case. All solid state, three speed, two inputs per channel with independent mixing, all incorporate a range of facilities

unparalleled in any other recorder. Retail prices are from £150 incl. P.T.

Follow the professionals; choose the recorder you know will serve you best at home or in your work: Ferrograph—it makes sound sense. See your nearest stockist or send the coupon for details and address of nearest Ferrograph specialist or ring 01-589 4485.

Ferrograph

A member of the Wilmot Breeden Group

To the Ferrograph Co Ltd,
Mercury House, 195 Knightsbridge,
London, S.W.7.

Please send me a free brochure
on the Ferrograph Series 7
or the Ferrograph Manual
for which I enclose £1.

Name _____

Address _____

TR

SONY

Model TC-630—the complete stereo sound control centre. Echo and sound-on-sound recording at the flick of a switch. Multiple inputs for stereo tuner, microphone, auxiliary speakers and optional turntable. Further refinements include three heads, three speeds, dual VU meters, retractable pinch roller, noise suppressor, and scrape filter.

Compact and superbly built, the TC-630 has a built-in stereo amplifier delivering a full 15 watts per channel rated output. Two lid-integrated **What more can we add?**

Model TC-630, recommended retail price £199:15:0

Specification

Recording system 4-track stereo/mono recording and playback.

Power requirements AC 100, 110, 117, 125, 220 or 240V, 50/60 Hz.

Power consumption 40 watts.

Tape speed 7½ ips (19 cm/s), 3¾ ips (9.5 cm/s) 1¾ ips (4.8 cm/s).

Reel capacity 7 in. (18 cm) or smaller.

Frequency response 30 Hz–22 kHz at 7½ ips; 30 Hz–13 kHz at 3¾ ips; 30 Hz–10kHz at 1¾ ips.

Bias frequency 160k Hz.

Wow and flutter 0.09% at 7½ ips; 0.12% at 3¾ ips; 0.16% at 1¾ ips.

Power output 15 watts per channel.

Signal-to-noise ratio 50 dB.

Harmonic distortion 1.2% at rated output (overall); 0.5% at rated output (amplifier).

Level indication Two VU meters.

Inputs Microphone: sensitivity –72 dB (0.2 mV), impedance 250 ohms.

Tuner: sensitivity –22 dB (0.06V), impedance 100k ohms.

Auxiliary: sensitivity –22 dB (0.06V), impedance 560k ohms,

Phono input (MM or MC cartridge): sensitivity –53 dB (2 mV), impedance 14k ohms.

Outputs Line: output level 0 dB (0.775V), impedance 100k ohms.

Headphone: output level –28 dB (30 mV), impedance 8 ohms.

External speaker: impedance 8 ohms.

Lid speaker: impedance 8 ohms.

Rec/PB connector Input: sensitivity –40 dB (7.75 mV), impedance 10k ohms.

Output: output level 0 dB (0.775V) impedance 100k ohms.

Dimensions 17¾ in. (w) x 20 in. (h) x 11½ in. (d).

Weight 46 lb. 3 oz.

Supplied accessories Microphone (F-45) (x2), Sony pre-recorded 5 in. tape, Sony empty reel (R-7A), connection cord (RK-74), head cleaning ribbon, reel cap (x2).

Optional accessories Speaker system (SS-3000), telephone pick-up (TP-4), stereo headset (DR-5A) (8 ohms), microphone mixer (MX-6S).

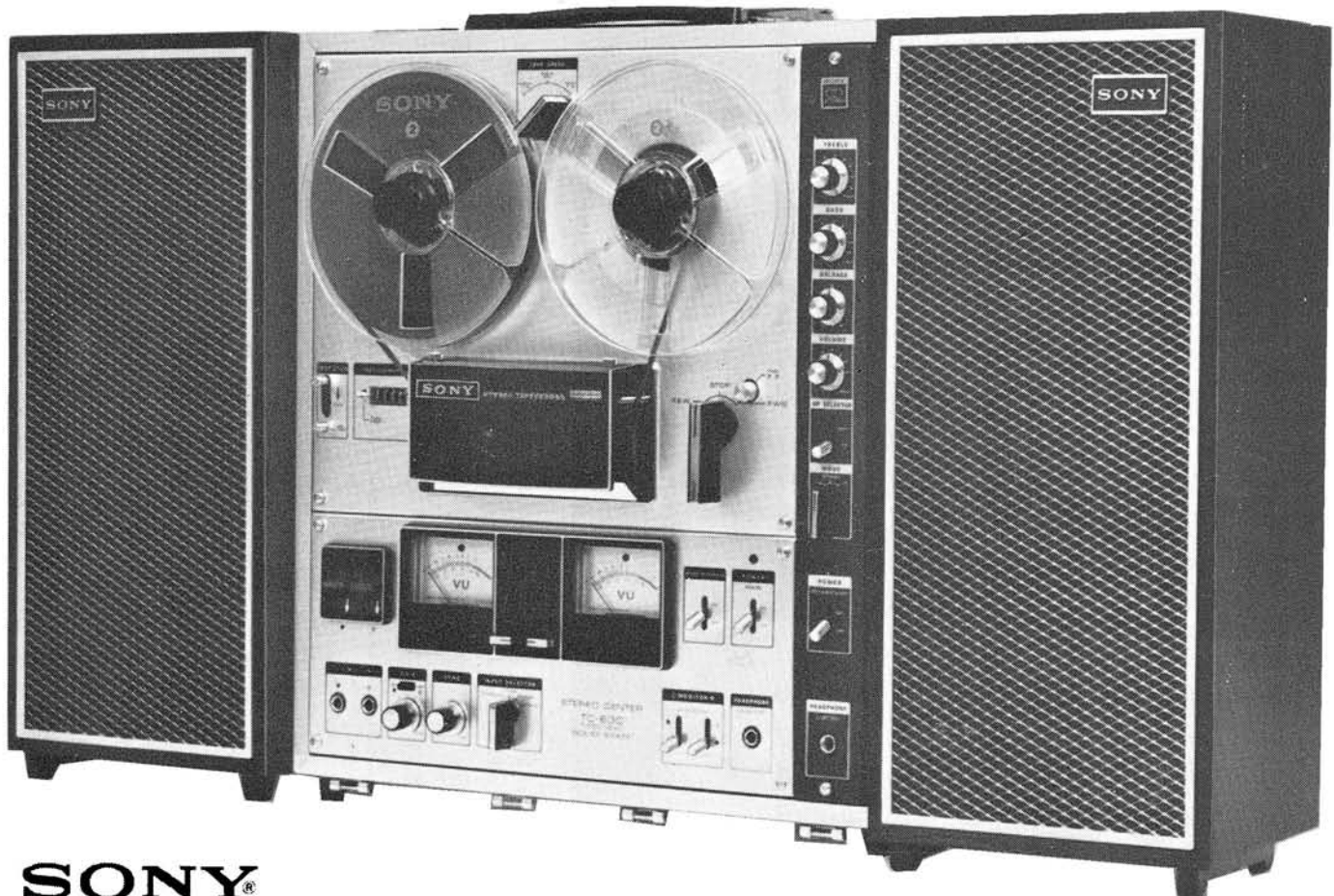

SONY

RESEARCH MAKES THE DIFFERENCE Sony (UK) Ltd Ascot Road, Bedfont, Feltham, Middlesex

Scotch

MAGNETIC TAPE

WILDLIFE TAPE RECORDING CONTEST

FIRST PRIZE

Tandberg Model 11 Field Recorder plus Gramplan 24" Parabolic Reflector (Total value £183) for 3M Wildlife Sound Recordist of the year

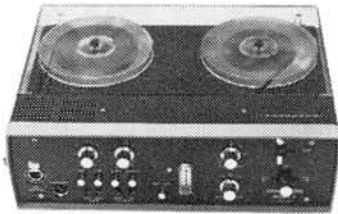

JUNIOR AWARD

Bush TP. 60 Cassette Recorder (value 26 gns.)

Rules and Entry Forms from
W. R. Bowles, 3M Company Ltd., 3M House,
Wigmore Street, London, W1A 1ET.

(closing date 30th November 1969)

Sponsored by 3M in conjunction with
The Wildlife Sound Recording Society

3M and 'Scotch' are trademarks



HEATHKIT ... for the finest selection of Hi-Fi equipment!



All in the latest Catalogue . . . and it's FREE on request!

- Stereo Amplifiers
- Stereo Receivers
- Stereo FM Tuners
- Speaker Systems
- Stereo Tape Recorder
- Garrard Players
- Shure Cartridges

Many other models for family entertainment.



DAYSTROM LTD.

Dept. HT-10, Bristol Rd., Gloucester GL2 6EE.

Please send me my FREE catalogue immediately.

Name

Address.....

PHILIPS FAMILY TAPE RECORDER

OUR PRICE

36!^{GNS}

List Price

£46.13.11



ALSO COMPLETE PHILIPS RANGE INCLUDING— N 2200 CASSETTOPHONE—

Your choice of music anywhere. Trim, streamlined musicassette player. 76 hour batteries. All transistor amplifier. Our Price 9½ gns. List price 13 gns. Only a few left.

GL 559 Smart, attractive loudspeaker enclosure. 6 watt. Size 10½" x 7½" x 7½". List Price £11. Our Price 8½ gns.

EL 3575 Full stereo tape recorder. Duoplay and multiplay integrated. First class frequency response and reproduction with full tonal values. List Price approx. £101. Our Price 72 gns.

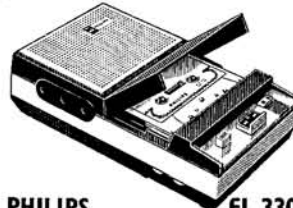

PHILIPS EL 3302 CASSETTE PORTABLE RECORDER

OUR PRICE

22^{GNS.}

LIST PRICE

£28.7.0

A real gem from Philips. Record or playback, anywhere, instantly. Just snap a Compact Cassette or Musicassette. Powered by five 1.5 Volt batteries — mains unit available. Lockable record control with playback, re-wind and fast wind. Microphone with remote stop/start control. External speaker sockets. Supplied with carrying case, blank and demonstration cassettes, library rack, etc.

DON'T MISS THESE VALUE FOR MONEY OFFERS...

Send coupon for **INTEREST FREE**

Easy Terms

range of the biggest names in the sound business. Our amazing "Specials" and offers will delight you. Interest free easy terms are available. If you can't call, write or phone for details. Our rapid reply mail order system is very popular.

N 4305

Everything the family could want in a tape recorder. Record your children's first words, music lessons, etc. A lifetime's enjoyment. Superb quality won't let you down. Four tracks, two speeds. Excellent reproduction and many features of much more expensive recorders. Supplied complete with microphone, recording/playback lead, 5" reel of long play tape, 5" empty spool.

Ferrograph

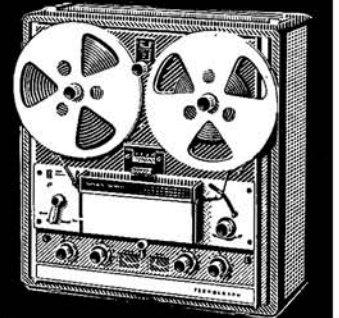

FERROGRAPH MODEL 713

A mono system of tremendous potential. Vertical or horizontal operation. Silicon solid state electronics. 3 motors (no belts). Half track. Tape speeds 1½, 3½, 7½. Output: 10 watts RMS.

OUR PRICE £153.6.3

List Price £174.13.6.

MODEL 702/4 A superb stereo system. Specification similar to 713 with no output stage. Damped tension arms for slur-free starting. Will mix four inputs into one channel. Half or quarter track. **OUR PRICE £173.8.5**

List Price £194.15.8.

MODEL 722/4 A masterpiece in stereo equipment. Specification similar to 702/4 with an output of 2 x 10 watts. A speaker for each channel. Unit construction, etc., etc. Must be heard and compared. **OUR PRICE £194.3.1**

List Price £204.14.9.

In extremely short supply— Preference given to REW customers!

Come along to either of our showrooms and you can see and hear the equipment of your choice. Rew are the only authorised Philips Audio Centre in South London. Our experienced staff will help you select from a comprehensive range of the biggest names in the sound business. Our amazing "Specials" and offers will delight you. Interest free easy terms are available. If you can't call, write or phone for details. Our rapid reply mail order system is very popular.

REW AUDIO VISUAL CO

HEADQUARTER SHOWROOMS AND MAIL ORDER: DEPT. TR, 266-8 UPPER TOOTING RD., LONDON, S.W.17. Tel. 01-672 4471/2 and 9175.

WEST END SHOWROOMS: 146 CHARING CROSS ROAD, LONDON, W.C.2. Telephone: 01-836 3365 (opposite Astoria Cinema).

NAME

ADDRESS



NATIONAL



PAIRED FOR POWER SA-54/RS-768US

National have the know-how when it comes to tape equipment tough enough to take an enthusiasts work-load, sensitive enough to catch the most elusive sound. Equipment like the *RS-768US 3 Head Stereo Tape Deck*, with extra-wide frequency response range of 20-27,000 Hz, Wow and Flutter down to under 0.09 NFD tape noise disturbance filter, plus sound-on-sound and sound-with-sound recording and all the other built-in 'extras' that makes precision tape work so simple with National.

NOW National have paired the RS-768US with their new *SA-54 Stereo Tuner Amplifier*. It's a Solid State, 90 Watt FM/AM unit with 2 high sensitivity, high selectivity Field Effect Transistors (to say nothing of 53 hard working 'cooking' TR's), Ceramic Multiplex Filter, Overload Protector Circuit and LuminaBand Tuning and slide controls.

The SA-54, like all National units, is available on its own. But we *know* it makes the ideal Amplifier for the RS-768US Tape Deck. When you've tried them as a system we're sure you'll agree.

**All National audio, radio and video models are on show at the London showrooms at 9 Connaught Street, London, W.2. Free colour brochures are available on all National models from:*



National take your entertainment seriously

United Africa House, 1-16 Blackfriars Road, London, S.E.1.

New Tandberg 1600X stereo tape deck

4 tracks. Frequency response: 40 - 18,000 ; 40 - 14,000 ; 40 - 8,000 cycles \pm 2dB at 7½, 3¾ and 1⅞ i.p.s. respectively. Signal-to-noise ratio better than - 55dB - 53dB and -52dB at 7½, 3¾ and 1⅞ i.p.s. respectively. Wow and flutter less than 1 R.M.S., -15 R.M.S. and, 35 R.M.S. at 7½, 3¾ and 1⅞ i.p.s. respectively. Cross talk better than - 60dB. -9v output per channel. Teak cabinet. £89.10.0

Send me full details

NAME

ADDRESS

Farnell - Tandberg Dept.TR5
Hereford House
Vicar Lane, Leeds 2



Cross-field bias head. Under £90

move up to Tandberg

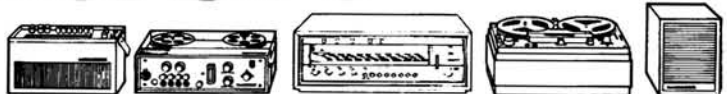

Farnell-Tandberg Ltd., Hereford House, Vicar Lane, Leeds 2.

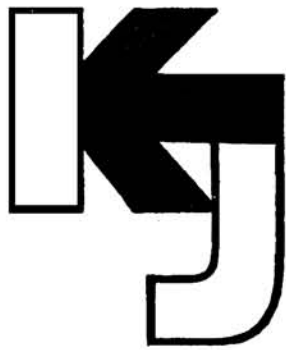

ILFORD -ZONAL TAPE UP TO 40% OFF!

NEW KJ SPECTACULAR

From the Motion Picture and Magnetic Products Division of **ILFORD LTD.** we are proud to present a New Stupendous **BARGAIN OFFER!** Never before have you been offered such a breathtaking opportunity. **ILFORD-ZONAL** premium grade magnetic tape (extensively used by the B.B.C.) at a terrific reduction of 40%! Brand New, Boxed, Fully Guaranteed and complete with leaders, trailers and stop foil. **UNIQUE TO KJ.**

DESCRIPTION	LIST PRICE	ONE	THREE	SIX
900' on 5" reel Long Play P.V.C. ...	29/1	17/6	50/6	96/6
1200' on 5 1/2" reel Long Play P.V.C. ...	36/1	22/6	65/-	125/-
1800' on 7" reel Long Play P.V.C. ...	51/4	29/6	86/-	165/-
1200' on 5" reel Double Play (Polyester) ...	43/1	27/9	81/-	157/6
1800' on 5 1/2" reel Double Play (Polyester) ...	56/1	36/-	105/-	204/-
2400' on 7" reel Double Play (Polyester) ...	78/10	49/6	145/6	285/-

Post and Packing 2/6 Orders over £5 post free

BRANDED TAPES 20% OFF!

Scotch

Agfa

GRUNDIG

BASF



DESCRIPTION	LIST PRICE	ONE	THREE	SIX
900' L/P on 5" reel ...	29/-	23/6	69/9	137/9
1200' L/P on 5" reel ...	36/-	29/-	86/-	170/-
1800' L/P on 7" reel ...	51/-	41/6	123/-	243/-
1200' D/P on 5" reel ...	43/-	34/6	102/3	202/-
1800' D/P on 5 1/2" reel ...	56/6	45/6	135/-	266/9
2400' D/P on 7" reel ...	79/-	63/6	188/3	372/-
1800' L/P Dynarange ...	58/-	46/6	137/9	272/3

Orders over £5 post free

The above are examples from the complete ranges held in stock. SEE OUR CATALOGUE FOR FULLER INFORMATION.

K. J. ENTERPRISES (Dept. TR10)

(HEAD OFFICE & MAIL-ORDER DIVISION)
33 BRIDLE PATH, WATFORD, HERTS.

Telephone: WATFORD (92) 22338 (3 lines)
(Close to Watford Junction Station)

SHOWROOMS (For callers only)

17 The Bridge, WEALDSTONE, MIDDX.

(Opposite Harrow & Wealdstone Station)
Telephone: 01-427 7758

HOURS: 9.30 a.m. — 5.30 p.m. Closed Lunch 12.30 — 1.45.
Close 1 p.m. Saturday

FANTASTIC DISCOUNT PRICES

- Recording Tapes
- Tape-Recorders
- Hi-Fi Equipment
- FM, AM and AM Radios
- Record Players
- Microphones
- Headphones
- Amps. and Tuners
- Turntables
- Cartridges
- Loudspeakers
- Plugs and Leads
- Accessories

FREE

1969
CATALOGUE
140 Pages
SEND TODAY



BARGAIN OF THE MONTH PHILIPS/STELLA 4-TRACK TAPE RECORDER Model 9123

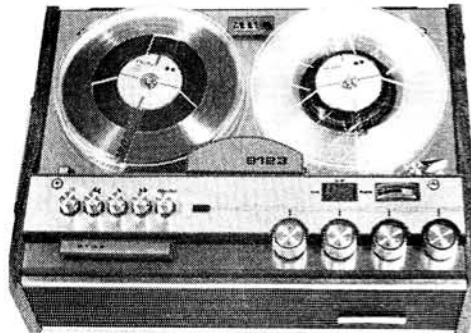

SPECIAL OFFER!

LIST PRICE £60-0-10

Our Price **£48**

Carriage 10/-
4 TRACK, 2 SPEEDS
(STEREO PLAYBACK)
Full details available



Compact Cassettes UP TO HALF PRICE

Compact Cassettes with 60, 90 & 120 minutes playing time, Brand New and packed in normal plastic library box. Available at this exceptional price.

	MC.60	MAXELL MC.90	MC.120
Standard pattern to fit	1 for 10/6	1 for 14/-	1 for 18/6
Philips, Stella, Elizabethan	3 for 30/-	3 for 40/6	3 for 54/-
Dansette, Sanyo, Ferguson,	6 for 55/6	6 for 78/-	6 for 105/-
Bush, HMV, Sony, etc.	12 for 105/-	12 for 150/-	12 for 204/-

Post and Packing 2/6. Orders over £3 post free:

Must not be confused with cheaper American Overture Cassettes advertised elsewhere

BRANDED CASSETTES (BASF or PHILIPS)

	ONE	THREE	SIX
C.60	14/3	42/3	83/6
C.90	20/3	60/-	118/6
C.120	27/-	80/-	158/-

Post and Packing 2/6. Orders over £5 post free.

WE'VE MOVED!



Have you been impressed by the KJ SUPER SERVICE? We hope so, and the ever increasing volume of mail-order seems to prove the point. To maintain efficient handling of your requirements, we have taken a further 8,000 square feet of warehousing and office premises to house our Head Office and Mail-Order Division. All correspondence should now be addressed to 33 Bridle Path, Watford, Herts. WD2 4AA.

BRITAIN'S LARGEST SPECIALISTS

At every NUSOUND showroom you'll find a wonderfully comprehensive range of equipment and expert staff with many years experience in this ever growing and highly specialised field—in which the NUSOUND reputation is "Second to None".

Every make and model of Tape Recorder and Hi-Fi Unit is available for immediate demonstration by our specialist staff who will be delighted to assist you in selecting equipment to suit your individual requirements. Only from NUSOUND can you benefit from all these invaluable features—the most comprehensive range of equipment on display in the country, competitive prices and special offers, expert staff, free technical advice, immediate demonstration of any model and the finest after-sales servicing available.

Visit any NUSOUND centre and you'll be certain of 100% Service and Satisfaction

SPECIAL AKAI BARGAIN!

MODEL 1710W STEREO TAPE RECORDER

Features 3 speeds, 1½, 3½ and 7½ ips, 4 track stereo! monaural recording and playback facilities. Two VU meters. Stereo headphone jack socket. Tone and Volume controls. Built in speakers etc. Complete in oil finish wooden cabinet. List Price £109.17.3.

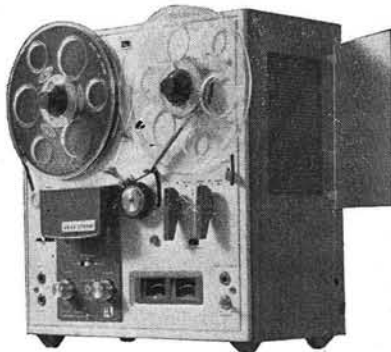

NUSOUND PRICE

89 GNS.

SENSATIONAL STEREO OFFERS!

As Britain's Largest Specialists our tremendous purchasing power enables us to offer you the famous makes—Garrard, Goldring, Rogers, Decca, Arena, Philips, Wharfedale, etc. etc.—at unbelievably low prices. We offer over 30 Hi-Fi Stereo systems utilising these famous makes all showing substantial savings off our normal list prices.



A Nusound Stereo System represents the finest value for money available today. Every system is complete with all leads, plugs, etc., carrying full manufacturers' guarantees and backed by 100% Nusound after sales service.

Call into any of our showrooms or write to Dept. TR/OT., 24 Oxford Street, London, W.1 for full details.

NuSound

BRITAIN'S LARGEST SPECIALISTS

- 24 OXFORD STREET, LONDON, W.1. Telephone: 01-580 4638
(25 yards Tottenham Court Tube Station)
- 82 HIGH HOLBORN, LONDON, W.C.1. Telephone: 01-242 7401
- 228 BISHOPSGATE, LONDON, E.C.2. Telephone: 01-247 2609
(Opposite Liverpool Street Station)
- 242/4 PENTONVILLE RD., LONDON, N.1. Telephone: 01-837 8200
- 360 KILBURN HIGH RD., LONDON, N.W.6. Telephone: 01-624 1656
- 87/100 ILFORD LANE, ILFORD, ESSEX. Telephone: 01-478 2291
- 36 LEWISHAM HIGH ST., LONDON, S.E.13. Telephone: 01-852 2399

Hours of business: Oxford St. 6 days a week; Bishopsgate closed Sat.—Open Sun. 10-2; High Holborn half day Sat.; Lewisham, Ilford, Kilburn, Pentonville Rd., half day Thurs.

DISCOUNTS :: TERMS :: DEMONSTRATIONS

F. CAVE, Tape Recorder & Hi-Fi Specialist

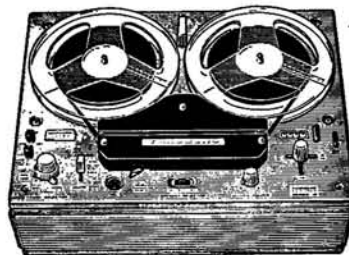

CAVES are
the TANDBERG
SPECIALISTS

Special discounts
on SANYO
for a
limited period

Tape Recorders Available: Teleton, Standard, Philips, Akai, Ferrograph, Awia, Fidelity, Grundig, Marconiphone, Revox, Tandberg, Telefunken, Wyndson, National, Truvox and many others.

Hi-Fi Equipment Available: Armstrong, Dual, Goodmans, Grampian, Leak, Lowther, Lux, Philips, Quad, Radon, Rogers, Jordan-Watts, K.E.F., Sanyo, Teleton, Celestion, Decca, Connoisseur, Goldring, Thorens, Transcriptor, Tannoy, Kenneth J. Elwin, Ortofon, Bowers & Wilkins and many others.

F. CAVE Tel: 01-948 1441
Up to 8 p.m.

5 BRIDGE STREET, RICHMOND, SURREY

Mail Orders: Dept. TR, 27 Hill St., Richmond.
2/6 P.O. for catalogue or S.A.E. for list

Quality First

with

FILM INDUSTRIES Ribbon microphones



From a review of the Model M8S
"... The Film Industries M8S
ribbon microphone has a most
attractive appearance coupled with
a performance which, in many
respects, can stand comparison
with the best designs at three or
four times its price."

FILM INDUSTRIES LTD.

Station Avenue
Kew Gardens, Surrey
TELEPHONE: RIC 8078

Please send me an illustrated brochure

Name

Address

Once you've heard the Telefunken Acusta hi-fi layout, you'll realise how long you've been in ignorance of really sweet sound.

But its superb performance isn't really surprising. In the Acusta Telefunken have only done what they've been doing

all along.

Building first class equipment to the very stringent German hi-fi standards DIN 45 500.

And since they've made equipment to those sort of standards everything they do is better, more advanced.

So visit stand 26 in the

National Hall at the Audio Fair and experience the Acusta and the whole range.

You don't know what you're missing 'til you've heard it.

AEG/Telefunken
27 Chancery Lane
London WC2



**What you've never heard,
you've never missed.**



**INCORPORATING
SOUND AND CINE**

EDITOR

JOHN CRABBE

DEPUTY EDITOR

DAVID KIRK

ADVERTISEMENT MANAGERROBIN WELLS

Editorial and Advertising Offices:
LINK HOUSE,
DINGWALL AVENUE,
CROYDON, CR9 2TA
Telephone: 01686 2599

© Link House Publications Ltd., 1969
All rights reserved

COVER PICTURE

Part of the Moog Synthesizer 3 is shown with keyboard and *glissando* unit. Further details will be found on page 417. A synthesizer for home constructors is described on page 406 by Robert Youngson

SUBSCRIPTION RATES

Annual home and overseas subscription rates to *Tape Recorder* and its associated journal *Hi-Fi News* are 30s. and 47s. respectively, U.S.A. \$4.30 & \$5.60. Six-month subscriptions are 15s. (*Tape Recorder*) and 24s. (*Hi-Fi News*), from Link House Publications Ltd., Dingwall Avenue, Croydon, CR9 2TA.

Tape Recorder is published on the 14th of the preceding month unless that date falls on a Sunday, when it appears on the Saturday.

WHEN A JOURNAL such as ours sets out to review an item of equipment produced for the domestic consumer, it is fully entitled to test that product exactly as submitted. This is the condition in which the general public would use the equipment, and any pre-test readjustment of a sample would be both misleading and dishonest.

However, when a recorder aimed at the *studio* market is reviewed (this issue carries our first review of this kind since the imposition of purchase tax on domestic recorders) the situation becomes extremely complicated. To start with, no self-respecting professional would use a recorder exactly as supplied by a manufacturer. He would make a preliminary check that all mechanical and electronic characteristics were within specification (in other words, that the recorder worked) and then set up the amplifiers and oscillator to suit his own preferred brand of tape. A studio engineer does not wish to read a reviewer's criticism of poor head alignment, maladjusted equalisation, or under-biasing. His interest is in knowing the potential optimum performance of a typical model when adjusted to the most suitable (again, in his opinion) tape.

Even the notion of 'optimum performance' varies between individual engineers and can hardly be expected to coincide with the reviewer's. Frequency response, noise level, distortion, print-through, spreading and speed instability are largely interchangeable. There is no perfect resolution for this dilemma.

If a reviewer went to the lengths of setting up each recorder for every important contemporary brand of professional tape (an appallingly tedious, time-consuming and expensive task), the published results would tell the reader nothing about consistency between samples or about long-term reliability.

Some guide to consistency might be gained from testing two or three samples, and we know that some manufacturers and importers would be prepared to tolerate this kind of strain on their stocks; others would not. This doubles or triples the demands on a reviewer's time, to the point of needing at least 30 working hours to complete his tests. A twin-channel recorder could take almost twice as long, while a multi-track console, with four, eight, 16 or 24 different channels to set up and test, might require some three weeks. This is the period taken by Decca, for example, when preparing a newly accepted multi-track Studer.

Assessing long-term reliability is a still greater problem. A bench soak-test can provide some guide, albeit dubious, to the short-term reliability of a sample, and knowledge of tape transport engineering may show the components most likely to fail. But nothing short of a year's studio operation will reveal the true effects of ageing in normal use—the single most important feature of a tape recorder.

Faced with so many difficulties, it should be clear to all concerned that any review of a professional recorder must inevitably be a compromise. In the case of non-portable console equipment, manufacturers or importers can in many cases afford to have only one sample in circulation. This is often the only 'free' machine in the country. We have been invited, in such instances, to send our reviewer to the relevant company's premises and conduct tests on the spot. The reviewer need not uproot his test gear, we have been told, since he is welcome to use the company's own. Regrettably, we have been obliged to turn down these offers since we could summon no respect for a reviewer who accepted such conditions. Would you invest in a studio machine after reading a report of that kind? We doubt it.

FEATURE ARTICLES

- 398 AN AUTOMATIC TAPE TRANSPORT CONTROL SYSTEM—Part Two
By R. L. White
- 405 INSIDE EMI
By Richard Golding
- 406 THE SYNTHESIS OF MUSICAL INSTRUMENT TONE—Part One
By Robert M. Youngson
- 411 THE SOUND STUDIO—Part Seven
By K. R. Wicks
- 415 SO YOU WANT TO BE A PRODUCER
By Peter Bastin

REGULAR ITEMS

- 397 WORLD OF TAPE
- 402 TAPE RECORDER SERVICE
By H. W. Hellyer
- 417 NEW PRODUCTS

EQUIPMENT REVIEWS

- 418 UHER 1000 PILOT PROFESSIONAL
By Terence Long
- 423 FI-CORD 800 AND 850 CAPACITOR MICROPHONES
By Stanley Kelly

Henry Maxwell is on holiday

PHILIPS



**In this day and age,
sound thinking is bound
to get you somewhere
Straight to Philips**

People who appreciate a find sound more often than not come to Philips.

Not so bold a claim when you think about it.
Consider Philips' experience in sound reproduction.
Years and years of it. Consider the research they've don in the field. And what that research has produced in the way of new sound techniques and equipment.
So if you want the best in tapes, get Philips. Sound thinkers usually do.

And what goes for tapes, goes for recorders too.

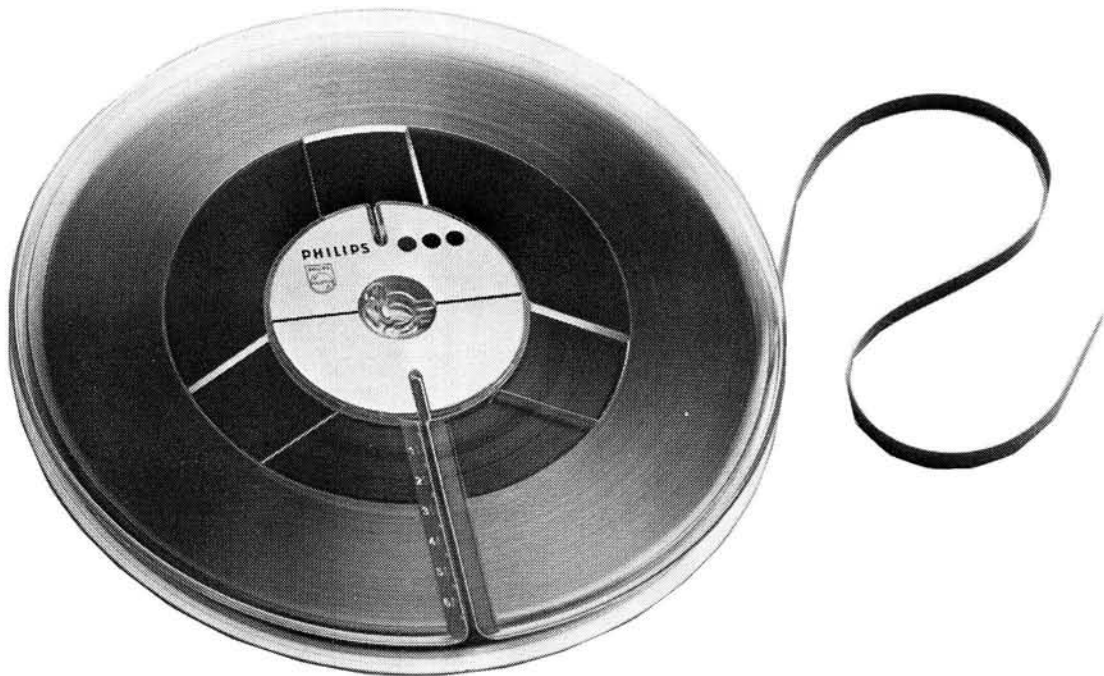

PHILIPS ELECTRICAL LTD., CENTURY HOUSE, SHAFTESBURY AVENUE, LONDON, W.C.2.

EUROPEAN WILDLIFE RECORDING CONTEST
A WILDLIFE TAPE recording competition is being organised by the BBC Natural History Unit in Bristol as one of its contributions to the European Conservation Year 1970. Entrants from any West European country, including Britain, will be invited to submit tapes of birds, insects, amphibians or mammals. The event will be launched in Strasbourg during February 1970, results being given in London the following November. A 'Golden Nightingale' award will be presented to the winner. J. F. Burton, Natural History Unit Sound Librarian, is administering the competition from *Broadcasting House, Whiteladies Road, Clifton, Bristol 8* (Tel. Bristol 32211). Entry forms and rules will be distributed in February.

BRILLE TAPE RECORDINGS

ENGINEERS AT THE Argonne National Laboratory, USA, are developing a system capable of storing braille characters on magnetic tape for

Marlene Dietrich. *Richard Lock, 34 Carrington Avenue, Boreham Wood, Hertfordshire* (Tel. 593-5762).

TAPE RECORDERS APRIL/MAY

PRODUCTION OF TAPE recorders in April was 2% higher than in the corresponding month of 1968, while output in May, although higher than in April, was 17% lower than in May 1968. Compared with 1968, stocks of UK manufactured machines were 47% higher at the end of April and 42% higher at the end of May. Stocks of foreign recorders were 63% and 27% higher respectively. The number of UK manufactured recorders delivered in April was the same as in the corresponding month of 1968, while that for May was 42% lower than in the previous year. The number exported was 30% lower in April and 2% lower in May. Deliveries of factored foreign machines, however, rose by 32% in April and 12% in May.



FERROGRAPHS RECORD APOLLO

MORE THAN FORTY Ferrograph *Series 7* recorders are now being used by the BBC. Several models were employed during the Apollo 11 mission for continuous 24-hour monitoring of the NASA commentary from America.

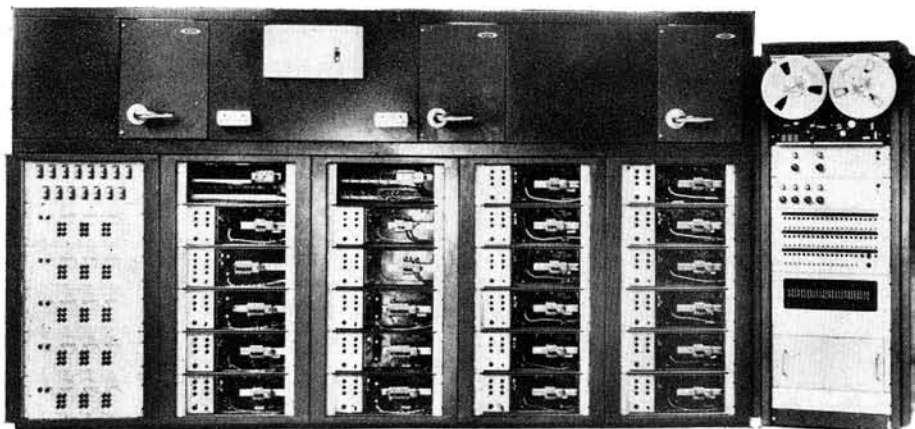

Four-track TRD tape-recorder feeds an automatic programmed unit at Caernarvon Castle. See 'Caernarvon Son et Lumière'

fingertip-reading reproduction. When perfected, the device will reproduce raised characters on an endless plastic belt, the belt speed being controlled by the reader. After each cycle, the belt will be erased before a new dot pattern is impressed. Belt life is said to be of the order of weeks or months. The braille equivalent of a printed book is at present about 50 times more bulky. Recorded on tape, the size would be reduced to that of a typewriter ribbon.

SON ET LUMIÈRE CONSULTANT

RICHARD LOCK, who was responsible for the Son et Lumière effects at Hampton Court, Salisbury Cathedral, Kenilworth Castle and the Tower of London, has now set up on his own as a consultant on sound techniques and sound/light installations. Mr. Lock organised sound equipment for the National Eisteddfod and was more recently concerned with the London production of *Charlie Girl* and *The Four Musketeers*. He is sound advisor in the UK to

CAERNARVON SON ET LUMIÈRE

CAERNARVON CASTLE, recently the scene of the Prince of Wales' Investiture, is now the site of a Son et Lumière. DKNS Associates Ltd. promoted the event, the equipment being installed by Electrosonic Ltd., *47 Old Woolwich Road, London S.E.10*. A 4-track 12mm TRD recorder provides one control and three sound tracks, feeding a total of seven Vitavox *Bitone Major* horn loudspeakers via six Electrosonic ES1799 70 W 100 V transistor amplifiers. The sound programme was produced at CTS Studios, Recorded Sound Studios, and Rossiter Studios, from a script by Wynford Vaughan Thomas. All loudspeaker and light switching is governed by the control track, a silicon IC multiplex programme unit eliminating the need for a conventional step-by-step store. The multiplex equipment is mounted in the tape transport rack, beneath the audio controls. Fifteen ES1093 modular automatic dimmers and 22 ES1006 dimmers are contained in the racks to the left of the recorder. In the back of the cabinet, not visible in the picture above, are the power amplifiers.

PHILIPS TO MAKE CHROMIUM TAPE
A LICENCE to manufacture chromium dioxide tape in Europe has been granted to Philips Gloeilampenfabrieken, Eindhoven, by DuPont. No further details have been announced.

HH ELECTRONIC MOVE

HH ELECTRONIC, manufacturers of test equipment and amplifiers, have moved to a new address: *Industrial Site, Cambridge Road, Milton, Cambridge CB4 4AZ* (Tel. Cambridge 63070).

NEXT MONTH

THE CONSTRUCTION of a transistor capacitor microphone will be described by John Penty. Richard Golding examines 16 and 8 mm sound synchronisation equipment while Alec Tutchings reviews the 38 cm/s Revox A77/HS. To be published two days before the opening of the International Audio Festival and Photo-Cine Fair, the issue will carry an up-to-date preview of tape and studio equipment.

AN AUTOMATIC TAPE TRANSPORT CONTROL SYSTEM

the second
of a two-part
constructional
feature
by R.L.White

THE binary counter consists of four toggles with the output of one feeding into the input of the next, the first one being fed from the Schmitt trigger circuit. Since each toggle is a two-state device, the total number of states for the counter as a whole is 2^4 which is 16. Since two of these states are used for the ends of the tape, this leaves 14 sections of tape which may be selected. If more possible selections are needed then more toggles may be added. For instance, five toggles will give a total of 32 possible states and therefore 30 sections which may be selected. The four toggles are denoted by the letters D, E, F and G, and the 16 states of the counter are numbered from 0 to 15.

Counter Direction Control

Since the counter has to keep in step with the tape whether it is winding or rewinding it is necessary to make the counter count both up and down. The states of the D, E, F and G outputs are shown below:

	D	E	F	G
0	0	0	0	0
1	0	0	0	1
2	0	0	1	0
3	0	0	1	1
4	0	1	0	0
5	0	1	0	1
6	0	1	1	0
7	0	1	1	1
8	1	0	0	0

9	1	0	0	1
10	1	0	1	0
11	1	0	1	1
12	1	1	0	0
13	1	1	0	1
14	1	1	1	0
15	1	1	1	1

For normal upward counting, toggle F switches when the output from G changes from 1 to 0, E switches when the output from F changes from 1 to 0 and D switches when the output from E changes from 1 to 0. If, however, the toggles are made to switch when the preceding toggle output changes from 0 to 1, then the counter will count down. The toggles always change state when their input is changed from 1 to 0 but when G changes from 0 to 1, \bar{G} changes from 1 to 0. Therefore if F is triggered from \bar{G} , E from \bar{F} and D from \bar{E} , then the counter will count down. The circuit used to perform this changeover is shown in fig. 9.

If diodes D2 are reverse biased and diodes D1 are not, then the outputs G, F and E will trigger their following toggles and the counter will count up, but if diodes D1 are reverse biased and diodes D2 are not, then \bar{G} , \bar{F} and \bar{E} will trigger their following toggles and the counter will count down. It is essential that the state of the toggles should not be changed when the counting direction is reversed and to achieve this the capacitors are charged relatively slowly through high value resistors.

Binary to 1 of 16 Converter

The binary to 1 of 16 converter consists of 15 4-input AND gates which are wired to the outputs of the toggles as shown in fig. 10. State 15 does not give an output since this is

the end of the tape and cannot be selected. The easiest way to construct this unit is to lay it out as the circuit is drawn. The prototype unit was made on *Lektrokit* board with the input wires on one side and the output wires at right angles on the other side. The diodes are put on the same side as the output wires and connected through the holes to the input wires.

Coincidence Detector

The coincidence detector consists of a further input on each AND gate in the binary to 1 of 16 converter, each of these inputs being connected to the output from the appropriate selector key. This means that there will be a logic 1 output from a gate only when the counter is set to that number and the corresponding key is also pressed. The outputs from these AND gates are fed into a 14 input OR gate which will have a logic 1 output whenever coincidence exists. The output from the AND gates is also used to release the selector keys.

Key Control Circuit

The latching coils for the keys are controlled by transistors. Each transistor is normally in the on state, but can be switched off via a capacitor from the coincidence detector which then releases the key. This circuit is shown in fig. 11. The switch consists of the contact between the key and the magnet. The capacitors should be about $1\mu\text{F}$. If the keys will not release reliably then either the key should be bent up a little or else the capacitor increased in value.

Key Pressed Detector

The key pressed detector consists of a 14-input OR gate which gives a logic 1 output when one or more keys are pressed. The circuit

FIG. 9 COUNTER WITH DIRECTION CONTROL

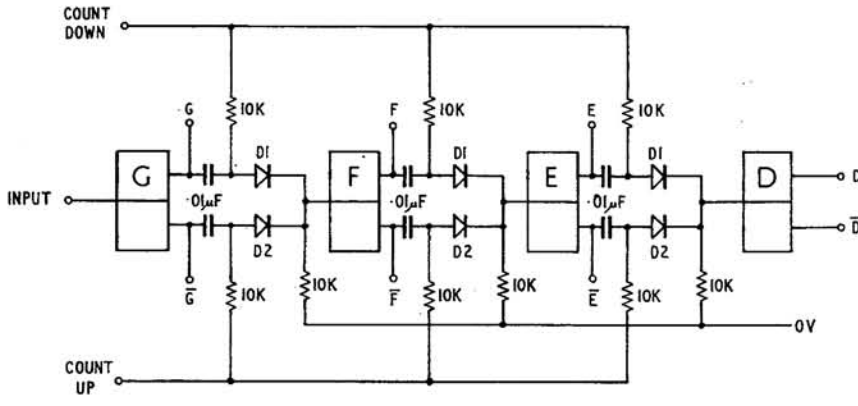

FIG. 10 BINARY TO 1 OF 16 CONVERTER

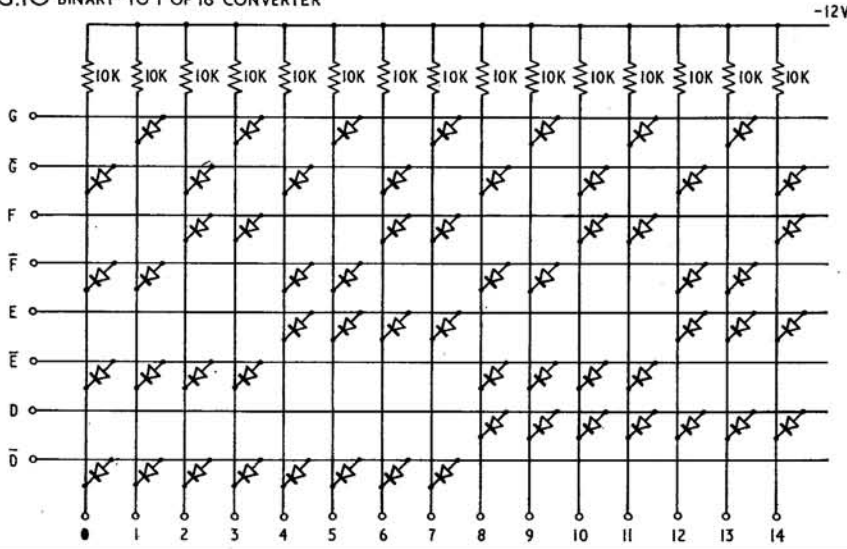

FIG. 11 KEY CONTROL CIRCUIT

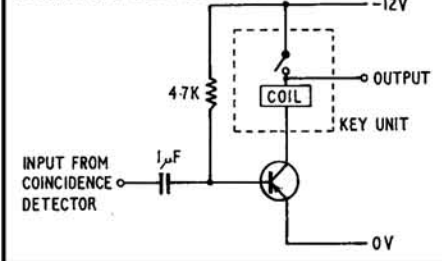

FIG. 12 KEY PRESSED AND COINCIDENCE DETECTORS

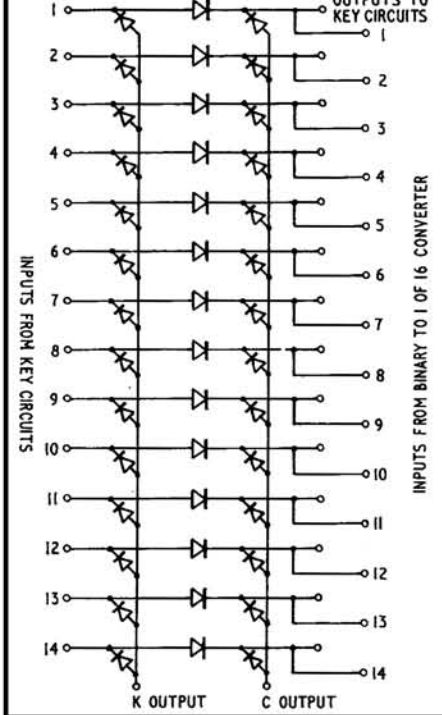
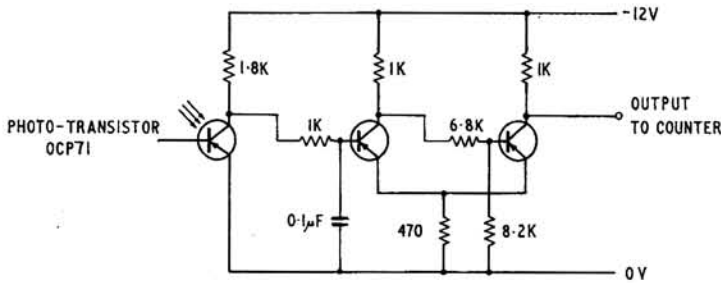
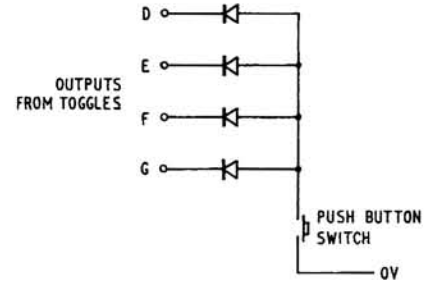

FIG. 13 PHOTO-TRANSISTOR AND SCHMITT TRIGGER



COUNTER RESET CIRCUIT



for this is shown in fig. 12.

Counter Reset

In order to re-set the binary counter to zero, a push-button switch is provided. This connects the D, E, F and G, outputs from the toggles to the zero volt line via diodes and therefore resets all the toggles.

Schmitt Trigger

This circuit is shown in fig. 13. The input

comes from the photo-transistor which does not switch on fast enough to operate the counter. The output from the Schmitt Trigger has a much faster rise time which will reliably trigger the counter. If the photo-transistor is too sensitive, or if the lamp is too bright, it is possible for the counter to step on for small scratches on the tape. The easiest way to cure this is to adjust the brightness of the lamp. It is anyway important that the lamp should not

be too bright if the tape is likely to touch it since recording tape will easily melt.

Tape Deck Control Circuit

The outputs from the various circuits are denoted as follows:

- Coincidence output = C
- Key pressed output = K
- Zero output = O

(continued overleaf)

From these we wish to generate the WIND, REWIND, PLAY and STOP signals.

The tape deck is only stopped when the tape is in the zero position but it must start to wind when a key is pressed.

Therefore $STOP = O.\bar{K}$

The tape deck must wind when a key is pressed but not if coincidence exists.

Therefore $WIND = K.C$

The tape deck will play when coincidence exists and, since this cannot happen unless a key is pressed, it is only necessary to have $PLAY = C$

The tape deck should rewind when all the keys have been released as long as the tape is not in the zero position.

Therefore $REWIND = \bar{K}.\bar{O}$

Signals also have to be generated to operate the counter direction control circuit. When a key is pressed the counter must count up and when no key is pressed it must count down.

Therefore $COUNT\ UP = K$
 $COUNT\ DOWN = \bar{K}$

The circuit used for generating all these signals is shown in fig. 14. These circuits provide all the interlocks necessary for operating the tape deck if one relay is used for each function. If, however, some degree of interlocking is provided by the relays then it should be possible to simplify this circuit.

The circuit shown in fig. 15 performs the same functions as in fig. 14 but in this case a STOP signal is provided whenever the deck finishes winding or rewinding. This allows time for the tape to slow down when going from wind to play or from rewind to wind (this latter case should not occur unless a key is accidentally pressed while the tape is being rewound). It is assumed that the deck can be switched directly from play to wind or rewind. In the previous circuit these STOP signals would have to be provided by delaying the operation of the relays. The capacitors in fig. 15 should be about 200 μF which will give about one second delay. If a longer delay is needed, these capacitors should be increased in value.

Relay Drivers

The signals from the tape deck control circuit are fed into relay drivers which operate the relays. The circuit for one of these is shown in fig. 16. It is suitable for relays having a resistance of 500 ohms or more which will operate from 12 V. Also shown in fig. 16 are the arrangements necessary for delaying the operation of a relay and for performing some of the logic in the relays.

Testing the Complete Equipment

It will first be necessary to produce an experimental tape with transparent markers

FIG. 14 TAPE DECK CONTROL CIRCUIT (WITH NO DELAYS)

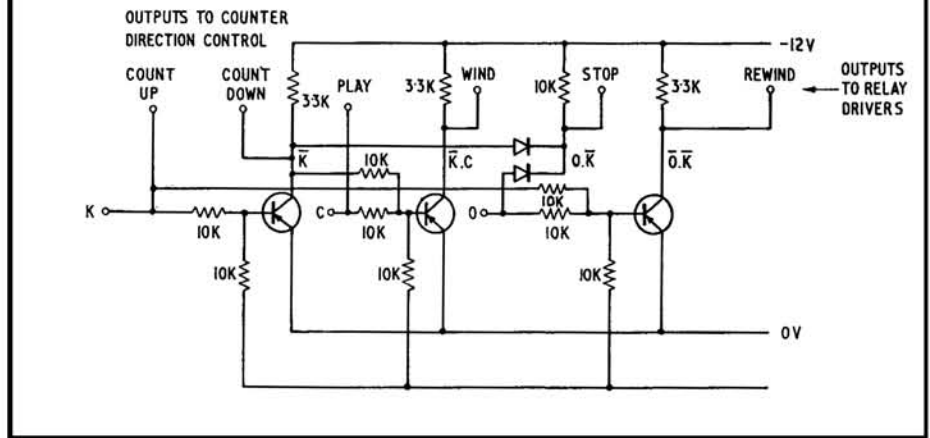

FIG. 15 TAPE DECK CONTROL CIRCUIT (WITH DELAYS)

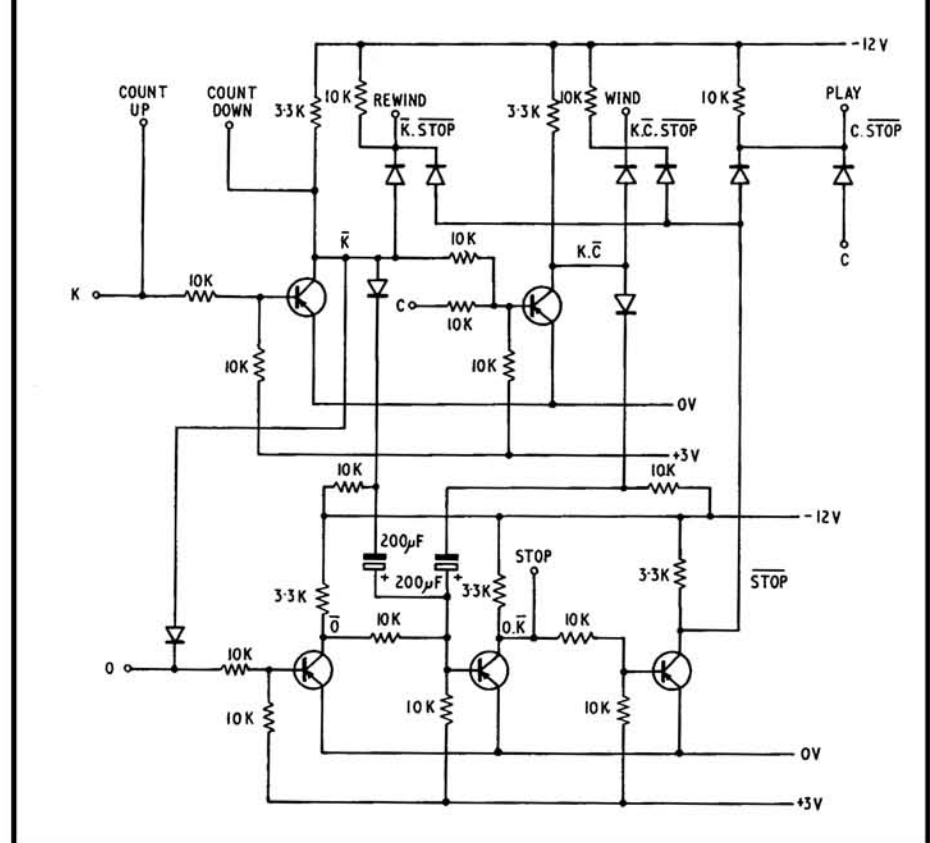
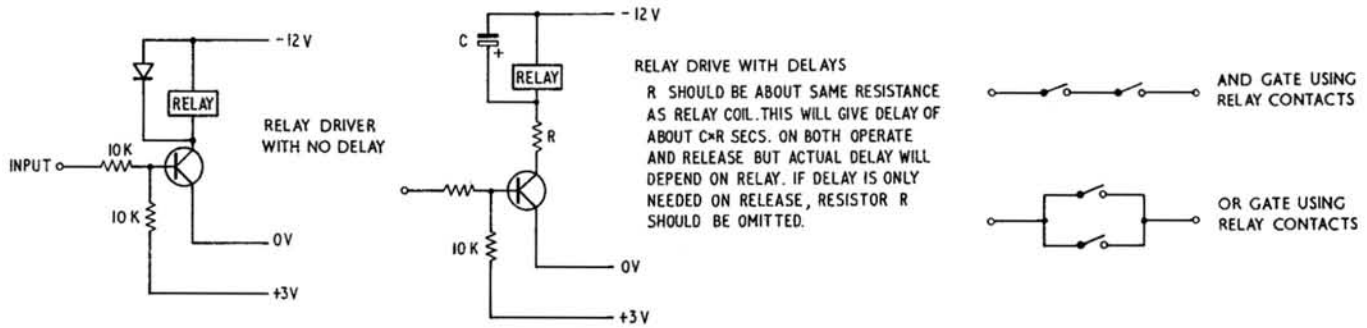

FIG. 16 EXAMPLES OF RELAY LOGIC



inserted. Some form of indicator will also be needed in order to determine the logic levels in the various parts of the circuit. The best way of doing this is with a 12 V meter (which may be a 1 mA meter with a 15 K resistor in series), since this will show small discrepancies in the voltage levels. Failing this, the circuit shown in fig. 17 may be used. It will anyway be very useful if four of these circuits could be made in order to show the state of the counter.

The tape should be loaded on to the deck and the re-set button pressed. The state of the counter can be checked either by looking at the output states of the four toggles and comparing them with the table in section 9 or else by disconnecting the binary to 1 of 16 converter from the coincidence detector and then looking for the output from the converter which is at logic 1. There will be no output from the converter if it is still connected to the coincidence detector unless the corresponding key is also pressed. The tape deck should then be set to play and the output from the counter watched to ensure that it counts up one as each marker passes. For the time being the COUNT UP wire on the counter direction control should be connected to the 12 V line and COUNT DOWN to the zero volt line. If these conditions are reversed then the counter should count down.

If the counter is operating correctly, the binary to 1 of 16 converter may be connected to the coincidence detector which should also be connected to the key circuits. The counter should be re-set and then a selector key pressed and the tape deck set to play. When the counter reaches the number of the key which has been pressed, a logic 1 should appear on the output of the coincidence detector and when the counter steps on one this output should return to logic 0 and the key should be released. If the key pressed detector is also

connected there should be a logic 1 output from this as long as a key is latched.

When all these circuits are working, they may be connected to the tape deck control. The logic level on the outputs from this circuit should be as follows (N.B. If it is necessary to measure logic levels on the bases of transistors, a logic 1 is only about 0.5 at this point. It may therefore be difficult to see the difference between a 1 and a 0):

- (a) No keys pressed, counter set to zero:
STOP=1, WIND=0, REWIND=0, PLAY=0,
COUNT UP=0, COUNT DOWN=1.
- (b) Key pressed, counter not set to the number of the key which has been pressed:
STOP=0, WIND=1, REWIND=0, PLAY=0,
COUNT UP=1, COUNT DOWN=0.
- (c) Key pressed, counter set to number of that key:
STOP=0, WIND=0, REWIND=0, PLAY=1,
COUNT UP=1, COUNT DOWN=0.
- (d) No key pressed, counter not set to zero:
STOP=0, WIND=0, REWIND=1, PLAY=0,
COUNT UP=0, COUNT DOWN=1.

If all these signals are correct, the COUNT UP and COUNT DOWN outputs may be connected to the counter direction control and the STOP, WIND, REWIND and PLAY outputs connected to their relay drivers. The relays should also be connected to the tape deck. The equipment can then be tested as a whole.

Construction and Components

The layout of the circuits is not critical except that it is important to observe the following rules with respect to the relay circuits. Since a large voltage pulse is generated when a relay is switched off, the relay circuits and all connections to them should be kept separate from the logic circuits and in particular the binary

FIG. 17 INDICATOR CIRCUIT

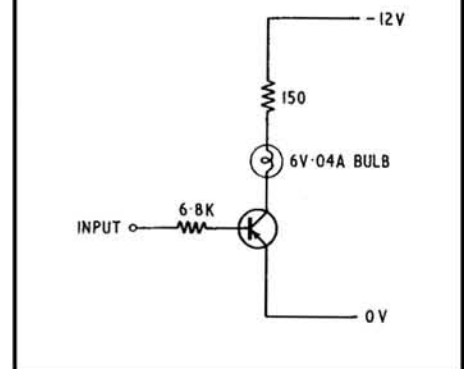

counter and Schmitt Trigger. If possible the relays should be mounted on the tape deck. The power supply rails for the relay circuits should also be kept separate from those for the logic circuits and joined together as close to the power supply as possible. In general the circuit is immune to interference and this will only show itself in erratic switching of the counter.

Most of the components are not critical. Any type of 20% resistor may be used. The type of diode is not particularly important, in fact the prototype used a combination of point contact germanium diodes and silicon junction diodes. The type of transistor used in the logic circuits is not critical but those used in the key latching circuits should be capable of carrying 100 mA continuously and those in the relay drivers should have a breakdown voltage of more than 30 V. The working voltage of the electrolytic capacitors should be more than 12 V.



SONY TC260

BY H. W. HELLYER

WE are hopping about a bit in our selection of Sony models to maintain some continuity in descriptions of the mechanisms of related machines. Following the numbered sequence would mean a lot of extra work for our illustrators. So we skip the *TC250* and come back to it later, looking this month at the *TC260*, and laying the ground for the *TC530*.

The differences in electronics are quite considerable and worth our drawing some comparisons. Last month, we saw the last of the hybrids; this month an all-transistor design and a change to the 'suitcase' style with squared-off rugged heaviness that features in all the Sony middle-generation machines. To follow, an introduction to the silicon transistor designs (from which, I fear, we shall later have to revert again).

This is quite a comprehensive machine but, because of the common record/play main switch, we cannot parallel a mono channel to feed both speakers.

As this is the sort of function that people expect, we give a small modification in fig. 3, which simply entails adding a two-pole three-way switch between the line output socket and the main connector to the output stages, giving left or right output from the preamps on both channels outputs or, in the middle position, the normal stereo function. This sort of modification can apply to several other machines, including the *TC250A*, where it is very necessary.

Dismantling for initial tests raises a few problems and is made much easier with an octal plug and socket flylead to connect the deck to the main amp, without having to take

the latter from the cabinet, which is rarely needed. There are five screws in the base, and the (two screws) handle to remove, after which the cabinet can be lifted away from the inverted deck plus preamps, leaving the 8-pin female connector flying.

Taking off the top panel involves us in a few removals, as with the *TC200*, including not only the speed change, function selector and the pressure roller but also the gain controls under the input flap. These are invariably tight and do not like being levered with kitchen knives. In all cases where knobs are preventing panels from removal, if the panel itself is pressed upwards slightly it will help 'start' the knobs. Sony employ the milled grip, split spindle technique on much of their apparatus, and knobs fit tightly. Trouble often comes when refitting because there is no 'right' position for the knob as with a flatted spindle, so it is wise to turn controls to their end limits and refit knobs to the marked indications. A small point but one that may save some frustration.

If you wish to work on the main amplifier or speaker wiring, without removing the deck, this too can be done. The knobs pull off in the same way, with extra care being needed for the concentric replay gain controls.

There are two mains transformers in this and similar machines. One is mounted on the main deck, supplying the AC for motor and dial lamps, for the full-wave rectifier that supplies the 24 V DC rail, and also for a supply, via the 8-pin link, at 117 V, which powers the main amplifier section. A second transformer on the output panel picks up this supply and rectifies and regulates it via a series transistor, taking 700 mA in the common negative line. So this section is a self-contained 117 V powered amplifier and can be treated as such for service, which makes life easy.

The oscillator is on a printed panel on the main deck, which also contains the simple power supply parts, and is easy to get at with the deck removed. If you want to get the panel loose, it is not quite so straightforward. There are two holding screws at the inside end of the panel, but the outer end is clipped into a bracket and it is necessary to exercise a little care when releasing it and swivelling the panel to the extent of the attached leads.

Similarly, although you can get at the larger preamp panel for testing, changing components will generally entail lifting it free, and this

means that the main record/play switch has to be uncoupled from its spring. The trick is to bend a piece of wire into an eyelet, hook it over the end of the spring and extend the latter, allowing the PVC tube to slide over your hook.

Always replace that tube, however much of a fiddle it may seem. And never attempt to release the switch rod by turning the adjusting nuts. Apart from the fact that they are fiercely tight, thanks to Sony's liberal use of Neji paint, which sets rock-hard, the adjustment is quite fine, and some weird troubles can ensue if either the spring is stretched or the rod is out of true.

I must confess that, when servicing this and other machines built this way, I am tempted to mount smaller components and particularly input transistors, on the print side of the board, after pushing through the old ones and shaking them loose. Sony may disapprove but, when you consider that selection of the *2SD64* pairs to get the best signal-to-noise figure sometimes requires a choice from half-a-dozen, the practice may be justified.

Having mentioned the input transistors, I must have a little carp. In a previous article I mentioned that a change to *BC108/BC109* circuitry effected an undoubted improvement and was immediately asked for chapter and verse on the conversion. Manufacturers do not always approve of our recommending changes to their design, and we have to be careful in this respect. But even the most conservative designer will have to admit that improved components permit an upgrading of his pet. I would ask readers who possess machines like this, with rather noise-prone input stages, to wait a short while for the circuit of the *TC530*, where the use of *2SC401* silicon devices in a very similar circuit may spark off a few ideas. Silicon input transistors make a great deal of difference but, because of changed parameters, the bias and load components have to be altered—they are never direct replacements.

The signal-to-noise ratio of this machine, all being well, is 50 dB at peak recording level and for an overall distortion level of 3%. Now this statement needs some qualification. Alec Tutchings has already pointed out in his reviews that the 0 dB level for several tape recorders, especially some Japanese ones, is several dB below what we would expect. The VU meters are not heavily damped, and with wildly fluctuating source signals it is sometimes necessary to run into apparent overload to

(continued on page 414)

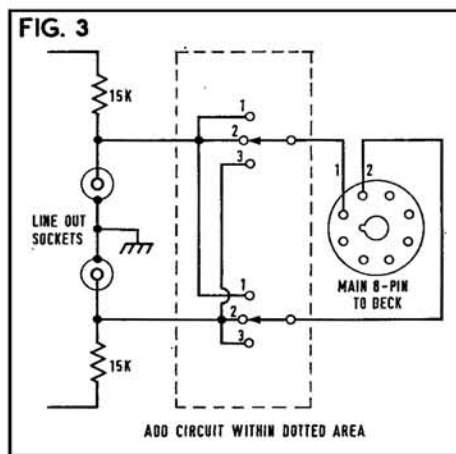
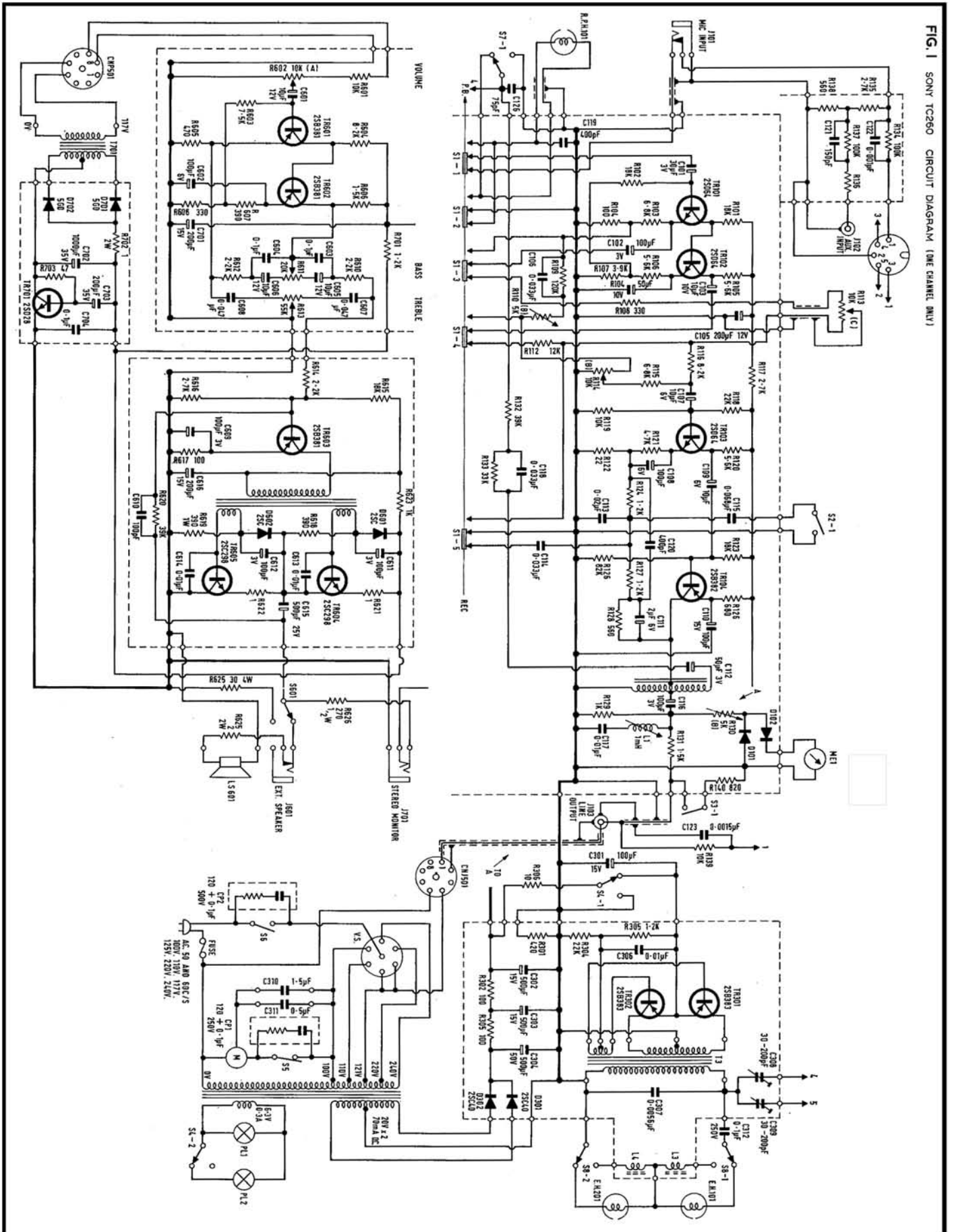

FIG. 1 SONY TC250 CIRCUIT DIAGRAM (ONE CHANNEL ONLY)



For the man who will only settle for perfection...

Ferguson make this 3 speed, 4 track stereo tape recorder.

This is the one. The stereo tape recorder that every real enthusiast wants to get his hands on. Ferguson know what you want from a stereo tape recorder and they've packed all your needs into the 3244.

Just imagine your ideal tape recorder and see how it checks out with the 3244.

- Stereo/Mono recording and reproduction.
- 3 speeds - $7\frac{1}{2}$, $3\frac{3}{4}$, and $1\frac{1}{2}$ i.p.s.
- $\frac{1}{4}$ track stacked stereo heads
- Transistor amplifier channels
- Clutched dual concentric controls
- Input mixing
- Calibrated record level meters
- Latching pause control
- Auto stop at tape ends
- Remote pause facility
- Monitoring while recording on built in speakers
- Track transfers on mono
- Second channel monitoring
- Interlocked controls
- Comprehensive input/output sockets
- Two dynamic microphones, 1,200 ft of tape, take-up spool, connecting lead and remote pause switch on 20ft lead.

Not only does the 3244 sound great but it looks great too in its teak veneered cabinet and neutral tinted transparent lid which is designed to match Ferguson Unit Audio equipment.

So if you take stereo tape recorders as seriously as Ferguson do, go along to your nearest dealer and ask for a demonstration. When you've heard the 3244 you'll know that it sounds like a tape recorder should.



£93-5s.

FERGUSON tape recorders

To: British Radio Corporation Limited,
284, Southbury Road, Enfield, Middlesex.
Please send me a full colour leaflet for the
Ferguson 3244 stereo tape recorder.

NAME _____

ADDRESS _____

G.5 A



British Radio Corporation is a member of the Thorn Group.

inside EMI

Richard Golding visits the Emitape laboratories

A GREAT deal of attention has been given in these columns to the evolution of tape recording equipment over the years. We read also that, in the field of instrumentation, tape mechanisms have been evolved with characteristics that put audio standards to shame. I hear

Professional applications laboratory



that a detailed description of the Dolby noise reduction system will be published in this journal in the next few months. All very interesting, but what about tape? Crolyn has yet to be marketed as a commercial proposition so what have the tape manufacturers done to keep up with the advance in equipment, especially professional equipment? This last thought triggers off a new one. What is the difference between domestic and professional tape? Would the amateur benefit by paying a few extra shillings for professional tape? To cut a long story short, I phoned Emitape and was invited to inspect the factory at Hayes, Middlesex.

The EMI tape production line comprises mixing, coating and slitting rooms which are divided into 'clean' and 'ultra-clean' areas separated by an airlock system through which the staff must enter to work. In the first plant, lacquer binder is dissolved in a solvent and then mixed with the oxide to achieve uniform dispersion. The dispersion passes from the tanks through a filtration plant and then on to the coating machines. There, it is spread evenly across a 400 mm moving base sheet, a sensing

element monitoring coating thickness. Uniformity in the thickness of this coating depends on several factors, including the exact accuracy of the film drive mechanism, the degree of temperature control, and the consistency of the dispersion.

The film is now passed through a magnetic field to align the oxide particles along the plane in which recording will ultimately occur. This increases the sensitivity of the tape and consequently lowers the noise level. Next, the film passes through a heated drying chamber.

Rotary knives slit the coated film into tapes of the correct width. This slitting equipment, again, is machined to very close tolerances for

Domestic applications
laboratory



Base film cleansing
machine

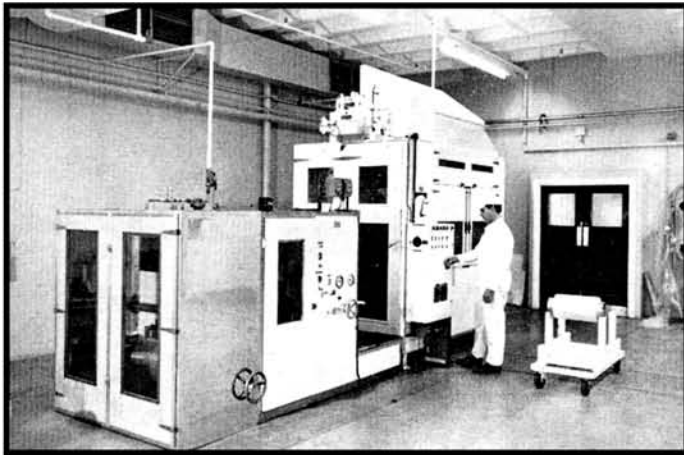

the tape must not show any imperfections such as burred or flaking edges. Constant tension is maintained on the tape throughout the slitting operation. The slit tapes are now wound on to large reels and are finally transferred to branded Emitape spools.

Tape testing forms a major part of the EMI production line and the Main Quality Control Room is going all-out day and night. Samples are taken from both the edges and centre of the tape spreads (240 reels of tape to one spread) and put through a 20-hour continuous-run tape test. This is to check physical characteristics and wear properties. Extensive records are kept and EMI can refer back to any tape spread.

Short-term wear tests are also done on sample tapes: over 100 passes, with a readout for every tenth pass to check dropouts

uniformity. The equipment used in testing professional tape includes a BTR2, TR52, TR90, and Bruel & Kjaer pen recorder. A special loop test handles 100,000 passes for a sample tape from each dope batch. A dropout pen recording is made for every reel of professional EMI tape.

I was very impressed by the obvious efficiency of this test room, and by the dedication of the staff, but for me the highlight of the visit was the Applications Laboratory. This is used to develop new test methods and to advise the chemists on the electro-acoustic properties of tape. It contains a variety of equipment to reproduce studio conditions with Philips, EMI,

and Nagra, Uher, Ferrograph and Revox.

The technicians here are looking for new methods to measure the parameters of experimental tapes produced by the research and development chemists. (Everyone in EMI agrees that the relationships of certain magnetic properties to audio recording are not yet fully understood and that continuous research is necessary in order to obtain the further knowledge that is necessary for the future development of magnetic recording tape.)

First I was shown the main equipment in the lab, a modified BTR2 with low noise electronics and ferrite heads.

Professional tape was being tested at that moment and an engineer was comparing one tape against another, using a variety of test equipment. Similar machines running at 38

(continued on page 425)

the synthesis of musical instrument tone

THE possibility of synthesising musical tone by electronic means has been a constant stimulus since the first practical oscillators were invented. A considerable background of acoustical knowledge already existed: analytical studies of the air pressure changes subserving musical tone, remarkable in their detail, had laid the foundations of the subject and indicated the lines of approach. Indeed, the early difficulties arose less from want of knowledge on what was to be done than from technical inadequacies in the means of doing it.

These inadequacies no longer exist: the resources of contemporary electronic techniques are more than sufficient for the purpose. It is now possible so effectively to simulate the output characteristics of the majority of solo musical instruments as to impose upon the air pressure patterns substantially identical to those caused by the original. Given identical air waveforms, there is, of course, no audible means of distinguishing the true nature of the source.

To justify itself, such synthesis must achieve more than mere verisimilitude. If the synthesiser is harder to play than the model, or the cost many times greater, it fails. But if the analogue enables a player of limited skill easily to solve problems of musical technique and artistry, if a single portable device can produce the effect of any of a range of instruments, then the process is clearly justified. The criteria must, at all times, be musical and artistic rather than technological.

In so far as it purports to be an effective copy of musical instrument sound, electronically synthesised tone has, from its inception to date, quite rightly aroused the opprobrium of musicians. Further, much of what has been produced as 'new sound', with a claim for musical quality in its own right, has likewise and, I think, justifiably, been dismissed by some as unworthy of serious consideration. An exception to this may be the use of electronically and electromechanically produced tones, taped, treated and edited, for the purpose of musique concrète and other experimental genres, but these are outside the scope of this study.

Electronic and electrostatic organs have now passed through several distinct generations of evolution and those among the best contemporary designs, produced deliberately as substitutes for pipe organs, achieve a high standard of synthesis. But, paradoxically, the more effectively an electronic organ simulates a pipe organ, the less likely it is to qualify as an adequate synthesizer of musical instrument tone. I would not wish to imply that a pipe

organ is not a musical instrument; far from it. The point I am making is that the pipe organ itself is an imitator and, by and large, a poor one. Diapason and extreme bass tone apart, every stop in the most comprehensive pipe organ specification is explicitly or implicitly an imitation of some solo instrument or combination of these.

Because of its pretention to be a 'one man orchestra', the organ is necessarily very restricted in the degree of control which can be imposed upon each individual tone. This divergent design outlook, and the consequent rigidity of characteristics, is one of the reasons for the organ's failure as an imitator (and to some extent as a musical instrument). In our case, our purpose is to apply all available manipulative resources to the achievement of maximal control over a single complex entity: our design orientation is convergent.

Analysis must necessarily precede synthesis and the success of the latter depends directly on the accuracy and detail of the former. Let us therefore consider what we know about our model.

The most surprising feature of an analysis of a solo instrument's musical output is the number of distinguishable parameters: it will be seen that the difficulty in synthesis is roughly proportional to the extent to which possible parameters are present. I shall be dealing with the following: pitch, temperament, loudness, opening shape of waveform envelope, starting transients, order of onset of harmonic components, harmonic content, formants, vibrato, tremolo, portamento and the parameter of 'uncertainty' (which, surprisingly enough, turns out to be most important). These parameters are closely inter-related so that, for instance, we must consider variations in loudness with changes in pitch, variations in the opening shape of the waveform with loudness and pitch, variations in the harmonic content with loudness, pitch, mode of playing, and so on. I shall also touch on the effect of the environmental factors of reverberation, room resonance and absorption.

This catalogue is certainly not exhaustive but I think it covers the most important elements. Its chief significance, here, is to emphasise the detail into which it is necessary to go before the problem can be realistically stated.

Pitch, Temperament and Vibrato

These three are so closely related that they cannot be treated separately.

The frequency range of the solo musical instruments is usually a little over three octaves on fundamentals, and up to or beyond the

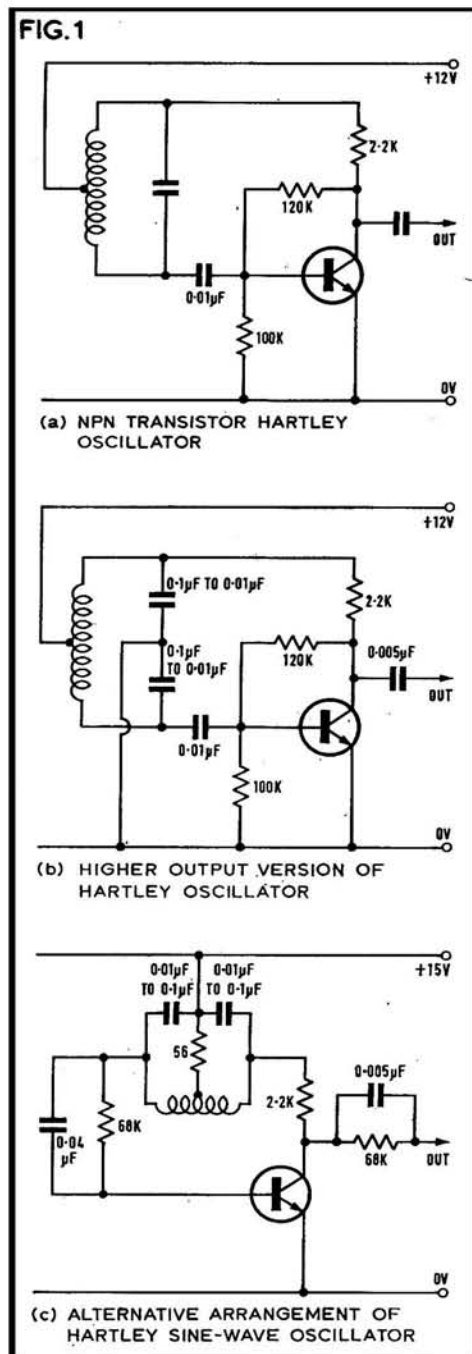

the synthesis of musical instrument tone

The first of a series of articles
covering the theory of
sound synthesis and the construction
of a highly versatile synthesizer

By Robert M. Youngson

limits of audibility on partials. No problems arise either in covering or in appropriately locating the range. A list of typical frequency ranges of common instruments is given in Table 1.

Some attention must, however, be paid to the question of pitch stability and, ideally, this should be neither better nor worse than that of the model. Poor frequency stability is, of course, unacceptable, since a musical instrument must stay in tune. Not so obvious, however, is the fact that in instruments such as flutes, oboes, clarinets, bassoons, and those where the pitch of the notes is determined by natural harmonic series (brass instruments), a standard of frequency stability much higher than that of the natural instrument precludes the simulation of those slight variations in intonation caused by small changes in air pressure, embouchure, etc., which may be a characteristic feature of the original.

Frequency stability of a very much higher order than that found in musical instruments is easily realised by the use of oscillators whose resonant frequency is determined by the mechanical vibration of bodies such as quartz crystals and tuning forks. Such oscillators, while important in some systems of additive tone synthesis (see below) are, however, unsuitable for reasonably compact attempts at the synthesis of solo musical instruments.

The question of frequency stability is, of course, fundamentally related to the method adopted for the selection or control of pitch and this, in turn, is determined by the temperament capacity of the model. This parameter is dealt with below, but it will be clear that an instrument such as a violin, capable of playing all possible intervals within the octave and thus of playing in strict temperament, cannot employ either a conventional keyboard or fixed frequency oscillators.

Temperament is a parameter about whose importance some controversy is to be expected, the opinion of any critic being determined by the acuity of his sense of pitch. Keyboard instruments must necessarily be tuned to equal temperament if 12 keys to the octave are to suffice for the playing of many more than 12 tones. The violinist on the other hand can, if he has a good ear, does play as nearly to strictly-tempered intervals as his instrument will allow (which is why a violin playing with a piano often sounds out of tune). In most cases, and especially in rapid passages, the difference between equal temperament tuning and strict temperament goes unnoticed, but certain intervals, in slow tempo, played on an equal temperament instrument, can sound

painfully out of tune if one is able to compare them directly with pure intervals. Our acceptance of equal-temperament tuning, as a satisfactory compromise, is really a matter of conditioning.

For these reasons it is essential that any serious attempt to synthesise free-intervals instruments such as the bowed string instrument must make provision for adjustment of the pitch of each note in the chromatic scale, above and below the equal-temperament frequency.

Vibrato, which is a feature of almost all instrumental tone and an important vehicle of musical expression, is an essential parameter in synthesis. It is, however, equally essential that you should be able to apply vibrato independently, at will, to each separate tone and that both the rate and depth should be under direct control. This requirement precludes any of the systems commonly used in electronic organs in which the whole output, or an entire section, is modulated by vibrato (or more commonly tremolo). Such systems, although cheap and easily arranged, are essentially unnatural, firstly because the phase changes are common to all notes and secondly because electronically produced vibrato is too regular in its frequency and depth.

Tremolo (cyclical loudness variation) is largely an artificial entity and plays little part in serious attempts at synthesis. Obviously a small element of tremolo will always coexist with natural vibrato but it is unnecessary to go to the trouble of allowing for this in the circuitry, as the difference in the effect on the ear is negligible.

For pre-tuned instruments we require a set of oscillators each being of adequate frequency stability, but each being capable of easy control of frequency for a fraction of a semitone on either side of the mean. This fraction should not exceed half a semitone and, in practice, the variation employed will normally be less than this. A number of well-tried oscillators, of appropriate frequency stability, fulfil this requirement, one of the most suitable being the much-used Hartley oscillator shown in figs. 1 and 2. Another suitable type, which has the advantage of employing an untapped coil, is the emitter-coupled oscillator, two versions of which are shown in figs. 3 and 4.

The variable-frequency requirement can be met in several ways. With stable LC oscillators, the loading of the amplifier on the resonant circuit is so slight that the frequency is almost unaffected by changes in the amplifier constants and one must vary either the inductance or the capacitance of the tank. Most commonly in

such oscillators, when used at audio frequencies, the inductor is wound on a ferrite core in a threaded mount to facilitate tuning. The rate of change of inductance by this method is, however, far too slow for our purposes. The alternative of using a sliding unthreaded core leads to problems in maintaining the basic tuning and causes excessive frequency swing for a small movement. Probably the most practical way to achieve the right degree of control is to change the inductance slightly by approximating to the coil a small movable mass of metal. This must be positioned so that the pitch can be varied both above and below the mean value and the mounting must be such that the movable metal returns reliably to the correct position when left alone. The metallic vane should not be able to approach too near to the coil or excessive drop in pitch will result,

(continued overleaf)

FIG. 2 PNP HARTLEY OSCILLATOR

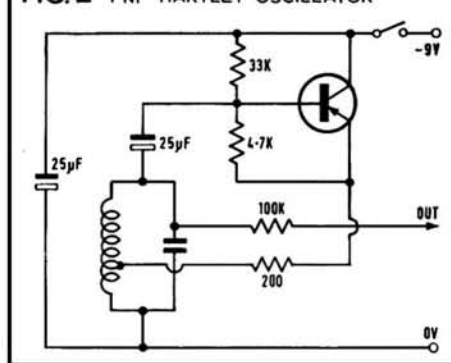

FIG. 3 EMITTER-COUPLED SINE-WAVE OSCILLATOR

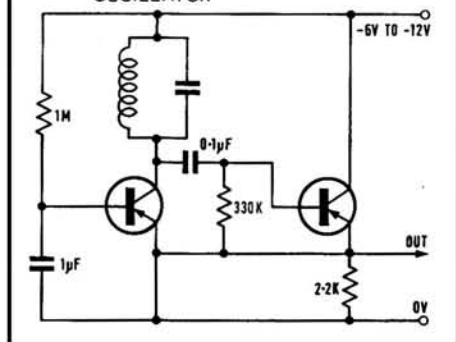

FIG. 5 ARRANGEMENT FOR PITCH (OR GATE) SWITCHING GIVING CONTROL OVER VIBRATO AND INTONATION

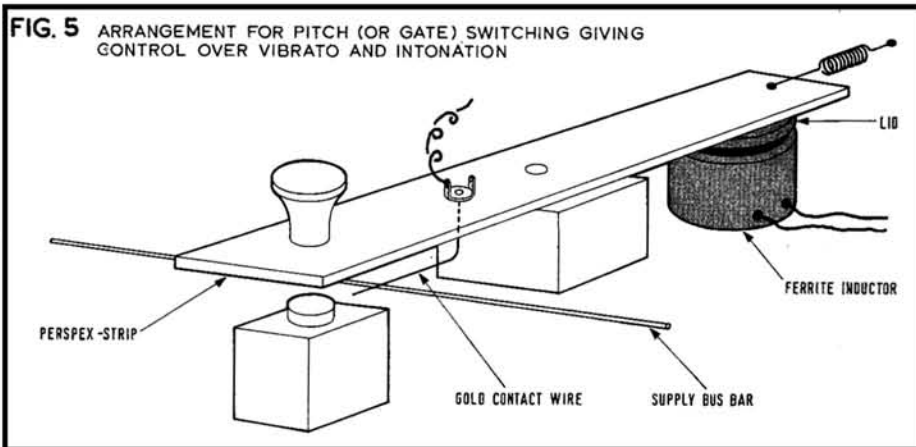

FIG. 4 SQUARE-WAVE OSCILLATOR (I.D. TOWERS)

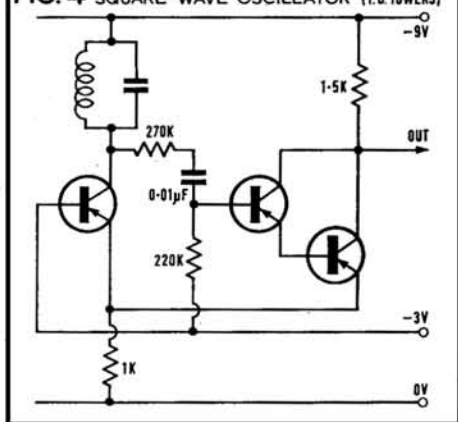

FIG. 6 STANDARD KEYBOARD DIMENSIONS FOR ONE OCTAVE. CONVENTIONAL KEYBOARDS ARE NOT SUITABLE BUT DIMENSIONS AND SPACIAL RELATIONSHIPS MATTER.

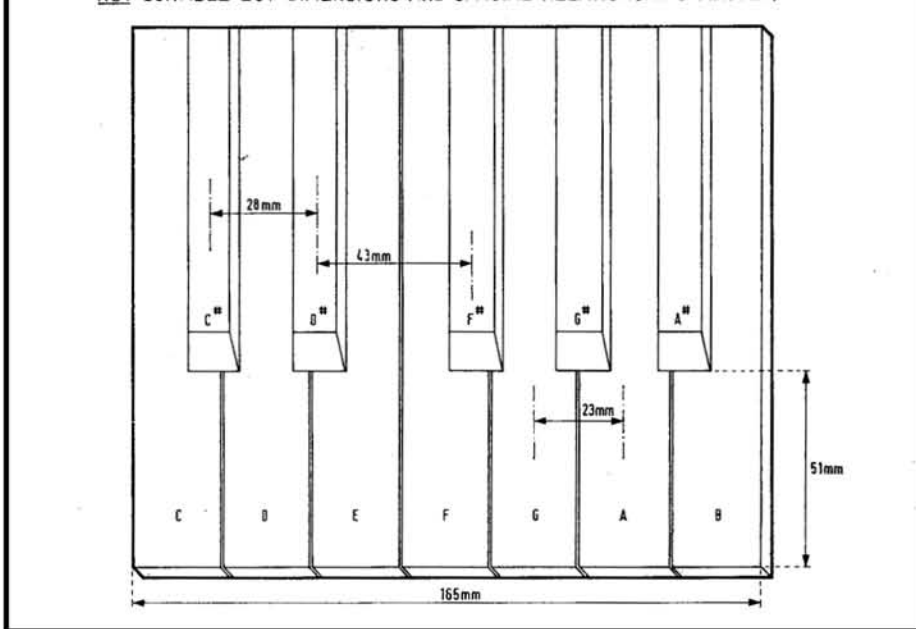
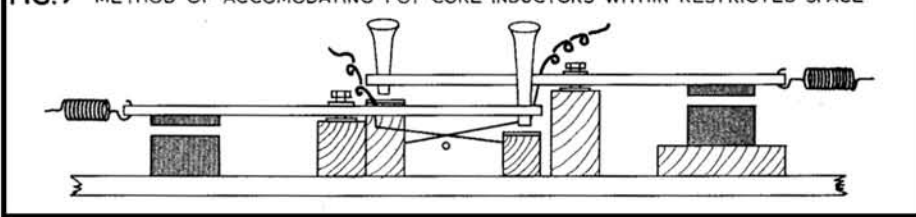

FIG. 7 METHOD OF ACCOMODATING POT CORE INDUCTORS WITHIN RESTRICTED SPACE



and its dimensions should be chosen empirically to produce the right degree of control.

This method makes possible a way of combining note switching, fine control over intonation and vibrato in one mechanism. A suitable arrangement consists of a slight hollowed finger button or narrow key, which, on depression, closes the switch energising the appropriate oscillator, but which also, on being moved from side to side, slightly alters the pitch above and below the mean. The latter facility can be arranged so that moving the button to the right raises the pitch. Fig. 5 indicates the principle and suggests a practical design.

3mm acrylic sheet (*Perspex*) 8mm wide will

give a suitable playing weight at about 76mm from the fulcrum but, as you will have to stagger the line of the inductors to achieve conventional separation of the playing buttons, you will have to vary the breadth of the strips in order to get uniform playing weight. Plastic golf tees can be used for finger buttons, the Perspex strip being drilled and the points of the tees cut off. Gold-clad silver wire should be used for the contacts (this is surprisingly cheap). Perspex may be glued with chloroform. The strip must be free to move laterally about its central pivot and the spring must keep the movable vane in a constant location when untouched. The stop should not offer appreci-

able friction. If the finger buttons stems are made a tight push fit in the acrylic strips, a suitably drilled cover panel may be fitted before the buttons are inserted.

You will find that open oscillator inductors cannot be kept far enough apart to avoid considerable mutual coupling. The degree of miniaturisation required, together with a suitable closed field, can at present only be achieved by using ferrite pot cores. These must not, however, be totally closed or pitch control, by the method suggested, will be impossible. The type of core shown in fig. 5, with the lid used as the tuning vane, is suitable.

A problem arises when the standard keyboard dimensions are checked (fig. 6) and it is found that 12 inductors have to be accommodated within the 165mm length of one octave. The oscillator circuitry is, of course, accommodated remotely from the inductors. Even so, unless your pot cores are very small you will find that you must work on two separate vertical levels, extending the shafts of half of the playing buttons accordingly, and arranging the inductors in two parallel rows with the buttons in the middle (fig. 7).

Basic tuning of the oscillators to the equal temperament scale can, of course, be effected by varying either the inductance or the shunt capacitance, or both. Many pot cores have a central ferrite rod which can be screwed in and out for fine control of inductance and if such are used, the preliminary rough tuning of the inductors, before installation, will be facilitated. Unfortunately, once all the cores are mounted, retuning by core adjustment may be physically awkward and it may be necessary to rely on other methods. Trial and error selection of tuning capacitors (variations in tolerance here being a positive advantage) is feasible but tedious, and parallel combinations will be necessary in most cases. Large compression type trimmer or 'padder' capacitors in parallel with fixed capacitors can give sufficient range but are difficult to adjust. Perhaps the most satisfactory method with a fixed value inductor is to shunt the tank with a variable resistor as in fig. 8. Use the highest value of resistance which gives you the necessary degree of control. It is better not to resort to adjustments of the neutral position of the vibrato vane as a means of tuning, as this may prejudice uniformity in the effect of finger movement.

In winding the inductors it is unnecessary to aim for a progressive reduction in the number of turns from the bass end to the treble. It will

FIG. 8 METHOD OF ARRANGING TUNER ADJUSTMENT OF LC OSCILLATOR WHEN IT IS INCONVENIENT TO VARY INDUCTANCE.

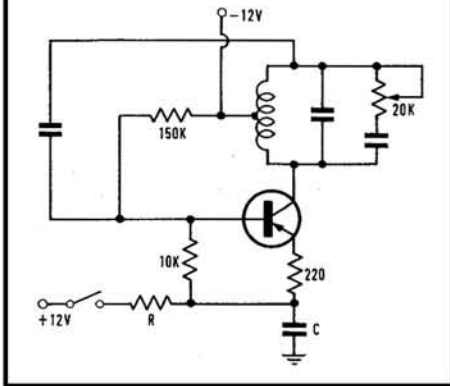

be quite satisfactory to make only three or four changes per octave and to compensate by larger variations in the capacitance.

Since inductance is a function of so many different factors, only a rough indication of the number of turns required can be given, but you may find it useful to note that 3,000 turns of 38 gauge copper wire on a Mullard LA5 pot core, tuned with a 0.2 μ F capacitor, will resonate around C¹ (C above middle C), namely 523 Hz. It is best to aim initially for the middle of the tuning range of the instrument so that, if you miss, you can use the inductor for a higher or lower note.

The formula (for the LA5) is No. of turns = $135\sqrt{L}$ where L=inductance in mH may be useful in conjunction with the nomogram in Table 2, but you can get along quite well using a piano if you keep the capacitance values rising as the pitch falls.

This particular method of pitch selection and control is, of course, only one of many ways in which the job can be done. It is simple, easily made and works very well. The important thing is that the means of control should be provided. You will not have to experiment very long with a few such devices before you realize that a high degree of control is fundamental to the whole business of effective synthesis. There is a world of difference between notes selected and played in this way and the same notes played on the keyboard of an electronic organ. Do not be discouraged if you have no previous experience of using finger and hand vibrato and find that your early effects sound unmusical. The trick is easily acquired and can be practised at any time.

A few practical points on the construction of the control units. If the ferrite disc is mounted concentrically above the pot core inductor, excessive movement will be required to produce the necessary pitch swing. If mounted eccentrically, however, so that the disc overlaps about half the diameter of the face of the inductor, it is easy to produce a pitch change appropriate to the finger excursion. You should arrange that movement of the finger button to the right causes the disc to uncover the coil and thus raise the pitch. This means that the disc must be offset to the left.

The position of the ferrite disc, relative to the coil, is determined by the position of the pring anchorage point at the end of the perspex strip remote from the finger button. A

TABLE 1. INSTRUMENTS AND THEIR PITCH

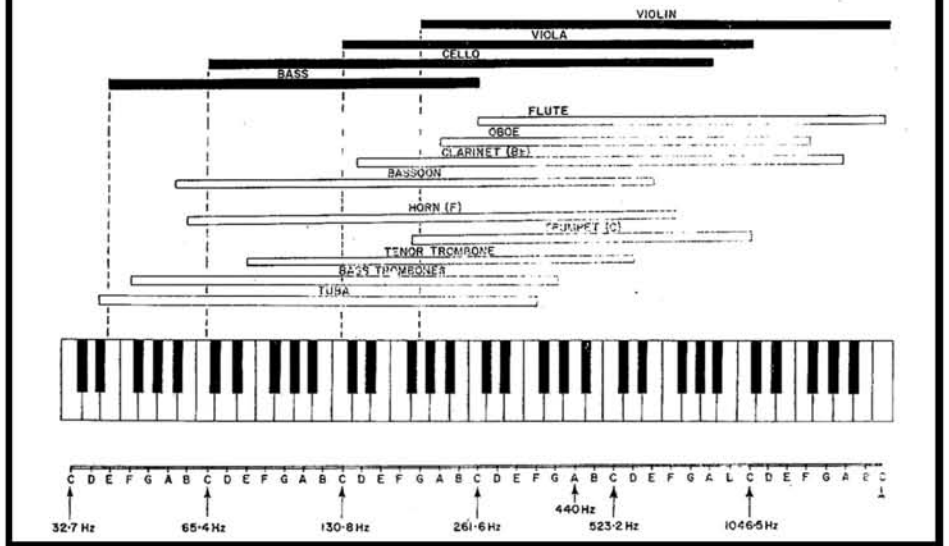

line joining this point to the pivot-point of the strip will be the resting axis of the strip and will determine the effective diameter of the ferrite disc. The spring must be strong enough to keep the gap between the disc and the face of the pot core reasonably constant, at about 1.5mm, and to ensure accurate recentering when the finger-button is left alone. It will not be strong enough to prevent the disc rising a little when the finger-button is depressed, but this has not been found to be a problem as the associated oscillator is not energised until the depression of the button (and consequent rise of the disc) is almost complete. You will save yourself a good deal of trouble (e.g., from frequency instability) if you avoid too narrow a gap between the ferrite disc and the pot core face. If you make the gap too large, however, you will have no control of pitch at all.

A stop-surface must be fitted below the push-button, and the strip (or, better, the protruding shaft of the plastic finger-button) should bed down on this surface just after the switch contact closes. The stop surface must, moreover, have a sufficiently low coefficient of friction to permit easy lateral sliding movements and thus allow free vibrato. Polished acrylic sheet, of the same stock from which the main strips were cut, was found to be eminently satisfactory for this.

An improved alternative to the open gold wire and bus-bar switching arrangement suggested is the use of totally sealed 'reed' switches, each being closed by means of a small permanent magnet mounted under the finger-button. You must ensure that each magnet remains effective, in keeping its switch closed, over the whole range of lateral movement of the finger end of the strip. These reed switches are claimed to tolerate many millions of operations without failure and they can switch currents very much larger than those we are concerned with. It is likely that they will find ever-increasing application in musical instrument work.

If you are unhappy about relying on the flexibility of a Perspex strip, you can, of course, fit a rigid arm and spring-load the finger-buttons so that they carry down the magnets to actuate the switches. To be continued

TABLE 2. RESONANT L AND C

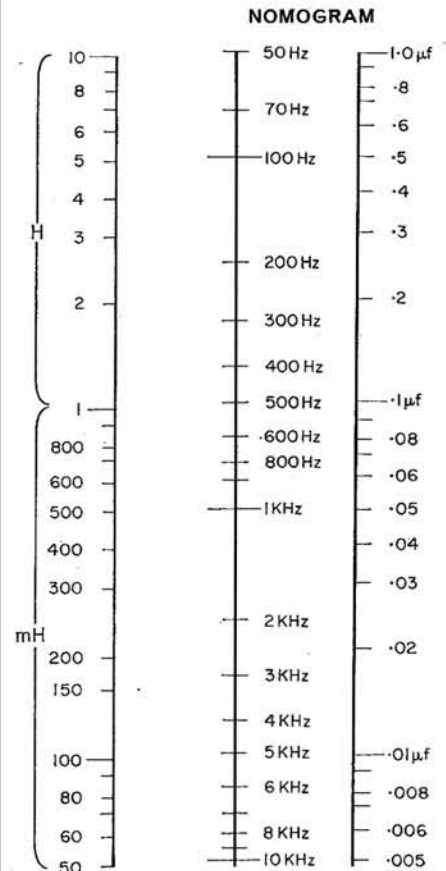

PLACE A STRAIGHT EDGE BETWEEN SELECTED VALUES IN ANY TWO COLUMNS AND READ OFF THE THIRD, UNKNOWN PARAMETER IN THE REMAINING COLUMN. FOR COIL WINDING DETAILS SEE TEXT L.H. COLUMN



Model MR 939

Solid-state, 4-track, 3-speed stereo tape recorder

"In summarising our conclusions we can say that the Sanyo MR-939 is the most complete and compact stereophonic record playback unit we have come across with a performance well within its manufacturer's specification"
Tape Recording Magazine July 1968

Solid state circuitry delivering 7-watts maximum music power per channel. 4-track stereo/monaural operation. 3 speeds selected by single lever. Recording levels controlled by 2 illuminated VU meters. Sound-on-sound, sound-with-sound facilities. Jacks for line out, speaker, stereo headphone outputs, microphone and auxiliary inputs. DIN (Record/Playback Connector). Automatic shut-off device. Vertical or horizontal operation.

SPECIFICATIONS

Recording system AC bias 4 track
Erasing system AC erase 4 track
Tape speeds
7½ ips (19cm/sec)
3¾ ips (9.5 cm/sec)
1⅞ ips (4.8 cm/sec)
Wow & Flutter
7½ ips: 0.15% R.M.S.

3¾ ips: 0.20% R.M.S.
1⅞ ips: 0.30% R.M.S.
Recording time
64 min at 7½ ips (Stereo 1200 ft. tape)
128 min at 3¾ ips (Stereo 1200 ft. tape)
256 min at 1⅞ ips (Stereo 1200 ft. tape)
Level indication VU meter x 2
Output power
Music power 7W x 2
Undistorted 4W x 2
Frequency response
7½ ips 20-20,000 c/s (30—15Kc ± 3db)
3¾ ips 30-13,000 c/s
1⅞ ips 30-8,000 c/s
Signal-to-noise ratio 45 db
Crosstalk
50 db (channel-channel)
65 db (track-track)
Output impedance
Line out: 2 Kohm
Speaker out: 8 ohm
Headphone: 10 Kohm
Input impedance
Microphone: 50 Kohm
Aux: 100 Kohm
Record/play DIN connector
Input: 10 Kohm
Output: 2 Kohm

Microphones
Two dynamic microphones
Speakers
Two 4" free edge permanent dynamic speakers
Voice coil impedance 8 ohm
Power source
AC 100V, 117V, 125V, 220V, 240V
50-60 c/s
Dimensions
Main unit: 18½ x 6" x 13¾"
(470 x 150 x 350 mm)
Speaker boxes: 9" x 5" x 13¾"
(230 x 130 x 350 mm)
Weight 36.3 lbs (16.5 kg)

The MR-939 is available from the Sanyo dealer in your area, specially selected for first-class before-and-after-sales service. Or you can write for an illustrated leaflet to:

Sanyo Marubeni (U.K.) Ltd.,
Bushey Mill Lane, Watford, Herts.
Telephone: 92 25355

 **SANYO**

People the world over agree there's something about a Sanyo

THE SOUND STUDIO

PART SEVEN A HISTORY OF STUDIO RECORDING EQUIPMENT

BY K. R. WICKS

IN the early days of sound recording, the performers would be arranged in front of a large horn with the louder instruments at the back of the room and the quieter ones in front. The sound entering the horn was fed by means of a tube to the head of the recorder, the acoustic power being sufficient to vibrate the cutter to effect a recording in the wax disc. The quality of the shellac pressing eventually obtained was poor compared with modern recordings, as much coloration was caused by mechanical resonances in the system, and the noise level was fairly high. Nevertheless, considering the rather crude apparatus used, the results in many cases were surprisingly good.

In 1925, 'electric' recordings made their appearance and these were a great improvement on the earlier 'acoustic' recordings, as it was then easier to manipulate the frequency response, and eliminate most of the coloration previously experienced. The excellence of the new recordings could not be fully experienced by the general public at that time, as reproduction was, almost without exception, by means of the acoustic 'sound box'. Even as late as

after the recording cutter, similar to the way in which tape recordings are monitored today.

Long programmes were recorded on a number of 43cm discs with 'overlap changeovers', that is, the material at the end of the first disc would be recorded at the start of the second disc, and so on. On reproduction, when nearing the end of one disc, the next would be started and, listening on 'prefade', the speed and pickup position would be adjusted until

found in seconds whereas, with tape, more time is needed because of spooling.

Tape recording as we know it today is a much more recent development than disc recording in spite of the fact that the basic principles of both systems were known at the turn of the century. Early machines used thin wire or tape made of steel, and the main problems were those of frequency response and noise. Editing was difficult and time consuming for it was necessary to weld the joints together. During the second World War, an oxide-coated plastic tape was developed in Germany and this was the start of the tape recording boom.

The BBC, who had been using steel tape (as well as disc), started to use the oxide-coated tape which was more convenient than steel tape and capable of a much better response and noise level, as well as being easy to edit. In the fifties the number of direct disc recordings made by the BBC began to decline as more and more use was made of tape, but by 1960 these discs had still not been completely eliminated. They continued to be used for a year after that, mainly for newsreel purposes, until finally giving way to tape.

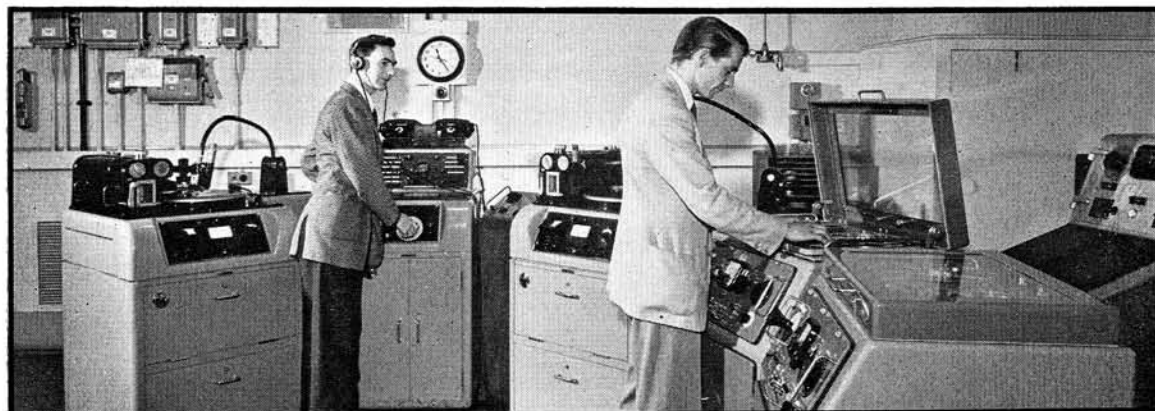

Combined disc and (BTR4) tape recording channel employed at Broadcasting House in 1954.

1945, 75% of all gramophones in the UK used this method of reproduction, although the situation was to change with the development of the long playing record.

Another system of disc recording was that developed by the BBC and known as the 'direct' method. Instead of cutting a wax original and then obtaining a pressing by means of a fairly lengthy process, the recording was cut directly on a lacquer-coated aluminium disc which could be replayed in the normal way. The fairly soft lacquer used meant that the recording could not be regarded as permanent and after a dozen playings the surface noise would be noticeably higher. However for most purposes the direct discs were ideal and from them permanent pressings could be obtained, if desired, in the same way as from wax originals. An advantage of direct discs was that they could be monitored while being made, using a pickup in the groove just

the discs were running 'in sync'. The first disc would then be faded down and the second faded up simultaneously. This procedure would appear to be a difficult one, but it is in fact easier than it sounds.

Much use was made of direct recordings for news reports. After recording, the discs would be handed to the *Radio Newsreel* studio where they would be listened to in order to decide what editing, if any, was necessary. To edit a disc, it would first be marked accordingly with a chinagraph pencil, then played, quickly fading out and lifting the pickup when required, moving it to the next marked position and fading up again, the output being recorded on another disc to produce the final edited version. This is another procedure which is much easier in practice than it sounds, and editing this way often takes considerably less time than would the same material on tape. Another advantage is that any particular item on a disc is easily

STUDIO TAPE RECORDERS

The tape machines used most by the BBC have been the *BTR2* and the *TR90*, both made by EMI. Since the early fifties the *BTR2*s have given excellent service, and are by far the best recorders for use in permanent broadcast studios. These machines were originally intended for use at 76 or 38 cm/s but, by reducing the diameter of the capstan, speeds of 38 and 19 cm/s are obtained, the former being used for most recorded programmes and giving 32 minutes running time on standard tape on a 27 cm spool (730 m of tape). Most recorded programmes are, therefore, accommodated on one reel, although for such things as plays and concerts, changeovers from one reel to another are usually necessary. A speed of 19 cm/s is used for news despatches and items for programmes such as *Today*, where the interviews are recorded 'in the field' on portable machines, (continued on page 413)

AKG Headsets:

High fidelity reproduction with comfort



With any AKG Headset, you can be sure of perfect reproduction with no unnecessary background disturbance. Every AKG Headset is superbly designed to give maximum comfort combined with maximum efficiency



AKG K20
Dynamic/Stereo Headphones

The best value in quality headsets: unparalleled reproduction at such low cost, with large cushioned ear pads. Balanced reproduction from 30-20,000 Hz.



AKG K50
Dynamic Moving-Coil Mono/Stereo Headphones

High-fidelity reproduction due to wide frequency response of 20 - 20,000 Hz. Available with 400 or 75 Ohm Impedance.



AKG K60
Dynamic Moving-Coil Mono/Stereo Headset

Robust double headband, soft ear cushions. Gives faithful reproduction with smooth bass response, and balanced middle and upper ranges. Frequency 20-20,000 Hz.

Find out more about AKG head-sets and microphones from:



Politechna (London) Ltd. 182-184 Campden Hill Road, London, W.8. 24 Hr. Telephone: 01-727 0711 Telex: 23894

AKG microphones

BASF 30% OFF!

Fantastic offer of world-famous BASF magnetic recording tape at near wholesale price! Brand new, fully guaranteed. Each tape supplied in the superb BASF plastic swivel box. (3" tapes in plastic mailing boxes.)

STANDARD PLAY	List Price	Our Price	DOUBLE PLAY	List Price	Our Price
5" 600' ...	22/3	15/-	3" 300' ...	15/-	10/6
5½" 900' ...	29/5	20/6	4" 600' ...	26/1	18/3
7" 1200' ...	36/7	25/6	5" 1200' ...	43/3	30/3
			5½" 1800' ...	56/5	39/6
LONG PLAY			7" 2400' ...	79/7	55/6
3" 210' ...	9/6	6/9	TRIPLE PLAY		
4" 450' ...	15/7	10/9	3" 450' ...	23/-	16/-
5" 900' ...	29/3	20/6	4" 900' ...	40/1	28/-
5½" 1200' ...	36/5	25/6	5" 1800' ...	67/3	47/3
7" 1800' ...	51/7	36/-	5½" 2400' ...	91/5	64/-
BASF LOW NOISE COMPACT CASSETTES			7" 3600' ...	116/7	81/6
C.60 ...	17/7	12/3	Post and Packing 2/6 per order.		
C.90 ...	25/1	17/6			
C.120 ...	33/7	23/6			

LEDA TAPES (D) 17 LEIGH PARK ROAD, LEIGH-ON-SEA, ESSEX
London office: Tel.: 01-226 7004.

MAINS DISTRIBUTORS UNITS

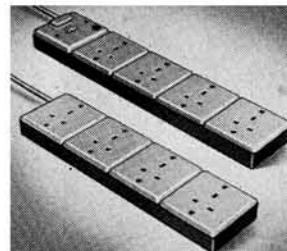

will complete your Hi-Fi system . . .

for TRANSCRIPTION UNITS
AMPLIFIERS
TAPE RECORDERS
TUNERS

White or Brown sockets

Send for details to
APPLIED ELECTRONICS & AUTOMATION LTD
RIPLEY, SURREY Trade Terms available

TAPES at quantity DISCOUNTS

from 5% for £1 to 25% for £14.
Top brands and others at half the price.
Any assortment.

KIRKMAN, 40 The Broadway,

CRAWLEY, SX.

THE SOUND STUDIO CONTINUED

and later copied, edited and put on to separate 13 cm spools for insertion into the programme. (Often the original quality is so chronic that nothing would be lost by making the copies at 4.75 cm/s.)

The *BTR2* is a simple recorder with few refinements. The main features on the front panel are the record gain control, replay fader, monitoring meter, and variable spooling control. Access to the amplifiers and their preset controls is obtained by opening the doors in front of the machine. Although the recorder can be used by itself for recording, in practice this is rare. The usual arrangement is to have a pair of them, one on each side of a linking console. This is simply a small unit with communications facilities, record and replay selectors, monitoring, a record gain control, and a jackfield. The two machines, with a linking console and a high quality loud speaker unit, are the basic essentials for a recording channel. Before a recording is made, the channel is lined up, the procedure being as follows:-

Check the PPM zero and then, by plugging a 1 kHz reference tone to the channel input on the jackfield, switch the PPM key to 'input' and check the sensitivity. Great care is taken to ensure that the reference tone is kept at .775 V, which corresponds to the BBC zero level, and the meter is adjusted to give a reading of '4' on the scale. The law of the meter is then checked using the calibrated record gain control on the console to adjust the tone to levels of +8 dB and -8 dB which should read '6' and '2' respectively on the meter. The PPM amplifier is contained in the console and is adjusted to obtain the required sensitivity and law.

When the meter calibration is satisfactory, a line-up tape containing tone recorded at an accurately determined level is played on one machine and the output monitored on the PPM, the replay amplifier being adjusted to give a reading of '4' on the PPM. This procedure is repeated with the other machine, and then the record amplifiers are adjusted by first loading a blank tape and recording some reference tone. The bias level is initially reduced, then gradually increased so that the recorded tone, as indicated by the meter (still monitoring the replayed output) reaches a peak

level. The optimum setting is obtained by further increasing the bias level by an amount sufficient to cause the recorded level to drop 2 dB below the peak, this setting being generally considered to give the best compromise between distortion, output level, and signal-to-noise ratio. Having fixed the bias, the pre-set record gain control on the amplifier is adjusted to give a reading of '4' on the PPM. The second machine is similarly adjusted, and the channel is then ready for recording. The line-up procedure ensures that material recorded from a standard source will be recorded at the correct level and will be reproduced at the same level from any correctly adjusted machine.

After lining up, it is customary to record a reference tone at the beginning of each reel to enable the replay level from a machine to be checked whenever the tape is to be played back. Just before the recording is to commence, the incoming line is monitored on the loudspeaker, and when a cue is heard from the studio the machine is started and the replayed output is then monitored to check the quality of the recording. Level adjustments for such recording sessions should not normally be made by the recording channel, as it is up to the studio originating the material to restrict the dynamic range so that (1) no peaks greater than +8 dB occur, and (2) levels below -8 dB do not occur for long periods.

It has been explained earlier in this series why it is necessary to reduce dynamic range. Briefly, the broadcast transmitters are adjusted so that a zero level signal gives about 40% modulation. Thus peaks of +8 dB ('6' on the meter) indicate 100% modulation, and higher signal levels are dealt with by limiters placed in the circuit just before the transmitters in order to prevent overmodulation. At the low level end of the scale, noise considerations make it undesirable to have any long periods with peaks below the -8 dB mark ('2' on the meter).

Sometimes radio producers want a few particularly loud noises to add drama to their programme and so they arrange with the studio manager (who operates the control desk) that peaks of '6½' instead of '6' will be all right. (Unfortunately no one has told the studio staff about limiters or the fact that overmodulation is a bad thing, they just know that '6' is a magic number on the scale that the needle is not supposed to pass.) When high peaks are noticed by the recording engineer, these are queried with the studio personnel, who firmly



EMI TR90 console

(continued overleaf)

Trolley-mounted TR90 and (in distance) Leavers-Rich recorders at Central Recording Room H58, Broadcasting House Extension, 1962.



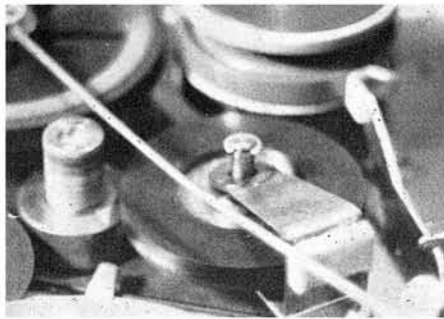

Fig. 2 Idler return spring

achieve the best balance between noise and distortion. On this machine, 0 dB indication is 12 dB below tape saturation.

The same stricture about the heads applies to this machine as was mentioned last month. Regular cleaning is imperative and this must include attention to the pressure pads. Note that the exact position of the flap plate depends on its mounting, and the retardation on the setting of the claw. Plenty of care in setting up pays dividends.

Other parts of the deck assembly are much the same as we saw last month, although there are small changes to the selector cam arrangement and there is also the return leaf spring for the take-up and fast-winding idler, illustrated below. Do not be tempted to bend this leaf spring to improve the 'fall' of the idler. If it shows reluctance, as sometimes it does, the trouble is more likely to be grit on the rider

spindle, a binding lower lever, a spindle out of true, or even an excess of lubricant which has a gripping effect quite foreign to its purpose.

Once or twice I have had peculiar problems with selector mechanisms on these machines which have turned out to be no more than slackened screws (shades of Grundig!). One such screw is that holding the inner end of the lower swivel arm whose roller sits in the cam detents, and is held in by a spring. The method of screw fitting is good, with a spacer in an enlarged hole in the bracket. But if the screw loosens, the bracket slops about and the erratic action is not always obvious because the spring keeps it tight.

There is a tempting number of presets in this machine, and it is possible to get into a disturbing tangle if experiments are made to compensate for, say, low input level, by altering the record gain presets and the meter indication, and then, criminally, the equalisation, to get coincident readings on the meters. Yes, I've seen it done! This is one of those machines where I like to proceed backwards, getting the record channel up to scratch before proceeding to replay. Simply because the two functions are admirably separated, and a very exact setting up procedure can be followed.

Because the auxiliary input of this machine is fed to the microphone socket via the matching network and the isolating switch, this is a convenient point at which to inject an input. Measurements are taken at the auxiliary output sockets, using a valve voltmeter, with 0 dB at 775 mV. To be absolutely accurate, one should load each socket separately and switch the valve voltmeter across each output, maintaining a constant load. Sony give no details of measuring methods, but I have had false indications if the unused channel is left unloaded, or, worse, if the channels are combined. Load with 100 K.

In the Sony service manuals, step diagrams showing the expected levels relative to 0 dB save a lot of wordage and an example will be given here as soon as space is available. For our purpose, we need to check the gain step by step back to the Auxiliary input, from a +12 dB measurement at the head drive side of the drive transformer to an 0 dB reading at the collector of the driver 2SB382 (error on the Sony diagram here—where an emitter measurement is shown), and stage by stage back to a -10 dB input. There is negative feedback to be considered over the third stage and again over the second stage, and some care is needed to interpret the figures. There seems little purpose in detailing all the readings now: perhaps we may leave this for a specification test at a later stage of this short series on Sony.

The most important initial check will be of recording bias. Measurement is taken across a 1 K resistor inserted in series with the earth return lead of the record/play head. This should give us a reading of 1.2 V on a valve voltmeter, adjusting the trimmer (one for each channel, postage stamp type compression trimmers on the power supply and oscillator board, the lower one for the left channel). After this, return to the auxiliary output socket with the meter, and adjust the trap coils on the main board (each side of the stud end of the record/play slide switch) for minimum bias breakthrough. Left and right channels are easy to identify on this board. The layout is symmetrical, mirror-image style, with the right channel nearer the middle of the machine.

Also on this board is the meter calibration adjustment but this is done, curiously enough, during playback tests. Japanese manufacturers have a design habit of reading off signals quite late in the circuit and leaving the meter in circuit during play; hence these tests which will be treated in detail next month.

THE SOUND STUDIO CONTINUED

deny that any peaks over '6' have occurred (they know that recording engineers, for some reason, don't seem to appreciate the finer points of dramatic production). As everybody knows, two wrongs make a right, and the recording engineer eventually reduces the recording level by 2 dB to restrict the highest peaks to their permitted level. This not only prevents distortion when broadcasting but also ensures that the engineer is not blamed for making a non-standard recording. (Nowadays, the tendency is to provide recording facilities in the studios themselves, allowing more co-operation and understanding among the people concerned than had previously been possible.)

When the length of programme makes it necessary to use more than one reel of tape, a short overlap is recorded which is later edited at a convenient point to a 'butt' changeover. When the programme is eventually reproduced, the second machine has to be started so that as the first tape ends, the second one begins. This is not difficult as the recording report accompanying the tape gives the duration and 'out cue', and a few turns of red trailer are joined to the end of the tape. When a change-over point is known to be imminent, an eye is

kept on the tape, and an ear on the loudspeaker. Just before the red trailer goes through, the out cue should be heard and the second machine, previously set up on prefade and then switched into circuit, is started at an appropriate moment. Experience with any type of tape machine soon allows very accurate changeovers to be carried out. The nearest point to the capstan at which the start of the recording can be set up without fear of wow is soon found, and the exact moment when the second machine should be started is given by the arrival of the red trailer at a predetermined point on the first machine.

To facilitate changeovers on reproduction, the BTR2 has an 'auto follow' button on the deck which enables the other machine to be started remotely as soon as the red trailer is seen by the operator, who would be standing in front of the first machine. This is a very useful feature as, without it, the physical size of these machines would require the operator to have at least one very long arm, and would cause considerable recruitment difficulties. In addition to having the auto follow facility, the BTRs can, of course, in common with all professional recorders, be set up then started from a remote studio, in either the record or the playback mode.

The features necessary on tape recorders used in broadcast studios are few compared with

those considered essential by manufacturers of domestic equipment. One high level input socket is sufficient, as microphones are mixed on the studio desk, and the recorder has merely to be able to accept the high level output of the studio. Tone controls are not required as the output signal from the machine should be correct, assuming that the recording was satisfactory. The occasional non-standard tapes dealt with by copying via a correction unit in order to obtain a recording which can be replayed in the normal way. Level meters fitted to recorders are rarely needed (although usually fitted) as in most cases, it is more convenient to use the meter on the linking console or control desk.

Needless to say, the frequency response, wow and flutter, and noise figures must all be good, but not necessarily as fantastic as the figures claimed by some manufacturers of domestic machines, whose aim is to sell to a gullible public as much rubbish as possible.

Looking through the August edition of this magazine expecting to find some evidence of this in advertisements, I noticed an article by John Shuttleworth in which he was making the same point. In addition to what was said there, I would add that some manufacturers are inclined to use a lower-than-optimum bias

(continued on page 421)

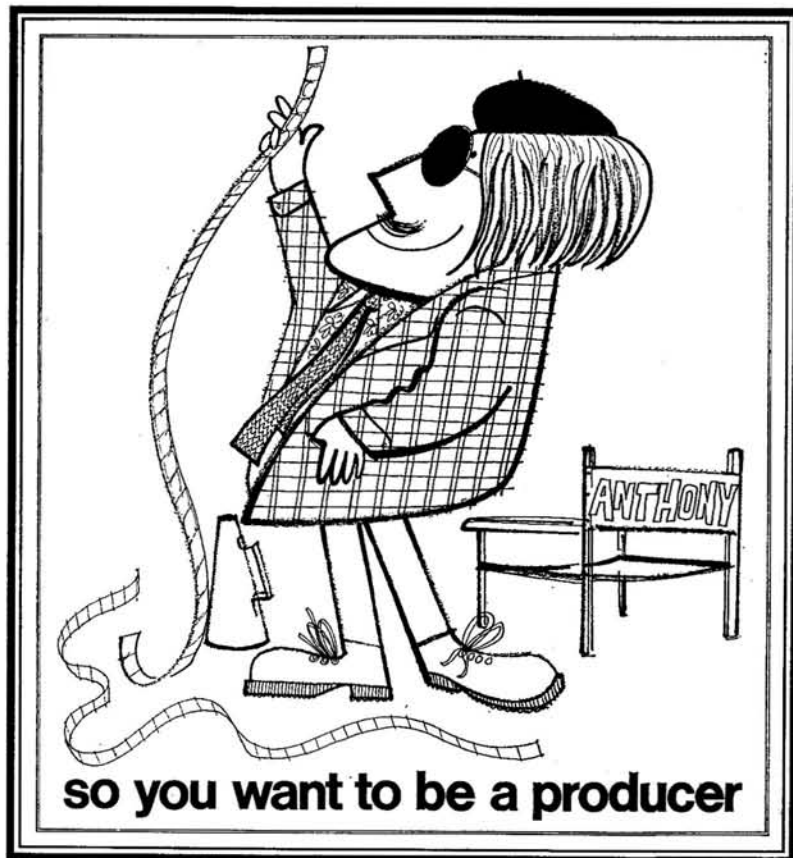

By Peter Bastin

THE popular conception of a film, television or radio producer is a tweedy sort of fella with suede shoes, a woolly tie and long lank hair. He lives, sleeps and dreams Producing, drives a Ferrari and lives in a mews flat next to Simon Templar. In point of fact, producers are often very ordinary blokes in blue suits. They live (if they're lucky) in a detached house in the suburbs, drive Fords and have nightmares about Producing. But the odd thing is that they *always* have slightly-glamorous names like Mark or Anthony or even David—never a Sid or a Bert amongst them.

The biggest problem in observing their hierarchy is to decide who and what is a producer and who and what is a director. If you read your *Radio Times* you will find that television productions are often produced by A and directed by B. Radio programmes are almost always just *produced*. In the film world, of course, the producer is the man who *produces* the film from the studios—the Big Guy who holds all the reins of finance and actual studio production. The director is the man who stands on the floor and shouts everyone into action.

Whatever you may like to call him (and some people like to call him all sorts of things), there must be some poor wallah who is *responsible* for the production; a team leader, a foreman, a managing director, according to your station in life. It is he who must stop the chorus girls scratching each other's eyes out, break up the temperamentalities, smooth out the lumpy bits in the script and remove the

bags of hot chips from the cameramen. He must be a politician, a whip-brandisher, a diplomatist, and a real go-getter. He must have a voice which can wheedle, shout or screech and he should, preferably, be bigger than anyone else in the studio. He is never seen or heard by the public but suffers torments when the critics (who don't know much anyway) tear his masterpiece to bits or letters come in from Notting Hill Gate complaining about the programme. He is by far the most important man in the studio, whether it be a film, television or radio studio.

There is one thing I like about professional studios and that is the environment created by the people in them. The BBC has an atmosphere of its own and the mighty corporation exists on a basis of christian names. Independent Television has much the same feel about it except they mainly wear striped shirts. The atmosphere everywhere, from executive office to studio, is one of complete chaos. I paid a visit to a Local Radio station a little while ago. The station manager's office was minute, shared by his secretary and an unswitchable monitor speaker, running for 21 hours a day. The desks were strewn with papers. So were the window sills. So was the floor. Cups of tea, on delivery, were placed precariously on top of piles of paper and tape boxes and wobbled about like malarious jellyfish to the reverberant oonk of the monitor. Filing did not, apparently, exist. Broadcasting House in London shares the same jovial attitude but the rooms are nicer and there are extra tables to strew papers on. It is frowned upon to deposit

anything but amateur tape-recordists on the floor.

And this is the Producer's stamping ground. Here, he weaves his magic spells; here he bellows and persuades, cajoles and threatens. And it is here that he can survive or fall. In the small and somewhat remote world of sound recording, we must learn our lessons from these brave (I mean it) souls. We must not dismiss them as part of the credits or as chaps who sit behind a glass panel, yawning and sucking at a coke bottle. Before any sort of show can get on to the screen or into your Japanese transistor set, a very great deal of work has to be done. The first thing is to have a get-together of all the participants. The producer gives them all some tea, then outlines his plan of action. He must *have* a plan of action, otherwise everyone might just as well go home. A good producer, as soon as he meets someone who is worthy of broadcasting, can forecast the style and format of his programme and, generally, he sticks to his first impressions. Some of the participants may raise objections to his plan or offer criticisms, in which case everyone has a rethink. Eventually—and that may mean months—a working draft is arrived at. The show is then rehearsed and problems previously not anticipated come to light. Maybe Mr. A's voice is too loud. All right, we'll reposition him. Maybe Miss B can't get her pretty little tongue round that awkward phrase. OK, we'll rewrite that bit. And so on until everything is tied up nice and neatly.

The responsibilities, therefore, of the professional producer cover all aspects of the *interpretation* of the script: he is not responsible for writing it, nor, for that matter, making alterations to it which may affect its import. He is responsible for editing it and making sure that it is presented in the best possible way. This will entail the choice of actors, types of microphone, use of reverberation, effects and inserts. And it will be the producer who selects the music, if music there is. In the studio, he listens, directs, starts and stops. He plays back the recording to demonstrate errors, he times the programme, cuts it or fills it out as may be necessary. And when it's all over, he can go home and sleep peacefully or have nightmares.

Let us imagine that we are to produce a ten-minute programme—a sort of magazine programme which doesn't waste time. We have a street interview, a 'celebrity', and a wide choice of music. Firstly, then, let us draw up an operational schedule:

Introductory music	10 seconds
Introduction (spoken)	10 seconds
Music	2.00 minutes
Street interview	1.00 minutes
Music	2.00 minutes
Anecdote	30 seconds
Guest speaker	2.00 minutes
Music	2.00 minutes
Conclusion	5 seconds
Closing music	5 seconds

Now the aim of this short programme is to produce lively entertainment with sustained interest. The items, therefore, must be as contrasting as possible in order to keep the listener awake. The programme must 'flow'—there must be no sudden jumps from one

(continued overleaf)

Your Tape Dealer

LONDON AREA

FOR ALL LEADING AUDIO EQUIPMENT

hifi Classical Records by Mail Service
hampstead
HIGH FIDELITY
91a Heath Street, Hampstead, N.W.3.
Tel. HAMpstead 6377

HAVEN
196-198 SOUTH EALING RD.
HI-FI LONDON W.5
Tel. 01-560 0194

LASKY'S RADIO

Stockists for all the leading makes of Tape Equipment
207 EDGWARE ROAD, W.2. Tel.: PAD 3271
118 EDGWARE ROAD, W.2. Tel.: PAD 9789
33 TOTTENHAM CT. RD., W.1. Tel.: MUS 2605
42 TOTTENHAM CT. RD., W.1. Tel.: LAN 2573
152/3 FLEET STREET, E.C.4. Tel.: FLE 2833

TAPE RECORDER HI-FI CENTRE (SHEEN) LTD

SPECIALISTS IN TAPE RECORDERS, ACCESSORIES, HI FI EQUIPMENT

YOUR CENTRE FOR FRIENDLY HELP, SALES AND SERVICE

3 & 4 STATION PARADE, Open until 8 p.m. on Fridays
SHEEN LANE, SHEEN, PROSPECT 0985
LONDON, S.W.14 Opposite Mortlake Station, S.R.

CHESHIRE

go scandinavian hi-fi . . .

Bang & Olufsen, Tandberg, Arena Dynatron, Radford, Sony, Philips, Quad, Leak, Fisher, Sanyo, Pioneer, Akai, Sansui, Wharfedale, Armstrong, Rogers, Ferrograph, Trio, Dual, Bryan, Normande, Eddystone, Goodmans, Scott, Braun, Telefunken, Grundig, etc.

the hi-fi and tape recorder lounge

● EXPERT STAFF ● ADVICE SERVICE ● PART EXCHANGE
● Home Dems ● After Sales Service ● Comparator Dems

GREEN LANE, WILMSLOW, CHES. SK9 1LR
Ring Wilmslow 24766 and ask for Mr. Bird
Closed Weds. except by appointment

CHESHIRE

Charlesworths
HI-FI & CINE CENTRES

112 FOREGATE STREET, CHESTER. Tel. 25075
and 28 HIGHTOWN, CREWE. Tel. 3327

For all leading makes of Audio and
Photographic equipment

*Spacious demonstration studio *Easy Parking
*Half Day Wednesday

SO YOU WANT TO BE A PRODUCER

CONTINUED

subject to the next—and the best way to achieve this is with a linking commentary. The introductory music should be lively and recognisable and the spoken introduction to the programme can be spoken over the music, the latter being faded out towards the end of the speech. All 'insert' music should be pre-recorded in preference to direct disc recording to enable greater cueing control to be observed. The street interview and the guest speaker should also be prerecorded and edited. Two machines are essential, although the programme could be produced on a 2-track machine capable of mixing two parallel tracks. All the 'insert' music and interviews should be lined up ready on the feeder machine and released on to the master machine by using the pause control. Commentary, introduction and closing talk should, of course, be live.

The first music insert should be lively and, if possible, connected in some way with either the introduction or the following street-interview. This may not always be possible and the matter should not be so forced that the result is dead corny. The second piece of music could be something rather special—a sort of 'star-spot' and the anecdote could well be connected to it: 'Listening to Greensleeves reminds me of the time when I had an old green jacket which I used for weeding the garden . . .'. The guest-spot should be the highlight of the programme and should be introduced carefully or, possibly, not introduced at all. There is sometimes a tendency to over-announce and the technique of going straight into an interview has a lot to commend it on the grounds of slickness and time-saving. Any editing which has to be done on the completed tape should, if possible, be done by copy-editing. Splices make some recorders wov and should be reserved for the earlier stages.

The order of procedure for our production should run something like this:

- (1) Script prepared, edited and checked for timing, allowing for inserts. Further editing if necessary to comply with time requirements.
- (2) Dry run, using prerecorded inserts. Check timing and allow about five seconds at the end of the tape. This will compensate for any small timing errors or speed variations in other machines. It also allows a margin of tape for splicing into another tape, still retaining the full ten minutes.
- (3) The Take. Just do your best.
- (4) If necessary, dub the master tape on to your other machine to correct levels between items, to add reverberation, or to add a further track of effects.

On the face of it, it all seems very simple but, believe me, a stumbled word or a half-second gap can ruin a programme just as effectively as a bomb in the studio. Some of the pitfalls to guard against are: pauses, clicks, disturbing and unrelated levels, background noise, conflicting quality between location and studio machines and microphones, technical jim-jams such as hum and bad connections, foot-tapping, wheezy breathing, thermostats on heaters, clocks, lighter-clicking, knocking-over things,

tape-ends flapping, tapes swishing on reels, noise from stationary machines, doors opening, coughs, wind (internal and external), and so on. I know that a lot of these are sheer common sense, but a lot of them—such as foot-tapping, wheezy breathing and thermostats—tend to be forgotten about. It is a very good idea to turn your microphone control to zero when recording the inserts from the other machine. Most disturbing noises occur when you are not actually recording yourself.

On the question of equipment, it is necessary to have first-class machines if your work is to be broadcast. Both machines should, if possible, be of the same manufacture and both should have azimuth adjustments to match so that one is not woolly and the other topky. Some very expensive machines do not reproduce at all well on BBC equipment and I have found that the Ferrographs have very similar characteristics to BBC equipment. Tape speed should be either 38 or 19 cm/s, although tapes at lower speeds *might* (and I say *might*) be accepted if the material is very good. The tape should be recorded on one track only and the other half of the tape should be blank. The reason for this is that if, as is likely, the tape is replayed on a full-track machine, any other tracks will be heard, with predictable results!

The microphones should be of the pressure (dynamic) type rather than ribbons which tend to emphasise bass frequencies unless raised above chest level. The microphone should be uni-directional or cardioid in pick-up characteristics in order that the majority signal comes from the front with none at the side and very little at the back. Boom-mounting is recommended to avoid table-thumps. If the recorders do not mix, a good mixer is essential. But I would hesitate to recommend most transistorised units, due to residual hiss. The best advice in this direction is to build your own low-level mixer—just a series of potentiometers and jack sockets. And don't forget a stopwatch.

If your programme is for home-consumption, the high standards above may not be necessary, although desirable. Just because it is only old Uncle Sid and the Bulstrodes from next door who will listen, there is no excuse for a badly-produced tape. Always use virgin tape for your master copy and *always* clean and demagnetise the heads before starting work. If your studio contains only a 25-guinea recorder and a portable record-player, there is no need to for go the job. So long as you have either a pause-control on the machine or the ability and financial backing to chop up tape, you can still produce a good programme. The procedure is much the same, differing only in the fact that you would be unable to fade in inserts. Music can still be mixed with speech if the machine mixes and, if you are very careful in the use of the pause control or razor blade, your joins will not be noticed.

The essentials of successful production, I think, are a good sense of timing and balance, prerecorded material to leave you free to concentrate on your own commentary, and great enthusiasm. The professionals take all these things in their stride because it is their job and they are, largely, very successful at it. The fact that they may wear suede shoes and beards, drink Campari or brown ale, and live in caravans in Hyde Park, doesn't really make much difference.

MOOG ELECTRONIC MUSIC SYNTHESIZER

THE three basic synthesizers produced in the USA by the R. A. Moog Company are now being handled in Britain by Audiotek. *Synthesizer 1*, the simplest version, comprises two voltage-controlled oscillators, two voltage controlled amplifiers, a white noise generator, voltage controlled low-pass filter, reverberation unit, fixed bank filter, envelope generator, keyboard, ribbon controller and power supply. It is aimed at electronic music composers with limited capital and costs £2,345.

Synthesizer 2 incorporates an additional voltage-controlled oscillator and amplifier, a second envelope generator, and a four-channel mixer. Price is £3,301.

Synthesizer 3 is the most flexible system, designed for studio application, with a total of ten voltage-controlled oscillators, three voltage-controlled amplifiers, white noise generator, three voltage-controlled filters reverberation unit, three envelope generators, a fixed filter bank, keyboard and ribbon, controller, five-channel mixer and a power supply. This model, which can also be built up from the 2 and 3 versions, costs £4,198.

A CBS LP gramophone record made with a Moog Synthesizer and entitled *Switched-On Bach* has sold over 200,000 copies in the USA. It is currently on sale in the UK.

Distributor: Audiotek, 1 Little Rivers, Welwyn Garden City, Hertfordshire. (Tel. 96 28851).

PROFESSIONAL STEREO PORTABLE

HAVING recovered their Neuchatel premises from Kudelski, Stellavox are now manufacturing a battery powered stereo recorder for the film and broadcasting markets. The *SP7*, first news of which was published in our September issue, can be operated at any speed between 2.6 and 76 cm/s, suitably equalised. Balanced inputs are provided for dynamic or capacitor microphones, level control being either manual or automatic. Signal level is displayed on a twin Modulo-meter. Versions of the *SP7* are available for full-track mono and film-sync operation, prices being around £400.

Distributor: Audio Engineering Ltd., 33 Endell Street, London W.C.2. (Tel. 01-836 0033).

ELCOM PPM UNITS

A PEAK programme meter module designed to measure signal levels in 600-ohm balanced or unbalanced circuits without affecting the programme has been introduced by Elcom. The *AE Series* employs an Ernest Turner 643 moving-coil unit and comprises an input transformer, buffer amplifier, full-wave rectification and logarithmic DC amplifier. The silicon transistor circuit is mounted on a printed board behind the 643 and can power up to four slave meters.

Three scales are available, all calibrated in 4 dB white intervals on black. *Series A* covers -22 to +4 dB while *Series E* is -12 to +12 dB, to European broadcasting standards. *Series B* is to the BBC standard, from -14

dB at point '1' to +12 dB at point '7'. A 1 kHz tone at 0.775 V RMS, 600 ohms, reads point '4'. Reading accuracy across the scale is ± 0.2 dB from 40 Hz to 20 kHz. Manufacturer: Elcom (Northampton) Ltd., Ross Road, Weedon Road Industrial Estate, Northampton NN5 5AD. (Tel. 0604 51873).

RAPID-REPEAT RECORDER

A RELATIVELY simple recorder with rapid-repeat facilities is now available from Grundy & Partners, based on the two-speed Thorn deck and aimed at the educational market. The *R/R100* operates at 9.5 and 4.75 cm/s and is capable of repeating either of two tracks, or both, in sections lasting up to 18 seconds. The sections are stored temporarily in a reservoir and wound back on to the left-hand supply spool. A timing circuit halts the tape after 18 seconds to prevent damage.

Manufacturer: Grundy & Partners Ltd., 163 High Street, Hampton Hill, Hampton, Middlesex. (Tel. 01-979 9901).

THREE NEW SONY'S

TWO mains stereo recorders and a mains/battery mono machine are now being imported by Sony (U.K.). The *TC.666D* is a $\frac{1}{2}$ -track three-motor tape unit with a hysteresis-synchronous capstan drive. Tape speeds are 19 and 9.5 cm/s and the spool capacity is 18 cm. Solenoid mode selectors and automatic reverse facilities are included, price being £264 10s. with tax. Microphone input sensitivity (through miniature jacks) is 0.19 mV at 600 ohms for an auxiliary output of 0.775 V RMS at 100 K. A stereo headphone monitor socket supplies 10 or 28 mV at 8 ohms. Dimensions are 437 x 208 x 423 mm.

The £199 15s. *TC.630* is supplied complete with detachable lid loudspeakers and employs a single-motor transport. Speeds are 19, 9.5 and 4.75 cm/s, claimed wow and flutter at 19 cm/s being 0.09%. The same figure is quoted for the *TC.666D*.

Distributor: Sony (U.K.) Ltd., Ascot Road, Clockhouse Lane, Bedford, Middlesex. (Tel. 69 50021).

TELEFUNKEN AUTOMATIC

A SINGLE-speed 9.5 cm/s $\frac{1}{2}$ -track recorder with automatic and manual gain control is one of several new additions to the Telefunken range. The *M202* incorporates a 2.5 W power amplifier and (when the recorder is used horizontally) an upward facing internal loudspeaker. Headphone and external speaker monitoring facilities are provided, all input/output sockets being DIN. A Plexiglass dust cover hinges over the reels, leaving the controls free. Price is £72 19s. 6d.

The *M501* is a $\frac{1}{2}$ -track 9.5 cm/s machine costing £43 11s. 6d. with the unusual feature of a sliding tape length counter mounted across the 170 mm front panel.

Distributor: AEG (Great Britain) Ltd., 27 Chancery Lane, W.C.2. (Tel. 242 9944).



SONY TC.666D

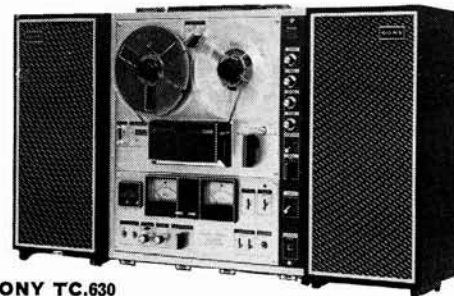

SONY TC.630

TELEFUNKEN
M501**GRUNDY R/R100**

FIG. 1 UHER 1000 PILOT CIRCUIT DIAGRAM



equipment reviews

UHER 1000 PILOT PROFESSIONAL BATTERY PORTABLE

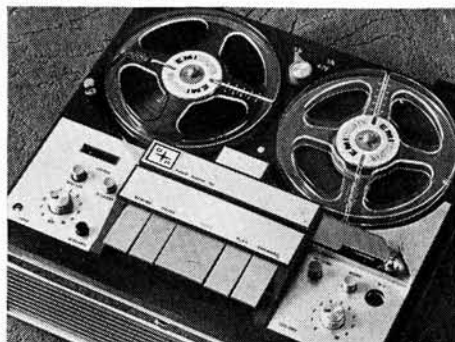
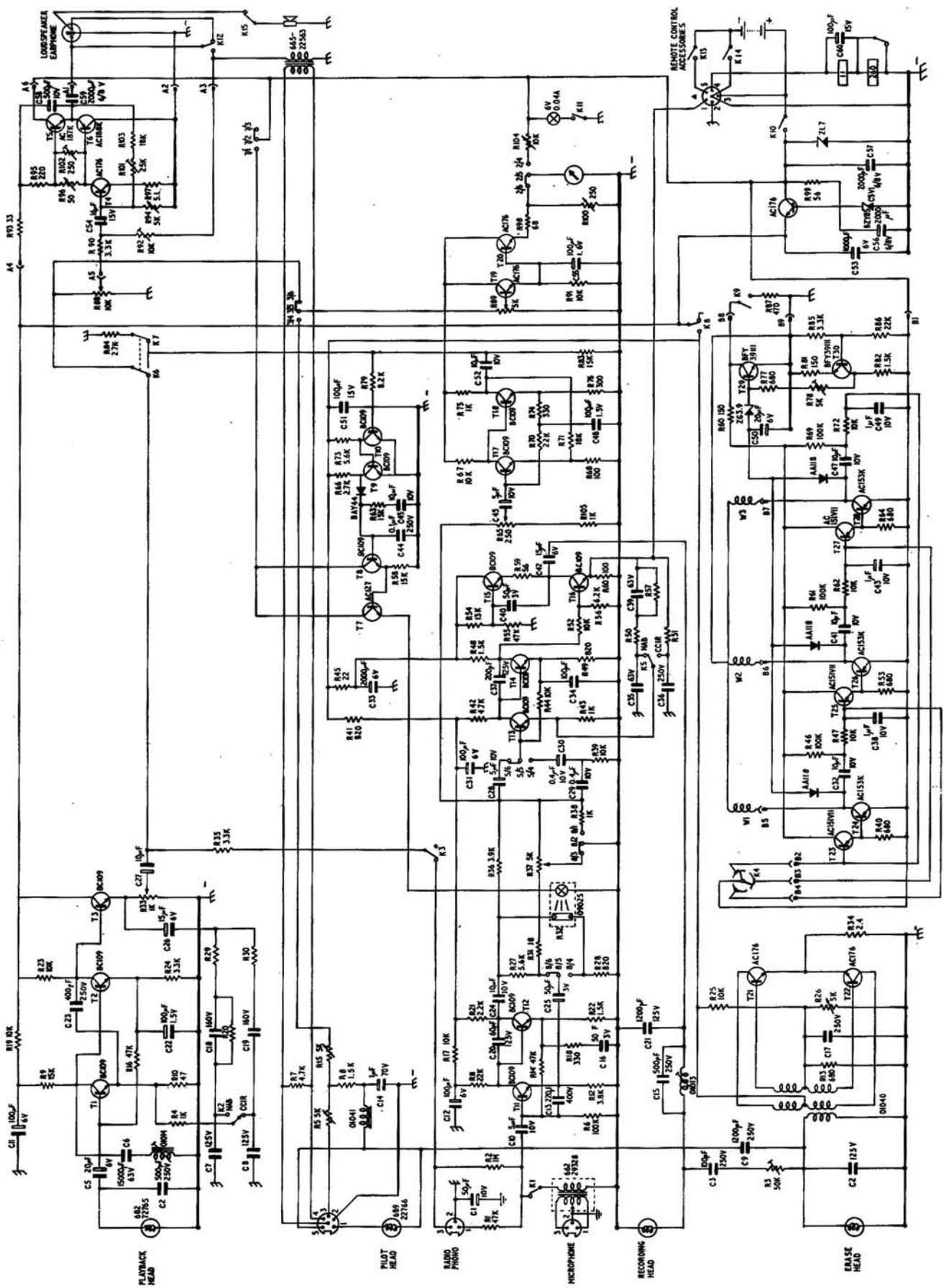

THE Uher 1000 Report Pilot is a self-contained transistor battery portable professional taperecorder developed mainly to meet the requirements of the film industry, with a frame synchronised sound recording pilot-tone system in accordance with DIN standards. It is also useful for 'on the spot' work on account of its light weight and ease of operation.

Tape transport mechanism is controlled by piano type keys and the tape speed is 19 cm/s. The recorder is of the full-track type with separate heads and amplifiers for recording and playback. Recording pre-emphasis and playback equalisation can be selected to comply with CCIR 70 μ S or NARTB 50 μ S characteristics. Recording and playback of the pilot frequency, in accordance with DIN 15 575, is accomplished by a separate head.

MANUFACTURER'S SPECIFICATION (19 cm/s). Single-speed professional battery portable with DIN variable-area synchropulse. **Wow and flutter:** $\pm 0.5\%$. **Absolute speed deviation:** $\pm 0.5\%$. **Frequency response:** Not specified. **Signal-to-noise ratio:** 52 dB. **Distortion:** 2% total, 1.2% 3rd harmonic, with CCIR equalisation (at line output, 4.4 V into 600 ohms). **Spool capacity:** 13 cm. **Tape heads:** Pilot, full-track erase, record and playback. **Microphone input:** 0.3 mV at 200 ohms, balanced. **High level inputs:** 10 to 500 mV or 200 mV to 4 V, unspecified impedance. **Line output:** 4.4 V at 600 ohms. **Auxiliary output:** 450 mV at 15 K. **Synchro pulse output:** 0.04 mV (DIN 15 575). **Features:** Switched CCIR/NARTB equalisation, electronic speed control, automatic and manual gain control, off-tape monitoring, internal monitor loudspeaker, calibrated VU meter. **Power supply:** Five Ever Ready HPU2 cells or equivalent. Z 211 6 V storage battery and charger available. **Dimensions:** 270 x 215 x 85 mm. **Weight:** 3 kg. **Price:** £277 10s. 1d. **Manufacturer:** Uher Werke Munchen, 8 Munchen 47, Postfach 37, West Germany. **Distributor:** Bosch Ltd., Radlett Road, Watford, Hertfordshire.

TEST REPORT

Model: Uher 1000 Report Pilot
Tape: BASF LGS35
Speed measured: 19 cm/s
Characteristic: 70 μ S

FREQUENCY RESPONSE

	REPLAY (dB)	OVERALL (dB)
31.5 Hz	-3.5	-5
40	-2.75	-4
63	-0.25	-1.8
125	+0.25	0
250	+0.25	+0.5
500	-0.7	+0.25
1 kHz	0	0
2 k	+0.25	+0.75
4 k	+0.48	+0.75
6.3 k	+1.1	+1
8 k	+1	+1.5
10 k	+0.5	+2
12.5 k	+0.5	+1.5
14 k	+0.75	0
16 k	+1.1	-4
18 k	+2	-7

WOW AND FLUTTER (13 cm reel)

	START	END
WOW	.12%	.14%
FLUTTER	.13%	.13%
TOTAL	.15%	.15%

SIGNAL TO NOISE RATIO (referred to 32 mM/mm RMS tape flux at 1 kHz): 56 dB

HARMONIC DISTORTION (unweighted) at 32 mM/mm RMS tape flux): 1.25%

RECORD RESPONSE 31.5 Hz to 14 kHz ± 1.5 dB

Similar results obtained with 50 μ S characteristic

A rugged metal case and design permit operation in any position and the recorder is, to a great extent, insensitive to acceleration forces, mild shock and vibration.

Power supply can be from five U2 dry cells, nickel cadmium rechargeable cells, a car battery of 6, 12 or 24 V, or from the mains (110 to 250 V AC) via a power supply unit.

A microphone socket is located in the lower right-hand corner of the front panel for the connection of dynamic microphones with a source impedance of 200 ohms. It is wired in accordance with pattern N of DIN 45 594.

On the right-hand side of the recorder there is another input socket. Contacts 1 and 2, input impedance 47 K, are for a signal of 10 to 350 mV RMS. Contacts 2 and 3 of the same socket, input impedance 1 M, are for a signal of 200 mV to 6 V RMS. When the recorder is set for playback, contacts 3 (live) and 2 (earth) will supply a maximum level of 500 mV RMS from a source impedance of 4.7 K, when playing a tape of standard reference level, i.e. RMS tape flux, at 1 kHz, of 32 mM/mm.

A socket for the connection of the pilot frequency generator in the camera is located on the left-hand side of the recorder—contacts 1 and 2 earth, contact 3 live. Pilot frequency output is across contacts 1 and 5. Contacts 4 and 6 of this socket constitute a balanced line output at a level of 4.4 V RMS (i.e. +15 dB across a load impedance of 600 ohms with tape of standard reference level).

Another output socket is provided on the right-hand side of the case for connection of medium impedance (60 to 400 ohms) headphones. This socket may also be used for feeding a 4-6 ohms loudspeaker and, depending on the way the plug is inserted into the socket, the internal loudspeaker is disconnected or remains operative.

(continued on page 421)

GUARANTEED QUALITY AND SATISFACTION

4 TRACK STEREO/MONO

	Deposit		12 Monthly Payments		Cash Price	
	£	s. d.	£	s. d.	£	s. d.
Philips EL3312	23	4 1	3	14 5	67	17 1
Philips N4464	26	17 0	4	5 0	77	17 0
Ferguson 3232	33	5 0	5	1 10	93	5 0
Sony MR929	33	4 9	5	6 10	97	4 9
Philips N4407	35	15 10	5	13 4	103	15 4
Akai 1710W	37	15 7	6	2 1	111	0 5
Sony MR939	38	13 6	6	2 3	112	0 2
Sony TC230	40	11 9	6	15 0	121	11 9
Telefunken 204TS	41	19 0	6	13 4	124	19 0
Grundig TK247	45	10 9	7	2 4	130	18 9
Sony MR990	44	18 0	7	5 0	131	18 1
Philips 4408	46	19 5	7	8 9	136	3 10
Sony TC530	49	12 3	8	1 8	146	12 3
Tandberg 1241X	49	0 0	8	6 8	149	0 0
Beocord 2000K	53	5 0	8	17 6	159	15 0
Beocord 2000T	55	5 0	9	4 2	165	15 0
National Console-Aire	62	0 0	10	5 0	185	0 0
Akai M9	68	12 4	10	16 8	198	12 4
Akai 1800SD	68	12 4	11	1 2	202	13 10
Ferroglyph 724	68	16 9	11	6 8	204	16 9
Revox 1222/4	74	11 0	12	8 6	223	13 0

4 TRACK MONAURAL

Fidelity Braemar	11	12 8	1	17 4	34	4 8
Fidelity Studio	15	17 10	2	10 2	46	0 10
Grundig TK144	16	10 1	2	11 11	47	13 1
Philips 4307	16	15 3	2	13 1	48	11 11
Ferguson 3228	16	16 8	2	13 4	48	16 0
Ferguson 3238	20	12 0	3	5 0	59	12 0
Philips 4308	20	14 2	3	5 7	60	0 10
Ferguson 3216	22	16 0	3	12 2	66	2 0
Tandberg 1541	28	0 0	4	10 0	82	0 0
Reps HW10-4T	28	16 9	4	11 2	83	10 1

STEREO TAPE UNITS

	Deposit		12 Monthly Payments		Cash Price	
	£	s. d.	£	s. d.	£	s. d.
Sony MR801	27	9 5	4	6 8	79	9 5
Akai 4000D	29	10 0	4	16 8	87	10 0
Tandberg 1641X	30	0 0	4	19 2	89	10 0
Sony TC355	34	2 6	5	10 0	100	2 6
Beocord 1500	42	10 0	7	0 0	126	10 0
Tandberg 62/64X	42	10 0	8	13 4	157	0 0
Beocord 1800	60	15 0	9	18 4	179	15 0
Revox 1102/4	63	19 0	10	6 8	187	19 0
Ferroglyph 702/704	64	15 8	10	16 8	194	15 8

Special Offer

AKAI M9 High Fidelity Stereo - 50 GNS. OFF
Cross-field Head. 40 Watts Music Power 4 Tracks, 4 Speeds.

Sound-on-Sound Three Heads, 2 Built in Speakers.
BRAND NEW. MAKERS 12 MONTHS GUARANTEE & INSTRUCTIONS - 145 Gns.

INTEREST FREE H.P. TERMS Deposit £52 5s. 0d.
12 Monthly Payments £8 6s. 8d.

AKAI 1710W
BRAND NEW. Reduced from 104 Gns.
Our Price 85 Gns.

Interest Free H.P. Terms. Deposit £30 5s. 0d.
12 Monthly Payments £4 18s. 4d.

PHILIPS EL3302 Cassette
Brand New. Special Offer 24 Gns.

INTEREST FREE H.P. TERMS

OPEN SATURDAY 6 p.m. FRIDAY 6.30 p.m.
IF UNABLE TO CALL, WRITE FOR BROCHURES, PART EXCHANGES
ALSO 18 AND 24 MONTHLY TERMS.

Telefunken Special Offer



TELEFUNKEN 300 Battery/Portable

- 5" Tape capacity.
- Volume and Stop/Start controls in handle.
- Complete with micro phone. Reduced from 61 Gns. Our price 45 Gns. Initial Deposit 15 Gns. 12 monthly Instalments £2.12.6.

TELEFUNKEN 301
Similar specification as for Model 300 but 4-track. Reduced from £70.17.6. Our price 51 Gns. Initial Deposit 17 Gns. 12 monthly Instalments £2.19.6.

TELEFUNKEN 302
• 4-Track
• 2 speeds 3½ & 1½ ips. Reduced from £77.8.9. Our Price 56 Gns. Initial Deposit £19.12.0. 12 Monthly Instalments £3.5.4.

TELEFUNKEN 203 TS
• Mono/Stereo 4-Track
• Sound-on-Sound 2 speeds 3½ & 1½ ips. Complete with TD21 Microphone Reduced from 86 Gns. Our Price 64 Gns. Initial Deposit £23.4.0. 12 Monthly Instalments £3.13.4.

THE RECORDER CO

(DEPT. R) 186-188 WEST END LANE, WEST HAMPSTEAD, LONDON, NW6
Telephone: 01-794 4977

It's easy to get to S.W.16

With so many shops to choose from, there must be excellent reasons why people prefer to buy more and more from Francis of Streatham. Perhaps you would care to find out by calling or writing to us about your requirements in tape and hi-fi equipment too. (S.a.e. with written enquiries please.)

EVERYTHING IN RECORDERS AND HI-FI ON THE BEST OF TERMS

- ★ VERY LARGE STOCKS OF EQUIPMENT AND ACCESSORIES
- ★ NO EXTRA FOR CREDIT UP TO 18 MONTHS
- ★ FREE SERVICE DURING GUARANTEE PERIOD—OWN SERVICE DEPT.

We are TANDBERG specialists and carry full stocks of these famous products. Also FERROGRAPH, VORTEXION, AKAI, PHILIPS, ETC., ETC.

Part Exchange facilities
FOR A FAIR and DEPENDABLE DEAL—BUY IT FROM

SPECIAL OFFER
Gerrard SP25 Motor/Turntable Unit, Mk. II
brand new in maker's carton and guaranteed
Post paid in U.K. £12 0 0

GOOD SELECTION OF RE-CONDITIONED RECORDERS AVAILABLE. ATTRACTIVE PRICES. PERSONAL SHOPPERS ONLY

FRANCIS OF STREATHAM

169-173 STREATHAM HIGH ROAD, LONDON, S.W.16

Between St. Leonard's Church and Streatham Station Phone: 01-769 0466: 01-769 0192

Please note our only address. Free Car Park, Prentis Road nearby
OPEN ALL DAY SATURDAY—EARLY CLOSING WEDNESDAY

You take no chances when you purchase our brand new British Recording Tapes. Manufactured by reputable British firm. Fitted leaders, polythene bag and boxed (ex. 3"). These tapes are not to be confused with sub-standard imported or used taped. All 100% tested and fully guaranteed.

This month free coloured leaders with all tape orders

Standard Play		Long Play	
3" 150'	2/-	3" 220'	2/3
4" 300'	4/-	4" 400'	5/-
5" 600'	6/-	5" 900'	8/-
5½" 900'	7/6	5½" 1200'	10/-
7" 1200'	9/-	7" 1800'	13/-
Double Play		Empty Spools	
3" 350'	4/-	3" ...	8d
4" 600'	6/-	4" ...	1/8
5" 1200'	11/6	5" ...	1/9
5½" 1800'	16/-	5½" ...	2/-
7" 2400'	19/6	7" ...	2/3

Compact tape cassettes. 100% perfect, fully guaranteed, not to be confused with Maxwell.

All supplied in plastic library cases.
C. 60 7/6, C. 90 10/-, C. 120 14/6. P & p 2/- per order.

N. WALKER TAPES

28 Linkscroft Avenue, Ashford, Middlesex.
Phone: 53020

UHER 1000 PILOT REVIEW CONTINUED

A push-button selects a filter which attenuates frequencies below 150 Hz at 6 dB per octave whilst a stroboscope allows a precise check of tape speed. If necessary the motor speed can be adjusted.

There is an automatic recording level button, recommended for use on speech only. On test the results were very satisfactory and fluctuations of background noise, found in many other systems, were practically inaudible.

The Uher 1000 Report Pilot is a progressive design, not a copy of any previous models but a considerable improvement on them. The review machine, minus instruction book, together with an Electro-Voice 642 Cardiline microphone, were loaned to a relatively inexperienced friend who produced an excellent recording of nightingale song at the first attempt.

One can see from the test chart that the CCIR 70 μ S record response was very even and within 1.5 dB from 31.5 Hz to 14 kHz: similar results were obtained with the NARTB 50 μ S characteristic.

Signal to noise and harmonic distortion figures were very acceptable. A total record/play RMS value of 0.15% for wow and flutter, although well within specification, is in my

THE SOUND STUDIO CONTINUED

setting which will effectively extend the HF response of the recorder although causing increased distortion. Since more notice tends to be taken of frequency response figures than of any other item in the specification, the appeal to the prospective buyer is increased. Sometimes no distortion figures are quoted, or if they are they are so vague as to be meaningless. Similarly, frequency response figures (as was mentioned by J.S.) are often quoted without stating a tolerance, so the general public is eventually conditioned into thinking that a machine with a response going up to 12 kHz (± 2 dB) is rather poor, whereas the fact is that many professional machines have just such a specification.

It is highly desirable, particularly in broadcasting studios, that the response of all equipment is as flat as possible over the working range. A tape might for convenience be copied, edited, then used as an item in a programme being recorded, so that by the time the material is broadcast it has been modified by the response characteristics of several tape machines, and any deviation from a flat characteristic would, of course, be multiplied by this process. A recorder with a specification quoting ± 3 dB could legitimately have a peak of +2 dB at some frequency which would result in the output being doubled at that frequency if a recording were made, then copied twice. Such a recorder would seem good from its specification but would be useless for professional purposes.

Another important consideration not indicated by the specification is the ease of editing. Many decks are apparently designed to make it impossible to get a chinagraph pencil near the playback head, making them useless as studio machines. One of the most important

opinion excessive for professional equipment, even if it is portable and even if the final product is for a film sound track, where standards are not always of the highest. Fortunately on this recorder, wow and flutter were produced in almost equal proportions, tending to lower the integrated figures by partial cancellation.

Results could be improved if a substitute were found for the Neoprene ring attached to the underside of the capstan flywheel which is driven at right angles by a layshaft. This ring is not homogeneous, wears unevenly, and passes on its faults to the capstan. I have tried grinding similar rings to a higher degree of precision but with little improvement.

Two other criticisms: one cannot monitor on 'record' without the capstan running and surely the price of £277 10s. 1d. for the basic machine is very high indeed when one considers its limitations. With a really first class capstan drive this outlay would be adequately justified.

During the tests a transistor failed in the speed control circuit with the result that the tape romped at 30 cm/s; the fault was corrected by Messrs. Bosch Ltd, who stated that this was a most unusual occurrence!

To sum up, a delightfully light and easy machine to use but something should be done about that wobble. **Terence Long**

requirements of a professional machine is that it should stand up to prolonged use without adverse results. This is where many otherwise good recorders fail, and where the BTR2 has shown its superiority. The BBC has recently decided to keep their BTR2s as, although they are quite old, no other machine has been found which will come up to the same standards of reliability.

The EMI TR90 has very similar facilities to the BTR2, but is a smaller machine, usually trolley mounted for ease of transportation. Reliability is very good but editing is more difficult. When servicing is necessary, some time may be needed in gaining access to the faulty parts; for instance, replacing indicator lamps can be a rather lengthy job.

During the installation of new studios around 1961/2, the BBC started to purchase cheaper machines than those made by EMI, but the result was that the failure rate became much higher. Some Philips and Leavers Rich machines were incorporated, the latter being the standard machine used in London continuity studios for playing recorded programmes (and occasionally in the early morning for recording announcements, to enable the announcer to get his breakfast when he should be giving time-checks at ten-minute intervals). In general, these machines, although capable of excellent quality, fail to provide the reliability and ease of operation needed for broadcasting, and the money saved by purchasing cheaper machines is soon spent in higher maintenance costs.

This article has been devoted to basic full-track recorders, and the general requirements and procedures of studio recording. It is hoped to cover multitrack techniques, which are such an important part of modern commercial studio practice, in a separate series in the not too distant future.

Your Tape Dealer

CHESHIRE (contd)

VIDEO AND HI-FI STUDIO

Hire or Buy	Listen to the Best
<ul style="list-style-type: none"> ★ Cameras ★ Monitors ★ Video Tape Recorders ★ Ampex ★ Ikegami ★ G.E.C. ★ Loewe Opta 	<ul style="list-style-type: none"> ★ Bryan ★ Truvox ★ Leak ★ Goodmans ★ Goldring ★ Thorens ★ Eagle ★ ETC.
FULL SERVICE OFFERED	
Holiday Bros. (A.V.) Ltd. 61b Shaw Heath Stockport	

DEVON

THE SOUTH WEST

Tom Molland Ltd.

Invite you to visit their well-equipped Demonstration Theatre and compare all the leading makes of Hi-Fi and Tape Equipment at

110 CORNWALL STREET, PLYMOUTH
Telephone 69285

Immediate delivery to ALL Areas

HAMPSHIRE

High Fidelity Specialists



Hamilton Electronics (Southampton) Ltd.
35 London Road, Southampton. Phone: 28622. 3 Lines

FORRESTER'S

NATIONAL RADIO SUPPLIES LTD.

70-72 HOLDENHURST ROAD
BOURNEMOUTH HANTS

Largest hi-fi and radio component store in the south Tel: 25232

HERTFORDSHIRE

WATFORD

High Fidelity Centre

at RADIOLUX Ltd.

36 WOODLANDS PARADE, HIGH ST.

WATFORD (opposite the pond)

WATFORD 29734, 41029

IF IT'S GOOD — WE STOCK IT!

Demonstrations in our Stereo Theatre. Also home demonstrations with no obligation.

NOTTINGHAMSHIRE

Nottingham Tape Recorder Ltd.

BURTON ST. 2 mins. Victoria Station

Specialists in all the best makes of

- TAPE RECORDERS ● AMPLIFIERS ●
- HI-FI DISC EQUIPMENT ●

Telephone: Nottingham 45222

HI-FI in the Home

by John Crabbe, editor of Hi-Fi News and Tape Recorder

"the most up-to-date and comprehensive treatment on domestic hi-fi yet in print"

AUDIO RECORD REVIEW

"gives copious advice on practically any aspect of the topic you can imagine . . . Should be a very useful guide to anyone on the threshold of heavy expenditure who is rightly wary of the smooth talk in the hi-fi shop"

THE MUSICAL TIMES

"written with the authority of a dedicated professional, it could well become a recognised standard on the subject . . . Deserves a place on the bookshelf of all who are interested in improving the quality of sound reproduction in the home"

ELECTRICAL & RADIO TRADING

"a practical and helpful book . . . Mr. Crabbe explains everything and includes a sizeable glossary and plenty of diagrams"

THE TIMES

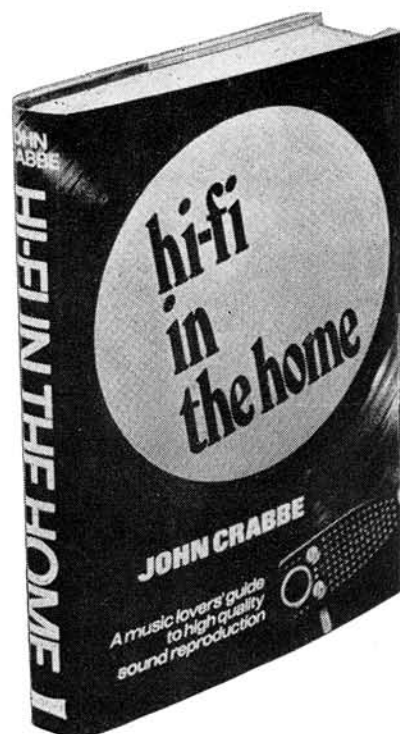

**40/- from booksellers
or direct from the Publishers (post 2/-)**

BLANDFORD PRESS, 167 HIGH HOLBORN, LONDON, W.C.1

**WE SPECIALISE IN BRAND NEW
TOP QUALITY BRITISH P.V.C. MYLAR & POLYESTER
RECORDING TAPES WITH FITTED LEADERS, Etc., EX 3"**

Thanks to bulk purchase we can offer tensilised HI-FI tapes, manufactured by a British firm of world repute. All boxed individually (sealed if required) in polythene. Our tapes are not to be confused with imported sub-standard or used tapes. Full-money refund if not delighted.

This month :- DRY "SPLICE" (3/9) given FREE with every order.

Std.	L.P.	D.P.	Boxed
Length ea. 3 for	Length ea. 3 for	Length ea. 3 for	empty spls
3" 150' 2/- 5/9 3" 220' 2/6 7/- 3" 400' 4/6 13/- 3" 7d.			
4" 300' 4/- 10/- 4" 450' 5/- 14/- 4" 600' 6/9 19/6 4" 1/8			
5" 600' 6/- 17/6 5" 900' 8/- 23/6 5" 1200' 12/6 37/- 5" 1/9			
5 1/2" 900' 7/- 20/6 5 1/2" 1200' 10/6 30/6 5 1/2" 1800' 17/- 50/- 5 1/2" 1/9			
7" 1200' 9/- 25/6 7" 1800' 13/- 38/6 7" 2400' 21/- 61/- 7" 2/-			

All orders despatched by return. Postage and Packing 1/9 per order.

STARMAN TAPES, 421 Staines Road, Bedfont, Middlesex

YOU CAN HAVE GOOD SOUND EQUIPMENT

if you choose



Grampian Reproducers Ltd. Hanworth Trading Estate, Feltham, Middlesex

SAVE UP TO 45%

on	List Price	Our Price
Black Long-Life Zonatape 5" SP	22/2	12/2
5 1/2" SP	29/5	16/2
7" SP	36/7	21/3
5" EP	29/1	18/1
5 1/2" EP	36/1	22/7
7" EP	51/4	32/-

● A first class POLYESTER based recording tape manufactured for professional use... must be the best offer yet for tape of this quality!

● POST & PACKING 2/6

● ORDERS OVER £5 POST FREE

TATLOCK & TINGLEY

PILGRIMS HOLT, MARGERY LANE,
LOWER KINGSWOOD, SURREY.



To all TAPE Recordists: P.V.C. & Polyester Tapes
BUY BRITISH
YOU SAVE MONEY AND



SAVE THE POUND "A STERLING IDEA"

"... high quality and rapid service I have found in you ..."

N.F.H. of Canterbury.

The playbacks are crystal clear and I am sure no better results could be obtained by other dearer brands on the market.

Yours sincerely,
W. S., Hants.

New	3"	5"	5 1/2"	7"
Stan. Play ea. 3 for	150' 2/- 5/9	600' 6/- 17/6	900' 7/- 20/6	1200' 9/- 25/6
Long Play ea. 3 for	240' 2/6 7/-	900' 8/- 23/6	1200' 10/6 30/6	1800' 13/- 38/6
Double Play ea. 3 for	300' 4/6 13/-	1200' 12/6 37/-	1800' 17/- 50/-	2400' 21/- 61/-

Free List full Range of Triple-Play

Mora Trading Co. (TR7/10) Postage 1/9 per order
Mora Works, Mora Road, N.W.2 Posted the same day.
Money-back gtd.

FI-CORD 800 AND 850 CAPACITOR MICROPHONES

MANUFACTURER'S SPECIFICATION. Studio transistor capacitor microphones with omnidirectional (*FC800*) and cardioid (*FC850*) capsules. **Frequency response:** 30 Hz-18 kHz ± 2 dB. **Output levels:** 0.2 mV/ μ B. **Load impedance:** 200 ohms minimum (balanced). **Source impedance:** 50 ohms maximum. **Equivalent self-noise:** 25 phons. **Maximum SPL for 0.5% THD:** not less than 200 μ B (120 dB ref 0.0002 μ B). **Power supply:** 45 to 50 V at 0.4 mA, phantom. **Battery life:** approx 200 hours. **Dimensions:** 113 x 19 mm (*FC800*), 120 x 19 mm (*FC850*). **Price:** £38 12s (*FC800*), £42 18s (*FC850*). **Manufacturer:** Fi-Cord International, Charlwoods Road, East Grinstead, Sussex.

UNTIL a few years ago, microphones with a guaranteed ± 2 dB response over a 30 Hz to 18 kHz frequency range were unheard of except in laboratory measuring units costing upwards of £100. These microphones were invariably capacitors, usually had to be kept in a desiccator, and were not the most robust of animals; but new materials and manufacturing techniques have now resulted in robust capacitor microphones which rival, if not exceed, the specifications of laboratory instruments of, say, five years ago.

The concept of the capacitor transmitter is not new, having been developed by Wente towards the end of the First World War. From its inception, by virtue of the simple mechanical construction and lightweight diaphragm, it has been an ideal instrument for extended frequency response requirements, being free from 'the bumps' and 'wiggles' normally associated with moving-coil microphones. The trouble with early capacitor transmitters was unreliability due to moisture causing leakage, and sometimes corrosion of the aluminium diaphragm (usually critically spaced by a thou or so from the back plate). The necessity for a high polarising voltage between 100 and 200 V, and of a valve amplifier presenting a high input impedance, usually of the order of 50 M, to be contained in a shielded enclosure immediately adjacent to the microphone, made the complete assembly somewhat bulky compared with dynamic type microphones.

New materials, such as spluttered polyester films, and sintered metallic or ceramic back plates, have eased manufacturing tolerances and enable reduced clearances to be used, thus increasing sensitivity without reducing frequency response. Application of transistor techniques has considerably reduced the bulk of the head amplifier, and the result is the slim pencil form capacitor microphone of today.

A correct assessment of the Fi-Cord microphones imposes even more stringent conditions on the measuring equipment: the obvious method is to use a reciprocity

technique, preferably with three substantially similar microphones. This will give a pressure calibration to an accuracy of ± 0.5 dB to a limiting frequency of a few thousand Hz, providing that a suitable coupler of accurately known dimensions is used, with hydrogen as a coupling medium. This is expensive in equipment and time, and the results must then be interpreted in terms of free field conditions, which is not always easy unless the microphone is of a simple geometrical form. Free field reciprocity calibration is difficult, principally because of the signal-to-noise ratio.

An alternative method is to set up a monitored free field. The monitoring microphone should have a flat response over the frequency range required and is used to control the gain of the amplifier feeding the loudspeaker. The microphone under test is placed adjacent to the standard microphone and it is assumed that the field is identical at the face of the two microphones. This premise is substantially correct although reflection between the two microphones may cause a 'wobble' at some critical frequency. This can be allowed for by measuring the frequency response twice, the separation of the microphones being different in each run. Fig. 1 shows the general schematic of the set up, and fig. 2a is the response of the complete system including

loudspeakers without gain control, and it is seen that the variation in sound field is within ± 6 dB from 40 Hz to 20 Hz. Application of the automatic gain control system results in a flat field ± 1 dB from 30 Hz to beyond 20 kHz (see fig. 2b). Experiments show that the field is substantially linear (± 0.5 dB) in the plane of the measuring microphone diaphragm over a radius of 60 mm.

After this dissertation on microphone philosophy and measuring technique, to the task in hand... The models Messrs. Fi-Cord submitted for test were the *FC 800* and the *FC 850*. The model *FC 800* is an omnidirectional pressure type microphone. The *FC 850* is similar to the *FC 800* but has a cardioid capsule giving a front-to-back separation of approximately 20 dB. These microphones are capacitor transmitters with a transistor pre-amplifier and matching transformer built into the case. Physically, they are elegant, slim units, about 115 mm long and 20 mm in diameter. The case is satin chrome and the base of the microphone is terminated in a three-pin DIN plug. The *FC 850* is about 6 cm longer than the *FC 800*, and has a number of slots in the top end of the case to provide 'back pressure' on the microphone diaphragm. The output load impedance of both microphones is nominally

(continued on page 425)

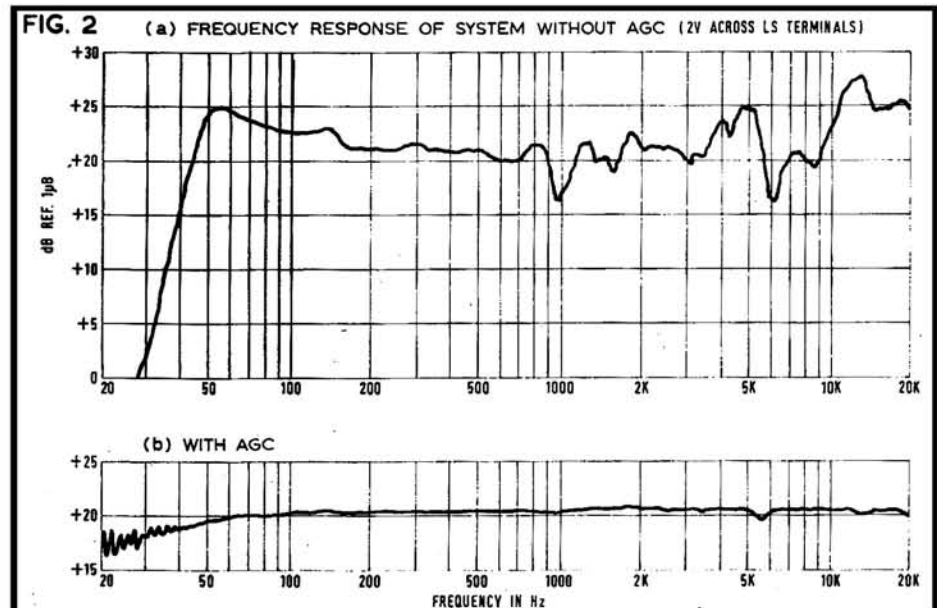
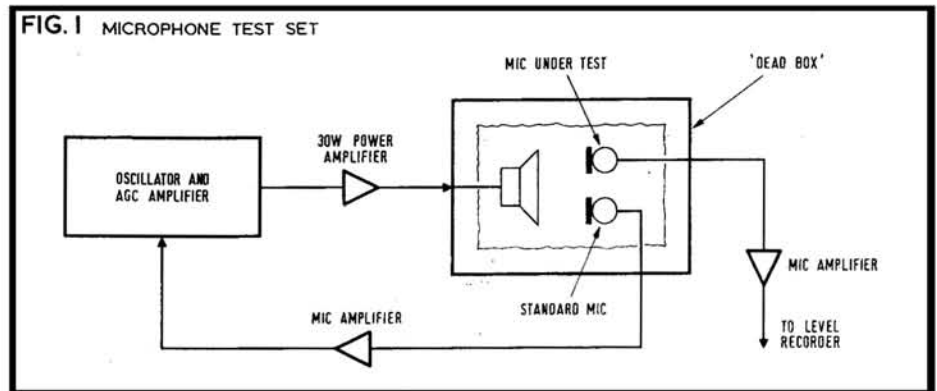

FC800



FC850

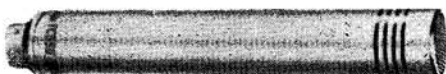

Your Tape Dealer

LANCASHIRE
STOCKPORT AUDIO CENTRE
FINEST IN NORTH WEST

★ ALL MODELS ON COMPARISON DEMONSTRATION
★ EVENING DEMONSTRATIONS BY APPOINTMENT

FAIRBOTHAM & CO. LTD.,
58-62 Lower Hillgate, STO 4872

BOLTON Specialists in
High Fidelity Sound

H. D. HIRK
Stereolectrics LIMITED

203 St. George's Road
Phone 23093

BOLTON

J. SMITH & SON

HI-FI EQUIPMENT — STEREOGRAMS
TAPE RECORDERS — 2 SHOWROOMS
B & O, Dynatron, Hacker, Quad, Leak, Radford,
Armstrong, Ferrograph, Revox, Truvox, Uher,
Decca, Garrard, Thorens, Goodmans, KEF, etc.
Comparator Demos — Closed all Tuesday
Specialists in 'SOUND' for 36 years

184 THE ROCK, BURY Tel: 1242

ST. HELENS
HAROLD STOTT LTD.
Hi-Fi Consultant

Tape Recorder Specialist. Agents
for all leading makes including Akai
B & O, Revox, Sony, etc. Advice and
demonstrations given willingly.

18 Westfield Street, St. Helens

NORTHUMBERLAND
SOUND EQUIPMENT SPECIALISTS

Morton
sound Tel. 2-6902
20142

12 OXFORD STREET
NEWCASTLE UPON TYNE 1

SURREY

FARNHAM SURREY

- ★ Stockists of all good Hi-Fi apparatus.
- ★ Comparative demonstrations.
- ★ We offer a real after sales service.
- ★ Easiest of terms
- ★ No parking problems.

Lloyd & Keyworth Ltd.
THE RECORD SHOP
26-27 DOWNING STREET, FARNHAM
SURREY Telephone: Farnham 5534
SURREY AND HAMPSHIRE'S HI-FI SPECIALISTS

Your Tape Dealer

SURREY (continued)

CROYDON'S
TAPE RECORDER CENTRE

All leading makes in stock, Hi-Fi equipment, cabi-
nets, etc. Service agents for AKAI Tape Recorders

SPALDING ELECTRICAL LTD.,
352/354 Lower Addiscombe Road,
CROYDON.

Addiscombe 1231/2040

SUSSEX

A UNIQUE HI-FI SERVICE

BOWERS & WILKINS

Becket Buildings, Littlehampton Rd.
WORTHING Tel. 64141

WARWICKSHIRE

BIRMINGHAM
TAPE RECORDER CENTRE
266 BROAD STREET, BIRMINGHAM 1
(Opposite Bingley Hall)

Most leading makes high fidelity equipment
Part exchanges welcomed

Telephone Midland 2680

BIRMINGHAM — SOLIHULL

For the best in equipment visit

C.H. (HIGH FIDELITY) LTD

Hi-Fidelity Centre
167-169 Bromsgrove St.,
BIRMINGHAM 5
021-692 1487

12 Drury Lane,
SOLIHULL
WARWICKSHIRE
021-705 7999

Demonstrations by appointment

Coventry's 100% tape recorder and hi-fi
specialists for service and sales.

Akai — Ampex — Bang & Olufsen —
Ferrograph — Leak — National —
Radford — Revox — Sony —
Tandberg — Truvox — Wyndsor

Coventry Tape Recorder Service
33 King William Street, Coventry
Telephone Coventry 29668

GRIFFIN RADIO LTD
(the high fidelity people)

Fully comprehensive stocks and
advisory service for

Monaural and Stereophonic High Fidelity,
Radio, Tape and Disc Equipment

64 BRISTOL STREET
BIRMINGHAM Tel. 021-692 1359

Your Tape Dealer

WARWICKSHIRE (continued)

GOLIN G. TURNER
M.I.P.R.E.

For all Tape Recorders and Hi-Fi require-
ments. All leading makes supplied. 20%
reduction on Tapes.

39 YORK ROAD, KINGS HEATH,
BIRMINGHAM 14 021-444 4182

SCOTLAND
GLASGOW

Scotland's Leading Tape Recorder, Video and Hi-Fi
Specialists

G. H. STEELE LTD.
Hear true Hi-Fi sound on our 22 speaker comparator
system. 14 Hi-Fi combinations ready for demonstration.
SONY VIDEO CENTRE

Agents for: Armstrong, Leak, Fisher, Rogers, Quad,
B & O, Goldring, Garrard, Thorens, Connoisseur,
Goodmans, Wharfedale, Kef, Celestion, Decca,
Truvox, Philips, Sony, Arena, Revox, Tandberg,
Brenell, Ferrograph, Akai, Uher, Grundig.

CREDIT TERMS — PART EXCHANGES
Repairs and Servicing Tel. Douglas 7124

141 St Georges Road, Glasgow C3

Recording Studios

mjb recording and
transcription service

Mono and Stereo records, latest cutting methods, auto-
matic varigroove, feedback cutter heads, limiters and
equalisers, techniques hitherto available only to the
professional, facilitating high undistorted cutting levels
and extended playing times even from amateur recordings.
Booklet available.

45 HIGH STREET
BURNHAM, BERKS.

Tel. Bourne End 22231 Member A.P.R.S.

POST THIS COUPON FOR A REGULAR COPY OF TAPE RECORDER

Subscription Department, TAPE
RECORDER, Link House, Dingwall
Avenue, Croydon, CR9 2TA.

Please send me a copy of each issue
of TAPE RECORDER for
months commencing with the
issue for which I enclose remittance
of £.....s.....d.

Name

Address

.....T.R.

Home and Overseas 30/- (12 months)
15/- (6 months). U.S.A. \$4.30 (12 months)

INSIDE EMI CONTINUED

cm/s are used in the factory for testing the uniformity of every professional tape, throughout its length, prior to its leaving the factory.

At the same time another engineer was evaluating some 6.25 mm domestic tape using a professional tape transport modified for this purpose. This was part of the 'type approval procedure' for every new generation of tape. These tests last anything up to six months with field and storage tests, together with hot and cold climatic testing.

In another area I was surprised to see some

3.8 mm cassette tape being measured at 15 kHz at a tape speed of 4.75 cm/s. I was told that one should never belittle domestic tapes; in some ways they have a more difficult job to do than professional tape running at 38 cm/s.

The great problem that plagues all tape manufacturers occupies a great deal of EMI thought: what should be aimed for, low noise or low print-through? The domestic EMI *Afonic* opts for low noise and a modified version of this tape will be marketed as professional *Emitape 815*. But there is no getting away from the fact that, as a rule, low noise tapes give a somewhat worse print when compared with other types.

Typical weighted signal-to-noise ratios that can be achieved on professional tape are of the order of 70 to 72 dB using 6.25 mm tape recorded full-track, whereas the best signal-to-print figures are of the order of 64 dB, therefore the print-through factor is often of first importance to professional recording engineers.

No matter how good the tape is it should always be the studio rule to store tape with the trailer out, in cool conditions, and away from all magnetic fields. With the trailer out, the remanence from print-through can be reduced by respooling with the result that there will be a 4-5 dB improvement in the unwanted print signal. Print-through is a very complicated business and can be affected by type of oxide, thickness of coating, thickness of film base, frequency, temperature, reeling tension, and conditions and length of storage. Engineers usually have a preference for either low noise or low print-tape, and there is always strong disagreement in the recording industry as to which is of prime importance; to a large extent this will depend on the type of recording but, where archives are important and it is necessary to store tape for fairly long periods, the preference is always for a low print tape. When studying the manufacturer's specifications the following points should be noted: a low print professional tape specification would quote print figures in the order of -58 to -61 dB after leader out storage and no rewind, or -62 to -65 dB after trailer out storage, rewind once. However, for recordings of modern pop music, tapes with print figures of -56 dB without rewind or -60 dB after rewind are quite satisfactory.

Ball mills

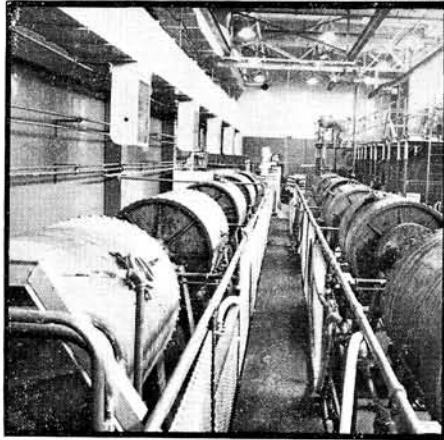

Slitting machine



FI-CORD 800/850 REVIEW CONTINUED

200 ohms balanced to ground, and power is supplied via the phantom technique, power requirements being 45 V at 0.4 mA, which can be obtained either from batteries or a small mains power supply. The very modest power requirements permit extended use without fear of battery failure.

The claimed sensitivity of both microphones is a minimum of 200 μV per μB and was easily met, being about 6 dB higher than the specification. The equivalent self-noise (i.e. the deafness) of the microphone, is claimed to be 25 phons. The actual noise generated by the microphone in absence of any signal was 1.5 μV , corresponding to a noise level of 22 phons. In both instruments the specification was met. It should be noted that this noise level gives a dynamic range in excess of 80 dB for these microphones.

The claimed frequency response is 30 Hz 18 kHz ± 2 dB. Figs. 3a and b show the response of the *FC 800*, in which the claim is met, and the *FC 850*, in which the low frequency response does not meet the specified claim. The front-to-back separation of the *FC 850* averages about 15 dB, which again does not quite meet the specification, but is adequate for all normal usage. At sound levels of +120 dB, reference 1 μB , the inherent distortion could not be measured and, after exposure to a level of +135 dB reference 1 μB for half an hour, the sensitivity and frequency response of the microphones was unimpaired.

No drop test was performed on these units,

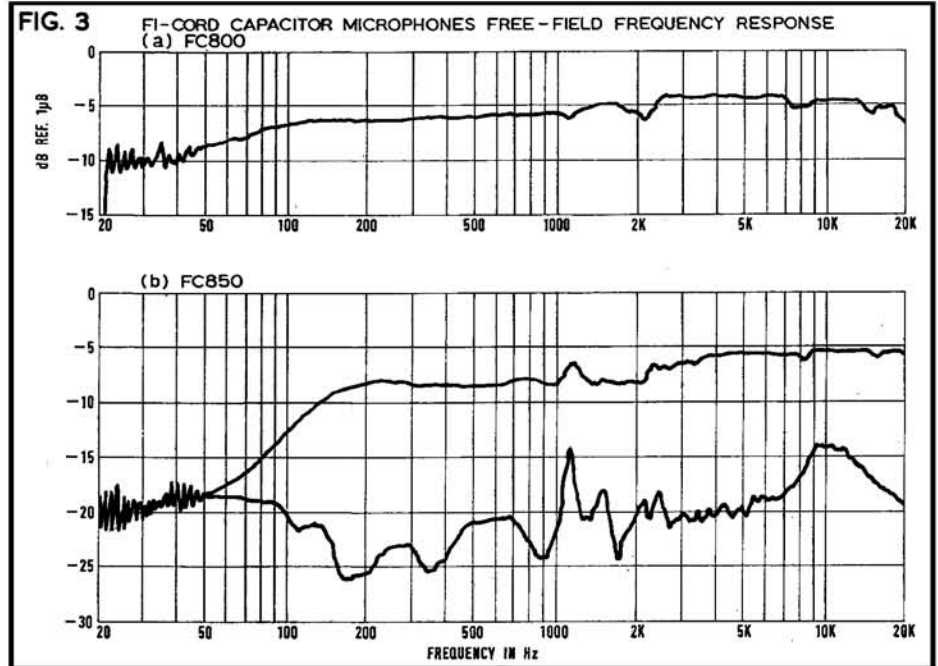

it being assumed that engineers handling them will treat them with more respect than the average pop group.

A range of accessories is available, including windshields, stands, power units, and special connecting cable complete with plugs in 10 and 20m lengths.

To summarise: these are beautiful instru-

ments, extremely well produced, and presented in fitted cases. The *FC 800* easily meets its claimed specification, as does the *FC 850*, except for the drop in LF response. These British units represent exceptionally good value for money, being approximately half the price of foreign produced units of similar performance.

Stanley Kelly

CLASSIFIED ADVERTISEMENTS

Advertisements for this section must be pre-paid. The rate is 6d. per word (private), minimum 7s. 6d. Box Nos. 1s. 6d. extra. Trade rates 1s. per word, minimum 15s., Box Nos. 2s. extra. Copy and remittance for advertisements in **NOVEMBER 1969** issue must reach these offices by **19th SEPTEMBER** addressed to: The Advertisement Manager, Tape Recorder, Link House, Dingwall Avenue, Croydon CR9 2TA.

Replies to Box Nos. should be addressed to the Advertisement Manager, Tape Recorder, Link House, Dingwall Avenue, Croydon, CR9 2TA, and the Box No. quoted on the outside of the envelope. The district after Box No. indicates its locality.

SITUATIONS VACANT

Wanted: Recordist. Details S.A.E. Trans World Radio and Television Service, Fleet Street House, Great Wakering, Essex.

Multi Tape Copying. Vacancy, age 23 upwards, to take charge after training. Responsibility for quality, production planning and stock. Maintenance experience an advantage. Box No. 555 (London).

FOR SALE—PRIVATE

Solid State Stereo Tape Recorder, Eagle TC450. Vertical or Horizontal operation, 4-track stereo and mono record/playback (as reviewed in *Tape Recorder* Sept. '68), in pristine condition. A few hours use only. Cost £69. Bargain at £40 o.n.o. Box No. 553 (Kent).

National mains recorder (speeds 3¼ and 7½), a very high quality machine, giving remarkable sound, accept £30. Mr. Russell, 59 Knightsbridge Court, Sloane Street, S.W.1.

Telefunken TD300 Microphone for Magnetophon 300 £3. Adam, Officers Mess, RAF Church Fenton, Tadcaster, Yorks.

Sanyo Cassette tape recorder, as new, £15. Abbott, 48 Cornmill Drive, Liversedge, Yorks.

Telefunken tape recorder 75-15 model 2-track, has been kept in mint condition, £20. E. Foster, 72 Vimy Rd., Billesley, Birmingham.

Dynatron TLS2: 3 ohm 5 watt Bass, treble, X-over, in teak. Excellent tape extension. New speakers, bargain £12 o.n.o. A. Grove, The Garth, Greenhill Pk. Rd., Evesham, Worcs.

Tape recorder for sale, twin track, cost £60, wants £32. Mr. T. Sturgess, 69 Bridport House, College Gardens, Edmonton, N.18.

Akai 1700, as new, in makers carton, £55. Elston, 15 Burgundy Close, Locksheath, Southampton, Hants.

FOR SALE—TRADE

Blackburn has Lancashire's leading Hi-Fidelity/Tape Recorder stockists and Electronic Engineers at Holdings Audio Centre, Mincing Lane/Darwent Street, Blackburn (Tel. 59595).

Pre-recorded American Stereo Tapes. 7½ ips. Cheap as records. Bernsteins, Mahler, Maazels, Sibelius, Karajan, Beethoven Symphonies. £15 per set of 5 tapes incl. PT and duty (any duty or purchase tax charged by the postman will be refunded—see instruction slip in tape box). £3 cheaper than records. PO 5s. for complete catalogue. Postereo Tapes, 9 Darley St., Harold's Cross, Dublin 6, Eire.

American jingles and pirates, sample tape 6s. or s.a.e. for lists. John Coles, 44 Kenton Gardens, Kenton, Middx.

W.H.M. 8 transistor Audio Limiter/Compressor in modular form. Full frequency range. 20 db overload capacity. P.P.M. attack. Fast recovery . . . no 'hole'. Low distortion. £15 net (UK), 2 year guarantee. 35 Villiers Road, Watford WD1 4AL.

STUDIO FACILITIES

Studio Sound Recording Studios. Recording and disc transcription service. Latest high-level cutting techniques. Mono and stereo records. Exceptional quality obtained from amateur recordings. Members A.P.R.S., 31-36 Hermitage Road, Hitchin, Herts. Telephone Hitchin 4537.

Your tapes to disc. 7in. 45—25/-, 10in. L.P.—55/-, 12in. L.P.—65/-. 4-day postal service. Masters and Vinylite pressings. Top professional quality. S.A.E. photo leaflet: Deroystudios, High Bank, Hawk Street, Carnforth, Lancs.

Your own tapes transferred on to discs. Send for details: R. J. Foley Tape to Disc Service, 112 Beach Road, Scrabby, Great Yarmouth, Norfolk.

Graham Clark Records. Tape to disc pressings. 23 The Grove, Walton-on-Thames, Surrey. Tel. Walton 25627.

TAPE EXCHANGES

You too can belong to Britain's largest, the World's friendliest, foremost tape-X-Change: Worldwide Tapetalk, 35 The Gardens, Harrow, Particulars 4d; sample magazine 1s. 4d. (stamps).

MISCELLANEOUS

Dictating and Audio Service Ltd., 5 Coptic Street, London, W.C.1. (Near the British Museum). Telephone: 636 6314/5. Authorised Service Agents. Grundig, Philips and other leading makes of Tape Recording equipment repaired to Manufacturers' Standards by skilled staff, using modern test equipment—audio generators, oscilloscopes, audio voltmeters, etc.

Skilled tape recorder repairs carried out by expert personnel of many years' experience backed by extensive test equipment: Wow and flutter meter, audio valve voltmeter, audio generator, oscilloscope, etc., with final test performance figures quoted if required—Ferrograph specialists. Tape Recorder Centre, Tel-Lee-Radio, 220 The Broadway, Wimbledon, S.W.19. 01-542-4946.

WANTED

Lee Electronics. The Tape Recorder and Hi-Fi Specialists wish to purchase good quality Tape and Hi-Fi Equipment for cash. 400 Edgware Road, W.2. Phone PAD 5521.

Highest prices offered for good quality Tape Recorders and Hi-Fi. R.E.W., 266 Upper Tooting Road, London, S.W.17.

GOOD QUALITY TAPE RECORDERS PURCHASED FOR CASH. TELEPHONE 01-472-2185.

Wanted: tape recorder or tape deck having sound on sound facilities. Any make considered. Tandberg deck preferred. Must be excellent condition. Also set of good quality headphones. Write with details to: Widd, 2 Albert Street, Bridlington, Yorks.

CLASSIFIED ADVERTISEMENTS ORDER FORM

To: TAPE RECORDER, Classified Advertisements Dept., Link House, Dingwall Ave., Croydon CR9 2TA 'Please insert the advertisement indicated below. (Please write BLOCK LETTERS to avoid errors.)

NAME.....ADDRESS.....
 NUMBER OF INSERTIONS
 CHEQUE/P.O. ENCLOSED £ : : :

RAPID RECORDING SERVICE

LPs FROM YOUR OWN TAPES
 48-HOUR SERVICE
 MASTER DISCS AND PRESSINGS
 RECORDING STUDIO
 DEMONSTRATION DISCS
 MOBILE RECORDINGS—ANY DISTANCE

Multi-channel facilities for transfer to 8 or 16mm film tracks. Sound effects library on discs.

Brochure on request from

Rapid Recording Service
 21 BISHOPS CLOSE, LONDON, E.17

Residual magnetism may endanger your tapes every time you play them:

For only 60/- the Ferrograph Defluxer protects them.

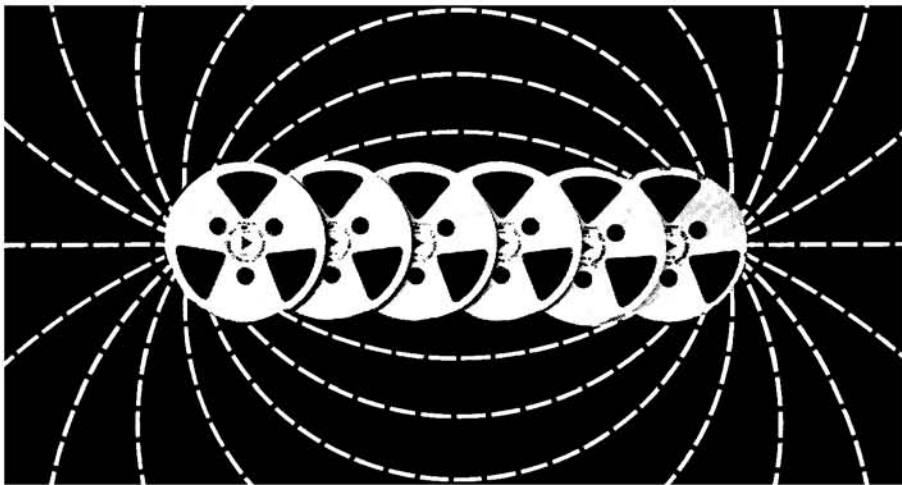

No professional studio would ever record without defluxing the heads and tape guides; so it is sensible that you, too, should follow this procedure at home. Once you have made a recording, or bought a pre-recorded tape, you must ensure that your sound is protected.

Electrical pulses, or magnetic materials such as in loudspeakers nearby, can cause magnetization of the heads and guides which increases background noise and reduces high-frequency response.

Prevent any possibility of ruining your tapes. This unique

Ferrograph Defluxer is simple and quick, and can be used with practically any make of tape recorder. Once you start using it, your valuable, often irreplaceable tapes are protected against magnetization: surely it is worth just 60/- protection money! Call at your Ferrograph dealer, or send this coupon with your cheque/P.O. for a Defluxer. Money back guarantee if not satisfied.

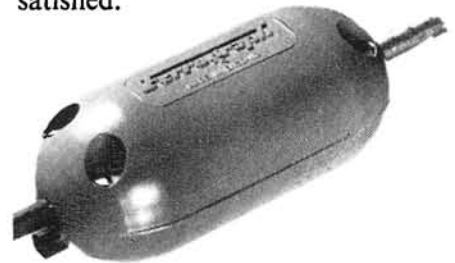

Ferrograph

A member of the Wilmot Brecken Group

To: The Ferrograph Co Ltd
Mercury House
195 Knightsbridge London SW7
Telephone: 01-589 4485

Please send me a Ferrograph Defluxer, complete with easy instructions for use.

I enclose cheque/P.O. for £3, crossed and made payable to the Ferrograph Co Ltd.

Name _____

Address _____

(BLOCK CAPITALS)

TR

THE MAGNIFICENT WORLD



Model 4000D

4 TRACK STEREO TAPE DECK—4000D

*4 track stereo/monaural recording and playback *2 speeds, 3 heads *All silicon transistorized pre-amplifier *Automatic shut off, Instant stop control *Tape cleaner *ONE MICRON GAP HEAD *Magnificent oil-finished wooden cabinet *For increased stereo enjoyment, use the matching AA-6000, 120 watt solid state amplifier and the matching speaker SW130 (2 way, 25 watt input).

MIGNON STEREO TAPE RECORDER—1710L

*4 track stereo/monaural recording and playback *3 speeds *Automatic shut off *Pause lever *Tape cleaner *Tape lifter in fast forward/rewind operation *4 hours maximum stereo recording capacity with a 1,200 feet tape *Beautiful black vinyl leather cabinet *For increased stereo enjoyment, use the matching high compliance speaker SW-50.

CARTRIDGE/REEL-TO-REEL STEREO TAPE RECORDER—X-1800SD

*8 track stereo cartridge recording and playback *Transfer from open reel to cartridge *4 track stereo/monaural recording and playback *Wide frequency CROSS-FIELD HEAD *ONE MICRON GAP HEAD *Magnificent oil-finished wooden cabinet *For increased stereo enjoyment, use the matching speaker SW-130 (2 way, 25 watt input).

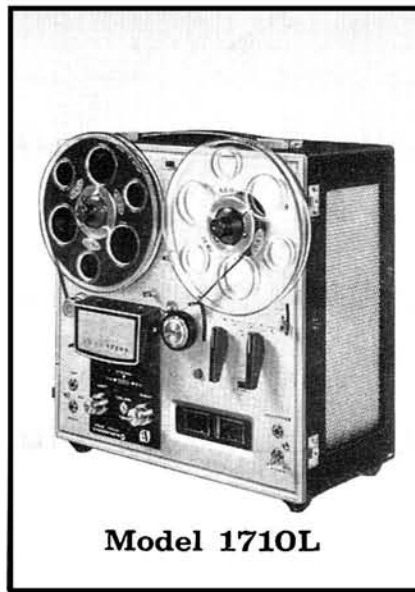

Model 1710L

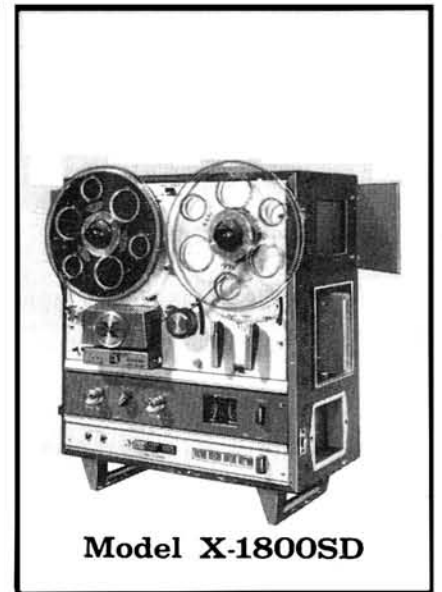

Model X-1800SD

Prove it by the sound!
..... prove it with

AKAI® CROSS-FIELD HEAD