

**APRIL 1969 2s 6d**

# **tape recorder**

---

**PRODUCING A  
DEMONSTRATION TAPE**

---

**A SILICON TRANSISTOR  
STEREO TAPE AMPLIFIER**

---

**THE SOUND STUDIO--  
FIRST OF A NEW SERIES**

---

**A SINE/SQUARE  
AUDIO GENERATOR**

---

**CHOOSING AND USING  
MONITOR HEADPHONES**

---

**NATIONAL STEREO TAPE  
UNIT REVIEW**

---



**Top quality, high performance tape,  
so sensibly priced—  
plus free insurance for your tape recorder**



**and now you can get this superb tape splicer  
for half price when you buy 'Synchronotape'**

It makes such sound sense when you buy SYNCHROTAPE—now more than ever. For not only do you get free insurance up to £25 for your recorder as protection against theft or fire, but each reel of SYNCHROTAPE that you buy, from 5" to 7", contains a special offer coupon towards the purchase of the superb Adastra 'Instant Cut & Trim' tape splicer for only 7/6. (usual price 15/-). *This Offer is restricted to the U.K. and Eire only.*

\*...and yet another SYNCHROTAPE-PLUS feature!  
Free booklet with unique Recording Log and Technical data now included in all Synchronotape packs from 4" upwards.



SIZE	STANDARD	LONG	DOUBLE	TRIPLE
BASE	P.V.C.		POLYESTER/P.V.C.	
2½"		200' - 5/9d.	300' - 8/9d.	
3"	150' - 4/9d.	225' - 6/3d.	300' - 8/9d.	450' - 13/9d.
4"		450' - 12/-	600' - 18/-	900' - 27/-
5"	600' - 15/-	900' - 18/6d.	1200' - 28/6d.	1800' - 45/-
5½"	900' - 18/6d.	1200' - 22/6d.	1800' - 36/-	2400' - 57/6d.
7"	1200' - 22/6d.	1800' - 28/6d.	2400' - 48/-	3600' - 75/-

COMPREHENSIVE TAPE-EDITING KIT WITH SPLICER—29/6d. plus 6/6 PT.

**How to get your Adastra Tape Splicer** Send three of the splicer offer coupons with a postal order for 7/6d, together with your name and address on the order form supplied to: Adastra Electronics Limited. Within 14 days you will receive your tape splicer, postage free, and with full instructions for use.

**'Synchronotape'**  
ADASTRA ELECTRONICS LIMITED

A range of 21 top quality, high performance tapes  
167 Finchley Road, London, N.W.3 (Tel: MAI 8164/5)

## EXCLUSIVE T.R.C. OFFERS

Only at the Tape Recorder Centre and branches can you buy the exceptional TELEFUNKEN 204TS and take your pick of one of the two amazing Money Saving Offers detailed below!

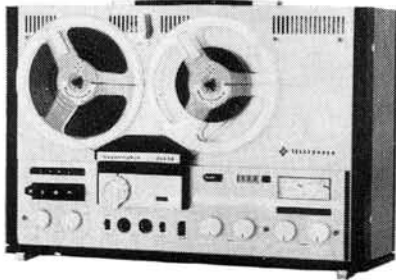

### Telefunken

#### 204TS STEREO TAPE RECORDER

An all-stereo tape recorder for vertical or horizontal operation. Fully transistorised incorporating 1½, 3½, 7½ i.p.s. 7in. reels. Two 6 watt amplifiers, stereo/mono record/replay facilities, two separate VU meters, two separate volume controls, two separate tone controls. Inputs for mike, radio/gram. Outputs for headphones and extension speaker.

A recorder with style for connoisseurs. Price 119 gns.

★ ★ ★ ★ ★ ★ ★ ★ ★ ★ ★ ★ ★ ★ ★ ★  
OFFER ONE **50% OFF!!**

#### A.K.G. STEREO HEADPHONES & MIKES

PAIR OF A.K.G. D9D—HL High quality Dynamic Microphones

For hand or table use. Frequency response 50-15,000 Hz. Complete with elegant anodised aluminium detachable stands in presentation boxes. List Price £12.10.0 pair.



#### A.K.G. Dynamic Stereo Headphones. Model K50

Enjoy the thrill of stereo with these superb headphones. Elegant and lightweight with crystal clear reproduction. Frequency response 20-20,000 Hz. Impedance matches Telefunken 204TS Brand New. List Price £9.10.0. The above items (total list price £22.0.0) can be yours for only £11.0.0 when purchased with the Telefunken 204TS.

★ ★ ★ ★ ★ ★ ★ ★ ★ ★ ★ ★ ★ ★ ★ ★  
OFFER TWO **50% OFF!!**

#### PAIR OF D.N.H. HIGH FIDELITY SPEAKER ENCLOSURES by Norway's Largest Speaker Manufacturers

The ideal loudspeakers for use with the Telefunken 204TS matched in appearance and performance. Enjoy to the full the true stereo quality that the 204TS is capable of. Each fitted high quality twin cone 8½" speaker 10 watt handling capacity. Not mini speakers—size 11" x 7" x 15½" high. Teak finished on all sides with cloth fronts for vertical or horizontal use. Normally sold at £33.12.0 these superb speakers can be yours for only 16 gns. when purchased with the Telefunken 204TS.



THE LARGEST SHOWROOMS IN GREAT BRITAIN  
DEVOTED EXCLUSIVELY TO TAPE RECORDERS &  
TAPE RECORDING EQUIPMENT

## SCCH!!

YOU KNOW WHO TAPE

UP TO **60% OFF!!**

We are not allowed as a condition of our bulk purchase of this tape to state the manufacturers, as we are able to sell at such a ridiculously low price that it makes the official price list seem astronomical!! Suffice it to say that this superb polyester based low noise tape is manufactured by one of the world's leading British/American based companies and cannot be bettered in quality or price.

Supplied on reels, without leaders in plain white boxes under the NuSound brand name we are able to offer these at the ridiculously low prices below.

	BRANDED PRICE	OUR PRICE
5" STANDARD 600 ft.	22/2	15/-
5½" STANDARD 900 ft.	29/5	18/6
7" STANDARD 1200 ft.	36/7	22/6
5" LONG PLAY 900 ft.	29/2	18/6
5½" LONG PLAY 1200 ft.	36/5	22/6
LONG PLAY 1800 ft.	51/7	28/6

Please add P. & P. 2/6 extra

## MAIL ORDER DEPARTMENT

FOR EXPRESS SERVICE SEND YOUR ORDERS TO  
THE TAPE RECORDER CENTRE LIMITED  
MAIL ORDER DEPT. TR/AP,  
MAGNATAPE HOUSE,  
191/193 PLASHET ROAD, UPTON PARK,  
LONDON, E.13.  
GIRO ACCOUNT No. 58-271-0006

## SAVE ON STELLA!

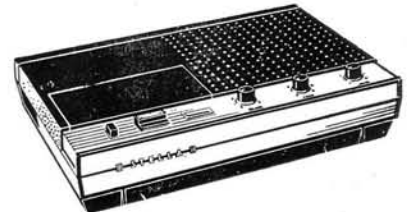

STELLA CASSETTE RECORDER MODEL ST.9112  
AC/DC MAINS AND BATTERY PORTABLE

LIST PRICE £42.8.8 OUR PRICE **29½ GNS.** P. & P. 10/6

Features include Automatic record level volume control. Separate tone and volume controls with large upward facing loudspeaker giving high quality reproduction. Outlet socket for extension loudspeaker and connection to Hi-Fi amplifier. Ideal for home or outdoor use. Operates from AC 200/240v. or six U11 batteries. Complete with dynamic microphone, remote control switch, demonstration cassette, cassette holder, rack, recording lead, instruction book and makers guarantee.

# THE TAPE RECORDER CENTRE



82 HIGH HOLBORN, LONDON, W.C.1. TELEPHONE: CHAncery 7401/8354

82 HIGH HOLBORN, W.C.1. Tel. 01-242-7401  
228 BISHOPSGATE, E.C.2. Tel. 01-247-2609

242/4 PENTONVILLE RD., N.1. Tel. 01-837-8200  
360 KILBURN HIGH RD., N.W.4. Tel. 01-624-1656

36 LEWISHAM HIGH ST., S.E.13. Tel. 01-852-2399  
87/100 ILFORD LANE, ILFORD. Tel. 01-478 2291



# Faithful Reproduction

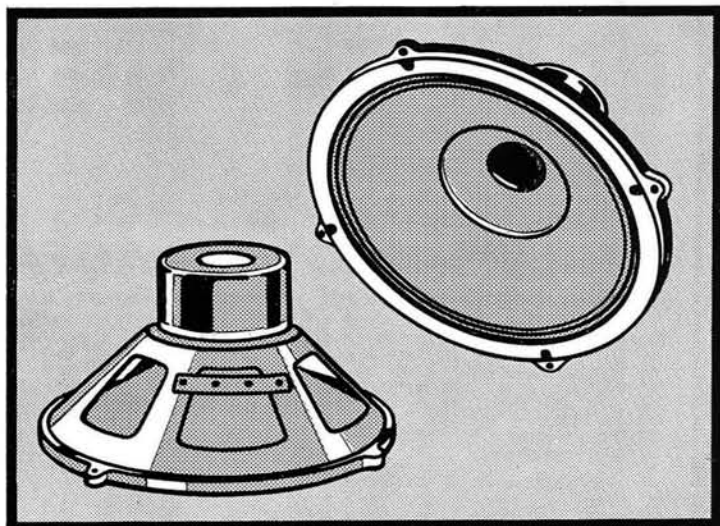

## with the Grampian TC12 loudspeaker

The Grampian TC12 loudspeaker is a high quality twin cone unit at a reasonable price. The loudspeaker is built of high quality materials to a rigid specification and is eminently suitable for good quality sound reproduction. Let us send you full details or better still go and hear one at your local dealers now.

Design for suitable cabinet available.

Grampian manufacture high grade microphones, parabolic reflectors, windshields and accessories, also mixers and amplifiers.

**Grampian** SOUND EQUIPMENT  
Integrity that you hear

Send for leaflet giving full details

## GRAMPIAN REPRODUCERS LTD

Hanworth Trading Estate, Feltham, Middlesex  
Tel: 01-894 9141/3 Cables REAMP, FELTHAM

## *Fantastic new* rank nivico

VTR System now showing at

# WALLACE HEATON



A complete video tape recording and playback system for **£595**

(Recorder — TV camera  
19" TV Monitor/Receiver)

Your own closed circuit TV system, it also records TV programmes — or you can make your own! The RANK NIVICO system is compact enough in size and price to find hundreds of applications in business, science and education.

### Continuous demonstrations:

in the city  
Wallace Heaton (City Sale)  
93 Fleet Street  
London, E.C.4

in the West end  
Wallace Heaton  
127 New Bond Street  
London, W.1

*Literature is available on application*





# K. J. ENTERPRISES

BRITAIN'S PREMIER MAIL-ORDER AUDIO SPECIALISTS

Immediate despatch on Advertised Lines.

Send Cash with Order.

DISCOUNT BARGAINS \* VAST STOCKS OF TAPE & EQUIPMENT \* REFUND GUARANTEE.

## BRANDED TAPES

### 20% OFF!

BASF—EMI—GRUNDIG—PHILIPS  
SCOTCH—AGFA

Brand new, Fully Guaranteed and in normal manufacturer's pack

STANDARD PLAY	LIST PRICE	OUR PRICE	DOUBLE PLAY	LIST PRICE	OUR PRICE
5" 600' }	22/2	18/-	3" 300' Not Scotch	14/3	11/6
5 1/2" 900' } Except Agfa	29/5	24/-	3" 400' Scotch only	16/7	13/3
7" 1200' }	36/7	29/6	4" 600' }	26/-	21/-
<b>LONG PLAY</b>			4 1/2" 900' Agfa, BASF only	31/-	25/-
3" 210' Not Scotch	9/3	7/6	5" 1200' }	43/2	34/9
3" 300' Scotch only	9/7	7/9	*5 1/2" 1800' }	56/11	46/-
4" 450' }	14/9	12/-	*7" 2400' }	79/-	63/6
4 1/2" 600' BASF, Agfa only	22/-	18/-	10" 4600' Agfa only	140/9	112/9
*5 1/2" 900' }	29/2	23/6	<b>TRIPLE PLAY</b>		
*5 1/2" 1200' }	36/5	29/6	3" 450' Not Scotch	22/3	18/-
*7" 1800' }	51/7	41/6	3" 600' Scotch only	24/10	19/9
8 1/2" 2400' BASF, Scotch	74/-	58/9	4" 900' }	40/-	32/3
10" 3280' Agfa only	85/9	68/9	*4 1/2" 1200' Agfa, BASF only	50/-	40/3
10" 3600' BASF only	96/6	77/6	5" 1800' Not Scotch	67/2	54/-
10 1/2" 4200' Agfa, BASF only	113/6	89/3	5 1/2" 2400' } Agfa, BASF	91/4	73/6
			7" 3600' } only	116/6	93/6
<b>SCOTCH DYNARANGE (L/P)</b>			<b>COMPACT CASSETTES</b>		
5" 900' }	32/8	26/3	C.60	17/6	14/3
5 1/2" 1200' }	41/-	33/-	C.90	25/-	20/3
7" 1800' }	58/1	46/6	C.120	33/6	27/-
8 1/2" 2400' (Metal Reel)	84/3	67/6			

GRUNDIG TAPE AVAILABLE ONLY WHERE MARKED WITH ASTERISK

Postage and packing 2/6. Orders over £3 post free.

## AMPEX TAPE—SAVE 30%

A special offer of top quality, premium grade, mylar (Polyester) base tape with Full Leader and Stop Foil. Boxed and Fully guaranteed.

TYPE	DESCRIPTION	LIST PRICE	ONE	THREE	SIX
541-12	1150' on 5 1/2" reel Long Play	...	35/-	24/6	71/-
551-12	1200' on 5" reel Double Play	...	42/-	29/6	86/-
551-16	1650' on 5 1/2" reel Double Play	...	55/-	33/6	97/6
551-24	2400' on 7" reel Double Play	...	77/6	49/6	145/6

POST AND PACKING 2/6. ORDERS OVER £3 POST FREE.

## SPECIAL OFFER COMPACT CASSETTES



up to HALF PRICE

Compact Cassettes with 60 and 90 minutes playing time. Brand New and packed in normal plastic library box. Available at this exceptional price.

MC.60	MC.90
1 for 10/6	1 for 14/-
3 for 30/-	3 for 40/6
6 for 55/6	6 for 78/-
12 for 105/-	12 for 150/-

Standard pattern to fit Philips, Stella, Elizabethan Dansette, Sanyo, etc.

Post and Packing 2/6. Orders over £3 post free.

**K. J. ENTERPRISES** (Dept TR4) 17 THE BRIDGE, WEALDSTONE, MIDDLESEX (Opposite Harrow and Wealdstone Station). 01-427 7758. Showroom hours: 9.30a.m. - 5.30p.m. Closed Lunch 12.30 - 1.30p.m. Close 1p.m. Saturday.

## ILFORD - ZONAL TAPE

### 40% OFF!



### NEW KJ SPECTACULAR

From the Motion Picture and Magnetic Products Division of ILFORD LTD. we are proud to present a New Stupendous BARGAIN OFFER! Never before have you been offered such a breathtaking opportunity. ILFORD-ZONAL premium grade magnetic tape (extensively used by the B.B.C.) at a terrific reduction of 40%! Brand New, Boxed, Fully Guaranteed and complete with leaders, trailers and stop foil. **UNIQUE TO KJ.**

DESCRIPTION	LIST PRICE	ONE	THREE	SIX
900' on 5" reel Long Play P.V.C.	...	29/1	17/6	50/6
1200' on 5 1/2" reel Long Play P.V.C.	...	36/1	22/6	65/-
1800' on 7" reel Long Play P.V.C.	...	51/4	29/6	86/-
1200' on 5" reel Double Play (Polyester)	...	43/1	27/9	81/-
1800' on 5 1/2" reel Double Play (Polyester)	...	56/1	36/-	105/-
2400' on 7" reel Double Play (Polyester)	...	78/10	49/6	145/6

Post and Packing 2/6 Orders over £3 post free

SPECIALISTS IN PHILIPS, GRUNDIG, FERGUSON, SANYO & EAGLE EQUIPMENT

## BARGAIN OF THE MONTH

### PHILIPS 4-TRACK TAPE RECORDER

SAVE £7.15.0!

LIST PRICE £48.12.0 OUR PRICE £40.17.0



Carriage 10/-

Model N 4307

Superb reproduction, beautifully designed, simple operation. The N4307 Philips Tape Recorder incorporates all the famous Philips features.

#### SPECIFICATION

Frequency Range—60-14,000 Hz. Signal to Noise—45 db. Wow and Flutter—±0.25%. Output Power—2 watts. Inputs—Mic. 2mV, Radio/Diode 2mV, Gram. 100mV. Power Supply—Mains Voltage 110/250v. Dimensions—16 1/2" x 11 1/2" x 5 1/2".

- Mono recording and playback at 3 1/2 i.p.s. Takes 7" spools.
- Provision for mono playback of two parallel tracks.
- Monitoring facilities.
- Position indicator.
- Tone control.
- Socket for direct recording from Mic./Record player.
- Extension speaker socket.
- Stylishly housed in wooden cabinet.
- Complete with microphone, tape and spool.

# FREE

Our New 100 page illustrated catalogue sent entirely FREE on request. Britain's most specialised comprehensive range of recording tape, Accessories and Audio equipment. 20,000 reels of tape always in stock with reductions ranging up to 50%.

# Ferrograph New Generation Series 7-



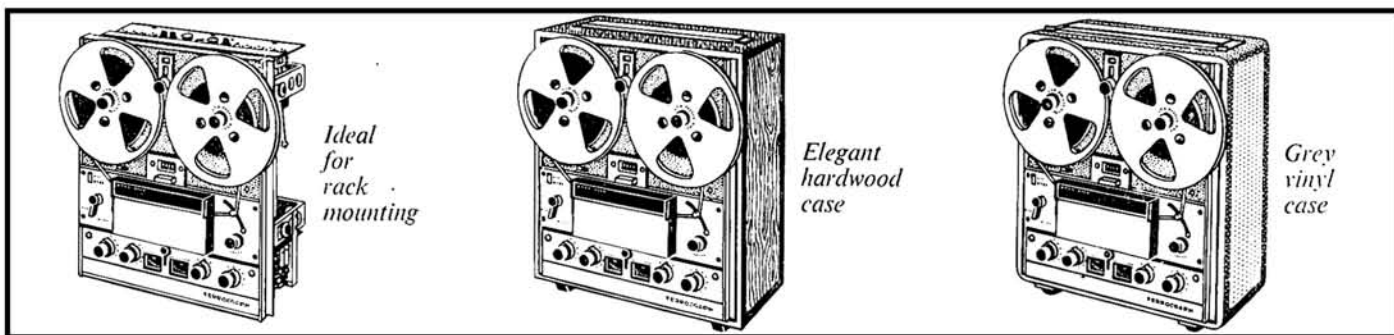

*Ideal for rack mounting*

*Elegant hardwood case*

*Grey vinyl case*

# not a year old and already a classic

Ferrograph Tape Recorders, Series 1 to 6, have been famous since 1949, and although Series 7 was introduced only a year ago it is already acknowledged as a classic. No other recorder to-day gives you quality like this, reliability like this, and offers so many desirable facilities.

It has the finest specification—and when Ferrograph gives you a figure, it is a conservative minimum. Ferrograph guarantees it. Every instrument is finally individually adjusted for optimum performance. With Ferrograph you know where you are—exactly.

Available in Mono, and in Stereo with and without end amplifiers; embodying a unique range of 30 features including:

- All silicon solid-state electronics with FET input stages and wide input overload margins.
- Vertical or horizontal operation.
- Unit construction: The 3 individual units i.e. tape deck, power unit and amplifier complex are mounted on a single frame easily removable from cabinet for service or installation in other cabinets or racks.
- 3 motors (no belts).
- 3 tape speeds.
- Variable speed spooling control for easy indexing and editing.
- Electrical deck operation allowing pre-setting for time-switch starting without need for machine to be previously powered.
- Provision for instantaneous stop/start by electrical remote control.
- Immediate access head block for editing and cleaning.
- Single lever-knob deck operation with pause position.
- Independent press-to-record button for safety and to permit click-free recordings and insertions.
- Adjustable reel height control.
- Damped tension arms for slur-free starting.
- 8½" reel capacity.
- Endless loop cassette facility.
- Provision for signal operated switching units.
- Internal loud speakers (2)—1 each channel on stereo, 2 phased on mono.
- 4 digit, one-press re-set, gear-driven index counter.
- 2 inputs per channel with independent mixing (ability to mix 4 inputs into one channel on stereo machine).
- Signal level meter for each channel operative on playback as well as record.
- Tape/original switching through to output stages.
- Re-record facility on stereo models for multi-play, echo effects etc., without external connections.
- Meters switchable to read 100 kHz bias and erase supply with accessible preset adjustment.
- Three outputs per channel i.e. (1) line out—level response. (2) line out—after tone controls. (3) power output—8-15 ohms.
- Power output 10W per channel.
- Independent tone controls giving full lift and cut to both bass and treble each channel.
- Retractable carrying handle permitting carrying by one or two persons.
- Available in several alternative presentations.

U.K. Retail prices from £135 incl. P.T. Please see next page for list of Ferrograph Stockists



# FERROGRAPH

THE FERROGRAPH CO LTD, FERROGRAPH HOUSE, 84 BLACKFRIARS ROAD, SE1. TELEPHONE: 01-928 1981



# Listen for yourself

To *know* the Ferrograph New Generation Series 7 you must look at it, listen to it, for yourself. You will find New Generation instruments soon in stock at many of the best tape-recording and Hi-Fi specialists in the country, including the following:

## Ferrograph stockists

- London Dealers**  
Telesonic Ltd.,  
92 Tottenham Court Rd.,  
London, W.1.  
Larg's of Holborn Ltd.,  
76/77 High Holborn,  
London, W.C.1.  
Nusound,  
82 High Holborn,  
London, W.C.1.  
Nusound,  
228 Bishopsgate,  
London, E.C.2.  
Nusound,  
360 Kilburn High Road,  
London, N.W.6.  
Nusound,  
36 Lewisham High Street,  
London, S.E.13.  
Francis of Streatham,  
169-171 Streatham High  
Road, London, S.W.16.  
Hampstead High Fidelity  
Ltd.,  
91 Heath Street,  
London, N.W.3.  
The Recorder Company,  
188 West End Lane,  
London, N.W.6.  
C. C. Goodwin Ltd.,  
7 The Broadway,  
London, N.22.  
Nusound,  
2 Maryland Point  
Station, Stratford,  
London E.15.  
Studio Tapes Ltd.,  
199 Hoe Street,  
Walthamstow, E.17.
- Aberdeen**  
Aberdeen Sound Centre  
25a Belmont Street,  
C. Bruce Miller,  
51 George Street,  
Aberdeen Radio Ltd.,  
9 Hadden Street.
- Banstead**  
Raylec Ltd.,  
43 High Street,  
Banstead, Surrey.
- Barnsley**  
Geoffrey Barnard,  
3 Pitt Street.
- Barnstaple**  
O. Nicklin & Son Ltd.,  
The Square.
- Bath**  
C. Milsom & Son Ltd.,  
Northgate.
- Birkenhead**  
James McKenzie Ltd.  
Grange Road.
- Birmingham**  
C.H. (High-Fidelity)  
Ltd.,  
167/169 Bromsgrove St.,  
Birmingham 5.  
Chas. H. Young Ltd.,  
170 Corporation Street,  
Griffin Radio Ltd.,  
94 Bristol Street,  
Birmingham 5.
- Blackburn**  
Holdings of Blackburn  
Ltd.,  
39-41 Mincing Lane.
- Blackpool**  
F. Benfell Ltd.,  
17 Cheapside.
- Bolton**  
Harker & Howarth  
(Music) Ltd.,  
Goodwin Street,  
Bolton, Lancs.
- Bournemouth**  
Tape Recorders  
(Bournemouth) Ltd.,  
874 Christchurch Rd.,  
Boscombe, Bournemouth.
- Brighton**  
John King Films Ltd.,  
71 East Street.  
Avery's Ltd.,  
77 St. James's Street.  
Lanes Radio Ltd.,  
11 Gardiner Street.
- Bristol**  
Tape Recorder and Hi-Fi  
Centres Ltd.,  
Stokes Croft.  
Sound Selection Ltd.,  
361-363 Gloucester Road,  
Bristol 7.
- Bromley**  
Bromley Sound,  
22 Letchworth Drive.
- Bury**  
John Smith & Son (The  
Rock) Ltd.,  
184 The Rock,  
Bury, Lancs.
- Cambridge**  
University Audio,  
1-2 Peas Hill.  
K.P. Cameras Ltd.,  
12a Kings Parade.
- Canterbury**  
Canterbury Hi-Fi,  
St. Dunstan Street.
- Cardiff**  
Sound Film Services  
Ltd.  
(Cinema Liaison Ltd.),  
27 Charles Street.
- Carlisle**  
Misons,  
Citadel Road.
- Coventry**  
Coventry Tape Recorder  
Services,  
33 King William Street.  
R.E.S. Ltd.,  
13 City Arcade.
- Crewe**  
Charlesworths of  
Crewe Ltd.,  
28 Hightown,  
Crewe, Cheshire.
- Darlington**  
Geoffrey A. Williams &  
Son Ltd.,  
Blackwell Gate.
- Derby**  
Victor Buckland Ltd.,  
41-49 London Road.
- Doncaster**  
Tom Jaques Ltd.,  
16 Wood Street,  
Doncaster, Yorks.
- Edinburgh**  
J. Nicolson (Hi-Fi  
Corner) Ltd.,  
1 Haddington Place,  
Edinburgh 7.
- Epping**  
Chew and Osborne  
Ltd.,  
148 High Street.
- Exeter**  
Electrosure Ltd.,  
162-163 Fore Street.
- Farnham**  
Lloyd & Keyworth Ltd.,  
26-27 Downing Street,  
Farnham, Surrey.
- Gerrards Cross**  
Edric Films Ltd.,  
34-36 Oak End Way,  
Gerrards Cross, Bucks.
- Gillingham**  
E. Hadaway,  
Walling Street.
- Glasgow**  
McCormacks (Music)  
Ltd.,  
33 Bath Street,  
Glasgow, C.2.
- Goodmayes**  
Unique Radio Ltd.,  
6 The Facade,  
Goodmayes, Essex.
- Gravesend**  
Bennett & Brown Ltd.,  
50, 60b and 60c  
Wrotham Road,  
Gravesend, Kent.
- Great Yarmouth**  
Norfolk Radio,  
12 Broad Row,  
Great Yarmouth.
- Guildford**  
P.J. Equipments,  
21 Onslow Street.
- Huddersfield**  
J. Wood & Son Ltd.,  
67 New Street,  
Huddersfield, Yorks.
- Ilford**  
Nusound,  
87-100 Pioneer Market,  
Ilford Lane,  
Ilford, Essex.
- Kirkcaldy**  
Caithness Brothers,  
270 High Street.
- Leamington Spa**  
W. M. Tysons,  
41 Russell Street,  
Leamington Spa, Warks.
- Leeds**  
Becketts Film Services  
Ltd.,  
The Headrow,  
Leeds 1, Yorks.
- Leicester**  
United Film Services,  
7 Kings Street,  
Tape Recorder Centre,  
72a Church Gate.
- Linton**  
H. S. W. Speechley &  
Co.,  
49 High Street,  
Linton, Cambs.
- Liverpool**  
Beaver Radio (Liverpool)  
Ltd.,  
20-22 Whitechapel,  
Liverpool, Lancs.
- Luton**  
Coventry Radio Ltd.,  
189 Dunstable Road,  
Luton, Beds.
- Maidstone**  
Sloman & Pettit,  
Pudding Lane.
- Manchester**  
Lancs Hi-Fi Ltd.,  
8 Deansgate,  
Manchester 3.  
Godleys Radio & T.V.  
Ltd.,  
Shude Hill.
- Mansfield**  
Syd Booth,  
11 Queens Street.
- Middlesbrough**  
McKenna & Brown Ltd.,  
122 Linthorpe Road,  
Middlesbrough, Yorks.
- Newcastle-upon-Tyne**  
Turners (Newcastle-  
upon-Tyne) Ltd.,  
Camera House, Pink  
Lane.  
J. G. Windows Ltd.,  
1-7 Central Arcade.
- Northampton**  
Audiocraft Ltd.,  
Abington Square.
- Nottingham**  
Petes Electronics Ltd.,  
165 Arkwright Street.
- Nuneaton**  
Taylors Pianos Ltd.,  
119 Abbey Street.
- Oxford**  
L. Westwood Ltd.,  
George Street.
- Plymouth**  
A. E. Ford Ltd.,  
84 Cornwall Street.
- Portsmouth**  
H. R. Knight,  
71 Tangier Road.
- Redcar**  
McKenna & Brown Ltd.,  
135 High Street,  
Redcar, Yorks.
- Rugby**  
Berwick Hi-Fi Centre,  
5 Sheeps Street,  
Rugby, Yorks.
- Salisbury**  
Suttons Hi-Fi Centre  
Ltd.,  
50 Blue Boar Row.
- Skegness**  
Norman Throp Ltd.,  
68 Lumley Road.
- Sheffield**  
Sheffield Photo Co. Ltd.,  
6 Norfolk Row,  
Fargate.
- Shrewsbury**  
Avon Hi-Fi Ltd.,  
13 Wyle Cop.
- Southampton**  
Hamiltons Ltd.,  
35 London Road.
- Southport**  
Wayfarers Radio Ltd.,  
Burton Arcade.
- Stafford**  
Tom Reekie Ltd.,  
10 Bridge Street.
- St. Helens**  
Harold Stott Ltd.,  
18 Westfield Street.
- Stoke-on-Trent**  
Wilson's Radio Ltd.,  
30-32 Liverpool Road.
- Stockport**  
W. J. & M. Bayliss Ltd.,  
611 Gorton Road,  
Reddish, Stockport.
- Swansea**  
W. J. Holt Ltd.,  
Picton Arcade.
- Teddington**  
Daytronic Ltd.,  
119a High Street,  
Teddington Lock, Middx.
- Truro**  
John Fry Ltd.,  
Hi-Fi Centre,  
6 Cathedral Lane,
- Fords, 9 Pytar Street,**
- Winchester**  
Southern Recorder  
Service,  
34 St. George's Street.
- Woking**  
D. W. Hughes & Sons  
Ltd.,  
5 Central Buildings,  
Chobham Road.
- Worcester**  
Johnson's Sound Service,  
Sibbury.
- Wilmslow**  
Transistor Centre,  
Green Lane,  
Wilmslow, Cheshire.
- Worthing**  
Bowers & Wilkins Ltd.,  
1 Beckett Buildings,  
Littlehampton, Worthing.

If none of these is near enough to you, in case of difficulty, or for free literature, send us the coupon, or give us a ring on WATERloo 1981.

# FERROGRAPH

To The Ferrograph Co Ltd Ferrograph House 84 Blackfriars Road London SE1

- Please send me a free brochure on the Ferrograph New Generation Series 7
- or the new Ferrograph Manual for which I enclose £1

NAME .....

ADDRESS .....

TR

the tape recorder with  
the hearing-is-believing sound

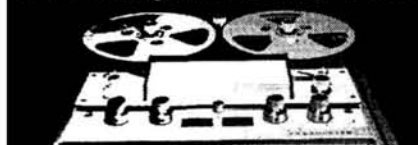

# tape recorder

APRIL 1969 VOLUME 11 NUMBER 4

INCORPORATING  
SOUND AND CINE

## EDITOR

JOHN CRABBE

## DEPUTY EDITOR

DAVID KIRK

## ADVERTISEMENT MANAGER

ROBIN WELLS

Editorial and Advertising Offices:  
LINK HOUSE,  
DINGWALL AVENUE,  
CROYDON, CR9 2TA  
Telephone: 01-686 2599

© Link House Publications Ltd., 1969  
All rights reserved

## COVER PICTURE

Acousto-ornithologist, spotted nestling in grass near Hayes. Note the EMI L4 battery recorder (with off-tape monitoring), the highly directional Sennheiser microphone (with windshield), the binoculars, the headphones, and the traditional hat.

## SUBSCRIPTION RATES

Annual home and overseas subscription rates to *Tape Recorder* and its associated journal *Hi-Fi News* are 30s. and 47s. respectively. U.S.A. \$4.30 & \$5.60. Six-month subscriptions are 15s. (*Tape Recorder*) and 24s. (*Hi-Fi News*), from Link House Publications Ltd., Dingwall Avenue, Croydon, CR9 2TA.

*Tape Recorder* is published on the 14th of the preceding month unless that date falls on a Sunday, when it appears on the Saturday.

ANY TAPE RECORDIST worthy of the name, states Terence Mendoza on page 160, could make a success of producing demonstration tapes. The demonstration he has in mind concerns the abilities of 'pop' (is there no alternative to that infernal monosyllable?) and folk musicians. A competent enthusiast could equally well demonstrate the abilities of amateur orchestras for the benefit of his local radio station, or perhaps the capabilities of his tape recorder for the benefit of its manufacturer. Akai have supplied lively demonstration tapes with all their models, or nearly all, we have reviewed. The tapes are more meaningful than one might suspect, since they are copied on the very recorders with which they are sold, not merely run off on an Ampex.

Few other manufacturers have given serious attention to preparing demonstration tapes for their recorders, possibly because few have any real experience of recording. They might conceivably welcome first-generation recordings made by owners of their equipment as the basis for a 'here's what you can do' demonstration programme.

A wealth of artistic talent exists in every town and village community. Local orchestras, amateur dramatists, spare-time bands, private music-teachers—all seem to live in ignorance or fear of the tape recorder, yet all would appreciate the facilities offered by a well-equipped and experienced recordist.

The ultimate goal of some tape enthusiasts is to earn the title 'semi-professional' by making money from their potentially expensive hobby. Would Akai pay an enterprising enthusiast for an *Akai Around the World* programme? Would Tandberg, Revox and Telefunken welcome similar approaches by amateurs? Ferrograph have an active Owners' Club to themselves and, consequently, every facility for producing demonstration tapes. By the same token, however, their good reputation is so widespread that they hardly need further sales promotion.

Contributor Peter Bastin recently bought himself a Stylophone pocket electronic organ, plugged it into a Ferrograph, and produced a series of multi-track musical ditties. Being more than pleased with the results, he sent copies to the organ manufacturer, Dubreq Ltd. Dubreq, it transpired, had once been in the recording business themselves and were delighted with the Bastin compositions. Now there is no reason on Earth why similar tactics should not be employed for microphones, reflectors, mixers, or even magnetic tape—anything capable of generating or processing sound. By approaching manufacturers and importers in this way, recording enthusiasts could make a thorough nuisance of themselves. Their offerings might even, on occasion, be accepted and paid for.

An audible equivalent of the journal *Tape Recorder* might offer an appropriate and

profitable medium for the sound recordist (we do pay for written contributions, as readers probably appreciate). Recorded magazines are unlikely to appear, however, until the day that large-scale tape copying becomes a practical and economic proposition. Until recently an LP disc took 60 seconds to emerge from the melting pot. Improvements in disc chemistry have lately reduced this time to 35 seconds (at the expense of 2 dB signal-to-noise ratio). By contrast, a 30 minute 19 cm/s track dubbed speed-to-speed at 152 (19 x 8) cm/s takes nearly four minutes excluding lacing up. Further research into magnetic contact printing might allow the copying speed to be raised, but would probably present flutter problems which, at one sixtieth the recording speed, could result in distressing wow. Contact printing is now being used for videotape copying, where conventional high speed dubbing is ruled out by the very high frequencies involved; the basic 4 MHz is bad enough.

Several years ago a magnetic mat system was developed for the dictation market. An oxide-coated sheet, about the size of this page, was scanned in parallel tracks by a conventional record/play head. The sheet could be posted, apparently even folded, and labelled on its reverse side with a pen or typewriter. Whatever their disadvantages, magnetic discs or mats lend themselves more readily than tape to contact printing. There is scope for experiment and exploitation, here, with a superior alternative to the cassette as the prize.

## FEATURE ARTICLES

- 149 WHICH EARPHONE?  
By Anthony Eden, David Robinson and John Fisher
- 156 A SILICON TRANSISTOR STEREO TAPE AMPLIFIER  
By T. J. Melville
- 160 PRODUCING DEMONSTRATION TAPES  
By Terence Mendoza
- 166 THE SOUND STUDIO—Part One  
By K. R. Wicks

## REGULAR ITEMS

- 143 WORLD OF TAPE
- 145 SOUND WORKSHOP  
By F. C. Judd
- 162 TAPE RECORDER SERVICE  
By H. W. Hellyer
- 171 CLOSED CIRCUIT  
By Richard Golding

## EQUIPMENT REVIEWS

- 172 NATIONAL STEREO TAPE UNIT  
By A. Tutchings

# The bare essential. Telefunken M250hifi.

This stereo tape deck gives you all you need.

Designed to become part of a great hi-fi system.

It has all the essential qualifications. With the right amplification and speaker units it produces sound that defies description.

The Telefunken M250 hifi has separate record and playback heads for echo and reverberating effects.

Multi-function switch.

Separate pre-set level controls.

Separate sliding controls for frequency modulation.

Before and off tape monitoring facilities.

A & B monitoring.

Signal/noise ratio  $\geq 54$ dB.

And it complies with the stringent requirements of DIN 45 500 - the official German hi-fi standards.

These are the bare facts.

Get the full story from your dealer or write direct.

AEG/Telefunken  
27 Chancery Lane  
London WC2





#### DOLBY PRICE REDUCTION

THE PRICE of the Dolby A301 Audio Noise Reduction System has been reduced from £700 to £560. This has been made possible by improved production facilities available to Dolby Laboratories at their new 1,000 square metres premises—346 Clapham Park Road, London S.W.9. (01-720 1111). From the first series of nine units sold in 1966 to the Decca Record Company, Dolby have expanded to produce 300 A301 units for some 90 recording and broadcasting organisations throughout the world. Decca, Pye, RCA, Columbia, Elektra-Nonesuch and Vanguard are among the main users of the Dolby system, which achieves a 10 dB improvement in signal-to-noise ratio in high quality recording systems.

#### ELCOM EQUALISERS

DETAILS OF THE new EQ series of equalisers are given in Technical Data Sheet 109, now available from *Elcom (Northampton) Ltd., Weedon Road Industrial Estate, Northampton*. The EQ units provide treble and bass boost/cut controls with mid lift/cut at four spot frequencies. Inputs and outputs are 600 ohms unbalanced, frequency response being 30 Hz - 20 kHz  $\pm$  1dB in the flat position. Presence may be introduced in 2 dB steps up to  $\pm$  10 dB at 1.4, 2.8, 4 and 5.6 kHz. Bass and treble may be varied in 3 dB steps from -15 dB to +12 dB. Noise level is -90 dBm with 0.3% distortion at maximum output (+15 dBm).

AUDIO/PHOTO FAIR CONTINUING TO EVOLVE AKAI, AIWA, BASF, Ferguson, Ferrograph, Lustraphone, Microfonbau, Nivico, Philips, Vortexion, Bang & Olufsen and Agfa-Gevaert are the only specialist recording equipment manufacturers yet to have applied for bookings at the 1969 Audio Fair. This exhibition will be held alongside the Photo-Cine Fair at Olympia from October 16 to 22. To provide some degree of sound insulation, exhibitors will be housed in 6 x 5 metres demonstration rooms with absorbent wall and roof covering in addition to floor carpets. Doorways will incorporate sound baffles based on the designs seen at the Dusseldorf audio exhibition.

#### NOVEMBER 1968 STATISTICS

TAPE RECORDER PRODUCTION in the UK during November was 14% lower, at 16,489 machines, than in November 1967. Compared with November 1967, however, stocks of British and imported recorders were both higher, by 6% and 14% respectively. Total deliveries to retailers of British machines were 27% lower in number, and 30% in value, than during November 1967. Exports were 5% lower in number but 12% higher in value.

150 ENTRIES TO 3M WILDLIFE COMPETITION MORE THAN 150 entries were received for the 3M Wildlife Tape Recording Competition, organised recently by the 3M Company and the Wildlife Sound Recording Society. A panel of judges, including Philip Hobson of 3M and John Burton of the BBC Natural History Unit, spent nine hours comparing contributions from a wide area of the country. The contest was divided into three categories, the most popular being Individual Species of Birds which attracted 68 entries. Magnus Sinclair of Haroldswick, Shetland, produced

the winning recording on a Fi-Cord 202 with a tape, made at 5 a.m. on the Isle of Unst, of a family of curlews. Runner-up was Reginald Tassell of Devon, who captured a raven's call with a Grampian DP4 and Uher 4000L. David Page of Derby received commendation for his Nagra 3 recording of lapwings made last May on the Isle of Skye.

Winner of the Mammals, Reptiles and Amphibians section was Norman Wylie-Moore, of Heathfield, East Sussex, who set out to record a nightingale and returned with a vixen barking her way through trees. Mrs. Anne Dunn, of Ashurst, Southampton, was runner-up with her recording of a grey squirrel swearing at a cat, while J. H. D. Hooper of Staines was commended for ultrasonic bat recordings made with an Uher coupled to a Holgate ultrasonic receiver.

Rarities, the third category, was won by Keith Briggs of Colne, Lancashire, who left his Tandberg 11 near a nest of choughs in a Welsh slate quarry. Returning to the scene, he found a tape of parent birds feeding their young. Jack Skeel and Brian Bourne of Ashford, Kent, were runners-up. They taped the cheeping of an unhatched curlew through a 3 mm hole in the shell of an egg, with the background of a parent bird calling overhead.

Prizes (Scotch magnetic tape) and awards will be presented at the British Institute of Recorded Sound by naturalist Peter Scott on March 20.

#### BRISTOL TAPE RECORDER CENTRE CHANGES ADDRESS

BRISTOL TAPE RECORDER and Hi-Fi Centres Ltd. have moved a few doors away from the old premises to 82 Stokes Croft, Bristol BS1 3RJ.

#### HIRSCHMANN COMPONENTS

RICHARD HIRSCHMANN COMPONENTS are now being imported by Electrooustic Ltd., 73b North Street, Guildford, Surrey. A range of sockets, plugs, terminals, clips and test prods is covered in a catalogue available on request.

#### BLANKET GUARANTEE FOR FI-CORD MICROPHONES

A FIVE-YEAR GUARANTEE against faults, accidents and long-term wear has been issued by Fi-Cord for their 1969 range of transistor capacitor microphones. The company claim the microphones to be exceptionally robust and will replace or repair damaged units without charge and without question. Further details are available from Fi-Cord International Ltd., Charlwoods Road, East Grinstead, Sussex.

#### PETER LANE JOINS LEEVERS-RICH

LEEVERS-RICH ANNOUNCE the appointment of Peter Lane as an executive in the department responsible for marketing multi-channel recorders to studios. Mr. Lane formerly headed his own beat group, The Moe-Henries, and appeared in the musical 'Half a Sixpence'.

#### FERROGRAPH MOVE TO NEW LONDON OFFICE

THE LONDON OFFICE of the Ferrograph Company recently moved to *Mercury House, 195 Knightsbridge, London, S.W.7*. Shure Electronics, who shared the old premises, remain at 84 Blackfriars Road, London S.E.1.



#### BACKGROUND MUSIC ON HIRE

THE CANTATA 700 background music system is now available on rental terms. The equipment comprises a typewriter-size tape player with a 700-piece cartridge which plays for 25 hours before repeating. It may be purchased outright for £273 (including tax and three years performing rights) or hired for a typical 39s. 6d. per week. Up to 30 supplementary speakers can be powered from the player without additional amplification, each speaker costing about 1s. per week rental. Five 25-hour cartridges are available for the Cantata, with a total of 3,500 pieces. 3M claim that the use of selected background music in factories and workshops has been shown to increase production by up to 15% in certain cases.



#### FIRE AT BASF

BUSINESS HAS RETURNED to normal following the upheaval of a fire, on Sunday January 19, at the BASF warehouse in Gillespie Road, London N.5. The fire was discovered at about 7 a.m. and was extinguished just after 9 a.m. Undamaged stocks have been retrieved and fresh supplies were flown from Germany the following day.

#### NEXT MONTH

ARTURO STOSBURG describes the considerations involved in designing the Revox A77 capstan servo system while Peter Clifford, in an article based on his recent BKSTS lecture, considers the impact of metrication on the film, sound and television industries. Alec Tutchings will review the back-biased Tandberg 12X.

# SONY

For the music audiophile . . . the new precision TC-255 stereo tape deck four tracks, two channels for stereo/mono recording and playback.

Handsomely encased in a walnut grained cabinet, this model will grace any decor and is easily connected to Hi-Fi systems to provide a whole new world of musical entertainment at your fingertips.

Model TC.255 for discerning music lovers.

*Recommended retail price £82.18.6.*

## Specifications

Recording system	4-track stereo/mono recording and playback.
Power requirement	100, 110, 117, 125, 220 or 240V AC 27W, 50/60 Hz
Tape Speed	7½ ips (19cm/s) 3¾ ips (9.5cm/s) 1½ ips (4.8cm/s)
Reel Capacity	7" or smaller
Frequency Response	30-20,000 Hz at 7½ ips 50-17,000 Hz at 3¾ ips ±3dB at 7½ ips 30-13,000 Hz at 1½ ips
Signal-to-noise ratio	Better than 52dB
Wow and Flutter	Less than 0.15% at 7½ ips Less than 0.25% at 3¾ ips
Harmonic distortion	Less than 1.8% at 0dB line output
Level indication	Dual VU meter
Fast forward and rewind time	Within 2 min. 30 sec. (1,200' tape)
Inputs	Microphone input jack: Sensitivity -72dB (0.19mV) Impedance 600 ohms Auxiliary input jack: Sensitivity -22dB (0.06V) Impedance approx. 100K ohms
Outputs	Line output jack: Output level 0dB (0.775V) Impedance 100K ohms Headphone jack: Output level -28.5dB (0.029V) Impedance 8 ohms
Dimensions	15⅝" × 7½" × 13¾"
Weight	18lbs
Assessories	Empty reel R-7A 1 Connecting cord RK-56 2 Head cleaning ribbon 1 Reel cap 2 Dust protector DP-255L 1 Motor pulley 1
Optional accessories	Stereo headset DR-3A Microphone mixer MX-600M Microphone F-98 or equivalent

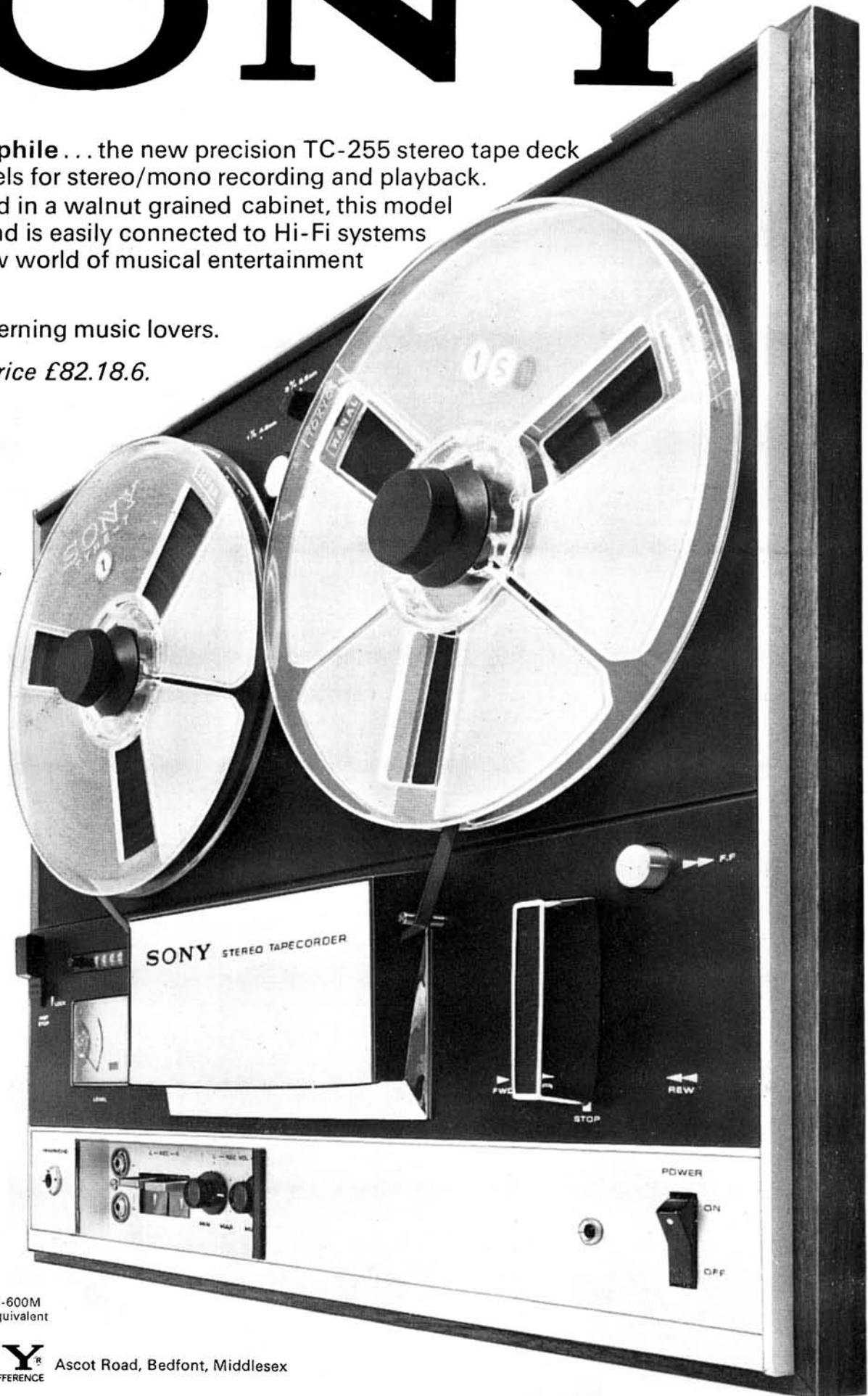

# SOUND WORKSHOP

A SINE/SQUARE  
AUDIO GENERATOR  
BY F. C. JUDD

THE audio signal generator circuit given in fig. 1 employs a Wien bridge oscillator originally designed by Mullard, coupled with a squaring circuit of my own design. The transistors used are readily available, as also are the remainder of the components and a suitable case. An audio signal generator of this calibre has many uses in the sound workshop for testing purposes and is an excellent signal source for electronic effects and music. The sine-wave output has less than 0.75% distortion and the square-wave rise-time is better than 1  $\mu$ S. Properly constructed, and using the components specified, the generator should perform as follows:

- Output: 0 to 1V RMS sine or square-wave.
- Square-wave mark/space: 1 to 1.
- Frequency Ranges: 15-150 Hz, 150 Hz-1.5 kHz, 1.5-15 kHz, 15-100 kHz.
- Distortion: Less than 0.75% (1K minimum load).
- Square-wave Rise-time: Better than 1  $\mu$ S.
- Output Level:  $\pm 0.5$  dB 15 Hz-100 kHz.

The output voltage is not affected by loads greater than 1K and up to one metre of co-axial (70-ohm) cable can be used without spoiling the fast rise-time of the square-wave.

The oscillator is a phase shift type employing a Wien bridge network to determine the frequency. As the capacitive elements of the Wien bridge are fixed, frequency variation over each of the four ranges is obtained by varying the resistive elements, namely Vr1 and Vr2. Top grade wire-wound potentiometers must be used for Vr1 and Vr2. The bridge also includes the internal base resistance of Tr1, together with its emitter resistors R4 and R5. The p-n-p and n-p-n pair of transistors Tr1 and Tr2 provide the first stage with high gain and the unbypassed emitter resistors of Tr1 and Tr2 allow for ample negative feedback and a clean sinusoidal waveform at the output. The thermistor, which is an STC 53, ensures constant ampli-

(continued on page 147)

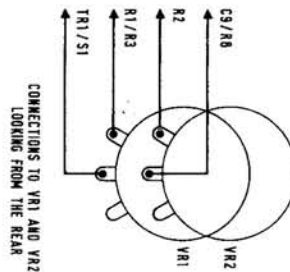
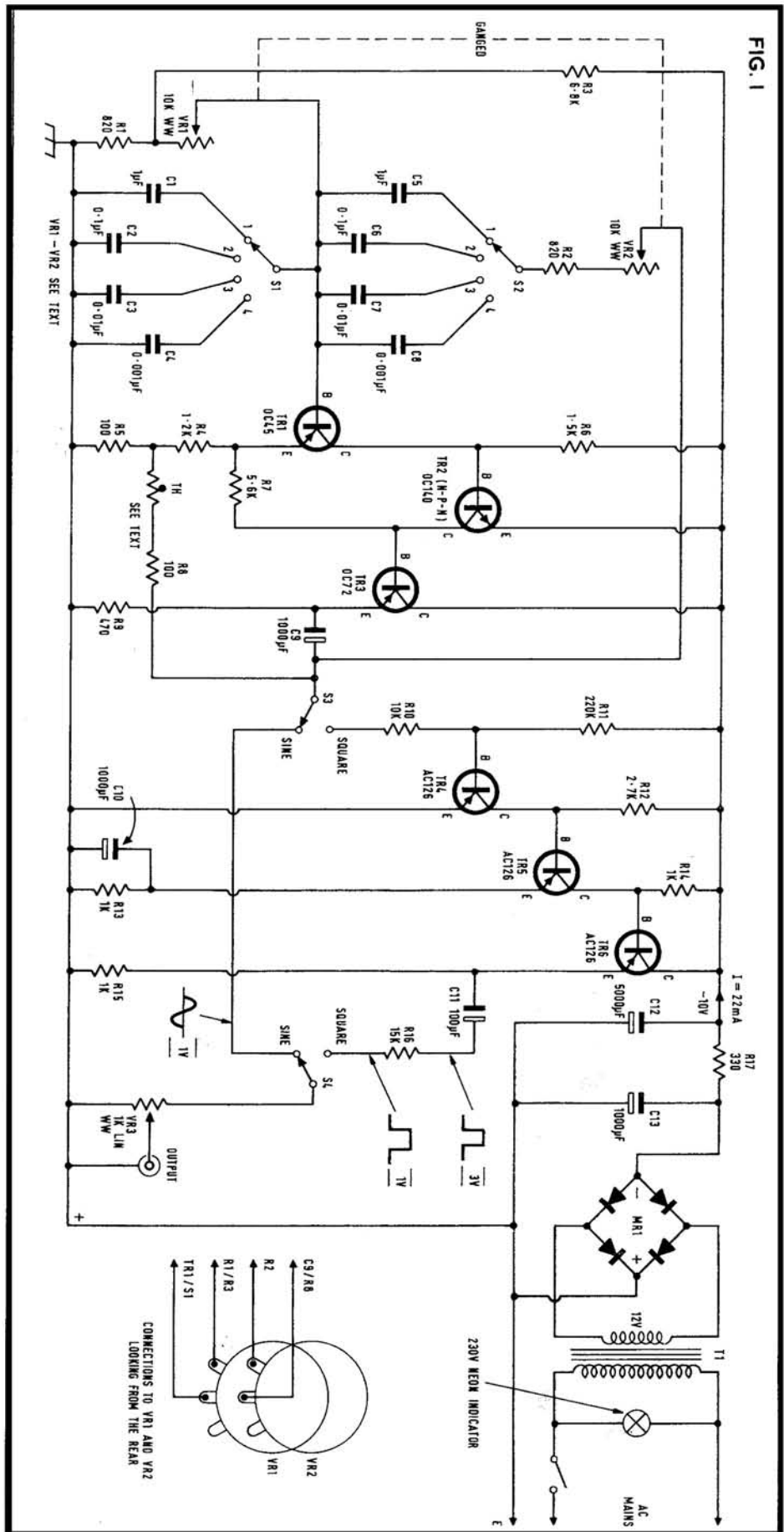



# A match to remember.

We'd like to tell you about Grundig Systemised Audio.

The Grundig RTV 350, PS3 record changer and our loudspeaker enclosures.

All for £147.18.7.

The RTV 350 is a neat compact unit comprising a high-quality AM/FM tuner, pre-amplifier and power amplifier.

It is fully transistorised and has a large, easy-to-read tuning scale for extra-easy station selection.

It also has a built-in stereo decoder and an indicator to show when stereo transmission is being received.

Then there's the Box 8 loudspeaker system—for full stereo effect.

Each box contains a twin-cone high-flux loudspeaker for ultimate reproduction of delicate or heavy notes.

The base response is outstanding—with no distortion. A quality you normally find only in much larger speaker systems.

The PS 3 record changer completes Grundig Systemised Audio. 4 speeds, micro-lift pick-up, sapphire and diamond styli, in a beautiful walnut finish with a transparent Perspex lid.

You can see this package deal at your local Grundig dealer.

Ask him.

He'll know the score.

Grundig (Great Britain) Limited, London S.E.26.

A MEMBER OF THE BRITISH INDUSTRIAL HOLDINGS GROUP



**GRUNDIG**

For people who listen.

tude at the output regardless of small changes in supply voltage and temperature.

To obtain square-wave signals, the output from the oscillator is switched to drive a squaring circuit comprising an overdriven amplifier and an emitter follower (Tr4, 5 and 6). The output from Tr6 is returned to the amplitude control Vr3. Several types of transistor were tried for this circuit, which is not critical in operation except for the level of the driving signal. This matter will be dealt with later.

The generator is self powered from the mains, the total HT current being approximately 22 mA at 10 V. Generous smoothing has been employed to reduce 50 Hz ripple to an amount which can be considered negligible.

The entire generator can be housed in an Electronics 46R.085.A diecast box (22.2 x 14.6 cm). All controls are mounted on the lid of the box, which becomes the front panel. The components for the Wien bridge oscillator are mounted on one piece of Veroboard and the components for the squaring circuit on another the same size. The power supply calls for a small sub-chassis.

Layout on each of the two Veroboards is shown in fig. 2. Note that these are as in the original generator and also as shown in the photographs. The layout is not critical. The ganged potentiometers Vr1 and Vr2, which form the frequency control, are wire wound and can be obtained complete from Colvern (see components list). The connections to these controls are shown in the inset of fig. 1 and allow for increase in frequency with clockwise rotation. The calibrated dial given as fig. 3 is full size and can be cut out and used with reasonable accuracy. A Perspex cover is desirable but not essential. This could alternatively be made from thick celluloid or similar transparent material. The Perspex dial cover was originally made by first cutting out the disc with a fretsaw. The disc was then mounted in an electric drill and the edge smoothed and beveled with a surfum tool. A hair line pointer was also produced from

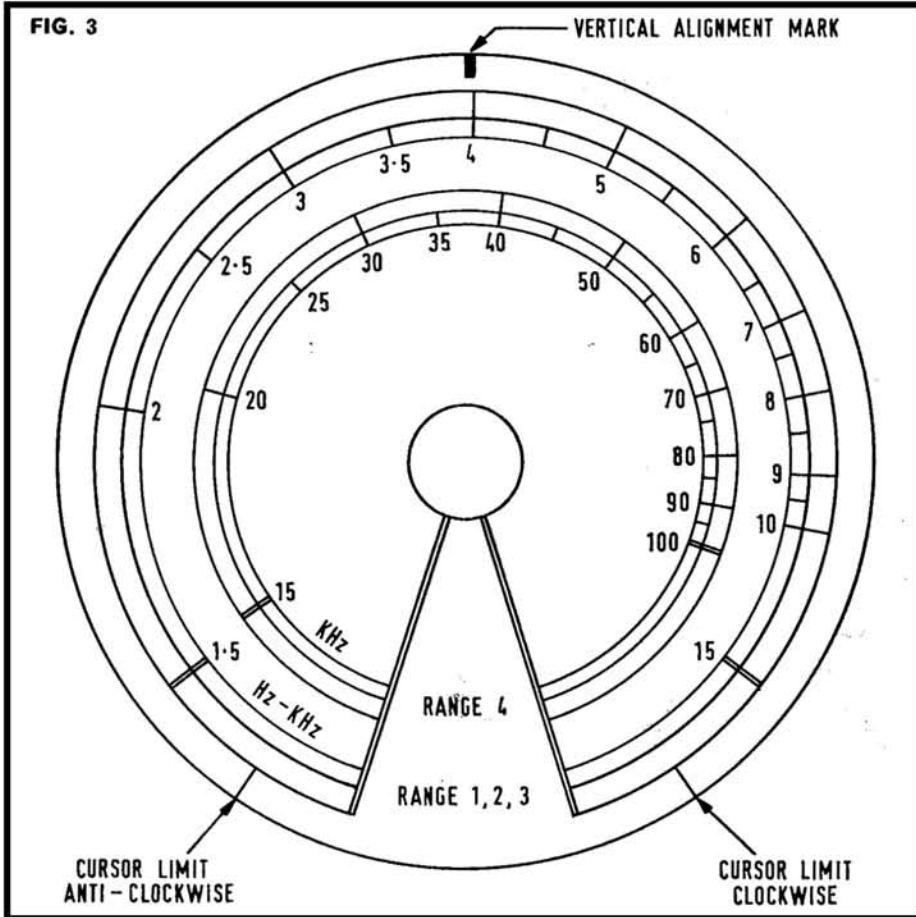

Perspex and fitted to a large flat-backed control knob.

Ideally an instrument of this nature should be calibrated against one of known accuracy with the help of an oscilloscope. The dial (fig. 3) will be accurate enough for general purposes providing the components are exactly as specified in the circuit. However, checks can be made against audible tones of known frequency such as tuning pipes or forks, a concert-pitch piano or BBC tuning

signals. This becomes more difficult as the frequency increases; particularly above 1 kHz. The output amplitude can be checked with an oscilloscope or a valve-voltmeter but note that an oscilloscope will display peak-to-peak voltage. The output signal amplitude is approximately proportional to the dial calibration i.e., 10 will be full output or 1 V RMS, 9 will be 900 mV and so on.

No difficulty should be experienced in  
(continued on page 165)

FIG. 2

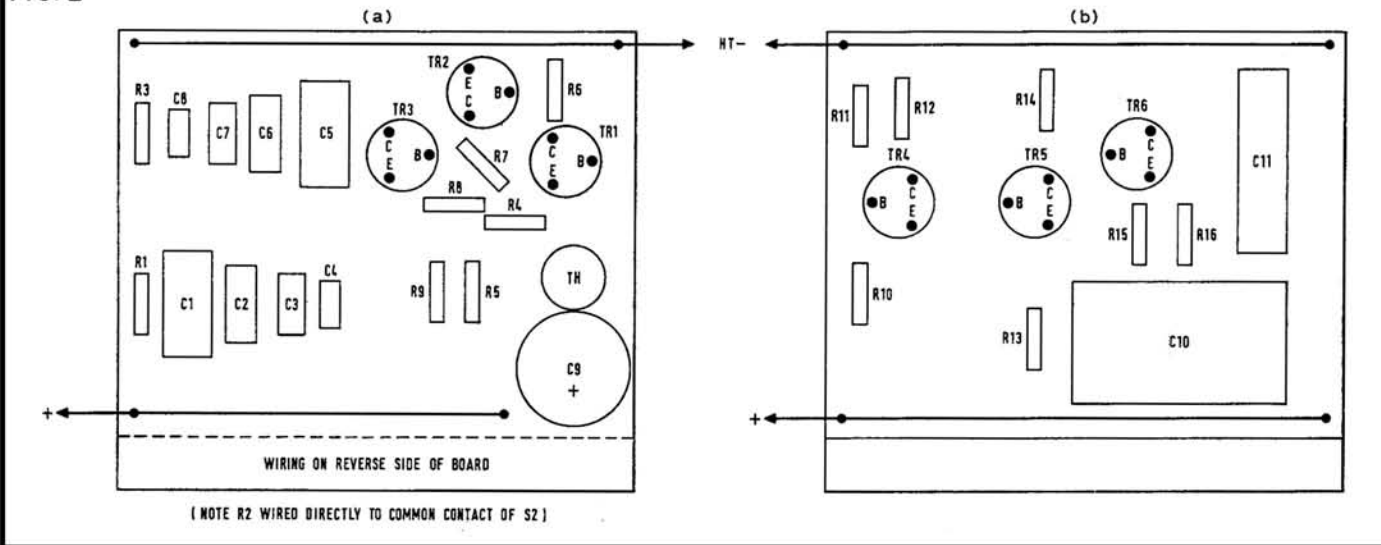

# Bib AUDIO AIDS AND ACCESSORIES make all the difference

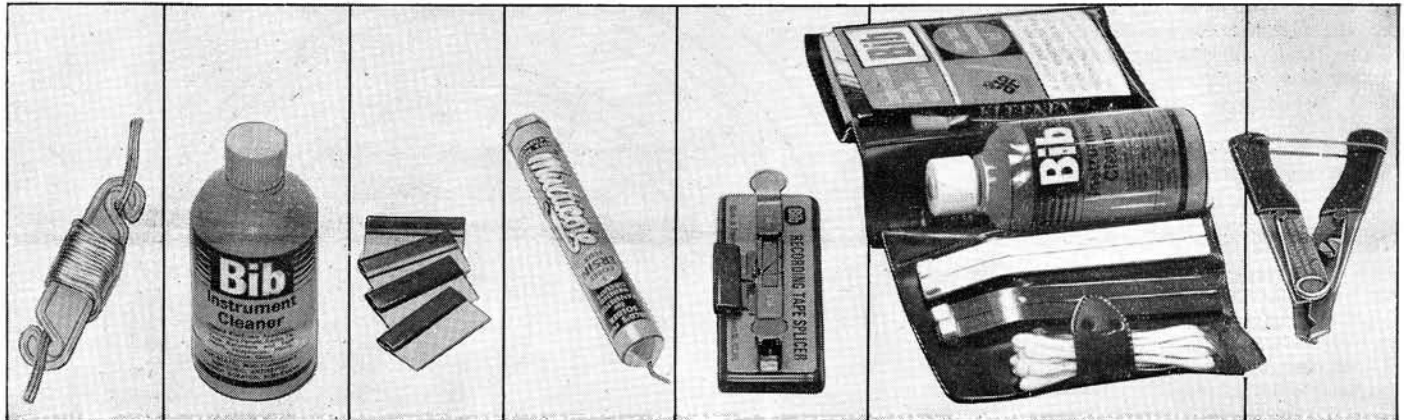

### Flex Shortener

Shorten without cutting, audio cables and flexes. Made of unbreakable plastic. Packet of 4 Bib Flex Shorteners 2/6.

### Instrument Cleaner

Cleans record players, tape recorders, metal, plastic and glass. Anti-static and non-flammable. Bib Instrument Cleaner. 4 oz. bottle. 4/6d.

### Precision Tape Cutters Size M

Set of four stainless steel cutters, with special plastic grips, for all types of magnetic recording tape. 2/11d. inc. P.T.

### Ersin Multicore Solder. Size 15 Dispenser

Solder easily plugs and cables with 5-core Ersin Multicore Solder. Size 15 Dispenser contains 21 ft. of 60/40 22 s.w.g solder 3/-.

### Recording Tape Splicer

Invaluable for precise and easy splicing and also for accurate tape editing. Fitted with clamps for holding tape while splicing diagonal or butt splices. Chrome-plated on special non-slip base, complete with razor cutter. 19/6d.

### Tape Head Maintenance Kit

The technical editors of the leading audio journals have undertaken comprehensive tests of this kit and recommend it unreservedly. Saves repair costs, ensures better recording and reproduction of reel and cassette recorders. Bib Tape Head Maintenance Kit has 2 each applicator and Polisher tools, 10 applicator and Polisher sticks. Double-ended brush, packet of tissues, and bottle of Bib Instrument Cleaner in plastic wallet. 16/10d. inc. P.T. Replacements available.

### Automatic Opening Wire Stripper & Cutter

Fitted with automatic opening spring for quick flex and cable stripping. Screw adjusts for different wire sizes. Plastic covered handles with locking ring. 8/6d.



All prices are recommended retail. Obtainable from most audio stockists. If in difficulty send cash with 1/- for postage and packing for orders less than 10/- and 2/6 for orders above 10/- (U.K. only) to:

**Bib Division, Multicore Solders Ltd., Hemel Hempstead, Herts.**

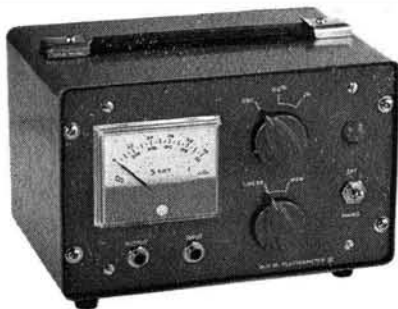

**W.H.M.**  
WOW AND  
FLUTTER  
METER  
(R.M.S)  
MODEL III

**SYDNEY HOUSE, 35 VILLIERS ROAD, WATFORD**  
**W.D.I. 4AL**

## WE SPECIALISE IN BRAND NEW TOP QUALITY BRITISH P.V.C. MYLAR & POLYESTER RECORDING TAPES WITH FITTED LEADERS, Etc., EX 3"

Thanks to bulk purchase we can offer tensilised HI-FI tapes, manufactured by a British firm of world repute. All boxed individually (sealed if required) in polythene. Our tapes are not to be confused with imported sub-standard or used tapes. Full-money refund if not delighted.

This month: "DRY SPLICE" (3/9) given FREE with every order.

Std.		L.P.		D.P.		Boxed	
Length	ea. 3 for	Length	ea. 3 for	Length	ea. 3 for empty spls	Length	ea. 3 for
3" 150'	2/- 5/9	3" 220'	2/6 7/-	3" 400'	4/6 13/-	3" 7d.	3" 7d.
4" 300'	4/- 10/-	4" 450'	5/- 14/-	4" 600'	6/9 19/6	4" 1/8	4" 1/8
5" 600'	6/- 17/6	5" 900'	8/- 23/6	5" 1200'	12/6 37/-	5" 1/9	5" 1/9
5 1/2" 900'	7/- 20/6	5 1/2" 1200'	10/6 30/6	5 1/2" 1800'	17/- 50/-	5 1/2" 1/9	5 1/2" 1/9
7" 1200'	9/- 25/6	7" 1800'	13/- 38/6	7" 2400'	21/- 61/-	7" 2/-	7" 2/-

All orders despatched by return.

Postage and Packing 1/9 per order.

**STARMAN TAPES, 421 Staines Road, Bedfont, Middlesex**



To all TAPE Recordists: P.V.C. & Polyester Tapes  
**BUY BRITISH**  
YOU SAVE MONEY AND



SAVE THE POUND  
"A STERLING IDEA"

... "high quality and rapid service I have found in you" ...

N. F. H. of Canterbury.

The playbacks are crystal clear and I am sure no better results could be obtained by other dearer brands on the market.

Yours sincerely,  
W. S., Hants.

	3"	5"	5 1/2"	7"
<b>New</b>				
Standard Play each 3 for	150' 2/- 5/9	600' 6/- 17/6	900' 7/- 20/6	1200' 9/- 25/6
Long Play each 3 for	240' 2/9 7/9	900' 8/- 23/6	1200' 10/6 30/6	1800' 13/- 38/6
Double Play each 3 for	300' 4/6 13/-	1200' 12/6 37/-	1800' 17/- 50/-	2400' 21/- 61/-

Free List full Range of Triple-Play

**Mora Trading Co. (TR6/3)**  
Mora Works, Mora Road, N.W.2

Postage 1/9 per order  
Posted the same day  
Money-back gtd.

## MORE QUALITY BARGAINS IN

# EXCHANGE & MART 8d

EVERY THURSDAY

if you are a **RADIO, TV**  
or **TAPE** enthusiast



# Which Earphone?

Independent reports on ten pairs of earphones, prepared by Anthony Eden, David Robinson and John Fisher

**ANTHONY EDEN** examines the Koss SP-3XC, Koss KO727, Sharpe HA10, Akai ASE-9S, Eagle SE21 and Eagle SE1.

## Koss SP-3XC

THESE STEREOPHONES are the cheapest model available in the Koss range and retail at £11 15s. An instruction booklet was provided, written in five languages. A plate carrying a stereo socket was provided with two 15-ohm series attenuator resistors. The purpose of this plate is to provide a permanent stereo socket from the output of an amplifier (assuming the amplifier is not already fitted with a 'phones' socket). The headphones were finished in brown and gold with the left and right channels clearly marked on the headband. The headband has a soft sponge cushion for the part in contact with the head. The earpiece cushions, which were removable for cleaning, were finished in a soft sponge foam, covered in vinyl.

Unlike the other two Koss headphones reviewed, there was ample headband adjustment. This adjustment was effected by moving each earpiece up and down a wire frame. The wire frame could be bent inwards to make a better fit with the ears, but generally it was found that the wire frames were not sufficiently strong to make a very tight fit on the head. For this reason, the earpieces were not able to exclude external noises very well. Although the earpiece cushions were made from soft sponge, the vinyl covering



gave the impression of poor fitting around the ears. Overall quality was excellent and again the sensitivity was high. The instructions warned of connection problems to certain types of amplifier. These headphones offered good value for money.

## Koss 727

THESE HEADPHONES represent a standard which one expects from a manufacturer of the reputation of Koss. An excellent instruction leaflet was provided, with a warning about connecting the headphones to amplifier output terminals without a common earth connection. The headphones are finished in brown and cream. There are no markings indicating which is the left or right earpiece. On each earpiece is a soft removable ear cushion. A coiled connecting lead is provided. The earpieces fitted tightly over the ears and external noise exclusion was good. The earpieces did not fit the shape of the ears very well and it became tiring to wear the headphones for an hour or so. The quality of reproduction was excellent, with a smooth quality throughout the audio range. Sine-wave tests showed that the headphones were capable of reproducing tones from 30 Hz up to at least 15 kHz. These headphones reproduced music extremely well, and the sensitivity was high.

## Sharpe HA10

SHARPE HEADPHONES are manufactured in Canada and imported by S. G. Brown. The instructions suggest suitable connecting circuits for various types of amplifier, but no warning is given of the danger of connecting to amplifiers with no common earth output point. The headphones are finished in a mid-grey colour, the headband being made from a flexible plastic material. Adjustment is made by way of the two sliding metal bars which form part of the headband. Quite a large pressure is required to alter the earpiece positions. The earpieces had very soft air and foam earpads, which were removable for cleaning. The earpieces are angled to fit the shape of the ears, but no markings indicate which is the left or right earpiece.

Despite a quite high pressure against the ears, these headphones were comfortable to wear for long periods once it had been ascertained which way round the headphones should be (connecting lead from left earpiece). To have the headphones the wrong way round, in this case, did not cause discomfort, but failure to mark the earpieces is a point overlooked by the manufacturer. The soft

earpads provided excellent exclusion of external sounds. Headband adjustment was considered to be adequate by those who tested the headphones. Overall performance was considered quite adequate, but the bass was not as convincing as other models. The sensitivity of these headphones was slightly lower than the Koss range. Recommended for recording under high external noise conditions.

## Akai ASE9S

THESE HEADPHONES came into the lower price category of those tested. The headphones were finished in black and white plastic. The earpieces, which were not marked with left and right channels, had earpads of air-filled rubber and were non-removable. Earpiece adjustment is effected by moving each earpiece up and down a metal rod. In addition to this there was sideways adjustment, so that the earpieces could fit the contours of a wide variety of headshapes. A tone control was provided on each earpiece.



The tone control, which proved to be a mechanical bass cut device, was considered to be no more than a gimmick, for ample tonal variation is available in virtually all amplifiers. The earpads fitted over the ears very comfortably but were not particularly effective at excluding external noises. Ample adjustment was possible for the earpieces but, due to the narrow headband and its odd shape (the Japanese must assume everyone has flat heads!), quite high pressure was put on one part of the head. However, this was a small criticism which could be easily overcome by putting a piece of sponge underneath the headband or reshaping the headband altogether. Once this modification had been effected, the headphones were found to be very comfortable over long periods of use. Sound quality was considered very good with excellent bass, but with a slightly less clean treble response than its more expensive counterparts. Sensitivity was very high and considering their modest price, the Akai headphones were regarded as the best value for money of those headphones tested.

## Eagle SE21

THESE HEADPHONES were finished in a mid-grey plastic, the earpieces being connected by a double headband. Each earpiece was fitted with non-removable foam earpads. Each

*(continued on page 151)*

# HEATHKIT offer the Best Selection of Hi-Fi Equipment in this CATALOGUE

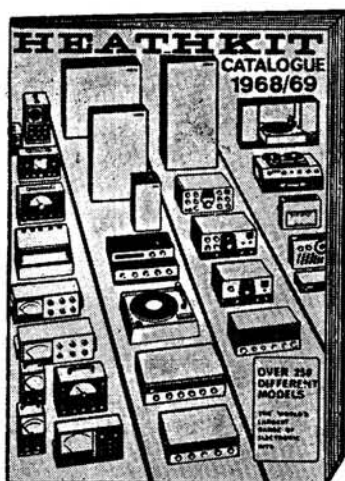

it's  
**FREE**  
on  
request

- STEREO AMPLIFIERS
- STEREO RECEIVERS
- STEREO FM TUNERS
- SPEAKER SYSTEMS
- STEREO TAPE RECORDERS
- GARRARD PLAYERS
- SHURE CARTRIDGES

and many other domestic and hobby models including Stereo Record Players, Transistor radios, Car Radios, SW Receivers, Audio test and service equipment. All available as kits or factory assembled ready to use models.



DAYSTROM LTD., Dept HT-4 GLOUCESTER, GL2 6EE  
Tel.: 24951

Please send me  FREE COLOUR CATALOGUE

Name.....

Address.....

# RESLOSOUND microphones

Precision engineered give the sensitive acoustic performance required today

**BRING YOU ADDED SALES VOLUME**

## CPD2

Cardioid Pencil Dynamic Microphone—improved version of the well known Reslo CPD microphone. Most suitable for:

High quality music recording, general sound reinforcement, loud close singing or speaking if used with an amplifier incorporating reasonable bass cut.

Frequency response is smooth over the range 70 c/s to 16 Kc/s.

Rear response better than 20 dB below the front from 100 c/s to 1 Kc/s and over 14 dB from 1 Kc/s to 16 Kc/s dropping to 30 dB at upper presence frequencies.

Impedance values: CPD2/L-30/50 ohms. or 600 ohms.

Supplied with 18' of dual impedance cable. .. £17/15/0

CPD2/M—200 to 300 ohms. £17/10/0

CPD2/H—30/50 ohms or Hi-Z.

Appropriate cable set to order £17/15/0

## MPD2

Small hand model microphone fitted with 6 yds. of directly connected cable.

Frequency response smoothly maintained over the range of 50 c/s to 15,000 c/s.

Polar response omni directional.

MPD2/L .. £5 10 0

MPD2/H .. £6 10 0

## UDI

An improved uni-directional high output or stand, dynamic microphone (super cardioid) incorporating an internal anti-pop filter. Supplied in black presentation case, and with 18' of directly connected screened cable. Frequency response: — 10 dB at 100 c/s — 4 dB at 15 Kc/s ref. 1 Kc/s. Well maintained over the range 100 c/s to 16 Kc/s.

Sensitivity: (hi-Z) 58 dB below 1 V/dyne/cm<sup>2</sup>.

UDI/L (50 or 600 ohms) £19 10 0

UDI/M (200-300 ohms) £19 5 0

UDI/H (High Impedance only) £19 10 0

In addition to their World famous series of bi-directional and cardioid Ribbon Microphones Reslo manufacture a complete range of public address amplifiers and loudspeakers—line source and reflex horns.

Write or telephone for full particulars.



**RESLOSOUND LIMITED**  
SPRING GARDENS, LONDON ROAD,  
ROMFORD, ESSEX

Tel. Romford 61926 (3 lines). Telex: 25356

## WHICH EARPHONE ? CONTINUED

earpiece had two drivers, a 'woofer' and 'tweeter' speaker, and the tweeter level was governed by variable controls. Adjustment of the earpieces could be varied over a very wide range. No markings indicated which was the left or right earpiece. Retail price is £8 19s. 6d.

A friend commented that little research had gone into producing some of these headphones, especially the earpieces. The SE21 was a good example. Whilst the rectangular shaped earpieces covered all but an elephant's ears, they certainly could not be described as fitting one's ears. This coupled with the fact that the fit was very loose on the head meant that external noises were not excluded. For all this, the headphones were quite comfortable to wear for long periods. Again the tweeter controls were considered to be an unnecessary gimmick. Possibly due to the inclusion of two speakers in each earpiece and a tweeter control, the sensitivity of the headphones was lower than on other review models. The bass was unusually prominent and, to avoid damage to one's ears, at high levels, required about 10 dB of bass cut at 50 Hz. The top registers were acceptable without being described as very clean. Overall, whilst being acceptable under domestic conditions these headphones cannot be strongly recommended for location, tape recording.

### Eagle SE1

THESE WERE the lowest priced headphones (retailing at £4 9s. 6d.) sent for review. The headphones were finished in grey plastic and had very wide adjustments of the earpieces. The earpieces had non-removable foam earpads and were rectangular in shape. The headband consisted of two plastic coated spring metal strips, and the springs were able to produce a strong pressure against the ears. There were no markings to indicate left and right channels.

The headphones gave a good account of themselves from a quality point of view and produced a clean and acceptable sound. The sensitivity was very high—the highest of any submitted for review. However, the headphones must have successfully avoided being worn by their designer (unless he were a Sumo wrestler)—for they appeared to

### SHARPE HA10



represent the ultimate in discomfort. The headband puts a very strong grip on the earpieces which after a few minutes becomes very uncomfortable added to which the bottom of each earpiece presses against a nerve which becomes most painful if one tries to speak with the headphones on. The headband shape is similar to the Akai—with the whole weight of the headset on one part of the head. Considering the very acceptable sound quality of the earpieces, and their very reasonable price, this would appear to offer a method of acquiring a reasonable pair of headphones at modest cost. Almost certainly, if much use is intended for these headphones, it would be well worth reshaping and covering the headband, and remaking the earpads with a softer material.

The Koss coiled telephone type of lead was considered a worthwhile inclusion. After a wide variety of practical trials, the complete exclusion of external sounds was not considered very important; it merely requires the headphone amplifier volume to be increased slightly. In all cases distortion level was found to be well above a comfortable listening level, even under high external noise conditions.

The best general purpose, value for money, headphones were considered to be the Akai ASE9S and, for more stringent requirements in making live recordings, the Sharpe HA10.

Finally, I have never understood the reason for adopting 8 ohms per earpiece as standard, since direct output matching is not possible without attenuator resistors. High impedance headphones have an important advantage, for they require far less power and can be used across dummy speaker loads, or driven from a low output impedance emitter-follower transistor amplifier. In other words, power amplifier facilities are not required to drive the headphones, and an adequate voltage drive can be obtained from a preamplifier stage.

A.J.E

**DAVID ROBINSON** examines the Akai ASE9S, Beyer DT48S, Beyer DT96A, Eagle SE1, Eagle SE21, Koss SP9XC, Koss KO727, Koss PRO4A and Sharpe HA10.

COMPARISONS between earphones present more problems than most other pieces of audio equipment. In testing loudspeakers, amplifiers and microphones, it is easy to make rapid comparisons, switching instantly from one model to another. But by the time one has removed a pair of earphones, fitted and adjusted a second pair, the aural memory is beginning to fade.

However, by using music well-known to the tester, and with frequent reference to the same music played through a loudspeaker, some firm conclusions on the relative merits of the models emerged.

I tested nine pairs of earphones, ranging in price from £5 to £32. The tests performed fall into two categories, one concerned with physical, and the other with acoustic properties. The results are summarised in tabular form.

The first problem was, as usual, that of connectors. Most of the phones were supplied



EAGLE SE21

with three-connector jack plugs, similar to the post office type; this seems to be the standard socket provided on the majority of amplifiers with earphone facilities, which at the moment means mainly American and Japanese units. The two Beyer units came with two-pin DIN plugs; the DT48S was wired for stereo with a labelled plug for each channel, and the DT96A with one for mono. To make testing easier, three-way jacks were fitted on these two as well, and at the same time the 96A converted for stereo—which was an easy matter, as all four leads were brought to the existing plug. (This earphone is supplied with a plug-in cable wired for mono or stereo as specified at the time of ordering.)

The second problem was that not all the earphones were labelled for the left and right ears; this must be a very easy step in manufacture but its omission can be very annoying during use. In checking this on all the phones, two sets which were labelled were found to be wired to the jackplug differently. Convention on a three-way jack seems to be left channel to the tip and right to the ring, but one of the sets was the other way round. Both these sets came from the same manufacturer! The sleeve is common; and here only Koss point out that a common ground connection is not always satisfactory, particularly where the two power amplifiers are on a separate chassis. In this case, separate plugs for each earpiece may have to be used to avoid loops—all the phones used four wires, and the commoning occurred only in the plug.

Eventually all the phones were correctly wired to standard jacks, and the first tests, on physical properties, were begun. Comfort is perhaps the most important, particularly as in their nature the earphones should fit tightly and might be worn for at least an hour at a time. Most of the sets had foam rubber earpads, with two exceptions. One set had pads of solid soft rubber, and was the most uncomfortable of the nine. The most expensive Koss pair used liquid filled pads, which made a very good seal at the ears and was at the same time the most comfortable to wear.

Freedom of movement is also important to prevent the feeling of being tethered, and there

(continued on page 153)





# LUXOR

## brings you the Swinging Sound from Sweden

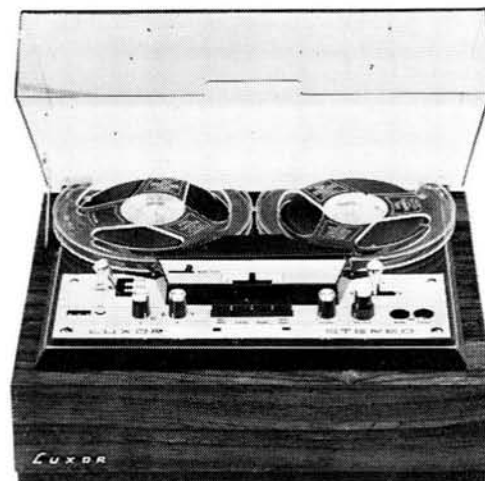

**MP613 MALAR**

Stereo Tape Recorder—4-track, 3-speed. Frequency response: 7½ i.p.s. 50—19,000 c/s. 3½ i.p.s. 50—12,000 c/s. 1½ i.p.s. 80—6,000 c/s. Output 4 watts mono, 2 x 2 watts stereo. Automatic stop, three position speaker switch. Dual volume control. Four push buttons: recording (special lock prevents erasing) radio, gramophone and microphone. Three position channel selector. High speed rewind. Instant stop. Pause control. Built-in four-channel mixer, multi playback, synchro playback. Combination head, fine laminated Fe-Ni-core, range 50 dB. Max. 7" reel. Available in teak or rosewood with transparent dust cover. Size 15½" x 12½" x 7".

*For name and address of nearest stockist phone or write*

### LUXITONE

84 Bolsover Street, London W.1.  
Telephone 01-636 2901 (4 lines)



## HI-FI in the Home

by John Crabbe, editor of Hi-Fi News and Tape Recorder

"the most up-to-date and comprehensive treatment on domestic hi-fi yet in print"

**AUDIO RECORD REVIEW**

"gives copious advice on practically any aspect of the topic you can imagine . . . Should be a very useful guide to anyone on the threshold of heavy expenditure who is rightly wary of the smooth talk in the hi-fi shop"

**THE MUSICAL TIMES**

"written with the authority of a dedicated professional, it could well become a recognised standard on the subject . . . Deserves a place on the bookshelf of all who are interested in improving the quality of sound reproduction in the home"

**ELECTRICAL & RADIO TRADING**

"a practical and helpful book . . . Mr. Crabbe explains everything and includes a sizeable glossary and plenty of diagrams"

**THE TIMES**

**40/- from booksellers  
or direct from the Publishers (post 2/-)**

**BLANDFORD PRESS, 167 HIGH HOLBORN, LONDON, W.C.1**



**WHICH EARPHONE ? CONTINUED**



**KOSS PRO4A**

is no doubt that the retractile cords (similar to the coiled lead on a modern telephone handset) are the most suitable. The only earphones with this very desirable feature were the two more expensive Koss types. The Akai phones were connected by a very stiff, thick and therefore cumbersome lead; all the others were fairly flexible.

Earphones are often shared around a family, and for this to be successful it must be easy to adjust the headbands for varying head shapes and sizes. The Sharpe *HAI0* were nearly impossible to adjust once they were on, while the Akai were so easy that they slipped in use. The Koss *PRO4A* were the easiest.

Next the earphones were given a vote on appearance—always of course a very subjective matter!

The remaining tests were all acoustic. As all earphones are very much more sensitive than even the most inefficient loudspeaker, it is not sufficient to plug them in across an existing speaker outlet. If this is done, the amplifier volume control has to be set at an impossibly low position; and the amplifier noise (even in the very best of amplifiers) is applied directly to the sensitive phones—and this is very noticeable. The correct method of connecting the phones is to put an attenuator in series with each earpiece and the amplifier output, plus a switch if required to cut out the speaker. (With valved amplifiers, it is advisable to switch in at the same time a dummy load of equal impedance to the normal speaker, rather than leave the transformer effectively open circuit.) The Koss *SP3XC* came with a very useful accessory adaptor plate, consisting of a phone jack to suit the plug, and two 150-ohm 2 W series resistors all mounted on a small plate. This gives an attenuation of about 30:1 which is suitable, and makes the whole business of connecting earphones much simpler. A similar arrangement was used for all the tests, except for the sensitivity measuring test which used a voltage source for true comparative results. In practical terms, a 1 W or 2 W amplifier is more than sufficient to drive all the units, and such amplifiers form the basis of the earphone amplifiers which can be bought.

(continued on page 155)

MODEL	Price	Impedance (ohms)	Cable	Plug	Ears Marked	Cable Leaves	Ear Surround	Headset Wght (oz)	Comfort	Ease of Adjustment	Appearance	Sound Isolation	Sound Leakage	Sensitivity	Piano	Orchestral	Singing Voice	Other features
AKAI A5E8S	£8 10s	8	Solid very stiff	GPO jack	No	Left	Solid thin rubber	15	..	..	..	..	..	..	..	..	..	Separate damping (bass) controls
BEYER DT48S	£32 11s 11d	25	Flat twin	Two din	Yes	Centre (Y)	Foam	14	..	..	..	..	..	..	..	..	..	4 ohm also available
BEYER DT96A	£11 6s 11d	400	Flat twin	Din mono	No	One side	Foam	6.25	..	..	..	..	..	..	..	..	..	Price with large circumaural noise cancelling earpieces. Also available with small earpads or no pads
EAGLE SE1	£4 5s 9d	8	Solid	GPO jack	No	Right	Foam	9	..	..	..	..	..	..	..	..	..	Separate tweeter controls
EAGLE SE21	£9 9s	8	Solid	GPO jack	Incorrectly	Left	Foam	14.5	..	..	..	..	..	..	..	..	..	Separate tweeter controls
KOSS SP3XC	£11 15s	4	Solid stiff	GPO jack	Yes	Left	Foam	15	..	..	..	..	..	..	..	..	..	Complete with prewired attenuator and socket for wiring to amplifier
KOSS KO727	£16 10s	4	Retractile	GPO jack	No	Left	Foam	16	..	..	..	..	..	..	..	..	..	
KOSS PRO4A	£23	50	Retractile	GPO jack	Incorrectly	Right	Flued	20	..	..	..	..	..	..	..	..	..	
SHARPE HA10	£19 2s	4	Flat twin	GPO jack	No	Left	Foam	16	..	..	..	..	..	..	..	..	..	

# CHILTON

**This month we give details of the Chilton Stereo Portable Recorder, which can be the basis of a Hi-Fi set-up.**

- ★ Provision for microphone, radio and low output magnetic cartridge.
- ★ As an amplifier only with Baxandall Bass and Treble controls.
- ★ 10 watts R.M.S. per channel and fully protected by stabilised supply.
- ★ 4 Loudspeakers in rattle free cabinet (2 each side).
- ★ Solenoid controlled mechanism.
- ★ Quiet running deck, very cool even with prolonged use.
- ★ Fully transistorised on 10 printed circuit boards.
- ★ 3 head system and three speeds—19, 9.5, 4.75 cm/s.

We respectfully suggest you have a demonstration, as volume and quality of reproduction are both impressive.

**Finish:** Charcoal grey with stainless steel rim.

**Weight:** 38 lb.

**Recommended price:** 141 Gns. incl. P.T.

**Chassis version from** 124 Gns. incl. P.T.

**Magnetic Tapes Ltd., Chilton Works,  
Garden Road, Richmond, Surrey  
Telephone: 01-876 7957**



# Opportunity Offers at R.E.W

**FREE!** To every purchaser of the fabulous AKAI M9 (right), a FREE pair of Wharfedale Denton Loudspeakers listed at 30 gns. a pair.

**AKAI M9 High Fidelity Stereo Tape Recorder** Cross-field Head. All Silicon Transistor Amplifier. 4-track stereo/monaural recording and playback. 3 speeds (1½, 3½ and 7½ ips) plus 15 ips with 15 ips adaptor kit. Wide Cross-field frequency response. Sound on sound. £195.



**AKAI 1710W Stereo Tape Recorder** (left). The Shield Type Head for High S/N Ratio. 4-track stereo/monaural recording and playback. 3-speeds (1½, 3½ and 7½ ips (15 ips optional). Automatic shut off. Pause lever. Tape cleaner. Tape shifter in fast forward/rewind operation. 4 hours maximum stereo recording capacity with a 1,200 feet tape. DIN jack. Stereo headphone jack. 3-digit index counter with reset button, VU meters. Finely oil-finished wooden cabinet. List price £109. Our price £89 10s.

Also available at opportunity prices:—

	List Price	Our Price
Philips EL3575 Stereo Tape Recorder ...	£101 19 4	72 gns.
Akai 3000D Stereo Tape Deck, all facilities ...	£105 11 4	£89 10 0
Telefunken 204E Stereo Tape Recorder ...	£136 0 0	99 gns.
Sanyo 929 Stereo Tape Recorder ...	£96 0 0	79 gns.
Philips EL3555 Stereo Tape Recorder ...	Reduced to	69 gns.
Telefunken M301 battery portable Tape Recorder	£69 12 0	54 gns.
Telefunken M302 battery portable Tape Recorder	£76 0 10	59 gns.
Aiwa TP1004 Stereo batt./mains Cassette Tape Rec.	£62 7 3	48 gns.
Aiwa TP730 battery/mains Tape Recorder	£37 5 10	29 gns.
Denon battery/mains Cassette Tape Recorder	£28 5 10	22 gns.

All the above brand new fully guaranteed and in makers cartons. Hire purchase terms available, one-third deposit, balance plus 10% over 12 months.

**rew**

★ LEADERS IN MAIL ORDER HI-FI

**R.E.W. (EARLSFIELD) LTD., Dept. T.R.**

Mail Order, 266/8 UPPER TOOTING ROAD, LONDON, S.W.17.  
Telephone 01-672-4471/2 and 9175

And at 146 CHARING CROSS ROAD, LONDON, W.C.2.  
Telephone 01-836-3365





KOSS KO727

Music listening tests were made using three well-known records. Piano tested the transient response, an orchestral piece the frequency response, and choral music the distortion. The earphones I liked best were the Beyer *DT48S*, followed closely by the Koss *PRO4A*. The frequency response of the Beyer seemed further extended, and the piano was more lifelike; it also handled the choral passages with greater ease, but both phones were impressive in their smoothness. The cheaper phones all produced some intermodulation with the female choral singing.

The Akai set had variable acoustic damping, which has the effect of varying the bass response and this control was set for each ear at about 75% in; more than this gave a tubby sound as the LF response was not matched by the upper end. The Eagle *SE21* has a variable tweeter control on each ear and these gave the best result at a maximum setting.

Results of all my tests are summarised in the table. Of the more expensive earphones, the Koss *PRO4A* is the best, considering all points. The Beyer *DT48S* gives better sound reproduction, but it is not as comfortable and it is considerably more expensive than the Koss.

In the medium price range, the Beyer *DT96A* is the best all-rounder; it is very light, easy to adjust, and very comfortable to wear. It also has an advantage in that the impedance is 400 ohms which can be driven very easily from a simple amplifier such as an emitter follower—and this can be a distinct blessing in a mobile recording session as it can save carrying heavy power amplifiers about. But the final decision is with your ears. So listen to as many different sets as possible, and let your ears do the choosing. **D.P.R.**

**JOHN FISHER** examines the AKG *K60*, Beyer *DT96A* and Beyer *DT48S*.

FOR several months I have been casting envious glances at some of the expensive new headphones that have been appearing, having already developed a liking for the well established AKG *K50* on recording sessions when for various reasons I have been unable to use

my *Maxims* for monitoring. Phones do have the advantage of being light and compact, and of requiring relatively little drive. With noise-excluding pads, they can at a pinch be used in the same room as a performance provided one is well back from the sound source. I was therefore particularly pleased when two sets of Beyer phones arrived for field trial, followed shortly by the latest AKG creation.

All these headphones are expensive by comparison with the tinny monstrosities sold for use with transistor radios or with cheaper tape recorders, and are on the whole also more delicate. All three are of 'hi-fi' quality, if the term can be used meaningfully, and capable of pleasing results. It was particularly interesting to be able to compare the three sets with each other and with small loudspeakers. As with loudspeakers, each set produced a slightly different sound and, as with choosing a loudspeaker, it was some while before one became sufficiently used to each set to decide a preference.

In some respects microphone balancing in a small control room is easier with phones, once one is used to them, as one can move one's head without upsetting the balance of the channels—as happens with a closely spaced pair of speakers under cramped conditions. While clinging to my *Maxims* for monitoring where practical, I am now more convinced than ever that a pair of headphones are a good thing to have around (Father Christmas please note!)

The *DT96A* are the less expensive of the Beyer phones submitted, costing £7 16s. 9d. which is by no means cheap. Sound quality is pleasant, with a slight tendency to chestiness on certain types of material including speech; there is also a slight lack of top and upper middle/treble frequencies. Some material—female and boys' voices, even strings occasionally, and white noise—take on a hint of rasping quality at some pitches which is noticeable though not objectionable after the silky quality of the other two pairs. I felt the sound was never quite as clean. A useful sound level was obtained with about 100 mV input; the phones handle considerably more but the bass does tend to overload at very high levels when listening to dance or pop music, or organ music with powerful pedal stops.

Physically the *DT96A* are somewhat similar to the AKG *K50* and to one of the less expensive Foster sets. They are light, with small plastic earpieces on sliding rocker contacts. The optional clip-on padded and ventilated ear-muffs are a great improvement on the *K50* rubber ear-steamers (I did not have the smaller Beyer earpads to try) and the muffs clip on over white plastic flat earpieces. Sound is not so good without the muffs. The light plastic-covered metal frame holds the phones gently on to the ears which do not get hot even after long periods of listening. The lead plugs into one earpiece so that it is detachable for storage—a very sensible idea which will I hope avoid the bogey of cracked leads. A moulded clip on the end of the headband anchors the lead and takes strain off the plug.

Stereo was pleasant though slightly variable and the image less crisp than on the other two sets; whereas *K50*'s sometimes add a slight

whiskeriness to the sound, the response of the *DT96A* becomes apparent lower down and I began also to suspect greater differences between the channels at the upper-mid frequencies than I had noticed with *K50*—however, more of this later. One had the feeling of rather more bass than with *K50* to the extent of the slight chestiness in upper bass frequencies which a normal tone control does not entirely compensate.

The *DT48S* phones both look and sound more opulent. They come in an elegant black foam-padded simulated leather case to protect them in transit and when not in use. The phones are a domestic version of the professional *DT48* phones, having concessions to comfort such as the easily adjusted headband with foam-padded cushion and padded ear muffs in place of the rubber pads on the standard version. The leads are permanently attached, with soft rubber sleeve to each cable where it enters the metal casing. Should the leads crack through, they will have to be unsoldered from inside the phones, but a check inside the housing showed this should not be too difficult, should it ever be necessary, provided one has a really miniature soldering iron bit.

The headphone drive unit is contained in an aluminium housing, with screw-on backplate, which swivels on the headband (your reviewer's hair tended to get caught in this swivel!). The ventilated ear muffs are fixed in position and are shaped to fit the ears one way round; the phones and DIN two-pin plugs are labelled to ensure correct channel sense. The leads have plastic slides to prevent them splitting.

Although heavier than the *DT96A*, the *DT48S* phones are very comfortable indeed to wear. They feel luxurious and cause no fatigue or headaches although their grip is the firmest of the three reviewed. All this for just £32 11s. 11d! But for this amount one expects more: one gets it. There is a silkiness and utter ease about the sound that belies the manufacturer's own 'typical response' curve (which looks horrid).

By comparison with the AKG *K60*, one has a slight feeling that the top frequencies are down and that the treble could stand out a little more without becoming harsh: yet one would hardly complain of a definite lack. Let us just say there is a difference in sound colour and that both types are very pleasant. There are no marked irregularities in response, the sound is tight and well maintained in the bass, smooth in the treble and top, and clean and clear; loud sounds can be produced throughout the audio range without serious distortion. Equally, the sound is natural at low levels. The muffs are very effective in excluding noise, and if you converse with phones on, beware of shouting.

The *K60* phones come in a moulded polystyrene foam pack in a cardboard carton, with no travel case which seems a great pity. Like the established *K50*, they are lightweight and beautifully made. A double headband covered in plastic houses the conductors carrying the signal from the cable entry on the left to the right. The earpieces are larger and superficially more elaborate than the *K50*, obviously intended to be used with the very

(continued on page 175)

# a silicon transistor stereo tape amplifier

First of a two-part  
constructional  
feature by  
**Terence Melville**

SOME time ago I found myself in need of a high quality stereo tape unit, the type fitted with three heads, two separate replay preamplifiers and two record amplifiers. But commercial units were far too expensive even to be considered, especially after the Chancellor's kill-joy activities in the last Budget, so some circuits were investigated with a view to producing an inexpensive home-made job using a Collaro Studio deck which was to hand.

Few satisfactory designs were available but circuits published by the American General Electric Company seemed to make an excellent starting point. These constitute the basis of the present design, the only important modification being adaptation to all silicon circuitry. Using readily available low-cost devices it should be possible with careful buying of the other components, to build the complete amplifier (excluding the actual deck) for about £10. The names and addresses of suppliers will be given, where appropriate, and their prices for the necessary parts; but this is only intended as a guide to possible sources. Lower prices may well exist and the ones quoted are no doubt subject to alteration.

No power amplifiers are included in the

design, since the completed unit is intended to be used in conjunction with an established audio reproduction system, preferably one whose amplifier has A-B monitoring facilities. Using the prototype with a commercial stereo amplifier, it performs very well for its modest cost. As far as the ear can tell, which is after all what matters, it compares very favourably with the electronics built into commercial tape units costing £150 and more.

A few words should be said about the general method of construction and layout employed in the prototype. The main ingredients are housed in an aluminium case (bought under the guise of chassis-cum-baseplate) measuring 25.4 x 17.8 x 6.4 cm. The mains unit is kept separate, being situated at least 30 cm away, and is connected to the main unit by a multi-lead cable. At first, it was intended to stick the entire works into one box, but no matter what precautions were taken, even screening with steel plate, it was found impossible to eliminate completely the hum radiated from the mains transformer and picked up by the highly sensitive front-ends of the preamps. This problem is frequently inadequately solved by manufacturers of integrated systems, and is a prime fault in my own factory-made amplifier. The erase and bias oscillator is also excluded from the centre of operations but this will be discussed later.

Since printed circuit boards were not available, two Veroboards were used in the prototype. These are small sheets of pressed Bakelite with strips of copper foil running along one surface and pierced by a matrix of holes. Into these are inserted the leads of the components, which are soldered in position in the same way as on an ordinary p.c. board. Even the novice

should find Veroboard extremely easy to use.

It is not thought worthwhile to reproduce diagrams of possible layouts, since these will depend not only on the whim of the constructor but on the size and shape of boards used, and the size of the components. Layout might well seem a problem if one has to work it out for oneself. Indeed this phobia afflicted the author initially, until the 'obvious' method was discovered. This entails placing the Veroboard and the circuit diagram alongside, and inserting components in roughly the same positions as drawn on the diagram. The bottom copper strip becomes the earth line, and the top one carries the DC supply. In practice, it was found convenient to have two strips at different points on the board and for these to be connected by a jumper wire. By moving a few components about, mainly into a diagonal plane, a compact layout can be rapidly established; the continuity of the copper strips is broken where required by using the special tool available, or a penknife. It is, however, advisable to ensure that those strips—or most of them—carrying components that require an external connection, continue unbroken to one or other end of the board to simplify later wiring. Using this method, it is virtually impossible to get feedback problems through mixing up components in the input and output sections of the circuit.

## PLAYBACK PREAMPLIFIERS

Each preamp is built around three silicon n-p-n transistors, of which the first is the most crucial as regards noise. All amplifiers generate a certain amount of noise and, generally, the greater the degree of amplification required, the greater the total noise generated in the

FIG.1 PLAYBACK PREAMPLIFIER (ONE CHANNEL)

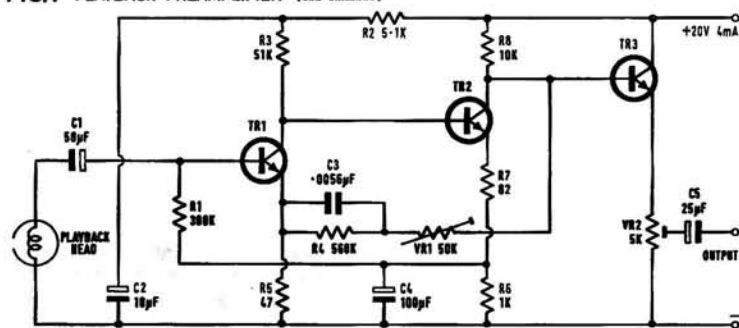
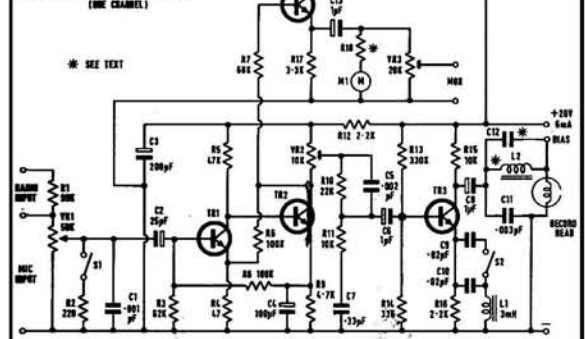

FIG.2 RECORD AMPLIFIER (ONE CHANNEL)



# a silicon transistor stereo tape amplifier

circuit. The output from a tape-head is usually of a very low order, often only 1 mV or less, even with a well-modulated tape. (Magnetic pickup cartridges, contrary to popular opinion, produce a much higher EMF than this. A disc of 'loudness' comparable to our well-modulated tape can result in 20 mV or more being generated by the cartridge at peaks; hence, noise problems in a tape replay system are likely to be much more serious.) If this low-level signal were not handled very carefully by the input stage of the preamp, the amount of noise superimposed could well be intolerable.

The present design (fig. 1) uses the excellent 2N3391A transistor, which has a typical noise factor (NF) of only 1.8 dB (Ideal NF is 0 dB). This can be further 'optimised', as the Americans say, by the device's associated circuitry. For an optimum NF, collector current must be about 350  $\mu$ A and the source resistance about 200 ohms (not to be confused with source AC impedance, which, being frequency-dependent, is not a constant). The average tape-head does, in fact, have a DC resistance of about this value, so this transistor is ideal for this particular application.

Generally speaking it is not practicable always to run a transistor at its optimum NF in other parts of an amplifier chain, since low collector and base currents are essential. So for the second stage a transistor with a low maximum NF was chosen. The 2N3391A and the 2N2926 both have a maximum NF of 5 dB, whereas the very cheap BC109 and BC169 are 4 dB. There is no great objection to using either of the other types if these are already to hand, or indeed a 2N3707 (5 dB), 2N929 (4 dB) or 2N930 (3 dB). The only cautions relevant to using other transistors are that

different hfe's may affect the accuracy of the frequency correction circuit, which depends on loop gain. But, if the AC  $\beta$  is around 150-300 (as with the 2N2924 specified by General Electric—a 25 V version of the 2N2926/Y), the equalisation should be fairly accurate. The hfe of the BC109B and the BC169B does in fact extend over this limit, but since the equalisation is variable anyway, little difference was noticeable on swapping this type for the 2N2926/Y. The other problem is that transistors with higher gain may give rise to instability but, with VR1 adjusted appropriately, this should not be a problem.

The NAB equalisation circuitry includes R4, C3 and VR1. Its effect is to provide a boost (reaching 22 dB at 50 Hz, reference 1 kHz, and 32 dB at 50 Hz, reference 10 kHz) to the lower frequencies attenuated in the replay process. Tape-head transfer response falls at 6 dB per octave below about 2 kHz. This bass boost is achieved by negative feedback between Tr1 and Tr2, attenuating the treble frequencies uniformly above 10 kHz and progressively less below that figure. R4 is really an additional element in the feedback loop of C3 and VR1. Its function is to level off the bass boost at around 50 Hz, due to the fact that the NAB system slightly emphasises bass frequencies in the recording process, providing 3 dB boost at 50 Hz.

The amount of bass boost or treble attenuation required on playback depends on the tape speed employed, and most significantly on the replay head. To take the first point, some sort of switching arrangement should in theory be incorporated into the equalisation circuit, but none is provided for in the prototype, since only two deck speeds are ever employed (19

and 9.5 cm/s). It is found that if VR1 is adjusted for the 19 cm/s response, the treble control on the main amplifier easily brings the 9.5 cm/s response into line. This economy saves a certain amount of wiring between VR1 on the back panel of the case and the tape speed switch on the front. If desired, a resistor of about 12 K can be switched in series with VR1 for NAB response at the lower speed.

All tape-heads suffer some loss of treble response on replay unless exactly matched to the preamp's input impedance, or tuned by a capacitor wired in parallel. Since this attenuation varies from one head to another, some sort of variable tuning element is required in the preamp circuit if it is to be genuinely versatile. In this design, the treble attenuation of the bass boost (!) circuit is made variable, thus killing two adjustment birds with one stone.

The Tr1/Tr2 circuit produces an equalised signal up to 1 V, and feeds the main amplifier via Tr3, an emitter-follower. Because this latter has a low output impedance, short connecting leads between the two units are unnecessary; it is also able to match an amplifier of practically any input impedance. The preset level control VR2 is adjusted to suit the main amp's input sensitivity. Virtually any *n-p-n* transistor can be used for Tr3, though one always feels a low-noise type is preferable. The transistors specified in the components list are all very similar; the BC107 and BC167 are high voltage versions of the BC108 and BC168, and all these have rather higher maximum NFs than the BC109 and BC169. It should be noted that the BC107 series are metal-cased devices and have different lead-outs to the BC167 series.

(continued on page 159)

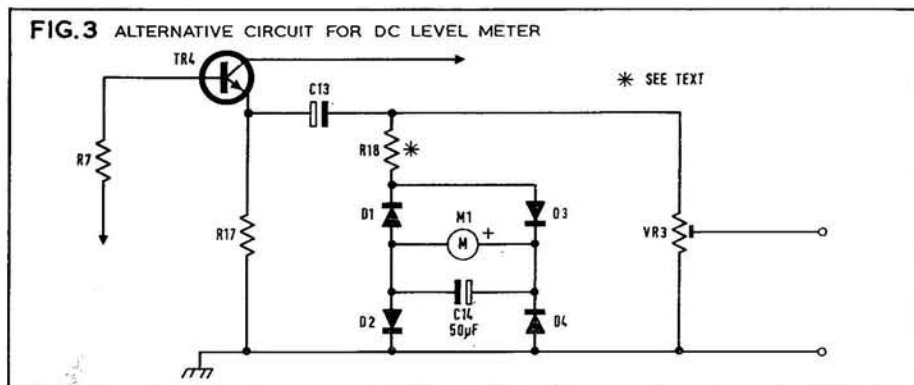





# ONE WAY TO SATISFACTION

4-TRACK STEREO/MONO	Deposit		12 Monthly Payments		Cash Price	
	£	s. d.	£	s. d.	£	s. d.
Philips EL3312...	16	19 10	4	3 4	66	19 10
Ferguson 3232...	22	18 3	5	14 7	91	13 0
Sony TC200...	23	15 0	5	18 9	95	0 0
Sanyo MR929...	24	0 0	6	0 0	96	0 0
Philips EL3555...	25	19 4	6	5 8	101	19 4
Aiwa TP1012...	26	0 0	6	5 2	102	18 7
Akai I710W...	27	17 3	6	16 8	109	17 3
Sanyo MR939...	28	0 0	6	16 8	110	0 0
Sony TC260...	29	5 0	7	5 0	116	5 0
Tandberg 12/21/41	31	10 0	7	17 6	126	0 0
Philips EL4408...	33	16 8	8	6 8	133	16 8
Telefunken 204'E	34	12 5	8	10 0	136	12 5
Beocord 2000K	39	10 0	9	13 4	155	10 0
Beocord 2000T	40	10 0	10	2 6	162	0 0
Sony TC530...	41	10 0	10	6 3	165	5 0
Ferrograph 722/4	46	15 0	11	10 5	185	0 0
Akai M9...	49	3 5	12	3 4	195	3 5

STEREO TAPE UNITS						
	£	s. d.	£	s. d.	£	s. d.
Sanyo MR-801...	20	0 0	4	13 4	78	0 0
Sony TC250A...	20	10 0	4	18 4	79	10 0
Akai 3000D...	26	11 4	6	11 8	105	11 4
Sony TC350...	27	5 0	6	16 3	109	0 0
Beocord 1500...	31	10 0	7	11 8	122	10 0
Tandberg 62/64X	36	18 0	9	0 0	144	18 0
Ferrograph 702/70440	6	8	10	0 0	160	6 8

4-TRACK MONAURAL						
	£	s. d.	£	s. d.	£	s. d.
Grundig TK140	11	14 6	2	18 4	46	14 6
Philips EL4305...	11	17 9	2	16 8	45	17 9

4-TRACK MONAURAL	Deposit		12 Monthly Payments		Cash Price	
	£	s. d.	£	s. d.	£	s. d.
Ferguson 3226...	11	18 0	2	16 8	45	10 0
Telefunken 201	11	18 9	2	19 7	47	13 9
Ferguson 3228...	11	19 0	3	0 0	47	19 0
Philips EL4306...	14	1 8	3	10 0	56	1 8
Ferguson 3230...	14	13 0	3	13 2	58	11 0
Ferguson 3216...	16	19 0	4	0 0	64	19 0
REPS M10	18	18 0	4	14 6	75	12 0
Wyndor						
Vanguard	18	18 0	4	14 6	75	12 0
Truvox R54	18	18 3	4	14 11	75	17 3
Tandberg 1526...	20	19 0	5	3 4	82	19 0
Truvox R204	31	14 2	7	15 0	124	14 2

MAINS TWIN TRACK						
	£	s. d.	£	s. d.	£	s. d.
Fidelity Playtime	7	18 6	1	16 8	29	18 6
Ferguson 3224...	8	6 0	2	1 4	33	2 0
Grundig TK120	9	17 6	2	9 2	39	7 6
Philips EL3310...	10	5 10	2	11 5	41	2 10
Tandberg 1521...	18	19 6	4	10 0	72	19 6
Truvox R52	18	18 3	4	14 11	75	17 3
Beocord 1100	24	10 0	6	2 6	98	0 0
Brenell Mk. V/3						
Std.	26	17 9	6	10 0	104	17 9
Brenell MkV/3Mtr28	0	2	7	0 0	112	0 2
Truvox R202	31	14 2	7	15 0	124	14 2
Brenell V/3/M...	32	16 8	8	5 0	131	16 8
Ferrograph 713	33	18 4	8	9 7	135	18 4
Ferrograph 713/H	35	16 8	8	16 8	141	16 8

INTEREST FREE H.P. TERMS. OPEN SATURDAY 6 p.m. FRIDAY 6.30 p.m. IF UNABLE TO CALL WRITE FOR BROCHURES. PART EXCHANGES. ALSO 18 AND 24 MONTHLY TERMS

## TELEFUNKEN REDUCED PRICES



### TELEFUNKEN 300TS

★ Telefunken 300TS Battery/Portable. ★ 5" Tape capacity. ★ Volume and Stop/Start controls in handle. ★ Complete with microphone. Reduced from 61 gns. **Our price 45gns.**

### TELEFUNKEN 301TS

Similar specification as for Model 300TS, but 4-track. Reduced from £70 17s. 6d. **Our price 51gns.**

### TELEFUNKEN 302TS

★ 4-Track. ★ 2 speeds, 3½ and 1½ i.p.s. Reduced from £77 8s. 9d. **Our price 56gns.**

### TELEFUNKEN 203TS

★ Mono/Stereo. ★ 4-track. ★ Sound-on-Sound. ★ 2 speeds, 3½ and 1½ i.p.s. ★ Complete with TD21 Microphone. Reduced from 86 gns. **Our price 64gns.**

# THE RECORDER CO

this is the name

(DEPT. R) 186-188 WEST END LANE, WEST HAMPSTEAD, LONDON, NW6

Telephone: 01-794 4977

## Hi-Fi and tape recorder enthusiasts...

# AUDIO ANNUAL '69 is out now! 7/6

Brim-full as usual of informative articles by the leading authorities in your particular field.

- Main features include:
- ★ A lifetime of audio
  - ★ The end of inner-groove distortion
  - ★ Waveforms and musical quality
  - ★ Problems of the record reviewer
  - ★ Monitoring loudspeakers and their design
  - ★ Basis of modern audio units

**PLUS** authoritative reviews of hi-fi and tape equipment.

A LINK HOUSE GROUP PUBLICATION

Obtainable at your local newsagent/bookseller. If you can't get a copy, we can send you one for 7/6. Send to: Link House, Dingwall Ave., Croydon CR9 2TA

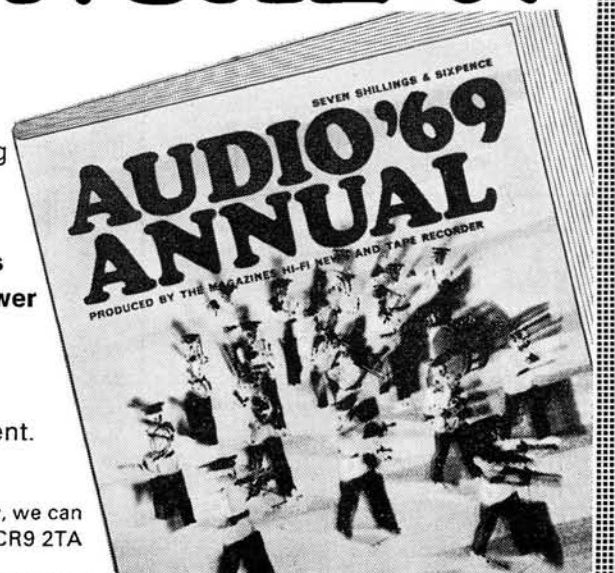

In the original instrument both preamps were accommodated on one Veroboard measuring 9.5 cm square. This was divided into two equal halves, the components on each half being completely independent, apart from jumper wires connecting the earth and supply lines. In some ways it is preferable to use separate boards for the two preamps, as it was found that the proximity of the two circuits and their associated external wiring tended to introduce a significant amount of crosstalk. The circuit board is mounted on to the upper panel of the case by means of holes drilled through both the board and the case. Some 6BA bolts are then inserted, with large rubber grommets acting as spacers between board and panel.

The preset potentiometers used by the author are panel-mounting TV types. These were preferred to printed board varieties, as adjustments could be made without opening up the works and so letting in hum, not to mention a jumble of radio interference. The transistors used have FT's of up to 300 MHz, and are acutely sensitive to RF intrusions. Effective screening is therefore essential, even if mains hum is no longer a problem. The connecting lead from preamp to tape head should be as short as possible, and to reduce hum pick-up the outer screen should be of the matted rather than stranded type. Connecting leads should also be kept well away from the deck's motors, and earthed only at the preamp end. One screened wire can be used to earth the metal parts of the deck itself.

The prototype preamps have been used with low, medium and high impedance heads, and with VR1 adjusted accordingly good results have been obtained. The signal-to-noise ratio obtained will depend on the sensitivity of the heads used and, of course, on the tape's level of modulation. However, with a medium impedance ¼-track Mumetal head, noise levels of -55 dB or better should be obtained. At 19 cm/s the overall frequency response should be predominantly flat, with tapes recorded to NAB, from 50 Hz to 15 kHz. G.E. quote  $\pm 1$  dB. They also quote THD as being 0.25%, all of which is rather fine.

Moving now to the recording amplifiers fig. 2, each circuit is built around four transistors. Tr1 and Tr2 are straight-through amplifiers and are followed by a passive bass and treble emphasis circuit feeding Tr3. This transistor amplifies the signal up to a suitably high level, and also modifies it further, so that the treble response at its collector is boosted to the NAB recording characteristic. Tr4 is fed direct from the collector of Tr2, to power a VU meter (or other level meter) and to provide an uncompensated output to a power amplifier for monitoring purposes.

For Tr1, a 2N3391A was selected since this gave such good results in the first stage of the replay preamps. Much the same circuitry was adopted and, since low-level low-noise amplification is the main requirement, collector and base currents are again kept low. This, however, means that the input stage will be overloaded if a signal of more than a few millivolts is applied. The easiest solution to this problem is to place the main level control right at the

front, before Tr1 gets to work on the signal. With this arrangement, it should be impossible to overload the input stage under any circumstances, even if several volts are fed in, provided, of course, that VR1 is not one of those pots with a slider that stops an inch short of the end of the track!

In fig. 2, the mic socket is connected in such a way that the input signal can be applied neat to the base of Tr1, to obtain maximum sensitivity (on the prototype, sensitivity is about 1.5 mV). The input from a tuner normally needs diluting, however, since few tuners are likely to give less than 10 mV, and if some obscure terminal on the main amplifier is one's signal source, one is quite likely to have half a volt on one's hands. With the present arrangement, R1 and R2 act as a potential divider (with S1 closed), and sensitivity is about 50 mV. This can be reduced or increased as appropriate by increasing or reducing the value of R1. The bright-eyed will have noticed that R2 is very oddly connected to the slider of VR1, not to the bottom end of R1. The reason for this is that the source resistance for Tr1 must be kept low if the noise level of the stage is to be kept to a minimum. The side-effect of this arrangement is that VR1 acts in a non-linear manner (logarithmic to the base  $n$ , where, for want of a computer,  $n$  remains undetermined); however, the effect is not so acute as to make reasonable use of the control impossible. One answer to this for the purist would be to switch in a separate 1 K pot for the radio input, and abandon R2. A second answer, for use with a 100 mV+ source, would be to feed the signal direct to the base of Tr2 via a switch, 10 K pot and 1 $\mu$ F capacitor.

All this implies that the noise level on the mic input will be degraded relative to that on the radio input. This is unfortunately true. But if the output transformer of one's microphone has a DC resistance of less than 1 K, it could be wired direct to the slider of VR1. This hock-up has been found to reduce noise appreciably, at the expense of the level control's behaving rather peculiarly. Anyone put off by this scare-mongering about noise should not be unduly alarmed. These are just suggestions for the addict who wants the best possible noise level, and who likes dabbling. With the circuit as drawn, noise level on the radio input of the prototype (to monitor output, reference 50 mV input for tape modulated 6 dB down) is about -65 dB, and provided a sufficiently sensitive dynamic microphone is used, noise level on the mic input is unlikely to be worse than -45 dB, and normally rather better.

As in the playback preamp, Tr1 takes its base bias from the emitter of Tr2; but in this circuit it is worthwhile to incorporate a higher level of overload control for Tr1. Accordingly, the emitter load resistor of Tr2 is increased to 4.7 K, so that variations in the emitter current produce greater variations in the voltage available to bias Tr1. The voltage reaching the base of Tr1 is stabilised to some extent by incorporating the potential divider R8 and R3. The theory is that when a large signal is applied to the base of Tr1, current increases in the collector and in consequence in Tr2. A higher DC voltage is then fed back to Tr1's base, and biases the transistor further into the *on* state. This raises the overload level of Tr1, and

hence also reduces distortion in the circuit. Distortion is further reduced by the AC and DC negative feedback link R6.

VR2 in the collector load of Tr2 is a preset sensitivity control, and its adjustment will be described later. The slider of VR2 is connected to a *passive* response shaping circuit. (An *active* circuit consists of a feedback loop of some sort, as in the replay preamp.) The operation of the circuit is independent of the gain of previous stages, and so anyone who wants to increase the overall gain of the amplifier can try replacing the BC109B (for Tr2) with a BC109C (similarly with the BC169 plastic types). The author has not tried this substitution, and so cannot guarantee its stability. However, if instability does occur, R6 can be reduced in value as appropriate, though this will lessen the available increase in gain. The experimenter could similarly try substituting a 2N3390 for Tr1 (unfortunately the very low-noise 'A' versions are not available for this higher gain type).

To get back to frequency compensation, R10, R11, C5 and C7 constitute the first part of a circuit designed to compensate the recording signal to the NAB frequency-weighting characteristic. In all the internationally established recording systems, the higher frequencies are boosted in the recording process to compensate for treble losses in the electromagnetics of tape/head signal transfer. In the NAB system, the turnover frequency is 3.2 kHz, which means in practice that frequencies below about 1.5 kHz are attenuated uniformly, and attenuation above that figure becomes progressively less. With frequencies between 200 Hz and 1.5 kHz, R10 and R11 act as a potential divider between stages two and three of the amplifier. At frequencies above 1.5 kHz, C5 begins to shunt R10, producing an increasing amplitude of signal at the base of Tr3 as the frequency rises. And as the frequency falls below 200 Hz, the capacitive reactance of C7 increases. The effect of this is to give a small amount of bass boost to the recorded signal (+3 dB at 50 Hz, reference 1 kHz) and is again a feature of the NAB characteristic. If the potential constructor is afflicted with inadequate bass in the rest of his hi-fi set-up—as caused by using small infinite baffle loudspeakers or an amplifier that hums when the bass control is turned up, the value of C7 may be reduced to achieve extra bass boost. The use of a 0.25  $\mu$ F capacitor for example, will raise the response at 50 Hz to +5.5 dB, reference 1 kHz.

The second part of the frequency-compensation network is incorporated into the emitter circuit of Tr3. The emitter load, which introduces negative feedback, is a resistor; it is shunted by a tuned circuit, whose resonant frequency is selected by switching the value of the series capacitor. The prototype uses a Repanco DRR2 medium and long wave aerial coil for L1, though the cheaper DRX1 is equally suitable. Connection details are supplied with all Repanco products, so none will be given here. Connected for use as a LW coil, inductance is about 2 mH, but by fitting two iron dust core slugs to the former (which is ready-tapped for the purpose), the inductance is increased to about 3 mH. By appropriate choice of C9 and C10, the treble response of

(continued on page 175)



---

# PRODUCING DEMONSTRATION TAPES

By Terence Mendoza

**T**HOUGH a great many artists and groups are signed up by recording companies every year there is always, in every town, another dozen similar groups with equal talent hoping for the opportunity to be in that position. Surprisingly, it is the keen tape-recording enthusiast who can help them toward this aim.

Before any group can ever consider making a disc, they have to produce a sample of their work; they have to make a demonstration tape or disc. This is circulated to commercial recording managers who if they like it, may consider the group for a contract. If not, the group receives a 'don't-call-us, we'll-call-you' type of letter. If you think you are an enthusiast worthy of your name, you should have the ability to produce these tapes. Expensive or complex equipment is not essential though, obviously, the better the equipment is, the better the recordings can be. I use a  $\frac{1}{2}$ -track three speed Truvox and another machine with an extra head fitted for dubbing and special effects. For more intricate effects, I can usually arrange to borrow a third machine. Several fairly inexpensive moving-coil microphones and home-built items like an echo delay unit and four-channel mixer complete my set-up.

A special studio is also unnecessary. In my case, I can convert my bedroom fairly easily into the studio and the adjoining room into a control room.

The rooms to be used as studio and control should always be prepared well in advance. The studio needs special attention on the following points:

Outside sounds, like aircraft passing overhead, obviously cannot be completely blotted out. The only solution to this problem is to stop the recording and wait for the offender to get out of microphone range. Traffic noises and bird calls can be fairly effectively muted by closing all windows and drawing curtains. A blanket hung on top of the curtain will improve matters further though after a few hours work, the atmosphere in the room may easily be mistaken for a Turkish bath. Mowing machines and children at play can be silenced, temporarily at least, by an explanation of your predicament. Around the house, vacuum cleaners, and transistor radios with their piercing tweeters, seem the most microphone prone.

Inside the actual studio, beware of those unwelcome soloists—ticking clocks and groaning chairs. Remove the clock and replace any squeaky chair with one of a more quiet disposition. When linking the studio to the

control room, remember that induction is likely to occur if microphone leads are run close to mains leads for any distance, and a mains hum could mar the recording. With a group, whether pop, folk or classical, it is likely that certain notes produced by their instruments correspond to the natural vibrating frequency of objects around the studio. If these notes are of sufficient intensity, they will set these objects vibrating, producing a buzzing or ringing sound. The cure is to blanket the objects or remove them. Snare-drums, glassware, cymbals, ashtrays, lampshades, vases and loose screws often suffer from this malady. The best way to check all these conditions is to set up the microphones approximately as they will be used in the studio; connect them to the recorder with the microphone gain controls turned up rather more than will be necessary for the actual recording, then monitor the signal with a pair of headphones. Extraneous sounds and sympathetic ringing can be picked out very easily, as can faulty acoustics.

A typical domestic room sounds natural to our ears as we can focus the sound we want to hear; the microphone, however, is not selective—it picks up everything present, including all of the unwanted sound which has been reflected (much as light is reflected) around the room. These fast echoes are termed reverberations and must be cut down or the recording will sound as though it were made in a bathroom. The easiest method, without incurring expense, is to place cushions or blankets strategically on any large, flat smooth, or shiny, surface that is liable to reflect sound—windows, mirrors, hard furniture and doors. It is possible to overdo blanketing, giving a 'dead' acoustic to the recording. The ideal acoustics are arrived at by monitoring a subject singing the same distance from the microphone as your artist will be, while at the same time placing the cushions and blankets in various positions until your subject sounds neither 'bathroomy' nor 'dead'—in the acoustic sense of the word! As you will have gathered, I consider blankets to be one of the most important requisites in the home studio.

You may think that most of these precautions are a needless waste of time, but it is surprising the amount of aggravation a creaky chair or vibrating vase can cause on an otherwise impeccable tape. Having prepared studio and control room, the next stage is to align the equipment. The artists are needed now so the best plan is to allow several hours





FIG. 1

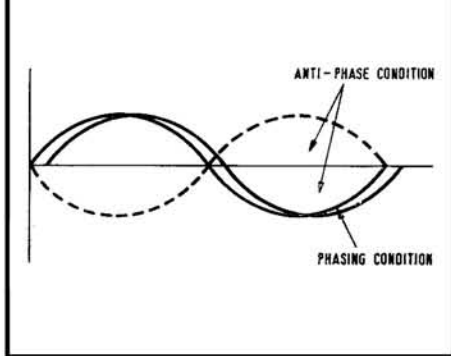

for the preparation of the rooms, having informed the artists well in advance the time they are expected to arrive. You should comfortably position them with regard to their instruments—a guitarist will require less room than a drummer but more room than a singer, and so on. Possibly they have some formation they use on stage (assuming they have aspired to these sacred heights) in which they are most at ease; but beware of the condition where one instrument completely drowns the rest. When they have been positioned, give them plenty of time to tune their instruments and rehearse. Actually, a good idea is to aim for no more than two songs in an afternoon. Using their rehearsal, you can now get the correct microphone balance.

First decide which microphones should be used and which instruments/voices they should be responsible for. I prefer using microphones with cardioid polar characteristics (attenuated sound pick-up at the rear) because this makes life much simpler when trying to achieve a balance between two microphones than is the case with omnidirectional units (equal sound pick-up from all sides).

The best advice I can give here is experimentation. Suppose a duet who both sing and play acoustic guitars is to be recorded (this method can equally well be applied to any other combination of singers and instrumentalists). Begin by placing each microphone halfway between the artist's guitar and mouth. Then, turn down the gain control of one microphone and ask the artist facing the other (live) one to perform his score normally. Monitoring on headphones, you can then shift the microphone about until you hear the best balance between guitar and voice. Voice should be louder than guitar otherwise the words will become inaudible. Do not have the microphone too near the singer's mouth or he will sound flat and his 'p' and 'b' will explode on the microphone, making popping noises. You sometimes can cure this by using a windshield. Equally as good are several layers of handkerchief or a foam-rubber 'cap'.

Once the first artist's microphone balance is correct, the same procedure is adopted for balancing the signal coming from the second microphone. While the two continue to rehearse, their signals are balanced against each other until the most pleasing effect is reached. Slight microphone readjustment may still be required as you may find one sound source is too loud compared with the rest, or not as tuneful. In this case the mixing controls

FIG. 2

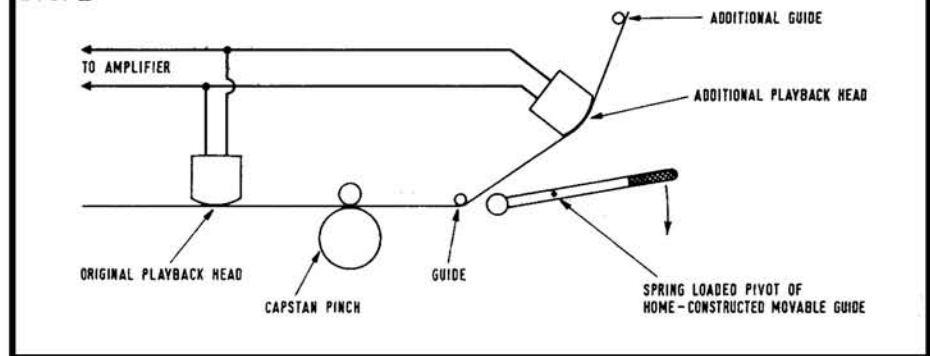

can lift it out of the aural foreground and move it back a little where it will blend in more.

If the control room is sufficiently sound-proofed, a good speaker is better than headphones for monitoring the recording, mainly because it is easier on the ears. The modulation indicator on the tape recorder should be adjusted to give the maximum possible deflection without distortion. This ensures a good signal-to-noise ratio on the recording and makes tape hiss less noticeable, as it can become very obtrusive after several dubs. A tape speed of at least 19 cm/s is almost imperative, again for keeping the recording quality high. The time has finally arrived to place the tape on the recorder—avoid using warped spools as they tend to produce wow and flutter.

Now for 'Take One' of the first song; give a ten second count-down, the last three silently to yourself. Start the tape on the fifth second—this allows for the initial bounce and speed instability due to spool inertia. Instruct one of the artists to mouth their own count-down to the song after your ten second count-down. By this I mean the 'one-and-two-and-away-we-go!' type of introduction so that they can get an idea of the speed of beat. This enables all the performers to start together, and ensures a period of silence before the song which makes for easier editing and dubbing. The main tip for the actual recording is to make sure no notes are over-modulated. At the end of the song the artists should remain quiet while you fade all the gain controls to nil. Now you should replay the tape over the best replay system you can muster so that all concerned can sit back and listen as critically as they can. You should listen especially for dropout (sudden temporary signal loss) which may be present on the actual tape caused by dust or faulty manufacture; hiss, crackles (loose connection somewhere), voices overriding others (one artist subconsciously leaning closer to the microphone while singing) and any other possible faults must all be detected at this stage. You should not be satisfied until every fault is rooted out and a perfect recording is obtained. I have found that five or six 'retakes' are not unusual to get the best results.

At this stage, quite a few 'tricks of the trade' can effectively be used for doctoring the sound. The correct way is to decide what effect (if any) is wanted, then experiment; not the other way round.

Slight reverberation tends to enhance the

sweetness of the voice provided it is well under the voice signal. This can be done crudely using a machine with separate recording and playback heads. If operated at 19 cm/s the delay between the recording and playback should not be more than half a second. If the playback head is connected via an amplifier to a speaker in the same studio as the recording microphones, by careful adjustment of speaker position and playback amplifier volume a very pleasing reverberation-cum-echo can be produced.

A different type of taped echo is obtained if the playback amplifier is connected back into the line socket without the sound having to travel through the air.

Phasing or 'skying' is used nowadays on pop records, notably the Beatles' *Sergeant Pepper* and *Magical Mystery Tour* albums. There are two possible methods, the first being fairly easy though needing three relatively accurate machines and plenty of patience. The master is placed on Machine A and dubbed on to Machine B. It is an advantage to tape a click on the master tape several seconds before the song. The two identical tapes are then fed into Machine C, via either a simple patch network or a mixer. Firstly, the output levels of the two types are adjusted to give the same meter deflection on Machine C; then, synchronizing both clicks, start the tapes, recording on Machine C. When the two recordings are almost synchronized, the effect will become apparent. A point occurs almost resembling dropout; this is when the two signals are in the anti-phase condition (see fig. 1).

This method will probably not work properly at the first attempt and the only way to phase a complete passage is, as the adage goes, to try, try and try again, combining the phased sections of each attempt.

Another method if you are a do-it-yourself enthusiast is to mount another record/replay head on your machine further from the original one. This should be set to operate on the bottom track, unlike the original head which operates on the upper track. The two heads are connected in parallel (see fig. 2). When recording, an identical signal will occur on both tracks. If, on replay, a minute tape loop is induced between the two heads, the combined signal will become skyed. This method is much more controllable.

Any sound effects which help to create the desired mood can be mixed in while dubbing from one machine to another. Wind, sea.

(continued on page 165)



## TRUVOX SERIES 100 CONTINUED

BY H. W. HELLYER

**I**n the service manual, frequency response tests for the Truvox *Series 100* models are skated over very lightly. In fact, the gist of the instructions to the engineer can be summed up in the final couple of paragraphs of last month's article—and this is just not good enough.

As with all three-head machines, the playback - after - recording facility becomes a tempting short-cut. If all is well, it is quite true that much time may be saved by simply recording a standard input and monitoring it at the replay output. Even where we have to set up test gear to do so, the A-B test method (switching from source to tape) is a favourite type of check to carry out. But if we make the

routine 'sharpening up' adjustments to achieve the required response, our short-cut may prove to have led us over some rocky ground.

This is because of our old bugbear, compatibility. We have to work to *replay* standards. Any tape we record, played back on a machine equalised to the standard time constants, should produce a 'flat' signal at the output of that machine, and, by implication, of any other similar machine. So much is fundamental.

It stands to reason, therefore, that tests on any machine should begin with a check of the replay mode. Test tapes are available for the purpose and, though they may not be cheap, they are indispensable to the chap who has occasion to vet his machine for professional reasons, or fussy non-professional ones, come to that! If the exchequer does not run to test tapes, there is no objection to making one yourself when the machine is new, or after it has been checked on trustworthy test gear, using a steady tone for set periods of time, and various programme sources with which you are familiar. If you *know* there was a tingle from the kitchen department during that bar of the overture, and you miss it on replay, you do not need any test gear to tell you that your machine has fallen off at the top end of its frequency response.

Having said which, let us revert to the testing of the Truvox. On the recorders, as distinct from the tape units, the power amplifier has to be considered, and I always find it advisable to do a double check. That is, frequency response, and other tests, are made with a measured output at the line socket which, in this range of machines, disconnects the signal feed to the output section. Having got things right, it is desirable to test the output section quite separately, as one would for a normal amplifier. There should be no correction, apart from normally adjustable tone controls, in this output section. Unhappily, on some machines, additional 'tickling-up' of the response is achieved by feedback loops from the output section in the guise of 'fixed' or 'preset' tone controls.

After the preamplifier section and the main amplifier have each been tested, a further test should be made, right through the machine.

The important adjustment for correct setting of the replay sensitivity is the 2 K emitter bias

preset of the playback preamplifier stage. The manual requires that one should record a 1 kHz tone with the input level adjusted to indicate -10 dB on the modulation meter, then replay this recorded tone and adjust the preset to give the same reading on the valve-voltmeter (already connected at the line output socket). I prefer to work the other way around and note that a prerecorded test tape should give between 750 mV and 1 V at the line output, during the 1 kHz band. Having adjusted the preset for this level, and checked that the signal-to-noise ratio is better than 40 dB, also at this preamp output (more about this factor anon), we can record a signal to give an 0 dB reading, noting that this tone, monitored at the line output, should produce the same reading as we had originally. Under these conditions, the input level to the microphone socket should be 0.5 mV, and to the gram socket, no more than 50 mV (with the main input gain controls at maximum). A similar preset in the emitter of the microphone stage preamp allows spot-on adjustment.

The response can then be checked by using this 1 kHz tone as reference, and altering the frequency to various figures within the specification, noting that variation of output reading for *overall response* is within  $\pm 3$  dB. For replay-only response, I like to get the variation within  $\pm 2$  dB, and, in all fairness to Truvox, this can be done when all is in order.

When checking the overall responses, some top end boosting may be noted, and it is then necessary to go back to recording checks. A gain of 12 dB, rising to 16 dB, is quoted at frequencies between 17-20 kHz at 19 cm/s, and 10-13 kHz at 9.5 cm/s during recording. The test should be made at a level which gives a -10 dB reading, not the full input to read 0 dB. This is quite important to avoid spurious readings. Connection of an oscilloscope across the output will soon show the relevance of this test.

At this point, assuming we have tested the oscillator—one of the weaker Truvox points, I fear, on this and other models—we may tickle up the top end with a little adjustment of the series bias preset capacitor, very conveniently mounted right at the front. On the deck-only models, *PD102* and *PD104*, this adjustment can be critical to get the channels in step. As hiss is one of the very real and almost irremediable problems, despite the change from the single pressure arm to the three-pad system, we may find it advisable to lose a little of the top response at the utmost limit of 17 kHz on 19 cm/s, and adjust the trimmer of the channel with the lower bias up to that with the higher, checking not for actual bias reading across the head winding, but for optimum response. This is not cheating—after all, bias should be adjusted to suit the tape in use, not for some magic figure.

A little while ago we skipped lightly past the problem of noise. To revert to this point, a noise figure of -40 dB was mentioned, but this was at the line output. We have presumably checked the output section of the recorder versions for a clean signal when this was injected at the input to the power amplifier, actually the same point, but physically inconvenient, as insertion of a jack into the socket open-circuits the feed to the main amplifier. Connect instead to Tag 47 on the main amplifier

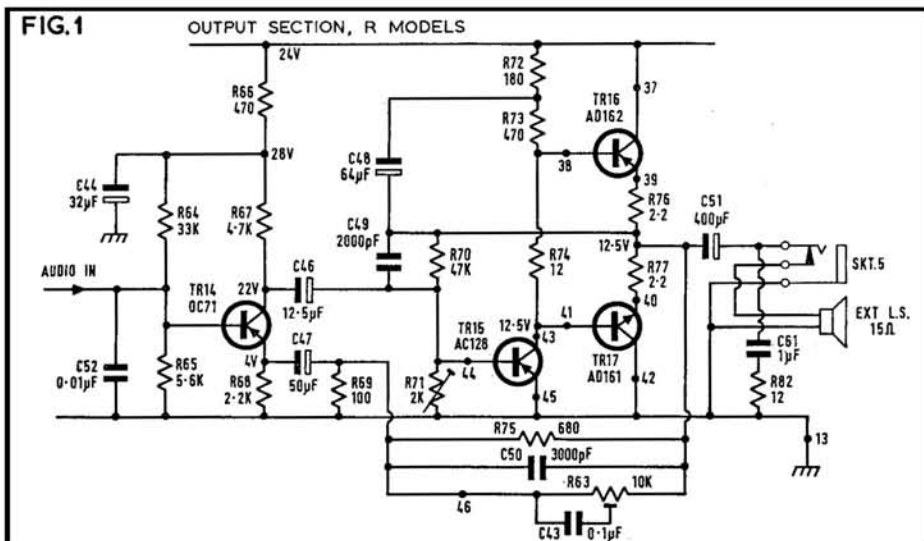

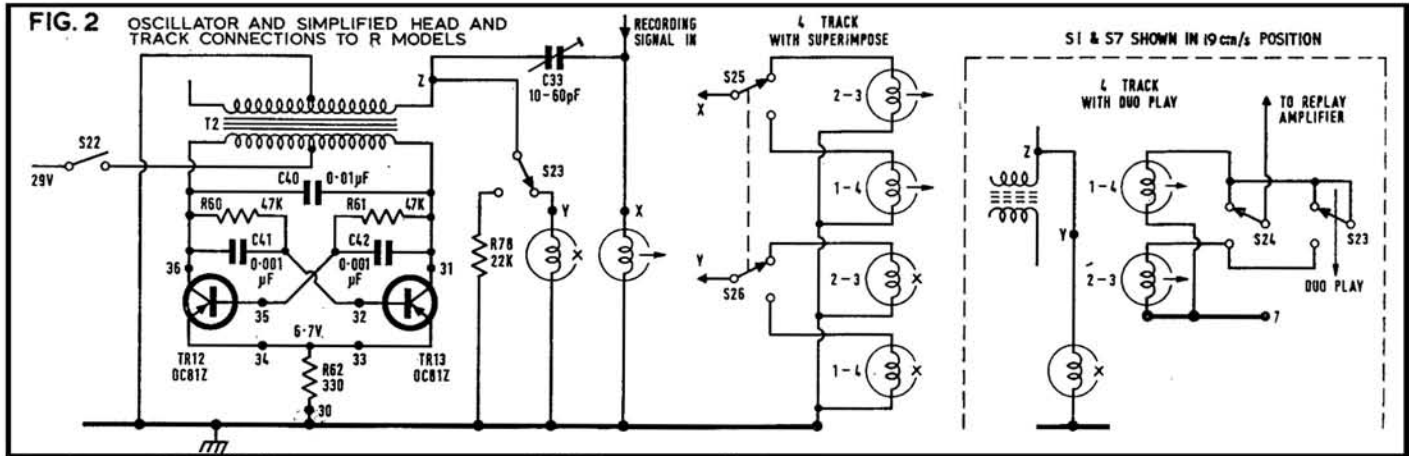

printed circuit board. But this test is not completely valid. An overall test is needed for any assessment of signal-to-noise ratio, and we must again record our reference tone. Note the output across a 15 ohm load resistor wired to a jack inserted in the external speaker socket, wind up the input to give us an 0 dB indication and, with controls at maximum on playback, check the hum content of the signal. An oscilloscope is a great help here, but even without it we can note a very marked alteration in hum as the mains transformer is swivelled slightly. This is easily done: the transformer is held by two screws to a plate with captive nuts. Very slight slackening of the screws allows sufficient play. Do not loosen too much, or you will introduce queer noises!

On the PD models, the transformer has to be oriented for the best hum compromise between channels. On these models, too, it is a little more difficult to gauge, as the reading must perforce be taken at the line output, there being no power amplifier. Which brings us to one small point apropos noise figures: when taking these measurements across line outputs, with the oscillator working, look out for bias breakthrough that may give a misleading indication. At the output, it should certainly not be evident, it will make a difference to the reading on a good valve-voltmeter—and, ironically, the better the meter, the greater the effect.

The point was raised by our vigilant friends

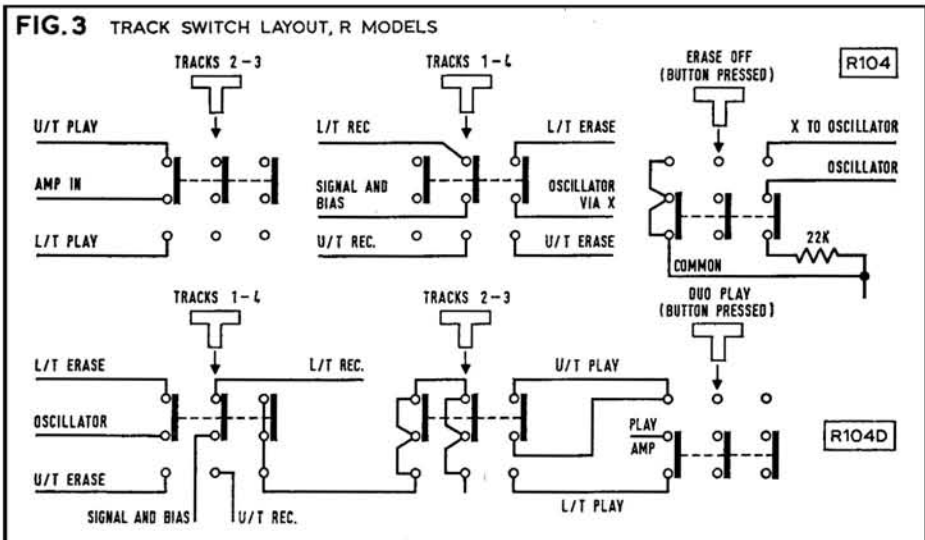

in the Friern Barnet Tape Club who met this problem with their Bang and Olufsen 2000 models. The secretary very kindly took time to make some experiments and detail them to me, following my notes on B & O service. I have since had some fun with a recently acquired 2000T and can vouch for their findings. The only real answer is to filter the output readings and note in which bands the apparent noise gives most trouble.

Before leaving the subject of noise, allow me to comfort the chaps who make careful tests of specifications, assiduously following the instructions in their handbooks. Please do not be too alarmed at small divergences. They may have reasons quite unconnected with the quality of your machine. For instance, Truvox say: measure output at full modulation, then replay 'an unrecorded tape' and compare. Well, what do they mean by unrecorded? You can get variations of as much as 2 dB between a new, unrecorded tape (and between different samples of the same make, let alone different makes), a tape previously recorded then erased with your machine, and a tape bulk-erased with any of the devices sold for this purpose. I prefer taking the worst figure, and find that an erased tape on second erasure after full modulation gives something near the expected figure.

A minor improvement to some of the full recorders can sometimes be effected by fitting the filter shown in fig. 1, a 1 µF capacitor in series with a 12-ohm resistor, across the loud-speaker output. This should have been done to all machines that employ the power pack with a combined DC supply to the power amplifier. The other type of power pack, with separate feed to the output section, should not need this filter to reduce any tendency to instability.

Of the drawings that I hope may find some  
(continued on page 165)

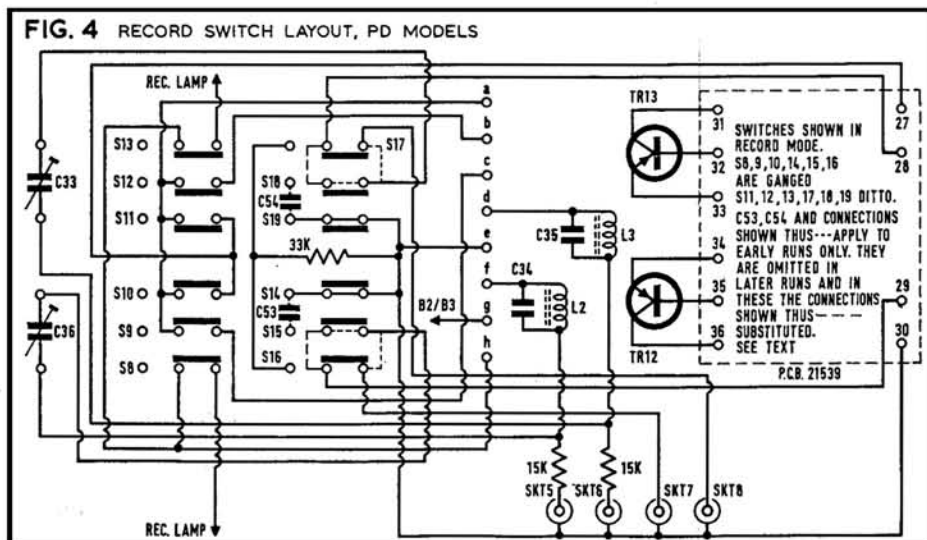



# Ferrograph F.307 — a new stereo amplifier

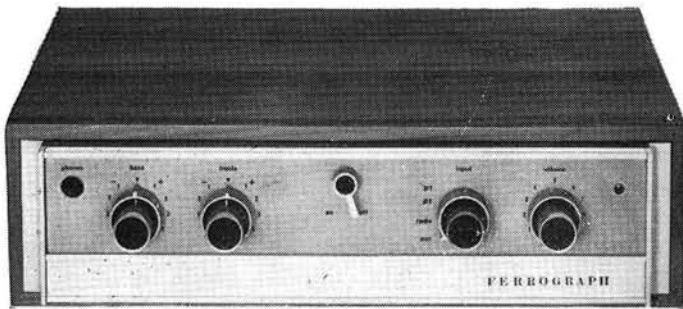

the quality companion  
for the Ferrograph  
Series 7 tape recorders  
and any good  
Hi-Fi system

Ferrograph's Stereo Amplifier Type F307 was developed alongside the Ferrograph New Generation Series 7 Tape Recorders, to the same standards of quality and reliability. It is an integrated stereo amplifier with a unique combination of facilities, compatible with all Ferrograph Series 7 and with other top-quality recorders and Hi-Fi systems.

Features include: independent adjustment of each channel for tone and gain; high power output; frequency response 15 Hz to 30 kHz  $\pm$  1/3 dB; minimal distortion, hum and noise; choice of four inputs.

See and hear this new instrument at your local Ferrograph stockist or use the coupon on page for details and name of nearest Ferrograph specialist.

## FERROGRAPH

The Ferrograph Co Ltd  
Mercury House, 195 Knightsbridge, London SW7  
Telephone: 01-589 4485

## Have you noticed it too?

With so many shops to choose from, there must be excellent reasons why people prefer to buy more and more from **Francis of Streatham**. Perhaps you would care to find out by calling or writing to us about your requirements in tape and hi-fi equipment too. (S.a.e. with written enquiries please.)

## EVERYTHING IN RECORDERS AND HI-FI ON THE BEST OF TERMS

- ★ VERY LARGE STOCKS OF EQUIPMENT AND ACCESSORIES
- ★ NO EXTRA FOR CREDIT UP TO 18 MONTHS
- ★ FREE SERVICE DURING GUARANTEE PERIOD—OWN SERVICE DEPT.

We are TANDBERG specialists and carry full stocks of these famous products.

Also FERROGRAPH, VORTEXION, AKAI, PHILIPS, ETC., ETC.

FOR A FAIR and DEPENDABLE  
DEAL—BUY IT FROM

**SPECIAL OFFER OF WORLD FAMOUS 'SHAMROCK' TAPE**  
Brand new, top quality polyester.  
2400', 7" reel ... 25/-  
1800', 7" ... 21/-  
1200', 7" or 5½" or 5" ... 15/-  
900', 5" ... 12/6  
600', 5" ... 10/-  
P. and P. 1/6 per reel. Orders over £3 post free. Cash with order please.

## FRANCIS OF STREATHAM

169-173 STREATHAM HIGH ROAD, LONDON, S.W.16

Between St. Leonard's Church  
and Streatham Station

Phone: 01-769 0466: 01-769 0192

Please note our only address Free Car Park, Prentis Road nearby  
OPEN ALL DAY SATURDAY—EARLY CLOSING WEDNESDAY

We are happy to announce that we can now supply

## BRAND NEW BRITISH & GERMAN RECORDING TAPES

P.V.C. POLYESTER & MYLAR

Both manufactured by world reputable British and German firms. Fitted with leaders and stop foils. Not rejects or sub-standard in any way—tapes are splice free and are boxed. Remember: full refund plus postage should goods not meet with your full approval.

Standard Play	Length	English price	German price
3"	150'	2/6	2/-
4"	300'	4/-	3/6
5"	600'	9/-	6/6
5½"	900'	11/6	8/-
7"	1200'	16/-	10/-
Long Play			
3"	220'	3/-	2/6
4"	450'	6/-	5/-
5"	900'	11/6	9/-
5½"	1200'	16/-	10/6
7"	1800'	23/-	14/-
Double Play			
3"	400'	6/-	4/-
4"	600'	8/6	7/-
5"	1200'	21/-	13/-
5½"	1800'	24/-	17/-
7"	2400'	39/-	22/-

EMPTY SPOOLS: 3" 9d. 5" 2/-, 5½" 2/3. 7" 2/6.

Compact Tape Cassettes at half price. 60, 90 and 120 minutes playing time, in original plastic library cases. MC60 8/9, MC90 12/6, MC120 18/6.

**N. WALKER Ltd.**

28 Linkscroft Ave., Ashford, Middx.

Phone: 53020

## TAPE RECORDER SERVICE CONTINUED

space this month, I felt it best to give priority to the head and track switch wiring diagrams. These are the parts of the Truvox *Series 100* that appear to cause the most confusion for the newcomer to these models. In practice, the head wiring is easy, for the anchor posts behind the head assembly allow immediate connection to be made for all tests—a feature that could well be emulated by many other manufacturers. But the track switching, and the superimpose or duoplay switching, can cause a little confusion unless shown in as near a layout form as we can manage. All depends on the draughtsmen at Link House. They deserve medals at times, having to interpret my surrealistic scribbles!

The switching circuit of the PD models is also important, especially as there are links present on some earlier versions that may be omitted or changed in later runs. This applies to the record switch layout and is an attempt to reduce unwanted erasure when recording on one track only—erase cross-tracking, in other

words. The switches are shown in the record mode and it will be seen that the links of the small dotted line would possibly provide a leakage path, with the damping capacitor, for the channel switched to play. This allows the oscillator, which is, of course, fully powered, to partially energise the unused winding of the erase head. So the dotted links are removed, and the capacitors, and a direct link between the adjacent switch sections is fitted instead. If you have an early version of the PD models and suffer from this mono recording problem, you are well advised to check the wiring.

Finally, an important factor in getting the best from a Truvox is correct head alignment. The system they use of making the upper head mounting plate a datum level is a good one, giving immediate checks on horizontal tape running, and a primary visual aid to alignment. Our final diagram shows the head mounting arrangement for the guides and heads of the  $\frac{1}{2}$ -track versions, with adjustments. Although the alignment depends on screw settings, it must be remembered that there can be manufacturing variations, and if an erase

FIG. 5

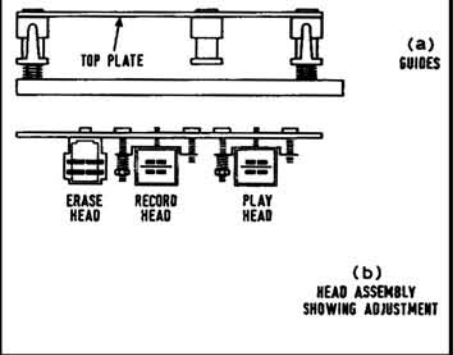

head is replaced, the only way of making sure is to experiment with shims between the head and mounting plate. Record/play heads have more scope for screw adjustment.

## PRODUCING DEMONSTRATION TAPES CONTINUED

twittering birds and church bells all seem to make their fair share of appearances on pop discs nowadays. Don't ask me why!

Multiplay is also possible but I do not propose to describe it in great detail here as many articles have already been written on this subject. Basically it means playing the original recording back on Machine A while taping it on Machine B (which also has a microphone connected into its mixing facilities). The artist listens via headphones to the monitor of Machine B and he thus is able to accompany the original signal.

The master recording having been completed, a length of leader tape is spliced as

close as decently possible to the first note of the tune and another length to where the last note dies away. Copies can now be made, suitable for sending to the record companies. LP tape is best suited for this purpose as it is tough but flexible enough to wrap closely against the heads. Empty film spools are ideal for holding enough tape at 19 cm/s for one tune. Only record on one track of the tape.

The recordings should be accompanied by a photograph of the performer/s, together with a card giving details of the recording—titles, names, tape speed, and so on.

Finally a list of companies who will at least give your tape a fair listening, even if only to react with a 'don't-call-us, we'll-call-you'.

### Artist and Repertoire Department:

- Apple Publishing Ltd., 3 Saville Row, London W.1.
- C.B.S. Records, 28-30 Theobalds Road, London W.C.1.
- Decca Record Co., Decca House, Albert Embankment, London S.E.1.
- EMI Records, EMI House, 20 Manchester Square, London W.1.
- Fontana/Philips Records Ltd., Stanhope House, Stanhope Place, London W.2.
- Immediate Record Co. Ltd., Immediate House, 63/69 New Oxford Street, W.C.1.
- M.G.M. Records Ltd., 2 Dean Street, London W.1.
- Pye Records Ltd., ATV House, Great Cumberland Place, London W.1.

## SOUND WORKSHOP CONTINUED

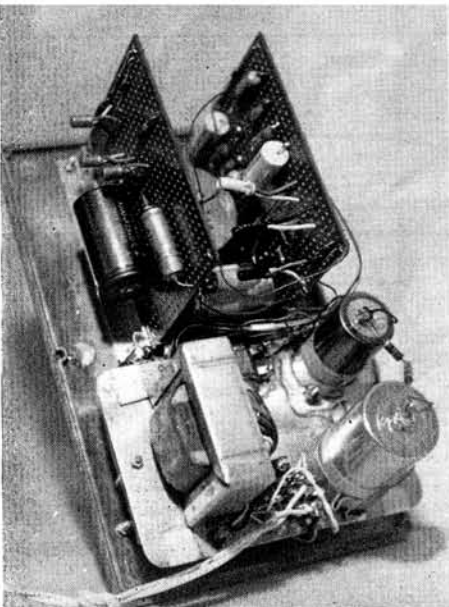

getting a true square-wave output with a fast rise time. The component values of the squaring circuit have been adjusted to cope with variations in transistors but it is essential that the waveform at the input to the squarer (the base of Tr4) should be a sine-wave.

Should the sine-wave output voltage be slightly lower or higher than the specified 1V RMS, it may be necessary to change the value of R8 which is in series with the thermistor. For higher output, decrease R8 to 47 or 68 ohms or even to zero should this be necessary. A slight variation of R16 (nominally 15 K) might then be necessary to produce the correct amplitude for the square-wave output.

### COMPONENTS LIST

Diecast Case	Electroniques 46R.085.A
Potentiometer VR1, VR2 (10K + 10K wire-wound)	Colvern CLR5018/15F 10 K + 10 K, G
Potentiometer VR3 1K wire-wound	Electroniques P21/1K
Thermistor TH	Electroniques STC R53

Resistors	0.25W 10% tolerance
Capacitors C9, C10, C11 C12, C13 other capacitors	12 V working 25 V working Paper, values as circuit
Transistors—Tr1 Tr2 Tr3 Tr4, Tr5, Tr6	Mullard OC45 Mullard OC140 Mullard OC72 Henry's Radio AC126
Calibrated control knob 1-10	Henry's Radio NK2
Rectifier MR1	Henry's Radio 1H3
Mains Transformer T1	Henry's Radio PS 12/1
Neon Indicator	Henry's Radio mains panel neon 220-250 V
Switches S1-S2 S3-S4	Henry's Radio Wafer 2-pole 4-way Henry's Radio Wafer 2-pole 2-way

The coaxial socket, frequency control and pointer knobs, on/off switch, and Veroboard can be obtained, like all the components with the exception of the Colvern Potentiometer (VR1-VR2), from Henry's Radio Ltd., 303 Edgware Road, London W1, or Electroniques (STC) Ltd., Edinburgh Way, Harlow, Essex. The diecast case can only be obtained from Electroniques. The address of Colvern Ltd. is Spring Gardens, Romford, Essex.

# THE SOUND STUDIO

## Part 1 The Nature of Sound

By K. R. Wicks

**T**HIS series will cover the theory and practice of sound studio techniques, dealing in turn with the nature of sound, the studio itself, microphones, mixers, monitoring equipment, and all the other basic elements which make up the programme chain. Finally, recording equipment and methods will be discussed.

The term 'sound' is not as easy to define as it would first appear. Indisputably, sound in its objective sense may be described as 'longitudinal vibrations set up in a medium by a vibrating body', but the difficulty comes when trying to fix the limits of the so-called audio frequency range, as hearing ability and characteristics may differ considerably from person to person.

The results of tests by Robinson and Dadson in 1956, show that the age of the listener is of vital significance. A person aged twenty can expect his hearing ability at a frequency of 15 kHz to have deteriorated by about 15 dB by the time he is thirty. Moreover, the rate of deterioration increases rapidly with age, so that, at this same frequency, the hearing ability of a person of fifty might be as much as 50 dB

worse than when he was twenty. At lower frequencies, this effect is less marked, the graph (fig. 1) showing the approximate deteriorations expected at various frequencies.

It is, therefore, not easy to fix the upper limit of the 'audio range'; difficulties occur also when considering the lower limit, although ageing of the listener is of little importance in this case.

The frequency response of the human hearing system varies a great deal according to the intensity of the sound, the effect being most noticeable at the low frequency end of the band. Near the *threshold of hearing* the intensity of a 35 Hz note will need to be about 60 dB higher than that of a 1 kHz note in order for the two tones to sound equally loud.

At higher levels the effect is much less marked, i.e. the difference in intensity between low and medium frequency tones of equal loudness becomes less as the loudness level increases. The well known Fletcher-Munson curves (fig. 2) illustrate this point.

Also, it can be seen that the lower the frequency, the smaller the range of intensity between the limits of *hearing* and *feeling*, so that as frequency is decreased, the chance of a vibration being *heard* becomes progressively smaller compared with the chance of it being either 'felt' or inaudible.

From all this, it is obvious that no precise limits can be fixed for the audible range, though the fairly arbitrary figures of 20 Hz-20 kHz are a sufficient guide for most purposes.

The practical significance of the differing hearing abilities of individuals is usually overlooked but is, in fact, of considerable importance, as the following incident illustrates.

In the London centre of a well known broadcasting organisation, a studio complained to the central control room that a high pitched whistle was audible on the studio output. The control room supervisor monitored the studio output on his speaker but was unable to hear the induction which was the cause of the complaint, although it was plainly audible to the younger technicians who were naturally reluctant to suggest to their supervisor that he had 'cloth ears'.

In this case some considerable time elapsed

before efforts were made to trace the fault, as the supervisor would not readily agree that one existed.

Another practical problem is that of obtaining a satisfactory *balance* between high and low frequency sounds in any programme material. On speech, one listener may hear what he considers to be excessive sibilance, although the material may sound normal to another listener.

If two people are allowed to adjust the bass and treble controls of an amplifier to what they consider the optimum points, the settings they choose may differ considerably, even when both listeners consider that they are good judges of sound quality. The chosen tone control settings depend upon the listeners' hearing characteristics to some extent, although the personal preference of the individual may be the over-riding factor.

Whatever the cause, the fact is that differences of opinion often arise regarding the tonal balance of programme material and, in broadcasting studios, reference is sometimes made to a Quality Check Room where an engineer listens on high quality equipment, giving his opinion and recommending correction when necessary.

Unfortunately, the quality check engineer may have a different opinion to everyone else and, in my experience, often does. Needless to say, this causes confusion all round.

Similar problems often arise, and there does not seem to be much that can be done, although matters would be simplified if those involved understood the subjective nature of the appreciation of sound.

The Fletcher-Munson curves are contours of *equal loudness*, the bottom curve indicating the threshold of hearing—the intensity required for the sound to be just audible to the 'average ear'. The top curve indicates the threshold of feeling. At this high intensity level, the ear tends to protect itself by separating the malleus (hammer) and incus (anvil) bones, the muscular strain required giving rise to a sense which is predominantly one of pain.

One important conclusion to be drawn from the curves is that the ear is most sensitive to  
(continued on page 169)

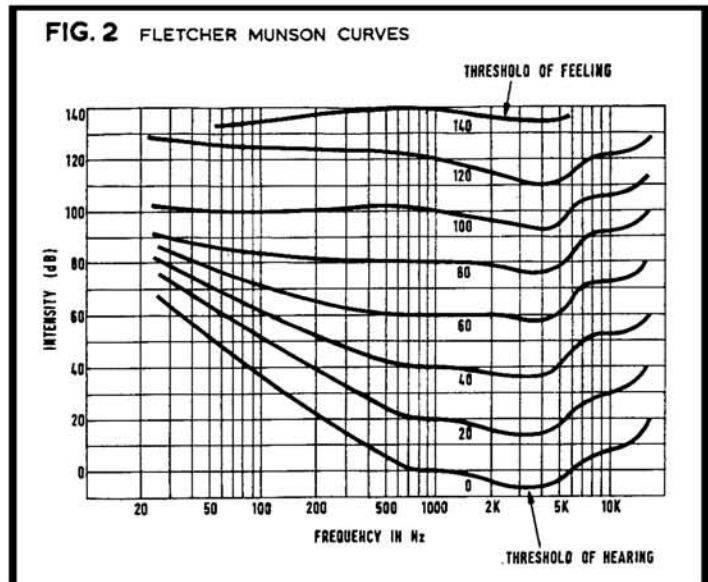
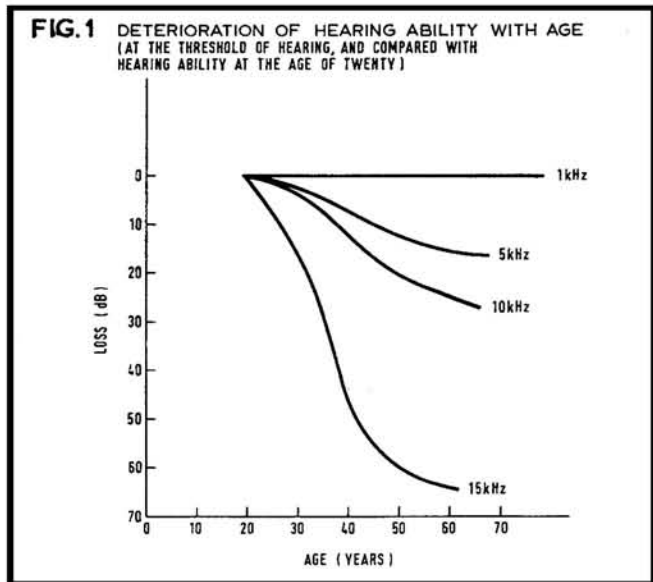



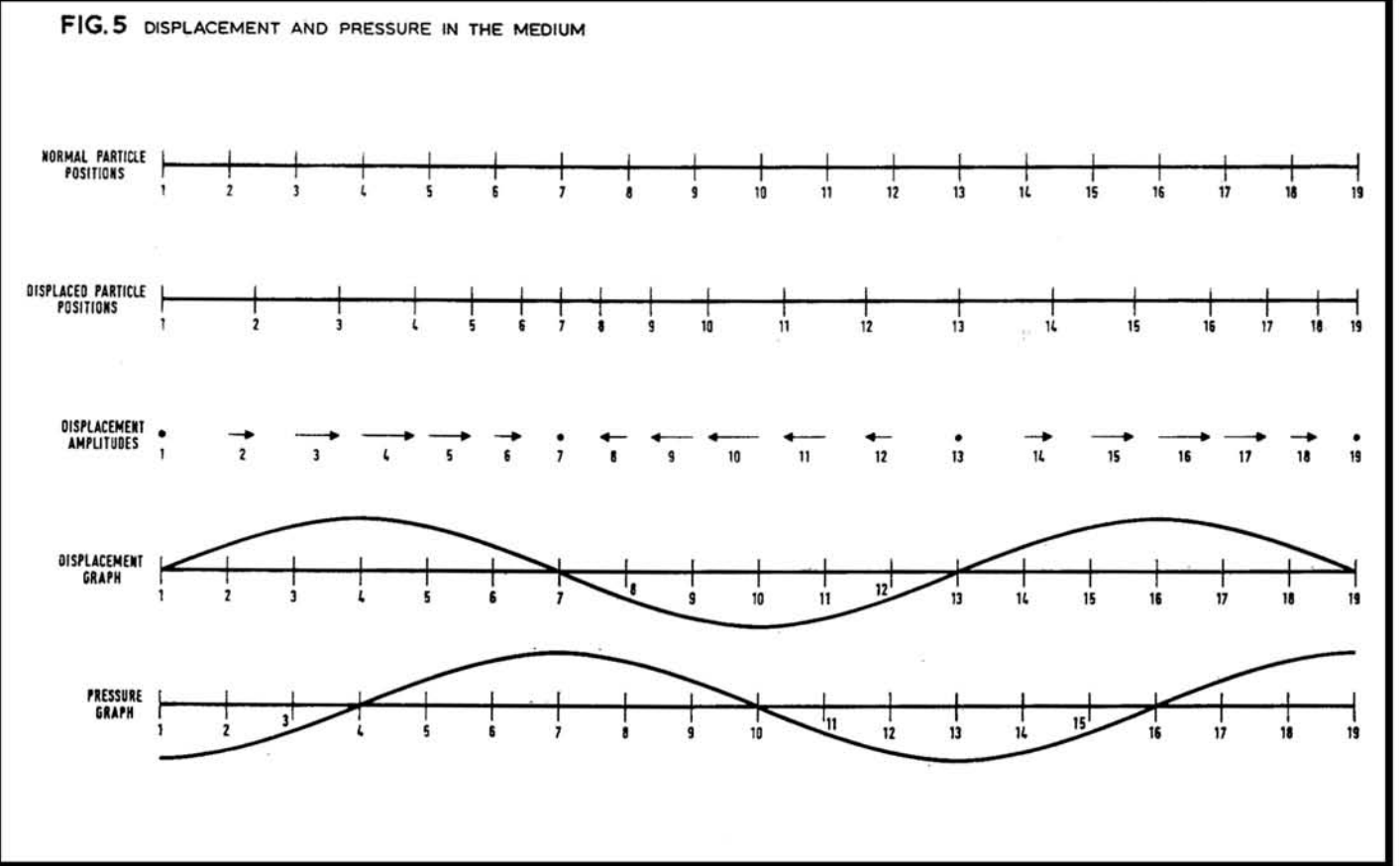
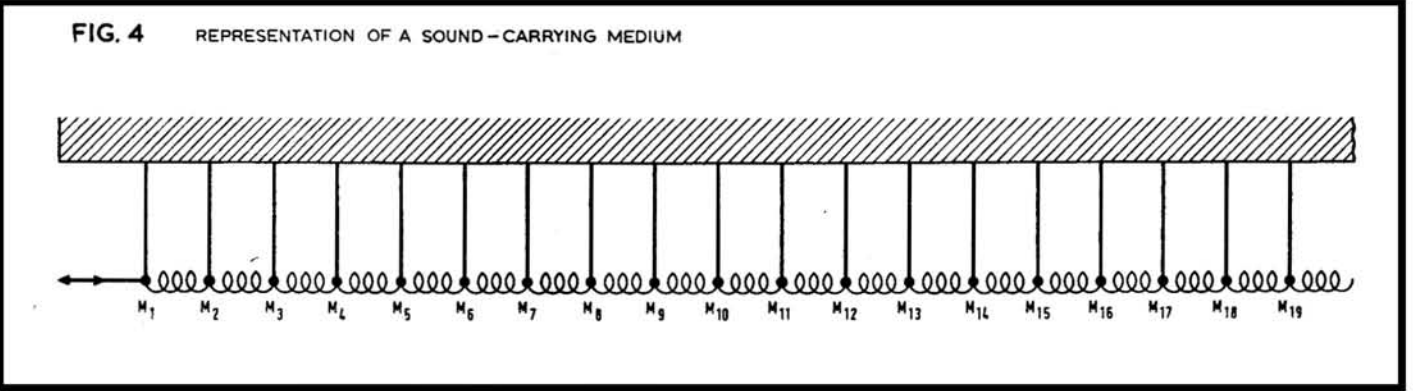
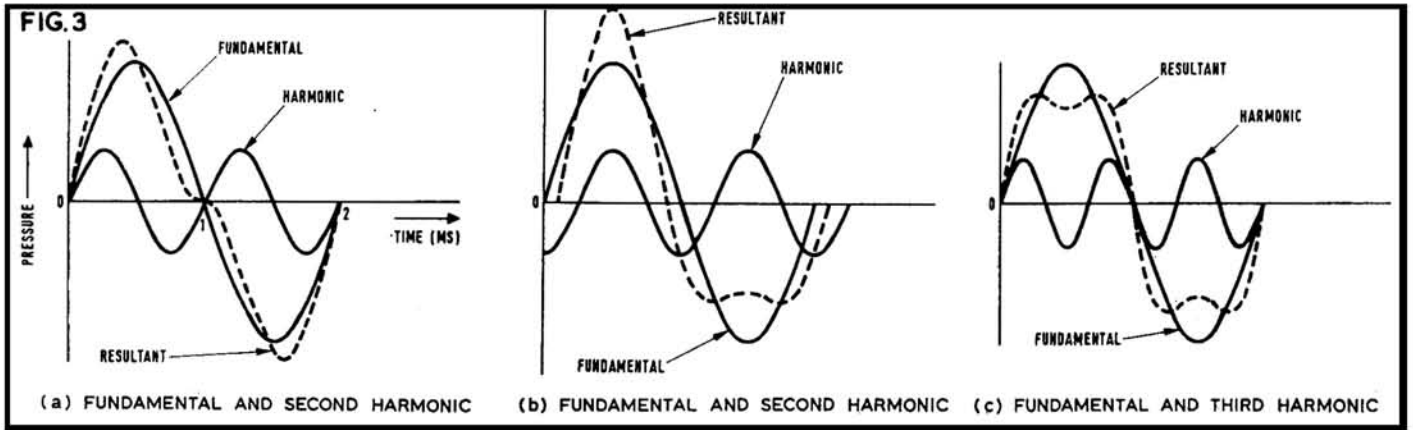

It should be noted that the horizontal axis indicates distance (not time) and the pressure wave *leads* the displacement wave by 90°. (The waves are taken to be travelling from left to right, as in fig. 4.)

# ARE KOSS STEREOPHONES BETTER THAN YOUR SPEAKERS?



**Model KO 727  
Wide-Range Stereophone**  
Will accept up to 60 watts per channel, for any system with 4, 8 or 16 ohm output. Foam-filled ear cushions removable for easy cleaning. New 8' coiled cord for added convenience. Fully adjustable for comfortable private listening over longest periods.

£16.10.0

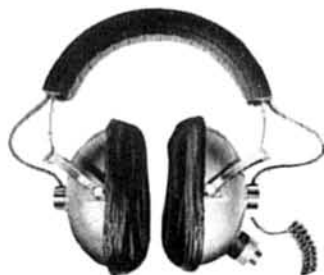

**Model PRO-4A  
Professional Headset**  
Engineered to meet most rigid and rugged requirements. Shock- and shatter-proof. Adjustable spring steel headband, fluid filled cushions give more efficient sound-seal. High-quality drivers for unusually smooth frequency response. Removable cushions. Equipped for boom mike.

£23.0.0



**Model SP-3XC Stereophones**  
Extremely sensitive 3 1/2" sound reproducers in each earpiece. Catches any sound the ear can hear. Soft sponge foam ear and head cushions. Frequency Response: 10-15,000 cps. Impedance: 4-16 ohms. With T-2 Adapter Plate connects to any system that will play speakers.

£11.15.0



**Model ESP-6  
Professional Electrostatic Headphones**  
A completely new concept in headphones, incorporating self-energised diaphragms eliminating the moving cone driver element, achieving a frequency response obtainable in the past only through complex electrostatic speakers. Complete with fitted portable carrying case and individually measured response curve. Details of design and performance on request.

£45.0.0

Leaflets and name of your local dealer from:

**TAPE-MUSIC DISTRIBUTORS LTD**

11 Redvers Road · London N22 · Telephone: 01-888 0152

**F. CAVE** ★ CASH DISCOUNTS  
★ TERMS  
★ MAIL ORDER SERVICE

TAPE RECORDER AND HI-FI EQUIPMENT SPECIALIST

AKAI - TANDBERG - SANYO - REVOX - TRUVOX  
PHILIPS - ETC.

AKAI 3000D ... ..	£85 0 0
AKAI I710W ... ..	£87 10 0
AKAI M9 ... ..	£159 0 0
STANDARD Cassette ...	£17 17 0
PHILIPS Cassette EL3302...	£24 19 0
PHILIPS Stereo EL3575 ...	£79 0 0
SANYO MR800 ... ..	£79 9 1
SANYO MR801 ... ..	£69 19 9
SANYO MR929 ... ..	£86 4 6
GRUNDIG TK120 ... ..	£28 18 6
GRUNDIG TK140 ... ..	£34 10 0
GRUNDIG TK145 ... ..	£39 10 0
PHILIPS EL3572 ... ..	£25 10 0
PHILIPS EL8578 ... ..	£42 10 0
TELETON 710 ... ..	£24 10 0

BUY NOW WHILE STOCKS LAST AT THESE PRICES

Send s.a.e. for tape discounts

**F. CAVE** 27 HILL STREET, RICHMOND  
940-0632 or 948 1441 up to 8 p.m.

# RECORD BUYERS NEED AUDIO

## RECORD REVIEW

WHY? BECAUSE it has the most expert and forthright panel of reviewers in the business. A record buyer can save time and money by studying ARR first. And if he's extra busy he need only look at the

ratings—exclusive to AUDIO RECORD REVIEW. Only 2s. 6d. at bookstalls or by post from AUDIO RECORD REVIEW, Heathcock Court, Strand, London, W.C.2. Every month on the 1st.

changes in intensity at low frequencies, the differences in intensity between the equal loudness contours being significantly smaller at low frequencies than at middle and high frequencies.

The unit of loudness is the phon, and at the reference frequency of 1 kHz, the number of phons is made numerically equal to the intensity level of the tone in decibels, the reference intensity level being the threshold of hearing, as shown in the diagram.

As the threshold varies with individuals and with frequency, an arbitrary standard had to be agreed and at the International Acoustical Conference in Paris in 1937, an acoustical pressure of 0.0002 dynes/cm<sup>2</sup> at 1 kHz was adopted as the standard. At any other frequency, the number of phons is given by the level in decibels of a 1 kHz tone which sounds equally as loud as the tone under consideration.

Another method of specifying loudness level is based on the loudness unit (LU). A tone will sound twice as loud if its level in loudness, measured in LUs, is doubled. Conversion from phons to LUs is carried out by reference to a standard graph, usually one which was derived in 1942 and adopted as the ASA standard. Loudness is sometimes quoted in sones, the sone being equal to 1,000 LU. As is often the case with standards derived by experiment, results different from those adopted have since been obtained.

In 1954, W. R. Garner produced a conversion graph on a new basis, and obtained results which were significantly different to those given by the ASA standard. Garner's unit of loudness was named the  $\lambda$  (lambda) unit, and again a chart is required for conversion from phons. Loudness levels are most often quoted in phons, and this unit will be used in this series. The following approximate figures are quoted to give a rough idea of the loudness levels of some common sounds.

Sound	Phons
Pneumatic Drill (1.6 metres)	115
Busy Street	85
Normal Speech (1 metre)	60
Whisper (1 metre)	20

While the importance of wavelength is appreciated in connection with such subjects as microphones, loudspeakers and sound treatment, it is surprising how few people have a vague idea of the wavelength at any given frequency, although it is, of course, easily calculated from the equation  $\lambda = v/f$ , where  $\lambda$  is wavelength,  $v$  is the velocity of sound in the medium, and  $f$  the frequency.

#### 340 METRES PER SECOND

The velocity of sound being about 340 metres per second, it is of use to remember that the wavelength of a 1 kHz tone is about a third of a metre. As the quantities  $f$  and  $\lambda$  are inversely proportional, a wavelength of 10 cm obviously corresponds to about 3.4 kHz, and so on.

If the frequency of a steady tone is increased in steps, the increments will sound equal if the frequencies used form a geometric progression, i.e. if the series of frequencies is of the form  $f_0, f_0r, f_0r^2, f_0r^3, \dots$ , where  $f_0$  is any frequency, and  $r$  the common ratio of the series, the latter determining the musical interval between

successive tones. Taking the special case where  $r=2$ , the interval between successive notes would be one octave.

Two notes may have the same pitch, but sound entirely different in quality. The quality of a fundamental sine-wave will be altered if harmonics (i.e. integral multiples) of the fundamental are added to it. The diagrams (fig. 3) show a fundamental frequency with the addition of (a and b) an even harmonic, and (c) an odd harmonic. These waveforms are still relatively simple, and the ear would analyse these easily, so that the separate components would be heard. It is interesting to note that if the phase of a harmonic relative to the fundamental is altered, the wave shape changes but the ear cannot detect the change, being aware of the components and their amplitudes but not of their relative phase. Thus, sound waves with shapes such as those in (a) and (b) would be indistinguishable to the listener.

The sound waves emitted by musical instruments are often very complex, containing a large number of harmonics, and a listener can usually identify a particular instrument by what he describes as the 'tone' of the note. Indefinable terms such as 'harshness' or 'mellowness' of the sound creep in, in order to explain the type of sound.

There is, however, another factor which affects the listener's appreciation of a sound. The initial part of a note produced by a musical instrument has a rather different waveform to the rest, as the string or air of the instrument has first to be set in motion. After this *transient* stage, the vibrations have merely to be maintained, and the waveform then becomes regular. When the musician stops playing a note, a small time elapses before the vibrations cease.

#### DIFFICULT TO IDENTIFY

This change of waveform at the start and finish of a note is usually more important than the listener realises when trying to identify an instrument. This can be verified experimentally: If a series of notes of the same pitch played on different instruments is recorded, and the start and finish of each note are removed by editing, the instruments become much more difficult to identify.

A common analogy used to represent a sound-carrying medium consists of a row of suspended weights connected by springs as shown in fig. 4. Regular horizontal oscillations of  $m_1$  are carried through the 'medium' in the same way as sound is carried through the air, and all the weights vibrate at the same rate but with various phase relationships with respect to  $m_1$ .

The velocity of the wave is given by Newton's formula:

$$v = \sqrt{\frac{\text{elasticity}}{\text{density}}}$$

Knowing the frequency of the oscillations, the wavelength  $\lambda$  can be found, and the oscillation of the weights a distance  $\lambda$  apart will be found to be mutually in phase. At any given instant, the displacements of the masses will be such that they form various compressions and extensions of the springs, fig. 5 showing the normal or rest positions, and the displaced positions of the masses at a particular instant. From this it can be seen that at this

instant, the mass  $m_7$  experiences a pressure maximum, whilst mass  $m_{12}$  experiences a pressure minimum, and these extremes of pressure occur at zero particle displacement.

Assuming that  $m_1$  is subjected to simple harmonic motion in the horizontal plane, a graph of particle displacements over a given distance will be sinusoidal (ignoring the decrease in amplitude with increase of distance from the source). The graph of pressure will also be sinusoidal, but will be  $\lambda/4$  out of phase with the displacement curve.

From a mathematical point of view, this is because the pressure at any point is proportional to the particle velocity which, in turn, is equal to the rate of change of the displacement with respect to time.

If the instantaneous displacement is  $a$ , and the peak displacement  $A$ , the wave may be represented in the normal manner by:

$$a = A \sin \omega t$$

where  $\omega$  is angular velocity (radians/second) and  $t$  is time (seconds).

$$\begin{aligned} \text{Then the particle velocity} &= \frac{d}{dt} \cdot A \sin \omega t \\ &= A \omega \cos \omega t. \end{aligned}$$

Since pressure  $P$  is proportional to particle velocity, then  $P = K A \omega \cos \omega t$ , where  $K$  is a constant.

Since the pressure wave contains the term  $\cos \omega t$ , it must obviously lead the displacement curve  $A \sin \omega t$  by  $90^\circ$ .

From the equation  $P = K A \omega \cos \omega t$ , it can be seen that the pressure is directly proportional to the displacement.

Relationship between Intensity and Displacement: Intensity equals power per unit area ( $\frac{W}{\Delta}$ ), and the power in a sound wave is proportional to the square of the displacement amplitude  $A$  (just as electrical power is proportional to the square of voltage). Thus, it follows, that  $I \propto A^2$ .

Relationship between Intensity and Distance: consider a point source of power  $W$ , radiating omnidirectionally from  $O$ . The intensity of sound will be constant over the surface of any sphere centre  $O$ , and will be equal to  $\frac{W}{\Delta}$  watts/unit area, where  $\Delta$  is the surface area of the sphere. Therefore  $I \propto \frac{1}{\Delta}$ .

Since  $\Delta$  is proportional to the square of  $d$ , the distance from the source (i.e. the radius of the sphere), then  $I \propto 1/d^2$ .

The results so far obtained may be summarised thus:

- (1)  $P \propto A$  Pressure proportional to Displacement.
- (2)  $I \propto A^2$  Intensity proportional to Displacement squared.
- (3)  $I \propto 1/d^2$  Intensity inversely proportional to Distance squared.

From the above, three further relationships can be derived:

- (4)  $I \propto P^2$  Intensity proportional to Pressure squared.
- (5)  $A \propto 1/d$  Displacement inversely proportional to Distance.
- (6)  $P \propto 1/d$  Pressure inversely proportional to Distance.

These relationships and other information contained in this article will be referred to from time to time throughout the series. Next month, acoustics and sound treatment of studios will be discussed.



# AKG smooth microphones with smooth performance

AKG offers you a range of microphones that look good, sound better, and give unrivalled performance at an economic price. Choose from:

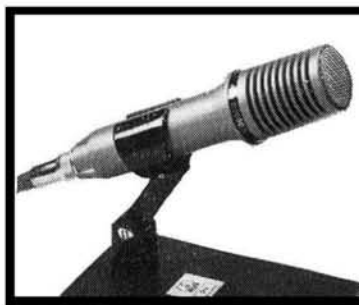

## AKG D-200

Dynamic two-way cardioid microphone with smooth frequency response superbly suited to fidelity recordings. Very strong and rugged metal construction complete with quick release pivot stand adaptor.



## AKG D-202

High-quality, dynamic. Two-way cardioid design — separate high- and low-frequency systems in a single housing for powerful directional performance and level frequency response. Minimum feedback. With unique housing design.



## AKG D-9D

Dynamic omnidirectional microphone to give sensitivity and style at extremely low cost. Level response over wide frequency range. Elegant styling—robust construction with metal grill and plastic body complete with attractive table stand.

Find out more about AKG mikes from



Politechna (London) Ltd. 182-184 Campden Hill Road, London, W.8. 24 Hr. Telephone: 01-727 0711 Telex: 23894

# AKG microphones

# BBC tv FILM RECORDISTS

BBC tv requires fully qualified and experienced technicians as Holiday Relief Film Recordists (£31-5-0d. per week) and Assistant Film Recordists (£23-7-0d. per week) for the summer months.

Initial appointment for two months. Possibility of extension for further four months.

Based in London.

Write, giving age and full particulars of relevant experience to:—

**General Manager,  
Film Operations and Services,  
Television Film Studios, Ealing Green,  
London, W.5.**

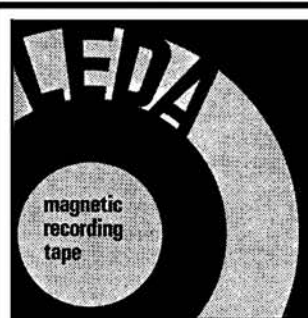

## FULLY GUARANTEED

Size Base	Standard P.V.C.		Long	
	3"	150'	2/6	225'
4"	300'	4/3	450'	5/6
5"	600'	8/9	900'	10/3
5½"	900'	10/6	1200'	12/6
7"	1200'	12/6	1800'	17/9

Size Base	Double POLYESTER		Triple	
	3"	300'	4/6	600'
4"	600'	8/6	900'	13/3
5"	1200'	15/9	1800'	23/6
5½"	1800'	19/9	2400'	29/9
7"	2400'	22/6	3600'	39/9

Factory Fresh. Superb Quality. Leaders, Trailers and Stop Foils on all sizes 5" and above. We supply many local authorities and professional recording studios. May we supply you? P. & P. 2/6 per order. S.A.E. Full Lists.

**LEDA TAPES (D), 30 BAKER ST., LONDON, W.1.**

Phone: 01-226 7004

## OPENING the BIBLE

by Stuart Allen

Principal of Wilson Street Chapel, London E.C.2  
(Non-denominational)

A series of HALF-HOUR TAPE RECORDED ADDRESSES at 1½ ips, 4 track, on 5 inch spools. The first twelve addresses are available for £1 from:—

**Mr. B. MARPLE (TR), 20 Rowley Gardens, Littleover,  
DERBY, DE3 7GF**

Money refunded if not satisfactory

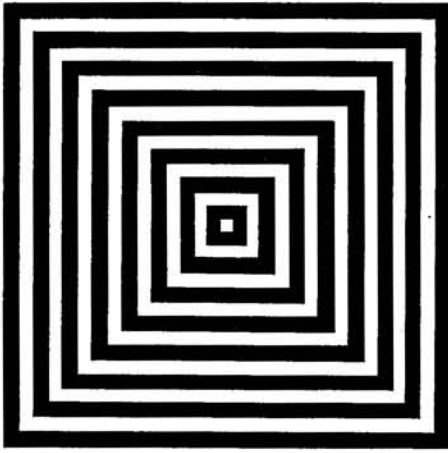

# CLOSED CIRCUIT

## PLANNING A CLOSED-CIRCUIT TELEVISION SYSTEM PART TWO

BY RICHARD GOLDING

Ampex 1200



THE planning of the vast ETV network for London schools was first begun in May 1965, a good three years before its inception. After a full enquiry, an outline plan was submitted for approval. This was given by the Educational Committee in December 1965 and a target date for the opening of Phase One was set for September 1968. This was to give 90,000 children in 300 schools in Islington, Hackney and Tower Hamlets their own CCTV service with Phase Two, twelve months later, taking in the remaining 900 schools in the Inner London Area.

The site available for Phase One was an old school, on three floors, in Laycock Street, Islington, and this was handed over for the sole use of the ETV system. The GPO then began laying a network of coaxial cable under London's streets, mainly in existing telephone ducts, together with the development of special transmission equipment. The cables were capable of carrying at least seven video channels simultaneously.

The brief for September 1968 involved the production of fourteen series containing nearly 200 programmes, all to be made at Laycock and transmitted during the first year. These included programmes for 15 years old school leavers on Housecraft and Social Studies, French for Primary schools, programmes on Business Machines, and Local Studies (Looking at London). For adults there was a series on Visual Aids, and another on Plastics. Transmissions were to take place on five days a week between 10 a.m. and 7.30 p.m. and the programmes were to be repeated three or four times a week to suit varied timetables. In September 1969 the service would be transferred to a permanent centre in Battersea to transmit to the whole of the ILEA with a final requirement of 3,520 receivers.

Mr James Wykes was appointed Director of the ETV service and began making up his staff long before the opening of the service. These included administration personnel, cameramen and engineers, and 45 ILEA teachers to take over the roles of scripting, directing and presenting. The technicians all had professional experience, and the teachers first received training in smaller units such as Goldsmiths' College CCTV unit, and then an intensive training period at Laycock before being seconded to the service for up to two years.

The technical planning was for one production suite, a training studio, a master control room to house the VTRs and transmission switcher, a room assigned to the GPO for the modulators and transmission equipment, a maintenance workshop, and a two-camera mobile TV unit. Ancillary areas included a photographic department, graphics and scenic shop, rehearsal areas, a film viewing and editing area, and production and administration offices.

Most of this went exactly to plan and the first six months of the ETV service has been an outstanding success. To see just how the school had been converted to a huge CCTV centre, and what equipment was being used, I went over to Islington myself.

The production suite is on the top floor of the school. This consists of the studio, production gallery, sound control room, and the telecine room. The four rooms form a block with good vision and sound communication.

The studio is 7 x 8 metres and is fitted with a curved cyclorama covering two walls. Air conditioning is provided and the ceiling (which is fairly high) and walls are acoustically treated. The floor is wooden but has been sanded and covered with lino to make it flat for tracking. Lighting comprises 2 kW, 1 kW and 500 W spots, and scoops for providing fill-light 30 x 2 kW lighting outlet sockets are provided 20 of these being dimmable by the vision engineer (the most complex set so far used 25 lamps). The studio is equipped with three 11.5 cm EMI 203 image-orthicon cameras each carrying 5, 7.5, 13 and 20.5 cm lenses. The cameras are mounted on Vinten hydraulic pedestals and Vinten pan-and-tilt heads. The camera control units have joystick remote controls grouped for operation by the vision engineer, Richard Thompson, who also controls the 16 mm telecine which has facilities for magnetic stripe recording on film and for reproducing both optical and magnetic track. Richard Thompson was with BBC TV for a number of years and came to ILEA after four years working on colour TV in New York. Colour, he believes, has a great future for educational TV. He sits in the production gallery with the director (ILEA teacher) and the vision mixer and is in the best position to give on-the-spot advice to the directors, whose lack of professional experience often leads them into difficult situations. The vision mixing unit has six inputs, and the gallery also carries seven 35.5 cm picture monitors for viewing of all inputs and transmission. A comprehensive talkback system is provided.

The sound control room, where I spent a great deal of time talking to Robin Dolman and John Gardner, the sound engineers, has a 12-input Elcom mixer, each input being high or low level with preset level control, prehear, foldback, and echo. The inputs can be routed via a 'red' or 'green' group, and main faders and group faders allow comprehensive mixing. A jackfield involving all inputs provides facilities for the insertion of frequency correcting filters into any channel or group. Sound monitoring is by PPMs and a KEF speaker system. A twin-turntable unit provides record reproduction, and two EMI BTR4 recorders complete the high level input equipment. The microphone selection includes a number of capacitors, neck microphones and dynamic microphones (AKG D25) for the Mole Richardson boom in the studio. The sound boom is used quite a lot, between 50% to 75% of productions, although neck microphones are used with the appropriate frequency correction. 'Intelligibility is of paramount importance,' said John Gardner. 'And, as we know that all programmes will be listened to in classrooms, frequently in far from ideal conditions, we try to compensate for this by rolling off some of the bass and putting in a slight presence peak. In order to increase the mean power broadcast we frequently use a Pye compressor. Like the broadcasting organisations, we have to depart from purist techniques in order to get the best results for the viewer.'

Both John and Robin came from the BBC after many years of radio and TV experience. Robin came first and it was his job to plan the sound system. The Elcom sound mixer was made to his specifications and took six months to complete. He now has plans for an 18-

(continued on page 177)

FIG. 1 NATIONAL RS-766US CIRCUIT DIAGRAM (ONE CHANNEL ONLY)

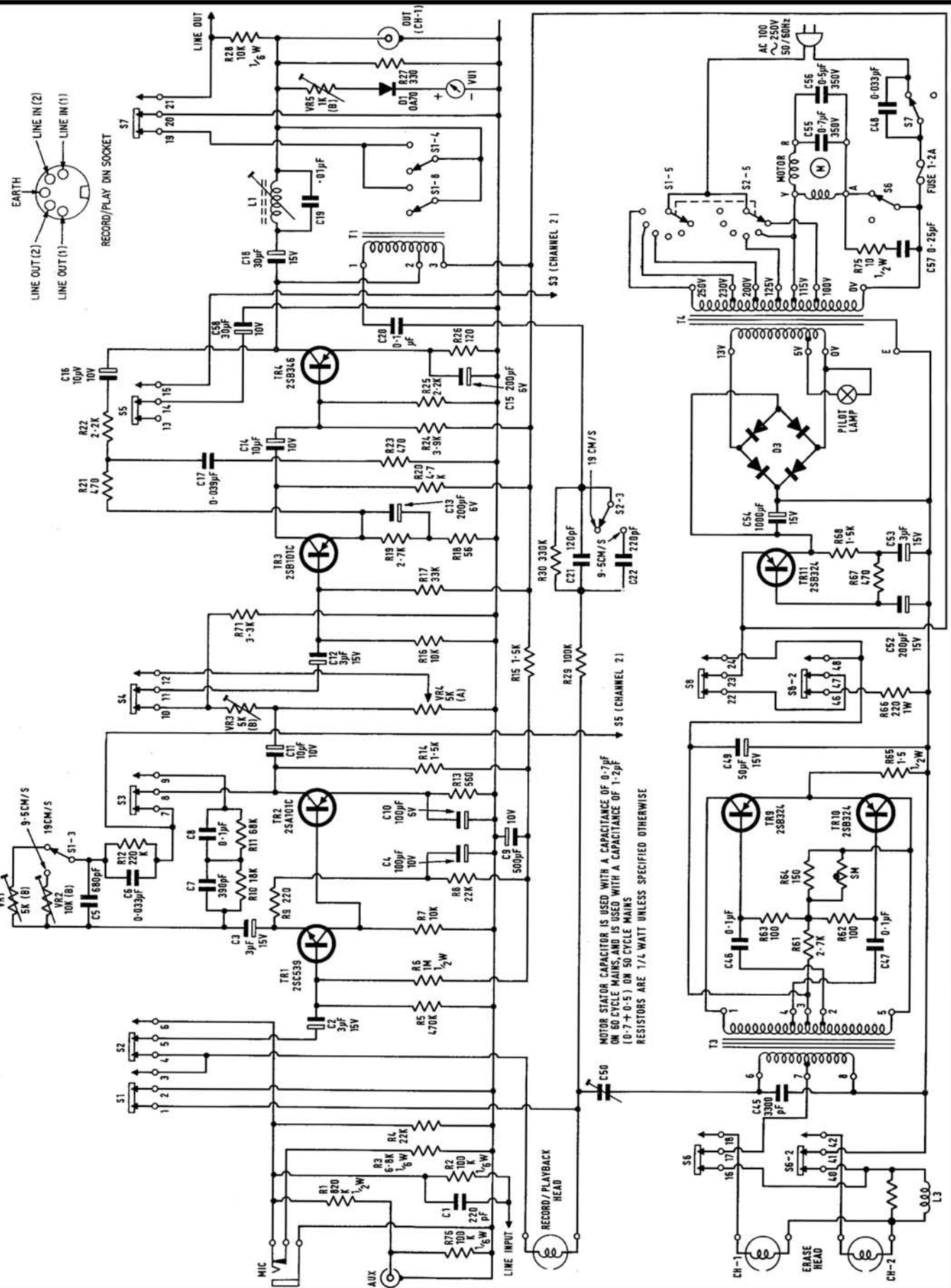



# equipment reviews

## NATIONAL RS-766US

### MANUFACTURER'S SPECIFICATION

(19 cm/s). Quarter-track stereo tape unit delivering 1 V to line outputs at peak recording level. **Wow and flutter:** 0.1% RMS. **Frequency range:** 30 Hz-18 kHz. **Signal-to-noise ratio:** 50 dB. **Oscillator frequency:** 50 kHz. **Spool Capacity:** 19 cm. **Tape speeds:** 19, 9.5 and 4.75 cm/s. **Modulation indicators:** Meters. **Sockets:** Miniature jack (microphone); duplicate DIN/Phono (line in/out). **Dimensions:** 35 x 28 x 14 cm (w x l x h). **Price** £17 13s. 7d. **Manufacturer:** Matsushita Electric Trading Co. Ltd., P.O. Box 288, Central Osaka, Japan. **Distributor:** United Africa Co. Ltd., United Africa House, Blackfriars Road, London S.E.1.

ALL recording controls are grouped on the left hand side of the control panel. The record level meters are placed directly above the appropriate record level controls and a transparent sliding window covers the record buttons which are locked in position by rotating the right hand tape motion control from the off position to either play or pause. The mechanical control lever can be moved anticlockwise for fast rewind, one step clockwise for play, two steps forward for pause and fully clockwise for fast forward wind. 300 metres of LP tape are wound or rewound in about 4 minutes.

The tape position indicator registers 15 digits for 10 turns of the supply reel and the counter can be reset to zero by push button.

The drive motor is a heavy duty four pole synchronous motor and a change of mains frequency from 50 to 60 Hz can be accommodated by removing the thin walled capstan sleeve and altering a tap on the motor phasing capacitor. The top traces of fig. 2 show the cumulative record play wow and flutter to be 0.09% RMS in the cancelling state and 0.11% when in phase. The main flutter is at 25 Hz motor rotation frequency. At 9.5 cm/s there is evidence of high frequency friction flutter which is limited by the 120 Hz cut-off frequency of the pen recorder but contains random high frequency 'grass' up to much higher frequencies when examined on a wide range CRO. At the lowest speed, cancellation of the 25 Hz flutter and the friction noise occurred several times a second but the mean integrated wow and flutter reading remained fairly constant between 0.25% and 0.3% RMS. In contrast to this rather 'dirty' record/play performance, the play-only readings from 19 and 9.5 cm/s low wow and flutter test tapes showed absolutely steady readings of 0.09% combined wow and flutter at both speeds, and even more surprisingly, 0.05% to 0.06% wow only at either speed. This would seem to indicate that the friction flutter is occurring at or near the record head. I cleaned all pads and tape guides and held off the autostop tape feeler during recording without altering the effect.

The play-only responses were measured on  
(continued on page 174)

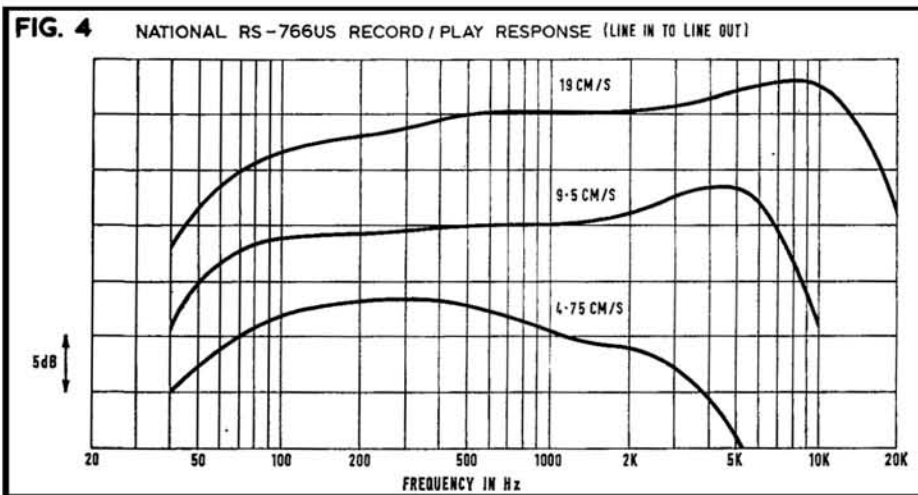
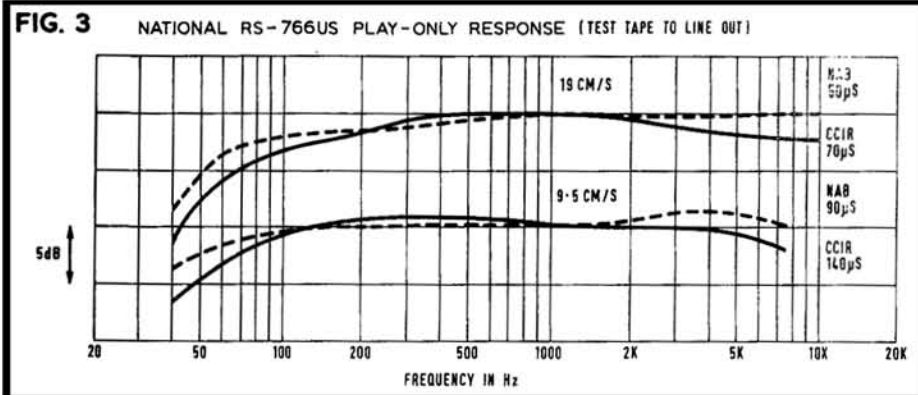
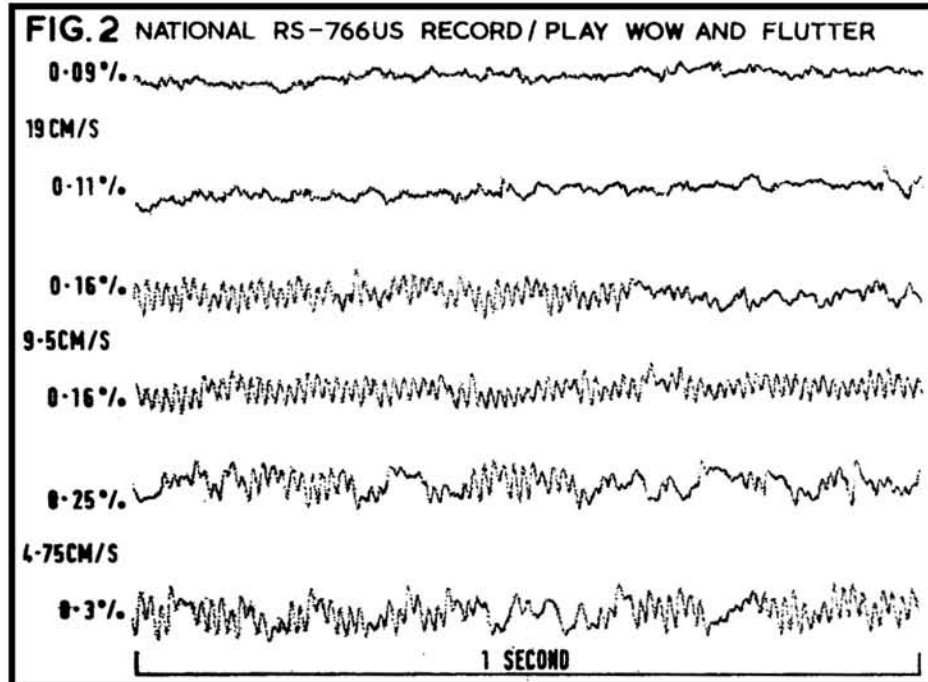



NAB and CCIR test tapes to give the responses of fig. 3. It will be seen that the equalisation is very close to the NAB 50 and 90  $\mu$ S time constants.

System noise, with no tape passing the heads, was 49 dB below the output when playing reference peak recording level tape (32 mM/mm). Reference level was recorded with the record level meter needle just at the top of the red sector of the scale. Total distortion at reference recording level was 2%. Erased peak recording level showed tape noise 46 dB below reference level unweighted but with some of the reading due to low level hum. Filtering the output with a 250 Hz high pass filter to remove the hum gave a noise and hiss reading of 52 dB.

Record/play tests gave the responses of fig. 4 which are reasonable without being outstanding at the two higher speeds, but pretty poor at the lowest speed of 4.75 cm/s.

The circuit diagram shows that a tapped choke or auto transformer is used in each record amplifier output stage to step up the signal voltage to the record head feed circuit. As the head feed resistor totals 430 K, the reason is clear enough, but I can see no virtue in such a scheme over using a lower feed resistor of say 50 K and peaking the record amplifier response for correct recording pre-emphasis.

Listening tests showed extremely 'gritty' sound quality which certainly did not agree with the pure tone test distortion figure of

2% at peak record level meter deflection.

Prerecorded tapes sounded clean and smooth, but were obviously recorded at a much lower level. The recording tests were repeated using lower and lower indicated recording levels until the meter pointers were barely lifting from the stop. The recordings were now clean, if a little 'top' heavy, and CRO comparisons with known properly recorded tapes showed that peaks were reaching similar levels. This is therefore an extreme case of VU meters with very unsuitable dynamic characteristics which do not register true peak recording levels except on sustained tones.

COMMENT

If I had to use this recorder as part of an audio reproduction installation, I would set the gain of the external power amplifiers so that a good prerecorded tape gave a reasonable listening level and then record at about this level. Remember that the playback gain of the RS-766U is fixed and that the ear is better than any meter in judging sound level in a constant acoustic environment. In this way the VU meters could be disregarded altogether as they are worse than useless for indicating true recording levels on the tape.

As a player the RS-766U has low wow and flutter, good signal-noise ratio and excellent equalisation. As a recorder it leaves much to be desired, but used in the way described above reasonable recordings can be achieved despite its obvious shortcomings.

A. Tutchings

## A couple of things for the record.



Everybody has heard of Grundig Tape recorders. But not everyone is quite so wise about Grundig tapes and accessories. But they're the best. And we don't mind what machine you use them on. You'll still notice the difference. Then there's our mikes. Superb quality studio standard. Moving-coil, omni or directional. For reasonable prices. If you're keen on your sound equipment, Grundig accessories will bring out the best in what you've got.



Write for the name and address of your nearest Grundig Accessories specialist.

Grundig (Great Britain) Ltd., London S.E.26  
A Member of the British Industrial Holdings Group

## MARUBENI-IIDA

### Electronic Equipment Division

Due to their continuing programme of expansion Marubeni Iida wish to appoint a number of

## SALES REPRESENTATIVES

and vacancies exist in all areas. Applicants should be of smart appearance and with good educational background. Must have first-class knowledge of audio products and have good connections with hi-fi and photographic dealers throughout the United Kingdom. A clean driving licence is essential. Company car is provided together with usual fringe benefits. Salary by negotiation. Applications giving full details should be addressed in writing to

The Marketing Manager,  
Electronic Equipment Division,  
MARUBENI-IIDA LTD.,  
164 Clapham Park Road, London, S.W.4.

## WHICH EARPHONE ? CONTINUED

soft padded clip-on *Z60* muffs rather than without. There are two vents at the back of each ear piece which are covered inside with a thin layer of foam plastic (for damping or just to keep dust out?) As a whole the phones are more substantial than the *K50* but lighter than, and at least as comfortable as, the *DT48S*.

The *K60* appear to give a greater output without distortion than the *K50*, which I have sometimes found particularly difficult to judge tape overload with, the *DT48S* produces still more signal. The sound of the *K60* is effortless and images sharp. Speech is clean, voices and strings are natural, the harpsichord sounds particularly good, and organ excellent with just a shade of bass lift. The *K60* phones are a definite and worthwhile improvement on the *K50*, if AKG will forgive my saying so.

I was supposed to be doing a field trial only, with no measurements. But I could not resist the temptation to do some very simple tests, and tried feeding the phones with white noise and tone. The *DT96A* seemed to fall off a bit above 2-3 kHz although the output was quite audible to 15 kHz or so (my ears cut off at about 18 kHz). The *DT48S* also seemed down just a little around 3-5 kHz, though on noise test the response seemed noticeably smoother than the *DT96A* which had a slight hollowness to the sound. The *K60* response seemed a little up at the higher end, 8 kHz and above, and extreme top was more evident; on noise their response was smooth, only the merest suggestion of whiskers at the top.

The tone tests were revealing in terms of differences between channels, and I think this casts some light on the better stereo performance of the more expensive phones which appear to be more closely matched. The differences on all the phones were more noticeable in their effect on image position,



AKG K60

on tone, than the differences with a pair of Goodmans *Maxims* in a small room—on the other hand the irregularities should always be

	DT96A	DT48S	K60
1K	central	central	central
3K	right	central	central
3.5K	central	central	central
4K	left	central	central
4.5K	right	central	central
5K	left	central	right
6K	central	central	left
7K	right	central	central
8K	slightly right	right	right
10K	left	left	right
12K	central	right	right
14K	right	right	slightly l
15K	central	left	slightly r
16K	left	left	left
18K	—	central ?	central ?

the same, whereas the speaker performance at different locations is slightly unpredictable. Although the *Maxims* produced differences in image position down to lower frequencies than the phones, presumably due to the effect of reflections and furnishings, the effect and shift was less marked than with the phones. I think the differences tell quite a bit of the stereo story and supplement my subjective impressions, so the results are tabulated in terms of major shifts to the right or left.

To comment objectively and choose between these phones would be difficult. All three are good and one set costs considerably less than the other two. The *DT96A* are not as good as the more expensive phones but, at the price, I would be very satisfied with a set and they must be considered worthy competition for the *K50*. To decide between these two must be a matter of individual taste and choice between compromises: whichever one buys would be money well spent. Does one get more for one's money with the more expensive headphones? Clearly one does.

Both the *K60* and the *DT48S* are excellent. I very slightly prefer the *DT48S* for outside recordings, but the lightness and softness of the *K60* might sway me if I were going to use the phones for long periods at a stretch as they are the most comfortable to wear. The metal casing of the Beyer *DT48S* should stand up to maltreatment better than the plastics of the AKGs—one never intends that they shall be treated roughly but, even on the best organised recording sessions, accidents do occasionally happen. For my own use, I would probably choose the *DT48S* if I had the money to spare, but I am equally certain that anyone who bought the *K60* would be highly satisfied and would use them happily and without hesitation. Three pieces of well made equipment, which sound good, look good, feel good and do the job for which they were intended, with the price related to what you get. **J.H.F.**

## STEREO TAPE AMPLIFIER CONTINUED

the amplifier can be peaked to a selected frequency.

Assuming a flat system response from 50 Hz to 15 kHz is a basic requirement for recording at 19 cm/s, the peaked frequency selected is 20 kHz; the response of the amplifier at this frequency is boosted to approximately 25 dB above that at 1 kHz. For 9.5 cm/s recording, S2 is closed and peak response occurs at 14 kHz. This level of treble boost is quite high, but has distinct advantages as will be seen. The use of a tuned circuit in the design means that the response above the selected peak frequency falls steeply, and so helps to reduce spurious signals that might be present at the amplifier output (e.g. RF, multiplex switching tones, heterodynes from the bias oscillator). The value of L1 is not really critical, since the Q of the tuned circuit is damped by R16. If a 10 mH inductor is used, C9 should be .0068  $\mu$ F and C10 .0047  $\mu$ F.

L2, C11 and C12, together with C1 are components of the bias trap circuit which will be described in conjunction with the oscillator design.

Some sort of recording level indicator is normally essential, since all but the really expensive recorders are not equipped with facilities for off-the-tape monitoring. However, as the present design is intended to provide and to be used with a tape deck with a third head and a main amplifier with such an eat-your-cake-and-record-it facility, a level meter becomes an optional extra. Furthermore, the case for having a dial to peer at becomes even more absurd in view of the fact that unless one has access to oscilloscopes, etc., one adjusts the output of the meter amplifier by listening to the cake ingested on the tape.

In fig. 2, M1 is a volume unit meter, responsive to AC. In his naive youth, the author was under the impression that VU meters were standardised devices, designed to register 0 dB on the scale with an input of 775 mV. However, on doing some research into VU meters, he can report that any such impressions are hopelessly ill-founded, and hence no value is specified on the diagram for R18. Fig. 3 shows a suitable hook-up for those wishing to use a DC level meter. Full-wave rectification is advised to avoid partial rectification of the signal at the monitor output. This circuit also increases the

effective sensitivity of the meter.

If the movement of the meter to be used is mechanically well damped, C14 may be unnecessary. Frequently, however, damping is inadequate, and a large parallel capacitor was found to alleviate such a situation. After all, a meter becomes even more redundant if its pointer performs a non-stop tango! Level meters can be quite expensive, but edgewise types with a 1½ in. scale and made by Smiths were obtained for 15s each from Messrs Patrick and Kinne of 81 Park Lane, Romford, Essex. These were found to have a f.s.d. of 200  $\mu$ A and an internal resistance of 1 K. With these meters, 5.1 K resistors were chosen for R18 in the prototype. Duxford Electronics also sell 50  $\mu$ A level meters (1 x 1½ in.) at 17s 6d. The author, incidentally, managed to discover a pair of ex-W.D. VU meters measuring 6 x 5 in. in an army surplus junk shop, and which cost 5s each, but most readers will probably not be that lucky. They really are impressive, and one feels quite justified in peering at them whilst recording Beethoven's Ninth, say, and listening for over-modulation of the tape.

A description of the setting-up procedure will follow the section on the oscillator design, which will commence next month's article.



## Your Tape Dealer

LONDON AREA

FOR ALL LEADING  
AUDIO EQUIPMENT

# hifi

Classical Records  
by Mail Service

hampstead  
**HIGH FIDELITY**

91a Heath Street,  
Hampstead, N.W.3.  
Tel. HAMPstead 6377

# HAVEN

196-198 SOUTH EALING RD.

# Hi-Fi

LONDON  
W.5  
Tel. 01-560 0194

# LASKY'S RADIO

Stockists for all the leading makes of Tape Equipment

207 EDGWARE ROAD, W.2. Tel.: PAD 3271  
118 EDGWARE ROAD, W.2. Tel.: PAD 9789  
33 TOTTENHAM CT. RD., W.1. Tel.: MUS 2605  
42 TOTTENHAM CT. RD., W.1. Tel.: LAN 2573  
152/3 FLEET STREET, E.C.4. Tel.: FLE 2833

## TRPE RECORDER HI-FI CENTRE (SHEEN) LTD

SPECIALISTS IN TAPE RECORDERS, ACCESSORIES,  
HI-FI EQUIPMENT

YOUR CENTRE FOR FRIENDLY HELP, SALES AND  
SERVICE

3 & 4 STATION PARADE Open until 8 p.m. on Fridays  
SHEEN LANE, SHEEN PROSPECT 0985  
LONDON, S.W.14 Opposite Mortlake Station, S.R.

CHESHIRE

go scandinavian hi-fi . . .

Bang & Olufsen, Tandberg, Arena, Dynatron, Radford,  
Sony, Philips, Quad, Leak, Fisher, Sanyo, Pioneer, Akai,  
Sansui, Wharfedale, Armstrong, Rogers, Ferrograph,  
Trio, Dual, Bryan, Normende, Eddystone, Goodmans,  
Braun, etc.

the hi-fi and tape recorder lounge

● EXPERT STAFF ● ADVICE SERVICE ● PART EXCHANGE  
● Home Dems ● After Sales Service ● Comparator Dems

GREEN LANE, WILMSLOW, CHES. SK9 1LR  
Ring Wilmslow 24766 and ask for Mr. Bird  
Closed Weds. except by appointment

FOR ALL YOUR REQUIREMENTS . . .

# CHARLESWORTH'S

OF CREWE LTD.

Head Office : 14 Hightown, Crewe. Tel. 3327

Hi-Fi CENTRE: 28 HIGHTOWN, CREWE

Technical Division : 19 Ludford Street, Crewe

## Your Tape Dealer

CHESHIRE (contd)

### VIDEO AND HI-FI STUDIO

Hire or Buy	Listen to the Best
★ Cameras	★ Bryan
★ Monitors	★ Truvox
★ Video Tape Recorders	★ Leak
★ Ampex	★ Goodmans
★ Ikegami	★ Goldring
★ G.E.C.	★ Thorens
★ Loewe Opta	★ Eagle
FULL SERVICE OFFERED	★ ETC.

Holiday Bros. (A.V.) Ltd. 61b Shaw Heath  
Stockport

DEVON

### THE SOUTH WEST

## Tom Molland Ltd.

Invite you to visit their well-equipped  
Demonstration Theatre and compare all  
the leading makes of Hi-Fi and Tape  
Equipment at

110 CORNWALL STREET, PLYMOUTH  
Telephone 69285  
Immediate delivery to ALL Areas

ESSEX

### EPPING — ESSEX

## CHEW & OSBORNE LTD.

148 HIGH ST. TEL: 4242

AKAI — AMPLEX — ARENA — ARMSTRONG — AUDIO  
TECHNICA — B & O — BRYAN — CELESTON  
FERROGRAPH — FISHER — GARRARD — GOLDRING  
GOODMANS — HACKER — KEF — LEAK — LOWTHER  
PHILIPS — QUAD — RADFORD — REVOX — ROGERS  
SHURE — SONY — THORENS — TRUVOX  
WHARFEDALE — WYNDSOR  
Home and Showroom Demonstrations:  
After Sales Service — H.P. Facilities  
Equipment and Records by post

GLOUCESTERSHIRE

# Sound Selection

OF BRISTOL

Tape Recorder and Hi-Fi  
Specialists (Demonstration Room)

361-363 GLOUCESTER ROAD,  
BRISTOL 7. Tel. 41181

REVOX  
SPECIALIST

HAMPSHIRE

## High Fidelity Specialists



Hamilton Electronics (Southampton) Ltd.  
35 London Road, Southampton. Phone: 28622 3 Lines

### FORRESTER'S

## NATIONAL RADIO SUPPLIES LTD.

70-72 HOLDENHURST ROAD  
BOURNEMOUTH HANTS

Largest hi-fi and radio component  
store in the south Tel: 25232

## Your Tape Dealer

HERTFORDSHIRE

### WATFORD

## High Fidelity Centre

at **RADIOLUX Ltd.**  
36 WOODLANDS PARADE, HIGH ST.

WATFORD (opposite the pond)

WATFORD 29734, 41029

IF IT'S GOOD—WE STOCK IT!

Demonstrations in our Stereo Theatre. Also home  
demonstrations with no obligation.

LANCASHIRE

### STOCKPORT AUDIO CENTRE

FINEST IN NORTH WEST



★ ALL MODELS ON COMPARISON DEMONSTRATION  
★ EVENING DEMONSTRATIONS BY APPOINTMENT

FAIRBOTHAM & CO. LTD.,  
58-62 Lower Hillgate, STO 4872

BOLTON

Specialists in  
High Fidelity Sound

H. D. NIKK  
*Stereolectrics*  
LIMITED

203 St. George's Road  
Phone 23093

BOLTON

## J. SMITH & SON

HI-FI EQUIPMENT — STEREOGRAMS  
TAPE RECORDERS — 2 SHOWROOMS  
B & O, Dynatron, Hacker, Quad, Leak, Radford,  
Armstrong, Ferrograph, Revox, Truvox, Uher,  
Decca, Garrard, Thorens, Goodmans, KEF, etc.  
Comparator Dems — Closed all Tuesday  
Specialists in 'SOUND' for 36 years

184 THE ROCK, BURY Tel: 1242

ST. HELENS

## HAROLD STOTT LTD.

Hi-Fi Consultant

Tape Recorder Specialist. Agents  
for all leading makes including Akai  
B & O, Revox, Sony, etc. Advice and  
demonstrations given willingly.

18 Westfield Street, St. Helens

NORTHUMBERLAND

### SOUND EQUIPMENT SPECIALISTS

# sound

Tel. 2-6902  
20142

12 OXFORD STREET

NEWCASTLE UPON TYNE 1

channel mixer for the second studio. They both enjoy working in ETV but claim that it is a more complex operation than schools TV on the national network.

The training studio is on the same floor as the production suite and carries three Marconi vidicon cameras, a vision mixer similar to that in the production gallery, and a simplified sound mixer. Next door is the preview theatre where experimental programmes and students' work may be screened.

On the first floor are the production and administration offices. Down on the ground floor is the master control room. This contains the 625 line broadcast type sync pulse generator (Marconi double unit with changeover) and the distribution amplifiers to send the required pulses to the production suite and technical areas. The master mixer is of auto-preview type and can accommodate eight sources; it is usually operated in a married condition but separate picture and sound switching can be employed. In this room are the two Ampex 1200 quadruplex VTRs (see photo). One is used principally for recording and is fitted with electronic editor. The other is used for transmission and is fitted with an AMTEC unit which corrects for head-timing errors. Both machines can be operated as synchronous sources and used for insert purposes. The value of the electronic editor is that new scenes can be inserted in previously recorded videotapes, or production errors can be rectified by undetectable, electronically spliced inserts. It is also useful in combining programme material to make original tapes. For example, live-action shots, prerecorded sequences, and cuts from telecine film or slides may be assembled quite smoothly to make up a complete programme. The AMTEC (Ampex Time Element Compensator) provides line-by-line compensation for timing errors in the composite signal. In this way picture geometric distortions from any cause—skewing, scalloping, quadrature, essing, and waterfall—may be eliminated. In addition, the system extends the tolerance for error in video head alignment and effects instant correction at splice points, even when the two tapes are from recorders with differing head alignments. Another feature of the new Ampex quadruplex VTRs is the *Mark Ten High Efficiency Video Head*. This contains 'unitized transducers' which permit close matching of individual 'dimes' on any head drum for similarity of electrical and mechanical characteristics.

In the master control room there is also a test pattern generator. There are two vidicon cameras mounted before an effects box to provide the interval signal which is transmitted between programmes and the 'one minute cue' which is transmitted before each programme.

The Outside Broadcast unit consists of a single-decker bus adapted to accommodate a four-man crew and equipment including two cameras, sound and vision mixer, talkback amplifiers, microphones and Ampex helical-scan VTRs. (There are some 20 Ampex 5003 and 7003 machines in use at the centre.) The capital cost of this OB unit was £14,300 and the annual running costs, including depreciation, are estimated around £11,000.

## Your Tape Dealer

NOTTINGHAMSHIRE

### Nottingham Tape Recorder Ltd.

BURTON ST. 2 mins. Victoria Station

Specialists in all the best makes of

- TAPE RECORDERS ● AMPLIFIERS ●
- HI-FI DISC EQUIPMENT ●

Telephone: Nottingham 45222

OXFORDSHIRE

## Westwoods

for the

TAPE RECORDER

of your choice

46 George Street

Oxford 47783

SHROPSHIRE

### SHREWSBURY'S NEW SOUND CENTRE

Ferrograph-Leak-Akai-Rogers-Goodman etc.

HEAR THEM IN OUR DEMONSTRATION STUDIO

OPEN ALL DAY  
TUESDAY-SATURDAY



Hi-Fi Ltd.

13 WYLE COP.

Tel. 55166

(facing the famous Lion Hotel)

SURREY

FARNHAM

SURREY

- ★ Stockists of all good Hi-Fi apparatus.
- ★ Comparative demonstrations.
- ★ We offer a real after sales service.
- ★ Easiest of terms
- ★ No parking problems.

### Lloyd & Keyworth Ltd.

THE RECORD SHOP

26-27 DOWNING STREET, FARNHAM

SURREY Telephone: Farnham 5534

SURREY AND HAMPSHIRE'S HI-FI SPECIALISTS

## CROYDON'S

TAPE RECORDER CENTRE

All leading makes in stock. Hi-Fi equipment, cabinets, etc. Service agents for AKAI Tape Recorders

SPALDING ELECTRICAL LTD.,  
352/354 Lower Addiscombe Road,  
CROYDON.

ADDIscombe 1231/2040

SUSSEX

WORTHING, SUSSEX

Stocking Ferrograph, Revox, Sony, Tandberg, Truvox, Philips, EMI, Luxor, etc., on fully comparative Demonstration

BOWERS & WILKINS LTD.

1 Becket Bldgs., Littlehampton Road,  
Worthing 5142

## Your Tape Dealer

WARWICKSHIRE

BIRMINGHAM

### TAPE RECORDER CENTRE

266 BROAD STREET, BIRMINGHAM 1  
(Opposite Bingley Hall)

Most leading makes high fidelity equipment  
Part exchanges welcomed

Telephone Midland 2680

Coventry's 100% tape recorder and hi-fi specialists for service and sales.

Akai — Ampex — Bang & Olufsen —  
Ferrograph — Leak — National —  
Radford — Revox — Sony —  
Tandberg — Truvox — Wyndors

### Coventry Tape Recorder Service

33 King William Street, Coventry  
Telephone Coventry 29668

## GRIFFIN RADIO LTD

(the high fidelity people)

Fully comprehensive stocks and  
advisory service for

Monaural and Stereophonic High Fidelity,  
Radio, Tape and Disc Equipment

94 BRISTOL STREET

BIRMINGHAM 5 Telephone MID 1359

YORKSHIRE

## TAPE RECORDER CENTRE (HALIFAX)

For all the best in Tape Recorders  
and Hi-Fi Sales and Service

30 King Cross Street,  
Halifax Phone 66832



SCOTLAND

GLASGOW

Scotland's Leading Tape Recorder, Video and Hi-Fi  
Specialists

G. H. STEELE LTD.

Hear true Hi-Fi sound on our 22 speaker comparator  
system. 14 Hi-Fi combinations ready for demonstration.

SONY VIDEO CENTRE

Agents for: Armstrong, Leak, Fisher, Rogers, Quad,  
B & O, Goldring, Garrard, Thorens, Connoisseur,  
Goodmans, Wharfedale, Kef, Celestion, Decca,  
Truvox, Philips, Sony, Arena, Revox, Tandberg,  
Brenell, Ferrograph, Akai, Uher, Grundig.

CREDIT TERMS — PART EXCHANGES  
Repairs and Servicing Tel. Douglas 7124

141 St Georges Road, Glasgow C3

## Recording Studios

**mjb** recording and  
transcription service

Mono and Stereo records. latest cutting methods, auto-  
matic varigroove, feedback cutter heads, limiters and  
equalisers, techniques hitherto available only to the  
professional, facilitating high undistorted cutting levels  
and extended playing times even from amateur recordings.  
Booklet available.

45 HIGH STREET  
BURNHAM

Tel. 61303 BERKS

# CLASSIFIED ADVERTISEMENTS

Advertisements for this section must be pre-paid. The rate is 6d. per word (private) minimum 7s. 6d. Box Nos. 1s. 6d. extra. Trade rates 1s. per word, minimum 15s., Box Nos. 2s. 6d. extra. Copy and remittance for advertisements in **MAY 1969** issue must reach these offices by **17th MARCH** addressed to: The Advertisement Manager, Tape Recorder, Link House, Dingwall Avenue, Croydon CR9 2TA.

Replies to Box Nos. should be addressed to the Advertisement Manager, Tape Recorder, Link House Dingwall Avenue, Croydon CR9 2TA, and the Box No. quoted on the outside of the envelope. The district after Box No. indicates its locality.

## SITUATIONS VACANT

**Hi-Fi and Tape Recorder salesman** required by R.E.W. (Earlsfield) Ltd., at their Tooting branch. Good pay and conditions. Apply the Manager, 266 Upper Tooting Road, London S.W.17. Tel. 01-672 9175 or 672 8267.

**Wanted**—young man interested in tape recorders—apply Magnegraph Recording Co. Ltd., 1 Hanway Place, W.1.

**Sales Representatives . . . see page 174.**

**BBC tv Film Recordists . . . see page 170.**

## MISCELLANEOUS

**Repairs.** Our modern service department equipped with the latest test equipment (including a wow and flutter meter and multiplex Stereo Signal Generator) is able to repair Hi-Fi and Tape Recording equipment to manufacturer's standards. Telesonic Ltd., 92 Tottenham Court Road, London, W.1. 01-636-8177.

**Skilled tape recorder repairs** carried out by expert personnel of many years' experience backed by extensive test equipment: Wow and flutter meter, audio valve voltmeter, audio generator, oscilloscope, etc., with final test performance figures quoted if required—Ferrograph specialists. Tape Recorder Centre, Tel-Lee-Radio, 220 The Broadway, Wimbledon, S.W.19. 01-542-4946.

**Tape Recorder Repairs.** Executed expertly, efficiently, economically by The Tape Recorder Centre. See page 135 for branch address.

## TAPE EXCHANGE

Send **shilling** (stamps) for copy of our magazine and see what makes our members tick! The world's most go-ahead Tape-X-Change, **WORLDWIDE TAPETALK**, 35 The Gardens, Harrow.

## FOR SALE—TRADE

**Blackburn** has Lancashire's leading Hi-Fidelity/Tape Recorder stockists and Electronic Engineers at Holdings Audio Centre, Mincing Lane/Derwent Street, Blackburn (Tel. 59595.)

**Always be careful** (and money-wise) before buying quality equipment. Send your requirement list to Audio Supply Association for evaluation and quotation. See below . . .

**If quality matters** consult first our 70-page photographically illustrated catalogue with technical specifications (5/6). Members enjoy unbiased advisory service, preferential terms. Membership 7/6. Our associates also manufacture records from your own tapes, or record the Master at our studios (Steinway Grand). Bulk terms for choirs, fund-raising. Please specify requirements. Audio Supply Association, 18 Blenheim Road, London W.4.

**Absolutely genuine.** Up to 50% off retail prices of Recording Tape. Up to 25% off pre-recorded tapes including cassettes. Up to 25% off Hi-Fi equipment. Send 6d stamp for full details to: BCM/tape unlimited, London, W.C.1.

**Absolutely free,** huge catalogue listing pre-recorded mono and stereo tapes. Many carrying a discount of as much as 30%. Don't buy another tape until you've seen this new list. Send 4d stamp to BCM/tapes unlimited, London, W.C.1.

**Discount and Service.** We are the only dealers offering big discounts on all hi-fi, tape recorders, radio, record-players, etc., plus servicing facilities. Our highly trained engineers can service all equipment supplied by us. All equipment is brand-new, guaranteed and supplied in makers sealed cartons. All makes supplied—return of post service. Send s.a.e. with your enquiry and we will quote same day. **DISCOUNT AUDIO (TR)**, 192 Broadway, London S.W.19.

## RAPID RECORDING SERVICE

LPs FROM YOUR OWN TAPES  
48-HOUR SERVICE

MASTER DISCS AND PRESSINGS  
RECORDING STUDIO  
DEMONSTRATION DISCS

MOBILE RECORDINGS—ANY DISTANCE

Multi-channel facilities for transfer to 8 or 16mm film tracks. Sound effects library on discs.

Brochure on request from

**Rapid Recording Service**  
21 BISHOPS CLOSE, LONDON, E.17

## STUDIO FACILITIES

**Studio Sound Recording Studios.** Recording and disc transcription service. Latest high-level cutting techniques. Mono and stereo records. Exceptional quality obtained from amateur recordings. Members A.P.R.S. 31-36 Hermitage Road, Hitchin, Herts. Telephone Hitchin 4537.

**Your tapes to disc.** 7in. 45—25/-, 10in. L.P. —55/-, 12in. L.P.—65/-. 4-day postal service Masters and Vinylite pressings. Top professional quality. S.A.E. photo leaflet: Deroy Studios, High Bank, Hawk Street, Carnforth, Lancs.

**Your own tapes transferred on to discs.** Send for details: R. J. Foley Tape to Disc Service, 112 Beach Road, Scratby, Great Yarmouth, Norfolk.

**J & B Recordings.** Tape to disc—latest high level disc cutting, all speeds. Mastering pressings, studio, mobile. 14 Willows Avenue, Morden, Surrey. MITcham 9952.

**Graham Clark Records.** Tape to disc—pressings. 23 The Grove, Walton-on-Thames, Surrey. Tel. Walton 25627.

**Location Specialists.** Full mobile stereophonic recording facilities. Write or 'phone Richard Daniel, 4 Latham Road, Twickenham, Middlesex. 01-892-9599. 01-534-0066.

**Pressing Specialists.** Stereo/mono discs manufactured from your tapes, e.g. 99 off 7" EP Mono 10/4 each. 99 off 12" LP Mono 15/- each. Mobile recording service available. Please send for full particulars. North Surrey Recording Co., 59 Hillfield Ave., Morden, Surrey. 01-648-6345.

## FOR SALE—PRIVATE

**Grampian Reverberation Unit,** mint condition. New batteries. Complete with carrying case. £35. Phone 01-504-9315 between 9 a.m. and 6 p.m. only.

## WANTED

**Lee Electronics.** The Tape Recorder and Hi-Fi Specialists wish to purchase good quality Tape and Hi-Fi Equipment for cash. 400 Edgware Road, W.2. Phone PAD 5521.

**Highest prices offered** for good quality Tape Recorders and Hi-Fi. R.E.W., 266 Upper Tooting Road, London, S.W.17.

**GOOD QUALITY TAPE RECORDERS AND HI-FI EQUIPMENT PURCHASED FOR CASH.** TELEPHONE 01-472 2185.

**Cash for your unwanted records.** Good prices for C. & W., Jim Reeves, Andy Williams, Englebert, etc. Send list with s.a.e. for free estimate. Duckworths Records, Bottesford, Notts NG13 0EF.

**Civic; 4-track, 3-speed, Collaro Mk. IV deck,** Consider alternative machine having this mechanism. Please contact P. L. Smith, 60 Ridge Terrace, Wood Lane, Leeds LS6 2DA.

**Truvox L.S.100 speaker** required, 27" x 18" x 7 1/2". Please phone A. Cayless, Weybridge 43816 (daytime only).

**Ferrograph 633** or late Series 5 mono recorder. State condition and price. A. R. Caveen, 12, Birket Avenue, Wallasey, Cheshire.





# The missing Link that puts stereo tape into your Hi-Fi system!

This superb tape unit completes *your* system. You already have a power amplifier and a pair of speakers! Now add the Akai 3000D. The Akai 3000D has: ● three heads — erase, record and playback ● frequency response 30 to 22,000 Hz  $\pm 3$  db at  $7\frac{1}{2}$  ips. ● Signal to noise ratio: better than 50 db. ● first class tape transport. ● two speeds  $3\frac{3}{4}$  and  $7\frac{1}{2}$  ips. ● Headphone monitoring (or listening) when the unit is used away from your system. Everything you've ever wanted—ever needed in a stereo tape unit. for 85 gns.

**AKAI**



**PULLIN**  
PHOTOGRAPHIC

(A Company within the Rank Organisation)

To: PULLIN PHOTOGRAPHIC DEPT. TR4  
11 Aintree Road, Perivale, Middx.

Please send me details of the 3000D.

NAME .....

ADDRESS .....



Discover a remarkable new experience in musical realism. EAGLE'S range of Stereo Headphones offers the ultimate in listening pleasure for the discriminating music lover.



**Model SE.1** has a 3in. High Flux Density Speaker. Broad frequency response of 25-15,000 cps . . . such good value at £4 19s. 9d.

**Model SE.21** has a 2½in. LF Woofer, ½in. HF Tweeter, Wide frequency response of 25-18,000 cps and equipped with individual Tweeter controls and input attenuators . . . such good value at £9 18s. 5d.

**Model SE.28** is a Studio Quality Headset with an extended frequency response of 20-20,000 Hz. Separate adjustable attenuators incorporated in each dome . . . such good value at £11 0s. 6d.

**Model LS.2W** is a Stereo Headphone Control Centre in a Walnut Cabinet permitting the use of two pairs of Stereo Headphones with facilities for adjusting the volume level on each channel . . . such good value at £3 6s. 2d.

Full details available on request or visit your EAGLE Dealer and inspect these exciting models



Sole Distributors  
B. Adler & Sons (Radio) Ltd.  
Audio Division  
Coptic Street, London, W.C.1