

# RADIO & ELECTRONICS CONSTRUCTOR

Vol. 26 No. 12

JULY 1973

20p

## MINIATURE 3 CHANNEL MIXER

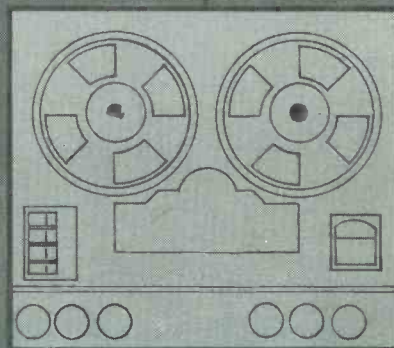
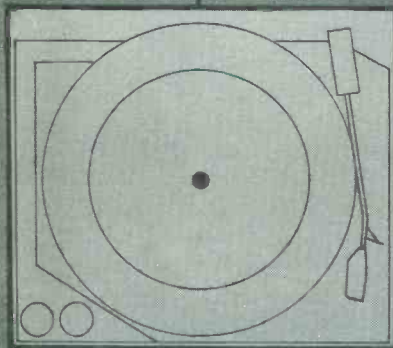

**ALSO  
FEATURED**

CASSETTE RECORDER. MAINS UNIT  
INDEX VOLUME 26 August 1972 - July 1973



## Each £3 unit of Home Unit Insurance gives you protection up to the limit shown

This is the simplified insurance you have been waiting for. Not just cover on the contents of your home but a package of personal protection you and your family need. And it's how we save you so much money: just ONE policy to issue instead of nine!  
 You can build up to the cover you need by additional units

(or 1/2 units after the first) up to a maximum of five. So simple. So easy. Apply to your Broker, Agent or local office of a General Accident company. The Home Unit Policy can replace your existing insurances And remember - as you buy more possessions just add more Home Units at any time. *Quote Ref. 20/9468*

## THE GENERAL ACCIDENT FIRE & LIFE ASSURANCE CORPORATION LTD

Metropolitan House, 35 Victoria Avenue,  
 Southend-on-Sea, Essex, SS2 6BT

It pays to be protected by a **General Accident** company

Please send me further particulars of the Home Unit Insurance.

Name.....

Address.....

20/9468



# BI-PRE-PAK

## SUPPLIERS OF SEMI-CONDUCTORS TO THE WORLD



**COMPLETE  
TELEPHONES**

EX. G.P.O. NORMAL  
HOUSEHOLD TYPE

**ONLY £1.05**

POST & PACKING 45p EACH



**TELEPHONE DIALS**

Standard Post Office type.  
Guaranteed in working order.

**ONLY 27½p**

POST & PACKING 16½p

### TESTED AND GUARANTEED PAKS

B79	4	IN4007 Sil. Rec. diodes, 1,000 PIV lamp plastic	55p
B81	10	Reed Switches, 1" long, 3/8" dia. High speed P.O. type	55p
B99	200	Mixed Capacitors. Approx. quantity, counted by weight	55p
H4	250	Mixed Resistors. Approx. quantity counted by weight	55p
H7	40	Wirewound Resistors, Mixed types and values.	55p
H9	2	OC71 Light Sensitive Photo Transistor	55p
H28	20	OC200/1/2/3 PNP Silicon uncodded TO-5 can	55p
H30	20	1 Watt Zener Diodes, Mixed Voltages 6.8-43V.	55p
H35	100	Mixed Diodes, Germ. Gold bonded, etc. Marked and Unmarked.	55p
H38	30	Short lead Transistors, NPN Silicon Planar types.	55p
H39	10	Integrated Circuits, 6 Gates BMC 962, 4 Flip Flops BMC 945	55p
H40	20	BFY50, 2, 2N696, 2N1613 NPN Silicon uncodded TO-5	55p
H41	2	Sil Power transistors comp pair BD131 132	55p

### UNMARKED UNTESTED PAKS

B66	150	Germanium Diodes Min. glass type	55p
B83	200	Trans. manufacturers' rejects all types NPN, PNP, Sil. and Germ.	55p
B84	100	Silicon Diodes DO-7 glass equiv. to OA200, OA202	55p
B86	100	Sil. Diodes sub. min. IN914 and IN916 types	55p
B88	50	Sil. Trans. NPN, PNP equiv. to OC200/1 2N706A, BS195A, etc.	55p
B1	50	Germanium Transistors PNP, AF and RF	55p
H46	40	250mW, Zener Diodes DO-7 Min. Glass Type	55p
H17	20	3 amp. Silicon Stud Rectifiers mixed volts.	55p
H15	30	Top Hat Silicon Rectifiers, 750mA, Mixed volts.	55p
H16	15	Experimenters' Pkt of Integrated Circuits. Data supplied	55p
H20	20	BY126/7 Type Silicon Rectifiers 1 amp plastic. Mixed volts.	55p
H34	15	Power Transistors, PNP, Germ. NPN Silicon TO-3 Can.	55p

### MAKE A REV COUNTER FOR YOUR CAR

The 'TACHO BLOCK'. This encapsulated block will turn any 0-1mA meter into a linear and accurate rev. counter for any car with normal coil ignition system.

**£1.10 each**



OVER  
**1,000,000**  
TRANSISTORS IN STOCK

We hold a very large range of fully marked, tested and guaranteed transistors, power transistors, diodes and rectifiers at very competitive prices. Please send for free catalogue.

**600,000** Silicon planar plastic transistors. Unmarked, untested, factory clearance. A random sampling showed these to be of remarkably high quality.

Audio PNP, similar to ZTX500, 2N3702 3, BCY70 etc.  
Audio NPN, similar to ZTX300, 2N3708, 9, BC107 8 9, BC168 9 etc.  
Please state Audio NPN or Audio PNP when ordering.  
ALL AT 500 for £3.30; 1,000 for £5.50, 10,000 for £44 P. & P. 11p 1,000

### OUR VERY POPULAR 4p TRANSISTORS

TYPE "A": PNP Silicon alloy, TO-5 can.  
TYPE "B": PNP Silicon, plastic encapsulation.  
TYPE "C": PNP Germanium AF or RF.  
TYPE "F": NPN Silicon plastic encapsulation.  
TYPE "G": NPN Silicon similar ZTX 300 range  
TYPE "H": PNP Silicon similar ZTX 500 range

**8** RELAYS FOR VARIOUS TYPES P & P 27p **£1.10**

Our famous PI Pak is still leading in value for money.

Full of Short Lead Semiconductors and Electronic Components, approx. 170. We guarantee at least 30 really high quality factory marked Transistors PNP & NPN, and a host of Diodes & Rectifiers mounted on Printed Circuit Panels. Identification Chart supplied to give some information on the Transistors.

Please ask for Pak P.1. Only 55p 11p P & P on this Pak.

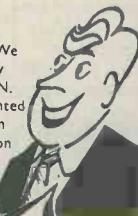

### A CROSS HATCH GENERATOR FOR £3.85 !!!

YES, a complete kit of parts including Printed Circuit Board. A four position switch gives X-hatch, Dots, Vertical or Horizontal lines. Integrated Circuit design for easy construction and reliability. This is a project in the September edition of Television.

This complete kit of parts costs £3.85, post paid.

A MUST for Colour T.V. Alignment.

### STEREO DECODER £4.95

A ready built unit, ready for connection to the I.F. stages of your existing FM Radio or Tuner Unit. A tell-tale light can be connected to show the presence of a Stereo transmission and correct operation of the Unit.  
The Unit is in the form of a small printed circuit, and no further alignment is necessary, as all preset adjustments have already been carried out at the factory.  
It is recommended that a L.E.D. is used as the Indicating light and a suitable device is available from us at 36p.  
Supplied with necessary instructions and written guarantee.

**FREE CATALOGUE FOR**

TRANSISTORS, RECTIFIERS, DIODES, INTEGRATED CIRCUITS, FULL PRE-PAK LISTS



**100,000**

Plastic Power Transistors in stock, more on way!  
**NOW IN TWO RANGES**

There are 40W and 90W Silicon Plastic Power Transistors of the very latest design, available in NPN or PNP at the most shatteringly low prices of all time. We have been selling these successfully in quantity to all parts of the world and we are proud to offer them under our Tested and Guaranteed terms. Range 1. VCE. Min. 15. HFE. Min 15.

40 Watt	1-12	13-25	26-50
90 Watt	22p	20p	18p
	26½p	24½p	22p
Range 2. VCE. Min 40.	HFE Min 40.		
40 Watt	1-12	13-25	26-50
90 Watt	33p	31p	29p
	38½p	36½p	33p

Complimentary pairs matched for gain at 3 amps. 11p extra per pair. Please state NPN or PNP on order.

### INTEGRATED CIRCUITS

We stock a large range of I.C.s at very competitive prices (from 11p each). These are all listed in our FREE Catalogue, see coupon below.

### METRICATION CHARTS now available

This fantastically detailed conversion calculator carries thousands of classified references between metric and British (and U.S.A.) measurements of length, area, volume, liquid measure, weights etc. Pocket Size 15p Wall Chart 18p

**LOW COST DUAL IN LINE I.C. SOCKETS**  
14 pin type at 16½p each } Now new low profile type  
16 pin type at 18p each }

### BOOKS

We have a large selection of Reference and Technical Books in stock.

These are just two of our popular lines:  
B.P.I. Transistor Equivalents and Substitutes: 40p  
This includes many thousands of British U.S.A., European and C.V. equivalents.

The Hifite Radio Valve & Transistor Data Book 9th Edition: p. & p. 234p. 75p  
Characteristics of 3,000 valves and tubes. 4,500 Transistors, Diodes, Rectifiers and Integrated Circuits.

Send for lists of publications

N.B. Books are void of V.A.T.

Please send me the FREE Bi-Pre-Pak Catalogue

NAME

ADDRESS

All prices include 10% V.A.T.

MINIMUM ORDER 50p. CASH WITH ORDER PLEASE. Add 11p post and packing per order. OVERSEAS ADD EXTRA FOR POSTAGE

**BI-PRE-PAK LTD**  
Co. Regd. No. 820919

DEPT. C, 222-224 WEST ROAD, WESTCLIFF-ON-SEA, ESSEX, S50 9DF  
TELEPHONE: SOUTHEND (0702) 46344

# COMPONENTS

HOBBYIST - AMATEUR - DOMESTIC SURPLUS - INDUSTRIAL - BULK OFFERS  
 JUST A FEW OF OUR BARGAINS ARE LISTED BELOW - PAY US A VISIT OR SEND STAMPED ADDRESSED ENVELOPE FOR A QUOTE ON YOUR REQUIREMENTS

MAINS POWER SUPPLY UNIT. 400m/A. 6-7.5-9-12 VOLT MADE TO SELL AT £5.25 OUR PRICE £3.50

VALVE BASES	
Chassis or printed circuit B9A - B7G	3p
Chassis UX7 - B5 - UX5 - B9G	3p
Shrouded chassis B7G - B9A	4p
Octal chassis	4p
B8A chassis	5p
B12A tube base	3p

TAG STRIP	
6 way	2p
Single	1p

1 1/4 glass fuses— 250 m/a or 3 amp (box of 12)	6p
3" tape spools	4p
FX2236 FerroX Cores	5p
PVC or metal clip on M.E.S. bulb holder	3p
All metal equipment Phono plug	2p
Bulgin, 5mm Jack plug and switched socket (pair)	20p
12 volt solenoid and plunger	25p
250 RPM 50 c/s locked frequency miniature mains motor	50p
200 OHM coil, 1 1/4" long, hollow centre	10p
Relay, P.O. 3000 type, 1,000 OHM coil, 4 pole c/o	60p
R.S. 12 way standard plug and shell	50p

SWITCHES			
Pole	Way	Type	
4	2	Sub. Min. Slide	10p
6	4	Wafer Rotary	12p each
4	3		
3	7		
2	5		
1	3		
1	3	+ off Sub. min. edge	10p
1	3	13 amp small rotary	12p
2	2	Locking with 2 to 3 keys	£1.50
2	1	2 Amp 250V A.C. rotary	20p
1	2	Toggle	10p

### VALVES - NEW AND BOXED

DY86	44p	EM87	90p	PL84	46p
EB91	26p	EL84	36p	PY81	40p
ECC82	36p	EY86	46p	PY82	42p
ECC83	36p	EZ80	30p	PY88	52p
ECH81	44p	PCC84	50p	UABC80	58p
EABC80	46p	PCC89	62p	UCL82	50p
EBF89	44p	PCF80	38p	UL84	50p
ECL82	44p	PCF82	50p	UY85	42p
ECL86	56p	PCL82	38p	UM84	32p
EF80	36p	PCL84	50p	UCH81	44p
EF85	44p	PCL85	64p	6BA6	26p
EF86	44p	PCL86	56p	12E1	£2.50
EF91	52p	PL36	78p	SIIE12	£5.00
EF183	40p	PL81	72p	MANY	
EF184	44p	PL83	56p	OTHERS	

### RESETTABLE COUNTER

English Numbering Machines LTD.  
 MODEL 4436-159-989

6-14 volt, 6 digit, illuminated, fully enclosed. £2.50

TO3 Mica Washer	2p
3" Standard Tape - Boxed	15p
GP91-1 Cartridge, turnover stylii	65p
GC10/4B Cold Cathode	£5.00

1/8 1/4 1/2 watt	1p
1 watt	1 1/2p
Up to 10 watt wire	8p
15 watt wire wound	10p

### RESISTORS

5K or 500K	3p
------------	----

### SKELETON PRESETS

Standard size, 10 for 4p	
--------------------------	--

### SAFETY PINS

Standard size, 10 for 4p	
--------------------------	--

### THORN PTO2E 10-6s CHASSIS SOCKET 40p

5K switched volume control	15p
5K Log Pot	10p
1meg Tandem Pot	15p

### THERMISTORS

VA1040	
VA1055	
VA1066	10p each
VA1077	
VA1100	

### STEEL BOX WITH LID

10 x 5 1/2 x 3" grey hammer finish	£1
------------------------------------	----

### RELAYS

6 volt, 2 pole c/o heavy duty contacts	50p
Mains 3 pole c/o heavy duty contacts	
ex equipment	35p

### ELECTROLYTICS

Mullard C426, TCC, CRL, CCL, HUNTS, STC SUB MINIATURE, ETC.

MFD	Volt	MFD	Volt	
16	50	20	12	4p each
260	12	500	6	
50	50	100	25	2p each
100	18	100	6	
125	10	6	3	3p
8	50	8	6	
12	20	25	6.4	7p
10	20	250	18	
8.2	20	400	16	6p
50	25	400	40	
2.5	64	8	500	10p
25	25	100	200	

### CONDENSERS

MFD	Volt	
0.005	500	2p each
0.001	1,250	
3.3PF	500	2p each
500 PF	500	
1000 PF	500	3p each
2,200PF	500	
3,300PF	500	3p each
0.1	350	
0.1	500	3p each
0.25	150	
0.03	350	3p each
0.13	350	
0.056		5%
0.061		
0.066		350V
0.069		
0.075		4p each
0.08		
0.1	1,500	4p each
0.25	350	

### TUNING GANG

100PF, 50PF, 33PF 20p each

### TRIMMERS

30PF Beehive	10p each
12PF P.T.F.E.	
2,500PF 750V	
33PF MIN. AIR SPACE	

0.5	350	5p
0.22	250	5p
0.25	500	5p
1MFD	350 volt	10p
5MFD	150 volt	40p
10MFD	150 volt	50p
0.03	12 volt	2p
470PF	500 volt	2p
8MFD	800 volt electrolytic	75p

### WIREWOUND POTS

250, 300 OHM, 1K, 4 watt, 10K, 20K, 50K, all at 10p each

### RECORD PLAYER CARTRIDGE

ER.5XME Mono, with turn over styli, single hole fixing 35p

### GREEN INDICATOR

Takes M.E.S bulb 10p

### CONNECTOR STRIP

Belling Lee L1469, 12 way polythene. 5p each

### CAN CLIPS

1" or 1 3/8" or 3/4" 2p

### T.O.5 HEATSINKS

Style 154 high conductivity 5p

### PAXOLINE

3 x 2 1/2 x 1 1/8" 2p

4 5/8 x 1/2 x 1 1/8" 2 for 1p

220K 3 watt resistors 2p

VALVE RETAINER CLIP, adjustable 2p

### OUTPUT TRANSFORMERS

Sub-miniature Transistor Type 20p

3 pin din to open end, 1 1/2yd twin screened lead 35p

10 mtrs loudspeaker extension lead fitted 2 pin din plug and socket 40p (retail 70p)

# THE RADIO SHACK

161 ST. JOHNS HILL, BATTERSEA, LONDON S.W.11

Open 10 a.m. till 7 p.m. Monday to Saturday

Phone 01-223 5016



### SEMICONDUCTORS

Full spec. marked by Mullard, etc. Many other types in stock

AC127 .. 10p	BC149 .. 8p	BFX30 .. 25p
AC187/8 .. 14p	BC157 .. 12p	BFX88 .. 20p
AD149 .. 35p	BC158 .. 8p	BSV64 .. 40p
AD161 .. 27p	BC159 .. 12p	BU105/01 .. £1.75
AD162 .. 27p	BCY40 .. 25p	OC35 .. 28p
Matched pair .. 50p	BCY70 .. 14p	2N706 .. 8p
AF116 .. 12p	BCY71 .. 18p	2N2219 .. 19p
AF117 .. 12p	BD131 .. 40p	2N2401 (ASY26-27) 15p
AF139 .. 28p	BD132 .. 50p	2N2904 .. 17p
AF178 .. 40p	BD135 .. 26p	2N2905 .. 21p
AF180 .. 45p	BF115 .. 23p	2N2906 .. 15p
AF239 .. 30p	BF179 .. 30p	2N2907 .. 18p
BC107/8/9 .. 7p	BFY51 .. 10p	2N3055 .. 35p
BC147 .. 8p	BFY52 .. 12p	2N3053 .. 15p
BC148 .. 8p	BFX29 .. 25p	

### BRIDGE RECTIFIERS

Amp	Volt		Amp	Volt	
1	1,600	BYX10 .. 30p	2	30	LT120 .. 30p
1	140	OSH01-200 .. 30p	0.6	6-110	EC433
1.4	42	BY164 .. 35p	Encapsulated with built-in heat sink .. 15p		
Plastic types					

### 1 AMP RECTIFIERS

IN4002	100 volt	4p
IN4003	200 volt	5p
IN4004	400 volt	7p
IN4005	600 volt	9p
IN4006	800 volt	10p
IN4007	1,000 volt	15p

### HIGH POWER RECTIFIERS

	Amp	Volt	
BYX38-600	2.5	600	25p
BYX38-300	2.5	300	20p
BYX38-900	2.5	900	28p
BYX38-1200	2.5	1,200	30p
BYX49-600	2.5	600	25p
BYX49-300	2.5	300	20p
BYX49-900	2.5	900	28p
BYX48-300	6	300	27p
BYX48-600	6	600	32p
BYX48-900	6	900	40p
BYX48-1200	6	1,200	60p
BYX72-150R	10	150	24p
BYX72-300R	10	300	35p
BYX72-500R	10	500	43p
BYX42-300	10	300	40p
BYX42-600	10	600	45p
BYX42-900	10	900	55p
BYX42-1200	10	1,200	75p
BYX46-300*	15	300	2.50
BYX46-400*	15	400	£2.90
BYX46-500*	15	500	£3.20
BYX46-600*	15	600	£3.80
BYX20-200	25	200	35p
BYX52-300	40	300	£1.75
BYX52-1200	40	1,200	£2.25

\*Avalanche type

N50 ohm free plug (UG21D/U)	50p
N50 ohm square socket (UG58A/U)	50p
1" Terryclips black plastic coated, or chrome finish	4p
Cinch 10-way terminal block	15p
Pair of LA2407 Ferroxc cores with adjuster	25p
Chrome Car Radio fascia	15p
Rubber Car Radio gasket	10p
DLI Pal Delayline	£2.00
Relay socket	12p
Take miniature 2PCO relay	
B9A valve can	2p
0-30 in .5 segments, black pvc, 360° dial, silver digits, self adhesive, 4 1/2" dia.	15p

### OPTO ELECTRONICS

ORP12	43p	Photo transistor	
BPX40	25p	BPX29	80p
BPX42	£1	OCP71	30p
BPY10	75p		
BPY68	75p		
BPY69	£1		
BPY77	75p		
Diodes		CQ11B	£4
		Infra red transmitter	

### F.E.T.'s

BFW10	40p	
BSV79	90p	
BSV80	80p	
N. Channel		
BSV81 M.O.S.T.	£1	
BFS28 Dual M.O.S.T.	90p	
Plastic, Transistor or Diode Holder		1p
Transistor or Diode Pad		1p

Phillips Iron Thermostat	15p
Bulgin 2-pin flat plug and socket	10p
McMurdo PP108 8 way edge plug	15p
300 ohm moving coil insert 4103D 1 3/4" diameter. Make ideal mike or speaker for communication work	25p

### TESTED UNMARKED OR MARKED AMPL LEAD EX NEW EQUIPMENT

AC128	6p	OC44	6p
ACY17-20	8p	OC71	6p
BCY70/1/2	8p	OC72	6p
BCY30-34	10p	OC200-5	6p
BY127	8p	2N2926	5p
BZY88 series	6p	Germanium diode	3p
OA5/7/10	10p	GET111	20p
OA47/81	4p	GET120	
OA200-5	6p	(AC128 In 1"sq. heat sink)	20p
OC23	20p		
OC29	25p		

### THYRISTORS

Amp	Volt		
1	240	BTX18-200	30p
1	240	BTX30-200	30p
5.6	700	BT106	85p
6.5	300	BT102-300R	42p
6.5	500	BT102-500R	60p
6.5	500	BT107	90p
6.5	500	BT108	90p
6.5	500	BT101-500R	68p
6.5	500	BT109-500R	90p
20	600	BTW92-600RM	£3.00
15	800	BTX95-800R Pulse Modulated	£12

### OTHER DIODES

Centercel	5p
IN916	6p
BA145	14p

### TRIACS

Amp	Volt		
6	400	BT110-400 Plastic	75p
25	900	BTX94-900	£6.50
25	1200	BTX94-1200	£9

DIAC BR100	30p	WESTINGHOUSE 28TIO 30 AMP1000VOLT THYRISTER WITHOUT NUT	£5
------------	-----	---	----

PHOTO SILICON CONTROLLED SWITCH BPX66 PNP 10 amp	£1
--	----

### PAPER BLOCK CONDENSER

0.25MFD	800 volt	30p
1MFD	400 volt	15p
2MFD	250 volt	20p
2MFD	1.5 kv	50p
15MFD	150 volt	25p

### WIREWOUND SLIDER

150 Ohm, 250 Ohm 5K 4p each

### INDICATORS

12 volt red or mains neon amber, push fit round, chrome bezel 15p each

Rotor with neon indicator, as used in Seafarer, Pacific, Fairway depth finders 20p each

100MFD 250/275V electrolytic can 20p

### DEE PLUG

McMurdo DA15P 15 way chassis plug 20p

Fairway 18009 Coax. socket 5p

### TIE CLIPS

Nylon self locking 3 1/2" 1p; 7" 2p

### CINCH 150

12 way edge socket 10p

BELLING LEE L1354 TV Aerial diplexer 10p

SMALL ORDERS, ENCLOSE SUITABLE STAMPED ADDRESSED ENVELOPE

LARGE ORDERS, ADD SUFFICIENT FOR POSTAGE, INSURANCE, ETC.

TOTAL GOODS PLUS CARRIAGE, ADD 10% V.A.T.

# THE RADIO SHACK

161 ST. JOHNS HILL, BATTERSEA, LONDON S.W.11

Open 10 a.m. till 7 p.m. Monday to Saturday

Phone 01-223 5016

# DENCO (CLACTON) LIMITED

## 355-7-9 OLD ROAD, CLACTON-ON-SEA, ESSEX

Our components are chosen by Technical Authors and Constructors throughout the World for their performance and reliability, every coil being inspected twice plus a final test and near spot-on alignment as a final check.

Our General Catalogue showing full product range	..	20p
DTB4 Transistor & Valve circuitry for D.P. Coils	..	20p
DTB9 Valve Type Coil Pack Application circuitry	..	20p
MD.1 Decoder Circuitry for Stereo Reception	..	21p

All post paid, but please enclose S.A.E. with all other requests in the interests of retaining lowest possible prices to actual consumers

# Give us six months, and we'll turn your hobby into a career.

You have a hobby for a very good reason. It gives you a lot of pleasure.

So if you can find a job that involves your hobby, chances are you'll enjoy your work more, and you'll do better work.

Now CDI can help you find such a job. A job where you'll be responsible for the maintenance of a computer installation. A job that pays well too. If you're interested in mechanics or electronics (without necessarily being a

mathematical genius), have a clear, logical mind and a will to work, then we can train you to be a Computer Engineer inside six months.

So give us a call. CDI. We're the Training Division of one of the world's largest computer manufacturers. And we have the experience to know if you can make it. A ten minute talk with us, and you could be on the way to spending the rest of your life with your hobby.

Ring  
**01-637 2171**

between 9 a.m. and 9 p.m. and ask for Mr. REECE

It's quicker and easier to phone, but if you prefer, send this coupon to: Control Data Institute, Wells House, 77 Wells Street, London, W.1.  
*Please give me further information.*

Name

Address

Age

Phone

RCB

CONTROL DATA  
INSTITUTE

CONTROL DATA  
LIMITED

The Training Division of one of the world's  
largest Computer manufacturers.

RADIO & ELECTRONICS CONSTRUCTOR



# THIS IS THE FIRST PAGE OF THE GREAT BI-PAK SECTION

## BRAND NEW FULLY GUARANTEED DEVICES

AC 107	22p	AD 149	55p	BC 143	33p	BD 131	55p	BF 179	33p	C 444	38p	2G 301	21p	2N 1613	22p	2N 2926(R)	11p	2N 3906	30p
AC 113	22p	AD 161	36p	BC 145	49p	BD 132	66p	BF 180	33p	C 450	24p	2G 302	21p	2N 1711	22p	2N 2926(B)	11p	2N 4058	13p
AC 115	25p	AD 162	36p	BC 147	11p	BD 133	71p	BF 181	33p	MAT 100	21p	2G 303	21p	2N 1889	35p	2N 3010	15p	2N 4060	11p
AC 117K	22p	AD 161 and	60p	BC 148	11p	BD 135	44p	BF 182	44p	MAT 101	22p	2G 304	26p	2N 1890	49p	2N 3011	15p	2N 4061	13p
AC 122	13p	AD 162(MP)	60p	BC 149	13p	BD 136	44p	BF 183	44p	MAT 120	21p	2G 306	44p	2N 1893	40p	2N 3053	18p	2N 4062	13p
AC 125	18p	ADT 140	55p	BC 151	22p	BD 138	55p	BF 184	27p	MAT 121	22p	2G 308	38p	2N 1947	26p	2N 3054	50p	2N 4284	18p
AC 126	18p	AF 114	26p	BC 152	13p	BD 139	60p	BF 185	30p	MPF 102	46p	2G 309	38p	2N 1949	38p	2N 3055	55p	2N 4285	18p
AC 127	18p	AF 115	26p	BC 153	31p	BD 140	66p	BF 186	33p	MPF 104	40p	2G 319	22p	2N 1994	38p	2N 3056	15p	2N 4286	18p
AC 128	18p	AF 116	26p	BC 154	33p	BD 140	66p	BF 187	33p	MPF 105	40p	2G 339A	17p	2N 1994	38p	2N 3057	15p	2N 4287	18p
AC 132	15p	AF 117	26p	BC 154	20p	BD 140	66p	BF 188	33p	OC 19	38p	2G 344	20p	2N 2217	24p	2N 3058	15p	2N 4288	18p
AC 134	15p	AF 118	38p	BC 157	20p	BD 145	66p	BF 196	15p	OC 20	69p	2G 345	20p	2N 2218	22p	2N 3059	18p	2N 4290	18p
AC 137	15p	AF 124	33p	BC 158	13p	BD 176	66p	BF 197	15p	OC 22	42p	2G 371	17p	2N 2219	22p	2N 3060	23p	2N 4291	18p
AC 141	15p	AF 125	27p	BC 159	13p	BD 177	71p	BF 200	49p	OC 23	46p	2G 371B	18p	2N 2220	24p	2N 3063	23p	2N 4292	18p
AC 141K	18p	AF 126	31p	BC 160	49p	BD 178	71p	BF 202	£1.04	OC 24	61p	2G 373	18p	2N 2221	22p	2N 3064	31p	2N 4293	18p
AC 142	15p	AF 127	31p	BC 161	55p	BD 179	77p	BF 257	49p	OC 25	42p	2G 374	18p	2N 2222	22p	2N 3065	46p	2N 5172	13p
AC 142K	18p	AF 127	31p	BC 161	13p	BD 180	77p	BF 258	66p	OC 26	27p	2G 377	33p	2N 2228	18p	2N 3414	16p	2N 5457	35p
AC 142L	18p	AF 127	31p	BC 161	13p	BD 180	77p	BF 258	66p	OC 26	27p	2G 377	33p	2N 2228	18p	2N 3414	16p	2N 5457	35p
AC 142K	18p	AF 127	31p	BC 161	13p	BD 180	77p	BF 258	66p	OC 26	27p	2G 377	33p	2N 2228	18p	2N 3414	16p	2N 5457	35p
AC 151	16p	AF 178	55p	BC 168	13p	BD 185	71p	BF 259	93p	OC 28	55p	2G 378	17p	2N 2369	15p	2N 3415	16p	2N 5458	35p
AC 154	22p	AF 179	55p	BC 169	13p	BD 186	71p	BF 263	60p	OC 29	55p	2G 381	17p	2N 2369A	15p	2N 3416	16p	2N 5459	35p
AC 155	22p	AF 180	55p	BC 170	13p	BD 187	77p	BF 270	60p	OC 35	46p	2G 382	17p	2N 2411	26p	2N 3417	31p	2N 5501	55p
AC 156	22p	AF 181	49p	BC 171	15p	BD 188	77p	BF 270	60p	OC 36	55p	2G 401	33p	2N 2412	26p	2N 3525	32p	2N 502A	46p
AC 172	26p	AF 186	49p	BC 172	15p	BD 189	82p	BF 271	33p	OC 41	22p	2G 414	33p	2N 2646	51p	2N 3646	10p	2N 5322	46p
AC 165	22p	AF 239	40p	BC 173	15p	BD 190	82p	BF 272	88p	OC 42	26p	2G 417	27p	2N 2711	23p	2N 3702	11p	2N 5303	60p
AC 166	22p	AF 239	40p	BC 173	15p	BD 190	82p	BF 272	88p	OC 42	26p	2G 417	27p	2N 2711	23p	2N 3702	11p	2N 5303	60p
AC 167	22p	AL 103	71p	BC 175	24p	BD 195	93p	BF 273	38p	OC 44	16p	2N 388	38p	2N 2712	23p	2N 3703	11p	2N 5304	77p
AC 168	26p	ASV 26	27p	BC 177	21p	BD 196	93p	BF 274	38p	OC 45	14p	2N 388A	60p	2N 2714	23p	2N 3704	12p	2N 5305	92p
AC 169	26p	ASV 27	27p	BC 178	21p	BD 198	99p	BF 275	30p	OC 71	11p	2N 404	22p	2N 2904A	23p	2N 3706	10p	2N 5307	92p
AC 176	22p	ASV 28	27p	BC 179	21p	BD 199	£1.04	BF 276	24p	OC 72	15p	2N 524	46p	2N 2905	23p	2N 3707	12p	2N 5321	61p
AC 177	26p	ASV 29	27p	BC 180	26p	BD 200	£1.04	BF 277	24p	OC 74	15p	2N 527	54p	2N 2905A	23p	2N 3708	7p	2N 5322	46p
AC 178	31p	ASV 30	27p	BC 181	26p	BD 205	88p	BF 278	24p	OC 75	16p	2N 598	46p	2N 2906	16p	2N 3709	10p	2N 5322A	46p
AC 179	31p	ASV 31	27p	BC 182	11p	BD 206	88p	BF 279	24p	OC 76	16p	2N 599	49p	2N 2906A	20p	2N 3710	10p	2N 5323	61p
AC 180	18p	ASV 32	27p	BC 182L	11p	BD 207	£1.04	BF 280	24p	OC 77	14p	2N 696	14p	2N 2907	24p	2N 3711	10p	2N 5324	77p
AC 180K	22p	ASV 34	27p	BC 183	11p	BD 208	£1.04	BF 50	22p	OC 81	16p	2N 697	14p	2N 2907A	24p	2N 3819	31p	2N 5325	77p
AC 181	18p	ASV 35	27p	BC 183L	11p	BDY 20	£1.10	BFY 51	22p	OC 81D	16p	2N 698	26p	2N 2923	15p	2N 3820	55p	2N 5326	77p
AC 181K	22p	ASV 36	27p	BC 184	13p	BF 115	26p	BFY 52	22p	OC 82	16p	2N 699	38p	2N 2924	15p	2N 3821	38p	2N 5327	77p
AC 187	24p	ASV 37	27p	BC 184L	13p	BF 117	49p	BFY 53	18p	OC 82D	16p	2N 706	9p	2N 2925	15p	2N 3823	31p	2N 5327	46p
AC 187K	24p	ASV 38	27p	BC 185	31p	BF 118	77p	BPX 25	93p	OC 83	22p	2N 706A	10p	2N 2926	14p	2N 3824	31p	40361	44p
AC 188	24p	ASZ 21	44p	BC 187	31p	BF 119	77p	BPX 19	16p	OC 84	22p	2N 708	10p	2N 2926(Y)	17p	2N 3904	33p	40362	44p
AC 188K	22p	BC 107	10p	BC 207	12p	BF 121	49p	BSX 20	16p	OC 139	22p	2N 711	33p	2N 2926(O)	11p	2N 3905	31p		
AC 197	27p	BC 108	10p	BC 208	12p	BF 123	55p	BSY 25	16p	OC 140	22p	2N 717	38p						
AC 198	22p	BC 109	11p	BC 209	13p	BF 125	49p	BSY 26	16p	OC 169	27p	2N 718	26p						
AC 199	22p	BC 110	11p	BC 210	12p	BF 127	55p	BSY 27	16p	OC 170	27p	2N 718A	55p	AA 119	9p	BY 130	17p	OA 47	7p
AC 200	22p	BC 114	11p	BC 212L	12p	BF 152	60p	BSY 28	16p	OC 171	27p	2N 726	31p	AA 120	9p	BY 133	23p	OA 70	7p
AC 201	22p	BC 115	16p	BC 214L	12p	BF 153	49p	BSY 29	16p	OC 200	27p	2N 727	21p	AA 129	9p	BY 164	55p	OA 75	7p
AC 202	17p	BC 116	16p	BC 225	27p	BF 154	49p	BSY 30	16p	OC 201	31p	2N 743	22p	AA 130	10p	BY 38.30	46p	OA 81	7p
AC 203	19p	BC 117	16p	BC 226	38p	BF 155	77p	BSY 31	20p	OC 202	31p	2N 744	22p	AA 131	11p	BY 210	38p	OA 89	10p
AC 204	21p	BC 118	11p	BCY 30	26p	BF 156	53p	BSY 40	31p	OC 203	27p	2N 914	15p	BA 100	11p	BYZ 11	33p	OA 90	61p
AC 205	21p	BC 119	38p	BCY 31	28p	BF 157	60p	BSY 41	31p	OC 204	38p	2N 918	33p	BA 116	23p	BYZ 12	33p	OA 91	61p
AC 206	21p	BC 120	88p	BCY 32	34p	BF 158	60p	BSY 95	14p	OC 205	38p	2N 929	23p	BA 126	24p	BYZ 13	27p	OA 95	7p
AC 207	31p	BC 125	13p	BCY 33	34p	BF 159	66p	BSY 95A	14p	OC 209	47p	2N 930	23p	BA 148	15p	BYZ 16	44p	OA 200	61p
AC 208	31p	BC 126	20p	BCY 34	27p	BF 160	44p	Bu 105	£2.20	P 366A	47p	2N 1131	24p	BA 154	13p	BYZ 17	36p	OA 202	71p
AC 209	31p	BC 126	20p	BCY 34	27p	BF 160	44p	Bu 105	£2.20	P 366A	47p	2N 1131	24p	BA 155	15p	BYZ 18	38p	SD 10	51p
AC 210	31p	BC 132	13p	BCY 70	15p	BF 162	44p	C 400	33p	OC 37	44p	2N 1302	15p	BA 156	14p	BYZ 19	31p	SD 19	51p
AC 211	31p	BC 135	13p	BCY 72	15p	BF 164	44p	C 407	27p	ORP 12	44p	2N 1303	15p	BA 157	14p	BYZ 20	31p	IN 34	7p
AC 212	31p	BC 136	16p	BCZ 10	22p	BF 165	44p	C 424	22p	ORP 60	46p	2N 1305	18p	BA 158	15p	BYZ 21	31p	IN 34A	7p
AC 213	31p	BC 137	16p	BCZ 11	27p	BF 167	24p	C 425	38p	ORP 61	46p	2N 1306	14p	BA 159	15p	BYZ 22	31p	IN 91A	61p
AC 214	31p	BC 139	44p	BCZ 12	27p	BF 173	24p	C 426	38p	ST 140	14p	2N 1307	18p	BA 159	15p	BYZ 23	31p	IN 91B	61p
AD 140	53p	BC 140	33p	BD 121	66p	BF 176	38p	C 428	22p	ST 141	33p	2N 1308	25p	BA 159	15p	BYZ 24	31p	IN 91C	61p
AD 142	53p	BC 141	33p	BD 123	71p	BF 177	38p	C 441	33p	TIS 43	33p	2N 1309	25p	BA 159	15p	BYZ 25	31p	IN 91D	11p
AD 143	42p	BC 142	33p	BD 124	66p	BF 178	38p	C 442	33p	UT 46	30p								

## DIODES & RECTIFIERS

AA 119	9p	BY 130	17p	OA 47	7p
AA 120	9p	BY 133	23p	OA 70	7p
AA 129	9p	BY 164	55p	OA 75	7p
AA 130	10p	BY 38.30	46p	OA 81	7p
AA 131	11p	BY 210	38p	OA 89	10p
BA 100	11p	BYZ 11	33p	OA 90	61p
BA 116	23p	BYZ 12	33p	OA 91	61p
BA 126	24p	BYZ 13	27p	OA 95	7p
BA 148	15p	BYZ 16	44p	OA 200	61p
BA 154	13p	BYZ 17	36p	OA 202	71p
BA 155	15p	BYZ 18	38p		



# The largest selection

## NEW LOW PRICE TESTED S.C.R.'S.

PIV	1A	3A	5A	5A	7A	10A	15A	20A
TO3	TO6	TO66	TO61	TO34	TO34	TO34	TO34	TO34
Each	Each	Each	Each	Each	Each	Each	Each	Each
30	0.23	0.27	0.38	0.38	0.51	0.55	0.58	1.26
100	0.27	0.36	0.51	0.51	0.55	0.64	0.69	1.54
200	0.38	0.40	0.54	0.54	0.62	0.67	0.82	1.76
400	0.47	0.51	0.61	0.61	0.73	0.82	1.02	1.92
600	0.58	0.62	0.75	0.75	0.84	1.06	1.37	
800	0.69	0.77	0.88	0.88	0.99	1.32	1.65	4.40

## SILICON RECTIFIERS—TESTED.

PIV	200mA	750mA	1A	1.5A	3A	10A	30A
(DO T)	(SO 15)	(SO 16)	(SO 16)	(SO 10)	(SO 10)	(SO 10)	(SO 30A)
£	£	£	£	£	£	£	£
50	0.04	0.05	0.05	0.07	0.15	0.23	0.66
100	0.04	0.06	0.05	0.14	0.17	0.25	0.82
200	0.05	0.10	0.06	0.15	0.22	0.26	1.10
400	0.06	0.14	0.07	0.22	0.30	0.40	1.37
600	0.07	0.17	0.11	0.25	0.37	0.49	2.04
800	0.11	0.18	0.12	0.27	0.40	0.60	2.20
1000	0.12	0.27	0.15	0.33	0.50	0.89	2.75
1200	—	0.36	—	0.42	0.62	0.82	—

## TRIACS

V <sub>BO</sub> M <sub>A</sub>	4A	10A	
TO6	TO66	TO48	
2p	2p	2p	
100	0.33	0.55	0.77
200	0.55	0.66	0.82
400	0.82	0.99	1.21

## DIACS

FOR USE WITH TRIACS	BR100	(D32)	40p	each
---------------------	-------	-------	-----	------

## FREE

One 50p Pak of your own choice free with orders valued \$4 or over.

## BRAND NEW TEXAS GERM. TRANSISTORS

Pak No.	EQVT
T1	8 243713 OC71
T2	8 11374 OC76
T3	8 11216 OC1D
T4	8 24381T OC81
T5	8 24382T OC92
T6	8 24384B OC44
T7	8 24345R OC45
T8	8 20378 OC78
T9	8 20399A 2N1302
T10	8 20417 2N117

All 55p each pak

2N2060 NPN SIL. DUAL TRANS. CODE D1699 TEXAS. Our price 27p each.

120VCB NIXIE DRIVER TRANSISTOR. Sim. BSX21 & CA07. 2N1899 FULLY TESTED AND CODED ND. 120. 1-24 18p each. TO-5 NPN. 25 up 16p each. 100 up 15p each.

Sil. trans. suitable for P.E. Organ. Metal TO-18. Eqvt. ZTX300 p6 each. Any Qty.

## POWER TRANS BONANZA!

GENERAL PURPOSE GERM. PNP Coded Q100. BRAND NEW TO-3 CASE. POS8. REPLACE.—OC29-29-30-35-36. NKT 401-403-404-406-408-430-451-482-483. T1027-3028. 2N250A. 2N456A-457A-458A. 2N811 A & B. 2N220-222. ETC. VCB0 80V VCB0 50V IC 10A FT. 30 WATTS Rte 30-170.

PRICE 1-24 25-99 100 up  
52p each 44p each 41p each

SILICON High Voltage 800V NPN TO-3 case. O.P. Switching & Amplifier Applications. Brand new Coded R 2400 VCB0 250V VCB0 100V 6A/30 Watts. RFE type 20/7 5MBZ.

OUR PRICE EACH: 1-24 25-99 100 up  
35p 50p 44p

## ADI61/ADI62 P.N.P.

M/P COMP GERM TRANS. OUR LOWEST PRICE OF 61p PER PAIR

## KING OF THE PAKS Unequaled Value and Quality

# SUPER PAKS NEW BI-PAK UNTESTED SEMICONDUCTORS

Satisfaction GUARANTEED in Every Pak, or money back.

Pak No.	£p	
U1	120 Glass Sub-Min. General Purpose Germanium Diodes	55p
U2	60 Mixed Germanium Transistors AF/RF	55p
U3	75 Germanium Gold Bonded Sub-Min. like OA5, OA47	55p
U4	40 Germanium Transistors like OC81, AC128	55p
U5	60 200mA Sub-Min. Silicon Diodes	55p
U6	30 Sil. Planar Trans. NPN like BSY95A, 2N706	55p
U7	16 Sil. Rectifiers Top-Hat 750mA Vltg. Range up to 1,000	55p
U8	50 Sil. Planar Diodes DO-7 Glass 250mA like OA200/202	55p
U9	20 Mixed Voltages. 1 Watt Zener Diodes	55p
U10	20 BA50 charge storage Diodes DO-7 Glass	55p
U11	25 PNP Sil. Planar Trans. TO-5 like 2N1132, 2N2904	55p
U12	12 Silicon Rectifiers Epoxy 500mA up to 800 PIV	55p
U13	30 PNP-NPN Sil. Transistors OC200 and 2S 104	55p
U14	150 Mixed Silicon and Germanium Diodes	55p
U15	25 NPN Sil. Planar Trans. TO-5 like BFY51, 2N697	55p
U16	10-3Amp Silicon Rectifiers Stud Type up to 1,000 PIV	55p
U17	30 Germanium PNP AF Transistors TO-5 like ACY 17-22	55p
U18	8 6Amp Silicon Rectifiers BVZ13 Type up to 600 PIV	55p
U19	25 Silicon NPN Transistors like BC108	55p
U20	12 1.5Amp Silicon Rectifiers Top-Hat up to 1,000 PIV	55p
U21	30 A.P. Germanium Alloy Transistors 2G300 Series & OCT1 55p	
U22	30 MADT's like MHz Series PNP Transistors	55p
U23	40 Germanium 1 Amp Rectifiers GJM Series up to 300 PIV	55p
U25	25 300 MHz NPN Silicon Transistors 2N708, BSY27	55p
U26	30 Fast Switching Silicon Diodes like IN914 Micro-Min.	55p
U27	12 NPN Germanium AF Transistors TO-1 like AC127	55p
U29	10 1Amp SCR's TO-5 can. up to 600 PIV CRS1/25-600	£1.10
U30	15 Plastic Silicon Planar Trans. NPN 2N2926	55p
U31	20 Sil. Planar Plastic NPN Trans. Low Noise Amp 2N3707	55p
U32	25 Zener Diodes 400mV DO-7 case 3-18 volts mixed	55p
U33	15 Plastic Case 1 Amp Silicon Rectifiers IN4000 Series	55p
U34	30 Silicon PNP Alloy Trans. TO-5 BCY26 2S3024	55p
U35	25 Silicon Planar Transistors PNP TO-18 2N2006	55p
U36	25 Silicon Planar NPN Transistors TO-5 BFY50/51/52	55p
U37	30 Silicon Alloy Transistors SO-2 PNP OC200, 2S322	55p
U38	20 Fast Switching Silicon Trans. NPN 400 MHz 2N3011	55p
U39	30 RF. Germ. PNP Transistors 2N1303/5 TO-5	55p
U40	10 Dual Transistors 6 lead TO-5 2N2060	55p
U41	25 RF Germanium Transistors TO-5, OC45, NKT72	55p
U42	10 VHF Germanium PNP Transistors TO-1 NKT667, AP117	55p
U43	25 Sil. Trans. Plastic TO-18 A.F. BC113/114	55p
U44	20 Sil. Trans. Plastic TO-5 BC115/116	55p
U45	7 3A SCR. TO66 up to 600 PIV	£1.10

Code Nos. mentioned above are given as a guide to the type of device in the Pak. The devices themselves are normally unmarked.

SILICON PHOTO TRANSISTOR. TO-18. Lens end NPN. Min. to BP 25 and 50. BRAND NEW. Full data available. Fully guaranteed. Qty. 1-24 25-99 100 up  
Price each 50p 44p 27p

F.E.T.'S  
2N3819 31p  
2N3820 55p  
2N3821 31p  
2N3823 31p  
2N5458 35p  
2N5459 44p  
BFW 10 66p  
MPF105 40p

NEW EDITION 1971 TRANSISTOR EQUIVALENTS BOOK. A complete cross reference and equivalent book for European, American and Japanese Transistors. Exclusive to BI-PAK 99p each. Red cover edition.

A LARGE RANGE OF TECHNICAL AND DATA BOOKS ARE NOW AVAILABLE. EX. STOCK. SEND FOR FREE LIST.

VCBO 100V VCB0 50V IC 10A. RFE type 100/18 5MBZ. OUR PRICE PER PAIR: 1-24 25-99 100 up  
66p 60p 55p

## QUALITY TESTED SEMICONDUCTORS

Pack Description	Price £p	
Q1	20 Red spot transistors PNP	55p
Q2	16 White spot R.F. transistors PNP	55p
Q3	4 OC 77 type transistors	55p
Q4	6 Matched transistors OC44/45/81/81D	55p
Q5	4 OC 75 transistors	55p
Q6	5 OC 72 transistors	55p
Q7	4 AC 128 transistors PNP high grain	55p
Q8	4 AC 126 transistors PNP	55p
Q9	7 OC 81 type transistors	55p
Q10	7 OC 71 type transistors	55p
Q11	2 AC 127/128 Comp. pairs PNP/NPN	55p
Q12	3 AF 116 type transistors	55p
Q13	3 AF 117 type transistors	55p
Q14	3 OC 171 R.F. type transistors	55p
Q15	7 2N2928 type. Epoxy trans. and colours	55p
Q16	2 GET890 low noise Germ. trans.	55p
Q17	5 NPN 2 x ST.141 and 3 x ST.140	55p
Q18	4 MADT 2 x MAT 100 & 2 x MAT 120	55p
Q19	3 MADT's 2 x MAT 101 & 1 x MAT 121	55p
Q20	4 OC 44 Germanium transistors A.F.	55p
Q21	4 AC 127 NPN Germanium transistors	55p
Q22	20 NKT transistors A.F. R.F. coded	55p
Q23	10 OA 202 Silicon diodes sub-min.	55p
Q24	8 OA 8 diodes	55p
Q25	15 IN914 Silicon diodes 75PIV 75mA	55p
Q26	8 OA95 Germanium diodes sub-min	55p
Q27	2 10A 600 PIV Sil. rectifiers U5425R	55p
Q28	2 Silicon power rectifiers BYZ 13	55p
Q29	2 Silicon trans. 2 x 2N696, 1 x 2N697, 1 x 2N698	55p
Q30	7 Sil. switch transistors 2N706 NPN	55p
Q31	6 Sil. switch transistors 2N708 NPN	55p
Q32	3 PNP Sil. trans. 2x2N1131, 1x2N1132	55p
Q33	3 Silicon NPN transistors 2N171	55p
Q34	7 Sil. NPN trans. 2N2969, 500MHz (code P397)	55p
Q35	3 Sil. PNP TO-5, 2x2N2904 & 1x2N2905	55p
Q36	7 2N3846 type. 18 plastic 300 MHz NPN	55p
Q37	3 2N3853 NPN transistors	55p
Q38	7 PNP trans. 4 x 2N3703, 3 x 2N3702	55p
Q39	7 NPN trans. 4 x 2N3704, 3 x 2N3705	55p
Q40	7 NPN trans. 4x 2N3707, 3 x 2N3708	55p
Q41	1 Plastic NPN TO-18 2N3804	55p
Q42	6 NPN transistors 2N5172	55p
Q43	7 BC 107 NPN transistors	55p
Q44	7 NPN trans. 4 x BC 108, 3 x BC 109	55p
Q45	8 BC 113 NPN TO-18 transistors	£1.10
Q46	3 BC 115 NPN TO-5 transistors	55p
Q47	6 NPN high grain trans. 3 x BC167, 3 x BC168	55p
Q48	4 BCY 70 PNP transistors TO-18	55p
Q49	4 NPN trans. 2 x BFY61, 2 x BFY62	55p
Q50	7 BSY 28 NPN switch trans. TO-18	55p
Q51	7 BSY 85A NPN trans. 300MHz	55p
Q52	2 BCY 80 type silicon rectifiers	£1.10
Q53	25 Sil. & germ. trans. md all mkt new £1.65	

## ELECTRONIC SLIDE-RULE

The MK Slide Rule, designed to simplify electronic calculations features the following scales:—  
• Conversion of Frequency and Wavelength. Calculation of L, C and f of tuned circuits. Reactance and self inductance. Area of circles. Volume of cylinders. Resistance of conductors. Weight of conductors. Decibel calculations. Angle functions. Natural Logs. & 'e' functions. Multiplication & Division. Squaring, cubing and square roots. Conversion of kW and Hp.  
A must for every electronic engineer and enthusiast. Size 22cm x 4cm. Complete with case and instructions. PRICE EACH: £3.68!

## DTL & TTL INTEGRATED CIRCUITS

### INTEGRATED CIRCUIT PAKS

Manufacturers "Fall Outs" which include Functional and part Functional Units. These are classed as "out-of-spec" from the maker's very rigid specifications, but are ideal for learning about I.C.'s and experimental work.

Pak No.	Contents	Price	Pak No.	Contents	Price	Pak No.	Contents	Price
UIC00	12 x 7400	55p	UIC46	5 x 7446	65p	UIC86	5 x 7486	55p
UIC01	12 x 7401	55p	UIC47	5 x 7447	55p	UIC87	5 x 7487	55p
UIC02	12 x 7402	55p	UIC48	5 x 7448	55p	UIC91	5 x 7491	55p
UIC03	12 x 7403	55p	UIC50	12 x 7450	55p	UIC92	5 x 7492	55p
UIC04	12 x 7404	55p	UIC51	5 x 7451	55p	UIC93	5 x 7493	55p
UIC05	12 x 7405	55p	UIC52	12 x 7452	55p	UIC94	5 x 7494	55p
UIC06	8 x 7406	55p	UIC54	12 x 7454	55p	UIC95	5 x 7495	55p
UIC07	8 x 7407	55p	UIC60	12 x 7460	55p	UIC96	5 x 7496	55p
UIC10	12 x 7410	55p	UIC70	8 x 7470	55p	UIC98	5 x 7498	55p
UIC13	12 x 7413	55p	UIC72	8 x 7472	55p	UIC121	5 x 74121	55p
UIC20	12 x 7420	55p	UIC73	8 x 7473	55p	UIC141	5 x 74141	55p
UIC30	12 x 7430	55p	UIC74	8 x 7474	55p	UIC151	5 x 74151	55p
UIC40	12 x 7440	55p	UIC75	8 x 7475	55p	UIC154	5 x 74154	55p
UIC41	5 x 7441	55p	UIC76	8 x 7476	55p	UIC193	5 x 74193	55p
UIC42	5 x 7442	55p	UIC80	5 x 7480	55p	UIC199	5 x 74199	55p
UIC43	5 x 7443	55p	UIC81	5 x 7481	55p	UIC X1	25 Asst.	
UIC44	5 x 7444	55p	UIC82	5 x 7482	55p			
UIC45	5 x 7445	55p	UIC83	5 x 7483	55p			

Paks cannot be split, but 25 assorted pieces (our mix) is available as PAK UIC X1.

BI-PAKS NEW COMPONENT SHOP NOW OPEN WITH A WIDE RANGE OF ELECTRONIC COMPONENTS AND ACCESSORIES AT COMPETITIVE PRICES 18, BALDOCK STREET (A10), WARE, HERTS. TEL: 61593. OPEN MON. - SAT. 9.15 a.m. to 6 p.m. FRIDAY UNTIL 8 p.m.

All Mail Orders please add 10p post and packing. Send all Orders to Bi-Pak P.O. Box 6, Ware, Herts.



# -the lowest prices!

## 74 Series T.T.L. I.C.'s

Bi-Pak Still Lowest in Price.  
Full Specification Guaranteed.  
All Famous Manufacturers.

	1	25	100 +		1	25	100 +
SN7400	0.16	0.15	0.13	SN7490	0.73	0.70	0.64
SN7401	0.16	0.15	0.13	SN7491	£1.10	£1.04	0.99
SN7402	0.16	0.15	0.13	SN7492	0.73	0.70	0.64
SN7403	0.16	0.15	0.13	SN7493	0.73	0.70	0.64
SN7404	0.16	0.15	0.13	SN7494	0.91	0.81	0.75
SN7405	0.16	0.15	0.13	SN7495	0.84	0.81	0.75
SN7406	0.26	0.24	0.21	SN7496	0.64	0.59	0.56
SN7407	0.26	0.24	0.21	SN74100	£1.11	£1.76	£1.71
SN7408	0.29	0.18	0.17	SN74104	£1.06	£1.03	0.97
SN7409	0.20	0.18	0.17				
SN7410	0.16	0.15	0.13	SN74105	£1.06	£1.03	0.97
SN7411	0.27	0.26	0.25	SN74107	0.11	0.12	0.39
SN7412	0.26	0.24	0.21	SN74109	£1.06	£1.03	0.97
				SN74110	0.30	0.28	0.25
SN7413	0.32	0.29	0.26	SN74111	£1.37	£1.26	£1.21
SN7414	0.47	0.44	0.42	SN74114	£1.10	£1.01	0.99
SN7415	0.47	0.44	0.42	SN74115	£1.09	£1.73	£1.21
SN7416	0.16	0.15	0.13	SN74116	0.44	0.40	0.37
SN7417	0.16	0.15	0.13				
SN7418	0.35	0.33	0.29	SN74122	£1.84	£1.63	£1.21
SN7419	0.55	0.53	0.49	SN74123	£3.04	£2.97	£2.86
SN7420	0.49	0.46	0.44	SN74141	0.73	0.70	0.64
SN7421	0.49	0.46	0.44	SN74145	£1.68	£1.34	£1.43
SN7422	0.49	0.46	0.44	SN74150	£3.30	£2.97	£2.75
SN7423	0.77	0.71	0.66	SN74151	£1.10	£1.04	0.99
SN7424	0.16	0.15	0.13	SN74152	£1.32	£1.21	£1.01
SN7425	0.49	0.46	0.44	SN74154	£1.98	£1.87	£1.76
SN7426	0.49	0.46	0.44				
SN7427	0.49	0.46	0.44				
SN7428	0.77	0.71	0.66	SN74155	£1.54	£1.43	£1.32
SN7429	0.16	0.15	0.13	SN74156	£1.54	£1.43	£1.32
SN7430	0.16	0.15	0.13	SN74157	£2.09	£1.98	£1.87
SN7431	0.73	0.70	0.64	SN74160	£1.98	£1.87	£1.76
SN7432	0.73	0.70	0.64	SN74161	£1.98	£1.87	£1.76
SN7442	£1.43	£1.37	£1.32	SN74182	£4.40	£4.12	£3.85
SN7443	£1.43	£1.37	£1.32	SN74183	£1.30	£1.23	£1.05
SN7444	£1.58	£1.51	£1.29	SN74184	£3.65	£3.50	£3.29
SN7445	£1.06	£1.03	0.97	SN74185	£2.71	£2.62	£2.54
SN7446	£1.10	£1.06	£1.04	SN74186	£3.85	£3.57	£3.30
SN7447	£1.10	£1.06	£1.04	SN74187	£2.53	£2.42	£2.31
SN7448	£1.10	£1.06	£1.04	SN74188	£1.76	£1.85	£1.84
SN7449	0.16	0.15	0.13	SN74189	£2.75	£2.54	£2.53
SN7450	0.16	0.15	0.13				
SN7451	0.16	0.15	0.13				
SN7452	0.16	0.15	0.13				
SN7453	0.16	0.15	0.13				
SN7454	0.16	0.15	0.13				
SN7455	0.16	0.15	0.13				
SN7456	0.12	0.29	0.29				
SN7457	0.32	0.29	0.26				
SN7458	0.40	0.38	0.35				
SN7459	0.49	0.47	0.46				
SN7460	0.14	0.43	0.42				
SN7461	0.73	0.70	0.64				
SN7462	£1.32	£1.26	£1.21				
SN7463	0.56	0.54	0.51				
SN7464	£1.21	£1.14	£1.14				
SN7465	£1.10	£1.04	0.99				
SN7466	£3.96	£3.86	£3.74				
SN7467	0.35	0.34	0.33				
SN7468	£5.05	£5.77	£5.50				
SN7469							

## BI-PAK DO IT AGAIN!

### 50W pk 25w (RMS)

0.1% DISTORTION  
HI-FI AUDIO AMPLIFIER  
THE AL50



- ★ Frequency response 15Hz to 100,000 - 1dB. **ONLY**
- ★ Load - 3, 4, 8 or 16 ohms. **£3.58 each**
- ★ Distortion - better than 0.1% at 1KHz.
- ★ Signal to noise ratio 80dB.
- ★ Supply voltage 10 - 35 Volts.
- ★ Overall size 63mm x 105mm x 13mm.

Tailor made to the most stringent specifications using top quality components and incorporating the latest solid state circuitry and ALSO was conceived to fill the need for all your A.F. amplification needs. FULLY BUILT - TESTED - GUARANTEED.

## STABILISED POWER MODULE SPM80

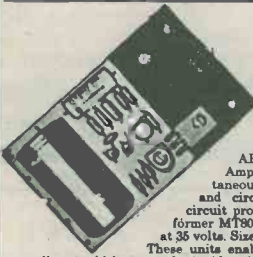

AP80 is especially designed to power 2 of the AL50 Amplifiers, up to 16 watt (rms) per channel, simultaneously. This module embodies the latest components and circuit techniques incorporating complete short circuit protection. With the addition of the Mains Transformer MT80, the unit will provide outputs of up to 1.5 amps at 35 volts. Size: 62mm x 106mm x 30mm. These units enable you to build Audio Systems of the highest quality at a hitherto unobtainable price. Also ideal for many other applications including: Disco Systems, Public Address, Intercom Units etc. Handbook available 10p.

## TRANSFORMER BMT80 £2.15 p. & p. 25p. STEREO PRE-AMPLIFIER, TYPE PA100

Built to a specification and NOT a price, and yet still the greatest value on the market, the PA100 stereo pre-amplifier has been conceived from the latest circuit techniques. Designed for use with the AL50 power amplifier system, this quality made unit incorporates no less than eight silicon planar transistors, two of these are specially selected low noise NPN devices for use in the input stages.

Three switched stereo inputs, and rumble and scratch filters are features of the PA100, which also has a STEREO/MONO switch, volume, balance and continuously variable bass and treble controls.



**SPECIFICATION**  
Frequency Response 20Hz - 20KHz ± 1dB  
Harmonic Distortion better than 0.1%  
Inputs: 1. Tape Head 1.25 mV into 50KΩ  
2. Radio, Tuner 35 mV into 50KΩ  
3. Magnetic P.U. 1.5 mV into 50KΩ  
All input voltages are for an output of 250mV. Tape and P.U. inputs equalised to RIAA curve within ± 1dB, from 20Hz to 20KHz.  
Base Control ± 15dB @ 20Hz  
Filters: Rumble (High Pass) 100Hz  
Scratch (Low Pass) 8KHz  
Signal/Noise Ratio better than - 65dB  
Input overload + 26dB  
Supply + 35 volts @ 20mA  
Dimensions 292mm x 82mm x 36mm

**SPECIAL COMPLETE KIT COMPRISING**  
1 AL50's, 1 SPM80, 1 BMT80 and 1 PA100 **ONLY £25.30 FREE p & p.**  
All prices quoted in new pence. Clro No. 388-7006  
Please send all orders direct to warehouse and despatch department

# BI-PAK

## P.O. BOX 6, WARE · HERTS

Postage and packing add 10p. Overseas add extra for airmail.  
Minimum order 50p. Cash with order please.  
**Guaranteed Satisfaction or Money Back**

## LINEAR I.C.'s - FULL SPEC.

Type No.	1-24	Price	25-99	100 up
BP 201C—SL201C	69p	58p	49p	49p
BP 701C—SL701C	69p	55p	49p	49p
BP 702C—SL702C	69p	55p	49p	49p
BP 702C—72702	58p	49p	44p	44p
BP 709—72709	39p	37p	33p	33p
BP 709P—A709C	49p	31p	30p	30p
BP 710—72710	49p	46p	44p	44p
BP 711—A711	49p	47p	44p	44p
BP 741—A741	59p	50p	45p	45p
μA 703C—μA703C	31p	28p	26p	26p
TA A263	77p	66p	60p	60p
TA A293	99p	82p	77p	77p
TA A350	167p	174p	165p	165p
EA1000	£2.89			

## LOGIC DTL 930 SERIES I.C.'s

ROCK BOTTOM PRICES

Type No.	1-24	Price	25-99	100 up
BP930	13p	12p	11p	11p
BP932	14p	13p	12p	12p
BP933	14p	13p	12p	12p
BP935	14p	13p	12p	12p
BP944	14p	13p	12p	12p
BP945	27p	26p	24p	24p
BP946	13p	12p	11p	11p
BP948	27p	26p	24p	24p
BP951	71p	66p	60p	60p
BP952	12p	12p	11p	11p
BP9093	44p	42p	38p	38p
BP9094	44p	42p	38p	38p
BP9097	44p	42p	38p	38p
BP9099	44p	42p	38p	38p

Devices may be mixed to qualify for quantity price. Larger quantity prices on application. (DTL 930 Series only).

## NUMERICAL INDICATOR TUBES



MODEL	CD68	GR 116	3015F
Anode voltage (Vdc)	170 min	175 min	5
Cathode cur'nt(mA)	2.3	14	
Numeral height (mm)	16	13	9
Tube height (mm)	47	32	22
Tube diameter (mm)	19	13	12
I.C. driver rec.	BP41 or 141	BP41 or 141	BP47
PRICE EACH	£1.87	£1.71	£1.50

All indicators 0.9 + Decimal point: All side viewing: Full data for all types available on request.

## RTL MICROLOGIC CIRCUITS

	Price each	1-24	25-99	100 up
Epoxy TO-5 case	39p	31p	30p	30p
uL900 Buffer	39p	31p	30p	30p
uL914 Dual 2/1p	39p	31p	30p	30p
uL923 P-K flip-flop	59p	50p	45p	45p

Date and Circuits Booklet for IC's Price 7p.

## DUAL IN LINE SOCKETS

14 & 16 Lead Sockets for use with DUAL IN-LINE I.C.'s. TWO RANGES PROFESSIONAL AND NEW LOW COST.

Prof. Type No.	1-24	25-99	100 up
TS014 pin type	33p	30p	27p
TS016 pin type	38p	35p	33p
Low Cost No.			
BPS 14	16p	14p	13p
BPS 16	17p	15p	13p

# THE MODERN BOOK CO

## THE RADIO AMATEUR'S HANDBOOK 1973

by The American Radio Relay League      Price £2.95

**UNDERSTANDING ELECTRONIC CIRCUITS**  
by I. R. Sinclair      £3.60

**HOW TO GET THE BEST OUT OF YOUR  
TAPE RECORDER** by P. J. Guy      £1.60

**125 ONE-TRANSISTOR PROJECTS**  
by R. P. Turner      £1.40

**DIGITAL LOGIC BASIC THEORY & PRACTICE**  
by J. H. Smith      £1.60

**TEST INSTRUMENTS FOR ELECTRONICS**  
by M. Clifford      £1.40

**RAPID TV REPAIR**  
by G. W. Heath      £1.40

**INSTALLING & SERVICING ELECTRONIC  
PROTECTIVE SYSTEMS**

by H Swearer      £1.40

**MAKING TRANSISTOR RADIOS  
A BEGINNER'S GUIDE**

by R. H. Warring      £1.30

**BEGINNER'S GUIDE TO PRACTICAL  
ELECTRONICS** by R. H. Warring      £1.40

**PRACTICAL SOLID-STATE PRINCIPLES  
& PROJECTS** by K. W. Sessions      £1.25

**SERVICING TRANSISTOR RADIO  
RECEIVERS** by F. R. Pettit      80p

**ELECTRONIC PUZZLES & GAMES**  
by M. Mandl      £1.25

**104 EASY PROJECTS FOR THE  
ELECTRONICS GADGETEER**

by R. M. Brown      £1.25

**WORLD RADIO & TV HANDBOOK 1973**  
£3.12

**RADIO HANDBOOK**  
by W. I. Orr      £7.79

**TRANSISTOR AUDIO & RADIO CIRCUITS**  
by MULLARD      £1.95

**TRANSISTOR CIRCUIT GUIDEBOOK**  
by B. Wels      £1.30

**HOW TO READ ELECTRONIC CIRCUIT  
DIAGRAMS** by R. M. Brown      £1.40

ALL PRICES INCLUDE POSTAGE

We have the Finest Selection of English and American Radio Books in the Country

**19-21 PRAED STREET (Dept RC) LONDON W2 1NP**

Telephone 01-723 4185

**NOW AVAILABLE . . .**

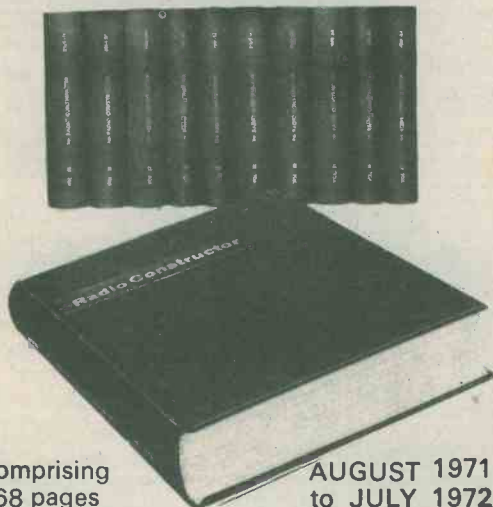

Comprising  
768 pages  
plus index

AUGUST 1971  
to JULY 1972

## LATEST BOUND VOLUME

### No. 25

of  
**"The Radio Constructor"**  
**FOR YOUR LIBRARY**

**PRICE £2.00 P&P 29p**

**BOUND VOLUME NO. 23 (August 1969 to July 1970)**

**BOUND VOLUME NO. 24 (August 1970 to July 1971)**

Limited number of these  
volumes still available.

**PRICES Volume 23 £1.88 Postage 29p Volume 24 £2.00 Postage 29p**

We regret all earlier volumes are now completely sold out.  
Available only from

**DATA PUBLICATIONS LTD., 57 MAIDA VALE, LONDON, W9 1SN**



## PRECISION

### POLYCARBONATE CAPACITORS

Close tolerance professional capacitors by well-known manufacturer. Excellent stability and extremely low leakage. All 63V D.C.

0.47µF:	±5%	30p;	±2%	40p;	±1%	50p
1.0 µF:	±5%	40p;	±2%	50p;	±1%	60p
2.2 µF:	±5%	50p;	±2%	60p;	±1%	75p
4.7 µF:	±5%	70p;	±2%	90p;	±1%	115p
6.8 µF:	±5%	95p;	±2%	115p;	±1%	150p
10.0 µF:	±5%	110p;	±2%	140p;	±1%	180p
15.0 µF:	±5%	160p;	±2%	210p;	±1%	270p

### NEW! — TANTALUM BEAD CAPACITORS

Values available .1, .22, .47, 1.0, 2.2, 4.7, 6.8µF at 35V, 10µF 25V, 15µF 20V, 22µF 15V, 33µF 10V, 47µF 6V, 100µF 3V. All at 9p each; 6 for 50p; 14 for £1.00. Special pack, 6 off each value (78 capacitors) for £5.00.

**TRANSISTORS:** BC107; BC108; BC109 all at 9p each. 6 for 50p; 14 for £1.00; AF178 at 35p each or 3 for 95p. All brand new and marked.

**POPULAR DIODES:** IN914 - 7p each; 8 for 50p; 18 for £1.00 IN916 - 9p each; 6 for 50p; 14 for £1.00. IS44 - 5p each; 11 for 50p; 24 for £1.00. All brand new and marked.

**400mW ZENER DIODES:** Values available 4.7, 5.6, 6.8, 7.5, 8.2, 9.1, 10, 11, 12, 13.5, 15 volts. All new and marked. All at 9p each; 6 for 50p; 14 for £1.00. SPECIAL 6 off each voltage (66 zeners) £4.25

**SILICON PLASTIC RECTIFIERS** 1.5 amp wired-ended D027. 100 PIV at 8p each or 4 for 30p; 400 PIV at 9p each or 4 for 34p; 800 PIV at 14p each or 4 for 50p.

**RESISTORS:** Carbon film 5%  $\frac{1}{4}$ w at 40°C,  $\frac{1}{2}$ w at 70°C. Range 2.2Ω-2.2MΩ. E12 series i.e. 10, 12, 15, 18, 22, 27, 33, 39, 47, 56, 68, 82, and their decades. All at 1p each. 8p for 10; 70p for 100 of any one value. Special pack 10 off each value 2.2Ω to 2.2MΩ (730 resistors) for £5.00.

**440V A.C. CAPACITORS:** 0.1µF: Size 1 $\frac{1}{8}$ " x  $\frac{1}{2}$ ", 25p each  
0.25µF: Size 1 $\frac{3}{8}$ " x  $\frac{5}{8}$ ", 30p each 0.5µF: Size 1 $\frac{3}{8}$ " x  $\frac{1}{2}$ ", 35p each  
1.0 µF: Size 2" x  $\frac{1}{2}$ ", 45p each 2.0µF: Size 2" x 1", 75p each

Suitable for use on C.D. ignition, 250V A.C. motors, etc.

5p p. & p. on all orders below £5. Please add 10% V.A.T.

MARCO TRADING

Dept. R7 The Maltings, Station Road, Wem, Salop



## "I MADE IT MYSELF"

Imagine the thrill you'll feel! Imagine how impressed people will be when they're hearing a programme on a modern radio you made yourself.

# Now! Learn the secrets of radio and electronics by building your own modern transistor radio!

Practical lessons teach you sooner than you would dream possible.

What a wonderful way to learn - and help qualify yourself for a new, better-paid career! No dreary ploughing through page after page of dull facts and figures. With this fascinating Technatron Course, you learn by building!

You build a modern Transistor Radio ... a Burglar Alarm. You learn Radio and Electronics by doing actual projects you enjoy - making things with your own hands that you'll be proud to own! No wonder it's so fast and easy to learn - this way. Because learning becomes a hobby! And what a profitable hobby. Because opportunities in the field of Radio and Electronics are growing faster than they can find people to fill the jobs!

**No mathematics, no soldering - yet you learn faster than you ever dreamed possible.**

Yes! Faster than you can imagine, you pick up the technical know how you need. Specially prepared step-by-step lessons show you how to: read circuits - assemble components - build things - experiment. You enjoy every minute of it!

You get everything you need. Tools. Components. Even a versatile Multimeter that we teach you how to use. All included in the course AT NO EXTRA CHARGE! And this is a course anyone can afford. You can even pay for it in easy payments - in fact you could make extra cash from spare-time work when you've turned yourself into a qualified man through B.I.E.T. training.

**So fast, so easy, this personalised course will teach you even if you don't know a thing today!**

No matter how little you know now, no matter what your background or education, we'll teach you. Step by step, in simple easy-to-understand language, you pick up the secrets of radio and electronics.

You become a man who makes things, not just another of the millions who don't understand. And you could pave the way to a great new career, to add to the thrill and pride you receive when you look at what you have achieved. Within weeks you could hold in your hand your own powerful radio. And after the course you can go on to acquire high-powered technical qualifications, because B.I.E.T.'s famous courses go right up to City & Guilds levels.

**Send now for FREE 76 page book - see how easy it is - read what others say!**

Find out more now! This is the gateway to a thrilling new career, or a wonderful hobby you'll enjoy for years. Send the coupon now. There's no obligation.



MULTIMETER Model 200H  
20,000 ohm/volt **£5.28**

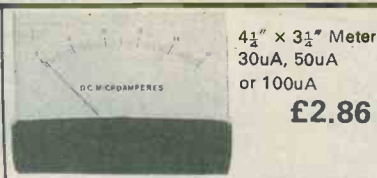

4 $\frac{1}{2}$ " x 3 $\frac{1}{2}$ " Meter  
30uA, 50uA  
or 100uA  
**£2.86**



CARDIOID DYNAMIC  
MICROPHONE Model UD-  
130 Frequency response 50-  
15,000 cps. Dual Impedance  
50K & 600 ohms **£4.95**



MULTIMETER Model  
C-7081GN Range Doubler  
50,000 ohm/volt High Sensi-  
tivity Meter **£12.37**



Small DYNAMIC MICRO-  
PHONE as pictured or similar  
with remote on/off switch  
**£1.27**

Large S.A.E. for List No. 5. Special Prices for quantity quoted on request. Add 10p for P&P on orders under £5.

M. DZIUBAS

158 Bradshawgate, Bolton, BL2 1BA, Lancs.

All above prices include 10% V.A.T.

All items advertised in previous numbers of this magazine still available.

**POST TODAY FOR FREE BOOK**

To: BRITISH INSTITUTE OF ENGINEERING TECHNOLOGY QH/BRE07  
Aldermaston Court, Reading RG7 4PF

Yes, I'd like to know more about your course. Please send me free details—plus your big, 76-page book that tells about all your courses.

NAME \_\_\_\_\_

ADDRESS \_\_\_\_\_



BRITISH INSTITUTE OF ENGINEERING TECHNOLOGY

# COMPRESSION TRIMMERS

\*WE STOCK THE LARGEST RANGE IN THE U.K. (Possibly in Europe!)

Here's a page from our Catalogue showing a few typical types

## HOME RADIO (COMPONENTS) LTD. TRIMMER CAPACITORS

Maker: CYLDON

Cat. No.	Maker's No.	Size	Capacity	Price
VC29D	CBB/30	$\frac{3}{4} \times \frac{3}{8} \times \frac{1}{2}$ inches	3-30 pF	10p
VC29E	CAA/40		3-40 pF	10p
VC29F	CAA/80		10-80 pF	10p
VC29H	CAA/180		60-180 pF	12p

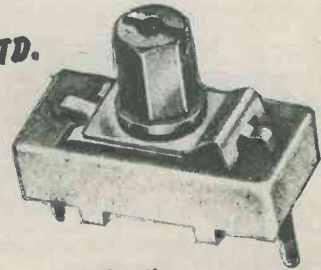

CA-CB types

VC29J	MT31A/9	$\frac{3}{8} \times \frac{7}{8} \times \frac{3}{8}$ inches	1.5-20 pF	8p
VC29LA	MT31A/3		3-40 pF	8p
VC29LC	MT31A/12		7-60 pF	10p
VC29K	MT31A/4		10-80 pF	9p
VC29LB	MT31A/5		30-140 pF	10p
VC29L	MT31A/13		60-180 pF	11p



MT31A types

VC29M	MT25/18	$\frac{5}{8} \times \frac{7}{8} \times \frac{3}{8}$ inches	1.5-25 pF	11p
VC29MA	MT25/1		2.5-40 pF	11p
VC29MB	MT25/2		3.5-70 pF	12p
VC29N	MT25/3		20-150 pF	12p
VC29P	MT25/4		45-250 pF	12p

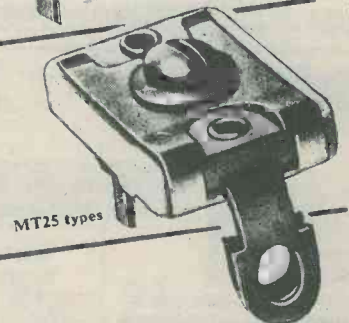

MT25 types

VC29PA	TP1	$\frac{5}{8} \times \frac{7}{8} \times \frac{3}{8}$ inches	10-110 pF	12p
VC29Q	TP4		20-250 pF	11p
VC29R	TP12		50-450 pF	14p
VC29RB	TP11		150-750 pF	17p
VC29S	TP7		300-1000 pF	18p
VC29SA	TP10		400-1250 pF	19p
VC29SB	TP29		500-2000 pF	22p

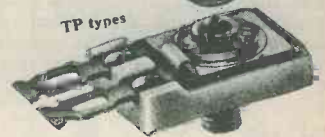

TP types

Also a large range of Air Dielectric Trimmers in stock

The famous Home Radio Components Catalogue lists 6,785 items—1,750 of them illustrated.

\* Send now for catalogue

**POST THIS COUPON**  
with cheque or P.O. for 77p.

The price of 77p applies only to catalogues purchased by customers in the U.K. and to BFPO addresses.

Please write your Name and Address in block capitals

NAME .....

ADDRESS .....



HOME RADIO (Components) LTD.

Dept. RC, 234-240 London Road, Mitcham CR4 3HD

Regd. No.  
912966  
London

RADIO & ELECTRONICS CONSTRUCTOR



# RADIO & ELECTRONICS CONSTRUCTOR

JULY 1973

Vol. 26 No. 12

CONTENTS

Published Monthly (1st of Month)  
First Published 1947

*Incorporating The Radio Amateur*

*Editorial and Advertising Offices*  
57 MAIDA VALE LONDON W9 1SN

*Telephone* 01-286 6141      *Telegrams*  
Databux, London

© Data Publications Ltd., 1972. Contents may only be reproduced after obtaining prior permission from the Editor. Short abstracts or references are allowable provided acknowledgement of source is given.

*Annual Subscription:* £2.70 (U.S.A. and Canada \$7.00) including postage. Remittances should be made payable to "Data Publications Ltd". Overseas readers please pay by cheque or International Money Order.

*Technical Queries.* We regret that we are unable to answer queries other than those arising from articles appearing in this magazine nor can we advise on modifications to equipment described. We regret that such queries cannot be answered over the telephone; they must be submitted in writing and accompanied by a stamped addressed envelope for reply.

*Correspondence* should be addressed to the Editor, Advertising Manager, Subscription Manager or the Publishers as appropriate.

*Opinions* expressed by contributors are not necessarily those of the Editor or proprietors.

*Production.*—Web Offset.

CASSETTE RECORDER MAINS UNIT by S. Essex	740
BOOK REVIEW	743
UNIUNCTION METRONOME (Suggested Circuit 272) by G. A. French	744
QSX by Frank A. Baldwin	747
NEWS AND COMMENT	748
MODIFYING THE GC1U RECEIVER – Part 1 by P. Cairns, R. Tech.Eng., M.I.P.R.E., G3ISP	750
SERVICING THE TRANSISTOR PORTABLE Part 2, by Vivian Capel	757
MINIATURE THREE CHANNEL MIXER by R. A. Penfold	760
NEW PRODUCTS	765
SHORT WAVE NEWS by Frank A. Baldwin	766
RANDOM OUTPUT GENERATOR by E. F. Whitman	768
ASTABLE MULTIVIBRATORS – Part 2 by A. Foord	770
CHOOSING A MULTIMETER by P. Jefferson	773
IN YOUR WORKSHOP – Servicing and Amplifiers	776
INDEX VOLUME 26 August 1972–July 1973	790
CONSTRUCTOR'S DATA SHEET No. 76 (Resonant Frequencies – IV)	iii

Published in Great Britain by the Proprietors and Publishers, Data Publications Ltd, 57 Maida Vale, London, W9 1SN

The Radio & Electronics Constructor is printed by Carlisle Web Offset.

**AUGUST ISSUE WILL BE  
PUBLISHED ON AUGUST 1st**

# CASSETTE RECORDER MAINS UNIT

by S. ESSEX

**A simple stabilized power unit suitable for use with battery operated cassette recorders requiring supplies of 6, 7.5 or 9 volts.**

**M**ANY HOMES NOW POSSESS A CASSETTE TAPE RECORDER or musicassette player, and a large proportion of these are powered by ordinary dry cells such as the type U11 or U2. The use of batteries gives the recorder the advantage of portability, but this advantage soon proves to be expensive as the cost of running the recorder can work out at several pence per hour. The writer realised that a mains supply unit would be useful for operating the recorder at home over long periods of time, and that this would reduce the running costs to less than one-hundredth of a penny per hour. Quite a saving!

## CHOICE OF CIRCUIT

After having decided on a mains supply unit, the next question was to choose between the alternatives of a stabilized or an unstabilized circuit. Although the latter has the advantages of smaller size and lower cost, its disadvantages, namely that its output voltage varies with load current and that it will in most instances have a higher ripple content in the output, make the stabilized form more suitable for the present application. Ripple is reduced by the stabilization action, which ensures that the output voltage remains constant within close limits whatever load is applied. This results in the supplied recorder working consistently at its best.

The circuit employed is shown in Fig. 1. The mains input is applied, via fuse F1, to the primary of the mains transformer T1. There is no on-off switch, the unit coming into operation as soon as its input supply lead is plugged into the mains. The transformer provides a secondary voltage of 13 volts r.m.s., which is rectified by the bridge rectifier given by D1 to D4. Capacitor C1 functions as a reservoir capacitor, ensuring that the rectified voltage across it remains at a high level between the half-cycle peaks when the diodes conduct. The voltage on the negative terminal of C1 is applied to the collector of transistor TR1.

This transistor functions as an emitter follower, the voltage at its emitter being slightly lower, due to the small drop across the emitter-base junction, than the voltage on its base. The base voltage is held steady by zener diode ZD1, which is kept at its zener voltage level by the current flowing through R1 and R2. A second electrolytic capacitor, C2, provides smoothing for the voltage appearing at the junction of R1 and R2 and this, together with the low slope resistance of the zener diode, results in a relatively ripple-free voltage of TR1 base. Capacitor C3 provides further smoothing and ensures a low impedance output. Fuse F2 provides protection against output overload.

The author's power supply unit is employed with a Ferguson Model 3240 battery cassette recorder, which requires a voltage of 7.5 volts at about 100mA. In



*The unit coupled to a cassette recorder*



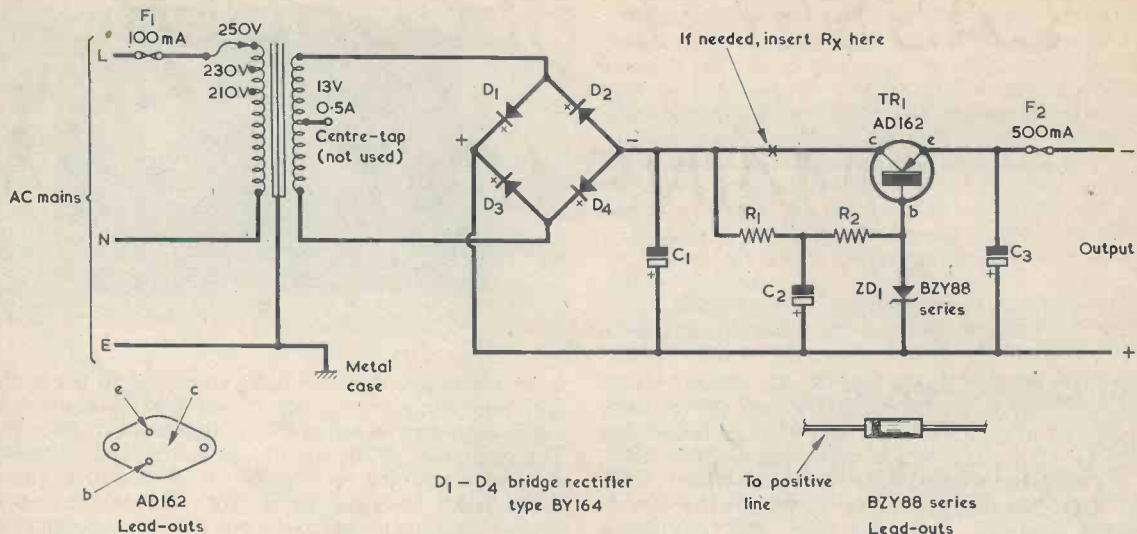

Fig. 1. The circuit of the recorder mains supply unit. The zener diode type depends upon the output voltage required

## COMPONENTS

### Resistors

R1	330 $\Omega$ , $\frac{1}{2}$ watt, 5% (6V version)
	270 $\Omega$ , $\frac{1}{2}$ watt, 5% (7.5V version)
	180 $\Omega$ , $\frac{1}{2}$ watt, 5% (9V version)
R2	330 $\Omega$ , $\frac{1}{2}$ watt, 5% (6V version)
	220 $\Omega$ , $\frac{1}{2}$ watt, 5% (7.5V version)
	180 $\Omega$ , $\frac{1}{2}$ watt, 5% (9V version)
Rx	12 $\Omega$ , 3 watt, 10% (6V version)
	8.2 $\Omega$ , 2 $\frac{1}{2}$ watt, 10% (7.5V version)
	5.6 $\Omega$ , 2 watt, 10% (9V version)

### Capacitors

(All capacitors Mullard Miniature Electrolytic)

C1	640 $\mu$ F, 25V
C2	200 $\mu$ F, 10V
C3	125 $\mu$ F, 16V

### Transformer

T1	Mains transformer, secondary 13 volts centre-tapped at 0.5 amp (R.S. Components - see text)
----	---

### Semiconductors

TR1	AD162 (complete with mica washer and insulating bushes)
D1-D4	Silicon bridge rectifier type BY164
ZD1	BZY88C6V2 (6V version)
	BZY88C7V5 (7.5V version)
	BZY88C9V1 (9V version)

### Fuses

F1	100mA 20mm. fuse
F2	500mA 20mm. fuse

### Miscellaneous

Metal case type AB9 (see text)  
 2 fuseholders, 20mm. chassis-mounting  
 2 grommets (to suit input and output leads)  
 2 plastic cable clips (to suit input and output leads)  
 Perforated board or plain Veroboard (0.15 in. pitch)  
 Nuts, bolts, solder tags, etc.

consequence, ZD1 in the prototype was a 7.5 volt type. The actual output voltage given in this particular instance was 7.6 volts. There will be a slight difference in output voltage for different zener diodes which are rated at a nominal 7.5 volts, because of variations within tolerance of their actual zener voltages. The circuit may also be employed to give outputs of 6 volts or 9 volts by using different zener diodes and different values for R1 and R2. These alternatives are shown in the Components List.

The resistor Rx is discussed later.

## COMPONENTS

The components are all standard types. Transformer T1 is an R.S. Components 'Standard Filament' transformer having a centre-tapped secondary giving 13 volts at 0.5 amp. No connection is made to the centre tap. This transformer is available from suppliers of R.S. Components parts such as Chromasonic Electronics, 56 Fortis Green Road, London, N10 3HN. It is also available from Home Radio under Cat. No. TH5D. Diodes D1 to D4 are given by a silicon bridge rectifier

A view of the unit with the cover removed

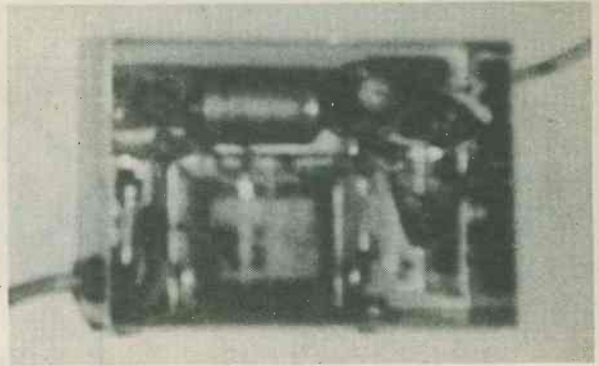

type BY164 (Home Radio and Radio Shack) which contains all four diodes in a single module. All the parts are mounted in an aluminium box with lid measuring 4 by 2 $\frac{3}{4}$  by 1 $\frac{1}{2}$  in., and which is retailed as 'type AB9'. This is available from Electrovalue or from Home Radio (Cat. No. Z239). As the layout in this box is somewhat compact, beginners may prefer to use a slightly larger case. Before use, ventilation holes are cut in the bottom of the case as will be described shortly.

For safety the box must be reliably earthed via the earth lead of a 3-core mains lead which is properly terminated in a 3-pin plug. Also, the mains lead should pass through a grommet in the side of the box and be securely clamped with a plastic clip. A grommet and plastic clip should be similarly provided for the output lead.

A suitable general layout is shown in Fig. 2. Here it can be seen that the mains transformer is bolted to one side of the box. If the secondary tags are uppermost this enables a good proportion of the mains wiring to be hidden, where it cannot be touched accidentally. When this method of mounting is employed the inside bottom of the box, apart from the ventilation holes and the area which is in contact with the transistor heat sink, should be covered with self-adhesive plastic sheet to minimise the risk of short-circuits. A number of strips of p.v.c. insulating tape may be used here in the absence of

other materials. The two fuses employed in the prototype were 20mm. types, being located in chassis-mounting fuse holders on either side of the mains transformer. The remainder of the circuit, apart from the transistor, may be assembled on a piece of perforated insulated board, such as plain Veroboard without the copper strips, this being bolted to the box bottom and separated from it by spacers or pillars.

The heat sink for the transistor consisted of a piece of aluminium about  $\frac{3}{32}$  in. thick having a surface area of 1 $\frac{3}{8}$  by 2 $\frac{1}{2}$  in., with a bent-over section  $\frac{1}{2}$  in. wide. See Fig. 3. This was bolted direct to the bottom of the box, the self-adhesive plastic being removed over the area where the heat sink and case metal are in contact. Thus, further heat sinking is provided by the case. The transistor is insulated from the heat sink by the usual mica washer and insulating bushes. The mica washer will be helpful for marking out the holes required for the transistor, but it must be handled with care to prevent the mica fracturing. Temperature rise in the box can be reduced by cutting large ventilation holes in the lid, these holes and those in the bottom being covered on the outside by perforated board or plain Veroboard to prevent prying fingers from touching the live mains points.

The output lead may be terminated in a manner suitable for the cassette recorder with which the unit is

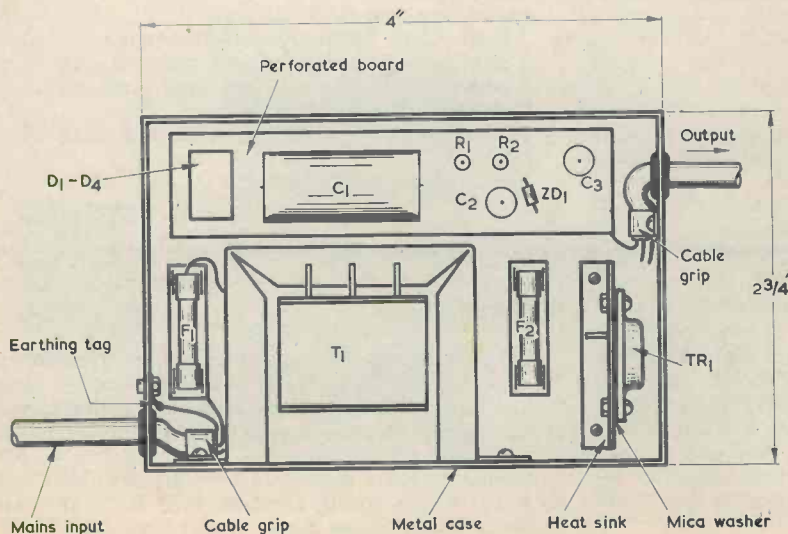

Fig. 2. Layout of components inside the metal case. The case must be reliably connected to the mains earth



## TESTING

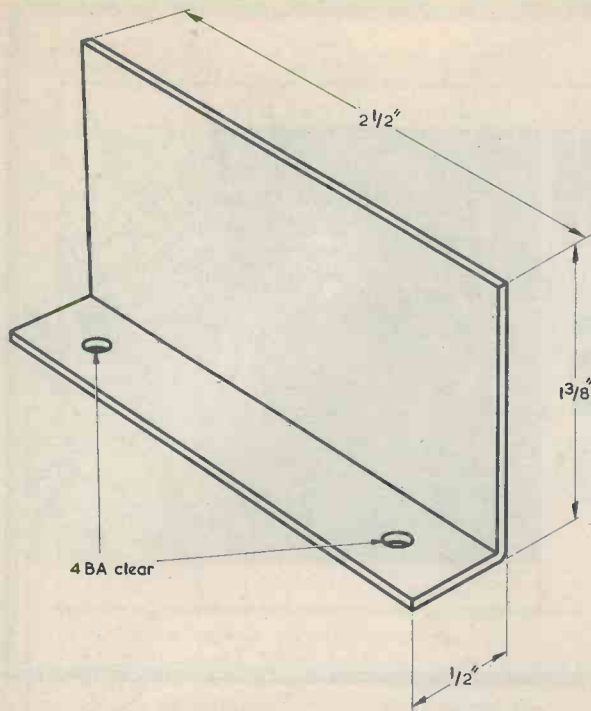

Fig. 3. Dimensions of the heat sink

After wiring has been completed and checked, the unit may be tested. It should *not* be connected to the cassette recorder at this stage. With the mains connected and no load on the output of the unit a voltage of about 18 volts should appear across C1. The output voltage is next checked, and this should be close to the nominal zener voltage of the zener diode used. If the voltage is low, at less than 1 volt, a possible fault is that the zener diode has been connected wrong way round.

If all is satisfactory, the output of the unit may then be coupled to the recorder, taking great care to ensure correct polarity.

No problem with overheating of the transistor was observed with the prototype unit despite long periods of use. If, due to higher load currents or the use of too small a heat sink, the temperature rises excessively, a resistor may be inserted between the negative terminal of C1 and the collector of the transistor at the point indicated in Fig. 1. This resistor is Rx, and it dissipates some of the power which is handled by the transistor. Suitable values for Rx, should it be needed, are given in the Components List. The temperature of the transistor can be observed by touching it with a finger, taking care to avoid touching any live mains points.

The mains should not be applied with the recorder connected and switched on, as the resulting charging surge in C1 will probably blow fuse F1. This drawback could, if desired, be overcome by using an anti-surge fuse of around 80mA for F1, since such a fuse will pass the occasional surge but still blow on overload. If the simple precaution of not applying the mains with the recorder connected and switched on is observed, the unit will give good service for many years to come. ■

to be used. Note that neither of the output leads is earthed.

# BOOK REVIEW



**SUN EARTH and RADIO** By J. A. Ratcliffe

256 pages, 5½ x 7½ in. Published by The World University Library. Price £1.75p.

The behaviour of radio waves is of interest to those who are shortwave listeners in particular; to radio amateurs especially and to everyone who wants to understand the vagaries of radio reception, be it only in relation to the daily radio programmes received on their domestic radio receivers.

An understanding of the processes involved in their propagation necessitates a consideration of the nature of the radio waves themselves as well as the media through which they pass. This book covers these aspects of the matter very thoroughly and in a clear, readable manner, and it illustrates very well the great progress made in understanding these phenomena in recent years. For those whose knowledge of this topic has been somewhat 'basic' it is surprising to learn what strides have been made recently in this branch of science.

Introductory chapters describe how radio waves have been used to investigate the magnetosphere and the ionosphere – the two layers of charged particles in the upper atmosphere, which determine the behaviour of radio waves. The electron structure of the ionosphere and the effect of solar radiations upon it are then fully considered and the nature of the ionising radiations is considered in some detail. The ionosphere and its relationship to radio communication is specifically considered and the book ends with recent advances in this branch of science.

This is a book which can be recommended to the reader who wants a better understanding of this topic than is available in the usual section on this subject to be found in the conventional amateur radio handbooks.

# UNIUNCTION METRONOME

by G. A. FRENCH

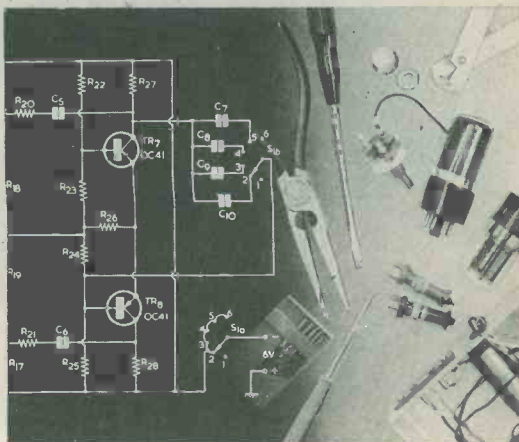

**E**LECTRONIC METRONOMES INCORPORATING unijunction transistor relaxation oscillators are by no means new devices and a number of designs for these have been published in the technical press from time to time. In those designs which the writer has seen the audible output is somewhat low. The present article sets out to describe a unit which offers a relatively high output.

The reason for the popularity of the unijunction transistor in electronic metronomes is that it can be connected up in a very simple relaxation oscillator circuit whose frequency is capable of being varied by means of a single potentiometer. The unijunction oscillator produces a series of sharp regularly spaced pulses which can be amplified and fed to a speaker, whereupon they become reproduced as "clicks". Unfortunately, the sound energy in a "click" is relatively low and it is for this reason that it becomes difficult to achieve high acoustic output. The metronome design to be described here tackles this problem by means of a "brute force" approach and the circuit, when switched to its highest output level, causes current pulses of the order of 1 amp to be passed through the coil of a 3Ω loudspeaker. The resulting "clicks" are in consequence reproduced at quite a high level and should be adequate for most purposes. The displacement of the loudspeaker cone during the "clicks" is, so far as can be determined visually, of the same order as is given when a 3 volt battery is connected to the speaker.

## THE CIRCUIT

The circuit of the electronic metronome appears in Fig. 1. In this diagram TR1, a 2N2646, is the unijunction transistor and it is connected in a conventional unijunction relaxation oscillator arrangement. After the on-off switch, S2, has been closed, C2 commences to charge by way of VR1 and R1. The voltage on the emitter of TR1 rises. When this voltage reaches triggering level, the unijunction transistor exhibits negative resistance and C2 discharges rapidly into whatever resistance is present between the base 1 of the transistor and the negative supply rail. The unijunction transistor reverts to normal operation when C2 is nearly fully discharged, whereupon C2 commences to charge once more and a further cycle commences. The rate of charge in C2, and hence the frequency of oscillation, is controllable by means of VR1. The capacitor charges more quickly, and frequency increases, when the resistance inserted into circuit by VR1 decreases.

During the negative resistance period when C2 discharges, a voltage pulse appears at the base 1 of the unijunction transistor. This pulse has the shape shown in Fig. 2. The discharge current from C2 flows through R3 and (ignoring the small current flow in VR2) through the base-emitter junction of TR2. Component values are such that TR2 is turned hard on for at least part of the period of the pulse, thereby applying nearly the full 9 volts from the supply across the loudspeaker and

whichever of R4 to R6 has been selected by S1. If S1 is in position 3 this voltage is applied across the speaker and the 5Ω resistor R6, whereupon a current of the order of 1 amp can be expected to flow through the speaker coil. Positions 1 and 2 of S1 select higher values of series resistor and produce lower audible outputs from the metronome. It is necessary to use a switch to control volume rather than have a series wire-wound potentiometer, since the latter would require wire in its track which was capable of passing 1 amp and would, in consequence, be a very bulky component.

Between pulses, the silicon material in TR1 between base 2 and base 1 functions as a resistor. The resistance offered between the two bases of a 2N2646 lies between 4.7 and 9.1kΩ, and VR2 is adjusted such that, in the absence of pulses, the base of TR2 is just below the level at which this transistor commences to conduct. Thus, the transistor is fully cut off in the absence of pulses and is hard on in the presence of pulses. Circuit operation is, therefore, at its most efficient. A very low impedance across the supply rails is provided by C1, and this allows a high pulse current to flow in the speaker even when the battery, in ageing, offers a relatively high internal resistance.

TR2 is a silicon power transistor type BD124. A silicon device is used here because a silicon transistor does not turn on until its base is some 0.6 volts higher in potential than its emitter. This ensures that it can be reliably taken into cut-off, between



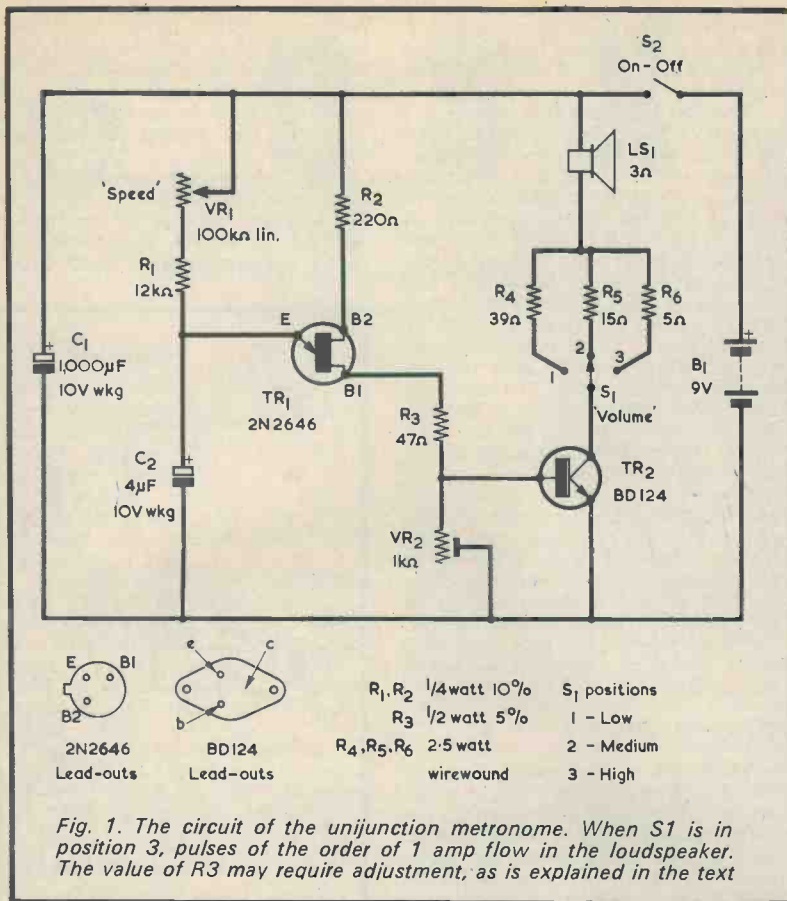

Fig. 1. The circuit of the unijunction metronome. When S<sub>1</sub> is in position 3, pulses of the order of 1 amp flow in the loudspeaker. The value of R<sub>3</sub> may require adjustment, as is explained in the text

pulses, by the appropriate adjustment in VR<sub>2</sub>. A power type is employed simply because it is capable of passing the fairly heavy collector currents involved. As the pulses of current in the collector circuit are of very short duration, dissipation in TR<sub>2</sub> is low and it does not need to be mounted on a heat sink.

Dissipation in the three series resistors, R<sub>4</sub> to R<sub>6</sub>, is also low, but they still have to pass pulses of relatively high current. It is for this reason

that they are specified as wire-wound types. The value of R<sub>3</sub> may need to be altered and this point is discussed shortly.

The loudspeaker should be a type which is capable of handling at least 3 watts of audio power, and its audible output is increased if it is mounted in a cabinet to provide a baffle effect. *Miniature low-power speakers must on no account be used in this circuit as they may be damaged by the pulse currents.*

The frequency range offered by VR<sub>1</sub> with the prototype was approximately 1 pulse per second when VR<sub>1</sub> was set to insert full resistance and approximately 7 pulses per second when this potentiometer was adjusted for minimum resistance. If it is desired to use the device as a photographer's metronome giving one pulse per second, R<sub>1</sub> and VR<sub>1</sub> may be changed accordingly. R<sub>1</sub> could be increased to 47kΩ and VR<sub>1</sub> made a pre-set potentiometer which is adjusted for a speed of 1 pulse per second.

Unfortunately, pulse frequency varies somewhat with battery voltage. For most applications this should not be a disadvantage, and the battery can be discarded when its voltage has fallen to some 8 volts, in which case changes in frequency will not be great. If a high level of frequency stability is required the unit, or at least the emitter and base circuits of TR<sub>1</sub>, must be powered by a stabilized supply.

The current consumption from the battery in the prototype with R<sub>3</sub> at 47Ω was less than 4mA at the slowest speed, and was approximately 30mA at the highest speed.

## COMPONENTS

The two transistors used in the circuit are commonly encountered types which are readily available. VR<sub>1</sub> is a panel-mounting potentiometer whilst VR<sub>2</sub> is a skeleton pre-set type. Both the capacitors should be good-quality components. In the prototype, C<sub>2</sub> was a Mullard Miniature electrolytic. The 9 volt battery should be a reasonably large type, such as the Every Ready PP9.

S<sub>1</sub> is a rotary switch. It would be best to avoid using one of the popular miniature rotary switches that are currently available and to employ instead a standard size wafer switch whose moving contact passes between two fixed contacts at each position. Such a switch would be more capable of passing the currents involved. S<sub>2</sub> can be a standard toggle switch.

As was just mentioned, the value of R<sub>3</sub> may need to be changed. The value of 47Ω specified in the circuit diagram takes up the case where TR<sub>2</sub> is at the bottom of its hFE spread. It was found, in the prototype, that the peak value of the pulse appearing at the base 1 of TR<sub>1</sub> was a little higher than 3 volts. This means that, allowing for base-emitter voltage drop in TR<sub>2</sub>, the voltage appearing across R<sub>3</sub> in the presence of pulses is about 2.5 volts. At the same time, the minimum hFE quoted for the BD124 (at a collector current of 2 amps) is 25, with the consequence that a bottom-limit BD-124 requires a base current of 40mA if it is to pass a collector current of 1 amp. By giving R<sub>3</sub> a value of 47Ω, a base current of about 50mA becomes available. This ensures that TR<sub>2</sub> is taken fully into conduction at

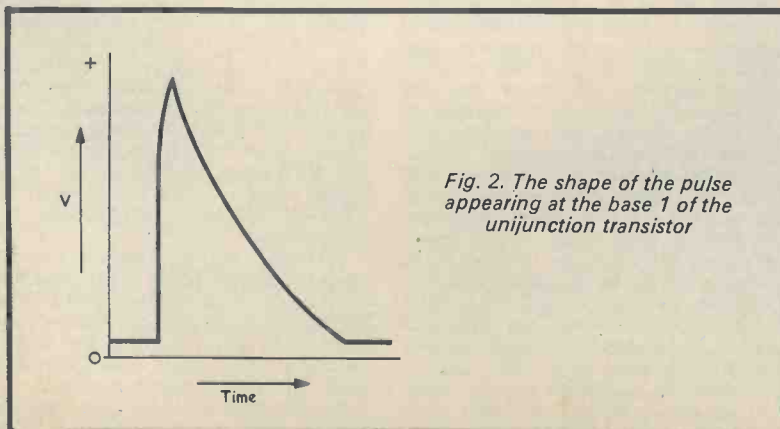

# BUY THIS BEST SELLER

## T.V. FAULT FINDING 405/625 LINES



### REVISED & ENLARGED

Edited by J. R. Davies

124 pages Only 50p

Over 100 illustrations, including 60 photographs of a television screen after the appropriate faults have been deliberately introduced.

Comprehensive Fault Finding Guide cross-referenced to methods of fault rectification described at greater length in the text.

Price 50p from your Bookseller

or post this Coupon together with remittance for 56p (to include postage) to

**DATA PUBLICATIONS LTD.**  
57 Malda Vale, London, W.9

Please send me the 4th revised edition of TV Fault Finding, Data Book No. 5

I enclose cheque/crossed postal order for.....

NAME .....

ADDRESS .....

R.C. Block Letters Please

the peak of the pulse shown in Fig. 2, and that it is at or near full conduction for the upper part of the pulse near the peak.

The 2N2646 is capable of a base 1 current of 50mA, but there is no point in having a semiconductor device pass a greater current than is necessary. Since it is doubtful in practice that the gain of TR2 will be anywhere near its bottom limit it is probable that there will be, in most units built up to the circuit of Fig. 1, no significant loss in output if R3 is increased in value to 100Ω, thereby halving the base 1 current in TR1. This point has to be checked experimentally after the circuit has been assembled. An intriguing feature of this situation is that increasing the value of R3 to 100Ω causes the rate of discharge in C2 when TR1 triggers to be halved, whereupon the pulse waveform of Fig. 2 becomes twice as wide. In consequence, if TR2 is a high-gain specimen the increase in the value of R3 may result in TR2 becoming fully conductive over a higher section of the pulse; but, compensating for this, the widening of the pulse will still allow TR2 to be conductive for nearly the same amount of time.

### CONSTRUCTION

The circuit may be assembled in any convenient manner, and layout is not important. As was stated earlier, the speaker should be fitted in a cabinet. This cabinet could house the parts, with VR1, S1 and S2 mounted on the front panel. The connection between R3 and base 1 of TR1 should be of a temporary nature during construction.

When completed, VR2 should be adjusted to insert minimum resistance into circuit and the metronome switched on by means of S2. The resistance inserted by VR2 should then be increased slowly until pulses are heard at good amplitude with S1 set to position 3. VR2 should not be advanced any further than this at the present stage, and the operation of VR1 and S1 should then be checked.

Next, set VR1 to insert maximum resistance, set S1 to position 3 and switch off at S2. Connect a meter switched to read 100mA full-scale in series with the positive battery lead and ensure that C1 is reliably in circuit (as, otherwise, the meter may be damaged by the pulses of loudspeaker current). Switch on at S2. The meter needle will give a kick at switch-on as C1 charges, after which it will read the current drawn by the metronome. Set VR2 to insert minimum resistance into circuit once more, thereby stopping the pulses being reproduced by the loudspeaker. Slowly advance VR2 so as to insert more resistance into circuit. As VR2 advances, the pulses will become audible again. The meter needle will kick up to some 10 to 20mA at the pulses, falling to a value very near zero between them. When VR2 slider

passes a certain point the current between pulses will noticeably increase. The final position for VR2 is just before the point at which the current between pulses commences to increase. This setting is not very critical.

After this process, switch off at S2 again and insert a 47Ω ½ watt 5 or 10% resistor between R3 and base 1 of TR1, as in Fig. 3(a). Switch on again and temporarily short-circuit

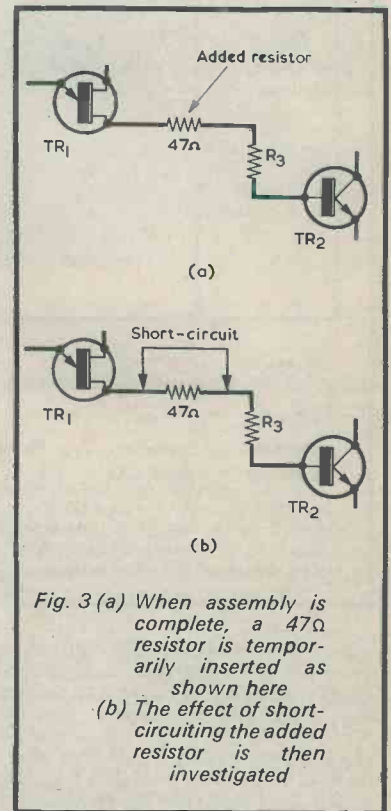

Fig. 3 (a) When assembly is complete, a 47Ω resistor is temporarily inserted as shown here  
(b) The effect of short-circuiting the added resistor is then investigated

this resistor with a piece of wire, as illustrated in Fig. 3(b). S1 should be in position 3 for this check and it is helpful to adjust VR1 for a fairly high pulse frequency. If the audible level is higher with the added resistor short-circuited, then the correct value for R3 is 47Ω. If there is no significant alteration in audible level when the added resistor is short-circuited then R3 can be changed to 100Ω ½ watt, 5 or 10%. The added resistor is removed and R3 (either as 47Ω or as 100Ω) finally wired in. If R3 is changed to 100Ω the setting of VR2 should be re-checked.

VR1 may be fitted with a pointer knob and a scale which is calibrated in terms of pulses per minute. For all but the highest speeds the calibration may be made by counting the pulses whilst observing a watch with a sweep second hand. Such a calibration should be quite adequate for most applications where a metronome is used.





# Q S X

By  
**FRANK A. BALDWIN**  
(All Times GMT)

The subject of clandestine radio stations is always of interest to many short wave listeners. Some of the less well known clandestines were mentioned in the last issue of this magazine — see under 'Short Wave News for DX Listeners' — and to commence with here we report reception of another under-cover transmitter.

On **9555** the Iranian Revolutionaries Radio was heard opening at 1858 with slogans and propaganda in Farsi (Persian) which went turgidly on to sudden sign-off at 1957. A short interlude of military music at 1901 was the only light relief!

Radio Pathet Lao is another pro-communist clandestine that should prove of interest to the DX hunter. Try **7310** around 2300 or 1530.

## ● LATIN AMERICA

Two recent late night sessions have produced a few Latin Americans although, at the time of writing, the 'season' for reception of these stations had not by any means got into its stride.

- 4679 0250** HCWE1 Radio Nacional Espejo, Quito, Ecuador, with light orchestral music, YL in Spanish and identification. This one has a 24 hour schedule, 5kW (64.11m).
- 4755 0302** Radio Difusora de Maranhao, Sao Luis, Brazil, announcements in Portuguese, National Anthem and sign-off. Schedule is from 0800 to 0300, 5kW (63.09m)
- 4820 0231** HRVC La Voz Evangelica, Tegucigalpa, Honduras Republic, with hymns accompanied by the piano. Schedule 1000 to 0430, 5kW (62.24m).
- 4832 2315** TIHB Radio Capital, San Jose, Costa Rica, Latin American music and identification. Has a 24 hour schedule, 1kW (62.08m).
- 4905 0154** ZYZ20 Radio Relogio, Rio de Janeiro, Brazil,

two short pips and one tone every minute as time checks, with ticks every second superimposed over OM in Portuguese, identification at 0200. ZYZ20 has a 24 hour schedule, 5kW (61.16m).

- 4915 0400** HJSG Radio Guatapurí, Valledupar, Colombia, with a newscast in Spanish after identification. Schedule 1100 to 0500, 1kW (61.03m).
- 4923.5 0219** HCRQ1 Radio Quito, Ecuador, with Latin American songs after station identification. Schedule is from 1045 to 0430, 3kW (60.94m).
- 5035 0330** ZYW22 Radio Anhanguera, Goiania, Brazil, with songs, music and identification. Schedule 0900 to 0400, 1kW (59.58m).
- 5045 0345** CP38 Radio Altiplano, La Paz, Bolivia, plaintive Andean music heard from 0335, then identification. CP38 has a 24 hour schedule, 5 kW (59.46m).
- 11925 2148** ZYR78 Radio Bandeirantes, Sao Paulo, Brazil, sports commentary in Portuguese. Schedule 2100 to 0530, 10kW (25.16m).

## ● AUSTRALIA

- 6055 2100** Darwin with the world news in English after 6 'pips' and station identification.
  - 9570 0846** Shepparton with a programme in English about the Australian cricket scene.
- The above are transmitters of the Overseas Service. From the DX point of view, an interesting outlet of the Domestic Service is that of Brisbane on the 60 metre band. Logged here in early May on:
- 4920 1952** VLM4 Brisbane, opening with dance music records, good morning greetings, 'Waltzing Matilda', 6 'pips' and

time-check for 6 a.m. (at 2000 GMT) followed by the world news. Schedule 2000 (Sundays 2030) to 1402, 10kW (60.98m).

## ● INDONESIA

- 4805 2154** YDF4 Jakarta, Indonesia, series of six musical chimes repeated until announcements and news in Indonesian at 2200 lasting to 2209.

## ● WINDWARD ISLANDS

- 5015 2304** WBS Grenada, world news in English (relay of BBC World Service).

## ● CAMEROON

- 4972 2049** Radio Yaounde, African drums and chants, ideal material for those with tape recorders.

## ● ANGOLA

- 4793.5 2110** CR6RG Radio Commercial de Angola, Sa da Bandeira, with YL in Portuguese songs under hetro (listed 4795).
- 4937 2037** CR6RS Radio Clube do Lobito, Portuguese songs, announcements and music.
- 4985 2000** CR6RB Radio Ecclesia, Luanda, with identification in Portuguese after music programme.
- 5060 1919** CR6RD Radio Clube do Huambo, with a programme of light orchestral music and announcements in Portuguese.

## ● MALAYSIA

- 4845 2200** Kajang, Radio Malaysia opening with 6 'pips', National Anthem and newscast in Tamil.

## ● KENYA

- 4805 2100** Nairobi, station identification, newscast in English and sign-off at 2108.

## ● CHINA

- 4380 2010** PLA Fukien, with Chinese songs and music, announcements by YL.
- 4864.5 2155** Lanchow, talk in Chinese by OM, some CW QRM on channel.
- 4905 2034** Radio Peking, Chinese orchestral music, YL with songs.

## AVO'S FIRST PANEL METERS

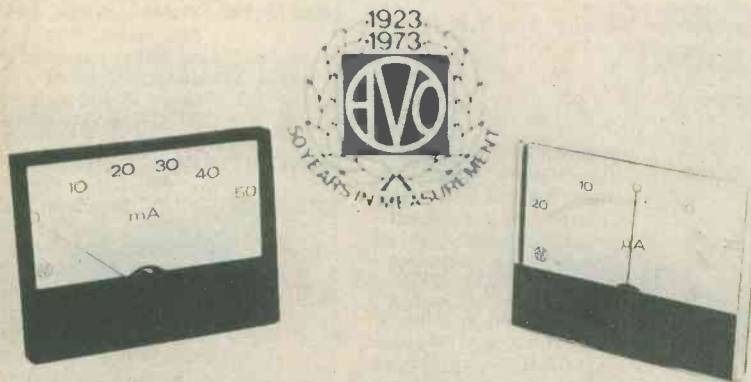

First panel meter from Avo Limited, the Dinline Fifty range of eight matching models with two alternative presentations.

AVO celebrated their Golden Jubilee with the introduction of their first-ever range of panel mounting meters – the new Dinline Fifty range.

These new AVO panel meters were launched at the International Electronic Components Exhibition.

The range is available in a matching series of eight models with two alternative presentations, one moulded in tough ABS material with matt black finish and glass window, the other moulded in clear Macralon giving a clearview appearance and ensuring entirely shadow-free readings. This second presentation is available with either a matt black escutcheon or a range of colours to customer requirements. A low arc line is offered as standard and all models combine the well-known AVO reputation for reliability with compact modern styling and clear readability to meet virtually all requirements.

Standard features include comprehensive preferred ranges, accuracy to BS 89/70 Part 1 and a sensitivity of 1000Ω/V. Many other special features are available including optional stud positioning, enabling customers to up-date their equipment without alteration to existing panel cut-outs, non-standard accuracies, higher sensitivities, mirror scales, off-set or centre zero and special scaling to customer requirements.

Enquiries for Dinline Fifty panel meters, from equipment manufacturers, should, in the first instance, be made direct to Avo Limited, Archcliffe Road, Dover, Kent.

## NEW PNEUMATIC CALL UNIT

Nelson Tansley's Pneumatic Call Units are now available in a number of forms, with either a squeeze bulb on a flexible tube or a wall-mounted push-pad as the call component.

In principle the pneumatic system comprises the call component coupled by tubing to a sensitive bellows unit which operates a sealed spark-free microswitch.

The pneumatic units are particularly suitable for applications where direct switching, even at low voltages constitutes a hazard. Such applications occur, for example, in geriatric wards, bathrooms and shower cubicles where the electric-shock danger is particularly acute.

An important feature of the pneumatic call units are their complete freedom from fire risk. They are,



Call Unit with flexible air tube.

therefore, ideally suited for use in oxygen tents.

They also offer obvious advantages for operating theatres, where a spark from an open switch could ignite highly inflammable gases to cause an explosion; and the waterproof construction also permits direct hosing without risk of damage.

An outstanding feature of the pneumatic system is the ease with which a call can be made, even by a weak or severely handicapped person, using the hand, elbow or foot. The sensitivity of the units can be preset to meet such requirements.



## GRILLE MATERIAL

Expamet expanded aluminium with colour anodised finish is an attractive material for making all types of grilles for speakers and ventilation openings in equipment and hi-fi cabinets. Used for many years by leading electronics companies it is now available to the hi-fi, electronics and radio amateur. It is sold by many d.i.y. retailers and meshes may be selected from a display stand containing four different patterns packed in colourful sleeves.



# COMMENT

## OSCAR BEING WELL USED

At the time of writing, the Amateur Radio Satellite, OSCAR 6, has completed over two thousand five hundred orbits. That it is being well used for communication by radio amateurs is well shown by the reports steadily coming in of the many contacts made throughout the world via OSCAR 6.

The American Amateur Radio League, is now offering a special certificate for contacts via OSCAR. Points are awarded on a contact-country-continent basis, and certificates are awarded to those stations accumulating 1,000 points. The first 'G' station to be awarded this Certificate is Pat Gowen, G3IOR, of Norwich, who to date has worked a total of 174 amateur radio stations - 137 in 24 European countries, 26 in U.S.A., 9 in Russia and 2 in Canada. A pretty impressive log! And he has done this with quite modest equipment, viz., a three element Yagi at 50 feet on the 10 metre receiving side, with a good home built 10 metre receiver, and 12 watts to a 6 over 6 slot fed antenna for transmitting on the 2 metre circuit, tilted 7 degrees to the horizon, 30 feet high.

OSCAR 6 is now turned off during part of the week to give the solar cells adequate time to recharge the batteries. It is fully functional on Thursdays, Saturdays, and Mondays, at the time of writing.

## IN PARLIAMENT

In a written parliamentary answer to a question by Mr. John Hannam, M.P., asking what action he proposed to take following representations made to him to restore regional broadcasting on medium frequencies in the South West, Sir John Eden, Minister of Posts and Telecommunications, stated:

"I have authorised the BBC to install low-power transmitters at Exeter, Barnstaple, Torbay, Plymouth and Redruth to broadcast on medium frequencies the programmes carried on the VHF transmissions of Radio 4, which include regional items."

## IN BRIEF

- Sales office of ITT Components Group's Thermistor Division, formerly in Harlow, has moved to Stephen Street, Taunton, Somerset. It is now at the same location as the factory.
- Special Event Station: GB3MKB - Ballycastle, Co. Antrim, June 30-July 7, operated by Belfast YMCA ARC for local Marconi-Kemp 75th Anniversary. Specially printed postal covers (Ballycastle or Rathlin Is. postmark) a, regional stamp 15p or 3 IRC's; b, Marconi-Kemp 9p stamp 20p or 4 IRC's. Postmark on separate covers - a, 25p or 5 IRC's; b, 35p or 7 IRC's; apply UDC Office, Ballycastle, Co. Antrim. All bands operation, contacts count towards G16YM Golden Jubilee Award.
- Lindair House in Tottenham Court Road is Europe's first department store devoted to hi-fi, audio and video equipment and, according to Chairman, Bennie Linden, its 23,000 square feet of space, coupled with its stock of more than £1m worth of hi-fi equipment, establishes Lindair House as the biggest specialist outlet of its kind in the world.
- Four new Fellowships have been awarded by The Royal Television Society. The new Fellows are: Walter Anderson, Ivan James, Charles Marshall and Peter Rainger.
- The British Amateur Electronics Club's Exhibition is being held at the Shelter, Esplanade, Penarth, Glam., from 21st to 28th July.
- AMF Potter and Brumfield have received from Swift Hardman Ltd., an order for no less than fifty-five thousand relays. This is believed to be the largest single order ever placed by a distributor with any manufacturer in the United Kingdom.

## EASY-CARRY PACKS FOR RECORDING TAPE



Improved handling, identification and storage of EMI professional recording tape should follow the introduction of the new easy-carry packs with handles.

The first pack size to be introduced accommodates 2 in. tape on 10½ in. diameter reels. Emitape 815 and 816 professional recording tape on this size of reel is in extensive use in studios. A 10½ in. reel of two inch tape weighs about 9 lb. (4 kg.).

Packs for reels of 1 in. and ½ in. multi-track tape will be introduced during the summer.

A valuable feature of the new pack, is the provision of white panels on one edge of the pack to carry identification on the library shelf and a large panel on the rear carrying a form on which to enter data about the recordings on the tape.



# MODIFYING THE GC1U RECEIVER. Part 1.

by P. Cairns, R. Tech. Eng., M.I.P.R.E., G3ISP

This is the first of two articles describing modifications which have been successfully carried out on the Heathkit 'Mohican' Communications Receiver Model GC-1U. The concluding article will appear next month.

## Editor's Note

The modifications described in this and next month's articles should be carried out only by the experienced constructor who fully understands the principles involved. We have been asked by Heath (Gloucester) Limited to point out that the GC-1U is no longer a current Heathkit model and is therefore no longer available, and that Heath cannot supply any of the parts needed for the modifications nor can they enter into any correspondence concerning them. Further, under their general terms Heath (Gloucester) Limited cannot accept equipment for service which has been modified in any way.

THIS TWO-PART SERIES DESCRIBES SOME MODIFICATIONS to the popular GC-1U communications receiver which should provide improved performance, stability and s.s.b. reception. The two principal points discussed are the inclusion of an internal regulated mains power unit to replace the existing UBE-1 eliminator unit normally used with this receiver and the addition of a simple internal product detector for improved s.s.b. reception. Whilst the circuits described relate principally to the GC-1U receiver, the product detector could be applied to many receivers which lack this facility. The power unit, with minor changes, could also be used to supply most transistor receivers from the domestic mains supply. The circuits therefore offer some scope to the practical experimenter as, with minor modifications, they could be applied to many receivers other than the type specifically mentioned here. These points will be discussed next month.

The GC-1U is essentially a good general purpose receiver, being found in a great many amateur and s.w.l. stations throughout the world. It is however a little 'dated', having been one of the first all-transistor communications receivers to appear on the amateur market. It was designed for battery operation with the choice of the UBE-1 eliminator as an optional extra for mains operation, this unit fitting into the receiver internal battery box. Compact size, good sensitivity and reasonable selectivity, together with wide frequency coverage and excellent bandwidth features, are included among its better points. Its performance on s.s.b. is not particularly good, however, and both short term and long term frequency drift, particularly on the h.f. bands, is sometimes noticeable. This is particularly so when the dial light switch on the front panel is operated. This switch is provided in the interests of power economy when using batteries.

## NEW POWER SUPPLY

The first necessity was considered to be a stable power supply. The load characteristic of the UBE-1 eliminator as checked by the author is shown in Fig. 1. As can be seen, taking the extremes of load variation with and without dial lights (indicated in the diagram as 'maximum load change'), the d.c. supply variation was 3.8 volts. The d.c. output was also directly proportional to changes in mains voltage. The output of the alternative power supply, which will next be described, is also shown in Fig. 1 for comparison.

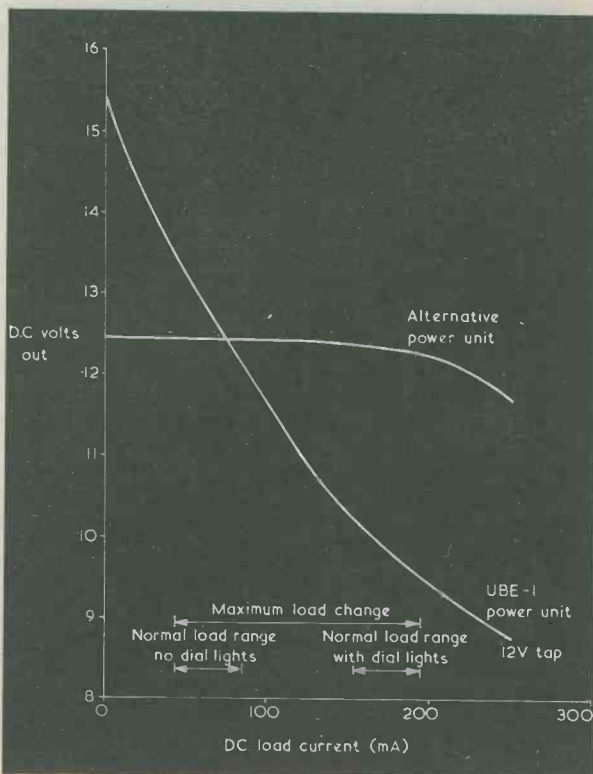
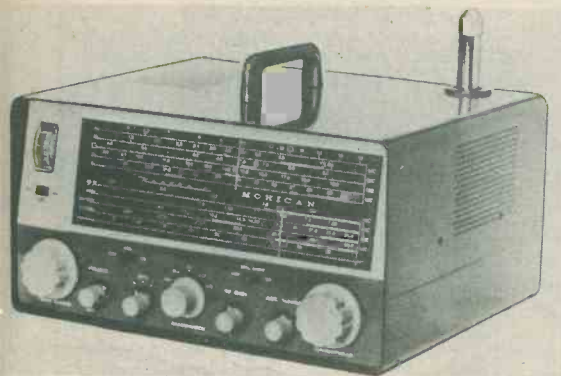

Fig. 1. Regulation curves obtained by the author with the original mains unit and the alternative unit





improved, being 0.1% as against 0.35% at 100mA. The receiver power circuits are also simplified, as can be seen in the 'before and after' circuit diagrams of Figs. 2 (a) and (b). All components designated in the receiver circuits relate to those in the published circuit diagram and receiver handbook.

The alternative power unit is quite conventional and uses standard components. It is designed to fit into the receiver internal battery box. The secondary output from a small mains transformer, T1, is fed into an encapsulated diode bridge, this providing full-wave rectification. T1 is an R.S. Components 'filament transformer' offering 16.3 volts at 0.3 amp centre-tapped (Home Radio Cat. No.TH5A) whilst the diode bridge is a Mullard BY164 (available in the Home Radio semiconductor list under the same number). Smoothing is provided by the filter circuit consisting of C1, R1 and C2, R1 also providing current limiting for the zener diode D5, which stabilizes the 12 volt d.c. output. This diode is of the stud-mounting variety and is mounted on a 1½ in. square aluminium plate which acts as a small heat sink. The output is fed via the Internal-External switch to the receiver circuits. The muting link is left in the positive line, whilst C22 is retained to decouple the supply line at radio frequencies. An additional smoothing capacitor, C3, is added in the receiver to further reduce ripple and ensure negligible

The circuit diagram of the alternative power unit is given in Fig. 2(b) with the original circuit, for comparison, in Fig. 2 (a). As can be seen from the curve in Fig. 1, the maximum voltage change with the new supply unit is only 0.2 volt, a regulation improvement of almost 20 times. The ripple factor is similarly

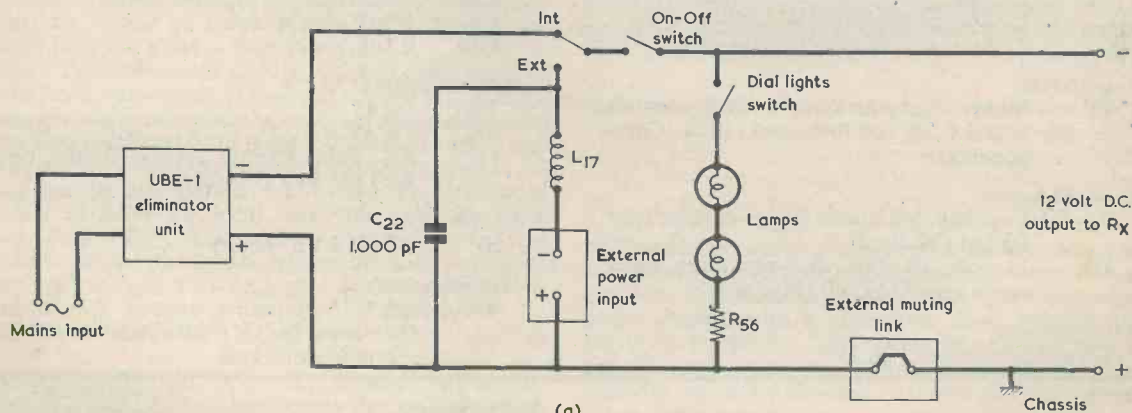

(a)

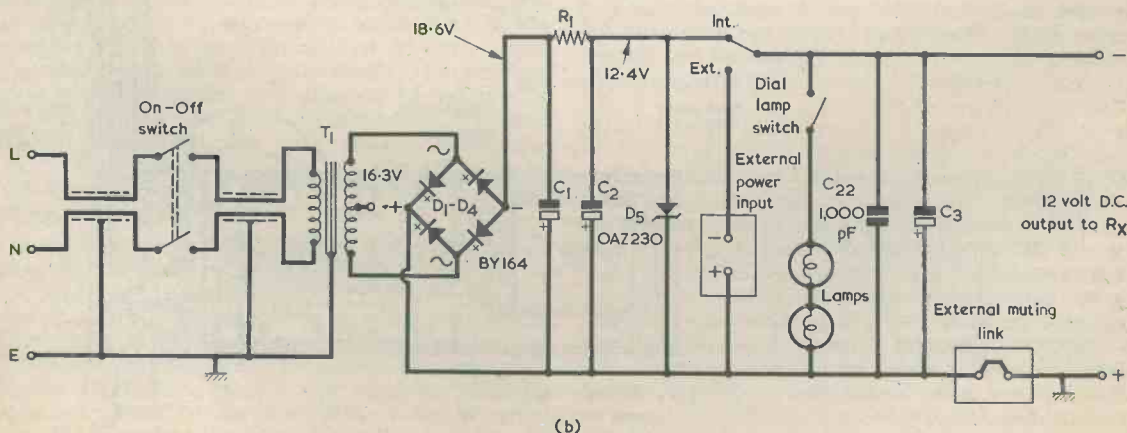

(b)

Fig. 2 (a). The original mains power circuit  
(b). Modified circuit incorporating the alternative power supply

hum even at maximum volume. The dial lights and light switch are connected directly across the 12 volt receiver supply. Economy resistor R56 and r.f. choke L17 can be omitted.

One further disadvantage with the original circuit was that no mains switch was incorporated in the UBE-1 eliminator, the on-off receiver switch on the a.f. volume control being in the 12 volt d.c. line. This meant that the mains transformer primary was permanently energised, even with the receiver switched off. In the alternative circuit the switch is taken out of the d.c. line and put into the mains supply to T1 primary. The double-pole switch required is already on the rear of the a.f. volume control and can be safely used for this purpose, being rated at 250 volts 1 amp a.c. Insulated twin screened cable is used to take the mains supply both to and from this switch, and this prevents hum pick-up in the adjacent circuits on the receiver printed board. The mains wiring is terminated at a 6-way tagstrip fixed to the side of the battery box, as shown in Fig 3.

## COMPONENTS

### Power Supply

#### Resistor

R1 25Ω 5 watts wire-wound

#### Capacitors

C1 1,000μF electrolytic, 25 V.Wkg  
C2 1,000μF electrolytic, 15 V.Wkg  
C3 2,500μF electrolytic, 15 V.Wkg

#### Transformer

T1 Mains 'filament transformer', secondary 16.3V 0.3A centre-tapped. (R.S. Components)

#### Semiconductors

D1-D4 Encapsulated silicon bridge rectifier type BY164 (Mullard)  
D5 12 volt, 10 watt, stud-mounting zener diode type OAZ230 (Mullard)

#### Miscellaneous

6-way tagstrip (see Fig. 3)

## COMPONENTS

### Product Detector

#### Resistors

(All fixed values ½ watt 10%. R47 and R54 are new values for existing resistors.)

R1 100kΩ  
R2 5.6kΩ  
R3 220Ω  
R4 3.3kΩ  
R5 6.8kΩ  
R6 330kΩ  
R7 3.3kΩ  
R8 2.2kΩ  
R9 220Ω  
R10 470Ω  
R11 470Ω  
R12 750Ω  
R47 1kΩ potentiometer, linear wire-wound  
R54 2.2kΩ

#### Capacitors

C1 100pF silvered mica  
C2 100pF silvered mica  
C3 0.1μF plastic foil  
C4 680pF silvered mica  
C5 0.0068μF plastic foil  
C6 0.1μF plastic foil  
C7 1μF plastic foil  
C8 0.47μF plastic foil (see text)  
C9 0.1μF plastic foil  
C10 0.1μF plastic foil

#### Semiconductors

TR1 OC45  
TR2 OC45  
D1 6.8 volt 400mW zener diode type BZY88C6V8 (Mullard)

#### Switch

S1 2-pole 3-way rotary

#### Miscellaneous

Veroboard, 0.15 in. matrix, approx. 2 by 2½ in.  
(12 strips by 13 holes) Aluminium for mounting brackets

Fig. 3. Layout of the components in the new mains supply unit

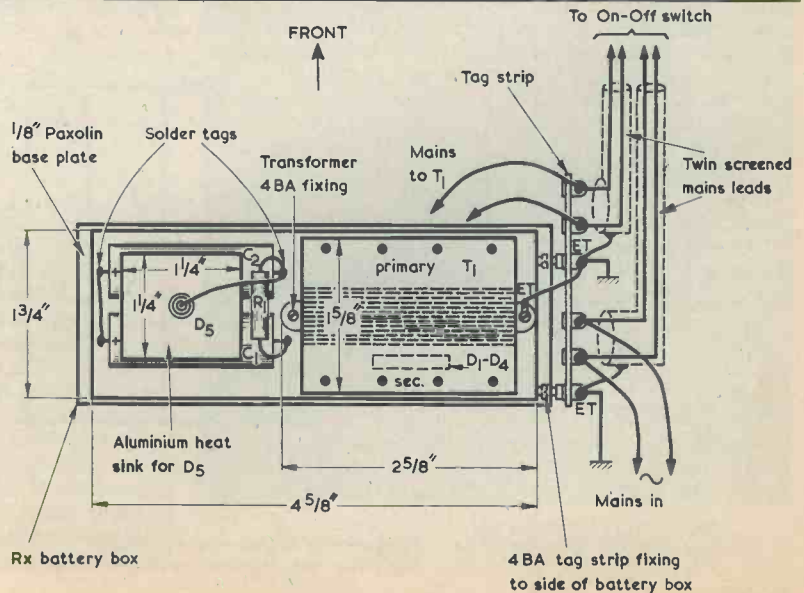



## POWER UNIT CONSTRUCTION

The construction of the power unit should offer no problems. The components are mounted on an  $\frac{1}{8}$  in. Paxolin board resting on the bottom of the battery box, the capacitors and resistor being mounted between solder or turret tags mounted in the board. Add an insulating strip of Paxolin to ensure that the bottoms of these tags do not short-circuit against the metal base of the battery box. The zener diode, D5, is mounted, as already mentioned, on a  $1\frac{1}{4}$  in. square heat sink, and it is soldered between the appropriate tags by means of the 18 s.w.g. wire so that it becomes self-supporting. The encapsulated diode bridge is beneath T1 top plate, being wired directly to the appropriate secondary tags.

A general view of the power unit, together with the relevant dimensions, is given in Fig. 3 and a list of the additional parts required appears in the accompanying Components List. A small grommet can be let into the back of the receiver cabinet to allow for the outgoing mains lead. The extra smoothing capacitor, C3, is positioned under the i.f.-a.f. printed board, being fastened to the underside plate of the chassis by means of an insulated spring clip secured by a 6BA counter-sunk screw. As the can will normally be common to the negative lead of the capacitor it must be insulated from the chassis which is, of course, positive. Hence the use of an insulated clip. The mains cables going to and from the power switch are held in place along the top edge of the printed board by small clips, these being fixed to the chassis by means of the existing 6BA screws which already hold the printed board in place.

When the new power unit is completed the receiver can be tried out with it. If desired, voltage and current checks may be made, and the readings obtained should be approximately equal to those indicated in Figs. 1 and 2 (b). An improvement in overall stability should be noted, particularly on the h.f. bands. The frequency stability of both the local oscillator and the b.f.o., should be virtually unaffected by the operation of the dial light switch, by normal changes in mains voltage or by changes in the r.f. and a.f. gain control settings.

## RESISTOR SUBSTITUTION

Before dealing with the product detector, two further points of a more general nature may first be mentioned. After completing and testing the power unit, a complete check and if necessary, a complete realignment of the receiver, is worth-while. This assumes, of course, that the necessary signal generator is available. The complete alignment procedure for both i.f. and r.f. sections is fully described in the receiver handbook. Whilst a complete realignment can take several hours, the writer found it well worth-while in terms of increased sensitivity and selectivity and accurate local oscillator tracking.

The second point refers to the replacing of all existing carbon resistors by high stability metal oxide types. This gives a much improved performance with regard to noise. The older type of standard carbon resistor tends to be rather noisy, whilst the new 5% metal oxide resistor has a much superior noise and long-term stability factor. The r.f. and frequency changer circuits are particularly sensitive to this form of noise. Besides reducing the noise level by a noticeable amount, the long-term stability of the overall circuits is much improved by changing to this type of resistor. While again this task is rather time-consuming, and metal

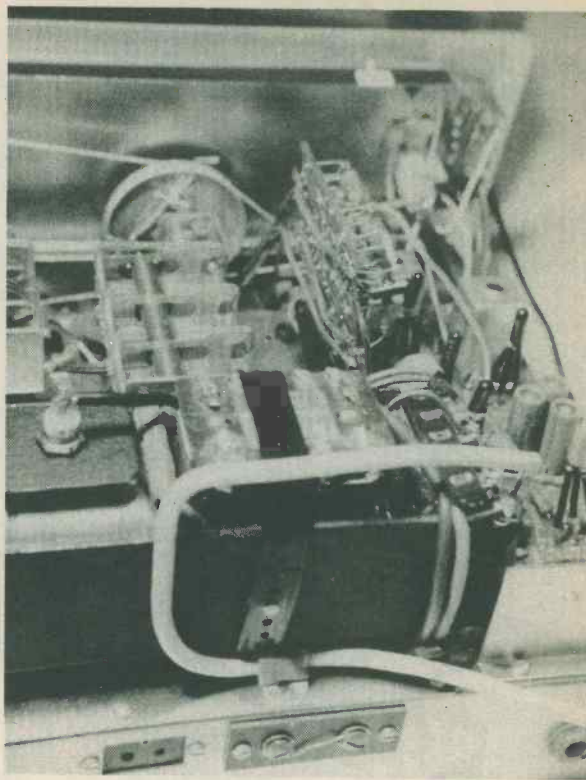

*A view of the new power supply unit fitted in the battery box*

oxide resistors are more expensive than carbon types, the writer considers the results worth the extra time and expense. This modification can be recommended for any older receiver with a high noise level, whether it be valve or transistor. The writer has carried out this modification on several older receivers and has always found it extremely effective in improving the signal-to-noise performance.

The replacement of the older type paper capacitors by new polyester types, particularly in r.f. and i.f. bypass and decoupling circuits, also helps to improve overall receiver performance and stability.

## S.S.B RECEPTION

The inclusion of a product detector for s.s.b. reception was considered necessary for improved s.s.b. performance. With the original circuit s.s.b. reception was achieved by the earlier method of switching on the b.f.o., tuning in the required s.s.b. signal, reducing the r.f. gain as much as possible and readjusting the b.f.o. control for final tuning, the a.m. detector being left to resolve the signal. Such a method has several disadvantages. Any drift in the local oscillator frequency or b.f.o. frequency is sufficient to cause severe distortion or even a completely unreadable signal. Sudden changes in r.f. signal strength or changes in r.f. gain setting can produce a similar effect. To a certain extent, all these problems can be overcome by the inclusion of a well stabilized supply and a simple product detector.

# Use the NEW Strip-fix Plastic PANEL SIGNS



★ SET 3 - Wording - WHITE

★ SET 4 - Wording - BLACK

Over 1,000 words and symbols,  
covering more than 300 terms, in  
each set

Illustration of actual size = RADIO

- Easy to fix - Just cut out words required remove backing and press down
- Stapled in booklet form
- Designed to hang above workbench
- Pocket for loose cuttings
- Professional finish

## 38p per set

including V.A.T.

(postage 3p)

The Perfect Transfer for  
the Home Constructor

Available from  
Data Publications Ltd.  
57 Maida Vale, London W9 1SN

The existing third i.f. stage and b.f.o. stage are shown in Figs. 4 (a) and (b) respectively. Fig. 5 shows the added product detector circuitry and its interconnection into the two stages illustrated in Figs. 4 (a) and (b). Also shown is the added function switch S1 (a) (b). The circuit is designed so as to keep the number of modifications to the receiver to a minimum.

The circuit in Fig. 5 shows a simple product detector TR1, the circuit functioning on a non-linear characteristic. The b.f.o. output is fed via C2 into TR1 base, this signal being mixed with the i.f. output taken from transistor X6 emitter via C1. (The previous b.f.o. coupling capacitor, C60, is now removed.) The resultant product of these two signals is developed in amplified

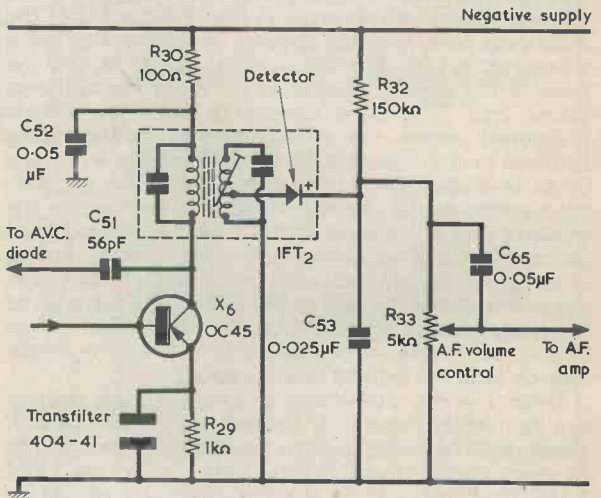

(a)

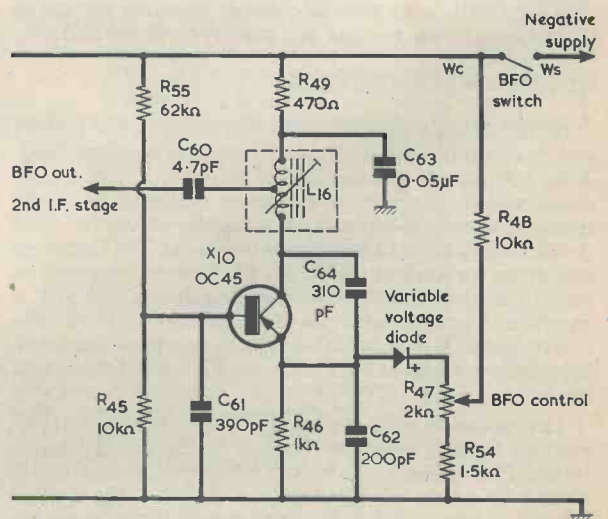

(b)

Fig. 4 (a). The third i.f. stage of the receiver in unmodified form  
(b). The unmodified b.f.o. stage.



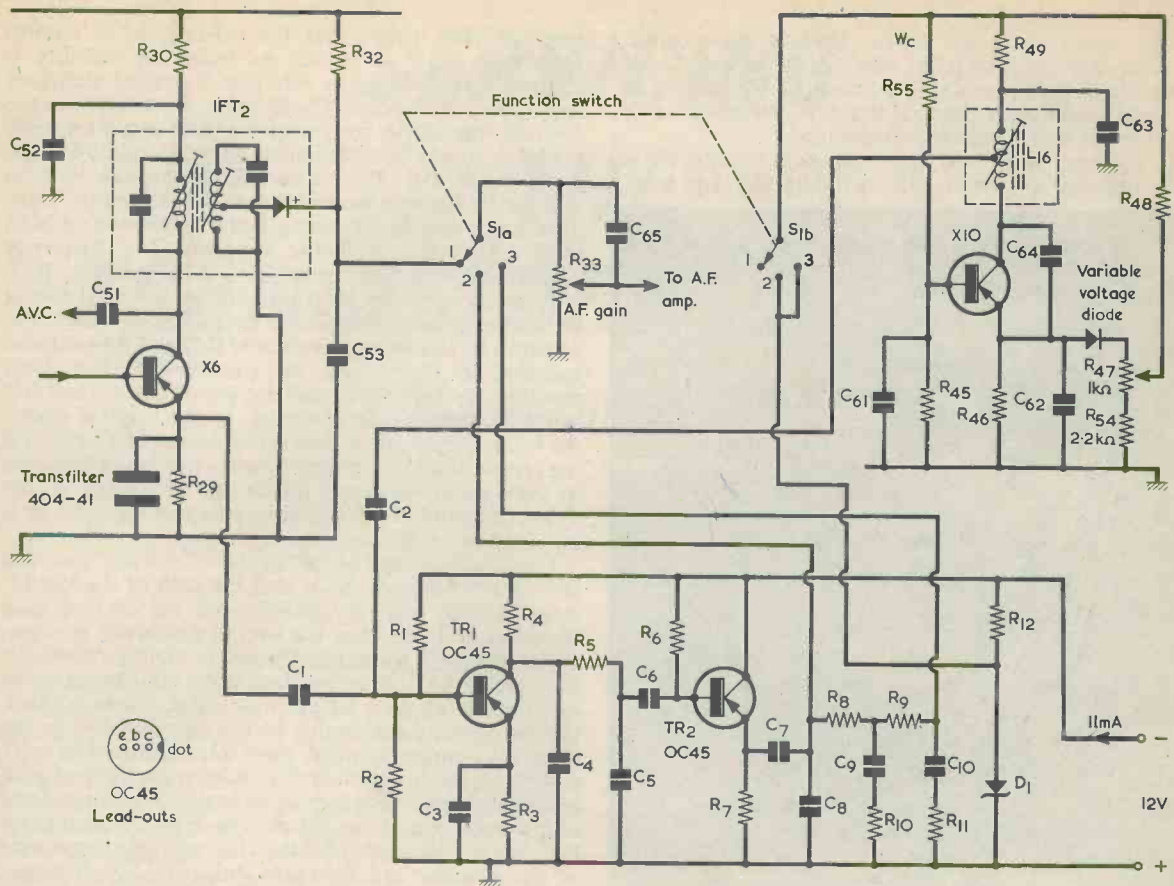

Fig. 5. The added product detector circuit, including the interconnections to the third i.f. and b.f.o. stages

form across load resistor R4 and fed into the filter circuit C4, R5, C5. The characteristics of this filter help give the resultant output the correct shape and frequency bandpass, the insertion loss involved being catered for by the signal gain achieved in TR1.

The filter output is fed via coupling capacitor C6 to the emitter follower TR2, the final output signal being developed across emitter load resistor R7. The purpose of TR2 is to give isolation between detector TR1 and the audio output circuits and also to provide a low impedance output for easy matching into the audio input circuit. The final output is taken via blocking capacitor C7, through the function switch S1, to the receiver first audio stage.

An optional extra audio filter circuit is also connected, via isolating resistor R8, to the output. This filter is formed by R9, R10, R11, C9 and C10 and it is a simple low-pass circuit which can be switched in by the function switch to give a narrow audio acceptance band. Such a facility can prove useful in both s.s.b. and c.w.

modes. It would normally only be used under crowded band conditions and in effect it helps to improve selectivity. The filter can, however, be omitted if required. C8 forms a capacitor divider in conjunction with C7 and provides simple top cut. It clips overall upper bandwidth limits to an acceptable level, though it does tend to reduce sensitivity slightly. Its value can be altered to suit individual receivers.

Function switch S1 (a) (b) allows selection of a.m., s.s.b./c.w., and narrow band s.s.b./c.w. on positions 1, 2 and 3 respectively, and section (a) is inserted between the last i.f. stage and the a.f. input. In position 1 the output from the a.m. detector is taken directly, via S1 (a) to the a.f. input. In positions 2 and 3 the outputs from the product detector are taken to the a.f. input while the a.m. detector is left out of circuit. At the same time the supply to the b.f.o. is switched in by S1 (b). It will be noticed that the i.f. output is taken from the emitter of X6. This was done to avoid having to break into the I.F.T.2 circuit, with the resultant damping

which would result due to the loading effect of the product detector. The point selected has a much lower impedance and is much less prone to the effects of external loading. In practice the a.m. performance of the receiver was completely unchanged.

In common with most simple product detectors it is still necessary to carry out final tuning with the b.f.o.

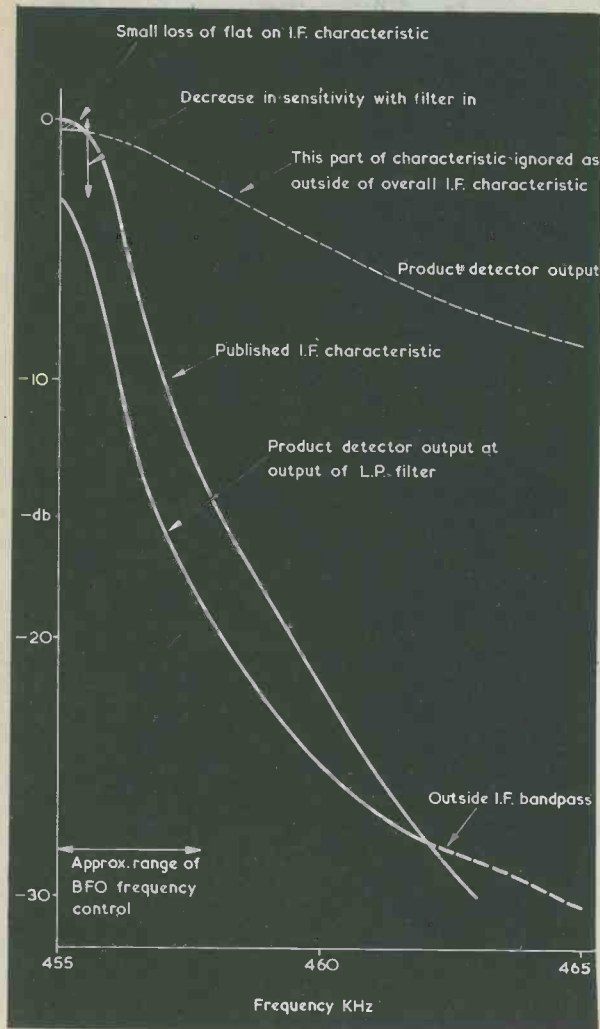

Fig. 6. The relative differences in sensitivity between the product detector output and published i.f. output. The measured characteristics are static only

control. This meant that the existing b.f.o. control required a little attention. As frequency stability is extremely critical it was felt that a special stabilized supply was warranted. The existing zener diode in the receiver was left to cope with the local oscillator only, the b.f.o. supply being taken via S1 (b) from the 6.8 volt zener diode D1. This is connected through limiting resistor R12 across the stabilized 12 volt supply. Thus, in effect, a double stabilizing factor is present on both local and b.f.o. oscillator supplies. The frequency variation covered by the existing b.f.o. control, R47, was found to be too great, making incremental tuning somewhat difficult. A smaller frequency coverage was obtained by changing the values of R47 and R54 to those specified in Fig. 5 and the Components List. This modification kept the overall d.c. conditions correct and provided greater ease of tuning. In the original circuit the b.f.o. supply was turned on by means of a switch on the rear of the b.f.o. potentiometer, this being operated by pulling out the centre spindle. As the supply is now switched on by S1 (a) (b), this control is replaced by a standard potentiometer.

One disadvantage of taking the i.f. output from the emitter of transistor X6 is that the gain of the last i.f. stage is lost. This is compensated for by the gain obtained in TR1. Thus the overall sensitivity is maintained although the selectivity suffers slightly. When the low pass audio filter is switched in (S1 (a) (b) in position 3) an apparent drop in sensitivity is of course noticed, this being unavoidable due to the insertion loss in the filter. As, under crowded band conditions, sensitivity is often of less importance than selectivity, this loss is of negligible importance in most instances. When measured under static signal conditions, the apparent sensitivity loss was in the order of 3db. The static characteristics of the detector and filter are shown in Fig. 6 superimposed over the published i.f. characteristic of the receiver. It can be seen that negligible flat loss occurs with the product detector in circuit. The choice of germanium OC45 transistors was simply in order to keep the modifications in line with the existing receiver circuit, this type already being used both for the i.f. stages and the b.f.o. The additional circuits will be virtually unaffected by normal temperature changes met with in practice.

Constructional details for adding the product detector circuit will be given next month. More precise details of the Veroboard and the brackets required for its mounting, as included in the Components List, will also be provided next month. The relatively large value capacitors specified for C7 and C8 are available from several suppliers, including Marco Trading, The Maltings Station Road, Wem, Salop. As will be explained in the next article, C8 may require adjustment in value.

(To be concluded)

## BACK NUMBERS

For the benefit of new readers we would draw attention to our back number service.

We retain past issues for a period of two years and we can, occasionally, supply copies more than two years old. The cost is the cover price stated on the issue, plus 6p postage.

Before undertaking any constructional project described in a back issue, it must be borne in components readily available at the time of publication may no longer be so.

We regret that we are unable to supply photo copies of articles where an issue is not available. Libraries and members of local radio clubs can often be very helpful where an issue is not available for sale.



# SERVICING THE TRANSISTOR PORTABLE

Part 2 by Vivian Capel

In this concluding article of our 2-part series the problem of low sensitivity is dealt with. Also described is the procedure of alignment using received signals

THE COMMON CAUSES OF NO-SIGNAL AND DISTORTION faults were dealt with in the first article, published last month. Low sensitivity is another trouble that is often encountered. As with other faults, the battery voltage should be checked first; whilst a low battery voltage normally produces distortion, many modern circuits allow the battery voltage to fall appreciably before distortion takes place, and in these cases low volume or sensitivity can be the first symptom of a failing battery.

Almost any stage can give rise to low sensitivity, but not often the output stage as troubles here usually produce distortion. A quick check as to whether the trouble exists before or after the detector is to detune and turn the volume up. A strong background hiss suggests that the audio circuits are in order and that the trouble is in the earlier stages.

## MECHANICAL DAMAGE

As with the other faults dealt with last month, mechanical damage is responsible for many low-sensitivity troubles. A very frequent cause is a broken ferrite aerial rod; the ferrite material is very brittle and is usually the first thing to suffer in a fall. Sometimes the effect of a broken rod is not too great, although there is bound to be some loss of signal and the rod will still, of course, have to be replaced. Also, the coils may become misplaced, thereby upsetting the r.f. alignment and there may even be a broken wire. The coils can become loose without the rod being broken and so this should be one of the first things to check.

When obtaining a replacement rod make sure that the diameter is correct as well as the length. Most rods are standard sizes which can be readily obtained from the component firms.

Sometimes, when a rod breaks, the coils are damaged by impact against some sharp component or object. The long-wave coil, being usually wave-wound, often suffers, with damage penetrating to several layers. This may cause a complete open-circuit or short-circuit of several turns. Do not be misled by the fact that both

wavebands are affected, short-circuited turns will affect any other coil on the rod just as short-circuited turns on a transformer winding affect the whole transformer.

Faulty transistors are also fairly common, and these can be diagnosed in the same way as with the other faults, by voltage readings and by shunting a replacement across the suspected transistor. A signal tracer or injector can be useful for comparing the gain along the r.f. and i.f. stages and thus localizing the defective stage. A check on the i.f. stages can be made by detuning each i.f. transformer in turn. There should be a sharp tuning peak in each case with the possible exception of the final transformer, which will be damped by the detector diode. If it is possible to rotate the core by more than a turn or so without any drop in volume, the associated

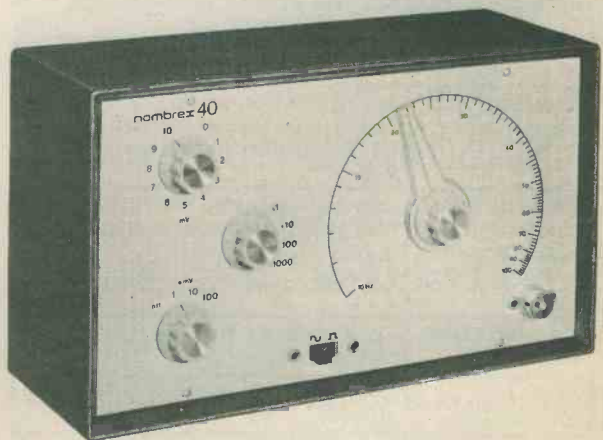

A wide range of test equipment is manufactured by Nombrex (1969) Ltd., Exmouth, Devon. Shown here is the Nombrex Model 40 low frequency signal generator which offers outputs from 10Hz to 100kHz in four switched decade ranges

stage would appear to be faulty. Sometimes a stage may be completely inoperative, yet low-volume results can still be obtained due to stray coupling from the preceding stage. Thus the signal 'jumps' the offending stage. Where a good peak is obtained there is unlikely to be a fault in that part of the circuit. Return each core to its optimum position before passing to the next.

## ALIGNMENT

Now we come to the matter of alignment. Knocks and jolts can loosen cores and coils and throw the alignment out, but more commonly it is the owner who, when performance falls due to some other cause such as the battery, catches sight of the trimmers and proceeds to screw them all up tight! Whatever the cause though, and even with a set which is working tolerably well, an alignment will often bring a marked improvement.

Conventional alignment procedure calls for the use of a signal generator, an output meter and the maker's alignment instructions. However, this is not at all necessary with the simple circuits encountered in receivers of the type being discussed, and in fact the time involved in setting up the equipment would make the job uneconomic. Few professional engineers align these receivers by any other means except by ear and broadcast transmissions, using test equipment only with the more sophisticated sets and those with an f.m. band.

Firstly the i.f. transformers are aligned. A radio transmission should be chosen that is weak in order to avoid a.g.c. action, yet which is steady and not subject to fading. One of the more distant B.B.C. medium wave stations will usually serve the purpose. Volume is kept low as the ear is more sensitive to volume changes at the lower end of the range.

It can be assumed that the i.f. transformers are already near their correct frequency. Exact frequency is not important (some new sets of the same model have been received from the makers aligned to slightly different i.f. frequencies) as long as they are all tuned to the same one. Staggered tuning is not often en-

Table I

Alignment of receivers with separate oscillator long wave trimmer

Tune to:	Adjust:
Weak medium wave station	3rd i.f. transformer for max. volume 2nd i.f. transformer for max. volume 1st i.f. transformer for max. volume Repeat
Radio 3, 464 metres station near 200 metres, or Radio 1, 247 metres	Osc. coil for correct dial setting Osc. gang trimmer for correct dial setting Repeat
Radio 2, 1,500 metres	Long wave osc. trimmer for correct dial setting
Weak long wave station	Long wave aerial coil for max. volume
Radio 3, 464 metres, or nearby weak station. Weak station near 200 metres	Medium wave aerial coil for max. volume Aerial gang trimmer for max. volume Repeat



The Nombrex Model 44 inductance bridge, which is capable of measuring inductances from 1 $\mu$ H to 100H. This incorporates two measuring processes, allowing readings to be taken with air-cored and iron-cored inductors

countered with this class of receiver. All then that needs to be done is to tune each transformer, starting from the last one, for maximum volume, repeating the procedure at least once. If a weak station is used there will be a background hiss from the local oscillator, and it is sometimes easier to listen to this when making adjustments as this is steady whereas the programme content is varying. Always use the correct trimming tool for adjusting the transformer cores.

Next comes the oscillator. Circuits differ somewhat here, and the differences affect alignment considerably. Most circuits use a single oscillator coil for both wavebands, an additional parallel fixed capacitor being switched into circuit on long waves. In some cases, however, a long wave oscillator trimmer is switched in as well, and the alignment procedure depends on whether this trimmer is present or not.

First of all, then, look for a trimmer apart from those across the two sections of the tuning capacitor. Those sets having a bandspread medium wave band in addition to the normal medium wave range will have extra trimmers and these will have to be identified. This can be done by giving each trimmer a slight turn back and fourth and noting which waveband is affected. Oscillator

Table II

Alignment of receivers without oscillator long wave trimmer

Tune to:	Adjust:
Weak medium wave station	3rd i.f. transformer for max. volume 2nd i.f. transformer for max. volume 1st i.f. transformer for max. volume Repeat
Radio 2, 1,500 metres, and Radio 3, 464 metres. Station near 200 metres, or Radio 1, 247 metres	Osc. coil for compromise dial setting Osc. gang trimmer for correct dial setting Repeat
Weak long wave station	Long wave aerial coil for max. volume
Radio 3, 464 metres or nearby weak station. Weak station near 200 metres	Medium wave aerial coil for max. volume Aerial gang trimmer for max. volume Repeat



trimmers tune sharply and have the effect of tuning the entire receiver, whilst aerial trimmers are more flat.

## SEPARATE TRIMMER

If we have a straightforward two-waveband receiver with a separate long wave oscillator trimmer, we start with the medium wave band. Tune in a station near the low frequency end of the scale (i.e. with the 2-gang capacitor near maximum), Radio 3 on 464 metres being suitable. Adjust the oscillator coil core to bring the station to the correct point on the station scale. Now tune to the other end of the band and tune in a suitable station; a station near 200 metres or Radio 1 on 247 metres will do. Adjust the oscillator trimmer on the 2-gang capacitor to bring the station onto the correct point on the scale. Repeat both adjustments for optimum accuracy.

Switch next to long waves and adjust the long wave oscillator trimmer to bring the Radio 2 programme in at 1,500 metres. This will not affect the medium-wave alignment.

If the set does not have a long wave oscillator trimmer a different procedure must be adopted because adjustments will affect both wavebands. First, switch to long waves and adjust the oscillator coil core to bring in the Radio 2 programme at 1,500 metres. Now switch to medium waves and check that the Radio 3 programme or a similar station at the low frequency end of the band comes in at the right point on the dial. If it does not, the oscillator core must be re-adjusted to effect this. It may now be found that the Radio 2 programme is off calibration, so a compromise must be reached between the two. As the long wave stations are broader tuned than those of the medium wave, it is usually better to arrange for the larger error to be on the long wave band. Next, tune to the high frequency end of the medium wave band and bring in a station near 200 metres or Radio 1 in the correct place by the oscillator trimmer on the 2-gang capacitor. As this will affect the other settings, the three adjustments may have to be repeated several times to bring about a satisfactory compromise.

Finally there are the aerial circuits. Weak stations should be used for aerial alignment. For the long wave band all that is needed is to slide the long wave coil (the larger one) along the ferrite rod for best results. A weak long wave station can be chosen for this in preference to the Radio 2 programme, and adjustment is made for maximum volume.

Then switch to medium waves. The low frequency end of the medium wave band is set up by moving the medium wave aerial coil along the ferrite rod followed by an adjustment of the aerial trimmer on the 2-gang capacitor at the high frequency end. These two adjustments may need to be repeated to find the optimum settings. If no means of ensuring that the aerial coils remain steady in their new positions is provided, melt some wax over the coil ends to secure them to the ferrite rod.

In the case of sets with a separate long wave trimmer, both oscillator and aerial circuits can be adjusted before passing to the long wave band. However, with those without such a trimmer all oscillator adjustments must be carried out first because of their interdependence.

By following the hints and tips, as used in dealers' workshops, which have been given here and in last month's issue, speedy and economical repairs are possible in a large number of cases. ■

JULY 1973

# RADIO & ELECTRONICS CONSTRUCTOR

## OUR NEXT ISSUE FEATURES

### FOUR-BAND TRANSISTOR SUPERHET

Part 1  
by R. A. Penfold

This article, the first of a two-part series, describes a fully solid-state superhet receiver covering the medium wave band and three short wave bands extending from 180 to 9.5 metres.



### A.C. MILLIVOLTMETER

by A. P. Roberts

This battery operated instrument has a flat frequency response from approximately 25Hz to higher than 100kHz, and offers ranges from 0-1 mV to 0-500 mV.



### SIMPLE SOLDERING SCHEME

by W. J. Gadsby

A trouble-free method of overcoming an occasional workshop problem.



### MODIFYING THE GC-1U RECEIVER Part 2 (Conclusion)

PLUS

MANY OTHER ARTICLES

PRICE 20p

ON SALE 1st AUGUST

ORDER YOUR COPY NOW

Copies may also be obtained direct from the Publishers, 26p. including postage. Published by Data Publications Ltd. 57 Maida Vale, London W9

# RADIO & ELECTRONICS CONSTRUCTOR



## Cover Feature

**T**HIS MIXER IS ASSEMBLED IN A BOX WHICH MEASURES only  $4\frac{1}{2}$  by  $2\frac{1}{2}$  by 1 in. deep, yet it is completely self-contained, power being obtained from an internal 9 volt battery. Three inputs are provided at nominal input impedances of  $50k\Omega$ ,  $500k\Omega$  and  $1M\Omega$ , but other combinations of these impedances can be used according to the constructor's requirements. Individual volume controls are provided for each channel.

Five inexpensive silicon transistors are employed in the circuit. Current consumption from the PP3 battery is approximately 4mA, giving a very reasonable battery life.

### PASSIVE MIXER CIRCUIT

Before proceeding to a description of the mixer unit it will be of interest to examine a passive mixer circuit. A typical example is given in Fig. 1 and this represents the basis of a large number of mixers. It is really a simple voltage adding circuit.

In Fig. 1, VR1, VR2 and VR3 are the volume controls for their respective channels. The fixed resistors R1, R2 and R3 between the potentiometer sliders and the output are required to provide a certain degree of isolation between the volume controls. If these resistors were omitted, adjustment to any one control could seriously affect the level of the other two channels.

Operation of the circuit is fairly obvious. The voltage at the output is the sum of the three input voltages divided by the degree of attenuation inherent in the circuit. The attenuation will depend upon the setting of the volume controls and the impedance into which the output of the circuit is coupled.

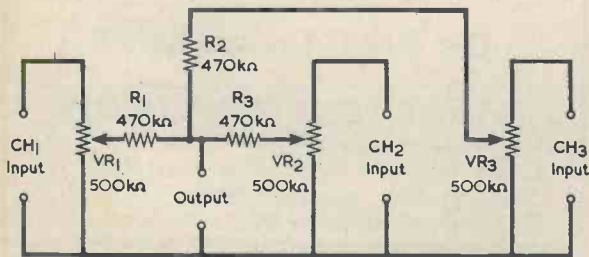
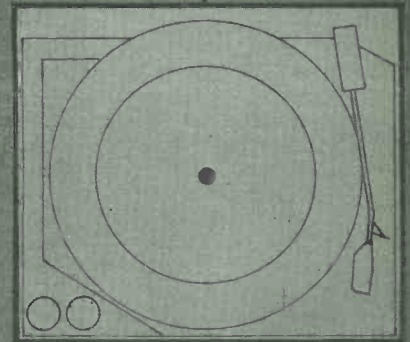
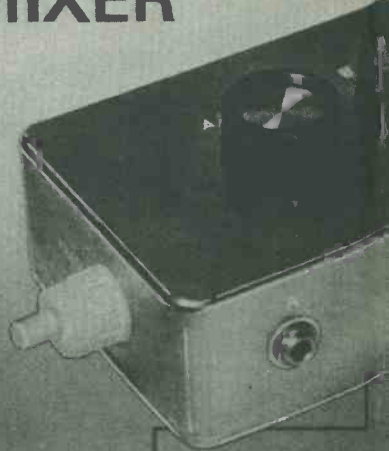

Fig. 1. Circuit diagram for a simple 3-channel passive audio mixer

# MINIATURE 3 MIXER



A completely self-contained audio mixer which provides input impedances of  $50k\Omega$ ,  $500k\Omega$  and  $1M\Omega$ . An integral power supply is provided.



RADIO & ELECTRONICS CONSTRUCTOR



# CHANNEL

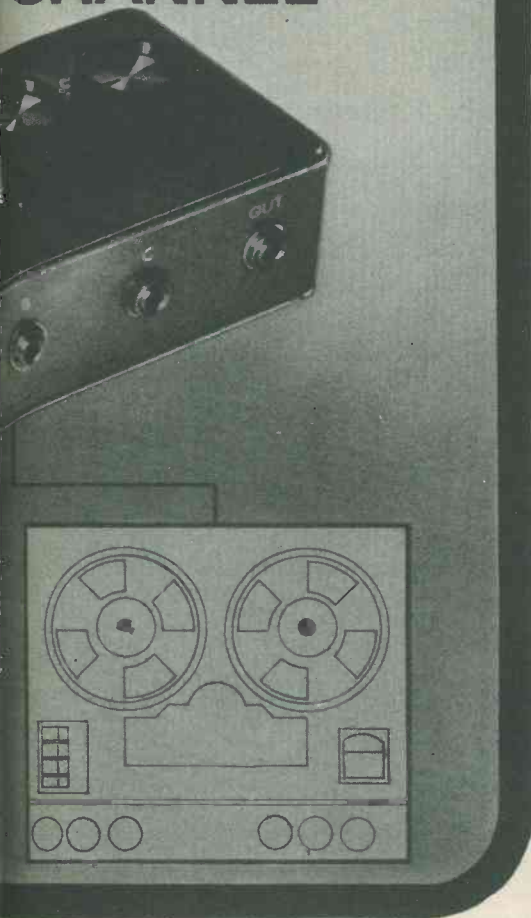

contained 3 channel  
h provides nominal  
of 50k $\Omega$ , 500k $\Omega$  and  
amplifier is incor-  
ted.



JULY 1973

by R. A. Penfold

## COMPONENTS

### Resistors

(All fixed values  $\frac{1}{4}$  or  $\frac{1}{8}$  watt miniature, 10%)

R1	100k $\Omega$
R2	100k $\Omega$
R3	1M $\Omega$
R4	560k $\Omega$
R5	1M $\Omega$
R6	39k $\Omega$
R7	39k $\Omega$
R8	39k $\Omega$
R9	100 $\Omega$
R10	2.2k $\Omega$
R11	2.2k $\Omega$
R12	1.5M $\Omega$
R13	1k $\Omega$
VR1	5k $\Omega$ potentiometer, log
VR2	5k $\Omega$ potentiometer, log
VR3	5k $\Omega$ potentiometer, log

### Capacitors

(All miniature – see text)

C1	1 $\mu$ F electrolytic, 10 V.Wkg
C2	0.47 $\mu$ F plastic foil
C3	0.22 $\mu$ F plastic foil
C4	10 $\mu$ F electrolytic, 10 V.Wkg
C5	10 $\mu$ F electrolytic, 10 V.Wkg
C6	100 $\mu$ F electrolytic, 10 V.Wkg
C7	10 $\mu$ F electrolytic, 10 V.Wkg
C8	220pF ceramic wafer

### Transistors

TR1	2N3702
TR2	2N3702
TR3	2N3702
TR4	2N2926, Y or G
TR5	2N2926, Y or G

### Switch

S1	S.P.S.T. switch (see text)
----	----------------------------

### Battery

B1	9 volt battery type PP3 (Ever Ready)
----	--------------------------------------

### Miscellaneous

- 4-off 3.5mm. jack sockets
- Veroboard panel, 0.1 in. matrix, 9 strips by 15 holes
- Battery connector clips
- Diecast box type 7134P (Eddystone)
- 3 control knobs

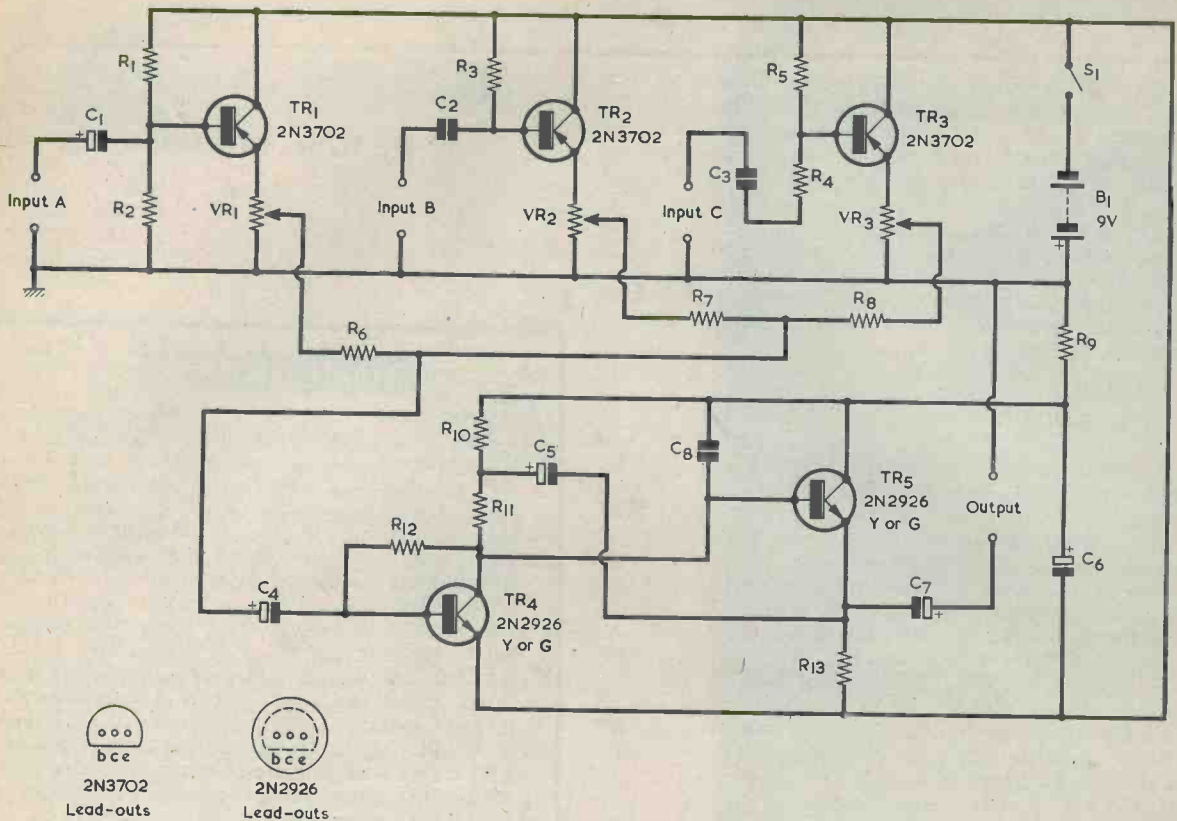

Fig. 2. The circuit of the 3-channel mixer with integral amplifier which is described in this article. The three inputs and the output are connected to jack sockets

## ACTIVE MIXER

Whilst circuits of the type shown in Fig. 1 are adequate, they have two main disadvantages. Firstly, there is the fact that there is a substantial loss between each input and the output, even with the volume controls set at maximum. Secondly, the input impedance of each channel varies considerably with the settings of the volume controls. If more channels were to be added to the circuit, the situation would be worsened. This state of affairs can be improved by raising the values of the fixed resistors, but this would result in an increase in the attenuation given by the circuit.

In an active mixer, an amplifier is used to boost the output of a passive mixer and thus overcome the attenuation problem. The circuit diagram of the active mixer constructed by the author is shown in Fig. 2.

The mixing section of this circuit is given by VR1, VR2, VR3, R6, R7 and R8. It will be seen that, when compared with the circuit of Fig. 1, the value of the fixed resistors has been greatly increased in proportion to that of the potentiometers.

An emitter follower is used at each input. An emitter follower has slightly less than unity voltage gain, but it offers a high input impedance and a low output impedance. The input impedance is approximately equal

to the emitter load resistance multiplied by the current gain of the transistor, this impedance being shunted by the base bias resistor or resistors.

Channel A has purposely been given values of biasing resistor which shunt the input heavily. This is done to give an input impedance of slightly less than 50kΩ, and is suitable for moving coil microphones having matching transformers intended for this impedance. Channel B has an input impedance of approximately 500kΩ and can take a signal from a tape recorder, etc. Channel C has basically the same circuit as Channel B, but the input impedance has been raised to approximately 1MΩ by the addition of the series resistor R4. In consequence, the sensitivity of this input is only about half that of the other two. It can take the output from a crystal microphone or ceramic pickup, etc.

Should the constructor feel that a different combination of input impedances would suit his purposes better, there is no reason why the input circuits should not be changed around to accommodate these needs. For instance, if the unit was required as a microphone mixer for three 50kΩ moving-coil microphones, then the input circuit for Channel A (comprising C1, R1 and R2) could be repeated at the inputs for Channels B and C.

Transistors TR4 and TR5 function as voltage amplifier and emitter follower output stages respectively.

RADIO & ELECTRONICS CONSTRUCTOR



TR4 is biased by R12, which is connected to its collector. This collector couples directly to the base of TR5, the signal at TR5 emitter appearing across the output load resistor R13 and being fed back, also, to the junction of R10 and R11 via C5. This bootstrapping technique offers an increase in the voltage gain provided by TR4.

The bootstrapping process operates in the following manner. If an input signal causes an increase in the voltage at the collector of TR4 there will be a similar and nearly equal increase at the emitter of TR5. The latter increase is coupled to the junction of R10 and R11, with the result that any increase in the voltage at the lower end of R11 is matched by a similar and nearly equal increase at its upper end. There is therefore an almost constant voltage across R11 and it offers what is effectively a very high resistance to a.c. signals. This apparently high resistance causes TR4 to give a very high voltage gain.

### CONSTRUCTION

The components are housed in an Eddystone diecast box type 7134P. This is available from Home Radio under Cat. No. E896. All the fixed resistors and capacitors should be miniature types. The electrolytic capacitors are specified as 10V.Wkg but it will be in order to employ capacitors with higher working voltages if these enable available miniature types to be used. If, for instance, the capacitors are all Mullard Miniature Electrolytic types, C1 may be 40V.Wkg, and C4, C5 and C7 may be 16V.Wkg. An alternative for C6 is the 125 $\mu$ F 10V.Wkg capacitor in the Mullard Miniature Electrolytic range, and this may be used if a suitable 100 $\mu$ F capacitor cannot be obtained. The Home Radio Cat. Nos. for the capacitors just mentioned are 2CH05 (1 $\mu$ F), 2CH23 (10 $\mu$ F) and 2CH60 (125 $\mu$ F). C8 may be any small miniature capacitor, such as ceramic wafer (Home Radio Cat. No. C87N). The components employed in the prototype for C2 and C3 are not standard types, but Mullard Miniature Foil capacitors

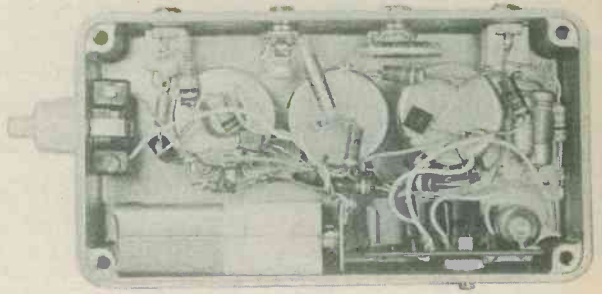

The wiring and component layout inside the case

Type C280 will fit in here. The 0.4 $\mu$ F capacitor is listed under Home Radio Cat. No. 2EH58 and the 0.22 $\mu$ F capacitor under Home Radio Cat. No. 2EH53. The three potentiometers are small modern types having a body diameter of  $\frac{1}{4}$  in. or less. The on-off switch used in the author's unit is a push-on push-off switch obtained from Woolworth's stores. A small slide switch could be fitted in its place, if desired.

Since there is not a great deal of space inside the case, point-to-point wiring, in which some junctions are not anchored at individual tags, is used in the assembly of the three input emitter follower circuits. Fig. 3 shows much of this wiring, part of it having been omitted for reasons of clarity. The omitted wiring consists of the following. First, an insulated wire connects together the three transistor collectors and then continues to one side of the on-off switch. A flexible insulated wire terminated in the battery negative clip is connected to the other side of the switch. An insulated wire joins

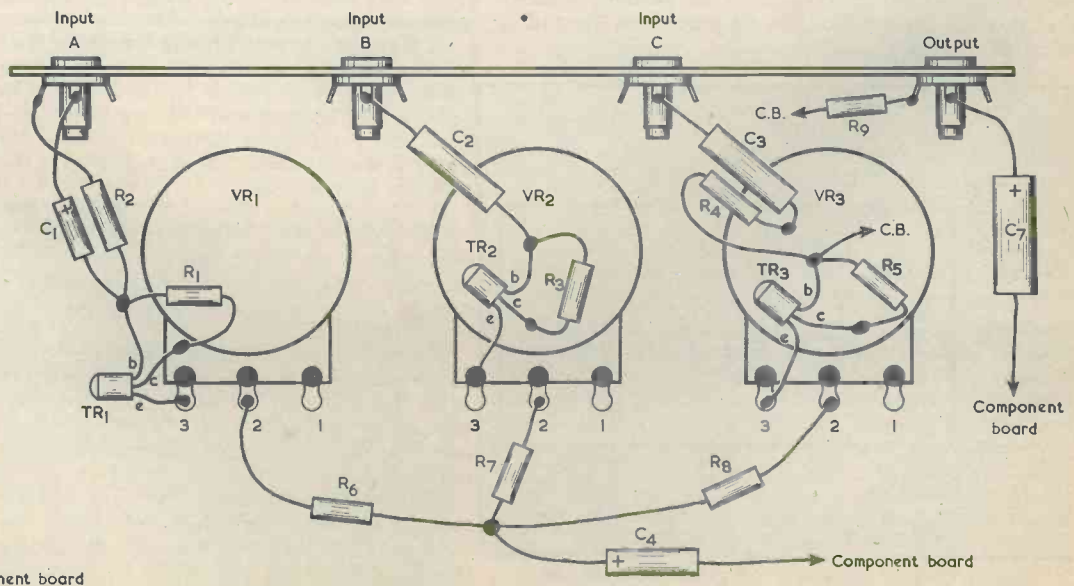

Fig. 3. The main wiring around the jack sockets



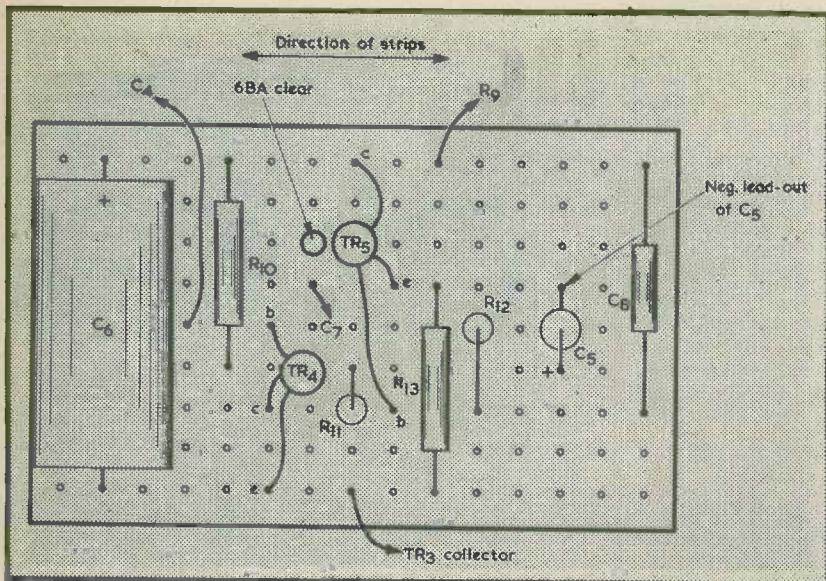

Fig. 4. The Veroboard assembly, seen from the components side

together the tags 1 on the three potentiometers and then connects to the earthy tag of input jack A. A flexible insulated lead terminated in the positive battery clip connects to the earth tag of input jack B. It will be found helpful not to fit R9, C4 and C7 at this stage.

A small Veroboard panel, of 0.1 in. matrix and having 9 strips, each with 15 holes, is used for the amplifier assembly. None of the strips is cut, but a 6BA clear hole is drilled out as indicated in Fig. 4, which shows the component side of the board. As can be seen from the photograph illustrating the interior of the unit, this board is mounted to the box side opposite jack C and the output jack, with C6 near the end of the case. The corresponding 6BA clear mounting hole in the box side may be marked out with the aid of the Veroboard panel after this has been drilled. Its distance from the end is indicated in Fig. 5.

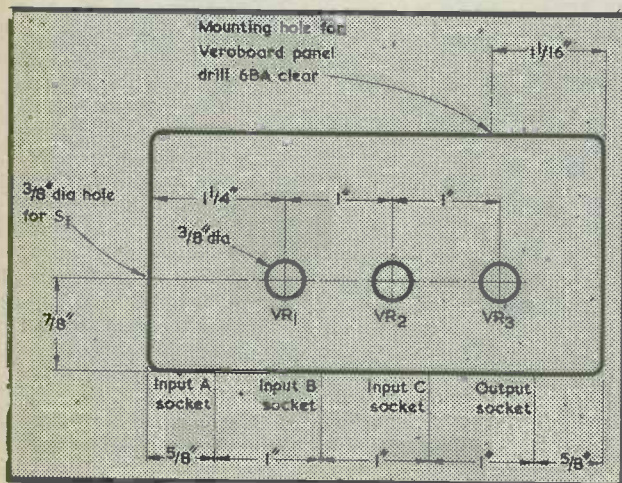

Fig. 5. Drilling details for the case. The positions of the 6BA clear hole and the holes for the on-off switch and jack sockets are discussed in the text

To prevent the strips on the copper side of the Veroboard from short-circuiting against the inside surface of the case, and also to prevent the board edge from fouling the locating ridge on the case cover, a few washers made from an insulating material should be passed over the 6BA mounting bolt to space off the Veroboard panel. There should be sufficient washers to space the Veroboard away from the case inside surface by  $\frac{1}{8}$  in.

It will be noted from Fig. 4, that a lead passes from the board to TR3 collector. This lead picks up the negative supply for the amplifier. There are connections also from the board to C4, C7 and R9. The requisite leads are fitted to the board before it is mounted. They may then be cut to the correct length, the appropriate components fitted and final connections made up.

A diagram showing drilling details for the front panel of the case is given in Fig. 5. The view here is looking down on the front panel. The holes in the side and end for the jack sockets and the switch are all  $\frac{3}{8}$  in. down from the front panel surface. The hole diameters for the jack sockets should be such as to suit the particular make of sockets used.

It is possible that the inside surface of the case cover could touch one or more parts of the point-to-point wiring when the cover is fitted. Should this risk exist, strips of adhesive p.v.c. insulating tape should be applied to the inside surface of the cover at the appropriate positions.

The case cover, when bolted down, should hold the battery firmly in position. If the battery is found to be at all loose, a pad of foam rubber or plastic may be affixed to the back of the front panel over the area occupied by the battery, and another pad, similarly positioned, to the inside of the cover.

To complete the unit, the case should either be cleaned and then painted, or polished to give a bright natural finish. Legends to indicate control and jack functions may then be applied to the front and sides. These legends being taken from 'Panel Signs' Set No. 3. 'Panel Signs' are available from the publishers of this journal.



# New Products

## VACUUM RECORD CLEANER

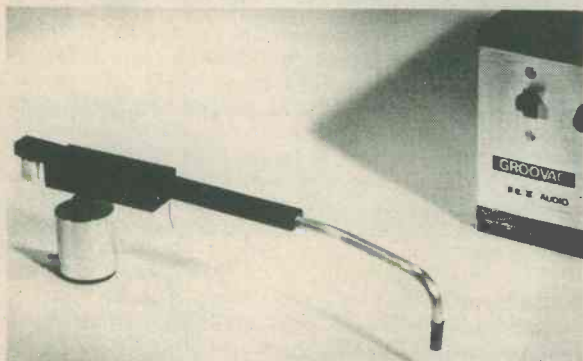

R.I. Audio, claim that their new "Groovac" record cleaner is the only unit available which removes dust from records by vacuum cleaning.

The suction method is available for the effective removal of the fine dust particles which collect inside record grooves and which are responsible for record and stylus wear. A tracking force of only 0.7 gram has been achieved by using a lightweight design with lubricated-for-life bearings throughout.

The Groovac consists of a precision lightweight arm, and a suction unit which is acoustically isolated in a special enclosure. The suction unit has been designed to be inaudible at a distance of 2 metres; it has a mains switch and indicator, and is attractively finished in teak. It mounts by means of an extremely convenient magnetic base, and its height is adjustable to suit different turntables. When not in use it is simply rotated outwards and lowered onto its integral rest.

Price £6.90 plus VAT. Further details from R.I. Audio, Kernick Road, Penryn, Cornwall.

## REVOLUTIONARY CLIP

Herbert Terry & Sons Limited, spring manufacturers of Redditch, England, announce the launch of their revolutionary "Clipco" do-it-yourself clip.

"Clipco" is versatile, easily fixed, no screwing required, of unbreakable, resilient rust-free nylon which prevents damage to articles. "Clipco" solves

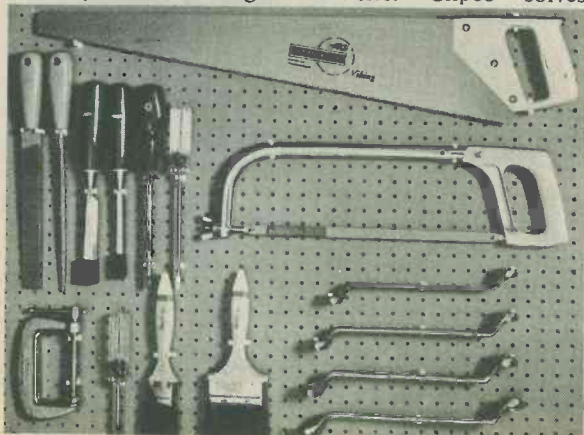

## ADJUSTABLE BENCH VICE

A new model of the Oryx adjustable bench vice is available from W. Greenwood Electronic Limited, 21 Germain Street, Chesham, Bucks. HP5 1LL. The vice has been restyled to present a completely versatile laboratory tool. The new model now comprises four parts: the bench clamp, steel ball joint so that the whole unit above the bench can be easily moved, a rotating head and the miniature adjustable vice.

Each of the parts is adjusted to suit the position of the component in the jaws and to give complete rigidity. The clamp will fix onto surfaces up to 85mm thick and the jaws open to a maximum distance of 47mm. The fibre faced jaws have replaceable pads and will hold the most delicate components without damage.

The new bench vice is available at £13.15 from W. Greenwood and the distributors Electroplan Limited, PO Box 19, Orchard Road, Royston, Herts. SG8 5HH.

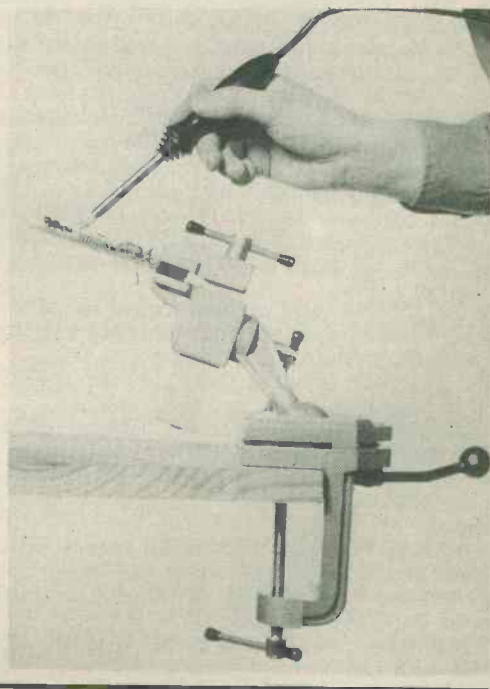

many fixing problems around the home and is a specially designed dual purpose plug which ensures efficient fixing to walls, tiles, wood and pegboard. The applications include holding tools in the garage or shed, bathroom fixtures, kitchen utensils, electric wires and cables, display boards and many garden and greenhouse fixings.

"Clipco" was launched at the recent Hardware Trade Fair at Olympia, is now available from hardware stores, and do-it-yourself shops.

"Clipco" are available in three choices of visual blisters, containing 8, 9 or 10 clips, dependent on size and shape. The recommended retail price of blisters is 21p to 23p. They are also available in bulk - 100 at £2.18.

# SHORT WAVE NEWS

FOR DX LISTENERS



By Frank A. Baldwin

Times = GMT

Frequencies = kHz

Like most other short wave broadcast bands, the 15MHz range offers some interesting programmes from stations around the world, not all of them easy to log by any means despite the comparatively high powers used. Some stations are not regularly reported here in the U.K. owing to the fact that they are, more often than not, 'buried' under more local and powerful transmitters and the listener must therefore await propagation conditions which favour the weaker transmission. Recently, such conditions occurred when the VOA (Voice of America) transmitter on 15225 (19.71 metres) at Greenville was 'down', allowing BED99 at Taipei, Taiwan, to be logged here in the U.K. We logged Taipei at 1832 when a programme of classical music with announcements in English was being radiated.

BED99 has also been logged by Bob Iball of Langold, Worksop, an old-timer SWL who heard the station identification at 1840 as "The Voice of Free China broadcasting from Taipei in Taiwan". Bob also heard them again on a later date at 1400 on the parallel channel of 17720 (16.93m), this being BED39.

Bob also logged on this band Radio Japan at 1100 on 15195 (19.74m), also in parallel on 17855 (16.80m); BBC Tebrau closing at 1830 on 15310 (19.60m); Kuwait at 1845 on 15415 (19.46m) and Peking on 15030 (19.96m) at 1540.

On the 15MHz band we have logged the following: Radio Canada International on 15325 (19.58m) at 2115 with the world news in English.

BBC Ascension Island on 15400 (19.48m) at 1742 with a talk in English on crime and the criminal.

Voice of America, Monrovia, Liberia, on 15445 (19.43m) at 1904 with the world news in English.

Hanoi, North Vietnam, on 15012.5 (19.99m) at 1802 with the news, from the N. Vietnamese point of view, in English.

WIBS Radio Grenada, Windward Islands, on 15105 (19.86m) at 2025 with pop songs and music and the announcement "Advertising stimulates the economy, advertise on Radio Grenada".

ZYN32 Radio Nacional Brasilia, on 15445 (19.43m) at 2036 with station identification in French followed by guitar music.

## AROUND THE DIAL

### ● ITALY

Rome may be heard with a programme in English, directed to the U.K. on 11800 (25.42m) at 1945, at which time it was logged here.

### ● FINLAND (1)

OIX8 Pori, logged on 11755 (25.52m) at 2040 with news of Finnish affairs in English.

### ● IRAQ

Baghdad heard with station identification at 2011,

in English, on 9745 (30.78m), programme in English from 2000.

### ● SYRIA

Damascus may be heard at 2000 on 9655 (31.07m) when station identification and the English programme commences.

### ● IRAN

Teheran on 9022 (33.25m) at 2015 with news of Iranian affairs in English.

### ● BULGARIA

Sofia on 9700 (30.93m) at 1930 with a programme in English for the U.K. Also on 6070 (49.92m) at 1942 with identification and an Amateur bands Dx programme.

### ● ECUADOR

HCJB Quito can be heard on 11845 (25.33m) at 2117 in German and also on 15315 (19.59m) at 2045 with identification after the English programme and into French at 2046.

For morning listeners, HCJB can be heard at 0745 on 11915 (25.18m) with a programme in English, we logged a programme about crime and punishment.

### ● AUSTRALIA

Radio Australia, Shepparton, is to be heard at 0734 on 9570 (31.35m) at which time we heard a programme about Australian internal affairs. Radio Australia can also be logged at 0643 on 11765 (25.50m) with the tuning signal "Waltzing Matilda" (musical box rendition), the "laugh" of the Kookaburra bird, station identification at 0645, musical programme and the world news at 0715.

### ● ZAIRE

Kinshasha is to be heard at 1925 on 4879 (61.48m) with announcements in French and, more often than not, African music complete with drums and other percussion instruments.

### ● NIGERIA

Benin City can often be logged around 2200 on the regular 4932 (60.83m) channel (when the teletype transmitter is silent). We heard them recently at 2304 when signing-off with the National Anthem.

### ● FINLAND (2)

OIX2 Pori may be heard at 1815 with news of Finnish affairs on 9555 (31.40m). Also at 2050 with a review of the Finnish Press on 15185 (19.76m), this being OIX4 at Pori.

### ● SOUTH AFRICA

Radio RSA from the Johannesburg transmitter has an External Service in English to Europe from 1800 to 1850 on 11970 (25.06m) and on 15175 (19.77m). On



Sundays there is a programme for the U.K. from 1000 to 1050 on 17780 (16.87m) and on 21490 (13.96m). From 2215 to 2315 (also to North America) on 9525 (31.50m), 9695 (30.94m), 11900 (25.21m) and on 11970 (25.06m).

#### ● NORWAY

The Overseas Service of Radio Norway, Oslo, broadcasts a programme in English, "Norway this Week", for Europe as follows - from 0200 to 0230 on 9550 (31.41m), 11860 (25.30m) and on 15175 (19.77m); from 0400 to 0430 on 9610 (31.22m), 9645 (31.10m) and on 11860; from 0600 to 0630 on 11850 (25.32m), 17825 (25.37m), 21655 (13.85m) and on 21730 (13.81m). From 1200 to 1230 on 6130 (48.94m), 15175, 21655, 21730 and on 25900 (11.58m); from 1800 to 1830 on 6130, 17825, 21655, 21730 and on 25900. From 0100 to 0030 on 9550, 11860 and on 15175.

#### ● SAUDI ARABIA

From Jiddah, programmes in English are radiated from 1100 to 1250 (from 1000 on Thursdays and Fridays) on 11855 (25.31m) and from 1700 to 1955 on the same channel.

#### ● CANADA

Radio Canada broadcasts to Europe in English as follows - from 0700 to 0730 on 9655 (31.07m) and on 11825 (25.37m); from 1217 to 1315 on 15325 (19.58m), 17820 (16.84m) and on 21595 (13.89m); from 1515 to 1522 (newscast) on 15325, 17820 and on 21595; from 2115 to 2158 on the latter three channels.

#### ● CLANDESTINE

In the last issue of this journal we made mention of several Clandestine stations that can be heard on the short wavebands (see also QSX this issue) and we conclude here with mention of yet another 'undercover' station which may be logged.

On 9573 (31.33m) a powerful transmitter radiates anti-Saudi regime programmes of propaganda interspersed with music and songs. We logged the "Voice of the People from the Heart of the Arabian Peninsular" when signing-on with a march and identification repeated twice (in Arabic) until sign-off at 1900 with identification and a repeat of the march.

### CURRENT SCHEDULES

#### ● MALAWI

Blantyre can sometimes be heard, if conditions are right, on 3380 (88.76m) around 2100. We logged them at 2053, when a programme of African songs and music was being radiated.

#### ● INDIA

India can be heard on a multitude of channels at various times throughout the day, some of those logged recently are listed below.

Delhi on 11740 (25.55m) at 2050 with the news in English until 2105 then talk about Pakistan.

Delhi on 9525 (31.50m) at 2015 with "Radio News-reel" in English.

Delhi on 9912 (30.27m) at 2015 with programme on Indian space probe in English.

Delhi on 7215 (41.58m) at 2030 with programme in English.

Delhi on 11620 (25.82m) at 1800 with a newscast in English after station identification.

#### ● SOUTH AFRICA

Springbok Radio, one of the Internal Services of the SABC, can be heard at 0243 on 3997 (75.05m) when we listened to some English musical comedy songs on records.

#### ● PORTUGAL

Sines is to be logged on 11865 (25.28m) at 1937 with a programme of music and songs in Portuguese.

#### ● SPAIN

Noblejas can be heard at 1930 on 11920 (25.17m), at which time we listened to a programme of Spanish music and songs.

#### ● MOZAMBIQUE

Radio Clube de Mozambique on 4855 (61.79m) can often be logged in the evenings here in the U.K. We heard them recently at 2215 when they were signing-off with the National Anthem, quite the easiest Mozambique station to log on the 60m band.

#### ● ANGOLA

CR6RB Radio Ecclesia, Luanda, operates on 4985 (60.18m) where we logged them at 1927 with a talk in Portuguese under some CW QRM.

CR6RO Radio Clube do Bie, Silvo Porto, is on 4895 (61.29m) being heard at 2116 with songs in Portuguese, Latin American-type music and station announcements.

#### ● ISRAEL

Kol Yisrael has an External Service from the Jerusalem transmitter, in English to Europe as follows - from 0500 to 0515 on 9009 (33.30m), 11865 (25.28m) and on 11945 (25.12m). From 1130 to 1200 on 11865, 15425 (19.45m) and on 17870 (16.82m). From 2000 to 2045 on 9009, 11705 (25.63m), 15165 (19.78m) and on 15425.

---

## CLUB EVENTS

● Cornish Radio Amateurs are holding their 1973 Mobile Rally at Treviglas School, Newquay, Cornwall, on 8th July. Further information from G. Tremelling, G3FWG, Finnartmore, Oakland Park, Falmouth.

● The Barking Radio & Electronics Society will be operating at the Dagenham Town Show on the 7th and 8th July. Bands in use will be 160m to 2m inclusive. There will be a mobile talk-in station operating on 145MHz - call sign GB2DTS. Details from R. E. Clark, G8BXC, 62 Waltham Road, Woodford Bridge, Essex, IG8 8DN.

● Scarborough Amateur Radio Society annual rally at Burniston Barracks on 15th July. Details from P. B. Briscombe, G8KU, "Roseacre", Irton, Nr. Scarborough, Yorks.

● Derby and District Amateur Radio Society will be taking a stand at the National Amateur Radio and Electronics Exhibition at Leicester in October.

The theme is to be "Sixty Years of Radio" and is their contribution to the RSGB's Diamond Jubilee Celebrations.

The society's programme for July is: 4th, Surplus Sale by Auction: 11th, Mobile Operation, talk by Tom Darn, G3FGY: 18th, D.F. Practice Night: 25th, Visit from VK4KS "DXpedition to Mellish Reef in Coral Sea". Tape and Slides.

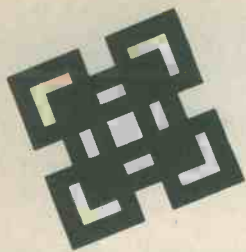

# RANDOM OUTPUT GENERATOR

by E. F. Whitman

A simple and instructive device which illustrates basic logic principles.

**T**HE DEVICE WHICH FORMS THE SUBJECT OF THIS SHORT article can be described as a complicated method of tossing a coin! Nevertheless, it is an amusing gadget having attractive presentation, and it can be made up into a small pocket unit complete with its own battery.

The basis of the device is a generator which causes either one of two light emitting diodes to be illuminated by random selection whenever a switch is thrown. An initial examination of the circuit indicates that a true 50:50 random distribution between the two l.e.d.'s should be given as soon as the unit has been assembled, but in practice there may be a tendency for one l.e.d. to be illuminated more frequently than the other. If this tendency appears, it can be cancelled out by suitably adjusting a capacitor value in the circuit.

## CIRCUIT FUNCTIONING

The circuit of the generator appears in Fig. 1. When in this diagram S2 is closed, the multivibrator given by TR1 and TR2 runs at around 3kHz and drives a bistable consisting of two cross-coupled t.t.l. NAND gates.

The two NAND gates are part of a quadruple NAND gate type 7400, and their operation may be understood by remembering that the output of a 2-input t.t.l. NAND gate is high (corresponding to 1) when either one or both of its inputs is low (corresponding to 0). The NAND gate output goes low only when both its inputs are high.

Let us first examine the circuit at an instant in the multivibrator cycle when TR1 is off and TR2 is on. Since TR1 is off, the voltage on its collector is close to that of the positive supply rail and is, in consequence, high. On the other hand, the voltage on the collector of TR2 is close to the negative supply rail and is therefore low. Since a low voltage is thus applied to input pin 5 of the lower NAND gate its output must be high. This high output is passed to input pin 2 of the upper NAND

gate, which is also obtaining a high input on its input pin 1 from the collector of TR1. As a result, the output of the upper NAND gate, at its pin 3, is low.

Summing up the situation so far, when TR1 is off and TR2 is on, the output of the upper NAND gate is low and the output of the lower NAND gate is high. Due to the symmetry of the circuit the reverse applies during the next half-cycle of the multivibrator. When TR1 is on and TR2 is off the output of the upper NAND gate is high and the output of the lower NAND gate is low.

Each l.e.d. becomes illuminated when the output of the NAND gate to which it connects is low. Current then flows from the positive to the negative supply rail through the series 240Ω resistor, through the l.e.d. in a forward direction, and then through the output transistor inside the t.t.l. NAND gate integrated circuit. The alternative method of connecting an l.e.d. to a t.t.l. NAND gate, i.e. directly between the output and the negative supply rail, cannot be used here as it would prohibit fan-out to the other NAND gate input.

The circuit is started by closing S1 with S2 closed. The multivibrator then runs, causing both l.e.d.'s to be switched on and off continually. The speed of switching is, of course, far too fast to be followed visually, and both l.e.d.'s appear to be continually illuminated. Switch S2 is then opened. The multivibrator ceases to run and the collector of whichever transistor was on at the instant of switching off immediately rises to the potential of the positive supply rail, causing a high input to be passed to the gate to which it couples. But that gate will already have a low input from the output of the other gate and will be unaffected, continuing to produce a high output. Thus, if the multivibrator is disabled when TR1 is off, causing the upper gate output to be low, that output will remain low after the multivibrator ceases running. Similarly, the output of the lower gate will remain high. The bistable formed by the two NAND gates has the ability to remain in its last state



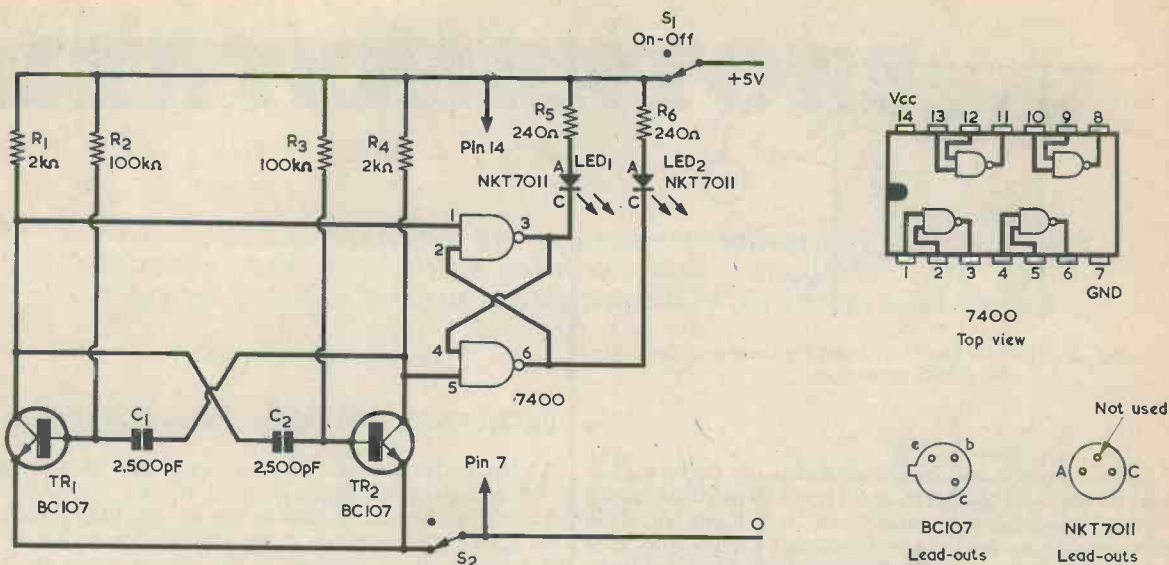

Fig. 1. The circuit of the random output generator. Either LED1 or LED2 remains illuminated after S2 is opened

when both its inputs go high.

It is a matter of pure chance whether TR1 or TR2 is off at the instant of switching off the multivibrator, with the result that (assuming perfect symmetry in the circuit) there is a 50:50 probability of either LED1 or LED2 remaining illuminated. Since the illuminated l.e.d. now receives a continuous current it glows at a brighter level than occurred when both the l.e.d.'s were lit up.

The circuit can be run again by closing S2, with the result that both l.e.d.'s light up once more, and then opening it again, whereupon only one of the two l.e.d.'s remains illuminated.

The device uses only two of the four NAND gates in the 7400 i.c., no connections being made to the other two gates. If desired, a second multivibrator could be added, this coupling to the remaining two i.c. gates. These would be similarly connected as a bistable, and their outputs would feed two further l.e.d.'s. S2 then becomes a double pole switch, its extra pole breaking the negative supply to the second multivibrator. This addition would produce four possible random configurations of l.e.d. illumination.

## COMPONENTS

All the components for the circuit are readily available. The light emitting diodes used by the author were Newmarket NKT7011, obtained from Electrovalue Ltd., 28 St. Judes Road, Englefield Green, Egham, Surrey, TW20 0HB. These are rated at a maximum current and power of 50mA and 100mW respectively, and it is probable that other l.e.d.'s with similar ratings should work equally well. The writer has, however, only checked the circuit with the NKT7011 types. It is important to ensure that they are connected into circuit with correct polarity.

The 7400 i.c. or one of its equivalents is available from

virtually all suppliers of t.t.l. integrated circuits. Its Texas Instruments type number is SN7400N. The inset in Fig. 1 showing the 7400 pins is a top view, with the pins pointing away from the reader. The insets showing the transistor and l.e.d. lead-outs have the lead-outs pointing towards the reader.

For satisfactory snap action, both the switches should be toggle types. All resistors are  $\frac{1}{4}$  watt and R1 and R4 may be 5%. The tolerances in R5 and R6 are discussed later.

At first sight, it would appear that a 50:50 random distribution of l.e.d. illumination would be given if R2 and R3, and C1 and C2, were closely matched, since the multivibrator would then give a true 50:50 sequence of half-cycles. Unfortunately, however, the voltage at the collector of each transistor is not a true square wave because there is slight rounding, due to the cross-coupling capacitor, on the positive-going edge. Also, since the two NAND gates may have slightly different threshold voltages for the input transition from low to high, a departure from true 50:50 operation of the bistable may result. Another factor is that each transistor, when turning on, has to draw a relatively heavy collector current through the associated NAND gate input to take the latter low, and so a further slight departure from 50:50 bistable operation is feasible if the two transistors have different gain figures.

The constructor can, because of these factors, employ one of two approaches with respect to R2, R3, C1 and C2. The first of these is to use resistors and capacitors which are matched within 1 or 2% and, if a transistor tester is available, transistors having similar gain figures. In the rather unlikely event of l.e.d. illumination distribution then not being 50:50, the biasing approach shortly to be described can be brought into use. Alternatively, the constructor may use normal wide tolerance components, being prepared to carry out the biasing process which will in this case almost certainly

be required.

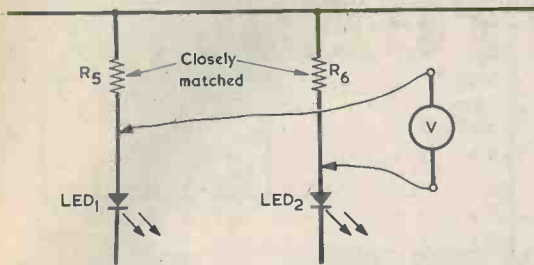

Fig. 2. A simple method of setting up the circuit for 50:50 operation

After the unit has been completed, its performance may be checked by operating S2 some 60 to 70 times and noting the number of times each l.e.d. lights up. This process is by no means as tedious as it sounds since it is merely necessary to put a mark in one of two columns on a sheet of paper for each operation. After this number of functions the distribution in the lamps should be 50:50, or very nearly so. If LED1 lights up more frequently than LED2, this means that TR1 may be considered as being off for a longer period in the multivibrator cycle than is TR2. The effect can be cancelled out by increasing C2 by experimentally connecting added capacitance across it, thereby increasing the off period for TR2. Similarly, if LED2 predominates, extra capacitance should be added across C1. Several counting checks should soon establish the value of capacitance finally needed.

The addition of bias capacitance may be carried out more quickly if an oscilloscope is available, since it is then merely necessary to find the added capacitance which, when S2 is closed, causes waveforms of equal duration to appear across R5 and R6. R5 and R6 may either be 5% or they may be closely matched in value. In the latter instance, a further approach for finding the required value of bias capacitance becomes possible. This consists of closing S2 and of connecting a voltmeter switched to read a low voltage across the lower ends of R5 and R6, as in Fig. 2. Voltmeter polarity is unimportant. Extra capacitance is added, across C1 or C2 as applicable, until the voltmeter reads zero. This last procedure assumes equal forward voltage drops and similar current waveforms in the two l.e.d.'s, but in practice it should prove quite adequate and can be finally confirmed by the 60 to 70 switch operations just mentioned.

Although the 7400 may not, for serious work, be operated at supply voltages lower than 4.75 volts, the present circuit should operate satisfactorily from a 4.5 volt battery. The prototype functioned without trouble with a battery whose voltage had dropped to as low as 4 volts. Current consumption at 4.5 volts is a little less than 20mA with S2 either open or closed.

Light emitting diodes offer an attractive and unusual form of circuit monitor. If the design of Fig. 1 is housed, with its battery, in a small box having the two diodes and the two switches on the front panel, it forms a unique little unit which can provide a considerable amount of amusement and entertainment for its user and his friends.

# ASTABLE

Part 2

by A. Foord

## FREQUENCY AND DUTY CYCLE CONTROL

WHEN ADJUSTABLE CONSTANT CURRENT SOURCES ARE added to the base sections of the conventional astable multivibrator, then frequency and duty cycle can be varied independently. The off time for each half of the astable circuit depends on the output swing and the rate at which the timing capacitor is charged. In the circuit of Fig. 7, transistor TR1 is used for the variable current source for the timing circuit associated with TR3. This current will be approximately:

$$I_3 = \frac{V_{cc} - V_e}{R_1}$$

The off time for TR3 will be:

$$t(\text{off}) = \frac{C_1 V_0 R_1}{V_{cc} - V_e}$$

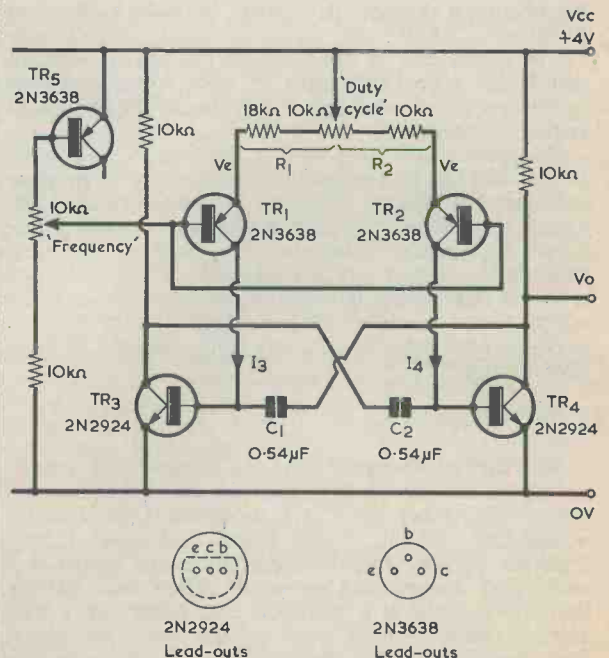

Fig. 7. Astable multivibrator circuit with independent control of frequency and duty cycle



# MULTIVIBRATORS

In this concluding article our contributor describes multivibrator frequency and duty cycle control, and concludes with multivibrator circuits incorporating the SN74121 integrated circuit

and the off time for TR4 will be:

$$t(\text{off}) = \frac{C2 \cdot V_O \cdot R2}{V_{cc} - V_e}$$

The duty cycle of TR3 is

$$\frac{R1}{R1 + R2}$$

which is independent of frequency.

The frequency may be adjusted independently of the duty cycle by changing  $V_e$ . For the component values shown the duty cycle (when TR4 is off) can be varied between 26% and 51% while the frequency remains constant within 2%. Alternatively, the frequency can be varied between 66 and 238Hz while the duty cycle remains constant within 2%. The base-emitter junction of TR5 provides a temperature compensated voltage which tracks any changes in  $V_{be}$  for TR1 and TR2 and reduces the effects of ambient temperature variations on the constant currents generated by these transistors. This arrangement is essential at the low voltages chosen for this particular circuit where the base to emitter voltage drops are significant.

The minimum constant current values should be high enough to make sure that TR3 and TR4 saturate. This is no problem with modern high gain transistors.

The 2N3638 transistors specified in Fig. 7 may be obtained from G. W. Smith & Co. (Radio) Ltd., 11-12 Paddington Green, London, W.2. However, the circuit will work with many small-signal transistors; TR1, TR2 and TR5 should be similar, as also should TR3 and TR4. Suitable alternatives would, for instance, be BC214 (p.n.p.) and BC184 (n.p.n.)

## USING SN74121 MONOSTABLES

The SN74121 is a monostable multivibrator with d.c. triggering from positive or gated negative going inputs, and with an inhibit facility. The normal Q and not-Q output pulses are available, with a fan-out of 10 and t.t.l. compatibility. The basic block diagram is shown in Fig. 8.

A1 and A2 are negative edge logic trigger inputs and will trigger the monostable when either (or both) go low with B high. B is the positive edge Schmitt trigger input for slow edges or level detection, and will trigger the monostable when B goes high with either A1 or A2 in the low state.

Output pulse lengths can be varied from 40ns to 40S with suitable timing components. Where a narrow pulse

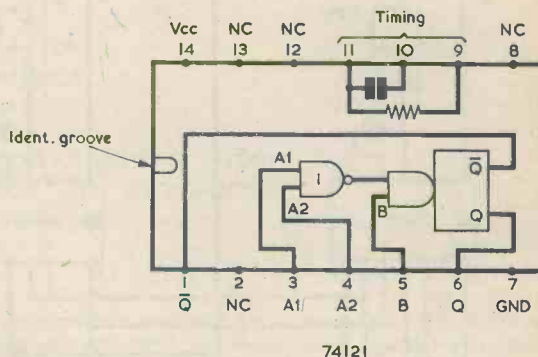

Fig. 8. The basic SN74121 monostable multivibrator. This is a top view for 14-pin d.i.l. and gives terminal locations

is required for set/reset purposes a typical pulse length of 30ns may be achieved without external components. For this arrangement pin 9 is connected to pin 14 and pins 10 and 11 are left open-circuit. For longer pulses, timing capacitors between 10pF and 1,000μF may be connected across pins 10 and 11. When these capacitors are electrolytic the positive plate connects to pin 10. Also, external timing resistors from 2kΩ to 40kΩ may be connected. The internal limiting resistance is a nominal 2kΩ and may be used as part of the total resistance where required. For accurate repeatable pulse widths the external resistance should be connected between pins 11 and 14 with pin 9 left open-circuit. In this case the minimum resistance must be 2kΩ or more. The pulse width is given by:

$$t = 0.69 CR \text{ secs.}$$

## SN74121 ASTABLE MULTIVIBRATOR

A gated astable multivibrator can be produced by using two monostables in a closed loop configuration, as in Fig. 9. If R1 and R2 are ganged then the mark-space ratio will remain constant as the total period is varied. Alternatively, the two resistors can be varied independently to give the mark-space ratio required.

The multivibrator can be released by either a negative gate at A1 and A2 or a positive gate at B. If the gate closes part of the way through the cycle the multivibrator will complete the cycle before stopping.

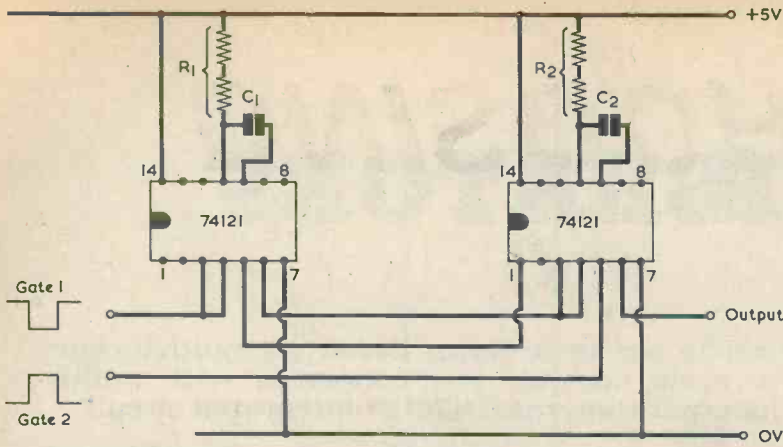

Fig. 9. A gated astable circuit using two SN74121's

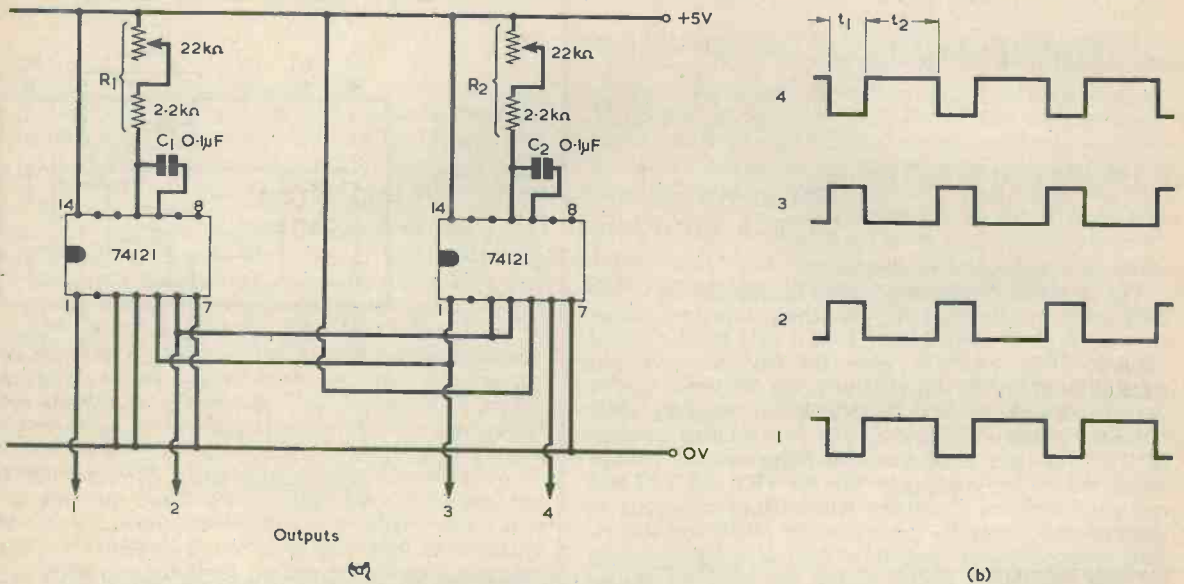
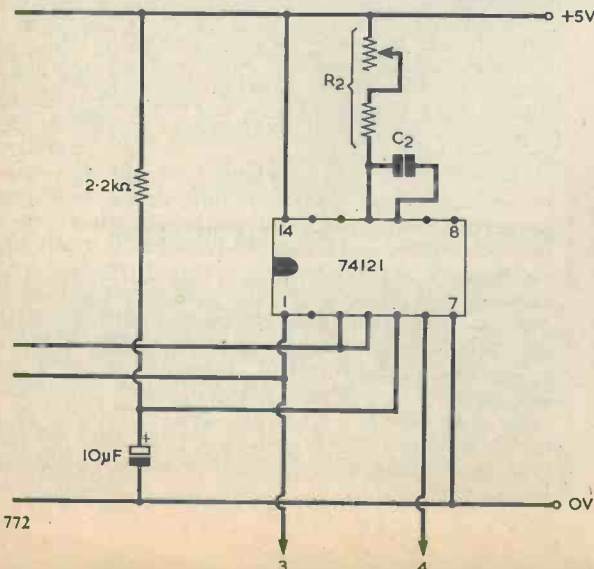

Fig. 10 (a). A free running astable circuit incorporating two SN74121's  
(b). The waveforms appearing at the four outputs

Fig. 11. The modification required if the start of the astable multivibrator is to be delayed



For the circuit to free run, gate 1 must be taken to earth and gate 2 to the 5 volt positive rail, as in Fig. 10 (a). Since the inputs to each monostable are d.c. coupled there should be no difficulty in the circuit starting. The circuit values in Fig. 10 (a) are typical and can be varied to suit the application. If it is required that the multivibrator starts shortly after power has been applied this can be achieved by delaying the rise time of the B gate input, as shown in Fig. 11. This is useful where other logic circuits have to settle down before a clock is applied.

The timing of the outputs, as indicated in Figs. 10 (a) and (b) is:

$$t_1 = 0.69 \times C_1 R_1 \text{ secs}$$

$$t_2 = 0.69 \times C_2 R_2 \text{ secs.}$$

The total period is therefore:

$$T = 0.69 (C_1 R_1 + C_2 R_2) \text{ secs,}$$

and the frequency, in hertz, is 1 divided by this period. ■

(Concluded)

RADIO & ELECTRONICS CONSTRUCTOR



# CHOOSING A MULTIMETER

by  
P. Jefferson

Some notes on a topic which often  
causes confusion for the newcomer  
to electronics.

**B**EGINNERS IN RADIO AND ELECTRONICS SOON FIND that a measuring instrument is virtually essential if full value is to be obtained from their hobby. There are few things so frustrating as to find that a newly constructed unit does not function and then have no means of finding where the fault lies. Without some form of testmeter it is almost impossible to carry out troubleshooting other than on a guess-work basis.

## WIDE RANGE

Having decided that a multimeter is to be obtained, the constructor will probably next consult advertisements and the catalogues of the larger mail-order houses to see what instruments are available. And this is where confusion is liable to commence because multimeters are available at prices ranging from less than £2 to around £40. What is the best model to buy?

This article cannot, of course, recommend particular makes and models of multimeter, but it will nevertheless give some general guidance lines which should assist the constructor in forming his own choice. So far as the cost of a multimeter is concerned, it is generally true that accuracy, reliability, robustness and the number of ranges offered all increase in proportion to cost. It would seem more than reasonable to assume that a £30 instrument would offer a superior performance when compared with one priced at £3, and such indeed is, of course, the case. However, the £30 meter would be more fitting in a laboratory or in a busy service workshop than in a home-constructor's den, where it is probable that only occasional measurements will be needed. An inexpensive meter, provided it is treated with reasonable care, can be an invaluable asset for constructional work.

It is possible that some constructors may prefer to build their own multimeters. This is an admirable approach, but it should be noted that the cost of the

components required for a home-made multimeter can be greater than the price of a complete instrument offering a comparable performance, and the latter has the advantage of having a scale which is directly calibrated in terms of the ranges covered. Specialised test instruments for home-construction are described from time to time in this journal, but these are intended for measurements which cannot be undertaken with a standard multimeter, or they are designed to offer an exceptionally high sensitivity for voltage readings.

## VOLTAGE MEASUREMENTS

In general, multimeters are employed far more frequently for d.c. voltage measurements than for any other purpose, and the prospective purchaser should first check that the d.c. voltage ranges available in any particular multimeter will meet his requirements. When working with transistor equipment many measurements will be of direct voltages below 10 volts, and a voltage range capable of reading such voltages is necessary. There is still plenty of domestic equipment in use which employs valves (and a surprisingly large number of home-constructors still prefer to build valve units rather than their transistor equivalents), so voltage ranges capable of reading h.t. voltages between some 200 and 350 volts should also be available. A top voltage range of the order of 0-1,000 volts is, again, very desirable. Virtually all multimeters currently available can measure these voltages, the more expensive models normally having a larger number of ranges. The availability of a large number of ranges means that a range can usually be selected which enables a particular voltage to cause a relatively large deflection of the meter needle. Accuracy is likely to be higher, and meter readings easier to assess, when there is a large deflection of the needle.

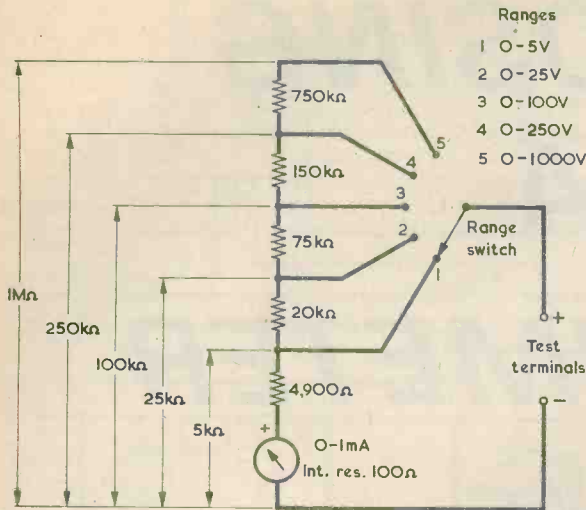

Fig. 1. The basic form of the voltmeter section of a multimeter. Alternative voltage ranges can, of course, be provided

Voltmeter sensitivity is an important feature. Basically, the voltmeter circuits of a multimeter take up the form shown in Fig. 1 which assumes, for purposes of illustration, voltage ranges of 0-5, 0-25, 0-100, 0-250 and 0-1,000 volts. There is a single basic meter movement, and the range switch selects different values of series resistance. It is assumed in Fig. 1 that the basic meter has a full-scale deflection (or f.s.d.) of 1mA and that it has an internal resistance (given mainly by the wire in its coil) of 100Ω. If we give the resistor which is switched into circuit on the 0-5 volt range a value of 4,900Ω then the total resistance between the test terminals for this range comes to 5kΩ. Should we apply 5 volts to the test terminals a current of exactly 1mA will flow through this 5kΩ resistance and the meter needle will travel to f.s.d., as is required. For the 0-25 volt range, we give the next series resistor a value of 20kΩ. The total resistance between the test terminals is now 20kΩ

plus 4,900Ω plus 100Ω, or 25kΩ; and a current of 1mA will once again flow when a voltage of 25 volts is applied. Following similar reasoning the next resistance up is 75kΩ, giving a total resistance, on the 0-100 volt range, of 100kΩ. The final two resistors are 150kΩ and 750kΩ, giving total resistances of 250kΩ and 1MΩ respectively.

It will be seen that the resistance presented to the test terminals on any voltage range is equal to 1kΩ multiplied by the f.s.d. figure for the range. The meter of Fig. 1 can, in consequence, be described as having a sensitivity of 1kΩ per volt, or of 1,000Ω per volt. Thus, a voltmeter which consumes 1mA at full-scale deflection has a sensitivity of 1,000Ω per volt. If the basic meter in Fig. 1 gave full-scale deflection at 500μA (which is half of 1mA) all the resistance values for each range would need to be doubled and we would then say that the meter has a sensitivity of 2,000Ω per volt.

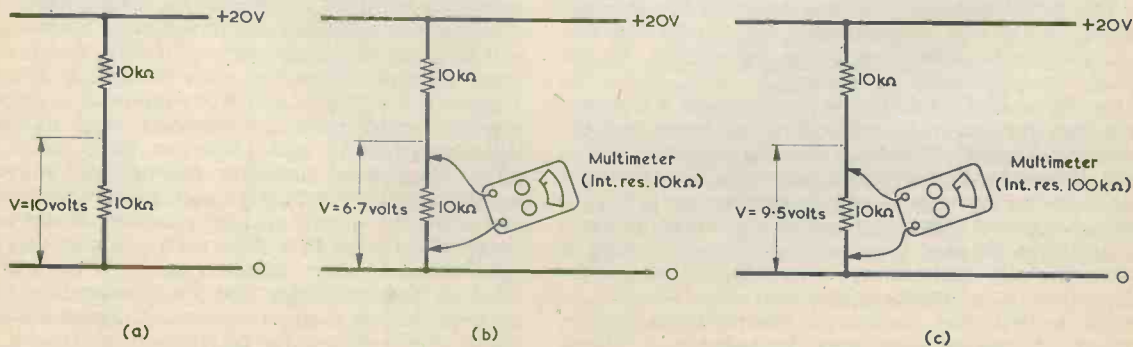

Fig. 2. Demonstrating the effect of meter resistance on voltage readings. In (a) two 10kΩ resistors are in series. A 1,000 ohms per volt multimeter switched to a 0-10 volts range in (b) causes the voltage across the lower resistor to fall to 6.7 volts. The 10,000 ohms per volt meter in (c) indicates 9.5 volts



Should the basic meter have an f.s.d. value of  $100\mu\text{A}$ , then the resistance values in Fig. 1 would need to be 10 times greater, and the voltmeter would be said to have a sensitivity of  $10,000\Omega$  per volt. A voltmeter whose basic meter movement gave f.s.d. at  $50\mu\text{A}$  would have a sensitivity of  $20,000\Omega$  per volt, and so on.

The importance of meter sensitivity is demonstrated in Figs. 2 (a), (b) and (c). In Fig. 2 (a) we have two  $10\text{k}\Omega$  resistors in series across a 20 volt supply, and we want to measure the voltage across the lower one. Common sense tells us that this voltage is 10 volts, but let us see what happens when we try to measure the voltage with a multimeter. In Fig. 2 (b) we apply a multimeter having a sensitivity of  $1,000\Omega$  per volt and switched to a 0-10 volt range. The meter presents a resistance, at its test terminals, of  $10\text{k}\Omega$  and this is effectively in parallel with the lower  $10\text{k}\Omega$  resistor, making the total lower resistance equal to  $5\text{k}\Omega$ . The voltage across the meter is now one-third of the total 20 volts available, or 6.7 volts, and *this is the voltage which the meter needle will indicate*. In Fig. 2 (c) we apply a testmeter having a sensitivity of  $10,000\Omega$  per volt and similarly switched to a 0-10 volt range across the lower resistor. The meter now applies a resistance of  $100,000$  ohms in parallel with the lower  $10\text{k}\Omega$  resistor, giving a total resistance which works out at  $9.09\text{k}\Omega$ . The voltage across the meter is now 9.5 volts and this is the voltage which the meter will indicate.

It can be seen that, whilst neither meter gives an accurate indication of voltage, the indication given by the more sensitive one, that with the sensitivity of  $10,000\Omega$  per volt, is closer to the required reading. Because of the fact that a multimeter inevitably consumes current when reading voltage, and thereby gives incorrect indications when measuring voltage in circuits containing series resistance, it is generally desirable to choose a model having a reasonably high sensitivity. For practical constructional work a meter with a sensitivity of  $10,000$  or  $20,000\Omega$  per volt will in general be quite adequate. Some relatively low-cost meters have sensitivities of  $50,000\Omega$  per volt or even  $100,000\Omega$  per volt and these will, of course, offer greater sensitivity. Despite these points, much valuable work can be carried out with the aid of a meter having a sensitivity of only  $1,000\Omega$  per volt, but it has to be remembered that its relatively low resistance can significantly alter voltages in circuits where there is series resistance. Meters having sensitivities lower than  $1,000\Omega$  per volt are best avoided unless offered at real bargain prices.

## CURRENT RANGES

The direct current ranges given by a multimeter should cover f.s.d. values of at least  $1\text{mA}$  to  $100\text{mA}$ , and these will cope with most requirements in valve and transistor equipment. Current ranges both above and below these two figures would, naturally, be an asset, although they may not be employed frequently in practice.

Resistance ranges tend to increase both in accuracy and the actual resistance values catered for as multimeter cost rises. In the cheaper models resistance readings can by no means approach the accuracy given by a resistance bridge, but the indications given can still be of considerable help, particularly in such applications as checking coils for continuity and the like. They can also be of help in selecting matched resistors from a batch, two resistors being chosen which give the

same or very nearly the same meter indication, even if this indication differs slightly from the nominal resistance value.

The preceding remarks concerning voltage and current ranges apply to d.c. measurements. Some quite inexpensive multimeters offer a.c. voltage ranges as well, and the constructor may be undecided as to whether or not he should obtain a meter incorporating this facility. Opinions on the usefulness of a.c. voltage ranges are liable to vary from constructor to constructor but, so far as work at home is concerned, the a.c. ranges will probably only be employed for measuring mains voltages, mains transformer secondary voltages, valve heater voltages and a.f. output voltages. The alternating voltage ranges in a multimeter usually have a lower ohms per volt figure than the direct voltage ranges, but this is not normally a disadvantage as the voltages most likely to be measured are nearly always provided by components or circuits having low or negligible series resistance.

The more expensive multimeters have alternating current ranges as well. These are, however, much more likely to be used by the serious experimenter or engineer than by the home-constructor, who will rarely have occasion to employ them.

## METER MAINTENANCE

After having made his selection and purchased his multimeter, the constructor should next ensure that it is looked after correctly.

All multimeters need to be treated with respect, and they should not be subjected to knocks or similar physical misuse. In general, the cheapest meters will be the most fragile, for the obvious reason that some robustness has had to be sacrificed in the interests of keeping costs low. It may be found also that some of the inexpensive meters give their most accurate readings when they are laid flat on their backs. This is not a serious disadvantage and merely represents a factor which has to be borne in mind when using the meter.

Many of the lower cost meters have no overload protection, and great care must be taken to ensure that excessively high voltages or currents are not accidentally applied to them. The least damage that can result from an overload is a bent pointer caused by its rapid travel to the right-hand end-stop, and the worst is a burnt-out coil or coil springs, or burnt-out internal resistors. When in doubt, select a voltage or current range which is higher than that for the anticipated voltage or current to be measured. The correct range can then be selected after the indication on the higher range shows that it is safe to do so.

Never leave a multimeter switched to a current or a resistance range after work with it has finished. It is quite easy to absent-mindedly pick up the test leads later and apply them to a source of high voltage or current. The best plan is to always switch the meter to its highest voltage range before putting it away. The meter should not be left lying on the bench whilst other work is being carried out, or it will soon pick up the dirt and detritus present on nearly all benches. It is better to keep it out of the way in its own box.

Finally, on receiving the meter any instructions that come with it should be read carefully. Apart from warning against possible misuse, these instructions may also advise the constructor of applications for the meter he'd never even thought about! ■

# In your workshop



This month Smithy the Serviceman, aided as always by his able assistant, Dick, embarks on the repair of a faulty stereo record player. In the process he is able to point out to Dick some of the more interesting and ingenious aspects of commercial design in this field.

Now this should be just the job!"

With a smile of satisfaction, Dick selected a small stereo record player turntable unit from the "For Repair" rack and carried it over to his bench. He then returned to the rack and picked up the two speakers which were intended for use with the turntable unit, placed them at either end of his bench, and plugged them into the turntable section. He next connected this to the mains and switched on. The little turntable motor whirred into life and was just audible as it rotated busily.

Dick reached up to the shelf above his bench and took down several 45 r.p.m. discs. He placed these on the spindle of the unit, fitted the retaining arm above them and actuated the auto-change control lever. After several seconds the bottom record clattered down onto the turntable, whereupon the pick-up rose, moved over and descended upon it. A weak tinny sound of music became audible from the pick-up stylus.

## ONE CHANNEL ONLY

The turntable unit incorporated the stereo amplifier, which had independent volume controls for each channel, and Dick advanced these. At once the music on the record became audible from the right-hand speaker, reproduced at adequate volume and with acceptable quality. The left-hand speaker was silent at all settings of the left-hand volume control.

Dick switched off the record player and pulled the left-hand speaker plug from its socket at the rear. He carefully examined the wiring to this plug. It looked all right. He selected a low ohms range on his testmeter and applied its test prods to the two pins of the speaker plug. The meter needle moved to a low resistance reading and there was a confirmatory crackle from

the speaker.

Dick returned the speaker plug to its socket and switched on again. For a second or so, the right-hand speaker gave voice to music of rapidly ascending frequency as the turntable rotation increased to full speed; after which the music was reproduced at the correct pitch. The left-hand speaker was still silent. Dick rocked its plug in the socket on the turntable unit, but to no avail. He switched off once more and stared thoughtfully at the record player.

"Having trouble?" enquired a voice in his ear.

Dick started violently then turned, glowering, towards the Serviceman.

"Hell's teeth," he snorted, "you've done it again!"

"Done what again?"

"Crept up on me," said Dick indignantly. "You're always doing it. Just when I'm concentrating on a job you pussy-foot up behind me and scream abuse in my lug-hole."

"I was not screaming abuse or any other such thing," replied Smithy stiffly. "I was merely venturing a polite and helpful enquiry as to whether you were having any difficulties."

"Well, perhaps you were, too," conceded Dick reluctantly. "Nevertheless, you still just about scared the living daylights out of me. As it happens I am having a bit of trouble. I was just pondering what to do next with this stereo record player."

"What's the snag?"

"The left-hand channel is dead. As you know, this sort of thing is often caused by something simple, like a lead broken off at the speaker plug. And so I checked that, but there's nothing wrong there."

"It looks as though you'll have to get the works out then," commented Smithy. "Still, there is a further thing you can check before you do that, and that's to see that all the connections

are properly made at the pick-up cartridge. Those little spring connectors tend to come off occasionally."

Dick raised the pick-up arm and examined the cartridge connections. He replaced the pick-up on the record.

"The connections," he remarked, "are all right."

"You shouldn't move the pick-up arm of a record player around when it's half-way through a cycle of auto-change operations," said Smithy critically. "You should actuate the changer mechanism so that the arm is finally disengaged and at rest, and then do the moving around."

"I've moved pick-up arms in the middle of auto-change cycles before now," replied Dick defensively, "and it doesn't seem to have done any harm."

"Perhaps not," persisted Smithy, "but that's only because modern record-changers are robust and can stand up to maltreatment. Anyway, I won't keep on about it and, seeing that those cartridge connections are all right, you'll now definitely have to get that record player chassis out. Whilst you're doing that I'll see if I can find a service sheet for it. I'm beginning to get rather interested in this record player."

Whilst Smithy walked over to the filing cabinet, Dick examined the turntable unit. He removed the screws securing the front panel and found he was able to withdraw the complete amplifier chassis sufficiently far for testing purposes without disconnecting the leads which passed from it to the gram deck. Smithy returned with the required service sheet and laid it on the bench, opened out at its circuit diagram. (Fig. 1.)

## TWIN AMPLIFIERS

"Humph," he remarked, "it's a nice simple arrangement, and it shouldn't take us long to find the fault. Incident-

RADIO & ELECTRONICS CONSTRUCTOR



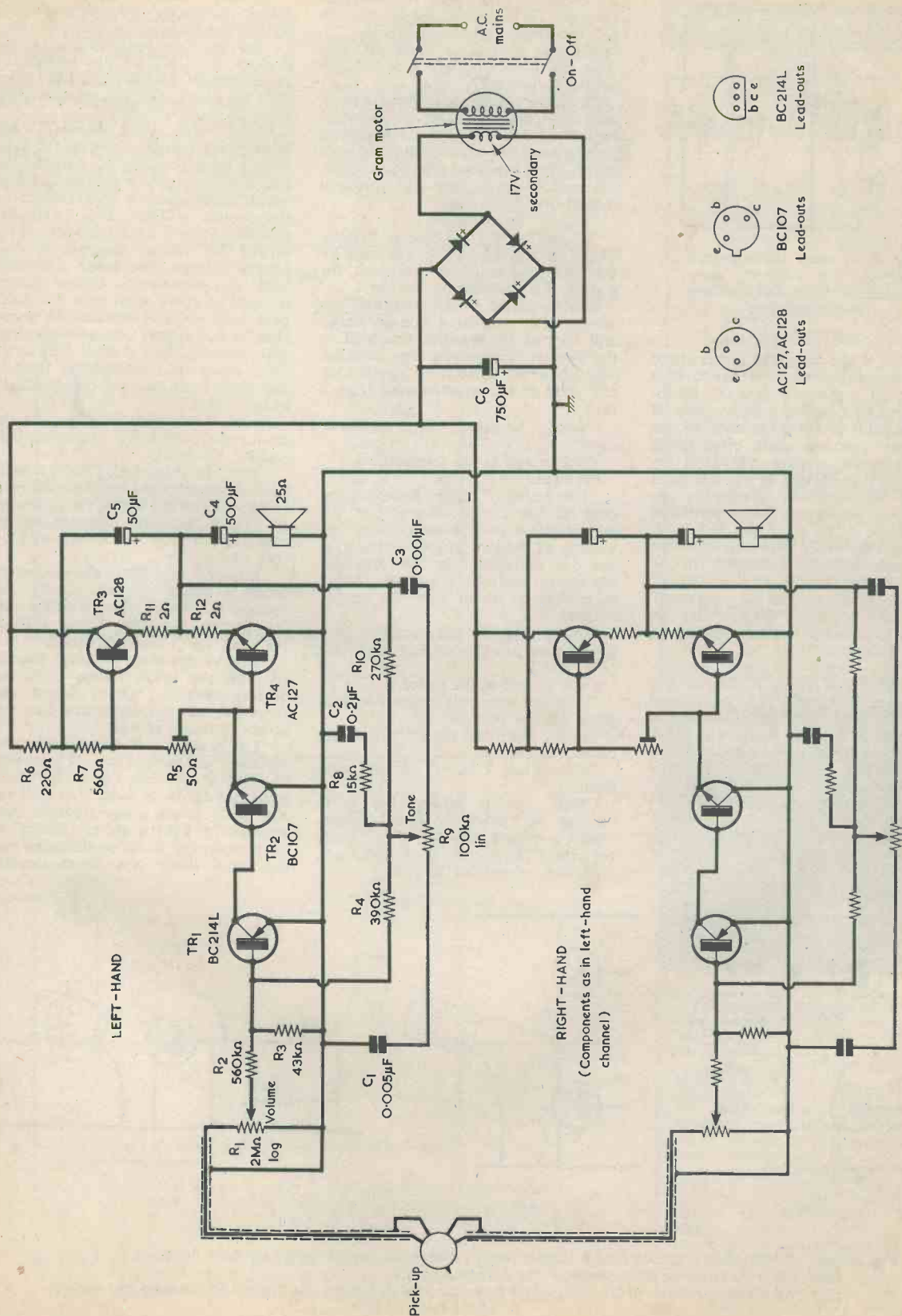

Fig. 1. Typical small stereo record player circuit. Resistor and capacitor values are representative of commercial practice

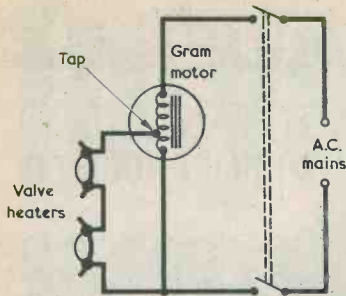

Fig. 2. In some valve record players, the heaters were supplied by a tap in the motor winding

ally, one of the delightful things about stereo amplifiers, so far as servicing is concerned, is that you have two identical amplifiers sitting side by side. If you've got a really sticky snag in one amplifier you can quite often get a lead towards tracing the fault by checking the voltages in various parts of the two circuits, comparing the ones you get in the faulty amplifier with those in the good one. However, we might be lucky here and find that the snag is simple enough to be traced in the faulty amplifier without having to check against the good one."

"I see," remarked Dick, "that the supply is obtained from a winding on the gram motor."

"That's right," agreed Smithy. "This is an old dodge, of course, and it enables the amplifiers to be isolated from the mains without the expense of a separate mains transformer. A similar sort of approach was used in the old valve record players. Some of these had a tap in the motor winding, and this fed the valve heaters." (Fig. 2.)

Smithy walked over to his bench, picked up his stool and returned. He sat down purposefully in front of Dick's bench.

"Now, we won't want that stack of records you've loaded on the spindle for the time being," he stated. "So could you please get them off, and then reject the one which is actually on the turntable?"

Obediently, Dick removed the stack of records, after which Smithy switched on the amplifier. The record remaining on the turntable became audible once more. Dick operated the reject lever, whereupon the pick-up arm rose and moved over to its rest.

"Okay?" he enquired.

"Okay," confirmed Smithy briskly. "Let's take a few voltage readings on this left-hand amplifier. Let's see, for a start, if it's getting any power."

Smithy pulled Dick's testmeter towards him, selected a voltage range and clipped the positive test lead to the chassis. Examining the amplifier printed circuit closely, he applied his test prod to the negative rail. (Fig. 3 (a).)

"What," he asked, "does the meter say?"

Dick peered at the testmeter.

"It's reading 22 volts."

"Fair enough," replied Smithy, glancing at the circuit diagram of the record player. "I'll now check the voltage at the two output emitters. If the d.c. conditions in this amplifier are correct the output emitters should be sitting at about half the supply voltage."

Smithy applied his negative test prod to the junction of R11 and R12. (Fig. 3(b).)

Dick looked at the meter.

"Are you sure you've got the right place on the board?"

Smithy examined the printed circuit panel closely.

"I'm certain I have," he said confidently.

"Well, you're getting the same reading as before," stated Dick. "Wait a minute, though, it isn't quite the same! The present reading is a wee bit lower, at around 21 volts."

"Good," said Smithy, pleased. "That means we've found something wrong first go."

"We must have found the fault, too," pronounced Dick. "If the reading on the emitter of TR3 is just a little lower than the supply rail voltage, then TR3 must be short-circuited."

"Hey, hold your horses," said Smithy, reprovingly. "It's far too early yet to start jumping to conclusions, and there are quite a few other things which could cause a high voltage on the emitter of TR3. This particular amplifier doesn't have a pre-set pot for setting the output emitters to half supply voltage, like some amplifiers with complementary output stages do, and so there must be a d.c. feedback loop which is intended to ensure that the half supply voltage is obtained automatically. Our present snag could quite easily be caused by a fault in that loop. Let's have another butcher's at the circuit."

Smithy examined the circuit in the service sheet for a few moments, then nodded his head.

"Yes," he remarked, "the d.c. feedback arrangements are pretty obvious."

He selected the lowest voltage range on Dick's testmeter and applied the negative test prod to the base of TR1. (Fig. 3(c).)

"Blimey," said Dick, glancing at the meter, "you're getting hardly any voltage at all now. The needle's indicating about 0.1 volt, if that. Perhaps it's TR1 that's short-circuited!"

"You've got short-circuited transistors on the brain today," returned Smithy shortly. "Don't forget that there are other components that can go short-circuit as well."

"I'm beginning to find all this a bit baffling," confessed Dick. "The emitter of TR3 is at very nearly the same potential as its collector but you say that TR3 is not short-circuited. And the base of TR1 is at very nearly the same potential as its emitter and you say that that's not short-circuited

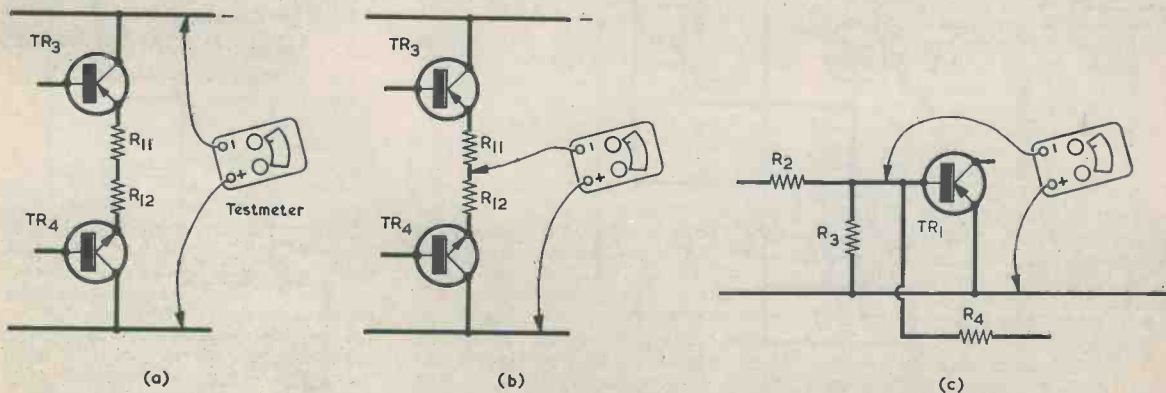

Fig. 3 (a). Smithy first checked that a supply was available for the left-hand channel amplifier  
 (b). He next checked the voltage at the output emitters  
 (c). As a consequence of the readings he had obtained, Smithy proceeded to measure the voltage at the base of TR1



either.”

“I didn’t say definitely that one or other of those transistors might *not* be short-circuit,” replied Smithy testily, “but that’s only because it doesn’t do to be too dogmatic in the servicing game. At the same time, though, I do say that quite a few of the other components in the amplifier could be causing the symptoms we’ve got here. Now, that low voltage reading on TR1 base means that it’s more than prob-

able that there isn’t enough bias current getting to it. Since TR1 is a silicon transistor, its base needs to be about 0.6 volt higher than its emitter, and that is certainly not happening here. The base current to TR1 flows through R10 and R4, so let’s see what voltages we get at these resistors.”

Smithy selected a higher voltage range on Dick’s meter and placed the negative test prod on the junction of R10 and R4. (Fig. 4(a).)

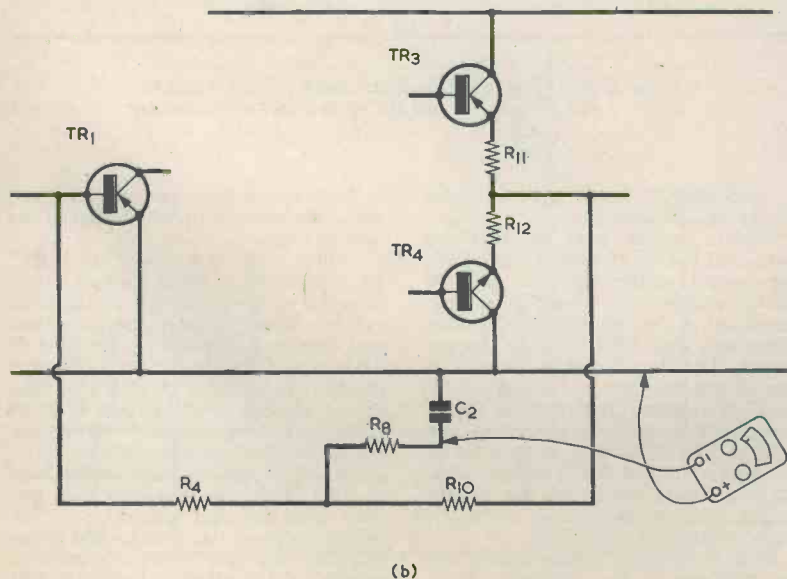
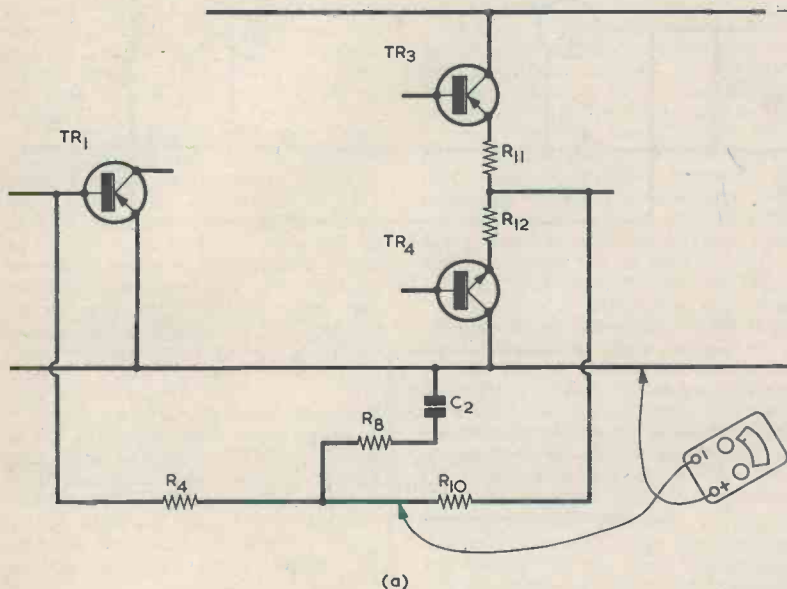

Fig. 4 (a). Following the previous measurements, Smithy next checked the voltage at the junction of R4 and R10  
 (b). Smithy finally traced the fault by checking the voltage across C2

## Your Local Supplier

LONDON

### THE MODERN BOOK CO.

Largest selection of English & American radio and technical books in the country.

19-21 PRAED STREET,  
LONDON, W2 1NP  
Tel: 01-723 4185/2926

## ST. HELEN'S RADIO

Hi-Fi Equipment  
Tape Recorders  
Radio Receivers  
Television

SPECIALISTS IN RADIO  
& ELECTRONIC TEXTBOOKS

ST. HELENS GARDENS  
LONDON, W.10  
Tel: 01-969 3657

HAMPSHIRE

## BOURNEMOUTH

LARGEST HI-FI AND  
RADIO COMPONENT  
STORE IN THE SOUTH

FORRESTERS NATIONAL  
RADIO SUPPLIES LTD.

70-72 Holdenhurst Road  
Bournemouth  
Telephone 25232

LANCASHIRE

### AERIAL BOOSTERS

We make three types, L11 - VHF Radio,  
L12 - VHF 405 TV, L45 - UHF 625 TV.  
Price £2.95

### TELEVISION VALVES

All types of TV Valves in stock, any  
five for 45p

### TRANSISTOR - DIODES

BC113, BC115, BC117, BC135, BC171,  
BF173, BA102, BA129. Brand new,  
Price 1/10p any 100 - £7.

### ERIE CERAMICS

4.7PF, 5PF, 6.8PF, 10PF, 12PF, 18PF,  
18.5PF, 550PF, 820PF, 1000PF,  
1200PF, 1500PF, 1800PF, 2700PF,  
3300PF, 8200PF.

Many other values in stock.  
Price 1/3p, 10/20p, 25/35p.

S.A.E. for Leaflets, P. & P. 10p.

Velco Electronics (R),  
Ramsbottom, Bury, Lancs.

"Half a mo," called out Dick. "I'll have to switch down to a lower voltage range. Ah, here we are! The meter's reading about 1 volt."

"Is it, indeed?" remarked Smithy. "Then that means that either R10 has gone high in value or that something is dragging its junction with R4 down towards chassis. Let us undertake an exploratory prod at C2."

He applied the test prod to the junction of R8 and C2. (Fig. 4(b).)

"There's no reading in the meter at all now," announced Dick. "Not even a suspicion of one."

"Then that's it," grinned Smithy. "Either C2 is short-circuit or there's a short in the print across it. But it will almost certainly be the capacitor itself."

## FEEDBACK LOOP

Smithy rose, switched off the record-player, and let his assistant take over. After a check with his testmeter switched to an ohms range, that worthy soon established the fact that C2 was indeed short-circuit, and he quickly obtained a replacement and soldered it into circuit. He next switched on the record-player and checked the voltage at the emitter of TR3. This was now sitting sedately at the more respectable potential of 10.5 volts.

"Fine," said Smithy. "Try her out!"

Dick set up the auto-change and started it in operation. After some seconds the recorded music became audible again. But it was, this time, reproduced by both loudspeakers. The left-hand channel was now functioning as efficiently as the right-hand channel. Dick and Smithy listened contentedly until the record came to an end, and then the Serviceman switched off the record-player.

"You certainly cleared that one up pretty smartly," commented Dick. "I still can't see what was happening, though. How on earth can a shorted capacitor cause the base of one transistor to go low in voltage and the emitter of another to go high?"

"The chain of events is quite simple if you take them in stages," said Smithy in reply. "Before going any further, let's just see what each transistor in the amplifier does. TR1 is connected as a common emitter device, which means that it offers voltage amplification and that the signal on its collector is 180° out of phase with that on the base. When the base goes negative the collector goes positive, and vice versa. All the other three transistors in the amplifier are emitter followers, with the result that they offer current amplification only, with no change in phase. Thus, when the base of TR1 goes negative the emitters of TR2, TR3 and TR4 go positive, and when the base of TR1 goes positive the emitters of TR2, TR3 and TR4 go negative. All right so far?"

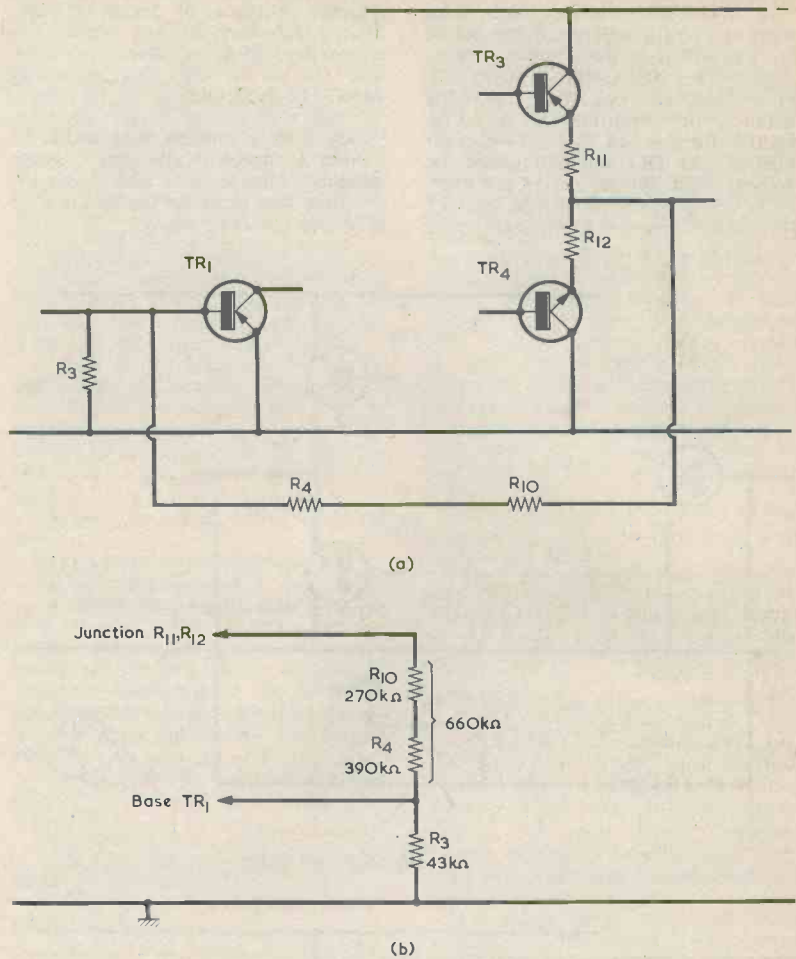

Fig. 5 (a). The d.c. feedback path in the amplifier  
(b). R10, R4 and R3 form a potential divider

"Definitely," said Dick. "What comes next?"

"What comes next is that we examined the d.c. feedback path from the output emitters to the base of TR1," said Smithy. "Since we're only interested in d.c. conditions we ignore capacitors and look only at the resistors. The d.c. feedback path from the output emitters is then given by the 270kΩ resistor, R10, and the 390kΩ resistor, R4, which connects to the base of TR1. TR1 base is then taken to chassis via the 43kΩ resistor, R3. R2 and R1 are across R3, but we can ignore these as their values are much higher than that of R3."

With his finger, Smithy traced out the resistors in the feedback chain. (Fig. 5(a).)

"Now," he went on, "we have a simple potential divider here with R10 plus R4 giving the resistance above the base of TR1, and R3 the resistance below the base." (Fig. 5(b).)

Smithy took out a pen and scribbled some calculations in the margin of the service sheet.

"These resistance values are such," he continued, "that about one-fifteenth to one-sixteenth of the total voltage between the output emitters and chassis is applied to the base of TR1. Now let's assume that, for some reason, the emitters of TR3 and TR4 are at chassis potential and that we allow them to go negative. When the output emitters are at chassis potential there will be zero voltage on the base of TR1 and this transistor will not pass any collector current. As the output emitters rise towards the negative rail they will eventually reach a voltage which allows about 0.6 volt to appear between the base and the emitter of TR1. This transistor will now come on and commence to pass collector current, and the corresponding voltage at the output emitters will then be about 15.5 times 0.6, or 9.3



volts. TR1 needs a few microamps of base current to arrive at its operating point and so the voltage at the output emitters will then rise a little more to provide this. The circuit is now in a d.c. stabilized condition. If, for instance, the output emitters try to go positive the base of TR1 will also go positive and TR1 will counteract the change. And if the output emitters try to go negative, so will the base of TR1 and this transistor will once more counteract the change."

"Gosh," breathed Dick, highly impressed, "that's a really crafty bit of circuit operation. The output emitters stay at around half supply voltage simply because TR1 comes on when its base is 0.6 volt negative of its emitter."

"That's it," confirmed Smithy, "and the voltage at the output emitters depends upon the resistance values in the d.c. feedback chain back to TR1 base. I calculated the output voltage as a little more than 9.3 volts but, as we found when we measured it in the particular amplifier we are working on, it can vary slightly from this figure. This is due to the fact that the base voltage required for TR1 to come on is not *exactly* 0.6 volt, but is only approximately so."

"I can see now why the short-circuit at C2 produced such weird results," said Dick excitedly. "With C2 being short-circuited there wasn't enough voltage at TR1 base to even bring it on. Its collector went highly negative and all the other transistors, being emitter followers, went negative as well."

"Exactly," agreed Smithy. "It's an extreme instance of the case that, when TR1 base goes positive, the output emitters go negative."

### TONE CONTROL

But Dick's interest had suddenly turned to some of the other components in the circuit.

"I see that the tone control is also connected to the feedback chain," he remarked, pointing at the circuit diagram. "It's given by R9, C1 and C3." (Fig. 6.)

"Ah yes," said Smithy. "Now, when we start talking about capacitors we find ourselves looking at the a.c. feedback circuit. If, in the present design, the slider of R9 is taken to the C3 end of its track, then C3 is effectively in parallel with R10. This means that feedback current increases as frequency rises. The amplifier will therefore offer reduced amplification at the higher frequencies and the result will be a treble cut or bass boost."

"Why, so it will be," exclaimed Dick. "Let's see if I can work out what happens when the slider of R9 is at the C1 end."

Dick thought for a moment as he considered the circuit in this condition.

"Well," he said, "what will take place here is that some of the feedback current will go to chassis by way of C1 instead of to the base of TR1, and that the amount of current passing through C1 will go up as frequency increases. Because of this there will be less feedback at the treble frequencies. The amplifier will offer greater ampli-

## Your Local Supplier

### SOMERSET

#### RESISTORS UNREPEATABLE CLEARANCE LINE TOP QUALITY CARBON FILM

$\frac{1}{20}$ ,  $\frac{1}{10}$ ,  $\frac{1}{5}$ ,  $\frac{1}{2}$ ,  $\frac{1}{1}$ ,  $\frac{1}{2}$ ,  $\frac{1}{1}$ -2 watt 5% Tol. Std. Limited No. 2% Hi-Stab.  $\frac{1}{8}$  &  $\frac{1}{4}$  W. only. Wide Choice Values, E24 Series But NOT COMPLETE RANGES Values, your choice in 5s, nearest Subs. given if not available.

5% Std. 55p/100, £5/1,000 No V.A.T. Hi-Stabs. 75p/100, £6/1,000 Post Free C.W.O.

Special Offer 1,000 Assorted £3. Min. 100 different types given.

WRAP RESISTORS,  
9 Ellen Close,  
North Petherton  
Som.

Tel:  
N. Petherton  
662501

### SURREY

## WITWORTH TRANSFORMERS

### TV Line out-put transformers

Manufacturers of the largest range in the country. All makes supplied.

Free catalogue.

Modern

BAIRD, BUSH, GEC, PHILIPS

Replacement types ex-stock.

For "By-return" service, contact London 01-948 3702

Tidman Mail Order Ltd., Dept. R.C.

236 Sandycombe Road,

Richmond, Surrey TW9 2EQ

Valves, Tubes, Condensers, Resistors, Rectifiers and Frame out-put Transformers, Mains Transformers also stocked. Callers welcome.

### SUSSEX

## E. JEFFRIES

For your new television set  
tape recorder, transistor radio  
and hi-fi equipment

PHILIPS, ULTRA, INVICTA  
DANSETTE, MASTERADIO, PERDIO,  
MARCONI, PHILCO FIDELITY

6A Albert Parade  
Victoria Drive,  
EASTBOURNE SUSSEX

### EIRE

## PEATS for PARTS

ELECTRONIC COMPONENTS  
RADIO & TELEVISION

For the convenience of Irish  
enthusiasts we supply

The Radio Constructor

Data Books and

Panel-Signs Transfers

Also a postal service

Wm. B. PEAT & Co. Ltd.

28 PARNELL STREET  
DUBLIN 1

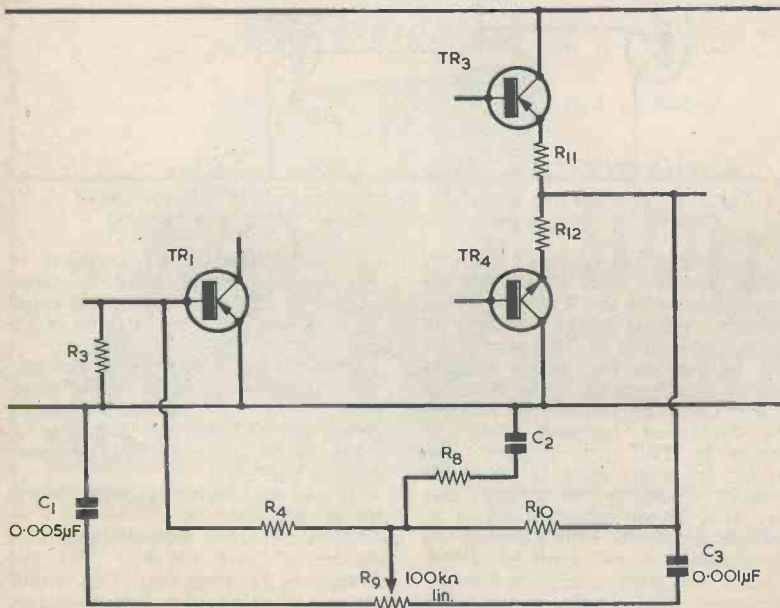

Fig. 6. R9, C1 and C3 provide the tone control circuit

## BUILD THE TREASURE TRACER



### METAL LOCATOR MK III

- Incorporates varicap tuning for extra stability
- Weighs only 22oz and has perfect balance
- Loudspeaker or ear-phone operation (both included)
- Handle knocks down to only 17in. for transport
- Ministry approved design
- Excellent sensitivity and stability
- Kit can be built using only soldering iron, screwdriver, pliers and wire snips
- Drilled, tinned, fibre-glass p.c. board with component siting printed on
- Fitted with Faraday Screen.

SEND S.A.E. FOR LEAFLET

Complete kit with pre-built search coil	£9.80	Built, tested and Guaranteed.	£13.75
Plus 35p Post inc. V.A.T.		Plus 35p Post inc. V.A.T.	

MINIKITS ELECTRONICS,  
35f Langley Drive, Wanstead,  
LONDON E11 2LN (Mail order only)

fication at these frequencies and the result will be a treble boost."

"That's it," confirmed Smithy. "And you will get intermediate levels of cut and boost for intermediate settings of R9, R8 and C2 are also in the a.c. feedback chain and these will mainly influence the overall gain of the amplifier. If anybody wanted to build up an amplifier using a circuit of this nature they would need to experiment with the values of these two components to suit the particular pick-up they were using. The latter would need to be a crystal or ceramic type, incidentally."

"I see," remarked Dick, "that there is the usual electrolytic coupling the output emitters to the speaker. But there's another electrolytic, C5, coupling the output emitters to the junction of R6 and R7. What's that for, Smithy?" (Fig. 7.)

"It's to provide bootstrapping," explained Smithy.

"Bootstrapping?" repeated Dick dubiously. "I think I know what that means, but a little refresher course wouldn't come amiss!"

to TR2 and TR1."

"A smoothing capacitor? Come off it, Smithy, you must be joking!"

"No, I'm not," said Smithy. "As you can see, the supply circuit is of a very rudimentary nature, consisting simply of a bridge rectifier feeding directly into the reservoir capacitor, C6. There is liable to be some ripple across C6, particularly when the amplifier draws a heavy current, but this doesn't matter because TR3 is an emitter follower. TR3 acts here as a sort of electronic smoothing device, since the voltage at its emitter is dependent upon the voltage at its base regardless of changes, within reason, in collector potential. So any ripple across C6 doesn't find its way to the emitter of TR3. Or at least it doesn't provided that, on signal peaks, the troughs between ripple peaks don't take the supply voltage too close to the base voltage of TR3. However, the value of C6 should be large enough to ensure that this doesn't happen."

"I can see it all now," put in Dick. "Since TR3 causes the voltage at its base to be effectively smoothed, then

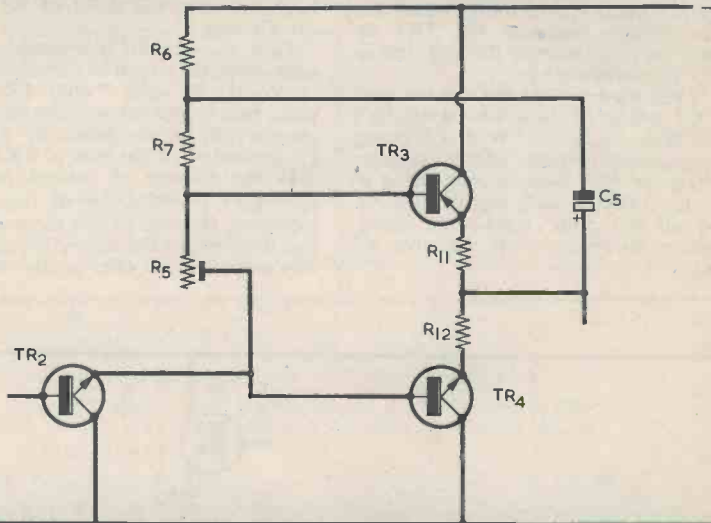

Fig. 7. C5 couples the output of the amplifier back to the junction of R6 and R7, thereby giving both bootstrapping and smoothing

"Fair enough," chuckled Smithy. "Well, what C5 does is to bootstrap the junction of R6 and R7 to the output emitters. When, whilst handling a signal, the emitter of TR2 goes negative, so also do the output emitters and so also, because of the presence of C5, does the junction of R6 and R7. The same happens when the emitter of TR2 goes positive. The results are that there is almost a constant voltage across R7 and that very little signal current flows in it. Because of this R7 behaves, so far as signal current is concerned, as though it has a very high value of resistance, whereupon TR2 emitter is presented with what is, effectively, a very high resistance load. Another function carried out by C5 is that it acts as a smoothing capacitor for the supply

the positive end of C5 connects to this smoothed circuit point. In consequence, it acts as a smoothing capacitor connected to the junction of R6 and R7."

"That's the idea," said Smithy. "This amplifier circuit is one of those designs which are deceptively simple on the surface but which contain quite a few subtle features when you start digging into them."

"I wonder," queried Dick, "what the output power is."

"You can work that out from first principles," said Smithy. "The rail voltage is 22 volts and the output emitters sit at about half this voltage. Allowing for small discrepancies here, it would be reasonably safe to assume that the output emitters can swing both positive and negative by about 10

## RADIO & ELECTRONICS CONSTRUCTOR

ANNUAL SUBSCRIPTIONS to this magazine may be obtained through your newsagent or direct from the publishers ONLY £2.70 per year, post free

Please send remittance with name and address and commencing issue required to:

DATA PUBLICATIONS LTD  
57 Malda Vale London W9 1SN



volts peak. This corresponds to 7 volts r.m.s. The speaker impedance is 25Ω nominal and it would be advisable to say that the load applied to the output emitters is this figure plus a few odd ohms due to the presence of C4, R11 and R12. An output load figure of 28Ω or so would be realistic. The output power is then r.m.s. voltage squared divided by impedance, or 7 squared divided by 28."

Smithy scribbled some further figures in the margin of the service sheet.

"Ah yes," he said, "that comes out as 1.75 watts. It's always advisable to be a bit cautious with these output power figures and so it would be safe to assume an actual output power of around 1.5 watts."

"I suppose," commented Dick, "that R5 is set up in the usual way so that TR3 and TR4 pass a small current under quiescent conditions."

"That's right," agreed Smithy. "If you were starting from scratch you'd adjust R5 to put minimum resistance into circuit and insert a current reading meter between the collector of TR3 and the negative supply rail. The resistance inserted by R5 would then be increased until the meter indicated about 5mA or so under quiescent conditions. The same approach would apply for the corresponding base potentiometer in the right-hand channel."

#### DON'T RING US

"Oh well," said Dick, rising from his stool," it looks as though we've

got another servicing job out of the way."

"Yes, indeed," replied Smithy, also rising. "You'd better button up this record player now and get on with the next gubbins that requires fixing."

"D'you know, Smithy," said Dick chattily, "I'm glad I went in for servicing as a career. There must be more fun in servicing than there is in any other job."

"I agree with you there," remarked Smithy. "The great thing about servicing is the special feeling of achievement you get after you've traced a really obscure fault and got a piece of equipment back into working order again."

"You're dead right there," responded Dick enthusiastically. "Hey, hang on a jiffy!"

A look of agonised concentration spread over his face. With a sinking heart, Smithy realised that Dick was being visited, as occurred on occasion, by his Muse.

"Here, Smithy," said Dick proudly, as his brow cleared, "what do you think of this?"

He struck a pose indicative of the creative artist.

*"I could have been a bricklayer*

*Or even a window displayer,*

*But I get far more kicks*

*When I'm able to fix*

*A stereophonic gram player!"*

The shuddering Serviceman, as he sought the sanctuary of his own bench, had to admit that, in Dick, he certainly had an assistant who was totally unique. He should be so unlucky. ■

## LOUDSPEAKER BARGAINS



Fane pop 100 watt 18" 8/15 ohm	£21.45
Fane pop 60 watt 15" 8/15 ohm	£12.26
Fane pop 50 watt 12" 8/15 ohm	£10.17
Fane pop 25/2.25 watt 8/15 ohm	£5.94
Fane pop 15" 12" 15 watt 8/12 ohm	£7.50
Fane 122/10 or 122/12	£9.90
Fane Crescendo 15" 8 or 15 ohm	£27.50
Fane Crescendo 12" 8 or 15 ohm	£24.20
Fane 8" d/cone 808T 8 or 15 ohm	£2.64
Fane 8" d/cone, roll surr. 807T. 8 or 15 ohm	£3.16
Baker Group 25 3, 8 or 15 ohm	£6.00
Baker Group 35 3, 8 or 15 ohm	£7.50
Baker De Luxe 12" d/cone	£9.62
Baker Major	£7.50
EMI 13 x 8 3, 8 or 15 ohm	£2.25
EMI 13 x 8 type 150 d/cone 3, 8 or 15 ohm	£2.58
EMI 13 x 8 type 450 /vw 3, 8 or 15 ohm	£3.85
EMI 13 x 8 type 350 3 ohm	£8.25
EMI 6 1/2" 93850 4 or 8 ohm	£2.80
Elac 9 x 5 RM 109 15 ohm	£2.53
Elac 9 x 5 59 RM 114 8 ohm	£2.53
Elac 6 1/2" d/cone 6 RM 220 8 ohm	£2.59
Elac 6 1/2" d/cone roll surr. 6 RM 171 8 ohm	£3.22
Elac 4" tweeter TW4 3 or 15 ohm	£1.21
Celestion PSB for Unilex	£2.16
Celestion MF 1000 25 watt horn 8 or 15 ohm	£10.45
Elac 5" 3 ohm	£1.75
Elac 7" x 4" 3 or 8 ohm	£1.52
Elac 8" x 5" 3, 8 or 15 ohm	£1.93
Wharfedale Bronze 8 RS/DD	£3.11
Wharfedale Super 8 RS/DD	£5.50
Wharfedale Super 10 RS/DD	£9.80
Goodmans 8P 8 or 15 ohm	£13.80
Goodmans 10P 8 or 15 ohm	£4.49
Goodmans 12P 8 or 15 ohm	£11.55
Goodmans 15P 8 or 15 ohm	£17.05
Goodmans 18P 8 or 15 ohm	£29.70
Goodmans Twinaxiom 8	£6.79
Goodmans Twinaxiom 10	£7.61
Goodmans Axent 100	£6.60
Eagle DT 33 dome tweeter 8 ohm	£4.95
Eagle HT 15 tweeter 8 ohm	£3.46
Eagle CT 5 tweeter 8 ohm	£1.21
Eagle MHT 10 tweeter	£3.30
Eagle CT 10 tweeter	£1.92
Eagle X overs CN 23, 28 216	£1.10
Kef T27	£4.67
Kef T15	£5.50
Kef B 110	£6.16
Kef B 200	£7.42
Kef B 139	£10.72
Kefkit 2	£24.75
Richard Allan 12" d/cone 3 or 15 ohm	£2.20
Richard Allan 8" 3, 8 or 15 ohm	£2.27
10" x 6" 3, 8 or 15 ohm	£1.92
8" x 5" 3 or 8 ohm	£1.38
7" x 4" 3 or 8 ohm	£1.38
3" 8 ohm or 80 ohm	£0.65
2 1/2" 64 ohm	£0.65
Speaker matching transformer 3/8/15 ohm	£1.10
Adastra Hiten 10" 10 watt 8 or 15 ohm	£2.80
Adastra Top 20 12" 25 watt 8 or 15 ohm	£2.82

### STEPHEN SPEAKER KITS AND CABINETS

send for illustrated brochure and list of recommended speakers.

#### CAR STEREO SPEAKERS — ask for leaflet

PA/Disco amplifiers: (carr. and ins. (£1.00))	
Baker 100 watt	£46.00
Linear 30/40	£25.00
Linear 40/60	£30.00
Linear 80/100	£50.00

#### FREE with speaker orders over £7 "HiFi Loudspeaker Enclosures" book

All units guaranteed new and perfect. Prompt despatch. Carriage and insurance 25p per speaker. (Tweeters and Crossovers 15p. each).

## WILMSLOW AUDIO DEPT RC

SWAN WORKS, BANK SQUARE, WILMSLOW, CHESHIRE. SK91HF

# Simple Short-Wave Receivers



by F. A. Baldwin

FOR ONLY

# 80p

P. & P. 6p

140 Pages (5 1/2 x 8 1/2 in)

TO DATA PUBLICATIONS LTD 57 Maida Vale London W9 1SN

Please supply..... copy(ies) of 'Simple Short Wave Receivers',

Data Book No. 19. I enclose cheque/crossed postal order for.....

NAME .....

ADDRESS.....

# G & H ELECTRONICS

14 Sunny Hill Road, London S.W. 16.

141 Crofton Lane, Orpington, Kent. Tel: Orpington 31138

K.B. Record Player Cabinets, 4 col. 2 types, new £3 ea. Complete kit for above £16. p.p. 50p.  
 K.B. Deluxe Stereo Cabinets £2.00 ea. Deluxe chrome knobs, set of 4 48p. Mains/battery radios, new, £7.50 ea.  
 K.B. and R.G.D. Transistor Radio Cabinets, 10 types available, various colours and sizes, new and boxed 25p ea. Set of Dial knobs for above 12p per set.  
 Attractive Mains Radio Cabinets, choice of 3 types, colour cream or brown, £1 ea. Knobs if required, 12p per set. p.p. 15p.

## Full range of Radio & TV Components

	p.p.	
Elect Cond. from	10p	Volume controls dual: ganged, less switch
Bias Cond. from	4p	with switch
Resistors from	1p	Chrome handles 10"
T.V. Droppers from	20p	Blue PVC chrome with clips 5"
Valve holders	5p	Black 10", plastic handles
Valves from	25p	Polished wood table ends, per set
Ferrite rods	5p	Deluxe steel Legs, 10", black with black chrome feet.
Complete with coils	30p	Set of 4
Speaker Transformer	25p	Brass hinges, each
Main trans. from	£1.50	Piano hinges, each
Chokes, 10H 150MA	50p	
Var. Cond.	35p	
V.H.F. tuners	£1.50	
T.V. tuners	£2.00	
Volume controls, less switch	10p	
with switch	15p	

P & P on above 10p each

Solo Soldering Gun, self-feed type, with 2 oz reel of solder, in case, 110V or 6V Wkg. 60p, P & P 25p

**ALL COMPONENTS DESPATCHED WITHIN 24 HOURS**

# 'YOUR CASE' NOW SOLVED

BLACK P.V.C. BOXES AVAILABLE



IDEAL FOR ELECTRONIC APPARATUS AND SPECIAL RIG ENCLOSURES

- ★ ROBUST MOULDING
- ★ ALL INSULATED
- ★ EASY TO CUT AND DRILL
- ★ SELF FINISH
- ★ NON-RUSTING
- ★ SELF EXTINGUISHING

Length	Width	Depth	Price each	P. & P. each
4 in.	4 in.	1½ in.	38p	13p
4 in.	4 in.	2 in.	41p	14p
6 in.	3 in.	1½ in.	38p	14p
6 in.	4 in.	2 in.	52p	14p

ALLOW 21 DAYS FOR DELIVERY  
 ORDERS OVER £8 P. & P. FREE  
 QUOTATIONS GIVEN FOR LARGE QUANTITIES

**ADAPTABOX, DEPT. REC**  
**26 WELBY GARDENS, GRANTHAM**  
**LINCS. NG31 8BN**

# NEW STYLE SELF-BINDER

for "Radio & Electronics Constructor"

The "CORDEX" Patent Self-Binding Case will keep your issues in mint condition. Copies can be inserted or removed with the greatest of ease. Rich maroon finish, gold lettering on spine.

Specially constructed Binding Cords are made from Super Linen of great strength, very hard twisted and twice doubled. They are attached to strong RUSTLESS Springs under tension, and the method adopted ensures PERMANENT RESILIENCE of the Cords. Any slack that may develop is immediately compensated for and the Cords will always remain taut and strong. It is impossible to overstretch the springs, as a safety check device is fitted to each.

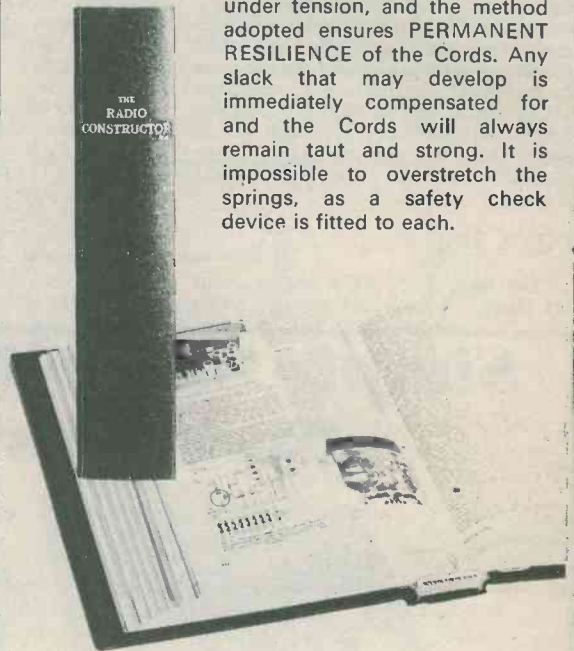

PRICE **83p** P. & P. 14p

including V.A.T.

Available only from:—

**Data Publications Ltd.**

**57 Maida Vale London W9 1SN**



# SMALL ADVERTISEMENTS

Rate: 4p (9d) per word. Minimum charge 60p (12/-).  
Box No. 10p (2/-) extra.

Advertisements must be prepaid and all copy must be received by the 4th of the month for insertion in the following month's issue. The Publishers cannot be held liable in any way for printing errors or omissions, nor can they accept responsibility for the *bona fides* of advertisers. (Replies to Box Numbers should be addressed to: Box No. —, *Radio and Electronics Constructor*, 57 Maida Vale, London, W9 1SN)

**MINI MAINS TRANSFORMERS.** 30 x 30 x 37mm. Cool, quiet, British. Pri: 220/250V. Type MT3, 3-0-3V rms, 300mA, £1. MT7, 7-0-7V, 120mA, £1. VAT included. Use MT3 for 3V or 6V rectified d.c., MT7 for 9V or 18V. Circuits supplied. Mail order only. U.K. post 5p per order. Amatronix Ltd., 396 Selsdon Road, South Croydon, Surrey, CR2 0DE.

**BUILD THE MULLARD C.C. TV CAMERA.** Complete kits now available from Crofton Electronics. Send large s.a.e. for details to: 15-17 Cambridge Road, Kingston-Upon-Thames, Surrey. Reply by post. No callers please.

**WANTED:** Early books on wireless, pre-1925. Details to Box No. G198.

**CATALOGUE NO. 18,** containing credit vouchers value 50p, now available. Manufacturers new and surplus electronic and mechanical components, price 23p post free. Arthur Sallis Radio Control Ltd., 28 Gardner Street, Brighton, Sussex.

**SERVICE SHEETS** for Televisions, Radios, Transistors, Tape Recorders, Record Players, etc., from 5p. with free Fault Finding Guide. Catalogue 15p. Please send S.A.E. with all orders/enquiries. Hamilton Radio, 47 Bohemia Road, St. Leonards-on-Sea, Sussex. Telephone Hastings 29066.

**WANTED:** Copy of the original RTTY Manual produced by the British Amateur Radio Teleprinter Group. Box No. G206.

**BUILD IT in a DEWBOX** robust quality plastic cabinet 2 in. x 2 1/2 in. x any length. S.A.E. for details. D.E.W. Ltd., 254 Ringwood Road, Ferndown, Dorset. Write now - right now.

**BURGLAR AND FIRE ALARMS.** Complete Master Control Module now available from our own panels. Ideal for all alarm/switching circuits. With data sheet etc. £6.85. Complete alarm kits £49.50. Magnetic switches, Sensors, Panels, available. Castle Alarms, P.O. Box WO6, Windsor, Berks.

**UNIQUE VHF KITS, 80 - 180 MHz.** Receiver, tuner, converter. World wide sales. £4.50p. S.W. Kits also available. S.A.E. for literature. Johnsons (Radio C), Worcester, WR1 3QQ.

**FOR SALE:** 50 n.p.n., unmarked, untested transistors, like BC107/8/9, 50p. Monofilament unshathed light guide, 10p per metre. J. Fulton, Derrynaseer, Dromore, Co. Tyrone, Ireland.

**CHROMASONIC ELECTRONICS.** New list 10p, post free. Data Dept., 56 Fortis Green Road, London, N10 3HN.

**FOR SALE:** Avo electronic testmeter and r.f. signal generator. S.A.E. for details. Box. No. G212.

(Continued on page 787)

## BENTLEY ACOUSTIC CORPORATION LTD.

All prices inclusive of V.A.T.

The Old Police Station, Gloucester Road, LITTLEHAMPTON Sussex, PHONE 6743

0A2	.33	12AV6	.28	EAF42	.48	EL85	.40	PD500	1.44	UL41	.54
0B2	.33	12BR7	.30	EAF801	.50	EL86	.38	PEN45	.40	UL84	.28
5U4G	.30	12BE6	.30	EB34	.20	EL91	.23	PEN45DD	UY41	.38	
5V4G	.35	12BH7	.27	EB91	.10	EL95	.32	UY85	.23		
5Y3GT	.30	12K5	.50	EB241	.48	EL80	.75	PFL200	.50	X41	.50
5Z4G	.34	19A05	.24	EB281	.29	EM80	.37	PL36	.46	AC165	.28
6/30L2	.53	20P4	.89	EBF80	.30	EM81	.37	PL81	.42	AD140	.40
6AQ5	.21	30A5	.44	EBF83	.38	EM83	.75	PL82	.28	AD149	.55
6AT6	.18	30C15	.55	EBF89	.26	EM84	.31	PL83	.30	AD161	.50
6AU6	.19	30P17	.74	EC92	.34	EM87	.49	PL84	.28	AD162	.50
6AV6	.28	30C18	.69	ECC31	.50	EY51	.35	PL504	.60	AF114	.28
6BA6	.19	30F5	.61	ECC35	.95	EY81	.35	PL508	.90	AF115	.17
6BE6	.20	30FL1	.58	ECC81	.16	EY83	.54	PY33/2	.50	AF121	.33
6BH6	.43	30FL2	.60	ECC82	.19	EY87/6	.27	PY81	.24	AF126	.20
6B16	.39	30FL14	.66	ECC83	.21	EY88	.40	PY82	.23	BC107	.14
6BR7	.79	30L15	.55	ECC84	.28	EZ40	.40	PY83	.26	BC108	.14
6BW6	.72	30L17	.65	ECC85	.32	EZ80	.19	PY88	.31	BC113	.28
6B9W	.50	30P17	.69	ECC88	.35	EZ81	.20	PY80	.31	BC118	.25
6BZ6	.31	30P19	.65	ECF80	.27	GY501	.75	PY801	.31	BC211	.42
6C4	.28	30P11	.57	ECF82	.25	GZ34	.47	QQV03		BF159	.28
6CU5	.30	30P13	.75	ECF86	.64	HVR2	.53	T0	1.20	BF163	.22
6E1	.59	30P15	.87	ECH35	.50	KTW61	.63	R19	.28	BF180	.33
6F6G	.35	35A3	.48	ECH81	.25	KTW62	.63	U25	.65	BY100	.20
6F6G	.45	35LGT	.42	ECH81	.25	KTW63	.50	U26	.60	BY126	.17
6F23	.65	35W4	.23	ECH83	.38	KT41	.98	U191	.63	BY127	.28
6F28	.60	35Z4	.24	ECH84	.34	KT66	.80	U251	.62	OA91	.10
6H6GT	.15	35Z5	.30	ECL80	.28	PC86	.44	U301	.40	OA95	.10
6I6GT	.29	50C15	.30	ECL82	.28	PC88	.44	U801	.76	OC23	.42
6K7G	.12	50C5	.32	ECL83	.50	PC89	.36	UARCNO		OC24	.42
6K8G	.33	50L6GT	.45	ECL84	.54	PC97	.36	PC90	.29	OC25	.42
6L6GT	.50	90C1	.59	ECL86	.33	PC90	.29	UBC41	.45	OC35	.35
6L6GT	.45	DAF91	.22	ECL86	.33	PCC84	.27	UBC81	.40	OC34	.11
6O7GT	.43	DAF96	.36	EFA1	.58	PCC89	.42	URF89	.33	OC45	.12
6V6G	.17	DF91	.14	EF80	.21	PCC189	.46	UC92	.35	OC70	.14
6V6GT	.27	DF96	.36	EF83	.54	PCF80	.26	UC84	.33	OC71	.12
6X5G	.25	DK91	.28	EF85	.45	PCF82	.30	UC85	.33	OC72	.12
6X4	.20	DK92	.50	EF86	.27	PCF84	.40	UCF80	.31	OC74	.25
7Y4	.60	DK96	.45	EF89	.23	PCF86	.44	UCH42	.57	OC75	.12
9D7	.78	DL92	.26	EF91	.17	PCF801	.28	UCH81	.29	OC78	.17
10F1	.75	DL91	.35	EF92	.11	PCF802	.37	UCF82	.38		
10F18	.35	DY87/6	.22	EF182	.25	PCF806	.55	UCL83	.54	OC81	.12
12A6	.63	DY802	.29	EF184	.27	PCL82	.29	UF41	.50	OC81D	.12
12AC6	.40	EB8CC	.60	EH90	.34	PCL83	.54	UF80	.35	OC82	.12
12AD6	.40	E180F	.90	E134	.42	PCL84	.32	UF85	.34	OC82D	.12
12AE6	.48	EA50	.27	EL41	.53	PCL85	.37	UF86	.63	OC83	.22
12AT6	.23	EAB80		EL84	.21	PCL86	.36	UF89	.27	OC84	.26
12AU6	.21		.29								

All goods are unused and boxed, and subject to the standard 90-day guarantee. Terms of business: Cash or cheque with order only. No C.O.D. orders accepted. Despatch charge 9p per order up to three items, each additional item 3p extra. Orders over £5 despatched free. All orders despatched same day by first class mail. Terms of business available on request. Any parcel insured against damage in transit for only 3p extra per order. Business hours 9 a.m.-5.30 p.m., Mon.-Fri. Closed 1-2 p.m. Please enclose S.A.E. with all enquiries.

## FREE TO AMBITIOUS ENGINEERS

THE LATEST EDITION OF NEW OPPORTUNITIES

### SEND FOR YOUR FREE COPY TO-DAY

NEW OPPORTUNITIES is a highly informative 76 page guide to the best paid engineering posts. It tells you how you can quickly prepare at home for a recognised engineering qualification and outlines a wonderful range of modern home study courses in all branches of Engineering. This unique book also gives full details of the Practical Radio & Electronics courses administered by our Specialist Electronics Training Division - explains the benefits of our free Appointments and Advisory service and shows you how to qualify for five years promotion in one year.

### PRACTICAL EQUIPMENT INCLUDING TOOLS

The specialist Electronics Division of B.I.E.T. NOW offers you a real laboratory training at home with all the practical equipment you need, plus basic practice and theoretical Courses for beginners in Radio, TV, Electronics, etc.

#### CUT OUT THIS COUPON

Tick or state subject of interest. Post to address below.

AMSE (Elec)  City & Guilds Certificate  RTEB Certificate   
Radio Amateurs' Exam  DMG Certificate  Colour TV   
Electronic Engineering  Computer Electronics  Radio and TV   
Servicing  Practical Electronics  Practical TV and Radio

### BRITISH INSTITUTE OF ENGINEERING TECHNOLOGY

Dept. (BRE 19), Aldermaston Court, Reading RG7 4RF

Accredited by the Council for the Accreditation of Correspondence Colleges

QC BRE 19

NAME .....

(BLOCK CAPITALS PLEASE)

ADDRESS .....

OTHER SUBJECTS..... AGE.....

# RADIO MODELLER

**RM**  
BOOK  
SERIES

## ELECTRONIC BOOKS

### ● MODEL RADIO CONTROL

Detailing both Theory and Practice, this book, by leading authority Paul Newell, will become the standard reference work. A brief historical survey leads up to a detailed description of proportional systems, with over 100 illustrations, including theoretical circuits and p.c. layouts for an advanced digital system.

134 pages. Price £2-25 U.K. Postage 13p

### ● SINGLET SET

The Singlet Transmitter, Superhet and Super-regen receivers, are now all three available in one book. Complete construction details with full size p.c. layout, components list etc. Ideal introduction to the hobby for the home constructor. 20 pages.

Price 30p. U.K. Postage 3p

### ● LOW COST PROPORTIONAL

Modellers who want to save money buy this volume when converting single channel equipment to simple proportional. They find a wealth of really up to date information in the clear descriptions, full size practical and working drawings, plus over a dozen circuit modules for pulse proportional units.

118 pages.

Price £1-05 U.K. Postage 11p



ON SALE NOW at all leading shops or direct from:—

RADIO MODELLER, BOOK SALES, 64 Wellington Road, Hampton Hill, Middx.

## PLAIN-BACKED NEW STYLE SELF-BINDERS

The "CORDEX" Patent Self-Binding Case will keep your copies in mint condition. Issues can be inserted or removed with the greatest of ease. Specially constructed Binding cords are made from Super Linen of great strength, very hard twisted and twice doubled. They are attached to strong RUSTLESS Springs under tension, and the method adopted ensures PERMANENT RESILIENCE of the Cords. Any slack that may develop is immediately compensated for, and the Cords will always remain taut and strong. It is impossible to over-stretch the springs, as a safety check device is fitted to each.

# 77p

P. & P. 14p

including V.A.T.

Available only from:—

## Data Publications Ltd.

### for your other magazines

(max. format 7½" x 9½")



COLOURS: MAROON OR GREEN

(If choice not stated, colour available will be sent)

## 57 Maida Vale London W9 1SN



## SMALL ADVERTISEMENTS

(Continued from page 785)

**100,000 COMPONENTS TO CLEAR.** Packs of 50 asstd.-25p, Analogue computer for sale cheap - offers? - Grimsby Electronics, 64 Tennyson Road, Cleethorpes, Lincs. (Mail order only.) List 5p.

**FOR SALE:** Transistor amplifier 80p, Vol./tone control panel 75p, 405 i.f. amp. panel 75p, wavechange & osc. panel 75p, LW-MW rod aerial 25p. All the above with circuit £3.00. Skeleton presets, slider or rotary, 200k & 2 Meg, 10 for 25p. Please include p. & p. R. Archer, 9 Pine Grove, Maidstone, Kent.

**CONVERT A TV SET** into an oscilloscope. Complete instructions. £1.00. Easy step by step. Box No. G213.

**WHY NOT TRY YOUR HAND AT TV?** Ex-rental and untried. 19" 625 with u.h.f. tuner, £4.50. 23" 625 with u.h.f. tuner, £6.50. 19" 2 channel sets, £1.50. New mains transformers in 240 volts a.c. out to 6 volts, 60p. All sets complete. Callers only. 103 Goldhawk Road, Shepherds Bush, London W.12. Telephone: 01-743 6996.

**WANTED:** National 401S solid state battery/mains Tape Recorder with "reverse-a-track" facility. Box No. G214.

**WORLD DX CLUB** covers all aspects of SWLing on Amateur and Broadcast Bands through its monthly bulletin "Contact". Membership costs £1.38 a year. Enquiries to Secretary, WDXC, 11 Wesley Grove, Portsmouth, Hants., PO3 5ER.

**FOR SALE:** Top quality Sinclair Executive Electronic Calculators at £40 each, including postage to any part of the world. Reply by post only. No callers please. Allow 30 days for delivery. Reply promptly as stocks are limited. John Conradsen, 505 Park Lane Flats, Bloemfontein, O.F.S., South Africa.

**FOR SALE:** 100 BZY88, unmarked, untested zeners 50p. IN4007, 10p. 10 for 60p. J. Fulton, Derrynaseer, Dromore, Co. Tyrone, Ireland.

**FIBRE GLASS CIRCUIT BOARD.** 1/8" single sided, 1 1/2 p per sq.inch; double sided, 2 1/2 p per sq. inch. F. Freemantle, Dept. RC100, 18 Pennine Road, Millbrook, Southampton, Hants.

**WANTED:** Valves - 6AZ8, 6BJ7, 12AX7 and 5U4-GB. Must be in new condition. Box No. G215.

**JOIN THE INTERNATIONAL S.W. LEAGUE.** Free services to members including Q.S.L. Bureau, Amateur and Broadcast Translation, Technical and Identification Dept. - both Broadcast and Fixed Stations, DX Certificates, contests and activities for the SWL and transmitting members. Monthly magazine, *Monitor*, containing articles of general interest to Broadcast and Amateur SWLs, Transmitter Section and League affairs, etc. League supplies such as badges, headed notepaper and envelopes, QSL cards, etc., are available at reasonable cost. Send for League particulars. Membership including monthly magazines, etc., £2.00 per annum. (U.K. and British Commonwealth), overseas 6 Dollars or £2.50. Secretary ISWL, 1 Grove Road, Lydney, Glos., GL15 5JE.

**MAGNIFIERS:** Ideal for the inspection of printed circuit boards, etc., S.A.E. for list to: Revor Optical & Technical, 36 Baker Street, London W1M 1DG.

**QUALITY 1/2 TRACK RECORD/PLAY TAPE HEADS.** Mounted in mumetal cases. Only 55p each. 117 Horton Road, Brighton, Sussex, BN1 7EG.

(Continued on page 789)

## D.I.Y. TECHNICAL BOOKS

RADIO RECEIVER SERVICING GUIDE .....	£1-90
101 EASY HAM RADIO PROJECTS .....	£1-50
101 EASY AUDIO PROJECTS .....	£1-40
RAPID T.V. REPAIR (224 pp) .....	£1-30
ELECTRONIC GAMES AND TOYS YOU CAN BUILD .....	£1-40
PAL RECEIVER SERVICING GUIDE (280 pp) .....	£3-50
BASIC ELECTRICITY (6 VOLUMES, 630 pp, 600 ILLUS.) .....	£5-10
ELECTRONIC DESIGNERS HANDBOOK .....	£3-40
BASIC ELECTRONICS (6 VOLUMES, 674 pp, 700 ILLUS.) .....	£5-10
ELECTRICITY, ELECTRONICS MADE SIMPLE .....	Each 35p
RADIO HANDBOOK (896 pp) .....	£5-50
1-2-3-4- SERVICING STEREO AMPLIFIERS (240 pp) .....	£2-50
MAKING & REPAIRING TRANSISTOR RADIOS, ADVANCED RADIO CONTROL, EASY WAYS TO SERVICE RADIO RECEIVERS, BEGINNERS GUIDE TO T.V. REPAIR, PRACTICAL HAM RADIO PROJECTS, HI-FI PROJECTS FOR THE HOBBYIST .....	Each £1-00
HOW TO BUILD SPEAKER ENCLOSURES .....	£1-50
HI-FI STEREO SERVICING GUIDE, 99 ELECTRONIC PROJECTS, 99 WAYS TO IMPROVE YOUR HI-FI .....	Each £1-50
ELECTRONICS FOR THE BEGINNER, T.V. SERVICING MADE EASY, 101 QUES. & ANSWERS ABOUT AM, FM & SSB .....	Each £1-75
HOW TO REPAIR SMALL APPLIANCES .....	£1-20
ADD 10% FOR PDSTAGE AND PACKING	
WHEEL (RC) 41A ADELAIDE GROVE, LONDON, W12	

### MICROJET WELDER

**A TINY FLAME UP TO 5000°F!**

**WELDS-BRAZES SOLDERS INC. FLAME TIPS**

**£12.65**

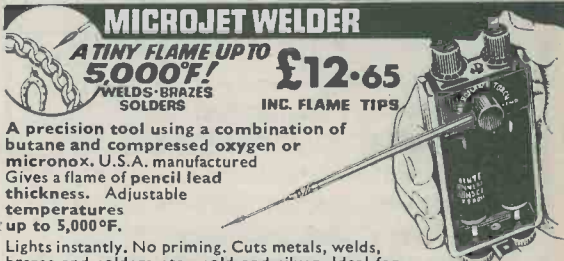

**A precision tool using a combination of butane and compressed oxygen or micronox. U.S.A. manufactured**  
Gives a flame of pencil lead thickness. Adjustable temperatures up to 5,000°F.

Lights instantly. No priming. Cuts metals, welds, brazes and solders etc., gold and silver. Ideal for electronic construction and all fine precision work, clock makers, silver-smiths, etc. Up to 40 minutes operation using fuel supplied. Replacement set of 2 micronox and 1 butane cylinders £1.45 inc. post. Complete with detailed instruction. Only £12.65 plus 35p p. & p. Send £13.00.

**JOHN DUDLEY & CO. LTD., (Dept. RC3), 301 Cricklewood Lane London, N.W.2. Tel.: 01-458 5917 Callers welcome - Open Sats.**

## SYNTHESISER MODULES

Voltage-controlled modules for synthesiser construction and other musical **MIRACLES!** Catalogue 15p. D.E.W. Ltd., 25 Ringwood Road, Ferndown, Dorset.

## THIS MONTH'S BARGAIN FOR BARGAIN HUNTERS

100 square ins. (min.) packs of best quality mixed veroboard only £1.15p post/packing free. C.W.O. to **PASSINGHAM'S ELECTRONICS** 5 Dale Street, Bradford 1, Yorkshire. Tel. Bradford 25388

### SPECIAL KITS

MINIATURE CARBON FILM RESISTOR KIT 1 10 each E12 value 22Ω to 2.2M Total 610 £3.00.  
CAPACITOR KIT 1.50V Disc Ceramic. 10 each value (pf) 22, 33, 47, 68, 100, 150, 220, 330, 470, 680, 1,000. Total 110 £1.40. ANTEX X25. Soldering Iron 25 watt. Rec. Retail £1.92 Our Price £1.67 (inc P & P) C.W.O. P & P 8p. **NEK ELECTRONICS (R3)**, 28 Carnegie Road, St. Albans, Herts.

**ZN414 FERRANTI RADIO CHIP**  
**£1.25** TFJ ELECTRONICS  
inc. P/P+VAT 25 EASTBURY COURT  
LEMSFORD ROAD  
Mail order only. ST. ALBANS, HERTS

# THE 'PLUS' CATALOGUE

+ Technical data + Countless bargains + Discounts



+

25p

## REFUND VOUCHER

The Electrovalue Catalogue now costs 25p (post free, surface mail) and is well worth it for its technical information. But we include with it a 25p refund voucher for spending on orders for £5 or more. You will find this catalogue a great money saver in every way.

- 96 Pages. (4th printing)
- Transistors, with technical specs.
- I.C.s with working diagrams
- Resistors, capacitors, components
- Diagrams, tables, information
- GENUINE DISCOUNTS

**ELECTROVALUE LTD.** Dept. R.C.7  
 28 St. Judes Rd., Englefield Green, Egham, TW20 0HB  
 9-6 daily: 1.0 p.m. Sat. Telephone Egham 3603

# VISIT LONDON'S LIGHTHOUSE

*our lighthouse keeper  
wants to meet you!*

Jim Roche has been Imhofs Eddystone lighthouse keeper for a good few years now - so who better than he to guide you into the right channel, for an Eddystone communications receiver:



Model 1001 - general-purpose receiver with reception facilities for CW, MCW, AM and SSB. Provision for crystal control on 10 channels.

EC10 Mk II still 'Top of the Pops' in the modest pricerange of communication receivers. Embodies features usually only found in the more expensive designs.



**IMHOFS**

112-116 New Oxford Street  
 London WC1A 1HJ  
 telephone 01-636 7878 R81

## DATA BOOK SERIES

- DB5 TV FAULT FINDING**  
 124 pages. Price 50p, postage 6p.
- DB6 RADIO AMATEUR OPERATOR'S HANDBOOK**  
 80 pages. Price 45p, postage 6p.
- DB16 RADIO CONTROL FOR MODELS**  
 192 pages. Price 75p, postage 8p.
- DB17 UNDERSTANDING TELEVISION**  
 512 pages. Price £2.10, postage 25p.
- DB18 AUDIO AMPLIFIERS**  
 128 pages. Price 53p, postage 6p.
- DB19 SIMPLE SHORT WAVE RECEIVERS**  
 140 pages. Price 80p, postage 6p.

I enclose Postal Order/Cheque for..... in payment for.....

NAME .....

ADDRESS .....

(BLOCK LETTERS PLEASE)

*Postal Orders should be crossed and made payable to Data Publications Ltd.  
 Overseas customers please pay by International Money Order.  
 All publications are obtainable from your local bookseller.  
 Data Publications Ltd., 57 Maida Vale, London W9 1SN*

**PLEASE MENTION THIS MAGAZINE WHEN WRITING TO ADVERTISERS**



## SMALL ADVERTISEMENTS

Continued from page 787)

**ESSEX GARDENERS.** Buy your bedding and rock plants, shrubs, etc., also cacti from May's Nurseries, 608 Rayleigh Road, Hutton, Brentwood, Essex. Callers only. Monday to Saturday.

**RELAYS.** P.O. 3000 type, from 10p. Uniselectors from 75p. Ex-equipment. Box No. G216.

**4-DIGIT COUNTERS,** 500Ω, 25p. 100  $\frac{1}{2}$ - $\frac{1}{2}$ W resistors, 50p. J. Fulton, Derrynaseer, Dromore, Co. Tyrone, Ireland.

**COMPUTER BOARDS - CHEAP!** 10 without transistors £1.00, 10 with transistors (inc. power trans. and h/sinks) £1.50, p/p 20p. AMPEX boards - inc. min. 4 trimpots - 4 for £1.00; with 2 Motorola power transistors 4 for £1.50, p/p 20p. Belling-Lee 25x plug and sockets, 30p each, p/p 5p, 4 for £1.00, p/p 15p. Continental 56-way edge connectors, 10 for £1.00, p/p 15p. Multicore cable e.g. x 24 at 15p yard. All items used but excellent condition. Many more items. Enquiries welcome. Tope, 31 Wood Lane, London N.W.9. Telephone: 01-205-5965.

**"MEDIUM WAVE NEWS"** Monthly during Dx season - Details from: K. Brownless, 7 The Avenue, Clifton, York.

**5 N-CHANNEL FETS TYPE 3819E** for £1.00. Full spec. devices complete with circuit details for building voltmeter, timer, ohmmeter, etc., or send 10p for full list of FETS and other top quality transistors available at bargain prices. Redhawk Sales Ltd., 45 Station Road, Gerrards Cross, Bucks. Mail order only.

**WANTED:** S/Sheet, circuit, for Perdio 8" mains batt/portable TV. S. No. TR75865. J. Woosnam, Lieaust, Mochdre, Nr. Newtown, Montg.

**THE BRITISH AMATEUR ELECTRONICS CLUB.** A club for all who are interested in electronics as a hobby. Quarterly Newsletter sent free to members. Subscription 50p per year. Details from Hon. Secretary, J. G. Margetts, 17 St. Francis Close, Abergavenny. Mon.

**COMPONENTS GALORE.** Pack of 500 mixed components, manufacturers' surplus plus once used. Pack includes resistors, capacitors, transistors, diodes, I.C., pots, coils, etc. Tremendous value. Send £1 plus 10p p. & p. Caledonian Components, Strathmore Road, Thornton, Fife.

**LOW DEFINITION TELEVISION REVIVAL.** Interested in Baird-type TV? Write to: LDTV, 1 Burnwood Drive, Wollaton, Nottingham.

**SMALL TANNOY SPEAKER WANTED,** ex-Admiralty pattern would do. Leeves, West Stone, Kingsnympton, Umberleigh, N. Devon.

### PERSONAL

**JANE SCOTT FOR GENUINE FRIENDS.** Introductions to opposite sex with sincerity and thoughtfulness. Details free. 3p stamp to: Jane Scott, 50/CON Maddox Street, London W1R 0LY.

**HOLIDAY ACCOMMODATION.** Burwood Lodge Hotel. Dawlish Road. Teignmouth. South Devon. Especially suitable for parents with young children. Facing south. on the cliffs. direct access by private path to the sea. Mothers' kitchen. automatic washing machines. baby listening service. Licensed lounge. Ample free parking.

**IF YOU HAVE ENJOYED A HOLIDAY** on the Norfolk Broads, why not help to preserve these beautiful waterways. Join the Broads Society and play your part in determining Broadlands future. Further details from:- The Hon. Membership Secretary, The Broads Society, "Icknield", Hilly Plantation, Thorpe St. Andrew, Norwich, NOR 85S.

## ESSENTIAL BOOKS

**THE MODERN DICTIONARY OF ELECTRONICS.** Contains concise definitions of more than 18,000 terms in electronics, communications, micro-electrics, fibre optics, semi-conductors, computers, medical electronics. Fully illustrated. Essential to any collection of electronics reference books. Ideal for workshop and laboratory. £6.50 post free.

**HOW TO MAKE WALKIE-TALKIES FOR LICENSED OPERATION.** Only 40p p.p. 10p.

**HANDBOOK OF BASIC ELECTRONIC EQUIPMENT.** Gives specific details of the components and equipment used in Radio, Television, Tape-Recording, Record Playing, Short Wave Listening, Amateur Radio. Enables you to choose the best components and accessories and use them economically and safely. Illustrated. £1.75 post free.

**RADIO HANDBOOK.** Latest impression. 974 pages. W. I. Orr. 19th edition. A comprehensive communications handbook written especially for the radio enthusiast and electronics engineer. Includes every aspect of radio likely to be of interest to the constructor and amateur. Contains the latest designs and developments. £7.50 post free.

**THE GOVERNMENT SURPLUS WIRELESS EQUIPMENT HANDBOOK.** Gives circuits data and illustrations plus valuable information for British/USA receivers, transmitters, trans/receivers. With modifications to sets and test equipment. Latest impression £3.25 including postage.

**DIRECTORY OF GOVERNMENT SURPLUS WIRELESS EQUIPMENT DEALERS.** Gives details of surplus wireless equipment stores and dealers including addresses, plus equipment and spares that they are likely to have available. A valuable book only 40p p.p. 10p. Allow 28 days for delivery as directory is being brought up to date.

**99 WAYS TO IMPROVE YOUR SHORTWAVE LISTENING.** Essential to all SWLs £1.90 post free.

PERSONAL CALLERS WELCOME AT OUR NEW SHOWROOM & TRADE COUNTER. Hartleys Yard, Off Town Street, ARMLEY LEEDS 12. Just past The White Horse Inn. The North's largest selection of Radio and Electronics Books plus thousands of books on all subjects at discount prices.

**PROBLEMS IN ELECTRONICS WITH SOLUTIONS.** A must for the student, technician, and electronics engineer. Contains 349 problems, answers and how they were arrived at. Includes all aspects of electronics, amplifiers, power supplies, computers, aeriels, waveguides, transmission lines. 307 pages. Only 90p. p.p. 10p.

**COSMIC RADIO WAVES.** Start a new hobby - RADIO ASTRONOMY. This big book of 444 pages is an ideal handbook for the beginner and established enthusiast. Numerous photographs and illustrations. Published by Oxford University Press. Price £2.50. p.p. 25p.

**THE SCATTERING AND DIFFRACTION OF WAVES.** A goldmine of information for the experimenter, amateur and scientist. Profusely illustrated. Published by Oxford University Press. Price £1.60 post free.

**TRANSISTOR SUBSTITUTION HANDBOOK.** Gives the substitutes for thousands of European, American and Japanese transistors. Where no substitute is available shows how to select a replacement. Includes over 10,000 types. £1.40 post free.

**HANDBOOK OF SATELLITES AND SPACE VEHICLES.** A comprehensive working handbook that provides important data both tabular and graphical enabling space scientists, technicians and telecommunication engineers to acquire a greater working knowledge of satellite and space vehicle design, launching, orbiting etc. Includes a detailed coverage of COMMUNICATIONS IN SPACE. An imposing book of 457 pages. Published at £8.20. Available at the trade price of £6.50 post free.

All mail order to: Dept. R.C. GERALD MYERS (Bookseller & Publisher), 18 SHAFESBURY STREET, LEEDS LS12 3BT. Callers welcome to new showroom address shown in advert.

## MORSE MADE EASY!!!

**FACT NOT FICTION.** If you start RIGHT you will be reading amateur and commercial Morse within a month. (Normal progress to be expected.) Using scientifically prepared 3-speed records you automatically learn to recognise the code RHYTHM without translating. You can't help it, it's as easy as learning a tune. 18-W.P.M. in 4 weeks guaranteed. Beginner's Section only £3.30. Complete course £4.50 (Overseas £1 extra). Details only, 4p stamp. 01-660 2896

G3HSC/Box 38, 45 GREEN LANE, PURLEY, SURREY.

## FREQUENCY LIST TRANSFERS

We have a limited supply of sheets of Dial Frequency Transfers in black. Short Wave frequencies 1.8Mc/s to 32Mc/s and 144Mc/s and 146Mc/s. Includes amateur band marker frequencies at 100kc/s points and other short wave frequencies from 2 to 32Mc/s at every 500kc/s points. Each frequency is repeated. Two sheets for 5p, five sheets for 10p, postage 3p.

DATA PUBLICATIONS LTD.,  
57 Maida Vale, London W9 1SN.

# INDEX TO VOLUME TWENTY-SIX

## August 1972 - July 1973

### AMPLIFIERS

High Input Impedance Amplifier, by G. A. French	552	Apr. '73
Integrated Circuit Amplifier - Veroboard Project 3	168	Oct. '72
Telephone Amplifier and Baby Alarm, by M. G. Argent	377	Jan. '73
The 'Jubilee' 8-Watt Amplifier, Part 1, by J. R. Davies	32	Aug. '72
The 'Jubilee' 8-Watt Amplifier, Part 2, by J. R. Davies	84	Sept. '72
The 'Sliding Junior' Amplifier, by Sir Douglas Hall, K.C.M.G., M.A. (Oxon)	685	June '73

### AMPLIFIER ANCILLARIES

Crystal Microphone Pre-Amplifier, by R. A. Penfold	568	Apr. '73
Miniature Three Channel Mixer, by R. A. Penfold	760	July '73

### ELECTRONICS

Astable Multivibrators, Part 1, by A. Foord	710	June '73
Astable Multivibrators, Part 2, by A. Foord	770	July '73
Constant Current Lamp Circuit, by L. Stephenson	438	Feb. '73
Cyclops (Electronic Robot), Part 2, by L. C. Galitz	22	Aug. '72
Cyclops (Electronic Robot), Part 3, by L. C. Galitz	108	Sept. '72
Cyclops (Electronic Robot), Part 4, by L. C. Galitz	180	Oct. '72
Cyclops (Electronic Robot), Part 5, by L. C. Galitz	237	Nov. '72
Cyclops (Electronic Robot) - Conclusion, by L. C. Galitz	320	Dec. '72
Decimal Binary Converter, by J. Roberts	56	Aug. '72
Dual Voltage Power Supply, by G. A. French	143	Oct. '72
Final Notes on Cyclops, by L. C. Galitz	701	June '73
Finding Bias Resistance Values, by J. R. Davies	705	June '73
Improved Digital Display, by D. A. Nicole, G8CYJ	104	Sept. '72
Modifications To Cyclops, Part 1, by L. C. Galitz	579	Apr. '73
Modifications To Cyclops, Part 2, by L. C. Galitz	638	May '73
Notes on Semiconductors, Further Notes 9, by P. Williams	21	Aug. '72
Notes on Semiconductors, Further Notes 10, by P. Williams	79	Sept. '72
Notes on Semiconductors, Further Notes 11, by P. Williams	145	Oct. '72
Power Supply Design, by A. Foord	556	Apr. '73
Quiz Detector, by M. Jennings	327	Dec. '72
Random Output Generator, by E. F. Whitman	768	July '73
R-S Precedence Detector, by R. J. Caborn	627	May '73
The Schmitt Trigger, by A. Foord	484	Mar. '73
Unijunction Metronome, by G. A. French	744	July '73
Unusual Transformer Effect, by A. L. Chivers	256	Nov. '72
Using The F.E.T., by M. Harding	288	Dec. '72

### GENERAL

Automatic Battery Monitor, by G. A. French	77	Sept. '72
Automatic Lamp Switch, by G. A. French	682	June '73
Building a Speaker Cabinet, by Arthur C. Gee, G2UK	178	Oct. '72
Building H. T. Supplies, by F. G. Rayer, Assoc. I.E.R.E., G30GR	420	Feb. '73
Club Events	643	May '73
Combination Lock, by J. D. Parkinson	691	June '73
D.C. to A.C. Inverter - Kit Review	447	Feb. '73
Electric Art Mobile, by D. P. Newton, B.Sc.	174	Oct. '72
Electronic Metronome, by M. G. Argent	74	Sept. '72
High-Speed Train Communications	260	Nov. '72
Household Burglar Alarm, by J. R. Davies	632	May '73
Isolated Triac Control Circuit, by G. A. French	620	May '73
'Laser Line'	241	Nov. '72
Light-Emitting Diode Circuits, by G. A. French	490	Mar. '73
Logic Supply Unit, by A. Foord	504	Mar. '73
Mains Failure Warning Device, by R. E. Stewart	512	Mar. '73
Mazda Booklet	511	Mar. '73
Measuring Small Capacitors, by R. E. Stewart	92	Sept. '72
Metal Oxide Varistors, by J. B. Dance, M.Sc.	624	May '73
New Eddystone Receiver	623	May '73
Notes for Newcomers	175	Oct. '72
Oscar - Progress Report, by Arthur C. Gee G2UK	709	June '73
Oscilloscope Photography, by A. Foord	148	Oct. '72
Party Line for Computers	395	Jan. '73
Photographers Metronome, by G. A. French	234	Nov. '72
Relaxation Oscillator, by J. Evans	52	Aug. '72
Road-Ice Warning, by D. P. Newton, B.Sc.	164	Oct. '72



Servicing The Transistor Portable, Part 1, by Vivian Capel ..	676	June	'73
Servicing The Transistor Portable, Part 2, by Vivian Capel ..	757	July	'73
Single Sideband for Beginners, by R. A. Butterworth ..	30	Aug.	'72
Switch Abbreviations ..	292	Dec.	'72
Switched Earth Supply Unit, by Vincent S. Evans, G8EDM ..	193	Oct.	'72
Tin in the Electronics Industry ..	566	Apr.	'73
Two Colour Cathode Ray Tubes, by J. B. Dance, M.Sc. ..	551	Apr.	'73
Two Metre Halo for Boat Use, by Arthur C. Gee, G2UK ..	630	May	'73
Windows for Viewing The Universe, by J. B. Dance, M.Sc. ..	425	Feb.	'73
50 Years 'On The Air' ..	236	Nov.	'72

### IN YOUR WORKSHOP

A to Z ..	261	Nov.	'72	Multivibrator Operation ..	457	Feb.	'73
A.G.C. Fault ..	401	Jan.	'73	Negative Feedback ..	45	Aug.	'72
Bias Current ..	586	Apr.	'73	New Transistor ..	400	Jan.	'73
Cassette Recorder Snag ..	188	Oct.	'72	Non-Linear Resistors ..	652	May	'73
Checking Performance ..	119	Sept.	'72	One Channel Only ..	776	July	'73
Circuit Modes ..	714	June	'73	Or and Nor Gates ..	336	Dec.	'72
Coercivity ..	587	Apr.	'73	Plugs and Sockets ..	401	Jan.	'73
Collector Waveform ..	458	Feb.	'73	Potential Divider ..	648	May	'73
Complete Circuit ..	717	June	'73	Quasar ..	265	Nov.	'72
Component Values ..	458	Feb.	'73	Reactive Couplings ..	48	Aug.	'72
Construction ..	117	Sept.	'72	Resistance ..	647	May	'73
D.C. Bias ..	590	Apr.	'73	Reverse Amplification ..	715	June	'73
Erase Oscillator ..	521	Mar.	'73	Reverse Voltages ..	460	Feb.	'73
Faulty Radio ..	396	Jan.	'73	Switch-On Resistor ..	189	Oct.	'72
Feedback Loop ..	780	July	'73	Switching Circuit ..	718	June	'73
Frequency Response ..	46	Aug.	'72	Tape Recorder ..	521	Mar.	'73
Full Tester Circuit ..	116	Sept.	'72	Tone Control ..	781	July	'73
Further Supply ..	120	Sept.	'72	Transfer Characteristics ..	588	Apr.	'73
Ground Wave ..	262	Nov.	'72	Transistor Identifier ..	713	June	'73
Hartley Oscillator ..	523	Mar.	'73	Twin Amplifiers ..	776	July	'73
Integrated Circuits ..	49	Aug.	'72	Two-Tone Oscillator ..	460	Feb.	'73
Internal Circuit ..	331	Dec.	'72	Vary Motor Load ..	190	Oct.	'72
Inverter Function ..	333	Dec.	'72	Voltage Doubler ..	115	Sept.	'72
Lamp Indicator ..	335	Dec.	'72	Voltage Measurements ..	524	Mar.	'73
Load Line ..	263	Nov.	'72	X-Rays ..	266	Nov.	'72
Logic Circuit ..	330	Dec.	'72	Zener Diodes ..	114	Sept.	'72
Low Resistance Meter ..	650	May	'73				

### RECEIVERS

AR88 Modifications, by James Kerrick ..	516	Mar.	'73
High-Gain Silicon Reflex Receiver, by G. W. Short ..	300	Dec.	'72
Modifying The GCIU Receiver, Part 1, by P. Cairns, R.Tech.Eng., M.I.P.R.E., G3ISP ..	750	July	'73
Radio 2 Tuner - Veroboard Project 2 ..	152	Oct.	'72
Reflex Transistor V.H.F. Portable, by Sir Douglas Hall, K.C.M.G., M.A. (Oxon) ..	370	Jan.	'73
Short Wave Crystal Sets, by J. Braunbeck ..	82	Sept.	'72
Silicon Network Pocket Portable, by F. G. Rayer, Assoc. I.E.R.E., G30GR ..	696	June	'73
Superhet for 144-146 MHz, by D. F. W. Featherstone ..	160	Oct.	'72
The 'Hiflex' Personal Receiver, by Sir Douglas Hall, K.C.M.G., M.A. (Oxon) ..	612	May	'73
The 'Hybridyne' Medium Wave Portable Receiver, by Sir Douglas Hall, K.C.M.G., M.A. (Oxon) ..	572	Apr.	'73
The 'S.A. Junior' Portable Receiver, by Sir Douglas Hall K.C.M.G., M.A. (Oxon) ..	226	Nov.	'72
Transmitter-Receiver for 160 Metres, Part 1, by F. G. Rayer, Assoc. I.E.R.E., G30GR ..	440	Feb.	'73
Transmitter-Receiver for 160 Metres, Part 2, by F. G. Rayer, Assoc. I.E.R.E., G30GR ..	508	Mar.	'73

### RECEIVER ANCILLARIES

Low Voltage Timer, by R. L. Graper ..	220	Nov.	'72
Receiver Headphone Adaptor, by C. M. Lindars ..	39	Aug.	'72
R.F. Amplifier Using Dual Gate F.E.T., by N. Friel ..	436	Feb.	'73
Simple Receiver Modification, by M. J. Powell, B.Sc. (Eng.), GW31JE ..	158	Oct.	'72
The 'Nightrider', by G. A. French ..	18	Aug.	'72

### TAPE RECORDING

Cassette Recorder Mains Unit, by S. Essex ..	740	July	'73
--	-----	------	-----

### TEST EQUIPMENT

A.F. Signal Generator, by R. A. Penfold ..	96	Sept.	'72
Audible Continuity Tester, by P. T. Jenkins ..	548	Apr.	'73
Choosing a Multimeter, by P. Jefferson ..	773	July	'73
Comprehensive Transistor Analyser, Part 1, by H. T. Kitchen ..	356	Jan.	'73
Comprehensive Transistor Analyser, Part 2, by H. T. Kitchen ..	450	Feb.	'73
D.C. Voltmeter, by G. A. French ..	294	Dec.	'72
Diode and Heater Tester, by T. Samuel ..	166	Oct.	'72
Direct-Reading Capacitance Meter, by F. Griffiths ..	10	Aug.	'72
High Resistance Voltmeter, by P. James ..	564	Apr.	'73
Integrated Circuit Ohmmeter, by G. A. French ..	431	Feb.	'73
Multimeter Input Resistance Booster, by M. N. Pointing and G. A. Miller ..	252	Nov.	'72
Sensitive Microammeter, by G. A. French ..	366	Jan.	'73

Square Wave and Pulse Conversion Unit, by P. Cairns, R.Tech.Eng., M.I.P.R.E., G3ISP ..	495	Mar. '73
Transistor Curve Tracer, by D. W. Nelson ..	428	Feb. '73
Transistorised Oscilloscope, Part 1, by R. A. Penfold ..	309	Dec. '72
Transistorised Oscilloscope, Part 2, by R. A. Penfold ..	382	Jan. '73
Wide-Band Signal Injector - Veroboard Project 1 ..	140	Oct. '72
Zener Diode 'Buzzer', by R. J. Caborn ..	42	Aug. '72

**TRANSMITTING**

The 'Wyvern' 160 Metre Solid State Transmitter, Part 1, by John R. Green, B.Sc., G3WVR ..	244	Nov. '72
The 'Wyvern' 160 Metre Solid State Transmitter, Part 2, by John R. Green, B.Sc., G3WVR ..	304	Dec. '72
The 'Wyvern' 160 Metre Solid State Transmitter, Part 3, by John R. Green, B.Sc., G3WVR ..	390	Jan. '73
Transmitter-Receiver for 160 Metres, Part 1, by F. G. Rayer, Assoc. I.E.R.E., G30GR ..	440	Feb. '73
Transmitter-Receiver for 160 Metres, Part 2, by F. G. Rayer, Assoc. I.E.R.E., G30GR ..	508	Mar. '73
Two Metre Halo for Boat Use, by Arthur C. Gee, G2UK ..	630	May '73

**RADIO TOPICS**

54 Aug. '72	120 Sept. '72	198 Oct. '72
268 Nov. '72	329 Dec. '72	463 Feb. '73
529 Mar. '73	655 May '73	720 June '73
July '73		

**CAN ANYONE HELP?**

15 Aug. '72	156 Oct. '72	363 Jan. '73
643 May '73		

**NEWS AND COMMENT**

16 Aug. '72	80 Sept. '72	146 Oct. '72
232 Nov. '72	298 Dec. '72	364 Jan. '73
426 Feb. '73	488 Mar. '73	554 Apr. '73
618 May '73	680 June '73	748 July '73

**QSX**

95 Sept. '72	258 Nov. '72	369 Jan. '73
503 Mar. '72	617 May '73	747 July '73

**SHORT WAVE NEWS**

40 Aug. '72	106 Sept. '72	186 Oct. '72
242 Nov. '72	318 Dec. '72	388 Jan. '73
448 Feb. '73	514 Mar. '73	584 Apr. '73
644 May '73	694 June '73	766 July '73

**RECENT PUBLICATIONS AND BOOK REVIEWS**

28 Aug. '72	255 Nov. '72	328 Dec. '72
380 Jan. '73	487 Mar. '73	571 Apr. '73
626 May '73	684 June '73	743 July '73

**NEW PRODUCTS**

44 Aug. '72	157 Oct. '72	225 Nov. '72
337 Dec. '72	381 Jan. '73	435 Feb. '73
494 Mar. '73	563 Apr. '73	646 May '73
693 June '73	765 July '73	

**TRADE NEWS**

29 Aug. '72	94 Sept. '72	173 Oct. '72
259 Nov. '72	293 Dec. '72	528 Mar. '73

**CONSTRUCTOR'S DATA SHEET**

No. 65 British Association Screws ..	..	..	..	..	..	..	..	..	..	iii	Aug. '72
No. 66 Meter Shunts I ..	..	..	..	..	..	..	..	..	..	iii	Sept. '72
No. 67 Meter Shunts II ..	..	..	..	..	..	..	..	..	..	iii	Oct. '72
No. 68 Coil Data I ..	..	..	..	..	..	..	..	..	..	iii	Nov. '72
No. 69 Coil Data II ..	..	..	..	..	..	..	..	..	..	iii	Dec. '72
No. 70 Coil Data III ..	..	..	..	..	..	..	..	..	..	iii	Jan. '73
No. 71 Coil Data IV ..	..	..	..	..	..	..	..	..	..	iii	Feb. '73
No. 72 Coil Data V ..	..	..	..	..	..	..	..	..	..	iii	Mar. '73
No. 73 Resonant Frequencies I ..	..	..	..	..	..	..	..	..	..	iii	Apr. '73
No. 74 Resonant Frequencies II ..	..	..	..	..	..	..	..	..	..	iii	May '73
No. 75 Resonant Frequencies III ..	..	..	..	..	..	..	..	..	..	iii	June '73
No. 76 Resonant Frequencies IV ..	..	..	..	..	..	..	..	..	..	iii	July '73



## RESONANT FREQUENCIES IV

The Table gives calculated resonant frequencies, in Hz, for tuned circuits having inductances from 10 to 800mH and capacitances from 100pF to 0.1 $\mu$ F. Thus, 60mH and 1,000pF are resonant at 20,100Hz.

Inductance (mH)	100pF	250pF	400pF	1,000pF	2,500pF	4,000pF	0.01 $\mu$ F	0.025 $\mu$ F	0.04 $\mu$ F	0.1 $\mu$ F
10	159,000	101,000	79,600	50,300	31,800	25,200	15,900	10,100	7,960	5,030
20	113,000	71,200	56,300	35,600	22,500	17,800	11,300	7,120	5,630	3,560
30	91,900	58,200	46,000	29,100	18,400	14,500	9,200	5,820	4,600	2,910
40	79,600	50,300	39,800	25,200	15,900	12,600	7,960	5,030	3,980	2,520
50	71,200	45,000	35,600	22,500	14,200	11,300	7,120	4,500	3,560	2,250
60	65,000	40,200	32,500	20,100	13,000	10,000	6,500	4,020	3,250	2,010
70	60,200	38,100	30,000	19,000	12,000	9,520	6,020	3,810	3,010	1,900
80	56,300	35,600	28,200	17,800	11,300	8,900	5,630	3,560	2,820	1,780
90	53,100	33,400	26,500	16,800	10,600	8,390	5,310	3,340	2,650	1,680
100	50,300	31,800	25,200	16,000	10,100	7,960	5,030	3,180	2,520	1,590
200	35,600	22,500	17,800	11,300	7,120	5,630	3,560	2,250	1,780	1,130
400	15,900	13,000	12,600	7,960	5,030	3,980	2,520	1,590	1,260	795
600	20,500	13,000	10,300	6,510	4,110	3,250	2,050	1,300	1,030	651
800	17,800	11,300	8,900	5,630	3,560	2,810	1,780	1,130	890	563

More of everything at the right price. All your electronic requirements within 200 yards - call and see for yourself.

### BUILD THE TEXAN

**FREE TEAK CABINET** with complete kits  
**FEATURES** New slim design with 6 - IC's, IC sockets, 10 silicon transistors, 4 rectifiers, 2 zeners, Special Gardeners low field slim line transformer. Fibre glass PC panel. Complete chassis work.  
**HIGH QUALITY AND STABILITY ARE PREDOMINANT FEATURES** - DEVELOPED BY TEXAS ENGINEERS FOR PERFORMANCE, RELIABILITY AND EASE OF CONSTRUCTION.  
**FACILITIES** On/off switch indicator, headphone socket, separate treble, bass, volume and balance controls, scratch and rumble filters, mono/stereo switch, Input selector: Mag. P.U., Radio Tuner, Aux. Can be altered for Mic. Tape, Tape head etc. (Parts list Ref. 20 on request.)  
 Constructional details Ref. No.: 21 30p  
 Designed approved kits distributed by Henry's Radio Ltd.

SPECIAL KIT PRICE **£28.50**

Complete with FREE TEAK CABINET P & P 45p

### 20+20 WATT INTEGRATED I.C. STEREO AMPLIFIER

(As featured in "Practical Wireless" May to August 1972)



SLIM DESIGN WITH SILVER TRIM  
 Overall chassis size 14 1/2" x 6" x 2" high

#### ELECTRONIC KITS

Henry's introduce new huge range of audio and electronic kits now in stock, everything supplied, tremendous value. Detailed list Ref. no. 14 on request.

#### I.C. RECEIVER

ZN 414 Radio integrated circuit as featured in *Practical Wireless*, January 1973. Article reprint ref. No. 19 10p  
 Price £1.20

#### BATTERY TAPE DECK

Garrard 9 volt Tape deck with heads, etc., As previously advertised. Limited quantity. £9.50 post 30p.

#### LEARN A LANGUAGE

Recorded Cassettes with step by step phrase books, French, German, Spanish, Italian. £1.36 per course. £5.00 per set of four.

#### ULTRASONIC TRANSDUCERS

Operate at 40kc/s up to 100 yds. Ideal remote switching and signalling. Complete with data and new I.C. circuits.  
 PRICE PER PAIR £5.90. Post 10p.

#### MARROT TAPE HEADS 4 TRACK MONO or 2 TRACK STEREO

"17" High Impedance £2.00  
 "18" Med Impedance £2.00  
 "36" Med-Low Imp. £3.50  
 Erase Heads for above 75p  
 "63" 2 track mono - Hi Imp. £1.75  
 "43" Erase Head for above 75p

#### 7 SEG & NIXIE TUBES

(Post 15p per 1 to 6)  
 XN3, XN13, GN4 0-9 Side view with data 85p  
 GNP 7, GNP 8 0-9 Side view with decimal points and data 95p.  
 3015F 7-segment £2 each, £7 per 4 with data.  
 12 and 24 hour clock circuits for above. Ref. No. 31 15p.

#### MINIATURE AMPLIFIER

5 transistor, 300mW o/p. Fitted volume and sensitivity control 9v operated. £1.75 each P/P 15p.

#### DISCO SPOTBANK

as illustrated on the front cover of *Practical Wireless*, April '73. £12.75 p. & p. 35p.

#### QUALITY SLIDER CONTROLS

60mm stroke singles and ganged. Complete with knobs 5K, 10K, 25K, 100K, 250K, 500K, 1 meg. Log. and Lin. 40p each. 10K, 25K, 50K, 100K, 250K. Log. and Lin. ganged. 60p each.

#### HI-FI EQUIPMENT

Warehouse prices with BIG DISCOUNTS plus demonstrations (for callers) and GUARANTEES.  
 FREE: 24 page detailed brochure (Ref. no. 17).  
 You can see the savings!

### LOW COST HI-FI SPEAKERS

E.M.I. Size 13 1/2" x 8 1/2"  
 Large Ceramic Magnet.  
 TYPE 150 6 watt, 3, 8 or 15 ohms. £2.20. Post 22p.  
 TYPE 150TC Twin cone version £2.75. Post 22p.  
 TYPE 450 10 watt with twin tweeters and crossover, 3, 8 or 15 ohms. £3.50 Post 25p.  
 TYPE 350 20 watt with tweeter and crossover, 8 and 15 ohms. £7.50 Post 28p.



POLISHED CABINETS 150, 150TC, 450 £4.60. Post 30p.  
 ASSEMBLED IN POLISHED CABINETS (8 ohms)  
 Series 6 (Assembled 150TC) per pair £16.50 post 70p  
 Series 8 (Assembled 450) per pair £18.95 post 70p

### NEW MW/LW TUNER TO BUILD ML-3

Uses Mullard Module. Slow motion tuning. Built in battery. Ferrite aerial. Overall size 7" x 2 1/2" x 3 1/2". TOTAL COST TO BUILD £4.85. Post 15p.



### "BANDSPREAD" PORTABLE TO BUILD

Printed circuit all-transistor design using Mullard RF/IF Module Medium and Long Wave bands plus Medium Wave Bandspread for extra selectivity. Also slow motion geared tuning, 600mW push-pull output, fibre glass PVC covered cabinet, car aerial socket. Attractive appearance and performance. TOTAL COST TO BUILD £7.98 p.p. 32p. (Battery 22p.)



### HENRY'S CATALOGUE

Fully detailed and illustrated covering every aspect of Electronics - plus data, circuits and information.

10,000 Stock lines at Special Low Prices and Fully Guaranteed.

PRICE **55p** Post Paid

(40p FOR CALLERS)

PLUS! FIVE 10p VOUCHERS

Send to this address - Henry's Radio Ltd. (Dept. RC), 3 Albemarle Way, London, E.C.1. - for catalogue by post only. All other mail and callers to "303", see above.

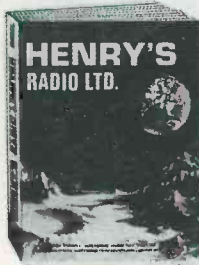

### HIGH QUALITY CASSETTES

The best UK low noise tapes but at a special price. 'Living Sound' cassettes meet the highest international standard (IEF 94A). Full guarantee. Post paid. Made by EMI especially for Henry's

	3 for	6 for	10 for
C60	1.10	2.00	3.10
C90	1.47	2.85	4.65
C120	1.80	3.50	5.60

### TEST EQUIPMENT

#### JUST A SELECTION

SE250B Pocket Pencil Signal Injector £1.90  
 SE500 Pocket Pencil Signal Tracer £1.50  
 TH133D Robust 2k/Volt. £4.95 With case £4.99  
 TE15 Grid Dip Meter 440 KHz - 280 mHz £13.45  
 500 30 K. Volt Multimeter £9.25. With leather case £10.50  
 200H 20K/Volt Multimeter £4.20. With case £4.95  
 AF105 50K/Volt Multimeter £8.50. With case £9.50  
 U4341 AC/DC Multimeter with transistor tester with steel case £10.50  
 TE20D RT Generator 120KHz 500MHz £16.50  
 Carr 35p  
 TE22D Audio Generator 20Hz 200KHz £17.50  
 Carr 35p  
 CI5 3" Pulse Scope 10Hz - 10mHz £39.00  
 Carr 50p  
 TE65 Valve Voltmeter 28 ranges Carr 40p £17.50



ALL NOMBREX MODELS IN STOCK

### BUILD THIS VHF FM TUNER

5 TRANSISTORS 300 kc/s BAND-WIDTH. PRINTED CIRCUIT. HIGH FIDELITY REPRODUCTION. MONO AND STEREO.

A popular VHF FM Tuner for quality audio reception of mono and stereo. There is no doubt about it - VHF FM gives the REAL sound. All parts sold separately. Free Leaflet No. 3, & 7.

TOTAL £6.97, p.p. 20p. Mk. 1 Decoder Kit £5.97.  
 Built IC Decoder £6.50. Tuning meter unit £1.75.

Mains unit for Tuner and/or Decoder PS6/12 £3.25. Post 20p.

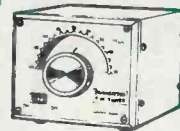

### PA-DISCO-LIGHTING

UK's Largest Range - Write phone or call in. Details and demonstrations on request.

DJ30L 3 Channel sound to light unit 3Kw £29.50  
 DJ40L 3 Channel Mic (built in) to light 3 Kw £38.75  
 DJ70S 70 watt Disco amp/mixer £49.75  
 DISCOAMP 100 watt Disco amp/mixer £65.85  
 DJ105S 30 watt Disco amp/mixer £32.25  
 Anti-Feedback Quality Mic. £11.50  
 DJ700 70 watt £52.75  
 DJ500 50 watt P.A. Amp £43.95  
 DJ1000 100 watt £63.00  
 DJ300 150 watt rms Group Valve Amp £86.00 Ref. No. 18  
 ● Portable Discos - Details on request ● Credit terms for callers



### SINCLAIR PROJECT 60 MODULES-SAVE POUNDS

Z30 £3.57 Z50 £4.37  
 STEREO 60 £7.97 P25 £3.97  
 PZ6 £6.37 PZ8 £4.77  
 Transformer for PZ8 £2.95  
 Active Filter Unit £4.45  
 Stereo FM Tuner £16.95  
 IC12 £1.80, Q16's £15.9p.  
 Post etc. 20p per item Post 25p.  
 PACKAGE DEALS Post 25p.  
 2 x Z30, Stereo 60, PZ5 £15.95  
 2 x Z30, Stereo 60, PZ6 £18.00  
 2 x Z50, Stereo 60, PZ8 £20.25  
 Transformer for PZ8 £2.95  
 PROJECT 605 KIT £19.95



Huge range of transistors and semi-conductors in stock. Free brochure. Ref. 36 on request.

## VAT

ALL PRICES are exclusive of 10% Value Added Tax which must be added to all orders, including carriage/packing. (Note: catalogue is not subject to V.A.T.)

# Henry's RADIO LIMITED

EDGWARE ROAD, W2

404-406 Electronic Components and Equipment 01-402 8381  
 354-356 High Fidelity and Tape Equipment 01-402 5854/4736  
 309 PA-Disco-Lighting High Power Sound 01-723 6963  
 303 Special offers and bargains store  
 All mail to 303 Edgware Road, London W2 1BW

Open: 9 am-6 pm  
 6 days a week  
 (300 closed  
 Thursday)  
 All stores open  
 all day Saturday