

# RADIO CONSTRUCTOR

& ELECTRONICS

Vol. 26 No. 1

AUGUST 1972

20p

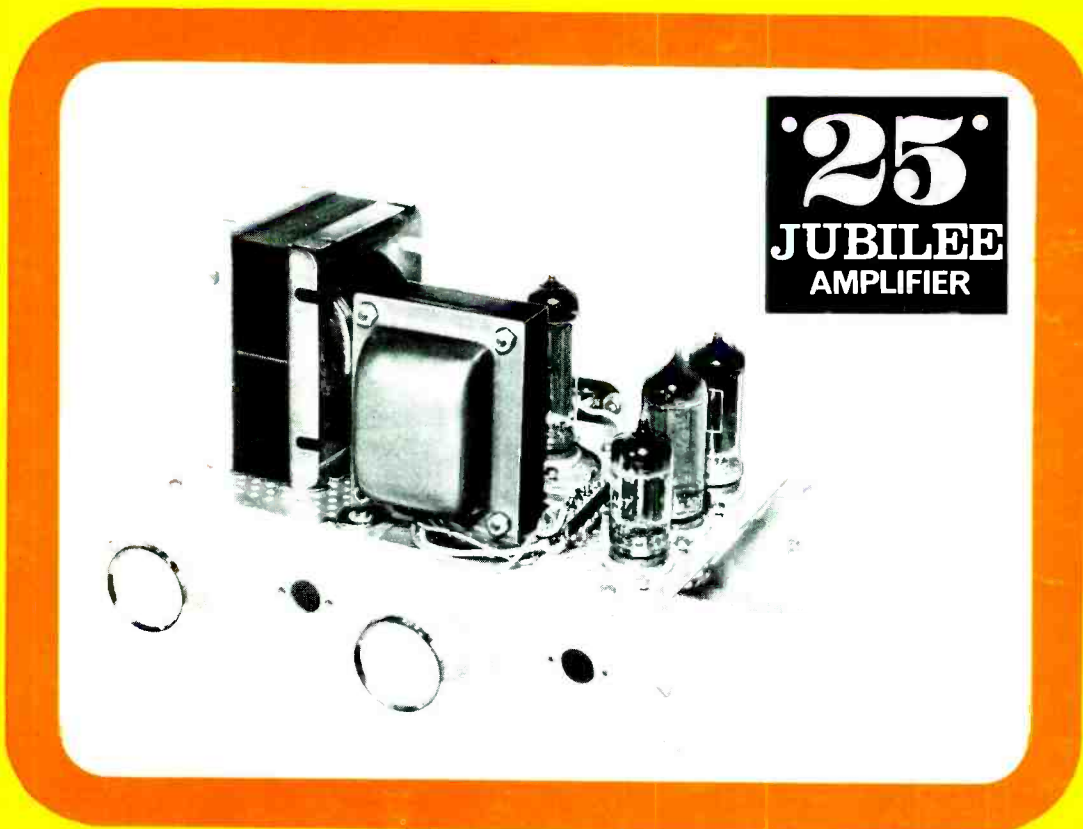

## THE 'JUBILEE' 8-WATT AMPLIFIER

Employs two 6BW6 beam tetrodes in a push-pull output stage. This easily constructed amplifier offers a high output with low distortion.

*Special*  
IN THIS ISSUE

Zener Diode 'Buzzer'  
Direct-Reading Capacitance Meter

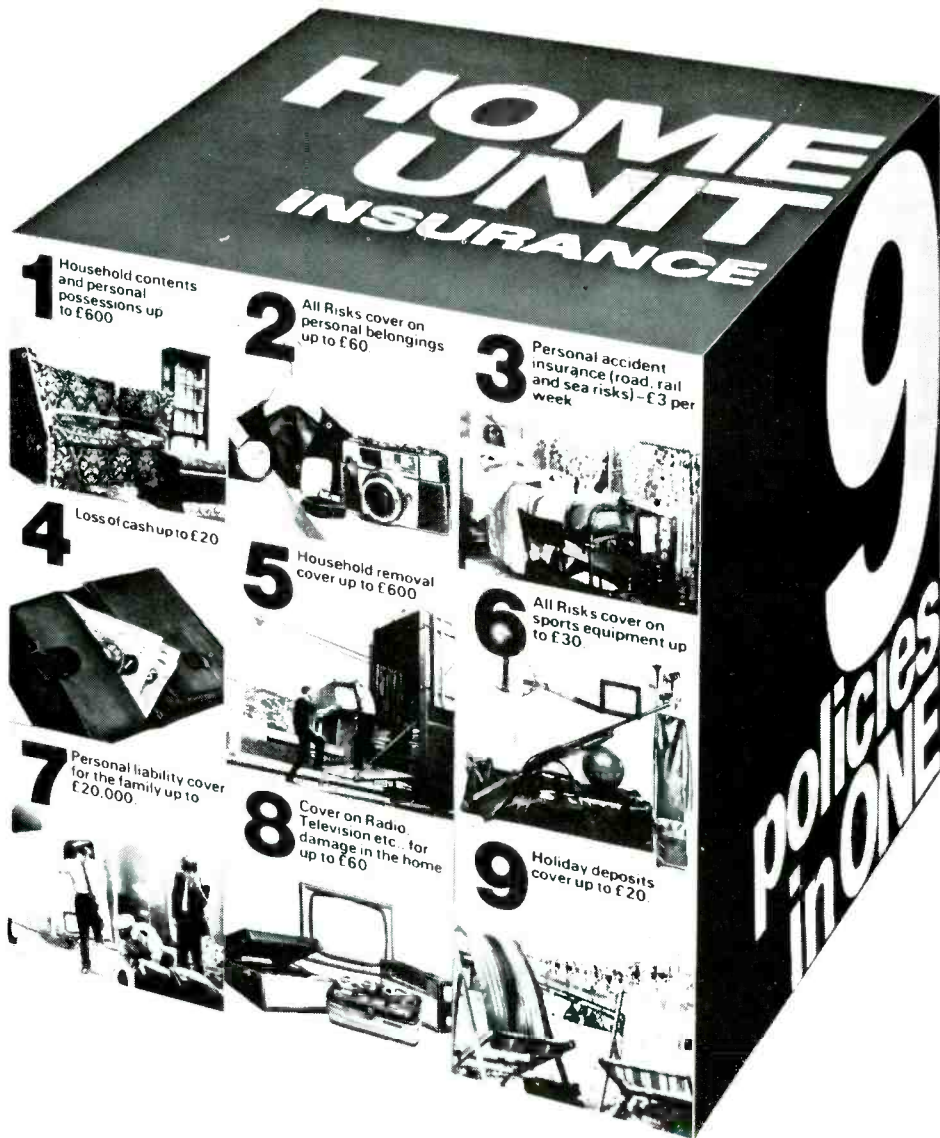

**Each £3 unit of Home Unit Insurance gives you protection up to the limit shown**

This is the simplified insurance you have been waiting for. Not just cover on the contents of your home but a package of personal protection you and your family need. And it's how we save you so much money: just ONE policy to issue instead of nine!  
 You can build up to the cover you need by additional units

(or 1/2 units after the first) up to a maximum of five. So simple. So easy. Apply to your Broker, Agent or local office of a General Accident company. The Home Unit Policy can replace your existing insurances. And remember - as you buy more possessions just add more Home Units at any time.

**THE GENERAL ACCIDENT FIRE & LIFE ASSURANCE CORPORATION LTD**

Metropolitan House, 35 Victoria Avenue,  
 Southend-on-Sea, Essex, SS2 6BT

It pays to be protected by a **General Accident** company

Please send me further particulars of the Home Unit Insurance.

Name.....

Address.....

.....

.....

5304

# THE MODERN BOOK CO

## NEWNES RADIO ENGINEER'S POCKET BOOK £1.20 Postage 6p

GE Electronics Experimenters Circuit Manual £1	Postage 5p	110 Integrated Circuit Projects for the Home Constructor	by R. M. Marston £1.20	Postage 6p
Integrated Circuit Pocket Book		Audio Amplifiers	by Davies 52½p	Postage 6p
by R. G. Hibberd £2.50	Postage 10p	The Manual of Car Electronics	by R. F. Graf £3.50	Postage 10p
Handbook of Transistor Equivalents and Substitutes		Foundations of Wireless and Electronics	by M. G. Scroggie £1.80	Postage 15p
by B. B. Babani 40p	Postage 5p	Practical Integrated Circuits	by McEvoy 90p	Postage 10p
99 Ways to Improve your Hi-Fi		The Hi-Fi and Tape Recorder Handbook	by Gordon J. King £2	Postage 15p
by L. Buckwalter £1.50	Postage 5p	ABC's of Electronic Power	by R. P. Turner £1.50	Postage 10p
Audio Technicians Bench Manual		Radio Valve and Transistor Data	by A. M. Ball 75p	Postage 10p
by J. Earl £3.00	Postage 10p			
Practical Design with Transistors				
by M. Horowitz £2.40	Postage 10p			
GE Transistor Manual				
£1.10	Postage 10p			
F.M. Radio Servicing Handbook				
by Gordon J. King £3	Postage 10p			

We have the Finest Selection of English and American Radio Books in the Country

**19-21 PRAED STREET (Dept RC) LONDON W2 1NP**

Telephone 01-723 4185

## COMPONENTS

HOBBYIST - AMATEUR - DOMESTIC  
SURPLUS INDUSTRIAL - BULK OFFERS

BY127 RECTIFIER Diode 1,000 P.I.V., 1 amp 5p.

2N 3055/BDY20 Solitron full spec., marked power transistor 45p.

2N 2926-BC107-8-9 Transistors 5p.

RECORD PLAYER CARTRIDGE ER5MXE Mono with turn-over styli. Built in carrier, single hole fixing 35p. Below wholesale price of stylus alone.

NEON INDICATOR Arcoelectric 240v amber, round, snap-in fixing, with chrome bezel 15p. Below wholesale price.

25MFD 25 VOLT Miniature Electrolytic 4p.

T.O.3. MICA Power Transistor Washer 2p.

RESISTORS ¼-½ watt 5 or 10% 1p.  
1 watt 1½p. Up to 10 watt wirewound 8p.  
15 watt wirewound 10p.

STAMPED, ADDRESSED ENVELOPE WITH ORDER

**THE RADIO SHACK** MON-SAT  
10AM-8PM

161 ST. JOHN'S HILL  
BATTERSEA, S.W.11 01-223 5016

## TECHNICAL TRAINING in Radio, Television and Electronic Engineering

Let ICS train You for a well-paid post in this expanding field. ICS courses offer the keen, ambitious man the opportunity to acquire, quickly and easily, the specialized training so essential to success. Diploma Courses in Radio, TV Engineering and Servicing, Colour TV Servicing, Electronics, Computers, etc. Expert coaching for:

- \* C&G. TELECOMMUNICATION TECHNICIANS CERTS
- \* RADIO AMATEURS EXAMINATION
- \* GENERAL RADIOCOMMUNICATIONS CERTIFICATES
- \* C&G. RADIO SERVICING THEORY

### CONSTRUCTOR COURSES

Build your own transistor portable, signal generator, multi-test meter—all under expert guidance. POST THIS COUPON TODAY and find out how ICS can help YOU in your career. Full details of ICS courses in Radio, Television and Electronics will be sent to you by return mail.

Member of the ABCC.

Accredited by the C.A.C.C.

Name \_\_\_\_\_ Age \_\_\_\_\_  
BLOCK CAPITALS PLEASE

Address \_\_\_\_\_

### INTERNATIONAL CORRESPONDENCE SCHOOLS

PA 33

INTERTEXT House,  
Stewarts Road,  
London SW8 4UJ

**ICS**

Gets you there.

# The largest selection

## NEW LOW PRICE TESTED S.C.R.'s

PIV	1A	3A	7A	10A	15A	30A
TO-5	TO-66	TO-66	TO-48	TO-48	TO-48	TO-48
\$p	\$p	\$p	\$p	\$p	\$p	\$p
30	0.28	0.25	0.47	0.50	0.58	1.15
100	0.25	0.38	0.58	0.68	0.83	1.40
200	0.35	0.57	0.87	0.81	0.75	1.50
400	0.43	0.47	0.67	0.75	0.63	1.75
600	0.53	0.57	0.77	0.97	1.25	—
800	0.63	0.70	0.90	1.20	1.50	4.00

## SIL. RECTS. TESTED

PIV	300mA	750mA	1A	1.5A	3A	10A	30A
\$p	\$p	\$p	\$p	\$p	\$p	\$p	\$p
50	0.40	0.05	0.05	0.07	0.14	0.21	0.47
100	0.04	0.06	0.05	0.13	0.16	0.23	0.75
200	0.05	0.08	0.06	0.14	0.20	0.24	1.00
400	0.06	0.11	0.07	0.20	0.27	0.37	1.25
600	0.07	0.16	0.10	0.23	0.34	0.46	1.85
800	0.10	0.17	0.13	0.25	0.37	0.55	2.00
1000	0.11	0.25	0.15	0.30	0.46	0.83	2.50
1200	—	0.33	—	0.33	0.57	0.75	—

## TRIACS

V <sub>BO</sub> M	2A	6A	10A
TO-1	TO-66	TO-48	
\$p	\$p	\$p	
100	30	50	75
200	50	60	90
400	70	75	1-10

## DIACS

FOR USE WITH TRIACS  
BR100 (D32) 87p each

## UNIJUNCTION

UT48. Evt. 2N2646. Evt. T1843. BN3060 27p each. 2N-99 25p 100V 20p.

## NPN SILICON PLANAR

HC107/108 10p each. 30-99 9p. 100 u. off. 8p each. 1,000 off. 7p each. Fully-tested and cooled TO-18 case.

## FREE

One 50p Pak of your own choice free with orders valued \$4 or over.

## SPECIAL OFFER

2N2926 (Y) (O) 10 for 50p, 25 for \$1 20,000 TO CLEAR

## CADMIUM CELLS

ORP12 45p  
ORP60, ORP61 40p each

GENERAL PURPOSE NPN SILICON SWITCHING TRANS. TO-18 SIM. TO 2N708-8, BSY27 2N95A. All usable devices no open or short circuits. ALSO AVAILABLE in PNP Sim to 2N2906. BCY70. When ordering please state preference NPN or PNP.

\$p 100 For 1.75  
20 For 0.50 500 For 7.50  
50 For 1.00 1000 For 18.00

## PHOTO TRANS.

OCPT1 Type. 48p

## SIL. G.P. DIODES 5p

300mW 30 0.50  
40PIV(Min.) 100 1.50  
Sub-Min. 500 5.00  
Full Tested 1,000 9.00  
Ideal for Organ Builders.

## D12D1 Silicon Unilateral switch 50p each.

A Silicon Planar, monolithic integrated circuit having thyristor electrical characteristics, but with an anode gate and a built-in "Zener" diode between gate and cathode. Full data and application circuits available on request.

## NEW LINE

Plastic encapsulated 2 amp Bridge Rect. 50 v RMS 32p each  
100 v RMS 37p each  
400 v RMS 46p each  
Size 15 mm x 6 mm

## KING OF THE PAKS Unequaled Value and Quality

# SUPER PAKS

## NEW BI-PAK UNTESTED SEMICONDUCTORS

Satisfaction GUARANTEED in Every Pak. or money back.

Pak No.	Description	5p
U1	120 Glass sub-min. general purpose germanium diodes	0.50
U2	60 Mixed germanium transistors A/F/R	0.50
U3	75 Germanium gold bonded diodes sim. OA5, OA47	0.50
U4	40 Germanium transistors like OC81, AC128	0.50
U5	60 200mA sub-min. Sil diodes	0.50
U6	30 Silicon planar transistors NPN sim. BSY95A. 2N706	0.50
U7	16 Silicon rectifiers Top-Hat 750mA up to 1,000V	0.50
U8	50 Sil planar diodes 250mA, OA 200/202	0.50
U9	20 Mixed volts 1 watt Zener diodes	0.50
U11	25 PNP silicon planar transistors TO-5 sim. 2N1132	0.50
U13	30 PNP-NPN sil. transistors OC200 & 2S104	0.50
U14	150 Mixed silicon and germanium diodes	0.50
U15	25 NPN Silicon planar transistors TO-5 sim. 2N697	0.50
U16	10 1/2-Amp silicon rectifiers stud type up to 1000 PIV	0.50
U17	30 Germanium PNP AF transistors TO-5 like ACY 17 22	0.50
U18	8 6-Amp silicon rectifiers BYZ13 type up to 600 PIV	0.50
U19	25 Silicon NPN transistors like BC108	0.50
U20	12 1.5-Amp silicon rectifiers Top-Hat up to 1,000 PIV	0.50
U21	30 A.F. germanium alloy transistors 2G300 series & OC71	0.50
U23	30 Mads' like MAT series PNP transistors	0.50
U24	20 Germanium 1-Amp rectifiers GJM up to 300 PIV	0.50
U25	25 300Mc's NPN silicon transistors 2N708, BSY27	0.50
U26	30 Fast switching silicon diodes like IN914 micro-min	0.50
U29	10 1/2 Amp SCR's TO-5 can up to 600 PIV CRST1 25 600	1.00
U31	20 Sil Planar NPN trans. low noise amp 2N3707	0.50
U32	25 Zener diodes 300 mW D07 case mixed volts. 3-18	0.50
U33	15 Plastic case 1 amp silicon rectifiers IN4000 series	0.50
U34	30 Sil PNP alloy trans. TO-5 BCY26, 2S302 4	0.50
U35	25 Sil planar trans. PNP TO-18 2N2906	0.50
U36	25 Sil planar NPN trans. TO-5 BSY50/51/52	0.50
U37	30 Sil alloy trans. SO-2 PNP. OC200 2N322	0.50
U38	20 Fast switching sil trans. NPN. 400Mc/s 2N3011	0.50
U39	30 RF germ. PNP trans. 2N1303 5 TO 5	0.50
U40	10 Dual trans. 6 lead TO-5 2N2060	0.50
U41	25 RF germ. trans. TO-1 OC45 NKT72	0.50
U42	10 VHF germ. PNP trans. TO-1 NKT667 AF 117	0.50
U43	25 Sil. trans. plastic TO18 A.F. BC113/114	0.50
U44	20 Sil. trans. plastic TO-5 BC115/116	0.50
U45	7 3-Amp SCR's TO-66 case up to 600V	1.00

Code Nos. mentioned above are given as a guide to the type of device in the Pak. The devices themselves are normally unmarked.

## NEW QUALITY TESTED PACKS

Pack	Description	Price 5p
Q1	20 Red spot trans PNP	0.50
Q2	16 White spot R.F. trans PNP	0.50
Q3	4 OC77 type trans.	0.50
Q4	6 Matched trans. OC44/45/81/81D	0.50
Q5	4 OC75 transistors	0.50
Q6	4 OC72 transistors	0.50
Q7	4 AC128 trans. PNP high gain	0.50
Q8	4 AC126 trans. PNP	0.50
Q9	7 OC81 type trans.	0.50
Q10	7 OC71 type trans.	0.50
Q11	2 AC127 128 comp. pairs PNP/NPN	0.50
Q12	3 AF116 type trans.	0.50
Q13	3 AF117 type trans.	0.50
Q14	3 OC171 H.F. type trans.	0.50
Q15	5 2N2926 sil. epoxy trans.	0.50
Q16	2 CFT890 low noise germ. trans.	0.50
Q17	3 NPN SFT11 & 2 SFT10	0.50
Q18	4 Mads' 2 MAT 100 & 2 MAT 120	0.50
Q19	3 Mads' 2 MAT 101 & 1 MAT 121	0.50
Q20	4 OC14 germ. trans. A.F.	0.50
Q21	3 AC127 NPN germ. trans.	0.50
Q22	20 NKT trans. A.F. R.F. coded.	0.50
Q23	10 OA202 diodes sub-min.	0.50
Q24	8 OA81 diodes	0.50
Q25	6 IN914 sil. diodes 751V 75mA	0.50
Q26	8 OA95 germ. diodes sub-min. IN69	0.50
Q27	2 10A 600V sil. rect. 15A5R	0.50
Q28	2 Sil. power rect. BYZ13	0.50
Q29	4 Sil. trans. 2 2N696, 1 2N697, 1 2N698	0.50
Q30	7 Sil. switch trans. 2N706 NPN	0.50
Q31	6 Sil. switch trans. 2N708 NPN	0.50
Q32	3 1/2NPN sil. trans. 2 2N131, 1 2N132	0.50
Q33	3 Sil. NPN trans 2N1711	0.50
Q34	7 Sil. NPN trans. 2N2669, 500MHz	0.50
Q35	3 Sil. PNP TO-5 2 2N2904 & 1 2N2905	0.50
Q36	7 2N3646 TO-18 plastic 300MHz NPN	0.50
Q37	3 2N3051 NPN sil. trans.	0.50
Q38	4 NPN trans 4 2N3703, 3 2N3702	0.50
Q39	7 NPN trans 4 2N3704, 3 2N3705	0.50
Q40	7 NPN amp. 4 2N3707, 2 2N3708	0.50
Q41	3 Plastic NPN TO-18 2N3904	0.50
Q42	6 NPN trans 2N5172	0.50
Q43	7 BC107 NPN trans.	0.50
Q44	7 NPN trans 4 BC108, 3 BC109	0.50
Q45	3 BC113 NPN TO-18 trans.	0.50
Q46	3 BC115 NPN TO-5 trans.	0.50
Q47	6 NPN high gain 3 BC167, 3 BC168	0.50
Q48	1 BCY70 NPN trans. TO-18	0.50
Q49	3 NPN trans. 2 BFY52, 1 BFY52	0.50
Q50	7 BSY28 NPN switch TO-18	0.50
Q51	7 BSY95A NPN trans. 300MHz	0.50
Q52	8 BY100 type sil. rect.	1.00
Q53	25 Sil & germ. trans. mixed all marked new	1.50

## PRINTED CIRCUITS—EX-COMPUTER

Marked with semiconductor and component 10 boards give a guaranteed 30 trans and 30 diodes. Our price 10 boards, 50p. Plus 10p P & P. 100 Boards £3. P & P. 30p.

## POWER TRANSISTOR BONANZA!

**GENERAL PURPOSE GERM. PNP REPLACEMENT**—OC25-28-29-30-35-36. NKT 401-403. 404-405-406-450-451-452-453. T13027-3028, 2N250A, 2N456A-457A-458A, 2N511 A & B, 2G220-222, ETC. VCBO 80V VCEO 50V IC 10A PT. 30 WATTS Hfe 30-170.

PRICE 1-24 25-99 100 up  
45p each 40p each 35p each

**SILICON High Voltage 250V NPN TO-3 case. G.P. Switching & Amplifier Applications. Brand new Coded R 2400 VCBO 250V VCEO 100V IC 6A/30 Watts. HFE type 20/IT 5MHZ. OUR PRICE EACH:**

1-24 25-99 100 up  
50p 45p 40p

**EX-STOCK TYPE EACH AS PRICED**

OC20 50p OC28 40p AD149 45p BD131 70p BD139 75p  
OC22 30p OC29 40p AL102 85p BD132 80p BD140 85p  
OC23 25p OC30 35p AL103 85p BD133 75p BD155 75p  
OC24 45p OC36 40p BD121 80p BD138 80p BU105 25p  
OC25 25p AD140 40p BD123 75p BD137 70p 2N3054 45p  
OC26 85p AD142 40p BD124 70p BD138 80p

**AD161 PNP**  
M/P COMP GERM TRANS. OUR LOWEST PRICE OF 55p PER PAIR.

**AD162 PNP**  
SILICON 50 WATT MATCHED NPN/PNP R1P 19 NPN TO-3 Plastic. R1P 20 PNP. Brand new VCBO 100V VCEO 50V IC 10A. HFE type 100/IT 3MHz. OUR PRICE PER PAIR 1-24 25-99 100 prs. prs. prs. 60p 55p 50p

**SILICON PHOTO TRANSISTOR.** TO-18 Lens and NPN 8mm. to BP 25 and P21. BRAND NEW. Full data available. Fully guaranteed. Qty. 1-24 25-99 100 up  
Price each 45p 40p 35p

## F.E.T.'S

2N3819	35p
2N3820	30p
2N3821	35p
2N3823	30p
2N5458	50p
2N5469	40p
BFW 10	40p
MPF105	40p

**NEW EDITION 1971 TRANSISTOR EQUIVALENTS BOOK.** A complete cross reference and equivalents book for European, American and Japanese Transistors. Exclusive to B.I.P.A.K. 90p each. Red cover edition.

A LARGE RANGE OF TECHNICAL AND DATA BOOKS ARE NOW AVAILABLE IN STOCK. SEND FOR FREE LIST.

**OUR STOCKS** of individual devices are now too numerous to mention in this advertisement. Send S.A.E. for our listing of over 1,000 Semiconductors. All available Ex-Stock at very competitive prices.

## RTL Micrologic Circuits

Epoxy TO-5 case Price each  
uL800 Buffer 1-34 25-99 100 up  
50p 35p 27p  
uL814 Dual 2/p gate 35p 33p 27p  
uL923 J-K flip-flop 50p 47p 45p  
Data and Circuits Booklet for IC's Price 7p.

## DUAL IN LINE SOCKETS

14 & 16 Lead Sockets for use with DUAL IN-LINE I.C.'s. TWO RANGES 'PROFESSIONAL AND NEW LOW COST.

Prof. Type No. 1-24 25-99 100 up  
TSO14 pin type 30p 27p 25p  
TSO16 pin type 35p 32p 30p

Low Cost No.  
RPS 14 15p 13p 11p  
RPS 16 16p 14p 12p

# the lowest prices!

## 74 Series T.T.L. I.C's DOWN AGAIN IN PRICE



Check our 74 Series List before you buy any I.C's. Our prices are the lowest possible. All devices ex-stock. Full spec. guaranteed

BI-PAK Order No.	Price and qty. prices			BI-PAK Order No.	Price and qty. prices		
	1-24	25-99	100 up		1-24	25-99	100 up
BP00-8N7400	0.15	0.14	0.12	BP86-8N7486	0.88	0.80	0.78
BP01-8N7401	0.15	0.14	0.12	BP90-8N7490	0.67	0.64	0.68
BP02-8N7402	0.15	0.14	0.12	BP91-8N7491AN	0.67	0.64	0.78
BP03-8N7403	0.15	0.14	0.12	BP92-8N7492	0.67	0.64	0.88
BP04-8N7404	0.15	0.14	0.12	BP93-8N7493	0.67	0.64	0.88
BP08-8N7405	0.15	0.14	0.12	BP94-8N7494	0.77	0.74	0.88
BP07-8N7407	0.18	0.17	0.16	BP95-8N7495	0.77	0.74	0.88
BP08-8N7408	0.18	0.17	0.16	BP96-8N7496	0.77	0.74	0.88
BP09-8N7409	0.18	0.17	0.16	BP100-8N74100	1.75	1.65	1.55
BP10-8N7410	0.18	0.14	0.12	BP104-8N74104	0.97	0.94	0.88
BP13-8N7413	0.29	0.28	0.24	BP105-8N74105	0.97	0.94	0.88
BP16-8N7416	0.48	0.40	0.38	BP107-8N74107	0.40	0.38	0.36
BP17-8N7417	0.48	0.40	0.38	BP110-8N74110	0.45	0.53	0.50
BP20-8N7420	0.15	0.14	0.12	BP115-8N74115	1.25	1.18	1.00
BP30-8N7430	0.15	0.14	0.12	BP119-8N74119	1.35	1.25	1.10
BP40-8N7440	0.15	0.14	0.12	BP121-8N74121	0.67	0.64	0.58
BP41-8N7441	0.67	0.64	0.58	BP141-8N74141	0.67	0.64	0.58
BP42-8N7442	0.67	0.64	0.58	BP144-8N74144	1.50	1.40	1.30
BP43-8N7443	1.95	1.85	1.75	BP150-8N74150	1.00	0.95	0.90
BP44-8N7444	1.95	1.85	1.75	BP151-8N74151	1.00	0.95	0.90
BP45-8N7445	1.95	1.85	1.75	BP153-8N74153	1.20	1.10	0.95
BP46-8N7446	0.97	0.94	0.88	BP154-8N74154	1.80	1.70	1.60
BP47-8N7447	0.97	0.94	0.88	BP155-8N74155	1.40	1.30	1.20
BP48-8N7448	0.97	0.94	0.88	BP156-8N74156	1.40	1.30	1.20
BP50-8N7450	0.15	0.14	0.12	BP160-8N74160	1.80	1.70	1.60
BP51-8N7451	0.15	0.14	0.12	BP181-8N74181	1.80	1.70	1.60
BP53-8N7453	0.15	0.14	0.12	BP184-8N74184	2.00	1.90	1.80
BP54-8N7454	0.15	0.14	0.12	BP185-8N74185	2.00	1.90	1.80
BP60-8N7460	0.15	0.14	0.12	BP181-8N74181	2.75	2.60	2.40
BP70-8N7470	0.29	0.28	0.24	BP182-8N74182	0.97	0.94	0.88
BP72-8N7472	0.29	0.28	0.24	BP190-8N74190	3.50	3.25	3.00
BP73-8N7473	0.37	0.35	0.32	BP191-8N74191	3.50	3.25	3.00
BP74-8N7474	0.37	0.35	0.32	BP192-8N74192	3.50	3.25	3.00
BP75-8N7475	0.47	0.45	0.42	BP193-8N74193	2.10	1.95	1.75
BP76-8N7476	0.48	0.40	0.38	BP195-8N74195	1.10	1.05	0.95
BP80-8N7480	0.67	0.64	0.58	BP196-8N74196	1.80	1.70	1.60
BP81-8N7481	0.97	0.94	0.88	BP197-8N74197	1.80	1.70	1.60
BP82-8N7482	0.97	0.94	0.88	BP198-8N74198	5.50	5.00	4.00
BP83-8N7483	1.10	1.05	0.95	BP199-8N74199	5.50	5.00	4.00

PRICE-MIX. Devices may be mixed to qualify for quantity prices.  
PRICES for quantities in excess of 500 pieces mixed, on application.  
Owing to the ever increasing range of TTL 74 Series, please check with us for supplies of any devices not listed above, as it is probably new in stock. WARE 3442.

### LINEAR I.C's— FULL SPEC.

Type No.	1-24	25-99	100 up
BP 201C-8L201C	65p	60p	45p
BP 701C-8L701C	65p	60p	45p
BP 702C-8L702C	65p	60p	45p
BP 702-72702			
BP 709-72709	58p	45p	40p
BP 709P-μA709C	58p	45p	40p
BP 710-72710	58p	45p	40p
BP 711-μA711	58p	50p	45p
BP 741-72741			
μA 703C-μA703C	45p	35p	27p
TAA 283-	70p	60p	55p
TAA 293-	90p	75p	70p
TAA 350	170p	150p	160p

### LOGIC DTL 930 SERIES I.C's ROCK BOTTOM PRICES

Type No.	1-24	25-99	100 up
BP930	12p	11p	10p
BP932	13p	12p	11p
BP933	13p	12p	11p
BP935	13p	12p	11p
BP936	13p	12p	11p
BP944			
BP945	13p	12p	11p
BP946	12p	11p	10p
BP948	25p	24p	22p
BP961	65p	60p	55p
BP962	12p	11p	10p
BP963	40p	35p	32p
BP9094	40p	35p	32p
BP9097	40p	35p	32p
BP9099	40p	35p	32p

Devices may be mixed to qualify for quantity price. Larger quantity prices on application. (DTL 930 Series only).

### NUMERICAL INDICATOR TUBES

MODEL	CD66	GR 116	3015F
Anode voltage (Vdc)	170	175	5
Cathode cur'nt(mA)	2.3	1.4	
Numeral height (mm)	16	13	9
Tube height (mm)	47	32	22
Tube diameter (mm)	19	13	12
I.C. driver rec.	BP41 or 141	BP41 or 141	BP47
PRICE EACH	£1.70	£1.55	£1.90

All indicators 0.9 x Decimal point: All side viewing: Full data for all types available on request.

### BI-PAK DO IT AGAIN!

## 50W pk 25w (RMS) 0.1% DISTORTION HI-FI AUDIO AMPLIFIER THE AL50

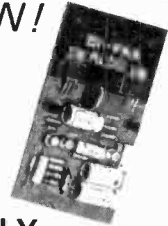

- ★ Frequency response 15Hz to 100,000 - 1dB. **ONLY £3.25p each**
- ★ Load - 3, 4, 8 or 16 ohms.
- ★ Distortion - better than 1% at 1kHz.
- ★ Signal to noise ratio 80dB.
- ★ Supply voltage 10 - 35 Volts.
- ★ Overall size 63mm x 105mm x 13mm.

Tailor made to the most stringent specifications using top quality components and incorporating the latest solid state circuitry and ALSO was conceived to fill the need for all your A.F. amplification needs. FULLY BUILT - TESTED - GUARANTEED.

### STABILISED POWER MODULE

AP80 is especially designed to power 2 of the AL50 Amplifiers, up to 15 watt (rms) per channel, simultaneously. This module embodies the latest components and circuit techniques incorporating complete short circuit protection. With the addition of the Mains Transformer MT80, the unit will provide outputs of up to 1.5 amps at 35 volts. Size 63mm x 105mm x 30mm.

These units enable you to build Audio Systems of the highest quality at a hitherto unobtainable price. Also ideal for many other applications, including: Disco Systems, Public Address, Intercom Units, etc, Handbook available 10p.

### STABILISED POWER MODULE SPM80 £2.95

TRANSFORMER BMT80 £1.95 p & p 25p.  
SPECIAL COMPLETE KIT COMPRISING 2, AL50's, 1, SPM80 & 1, BMT80 ONLY £11, FREE p & p

### DTL & TTL INTEGRATED CIRCUITS

Manufacturers' "Fall out" - out of spec. devices including functional units and part function but classed as out of spec. from the manufacturers' very rigid specifications. Ideal for learning about I.C's and experimental work.

Pack No.	12 x μA 930	50p	Pack No.	8 x μA 948	50p
UIC822	12 x μA 832	50p	UIC961	5 x μA 961	50p
UIC833	12 x μA 933	50p	UIC961	12 x μA 961	50p
UIC835	12 x μA 835	50p	UIC9083	5 x μA 9083	50p
UIC836	12 x μA 836	50p	UIC9094	5 x μA 9094	50p
UIC844	12 x μA 844	50p	UIC9097	5 x μA 9097	50p
UIC845	8 x μA 845	50p	UIC9099	5 x μA 9099	50p
UIC846	12 x μA 846	50p	UICX 25	Assorted 930 Series	£1.50

Packs cannot be split but 25 Assorted Pieces (our mix) is available as Pack UICX9 Data Booklet available for the BP930 Series, PRICE 15p

UIC00-12x7400N	50p	UIC46-5x7446N	50p	UIC81-5x7481N	50p
UIC01-12x7401N	50p	UIC47-5x7447N	50p	UIC82-5x7482N	50p
UIC02-12x7402N	50p	UIC48-5x7448N	50p	UIC83-5x7483N	50p
UIC03-12x7308N	50p	UIC50-12x7450N	50p	UIC86-5x7486N	50p
UIC04-12x7404N	50p	UIC51-12x7451N	50p	UIC90-5x7490N	50p
UIC05-12x7405N	50p	UIC53-12x7453N	50p	UIC91-5x7491N	50p
UIC10-12x7410N	50p	UIC54-12x7454N	50p	UIC92-5x7492N	50p
UIC13-8x7413N	50p	UIC56-12x7456N	50p	UIC93-5x7493N	50p
UIC20-12x7420N	50p	UIC70-8x7470N	50p	UIC94-5x7494N	50p
UIC40-12x7440N	50p	UIC72-8x7472N	50p	UIC95-5x7495N	50p
UIC41-5x7441AN	50p	UIC73-8x7473N	50p	UIC96-5x7496N	50p
UIC42-5x7442N	50p	UIC74-8x7474N	50p	UIC121-6x74121N	50p
UIC43-5x7443N	50p	UIC76-8x7476N	50p	UICX1-25xAss't'd	74's £1.50
UIC44-5x7444N	50p	UIC78-8x7478N	50p		
UIC45-5x7445N	50p	UIC80-5x7480N	50p		

All prices quoted in new pence. Giro No. 388-7006  
Please send all orders direct to warehouse and despatch department

# BI-PAK

## P.O. BOX 6, WARE, HERTS

Postage and packing add 7p. Overseas add extra for airmail. Minimum order 50p. Cash with order please.

Guaranteed Satisfaction or Money Back

# Now! A FAST EASY WAY TO LEARN BASIC RADIO & ELECTRONICS

 Build as you learn with the exciting new **TECHNATRON** Outfit! No mathematics. No soldering—you learn the **practical way.**

Learn basic Radio and Electronics at home – the fast, modern way. Give yourself essential technical ‘know-how’ – like reading circuits, assembling standard components, experimenting, building – quickly and without effort, and enjoy every moment. B.I.E.T.’s Simplified Study Method and the remarkable **TECHNATRON** Self-Build Outfit take the mystery out of the subject, making learning easy and interesting.

**Even if you don't know the first thing about Radio now, you'll build your own Radio set within a month or so!**

and what's more, you will understand exactly what you are doing. The **TECHNATRON** Outfit contains everything you need, from tools to transistors – even a versatile Multimeter which we teach you to use. All you need give is a little of your spare time and the surprisingly low fee, payable monthly if you wish. And the equipment remains yours, so you can use it again and again.

**You LEARN – but it's as fascinating as a hobby.**

Among many other interesting experiments, the Radio set you build – and it's a good one – is really a bonus. This is first and last a teaching course, but the training is as fascinating as any hobby and it could be the springboard for a career in Radio and Electronics.

A 14-year-old could understand and benefit from this Course – but it teaches the real thing. The easy to understand, practical projects – from a burglar-alarm to a sophisticated Radio set – help you master basic Radio and Electronics – even if you are a ‘non-technical’ type. And, if you want to make it a career, B.I.E.T. has a fine range of Courses up to City and Guilds Standards.

**New Specialist Booklet**

If you wish to make a career in Electronics, send for your **FREE** copy of ‘**OPPORTUNITIES IN TELECOMMUNICATIONS / TV AND RADIO**’. This brand new booklet – just out – tells you all about **TECHNATRON** and B.I.E.T.’s full range of courses.



**FREE**

**BRITISH INSTITUTE OF ENGINEERING TECHNOLOGY**

Dept. B9, ALDERMASTON COURT, READING RG7 4PF  
Accredited by the Council for the Accreditation of Correspondence Colleges.

**POST THIS COUPON FOR FREE BOOK**

Please send book and full information – free and without obligation.

NAME..... AGE.....  
(BLOCK CAPITALS PLEASE)

ADDRESS.....

.....

**BIET** OCCUPATION.....

To B.I.E.T. Dept. B9, Aldermaston Court, Reading RG7 4PF

# Latest Bound Volume No. 24

of

## “The Radio Constructor” FOR YOUR LIBRARY

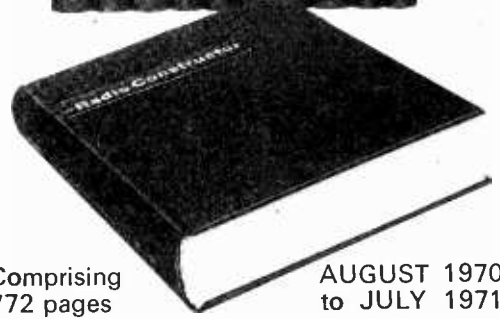

Comprising 772 pages plus index

AUGUST 1970 to JULY 1971

**PRICE £2.00 Postage 29p**

BOUND VOLUME NO. 23  
OF  
“THE RADIO CONSTRUCTOR”  
AUGUST 1969 to JULY 1970  
Limited number of this volume still available  
PRICE £1.88 Postage 29p

We regret all earlier volumes are now completely sold out.

Available only from  
**DATA PUBLICATIONS LTD.,**  
57 MAIDA VALE, LONDON, W9 1SN

# BI-PRE-PAK



**COMPLETE TELEPHONES**  
Normal household type as supplied to the Post Office, ex. G.P.O. Only **95p** each, p. & p. 35p each.



**TELEPHONE DIALS**  
Standard Post Office type. Guaranteed in working order.  
**ONLY 50p**  
p. & p. 15p.

## TESTED AND GUARANTEED PAKS

B2	4	Photo Cells, Sun Batteries, 0.3 to 0.5V. 0.5 to 2mA.	50p
B79	4	1N4007 Sil. Rec. diodes, 1,000 PIV lamp plastic	50p
B81	10	Reed Switches, mixed types large and small	50p
B99	200	Mixed Capacitors. Approx. quantity, counted by weight	50p
H4	150	Mixed Resistors. Approx. quantity counted by weight	50p
H7	40	Wirewound Resistors. Mixed types and values.	50p
H8	4	BY127 Sil. Recs. 1000 PIV. 1 amp. plastic	50p
H9	2	OC711 Light Sensitive Photo Transistor	50p
H12	50	NKT155/259 Germ. diodes, brand new stock clearance	50p
H28	20	OC200/1/2/3 PNP Silicon uncoated TO-5 can	50p
H30	20	1 Watt Zener Diodes, Mixed Voltages 6.8 - 43V.	50p
H35	100	Mixed Diodes, Germ. Gold bonded, etc. Marked and Unmarked.	50p
H38	30	Short lead Transistors, NPN Silicon Planar types.	50p

## UNMARKED UNTESTED PAKS

B66	150	Germanium Diodes Min. glass type	50p
B83	200	Trans. manufacturers' rejects all types NPN, PNP, Sil. and Germ.	50p
B84	100	Silicon Diodes DO-7 glass equiv. to OA200, OA202	50p
B86	50	Sil. Diodes sub. min. 1N914 and 1N916 types	50p
B88	50	Sil. Trans. NPN, PNP equiv. to OC200/1 2N706A, BS Y95A, etc.	50p
B1	50	Germanium Transistors PNP, A.F. & R.F.	50p
H6	40	250mW. Zener Diodes DO-7 Min. Glass Type	50p
H34	15	Power Transistors, PNP, Germ. NPN Silicon TO-3 Can.	50p
H17	20	3 amp Silicon Stud rectifiers, mixed volts	50p
H15	30	Top Hat Silicon Rectifiers, 750mA. Mixed volts	50p
H16	8	Experimenters' Pak of Integrated Circuits. Data supplied	50p
H20	20	BY126/7 Type Silicon Rectifiers 1 amp plastic. Mixed volts.	50p

## MAKE A REV COUNTER FOR YOUR CAR

The 'TACHO BLOCK'. This encapsulated block will turn any 0-1mA meter into a linear and accurate rev. counter for any car with normal coil ignition system.

**£1 each**



## OUR VERY POPULAR 3p TRANSISTORS

TYPE "A" PNP Silicon alloy, TO-5 can.  
TYPE "B" PNP Silicon, plastic encapsulation.  
TYPE "E" PNP Germanium AF or RF.  
TYPE "F" NPN Silicon plastic encapsulation.

## FULLY TESTED AND MARKED SEMICONDUCTORS

	£p		£p
AC107	0-15	OC170	0-23
AC126	0-15	OC171	0-23
AC127	0-17	OC200	0-25
AC128	0-15	OC201	0-25
AC176	0-20	2G301	0-13
ACY17	0-20	2G303	0-13
AF239	0-30	2N711	0-50
AF186	0-20	2N1302-3	0-15
AF139	0-30	2N1304-5	0-17
BC154	0-20	2N1306-7	0-20
BC107	0-10	2N1308-9	0-22
BC108	0-10	2N3856FET	0-40
BF194	0-15	2N4416FET	0.35
BC109	0-10	Power Transistors	
BF274	0-20	OC20	0-50
BFY50	0-15	OC23	0-30
BSY25	0-13	OC25	0-25
BSY26	0-13	OC26	0-25
BSY27	0-13	OC28	0-30
BSY28	0-13	OC28	0-30
BSY29	0-13	OC35	0-25
BSY95A	0-10	OC36	0-37
OC41	0-15	AD149	0-30
OC44	0-13	AUY10	1-25
OC45	0-10	25034	0-25
OC71	0-10	2N3055	0-50
OC72	0-10	Diodes	
OC81	0-13	AA Y42	0-10
OC81D	0-13	OA95	0-07
OC83	0-18	OA79	0-07
OC139	0-13	OA81	0-07
OC140	0-15	1N914	0.06

## F.E.T. PRICE BREAKTHROUGH!!

This field effect transistor is the 2N3823 in a plastic encapsulation, coded as 3B23E. It is also an excellent replacement for the 2N3819. Data sheet supplied with device. 1-10 30p each, 10-50 25p each, 50+20p each.



## TRANSISTOR IGNITION! AS USED BY RACING DRIVERS!

**NOW** We introduce a Transistorised Ignition that is **NOT** a Kit at LESS than Kit price! The Super Spark, Mark II is ready to go. Installation time—10 minutes. It operates on a unique and newly discovered principle that drives a standard ignition coil with a fantastic peak of 400V. The solid impact gives 45,000 Volts right to the sparking plug and gives cooler running, longer plug life, more M.P.G. and greater B.H.P. Contact breaker life is extended indefinitely and no visible burning will ever take place. The circuitry is all silicon solid state and is engineered for top dependable performance on any car with standard ignition coil. Every unit is tested before despatch and each carries a full guarantee. Gives a full spark at up to 10,000 RPM!

Please state positive or negative earth on order.

**SUPER SPARK**  
**£9.95**

P. & P. 25p.

## FREE CATALOGUE

FOR TRANSISTORS, RECTIFIERS, DIODES, INTEGRATED CIRCUITS, FULL PRE-PAK LISTS.



## 8 RELAYS FOR £1

VARIOUS TYPES P. & P. 25p.

### COLOUR T.V. LINE OUTPUT TRANSFORMERS

Designed to give 25kV when used with PL509 and PY500 valves. As removed from colour receivers at the factory.

**NOW ONLY 50p each**  
post and packing 23p.

Quantity	1-10	10-50	50+
BB105 Varicap Diodes	10p	8p	6p
OC71 or 72 Fully Tested	Unmarked	5p	4p
Matched Sets 1-OC44 and 2-OC45's. Per Set.	25p	20p	15p
OA47 Gold-Bonded Diodes, Marked and Tested	3p	3p	2p
1-watt Zener Diodes 7-5, 24, 27, 30, 36, 43 Volts	5p	4p	3p
10-watt Zener Diodes 5-1, 8-2, 11, 13, 16, 24, 30, 100 Volts	20p	17p	15p
Micro Switches, S/P, C/O	25p	20p	15p
1-amp Bridge Rec's 25-volt	25p	22p	20p

### INTEGRATED CIRCUITS

SL403D Audio Amp, 3-Watts	1.50	1.37	1.32
709C Linear Opp. Amp.	25p	20p	15p
Gates, Factory Marked and Tested by A.E.I.	25p	22p	20p
J. K. Flip-Flops Factory, Marked and Tested by A.E.I.	40p	35p	30p
SN7490 Decade Counter	50p	45p	40p
UL914 Dual 1/2 P Gate	40p	35p	30p

### LOW COST DUAL INLINE I.C. SOCKETS

14 pin type at 15p each  
16 pin type at 16p each.

### BOOKS

We have a large selection of Reference and Technical Books in stock.

These are just two of our popular lines: <b>B.P.1 Transistor Equivalents and Substitutes;</b>	40p
This includes many thousands of British U.S.A., European and C.V. equivalents. <b>The Iliffe Radio Valve &amp; Transistor Data Book 9th Edition. P. &amp; P. 21p.</b>	75p
Characteristics of 3,000 valves and tubes, 4,500 Transistors, Diodes, Rectifiers and Integrated Circuits.	
Send for lists of these English publications.	

Please send me the FREE BI-Pre-Pak Catalogue.

NAME .....

ADDRESS .....

MINIMUM ORDER 50p. CASH WITH ORDER PLEASE. Add 10p post and packing per order. OVERSEAS ADD EXTRA FOR POSTAGE

# BI-PRE-PAK LTD

DEPT. C, 222-224 WEST ROAD, WESTCLIFF-ON-SEA, ESSEX, SS0 9DF  
TELEPHONE: SOUTHEND (0702) 46344

# DENCO (CLACTON) LIMITED

## 355-7-9 OLD ROAD, CLACTON-ON-SEA, ESSEX

Our components are chosen by Technical Authors and Constructors throughout the World for their performance and reliability, every coil being inspected twice plus a final test and near spot-on alignment as a final check.

Our General Catalogue showing full product range	.. 16p
DTB4 Transistor & Valve circuitry for D.P. Coils	.. 16p
DTB9 Valve Type Coil Pack Application circuitry	.. 16p
MD.1 Decoder Circuitry for Stereo Reception	.. 20p

All post paid, but please enclose S.A.E. with all other requests in the interests of retaining lowest possible prices to actual consumers

### PRECISION

#### POLYCARBONATE CAPACITORS

**Fresh Stock - Fully Tested and Guaranteed**

Close tolerance professional capacitors by well-known manufacturer. Excellent stability and extremely low leakage. All 63V D.C. Prices as follows:

0.47  $\mu$ F:  $\pm 5\%$  30p;  $\pm 2\%$  40p;  $\pm 1\%$  50p; Size  $1\frac{1}{8}'' \times \frac{1}{2}'' \times \frac{1}{2}''$   
 1.0  $\mu$ F:  $\pm 5\%$  40p;  $\pm 2\%$  50p;  $\pm 1\%$  60p; Size  $1'' \times \frac{3}{8}'' \times \frac{1}{2}''$   
 2.2  $\mu$ F:  $\pm 5\%$  50p;  $\pm 2\%$  60p;  $\pm 1\%$  75p; Size  $1'' \times \frac{3}{8}'' \times \frac{3}{8}''$   
 4.7  $\mu$ F:  $\pm 5\%$  70p;  $\pm 2\%$  90p;  $\pm 1\%$  115p; Size  $1\frac{1}{2}'' \times \frac{1}{2}'' \times \frac{3}{8}''$   
 10.0  $\mu$ F:  $\pm 5\%$  110p;  $\pm 2\%$  140p;  $\pm 1\%$  180p; Size  $1\frac{3}{8}'' \times \frac{1}{2}'' \times \frac{3}{8}''$   
 15.0  $\mu$ F:  $\pm 5\%$  160p;  $\pm 2\%$  210p;  $\pm 1\%$  270p; Size  $1\frac{3}{8}'' \times 1'' \times \frac{7}{8}''$

#### SPECIAL OFFER - 400 mW ZENER DIODES

Values available 6.8, 7.5, 8.2, 9.1, 10, 11, 12, 13.5, 15V  
 All new and colour-coded DO35. Price 12p each, 5 for 50p, 12 for £1.00.

**TRANSISTORS:** BC107; BC108; BC109 (please state which), all at 9p each, 6 for 50p; 14 for £1.00; May be mixed to qualify for lower price. All brand new to full manufacturer's specification.

**POPULAR DIODES:** IN914 - 7p each; 8 for 50p; 18 for £1.00  
 IN916 - 9p each; 6 for 50p; 14 for £1.00. IS44 - 5p each; 11 for 50p; 24 for £1.00. All brand new and marked.

**RESISTORS:** Carbon film  $\frac{1}{4}$  watt 5%. Range 2.2 $\Omega$ -2.2M $\Omega$  E12. Series i.e. 10, 12, 15, 18, 22, 27, 33, 39, 47, 56, 68, 82, and their decades. All at 1p each. 8p for 10 of any one value; 70p for 100 of any one value. Special development pack 10 off each value 2.2 $\Omega$  to 2.2M $\Omega$  (730 resistors) for £5.00.

**440V A.C. CAPACITORS:** 0.1  $\mu$ F: Size  $1\frac{1}{8}'' \times \frac{1}{2}''$ , 25p each  
 0.25  $\mu$ F: Size  $1\frac{1}{8}'' \times \frac{3}{8}''$ , 30p each 0.5  $\mu$ F: Size  $1\frac{1}{8}'' \times \frac{3}{8}''$ , 35p each  
 1.0  $\mu$ F: Size  $2'' \times \frac{3}{8}''$ , 45p each 2.0  $\mu$ F: Size  $2'' \times 1''$ , 75p each

**LIGHT DIMMERS:** 440V A.C. capacitors listed above are ideal for dimming filament bulbs (unsuitable for fluorescent tubes). We suggest 1  $\mu$ F for dimming 25W bulb, 2  $\mu$ F for a 40W or 60W bulb, 5p post and packing on all orders below £5

**V.ATTWOOD, Dept C.2., P.O. Box 8, Alresford, Hants.**

## To All Users of Industrial Electronics

Take advantage of our very competitive prices and high quality workmanship.

DESIGN AND CONSTRUCTION OF INDUSTRIAL ELECTRONICS EQUIPMENT. INDUCTION HEATING GENERATORS. METAL DETECTORS, POWER SUPPLIES, AUTOMATION AND CONTROL EQUIPMENT.

HIGH QUALITY  
 SHORT DELIVERY TIMES,  
 TWO YEARS GUARANTEE

DESIGNS CONSTRUCTED TO CUSTOMERS OWN SPECIFICATIONS

WRITE FOR FULL DETAILS TO:

**“E.B.E.H. A. KYPRIOTIS”  
 LABORATORIES OF  
 INDUSTRIAL ELECTRONICS**

OFFICE  
 ANDROMAHIS 50, KALLITHEA  
 ATHENS, GREECE

FACTORY  
 PAPAFLISSA 3, TSAKOS  
 AGHIA PARSKEVI  
 ATHENS, GREECE

RADIO & ELECTRONICS CONSTRUCTOR



# This remarkable catalogue

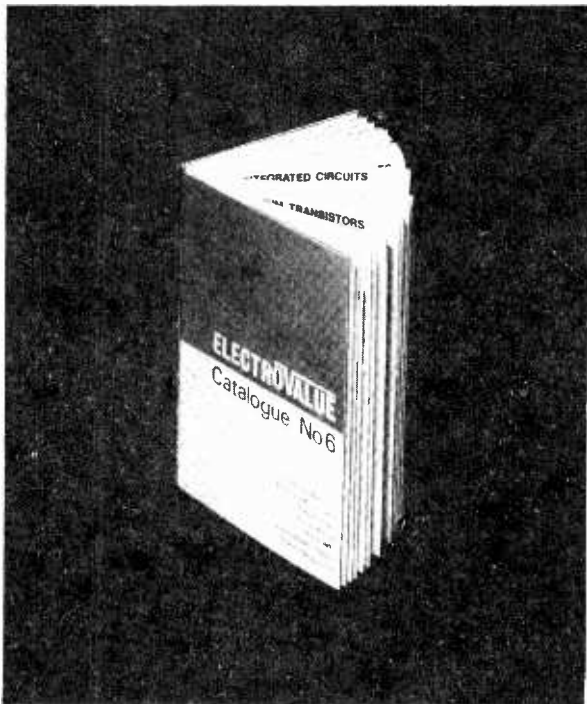

Comprises 96 pages, plus covers, packed with thousands of items of importance to every constructor. Also pages of I.C. diagrams, semi-conductor outlines, transistor characteristics and tables of equivalents. Hundreds of resistors and capacitors are detailed. Also included many other components, accessories, materials and tools. There is much other valuable information besides. The Electrovalue Catalogue No. 6 costs but 10p post free. Orders for goods are dealt with very promptly and satisfaction guaranteed. Postage free for all orders over £2.00 in U.K.

- SUBSTANTIAL DISCOUNTS
- EVERYTHING BRAND NEW—  
No seconds, 'surplus' or clearance bargains
- PROMPT DELIVERY
- SPECIAL TERMS FOR LARGE QUANTITY BUYERS

## ELECTROVALUE LTD.

Dept RC.3

28 ST. JUDES RD., ENGLEFIELD GREEN, EGHAM, SURREY, TW20 0HB  
Tel: Egham 3603 : Telex 264475 : Hours 9-5.30 : Sat. 1.0 p.m.

## RSGB BOOKS FOR YOU

Just published

### New (fourth) edition of the ever-popular AMATEUR RADIO TECHNIQUES

by Pat Hawker, G3VA

Aimed at extending the reader's awareness of new devices and techniques. Provides a source book for many useful circuits and aerials. An *ideas* book rather than a constructional manual, but an ideas book that will prove its value time and time again.

Substantially enlarged edition comprising 256 pages with over 600 diagrams. New material and features include more emphasis on integrated circuits, a quick guide to digital electronics, and much additional information on the cure of TV interference and on aerials.

£1.80 including postage and packing

### RAE MANUAL

by G. L. Benbow, G3HB Sixth (1972) edition

The standard work for all would-be licensed radio amateurs studying for the Radio Amateurs' Examination. A completely re-written edition brought fully up to date to meet the present examination syllabus requirements.

96 pages

90p post paid

These are two of a complete range of technical publications, log books and maps, all obtainable from:

**RADIO SOCIETY OF GREAT BRITAIN**  
35 DOUGHTY STREET, LONDON, WC1N 2AE

### REVERBERATION UNIT KIT Mk III

6 transistor reverberation chamber to which microphones, instruments, etc., may be connected for added dimensional effect. The output is suitable for most amplifiers and the unit is especially suitable for use with electronic organs. A ready-built spring and transducer assembly is used.

Complete easy-to-build kit, with constructional notes and circuits £7.50. Pre-drilled and printed case £2.00 extra All parts available separately.



### WAH-WAH PEDAL KIT Mk III



The Wilsic Wah-Wah pedal comprises a SELECTIVE AMPLIFIER MODULE KIT, containing all the components to build a two transistor circuit module, which may be used by the constructor for his own design or fitted to the FOOT VOLUME CONTROL PEDAL (as photo) converting it to Wah-Wah operation. This pedal is in strong fawn plastic and fitted with output lead and screened plug. Selective amplifier module kit £1.75. Foot Volume control pedal £5.13. COMPLETE KIT £6.50. Add 38p for assembly of module.

Complete easy-to-build kit, with constructional notes and circuits £7.50. Pre-drilled and printed case £2.00 extra All parts available separately.

### WILSIC VIBRATO UNIT

A new kit to build a self-contained vibrato foot switch unit. 4-silicon transistor circuit in tough grey hammered finish metal cabinet. Variable speed and depth controls and on-off foot switch. Ideal for guitars but unsuitable for high level inputs.

COMPLETE KIT £5.25, all parts available separately.

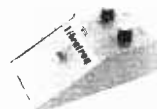

THE WILSIC BOOK OF CIRCUITS contains the full instructions for the Reverb unit, Wah-Wah pedal and our Vibrato unit.  
PRICE ONLY 15p

SEND 5p in stamps for latest catalogue (Spring 1972) of Hi-Fi, components, guitars, etc., etc. Friendly, high-speed service.



**WILSIC ELECTRONICS LTD.**

6 COPLEY ROAD, DONCASTER, YORKS

**C**  
**H**OME RADIO  
**H**OME RADIO  
**P**  
**H**OME RADIO  
**H**OME RADIO  
**N**  
**H**OME RADIO  
**E**  
**H**OME RADIO  
**T**  
**S**

**HOME RADIO (Components) LTD.**  
 Dept. RC, 234-240 London Road,  
 Mitcham CR4 3HD. 01-648 8422

When you think  
 of **COMPONENTS**  
 think of **HOME RADIO** COMPONENTS LTD.

Some things in life are just about inseparable – eggs and bacon, sausage and mash, Tweedle Dum and Tweedle Dee! Think of one and you think of the other. That's how thousands of radio and electronic enthusiasts think of Components and Home Radio Ltd. When they need the first they automatically contact the second. They simply flip through their Home Radio Catalogue, locate the items they need and telephone or post their order.

If you have not yet experienced the simplicity and satisfaction of linking Components and Home Radio, why not make a start now? First of all you'll need the catalogue . . . in its 315 pages are listed more than 8,000 components, over 1,500 of them illustrated. Every copy contains ten vouchers, each worth 5p when used as instructed. The catalogue costs 70p including postage and packing. Drop us a line or use the coupon below.

**POST THIS COUPON with your cheque or postal order for 70p**



It would help us considerably if we knew whether this was your first Home Radio Components Catalogue. If it is, please place a tick in the box.

This is my first HR Components Catalogue

Name .....

Address .....

.....

**HOME RADIO (Components) LTD.**  
 Dept. RC, 234-240 London Road, Mitcham CR4 3HD



**24-hour Phone Service. Ring 01-648 8422**

Ask for details of our Credit Account Service.

The price of 70p applies only to catalogues purchased by customers in the U.K. and to BFPO addresses.

# RADIO CONSTRUCTOR

& ELECTRONICS



Incorporating  
THE RADIO AMATEUR

AUGUST 1972

Vol. 26 No. 1

CONTENTS

Published Monthly (1st of Month)  
First Published 1947

Editorial and Advertising Offices  
57 MAIDA VALE LONDON W9 1SN

Telephone 01-286 6141  
Telegrams Databux, London

© Data Publications Ltd., 1972. Contents may only be reproduced after obtaining prior permission from the Editor. Short abstracts or references are allowable provided acknowledgement of source is given.

Annual Subscription: £2.70 (U.S.A. and Canada \$7.00) including postage. Remittances should be made payable to "Data Publications Ltd". Overseas readers please pay by cheque or International Money Order.

*Technical Queries.* We regret that we are unable to answer queries other than those arising from articles appearing in this magazine nor can we advise on modifications to equipment described. We regret that such queries cannot be answered over the telephone; they must be submitted in writing and accompanied by a stamped addressed envelope for reply.

*Correspondence* should be addressed to the Editor, Advertising Manager, Subscription Manager or the Publishers as appropriate.

*Opinions* expressed by contributors are not necessarily those of the Editor or proprietors.

*Production.*—Web Offset.

DIRECT-READING CAPACITANCE METER by F. Griffiths	10
CAN ANYONE HELP?	15
NEWS AND COMMENT	16
THE 'NIGHTRIDER' (Suggested Circuit 261) by G. A. French	18
NOTES ON SEMICONDUCTORS (Further Notes—9. 98.4 ?) by Peter Williams	21
CYCLOPS (Electronic Robot) — Part 2 by L. C. Galitz	22
BOOK REVIEWS — Radio Control	28
TRADE NEWS	29
SINGLE SIDEBAND FOR BEGINNERS by R. A. Butterworth	30
THE 'JUBILEE' 8-WATT AMPLIFIER by J. R. Davies	32
RECEIVER HEADPHONE ADAPTOR by C. M. Lindars	39
SHORT WAVE NEWS by Frank A. Baldwin	40
ZENER DIODE 'BUZZER' by R. J. Caborn	42
NEW PRODUCTS	44
IN YOUR WORKSHOP	45
RELAXATION OSCILLATOR by J. Evans	52
RADIO TOPICS by Recorder	54
DECIMAL BINARY CONVERTER by J. Roberts	56
RADIO CONSTRUCTOR'S DATA SHEET No. 65 (British Association Screws)	iii

Published in Great Britain by the Proprietors and Publishers, Data Publications Ltd, 57 Maida Vale, London, W9 1SN

The Radio Constructor is printed by Carlisle Web Offset.

SEPTEMBER ISSUE WILL BE  
PUBLISHED ON SEPTEMBER 1st

# DIRECT-READING CAPACITANCE METER

by  
F. Griffiths

This instrument employs simple principles and offers sharp readings from 0.5 to 400pF together with useful indications from 400 to 4,000pF.

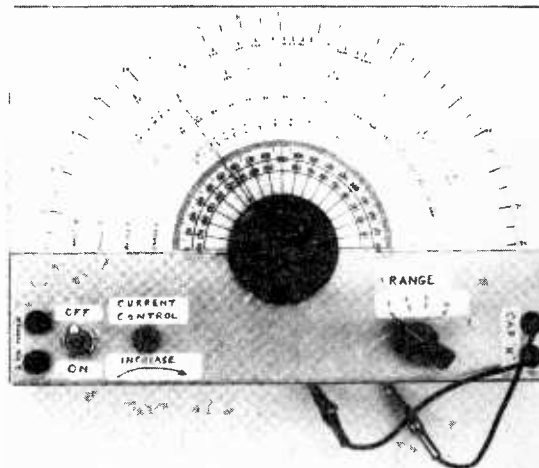

THE INSTRUMENT TO BE DESCRIBED WILL MEASURE capacitors from 0.5pF to 4,000pF in four ranges. It is not a capacitance bridge, and it is a simple matter to measure any capacitance within the range. It is only necessary to clip in the capacitor to be measured, switch on, and adjust one knob until a sharp and relatively large increase in current as shown in a meter is observed, whereupon the capacitance can be read directly from a scale.

## BASIC CIRCUIT

The basic circuit is shown in Fig. 1 and it will be noticed that the main section consists of a transistor oscillator of the type that is frequently used in present-day superhet transistor sets.

Regeneration is obtained by coupling the collector coil to the emitter coil via the mutual inductance between them. Both these coils are also coupled to a third coil which, when tuned by the capacitor VC, determines the frequency of oscillation. These oscillations are fed from the base of the transistor via C2 to coil L1, one winding of which is tuned by the unknown capacitor Cx, together with C1 which is pre-set in the prototype to about 25pF.

A pointer traversing a scale affixed to the spindle of VC, and the purpose of C1 is to set the minimum reading to about a quarter of the way along the scale on the lowest range.

When the two tuned circuits are at exactly the same resonant frequency, the current in the meter in series with the negative supply increases sharply. With the instrument calibrated on all of its four ranges, the unknown capacitance can be read off the dial directly.

The complete circuit is shown in Fig. 2. The winding in L2 between pins 3 and 4 is tuned by three different values of capacitance according to the position of the range switch, S1. In position 1 the capacitor C4, of 68pF, is in series with one half of the 2-gang capacitor, C7 (a)(b), each section of which has a maximum capacitance of 365pF. Thus the maximum tuning capacitance on Range 1 is 68pF in series with 365pF, or approximately 57pF. On Range 2 the series capacitor is cut out and tuning is carried out with one 365pF section of the 2-gang capacitor. On Range 3 both sections of the 2-gang capacitor are used for tuning,

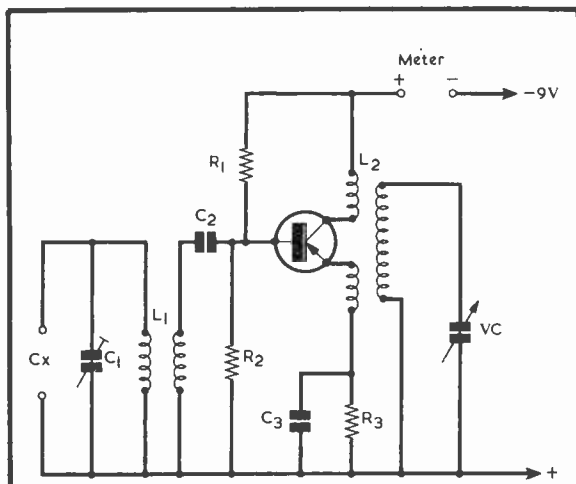

Fig. 1. The basic technique employed in the capacitance measuring instrument. Vc is calibrated in terms of capacitance and is adjusted for maximum indication in the meter

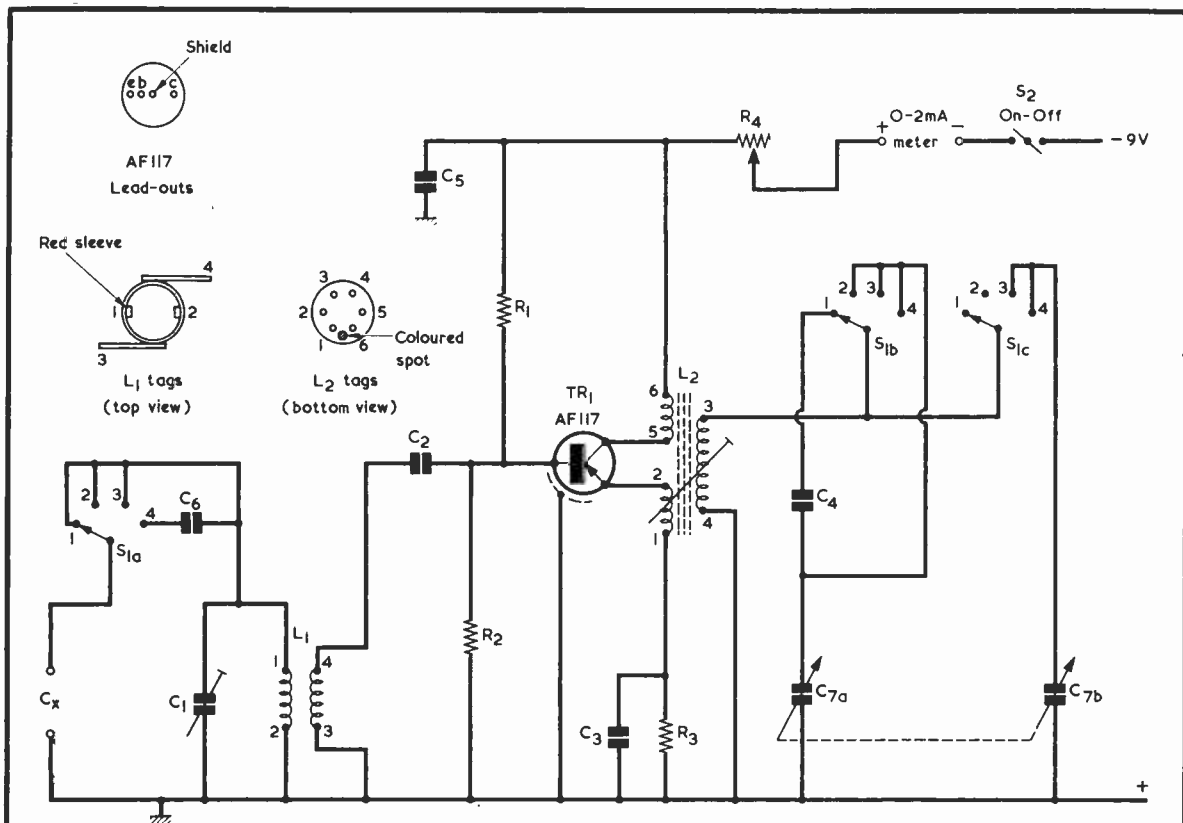

Fig. 2. Full circuit diagram for the instrument

## COMPONENTS

### Resistors

(All fixed values  $\frac{1}{4}$  watt 10%)

- R1 47k $\Omega$
- R2 6.8k $\Omega$
- R3 1.2k $\Omega$
- R4 5k $\Omega$  potentiometer, wire-wound

### Capacitors

- C1 30pF trimmer, Mullard air-spaced concentric
- C2 0.022 $\mu$ F, 125V. Wkg., Mullard tubular polyester
- C3 0.022 $\mu$ F, 125V. Wkg., Mullard tubular polyester
- C4 68pF, 1% silvered mica
- C5 0.047 $\mu$ F, 125V. Wkg., Mullard tubular polyester
- C6 300pF, 1%, silvered mica
- C7(a)(b) 365 + 365pF variable, 2-gang, Jackson type O

### Coils

- L1 Wearite type PA7 (Home Radio Cat. No. C083G)
- L2 Weyrad (Weymouth) type P50/1AC

### Transistor

- TR1 AF117

### Switches

- S1(a)(b)(c) 3-pole 4-way miniature rotary
- S2 s.p.s.t. toggle

### Battery

- 9-volt battery type PP3

### Sockets etc.

- 1 red wander-plug socket
- 1 black wander-plug socket
- Battery connectors
- 2 crocodile clips

### Miscellaneous

- Chassis, Paxolin, Perspex (see text)
- Half-circle protractor, 2in. radius
- Knobs (as required)
- Pasteboard or thick white paper
- Nuts, bolts, solder tags, etc.

giving a maximum of 730pF. On Range 4 the tuning of L2 is the same as for Range 3, but now C6, of 300pF, is connected in series with the unknown capacitance Cx. This in effect means that much higher capacitance values may be measured. For instance, with a Cx of 1,000pF in series with 300pF the actual value tuning L1 is approximately 230pF.

The reason for switching in C6 on Range 4 is that the rise in meter current tends to be less sharp for L1 tuning capacitances above 400pF. The presence of C6 enables values of Cx much higher than 400pF to be measured whilst still limiting the tuning capacitance to slightly less than 300pF.

Range 1 is calibrated from 0.5 to 11pF, Range 2 from 10 to 200pF, Range 3 from 50 to 400pF, and Range 4 from 100 to 4,000pF. Range 4 does not give precise results and is included to give a general indication of capacitance rather than for close measurement. Capacitances from 100 to 400pF are best checked on Range 3.

The 5kΩ variable resistor, R4, is included in order that the current in the meter can be reduced should oscillations increase to such an extent that the pointer of the meter reaches full-scale deflection.

Before proceeding to constructional matters, it may be mentioned that the coil employed for L2 is a standard medium-wave oscillator coil intended for use in transistor radios. The coil in the L1 position is an air-cored aerial coupling coil which would normally cover 250 to 750 metres when tuned by a 500pF capacitor.

## CONSTRUCTION

The author's instrument is made up on an aluminium chassis measuring 10in. long by 7in. wide by 2½in. deep. What would normally be the top of the chassis is used here as the front panel, the components being fitted to the underside. The dimensions are not critical, but a smaller chassis would result in too cramped a scale. A larger chassis would be an advantage, giving a greater arc of scale and thus greater spacing between calibration

markings. It was thought advisable to use an external meter such as an Avo Model 7, which has a 0–2mA range, but if desired an internal panel-mounting meter could be employed instead. In this case a larger chassis would be required to accommodate the meter. It may be difficult to obtain a 0–2mA panel-mounting meter, whereupon a 0–1mA movement, shunted by a resistor equal to its internal resistance to halve its sensitivity, can be used instead.

Any 9 volt battery can be employed, and a PP3 is adequate since the normal running current is only about 1mA.

Fig. 3 shows the disposition of the components mounted on the front panel (i.e. the top of the chassis), and it is initially necessary to drill holes for the two sockets, the two grommets and for S1, S2 and VR1. The dimensions shown here, and those which follow, apply to the chassis used for the prototype. They may be modified as necessary to suit alternative sizes of chassis.

The 2-gang capacitor is mounted with three 4BA countersunk screws equi-spaced on a circle of ½in. radius. Avoid using screws that are too long, as these will foul the vanes of the capacitor. The spindle of the 2-gang capacitor is on the vertical centre-line of the panel, and the other controls may be spaced away from it as shown. The two terminals at the left and the two grommets at the right should balance each other dimensionally. Their exact positioning is not important but the two sockets and two grommets are about ¾in. from each other. The two sockets take connections from the external meter, whilst the two grommets allow the passage of test leads terminated in crocodile clips for connection to the capacitor being measured. Two 6BA clearance holes are also required, positioned as shown. These should be well countersunk on the front surface of the panel.

Most of the smaller components on the inside of the chassis are mounted on a strip of Paxolin measuring 9¾in. long by 2in. wide by 1/16in. thick. See Fig 4. A second Paxolin strip of the same dimensions is also required, this being used to insulate the wiring and

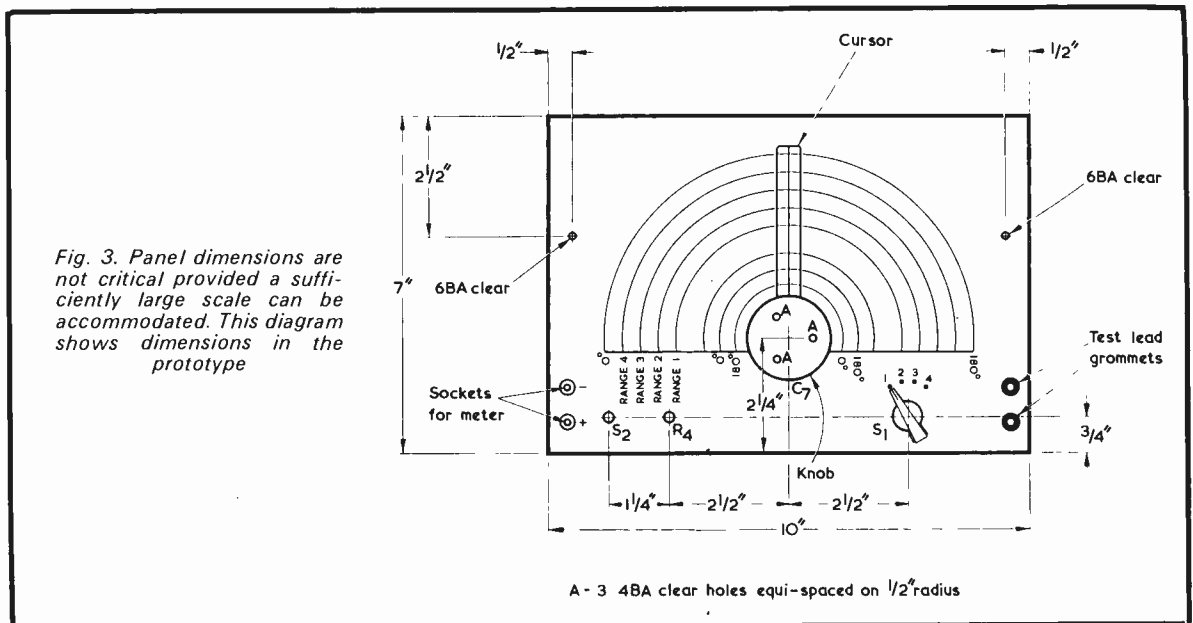

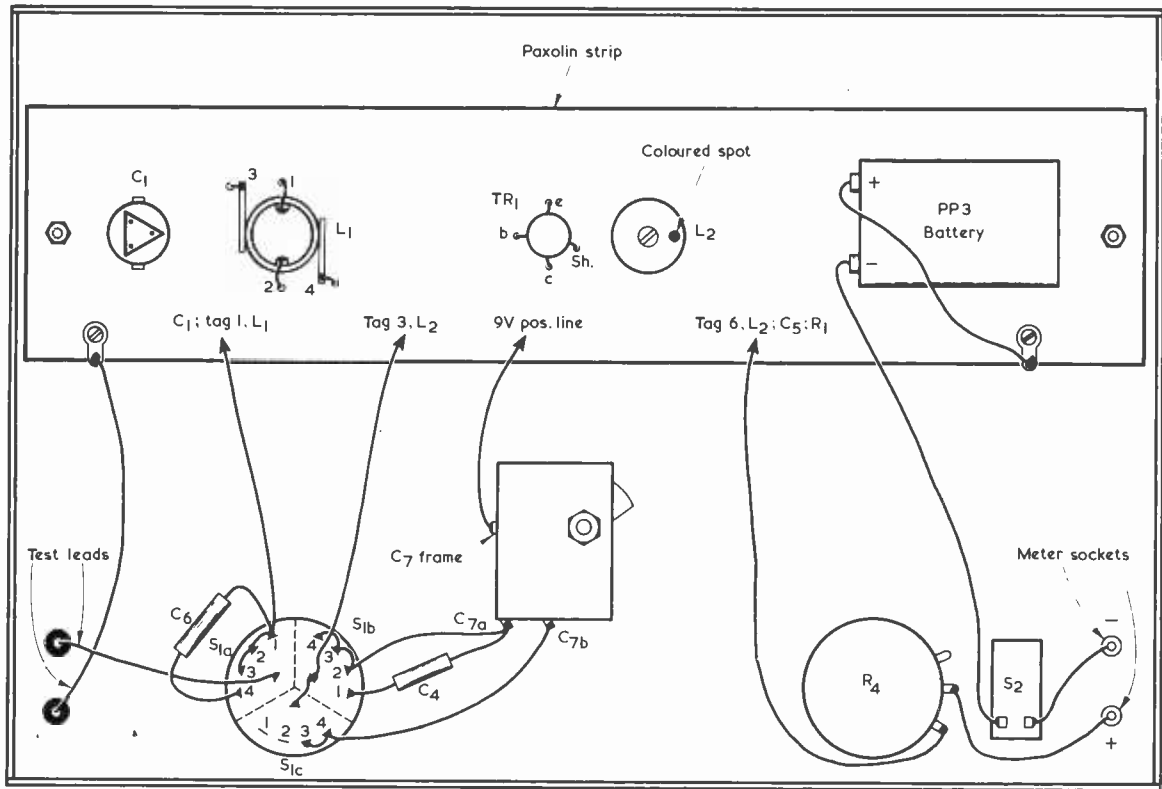

Fig. 4. Wiring behind the front panel

components on the first strip from the back of the front panel. Each Paxolin strip requires a 6BA clearance hole at its ends to correspond with the two 6BA clearance holes in the front panel. Two 1in. 6BA screws are passed through the holes in the chassis and the second of the Paxolin strips is bolted directly against the back of the front panel. Another nut is threaded on each screw but is not tightened up. It will later be set to a position which enables the first strip to be adequately spaced from the second after it has been wired up. Two further 6BA nuts on the outside will then finally hold the Paxolin strip with the components in position.

As may be seen from Fig. 4, C1, L1 and L2 are mounted direct to the Paxolin strip. Four holes are drilled around L1 to allow wires from its tags to pass through to the underside of the Paxolin. Four holes are also drilled to take the leads from TR1. R1, R2, R3, C2, C3 and C5 are positioned below the Paxolin strip, being wired up as shown in Fig. 5. Where it is desired to anchor a lead, small solder tags may be judiciously fitted, as required. It is also necessary to provide a mounting for the PP3 battery, which appears on the same side of the Paxolin strip as the coils and transistor. Leads from the Paxolin strip assembly pass down to the components mounted directly to the front panel, as shown in Fig. 4. These leads should initially be left longer than is required, so that they may be cut to the requisite length after the Paxolin strip with the components has been finally mounted. A 6BA solder tag at the C1 end provides an anchorage for one

of the test leads. A second 6BA solder tag at the other end of the strip gives an anchorage for the positive battery lead.

After all the components are mounted and wired up, the scale and cursor assembly are fitted to the front panel. The scale is a sheet of white cardboard or stiff

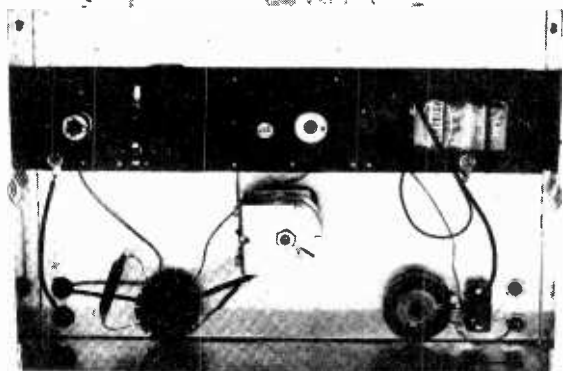

A view inside the capacitance meter. This is assembled on a standard aluminium chassis

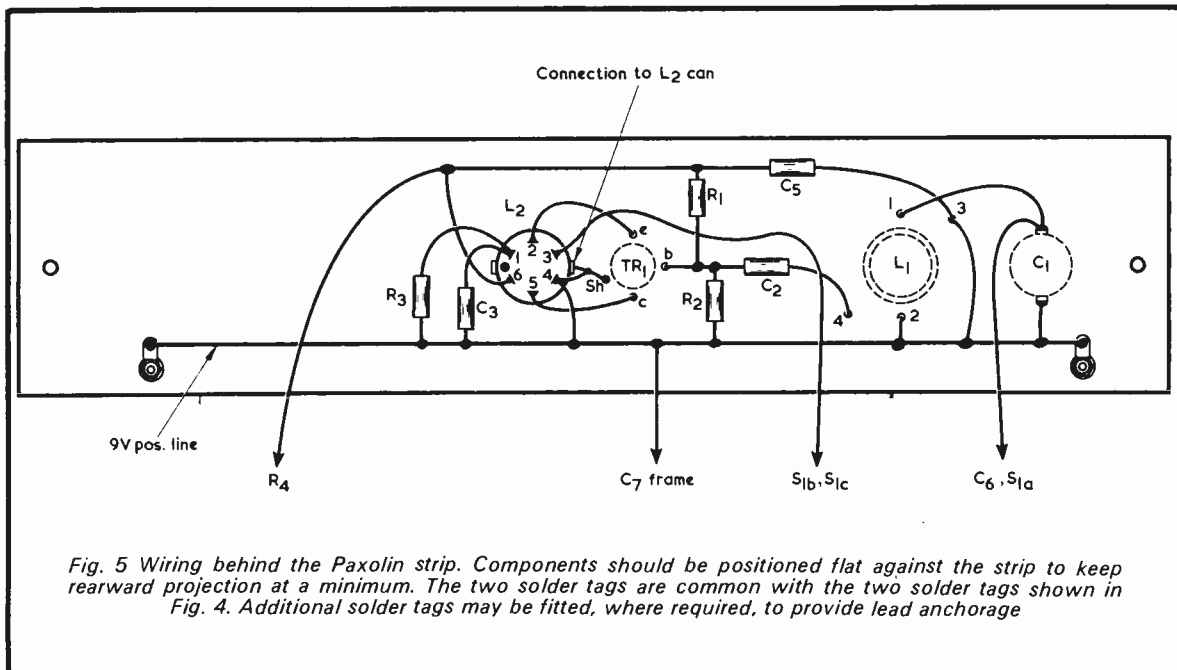

white paper measuring 10in. by 4½in. and is fixed to the chassis with an adhesive. The top edge is ½in. from the adjacent chassis edge. Take up the half circle protractor and drill a hole at the point marking the centre of the circle, first with a small centre drill then finally with a ¼in. drill to provide a hole capable of taking the ¼in. spindle of the 2-gang capacitor. The protractor is fixed with adhesive to the scale and squared up with its bottom edge.

Next, select a strip of Perspex 5½in. long by about ¾in. wide and about 1/16in thick. This will function as the cursor. Scribe a line down the centre of its length and fill this in with black heel-ball or indian ink. Drill a ¼in. hole, centred on the scribed line and 4½in. from one end. Select a 2in. diameter control knob having a reasonable amount of flat surface on its underside and insert it in a short length of ½in. rod, tightening up the grub screw. Feed the cursor on to this short spindle with its scribed line away from the front of the knob and secure the two together with an adhesive such as Evo-Stik. When the adhesive has set, the spindle is removed. A series of five 1/16in holes, each centred on the scribed line, are next drilled down the length of the cursor in the following manner. The end hole is ½in. from the end of the cursor remote from the knob and the four further holes are spaced away from this at ½in. intervals. When the cursor has been completed, the cursor and knob assembly are fitted to the spindle of the 2-gang capacitor.

The holes in the cursor are used to scribe the arcs for each range. The outside arc, of about 4½in. radius, is used to make an enlarged protractor from the small one at the centre for ease of calibration. Calibration marks can be made by making dots through the outside hole with a propelling pencil, the lead of which has been extended to reach through to the scale.

The next arc, moving towards the centre is for Range 4, which covers 100 to 4,000pF. This is followed by Range 3, 50 to 400pF; Range 2, 10 to 200 pF; and Range 1, 0.5 to 11pF.

## CALIBRATION

The best method of calibrating the instrument consists of taking readings with close-tolerance capacitors of known values and of then drawing graphs accordingly. The reference calibration on the instrument scale is the outside protractor scale. As is to be expected, the more capacitors that are available, the better the curves. The capacitors should be ± 1% or better. Due to the overlap between the ranges some capacitors can be used for calibrating more than one range. Suitable parallel and series combinations of calibration capacitors will help in providing a large quantity of calibration points. The graph paper used should be of the type having 10 squares to the inch.

When the graphs are completed, calibration marks can be transferred from the curves to the range arcs by marking the latter with a propelling pencil lead through the appropriate hole in the cursor. With this approach, capacitor C1 should be left at about four-fifths of maximum value throughout the operation.

If the reader does not have access to a complete set of close-tolerance capacitors an alternative method consists of making up a calibration from the table which accompanies this article, and which shows the measurement points obtained with the author's instrument. Any intermediate points required may be obtained by drawing graphs, as with the first method. This second method will not be so accurate but may still give fairly good results. It is essential that C4 and C6 have exactly the values specified, whereupon the results given by use of the table are mainly dependent upon the accuracy of capacitance in the 2-gang capacitor as it is rotated. Discrepancies between coils may also affect the accuracy. When using this method it will still be necessary to check results with close tolerance capacitors; say, three for each range, one having a value near the maximum end of the range, one near the centre and one near the bottom end. These will then enable the instrument to be brought



### Calibration points obtained with the prototype

Range 1		Range 2		Range 3		Range 4	
Cap. (pF)	Degrees	Cap. (pF)	Degrees	Cap. (pF)	Degrees	Cap. (pF)	Degrees
0.5	49	10	36	50	39	100	46½
1	51	20	43	100	56½	200	61½
2	54½	30	51	150	73	300	71½
3	59	40	58	200	90	400	78¼
4	63¾	50	64½	250	107	500	83½
5	68	60	71½	300	124	600	88
6	74	70	78	350	141½	700	91
7	80	80	84½	400	158	800	93½
8	87	90	92			900	96
9	94	100	99			1,000	98
10	102	110	106			1,500	103½
11	117½	120	113			2,000	108
		130	120			2,500	109¾
		140	127			3,000	111½
		150	134			3,500	112½
		160	141			4,000	113½
		170	148				
		180	155				
		190	162				
		200	166				

as close to the calibration as possible by means of adjustment of the core in L2 and, at the low capacitance end of Range 1, adjustment of C1.

As is to be expected, the positions of the test leads relative to each other will have an effect on the reading obtained when measuring very low values of capacitance and it is advisable to carry out both the calibration and measurement of low values of capacitance with the leads well spaced. The provision of a zero capacitance mark on the Range 1 scale will assist in indicating whether the test leads, due to their mutual positioning, are introducing excessive capacitance. To overcome

this difficulty, some constructors may prefer to fit two insulated test terminals at the front panel at the points where the test lead grommets are situated in the author's design. Very low value capacitors may then be connected directly to these terminals. For measuring larger values, two test leads with crocodile clips may be connected to the terminals, their clips connecting to the capacitor being checked.

The author's instrument was fitted with a back made of insulating material. If a metal back plate is employed, calibration must be carried out with this plate in position.

## CAN ANYONE HELP?

*Requests for information are inserted in this feature free of charge, subject to space being available. Users of this service undertake to acknowledge all letters, etc., received and to reimburse all reasonable expenses incurred by correspondents. Circuits, manuals, service sheets, etc., lent by readers must be returned in good condition within a reasonable period of time.*

**Replacement 3-button 'Long', 'Medium' and 'Off' wave-change switch for Ferguson 7-transistor portable Model No. 453**—M. W. Peters, 19 Elmside, Onslow Village, Guildford, Surrey — Unable to obtain the replacement through normal channels.

**Transmitter Telesonic, YA 4911, 1945, M.E.C.**—P. Jenkins, 30 Gainsborough Road, North Finchley, London, N12 8AG — Manual or any other information loan or purchase.

**Short Wave Magazine, August 1966 issue.**—Dr. A. C. Gee, East Keal, Romany Road, Oulton Broad, Suffolk. — To purchase.

**Radio Constructor, September 1967 issue.**—R. Williams, 38 Wheatlands Drive, Bradford, Yorkshire, BD9 5JJ. — To purchase or borrow.

**V.T.V.M. A.Min. CT54, Philips Tape Recorder EL 3527. B.S.R. Tape Recorder "Majestic".**—J Moore, 7 Newcastle Road, Liverpool 15. — Any information, circuit diagram or manual.

**Marconi Sig. Gen. TF 144 G, Instruction Manual EB144G. Dumont Oscillograph, Type 241, Circuit.**—D. W. Tilleard, 81 Torre Hill, Leeds, LS9 6NJ — Loan or purchase.

**RCA, BC-348-O Receiver.**—J. O'Donoghue, Ballinaboula, Dingle, Co. Kerry, Ireland — Manual or any other information.

**R.1155 Receiver.**—M. Zagorski, 7 Ferry Row, Invergordon, Ross-Shire — Circuit diagram insufficient information, component values and layout required.

**Advance Signal Generator Type B4A.**—J. Warren, 64 Siddens Road, London, S.E.23 — Circuit or Manual, loan or purchase.

**Radio Constructor, April 1964 issue. Everyday Electronics, November 1971 issue.**—T. C. Rickard, 10 Berridge Road, Sheerness, Kent — To purchase or borrow.

**S.T.C. Crystal Unit Type 4434/E.**—K. G. Lunn, 6 Leacote Drive, Tettenhall, Wolverhampton, Staffs. — Wanted to purchase.

## THE MULTI-MINI TWIN VICE



A most useful accessory is the Multi-Mini Twin Vice, made by the Coventry Movement Co. Ltd.

As can be seen from the photograph below, this instrument enables a number of items to be soldered at the same time.

It has numerous uses around the workshop: it can be used to aid the assembly of small mechanisms or components: will hold most objects whilst they are being filed, machined or worked on: brazing, soldering or gluing small objects is made infinitely easier.

The two vice heads can be independently adjusted and will grip round, flat, square or hexagonal section parts. Rubber jaws are provided and can be attached to the metal jaws if required. All the adjustments are easy to make and a small wrench rod is provided to help tighten up the locking nuts on the stand. The grip is positive and reliable and the design of the whole instrument is such that there are an infinite number of positions of the vices in relation to one another to cover practically any 'holding' situation which may be required.

The vice can be obtained from Home Radio (Components) Ltd., 234-240 London Road, Mitcham, Surrey, CR4 3HD.

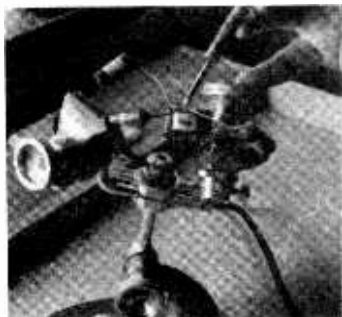

## FISHING IN THE DARK?

A small television camera which can detect fish schools in the dark from an aircraft is being tested in the United States. It is being flown at altitudes of up to 6,000 feet by the U.S. National Marine Fisheries Service in a new approach to ocean fish detection and assessment.

If the tests are successful, the camera could be produced for use by the fishing industry. An aircraft equipped with it may be able to guide a fleet of fishing boats to the most productive fishing grounds.

The camera detects the dim glow of plankton when it is disturbed by fish feeding on it. The plankton glow outlines the entire school of fish and from that outline scientists can determine the species of the school. In recent tests over U.S. coastal waters near California and the Gulf of Mexico, concentrations of anchovies, menhaden, mullet and saury were detected.

The technique could help scientists study the distribution and abundance of many types of marine resources and also the behaviour patterns of various types of fish.

The camera can gather images with little light because of a light intensifying tube that strengthens faint glows in an otherwise dark scene. It weighs only 10.5 pounds and requires only 12 watts of power, supplied by a 12-volt battery. Both the experimental camera and tube were built by the RCA Industrial Tube Division at Lancaster, Pennsylvania.

The camera is easy to operate and its images are displayed on a small television monitoring screen. Simultaneously, the images are recorded on video tape for later playback.

## PENNANTS TO BE WON IN BBC WORLD RADIO CLUB QUIZ

World Radio Club, the BBC World Service programme for radio enthusiasts and DXers, has 11,000 members.

The Club is running a monthly quiz for members with handsome pink and purple pennants as prizes.

World Radio Club is broadcast in the BBC World Service on Thursdays at 1245 GMT, Fridays at 2345 and Sundays at 0815 GMT. Membership is free and all listeners have to do to join is write to World Radio Club, BBC, Bush House, London.

DX News is a regular item each week, and with all the resources of the BBC at the disposal of the World Radio Club, it really is newsworthy. Members who write for help with practical listening problems will be answered by post or over the air.

## AMSAT DISAPPOINTMENT OVER SKYLARC

AMSAT's proposal to provide a 10 metre SSB amateur radio station aboard the SKYLAB project, being planned by NASA for launch in 1973, has not received approval by the NASA Administration.

Dale D. Myers, Associate Administrator for Manned Space Flight, in a letter to AMSAT President, Perry Klein, K3JTE, says that, very serious consideration was given to this proposal "to provide a radio amateur communications package for leisure time use by the crew of Skylab", but, "It is with real regret that I must inform you, that in spite of the broad appeal of your concept and a generally favourable disposition to encourage AMSAT activities, NASA has concluded that we cannot add it to SKYLAB at this stage of the program".

One of the astronauts who has been selected for service aboard SKYLAB is a radio amateur, Dr. Owen Garriott, W5LFL.

RADIO & ELECTRONICS CONSTRUCTOR

# COMMENT

## RHYTHM BOXES IN ELECTRONIC ORGANS

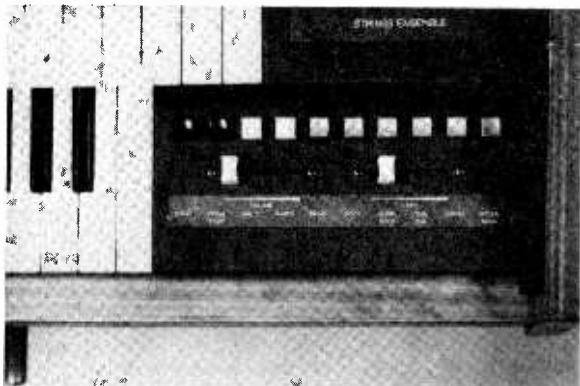

SGS/ATES is now producing a custom designed integrated circuit, built according to their well-established MOS nitride "PLANOX" technology, for a brand new application: rhythm boxes in electronic organs.

This custom design, is the result of successful co-operation at two levels.

The research department of Eminent, makers of electronic organs in Holland, and a professional drummer looked after the musical part. For the electronic part the Eminent engineers worked closely with the SGS MOS design team in Italy.

The resulting rhythm boxes are sold under the trade name RITHMIX either as built-in optional accessories or as independent units.

This MOS rhythm generator consists of eight different pattern configurations selectable externally by simple pushbuttons. Each pattern can trigger the reproduction of the sounds of up to twelve different percussion instruments, such as drums, cymbals, etc.

The sounds which they generate form an accompaniment for the organist, providing him with such rhythms as march, swing, rock, slow rock, cha-cha-cha, samba, bossa nova, or with a combination of these.

Although the idea of rhythm accompaniment is not new, the novelty of the current product lies in the use of the most advanced semiconductor technology, which, while it offers improved and more complete musical simulations, also reduces costs and the overall size of the unit.

A counter, integrated in the device, driven by an external adjustable oscillator, can sequentially scan the selected pattern to generate the various rhythms.

In the range of rhythm boxes available from Eminent and designed around the SGS MOS custom IC, there is in addition to the simple foot-operated start-stop types, a version presenting an even more far-reaching innovation whereby the speed of the rhythm automatically follows the speed of the player.

AUGUST 1972

## IN BRIEF

● Mullard Ltd. and the BBC are to stage a 2-month exhibition at Mullard House in connection with the BBC's 50th Anniversary this year.

Entitled *BBC 50 - The Technical Story* the exhibition will run from 2nd November to 21st December.

● Two well known radio clubs are holding mobile rallies on Sunday 13th August.

Derby Amateur Radio Society's mobile rally will be at Rykneld School, Bedford Street, Derby - details T. Darn, G3FGY, Sandham Lodge, Sandham Lane, Ripley, Derby.

Torbay Amateur Radio Society will be holding their rally at the Newton Abbot Rugby Ground, Newton Abbot, Devon - details from D. Webber, G3LHJ, 14a Keyberry Park, Newton Abbot, Devon.

● Electronic component distributors SDS-WEL Components Ltd., have simplified their title to SDS Components Ltd.

● The Electron Tube Division of EMI Electronics Ltd., has produced a new wall chart giving spectral sensitivity curves for photo-emissive cathodes.

Free copies of this 23in. x 16in. chart are available from the Sales Manager, Electron Tube Division, EMI Electronics Ltd., 243 Blyth Road, Hayes, Middlesex.

● Characteristics of 136 microwave tubes are presented in a new catalogue published by the M-O Valve Co. Ltd.

Copies of "Microwave Tubes and Devices" are available on application to The M-O Valve Co. Ltd., Brook Green Works, London, W.6.

● Ulster Television is to introduce live colour TV programming in the autumn, and has ordered Marconi Mark VIII automatic colour TV cameras to inaugurate this new service from their Belfast studios.

● The Sound Broadcasting Act, which came into force on 12th July, extends the functions of the former Independent Television Authority (now renamed the Independent Broadcasting Authority) to include the provision of a service of local sound broadcasting.

● The very successful junk sale organised last year by the Star Short Wave Club, Leeds, on behalf of the Radio Amateur Invald Bedfast Club is to be repeated again in September.

T. Leeman, G8BUU, of 115 Asket Drive, Seacroft, Leeds, LS14 1HX, will be pleased to hear from any readers who would like to donate surplus electronic equipment to a good cause - collection service operates. £160 was raised last time the target this time is £250.



*I don't know what the younger generation is coming to!*

# THE 'NIGHTRIDER'

by G. A. FRENCH

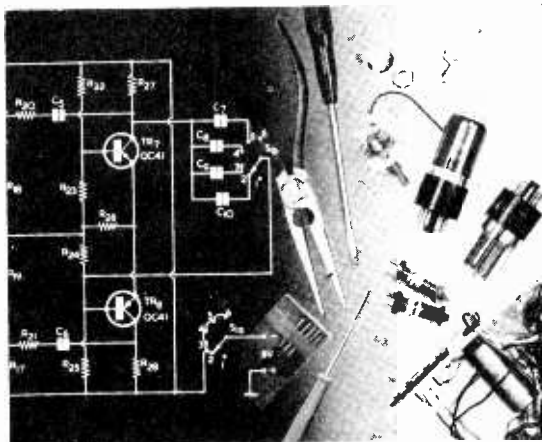

THERE ARE PROBABLY FEW OF US who, after having set the bedside transistor radio to a suitable programme at the end of a tiring day, have not then at some time fallen fast asleep, to wake up next morning to the sound of the radio which has been left switched on all night! The device which forms the subject of this 'Suggested Circuit' article is intended to overcome this problem, and it automatically turns off the radio after a pre-set time. It also offers the advantage that there is no need to bother to switch off the receiver before settling down to sleep, since the device will itself ensure that the set is turned off automatically.

The circuit may be employed with any transistor radio incorporating a single battery and having the usual large-value electrolytic capacitor across its supply lines, and it is capable of being set up to give turn-off delays up to an hour or more. A slight disadvantage with the circuit is that it causes a drop of 0.65 volt to be given in the receiver supply voltage, with the result that it may cause a receiver with a nearly fully discharged battery to cease functioning when the device is switched in. It has to be emphasised also that the circuit is experimental in one respect since it relies on one of the components having a performance in excess of manufacturers' normal specifications. It is, however, a simple matter to check whether the component concerned is suitable for the present application before the circuit is made up.

Before proceeding to technical details it may be mentioned that the title given to the device is, of course, adapted from the well-known B.B.C. sound radio programme 'Nightride'.

## THE CIRCUIT

The circuit of the switching device is shown in Fig. 1. In this diagram the lead from the negative terminal of the receiver battery is broken and two connections from the switching device inserted. When, in this device, switch S1(a)(b) is in position 1, S1(a) short-circuits the leads to the receiver whereupon the latter may be switched on and operated in the normal manner.

At the same time, S1(b) disconnects battery B1 from the device components

On setting S1 to position 2 the short-circuit is taken from the leads to the receiver and battery B1 connects to the device circuitry. To start the unit operating push-button S2 is pressed; this charges capacitor C1 and causes its positive plate to achieve the same potential as the positive terminal of the battery. Transistor TR3 functions as an emitter follower and a voltage about

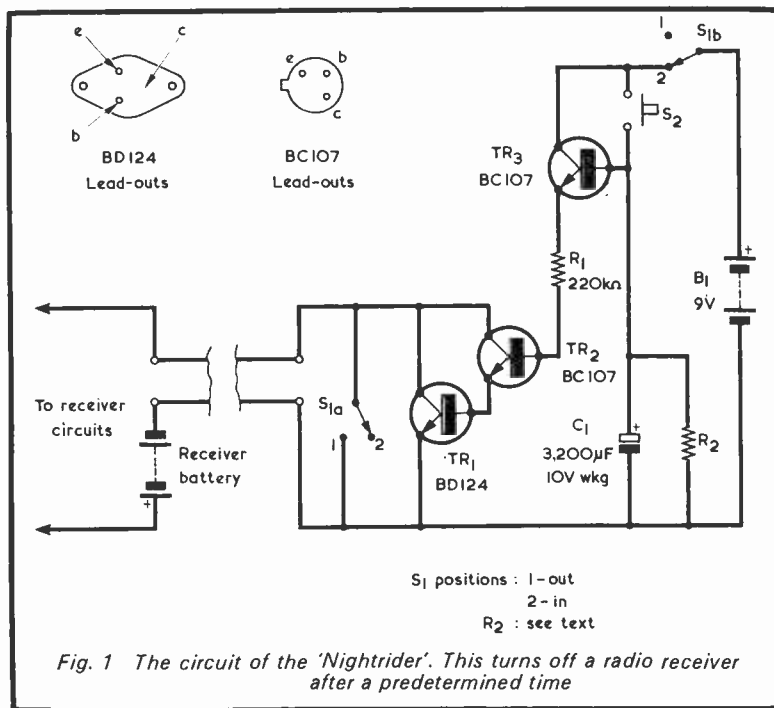

0.6 volt lower than that on the positive plate of C1 appears at its emitter. This voltage causes a current to flow through R1 into the base of TR2, which is the first transistor of a Darlington pair. Both this and the second transistor in the Darlington pair, TR1, become conductive, whereupon the supply circuit for the receiver is completed and the latter commences to operate. Under these conditions there is a drop of 0.65 volt across the emitter and collector of TR1.

As soon as push-button S2 is released, C1 commences to discharge via R2 and its own leakage resistance whereupon the voltage on its positive plate and that on the emitter of TR3 start to fall. Because of its high value, the discharge in C1 is very slow, and what is relatively a considerable time elapses before the voltage on TR3 emitter falls to a level at which insufficient current flows via R1 to maintain TR2 and TR1 fully conductive. The voltage across TR1 increases from its 0.65 volt value with the result that, after a short period, the receiver ceases to operate. C1 still continues to discharge and the final situation consists of the total receiver battery voltage appearing across TR1, with the result that the only current flowing from the receiver battery is given by leakage current in TR1 and TR2. Since both of these transistors are silicon types, this leakage current will normally be very low. Similarly, the only current drawn from B1 is given by leakage current in TR3, and this will similarly be very low.

The receiver can be brought back into operation either by pressing S2 again, or by setting S1(a)(b) to position 1.

To sum up the circuit operation just described, the 'Nightrider' unit is employed in the following manner. Initially, switch S1(a)(b) is in position 1. The receiver is turned on by means of its own on-off switch and is tuned in to the transmission required. S1(a)(b) is then set to position 2 and push-button S2 is pressed. The receiver will then continue to play until capacitor C1 has discharged sufficiently to cause it to turn off.

A feature of the circuit to which especial attention has been paid in design is concerned with keeping current consumption to a low level. The collector and base current of TR1 and the collector current of TR2 are all obtained 'free', insofar that they are provided by the current which is needed in any case to power the receiver. These currents do not impose any extra drain on either the receiver battery or on battery B1. At the same time, the current drawn by TR3 from B1 is extremely low. In the prototype circuit this current was of the order of 32µA immediately after push-button S2 was pressed, falling to around 1µA - at which level TR1 and TR2 commenced to cease being fully conductive - then continuing on to virtually zero level. A short while after

TR1 and TR2 had become fully non-conductive it was found that neither the current drawn from the receiver battery nor that drawn from B1 produced any detectable deflection in a meter switched to read 50µA f.s.d.

A circuit offering much the same facilities could be given by omitting TR3 and R2 and returning R1, with a suitably altered value, to the positive plate of C1. C1 would then discharge directly into the base of TR2, providing the low current needed to keep this transistor and TR2 fully conductive. It was found, however, that the inclusion of TR3 resulted in an improved performance with a more rapid turn-off at the end of the timing period; and the author felt that this justified the use of this transistor together with R2, even though TR3, in functioning as an emitter follower, passes a very low current only.

### COMPONENTS

Of the transistors, TR2 and TR3 are standard n.p.n. silicon transistors type BC107. TR1 is a silicon power transistor type BD124. A power transistor is employed here simply because it is capable of withstanding a relatively heavy collector current, as would be given if, whilst S1(a)(b) were in position 2, the receiver happened to be switched off and on again by its own on-off switch. A momentary heavy current would then be given as the receiver battery charged up the large-value electrolytic capacitor connected across the receiver supply lines. The power dissipation in TR1 is low and it does not need to be mounted on a heat sink.

The running current drawn from B1 is exceptionally low and any small 9-volt battery may be employed here. Its active life should not be much shorter than its shelf life.

The most important component is the electrolytic capacitor C1, and this is the component which puts the circuit in the experimental category since it is required to have a leakage current considerably lower than the maximum specified by the manufacturer. It has been the writer's experience that modern high-value low voltage electrolytic capacitors, including in particular the Mullard types, have leakage currents that may be described as being fantastically low. The capacitor employed in the prototype was a Mullard 3,200µF 10 volt component type C431 (Home Radio Cat. No. 2CG49) but it is possible that almost any modern electrolytic capacitor with a working voltage in excess of 9 volts and a value of 2,500µF or more could be employed instead. Since the low leakage current is not covered by manufacturer's specification, its existence in any particular capacitor cannot be guaranteed, and constructors must accept this fact if they intend to purchase the component new.

## BUY THIS BEST SELLER

### T.V. FAULT FINDING 405/625 LINES

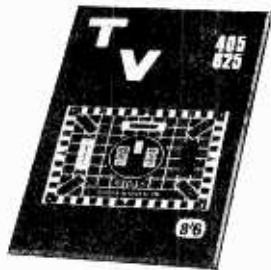

### REVISED & ENLARGED

Edited by J. R. Davies

124 pages Only 50p

Over 100 illustrations, including 60 photographs of a television screen after the appropriate faults have been deliberately introduced.

Comprehensive Fault Finding Guide cross-referenced to methods of fault rectification described at greater length in the test.

Price 50p from your  
Bookseller

or post this Coupon together  
with remittance for 50p  
(to include postage) to

DATA PUBLICATIONS LTD.  
57 Malda Vale, London, W.9

Please send me the 4th revised edition of TV Fault Finding, Data Book No. 5

I enclose cheque/crossed postal order for.....

NAME .....

ADDRESS .....

.....

R.C. Block Letters Please

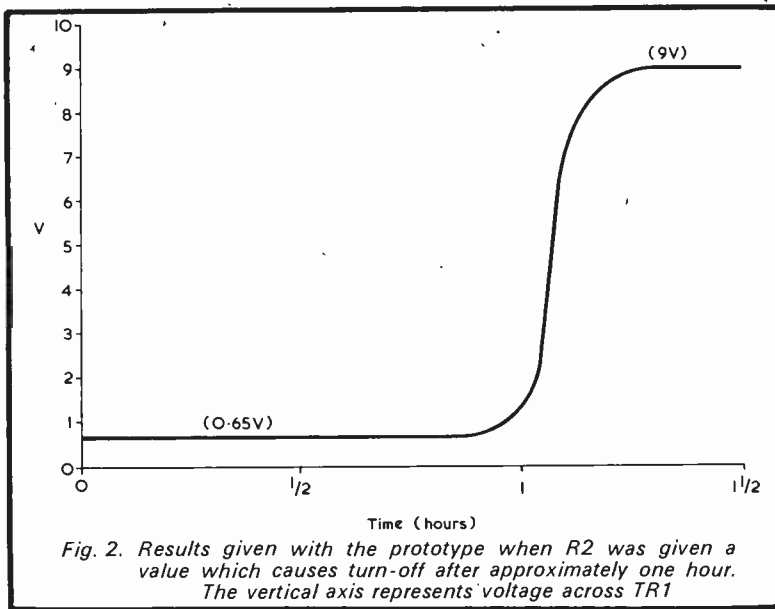

The usefulness of any capacitor for the present circuit should be ascertained before obtaining the other components, and this point may be checked in the following manner. Charge up the capacitor it is intended to use by connecting it to a 9-volt battery. If the capacitor has been in store for a long period it should be connected to the battery for a minute or so. Then disconnect the battery and, after an hour, check the voltage across the capacitor with a high resistance voltmeter. When checked in this manner the capacitor used by the author gave a reading of 7.5 volts after the hour had elapsed. If the capacitor to be employed in the circuit offers similar results then it should be satisfactory.

The value required in R2 has to be found experimentally, since it depends upon the length of the timing period required, the actual capacitance within tolerance and leakage current of capacitor C1, and the gains of TR1 and TR2. With the prototype it was found that a period of approximately one hour was given by using a 430kΩ resistor in the R2 position. Fig. 2 gives a graph which shows circuit performance when R2 had this value, and was obtained by connecting a voltmeter across the collector and emitter of TR1 whilst the circuit was coupled to a transistor radio drawing an average current of about 12mA from a 9-volt battery. It will be seen that, after S2 was pressed and released (at the zero hours point) the voltage across TR1

remained constant at about 0.65 volt until some 52 minutes had elapsed. It then started to rise relatively rapidly, reaching a value of 7.5 volts at about 1 hour 6 minutes, after which the rate of increase in voltage reduced. Virtually the full 9 volts appeared across TR1 after 1 hour 15 minutes, and at 1 hour 25 minutes no detectable current flowed from the receiver battery.

Since the finding of the value required in R2 can be rather a tedious process it will be helpful to initially connect, say, a 10kΩ resistor in this position. The length of the resultant timing period may next be measured with the aid of a watch having a second hand. The final value required in R2 can then be found, very approximately, by applying the requisite multiplying factor. As an example of this procedure, it was found with the prototype that the value of 10kΩ in R2 gave a period of 85 seconds. To obtain a timing period of 1 hour (and ignoring leakage current in C1) the value required in R2 would then need to be 10kΩ multiplied by 3,600 (60×60 seconds) and divided by 85, or 424kΩ. A 430kΩ resistor was tried and was found to give the result given in Fig. 2.

## RECEIVER CONNECTIONS

As the controlled receiver will have its own high-value bypass electrolytic capacitor across its supply lines it is in order to couple the 'Nightrider' device to it by means of a short length of twin flex. The connections at the receiver could consist of a simple home-made battery plug adaptor which can be temporarily fitted when the device is to be used. A neater approach would consist of fitting a closed-circuit jack at the receiver, this being in series with the negative battery lead. This jack would then keep the receiver battery circuit completed when no plug was inserted. If a jack plug coupled to the timing device were inserted, the device would then be automatically connected in series with the receiver battery.

It is important that the connections between the device and the receiver have the polarity shown in Fig. 1. If the connections are reversed there is a possibility that the base-emitter voltage rating of TR1 may be exceeded by the reverse voltage from the receiver battery.

It will be evident from Fig. 1 that the battery of the receiver could be employed, instead of B1, to charge capacitor C1 and power transistor TR3. This course can be adopted if it is decided to instal the timing components inside the receiver cabinet, thereby making the 'Nightrider' facility an integral part of receiver operation. The circuit required is shown in Fig. 3. This is virtually the same as Fig. 1, with the exception that only one battery is employed. This battery may be 6, 9 or 12 volts, capacitor C1 being given a working voltage to suit.

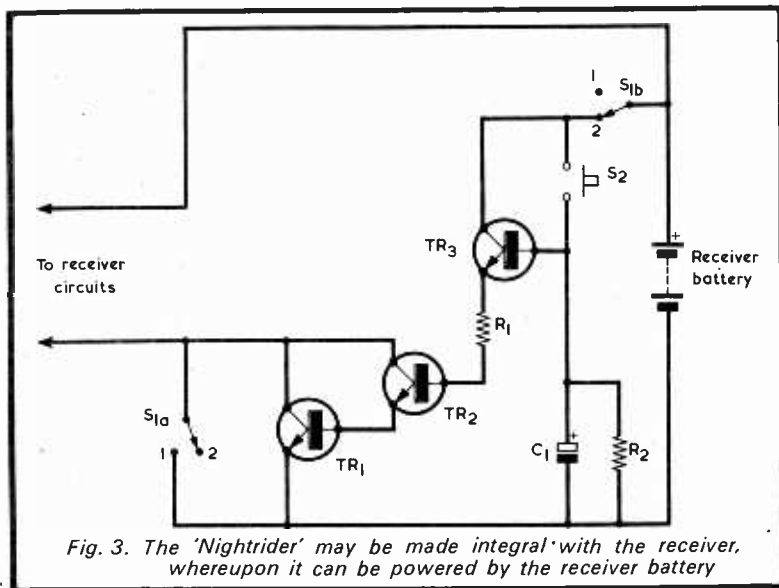



# NOTES ON SEMICONDUCTORS

## Further Notes—9 98-4 ? by Peter Williams

The fact that the voltage across a diode varies with temperature is put to good use in the electronic thermometer described here.

IT IS FREQUENTLY USEFUL TO STAND A PIECE OF information on its head and see what it looks like upside-down. We have seen that a forward biased diode or a transistor  $V_{be}$  both have a p.d. that changes with temperature. In transistor circuit design we expend much effort in trying to overcome this effect, so that circuit behaviour is independent of temperature. Now let us try to turn this effect into an advantage.

### TEMPERATURE/VOLTAGE CHANGE

If the voltage across a diode is measured at one temperature and with a given current through it, then when the temperature increases the voltage will fall. The change in voltage is a direct measure of the change in temperature. By balancing out this voltage against a constant reference voltage the meter zero can be made to coincide with any particular temperature, though  $0^{\circ}\text{C}$  would be a particularly convenient one. If the meter then has its sensitivity adjusted so that at  $100^{\circ}\text{C}$  it reads full scale the intervening readings should be accurate to within a degree or so, since the temperature coefficient of voltage is reasonably constant over this range.

However a number of problems remain. The reference voltage has to be variable to suit different diodes, but stable over the temperature range. Secondly the change in voltage is quite small – about 200mV for the full temperature range. The latter problem has fortunately already been solved in an earlier note. The amplified diode has all the characteristics of a whole chain of diodes, in which both the voltage and its variation with temperature are stepped up pro rata.\*

A possible circuit is shown in the diagram. The currents in the transistor and in its associated potential divider are each about 1mA and with a  $V_{be}$  of about 0.6V, the bridge will balance at about a little over 6V. The transistor should be at the end of a probe which can be held against a flat surface at  $0^{\circ}\text{C}$ , e.g. a metal can containing a water/ice mixture. The surfaces both of transistor and container should be flat. With dome-headed epoxy/plastic transistors the dome can be filed flat with care and provided the experimenter is willing to take the risk of damaging the transistor.

If the transistor is then held against a similar surface of a vessel containing water at boiling point then  $R_6$  can be adjusted for meter full-scale. If now the probe is placed under the armpit as a check, the temperature

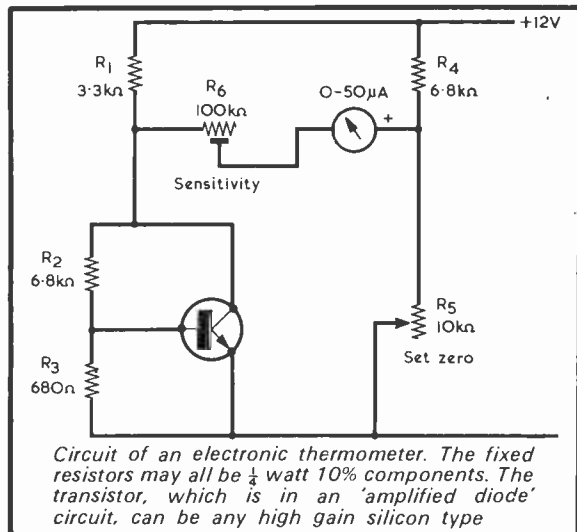

should not differ greatly from  $37^{\circ}\text{C}$ . It is possible to use this as a 'zero-check' later in that if the supply voltage cannot be properly stabilized, it is the zero that shifts rather than the sensitivity. Thus the sensitivity control should *not* be reset once calibrated, while the set-zero control may be adjusted to give the correct reading at any known temperature. Then all other readings should be reasonably correct. For high accuracy there can be no substitute for a stable supply and proper calibration.

The sensitivity of the instrument as just described is about  $-20\text{mV}$  for each rise in temperature of one degree, i.e. the full scale meter sensitivity required is about 2V while the meter current should preferably be  $50\mu\text{A}$ . If meters with higher current requirements are used, the value of the resistors will need to be scaled down accordingly.

The procedure just described is employed when the device is to be used for surface temperature measurement, and it can be useful in checking the surface temperature of power transistors (not small ones or in the process it may provide significant cooling and give an optimistic reading). There are many cases where we would like to observe small changes in temperature. This is difficult with a circuit such as this, with its dependence on the stability of a supply voltage. The next note shows a different approach that gets around this problem.

\* See 'Notes on Semiconductors – 5; The Amplified Diode' published in the July 1971 issue.

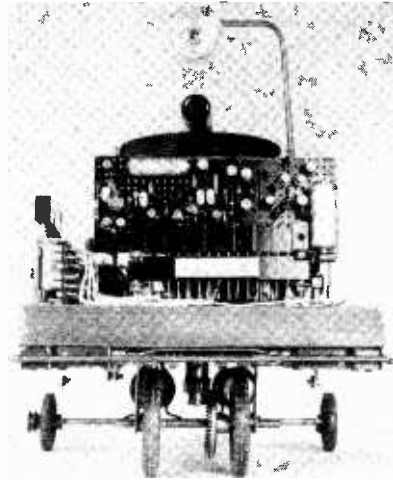

## PART TWO

by  
L. C. Galitz

**This is the second article in a series about robots and cybernetic devices. The first article was concerned with various types of robot and introduced Cyclops, an auto-robot. This article deals with the construction of the chassis and the mechanics of Cyclops.**

**C**YCLOPS IS RATHER AN UNUSUAL ELECTRONIC DEVICE, because he must be totally self-contained and mobile. Therefore, all the various bits and pieces must be mounted on a stout chassis.

In the good old days of radio, a piece of electronic equipment was not a piece of electronic equipment unless it was built on a sturdy professional-looking metal chassis; and the electronics enthusiast of that bygone age also had to be handy with his chassis punch, Allen Keys, and thread tapping sets. Unfortunately, his present-day contemporary excels with the use of the soldering iron, but his heart is not with the field of mechanics. For this reason, all the metalwork and gearing systems in Cyclops are based on readily available Meccano, and the main chassis is made of wood.

The author chose a piece of veneered chipboard for two main reasons. Firstly, it is very easy to work with, and secondly, it has a pleasing appearance. Those more capable at the art of woodworking may chose a piece of blockboard, and some may prefer a sheet of metal. Whatever material is chosen, it must be light, rigid and strong, because relays, batteries or accumulators, and motors will be supported by the chassis, and it is useless if the material sags or twists under the strain.

### CHASSIS LAYOUT

The chassis is 10in. by 7in., and, in the author's case, was  $\frac{3}{4}$ in. thick. Fig. 6 shows the layout of the mechanics, and also the positions of the various pieces of equipment mounted on the chassis.

It will be remembered from the first article that there are two motors. One motor (Motor 1) drives a pair of front wheels mounted on a common axle so that the robot can move. These two front wheels are mounted on a unit which (due to Motor 2) revolves about a vertical axis, and thereby changes the direction in which the front wheels are pointing. Thus, rotation of the front wheel unit changes the direction in which the robot moves.

The most obvious way of arranging the rotation of the front wheel unit, whilst still allowing mechanical power to be applied to the front wheels, is given by mounting the front drive motor on the unit itself, with electrical power fed to it by a system of slip rings. The scan motor (i.e. Motor 2) would then rotate the entire front drive unit complete with its own motor. This method was in fact used on earlier prototypes, but had to be discarded for several reasons. Firstly, there is always difficulty in arranging slip rings which give low

RADIO & ELECTRONICS CONSTRUCTOR



losses. Further, home-made slip rings often supply power to the rotating unit intermittently. Finally, there is the problem that the rotating front wheel unit must be fairly bulky to accommodate the motor, gears and the big front wheels whereupon, since this unit has to be pivoted at the top, the result is very poor overall stability of the assembly.

For these reasons, a method was sought by means of which *both* motors could be secured firmly to the chassis, and reference to Fig. 7(a) and (b) shows how this is accomplished. In this diagram the identifying numbers are the corresponding Meccano part numbers.

Power from the main drive motor is transmitted through the small pinion (part no. 26) to the contrate wheel (part no. 28). This gearing turns the mechanical power through 90°, so that it is now in a vertical plane. The power goes through the shaft (part no. 15b) which is supported by the double bent strip (part no. 45) and the hole in the chassis. Below the chassis the shaft passes through several washers, through the centre hole of a large gear wheel (part no 27b), to which it is *not* secured and, after several further washers, terminates in a second pinion (part no 26.) This pinion engages with a second contrate wheel (part no. 28) which is coupled to the axle of the front wheels. Thus,

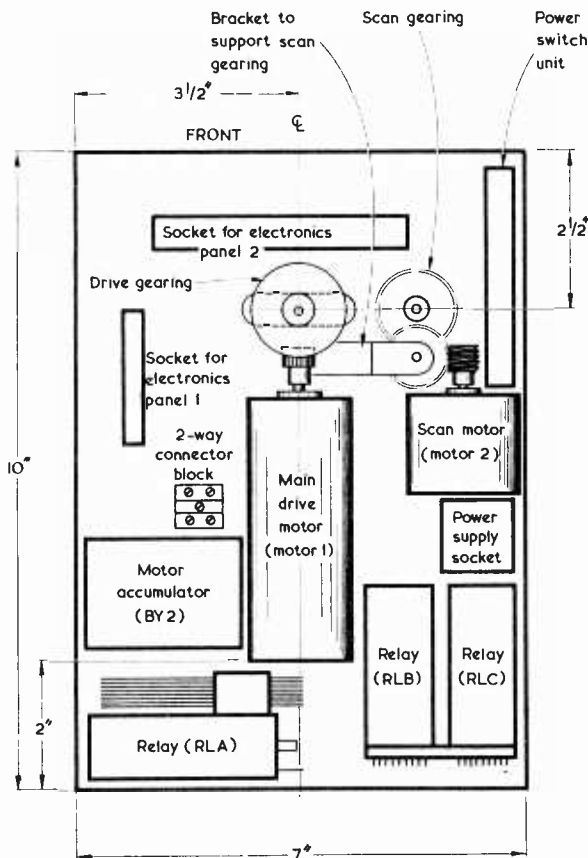

Fig. 6. Top view, illustrating the layout of the main components on the chassis of Cyclops. Some of the parts shown are discussed in later articles

## COMPONENTS

### Meccano Parts

1 off	1a	9½ in.	Perforated Strip Large Bracket.
1 off	3	3½ in.	Perforated Strip Bracket for Scan Gearing
2 off	5	2½ in.	Perforated Strip Front Wheel Brackets
2 off	6	2 in.	Perforated Strip Rear Axle Supports.
1 off	6a	1½ in.	Perforated Strip Scan Gearing Support
1 off	13a	8 in.	Axle Road Rear Axle
1 off	15b	4 in.	Axle Rod Vertical Drive Shaft
1 off	16b	3 in.	Axle Rod Front Axle
2 off	21	1½ in.	Pulley Front Wheels
2 off	22	1 in.	Pulley Rear Wheels
1 off	23a	½ in.	Pulley Rear Wheel Keeper
2 off	26		Pinion ½ in. diam. ¼ in face
2 off	27b	3½ in.	Main Drive Pinions Gear Wheels Front Drive and Eye Unit Supports
2 off	28	1½ in.	Contrate Wheels Main Drive Gears
1 off	37		Nuts and Bolts. Pkt. of 24
2 off	45		Double Bent Strip Jack Socket Mount and Main Drive Guide
2 off	126		Trunnion Rear Axle Bracket
2 off	142c	1 in.	Motor Tyre
2 off	142d	1½ in.	Motor Tyres for Rear Wheels Motor Tyre Motor Tyres for Front Wheels

### Ripmax Gears and Shafts

(Available from good model shops)

3 off	10-tooth gears
1 off	30-tooth gears
1 off	Worm Set (Consists of one worm gear and one 36-tooth matching gear)
1 off	steel shaft, 5½ in. long
1 off	steel shaft, 2½ in. long

### Motors

Main Drive Motor: Richard II Monoperm Super, Marx Luder EM52 (Ripmax Ltd.)

Scanning Motor: Ripmax Orbit EM505 (Ripmax, Ltd.)

### Miscellaneous

One 3.5mm Jack Plug and Socket  
Washers (as required)  
10in × 7in Chassis (see text)

M. W. Models, 165 Reading Road, Henley-on-Thames, Oxon, RG9 1DP, are offering special Kits of the Meccano parts-see small advertisements.

## SCANNING MECHANISM

The front wheel unit is mounted on a large gear wheel so that the scanning mechanism can be directly coupled to it. The scan motor is smaller than the main drive motor and has a Ripmax worm gear bolted to its output shaft. This engages with the gear train shown in basic form in Fig. 10(a). The worm gear drives a Ripmax 36-tooth gear mounted on the same shaft as a Ripmax 10-tooth gear. The latter, in its turn, drives a Ripmax 30-tooth gear mounted on a long shaft which passes through the chassis. Below the chassis a Ripmax 10-tooth gear mounted on this shaft engages with the large Meccano gear wheel (part no. 27b) on which the front wheels are mounted. Above the chassis, and in the upper part of the robot assembly, another Ripmax 10-tooth gear on the long shaft engages with a further large Meccano gear wheel (also part no. 27b) on which the eye is mounted. This upper 10-tooth gear can be seen in the photographs accompanying this and last month's article. It will be helpful also to refer to Figs. 10(b) and (c). Fig. 10(b) shows the 36-tooth and 10-tooth gears on their common shaft, whilst Fig. 10(c) shows the long shaft which carries the two 10-tooth gears which engage with the large Meccano gear wheels on the front wheel unit and the eye unit. In Fig. 10(c) the large gear wheel for the eye unit is omitted.

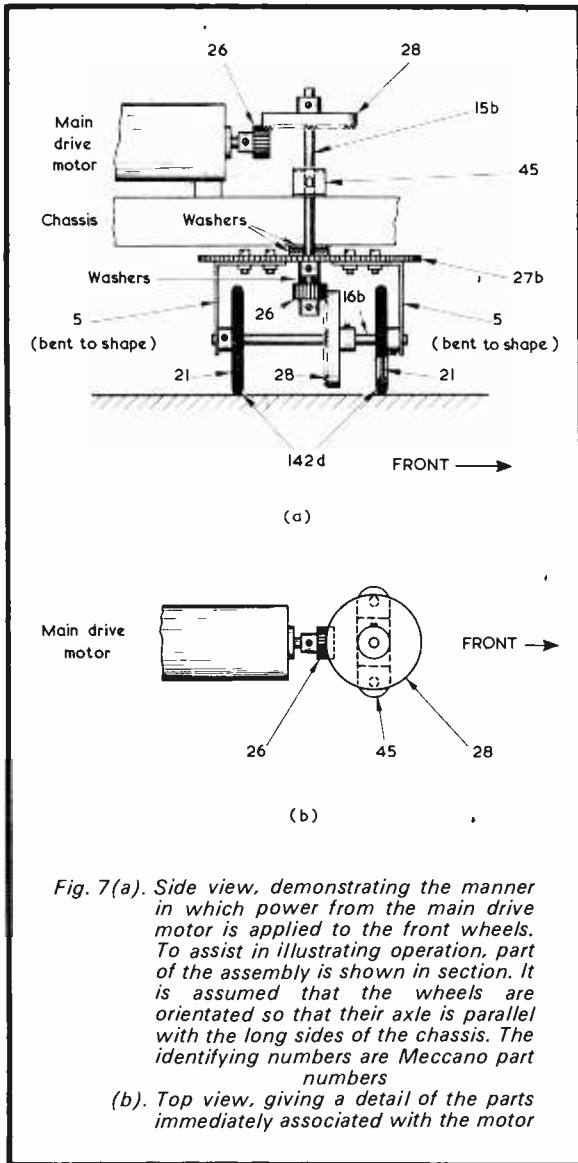

Fig. 7(a). Side view, demonstrating the manner in which power from the main drive motor is applied to the front wheels. To assist in illustrating operation, part of the assembly is shown in section. It is assumed that the wheels are orientated so that their axle is parallel with the long sides of the chassis. The identifying numbers are Meccano part numbers

(b). Top view, giving a detail of the parts immediately associated with the motor

the power from the main drive motor, which is firmly mounted on the chassis, is finally applied to these wheels, causing them to rotate.

The front wheel axle is secured at its ends by two perforated strips (part no. 5) bent to shape, these being secured to the large gear wheel (part no. 27b).

The rear wheels are mounted on a rear axle supported by two brackets, as shown in Figs. 8(a) and (b), taking up the position illustrated in Fig. 9. One wheel is bolted onto the axle, whilst the other is free to rotate. This method of assembly is adopted because, if both wheels were bolted directly to the axle, one wheel would be forced to skid when Cyclops moved in a direction other than straight forward or straight backward. The free wheel is kept in place by a small pulley bolted to the axle. It was found that the spring retaining clips made for the purpose created too much friction when rubbing against the wheel.

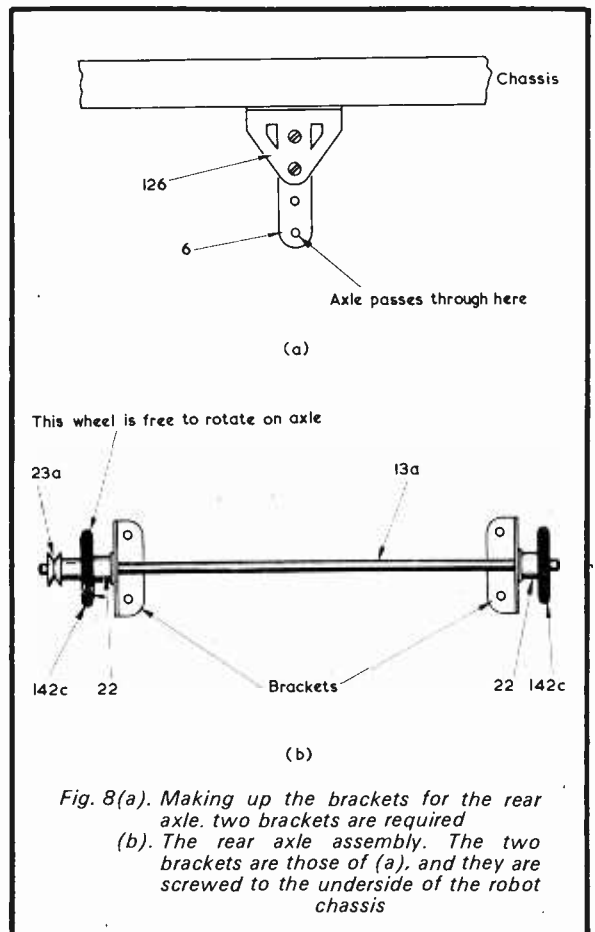

Fig. 8(a). Making up the brackets for the rear axle. two brackets are required

(b). The rear axle assembly. The two brackets are those of (a), and they are screwed to the underside of the robot chassis

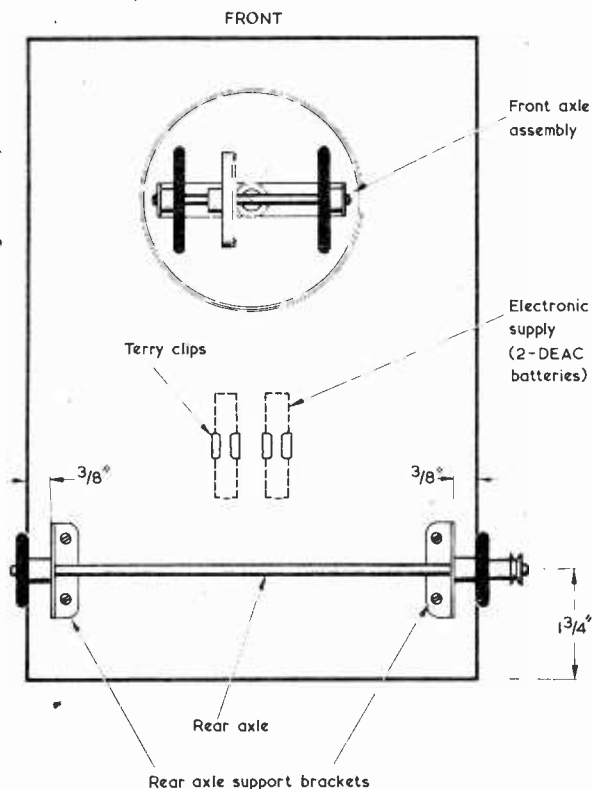

Fig. 9. Underside view, illustrating the position taken up by the rear axle assembly. Also shown are two Deac batteries. These will later be used to power the electronics

The two vertical shafts of Figs. 10(b) and (c) are steadied by means of perforated Meccano strips. Washers are soldered to these to provide smaller holes for the shafts to pass through. It will be appreciated that, since the large gears carrying the front wheels and the eye are turned by similar gear wheels on a common shaft, the two large gears rotate in unison. In consequence, Cyclops always looks in the direction he is going.

A further point is that the eye gear wheel rotates on a jack plug, which acts as a pivot. The use of a jack plug for this function is discussed in detail later in this article.

## MECHANICAL CONSTRUCTION

Before commencing the mechanical construction a suitable chassis material must be chosen. As was mentioned earlier, this must be strong because it supports several heavy pieces of equipment, and must not sag under the strain. After all, Cyclops tips the scales at half a stone! This chassis is 10in. by 7in.

Firstly, the main drive equipment must be made. The main drive motor is one which has an integral gearbox. The motor itself is a 'Monoperm Super' and the entire motor and gearbox is manufactured by Marx Luder. The gearbox has six ratios, the one which is used here being 6:1. The more experienced constructor may wish to choose alternative gear arrangements, but

AUGUST 1972

the author found it of advantage to have a variable torque available. This facility is especially useful when components differing in weight are employed in other parts of the construction since a different ratio may then be required to give optimum running conditions. Also, high precision is required to mount gears handling high torques efficiently if these are external to the motor.

The motor has an integral bracket and is screwed to the chassis so that its axis coincides with the centre line of the chassis, and is positioned such that its rearmost point is 2in. from the rear of the chassis. A 3/8in. hole is then drilled in the chassis 2 1/2in. from the front, this hole lying on the centre line of the chassis. This hole takes the vertical drive shaft. As shown in Fig. 7, a double-bent strip (part no. 45) is then screwed to the chassis so that its centre hole coincides with the hole just drilled. A contrate wheel is now bolted to the vertical shaft and this assembly passed through the chassis from above. A pinion is bolted onto the motor shaft such that the contrate wheel meshes with it.

The front drive unit is now made up as in Fig. 7(a). A large gear wheel is taken, and two brackets are bolted to the holes provided. These brackets are Meccano strips (part no. 5) bent so that two holes lie to one side of the bend, and the remaining three to the other side of the bend. Also, the curved ends of the 2-hole strip sections are cut away so that the strips clear the bush of the large gear wheel. The bend is a 90° one, and the brackets are bolted to the large gear wheel with two screws so that the three-hole sections are at right angles to the wheel surface. The front wheel axle is passed through the end holes of the brackets, taking up the two road wheels and the other contrate wheel. The two road wheels are next bolted to the axle with their bushes close to the brackets. Two washers are passed over the vertical shaft to allow the bolts on the large gear wheel to clear the underside of the chassis, and then the front drive unit is placed onto the vertical shaft. Two more washers are passed onto the vertical

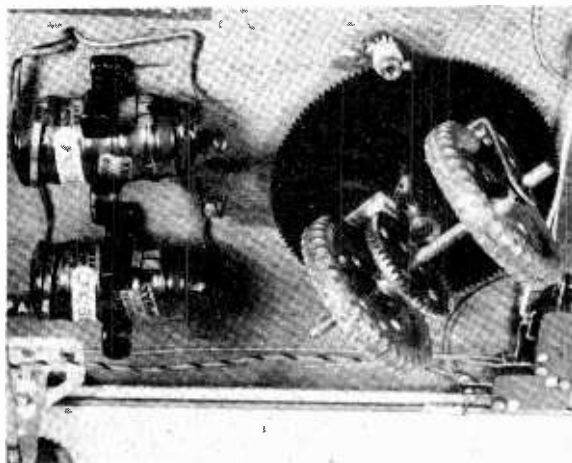

View under the chassis, showing the front wheel assembly. The small white 10-tooth gear in the scanning train which rotates the front wheel unit is clearly visible, as also are the pinion and contrate wheel which drive the front wheels themselves. Also to be seen are the two Deac batteries which power the electronics and two microswitches in the touch stimulus system

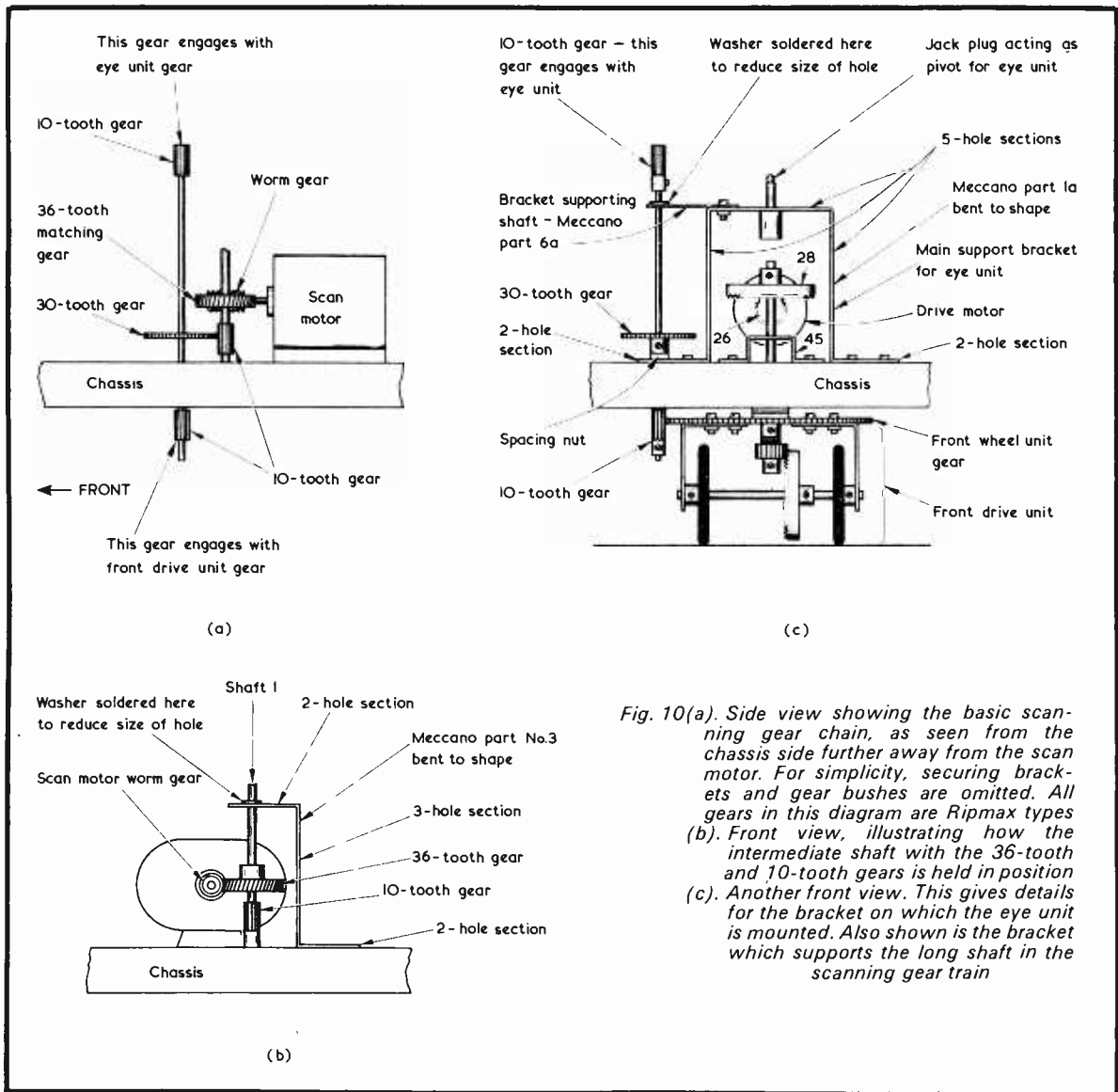

Fig. 10(a). Side view showing the basic scanning gear chain, as seen from the chassis side further away from the scan motor. For simplicity, securing brackets and gear bushes are omitted. All gears in this diagram are Ripmax types (b). Front view, illustrating how the intermediate shaft with the 36-tooth and 10-tooth gears is held in position (c). Another front view. This gives details for the bracket on which the eye unit is mounted. Also shown is the bracket which supports the long shaft in the scanning gear train

shaft, and then a pinion is bolted on such that when the front wheel unit is pushed against the chassis the drive motor pinion meshes easily, and without any pressure, with the contrate wheel above the chassis. The second contrate wheel is bolted to the road wheel axle so that it, too, meshes easily with its pinion. If desired, the motor can be powered by a 6-volt d.c. supply whereupon, if the large gear wheel is held still, the road wheels should rotate.

The rear wheel assembly is next made up. Two trunnions are taken, and onto each one is bolted a 2in. perforated strip with two nuts and bolts, as in Fig. 8(a). The two resulting brackets are then screwed to the underside of the chassis, so that the rear end of each trunnion is  $1\frac{1}{2}$ in. away from the rear of the chassis, and the face of each trunnion is  $\frac{3}{8}$ in. inside the chassis edge. The rear wheels are fitted to the rear axle as shown in Figs. 8(b) and 9.

## SCANNING SYSTEM

We now come to the eye scanning system. This is built 'backwards'; in other words, the last gears in the chain are fitted first, and the affixing of the motor comes last. Refer to Figs. 10(a), (b) and (c) as necessary when fitting the parts concerned. A  $\frac{3}{8}$ in. hole is drilled through the chassis 3in. from the chassis front and approximately  $3\frac{3}{8}$ in. distant from the vertical main drive shaft. The exact position for the hole is found by holding one of the 10-tooth gear wheels so that it meshes with the large gear wheel under the chassis, and then marking the position where its axle must pass through the chassis. The 10-tooth gear wheel is temporarily bolted onto a  $5\frac{1}{2}$ in. length of axle, and passed from the underside of the chassis up to the top. The 30-tooth gear wheel is temporarily bolted to the axle.

Another 10-tooth gear wheel is held against the

Close-up view of the mechanics above the chassis. The scan motor worm gear may be observed as it meshes with the 36-tooth matching gear. The 10-tooth gear beneath the latter is obscured, but its position can be deduced from the position of the 30-tooth gear with which it meshes. The long shaft on which the 30-tooth gear is fitted also carries the 10-tooth gear under the chassis and the 10-tooth gear above the chassis which rotates the eye unit at the top. The eye unit was removed for this photograph

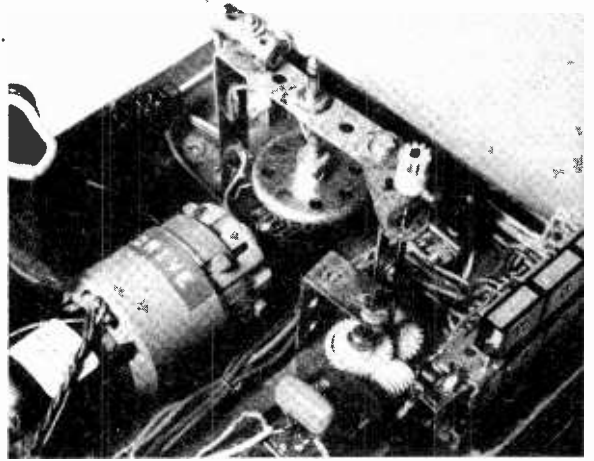

30-tooth wheel, and the position that its axle must take up is marked on the top of the chassis. A  $\frac{3}{8}$  in. hole is drilled at this point, but only part-way through the chassis. The second shaft is  $2\frac{1}{2}$  in. long, and a bracket is made up to support it from a Meccano perforated strip  $3\frac{1}{2}$  in. long (part no. 3). The strip is bent first through  $90^\circ$  with two holes to one side of the bend and the remaining five to the other side of the bend. It is then bent through  $90^\circ$  again, so that there are two holes between the other end of the strip and the second bend, leaving three holes between the bends. The bends go in opposite directions, as illustrated in Fig. 10(b). A small washer with internal diameter of  $\frac{3}{8}$  in. is soldered at one of the holes at the end of the bracket to reduce the diameter of the hole to that required by the axle. This bracket is now screwed to the chassis so that the small  $\frac{3}{8}$  in. hole through the washer is directly above the hole just drilled in the chassis. The 36-tooth gear which is part of the worm set is now temporarily bolted to the axle which passes through the bracket and into the corresponding chassis hole, and the worm gear is bolted to the spindle of the motor. The motor is now positioned so that the worm gear meshes with the 36-tooth gear wheel, the axis of the motor being parallel to the long side of the chassis. The motor is then screwed to the chassis by means of the bracket supplied.

## EYE UNIT

The bracket holding the eye unit pivot is now made up out of a  $9\frac{1}{2}$  in. length of Meccano perforated strip (part no. 1a), this being bent so that the two feet each

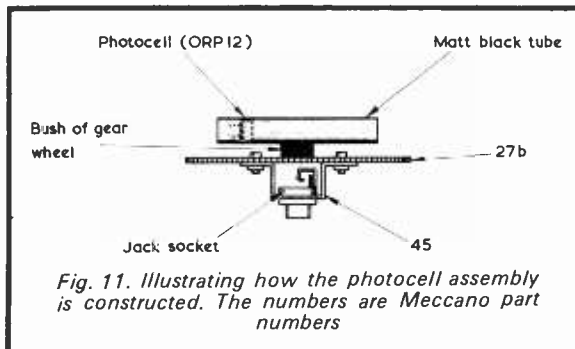

Fig. 11. Illustrating how the photocell assembly is constructed. The numbers are Meccano part numbers

have two holes, the uprights each have five holes, and the top section has five holes. See Fig. 10(c). The middle hole at the top is enlarged to  $\frac{1}{8}$  in. diameter to take the threaded part of a 3.5mm. jack plug, which is then soldered in place. The bracket is now screwed to the chassis with the spindle of the jack plug directly over the vertical main front wheel drive spindle, and with the top of the bracket parallel to the short sides of the chassis. A  $1\frac{1}{2}$  in. length of Meccano perforated strip (part no. 6a) is bolted to the top section of the bracket so that the hole at the other end is over the hole in the chassis which takes the axle having the 10-tooth gear and which meshes with the large gear on the front wheel unit. The strip is loosely bolted in place. A washer with an inside diameter of  $\frac{3}{8}$  in. is soldered at the end hole of the strip to take the axle which will later pass through it.

The construction of the first part of the eye unit now takes place, and Fig. 11 should be consulted. The second large gear wheel (part no. 27b) is taken, and on the side opposite the bush is bolted another double bent strip (part no. 45). This has its central hole enlarged to  $\frac{1}{2}$  in. to take a 3.5mm. jack socket, which is fixed in place. This unit will eventually carry the photoelectric cell. It will be seen that the jack socket fits over the jack plug on the large bracket, and the eye is therefore free to rotate about the same axis as the front wheel unit. At the same time, the jack plug and socket allow electrical connection to be made to the photoelectric cell whilst the eye unit rotates. This idea was borrowed from 'In Your Workshop' in the September 1969 issue\*. An alternative method of arranging the eye would be for the eye to look straight down the axis of rotation of the unit, and for a mirror to be set at  $45^\circ$  on the unit, the eye would look along the direction in which the robot was moving, but the former method is preferred because it allows a lower overall height for the model. For those interested in the mirror approach, a diagram showing the method is given in Fig. 12.

(The photocell and tube assembly of Fig. 11 need not be constructed and wired at this stage. Further details on the assembly will be given in Part 4).

\* The jack plug and socket scheme was a 'reader's hint' submitted by B. Richardson.—Editor.

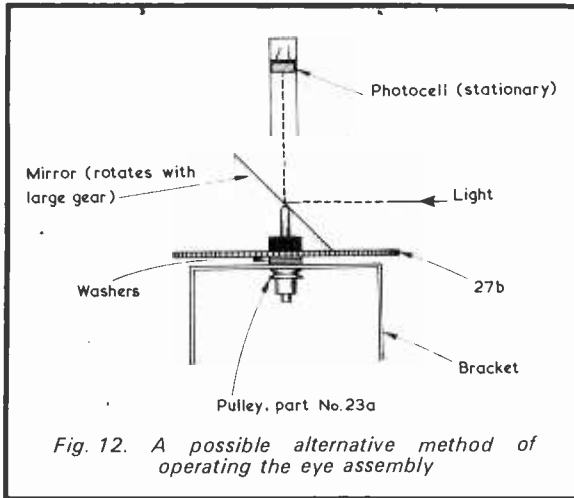

Fig. 12. A possible alternative method of operating the eye assembly

The eye unit is placed on the large bracket by way of the jack plug and socket, and the long axle is passed through the perforated strip (part no. 6a) at the top, and the chassis. Two 10-tooth gear wheels are bolted

to the axle; one at the bottom underneath the chassis, meshing with the large gear of the front wheel drive unit, and the other at the top, above the perforated strip and meshing with the large gear wheel on the eye unit. The position of the perforated strip is then finally adjusted so that the top 10-tooth wheel meshes comfortably with the large gear wheel on the eye unit, and it is then bolted firmly down.

After this, all the gears are permanently assembled. First, the 10-tooth wheel at the top is removed, and the long axle is pushed down until its top is below the perforated strip. A spacing nut (see Fig. 10(c)) and the 30-tooth wheel are threaded on. The axle is then pushed up again, and all the gears bolted firmly on. Finally, the 10-tooth wheel at the top is put back on again. The gears on the short shaft are bolted in position as in Fig. 10(b). The scanning system can now be tried out with a 6 volt d.c. supply for smooth running, and it should be checked that both the front wheel drive unit and the eye unit turn together in unison.

This concludes the details of the main mechanical construction. In the next article details of the basic reflex circuitry will be given.

(To be continued)

# BOOK REVIEWS

## RADIO CONTROL



**THE PROPO BOOK** by "Radio Modeller" Staff.  
118 pages, 5½ × 8½ in. Published by Radio Control Publishing Co. Ltd. Price £1.25.

The purpose of this book is to introduce aeromodellers to the present sophisticated method of flying a model aircraft by radio control. 'Propo', as proportional control is abbreviated to, gives a finesse of control not found in any other system. As one moves the control stick on the transmitter, so the corresponding control in the aircraft follows in a similar manner. A small movement in transmitter control gives a similar movement in receiver response in the aircraft, i.e. the system gives proportional control in the aircraft to that set up on the transmitter.

This system has become so popular, that it may very soon become the only one to be used in future, and it has become widely adopted by the manufacturers of R/C equipment for the aeromodeller, as the system of choice. Complete propo R/C systems are quite expensive and if one purchases one, it is essential it be installed correctly in the model and used properly, if calamity and disaster is to be avoided!

This book covers all aspects of choosing propo-gear, installing it and maintaining it. Valuable information is given on linking systems from the equipment to the control surfaces. Pre-flight checks, fault finding and much else is adequately covered. A most useful feature in the book, is a series of full size diagrams of fourteen of the most popular servos in present use, giving all dimensions needed for planning and installing in the model.

For someone wanting to make the change from single channel, with its restricted control, to the precision of 'propo' control, this book is essential reading.



**LOW COST PROPORTIONAL.** By W. P. Holland.  
118 pages, 5½ × 8½ in. Published by Radio Control Publishing Co. Ltd. Price £1.05.

If you are one of those who has had some experience of single channel radio control and wants to progress to the advantages of proportional control but who prefers the interest and experience – and the saving in expense – of building your own equipment to buying and assembling ready made propc systems, in your models, "Low Cost Proportional", in the RM Book Series, will tell you how to go about it. This publication really does cover its subject matter thoroughly. It starts off by explaining the advantages of proportional control; then deals with elementary pulse systems and methods of pulsing the radio carrier; goes on to deal with motorised actuators and explains the now well known "Gallop Ghost" system. The electronic side of the system is as adequately covered as the mechanical and the book is thoroughly practical as well as giving the necessary theoretical coverage. This is a book which can be recommended to the radio constructor of radio control equipment with every confidence.

## U.S.A. PATENT FOR RENDAR INSTRUMENTS LTD.

Rendar Instruments Ltd. are a British Company specialising in the design and manufacture of a wide range of standard-size, mini and sub-miniature electronic components.

They have secured their first U.S.A. Patent, which is for their miniature 3-terminal jack plug (code R22300/01) which suits their miniature 3-way jack socket (code R32300/08).

The first figure of the code denotes the product group (for example: knobs, jack plugs, jack sockets, connectors, switches), and the succeeding numbers describe the actual product and its various specifications with increasing definition, including colour and any unusual features.

The Rendar miniature 3-terminal jack plug is available in both screened and unscreened versions. The body of the screened plug is of bright, nickel-plated brass, whereas the unscreened plug has a thermoplastic cover of black (other colours can be supplied for quantity orders).

The probe section is of silver-plated brass, diameter 3.56 mm, length 18.5 mm. The overall length of the jack plug is 39.1 mm (1.54ins.). The plug has been rated for a test voltage of 1,500 Volts DC, solder terminations are provided, and minimum insulation resistance between any two conductors is  $10^3$  Megohms (measured at 500 Volts DC).

The Rendar miniature 3-way jack socket has a body of high melting point thermoplastic, with spring contacts of phosphur bronze (gold flash finish). The mounting bush is of nickel-plated brass, behind which is a nickel-plated brass washer and a polythene washer. Overall length from front to rear is only 18.8mm (0.74ins.).

Enquiries should be sent direct to Rendar Instruments Ltd., Burgess Hill, Sussex.

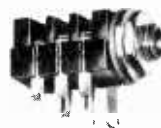

**RENDAR 3-WAY MINI JACK SOCKET R32300/08**



**RENDAR UNSCREENED MINI JACK PLUG R22300**



**RENDAR SCREENED MINI JACK PLUG R22301**

## RSM06 PROXIMITY SWITCH



Smallest in FR Electronics' range of magnetically actuated proximity switches is the RSM06. Just 40 mm long, the type is available with either normally open or changeover contacts rated at 15 VA and 3 VA respectively. It was designed for use in limit - switching and position indication applications as an alternative to micro and other mechanical switches. As the contacts are completely isolated from the working environment and no physical contact is necessary for switching, this type of switch offers better reliability than its more conventional counterparts.

For details contact FR Electronics, Wimborne, Dorset.

## MULTI-FREQUENCY TONE UNIT

Due to an increasing demand for multi-frequency tone encoder/decoder capability in two-way radio equipment, Alpha has introduced the new model MT-40 Multi-Frequency Tone Selector Control Head.

Measuring only  $2" \times 5\frac{1}{2}" \times 4\frac{3}{4}"$ , the MT-60 encoder can send up to six, independent, operator selected tones ranging from 20 Hz to 3,000 Hz, and can be either continuous tone or pulsed tone. When used as an encoder/decoder combination, the MT-60 can be set for any of a number of encode/decode modes.

The MT-60 is designed to occupy a minimum of space, and yet be sufficiently rugged to withstand the demands of use in heavy duty vehicles.

Complete step by step installation instructions are provided for most models of mobile and base station radios.

The MT-60 is especially suitable for application in any radio system requiring multiple repeater access, individual or group selective calling, or remote control functions.

AUGUST 1972

The desired tone frequencies are determined by miniature plug-in frequency determining modules and can be easily field added or changed. Frequency modules can be factory exchanged for a different frequency for a small service charge, within the two-year warranty period.

Free applications engineering help is available. For information write Alpha Electronic Services Inc., 8431 Monroe Ave., Stanton, California 90680.

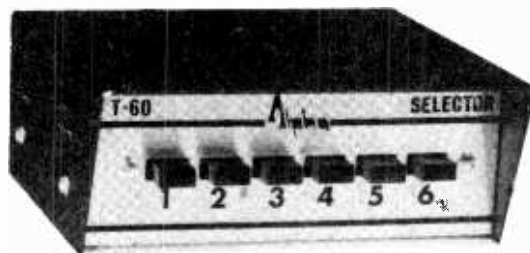

# SINGLE SIDEBAND FOR BEGINNERS

by

R. A. Butterworth.

## An introduction to amateur single sideband transmission and reception.

**T**HIS ARTICLE IS NOT MEANT FOR THE ADVANCED enthusiast but, rather, for those such as the younger reader whose main studies at the moment are for his 'O' and 'A' levels and whose interests in a hobby have to take second place. It is felt that if a simple explanation of single sideband transmission and reception which does not require too much concentration can be given, then it would serve as a 'breather' and at least help to keep the reader in touch with one of the most commonly used methods of communication.

The intention is to deal with the subject in three parts, these consisting of, first, a little history, second, the transmission, and third, the reception of single sideband signals.

### HISTORY

In common with many other present-day methods of communication, the basic principles of single sideband (or s.s.b.) transmission and reception were known years ago but could not be put to practical use because the state of the art was not sufficiently advanced at the time. Commercial companies used s.s.b. in the early '30s, but the complexities and what was then considered to be the almost impossible degree of frequency stability required put consideration of the system beyond the resources of the amateur. In fact, at that time a frequency drift of 20 to 30Hz was considered to be the maximum permissible. Now, 100 to 200Hz error can give acceptable results for amateur standards if the audio frequency range is limited to 300 to 3,000Hz. Hardly hi-fi, but quite sufficient for voice communication.

It was about 1936 when the amateurs started to experiment. Up to that time receivers, whilst good enough for a.m. and c.w., lacked the selectivity and oscillator stability that was necessary for the new mode. With the appearance of better receivers and transmitters v.f.o.'s (variable frequency oscillators used for exciting transmitters) by the later 1940s, a number of amateurs were handling worth-while 2-way contacts. Interest quickened rapidly because, although the new method of speech communication was considerably more

complicated than amplitude modulation (a.m.) it gave two very big advantages. These were that the effective transmitter output was four times greater for the same power input to the transmitter and that only half the frequency space was required.

### S.S.B. WORKING

It is necessary next to recap a little on amplitude modulation, now sometimes referred to by amateurs as 'ancient modulation'. To transmit a.m. we generate an r.f. signal, amplify it and, in the final amplification stage, modulate it by mixing it with the audio signal to be transmitted. See Fig. 1. The modulation signal is then fed to the transmitter aerial. At the receiving end we

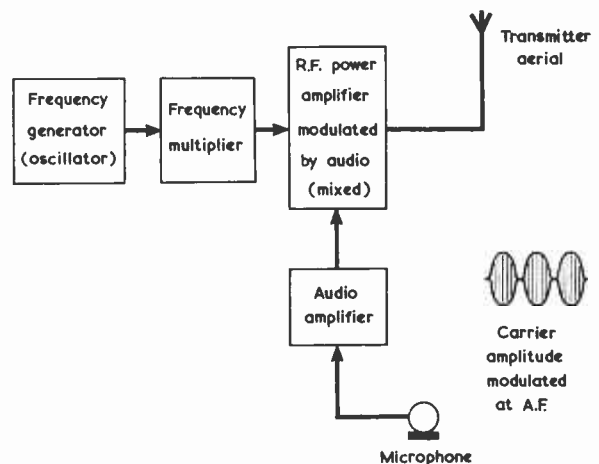

*Fig. 1. A typical a.m. transmitter, showing also its aerial output waveform, this consisting of the r.f. carrier 100% modulated by the audio signal. The frequency multiplier stage is not an essential feature, and the frequency generator can, if desired, couple directly to the r.f. power amplifier*

RADIO & ELECTRONICS CONSTRUCTOR



pick up this signal, amplify it, and pass it to the detector. After detection the r.f. carrier signal, which initially needed a great deal of power for its transmission, is then side-tracked by a filter and *thrown away!* All that is left is the audio component of the signal. The waste of power can be visualised when it is remembered that 50 watts of audio power are required to 100% modulate a 100 watt carrier, and yet the carrier does not in itself carry any signal information.

With s.s.b. we do the same as with a.m. but in a very much more economical and power-saving way; and we get at the receiver what we were after in the first place, namely, the audio content or intelligence which is conveyed in the transmitter sidebands. The sidebands are shown in the accompanying spectrum diagram, Fig. 2, in which  $F_c$  is the carrier frequency, and  $F_m$  is the modulating frequency. Just as in a receiver mixer we get sum and difference frequencies from the transmitter, these being  $F_c$  plus  $F_m$  and  $F_c$  minus  $F_m$ . Since one sideband is a mirror-image of the other and thereby contains the same audio intelligence, there is no necessity to transmit both and, in s.s.b. working, we simply dispense with one of them.

In an s.s.b. transmitter we start off by generating a carrier, mixing it with the modulating audio signal, and then suppressing the carrier. This leaves us with the two sidebands and a suppressed carrier. We then filter or phase out the sideband which is not required, leaving us with the upper sideband (u.s.b.) or lower sideband (l.s.b.), which is next amplified and fed to the transmitter aerial. At the receiver we pick up the single transmitted sideband, add an oscillation from a local oscillator to replace the missing carrier and feed the result to a detector. The latter can be a standard a.m. detector but better results are given with the use of a *product detector*, which is especially designed for the demodulation of s.s.b. signals.

This description of s.s.b. operation is considerably simplified, but it should be sufficient to give a basic understanding of the system. It will also enable us to understand what is required in an average short wave receiver not specifically intended for s.s.b. operation if we are to make sense of some of the horrible noises which can be heard on the amateur bands.

## TUNING IN S.S.B.

Let us start with a warning. Cheap valve or transistor sets with a short wave band or bands are made to cover the short wave broadcast transmissions only. Any s.s.b. signals that are picked up will be reproduced as very distorted speech which cannot be unscrambled because receivers of this nature do not have a beat frequency oscillator (or b.f.o.).

More advanced short wave receivers, intended for a.m. and c.w. (or morse) reception, can be used to resolve s.s.b. signals by employing the b.f.o. to insert the missing carrier. For good results the b.f.o. and the receiver local oscillator must both have very good frequency stability. Normally, the b.f.o. will be able to tune some 3kHz above and below the intermediate frequency of the receiver. It is necessary for the b.f.o. to be capable of being varied in frequency because some s.s.b. stations transmit the upper sideband whilst others transmit the lower sideband, and the tuning range of the b.f.o. must cover both. Also, the amplitude of the b.f.o. signal must be large relative to that of the received signal at the detector of the receiver.

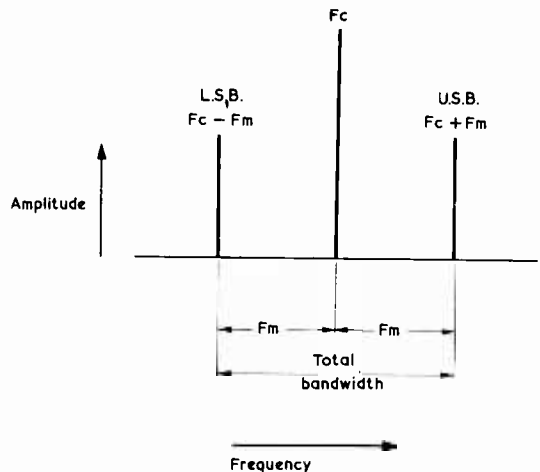

Fig. 2. Spectrum diagram illustrating the signal radiated by an a.m. transmitter.  $F_c$  indicates carrier frequency, and  $F_m$  modulating frequency. It is assumed that modulation depth is 100%

There are three steps in resolving an s.s.b. signal. First, tune the receiver for strongest signal, either by ear or by whatever tuning indicator is fitted to the set. Second, turn down the r.f. and/or i.f. gain controls. It is useless to turn down the a.f. volume control. Third, switch in the b.f.o. and tune it one way or the other until the reproduced voice sounds natural.

If, when receiving a u.s.b. signal, the b.f.o. is tuned to too high a frequency the voice becomes deeper and deeper; if the b.f.o. is tuned to too low a frequency the voice becomes higher and higher. The reverse effect is given with an l.s.b. signal.

Once the b.f.o. has been set, it should not be necessary to adjust it unless bands are changed. Generally, s.s.b. signals below about 7MHz are transmitted on the lower sideband, whilst those above are on the upper sideband. The a.f. volume control, once set, needs very little adjustment either. The r.f. gain and tuning controls are those which offer the main control, and these require a little more care than usual to maintain good reproduction of the voice. Good frequency stability is very important, as will soon be apparent when using very cheap simple receivers, which may require frequent adjustments to keep in tune.

Reception will, of course, be easier to carry out with a receiver which is specifically intended for s.s.b. reception and which has a proper product detector. A disadvantage with employing a receiver designed for a.m. and c.w. only is that the signal injection from the b.f.o. is at rather low level for s.s.b. detection.

It must be stressed that this article leaves a few gaps in the s.s.b. picture, but this has been intentional in the interests of simplicity for the beginner. The reader should not expect instant results in the reception of s.s.b. signals and it may require quite a little practice before the knack of receiver adjustment is acquired. But once started, it becomes possible to pick up a lot of interesting communications, particularly on the amateur bands, that would otherwise be missed because they sounded like secret coded signals or a fierce fight on a duck pond.

# The 'JUBILEE' 8-Watt

J. R.

## Cover Feature

Employing two 6BW6 beam tubes, this easily constructed amplifier has very low distortion. This month the circuit and preliminary description of assembly will be given in the concluding part of the next

The *Radio Constructor* celebrated its 25th year of publication with the July 1972 issue. It is fitting, therefore, to describe the present project as the 'Jubilee' Amplifier.



THE 'JUBILEE' A.F. AMPLIFIER IS UNASHAMEDLY A valve design. This fact will please those readers who still prefer to work with valves rather than semiconductors. Constructors who feel that valves are out-dated may nevertheless be interested in considering the following facts. First, the two output valves employed in this amplifier operate in push-pull Class AB1 under conditions which, even before the application of negative feedback, offer a total distortion at full power of only 1%. Second, since the current drawn from the h.t. supply is very nearly constant at all signal levels there is no necessity for a stabilized power supply. Third, there is no problem with crossover distortion and, fourth, the valves employed are robust and do not suffer any ill effects due to overload or the accidental short-circuiting of the speaker connections.

Opposing these advantages are the points that the amplifier is bulkier and heavier than a solid-state equivalent and that higher voltages are involved. Since an amplifier is normally operated in a single location in the house the questions of bulk and weight may not be as important as would occur with other types of equipment.

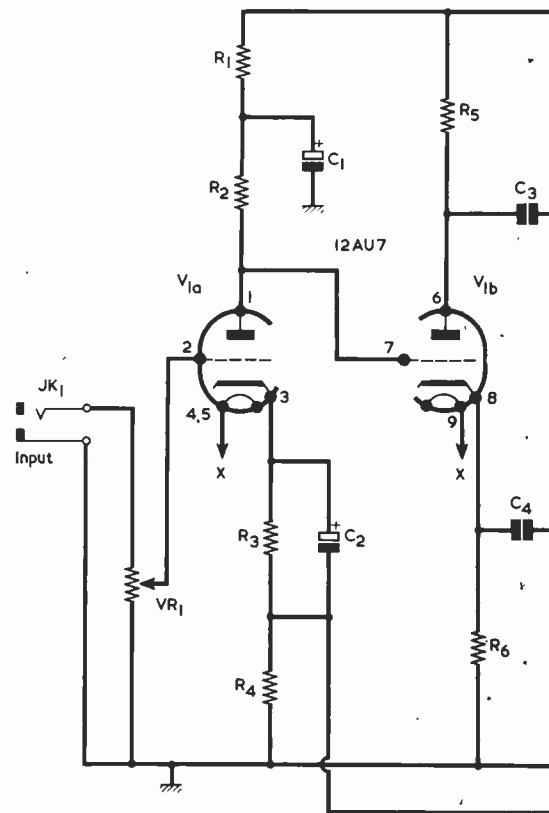

RADIO & ELECTRONICS CONSTRUCTOR

# Amplifier

avies

les in a push-pull output stage, offers a high output with low is described, together with a ply. Final constructional details onth.

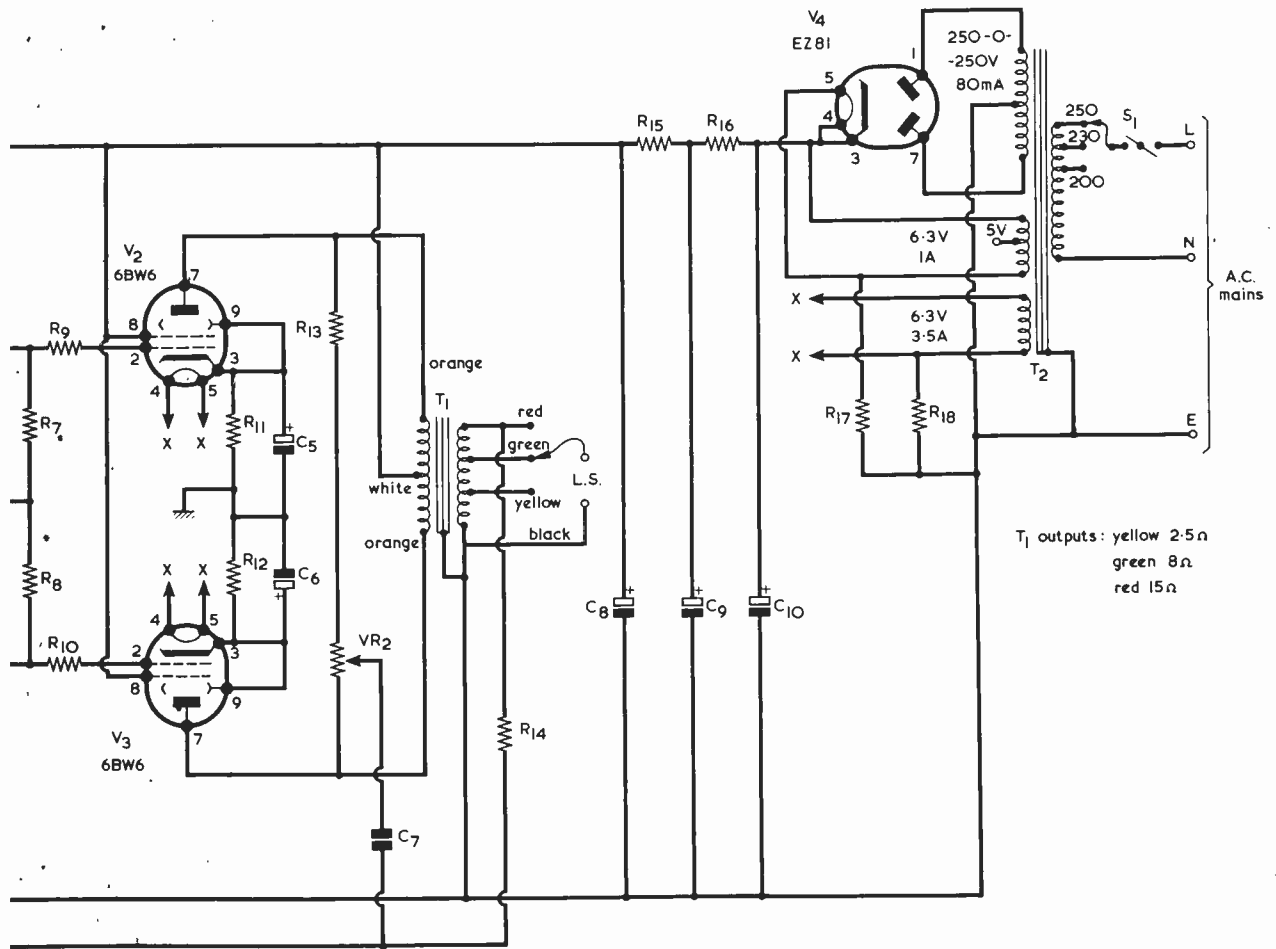
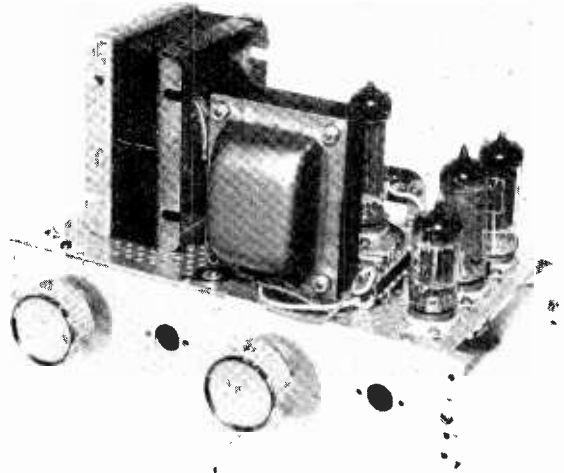

Fig. 1. The circuit of the 'Jubilee' 8 watt amplifier  
AUGUST 1972



## VALVE LINE-UP

The valves employed in the 'Jubilee' amplifier are a 12AU7 double-triode which functions as voltage amplifier and phase-splitter, two 6BW6 beam tetrode output valves and an EZ81 full wave h.t. rectifier. The 6BW6 is the B9A version of the octal-based 6V6, the latter being deservedly one of the most popular a.f. output valves ever introduced.

The chassis is made entirely from Lektrokkit parts and the various sections are simply fastened together with 6BA nuts and bolts. Virtually the only 'heavy metal-work' involved in constructing the amplifier consists of cutting the volume and tone control spindles to the requisite length! The result is that a work-room is not necessary for the assembly of the amplifier as, apart from a hacksaw for the two spindles just mentioned, the only tools required are screwdriver, pliers, cutters and soldering iron. A small file may, perhaps, also be needed if the Lektrokkit lead-through insulators employed happen to be difficult to insert.

The use of prefabricated metal parts for the chassis incurs some limitations in the layout of components. The two controls cannot, for instance, be positioned symmetrically about the centre of the chassis. Their asymmetry can, however, be taken up in the styling of the cabinet in which the amplifier is housed. Also, it was found necessary to position the output transformer a little closer to the mains transformer than the author would otherwise like to do. This proximity results in the appearance of a very low 50Hz hum in the output of the amplifier. This hum is only just perceptible under no-signal conditions in a completely quiet room and, to the writer's mind, is negligibly low in level. Nevertheless, its existence must be mentioned. The hum could not be detected when the amplifier was reproducing records or the output of a radio tuner unit.

## THE CIRCUIT

The circuit of the amplifier appears in Fig. 1. The input signal, which may be at the level provided by a crystal or ceramic pick-up cartridge, or by a radio tuner unit, is applied to input jack JK1 and, thence, to volume control VR1. The slider of VR1 taps off the desired volume level required and couples to the grid of V1(a). V1(a) is a voltage amplifier and its anode connects directly to the grid of the phase-splitter, V1(b). Equal and out-of-phase signals then appear at the anode and cathode of V1(b).

The direct connection between V1(a) anode and V1(b) grid is possible because the values of R1, R2, R3 and R4 are such that the anode of V1(a) has a

potential above chassis that is approximately one third of the main h.t. potential at the upper end of R5. The grid of V1(b) is maintained at this potential, whereupon its cathode goes positive of the grid by the bias voltage (actually, about 2.8 volts) needed to maintain current flow in R5 and R6. R5 and R6 are equal-value resistors, with the result that, since the same current flows through them, equal voltages appear across them. If, during a signal cycle, the grid of V1(b) goes positive so also, due to cathode follower action, does its cathode, resulting in an increased voltage drop across R6. The voltage across R5 similarly increases. The upper end of R5 is, however, held at a fixed potential, and the increase in voltage across this resistor results in the anode of V1(b) going negative by the same amount as the cathode of V1(b) goes positive. Thus, V1(b) produces out-of-phase signals at its anode and grid, introducing virtually no distortion in the process. An added bonus in the circuit is that the direct connection between V1(a) anode and V1(b) grid obviates the coupling capacitor and grid resistor that would otherwise be required, whereupon there is not only a simplification of the wiring and a saving in components but also a complete absence of phase shift between the two electrodes. Further, a cathode bias resistor for V1(b) is not needed.

The anode and cathode of V1(b) couple, via C3 and C4, to the control grids of the two output valves V2 and V3. R7 and R8 are grid resistors, whilst R9 and R10 are 'grid stoppers'. 'Grid stoppers' are commonly encountered in amplifiers of this nature, and their function is to prevent any tendency for the output stage to oscillate at a supersonic frequency. At such a frequency the input capacitance of each valve presents a reactance that is relatively low when compared with the resistance of the 'grid stopper', with the result that, should any supersonic feedback signal be present at the end of the 'grid stopper' remote from the grid, that signal is strongly attenuated at the grid itself.

The anodes of V2 and V3 couple to the outside ends of the primary of output transformer T1. The secondary of this transformer offers three outputs, these being at impedances of 2.5Ω, 8Ω and 15Ω. The whole of the secondary also appears in the negative feedback circuit, the signal on the 15Ω tap being fed back, via the potentiometer given by R14 and R4, to the cathode circuit of V1(a).

The negative feedback circuit includes the treble-cut tone control VR2. The track resistance of this potentiometer is approximately equal to R13, with the consequence that, since the anodes of V2 and V3 carry signals that are equal and apposite in phase, there is virtually zero signal at the junction of VR2 and R13. Thus, when the slider of VR2 is at the upper end of its track (upper as shown in Fig. 1) no output signal is applied as feedback. If the slider of VR2 is moved continually towards the lower end of its track a continually increasing output signal becomes available, this being fed back via C7 to the cathode circuit of V1(a). Since the reactance of C7 decreases as frequency rises, the higher audio frequencies are fed back with greater amplitude than the lower audio frequencies and, in consequence, the amplifier gives reduced gain at these higher frequencies. The overall effect is that a smooth control of tone is provided by VR2, with maximum attenuation of the higher frequencies when VR2 slider is at the bottom end of its track.

The power supply section of the amplifier employs standard circuitry. The a.c. mains supply is applied to

## COMPONENTS

### Resistors

(All fixed values  $\frac{1}{4}$  watt 5% unless otherwise stated)

R1	27k $\Omega$
R2	100k $\Omega$
R3	2.2k $\Omega$
R4	100 $\Omega$
R5	27k $\Omega$ $\frac{1}{2}$ watt 2%
R6	27k $\Omega$ $\frac{1}{2}$ watt 2%
R7	470k $\Omega$
R8	470k $\Omega$
R9	4.7k $\Omega$ 10%
R10	4.7k $\Omega$ 10%
R11	270 $\Omega$ 1 watt
R12	270 $\Omega$ 1 watt
R13	47k $\Omega$
R14	750 $\Omega$
R15	270 $\Omega$ 2 watts 10%
R16	470 $\Omega$ 5 watts 10%
R17	220 $\Omega$
R18	220 $\Omega$
VR1	1M $\Omega$ potentiometer, log
VR2	50k $\Omega$ potentiometer, linear, with switch
S1	

### Capacitors

C1	50 $\mu$ F electrolytic, 350V Wkg.
C2	25 $\mu$ F electrolytic, 6.4V Wkg.
C3	0.022 $\mu$ F paper or plastic foil, 350V Wkg.
C4	0.022 $\mu$ F paper or plastic foil, 350V Wkg.
C5	80 $\mu$ F electrolytic, 25V Wkg.
C6	80 $\mu$ F electrolytic, 25V Wkg.
C7	0.01 $\mu$ F paper or plastic foil, 150V Wkg.
C8	50 $\mu$ F electrolytic, 350V Wkg.
C9, C10	32 + 32 $\mu$ F dual electrolytic, 350V Wkg.

### Transformers

T1	Output transformer, Electrovoice I17A (Cat. No. T06, Home Radio)
T2	Mains transformer, Douglas type MT1AT Secondaries, 250-0-250V at 80mA, 6.3V at 3.5A, 6.3V at 1A (tap at 5V). (Henry's Radio)

### Valves

V1	12AU7
V2	6BW6
V3	6BW6
V4	EZ81

### Switch

S1	S.P.S.T. (part of VR2)
----	------------------------

### Socket

JK1	Standard phone jack (Cat. No. J2, Home Radio)
-----	---

### Miscellaneous

2-way terminal strip (Cat. No. Z101D, Home Radio)  
2 knobs  
4 B9A valveholders  
 $\frac{3}{8}$ in. grommet  
 $\frac{1}{2}$ in. grommet  
5 6BA solder tags  
8 6BA plain washers  
 $\frac{3}{8}$ in. washer (see text)  
3 doz. 6BA nuts and bolts  
3-core mains lead with plug  
2 ft. screened cable  
8 in. sleeving  
P.V.C. covered connecting wire

### Lektrokit Chassis Parts

(See text for details)

1 Chassis Plate No. 1, Part No. LK111  
1 Chassis Plate No. 2, Part No. LK121  
4 Chassis Rails, Short, Part No. LK211  
1 Packet of 10, Bracket No. 2, Part No. LK2321  
1 Packet of 10, Tagstrip 5-way, Part No. LK2231  
1 Packet of 10, Plastic Clip No. 3, Part No. LK2831  
1 Packet of 10, Lead-Through Insulators, No. 1, Part No. LK2021

the primary of T1. The h.t. secondary of this transformer couples to the anodes of the full-wave rectifier V4. A valve rectifier is employed here purely for practical expediency and not because of any desire to exclude semiconductor rectifiers, which would cope equally well. It so happens that, with the Lektrokit parts employed for the chassis, a B9A hole is available for a valve rectifier and it is about as simple to wire up a B9A valveholder as it would be to wire up, say, silicon rectifiers on tagstrips. A contact-cooled h.t. rectifier could also have been used but its mounting might have necessitated some 'metalworking' on the Lektrokit chassis parts, a procedure which the present design sets out to avoid. The h.t. current drawn from the supply is approximately 75mA.

One of the two 6.3 volt mains transformer secondaries supplies the heater of the rectifier whilst the other connects to the heaters of V1, V2 and V3. Two equal-value resistors, R17 and R18, are connected in series across this second 6.3 volt winding, their junction connecting to chassis. The function of these two resistors is to provide a virtual 'centre-tap' in the 6.3 volt winding which is at chassis potential.

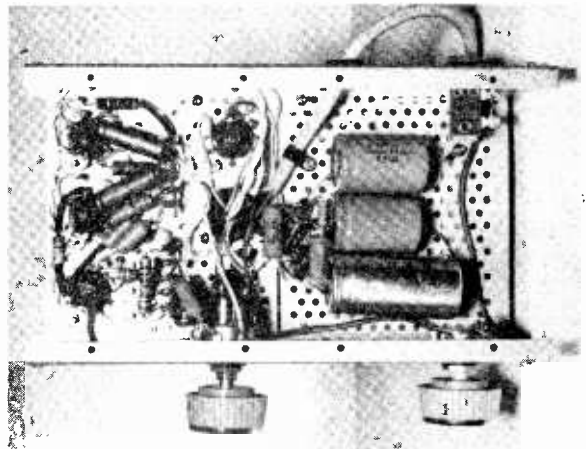

The under-chassis wiring. The layout is reasonably compact without being too crowded

# 25 JUBILEE AMPLIFIER

## COMPONENTS

All the components employed in the amplifier are standard types and little difficulty should be experienced in obtaining them. Where applicable, suitable sources of supply are named.

Of the resistors, R5 and R6 are the most critical, and these should have a tolerance of  $\pm 2\%$ . If  $\pm 2\%$  resistors cannot be obtained in  $27k\Omega$ , it will be in order to use two  $24k\Omega \pm 2\%$  or two  $30k\Omega \pm 2\%$  resistors instead. The actual values, from  $24k$  to  $30k\Omega$ , are less important than the fact that the two resistors should be matched to each other. R11 and R12 are specified as  $\pm 5\%$ . A marginal improvement in performance will be given if  $\pm 2\%$  resistors are used here, and the constructor can employ such resistors if he wishes. The same applies to R7 and R8 which are specified in the Components List as  $\pm 5\%$ . A slight improvement would be giving by using  $\pm 2\%$  resistors instead.

The cathode bias electrolytic capacitors, C2, C5 and C6 should be small modern types, and an excellent choice would be given by Mullard miniature components. There is plenty of space for the remaining electrolytic capacitors. C9 and C10 are given by a  $32 \times 32\mu F$  dual electrolytic capacitor in a single can. All capacitors are wire-ended.

The Lektrokit chassis parts are all obtainable from Home Radio, the Home Radio Cat. No. being the same as the Lektrokit Part No. The appearance of the various parts will be evident from the assembly diagrams which will be dealt with shortly. The 5-way tagstrips Part No. LK2231, the plastic clips Part No. LK2831, brackets Part No. LK2321 and the lead-through insulators Part No. LK2021, are all sold in packets of 10, with the consequence that some will be left over when the amplifier has been completed. If desired, the clips and brackets could be home-made as they are very simple items of hardware and only two of each are employed in the amplifier.

Nearly all the mechanical assembly is carried out by means of 6BA nuts and bolts, of which nearly 3 dozen are required. The bolts may be  $\frac{3}{8}$  in. cheese-head or close to this size. Eight 6BA plain washers are also required for securing the two transformers. The mounting holes for these transformers are 2BA clear and the plain washers are needed under the 6BA mounting screw heads to ensure that the mounting holes are fully covered. If the jack socket specified is employed for JK1, a  $\frac{3}{8}$  in. washer, either plain or spring, and of the type that is normally passed over the bush of a potentiometer, should be placed under its securing nut since the hole in the appropriate Lektrokit part is rather large for it. If either of the potentiometers employed in the amplifier is supplied with two washers, one of these may be used for the jack socket. Otherwise, the washer may be obtained from another component or from the spares box.

## ASSEMBLY

The first process to be carried out is mechanical assembly. To commence, take up two of the Chassis Rails, Short, and bolt them together with two 6BA nuts and bolts, as shown in Fig. 2. Repeat this process with the remaining two Chassis Rails, Short. These now form the front and back of the chassis and we shall refer to them as 'chassis rail assemblies'.

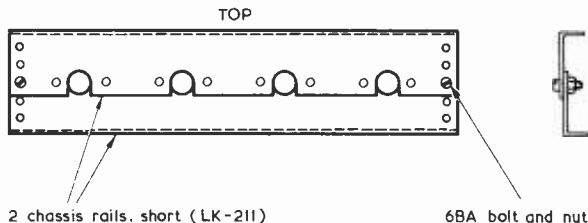

Fig. 2. How the front and rear chassis rail assemblies are made up

Take up the Chassis Plate No.1 (which is the plain perforated plate) and the Chassis Plate No. 2 (which is the perforated plate with six valveholder holes) and secure them to the two chassis rail assemblies in the manner shown in the top view given in Fig. 3. The resulting chassis is adequately rigid for the present requirements without any further strengthening. There are eight 6BA clear holes on the bottom edges of the front and rear chassis rail assemblies, and any of these can take self-tapping screws if, later, the amplifier is housed in a cabinet.

Next refer to the above-chassis view given in Fig. 4, the below-chassis view given in Fig. 5 and the end view of mains transformer T2 given in Fig. 6. Place the mains transformer on the chassis with its secondary tags to the left (left as shown in Fig. 4) and with the tags taking up the positions shown in Fig. 6. Position the transformer so that it is approximately in the position shown in Fig. 4, then slightly move it if necessary so that its four mounting slots coincide with four holes in the Lektrokit perforated plate. Secure the transformer with four 6BA nuts and bolts, putting plain washers under the bolt heads. The two right-hand bolts (in Fig. 4) simply secure the transformer to the chassis in normal fashion but, of the two left-hand bolts, one also secures a solder tag below the chassis whilst the other secures a solder tag above and another above the chassis. The below-chassis tags are shown in Fig. 5 and the above-chassis tag in Fig. 6.

Position output transformer T1 in the approximate position illustrated in Fig. 4. The primary leads (white and orange) and the secondary leads (black, yellow, green and red) should appear on the sides indicated in the diagram. If necessary, move T1 slightly so that its mounting holes coincide with holes in the perforated plates. Its two front mounting holes should correspond with the front row of holes in the plates. Then secure the transformer with four 6BA screws having plain washers under their heads. Note that one of the mounting bolts secures a tagstrip under the chassis, this being the right-hand tagstrip illustrated in Fig. 5. The actual positioning of this tagstrip may differ slightly from that shown in Fig. 5, but this does not matter provided that it has the correct orientation and is secured under the correct mounting nut for T1.

Fig. 3. Top view showing the two Chassis Plates in position

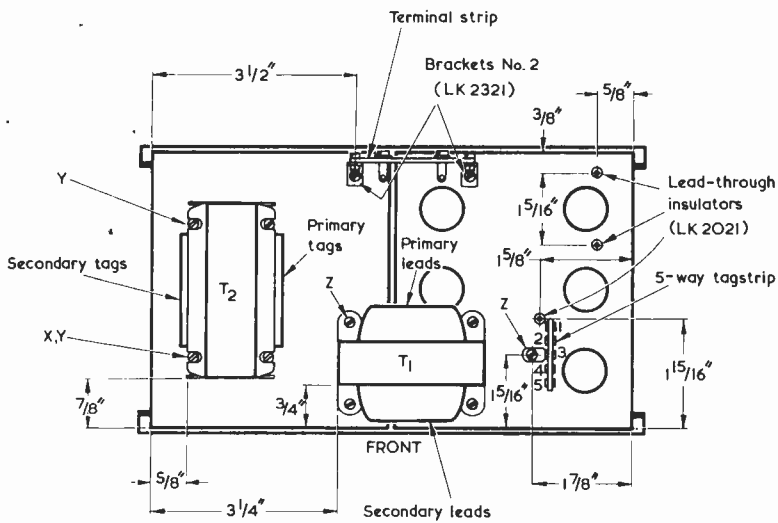
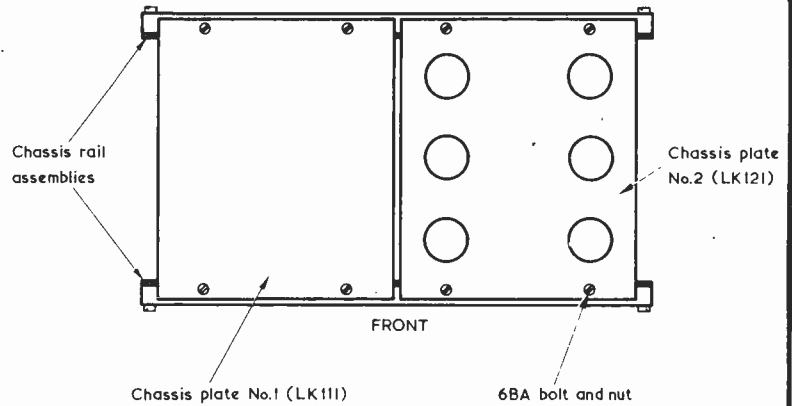
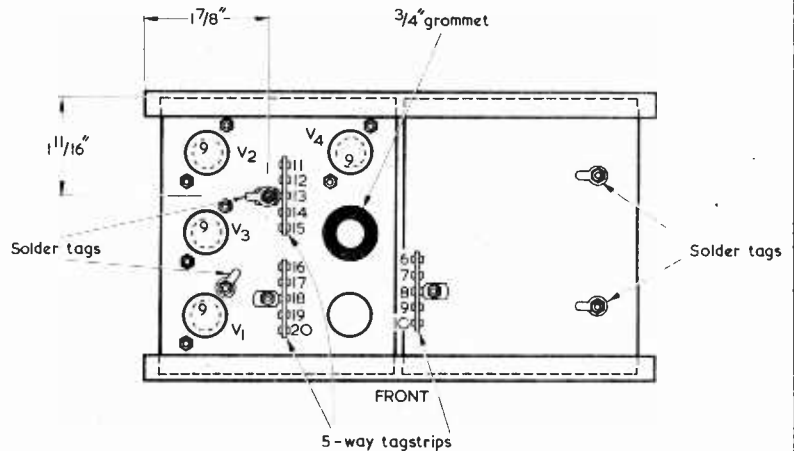

Fig. 4. The components mounted above the chassis

- X - solder tag above chassis
- Y - solder tag below chassis
- Z - tagstrip below chassis

Fig. 5. Below-chassis view, illustrating tagstrip and valve-holder orientation



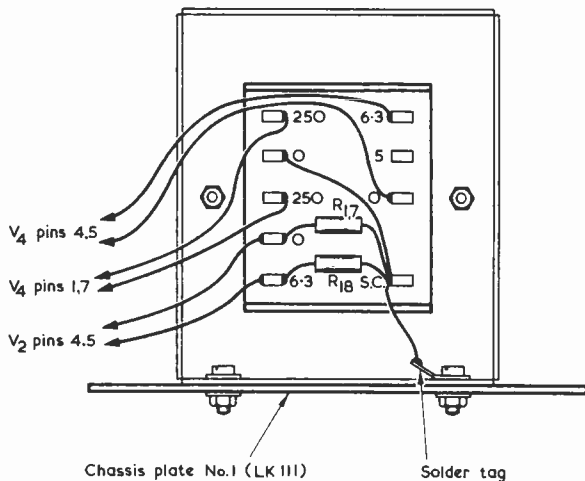
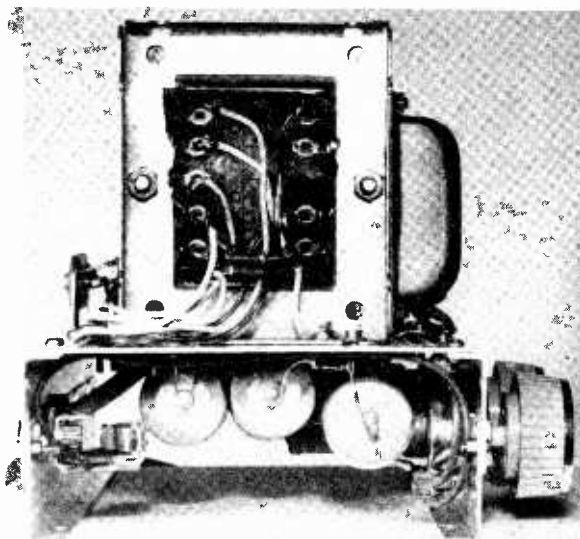

Fig. 6. End view of the mains transformer. The wiring details shown will be referred to in next month's issue



End view, illustrating the orientation and wiring of the mains transformer T2

Return again to Fig. 4 and loosely assemble the 2-way screw terminal strip to the two Brackets No. 2 (LK2321) using 6BA nuts and bolts. These brackets have a long section (about  $\frac{3}{4}$ in) and a short section (about  $\frac{1}{2}$ in.). It is the long sections which appear behind the terminal strip and the short sections which are bolted to the chassis. Find two holes in the rearmost row of perforated holes on the plates which enable the terminal strip to take up the position shown in Fig. 4. It may be found that exactly coincident holes are not available, but it should be possible to mount the brackets to the chassis, using 6BA nuts and bolts, without excessive mechanical strain being placed on the terminal strip. Tighten up all the nuts and bolts. Take care that the inside edges of the brackets do not short-circuit to the metal-work associated with either of the screw terminals.

Three lead-through insulators have to be fitted to the Chassis Plate No. 2, these being inserted from above into the Chassis Plate holes as indicated in Fig. 4. The writer found it necessary to file off the flash line (i.e. the line given where the two halves of the mould meet) on these insulators before they could be fitted, but this process only required a few touches with a file and he may have been unlucky enough to have obtained a bad batch of insulators.

Next, fit the tagstrip shown in Fig. 4, noting that the same 6BA nut and bolt also secure another tagstrip under the chassis as illustrated in Fig. 5. Fig. 5 shows a further tagstrip which is fitted under the chassis, and this appears on the same front-to-back row of holes as the previous two. Note that a solder tag is mounted under its securing nut.

The final assembly task consists of fitting the four B9A valveholders and the  $\frac{3}{4}$ in. grommet. The valveholders are mounted with the orientation shown in Fig. 5, a solder tag being secured under one of the mounting nuts for V1 valveholder, as illustrated. The grommet fits in the centre right-hand valveholder hole. The sixth valveholder hole is covered by transformer T1, and no component is fitted to it.

#### NEXT MONTH

This completes the mechanical assembly of the 'Jubilee' amplifier. In next month's concluding article the process of wiring up will be described.

(To be concluded)

## BACK NUMBERS

For the benefit of new readers we would draw attention to our back number service.

We retain past issues for a period of two years and we can, occasionally, supply copies more than two years old. The cost is the cover price stated on the issue, plus 6p postage.

Before undertaking any constructional project described in a back issue, it must be borne in mind that components readily available at the time of publication may no longer be so.

We regret that we are unable to supply photo copies of articles where an issue is not available. Libraries and members of local radio clubs can often be very helpful where an issue is not available for sale.



# Receiver Headphone Adaptor

by  
C. M. Lindars

An adaptor which will be found helpful in clearing hum when headphones are used with medium priced communications receivers

THE PIECE OF EQUIPMENT TO BE DESCRIBED WILL BE found of use to readers who use headphones with the medium priced communications receivers. Many receivers in this class do not boast a sophisticated smoothing system in the h.t. line, and therefore a degree of hum is introduced into the background which becomes an annoyance when using headphones.

Even after steps are taken to improve the smoothing, a certain amount of residual hum remains. The author uses a pair of low impedance ex-Government headphones, style DLR5, as these are found to be very sensitive and satisfactory for most purposes.

## MISMATCH

Nevertheless, there is a considerable degree of mismatch when these headphones are plugged into the  $8\Omega$  output socket of a communications receiver, since the output transformer of the receiver does not work into a correct load.

The mismatch is cleared by using an adaptor having the circuit shown in Fig. 1. In this, an  $8\Omega$  2 watt resistor provides a correct load for the receiver output stage, whilst the  $0.1\mu\text{F}$  capacitor attenuates the lower frequencies and thereby reduces the hum level in the headphones. The  $0.1\mu\text{F}$  capacitor suits the DLR5 phones, but readers using phones of higher impedance may prefer to employ a capacitor having a smaller value. The 2 watt loading resistor should naturally be of a value corresponding to the output impedance of the receiver and need not necessarily be  $8\Omega$ .

The author was able to fit the components into an ex-Government high-to-low impedance head-set transformer unit type MC-385-D. This consists of a small

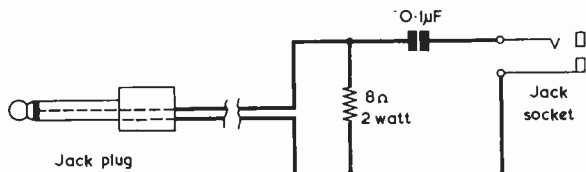

Fig. 1. Circuit of the headphone adaptor. The resistor, capacitor and jack socket may be housed in a small case, if desired

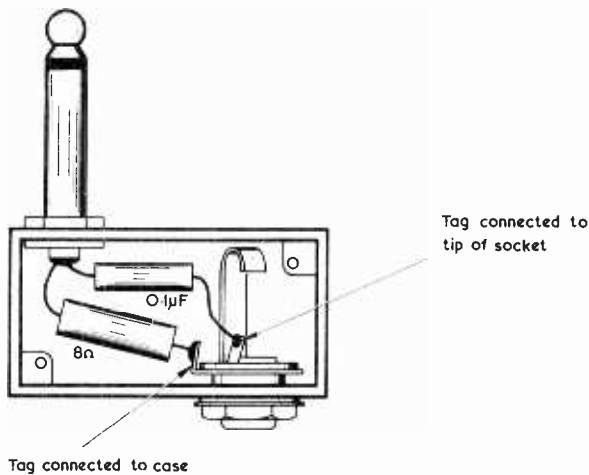

Fig. 2. A particularly neat construction is given by mounting the resistor and capacitor in a modified ex-Government transformer unit type MC-385-D

rectangular metal case fitted with a jack socket and having an integral jack plug. Units of this type were commonly available in the surplus stores some years ago and there should still be quite a few around, although the author, at the time of writing, cannot specify a particular retail source. A few brief notes on the modification of the unit to the circuit of Fig. 1 may be of interest.

The lid of the ex-Government transformer unit is gently prised off after drilling out the two securing rivets to a depth of about  $\frac{1}{16}$  in. with a No. 30 drill. The transformer and wax inside the case are next removed. If it is intended to retain the transformer for other purposes, care must be exercised when removing the wax and unsoldering the transformer leads.

Using a pair of pliers, the alloy partition inside the case is next gently broken away until there remains only a slight ribbing close to the inside walls of the case. The jack plug and socket tags are next cleared of solder using a fairly hot iron, and the resistor and capacitor fitted, as shown in Fig. 2.

The lid of the case may then be refitted by any convenient means, such as a single 6BA countersunk bolt and nut passing through central holes in the lid and the bottom of the case. ■

# SHORT WAVE NEWS

## FOR DX LISTENERS

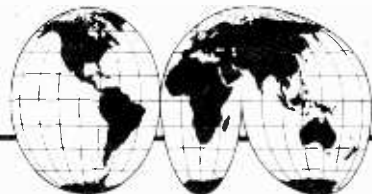

By Frank A. Baldwin

Times = GMT

Frequencies = kHz

Radio Garoua in the Republic of Cameroon is on the air from 0500 to 2200 on **5010** (59.88 metres) and has recently been reported with a news service and programme in English from 1830 to 1900. The main programming is in French and African vernaculars. The channel is subject to some commercial interference at times, often throughout a whole evening, but on some occasions the station can be heard 'in the clear'. The address is - Radio Garoua, B.P.103, Garoua.

The Cuba of Fidel Castro can be heard broadcasting to Europe, in English, from 2010 to 2140 on **17815** (16.84m), according to the latest (at the time of writing) news. However, this channel is also being currently used by HCJB at the same time, therefore the chances of hearing Radio Havana are considerably reduced. The address of Radio Havana is - Radio Habana, Apartado 7026, La Habana, Cuba.

HCJB (Herald Christ Jesus Blessing) La Voz de Los Andes, Quito, Ecuador, has been logged here in the U.K. at 2015 with identification in English and the usual evangelical programming. HCJB has also been currently heard, in parallel, on **15300** (19.61m). Both the **17815** and the **15300** channels provide good reception, conditions being reasonable, here in the U.K.

### 15MHz AND ALL THAT

For a real Dx thrill, return to the **15300** channel at 2200 when, if conditions are right, you may log NHK Tokyo - a station not often heard here in the U.K. We heard the station identification in English at 2200 followed by a newscast in English. Reception of Japan is not an easy matter and Tokyo is not therefore often mentioned in the SWL press of this country.

Around this same area of the dial, listen on **15265** (19.66m) at 1800 for the news in English from Kabul, Afghanistan, where it has recently been reported by BADX (British Association of Dx'ers).

If you are still hanging around this part of the spectrum at 1930 or so, keep an ear open for Radio Kinshasha on a measured **15248** (19.67m) when it was logged here with African music.

Still dealing with the 15MHz band, try **15185** (19.76m) at 2130 and hear the full identification of WINB Red Lion, in the U.S.A. The address is - World Inter-National Broadcasters, P.O. Box 88, Red Lion, Pennsylvania.

The frequency of **15105** (19.86m) could produce for you either Radio Grenada of the West Indies Broadcasting Service around 2100 or, if you rise early enough, (0659) NHK Tokyo with interval signal, station identification followed by the English programme beamed to the U.S.A., both according to BADX.

Two other interesting channels on this band are **15155** (19.80m) where one may hear ZYB9 Radio Dif de Sao Paulo, Brazil, with programming in Portuguese, usually around 2200 or so, although we recently logged

it as early as 1920 and **15450** (19.41m) where the new experimental service of Radio Nacional de Brasilia, in English to Europe, may be heard around 2345 onwards.

### TIME CHECK - 1

For those readers who would like to 'have-a-go' at the foregoing 15MHz transmissions on a time check basis, and we gather there are quite a few, the stations are listed here in GMT order.

15MHz BAND			
GMT	Freq.	Stn.	Rcvd.
1800	15265	R. Kabul	
1930	15248	Kinshasha	
2015	15300	HCJB	
2100	15105	Grenada	
2130	15185	WINB	
2200	15300	Tokyo	
2200	15155	ZYB9	
2345	15450	Brasilia	

Tick-off, when they have been logged, in the Rcvd. column.

### NOW HEAR THESE

#### ● ETHIOPIA

This country may be heard, according to BADX, on **9580** (31.32m) at 1600 with the English programme and with news at 1630.

#### ● NEPAL

Radio Nepal, which recently made news when it was heard on **5000**, has been logged on **9601** (31.25m) from 0720 to 0950 and from 0120 to 0350 with the news in English at 0302.

#### ● SAUDI ARABIA

The Saudi Arabia Broadcasting Service has been heard with a new transmission on a new frequency. A programme in Arabic was logged from 0115 to past 0215 on **9613** (31.21m).

#### ● ABU DHABI

Abu Dhabi Radio has been heard signing on at 0225 with an interval signal of 18 notes on **9618V** (the V = frequency varies from day to day, plus or minus that given). The frequency **9618** equals 31.19m. (BADX).

#### ● SEYCHELLES

The Far Eastern Broadcasting Association in the Seychelles may be logged from 1730 in English to 1800, then into Arabic until sign-off at 1900 on **11955** (25.09m). Also in parallel on **15435** (19.44m) but with QRM (interference) from Moscow.

#### ● FINLAND

Helsinki can be heard at 1800 on **15185** (19.76m) with the programme in English. Also in parallel on **9555** (31.40m) and **11755** (25.52m).

RADIO & ELECTRONICS CONSTRUCTOR

● **UGANDA**

Kampala has been logged here at 2010 on the regular 4976 (60.29m) channel with the news in English and comment on world affairs.

● **CANADA**

Sackville was heard at 2125 on 17820 (16.84m) when a programme in English about Canadian architecture was being radiated.

● **GABON**

Libreville on 4777 (62.80m) with its 100kW transmitter is often one of the best signals from Africa on the 60m band. Heard here recently at 2040 with an orchestra (?) of African drums and percussion instruments rendering a very 'catchy' beat rhythm.

● **DOMINICAN REPUBLIC**

La Voz de las Fuerzas Armadas can often be logged quite early in the evening on 4825 (62.18m). It was recently logged here at 2155 at quite a surprising signal strength considering the comparatively low power of the transmitter - 3kW.

● **UPPER VOLTA**

Ouagadougou on 4815 (62.31m) with a 4kW transmitter is another African that can often be logged here in the U.K. at a good signal strength, being logged here at 2035 with African music followed by a talk in French.

● **BRAZIL**

A Brazilian station that can often be logged quite early - for LA stations that is - in the evening is ZYX2 on 4995 (60.06m). Radio Brasil Central is listed at 5kW and has been heard here at 2135 with a sports commentary in Portuguese.

● **MOZAMBIQUE**

Another African station worth listening for is Radio Clube Mozambique on 4762 (63.00m) 10kW. We logged this one at 2020 with LA-type music followed by a talk in French.

**TIME CHECK - 2**

As in Time Check - 1, we list here the stations mentioned in Now Hear These.

GMT	Freq.	Country	Rcvd.
0115	9613	Saudi Arabia	
0225	9618	Abu Dhabi	
0302	9601	Nepal	
1600	9580	Ethiopia	
1730	11955	Seychelles	
1800	15185	Finland	
2010	4976	Uganda	
2020	4815	U. Volta	
2040	4777	Gabon	
2125	17820	Canada	
2135	4995	Brazil	
2155	4825	Dom. Rep.	

**CURRENT SCHEDULES**

● **POLAND**

The latest schedule of Radio Warsaw, to Europe in English, is as follows - from 0630 to 0700 on 7285 (41.18m), 9540 (31.45m) and 9675 (31.01m). From 1200 to 1230 on 7285 and 9675; from 1600 to 1630 on 6035 (49.71m), 7125 (42.11m), 7285 and 9675, also from 1830 to 1900 on the latter four channels. From 2030 to 2100 on 7285 and 9675 and from 2230 to 2300 on 5995 (50.04m), 6135 (48.90m), 7285 and on 9675.

● **ROMANIA**

Radio Bucharest broadcasts to Europe, in English, as follows - from 1300 to 1330 on 9690 (30.96m), 11940 (25.13m) and on 15250 (19.67m); from 1930 to 2030 on 9570 (31.35m) and on 11775 (25.48m); from 2100 to 2130 on 9690 and on 11940.

● **CZECHOSLOVAKIA**

Radio Prague schedule, in English to the U.K. is as follows - from 1500 to 1530 on 6055 (49.55m) and on 9505 (31.56m); from 1630 to 1700 on 5930 (50.59m) and on 7345 (40.85m); from 1900 to 1930 on 5930 and on 7345 and from 2200 to 2230 on 6055.

● **EAST GERMANY**

Radio Berlin International broadcasts to Europe, in English, from 1815 to 1900 on 6080 (49.34m), 6115 (49.06m), 7185 (41.75m) and on 7300 (41.09m). To the U.K. from 2130 to 2215 on 6080, 6115, 7185, 7300 and on 9730 (30.83m); from 2245 to 2330 also on the latter five channels.

● **BULGARIA**

Radio Sofia, in English to the U.K., from 1930 to 2000 on 6070 (49.42m) and 9700 (30.93m) and from 2130 to 2200 on the same channels.

**BBCMS**

The BBC Monitoring Service, sometimes quoted in SWL literature here in the U.K., is undoubtedly a shadowy and mysterious organisation to most short wave listeners. Many however are vaguely aware that a round-the-clock listening watch is maintained on the short waves and on other frequencies but at this point their knowledge ends.

The rows of communication receivers, the vast aerial farm, the system and the organisation itself is all clearly described by one of the two SWL's who recently gained permission (a rare honour) to visit this complex reception site at Caversham Park.

A 12 page foolscap detailed description of BBCMS and its work, the only published details known to the writer, is available from Alan B. Thompson, 16 Ena Avenue, Neath, Glamorgan SA11 3AD, price 20p post paid. "BBCMS - A Layman Looks at Caversham Park" is comprehensive, accurate (checked by BBCMS) and exclusive.

# ZENER DIODE 'BUZZER'

by  
R. J. Caborn

Producing a near-square wave at 50Hz, this little unit has a number of uses in the servicing of audio equipment.

IT IS NOT ALWAYS REMEMBERED THAT, whilst a zener diode operates in its intended manner when current flows through it in the reverse direction, it functions as an ordinary diode when current passes through it in the forward direction. This fact provides the basis for the simple item of test equipment now to be described.

## CIRCUIT OPERATION

The circuit of the unit appears in Fig. 1. Here, any mains transformer having a secondary voltage between 200 and 250 is coupled to the series combination of resistor R1 and the 4.7 volt zener diode ZD1. On half-cycles when the upper end of the transformer secondary is positive the diode functions as a zener diode and, over nearly all of each half-cycle, allows a voltage of about 4.7 to appear across its terminals. On half-cycles when the upper end of the transformer secondary is negative the diode functions as an ordinary silicon diode, and allows about 0.6 volt to appear across it.

The effect is illustrated in Fig. 2 which shows the waveform appearing at the upper terminal of the diode on successive half-cycles. As will be apparent, this waveform is very nearly a square wave, but there is in practice a slight rounding at the corners since the diode does not go abruptly into zener or forward conduction as the voltage applied to it passes through the appropriate level. It is to keep this rounding to a low level that R1 is given the rather small value of 22kΩ. This allows an average current of about 10mA to flow on each half-cycle, thereby taking the diode quickly into and out of full zener or full forward conduction as the voltage across the transformer secondary increases and decreases. There is also a very slight delay in the transitions from zener to forward conduction and from forward to zener conduction, this being given by the time needed for the 50Hz sine wave to change from 4.7 volts positive to 0.6 volt negative as its polarity changes, or from 0.6 volt negative to 4.7 volts positive as its polarity changes in the opposite direction.

These factors cause the waveform across the diode to fall short of the ideal square wave shape. Nevertheless, the waveform is still sufficiently close to a square wave to contain a large number of harmonics of 50Hz, and it is this factor which provides the main usefulness of the unit.

The near-square wave signal across the diode is coupled via C1 to the potentiometer R2, which acts as an output attenuator. Its slider connects by way of C2 to the upper output terminal. A flexible test lead is connected to each of the output terminals.

## USING THE UNIT

The unit is intended for the servicing of audio amplifiers. The lower test lead is clipped to the chassis of the amplifier being checked whilst the upper test lead is employed as a signal-injection probe. If it is applied to a high impedance signal point in a serviceable amplifier it causes the amplifier loudspeaker to reproduce a raucous buzz which is very similar in sound to the frame buzz given in TV

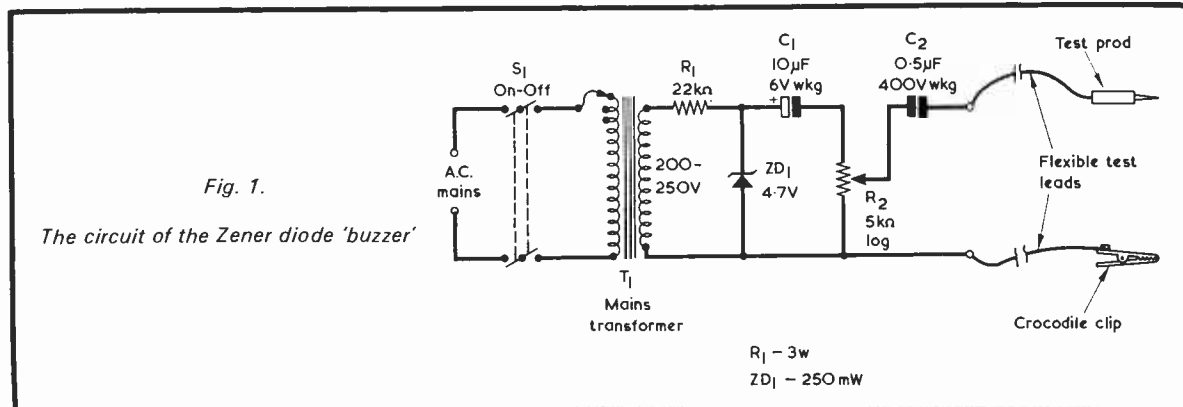

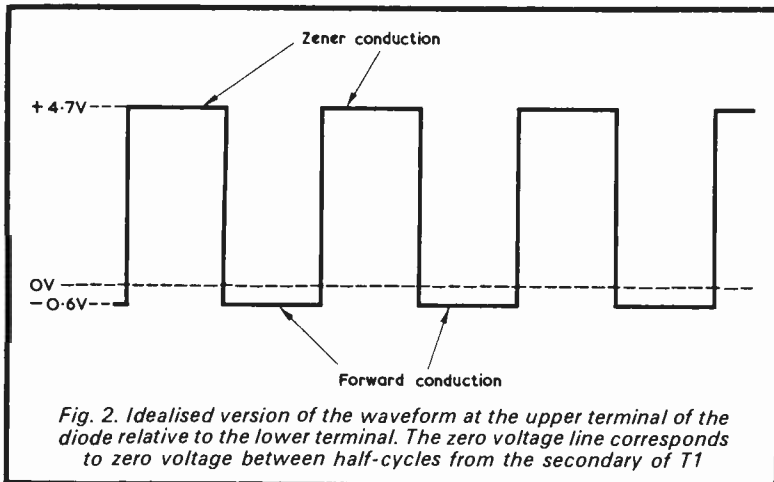

sets. This buzz is the reason for the name which has been given to the unit in the title of this article.

With valve amplifiers the output of the unit is more than adequate to give a loud signal when applied to the grid of an output valve. With transistor amplifiers it should with conventional

transistor amplifiers. However, a higher injection current into transistor amplifiers would result if the capacitor following R2 had a larger value. If the constructor has no objections to the addition of a further switch, he may employ the alternative circuit coupling R2 to the test prod which is shown in

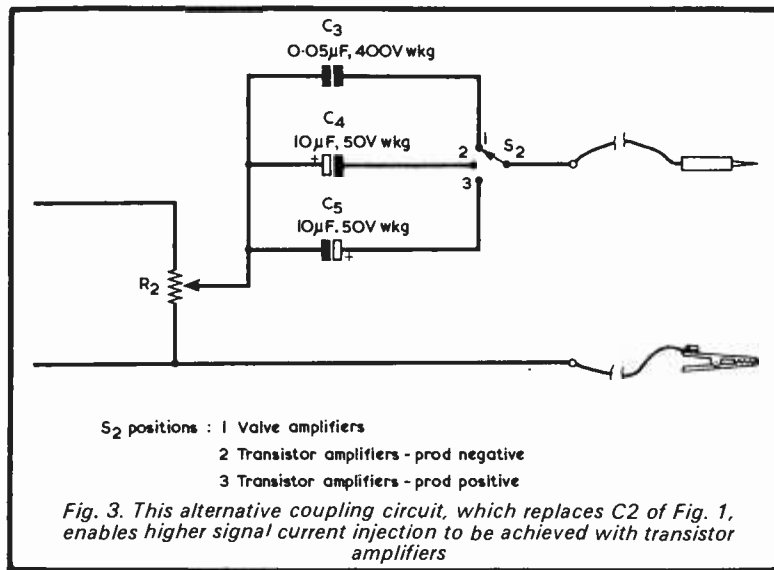

circuits provide a good signal if applied to the base of an output transistor. A little experience with working amplifiers soon enables the user to assess its performance.

So far as components are concerned, the mains transformer may, as already stated, be any type having a secondary voltage between 200 and 250. The current drawn from the secondary is only about 10mA. Capacitor C1 is shown as 10µF, but it could in practice have any value from 5µF to 20µF. C2 is shown as 0.5µF 400 V. Wkg., and is a paper or plastic foil component. This value should provide a reasonable compromise between cost and performance with both valve and trans-

istor amplifiers. In this diagram, switch S2 selects either C3, a paper or plastic foil capacitor, for work with valve amplifiers, or the electrolytic capacitors C4 or C5 for work with transistor amplifiers. C4 is selected if the test prod is to be applied to points in the amplifier which are negative of its chassis, and C5 is selected when the test prod is to connect to points in the amplifier which are positive of its chassis. Again, component values are not critical, and variations on those shown are permissible. C3 can in practice have any value between 0.02 and 0.2µF, whilst C4 and C5 can each have any value between 5 and 20µF.

# AUDIO AMPLIFIERS



**16 Transistor & Valve Designs for the Home Constructor**

*Amplifiers for Tuner Units, Record Players, Tape Recorders, Public Address, etc., etc.*

Includes contributions by such well-known authors as

A. S. Carpenter, A. Kinloch, E. Govier, G. A. French, F. G. Rayer, P. F. Bretherick, K. Jones, D. Aldous, R. Murray-Shelley, C. Swires, G. A. Stevens and V. E. Holley.

Edited by J. R. Davies

124 pages

**PRICE 53p**

Postage 6p

To: **DATA PUBLICATIONS Ltd., 57 Maida Vale London W9**

Please supply ..... copy(ies) of "Audio Amplifiers", Data Book No. 18. I enclose cheque/crossed postal order for.....

Name.....

Address.....

.....

.....

..... RC

**BLOCK LETTERS PLEASE**

# New Products

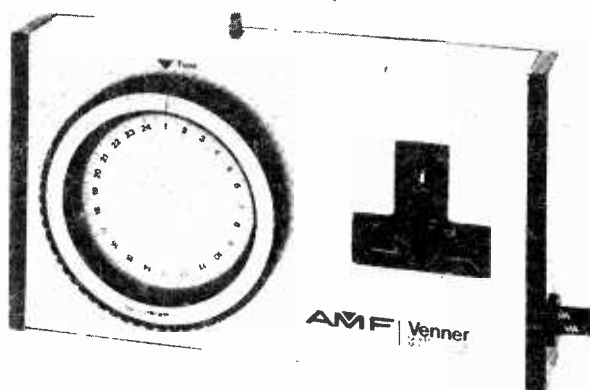

## VENNER INTRODUCE AUTOPOINT 80 FREE-STANDING TIMER

The AMF Venner range of domestic time switches now includes the Autopoint 80 timer capable of switching up to 13 amps, is designed for controlling the operation of heaters, lamps, radio and electric blankets, etc. It can also find application as a master On/Off control for lighting, or for control of an "intruder deception" lamp in the home. The Autopoint 80 is fitted with easily-adjusted trips on a 24-hour timing dial, which can be set to provide any length of "ON" period during the 24-hour cycle. Operation of an "Advance" button at the top of the casing sets the timer to the next preset condition. The switched output is taken from an integral shuttered 13 amp socket, connexion from the mains being via an attached flexible 3-core cable.

The case is of robust metal and shock-resistant plastic construction. The timer is small enough simply to lie near the controlled appliance.

## BULGIN RANGE OF CONTROL KNOBS

A highly polished black moulded Control Knob supplied with a Spin Decor Disc. Satin finish and other body colours available. Push fixing to  $\frac{1}{4}$ " flatted shafts, this shallow knob has finely ribbed sides and is designed for use with components mounted on a sub-panel. It has an extended rear boss which is keyed to provide means of stopped rotation if required.

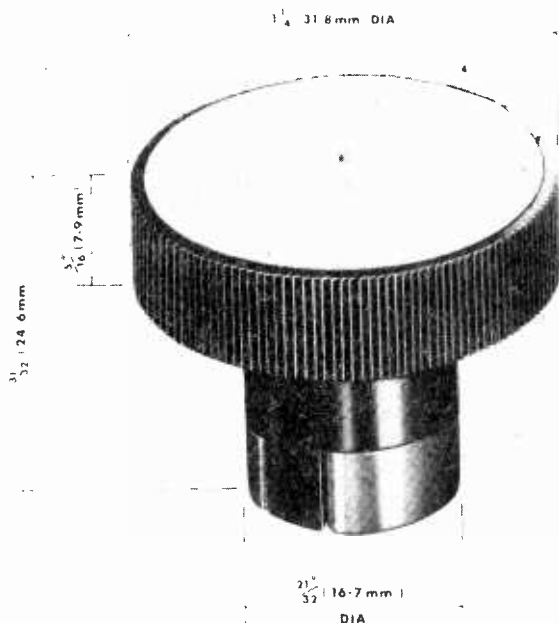

## POWERCARDS - PLUG-IN/CHASSIS MOUNTED POWER SUPPLIES

A range of low-cost stabilised power supplies for plug-in or chassis mounted use - known as 'Powercards' - is announced by ITT.

There are five Powercards immediately available. Two models have single outputs of 5 to 6V at 1.5A and 12 to 15V at 500mA. Three dual output units provide 250mA outputs with voltage options of 12 to 15V tracking, 12 to 15V independent and asymmetric outputs of 12 to 15V/5 to 6V. All powercards are suitable for input voltages of 100 to 132V and 200 to 264V at 48 to 65Hz, thus eliminating the need for tap changes within a voltage range.

Powercard units have three major protection features, i.e. reverse polarity protection, parallel protection and current limiting protection. Additionally as protection for t.t.l. circuits the 5V unit has crowbar over-voltage protection.

Performance characteristics matched to the major integrated circuit families - digital, linear and operational amplifiers - coupled with extreme compactness makes the Powercard range electrically and mechanically suitable for a wide range of applications.

Key features of the Powercard design are the metal cover which acts as a heat-sink so giving the units their low profile and robustness, and the use of a toroidal transformer. The latter minimises magnetic leakage and cuts down radiation.

For further information contact ITT Components Group Europe, Rectifier Product Division, Edinburgh Way, Harlow, Essex.

RADIO & ELECTRONICS CONSTRUCTOR

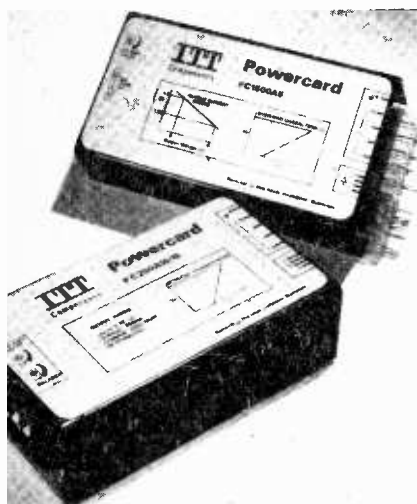

# In your workshop



As is usual in August, Smithy the Serviceman and his able assistant, Dick, leave the confines of the Workshop and take a little holiday together. On this occasion we find them embarking for a day by the sea, submitting themselves in the process to the hospitality of British Rail. Smithy also takes the opportunity to expound upon the basic principles of negative feedback

**B**LIMEY SMITHY, LET THEM GET OFF first!"

The train had just pulled in to the platform, whereupon Dick and Smithy had found themselves facing a series of first class carriages. Smithy had at once run towards the nearest second class carriage whilst his assistant strolled along unhurriedly in his rear. The last of the passengers getting off were just leaving the carriage when Dick caught up with the perspiring Serviceman. That worthy muttered irritably to himself as the final passenger leisurely proceeded to unload a vast quantity of suitcases and parcels.

"For goodness' sake," went on Dick, "stop panicking, Smithy. There'll be stacks of room for you and me."

"I'm not panicking," replied Smithy impatiently. "It's just that I like to get a proper seat when I'm on a train. I like to get a seat that's right by the window and facing the engine."

At last the passenger took out his ultimate parcel, whereupon Smithy rushed inside. The carriage was of the open type with tables, each table having a double seat on either side. Nearly all the seats were fully occupied, but there was one table at which there were no passengers.

## NEGATIVE FEEDBACK

With Dick following unconcernedly, Smithy moved quickly towards the empty table. As he reached it he paused and frowned.

"Now, let's get my bearings," he remarked doubtfully. "Which of these seats is facing the engine?"

Dick had already slipped nonchalantly into one of the window seats.

"Take the seat opposite me," he suggested. "That should be all right."

Hastily, Smithy manoeuvred himself into the seat indicated by his assistant. He took out a handkerchief and mopped his brow.

"This is a bit of all right, isn't it?" he remarked cheerfully, as he looked around him. "It certainly makes a change from the old Workshop."

"It would be a bit of all right," returned Dick severely, "if you'd stop fussing around all the time like an old hen who's looking for somewhere to lay her eggs. It was bad enough even before the train got in. You must have looked at that darned time-table at least six times, as well as asking no less than three porters when the train was due. And then, when the train *did* come in, you went haring up the platform as though your life depended on your getting a seat."

"Well, I've got a seat now," retorted Smithy smugly. "So I can relax and enjoy myself. There's nothing I like better than a train ride, even if it's only because it's somebody else who's driving!"

At that instant there was a click from the station loudspeaker system, followed by a loud howl. The howl suddenly stopped, after which the loudspeakers announced the destinations of the train in which Dick and Smithy were sitting.

"The station announcer," chuckled Smithy, "seems to be having a bit of a feedback problem."

"He's not the only one," replied Dick unexpectedly. "I've got one, too."

"A feedback problem?"

"That's right," stated Dick. "I'm in the process of mending a record-player amplifier for a mate of mine. This has got negative feedback and, just for the sake of interest, I tried it out with the negative feedback disconnected. Do you know, Smithy, that amplifier was quite a lot more sensitive without the negative feedback."

"Of course it would be, you twit," snorted Smithy. "Negative feedback is bound to reduce the gain of an amplifier."

"Then what's the point of it?" retorted Dick. "Why go to all the trouble of providing a high degree of gain in an amplifier if you're going to knock it all down again by adding negative feedback?"

Smithy sighed.

"The idea behind using feedback in an a.f. amplifier," he pointed out, "is to reduce distortion and noise."

"I can't see that," disputed Dick. "All negative feedback can do is simply cut down gain. What else can it do?"

Wearily, Smithy reached into his pocket, produced some letters and then unclipped his pen.

"Look," he said, "it's obvious that you haven't got a clue about negative feedback, so I'll just give you a demonstration of how it operates."

The Serviceman smoothed out a sheet from one of the letters and proceeded to draw a diagram on its blank side. (Fig. 1(a))

"Now here," he went on, "we have an ordinary a.f. amplifier. Let's say that its voltage gain is equal to A, which means that if you put in an input signal of 1 volt, the output will be A volts. Okay?"

Dick nodded. At that instant the guard's whistle was heard, together with a final slamming of doors. The train commenced to move.

"Right," said Smithy, completely intent on his diagram. "I am now going to add negative feedback to the amplifier. One way of doing this is to put a resistor in series with the earthy side of the input and to connect this to a second resistor which couples to the non-earthly side of the output. I'll call these two resistors R1 and R2 respectively."

Smithy added the two resistors whilst Dick looked on with interest. (Fig. 1(b)).

"I'd better," commented Dick, "ask the obvious question. Is the output of the amplifier in opposite phase to the input?"

"It is," confirmed Smithy. "When the non-earthly input terminal goes positive, the non-earthly output terminal goes negative, and vice versa. If the two terminals were in phase you'd have positive instead of negative feedback and the whole outfit would go into oscillation. As it happens, I've included some plus and minus signs on my diagram to illustrate the phase situation for one particular half-cycle input."

"So you have," returned Dick, looking more closely at Smithy's sketch. "I hadn't noticed them before."

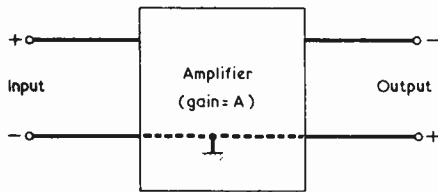

(a)

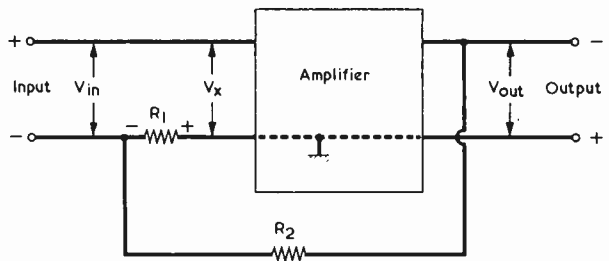

(b)

Fig. 1 (a) Block diagram for an a.f. amplifier without negative feedback. One input terminal and one output terminal is at chassis potential. The plus and minus signs indicate signal polarity at a particular half-cycle  
(b) Adding negative feedback to the amplifier

"Fair enough," commented Smithy. "You'll also note that I've called the voltage from the signal source  $V_{in}$ , the signal voltage at the actual input terminals of the amplifier  $V_x$ , and the output voltage  $V_{out}$ . We've already said that, without feedback, the amplifier has a gain of  $A$  times, so we can now say that  $A$  is equal to  $V_{out}$  divided by  $V_x$ . Or, that  $V_{out}$  is  $A$  times  $V_x$ ."

"The input voltage,  $V_{in}$ ," put in Dick, "will have to be larger than  $V_x$ , won't it? It's got to be equal to  $V_x$  plus the fraction of the output voltage which appears across  $R_1$ ."

"That's right," confirmed Smithy. "This state of affairs can be readily understood if you look at the plus and minus signs I've put alongside  $R_1$ . The next point to take in is that  $R_1$  and  $R_2$  form a potentiometer and the fraction of the output voltage which appears across  $R_1$  is equal to  $R_1$  divided by the sum of  $R_1$  and  $R_2$ . Let's scribble out the equations we've dealt with up to now. It's easier to work out this business on paper than to try and do it in your head."

Smithy wrote out the relationships. (Fig. 2).

"To make things easier," he went on, "I'll refer to  $R_1$  divided by the sum of  $R_1$  and  $R_2$  as  $n$ , whereupon we can say that the voltage across  $R_1$  is equal to  $n$  times  $V_{out}$ . Now, for the same output voltage,  $V_{in}$  has to be greater than  $V_x$  by the voltage across  $R_1$ , which means that  $V_{in}$  has to be  $V_x$  plus  $n$  times  $V_{out}$ . We've already seen that  $V_{out}$  is equal to  $A$  times  $V_x$  so we can next say that  $V_{in}$  is equal to  $V_x$  plus  $n$  times  $AV_x$ . And that is the same as  $V_x$  into  $1$  plus  $nA$ ."

As he spoke, Smithy wrote out the equations. He now turned the sheet round so that Dick could see them.

"Well," said Dick, "that seems to be clear enough. What you've shown is that, for the same output,  $V_{in}$  has to be  $1$  plus  $nA$  times greater than  $V_x$ ."

"That's correct," replied Smithy, turning the paper back again. "It follows from this that the overall gain

with feedback, which is  $V_{out}$  divided by  $V_{in}$ , becomes equal to  $AV_x$  divided by  $V_x$  into  $1$  plus  $nA$ . The  $V_x$ 's cancel out, giving you an overall gain of  $A$  divided by  $1$  plus  $nA$ ."

#### FREQUENCY RESPONSE

"Humph," grunted Dick dubiously. "And where does that lead us to?"

"To a very important result which applies for the case when  $nA$  is large," said Smithy. "When this happens, we can ignore the  $1$  in the bottom part of the fraction, and say that overall gain is approximately equal to  $A$  divided by  $nA$ , which simplifies down to  $1$  over  $n$ . We said at the beginning that we would represent  $R_1$  divided by the sum of  $R_1$  and  $R_2$  as  $n$ , so we can now finally say that the overall gain is approximately equal to the sum of  $R_1$  and  $R_2$  divided by  $R_1$ ."

"I still," continued Dick stubbornly, "can't see where all this is getting to."

"Don't you?" retorted Smithy. "Well now, let's say you have an a.f. amplifier which, without feedback, offers a gain of 5,000 times at 1kHz, and a gain of only 500 at 50Hz and 10kHz. Say we apply feedback such that  $R_1$  plus  $R_2$  divided by  $R_1$  is equal to 25."

Smithy scribbled out the figures and made some quick calculations.

"The feedback," he went on, "will cause the gain of the amplifier to be approximately 25 times at all the three frequencies. If you work out the figures accurately, the gain at 1kHz becomes 24.4 times and, at 50Hz and 10kHz, becomes 23.8 times. Which represents a far better frequency response than occurred without the feedback."

"You're still losing a lot of gain," objected Dick.

"Gain is no problem," retorted Smithy. "It's easy enough to get gain in an amplifier, as all you've got to do is provide the requisite number of stages and the appropriate amplifying devices. The whole beauty of negative feedback is that, provided it's applied to an amplifier having a high gain level, it causes the gain of the amplifier to be governed by the values of two resistors. The result is that the amplifier can offer a much flatter frequency response than it could without feedback."

"Ah," exclaimed Dick, as light suddenly dawned. "I see it all now! The idea is to give the amplifier a high gain without feedback and then use the feedback to give a low gain with a

$$A = \frac{V_{out}}{V_x}$$

$$V_{out} = AV_x \dots\dots\dots(1)$$

Say  $\frac{R_1}{R_1 + R_2} = n$

$$\text{Then, } V_{in} = V_x + nV_{out}$$

$$= V_x + nAV_x$$

$$= V_x(1 + nA) \dots\dots\dots(2)$$

Combining (1) and (2):

$$\frac{V_{out}}{V_{in}} = \frac{AV_x}{V_x(1 + nA)}$$

$$= \frac{A}{1 + nA}$$

When  $nA$  is large:

$$\frac{V_{out}}{V_{in}} = \frac{A}{nA}$$

$$= \frac{1}{n}$$

$$= \frac{R_1 + R_2}{R_1}$$

Fig. 2 The calculations jotted down by Smithy as he evaluated the overall gain of the amplifier of Fig. 1(b)



really flat frequency response."

"That's about it," confirmed Smithy, glancing for the first time out of the window. "Negative feedback offers quite a few other advantages as well. Hey, what's all this?"

"What's all what?"  
"This seat of mine. I'm travelling backwards!"

Dick grinned.  
"I wondered how long it would be before you noticed."

"Why, you crafty devil! You pinched the seat facing the engine whilst I was trying to work out which one it was. I call that a rotten low-down trick."

"Despicable."  
"The sort of thing one wouldn't do to one's worst enemies."

"An action," stated Dick, "which would stink in the nostrils of decent men."

Smithy glared irately at his completely unperturbed assistant.

"There's no pleasure in going out with you," he complained bitterly. "You don't have friends, mate. You just know people of whom you hope to take advantage."

"Oh, come on, Smithy," remonstrated Dick. "We only caught this train so that we could have a day by the sea. You can sit facing the engine when we come back."

"All right, then," grumbled Smithy. "And I'll hold you to that, too."

The Serviceman gazed moodily out of the window. The carriage swayed slightly as its wheels beat out their familiar clackety-clack rhythm.

"You were saying," Dick reminded him gently, "that negative feedback offers other advantages in addition to the provision of a flat frequency response."

Smithy tore himself away from his dissatisfaction with the present seating arrangements.

"Was I?" he said absent-mindedly. "How far had I gone?"

"You said," prompted Dick, "that the beauty of negative feedback is that, provided the amplifier gain without feedback is high, the overall gain with feedback is governed by the value of the feedback resistors."

"Ah yes," said Smithy, "so I did. I think I should say here that, in the case of a standard a.f. amplifier, there are likely to be lower and higher frequencies at which the amplifier gain without feedback falls to a very low level. Obviously, negative feedback cannot improve the performance of the amplifier at these frequencies. With a well designed amplifier such frequencies will, in any case, be well outside the audio spectrum."

"What," asked Dick, returning to his previous question, "about those other advantages of negative feedback?"

"The other advantages?" repeated Smithy. "Well now, negative feedback also reduces distortion produced in the amplifier itself. This distortion will show itself in the form of unwanted

harmonics of the input signal. That is to say, if we feed a pure sine wave into an amplifier which causes distortion, that sine wave will appear at the amplifier output together with a number of harmonics. When negative feedback is applied to the amplifier it does two things. It first of all reduces the gain offered to the sine wave. Secondly, it causes the harmonics generated inside the amplifier to be fed back from the output to the input whereupon they become largely cancelled out. To take an example, let's say that we have an amplifier which, without feedback, has a gain of 1,000, and that we add feedback which brings its gain down to 50. This means a reduction in gain of 20 times. If, without feedback, that amplifier had 4% harmonic distortion, the feedback will reduce it by 20 times, with the result that the amplifier, with feedback, will offer a harmonic distortion of 0.2% only."

"Blow me," said Dick, impressed. "That really is something."

"Also," continued Smithy, warming to his theme, "the feedback will reduce any hum and noise that is produced in the amplifier, because the hum and noise voltages are similarly fed back to the input in antiphase."

"I'm really beginning to see the advantages offered by negative feedback now," remarked Dick. "What I'm not too clear about, though, is how the signal is fed back to the input in practice. In your circuit you showed me a resistor in series with the earthy input from the signal source. Wouldn't that be a difficult thing to arrange in a practical circuit?"

"It would be," agreed Smithy, scribbling two further circuits on the blank side of the letter he had taken from his pocket. "With valve amplifiers the usual practice is to take the feedback from the output transformer secondary and apply it to the cathode of the first valve inside the feedback loop. Like this."

Smithy indicated the first of his two diagrams. (Fig. 3(a).)

"The output at the speaker transformer secondary," he went on, "is at low impedance, and is quite capable of being coupled to the fairly low impedance offered by the valve cathode. Notice that we retain the fixed potentiometer offered by R1 and R2. R1 will have a value which is lower than that required for the cathode bias of the valve. The total cathode bias resistance is then provided by R1 and the resistor above it, the latter being bypassed by the parallel electrolytic capacitor."

"Could you take the feedback from the primary of the output transformer?"

"If you wanted to," replied Smithy. "You would, of course, need a series isolating capacitor because of the h.t. voltage on the primary. But it is much better to take the feedback from the output transformer secondary since the output transformer can itself introduce quite a bit of distortion, and

## Your Local Supplier

LONDON

Established 1910

### H. L. SMITH & CO. LTD.

*Comprehensive stocks of components by all leading makers*

287-9 EDGWARE ROAD  
LONDON W2 1BE

Tel: 01-723 5891

### THE MODERN BOOK CO.

*Largest selection of English & American radio and technical books in the country.*

19-21 PRAED STREET,  
LONDON, W2 1NP

Tel: 01-723 4185/2926

## ST. HELEN'S RADIO

Hi-Fi Equipment  
Tape Recorders  
Radio Receivers  
Television

*SPECIALISTS IN RADIO & ELECTRONIC TEXTBOOKS*

ST. HELENS GARDENS  
LONDON, W.10

Tel: 01-969 3657

NEW  
**15 Watt Hi-Fi AMPLIFIERS**  
£3.75 each plus 25p postage & packing

**7 TRANSISTORS - GUARANTEED PRINTED CIRCUIT - TESTED DESIGN BUILT - INSTRUCTIONS**

A great new 15 watt Hifi amplifier is now available at the low cost of £3.75. Just look at the specification—Power 15 Watts R.M.S., frequency response 15-19000 c/s. Signal to noise ratio better than 70 db. Harmonic distortion 0.1%. Input sensitivity 750 mv into 2k. These make the H. Electronics Hifi amplifier the best at its price—order now.

**H-ELECTRONICS.**  
105, Grange Road, London, S.E. 25

the feedback will reduce this. Another factor is that the impedance offered by the speaker will vary at different frequencies from its nominal value, and the feedback will take care of this, too."

"What about transistor amplifiers?"  
 "You have rather more freedom here," said Smithy, indicating the second of his two circuits. (Fig. 3(b).) "In a transistor amplifier the two output transistors usually work directly into the speaker and a fairly common approach for negative feedback con-

sists of coupling this back, via a resistor, to the emitter of an earlier transistor which is in the common emitter mode. An important advantage with transistor amplifiers is that it is possible to have direct couplings without coupling capacitors between most, if not all, of the stages."

### REACTIVE COUPLINGS

"Coffee, sir?"  
 Smithy looked up in surprise as a white-jacketed figure stood at his side.

"Why yes, please."  
 The waiter deposited two plastic cups on the table, then proceeded down the carriage.  
 "Blimey," said Smithy, "this is something new, isn't it?"  
 "What, coffee brought round to your table? It's a 'scheme that's been operating for quite some time now on some of the regions in British Rail."  
 "Well," said Smithy appreciatively, "I must say I'm all for it."  
 But Dick was more interested in negative feedback than in British Rail catering.

"What did you mean just now," he asked, "when you said that an important advantage with transistor amplifiers is the fact that they can have direct coupling between the stages?"  
 "What I meant," said Smithy, "was that there is a corresponding reduction in phase-shift throughout the amplifier. Look, for instance, at the situation where there is a coupling capacitor between two stages in an amplifier. The reactance of the capacitor increases as frequency falls, with the result that at a very low frequency the reactance will become considerably greater than the following resistance. The capacitor will then introduce a phase shift which tends toward 90 degrees. You will also get phase shifts due to the inductance of the output transformer, should one be used, and the inductance of the speaker. Each reactive component in the amplifying chain is bound to introduce a sizeable phase shift at *some* frequency, and so a basic approach in the design of an amplifier having negative feedback is to keep the number of reactive components inside the feedback loop to a low figure. If there are too many reactive components you may be unlucky enough to have an overall phase shift of 180° at one particular frequency. The feedback will then become positive and the amplifier may oscillate at the frequency at which the 180° phase shift occurs."

"Would that frequency be in the audio range?"  
 "Not necessarily," replied Smithy. "It could be either below or above the audible range. If it was below, it would become evident as motor-boating, but if it was above you wouldn't be able to hear it except, perhaps, as a hiss. A supersonic oscillation of this kind would still affect amplifier operation, however, and would normally cause the amplifying devices, whether they be valves or transistors, to operate under incorrect bias conditions. It's usually fairly easy, incidentally, to detect the presence of supersonic oscillation due to incorrectly operating negative feedback. You insert a current-reading meter in series with the supply to the amplifier and bypass the feedback application point to chassis with an electrolytic capacitor of around 20μF or so. If the current reading changes then the amplifier is almost certainly oscillating at a supersonic frequency." (Figs. 4(a) and (b).)

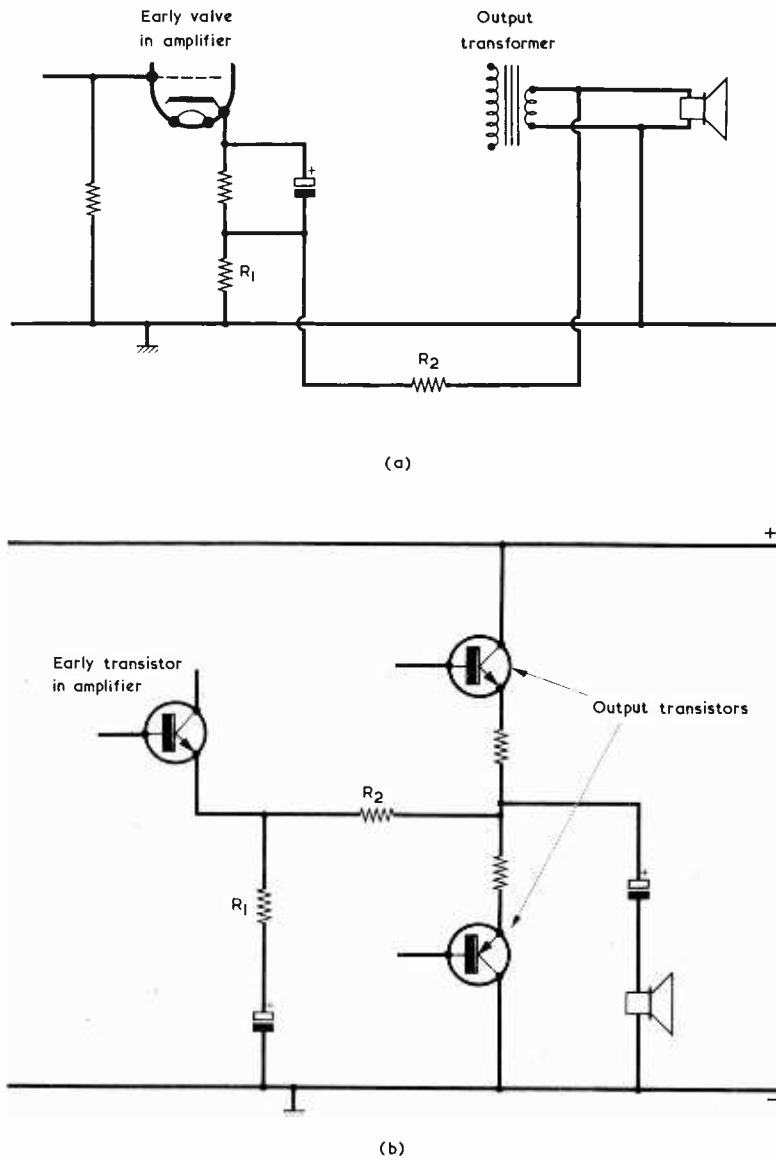
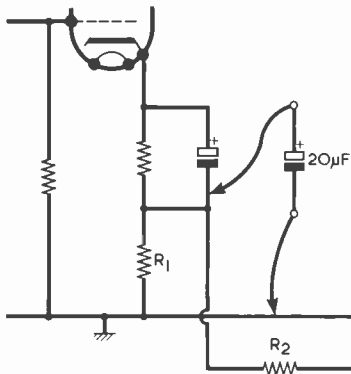
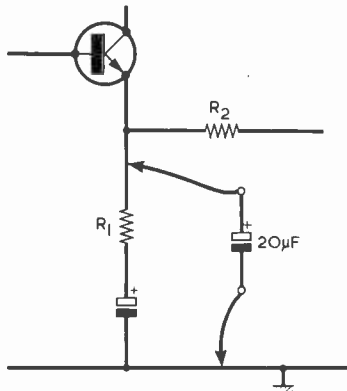

Fig. 3 (a) A common method of providing negative feedback in a valve amplifier  
 (b) An example of negative feedback in a transistor amplifier



(a)



(b)

Fig. 4 (a) If supersonic oscillation due to incorrectly operating negative feedback occurs in a valve amplifier, the h.t. current will vary if the feedback application point is bypassed to chassis by an electrolytic capacitor of around 20uF

Fig. 4 (b) Similar conditions in a transistor amplifier may be checked in the same manner

"Black or white, sir?"

Again, Smithy looked up in surprise. A second waiter, bearing a tray with two pots and a selection of sandwiches, hovered over him and swayed expertly in time with the rocking of the train.

"Er, white, please."

The waiter placed his tray on the table, poured out Smithy's coffee and then proceeded to carry out the same function for Dick. Smithy next selected a cheese and tomato sandwich whilst Dick picked a ham sandwich. Smithy busily occupied himself with removing the Cellophane from his sandwich.

"That will be twenty-eight pence, sir."

Smithy frowned and glanced at his assistant.

"Have you got any loose change, Dick?"

Dick dug into his pocket and produced four pennies, which he placed on the table.

"Will that help?"

"Don't say," snorted Smithy irritably, "that you've come out for the day with only four pennies on you."

"Of course I haven't," replied Dick indignantly. "I've got ten quid in my wallet."

"Then perhaps you could pay for the coffee and sandwiches."

"It's in the form of a ten-pound note."

Smithy glared at his assistant, then proceeded to search through his own pockets. Eventually he produced a purse from which he reluctantly extracted twenty-four pence. Grinning broadly, the waiter picked up the coins and carried on down the carriage.

"Dash it all, Smithy," said Dick

wrathfully. "Every time I go out with you, you show me up!"

"Show you up?" repeated Smithy incredulously. "You come out with nothing less than a ten-pound note and then you accuse me of showing you up. How have I shown you up?"

"With all this business of keeping your money in a purse. Blimey, you'll be carrying a hand-bag next!"

"I shall be doing no such thing," replied Smithy, deeply affronted.

#### INTEGRATED CIRCUITS

Bad-temperedly, the Serviceman munched his sandwiches and stared out of the window. Suddenly, the clacking of the wheels on the rails ceased and the train proceeded on its way almost soundlessly.

"Ye gods," ejaculated Smithy. "What's happened now? We must have come off the lines or something!"

Dick looked at him scornfully.

"Don't you know anything about trains?" he asked. "All that's happened is that we've gone onto a section of track that uses long unbroken rails. If you look at the track alongside you'll see there's quite a long distance before one rail joins up to the next."

Fascinated, Smithy gazed at the track alongside that on which they were running.

"Well, I'm dashed," he remarked after a moment. "I never knew about these long rails before."

He finished his sandwich, then drained his cup of coffee. Dick had already finished his.

"Let's get back to negative feedback," remarked Dick. "You were saying that, if there are too many

**Your Local Supplier**

HAMPSHIRE

**BOURNEMOUTH**

LARGEST HI-FI AND  
RADIO COMPONENT  
STORE IN THE SOUTH

FORRESTERS NATIONAL  
RADIO SUPPLIES LTD.

70-72 Holdenhurst Road  
Bournemouth

Telephone 25232

SURREY

**WITWORTH  
TRANSFORMERS**

**TV Line out-put transformers**

Manufacturers of the largest range in the country. All makes supplied.

Free catalogue.

Modern

BAIRD, BUSH, GEC, PHILIPS

Replacement types ex-stock.

For "By-return" service, contact London 01-948 3702

Tidman Mail Order Ltd., Dept. R.C.

236 Sandycroft Road,

Richmond, Surrey TW9 2EQ

Valves, Tubes, Condensers, Resistors,  
Rectifiers and Frame out-put Transformers,  
Mains Transformers also stocked.  
Callers welcome.

SUSSEX

**E. JEFFRIES**

For your new television set  
tape recorder, transistor radio  
and hi-fi equipment

PHILIPS, ULTRA, INVICTA  
DANSETTE, MASTERADIO, PERDIO,  
MARCONI, PHILCO FIDELITY

6A Albert Parade  
Victoria Drive,  
EASTBOURNE SUSSEX

EIRE

**PEATS for PARTS**

**ELECTRONIC COMPONENTS  
RADIO & TELEVISION**

For the convenience of Irish  
enthusiasts we supply

The Radio Constructor  
Data Books and  
Panel-Signs Transfers

Also a postal service

**Wm. B. PEAT & Co. Ltd.**  
28 PARNELL STREET  
DUBLIN 1

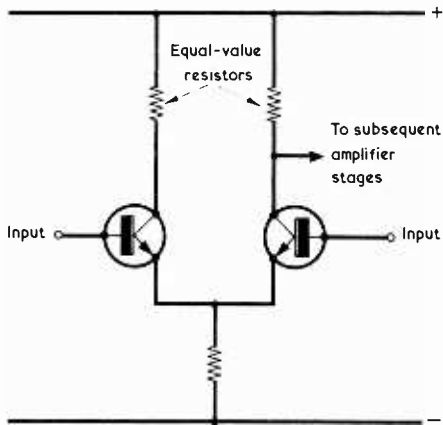

Fig. 5 Basic circuit of a differential amplifier. It is assumed that the input circuits provide the requisite bias for the transistors. (In an i.c. operational amplifier the common emitter resistor is replaced by a 'constant current' transistor)

reactive components inside the negative feedback loop, there is a risk of positive feedback at some frequency."

"So I was," confirmed Smithy. "I should add that where this state of affairs exists the amplifier will normally only go into oscillation at a certain level of feedback. The amplifier may be quite stable at low levels of feedback but will break into oscillation when the feedback level is increased. If an amplifier of this nature has a level of negative feedback which is below the oscillation point it may still exhibit a peak in its response at the frequency where the phase shift is 180 degrees. This is because there is still positive feedback at that frequency."

"So far as I can see," remarked Dick, "the best approach simply consists of using the minimum number of reactive components inside the feedback loop."

"That's certainly the best way of doing things," confirmed Smithy. "And, as I mentioned just now, it's possible to use direct couplings throughout in a transistor amplifier. Another type of amplifier, the integrated circuit operational amplifier also has direct coupling all the way through, and this is almost always operated with negative feedback to control its characteristics."

"Operational amplifier? What's an operational amplifier?"

"It's an integrated circuit which was initially intended for analogue computer work," replied Smithy. "It is simply a combination of transistors, diodes and resistors which provide an exceptionally high level of gain, all of these being accommodated on the tiny silicon chip which forms the integrated circuit. The gain can be of the order of 10,000 to 100,000 times. I haven't got time to show you a complete operational amplifier circuit now, but all you need to know is that it has a single output terminal and two input terminals. One of these last two terminals is the inverting input and the other is the non-inverting input."

"Hey," put in Dick, "hang on a bit! What's all this business of inverting and non-inverting inputs?"

"If," said Smithy in reply, "you feed a signal into the inverting input terminal of an operational amplifier, the amplified signal at the output terminal is 180 degrees out of phase with it. At the same time, if you feed a signal into the non-inverting input terminal the output is in the same phase."

"How do you get these two inputs?"

"By using a differential amplifier stage at the input end of the op-amp," replied Smithy. "The basic circuit of a differential amplifier looks like this."

Smithy drew out a further circuit on the letter. (Fig. 5).

"As you can see," he went on, "the two transistors in the differential stage form a long-tailed pair and the output signal to the subsequent amplifier stages is taken from the collector of the second transistor. If the base of this transistor goes positive its collector goes negative. On the other hand, if the base of the first transistor goes positive the collector of the second transistor

also goes positive."

"I can see how that happens," remarked Dick brightly. "When the base of the first transistor goes positive so also does its emitter and the emitter of the second transistor. This is the same as the base of the second transistor going negative, which means that the collector of the second transistor also goes positive."

"You've got it," confirmed Smithy. "You can see from this that if you have a differential amplifier stage at the input end of an operational amplifier you can have two input terminals. Since the differential stage is directly coupled to the remaining transistors in the op-amp, one of the differential stage inputs can be the inverting input and the other the non-inverting input. About the same degree of amplification is given to a signal applied to either input."

"What have these inputs got to do with negative feedback?"

"They allow very convenient negative feedback circuits to be set up," replied Smithy. "One of the simplest of these is given when the input signal is applied to the non-inverting input and the output signal is fed back to the inverting input."

Smithy selected a further sheet of paper and drew out another diagram. (Fig. 6.) The wheels of the carriage clattered as they passed over a series of points, and the train commenced to slow down.

"I've used the usual triangular amplifier symbol for the op-amp," continued Smithy. "The output comes out at the right hand point and the two inputs are on the left-hand side. The inverting input is identified by a minus sign and the non-inverting input by a plus sign. As you can see, I've applied negative feedback to the inverting input by means of a fixed potentiometer consisting of two resistors, R1 and R2. Just as we had with the earlier instances of negative feedback, the overall gain is equal to the sum of R1 and R2 divided by R1."

Fig. 6 An operational amplifier with a feedback circuit which is analogous with Fig. 1 (b)

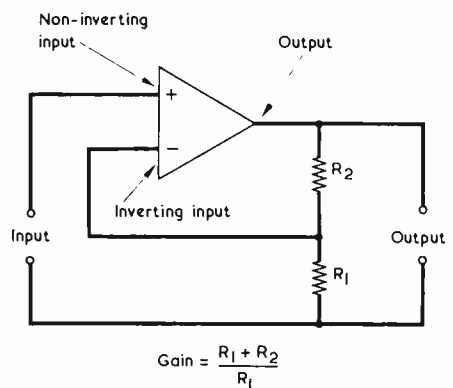

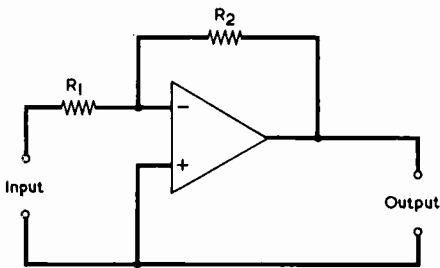

$$\text{Gain} = \frac{R_2}{R_1}$$

Fig. 7 Another method of applying feedback to an operational amplifier

## DESTINATION

The train had now almost completely stopped. Several passengers rose from their seats and made their way to the doors.

"There's another method of applying negative feedback to an op-amp," went on Smithy, completely oblivious to his surroundings as he sketched out a further circuit. (Fig. 7.) "In this case the non-inverting input is held at earth potential so far as a.f. is concerned. The input is then applied via a resistor R1 to the inverting input and the output is fed back to the inverting input via a second resistor, R2. If the source of input signal has zero internal resistance the gain is then equal to R2 divided by R1. If the source of input signal has an internal resistance, this is lumped in with R1 for the purpose of the calculation."

The train had now stopped completely and passengers were leaving the carriage.

"How do you arrive at that gain figure of R2 divided by R1?"

"It's pretty easy to visualise," replied Smithy. "Let's say that R2 is 10 times the value of R1, so that the overall gain is 10 times. If we now take the input negative by 0.1 volt, the output of the amplifier will go positive. At 1 volt positive the output will counterbalance the negative-going signal at the inverting input, and it will then remain at this level. Actually, the inverting input terminal will itself go very slightly negative but, because of the fantastically high gain of an op-amp, the change in its potential will be very tiny."

Smithy stopped for a moment, vaguely aware that the remaining two seats at their table had become occupied by new passengers. Dick was completely engrossed in Smithy's explanation.

"Since the voltage variation at the

inverting input," said Smithy, "is negligibly low, the inverting input can be considered as being a 'virtual earth' and the input resistance of the amplifier and feedback combination then becomes equal to R1. Okay?"

The train commenced to move.

"I'll say," replied Dick appreciatively. "Gosh, Smithy, you've certainly given me some gen on negative feedback today that I didn't know before."

"I'm glad I was able to be of help," replied Smithy, folding up his letters and returning them to his pocket. "Anyway, that's enough technical stuff for now, so let's start thinking about our day out instead."

He glanced at the person who was now sitting beside him. This heavily bearded worthy was attired in loose-fitting clothes which had been apparently cut out from flowered wall-paper. Hastily, Smithy turned his eyes towards the newcomer alongside Dick. This was a stout blowzy lady carrying a very moist baby which, at that moment, was busily regurgitating a large quantity of milk. In desperation Smithy looked out of the window, to see the last board identifying the station they were leaving.

"Hell's teeth," he roared at Dick. "We should have got out there!"

Dick, pushed hard up against the carriage wall by the lady with the baby could do nothing but make a mournful grimace at the Serviceman.

The young man with the flowered vestments produced a transistor radio which he turned on very loud.

The stout lady laid her baby on the table and proceeded to change it. The baby's nether regions were oriented directly towards the horrified Serviceman.

The baby broke into uncontrolled screaming.

Then the ticket inspector arrived. ■

# NEW BOOKS

**ABC'S OF ELECTRONIC POWER**  
By Rufus P. Turner £1.50

**THE MANUAL OF CAR ELECTRONICS**  
By Rudolph F. Graf & George J. Whalen £3.50

**99 WAYS TO IMPROVE YOUR HI-FI**  
By Len Buckwalter £1.50

**PRACTICAL DESIGN WITH TRANSISTORS**  
(Rev. Edition)  
By M. Horowitz £2.40

**The Mazda Book of PAL RECEIVER SERVICING**  
By D. J. Seal £3.50  
(Published: Foulsham Tech.)

**INTRODUCTION TO VIDEO RECORDING**  
By W. Oliver £1.50  
(Published: Foulsham Tech.)

**FOULSHAM-SAMS TECHNICAL BOOKS**  
(W. FOULSHAM & CO. LTD.)  
VEDVIL RD., SLOUGH, BUCKS, ENGLAND

*The*  
**RADIO CONSTRUCTOR**

**ANNUAL SUBSCRIPTIONS**

to this magazine  
may be obtained  
through your  
newsagent

or direct from the  
publishers

**ONLY £2.70**

per year, post free

Please send remittance with name and address and commencing issue required to:

**DATA PUBLICATIONS LTD**  
57 Malda Vale London W9 1SN

# RELAXATION OSCILLATOR

by  
J. Evans

A relaxation a.f. oscillator which employs few components and offers a high output.

THIS A.F. OSCILLATOR EMPLOYS TWO READILY AVAILABLE transistors, requires fewer components than a standard multivibrator, and generates a loud and distinctive audio tone. It may be used as an audio warning device in place of a bell or buzzer, or as a continuity tester. In the latter application it offers the advantage that evidence of continuity is given by audible means, with the result that the operator can keep his eyes all the time on the circuits he is checking.

## CIRCUIT OPERATION

The circuit of the relaxation oscillator appears in the accompanying diagram and, as may be seen, is simplicity itself.

Any signal on the base of TR1 appears, in amplified form and shifted through 180°, at its collector. This amplified signal is applied to the base of TR2 where it is, in turn, further amplified and shifted through 180°. Positive feedback from TR2 collector is applied to TR1 base via C1, and the circuit then oscillates at a low audio frequency which is dependent upon the values of C1, R1 and R3, together with the inductance presented to the circuit by output transformer T1. The current drawn from the 6 volt supply is approximately 40mA.

Resistor R2 limits the signal current fed back to TR1 and promotes stable operation. R4 is a limiter resistor whose function is to provide some protection for TR1 if, due to a fault, the circuit fails to oscillate. A measure of protection for TR2 is provided, for the same condi-

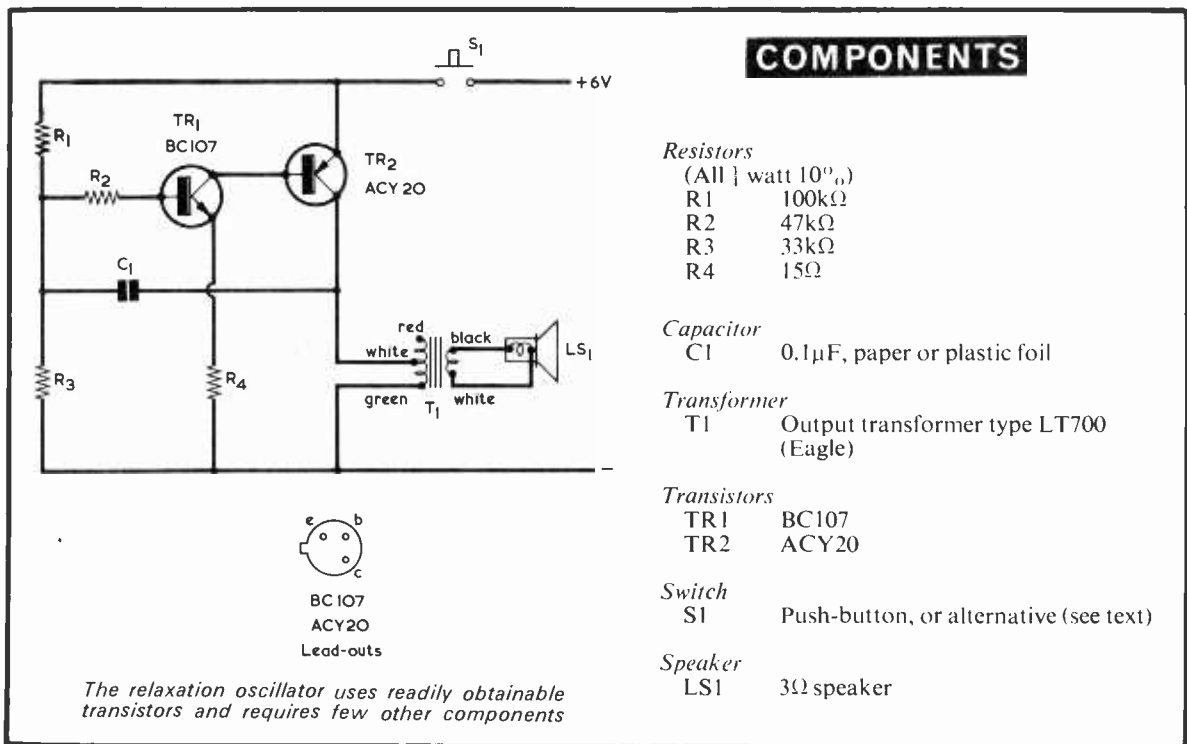

tion, by the d.c. resistance offered by the half of T1 primary which appears in its collector circuit, and which is of the order of  $20\Omega$ . However, neither transistor is *fully* protected and it is advisable, when the oscillator has been assembled, to apply the supply momentarily only and ensure that oscillation occurs. Oscillation should appear instantaneously, whereupon all is well and the oscillator is ready for use. No trouble was experienced with the author's circuit on this account and, indeed, it would be doubtful if a circuit offering such obvious positive feedback as this one does could fail to oscillate! Nevertheless, it is better to be safe than sorry, and no harm results from carrying out the

cautious initial check just described. If it is anticipated that the oscillator will run for long periods, TR2 should be fitted with a small heat sink, such as the type H2 available from Henry's Radio, Ltd.

Output transformer T1 is an Eagle component type LT700. No connection is made to its red primary lead.

Switch S1 may be a push-button, as shown, a relay contact set, or any other type of switching device according to the application required. If the oscillator is to be used as a continuity tester, S1 can be replaced by two terminals, to which are connected a pair of flexible leads terminated in test prods or test clips.

# RADIO CONSTRUCTOR

& ELECTRONICS

**NEXT  
MONTH**

## FEATURES

### A.F. SIGNAL GENERATOR

by R. A. Penfold

This generator offers both sine and square wave output and it covers 15Hz to 150Hz in four ranges

### ELECTRONIC METRONOME

by M. G. Argent

### SHORT WAVE CRYSTAL SETS

by J. Braunbeck

### THE 'JUBILEE' 8-WATT AMPLIFIER

Part 2 - (conclusion)

by J. R. Davies

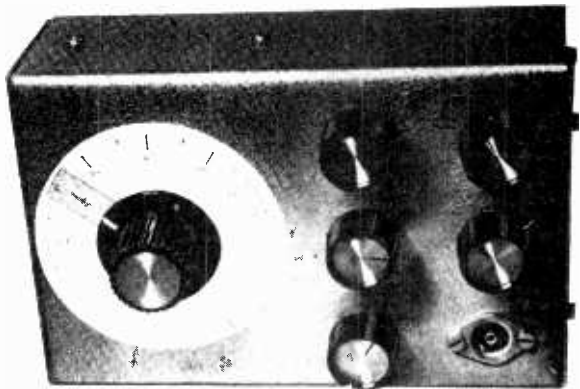

### USUAL SUPPORTING FEATURES

\* \* \*

### DATA SHEET 66 (Meter Shunts I)

\* \* \*

### MANY OTHER INFORMATIVE AND CONSTRUCTIONAL ARTICLES

\* \* \*

PRICE 20p

ON SALE 1st SEPTEMBER

ORDER YOUR COPY **NOW**

Copies may also be obtained direct from the Publishers, 26p. including postage. Published by Data Publications Ltd, 57 Maida Vale, London W.9

# Radio Topics

## By Recorder

**T**IME AND ELECTRONICS ARE INEXTRICABLY intermingled, and it is difficult to conceive of any electronic operation in which time does not appear as an inevitable adjunct.

The accompanying photograph illustrates a situation in which electronics and time are particularly intermixed. The three components visible inside the empty wrist watch frame consist of a quartz crystal, an i.c. divider and a miniature motor. These components, available from Motorola, form the heart of an electronic wrist watch, and all that is additionally required are a miniature trimming capacitor, a miniature battery, a conventional watch dial and hands, and standard gearing to couple the motor to the hands and day and date display. Motorola state that they believe this is the first time that such a set of matched components for an electronic watch has been made available by a single manufacturer.



*Electronic components, manufactured by Motorola, which form the basis of an ultra-high-precision wrist watch*

## CRYSTAL FREQUENCY

The crystal, Motorola type MTQ 21, operates at a frequency of 32.768kHz, and is contained in a package measuring only 18.8 by 3.3 by 4.19 mm. Such a size is practical for use in a man's style wrist watch. If you divide two into 32,768 sixteen times, the answer is 1. The accompanying integrated circuit contains, in consequence, 16 divide-by-two flip-flops, whereupon 1-second pulses become available for the miniature motor. But we'll come back to the i.c. later.

The precision operation of the crystal is such that its frequency drifts with time by only 5 parts per million for the first year, and 2 p.p.m. for each year thereafter. These figures represent, respectively, time errors of 75 seconds per year and 30 seconds per year. The frequency tolerance of the crystal proper is 15 p.p.m., and this and the tolerances of the associated electronic circuitry can be easily adjusted out by a miniature trimming capacitor.

Normally, the crystal would be regarded as the most vulnerable component of the system. The type MTQ 21 crystal can, however, survive very high shock and vibration levels, and it is stated that its frequency varies by only 2 p.p.m. when subjected to repeated 1,000g shocks or vibrated with a force of 10g at 30 to 500Hz. Temperature variations, the greatest enemy of quartz crystal precision, account for a change of only -40 p.p.m. for the complete watch system at the temperature extremes of -10 to +60°C. Since the temperature variation follows a parabolic curve centred on 28°C, timing errors due to the temperature changes met in normal use are negligible.

The accompanying integrated circuit, type MC 6160, uses silicon-gate CMOS (complementary metal-oxide-silicon) circuitry. It comprises 312 transistors and diodes on a silicon chip measuring only 2 by 2.5mm., this being housed in a 5 by 6.25 by 1.7 mm. ceramic case.

The basic CMOS flip-flop circuit consists of two MOS transistors with opposite (i.e. complementary) modes of operation connected in series to act as an electronic switch. One transistor is on and the other off with the switch 'on' and vice versa with the switch 'off'. Since always one transistor is off, only an extremely low leakage current flows.

Normally, the electronic gate to which the control voltage is applied to switch the transistors is made of metal. In this circuit, however, the gate is formed from the same silicon that forms the bulk of the device, enabling the dimensions to be more accurately controlled for further reduction of the current drawn. In consequence, the current drawn by the integrated circuit is only 5µA from a 1.5 volt silver-oxide battery and 4.5µA from a 1.3 volt

mercuric oxide battery.

The miniature type MTM motor, measuring 2.7 mm. high by 6.35 mm. in diameter, rotates 180° for each of the 1-second input pulses from the integrated circuit. Although it draws an average current of only 10µA from a 1.5 volt battery and 8.5µA from a 1.3 volt battery, it produces sufficient torque to drive conventional hands and day and date display via suitable gearing.

Typical silver oxide and mercuric oxide batteries suitable for powering the watch for over a year measure only 5.6 mm. high by 11.6 mm. in diameter.

The current drawn by the integrated circuit increases as the frequency rises so that the 32.768kHz frequency is a compromise between the current drawn and the size of the crystal. At present, the crystal size is suitable for man's style watches. Developments currently taking place in Motorola laboratories are aimed towards circuitry which can operate at higher frequencies with smaller crystals, but at the same current, for 12 month's operation of a lady's style electronic watch from one battery.

## HOT BATTERY

Sometimes, a simple fault can be located without benefit of test gear at all.

A couple of days ago I was playing around with an experimental transistor circuit which I'd powered temporarily by means of three 3 volt cycle lamp batteries (the Ever Ready No. 800 type) which were connected up in series. I had to leave the job for several minutes and, when I returned, I found that the circuit had stopped working. Since things were in a bit of a tangle on the bench, I had to lift one of the batteries to get at the testmeter leads.

That battery was noticeably warm to the touch. A quick glance then revealed what had gone wrong. The ends of the two outside leads from the battery, which were twisted to make contact with two further leads from the experimental circuit, had accidentally come together, resulting in a dead short-circuit. Those poor cycle lamp batteries had been giving their all, and had warmed up quite appreciably in the process.

I must confess that the idea of a battery as a self-powered heating device did grab my imagination for a moment. The ultimate in electrical heating simplicity would, one assumes, be a short-circuited dynamo wound with resistance wire. But I put such thoughts away from me resolutely as I went off in search of another source of 9 volts.

Incidentally, those cycle lamp batteries represent quite a good buy for experimental work. It is no problem at all to solder wires to their brass connection strips, and they provide voltages which can easily be varied in



steps of 3 volts. At a pinch one can get 1.5 volt steps from them too, this being done by simply breaking the cells of an individual battery away from each other and connecting to the internal wire between them. But their greatest advantage is their relatively low cost and their mechanical and electrical robustness. For instance, I've just checked those three woefully maltreated batteries and they have recovered such that their total voltage is now nearly 9 volts again. Immediately after the short-circuit it was just in excess of 1 volt.

## NEW EDDYSTONE RECEIVERS

I have two further photographs this month, and these illustrate receivers from the new Eddystone 1000 Series, which has just been announced. Eddystone Radio Ltd. is part of Marconi Communications Systems Ltd., Marconi House, Chelmsford, CMI IPL.

The performance of the 1000 Series sets has been designed to cover the requirements of the professional user, while the cost has been kept within the reach of the enthusiastic amateur and the keen short wave listener. Priced in the U.K. at between £200 and £300 according to type, the sets fill an important gap between the high stability, high performance type of receiver which costs anything from £500 up to well beyond £1,000, and the low cost set retailing at less than £100.

The five models in the Series cover a wide range of applications for professional and amateur use. They consist of the Model 1000, which is the basic model and which gives general purpose h.f./m.f. communications reception; the Model 1001, which is similar to the Model 1000, but which also has up to ten crystal controlled channels; the Model 1002, a high quality broadcast receiver covering h.f.

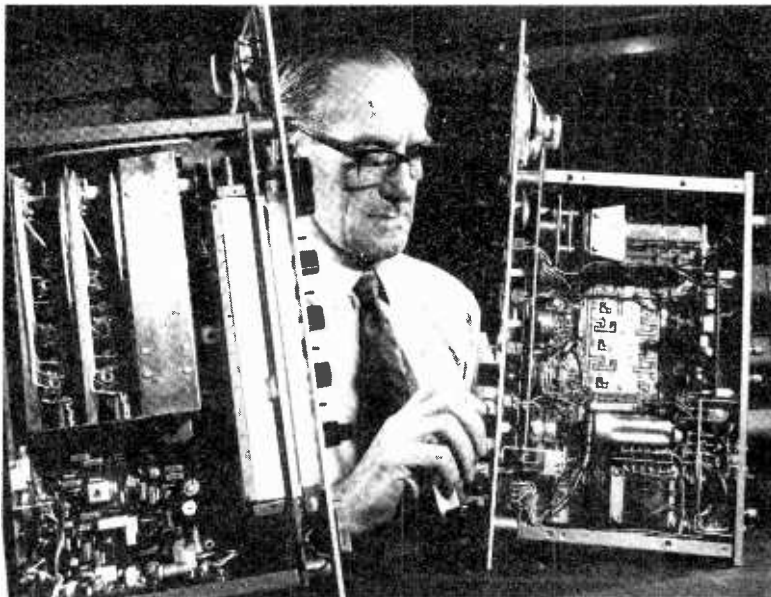

*Two views of the Eddystone Model 1004 maritime receiver. The inspector is carrying out production line mechanical checks*

and m.f. bands with amplitude modulation and the v.h.f. band with frequency modulation (including stereo reception); the Model 1004, a receiver intended for maritime applications; and finally the Model 1005. The last is a general purpose crystal controlled receiver designed to provide facsimile reception. In all the receivers the h.f. range extends up to 30MHz.

The 1000 Series is based on a modular form of construction which allows the fundamental design to be adapted simply to provide a wide range of specialist functions to cover many different applications. The receivers are completely solid state, and incorporate a number of very advanced techniques to provide high performance and reliability.

The form of construction adopted is completely flexible in production, requiring only the selection of appropriate modules and chassis to build up any one of the five receivers. Approximately 70% of the circuitry is common to all the sets in the range. The basic chassis unit is common to all the receivers. Within this chassis a series of modular units, sub-assemblies and printed circuit boards are linked by interwiring harnesses.

Integrated circuits and field effect transistors are employed, not only to improve performance and simplify construction but also to reduce costs. For example, the complete inter-

mediate frequency stage is designed around an i.c. and needs no tuning or alignment. This produces a considerable saving in production testing as well as simplifying routine maintenance and tuning of the set. Similarly, an a.f. integrated circuit delivers up to 1 watt of audio output.

A particular feature of the new range is the inclusion of an internal power supply unit with a rechargeable emergency nickel cadmium battery incorporated as a standard feature. The power unit is designed to work from standard 40 to 60Hz power supplies. An input socket is also provided to enable an external 12/24 volt d.c. supply to be used at sites where a.c. mains is not available.

One of the photographs shows the Model 1001. Here, the crystal selector unit can be seen mounted on the left of the fascia panel. The other photograph gives two different views of the 1004 maritime receiver as it undergoes final mechanical checks on the assembly line.

## FETRONS

Despite the fact that the semiconductor has ousted the valve in nearly all new electronic designs, there still remain large quantities of ready-built electronic equipment employing valves which is perfectly serviceable and is capable of remaining so for many



*One of the models in the new Eddystone medium cost series of receivers. This is the Model 1001*

more years to come. This situation is particularly true in the field of telephone communications and such things as telephone repeaters must, throughout the world, employ very many millions of valves.

All this valved equipment represents a considerable capital outlay and the only disadvantage with it is that the valves have to be replaced as they wear out. The cost of valve replacement would not justify scrapping the equipment and fitting transistorised gear in its place.

An ingenious solution to this state of affairs is now provided by a very new device called the Fetron (and I am indebted for this information to *Electronics* of April 10th, and the article in that issue 'Vacuum Tubes Yield Sockets to Hybrid JFET Devices' by Bruce Burman). A Fetron is a semiconductor device which simulates the performance of a valve, and it plugs into an existing valveholder without any necessity to change the circuitry around that valveholder. Thus, an ailing valve can be replaced by simply plugging in a Fetron, whereupon the circuit concerned is immediately converted to solid state and no future changes of valve will be required. Also, an entire equipment may be readily converted, with Fetrons, to transistor operation at one step, whereupon it offers a much higher long-term reliability and its capital cost is not lost. Further factors are that Fetrons do not require any heater current nor, when they replace pentodes, any screen-grid current. Gear which has been converted to Fetron operation runs cooler and requires less power.

The Fetron is housed in a metal case a little smaller than that of the valve it replaces, and it has pins at its base which follow the B7G or B9A pattern as applicable. Obviously, much of the space inside the housing is wasted, because the semiconductor device inside consists of a small chip only. Connections are usually made only to the pins which correspond to valve cathode, control grid and anode.

A typical Fetron, the TS6AK5, is a replacement for the r.f. pentode type 6AK5. In order to achieve pentode-like characteristics and the ability to work at high anode voltages, two specially designed junction f.e.t.'s are employed in a cascode configuration. Two separate high voltage f.e.t.'s are employed in another Fetron which is designed to replace the 12AT7 twin triode. The Fetron characteristics are not exactly the same as those of the valve it replaces, and in many cases it offers an improved performance in terms of gain and noise.

Telephone companies in the U.S.A. are now busily carrying out evaluation and trial applications. Up to last April, Fetrons on trial for up to 8 months had shown no significant failures or degradations. ■

# DECIMAL BINARY CONVERTER

by  
J. Roberts

**Requiring no complicated parts or circuitry, this converter offers a useful introduction to the concept of binary numbers.**

**T**HE SIMPLE CIRCUIT TO BE DESCRIBED displays, by means of small m.e.s. pilot lamps, binary numbers corresponding to the decimal numbers 1 to 12. It is particularly instructive in illustrating an increase to the next power of 2 when adding 1 to the binary equivalent of a figure such as decimal 7. The presence of a binary 1 is indicated by the illumination of a pilot lamp.

## DECIMAL-BINARY EQUIVALENTS

The decimal numbers 1 to 12 were chosen because they can be selected by a single-pole 12-way rotary switch, such switches being readily available as single wafer types.

A table listing the binary equivalents of decimal 1 to 12 is given in Fig. 1. Newcomers will note that the binary numbers do not have a digit higher than 1. If binary 1 is added to binary 1 the result is binary 10. This is similar to what occurs in decimal, in which there is no digit higher than 9. If we add decimal 1 to decimal 9 we get decimal 10.

According to its position in a number, each of the 1's in binary stands for

a power of 2. Thus, 100 in binary represents 2 squared, 1,000 in binary represents 2 cubed, and so on. The

DECIMAL	BINARY
1	1
2	10
3	11
4	100
5	101
6	110
7	111
8	1000
9	1001
10	1010
11	1011
12	1100

*Fig. 1. The binary equivalents of decimal 1 to decimal 12*

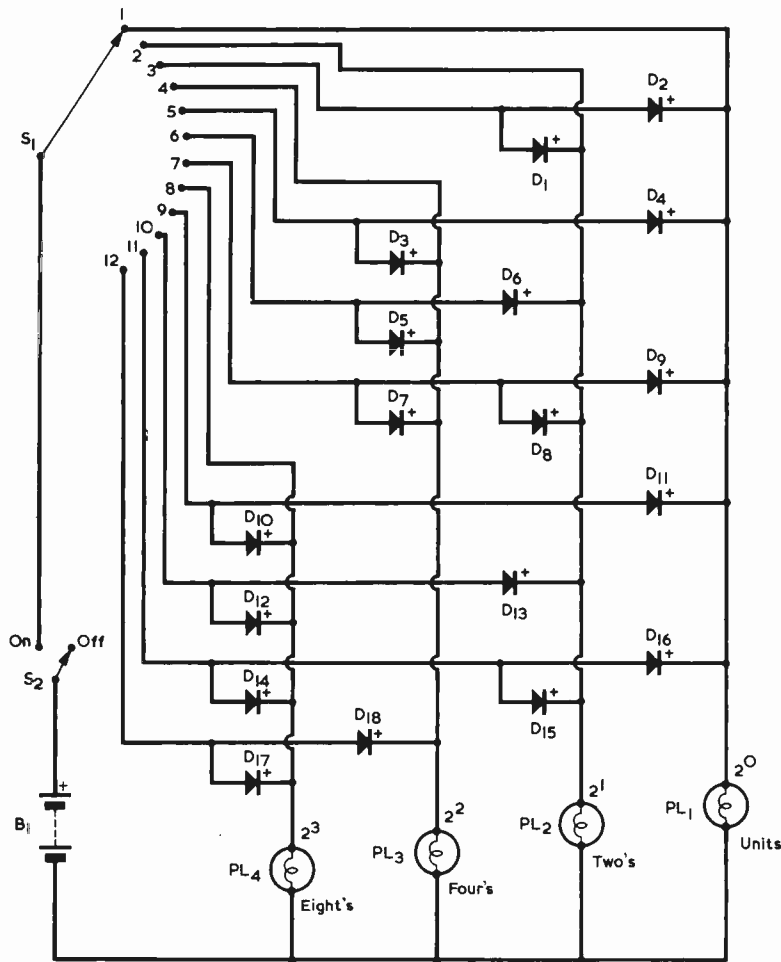

Fig. 2. Computing circuit which changes the decimal input selected by S1 to a binary output at the four pilot lamps

via diodes D5 and D6, causes 110 to be displayed; whilst position 7, via diodes D7, D8 and D9, gives 111. Position 8 of S1 gives a direct connection to pilot lamp PL4, which then glows on its own, giving a display of binary 1000. Position 9, by way of D10 and D11, gives 1001; position 10, by way of D12 and D13, gives 1010; position 11, by way of D14, D15 and D16, gives 1011; and position 12, by way of D17 and D18, gives 1100.

The circuit given in Fig. 2 represents, for switching positions 1 to 9 and the associated diodes, a standard computing circuit for changing a decimal input to a binary output. The decimal numbers 10, 11 and 12 were added here to take advantage of the extra positions offered by a normal 12-way switch.

The bulbs can be any small m.e.s. type, but it is advisable to employ relatively high-voltage types since these consume less current and ease the forward current requirements needed in the diodes. The use of relatively high voltage bulbs also results in almost the same degree of illumination for each bulb regardless of whether it is supplied from the battery direct or via a diode, since the forward voltage drop in the diode becomes proportionately low when compared with battery voltage. A good choice of bulb is a 12 volt 0.18 amp type, available from Home Radio under Cat. No. PL13. The corresponding diodes can be any silicon rectifiers having a forward current rating of 1 amp or more. This rating should cope with the momentary surge current which occurs when any lamp is switched on from cold. The rectifiers are required, of course, to isolate the individual number circuits from each other. The battery should have the same voltage as the lamp rating. With the bulbs just mentioned, this will be 12 volts.

binary number 1,100 represents 2 cubed plus 2 squared and, as may be seen from the table, is equal to decimal 8 plus decimal 4, i.e. decimal 12. It will be recalled that, in decimal, 100 represents 10 squared and 1,000 represents 10 cubed. The decimal number 1,100 is equal to decimal 10 cubed plus decimal 10 squared.

The similarity between the decimal and binary systems becomes evident when we observe that the *base*, or *radix*, in the decimal system is 10, whilst with binary it is 2.

Returning to the binary numbers in the table of Fig. 1 we may note that binary 10 and binary 1 also represent powers of 2. Binary 10 is 2 to the power of 1, and binary 1 is 2 to the power of zero.

### CONVERTER CIRCUIT

We may now turn to the converter circuit, which is shown in Fig. 2.

We start off by setting S1 to position

1 (which corresponds to decimal 1) and setting S2 to 'On'. Current will now flow from the positive terminal of battery B1 via switch S1 to pilot lamp PL1. ('Conventional current', flowing from positive to negative, will be assumed here.) Pilot lamp PL1 glows, to indicate the binary number 1. If we set S1 to position 2, pilot lamp PL2 lights up and PL1 is extinguished. The lamps thus indicate the binary number 10.

If we next put S1 to position 3, current flows from the positive terminal of the battery via diodes D1 and D2 to both PL2 and PL1. These both light up to indicate binary 11. With S1 at position 4, pilot lamps PL2 and PL1 become extinguished and PL3 becomes illuminated. The lamps thus indicate binary 100. Turning S1 to position 5 causes current to flow via D3 and D4 to PL3 and PL1, which then indicate the binary number 101.

The procedure continues for the remaining settings of S1. Position 6,





# SMALL ADVERTISEMENTS

Rate: 4p (9d) per word. Minimum charge 60p (12/-).  
Box No. 10p (2/-) extra.

Advertisements must be prepaid and all copy must be received by the 4th of the month for insertion in the following month's issue. The Publishers cannot be held liable in any way for printing errors or omissions, nor can they accept responsibility for the *bona fides* of advertisers. (Replies to Box Numbers should be addressed to: Box No. —, *The Radio Constructor*, 57 Maida Vale, London, W9 1SN)

**CHROMASONIC ELECTRONICS** is well and living at 56 Fortis Green Road, London N10 3HN. 40 page illustrated catalogue 20p. post free.

**SERVICE SHEETS (1925-1972)** for Televisions, Radios, Transistors, Tape Recorders, Record Players, etc., by return post, with free Fault-Finding Guide. Prices from 5p. Over 8,000 models available. Catalogue 13p. Please send S.A.E. with all orders/enquiries. Hamilton Radio, 54 London Road, Bexhill, Sussex. Telephone: Bexhill 7097.

**MINT, BRANDED BC169C** super-gain low noise npn, 10p. AD161/AD162 complementary pairs, 60p. Mail order only, U.K. post 5p. **AMATRONIX LTD.**, 396 Selsdon Road, South Croydon, Surrey CR2 0DE.

**MECCANO FOR "CYCLOPS"** - Special Pack of all Meccano parts required - £2.98 including postage. Send off today to *The Meccano Spare Parts Specialists* and start building! "Everything Meccano" at M. W. MODELS, 165 Reading Road, Henley-on-Thames, Oxon. Telephone 3342.

**FOR SALE:** Cossor transistorised portable, LW, MW and VHF. Black leather. 6½ x 4 x 2in. £5. Box No. G179.

**BUILD IT** in a **DEWBOX** robust quality plastic cabinet 2 in. x 2½ in. x any length. S.A.E. for details. D.E.W. Ltd., 254 Ringwood Road, Ferndown, Dorset. Write now - right now.

**NEW CATALOGUE NO. 18**, containing credit vouchers value 50p, now available. Manufacturers new and surplus electronic and mechanical components, price 23p post free. Arthur Sallis Radio Control Ltd., 28 Gardner Street, Brighton, Sussex.

**TRANSFORMERS REWOUND.** Output or mains types. Specials made to order at reasonable prices. S.A.E. Enquiries. Ratcliffe, 18 Beech Avenue, Thongsbridge, Huddersfield, Yorks., HD7 2SX.

**RECORD TV SOUND** using our loudspeaker isolating transformer. Provides safe connection to recorder. Instructions included. £1 post free. Crowborough Electronics (R.C.), Eridge Road, Crowborough, Sussex.

**FOR SALE: VHF KIT, 80 - 180 MHz.** Receiver, tuner, converter. World wide sales. Incomparable. £4.00 or s.a.e. for literature. Johnsons (Radio C), Worcester WR1 2DT.

**STAMP COLLECTION** for sale. Catalogue value £150. Offers? Box No. G180.

**'SHORTWAVE VOICES OF THE WORLD'**, £1.55; an exceptional book. *World Radio TV Handbook*, £2.80. *How To Listen to the World*, £1.35. Under £2 postage 10p worldwide. I.R.C./3p for price list. (Mail only). David McGarva, Box 114B, Head Post Office, Edinburgh, EH1 1HP.

**FOR SALE:** Turmix Swiss kitchen mixer, with liquidiser and 3 sets stirring attachments. 240V, 50Hz. Full working order. £8. Box No. G182.

(Continued on page 61)

## BENTLEY ACOUSTIC CORPORATION LTD.

38 Chalcot Road, Chalk Farm  
LONDON, N.W.1.  
01-722-9090

The Old Police Station  
Gloucester Road  
LITTLEHAMPTON Sussex  
PHONE 6743

Please forward all mail orders to Littlehampton

OA2 .30	12BE6 .30	EBC4J .48	EM81 .37	PL83 .30	UY41 .38
OB2 .30	12BH7A .29	EBC8I .29	EM83 .75	PL84 .28	UY85 .23
5U4G .30		EBF80 .30	EM84 .37	PL504 .50	X41 .50
5V4GT .33	12K5 .27	EBF83 .38	EN87 .34	PL508 .90	AC165 .25
5Z4G .33	19AQ5 .24	EBF89 .26	EY51 .29	PL509 1.30	AD140 .36
6/30L2 .53	20P4 .89	EC92 .34	EY81 .35	PL802 .75	AD149 .50
6AQ5 .21	30C15 .55	ECC33 1.50	EY83 .54	PX4 .116	AD161 .45
6AT6 .18	30C17 .74	ECC81 .16	EY87 .62	PY332 .50	AD162 .45
6AU6 .19	30C18 .58	ECC82 .19	EY88 .40	PY81 .24	AF114 .25
6AV6 .28	30F5 .61	ECC83 .21	EZ40 .40	PY82 .23	AF115 .15
6BA6 .19	30FL1 .58	ECC84 .28	EZ80 .19	PY83 .26	AF121 .30
6BE6 .20	30FL2 .58	ECC85 .32	EZ81 .20	PY88 .31	AF126 .18
6BH6 .43	30FL14 .66	ECC88 .35	EY876 .27	PY500 .95	BC107 .13
6BJ6 .39	30L15 .55	ECC80 .27	EY88 .40	PY800 .31	BC108 .13
6BR7 .79	30L17 .65	ECC82 .25	HVR2 .53	PY801 .31	BC113 .25
6BR7 .79	30P12 .69	ECC86 .64	KTW61 .63	QVQV3/	BC118 .23
6BW6 .72	30P19 .55	ECH42 .57	KTW62 .63	10 1.20	BC211 .38
6BW7 .50	30PL1 .57	ECH81 .25	KTW63 .50	R19 .28	BF159 .25
6BZ6 .31	30PL13 .75	ECH83 .38	KT66 .80	U19 .173	BF163 .20
6C4 .28	30PL14 .62	ECH84 .34	PC86 .44	U25 .62	BF180 .30
6CU5 .30	30PL15 .87	ECL80 .28	PC88 .44	U26 .53	BF186 .18
6F1 .59	35LGGT .42	ECL82 .28	PC89 .42	U191 .16	BY126 .15
6F18 .45	35W4 .23	ECL83 .52	PC900 .29	U251 .62	BY127 .18
6F23 .65	35Z4 .24	ECL84 .54	PCC84 .27	U301 .40	OA81 .09
6F28 .60	35Z5 .30	ECL86 .33	PC88 .39	U801 .76	OA91 .09
6F40GT .15	30LGGT .45	EFC85 .63	PC89 .42	UABC80	OA95 .09
6K7G .10	DAF91 .20	EF41 .58	PCC189 .46	OC23 .38	OC23 .38
6K8G .16	DAF96 .33	EF80 .21	PCF80 .26	UBC81 .40	OC24 .38
6LG6GT .39	DF91 .14	EF83 .54	PCF82 .30	UBF80 .28	OC25 .38
6Q7GT .43	DF96 .34	EF85 .25	PCF84 .40	UBF89 .23	OC26 .32
6L40GT .17	DK91 .26	EF86 .27	PCF86 .44	UC92 .35	OC44 .10
6V6G .17	DK92 .35	EF89 .23	PCF801 .28	UC84 .33	OC45 .11
6X4 .20	DK96 .35	EF91 .17	PCF802 .37	UC85 .33	OC46 .15
7Y4 .60	DL92 .23	EF92 .28	PCF806 .55	UCF80 .37	OC70 .13
8D47 .18	DL94 .32	EF181 .25	DL82 .29	UCF82 .57	OC71 .11
10F1 .75	DL96 .35	EF184 .27	PC183 .54	UCF81 .29	OC72 .11
10F18 .35	DY876 .22	EH90 .34	PCL84 .32	UCF82 .30	OC74 .23
12A6 .63	DY802 .29	EL34 .44	PC1805 .37	UC183 .48	OC75 .11
12AC6 .40	EB8C .60	EL41 .36	PC186 .36	UF41 .50	OC78 .15
12AG6 .40	E180F .90	EL42 .53	PD500 1.44	UF80 .35	OC8D .15
12AE6 .48	EABC80	EL84 .21	PEN45 .40	UF85 .34	OC81 .11
12AE7 .23		EL91 .23	PFL200 .50	UF86 .63	OC8D .11
12AU6 .21	EAF42 .48	EL95 .32	PL36 .46	UF89 .23	OC82 .11
12AV6 .28	EB84 .20	EL180 .25	PL81 .2	UL41 .54	OC83 .20
12BA6 .30	EB91 .10	EM80 .37	PL82 .28	UL84 .28	OC84 .24

All goods are unused and boxed, and subject to the standard 90-day guarantee. Terms of business: Cash or cheque with order only. No C.O.D. orders accepted. Post/packing charge 3p per item subject to a minimum of 9p per order. Orders over £5 post free. All orders despatched same day by first class mail. Complete catalogue with conditions of sale 7p post paid. Any parcel insured against damage in transit for only 3p extra per order. Business hours 9 a.m.-5.30 p.m. Sats. 9 a.m.-1 p.m. Littlehampton closed Sats. No enquiries answered unless S.A.E. enclosed for reply.

## FREE TO AMBITIOUS ENGINEERS

— THE LATEST EDITION OF ENGINEERING OPPORTUNITIES

### SEND FOR YOUR FREE COPY TO-DAY

**NEW OPPORTUNITIES** is a highly informative 76 page guide to the best paid engineering posts. It tells you how you can quickly prepare at home for a recognised engineering qualification and outlines a wonderful range of modern Home Study Courses in all branches of Engineering. This unique book also gives full details of the Practical Radio & Electronics Courses administered by our Specialist Electronics Training Division - explains the benefits of our free Appointments and Advisory service and shows you how to qualify for five years promotion in one year.

### PRACTICAL EQUIPMENT INCLUDING TOOLS

The specialist Electronics Division of B.I.E.T. NOW offers you a real laboratory training at home with all the practical equipment you need, plus Basic Practice and Theoretical Courses for beginners in Radio, TV, Electronics, etc.

### BRITISH INSTITUTE OF ENGINEERING TECHNOLOGY

Dept. (B10), Aldermaston Court, Reading RG7 4PF

### SEND OFF THIS COUPON TO-DAY!

Tick subjects that interest you:

AMSE (Elec)  City & Guilds Certificate  RTEB Certificate   
Radio Amateurs' Exam  DMG Certificate  Colour TV   
Electronic Engineering  Computer Electronics  Radio and TV   
Servicing  Practical Electronics  Practical TV and Radio   
Please send booklets & full information without cost or obligation.

NAME..... AGE.....

(BLOCK CAPITALS PLEASE)

ADDRESS .....



OCCUPATION.....

To: BIET Dept. B10, Aldermaston Court, Reading RG7 4PF

Accredited by the Council for the Accreditation of Correspondence Colleges

# RADIO MODELLER



## ELECTRONIC BOOKS

### ● MODEL RADIO CONTROL

Detailing both Theory and Practice, this book, by leading authority Paul Newell, will become the standard reference work. A brief historical survey leads up to a detailed description of proportional systems, with over 100 illustrations, including theoretical circuits and p.c. layouts for an advanced digital system.

134 pages. Price £2.25 U.K. Postage 13p

### ● SINGLET SET

The Singlet Transmitter, Superhet and Super-regen receivers, are now all three available in one book. Complete construction details with full size p.c. layout, components list etc. Ideal introduction to the hobby for the home constructor. 20 pages.

Price 30p. U.K. Postage 3p

### ● LOW COST PROPORTIONAL

Modellers who want to save money buy this volume when converting single channel equipment to simple proportional. They find a wealth of really up to date information in the clear descriptions, full size practical and working drawings, plus over a dozen circuit modules for pulse proportional units.

118 pages.

Price £1.05 U.K. Postage 11p



ON SALE NOW at all leading shops or direct from:-

RADIO MODELLER, BOOK SALES, 64 Wellington Road, Hampton Hill, Middx.

## DATA BOOK SERIES

- DB5 TV FAULT FINDING  
124 pages. Price 50p, postage 6p.
- DB6 RADIO AMATEUR OPERATOR'S HANDBOOK  
80 pages. Price 45p, postage 6p.
- DB16 RADIO CONTROL FOR MODELS  
192 pages. Price 75p, postage 8p.
- DB17 UNDERSTANDING TELEVISION  
512 pages. Price £2.10, postage 25p.
- DB18 AUDIO AMPLIFIERS  
128 pages. Price 53p, postage 6p.
- DB19 SIMPLE SHORT WAVE RECEIVERS  
140 pages. Price 80p, postage 6p.

I enclose Postal Order/Cheque for.....in payment for.....

NAME .....

ADDRESS .....

(BLOCK LETTERS PLEASE)

*Postal Orders should be crossed and made payable to Data Publications Ltd.*

*Overseas customers please pay by International Money Order.*

*All publications are obtainable from your local bookseller.*

*Data Publications Ltd., 57 Maida Vale, London W9 1SN*

## SMALL ADVERTISEMENTS

(Continued from page 59)

**MOSLEY DIPLOMAT 2**, 2 metre 5/8 wave omnidirectional ground plane antenna. £3. Box No. G183.

**"GOVERNMENT SURPLUS WIRELESS EQUIPMENT HANDBOOK"**. Contains circuits, data, illustrations and valuable information for British/USA receivers, trans/receivers. Includes modifications to sets and test equipment. Price £2.85, p.p. 15p. Wanted all types of communications receivers and test equipment. Top Prices paid. What have you? Gerald Myers (RC), 18 Shaftesbury Street, Leeds LS12 3BT.

**HOLIDAY ACCOMMODATION.** Burwood Lodge Hotel, Dawlish Road, Teignmouth, South Devon. Especially suitable for parents with young children. Facing south, on the cliffs, direct access by private path to the sea. Mothers' kitchen, automatic washing machines, baby listening service. Licensed lounge. Ample free parking.

**URGENTLY REQUIRED:** Pre-war Lissen A.C. Skyscraper receiver and Lissen Hi-Q components. Litherland, 11 Birch Grove, Chippenham, Wiltshire. Telephone: Chippenham 50707.

**BOOKS TO CLEAR:** *Science Survey 3*, Vista Books, 50p. *Disease and its Conquest*, 25p. *Ski-ing for Beginners*, 25p. *Moscow, A Short Guide*, 30p. *Thyratrons*, Philips Tech. Lib., 20p. *The Colour of Canada*, 50p. Box No. G184.

**JOIN THE INTERNATIONAL S.W. LEAGUE.** Free services to members including Q.S.L. Bureau, Amateur and Broadcast Translation, Technical and Identification Dept. - both Broadcast and Fixed Stations, DX Certificates, contests and activities for the SWL and transmitting members. Monthly magazine, *Monitor*, containing articles of general interest to Broadcast and Amateur SWLs, Transmitter Section and League affairs, etc. League supplies such as badges, headed notepaper and envelopes, QSL cards, etc., are available at reasonable cost. Send for League particulars. Membership including monthly magazines, etc., £2.00 per annum. (U.K. and British Commonwealth), overseas 6 Dollars or £2.50. Secretary ISWL, 1 Grove Road, Lydney, Glos., GL15 5JE.

**FOR SALE:** *Radio Constructor* November 1949 to June 1970 complete. *Wireless World* November 1939 to December 1964. *Practical Wireless* 1949 to 1959. *Television* 1st issue April 1950 to 1963. Plus others. Lists. Priest, 21 Levens Grove, Blackpool, Lancs.

**MARINE TYPE SPEAKER**, 7in. circular metal case, £1.50. Tannoy p/a type weather-proofed microphone, £1. Marine freq. xtals, 2009, 2306, 2381kHz 3/4in. pin spacing, £1. Box No. G185.

**POSTAL ADVERTISING?** This is the Holborn Service. Mailing lists, addressing, enclosing, wrapping, facsimile letters, automatic typing, copy service, campaign planning, design and artwork, printing and stationery. Please ask for price list. - The Holborn Direct Mail Company, Capacity House, 2-6 Rothsay Street, Tower Bridge Road, London, S.E.1. Telephone: 01-407 1495.

**"MEDIUM WAVE NEWS"** Monthly during Dx season - Details from: K. Brownless, 7 The Avenue, Clifton, York.

**FOR SALE: OSCILLOSCOPE**, Ministry type CT52, miniature 2 1/4 inch CRT. V.G.C. with handbook, £20. Marconi attenuator TF338 variable 0-100dB. V.G.C. £6. Offers, enquiries, S.A.E. Carriage extra. Box No. G188.

**ARE YOU A MOTORING ENTHUSIAST?** The Seven-Fifty Motor Club caters for all types of motor sport-racing, rallies, hill climbs, etc. Monthly Bulletin free to members. For full details write to: The General Secretary, Colin Peck, "Dancers' End", St. Winifred's Road, Biggin Hill, Kent.

(Continued on page 63)

# RADIO OPERATORS

DO  
YOU  
HAVE

PMG I  
PMG II  
MPT  
2 YEARS'  
OPERATING  
EXPERIENCE

?

POSSESSION OF ONE OF  
THESE QUALIFIES YOU  
FOR CONSIDERATION  
FOR A RADIO OFFICER  
POST WITH THE  
COMPOSITE SIGNALS  
ORGANISATION

Onsatisfactory completion of a 7 months specialist training course, successful applicants are paid on scale rising to £2365 pa; commencing salary according to age - 25 years and over £1664 pa. During training salary also by age, 25 and over £1238 pa with free accommodation.

The future holds good opportunities for established (ie pensionable) status, service overseas and promotion.

Training courses commence every January, April and September. Earliest possible application advised.

Applications only from British-born Male and Female UK residents up to 35 years of age (40 years if exceptionally well qualified) will be considered.

Full details from:

Recruitment Officer,  
Government Communications  
Headquarters,

Room A/1105,  
Oakley Priors Road,  
CHELTENHAM,  
Glos., GL52 5AJ.

Tel: Cheltenham 21491. Ext. 2270.

# A fascinating foundation for your child's future...

In Radio & Electronics with



## Radionic Construction Kits



**NO SOLDERING  
BATTERY OPERATED**

A teenager will enjoy many exciting hours constructing experiments with his Radionic Kit.

Not only is it entertaining and absorbing but the knowledge gained of the principles of electronics is invaluable in helping with general studies for higher education. So simple and practical to use—and there is no soldering whatsoever.

You couldn't choose a better gift for any occasion—or why not just buy one anyway?

### Radionic Products Limited

St. Lawrence House, Broad Street,  
Bristol BS1 2HF. Tel. 0272 25351.

A member of the ICI Group of Companies.

**PHILIPS**

Please send me literature on Radionic radio and electronics construction kits.

NAME \_\_\_\_\_

ADDRESS \_\_\_\_\_  
\_\_\_\_\_

R.C.

# NEW STYLE SELF-BINDER

for "The Radio Constructor"

The "CORDEX" Patent Self-Binding Case will keep your issues in mint condition. Copies can be inserted or removed with the greatest of ease. Rich maroon finish, gold lettering on spine.

Specially constructed Binding Cords are made from Super Linen of great strength, very hard twisted and twice doubled. They are attached to strong RUSTLESS Springs under tension, and the method adopted ensures PERMANENT RESILIENCE of the Cords. Any slack that may develop is immediately compensated for and the Cords will always remain taut and strong. It is impossible to overstretch the springs, as a safety check device is fitted to each.

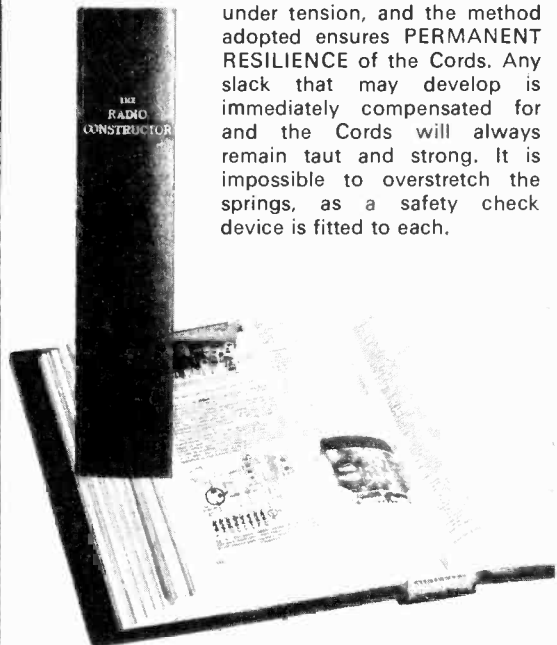

PRICE **75p** P. & P. 14p

Available only from:—

**Data Publications Ltd.**  
57 Maida Vale London W9 1SN



## SMALL ADVERTISEMENTS

(Continued from page 61)

**FOR SALE:** CODAR CR70A receiver and preselector. In excellent condition. Almost unused. Private sale. £20.00. Box No. G189.

**IF YOU HAVE ENJOYED A HOLIDAY** on the Norfolk Broads, why not help to preserve these beautiful waterways. Join the Broads Society and play your part in determining Broadlands future. Further details from:- The Hon. Membership Secretary, The Broads Society, "Icknield", Hilly Plantation, Thorpe St. Andrew, Norwich, NOR 85S.

**FOR SALE:** Heathkit radio gear: Oscilloscope £37, Sine/square generator £22, Millivoltmeter £19, Valve-voltmeter £20, Wattmeter £25. Quad 22 and Armstrong 12-12 watt stereo amplifier £39. All in excellent condition. Box No. G190.

**WORLD DX CLUB** covers all aspects of SWling on Amateur and Broadcast Bands through its monthly bulletin "Contact". Membership costs £1.38 a year. Enquiries to Secretary, WDXC, 11 Wesley Grove, Portsmouth, Hants., PO3 5ER.

**MEDICAL FORCEPS.** Stainless steel 5 in. Ratchet locking. A real friend in the radio workshop. 55p. inc. postage. Send cash or cheque with order to: B. Mitchinson, 4 Fraser Close, Bexley, Kent.

**WANTED URGENTLY** for cash by dedicated fisherman, pair portable transistorised trans/receivers, self contained. Good condition. Box No. G191.

**ESSEX GARDENERS.** Buy your bedding and rock plants, shrubs, etc., also cacti from May's Nurseries, 608 Rayleigh Road, Hutton, Brentwood, Essex. Callers only. Monday to Saturday.

**FOR SALE:** D.C., A.F., I.F. or R.F. amplifiers 50p (gain 3,600T, 3,600T, 24dB, 24dB respectively), size 1 cm. x 1 cm. x 1/2 cm., f=200MHz max. 1C12 £2.00; SN72741 40p; 2N706, 2N3702, 2N2926, 2N2501, 2N2412, all 5p each. All items 5p P. & P. M. Watterson, 28 Beltoy Road, Kilroot, County Antrim, N. Ireland.

**THE BRITISH AMATEUR ELECTRONICS CLUB.** A club for all who are interested in electronics as a hobby. Quarterly Newsletter sent free to members. Subscription 50p per year. Details from Hon. Secretary, J. G. Margetts, 17 St. Francis Close, Abergavenny, Mon.

**TUITION GIVEN** in practical maths for Telecomms., and ordinary level maths. Telephone: 01-385-5288 evenings.

**FREQUENCY LIST TRANSFERS.** We have a limited supply of sheets of Dial Frequency Transfers in black. Short Wave frequencies 1.8Mc/s to 32Mc/s and 144Mc/s and 146Mc/s. Includes amateur band marker frequencies at 100kc/s points and other short wave frequencies from 2 to 32Mc/s at every 500kc/s points. Each frequency is repeated. Two sheets for 5p, five sheets for 10p, postage 3p. Data Publications Ltd., 57 Maida Vale, London W9 1SN.

## SYNTHESISER MODULES

Voltage-controlled modules for synthesiser construction and other musical MIRACLES! Catalogue 15p. D.E.W. Ltd., 254 Ringwood Road, Ferndown, Dorset.

# PLAIN-BACKED NEW STYLE SELF-BINDERS

for your other magazines

(max. format 7 1/2" x 9 1/2")



The "CORDEX" Patent Self-Binding Case will keep your copies in mint condition. Issues can be inserted or removed with the greatest of ease. Specially constructed Binding cords are made from Super Linen of great strength, very hard twisted and twice doubled. They are attached to strong RUSTLESS Springs under tension, and the method adopted ensures PERMANENT RESILIENCE of the Cords. Any slack that may develop is immediately compensated for, and the Cords will always remain taut and strong. It is impossible to overstretch the springs, as a safety check device is fitted to each.

**COLOURS: MAROON OR GREEN**

(If choice not stated, colour available will be sent)

**PRICE 70p** P. & P. 14p

Available only from:—

**Data Publications Ltd.**  
57 Maida Vale London W9 1SN

# CHASSIS and CASES by



**H. L. SMITH & CO. LTD.**  
287/9 Edgware Road  
London W2 1BE  
TEL: 01-723 5891

## BLANK CHASSIS

FOUR-SIDED 16 SWG ALUMINIUM

Size	Price	Base	Size	Price	Base
6x4x2"	34p	17p	10x8x2½"	66p	30p
7x4x1½"	33p	18p	12x7x2½"	66p	33p
7x5x2"	40p	19p	12x9x2½"	76p	38p
8x4x2"	38p	19p	13x8x2½"	76p	38p
8½x5½x2"	44p	21p	14x7x3"	80p	36p
9x7x2"	50p	26p	14x10x2½"	88p	47p
10x4x2½"	50p	21p	15x10x2½"	92p	50p
12x4x2½"	55p	22p	17x10x3"	£1.10	55p
12x5x3"	66p	26p	Plus post and packing		

### CASES ALUMINIUM, SILVER HAMMERED FINISH

Type	Size	Price	Type	Size	Price
N	8x6x2"	£1.00	W	12x7x7"	£2.50
N	6x6x3"	£1.05	W	15x9x8"	£3.15
N	4x4x4"	80p	Y	8x6x6"	£2.25
U	5½x4½x4½"	£1.15	Y	12x7x7"	£2.80
U	8x6x6"	£1.45	Y	13x7x9"	£3.15
U	9½x7½x3½"	£1.55	Z	15x9x9"	£3.35
U	15x9x9"	£3.00	Z	17x10x9"	£4.15
W	8x6x6"	£1.90	Z	19x10x8½"	£4.25

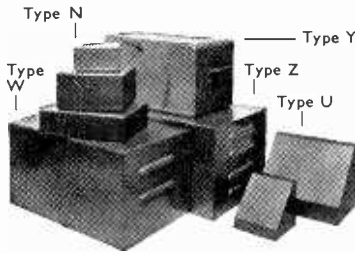

Type N has removable bottom, Type U removable bottom or back, Type W removable front, Type Y all screwed construction, Type Z removable back and front. Plus p.&p.

### TO FIT OUR CASES

7x5½x1½"	38p	21p	12x6½x2"	60p	33p
7x5½x2"	43p	21p	14x8½x2"	74p	44p
11x6½x1½"	48p	30p	15½x9½x2½"	94p	52p
11x6½x2"	55p	30p	17½x9½x2½"	£1.05	59p

Plus post & packing

PANELS: Any size up to 3ft. at 36p sq. ft. 16 s.w.g. (18 s.w.g. 32p). Plus postage and packing

**YUKAN SELF-SPRAY** 50 PROFESSIONAL THE YUKAN AEROSOL WAY - air drying GREY HAMMER OR BLACK WRINKLE (CRACKLE) finishes

Yukan Aerosol sprays contain 45g fine quality, durable easy instant spray. No stove baking required. Hammers available in grey and blue, 92p car. pd. Modern Eggshell Black Wrinkle (Crackle) producing a 3D textured finish, 92p car. pd. all at 87p per push-button self-spray can at our counter. Also durable, heat and water resistant Black Matt finish (339g self-spray cans only) 77p car. pd. SPECIAL OFFER - One can plus optional transferable snap-on trigger handle (value 25p) for 98p car. pd. Choice of 13 self-spray paint colours and primer (motor car quality) also available. Please enclose cheque or crossed P.D. for total amount direct to: DEPT RC/8 YUKAN, 307a EDGWARE ROAD, LONDON W2 1BN. We supply many Government Departments, Municipal Authorities, Institutes and Leading Industrial Organisations - We can supply you too. Now British - even better.

## MORSE MADE EASY!!!

**FACT NOT FICTION.** If you start RIGHT you will be reading amateur and commercial Morse within a month. (Normal progress to be expected.) Using scientifically prepared 3-speed records you automatically learn to recognise the code RHYTHM without translating. You can't help it, it's as easy as learning a tune. 18-W.P.M. in 4 weeks guaranteed. Complete course £4.50 (Overseas £1 extra). For further details of course ring s.t.d. 01-660 2896 or 01-668 3255 or send 4p stamp for explanatory booklet to: G3HSC/Box 38, 45 GREEN LANE, PURLEY, SURREY.

**GOLDEN HUNTER**  
from £10.50

Powerful metal detector  
locates buried coins, metal etc.  
Send for illus. literature  
**UNDERGROUND EXPLORATION LTD**  
DEPT 21 FARADAY HOUSE  
P.O. BOX 1 - HAILSHAM - SUSSEX

# SMALL ADVERTISEMENTS

Use this form for your small advertisement

To: The Advertisement Manager, Data Publications Ltd., 57 Maida Vale, London W9 1SN

Please insert the following advertisement in the ..... issue of THE RADIO CONSTRUCTOR

16 words at 4p = 64p.

**ALL WORDING IN BLOCK LETTERS PLEASE**

I enclose remittance of.....being payment at 4p a word. MINIMUM 60p. Box Number, if required, 10p extra.

NAME.....  
ADDRESS.....

Copy to be received four weeks prior to publication. Published on the 1st of every month.

Please mention **THE RADIO CONSTRUCTOR** when writing to advertisers

## British Association Screws

The Table gives dimensions for British Association screws from 0 B.A. to 14 B.A. Clearance holes should be slightly wider than full diameter, and tap holes should be slightly wider than core diameter. Also given are suggested clearance and tap drills up to 10 B.A.

Thread Number	Full Diameter (in.)	Clearance Drill	Core Diameter (in.)	Tap Drill	Threads per in.	Threads per cm.
0	0.236		0.189	No. 12	25.5	10.0
1	0.209	No. 2	0.166	No. 18	28	11.0
2	0.185	No. 10	0.147	No. 25	32	12.5
3	0.161	No. 18	0.127	No. 30	34.5	13.5
4	0.142	No. 25	0.111	No. 33	38.5	15.3
5	0.126	No. 29	0.098	No. 39	43	17.0
6	0.110	No. 31	0.085	No. 43	48	19.0
7	0.098	No. 36	0.076	No. 47	53.5	21.0
8	0.087	No. 41	0.066	No. 51	60	23.5
9	0.075	No. 46	0.056	No. 53	66	26.0
10	0.067	No. 49	0.050	No. 55	72.5	28.5
11	0.059		0.044		82.5	32.5
12	0.051		0.037		91.5	36.0
13	0.047		0.034		101.5	40.0
14	0.039		0.028		110	43.5

# HENRY'S RADIO LIMITED

## ENGLAND'S LEADING ELECTRONIC CENTRES

HENRY'S RADIO

HI-FI · ELECTRONIC COMPONENTS · TEST · PA · DISCO THEQUE · LIGHTING · MAIL ORDER

### BUILD THE TEXAN

#### 20 + 20 WATT INTEGRATED I.C. STEREO AMPLIFIER

FREE TEAK CABINET with complete kits  
(As featured in "Practical Wireless" May to August 1972)

**FEATURES** New slim design with 6 - IC's, IC sockets, 10 silicon transistors, 4 rectifiers, 2 zeners. Special Gardeners low field slim line transformer. Fibre glass PC panel. Complete chassis work.  
**HIGH QUALITY AND STABILITY ARE PREDOMINANT FEATURES - DEVELOPED BY TEXAS ENGINEERS FOR PERFORMANCE, RELIABILITY AND EASE OF CONSTRUCTION.**

**FACILITIES** On/off switch indicator, headphone socket, separate treble, bass, volume and balance controls, scratch and rumble filters, mono/stereo switch, input selector, Mag. P.U., Radio Tuner, Aux. Can be altered for Mic Tape - Tape head etc.  
(Paris list Ref. 20 on request)  
Design approved kits only available from Henry's

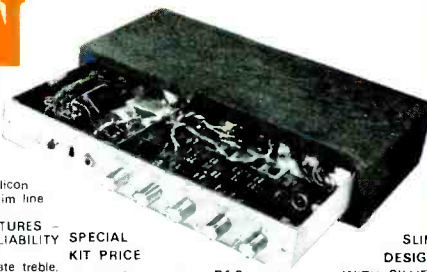

**SPECIAL KIT PRICE**  
**£28.50** P&P 45p

(Complete with FREE TEAK CABINET)

**SLIM DESIGN WITH SILVER TRIM.**  
Overall chassis size 14½" x 6" x 2" high

**RECORD DECKS CHASSIS (Post 50p)**

SP25/3	£10.75	HT70	£15.00
MP60	£10.40	MP610	£14.15
AP76	£18.95	GL72	£22.25
WITH PLINTH/COVER (Post 70p)			
MP60	£17.20	TD150AB	£41.45
HT70	£21.60	PL12AC	£35.25
HL(GL75)	£35.25	BD2	£32.25
MP610	£20.35		
CART/PLINTH/COVER (Post 70p)			
(HL) AP76/G800/PC			£29.95
(HL) SP25 3/G800H/PC			£18.95
HT70/G800/PC			£27.00
(HL) 2025TC/9TAHCD/PC			£13.50
MP60/SC5MD/PC			£17.25
(HL) GL75/G800E/PC			£44.15
(HL) GL72/G800/PC			£34.50

**ULTRASONIC TRANSDUCERS**  
Operate at 40kc/s up to 100 yds. Ideal remote switching and signalling. Complete with data and circuits.  
PRICE PER PAIR £5.90 Post 10p

### LOW COST HI-FI SPEAKERS

E.M.I. Size 13½" x 8½" Large Ceramic Magnet.

**TYPE 150** £6 watt, 3, 8 or 15 ohms £2.20, Post 22p.

**TYPE 150TC** Twin Cone version £2.75, Post 22p.

**TYPE 450** 10 watt with twin tweeters and crossover, 3, 8 or 15 ohms £3.85, Post 25p.

**TYPE 350** 20 watt with tweeter and crossover, 8 and 15 ohms. £7.70, Post 28p.

**POLISHED CABINETS** For 150, 150TC and 450 £4.60. Post 30p.



### TEST EQUIPMENT

SE250B	Pocket Pencil Signal Injector	£1.90
SE500	Pocket Pencil Signal Tracer	£1.50
1E15	Grid Dip Meter 440 KHz - 280 MHz	£13.45
500	30 K/Volt Multimeter	£9.25
	With leather case	£10.50
200H	20K/Volt Multimeter	£4.20
	With case	£4.95
AF105	50K/Volt Multimeter	£8.50
	With case	£9.50
U3341	AC/DC Multimeter with transistor tester with steel case	£10.50
TE20D	RF Generator 120KHz - 500MHz, Carr 35p	£15.95
TE22D	Audio Generator 20Hz - 200KHz, Carr 35p	£17.50
TO3	3-Scope 11Hz - 11MHz, Carr 50p	£39.00
CI-5	3-Pulse Scope 10Hz - 10MHz, Carr 50p	£39.00
TE65	Valve Voltmeter 28 ranges, Carr 40p	£17.50



### NEW MW/LW TUNER TO BUILD ML-3

Uses Mullard Module  
Slow motion tuning

Built in battery. Ferrite aerial. Overall size 7" x 2½" x 3½".  
**TOTAL COST TO BUILD £4.85** Post 15p. All parts sold separately - Leaflet No. 6.

### BUILD THIS VHF FM TUNER

5 TRANSISTORS 300 kc/s BAND-WIDTH, PRINTED CIRCUIT, HIGH FIDELITY REPRODUCTION, MONO AND STEREO.

A popular VHF FM Tuner for quality and reception of mono and stereo. There is no doubt about it - VHF FM gives the REAL sound. All parts sold separately. Free Leaflet No. 3 & 7.

**TOTAL £6.97**, p.p. 20p. Decoder Kit £5.97.  
Tuning meter unit £1.75.  
Mains unit (optional) Model PS900 £2.47, Post 20p.  
Mains unit for Tuner and Decoder PS1200 £2.62, Post 20p.

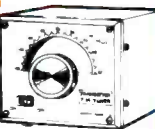

### "BANDSPREAD" PORTABLE TO BUILD



Printed circuit all transistor design using Mullard RF/IF Module. Medium and Long Wave bands plus Medium Wave Bandspread for extra sensitivity. Also slow motion geared tuning 600mV push-pull output, fibre glass PVC covered cabinet, car aerial socket. Attractive appearance and performance. **TOTAL COST TO BUILD £7.98** p.p. 32p (Battery 22p).

All parts sold separately - Leaflet No. 2  
**"T.M.B.L.W. PORTABLE"** (as previously advertised) £6.98 p.p. 35p. From stock. (Leaflet No. 1).

### PA-DISCO-LIGHTING

UK's Largest Range - Write phone or call in. Details and demonstrations on request.

DJ30L	3 Channel sound to light unit 3Kw	£26.50
DJ40L	3 Channel Mic (built in) to light 3 Kw	£37.50
DJ70S	70 watt Disco amp/mixer	£49.75
DISCOAMP	100 watt Disco amp/mixer	£67.50
DJ105S	30 watt Disco amp/mixer	£31.00
Anti-Feedback Quality Mic		£11.50
SDL	12" 50 watt 8 ohm Full range Speaker	£12.95
DECKS	Use MP60 or SP25/3 see above.	
	Matching cartridge SC5M	£2.62 Ref No. 18.



### CATALOGUE

Fully detailed and illustrated covering every aspect of Electronics - plus data, circuits and information.

10,000 Stock lines at Special Low Prices and Fully Guaranteed.

**PRICE 55p** (40p FOR CALLERS) Post Paid

**PLUS! FIVE 10p VOUCHERS**

Send to this address - Henry's Radio Ltd (Dept. RC), 3 Albemarle Way, London, E.C.1 - for catalogue by post only. All other mail and callers to "303", see below.

### SINCLAIR PROJECT 60 MODULES

- SAVE POUNDS

Z30	£3.57	Z50	£4.37
ST160	£0.79	P25	£3.97
P26	£6.37	P28	£4.77
Transformer for P28	£2.95		
Active Filter Unit	£4.45		
Stereo FM Tuner	£16.95		
IC12	£1.80	Q16	£1.15 p.p.
			Post etc 20p per item



**PACKAGE DEALS** Post 25p.  
2 x Z30, Stereo 60, P25 £15.95  
2 x Z30, Stereo 60, P26 £18.00  
2 x Z50, Stereo 60, P28 £20.25  
Transformer for P28 £2.95  
**NEW PROJECT 605 KIT** £19.95

### TEXAS PUBLICATIONS

1-100 watt Amplifiers and Pre-Amplifier Layouts and data £1.25  
77 pages.  
700 page IC Data Book (No. 2) All T.T.L.C. £6.00  
420 page Transistor Data (No. 3) 60p  
340 page Transistor Data (No. 4) 60p (Post etc. 20p each)

### POWER INTEGRATED CIRCUITS

Plessey SL403D - 3 watt with 8 page data layouts and circuits £1.50  
P.C. Board 60p. Heat Sink 14p  
Sinclair IC12 - 6 watt with data and circuits £1.80.  
TH9013P - 20 watt Power Amp Module £4.87  
TH9014P - IC Preampifier £1.50  
Data/Circuits Book for above No. 42 10p

### 7 SEG & NIXIE TUBES

(Post 15p per 10 to 6)  
XN3, XN13, GN6 9 Side view with data 85p  
GNP-7, GNP-8 0-9 Side view with decimal points and data 95p  
3015F 7-segment £2 each, £7 per 4 with data.  
12 and 24 hour clock circuits for above, Ref. No. 31 15p.

### MINIATURE AMPLIFIER

5 transistor, 300mV o/p. Fitted volume and sensitivity control 9 volt operated. £1.75 each P/P 15p

### QUALITY SLIDER CONTROLS

60mm stroke singles and ganged. Complete with knobs. 5K, 10K, 25K, 100K, 500K, 1 meg. Log and Lin. 45p each. 10K, 25K, 50K, 100K, Log and Lin ganged. 75p each.

### HI-FI & TAPE EQUIPMENT

Acknowledged as UK's largest stockists with lowest prices plus 12 months guarantee. Write or call for FREE 12 page lists (Ref 16/17)

**TRANSISTORS - IC'S - RECTIFIERS - SCR'S - TRIAC'S etc.**  
NEW FREE LISTS  
Ref. No. 36 on request

## MORE OF EVERYTHING AT LOW PRICES ALWAYS FROM HENRY'S

All the parts you need plus Data and Circuits - Get a Catalogue - it's all in there!

Electronic Components, Audio and Test Gear Centre  
404/406 EDGWARE RD,  
LONDON, W.2.  
Tel: 01-402 8381/8382

High Fidelity & Tape Equipment Centre  
354/356 EDGWARE RD.,  
LONDON, W.2.  
Tel: 01-402 4736/5854

Disco - PA - Lighting Equipment Centre  
309 EDGWARE ROAD,  
LONDON, W.2.  
Tel: 01-723 6963

Mail Order, Industrial Sales and Special Bargain Shop  
303 EDGWARE ROAD,  
LONDON, W.2.  
Tel: 01-723 1008/1009

"309", "354", "356", "404" & "406" OPEN SIX FULL DAYS A WEEK 9am to 6pm MONDAY TO SATURDAY