

# THE RADIO CONSTRUCTOR

Vol. 25 No. 8

MARCH 1972

20p

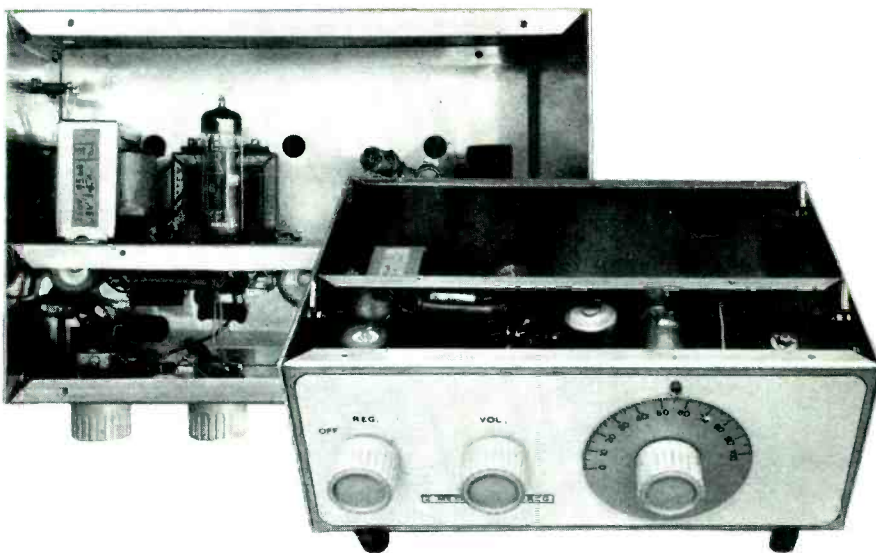

## 'EASY' 2 METRE RECEIVER

Employs a super-regenerative detector, 3 valves  
and offers no alignment problems

**FEATURED  
IN THIS ISSUE**

**Transistor Crystal Marker Unit  
D.C. Voltmeter**

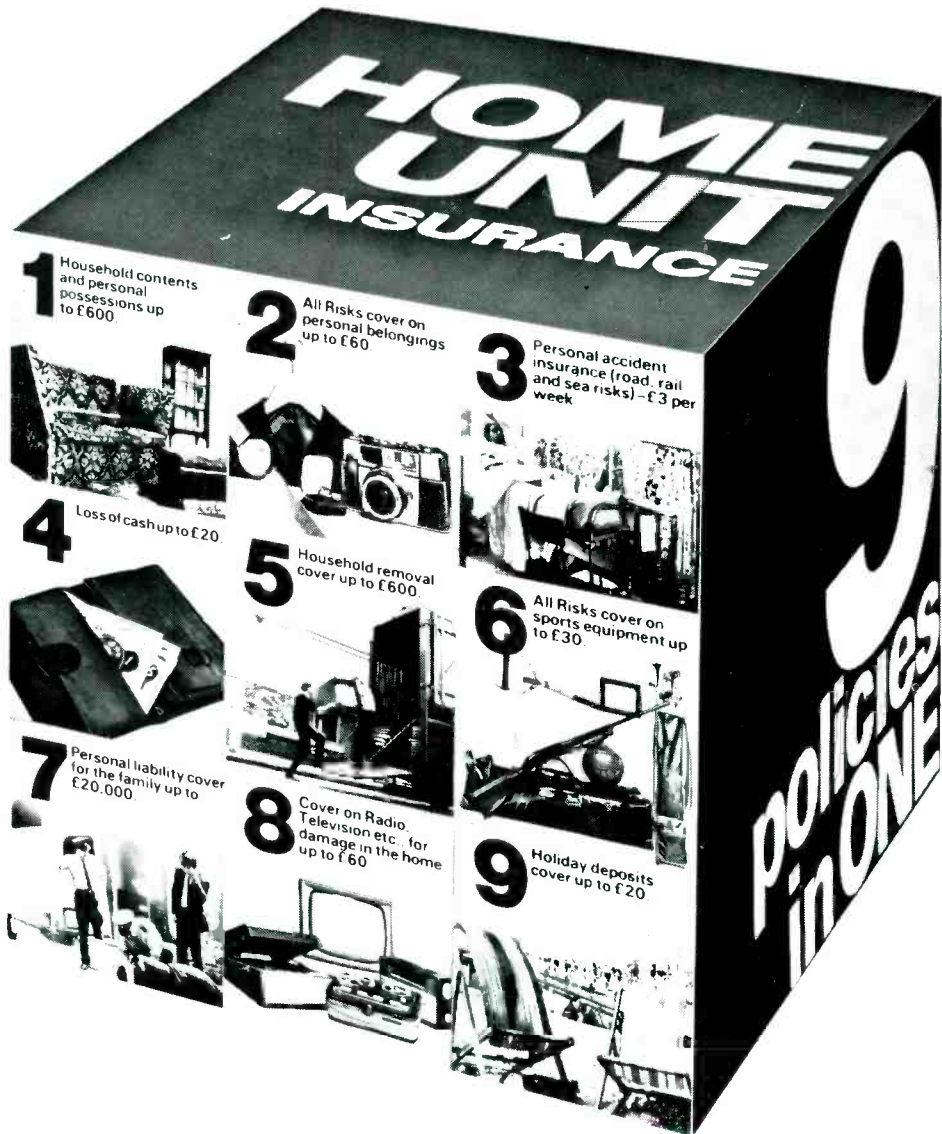

**Each £3 unit of Home Unit Insurance gives you protection up to the limit shown**

This is the simplified insurance you have been waiting for. Not just cover on the contents of your home but a package of personal protection you and your family need. And it's how we save you so much money: just ONE policy to issue instead of nine! You can build up to the cover you need by additional units

(or 1/3 units after the first) up to a maximum of five. So simple. So easy. Apply to your Broker, Agent or local office of a General Accident company. The Home Unit Policy can replace your existing insurances And remember - as you buy more possessions just add more Home Units at any time.

**THE GENERAL ACCIDENT FIRE & LIFE ASSURANCE CORPORATION LTD**

Metropolitan House, 35 Victoria Avenue,  
Southend-on-Sea, Essex, SS2 6BT

It pays to be protected by a **General Accident** company

Please send me further particulars of the Home Unit Insurance.

Name .....

Address .....

.....

.....

# DENCO (CLACTON) LIMITED

## 355-7-9 OLD ROAD, CLACTON-ON-SEA, ESSEX

Our components are chosen by Technical Authors and Constructors throughout the World for their performance and reliability, every coil being inspected twice plus a final test and near spot-on alignment as a final check.

Our General Catalogue showing full product range	..	16p
DTB4 Transistor & Valve circuitry for D.P. Coils	..	16p
DTB9 Valve Type Coil Pack Application circuitry	..	16p
MD.1 Decoder Circuitry for Stereo Reception	..	20p

All post paid, but please enclose S.A.E. with all other requests in the interests of retaining lowest possible prices to actual consumers

# STAY TUNED WITH JACKSON

TYPE P22 AM/FM 2 GANG  
CAPACITOR CATALOGUE NO. 4300



When you use Jackson capacitors, you know you're using tried and tested components. Jackson capacitors are made to the most exacting standards under rigorous supervision. As a result, they give perfect reliability over a very long life. What's more, you can have components custom made to suit your individual requirements.

Our skilled personnel and bang up to date equipment are backed by 45 years of experience in the communications field. And that's your guarantee of a reliable product



Write for fully illustrated catalogue.

**JACKSON BROTHERS  
(LONDON) LIMITED**

KINGSWAY, WADDON, CROYDON, CR9 4DG.  
TEL: 01-681 2754/7 U.S. OFFICE: M. SWEDGAL,  
258 BROADWAY, NEW YORK, N.Y. 10007.

## COMPONENTS

HOBBYIST - AMATEUR - DOMESTIC  
SURPLUS INDUSTRIAL - BULK OFFERS

### SELECTED PACKS 50p plus 10p Post/Pack

- 61 5 x 12pf, P.T.F.E. trimmers.
- 62 4 x 2, 500pf, 750 volt, trimmer.
- 63 3 x 1 meg tandem, volume controls.
- 64 6 to 15 volt motor, as used in Seafarer, Fairway and Pacific depth finders.
- 65 250 rpm miniature frequency locked mains 50c/s motor.
- 66 3 x rotor with neon indicator as used in Seafarer, Fairway and Pacific depth finders.
- 1 20 x 5k carbon presets.
- 2 4 x 6 pole 4 way wafer switch.
- 3 15 x 5k wire wound slider.
- 4 4 x 1 pole 11 way wafer switch.
- 5 6 x BY127 type rectifier diode.

\* \* \* \* \*

Steel box with lid, grey hammer finish, 10" x 5½" x 3"  
£1, post 20p.

6 digit, 6 to 14 volt resettable counters with locking facilities, £1.50, post, etc. 15p.

Tape deck with heads, £2.50, post, etc. 25p.

6⅞" diam. polished chrome metal reflectors. Ideal for strobe, light beam tranceivers, etc. 25p, post, etc., 10p.

**THE RADIO SHACK** MON-SAT  
9AM-8PM

161 ST. JOHN'S HILL

BATTERSEA, S.W.11

01-223 5016







# Now! A FAST EASY WAY TO LEARN BASIC RADIO & ELECTRONICS



Build as you learn with the exciting new **TECHNATRON** Outfit! No mathematics. No soldering—you learn the *practical way*.

Learn basic Radio and Electronics at home – the fast, modern way. Give yourself essential technical 'know-how' – like reading circuits, assembling standard components, experimenting, building – quickly and without effort, and enjoy every moment. B.I.E.T.'s Simplified Study Method and the remarkable **TECHNATRON** Self-Build Outfit take the mystery out of the subject, making learning easy and interesting.

Even if you don't know the first thing about Radio now, you'll build your own Radio set within a month or so!

... and what's more, you will understand exactly what you are doing. The **TECHNATRON** Outfit contains everything you need, from tools to transistors – even a versatile Multimeter which we teach you to use. All you need give is a little of your spare time and the surprisingly low fee, payable monthly if you wish. And the equipment remains yours, so you can use it again and again.

**You LEARN – but it's as fascinating as a hobby.**

Among many other interesting experiments, the Radio set you build – and it's a good one – is really a bonus. This is first and last a teaching course, but the training is as fascinating as any hobby and it could be the springboard for a career in Radio and Electronics.

A 14-year-old could understand and benefit from this Course – but it teaches the real thing. The easy to understand, practical projects – from a burglar-alarm to a sophisticated Radio set – help you master basic Radio and Electronics – even if you are a 'non-technical' type. And, if you want to make it a career, B.I.E.T. has a fine range of Courses up to City and Guilds standards.

### New Specialist Booklet

If you wish to make a career in Electronics, send for your **FREE** copy of 'OPPORTUNITIES IN TELECOMMUNICATIONS / TV AND RADIO'. This brand new booklet – just out – tells you all about **TECHNATRON** and B.I.E.T.'s full range of courses.



## FREE

### BRITISH INSTITUTE OF ENGINEERING TECHNOLOGY

Dept. B9, ALDERMASTON COURT, READING RG7 4PF  
Accredited by the Council for the Accreditation of Correspondence Colleges.

### POST THIS COUPON FOR FREE BOOK

Please send books and full information — free and without obligation.

NAME ..... AGE .....

(BLOCK CAPITALS PLEASE)

ADDRESS .....

.....

OCCUPATION .....



To B.I.E.T. Dept. B9, Aldermaston Court, Reading RG7 4PF

**NOW AVAILABLE . . .**

## LATEST BOUND VOLUME

### No. 24

of

## "The Radio Constructor" FOR YOUR LIBRARY

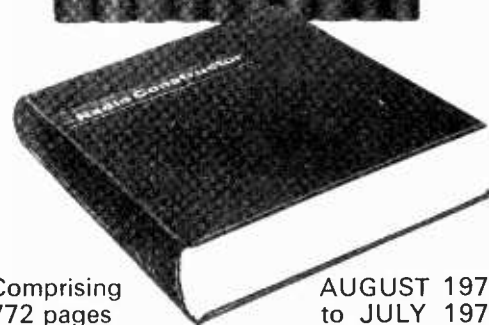

Comprising 772 pages plus index

AUGUST 1970 to JULY 1971

### PRICE £2.00 Postage 28p

BOUND VOLUME NO. 23

OF

"THE RADIO CONSTRUCTOR" AUGUST 1969 to JULY 1970

Limited number of this volume still available

PRICE £1.88 Postage 28p

We regret all earlier volumes are now completely sold out.

Available only from  
**DATA PUBLICATIONS LTD.,**  
57 MAIDA VALE, LONDON, W9 1SN

# BI-PRE-PAK



## TELEPHONE DIALS

Standard Post Office type  
Guaranteed in working order.

**ONLY 50p**

## COMPLETE TELEPHONES

Normal household type as supplied to the Post Office, ex. G.P.O. Only **£1** each. p. & p. 35p each.

### NEW TESTED AND GUARANTEED PAKS

B2	4	Photo Cells, Sun Batteries, 0.3 to 0.5V, 0.5 to 2mA.	50p
B79	4	IN4007 Sil. Rec. diodes, 1,000 PIV lamp plastic	50p
B81	10	Reed Switches, mixed types large and small	50p
B99	200	Mixed Capacitors. Approx. quantity, counted by weight	50p
H4	250	Mixed Resistors. Approx. quantity, counted by weight	50p
H7	40	Wirewound Resistors. Mixed types and values.	50p
H8	4	BY127 Sil. Recs. 1000 PIV, 1 amp. plastic	50p
H9	2	OC71 Light Sensitive Photo Transistor	50p
H12	50	NKT155/259 Germ. diodes, brand new stock clearance	50p
H18	10	OC71/75 uncodded black glass type PNP Germ.	50p
H19	10	OC81/81D uncodded white glass type PNP Germ.	50p
H28	20	OC200/1/2/3 PNP Silicon uncodded TO-5 can	50p
H29	20	OA47 gold bonded diodes uncodded MC52	50p

### NEW UNMARKED UNTESTED PAKS

B66	150	Germanium Diodes Min. glass type	50p
B83	200	Trans. manufacturers' rejects all types NPN, PNP, Sil. and Germ.	50p
B84	100	Silicon Diodes DO-7 glass equiv. to OA200, OA202	50p
B86	50	Sil. Diodes sub. min. IN914 and IN916 types	50p
B88	50	Sil. Trans. NPN, PNP equiv. to OC200/1/2N706A, BSY95A, etc.	50p
B1	50	Germanium Transistors PNP, A.F. & R.F.	50p
H6	40	250mW Zener Diode DO-7 Min. Glass Type	50p
H10	25	Mixed volts, 1 1/2 watt Zeners Top hat type	50p
H17	20	3 amp. Silicon Stud rectifiers, mixed volts	50p
H15	30	Top Hat Silicon Rectifiers, 750mA. Mixed volts	50p
H16	8	Experimenters' Pak of Integrated Circuits. Data supplied	50p
H20	20	BY126/7 Type Silicon Rectifiers 1 amp plastic. Mixed volts	50p

## MAKE A REV COUNTER FOR YOUR CAR

The 'TACHO BLOCK'. This encapsulated block will turn any 0-1mA meter into a linear and accurate rev. counter for any car with normal coil ignition system.

**£1 each**



## OUR VERY POPULAR 3p TRANSISTORS

TYPE "A" PNP Silicon alloy, TO-5 can.  
TYPE "B" PNP Silicon, plastic encapsulation.  
TYPE "E" PNP Germanium AF or RF.  
TYPE "F" NPN Silicon plastic encapsulation.

### FULLY TESTED AND MARKED SEMICONDUCTORS

4p		6p	
AC107	0 15	OC170	0 23
AC126	0 13	OC171	0 23
AC127	0 17	OC200	0 25
AC128	0 13	OC201	0 25
AC176	0 25	2G301	0 13
ACY17	0 15	2G303	0 13
AF239	0 37	2N711	0 50
AF186	0 50	2N1303-3	0 20
AF139	0 50	2N1304-5	0 25
BC154	0 25	2N1306-7	0 30
BC107	0 13	2N1308-9	0 35
BC108	0 13	2N3819FET	0 45
BF194	0 15		
BC109	0 14	<b>Power Transistors</b>	
BF274	0 15	OC20	0 50
BFY50	0 20	OC23	0 30
BSY25	0 57	OC25	0 25
BSY26	0 13	OC28	0 25
BSY27	0 13	OC26	0 30
BSY28	0 13	OC28	0 30
BSY29	0 13	OC35	0 25
BSY95A	0 13	OC36	0 37
OC41	0 15	AD149	0 30
OC44	0 13	AU710	1 25
OC45	0 13	25034	0 25
OC71	0 13	2N3055	0 50
OC72	0 13	<b>Diodes</b>	
OC81	0 13	AA42	0 10
OC81D	0 13	OA95	0 19
OC83	0 13	OA79	0 09
OC139	0 20	OA81	0 09
OC140	0 17	IN9114	0 07

## F.E.T. PRICE

### BREAKTHROUGH!!

This field effect transistor is the 2N3823 in a plastic encapsulation, coded as 3823E. It is also an excellent replacement for the 2N3819. Data sheet supplied with device. 1-10 30p each, 10-50 25p each, 50+ 20p each.



## BULK BUYING CORNER

NPN/PNP Silicon Planar Transistors, mixed, untested, similar to 2N706/6A/B, BSY26-29, BSY95A, BCY70, etc. **£4.25** per 500; **£8** per 1,000.

Silicon Planar NPN Plastic Transistors, untested, similar to 2N3707-11, etc. **£4.25** per 500; **£8** per 1,000.

Silicon Planar Diodes, DO-7 Glass, similar to OA200/202, BAY31-36, **£4.50** per 1,000.

NPN/PNP Silicon Planar Transistors, Plastic TO-18, similar to BC113/4, BC153/4, BF153/160, etc. **£4.25** per 500; **£8** per 1,000.

OC44, OC55 Transistors fully marked and tested, 500+ at 8p each; 1,000+ at 6p each.

OC71 Transistors, fully marked and tested, 500+ at 6p each; 1,000+ at 5p each.

3823E Field effect Transistors. This is the 2N3823 in Plastic Case, 500+ 13p each; 1,000+ 10p each.

### 1 amp Miniature Plastic Diodes:

IN4001, 500+ at 4p each; 1,000+ at 3p each.  
IN4004, 500+ at 5p each; 1,000+ at 4p each.  
IN4006, 500+ at 6p each; 1,000+ at 5p each.  
IN4007, 500+ at 8p each; 1,000+ at 7p each.

## FREE CATALOGUE AND LISTS FOR

TRANSISTORS, RECTIFIERS, DIODES, INTEGRATED CIRCUITS, FULL PRE-PAK LISTS & SUBSTITUTION CHARTS



## CLEARANCE LINES

### COLOUR T.V. LINE OUTPUT TRANSFORMERS

Designed to give 25kV when used with PL509 and PY500 valves. As removed from colour receivers at the factory.

**NOW ONLY 50p each**  
post and packing 23p.

Quantity	1-10	10-50	50-
BB105 Varicap Diodes	10p	8p	6p
OC71 or 72 Fully Tested Unmarked	5p	5p	4p
Matched Sets 1-OC44 and 2-OC45's. Per Set	25p	20p	15p
Matched Sets of OC45's 1st and 2nd IF	15p	12p	10p
OA47 Gold-Bonded Diodes, Marked and Tested	3p	3p	2p
1-watt Zener Diodes 7.5, 24, 27, 30, 36, 43 Volts	5p	4p	3p
10-watt Zener Diodes 5-1, 8.2, 11, 13, 16, 24, 30, 100 Volts	20p	17p	15p
Micro Switches, S/P, C/O	25p	20p	15p
1-amp Bridge Rec's 25-volt	25p	22p	20p

### INTEGRATED CIRCUITS

SL403D Audio Amp, 3-Watts	2-00	1-95	1-80
709C Linear Opp. Amp.	25p	20p	15p
Gates, Factory Marked and Tested by A.E.I.	25p	22p	20p
J. K. Flip-Flops Factory, Marked and Tested by A.E.I.	40p	35p	30p
SN7490 Decade Counter	50p	45p	40p
UL914 Dual 2 1/2 Gate	40p	35p	30p

### LOW COST DUAL INLINE I.C. SOCKETS

14 pin type at 15p each  
16 pin type at 16p each.

### BOOKS

We have a large selection of Reference and Technical Books in stock.

These are just two of our popular lines:  
**B.P.I. Transistor Equivalents and Substitutes;** 40p  
This includes many thousands of British U.S.A., European and C.V. equivalents.  
**The Hifire Radio Valve & Transistor Data Book 9th Edition;** 75p  
Characteristics of 3,000 valves and tubes, 4,500 Transistors, Diodes, Rectifiers and Integrated Circuits.  
Send for lists of these English publications.

Please send me the FREE Bi-Pre-Pak Catalogue.

NAME .....

ADDRESS .....

MINIMUM ORDER 50p. CASH WITH ORDER.  
PLEASE Add 10p post and packing per order.  
OVERSEAS ADD EXTRA FOR POSTAGE

# BI-PRE-PAK LTD

DEPT. C, 222-224 WEST ROAD, WESTCLIFF-ON-SEA, ESSEX, SS0 90F  
TELEPHONE: SOUTHEND (0702) 46344

# JERMYN 50p BARGAIN PACKS

All fully coded, all from well-known manufacturers and now available, while stocks last, at better than bulk-buyer's prices! Cash with order only.

1N4148 (=1N914)	Signal Diode	18 for 50p
1N5060 (=A14D)	1 Amp Rectifier 400V avalanche protected	7 for 50p
2N2923	NPN Silicon Transistor hfe 90-180 (25v)	7 for 50p
2N2926 (Red)	NPN Silicon Transistor hfe 55-110	8 for 50p
2N3391A	Si NPN Hi Gain (250-500) low noise transistor	3 for 50p
2N3402	Medium power (driver) 900mw 25v Hfe 75-225	6 for 50p
C6U	1.6 amp general purpose 25v SCR in TO5 case	3 for 50p

Post and packing 10p for 1 or 2 packs; 3 packs or more post free.

Order any quantity, till sold (but we regret packs cannot be subdivided).

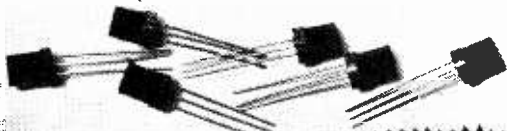

P.O. or Cheque payable  
Jermyn Industries,  
Vestry Estate,  
Sevenoaks, Kent.

Star Bargain  
Sprague (Pirgo) Triacs  
PT406S (6 amp 400v)  
48p each

## RADIO AMATEURS

The Radio Society of Great Britain  
is YOUR national society

YOU NEED THE RSGB!

THE RSGB MUST HAVE  
YOUR SUPPORT!

Benefits of membership include:

Representation in amateur radio matters at national and international level.

*Radio Communication*, the Society's monthly journal; technical publications; QSL Bureau; Contests and Operating Awards.

Write for full particulars of membership to:

The General Manager, RSGB (RC),  
35 Doughty Street, London WC1N 2AE

# RADIO MODELLER

RM  
BOOK  
SERIES

## ELECTRONIC BOOKS

### ● MODEL RADIO CONTROL

Detailing both Theory and Practice, this book, by leading authority Paul Newell, will become the standard reference work. A brief historical survey leads up to a detailed description of proportional systems, with over 100 illustrations, including theoretical circuits and p.c. layouts for an advanced digital system.

134 pages. Price £2.25 U.K. Postage 13p

### ● SINGLET SET

The Singlet Transmitter, Superhet and Super-regen receivers, are now all three available in one book. Complete construction details with full size p.c. layout, components list etc. Ideal introduction to the hobby for the home constructor. 20 pages.

Price 30p. U.K. Postage 3p

### ● LOW COST PROPORTIONAL

Modellers who want to save money buy this volume when converting single channel equipment to simple proportional. They find a wealth of really up to date information in the clear descriptions, full size practical and working drawings, plus over a dozen circuit modules for pulse proportional units.

118 pages. Price £1.05 U.K. Postage 11p



ON SALE NOW at all leading  
shops or direct from:-

RADIO MODELLER, BOOK SALES, 64 Wellington Road, Hampton Hill, Middx.

454

THE RADIO CONSTRUCTOR



# THE MODERN BOOK CO

## 1972 WORLD RADIO - TV HANDBOOK A COMPLETE DIRECTORY OF INTERNATIONAL RADIO AND TELEVISION

£2.80

Postage 10p

### Fundamentals of Radio Servicing

by B. W. Hicks. £1.50 Postage 10p

### Colour Television with Particular Reference to the Pal System

by G. N. Patchett. £2.50 Postage 8p

### Transistor Electronic Organs for the Amateur

by A. Douglas & S. Astley. £1.10 Postage 10p

### Radio & Servicing Handbook

by Gordon J. King. £3. Postage 20p

### Mullard Transistor Audio & Radio Circuits

£1.50 Postage 10p

### Coil Design & Constructional Manual

by Bernards Radio Manual. 30p Postage 5p

### T.V. Fault Finding 405/625 Lines

by J. R. Davies. 50p Postage 6p

### RSGB Amateur Radio Call Book 1972

by R.S.G.B. 50p Postage 6p

### Radio Amateur Operator's Handbook

by Data Publications. 45p Postage 6p

### Hi-Fi for the Enthusiast

by M. L. Gayford. £2 Postage 10p

### Hi-Fi Year Book 1972

£1.25 Postage 20p

### Television Engineers' Pocket Book

by J. P. Hawker & J. A. Reddihough. £1.40 Postage 10p

### Foundations of Wireless & Electronics

by M. G. Scroggie. £1.80 Postage 20p

### 110 Integrated Circuit Projects for the Home Constructor

by R. M. Marston. £1.20 Postage 10p

### VHF-UHF Manual

by G. R. Jessop. £1.60 Postage 15p

### Radio Valve & Transistor Data

by A. M. Ball. 75p Postage 10p

We have the Finest Selection of English and American Radio Books in the Country

**19-21 PRAED STREET (Dept RC) LONDON W2 1NP**

Telephone 01-723 4185

### REVERBERATION UNIT KIT

6 transistor reverberation chamber to which microphones, instruments, etc., may be connected for added dimensional effect. The output is suitable for most amplifiers and the unit is especially suitable for use with electronic organs. A ready-built spring and transducer assembly is used. Complete easy-to-build kit, with constructional notes and circuits **£7.50**. Pre-drilled and printed case **£1.70** extra. All parts available separately.

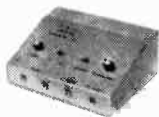

### WAH-WAH PEDAL KIT

The Wilsic Wah-Wah pedal comprises a SELECTIVE AMPLIFIER MODULE KIT, containing all the components to build a two transistor circuit module, which may be used by the constructor for his own design or fitted to the FOOT VOLUME CONTROL PEDAL (as photo) converting it to Wah-Wah operation. This pedal is in strong fawn plastic and fitted with output lead and screened plug. Selective amplifier module kit **£1.75**. Foot Volume control pedal **£5.13**. COMPLETE KIT **£6.50**. Add 38p for assembly of module.



### WILSIC VIBRATO UNIT

A new kit to build a self-contained vibrato foot switch unit. 4-silicon transistor circuit in tough grey hammered finish metal cabinet. Variable speed and depth controls and on-off foot switch. Ideal for guitars but unsuitable for high level inputs. COMPLETE KIT **£5.25**, all parts available separately.



THE WILSIC BOOK OF CIRCUITS contains the full instructions for the Reverb unit, Wah-Wah pedal and our Vibrato unit. PRICE ONLY 15p

SEND 5p in stamps for latest catalogue (Autumn 1971) of Hi-Fi, components, guitars, etc., etc. Friendly, high-speed service.



**WILSIC ELECTRONICS LTD.**

6 COPLEY ROAD, DONCASTER, YORKS

## TECHNICAL TRAINING in Radio, Television and Electronic Engineering

Let ICS train You for a well-paid post in this expanding field. ICS courses offer the keen, ambitious man the opportunity to acquire, quickly and easily, the specialized training so essential to success. Diploma Courses in Radio, TV Engineering and Servicing, Colour TV Servicing, Electronics, Computers, etc. Expert coaching for:

- \* C&G. TELECOMMUNICATION TECHNICIANS CERTS
- \* RADIO AMATEURS EXAMINATION
- \* GENERAL RADIOCOMMUNICATIONS CERTIFICATES
- \* C&G. RADIO SERVICING THEORY

### CONSTRUCTOR COURSES

Build your own transistor portable, signal generator, multi-test meter—all under expert guidance. POST THIS COUPON TODAY and find out how ICS can help YOU in your career. Full details of ICS courses in Radio, Television and Electronics will be sent to you by return mail.

Member of the ABCC.

Accredited by the C.A.C.C.

Name \_\_\_\_\_ Age \_\_\_\_\_

BLOCK CAPITALS PLEASE

Address \_\_\_\_\_

3.72

### INTERNATIONAL CORRESPONDENCE SCHOOLS

Dept. FA33.

Intertext House, Stewarts Road, London SW8 4UJ





*Call 'em what you will ...*

*... the best place  
to get them is*

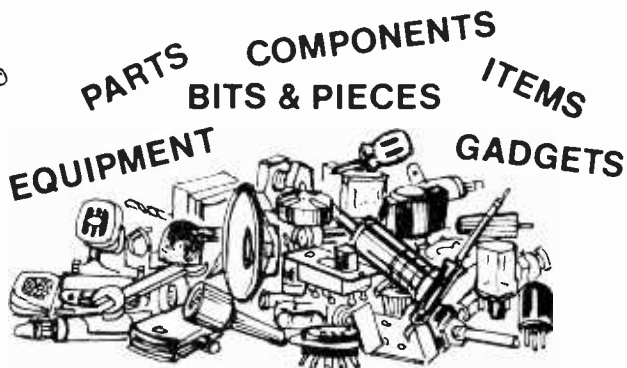

# HOME RADIO (COMPONENTS) LIMITED

240 London Road, Mitcham. CR4 3HD

Phone: 01-648 8422



Until you've tried the service provided by Home Radio (Components) Limited you've no idea how simple it can be tracking down and obtaining components. It becomes a pleasure instead of a bind! But first you need the Home Radio Catalogue, listing over 8,000 components, more than 1,500 of them illustrated. At 70 pence, including p & p, it's a gift – especially as every copy contains 10 vouchers each worth 5 pence.

Send coupon today.

● 24-hour Phone Service  
Ring 01-648 8422

Ask for details of our  
Credit Account Service.

The price of 70p applies only to catalogues purchased by customers in the UK and to BFPO addresses.



**POST THIS COUPON with your  
cheque or postal order for 70p.**

Please write your Name and Address in block capitals

Name \_\_\_\_\_

Address \_\_\_\_\_

\_\_\_\_\_

\_\_\_\_\_

**HOME RADIO (COMPONENTS) LTD., Dept. RC,  
234-240 London Road, Mitcham, Surrey CR4 3HD.**



# THE Radio Constructor



Incorporating THE RADIO AMATEUR

MARCH 1972

Vol. 25 No. 8

## CONTENTS

Published Monthly (1st of Month)  
First Published 1947

Editorial and Advertising Offices  
57 MAIDA VALE LONDON W9 1SN

Telephone 01-286 6141      Telegrams  
Databux, London

© Data Publications Ltd., 1972. Contents may only be reproduced after obtaining prior permission from the Editor. Short abstracts or references are allowable provided acknowledgement of source is given.

Annual Subscription: £2.70 (U.S.A. and Canada \$7.00) including postage. Remittances should be made payable to "Data Publications Ltd". Overseas readers please pay by cheque or International Money Order.

*Technical Queries.* We regret that we are unable to answer queries other than those arising from articles appearing in this magazine nor can we advise on modifications to equipment described. We regret that such queries cannot be answered over the telephone; they must be submitted in writing and accompanied by a stamped addressed envelope for reply.

*Correspondence* should be addressed to the Editor, Advertising Manager, Subscription Manager or the Publishers as appropriate.

*Opinions* expressed by contributors are not necessarily those of the Editor or proprietors.

*Production.*—Web Offset.

TRANSISTOR CRYSTAL MARKER UNIT	458
NOTES ON SEMICONDUCTORS (Further Notes – 4. Protection Money)	463
NEWS AND COMMENT	464
QSX	466
'MAGIC' NUMBER INDICATOR (Suggested Circuit No. 256)	467
D.C. VOLTMETER	469
DEALING WITH HIGH TENSION SHORTS	475
TRADE NEWS	479
'EASY' 2 METRE RECEIVER	480
SILICON TRANSISTOR SIREN	487
D.C. MOTOR CONTROLLER	488
1919 RADIO TRANSMITTER	490
A BETTER PRINTED CIRCUIT RESIST	491
A MODERN HOMODYNE RECEIVER – Part 1	492
FARAD ELECTROLYTIC CAPACITORS	495
SHORT WAVE NEWS	496
IN YOUR WORKSHOP	498
RADIO CONSTRUCTOR'S DATA SHEET No. 60 (Millimetre-Inch Table I)	iii

Published in Great Britain by the Proprietors and Publishers, Data Publications Ltd, 57 Maida Vale, London, W9 1SN

The Radio Constructor is printed by Cartisle Web Offset.

APRIL ISSUE WILL BE  
PUBLISHED ON APRIL 1st

# TRANSISTOR CRYSTAL MARKER UNIT

By

P. Cairns, M.I.P.R.E., R.Tech.Eng., G3ISP

Capable of accepting crystals between 50 and 500kHz, this marker oscillator provides high level calibration 'pips' up to higher than 30 MHz.

THIS ARTICLE DESCRIBES A FREQUENCY MARKER crystal oscillator for use with virtually all types of communications receiver. The purpose of such marker units is to enable a very accurate h.f. oscillator of known frequency and high harmonic content to be switched into the receiver aerial input. With the receiver b.f.o. switched on, an audible beat note is then heard at regular frequency intervals across all bands of the receiver. Popular choice of frequencies for such markers are 100, 250 and 500kHz, though 1MHz is occasionally used. Crystals are in standard use for these devices as they allow high frequency stability to be achieved over an almost indefinite period. The specification of the marker unit to be described here is given in Table I.

## MARKER FREQUENCY

The choice of frequency made by the writer was 250kHz, this representing a fair compromise between too wide and too narrow a marker interval. As most communications receivers are calibrated in at least 0.5MHz intervals this allows not only these points to be checked but also the 1MHz points. Any 250kHz markings between these two points can also be checked. Calibration between 250kHz steps is by means of the vernier or logging scale of the receiver, the number of degrees between any two 250kHz points being divided into the appropriate number of kHz. Thus, if the range between two marker points is logged as 10 degrees, each degree represents 25kHz.

TABLE I  
*General Specification*

Output.	50kHz to 500kHz; frequency and accuracy determined by crystal. Maximum output 6 volts peak-to-peak square wave. Rise time approximately 50nS.
Supply.	With low voltage circuit, 9 - 12 volts d.c. Current drain at 9 volts: 9.5mA. With high voltage supply circuit, 150 - 330 volts d.c.
Dimensions.	1½ by 1½ by 2in. high. Components mounted on standard octal plug.

As some constructors may however already have crystals of other frequencies to hand (100kHz are quite common), or may prefer another choice of frequency to line up with a particular receiver's dial markings, the circuit was designed to function with crystals of any frequency between 50kHz and 500kHz. Several crystals of both these frequencies, together with others which lay between these extremes, were tried out in practice with complete success.

While the actual crystal used and specified by the writer is mounted in a B7G based glass envelope, other types of crystal having the standard ½in. or ¾in. two-pin spacing can be employed. The accuracy of the marker frequency will of course depend upon the accuracy and type of crystal used. Most crystals of the type used for frequency markers in the 100-500kHz range have accuracies of better than 0.1%. This is quite adequate for most general communications purposes. Frequency checks were carried out on a batch of assorted crystals, many of them ex-surplus, the frequencies being measured on a digital counter. The worst error measured was -0.13% while the least error was -0.015%. The crystal used by the writer had a measured frequency of 250,049Hz. (± 0.02%).

The cost of the crystal depends of course very much upon the type and accuracy required. Surplus types are generally available in the 75p to £1.50 range. New types of higher accuracy are available, and cost a number of pounds.

The inclusion of a crystal marker in a communications receiver can be a decided advantage allowing, as it does, a constant and accurate check on dial and frequency markings on all bands. To ensure adequate output at the higher frequencies, a waveform having a high harmonic content is desirable. This means a fast rise time. The waveform rise time of the unit described is in the region of 50nS, thus allowing calibration checks well in excess of 30MHz. An oscillogram showing the output waveform appears in one of the accompanying photographs. While some receivers have a self-contained marker unit, many manufacturers advertise them as optional extras for their range of receivers, and prices noted on the commercial market vary between £6 and £9.75. The

THE RADIO CONSTRUCTOR

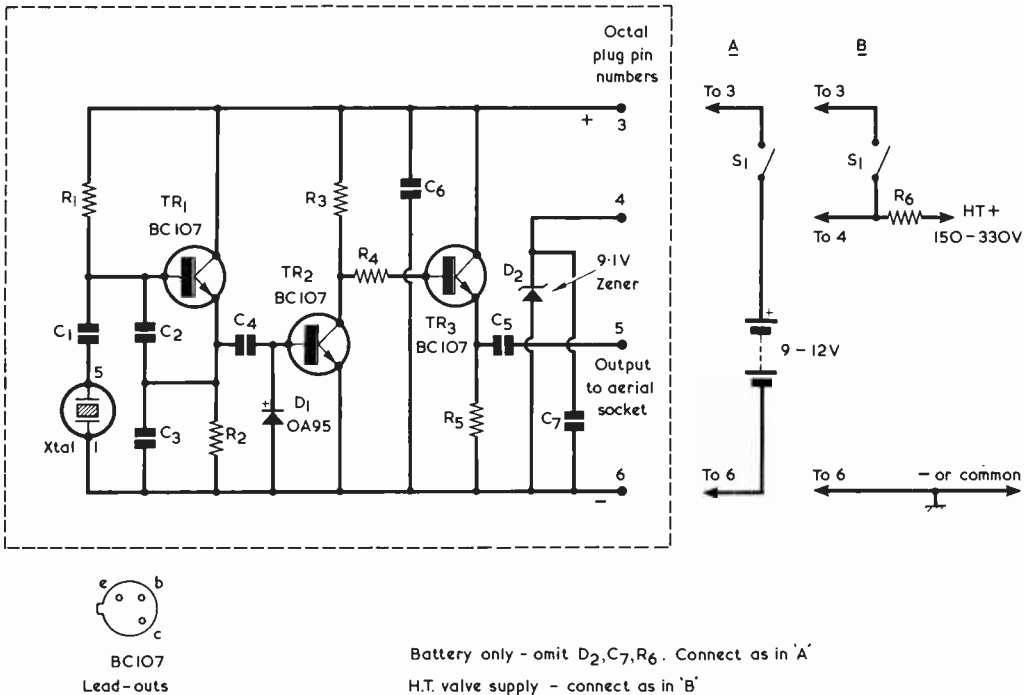

Fig. 1. The circuit of the marker unit. The components within the dashed outline are mounted on the octal plug. S<sub>1</sub> and R<sub>6</sub> (if used) are positioned, externally, in the receiver with which the marker unit is employed

## COMPONENTS

### Resistors

(All  $\frac{1}{4}$  watt 5% unless otherwise stated)

R1 220k $\Omega$

R2 4.7k $\Omega$

R3 1k $\Omega$

R4 10k $\Omega$

R5 1k $\Omega$

\*R6 10k $\Omega$  - 18k $\Omega$  (see Table II), 12 watt wirewound, Cat. No. R17A (Home Radio)

### Capacitors

C1 470pF silvered mica

C2 0.01 $\mu$ F polyester

C3 100pF silvered mica

C4 0.002 $\mu$ F polyester

C5 1-5pF ceramic (see text)

C6 0.33 $\mu$ F polyester

\*C7 1 $\mu$ F polyester

### Semiconductors

TR1 BC107

TR2 BC107

TR3 BC107

D1 OA95

\*D2 9.1V 5% 400mW zener diode type BZY88-C9V1

\*Not required with 9-12V supply

### Switch

S<sub>1</sub> s.p.s.t. toggle

### Crystal

250kHz crystal, or frequency as desired (see text)

### Miscellaneous

Crystal holder, to suit crystal used

Veroboard, 0.15in. matrix (see Fig. 2)

Octal plug and socket

cost of the unit described, less crystal, is at the time of writing just short of £2.

## CIRCUIT DIAGRAM

The complete circuit diagram is shown in Fig. 1. The two types of power connection available are also

illustrated. With transistor receivers using batteries or a 9-12 volt power unit, components D<sub>2</sub>, C<sub>7</sub> and R<sub>6</sub> are omitted. For use with mains valve receivers having a conventional h.t. supply, these components are included, R<sub>6</sub> functioning as an external dropper resistor. To allow for a wide range of possible h.t. voltages the value of R<sub>6</sub> should be selected from the values shown in



H.T. Voltage	Value of R6
150 - 190	10kΩ
190 - 230	12kΩ
230 - 280	15kΩ
280 - 330	18kΩ

Table II. The extra current drawn from the h.t. supply is of the order of 17mA.

The circuit in Fig. 1 shows TR1 connected as a Colpitts oscillator in the emitter follower mode. The oscillatory circuit is provided by the crystal which is working in the parallel mode of resonance. C1 providing series blocking and R1 base bias. The output is developed across the emitter load R2 while the necessary positive feedback is achieved across the capacitor divider C2, C3, the centre point being tapped into the signal output from the emitter.

The oscillator output is fed via the coupling capacitor C4 to the base of the squaring amplifier TR2. D1 and the base-emitter junction of TR2 provide symmetrical clipping of the input waveform, D1 also providing a d.c. return for TR2 base. This clipped waveform is amplified by TR2, the drive being sufficient to run this stage between cut-off and saturated conditions and thereby allowing a very fast rise time to be achieved. The squared output signal which is developed across the collector load resistor, R3, is d.c. coupled via the limiting resistor R4 into the base of TR3.

TR3 is an emitter follower output transistor, this providing a very low output impedance and so ensuring negligible loading effect by the receiver aerial input circuit. This stage also gives isolation between the aerial circuit and the oscillator and squaring amplifier. The output developed across the emitter load, R5, is coupled to the receiver aerial circuit via capacitor C5. The value of this component determines the degree of marker signal fed into the receiver and its value will depend to a large extent upon the sensitivity of the receiver in use. Details for setting this capacitor value are given later.

When used with battery or 9-12 volt power units the supply is simply connected to the supply via S1, as shown by 'A' in Fig. 1. C6 provides decoupling of the supply line. In the case of mains-derived valve h.t.

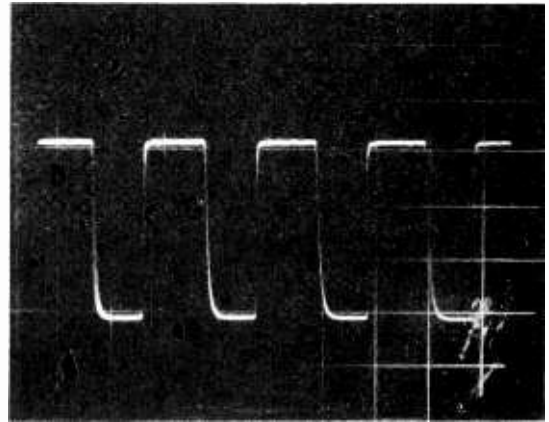

Trace given at 250kHz by the prototype. Signal amplitude is 6 volts peak-to-peak

supplies, the marker supply is taken from the zener stabilizer, D2, which is fed via the appropriate dropper resistor, R6, as illustrated by 'B'. S1 is again used to turn the unit on and off. The zener diode and dropper resistor are decoupled by C7.

## CONSTRUCTION

The type of construction employed by the writer achieves a high degree of compactness, the use of Veroboard allowing reasonably constant results to be given in different units built up to the circuit. The parts are mounted on an octal base, which allows the unit to be easily removed for servicing or for use with another receiver. Most commercial marker units are of the plug-in type. Other types of construction and mounting can be used, however, the circuit not being excessively critical as regards to layout.

The complete circuit, except for R6 and the crystal, is wired on a piece of Veroboard measuring some 2 by 1½ in., this being cut to provide the strips and holes shown in Fig. 2. The component layout on this board is also given in Fig. 2. Note the letters 'A' and 'K' alongside the connection points for D1 and D2. These indicate the anode and cathode ends of each diode

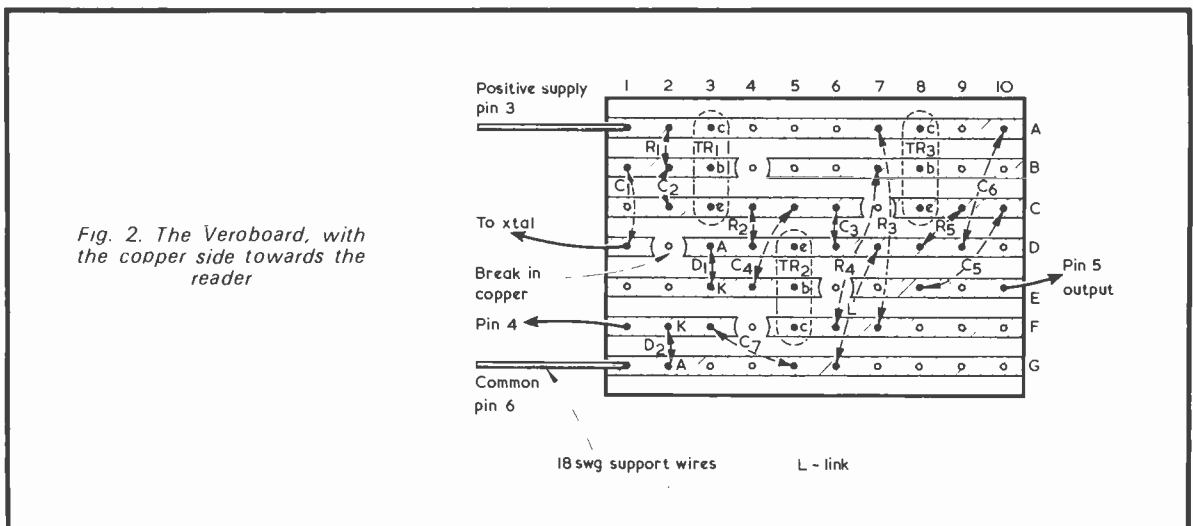

Fig. 2. The Veroboard, with the copper side towards the reader

respectively. A 5pF capacitor may be temporarily fitted in the C5 position.

After fitting the components, the Veroboard is mounted vertically on the edge of the octal plug by means of two lengths of 18 s.w.g. tinned copper wire. This octal plug is mounted in the centre of a 1½ in. square piece of ¼ in. Paxolin, which forms a base plate. The 18 s.w.g. wire is soldered between the outer copper strips on the bottom of the Veroboard, these being positive and common supply lines, and the appropriate pins in the octal plug, which are pins 3 and 6 respectively. The support wires are bent to shape so as to allow the Veroboard to sit comfortably on the upper edge of the plug base while allowing the ends of the wire to be located directly into the appropriate plug pins.

The crystal holder is mounted in a similar manner on short lengths of 18 s.w.g. support wire, the wires being terminated in pins 2 and 7 of the octal plug. These two pins are unused, and no connections are made to the corresponding tags of the valveholder into which the assembly is plugged. The author used a crystal on a B7G base, and the 18 s.w.g. support wires were taken to pins not employed for the crystal connections. The latter are pins 1 and 5. If a 2-way crystal socket is used, the 18 s.w.g. wires could be soldered to the same pins as are used for circuit connection. Wiring between the crystal socket and the Veroboard and between the Veroboard and pins 4 and 5 of the octal plug is carried out with short direct lengths of p.v.c. covered wire. The earthy side of the crystal may connect to the 18 s.w.g. support wire soldered to pin 6. Figs. 3 and 4 give top and side views of the assembly.

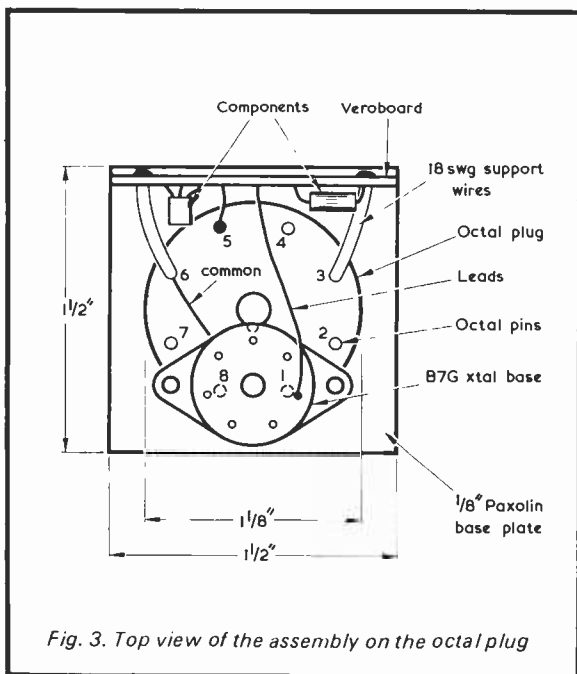

Fig. 3. Top view of the assembly on the octal plug

The corresponding octal valveholder is fitted at a convenient point in the receiver with which the marker unit is to be employed. Connections are then made to tags 3 and 6, or to tags 3, 4 and 6, of the valveholder, as indicated by 'A' or 'B' in Fig. 1. If R6 is used, it should be positioned away from the oscillator section of the receiver.

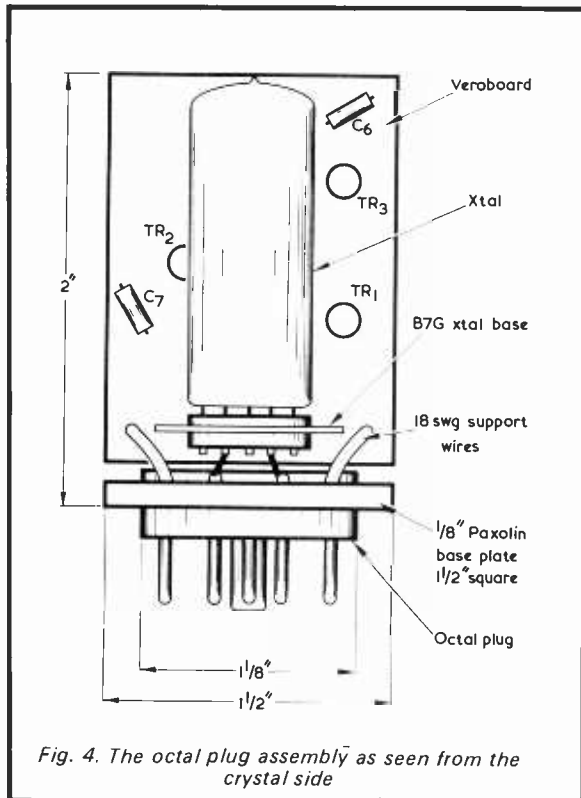
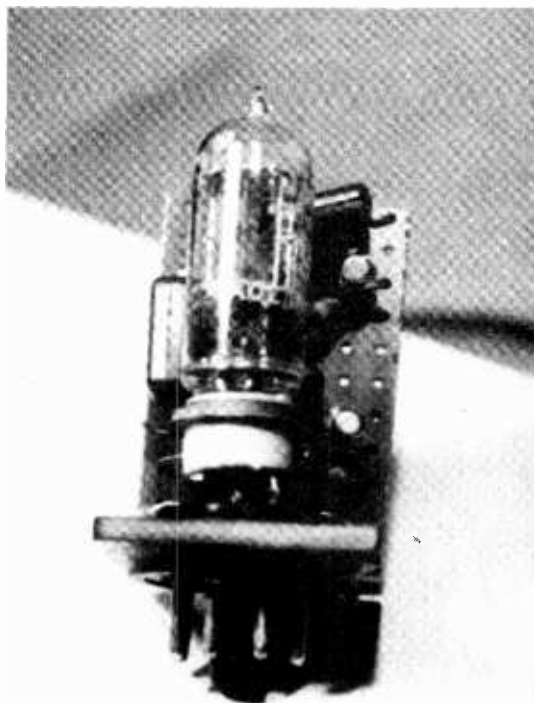

Fig. 4. The octal plug assembly as seen from the crystal side



A view of the unit from the side on which the crystal appears



Side view of the completed marker unit, with the parts mounted on the octal plug

## TESTING

When the unit is completed and connected into the receiver, the supply is switched on and the functioning of the unit checked. If an oscilloscope can be brought into use the waveform can be checked by connecting the Y1 input between TR3 emitter and the common supply line. If no oscilloscope is available the output from socket tag 5 is taken to the receiver aerial input socket. The receiver b.f.o. is switched on and the receiver tuned to a suitable point on the dial. For a 250kHz crystal, 500, 750kHz and 1, 1.25, 1.5, 1.75MHz, etc., are suitable points at the lower end of the tuning range. When the receiver is tuned over these points a strong beat note should be heard. It will be necessary to reduce the r.f. gain to a relatively low level to prevent overloading the receiver.

Having proved that the marker unit is functioning correctly it only remains to set the value of C5 for the best level of coupling into the aerial circuit. With the marker unit switched on as just described, select the high frequency end of the receiver h.f. band. In most types of standard receiver this will be in the region of 30MHz. The r.f. gain can be increased to near-maximum. Tune about this point until the beat note is heard. With a 250kHz crystal, beats will be noted on 29.5, 29.75, 30, 30.25 and 30.5MHz, etc. The aerial should be disconnected during these tests. The strength of the beat note around 30MHz will depend to a large extent on the sensitivity of the receiver in use. Thus, the value of C5 can only be selected under test.

With conditions set up as just described, reduce the value of C5 until the beat note falls to an average level of audio output with the receiver set to maximum r.f. gain. With highly sensitive receivers, values in C5 of even 0.5 or 1pF may still be too large, and the output lead from tag 5 of the valveholder may have to be even more loosely coupled to the aerial input. In this instance the lead from tag 5 is brought into close proximity with the aerial input socket or lead, but no direct connection

is made. In some cases the coupling lead from tag 5 may have to be screened to prevent stray coupling to other circuits.

With the value of C5 set, the unit is complete and ready to be switched into service at any time. Not only does the use of a frequency marker allow instantaneous calibration checks at the press of a switch, but it will also indicate any long term deterioration in receiver alignment.

While the crystal marker described so far has only been considered as a permanent sub-unit for internal use with a receiver, it could of course be built in a separate case with internal battery or power supply. Such a unit could then be employed not only with a number of different receivers but also as a general purpose frequency standard. The modified circuit in Fig. 5 can be used with the unit, allowing not only a variable output for general use but also for receiver/marker aerial coupling arrangements which obviate the necessity of having to make any internal connections to the receiver. Such a unit will find many uses in the short wave listener's shack and on the test bench.

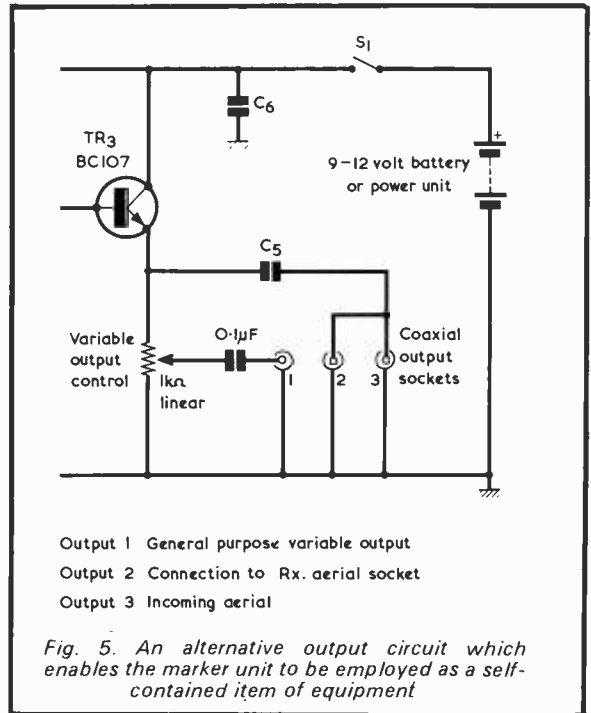

## CRYSTAL AVAILABILITY

As stated earlier in this article, the unit may employ crystals having frequencies other than 250kHz. 100kHz crystals are available from Home Radio. 250kHz S.T.C. Crystals Type 4013/CT on a B7G base are available in 1-off quantities from ITT Components Group Europe, Standard Telephones and Cables Ltd., Quartz Crystal Division, Edinburgh Way, Harlow, Middlesex. Also, 250kHz Crystals Type QO1655C, similarly on a B7G base, are available in 1-off quantities from Specialized Components Division, Marconi Communication Systems Ltd., Radford Crescent, Billericay, Essex. A large range of surplus types, some with 'round figure' frequencies, are generally available from Henry's Radio. ■

# NOTES ON SEMICONDUCTORS

## Further Notes – 4

# PROTECTION MONEY

by

PETER WILLIAMS

The addition of a single resistor prevents damage in a series regulator circuit in the event of load short-circuit. The circuit described in last month's note forms the basis of the present discussion.

**F**INAGLE'S FIRST LAW: IN ANY LABORATORY experiment, if anything can go wrong it will. This, the most scientific form of folk wisdom, equivalent to Murphy's Law or the Law of Constant Cussedness, is one that the experimenter should learn at his mother's apron strings (or coaxial cables if he has chosen parents wisely.) In the context of voltage regulators it leads to the following axiom: short-circuit of the load will always occur at the instant at which the maxima of supply voltage and temperature coincide.

### LOAD SHORT-CIRCUIT

For the example treated last month, a short-circuit of the load at the instant of maximum supply voltage could have disastrous results. The base current of the transistor would then be a little over 4mA ( $11.5V/2.7k\Omega$ ) while the maximum transistor current gain might be well over 200 if the minimum were 60. Hence the collector current might try to increase towards 1A which would result in a transistor dissipation of 12W – for a very *short* time. Thus it would be unwise to operate such a regulator with loads that could be readily short-circuited.

There is one simple means of minimizing the dissipation, as shown in the diagram. A resistor R2 may be inserted in series with the collector of the transistor (a) to minimize the short-circuit current and (b) to absorb part even of this reduced power. It can do this with no noticeable deterioration in regulation since the transistor parameters depend only slightly on  $V_{ce}$  provided this is more than enough to keep the transistor out of saturation.

A minimum  $V_{ce}$  of 1V is usually adequate (or down to less than half of this value if a small drop in output voltage is acceptable). Thus, in the example, to avoid saturation at the lowest supply voltage and maximum

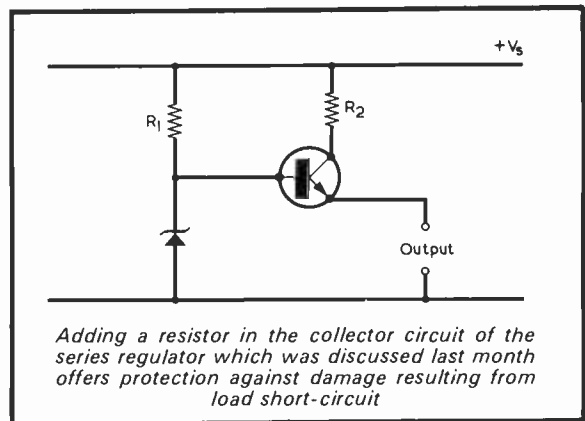

current we have a voltage across  $R_2$  of  $9V - (6 - 0.5)V = 2.5V$ . With a maximum current of 30mA this gives  $R_2 = 82\Omega$  (nearest preferred value to  $2.5V/30mA$ ). Now even with a short-circuit the load current cannot exceed about 150mA ( $12V/82\Omega$  base current). Further under these conditions the transistor is saturated with small p.d. across it and correspondingly low dissipation.

The worst case dissipation for this circuit is in fact when the p.d. across the transistor is half the difference between supply and output voltages. This voltage is 3V, (half of  $12 - 6V$ ), and the corresponding current is about 37mA ( $3V/82\Omega$ ). Hence the worst case dissipation is still only 110mW, which is a considerable improvement on that without the limiting resistor. It is still true however that the short-circuit ratings of higher power supplies can cause damage to the circuits they supply in the event of a fault. In the next note a simple means of current limiting will be considered, by the addition of a single transistor. ■

## DAYSTROM/SCHLUMBERGER DROP-PROOFED METER

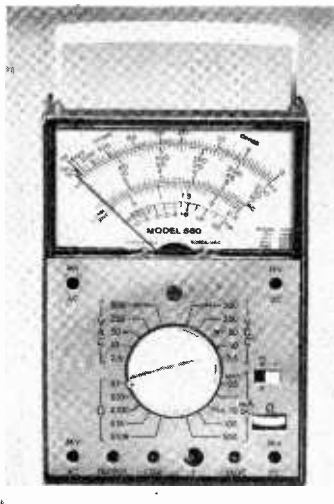

A portable multimeter is as essential to the electronic technician as a stethoscope is to a doctor. Trouble-shooting and testing start with the multimeter which is an indispensable part of the 'travelling' tools most technicians take on the job.

Even an ordinary multimeter is constructed like a watch with a jewelled movement, and it can't take day-to-day handling in a rough environment without losing accuracy.

To cope with this problem DAYSTROM has introduced a group product – the 660 series drop-proofed multimeter. These precision meters are warranted to operate within specification after being dropped from a height of five feet. The meter mechanism floats inside a sealed, high-impact plastic case. In addition the new multimeters have temperature compensation, with shielded and electrically protected meter movement. The meter maintains accuracy in extreme environments and will not be damaged if, as sometimes happens, the user accidentally connects it to a high voltage source.

Daystrom salesmen sometimes demonstrate the 600 series by throwing the meter on the customer's floor. So far, customers have had a worse shock than the meter!

## IN BRIEF

- The membership lists of the Radio Amateur Invalid and Bedfast Club show a membership of nearly 400 in 13 countries. Approximately two-fifths of the members hold amateur licences.

- Mr. Christopher Chataway, Minister of Posts and Telecommunications, announced in the House of Commons his agreement to licence, on an experimental footing, a scheme to transmit locally initiated TV programmes in the Woolwich area until July 1976. The transmissions will be by cable and there will be no advertising.

- Lord Willis, the playwright and

TV scriptwriter, creator of Dixon of Dock Green and many other TV series, has become chairman of Network Broadcasting Ltd., the commercial radio company.

- A club calling itself the 'Union of European Testcard Hunters' was formed in Holland just over a year ago, its aim: to encourage TV-DX.

The club wishes to extend its membership in the U.K. Those interested should write to P.D. van der Kramer, Europese Testbeeldjagers, Diepenbroekstraat 2, Slikkerveer-3210, Holland.

- 'A total of about 90 million joints are soldered each day in Britain.' This was stated during a session on solders and soldering which constituted part of a conference on 'Tin in Modern Technology' organised by the Tin Research Institute in conjunction with the British Institute of Metals.

- Clayridge Electronics Ltd., of 2 Stoke Newington High Street, London, N16 7PL have just issued a new edition of their radio and TV component catalogue. Readers requiring the catalogue should write to above address.

## ABERDEEN UNIVERSITY CARRIES OUT ACCEPTANCE TESTS ON COLOUR TV EQUIPMENT ORDERED FROM EMI

An EMI type '2001' colour television camera is checked out by television engineers from Aberdeen University during acceptance tests at the Hayes (Middlesex) plant of EMI Electronics Ltd. Altogether, EMI's Television Equipment Division is supplying the Scottish university with five '2001' broadcast cameras and a fully-equipped colour video recording vehicle (seen here in the background).

Aberdeen University is believed to be the first European teaching establishment which will use full broadcast colour equipment for making educational television material for a closed circuit television network. The 20 ft. long video recording van, equipped with three of the EMI cameras, will also be the first of its type to be fitted with colour broadcast equipment.



The photograph shows (L to R): Mr. J. Kilpatrick, senior engineer, Aberdeen University Television Service; Mr. E. A. Morley, UK sales manager, Television Equipment Division; and Mr. J. Woodward-Nutt, chief engineer, Aberdeen University Television Service



# COMMENT

## AMSAT PROGRESS

The Radio Amateur Satellite Corporation – AMSAT was started in 1969 to provide satellites and space experiments for the amateur radio service. In a recent issue of the AMSAT NEWSLETTER their President, Perry I. Klein, K3JTE, in his Annual Report for 1971, outlines the progress made to date and the various projects currently underway.

Membership of AMSAT is now over 460, with some 40 societies in group membership, and radio amateurs in 30 countries are represented.

Amongst the accomplishments to date, mention is made of the AMSAT – Aircraft Flight Tests, made in connection with the AMSAT – OSCAR – B Satellite project, in which two series of aircraft flights with a prototype translator being developed for the A-O-B project were made. It is estimated that between 200–300 amateur radio stations took part and one station alone made 17 two-way contacts through the translator. The main purpose of these translator flight tests, was to help interested amateurs prepare for operation with the A-O-B satellite and to gain useful technical and operational experience in using the Satellite once it is in orbit.

AMSAT provided much of the background supporting material on Amateur Satellites to several of the delegations represented at the ITU World Administrative Radio Conference on Space Telecommunications and Radio Astronomy in July 1971, at which a new 'Amateur Satellite Service' was authorised with provision in the 40, 20, 15, 10, 2 and  $\frac{3}{4}$  metre bands for amateur satellite operation.

Considerable progress has been made with AMSAT-OSCAR-B which it is hoped will be launched sometime in 1972. NASA has undertaken to launch this satellite, which will ride piggy-back with the ITOS-D meteorological Satellite which is being planned and will be put into a 1500 Km polar orbit.

Another proposed project, is to provide amateur radio equipment for use in the ATS-G NASA Satellite to be launched in 1975. This is to be known as *SYNCART* - *Synchronous Amateur Radio Translator*. The ATS-G Satellite, will be in a geostationary orbit and will have a 30 ft. parabolic reflector, which will be available for amateurs to use and will provide the rare opportunity for amateurs to use a synchronous satellite on a regular basis with modest amateur equipment.

NASA is also planning an orbital, manned laboratory, scheduled for launch in 1973. This project, named SKYLAB may also have an AMSAT sponsored project, named SKYLARC aboard, which is to provide 10 metre communication through amateur radio channels on SSB with the astronauts. One of the astronauts is training for SKYLAB. Dr. Owen Garriott, is a radio Amateur, W5LFL.



Pye Telecommunications Limited has announced a new compact, remotely-controlled base station for its radiotelephone systems, known as the type F9U.

This unit fully satisfies the market requirements for a remotely-controlled 5 watt base station for UHF mobile radiotelephone schemes. The controller is no larger than a desk top intercom.

Remote control permits closer installation of the base station to its antennas for minimal feeder loss and greater efficiency – an important factor when using UHF.

The design features great flexibility in mounting the equipment. Although primarily intended for wall mounting, the unit can be easily and conveniently fitted to any suitable horizontal or vertical surface. A mounting cradle, supplied as standard, enables the equipment to be easily dismounted.

If required, the equipment can be simply fixed to the cradle to prevent unauthorised removal. The equipment cover is fitted with a tamper-proof catch. The extensive use made of high quality silicon integrated circuits results in fewer components, higher reliability and easier maintenance. Fully coded printed circuit boards provide easy access to all components.



*"Congratulations – Your I.C. INTRUDER ALARM is a complete success!" (With apologies to the author of the article which appeared in our January issue)*

**Q****S****X**

By

**FRANK A. BALDWIN**  
(All Times GMT)

The most interesting news in the world of Broadcast band short wave listening this time is undoubtedly the appearance of Radio Nepal on approximately 5000kHz. The old channel of 9590kHz has been vacated for the afternoon transmission, the new frequency of 5000kHz being in parallel with the usual 4600kHz. The new channel presents a better chance of reception for listeners in the U.K. than that of 4600kHz, this latter frequency being subject to communications interference. Radio Nepal, Katmandu, from the signal strength measured here, would appear to be using the 100kW transmitter on 5000kHz. Logged in mid-December, R. Nepal was heard with Arabic-type music and songs, through the time signals of MSF, with sudden closedown at 1550, presumably due to a fault at the transmitter. In general, the station may be heard from around 1500 to 1650 sign-off and also from around 0115 to past 0145. The frequency is subject to some variation and has been measured on channels varying from 4999.5kHz to 5002kHz.

Another flurry of excitement has been caused by the appearance of VOA (Voice of America) Tangier on the 'out of band' channel of 5436kHz, where it has been logged several times of late with a programme of Arabic-type music and also recorded English musical comedy music. Entitled "The Happy Time", the programme was heard from 2030 until 2057, at which time the news in Arabic was radiated followed by station identification in English and sign-off at 2100.

In the new state of Bangla Desh, Dacca is now on the air with English and Bengali announcements on 15520kHz and other channels - see Short Wave News. Identification is "Radio Bangladesh, Dacca" or "Bangladesh Betar Kendra, Dacca", according to the British Association of Dx'ers (BADX).

### ● PROGRAMMES IN ENGLISH

Continuing from the last instalment under this heading (January issue) a few more transmissions in English that may be heard by readers are listed herewith, the times being stated first so that some individual planning can be made.

466

- 1200 11785** (25.46m) 100kW Vienna, Austria, the news in English.
- 1500 9860** (30.43m) 240kW Peking, China, news of life and events in China with commentaries.
- 1900 5930** (50.59m) 100kW Prague, Czechoslovakia, world news from the Czechoslovak point of view.
- 2045 6190** (48.47m) 100kW Vatican, Vatican State, world news and that of the Catholic church.
- 2145 6025** (49.79m) 15kW Budapest, Hungary, short wave listeners Dx programme.
- 2145 6070** (49.42m) 50/100kW Sofia, Bulgaria, programme about scientific research and achievements in Bulgaria.
- 2200 9805** (30.59m) 100kW Cairo, U.A.R., news and views from the Arabic world, directed to Europe.

### ● FAR EASTERN DX

Although not so good as last year, conditions for the reception of stations in the Far East have perked up on odd occasions, those transmissions which we have logged being shown here. By the time this appears in print, the 'season' for reception of this area will be waning therefore budding Dx'ers should listen on the channels shown in the hope that they will log something worthwhile in the remaining time available.

**3935kHz 2145** (76.24m) 35kW Ryyukyu Islands (Okinawa), VOA (Voice of America) transmitter with the news in Korean followed by the identification in English "This is the Voice of America completing this transmission from Okinawa on this frequency" and sign-off at 2200.

**4890kHz 2000** (61.35m) 10kW VLT4 Port Moresby, Papua, with news and comment in Pidgin English through to 2015 when signals faded into the noise level.

**4907kHz 1725** (61.14m) 15kW Phnom-Penh, Khmer Republic (formerly Cambodia) with songs and music in typical Asian style. Those readers who have not yet heard this station would do well to listen on this channel, the music is most distinctive, more often than not including the clashing of gongs and cymbals. It is easy to

visualize the dragons and pagodas!

**5052kHz 1618** (59.38m) 10kW Singapore radiating a programme of musical comedy songs from the English stage, King's Rhapsody, White Horse Inn - and all that!

### ● CHINA

This country can, of course, be easily heard on many differing channels, most of them listed as Peking with powers up to 240kW. However, the actual location of some of these transmitters is open to speculation but one that may interest readers is that of the People's Liberation Army (PLA) at Fukien operating on 7280kHz (41.21m), where it has been heard from midnight onwards with the Home Service. The PLA operate on many short wave frequencies, that most reported probably being the transmitter on 3900kHz (76.92m).

Peking has been logged here recently on 3940kHz (76.15m), 4865kHz (61.66m), 4905kHz (61.16m) and on 5145kHz (58.32m). The identification of Fukien is "Chungkuo jen min fan chun Fuchien chien hsien kwang po tien tai".

### ● HERE AND THERE

Some short wave stations are easy to log whilst others are relatively more difficult. In the main, the latter category tend to be on the LF bands, such stations having lower powers mainly for the reason that they are intended for local service and not for international audiences. Unfortunately for the Dx'er, the LF bands also carry a multiplicity of commercial services which cause considerable interference to the wanted transmission, thereby making reception difficult to say the least. However, despite the continuing problems, Dx'ers continue to rove these bands and battle on undaunted by the continuing cacophony! A few of the stations that can be heard with a modicum of luck on these frequencies are listed below.

**4777kHz 2245** (62.80m) 100kW Libreville, Gabon, logged when featuring African songs and drums interspersed with announcements in French.

**4807kHz 1737** (62.41m) 4kW St. Denis, Reunion Is., light music selections and announcements in French. This one is not so easy to log.

**4880kHz 1956** (61.48m) 10kW Kinshasha, Congo, drama in African dialect followed by typical rhythmic drum beats. ■

THE RADIO CONSTRUCTOR

# 'MAGIC' NUMBER INDICATOR

by G. A. FRENCH

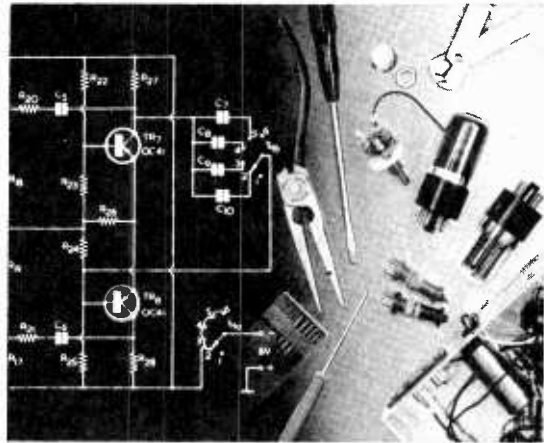

RECENT ARTICLES IN THE 'SUGGESTED Circuit' series have been more than usually long and have described rather ambitious projects. Because of this, the writer felt that it would make a pleasant change to produce a relatively short article for this month's issue and to devote it to the discussion of an extremely simple device. The circuit to be dealt with is very elementary in form and can be assembled by the veriest beginner. It offers an amusing effect which can be completely baffling to people who do not realise the secret behind the manner in which it is used.

## CIRCUIT OPERATION

The device consists of a small box containing a battery and having a front panel on which are mounted six push-buttons and two bulbs, one of the latter being red and the other green. The table which accompanies this article is also fitted on the front panel. The push-buttons are lettered A, B, C, D, E and F respectively. Pressing button D causes the green lamp to be lit, whilst pressing any of the other buttons causes the red lamp to be lit. The circuit appears in the accompanying diagram, in which the battery can be any 6 volt type with sufficient capacity to give a long life. An Ever Ready 'Lantern' battery type 996 would represent a good choice, as also would two 3-volt cycle lamp batteries (Ever Ready type 800) connected in series. The lamps can be 6 or 6.3 volt m.e.s. types fitted in panel-mounting holders having red and green lenses respectively. Suitable bulbs and holders with lenses are available from most radio retail sources, including Henry's Radio Ltd.

MARCH 1972

To demonstrate the 'magic' properties of the number indicator, an acquaintance is asked to write down on a piece of paper any number between 10 and 1,000,000. He is then asked to change the order in which the digits of the number appear, thereby forming a new number. Next, he is asked to subtract the smaller of the two numbers from the larger and to add together the digits in the result. After carrying out these operations he is finally asked to find, in the table, the number he has obtained and to press the corresponding button. In all cases, assuming he has carried out his

calculations correctly, the button indicated will be button D which, when pressed, will illuminate the green light.

This result will occur regardless of the original number and regardless of the order in which its digits are rearranged before carrying out the subtraction. The buttons other than D, which cause the red light to be illuminated, will only be recommended for use by the person carrying out the calculations has made an error.

It will be seen that the table lists numbers from zero to 59, each number having an accompanying button-

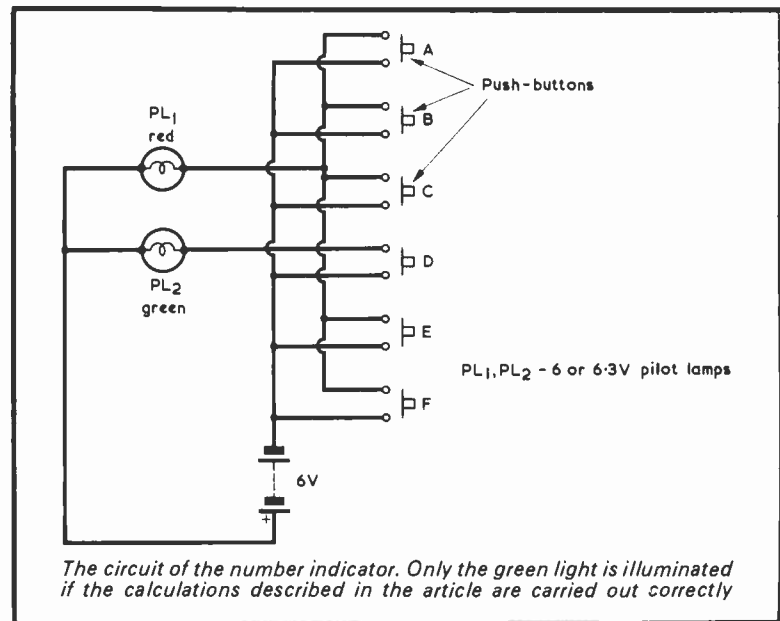

identifying letter alongside it. Thus, number 16 corresponds to button B and number 17 corresponds to button A. Closer inspection of the table will reveal that button D corresponds only to zero, 9, and multiples of 9, such as 18 and 27.

This is a small part of the secret of the indicator, and it arises from the fact that after the manipulations with the initial random number have been carried out as just described, the result is always zero, 9 or a multiple of 9. To give a demonstration let us choose, at random, the number 67981 and then rearrange its digits to give 18967. 67981 minus 18967 equals 49014. The digits of 49014, when added, equal 18, which is a multiple of 9. Interested readers will find it of interest to try the calculations with *any* initial number, and with *any* random rearrangement of its digits.

### EXPLANATION

The explanation for this intriguing phenomenon involves a little examination of elementary mathematics.

Most readers who have carried out simple division problems will have learned that a quick way of checking whether a number is divisible by 3 is to add up the digits in the number. If the solution results in 3 or a multiple of 3, then the number itself can be divided by 3. Take, for instance, the number 49713. The digits of this number add up to 24 which is a multiple of 3 and which thereby indicates that 49713 is divisible by 3, as it is. Note that we could, if desired, take the process a stage further by adding together the digits of 24. This gives us 6, again a multiple of 3.

If the initial number is even, and its digits add up to 3 or a multiple of 3, the number can be divided both by 3 or by 6.

So far as our present discussion is concerned we are more interested in numbers which can be divided by 9. Here we find that the same rule as for 3 applies. If the digits of any number add up to 9 or to a multiple of 9 that number is divisible by 9. For instance, the digits in the number 78615 add up to 27, whereupon we know that 78615 can be divided by 9. It may be noted, in passing, that the digits of 27 themselves add up to 9.

These peculiarities in numbers which can be divided by 9 are fairly well-known, particularly amongst those who carry out a large amount of mathematical calculations. There is, though, a further relationship between 9 and other numbers which is not by any means as well-known, and it is this relationship which forms the main part of the secret of the indicator and its table.

As we have already seen, if a number is not divisible by 9 the sum of its digits is equal to a figure which is similarly not divisible by 9. However, the amount by which that figure exceeds zero, 9 or the nearest multiple

TABLE

Number	Button	Number	Button	Number	Button	Number	Button
0	D	15	B	30	F	45	D
1	E	16	B	31	E	46	C
2	A	17	A	32	B	47	B
3	C	18	D	33	A	48	E
4	F	19	E	34	F	49	E
5	B	20	C	35	B	50	F
6	B	21	A	36	D	51	C
7	C	22	E	37	A	52	B
8	F	23	F	38	E	53	B
9	D	24	B	39	E	54	D
10	C	25	B	40	C	55	A
11	A	26	B	41	C	56	E
12	A	27	D	42	A	57	C
13	F	28	C	43	B	58	F
14	E	29	A	44	F	59	B

of 9 below it, *is equal to the remainder that is left after 9 has been divided into it*. Take, for example, the number 281, whose digits add up to 11. This sum exceeds 9 by 2. If we divide 281 by 9 we find that we get a remainder of 2. We also get a remainder of 2 if we divide 812, 821 and 128 (all variations of the original number) by 9. The digits of another number chosen at random, 94981, add up to 31 which is 4 more than 27 (the nearest lower multiple of 9). If 94981 (or any other arrangement of these digits) is divided by 9, the remainder is 4. Another number, 133, has digits which add up to 7. This is 7 in excess of zero, and 133 gives a remainder of 7 when divided by 9, as also do 313 and 331.

This state of affairs is quite easy to appreciate if we look upon any number which cannot be divided by 9 as being equal to the nearest lower multiple of 9 plus a remainder. The number we examined just now, 281 (which gives a remainder of 2) can be looked upon as 279 (the nearest lower multiple of 9) plus 2. This explanation takes account of the fact that zero is a multiple of 9, which of course it is since zero is 9 multiplied by zero.

We are now in a position to understand why, in the manipulation of a random number as initially described, the difference between the two numbers is always a multiple of 9. The original number consists of a multiple of 9 plus a remainder. When the digits of the number are changed around it consists of another multiple of 9 *plus the same remainder*. When the smaller number is subtracted from the larger we have the case where a multiple of 9 plus a remainder is subtracted from another multiple of 9 plus the same remainder. The remainders cancel out, and the result of the subtraction consists of a multiple of 9 minus another multiple of

9. This result must, itself, be a multiple of 9.

With the indicator, the lower and upper limits on the random numbers to be initially selected are chosen as 10 and 1,000,000. The number 10 is an obvious lower limit since the number chosen must have at least two digits if these are to be rearranged. The upper limit of 1,000,000 takes care of the extreme case where 1 (actually 0,000,001) is subtracted from 1,000,000 to give 999,999. The sum of the digits in 999,999 is 54 which is not so high as to make the table excessively large. Admittedly, a smaller table could be used if the person carrying out the calculations were asked to (in the present example) add the digits 5 and 4 together to give the smaller number 9. However, this approach would draw attention too early to part of the secret of the indicator table and its reliance on the relationship with the figure 9.

The table, as shown here, should not at first sight demonstrate too obviously that the buttons D correspond to zero, 9 and multiples of 9. After some experience of the calculations, nevertheless, most people will see that the answers they obtain are of this nature. It is extremely unlikely, though, that they will know *why* such answers are obtained and so the final mystery behind the functioning of the indicator and its table will still remain unexplained. ■

### NOVEL A.F. AMPLIFIER

Since the article under the above title was published in the January 1972 issue it has been found that best results are given with the value of R7 reduced to 100Ω. A transistor with low leakage current should be employed for TR1(a) in Fig. 1.

# D. C. VOLTMETER

by  
A. RUSSELL

**Incorporating a readily obtainable integrated circuit, this voltmeter has a sensitivity of  $100k\Omega$  per volt. Any ranges from 0–100mV to 0–100V can be provided to meet the particular requirements of the constructor.**

**T**HE D.C. VOLTMETER TO BE DESCRIBED HERE IS BASICALLY very simple, and ranges can be chosen between 100mV f.s.d. and 100V f.s.d. to suit individual requirements. Sensitivity is  $100k\Omega$  per volt on all ranges, which compares favourably with most multimeters, which are rarely rated better than  $40k\Omega$  per volt.

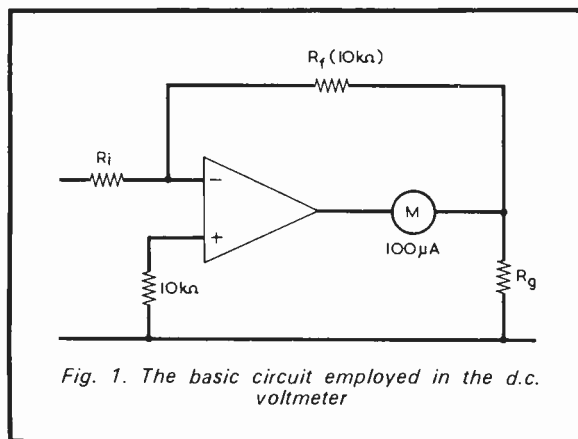

## CIRCUIT DESCRIPTION

First of all, let us look at the basic circuit, which is given in Fig. 1. The voltage to be measured is applied to  $R_i$ , which is chosen so that  $10\mu A$  flows when the required f.s.d. voltage is applied to it (remembering that we consider the inverting input to be at a virtual earth). Virtually all of this  $10\mu A$  flows through the  $10k\Omega$  feedback resistor,  $R_f$ , this being chosen to give a current gain of 10 times on all ranges. Since  $100\mu A$  flows through the meter for f.s.d.,  $90\mu A$  must flow through  $R_g$ . Hence the value of  $R_g$  should be  $10/9k\Omega$ , i.e.  $1.1k\Omega$  nominally. In practice, this is formed by a  $560\Omega$  fixed resistor in series with a  $1k\Omega$  variable resistor (the calibration control). This combination gives a leeway of about  $500\Omega$  either side of the nominal value, which will be ample.

MARCH 1972

Let us now look at the practical circuit in Fig. 2. Here, the range is altered by switching in various values for  $R_i$ . The resistor values required can be chosen from the Table. We are limited to a maximum of 100V in this design, since it is difficult to obtain close tolerance resistances above  $10M\Omega$ . However, in transistor circuitry we will rarely find voltages above 100V.

$R_6$  and  $D_1$  are included to protect the meter from forward overloads.  $D_1$  will conduct when the voltage across the meter and  $R_6$  is about 700mV. This voltage will be about 420mV when the meter is reading f.s.d., and so  $D_1$  should conduct when the excess voltage is about 70% of f.s.d., thereby protecting the meter movement. No reverse overload protection was included in the prototype, but if this is thought to be necessary, a germanium diode (such as the OA81) should be connected across the meter and  $R_6$  with its polarity opposite to that of  $D_1$ . This diode will conduct when its forward voltage is about 400mV, i.e. when the



*The complete voltmeter in its case. This measures 4 by 6 by 4in*

469



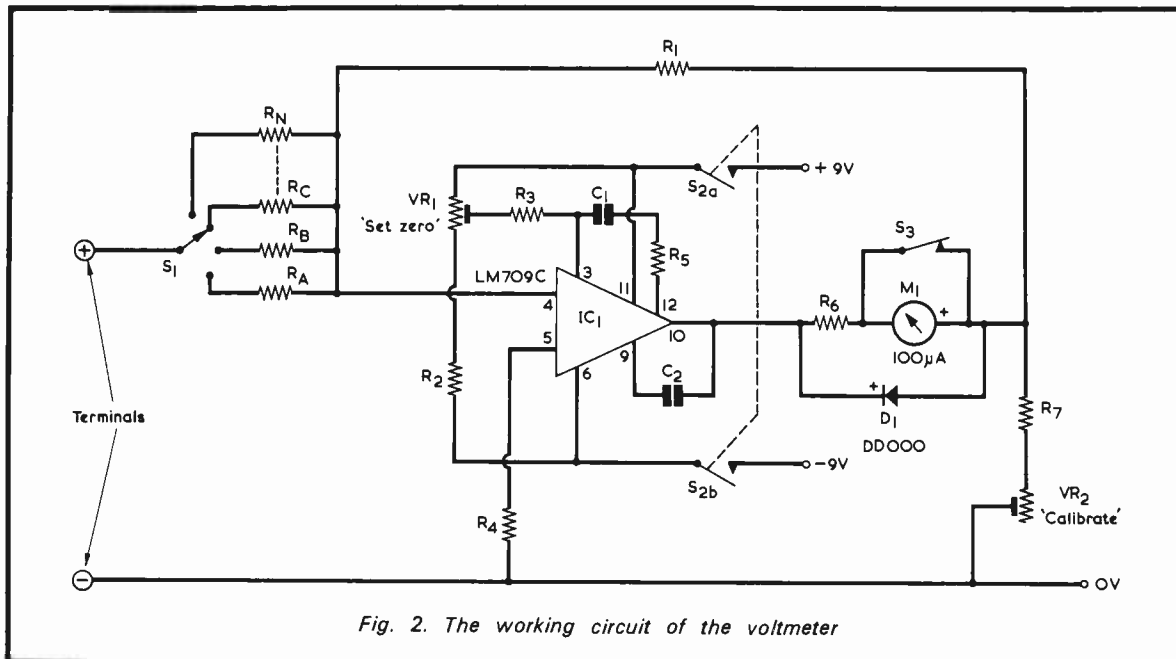

Fig. 2. The working circuit of the voltmeter

## COMPONENTS

### Resistors

(All fixed values  $\frac{1}{2}$  watt 10% unless otherwise stated)

- R1 10k $\Omega$
- R2 150k $\Omega$
- R3 430k $\Omega$
- R4 10k $\Omega$
- R5 1.5k $\Omega$
- R6 3.3k $\Omega$
- R7 560 $\Omega$
- RA-RN Input resistors, see text
- VR1 100k $\Omega$  potentiometer, preset, panel-mounting
- VR2 1k $\Omega$  potentiometer, preset, skeleton

### Capacitors

- C1 2,700pF silvered mica
- C2 100pF silvered mica

### Semiconductors

- IC1 Integrated circuit type LM709C, dual-in-line
- D1 DD000 (Lucas)

### Meter

- M1 0 – 100 $\mu$ A moving-coil, 38 Series (Henelec)

### Switches

- S1 1 pole miniature rotary (see text)
- S2 d.p.s.t. toggle
- S3 s.p.s.t. slide switch

### Batteries

- 2 9-volt batteries type PP3 (Ever Ready)

### Miscellaneous

- 1 Red insulated terminal
- 1 Black insulated terminal
- 2 Battery connectors
- 2 Pieces Veroboard, 0.1in. matrix (see Fig. 4)
- 1 Case (see text)
- 1 Pointer knob

applied voltage is about equal to f.s.d. the wrong way round.

C1, R5 and C2 are compensation networks as specified by the manufacturer of the integrated circuit.

VR1, R2 and R3 are also specified by the manufacturer to balance the offset current that will be present at the input. The offset current would cause the meter to read when no voltage is applied to the input terminals if it were not compensated.

S3 was added to short-circuit the meter terminals whilst transporting the unit. This protects the delicate meter movement, since any oscillations of its coil are damped out by the e.m.f. produced. Ideally, S2 and S3 should be combined, so that the meter is short-circuited automatically when the unit is switched off, but the author could not find a suitable switch at a suitable

price! The switch required would need two sets of normally open and one set of normally closed contacts.

## COMPONENTS

The design employs an LM709C integrated circuit, and the writer obtained this from L.S.T. Electronic Components, Ltd. The meter was a Henelec model from the '38 Series' with a 1.654 in. square face, and is available from Henry's Radio Ltd. The housing for the unit is a 'Stella 99' instrument case, available from E. R. Nicholls, 46 Lowfield Road, Stockport, Cheshire. This is supplied complete with front panel, handle and four rubber feet. Its dimensions are 4in. by 6in. by 4in.

The input resistors in the Ri position are not specified in the Components List, as these depend upon what

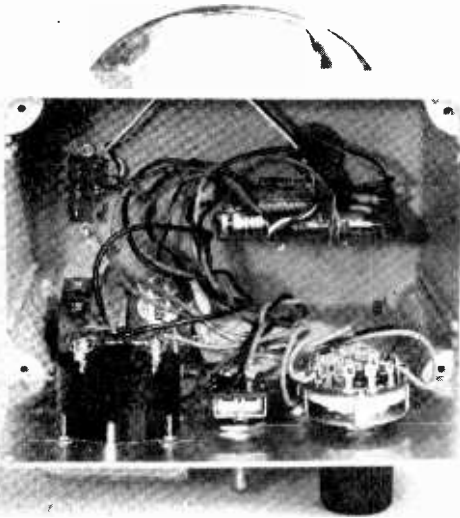

*The interior of the author's model. As is explained in the text, this differs slightly from the layout given in the constructional details*

ranges are desired. It should be remembered that a moving-coil meter reads most accurately on the latter part of the scale, and the values of f.s.d. that give the greatest accuracy are 10 and  $\sqrt{10}$ , i.e. 3.16. Thus, for general use, the best ranges to choose would be 1, 3 and 10 and multiples of these. However, the individual constructor may prefer to use an interval at 5, rather than 3, depending on his own requirements. The writer's unit employed 3 ranges only, whereupon the resistors were mounted on the same piece of Veroboard as the integrated circuit and associated components. However, it is probable that most constructors will employ more than 3 ranges, in which case it will be necessary to mount the input resistors on a separate board. This method is shown in the layout diagrams which follow, and these differ in this respect from the photograph showing the interior of the author's model. In the prototype the position of VR1 on the rear of the case also differs from that shown in the layout diagrams.

The input resistors may be selected as indicated in the Table, and should ideally be  $\frac{1}{2}$  watt 1% tolerance types. Unfortunately, many of the values shown may be difficult to obtain as single resistors in 1%, although

they could be made up of series or parallel combinations of resistors. With the loss of a little accuracy, 2% resistors can be employed, whereupon it becomes possible to use resistors from the Home Radio Cat. No. R10M  $\frac{1}{2}$  watt 2% range. Single resistors from this range may be used for the 10k $\Omega$ , 30k $\Omega$ , 100k $\Omega$ , 300k $\Omega$  and 1M $\Omega$  values. The 50k $\Omega$  value can be given by 20k $\Omega$  and 30k $\Omega$  in series, and the 500k $\Omega$  value by 200k $\Omega$  and 300k $\Omega$  in series. Values above 1M $\Omega$  can be provided by 1%  $\frac{1}{2}$  watt resistors in the Home Radio Cat. No. R12 range, 3M $\Omega$  being given by 1.8M $\Omega$  and 1.2M $\Omega$  in series, 5M $\Omega$  by 3.9M $\Omega$  and 1.1M $\Omega$  in series, and 10M $\Omega$  by 3.9M $\Omega$ , 5.6M $\Omega$  and 500k $\Omega$  in series.

Constructors having access to an accurate resistance-measuring bridge may be able to select suitable input resistors from wider tolerance components.

The range switch is a miniature rotary type having the same number of ways as there are ranges. Normal components of this type have several poles, and only one pole need be wired up here. Also, they are not readily available in 5-way with the result that, if 5 ranges are to be used, a 6-way switch with one way blank will be needed.

S3 is specified as a single-pole single-throw slide switch. These switches are normally available as double-pole double-throw, in which case the unwanted contacts are ignored.

## CONSTRUCTION

Veroboard with a matrix of 0.1in. must be used to accommodate the pins of the integrated circuit, and here a wise word of warning must be added. Soldering on 0.1in. matrix Veroboard is much more difficult than on the commoner 0.15in. matrix board, although if a few simple rules are followed the problems should not be unsurmountable. Use the smallest possible bit on your soldering iron, and don't allow mounds of solder to accumulate on it as these will inevitably fall onto the board sooner or later. If possible, use a fine gauge solder and, after the board is completed, check carefully for blobs of solder short-circuiting adjacent strips.

TABLE  
Values of input resistance ( $R_i$ , and  $R_A$  to  $R_N$  in Fig. 2) for different voltmeter ranges.

Ranges	$R_i$
0 - 100mV	10k $\Omega$
0 - 300mV	30k $\Omega$
0 - 500mV	50k $\Omega$
0 - 1V	100k $\Omega$
0 - 3V	300k $\Omega$
0 - 5V	500k $\Omega$
0 - 10V	1M $\Omega$
0 - 30V	3M $\Omega$
0 - 50V	5M $\Omega$
0 - 100V	10M $\Omega$

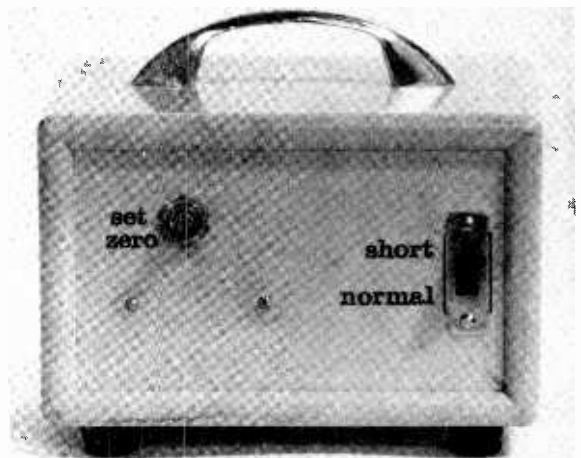

*The rear of the instrument. The slide switch short-circuits the meter movement to damp pointer movement when the instrument is being transported*

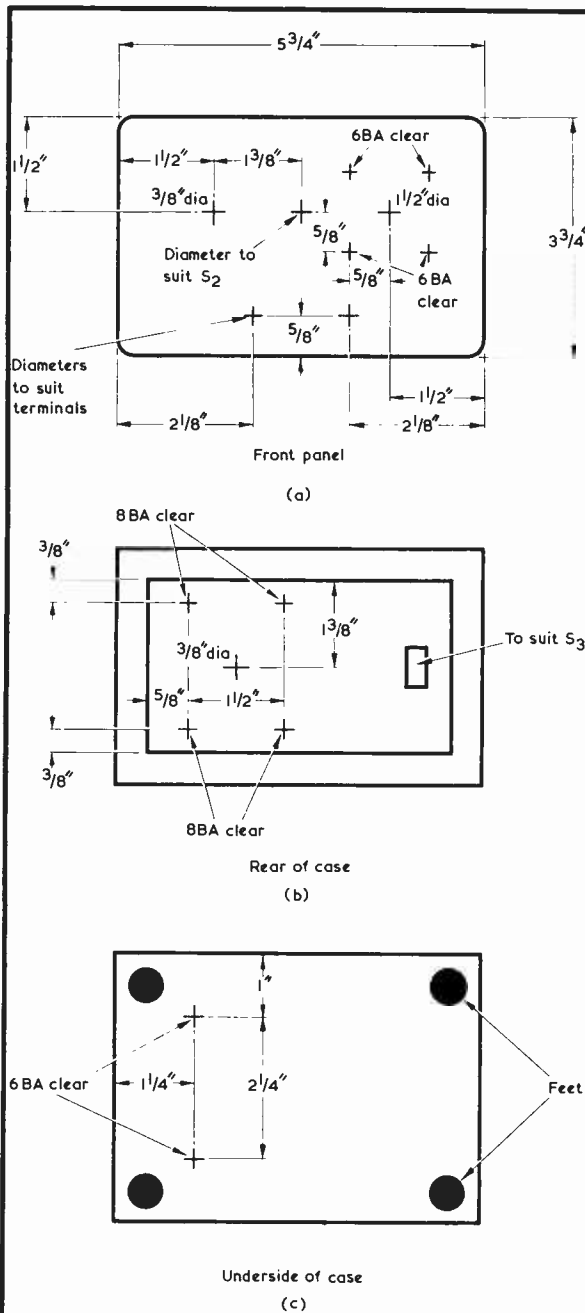

Fig. 3 (a) Drilling centres for the front panel, as viewed from the rear  
 (b) Hole centres at the back of the case  
 (c) The holes required in the case underside

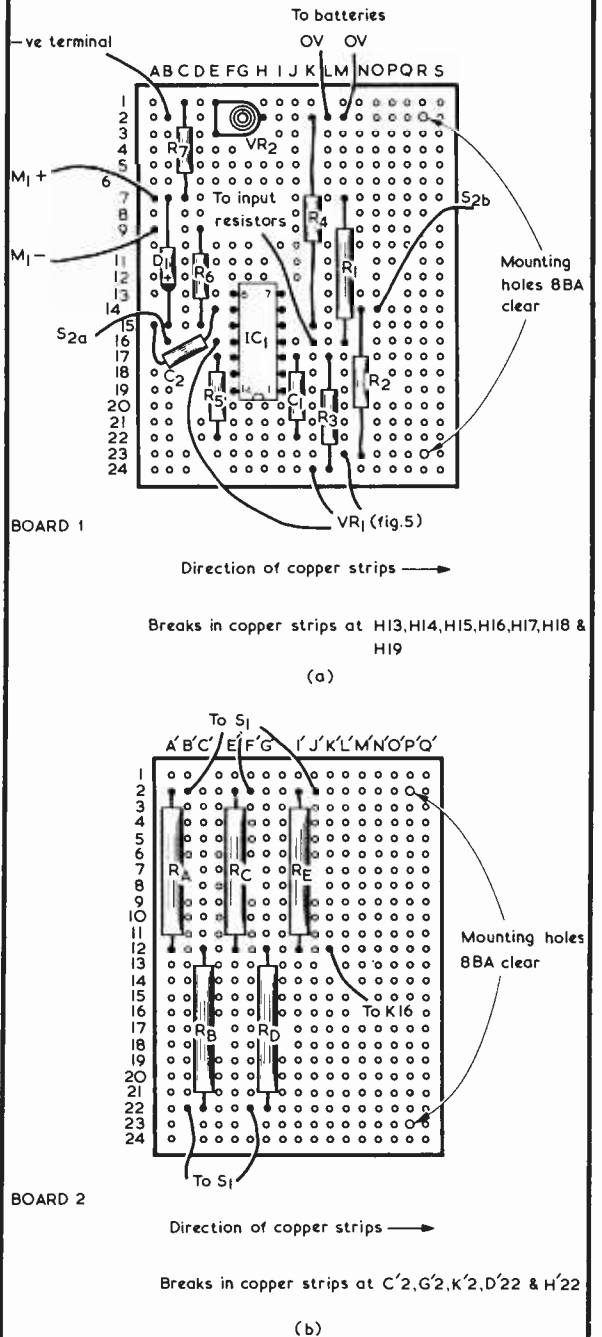

Fig. 4 (a) Board 1, viewed from the component side  
 (b) The component side of Board 2, with five input resistors fitted. Both boards can be cut from the standard  $3\frac{3}{4} \times 2\frac{1}{2}$  in. Veroboard size

Start off by drilling the case and front panel according to Fig. 3. The components should then be soldered onto the Veroboard as shown in Fig. 4, after drilling the mounting holes and making the specified breaks in the copper strips. A  $\frac{1}{16}$  in. twist drill is ideal for this. The integrated circuit should be the last component to be

connected, in order to avoid possible damage by overheating.

$VR_1$  and  $S_3$  should be wired up before fixing them to the rear of the case. On the other hand, the meter, the terminals,  $S_1$  and  $S_2$  should be secured to the front panel before they are wired up. The final wiring is

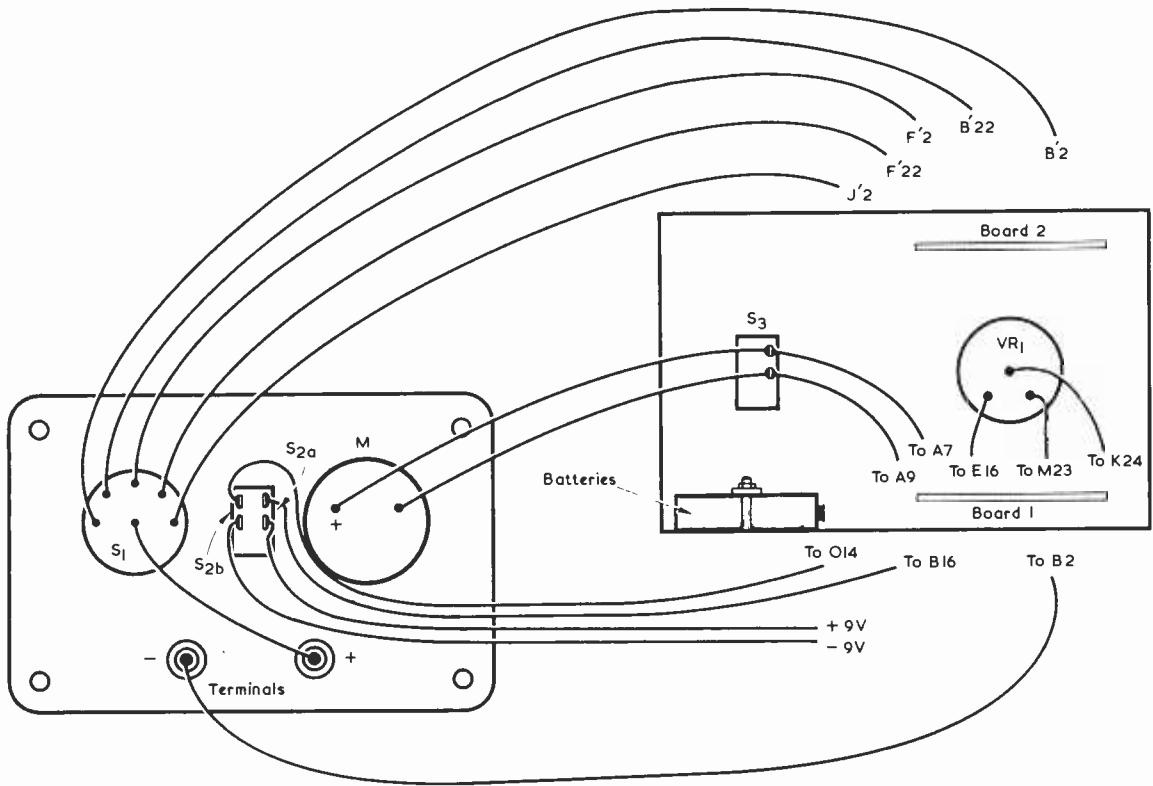

Fig. 5. The final steps in wiring and assembly. Again, five ranges are assumed

carried out as shown in Fig. 5.

Some constructors may prefer to modify the meter so that the letter 'V' covers the 'µA' indication. If this is to be done, gently prise off the clear plastic front and then apply a small white sticky label about 3/8 in. square with the letter 'V' printed on it to the meter scale to cover the 'µA' indication. The front can then be replaced and the meter bolted into position. This modification should only be attempted by constructors who are competent

to carry it out without damaging the meter movement. Care should be taken to ensure that no dust or dirt enters the meter case when its front is removed.

The diagrams show the wiring up of a unit with 5 ranges. As already mentioned, fewer or more ranges may be provided according to preference.

When the wiring is complete, the two Veroboard panels should be fixed in position using 8BA nuts and bolts. Each board is bolted to a 2 1/2 in. length of 1/2 by 1/2 in.

Another view of the front of the instrument. The prototype had three ranges, but further ranges can readily be added, as desired



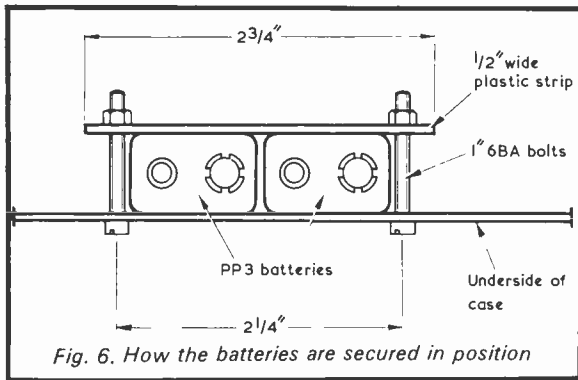

Fig. 6. How the batteries are secured in position

plastic angle, which is then bolted to the back of the case so that the boards project forwards. In the absence of plastic angle a similar form of insulated mounting should be devised. VR1 should be mounted between the two boards, as in Fig. 5.

Details of the battery holder can be seen in Fig. 6. The batteries are clamped in position under a piece of plastic or metal strip about 1/2 in. wide and 2 3/4 in. long,

this being bolted to the bottom of the case using 1 in. long 6BA bolts and nuts.

#### CALIBRATION

The only way to calibrate the unit is to measure a known voltage, this being given by either a standard cell or by a low impedance voltage source which can also be read using an accurate multimeter.

First, with the meter short-circuited by S3, adjust the screw on the front of the meter to zero the movement. Now, open S3 so that the unit is set up for normal use and switch on. Short-circuit the input terminals, and set the zero by means of VR1. Then calibrate the meter as described above, turning VR2 until the correct reading is indicated. If this causes the zero setting to be disturbed, reset VR1 and repeat the process until both the zero reading and calibration are correct.

When calibration is complete, the front panel can be screwed on to finish off the unit.

In use, there should only be a very small drift of the zero setting. Excessive zero drift indicates that the batteries need replacing. Both must be replaced together since positive and negative supply voltages should be the same.

# FEATURED NEXT MONTH

## Wide Range Linear Sawtooth Generator Part 1

By David Aldous

## The "Bass-Boost" Portable

By Sir Douglas Hall, K.C.M.G., M.A. (Oxon)

## V.H.F. Wavemeter

By F. G. Rayer, Assoc.I.E.R.E., G30GR.

## Half-a-Dozen Puzzlers



- ★ MORE CONSTRUCTIONAL PROJECTS
- ★ SHORT WAVE NEWS
- ★ SUPPORTING FEATURES
- ★ NEWS COVERAGE
- ★ DATA SHEET 61

ON SALE APRIL 1st  
PRICE 20p

# RADIO CONSTRUCTOR

Copies may also be obtained direct from the Publishers, 24p. including postage. Published by Data Publications Ltd, 57 Maida Vale, London W.9



# DEALING WITH HIGH TENSION SHORTS

By  
VIVIAN CAPEL

Many TV sets in use these days are of the fully valved or hybrid (valves and transistors) types. Valved radio receivers are also in common use. This article describes how short-circuits between the h.t. positive line and chassis in such receivers may be traced, and also gives some useful tips on the best approach towards general servicing

**T**HE MAJORITY OF TELEVISION SETS and quite a few valve radio receivers are fitted with a fuse of suitable rating in the h.t. line circuit. The first intimation of trouble arises when the user finds that his set is completely dead, and an investigation reveals that the h.t. fuse has blown. Usually he then fits another one, often of a higher rating, and hopes for the best. Sometimes, this gambit has the desired effect and no further trouble is experienced, so the user concludes that the fuse itself was faulty.

## FUSE EXAMINATION

This of course is rarely the case, although it sometimes does happen. A dry joint at the fuse cap can cause arcing, and over a period the heat from this arcing burns through the thin fuse wire and causes it to go open-circuit. A careful examination of the fuse will sometimes reveal whether this has happened.

If the fuse wire is still bright over most of its length and has just gone open-circuit where it is soldered into the cap, then this would indicate that the wire had not carried excess current and that possibly the fuse itself was defective. When the wire is broken in one place, usually near the centre where the heat conduction to the end caps is at a minimum, and this is accompanied by slight darkening of the wire, it indicates that a current somewhat in excess of the rating has been passed, causing overheating and fusing of the wire. When the wire has completely disintegrated leaving just

a few blobs of metal on the inside of the glass cartridge, then something more than just a slight excess has been passed. There has, instead been a very heavy current many times the fuse rating.

When a receiver is switched on initially, a momentary current surge flows which is greater than the normal running current. Valve heaters are of low resistance when cold and so pass extra current. The use of metal or silicon rectifiers applies the full h.t. voltage to the reservoir and smoothing capacitors immediately, not gradually as is the case with valve rectifiers which take a minute or so to warm up. Thus these high-value capacitors take their maximum charging current at the moment of switching on.

The switching-on surge can well exceed the rating of the main fuse, or of the h.t. fuse in the case of the charging capacitors. This can produce the 'mild' blowing of the fuse just noted, and the remedy is either to fit anti-surge fuses which resist overload for a short duration, or to increase the rating slightly. If this latter course produces a twinge of conscience, comfort may be obtained from the fact that many set-manufacturers have often had to do exactly the same thing, and have increased the specified value of a fuse during the production run of a particular model. Actually, the anti-surge fuses are not as successful in practice as may be hoped, and if the surge should be a little longer than expected they will blow anyway. They are also more expensive than normal fuses.

## CHARGING SURGES

Ideally, surges produced by charging capacitors in the h.t. line should be limited by series resistors in the h.t. line from the rectifier, and when modifying a TV receiver from a valve to a silicon rectifier, it is common practice to fit an extra surge limiter. The power rating must be high, at least 10 watts, because the resistor has to carry not only the normal h.t. current but also the ripple current through the reservoir capacitor. There will of course be a drop of h.t. voltage across the resistor.

In the case of television receivers with their large-value capacitors and high h.t. current, a heavy surge can be produced by switching the set off and then on again. This is because the capacitors discharge very quickly through the various h.t. circuits and so will take the full charging current again when switching on. Moreover, the valve heaters will still be warm and the valves will also pass h.t. current immediately on switching on. Thus the initial current will be greater than the normal switching-on surge. The moral here is that if the set is accidentally switched off, let it cool down for a few minutes before switching back on; you may miss part of the programme, but you will miss even more if the fuse blows!

If the fuse blows after the set has warmed up, or if it fails when switching on and is found on examination to have well and truly blown, then normal switching-on surge can be discounted

and we must look elsewhere for an actual fault.

Often physical indications pointing to the cause of the trouble can be seen without the need to use any test gear. Burnt or discoloured resistors are the most frequent examples. Usually, the resistor is a decoupling component to the screen-grid or anode of a valve in the receiver section and the associated decoupling capacitor will be found to have gone short-circuit. Other resistors may also be found to have become discoloured. These may be decoupling resistors connected in series along the h.t. positive line, and which were therefore also in the path of the excess current. They will be of lower value than the final one, and hence will not have dissipated so much power or suffered as much damage.

Usually, the discoloration is all that is wrong with such resistors and they can be left in circuit without changing. Measure them first, though, to make sure that they have the correct value. The final anode or screen-grid resistor will have burnt badly, and if not actually burnt-out will have changed value, usually going low, and so will have to be replaced along with the associated decoupling capacitor. The lesson from this is: do not attack the first discoloured resistor and its associated capacitor you may see, the real culprit may be further along the line. The one that is burnt out most is the one to go for.

Sometimes, we find bleeder networks of fairly low value across the h.t. supply. For example the screen-grid or cathode voltage to certain stages may be stabilised by one resistor going to the h.t. positive rail and another to chassis. If either of these decreases in value due to the heat dissipated in it, more current will pass, there will be more heat, and a further drop in value. The companion resistor will be called upon to pass more current, and this too will get hotter and will be equally likely to drop in value, thus passing even more current. Eventually both resistors are badly burnt and form a low resistance path across the h.t. supply. It is therefore always a good plan to look for such networks on the circuit diagram and check them before wasting a lot of time searching elsewhere.

## TESTMETER

The source of an h.t. short-circuit is not always visually obvious, in which case the testmeter must be brought into use. With this switched to an ohms range, a low resistance reading will be obtained between the h.t. positive line and chassis. The next thing is to localise the source of the reading. This can be rather a tedious job; many circuits are taken off the h.t. line and isolating the offending one can mean unsoldering many connections and re-measuring.

The work involved can, however,

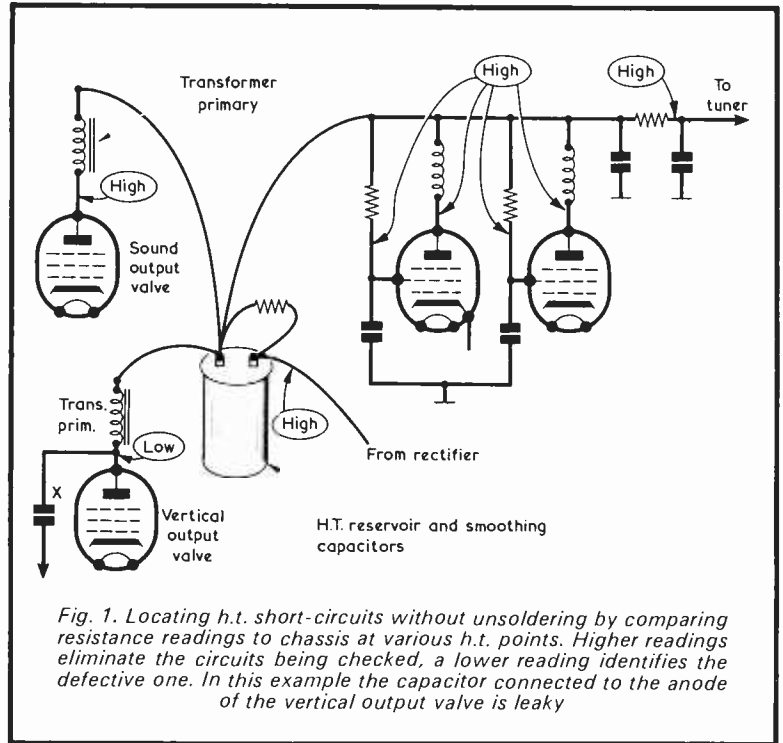

*Fig. 1. Locating h.t. short-circuits without unsoldering by comparing resistance readings to chassis at various h.t. points. Higher readings eliminate the circuits being checked, a lower reading identifies the defective one. In this example the capacitor connected to the anode of the vertical output valve is leaky*

be minimised by intelligently comparing the resistance readings at various points and tracing through to the lowest. It may happen that a number of wires are found connected to the smoothing capacitor, whose positive tag is often used as an anchoring point for the main h.t. supply leads, as shown in the example given in Fig. 1. One of these leads goes to the smoothing resistor or choke. If we measure at the other side of this resistor and find a higher resistance reading, we know the short-circuit is not there. Another lead passes to the sound output transformer, and if a reading taken on the anode of the sound output valve is also higher, then we must once again look elsewhere. A further lead is taken to the vertical output transformer and, here, a reading on the anode side of the primary winding shows a lower resistance to chassis than is given at the h.t. line. Thus, the fault is localised. The vertical output valve is removed from its holder to ensure that it is not responsible, but the reading persists. A capacitor is noticed going from the anode to the feedback linearity network, and it is found that the resistance to chassis on the other side of this component is the same. Disconnecting the capacitor and measuring across it confirms that it offers a dead short-circuit. After replacing it, it is as well to check for damage that might have been caused by the passage of the excess current, such as a burnt linearity control track.

This example illustrates the general principle that if readings are taken at

the other side of resistors or inductors that come directly from the h.t. positive line the appropriate circuit points can either be absolved or condemned without any unsoldering, this being done by simply noting whether the readings are higher or lower than the one obtained from the h.t. line itself.

## DIRECT CONNECTIONS

If the tests just outlined are not helpful, attention can be concentrated on those components that are connected directly to the h.t. rail without the intervention of series resistance. It should be remembered, when checking through a transformer primary, that it can develop a leak to the transformer core. If this leak occurs at the h.t. end of the winding, a high resistance reading will be obtained at the anode end and the circuit may be considered to be above blame. If in doubt, rather than disconnect the transformer it is often easier to loosen the fixing screws and move the transformer about. This will cause the resistance reading to fluctuate as contact with the chassis is broken.

When taking the readings, do not waste time measuring at the other side of high value resistors as, even if a dead short-circuit to chassis were present, the current would be insufficient to make any appreciable difference to the total h.t. current and would certainly not be enough to blow a fuse. Carbon resistors will most likely show the overheating signs

previously mentioned, so circuits fixed by them are not likely to be the faulty ones if the resistor looks fresh and clean. Wirewound resistors sometimes show the effects of overheating but not always since they usually run warm normally, hence circuits associated with them should be checked.

Capacitors will often be found connected to the h.t. line, but not all are decouplers; not all in fact are even returned to a point at or near chassis potential. A resistance reading on the other side will confirm whether or not there is a low resistance path to chassis. It should, of course, be equal to or less than the resistance reading from the h.t. line for the capacitor to be a suspect.

Sometimes, what we can call the 'intervening resistance' between the h.t. line and the suspected circuit is very low, too low to show any difference on whatever ohmmeter the reader may have at his disposal. Such circuits could be in the i.f. amplifier where the i.f. transformer primary (in the case of a television receiver) may only be a few ohms or less. In such a case it is difficult to ascertain which side gives the lower reading. If the short-circuit itself is of low resistance, a better indication may be obtained with a flashlamp bulb and a battery. These should be connected in series with a couple of flying leads and applied across the circuit. The point with lowest resistance to chassis can now be readily determined, as even an ohm in the circuit will cause a noticeable drop in the brilliance of the light.

## OTHER CAUSES

Now we come to the case where the h.t. fuse blows and yet the resistance from the h.t. line to chassis seems normal when measured with the set cold. By examining the fuse as previously described we can discover if the short-circuit is 'heavy' or 'mild'. If it is the latter and if the fuse blows rarely only, the trouble is possibly due to the switching-on surge, but if the fuse blows frequently then we must look further for the trouble.

There are many possibilities. Valves sometimes develop interelectrode leaks. These leaks more often than not are only present when the valve is hot and are absent when it is cold. Another cause is in the interstage coupling capacitors. One of these may leak or go short-circuit but, because of its position in the circuit, will not affect the h.t.-to-chassis resistance reading. However, when the set is running the defective component will apply h.t. from the previous anode to the following grid, and this, especially if the next valve is in an output stage, will cause an excessive anode current to pass and blow the h.t. fuse.

A similar effect can be caused if the cathode bypass capacitor in one of the output stages goes short-circuit, or the

cathode resistor drastically drops in value. Bias will be removed from the output stage grid and the anode current will increase.

Yet a further cause in television receivers is failure of the line oscillator. The line output stage usually has little if any standing cathode bias, the necessary bias resulting from the drive to its grid from the oscillator. It follows, then, that a cessation of oscillation and grid drive will cause a high increase in anode current, sufficient in most cases to cause the anode to glow red.

Fortunately, all these fault conditions, which are illustrated in Fig. 2, will have an observable effect on the performance of the circuit concerned in addition to drawing excess current from the power supply and blowing the fuse. Since the current will be limited by the saturation current of the valve concerned, little damage can be caused if the receiver is run for a few minutes in this condition. Thus, a clue can be obtained about the cause of the trouble by observing other symptoms.

As constant replacement of fuses can be expensive, the fuseholder contacts can be bridged by an ammeter switched to one of the higher ranges. This will afford further clues by indicating when the excess current flows and its magnitude. If the excess current flows immediately on switching on, the faults just described could not be responsible as they all depend on valve conduction which obviously requires that the valves are warmed up. Obviously, the meter must be on a sufficiently high current range to ensure that it will not be damaged by the current.

When the meter indicates that the fault is present a quick visual and aural check can be made of the various parts of the television receiver. Is the raster still present, and of normal width? Is the line and frame scan free from fold-over and reasonably linear? Is the sound of sufficient volume and without distortion? A negative answer to any of these questions will indicate the stage in which the fault is present. Voltage measurements, valve substitutions and other normal fault-finding techniques should then reveal the precise cause.

If there is no low resistance reading to chassis from the h.t. positive line when the set is cold, and if the fault is not due to excessive valve current, the trouble can be caused by components which break down only in the presence of high voltage. The ohmmeter battery voltage will be insufficient to cause the breakdown, and it hence gives no indication.

This high voltage breakdown can range from a dead short-circuit to a high resistance leak, and as a result the effects on the fuse will vary. Capacitors are the most likely offenders, but there are others. Tracking across the insulation from the carbon elements of controls that carry h.t. such as the brilliance control, to the earthed metal case is not uncommon. Tracking can also take place over the Paxolin terminal boards of transformers, and across interconnecting plugs and sockets.

About the only way to tackle this when there is no visual indication or effect on receiver performance is to isolate, so far as the receiver design allows, the individual h.t. circuits. There are two methods of doing this.

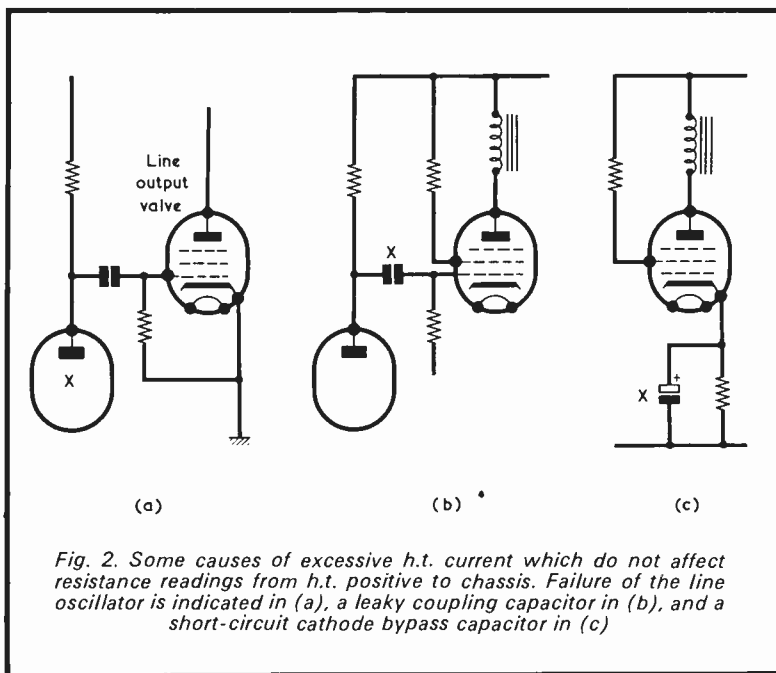

Fig. 2. Some causes of excessive h.t. current which do not affect resistance readings from h.t. positive to chassis. Failure of the line oscillator is indicated in (a), a leaky coupling capacitor in (b), and a short-circuit cathode bypass capacitor in (c)

First of all, each h.t. feed can be disconnected in turn and the receiver then switched on. This is repeated until the stage is reached where the fuse does not blow. The last circuit disconnected is then indicated as the culprit. The alternative method is to disconnect as many h.t. circuits as practicable at the start, and then re-connect them one at a time until the fuse blows. The advantage of the first method is that unsoldering is reduced to a minimum since it is possible that the defective circuit may be among the first few tried. On the other hand, however, we must blow a fuse at each try unless an ammeter is used. The second method is more economical as only one fuse will be blown, but of course more unsoldering will be necessary.

If the short-circuit is a bad one, as revealed by inspection of the fuse, and an ammeter is used to indicate when the current rises, it would be prudent to include a series limiting resistor in the meter circuit while tests are being made. This will not only protect the meter but also the rectifier, which may not take kindly to repeated heavy overloads.

### INTERMITTENT FAULTS

Finally, we come to the most difficult and irritating type of short-circuit – the intermittent. The set may work well for hours, days or even weeks, and then the fuse will blow. Immediate examination and testing will reveal no fault and, after replacing the fuse, the set will probably carry on for another extended period.

When the fault does occur and the fuse blows, it may be immediately on switching on, or after the set has been on for some while. If the latter is the case some symptom may occur which could give a clue as to its origin. If it occurs on switching on and the fuse is not badly blown, the switching on surge may be responsible, as previously discussed.

There remain the obstinate cases where no symptoms or other clues at all are to be found. The indiscriminate replacement of possible components can be frustrating and expensive unless one is fortunate enough to hit on the right one at the first attempt.

The final location of faults of this nature calls for some improvisation and patience, but if tackled systematically they can nevertheless be found and cured. One way of dealing with the problem is to split up as many of the h.t. supply leads as possible. Then, in series with each one, solder a fuse of say 100mA. The fuses can be prepared in advance by soldering an inch or two of insulated lead on one end. This lead can be connected to the point from which the original h.t. lead was removed, and then that lead can be soldered to the other end of the fuse. Do not apply the iron to the fuse caps for too long or the fuse wire may become unsoldered inside. Make sure

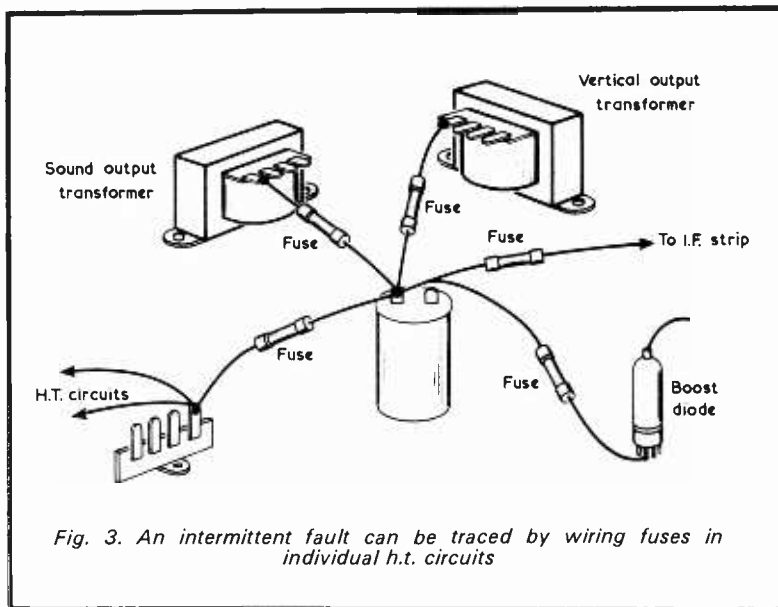

Fig. 3. An intermittent fault can be traced by wiring fuses in individual h.t. circuits

that the fuse caps are free from surrounding components and metal-work, so that there is no possibility of a short-circuit. If things are a bit close, apply some tape around the fuse caps. The general approach is shown in Fig. 3.

Having thus been doctored, the set is re-assembled and used in the ordinary way. The next time the fault occurs it should only be necessary to examine the added fuses to see which one has blown in order to identify the offending circuit. It is important that these added

fuses should be rated much lower than the normal h.t. fuse as otherwise this may still blow, leaving the added ones intact so that they do not indicate where the fault lies.

If the defective circuit is itself feeding several sub-circuits it may be necessary to repeat the process with each of these in order to narrow the field down still further. Fuses in the other circuits can be removed and the original connections restored once they have been eliminated. In this manner, it will eventually be possible to pin-point the defective component and replace it.

One baffling source of intermittent h.t. short-circuits is a leakage between the primary and secondary, or core, of a transformer. If the lead to this component is fitted with a temporary fuse in the manner described and if it is found later that it has blown, it could be mistakenly assumed that the trouble lay in the associated valve or any capacitor connected to the valve anode. If a fault in the transformer itself seems a possibility, fuses should be inserted on both the h.t. and anode sides of the primary winding, as in Fig. 4. The fuse on the anode side should be of a lower rating than that on the h.t. side; 100mA and 150mA respectively would be suitable values. If either the anode fuse or both blew, the fault would be in the anode circuit and the transformer could be absolved from blame, but if only the fuse on the h.t. side blew, then indeed the transformer would be indicated as responsible.

So it is with all servicing; by intelligent observation of all the symptoms and a systematic approach even the most obscure fault in the h.t. line can be located and rectified.

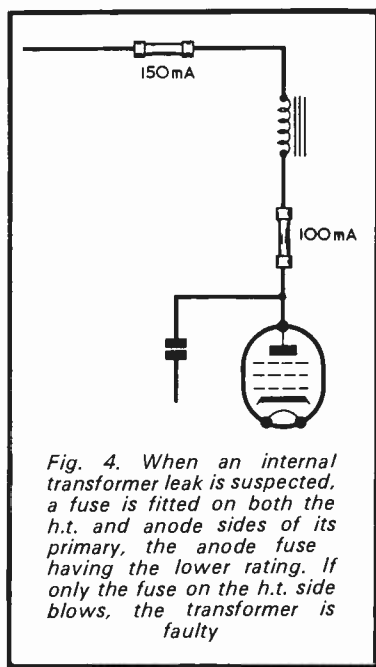

Fig. 4. When an internal transformer leak is suspected, a fuse is fitted on both the h.t. and anode sides of its primary, the anode fuse having the lower rating. If only the fuse on the h.t. side blows, the transformer is faulty

# Trade News . . .

## IMPROVED THERMAL CABLE STRIPPER

Adcola Products has incorporated a length stop device on the R400 thermal cable stripper to allow for accurate linear stripping of pvc and polythene cables.

The latest hand model also features an improved screw and locknut adjustment for cable or wire width.

Thermal cable stripping is claimed to be the safest method of stripping the insulation from cable to leave the wire exposed. A low heat on the fixed 'cutting' blade is used in place of a sharp cutting edge for cable stripping.

The R400 has a thermally controlled blade temperature specifically designed for stripping pvc and polythene and it will handle cables up to  $\frac{1}{4}$  in (3.2mm) thick.

The R400 is priced at £3.23 and the R310 at £2.90.

Further details of these thermal cable strippers are available free on request from Adcola Products Ltd., Adcola House, Gauden Road, London S.W.4.



## LOUDSPEAKER ENCLOSURES IN KIT FORM FROM EMI



*Assembling one of EMI's new loudspeaker enclosures which are available in a variety of finished wood veneers. Prices range from £5.80 for a small bookshelf model to £29.50 for a floor standing enclosure*

## NEW CERAMIC DISC CAPACITORS

A new range of ceramic disc capacitors (Type CSC) has been introduced by Seatronics (UK) Ltd. These general purpose disc capacitors are manufactured from high dielectric constant ceramics and are designed to provide high capacitance in a more compact size than is usual for capacitors in the voltage range of 50V to 500V.

The capacitance range is 1,000pF to 50,000pF (E6 series) and  $\pm 20$  per cent tolerance. The dielectric strength is 250 per cent of the rated working voltage and Type CSC may be used in ambient temperatures from  $-55^{\circ}\text{C}$  to  $+85^{\circ}\text{C}$ ; tan delta is 0.02 maximum.

For further information contact Seatronics (UK) Ltd., 22-25 Finsbury Square, London, EC2A 1DT.

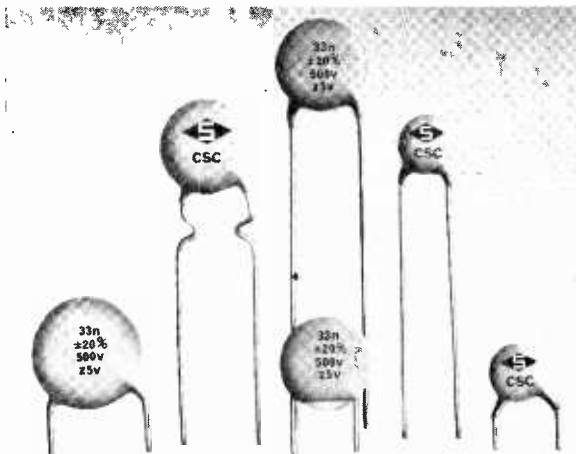

# EASY 2

# RECE

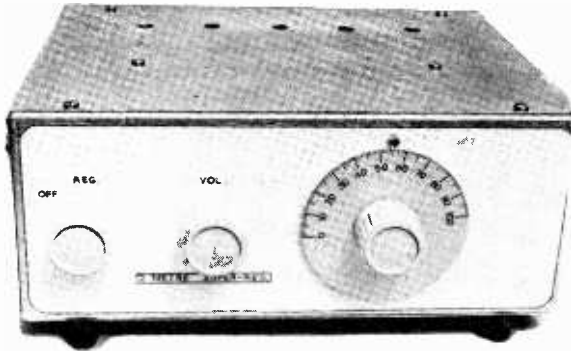

*The completed receiver. Despite the fact that the case is made up of standard chassis sections, the final appearance is neat and professional*

B

F. G. Rayer, Asso

Employing a super-regenerative alignment problems and employ: excellent project for the new



**Cover Feature**

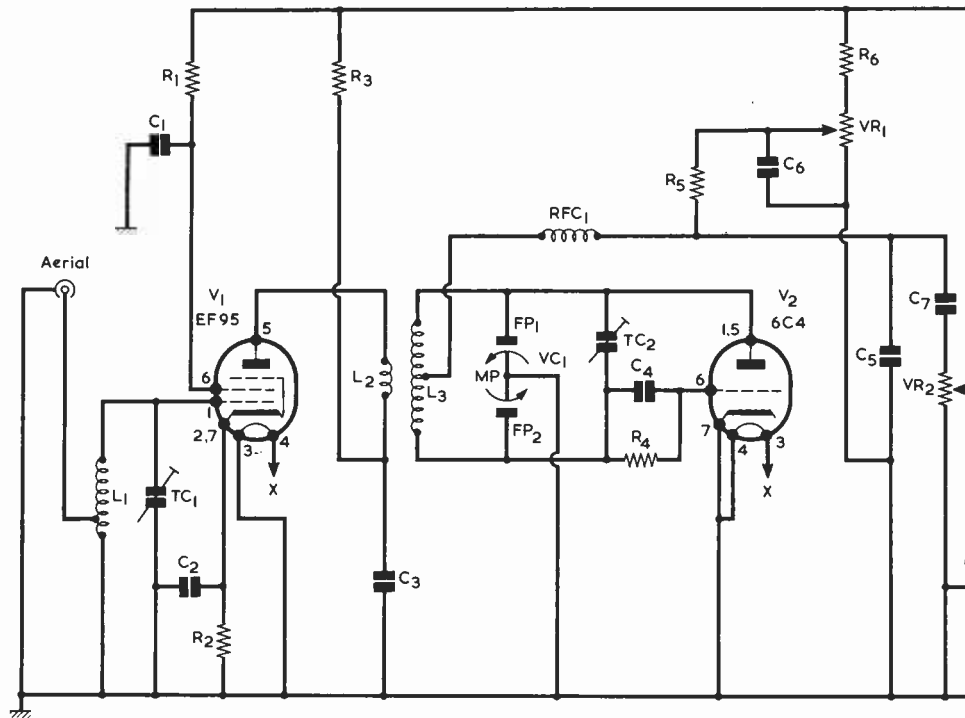

Fig. 1. The circuit of the 'Easy' 2  
THE RADIO CONSTRUCTOR

# METRE RECEIVER

.E.R.E., G30GR.

ector, this receiver offers no valves only. It represents an omer to 2 metre reception.

THIS RECEIVER IS OPERATED FROM 240 VOLT A.C. mains, and can be adjusted for reception over the range 120 to 150MHz, the actual tuning range for the 2 metre band being about 143.6 to 148MHz.

It is worth noting the three different methods commonly employed for obtaining 2 metre reception. First, a v.h.f. superhet designed for the purpose may be used, but building this is a lengthy and expensive procedure. Second, a converter, using a standard communications or equivalent receiver as a tunable i.f. amplifier and detector, represents a popular and good system; but it is necessary to have available the communications receiver. Third, a super-regenerative receiver can be employed, and this allows the home-constructor to receive 2 metre signals with the aid of a circuit design which is quite straightforward and which can be quite easily built.

### ADVANTAGES

The receiver described here comes into the third category, and it is interesting to compare its advantages and limitations with those of the first and second categories.

The great advantage of the super-regenerative receiver is its simplicity, and it is by no means a complex and difficult project to build. There are no alignment problems and it is easy to adjust frequency coverage. Also, the receiver can be made up as a complete unit, needing only connection to an aerial, mains supply and speaker.

One of the limitations of the super-regenerative receiver is its lack of selectivity. Where two or more transmissions are close in frequency and could be easily separated by a v.h.f. superhet or 2 metre converter and communications receiver, the super-regenerative receiver may be quite unable to separate them. It is also less sensitive than the superhet or the converter and receiver. Further, the super-regenerative receiver has a loud background hiss when tuning, but this completely disappears when a carrier of sufficient strength is received. The receiver is suitable for the reception of a.m. only, not c.w., s.s.b., or f.m.

In practice, a receiver like that described here represents a straightforward means of obtaining reception on v.h.f. frequencies, provided its limitations are understood. It is not suitable for 2-metre Dx, nor for sorting out as many transmissions as possible during a 2-metre contest. But it is capable of bringing in all sorts of interesting transmissions as well as the local 2 metre amateurs.

### CIRCUIT DETAILS

Fig. 1 gives the circuit. V1 is a v.h.f. pentode, providing useful gain and helping to isolate the aerial from the detector stage. L1 is tapped to match a dipole or similar aerial, and inductive coupling is provided to the next stage by L2. Grounded-grid and other circuits have various advantages in more complex equipment, but were not felt justified here for the V1 stage.

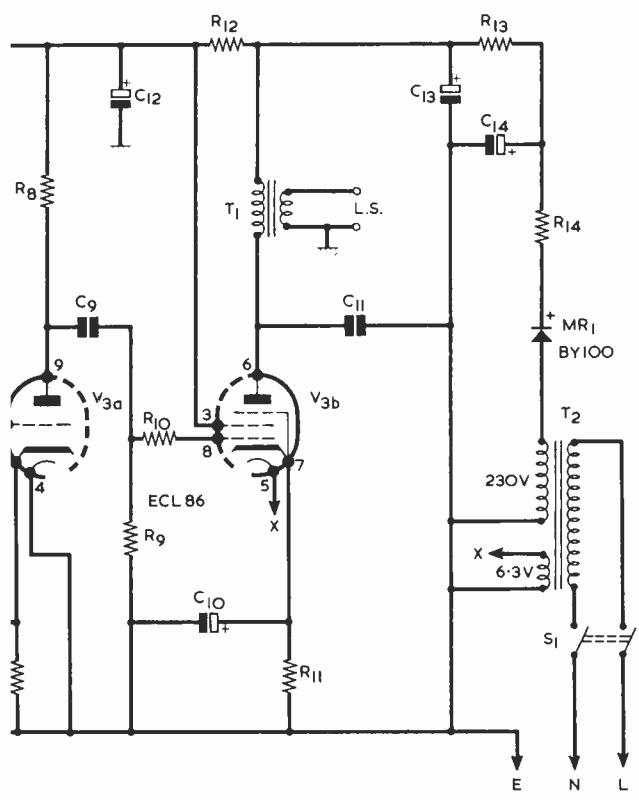

re Receiver



## COMPONENTS

### Resistors

(All fixed values  $\frac{1}{2}$  watt 10%, unless otherwise stated)

- R1 47k $\Omega$
- R2 180 $\Omega$
- R3 2.2k $\Omega$
- R4 8.2M $\Omega$
- R5 39k $\Omega$
- R6 20k $\Omega$
- R7 4.7k $\Omega$
- R8 220k $\Omega$
- R9 470k $\Omega$
- R10 47k $\Omega$
- R11 220 $\Omega$
- R12 5.6k $\Omega$  1 watt
- R13 1k $\Omega$  2 watt
- R14 270 $\Omega$  1 watt
- VR1 50k $\Omega$  potentiometer, linear, with switch S1
- VR2 1M $\Omega$  potentiometer, log

### Capacitors

- C1 2,000pF disc ceramic, 350V wkg.
- C2 2,000pF disc ceramic, 250V wkg.
- C3 2,000pF disc ceramic, 350V wkg.
- C4 47pF silvered mica, 250V wkg.
- C5 1,000pF tubular ceramic, 250V wkg.
- C6 0.25 $\mu$ F paper or plastic foil, 250V wkg.
- C7 0.01 $\mu$ F paper or plastic foil, 250V wkg.
- C8 4 $\mu$ F electrolytic, 6V wkg.
- C9 0.01 $\mu$ F paper or plastic foil, 350V wkg.
- C10 25 $\mu$ F electrolytic, 12V wkg.
- C11 0.01 $\mu$ F paper or plastic foil, 400V wkg.
- C12 32 $\mu$ F electrolytic, 350V wkg.
- C13 32 $\mu$ F electrolytic, 350V wkg.
- C14 16 $\mu$ F electrolytic, 350V wkg.
- VC1 Split-stator, approx. 5 + 5pF (see text)
- TC1 30pF trimmer, Mullard concentric
- TC2 30pF trimmer, Mullard concentric

### Transformers

- T1 Speaker transformer, Cat. No. TO46 (Home Radio)
- T2 Mains transformer, primary 240V, secondaries 230V at 45mA and 6.3V at 1.5A, Cat. No. TM26A (Home Radio)

### Coils

L1, L2, L3, RFC1, See text

### Valves

- V1 EF95
- V2 6C4
- V3 ECL86

### Rectifier

MR1 BY100

### Switch

S1 d.p.s.t., part of VR1

### Speaker

3 $\Omega$  moving-coil speaker

### Sockets

- 1 coaxial aerial socket
- 1 2-way speaker socket strip
- 1 B9A valveholder
- 2 B7G valveholders with skirts and screening cans (for V1 and V2)

### Metal-Work

- 3 flanged members, 10 × 4 in., Cat. No. CU58A (Home Radio)
- 2 flat plates, 7 × 4 in., Cat. No. CU158 (Home Radio)
- 2 flat plates, 10 × 7 in., Cat. No. CU188 (Home Radio)

### Drives, Knobs

- 1 Ball drive, Jackson type 4511/F, Cat. No. DL50A (Home Radio)
- 1 3 in. aluminium scale, Cat. No. DL72 (Home Radio)
- 1  $\frac{1}{4}$  in. spindle coupler, Cat. No. DL52 (Home Radio)
- 3 knobs, Cat. No. KN84F (Home Radio)

### Miscellaneous

- 1 2-way tagstrip (see Fig. 2)
- 1 10-way tagstrip (see Fig. 3 and text)
- 4 plastic feet, Cat. No. Z146 (Home Radio)
- 3-way mains cord
- Grommets, solder tags, etc.

V2 is the super-regenerative detector, regeneration being controlled by VR1. The grid resistor and capacitor values allow the stage to go in and out of oscillation at a supersonic frequency, and regeneration is advanced far beyond the point used with an ordinary regenerative detector. VC1 is the tuning capacitor, operated by a ball-drive reduction gear, and trimmer TC2 allows the band covered by VC1 to be accurately set.

V3 is a 2-stage audio amplifier, with VR2 providing gain or volume control. The triode section of V3 is the first a.f. stage, and the pentode section operates the loud-speaker through the output transformer T1.

The internal power supply provides h.t. from the secondary of the mains transformer T2. H.T. to earlier stages is progressively smoothed by the resistors R13 and R12 in the high tension positive line and by the

electrolytic capacitors C12 and C13, and the receiver is completely free from hum. The 6.3 volt winding on T2 supplies the heaters.

• Except for the effects of stray capacitance and wiring, the frequency is determined by L3, TC2 and VC1, so it is relatively easy to adjust band coverage. The details to be given are for the frequencies mentioned. TC1 is merely peaked for best reception.

## METALWORK

The form of assembly employed is easily achieved by using ready-made 'Universal Chassis' flanged members and flat plates, these being available from Home Radio. One 10 by 4in. flanged member provides the 'chassis' and most of the components are mounted

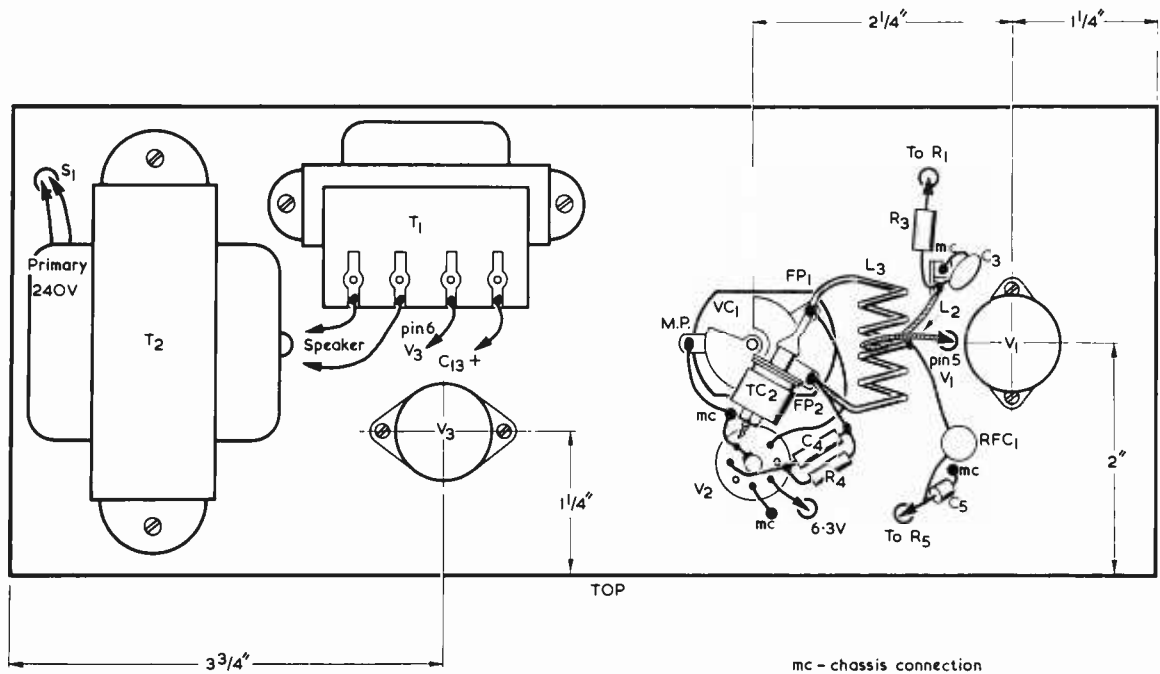

Fig. 2. Wiring and components on the rear of the flanged chassis member

on this. This 'chassis' is completely wired before fitting the other metal parts.

A second 10 by 4in. flanged part is used for the front panel, and is mounted by bolting on a 4 by 7in. flat plate on each side. The flanges of the 'chassis' and panel members face each other, and the edges of the flanges are separated by 2in. The panel surface is thus approximately 2 1/2in. from the 'chassis' surface. When later, at the completion of wiring, the panel is fitted, the few interconnecting leads from the panel components to the chassis can be soldered on, whereupon the receiver is ready for testing.

The case back is another 10 by 4in. flanged plate. A flat top plate is attached with self-tapping screws passing through the flanges of the front panel, central 'chassis' and back member. The bottom plate, which has four plastic feet fitted to it, is secured in the same way. Both the top and bottom plates are 10 by 7in. The bottom plate has half-a-dozen ventilation holes, made with the 3/8in. B7G chassis cutter used for the valveholder holes for V1 and V2. A row of 1/4in. or 3/8in. holes is made near the back of the top plate. These holes are, of course, cut before the plates are fitted.

The accompanying photographs give a good illustration of the method of assembly. In that showing the interior, the 10 by 4in. 'chassis' member is clearly seen between the front panel and the rear plate. The valves project on either side of this 'chassis'. V2 projects towards the front panel whilst V1 and V3 project away from the front panel. Both V1 and V2 have screening cans. The mains transformer and speaker transformer are on the same side of the 'chassis' as are V1 and V3. VR1 and VR2 are mounted directly on the front panel. VC1 is mounted on the 'chassis', being coupled to the ball-drive at the front panel by way of an extension spindle.

MARCH 1972

Three of the ventilation holes in the bottom plate can be seen in the photograph. The remaining three holes are also to the rear of the 'chassis', allowing adequate access of air to V3 and the mains transformer.

## INDUCTORS

Coil L1 is air-cored and self-supporting, and is wound with 16 s.w.g. or a similar stout tinned copper wire. Its outside diameter is 1/2in. It has 5 turns, spaced to occupy about 3/4in. length. The aerial tapping is soldered on at 1 turn from the earthy end of L1.

L3 is also air-cored and self-supporting, and it is wound with 16 s.w.g. or similar tinned copper wire. Its outside diameter is 5/8in. It has 5 turns, spaced to occupy about 3/4in. length. Its straight ends are 1/8in. long and are soldered directly to VC1. One lead of the r.f. choke is soldered to the centre of L3.

Coupling coil L2 is a single turn of insulated wire, or of 20 s.w.g. bare tinned copper wire covered with 1mm. sleeving. It has the same diameter as L3, and its ends are shaped to reach tag 5 of V1, (via a hole in the 'chassis') and C3. It is placed centrally in the spaced turns of L3. See the wiring diagram of Fig. 2.

The r.f. choke is wound upon a piece of insulated tube or rod 1 1/2in long and 1/8in. in diameter, using 34 s.w.g. enamelled wire. Pass the wire through a small hole, or cement it, about 1/8in. from one end of the tube or rod. This is now the top end of the choke, and is that which connects to the tap in L3. Wind 70 turns side by side and fix the other end of the wire. Do not varnish, paint or apply cement to the whole of the winding. The insulated rod can be mounted vertically on the 'chassis' by a small self-tapping screw driven into a hole drilled up into the centre of the rod. If a tube is used, screw or bolt a small piece of cork, wood or other material in place.

483

so that the tube is a push fit on it.

## TUNING CAPACITOR

Tuning Capacitor VC1 has two separate fixed plates, indicated in the diagrams as 'FP1' and 'FP2', and is approximately 5pF each section. It was made by stripping plates from a 100pF Jackson type C804 capacitor, so as to leave plates as shown in the 'Detail of VC1' inset in Fig. 3. All the fixed plates were pulled off with flat-nosed pliers. Moving plates were pulled off to leave two with double spacing at the back, and two with double spacing at the front. Two of the removed fixed plates are then taken, and one soldering lug is cut from each. One fixed plate is then soldered on the left-hand stud, and one on the right-hand stud, as in Fig. 3. Obviously, this is an operation which has to be carried out with care. In the diagrams 'MP' refers to the moving plates.

If available, a butterfly capacitor could alternatively

be used, though this would reduce the tuning rotation to 90 degrees. A small split-stator capacitor represents another alternative.

## CHASSIS WIRING

Mount the components shown in Figs. 2 and 3, following these diagrams for correct orientation of the valveholders and of VC1. Two solder tags are fitted at each valveholder for chassis connections. Also, a solder tag is fitted under the upper securing nut for T1, the tag being on the opposite side of the 'chassis' to the transformer. Drill the holes in the 'chassis' that are required for the passage of wires. All these holes should be fitted with grommets. Two holes are required near T2, one of these being for the connections to its primary. A second, larger, hole takes its secondary connections, together with connections to T1. The speaker transformer supplied may have tags positioned differently to those shown in Fig. 2, and this point should be checked before

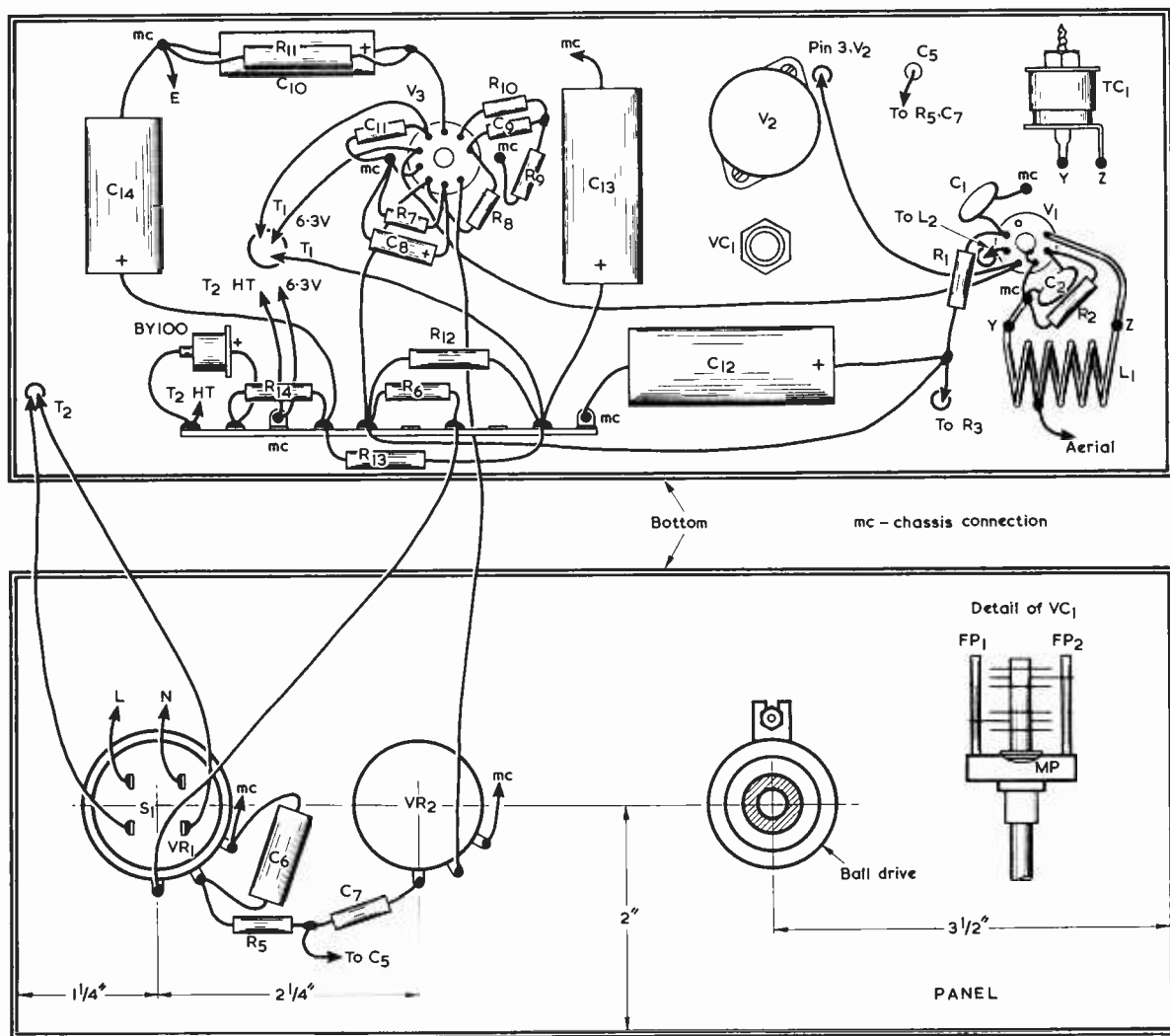

Fig. 3. The front of the chassis member and the back of the front panel. Also shown is a detail of VC1, illustrating the manner in which this component is made up

making connections to this component.

Carry out the wiring around V2 shown in Fig. 2. TC2 is soldered directly to VC1, between FP1 and FP2. Use 20 s.w.g. or stouter wire in the V2 stage, with all leads, except heater wiring but including those of C4 and R4, as short as possible. Shape the ends of L2 so that one end reaches the insulated tag supporting C3 and R3. The other end passes through a hole immediately adjacent to tag 5 of V1 valveholder.

The front, or flanged side, of the 'chassis' is then wired up as in Fig. 3. Solder L1 to tag 1 of V1 and to one of the chassis tags mounted at V1 valveholder. TC1 is soldered across the coil at points Y and Z. Bypass capacitors C1 and C2 should be connected with the minimum length of lead. The lead from R1 to tag 6 of V1 valveholder should also be short.

As illustrated in Fig. 3, a 10-way tagstrip supports the rectifier and other components shown. The tagstrip employed in the prototype is not a standard type as sold by the larger component retailers, and constructors may have to employ a strip in which different tags to those shown connect to chassis. A suitable strip would be the 12-way type, 3in. long, available from Henry's Radio. A slight rearrangement of the connections, to suit the different positions of the earthed tags, would then be required.

The 6.3 volt secondary leads from T2 pass through the hole in the 'chassis', as shown, and connect to tag 5 of V3 valveholder and to a chassis tag of the tagstrip. The h.t. secondary leads connect to the same chassis tag and to the negative side of the rectifier. The primary leads of T1 pass through the same hole and connect to tag 6 of V3 and, at the tagstrip, to the positive lead-out of C13. The secondary of T2 connects to a speaker socket strip which is mounted on the adjacent 7 by 4in. side plate. This connection will be made later, when the side plate is secured in position. Note that one side of T1 secondary (it does not matter which) connects to chassis. This connection is made, at the speaker socket strip, to a solder tag under one of the strip securing nuts, and is not shown in Figs. 2 and 3.

When the chassis wiring in Fig. 3 is completed it is as well to insert V2 and put on its screening can, as this is tricky (though not impossible) later.

The ball drive specified has a flange, tapped for two short 8BA screws. It is necessary to drill matching holes in the DL72 tuning scale. Place the scale on the drive and mark through the flange holes, so that the appropriate holes may be drilled in the scale. The fixing screws must be very short, or they will impede the rotation of the drive.

VR1 and VR2 are next fitted to the front panel and the components R5, C6 and C7 are wired up. The live and neutral wires of the 3-way mains cord may also be connected to the switch tags. The mains cord passes through an adjacent hole in the flat side plate and it is advisable to pass it through the hole at this stage even though the side plate is not yet mounted. The particular component employed for VR1/S1 may not have the same switch tag positioning as that shown in Fig. 3, and the switch tags should be identified with the aid of a continuity tester before any connections are made to them. The two tags to which the primary of T2 will later connect should be the upper ones, to provide ease of soldering.

The front panel is now mounted in place by fitting the two flat side plates. The speaker socket strip may then be wired up, as already described. A coaxial aerial socket is mounted on the side plate at the V1 end of the

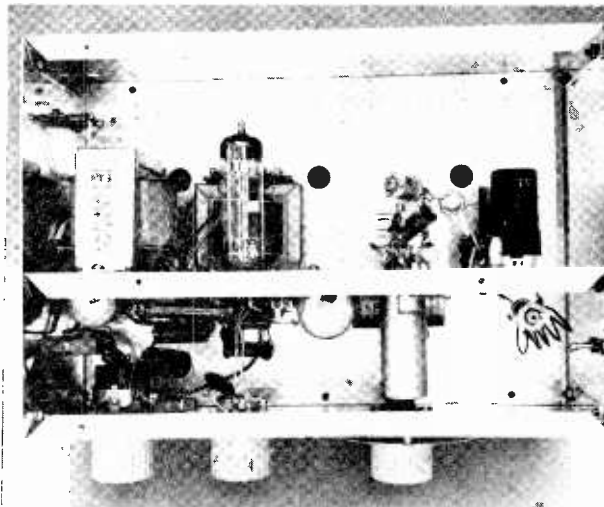

*Looking down into the receiver, this photograph clearly illustrates the method of assembling the metalwork and the positions of the main components*

'chassis', this being positioned so that its centre connector lug is close to the aerial tapping point in L1. A short length of stout wire connects this lug to the tap in the coil. The earth connection for the coaxial socket is made via the receiver metalwork.

Cut a length of  $\frac{1}{16}$ in. rod to couple the spindle of VC1 to the ball-drive. Put a shaft coupler on the rod, fit the rod in the drive bush, and line up the spindle with VC1. The coupler may then be slid along and fixed. The ball-drive is fitted and its lug is locked to the panel with a nut and bolt. The DL72 scale may next be fitted. A suitable panel marker for the scale can be provided by fitting a screw to the panel with its slot vertical, and filling this with paint. In the prototype, the front panel was covered with thin card and marked as shown, but it could be left bright or painted.

A few leads have to be added to complete wiring, and these run across from the 'chassis' to the panel as in Fig. 3. Take the wire from C5 across to the panel, then along against the panel to the junction of R5 and C7. A short wire from tag 1 of V3 runs across to the centre tag of VR2. The panel and chassis are only 4in. wide and there is no difficulty in reaching these wiring points. Also connected are the primary leads of T2 at S1, and the earth lead of the mains cord. The latter connects to the chassis tag under T2 securing nut, as shown. This tag may also take the two 'MC' connections from the front panel.

The mains lead should be a flexible cord preferably running to a 13 amp plug fitted with a 3 amp fuse. The colour coding is brown for Live, blue for Neutral and green-yellow for Earth.

The top flanged back plate may finally be fitted. The top and bottom plates can be added after the receiver has been tested and set up.

The speaker is external to the receiver and should be a 3 $\Omega$  type fitted in a cabinet or on a baffle board. It is important to note that the set should not be operated without a speaker connected. If T1 secondary is not loaded by a speaker there is a risk that high a.f. voltages may appear in the primary circuit and these could damage the transformer or the associated components,

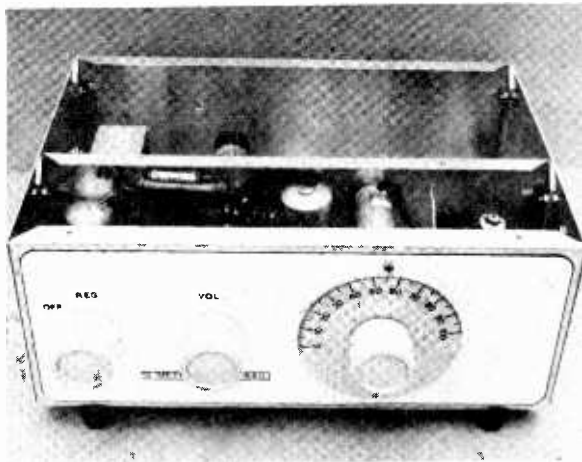

A view from the front with the top cover removed

## AERIAL

Various signals were received with a short vertical wire extending upwards from the aerial input socket, but results were very much improved with a dipole. The dipole feeder can be 75Ω coaxial cable, and may be of any convenient length. The inner conductor runs to the centre pin of the coaxial plug, and the outer conductor to the outside of the plug.

A suitable dipole for 2 metres is 38½ in. in overall length, and can be made from two pieces of alloy tubing, each 19 in. long, and fixed to a block of insulating material with their inner ends about ½ in. apart. Take the inner conductor of the coaxial cable to one element, and the outer conductor to the other element. The dipole can be raised on a pole, and can be set vertically or horizontally to suit the polarisation required. If it is placed horizontally, there is only a small directional effect, reception being slightly better broadside to the aerial.

Various multi-element aerials are often used for 2 metre reception. These are directive, and require to be faced towards the point from which signals originate. So some means of rotating these aerials will generally be required.

## SETTING UP

For the 2 metre band, both TC1 and TC2 are almost fully unscrewed. The exact length of the winding of L3 has considerable influence on frequency coverage, and the coil may be slightly compressed or stretched, if necessary. The same applies to L1.

Place VR2 about a quarter to one-third from the minimum volume position. Rotate VR1 until a loud hissing is heard in the speaker, showing that super-regeneration has started. Tune with VC1, at the same time adjusting VR1 to maintain this condition as needed.

When a reasonably strong transmission is tuned in, the hiss should cease. TC1 can then be peaked for best signal strength, but this capacitor tunes flatly and need only be re-adjusted if TC2 is altered. Use an insulated tool, as TC2 is connected to the h.t. positive circuit.

With weak signals, reception improves if VR1 is backed off a little. The way in which this control operates will soon become clear. VR2 adjusts the volume in the usual way.

In certain areas, and at some particular times, there is a lot of 2 metre Amateur activity. This is most likely during week-ends. In these circumstances, the 2 metre band will soon be found.

In other districts, and during the week, there may be very little 2 metre Amateur activity, shown by an absence of Amateur signals. The extent to which the transmissions of other services in the frequency coverage of the receiver are heard depends on local conditions and usage.

If difficulty is experienced in identifying received stations, it is of assistance to employ a wavemeter to indicate the frequency of reception. A very simple v.h.f. wavemeter, suitable for this function, will be described in next month's issue. ■

## GRUNDIG SPONSOR AMATEUR TAPE RECORDING CONTEST ON LOCAL RADIO

Grundig (Great Britain) Limited has organised an Amateur Tape Recording Contest running on eight BBC Local Radio stations. They include Birmingham, Derby, Leeds, Leicester, Manchester, Medway, Oxford and Stoke-on-Trent.

The contest is being run in co-operation with the organisers of the British Amateur Tape Recording Contest. The entry forms, which are available from local Radio stations, are identical to those of the National Contest so that all tapes can go forward for a national prize.

Grundig will award in each area a first prize of a £50 voucher towards any Grundig product and also tapes for the runners-up.

The contest which started on the 1st February will run till the 31st March 1972. This will allow time for the tapes to go forward to the National Contest before their closing date on the 30th June 1972.



# SILICON TRANSISTOR SIREN

By

J. Johnstone

This complementary pair multivibrator functions as a tone generator for a number of applications including that described here.

**I**N MANY CARS, THE OIL WARNING LIGHT IS NOT CLEARLY visible in daytime. If the oil pressure falls during a fast run, the driver may not notice until serious damage has been done to the engine. This simple siren will draw attention as soon as the pressure falls to a dangerous level. No doubt many other applications will come to mind.

## COMPLEMENTARY PAIR MULTIVIBRATOR

The circuit (Fig. 1) may seem an unusual arrangement and is in fact a complementary pair multivibrator. This circuit will work on either 6 volt or 12 volt systems. When power is supplied, C1 charges through R2 and the speaker coil until TR1 is turned on. This turns TR2 on, allowing C1 to recharge and repeat the cycle. The tone may be altered by changing the value of C1. All components are very generously rated, and many years of trouble-free use may be expected. The original unit has been operating for the past two years.

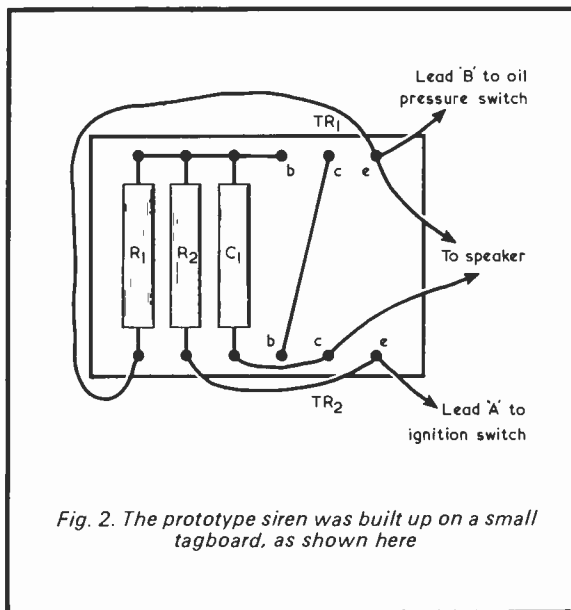
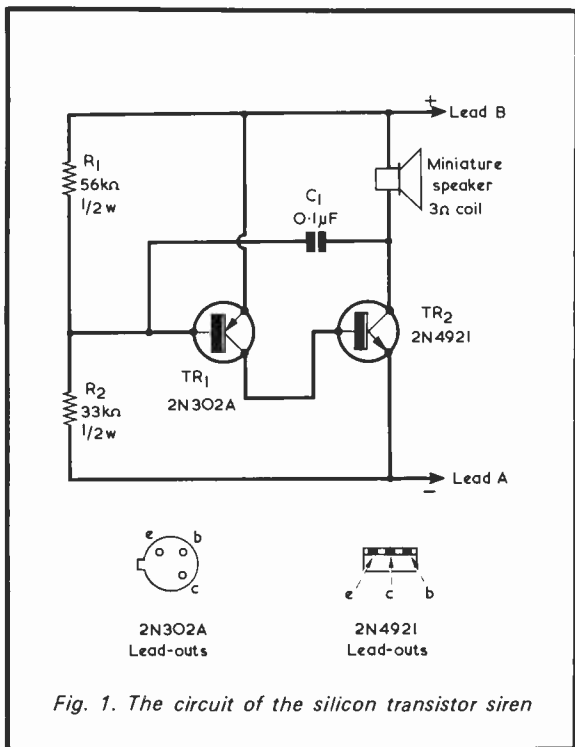

The components were assembled on a short length of miniature tag panel, as shown in Fig. 2. This was glued to the back of the speaker with Araldite epoxy resin adhesive. The speaker, in its turn, was bolted to the underside of the dashboard. If the car has positive earth return, connect up as shown. If it has a negative earth, lead 'A' should connect to the oil pressure switch and lead 'B' to the ignition side of the oil warning lamp.

## EDITOR'S NOTE

If difficulty is experienced in obtaining the transistors specified, the 2N302A may be replaced by any small p.n.p. germanium transistor of reasonable voltage rating and current handling capability, such as the ACY18. The 2N4921 is a Motorola silicon power transistor having a maximum VCEO of 40 volts, an hFE of 20-100, a maximum Ic of 500mA and a maximum power dissipation of 30 watts. A suitable alternative would be any silicon n.p.n. power transistor of roughly equivalent characteristics, such as the BD121. It need not be mounted on a heat sink. A 1 amp fuse in series with either the positive or negative supply lines would be desirable when initially testing the circuit. ■

# D. C. Motor Controller

By

R. WAKEMAN

Intended originally for the control of model trains, this variable voltage d.c. power supply unit incorporates features which could be profitably employed in other fields.

THE CIRCUIT SHOWN IN FIG. 1 WAS ORIGINALLY designed for use as a power control for electric train sets. The unit is capable of operating two locomotives at top speed.

By allowing power to pass to the motor in short bursts a greater take-up is achieved, giving steady even acceleration. The unit is protected from short-circuit on the output by a current limiting system.

The unit can be built separately or it can have its own built-in transformer and rectifier circuit capable of 1.5 amp maximum d.c. current.

## SPECIFICATION

The input requirements of the unit are 16 volts d.c. at 1.5 to 2 amp, and the average output voltage can be varied from 1.2 to 12.5 volts at 1 amp. The current limiting circuit starts to take effect at 1.2 amp and the short-circuit current limit is 1.5 amp continuous. Under short-circuit conditions the power dissipation of the series output transistor is 18 watts.

It should be pointed out that the short-circuit condition should not be maintained for exceptionally

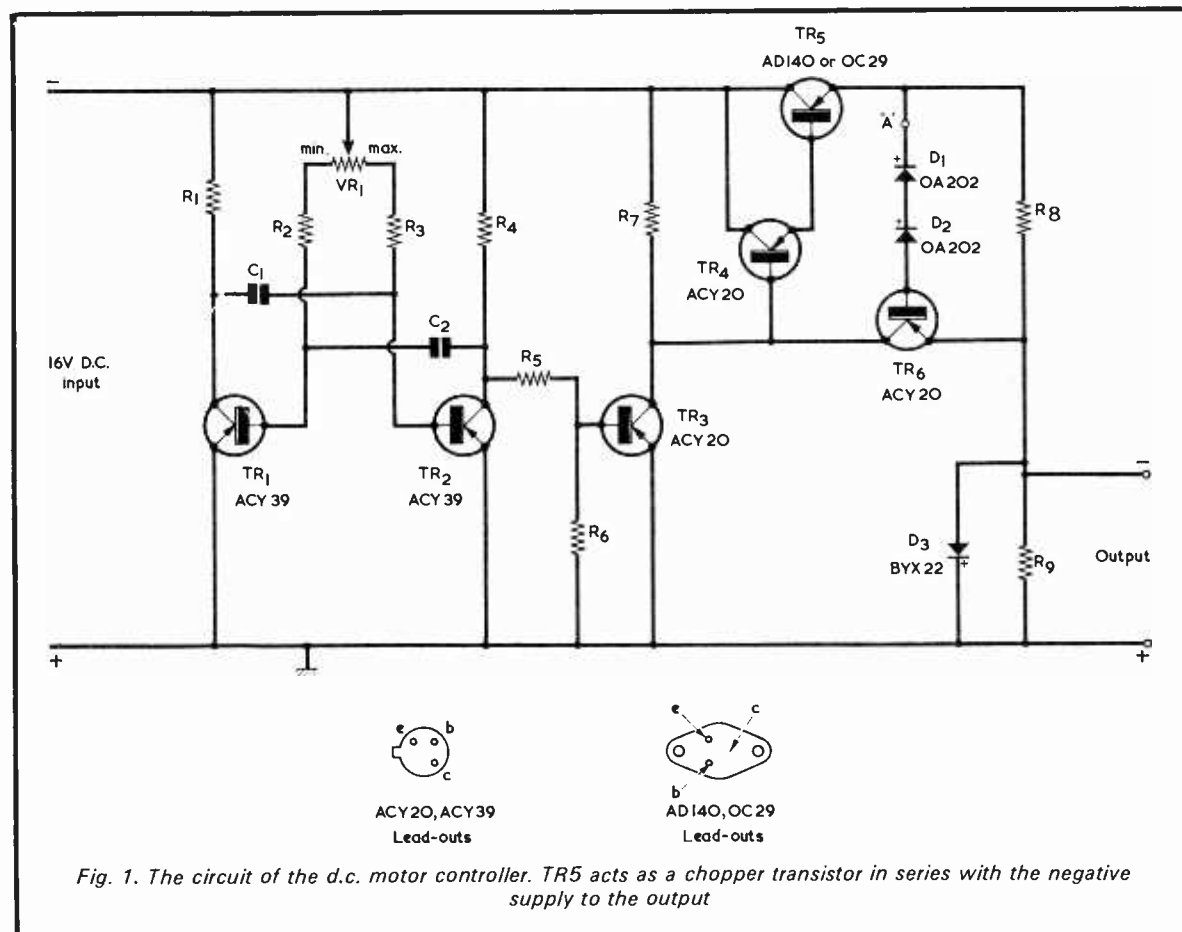



long periods as the series transistor is then run at its maximum dissipation rating for ambient temperatures up to 24°C. TR5 should be mounted directly, without mica washer, on a large heat sink such as the type H11, available from Henry's Radio, Ltd. The heat sink is insulated from the chassis of the unit.

### CIRCUIT DESCRIPTION

Fig. 1 gives the circuit of the controller. The transistors TR1 and TR2 are in a multivibrator configuration which produces a waveform at the collector of TR2 as shown in Fig. 2. The frequency of operation of the multivibrator is of the order of 200Hz.

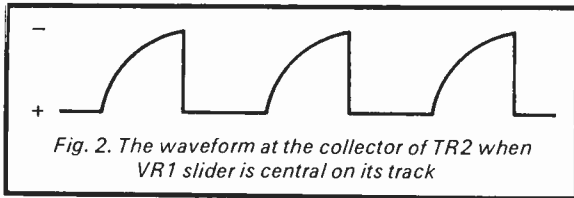

By varying the setting of VR1 the mark-to-space ratio of the multivibrator can be adjusted, the ends of the range being set by R2 and R3. Transistor TR3 functions as an amplifier and gives a fast rise leading edge to the pulses from the multivibrator, as shown in Fig. 3.

With the slider of VR1 at one end of its track, the waveform given in Fig 4(a) is obtained. With the slider of VR1 at the other end of its track, the resultant waveform is that shown in Fig. 4(b). These waveforms are applied to the output transistor, TR5, TR4 and TR5 being in the emitter follower configuration. As is to be expected, the average output voltage becomes

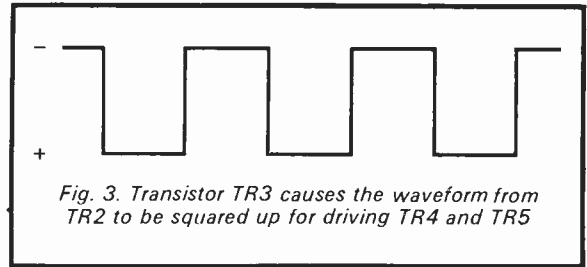

Fig. 3. Transistor TR3 causes the waveform from TR2 to be squared up for driving TR4 and TR5

larger as the period within the multivibrator cycle when TR5 base is negative increases.

R8 monitors the output current which is being taken by the load, the current limit being supplied by TR6 which drains off the base current of TR4 if an excess of current is drawn. It might appear that the value specified for R8 (0.5Ω) is low if current limiting is to commence at 1.2 amp. However, the current through R8 consists of high peaks due to the chopping action of TR5 and it is these peaks which provide the voltage needed to turn on TR6.

The function of D1 and D2 is to increase the current value to which the output is to be limited. If a lower value is required one diode should be removed or linked out. The diode D3 must be rated for 1 amp, a suitable type being the BYX22. Its function is to circulate the back e.m.f. of the motor, filling in the gaps between pulses and also allowing the motor to gradually stop after the output has been reduced to minimum.

If VR1 cannot be obtained as a carbon potentiometer with the value specified, a Bulgin wirewound component may be employed instead. This is available from Home Radio under Cat. No. VR22A.

### OPERATION

When used on an electric train set the controller is much superior to a smooth d.c. power pack type of arrangement. The pulses which are received by the train tend to make the motor creep; the leading edge of the wave, being sharp, gives rise to a high peak current which offers greater control of the motor at low

### COMPONENTS

#### Resistors

(All fixed values  $\frac{1}{4}$  watt 10% unless otherwise stated)

R1	2.2kΩ
R2	1.2kΩ
R3	1.8kΩ
R4	2.2kΩ
R5	33kΩ
R6	68kΩ
R7	2.2kΩ
R8	0.5Ω 1 watt wirewound
R9	150Ω 2 watt
VR1	15kΩ potentiometer, linear

#### Capacitors

C1	0.25μF paper or plastic foil
C2	0.25μF paper or plastic foil

#### Semiconductors

TR1	ACY39
TR2	ACY39
TR3	ACY20
TR4	ACY20
TR5	AD140 or OC29
TR6	ACY20
D1	OA202
D2	OA202
D3	BYX22

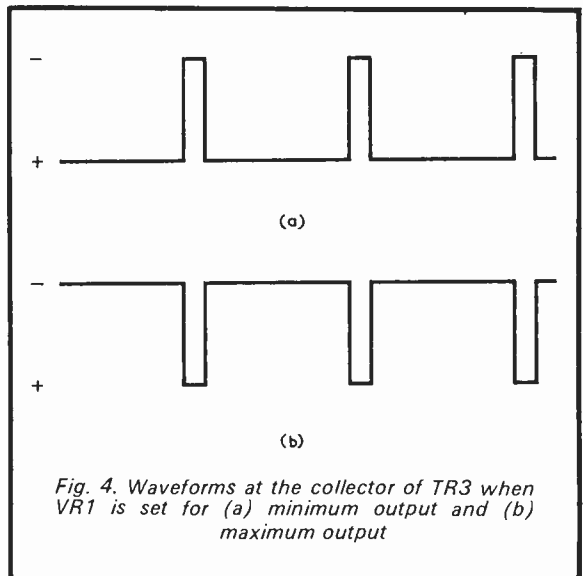
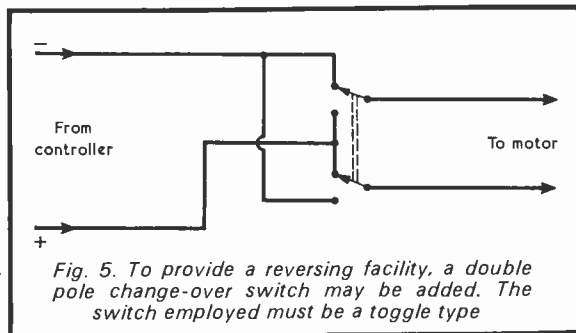

Fig. 4. Waveforms at the collector of TR3 when VR1 is set for (a) minimum output and (b) maximum output

speeds. When the train is stopped fast by VR1 being turned to give minimum output voltage, the regenerative action which ensues takes the train on for a couple of inches.

If derailment is caused and the lines are short-circuited then the current limit becomes effective and closes down the pack until the short-circuit is removed.

To facilitate reversing, a double pole change-over toggle switch can be added to the output to change the polarity. Such a switch is shown in Fig. 5.



The circuit of a suitable power supply to feed the control unit is given in Fig. 6. The transformer secondary should offer 12-0-12 volts at 1.5 amp or more. If difficulty is experienced in obtaining the transformer, a suitable alternative is the Douglas Type MT3 (Home Radio Cat. No. TMM1) which offers secondary voltages of 0, 12, 15, 20, 24 and 30 at 2 amps. The 12 volt tap may be used as the centre-tap for the circuit of Fig. 6, and the two rectifiers may be connected to the 0 and 24 volt taps. Suitable rectifiers are the BYZ12 or BYX38. (Both the BYX22 and BYX38 are given suffix numbers which indicate p.i.v. rating. The p.i.v. figures are, in all cases, well above the p.i.v. values encountered in the circuits discussed here.)

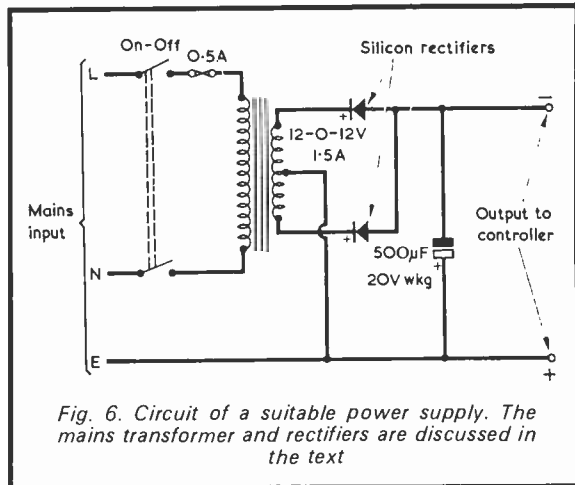

### TESTING

If an oscilloscope is available, check the output of the multivibrator to see that it conforms with Fig. 2, also check the output from TR3 to ensure that pulse width variation takes place. If no pulse is present at the extreme ends of VR1 travel the multivibrator has locked onto one side. The value of R2 or R3 as applicable should then be increased until the fault clears. In the absence of an oscilloscope, the multivibrator output should be audible in a loudspeaker coupled to the circuit via a step-down speaker output transformer, a series 0.1µF capacitor being inserted in one of the leads to the transformer primary.

The current limit can be checked by injecting a voltage between the D1 side of point 'A' and the emitter of TR6, point 'A' being open-circuited. A voltage of between 1 and 1.5, negative to D1, should turn off the output. No other setting-up is required. ■

## 1919 RADIO TRANSMITTER

Recently donated to the Royal Air Force museum is a 1919 aircraft radio transmitter complete with original test certificates. This valuable acquisition was discovered at a junk sale by Sid Law of Alexandra Road, Croydon. An R.A.F. spokesman engaged in researching the history of the set stated that the transmitter helped to fill in the early days of aircraft communication and that there are very few of the models still in existence.

Sid Law is active on the Radio Amateur Emergency Network with the call G3PAZ, which he operates from his living room. When asked why he didn't keep the 1919 transmitter for use in the Emergency Service he joked that 'under today's broadcasting conditions he would have found himself as a disc jockey on Radio 3'.

*Sid Law, donator to the Royal Air Force of a rare 1919 aircraft transmitter, makes a contact on the air. He operates under the call G3PAZ. (Photo: Frazer Ashford)*



# A BETTER PRINTED CIRCUIT RESIST

by

A. G. BLEWETT

Printed circuit boards can be quickly and reliably prepared by the method described here, which avoids the use of dopes or paints.

**I**N ORDER TO MAKE SUB-MINIATURE PRINTED CIRCUIT boards for radio control work recently, the author considered the two most popular methods of forming the resist in order to find the best where very small 'lands' are required.

The first, where the lands are formed by painting with dope or ordinary paints, was rejected outright as being too fiddly.

## ADHESIVE P.V.C.

The second, where adhesive p.v.c. (such as Fablon) is attached to the copper, and the areas to be etched are cut away, was thought to be better; but it still suffered from disadvantages. First, the p.v.c. stretches whilst being cut, and causes distortion of the shapes. Second, it is unnecessarily thick. Third, the adhesive bond is not complete enough to prevent etchant finding its way underneath at the edges, hence causing ragged edges; and, fourth, the adhesive is not strong enough to prevent very small areas (about  $\frac{1}{16}$  in. round or even smaller) from wandering, or even lifting from the copper.

All these disadvantages become more acute as the printed circuit board and its lands are reduced in area, as occurs with radio control boards and boards containing flat pack integrated circuits.

An alternative plastic resist which suffers from none of these disadvantages is a material used for covering model aircraft surfaces. This is sold in most model shops and is known as 'Solarfilm'.

'Solarfilm' is a polyester film a few thousandths of an inch thick, and has a heat activated adhesive on one side. This is protected by a removable clear film which is peeled off before use, as with Fablon.

The adhesive is activated at a temperature of between 250 to 280°F, and a domestic iron is used to 'iron' it on. The iron must have a temperature control.

## PROCEDURE

The best procedure for applying the material is described in the following steps.

MARCH 1972

1. First bring the iron to the right temperature. Too cool an iron will not activate the adhesive properly and will result in an incomplete bond. On the other hand, too high a temperature will melt the film itself, causing the iron to be covered in a sticky mess of hot plastic! Setting the thermostat on the iron to 'Low' or to 'Man-made fibres such as Acrilan and Courtelle' should be found about right. Check the iron temperature with a small sample piece of 'Solarfilm' before starting any job.

2. Clean the copper area of the printed circuit board thoroughly, bringing it up to a bright finish.

3. Cut the 'Solarfilm' with about  $\frac{1}{16}$  in. excess all round, and remove the protective backing.

4. Iron the film on to the copper side of the board, working from the middle towards the edges so as to avoid creases. Any bubbles that are formed can be pricked with a pin and ironed out flat.

5. Film at the edge of the board may be taken round to the non-copper side, being ironed at the edge and on the non-copper side. This achieves an edge seal and there is, of course, no need for neatness here.

6. Remove the high gloss on the 'Solarfilm' by rubbing lightly with fine sandpaper. This ensures that it will take the imprint of carbon paper successfully.

7. Interpose carbon paper between the film and the master drawing, being careful to align the two accurately, and then trace through.

8. Cut away the areas to be etched with a pointed modelling knife or similar, and remove with tweezers.

9. Etch the printed circuit board in the normal way.

10. Remove the remaining 'Solarfilm' to expose the finished printed circuit board.

This method is quite economical, a 36 by 26in. sheet of 'Solarfilm' costing only a little more, at the time of writing, than 50p. In cases of difficulty, sheets can be obtained direct from the manufacturers at 'Solarfilm', Euxton Mill, Dawbers Lane, Euxton, Nr. Chorley, Lancs, PR7 6EB.

The film comes in a range of colours, but white or yellow are considered best for this application, since they give the best contrast when used with blue or black carbon paper.

# A MODERN HOMODYNE RECEIVER

## Part 1

By  
G. W. Short

Recent interest in 'direct conversion' receivers has prompted our contributor to offer his own design. In this month's article he discusses the background to homodyne reception, leading up to the basic mode of operation employed in his receiver. In the concluding article, to be published next month, the receiver will be described in full.

**D**IRECT CONVERSION RECEIVER is a fairly recent term though, strictly speaking, it might be applied to any type of receiver which converts the incoming signal directly to audio. On this basis even a crystal set would qualify, but in fact the term is usually restricted to receivers in which the audio is recovered with the help of an oscillator.

### REACTION CIRCUIT

The simplest and earliest of this type of direct conversion receiver was the 'homodyne'. In its original form, described in 1924 by F. M. Colebrook, who became Director of the National Physical Laboratory, it was just a triode detector with 'reaction' (Fig. 1). The reaction was set to make the circuit oscillate strongly. As many readers will have discovered for themselves,

when a signal is tuned in with such an oscillating detector there is first of all an ear-splitting howl caused by the incoming carrier beating with the local oscillation. Then, as the circuit is adjusted closer and closer towards 'zero beat', a point is reached where the beat note suddenly disappears, and the incoming programme is heard, rather faintly and with background hiss but otherwise with good quality.

What has happened is that the local oscillation has become locked to the incoming carrier. The combined signal is then an ordinary a.m. signal with an abnormally strong carrier - the result of the local oscillation which, being now synchronised, adds to the signal carrier. The net result is an a.m. signal with a low depth of modulation, which makes for low distortion of the detected audio. The background hiss arises from the same cause as the background

hiss of a c.w. receiver when the b.f.o. is switched on or any sensitive receiver tuned to an unmodulated carrier. That is, the carrier or local oscillation beats with any r.f. noise close to it in frequency, giving a.f. noise at the output of the detector.

Colebrook's homodyne was a very simple affair, but it did embody the important principle of a local oscillation locked in frequency to an incoming carrier. All modern direct conversion a.m. receivers use this principle, though the means by which synchronism is obtained may be very different from Colebrook's direct-injection method.

The knowledge that an L.C. oscillator can be synchronised in this way predates Colebrook's homodyne by a small period. A little over a year earlier, Appleton (the ionosphere researcher) had written a learned paper

Fig. 1. An early approach to direct conversion reception consisted of using a triode detector with reaction, as illustrated in basic form here

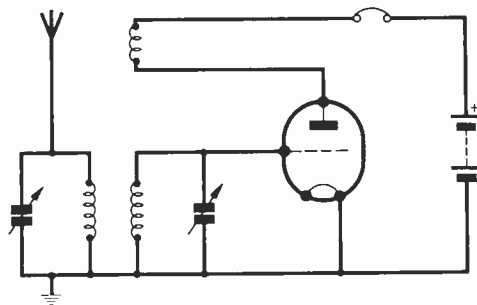
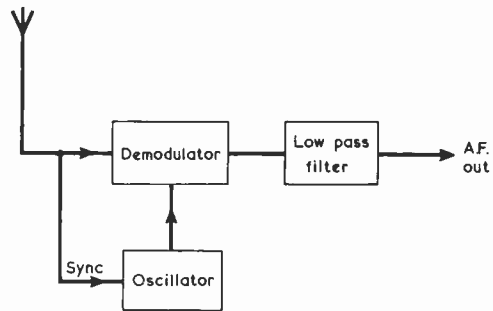

Fig. 2. Demonstrating typical synchrondyne operation



on the subject. Some of his co-workers had actually used Colebrook's method of reception.

Despite this promising beginning, the homodyne never became popular. This may seem strange in the light of present-day interest, but it should be remembered that the superheterodyne method of reception had already been invented and seemed to be the answer to all the problems of the day, since it gave high gain, good selectivity, and a simple method of automatic gain control.

In any case the domestic t.r.f. receivers of the twenties and thirties were often operated as homodynes . . . and very unpopular they were when this was done. In those days of long outdoor wire aerials, an oscillating detector first stage acted as a local c.w. transmitter producing, when off tune, annoying whistles in neighbouring sets. The outdoor aerial also brought with it a particular disadvantage. When it swayed in the wind, the resulting variations in capacitance to earth tended to throw the receiver out of synchronism.

## THE SYNCHRODYNE

As Colebrook had realised, the homodyne method of reception can give greatly enhanced selectivity. The way in which it does so is not very obvious from the original circuit, but it becomes clear when one examines the much improved form of the technique known as the 'synchrondyne' (Fig. 2).

In the synchrondyne the path of the incoming signal is split into two separate branches. One branch goes straight to the demodulator, that is, the circuit which carries out the direct conversion to audio. The demodulator is driven by an oscillator, and the other branch of the signal path goes to this oscillator: this is the synchronising path and its job is to injection-lock the oscillator to the incoming carrier of the wanted station.

Now, the demodulator, although usually regarded as a detector (and in certain forms called a 'product detector'), is in reality a kind of frequency changer. The unorthodox thing about *this* frequency-changer, however, is that, unlike the one in a

superhet where the oscillator is on a completely different frequency from the signal, here the oscillator is on exactly the same frequency. The 'i.f.' output is at the difference frequency between signal and local oscillation, but the difference frequency is zero! This does not mean that there is no output but that the output is at zero frequency, or d.c.

Not very useful, you may think. But this is where the nature of an a.m. signal comes into the picture. An a.m. signal has a carrier *and* sidebands. The oscillator in a synchrondyne is locked to the carrier frequency, so it is the carrier frequency only which gives a d.c. output. The sidebands, being on slightly different frequencies, give beat-frequency outputs. It just happens that the beat frequencies are the original modulation frequencies, so that the output of the demodulator consists of the original audio modulation frequencies which constitute the programme.

To take an actual example, suppose the carrier frequency is 200kHz, modulated by a.f. at 1kHz. There are in consequence the usual two sideband frequencies, one at 199kHz and the other at 201kHz. Both these beat with the local oscillation on 200kHz to give 1kHz, i.e. the original modulation. The same thing happens with any other modulating frequency, and for any mixture of frequencies which form a voice or music signal.

What happens to unwanted frequencies on other channels? The carrier of an adjacent channel, say 209kHz, gives an output from the demodulator of 9kHz. This is a whistle at a relatively high audio frequency, and is rejected by the low-pass filter which follows the demodulator, whose cut-off frequency can be set at, say, 5kHz. It will be clear that signals on channels above 209kHz, such as 218kHz, come out at still higher frequencies and are also rejected. What about unwanted channels on lower frequencies? If the next lower channel is at 191kHz it gives a beat at 9kHz, which is also dealt with by the low-pass filter. Any still lower channel comes out, once again, at a *higher* difference frequency and is likewise eliminated by the filter.

We therefore have the delightfully simple situation that, so long as the local oscillator stays locked to the wanted carrier, unwanted signals on any other frequency are eliminated. There is no possibility of 'second channel' (image frequency) breakthrough as in a superhet. Note, too, that the selectivity comes from the demodulation process; even r.f. tuning can, in theory, be dispensed with!

## OSCILLATOR STABILITY

The problem, of course, is to keep the oscillator synchronised, and we must now look at this requirement

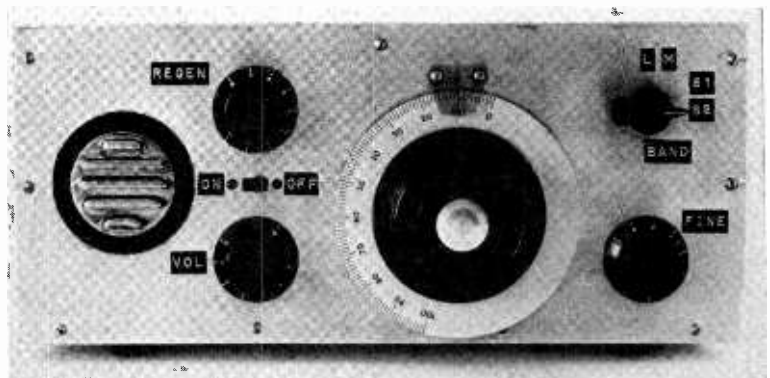

The panel layout of the author's homodyne receiver. Details of this will be given in the article to be published next month

more closely. Common sense suggests that the stronger the synchronising signal the easier it should be to lock the local oscillator. This is true, and it provides a starting point for an estimate of the stability needed from the oscillator.

Careful tests will show that even when the tuning is shifted a little to one side or other of the correct point the oscillator remains locked. The stronger the signal, the more detuning can be tolerated. This would be great if all one needed to do were to tune in to strong stations, but in the real world it is necessary to pluck a weak signal from a surrounding array of strong ones, each eager to jump in and take over. In theory, it is indeed possible to stay locked to the wanted weak carrier when there are strong unwanted ones nearby. To do it, you must increase the amplitude of the local oscillation. This makes it *harder* to lock, but it turns out that a weak signal tuned in 'right on the nose' can then dominate a strong one slightly off tune. The price demanded for this performance is great stability of frequency.

If the local oscillator were absolutely stable it would not be necessary to lock it at all. One would just set it to the right frequency and sit back. Unless the transmitter frequency drifted the receiver would stay tuned indefinitely. Unfortunately, absolutely stable oscillators just do not exist, so locking is necessary. If drift is very low, the locking signal need only be small, which is what we want.

How stable must the oscillator be? Suppose, to begin with, that we are in the rather favourable situation of having to lock to one signal when another, of exactly equal strength, is 10kHz away. Now let the oscillator drift, but without loss of sync. If it drifts towards the unwanted carrier, a point will be reached at the half-way mark between the two stations where

there is an even chance that the unwanted carrier will take command. In other words, the natural, unlocked frequency must not drift by more than half the channel spacing, in this case by 5kHz.

So far we haven't specified what the carrier frequency is. When we do, we find we have come to the crunch. If the wanted carrier is 500kHz, then the allowable drift in this case of 5kHz amounts to one per cent - 1 part per 100. Not a very difficult stability to achieve. But what if the carrier were 5MHz? A drift of 5kHz is now 1 part in 1,000. And at 50MHz, a stability of 1 in 10,000 is required, or 0.01%. Clearly, life gets harder as one goes up the frequency scale.

Next, look at the unfavourable situation where the unwanted carrier is not equal in strength to the wanted one but 100 times stronger. The oscillator must be 100 times more stable than before, and this calls for a drift of less than 1 part in 10,000 at 500kHz, 1 in 100,000 at 5MHz, and 1 in a million at 50MHz. Clearly, the synchrodyne is a receiver for lowish frequencies, or quick hands on the tuning control, or oscillators of exceptional stability.

The original synchrodyne designs, published in 1947, were for medium wave receivers. Their originator, D. G. Tucker (now Professor of Electrical Engineering at Birmingham University) had a background in line communications engineering and a special interest in the rectifier types of modulators and demodulators, such as the ring modulator, used in carrier telephony. These have the degree of linearity between input signal and output which is required in the synchrodyne, and were used in the most successful version, though Tucker did also produce a simple version using a triode-hexode frequency changer instead. The synchrodyne created a stir when it first appeared, but subsequent

research by Tucker showed that between 1924 and 1947 there had been a number of patented circuits which embodied the essential principle of separating the synchronising path from the main signal path.

## INTEREST REVIVES

The most obvious attraction of the synchrodyne (and homodyne, which can be regarded as a synchrodyne whose functions are all mixed up in one circuit) is its ability to provide high selectivity without the use of a lot of tuned circuits. There is, however, another less obvious attraction. It can be called in as an ally against what many communications engineers have come to regard as the last great enemy - intermodulation. In a shortwave receiver, the aerial tuned circuit cannot be made selective enough to get rid of strong interfering stations somewhere in the band to which it is tuned. The result is that the first stage of the receiver, usually an r.f. amplifier, is presented with a mixture of weak and strong signals. Since no amplifier is perfectly linear the consequence is that the weak ones have the modulation of the strong ones impressed upon them, and no amount of subsequent filtering (in i.f. stages, for example) can then get rid of the interference.

In a direct-conversion receiver, all the selectivity is obtained in one stage, the demodulator. And in the demodulator the strongest signal, the signal which overrides all others, is of course the local oscillation. By dispensing with r.f. amplification and feeding the input signals straight to a demodulator supplied with a good strong local oscillation there is a sporting chance that cross-modulation will be greatly reduced. This is of particular interest on the amateur bands, where there may be very strong interfering signals from broadcast transmitters or the amateur in the next street. Another encouraging fact is that for single-sideband suppressed carrier reception, now popular with amateur transmitters, a small frequency error at the local oscillator is permissible. Given a stability which confines drift to a few tens of cycles during a 'contact' there is no need to attempt precise synchronisation, which is just as well, since in a suppressed-carrier system there is no carrier to provide a locking signal. (It is possible, at the expense of great complexity, to derive one from the audio output, but that's another story).

## IMPROVING THE HOMODYNE

In general, however, we are interested in receiving ordinary double sideband a.m. signals with carrier and all. In this case it is absolutely necessary to synchronise the oscillator. For most purposes we need some r.f. amplification as well.

The original homodyne did give some protection against cross-modula-

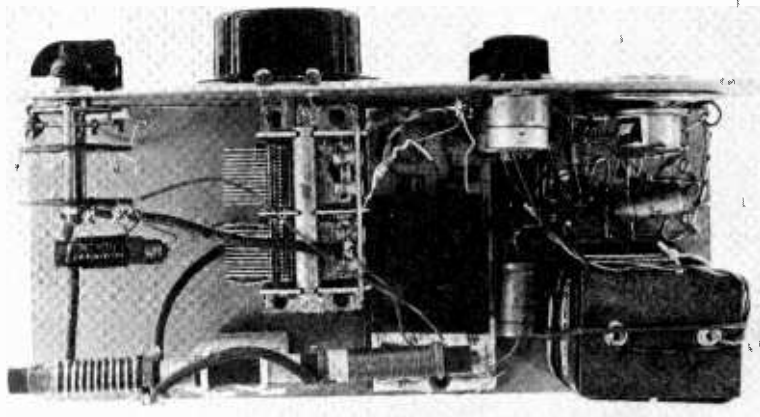

*A view inside the homodyne receiver. Signal pick-up on medium and long waves, and on two short wave bands, is provided by a ferrite rod aerial*

Fig. 3. The homodyne method of reception employed in the author's design

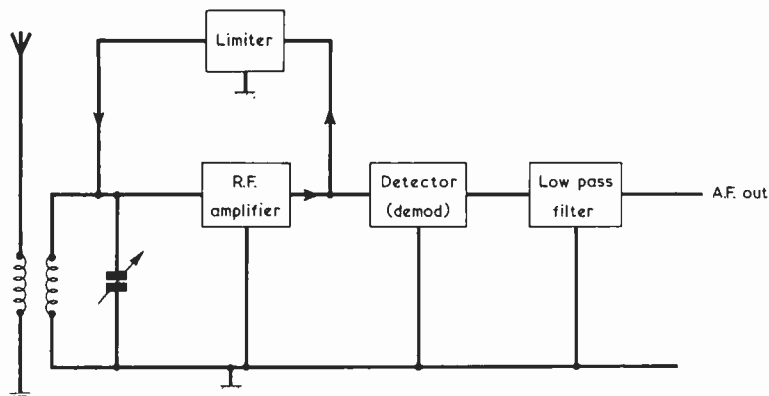

tion, by making the local oscillation the strongest "signal" around. But it provided no r.f. amplification. What is needed, then, is a circuit which preserves the simplicity of the homodyne but gives r.f. amplification as well. A way of achieving this is shown in Fig. 3.

In Fig. 3, signals are tuned by an aerial circuit, amplified by an otherwise untuned r.f. amplifier, and passed to a detector. So far all we have is a simple t.r.f. receiver. This is turned into a homodyne by introducing regenerative feedback (reaction) from amplifier output to the aerial circuit. This feedback takes place via a limiter. The job of the limiter is twofold: to suppress the modulation of the fed-back carrier and to prevent the amplitude of

oscillation from getting too large. What is fed back, when the circuit is oscillating strongly, is a more or less unmodulated carrier of fixed amplitude.

Provided that the fed-back carrier is not so strong that it overloads the amplifier any other signals present will still be amplified in the normal way, except that cross-modulation may be discouraged by making the oscillation stronger than any other signal.

No means of controlling regeneration (other than the limiter) are shown in Fig. 3, but it is very easy to add an attenuator between the limiter and the tuned circuit. Once this is done it becomes possible to set the circuit so that it acts either as a simple non-regenerative receiver with no "reaction",

or as a normal reacting t.r.f., or as a fully oscillating homodyne. For most purposes the ordinary regenerative t.r.f. condition is adequate, since it provides enhanced gain and selectivity without the need for the critical tuning of a homodyne. But when conditions are bad, with a strong interfering station or stations in the band, the superior selectivity of the homodyne is worth the trouble of the careful adjustment which this mode of reception calls for. Single-sideband transmissions can also be received, if the tuning is fine enough, once the knack of hitting the right tuning point is acquired. Readers who have not tried s.s.b. reception before are warned that it takes some practice!

(To be concluded)

## FARAD ELECTROLYTIC CAPACITORS

by

J. B. Dance, M.Sc.

**Very low voltage electrolytic capacitors are now available with capacitance values of no less than 50 farads.**

**C**APACITORS OF EXTREMELY LARGE VALUES - IN THE farad range - have been developed by the Gould Ionics Company. They are very useful in such applications as timing circuits which provide delays of the order of months. They can also be used as stand-by power sources, since a capacitor is essentially an energy storage device.

### DRY POWDERS

Unlike conventional electrolytic capacitors, the new devices contain only dry powders, including the special material rubidium silver iodide (RbAg4I5). One of the disadvantages is the low decomposition voltage (0.65V) of this material which limits the voltage per capacitor to about 0.6V.

MARCH 1972

Nevertheless, ten separate 50 farad capacitors of this type can be fitted into a cylindrical package of 2.5 inches in length by 1 inch in diameter. When connected in series, they form a 5 farad capacitor rated at 5V.

The devices will hold their charge for days or even for weeks. They are therefore being used as memory cells, each cell being of about .10mF capacity at 0.5V. One cell charged in June 1969 was found to have retained 97% of its initial charge when tested over 1½ years later!

Stable vibrators can be constructed using these capacitors to provide switching periods from 1 second to over a month.

The technique of depositing capacitors of this type directly onto integrated circuit substrates has, for example, produced a 500µF capacitor in a case 0.02 inch long by 0.032 inch diameter. Such developments should greatly extend the field of application of monolithic operational amplifiers, since previously it has been possible to employ only relatively small capacitor values in integrated circuits.

Miniature electrolytic capacitors often have a relatively high leakage current, but the types under discussion have capacitances of 160F per cubic inch and pass only a few picoamps (1pA = 1µµA). Their leakage resistance is about 10,000MΩ and they are free from catastrophic failure.

Further details may be obtained from the U.K. representatives, Messrs. Lyons Instruments Ltd., Hoddesdon, Herts.

495



# SHORT WAVE NEWS

## FOR DX LISTENERS

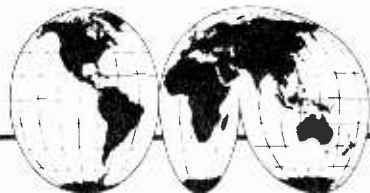

By Frank A. Baldwin

*Times = GMT*

*Frequencies = kHz*

### ● BANGLA DESH

Radio Bangla Desh commenced an Overseas Service on the 1st of January in the English language and this may be heard from 0230 to 0300 on **7095** (42.28m), formerly a channel of Radio Pakistan, and from 1230 to 1300 on **15520** (19.33m) also formerly used by R. Pakistan. The Home Service operates from 0300 to 0300 on **4915** (61.03m) in parallel with **7095** (the latter channel closes at 0220). News in English at 0145. From 0630 to 0800 on **7260** (41.32m) and on **9560** (31.38m) with the news in English at 0730. From 1100 to 1630 in parallel on **4915** (from 1315), **5855** (to 1300), **9853** (30.46m) and on **15520** (to 1220). The news in English is at 1205 and at 1515, all according to 'Bandsread', the journal of the British Association of Dx'ers (BADX).

### ● TURKEY

Voice of Meteorology, Box 401, Ankara, has been heard broadcasting music with announcements and weather news in Turkish on **6890** (43.52m) and also on **6900** (43.55m) from 0500 to 0700, 0800 to 0940, 1200 to 1615 and from 1800 to 1930.

### ● NORTH VIETNAM

The English schedule of the Voice of Vietnam is now as follows – daily from 0500 to 0530, weekdays from 0830 to 0900, daily from 1000 to 1030, 1300 to 1330, 1530 to 1600, 2000 to 2030 and from 2300 to 2330 on **7360** (40.73m), **7416** (40.46m), **9840** (30.49m), **10224** (29.34m) and on **15018** (19.97m).

### ● IRAN

Teheran now radiates the Home Service, until 1720, on the new channel of **7038** (42.62m) in place of **12175**. The new channel carries the External service from 1725 until 2130. Parallel channels for the Home Service are **3780** (79.32m), **7065** (42.46m) and **15085** (19.89m), according to BADX.

### ● ROUMANIA

The English broadcasts from Radio Bucharest to Europe are now from 1300 to 1330 on **11940** (25.13m) 120/240kW, **15250** (19.67m) 18/120kW, and on **17710** (16.94m) 120kW. From 1930 to 2030 on **9510** (31.55m) 18/120kW and on **11940**. From 2100 to 2130 on **7195** (41.70m) 18/100kW and on **9690** (30.96m) 50/120kW. To Africa from 1100 to 1130 on **11920** (25.17m) 18kW, **15250** (19.67m) 18/120kW and **17850** (16.81m) 100/120kW. To Asia from 1500 to 1530 on **11920**, **15250** and on **17760** (16.89m) 18/120kW. To the Pacific from 0654 to 0815 on **11940**, **15250** and on **17760**. To North America from 0130 to 0230, from 0300 to 0330 and from 0430 to 0500 on **5985** (50.13m) 100kW, **6190** (48.87m) 120kW, **9570** (31.35m) 240kW, **11810** (25.40m) 18/120kW, **11940** and on **15250**.

### ● MAURITIUS

Forest Side has been heard using **4870** (61.60m) instead of the listed **4850** channel, when broadcasting the BBC news in English. Mauritius is a small island of 720 square miles situated in the Indian Ocean and is one

of the Mascarene Islands. The capital is Port Louis, the volcanic island being surrounded by coral reefs. The official language is English but most of the islanders speak a French patois. Forest Side has a power of 10kW and the address is – Mauritius Broadcasting Corporation, Broadcasting House, Forest Side.

### ● LEBANON

The French transmission to North America from Radio Lebanon is from 0130 to 0200, in Arabic from 0200 to 0230 and in English from 0230 to 0300 on the reactivated channel of **9545** (31.43m) 100kW. Radio Lebanon can also be heard, in English, from 1830 until 1900 on **11705** (25.63m) 100kW.

### ● MEXICO

Radio Mexico has dropped the **21705** outlet and currently uses **9705** (30.91m) 20kW, **11770** (25.49m) 100kW and **17835** (16.82m) 100kW. The last mentioned channel is the most often reported in the SWL press and offers the best chance of reception here in the U.K. The address of XERMEX is – Apartado 20-620, Mexico 20.

### ● EGYPT

The schedule for the Voice of the Arabs programme, in Arabic, is as follows – from 0300 to 0600 on **7050** (42.55m) and on **9850** (30.46m) both 100kW. From 0600 to 1445 on **15475** (19.38m) 50/100kW, **17625** (17.03m) 50/100kW and on **17905** (16.75m) 50/100kW. From 1445 to 1630 on **15475** and on **17905**. From 1630 to 1700 on **7050**, **9850**, **15475** and on **17905**. From 1700 to 0030 on **7050** and on **9850**, according to BADX journal 'Bandsread'.

### ● AFGHANISTAN

Radio Afghanistan broadcasts to Europe, in English, from 1800 to 1830 daily on **9530** (31.48m) 100kW and on **11785** (25.46m) 100kW. Kabul may also be heard, in English, from 1400 to 1430 on **4775** (62.84m) 100kW according to the schedule but reception would be difficult on this channel for the average listener in the U.K. The address is – P.O. Box 544, Kabul.

### ● AFRICA

This continent can be heard almost the whole year round here in the U.K. on the lower frequency bands. A good 'marker station' indicating the prevailing reception conditions for Africa is Omdurman, Sudan, on **4994** (60.08m) 20kW, at least for the average listener. The 'dyed-in-the-wool' Dxr would, no doubt, choose a low-powered Angolan station for his 'marker'. If Omdurman can be heard with a very strong signal then the chances are that conditions are good for general African reception.

Some of the African stations recently logged indicate just what may be heard when using a makeshift indoor aerial.

**3336 1939** (89.95m) 4kW Ziguinchor, Senegal, with a programme of light music and announcements in French.

THE RADIO CONSTRUCTOR

- 3380 1936 (88.76m) 20/100kW Blantyre, Malawi, news in English.  
 4795 2146 (62.57m) 10kW CR6RG Radio Commercial de Angola, Sa da Bandeira, light music with announcements in Portuguese.  
 4875 1928 (61.54m) 20kW SABC Johannesburg, South Africa, record selections with announcements in Afrikaans.  
 4890 2154 (61.35m) 25kW Dakar, Senegal, light music with songs and announcements in French.  
 4976 1902 (60.29m) 7.5kW Kampala, Uganda, heard with a talk in English on the subject of Ugandan economics.  
 5047 1906 (59.43m) 100kW Lome, Togo, discussion in French.  
 5050 1908 (59.41m) 20kW Dar-es-Salaam, Tanzania, newscast in Swahili.

#### ● SOUTH AMERICA

- The 'season' for Latin American reception will shortly be upon us although, of course, LA's can be heard the whole year round. Those stations recently logged and which may interest readers are listed here.  
 4780 0009 (62.76m) 1kW YVLA La Voz de Carabobo, Valencia, Venezuela, songs in Spanish.  
 4825 2350 (62.18m) 3kW HIFA Voz de las Feurzas Armadas, S. Domingo, Dominican Republic, LA music and identification.  
 4870 2347 (61.60m) 5kW YVKP Radio Tropical, Caracas, Venezuela, LA music and songs in Spanish.  
 4890 2339 (61.35m) 5kW YVKB Nueva Radio Dif, Caracas, Venezuela, talk in Spanish.  
 4980 2315 (60.25m) 10kW YVOC Ecos del Torbes, San Cristobal, Venezuela, LA music and advertisements in Spanish.  
 6000 0055 (50.00m) 25kW PRK5 Radio Inconfidencia, Belo Horizonte, Brazil, identification and LA songs.  
 6095 0045 (49.22m) 7.5kW ZYB7 Radio Dif, Sao Paulo, Brazil, sports commentary and identification.  
 6160 0030 (48.70m) 10kW HJKJ Emisora Nueva Granada, Bogota, Colombia, LA music and full identification.  
 6185 0026 (48.50m) 10kW ZYR77 Radio Bandeirantes, Sao Paulo, Brazil, sports commentary in Portuguese.  
 9585 0058 (31.30m) 10kW ZYR56 Radio Excelsior, Sao Paulo, Brazil, discussion in Portuguese.  
 9685 0105 (30.98m) 7.5kW ZYR227 Radio Gazeta,

Sao Paulo, Brazil, commentary in Portuguese.

Listen out for the LA transmitters on the LF bands in the coming weeks, signal strengths will slowly build up as we go from Spring into Summer. If the static associated with the latter season of the year and commercial QRM (interference) allow, we should all have some success with our LA sessions.

#### ● A READER'S LOG

Julian Moss of Rayleigh, Essex, uses a Meridian 10-transistor portable receiver for his short wave roamings and requests that we include 'more down-to-earth loggings as a regular feature'. JM continues 'There must be as much excitement in tracking down the Lebanon on a transistor portable as in receiving some obscure LA (Latin American) transmitters on some £200 communications receiver'. Well JM, only a very few Dxers are equipped with such high-priced receivers, most have either 'surplus' equipment or relatively cheaper sets. However, that is another story, but I would be pleased to include readers loggings in this feature subject to available space; just send them along to the Editorial Office – the address is on the Contents page of this issue. Here are the loggings of JM.

- 5960 0815 HCJB Quito, Ecuador, English programme.  
 6025 2130 R. Portugal, English programme.  
 6170 2045 Kol Yisrael, Jerusalem, English programme.  
 7235 1535 R. Australia, English programme.  
 9460 2100 R. Pakistan, news in English.  
 9525 2245 RSA Johannesburg, programme in English.  
 9530 2230 VOA Monrovia, Liberia, signing-off.  
 9545 2045 R. Ghana, Accra, English programme.  
 9560 1020 NHK Tokyo, English programme.  
 9570 0735 R. Australia, Dx news.  
 9605 2130 CBC Montreal, in English.  
 9605 1945 R. Athens, Greece, in English.  
 9690 2000 WNYW New York, in English.  
 9745 2045 R. Baghdad, Iraq, German programme.  
 9805 2245 R. Cairo, in English.  
 11705 1905 R. Lebanon, in English.  
 11765 0735 R. Australia, in English.  
 11780 2000 HCJB Quito, in English.  
 11890 2030 WNYW New York, in English.  
 11910 1930 ETLF Addis Ababa, in English.  
 11950 1730 FEBA Seychelles, in English  
 11970 2238 RSA Johannesburg, news in English.

All of which goes to show just what can be achieved on the short waves with a 'domestic' receiver – well done JM!

## SUPER DX

Over the past few months, super Dx in the form of reception in the U.K. of signals from Papua and New Guinea, has been achieved and reported in the BADX journal 'Bandspread', to which due acknowledgements are made. Recently, reception of such stations as VL9BC on 3335 at 2000, when Radio Wewak was heard with drums and choral songs; VL8BD Radio Daru on 3305 at 2024 with light choral songs and Port Moresby on 4890 at around 2000 were made. Considering the low powers of these stations and the frequencies on which they operate, the reception of such transmissions in the U.K. equals super Dx by any standard.

MARCH 1972

# LAST LOOK ROUND

## 1972 WORLD RADIO-TV HANDBOOK

The 26th edition of this directory of the world's radio and television stations is undoubtedly the most comprehensive yet produced. Priced at £2.80, a very reasonable sum when one considers the vast amount of research and collation necessary to produce such a publication, the 384 page Handbook represents good value for money.

Of great importance and interest to SWL's, WRH – as it has become known over the years – is accepted all over the world as the 'bible' of those interested in short wave listening, not to mention the similar interests of medium wave and TV enthusiasts. The Short Wave Stations of the World list, some 23 pages in all, without which many SWL's would be lost when identifying stations, is the most complete available to the average listener.

All the usual features and listings have been brought up to date.

# In your work-shop



Regular readers will recall that, in last month's episode, Smithy reviewed the f.m. 'front-ends' employed in current a.m.-f.m. transistor radios, dealing also with automatic frequency control. He now returns to the subject of these radios and initiates his assistant, Dick, into the mysteries of a.m.-f.m. i.f. stages and the more modern versions of the f.m. ratio discriminator stage.

"A MAN OF HONOUR," COMPLAINED Dick bitterly, "would keep his promise."

"For goodness' sake," snorted Smithy irately, "don't keep on all the time."

"Well, it isn't fair," continued Dick. "You promised me ages ago that we would have a gen-session on the i.f. stages of transistor a.m.-f.m. radios, and yet you keep putting me off all the time."

"For a start," Smithy corrected him wearily, "it wasn't ages ago. It was just last month, after I'd finished telling you all about the f.m. front-ends in these receivers. Since that time, as it might have been noticeable to even someone as myopic as yourself, I've been snowed under with urgent work."

## A.M.-F.M. I.F. STAGES

"You aren't," Dick pointed out quickly, "snowed under now."

Helplessly, the serviceman looked around him. What Dick said was perfectly true. After a long run of heavy unremitting labour, the pressure of work had, that afternoon, suddenly ceased. Smithy glanced at his watch. There was at least an hour to go before he was due to lock up and go home.

"Oh, very well then," he remarked, shrugging his shoulders resignedly. "We'll have a go at those a.m.-f.m. i.f. stages then. You'd better come over to my bench, as I'll have to show you a few circuits and things."

"Good old Smithy," responded Dick enthusiastically, as he carried his stool over to Smithy's side of the workshop. "I knew you were a man of honour."

"And don't keep on about my honour," grunted Smithy tetchily.

"That happens to be something I hold in high esteem. It is not to be lightly bandied about."

"All right, all right," replied Dick soothingly. "I shan't mention it again."

"Fair enough," said Smithy. "Now, if you can remember our last technical rag-chew, I told you that the f.m. front-end design of a.m.-f.m. transistor radios has become pretty stabilized over the years, and that a typical front-end consists of two grounded-base transistors, one operating as r.f. amplifier and the other as mixer-oscillator. When we come to the i.f. stages of these sets, however, we find that circuit design is not quite as highly standardised. Nevertheless, all receivers of this type have i.f. amplifier circuits with a.m. i.f. and f.m. i.f. transformers connected in series, and the main differences lie in the more minor details."

"What's this business of having a.m. i.f. and f.m. i.f. transformers in series?"

"Connecting i.f. transformers in series is a common practice," said Smithy, "and it dates from the old valve a.m.-f.m. sets. I'll show you the sort of thing I mean."

Smithy pulled his note-pad towards him and sketched out several circuits.

"Here we are," he remarked, putting his pen back on the bench. "I've drawn a few examples of the sort of i.f. transformer circuits you're likely to encounter in transistor a.m.-f.m. receivers. In the first of these circuits there are two double-tuned i.f. transformers in series, the primaries being in the collector circuit of the first transistor, and the secondaries being in the base circuit of the following transistor."

Smithy pointed at the sketch of the two i.f. transformers in question. (Fig. 1(a).)

"Here," he went on, "the f.m. i.f. transformer is the one that's closer to both the collector and the following base, and it's tuned to 10.7MHz. The a.m. i.f. transformer follows it and is tuned to an intermediate frequency in the range of 450 to 475kHz, according to the make and design of the receiver. To make things easier in our discussion today, let's assume from now on that all the a.m. i.f. transformers we talk about are tuned to 470kHz, which is in fact one of the more common figures used."

"As you like," said Dick agreeably, as he settled himself more comfortably

on his stool. "When you have i.f. transformers in series like the ones you've drawn, isn't the tuning of one going to upset the tuning of the other?"

"Not to any significant degree," replied Smithy. "The beauty of the system is that the few turns of wire in the 10.7MHz i.f. transformer represent what is nearly a dead short to frequencies around 470kHz. At the same time, the fixed tuning capacitors across the windings in the 470kHz i.f. transformer are usually of the order of 200pF, and these offer quite a low reactance at 10.7MHz, the reactance being around 80Ω or so. Each of the tuned circuits is complete with its own parallel capacitor, and adjustments in one transformer do not then noticeably upset the tuning of the other. A rather fascinating aspect of the circuit is that, if you connect a signal generator to the base of the first transistor and some form of signal output level indicator to the collector of the second transistor, you'll get one band-pass peak as you take the signal generator through 470kHz and another as you take it through 10.7MHz. The circuit allows either i.f. transformer to function as if it were in circuit on its own."

"What stops the circuit from amplifying any 470kHz signals which may be present when you're receiving f.m., and any 10.7MHz signals which may be present when you're receiving a.m.?"

"The normal approach," said Smithy, "is to have a single 10.7MHz i.f. transformer on its own immediately following the f.m. front-end circuit, and this is sufficient to keep any 470kHz signals that may be present out of the i.f. stages when receiving f.m. signals. Most sets also have a single 470kHz i.f. transformer on its own immediately following the a.m. front-end, and this does the same thing to any 10.7MHz signals that may be knocking around. A further safeguard against breakthrough of the wrong i.f. is given by the fact that the outputs of the a.m. detector and the f.m. discriminator are switched before going into the a.f. stages of the set."

"I see," said Dick thoughtfully, "Let's get back to those other i.f. transformer circuits you've drawn."

"All right," replied Smithy. "Well now these alternative circuits represent variations in the basic theme given by the two double-tuned i.f. transformers

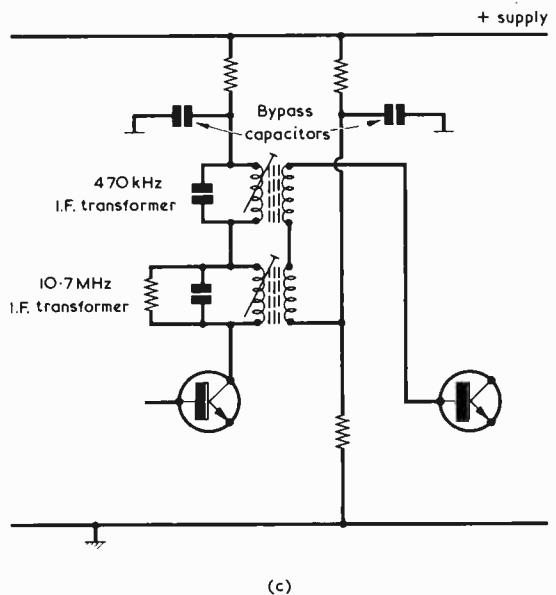
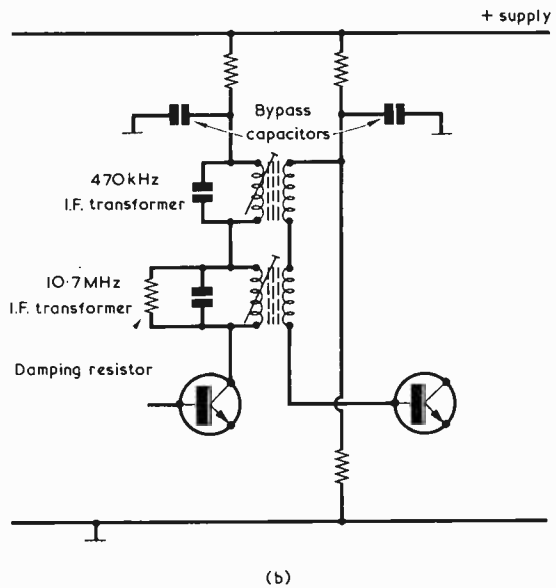
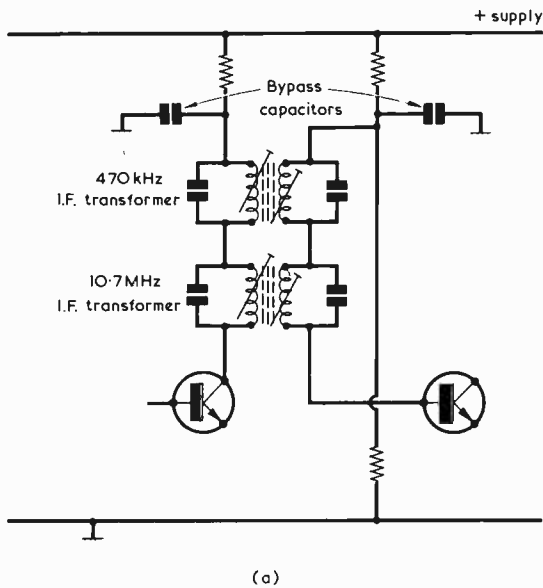

Fig. 1. Three basic methods of connecting in series the f.m. and a.m. i.f. transformers between i.f. transistors in a.m.-f.m. receivers. The circuit in (a) tends to appear in earlier receivers, and those in (b) and (c) in more recent sets. Frequently, connections may be made to part of a tuned winding via a tap instead of to the complete winding. (It should be noted that a number of receivers have the positive supply line connected to chassis instead of the negative line, as is assumed, for ease of explanation, in these and subsequent diagrams)

in series. A common practice nowadays consists of having a single tuned primary circuit in either one or both of the i.f. transformers with, usually, a damping resistor of some 2.5 to 6kΩ across the 10.7MHz primary."

Smithy indicated the second of his drawings (Fig. 1 (b)), then pointed to the third (Fig. 1 (c)).

"And here," he added, "is another variation, in which the primary of the 10.7MHz transformer is, as with the other circuits, closer to the collector of the first transistor, whilst the secondary of the 470kHz transformer is closer to the base of the second transistor."

### F.M. OVERLOAD DIODE

"Do these alternative circuits work in just the same way?" asked Dick.

"Oh yes," said Smithy. "The untuned secondary of the 10.7MHz transformer offers negligible impedance to 470kHz signals. On the other hand, the inductance of the untuned secondary on the 470kHz transformer can offer an appreciable reactance at 10.7MHz. However, its self-capacitance helps to bring its overall impedance down to a sufficiently low level for the circuit to function satisfactorily in practice at 10.7MHz."

"Are there any further variations on these circuits?"

"There are a few minor ones," replied Smithy. "For instance, as I mentioned just now, you may have one of the transformers in a pair single-tuned and the other double-tuned, and things like that. Also, some of the i.f. transformers may consist of a tuned primary and a tuned secondary in separate cans, these being joined by a low-value capacitor or an inductive link. But you'll find that the basic idea of having two i.f. transformers in series remains the same. One thing I haven't shown is that there is nearly

## Your Local Supplier

LONDON

Established 1910

### H. L. SMITH & CO. LTD.

Comprehensive stocks of  
components by  
all leading makers

287-9 EDGWARE ROAD  
LONDON W.2

Tel: 01-723 5891

### THE MODERN BOOK CO.

Largest selection of English &  
American radio and technical  
books in the country.

19-21 PRAED STREET,  
LONDON, W2 1NP  
Tel: 01-723 4185/2926

## ST. HELEN'S RADIO

Hi-Fi Equipment  
Tape Recorders  
Radio Receivers  
Television

SPECIALISTS IN RADIO  
& ELECTRONIC TEXTBOOKS

ST. HELENS GARDENS  
LONDON, W.10  
Tel: 01-969 3657

NEW

## 15 watt Hi-Fi £3.75 plus 25p postage each

### AMPLIFIERS

7 TRANSISTORS - GUARANTEED  
PRINTED CIRCUIT - TESTED  
DESIGN BUILT - INSTRUCTIONS

A great new 15 watt Hi-Fi amplifier is now available at the low cost of £3.75. Just look at the specification—Power 15 Watts R.M.S., frequency response 15-19000 c/s. Signal to noise ratio better than 70 db. Harmonic distortion 0.1%. Input sensitivity 750 mv into 2k. These make the H. Electronics Hi-Fi amplifier the best at its price—order now.

## H. ELECTRONICS.

105, Grange Road, London, S.E. 25

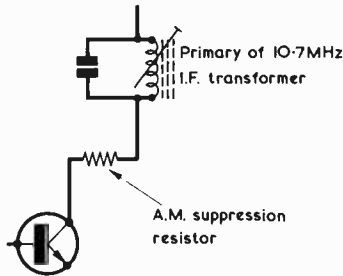

Fig. 2. It is common practice to insert a series resistor immediately after the collector of i.f. transistors in order to reduce the effect of a.m. interference

always a series fixed resistor immediately following the collector which feeds the i.f. transformers, this having a value of the order of 100Ω to 1kΩ."

Smithy scribbled in the resistor on his first circuit diagram. (Fig. 2.)

"What does that resistor do?"

"It reduces the effect of a.m. interference when you're on f.m.," replied Smithy. "It can be helpful, for instance, with impulsive interference such as is given by poorly suppressed car ignition systems. Another dodge you'll encounter occasionally is given by the addition of a point-contact germanium diode across a 10.7MHz i.f. transformer primary in an early i.f. stage of the receiver."

Smithy sketched out a circuit incorporating the diode. (Fig. 3.)

"That diode," he continued, "is included to prevent f.m. overload. If a very strong f.m. signal is received it causes the diode to conduct and to limit the amplitude of the signal."

Smithy stopped and turned to look at his assistant.

"All right so far?" he asked.

"Oh, definitely," replied Dick promptly. "I can see quite clearly now how an i.f. amplifier stage can

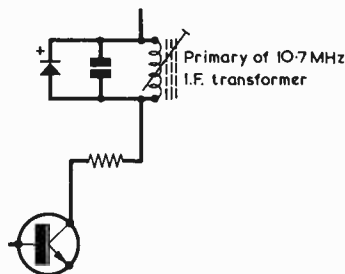

Fig. 3. In some receivers a germanium point-contact diode is connected across the primary of an early 10.7MHz i.f. transformer. The diode prevents overloading by strong f.m. signals

handle both the 470kHz and 10.7MHz intermediate frequencies. I'm not too certain, though, about the overall stage line-up of the complete a.m.-f.m. receiver."

"Then we'll deal with that next," pronounced Smithy, "with the aid of a few block diagrams. After having understood the points we've been talking about up to now you should be able to picture quite easily what each block stands for."

The Serviceman paused for a moment to collect his thoughts, then picked up his pen again.

"It's a little difficult to know where to start here," he confessed. "As I said at the beginning there is rather a wide variance in design between manufacturers of a.m.-f.m. receivers so far as the stage sequences they use for the i.f. section are concerned. I think my best plan will be to show you the two most frequently employed line-ups you're likely to encounter, and these will give you a good insight into the whole business. Here's the first line-up."

Smithy completed a drawing he had started whilst he was talking. (Fig. 4 (a).)

"This will do to commence with," he announced. "At the left hand end of the drawing you have the f.m. front-end, which obtains a supply from the receiver battery on f.m. only. It has an output at 10.7MHz which goes through a 10.7MHz i.f. transformer and, via a second section of the receiver a.m.-f.m. switch, to the a.m. mixer-oscillator transistor. On f.m. this transistor is uncoupled from the a.m. aerial and oscillator tuned circuits, and it functions as the first 10.7MHz i.f. amplifier, its output feeding into the 10.7MHz i.f. transformer which follows it. When the set is switched to a.m., the transistor is disconnected from the first 10.7MHz i.f. transformer and couples into the a.m. aerial and oscillator circuits, which will include the usual ferrite rod aerial coil or coils. The transistor then passes a 470kHz output into the first 470kHz i.f. transformer. The secondaries of the 10.7MHz and 470 kHz i.f. transformers are in series, and these couple into the i.f. amplifier transistor which follows them. This transistor, in turn, works into another pair of series-connected 10.7MHz and 470kHz i.f. transformers. These couple to a further i.f. amplifier transistor, which then feeds into the 10.7MHz ratio discriminator and 470kHz a.m. detector or circuits. The outputs of these are selected by another section of the overall a.m.-f.m. switch and are then passed to the a.f. stages of the receiver."

### ALTERNATIVE LINE-UP

"There's quite a bit of gubbins in that lot, isn't there?" remarked Dick.

"There is," agreed Smithy. "In fact, a fairly respectable bit of circuitry is involved. Now, let me show you a different approach."

He bent over his note-pad and

THE RADIO CONSTRUCTOR

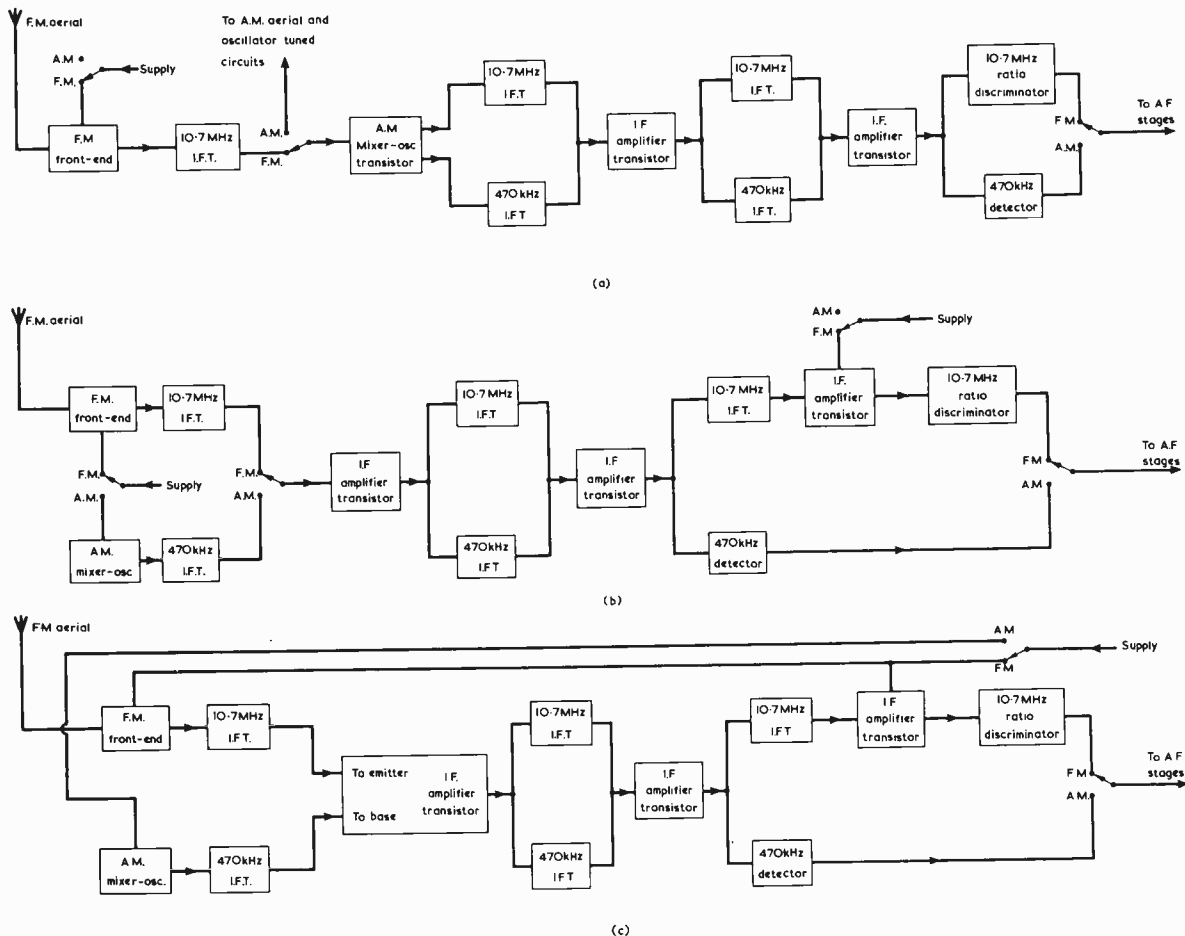

Fig. 4 (a) A common stage line-up employed in a.m.-f.m. receivers  
 (b) Another frequently used line-up  
 (c) A line-up, incorporated in some Pye receivers, which requires very simple a.m.-f.m. switching circuits

produced a further sketch. (Fig. 4 (b).) "This is another basic line-up," he remarked, pointing to the drawing. "Once again we have the f.m. front-end at the left, this working into the first 10.7MHz i.f. transformer. The a.m. mixer-oscillator is also at the left, and this feeds into the first 470kHz i.f. transformer. Either the f.m. front-end or the a.m. mixer-oscillator is brought into operation by applying the supply to it via a section of the receiver a.m.-f.m. switch. Another section of the a.m.-f.m. switch selects the outputs of the 10.7MHz and 470kHz i.f. transformers and applies them to the first i.f. amplifier transistor. This couples into a pair of series-connected 10.7MHz and 470kHz i.f. transformers which, in turn, couple into the next i.f. amplifier transistor. This feeds into a 10.7MHz i.f. transformer and into the 470kHz detector circuit. The 10.7MHz i.f. transformer works into a further i.f.

amplifier transistor, which is only switched into circuit on f.m., and thence into a 10.7MHz ratio discriminator circuit. The outputs of the 470kHz detector circuit and the 10.7MHz ratio discriminator circuit are, as before, selected by a section of the a.m.-f.m. switch, and they then pass on to the receiver a.f. stages." "I see," said Dick, gazing closely at Smyth's drawings. "I note, incidentally, that in both cases there are three transistors in the 10.7MHz i.f. amplifier chain and only two in the 465kHz i.f. amplifier chain." "That's right," agreed Smyth. "You need a bit more i.f. gain with the 10.7MHz signal than you do with the 470kHz one. Incidentally, I've been talking all the time about sections of the receiver a.m.-f.m. switch. Actually, there won't be a separate a.m.-f.m. switch as such, and the a.m.-f.m. switching will be controlled by the

wave-change buttons. These will, in most instances, simply select long waves, medium waves and v.h.f." Smyth looked again at the two block diagrams he had drawn. "Most of the a.m.-f.m. sets you'll encounter," he went on, "will have a stage line-up similar to one of the two I've just shown you. There's one interesting variant on the second one, incidentally, and it goes like this." Smyth tore the top sheet from his pad and drew out a further diagram. (Fig. 4 (c).) "This is much the same as the second one I showed you," he said, "but there is a difference in the manner in which the f.m. front-end and the a.m. mixer-oscillator couple into the first common i.f. amplifier. Both have their separate first i.f. transformer, and the 10.7MHz one couples into the emitter of the first common i.f. amplifier transistor whilst the 470kHz one

## Your Local Supplier

HAMPSHIRE

### BOURNEMOUTH

LARGEST HI-FI AND  
RADIO COMPONENT  
STORE IN THE SOUTH

FORRESTERS NATIONAL  
RADIO SUPPLIES LTD.

70-72 Holdenhurst Road

Bournemouth

Telephone 25232

NOTTINGHAM

### ARE YOU LOST FOR THAT VITAL SCREW?

0-8 BA screws, nuts & washers in  
Brass.

Copper, brass & aluminium sheet  
cut to your requirements.

Electric soldering irons & bits.

S.A.E. List.

Callers to our trade counter  
welcome.

Hours 8.30-5.00 Mon-Fri.

8.30-12.00 Sat.

The D.Q. Engineering Co. Ltd.,  
Kirkby Folly Road, Junction Mills,  
Sutton-in-Ashfield, Notts.  
Telephone Sutton-in-Ashfield 5785

SUSSEX

### E. JEFFRIES

For your new television set  
tape recorder, transistor radio  
and hi-fi equipment

PHILIPS, ULTRA, INVICTA  
DANSETTE, MASTERADIO, PERDIO,  
MARCONI, PHILCO FIDELITY

6A Albert Parade  
Victoria Drive,  
EASTBOURNE SUSSEX

YORKSHIRE

### WILSIC ELECTRONICS LTD.

Your local supplier for  
EAGLE PRODUCTS  
CYBERNAT MOTORING AIDS  
WILSIC HI-FI, MUSICAL  
EQUIPMENT, KITS, AND  
COMPONENTS

OUR CATALOGUE FREE  
Postage 5p

Eagle Products Catalogue  
Postage 5p

6 COPLEY ROAD  
DONCASTER

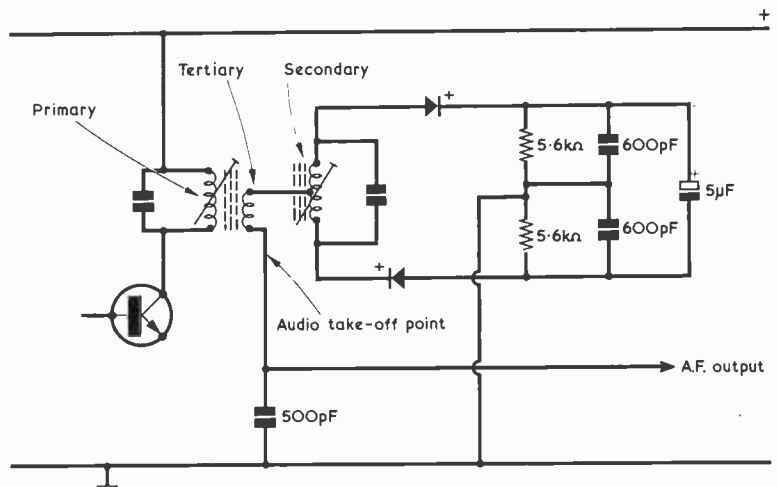

(a)

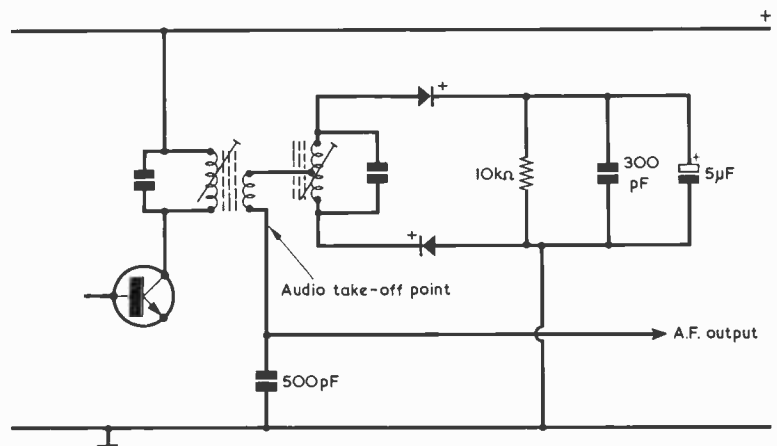

(b)

Fig. 5 (a) The basic balanced f.m. ratio discriminator circuit with representative component values

(b) The unbalanced version of the ratio discriminator. Component values are again representative

couples into the base of that transistor. The result is that the f.m.-a.m. switching is delightfully simple. All that is needed is one switch pole to switch the supply between the f.m. front-end and the a.m. mixer-oscillator, and another switch pole to select the output of the f.m. ratio discriminator or the a.m. detector. There is no necessity for the f.m.-a.m. switching to enter the i.f. signal circuits at all."

#### RATIO DISCRIMINATOR

"Blimey," remarked Dick, impressed. "That is neat. Incidentally, you haven't dealt with the a.m. detector and f.m. discriminator circuits yet. How about those?"

"Well," replied Smithy, "the a.m. detector section in these sets is pretty straightforward and uses a single

diode in normal fashion. However, the ratio discriminator circuit in more recent receivers is rather different from the earlier ones we used to play with in the past and it mightn't be a bad idea to make this the next subject to deal with."

"The main thing I remember about f.m. ratio discriminators," remarked Dick, "is that the discriminator transformer has what is described as a tertiary winding. That word 'tertiary' used to worry me no end until someone told me that it was only a posh word meaning 'third'!"

Smithy chuckled.

"Some of the terms in electronics can be a bit off-putting at first," he agreed. "At any event, and to do a bit of recapping, we need to remember that the basic type of ratio discriminator transformer used to have a

THE RADIO CONSTRUCTOR

primary winding, a secondary winding and that tertiary winding which puzzled you, and it appeared in a circuit like this."

Smithy drew out a ratio discriminator circuit on his note-pad. (Fig. 5 (a).)

"Here are your three windings," he remarked. "The primary, the secondary and the tertiary. You'll notice that the signal voltage causes the electrolytic capacitor following the diodes to charge up and this is what gives the ratio detector its inherent a.m. limiting action. If the signal voltage goes up, further current has to flow into the electrolytic capacitor to charge it to the increased voltage. This causes damping of the tuned windings with the result that the increase in signal voltage becomes largely nullified. Similarly, if signal voltage goes down, less charging current has to flow into the electrolytic capacitor and the tuned windings exhibit a higher effective Q, thereby largely compensating for the drop in signal voltage."

"I get it," exclaimed Dick. "Really, I suppose, the tuned windings are damped all the time by the resistance connected across the electrolytic capacitor. If signal voltage goes up, the windings are further damped by the charging current which flows in the electrolytic capacitor, and if signal voltage goes down the windings are less damped."

"That's the idea," said Smithy. "When a ratio detector circuit is set up accurately it gives a surprisingly high level of a.m. limiting. The circuit I've just shown you, by the way, is known as the 'balanced' type of ratio discriminator because of the chassis centre-tap into the resistance across the electrolytic capacitor. When the signal fed to this type of discriminator is at the centre frequency, the output voltage at the audio take-off point is at chassis potential. If the signal frequency is changed in one direction the audio take-off point goes positive of chassis, and if the signal frequency is changed in the other direction the audio take-off point goes negative of chassis. Which is, of course, the result of the circuit's ability to convert changes of frequency to changes of voltage."

"If," put in Dick, "there is a balanced ratio discriminator, can you have an unbalanced one, too?"

"Oh yes," confirmed Smithy. "I'll show you a simple version of the unbalanced ratio discriminator next."

Smithy busied himself once more with his pen, and produced the new circuit. (Fig. 5 (b).)

"Here we are," he remarked. "This is basically the same as the balanced circuit, but the chassis now connects to one end of the electrolytic capacitor and the resistance across it. Since there is no resistive centre-tap, the circuit saves a resistor. It also saves one of the two low-value capacitors across the electrolytic since, for symmetry in the balanced circuit, two equal low-value

capacitors were placed across the electrolytic with their junction coupling to chassis."

"Do you really need the single low-value capacitor across the electrolytic in the unbalanced version? Wouldn't the electrolytic be sufficient on its own?"

"You could use it on its own," replied Smithy, "but it would be better to leave the lower value capacitor in circuit as well. The latter will normally be a mica or a ceramic component and it will offer a better performance at signal frequency. The unbalanced f.m. discriminator functions in the same manner as the balanced type with the exception that, at centre frequency, the audio take-off point is not at chassis potential but is at a potential which is half of that developed across the electrolytic capacitor. The audio take-off point then goes positive and negative of that potential as the signal frequency varies on either side of the centre frequency."

"Are the more recent ratio discriminator circuits you mentioned just now balanced or unbalanced?"

"You get both types," said Smithy. "It will probably be easier if I start off by showing you an unbalanced type, so here goes."

Yet again, Smithy's pen moved briskly over his pad as he sketched out a further circuit. (Fig. 6 (a).)

"It looks," remarked Dick, as he examined Smithy's sketch, "as though the discriminator transformer in this new version of the circuit is split up into two separate sections."

"It is," confirmed Smithy. "What you now have is the primary in one screening can and the secondary in a second screening can. I've marked the individual windings L1 to L4 and, if you examine the circuit, you'll see that it's a fairly obvious development from the earlier type of unbalanced ratio detector. Winding L1 is the same as the original primary and it couples via the series capacitor and L3 to L4, the latter being the same as the original secondary. The centre-tap in L4 connects back to L2, which is the same as the old tertiary winding. The audio take-off point is then given at the lower end of L2."

"This new circuit," remarked Dick, "seems to be pretty well the same as the old one. All that's happened is that the primary and secondary windings have been shifted into separate cans."

"Exactly," confirmed Smithy. "Apart from any other advantages the new circuit may have, it makes it possible to control the inductive coupling between the primary and secondary a little more precisely than in the earlier circuit, where all the windings were on one former. When, in the later circuit, you set up the cores in L1 and L4, the core in L1 is adjusted for maximum voltage across the electrolytic capacitor at the centre signal frequency, and the core in L4 is adjusted so that the potential at the

## Your Local Supplier

YORKSHIRE

**PERFECT SPEAKERS** Ex TV.  
P.M. 3 Ohm (Minimum order 2)  
5in. Round or 8in. x 2½in. 12½p each  
Add 7½p per speaker p & pkg.

100 SPEAKERS for £15 delivered  
200 SPEAKERS for £25 delivered

**UHF TUNERS** Ex TV.  
(COMPLETE WITH VALVES)  
£2.50 each plus 50p p. & pkg.  
or 10 for £23 post free

**TRADE DISPOSALS** (Dept. RC)  
Thornbury Roundabout, Leeds Road,  
Bradford Telephone: 665670

EIRE

## PEATS for PARTS

**ELECTRONIC COMPONENTS  
RADIO & TELEVISION**

*For the convenience of Irish  
enthusiasts we supply*

The Radio Constructor  
Data Books and  
Panel-Signs Transfers

*Also a postal service*

**Wm. B. PEAT & Co. Ltd.**  
28 PARNELL STREET  
DUBLIN 1

*The*  
**RADIO CONSTRUCTOR**

**ANNUAL  
SUBSCRIPTIONS**

**to this magazine  
may be obtained  
through your  
newsagent  
or direct from the  
publishers  
ONLY £2.70  
per year, post free**

*Please send remittance with name  
and address and commencing issue  
required to:*

**DATA PUBLICATIONS LTD**  
57 Maida Vale London W9 1SN



# Mullard

## TECHNICAL BOOKS

### Mullard Data Book 1971/2

Gives Mullard abridged data in valves, picture tubes, semi-conductors and components etc. Index in colour. Including postage 35p

### Transistor Audio & Radio Circuits

For radio receivers, radiograms, record players, tape recorders, hi-fi equipment, fm, tuners and audio amplifiers. 204 pages illustrated. Including postage £1.60

### Semiconductor Devices

This book is an introduction to Semiconductor Electronics and its contents should be readily understood. The subject is treated non-mathematically. Numerous illustrations and diagrams. Including postage 42p

### A Programmed Book on Semiconductor Devices

This book is an integral programme which is a form of self instructional text. Fully illustrated. Including postage 70p

### 20 Electronic Experiments

Contents: Double beam simulator - IM/V meter - E.H.T. supply - Amplifier/oscillator - Transistor power supply - Electrometer - Scaler - Hall effect - AF/RF oscillator - Logic gates - Organ - etc. 74 pages illustrated. Including postage 70p

### Electronic Counting: Circuits, Techniques, Devices.

This book is intended to help engineers use electronics in solving their counting problems. 240 pages illustrated. Including postage £1.50

### Power Engineering using Thyristors

Volume 1. Techniques of Thyristor Power Control. Covers the latest power control technique using semi-conductor devices. 240 pages illustrated. Including postage £1.60

Post now to:  
**SELRAY BOOK  
COMPANY**  
60 Hayes Hill Bromley  
BR2 7HP

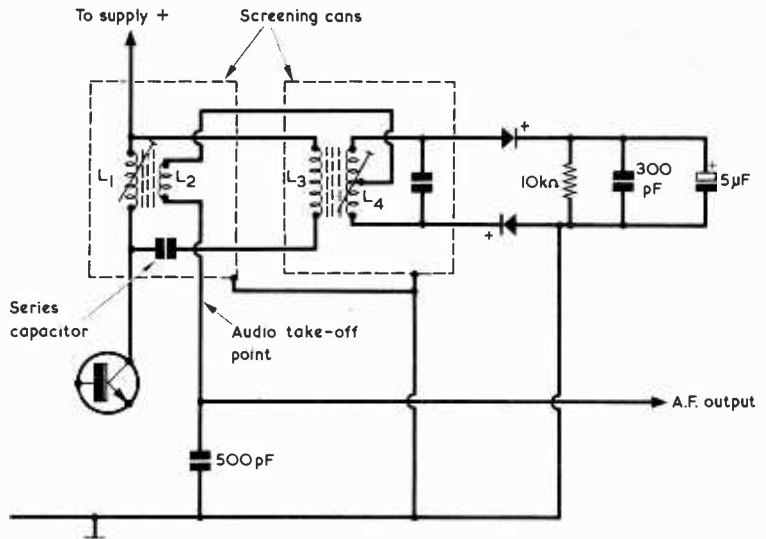

(a)

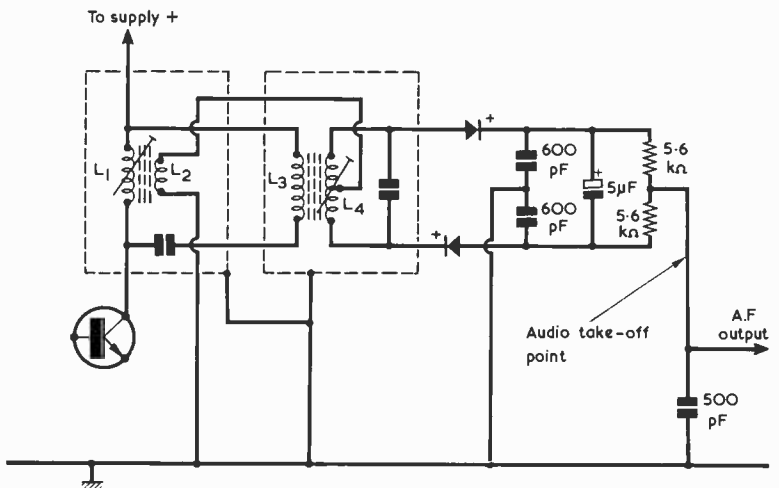

(b)

Fig. 6 (a) A modern version of the unbalanced ratio discriminator of Fig. 5(b). Here, and in (b), components have the same representative values as their counterparts in Fig. 5  
Fig. 6 (b) A commonly-encountered version of the basic balanced discriminator circuit. In some circuits, the junction of the two equal-value resistors across the electrolytic capacitor connects to chassis, and the audio take-off point appears at the lower end of L2

audio take-off point is half that across the electrolytic capacitor."

"That all seems fair enough," remarked Dick. "Now, what about the new version of the balanced ratio discriminator?"

"I'm drawing it out for you right now," replied Smithy. "I'll be able to show it to you in a jiffy."

Several moments later, Smithy

indicated the balanced ratio discriminator circuit to Dick. (Fig. 6 (b).)

"There's something fishy here," said Dick suspiciously. "For a start, the old audio take-off point is now going to chassis."

"Forget that for the moment," advised Smithy, "and just compare the circuit with the one for the unbalanced discriminator. We have the same

THE RADIO CONSTRUCTOR

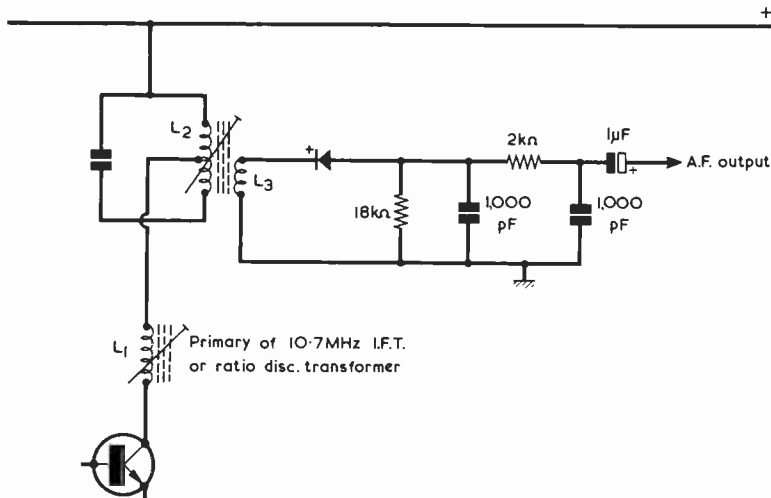

Fig. 7 Simplified circuit illustrating the a.m. detector stage of an a.m.-f.m. receiver

arrangement with windings L1, L2, L3 and L4, and since this is now a balanced discriminator circuit, the electrolytic capacitor has two equal value resistors connected across it to give a resistive centre-tap. Now, as with the earlier balanced ratio discriminator, this centre-tap could connect to chassis and you could get an audio take-off from the lower end of L2. Indeed, this arrangement is used in quite a few sets. But it is more common practice to connect the lower end of L2 to chassis and to take the audio from the resistive centre-tap. All you're doing, then, is to move the reference chassis connection from the resistive centre-tap to the lower end of L2. Got it?"

"Yes, I see what you mean," said Dick, frowning. "I assume that, when this particular circuit is set up, the audio take-off point from the resistive centre-tap is still at chassis potential when the input is at centre frequency."

"It is," confirmed Smithy. "You set up L1 for maximum voltage across the electrolytic capacitor and L4 for chassis potential at the new audio take-off point when a central input frequency is injected. The balanced version of the discriminator circuit is always employed in receivers having automatic frequency control, because the control voltage then swings positive or negative of chassis as receiver tuning is taken either side of the correct position. You'll remember we talked quite a bit about automatic frequency control during our last session."

"Do you," asked Dick, "get any variations in practice from the two discriminator circuits you've just shown me?"

"You'll find a few minor ones," replied Smithy. "For instance, the series capacitor between L1 and L3 is sometimes omitted, and L3 connects

directly across part of L1. Or, again, L1 and L3 are in series. But these are simply variations on a readily recognisable basic circuit."

#### A.M. DETECTOR

"Well, that's fine," said Dick enthusiastically. "There's only one point on these a.m.-f.m. receivers you haven't covered, and that's the a.m. detector circuit itself."

"The a.m. detector circuit won't take long to deal with," commented Smithy. "This part of the set is pretty simple."

For the last time that day, Smithy busied himself at his note-pad to produce his final circuit diagram. (Fig. 7.)

"This is the a.m. detector bit," he announced, pointing at the drawing. "If the receiver has the stage line-up I showed you in the first of my block diagrams, coil L1 here is the primary of the ratio discriminator transformer. And, if the receiver line-up is the same as my second block diagram, coil L1 is the primary of the last 10.7MHz i.f. transformer. The collector of the transistor couples via L1 to a tap in L2, which is tuned to 470kHz. The coupling coil L3 then feeds the a.m. detector diode which, in most receivers, also produces an a.g.c. voltage for a.m. operation as well. And that's all there is to it!"

"Blimey, Smithy," said Dick appreciatively. "You've really given me some useful gen on these a.m.-f.m. sets today. I shan't even ask you any more questions about them!"

"Is that a promise?"  
"Only for the time being," said Dick cheerfully. "I wouldn't be at all surprised to find that I have a few questions to ask you on something quite different in the very near future!"



Newest, neatest system ever devised for storing small parts and components: resistors, capacitors, diodes, transistors, etc. Rigid plastic units, interlock together in vertical and horizontal combinations. Transparent plastic drawers have label slots/handles on front. Build up any size cabinet for wall, bench or table top.

#### BUY AT TRADE PRICES!

Single units (1D) £1.35 per dozen, size approx. (2½" high, 2½" wide 5" deep) 2D £2.25 per dozen. 3D £2.35 for 8 units. 6D2 £3.65 for 8 units (2 3D's in 1 outer) 6D1 £3.30 for 8 units. Postage/Carriage 35p for orders under £5. Carriage paid for orders over £5.

#### PLUS QUANTITY DISCOUNTS!

Orders £5 and over DEDUCT 5% in the £  
Orders £10 and over DEDUCT 7½% in the £  
Orders £20 and over DEDUCT 10% in the £  
QUOTATIONS FOR LARGER QUANTITIES



**TMK 500**  
multi-meter  
30,000 ohms  
per volt D.C.

Mirror Scale

**ONLY £8.75**  
Plus p & p 24p.

- D.C. Volts. 0.25, 1, 2.5, 10, 25, 100, 250, 1000.
- A.C. Volts. 2.5, 10, 25, 100, 250, 1000.
- D.C. Current. 0.05, 5, 50, 500 mA and 12 Amps.
- Resistance 0-60k, 0-6megohms, 0-60 megohms. (mid scale 350, 35k & 350k)
- Decibels -20 to +56 db. (0db = 1mW 600 ohms.)
- Continuity Test. Internal buzzer.
- Size 6½" x 3½" x 2½"
- Complete with pair of heavy test leads.

**NEW MINI**  
**MULTI-TESTER**  
11 Scales

Volts, Amps, Ohms  
POCKET SIZE ONLY

**£2.25** Plus 15p  
p. & p.

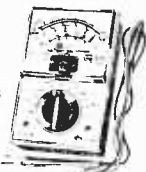

- ★ 1,000 ohm/volt
- ★ D.C. volts: 10, 50, 250, 1,000
- ★ A.C. volts: 10, 50, 250, 1,000
- ★ D.C. amps: 0-1-100mA
- ★ Resistance: 0-150Kohms
- ★ Size: 3½" x 2½" x 1"
- ★ Complete with test leads and battery

**IVORYET**  
LIMITED

Dept. RC3, 124  
Cricklewood Broadway,  
London, N.W.2  
Tel. 01-450 4844

# COMPONENT FACTORS DEPT. RC P.O. BOX No. 18, LUTON, BEDS. LU1 1SU

ALL GOODS BRAND NEW AND GUARANTEED BARGAIN PRICES DELIVERY BY RETURN

DIODES IDEAL FOR BATTERY CHARGER, ETC 100V 20A 50p		TRANSISTORS		INTEGRATED CIRCUITS		HUNTS M.E.F. RANGE		TUNNEL DIODES		CERAMIC		ELECTROLYTIC		Phono Plug 10p Phono Socket 5p Mains Transformer 32-0-32 at 150mA 50p Mains Transformer 150V at 20mA 5p at 550mA 75p Black Knob with Silver Disc 1/2 in. hole 5p	
SEND US YOUR PARTS LIST FOR A FREE QUOTATION WE HAVE THOUSANDS OF COMPONENTS NOT LISTED INCLUDING THE FOLLOWING CAPACITORS SILVER MICA POLYESTER POLYCARBONATE AND TANTALUM ALL AT LOW PRICES		2N 706 10p 2N 708 10p 2N 709 25p 2N 1671B (UJ) 80p 2N 1303 10p 2N 2904 25p 2N 3820 (FET) 50p 2N 3866 80p 8C 108 10p 8CV 30 20p 8CV 70 10p BFY 51 10p BFX 87 15p BSX 21 12p BSX 60 50p C 111 30p C 407 20p C 426 12p E 100 (FET) 50p ME 1120 10p P346A 8p V 405A 10p TIS 59 30p BFY 56 40p		MC 790P 80p MC 849P 35p MC 1027P £2.00 SN 7400N 15p SN 7410N 15p SN 7410N 15p SN 7410N 15p FJH 121 15p SN 7430N 15p SN 7440N 25p SN 7470N 30p SN 7493N 80p FJH 111 12p FJH 131 20p FJH 151 12p FJH 221 20p FJJ 121 30p 958 Decade £1.75		16 MFD 350V 10p 100 MFD 50V 10p 500 MFD 50V 12p 1000 MFD 12V 12p 2500 MFD 6V 10p 2500 MFD 12V 12p Transistor Equivalents Book 40p Collins Radio Co-axial Relays £3.00 Miniature Ceramic (Lemco All 750V) ± 10% 5PF, 10PF, 20PF, 25PF, 40PF, 75PF, 100PF, 120PF, 220PF. Price: 2/p each or 10 for 20p (same value)		1N 3717 £1.00 TD 715 50p TD 716 40p TD 717 50p 3V3 BZY 88C 10p 3V9 BZY 88C 10p 4V3 BZY 88C 10p 5V1 MZ5-115 10p 5V6 1N752A 15p 5V8 BZY 96C 15p 7V5 BZY 96C 15p 10V K542 10p 13V BZY 94C 15p 20V BZX 22 12p 24V BZY 88C 12p 39V 1N 5259 15p		1PF 500V 2p 270PF 50V 2p 0.0047 30V 2p 0-01 30V 3p 0-01 350V 2p 0-022 30V 2p 0-047 30V 2p 0-1 Disc 100V 2p 1-5-8PF Trimmer 2p 0.1µF 25V Disc 3p 3V3 BZY 88C 10p 3V9 BZY 88C 10p 4V3 BZY 88C 10p 5V1 MZ5-115 10p 5V6 1N752A 15p 5V8 BZY 96C 15p 7V5 BZY 96C 15p 10V K542 10p 13V BZY 94C 15p 20V BZX 22 12p 24V BZY 88C 12p 39V 1N 5259 15p		6-4MFD 25V 3p 84MFD 64V 5p 75MFD 25V 5p 220MFD 40V 10p 100MFD 6V 5p 1000MFD 50V 40p Miscellaneous P.V.C. Wire 50p 14/0076 100 yd. Or 1p per yard. Miniature R.F. chokes 0-22, 1, 1.5, 2.2, 12, 15, 22 µH 8p each Neon lamp A230. 5 for 20p 1/4W 5% carbon film resistors 10Ω-1M. 12, 1p Each or 10-25 0.8p 26-50 0.8p		Electrolytic Mullard C426 Range 1 MFD 40V 4p 4 MFD 40V 4p 8 MFD 40V 4p 10 MFD 16V 4p 16 MFD 40V 4p 32 MFD 10V 4p 40 MFD 16V 4p 50 MFD 6-4V 4p	
SILVER MICA 5PF 10% 500V 5p 10PF 5% 350V 8p 22PF 5% 350V 10p 27PF 5% 350V 10p 33PF 5% 350V 10p 47PF 5% 350V 10p 82PF 1% 500V 5p 75PF 5% 350V 10p 270PF 5% 350V 10p 320PF 5% 350V 8p 390PF 1% 500V 5p 500PF 5% 200V 18p 820PF 1% 500V 5p 2000PF 5% 200V 40p 4700PF 5% 50V 30p														Miscellaneous P.V.C. Wire 50p 14/0076 100 yd. Or 1p per yard. Miniature R.F. chokes 0-22, 1, 1.5, 2.2, 12, 15, 22 µH 8p each Neon lamp A230. 5 for 20p 1/4W 5% carbon film resistors 10Ω-1M. 12, 1p Each or 10-25 0.8p 26-50 0.8p	

TERMS: CASH OR CHEQUE WITH ORDER. POST AND PACKING FREE ON ORDERS ABOVE £5. FOR SMALLER ORDERS PLEASE ADD 10p. DISCOUNT: ORDERS ABOVE £10-10%, ABOVE £20-15%. ALL GOODS ADVERTISED ARE TOP GRADE PROFESSIONAL COMPONENTS AND SUBJECT TO A MONEY REFUND GUARANTEE IF NOT SATISFIED. WE HAVE MANY COMPONENTS NOT ADVERTISED. AND ENQUIRIES ARE WELCOME, BUT MUST ENCLOSE AN S.A.E. FOR REPLY. PRICES LIST 5p. TRADE ENQUIRIES WELCOME.

## HANDIPAK

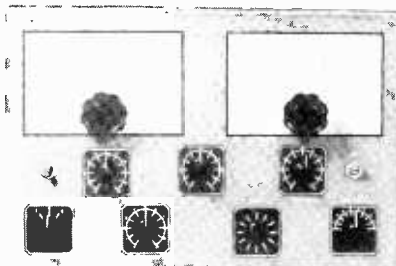

- Easy to fix
- Permanent and durable
- Stapled in booklet form
- Designed to hang above workbench
- Pocket for loose cuttings
- Professional finish

The Perfect Transfer for the Home Constructor

Each Set contains Six Sheets

## PANEL SIGNS

IDEAL FOR WORKSHOP USE

- ★ SET 3 - Wording - WHITE
- ★ SET 4 - Wording - BLACK (Over 1,000 in each set)
- Illustration of actual size = RADIO
- ★ SET 5 - DIALS (control panels have clear background)
- ★ SET 6 - DIALS (control panels have black background)

Frequency Lists in kHz and MHz.

**25p per set**  
(postage 2½p)

To: Data Publications Limited, 57 Maida Vale, London, W9 1SN.

Please supply PS3....., PS4....., PS5....., PS6.....

I enclose cheque/crossed postal order for.....

NAME.....

ADDRESS.....

(BLOCK LETTERS PLEASE)

# SMALL ADVERTISEMENTS

Rate: 4p (9d) per word. Minimum charge 60p (12/-).  
Box No. 10p (2/-) extra.

Advertisements must be prepaid and all copy must be received by the 4th of the month for insertion in the following month's issue. The Publishers cannot be held liable in any way for printing errors or omissions, nor can they accept responsibility for the *bona fides* of advertisers. (Replies to Box Numbers should be addressed to: Box No. —, *The Radio Constructor*, 57 Maida Vale, London, W9 1SN)

**SERVICE SHEETS (1925-1971)** for Televisions, Radios, Transistors, Tape Recorders, Record Players, etc., by return post, with free Fault-Finding Guide. Prices from 5p. Over 8,000 models available. Catalogue 13p. Please send S.A.E. with all orders/enquiries. Hamilton Radio, 54 London Road, Bexhill, Sussex. Telephone: Bexhill 7097.

**CHROMASONIC ELECTRONICS:** Potentiometers log or Lin Single less switch 12p. W/Switch 24p. Dual L/S 40p. W/S 52p. SL403D £1.50. F.M. Stereo modules as previously. 1/4 watt 5% hi-stabs, now 1p each less 25% for 100 or more mixed, or 33 1/3% for 100's of same type. New 1972 Catalogue 20p post free. 56 Fortis Green Road, London, N10 3HN.

**RECORD TV SOUND** using our loudspeaker isolating transformer. Provides safe connection to recorder. Instructions included. £1 post free. Crowborough Electronics (R.C.), Eridge Road, Crowborough, Sussex.

**NEW CATALOGUE NO. 18**, containing credit vouchers value 50p, now available. Manufacturers new and surplus electronic and mechanical components, price 23p post free. Arthur Sallis Radio Control Ltd., 28 Gardner Street, Brighton, Sussex.

**FOR SALE:** Creed Teletax transceiver type TR 105, £15. Ex-R.A.F. tuning fork drive unit type 114, £12. Box No. G167.

**BUILD IT in a DEWBOX** robust quality plastic cabinet 2 in. x 2 1/2 in. x any length. S.A.E. for details. D.E.W. Ltd., 254 Ringwood Road, Ferndown, Dorset. Write now - right now.

**WANTED:** 9.5mm cine equipment. Cameras, projectors, editors, splicers, film reels, etc. Details to: Box No. G169.

**MINI MAINS TRANSFORMER.** Robust, yoked, flying leads, 30 x 30 x 37mm, 0-230-250V to 7-0-7V rms, 120mA (9V rect. d.c.). Only £0.70, UK post 5p. Amatron Ltd., 396 Seisdon Rd., S. Croydon, Surrey CR2 0DE.

**POSTAL ADVERTISING?** This is the Holborn Service. Mailing lists, addressing, enclosing, wrapping, facsimile letters, automatic typing, copy service, campaign planning, design and artwork, printing and stationery. Please ask for price list. - The Holborn Direct Mail Company, Capacity House, 2-6 Rothsay Street, Tower Bridge Road, London, S.E.1. Telephone: 01-407 1495.

**"GOVERNMENT SURPLUS WIRELESS EQUIPMENT HANDBOOK."** Contains circuits, data, illustrations, components lists for British/U.S.A. receivers, transmitters, trans/receivers; includes modifications to sets and test equipment. Surplus/commercial cross-referenced transistor and valve guide. A gold mine of valuable information. Price £2.84. P. & P. 16p. Myers, (R), 112 Stainburn Crescent, Leeds 17, Yorks.

(Continued on page 509)

## BENTLEY ACOUSTIC CORPORATION LTD.

38 Chalcot Road, Chalk Farm      The Old Police Station  
LONDON, N.W.1.      Gloucester Road  
01-722-9090      LITTLEHAMPTON Sussex  
PHONE 6743

Please forward all mail orders to Littlehampton

OA2 .30	30FL2 .60	ECC83 .22	EY876 .30	PY33/2 .50	AC156 .20
OB2 .30	30L14 .68	ECC84 .24	EY88 .40	PY81 .24	AC157 .25
IS4 .22	30L15 .58	ECC85 .24	EZ40 .40	PY82 .24	AC165 .25
SZAG .34	30L17 .67	ECC86 .40	EZ80 .21	PY83 .26	AD140 .36
6/30L2 .55	30P19/4 .58	ECC88 .35	EZ81 .22	PY88 .32	AD149 .50
6A93 .22	30P4MR	ECC189	HVR2 .53	PY89 .53	AD188 .13
6AT6 .18	95	ECC189	KTW61 .63	PY800 .33	AD162 .45
6AV6 .28	30P12 .69	ECC80 .27	KTW62 .63	PY801 .33	AF114 .25
6BA6 .20	30P1 .59	ECC82 .26	KTW63 .50	QVVO/3	AF115 .15
6BE6 .21	30P13 .75	ECC86 .64	PC86 .47	10 .20	AF119 .23
6BH6 .43	30P14 .65	ECH42 .60	PC88 .47	R19 .30	AF121 .30
6BJ6 .39	30P15 .87	ECH81 .27	PC97 .36	U19 .173	AF126 .18
6BR7 .79	35A3 .48	ECH83 .39	PC900 .32	U25 .64	BC107 .13
6BW6 .72	35W4 .23	ECC84 .34	PC834 .29	U26 .56	BC108 .13
6BW7 .54	90C1 .59	ECL80 .30	PC88 .41	U191 .58	BC113 .25
6BZ6 .31	150B2 .58	ECL82 .30	PC89 .45	U251 .65	BC118 .23
6C4 .28	DAF91 .20	ECL83 .52	PCC189 .48	U301 .40	BCZ11 .38
6C4S .30	DAF96 .33	ECL84 .54	PC880 .28	U801 .93	BF199 .25
6F1 .59	DF91 .14	ECL86 .35	PCF82 .30	UABC80	BF163 .20
6F23 .68	DF96 .34	EF22 .63	PCF84 .40	UBC81 .40	BF180 .30
6F28 .60	DK91 .26	EF41 .58	PCF86 .44	UBF80 .30	BY100 .18
6HGCT .15	ECC92 .35	EF80 .22	PCF80 .22	UBF89 .30	BY127 .18
6K7G .10	DK96 .35	EF85 .26	PCF802 .40	UC92 .35	OA81 .09
6K8G .16	DL92 .25	EF86 .29	PCF806 .37	UC181 .30	OC25 .38
6N4 .20	DL94 .32	EF89 .23	PC182 .32	UC182 .34	OC25 .38
7Y .40	DL96 .35	EF91 .17	PC183 .38	UC183 .34	OC25 .38
9D7 .78	DY87/6 .24	EF92 .35	PC184 .34	UCF80 .33	OC23 .38
10F1 .75	DY802 .35	EF183 .26	PC1805	UCH42 .60	OC24 .38
10F18 .35	EBC81 .60	EF184 .29	PC186 .38	UC181 .30	OC25 .38
12F18 .63	E180F .90	EH90 .36	PC186 .38	UC182 .33	OC35 .32
12AT6 .23	EABC80	EL34 .44	PD500 .44	UC183 .48	OC44 .10
12AU6 .21	EL41 .53	EL41 .53	PEN45 .40	UF41 .50	OC45 .11
12AV6 .28	EA42 .48	EL42 .48	PF1200 .52	UF40 .55	OC46 .11
12BA6 .30	EB34 .20	EL84 .22	PL36 .47	UF85 .34	OC70 .13
12BE6 .30	EB91 .10	EL91 .23	PL38 .90	UF86 .63	OC71 .11
12BH7 .27	EBC41 .48	EL95 .32	PL81 .44	UF89 .27	OC72 .11
13K5 .50	EBC81 .29	EL80 .75	PL82 .30	UL41 .54	OC74 .23
19A05 .24	EBF80 .30	EM80 .38	PL83 .32	UL84 .31	OC75 .11
20P4 .89	EBF83 .38	EM81 .39	PL84 .30	UY41 .38	OC78 .15
30A5 .44	EBF89 .27	EM83 .75	PL504 .62	UY85 .25	OC78D .15
30C15 .60	EC92 .34	EM84 .31	PL508 .90	X41 .50	OC81 .11
30C17 .77	ECC33	EM87 .35	PL509 .130	AC113 .25	OC81D .11
30C18 .60	EY31 .150	EY31 .33	PL802 .75	AC127 .17	OC82 .11
30F5 .65	ECC81 .16	EY81 .35	PX4 .116	AC128 .20	OC83 .20
30FL1 .60	ECC82 .19	EY83 .54	PX25 .98	AC154 .25	OC84 .24

All goods are unused and boxed, and subject to the standard 90-day guarantee. Terms of business: Cash or cheque with order only. No C.O.D. orders accepted. Post/packing charge 3p per item subject to a minimum of 9p per order. Orders over £5 post free. All orders despatched same day by first class mail. Complete catalogue with conditions of sale 7p post paid. Any parcel insured against damage in transit for only 3p extra per order. Business hours 9 a.m.-5.30 p.m. Sats. 9 a.m.-1 p.m. Littlehampton closed Sats. No enquiries answered unless S.A.E. enclosed for reply.

## FREE TO AMBITIOUS ENGINEERS

— THE LATEST EDITION OF ENGINEERING OPPORTUNITIES

### SEND FOR YOUR FREE COPY TO-DAY

NEW OPPORTUNITIES is a highly informative 76 page guide to the best paid engineering posts. It tells you how you can quickly prepare at home for a recognised engineering qualification and outlines a wonderful range of modern Home Study Courses in all branches of Engineering. This unique book also gives full details of the Practical Radio & Electronics Courses administered by our Specialist Electronics Training Division - explains the benefits of our free Appointments and Advisory service and shows you how to qualify for five years promotion in one year.

### PRACTICAL EQUIPMENT INCLUDING TOOLS

The specialist Electronics Division of B.I.E.T. NOW offers you a real laboratory training at home with all the practical equipment you need, plus Basic Practice and Theoretical Courses for beginners in Radio, TV, Electronics, etc.

### BRITISH INSTITUTE OF ENGINEERING TECHNOLOGY

Dept. (B10), Aldermaston Court, Reading RG7 4PF

### SEND OFF THIS COUPON TO-DAY!

Tick subjects that interest you:  
 AMSE (Elec)    City & Guilds Certificate    RTEB Certificate     
 Radio Amateurs' Exam    DMG Certificate    Colour TV  
 Electronic Engineering    Computer Electronics    Radio and TV  
 Servicing    Practical Electronics    Practical TV and Radio  
 Please send booklets & full information without cost or obligation.

NAME..... AGE.....  
(BLOCK CAPITALS PLEASE)

ADDRESS .....



OCCUPATION.....

To: BIET Dept. B10, Aldermaston Court, Reading RG7 4PF  
 Accredited by the Council for the Accreditation  
 of Correspondence Colleges

# RADIO OPERATORS

**DO  
YOU  
HAVE**

PMG I  
PMG II  
MPT  
2 YEARS'  
OPERATING  
EXPERIENCE

?

POSSESSION OF ONE OF  
THESE QUALIFIES YOU  
FOR CONSIDERATION  
FOR A RADIO OPERATOR  
POST WITH THE  
COMPOSITE SIGNALS  
ORGANISATION

On satisfactory completion of a 7 months specialist training course, successful applicants are paid on scale rising to £2200 pa; commencing salary according to age - 25 years and over £1548 pa. During training salary also by age, 25 and over £1152 pa with free accommodation.

The future holds good opportunities for established (ie pensionable) status, service overseas and promotion.

Training courses commence every January, April and September. Earliest possible application advised.

Applications only from British-born UK residents up to 35 years of age (40 years if exceptionally well qualified) will be considered.

Full details from:

Recruitment Officer,  
Government Communications  
Headquarters,  
Room A/1105,  
Oakley Priors Road,  
CHELTENHAM,  
Glos., GL52 5AJ.  
Tel: Cheltenham 21491. Ext. 2270.

# NEW STYLE SELF-BINDER

for "The Radio Constructor"

The "CORDEX" Patent Self-Binding Case will keep your issues in mint condition. Copies can be inserted or removed with the greatest of ease. Rich maroon finish, gold lettering on spine.

Specially constructed Binding Cords are made from Super Linen of great strength, very hard twisted and twice doubled. They are attached to strong RUSTLESS Springs under tension, and the method adopted ensures PERMANENT RESILIENCE of the Cords. Any slack that may develop is immediately compensated for and the Cords will always remain taut and strong. It is impossible to overstretch the springs, as a safety check device is fitted to each.

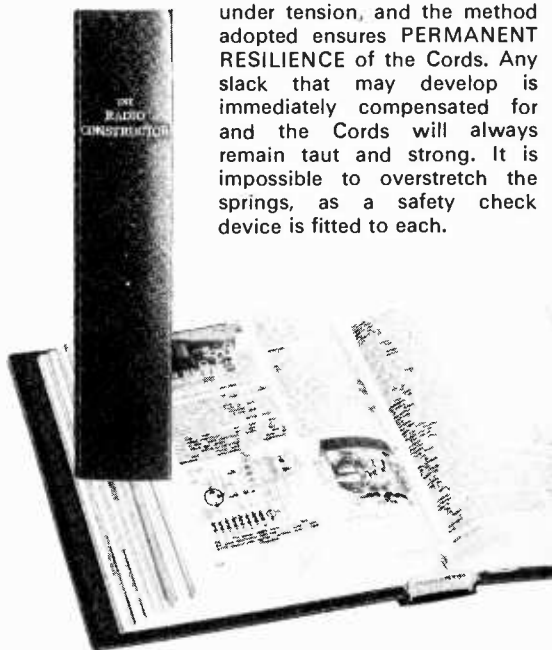

PRICE **75p** Postage 10p

Available only from:—

**Data Publications Ltd.**  
57 Maida Vale London W9 ISN

## SMALL ADVERTISEMENTS

(Continued from page 507)

**FOR SALE:** Electronic Devices (Cheltenham) Ltd. electric "bug" morse key. £10. Box No. G170.

**FOR SALE:** Small stamp collection £5. Box No. G.171.

**JOIN THE INTERNATIONAL S.W. LEAGUE.** Free services to members including Q.S.L. Bureau, Amateur and Broadcast Translation, Technical and Identification Dept. - both Broadcast and Fixed Stations, DX Certificates, contests and activities for the SWL and transmitting members. Monthly magazine, *Monitor*, containing articles of general interest to Broadcast and Amateur SWLs, Transmitter Section and League affairs, etc. League supplies such as badges, headed notepaper and envelopes, QSL cards, etc., are available at reasonable cost. Send for League particulars. Membership including monthly magazines, etc., £1.75 per annum. Secretary ISWL, 1 Grove Road, Lydney, Glos., GL15 5JE.

**FOR SALE:** Raven radio control Tx & Rx. Multichannel reed. £25. S.A.E. for details. Box No. G172.

**"WORLD RADIO TV HANDBOOK"** £2.80; Fortnightly updating bulletin available. SAE/IRC sample. "How to Listen To The World" £1.37. "SWL Address Book", stations, QSL policies, etc., £1.40. Frequency Lists, operating guides, 3p/IRC for price list (Mail only). Under £2. carriage 10p. Prices subject to change. D. McGarva, 16 Chambers Street, Edinburgh EH1 1HS.

**ARE YOU A MOTORING ENTHUSIAST?** The Seventy-Fifty Motor Club caters for all types of motor sport-racing, rallies, hill climbs, etc. Monthly Bulletin free to members. For full details write to: The General Secretary, Colin Peck, "Dancers' End", St. Winifred's Road, Biggin Hill, Kent.

**WORLD DX CLUB** covers all aspects of SWLing on Amateur and Broadcast Bands through its monthly bulletin "*Contact*". Membership costs £1.38 a year. Enquiries to Secretary, WDXC, 11 Wesley Grove, Portsmouth, Hants., PO3 5ER.

**FREE GIFT** when you request our quality stamps, supplied on approval. Generous discounts. Details from: Watson's Philatelic Service, 6 Beech Avenue, Brentwood, Essex.

**FOR SALE:** Transistorised signal generator. Ranges to 25Mc/s. Needs adjustment. £3. CRO tube 6 in. VCR97, £3. Box No. G174.

**WANTED:** Someone to build automatic thyristor dimmer as detailed in February issue of "*The Radio Constructor*". Offers? Somerville, The Laurels, Woodland Road West, Colwyn Bay, N. Wales.

**THE BRITISH AMATEUR ELECTRONICS CLUB.** A club for all who are interested in electronics as a hobby. Quarterly Newsletter sent free to members. Subscription 50p per year. Details from Hon. Secretary, J. G. Margetts, 17 St. Francis Close, Abergavenny, Mon.

**FREQUENCY LIST TRANSFERS.** We have a limited supply of sheets of Dial Frequency Transfers in black. Short Wave frequencies 1.8Mc/s to 32Mc/s and 144Mc/s and 146Mc/s. Includes amateur band marker frequencies at 100kc/s points and other short wave frequencies from 2 to 32Mc/s at every 500kc/s points. Each frequency is repeated. Two sheets for 5p, five sheets for 10p, postage 3p. Data Publications Ltd., 57 Maida Vale, London W9 1SN.

**FOR SALE TO CLEAR:** Valves at 13p each: VR91, CV136, DL92, N142, U142, 171DDP, DK81, EB91, 1S5, 3ML, 6AG5, 6AG6, 41MP, HP4106, U14, VT62, 801A, T20. 6 pin Eddystone coil formers, Cat 538, 10p. Eddystone sloping receiver stands, 50p per pair. Variable capacitor Txing 75-75 p.f. 50p. Woden mic. transf. M.T.101 50p. Box No. G175.

(Continued on page 511)

# PLAIN-BACKED NEW STYLE SELF-BINDERS

for your other magazines

(max. format 7½" x 9½")

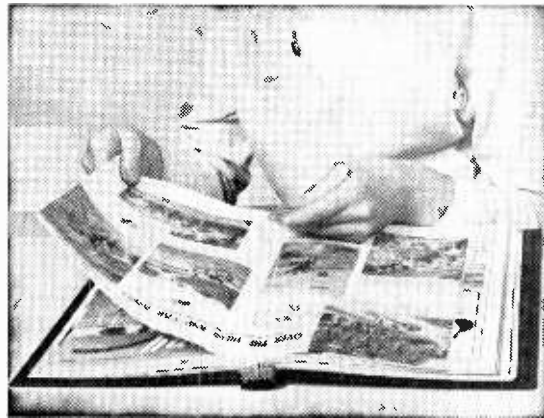

The "CORDEX" Patent Self-Binding Case will keep your copies in mint condition. Issues can be inserted or removed with the greatest of ease. Specially constructed Binding cords are made from Super Linen of great strength very hard twisted and twice doubled. They are attached to strong RUSTLESS Springs under tension, and the method adopted ensures PERMANENT RESILIENCE of the Cords. Any slack that may develop is immediately compensated for, and the Cords will always remain taut and strong. It is impossible to overstretch the springs, as a safety check device is fitted to each.

**COLOURS: MAROON OR GREEN**

(If choice not stated, colour available will be sent)

**PRICE 70p** Postage 10p

Available only from:—

**Data Publications Ltd.**  
57 Maida Vale London W9 1SN

**SAVE £££ ON BATTERIES WITH THE NEW SUPER  
MINATURE 9v. BATTERY ELIMINATOR.**



ONLY 2" LONG BY  
1½" DIAMETER.  
£1.50

**T.V. & F.M.  
OUTLET PANELS**

Flush fitting. Fits any  
standard conduit box.  
Single 30p.

Double VHF/UHF 40p  
RUN TWO T.V.'s

**FROM ONE AERIAL WITH A**

Low loss ferrite splitter VHF or UHF 60p.

Two Track Record/Playback Heads 40p

Bags of approx. 200 Assorted Resistors 50p

Bags of approx. 50 Assorted Condensers 50p

(All new top quality components. No rejects)

Send S.A.E. for lists of other components at

**BARGAIN PRICES.**

Valves, Transformers etc.

*All prices include postage and packing*

**ISHERWOODS ELECTRONICS,  
195 BURNLEY ROAD, BLACKBURN, LANCs.  
Tel: 57616**

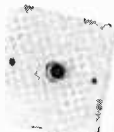

**SERIOUS AMATEUR CONSTRUCTORS**

need components of professional quality. Our Catalogue shows practically the entire range marketed by R. S. Components Ltd. ALL of these components, used extensively by industry are now made readily available to amateur constructors.

CATALOGUE, by return of post - only 25p, post free.

Some popular examples from our range

- 15A. Miniature mains transformer, 2 x 12 volt secondaries £1.10 each
- 15C. Hygrade filament transformer, 0 - 245 volt primary, 2 x 6.3 volt, 1.8 amp secondaries £1.95 each
- 39B. Capacitors, paper and polyester 1000 volt, 0.001, 0.0022, 0.0033, 0.0047 uF all at 5p each
- 52C. Miniature neon indicator 250 volts. Red, Amber, Clear all at 30p each  
Green 44p each
- 61B. Small perforated phenolic resin boards, 172 x 133 x 1.57mm, punched 6.35mm grid 22p each
- 61C. Small turret tags, to suit above boards, 144 per box 95p each
- 71B. Twin screened stereo wire, maximum 25m length 8p per metre
- 84C. Crocodile clips, standard or miniature sizes 4p each
- 85C. Plastic cable wrap spiral, ¼ inch, to secure up to ½ inch cable bunches. Per 5 metre coil 24p each
- 86D. Insulated 4mm socket terminals, in colours Black, Red, Green, Blue, White, Yellow 14p each
- 86E. Banana plugs to fit above terminals. Colours as above 6p each

ALL PRICES INCLUDE POST AND PACKING  
MINIMUM ORDER 50p  
MAIL ORDER ONLY FROM

**CELECTRON-E**

MAIL ORDER ELECTRONIC COMPONENTS  
P.O. BOX No 1, LLANTWIT MAJOR, GLAMORGAN. CF6 9YN.

**DATA BOOK SERIES**

- DB5 TV FAULT FINDING  
124 pages. Price 50p, postage 6p.
- DB6 RADIO AMATEUR OPERATOR'S HANDBOOK  
80 pages. Price 45p, postage 5p.
- DB16 RADIO CONTROL FOR MODELS  
192 pages. Price 75p, postage 8p.
- DB17 UNDERSTANDING TELEVISION  
512 pages. Price £2.10, postage 20p.
- DB18 AUDIO AMPLIFIERS  
128 pages. Price 53p, postage 6p.
- DB19 SIMPLE SHORT WAVE RECEIVERS  
140 pages. Price 80p, postage 6p.

*Postal Orders should be crossed and made payable to Data Publications Ltd.*

*Overseas customers please pay by International Money Order.*

*All publications are obtainable from your local bookseller.*

I enclose Postal Order/Cheque for.....  
in payment for .....

NAME .....

ADDRESS .....

.....(BLOCK LETTERS PLEASE)

**Data Publications Ltd.,  
57 Maida Vale, London W9 1SN**

## SMALL ADVERTISEMENTS

(Continued from page 509)

IF YOU HAVE ENJOYED A HOLIDAY on the Norfolk Broads, why not help to preserve these beautiful waterways. Join the Broads Society and play your part in determining Broadlands future. Further details from:- The Hon. Membership Secretary, The Broads Society, "Icknield", Hilly Plantation, Thorpe St. Andrew, Norwich, NOR 8SS.

FOR SALE: Codar CR-70A communication receiver. .55 - 30MHz, one year old. £14. Very good condition. Write: D. Porter, 170 Huthwaite Road, Sutton-in-Ashfield, Notts.

FOR SALE: VHF KIT, 80 - 180 MHz. Receiver, tuner, converter. World wide sales. Incomparable. £4.00 or s.a.e. for literature. Johnsons (Radio C), Worcester WR1 2DT.

FOR SALE: *The Radio Constructor*, June 1964 to December 1970, some Data Sheets missing. Offers? 33 Colne Road, Halstead, Essex.

"MEDIUM WAVE NEWS" Monthly during Dx season - Details from: K. Brownless, 7 The Avenue, Clifton, York.

NEW PLASTIC TRANSISTORS. NPN BC107B, hfe 240 to 500 45V, 7p. PNP BC178B hfe 240 to 500 25V, 10p. Manufacturers markings. Guaranteed. C.W.O. P. & P. 5p. Cross Electronics, Red Lodge, North Cove, Beccles, Suffolk.

"THE ANSWER" BUREAU, PRINCES RISBOROUGH, BUCKS. For sincere and genuine marriage/friendship introductions. Details free.

BEST QUALITY WIRE, P.V.C. Covering. 1/036" - 50m 60p; 100m £1.00. 23/0.19mm - 50m 80p; 100m £1.50. 37/006" silver plated copper - 50m £1.00; 100m £1.75. New P.O. 3,000 relays 1000Ω, 4 H.D. contacts - 35p. P. & P. 10p. per item. Similar used repairable relays 10 for £1.25 inc. postage. Poole Electronics, 68 Danecourt Road, Poole, Dorset.

MEDICAL LOCKING FORCEPS, 5 in., as mentioned "*In Your Workshop*" (July 1971). New in makers packing. 68p each including postage. Terms strictly c.w.o. Mail order only. Radwell Medical Equipment Co., 319 Shirley Road, Southampton, Hants., SO1 3HW.

IRISH READERS. All your electronic components supplied by mail order for your constructional projects. Apply to Toner Electronics, 20 Lismore Park, Waterford, Eire.

HOLIDAY ACCOMMODATION. Burwood Lodge Hotel, Dawlish Road, Teignmouth, South Devon. Especially suitable for parents with young children. Facing south, on the cliffs, direct access by private path to the sea. Mothers' kitchen. automatic washing machines, baby listening service. Licensed lounge. Ample free parking.

2N2926 - 8p, BC 109 - 8p, OC23 - ex-equipment 18p, OC83 - ex-equipment 5p, 50 - OC71/5's 50p. 300 diodes 50p. P. & P. 8p. Mr. R. Tustin, 45 Brockhurst Street, Walsall, Staffs.

ESSEX GARDENERS. Buy your bedding and rock plants, shrubs, etc., also cacti from May's Nurseries, 608 Rayleigh Road, Hutton, Brentwood, Essex. Callers only. Monday to Saturday.

WHITE ROSE RADIO SOCIETY MOBILE RALLY. Easter Sunday, 2nd April, 1972. At Lawnswood High School, Leeds 6, Yorkshire, junction of A660 Leeds-Otley Road and A6120 Leeds Ring Road. Club stand. Raffle. Ample car parking. Trade stands. Refreshments. Talk in on 160 and 2m. Bring and buy. Family occasion.

MARCH 1972

**YUKAN** SO PROFESSIONAL THE  
**SELF-SPRAY** YUKAN AEROSOL WAY -

Get these air drying GREY HAMMER  
NOW! OR BLACK WRINKLE  
(CRACKLE) finishes

Yukan Aerosol spraykit contains 453g fine quality durable easy instant spray. No stove baking required. Hammers etc. available in grey and blue. 90p can. Modern Eggshell Black Wrinkle (Crackle) producing a 3D texture. 1.10 can. 85p per push button self spray can. Our counter. Also durable heat and water resistant Black Matt finish (350g self spray cans only) 75p can. **SPECIAL OFFER** One can plus optional transferable snap on trigger hands (value 25p) for 96p can. Choice of 13 self spray plain colours (all hammer (motor car quality) also available). Please enclose cheque or crossed P.O. for total amount direct to:

**DEPT: RC/3 YUKAN, 307a EDGWARE ROAD, LONDON W2 1BN**

We supply many Government Departments, Municipal Authorities, Institutes and Leading Industrial Organisations. We can supply you too - open all day Saturday. Closed Thursday afternoons.

Other Yukan Air Drying Aerosols 453g at 90p. 1.10 can. 85p per push button self spray can. Our counter. Also durable heat and water resistant Black Matt finish (350g self spray cans only) 75p can. **SPECIAL OFFER** One can plus optional transferable snap on trigger hands (value 25p) for 96p can. Choice of 13 self spray plain colours (all hammer (motor car quality) also available). Please enclose cheque or crossed P.O. for total amount direct to:

**DEPT: RC/3 YUKAN, 307a EDGWARE ROAD, LONDON W2 1BN**

We supply many Government Departments, Municipal Authorities, Institutes and Leading Industrial Organisations. We can supply you too - open all day Saturday. Closed Thursday afternoons.



Now British - even better

## SYNTHESISER MODULES

Voltage-controlled modules for synthesiser construction and other musical MIRACLES! Catalogue 15p. D.E.W. Ltd., 254 Ringwood Road, Ferndown, Dorset

Coax Relays 10 and 24 volt Ampenol 50Ω £3.00. UHF83 Coax Panel Mounting Sockets, Elbows, Plugs, 12p each. Type C Coax Panel Mounting Sockets, 15p ea. High quality W.W. Pots. 5K, 10K, 50K 4-watt, 12p ea.; 5K 25-watt, 25p ea.; 10K 2-watt, 10p ea. Carbon Pots, 2 Meg., 500K, 500K Twin, 250K, 50K, 10K, 8p ea. 800V p.i.v. 2 amp Silicon Bridge Rectifier Boards, 35p ea. MAIL ORDER ONLY. ORDERS UP TO £1.00 add 10p.

**E.M.A., MONDAY'S LANE, ORFORD, WOODBRIDGE, SUFFOLK**

## FREQUENCY LIST TRANSFERS

We have a limited supply of sheets of Dial Frequency Transfers in black. Short Wave frequencies 1.8Mc/s to 32Mc/s and 144Mc/s and 146Mc/s. Includes amateur band marker frequencies at 100kc/s points and other short wave frequencies from 2 to 32Mc/s at every 500kc/s points. Each frequency is repeated. Two sheets for 5p, five sheets for 10p, postage 3p.

**DATA PUBLICATIONS LTD.,**  
57 Maida Vale, London W9 1SN.

## MORSE MADE EASY!!!

**FACT NOT FICTION.** If you start RIGHT you will be reading amateur and commercial Morse within a month. (Normal progress to be expected.) Using scientifically prepared 3-speed records you automatically learn to recognise the code RHYTHM without translating. You can't help it, it's as easy as learning a tune. 18-W.P.M. in 4 weeks guaranteed. Complete course £4.50 (Overseas £1 extra). For further details of course ring s.t.d. 01-660 2896 or 01-668 3255 or send 4p stamp for explanatory booklet to: G3HSC/Box 38, 45 GREEN LANE, PURLEY, SURREY.

## JOHN SAYS...

**RING MODULATOR** by Dewtron is professional, transformerless, 5 transistor, has adjustable F1/F2 rejection. Module £7. Unit £8.90. WAA-WAA Pedal kit of all parts, inc. all mechanics & instr. ONLY £2.95. **AUTO RHYTHM** from Dewtron modules. Simple unit for waltz, foxtrot, etc. costs £18 in modules. **SYNTHESISER MODULES** and other miracles. Send 15p for illust. list. **D.E.W. LTD., 254 Ringwood Road, FERNDOWN, Dorset.**



# CHASSIS and CASES by



**H. L. SMITH & CO. LTD.**  
287/9 Edgware Road  
London W2 1BE  
TEL: 01-723 5891

# BLANK CHASSIS

**FOUR-SIDED 16 SWG ALUMINIUM**

Size	Price	Base	Size	Price	Base
6x4x2"	34p	17p	10x8x2½"	66p	30p
7x4x1½"	33p	18p	12x7x2½"	66p	33p
7x5x2"	40p	19p	12x9x2½"	76p	38p
8x4x2"	38p	19p	13x8x2½"	76p	38p
8½x5½x2"	44p	21p	14x7x3"	80p	36p
9x7x2"	50p	26p	14x10x2½"	88p	47p
10x4x2½"	50p	21p	15x10x2½"	92p	50p
12x4x2½"	55p	22p	17x10x3"	£1.10	55p
12x5x3"	66p	26p			

### TO FIT OUR CASES

7x5½x1½"	38p	21p	12x6½x2"	60p	33p
7x5½x2"	43p	21p	14x8½x2"	74p	44p
11x6½x1½"	48p	30p	15½x9½x2½"	94p	52p
11x6½x2"	55p	30p	17½x9½x2½"	£1.05	59p

*Plus post & packing*

PANELS: Any size up to 3ft. at 36p sq. ft. 16 s.w.g. (18 s.w.g. 32p). *Plus postage and packing*

## CASES ALUMINIUM, SILVER HAMMERED FINISH

Type	Size	Price	Type	Size	Price
N	8x6x2"	£1.00	W	12x7x7"	£2.50
N	6x6x3"	£1.05	W	15x9x8"	£3.15
N	4x4x2"	80p	Y	8x6x6"	£2.25
U	4x4x4"	95p	Y	12x7x7"	£2.80
U	5½x4½x4½"	£1.15	Y	12x7x9"	£3.15
U	8x6x6"	£1.45	Y	15x9x7"	£3.35
U	9½x7½x3½"	£1.55	Z	17x10x9"	£4.15
U	15x9x9"	£3.00	Z	19x10x8½"	£4.25
W	8x6x6"	£1.90			

\*Height

Type N has removable bottom, Type U removable bottom or back, Type W removable front, Type Y all screwed construction, Type Z removable back and front. *Plus p.&p.*

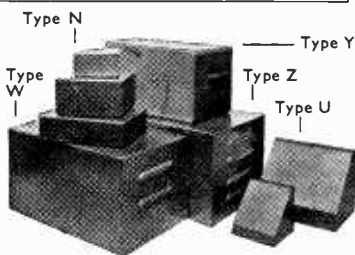

# BAGINTON ELECTRONICS

(G3TFC)

## MARKET CORNER, BAGINTON, WARKS. CV8 3AP

Phone Coventry (0203) 302668

CRYSTALS. £1 ea. 6001, 6009, 6010, 6016, 6021, 6024, 6031, 6046, 6054, 6076, 7002, 7005, 7010, 7017, 7032, 7047, 7054, 7060, 7077, 7080, 7090, 7099, 7127, 7129, 7270, 7816, 7833, 7850, 8007, 8081, 8090, 8820, 8837, 11764, and many others.

TYPE PTR 61E VHF AM TX/RX116-132mHz, 1 watt output. Size 6x8x11 weight 15 lb. Coils easy to modify for 144mHz. 4 gang TX & 2 gang RX variable capacitors. Valve line up: TX, EF91 osc, EF91 mult, EL91 driver, OV04-7 PA, EF91, 6BW6 mod, RX, EF91 RF, EF91 mix, EF91 osc, EF91 mult, 2x 6BA6 IF, 6BA6 AF, 6X4 rectifier, 195 volts HT from 12 volt + or - earth PSU. Each TX stage has a meter point. May be local or remote controlled. Circuit included. Black crackle case. p & p 75p. £15.

**WE WANT TO PURCHASE RADIO TELEPHONE EQUIPMENT, AIRCRAFT RADIO AND MANUALS**

**TECHNICAL INFORMATION SERVICE FOR AIRCRAFT RADIO**

S.A.E. enquiries Mail order

Shop open Saturdays and by appointment

100 WATT MODULATORS. 100 watts output for 10mV input. Transformer has 2500ohm main winding & separate PA screen winding. Speech clipping switched at 3, 8, 11, 14, 16, 19 db level and voice operated gain control incorporated. Valve line up. Push pull 6BR7 mic amp, 12AT7 amp, 6AL5 VOGAD, 12AT7 tone osc, push pull 6AM5 amp, 12AX7 cathode follower, 4 push pull parallel 5B254M modulators. Size 5x5x9, with circuit. Requires separate PSU LT & up to 600 volts HT. p & p 50p. £10.

# SMALL ADVERTISEMENTS

*Use this form for your small advertisement*

To: The Advertisement Manager, Data Publications Ltd., 57 Maida Vale, London W9 1SN

Please insert the following advertisement in the.....issue of THE RADIO CONSTRUCTOR

16 words at 4p = 64p.

**ALL WORDING IN BLOCK LETTERS PLEASE**

I enclose remittance of.....being payment at 4p a word. MINIMUM 60p. Box Number, if required, 10p extra.

NAME.....  
ADDRESS.....  
.....

*Copy to be received four weeks prior to publication. Published on the 1st of every month.*

Please mention **THE RADIO CONSTRUCTOR** when writing to advertisers

## Millimetre-Inch Table I

Continuing the metrication series, the Table lists inch equivalents to 'round number' millimetre values from 0.5 to 40mm. Inches are given to four significant figures.

<i>mm.</i>	<i>in.</i>	<i>mm.</i>	<i>in.</i>	<i>mm.</i>	<i>in.</i>	<i>mm.</i>	<i>in.</i>
0.5	0.01969	8.0	0.3150	15.5	0.6102	26.0	1.024
1.0	0.03937	8.5	0.3347	16.0	0.6299	27.0	1.063
1.5	0.05906	9.0	0.3543	16.5	0.6496	28.0	1.102
2.0	0.07874	9.5	0.3740	17.0	0.6693	29.0	1.142
2.5	0.09843	10.0	0.3937	17.5	0.6890	30.0	1.181
3.0	0.1181	10.5	0.4134	18.0	0.7087	31.0	1.220
3.5	0.1378	11.0	0.4331	18.5	0.7284	32.0	1.260
4.0	0.1575	11.5	0.4528	19.0	0.7480	33.0	1.299
4.5	0.1772	12.0	0.4724	19.5	0.7677	34.0	1.339
5.0	0.1969	12.5	0.4921	20.0	0.7874	35.0	1.378
5.5	0.2165	13.0	0.5118	21.0	0.8268	36.0	1.417
6.0	0.2362	13.5	0.5315	22.0	0.8661	37.0	1.457
6.5	0.2559	14.0	0.5512	23.0	0.9055	38.0	1.496
7.0	0.2756	14.5	0.5709	24.0	0.9449	39.0	1.535
7.5	0.2953	15.0	0.5906	25.0	0.9843	40.0	1.575

# HENRY'S RADIO LIMITED

HENRY'S RADIO

ENGLAND'S LEADING ELECTRONIC CENTRES

HI-FI · ELECTRONIC COMPONENTS · TEST · P.A. · DISCOTHEQUE · LIGHTING · MAIL ORDER

## 10th EDITION CATALOGUE

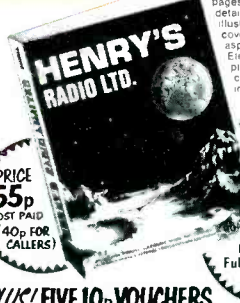

**350** pages fully detailed and illustrated covering every aspect of Electronics - plus data circuits and information

**10000** Stock lines at Special Low Prices and Fully Guaranteed

**PRICE 55p** POST PAID (40p FOR CALLERS)

**PLUS! FIVE 10p VOUCHERS FOR USE WITH PURCHASES**

Send to this address - Henry's Radio Ltd., (Dept. R.C.), 3 Albemarle Way, London, E.C.1 - for catalogue by post only. All other mail and callers to "303", see below. HENRY'S CATALOGUE IS A MUST FOR ELECTRONIC COMPONENTS OF ALL TYPES

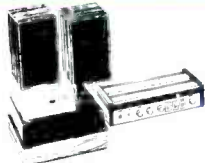

**SAVE UP TO 10% OFF TO ORDER ON RECOMMENDED PRICES**

**F2000 SYSTEM**  
Teleton F2000 Med/Stereo FM Tuner Amplifier, Garrard SP25/3, Goldring G800H, 2025TC/9TAHCD Auto with plinth and cover. Pair matching speakers K60. Size 16 x 9 1/2 x 6 1/2 in. All leads etc.  
List £54.65 Carr £2.93

**2200 SYSTEM**  
Rota 10 10 watts Stereo Amplifier, Garrard SP25/3, Goldring G800H, plinth and cover, pair of speakers SDL2 (or KN800) Size 18 x 10 1/2 x 7 1/2 in. All leads etc.  
List £65.50 Carr £2.94

**206B SYSTEM**  
Teleton SAQ206B 8 watts Stereo Amplifier, Garrard SP25/3, Goldring G800H, plinth and cover. Pair of speakers SDL1 (or K80) Size 15 x 10 1/2 x 7 1/2 in. All leads etc.  
List £55.95 Carr £2.90

**ROTEL SYSTEM**  
RX 150 8 watt Med/FM/FM stereo Tuner Amplifier, pair of SDL2 Speaker Systems 18 x 10 1/2 x 7 1/2 in. Garrard SP25/3, plinth, cover and Goldring G800H cart. All leads etc.  
List £99.95 Carr £2.50

**FREE** Latest Hi Fi & Tape Recorder 12 page Stock Discoun List plus over 100 Stereo Systems. Ref 16/17.

### PUBLIC ADDRESS, LIGHTING & DISCOTHEQUE EQUIPMENT

**DJ105S** 30 watt rms Amplifier, 4 inputs, master tone and volume controls etc. 8 ohm output. Cased portable. £33.50 Post 40p.

**DJ70S** 70 watt rms version. Cased portable. £53.00 Post 40p.

**DISCOAMP** 100 watt rms to 8 ohms, 4 inputs, separate bass and treble controls, PFL etc. Cased for cabinet or rack mounting £76.50 Post 40p.

**MCDONALD MP60** fitted to plinth with cover. SC5MD cartridge to match above amplifiers. £17.50 Post 70p.

**DJ30LII** 3 channel light control unit for above amplifiers. 3 x 1 K Watt. Treble, Bass and Mid range. £33.50 Post 35p

**EFFECTS PROJECTORS** - Coloured Rotating light patterns.  
**DISCO COLT** 250w Tungsten £22.50  
**LQ100** - 50 watt Q.I. £32.50  
**LQ1150** - 150 watt Q.I. £50.00

**FULL RANGE OF LIGHTING IN STOCK**



**SPECIAL!** Anti-Feedback Microphone designed and made for Henry's for all PA/Disco Equipment. £11.50

**LIGHT GUIDE** 64 fibres sheathed £1 per yd. Mono (0.00 1) £1.50 per 25 metre reel.

**COMPLETE RANGE OF DISCO/PA AND LIGHTING ON DISPLAY AT "309"**  
Call, write or phone for details and lists.

### TEST EQUIPMENT

Huge range in stock - too much to list here. It's all in the latest catalogue - prices - specifications etc. Also Panel Meters and Edge Meters.



**GARRARD MCDONALD GOLDRING TURNTABLES**

**CHASSIS (Post 50p)**  
SP25/3 £11.30 HT70 £16.60  
MP60 £11.30 MP610 £15.15  
AP76 £20.50 Zero 100S £41.37

**WITH PLINTH/COVER (Post 70p)**  
MP60 PC £17.85 HT70 PC £23.50  
HL75 PC £37.35 GL72P £32.95

**CAR/PLINTH/COVER (Post 70p)**  
GL72PC/G800 £35.95  
(HL) AP76/G800 £29.95  
HT70 PC/G800 £29.95  
MP60 PC/SC5M £17.50  
(HL) SP25/3/G800H £19.95  
(HL) 2025 TC/9TAHCD £14.95

**ULTRASONIC TRANSDUCERS**  
Operate at 40kc/s up to 100 yds. Ideal remote switching and signalling. Complete with data and circuits.  
**PRICE PER PAIR £5.90** Post 10p

**POWER INTEGRATED CIRCUITS**  
SL403D - 3 watt with 8 page data, layouts and circuits £1.50  
P.C. Board 60p. Heat Sink 14p  
IC12 - 8 watt with data and circuits £2.50  
TOSHIBA - 20 watt Power Amp Module £4.57  
TOSHIBA - IC Preamplifier £1.50  
TOSHIBA Data/Circuits Book No. 42 10p

**TEXAS PUBLICATIONS**  
1-100 watt Amplifiers and Pre-Amplifier. Layouts and data £1.25.  
(Price list No. 48A free)  
700 page IC Data Book (No. 2) 60p.  
400 page Transistor Data (No. 3) 60p.  
340 page Transistor Data (No. 4) 60p.  
(Post etc. 15p each. 20p per 2 or 3 books)

**NIXIE TUBES**  
**NIXIE TUBES** (Post 15p per 1 to 6)  
XN3, XN13, GN6-9 Side view with data 85p.  
GNP-7, GNP-8 9-9 Side view with decimal points and data 95p.  
GN4 0-9 End view with socket and data £1.75.

**SLIDER CONTROLS**  
Top quality 60mm singles and gangs. Complete with knobs. 5K, 10K, 25K, 50K, 100K, 500K, 1 meg, Log and Lin. 45p each. 10K, 25K, 50K, 100K, Log and Lin gang. 75p each.  
Post 1-5, 15p; 6 or more, 20p.

**TRANSISTORS, IC's etc.** Free list No. 36 on request.

## LOW COST HI-FI SPEAKERS

E.M.I. Size 13 1/2" x 8 1/2" Large Ceramic Magnet.

**TYPE 150** 6 watt, 3, 8 or 15 ohms £2.20. Post 22p  
**TYPE 150TC** Twin cone version £2.75. Post 22p  
**TYPE 450** 10 watt with twin tweeters and crossover, 3, 8 or 15 ohms. £3.85. Post 25p.  
**TYPE 350** 20 watt with tweeter and crossover, 8 and 15 ohms. £7.70. Post 28p.



**POLISHED CABINETS** For 150, 150TC and 450 £4.60. Post 30p.

### HIGH POWER AMPLIFIER MODULES

**MPA12** Quality transformerless low noise amplifiers suitable for all Audio, PA and Hi-Fi use. Modern compact designs. PA25 and PA50 supplied with plug harness for use with MU442 Power Supply.  
**MPA12/3** 18v, 0.8A, 12W, 3-4 ohm £4.50  
**MPA12/15** 30v, 0.5A, 12W, 12-15 ohm £5.25  
**MU24/40** Mains unit for 1 or 2 MPA12/3 or 15 £4.50  
**PA25 22-0-22v, 1A, 25W, 8 ohm** £7.50  
**PA50 22-0-22v, 2A, 50W, 3-4 ohm** £9.50  
**MU442** Mains unit for 1 or 2 PA25 or 1 only PA50 £6.00  
Post 20p per unit.

### ALL SILICON-FET PREAMPLIFIER AND MIXER SELF POWERED

All inputs. Adjustable input and output. DIN sockets. Tape in and out. Microphone. **PRICE** Post mixing. Suitable up to 4 - £10.50 30p. PA25 or 2 - PA50.

### 300mW TRANSISTOR AMPLIFIER MODEL 4-300

Fully assembled 5TR Amplifier. Size 5 1/2 x 3 1/2 x 2 1/2 in. 1-10mV adjustable sensitivity. Output 3-8 ohms. Fitted Vol. control. 9 volt operated. Thousands of uses plus low cost!  
**Price £1.75, p. 15p.**  
(or 2 for £3.25, p. 15p.)



### BUILD THIS VHF FM TUNER 5 TRANSISTORS 300 kc/s BAND-WIDTH, PRINTED CIRCUIT, HIGH FIDELITY REPRODUCTION, MONO AND STEREO.

A popular VHF FM Tuner for quality and reception of mono and stereo. There is no doubt about it - VHF FM gives the REAL sound. All parts sold separately. Free Leaflet No. 3 & 7.  
**TOTAL £6.97, p.p. 20p.** Cabinet 100p. Decoder Kit £5.97. Tuning meter unit £1.75.  
Mains unit (optional) Model PS900 £2.47. Post 20p.  
Mains unit for Tuner and Decoder PS1200 £2.62. Post 20p.



### SINCLAIR PROJECT 60 MODULES

— SAVE POUNDS!

Z30 £3.60; Z50 £4.38  
STEREO 60 £7.98; PZ5 £3.98  
PZ6 £6.38; PZ8 £5.97  
Transformer for PZ8 £2.95  
Active Filter Unit £4.75  
Stereo FM Tuner £20.25  
IC12 £2.50; O16's £8 each.  
Post etc. 20p. per item  
**ALSO IN STOCK**  
2000 £23.75; 3000 £31.50  
Post 50p. each



**PACKAGE DEALS**  
2 x Z30, Stereo 60, PZ5 £16.75  
2 x Z30, Stereo 60, PZ6 £18.25  
2 x Z50, Stereo 60, PZ8 £20.25  
Post 25p. each  
Transformer for PZ8 £2.95  
Post 20p.  
**NEW PROJECT 605 KIT**  
£20.95 Post 25p.

### "BANDSPREAD" PORTABLE TO BUILD



Printed circuit all-transistor design using Mullard BR/IF Module. Medium and Long Wave bands plus Medium Wave Bandspread for extra selectivity. Also slow-motion geared tuning, 600mW push-pull output, fibre glass PVC covered cabinet, car aerial socket. Attractive appearance and performance. **TOTAL COST TO BUILD £7.98** p.p. 20p. (Battery 22p)

All parts sold separately - Leaflet No. 2  
**17T M & L.W. PORTABLE** (as previously advertised) £6.98 p.p. 35p. From stock (Leaflet No. 1)

**MORE OF EVERYTHING AT LOW PRICES ALWAYS FROM HENRY'S**

\* Components in stock for most published designs - send large S.A.E. with list for parts quote for your circuit, or get a Catalogue - it's all in there!

Electronic Components, Audio and Test Gear Centre  
**356 EDGWARE ROAD, LONDON, W.2.**  
Tel: 01-402 4736

High Fidelity Sales & Demonstrations Centre  
**354 EDGWARE ROAD, LONDON, W.2.**  
Tel: 01-402 5854

P.A. Disco & Lighting Centre  
**309 EDGWARE ROAD, LONDON, W.2.**  
Tel: 01-723 6963

Mail Orders, Special Bargain Shop, Industrial Sales  
**303 EDGWARE ROAD, LONDON, W.2.**  
Tel: 01-723 1008/9

"309", "354" & "356" OPEN SIX FULL DAYS A WEEK 9 am to 6 pm MONDAY TO SATURDAY