

# THE RADIO CONSTRUCTOR

Vol. 24 No. 12

JULY 1971

20p



## I.C. STEREO AMPLIFIER

2.7 watts per channel  
Fully continuous bass  
and treble controls

**FEATURED**  
**IN THIS ISSUE**

**TRANSISTOR GAIN METER**  
**PUSH-BUTTON REMOTE CONTROL**



## Each £3 unit of Home Unit Insurance gives you protection up to the limit shown

This is the simplified insurance you have been waiting for. Not just cover on the contents of your home but a package of personal protection you and your family need. And it's how we save you so much money: just ONE policy to issue instead of nine!  
You can build up to the cover you need by additional units

(or  $\frac{1}{2}$  units after the first) up to a maximum of five. So simple. So easy. Apply to your Broker, Agent or local office of a General Accident company.

The Home Unit Policy can replace your existing insurances. And remember - as you buy more possessions just add more Home Units at any time.

# THE YORKSHIRE INSURANCE COMPANY LIMITED

Becket House, 36-37 Old Jewry, LONDON, E.C.2.

It pays to be protected by a **General Accident** company

Please send me further particulars of the Home Unit Insurance.

Name.....

Address.....

52-1-9468

# DENCO (CLACTON) LIMITED

## 355-7-9 OLD ROAD, CLACTON-ON-SEA, ESSEX

Our components are chosen by Technical Authors and Constructors throughout the World for their performance and reliability, every coil being inspected twice plus a final test and near spot-on alignment as a final check.

Our General Catalogue showing full product range	...	...	...	15p
DTB4 Transistor & Valve circuitry for D.P. Coils	...	...	...	15p
DTB9 Valve Type Coil Pack Application circuitry	...	...	...	<b>15p</b>
MD.1 Decoder Circuitry for Stereo Reception	...	...	...	20p

All post paid, but please enclose S.A.E. with all other requests in the interests of retaining lowest possible prices to actual consumers.

# Give us six months, and we'll turn your hobby into a career.

You have a hobby for a very good reason. It gives you a lot of pleasure.

So if you can find a job that involves your hobby, chances are you'll enjoy your work more, and you'll do better work.

Now CDI can help you find such a job. A job where you'll be responsible for the maintenance of a computer installation. A job that pays well too. If you're interested in mechanics or electronics (without necessarily being a

mathematical genius), have a clear, logical mind and a will to work, then we can train you to be a Computer Engineer inside six months.

So give us a call. CDI. We're the Education Division of one of the world's largest computer manufacturers. And we have the experience to know if you can make it. A ten minute talk with us, and you could be on the way to spending the rest of your life with your hobby.

Ring

# 01-637 2171

between 9 a.m. and 9 p.m. and ask for Mr Reckitt

It's quicker and easier to phone, but if you prefer, send this coupon to: Control Data Institute, Wells House, 77 Wells Street, London, W.1.

*Please give me further information.*

Name

Address

Age  Phone  6GI

**CONTROL DATA  
INSTITUTE**

**CONTROL DATA  
LIMITED**

The Education Division of one of the world's largest Computer manufacturers.







# Kit building is so easy

The unique HEATHKIT step-by-step method of construction defies error for the beginner as well as the experienced kit builder

## Economy SW Receiver

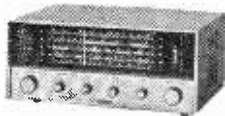

World wide reception.  
1-30MHz plus 550-1620KHz  
Kit K/GR-64 £25.00 Carr. 50p

## FM Stereo Tuner

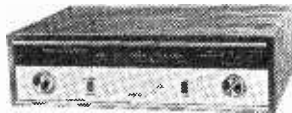

Concert hall realism - Amazing  
low price. Kit K/AJ-14 £27.00  
(Cab. extra) Carr. 40p

## Stereo Amplifier

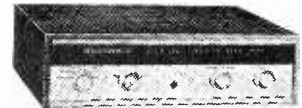

Heathkit unbeatable value -  
20W total power output.  
Kit K/AA-14 £32.00 Carr. 30p  
(Cab. extra)

**'Severn' AM/FM Radio**  
Beautiful looks - luxury sound  
Black 'vynide' case.

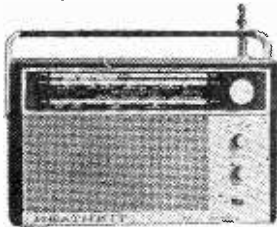

Kit K/Severn £19.90 Carr. 50p

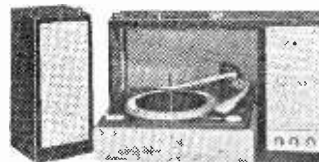

## Stereo Record Player

Exciting sound - budget price.  
Kit K/SRP-1 £32.50 Carr. 80p  
(Teak or Black/Rexine)

## 'Trent' Speaker



Compact size - lowest cost.  
Kit K/Trent £15.20 Carr. 60p  
(Teak or Walnut)



## Deluxe Car Radio

Heathkit value - powerful output.  
Two tone grey plus chrome  
trim. Kit K/CR-1 (less speaker)  
£13.80 Carr. 30p



## Thumb 'Tacho'

Measures RPM on any model  
engine at low cost.  
Kit K/GD-69 £9.50 Carr. 20p

## Electronic Workshop

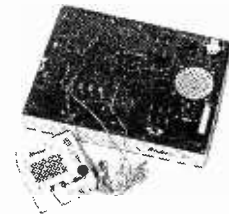

35 exciting experiments.  
Kit K/JK-18 £16.40 Carr 40p

**Hundreds of HI-FI, Radio, Test & other models to choose from.**



A Schlumberger Company

**HEATH (GLOUCESTER) LTD**  
GLOUCESTER GL2 6EE

Please send me FREE Catalogue

Name.....

Address.....

..... Post Code.....

Prices and specification may be subject to change.

53/6/71

# NOW YOU CAN BUILD THESE KITS IN $\frac{1}{4}$ hr TO THREE HOURS

Absolutely no knowledge of Radio Required — No Soldering  
Simple Picture Plans — Easy as ABC Directions

READY BUILT & TESTED

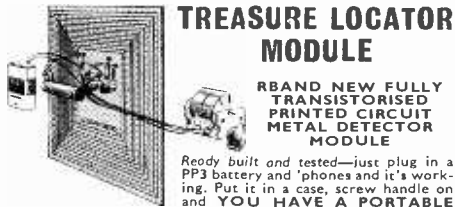

## TREASURE LOCATOR MODULE

REBAND NEW FULLY TRANSISTORISED PRINTED CIRCUIT METAL DETECTOR MODULE

Ready built and tested—just plug in a PP3 battery and 'phones and it's working. Put it in a case, screw handle on and YOU HAVE A PORTABLE TREASURE LOCATOR EASILY WORTH ABOUT £20! Extremely sensitive—penetrates through earth, sand, rock, wood, dirt, water, etc.—

ONLY £4.95 (99/-)

EASILY LOCATES COINS, GOLD, SILVER, WATCHES, JEWELLERY, NUGGETS, METALLIC ORE, HISTORICAL RELICS, BURIED PIPES, KEYS, NAIL-IN-TREES, ETC., ETC. Signals exact location by "beep" pitch increasing as you near buried metallic objects. PRINTED CIRCUIT SEARCH COIL so stable and sensitive it will detect certain objects buried SEVERAL FEET BELOW GROUND! GIVES CLEAR SIGNAL ON ONE COIN! You could even buy for your holiday with two or three days electronic beeping—It's almost like having a licence to print money! Unclaimed treasure now exceeds the combined wealth of all nations. ORDER NOW WHILE PRESENT STOCKS LAST—TREMENDOUS DEMAND EXPECTED AT THIS REMARKABLY LOW PRICE. DEMONSTRATIONS DAILY. ORDERS DESPATCHED IN STRICT ROTATION. SEND NOW £4.95 + 3p (99/-) extra. (High quality Danish Stethoscope headphones £2.75 (55/-) extra if required.)

## EAVESDROP ON THE EXCITING WORLD OF AIRCRAFT COMMUNICATIONS—JUST OUT VHF AIRCRAFT BAND CONVERTER

ONLY £2.37 (47/6)

Many thousands of v.h.f. Aircraft Band Converters now selling in U.S.A. Listen in to AIRLINES, PRIVATE PLANES, JETPLANES. Eavesdrop on exciting cross-talk between pilots, ground approach control, airport tower. Hear for yourself the disciplined voices hiding tenseness on talk downs. Be with them when they have to take nerve-ripping decisions in emergencies—tune into the international distress frequency. Covers the aircraft frequency band including HEATHROW, GATWICK, LUTON, RINGWAY, PRESTWICK, ETC., ETC. CLEAR AS A BELL. This fantastic fully transistorised instrument can be built by anyone nine to ninety in under two hours. (Our design team built four—everyone worked first time.) No knowledge of radio or electronics required. No soldering necessary. Fully illustrated simply worded instructions take you step by step. Uses standard PP3 battery. Size only  $4\frac{1}{2}$ " x  $3\frac{1}{2}$ " x  $1\frac{1}{2}$ ". All you do is extend rod aerial, place close to any ordinary medium-wave radio (even tiny portables).

NO CONNECTIONS WHATSOEVER NEEDED. Use indoors or outdoors. THERE WILL BE ENORMOUS DEMAND FOR THIS NEW DESIGN. SEND NOW ONLY £2.37 (47/6) + 27p (5/6) p. & p. for all parts, including case, nuts, screws, wire, etc., etc. (parts available separately).

## FIND BURIED TREASURE! TREASURE LOCATOR



NOW IT'S HERE AT LAST after experimenting for four and a half months with a multitude of different circuits and carrying out actual field tests with prototypes, our design team have come up with this real winner. This fully portable transistorised metal locator detects and tracks down buried metal objects—signals exact location with loud audible sound (no 'phones used)—uses any transistor radio which fits inside—no connections needed. FINDS GOLD, SILVER, LOST COINS, JEWELLERY, KEYS, WAR SOUVENIRS, ARCHAEOLOGICAL PIECES, METALLIC ORE, NUGGETS, ETC., ETC. Indoors or outdoors. Extremely sensitive, will signal presence of certain objects buried several feet below ground! No knowledge of radio or electronics required. Can be built with ease in one short evening by anybody from nine years of age upwards, with the instructions—It really is easy as A.B.C. Fully illustrated plans. Uses standard PP3 battery. No soldering necessary. Size of detector head  $1\frac{3}{4}$ " x  $10\frac{1}{2}$ " x  $2\frac{1}{4}$ ". Great demand expected at this remarkably low price—ORDER WHILE PRESENT STOCKS LAST. All parts including detector head case, nuts, screws, wire, simple instructions, etc., etc. ONLY £2.37 (47/6) + 27p (5/6) p. & p. (Sectional handle 75p (15/-) extra). Parts available separately. Made up looks worth £15!

ONLY £2.37 (47/6)

wonderfully clear, easy-to-follow, step-by-step, fully illustrated plans. Uses standard PP3 battery. No soldering necessary. Size of detector head  $1\frac{3}{4}$ " x  $10\frac{1}{2}$ " x  $2\frac{1}{4}$ ". Great demand expected at this remarkably low price—ORDER WHILE PRESENT STOCKS LAST. All parts including detector head case, nuts, screws, wire, simple instructions, etc., etc. ONLY £2.37 (47/6) + 27p (5/6) p. & p. (Sectional handle 75p (15/-) extra). Parts available separately. Made up looks worth £15!

## SOOTHE YOUR NERVES, RELAX WITH THIS AMAZING RELAXATRON

CUTS OUT NOISE POLLUTION—SOOTHES YOUR NERVES! Don't underestimate the uses of this fantastic new design—the RELAXATRON is basically a pink noise generator based on avalanche transistors. Besides being able to mask out extraneous unwanted sounds, it has other very interesting properties. For instance, many people find a rainstorm mysteriously relaxing, a large part of this feeling of well-being is directly traced to the sound of falling raindrops!—a well-known type of pink noise. A group of dentists have experimented on patients with this pink noise—NO ANAESTHETICS WERE USED! The noise ostensibly created a most definite reaction on these patients' nervous systems with the results that their pain systems were blocked. IF YOU WORK IN NOISY OR DISTRACTING SURROUNDINGS IF YOU HAVE TROUBLE CONCENTRATING, IF YOU FEEL TENSED, UNABLE TO RELAX—then build this fantastic Relaxatron. Once used you will never want to be without it—use this amazing pink noise generator whenever you feel uneasy, can't relax or wish to concentrate. TAKE IT ANYWHERE, pocket sized. Uses standard PP3 batteries (current use of so small that battery life is almost self-life). CAN BE EASILY BUILT BY ANYONE OVER 12 YEARS OF AGE using our unique, step-by-step, fully illustrated plans. No soldering necessary. All parts including case, a pair of crystal 'phones, components, nuts, screws, wire, etc., etc., no soldering. Send only £2.25 + 25p (45/- + 5/-) p. & p. (parts available separately.)

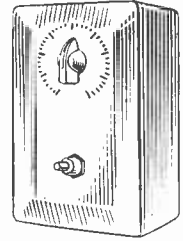

ONLY £2.25 (45/-)

## GET A GOOD NIGHT'S SLEEP—EVERY NIGHT! INGENUOUS ELECTRONIC SLEEP INDUCER

ONLY £2.75 (55/-)



CAN'T SLEEP AT NIGHTS? DO YOU WAKE UP IN THE NIGHT AND CAN'T GET OFF TO SLEEP AGAIN? WOULD YOU LIKE TO BE GENTLY SOOTHED OFF TO SATISFYING SLEEP EVERY NIGHT? Then build this ingenious electronic sleep inducer. It even stops by itself so you don't have to worry about it being on all night! The loudspeaker produces soothing audio-frequency sounds, continuously repeated—but as time goes on the sounds gradually become less and less—until they eventually cease altogether, the effect it has on people is very similar to hypnosis. A control is provided for adjusting the length of times, etc., all transistor, can be built by anyone over 12 years of age in about two hours. No knowledge of electronics or radio needed. Extremely simple, easy-to-follow, step-by-step, fully illustrated instructions included. No soldering necessary. Uses standard PP3 battery—extremely economical. Size only  $3\frac{1}{2}$ " x  $4\frac{1}{2}$ " x  $1\frac{1}{2}$ "—take it anywhere. All parts, including case, loudspeaker, components, nuts, wire, screws, etc., etc. THERE WILL BE A GREAT DEMAND FOR THIS UNIQUE NEW DESIGN—SEND NOW £2.75 + 25p (55/- + 5/-) p. & p. (parts available separately.)



ONLY £1.25 (25/-)

## UNIQUE RADIO FOR BEDROOM OR OFFICE

No Batteries No Electricity Never Wears Out Uses sensitive germanium diode originally evolved from wartime radar. Never buy a battery. Never use electricity. Never replace. Covers all medium waves. Clear beautiful cone. Size only  $4\frac{1}{2}$ " x  $4\frac{1}{2}$ " in beautiful case. ONLY 7 CONNECTIONS AND IT'S WORKING. No soldering necessary. CAN BE BUILT ALMOST BLINDFOLD IN UNDER 15 MINUTES! Ideal for absolute beginners from 8 years of age upwards. ONLY £1.25 + 13p p. & p., all parts including case. Germanium semi-conductor, tuning condenser, personal phone, screws. Simple as A.B.C. INSTRUCTIONS (parts available separately).

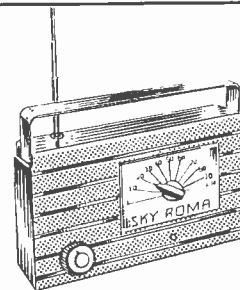

## SHORTWAVE TRANSISTOR RADIO

ONLY £2.25 (45/-)

CAN BE BUILT IN ONE EVENING! At last! After trying countless circuits searching for easy build, work first-time short wave. Giving advanced world-wide performance, we chose this "Sky Song". Anyone from 9 years up can follow the step-by-step, easy-as-A.B.C., fully illustrated instructions. (We built 10 prototypes and every one worked first time.) No soldering necessary. 76 stations logged on rod aerial in 30 mins. —Russia, Africa, U.S.A., Switzerland, etc. Experience thrills of world-wide news, sport, music, etc. Eavesdrop on unusual broadcasts. Uses PP3 battery. Transistorised (no valves). Size only  $3\frac{1}{2}$ " x  $4\frac{1}{2}$ " x  $1\frac{1}{2}$ ". As tremendous demand anticipated price held to only £2.25 (45/-) + 17p (3/6) p. & p. for all parts, including cabinet, screws, instructions, etc. (parts available separately.)

## NEW WORKING ELECTRONIC ORGAN

Don't confuse with ordinary electric organs that simply blow air over mouth-organ type reeds, etc. Eight months were spent in creating and testing this superb, revolutionary electronic organ. Fully transistorised—no valves. Proper self-contained loudspeaker. Fifteen separate keys span two full octaves—play the "Yellow Rose of Texas", play "Silent Night", play "Auld Lang Syne", play lots and lots of similar tunes on this real working electronic organ. Although it's no theatre organ it's certainly no tiny thing, it measures  $1\frac{1}{2}$ " x  $10\frac{1}{2}$ " x  $2\frac{1}{2}$ ". You have the thrill and excitement of building it together with the pleasure of playing a real, live, throbbing electronic organ. Take it anywhere, play on the go. NO KNOWLEDGE OF ELECTRONICS NEEDED—NONE WHATSOEVER. No soldering necessary, it really is as simple as A.B.C. to make. Anyone from 9 years upwards can build it easily in one short evening following the fully illustrated, step-by-step, simply worded instructions. BIG DEMAND ANTICIPATED FOR THIS UNIQUE INSTRUMENT at our low, low building price. ONLY £2.75 (55/-) + 23p (4/6) p. & p. for all parts, including case, loudspeaker, transistors, condensers, resistors, knobs, transformer, volume control, wire, nuts, screws, simple (but full) instructions, etc., etc. Uses standard battery (parts available separately). Have all the pleasure of making it yourself, finish with an exciting gift for someone.



ONLY £2.75 (55/-)

EXAMINE AT HOME FOR 7 DAYS. YOUR MONEY REFUNDED IN FULL IF NOT 100% DELIGHTED.

## CONCORD ELECTRONICS LTD (Dept. RC12)

8 Westbourne Grove, London, W.2. (Nr. Bayswater & Queensway Tubes. 1 minute ABC Cinema). Callers welcome 9 a.m.-6 p.m. inc. Saturday.

# Now! A FAST EASY WAY TO LEARN BASIC RADIO & ELECTRONICS



Build as you learn with the exciting new **TECHNATRON** Outfit! No mathematics. No soldering—you learn the *practical way*.

Learn basic Radio and Electronics at home – the fast, modern way. Give yourself essential technical 'know-how' – like reading circuits, assembling standard components, experimenting, building – quickly and without effort, and enjoy every moment. B.I.E.T.'s Simplified Study Method and the remarkable **TECHNATRON** Self-Build Outfit take the mystery out of the subject, making learning easy and interesting.

Even if you don't know the first thing about Radio now, you'll build your own Radio set within a month or so!

... and what's more, you will understand exactly what you are doing. The **TECHNATRON** Outfit contains everything you need, from tools to transistors – even a versatile Multimeter which we teach you to use. All you need give is a little of your spare time and the surprisingly low fee, payable monthly if you wish. And the equipment remains yours, so you can use it again and again.

**You LEARN – but it's as fascinating as a hobby.**

Among many other interesting experiments, the Radio set you build – and it's a good one – is really a bonus. This is first and last a teaching course, but the training is as fascinating as any hobby and it could be the springboard for a career in Radio and Electronics.

## FREE

### BRITISH INSTITUTE OF ENGINEERING TECHNOLOGY

Dept. B9, ALDERMASTON COURT, READING RG7 4PF

**POST THIS COUPON FOR FREE BOOK**

Please send books and full information – free and without obligation.



NAME \_\_\_\_\_ AGE \_\_\_\_\_

ADDRESS \_\_\_\_\_

**BIET** OCCUPATION \_\_\_\_\_

To B.I.E.T. Dept B9, Aldermaston Court, Reading RG7 4PF



#### New Specialist Booklet

A 14-year-old could understand and benefit from this Course – but it teaches the real thing. The easy to understand, practical projects – from a burglar-alarm to a sophisticated Radio set – help you master basic Radio and Electronics – even if you are a 'non-technical' type. And, if you want to make it a career, B.I.E.T. has a fine range of Courses up to City and Guilds standards.

If you wish to make a career in Electronics, send for your **FREE** copy of 'OPPORTUNITIES IN TELECOMMUNICATIONS / TV AND RADIO'. This brand new booklet – just out – tells you all about **TECHNATRON** and B.I.E.T.'s full range of courses.

# LATEST BOUND VOLUME No. 23

of  
**"The Radio Constructor"**  
**FOR YOUR LIBRARY**

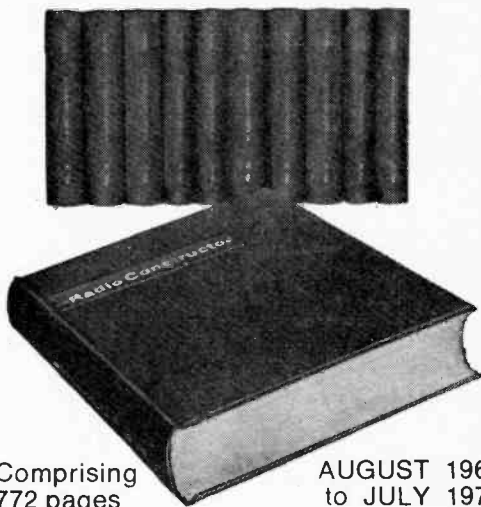

Comprising 772 pages plus index

AUGUST 1969 to JULY 1970

## PRICE £1.88 Postage 28p

#### SPECIAL DISCOUNT OF 50p

If you already have the copies comprising the volume, just cut the heading from each month's contents page, including title and month of issue, and send with your remittance, deducting special discount of 50p.

Thus, while having a splendid bound volume containing issues in mint condition, old copies will be retained for workbench use.

**PRICE £1.38 Postage 28p**

*We regret that, owing to increased costs, the special discount will be discontinued after 30th June next.*

#### Limited Number of Volume 22

**Price £1.75 Postage 28p**

(August 1968 to July 1969) still available  
*We regret earlier volumes now completely sold out.*

Available only from

**DATA PUBLICATIONS LTD.,**  
57 MAIDA VALE, LONDON, W9 1SN



# BI-PRE-PAK LIMITED

## FULLY TESTED AND MARKED

AC107 .15	OC140 .17
AC126 .13	OC170 .23
AC127 .17	OC171 .23
AC128 .13	OC200 .25
AC176 .25	OC201 .25
AC177 .15	2G301 .13
AF139 .13	2G303 .13
AF186 .37	2N1711 .50
AF239 .37	2N1302-3 .20
BC154 .25	2N1304-5 .25
BC171	2N1306-7 .30
= BC107 .13	2N1308-9 .35
BC172	BC113 .10
= BC108 .13	<b>Power</b>
BF194 .15	<b>Transistors</b>
BF274 .15	OC20 .50
BFY50 .20	OC23 .30
BSY25 .37	OC25 .25
BSY26 .13	OC26 .25
BSY27 .13	OC28 .30
BSY28 .13	OC35 .25
BSY29 .13	OC36 .37
BSY95A .13	AD149 .30
OC41 .13	AUY10 1.25
OC44 .13	2N3055 .63
OC45 .13	2S034 .25
OC71 .13	<b>Diodes</b>
OC72 .13	AAY42 .10
OC73 .17	OA95 .09
OC81 .13	OA79 .09
OC81D .13	OA81 .09
OC139 .13	IN914 .09

## CLEARANCE LINES

5L403D Audio Amp. ....	1-10	10-50	50+
IC. 709C Linear Opp. Amp. ....	2.00	1.95	1.80
A.E.I. Fully marked and tested Gates .....	50p	40p	35p
A.E.I. Fully marked and tested Flipflops .....	25p	22p	20p
OC71/72. Fully tested, unmarked .....	50p	40p	30p
Matched Sets, 1-OC44, 2-OC45. Per set .....	5p	5p	4p
Matched Sets, OC45, 1st and 2nd I.F. Per set .....	25p	20p	15p
TIC45 Thyristors .6A, 60V, Texas .....	15p	12p	10p
OA47 Gold bonded Diodes, marked and tested .....	15p	15p	12p
IW Zener Diodes 6.8, 7.5, 24, 27, 30 and 43 volts .....	3p	3p	2p
IOW Zener Diodes 7.5, 11, 13, 20 and 100 volts .....	5p	4p	3p
Micro Switches, S/P, C/O, popular size .....	20p	17p	15p
1 Amp. Bridge Rectifiers, 25V, RMS .....	25p	20p	15p
1 Amp. Plastic Rectifiers. These are voltage, reverse polarity and other rejects from the BY127 range. Ideal for low voltage Power Units, etc. Price: £1 per 100.	25p	22p	20p

**COLOUR T.V. LINE OUTPUT TRANSFORMERS**  
Designed to give 25KV when used with PL509 & PY500 valves. As removed from colour receivers at the factory.  
**ONLY £1 each. Post and Packing .25**

## NEW TESTED & GUARANTEED PAKS

B2	4	Photo Cells, Sun Batteries. 0.3 to 0.5V, 0.5 to 2mA.	50p
B79	4	IN4007 Sil. Rec. diodes, 1,000 PIV 1 amp plastic	50p
B81	10	Reed Switches, mixed types large and small	50p
B99	200	Mixed Capacitor. Postage 13p. Approx. quantity, counted by weight	50p
H4	250	Mixed Resistors. Postage 10p. Approx. quantity, counted by weight	50p
H7	40	Wirewound Resistors. Mixed types and values. Postage 8p	50p
H8	4	BY127 Sil. Recs. 1000 PIV, 1 amp. plastic	50p
H9	2	OC71 Light Sensitive Photo Transistor	50p
H12	20	NKT155/259 Germ. diodes, brand new stock clearance	50p
H18	10	OC71/75 uncodcd black glass type PNP Germ.	50p
H19	10	OC81/81D uncodcd white glass type PNP Germ.	50p
H28	20	OC200/1/2/3 PNP Silicon uncodcd TO-5 can	50p
H29	20	OA47 gold bonded diodes codcd MCS2	50p

**FREE!** Packs of your own choice up to the value of .50 with orders over £4.

## OUR VERY POPULAR 3p TRANSISTORS

FULLY TESTED & GUARANTEED.

- TYPE "A" PNP Silicon alloy, metal TO-5 can. 2S300 type, direct replacement for the OC200/203 range.
- TYPE "B" PNP Silicon, plastic encapsulation, low voltage but good gain, these are of the 2N3702/3 and 2N4059/62 range.
- TYPE "E" PNP Germanium AF or RF - please state on order. Fully marked and tested.
- TYPE "F" NPN Silicon, plastic encapsulation, low noise amplifier, of the 2N3707/8, 9, 10, 11 range

## BULK BUYING CORNER

NPN/PNP Silicon Planar Transistors, mixed untested, similar to 2N706/6A/8, BSY26-29, BSY95A, BCY70, etc.  
**£4.25 per 500. £8.00 per 1,000.**

Silicon Planar NPN Plastic Transistors, untested, similar to 2N3707-11, etc.  
**£4.25 per 500. £8.00 per 1,000.**

Silicon Planar Diodes, DO-7 Glass, similar to OA200/202, BAY31-36.  
**£4.50 per 1,000.**

NPN/PNP Silicon Planar Transistors, Plastic TO-18, similar to BC113/4, BC153/4, BF153/160, etc.  
**£4.25 per 500. £8.00 per 1,000.**

OC44, OC45 Transistors, fully marked and tested.  
**500 plus at 8p each. 1,000 plus at 6p each.**

OC71 Transistors, fully marked and tested.  
**500 plus at 6p each. 1,000 plus at 5p each.**

3823E Field effect Transistors. This is the 2N3823 in plastic case.  
**500 plus, 13p each. 1,000 plus, 10p each.**

1 Amp. Miniature Plastic Diodes  
IN4001 500+ 3p each. 1,000+ 3p each.  
IN4004 500+ 5p each. 1,000+ 4p each.  
IN4006 500+ 6p each. 1,000+ 5p each.  
IN4007 500+ 8p each. 1,000+ 7p each.

## NEW UNMARKED UNTESTED PAKS

B80	8	Dual Trans. Matched O/P pairs NPN, Sil. in TO-5 can.	.50
B83	200	Trans. Makers rejects. NPN/PNP. Sil. & Germ.	.50
B84	100	Silicon Diodes DO-7 glass equiv. to OA200, OA202.	.50
B86	50	Sil. Diodes sub. min. IN914 & IN916 types.	.50
B88	50	Sil. Trans. NPN, PNP. equivalent to OC200/1, 2N706A, BSY95A, etc.	.50
B60	10	7 Watt Zener Diodes. Mixed voltages.	.50
H6	40	250mW. Zener Diodes DO-7 min. Glass Type.	.50
H10	25	Mixed volts 1 1/2 watt Zeners. Top Hat type.	.50
B66	150	High quality Germ. Diodes. Min. glass type	.50
H15	30	Top Hat Silicon Rectifiers. 750mA. Mixed volts.	.50
H16	8	Experimenters' Pak of Integrated Circuits. Data suppd.	.50
H20	20	BY126/7 type Silicon Rectifiers 1A plastic to 100mv	.50

## F.E.T. PRICE

## BREAKTHROUGH !!!

This field effect transistor is the 2N3823 in a plastic encapsulation coded 3823E. It is also an excellent replacement for the 2N3819. Data sheet supplied with device.  
1-10 - 30p, 10-50 - 25p, 50 plus - 20p.

**MAKE A REV. COUNTER for your Car.** The 'TACHO BLOCK'. This encapsulated block will turn any 0-1mA meter into a perfectly linear and accurate rev. counter for **£1 each** any car.

## FREE CATALOGUE AND LISTS for- ZENER DIODES TRANSISTORS, RECTIFIERS FULL PRE-PAK LISTS & SUBSTITUTION CHART

MINIMUM ORDER .50 CASH WITH ORDER PLEASE. Add .10 post and packing per order. OVERSEAS ADD EXTRA FOR POSTAGE.

**P.O. RELAYS 8 FOR**  
Various Contacts and Coil Resistances. No individual selection. Post and Packing .25 **£1**

**FREE! A WRITTEN GUARANTEE WITH ALL OUR TESTED SEMICONDUCTORS**

# BI-PRE-PAK LTD

DEPT. C, 222-224 WEST ROAD, WESTCLIFF-ON-SEA, ESSEX  
TELEPHONE: SOUTHEND (0702) 46344

## Try the Home Radio quiz!



### Ordering components is easier and quicker with our CREDIT ACCOUNT SERVICE . . .

With the Home Radio Credit Account Service you can order components by telephone **any time, any day**. If you phone out of shop hours a recording machine takes your message for us to deal with when we open shop next day. If you want to order by post we provide Order Forms and Prepaid Envelopes. You settle your account just once per month. Of course for ordering your components you first need our Catalogue, and after you have been in the Service 12 months we regularly send you an up-to-date catalogue - FREE!

For full details of our Credit Account Service just drop us a line or phone 01-648 8422.

The answer to the Starter question is obvious - the ubiquitous HOME RADIO COMPONENTS CATALOGUE. You all got that right! And the answer to the Bonus question is - the same! May we explain "this most ingenious paradox"? The price is now 50 pence, **but** with each catalogue we now include 10 vouchers each worth 5 pence, when used as directed. This means that if you spend a quite modest sum in ordering components from us over a period the catalogue will have cost you **nothing** - bar 20 pence for post and packing. So then - for today's most useful electronics catalogue, 50p if you call and collect, or 70p if you send the coupon with a cheque or Postal Order. Join the winning team - **act now!**

### POST THIS COUPON NOW

**with your Cheque or P.O. for 70p**

The price of 70p applies only to catalogues purchased by customers in the U.K. and to BFPO addresses.



Please write your Name and Address in block capitals

Name \_\_\_\_\_

Address \_\_\_\_\_  
\_\_\_\_\_  
\_\_\_\_\_



HOME RADIO (COMPONENTS) LTD., Dept. RC,  
234-240 London Road, Mitcham, Surrey CR4 3HD.

# THE Radio Constructor



Incorporating THE RADIO AMATEUR

JULY 1971

Vol. 24 No. 12

## CONTENTS

Published Monthly (1st of Month)  
First Published 1947

Editorial and Advertising Offices  
57 MAIDA VALE LONDON W9 1SN

Telephone 01-286 6141      Telegrams Databux, London

© Data Publications Ltd., 1971. Contents may only be reproduced after obtaining prior permission from the Editor. Short abstracts or references are allowable provided acknowledgement of source is given.

Annual Subscription: £2.70 (U.S.A. and Canada \$6) including postage. Remittances should be made payable to "Data Publications Ltd." Overseas readers please pay by cheque or International Money Order.

Technical Queries. We regret that we are unable to answer queries other than those arising from articles appearing in this magazine nor can we advise on modifications to equipment described. We regret that such queries cannot be answered over the telephone; they must be submitted in writing and accompanied by a stamped addressed envelope for reply.

Correspondence should be addressed to the Editor, Advertising Manager, Subscription Manager or the Publishers as appropriate.

Opinions expressed by contributors are not necessarily those of the Editor or proprietors.

Production.—Letterpress.

THE 'STEREOSIM'	718
MULLARD JUBILEE ROSE COMPETITION	724
NOTES ON SEMICONDUCTORS - 5	725
TRANSISTOR GAIN METER (Suggested Circuit No. 248)	726
TELEPHONES FOR THE DEAF AND BLIND	728
NOW HEAR THESE	729
NEWS AND COMMENT	730
PUSH-BUTTON REMOTE CONTROL	732
ANIMATED ANIMALS	734
QSOX	737
FINDING FERRITE FRAME TURNS	738
I.C. STEREO AMPLIFIER	740
LATIN AMERICAN QUEST - 4	750
UNDERSTANDING BASIC PRINCIPLES (Part 5)	753
CURRENT SCHEDULES	757
IN YOUR WORKSHOP	758
INDEX	770
RADIO CONSTRUCTOR'S DATA SHEET No. 52 (P.N.P./N.P.N. Transistor Lead-outs)	iii

Published in Great Britain by the Proprietors and Publishers, Data Publications Ltd, 57 Maida Vale London, W9 1SN.

The Radio Constructor is printed by Kent Paper Company Ltd, London and Ashford, Kent.

**AUGUST ISSUE WILL BE  
PUBLISHED AUGUST 1st**

# THE 'STEREOSIM'

by

SIR DOUGLAS HALL, K.C.M.G., M.A.(Oxon)

**Consisting of a two-channel stereo a.f. amplifier and medium and long wave tuner, the 'Stereosim' provides full stereo reproduction with gramophone records, and a quasi-stereo effect with mono radio transmissions. No claims are made that the latter is true stereo, but the effect is comparable with that given by 'enhanced' recordings cut from an original mono source**

THE APPARATUS TO BE DESCRIBED in this article gives results which are unusual, as it produces quasi-stereophonic sound from Radio 2 on 1500 metres and from one local medium wave station of the listener's choice. While the effect is not, of course, as good as that obtained from first class stereo records, cut as such, it is, in the opinion of the author and of a musical friend, quite up to that produced by the increasingly common electronically altered stereo records which are variously described as 'enhanced' or 'transcription' and have been produced from original mono cuttings. The apparatus is also suitable for true stereo reproduction from stereo records.

The quasi-stereo effect on radio is produced by providing two detectors after the r.f. tuning stage, and two a.f. pre-amplifiers, one giving maximum amplification at the lowest audible frequencies, and

the other giving maximum amplification at the highest audible frequencies. The two outputs are fed to the two channels of a stereo amplifier and, as a result, one speaker reproduces low audio frequencies up to about Middle C, and the other the higher frequencies from Middle C upwards. The effect is that extreme bass comes from one speaker, and extreme treble from the other, but all other frequencies appear in breadth and depth between the two speakers.

Although quasi-stereo reception from Radio 2 should be found possible in most parts of the United Kingdom, it should be emphasised that a fairly strong signal is essential for best results, or else the necessary consequent adjustments within the apparatus to bring up the signal strength will reduce the treble response and the apparent stereo effect. For this reason a short aerial is used for Radio 2 instead of a ferrite aerial.

The apparatus is made in three separate units and there are no difficulties in construction, it can be undertaken by anyone who can use a soldering iron, a test meter, and simple tools, and who can recognise components. Although there are a few setting up adjustments, each of these is very simple. A glance at the Component Lists will show that the number of items required is not large, especially for apparatus which uses a total of 11 semiconductors.

It is suggested that the amplifier be made first, followed by the power pack. It will then be possible to use the apparatus for stereo record reproduction while the tuning-cum-pre-amplifier unit is being built, and to ensure that the amplifier is working correctly. For this reason components have been numbered accordingly rather than starting from the left of the circuit diagram, which is shown in Fig. 1.

## THE AMPLIFIER

The amplifier is shown between the dashed lines AB and CD. As the two channels are identical when used on gramophone it is only necessary to trace the signal through one channel. The switch, S1, is shown switched for gramophone reproduction in Fig. 1.

The signal is applied from the pickup cartridge to VR1A, which is one half of a ganged dual potentiometer used as a balance control on gramophone (but not on radio) to ensure equal acoustic volume from each channel, and thence to the volume control VR2A, which is also one half of a dual ganged potentiometer. TR1A is wired as a common collector device and offers a high input impedance for the cartridge when VR2A is at maximum. With VR2A set to a low volume level, the input impedance of TR1A is lowered by negative feedback. However, the high proportion of VR2A now in series with the cartridge still maintains a high load impedance for it.

TR1A is directly coupled to TR2A, a common emitter amplifier which, in turn, is directly coupled to TR3A. TR3A is a p.n.p. power transistor wired in the common collector configuration with a 25Ω speaker in its emitter circuit. Bias for all three transistors is settled by VR4A. This is adjusted once and for all to a setting which allows half the available direct voltage to be dropped across the speaker, thus giving conditions of maximum undistorted output.

VR3A, again one half of a dual ganged potentiometer, is a tone control. When the resistance it inserts into circuit is at maximum, negative feedback through VR2A and C1A is at maximum. This feed-



*The completed stereo record-player and receiver*



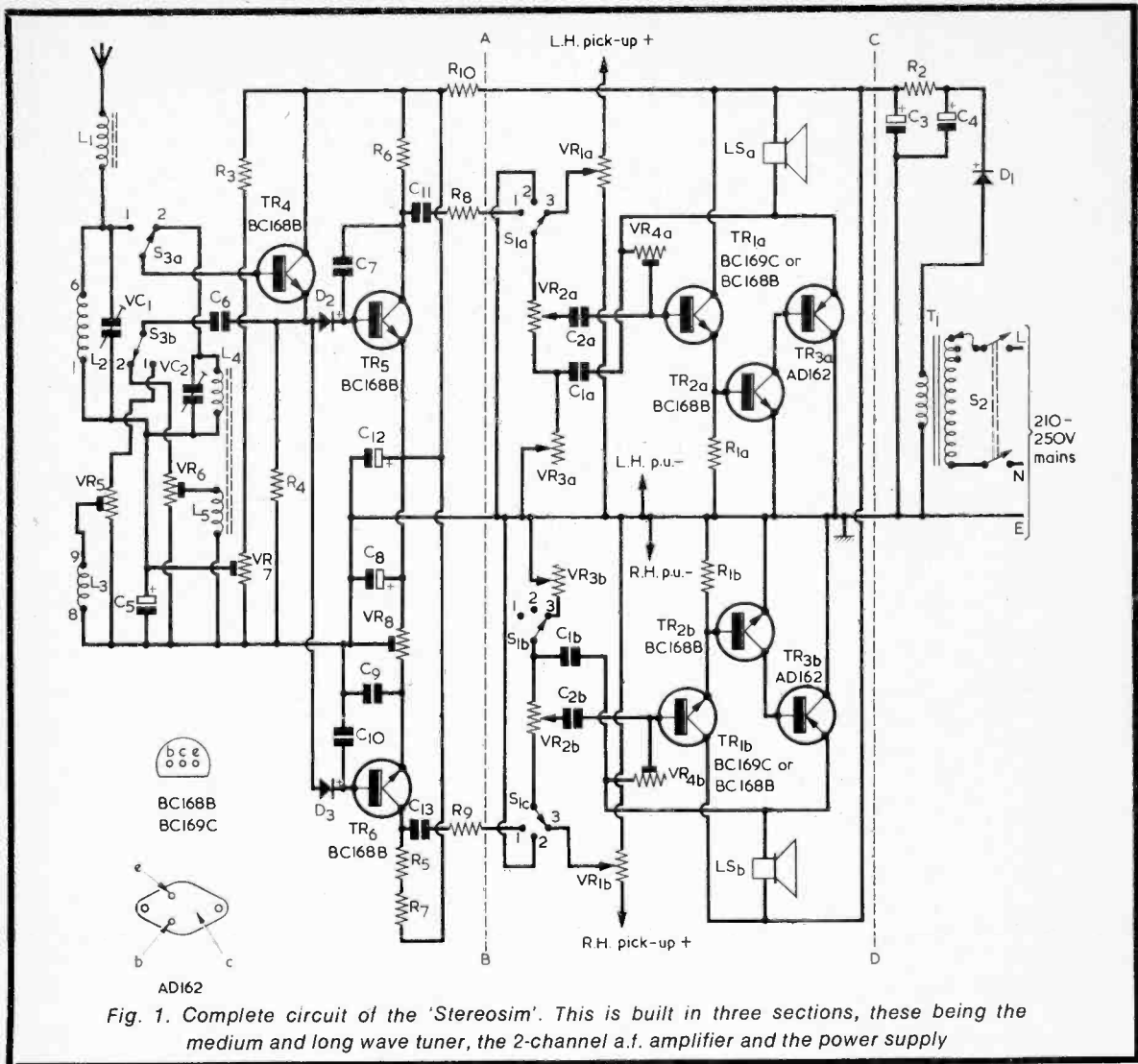
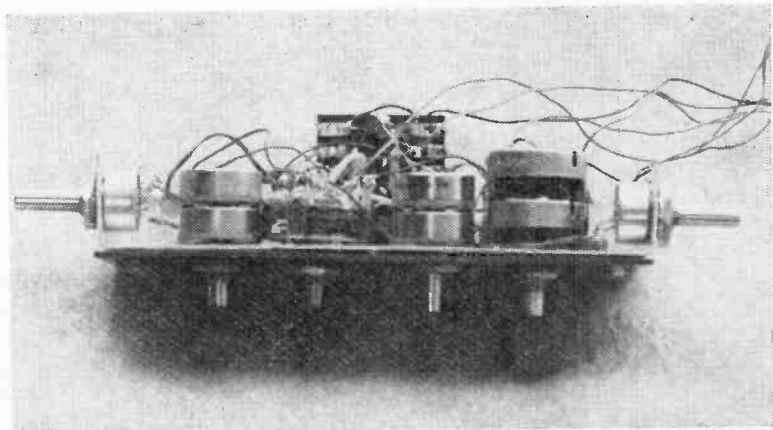

Fig. 1. Complete circuit of the 'Stereosim'. This is built in three sections, these being the medium and long wave tuner, the 2-channel a.f. amplifier and the power supply

back is at its greatest at high audio frequencies owing to the potentiometer effect of C1A and VR3A. At 50Hz C1A offers an impedance of about 60kΩ and only about one-seventh of the voltage across the combination of C1A and VR3A is fed back. As the resistance of VR3A is reduced, the differential effect between the higher and lower audio frequencies becomes less until, at zero resistance in VR3A, the feedback by way of VR3A and C1A becomes nil for all frequencies, though some feedback through VR4A still remains. VR3A therefore becomes a treble lift control at the position of minimum resistance. For best results on most records VR3A should be set close to or at the position which inserts maximum resistance into circuit, in practice this being fully clockwise.

JULY 1971



The 2-channel a.f. amplifier ready for fitting to the gram deck plinth

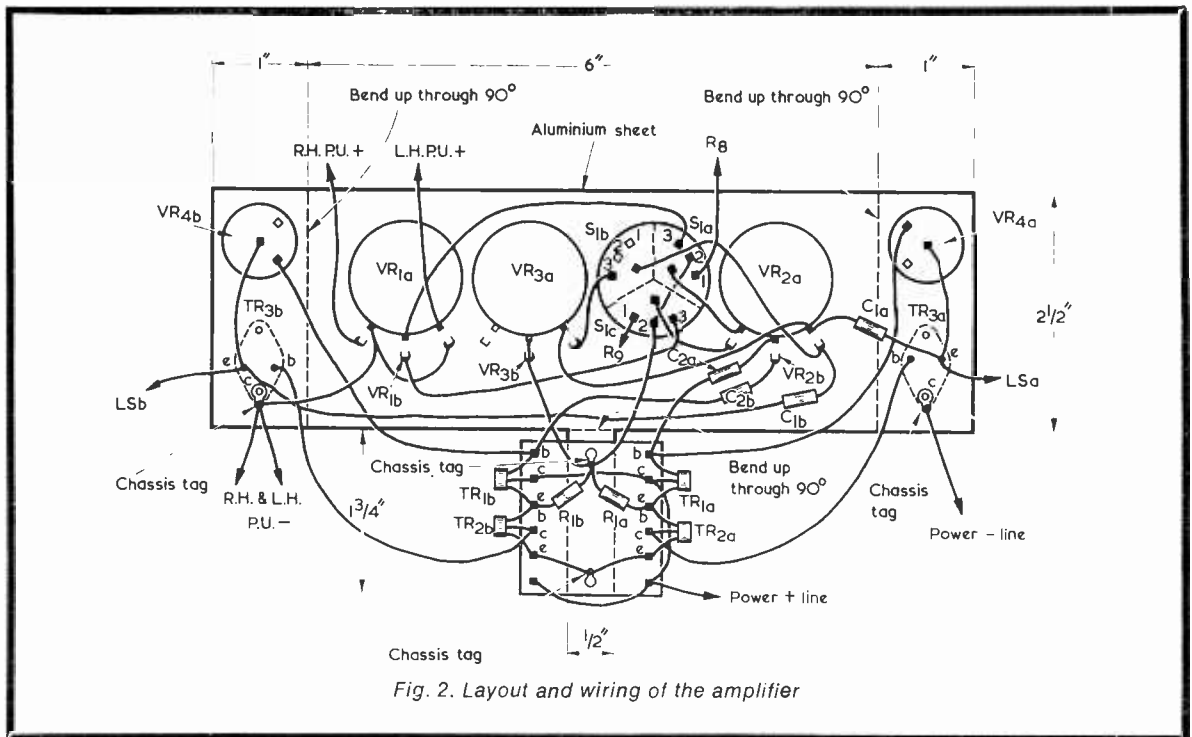

Fig. 2. Layout and wiring of the amplifier

### AMPLIFIER CONSTRUCTION

The practical arrangement for the amplifier section appears in Fig. 2. Components are mounted on a piece of aluminium which will be seen to consist of a rectangular section with a narrow tongue  $\frac{1}{4}$  in. wide protruding from the middle of one long side, on which a miniature 6-way tagboard is mounted. Bending should be done, as shown, after the metal has been drilled, but before components are mounted. No mica washers are needed for the two power transistors as their collectors are at negative line potential and are automatically so connected when mounted in position. When the two 1 in. ends of the aluminium have been bent up and VR4A and VR4B have been fitted, the spindles of these two controls project outwards. Since VR4A and VR4B are used as preset components their spindles are not fitted with knobs.

VR1A/B, VR2A/B and VR3A/B were obtained from Alpha Radio, 103 Leeds Terrace, Winton Street, Leeds 7, who also supplied the two speakers. VR4A and VR4B were obtained from LST Electronic Components, Ltd., who will also supply the two power transistors. Some dealers will only supply these as part of a pair with AD161 which is not required for this design. All other transistors used were obtained from Amatronix, Ltd.

When the amplifier has been completed as shown in Fig. 2, the power section may be made. This is a simple assembly. Its circuit appears on the right of the dashed line CD in Fig. 1, and its layout is shown in Fig. 3. T1 is a Radiospares filament transformer obtainable from many dealers including Home Radio, and the two large electrolytic capacitors are obtainable from Henry's Radio and others. Although the smoothing resistor, R2, is only  $4.7\Omega$  it provides an excellent degree of smoothing because of

the large capacitance of C3. Components are mounted on a piece of plywood measuring 8 in. by  $2\frac{1}{2}$  in. The power supply assembly also includes the two speaker phono sockets.

It is, of course, necessary to provide the gram deck with a suitable plinth in order that it may be correctly operated. This plinth should be made of wood and may have general dimensions to suit the deck employed. The deck used by the author is the Garrard SP25 Mk. II. The power supply, amplifier

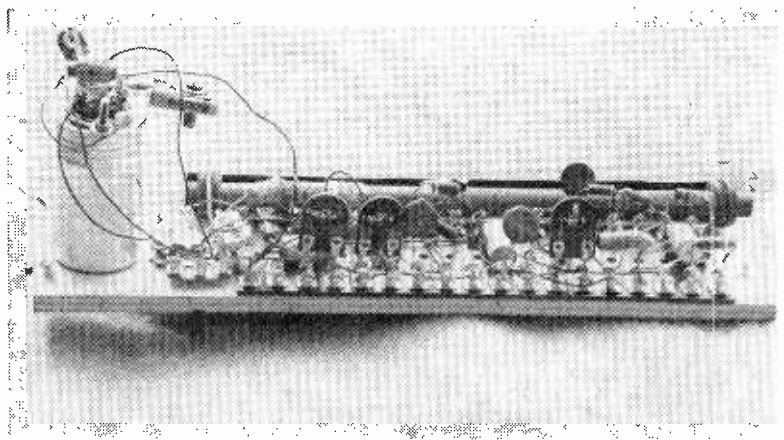

The receiver section. Note the round screening can in which the long wave aerial coil is mounted

and tuner unit are mounted on three sides of the plinth underneath the deck as shown in Fig. 5, so that the only dimensional requirements are that a depth of at least 2½ in. should be available and that the side which takes the tuner section must be at least 10 in. in length. For the time being, only the amplifier and power supply are being fitted. These should be installed as shown in Fig. 5 and the appropriate wiring carried out. At this stage, two wires, each about 12 in. long may be connected to tags 1 of S1(a) and S1(c) (see Fig. 2). These will later be connected, shortened as necessary, to the appropriate points in the tuner unit. It will be necessary to provide suitable holes in the plinth for the amplifier controls and for the mains switch and speaker sockets.

### SETTING-UP

After the units have been connected up, VR4A and VR4B are both set to insert maximum resistance. The speakers are plugged in and the mains supply is switched on. The direct voltage across C4, with the power unit under load, will be about 13 volts, with about 11 volts appearing across C3. A voltmeter should be set to give a clear reading of 5.5 volts, and clipped across LSA, VR4A being then adjusted so that a reading of between 5 and 6 volts is shown. 5.5 volts is ideal, but anything between 5 and 6 volts will do. Now repeat the performance for the other channel, and then return to channel A to make sure that the reading is correct, as an alteration in the load given by adjusting the second channel will slightly affect the direct voltage available. The process should be repeated until a final reading of 5.5 volts is given in each case. If this should prove impossible, on either channel, replace the direct lead between the centre tag of VR4 and the emitter of TR3 with a 6.8MΩ resistor. If, however, a high reading is given which is little affected by adjustment of VR4, the insulation of C1 or C2, or both, should be suspected and these components should be replaced. This trouble is very unlikely to occur if good new capacitors are used.

The amplifier is now complete and ready for use. It will be fully loaded by about 100mV and the Acos 94-1 ceramic cartridge was found ideal and not unduly expensive. VR1A/B may be adjusted to give correct balance between the two channels. Normally this will be given around its centre setting.

### TUNER SECTION

The tuner section may next be dealt with. The theoretical circuit

## COMPONENTS

#### Resistors

- R1A, R1B Each 2.2kΩ ½ watt 10%
- R2 4.7Ω 1 watt wirewound
- VR1A, VR1B Dual potentiometer, each section 1MΩ linear
- VR2A, VR2B Dual potentiometer, each section 2MΩ log
- VR3A, VR3B Dual potentiometer, each section 10kΩ log
- VR4A, VR4B Each 10MΩ potentiometer, linear

#### Capacitors

- C1A, C1B Each 0.05μF, paper or plastic foil
- C2A, C2B Each 0.1μF, paper or plastic foil
- C3 5,000μF electrolytic, 12V wkg.
- C4 2,000μF electrolytic, 15V wkg.

#### Transformer

- T1 Mains transformer, secondary 13V 0.5A (Home Radio Cat. No. TH5D)

#### Semiconductors

- TR1A, TR1B Each BC169C or BC168B
- TR2A, TR2B Each BC168B
- TR3A, TR3B Each AD162
- D1 Rectifier type DD000 (Lucas)

#### Switches

- S1 D.P.S.T., toggle
- S2 3-pole 3-way, miniature rotary

#### Speakers

- LSA, LSB Each 7in. by 4in., (see text)

#### Cartridge

- Acos GP94-1

#### Miscellaneous

- 6-way miniature tagboard (Home Radio Cat. No. BTS13)
- Aluminium panel, 8in by 4½in.
- 2 phono plugs and sockets
- Clamps for C3, C4 and mains cable
- Plywood, screws, etc.

### TUNER SECTION

#### Resistors

- (All fixed values ½ watt 10%)
- R3 18kΩ
- R4 4.7kΩ
- R5 33kΩ
- R6 10kΩ

- R7 10kΩ
- R8 100kΩ
- R9 100kΩ
- R10 1kΩ
- VR5 10kΩ, miniature skeleton preset potentiometer
- VR6 5kΩ, standard skeleton preset potentiometer
- VR7 5kΩ, standard skeleton preset potentiometer
- VR8 5kΩ, standard skeleton preset potentiometer

#### Capacitors

- C5 100μF electrolytic, 2.5V wkg.
- C6 0.01μF, paper or plastic foil
- C7 560pF, mica or ceramic
- C8 100μF electrolytic, 2.5V wkg.
- C9 0.1μF, paper or plastic foil
- C10 0.001μF paper or plastic foil
- C11 0.1μF, paper or plastic foil
- C12 100μF electrolytic, 12V wkg.
- C13 0.002μF, paper or plastic foil
- VC1 Mica trimmer, 250pF maximum
- VC2 Mica trimmer (see text)

#### Coils

- L1 2.5mH r.f. choke type CH1 (Repanco)
- L2, L3 Miniature Dual-Purpose coil, valve type, Blue, Range 1 (Denco)
- L4, L5 Home-wound on ferrite rod 8in. by ¼in. dia. (see text)

#### Semiconductors

- TR4 BC168B
- TR5 BC168B
- TR6 BC168B
- D2 OA91
- D3 OA91

#### Switch

- S3 2-pole 2-way, miniature rotary

#### Miscellaneous

- 18-way standard tagboard (Home Radio Cat. No. BTS10)
- B9A valveholder
- Plywood, screws, etc.

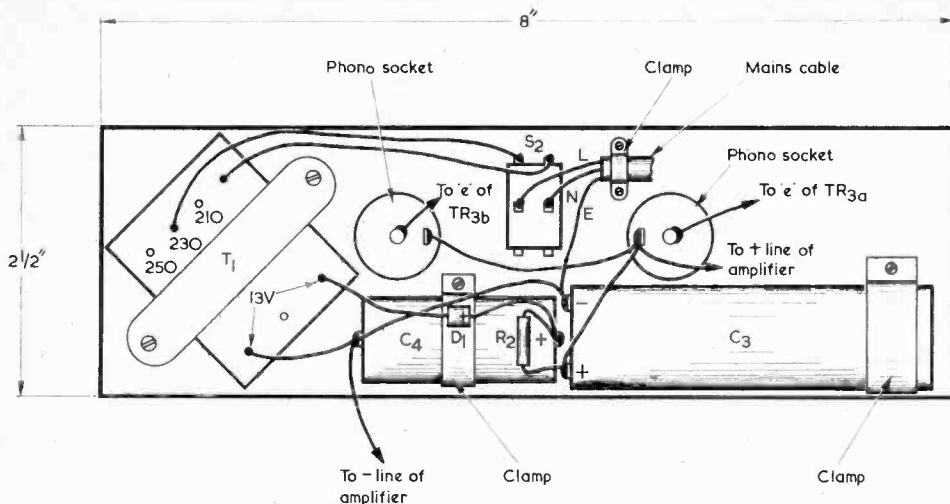

Fig. 3. How the power supply section is assembled. The constructor should connect to the primary tap of the mains transformer corresponding to his local mains voltage. The 230V tap is suitable for 240V mains

appears to the left of the dashed line AB in Fig. 1. S3 is seen switched to position 2 for the medium wave section. S1 should be considered as being turned to contacts 1. (The earthed contacts marked 2 on this switch provide screening and prevent any possible break-through of radio when listening to records.)

TR4 is a common collector radio frequency amplifier with the whole of the tuned circuit between base and earth. Output is taken from the emitter and provision for medium wave reaction is made through L5, VR6 and C6. It will only be necessary to advance VR6 a very short distance from zero setting. Excessive reaction must be avoided or results will be distorted and the apparent stereo effect minimised.

Reception on 1,500 metres is obtained by setting S3 to position 1, whereupon L2 and L3 are brought into a circuit similar to that used for L4 and L5. Reaction is provided in this case by VR5. L2, L3 are the windings on a standard coil in the Denco range and this, in the practical version, is mounted inside the screening can in which the coil is supplied. Choke L1 is included in circuit to prevent break-through of medium wave signals.

The amplified (as to current) radio frequency signal from TR4 is applied to two diodes, D2 and D3, D2 feeding a bass amplifier, TR5, and D3 feeding a treble amplifier, TR6. TR5 collector load, R6, is a 10kΩ resistor, and negative feed-

back of the higher audio frequencies takes place via C7. The collector load of TR6 consists of two resistors in series, R5 and R7, these providing a total resistance of 43kΩ. The only reason for splitting the load in this manner is to simplify the setting-up process, which will be described later. Negative feedback of the lower audio frequencies is given by the small-value capacitor, C9. In addition, the lower frequencies are attenuated by the small capacitance of coupling capacitor C13. R8, R9 and C10 are included to give stability. R10 and C12 provide decoupling and reduce hum.

It will be seen that VR3B is switched out of circuit on radio, though VR3A remains. As this control acts only on the bass amplifier, it gives bass boost as resistance is reduced. This is the opposite effect to that given on gramophone. Its function on radio is as a balance control. It is adjusted so that the middle frequencies - e.g. the human voice - appear about half way between the speakers. Balance is made possible because the treble amplifier, TR6, with its larger collector load, gives greater amplification than TR5. Balance is then achieved when negative feedback is reduced in the bass channel by adjusting VR3A.

#### TUNER ASSEMBLY

Details for construction of the tuner section are shown in Fig. 4, which is largely self-explanatory.

Many of the components are mounted on a standard 18-way tagboard which, in turn, is mounted on a piece of plywood measuring 10in. by 2½in. The ferrite rod assembly is fitted on a piece of Paxolin fixed to the edge of the plywood so that the Paxolin and plywood are at right angles. L4 has 65 turns of 32 s.w.g. enamelled wire, close-wound, and L5 has six turns of similar wire, also close-wound. The two windings are separated by ¼in. The rod is attached to the Paxolin by means of a grommet at each end and cord passing through suitable holes in the Paxolin. If the medium wave station is below about 220 metres VC2 should have a maximum capacitance of 50pF. 150pF is suitable for stations between 220 and 330 metres and 300pF for stations above 330 metres.

Coil L2, L3 is mounted in its can, which is screwed through its bottom to the plywood board. A hole is cut in the lid and a B9A valveholder bolted to the lid with the body of the valveholder and its tags facing outwards. The coil is then inserted into the holder and the lid screwed onto the can, with the coil inside, upside down, before the socket tags are wired up. Note that one unused socket tag, tag 3, is used as an anchor for the choke, L1.

For clarity, potentiometers VR6, VR7 and VR8 are shown laid out flat in Fig. 4. In practice they should be soldered into circuit so that they appear above the tags to which



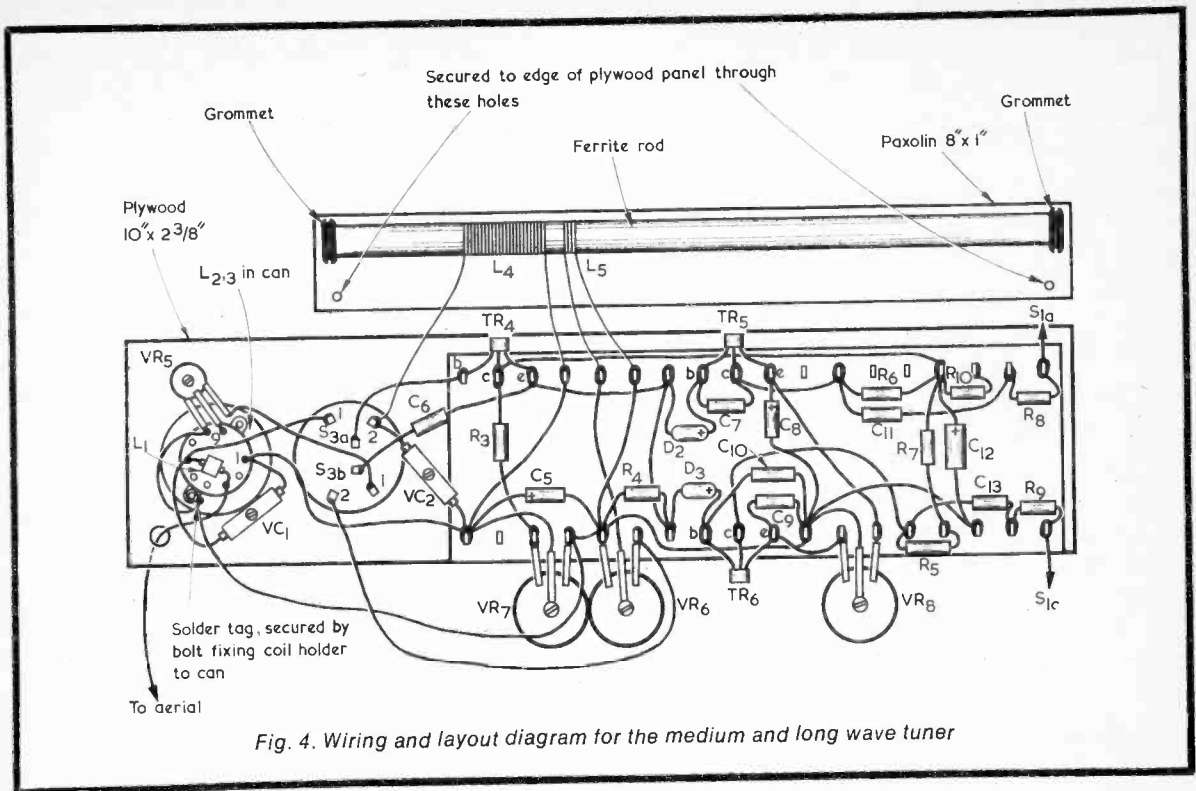

Fig. 4. Wiring and layout diagram for the medium and long wave tuner

they connect and do not project outside the edge of the board.

### RECEIVER ADJUSTMENTS

To set up the receiver, turn S3 to position 2, adjust VR7 fully anti-clockwise (anti-clockwise as shown in Fig. 4), VR6 fully clockwise (also as shown in Fig. 4) and VR8 to the central position. Set up a meter with a sensitivity of 10kΩ or more per volt to a range with a maximum of not less than 10 volts. Connect this meter across R6, with its positive lead to the junction of R6 and R10. Switch on the mains, and turn VR7 in a clockwise direction until a reading of exactly one volt is shown on the meter. Switch off, set the meter to read 1mA full scale, and connect it between the junction of R6 and TR5 collector and the junction of R7 and R5. Switch on again and watch for any movement of the meter needle, which should stay at or very near zero. If there is any movement of the needle, in either, direction adjust VR8 until a zero reading is given. Then switch the meter to give a full scale reading of 100 or 50μA and readjust VR8, if necessary, to give a zero reading. This last adjustment is a refinement and may be omitted if 1mA is the lowest current range given by the meter.

The object of these adjustments of VR7 and VR8 is to arrange that

TR5 and TR6 each pass a current of about 100μA.

Next, set VR6 a few degrees from its zero position and adjust VC2 until the desired medium wave station is tuned in. The setting of VR6 should be such as to provide

full loading of the amplifier with the volume control, VR2, set about 60° below maximum. The ferrite rod is directional and the plinth should be orientated for best results. If treble response is poor, connect a 10pF capacitor between

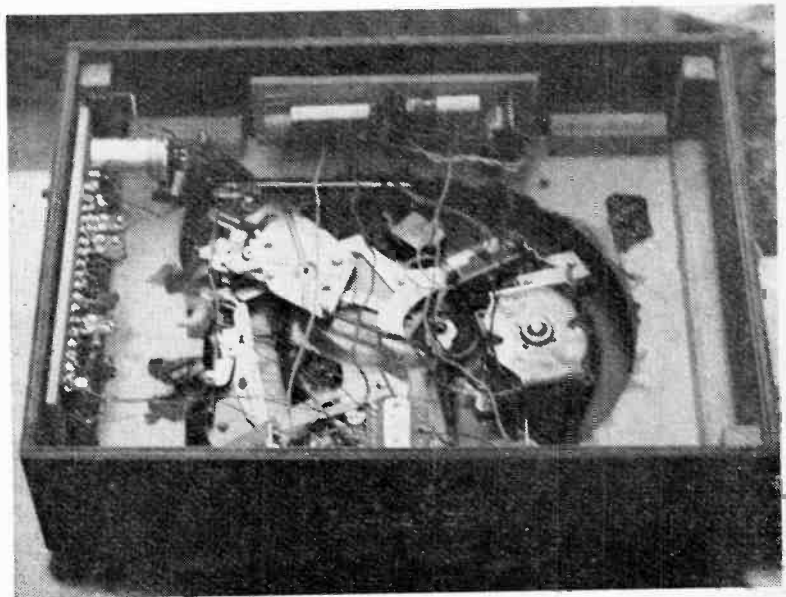

View underneath the gram deck. The power supply section may be seen at the rear

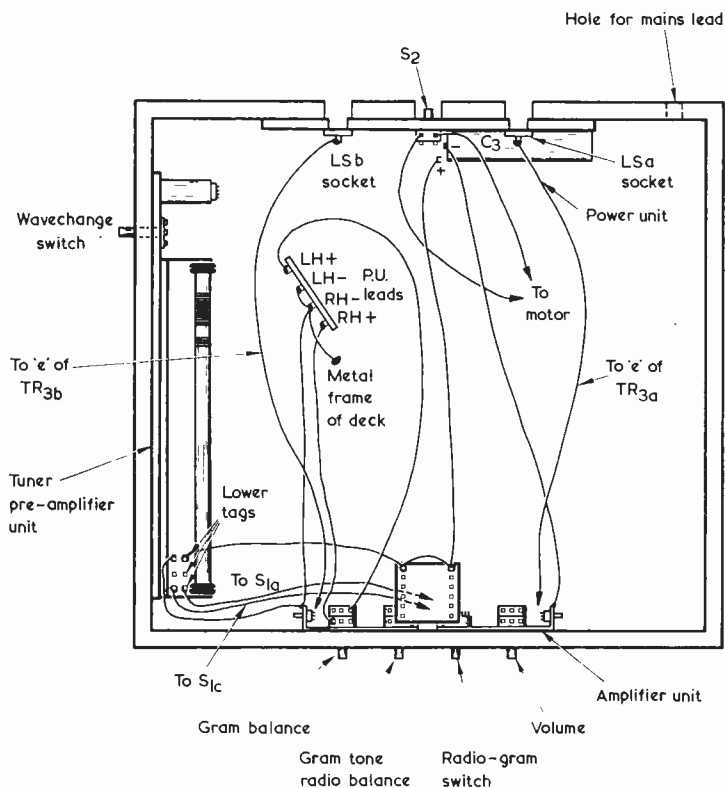

Fig. 5. The three assemblies fit to the underside of the gram deck plinth in the manner shown here

the end of L1 connected to the aerial and the contact of S3(a) marked 2. This will increase the input signal and allow VR6 to be turned back a little.

Now turn S3 to position 1 and adjust VC1 and VR5 so that Radio 2 is received, again with full loading of the amplifier at a setting of about 60° below maximum in VR2. The length of aerial for Radio 2 depends on the strength of the signal received. If the aerial is too short there will be a loss of the higher audio frequencies due to the need to raise sensitivity by setting VR5 to give excessive reaction. If the aerial is too long there may be interference from Continental long wave stations. A very short wire will suffice in some areas. At the author's home in South Devon about 20ft. of wire slung under the ceiling proved best.

Finally, it is really important to mount the speakers in large cabinets, and 18in. by 12in. by 6in. is recommended as minimum. These small speakers will produce excellent bass if housed in suitable cabinets. On the other hand, results will be very disappointing if they are encased in small boxes, and the sound will be no better than that given by the average portable receiver. The speakers should be connected for correct phase, the same terminals of each coupling to the phono socket inner and outer terminals.

## MULLARD JUBILEE ROSE COMPETITION

The Mullard Jubilee rose, created last year by Sam McGredy of Northern Ireland to celebrate the company's 50th anniversary, made a considerable impact on the world of horticulture, being awarded a Gold Medal of the National Rose Society. Thousands of these roses have been grown by amateur gardeners.

Following this, Mullard have announced their Rose Picture Competition, which is open to residents of the United Kingdom. Here are the details:

- Entrants are invited to submit a colour photograph (a print, not a transparency) or a painting in oils or water colours of a single Mullard Jubilee rose or a group of not more than 12.
- The rose or roses depicted must have been grown\* by the competitor and the entry must be solely his or her work. Not more than one photograph or one painting can be accepted from the same competitor.
- There are two sections to the competition: one for the general public and one for Mullard employees. Prizes and conditions are the same for both sections.
- Photographs must not exceed 12in x 10in. Paintings may be any size. All entries must be labelled on the back with the name and address of

the competitor in block capitals. In addition, photographs (which may have a matt or glossy finish) should carry such details as type of camera and film used, exposure time, aperture setting and other relevant information.

- Winning entries will become the property of Mullard Ltd. In addition, the company reserves copyright of them.

### Panel of Experts

The following prizes will be awarded for the best photographs and the best paintings in both public and employee sections as judged by a panel representing, photography, art and horticulture.

- 1st - £75.00
- 2nd - £50.00
- 3rd - £25.00

In all disputes the decision of the panel is final.

Entries must reach the address below by August 31st, 1971. Results will be announced in September, followed by a presentation of prizes in London.

Rose Picture Competition,  
Mullard Ltd.,  
Mullard House,  
Torrington Place,  
London, WC1E 7HD

\*planted and generally cared for.

The two-terminal transistor device described here is capable of offering a continuously variable stabilized voltage

## 5. THE AMPLIFIED DIODE

by  
**PETER WILLIAMS**

**B**EFORE MOVING ON TO THE MORE NORMAL APPLICATIONS of the transistor in amplifiers, oscillators, etc., there is yet another mode in which a transistor can give us a well-defined voltage over a range of currents. It is of great interest because with it we can fill in the gap between a single forward-biased diode at 0.6 volt and the low value Zeners at about 3 volts.

### ADJUSTABLE REGULATION

In Fig. 1 is a transistor having a potential divider between collector and emitter with the base tapped into it. For high gain transistors, and providing the current in the resistors is much greater than the base current,

$$V_{ce} = \frac{R_2 + R_1}{R_1} V_{be}$$

If the intended operating current is known,  $R_1$  may be chosen to carry, say half, at a nominal voltage drop of 600mV ( $V_{be}$ ) and  $R_2$  can be made variable to achieve any desired total voltage drop from  $V_{be}$  upwards to the breakdown voltage of the transistor. Hence the circuit becomes equivalent to  $n$  diodes in series where  $n$  may be any number from unity up, including fractions if needed. It then becomes ideal, for example, for biasing the output transistors in a Class-B audio amplifier since it can be adjusted to bias them to any desired current. For a quasi-

JULY 1971

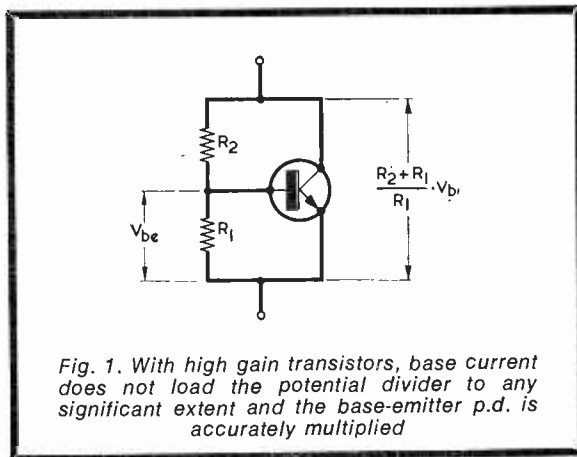

Fig. 1. With high gain transistors, base current does not load the potential divider to any significant extent and the base-emitter p.d. is accurately multiplied

complementary output as in Fig. 2, three diodes would be required and selection would be a real problem – often a variable resistor in series is needed. In such cases it is difficult to match the temperature drifts since two diodes and a resistor may have to balance the  $V_{be}$ 's on three transistors. This biasing arrangement is likely to become standard on audio power amplifiers, and is already appearing in recent designs.

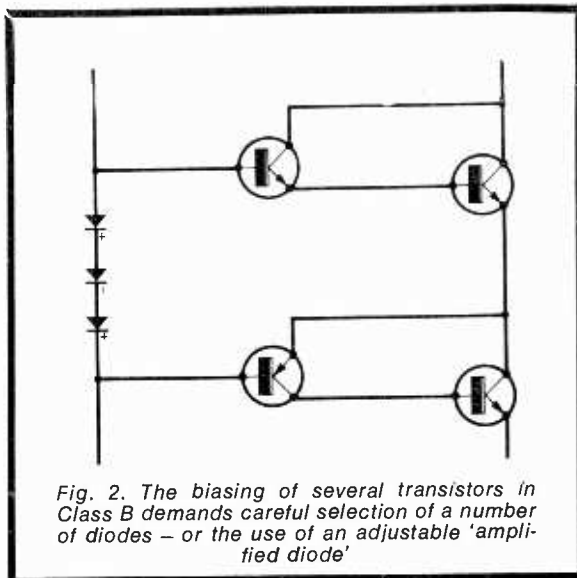
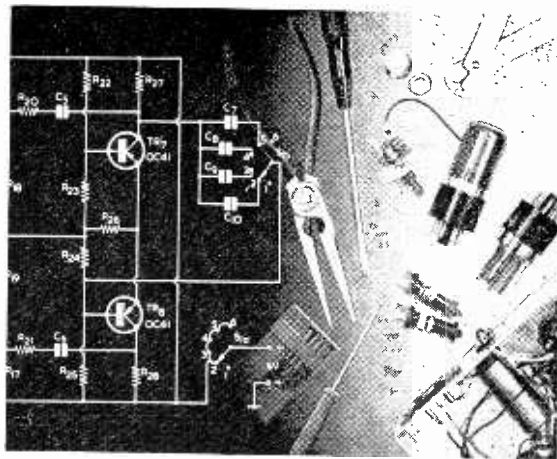

Fig. 2. The biasing of several transistors in Class B demands careful selection of a number of diodes – or the use of an adjustable 'amplified diode'

How does the amplified diode compare with Zener diodes in performance? Simply, it is less exact but more flexible. A 20% change in current usually gives a little over 1% change in voltage across it, regardless of setting, and this is adequate. The temperature drift must have the same percentage value as that of the diode of which it is a multiple, i.e. about  $-2\text{mV}/^\circ\text{C}$  in 600mV or  $-0.3\%/^\circ\text{C}$ . For home and laboratory use this probably means that the voltage will have an overall stability of about  $\pm 3\%$ . With the very low cost of planar transistors this makes the amplified diode well worth considering for simple stabilisers, particularly since its effective breakdown voltage can be so easily adjusted. ■

# TRANSISTOR GAIN METER

by G. A. FRENCH



IN THE LAST FEBRUARY ISSUE THE author described a transistor gain checker design in which the collector current of the transistor under test was set to a predetermined level with the aid of variable resistance between its base and the collector supply rail.\* The circuit was set up in such a manner that a virtually fixed voltage appeared across the variable resistance, with the result that the current which flowed into the transistor base was inversely proportional to the value of that resistance. It thus became possible to calibrate the variable resistance in terms of d.c. transistor gain, or hFE.

It has since occurred to the author that quite a different approach, also

incorporating calibrated variable resistance, can be employed to measure transistor hFE, and this different method is incorporated in the circuit to be described this month. The present design has a marginal advantage over the previous circuit in so far that slightly fewer components are employed and there is a measure of compensation for falling battery voltage, but the author feels that its main value lies in the somewhat unusual means adopted for hFE measurement. As with the previous checker, a relatively insensitive meter is used and the design ensures that it is impossible to pass excessive current through this meter or through the transistor under test.

is possible to evaluate the base-emitter current gain of the transistor in terms of the resistance inserted by the variable resistor.

This can be done in several ways, of which the easiest consists of stating, quite simply, that the value of the variable resistor must be  $600\Omega$  multiplied by the base-emitter current gain of the transistor. This fact is almost self-evident in itself: the same voltage appears across both resistances, and the current through the  $600\Omega$  resistance is equal to that in the variable resistor multiplied by the base-emitter current gain of the transistor. If we call the variable resistor R1, the  $600\Omega$  resistance R2, the base current I and the emitter current Ig (where g is the gain provided by the transistor) we have, from Ohm's Law,

$$R2 = \frac{3V}{Ig}$$

$$\therefore gR2 = \frac{3V}{I} \\ = R1.$$

It thus becomes possible to fit the variable resistor with a scale calibrated directly in terms of transistor gain. All that is then required is to adjust the variable resistor such that the meter indicates 5mA, and then read the corresponding gain from its scale. This reading is taken at an emitter current of 5mA with 3 volts across the transistor, which represents a reasonable set of test conditions for small transistors. The circuit would also enable power transistors to be checked for serviceable operation, although the gain figures obtained will vary from those given by such transistors in

## EMITTER FOLLOWER

Fig. 1 illustrates the basic method of operation. The transistor in this diagram, assumed to be a p.n.p. type, is the transistor whose gain is being checked. Connected in its emitter circuit is a 0-10mA meter in series with a resistor which causes a total resistance of  $600\Omega$  to appear across the two. Thus, the series combination forms a voltmeter which shows f.s.d. when a potential difference of 6 volts is applied to it.

If the variable resistor in Fig. 1 is adjusted so that the meter indicates 5mA, the potential difference across the effective voltmeter is 3 volts. The transistor is now functioning as an emitter follower and its emitter is 3 volts above the positive supply rail. Assuming zero voltage drop in the base-emitter junction of the transistor, and noting that the circuit is powered by a 6 volt battery, 3 volts will also appear across the variable resistor. With the circuit in this condition it

\*G. A. French, "Suggested Circuit No. 243 — Transistor Gain Checker", *The Radio Constructor*, February 1971.

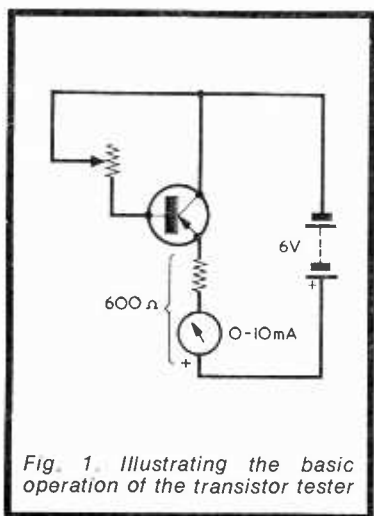

Fig. 1. Illustrating the basic operation of the transistor tester



their normal working circuits where they would pass much higher currents. It should be noted, incidentally, that the transistor in Fig. 1 cannot pass more than 10mA between collector and emitter even when fully bottomed because of the 600Ω series resistance. Also, excessive current cannot flow through the meter because it reaches f.s.d. at the 6 volts available from the battery. In the simplified circuit given in Fig. 1 it is possible for a fairly large base current to flow if the variable resistor is set to insert zero resistance into circuit, but in the practical version a series limiter resistor is provided to prevent the flow of high base current. Thus, the circuit is capable of automatically ensuring that excessive currents cannot flow in either the transistor or the meter.

Two further points need to be mentioned before proceeding to the practical design. We have referred, somewhat loosely, to the 'base-emitter current gain' of the transistor. To be precise, this is the d.c. current gain offered by the transistor in the emitter follower mode and it is equal to  $hFE + 1$ . For a simple item of test equipment such as we are considering at present it would be in order to ignore the '+ 1' part of the expression and simply assume that the gain figure is equal to  $hFE$ ; the resulting error would not be excessive even with low values of  $hFE$ . However, the '+ 1' term can easily

be taken up in the calibration of the variable resistor and so there is no necessity to ignore it.

The second point is that we assumed that, when the meter indicated 5mA, there was zero voltage drop across the base-emitter junction of the transistor. This assumption is reasonable if the transistor is of the germanium variety, but is somewhat less so if the transistor is a silicon type. With silicon transistors the voltage drop between base and emitter will be approximately 0.6 volts. For accurate gain measurements with silicon transistors the variable resistor in Fig. 1 needs to be adjusted so that 2.7 volts appears across it, whereupon 2.7 volts also appears across the 600Ω resistance in the emitter circuit, the remaining 0.6 volts being dropped across the transistor base-emitter junction. Once again, the same voltage appears across the variable resistor and the 600Ω resistance, and the variable resistor calibration is correct, as before. This situation corresponds to a reading in the meter of 4.5mA instead of 5mA.

### PRACTICAL VERSION

We may now turn our attention to the practical circuit, which is given in Fig. 2. As with Fig. 1, this is powered by a 6 volt battery, the terminals of which connect to S3(c) and S3(d). These are two sections of the polarity reversing switch and

enable either p.n.p. or n.p.n. transistors to be tested. With p.n.p. transistors the upper supply line is negative, and with n.p.n. transistors the upper supply line is positive. The remaining two sections of the switch, S3(a) and S3(b), reverse the polarity of the connections to the 0-10mA meter, M1. (The previous transistor checker employed germanium diodes to obviate a meter polarity reversing switch, but the present design requires linear indications at a number of points on the meter scale and a switching circuit is preferable.)

The variable resistor of Fig. 1 is now replaced by fixed limiter resistor R1 and, according to the position of S1, either VR1 or VR2. VR1 is calibrated in gain figures from 20 to 150 and VR2 in gain figures from 150 to 1,000.

A new circuit feature not shown in Fig. 1 is given by the push-button S2. This push-button is pressed before taking a gain measurement. When it is pressed, VR3 is set up to give an f.s.d. reading of 10mA in the meter. The operation is reminiscent of the adjustment of the zero-set potentiometer in an ohmmeter. The result is that, when the variable resistor in the base circuit is set up to give a 5mA reading in the meter (and assuming zero voltage drop in the base-emitter junction of the transistor being tested), the voltage across the variable resistance and that between the transistor emitter and the lower supply rail are both equal to half the actual battery voltage at the time of measurement. Thus, varying battery voltages are compensated for. If the variable resistor is set up for a reading of 4.5mA in the meter (as occurs when checking silicon transistors) falling battery voltage will, unfortunately, introduce small errors, and it is therefore advisable to discard the battery when its voltage falls below 5.5 volts. To maintain a check on battery voltage VR3 is provided with a scale having calibration marks (corresponding to f.s.d. in the meter) for 6.5, 6 and 5.5 volts.

To use the instrument, variable resistors VR2 and VR1 are set to insert maximum resistance into circuit and S1 is set to position 2. The transistor to be tested is connected to the test terminals and S3 set to give the appropriate polarity. S2 is next pressed, VR3 is adjusted for an f.s.d. reading in the meter and S2 is then released. VR2 is next reduced in value until the meter reads 5mA for a germanium transistor or 4.5mA for a silicon transistor. If this reading cannot be obtained within the calibration range of VR2, S1 is set to position 1, and VR1 adjusted for the desired meter reading. The gain of the transistor is then read from the scale of VR2 or VR1, as applicable.

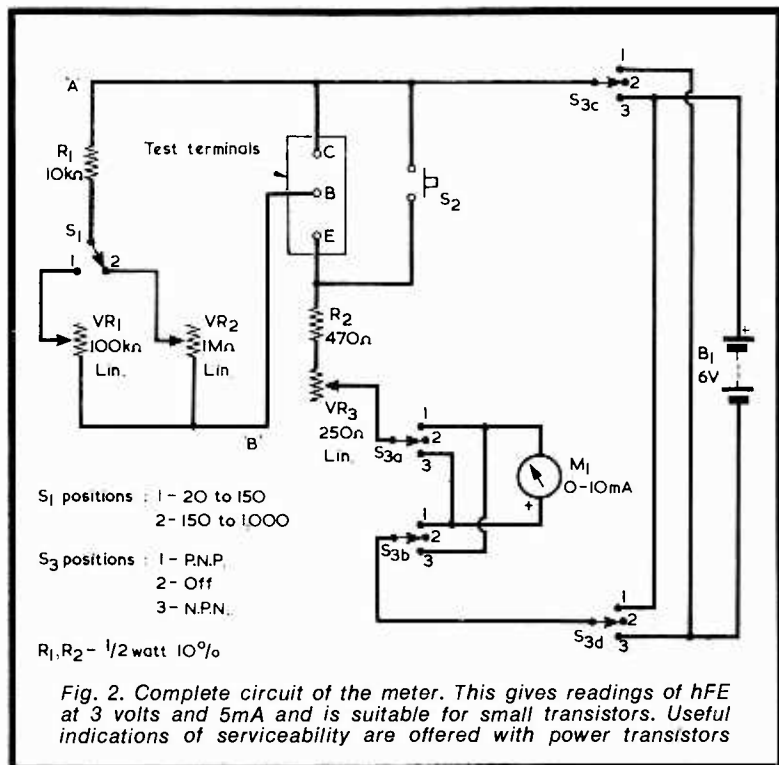

When it is desired to check a batch of transistors, VR3 need only be set up, with S2 pressed, at the start of the tests.

The current drawn from the battery varies between nearly zero and 10mA during the process of testing, and the battery can, in consequence, be expected to have a reasonably long life.

## COMPONENTS

The components required are all readily available types. S3 is a miniature 4-pole 3-way rotary switch. On no account must a miniature 4-pole 2-way rotary switch be employed instead. Switches of this type have make-before-break contacts and a centre blank position (corresponding to 'off') is essential if the battery is not to be short-circuited when switching from one polarity to the other. S1 may be a toggle or rotary switch, as desired, whilst S2 can be any panel-mounting push-button whose contacts close when it is pressed.

Meter M1 is a standard 0-10mA moving-coil meter.

Variable resistors VR1 and VR2 should be high grade components. The 'low-noise moulded track' types would be suitable. VR3 should be a wirewound type. All three variable resistors are fitted with pointer knobs and scales. That for VR3 is a simple one, and is calibrated with the three voltages just mentioned. The scales for VR1 and VR2 will need to be fairly large if a useful number of calibration points are to be included.

The 'test terminals' can consist of three separate terminals connected in parallel with a transistor holder. The transistor being tested is then plugged into the holder or connected to the terminals according to whichever is the more convenient.

The whole unit may be assembled in a case whose front panel is large enough to take the meter, the three switches, the test terminals, and the three variable resistor scales.

TABLE I		TABLE II	
Range 1 (calibration of VR1)		Range 2 (calibration of VR2)	
<i>hFE</i>	<i>Resistance (kΩ) between points 'A' &amp; 'B'</i>	<i>hFE</i>	<i>Resistance (kΩ) between points 'A' &amp; 'B'</i>
20	12.6	150	90.6
25	15.6	200	121
30	18.6	250	151
35	21.6	300	181
40	24.6	350	211
45	27.6	400	241
50	30.6	450	271
60	36.6	500	301
70	42.6	550	331
80	48.6	600	361
90	54.6	650	391
100	60.6	700	421
110	66.6	750	451
120	72.6	800	481
130	78.6	850	511
140	84.6	900	541
150	90.6	950	571
		1,000	601

## CALIBRATION

Calibration is carried out by connecting a resistance-reading meter between the points marked 'A' and 'B' in Fig. 2 and adjusting VR1 and VR2 so that the resistance values listed in the accompanying Tables I and II are given. These tables apply to VR1 and VR2 respectively, and give calculated resistance values for different *hFE* figures when the resistance, in ohms, between points

'A' and 'B' equals 600 (*hFE* + 1).

The easiest way of calibrating VR3 is given by connecting the unit to a variable voltage power supply and by finding the settings of this variable resistor which give f.s.d. readings in meter M1 at 6.5, 6 and 5.5 volts. If batteries only are available, an alternative approach is shown in Fig. 3. Here, the tester is coupled to a 9 volt battery by way of a 500Ω variable resistor, a voltmeter being connected across the tester battery terminals. The 6 volt battery has, of course, been removed. The 500Ω variable resistor and VR3 are then adjusted for f.s.d. readings in M1, with S2 pressed, at voltages of 6.5, 6 and 5.5. This process will be found a little fiddling because the settings of the 500Ω variable resistor and VR3 are inter-dependent but, since only three calibration points are required, the amount of time taken to carry out the procedure should not be excessively long. ■

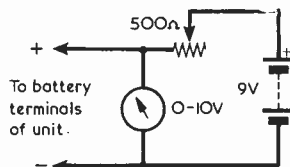

Fig. 3. To calibrate VR3, the 6 volt battery of the checker is removed and the external circuit illustrated here applied

## TELEPHONES FOR THE DEAF AND BLIND

It was a desire to teach the deaf to speak that brought Alexander Graham Bell to America more than a century ago. Now the deaf and the blind are able to speak over the phone, though not with their voices.

Ohio Bell recently installed the first two Code-Com sets for regular subscriber use in the Bell System. The sets - which contain a light, a sending key and a vibrating disc - enable the blind or deaf to tap out messages in code.

An ordinary telephone converts speech into electrical impulses that are transmitted and reconverted to speech at the receiver, but the Code-Com converts transmitted signals into flashes of light and vibrations of the disc or sensor pad. A deaf person watches the flashes of light; a deaf and blind person feels the vibrations of the disc. The key is employed to transmit.

A new machine developed by Bell Laboratories engineers makes use of a laser to draw patterns for tiny integrated circuits far more intricate than previously possible.

The Primary Pattern Generator, as it is called, employs a photographic plate on a moving table; an argon laser; modulators and lenses to control the laser beams, and a 10-sided mirror, rotating on air bearings, to reflect the laser beam and expose selected portions of the photographic plate. Its accuracy is such that it can produce the equivalent of a mile-long straight line with less than five-sixteenths of an inch deviation.

To attain such precision, it is necessary to operate the machine in a controlled-environment chamber, where the temperature is maintained within one-quarter degree Fahrenheit and each cubic foot of air contains fewer than 100 dust particles larger than one micron.

# NOW HEAR THESE

Times = GMT

Frequencies = kHz

## ● FINLAND

OIX4 Pori can be heard opening the afternoon transmission, with English announcements, at 1500 on 15185 (100kW). This transmission period is from 1500 to 1830, with the English programme from 1800 to 1830. Also in parallel on 9555 (15kW) and on 11755 (10kW). The address for reports is:- Oy Yleisradio AB, Kesakatu 2, Helsinki 26.

## ● VATICAN STATE

Vatican Radio may be heard with the world news in English at 1500 on 15120 (100kW). Reports should be addressed to:- Vatican Radio, Vatican City.

## ● CHINA

Peking radiates a programme in English at 1000 on 15060 (240kW). Reports to:- Broadcasting Administration, Fu Hsin Men, Peking.

The PLA (People's Liberation Army) transmitter at Fukien can be logged at 2000 with martial music and announcements in a Chinese dialect on 3400, power unknown.

## ● TANZANIA

The External Service from Dar-es-Salaam has been reported on the new frequency of 6105 with sign-on in English at 1600. The usual 4785 channel is in parallel.

## ● TAHITI

Radio Tahiti, Papeete, now has an outlet on 15170 in parallel with the old 11825 (20kW) channel. Reported heard from 0300 to 0800 sign-off.

## ● HONDURAS

HRVC 'The Evangelical Voice of Honduras', Tegucigalpa, can be heard with programmes in English from 0300 till close-down at 0457 with the National Anthem on 4820 (5kW). According to the closing announcements, reports are required and a reply will be sent by air mail. La Voz Angelica closes with the announcement, in English, "HRVC the Evangelical Voice of Honduras in beautiful Central America".

## ● PANAMA

HOU31 La Voz del Baru on 6045 (1kW) has a schedule from 1100 to 0500 and is the only station operating on the short waves from Panama. Reports are requested and should be sent to Apartado 160, David.

## ● POLAND

Radio Warsaw can be heard with a newscast in English at 2030 on 7270 (10kW). (See Current Schedules for further information on R. Warsaw).

## ● ALBANIA

Radio Tirana radiates a programme in English which can be heard at 2030 on 7065 (50/240).

## ● SWITZERLAND

Berne can be logged on 9535 (150/250) with a programme in English at 1115.

## ● DOMINICAN REPUBLIC

HIFA Voz de las Feurzas Arm. can be heard signing off at 0500 on 4825 (1kW) with the National Anthem and identification.

*Acknowledgements:-*

*BADX, Our Listening Post, SCDX*

JULY 1971

# RADIO CONSTRUCTOR

## AUGUST ISSUE

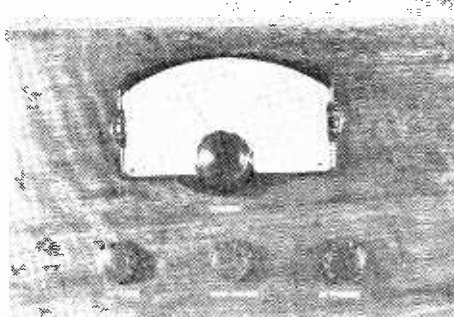

### THE BANDMASTER

A simple superhet design offering coverage of the short wave bands from 20 to 180 metres. An aerial trim control is provided and, for ease of tuning, each coil range is split into two halves. If the requisite coils and padding capacitor are obtained, the receiver can also provide coverage of the medium wave band.

### THE TRANSMATCH

The circuit is designed to enable transistors to be rapidly sorted into matched pairs or sets within quite close limits under small signal conditions.

### F.E.T. REFLEX RECEIVER

Adding an f.e.t. input stage to a well-trying reflex circuit improves selectivity and offers a wide latitude in ferrite aerial design.

## PLUS

- ★ MORE CONSTRUCTION PROJECTS
- ★ NEWS COVERAGE
- ★ SHORT WAVE SCENE
- ★ SUPPORTING FEATURES
- ★ DATA SHEET 53

ON SALE AUGUST 1st

PRICE 20p

Copies may also be obtained direct from the Publishers. 24p including postage. Published by: Data Publications Ltd. 57 Maida Vale, London, W.9

## INDUSTRIAL LASER CUTTER

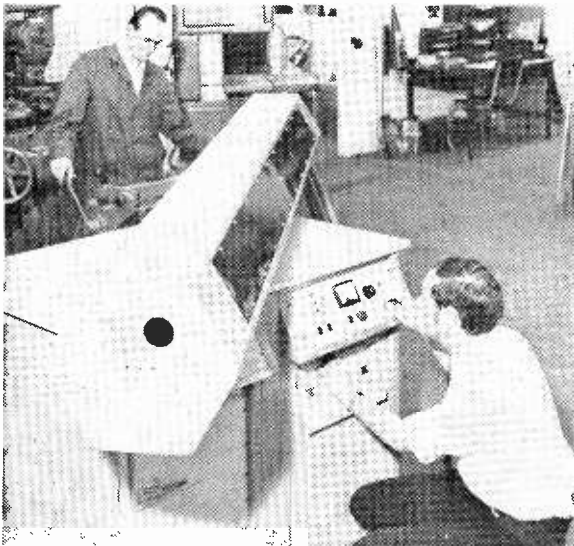

*The Elliott 'Laserblade' in a typical industrial environment. This infra-red laser has a continuous output power of 500 watts*

What is claimed to be the first truly industrial laser cutter has been developed by Elliott Automation Radar Systems, Ltd., and is now available for use in factories. Engineers of the Neutron Division at Borehamwood, Herts, have successfully developed a 500 watt carbon dioxide laser cutter which is smaller and more economical than any similar device currently available. Called 'Laserblade' and developed in association with the former Ministry of Technology, the new cutter was planned from the outset as an industrial machine rather than as an adaptation of laboratory research equipment.

Principal advantages of 'Laserblade' over earlier experimental laser cutters are the small size of the laser unit, its self-supporting, self-aligned housing and the use of a gas regenerating system which saves money by conserving over 90% of the helium and other gases normally lost. The guaranteed continuous output of more than 500 watts is sufficient to cut metal, plastics, wood, paper and cloth at high speed. Thin nylon can be cut at 800 feet per minute and mild steel sheet (0.03in.) at 20 feet per minute.

'Laserblade' is in a rigid housing 9 ft. long and can produce a focussed cutting beam only five thousandths of an inch in diameter.

The power supply is in a double 19 in. cabinet and the gas recirculation unit and controls are in a table-height console.

A laser cutter has the unique advantages that it does not require physical contact with the material being cut, makes a precise cut without residue or noise and leaves the cut edges extremely clean.

## LONDON PINPOINTED AS EUROPEAN ELECTRONIC CENTRE

All overseas records were broken at the recent International London Electronic Component Show at Olympia.

Figures for foreign exhibitors and visitors were the highest ever recorded, and Mr. Peter Middleton, chairman of the Exhibition Committee said: "This has certainly pinpointed London as the major European centre for the electronics industry."

Buyers and engineers from abroad numbered 4,307. This is 13.2 per cent above the record-breaking figure for the last exhibition. Of the 611 companies represented 253 were from overseas, including big government shows from America, France, Hungary, Israel and Russia.

Mr. Peter Middleton, chairman of the Exhibition Committee, reported at the close of the show:

"According to people experienced in market assessment, there are real signs that the electronics industry is on its way to recovery. We started the week in an atmosphere of optimism. We were right; the show has evaporated much of the gloom that has surrounded electronics."

"Britain needs an exports upsurge." Mr. Middleton added.

Mr. Ted Rees, chairman of Industrial Exhibitions Ltd., the organisers, said: "They talked about an electronic recession. There has been no sign of it here."

"It is good to see an industry, faced with hard times, tackling the problem of combining full-blooded selling with state-of-the-art technology."

"The people showing at Olympia have indicated the road to recovery for an entire industry. They have realised that technical brilliance can founder without the backing of commercial skill."

## WORLD DX CLUB/MEDIUM WAVE CIRCLE CONVENTION - 1971

The WDXC/MWC 3rd Annual convention will be held at Pembroke College, Cambridge, from Friday July 2nd to Sunday July 4th. Pembroke College is the third oldest college belonging to Cambridge University, being founded in 1346, and the college chapel was the first building to be designed by Sir Christopher Wren.

The main subjects to be dealt with at the convention are Broadcast Band Dx'ing in all its facets... international Short Wave Bands, tropical bands and medium wave bands. Some reference will be made to amateur operator transmitting and listening and TV Dx. It is hoped to operate an amateur radio transmitter GB3WDX, during the convention.

On the Saturday morning a visit will be made to one of the factories of Pye Ltd.

Cost of the convention, including bed, breakfast and an evening meal for two days will be £7.50. Accommodation will be in the college.

The convention is open to all Dx'ers. Full details are obtainable from Malcolm R. Peddar, 53 Garland Street, Bury St. Edmunds, Suffolk.

# COMMENT

## THE ELMA MULTITURN KNOB

Radiatron Components Ltd., of 76 Crown Road, Twickenham, Middlesex, announce a completely new addition to their well-known range of Elma collet fixing knobs – the ELMA multiturn knob.

The Elma multiturn has been carefully styled to match the basic design of the rest of the Elma knob range – thus allowing designers to give a consistent appearance to front panels even when multiturn components are used alongside others requiring only conventional knobs.

The maximum number of rotations of the Elma is 15 – each turn being accurately graduated to one-hundredth of a turn. The knob is collet fixing and is available for shaft diameters of  $\frac{1}{8}$ in. or  $\frac{1}{4}$ in., or 3, 4 or 6mm. The large outer rotating ring allows settings to be safely locked. The knob is available ex stock in any 3 colours – black, grey or red.

The price is £1.90 list for 1 off, with generous quantity discounts which allow much lower prices for production quantities.

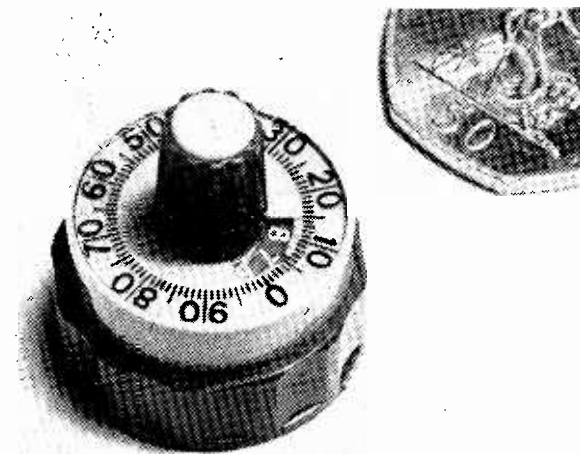

## IN BRIEF

● The Royal Television Society's Gold Medal, for outstanding contributions to television, has been awarded to T. H. Bridgewater, OBE., C.Eng., F.I.E.E. This medal was presented to Mr. Bridgewater by John Vernon, Chairman of the Royal Television Society Council, at a special luncheon.

● The M-O Valve Co. Ltd. has extended its range of 14cm. rectangular faced instrument cathode ray tubes with the introduction of the 1400G, a compact single gun mesh p.d.a. tube with 10 x 8cm. display area.

It features an aluminised screen and a p.d.a. voltage of 10kV for high brightness, and incorporates an internal graticule.

● Sir William Cook, CB., FRS., has been appointed Chairman of The Marconi International Marine Co. Ltd.

● Adcola Products Ltd. has extended its range of products with the introduction of a new range of multi-channelled solder wire.

Recommended prices are £1.96 per kilo for 16 swg wire, £2.02 for 18 swg and £2.18 for 22 swg.

● Robert Robinson is to join John Timpson, for three months, as the new co-presenter of Radio 4's popular morning magazine 'Today'.

● The British Amateur Electronics Club are again holding their very successful Exhibition of Electronic Games. The Exhibition is from 17th to 24th July, and is at the Shelter, centre of the Esplanade, Penarth, Glamorgan. (Last years Exhibition was televised by the B.B.C.) Proceeds to the British Empire Cancer Campaign.

The address of the Hon. Secretary, J. C. Margetts is: 17 St. Francis Close, Abergavenny, Mon.

● The R.S.G.B. have appointed a committee to consider the Society's Diamond Jubilee Celebrations in 1973.

## AN ELECTRIC MOTOR THAT RUNS RED HOT

A small electric motor that runs – literally "red hot" – at temperatures of more than 1,400°F. has been designed and tested by scientists of the U.S. General Electric Co. This is believed to be the highest temperature at which an electric motor has ever been operated.

The high-temperature device is a synchronous motor that measures four inches long by three inches wide by three inches high. It is similar in principle to the motors used in electric clocks, and runs on 110 volts.

The new motor takes advantage of special wire fabricated from a silver-palladium alloy coated with nickel. When operated at high temperatures in air, the wire creates its own electrical insulation as the nickel changes to nickel oxide.

JULY 1971

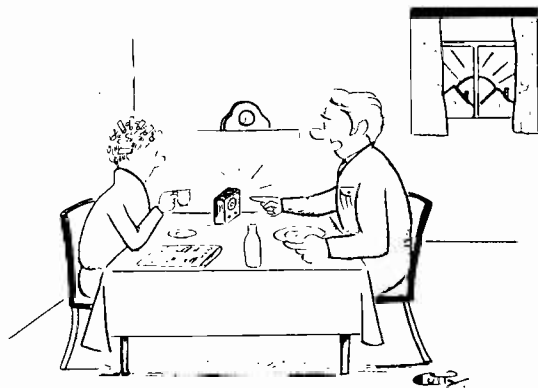

"If you ask me – that radio's slow"

# PUSH-BUTTON REMOTE CONTROL

by  
P. MUNRO

A remote switching circuit which can be operated by momentary pressure on one of any number of push-buttons. A pilot lamp at each push-button indicates whether the controlled equipment is switched on or not

THE SYSTEM DESCRIBED HERE WAS DESIGNED TO provide remote switching of an electrical device by means of a push-button from any of a number of convenient places. The push-button circuit functions at a low voltage with respect to earth but the controlled equipment can, if a relay with suitable contacts is employed, be run from the mains supply.

## CIRCUIT OPERATION

The equipment is controlled by momentarily completing a circuit by a push-button either to switch it on or off, i.e. push on - push off. This makes the system simple and foolproof in operation.

Basically, the circuit consists of a relay driven by a transistor with a pair of make contacts used to latch the relay, together with a capacitor which, when charged, provides base drive to the transistor and then, when discharged, shunts the base current long enough for the relay to release.

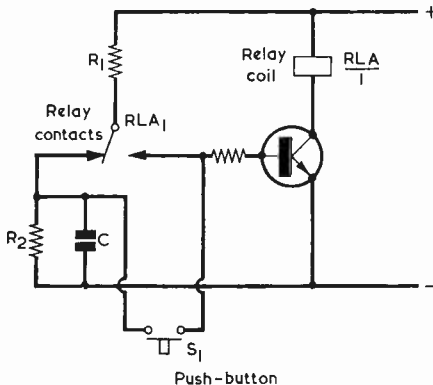

Fig. 1. The basic switching circuit. In the 'detached' method of presentation used here and in Fig. 2, relay contacts are shown separate from the relay coil and in the de-energised state

A circuit of this nature is shown in Fig. 1 and it operates in the following manner. A set of change-over contacts on the relay is used in the de-energised position to charge C through R1. R2 is of such a value that C charges to a final voltage which will

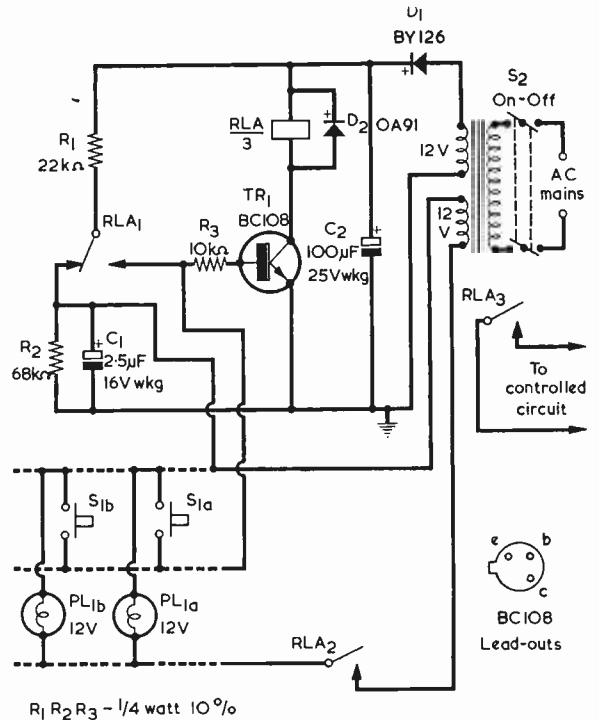

Fig. 2. The complete working circuit. Any number of push-buttons and pilot lamps may be wired into the circuit in parallel with those shown here

provide sufficient base drive to saturate the transistor when S1 is closed. The relay will then operate, removing the charging supply from C, which will now discharge through R2. At the same time, R1 provides a source of base current which enables the transistor to conduct the required holding current for the relay through its collector circuit.

When S1 is next closed C is completely discharged and appears as a short-circuit across the base-emitter circuit of the transistor. This then cuts off, causing the relay to fall out.

Since the switch simply completes a single wire circuit momentarily, any number of switches can be put in parallel and each will have identical control facilities at all times.

## WORKING CIRCUIT

As is shown in the working circuit of Fig. 2, a supply of 12 volts was chosen. This provides safe low voltage operation and suits relays, transistors and power supplies well.

A 12 volt relay has a coil resistance typically between 100 and 200Ω, thus drawing a maximum current of between 60 and 120mA.

The transformer used had two 12 volt secondaries each of which was rated continually at 250mA. One winding supplied the relay circuit and the other a set of pilot lamps which indicated whether the relay was energised or not. A pilot lamp was fitted at each push-button position.

Almost any semiconductor rectifier will rectify the current drawn from the transformer and the p.i.v.



of about 34 volts is not demanding. In the writer's case a BY126 was chosen as being easily available at low price and readily meeting this specification.

A BC108 transistor is suitable for relays having coil resistances of 150Ω or more. Its VCEO of 20 volts is adequate and the high gain and low leakage of this transistor type are also attractive.

A 10kΩ base resistor, R3, limits the base current during switch-on. Allowing for a base-emitter voltage drop of 0.5 volt, 11.5 volts is available to drive base current; the holding current of the relay is typically 60mA which at a gain of 200 demands approximately 300μA base current. Thus, if R3 is 10kΩ, R1 should have a value given by say 11 volts divided by 300μA less this 10kΩ, which results in a value of about 27kΩ. In practice, the value of 22kΩ finally chosen allows a little base current in hand.

The capacitor, when charged, must drive base current long enough for the relay to energise and it is also desirable that the charge in the capacitor is large enough to swamp the shunting effect of R2 while the push-button is held closed and the relay energises. From these considerations, and from experience, it is found that a value of around 3μF is suitable. In practice, the capacitor finally employed was a 2.5μF 16V wkg. component in the Mullard C426 range of miniature electrolytic capacitors.

It is desirable for C1 to charge up to some 9 volts when the relay is de-energised. Since R1 has a resistance of 22kΩ, this argues a value in R2 of around 68kΩ, as is shown in the diagram.

The circuit of Fig. 2 can, of course, be adapted to meet particular requirements. The separate pilot lamp circuit is not essential, but it is very useful since it enables anyone at a push-button to know whether the relay is energised or de-energised. The push-button and pilot lamp connections can be car-

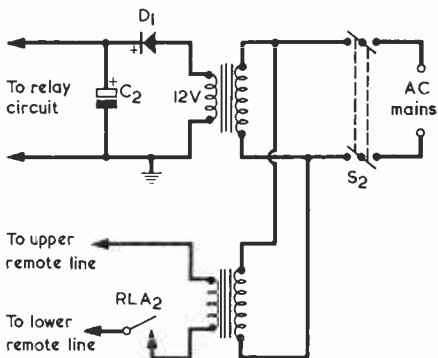

Fig. 3. Two separate mains transformers can be employed instead of the single transformer of Fig. 2, which may be difficult to obtain through home-constructor channels. The lower transformer in this diagram can have any secondary voltage suitable for small pilot lamps

ried by 3-core cable. If desired, the pilot lamp circuit and the relay circuit can be run from separate transformers, as in Fig. 3, whereupon a 6.3 volt heater transformer could be employed for the pilot lamp circuit, the lamps having the appropriate voltage rating. Whatever method of operation is employed, the mains transformer secondaries should have a current rating adequate for the load (relay or pilot lamp circuit) which they supply.

The relay should have a coil resistance of 150Ω or more and be capable of energising reliably at around 10 volts. Its contacts should be suitable for the equipment it controls. A reliable earth connection must be provided, it being made as shown in Fig. 2. ■

# PANEL SIGNS

IDEAL FOR WORKSHOP USE

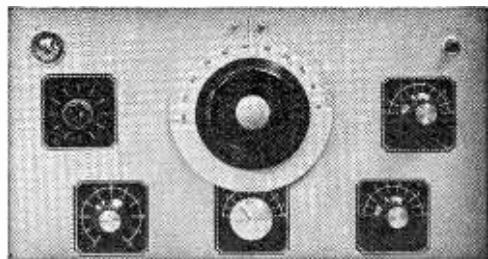

- ★ Set 3 Wording—WHITE
- ★ Set 4 Wording—BLACK
- ★ Set 5 DIALS—clear background
- ★ Set 6 DIALS—black background

The Perfect Transfer for  
the Home Constructor

Each Set contains Six Sheets

**25p per set**

(postage 3p)

To Data Publications Ltd.  
57 Maida Vale, London, W.9

Please supply:

.....Set 3 .....Set 4 .....Set 5 .....Set 6

I enclose cheque/crossed postal order for.....

Name.....

Address.....

# ANIMATED ANIMALS

by  
JAMES ROBERT SQUIRES

An unusual approach towards the provision of decoration and amusement in a child's bedroom

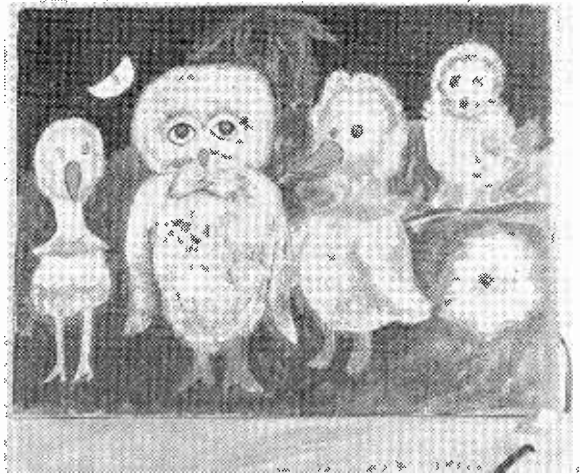

Front view of picture, illustrating small neon bulbs extending through eyes of birds, moon and flower

THOSE FEW PRECIOUS MOMENTS FOR A CHILD between waking and sleeping can be very frightening alone in his room in the darkness with his thoughts. However, if he has a friend such as the 'Animated Animals', fright changes to fascination. Slowly flashing lights add to his natural drowsiness and - POP - the child is fast asleep with all fears of the darkness forgotten.

How can you work this select piece of magic? Well, take a bunch of neon relaxation oscillators and combine their On-Off flashing with the pleasantness of a friendly picture the small child can enjoy during the daylight hours and the combination is sure to be a winner.

The picture illustrated in this article was painted by a professional artist, but in most households there is someone eager to show his talents with brush and canvas. As a suggestion you might use the very popular "paint-by-number" sets. Relatively easy to do, you could select scenes that feature stars, or eyes, or sparkling surf or perhaps night scenes that include windows of houses. Just remember that a neon bulb, about  $\frac{1}{8}$  in. in diameter will fill each point of light.

## HOW IT WORKS

The circuit, shown in Fig. 1, consists of five neon relaxation oscillators, each working at a different frequency. The youngest painted animal was selected to receive the fastest flashing 'eyes', the next oldest has eyes slightly slower. The mother and father have flashing eyes that are slower again. The final flasher is split between the Moon and the Flower. The total effect is flashingly fascinating.

It is necessary for the neon circuit to be isolated from the mains and this function is carried out by transformer T1. T1 may be any transformer suitable for operation with mains voltages which has a step-down ratio of 2:1. A readily available component is the Radiospares 'Midget' 250 volt transformer with a secondary of 125-0-125 volts. (This is obtainable from Home Radio under Cat. No. TM39.) Half the secondary is used here, connected as shown in Fig. 2(a). An alternative is a valve radio transformer having an h.t. secondary of 200-0-200 to 250-0-250 volts. This may be connected as shown

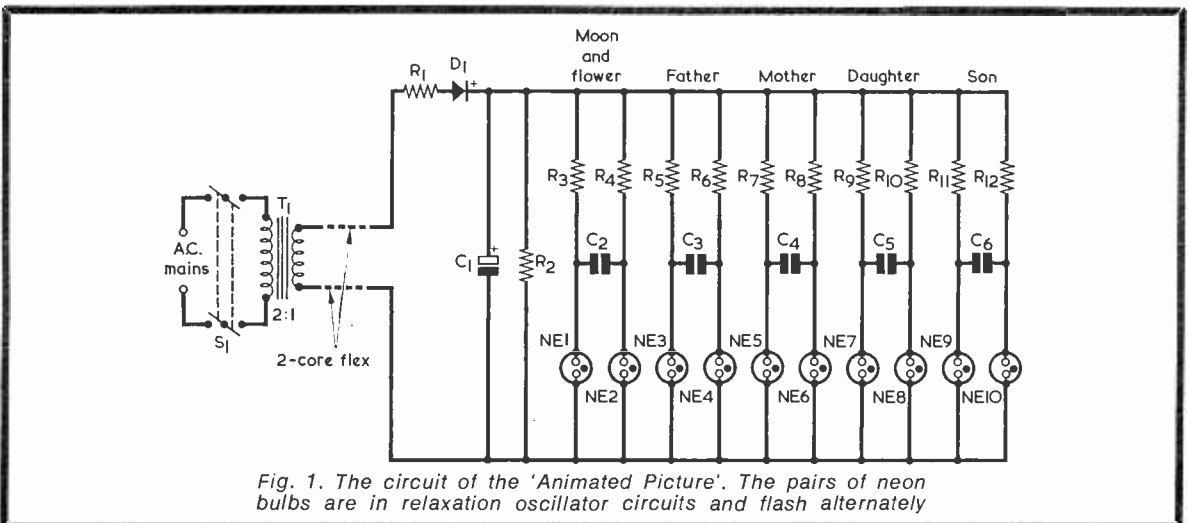

Fig. 1. The circuit of the 'Animated Picture'. The pairs of neon bulbs are in relaxation oscillator circuits and flash alternately

in Fig. 2(b), in which the secondary now becomes the primary. Choose a tap in what is now the secondary (but was previously the primary) which matches to the h.t. voltage rating. If this was 200-0-200 volts connect to the 200 (or 210) volt tap, and if it was 250-0-250 volts connect to the 240 (or 250) volt tap. The transformer, together with the on-off switch, is separate from the flashing eye picture, and it *must* be completely enclosed so that prying fingers cannot touch any of the mains or secondary connections. The latter, although carrying a voltage lower than that of the mains, can still give dangerous shocks and must be completely covered. Provide a few small holes for ventilation.

The circuit consumes negligible power and it could be left switched on continually. Nevertheless, it is still a good idea to switch it off when not in use. The 220K $\Omega$  resistor, R2, ensures that the 32 $\mu$ F electrolytic capacitor becomes fully discharged after switching off.

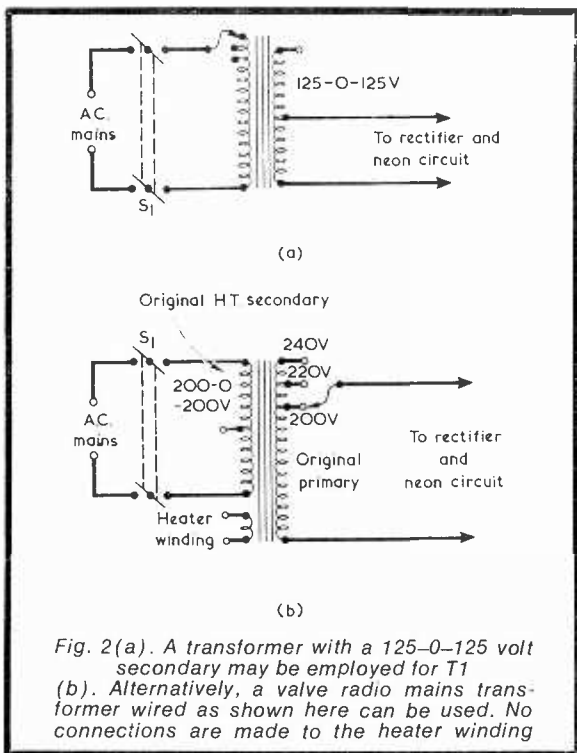

Fig. 2(a). A transformer with a 125-0-125 volt secondary may be employed for T1  
(b). Alternatively, a valve radio mains transformer wired as shown here can be used. No connections are made to the heater winding

## CONSTRUCTION

The general constructional approach may be seen in the photographs. In the author's model, capacitors C2 and C3 were made up with 0.5 $\mu$ F capacitors in parallel, three being used for C2 and two for C3. The use of single 0.5 $\mu$ F capacitors helps to reduce the depth taken up by the components. The parts are all assembled on a sheet of Paxolin, whose dimensions depend on the size of the picture and the size of the components. The author made up a printed board but the simplicity of the circuit hardly justifies the complication involved, and it would be easier to use plain Paxolin, or plain Veroboard without copper strips, pass component leads through appropriate holes and solder in the links and wiring on the reverse side. The soldered connections here

JULY 1971

## COMPONENTS

### Resistors

(All  $\frac{1}{4}$  watt 10% unless otherwise stated)

R1	33 $\Omega$ 1 watt
R2	220k $\Omega$ $\frac{1}{2}$ watt
R3	8.2M $\Omega$
R4	8.2M $\Omega$
R5	6.2M $\Omega$
R6	6.2M $\Omega$
R7	4.7M $\Omega$
R8	4.7M $\Omega$
R9	3.3M $\Omega$
R10	3.3M $\Omega$
R11	2.2M $\Omega$
R12	2.2M $\Omega$

### Capacitors

(All 0.5 $\mu$ F capacitors paper or plastic foil, 100V wkg.)

C1	32 $\mu$ F electrolytic, 200V wkg.
C2	1.5 $\mu$ F (3 x 0.5 $\mu$ F in parallel)
C3	1 $\mu$ F (2 x 0.5 $\mu$ F in parallel)
C4	0.5 $\mu$ F
C5	0.5 $\mu$ F
C6	0.5 $\mu$ F

### Transformer

T1 2:1 mains transformer (see text)

### Rectifier

D1 Selenium ('metal') rectifier, minimum ratings 200 volts at 30mA

### Switch

S1 d.p.s.t. switch, toggle

### Neon Bulbs

NE1-NE10 Neon bulbs, Hivac type 16L (Henry's Radio)

### Miscellaneous

Picture frame and canvas  
Connecting wire Circuit board, etc.

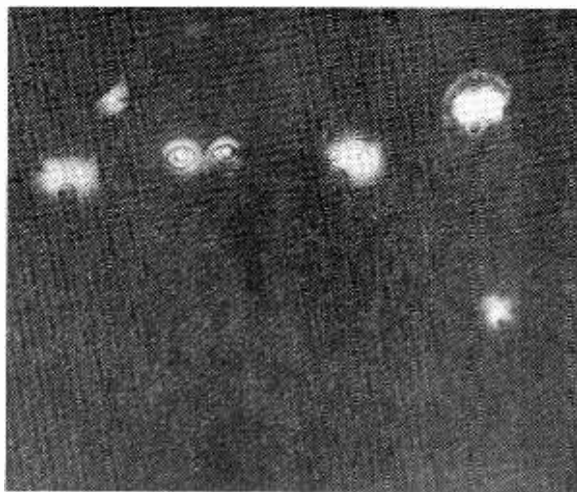

How the picture looks at night. There is enough light generated by the neons to clearly identify each character

735

should be smooth, and have no 'spikes' which could pierce the insulating tape that is later placed over them. Note that the picture is mounted on a wooden frame providing sufficient depth to take the components when the board is in its final position. One lead passes from each resistor-capacitor junction to each neon. The other neon terminations (those at the bottom in Fig. 1) are connected together and returned to a single point on the board. The connections are made direct to the wire lead-outs of the bulbs. If thin flexible connecting wire is used, the strain on these lead-outs is not excessive.

One important point is that the lead from transformer T1 must be adequately secured to the picture frame. When the photographs were taken, a second on-off switch was fitted in this lead to provide a more local control. However, this was later removed as it resulted in long periods during which transformer T1 only was connected to the mains.

Cut into the eyes of the picture from the painted side. Push a neon bulb into each eye hole also from the painted side. Allow the two rods or electrodes within the glass bulb to remain showing on the

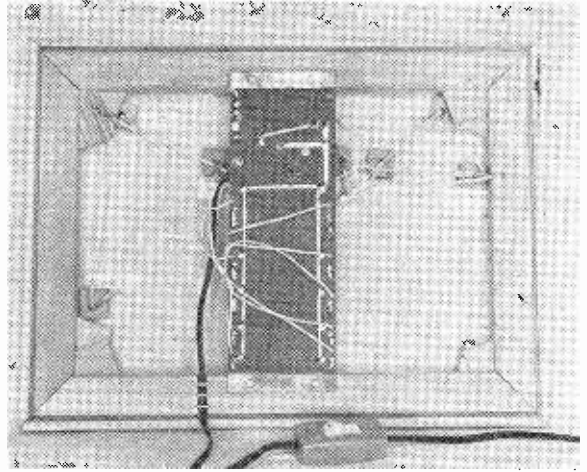

*Rear view with the circuit board mounted in its final position. After the back has been fitted, the picture is hung on the wall in normal fashion*

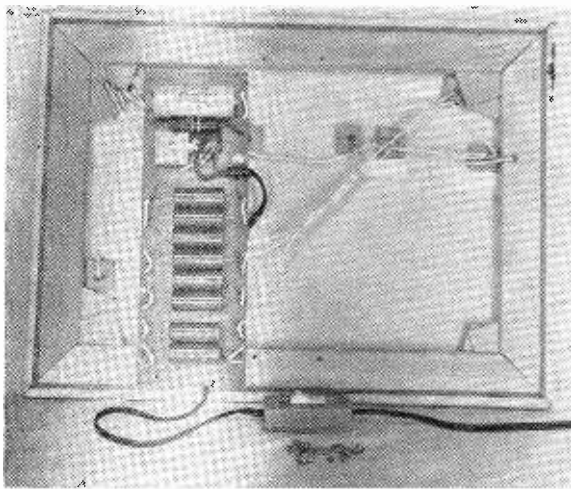

*Rear view of the assembly before the component board is secured to the picture canvas frame*

painted side of the picture. Apply liberal doses of airplane cement on the back of the picture, being careful not to allow this to seep through to the painted side. The author used small blocks of hard wood drilled in the centre to strengthen the neon mounting. These wood blocks are glued to the canvas. Measure and cut sufficient wire, depending on the size of your particular frame and painting, to reach the centres of the frame where the circuit board is to be mounted. Use care when wiring the neon bulbs so that the best visual effect is achieved.

Mount the circuit board and check that the eyes are flashing correctly. Place lengths of p.v.c. insulating tape over all exposed connections on the rear of the circuit board. Finally, box the back in with a hardboard panel so that all electrical connections are completely covered. Ensure that the panel is secured reliably in place with adequate wood-screws. Finally, fit a length of picture wire across the upper part of the back to enable the picture to be hung.

The Animated Picture is now ready to delight your children and, oh yes, perhaps a few older members of the family, too. Here's winking at you!

## HTV BUYS THE WORLD'S MOST ADVANCED TV CAMERA

Harlech Television are buying three of the new Marconi Mark VIII automatic colour television cameras as part of their current re-equipment programme in an order worth £80,000 placed with the Broadcasting Division of Marconi Communication Systems Limited, a GEC-Marconi Electronics company.

HTV's three cameras, together with a solid-state vision mixer and ancillary equipment, will be delivered in June of this year, and will go into immediate use in HTV's Cardiff studios. HTV will be the first British ITV company to have the Mark VIII in operation.

The unique facilities of the Mark VIII camera will be utilised to the full in Cardiff. The cameras will be in normal studio operation until 7 o'clock in the evening. Two will then be moved two floors up to the presentation studios where they will be used, remotely controlled, to televise the announcers presenting the West of England, and the Welsh services. The whole process of removal and setting up for transmission will take less than fifteen minutes. The speed of this operation is made possible both by the lightness and mobility of the camera, and by its completely automatic design: it has automatic line-up, automatic colour balance, automatic dynamic centring, and automatic check facilities, all push-button controlled.

Marconi recently announced sales of 21 of the new cameras to the Canadian Broadcasting Corporation, and report that the Mark VIII aroused great interest when it was demonstrated in Chicago earlier this year at the NAB Convention.

**Q****S****X**

by

**FRANK A. BALDWIN**  
(All Times GMT)**● AMATEUR BANDS**

In company no doubt with many other short wave listeners, the writer spent most of the available time devoted to these bands on that happy hunting ground the 14MHz band. For many years the favourite band for most Dx hunters, 14MHz provides something of interest almost throughout the twenty-four hours of the day. The best listening period at this location was that from around 1900 to midnight. Both the CW and SSB modes produced the goods.

The LF bands were found to be in the 'summer doldrums', at least during the above mentioned period, although one valiant session on 'Top Band', at the CW end, did produce some worthwhile loggings - and noise!

**1.8MHz**

**CW:** GC3APA/A, GM3HLQ, GW3RTR/A, HB9CM, OK1ATP, OK1DKR, OK1HAS, OK1KZE, OK2KMB, OK2SLS, OL4AMU, OL8ANL, OL9AMU.

**14MHz**

**CW:** CR6AI, CR7AM, CX9BT, EL2BZ, FM7WH, HK7UL, HK7XI, HP9KRT, KG4EO, KV4CK, LU8FBH, PJ2HT, PZ1AV, TU2CX, VP2GLE, ZE2JC, ZP5CS, ZS6ME.

**SSB:** CE5DF, CR4BC, CR6GA, CR6JA, CR6TP, ET3DS, HR2WTA, KP4GS, TA3GB, VK3SG, VP2GAR, VP2MY, VP6RG, VP8KF, VS9G, VU2BEZ, ZD7SD, ZP5EC, ZS5EH, 5VZAT, 5Z4DW, 5Z4KL, 8R1U, 9G1DY, 9J2JY. ZD7SD gave his QTH as POB 16, St. Helena; 9G1DY as POB 2949 Accra and CR4BC as POB 36 St. Vincent, Cape Verde Islands.

**21MHz**

**CW:** CO2BB, CR7AW, CR7EY, CX2CO, HC6EL, MP4BEU, OX3DL, PY2EYE, TI2LA, VP2EEL, ZC4IK.

**● BROADCAST BANDS**

One of the great problems besetting the Broadcast beginner listener is that of keeping up-to-date with the constant frequency and schedule changes that take place on these bands. In this country there are several organisations that disseminate news of this nature, details of these being shown below.

The British Association of Dx'ers (BADX) issue a fortnightly journal ('Bandspread') which is mailed by first class post. Devoted solely to the Broadcast bands. Address:- 16

Ena Avenue, Neath, Glam.

The International Short Wave League publish the monthly 'Monitor', this being devoted to both Amateur and Broadcast bands. Address:- 1 Grove Road, Lydney, Glos., GL15 5JE.

World Dx Club issue 'Contact' on a monthly basis, both Amateur and Broadcast interests are featured. Address:- 11 Wesley Grove, Portsmouth, Hants., PO3 5ER.

**● LATIN AMERICA**

**4820 0430 HRVC** La Voz Evangelica, Tegucigalpa, Honduras Republic. Heard with a programme in English until sign-off at 0457 with station announcements and National Anthem.

**4825 0500 HIFA** Voz de las Fuerzas Arm. S.Domingo, Dominican Republic, with closing announcements in Spanish and National Anthem. The power is 1kW and the schedule is from 1200 to 0500. Address:- Apartado 1350, Santo Domingo.

**4880 0440 YVMS** Radio Universo, Barquisimeto, Venezuela, heard with programme of Latin American songs. (61.48 metres).

**4900 0432 YVNK** Radio Juventud, Barquisimeto, closing with the National Anthem. Address:- Apartado 567 y 576, Barquisimeto. (61.22 metres).

**4905 0510 ZYZ20** Rio, Brazil, logged with a programme of typical Latin American music. (61.16 metres).

**4945 0437 HJDH** Radio Colosal, Neiva, Colombia, Latin American music and commercials. (60.67 metres).

**4965 0430 HJAF** Radio Santa Fe, Bogota, Colombia, heard with station identification and LA music. (60.42 metres).

**4970 2215 YVLK** Radio Rumbos, Caracas, Venezuela, programme of local music and station identification. Schedule is from 0930 to 0500, power is 10kW and the address is:- Apartado 2618, Caracas. (60.36 metres).

**6145 2240 ZYZ34** Radio Nacional, Rio, Brazil, with a 'futebol' (soccer) commentary. (48.82 metres).

**● AFRICA**

**3232 1905** Brazzaville, Congo, with programme of African music and announcements in French. (92.82 metres).

**3265 2044** Radio Clube de Mozambique, Lourenco Marques, heard with light music records and announcements in French. The address is:- P.O. Box 594, Lourenco Marques. (91.88 metres).

**3339 1825** Zanzibar, Tanzania, heard with African songs, chants and rhythmic music - very colourful! (89.85 metres).

**4765 2053** Radiodiffusion TV Congolaise, Brazzaville, Congo, logged often (power is 50kW) with African music and talks in French.

The address is:- B.P. 2241 Brazzaville. (62.95 metres).

**4911 2017** Lusaka, Zambia, heard with a talk in dialect, followed by African-type music and chants. (61.08 metres).

**4965 2010 SABC** Johannesburg, with music from the movies 'The Big Country' and 'High Noon', etc. (60.42 metres).

**4976 2005 Kampala**, Uganda, with a drama production in dialect. The power of this one is 3/8kW and the address:- Ministry of Information and Tourism, Broadcasting House, P.O. Box 2038, Kampala. Interval signal - African drums. This channel is the Red Network (Home Service), the Blue Network being heard on **5026**. According to the schedule, news in English is at 21.00. (60.29 and 59.70 metres respectively).

**4980 1927 Ejura**, Ghana, with a programme of 'pop' record requests.

**4994 1837 Omdurman**, Sudan, heard radiating Arabic chants and music. The address is:- P.O. Box 572, Omdurman. Power is 20kW. (60.08 metres).

**5010 1920** Radio Garoua, Cameroon, heard with a discussion in French. This one is difficult to log as the channel is normally occupied by a teletype transmitter. (59.88 metres).

**5035 1923 Bangui**, Central African Republic, heard with a talk in French. The channel is subject to QRM (interference) from Alma Ata, a USSR station. (59.58metres).

**5047 1925 Lome**, Togo, heard when radiating a programme of typical African music and songs. The power is 100kW and the address is:- Radiodiffusion du Togo, B.P. 434, Lome. The main programme language is French, and local dialects. (59.43 metres).

**7270 2000** RSA Johannesburg, with interval signal. Some interference from Radio Warsaw. (41.27 metres).

**● BEGINNERS' CORNER**

**7065 2030** Radio Tirana, Albania, with a programme in English. The power is 50/240kW and the address:- Radiodiffusion TV Albanaise, Rue Ismail Quemal, Tirana. (41.87 metres).

**7270 2030** Radio Warsaw, Poland, news in English. The power is 10kW and the address:- Polskie Radio I Telewizja, Komitet do Spraw Radio i TV, ul Noakowskiego 20, Warsaw. (41.27 metres).

**15120 1505** Vatican City, with the news in English. The power is 100kW and the address:- Vatican Radio, Vatican City.

**15185 1500 OIX4** Pori, Finland, opening transmission with English announcements. Transmits daily from 1500 to 1830 (English from 1800) on this channel and on 9555 and 11755 in parallel. Address:- Oy Yleisradio AB, Kesakatu 2, Helsinki.

# FINDING FERRITE FRAME UNITS

by  
**P. MANNERS**

## Two approaches to finding the correct number of turns required on home-wound ferrite rod aerials

**M**ANY EXPERIMENTERS WIND their own medium and long wave ferrite frame coils for use in home-constructed receivers. The usual approach towards ensuring that the correct number of turns is put on is to work from past experience or from data published in articles appearing in the radio journals. Frequently, it is possible to make only a rough initial guess at the number of turns required, this being particularly true if the ferrite rod to be used has dimensions different to those employed previously or to those specified in an article. The usual approach here is to wind on what will almost definitely be too many turns, and then take these off as required when the rod is installed in the receiver and the latter has been brought into working order. Final fine adjustments of inductance may then be made, if desired, by sliding the coil along the rod.

The process of taking off turns when the ferrite rod is fitted in the receiver is not difficult, but it can very often be fiddling and tedious, especially if the ferrite rod is mounted in a 'difficult' position which, because of layout requirements, cannot be altered.

### ABSORPTION METHOD

Using one of the two schemes to be described here, it is possible to find the number of turns required in the ferrite rod coil without mounting the rod in its receiver at all. Neither of the approaches requires test gear, the only extra equipment needed being a standard transistor superhet with full coverage of medium and long waves.

The first of the schemes is intended mainly for those who like to try out new ideas, and it enables the frequency range of the ferrite rod coil to be found by an absorption process. First, wind onto the rod what are assumed to be the correct number of turns plus a few

extra for experimental removal, and then connect across this coil the tuning capacitor to be used in the receiver in which the coil will be fitted. Use short leads between the coil and the capacitor. Switch on the transistor superhet, turn its volume control to full, and tune in a weak signal near the middle of the medium or long-wave range, as applicable. Weaken the signal still further by suitably rotating the receiver.

Then, position the ferrite rod whose coil is being checked parallel to the ferrite rod in the receiver and about 2in. away from it. Carefully adjust the tuning capacitor across the coil being checked until there is a sudden reduction in signal strength from the receiver. Gradually move the rod and coil being checked away from the receiver until the reduction in signal strength, as the external tuning capacitor is adjusted, is just noticeable. The ferrite rod coil and its tuning capacitor are then resonant at the frequency which the receiver superhet is receiving.

This process will now give an idea of the tuning capacitance needed for mid-range. If the turns in the coil being checked are sufficient, the procedure can be repeated with the receiver tuned to a weak station at the low frequency end of the band. Turns can next be taken off the ferrite rod coil, checking with the tuning capacitor across it each time, until the absorption effect takes place with the tuning capacitor nearly at full capacitance. The ferrite rod coil should then have the correct number of turns required for range coverage.

### SIGNAL BOOSTING

The absorption method just described gives useful results but difficulty may be experienced with some superhet receivers, which do not give evidence of the absorption

'dip' as readily as others. Because of this, the technique falls into the experimental category.

An alternative, and more positive, scheme is to use a signal *boosting* approach. Again, this consists of having the ferrite rod coil and its tuning capacitor tuned to the same station as the superhet receiver, but in this case the signal is not weakened but boosted. There is a possibility that the scheme could not be used in metal-framed buildings where signal pick-up is low, but that, so far as the author can see, is its only shortcoming.

The ferrite rod coil to be checked and its tuning capacitor are connected up as shown in Fig. 1 for medium waves, or as in Fig. 2 for long waves. An important feature is that the capacitor and coil must connect to a reliable earth. A suitable earth is provided by a mains earth connection. Note that the non-earthly lead between the capacitor and the coil needs to be about 6 to 8in. long.

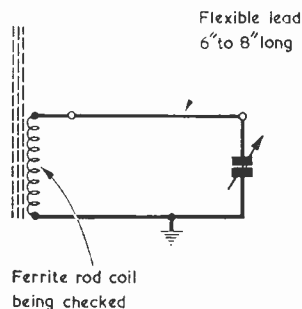

Fig. 1. A test circuit which enables ferrite rod medium wave coverage to be checked in conjunction with a standard domestic portable receiver

Dealing with medium waves first, the receiver is set to full volume, tuned to a weak mid-range signal and rotated to make this weaker again, as before. The ferrite rod and the coil being checked are, also as before, positioned about 2in. away from, and parallel with, the rod in the receiver. The tuning capacitor across the coil being checked is then rotated for an increase in output from the receiver. The rod is then moved away until the boost is just noticeable as the external tuning capacitor is rotated. It will be found that the setting is quite sharp. Once again the situation arises where the ferrite rod coil and its capacitor are tuned to the transmission picked up by the superhet. The coil can then be finally adjusted with a weak station at the low frequency end of



the medium wave band, as previously described.

What is happening here is that the 6 to 8in. length of wire is acting as an aerial. The small amount of signal it picks up is sufficient to allow the ferrite rod coil and the capacitor to resonate at that frequency and induce further signal voltage in the receiver aerial rod. With some transmissions the effect is surprisingly marked in intensity.

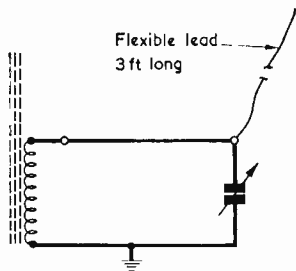

Fig. 2. For long wave tests an additional 3ft. of wire have to be added to function as an aerial

To carry out the process on long waves, about 3ft. of stranded insulated wire is connected to the non-earthly side of the ferrite rod and tuning capacitor as shown in Fig. 2, since there is not sufficient signal pick-up in the 6 to 8in. length of wire. This additional wire, which should be kept reasonably clear of earthed objects, introduces the slight disadvantage that the resultant capacitance to earth is too high to enable the tuned circuit to be checked at the high frequency end of the long wave band, if for any reason this should be desired, although it does not introduce too much error at the more important low frequency end.

#### FINAL POINTS

Before concluding, there are several final points to be made.

First, don't expect the tuning range given by the receiver in which the ferrite rod is fitted to be exactly the same as was obtained when the rod was outside. There are almost certain to be nearby components and materials which can slightly modify the range.

Second, before attempting to use

the signal boosting method for finding the turns required in a newly-wound coil, try the scheme with a ferrite rod and coil whose range is known. This enables the 'feel' of the process to be acquired, and gives a good idea of the ferrite rod spacing needed with the particular superhet receiver employed for the check.

Third, difficulties may arise on medium waves if a separate long wave coil having no connections made to it is fitted on the ferrite rod. The long wave coil may resonate with its own self-capacitance at a frequency close to the medium wave band and upset results with the medium wave coil. Remove the long wave coil when checking the medium wave coil.

Fourth and last, no mention has been made of coupling windings on the ferrite rod coils. These can be added after the tuned coil has been adjusted and will usually consist of the few turns at the earthy end that are needed for coupling into the input transistor base. Alternatively, the coil can be unwound, a tap provided at the appropriate number of turns from its earthy end, and the coil then re-wound. ■

## SOLID-STATE TV MICROWAVE LINK FROM EMI HAS RANGE OF 65 Km

The EMI type ML7A microwave link is a solid-state mobile unit for television applications. It is continuously tunable over the 7.1 GHz to 7.45 GHz frequency range and has a nominal output of 1 watt and an effective range of over 65 Km.

The lightweight and weather-proof ML7A can be set up for operation in a matter of minutes. Cable links between the control unit and the head units may be up to 120 m. in length at the transmitter and up to 180 m. at the receiver.

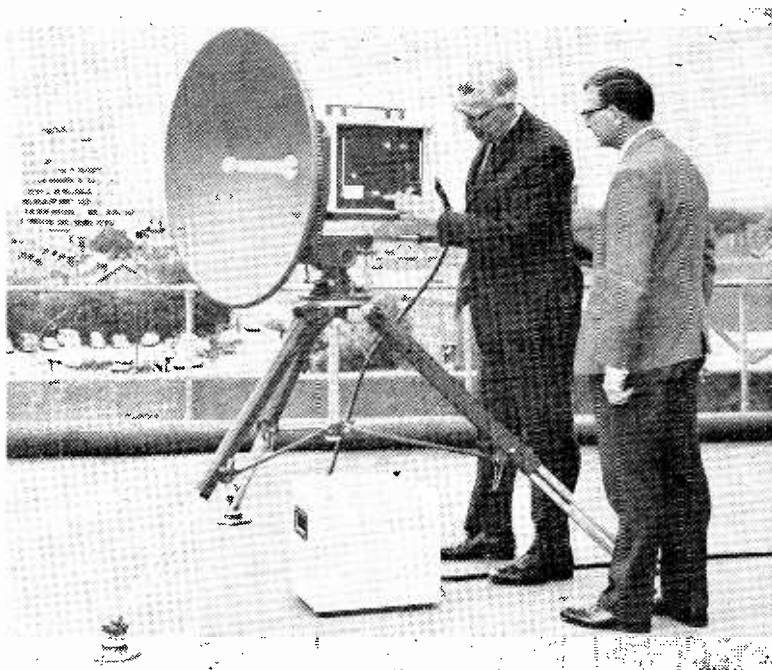

# I.C. STEREO AMPLIFIER

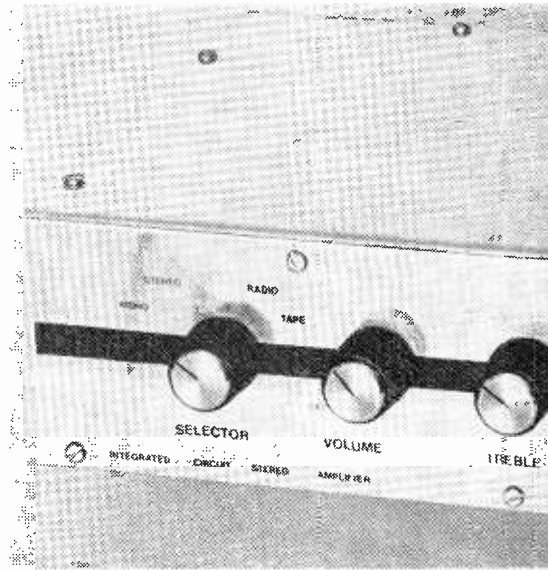

Offering an output of 2.7 watts per channel, a highly reliable circuit with fully component construction is eased by the use of a printed circuit board, and each channel is readily available.

THE STEREO AMPLIFIER TO BE DESCRIBED IN THIS article is based on a Radiospares integrated circuit, one of which is used in each channel. Amplifier input switching caters for stereo tape, stereo radio, stereo gram and mono gram. Power output per channel is 2.7 watts r.m.s., and input sensitivity is 160mV r.m.s. Total harmonic distortion at full output is 1% maximum, this dropping to around 0.5% at 2 watts and to lower values again at less output. Noise level is - 80dB max, hum level is - 72dB and crosstalk level is - 40dB. The minimum output load is 7.5Ω, and 8Ω speakers are recommended.

The amplification in each channel is provided entirely by the Radiospares integrated circuit just referred to. Two of these are mounted, together with the associated discrete components, on a single fully prepared printed circuit board having all holes drilled and the copper pattern solder coated. Component positions are indicated on the non-copper side of the board, where the appropriate circuit identifications are clearly printed. Thus, assembly of the printed circuit section of the amplifier requires little more than the ability to solder.

The amplifier can be powered by an economy mains transformer and bridge rectifier circuit or, at slightly higher cost, by a stabilised supply, the latter giving an improved performance due to the stabilisation it provides. The performance figures just given apply to the amplifier when it is powered by the non-stabilised supply.

A metal case with control functions printed on the front panel is available, as also is a wooden cabinet into which the metal case can fit. Further details on these are given later when the components are discussed.

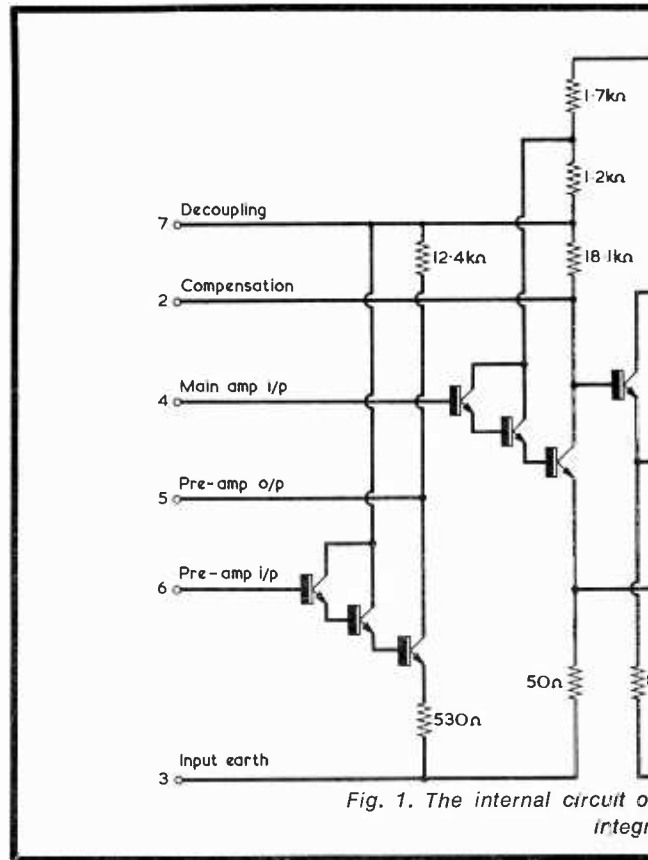
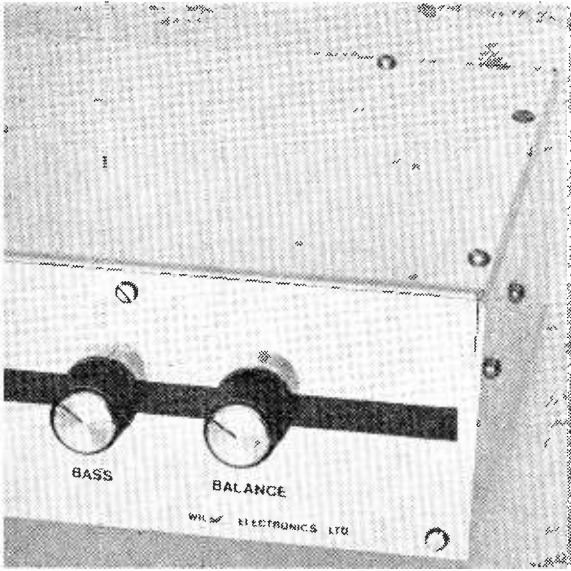

Fig. 1. The internal circuit of the integrated circuit.



**Cover Feature**

by

**R. J. CABORN**



...nel, this stereo a.f. amplifier employs  
inuuous bass and treble control. Con-  
eady-prepared solder coated printed  
the amplifier incorporates a modern  
e integrated circuit

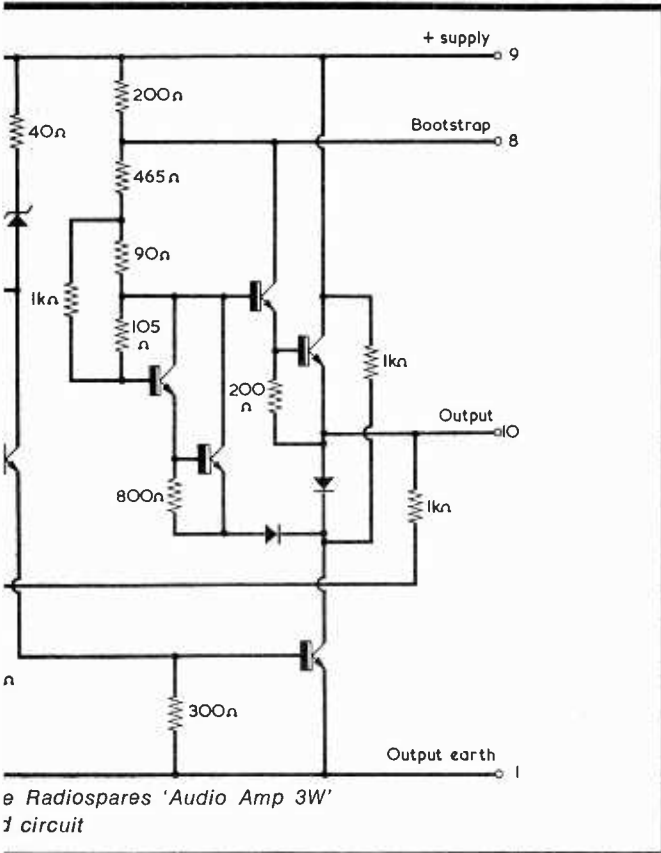

### THE CIRCUIT

The internal circuitry of the integrated circuit is given in Fig. 1. The a.f. input is applied at terminal pin 6, to the left-hand pair of transistors. These are in a compound emitter follower circuit and couple into a third common-emitter transistor, whose output is fed to terminal pin 5. This output is passed through external tone control circuits in the amplifier and is then returned to the integrated circuit at pin 4. The remaining transistors in the integrated circuit bring the signal up to full output level, the output being taken from pin 10. This pin is also coupled, by an external high-value capacitor, to pin 8, whereupon it provides bootstrapping of the collector loads for the transistors preceding the upper output transistor. Of the remaining terminal pins, pin 7 is decoupled to earth via an external large-value electrolytic capacitor, pin 2 is coupled to earth via a lower value capacitor to give compensation, and pin 9 connects to the positive supply. Pins 3 and 1 are the input and output earth connections respectively.

The integrated circuit has a dual-in-line encapsulation with 5 lead-outs on each side. As may be seen from the side view given in Fig. 2, it also has an integral heat shunt to which an external heat sink can be bolted. It is important to note that the integrated circuit must never be used without a heat sink of adequate size. The heat shunt projects further from one end of the transistor encapsulation than it does from the other. This factor enables lead-out positioning to be more readily identified and ensures that the integrated circuit cannot be inserted in a printed circuit board wrong way round. The heat shunt is intended to be connected to earth.

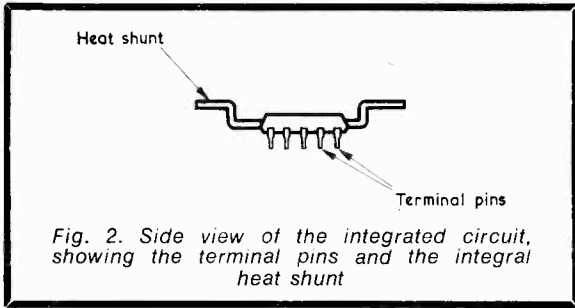

The circuit of the complete amplifier incorporating the integrated circuit is given in Fig. 3. The design of this amplifier, from RV1 onwards, is due to Radiospares, to whom full acknowledgement is given. At the left in the diagram are the six input sockets, these being for Tape, Radio and Gram. The inputs are selected by the function switch S1 and are then applied to the volume controls in the two channels of the amplifier. Since, after S1, both channels are identical, only the right-hand channel is shown in Fig. 3. In the practical version, all leads from the input sockets up to the volume controls

are screened but, for simplicity of presentation, this screening is omitted in the circuit diagram.

Returning to the input signal at the right-hand channel, this passes from volume control RV1 to terminal 6 of the integrated circuit via C1. The pre-amplifier output at terminal 5 next passes through the tone control network around bass control RV4 and treble control RV5 and returns to the integrated circuit at terminal 4. The output, at terminal pin 10, is coupled to the speaker by way of C14. Terminal pin 10 also couples to pin 8 via C11 to provide bootstrapping. C4, at pin 7, provides decoupling, whilst C12, at pin 2, gives compensation. The amplitude of the a.f. signal from terminal 5, in both channels, is controlled by RV2, which functions as a balance control. RV3 is a preset control which is set up for optimum d.c. conditions in the integrated circuit.

The circuit of the lower cost power supply is given in Fig. 4. This employs a filament transformer whose two 6.3 volt secondaries are connected in series to allow 12.6 volts r.m.s. to be applied to the bridge rectifier. The stabilised supply which may be used as an alternative is a Sinclair unit type PZ.7, this being available completely assembled.

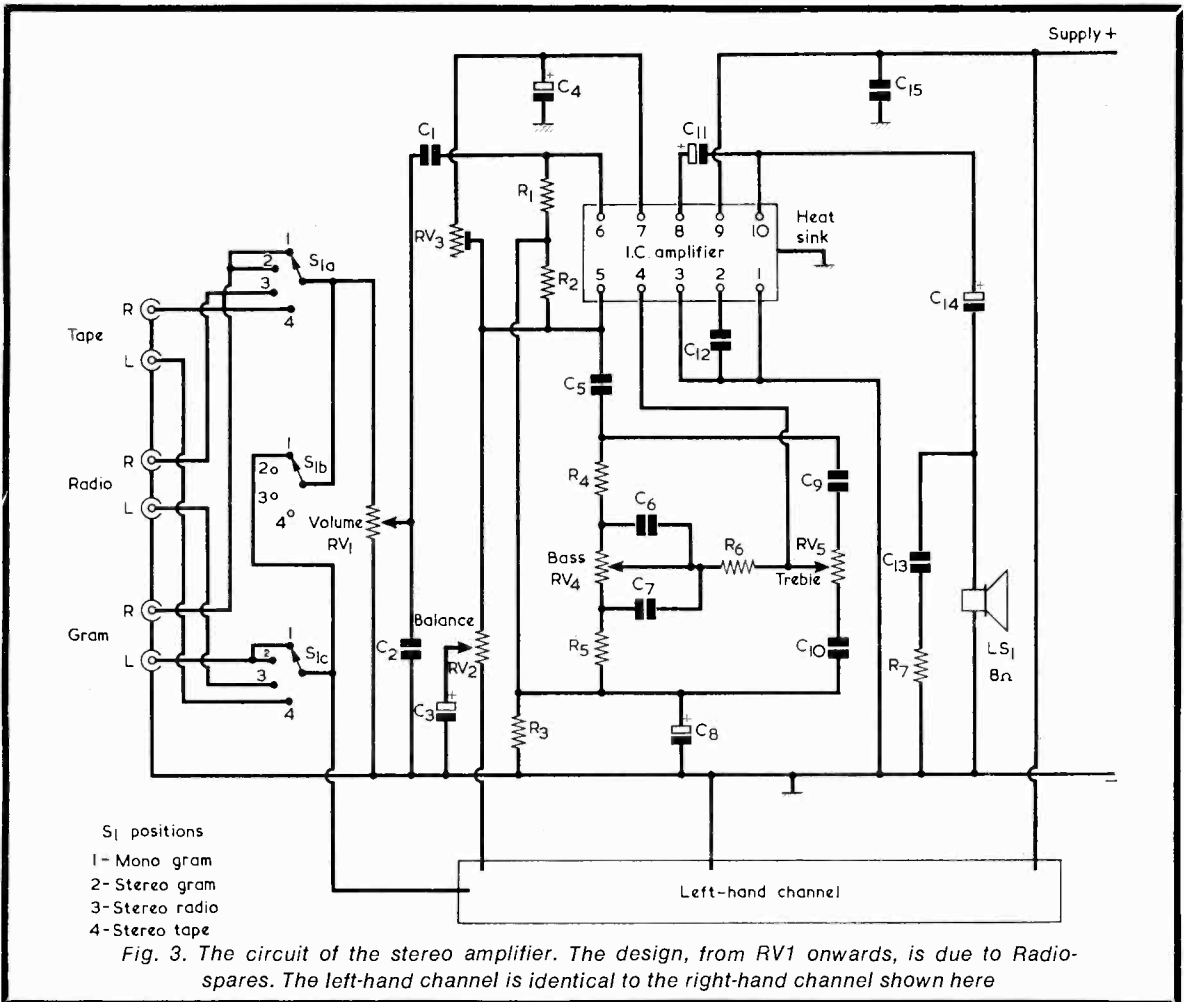

# COMPONENTS

## Resistors

(All fixed values  $\frac{1}{4}$  watt 5% high stability. Resistors marked with an asterisk (\*) are 1-off, all others are 2-off.)

R1	1M $\Omega$
R2	150k $\Omega$
R3	68k $\Omega$
R4	33k $\Omega$
R5	6.8k $\Omega$
R6	10k $\Omega$
R7	10 $\Omega$
*RV1	500k $\Omega$ , 'Tandem', log. with switch S2
*RV2	100k $\Omega$ , lin.
RV3	47k $\Omega$ , miniature preset
*RV4	250k $\Omega$ , 'Tandem', log
*RV5	250k $\Omega$ , 'Tandem', log

## Capacitors

(Capacitors marked with an asterisk (\*) are 1-off, all others are 2-off.)

C1	0.047 $\mu$ F polyester, 250V wkg.
C2	30pF silver-mica
*C3	10 $\mu$ F electrolytic, 50V wkg.
C4	25 $\mu$ F electrolytic, 25V wkg.
C5	0.22 $\mu$ F polyester, 250V wkg.
C6	0.01 $\mu$ F polyester, 250V wkg.
C7	0.047 $\mu$ F polyester, 250V wkg.
C8	2 $\mu$ F electrolytic, 150V wkg.
C9	1,000pF polystyrene
C10	4,700pF polystyrene
C11	100 $\mu$ F electrolytic, 25V wkg.
C12	0.01 $\mu$ F polyester, 250V wkg.
C13	0.047 $\mu$ F polyester, 250V wkg.
C14	1,000 $\mu$ F electrolytic, 25V wkg.
C15	0.47 $\mu$ F polyester, 250V wkg.

## Integrated Circuit

2-off 'Audio Amp 3W' (Radiospares)

## Fuse

F1 2 amp cartridge fuse, with chassis-mounting holder

## Switches

S1 3-pole 4-way, miniature rotary  
S2 D.P.S.T., ganged with RV1

## Power Supply

Either Stabilised supply type PZ.7 (Sinclair)  
Or Home-constructed supply

incorporating:

C16 5,000 $\mu$ F electrolytic, 25V wkg., in can with clamp

RECT 1 Bridge rectifier type REC41 (Radiospares)

T1 Filament transformer, secondaries 6.3V at 1.8A, 6.3V at 1.8A, 'Hygrade' (Radiospares)

## Printed Circuit Board

Printed circuit board, 'Stereo P.C.B.' (Radiospares)

## Sockets

6-off phono sockets  
4-off wander sockets

## Metalwork

Chassis, cover, front panel and 2-off heat sinks (Wilsic Electronics Ltd.)

## Miscellaneous

5-off knobs with pointer line  
6ft. 3-core mains lead  
6ft. screened lead  
1ft. tinned copper wire  
Connecting wire, nuts, bolts, etc.

## Cabinet (Optional)

All parts for cabinet, including teak or mahogany veneer (Wilsic Electronics Ltd.)

## COMPONENTS

The main components, i.e. the integrated circuits and the printed circuit board, are marketed by Radiospares. Radiospares components cannot be obtained direct by individual constructors and have to be purchased through retailers. In the present instance they are available, in company with the other Radiospares components required, from Wilsic Electronics Ltd., 6 Copley Road, Doncaster. Wilsic Electronics can also provide a complete kit for the amplifier, including a metal case with a front panel having control functions printed on it. This case may be fitted to the plinth of a gram deck or it may be housed in a free-standing wooden cabinet which is covered with mahogany or teak veneer. This cabinet can be assembled from parts supplied by Wilsic Electronics.

As may be seen from the accompanying Components List many of the components are duplicated in the two channels, two of each being required. The volume controls and tone controls for the two channels are ganged, dual or 'Tandem' potentiometers being employed here. RV1 is also ganged with the on-off switch for the amplifier.

A minor point is that capacitor C15 is specified as 0.47 $\mu$ F, whereas some Radiospares circuits may show this component as 0.1 $\mu$ F. The value of 0.47 $\mu$ F is correct and is the result of a change in circuit design by Radiospares. RV1 is specified as 500k $\Omega$

instead of the 2M $\Omega$  given in the Radiospares circuit, because of the difficulty in obtaining the higher value combined with an on-off switch. The effect on performance resulting from the use of the lower value potentiometer is almost negligible.

In the constructional details which follow, components in the right-hand channel will be distinguished by the suffix letter 'a', and those in the left-hand channel by the suffix letter 'b'.

## PRECAUTIONS

At this stage three important precautions must be listed, these applying to the amplifier after it has been wired up.

First, never short-circuit pin 4 of either integrated circuit to earth.

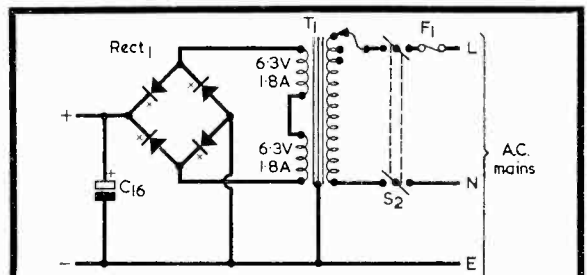

Fig. 4. Circuit of one of the two power supplies that may be employed with the amplifier

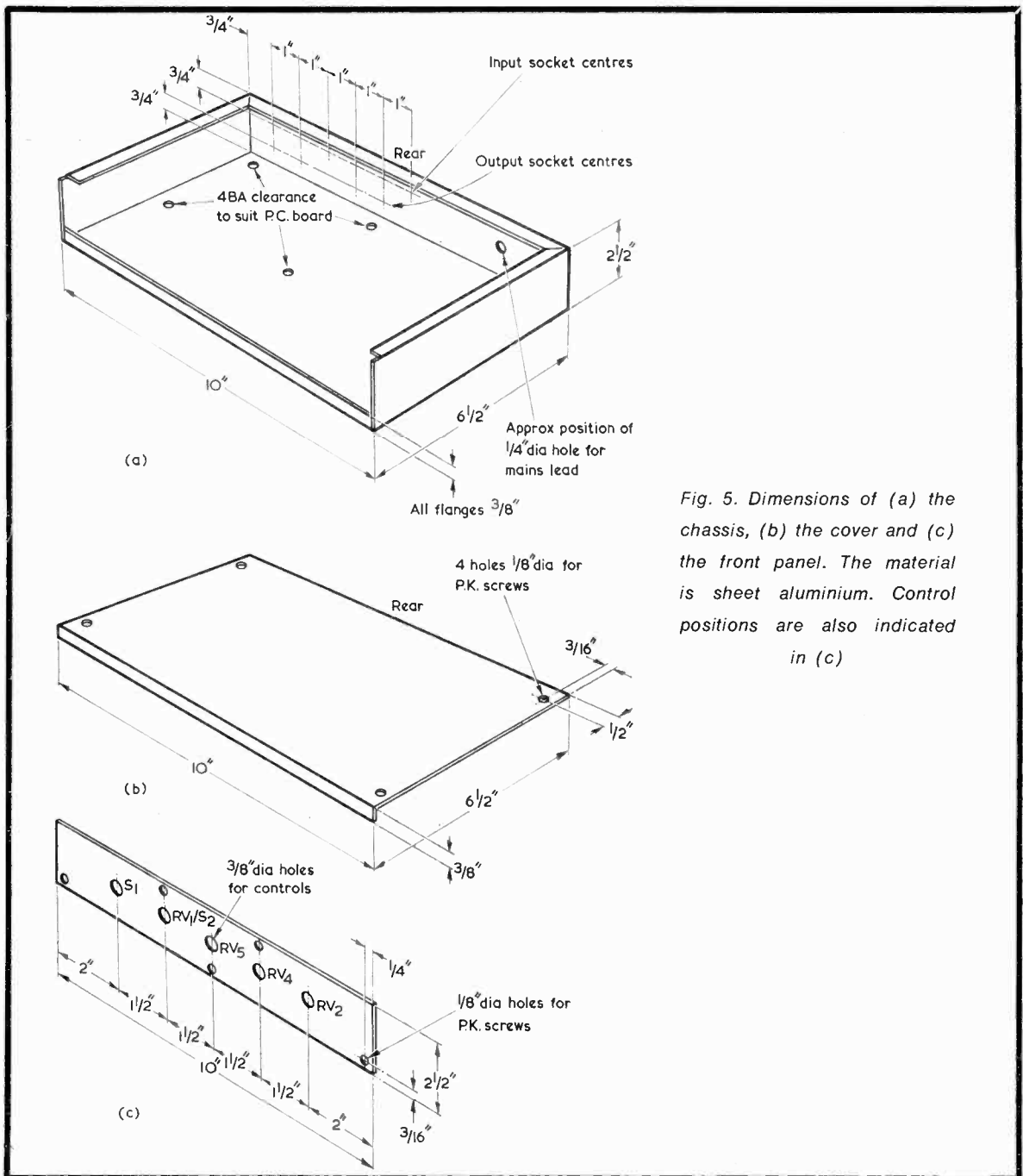

Fig. 5. Dimensions of (a) the chassis, (b) the cover and (c) the front panel. The material is sheet aluminium. Control positions are also indicated in (c)

Second, never short-circuit the output of either integrated circuit to earth.

Third, never switch on the amplifier without speakers connected.

Failure to observe any of these three points can result in irreparable damage to the integrated circuits.

## DRILLING DETAILS

Details of the metal case, cover and front panel are given in Figs. 5(a), (b) and (c) respectively. Holes require to be drilled for the input phono sockets and

for the output sockets, the latter being of the single insulated wander plug type. Hole diameters will depend on the particular sockets employed. Each phono socket will also require two holes for the mounting bolts, and these may be marked off from the sockets themselves. Four 4BA clearance holes are required for the printed circuit board, these being marked off from the board. The board, when fitted, takes up the position shown in the accompanying photograph of the inside of the amplifier, its left-hand edge being about 3/8 in. clear of the inside left-hand surface of the chassis, and its rear edge



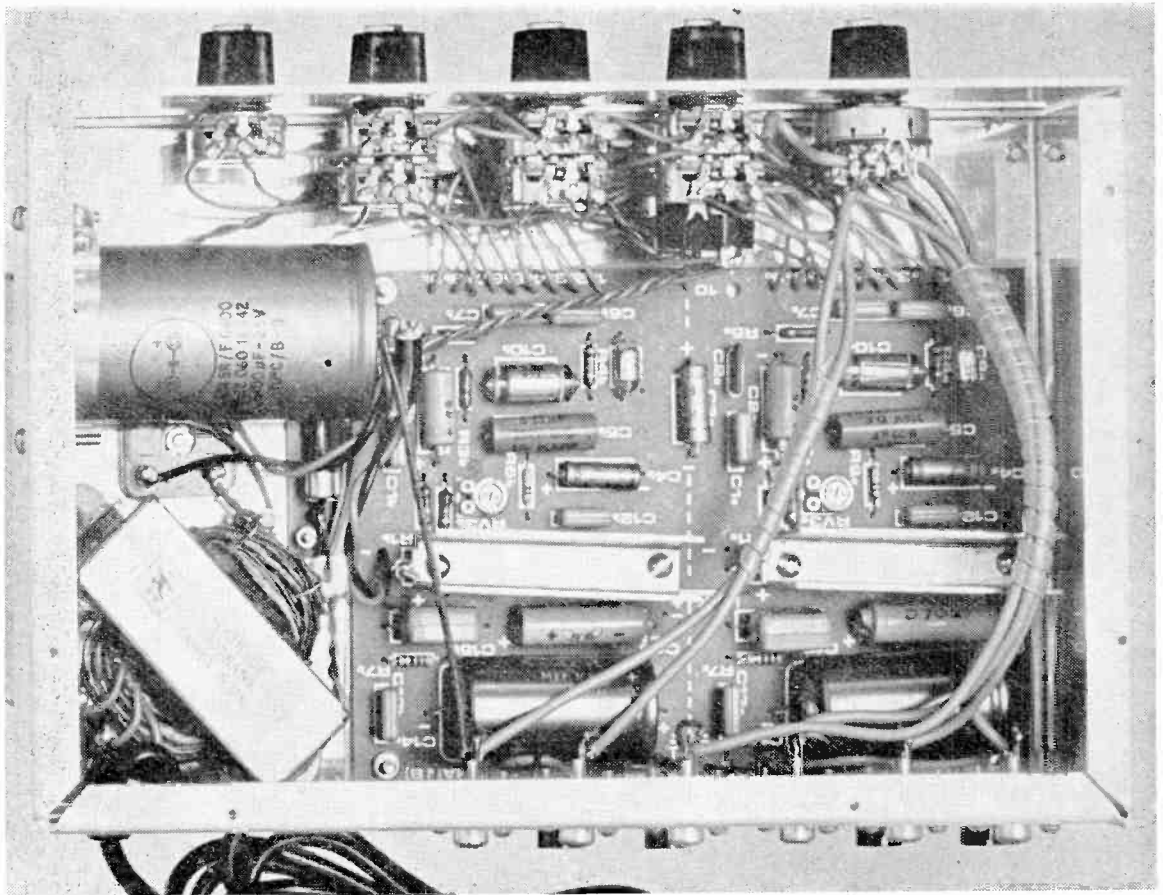

*Looking down into the chassis with the cover removed*

being about  $\frac{1}{8}$  in. clear of the inside rear surface. When the board is later fitted, the two rows of holes marked '1a' to '9a' and '1b' to '9b' are towards the front.

A  $\frac{1}{8}$  in. diameter hole has to be drilled in the rear apron of the chassis to take the mains lead, as shown in Fig. 5(a). The position of this hole is not critical. Also to be drilled are holes for self-tapping P.K. screws which secure the cover to the chassis and the front panel to the chassis and to the cover. When assembled, the front flange of the cover is behind the front panel. The threading holes for the P.K. screws may be marked out after the clearance holes have been drilled. If the screws provided in the Wilsic Electronics kit are used, the clearance holes are  $\frac{1}{8}$  in. diameter and the threading holes  $\frac{3}{32}$  in. diameter.

When all the holes indicated in Figs. 5(a), (b) and (c) have been drilled, further holes are required for the power supply. If the lower cost power supply is to be used it is necessary to mark out and drill, on the chassis deck, mounting holes for the mains transformer (two holes 4BA clear), rectifier (one hole 4BA clear) and fuseholder (two holes 6BA clear). See Fig. 10(b) and the photograph of the interior of the amplifier. The fuseholder will be about  $\frac{1}{8}$  in. clear of the right-hand edge of the printed circuit board when these components are finally fitted. On the right-hand side apron of the chassis two further

holes (4BA clear) are needed for the clamp of the electrolytic capacitor C16. If the alternative Sinclair PZ.7 stabilised supply is to be used it takes up the position shown in Fig. 10(a), with its printed circuit uppermost. It is secured by four 6BA bolts, for which appropriate holes should be drilled. Two further holes (6BA clear) are also required for the fuseholder.

This completes the small amount of drilling required. Ensure that all holes are finished off neatly and are free from burrs. No components are mounted at this stage.

#### **PRINTED CIRCUIT ASSEMBLY**

The next process consists of fitting the components to the printed circuit board. This task can be carried out very simply as all the component positions are indicated on the component side of the board, the component numbering corresponding with that in the Components List. The requisite polarity for electrolytic capacitors is also shown.

Care should be taken with all soldering, especially when working on the larger foil areas which cool the iron very quickly and therefore increase the risk of dry joints. The integrated circuits are soldered into position last, being previously fitted with heat sinks, as shown in Fig. 6. Note that a solder tag is secured under one of the heat sink securing bolt heads. This solder tag provides the earth connection for the integrated circuit heat shunt, and is con-

ected by means of a short length of bare wire to the printed circuit at the point shown on the board. Ensure that the integrated circuits are fitted right way round, as indicated by the outline printed on the board. The soldering to the integrated circuit terminals should be carried out as quickly as possible, to avoid overheating.

There is one hole in the board, adjacent to R1(a) and marked with a '-' sign, at which, with the present design, no connection is made. This hole provides the negative supply connection for the 'a' section of the board should this be employed on its own, after cutting the board into two sections, for a single mono amplifier.

Next, solder 7in. lengths of stranded wire to the board at the holes marked '1a' to '9a', '1b' to '9b', and at hole '10' in the centre. Solder 3in. lengths

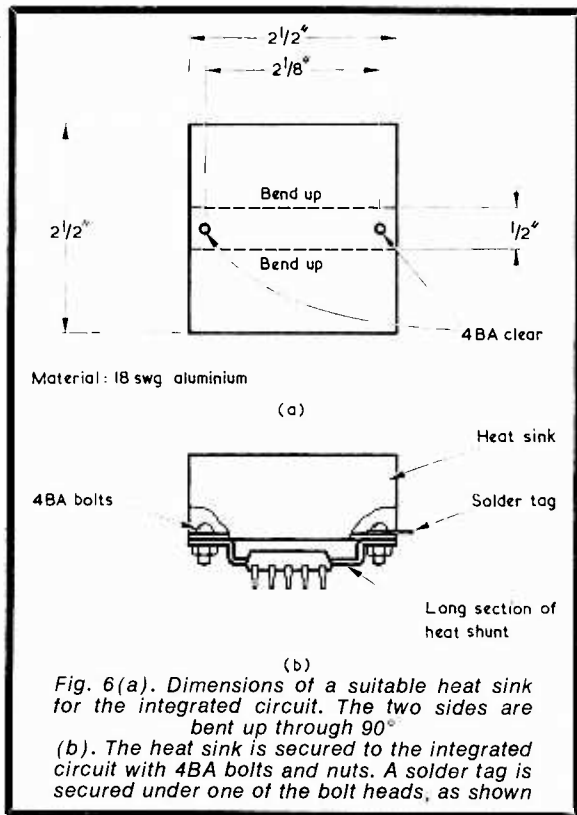

Fig. 6(a). Dimensions of a suitable heat sink for the integrated circuit. The two sides are bent up through 90°  
(b). The heat sink is secured to the integrated circuit with 4BA bolts and nuts. A solder tag is secured under one of the bolt heads, as shown

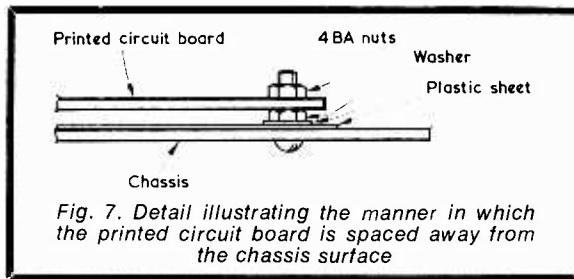

Fig. 7. Detail illustrating the manner in which the printed circuit board is spaced away from the chassis surface

### CHASSIS WIRING

Chassis wiring is next carried out as illustrated in Fig. 8. First, mount the four speaker sockets and connect the free ends of the 3in. leads from the board to these. The sockets are connected in the same order, from left to right, as the corresponding holes in the board.

Secure the front panel to the chassis by means of three P.K. screws at the lower edge. Mount RV1/S2, RV5, RV4 and RV2 to the front panel at the holes indicated in Fig. 5(c), fitting shake-proof washers to their bushes behind the panel. The tags of all these controls should be at the top for easy access. Fit the knobs to these controls such that the line on each knob is at the top when the appropriate control is at mid-travel. (This orientation may not coincide with that in which the knob grub-screw bears on the flat of the spindle, but it will be found that knob positioning is nevertheless adequately secure.)

Shortening as necessary, connect all the 7in. wires soldered at holes '1a' to '9a', '1b' to '9b' and at hole '10', to RV1, RV5, RV4 and RV2, following the wiring layout given in Fig. 8. It will be found most convenient to start at RV2 and work to the left, dealing with RV4, RV5 and RV1 in turn. The connections marked 'Inputs from S1' are not made at this stage. Although some of the leads now being wired are at amplifier input level, they do not need to be screened.

Next fit all six phono input sockets and solder an earth rail of bare tinned copper wire along all the socket outer connector tags. With normal phono socket construction, the outer connections will be automatically in contact with the metal of the chassis after mounting, and this provides the earth connection to the chassis for the amplifier. The earth rail is shown in Figs. 10(a) and (b).

Mount switch S1 at the front panel hole indicated in Fig. 5(c), fitting a shake-proof washer on its bush behind the panel. Orient it such that, when the knob is fitted with its grub-screw bearing on the spindle flat, the line on the knob points correctly at the switch function lines printed on the panel.

Following Fig. 9, wire up the phono sockets to switch S1, with screened cable. Note that, to prevent hum loops, the screened cable braiding is earthed at the socket end only. The braiding must be completely removed at the switch end. If any doubt exists concerning the tags which are brought into circuit at each switch position, check through with a simple continuity tester, such as a multi-testmeter set to an ohms range. For neatness, the screened

of heavy duty stranded wire at the four speaker outlet holes. Finally, solder 12in. lengths of heavy duty stranded wire at the two holes marked '+' and '-' adjacent to R1b and C15b. Employ red wire for the positive connection and black wire for the negative connection. These last two leads will later connect to the power supply.

All soldering on the printed circuit board is now complete. The joints on the copper side should be neat, without excessive protuberances or 'spikes' of solder.

The printed circuit board may now be mounted on the chassis, a sheet of plastic being interposed between its underside and the chassis to prevent short-circuits to the chassis surface. As already mentioned, the holes '1a' to '9a' and '1b' to '9b' are to

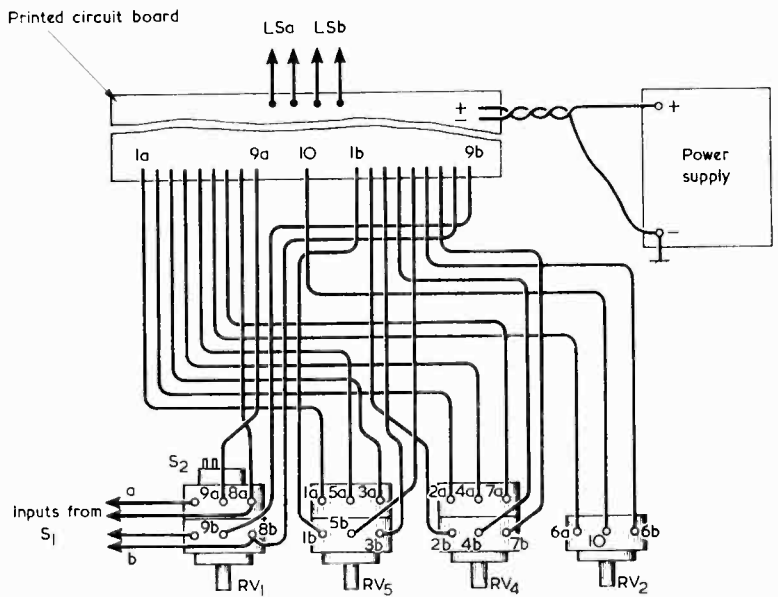

Fig. 8. The external wiring to the printed circuit board

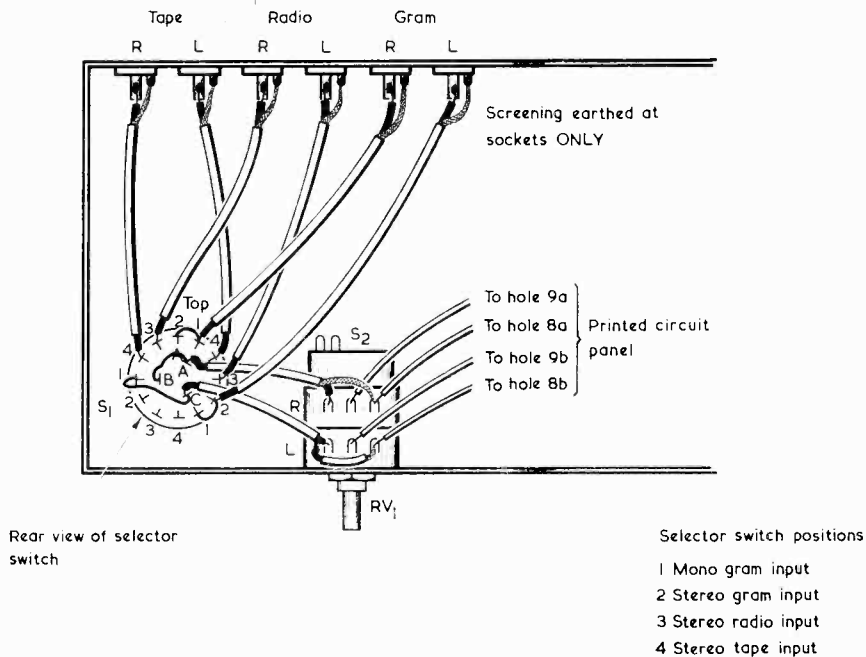
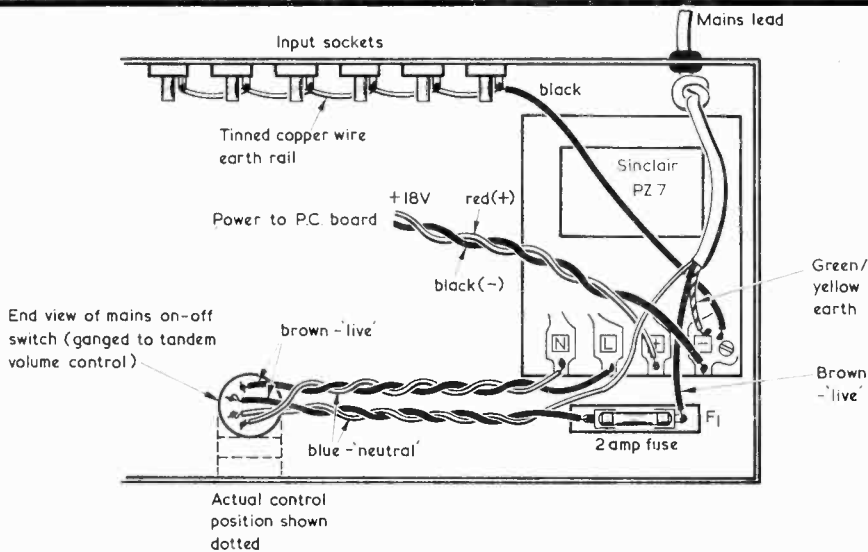
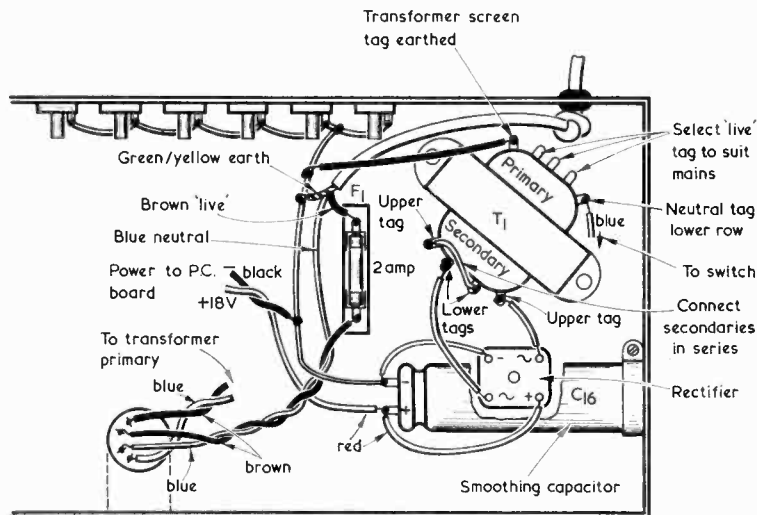

Fig. 9. The connections to the input selector switch



(a)



(b)

Fig. 10(a). Power section layout and wiring when the Sinclair stabilised power supply is employed  
 (b). The alternative lower-cost supply is wired up in the manner shown here

cables can be grouped together as illustrated in the photograph.

Again using screened cable, complete the connections between S1 and RV1. These are also shown in Fig. 9. The braiding is, once again, completely removed at the switch end, being connected to earth at the RV1 end only.

#### POWER SUPPLY

Next to be fitted is the power supply. First fit a grommet to the  $\frac{1}{4}$  in. hole in the rear of the chassis and thread the three-core mains lead through this. Tie a loose knot in the cable to provide anchorage inside the chassis.

If the Sinclair PZ.7 power supply is to be used, mount this and the fuseholder as shown in Fig. 10(a). Initially wire up all the connections shown in Fig. 10(a), except those for the two power supply leads from the printed circuit board. Note that the fuse is inserted in the brown ('live') lead, and that the green/yellow earth lead connects to the negative terminal of the power supply and to the earth rail at the input phono sockets. The mains wiring between the power supply and the on-off switch should be tightly twisted, as shown. The power supply should next be set up to give an output of 18 volts, as described in the Sinclair leaflet provided with it.

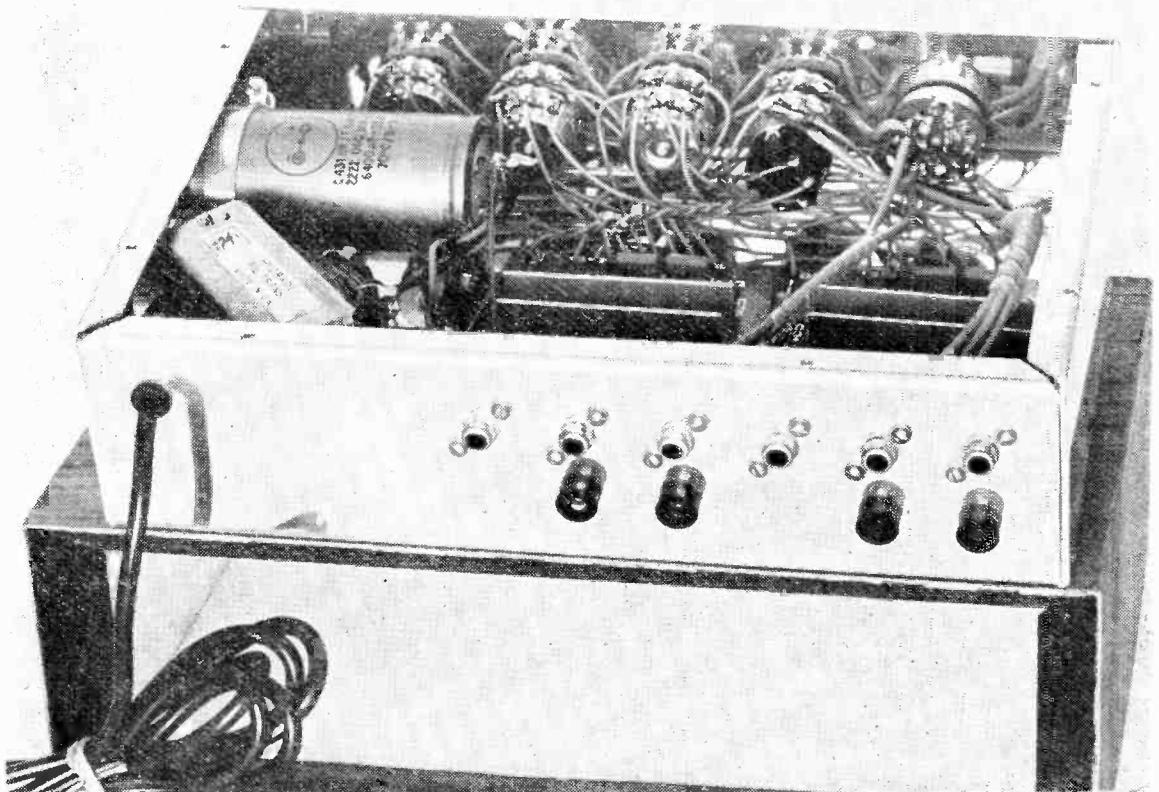
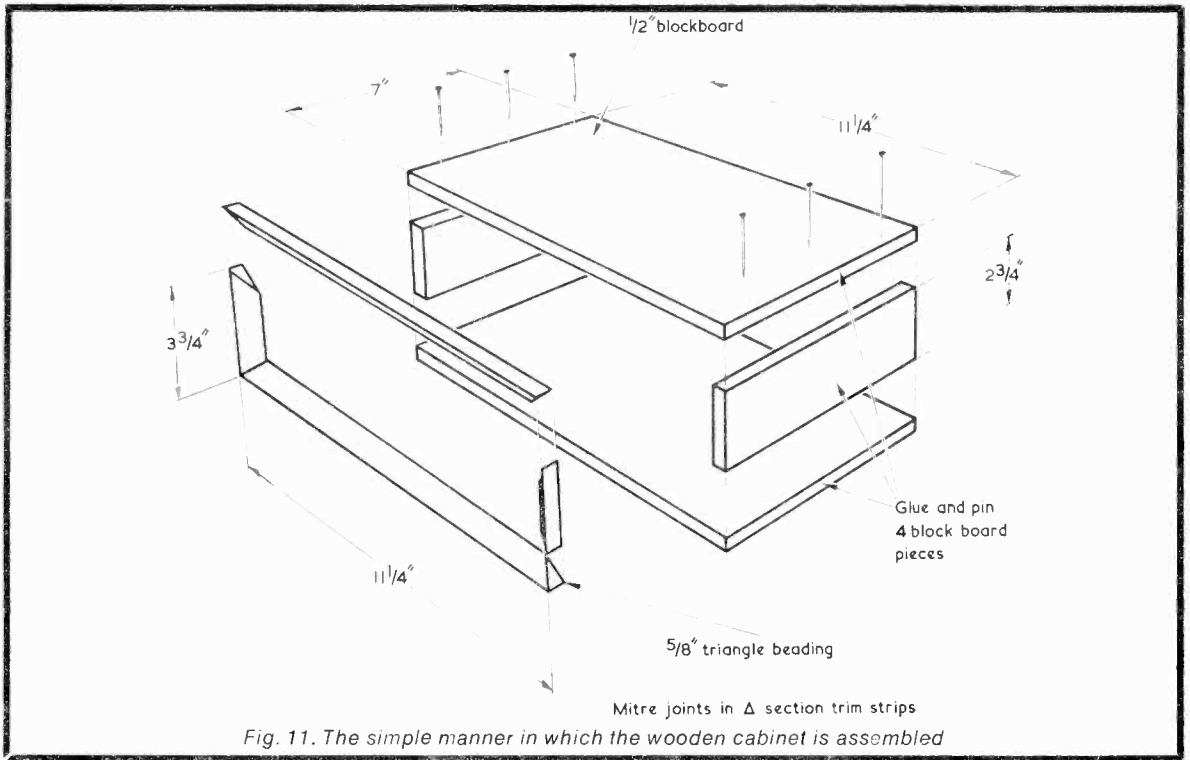

*A rear view of the chassis, illustrating the input and output sockets and showing the wiring to the input switch and potentiometers*

The two power supply leads from the printed circuit board may then be connected, shortening as necessary. These two leads must also be twisted together. Take care to ensure that connection is made with correct polarity.

If the lower cost power supply is to be used, the fuseholder, mains transformer and rectifier are mounted in the manner shown in Fig. 10(b). It will be necessary to solder the leads to the transformer primary before it is mounted. The leads to the rectifier should be soldered next, after which electrolytic capacitor C16 is mounted in position. Wiring is then completed as indicated in Fig. 10(b). Again, the fuse is in the brown ('live') mains lead, and the green/yellow mains lead connects to the earth rail and thence to chassis. The two 12in. power leads from the printed circuit board should be twisted together and will need to be shortened as required. Once more, take care to ensure that correct polarity is observed. The wires from the power supply section to the on-off switch should be tightly twisted together.

#### SETTING UP

Wiring-up is now complete. Bearing in mind the three precautions listed earlier, connect up the

speakers and switch on. The setting-up process consists of adjusting RV3 in each channel such that the direct voltage between pin 10 of each integrated circuit (the top left pin when the amplifier is viewed from the front) and earth is equal to half the supply voltage.

The input sensitivity of the amplifier on 'Gram' is suitable for crystal or ceramic cartridges, a recommended type being the J.2105 ceramic unit marketed by T.T.C. A magnetic cartridge, such as the J.2203 (also T.T.C.) requires a pre-amplifier, a suitable type being the Eagle PRE402.

#### WOODEN CABINET

If it is intended to fit the amplifier in a wooden cabinet, the latter is assembled as shown in Fig. 11. The metal case of the amplifier may be slid in so that its front panel is behind the triangle beading. It is secured by self-tapping screws which pass through holes in the bottom piece of wood and thread into the chassis deck at suitable points near the front, where they will not foul any internal components. The cabinet is finished off with teak or mahogany veneer, after which four rubber feet are fitted at the corners. ■



## Latin American Quest

### (4) COLOMBIA ECUADOR

### GUYANA VENEZUELA

THERE ARE THIRTEEN COUNTRIES ON THE ACTUAL South American continent, eight on the Yucatan Peninsula and six, taking the West Indies as a whole and excluding the Antilles, in the Caribbean area. In Latin American Quest, however, we are only concerned with those countries situated on the continent.

#### COLOMBIA - AN OUTLINE

The Republic of Colombia has an area of 455,335 square miles and a population of about 18,000,000. Situated in the North West part of the continent, it is the only nation in S.America with coasts on both the Atlantic and the Pacific. Bordered in the N.West by the Caribbean, in the S.West by the Pacific, in the South by Ecuador and Peru, in the S.East by Brazil and in the N. East by Venezuela, the capital is Bogota.

The country consists of mountains and uplands in the West and lowlands in the East. The latter part includes the tropical rain forests of the Amazon Basin and forms two-thirds of the total land area. In Colombia, the Andes mountain range is divided into three by the Cauca and Magdalena rivers.

The principal cities of the country are - Bogota, Tunja, Bucaramanga, Cucuta, Medellin, Manizales and Cali. The main ports are Buenaventura (Pacific), Barranquilla, Cartagena and Santa Marta (Atlantic). *Colombia - Short Waves*

Colombia is five hours behind GMT, the language is Spanish and the country is of interest to the beginner short wave listener in that it is relatively easy to log on the LF bands. Table 1 lists some of the Colombian stations frequently reported in the SWL press. The complete list of Colombian stations is long, only a few therefore being shown here.

TABLE 1

<i>kHz</i>	<i>kW</i>	<i>Station</i>	<i>Schedule GMT</i>
4845	1	HJGF Bucaramanga, "Radio Bucaramanga"	1000-0400
4855	1	HJFV Neiva, "Radio Neiva"	1000-0400
4905	1	HJAH Barranquilla, "Emisora Atlantico"	1000-0500
4915	1	HJSG Valledupar, "Radio Guatapuri"	1100-0500
4935	1	HJDE Villavicencio, "Radio Villavicencio"	0900-0500
4945	2.5	HJDH Neiva, "Radio Colosal"	24 hours
4955	50	HJCQ Bogota, "Radio Nacional"	1100 0500
4965	2.5	HJAF Bogota, "Radio Santa Fe"	24 hours
5020	1	HJFW Manizales, "Transmisora Caldas"	24 hours
5050	1	HJDW Medellin, "La Voz de Medellin"	1030-0500
5075	25	HJGC Bogota, "Accion Cultural Popular"	0900-0400
5095	50	HJGC Bogota, "Accion Cultural Popular"	0900-0400



## ECUADOR - AN OUTLINE

The Republic of Ecuador has an area of 108,478 square miles and a population of around 5,000,000. Ecuador derives its name from the Spanish word for equator, which traverses the country. The Republic is situated on the Western side of the South American continent and has a Pacific Ocean coastline. Quito is the capital city, being situated in the Andes at an altitude of 9,350 feet, some 15 miles south of the equator.

Two ranges of the Andes cross the country and there are many active volcanoes, Chimborazo and Cotopaxi being the best known. Frequent earthquakes, which cause much damage, are a feature of Ecuadorian life.

Ecuador is bounded on the West by the Pacific Ocean, the North by Colombia, and on the East and South by Peru, the principal port being Guayaquil. Guayaquil is on the Guayas river 30 miles above its entrance into the Bay of Guayaquil. The port was devastated by fire in 1896 and again in 1899 but is now a thriving community with a population of around 510,000.

Ecuador was liberated from Spain by Sucre with the victory at Pichincha in 1822 and became incorporated into Bolivar's Republic of Greater Colombia. At the dissolution of that union in 1830, Ecuador became a separate Republic. In 1832 Ecuador gained the Galapagos Islands. A border dispute with Peru still exists.

### *Ecuador - Short Waves*

Ecuador is five hours behind GMT. the languages are Spanish and Quechua ('Indian' dialect) and the country is easy to log on the short waves by means of the powerful transmitters of HCJB "The Voice

of the Andes" located at Quito.

Most of the Ecuadorian stations operate below 6MHz and are of relatively low power, ranging from a few hundred watts to 5kW. The transmitters of HCJB "La Voz de los Andes" are of 50 or 100kW and represent the only International Service emanating from Ecuador.

HCJB will QSL all correct reports, the address is Casilla 691, Quito, and the current (at the time of writing) frequency list of the 100kW channels are listed herewith. HCJB has been broadcasting religion-based and other programmes from Quito for some forty years.

kHz	kHz
9600	11765
9605	11910
9710	15115
9715	15300
11745	15375

The schedule of programmes in English, for Europe, is as follows: From 0700 to 0830GMT on 9605kHz and from 1845 to 2000GMT on 15300kHz. Programmes in English are radiated daily to many parts of the world almost throughout the 24 hours but the two mentioned above provide the best chance for listeners in this country to log Ecuador.

The full list of short wave stations is a long one and cannot be included in this article. Listed in Table III are a few transmitters that are often heard in the UK.

kHz	kW	Station	Schedule GMT
3340	10	HCVA4 Esmeraldas, "La Estacion de la Alegria"	1100-0500
3378	0.25	HCDY4 Esmeraldas, "Radio Iris"	1100-0500
4680	1	HCWE1 Quito, "Radio Nacional Espejo"	24 hours
4712	0.25	HCAV3 Loja, "Radio Luz y Vida"	1100-1300 1630-0500
4917	3	HCAH3 Zaruma, "Radio El Trebol"	2300-0300
4923	5	HCRQ1 Quito, "Radio Quito"	2300-0430
5025	3	HCOB5 Cuenca, "Radio Splendit"	1130-0400

## GUYANA - AN OUTLINE

Guyana, formerly British Guiana, became independent in 1966. The country has an area of 83,000 square miles and an estimated population of 650,000. The capital is Georgetown on the Demerara river. The population is somewhat polyglot - a few whites and Indians together with many East Indians and Negroes.

The British settlement in Guiana began in present Dutch Guiana around 1630. During the course of continental and colonial wars between the British, French and Dutch, the areas changed hands several times until the Congress of Vienna 1814/15 fixed

the boundaries of the three Guianas. The discovery of gold in British Guiana led to expansion and the Venezuela Boundary Dispute of 1887/99. Dutch Guiana is now known as Surinam.

Exports from Guyana consist of sugar, rum, rice, hardwoods, gold and diamonds - the Mazaruni fields are rich in the latter commodity.

### *Guyana - Short Waves*

Guyana is 3½ hours behind GMT, the language is English and the country is difficult to log, to say the least. Broadcasting in Guyana is on a commercial basis and the two short wave outlets are listed in Table IV.

The channel offering the best chance of hearing Radio Demerara is that of 3265kHz, at least in terms of UK reception. The most favourable time is from 0100GMT till sign-off.

Radio Demerara broadcasts the news at various

times during the schedule, often mentioning local place names. Favourable times for these are 0243 GMT, with possibly 0045GMT if conditions are good. The announcement, in English, is "This is Radio Demerara, Voice of Guyana".

TABLE IV

<i>kHz</i>	<i>kW</i>	<i>Station</i>	<i>Schedule GMT</i>
3265	2	Georgetown, "Radio Demerara" ... ..	0910-1030 2230-0245 (Sat 0345)
5980	2	Georgetown, "Radio Demerara" ... ..	1030-2230

### VENEZUELA - AN OUTLINE

The Republic of Venezuela is situated on the North of the South American continent, has an area of 352,141 square miles and a population of around 7,600,000. The capital city is Caracas, situated eight miles inland from its port of La Guaira. Caracas is at an altitude of about 3,000 feet and has a population of some 800,000.

Venezuela is bounded on the North by the Caribbean Sea - where the dependencies Margarita and Tortuga islands and several smaller groups are located - on the West by Colombia, in the East by Guyana and in the South by Brazil.

The chief cities, apart from Caracas, are Coro, Cumana, Maracaibo, Puerto Cabello, Barquisimeto and Valencia.

Columbus discovered the mouth of the Orinoco in 1498 and settlements were established on the coast in the early 16th century. Conquest of the interior was made by German adventurers, notably Nikolaus Federmann. Much raided by buccaneers, Venezuela began the war for independence from Spain in 1810 which became successful under the leadership of Bolivar who made the country part of Greater Colombia. In 1830 a successful separatist movement led by Páez resulted in Venezuela becoming a Republic.

Venezuela has four geographic areas, the coastal lowlands are rich in oil (chief export); the Orinoco basin has vast plains (llanos) which supports the cattle industry; the Guiana Highlands are for the most part unknown and unexplored and the Venezuela Highlands to the West of the country, a continuation of the Andes, supports most of the population - coffee is grown on the cool slopes and cacao (cocoa) in the foothills.

#### *Venezuela - Short Waves*

Venezuela is four hours behind GMT, the language is Spanish and the country is undoubtedly the easiest Latin American state to hear on the short waves. Some of the Venezuelan stations often reported by UK listeners are listed in Table V.

The country has many short wave outlets with powers of 1kW, mostly below 6200kHz. Those best heard in the UK have power of 5 and 10kW.

Venezuela, being situated on the North coast of the continent, and therefore relatively near the UK, is probably the most often reported country of South America in the SWL press here. In the Latin American Quest it will be found by experience that some of the most colourful 'LA mx' (Latin American music) is to be heard from Venezuela - have the tape recorder ready!

TABLE V

<i>kHz</i>	<i>kW</i>	<i>Station</i>	<i>Schedule GMT</i>
3355	1	YVLC Valencia, "Radio Valencia" ... ..	1000-0300
3395	1	YVOJ Merida, "Radio Universidad" ... ..	1100-0400
4800	10	YVMO Barquisimeto, "Radio Lara" ... ..	1000-0400
4810	2	YVMG Maracaibo, "Radio Popular" ... ..	1000-0300
4860	1	YVQE Maracaibo, "Radio Maracaibo" ... ..	0900-0400
4870	5	YVKP Caracas, "Radio Tropical" ... ..	1000-0400
4880	10	YVMS Barquisimeto, "Radio Universo" ... ..	1000-0400
4890	5	YVKB Caracas, "Radio Difusora Venezuela" ... ..	1000-0400
4900	10	YVNK Barquisimeto, "Radio Juventud" ... ..	1000-0400
4960	1	YVAQ Cumana, "Radio Sucre" ... ..	1000-0430
4970	10	YVLK Caracas, "Radio Rumbos" ... ..	0930-0500
4980	10	YVOD San Cristobal, "Ecos del Torbes" ... ..	24 hours
4990	15	YVMQ Barquisimeto, "Radio Barquisimeto" ... ..	24 hours

(To be continued)

## THE EXPORT SPONTAFLEX

In "The Export Spontaflex", published in the February 1971 issue, Fig. 3(b) shows the positive lead-out of C9 connecting to the emitter of TR3. The receiver will operate satisfactorily with this connection but, for optimum results, the positive lead-out of C9 should connect to the emitter of TR4, as in Fig. 1.

# BASIC UNDERSTANDING PRINCIPLES

by W. G. Morley

IN LAST MONTH'S ARTICLE WE discussed the quality factor, or Q, of a resonant or tuned circuit and noted that this increased as resistance and 'losses' in the resonant circuit decreased. We saw also that a resonant circuit with high Q offers greater selectivity than does one with a low Q. We dealt finally with transformers, including r.f. transformers of the type which may be used in a radio receiver to couple the aerial to its first stage.

We pass on, now, to the processes involved in the transmission of information to a receiver.

## INFORMATION TRANSMISSION

The simplest method of sending messages by way of radio consists of using the Morse code. A Morse key (whose contacts close when it is pressed) is coupled to a transmitter in such a manner that the latter transmits only when the key is pressed. If the key is operated to send the letter 'f', for which the Morse character is '...-', the transmitter output is similar to that shown in Fig. 1. For purposes of illustration it is assumed in Fig. 1 that the frequency of the transmitter output is very much lower than it would be in practice. Actually, there would be so many cycles in each 'dot' and 'dash' section that it would be impossible to reproduce them individually in a drawing, and the lines representing them would merge together. The frequency will also be considerably greater than the highest audible frequency to which the human ear can respond, and we could not listen to the Morse character by applying the r.f. signal, after reception, to a loudspeaker or pair of headphones. To receive Morse signals we therefore employ a circuit in the receiver which causes an audible tone to be generated whenever the transmitted signal is received. In consequence, this tone appears during the time when the Morse key is pressed and enables

In this concluding article in our short series, which has been written specifically for newcomers to radio, we discuss amplitude modulation and detection

us to hear, and recognise, the Morse characters which are being transmitted.

Before proceeding further it should be mentioned, for completeness, that there are a few specialised cases where radio transmissions are made at frequencies that are just below the highest frequency audible to the ear. We do not, however, encounter transmissions of this nature in normal radio work, in which all radio signals dealt with are at frequencies well above the upper limit of human audibility.

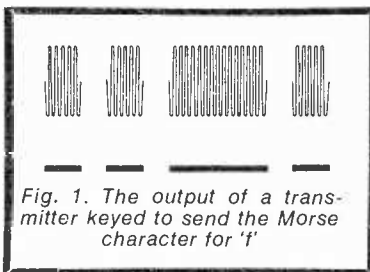

Fig. 1. The output of a transmitter keyed to send the Morse character for 'f'

The method of transmission employed for sending Morse messages is merely a 'switch-on' and 'switch-off' system, and it is obvious that we will require a system that is much more sophisticated if we intend to transmit a.f. signals, as are given by speech and music. There are several systems which allow the transmission of a.f. signals, the most widely used of these consisting of *amplitude modulation*, or *a.m.* In an amplitude modulation system the a.f. signal varies the amplitude, or largeness of the transmitted r.f. signal.

Fig. 2(a) shows the r.f. output of a transmitter which is continually switched on. As may be seen, the output has a constant amplitude and, in the terms of our present discussion, we would refer to it

as being 'unmodulated'. Fig. 2(b) shows slightly more than a cycle of an audio frequency which we wish to transmit. To do this we apply the audio frequency signal to the transmitter in such a manner that it controls the amplitude of its r.f. output, with the result that the transmitted signal takes up the appearance shown in Fig. 2(c). In this diagram the output is at maximum amplitude when the a.f. signal is at its uppermost peak and is at minimum amplitude when the a.f. signal is at its lowermost peak. The term 'amplitude modulation' can now be seen to be self-explanatory. The modulated r.f. output of the transmitter is described as the *carrier*, this being a particularly apposite term since it is the r.f. signal which is actually picked up by the receiver and it 'carries' with it the required a.f. signal.

When drawing an amplitude modulated wave it is customary to add two lines joining the outermost peaks on either side, as in Fig. 2(d). These lines constitute the *modulation envelope* of the signal. It should be noted that, as in Fig. 1, the frequency of the r.f. signal would in practice be much higher than is indicated by the r.f. cycles in Figs. 2(a), (c) and (d).

The process of amplitude modulation causes the maximum amplitude of the transmitted signal to be greater, and its minimum amplitude to be less, than the unmodulated value. This effect is illustrated in Fig. 3(a) in which the signal is unmodulated prior to line XY. If the modulating a.f. signal is a sine wave the maximum increase in amplitude, shown as dimension P, is equal to the maximum decrease in amplitude, which is shown as dimension Q. The ratio of either P or Q to the amplitude of an

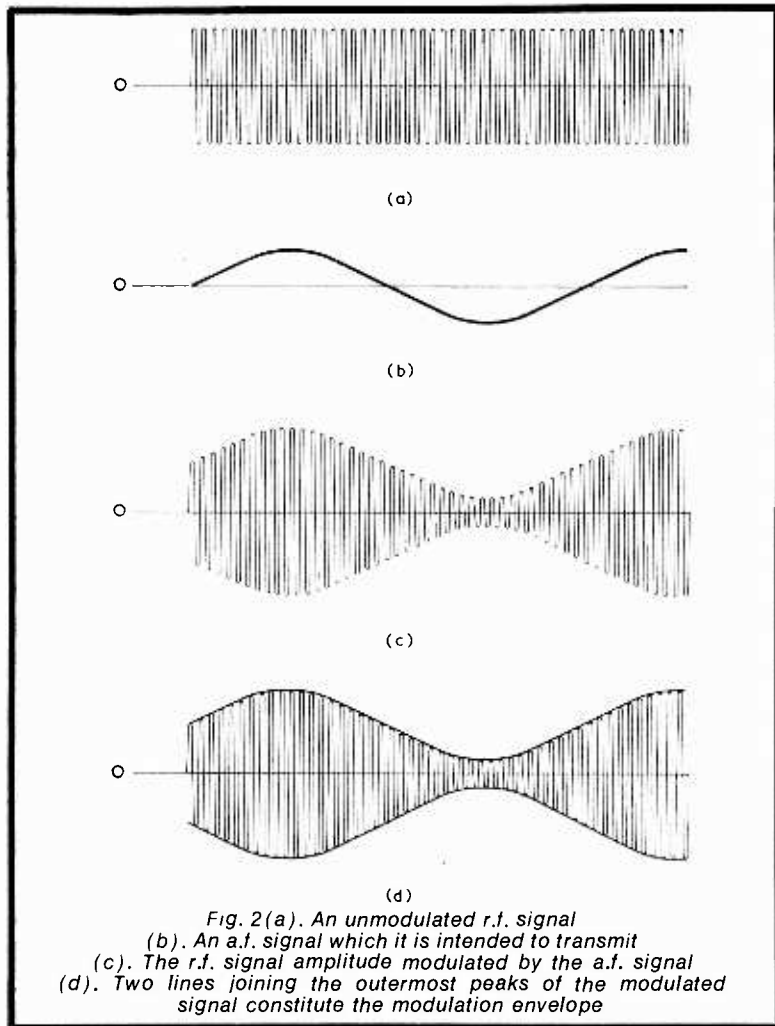

Fig. 2 (a). An unmodulated r.f. signal  
 (b). An a.f. signal which it is intended to transmit  
 (c). The r.f. signal amplitude modulated by the a.f. signal  
 (d). Two lines joining the outermost peaks of the modulated signal constitute the modulation envelope

unmodulated r.f. half-cycle, indicated as dimension R, defines the modulation depth of the signal. In Fig. 3(a), both P and Q are equal to one-half of R, and we say that the modulation depth is 50%. When the signal is unmodulated the dimensions P and Q disappear, and the modulation depth is zero. The maximum modulation depth which can be allowed to occur is given when P and Q are both equal to R, as is shown in Fig. 3(b). Here the modulation depth is 100%. Attempts to increase modulation depth above 100% result in severe distortion of the a.f. modulating signal. This condition, known as *overmodulation*, is clearly shown in Fig. 3(c), in which diagram the parts of the r.f. carrier which previously corresponded to minimum amplitude have disappeared completely.

Another factor resulting from the process of amplitude modulation is the appearance of two transmitted signals accompanying the carrier, their frequencies being spaced from

the carrier by the modulating frequency. These are the *sideband frequencies*, commonly referred to simply, as the *sidebands*, and they are at lower power than the carrier. To take an example, let us assume that a transmitter whose carrier frequency is 400kHz is amplitude modulated by an a.f. signal of 2kHz. The resulting sideband frequencies would consist of 402kHz (400kHz plus 2kHz) and 398kHz (400kHz minus 2kHz). If reclamation of the modulating a.f. signals is to be achieved at the receiver it is necessary for the latter to have tuned circuits capable of passing the sideband frequencies in addition to the carrier frequency. To take an extreme example, if the tuned circuits in a receiver were so selective that, when it was tuned to 400kHz, they did not allow signals outside the band 399 to 401kHz to pass through them, it would not be possible to reclaim the 2kHz modulating signal just mentioned!

This point explains why most commercially manufactured medium-

wave receivers offer an output in which the higher treble response is low or completely absent. Because of the excessively large number of stations in the medium-wave band these receivers require sufficient selectivity to enable a desired station to be tuned in without excessive interference from its neighbours. The fairly high selectivity which is then required results in the loss, in the desired signal, of the sidebands corresponding to the higher audio frequencies. Most medium-wave receivers offer a high level of attenuation to audio frequencies above some 4kHz.

There are other types of modulation in addition to amplitude modulation, the most common of these being *frequency modulation*, or *f.m.* With frequency modulation the amplitude of the carrier remains constant, and it is its frequency which is varied by the modulating signal. Frequency modulation is employed by radio stations operating on v.h.f., and is used in the sound channels of television transmissions in the u.h.f. band. In this short series, however, we shall concern ourselves with amplitude modulated signals only.

## SIGNAL RECLAMATION

In the article which appeared in last month's issue we saw that it is possible for a resonant circuit whose inductive section is the secondary of an r.f. transformer to tune in signals picked up by an aerial. The arrangement is shown in Fig. 4(a). Let us assume that we tune this circuit to receive the transmitted signal shown in Fig. 2(d), and then attempt to hear the modulation. We could, for instance, try the effect of connecting a pair of headphones across the tuned circuit, as in Fig. 4(b).

Such an experiment would, unfortunately, result in failure only, and we would hear nothing. The reason for this is that the headphone diaphragm obviously cannot respond to the frequency of the r.f. carrier and, even if it could, we would still be unable to hear any result since it would be well above the uppermost limit of the audio frequency range. On the other hand, we might reasonably expect the headphones to respond to variations in the average value of the transmitted r.f. signal when these variations occur at an audible frequency. A glance at Fig. 2(d) tells us, though, that the average value of the transmitted r.f. signal is always zero because increases and decreases in amplitude on the upper side of the zero line are balanced out by similar increases and decreases on the lower side of the zero line.

An additional component is required if the signals are to be made

THE RADIO CONSTRUCTOR

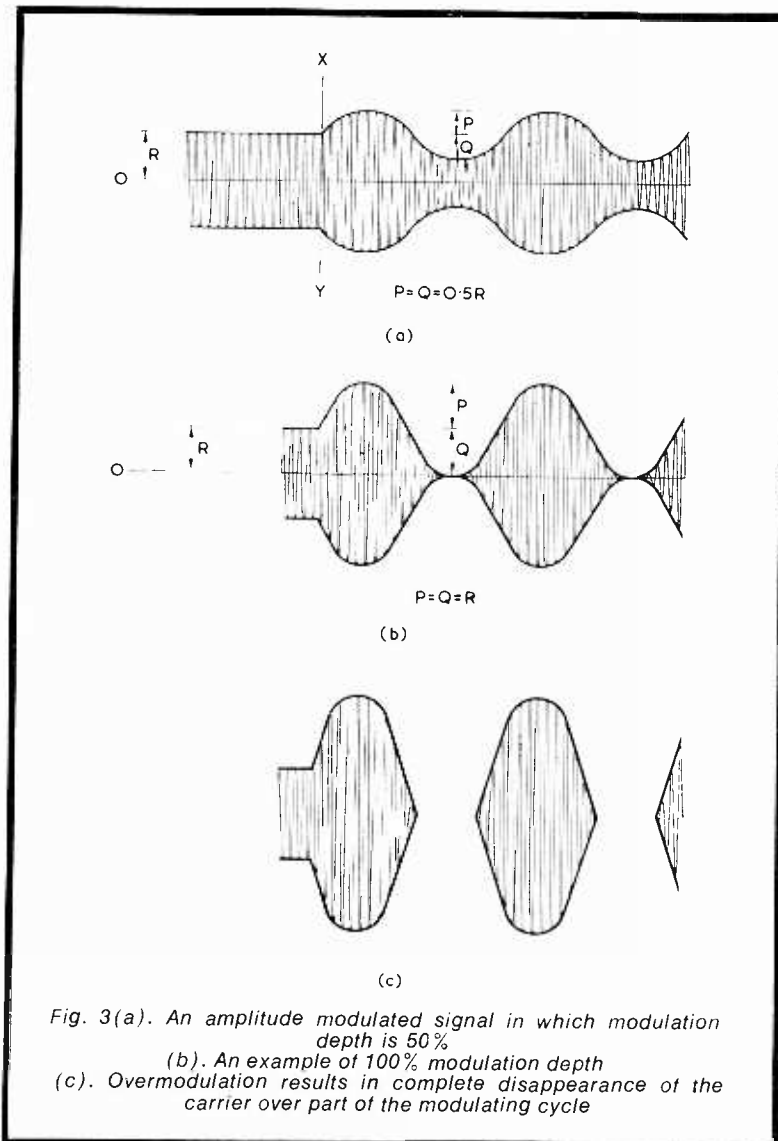

audible. This component is a *diode*, which is available either in valve form or in semiconductor form. The valve form appears in Fig. 5(a) and it comprises a heater, a cathode and an anode, all of which are enclosed in an evacuated glass envelope. The cathode has a specially prepared surface which, when raised in temperature by the heater, allows electrons to be emitted. If the anode is made positive of the cathode, as occurs in Fig. 5(b), the electrons (which are particles of negative electricity) become attracted to it and a circuit is set up. Electrons flow from the cathode, through the anode, through the battery and back to the cathode. In Fig. 5(c) the anode is made negative of the cathode. In this instance the electrons emitted by the cathode are not attracted towards the anode; no circuit is set up and no current

flows. We see, therefore, that a diode is a device which allows current to flow in one direction only.

In Fig. 6(a) we insert the diode in series with the resonant circuit and the headphones. (It is assumed that a source of power is connected to the heater of the diode so that the temperature of the cathode may be suitably raised.) We will at once hear the a.f. signal which originally modulated the transmitted signal of Fig. 2(d).

This dramatic change results from the fact that the diode passes current in one direction only; and to study the effect in full it is necessary to take into consideration the self-capacitance existing between the two leads of the headphones. This self-capacitance is shown as a physical capacitor in Fig. 5(b). The signal now applied to the phones has the appearance shown in Fig. 7, in which only alternate half-cycles of the r.f. carrier are allowed to pass through the diode. As is evident from the inset diagram, it is obvious that the average a.f. voltage now corresponds with the modulation envelope of the original signal. The inset diagram also gives a detail of what actually takes place at the r.f. signal peaks. As each peak approaches its maximum it commences to charge the effective capacitor across the headphone terminals. After the peak the capacitor then discharges slightly until the next peak arrives.

The diode of Fig. 6 acts as a *detector*, this being a term which was introduced in the early days of radio to describe any device which enabled radio signals to become audible. It is also, but less frequently, referred to as a *demodulator*. It will function equally well if the anode and cathode connections are reversed. The waveform at the upper headphone terminal

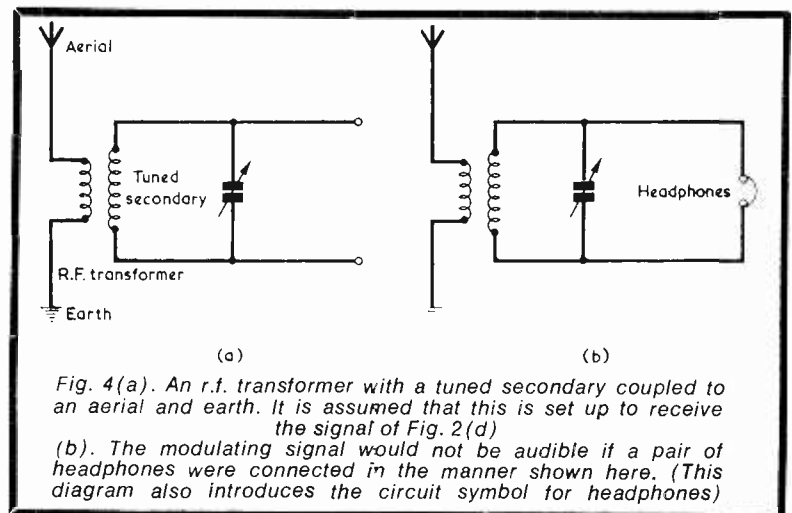

will then have the same appearance as in Fig. 7 with the exception that it will be on the negative side of the zero line instead of the positive side.

It should be noted that the detected waveform on the upper terminal of the headphones has an average direct voltage, which may be positive or negative according to the manner in which the diode is connected. This is the average voltage which appears over a number of audio frequency cycles and is proportional to the amplitude of the unmodulated carrier. The average direct voltage is not of importance in the simple arrangement of Fig. 7, but it can be put to use in more complex receivers.

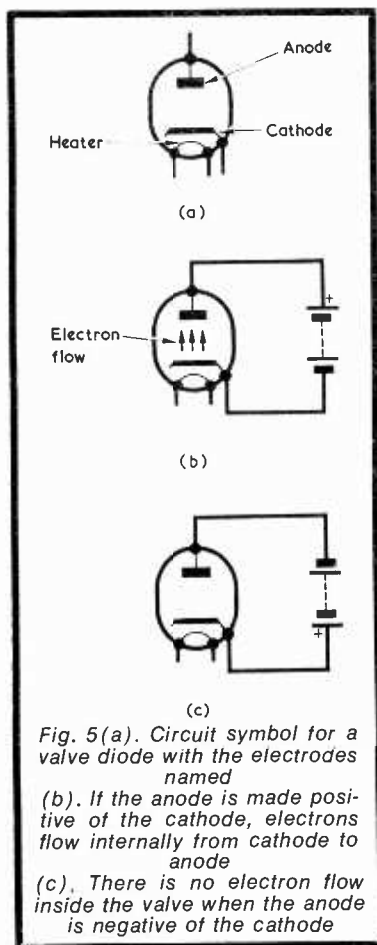

### ALTERNATIVE DIODE

The use of a valve diode as a detector is not as extensive in present-day receivers as it was in the past, and it is now common practice to employ a semiconductor germanium diode instead. This is a much smaller component and requires no heater supply. The symbol for the germanium diode (and for other semiconductor diodes) is given

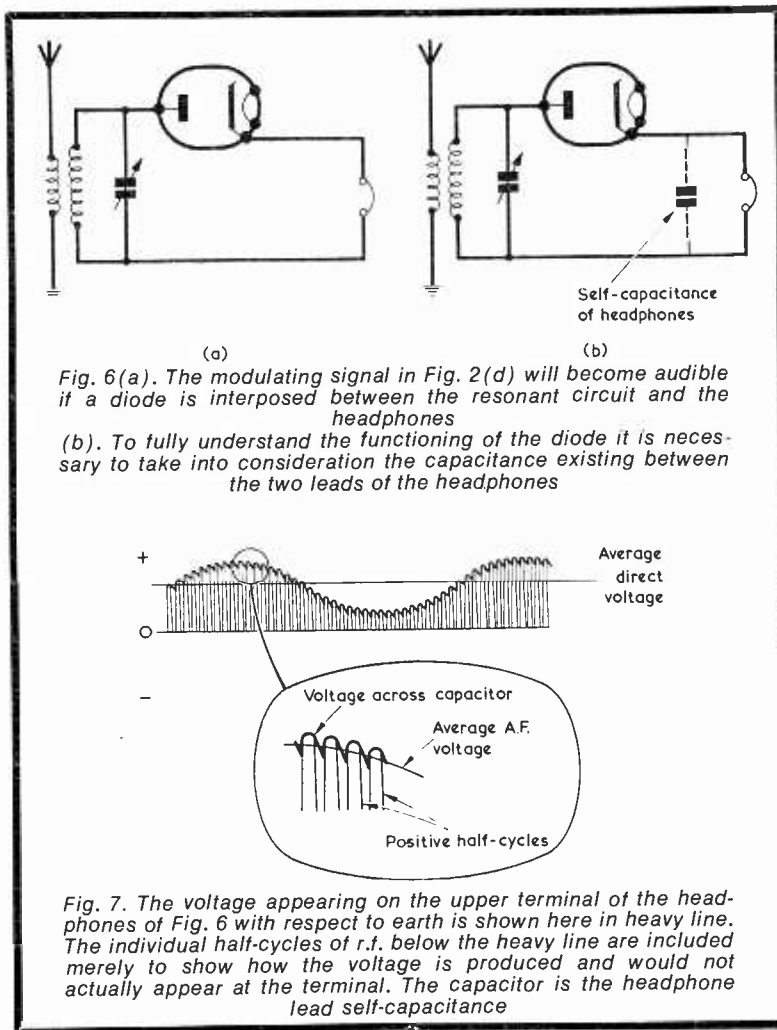

in Fig. 8, in which the two electrodes are, to correspond with valve terminology, labelled 'cathode' and 'anode'. Just as with a valve, the germanium diode allows current to flow when the anode is positive of the cathode.

If our simple detector circuit is to be followed by an a.f. amplifier, the headphones are replaced by a load resistor, R1, across which a capacitor, C1, is connected, this acting as a substitute for the self-capacitance of the headphone leads. See Fig. 9(a). It is evident from Fig. 7 that a low level of radio frequency voltage (given when the capacitor charges and discharges) will appear across the load resistor. This small r.f. signal does not trouble us when headphones are used, but it could be a nuisance if it were passed to a subsequent a.f. amplifier. It is removed by the combined action of R2 and C3. C3 has a value which causes it to have a low reactance at r.f. and a high reactance at audio fre-

quencies. Because of this, very little of the remanent r.f. signal from R1 appears across it, whilst nearly all of the required a.f. signal does. There is a further capacitor, C2, in series between R1 and C3. This has a value which offers a low reactance at a.f., and it ensures that the average direct voltage given after detection does not appear across the final resistor, R3. Often, as in Fig. 9(b), R3 consists of a potentiometer, its slider enabling a controllable amount of the detected

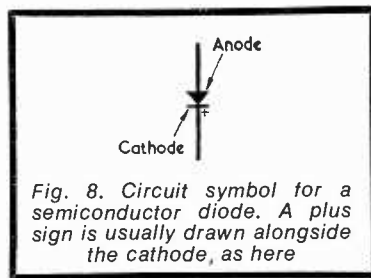



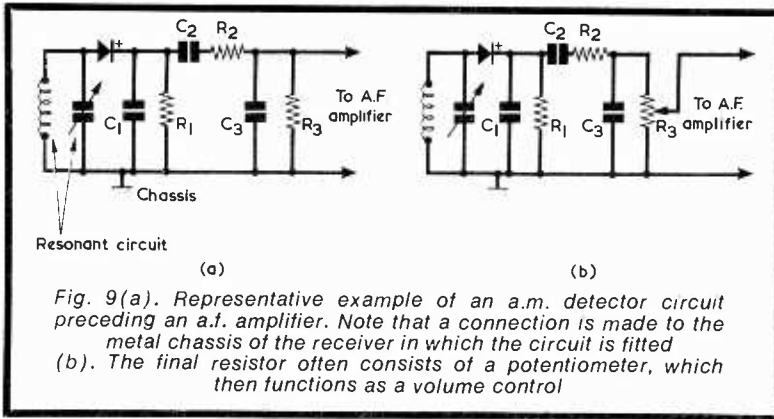

audio frequency signal to be passed to the subsequent a.f. amplifier. This potentiometer functions as a *volume control*.

In a more ambitious receiver,

there would be r.f. amplification *before* the detector circuit, the r.f. stages incorporating tuned circuits to ensure that a high level of selectivity is achieved.

## CONCLUSION

This now brings us to the end of our short series of articles devoted to the basic principles of radio. In the space available here it has not been possible to deal in depth with the subjects covered, but the treatment given should be adequate enough to enable the beginner to appreciate more thoroughly the other articles appearing in this journal. A much fuller treatment was published in the 'Understanding Radio' series which commenced in the August 1961 issue and concluded in the March 1970 issue. The present series offers a shortened version of the material in the earlier 'Understanding Radio' articles.

A new series following the 'Understanding . . . ' vein is now in preparation and further details will be given in future issues. ■

# CURRENT SCHEDULES

Times = GMT

Frequencies - kHz

## ★ LESOTHO

Radio Lesotho, Maseru, has been reported signing on at 1500 on **4800** (some reports state **4804**). A newscast in English is radiated at 1530. From 1600, broadcasts are in Sesotho, the national language.

## ★ EGYPT

Radio Cairo operates a service in English to North America from 0200 to 0330 on **9475** (100kW). A service in French for Quebec is radiated from 0100 to 0145 on **11710** (100kW). Both of these transmissions have been heard, as tests, on **11475** and **11630**.

## ★ GUATEMALA

TGNA Radio Cultural, Guatemala City, on **5955** (10kW) appears from observations to have an English schedule as follows:- from 0258 to 0404 on Sundays and Tuesdays; from 0045 to 0404 on Mondays. TGNA is in parallel on **9505** (10kW). Reports requested to:- Box 601, Guatemala City.

## ★ POLAND

Radio Warsaw has a North American service, in English, from 0200 to 0355 on **6135** (100kW), **7285** (15kW), **9525** (100kW), **11840** (40/100), **15120** (100kW) and on **15275** (40/100kW).

## ★ SWITZERLAND

Programmes from Berne, in English for Africa, are at 1100 on **15305** (100/250kW), **15430** (150kW), **17795** (100/150kW) and **21520** (100/150kW) and at 2100 on **11720** (100/150kW), **11865** (100/250), **15305** and **15430**.

Other transmissions in English from Berne may be heard at 0700, 1300, 1500 and 1730 daily also at 0845 from Monday to Saturday inclusive all on the above listed channels. Omnidirectional frequencies for Africa and Europe are **6165** (250kW), **9535** (150/250kW) and, from 1500, on **3985** (250kW).

## ★ CANADA

The Afro-European Service of Radio Canada may be heard from 0710 to 0745 on **9625**, **11935**, **15390**, **17820** and **21610**, the last three channels being a relay from BBC transmitters at Daventry.

The European Service, in English, can be heard from 1217 to 1313 on **15325** (250kW) and from 2115 to 2152 on **15325**, **17820** (250kW) and on **21595** (250kW).

## ★ PORTUGAL

The daily broadcasts by Ibra Radio over the Radio Trans-Europe transmitters are now on **9660** (100kW) from 1800 to 2100.

## ★ RHODESIA

The General Service of the Rhodesian Broadcasting Corporation can be heard on **7285** (20/100kW) from 1545 to 1632. Transmitter is located at Gwelo.

## ★ PAKISTAN

The news in English at dictation speed is radiated from 1000 to 1015 on **21710**. Dacca, in East Pakistan, can be heard with news in English at 1130 on **15519** (7.5/100kW).

## ★ NEW CALEDONIA

Radio Noumea now has a new outlet on **4912** where it has been heard with programmes in French from 0800 to 1100 sign-off. This channel is in parallel with **7170**, **9510** and **11710**.

## ★ LESOTHO

The Voice of Lesotho, Maseru, has the following schedule on **4800** (10kW). From 0400 to 0700, 1030 to 1200 and from 1500 to 2000. The address is - Lesotho National Broadcasting Service, P.O. Box 552, Maseru. Do not confuse transmissions from this station with those from Kisumu, Kenya on **4804**.

## ★ TAIWAN

The Voice of Free China has been heard on the additional frequency of **15125** in parallel with the usual Taipei channel of **9765** (50kW).

## ★ SEYCHELLES

The Far Eastern Broadcasting Association radiates programmes in English, mainly to India, from 0130 to 0200 on 11920 (50kW). The **15265** (50kW) channel is used in the evening from 1500 to 1645. Test transmissions have been heard, directed to the Middle East, from 1700 to 1800 on **15260**.

## ★ SYRIA

Beirut has been heard using **17830** for the 1830 to 2030 broadcasts to Europe and Africa. The English programme is from 1830 to 1900.

*Acknowledgements:- Our Listening Post, SCDX* ■

# In your workshop



This month's episode starts on a happy note as Smithy, accompanied by his able assistant Dick, leaves the dusty interior of the Workshop to sample the balmy pleasures of a bright July day. Not only do the pair take advantage of the health-giving rays of the sun, but they also devote their time to a discussion of the latest batch of hints received from readers

"Isn't there," he asked plaintively, "anything we can do?"

"Yes, there is," returned Smithy promptly. "We can sit here and keep quiet."

"I've been doing that for the last five minutes," grumbled Dick. "And I'm fed up with it. Don't you want to talk about anything?"

"Not particularly."

Dick subsided. Suddenly his eyes shone as he was visited by unanticipated inspiration.

"I know what we can do!"

"What?" grunted Smithy.

"Have a session on readers' hints. It's ages since our last one, and you must have got stacks of them lined up by now."

Smithy stirred and threw off his lethargy. He moved himself forward, causing all four legs of his chair to settle firmly on the ground.

"Do you know, Dick," he stated approvingly, "you have for once come out with a really good idea. It is quite a long time since the last session and I always enjoy going through these hints myself."

"Fine," said Dick, pleased. "If you tell me whereabouts you've put the readers' letters with the hints in, I'll pop inside and bring them out."

"There's no need," replied Smithy.

Carefully, the Serviceman reached inside his shirt and produced a handful of letters.

"Why, you crafty old devil," gasped Dick. "You had them with you all the time!"

"I always like," remarked Smithy mildly, "to be prepared for any situation that might crop up. Actually, though, I'd intended having a hint session anyway after I'd given my lunch a bit of time to settle down. If you hadn't suggested it I would have done so myself."

The Serviceman gravely leafed through the letters in his hand, then selected one and placed it at the top of the stack.

"Here's a good one to begin with," he remarked. "And it describes a method of making up a miniature switch for transistor equipment. Bring your chair up alongside mine so that you can see the sketch that's in this letter."

Obediently Dick rose and, taking his chair with him, settled down at the side of the Serviceman.

"To take advantage of this hint," said Smithy, pointing at a diagram in the letter (Fig. 1(a)), "you take a miniature closed-circuit jack and

Flat filed on plug tip

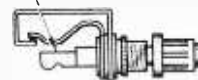

(a)

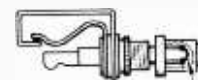

Link connecting tip and sleeve

(b)

Fig. 1(a). A simple miniature switch is given by a closed circuit jack and plug, a flat being filed on the tip of the plug

(b). The switch offers a changeover action if the tip and sleeve of the plug are linked together

plug and file a flat on the tip contact of the plug. You will then find that rotation of the plug opens and closes the contacts of the jack."

Smithy indicated a second sketch. (Fig. 1(b)).

"So far," he went on, "the idea is quite a simple one, but we now come to a crafty extension to the basic scheme I've just described. This consists of linking the tip and sleeve of the plug together, whereupon you obtain a changeover switch. The common contact here is the tip contact of the jack socket, which connects either to the switch contact or to the sleeve contact of the socket as the plug is rotated."

Dick studied the sketch for a few moments.

"That flat," he commented, "would have to be filed deep enough to ensure that the tip of the plug was well clear of the corresponding socket contact when the flat was uppermost."

"True," agreed Smithy. "It would probably be a good idea to glue

THE RADIO CONSTRUCTOR

"GO AWAY!" Pettishly, Smithy waved his hand at the butterfly which, for some reason conceivable only to the lepidopteral brain, was exhibiting an intense interest in his nose. Startled by the sudden movement, the creature fluttered off, rested for some moments on the reflector of the Workshop Band I aerial, then flew away in search of more congenial companionship.

Smithy grunted with satisfaction and tipped his chair further back against the outside wall of the Workshop.

The July sun beat down warm and bright. As a concession to the season Smithy had divested himself of his jacket, presenting to the world a pair of braces whose fully saturated puce hue had a brilliance calculated to startle the unwary. Over his head he had placed a handkerchief which was maintained in position by means of a knot tied at each corner.

Dick, seated nearby, was dressed in the gear. He had also left his jacket in the Workshop, and he wore a tank-top shirt, patched levis and floppy laceless suede boots with zip fasteners at the side.

## READERS' HINTS

The pair had just completed their lunch, and they had taken two chairs outside the Workshop so that they could spend the remainder of the lunch-break absorbing the beneficial rays of the sun. Smithy had surrendered himself completely to the heat. After some time, however, Dick commenced to fidget.

a strip of thin insulating material over the flat to ensure a positive disconnection when it was at the top. It might also be necessary to solder a ring of wire round the plug sleeve to prevent it falling out."

"Hang on a minute," broke in Dick excitedly, "I've just thought of another way of getting the changeover effect. With this alternative idea of mine you don't have a flat on the plug at all and all you do is link its tip and sleeve together. The tip contact of the socket then connects to the sleeve contact of the socket when the plug is inserted, and connects to its switch contact when the plug is removed. The result is rather like a key-operated switch. The switch can only be made to change over by inserting the plug."

### A.F. OUTPUT VALVE

"Very good," remarked Smithy approvingly. "What I like about these hint discussions is the way that one idea sparks off another one. Well now, let's turn to the next letter. Dear me, this is quite an interesting one, too."

Smithy read the letter quickly, then showed Dick a circuit diagram attached to it. (Fig. 2).

"In this letter," said Smithy, "our correspondent asks whether people are aware that the frame-grid r.f. pentode type EF184 makes a sensitive and economical output valve.

He states that it can be loaded sufficiently from the diode stage of a superhet as it has the high slope of 15mA per volt, and he estimates that, with an h.t. line of 180 to 200 volts, the valve gives about 500mW output. It requires a high ratio output transformer, offering about 11k $\Omega$  impedance to the anode."

"I wonder," asked Dick, "whether it would be of use as a gram amplifier following a high-output crystal or ceramic pick-up?"

"Well," said Smithy in reply, "the single-valve gram amplifier which was popular in recent years used a UL84, and that has a mutual conductance of only 10mA per volt. You should be able to get at least the same level of gain with an EF184, although it wouldn't be able to handle as much power. At any event, there would be no harm in carrying out a few experiments with the valve."

Smithy turned to the next letter in his hand and perused it carefully.

"Here's another knobby idea," he remarked. "It's a scheme for measuring and recording the positions of iron-dust cores in coil formers before you start adjusting them. It enables you to return the cores to their original settings if ever you make a mess-up of the adjustments and want to get back to the starting point again."

"This idea should be particularly useful," remarked Dick carelessly,

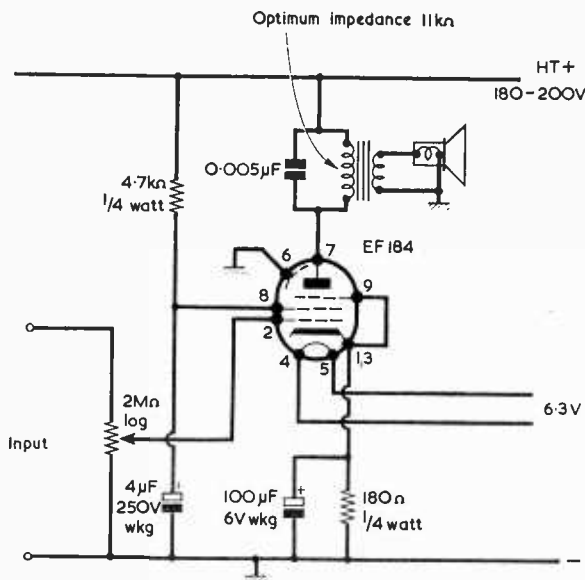

Fig. 2. The frame-grid r.f. pentode type EF184 may be employed as an a.f. output valve. An output transformer offering, with a 3 $\Omega$  speaker, an impedance close to the optimum value is the component available from Home Radio under Cat. No. TO47

This  
saves  
this



Prevention is best –  
you know it makes sense!

Endorsements are expensive! Our unique radar spotting device gives earliest possible warning of radar speed checks – up to 1/3rd of a mile on give and take roads (1½ miles on motorways) and helps you to be a better and safer driver. Self-contained, only 10½ ozs. Clips on sun visor. **DON'T WAIT UNTIL IT'S TOO LATE – ORDER NOW.**

To: Belding & Bennett, 01-668 3255 & 01-660 2896, (Box 38), 45 Green Lane, Purley, Surrey.

Send me Spotters at £13.75p each

Enclosed PO/Cheque £.....

Name.....

Address.....

Phone No. ....

Details only: Send 4p in stamps.

Trade enquiries welcome.

The  
**RADIO CONSTRUCTOR**

**ANNUAL  
SUBSCRIPTIONS**

to this magazine  
may be obtained  
through your  
newsagent  
or direct from the  
publishers

**ONLY £2.70  
per year, post free**

Please send remittance with name  
and address and commencing issue  
required to:

**DATA PUBLICATIONS LTD  
57 Maida Vale London W9 1SN**

"if you get into trouble with the iron-dust cores in TV i.f. strips."

Smithy threw a dour glance at his assistant.

"You must *never*," he intoned sternly, "attempt to adjust the coil cores in a TV i.f. strip unless you have the manufacturer's service manual in front of you and the test equipment that the manual says you should use for the job."

Dick raised his hands in the gesture of one who has experienced the futility of all endeavour.

"Dash it all, Smithy," he complained bitterly, "why do you always, whenever I make a statement like that, assume the worst in me?"

"Because," replied Smithy simply, "I know you."

"I wasn't," persevered Dick, determined to get the record straight, "inferring that you *should* start making TV i.f. adjustments without the proper gear. What I meant was that even with the correct equipment it's still a good plan to know the initial positions of the coil cores in case you have, for some reason, to go back to the start again."

"Very well, then," conceded Smithy, "I'll agree with *that* statement, so let's return to the hint. To determine the position of a core in a coil you use a fairly long 2BA nut and bolt, adjusting the position of the nut so that the tip of the bolt rests on the top surface of the core, and the underside of the nut rests on the top edge of the coil former. (Fig. 3). You can then remove the nut and bolt, measure the distance between the nut underside and the bolt tip with a rule and make a note of it. Okay?"

"Definitely," said Dick keenly. "Now that's what I call a really good idea."

"Alternatively," Smithy carried on, "you can use the depth gauge section of a pair of inexpensive vernier calipers to do the same thing. This gives you extremely accurate results, correct to a tenth of a millimetre, but the calipers can't be used if space is restricted."

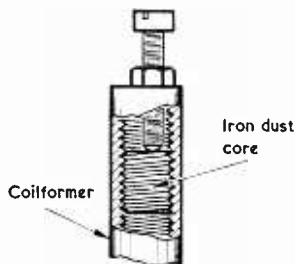

Fig. 3. Illustrating a method of determining the position of an iron-dust core in a coil former

Dick glanced at the sheet of paper in Smithy's hand.

"It looks," he remarked, "as though there's another hint in that letter."

"There is," confirmed Smithy, "and it's a useful dodge for repairing faulty solder joints at valve top cap connectors. As I need hardly tell you, faulty connections here constitute a fault that's as old as the hills. What usually happens is that a mechanical intermittent appears in the soldered joint between the cap and the wire lead going into the valve. Frequently the metal cap comes away from the glass entirely, whereupon, if the present hint is to be followed, part of the cap skirt is cut away so as to shorten it. The top of the valve should then be smeared with a suitable adhesive such as Araldite and the cap refitted. Since the cap is now shorter, more of the wire lead from the valve pokes through the hole in its centre, and it's easier to make a good soldered joint."

### CIRCUIT BOARD SPACERS

A shadow passed over the pair and they looked up.

"Blow me," snorted Dick in disgust, "if there isn't a dirty rotten old cloud up there. There wasn't a cloud in sight at all when we first came out."

"It's only a very small cloud," said Smithy soothingly. "It will soon pass over."

"I should think so, too," commented Dick. "It's stopping me getting my full ration of ultra-violet."

"Let's carry on with these hints," suggested Smithy, turning back to his letters. "Now, this next one describes a method of making spacers for raising printed circuit boards above chassis surfaces."

"That sounds intriguing," said Dick, forgetting about the cloud which had so uncharitably interposed itself between him and the sun. "I'm always looking around for printed circuit spacers, and particularly insulated ones."

"As it happens, the ones referred to here *are* insulated," Smithy informed him, "and they're cut from old ball point pens, the best pens to use being the very inexpensive transparent ones. You cut the barrels of these into suitable lengths with the aid of a simple jig, and these lengths then form the spacers."

"What sort of jig do you use?" Smithy handed his assistant a sheet on which the jig was sketched. (Fig. 4).

"Here's what it looks like," he said. "It consists of a flat piece of wood with two battens glued to it. There is a saw-cut in one batten which is spaced away from the stop by a distance equal to the height

required in the spacers. You simply feed the pen barrel up to the stop and cut away, with the saw guided by the saw-cut. When you've cut each section the internal tube which held the ink will fall out and you're left with the spacer."

"Blimey," said Dick, impressed, "that's neat, isn't it?"

"Oh definitely," returned Smithy. "Now let's have a look at the next letter. I see that this also describes something that's made out of wood."

"Is it another jig?" "Not exactly," replied Smithy. "Actually, it's a coil-winder. Have a look at the sketch whilst I explain what it's all about."

Dick took the diagram (Fig. 5) from Smithy and examined it.

"Gosh," he remarked. "A coil-winder made out of wood!"

"Wood," said Smithy reprovingly, "is an excellent material for simple mechanisms which are subject to only a little wear. The trouble with us metal-bashing types is that we tend to get into the habit of thinking that we should use metal or plastic for everything. We forget that wood is a lot easier to handle for many hobbyists and home-constructors. Anyway, let's get down to the letter."

Smithy read once more. "Our correspondent," he stated, "was faced with the problem of winding a coil having 4,000 turns of thin wire. Pretty well the only material he had to hand for making up a suitable coil-winder was a piece of scrap 1/4 in. plywood plus a few other oddments of wood. He first of all made a simple three-

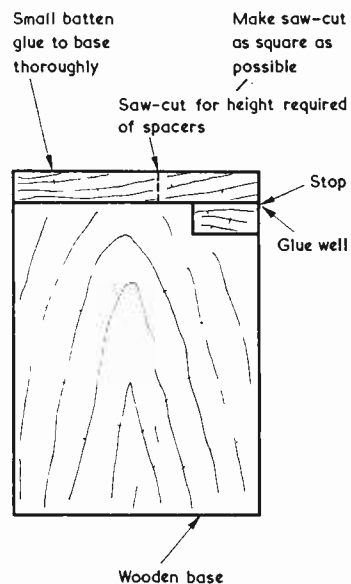

Fig. 4. A simple jig for cutting insulated spacing washers

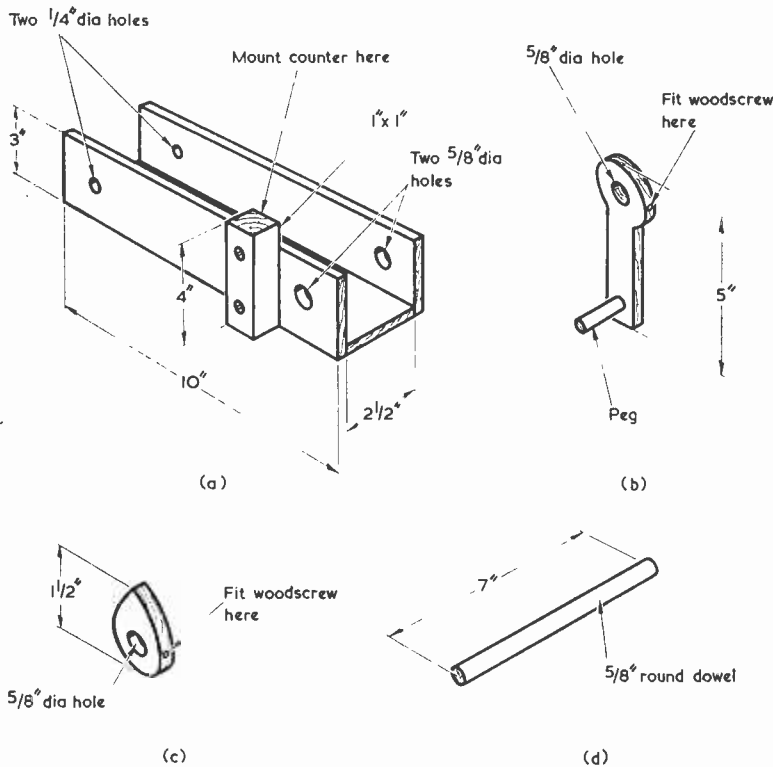

Fig. 5. The main parts of a home-constructed coil-winder. The frame appears in (a), the winding handle in (b), the eccentric wheel for actuating the counter in (c), and the dowel in (d)

sided frame out of the plywood, with two  $\frac{1}{4}$  in. holes at one end and two  $\frac{1}{2}$  in. holes at the other. He also made up a handle and an eccentric wheel, both of which fit onto a length of  $\frac{5}{8}$  in. round dowel. The handle and the wheel are secured to the dowel by passing a thin wood-screw through the side. The eccentric wheel actuates the plunger on a counter taken from an old knitting machine, and the dowel passes through the two  $\frac{1}{2}$  in. holes in the frame."

"Do you put the coil former on the dowel?"

"You do," confirmed Smithy. "The former is packed up in some suitable way so that it's concentric on the dowel and doesn't shift. The reel of wire fits on a length of  $\frac{1}{4}$  in. steel or brass rod passed through the  $\frac{1}{2}$  in. holes at the other end of the three-sided wooden frame. Once the winder has been assembled and the former and reel of wire fitted in place, the coil is then wound. The wire is guided onto the coil by gentle guidance from the finger and thumb of the left hand, whilst the handle is turned by the right hand."

"This winder is certainly simple enough," stated Dick. "What's more, it wouldn't take very long to make up."

"Very true," agreed Smithy. "In fact, it offers an excellent example

of what a good handyman can improvise with the help of odd materials. There are dimensions in the diagram but these aren't at all critical. Normally, you'd make the winder to dimensions that suit the particular coils you intend winding, or the particular wood you have on hand."

Smithy paused and basked appreciatively in the heat of the sun.

"That little cloud must have gone away by now," he remarked. "The sun's really bashing away at us now."

"It won't be for long," said Dick, screwing up his eyes and looking towards the sky. "There's a dirty great cloud hovering over the Gas Works, and it's creeping up on us all the time."

Smithy looked in the direction indicated by Dick.

"Dear me," he said uncertainly, "that cloud is a whacker. Oh well, I expect it will be a long time before it comes over us."

#### LOCKING FORCEPS

Shrugging his shoulders, Smithy dismissed the cloud from his thoughts. He put the letter describing the coil-winder at the bottom of the stack and examined that which was next revealed.

"This is quite an unusual hint,"

## Your Local Supplier

LONDON

Established 1911

### H. L. SMITH & CO. LTD

Comprehensive stocks of components by all leading makers

287-9 EDGWARE ROAD  
LONDON W.2

Tel: 01-723 5891

### THE MODERN BOOK CO.

Largest selection of English & American radio and technical books in the country.

19-21 PRAED STREET,  
LONDON, W2 1NP

Tel: 01-723 4185/2926

### ST. HELEN'S RADIO

Hi-Fi Equipment  
Tape Recorders  
Radio Receivers  
Television

SPECIALISTS IN RADIO  
& ELECTRONIC TEXTBOOKS

ST. HELEN'S GARDENS  
LONDON, W.10

Tel: 01-969 3657

BEDFORDSHIRE

### SURPLECTRONICS

THE SELF-SERVICE  
COMPONENTS SHOP  
THAT SAVES YOU MONEY

CHOOSE FROM 1200  
ASSORTED BOXES  
AT YOUR LEISURE

9 a.m. to 5.30 p.m. every day.  
Closed all day Wednesday

WE ARE IN LUTON  
AT 216 LEAGRAVE ROAD  
LUTON, BEDS

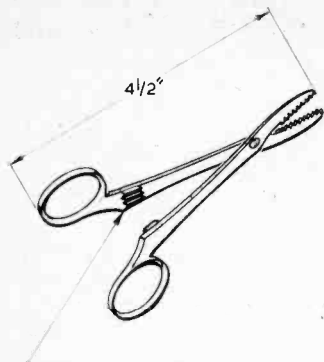

Notches engaging single notch on other handle giving 2-position locking

Fig. 6. A pair of medical locking forceps. These have a number of uses in electronic work including, in particular, employment as a heat shunt

he remarked. "The idea suggested is that medical locking forceps can be very conveniently employed as a heat shunt whilst soldering in transistors and similar components which are sensitive to temperature rise."

"Medical locking forceps?"

"That's right," confirmed Smithy. "The full title is 'Spencer Wells Artery Forceps', and they have interlocking notches on the handles which engage with each other and keep the forceps closed. (Fig. 6). If a wire requires a heat shunt during soldering you can grip it between the jaws of the forceps and simply leave them there. Both hands are then free to do the actual soldering. A small size of forceps is required, the best type being about 4 1/2 in. in overall length. Larger ones are manufactured but they're too bulky and heavy for use as a heat shunt. The forceps are very useful for quite a lot of other small jobs, too. They're almost like a miniature Mole wrench!"

"How do you get hold of them?"

"That part is not quite so easy," remarked Smithy. "Obviously, of course, they're not sold by the usual mail-order suppliers of radio components. They're available quite cheaply from surplus sources from time to time, and they can be bought new from surgical supply companies. They would then be rather more expensive but, even so, our correspondent reckons that they would still be a good buy because of their usefulness."

"This sounds," said Dick, "as though the best approach towards getting them is by what the Americans call 'through channels'."

"That would appear to be the case," agreed Smithy. "Chat up anybody with medical connections you know or, even, the local chemist if you're friendly enough with him.

With luck, you should be able to get a pair."

Smithy took up another letter and examined it.

"Hmm," he said. "Here's an idea from a reader who couldn't get a commercially manufactured medium wave transistor portable radio to track properly. He'd had to replace the two-gang tuning capacitor but couldn't get exactly the right type that was required. Rather than put up with poor reception at one end of the band, he devised a method whereby the aerial coil could be moved along the ferrite rod from outside the cabinet. Here's the basic idea."

Smithy handed Dick a sheet of paper on which details of the scheme were sketched out. (Fig. 7).

"As you can see," continued Smithy, "the approach is quite simple. The ferrite rod is at the back of the receiver and a cable cleat of the type used for mains wiring has one end bent in the form of a semicircle, this being stuck to the coil former with Araldite. The remainder of the cleat then projects through a slot cut in the back of the receiver cabinet."

"I get the idea," interrupted Dick. "You tune in a station in the normal way, then move the projecting part of the cleat along the slot until you get maximum signal strength."

"That's right," confirmed Smithy. "It goes without saying that it would be better to try and get the set to track properly in the first place, rather than incorporate a modification of this nature. If, however, good tracking is quite impossible to achieve after a non-standard tuning capacitor has been replaced, the present scheme could be considered better than just ditching the receiver or putting up with poor performance. And, of course, it's necessary for the ferrite rod to run parallel and close to the back of the receiver."

"It's a neat scheme," remarked Dick. "We certainly seem to be

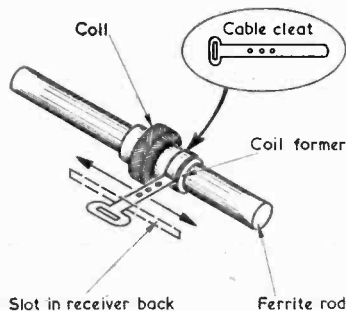

Fig. 7. Illustrating how a ferrite aerial coil may be moved along its ferrite rod from outside the case of the associated receiver

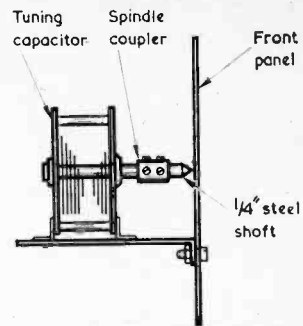

Fig. 8. A simple constructional aid which enables the height of a tuning capacitor spindle to be marked on a front panel

having a wide variety of hints today, Smithy."

"Here's another unusual one," said Smithy, as he read a further letter. "It describes a means of finding the correct height for the panel hole for a tuning capacitor spindle. What you employ is a spindle coupler to which is fitted a short length of 1/4 in. steel rod, the latter having been taken from an old worn-out volume control, or something similar. The end of the rod is ground or filed to a point."

Dick glanced over at the diagram in the letter Smithy was holding. (Fig. 8).

"I see what happens next," he said excitedly. "You assemble the front panel and chassis and fit the spindle coupler to the tuning capacitor shaft. You then hold the capacitor down on the chassis surface, and bring it up to the front panel so that the pointed end of the added shaft marks off the required height."

## NEON WARNING LAMP

"Yes, that's how the idea works," agreed Smithy. "Hallo, what's happened to the sun?"

"It's that dirty great cloud," replied Dick. "It's coming right over us now."

Smithy glanced up. The cloud in question loomed heavily over them, large and sullen.

"Blimey," he remarked. "It's moved a lot quicker than I expected. Oh well, not to worry about it. We'll deal with a couple more hints and then we'll go back inside and get down to work."

"Righty-ho," concurred Dick. "I must say that this hint session has filled up our lunch-break very nicely."

"It has, hasn't it?" replied Smithy. "Well now, the next hint is a simple safety device for use if you do servicing or experimental work on chassis which are connected to one side of the mains supply. Our correspondent says he would be the

first to admit that this isn't a new idea, but he hasn't seen it publicised for quite a few years now and he feels that it would be a good thing to suggest for newcomers. With which statement I fully agree."

"What's the device consist of?"

"Just a small neon bulb and a 220kΩ ¼ watt resistor," replied Smithy. "These are connected in series and the resistor then connects to earth. (Fig. 9). The earth can be given by the mains earth connection. The neon bulb is mounted at the rear of the work-bench at around eye level and it connects to a long flexible lead terminating in a crocodile clip. You attach this clip to the chassis of any equipment you're working on. If the chassis should happen to be connected to the live side of the mains the neon bulb will light up and give warning of the fact. If the chassis is connected to the neutral side of the mains the bulb stays extinguished."

"Stap me," said Dick, "that is a good idea. I'll rig one up on my own bench when I get a bit of spare time. What's the next hint, Smithy?"

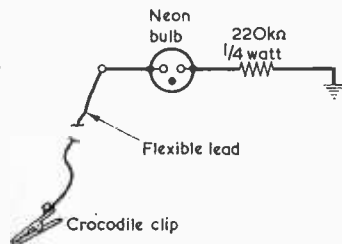

Fig. 9. The crocodile clip shown here is connected to the chassis of any equipment being serviced, whereupon the neon bulb lights up if the chassis is 'live'. A suitable neon bulb is the Hivac type 16L available from Henry's Radio

"I'm getting on to it now," said Smithy, "and don't forget that this is the last one in our present session. Here we are."

Smithy read the letter, then chuckled.

"This is quite an ingenious one," he remarked. "If ever you're pushed for a battery holder to take a single 1.5 volt cell of the pen-light variety, it's possible to improvise one quite easily by employing a moulded B7G valveholder with a skirt and a 2in. B7G valve screen. You simply insert the cell in the screen with the brass stud outwards, then fit the screen over the valveholder. The spring in the screen makes contact to the negative zinc case of the cell, and you connect to the brass stud by way of the centre spigot of the valveholder."

"Gosh, that's clever. If you wanted to, you could mount the valve-

holder on a chassis in the same manner as you would if you were going to use it to hold a valve."

"You could," agreed Smithy. "Provided, of course, that it was in order for the negative terminal of the cell to be at chassis potential. Oh no!"

#### END OF SESSION

"What's up?"

"I just felt a spot of rain. Darn it, there's another one."

"You're right," confirmed Dick. "I've just had a couple on me, too. We'd better get back inside."

Smithy put his sheaf of letters back inside his shirt. With a gesture which betokened years of habit he moved his hand towards the side of his body.

"Blast it," he snorted, finding that the pocket he sought was non-existent. "I'd forgotten I'd left my jacket inside."

"What're you looking for?"

"The Workshop key. Have you got yours with you?"

"Of course I have," replied Dick airily, as he felt in his pockets. By now the rain was beginning to fall quite heavily.

"Hurry up," grunted Smithy. "I'm getting soaked waiting for you."

The expression of confidence on Dick's face gradually changed to one of consternation.

"I haven't got my key either," he wailed. "I've left it inside, too."

"Then, you great hairy twit," exploded the Serviceman, "we're both locked out!"

"You," retorted Dick accusingly, "were the one who pulled the door shut."

By now the rain was increasing to a crescendo.

"The infuriating thing," said Smithy, adroitly changing the turn of conversation, "is that we could at least have sat in my car till the rain stopped. But . . ."

"But," chimed in Dick sarcastically, "the keys for the car are also in your jacket."

The sodden Smithy glanced at his assistant and forebore to make any further comment.

And thus we must take leave of the pair, each standing holding an upturned chair over his head to provide a small level of protection whilst the warm July rain flooded down over them. But, to alleviate any concern that may be felt towards the hapless Dick and Smithy, the post-script may be added that the rain-penetrated Dick was later able, after having obtained entirely illegal entry by way of the window behind Smithy's bench (at the expense of one broken pane, several valves that had been lying on the bench and Smithy's cherished test-meter), to admit the equally saturated Serviceman. And Smithy's subsequent comment that the British

## Your Local Supplier

HAMPSHIRE

### BOURNEMOUTH

LARGEST HI-FI AND  
RADIO COMPONENT  
STORE IN THE SOUTH

FORRESTERS NATIONAL  
RADIO SUPPLIES LTD.

70-72 Holdenhurst Road  
Bournemouth  
Telephone 25232

YORKSHIRE

### WILSIC ELECTRONICS LTD.

Your local supplier for  
EAGLE PRODUCTS  
CYBERNAT MOTORING AIDS  
WILSIC HI-FI, MUSICAL  
EQUIPMENT, KITS AND  
COMPONENTS

Send 15p (3/-) for our Catalogue  
Eagle Products Catalogue 20p (4/-)

6 COPLEY ROAD  
DONCASTER

EIRE

### PEATS for PARTS

ELECTRONIC COMPONENTS  
RADIO & TELEVISION

For the convenience of IRISH  
enthusiasts we supply.

The Radio Constructor  
Data Books and  
Panel-Signs Transfers

Also a postal service

Wm. B. PEAT & Co. Ltd.  
28 PARNELL STREET  
DUBLIN 1

weather has never been the same since the Met. Office was taken over by the Air Ministry just about caps it all completely. ■

#### EDITOR'S NOTE

The hints described in this episode of 'In Your Workshop' were submitted, in the order in which they appear, by C. P. Finn, H. E. Chamberlain, T. E. Millsom, A. Torrance, H. Riley, M. G. Robinson, B. Richardson, G. M. Watson, J. Peters and D. Snaith.

Further hints for this feature are welcomed, and payment is made for all that are published.



# THE MODERN BOOK CO

1971 THE RADIO AMATEUR'S HANDBOOK

by THE AMERICAN RADIO RELAY LEAGUE

£2.60

Postage 25p

**Pickups & Loudspeakers**

by John Earl. £3 Postage 10p

**Solid State Devices & Applications**

by Rhys Lewis. £2 Postage 10p

**Guide to Broadcasting Stations**

by Wireless World. 50p Postage 5p

**VHF-UHF Manual**

by G. R. Jessop. £1.05 Postage 10p

**The Hi-Fi & Tape Recorder Handbook**

by Gordon J. King. £2 Postage 10p

**T.V. Fault Finding**

by J. R. Davies. 50p Postage 5p

**Radio Valve & Transistor Data**

by A. M. Ball. 75p Postage 10p

**20 Solid State Projects for the Car & Garage**

by R. M. Marston. £1.20 Postage 5p

**Security Electronics**

by J. E. Cunningham. £1.70 Postage 5p

**Tape Recorders**

by H. W. Hellyer. £2.25 Postage 10p

**Simple Short-Wave Receivers**

by F. A. Baldwin. 80p Postage 5p

**Tuners & Amplifiers**

by John Earl. £2.10 Postage 10p

**Transistor Manual**

by J. F. Cleary. £1.05 Postage 10p

**Radio Communication Handbook**

by R.S.G.B. £3.15 Postage 25p

We have the Finest Selection of English and American Radio Books in the Country

**19-21 PRAED STREET (Dept RC) LONDON W2 INP**

Telephone 01-723 4185

## REVERBERATION UNIT KIT

6 transistor reverberation chamber to which microphones, instruments, etc., may be connected for added dimensional effect. The output is suitable for most amplifiers and the unit is especially suitable for use with electronic organs. A ready-built spring and transducer assembly is used.

Complete easy-to-build kit, with constructional notes and circuits £7.50. Pre-drilled and printed case £1.70. All parts available separately. Send 5p for circuit and construction details.



## WAH-WAH PEDAL KIT

The Wilsic Wah-Wah pedal comprises a SELECTIVE AMPLIFIER MODULE KIT, containing all the components to build a two transistor circuit module, which may be used by the constructor for his own design or fitted to the FOOT VOLUME CONTROL PEDAL (as photo) converting

it to Wah-Wah operation. This pedal is in strong fawn plastic and fitted with output lead and screened plug. Selective amplifier module kit £1.75. Foot Volume control pedal £5.13. COMPLETE KIT £6.50. Add 38p for assembly of module.



## I-C STEREO AMP KIT

A new kit from Wilsic to build a hi-fi integrated circuit stereo amplifier. 3 watts per channel with full tone controls and attractive veneered cabinet, or may be built into plinth unit. Complete amp kit with stabilised power pack £21.45; with economy power pack £18.50. Cabinet kit: teak 73½p, mahogany 66p. Full plans and detailed prices 10p.

Send 15p for latest catalogue with full details, circuits, etc., and SPECIAL DISCOUNT ORDER FORM.



**WILSIC ELECTRONICS LTD.**

6 COPLEY ROAD, DONCASTER, YORKS

## RSGB BOOKS FOR YOU

### VHF-UHF MANUAL

By G. R. Jessop, C.Eng., M.I.E.R.E., G6JP

2nd edition. Considerably enlarged and revised.

Transmitters, receivers and test equipment for use at vhf and uhf are all fully covered on a practical basis in this new edition. £1.80 post paid

### RADIO COMMUNICATION HANDBOOK

832 pages of everything in the science of radio communication. The Handbook's U.K. origin ensures easy availability of components. Complete coverage of the technical & constructional fields. A superb hard-bound volume. £3.50 post paid

### AMATEUR RADIO TECHNIQUES

By Pat Hawker, G3VA

Now in its third edition. A source of many useful circuits and aeriols incorporating the latest amateur techniques. Contains 208 pages and nearly 500 diagrams. £1.13 post paid

These are three of a complete range of technical publications, log books and maps, all obtainable from:

### RADIO SOCIETY OF GREAT BRITAIN

35 DOUGHTY STREET, LONDON, WC1N 2AE

# SMALL ADVERTISEMENTS

Rate: 4p (9d.) per word. Minimum charge 60p (12/-).  
Box No. 10p (2/-) extra.

Advertisements must be prepaid and all copy must be received by the 4th of the month for insertion in the following month's issue. The Publishers cannot be held liable in any way for printing errors or omissions, nor can they accept responsibility for the *bona fides* of advertisers. (Replies to Box Numbers should be addressed to: Box No. —, *The Radio Constructor*, 57 Maida Vale, London, W9 1SN

**NEW CATALOGUE NO. 18**, containing credit vouchers value 50p, now available. Manufacturers new and surplus electronic and mechanical components, price 23p post free. Arthur Sallis Radio Control Ltd., 28 Gardner Street, Brighton, Sussex.

**CONSTRUCTORS USED COMPONENTS.** Parcels at 50p each, including postage, 50 assorted resistors. 50 assorted capacitors. 10 electrolytic capacitors. 10 assorted knobs. 5 assorted potentiometers. 20 assorted valve bases. Please state which parcel required. Broadcast type twin gang variable capacitors at 18p each. Speakers at 50p each. 7 inch, 5 inch, 5½ x 3½ inch elliptical. P. & P. 18p. Box No. G142.

**SERVICE SHEETS (1925-1971)** for Televisions, Radios. Transistors, Tape Recorders, Record Players, etc., by return post, with free Fault-Finding Guide. Prices from 5p. Over 8,000 models available. Catalogue 13p. Please send S.A.E. with all orders/enquiries. Hamilton Radio, 54 London Road, Bexhill, Sussex.

**BUILD IT in a DEWBOX** robust quality plastic cabinet 2in. x 2½in. x any length. S.A.E. for details. D.E.W. Ltd., 254 Ringwood Road, Ferndown, Dorset. Write now - right now.

**FOR SALE:** Tlx type variable capacitor. 50-110pF, ½in. spacing £1. Tannoy P.A. Mic, £1.50. 1.5 - 3MHz Command receiver, £2. Motor generator. 12V 4A in. 400V .05A out. £1.50. Type 3 T/P ink rollers, 25p bottle. 200ft. Super-8 cine reels, 25p. Box No. G144.

**RECORD TV SOUND** using our loudspeaker isolating transformer. Provides safe connection to recorder. Instructions included. 70p plus 10p P. & P. Crowborough Electronics (R.C.), Eridge Road, Crowborough, Sussex.

**FOR SALE:** *International Encyclopedia of Stamps*. Published by IPC Magazines Ltd. Vol. 1, parts 1 to 14. Vol. 2, parts 1 to 13. Cover price 23p each part. Will sell at £2 per volume. Box. No. G149.

**5 TRANSISTOR 1 WATT AUDIO AMPLIFIERS**, for 7½-15V supply. Standard 3 ohm output. Only £1 each. Manley, 13 Randisbourne Gardens, Bromley Road, London S.E.6.

**TO CLEAR:** *Life World Library and Life Sunday Times World Library*. All at 30p post paid. South-Greece, Mexico, Russia, Italy, Britain, Japan, Brazil, France, India & Germany. Box No. G150.

**JOIN THE INTERNATIONAL S.W. LEAGUE.** Free services to members including Q.S.L. Bureau, Amateur and Broadcast Translation, Technical and Identification Dept. - both Broadcast and Fixed Stations. DX Certificates, contests and activities for the SWL and transmitting members. Monthly magazine, *Monitor*, containing articles of general interest to Broadcast and Amateur SWLs, Transmitter Section and League affairs, etc. League supplies such as badges, headed notepaper and envelopes, QSL cards, etc., are available at reasonable cost. Send for League particulars. Membership including monthly magazines, etc., £1.75 per annum. Secretary ISWL, 1 Grove Road, Lydney, Glos., GL15 5JE.

(Continued on page 767)

# BENTLEY ACOUSTIC CORPORATION LTD.

38 Chalcot Road, Chalk Farm  
LONDON, N.W.1.  
01-722-9090

The Old Police Station  
Gloucester Road  
LITTLEHAMPTON Sussex  
PHONE 6743

Please forward all mail orders to Littlehampton

5Z4G .35	ECC33	HVR2 .53	PL509 1.44	AC113 .25	BY105 .18
6A176 .20	1.58	KTW62 .63	PY32/33	AC127 .17	BY114 .18
6J30L2 .57	ECC81 .17	KT86 .82	PY81 .50	AC128 .20	BY126 .15
6B187 .79	ECC82 .20	KT81 2.00	PY81 .25	AC154 .25	BY127 .18
6BW6 .72	ECC83 .23	KT88 1.70	PY82 .25	AC156 .20	BY210 .25
6BW7 .57	ECC84 .30	PC86 .49	PY83 .27	AC157 .25	BY211 .25
6F14 .44	ECC85 .27	PC88 .49	PY88 .33	AD140 .36	BY212 .25
6F23 .70	ECC86 .40	PC95 .53	PY500 1.08	AD149 .50	BY213 .25
6F28 .70	ECC88 .35	PC97 .38	PY800 .35	AD161 .45	OA70 .10
6L6GT .39	ECC189	PCC00 .35	PY801 .34	AD166 .45	OA79 .09
9D7 .78	ECC189	PCC84 .31	OOVO3/	AF114 .25	OA81 .09
10C1 1.25	ECCF80 .28	PCC85 .29	1.0	AF115 .15	OA90 .13
10F18 .35	ECCF82 .28	PCC88 .44	R19 .31	AF119 .23	OA91 .09
12A6 .63	ECCF86 .65	PCC89 .46	U18/20 .75	AF121 .30	OA95 .09
30C15 .62	ECH42 .62	PCC189 .49	U19 1.73	AF126 .18	OA200 .09
30C17 .79	ECH81 .28	PCF80 .29	U25 .65	AF139 .65	OA202 .10
30C18 .63	ECH83 .40	PCF82 .31	U26 .59	AF180 .48	OC23 .38
30F5 .72	ECH84 .36	PCF84 .40	U191 .60	AF186 .55	OC24 .38
30FL1 .62	ECL80 .33	PCF86 .45	U301 .40	AF239 .38	OC25 .38
30FL2 .75	ECL82 .31	PCF200 .67	U801 .95	BA102 .45	OC26 .24
30FL14 .70	ECL83 .52	PCF801 .32	UABC80	BA115 .14	OC28 .60
30L15 .60	ECL86 .37	PCF802 .40	U25 .30	BA116 .25	OC35 .32
30L17 .71	EF22 .63	PCF806 .59	UBC81 .40	BA129 .13	OC36 .43
30P419R .60	EF41 .50	PCH200	UBF80 .29	BA130 .10	OC38 .43
30P4MR .60	EF80 .23	PC2 .62	UBF89 .31	BC107 .13	OC44 .10
30P12 .98	EF85 .28	PCL82 .33	UC2 .35	BC108 .13	OC45 .11
30P12 .69	EF86 .31	PCL83 .60	UCC84 .34	BC113 .25	OC46 .11
30PL1 .61	EF89 .24	PCL84 .35	UCC85 .35	BC118 .23	OC70 .13
30PL13 .78	EF91 .17	PCL805 .45	UCF80 .35	BCN115 .45	OC71 .11
DY802 .48	EF193 .27	R5 .42	UC21 .60	BCV12 .50	OC72 .11
DY802 .48	EF184 .30	PLC86 .40	UCH42 .61	BCY33 .30	OC74 .23
E88CC .60	EH90 .38	PEN45 .35	UCH81 .31	BCY34 .23	OC75 .11
EABC80	EL34 .46	PEN45DD	UCL82 .34	BCY38 .23	OC78 .15
	EL41 .54	PFL200 .54	UCL83 .49	BCY39 .25	OC78D .15
EAF42 .49	EL84 .23	PFL200 .54	UF41 .50	BCZ11 .38	OC81 .11
EB34 .20	EL95 .35	PL50 .37	UF50 .35	BF119 .45	OC81D .11
EB91 .11	EM80 .38	PL81 .45	UF85 .34	BFY50 .23	OC82 .11
EBC41 .48	EM81 .40	PL82 .31	UF86 .63	BFY51 .19	OC83 .20
EBC81 .33	EM84 .32	PL83 .33	UF89 .29	BFY52 .20	OC84 .24
EBF80 .32	EM87 .36	PL84 .31	UL41 .59	BF159 .25	OC123 .23
EBF83 .40	EY51 .35	PL504/	UL84 .32	BF163 .20	OC139 .23
EBF89 .30	EY86/7 .31	PL506 .64	UM80 .33	BF173 .38	OC140 .95
EC92 .35	EZ40 .40	PO508 1.16	UY41 .38	BF180 .30	OC169 .23
ECC32	EZ80 .22	PX4 1.16	UY85 .27	BY100 .18	OC200 .22
1.58	EZR1 .23	PX25 1.16	AA119 .15	BY101 .15	OC202 .43

All goods are unused and boxed, and subject to the standard 90-day guarantee. Terms of business: Cash or cheque with order only. No C.O.D. orders accepted. Post/packing charge 0.03 per item, subject to a minimum of 0.09. Orders over 5.00 post free. All orders despatched same day by first class mail. Complete catalogue with conditions of sale 0.07 post paid. Any parcel insured against damage in transit for only 0.03 extra per order. Business hours 9 a.m.-5.30 p.m. Sats. 9 a.m.-1 p.m. Littlehampton closed Sats. No enquiries answered unless S.A.E. enclosed for reply.



EST 1891

## TECHNICAL TRAINING in Radio, Television and Electronic Engineering

First class opportunities in Radio and Electronics await the ICS trained man. Let ICS train YOU to a well-paid post in this expanding field.

ICS courses offer the keen, ambitious man the opportunity to acquire, quickly and easily, his specialized training so essential to success.

Diploma Courses in Radio, TV Engineering and Servicing, Colour TV Servicing, Electronics, Computers, etc. Expert coaching for:

- \* C.&G. TELECOMMUNICATION TECHNICIANS CERTS
- \* C.&G. ELECTRONIC SERVICING
- \* R.T.E.B. RADIO AND TV SERVICING CERTIFICATE
- \* RADIO AMATEURS EXAMINATION
- \* RADIO OPERATOR CERTIFICATES

Examination Students Coached until Successful

### NEW SELF-BUILT RADIO COURSES

Build your own 5-valve receiver, transistor portable, signal generator, multi-test meter—all under expert guidance. POST THIS COUPON TODAY and find out how ICS can help YOU in your career. Full details of ICS courses in Radio, Television and Electronics will be sent to you by return mail.

Member of Association of British Correspondence Colleges

### INTERNATIONAL CORRESPONDENCE SCHOOLS

Dept. 248, Intertext House, Stewards Road, London, SW8 4UJ

Name . . . . . Age . . . . .

BLOCK CAPITALS PLEASE

Address . . . . .

7-71

# One year's electronics experience + ONC or C & G?

Then become a Radio Technician with the National Air Traffic Services. You would work on the installation and maintenance of a wide range of sophisticated electronic systems and specialised equipment throughout the U.K. You would be involved with RT, Radar, Data Transmission Links, Navigation Aids, Landing Systems, Closed Circuit T.V. and Computer Installations. You could also work on the development of new systems.

To qualify for entry to our training course you must be aged 19 or over, have at least one year's experience in electronics and preferably O.N.C. or C. & G. (Telecoms). Your starting salary would be £1,143 (at 19) to £1,503 (at 25 or over), scale max. £1,741 - shift duty allowances. Good career prospects.

Send NOW for full details of how you can become a Radio Technician. Complete the coupon and return to A. J. Edwards, C. Eng., M.IEE, Room 705, The Adelphi, John Adam Street, London WC2N 6BQ, marking your envelope 'Recruitment'.

I meet the requirements, please tell me more about the work of a Radio Technician

NAME \_\_\_\_\_

ADDRESS \_\_\_\_\_

(A/RC/18)

Not applicable to residents outside the United Kingdom

## NATS

National Air Traffic Services

# RADIO OPERATORS

Do you Hold  
PMG II OR PMG I OR  
New General Certificate  
OR had Two Years' Radio  
Operating Experience?

LOOKING FOR A  
SECURE JOB  
WITH GOOD PAY  
AND CONDITIONS?

Then apply for a post with the Composite Signals Organisation-these are Civil Service posts, with opportunities for service abroad, and of becoming established i.e. Non-Contributory Pension Scheme.

Specialist Training Courses (Free accommodation) starting January, April and September 1972.

If you are British born and resident in the United Kingdom write NOW for full details and application form from:

Recruitment Officer  
Government Communications  
Headquarters,

Oakley,  
Priors Road,  
CHELTENHAM,  
Glos., GL52 5AJ.  
Tel: Cheltenham 21491. Ext. 2270.

## SMALL ADVERTISEMENTS

(Continued from page 765)

**FOR SALE:** Specialist stamp collection. Space, Railway Centenary, ITU, IGY, etc. issues. Catalogue value approx. £150. Offers? S.A.E. for details. Another collection of early Space issues £25 o.n.o. Small general collection at £5. Box No. G151.

**MAGAZINES FOR SALE/EXCHANGE.** *Radio Constructor*, *Practical Electronics*, *Practical Television*. Single issues. Reasonable prices. All enquiries answered. Wanted: *Practical Wireless*. Charnley, 18 Nether Street, Finchley, London N12 7NL.

**WANTED:** Books, P.E. back numbers, etc., on electronic organs. Also components, instruments, AVO 8, etc. Hemming, 78 Oxford Street, Bristol 3. Telephone: 77524.

**WANTED:** Marine type sextant. Details & price to Box No. G152.

**CRYSTALS.** Marine frequencies. 2381, 2089, 2306, in holders with 1/4 in. pin spacing £2 each. Box No. G154.

**POSTAL ADVERTISING?** This is the Holborn Service. Mailing lists, addressing, enclosing, wrapping, facsimile letters, automatic typing, copy service, campaign planning, design and artwork, printing and stationery. Please ask for price list. - The Holborn Direct Mail Company, Capacity House, 2-6 Rothsay Street, Tower Bridge Road, London, S.E.1. Telephone: 01-407 1495.

**FOR SALE:** Old Scott Target hand-made radio, in old radiogram cabinet. In good order. Offers invited. Owen, 62 Minstead Road, East Howe, Bournemouth, Hants. Telephone: Northbourne 2745.

**RELAYS.** Sigma type 72AOZ, octal base, £1.50; Carpenter polarised, £1; D164816, £1.50. Box No. G155.

**HOLIDAY ACCOMMODATION.** Burwood Lodge Hotel, Dawlish Road, Teignmouth, S. Devon. Especially for parents with young children. Facing south, on the cliffs, direct access by private path to sea. Mothers' kitchen, automatic washing machines, baby listening service. Licensed lounge. Ample free parking.

**WORLD DX CLUB** covers all aspects of SWLing on Amateur and Broadcast Bands through its monthly bulletin "Contact". Membership costs £1.38 a year. Enquiries to Secretary, WDXC, 11 Wesley Grove, Portsmouth, Hants., PO3 5ER.

**IF YOU HAVE ENJOYED A HOLIDAY** on the Norfolk Broads, why not help to preserve these beautiful waterways. Join the Broads Society and play your part in determining Broadlands future. Further details from:- The Hon. Membership Secretary, The Broads Society, "Icknield", Hilly Plantation, Thorpe St. Andrew, Norwich, NOR 85S.

**TOP 20 TV VALVES,** 10p. PL504, PL36, PY33, 15p. P. & P. 4p per valve, over 12 valves post free. Guaranteed tested, ex-equipment, individually boxed. Resistors and capacitors all values and sizes. Leading manufacturers components and hi-fi equipment 10% or more off. 13 amp plugs 12p. Mains fuses 20p for 10. Tools, etc. P. & P. extra on all items. Trade enquiries welcomed, discount for quantity. S.A.E. for list. L. & D. Components Ltd., 71 Westbury Avenue, Wood Green, London N.22. Telephone: 01-888 2701.

**MAGAZINES FOR SALE:** "The Radio Constructor" - 1967 except June & October, 90p; all 1968 issues £1; all 1969 issues £1; or the lot £2.75 to clear. "Practical Wireless" - all 1969 issues £1; "Wireless World" - 1968, all except January, May, July & October; also copies of March, April, May & June 1969; the lot £1.50 to clear. Prices include postage. All in good condition. Box No. G162.

**"MEDIUM WAVE NEWS"** Monthly during Dx season - Details from: K. Brownless, 7 The Avenue, Clifton, York.

(Continued on page 768)

# TOO MUCH STOCK!!

—to list on one advertisement!

Yes, LST would need half this magazine to show their full range.



But 5p for postage will bring you our FREE components catalogue. 44 pages of semiconductors, integrated circuits, passive components, tools, kits, etc., etc.

Send this coupon to:

LST ELECTRONIC COMPONENTS LTD  
MAIL ORDER DEPT RC  
7 COPTFOLD ROAD  
BRENTWOOD  
ESSEX

Please send your "cat" to:

Name: .....

Address: .....

## FREE TO AMBITIOUS ENGINEERS

—THE LATEST EDITION OF ENGINEERING OPPORTUNITIES!

**SEND FOR YOUR FREE COPY TO-DAY**

**ENGINEERING OPPORTUNITIES** is a highly informative 74 page guide to the best paid engineering posts. It tells you how you can quickly prepare at home for a recognised engineering qualification and outlines a wonderful range of modern Home Study Courses in all branches of Engineering. This unique book also gives full details of the Practical Radio & Electronics Courses administered by our Specialist Electronics Training Division - explains the benefits of our free Appointments and Advisory service and shows you how to qualify for five years promotion in one year.

**'SATISFACTION OR REFUND OF FEE' TERMS**

We give a written agreement that if after completing one of our courses, you do not pass your examination or are dissatisfied in any other way we will refund your complete fee.

**PRACTICAL EQUIPMENT INCLUDING TOOLS**

The specialist Electronics Division of B.I.E.T. NOW offers you a real laboratory training at home with all the practical equipment you need, plus Basic Practice and Theoretical Courses for beginners in Radio, TV, Electronics, etc.

**BRITISH INSTITUTE OF ENGINEERING TECHNOLOGY**

Dept. (B10), Aldermaston Court, Reading RG7 4PF

— SEND OFF THIS COUPON TO-DAY! —

Tick subjects that interest you:

AMSE (Elec)  City & Guilds Certificate  RTEB Certificate   
Radio Amateurs' Exam  DMG Certificate  Colour TV   
Electronic Engineering  Computer Electronics  Radio and TV  
Servicing  Practical Electronics  Practical TV & Radio   
Please send booklets & full information without cost or obligation.



NAME .....

ADDRESS .....

.....

.....

OCCUPATION .....

To: BIET Dept. B10, Aldermaston Court, Reading RG7 4PF

# NEW STYLE SELF-BINDER

for "The Radio Constructor"

The "CORDEX" Patent Self-Binding Case will keep your issues in mint condition. Copies can be inserted or removed with the greatest of ease. Rich maroon finish, gold lettering on spine.

Specially constructed Binding Cords are made from Super Linen of great strength, very hard twisted and twice doubled. They are attached to strong RUSTLESS Springs under tension, and the method adopted ensures PERMANENT RESILIENCE of the Cords. Any slack that may develop is immediately compensated for and the Cords will always remain taut and strong. It is impossible to overstretch the springs, as a safety check device is fitted to each.

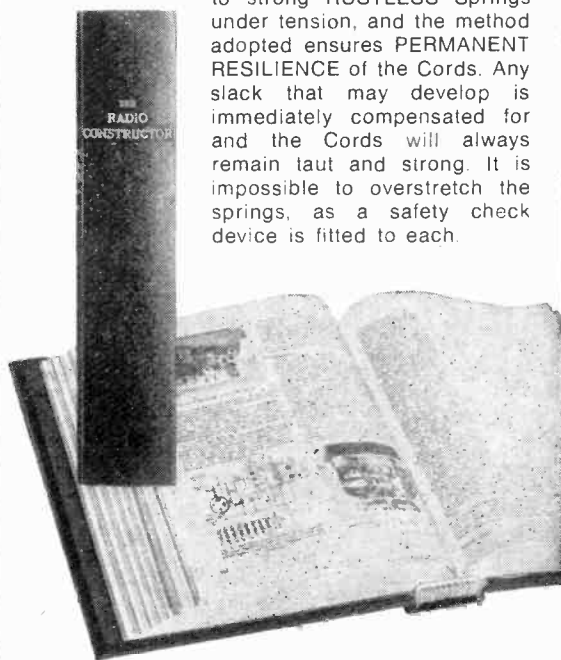

PRICE **75p** Postage 10p

Available only from:-

**Data Publications Ltd.**  
57 Maida Vale London W9 1SN

## SMALL ADVERTISEMENTS

(Continued from page 767)

**ARE YOU A MOTORING ENTHUSIAST?** The Seventy Motor Club caters for all types of motor sport-racing, rallies, hill climbs, etc. Monthly Bulletin free to members. For full details write to: The General Secretary, Colin Peck, "Dancers' End", St. Winifred's Road, Biggin Hill, Kent.

**VALVES TO CLEAR:** 801-A, VT136, VT62, DK91, T20, UX865S, HP4106, 41MP, 6B4G, 10LD, N142, U142, 10F9, TH141, 3ML, UY41, 171DDP, 3S4, VR91. All at 13p each postage paid. Box No. G165.

**FREE GIFT** when you request our quality stamps, supplied on approval. Generous discounts. Details from: Watson's Philatelic Service, 6 Beech Avenue, Brentwood, Essex.

**PRINTED CIRCUITS.** Capacity now available for prototypes or production runs. Artworks, Photographics, Etched Boards, and Assembly. Fast turn round. Send S.A.E. for quotations. Also copper laminated fibre-glass board single sided 1½p per square inch, double sided 2p per square inch, any size cut. Minimum order 50p. P. & P. plus 10%. Systematics, 18 Pennine Road, Millbrook, Southampton, Hants.

**SELLING UP.** Oscilloscope £30, solid-state voltmeter £15, CR Bridge £10. All nearly new. Large quantity components, many unused, £15 to clear. Box No. G166.

**ESSEX GARDENERS.** Buy your bedding and rock plants, shrubs, etc., also cacti from May's Nurseries, 608 Rayleigh Road, Hutton, Brentwood, Essex. Callers only. Monday to Saturday.

**WANTED:** *The Radio Constructor* Volume 18. Copies Nos. 1 (August), 2 (Sept.), 4 (Nov.), 5 (Dec.). all 1964. Your price by London cheque plus air mail costs all four copies. Also index to Vol. 18 (August 1964 to July 1965). Millar, 5H3AP, Post Box 381, Morogoro, Tanzania.

**AD161/AD162 POWER PAIRS,** matched for Mullard amplifier circuits. Mint, 60p pair, U.K. post 5p. S.A.E. list. Amatronic Ltd., 396 Selsdon Road, South Croydon, Surrey, CR2 ODE.

**FOR SALE:** Ex-American army oscilloscope A/APN4. Needs minor repairs, otherwise good condition. £9. Apply: Heydecker, Friends' School, Saffron Walden, Essex.

**BARGAINS.** P.S. Units, radio test gear, etc. S.A.E. lists. Don Smith, 12 Channel Heights, Bleadon, Weston-Super-Mare, Somerset. Telephone: Bleadon 672.

**SERVICE OSCILLOSCOPE.** Heathkit OS-2, perfect working order. Not a scratch. Only nine months old. £28. Telephone: 01-237-3704.

**FREQUENCY LIST TRANSFERS.** We have a limited supply of sheets of Dial Frequency Transfers in black. Short Wave frequencies 1.8Mc/s to 32Mc/s and 144Mc/s and 146Mc/s. Includes amateur band marker frequencies at 100kc/s points and other short wave frequencies from 2 to 32Mc/s at every 500kc/s points. Each frequency is repeated. Two sheets for 5p. five sheets for 10p, postage 2½p. Data Publications Ltd., 57 Maida Vale, London W9 1SN.

### JOHN SAYS . . .

**RING MODULATOR** by Dewtron is professional, transformerless, 5 transistor, has adjustable F1/F2 rejection. **Module £7.** Unit **£8.90** WAA-WAA Pedal kit of all parts, incl. all mechanics & instr. **ONLY £2.45.** **AUTO RHYTHM** from Dewtron modules. Simple unit for waltz, foxtrot, etc. costs **£16.55** in modules. **ORGAN PERCUSSION** and other fascinating effects. Send 15p for illust. list. **D.E.W. LTD.,** 254 Ringwood Road, **FERNDOWN,** Dorset.

# CHASSIS and CASES by



**H. L. SMITH & CO. LTD.**  
287/9 Edgware Road  
London W2 1BE  
TEL: 01-723 5891

## BLANK CHASSIS

FOUR-SIDED 16 SWG ALUMINIUM

Size	Price	Base	Size	Price	Base
6x4x2"	34p	17p	10x8x2 1/2"	66p	30p
7x4x1 1/2"	33p	18p	12x7x2 1/2"	66p	33p
7x5x2 1/2"	40p	19p	12x9x2 1/2"	76p	38p
8x4x2"	38p	19p	13x8x2 1/2"	76p	38p
8 1/2x5 1/2x2"	44p	21p	14x7x3"	80p	36p
9x7x2"	50p	26p	14x10x2 1/2"	88p	47p
10x4x2 1/2"	50p	21p	15x10x2 1/2"	92p	50p
12x4x2 1/2"	55p	22p	17x10x3"	£1.10	55p
12x5x3"	66p	26p			

## CASES ALUMINIUM, SILVER HAMMERED FINISH

Type	Size	Price	Type	Size	Price
N	8x6x2"	£1.00	W	12x7x7"	£2.00
N	6x6x3"	£1.05	W	15x9x8"	£3.15
N	4x4x2"	80p	Y	8x6x6"	£2.25
U	4x4x4"	95p	Y	12x7x7"	£2.80
U	5 1/2x4 1/2x4 1/2"	£1.15	Y	13x7x9"	£3.15
U	8x6x6"	£1.45	Y	15x9x7"	£3.35
U	9 1/2x7 1/2x3 1/2"	£1.55	Z	17x10x9"	£4.15
U	15x9x9"	£3.00	Z	19x10x8 1/2"	£4.50
W	8x6x6"	£1.90			

Type N

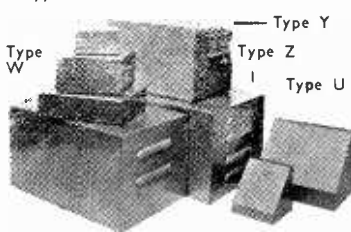

Type N has removable bottom, Type U removable bottom or back, Type W removable front, Type Y all screwed construction, Type Z removable back and front. Plus p. & p.

### TO FIT OUR CASES

7x5 1/2x1 1/2"	38p	21p	12x6 1/2x2"	60p	33p
7x5 1/2x2"	43p	21p	14x8 1/2x2"	74p	44p
11x6 1/2x1 1/2"	55p	30p	15 1/2x9 1/2x2 1/2"	94p	52p
11x6 1/2x2"	55p	30p	17 1/2x9 1/2x2 1/2"	£1.05	59p

Plus post & packing

PANELS: Any size up to 3ft. at 36p sq. ft. 16 s.w.g. (18 s.w.g. 32p). plus postage and packing

**YUKAN** SO PROFESSIONAL THE  
**SELF-SPRAY** YUKAN AEROSOL WAY—  
Get these air drying **GREY HAMMER**  
**NOW!** OR **BLACK WRINKLE**  
**(CRACKLE)** finishes

Yukan Aerosol spraykit contains 453g. fine quality, durable easy instant spray. No stove baking required. Hammers available in grey and blue. 90p carr. pd. Modern Eggshell Black Wrinkle (Crackle) producing a 3D textured finish. 90p carr. pd. all at 85p per push-button self-spray can at our counter. Also durable, heat and water resistant Black Matt finish (359g self-spray cans only) 75p carr. pd.

**SPECIAL OFFER:** One can plus optional transferable snap-on trigger handle (value 25p) for 86p carr. pd. Choice of 13 self-spray plain colours and primer (motor car quality) also available.

Please enclose cheque or crossed P.O. for total amount direct to  
**DEPT: N/4 YUKAN, 307a EDGWARE ROAD, LONDON W2 1BN**

We supply many Government Departments, Municipal Authorities, Institutes and Leading Industrial Organisations—We can supply you too. *Now British—even better*

*Other Yukan Air Drying Aerosols 453g at 90p include Zinc Chromate Clear Lacquer Metallic Grey, Blue*



## CIRCUITS! CIRCUITS!

Ten exciting circuits per month with instructions to build. Every month a completely new set. This month's circuits cover

**"TRANSMITTERS OF ALL KINDS"**  
only 50p per set of ten

Postage and packing free

Free Data and Technical A-Z cards. Build up the complete set month by month.

Cheques and PO's to Dept. R/C, Photonics, 3 Whitehall Gardens, London, E.4. *sae for details*

## DATA BOOK SERIES

- DB5 TV FAULT FINDING**  
124 pages. Price 50p, postage 6p.
- DB16 RADIO CONTROL FOR MODELS**  
192 pages. Price 75p, postage 8p.
- DB17 UNDERSTANDING TELEVISION**  
512 pages. Price £1.88, postage 20p.
- DB18 AUDIO AMPLIFIERS**  
128 pages. Price 53p, postage 6p.
- DB19 SIMPLE SHORT WAVE RECEIVERS**  
140 pages. Price 80p, postage 6p.

I enclose Postal Order/Cheque for ..... in payment for .....

NAME .....

ADDRESS .....

(Please use Block Capitals for both name and address)

Postal Orders should be crossed and made payable to Data Publications Ltd.

Overseas customers please pay by International Money Order.

All publications are obtainable from your local bookseller.

Data Publications Ltd., 57 Maida Vale, London W9 1SN

Please mention **THE RADIO CONSTRUCTOR** when writing to advertisers

# INDEX TO VOLUME TWENTY-FOUR

August 1970 - July 1971

## AMPLIFIERS

Hybrid A.F. Amplifier, by <i>S. Daniels</i> ... ..	416	Feb. '71
I.C. Stereo Amplifier, by <i>R. J. Caborn</i> ... ..	740	July '71
Integrated Circuit Gram Amplifier, by <i>H. Williams</i> ... ..	167	Oct. '70
One-Valve Record Player Amplifier, by <i>H. Williams</i> ... ..	20	Aug. '70
The "Door-Com", by <i>H. T. Kitchen</i> ... ..	228	Nov. '70
The "Sliding Challenger" Economy Amplifier, by <i>Sir Douglas Hall, K.C.M.G., M.A.(Oxon)</i> ... ..	31	Aug. '70
The 'Tri-add' Gram Amplifier, by <i>F. G. Rayer, G3OGR</i> ... ..	96	Sept. '70
Two-Transistor Amplifier, by <i>H. Williams</i> ... ..	222	Nov. '70

## AMPLIFIER ANCILLARIES

Cathode Signal Injection, by <i>E. Pearce</i> ... ..	84	Sept. '70
Crossover Networks, by <i>A. J. Whittaker</i> ... ..	101	Sept. '70
The 'Tri-Add' Pre-Amplifier, by <i>F. G. Rayer, G3OGR</i> ... ..	162	Oct. '70

## ELECTRONICS

Addition Computing Circuit, by <i>D. Snaith</i> ... ..	217	Nov. '70
Animated Animals, by <i>J. R. Squires</i> ... ..	734	July '71
Comprehensive Burglar Alarm System, by <i>P. Cairns, G3ISP</i> ... ..	398	Feb. '71
Efficient Water Level Sensor, by <i>G. A. French</i> ... ..	214	Nov. '70
F.E.T. Timing Circuit, by <i>R. B. Gray</i> ... ..	235	Nov. '70
High Accuracy Thermostat, by <i>H. V. Morris, G3TCX</i> ... ..	342	Jan. '71
Inexpensive Burglar Alarm, by <i>A. G. Wood</i> ... ..	354	Jan. '71
Light-Operated Speed Control, by <i>G. A. French</i> ... ..	337	Jan. '71
Pain Detector, by <i>J. T. Neill</i> ... ..	92	Sept. '70
Push-button Remote Control, by <i>P. M. Munro</i> ... ..	732	July '71
Sequential On-Off Switch, by <i>G. A. French</i> ... ..	662	June '71
Switch-Off Reminder, by <i>G. A. French</i> ... ..	79	Sept. '70
Thyristor Overload Trip, by <i>P. Meredith</i> ... ..	280	Dec. '70
Timer Without Electrolytics, by <i>J. Phillips</i> ... ..	465	Mar. '71
Ultra-Simple Tremolo Unit, by <i>D. W. Nelson</i> ... ..	144	Oct. '70
Visual Bell Indicator, by <i>G. A. French</i> ... ..	470	Mar. '71
Weather-Vane Repeater, by <i>C. Dickson</i> ... ..	289	Dec. '70

## GENERAL

Amateur Radio Scientific Studies ... ..	496	Mar. '71
AMSAT - Policy Outlined ... ..	170	Oct. '70
Apollo Communications ... ..	697	June '71
Constructing a Vertical 3-Band Trapped Dipole, by <i>A. S. Carpenter, G3TYJ</i> ... ..	538	Apr. '71
Crossword ... ..	110	Sept. '70
Electroluminescent Devices, by <i>J. B. Dance, M.Sc.</i> ... ..	366	Jan. '71
Experimenter's Power Supply, by <i>G. A. French</i> ... ..	274	Dec. '70
Extension Door Buzzer, by <i>A. G. D. Channon</i> ... ..	409	Feb. '71
Facsimile Reception for the Radio Amateur, by <i>Arthur C. Gee, G2UK</i> ... ..	161	Oct. '70
Finding Ferrite Frame Turns ... ..	738	July '71
First Mobile Radiotelephones for London Buses ... ..	371	Jan. '71
For the SWL, CW operating ... ..	29	Aug. '70
Four-Way Remote Control System, by <i>G. A. French</i> ... ..	14	Aug. '70
Gallium Arsenide F.E.T., by <i>J. B. Dance, M.Sc.</i> ... ..	287	Dec. '70
General Purpose Power Supply Unit, by <i>P. L. Matthews</i> ... ..	334	Jan. '71
Latin American Quest, Part 1 ... ..	554	Apr. '71
Latin American Quest, Part 2 ... ..	622	May '71
Latin American Quest, Part 3 ... ..	684	June '71
Latin American Quest, Part 4 ... ..	750	July '71
LCR Tone Control Circuit, by <i>G. W. Short</i> ... ..	604	May '71
Line-of-Sight Communication - A Closer Look, by <i>H. A. Cole, C.Eng., M.I.E.R.E.</i> ... ..	681	June '71
Low-Cost TV Aerial, by <i>T. White</i> ... ..	497	Mar. '71
Mains-Battery Power Supplies, by <i>D. Snaith</i> ... ..	27	Aug. '70
Miniature Power Unit, by <i>G. W. Short</i> ... ..	87	Sept. '70
Mullard Jubilee Rose Competition ... ..	724	July '71
Multi-Voltage Switching Circuit, by <i>W. Philips</i> ... ..	90	Sept. '70
Non-Overload Power Supply, by <i>J. Thompson</i> ... ..	612	May '71
Notes on Semiconductors, by <i>P. R. Williams</i> - 1 ... ..	478	Mar. '71
Notes on Semiconductors, by <i>P. R. Williams</i> - 2 ... ..	546	Apr. '71
Notes on Semiconductors, by <i>P. R. Williams</i> - 3 ... ..	621	May '71



Notes on Semiconductors, by P. R. Williams - 4	675	June	'71
Notes on Semiconductors, by P. R. Williams - 5	725	July	'71
Oscillating Valve E.H.T. Generator, by E. G. H. Mobbsy	428	Feb.	'71
S.E. Asian Quest - (1)	224	Nov.	'70
S.E. Asian Quest - (2)	285	Dec.	'70
S.E. Asian Quest - (3)	364	Jan.	'71
Secondary Wave Circuits, by J. Braunbeck	10	Aug.	'70
Secret Switch, by L. Morris	352	Jan.	'71
Sequential Latching Relay Circuit, by R. A. Butterworth, G8BI	473	Mar.	'71
Spark-Free Electrolytic Checker, by R. B. Dean	358	Jan.	'71
Switch-Off Flasher, by S. A. Thomas	429	Feb.	'71
Telephones for the Deaf and Blind	728	July	'71
The Infuriator, by C. P. Finn	415	Feb.	'71
Transformer Design for Mains Driven Bridges, by A. M. Sellick, A.M.I.E.R.E.	238	Nov.	'70
Transistor Power for Valve Amplifiers, by C. P. Finn	489	Mar.	'71
Two-Stage 'Adjustable Zener', by G. W. Short	220	Nov.	'70
VHF-FM Reception at 200 Miles, by D. Walsh	108	Sept.	'70

## IN YOUR WORKSHOP

A.F. Injection	693	June	'71
A.F. Output Valve	759	July	'71
A.F. Regeneration	248	Nov.	'70
A.F. Tracer	691	June	'71
Batteries	377	Jan.	'71
Circuit Board Spacers	760	July	'71
Complementary Output Stage	308	Dec.	'70
C.W. Phone Filter	247	Nov.	'70
Drive Ratios	569	Apr.	'71
D.T.L. Gate	182	Oct.	'70
Fault Location	311	Dec.	'70
Ferrite Aerials	374	Jan.	'71
High Voltage	440	Feb.	'71
H-Parameters	632	May	'71
Hybrid TV Receiver	499	Mar.	'71
Input Power	52	Aug.	'70
Locking Forceps	761	July	'71
Log Graph Paper	50	Aug.	'70
Logic Gates	176	Oct.	'70
Miller Effect	633	May	'71
Neon Warning Lamp	762	July	'71
Negative Feedback	313	Dec.	'70
NOR and NAND Gates	177	Oct.	'70
Oscillator Tuning	695	June	'71
Output Stage Operation	312	Dec.	'70
Piccolo	634	May	'71
Power Dissipation	52	Aug.	'70
Protective Diode	437	Feb.	'71
Removing Components	114	Sept.	'70
Resistance Substitution	112	Sept.	'70
R.T.L. Gate	181	Oct.	'70
Servicing Aids	372	Jan.	'71
Step-Down System	571	Apr.	'71
Surface Wave Filter	634	May	'71
Transformer Memory	440	Feb.	'71
T.T.L. Gate	184	Oct.	'70
Tuning Drives	565	Apr.	'71
Tuning Wand	372	Jan.	'71
Valve Checker	116	Sept.	'70
Video Checks	692	June	'71
Voltage Monitor	376	Jan.	'71
Xylonite	636	May	'71

## RECEIVERS

Direct Conversion Receivers, Part 1, by P. Dewhurst	479	Mar.	'71
Direct Conversion Receivers, Part 2, by P. Dewhurst	556	Apr.	'71
Modifications to the 'Trio' 9R-59DE Communications Receiver, by C. M. Lindars	152	Oct.	'70
Modifying the 'Trio' 9R-59DE Communications Receiver, Part 1	484	Mar.	'71
Modifying the 'Trio' 9R-59DE Communications Receiver, Part 2	540	Apr.	'71
Simple F.E.T. Regenerative Receivers, by A. S. Carpenter, G3TYJ	74	Sept.	'70
Simplified Transistor Superhet, by P. Dewhurst	44	Aug.	'70
The 'Crusader' Simple Superhet, Part 1, by F. A. Baldwin	347	Jan.	'71
The 'Crusader' Simple Superhet, Part 2, by F. A. Baldwin	419	Feb.	'71
The 'Crusader' Simple Superhet, Part 3, by F. A. Baldwin	488	Mar.	'71
The 'Crusader' Simple Superhet, Further Notes, by F. A. Baldwin	665	June	'71
The Export Spontaflex Receiver, by Sir Douglas Hall, K.C.M.G., M.A.(Oxon)	430	Feb.	'71
The 'Miniset' Two-Transistor Radio, by H. Williams	412	Feb.	'71
The 'Miniflex' Mark III Medium-Long Wave Tuner, by Sir Douglas Hall, K.C.M.G., M.A.(Oxon)	282	Dec.	'70

The 'Spontaflex' S.A.5 M & LW Portable, by Sir Douglas Hall, K.C.M.G., M.A.(Oxon)	654	June '71
The 'Stereosim', by Sir Douglas Hall, K.C.M.G., M.A.(Oxon)	718	July '71
The 'Tri-add' Tuner Unit, by F. G. Rayer, G30GR	206	Nov. '70
<b>RECEIVER ANCILLARIES</b>		
Aerial Switching and Tuning Unit, by Martin East, F.S.V.A.	676	June '71
The Treble-Two H.F. Bands Preselector, by A. S. Carpenter, G3TYJ	32	Aug. '70
Transistor R.F. Preselector, by D. Burge	590	May '71
<b>TAPE RECORDING</b>		
Reflex Tape Tuner, by G. C. Dobbs, G3RJV	156	Oct. '70
Understanding Tape Recording, Part 4, by W. G. Morley	40	Aug. '70
Understanding Tape Recording, Part 5, by W. G. Morley	104	Sept. '70
Understanding Tape Recording, Part 6, by W. G. Morley	171	Oct. '70
Understanding Tape Recording, Part 7, by W. G. Morley	242	Nov. '70
Understanding Tape Recording, Part 8, by W. G. Morley	302	Dec. '70
<b>TEST EQUIPMENT</b>		
Additional Resistance Ranges for Multimeters, by J. C. Eade, B.A.	24	Aug. '70
D.C. and Audio LCR Bridge, by C. Crosbie	526	Apr. '71
Dry Joint Detector, by G. A. French	598	May '71
Frequency Divider Signal Generator, by A. Kyriotis	270	Dec. '70
'Go—No-Go' Diode Tester, by J. Johnstone	233	Nov. '70
Meter Resistance, by W. E. Thompson, G3MQT	668	June '71
Oscilloscope Voltage Reference Unit, by G. A. French	532	Apr. '71
Simple Transistor Checker, by G. A. French	148	Oct. '70
Transistor Gain Checker, by G. A. French	406	Feb. '71
Transistor Gain Meter, by G. A. French	726	July '71
Transistor Sub-Standard Frequency Marker, by P. Cairns, G3ISP	138	Oct. '70
Transistor Tester, by H. Williams	462	Mar. '71
<b>TRANSMITTING</b>		
Logarithmic Speech Compressor, by R. A. Butterworth, G8BI	672	June '71
The 'Venturer' Transmitter, Part 1, by J. Brown, G3LPB	292	Dec. '70
The 'Venturer' Transmitter, Part 2, by J. Brown, G3LPB	360	Jan. '71
Tri-Band Ranger, Part 1, by David M. Pratt, G3KEP	548	Apr. '71
Tri-Band Ranger, Part 2, by David M. Pratt, G3KEP	608	May '71
<b>RADIO TOPICS</b>		
55 Aug. '70	119 Sept. '70	187 Oct. '70
315 Dec. '70	379 Jan. '71	443 Feb. '71
506 Mar. '71	699 June '71	
<b>CAN ANYONE HELP ?</b>		
78 Sept. '70	241 Nov. '70	482 Mar. '71
<b>NEWS AND COMMENT</b>		
18 Aug. '70	82 Sept. '70	150 Oct. '70
212 Nov. '70	278 Dec. '70	340 Jan. '71
410 Feb. '71	474 Mar. '71	536 Apr. '71
602 May '71	670 June '71	730 July '71
<b>QSX</b>		
81 Sept. '70	219 Nov. '70	370 Jan. '71
477 Mar. '71	607 May '71	737 July '71
<b>CURRENT TRENDS</b>		
277 Dec. '70		
<b>UNDERSTANDING BASIC PRINCIPLES</b>		
491 Mar. '71	560 Apr. '71	625 May '71
686 June '71	753 July '71	
<b>NOW HEAR THESE</b>		
37 Aug. '70	86 Sept. '70	160 Oct. '70
225 Nov. '70	288 Dec. '70	346 Jan. '71
414 Feb. '71	476 Mar. '71	535 Apr. '71
597 May '71	685 June '71	729 July '71
<b>CURRENT SCHEDULES</b>		
26 Aug. '70	95 Sept. '70	166 Oct. '70
234 Nov. '70	299 Dec. '70	359 Jan. '71
418 Feb. '71	483 Mar. '71	545 Apr. '71
623 May '71	680 June '71	757 July '71
<b>LATE NEWS</b>		
57 Aug. '70	121 Sept. '70	189 Oct. '70
253 Nov. '70	317 Dec. '70	381 Jan. '71
446 Feb. '71	508 Mar. '71	573 Apr. '71
637 May '71	701 June '71	

P.N.P./N.P.N. Transistor Lead-outs

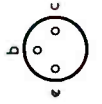

The Table lists commonly encountered transistors whose lead-out layout conforms with the diagram. The devices listed are in  $\text{TO-1}$ ,  $\text{TO-8}$ ,  $\text{TO-60}$ ,  $\text{TO-18}$  plastic,  $\text{TO-39}$  plastic or Mullard M9 encapsulations. The letter in brackets after each type-number indicates whether the transistor is germanium or silicon.

P.N.P.			N.P.N.		
AC128 (G)	NKT173/25 (G)	NKT274 (G)	2S323 (S)	AC187 (G)	NKT774 (G)
AC188 (G)	NKT174/25 (G)	NKT275 (G)	2S324 (S)	BC115 (S)	NKT781 (G)
BC116A (S)	NKT175 (G)	NKT275J (G)	2S325 (S)	BC117 (S)	2SD72 (G)
BC126A (S)	NKT211 (G)	NKT278 (G)	2S326 (S)	BC125A (S)	
BC153 (S)	NKT212 (G)	NKT281 (G)	2S327 (S)	BC134 (S)	
BC154 (S)	NKT 213 (G)	NKT301 (G)	2S3210 (S)	BC135A (S)	
BC225 (S)	NKT214 (G)	NKT302 (G)	2S3220 (S)	BC136 (S)	
MAT100 (S)	NKT215 (G)	NKT303 (G)	2S3221 (S)	BF153 (S)	
MAT101 (S)	NKT216 (G)	NKT304 (G)	2S3230 (S)	BF160 (S)	
MAT120 (S)	NKT217 (G)	NKT351 (G)	2S3240 (S)	BF176 (S)	
MAT121 (S)	NKT217S (G)	NKT352 (G)	2SB187 (G)	BLY14 (S)	
NKT11 (G)	NKT218 (G)	NKT603 (G)	2SB405 (G)	BLY55 (S)	
NKT12 (G)	NKT219 (G)	NKT612 (G)		C407 (S)	
NKT13 (G)	NKT270 (G)	NKT613 (G)		C424 (S)	
NKT72 (G)	NKT271 (G)	NKT618 (G)		C450 (S)	
NKT73 (G)	NKT272 (G)	NKT674 (G)		NKT713 (G)	
NKT172 (G)	NKT273 (G)	NKT675 (G)		NKT773 (G)	

# HENRY'S RADIO LIMITED

## ENGLAND'S LEADING ELECTRONIC CENTRES

HI-FI · COMPONENTS · TEST · PA · DISCOTHEQUE · ELECTRONIC ORGANS · MAIL ORDER



**MORE OF EVERYTHING AT LOW PRICES ALWAYS FROM HENRY'S**

\*Components from stock for almost all published designs.

**COMPLETELY NEW 10th EDITION CATALOGUE**

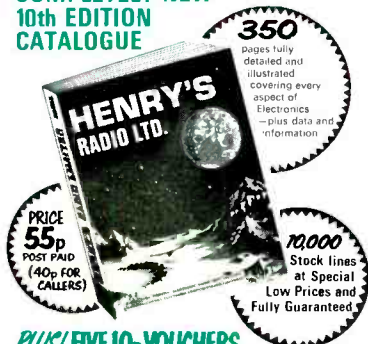

**PLUS! FIVE 10p VOUCHERS FOR USE WITH PURCHASES**

**FREE** to Industry, Educational or any Organisation, including Schools and Colleges etc. Apply on Official heading to our "303" address

**A NEW HENRY'S CATALOGUE IS A MUST FOR ELECTRONICS TODAY!**

### TRANSISTOR AMPLIFIERS

NEW RANGES NOW IN STOCK (Leaflets Ref. Nos. 6 & 8) Post etc. 20p

4-300 4 TR	9 Volt 300 mW	£1.75
104 4 TR	9 Volt 1 Watt	£2.12
304 4 TR	9 Volt 3 Watt	£2.47
555 6 TR	12 Volt 3 Watt	£2.75
PA7 6 TR	16 Volt 7 Watt	£3.62
608 6 TR	21 Volt 10 Watt	£4.12
410 4 TR	28 Volt 10 Watt	£4.97
MPA12/3 6 TR	18 Volt 12 Watt	£4.50
MPA12/15 6 TR	36 Volt 12 Watt	£5.25
Z30 9 TR	30 Volt 20 Watt	£3.75
PA25 10 TR (Special)	25 Watt	£7.50
Z50 30 Volt	40 Watt	£5.47
PA50 12 TR (Special)	50 Watt	£9.50
100 100W	with Power Supply	£45.00 post 45p

**OPTIONAL POWER SUPPLIES** Post. etc 20p  
 P 500 (One or Two) for 104, 304 £2.62  
 PS.20 (One or Two) for PA7 £3.47  
 MU24/40 (One or Two) for  
 P25 for Z30 £3.97 MPA12/3 or MPA12/15 £4.50  
 P28 for Z50 £5.97 or P26 for Z30 £6.97  
 P11 for 608 £2.87 P15 for 410 £2.62  
 MU442 for one or two PA25, or one only for PA50 £6.50

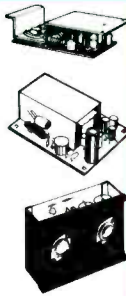

**HI-FI TO SUIT EVERY POCKET**

**CHOOSE FROM 100 STEREO SYSTEMS**

and a complete range of individual units in stock - Demonstrations all day - visit our new Hi-Fi Store. **LOW CASH or CREDIT/HP TERMS** (Credit terms from £30 purchase - callers only). **FREE** - Stock list No. 16/17 on request. **BEST VALUE IN U.K.**

### NEW MINIATURE LOW-COST AMPLIFIER

MODEL 4-300

9 volt operated or mains unit optional transformer (M798 70p) 1-10mV adjustable sensitivity P/P output for 3-8 ohms. Fitted volume control and leads. Size 5 1/2" x 1 1/2" x 3/4". Thousands of uses - takes magnetic, dynamic and crystal inputs direct. Output 300 mW - very high gain - built-in rectifier circuit. Complete with FREE leaflet No. 8.

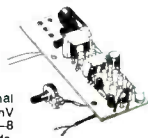

Price **£1.75** p&p 15p

### GARRARD TAPE DECK



Price **£9.97** p&p 33p

9 volt operated 2-speed tape deck fitted Record/Replay 1/2 track and Erase/Bias Osc. Head Complete with Oscillator/Record head circuit Unit size 9" x 6 1/2" x 1 1/2" and 2 1/2" below motor board. Takes up to 4" spools. Supplied brand new. 300ft. 3 1/2" Tape & Spool 40p

### HENELEC EQUIPMENT (as previously advertised)



#### SELF-POWERED SILICON PRE-AMPLIFIERS

FET 154 Stereo £16.50 Post 25p  
 FET 9/4 Mono with mike mixer £12.50 Post 20p

#### SILICON POWER AMPLIFIERS FOR USE WITH ABOVE

PA25 25 watts into 8 ohms £7.50 Post 20p  
 PA 50 50 watts into 4 ohms £9.50 Post 20p  
 MU442 Power Supply for 1 or 2 PA25's or 1 only PA50 £6.00 Post 20p

#### PACKAGE DEALS

FET.9/4 plus PA25 plus MU442 £25 Post 40p  
 FET 9/4 plus PA50 plus MU442 £27 Post 40p  
 FET.154 plus 2xPA25 plus MU442 £36 Post 50p  
 FET.154 plus 2xPA50 plus MU442 £40 Post 50p

#### NO SOLDERING—JUST EDGE CONNECTORS AND DIN PLUGS/SOCKETS

FREE BROCHURE No. 25

### BUILD YOURSELF A QUALITY RADIO

Excellent printed circuit design with full power output. Fully tuneable on both MW/LW bands. 7 Mullard transistors Fitted 5in speaker. Room-filling power. Easy to build with terrific results. Two-colour leathercloth cabinet with silvered front. All local and continental stations. Complete detailed instructions. Ask for Leaflet No. 1. Total cost **£6.98** p.p. 35p All parts sold separately.



### SINCLAIR PROJECT 60 PACKAGE DEALS

2xZ30 amplifier, stereo 60 pre-amp. P25 power supply. **£16.75** Carr. 40p Or with P26 power supply **£18.25**, Carr. 40p 2xZ50 amplifier, stereo 60 pre-amp, P28 power supply **£20.25**, Carr. 40p. Transformer for P28 **£2.25** extra. Any of the above with Active Filter unit add **£4.75** or with pair Q16 speakers add **£15.00** Also **NEW FM TUNER** Price **£21.00**

### BUILD THIS VHF FM TUNER

5 MULLARD TRANSISTORS 300 kc/s BANDWIDTH. PRINTED CIRCUIT. HIGH FIDELITY REPRODUCTION. MONO AND STEREO. A popular VHF FM Tuner for quality and reception of mono and stereo. There is no doubt about it - VHF FM gives the REAL sound. All parts sold separately. Free leaflet Nos. 3 & 7.



TOTAL **£6.97** p.p. 20p  
 Cabinet **£1.00**, Decoder Kit **£5.97**, Tuning Meter **£1.75**, Mains unit (optional) Model PS900 **£2.47**  
 Mains unit for Tuner and Decoder PS1200 **£2.62**

To: Henry's Radio Ltd. (Dept. RC),  
 3, Albermarle Way, London, E.C.1.

Please send \_\_\_\_\_ copies at 55p each Post Paid

I enclose Cheque/PO for \_\_\_\_\_

(Use BLOCK CAPITALS—cut out and send with Cheque or Postal Order (No cash please). Use only for ordering catalogue).

Name \_\_\_\_\_

Address \_\_\_\_\_

RC

Allow 7-10 days from date of posting.

Electronic Components,  
 Audio and Test Gear Centre  
**356 EDGWARE ROAD,  
 LONDON, W.2.**  
 Tel: 01-402 4736

High Fidelity Sales &  
 Demonstrations Centre  
**354 EDGWARE ROAD,  
 LONDON, W.2.**  
 Tel: 01-402 5854

Electronic Organs,  
 P.A. & Discotheque Centre  
**309 EDGWARE ROAD,  
 LONDON, W.2.**  
 Tel: 01-723 6963

Mail Orders, Special Bargain  
 Shop, Industrial Sales  
**303 EDGWARE ROAD,  
 LONDON, W.2.**  
 Tel: 01-723 1008/9

"354" & "356" OPEN SIX FULL DAYS A WEEK 9 am to 6 pm MONDAY TO SATURDAY