

# THE Radio Constructor

RADIO  
TELEVISION  
AUDIO  
ELECTRONICS

VOLUME 18                      NUMBER 8  
A DATA PUBLICATION  
TWO SHILLINGS & THREEPENCE

March 1965

“**oscar**”

Sub-Miniature  
R F Signal  
Generator



Modulated Light  
Broadcast Transmitter



Transistor Microphone  
Pre-Amplifier



Beginner's  
Pre-Selector



Peak Level  
Indicator

# THE EDDYSTONE HIGH STABILITY AMATEUR BANDS COMMUNICATIONS RECEIVER



-the  
**EA  
12**

The Eddystone "EA12" receiver is specially designed and built to give the extremely high performance, allied with ease of control, necessary for communications on the amateur bands under present-day conditions. With the many refinements included, this model will produce first-class results with all modes of signal.

The first oscillator is crystal controlled. The oscillator which is tuned simultaneously with the first intermediate frequency section has very high stability, as is so essential with reception of s.s.b. and c.w. signals. The correct degrees of selectivity for optimum performance are obtained in the second intermediate frequency (100 kc/s) stages.

A more than adequate degree of bandspread is provided by the superb slow-motion drive (140/1 reduction ratio) in conjunction with the wide linear scales, each of which covers 600 kc/s. A crystal calibrator and cursor adjuster permit accurate frequency resolution.

Other features to note—full coverage on six amateur bands; switched sideband selection; fine tuning control (s.s.b.); crystal filter; deep slot filter; noise limiter effective all modes; large "S" meter; two AGC time-constants; independent gain controls; stand-by sensitivity control; bright scale illumination; robust construction; modern styling and fine finish.

**£185**

*Comprehensive information obtainable from any Eddystone Distributor or from the Manufacturers:*

**STRATTON & CO.LTD. EDDYSTONE WORKS. BIRMINGHAM 31.**

Telephone: PRIORY 2231-4

Telegrams: STRATNOID BIRMINGHAM

Telex: 33708

# EXCEL in

# RADIO AND ELECTRONICS

AS A CAREER OR AS A FASCINATING HOBBY...

THERE IS AN ICS COURSE FOR YOU!

By taking an ICS specialised home study course you gain a sound theoretical and practical knowledge of valve and transistor circuits and servicing work while building your own 5-valve receiver, transistor portable (or a.f. amplifier), signal generator and multi-test meter. *All under expert tuition!*

ICS Construction Courses have been specially written and designed by experienced radio engineers to enable YOU to learn easily and quickly, in your own home, in your own time.

ICS training will take you from basic principles to advanced applications of various circuits, all made up from the kits supplied.

With the ICS Complete Radio and Electronics Construction Course you get SIX kits, including testing instruments, tools and first class components. And, what is most important, a personal library of Instruction Manuals.

If you are making a career in the Radio Industry, you will be interested in the wide range of examination and specialist diploma courses offered by ICS. These include:

Radio and Television Engineering, Industrial Television, Radio and Television Servicing, Colour Television, Electronic Technicians, Servomechanisms, Radio-Electronic Telemetry, Instrumentation, Principles of Automation, Calculus for Electronics, Digital and Analogue Computers.

Specialised coaching for Grad.I.E.R.E., C.&G. Telecommunication Technician's Cert. Radio & TV Servicing Cert. (R.T.E.B.), P.M.G. Certs. and Radio Amateur's Exam.

Examination students coached until successful

PRACTICAL INSTRUCTION!

1

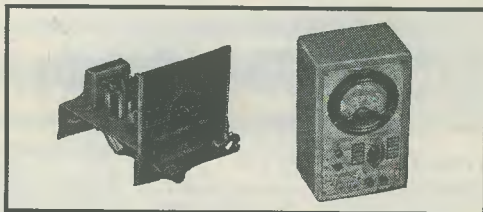

Assembly and use of signal generator and multi-test meter (especially valuable in servicing work).

2

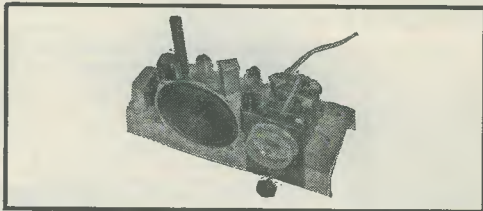

Construction of 5-valve 2-waveband AC/DC super-heterodyne receiver, and a number of instructional experiments, using testing instruments.

3

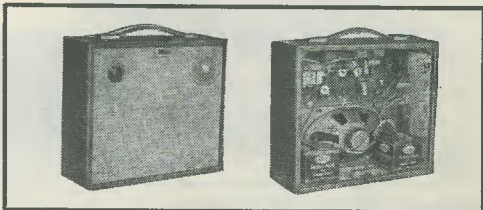

Construction of 6-transistor (with semiconductor diode) 2-waveband portable, and a number of instructional experiments, including a.f. amplifier with microphone pre-amplifier.

For full details  
of ICS Radio and  
Electronics Courses  
post coupon  
TODAY

ICS (DEPT. 248) INTERTEXT HOUSE  
PARKGATE ROAD, LONDON, S.W.11

NAME .....

AGE .....

ADDRESS .....

3.65

INTERNATIONAL CORRESPONDENCE SCHOOLS

Member of the Association of British Correspondence Colleges

# HI-FI AMPLIFIERS RECORD PLAYERS RADIO TUNERS

S-33

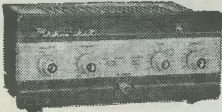

**GOLDRING LENCO TRANSCRIPTION PLAYER. Model GL-58.** With G-60 pick-up arm and Ronette 105 cartridge. **£20.1.3** incl. P.T.

AT-6



**GARRARD AUTO/RECORD PLAYER. Model AT-6.** With R 105 cartridge **£13.12.1** Decca Deram pick-up **£14.6.1** incl. P.T.

MA-12



**HI-FI MONO AMPLIFIER. Model MA-5.** A general purpose 5W Amplifier, with inputs for Gram., Radio. Presentation similar to S-33  
Kit **£10.19.6** Assembled **£15.10.0**

**HI-FI MONO AMPLIFIER. Model MA-12.** 12W output, wide freq. range, low distortion. Kit **£11.18.0** Assembled **£15.18.0**

**R.P.M. INDICATOR (Electronic Rev. Counter).** A must for the motoring enthusiast. For 4 cylinders, pos. or neg. earth. 12V. Send for details. (Assembled only) **£8.18.0**

S-99

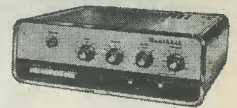

**HI-FI 6W STEREO AMPLIFIER. Model S-33.** 3 watts per channel 0.3% distortion at 2.5W/chnl., 20dB N.F.B. Inputs for Radio (or Tape) and Gram, Stereo or Monaural, ganged controls. Kit **£13.7.6** Assembled **£18.18.0**  
**DE LUXE STEREO AMPLIFIER. Model S-33H.** De luxe version of the S-33 with two-tone grey perspex panel, and higher sensitivity necessary to accept the Decca Deram pick-up. Kit **£15.17.6** Assembled **£21.7.6**

**HI-FI STEREO AMPLIFIER. Model S-99.** 18W output. Ganged controls. Stereo/Mono gram., radio and tape inputs. Push-button selection. Printed circuit construction. Kit **£27.19.6** Assembled **£37.19.6**

**POWER SUPPLY UNIT. Model MGP-1.** Input 100/120V, 200/250V. 40-60 c/s. Output 6.3V, 2.5A A.C. 200, 250, 270V, 120mA max. D.C.  
Kit **£5.2.6** Assembled **£6.12.6**

A wide range of American equipment available under direct mail order scheme. Full details and catalogue 1/- post paid.



## The Symbol of Extra Quality, Service,

### INSTRUMENTS

**DE LUXE LARGE-SCALE VALVE VOLTMETER. Model IM-13U.** Circuit and specification based on the well-known model V-7A but with many worth-while refinements. 6" Ernest Turner meter. Unique gimbal bracket allows operation of instrument in many positions. Modern styling. Kit **£18.18.0** Assembled **£26.18.0**

**AUDIO SIGNAL GENERATOR. Model AG-9U** 10 c/s to 100 kc/s, switch selected. Distortion less than 0.1%, 10V sine wave output metered in volts and dB's.  
Kit **£22.10.0** Assembled **£30.10.0**

**VALVE VOLTMETER. Model V-7A.** 7 voltage ranges d.c. volts to 1,500. A.c. to 1,500 r.m.s. and 4,000 peak to peak. Resistance 0.1Ω to 1,000MΩ with internal battery. D.c. input impedance 11MΩ. dC measurement, has centre-zero scale. Complete with test prods, lead and standardising battery.  
Kit **£13.18.6** Assembled **£19.18.6**

**MULTIMETER. Model MM-1U.** Ranges 0-1.5V to 1,500V a.c. and d.c.; 150μA to 15A d.c.; 0.2Ω to 20MΩ. 4½" 50μA meter. Kit **£12.18.0** Assembled **£18.11.6**

**R.F. SIGNAL GENERATOR. Model RF-1U.** Up to 100 Mc/s fundamental and 200 Mc/s on harmonics. Up to 100mV output.  
Kit **£13.8.0** Assembled **£19.18.0**

**T.V. ALIGNMENT GENERATOR. Model HFW-1.** Offers max performance at lowest cost. Covers 3.6 to 220 Mc/s fundamentals. Electronic sweep oscillators. Built in marker generators (5 Mc/s crystal).  
**£34.18.0** Kit  
**£44.10.0** Assembled

**5" GENERAL-PURPOSE LABORATORY OSCILLOSCOPE. Model IO-12U.** This outstanding oscilloscope, with its professional specification and styling, fulfils most laboratory and service requirements. Vertical frequency response 3 c/s to over 4.5 Mc/s, sensitivity 10mV r.m.s. per cm. at 1 kc/s. T/B covers 10 c/s-500 kc/s. Kit **£32.12.6** Assembled **£41.10.0**

**2½" PORTABLE SERVICE 'SCOPE. Model OS-1.** This is a light, compact oscilloscope, ideal for servicing, etc. Dimensions 5" x 8" x 14½" long. Wt. 10½lb. Fitted metal CRT shield. Kit **£22.18.0** Assembled **£30.8.0**

**ELECTRONIC SWITCH. Model S-3U (Oscilloscope Trace Doubler).** Enables a single beam oscilloscope to give simultaneous traces of two separate and independent signals. Switching rates approx. 150, 500, 1,500, 5,000 and 15,000 c/s. Sig. freq. response 0-100 kc/s. ±1dB. Separate gain controls and sync. output. Sig. input range 0.1-1.8V r.m.s. Kit **£12.18.0** Assembled **£18.10.0**



IM-13U



V-7A



RF-1U

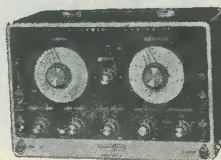

HFW-1

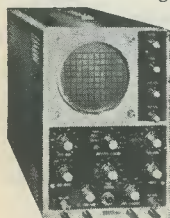

IO-12U



S-3U

### FOR THE MUSIC MAKER

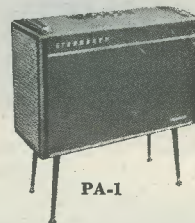

PA-1

**PA AMPLIFIER PA-1.** The ideal compact unit for VOCALISTS, INSTRUMENTALISTS, RECORDS, with 50 Watt output, 2 Heavy Duty Speakers. Variable TREMOLO. Elegant modern cabinet. Kit **£54.15.0**  
Assembled **£74.0.0**

Legs optional extra 17/6 set of 4

**POWER AMPLIFIER MA-50** 50W output. Kit **£19.18.0**  
Assembled **£27.18.0**

### ELECTRONIC ORGAN

(Transistorised.) Ideal for Soloists, Home use, Groups. FULL 20 WATTS VOLUME **£187.10.0** Matching bench **£14.10.0** extra

### TRANSISTOR RADIOS

**"OXFORD" LUXURY PORTABLE. Model UXR-2.** Specially designed for use as a domestic, car or personal portable receiver. Many features, including solid leather case. Kit **£14.18.0** incl. P.T.

**TRANSISTOR PORTABLE. Model UXR-1.** Pre-aligned I.F. transformers, printed circuit. Covers L.W. and M.W. Has 7" x 4" loudspeaker. Real hide case.  
Kit **£12.11.0** incl. P.T.

**JUNIOR EXPERIMENTAL WORKSHOP. Model EW-1.** More than a toy! Will make over 20 exciting electronic devices, incl: Radios, Burglar Alarms, etc. 72 page Manual. The ideal present! Kit **£7.13.6** incl. P.T.

**JUNIOR TRANSISTOR RADIO. Model UJR-1.** Single transistor set. Excellent introduction to radio. Kit **£2.7.6** incl. P.T.



UXR-2



UXR-1



UJR-1

### Money-back Guarantee

Daystrom Limited unconditionally guarantees that each Heathkit product assembled in accordance with our easy-to-understand instruction manual must meet our published specifications for performance or the purchase price will be cheerfully refunded.

## TAPE AMPLIFIERS — TAPE DECKS — CONTROL UNITS



FM-4U



MAGNAVOX

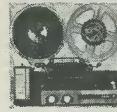

TRUVOX



AM/FM

**HI-FI FM TUNER. Model FM-4U.** Also available in two units. R.F. tuning unit (£2.15.0 incl. P.T.) with I.F. output of 10.7 Mc/s, and amplifier unit, with power supply and valves (£13.3.0). Total Kit **£15.18.0**

**TAPE RECORDING/PLAYBACK AMPLIFIER.** Thermometer type recording indicators, press-button speed compensation and input selection. Mono Model TA-1M. Kit **£19.18.0** Assembled **£28.18.0**  
Stereo Model TA-1S. Kit **£25.10.0** Assembled **£35.18.0**

**MONO CONTROL UNIT. Model UMC-1.** Designed to work with the MA-12 or similar amplifier requiring 0.25V or less for full output. 5 inputs. Baxandall type controls. Kit **£8.12.6** Assembled **£13.12.6**

**STEREO CONTROL UNIT. Model USC-1.** Push-button selection, accurately matched ganged controls to  $\pm 1$ dB. Rumble and variable low-pass filters. Printed circuit boards. Kit **£19.10.0** Assembled **£26.10.0**

**MAGNAVOX "STUDIO" TAPE DECK.** The finest buy in its price range. Operating speeds: 1 $\frac{1}{2}$ ", 3 $\frac{1}{2}$ " and 7 $\frac{1}{2}$ " p.s. Two tracks, "wow" and "flutter" not greater than 0.15% at 7 $\frac{1}{2}$ " p.s. **£14.19.6**

**TRUVOX D-93 TAPE DECKS.** High quality stereo/mono tape decks. D93/2,  $\frac{1}{2}$  track, **£36.15.0** D93/4,  $\frac{1}{2}$  track, **£36.15.0**

**HI-FI AM/FM TUNER. Model AFM-1.** Available in two units which, for your convenience, are sold separately. Tuning heart (AFM-T1—£4.13.6 incl. P.T.) and I.F. amplifier (AFM-A1—£21.16.6). Printed circuit board, 8 valves. Covers L.W., M.W., S.W., and F.M. Built-in power supply. Total Kit **£26.10.0**

# High-Performance... at no extra cost!



### SPEAKER SYSTEMS

**HI-FI SPEAKER SYSTEM. Model SSU-1.** Ducted-port bass reflex cabinet "in the white". Two speakers. Vertical or horizontal models with legs, Kit **£11.12.0**, without legs, Kit **£10.17.6** incl. P.T.

**COTSWOLD "MFS" SYSTEM.** Specially developed to give best possible results in small rooms. This minimum floor space model is based on standard Cotswold. Size: 36" high x 16 $\frac{1}{2}$ " wide x 14 $\frac{1}{2}$ " deep. Kit **£23.4.0** Assembled **£30.15.0**

**THE "COTSWOLD".** This is an acoustically designed enclosure 26" x 23" x 15 $\frac{1}{2}$ " housing a 12" bass speaker with 2" speech coil, elliptical middle speaker together with a pressure unit to cover the full frequency range of 32-20,000 c/s. Capable of doing justice to the finest programme source, its polar distribution makes it ideal for really Hi-Fi Stereo.

Kit **£23.4.0** Assembled **£30.15.0**

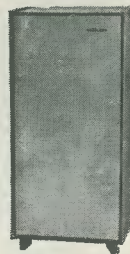

MFS

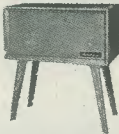

SSU-1

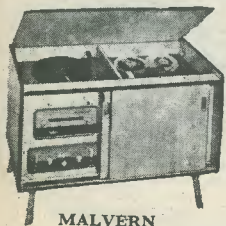

MALVERN

### HI-FI CABINETS

A wide range of equipment cabinets is available to meet the differing needs of enthusiasts. Designed for max. operating convenience or for where room space is an overriding consideration, this range includes kits, ready assembled cabinets or fully finished cabinets, and has at least one model to suit your requirements. Send for full details.

Prices from **£7.15.0** to **£44.2.0** incl. P.T.

### "AMATEUR" EQUIPMENT

**AMATEUR BANDS RECEIVER. Model RA-1.** To cover all the Amateur Bands from 160-10 metres. Many special features, including: half-lattice crystal filter; 8 valves; signal strength "S" meter; tuned R.F. Amp. stage.

Kit **£39.6.6** Assembled **£52.10.0**

**THE "MOHICAN" GENERAL COVERAGE RECEIVER. Model GC-1U.** With 4 piezo-electric transfilters, variable tuned B.F.O. and Zener diode stabiliser, this is an excellent fully transistorised general purpose receiver for Amateur and Short wave listeners. Printed circuits, telescopic aerials, tuning meter and large slide-rule dial

Kit **£37.17.6** Assembled **£45.17.6**

**160-10M TRANSMITTER. Model DX-100U.** Careful design has achieved high performance and stability. Completely self-contained.

Kit **£79.10.0** Assembled **£104.15.0**

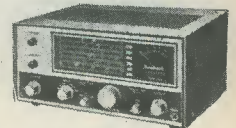

RA-1

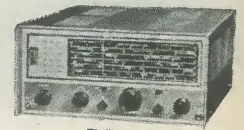

RG-1

**COMMUNICATIONS TYPE RECEIVER. Model RG-1.** A high performance, low cost receiver for the discriminating listener. Frequency coverage: 600 kc/s-1.5 Mc/s and 1.7 Mc/s-32 Mc/s.

Kit **£39.16.0** Assembled **£53.0.0**

**REFLECTED POWER METER. Model HM-11U.** And SWR Bridge indicates reliably, but inexpensively, whether the RF power output of your TX is being transferred efficiently to radiating antenna.

Kit **£8.5.0** Assembled **£10.10.0**



HM-11U

### AMERICAN HEATHKIT "AMATEUR" EQUIPMENT

A wide range of American Amateur SSB equipment is now available in the U.K. Why not send for full details of range, for example:

**80-10M RECEIVER. Model SB-300E.**

Of advanced design employing up-to-date construction techniques, its specification ensures unparalleled performance.

Kit **£133.14.0** (less speaker) + 15% import levy

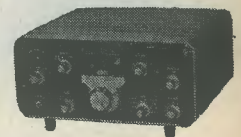

SB-300E

## SEND FOR FREE BRITISH HEATHKIT CATALOGUE

American catalogue also available 1/- post paid

Deferred terms available in U.K. over **£10**.  
Extended terms over **£75**. Send for details.

**DAYSTROM LTD** DEPT. RC. 3 GLOUCESTER

Without obligation please send me **FREE BRITISH HEATHKIT CATALOGUE** (Tick here)  
**FULL DETAILS OF MODEL(S)** \_\_\_\_\_  
(Please write in BLOCK CAPITALS)  
**NAME** \_\_\_\_\_  
**ADDRESS** \_\_\_\_\_  
DEPT. RC.3

# 7 VALVE AM/FM RADIOGRAM CHASSIS

Three Waveband & Switched Gram positions. Med. 200-550m. Long 1,000-2,000m. VHF/FM 88-95 Mc/s. Philips Continental Tuning insert with permeability tuning on FM & combined AM/FM IF transformers. 460 kc/s and 10.7 Mc/s. Dust core tuning all coils. Latest circuitry including AVC & Neg. Feedback. 3 watt output. Sensitivity and reproduction of a very high standard. Chassis size 13" x 6 1/2". Height 7 1/2". Edge illuminated glass dial 11 1/2" x 3 1/2". Vert. pointer Horiz. station names. Gold on brown background. A.C. 200/250V operation. Magic-eye tuning. Circuit diag. now available.

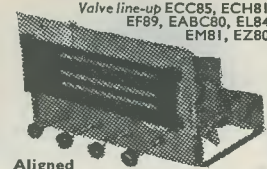

Valve line-up ECC85, ECH81 EF89, EAB80, EL84, EM81, EZ80  
 Aligned and tested ready for use. **£13.10.0** Carr. & ins. 7/6.  
 Comp. with 4 knobs—walnut or ivory to choice. Indoor FM aerial 3/6 ex. 3Ω P.M. Speaker only required. Recommended Quality Speakers 10" Rola, 27/6. 13 1/2" x 8" E.M.I. Fidelity, 37/6. 12" R.A. with conc. Tweeter, 42/6. Carr. 2/6.

# ANOTHER TAPE RECORDER BARGAIN

Manufacturers' end of production Surplus Offer



A 24 gns. Tape Recorder offered at the bargain price of only 15 gns. plus 10/- carr. Supplied in 3 Units already wired and tested. A modern Circuit for quality recording from Mike Gram or Radio, using latest B.S.R. Twin Track Monardeck Type TD2. Valve line-up—EF86, ECL82, EM84, EBS8 and Silicon Diode. Send for detailed list—3d. stamp.

**Completed Kit** comprising items below **BARGAIN PRICE 15 Gns.** + 10/- Carr.

2-tone Cabinet and 8" x 5" Speaker. Size 14" x 10 1/2" x 7 1/2" ..... £3 10 0 + 5/- Carr.  
 Wired Amplifier complete with 4 Valves, front Panel, Knobs, etc. .... £5 17 0 + 3/6 Carr.  
 B.S.R. Monardeck Type TD2 ..... £7 7 0 + 4/6 Carr.  
 Accessories: Mike, Tape, empty Reel, screened Lead and Plugs, Instructions, etc.... £1 0 0 + 2/- Carr.

Jack Plugs. Standard 2 1/2" Irganic Type, 2/6. Screened Ditto, 3/3. Miniature scr. 1 1/2", 2/3. Sub-min. 1/3. Jack Sockets. Open Irganic Moulded Type, 3/6. Closed Ditto, 4/-. Miniature Closed Type, 1/6. Sub-min. (deaf aid) ditto, 1/6. Stereo Jack Sockets, 3/6. Stereo Jack Plugs, 3/6. Phono Plugs, 9d. Phono Sockets (open), 9d. Ditto (closed), 1/-. Twin Phono Sockets (open), 1/3. Grundig Continental. 3 p. or 5 p. plug, 3/6. Sockets, 1/6.

## RECORDING TAPE

Famous American Columbia (CBS) Premier quality tape at NEW REDUCED PRICES. A genuine recommended Quality Tape—TRY IT Brand new, boxed and fully guaranteed. Fitted with leader and stop foils.

Standard	Double Play	Long Play	
5" 600'	13" 1,200'	31/6 900'	17/6
5 1/2" 900'	16" 1,800'	37/6 1,200'	19/6
7" 1,200'	21" 2,400'	47/6 1,800'	28/6

Post & Package per reel, 1/- plus 6d. each for additional reels.

New Boxed	Valves	Reduced Bargain Prices	Electrolytics All Types New Stock
IT4	3/6	EF80 7/6	PCF80 8/-
IR5	6/-	EF86 8/6	PCL83 10/6
IS5	6/-	EL33 12/6	PCL84 10/6
3S4	7/-	EL34 12/6	PCL85 11/6
3V4	7/-	EL84 7/-	PL36 10/6
ECC81	7/-	EY51 9/-	PL81 9/6
ECC82	7/-	EY86 9/-	PL83 8/-
ECC83	7/-	EY88 9/-	PY33 10/6
ECL80	9/-	EZ81 7/-	PY82 7/-
ECL82	10/-	GZ32 9/6	U25 10/6
ECL86	10/6	PCC84 8/-	UL84 9/-
			25/25V ... 1/9
			50/12V ... 1/9
			50/50V ... 2/-
			100/25V ... 2/-
			8/450V ... 2/3
			4/350V ... 2/3
			16 + 16/450V ... 5/6
			32 + 32/450V ... 6/6
			1000/25V ... 3/9
			2000 + 4000/6V ... 3/6
			Ersin Multicore Solder 60/40, 4d. per yard. Cartons 2/6, etc.

## DE LUXE R/PLAYER KIT

Incorporating 4 Speed Garrard Auto-Slim unit and Mullard latest 3 watt printed circuit amplifier (ECL 86 and EZ 80), volume, bass and treble controls, with 8" x 5" 10,000 line speaker. Superb quality reproduction.

Contemporary styled two-tone cabinet, charcoal grey and off-white with matching blue relief. Size: 17 1/2" x 16" x 8". **COMPLETE KIT £13.19.6** Carr. & ins. 10/-.

Illuminated Perspex escutcheon, 7/6 extra. Ready wired 30/- extra. 4 Contemporary legs (6" or 13") 12/6 per set. Catalogue & construction details 2/6 (free with kit)

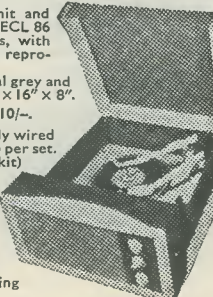

**STANDARD RECORD PLAYER KIT**  
 Using BSR UA14 Unit, complete kit £11.10.0, carr. 7/6. Ready wired Amplifier, 7" x 4" quality Speaker and O/P trans., £3.19.6, carr. 2/6. BSR UA14 Unit, £6.10.0, carr. & ins. 5/-.  
 Ravine covered cabinet in two-tone maroon and cream, size 15 1/2" x 14 1/2" x 8 1/2" with all accessories plus uncut record player mounting board 14" x 13", 59/6, carr. & ins. 5/-.

## 6 VALVE AM-FM TUNER UNIT

Med. and VHF 190m-550m, 86 Mc/s-103 Mc/s, 6 valves and metal rectifier. Self-contained power unit, A.C. 200/250V operation. Magic-eye indicator, 3 push-button controls, on/off, Med., VHF. Diodes and high output sockets with gain control. Illuminated 2-colour perspex dial 11 1/2" x 4", chassis size 13 1/2" x 4" x 5 1/2". A recommended Fidelity Unit for use with Mullard "3-3" or "5-10" Amplifiers. Available only at present as built-up units, aligned and tested ready for use.  
 Bargain Price £12.10.0. Carr. 5/-.  
 We hope to produce this popular unit in kit form very shortly.

**Volume Controls**—5K-2 Meg-ohms, 3" Spindles Morganite Midget Type. 1 1/2" diam. Guar. 1 year. LOG or LIN ratios less Sw. 3/-, D.P. Sw. 4/6. Twin Stereo less Sw. 6/6. D.P. Sw. 9/6 (100 k. to 2 Meg. only). 1/2 Meg. VOL Controls D.P. Sw. 3/6. Coax Plugs 1/6. Sockets 1/6. Couplers 1/3. Outlet Boxes 4/6.

**ENAMELLED COPPER WIRE**—1 lb. reels, 14g-20g, 2/6; 22g-28g, 3/6; 36g-38g, 4/3; 39g-40g, 4/6, etc.  
**TINNED COPPER WIRE**—14-22g, 2/6 ± lb.  
**PVC CONNECTING WIRE**—10 colours (for chassis wiring, etc.)—Single or stranded conductor, per yd., 2d. Sleeving, 1mm. and 2mm., 1d. yd., etc.

**COAX 80 OHM CABLE**  
 High grade low loss Cellular air spaced Polythene — 1/2" diameter. Stranded cond. Famous mfrs. Now only 6d. per yard.  
**Bargain Prices—Special lengths:**  
 20 yds. 9/-. P. & P. 1/6.  
 40 yds. 17/6. P. & P. 2/-.  
 60 yds. 25/-. P. & P. 3/-.  
**Coax Plugs 1/6. Sockets 1/6. Couplers 1/3. Outlet Boxes 4/6.**

**Condensers**—S/Mica all values 2pF to 1,000pF 6d. Ditto Ceramic 9d. each. .005. .01 and 1. etc., 1/- Paper Tubular 450V .001 mfd to .01 mfd and .1/350V 9d. .02-1 mfd 1/-. .25 mfd 1/6. .5 mfd 1/9.  
**Close Tol. S/Micas**—10% 5pF-500pF 8d. 60-5,000pF 1/-. 1 1/2 2pF-100pF 9d. 100pF-500pF 11d. 575pF-5,000pF 1/6. Resistors—Full Range 10 ohms-10 megohms 20% 1/4 and 1/2W 3d., 25 ohms-50K 3/-, 50K-2 Meg. (Carbon) 3/-.  
**Speaker Fret**—Expanded gilt anodised metal 1/4" x 1/4" diamond mesh, 4/6 sq. ft., multiples of 6" cut. Max. size, 4ft. x 3ft. 47/6. Carr. extra. Ditto, finer mesh, 4/6 sq. ft. Multiples 12" only, max size 3ft x 2ft. 27/6. Plus Carr.

**TYGAN FRET** (contemp. pat.) 12" x 12" 2/-, 12" x 18" 3/-, 12" x 24" 4/-, 18" x 48" 4/6, etc.

**BONDACOUST** Speaker Cabinet Acoustic Wadding, superior grade, 1" thick, 18" wide, any length cut 2/3 per ft, 6/- per yd.

**Transistor Components**  
 Midget I.F.'s—465 kc/s 1/2" diam. 5/6  
 Osc. Coil—1/2" diam. M/W. 5/3  
 Osc. coil M. & L.W. 5/9  
 Midget Driver Trans. 3.5:1 6/9  
 Ditto O/Put Push-pull 3 ohms 6/9

**Elect. Condensers**—Midget Type 15V 1mfd-50mfd, ea. 1/9. 100mfd, 2/-.  
 Ferrite Aerial—M. & L.W. with car aerial coupling coil, 9/3.  
**Condensers**—150V. wkg. .01 mfd. to .04 mfd., 9d. .05 mfd., .1 mfd., 1/- .25 mfd., 1/3. .5 mfd., 1/6, etc.

**Tuning Condensers.** J.B. "000" 208 + 176pF 8/6. Ditto with trimmers, 9/6. 365pF single, 7/6. Sub-min. 2" DILEMIN 100pF, 300pF, 500pF, 7/-.  
**Midget Vol. Control** with edge control knob, 5kΩ with switch, 4/9, ditto less switch, 3/9.

**Speakers P.M.**—2" Plessey 75 ohms, 15/6. 2 1/2" Continental 8 ohms, 13/6. 7" x 4" Plessey 35 ohm, 23/6.  
**Ear Plug Phones**—Min. Continental type, 3ft. lead, jack plug and socket. High Imp. 8/- Low Imp., 7/6. High sensitivity M/coil 8-10 ohms, 12/6.

## JASON FM TUNER UNITS

Designer-approved kit of parts:  
 FMT1, 5 gns. 4 valves, 20/-  
 FMT2, 7 gns. 5 valves, 35/-  
 JTV MERCURY 10 gns. 3 valves, 22/6.  
 JTV £13.19.6. 4 valves, 28/6.  
**NEW JASON FM HANDBOOK**, 2/6. 48 hr. Alignment Service 7/6. P. & P. 2/6.

## MULLARD "3-3" & "5-10" HI-FI AMPLIFIERS

**3 OHM AND 15 OHM OUTPUT**  
 "3-3" Amp. 3-valve, 3 watt, Hi-Fi quality at reasonable cost. Bass Boost and Treble controls, quality sectional output transformer, 40 ohms-25 kc/s, 1dB, 100mV for 3W, less than 1% distortion. Bronze escutcheon panel.  
**Complete Kit only £6.19.6.** Carr. 5/-. **Wired and tested 8 gns.**  
**MULLARD "5-10" AMPLIFIER**—5 valves 10W, 3 and 15 ohms output.  
**CONTROL PANEL KIT**  
 Bass, Treble and Volume controls with 4-position selector switch for radio, tape and pick-up and 11" x 4" escutcheon panel.  
**Amplifier Kit and Control Panel Kit £11.19.6.** Ditto ready wired £14.19.6.  
**2-VALVE PRE-AMP. UNIT**  
 Based on Mullard's famous 2-valve (2 x EF86) circuit with full equalisation with volume, bass, treble, and 5-position selector switch. Size 9" x 6" x 2 1/2". **Complete Kit £5.19.6.** Carr. 3/6. Ready built £7.19.6.



Mullard's famous circuit with heavy duty ultra-linear quality output tfr. Basic amplifier kit price £9.19.6. Carr. 7/6. Ready built 11 1/2 gns.

**CONTROL PANEL KIT**  
 Bass, Treble and Volume controls with 4-position selector switch for radio, tape and pick-up and 11" x 4" escutcheon panel.  
**Amplifier Kit and Control Panel Kit £11.19.6.** Ditto ready wired £14.19.6.

**2-VALVE PRE-AMP. UNIT**  
 Based on Mullard's famous 2-valve (2 x EF86) circuit with full equalisation with volume, bass, treble, and 5-position selector switch. Size 9" x 6" x 2 1/2". **Complete Kit £5.19.6.** Carr. 3/6. Ready built £7.19.6.

Send for detailed bargain lists, 3d. stamp. We manufacture all types Radio Mains Transfs. Chokes, Quality O/P Trans., etc. Enquiries invited for Specialists, Prototypes for small production runs. Quotation by return.  
**RADIO COMPONENT SPECIALISTS**  
 70 Brigstock Road, Thornton Heath, Surrey THO 2188. Hours: 9 a.m.-6 p.m., 1 p.m. Wed. Terms C.W.O. or C.O.D. Post and Packing up to 1/2 lb. 9d., 1 lb. 1/3, 3 lb. 2/3, 5 lb. 2/9, 8 lb. 3/6.





MAIL ORDERS TO:  
ROOM 7,  
54 WELLINGTON ST.,  
LEEDS 1.

Terms C.W.O. or C.O.D. No C.O.D. under £1. Postage 2/9 extra under £2. 4/6 extra under £5. Trade Supplied. S.A.E. with all enquiries, please. Personal shoppers welcomed at any of the branches below. Open all day Saturday.

**BRADFORD** 54/56 Morley Street  
(Half-day Wednesday)

**BRISTOL** 14 Lower Castle Street  
Half-day Wednesday

**BIRMINGHAM** 30/31 Gt. Western  
Arcade, opp. Snow Hill Station  
(No half-day)

**DERBY** 26 Osmaston Rd., The Spot  
(Half-day Wednesday)

**DARLINGTON** 13 Post House  
Wynd (Half-day  
Wednesday)

**EDINBURGH** 133 Leith Street  
(Half-day Wed.)

**GLASGOW** 326 Argyle Street  
(Half-day Tuesday)

**HULL** 51 Savile Street  
(Half-day Thursday)

**LEICESTER** 32 High Street  
(Half-day Thursday)

**LEEDS** 5-7 County (Mecca) Arcade  
(No half-day closing)

**LIVERPOOL** 73 Dale Street  
(No half-day closing)

**LONDON** 238 Edgware Road  
(Half-day Thursday)

**MANCHESTER** (No half-day)  
Callers welcome at our extensive new premises at 60A/60B Oldham Street

**MIDDLESBROUGH**  
106 Newport Road (Half-day Wed.)

**SHEFFIELD** 13 Exchange Street.  
Castle Market Bldgs.  
(Half-day Thursday)

**EX-GOV. 2V ACCUMULATORS** 16 A.H. Size 7" x 4" x 2". Brand New, 4/9 each. Three for 12/6. Carr. 5/-.

**JASON FMTI V.H.F./F.M. Radio Tuner** design. Total cost of parts including valves, Tuning Dial, Escutcheon, etc., £6.19.6.

**Fane Heavy Duty Hi-Fi Speakers**  
12" 15 ohms. Cast chassis. Exceptionally robust 2" diam. Voice Coil Assemblies. 122/10 20 watt, 5 gns.; 122/10A 20-watt, 6 gns.; 122/12 20 watt, 7 gns.; 122/12A 20 watt, 8 gns.; 122/14 22 watt, 9 gns.; 122/14A 22 watt, 10 gns.; 122/17 25 watt, £11.17.6.; 122/17A 25 watt, £12.17.6.  
12" 15 ohms. Cast chassis. Exceptionally robust 2" diam. Voice Coil Assemblies. 152/12 20 watt, 12 gns.; 152/12A 20 watt, 13 gns.; 152/14 27 watt, 14 gns.; 152/14A 27 watt, 15 gns.; 152/17 35 watt, 16 gns.; 152/17A 35 watt, 17 gns.  
"A" indicates dual cone type. 30-17,000 c.p.s. Send S.A.E. for leaflets. Terms available.

**FANE EXTRA HEAVY DUTY LOUD-SPEAKER 15" TYPE 153**. 40 watts. Total flux 375,000 lines. Extremely high sensitivity. 15 ohm voice coil. Only 18 gns. or Deposit 37/6 and 12 monthly payments of 31/6 (total £20.15.6d.)

**R.A. 12" 10 WATT SPEAKERS**. 3 ohm or 15 ohm. Excellent value at 59/6.

**R.S.C. G15 15 WATT AMPLIFIER**  
Suitable lead or rhythm guitar, gram, tape, "mike" or radio  
High-fidelity push-pull output. Separate bass and treble "cut" and "boost" controls. Twin separately controlled inputs so that two instruments or "mike" and pick-ups can be used at the same time. Loudspeaker is a heavy duty high flux 12" 20 watt model with cast chassis. Cabinet is well made and finished as Junior Model. Size approx. 18" x 18" x 8".  
Carr. 10/-, Send S.A.E. for leaflet. Or DEPOSIT 19 Gns. 2 gns. and twelve monthly payments of 33/3 (total 21 gns.).

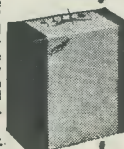

**BASS-MAJOR 30 WATT AMPLIFIER**  
A MULTI-PURPOSE HIGH FIDELITY, HIGH OUTPUT UNIT FOR VOCAL AND INSTRUMENTALIST GROUPS

Eminently suitable for bass, lead or rhythm guitar and all other musical instruments

\* Incorporating two 12" heavy duty 25-watt high flux (17,000 lines) loudspeakers with 2" diameter speech coils. Designed for efficiently handling full output of amplifier at frequencies down to 25 c.p.s.  
\* Dual Cone in 2nd speaker reproduces frequencies up to 17,000 c.p.s.  
\* Heavily made cabinet of convenient size 24" x 21" x 14" has an exceptionally attractive covering in two contrasting tones of Vynair.  
\* For 200-250V, 50 c.p.s., A.C. Mains operation.  
\* Four jack socket inputs and two independent volume controls for

simultaneous connection of up to four instrument pick-ups or microphones.  
\* Separate bass and treble controls providing more than adequate "Boost" or "Cut".  
\* LEVEL frequency response throughout the audible range.  
\* SUPERIOR TO UNITS AT TWICE THE COST.

Send S.A.E. for leaflet OR DEPOSIT of £4.3.0 and 12 monthly payments of £3.8.4  
**39 1/2 Gns.**  
Carr. 17/6. (Total 43 gns.)

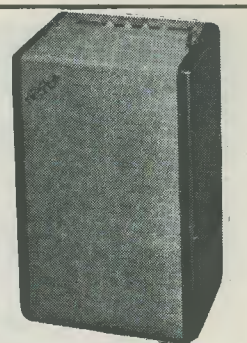

**HIGH FIDELITY 12-14 WATT AMPLIFIER TYPE A11**  
PUSH-PULL ULTRA LINEAR OUTPUT "BUILT-IN" TONE CONTROL PRE-AMP STAGES

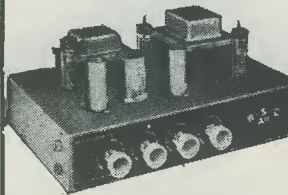

Two input sockets with associated controls allow mixing of "mike" and gram, as in A10. High sensitivity. Includes 5 valves, ECC83, ECC83, EL84, EL84, EZ81. High Quality sectionally wound output transformer specially designed for Ultra Linear operation and reliable small condensers of current manufacture. INDIVIDUAL CONTROLS FOR BASS AND TREBLE "Life" and "Cut". Frequency response—3dB 30-30,000 c/s. Six negative feedback loops. Hum level 60dB down. ONLY 23 millivolts INPUT required for FULL OUTPUT. Suitable for use with all makes and types of pick-ups and microphones. Comparable with the very best designs for STANDARD or LONG PLAYING RECORDS. FOR MUSICAL INSTRUMENTS such as STRING BASS, LEAD OR RHYTHM GUITARS, etc. OUTPUT SOCKET with plug provides 300V 30mA, and 6.3V 1.5A for supply of a Radio Feeder Unit. Size approx. 12" x 9" x 7". For A.C. mains 200-250V 50 c.p.s. Output for 3 and 15Ω speaker. Kit is complete to last nut. Chassis is fully punched. Full instructions and point-to-point wiring diagram supplied.  
(This unit can be supplied factory built and fully guaranteed for £10.19.6. Carr. 10/-) If required louvred metal cover with 2 carrying handles can be supplied for 18/9. TERMS ON ASSEMBLED detailing Cabinets, Speakers, Microphones, etc., with cash and credit terms.

300V 30mA, and 6.3V 1.5A for supply of a Radio Feeder Unit. Size approx. 12" x 9" x 7". For A.C. mains 200-250V 50 c.p.s. Output for 3 and 15Ω speaker. Kit is complete to last nut. Chassis is fully punched. Full instructions and point-to-point wiring diagram supplied.

(This unit can be supplied factory built and fully guaranteed for £10.19.6. Carr. 10/-) If required louvred metal cover with 2 carrying handles can be supplied for 18/9. TERMS ON ASSEMBLED detailing Cabinets, Speakers, Microphones, etc., with cash and credit terms.

**R.S.C. 4/5 WATT A5 HIGH-GAIN AMPLIFIER** A highly-sensitive 4-valve quality amplifier for home, small club, etc. Only 50 millivolts input for full output so is suitable for use with latest High-fidelity Pick-up heads and all other types of pick-ups and nearly all "mikes". Separate Bass and Treble Controls give full long-playing record equalisation. Hum level negligible, 71dB down, 15dB of Negative feedback used. H.T. of 300V 25mA and H.T. of 6.2V 1.5A available for supply of Radio Feeder Unit, or Tape-Deck pre-amplifier. A.C. mains input of 200-230-250V 50 c/s. Output for 2-3 ohms speaker. Chassis not alive. Kit complete with fully punched chassis (with baseplate). Gold Hammer finish, point-to-point wiring diagrams and instructions. Only £4.15.0, or assembled ready for use 25/- extra. Plus 3/6 carr., or deposit 22/6 and 5 monthly payments of 22/6 for assembled unit. (Total £6.15.0.)

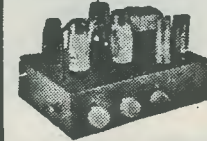

**R.S.C. CORNER CONSOLE CABINETS**  
Polished walnut veneer finish.  
**JUNIOR MODEL**. Size 20" x 11" x 8" for 8" x 5" or 10" x 6" speakers, £2.9.9.  
**STANDARD MODEL**. Size 27" x 18" x 12" for 8" or 10" speakers, £4.11.9.  
**SENIOR MODEL**. Size 30" x 20" x 15" for 12" Speaker. Suitable Speaker systems below. Only 7 gns.  
**R.S.C. BASS REFLEX CABINETS, JUNIOR MODEL**. Specially designed for W.B. HF1012 Speaker, but suitable for any good quality 10" speaker. Acoustically lined and ported. Polished walnut veneer finish. Size 18" x 12" x 10". Handsome appearance. Ensures superb reproduction for only £3.19.6.  
**STANDARD MODEL**. As above but for 12" speakers. Size 20" x 15" x 13". For vertical or horizontal use. £5.19.6. Set of legs with brass ferrules, 19/6.

**AUDIOTRONE HI-FI SPEAKER SYSTEMS**. Consisting of matched 12" 12,000 line, 15 ohm high quality speaker, crossover unit (consisting of choke, condenser, etc.) and Tweeter. The smooth response and extended frequency range ensure surprisingly realistic reproduction. Standard 10 watt rating £4.19.9. Carr. 5/-, or Senior 15 watt, £6.19.9. Carr. 7/6.  
W.B. "STENTORIAN" HIGH FIDELITY P.M. SPEAKERS HF1012. 10 watts rating. Where a really good quality speaker at a low price is required we highly recommend this unit with an amazing performance. Only £4.12.0. Please state whether 3 ohm or 15 ohm required.

**R.S.C. 30-WATT ULTRA LINEAR HIGH FIDELITY AMPLIFIER A10**

A highly sensitive Push-Pull high output unit with self-contained Pre-amp. Tone Control Stages. Certified performance figures compare equally with most expensive amplifiers available. Hum level 70dB down. Frequency response ±3dB 30-20,000 c/s. A specially designed sectionally wound ultra linear output transformer is used with 807 output valves. All components are chosen for reliability. Six valves are used, EF86, EF86, ECC83, 807, 807, GZ34. Separate Bass and Treble Controls are provided. Minimum input required for full output is only 12 millivolts so that any kind of microphone or pick-up is suitable. The unit is designed for Clubs, Schools, Theatres, Dance Halls or Outdoor Functions, etc. For use with Electronic Organ, Guitar, String Bass, etc. For standard or long-playing records. Output Socket provides L.T. and H.T. for Radio Feeder Unit. An extra input with associated vol. control is provided so that two separate inputs such as Gram and "Mike" can be mixed. Amplifier operates on 200-250V 50 c/s. A.C. mains and has output for 3 and 15 ohm speakers. Complete Kit of parts with fully punched chassis and point-to-point wiring diagrams and instructions. If required, performance guaranteed cover with carrying handles can be supplied for 19/9. The amplifier can be supplied, factory built, with EL34 output valves and 12 months' guarantee, for 14 gns. Send S.A.E. for leaflet. TERMS: DEPOSIT 34/6 and 9 monthly payments of 33/6 (total 16 gns.). Suitable mikes and speakers available at competitive prices.

**R.S.C. BASS/20 AMPLIFIER**

A multi-purpose unit, ideal for bass guitar. A highly efficient unit incorporating a massive 15" high flux loudspeaker specially constructed to withstand heaviest load conditions. Rating 25 watts. Individual bass and treble controls give ample "boost" and "cut". Two high impedance jack socket inputs are separately controlled. All controls are conveniently positioned in a recess on top of the cabinet. Cabinet is of substantial construction and attractively finished in two contrasting tones of Rexine and Vynair. Size approx. 24" x 21" x 13". Operation from 200-250V 50 c.p.s. A.C. mains.  
Send S.A.E. for leaflet. Or Deposit 29 1/2 Gns. £3.4.6 and 12 monthly payments of 51/6. (total 32 1/2 gns.). Carr. 17/6.

Send S.A.E. for leaflet. Or Deposit 29 1/2 Gns. £3.4.6 and 12 monthly payments of 51/6. (total 32 1/2 gns.). Carr. 17/6.

**12 in. 10-WATT HIGH QUALITY LOUDSPEAKER**

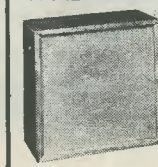

In walnut veneered cabinet. Gauss 12,000 lines. Speech coil 3 ohms or 15 ohms. Only £4.19.6 Carr. 5/-  
Terms: Deposit 11/3 and 9 monthly payments of 11/3 (total £5.12.6.)  
**12in. 20-WATT HI-FI LOUDSPEAKERS IN CABINETS**. Size 18" x 18" x 10". Finish as above. £7.19.6 Carriage 8/6  
Terms: Deposit 17/9 and 9 monthly payments of 17/9. (Total £8.17.6.)

# Nowhere in the entire

**I** a smaller set  
to build than  
the

## SINCLAIR MICRO-6

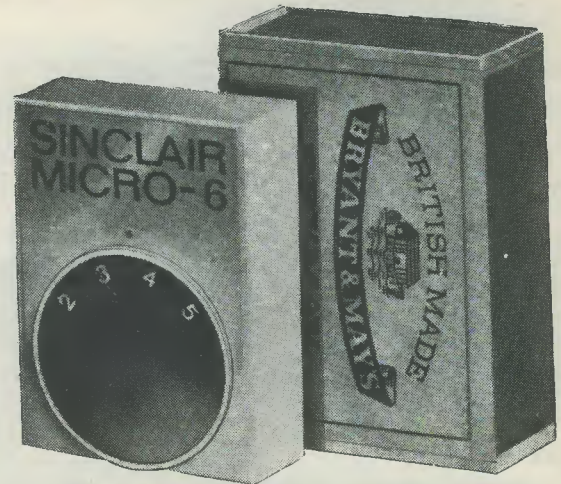

SIX-STAGE CIRCUITRY	BANDSPREAD FOR EASY LUXEMBOURG RECEPTION
SIZE ONLY 1 1/5" x 1 3/10" x 1/2"	TUNES OVER MEDIUM WAVES
WEIGHS LESS THAN 1oz.	PLAYS IN CAR, BUS, TRAIN, PLANE, etc.

THE 100% BRITISH DESIGNED SINCLAIR MICRO-6 continues unchallenged as the most remarkable receiver of its kind ever made available to the public anywhere in the world. It has special 6-stage circuitry yet is the smallest set on earth. Everything except the lightweight earpiece is contained in the smart, minute white, gold and black case which is appreciably smaller than a matchbox, as the illustration shows. With vernier-type tuning control, bandspread over the higher frequency end of the medium waveband and powerful A.G.C. to ensure fade-free reception of the most distant stations, the Micro-6 provides remarkable standards of performance. Quality of reproduction is outstandingly good, and again and again the set is reported to give excellent results where other sets cannot be used at all. Order yours now and you will at once see why the Micro-6 cannot be too highly recommended, both as an intriguing design to build, and a most practical radio to use.

ANYONE CAN BUILD IT IN AN EVENING

Building is simple. All parts including lightweight earpiece, case and dial, and 8-page instructions manual come to

### 59/6

Sinclair "Transista" well-styled, strong black nylon wrist strap **7/6**

Mallory Mercury Cell Type ZM312 (2 required) each **1/11**

Pack of 6 CHASSIS VIEW **10/6**

## SINCLAIR TR750 POWER AMPLIFIER

With built-in volume control and switch

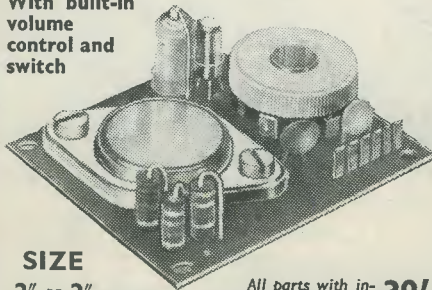

SIZE  
2" x 2"

All parts with instructions come to **39/6** Ready built and tested with instructions **45/-**

Another highly original Sinclair design, the TR750 enables the Sinclair Micro-6 Receiver to be used as a powerful car, domestic or portable loudspeaker set. A connecting plug is provided for this. The TR750 also has many other applications such as a record reproducer, intercom or baby alarm. An output of 750 milliwatts for feeding into a standard 25-30Ω loudspeaker requires only a 10mV input. Frequency response 30-20,000 c/s ±1dB. Power required -9 to 12 volts.

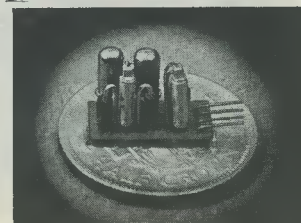

SINCLAIR  
MICRO  
AMPLIFIER

Makes an F.M. Transmitter, Broadband R.F. or Audio Amplifier

Smaller than a 3d. piece. Frequency response from 30 to 50,000 c/s ±1dB, and power gain of 60dB (1,000,000 times). It can be used as a sub-miniature hi-fi amplifier with an output suitable for any earpiece or even loudspeaker. Also makes an invaluable tool in the hands of the keen experimenter. All parts with instructions come to

### 28/6

# sinclair

**SINCLAIR RADIONICS LTD.,**  
COMBERTON, CAMBRIDGE Telephone: COMBERTON 682



# World will you find...

## 2 a constructor's amplifier using P.W.M. except for the **SINCLAIR X-10**

**INTEGRATED 10-WATT AMPLIFIER AND PRE-AMP**

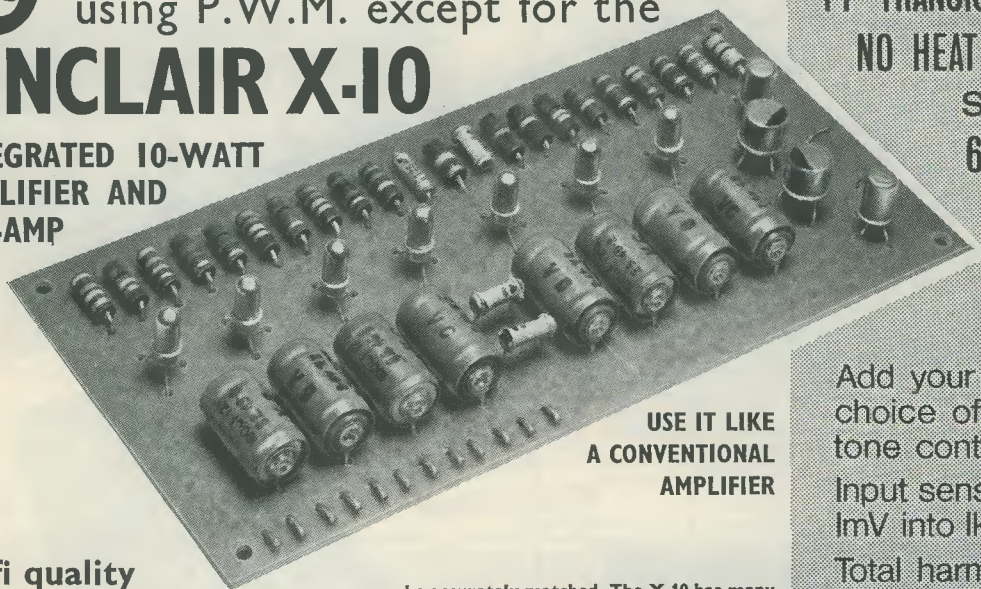

**USE IT LIKE A CONVENTIONAL AMPLIFIER**

**11 TRANSISTORS  
NO HEAT SINK  
SIZE  
6" x 3"**

Add your own choice of tone control  
Input sensitivity 1mV into 1k $\Omega$   
Total harmonic distortion <0.1%  
Output up to 10 watts into 15 $\Omega$   
Operates from 12 to 15 volts D.C.

### Hi-fi quality for very modest outlay

The Sinclair X-10 marks a radical departure from conventional amplifier design which is certain to influence future developments in the audio field enormously. Already the power and quality obtainable from this extremely small amplifier bring entirely new approaches to styling and housing domestic audio equipment, which the absence of heat sinks helps greatly. Leaving the X-10 user to add a tone control system of his own choice to the integrated pre-amplifier stage enables any sound input source to

be accurately matched. The X-10 has many other important advantages as a result of using Pulse Width Modulation, including incredibly low distortion figures, no falling off of higher frequencies, better transients and less current requirements. Indeed, the X-10 can be satisfactorily operated from a couple of 4/- lantern batteries. **THE SINCLAIR X-10 MANUAL** included with every X-10 explains how it functions, and also gives tone control and stereo matching circuits, none of which cost more than a few shillings. The X-10 Manual is available separately, price 1/-.

### X-10 USERS WRITE

"I was able to try it out yesterday and would like to say that I am very pleased with its performance."

R.M., Keighley  
"I must say that the amplifier certainly delighted myself and others with its crisp quality."  
W.L., Leeds 2

All parts including 11 transistors, building instructions and X-10 Manual come to

**£5.19.6**

Ready built and tested, with X-10 Manual

**£6.19.6**

X-10 Power Supply Unit (ready built) for Mono or Stereo. A.C. Mains 200-240V.

**£2.14.0**

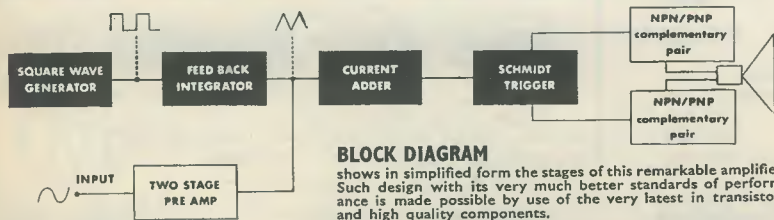

#### BLOCK DIAGRAM

shows in simplified form the stages of this remarkable amplifier. Such design with its very much better standards of performance is made possible by use of the very latest in transistors and high quality components.

**USE THIS COUPON TO ORDER TODAY**

FULL SERVICE FACILITIES ALWAYS AVAILABLE TO SINCLAIR CUSTOMERS

**TO SINCLAIR RADIONICS LTD., COMBERTON, CAMBRIDGE. Comberton 682**

Please send items detailed below £ s d

NAME \_\_\_\_\_

ADDRESS \_\_\_\_\_

TOTAL £ \_\_\_\_\_

For which I enclose cash/cheque/money order

RC-365

# JASON KITS

Jason were first to produce a stable switched f.m. tuner for reception of BBC transmissions and an outstanding success has been achieved with the introduction of simple-to-operate switched tuners to receive both f.m. and TV sound transmissions. Jason tuners and test equipment offer a wide choice of models designed to meet present-day requirements and are a delight to build.



**JTV2 SWITCHED TUNER** for the reception of all BBC f.m. transmissions and BBC-1 and ITV television sound channels at the turn of a switch. Foster-Seeley discriminator. Built-in power supply.

Sensitivity 10 $\mu$ V for 40dB quieting. Audio output 0.4V approx. All components, including turret and coil plate but less four valves—£14.0.4.

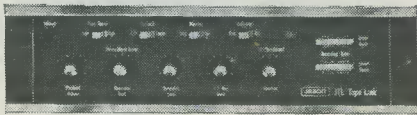

**JTL TAPE PRE-AMPLIFIER** designed to suit any tape deck or head. Will simultaneously record and play back stereo or mono using two or four-track heads.

Especially recommended for use with the Lorlin SB26 tape deck. (Send for details.) All components including valves, £22.1.0. Ready built and tested £30.9.0.

## OTHER JASON KITS

<b>FMT1 F.M. Tuner</b> , less valves	£5.19.0
<b>FMT2 F.M. Tuner</b> , less valves	£9.9.0
(less power supply components £7.15.0)	
<b>FMT3 F.M. Tuner</b> , less valves	£10.9.0
(less power supply components £8.15.0)	
<b>MERCURY 2 Switched Tuner</b> , less valves	£9.15.4
<b>ARGUS Transistor M.W. Tuner</b> , complete	£7.10.0
<b>AG10 Audio Generator</b> , complete	£15.19.0
<b>OG10 Oscilloscope</b> , less c.r.t.	£18.10.0
<b>W11 Wobbulator</b> , complete	£14.19.0
<b>EM10 Valve Voltmeter</b> , complete	£23
<b>SB26 Tape Deck</b> (built only) ½-track mono	31 gns.
4-track stereo	39 gns.

Write for descriptive leaflets and name and address of nearest stockist.

**Jason Electronic Designs Ltd.**  
18 TUDOR PLACE, TOTTENHAM CT. RD.  
LONDON, W.1.  
Telephone MUSeum 4666/8



## MULTIMINOR Mk4

The newly improved model of this famous AVO pocket size multi-range instrument has been enthusiastically acclaimed in all parts of the world for its high standards of accuracy and dependability as well as for its modern styling, its highly efficient internal assemblies, and its resistance to extremes of climatic conditions.

It is simple to use, one rotary switch for instant range selection, only one pair of sockets for all measurements, and a 2½ inch clearly-marked scale-plate. It is supplied in an attractive black carrying case complete with interchangeable test prods and clips, and a multi-lingual instruction booklet.



**RESISTANCE:** 0-2M $\Omega$  in 2 ranges, using 1.5V cell  
**SENSITIVITY:** 10,000 $\Omega$ /V on d.c. voltage ranges  
1,000 $\Omega$ /V on a.c. voltage ranges

to send you a full specification of this great little instrument. It measures only 7½" x 4" x 1½" and weighs only 24 oz.

**AVO LTD**

AVOCET HOUSE, 92-96 VAUXHALL BRIDGE ROAD,  
LONDON, S.W.1 Telephone: VICtoria 3404 (12 lines)



MM 19

19 set Instruction Handbook 3/6 each, p/p 6d.  
 1155 Instruction Handbook 3/6 each, p/p 6d.  
**H.R.O. Instruction Handbook**  
 3/6 each, p/p 6d.  
 Frequency Meter, BC 221 Instruction Hand-  
 book 3/6 each, p/p 6d.  
 46 Walkie Talkie Set Circuit and Notes  
 3/6 each, p/p 6d.  
 38 set A.F.V. Instruction Handbook  
 3/6 each, p/p 6d.  
 R.F. Unit 24 Circuit Diagram and Details  
 Price 1/6, p/p 3d.  
 R.F. Unit 25 Circuit Diagram and Details  
 Price 1/6, p/p 3d.  
 R.F. Unit 26 Circuit Diagram and Details  
 Price 1/6, p/p 3d.  
 Receiver R1355 Circuit Diagram and Details  
 Price 1/6, p/p 3d.  
 Receiver R1224A Circuit Diagram and Details  
 Price 1/6, p/p 3d.  
 R.1116/A Circuit Diagram and Details  
 Price 1/9 p/p 3d.  
 Wave Meter Class D Handbook, Mk. I, II  
 and III Price 3/6, p/p 6d.

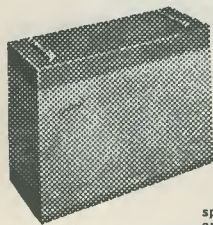

**Heavy Duty Loudspeakers in Robust Rexine Covered Cabinets**

(a) Suitable for bass and lead guitars. Incorporating two 12" high flux 15 ohm 25 watt loudspeakers, providing excellent frequency response. Cabinet size approx. 28" x 20" x 10 1/2". Rating 50 watts. Fitted with carrying handles.

Price 27 gns. or H.P. terms available. Deposit £2.17.0 and 12 monthly payments of £2.6.9. Carriage 15/- to be sent with order.

**Morse Keys.** Morse Key Assembly. Key with base, cover and terminals. Complete with lead. 6/11, p/p 2/- . 2 Morse keys for 12/6, post free.

**M.A.T. Transistors.** M.A.T. 100, 7/9; M.A.T. 120, 7/9; M.A.T. 121, 8/6. Ferrite slab aerials suitable for Transistor sets, 3/-, p/p 6d.

**Operators Unit.** Huge purchase enables us to offer at give-away price this unit containing standard jack socket, 250 mfd. electrolytic condenser, 4-way telephone socket, midjet selenium rectifier, etc. Price 3/6, p/p 9d.

**Matched Mullard Transistors.** One OC81D driver. Two OC81 output stage matched pair. Price 9/11 the set, p/p 1/-.

**American Signal Generator V.H.F. Model.** A well made instrument with a built-in crystal master oscillator. Exceptionally fine slow motion tuning with easily read scale. Stepped output and adjustable amplitude. Ideal for 2 metres and V.H.F. calibration. Price 49/6, p/p 5/-.

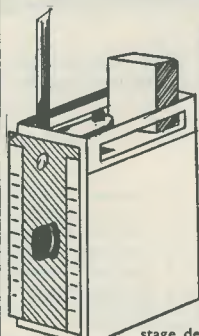

**VEHICLE RADIOTELEPHONE**

Originally used by the armed forces for field communication. This compact little unit can be powered by a car battery, and two 60V or 90V H.T. batteries. Communication is possible up to a distance of 3 miles in favourable terrain, and on testing the receiver we were able to receive many continental and maritime stations. Battery drain is less than 2 of an amp. Output stage de-commissioned to conform with regulations. Full wiring instructions provided.

Price 5 gns. each, carriage free. 2 for £10, carriage free.

**Goldenair Transistorised Sound Mixer.** A compact ultra-modern 4 channel fully transistorised microphone mixer, which permits the mixing of up to 4 instruments, i.e. tape, gram., tuner, etc. Self-contained and operating from a standard 9V battery. Handsomely finished case. Inputs and outputs take standard plugs. Price 47/6, p/p 2/6.

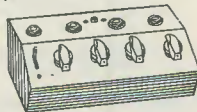

**Handy Power Pack.** Housed in compact metal case. 200/250V mains input. Output 250V D.C. 60 ma. fully smoothed. 6.3V at 2 amps. Can be used for powering almost any preamp or radio tuner. Price 39/6, p/p 2/6.

**Portable Mains Soldering Iron.** 30 watt version. Features removable handle that covers tip and barrel. Complete with lead and plug. Only 10/6, p/p 1/6.

**6 ohm Wire Wound Miniature Potentiometers** with Standard Spindle, has many uses. 1/6 each, p/p 6d. 2 for 3/-, post free.

**Crystal Set Kit.** A wonderful educational kit for all children. Provides hours of amusement while following the easy step by step instructions. It is powered entirely by wireless waves, eliminating the expense of batteries. No soldering required. Receives all main stations. Price 25/-, p/p 2/6.

**2-Way Sound Powered Telephone.** As used by the armed forces. These sound powered earpieces will work up to a distance of 1 mile without the use of batteries. Beautifully made, ideal for use in the house, office, or garden. Complete with connecting cable. Price 17/6, p/p 2/6.

**Double Throat Mics.** Double throat mics can be adapted for use with musical instruments. Price 5/11 each, p/p 9d.

**19 set Trans/Rec. Mains Power Pack.** Operate your 19 set receiver straight off the mains. Ready built power unit, complete with modification and fitting instructions. Price 59/6 p/p 3/6. Please state Model, MK. 2 or MK. 3.

**High quality Paxolin Sheets.** Strong high quality Paxolin sheets. Size 10 1/2 x 8 1/2 x 1/10". Three for five shillings, p/p 1/- . Six for 10/- post free. Twelve for 18/6 post free.

**Constructors' Parcel Type No. 2B.** All brand new items, not government surplus. 6 phono plugs, 2 continental plugs, 3 and 5 pin; 12 small croc. clips; 12 large croc. clips; 24 assorted new resistors; 3 pointer knobs; 3 coax plugs; 6 sheets of paxolin, approx. 10" x 8"; 2 sturdy panel mounting fuseholders; 6 multi-cored solder packs; 1 30-watt lightweight soldering iron. Price 29/11, p/p 3/6.

**High Impedance Personal Listening Ear-piece.** Suitable for all types of crystal sets and transistor sets. Complete with lead and plug. Price 4/11, p/p 6d.

**Lead Acid Cells.** Unspillable type. 2V at 16 A.H. Brand new. Size 4" x 7" x 2". 4/11 each, 3 for 12/6, p/p 3/- per cell.

**Multi Voltage Mains Transformer.** Primary 200/250 50 c/s. Secondary tapped as follows: 3V, 4V, 5V, 6V, 8V, 9V, 10V, 12V, 15V, 18V, 20V, 24V and 30V. All at 2 amps. Price 35/-, p/p 3/6.

**Battery Charge Adjuster.** Charge Rate Adjuster. Government manufacture. Easily fitted to charging circuit. 3/6 each, 2 for 6/6, p/p 1/- each.

**Resistor Colour Code Indicator.** Saves time and money. Gives the value of a resistor at a glance. Price 1/6, p/p 3d.

**Tank Aerials.** Fully interlocking copper sections one foot in length. Will make ideal dipoles, car or scooter aerials. Price 6 sections complete with canvas carrying case 3/6, p/p 1/6. Additional sections 6d. each. Please include sufficient postage.

**THE Goldenair "THIRTY" HI-FI AMPLIFIER**

A high quality 30-watt amplifier developed for use in large halls and clubs, etc. Ideal for bass, lead or rhythm guitars, schools, dance halls, theatres and public address. Suitable for any type of mike or pick-up. Valve line-up: two EF86; one ECC83; one GZ34; two EL34. Four separate inputs are provided with two volume controls. Bass and Treble controls are incorporated. Amplifier operates on standard 50 c/s mains. 3 ohm and 15 ohm speakers may be used. Perfected cover with carrying handles can be provided if required, price now 25/-.

go **Goldenair**

Customers are invited to see and hear this amplifier at our shop premises in Lambert's Arcade. Send S.A.E. for illustrated leaflet. Or deposit of £1.16.0 and twelve monthly payments of £1.9.2. Carriage 15/- to be sent with order.

**16 GNS.**

**TWICE THE QUALITY — HALF THE PRICE**

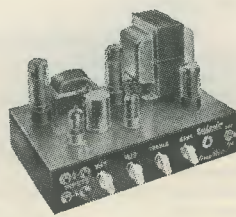

Postage rates apply U.K. only. S.A.E. with all enquiries  
 New walk round store open in Lambert's Arcade, Lower Briggate, Leeds 1, next to Halfords Cycle Shop. Open all day Saturday. 48 hr. despatch service, all mail orders to our Briggate House address.

Terms  
 Cash with order  
 5/- extra on C.O.D. orders  
 No C.O.D. under 30/-



Send 1/- for lists  
 Trade supplied  
 Orders from  
 abroad welcomed

**SONA ELECTRONIC CO (DEPT RC2) BRIGGATE HOUSE, 13 ALBION PL. LEEDS 1.**

# CLEARANCE of COMPONENTS

## at GREATLY REDUCED PRICES!

Here is your once-a-year chance! We must clear these lines to make way for new stocks. On the left-hand side we list the quantity available, in case you wish to make an offer for the lot. Call in or write . . . TO-DAY!

If ordering by post PLEASE INCLUDE 2/- EXTRA TO COVER POSTAGE AND PACKING:

Quantity	CO-AX PLUGS AND SOCKETS	Each
200	Films & Equipment Co-ax Plugs	1/-
40	Films & Equipment Co-ax Sockets	2/6
<b>CHOKES</b>		
100	Heavy Duty Suppressor Chokes	1/-
<b>CERAMIC COIL FORMERS</b>		
50	1½" x ½", with fixing lugs	1/-
<b>CONDENSERS (ELECTROLYTIC) SINGLES</b>		
100	500µF 25V T.C.C. 2½" x 1½"	1/6
30	300µF 25V T.C.C. 2" x 7/8"	1/9
100	250µF 50V T.C.C. 2½" x 1½"	1/6
20	250µF 50V T.C.C. 2" x 1"	1/6
30	100µF 50V T.C.C. 1½" x ¾"	2/-
40	32µF 150V T.C.C. 1½" x ¾"	1/6
20	25µF 50V T.C.C. 1½" x ¾"	1/-
200	16µF 375V T.C.C. 4½" x 1½"	4 for 2/-
200	16µF 350V Dubilier 2" x 1"	4 for 2/-
50	8µF 450V T.C.C. 1½" x ¾"	1/-
24	4µF 450V T.C.C. 1½" x ¾"	1/-
<b>CONDENSERS (ELECTROLYTIC) DOUBLES</b>		
10	8+8 475V Sprague (single hole fixing)...	2/-
250	16+16 300V T.C.C. 2½" x ¾"	1/6
<b>CONDENSERS (NON-ELECTROLYTIC)</b>		
100	4µF 600V Dubilier 4½" x 2" x 1½", Visconol Type	4/6
300	2µF 800V Dubilier 4½" x 2" x 1½", Visconol Type	3/6
200	2µF 600V Dubilier 2½" x 1½" x 1½"	2/6
300	2µF 500V Dubilier 2½" x 1½" x ¾"	1/6
300	2µF 500V Wego 2½" x 1½" x ¾"	1/-
50	.01µF 400V Hunts W97	1/-
<b>CONDENSERS (DISC CERAMICS)</b>		
250	5,000pF Erie	12 for 3/-
<b>CONDENSERS (HIGH VOLTAGE CERAMIC)</b>		
20	3pF 4kV working...	1/6
60	1,000pF 3kV working	2/6
50	200pF 10kV working	4/-
<b>CONDENSERS (TUNING)</b>		
20	3-gangs 500pF (each section)	5/6
20	3-gangs 350pF (each section)	5/6
10	2-gangs AM/FM 500pF and 10pF (each section)	3/6
24	2-gangs 50pF (each section)	4/6
3	Single gang 400pF	3/6
80	Single gang 160pF Eddystone S.W. Condenser	2/6
24	Single gang 50pF	3/6
80	Single gang 20pF Eddystone S.W. Condenser	2/6
50	Single gang 20pF	1/6
<b>CONDENSERS (TRIMMING AIR DIELECTRIC)</b>		
500	100pF Jackson type	3 for 2/-
50	30pF Polar (spindle ¼" long)	1/6
50	20pF Jackson Type	1/6

Quantity	CONDENSERS (TRIMMING, POSTAGE STAMP TYPE)	Each
200	300pF+1,000pF	6 for 2/6
500	50pF+50pF+50pF+50pF+50pF	1/-
<b>DIODES</b>		
60	High Quality, suitable FM	1/6
<b>METERS</b>		
34	40 Amp. (10mA without shunt), 2½" Scale	19/6
20	500 Micro-amp, 2½" Scale marked 0-15 and 0-600	15/-
<b>MICROPHONE INSERTS</b>		
250	Carbon Granule Inserts	4 for 2/-
<b>MISCELLANEOUS</b>		
6	Miniature Electric Motors	2/6
1	Scanning Coil, Type WB/108	5/-
2	Jason Audio-Attenuator, ready built (List £8)	£4
1	Jason Audio-Attenuator Kit (List £5 5s.)	£3
14	Deaf Aid Type Earphones	2/6
10	Gram Escutcheons. Speaker grille and hole either end for controls	2/6
12	Grundig Leads with jack plug	3/6
36	Handles, Brass, 4"	2/-
10	Handles, Metal, covered in grey plastic, 1½"	1/-
30	I.F. Transformers, 10 M/c	2/6
1	Kit G.E.C. Lite Writer (for children)	12/6
1	Kit G.E.C. Alarm System (for children)	12/6
100	Knobs, Television. Marked "Focus", "Brilliance", "Brightness", "Contrast". Fit ¼" spindle	Set of 4 1/-
100	Necked Knob with 1½" extension. Marked "Volume", "On-off". Fit ¼" spindle. Spring clip fixing	1/-
50	Panel Mounting Neon Lamps complete with G.E.C. tuneon bulb and suitable resistance for mains use	2/-
24	High Voltate Lead-throughs, 1½" x ¾", fixing disc 1½"	2/-
<b>POTENTIOMETERS</b>		
390	2MΩ Pre-sets	6 for 4/6
32	Bank of 4 Pre-sets, 1MΩ, 220k, 220k, 270k per bank	2/6
<b>RELAYS</b>		
60	Siemens high speed change-over Relays, 1,000Ω (500Ω each coil) per pair	15/-
<b>RESISTORS</b>		
700	1MΩ Wirewound 1% non-inductive. Surprise your friends, show them a million ohm wire-wound resistor, size 1" x ¾". Surprise us, too, by buying one!	6d.
<b>SWITCHES</b>		
50	Toggle Switches, D.P.D.T. 230V 3A	2/-
50	2-Pole 4-way Ceramic	3/6
50	4-Pole 4-way Ceramic	4/6
<b>TRANSFORMERS</b>		
10	Modulation 1:1:1 Gardiners. Very heavy duty	10/-
250	Output Transformers, 7kΩ to 3Ω, suitable ECL86. Made to high Admiralty specification. Make a cheap Stereo outfit	2 for 7/6
2	Frame Output Transformer for Magnavox and Supervisor	5/-
<b>VALVES</b>		
50	EF85 Mullard Valves. Brand new	5/-
12	EM80 Mullard Valves. Brand new	5/-
70	EF92 Mullard Valves. Brand new	5/-
200	TT11 Valves. Brand new	2/6
<b>VIBRATORS</b>		
12	24V Non-synch.	2/6
<b>VOLTAGE ADJUSTMENT PANELS</b>		
50	Philips Type Rotary Adjusters, marked 180, 200, 220, 240	1/-

To avoid delay make sure you add the extra 2/- for postage and packing.

Have you an up-to-date copy of the famous Home Radio Components Catalogue? It is a MUST for all constructors. Send 6/- (5/- plus 1/- post and packing) and your copy will be sent by return post.

**HOME RADIO LTD.** Dept. R.C., 187 LONDON ROAD, MITCHAM, SURREY. Phone: MITcham 3282

# THE Radio Constructor



Incorporating THE RADIO AMATEUR

MARCH 1965

Vol. 18, No. 8  
Published Monthly  
(1st of month)

*Editorial and  
Advertising Offices*

57 MAIDA VALE LONDON W9

*Telephone*  
CUNningham 6141

*Telegrams*  
Databux, London

First Published  
1947

Repair Your Meter, by <i>A. L. Jackson, A.M.S.E.</i>	516
Magnetically Operated Dry Reed Switch Circuits (Suggested Circuit No. 172), by <i>G. A. French</i>	520
Can Anyone Help?	522
Modulated-Light Broadcast Transmitter, by <i>Douglas Letts</i>	523
Wave-trap for Television, by <i>J. D. Benson, F.T.S.</i>	525
"Oscar" Sub-Miniature R.F. Signal Generator, by <i>Wallace Studley</i>	526
News and Comment	531
3-Stage Pre-Selector for the Beginner, Part 1, by <i>E. Govier</i>	532
Transistor Microphone Pre-Amplifier, by <i>A. D. M. Kinloch</i>	537
Peak Level Indicator, by <i>A. R. Hoare</i>	539
The "Crystarlet" Crystal-controlled F.M. Tuner, Part 2, by <i>Sir John Holder, Bart.</i>	541
Understanding Radio, by <i>W. G. Morley</i>	547
Bridge Building, Part 3, by <i>Craig Mackay</i>	552
In Your Workshop	555
The New Dual-Standard TV Sets, Part 11, by <i>Gordon J. King, Assoc. Brit.I.R.E., M.T.S., M.I.P.R.E.</i>	561
Radio Topics, by <i>Recorder</i>	565
Radio Caroline, by <i>F. C. Judd, A.Inst.E., G2BCX</i>	567

© Data Publications Ltd., 1964. Contents may only be reproduced after obtaining prior permission from the Editor. Short abstracts or references are allowable provided acknowledgement of source is given.

Annual Subscription 33s. (U.S.A. and Canada \$5) including postage. Remittances should be made payable to "Data Publications Ltd". Overseas readers please pay by cheque or International Money Order.

Published in Great Britain by the Proprietors and Publishers Data Publications Ltd. 57 Maida Vale London W9  
Printed by A. Quick & Co. (Printers) Ltd. Oxford Road Clacton-on-Sea England

# Repair Your Meter

By A. L. JACKSON, A.M.S.E.

*Practical advice on a subject which concerns all enthusiasts and engineers*

**M**EASURING INSTRUMENTS ARE THE EYES AND ears of the radio engineer and without them he is like a blind and deaf man stumbling about. These notes are aimed at giving practical hints on the most likely faults in measuring instruments and how to put them right. As there are many makes of universal test set the remarks will be mainly concerned with the popular Avometer range, leaving the reader to apply them to his own make. Since Avometers are available on the second-hand market it is felt that the majority of experimenters will have one or other of these models in his possession.

## Mechanical Details

All test sets are based on a moving coil meter of at least a thousand ohms per volt with various shunts and resistors to enable a wide range of voltages and currents to be measured. A battery and potentiometer allows resistance to be read direct from the scale. A current transformer permits a.c. current readings. Some instruments

have two or more thousand ohms per volt, which means finer wire on the coil and a small magnet gap. They are more useful since they take less current from the circuit, but are more liable to damage.

The coil former is of aluminium for lightness and to provide some measure of damping. Cemented on top of the wire at each end is a brass plate carrying a pointed pivot and a hairspring to take current into the coil. The hairspring coils are in opposition, one winding as the other unwinds. The pivots move in jewelled bearings which are mounted in a screw to take out end play, and they are spring loaded to take shock. The coil moves in the gap of a powerful permanent magnet. Great care is needed when removing a magnet to ensure that at no time is it without a keeper, or the magnetism will suffer. The instrument will then never read correctly.

With average use pivots will last fifteen to twenty years without repointing, as they are of hardened steel. With very old instruments the shellac holding the brass plates to the coil becomes brittle and a mechanical shock will cause it to break away, so it is necessary to be especially careful.

## Mechanical Faults

A common mechanical fault is a sticking instrument due to a foreign body having got into the gap and catching the coil as it moves round. If the gap is held up to the light the body can often be seen and carefully removed with a fine feather, otherwise the assembly must be dismantled and Plasticine rubbed round the gap. The pieces stick to this and come away with it. Unless one is used to delicate work this procedure is best left to someone who is. While a bench may look quite clean it is not wise to place the movement on it, for iron particles hide like germs and are just as dangerous. Use a clean piece of paper.

Worn pivots can cause sticking, but a more likely cause is a loose bearing allowing end play. This can be taken out by unlocking the nut and



Repair Your Meter!

screwing in with a driver. Care is needed for, with spring mounted jewels, it is not always easy to get the adjustment right due to compression of the spring. A little at a time, whilst gently blowing the pointer round to see if it is clear, is the method. Pushing the pointer round with a finger is too clumsy.

Enough has been said to show that if the reader is a little ham-handed he had better enlist the

services of a watchmaker friend or an instrument maker for mechanical repairs.

### Electrical Faults

By far the most common electrical fault is a burn out of the ohms resistor by putting volts on the ohms ranges. Even with a cut-out fitted the movement is saved but the resistor is not. Remove the instrument from its case, turn the

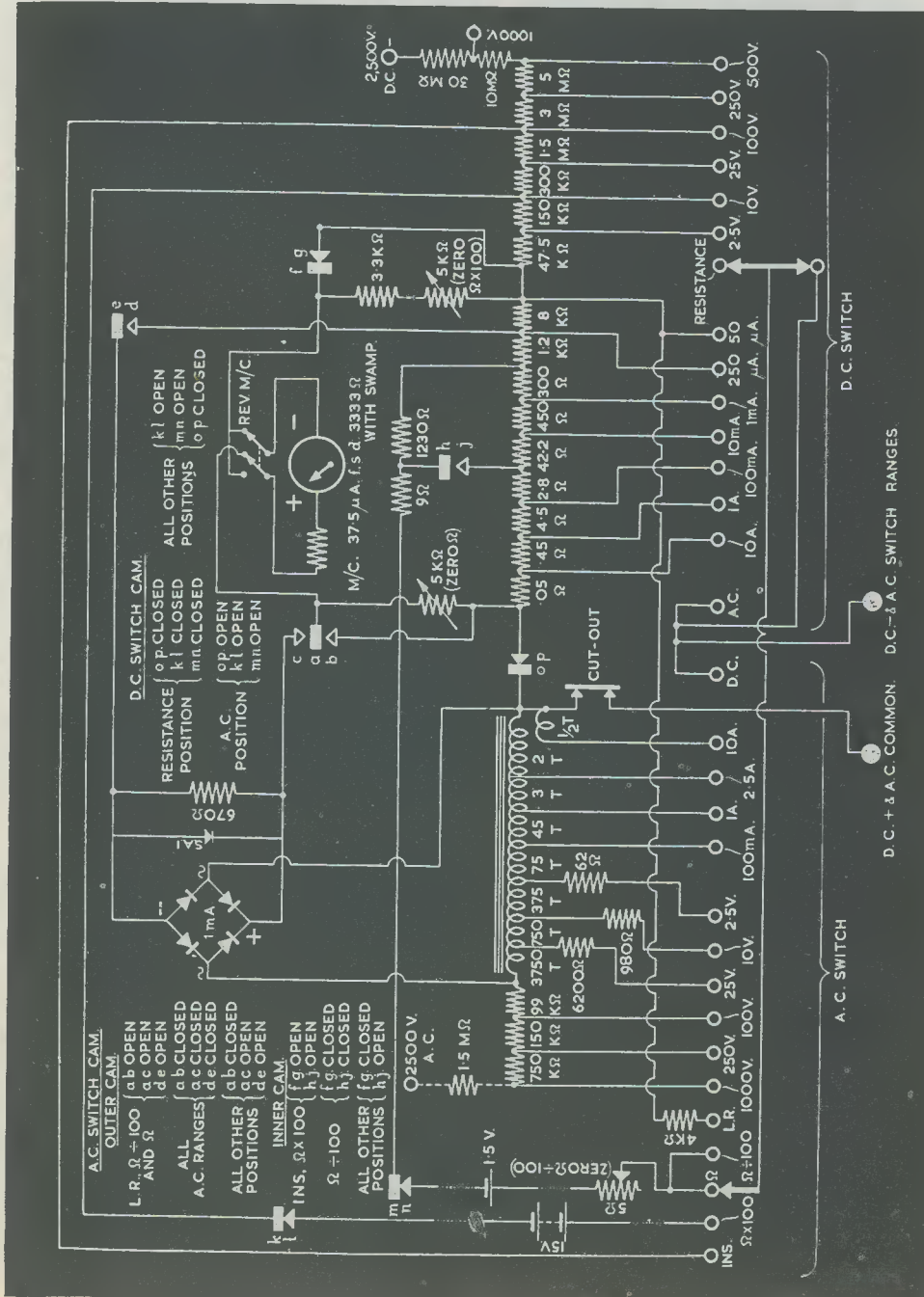

The circuit of the Model 8 Avometer Mk. II. (Coursey Avro Ltd.)

switch to the fault range and trace the wires from switch to resistor if you cannot see the burnt insulation. In Avometers this is on a card above the right hand switch. Using scissors, snip away the old wire and solder a short-circuit across its terminals. With the instrument back in its case adjust a length of suitable resistance wire across the terminals until the meter reads ohms zero. This must then be transferred to the resistance card and soldered into place. To wind it on, the whole card must be removed after making a sketch of the connections so they are put back on the same tags. This is important as it is difficult to sort them out again if they are remade incorrectly. Even if your circuit diagram gives exact values, another ohmmeter is needed to measure the resistance value required. The method just described avoids that, but make sure your batteries are O.K. first.

A similar method will deal with a burnt out volts resistor if wirewound. Locate the fault range by applying volts to each range in turn, working upwards. No reading indicates the faulty range. Locate the ends of the resistor via the switch wiring and short-circuit them. In this case the outside resistor must be in series with the supply. Check against the next lower range and adjust accordingly. This is not an ideal method but it will give a workable value.

Avometer resistors are mainly wirewound on cards, but the higher value resistors may be replaced with 1 watt high stability Welwyn or similar makes which are accurate to 1%. These are sold in whole values and not in preferred values. An approximate resistance may be obtained by using standard  $\frac{1}{2}$  watt composition types, but soldering these into place often results in the value altering. Such resistors are neither accurate nor stable enough for regular instrument use.

It is possible to calculate the value required but this means knowing the coil resistance. Since resistors are usually in series one has to subtract the value already in use. In some instruments d.c. and a.c. resistors are common, a tapping on the common resistor providing a.c. values, so it is best to check on both ranges.

Shunts hardly ever seem to give trouble, which is just as well since they are more difficult to adjust. Separate shunts are sometimes used, or a common tapped shunt. In the latter case a burn out will affect all shunt ranges. This will remove all the shunts from the instrument and probably result in a burned out coil. A shunt may be traced via the switch in the usual way but short-circuiting it is of no use. A new wire of similar gauge and composition must be soldered into place and carefully adjusted for length until the range reads correct compared with another higher or lower range.

#### A.C. Faults

On a.c., some form of rectifier is brought into use and these sometimes break down. The most common fault is for an instrument to read half

scale through one half of the rectifier being open-circuit. The rectifier should be replaced with one of the same make and type, or the calibration will not be correct. Average cost is around ten shillings. The rectifier must of course be connected correctly, and the polarity is usually marked on the Bakelite case.

Shunting is not suitable for a.c. and so a current transformer is generally used. Generally a primary winding will break down and, since this has some two thousand turns, rewinding is possible but tedious. The best answer is a new transformer from the makers at an average cost of around 30/- to £2. If one rewinds, the turns taken off should be counted if possible, otherwise it will have to be weighed and replaced with the same weight of similar gauge and covering. In this case final adjustment will be made by putting on or removing turns.

#### Switching

This is often complicated in a multi-range instrument. Avometer switches are solid affairs with heavy brass contacts and never give trouble. Sometimes they need cleaning if readings wander in use. Carbon tetrachloride is suitable and is marketed as the proprietary cleaning liquid "Thaw-pit". Brush the contacts well several times and finish with a solution of c.t.c. in which a little Vaseline has been dissolved. Radio dealers sell special switch cleaning fluids. Where wafer switches are fitted, be especially careful not to bend the contacts in cleaning, as they are frail. Above Avometer switches are fitted make-and-break switches to change from a.c. to d.c. and to connect the shunts and bring the 1,000 ohms range into use. These need cleaning as well. They are operated by a cam secured to the top of the shaft by a screw. It is not common, but the screw can become loose and allow the cam to move round.

The potentiometer wire and arms can get dirty and will pay for cleaning. So will the pegs and contact strips in the Avometer case connecting to the batteries.

#### Cut-Out

Avometers have a mechanical cut-out to protect the instrument. It is operated by the moving coil through springs and levers. At the bottom of the instrument and inside will be seen a small brass table. By slackening off the screw in front and the pillar at the rear this may be turned for adjustment. When the cut-out knob is pushed in, a lever drops into a slot on its spindle. The reverse end of the lever pushes on a bell crank arm. When the knob is released the lever catches on a jewel in the bell crank arm. An overload results in the bell crank arm moving and the lever hops out of the slot, opening the contacts. Correct settings are as follows:

Model 7. on 1 volt range the cut-out should operate with 9 volts but not with 4.5 volts.



Model 40. on 1.2 volt range it should operate with 12 volts but not with 6 volts.

Model 8. on 1mA range it should operate with 6 volts but not with 3 volts.<sup>1</sup>

Wear on the lever or the jewel will make it impossible to get these settings, and they may not be possible with very old and less sensitive instruments.

#### Divide-By-Two Button

There is also a divide-by-two button which doubles the scale reading when pressed. In effect it doubles the number of ranges. If it fails to work make sure the switch contacts are clean. Then try the wire from one contact to the "R" resistor, which may be broken in its covering. Finally check the bobbin which is switched in on all normal ranges and disconnected when the button is pressed. This is usually the right hand bobbin on the movement frame. A disconnected or broken wire to the "P" resistor could also cause this trouble.

#### Printed Circuits

Some of the latest instruments like the Avo Multi Minor have printed circuits for shunts, resistors and switching. Owing to the compact layout there is not room to replace with standard parts, so that the whole resistor card must be replaced. The makers sell these at quite moderate prices. It is easy to get the connections mixed in replacing a card, so make a sketch before starting.

#### Nickel-Chrome Wire

Another problem concerns soldering nickel-chrome resistance wire. The solder does not easily wet it with normal fluxes. "Jenolite" is very useful as a flux using non-cored solder though to tin properly, it may be necessary to make more than one cleaning and tinning operation. It is essential to tin properly first, or the final solder will hold the wire down without making a proper contact. Wash off with methylated spirits as some liquid fluxes have corrosive properties. Resistance wire in one ounce reels may be obtained by post from Post Radio Supplies, 33 Bourne Gardens, London, E.4. A stamp will get you a list of sizes and prices.

<sup>1</sup> The author confirms that it is correct to check the Model 8 cut-out on the 1mA range, and not a voltage range.—EDITOR.

#### Testing

Unless one has special means, testing is difficult except by the comparison method using other ranges or comparing with another instrument. Two standard 4.5 volt batteries checked by your dealer and the exact voltage noted may be used. Shunt them with a potentiometer of 5,000 ohms or so. Mount the potentiometer on a panel and fit to its knob a large card scale. At each end of its travel mark negative and positive and connect those sides to the batteries via a switch. If your potentiometer is linear the exact voltage noted may be divided round the scale equally. It is then possible to pick off any voltage desired for test. With a.c. a similar method may be used with the 6.3 volt winding of a mains transformer, or a higher voltage if available. Several grid bias or an h.t. battery with a much higher value potentiometer may be used for higher d.c. ranges.<sup>2</sup>

Using the same d.c. set-up shunts may be checked by applying a known voltage via a known resistor, providing that the battery can deliver the current required without volts drop.

All these are rough and ready checks, to be used if no other means of testing are available.

#### Balance

For accurate calibration, movements should be balanced. Small balance weights are provided, sometimes on screwed rods, and are secured with shellac. A warm soldering iron will melt this for the weights to be moved. Adjust them so that, with the pointer horizontal, it remains on zero, or any other position selected by the zero-adjust control, after movements to left and right. Then adjust so that with the pointer vertical, it remains on the same mark after movements to left and right. If necessary, a blob of shellac will provide a little extra weight. A small spring of copper wire may also be tried, or a small nut. Where more is needed try a coil of wire solder. Make sure that all weights are secured with shellac to prevent movement—if this is heated with an iron until it melts, it will quickly set hard.

<sup>2</sup> These methods could lead to error if the batteries are not used shortly after the initial test. It would be advisable to switch on the potentiometer as little as possible to avoid excessive battery drain, and the initial battery voltage should be measured with the potentiometer connected. We would suggest that, wherever possible, all check voltages be monitored by another meter which is known to be accurate.—EDITOR.

## ROYAL FESTIVAL HALL CLOSED-CIRCUIT TV FOR LATECOMERS

At most concert halls, latecomers are not admitted to the auditorium until the end of the first item. At the Royal Festival Hall, they are able to follow the programme on four 23in TV receivers, in the foyer on level four—red and green side—and in the two bars on level six. These continue to operate throughout the concert.

Unobtrusively mounted in the Circle spotlight housing, a type 6 minicamera fitted with a wide-angle lens transmits a picture of the entire stage. An autolight unit allows the camera tube sensitivity to be automatically adjusted to compensate for the wide disparity in ambient lighting when the house lights are turned up before and after the performance and during the intervals.

Additional 19in receivers provide a service to the general manager's office, and the office of the Director of Scientific and Industrial Research where some acoustic research is carried out.

All control equipment for the television system is housed in a single cubicle in the sound control room.

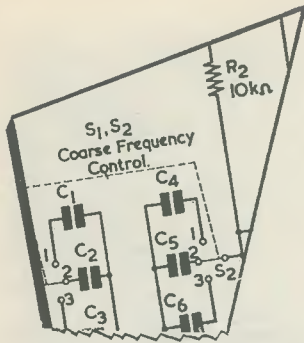

# Magnetically Operated Dry Reed Switch Circuits

By G. A. FRENCH

## SUGGESTED CIRCUIT No. 172

**A**N INTRIGUING LITTLE DEVICE, of which two versions have been available on the home-constructor market for the last year or so, is the dry reed switch. Dry reed switches are operated by magnetic fields and are capable of a wide range of applications.

So far as the writer is aware, dry reed switches have not been referred to in any home-constructor designs up to the time of writing and he felt that, even though the associated circuits are very simple, it would be of advantage to devote an article in the "Suggested Circuit" series to their capabilities.

### Construction

Dry reed switches, as currently available to home-constructors, have the basic construction shown in Fig. 1 (a). Two flat reed contacts having gold diffused surfaces are mounted in a glass tube filled with an inert gas, and are normally open. The reed contacts are made of springy magnetic material and, if a permanent magnet is held close to the tube, as in Fig. 1 (b), the ends of the reeds are attracted together and close. Thus, an external circuit can be completed merely by bringing a permanent magnet up to the switch. The polarity of the magnet is unimportant.

The dry reed switch may also be operated by an electric current, this being fed through a coil fitted over the tube, as illustrated in Fig. 1 (c). The writer feels, however, that operation by a permanent magnet is of greater interest, and the present article will give two simple examples of circuits which employ purely magnetic control.

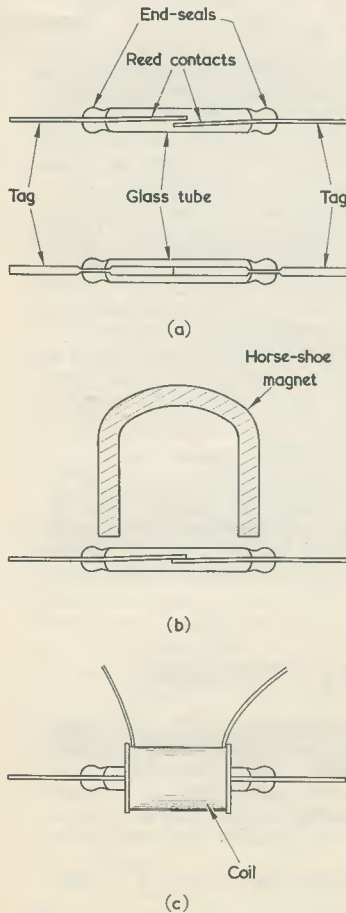

Fig. 1 (a). Two views of a dry reed switch with contacts open  
 (b). Bringing a magnet up to the dry reed switch causes the contacts to close. A horseshoe magnet is illustrated here, but a bar magnet whose poles take up the same position may also be used  
 (c). The contacts may be closed electro-magnetically by fitting a coil over the switch

It is claimed that the reliability of dry reed switches is very high and that they have a working life of about 100 times that of micro-switches. A limiting factor is that contact current ratings are rather low, the two types available to home-constructors having recommended ratings of 100mA and 250mA\*.

The writer checked one of the 250mA switches and found that it had a high degree of sensitivity. The contacts could be operated by a weak horseshoe magnet having a lifting power of only several ounces when the magnet poles were about  $\frac{1}{4}$ in away from the glass of the tube. More powerful magnets will, obviously, operate the device from greater distances; and a magnet specifically intended for use with the switch operated it from a distance of 0.3in. As was to be expected, the distance between the magnet poles and the glass tube required for initially closing the switch is less than that needed to maintain it in the closed position.

The dry reed switch rated at 250mA contact current has an overall length of about 3.5in, a glass tube length of 1.9in and a maximum glass tube diameter of 0.217in. The breakdown potential is greater than 500 volts d.c., and the operate time is less than 2 milliseconds. The 100mA version has an overall length of 1.45in, a glass tube length of 0.8in and a maximum glass tube diameter of 0.15in. Breakdown voltage is greater than 300 volts d.c., and operate time is less than 1 millisecond.

\* These two types of dry reed switch may be obtained from Proops Bros. Ltd., 52 Tottenham Court Road, London, W.1. Also available from the same suppliers are suitable permanent magnets, energising coils of the type shown in Fig. 1 (c), and insulated dry reed switch housings.

## Applications

There are a considerable number of applications for the dry reed switch in the domestic sphere, of which the most obvious are circuits which provide a remote indication when a door or window is opened. Circuits of this type may then be used for burglar alarms or shop door warning systems.

A circuit suitable for burglar alarm use is shown in Fig. 2, this causing a bell to sound whenever a door or window is opened. In Fig. 2 a dry reed switch is fitted to the frame of the door or window, a permanent magnet being mounted alongside it on the door or window itself. When the latter is closed, the dry reed switch is in the field of the magnet and its contacts make. When the door or window is opened the magnet is moved away from the dry reed switch, the contacts of which then break.

Since the dry reed switch contacts break, instead of making, when the door or window is opened, the warning circuit has to be operated by way of a relay or similar device. In Fig. 2 a relay is used. The circuit is set up by momentarily pressing button  $S_1$  whilst  $S_2$  is being closed. Assuming the dry reed switch contacts to be closed, this causes the relay to energise and to remain energised by means of its own changeover contacts. If at any time the door or window is opened, the dry reed switch contacts break the relay circuit, causing this to de-energise and its changeover contacts to complete the warning circuit. The warning bell then sounds, and will continue to sound until switched off by  $S_2$ . Even if the dry reed switch contacts are closed again the bell will not be silenced. This is because the energising circuit for the relay has been broken by its own contacts.

The circuit of Fig. 2 has the advantage, for a burglar alarm system, that the warning is given when a circuit is opened. The warning will similarly be given if any attempt is made to cut the wiring to the dry reed switch. More than one door or window can be protected by inserting more dry reed switch and magnet combinations in series with that shown in Fig. 2. In this case, a single wire can be run around the premises, this starting and ending at the relay unit. Dry reed switches are then inserted in series with the single wire at the desired protection points.

The relay energising circuit draws current all the time and it would

be best to employ an accumulator in the battery position, this being charged from time to time as required. A mains power unit *could* be employed to power the circuit but this would cause the alarm to be ineffective in the event of a mains failure. An alternative scheme, consisting of using a mains power unit for the relay circuit and a battery for the bell, is also unattractive because the bell will sound if the mains supply fails.

The relay should have a fairly low energising current in order to prevent too rapid a discharge of the battery. This energising current should not, of course, be greater than the rated contact current of the dry reed switch or switches employed. In practice, the energising current would normally be of the order of tens of milliamps only. A Post Office type 3,000 relay with a 500 $\Omega$  coil and a single changeover contact set will, for instance, energise quite reliably at 8 volts, whereupon the energising current required is only 16mA.

The voltage required of the battery is, of course, that needed to operate the relay. If this voltage is too high for satisfactory operation of the bell, resistance may be inserted at the point marked with a cross.

## An Alternative Circuit

Whilst the circuit of Fig. 2 offers the safeguards necessary in a burglar alarm system, the use of a relay makes it rather too cumbersome for such applications as a shop door warning device. What is required here is direct switching

of a bell or buzzer by the dry reed switch, and this may be achieved by the circuit of Fig. 3. An important proviso with this circuit is that the current drawn by the bell or buzzer should not exceed the contact rating of the switch, and this point is discussed later.

The dry reed switch in Fig. 3 differs in performance from that of Fig. 2 because its contacts close when the door is opened. It is fitted, as before, on the frame of the door. Mounted alongside it, and also on the frame, is magnet B. Magnet A is fitted to the door itself. When the door is closed, magnet A is on one side of the dry reed switch whilst magnet B is on the other side. These two magnets offer opposing fields which cancel out at the dry reed switch, whereupon the contacts of the latter remain open. When the door is opened, magnet A is moved away from the switch, with the result that this now receives the field from magnet B on its own. In consequence, its contacts close, and the bell or buzzer then sounds.

The positions of the magnets relative to the dry reed switch may be found a little critical, and it is advisable to find optimum spacings empirically on the work-bench before mounting the components in position on the door. An ohmmeter or continuity meter should be connected to the dry reed switch to indicate the condition of its contacts, and the magnets then moved around to give best results. It will probably be preferable to start off by positioning magnet B, on its own, just sufficiently near to the switch to

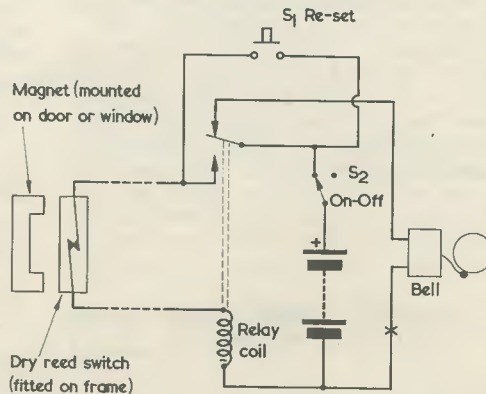

Fig. 2. Employing a dry reed switch in a burglar alarm system. The dry reed switch and magnet are positioned at the door or window to be protected, the remainder of the components being installed at a safe central point. The dashed circuit lines indicate the wiring which passes through the premises to the dry reed switch. The dry reed switch may be either a 100mA or 250mA type

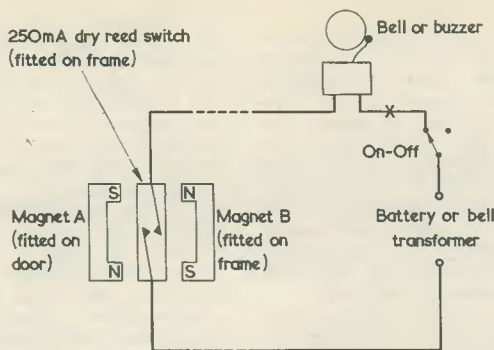

Fig. 3. A simpler circuit, suitable for use as a shop door warning device

cause its contacts to close reliably. The distance between magnet A and the switch for cancellation of the field should then be less critical.

A second point which will need to be satisfied is that the current drawn by the bell or buzzer does

not exceed the contact rating (250mA is suggested in Fig. 3) for the dry reed switch. Some electric bells, and in particular some of the low-cost types available in the popular stores, require a greater current than 250mA for normal operation.

The bell to be used should be connected up to the source of supply with an ammeter in series, and checked for reliable operation at 250mA or less. This procedure may require adjustment of the bell fixed contact. Should the current be initially too high, it may be lowered by reducing the supply voltage or inserting series resistance. (When the bell is to be run from a bell transformer and an a.c. ammeter is not available, it should be adequate to carry out this procedure with a d.c. supply of the same voltage as will be offered by the transformer.) If this check indicates that series resistance is needed to keep the bell current below the rated figure for the dry reed switch (as might occur with a bell transformer, whose output voltage cannot be reduced) such resistance may then be inserted, in the permanent installation, at the point indicated with a cross in Fig. 3.

## CAN ANYONE HELP?

Requests for information are inserted in this feature free of charge, subject to space being available. Users of this service undertake to acknowledge all letters, etc., received and to reimburse all reasonable expenses incurred by correspondents. Circuits, manuals, service sheets, etc., lent by readers must be returned in good condition within a reasonable period of time.

**Hallicrafters Receiver Type R1949.**—A. E. Harvey, 39 Curliou Road, Oakdale, Poole, Dorset—manual or circuit (similar to Hallicrafters S27D receiver).

\* \* \*

**Jason J2.10 Amplifier.**—J. A. Baker, 62 Highfield Road, Chelmsford, Essex—circuit diagram.

\* \* \*

**No. 88 Set, Type 3A.**—J. Hirst, Ashville College, Harrogate, Yorks—manual or circuit.

\* \* \*

**Hallicrafters SX25.**—J. Lowe, 1A South Street, Highfields, Doncaster, Yorks—borrow handbook or circuit.

**Transistor Receiver and D/F.**—R. D. Bryant, 79 Southdown Road, Portslade-by-Sea, Sussex—would like a reader to supply circuit covering 280–315 kc/s, 1,800–2,800 kc/s, long and medium waves with direction finder. Also transistorised tape recorder—both to work from either 6 or 12 volts.

\* \* \*

**BC348 and DST100 Receivers.**—S. Smith, 19 Hyde Road, Kenilworth, Warks—manuals or circuits for these receivers.

\* \* \*

**BC432 Receiver and LM11 Frequency Meter.**—K. J. Young, 182 Northumberland Court, Leamington Spa, Warks—any information.

# Modulated-Light Broadcast Transmitter

Douglas Letts

*The most ambitious modulated-light transmitter to date. A range of 150 yards in all directions is given by three 15 watt mains lamps mounted on the roof!*

## Editor's Note

Over the last few years, we have published a number of articles on modulated-light systems, the first of these, "Light Modulation" by G5UJ, appearing in the February 1960 issue. This was followed by "Light-Beam Transmitter-Receiver" by J. Emmett (April 1963), "Speech-on-Light System for Communication" by C. Morgan (January 1964) and "Modulated-Light Transmitter and Receiver" by M. J. Banthorpe (September 1964).

All the systems previously described employed bulbs of around flash-lamp size for transmission. Our present contributor, who was inspired in particular by Mr. Emmett's article, has gone a stage further and transmits modulated-light signals by way of three 15 watt mains-type bulbs. The transmitting bulbs are not focused on to the receiver but radiate in all directions. It is merely necessary to "aim" the receiver phototransistor at the transmitting bulbs to pick up the signal, and ranges up to 150 yards have been achieved.

This article is aimed at the more experienced experimenter, who will be able to obtain and bring into use equipment of the type employed by our contributor.—Editor.

**T**HIRTEEN YEARS AGO I WAS TOLD THAT SPEECH transmissions by a torch bulb couldn't be done. However, my eyes were opened by the article "Light-Beam Transmitter-Receiver" in *The Radio Constructor* for April 1963. I collected together a number of pieces of equipment including a tape recorder, an early Quad amplifier, as well as lamps, lenses, a gunsight and a number of other parts. When the installation was finished it worked far beyond my expectations.

The range in daylight was a circle of 100 yards radius. Speech and music came through well. Even though the response was poor above 2 kc/s, there was still something at these frequencies.

## The Transmitter

Fig. 1 shows a block diagram of the transmitter.

The tape recorder feeds a signal to the Quad amplifier and the output of the amplifier is mixed with a steady current from a d.c. power supply. The combined currents supply the lamps.

Fig. 2 shows the connections to the Quad amplifier, the mixing circuit and the lamp circuit.

Connection is made to the centre tap of the KT66 push-pull output transformer and to one anode only. The normal loudspeaker output terminals of the amplifier are used to drive a monitor loudspeaker via a switch and attenuating resistance. The mixing circuit has two components, these being a heavy duty choke and a coupling capacitor.

The choke,  $L_1$  in Fig. 2, is rated 10 Henries at 250mA, and is sufficiently large to pass the lamp currents and allow such low frequencies as reach the output stage to modulate the lamps. Low frequencies are attenuated in the amplifier by operating it with the bass control at minimum and the treble control at maximum. This compensates for the thermal "lag" or inertia of the lamps.

The coupling capacitor,  $C_1$  of Fig. 2, has to be large enough to fulfil two requirements. It must pass low frequency signals and it must not resonate with  $L_1$  in the signal frequency range. Three small electrolytic capacitors have been destroyed in this position, presumably by the high a.f. lamp current. A  $8\mu\text{F}$ , 600V wkg., oil-filled capacitor is now used and has given no trouble.

The d.c. supply provides 205 volts at about 170mA to the lamps. The output leads of this power supply are isolated from its chassis. The lamps are under-run by the d.c. supply, and there have been no lamp failures in 100 hours of transmitting time.

Two other means of monitoring are used as well as the loudspeaker. These are given by oscilloscope-monitoring terminals, each having  $0.05\mu\text{F}$  isolating capacitors in series, and by two 2.2 volt, 0.25 amp, "Lens End" torch bulbs. The latter are Ever Ready Cat. No. 2225.

The oscilloscope's main function is to check on amplifier overloading. Overmodulation occurs when the modulating voltage is sufficient to reverse the sign of the lamp current. In the present set-up, amplifier overloading occurs before overmodulation.

The torch bulbs in series with the lamp feed provide visible evidence that the roof lamps are on and being modulated. It is not necessary to go out into the open and get a stiff neck by staring skywards at the lamp mast, since a check on modulation quality is readily made by directing the portable

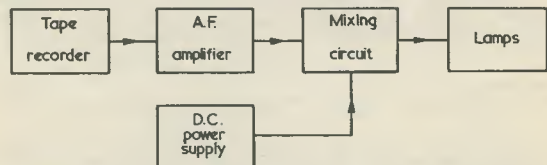

Fig. 1. Block diagram of the modulated-light transmitter

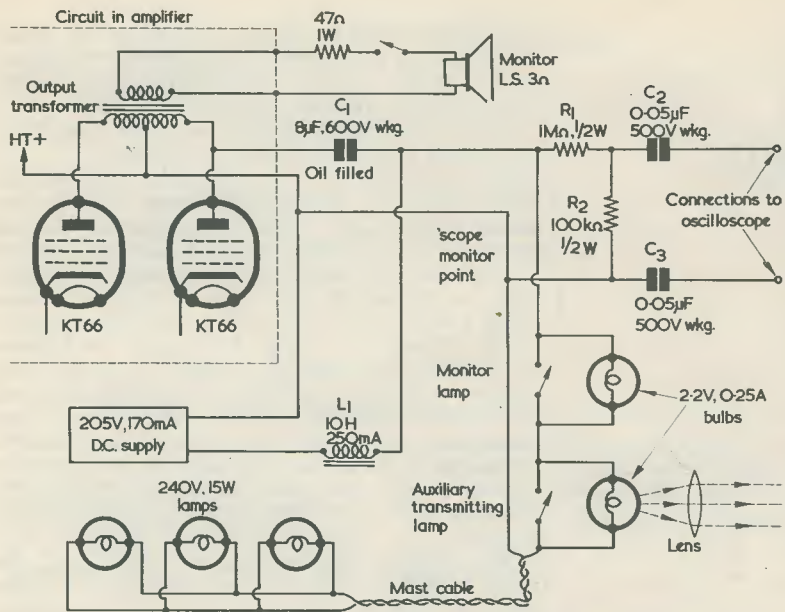

Fig. 2. The amplifier connections, mixer circuit and monitoring points at the transmitter

light receiver at the monitor lamp. One of the bulbs is used as an auxiliary transmitting lamp. This bulb and a lens is mounted on a board with Plasticine. The lens position is adjusted to give a narrow beam and it is directed where required from the transmitter room window. The lens has a diameter of 1 1/4 in and a focal length of about 4 in. Both torch bulbs have bypass switches.<sup>1</sup>

The auxiliary transmitting lamp, with its lens, has a greater range than the main lamps but it is very directional. It is currently being used for experiments with filters.

The main transmitting lamps are mounted upright on a roof mast, and spaced 120° apart without reflectors. Three 240 volt, 15 watt, plain glass types are employed. It was found that plain glass lamps gave a noticeably stronger signal than "pearl" lamps of the same rating. A number of small lamps are used in preference to a single lamp of equivalent power on the assumption that the thermal lag of low wattage lamps is smaller than that of high wattage lamps of the same voltage rating. However, no measurements have yet been made to confirm this.

### The Receiver

The heart of the portable light receiver is an OC71 with the paint scraped off.<sup>2</sup> The OC71

<sup>1</sup> An inexpensive convex "magnifying glass" lens will have a focal length around 4 in and could be used here. When switching on the d.c. supply it might be advisable to have the 2.2 volt bulbs short-circuited by their switches, as the cold filaments of the 15 watt lamps may draw a relatively heavy initial current.—EDITOR.

<sup>2</sup> This applies to earlier versions of the OC71. Currently manufactured transistors of this type are housed in completely opaque cases and cannot be modified for phototransistor operation in this way. An OCP71 phototransistor may be used in place of the modified OC71.—EDITOR.

is mounted on its side in a bed of Plasticine at one end of a cardboard tube. A lens, similar to that used with the auxiliary transmitter bulb, is fitted in a valve screening can which makes a push fit in the cardboard tube. This serves as a focusing draw-tube. The lens and OC71 assembly is strapped with Cellotape and Plasticine to an ex-Barracuda optical gunsight.<sup>3</sup> A few yards of light, flexible screened lead connects the OC71 to a pre-amplifier mounted on the back of a portable transistor superhet radio, the pre-amplifier output being connected to the radio's audio amplifier circuit. The OC71 and pre-amplifier circuit is given in Fig. 3.

The circuit of Fig. 3 is crude, but it works. For bright daylight, C<sub>1</sub> has a value of 2 μF as shown, and the range is 100 yards, extending to 150 yards at dusk. For night use, better results are given by reducing C<sub>1</sub> to 0.1 μF. The night range is 150 yards.

Much of the success of this receiver I attribute to careful focusing of the receiver lens. The beam width is just under one degree of arc at each of two sensitive spots on the emitter side of the OC71.

<sup>3</sup> The gunsight employed by the author is the ex-R.A.F. Sight Gun Prismatic Type G1, Ref. No. 7A/1661. This may be difficult to obtain through surplus suppliers at present but it does not, in any case, form part of the electronics of the receiver. It is used for "sighting" the phototransistor and lens assembly on to the transmitting lamps, and any suitable alternative gunsight or other means of obtaining such "sighting" could be employed in its place.—EDITOR.

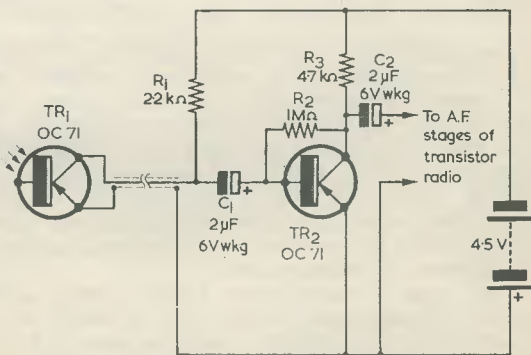

Fig. 3. The pre-amplifier at the receiver. The resistors are all half or quarter watt types. For working at night C<sub>1</sub> should be reduced to 0.1 μF

These spots are a little over one degree apart on this particular transistor. One is more sensitive than the other. With such high directivity of the receiver it is impossible to use it without the gunsight except at very short range.

### Testing

For test purposes a short tape loop is used on the tape recorder. On one track is an interrupted 600 c/s tone, and on the other a short announcement: "You are listening to a transmission by modulated light". For demonstration purposes a reel with a more varied programme is used. It is found advantageous to avoid programme material of variable strength and to keep the modulation

near the maximum as the lamp-light signal output increases at a greater rate than the modulation voltage. A related effect is especially noticeable when using the interrupted-tone test-loop. Although each tone burst is of constant amplitude, it is received as a tone burst with a build-up at the start.

I call this transmitter a "broadcast transmitter" to distinguish it from directional transmitters for use in point-to-point working. Time and money allowing, I hope to make improvements to the range and modulation characteristics. Happily, there is no shortage of ideas or paper to set them down, and my thanks go to the author of the article that originally inspired me.

## Wave-trap for Television

J. D. BENSON, F.T.S.

*"Forward scatter" transmissions in the range of 30 to 40 Mc/s, approximately coincident with the i.f. passband of TV receivers, can be particularly troublesome during the summer months. This article describes a simple wave-trap which is specifically designed to counteract interference of this type*

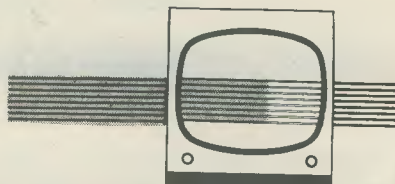

WITH THE ADVENT OF THE SUMMER MONTHS, television viewers and experimenters living in fringe areas often find reception marred by various types of interference. Probably the most annoying transmissions are those which come within the i.f. pass band of the sound channel. Whereas the eye can tolerate a fair degree of interference on vision, the ear is not so accommodating.

It was with this fact in mind that the subject of wave-traps was approached.

### "Forward Scatter"

One of the most offending forms of interference comes from "forward scatter" experimental stations and, whilst many television receivers are fitted with i.f. filters, it is found in many cases that these will not cope efficiently with this type of transmission.

Many types of wave-traps were tried by the author and it was eventually found that the trap shown in the accompanying diagram gave the most efficient results.

The construction is exceedingly simple and the unit can be built inexpensively from oddments taken from the scrap box. In some cases the wave-trap can be built directly into the receiver, thereby obviating any fittings, but this is not advised unless

the experimenter is an experienced television engineer.

It will be seen from the design that the unit plugs in externally, which makes it readily accessible for adjustment. In some cases it may be found that the trimmer has to be fully compressed; in such a case a fixed ceramic capacitor can be added in parallel to increase the range of adjustment.

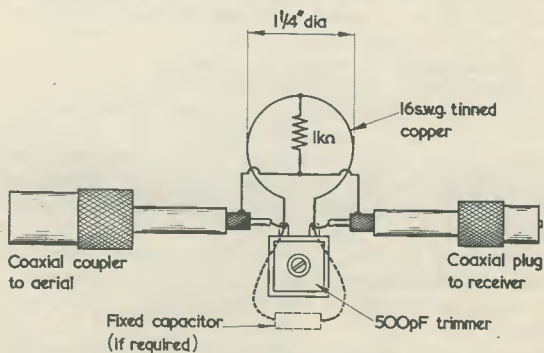

The inductance comprises a single turn of 16 s.w.g. tinned copper wire, a  $1k\Omega$   $\frac{1}{4}$  watt resistor connecting between its centre-tap and the lead coupling together the outer braiding of the two short lengths of coaxial cable. The trimmer is a compression mica component.



Cover Feature

# "Oscar"

## Sub-Miniature R.F. Signal Generator

Wallace Studley

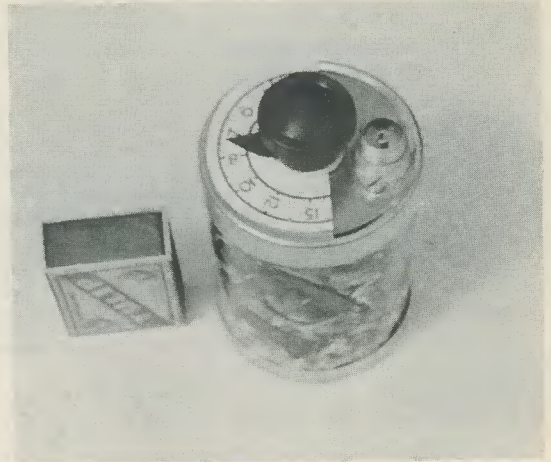

"OSCAR" IS A UNIQUE BUT EASILY CONSTRUCTED signal generating device using two transistors. One of the transistors supplies r.f. oscillations while the other provides an audio tone at about 400 c/s. The audio tone modulates the r.f. oscillator and thereby makes the signals suitable for receiver alignment or calibration. The device embraces a frequency range of 400 to 1500 kc/s and is a useful aid when aligning newly constructed medium and long waveband superheterodyne receivers.

This wave-range enables the intermediate frequencies around 465 kc/s to be aligned, as well as the medium wave band. The unit can also be made to give an output at 200 kc/s by connecting an additional 500pF capacitor ( $C_1$  in Fig. 1) across the tuning capacitor. Although not included in the prototype, such a capacitor could be coupled into circuit via a switch, if it was felt that a 200 kc/s output facility was desirable.

Mechanically "Oscar" is simplicity itself. The container is a section of cardboard tubing  $3\frac{1}{2}$ in long of the kind used for sending calendars and other unfoldable material through the post, this being fitted with tin lids at each end. Suitable card tubes are also available from floor coverings, linoleum, plastics, etc. Another alternative consists of using a cocoa tin.

One one of the lids—which are easily retained later with Sellotape—the whole assembly is mounted, as may be seen from the illustrations. Both oscillators make use of Veroboard, and each is constructed as a separate unit on a board measuring approximately  $1\frac{1}{2} \times 1$ in. This means that, if required, the audio oscillator can be built on its own—for Morse code practice perhaps—and if this is done the assembly will fit into a matchbox, complete with a 3 volt hearing aid battery type V0038 (Vidor). If the end of such a box is reinforced with Paxolin a suitable outlet socket can be fitted there.

As was just mentioned, the material used for the "Oscar" circuitry is Veroboard, this being easily obtainable through home constructor suppliers—as, indeed, is every other item specified. The type of Veroboard employed consists of thin Paxolin sheet which is plain on one side and is fitted on the reverse with copper conductor strips each 0.1in wide and spaced apart by a similar distance. Holes are provided in the copper strips with 0.2in spacing. It is very simple, therefore, to link together an almost wire-less circuit.

### Circuit Functioning

The complete circuit is shown in Fig. 1, the section to the left of the broken line comprising the r.f. generator. The separately built a.f. section is to the right of the broken line.

A single transistor is used in each section. Both of these function as feedback oscillators, with energy being fed back from collector to base. The phase and frequency of oscillation are dependent on the transformers  $T_1$  and  $T_2$ , the connections shown being those which will ensure correct working. The numerals associated with the terminals of  $T_1$  refer to the coil base spills, for which reference should be made to the inset key.

Both transistors function in grounded emitter connection and, whilst it is feasible to utilise a OC71 in the  $TR_2$  position, the type specified should be used at the  $TR_1$  location. It may be noted that some a.c. feedback is introduced in the emitter circuit of  $TR_2$  by way of  $R_8$ . This improves the waveform produced.

Range coverage is effected by tuning the main winding of  $T_1$  by means of  $C_5$ , this capacitor effectively connecting across the coil due to the presence of  $C_1$ . Transformer  $T_1$  is actually a medium wave aerial coil, and the writer has found that only the type specified offers the range required. The coil employed has an inductance that is higher



than normal, this being about  $271\mu\text{H} + 15\%$  (due to a fitted adjustable dust iron core) so allowing an extended low frequency coverage in conjunction with a 500pF variable capacitor.

Adequate a.f. injection into the r.f. circuit results from winding a short lead from point "X" around  $T_1$  as a single turn loop. The modulated output signal appears at the outlet socket. Excessive a.f. injection is undesirable. If the audio generator is to be built for use on its own, as mentioned earlier, the a.f. output can be extracted from point "X" and the positive line via a coaxial or similar socket. For Morse code practice do not, incidentally,

key the voltage supply feed or a crisp note will not result; key the output instead.

No attenuator is fitted to the r.f. oscillator output due to lack of space but, in a larger construction, a potentiometer could be used for  $R_2$  whereupon  $C_2$  should be connected to the slider to make amplitude variable.

The prototype "Oscar" is switched on and off by merely inserting or removing the battery, simple brass spring strips connecting with the battery terminals, as may be seen in Fig. 2. Care is necessary to ensure that the battery is not inadvertently inserted incorrectly with this arrangement, and

### Components List

#### Resistors

(All resistors  $\frac{1}{8}$  watt 10%)

- $R_1$  22k $\Omega$
- $R_2$  3.3k $\Omega$
- $R_{3,4}$  2.2k $\Omega$
- $R_5$  12k $\Omega$
- $R_{6,7}$  4.7k $\Omega$
- $R_{8,9}$  1k $\Omega$

#### Capacitors

- $C_1$  100 $\mu\text{F}$ , electrolytic, 10V wkg.
- $C_2$  5,000pF ceramic
- $C_3$  50pF ceramic or silver-mica
- $C_4$  10,000pF ceramic
- $C_5$  500pF, variable. "Dilemin" capacitor Cat. No. 4151 (Jackson Bros.)
- $C_6$  10,000pF ceramic
- $C_7$  2,000pF ceramic
- $C_8$  10,000pF ceramic
- $C_9$  500pF ceramic or silver-mica

#### Transformers

- $T_1$  Dual-purpose miniature coil, Blue, Range 2 (Denco)
- $T_2$  Sub-miniature interstage transformer, ratio 5:1, type D1001 (Ardente)

#### Transistors

- $TR_1$  OC44
- $TR_2$  OC45 (or OC71—see text)

#### Battery

9 volt battery type PP4 (Ever Ready)

#### Boards

2 pieces of Veroboard (0.2 x 0.2in hole matrix), each 1.6 x 0.9in (5 strips x 8 holes)

#### Connectors

Coaxial socket and plug  
Battery terminals

#### Miscellaneous

Case, knob, wire, etc.

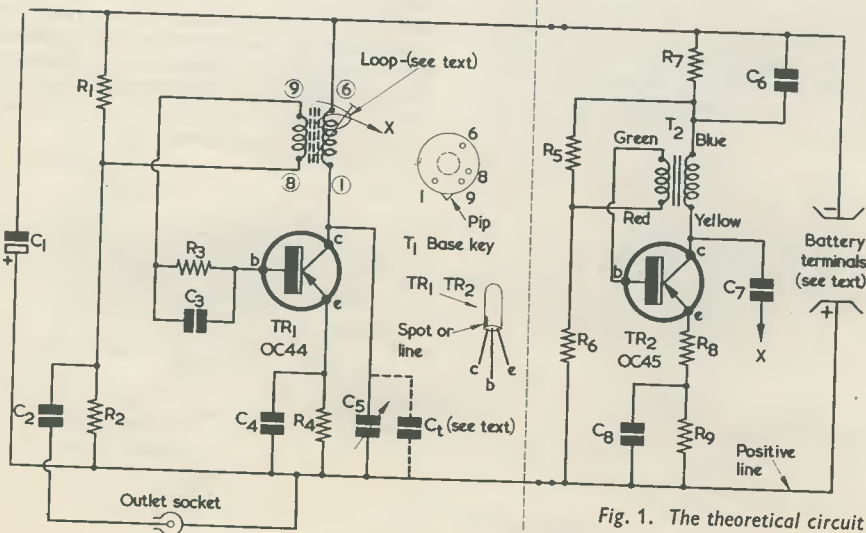

Fig. 1. The theoretical circuit

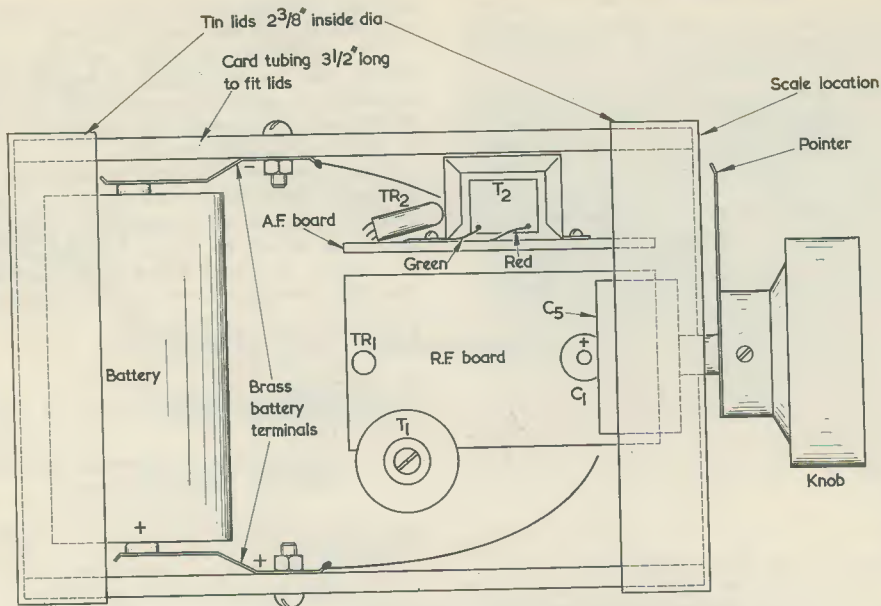

Fig. 2. Mechanical layout. The side of the a.f. board further away from the reader is adjacent to the upper side of the r.f. board

a more elegant switching method would consist of employing a sub-miniature jack for the outlet socket, this being fitted with a contact leaf to break the battery circuit. The total battery drain is less than 2mA!

Referring to Fig. 2 it may be observed that the two boards are mounted L-fashion at right angles to each other, the only physical connection between them being the positive and negative supply feeds.

The scale and its pointer are simply made from white card suitably inscribed with indian ink.

### Construction

The first step consists of finding a suitable container and of fitting lids, after which the tuning capacitor and outlet socket may be located. The tuning capacitor spindle emerges from the centre

and the coaxial socket is placed at a position which allows the capacitor knob to be rotated. Two rectangles of Veroboard are then cut from a sheet of the material using either a hacksaw blade or a fretsaw. Each board should agree with the dimensions shown in Fig. 3 and have five conductor strips with eight holes.

### Wiring the A.F. Board

Begin by cutting a channel across the board just deep enough to sever the conductor strips at "m", Fig. 3 (a); also sever the conductor at point "n". Use a hacksaw blade or a sharp pen-knife for this operation.

To simplify construction the strips and holes have been given letter and numeral designations in the diagrams and these will prove helpful also

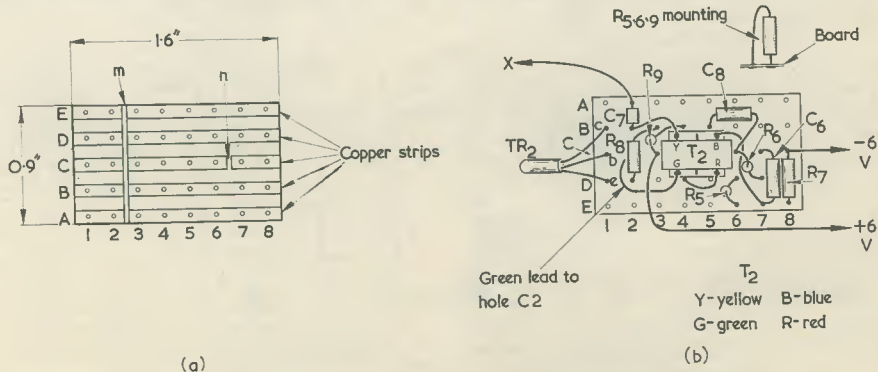

Fig. 3. The conductor side (a) and plain side (b) of the a.f. board

when the time comes to check the circuitry later. Before fixing any item slightly enlarge holes C3 and C6 since these accept not only the mounting lugs of T<sub>2</sub> but also the lead out wires of other items. Now fit T<sub>2</sub> and after passing its fixing clamp lugs through the enlarged holes bend them over inwards below. Do not solder the lugs, however, until one lead-out of R<sub>6</sub>, R<sub>9</sub>, C<sub>8</sub> and a flying lead have also been located, as shown in Fig. 3 (b). The remainder of the "wiring" is carried out exactly as shown, using sub-miniature items in all positions.

### Testing the A.F. Board

This is easily carried out by temporarily connecting a pair of high impedance headphones between point "X" and the battery positive line whilst applying a 3 to 6 volt battery. A loud note should be heard and this should approximate in frequency to 400 c/s. The oscillator may then be placed to one side.

### Wiring on R.F. Board

Space is slightly more restricted on the r.f. board and, because of this, three components are mounted on the conductor side. Before any components are mounted the conductors must be severed, as described earlier, but in this case between holes 3 and 4, as shown in Fig. 4 (a). After cutting the channel, T<sub>1</sub> is mounted. By orienting it as shown, pins 6 and 8 at its base will pass through the holes indicated. After soldering these pins cut off any excess, and it will be found that the coil is firmly mounted. All connections shown in Fig. 4 are then made except those to the outlet socket and to C<sub>5</sub>.

### Completing The Work

The r.f. board is firmly held in place by soldering the outlet socket lug to strip "C". See Fig. 4 (a). Two stiff copper wires acting as stays also connect from the inside of the tin lid—or from solder tags associated with the outlet socket fixing bolts—to strips "A" and "E". These copper stays also complete the positive supply circuit between strips A (holes 4 to 8) and E (holes 4 to 8). The two connections to C<sub>5</sub> can then be made,



The unit with lid and battery removed from container

after which the a.f. board may be brought close the r.f. board.<sup>1</sup> Interboard positive and negative supply lead connections are then made and a flying lead from point "X" is twisted around T<sub>1</sub>. The unit is now ready but it should not be inserted in its case until it has been calibrated.<sup>2</sup>

### Calibration

With a short length of cable connected between the generator outlet and the input of a transistor or other suitable receiver—and preferably via a dummy load or a 400Ω resistor—connect up the battery. Modulated oscillations due to "Oscar" should then be heard over the medium waveband. If a transistor set is in use keep its volume control setting as low as is practicable. A blank card dial temporarily affixed to the control lid of "Oscar" can be tentatively filled in using a pencil by beating the device against transmissions of known frequency. Try to arrange, by core adjustment in T<sub>1</sub>, that

<sup>1</sup> Holes 3 to 8 of strip "A" of the a.f. board (Fig. 3) are not used for connections. The copper stays could, therefore, be soldered between any of these holes and strip "A" (holes 4 to 8) or the lower stay wire of Fig. 4.—EDITOR.

<sup>2</sup> Calibration may shift slightly if the unit is later inserted into a cocoa tin, instead of into a non-metallic container.—EDITOR.

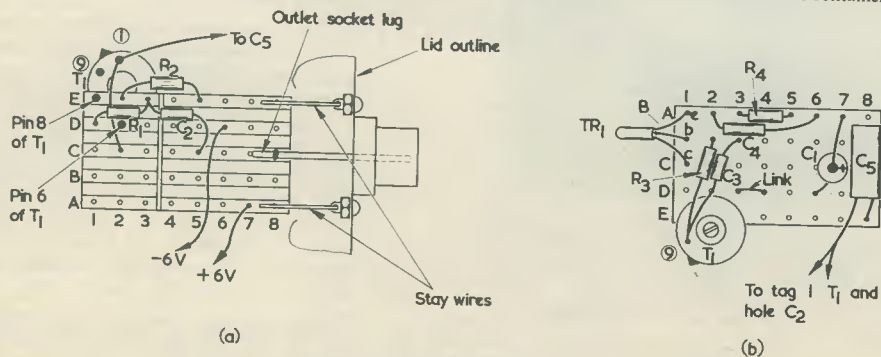

Fig. 4. The conductor side (a) and plain side (b) of the r.f. board

the Wales Home Service (881 kc/s) appears on the high frequency side of the mid-scale setting of  $C_5$ .

Various even figure points can be found by making use of the B.B.C. Light Programme and harmonics. For example if a 500pF capacitor ( $C_1$ ) is temporarily wired across  $C_5$ , "Oscar" can be made to generate a 200 kc/s signal which can be checked against the Light Programme on the long waveband of the receiver. When zero beat has been found, switch the receiver to medium waves and search around 500 metres until a signal due to "Oscar" reappears at 600 kc/s (third harmonic). Leaving the receiver set to this frequency disconnect  $C_1$  and adjust the generator dial until the signal fundamental is heard. This should appear at about 75% of full scale. Mark the scale "600". Leave "Oscar" as set and tune

the receiver until the note reappears at 1200 kc/s, then tune "Oscar" (to about 25% of full scale) to hear the fundamental. Mark the scale "1200". Many other calibration points—400, 800, and so on—can be similarly obtained by making use of harmonics and, although spurious responses may tend to be misleading at first, it is fairly easy with practice and patience to decide which is the correct one to choose.

The scale need not be directly calibrated, of course. A graph prepared against a 0–100° dial can be used instead, if preferred.

Final work consists of completing the scale in indian ink, locating the battery connectors and making the outside of the container attractive either by painting it or by affixing a suitable oddment of Fablon or other adhesive material.

## Heathkit Transistorised Regulated Power Supply — Model IP-20U

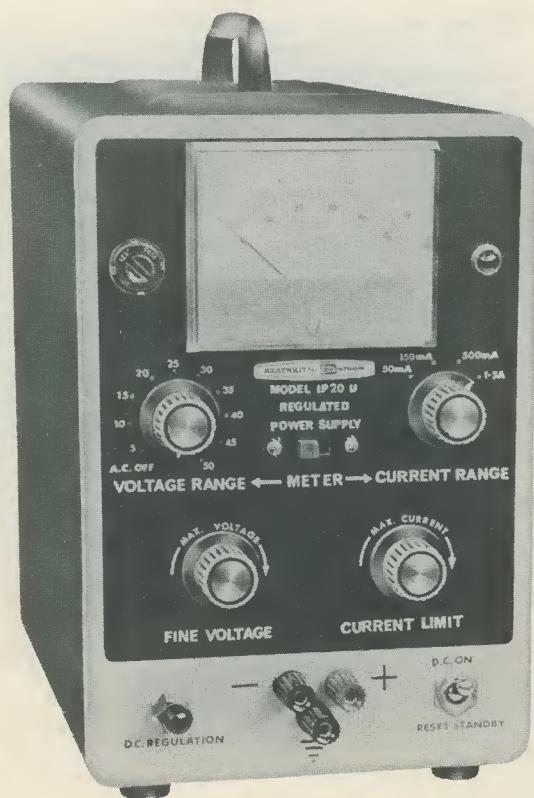

Delivering up to 1.5A, 0.5 to 50V d.c. with less than 150 $\mu$ V ripple the Heathkit model IP-20U will be invaluable wherever a well regulated variable power source is required. The power supply features an automatic current limiter to protect the load as well as its own circuitry, and an overload relay for protection in the case of a direct short circuit or heavy overload.

The power supply output is monitored with a 2 $\frac{1}{2}$ in scale meter, a slide switch selecting either current or voltage. The instrument has four current ranges, providing 50mA, 150mA, 500mA, and 1.5A, these also being shown by full scale deflection of the meter. There are ten voltage ranges, the full scale meter deflections being at 5, 15 and 50V. The d.c. regulation control makes it possible to obtain ideal d.c. regulation at any voltage setting from 1 to 50.

Other specification features are load regulation  $\pm 15$  millivolts (can be adjusted for no change); line regulation less than 0.005% change for 5% supply change; transient response less than 25 microseconds; output impedance less than 0.1 $\Omega$  d.c. to 10 kc/s, less than 0.5 $\Omega$  10 kc/s and up; output terminals positive, negative and chassis earth. Power requirements are 100–125V; 200–250V; 40–60 c/s, 136 watts at full load (50 volts at 1.5 amperes); Dimensions 9 $\frac{1}{2}$ in high x 6 $\frac{1}{2}$ in wide x 11in deep, net weight 16lb.

Available this month as an easily-assembled kit at £35 8s 0d, direct from Daystrom Limited, Gloucester.

# NEWS

## AND

# COMMENT

### Young Topics

In the Saturday feature in *The Daily Telegraph* under the above title, there appeared in a recent issue an article "You, too, can be a world explorer—if you go by Radio".

This article, by Derek Norman, has been described by the journal of the Amateur Radio Mobile Society as one of the best on Amateur Radio that they had read in a newspaper, and we entirely agree with their comment that the article was "concise, accurate, informative and most amusing".

We were particularly pleased with the accuracy of the information given, being such a refreshing change from the usual references to Amateur Radio in the National Press. Anyone reading about Amateur Radio for the first time would obtain a very good impression of the interest the hobby provides, how to start, and what you have to do to qualify for a transmitting licence. There was a section on radio construction, and we were gratified to see that we were one of the two magazines mentioned in that connection.

Incidentally the word "ham" was not mentioned once, which of course pleased us. It has been suggested that it would be a good idea if The Radio Society of Great Britain could include the article in their publicity.—we agree.

### Exports Up 40%

There is no doubt that the electronics industry can, and does, play an important role in overseas sales by this country, which are so necessary to uphold our standard of living.

An example of what can be done is given by Morganite Resistors Ltd., of Bede Estate, Jarrow, who have achieved export sales in 1964 which are over £700,000 and 40% above their previous best of £½ million.

Although the amount may not seem very large in comparison with Capital goods exports, this achievement represents the export of some 230 million resistors for radio, TV, computers and other electronic equipment.

With their recent entry into the U.S. market, Morganite can claim to be the predominant resistor

exporter in this country, covering almost 50 overseas markets.

This is a considerable success in a highly competitive market.

### A Senior Modeller

Air Vice-Marshal B. A. Chacksfield, Commandant-General of the Royal Air Force Regiment, has been appointed to succeed the late Lord Brabazon as President of the Society of Model Aircraft Engineers.

His interest in aircraft modelling dates from his apprentice days at R.A.F. Halton, when he was selected as a member of the 1930 British team for the Wakefield Trophy contest—the leading international event. He recalls that the Americans—then substantially ahead in the use of balsa wood—won handsomely. In more recent years, as Air Officer Commanding No. 22 Group he was host to the 1960 radio-controlled model championships at R.A.F. Kenley. He still takes a personal interest in modelling and during the past year has assisted his son, Flying Officer C. C. Chacksfield—a Vulcan pilot in No. 35 Squadron—with a radio-controlled model.

### For Your Diary

The International Short Wave League Broadcast Bands Contest, 1965, commences at 18.00 hrs. GMT on Saturday, 6th March, and concludes at 18.00 hrs. GMT on the Sunday.

The contest is only open to members. Details of membership can be obtained from the Honorary Secretary, Peter Bysh, International Short Wave League, 12 Gladwell Road, London, N.8. There is still time to join and be eligible to take part in the contest.

On 17th and 18th March, the International Golden Jubilee of Public Address Exhibition is to be held at the Kings Head, Harrow, Middlesex, from 10 a.m. to 6 p.m. on the first day, and from 10 a.m. to 5 p.m. on the following day.

Goodmans Industries are among the exhibitors and their exhibits will include the Audiom 91 Standard—18in diameter—50 watts power handling loudspeaker, in heavy demand for the Electric Guitar, Electronic Organ and Musical Instrument industry.

### The '65 Show

The National Radio Show is to be called The '65 Show, or, to give its full title—The '65 International Television Radio Record player Disc Tape recorder Stereo Hi-fi and Musical Instrument Show.

For the first time overseas manufacturers of all these types of equipment will be invited to participate alongside British companies in an international occasion for the television and radio industries of the world. The '65 Show will now rank as one of the major international television and radio shows and will be on a scale which will command the full attention of the world's leading buyers and will be the big export occasion of the year for British manufacturers.

Keynote of The '65 Show will be spectacular entertainment, and the layout and presentation of the Show will be entirely redesigned in order to provide the widest possible public appeal. To this end broadcasting and television organisations, manufacturers and the popular musical press will all be presenting continuous programmes, major displays and demonstrations throughout the period of the Show.

Special facilities will be extended to radio dealers throughout the country to enable them to bring customers in their area to the Show and attend to their requirements.

For The '65 Show there will be two simultaneous 405 line and one 625 line demonstration channels, together with AM/FM and medium and long wave radio wavelengths available to exhibitors simultaneously during the hours programmes are being broadcast on the public television networks. Exhibitors will thus be able to show all programmes simultaneously on different receivers on their stands. At all other times programmes will be broadcast on the organiser's own closed circuit network.

The '65 Show will be open to the public between 10 a.m. and 10 p.m. from 25th August to 4th September (excluding Sunday). It will be open to trade buyers only on 24th August.

The price of admission to the public will be 3s. 6d.—1s. 9d. children.

# 3-Stage Pre-Selector for the Beginner Part 1

E. GOVIER

*This two-part series has been specifically written for the beginner who has a little constructional experience and who owns either an older type communications receiver or one having no existing r.f. stage. The subject of r.f. amplification is introduced in general terms understandable to the beginner and linked with three constructional projects (1-, 2- and 3-valve designs) either of which may be undertaken separately as desired. The 1-valve unit is described this month, and next month's article shows how this may be converted to the 2-valve or 3-valve design, should these be desired*

THE WRITER OFTEN USES AS A standby receiver an early (circa 1930) communications receiver of American manufacture which is, in essence, a "dressed-up" 4+1 superhet, the line-up being exactly the same as any domestic radio of the period—the only major departure (apart from the black crackle metal cabinet and communication-type anodised aluminium dials) being the inclusion of a triode serving as a b.f.o. (beat frequency oscillator). With these old pre-war receivers, whose octal-based valves are not exactly up to modern standards, selectivity and sensitivity tend to be modest. Judging from recent perusals of small advertisements in various radio journals there are still many of these receivers being offered for sale, usually at reasonable prices.

For any beginner Short Wave Listener who is already in possession of a home-built t.r.f. or "straight" set and who does not feel capable of constructing a superhet design, such a purchase is indeed well worthwhile—provided a pre-selector is interposed between the receiver and the aerial.

Such communications receivers can, of course, be "hotted-up" by experienced constructors in order to considerably improve the overall performance. This process is not,

however, recommended where beginners are concerned for, apart from the usual lack of knowledge and experience, test equipment is also in most cases absent. All manner of unwanted side-effects can result from the "hotting-up" efforts of those not versed in superhet (communications types especially) design.

A far better and easier method for the beginner to adopt in order to considerably improve a receiver of the type under discussion is to construct a comparatively simple unit whose main function in life is to amplify the small radio frequency (r.f.) voltages fed from the aerial and pass these into the receiver input sockets. Moreover, if we include in the circuit a coil and a variable capacitor, the unit then becomes a tuned r.f. amplifier and will, in addition to amplifying the small signal voltages, select that signal which we require and help in rejecting those that we do not require. From the foregoing, the beginner will now see that two major advantages are conferred—there is added signal strength (r.f. gain) and improved selectivity. In simple terms, the former advantage implies that the "range" of the receiver is greatly increased. Signals that were formerly only just audible (or in many cases

inaudible) now become completely intelligible.

Other advantages are also gained by the inclusion of a pre-selector unit, these varying in degree according to the design of the unit and the receiver with which it is to be used. The advantages are that image breakthrough, heterodynes and i.f. breakthrough become eliminated. These three short-comings are fairly common in receivers having no tuned r.f. stage and are evident as audible whistles, "noises-off" and signals appearing at dial settings where in fact they should not be heard at all.

In most receivers there is, under no-signal conditions, an inherent noise level due to the normal operation of the valves in the circuit. Any signal received must overcome this generated noise in order to be intelligible. Unless this happens, no amount of amplification subsequent to the receiver, such as an audio amplifier, will enable the signal to be heard. Further, the noise level inherent in the first stage of the receiver is of very great importance since multigrad mixers such as heptodes and triode-heptodes (usually the first valve in a receiver without an r.f. stage) exhibit a high noise level with comparatively little gain. Our added tuned r.f. amplifier must therefore have as high a gain as possible consistent with a low noise level in order to provide an amplified signal which overcomes mixer noise.

From the foregoing we have then arrived at our first circuit (Fig. 1), this being a simple 1-valve tuned r.f. amplifier whose power supply may be taken from the receiver. If a power outlet socket is not provided at the rear of the set and the constructor does not wish to add the other pre-selector stages to be described next month, then the power will have to be provided by drilling through the rear apron of the receiver chassis, inserting a rubber grommet and feeding the three leads required (heater, chassis and h.t. positive respectively) through this grommet to the added unit. The receiver should be capable of providing the 10 to 15mA h.t. current required by the pre-selector.\*

From Fig. 1 it will be seen that

\* Beginners should ensure that the receiver in question is a.c. operated and is NOT a.c./d.c. Generally speaking, the receivers under discussion are mostly a.c. operated and include a mains transformer in the design thereby imparting complete isolation from the mains supply. The pre-selector unit must NOT obtain its power from a receiver having a "live" chassis.

## Components List

### Resistors

(All fixed values 20%)  
 R<sub>1</sub> 33kΩ 1 watt  
 R<sub>2</sub> 5kΩ ½ watt  
 R<sub>3</sub> 200Ω ½ watt  
 R<sub>4</sub> 5kΩ potentiometer

### Coils

Osmor type QA1, OA3, QA4 (see text)

### Pilot Light Assembly

Red, complete with bulb (H. L. Smith & Co. Ltd.)

### Chassis and Panel

(H. L. Smith & Co. Ltd.)

### Switch (S<sub>1(a)</sub>) (b) see text

### Tuning Dial

Scale, Ball Drive, Jackson Bros. type 4489. (Home Radio Ltd.)

### Capacitors

\*C<sub>1</sub> 410pF, single-gang variable, Jackson Bros. type 5250/1.  
 C<sub>2</sub> 0.01μF tubular (Mullard)  
 C<sub>3</sub> 0.01μF tubular (Mullard)  
 C<sub>4</sub> 100pF ceramic

### Valve

V<sub>1</sub> EF183 (Mullard)

### RFC

2.5mH (H. L. Smith & Co. Ltd.)

### Coaxial Plugs Sockets

Belling-Lee Sockets type L604/S, Plugs type L734/P/A. 2 of each. (Home Radio Ltd.)

### Miscellaneous

Valveholder (B9A) with centre spigot, grommets, knobs, nuts, bolts, 4-way tagstrips, etc.

\* Required for the 1-valve version only—see text. 500pF two-gang chassis mounting component required for 2 and 3-valve designs.

the valve chosen for the pre-selector is the Mullard EF183 variable mu r.f. pentode having a mutual conductance some 12.5mA per volt. It should be noted that the gain of an r.f. amplifier is roughly proportional to the mutual conductance of the valve used in such stage. The high gain of the EF183A has been achieved by specialised manufacturing techniques which we cannot deal with here. The input capacitance of the valve is similar to that of more conventional r.f. valves, with the added advantage that the signal-to-noise ratio at its output is very much greater.

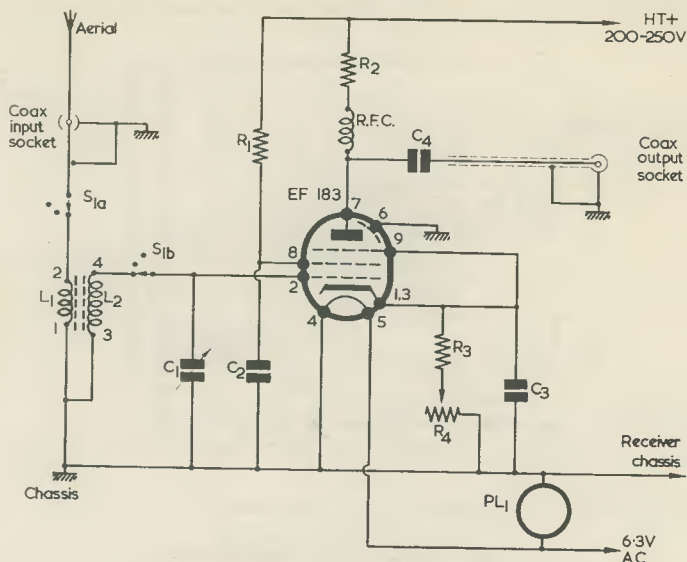

Fig. 1. Circuit of the simple 1-valve pre-selector

### Circuit

This circuit is that which should be built by the beginner who feels he is unable, or does not wish, to construct the 2 or 3-valve version to be described next month. Since there is only one tuned circuit, C<sub>1</sub> is a single-gang component. If the later versions will be eventually

required C<sub>1</sub> should be purchased as a two-gang component in the first instance.

The signal from the aerial is fed, via switch S<sub>1(a)</sub>, to the appropriate coil primary winding L<sub>1</sub>. The signal voltage is then induced into the secondary winding, L<sub>2</sub>, selected by S<sub>1(b)</sub>, is tuned by the

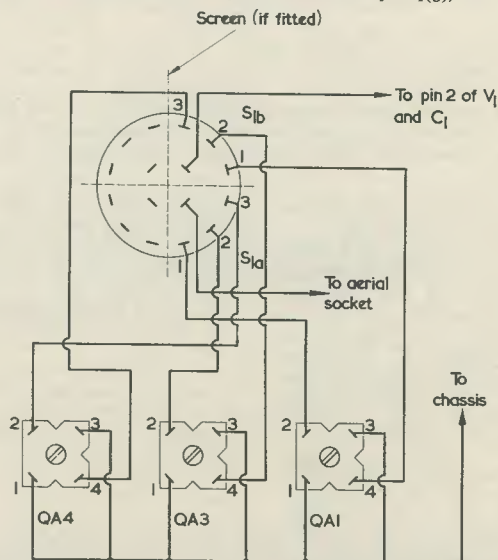
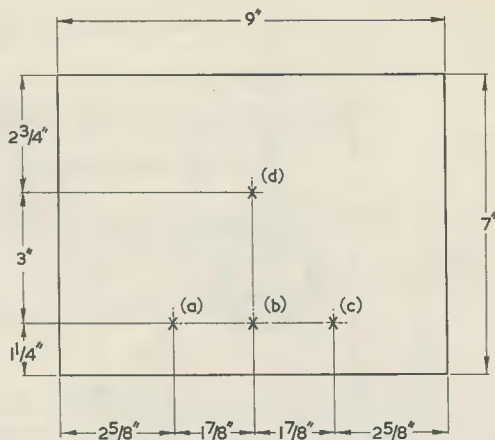
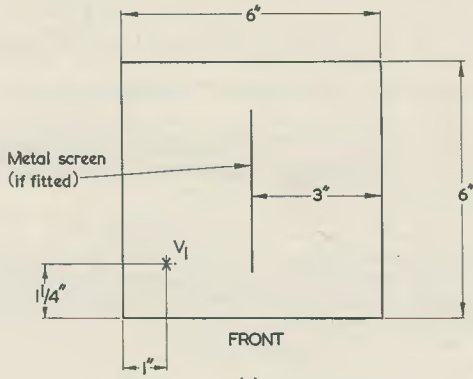

Fig. 2. Wiring details of the wavechange switch and three coils shown in "exploded" form. If the screen is fitted, all wiring should be on the V<sub>1</sub> side. The lead to the aerial socket is coaxial cable whose outer braiding is earthed at the socket. The chassis connection from the coils may be made either at V<sub>1</sub> valveholder or, when the screen is fitted, to the chassis tags mounted on this



(a)



(b)

Fig. 3 (a). Front panel measurements: (a) pilot lamp assembly, (b) wavechange switch, (c) r.f. gain control and (d) tuning control (b). Chassis dimensions. Note central metal screen, (see Fig. 6 and text)

variable capacitor  $C_1$  and passed to the pentode grid (pin 2).

The switch  $S_{1(a)}$ ,  $S_{1(b)}$  is a single component and beginners should not be deterred by the fact that the two sections are shown as separate entities in the circuit diagram. (See Fig. 2). Only one coil is shown in the circuit diagram for purposes of clarity although, in fact, three such coils are used in the design.

$S_{1(a)}$ ,  $S_{1(b)}$  is a 3-way, 4-pole wafer switch but, for those who only require the 1-valve design, it could be purchased as a 3-way, 2-pole type.

The three coils used are Osamor types QA1 (23 to 8.5 Mc/s), 13 to 35 metres; QA3 (8.5 to 2.5 Mc/s) 35 to 120 metres and QA4 (4.3 to 1.3 Mc/s) 70 to 230 metres. These frequency coverages assume the use of a 500pF variable tuning

capacitor ( $C_1$  of Fig. 1) but as a single-gang panel mounting component having this capacitance is somewhat difficult to obtain, the type specified here for the 1-valve circuit has a capacitance of 410pF;

this resulting in a slightly reduced frequency coverage but one which will not unduly affect the usefulness of the unit.

For those who aspire to the later designs, a two-gang 500pF component will be required, only half (the section nearer the panel) of this being used in the 1-valve design as a first step. Also required for the later designs will be a further set of coils (as listed above) but only one set is needed for the circuit of Fig. 1.

Fig. 2 shows an "exploded" view of the wiring between the switch  $S_{1(a)}$ ,  $S_{1(b)}$  and the three coils. A 3-way, 4-pole component is assumed, no connections being made to the two unused poles and their contacts.

$R_1$  supplies potential from the h.t. positive line to grid 2 (pin 8), this being bypassed to chassis via capacitor  $C_2$ .

Pin 6 of  $V_1$  should be wired direct to a suitable chassis earthing tag. H.T. positive is applied to the anode via the resistor  $R_2$  and the r.f.c. Grid 3 of  $V_1$  (pin 9) should be connected direct to both pins 1 and 3 of  $V_1$  (cathode) and taken to the centre tag of the potentiometer  $R_4$  via the resistor  $R_3$ . The potentiometer functions as an r.f. gain control.  $C_3$  is the cathode bypass component. Pins 4 and 5 of  $V_1$  are for the valve heater and pin 4 should be connected direct to chassis with pin 5 being taken to the 6.3 volt heater input line. It will be noted that a pilot lamp assembly (PL<sub>1</sub>) has been included in the circuit. This is not a necessity but it does enable the operator to ascertain that the unit is switched on as far as heater supplies are concerned.

The amplified r.f. output is taken from the pentode anode and passed to the output socket of the unit via the coupling capacitor  $C_4$ . As shown in Fig. 1, one end

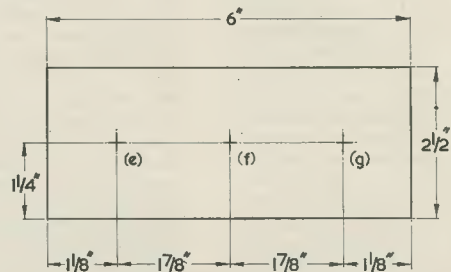

Fig. 4. Chassis back apron measurements: (e) r.f. output, (f) power input and (g) aerial input



of  $C_4$  should be connected to a short length of coaxial cable. This cable is connected at the other end to the output socket, the metal braiding being soldered to a suitable chassis mounted earthing tag at that socket.

Fig. 3 (a) shows the panel layout for the 1-valve unit, and it should be noted that this layout will also apply (with modifications) to the 2 and 3-valve designs. Chassis measurements are shown in Fig. 3 (b)—These similarly applying to the 2 and 3-valve circuits.

The metal screen indicated in Fig. 3 (b)—see Fig. 6—should be centrally mounted under the chassis by means of two 6BA nuts and bolts so that its length is from front to rear. The screen must be positioned as close to the wavechange switch,  $S_{1(a)(b)}$ , as possible without risks of short-circuits, and with due allowance being made for wiring-up. As is explained later, this screen need not be fitted to the 1-valve design.

Fig. 4 shows the chassis back-apron measurements, and is common to all designs.

#### Construction—1-Valve Design

Refer to Fig. 3 and drill, or cut-out, the aperture for  $V_1$  valveholder on the chassis. Next, drill the panel holes (a) for  $PL_1$  (if required); (b) for switch  $S_{1(a)}$ ,  $S_{1(b)}$ ; (c) for gain control  $R_4$  and (d) for the variable capacitor  $C_1$ .

Place the panel against the front apron of the chassis, secure the two firmly together and mark and drill the three holes (a), (b) and (c) in the chassis, using the panel as a template.

Mount  $V_1$  valveholder to the chassis ensuring, firstly, that an earthed soldering tag is mounted under one of the securing nuts and, secondly, that pin 2 of the valve is nearest to the switch. A small hole adjacent to pin 2 must be drilled in the chassis and fitted with a rubber grommet. This accommodates the lead from  $C_1$ .

Drill holes (e) r.f. output; (f) power input and (g) aerial input in the chassis back apron as shown

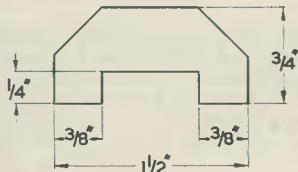

Fig. 5. Valveholder screen cut from small piece of tinplate

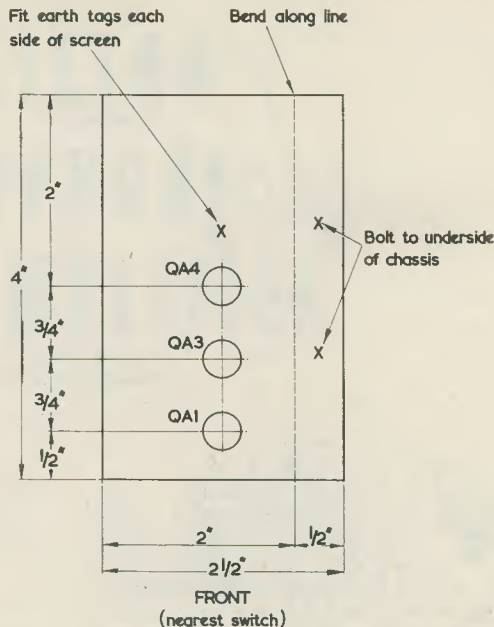

Fig. 6. Method of mounting the coils on the metal screen

in Fig. 4. Fit hole (f) with a rubber grommet and the remaining two holes with coaxial sockets, ensuring that the central connection does not foul the chassis at any point. Under one of the securing nuts of each socket fit a solder tag. To these tags are soldered the earthed braiding of the aerial input and the output coaxial cables, respectively.

Across the valveholder for  $V_1$  should now be soldered a small piece of tinplate to screen the output (pin 7) from the input (pin 2). This prevents instability at the high gain offered by the pentode, and it must be reliably connected to the chassis. This is done by soldering the screen across the valveholder such that it is connected at the centre to the central metal spigot, to pin 6, and to the earthed tag that was previously bolted into position with the valveholder. The dimensions of this small screen are shown in Fig. 5 and a plentiful supply of tinplate may be obtained from a discarded tin from the kitchen larder. Care should, however, be taken when cutting out the screen (preferably with tinsnips) as a slight slip may cause severe cuts. The screen, after cutting out, should be cleaned with the aid of a little petrol and a piece of rag prior to the soldering process.

The coils can now be mounted to the underside of the chassis and, with the 1-valve version, may be grouped conveniently around the switch with sufficient room allowed for connection purposes. However, this arrangement applies to the 1-valve design only. For those who intend to expand the circuit to the 2 and 3-valve designs, the coils should be mounted on the small metal screen shown in Fig. 6. This is bolted to the underside of the chassis deck with the coils pre-mounted, prior to securing into position the 2-gang 500pF variable capacitor required for the 2 and 3-valve designs. Coil mounting instructions are supplied with each coil and need not be repeated here. The coils should be mounted on the screen and in line, with the QA1 nearest the panel, the QA3 in the centre and the QA4 at the rear. If it is intended to build the later designs, a second set of coils will also have to be mounted to the screen before fixing the latter into position—it being much easier to carry out this task whilst the screen is outside the chassis. These coils should be mounted in the same relative positions as the first set of coils but slightly offset in order that the coil bases may be fitted to the screen without fouling each other. The second set of coils projects from the screen on

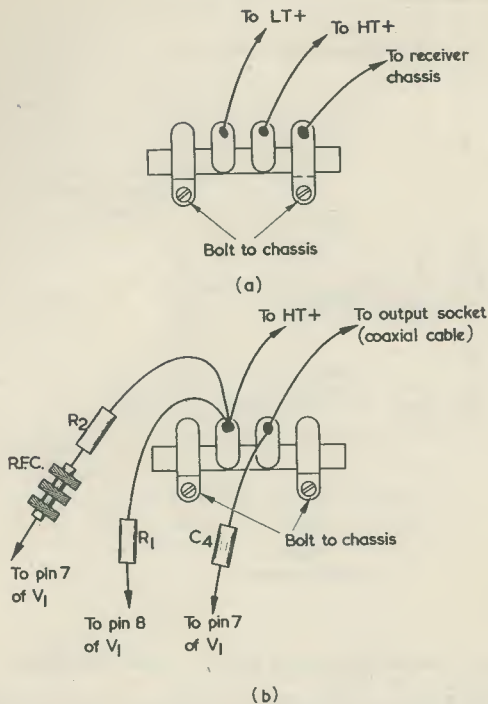

Fig 7 (a). Power input tagstrip and (b)  $V_1$  tagstrip showing component connections

the opposite side to the first. The first set of coils (those which are wired in at this stage) project on the same side as  $V_1$  valveholder.

A 4-way tagstrip should now be secured to the chassis at a point near the power input aperture—(f) of Fig. 4—and to the rear of the screen. Similarly a further

4-way tagstrip should be mounted into position to the rear of  $V_1$ , allowing sufficient distance from this valveholder for the soldering into position of  $R_1$ ,  $R_2$  and the r.f.c. (see Fig. 7). These tagstrips should be of the type having two earthed end tags for bolting to the chassis.

Wiring-up may now commence and an examination of the circuit diagram (Fig. 1) will show that all connection points have been numbered where applicable. The numbers around the valve refer, of course, to the tags of the valveholder looking at this component from the underside. These are numbered clockwise 1 to 9, commencing and finishing at the larger spacing in which is situated the connection from the central metal spigot. The coil tags are similarly numbered 1 to 4. Fig. 7 shows the wiring from two tagstrips, (a) being for the power input and (b) for the tagstrip near the valveholder.

#### Operation

With the valve inserted, the aerial plugged in and the connection between the receiver power supply and the aerial input made; select the range required on both the receiver and the pre-selector, advance the gain control  $R_4$  and bring the unit "into line" with the receiver frequency. That is, tune both the receiver and the pre-selector to the same frequency. If the unit is working correctly, this relationship will soon be apparent from the rise in signal strength obtained as the pre-selector is tuned through the same frequency as that selected by the receiver.

Throughout operations the pre-selector must be tuned "in step" with the receiver at all times.

Part 2, (the conclusion) will deal with the addition of a further tuned r.f. stage and a cathode follower output stage.

(To be concluded).

## M-O V. RECEIVE TRAVELLING WAVE TUBE CONTRACT FOR EARLY BIRD COMMUNICATIONS SATELLITE SYSTEM

The British Post Office has placed a contract with The M-O Valve Company Limited for high power travelling wave tubes for use in the "Early Bird" system, the world's first commercial communications satellite.

The tubes are water-cooled C-Band travelling wave amplifiers, giving an operating power output of 10kW at a frequency of 6301 Mc/s and will be used as transmitter amplifiers at Goonhilly Downs Station.

The tube uses a coupled-cavity slow wave structure of a type which gives high gain per unit length, good power handling capacity and freedom from unwanted oscillations. The tuning range of the r.f. structure is over 225 Mc/s and the small signal bandwidth better than 30 Mc/s (2dB points).

Focusing is achieved by means of rugged copper foil coils wound directly on to the tube body. This technique produces very good alignment between magnetic field and electron beam, thus reducing interception of the beam on the structure to a minimum. It also results in a much more compact assembly than could be obtained with a conventional solenoid, since the solenoid does not have to be large enough to pass over the waveguide outlets and also the good thermal contact between the coils and the body, which is water-cooled, avoids the necessity of having cooling fins or a cooling jacket on the magnet. The overall length of the tube is 36in, the diameter enclosing the waveguides  $12\frac{3}{4}$ in and the weight approximately 150lb.

The satellite, called HS303 and nicknamed Early Bird, will be launched this month into a stationary position 22,000 miles above the Atlantic to provide a 24-hour link between North America and Europe. It will transmit television programmes live, or provide up to 240 two-way telephone circuits.

# TRANSISTOR MICROPHONE PRE-AMPLIFIER

By A. D. M. KINLOCH

**T**HIS PRE-AMPLIFIER IS DESIGNED FOR USE WITH a low-impedance microphone and a medium or high gain amplifier having a medium or high input impedance.

## Voltage Amplifier

As may be seen from Fig. 1, the first stage is a grounded-base voltage amplifier and is directly coupled to the second stage, which is operated in the common-emitter mode. D.C. negative feedback is applied from the emitter resistors of the second stage to the base of the first, rendering the circuit thermally stable. At the same time, local a.c. negative feedback is applied to the second stage by the use of an undecoupled emitter resistor. The gain of the amplifier is controlled by applying a variable degree of overall a.c. negative feedback.

The method of connection adopted for the gain control in this design has two advantages which may not be immediately obvious. The first becomes evident when we consider what happens when  $VR_1$  has a low value. We see that the low-frequency impedance of  $C_3$  becomes comparable to that of the rest of the feedback path, so that less negative feedback is applied at low frequencies, bass emphasis being the result. Hence  $VR_1$  may be considered to be a loudness control or frequency compensated volume control. To appreciate the second advantage we note that the negative feedback voltage is developed across the microphone impedance, so that, if the microphone impedance increases for any reason, the feedback voltage increases also. Now it is a property of moving-coil speakers and microphones that their impedances at their major and minor resonant frequencies are higher than at other frequencies, and hence the negative feedback

## Components List

### Resistors

(All fixed resistors  $\frac{1}{4}$  watt 10%)

- $R_1$  22k $\Omega$  (see text)
- $R_2$  3.3k $\Omega$
- $R_3$  3.3k $\Omega$  (see text)
- $R_4$  3.9k $\Omega$  (see text)
- $R_5$  180 $\Omega$  (see text)
- $R_6$  220 $\Omega$
- $R_7$  1.2k $\Omega$

$VR_1$  20k $\Omega$  log, with switch (see text)

### Capacitors

(All capacitors are electrolytic)

- $C_1$  200 $\mu$ F 3V wkg.
- $C_2$  50 $\mu$ F 6V wkg.
- $C_3$  10 $\mu$ F 25V wkg.
- $C_4$  200 $\mu$ F 3V wkg.

### Transistors

- $TR_1$  ACY21
- $TR_2$  ACY21

### Battery

9 volt, type PP3

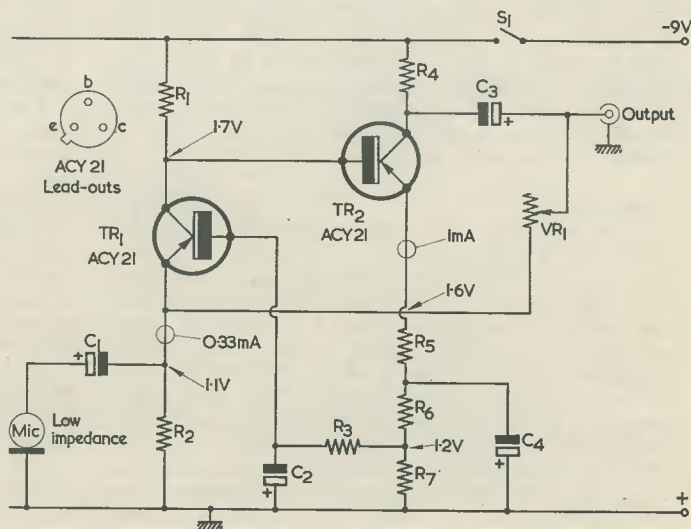

Fig. 1. The circuit of the microphone pre-amplifier

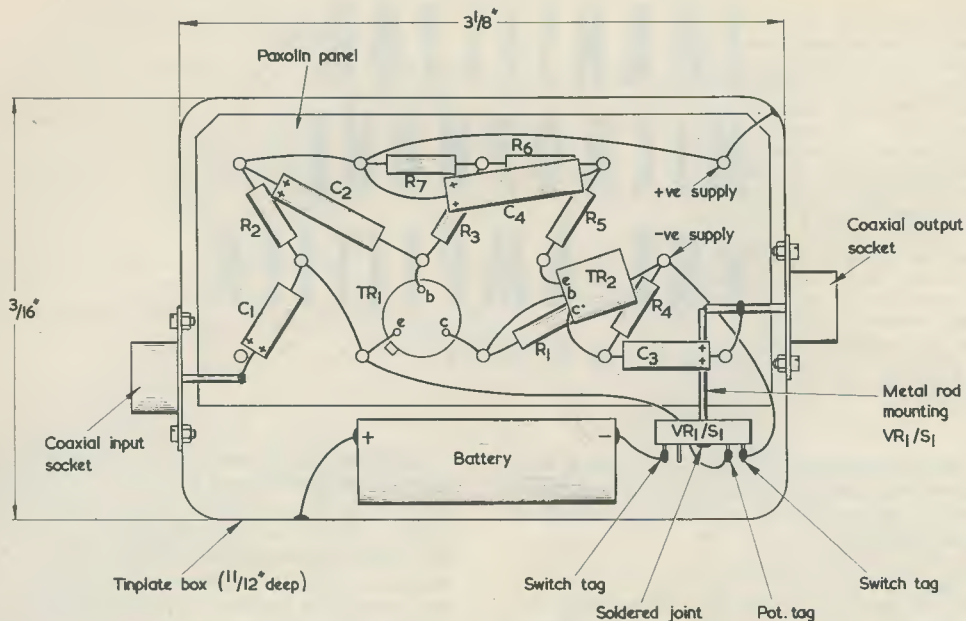

Fig. 2. The layout employed for the prototype

voltage at the microphone's resonant frequencies is greater than at other frequencies. In short, the amplifier tends to compensate for the humps in the microphone's frequency response curve.

In the prototype,  $R_1$  is an ordinary composition resistor, but a reduction of noise would probably result from the use of a high-stability resistor in this position. It might also be worthwhile to use high-stability resistors for  $R_4$  and  $R_5$ . The value of  $R_3$  in the prototype is  $33k\Omega$ , but this resistance is unnecessarily high for an amplifier which is not intended to deal with frequencies of the order of 1 c/s. The writer therefore suggests  $3.3k\Omega$  as a suitable value for  $R_3$ , especially as the thermal stability of the circuit is improved by the use of a lower d.c. feedback resistance.

### Construction

The prototype was constructed in a tinplate box fitted with a hinged lid. The layout is shown in Fig. 2. Component leads should be cleaned and tinned before mounting. Resin-core solder and a small electric soldering iron must be used and joints must be made as quickly as possible, being cooled immediately after the solder has wetted the joint. A heat shunt is essential when soldering in the transistors. Resistors are mounted first, then the capacitors and finally the transistors. Flexible leads should be attached to  $VR_1$  before it is mounted. In the prototype, the outer cover of the PP3 battery is removed to allow it to be fitted into the box, but this would not be necessary if a slightly larger box were used. If the outer cover is removed, the end plates of the battery should

be insulated from the surrounding metal by thin polythene. The Paxolin panel is insulated from the box by cardboard and plastic foam and may be secured by any convenient means. In the prototype it was held in position by the inside ends of the bolts securing the input and output sockets to the case. These had sleeving passed over them to prevent short-circuits.

Transistor  $TR_2$  is mounted on its side, whilst  $TR_1$  is mounted with its leads projecting upwards. Polythene sheet was placed under this transistor to prevent its case touching wires or anchor points underneath.

The circles shown in Fig. 2 represent anchor tags, or eyelets, in the Paxolin panel. All component leads should be sleeved if there is any risk of short-circuit.

The volume control and switch was mounted by passing a metal rod through its centre hole and soldering this at this hole and at the centre tag of the output socket. This also makes the connection to the potentiometer slider. Alternative controls may employ any other means of mounting and connection which is convenient. The component used by the writer was a type 20KSL, obtainable from Henry's Radio Ltd.

### Results

The prototype has been used with a transistor amplifier, a valve gramophone amplifier and a transistor tape recorder and has given satisfactory results in all three cases. The gramophone amplifier, however, was not fully loaded because it had only two stages of amplification.

# PEAK LEVEL INDICATOR

By A. R. HOARE

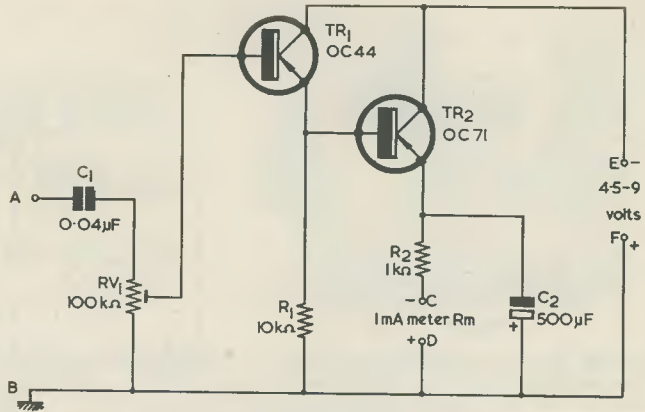

Fig. 1. The circuit of the peak level indicator

PEAK LEVEL INDICATOR CIRCUITS that include valves driving "Magic Eyes" or meters are restricted in use with tape recording and sound reproduction equipment if, because of the increasing application of transistors, a high voltage supply is not available. In this case, and in the case where a "Magic Eye" circuit has proved unsatisfactory, the circuit described here can be used to drive a moving coil meter and provide an inexpensive and reliable peak level indicator.

## Circuit Detail

The circuit is shown in Fig. 1, and can be used with the low voltage supply likely to be present in transistorised circuits. Alternatively, it can be used in valve circuits, if desired. The input impedance is of the order of 100kΩ, which is an acceptable load on most tape or audio amplifiers. Full scale deflection is achieved with a minimum input voltage of about 1 volt r.m.s., but of course the input potentiometer can be pre-set to give the required peak level reading.

A 1mA meter is illustrated, which would normally have an impedance

of 50-100Ω, but a more sensitive meter can be used if shunted to take 1mA at f.s.d. The circuit enables a rapidly changing input signal to be sampled for peak excursions which are, in effect, temporarily stored long enough to be seen on the meter. Signal on the input is current amplified by the two transistors, charging up C<sub>2</sub> to the negative peak of the signal (similar to compound emitter-follower action). After the signal peak, C<sub>2</sub> can only discharge through R<sub>2</sub>+R<sub>m</sub> as the two transistors will be reverse biased. Therefore, the decay time is related to C<sub>2</sub> (R<sub>2</sub>+R<sub>m</sub>) and can be adjusted by the value of C<sub>2</sub> to give suitable damping. The frequency response is approximately 3dB down at 40 c/s and 6 Mc/s when driven from a 75Ω source, the lower value being related to C<sub>1</sub>.

## Power Supply Details

The power supply can be provided in several ways.

A low capacity dry battery (independently switched) of 9 volts would last several months as the average current is only about 0.25mA.

A supply of -4.5 to 9 volts of rectified low tension can be used if the ripple is less than 1 volt peak-to-peak. If the supply is larger, it can be suitably decoupled to 9 volts, assuming a current of 2mA, as shown in Fig. 2. This steady current is needed to keep the voltage across the decoupling capacitor to a safe level.

The indicator can also be used with the h.t. supply normally found in valve circuits, by employing suitable decoupling, as shown in Fig. 3. In this instance, it is important to keep the ripple across the

decoupling capacitor below 10mV peak-to-peak, as this is in series with the input and will otherwise show up as a noticeable standing deflection. For example, with a 250V supply R<sub>s</sub> upon calculation is 120kΩ. With 100μF decoupling, the h.t. ripple can then be up to about 40V p-p.

## Construction

The constructed unit can be simple and small, suitable in fact to be mounted on the back of the meter. Fig. 4 shows a suggested layout.

## Application

The circuit can be used several ways: as a tape recording level indicator, as an audio power level indicator, as a stereo balance indicator, or as a radio tuning indicator.

Used as a tape recording level indicator, several test recordings should be made at noted increasing levels until distortion is just audible on playback. The peak level indica-

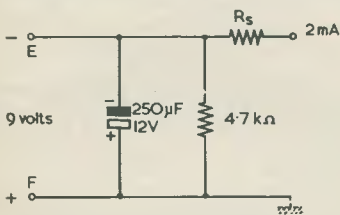
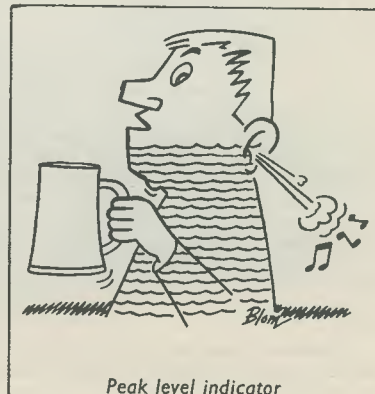

Fig. 2. Power supplies in excess of 9 volts can be applied to the unit via the decoupling circuit shown here



Peak level indicator

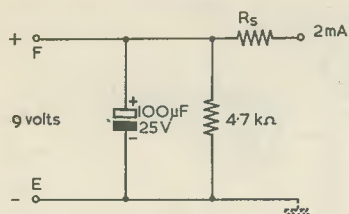

Fig. 3. A decoupling circuit which enables the indicator to function from valve h.t. supplies

tor can then be connected to the tape amplifier, and the input potentiometer set to give f.s.d. at the last recording level. Provided less than f.s.d. shows during normal recording, the recording will then be undistorted.

As an audio power level indicator, an r.m.s. voltmeter is needed to measure the power amplifier output, which should be connected to a dummy load of the loudspeaker value. Then with a variable level input signal (as given, for example, by a 6 volt supply and a potentiometer) the input potentiometer can be set to read, say, f.s.d. at 10W and the meter scale marked square law fashion for lower power levels; e.g.  $0.7\text{mA} = 5\text{W}$ ,  $0.5\text{mA} = 2.5\text{W}$ .

As a stereo balance indicator, either the peak level indicator

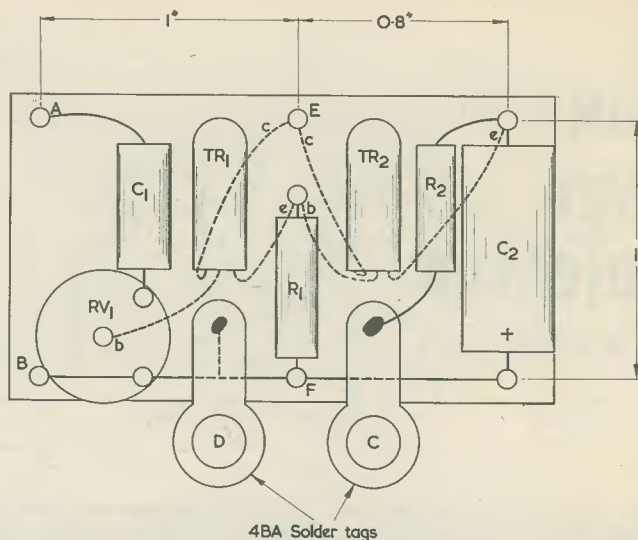

Fig. 4. A suitable practical layout which allows the unit to be mounted on the terminals of the meter. The 4BA solder tags are secured to the board with 8BA nuts and bolts

can be switched from one channel to the other, varying the balance control until both channels give the same deflection or, if the outputs are arranged to be in anti-phase, the balance control is varied until the sum of the two channels gives no deflection.

As a radio tuning indicator, the capacitor  $C_1$  can be short-circuited and the peak level indicator connected to a convenient point in the a.g.c. line. At optimum tuning, the a.g.c. voltage will be at a maximum and so will the deflection of the meter.

## V.H.F. Communications for Channel Tunnel Surveys

### Marconi Marine Supply 22 "Viscount" Transmitter/Receivers

In order to determine the feasibility and most suitable location for the proposed Channel Tunnel linking France and Britain, a detailed survey is being made of the geological conditions underseas and underground. The survey has been entrusted by the two Governments to the Channel Tunnel Study Group who have appointed five firms of engineering consultants (Rendel, Palmer & Tritton, Livesey & Henderson, Sir William Halcrow & Partners, S.O.G.E.I. and S.E.T.E.C.) as well as specialist technical consultants to help them with the work.

Part of the survey consists of boring in the sea-bed to obtain cores of the underlying ground. The contract for this work has been let to a Franco-British firm, Wimsey-Forasol. The contractor is employing a total of 11 craft of various sizes in order to complete the contract.

The need for rapid and reliable speech communications between all the vessels and with the two controlling shore stations at Dover and Calais is vital. To meet this requirement the contractor chose equipment from Marconi International Marine Co. Ltd., who are fitting "Viscount" v.h.f. transmitter/receivers to all the vessels and the shore stations on each coast. The sets will use a frequency channel specially arranged in consultation with Belgium by the British and French authorities.

The engineering consultants, having similar communication requirements, invited tenders from both British and French firms for appropriate equipment in order to establish reliable communication with their representatives on the contractor's vessels, their own three small craft, their land-based survey stations and their offices in Dover and Calais.

Marconi International Marine Co. Ltd., were chosen to supply "Viscount" v.h.f. transmitter/receivers which are at present being installed. The complexity of the communication links warranted the arrangement of a second frequency for unbroken communication between the Dover and Calais offices.

# The "Crystarlet"

## Crystal-controlled F.M. Tuner

Part 2

By SIR JOHN HOLDER, Bart.

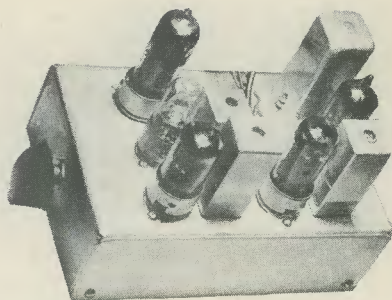

*In this, the concluding article describing the "Crystarlet" crystal-controlled f.m. tuner with switched station selection, full details are given of construction, wiring and alignment. An alternative ratio detector circuit is also discussed*

### The Chassis

FIG. 6 SHOWS THE CHASSIS DETAILS. THE MAIN measurements are almost identical with those of the "Crystella" unit described in the February and March 1963 issues, except that the chassis has been shortened due to the omission of one valve and one i.f. transformer. Dimensions for the screen and sides are given in Fig. 7.

The partition screen has been simplified and redesigned so that it can be fitted after the whole of the wiring has been completed.

Holes to take No. 4 P.K. self-tapping screws should be drilled in the chassis and screen flanges after bending up, using the holes in the side-pieces as templates.

### Wiring—First Steps

Wiring is easier if it is considered as being carried out in three successive "layers". The first of these consists of valveholder connections to chassis, bypass capacitors, grid resistors and cathode resistors. The last three groups of components should be close to, but not touching, the chassis. Make sure that all connections to chassis tags are well made because a dry joint here can cause plenty of trouble later on. In fact, if instability is experienced, it is a good bet that this is the cause of it. Wiring is shown in Fig. 8, and it should be noted that many of the connections are shorter, in practice, than those illustrated.

If  $C_{11}$ ,  $C_{13}$  and  $C_{21}$  are of the flat type, they can be stacked in a pile in this order, care being taken to ensure that the chassis end of  $C_{21}$  does not touch the "live" end of  $C_{13}$ .

Note that  $C_{24}$  is connected to pin 5 of  $V_3$  and  $C_{25}$  to pin 4 of  $V_4$  (pins 4 and 5 of each valve can be regarded as being joined together at v.h.f. frequencies via the heater, so that the two capacitors do the work of four).

Heater and h.t. connections can now be made using insulated wire, and including  $R_5$  and  $R_{22}$ .

Heater wires should be run in pairs close to the chassis. Twisting serves no useful purpose.

The tagstrips should be mounted after  $R_{18}$ ,  $R_{19}$  and  $R_{21}$  have been soldered to them.

### Second Steps

The second "layer" consists of the remainder of the wiring, with the exception of the items mentioned in the first paragraph, under "Final Steps" below. It is best to start at  $V_1$  and work round methodically in order to avoid mistakes and omissions.

The connections to crystals and between valveholders and transformers *must* be made by pieces of straight wire.

The external heater leads should lie flat against the chassis where they are inside it.

In connecting the diodes, great care should be taken not to overheat them. Each lead-out wire should be held in a pair of pliers whilst the connection is being made so as to "bypass" the heat as much as possible, and the minimum of heat should be applied.

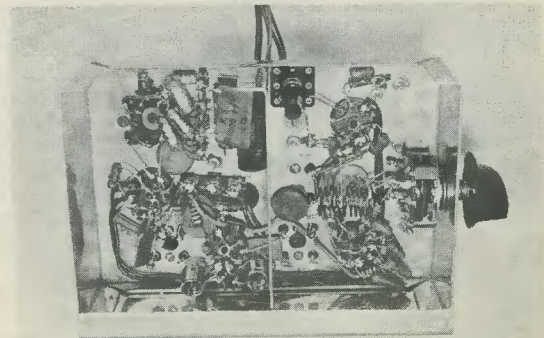

*The under-chassis wiring of the author's prototype. This uses the ratio detector circuit of Fig. 2*

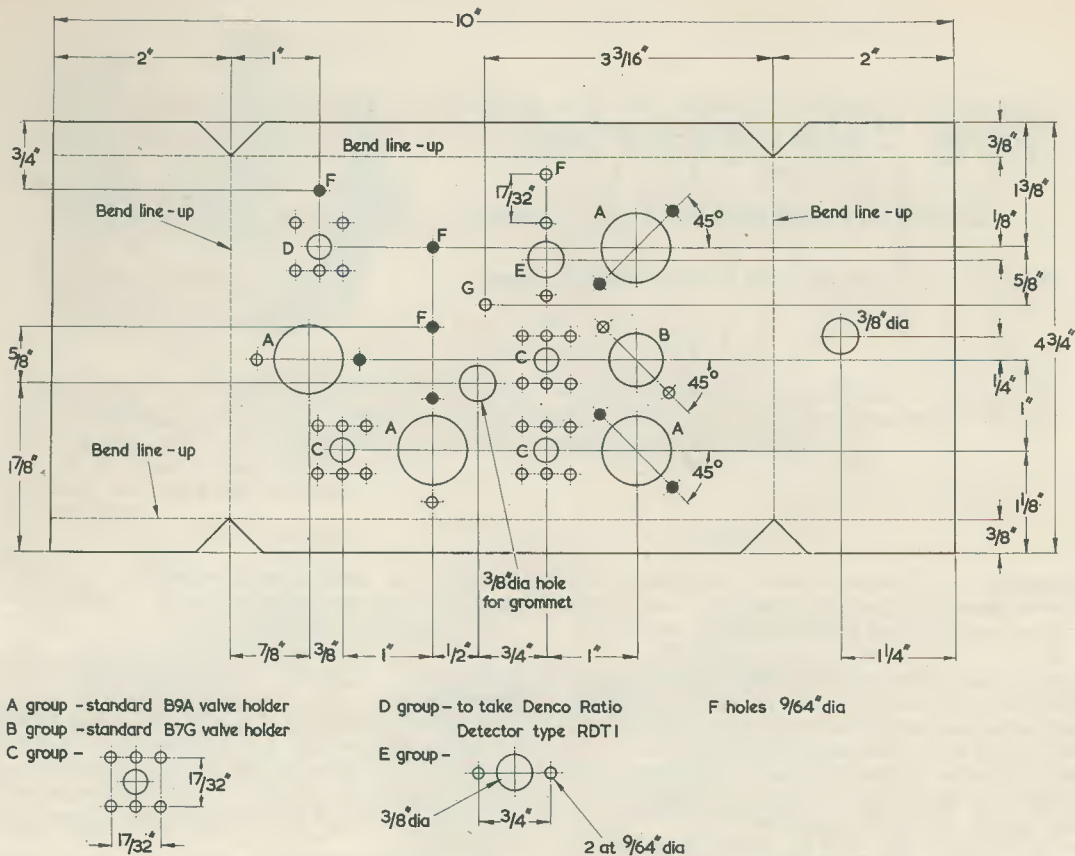

Fig. 6. The chassis dimensions. The shaded holes carry connections to chassis. In this diagram and in Fig. 7, holes marked "G" are drilled  $\frac{3}{32}$  in diameter. Corresponding holes to take No. 4 P.K. self-tapping screws are then made in the mating parts. The chassis material is 18 s.w.g. aluminium

### Final Steps

The last "layer" consists of the home-made coils together with  $R_2$ ,  $R_3$ ,  $C_3$ ,  $C_6$ ;  $C_{22}$  and  $C_{23}$ ; the h.t. filter resistors  $R_{12}$ ,  $R_{13}$  and  $R_{17}$ ;  $R_{23}$  and the three detector capacitors  $C_{15}$ ,  $C_{16}$  and  $C_{18}$ . The de-emphasis capacitor  $C_{19}$  can lie flat on top of  $C_{17}$ .

Components should not be positioned over valveholders as this will increase stray capacitances. An exception is  $C_6$  which must be so connected that its connections are as short as possible.  $C_6$  and its connection to  $L_2$  should be raised to not less than  $\frac{1}{4}$  in above the crystal connections and should be kept well clear of  $L_3$  (when fitted). Both the connections to pin 4 of  $L_2$  should be made with insulated wire.

The front end of  $L_3$  is soldered direct to the switch. See Fig. 9 and Fig. 4 (published last month). The rear end is connected to pin 1 of  $V_2$  via a short vertical length of thin wire soldered to the valveholder tag. This is to allow for subsequent adjustment of  $L_3$ , if needed.  $R_2$  and  $C_3$  rise vertically

and are joined at the top by the end of  $R_2$  which is bent at right angles for the purpose. The junction is then connected to the tap of  $L_3$  by a horizontal straight piece of wire  $\frac{1}{2}$  in long. It is important to adhere to this arrangement so as to avoid altering the inductance of  $L_3$ .  $R_3$  is connected in a straight line between the switch and pin 1 of  $V_2$ .

$L_8$  and  $L_9$  are soldered direct to the appropriate heater pins of the  $V_3$  valveholder, the axes of the coils being vertical.  $L_8$  should be at least  $\frac{1}{2}$  in clear of the partition screen and both coils should be  $\frac{1}{4}$  in clear of the side-piece. The upper ends are connected to pins 4 and 5 of  $V_2$ , using insulated wire run closely in the angle of the chassis.

$R_{23}$ ,  $C_{15}$ ,  $C_{16}$ , and  $C_{18}$  are mounted above the diodes and their connections must be as short as possible. Care must be taken to leave access to the slug of  $L_7$  without the screwdriver coming in contact with the diodes or  $R_{23}$ .

Every effort should be made to make the complete ratio detector section as compact and low-down as possible.



## Checking

On completion, check every connection with the circuit diagram. If the tuner will not work, it will most likely be due to wrong or badly-made connections. Pay particular attention to the connections to the valveholder pins. Before inserting the valves, use a continuity meter to check that there is no connection between h.t. positive and chassis, between h.t. positive and heaters, between heaters and chassis, and between the two heater connections.

The valves and crystal unit should then be inserted and as many of these tests as possible repeated. An internal short-circuit in a valve can be very annoying, especially if it is intermittent.

The diodes can only be tested before soldering in place. They should have a forward resistance of a few hundred ohms. The exact value is not so important as that they should both be the same. The reverse resistance should be a megohm or more.

Next, apply h.t. and heater supplies, switch on the power supply and check the h.t. voltages. The anodes of  $V_1$ ,  $V_2(a)$  and  $V_3$  should be only slightly lower in potential than the h.t. supply.  $V_2(b)$  anode will be around 100 volts and  $V_4$  anode will depend on the value of  $R_{17}$ , being probably about 50 volts.

Pins 1 and 3 of  $V_1$  should be 2 to 2.5 volts positive with respect to chassis and pin 3 of  $V_4$  about the same.

If no sounds are heard in the loudspeaker during these tests, it means that there is a wiring fault somewhere; and the offending stage can be located by tapping each grid connection successively with a screwdriver, a noise indicating that all stages after and including the one tapped are "alive".

## Adjusting the Front End

Alignment may now commence, and an aerial should be connected.

The slugs of  $L_1$  and  $L_2$  should be adjusted initially so that they are just entering the windings. *The makers' settings for the i.f. transformers and ratio detector should not be altered until the front end is working correctly.*

In all probability, at least one of the local f.m. programmes will now be heard.

The tuning of  $L_1$  is very broad and a good signal will be received with the slug in almost any position. On the other hand, although there is a range of adjustment over which  $L_2$  will work, it has a profound effect on  $L_3$ , as will be explained later.

If  $L_3$  has been correctly made, it should require little or no adjustment. Some readers who constructed the "Crystella" failed to get it to work at first, because they concentrated on adjusting  $L_3$  whereas, in fact,  $L_2$  was at fault. The oscillator is not temperamental and will do its best to work, but can be prevented from doing so if  $L_2$  is adjusted so as to load it incorrectly.

If  $L_3$  has been made so that it is already within the working limits, it will be found that there is a range of adjustment of  $L_2$  within which all the programmes will be heard. If the slug is screwed in too far, the oscillator will stop working on one or more of the three frequencies and the same thing will happen if it is withdrawn too far. It is of no account, however, if it should happen that the inductance of  $L_2$  is not high enough to prevent the oscillator from working when the slug is in the centre of the coil.

If the slug is withdrawn gradually, it will be found that signal strength (as indicated by the direct voltage between Test Point 2 and chassis) increases

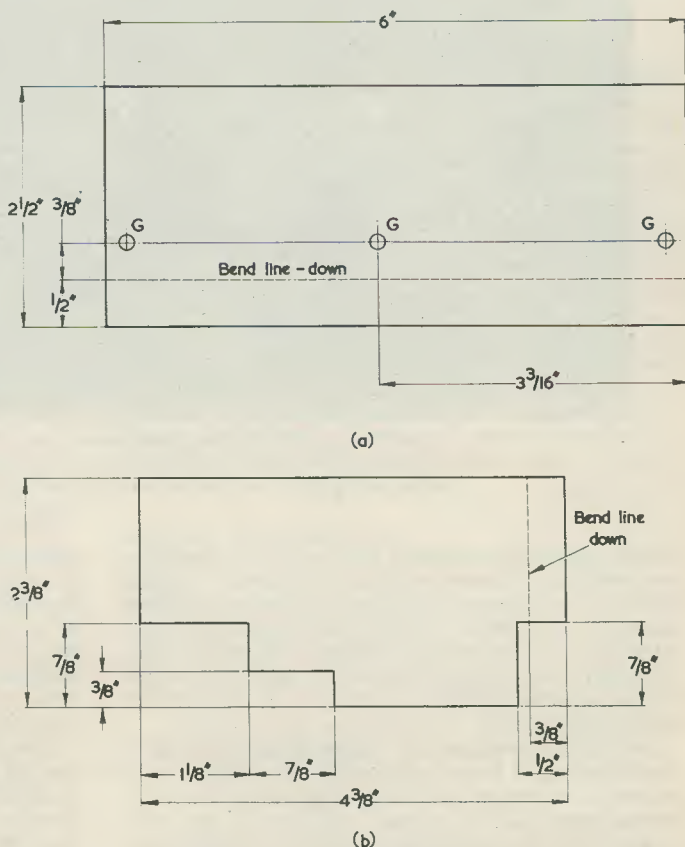

Fig. 7 (a). The side pieces. Two are required, one without the centre hole. Material is 18 s.w.g. aluminium  
(b). The partition screen. Again, the material is 18 s.w.g. aluminium

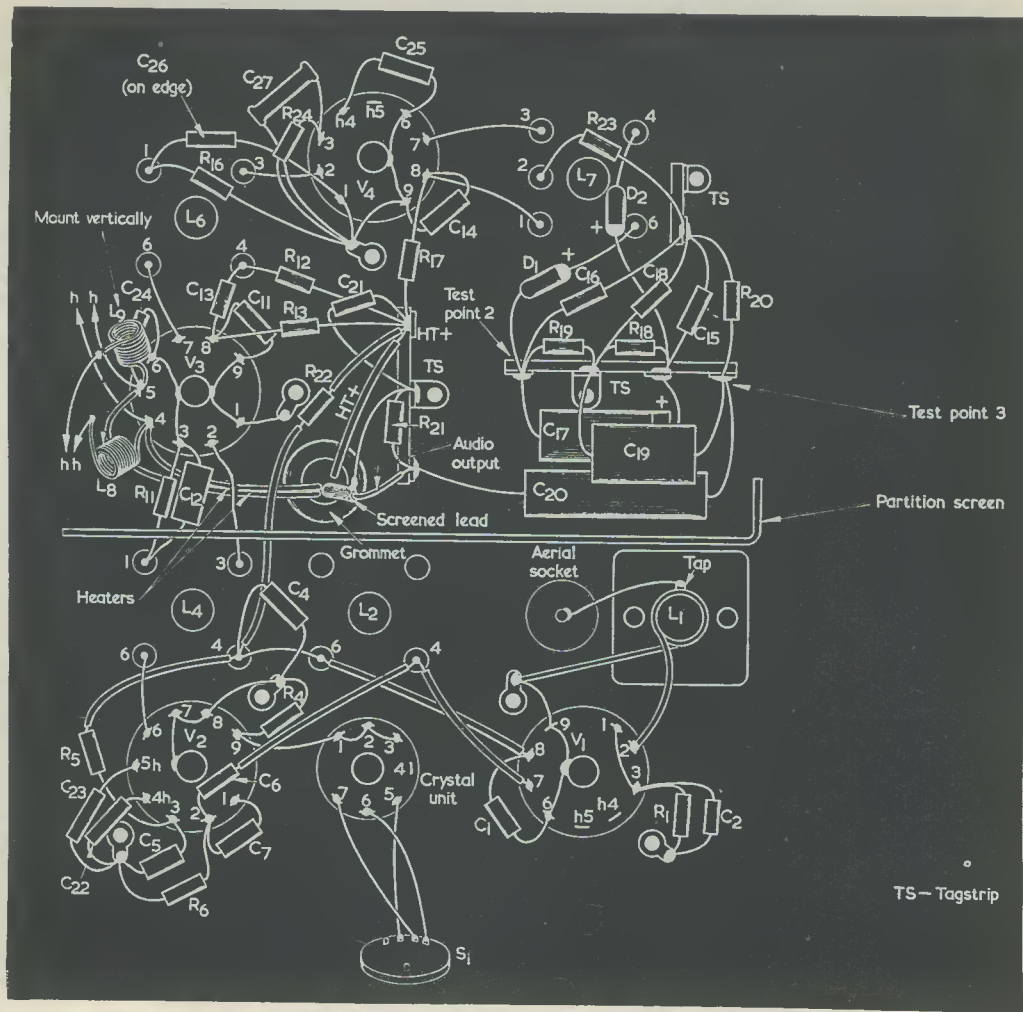

Fig. 8. The layout and wiring below the chassis. The heater, h.t. supply and audio output leads pass through the grommet to the top of the chassis. The heater wiring should conform to the circuit of Fig. 2

slightly but that it suddenly falls to zero at a certain slug position. If the slug is now screwed in again slightly, oscillation will only recommence if the oscillator is given a "kick" such as is given by operating the programme switch. The slug should be still further screwed in, until oscillation starts without external assistance and this is the correct adjustment.

Only if all programmes cannot be obtained at a single setting of  $L_2$  should  $L_3$  be adjusted. This is effected by extending or compressing the coil, taking care that, after each adjustment, the two "halves" of the coil are the same size. (If the Light Programme cannot be heard, compress the coil. If the Home Service cannot be heard, extend it.)

Only very small adjustment, if any, should be needed and after each adjustment, the tests on  $L_2$  should be repeated. If  $L_2$  and/or  $L_3$  are grossly

maladjusted, and particularly if the two "halves" of  $L_3$  are unequal, oscillation can take place independently of the crystals. This will be evidenced by microphonic noises if  $L_3$  is tapped. There may, also, be howls due to acoustic feedback from the loudspeaker. Again, a programme may be heard with the switch in the wrong position or, even, when it is in the "off" position.

This microphonic effect is caused by alterations in the self-capacitances of  $L_3$ , causing alterations of oscillator frequency which are dealt with by the detector as frequency modulations. When the oscillator is working correctly the crystal, and not the coil, controls the frequency, and variations in  $L_3$  have no effect as long as its value remains within the working limits.

It is interesting to note that an oscillator coil as flimsy as the one used here would be useless for a

non-crystal-controlled oscillator. Every loud note from the speaker would set up a howl.

Howls and/or squegging can also occur if there is feedback of i.f. harmonic into the front end. This can be caused by unduly long connections or by the detector circuit being too bulky. A "dry joint" to the chassis or a faulty bypass capacitor could also cause the trouble. If the tuner is correctly constructed, this type of instability should never occur.

It is possible to tell when the oscillator is working correctly even when no signals can be heard because, when oscillation takes place, there is a distinct rise of h.t. voltage at  $L_3$  tapping point.

An indication that no spurious oscillation is taking place is that the d.c. voltage at Test Point 2 should fall completely to zero when the programme switch is moved to the "off" position.

### Test Points

We have already referred to Test Point 2. A Test Point 1—the voltage at the lower end of  $L_6$  secondary—was used in adjusting the "Crystella" because the voltages at subsequent points in the circuit are influenced by automatic gain control. The "Crystaret" has a different kind of limiter and the voltage at this point is erratic. At the same time, there is no a.g.c., so that the voltage at Test Point 2 offers a true guide to the adjustment.

There is, however, a slight snag. Whereas the direct voltage at Test Point 1 in the "Crystella" circuit is steady, that at Test Point 2 is influenced by the presence of amplitude modulation and it usually fluctuates slightly about a mean figure. Such fluctuation should be disregarded.

### Intermediate Frequency Adjustment

When the constructor is satisfied that the front end is working correctly, all the cores of the i.f. transformer and the Ratio Detector primary (top coil) can be adjusted for maximum voltage at Test Point 2.

When alternating voltage is applied to the diodes, it is rectified and builds up a direct voltage across  $C_{17}$ . This voltage is proportional to the mean applied signal. Half of it can be measured by connecting a voltmeter on a 25 volt range between

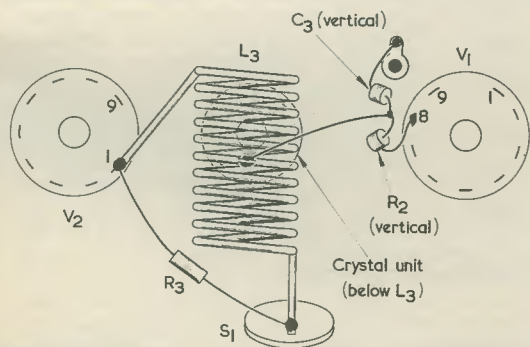

Fig. 9. Installing  $L_3$  and its associated components

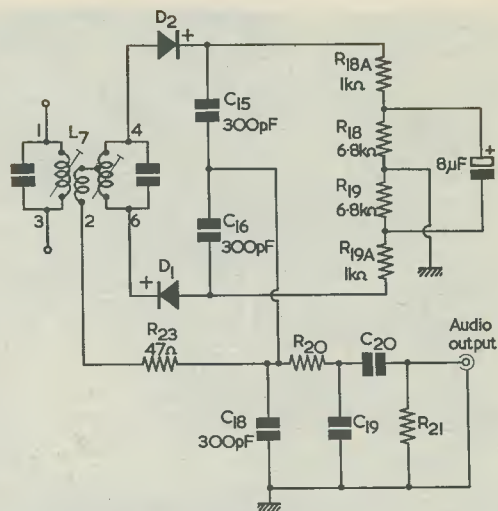

Fig. 10. An alternative ratio detector circuit. The  $8\mu\text{F}$  electrolytic capacitor may have a working voltage of 50 or 100

one side of  $C_{17}$  and the chassis. Test Point 2 is the negative side of  $C_{17}$ .

In adjusting the transformers, the usual remarks about false peaks apply, the correct peak, in every case, being that which occurs when the slug is nearest to the outer end of the coil. The best setting for  $L_1$  can also be found at this stage.

Having made these adjustments, transfer the meter to Test Point 3 and adjust the ratio detector secondary (accessible from inside the chassis) for zero reading. Here, there are three zeros, and the correct one is obtained in the following manner. Unscrew the slug completely and then progressively screw it in again. The voltage at Test Point 3 will rise and then fall to zero. This is the correct setting. A check is that the voltmeter should swing to either side of zero when the slug is screwed in or out slightly.

### Summary of Adjustments

All these instructions sound rather formidable, but in practice they are quite easy. They may be summarised in the following manner.

- (1) The tuner is very stable and docile. If given a chance it will work.
- (2) The front-end adjustments have a working range,  $L_2$  being the dominant adjustment (apart from selecting the correct crystal!).
- (3) By contrast, the rear end requires precise adjustment throughout, but the required settings differ little, if any, from those applied by the makers before the coils leave the factory.

As an indication of what may be expected, it was found that when the final version of the prototype was first switched on, all three programmes were audible and the only adjustment really needed was a slight alteration to the secondary of  $L_4$ .

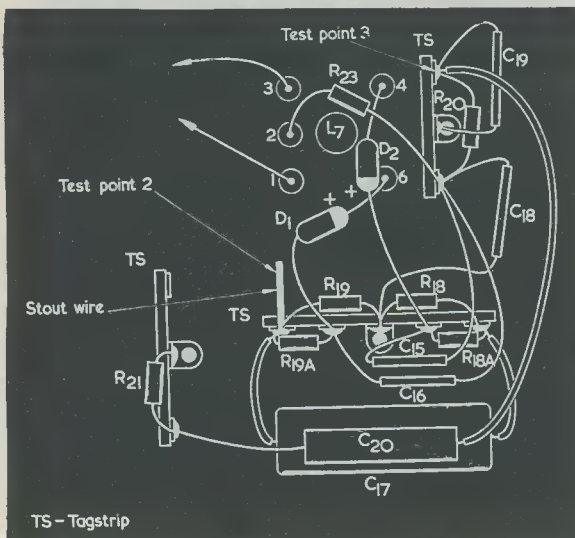

Fig. 11. Altered layout required by the circuit of Fig. 10. It should be noted that more tagstrip terminal points are needed here than for the layout shown in Fig. 8

### Adjusting the Gain

As the "Crystalet" has no automatic gain control, it is necessary to adjust the gain prior to the ratio detector, to suit the locality in which the tuner is to be operated. The gain is, to some extent, dependent on the h.t. supply voltage, but is fully controllable by altering the value of  $R_{17}$ .

Too small an input to the ratio detector will prevent it from working properly and cause distortion. The "Crystalet" detector works better with a larger voltage at Test Point 2, than is usual nowadays.

The objective is a gain which causes a voltage of between 10 and 20 volts at Test Point 2, with outside limits of 6 and 25.

The limiting action of  $V_4$  is greatest when it has an anode voltage of about 50, so that there should be a preference for a fairly high value for  $R_{17}$ . A valve of 22k $\Omega$  will probably give good results in the main service areas, lowering this to 10k $\Omega$  near the fringes.

Extreme range can be obtained by providing  $V_4$  with anode and screen-grid resistors of the same values as are used for  $V_3$ .

Extreme range can be obtained by providing  $V_4$  with anode and screen-grid resistors of the same values as are used for  $V_3$ .

### A Variation

It was intended that the "Crystalet" should be a simplified tuner and the ratio detector circuit

has been chosen to give the best all-round results consistent with easy construction; but an alternative, and rather more complicated and bulky circuit is here put forward, and readers who live in areas where multipath reception is troublesome may care to try it. A signal can be reflected from some large object, such as a block of skyscraper flats. If so, it will enter the receiver a fraction of a cycle later than the direct signal. This will give rise to amplitude modulation and under these conditions, it may be found that the alternative circuit, which conforms more closely to that recommended by Denco for use with their coils, will give better results. However, whether the extra complication and crowding of the chassis will be worth while can only be determined by trial. In some instances, it may even be found that the reverse is the case because, with only four valves, there are considerations other than optimum detector a.m. rejection which enter into the question. If the alternative circuit does effect an improvement, then the constructor will feel that his extra effort has been worth while.

The alternative ratio detector circuit is shown in Fig. 10. Where no value has been shown against a component, the value is the same as that in the standard circuit of Fig. 2. There is only just sufficient space in the chassis for the more numerous and, in some cases, larger components. Extra care is needed to avoid long connections to the "hot" portions and short-circuits. The leads to  $C_{17}$  and  $C_{20}$  should be insulated.

Fig. 11 shows the layout. If silver-mica capacitors are used for  $C_{15}$ ,  $C_{16}$  and  $C_{18}$ , they should be mounted on edge in the position shown. If rolled polystyrene ones are used, they can be mounted above the diodes, as in the standard version.

$C_{20}$  is not "hot" as regards i.f. harmonic and it can therefore lie on top of  $C_{17}$ , which must be tucked well down.

This detector has a somewhat lower sensitivity than the standard version. The voltage at Test Point 2 will therefore be lower, and 10k $\Omega$  will probably be best for  $R_{17}$ .

When measuring the voltage at Test Point 2 in the alternative circuit, there is a danger of touching the positive tag and the diodes may be damaged by the resulting excessive voltage. This danger can be minimised by soldering a short length of thick wire to Test Point 2. It should extend rearwards at an angle of about 45°. The test-prods can then be attached to this.

It is recommended that the constructor should first get the tuner working properly with the standard detector, and later change over to the alternative circuit, if he feels that it may provide an improvement.

(Concluded).

Next Month . . .

## SUPERHET S.W. RECEIVER FOR THE BEGINNER

# understanding radio

By W. G. MORLEY

## SMOOTHING CIRCUITS AND THE RESERVOIR CAPACITOR

IN LAST MONTH'S ISSUE WE CONTINUED OUR examination of the diode when employed as a rectifier in high tension power supply circuits. We saw how the addition of a reservoir capacitor to the half-wave rectifier resulted in a considerably "smoother" rectified voltage than was given by the rectifier on its own. We noted also that the rectifier is called upon to pass high peak charging currents; and that the half-wave circuit, with reservoir capacitor, may cause a peak inverse voltage of 2.828 times the r.m.s. value of the applied alternating voltage to appear across the rectifier.

### Full-Wave Rectifier With Reservoir Capacitor

Let us now examine the effect which is given by adding a reservoir capacitor across the load of a full-wave rectifier, as in Fig. 261 (a).

In Fig. 261 (b) we see the alternating voltage applied to the anodes of the full-wave rectifier, together with the voltage at the rectifier cathodes, the latter appearing across the load and the reservoir capacitor. This time the alternating voltage is shown as successive half-cycles without any interval between them (as occurred with the half-wave rectifier), and they consist of the positive half-cycles provided at each end of the transformer secondary relative to the centre-tap. Thus, the first half-cycle in the diagram could be that offered by the upper half of the secondary, the next half-cycle that offered by the lower half and so on. The reservoir capacitor now receives a charging current during every half-cycle, the current being passed first by one diode and then by the other diode. In the half-wave rectifier circuit we discussed last month the reservoir capacitor received a charging current during alternate half-cycles only.

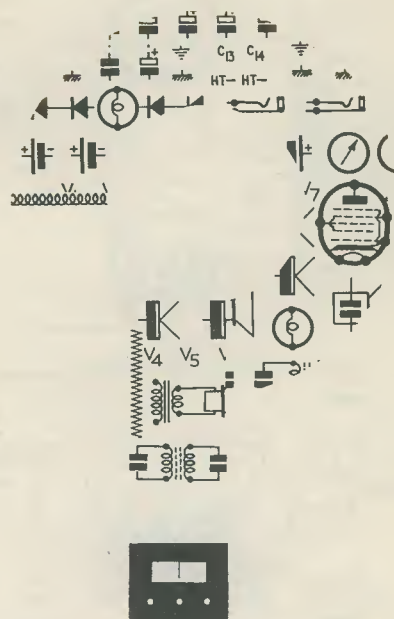

As with the half-wave rectifier, we obtain a direct voltage and an alternating ripple, and it is interesting to note that the fundamental frequency of this ripple is *twice* that of the alternating voltage applied to the transformer primary.<sup>1</sup> Also as before, a mean direct voltage is given, this appearing between the highest and lowest points of the ripple.

In Fig. 261 the reservoir capacitor is charged twice during each cycle instead of once. In consequence, and assuming the same working conditions (*i.e.* equal values of reservoir capacitance and load resistance, and equal applied voltages at the rectifier anodes relative to the negative end of the load) the rectified voltage offered by the full-wave circuit will be smoother than that offered by the half-wave rectifier. The rectified voltage offered by the full-wave circuit will also be higher, because the reservoir capacitor is charged twice as frequently.

The charging current in the reservoir circuit is shown in Fig. 261 (c). As is to be expected, this flows in alternate diodes during the periods when the reservoir capacitor charges. For the same rectifier output voltage (assuming equal values of reservoir capacitance and load resistance) the peak charging currents will be smaller in the full-wave circuit than in the half-wave circuit, this again being due to the fact that the reservoir capacitor is charged twice as frequently.

The mean direct voltage across the reservoir capacitor of Fig. 261 (a) will increase when the load current reduces and, if the load is removed altogether, will rise to the peak value (1.414 times the r.m.s. value) of the alternating voltage across

<sup>1</sup> The ripple voltages offered across the reservoir capacitor by the half-wave and full-wave rectifiers are not sine waves, and they both contain harmonics in addition to their fundamental frequency.

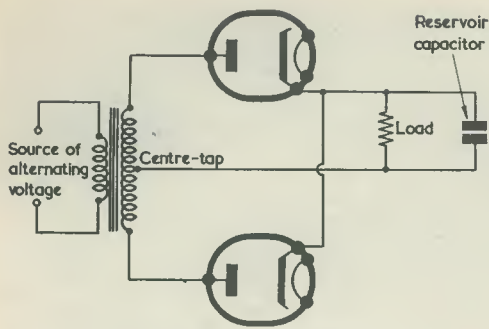

(a)

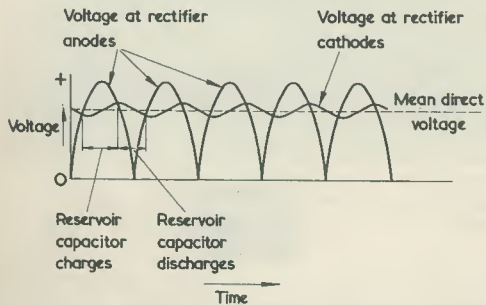

(b)

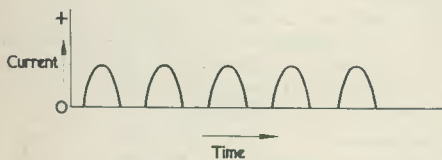

(c)

Fig. 261 (a). Adding a reservoir capacitor to the full-wave rectifier circuit  
 (b). The alternating voltage on the rectifier anodes, and the voltage at their cathodes. Both voltages are with respect to the lower end of the load resistor  
 (c). The charging current in the rectifiers

each half of the transformer secondary. The peak inverse voltage applied to each diode under no-load conditions is, therefore, 2.828 times the r.m.s. value of the alternating voltage across half the secondary, or 1.414 times the r.m.s. value of the voltage across the whole secondary. This fact can be readily demonstrated if, under no-load conditions, we temporarily remove one of the diodes, as in Fig. 262. The remaining diode then functions in the same manner as a half-wave rectifier with a reservoir capacitor where, as we have already noted, the peak inverse voltage is 2.828 times the r.m.s. value of the applied alternating voltage. In Fig. 262, the applied alternating voltage is that appearing across half the transformer secondary. Replacing the missing diode under no-load conditions does not alter these voltage relationships.

Valve rectifiers intended for full-wave operation normally employ two diodes in one envelope, and are specifically designed for use in full-wave circuits. The valve manufacturer's recommendations with regard to reservoir capacitance, maximum load current and limiting resistance then apply to the valve as employed in this type of circuit. Limiting resistance may be inserted as a physical resistor in series with each anode but, since the full-wave circuit requires a centre-tapped transformer winding, the effective internal resistance offered by each half of the latter may be greater than the minimum limiting resistance per anode specified for the valve, in which case no physical limiting resistors are necessary. With the half-wave circuit, which does not require a centre-tapped transformer winding, it is common practice to take the applied alternating voltage direct from the a.c. mains supply without a transformer. The mains supply may be assumed to offer an internal resistance of zero ohms in this application, whereupon for conventional valve rectifier circuits, a physical limiting resistor in series with the half-wave rectifier anode becomes necessary.

#### Bridge Rectifier With Reservoir Capacitor

Fig. 263 shows a reservoir capacitor connected across the load of a bridge rectifier. Since the bridge rectifier allows positive half-cycles without intervals between them to appear across the load and reservoir capacitor, the voltage across these components is the same as for the full-wave rectifier shown in Fig. 261. In company with the previous rectifiers we have considered, the mean direct voltage increases as load current decreases, reaching 1.414 times the r.m.s. value of the applied alternating voltage when, by removing the load, the load current is reduced to zero.

The peak inverse voltage for each diode in the bridge circuit is 1.414 times the r.m.s. value of the applied alternating voltage, and this may be demonstrated by considering the circuit when the applied alternating voltage is at peak value. Fig. 264 (a)

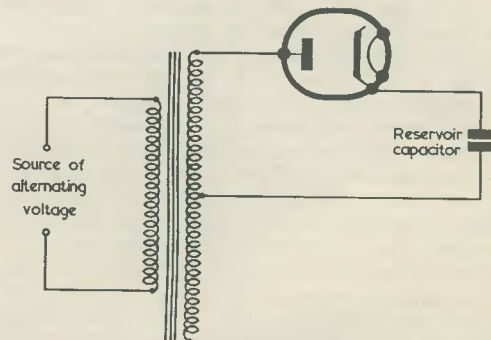

Fig. 262. The peak inverse voltage for each diode of the full-wave rectifier of Fig. 261 (a) is 2.828 times the r.m.s. value of the alternating voltage across half the transformer secondary. This fact is demonstrated by removing one of the diodes, whereupon the circuit resembles the half-wave rectifier

shows this situation, it being assumed that the upper terminal of the source of alternating voltage is positive and the lower terminal negative. The load shown in this diagram has a very high resistance, whereupon a voltage which is very nearly equal to the peak voltage appears across the reservoir capacitor. The polarities illustrated in Fig. 264 (a) correspond to conduction in  $V_2$  and  $V_3$ . Since the reservoir capacitor is charged to very nearly peak voltage, its right hand plate has negligible potential difference from the upper terminal of the source of alternating voltage. Similarly, its left hand plate has negligible potential difference from the lower terminal of the source of alternating voltage. The potentials which result at this particular instant of time could be given, with only negligible error, by removing  $V_2$  and  $V_3$  altogether, replacing them with short-circuits as illustrated in Fig. 264 (b). As now becomes apparent, the peak voltage is applied, with non-conducting polarity, across  $V_1$  and across  $V_4$ . The peak inverse voltage applied to these diodes is, therefore, the peak value of the applied alternating voltage, or 1.414 times its r.m.s. value.

If we repeat this exercise with the upper terminal of the source of alternating voltage negative and the lower terminal positive, we will find a set of conditions corresponding to conduction in  $V_1$  and  $V_4$ , and with the peak voltage applied with non-conducting polarity to  $V_2$  and  $V_3$ .<sup>2</sup>

When, last month, we referred to the advantages and disadvantages of the bridge rectifier and the full-wave rectifier we saw that the bridge rectifier has the disadvantage of needing two extra diodes and the advantage, particularly with high rectified voltages, of requiring only half as many turns in the secondary of a transformer supplying it. We may now see another advantage for the bridge rectifier. This is that, for a given rectified voltage

<sup>2</sup> The very high load resistance is included in Fig. 264 for purposes of explanation, as it ensures that the voltage across the reservoir capacitor does not quite reach full peak value. Had this occurred, there would have been no potential difference across the "conducting" diodes in the examples quoted and they could not, in consequence conduct! Without a load the circumstances shown in Fig. 264 (b) would still exist, but an accurate explanation would have needed to be a little more elaborate.

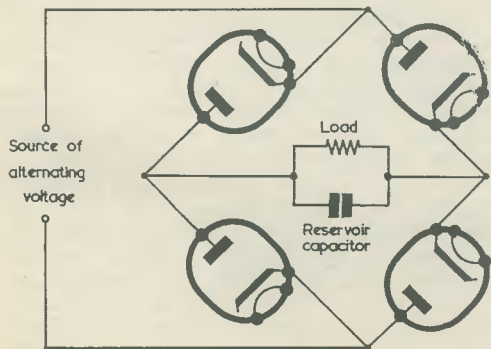
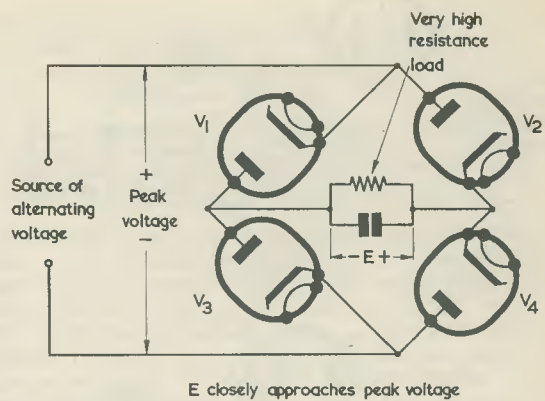
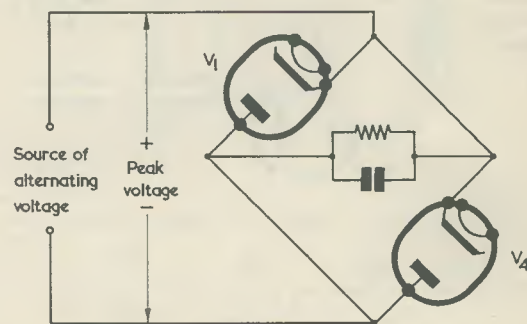

Fig. 263. A reservoir capacitor added to the bridge rectifier



(a)



(b)

Fig. 264 (a). The conditions which exist when peak voltage is applied to a bridge rectifier with the polarity shown

(b). When  $V_2$  and  $V_3$  are replaced by short-circuits, it can be seen that the inverse voltage across  $V_1$  and  $V_4$  is the peak value of the applied alternating voltage

output, its diodes may be rated at half the peak inverse voltage that is required for the diodes in the full-wave circuit.

### Filter Components

The addition of a reservoir capacitor to a rectifier circuit makes the rectified voltage smoother but, as we remarked last month, it does not make the voltage as smooth as would be given by, say, a battery. We shall now consider how additional smoothing may be carried out.

The voltage appearing across the reservoir capacitor comprises two "components",<sup>3</sup> these being the *d.c. component*, represented by the mean direct voltage, and the *a.c. component*, represented by the ripple voltage. What is now needed is a filter circuit which offers maximum opposition to the a.c. component and minimum opposition to the d.c. component. A suitable filter is illustrated in Fig. 265 (a), in which diagram we have a choke

<sup>3</sup> That is, two individual parts of a compound quality.

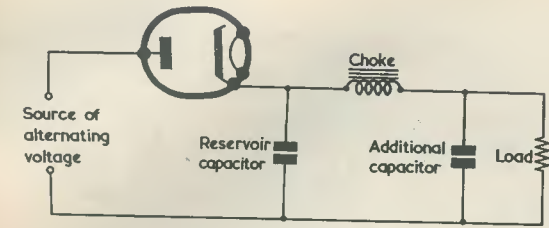

(a)

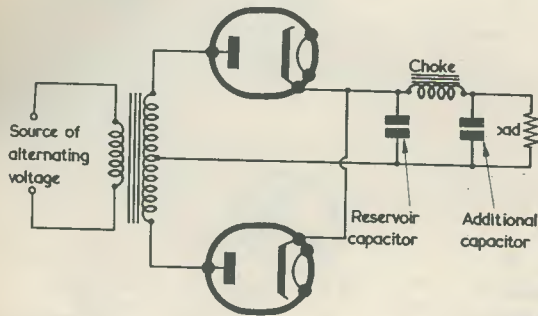

(b)

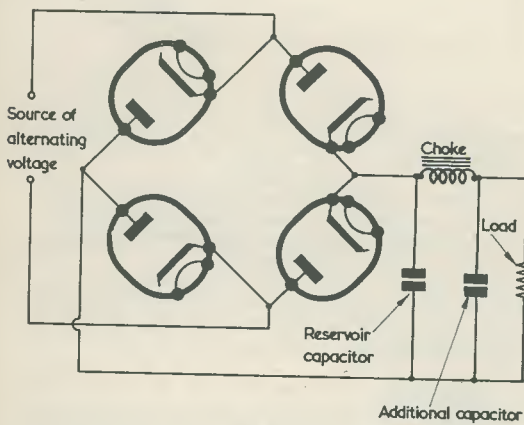

(c)

Fig. 265 (a). Adding a choke and capacitor after the reservoir capacitor causes a smoother voltage to appear across the load. In this instance the additional components appear after a half-wave rectifier

(b). The choke and additional capacitor following a full-wave rectifier

(c). Adding the choke and capacitor to the bridge circuit

after the reservoir capacitor, the choke being followed, in its turn, by a second capacitor. Because of its inductance the choke offers a high reactance to the a.c. component. At the same time the capacitor which follows it offers a low reactance

to the a.c. component. Thus (assuming suitable component values) most of the a.c. component appears across the choke and only a small part appears across the capacitor which follows it. So far as the d.c. component is concerned, the only opposition offered by the choke is the resistance of the wire with which it is wound; whilst the capacitor which follows the choke offers a very high resistance. The result is that the direct voltage across the load is only slightly lower than the mean direct voltage across the reservoir capacitor. Thus, the added choke and capacitor cause very little loss of the d.c. component, but they provide heavy attenuation of the a.c. component.

Fig. 265 (a) depicts a half-wave rectifier and, for the sake of completeness, Figs. 265 (b) and (c) show the choke and capacitor filter added to the full-wave and the bridge rectifier circuits. Assuming equal values in the reservoir capacitor and equal mean direct voltages across it, the choke and/or the following capacitor will require higher values in Fig. 265 (a) to achieve the same ripple voltage across the load than are needed for Figs. 265(b) and (c). This is because the voltage across the reservoir capacitor in the full-wave and bridge circuits is smoother, to start off with, than that given with the half-wave circuit. Also, the fundamental frequency of the half-wave ripple is half that of the full-wave ripple, which means that, at fundamental ripple frequencies, the choke offers half the reactance and the capacitor which follows it twice the reactance, causing the smoothing to be less effective.

The combination of reservoir capacitor, choke and second capacitor shown in Figs. 265 (a), (b) and (c) is capable of providing an adequately smooth high tension supply for many radio power supply applications. If further smoothing is required, a second choke and capacitor could be added, as in Fig. 266.

The alternating voltage supplying the rectifier will, almost inevitably, be obtained from the 50 c/s a.c. mains supply, with the result that the ripple across the reservoir capacitor has a relatively low frequency. Because of this, the choke requires a large inductance and it becomes necessary to employ an iron-cored component. (The presence of an iron core is indicated in Figs. 265 and 266 by the parallel lines drawn alongside the coil.) However, iron-cored chokes tend to be bulky and expensive and a frequent practice consists of employing a resistor instead, as in Fig. 267 (a). The resistor has the disadvantage that it offers the same impedance to ripple frequencies as to direct current, but this shortcoming can be offset, if necessary, by increasing the value of the capacitor which follows it. Alternatively, a further resistor and capacitor may be added, as illustrated in Fig. 267 (b). Despite the fact that higher capacitances may be needed in the circuits of Figs. 267 (a) and (b) than in Fig. 265, the overall cost may still be lower, with less chassis space taken up, than occurs when a choke is used. Resistor values for the circuits of Figs. 267 (a) and (b) have to be chosen



with a little care. If they are too low there may be too great a ripple voltage across the load; and if they are too high, too much direct voltage may be dropped across them. It is usually possible to arrive at a compromise solution to these two conflicting requirements. Sometimes it is necessary to provide a rectified voltage which has a very small ripple together with good regulation,<sup>4</sup> and a choke may then be essential.

Many radio circuits have separate sections which require high tension supplies with different ripple levels, whereupon it becomes convenient to use a circuit arrangement such as that shown in Fig. 268. In this diagram, circuits which do not need a low ripple level may be fed after the first section of the filter, the second section feeding circuits requiring a lower ripple level. There is, then, no unnecessary voltage drop across the resistors for the circuits which do not require the low ripple level. If desired, the first resistor of Fig. 268 could be replaced by a choke. In some radio receiver circuits it is even possible for one section of the receiver<sup>5</sup> to obtain its h.t. supply direct from the reservoir capacitor.

#### Component Values

We have, up to now, discussed the reservoir capacitor and the circuits which follow it without specifying actual component values. These vary for different applications, but it is general practice for the reservoir capacitance to lie between some 8 and 50 $\mu$ F. Reservoir capacitances tend to be higher in half-wave rectifier circuits because charging currents only appear once during each cycle. Within limits, an increase in reservoir capacitance results in an increase in rectified voltage. Suitable reservoir capacitances are specified in the rectifier manufacturers' literature, and it is inadvisable to use an excessively high reservoir capacitance in an attempt to obtain a high rectified voltage.

The capacitor following the choke or resistor will normally have a value which, similarly, lies between some 8 and 50 $\mu$ F. There is no restriction on maximum capacitance here, so far as rectifier operation is concerned, and the component may have any convenient value which provides the ripple level required and which suits the particular circuit supplied.<sup>6</sup>

These capacitor values are relatively large and are normally provided by electrolytic components. For high grade equipment in which reliability is of prime importance, paper capacitors may be used instead of electrolytic types, but these are larger and more expensive.

In use, the reservoir capacitor is alternately charged and discharged at the ripple frequency, and this process is equivalent to the passage of a ripple current through the capacitor. The ripple

<sup>4</sup> That is, there should not be an excessive drop in voltage across the load with increase in current.

<sup>5</sup> The output valve anode circuit.

<sup>6</sup> Many radio circuits require a high tension supply with a low internal impedance at a.c., and this may also be provided by the capacitor under discussion.

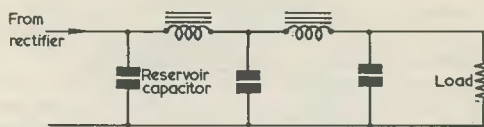
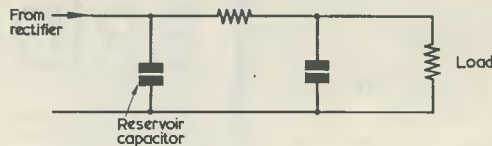
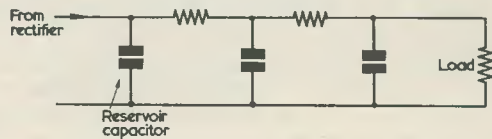

Fig. 266. A further choke and capacitor provide increased smoothing for the voltage across the load

current can cause heating in the reservoir capacitor with a risk of subsequent damage or breakdown, and it is important in commercial design work to ensure that the reservoir capacitor is rated to pass the ripple current which flows in the particular circuit in which it is fitted. Such a precaution cannot normally be observed by the amateur or the home-constructor because the necessary manufacturers' information is not generally available.



(a)



(b)

Fig. 267 (a). Using a resistor instead of a choke (b). Adding a further resistor and capacitor

However, it may be helpful, here, to point out that it is usual to manufacture two or three electrolytic capacitors in a single can specially for reservoir and smoothing applications, in which case the capacitor section which should be employed as reservoir is either indicated on the can or has its tag marked with a red spot. It is, also, a good design practice to mount the reservoir capacitor on a cool part of the chassis, well clear of heat-dissipating components.

Chokes employed in rectifier circuits normally have values lying between some 5 and 20 henrys

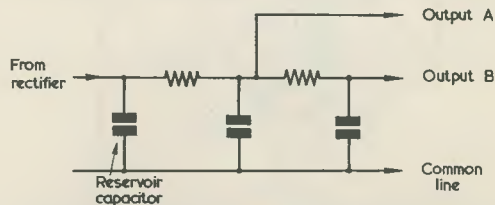

Fig. 268. Two outputs may be obtained from the circuit of Fig. 267 (b). Output A has a higher ripple level than Output B. Sections of a radio circuit may then connect to the common line and either Output A or Output B as required

at a current rating which should be equal to, or greater than, the direct current drawn by the load. Resistors employed in the circuit of Fig. 267 (a) have values of the order of 1 to 4k $\Omega$ . If the circuit of Fig. 267 (b) is used, resistor values may sometimes be as low as 300 $\Omega$ . Naturally, wattage ratings applicable to the power lost as heat in such resistors should be observed.

We have referred to wave forms being "smoother" than others, when their ripple voltage is lower. The term "smoothing" is, in practice, commonly applied to the process of reducing the ripple on a rectified voltage, and to the components which carry out this function. The choke of Fig. 265

may, therefore, be described as a *smoothing choke*, and the capacitor which follows it as a *smoothing capacitor*. The resistors in Figs. 267 (a) and (b) are, similarly, *smoothing resistors*. The reservoir capacitor may sometimes also be referred to as a "smoothing capacitor". This usage is rather unhelpful, however, since it does not allow this capacitor to be differentiated from the other capacitor (or capacitors) in the circuit.

#### Next Month

In next month's issue we shall examine rectifier circuits which do not employ a reservoir capacitor.

### Part Three

by Craig Mackay

# BRIDGE BUILDING

The third of a series of four articles which deal, from a strictly practical viewpoint, with the design and construction of bridge networks. This article discusses the various types of indicator which may be employed to give null readings, together with suitable power supply circuits

**A** BRIDGE CIRCUIT OBVIOUSLY CANNOT BE USED for measurement purposes unless it has a circuit or device capable of indicating the null or balancing point.

The simplest visual null-point indicator is the galvanometer, and this should be of the centre-zero variety. If a moving coil instrument is employed it is only suitable, on its own, for the resistance bridge when a cell provides the energising source.

In the more general purpose a.c. form of the bridge a moving coil meter may still be used, provided that the alternating voltage is rectified first. If, as is shown in Fig. 14, a full-wave bridge rectifier is used it is not necessary to employ a centre-zero instrument since, when the variable control is

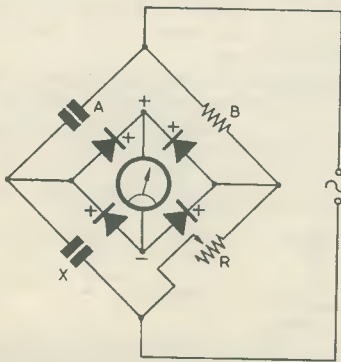

Fig. 14. A moving coil meter used as a null indicator requires a rectifier when an a.c. energising source is employed

moved through the balance position, it is only the phase of the voltage across the indicator that changes.

Precautions must be taken to ensure that the current flowing through the meter when the bridge is at its "greatest off-balance" position is not allowed to exceed the full-scale deflection value. To prevent excessive current flow, the meter may either be shunted by a pre-set variable resistor, as in Fig. 15 (a), or a variable resistor may be connected in series, as in Fig. 15 (b).

These precautions are necessary to protect the meter from being overloaded, but they have the disadvantage of reducing the sensitivity of the

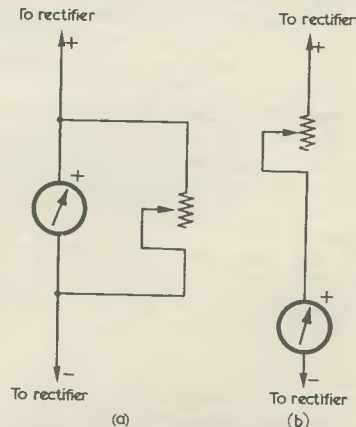
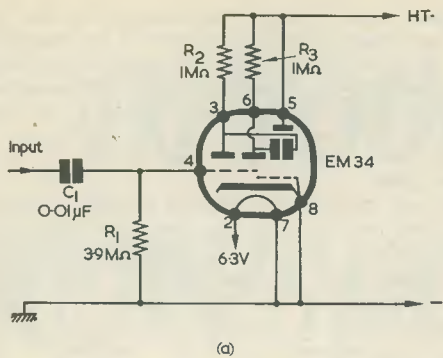
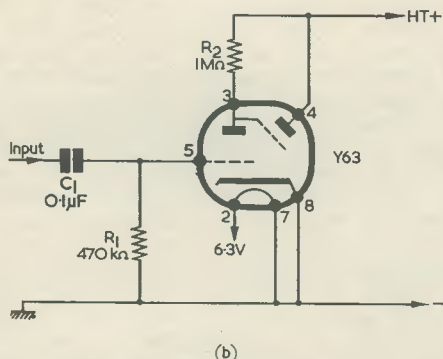

Fig. 15. Meter current may be limited by (a) a shunt resistor or (b) a series resistor



(a)



(b)

Fig. 16. Two Magic Eye null indicator circuits

bridge circuit.

It should be pointed out that a meter with a 1mA f.s.d. is usually capable of indicating an off-balance current of as little as  $10\mu\text{A}$ . Also, as it is the no-current point which is required, the meter need not be calibrated and, if it is, the scale is unimportant.

### The Magic Eye

A popular and reasonably inexpensive form of

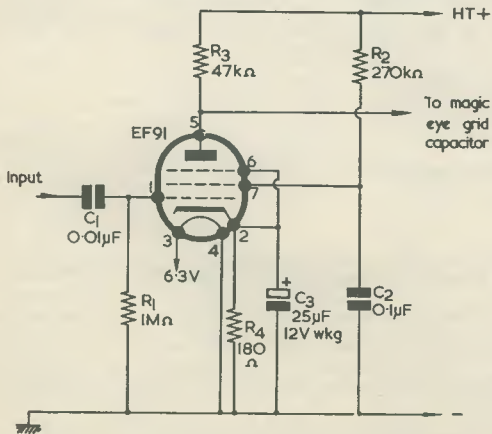

Fig. 17. A pre-amplifier for use with a Magic Eye

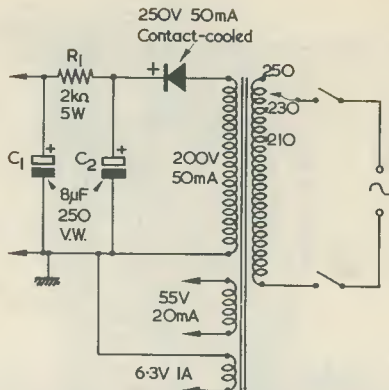

Fig. 18. A half wave power pack which is suitable for supplying an a.f. amplifier null indicator as well as energising the bridge

null indicator is the Magic Eye. Valves which could be used are the Y63, EM34, etc.

The EM34 has two shadows of different sensitivity; one is used for less sensitive preliminary balance setting, while the other is more sensitive and allows final adjustment. The Y63 has a variable-mu characteristic. Suitable circuits are shown in Fig. 16. Increased sensitivity may be had by adding an amplifying stage in front of the Magic Eye as in Fig. 17 and a circuit employing an EF91 is shown as an example. Virtually any valve could be used for the amplifier, but it should have a suitable cathode bias resistor, whose value can be found from valve tables. A triode valve could also be used.

Theoretically, when the bridge circuit is balanced the voltage across the null detector is zero. However, when the bridge components have a high impedance, pick-up from stray fields often becomes very troublesome, and the null indicator is then required to indicate a minimum value rather than zero. It is possible for the stray voltages to mask the null-point.

We shall now consider aural means of null-

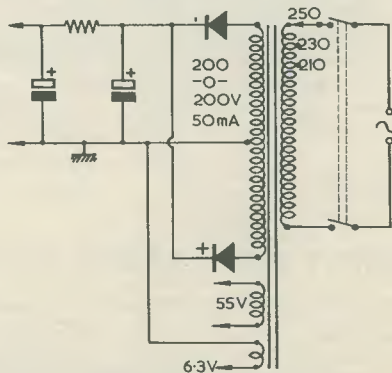

Fig. 19. A full-wave power pack. The h.t. smoothing components may have values similar to those in Fig. 18

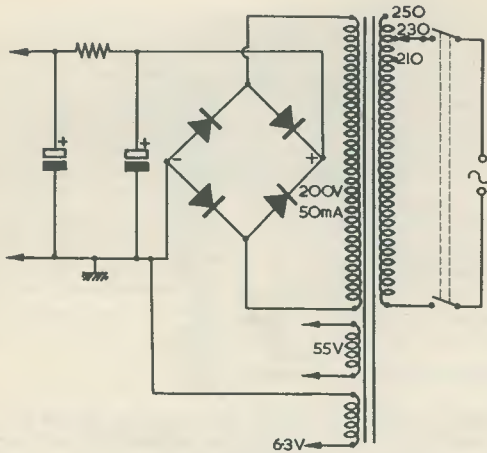

Fig. 20. A bridge rectifier power supply

point detecting. These have the advantages that it is possible to "hear" a minimum with surprising accuracy and, also, that it is possible to differentiate between signals of different frequency. The second point is valuable when high impedances are present, because hum pick-up voltage may be of the same magnitude as the voltages which appear at the null point, and the higher frequency of the oscillator voltage can be easily picked out.

#### Aural Null Indicators

The simplest aural null indication is, of course, given by a pair of headphones connected directly across the bridge. If, however, mains frequency is being used with low impedance components, then it may be found that headphones are not very effective or efficient at these frequencies.

One of the best methods is to use an ordinary audio amplifier with a relatively low output feeding a small loudspeaker. This method is used in a complete bridge design which will be described next month.

If extreme sensitivity is required an oscilloscope can be employed, since this gives a highly sensitive balance position as well as the added advantage of variable sensitivity. Also, the required frequency can be immediately observed. Nevertheless, it would be ridiculous to permanently tie up an

expensive oscilloscope to a bridge, and the time-wasting bother of having to connect up the oscilloscope to the bridge wherever it was required might not be desirable. Accordingly, an oscilloscope is seldom used as a null-point indicator so far as general work is concerned.

#### Power Units

The only remaining section of a bridge measuring instrument which has not yet been considered is the power supply. A double wound mains transformer *must* be used here for safety's sake. *The constructor will find that his bridge is a valuable instrument which is often used, and on no account must a "live chassis" circuit be employed.*

The power requirements are usually quite modest. The h.t. supply can easily be provided by a half wave rectifier giving between 150 volts and 250 volts at the required current. The only peculiarity of the power unit will be the extra winding on the mains transformer if mains frequency is to be used to energise the bridge, but this could be obtained from either a separate mains transformer or a step-up transformer working from the heater supply. The heater winding, in that case, should be capable of supplying the extra power required. A simple and effective circuit is shown in Fig. 18. This uses a small half-wave contact-cooled rectifier and a simple 2-section smoothing circuit. When the current drawn from the power pack is comparatively low, it is not necessary to use a low frequency choke in the smoothing circuit, and a high wattage resistor may be used instead.

Other circuits are, of course, possible, and full-wave or bridge rectifiers could be used (see Figs. 19 and 20). Also a valve rectifier could be employed in Figs. 18 and 19. Generally, contact-cooled or small "metal" rectifiers are preferable because they dissipate very little heat, and can be safely tucked away in a corner. If the delightfully small silicon rectifiers are to be used the maker's instructions must be consulted with regard to peak inverse voltage and limiting resistor value. This is important if such rectifiers are not to break down.

Next month, the construction and operation of a general-purpose R-C bridge built by the author will be described.

(To be concluded)

## LARGEST EVER RADIO AND ELECTRONIC COMPONENT SHOW

The Radio and Electronic Component Show will be held at Olympia, London, from the 18th to 21st May, 1965.

Following the great success of the 1963 Radio and Electronic Component Show when 48,902 buyers, including 2,600 from overseas visited the exhibition, more British radio and electronic component manufacturers are participating in the 1965 exhibition which will be the largest Radio and Electronic Component Show ever to be held in the United Kingdom occupying nearly 100,000 square feet of stand space.

Sponsored by the Radio and Electronic Component Manufacturers' Federation, the Exhibition is organised by Industrial Exhibitions Limited, 9 Argyll Street, London, W.1.

# IN YOUR WORKSHOP

This month Smithy the Serviceman, aided as always by his able assistant Dick, takes a look at the section of a television receiver which we all tend to take for granted—the series heater chain.



"THE HEATER CHAIN IS A DESIGN headache?" queried Dick incredulously. "You must be joking!"

"Of course I'm not joking," replied Smithy indignantly. "I'll admit that, out of the problems which beset the radio and television design engineer, the heater chain does not rank very high. But it still requires a lot of thought if it is going to be laid out correctly."

"Laid out correctly?" snorted the incredulous Dick. "Dash it all, Smithy, all the designer's got to do is to string the heaters all together in series. Just like a set of fairy lights."

"And that's all there is to it?"

"Just that."

The Serviceman gazed irritably at his assistant.

"What never ceases to madden me about you," he complained, "is that infuriating habit you have of making dogmatic statements when you haven't the faintest clue what you're talking about!"

"All right, then," replied Dick, nettled. "How are the heaters in a heater string connected?"

"In series, of course."

"Exactly," pronounced Dick triumphantly. "In other words, they're wired up just the same as the bulbs in a set of fairy lights!"

## Battling For Bottom Place

Wearily, Smithy switched off the television chassis on his bench, pushed his testmeter to one side and sat down.

"Let us," he remarked resignedly, "go over this particular conversation starting right from the beginning. As I recall it, I was happily engrossed in digging around in the chassis on my bench when you suddenly started chuntering away about heater chains."

"That's right," confirmed Dick. "The set I'm fixing has an open-circuit heater chain and, by the time I'd worked my way through eleven valves, all of which were fitted in awkward positions and all of which had perfectly good heaters, I was beginning to get highly cheesed off."

"I remember your exact comment," continued Smithy. "And, to be fair, this was most succinct and to the point. You said, 'Why the flaming heck don't the flaming manufacturers of these flaming TV sets run the flaming heaters in parallel from a flaming mains transformer instead of putting them in a flaming series heater flaming chain!'"

"I may," conceded Dick, "have expressed myself a little forcibly there."

"On hearing this," went on Smithy, "I made the assumption that you were making a genuine request for information. And so I replied that the main reason for series chains is an economic one. The series heater chain saves the cost of a large mains transformer. After which you stated 'Blow the cost, what about the service workers?' or words to that effect,

and then said that if all a TV designer had to do was to string out a lot of heaters on a printed circuit board you were going to pack in the servicing lark and become a designer yourself."

"I should jolly well think so, too," said Dick. "And, after that, you said that the heater chain can be quite a design headache."

"And so it is."

"But it can't be," protested Dick. "All the designer's got to do is to hook the heaters together just like a set of fairy lights."

"I do wish you wouldn't keep on about those dratted fairy lights," said Smithy peevishly. "Before you start laying down the law you should try working out a TV heater chain for yourself. As a start, whereabouts in the chain should the heater of the cathode ray tube go?"

"Pretty well anywhere, I would guess," replied Dick instantly. "It draws the same current as the valve heaters."

A gleam came into Smithy's eye. "What happens," he asked gently, "if the tube manufacturer states that, to prevent hum on the picture, the a.c. component of the potential between the c.r.t. cathode and heater should be no greater than 20 volts? That's quite a normal requirement, you know, for television picture tubes."

"Is it?" replied Dick a little doubtfully. "Well, let me see now. Why, you'd insert the tube heater near the chassis end of the chain.

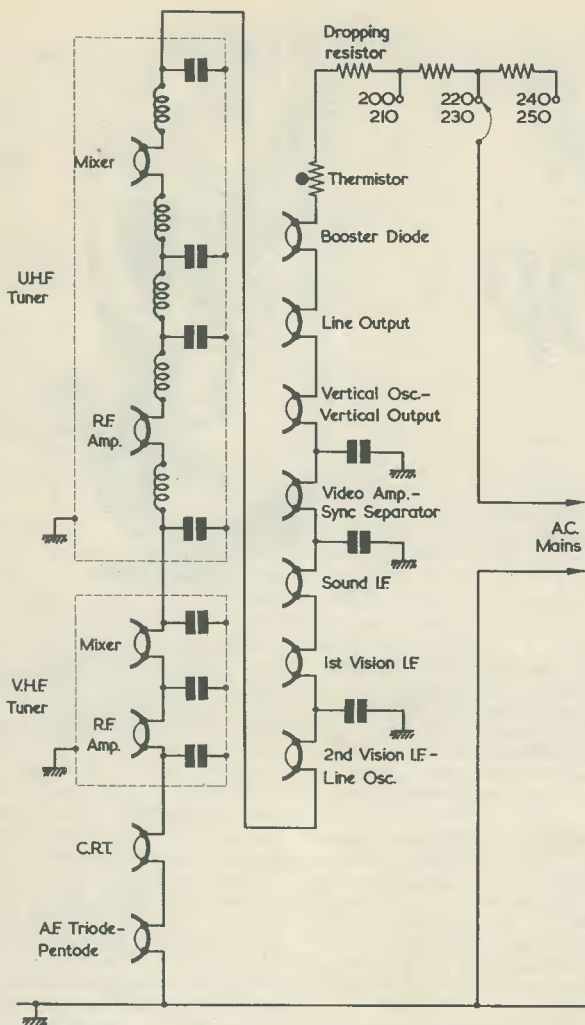

Fig. 1. A typical heater chain in a television receiver. Some of the heaters are for dual-function valves, and a silicon h.t. rectifier is assumed. All coils shown are u.h.f. chokes, and the capacitors have a value of 1,000pF

Which would soon clear up *that* little snag."

"Good," commented Smithy. "Now, what about the heaters of the valves in the tuner unit or tuner units?"

"Well?"

"The tuner unit valves," said Smithy, "are, as you know, handling the received signal at very low level. You wouldn't want to inject excessive hum into their cathode circuits now, would you?"

"I suppose not," replied Dick, grudgingly. "Still, the obvious answer here is to keep the a.c. component between their cathodes and heaters to a low level as well. So the tuner unit heaters would

need to be at the chassis end of the chain, too."

"Of course," agreed Smithy. "Then there are the early i.f. valves and the a.f. voltage amplifier, not to mention any flywheel sync valves which may be fitted."

"What," said Dick suspiciously, "about them?"

"It's rather a good idea," answered Smithy, "to try and keep hum out of the early i.f. valves and, in particular, out of the a.f. voltage amplifier. Also, valves in a flywheel sync circuit often have high impedances to chassis from their cathodes, and their performance can be upset if too much hum from the heater is injected into them."

A look of uncertainty crossed Dick's face.

"I should guess," he remarked a little unhappily, "that these valves would have to go to the chassis end of the heater chain, also."

"I couldn't agree more," said Smithy. "Up to now, and assuming a valve u.h.f. tuner, you've put the heaters of about eight valves *and* the c.r.t. at the chassis end of the chain. At 6.3 volts a heater, or thereabouts, at least one of these valves must be getting around 55 volts a.c. between cathode and heater. Some of the valves I've just mentioned need a lower heater-cathode a.c. voltage than the others, and so the next job consists of sorting out a suitable order in the chain for them to take up."

There was silence for a moment. "You may," said Dick reluctantly, "have a point there. Perhaps I did over-simplify things a little just now."

"Would you still say," purred Smithy, "that the heaters are strung together like a set of fairy lights?"

"Well," replied Dick unwillingly, "perhaps not."

The silence returned. Smithy maintained a quizzical glance on his assistant.

"O.K. Smithy," snorted Dick eventually, "I'll admit it—I'm shot down!"

"In flames," confirmed Smithy cheerfully. "And that's enough time wasted over *that* little business. Anyway, I do hope you've realised that there are quite a few valve heaters in a television receiver which *have* to be close to the chassis end of the chain. I've only referred to this question from the point of view of hum injection, but I should add that there are one or two other factors which have to be considered as well. These can all make the process of laying out a TV heater chain quite a fiddling operation."

With which words Smithy stood up, turned back to his bench and switched on the chassis he had been investigating.

#### Cathode Circuits

"Well, that," complained Dick, "is a dirty trick, I must say!"

With a sigh, Smithy switched off his chassis again. It was obvious that this heater thing would have to be seen through to the bitter end.

"Dash it all," continued Dick aggrievedly, "you can't leave me in mid-air just like this! I'm still not at all happy about this heater chain business. For instance, in some sets it's the c.r.t. heater which is at the chassis end, in others it's

the a.f. amplifier valve, and in others again it's a flywheel sync valve. There isn't any consistency between sets on the position each valve should take up."

"That's true enough," conceded Smythy. "And I don't mind going into a bit more detail to tell you why. Now, first of all, let's just think about the average TV receiver heater chain. (Fig. 1). In this you've got a string of heaters in series with a thermistor and a dropper resistor. There are other means of supplying the series string, but we won't go into them for the moment. Frequently inserted into the heater chain are a number of chokes, these most commonly being of the u.h.f. variety and fitted in the u.h.f. tuner. Further, we have a number of ceramic capacitors of around 1,000pF, these being inserted at strategic points to provide an r.f. bypass to chassis. The first difficulty we encounter in laying out a heater chain is that each heater has a small stray capacitance to its cathode and so an a.c. coupling exists between the two. The heater at the chassis end of the chain carries the same alternating voltage, relative to cathode, as it would if the heater were supplied by a mains transformer secondary with one side connected to chassis. The heater at the other end of the chain carries quite a high alternating voltage relative to its cathode, and this may easily be of the order of 100 volts or so."

"If that's the case," commented Dick, "you'd think that the heater chains of TV sets would have become standardised by now, with the valves most sensitive to cathode injection of hum proceeding in the same order from the chassis end."

"There are too many conflicting factors to allow that to happen" said Smythy. "Don't forget that the susceptibility of a cathode to hum pick-up depends on the impedance of its circuit to chassis and that this varies with different designs. Another point is that the printed wiring conductors which carry the heater voltage have stray capacitances to the conductors around them and they could cause undesirable hum pick-up in these also. Yet another factor is that the TV designer has to produce a printed circuit board in which the heater circuit conductors fit in with the general pattern of the board."

"This," commented Dick, "is beginning to get rather complicated."

"I told you," Smythy reminded him, "that the heater chain is something of a design headache."

Let me introduce yet another point. What happens if one of the heaters burns out?"

"The circuit is broken," replied Dick helpfully, "and all the other heaters go out as well."

"I know that, you twirp," snorted Smythy. "But what else happens?"

"What else can happen?" replied Dick. "Once one heater goes out, the remainder go out. One out, all out!"

"What happens," persisted Smythy, "potential-wise?"

Dick stroked his chin reflectively. "Well," he said hesitantly, "so far as potential is concerned all the heaters on the chassis side of the open-circuit heater assume chassis potential whilst all the others. . ."

Dick paused for a moment. "Do you know, Smythy, this is a thought. All the other heaters take up the full mains potential relative to chassis!"

"Exactly," replied Smythy. "With the result that any valve whose heater-cathode insulation is a bit below par is going to be subjected to far more strain than occurs in normal service, and it could well break down as a result. The most important heater in this instance is that in the c.r.t., because the c.r.t. is so much more expensive than any of the valves. It is quite feasible for the heater-cathode insulation of the c.r.t. to break down if the heater of a valve lower down the chain burns out. This demonstrates, incidentally, why it is an unwise practice to go around swapping valves indiscriminately in

a TV set without switching it off each time."

"I see your point," said Dick. "Anyway, getting back to the chassis end of the heater chain, it seems to me that the most favoured contender for this position is the c.r.t. Firstly, because it needs a low alternating voltage on its heater and, secondly, because it's so expensive."

"Fair enough," agreed Smythy. "Other major contenders are the triode-pentode a.f. valve and any flywheel sync valve whose cathodes have high impedance circuit paths to chassis. The a.f. valve heater is usually very near the chassis end of the chain even when the cathode of its triode is taken direct to chassis and the pentode cathode connects to chassis via a large-value electrolytic. (Fig. 2.) You'd think at first sight that, with connections such as this, no alternating voltage from the heater could be coupled into the cathodes via self-capacitance. Presumably, however, the valve still takes up a low position in the chain because the triode grid circuit is so very susceptible to hum pick-up, and it would be inadvisable to have any conductors carrying high alternating voltages nearby. So far as the other valves are concerned, it's impossible to be specific because different receiver designs have different requirements for each valve. The designer has to fit the heaters into the chain in an order which meets these requirements satisfactorily without upsetting printed circuit layout too much."

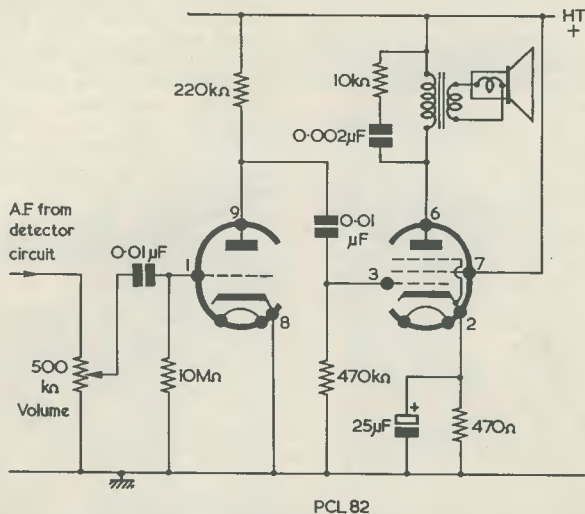

Fig. 2. A typical triode-pentode a.f. amplifier having very low impedances between cathodes and chassis. Despite this, the triode-pentode heater may still be inserted close to the chassis end of the heater chain

"Are there any valves which can be put *anywhere* in the chain?"

"Oh yes," replied Smythy. "If the h.t. rectifier is a valve, its heater can be right at the top end of the chain. So also could the heater of the line output valve or the booster diode. The line output cathode is almost inevitably connected straight to chassis, and its grid circuit is handling fairly high pulse voltages, anyway. Even more so for the booster diode, whose cathode receives pulses around 4kV from the line output transformer."

#### Alternative Heater Chain Circuits

"You said earlier," remarked Dick, "that some TV heater chains weren't supplied by a dropper resistor."

"That's right," agreed Smythy. "In some of the new sets the series chain is supplied by a small auto-transformer, which results in a considerable reduction in the heat dissipated inside the cabinet. Another new idea is to use a silicon rectifier in series with the heater chain. This passes current on alternate half-cycles only and so acts as a heater dropper. The

effective voltage after the diode is 0.707 times the voltage applied to it. This idea, incidentally, was described in 'Suggested Circuits' quite some time ago.\*"

"Good old G. A. French," chuckled Dick. "I must admit he's no slouch at getting the bright ideas into those circuits of his!"

"You'd better watch what you say, lad," warned Smythy. "It wouldn't half shake you if a long thin finger came creeping round the edge of the mag and hooked you off the page!"

"What a horrible thought," shuddered Dick. "Incidentally, the idea of a silicon rectifier heater dropper makes me think of all the boys at the Central Electricity Generating Board who are bashing out the old a.c. there. One half-cycle of which goes to keep the h.t. circuits going in our TV sets, whilst the other half-cycle keeps the heaters alight!"

"You've got a point there," grinned Smythy. "Anyway, can I now get back to this chassis I'm trying to repair?"

"I've just got one or two quickies outstanding," replied Dick promptly. "If you could clear these up for me, all my queries about heater chains will be answered"

"I suppose," said Smythy philosophically, "I'll get no peace until I do. Fire away, then."

"What about the ceramic capacitors bypassing the heater chain to chassis?" asked Dick. "Several times I've disconnected one of these, either intentionally when looking for a snag, or by accident. And in each case it hasn't made a blind bit of difference to the performance of the set!"

"That's feasible enough," commented Smythy. "In many cases, these heater chain bypass capacitors are inserted as a safeguard against possible trouble under certain conditions. If you were to take them all out, the receiver would very probably burst into violent oscillation. Which is not surprising when you consider that the heater wiring passes through all the stages of the receiver. These heater bypass capacitors are, in my opinion, rather more important in printed circuit receivers than they were in the old sets with conventional wiring."

"Why's that?"

"Mainly," said Smythy, "because there seems to be more tendency towards instability in an i.f. strip if it's made up on a printed circuit board than if it's made up on a metal chassis. The chassis gives a good solid mass of metal to which all earthing points can be taken whilst, with printed circuits, you don't get by any means so large an earthed area. The printed earth conductor is still, nevertheless, made to cover quite a good bit of space but it obviously cannot appear where other conductors are needed. The result is that there may be a greater tendency towards instability, and a well bypassed heater chain becomes rather more important."

"That's interesting," said Dick. "I should point out, though, that all the sets in which I disconnected the heater chain bypass capacitor were printed circuit types."

"That may well be," replied Smythy. "One possibility is that there *was* a harmful effect, but you didn't notice it."

"How come?"

"You might," said Smythy, "have introduced, say, a small kink into the vision i.f. response curve which wouldn't have been very noticeable on the picture. Or, again, there might have been a tendency towards instability on one channel of the v.h.f. tuner with the capacitor removed, and you mightn't have noticed this either. I wouldn't doubt that in quite a few receivers you could remove even more than one heater chain bypass capacitor without causing any serious deteriora-

tion of performance. On the other hand you might find that you'd introduced one or two odd little effects of the type I've just described."

"I see," said Dick. "Incidentally, another thing I've noticed is that some sets use disc ceramic capacitors in these bypass positions whilst others use tubular ceramic capacitors. Yet they're both about the same value, around 1,000pF. What's the difference?"

"There isn't a great deal in practice," replied Smythy. "The purpose of either type is to insert as little inductance as possible into the circuits they bypass. In general design work you can normally employ either type for nearly all bypass applications up to 100 Mc/s or more without experiencing any significant difference in performance provided you keep the lead lengths very short. This last point is *most* important. So far as servicing is concerned, however, you should always play safe and replace a tubular type with a tubular type and a disc type with a disc type."

"I suppose," said Dick, "that the short lead length is necessary to keep as much inductance as possible out of the bypass circuit."

"That's right," confirmed Smythy. "There's no point in providing a very low capacitive reactance if you're going to put a lot of inductance in series with it. Believe it or not, but I've even heard of a heater bypass circuit in a particular series of mass-produced TV tuners which, in some units, became resonant at a channel in Band I."

"Hey?"

"I'm perfectly serious," replied Smythy, "and this story is quite a true one. The tuner in question was one of the old PCC84-PCF80 jobs, and the heater tags of the two valveholders were joined together by about 1½ inches of ordinary connecting wire. These two tags were also bypassed to chassis by 1,000pF disc ceramics. (Fig. 3 (a)). After the tuner had been in production for a little while it was found that a small percentage gave a rather weird response curve at one of the channels in Band I, and this was eventually traced to a resonance in the heater bypass circuit."

"I don't get it," said Dick. "How can you get a resonance in a circuit like that? Both the 1,000pF capacitors are practically a dead short at Band I frequencies."

"They're still capacitors," replied Smythy. "Whereupon they enter a simple pi-tuned circuit, of which the inductive element is the piece of wire joining the two valveholder

\* G. A. French, "Suggested Circuits No. 146—Employing Silicon Rectifiers As Heater Droppers", *The Radio Constructor*, January 1963.



tags. (Fig. 3 (b)). And what better means of coupling energy from one stage to another could you have? The L/C ratio is, of course, very low indeed, because the 'L' bit is given by the piece of wire and the 'C' bit by two 1,000pF capacitors in series, which gives you 500pF. (Fig. 3 (c)). Despite its very low Q, however, this particular tuned circuit was still effective enough to give undesired coupling between the two valves on one of the channels in Band I, and to upset the response curve of the tuner at that frequency."

"How did they cure it? Put in a choke?"

"Nothing as expensive as that," laughed Smithy. "They just cut out one of the 1,000pF capacitors! All tuners assembled after that date were made without this capacitor, and they all sailed through Test and Alignment exactly as before. With the exception that none of them exhibited the peculiar Band I response."

#### Battery Filaments

"That," said Dick, "is certainly one for the book. Incidentally, I've only got one more query on heater chains."

"Good show," replied Smithy. "Let's clear it up, then."

"It's to do," said Dick, a little hesitantly, "with those battery/mains portables which use 1.4 volt valves."

"You're digging around in the past, aren't you?" queried Smithy. "Battery/mains radios of that type haven't been made for ages. There's no point now that the transistor radio, with its much cheaper battery requirements, is with us."

"We still get the odd battery/mains job in for repair," Dick reminded him. "Even if people don't use them very often as portables, they still employ them as mains receivers."

"True enough," conceded Smithy. "What's the query?"

"Well," said Dick, "the filaments in a battery/mains valve set are all connected in series. What I can never understand is why some of the filaments have fixed resistors across them."

"Oh that," said Smithy, reaching for a pad and a pencil. "I can soon tell you the reason for that! As you know, these sets normally employ four valves, these being a frequency-changer, an i.f. amplifier, a diode-pentode for detection and a.f., and an output pentode. The earlier receivers used valves with 50mA filaments and the later ones used valves with 25mA filaments. Right?"

"Right."

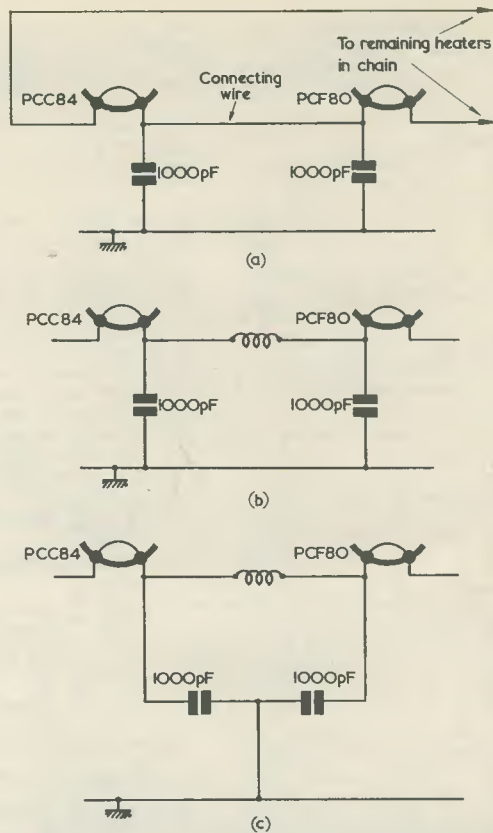

Fig. 3 (a). The heater decoupling circuit in a v.h.f. tuner unit. One 1,000pF capacitor bypasses the heater of the PCC84 r.f. amplifier, whilst the second 1,000pF capacitor bypasses the heater of the PCF80 oscillator-mixer

(b). In practice, the circuit of (a) functioned as a pi-tuned network, the inductance being provided by the connecting wire between the two valveholder tags

(c). If the circuit in (b) is rearranged in the manner shown here, it may be seen that the tuning capacitance is 500pF

"Now let's look at the filament supply circuit when it's powered by the mains," said Smithy, sketching out a circuit on the pad (Fig. 4 (a)). "The usual idea is to employ a half-wave metal rectifier and a smoothing circuit which provides both h.t. and a supply for the filaments via a dropping resistor. The h.t. is usually provided at 90 volts, to match up with the batteries fitted for battery operation. Individual sets vary in the order in which the valves appear in the string, but we can assume for the purpose of explanation that the output valve is at the bottom end of the filament chain. This valve will have a centre-tapped filament so that it can operate either at 1.4 volts or 2.8 volts, and in the present application it would be connected for 2.8 volts. The next filament up could be that for the

i.f. valve, the next one that for the frequency-changer and the last one that for the diode-pentode. O.K.?"

"Sure," said Dick. "I presume that the filaments would be either 50mA or 25mA types."

"That's right," confirmed Smithy. "Let's say for the moment that they're 25mA types. This means that we have 25mA flowing through the dropper resistor (Fig. 4 (b)). It'll make the explanation a little easier if we talk in terms of electron current going from negative to positive. Now, is the filament current the only current that flows?"

"So far as I can see, it is," replied Dick. "The only other possible currents are anode and screen-grid currents."

"Won't they affect circuit operation then?"

Dick shrugged his shoulders. "Hardly," he remarked indifferently.

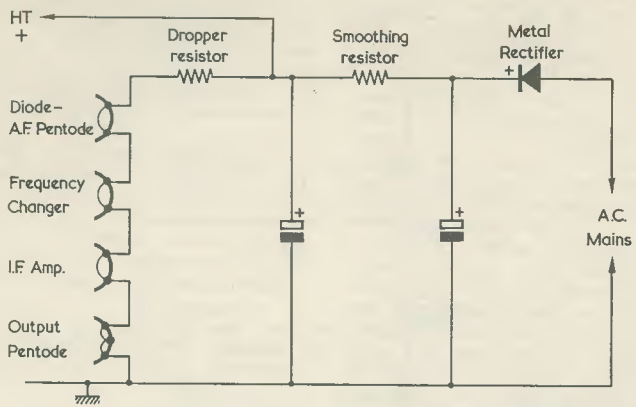

(a)

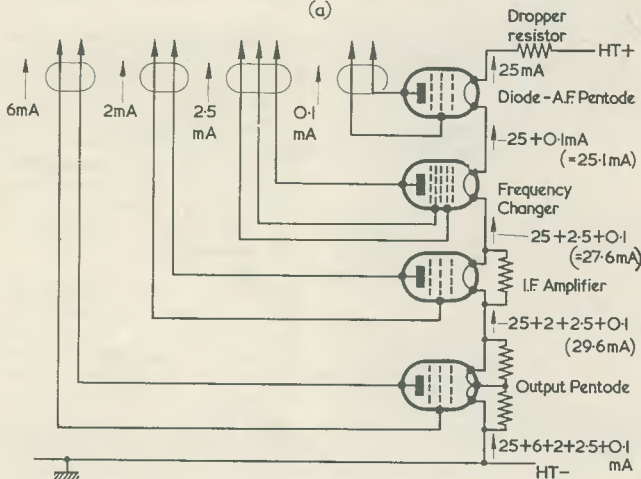

(b)

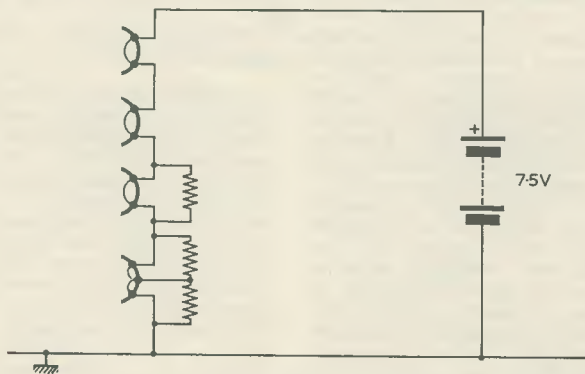

(c)

Fig. 4 (a). A typical filament supply circuit for a battery/mains receiver. The smoothing resistor has a somewhat high value, allowing about 90 volts to be applied to the dropping resistor and the h.t. positive line. The order in which the valve filaments appear in the chain may vary, in practical receivers, from that shown here

(b). Since the lower filaments pass the anode and screen-grid currents of the valves above them, fixed resistors have to be connected in parallel

(c). On battery operation, a 7.5 volt battery is connected across the chain, as shown here

"I can see," commented Smithy, "that you're starting to get dogmatic all over again!"

"Dogmatic?" queried Dick, stung. "What's so dogmatic about ignoring the anode and screen-grid currents when we're talking about a filament circuit?"

"We'll see about that," said Smithy. "Now, I've already drawn in an arrow representing the 25mA filament current, and I'm now going to add some more arrows for anode and screen-grid current. The combined anode and screen-grid current for the output valve will be around 6mA, that for the i.f. amplifier 2mA, and that for the diode-pentode about 0.1mA. These currents are all going in the same direction through the filament chain, and so they all add up. This means that the top filament passes 25mA only, but the next filament down passes 25mA plus the 0.1mA anode and screen-grid current of the top valve. The next filament down, the i.f. amplifier, passes 25 plus 2.5 plus 0.1mA, which comes to 27.6mA, and the bottom filament passes 25 plus 2 plus 2.5 plus 0.1mA, which equals 29.6mA."

"Blimey," said Dick, impressed. "I hadn't realised that the anode and screen-grid currents passed through the filaments lower down!"

"Well, they do," replied Smithy. "The filament of the second valve down passes 25.1mA, and the slight increase here shouldn't cause any trouble. But the third filament down passes 27.6mA, which is more than 10% over nominal. And the bottom filament passes 29.6mA, which is nearly 20% over nominal."

"I can now see why it's necessary to have resistors across the filaments," said Dick. "They're needed to pass the anode and screen-grid currents of the valves higher up."

"That's the idea," confirmed Smithy. "In the example I've just taken it would only be necessary to add resistors across the bottom two filaments. The extra 0.1mA through the filament of the second valve down shouldn't cause any serious trouble."

"You've added two resistors," objected Dick, "to the bottom filament. Why not use a single resistor across the whole filament?"

"I've added two resistors here," explained Smithy, "to equalise the currents in each half of the filament. The lower half of the output valve filament carries the portion of the anode and screen-grid current which is passed by the upper half, and

so it will need to have a parallel resistor somewhat lower in value than that across the upper half."

"Could the order of the valves change?"

"Oh yes," said Smithy. "And I should add that getting a suitable order for the valves will be nearly as complicated a job as working out the order for a TV heater chain. This is because of the necessity to provide suitable grid bias voltages, and of getting correct a.g.c. potentials throughout the circuit. However, whatever the order you'll still find that the filaments lower down the string have parallel resistors to carry the anode and screen-grid currents of the valves higher up. It will also be necessary to add bypass capacitors to the chain to prevent feedback along the filaments. You'll usually find a pretty fat electrolytic by-

passing one end of one of the a.f. filaments to chassis, together with, say, a 0.5 $\mu$ F capacitor at one of the r.f. filaments."

"What happens to the filament circuit when you switch a receiver of this type from mains to battery operation?"

"In conventional sets," replied Smithy, "the dropping resistor is disconnected, and a 7.5 volt battery connects across the heater string (Fig. 4 (c)). Also, a 90 volt battery feeds the h.t. circuits instead of the mains rectifier and smoothing components. The negative end of the 7.5 volt battery connects to the lower end of the filament chain and so operation is virtually the same as before. Whereupon, the parallel resistors across the filaments carry out exactly the same function as they did previously."

### Always The Last One

Smithy turned resolutely back to his bench and, with an air of great determination, once more switched on the chassis on his bench.

"And that," he remarked in a tone of finality, "is that. Let's hope you haven't got any more queries on heater chains!"

"There's only one."

"Dear oh dear me," said the long-suffering Serviceman, "and what is that?"

"Which valve," questioned Dick, "has the open-circuit heater in the TV I'm repairing now?"

"That," chuckled Smithy, "is the easiest question of the lot. From long and bitter experience I can tell you that it will be the heater in the very last valve you check!"

## The New Dual-Standard TV Sets

### PART 11

Gordon J. King

Assoc. Brit. I.R.E., M.T.S., M.I.P.R.E.

*This article examines the effect of interference pulses on 625 line reception, and deals fully with dual-standard line output stage switching as encountered in current 405-625 line receivers*

LAST MONTH WE SAW THAT impulsive interference on the 625 line vision signal results in sharp, peaky waveforms which rise positively, in the same direction as the sync pulses. Such pulses "look" to the picture tube as information which is characteristic of grey or black picture elements. They consequently produce grey or black spots on the picture as distinct from the white spots which similar pulses create on a 405 line picture.

This is very useful so far as the picture signal proper is concerned, for it means that on the 625 line service a vision interference limiter or spotter is not required. Unfortunately, however, positive-going interference pulses on a 625 line signal can disturb the operation of the synchronising circuits to some extent, for they may, in certain

circumstances, be mistaken for sync pulses by the sync separator.

The trouble occurs mainly on vertical synchronising, for the line circuits are often made immune from such effects on the '625 line standard by the use of flywheel-controlled sync, as we saw last month.

Let us suppose that the sync separator receives a signal upon which is superimposed a strong interference pulse having an amplitude greater than that of the sync pulses—see Fig. 32 (a). Two things happen. One, the noise pulse appears in amplified form at the anode or output of the sync separator, and two, a heavy value of grid current occurs at the sync separator input.

#### Sync Blocking

We have already discussed the

effect of the noise pulse proper so far as the line oscillator is concerned, but of probably greater significance is the large value of grid bias that the heavy flow of grid current evokes. This tends to hold the sync separator valve at cut-off for a period governed by the amplitude of the pulse and the time-constant of the separator grid circuit. In effect, then, there is a tendency for the sync separator to "block" subsequent to a burst of interference. This means that there is a cessation of sync pulse output from the sync separator during the blocking period, as shown in Fig. 32 (b).

While the line generator synchronising can survive this blocking effect, the vertical timebase, being directly triggered by the vertical sync pulses, will become somewhat unstable, resulting, characteristically, in vertical judder and rolling.

The trouble is not, of course, eased by interlace filters and clippers following the sync separator stage, since the action of these depends upon normal working of the sync separator. The solution is to render the sync separator itself insensitive to impulsive interference or, at least, to prevent it from blocking on interference pulses.

There are two ways of achieving this. One is by the use of a noise inverter preceding a conventional sync separator stage, and the other is by the use of a "noise-gated" sync separator, the latter having the advantage that an extra valve is not normally required.

The noise-inverter requires an inverter valve and preset control

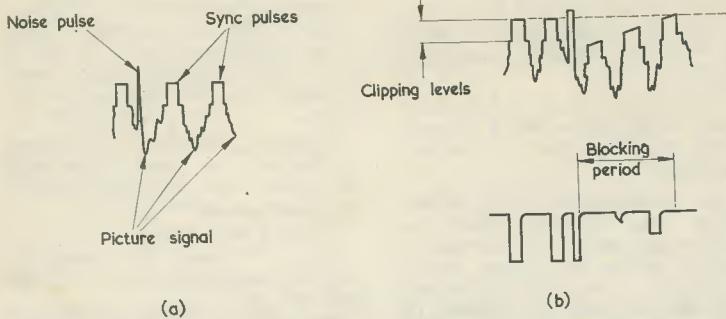

Fig. 32 (a). The formation of an interference pulse on a 625 line picture signal  
 (b). Such a pulse can block the sync separator and therefore cut off the sync pulses during the blocking period

for bias adjustment, the idea being to inject into the sync circuit an inverted pulse of interference so that cancellation of the direct pulse occurs.

### Noise-Gated Sync Separator

The noise-gated sync separator works in a similar manner, but the cancellation effect actually occurs in the sync separator valve which, in some circuits, is a heptode instead of the conventional pentode.

The circuit of a basic heptode sync separator is shown in Fig. 33. This employs the ordinary R and C time-constant ( $R_1$  and  $C_1$ ) coupling from the video signal to the second control grid of the heptode, and the sync signals are developed across the anode load resistor  $R_2$  in the usual manner. The screen grids are held at the necessary

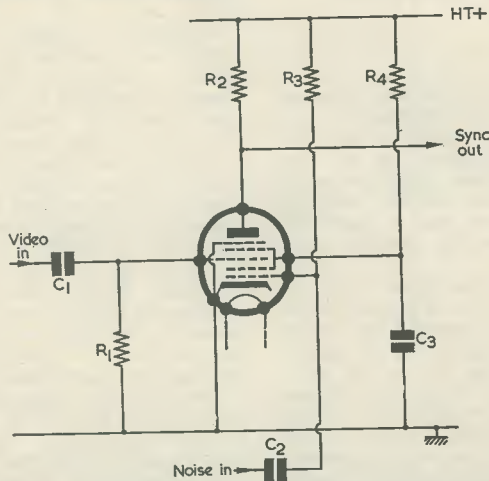

Fig. 33. The basic circuit of the heptode sync separator. This accepts inverted noise pulses on its first control grid, and works as an ordinary sync separator with the video signal applied to its second control grid. Blocking during interference is avoided because the inverted interference pulse at the first control grid takes the valve into cut-off for the period of the pulse

positive potential by  $R_4$ , and are decoupled by  $C_3$ .

The noise-gating part of the circuit is connected to the first control grid by  $C_2$  and  $R_3$ . A small flow of grid current results from the fact that  $R_3$  is returned to h.t. positive. Under interference-free conditions, therefore, the stage works in the same way as a pentode.

However, should a positive-going interference pulse arrive with the video signal at the second control grid, a negative-going replica pulse is fed simultaneously to the first control grid through  $C_2$ . The video signal and interference pulse at the second control grid are shown in Fig. 34 (a) and the inverted noise pulse at the first control grid in Fig. 34 (b).

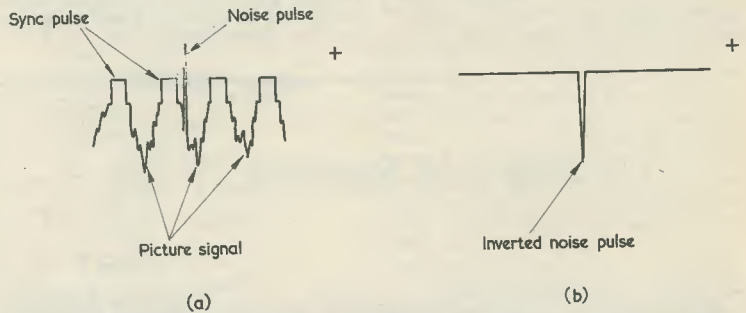

Fig. 34. At (a) is shown the video signal plus noise pulse which is applied to the second control grid of the heptode, whilst (b) illustrates the noise pulse only, as applied to the first control grid. In effect, the pulse at (b) cancels the noise pulse on the waveform at (a)

The negative-going pulse at the first control grid pulls the valve away from grid current and towards cut-off, and thus prevents an excessive charge occurring on  $C_1$  in the second control grid circuit. In this way, therefore, the blocking effect described in the preceding paragraphs is prevented. There is only a very slight disturbance to the sync pulses in the anode circuit, even though relatively heavy impulsive interference may be present.

A type of valve suitable for this application is the Mullard ECH84, and in simple circuits the noise signal is picked up from the video detector where the pulses have a negative polarity. More complex arrangements adopt separate noise detector circuits. These give greater noise immunity and less critical operation, for the simple circuit requires a preset potentiometer in the circuit of the first control grid to set the grid current for optimum results. Operation is also affected, somewhat, by the setting of the contrast control.

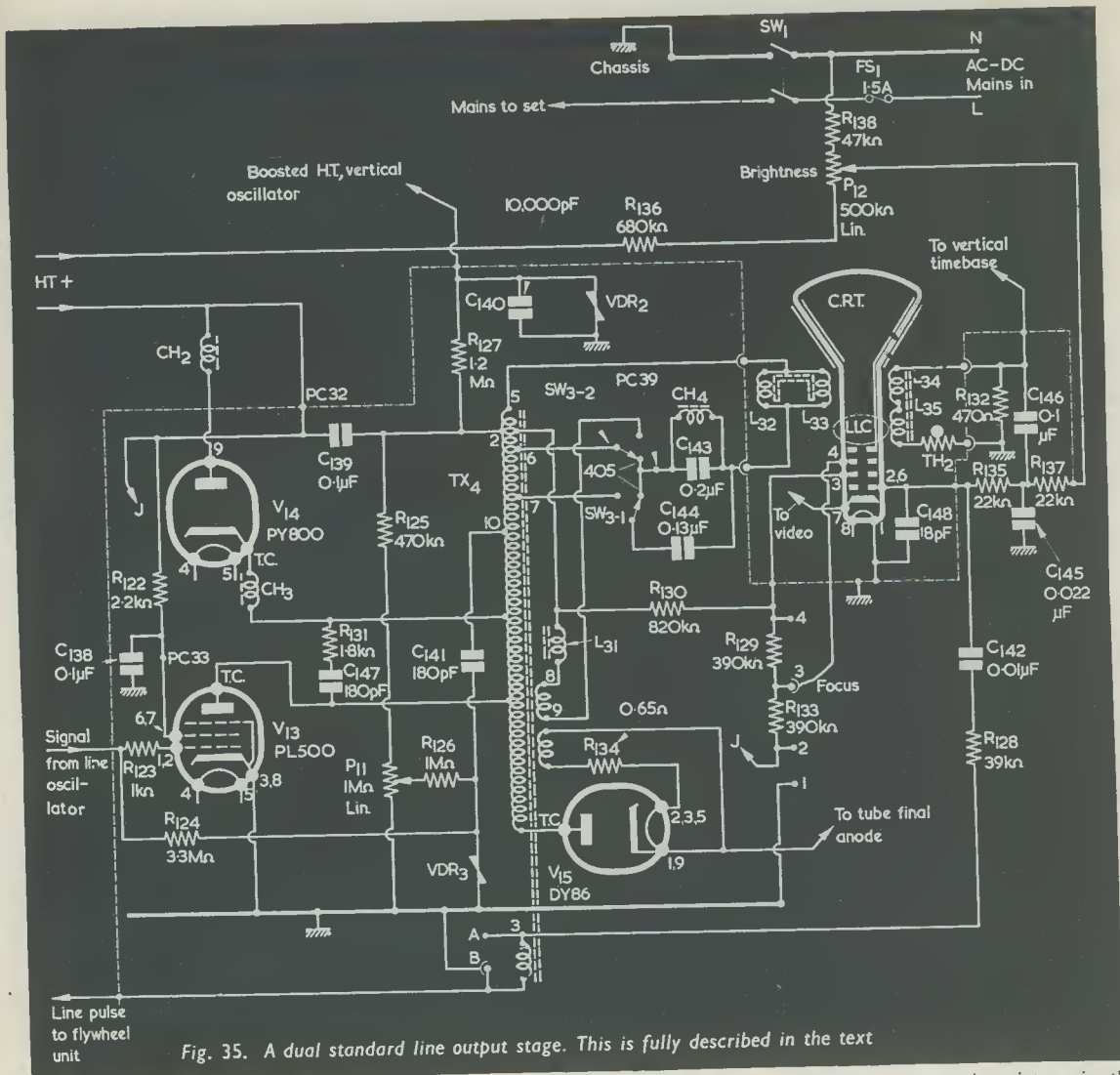

Fig. 35. A dual standard line output stage. This is fully described in the text

In some circuits, the triode section of the ECH84 is arranged as a pulse clipper or as a noise detector.

So much, then, for the synchronising circuits at 625 lines.

To follow last month's article on line oscillators, we now come to another important section in the dual-standard receiver—namely the line output stage.

#### Dual-Standard Line Output Stage

Fig. 35 gives the circuit of a dual standard line output stage as used in one of the latest Pye receivers. The tube electrodes and their associated circuits are also shown in this diagram since three of these (the first anode, the second anode and the focusing electrode) are in some way related to the line output stage, as we shall see.

In the majority of dual-standard sets, the line speed change is undertaken in the line oscillator circuit by various switch sections, as was shown last month. Unfortunately, however, it is not yet feasible to design a line output stage that will accept line signals at both 10,125 c/s and 15,625 c/s with full efficiency.

A line output stage designed for optimum result at 10,125 c/s will respond to signals at 15,625 c/s, but its efficiency is considerably impaired. To provide the large e.h.t. voltage and line scanning power needed for wide scanning angle picture tubes the line output stage has always to be at peak efficiency, and even a small sign of wear in a valve, h.t. rectifier, booster diode or associated part

will show up on the picture in the form of poor focus, insufficient width or poor e.h.t. regulation (as those of us whose job it is to service television sets well know!)

#### Third-Harmonic Tuning

Thus, to keep the efficiency high at both line speeds, switching in the line output stage is essential. The artifice which keeps the efficiency of modern line output stages at a high level is so-called third-harmonic tuning of the line flyback.

Due to the rapid change of current through the primary winding of the line output transformer during the line flyback (retrace) period, the inductive and capacitive elements are caused to "ring". A damped oscillation is produced because of the combination of

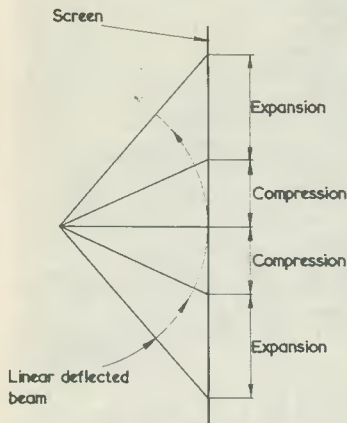

Fig. 36. As shown here, linear beam deflection causes expansion at the sides and compression at the centre of a picture. An S-correction circuit is required to combat this effect

capacitance and transformer leakage reactance. In very early receivers, flyback oscillation was suppressed, but for a number of years now the oscillation has been harnessed in such a way that it produces the first part of the line scanning stroke, during which period the line output valve itself is held at cut-off. The booster diode circuit is concerned with this function, and the resulting rectification of the waveform also produces an extra voltage which is added to the h.t. line voltage. This is called the boosted h.t. voltage.

It is not intended in this series to investigate in detail the mechanism behind this effect, since it has been adequately considered in the literature\*. However, a basic knowledge of the effect is essential for the proper understanding of the dual-standard line output stage.

As a means of improving the efficiency of line output stages, the oscillatory voltage is encouraged by low-loss transformers and ferrite cores, and a further improvement has been achieved by arranging for the ringing frequency resulting from the leakage reactance to be nearly three times the frequency of the line flyback. In this way the pulse voltage, as present at the anode of the line output valve, is reduced in amplitude while the pulse voltage at the anode of the e.h.t. rectifier valve is maintained at the high value necessary for producing the e.h.t. voltage. This factor not only improves the efficiency of the

line output stage but also makes for better e.h.t. regulation owing to the reduction in effective impedance of the e.h.t. circuit.

### S-Correction

Another feature of the modern line output stage is the capacitive coupling to the line scanning coils whose purpose is to provide the non-linear scanning rate required by the modern, wide-angle picture tube. Because the tube face is essentially flat, a linear deflection of the electron beam from one side of the screen to the other would result in the scanning spot traversing the screen at a lower rate at the centre than at each side. The effect would be shown on a picture as expansion at each side and compression at the centre (see Fig. 36).

Compensation is provided by feeding the line current to the scanning coils through a suitable value capacitor. This tends to slow up the scanning stroke at the beginning and the end and speed it up towards the centre, thereby closing up the sides of the picture and opening up the centre. The value of this capacitor is determined by various factors, one of which is, of course, the line scanning speed. Thus, it follows that this compensation requires switching over the two line standards. This is called "S-correction".

The third harmonic tuning of the line output transformer is achieved either by a small tuning capacitor or by the transformer loss inductance and self-capacitance (or both). It follows, therefore, that if the change of line speed also results in a change of the flyback time, then the third-harmonic tuning will also need to be switched.

Dual-standard timebases adopt one or two systems or a combination of both. One system is sometimes called the "constant flyback time" system and the other the "constant flyback ratio" system. These we shall call "constant-time" and "constant-ratio" respectively. With the constant-time system, the circuit is arranged so that the time of the flyback is the same on both line standards, while with the constant-ratio system the ratio of scan to flyback remains the same on both line standards. In the latter system, of course, the time of the flyback differs between the two line standards, so a receiver using this type of circuit would have facilities for switching the third-harmonic tuning. The S-correction capacitor is generally switched, over the two line speeds, on both systems.

Let us now examine the circuit

in Fig. 35. In this diagram there are two "standard change" switches, SW<sub>3-1</sub> and SW<sub>3-2</sub>. SW<sub>3-1</sub> is concerned with switching the S-correction capacitance. This capacitance (either a single capacitor or two in parallel) is always in series with the line scanning coils, these being L<sub>32</sub> and L<sub>33</sub> in the circuit under discussion.

The switches are shown in the "405" position, which means that on that standard C<sub>144</sub> and C<sub>143</sub> (the S-correction capacitors) are connected in parallel, the combination then being in series with the line scanning coils.

When SW<sub>3-1</sub> switches over to the "625" position the line scanning coils are fed from tap 7 on the transformer, but this time through C<sub>144</sub> alone. This gives the required 625 line S-correction. C<sub>143</sub> is removed by SW<sub>3-2</sub> going over to the "625" position, but at the same time this switch action introduces L<sub>31</sub> and the winding between taps 8 and 9 on the transformer as a shunt across taps 2 and 6. This function changes the third-harmonic tuning from that which the transformer itself provides on 405 lines to that suitable for 625 lines, bearing in mind that with this circuit the speed of the flyback changes over the two standards. It uses, therefore, the constant-ratio system.

These are the main line output stage switching functions, and the chief ones which are found in the majority of dual-standard models. To recapitulate, the S-correction is adjusted by the changing of the value of the capacitance in series with the line scanning coils (two capacitors in parallel increase the total capacitance, of course), while the third harmonic tuning is adjusted either by an alteration to the value of the third-harmonic tuning capacitor (as may sometimes be connected across a section of the transformer) or by switching in or out an extra shunt winding on the transformer, as in the circuit in Fig. 35. If the third-harmonic tuning is adjusted over the two standards, then the constant-ratio system is adopted in the line output stage.

### Line Scan Equalising

To provide an equalised line scan amplitude over the two standards the h.t. supply to the line output stage is sometimes adjusted in value by the switching in or out of a dropping resistor, or the tap to the line scanning coils on the line output transformer is changed. The latter occurs in Fig. 35, where connection to the scanning coils is made at tap 6 on 405 lines and at tap 7 on 625 lines.

\* See, for instance, "Understanding Television" by J. R. Davies, Data Publications Ltd.

### Timebase Stabilisation

Apart from these switching functions, the line output stage follows reasonably conventional practice. Various small chokes are included to suppress parasitic oscillation in the line output valve and switching transients during the scanning and flyback cycles. The first anode of the tube is fed from the boosted h.t. line. So also is the focusing anode, via an adjustable potential-divider ( $R_{130}$ ,  $R_{129}$  and  $R_{133}$ ). The vertical oscillator is also fed from the same source, via the stabilising arrangement comprising the voltage-dependent resistor ( $VDR_2$ ) and associated components.

The line output stage is stabilised against loading and voltage change effects by the use of a voltage-dependent resistor ( $VDR_3$ ) in the control grid circuit of the line output valve. As the value of this

resistor decreases with an increase in voltage across it, it can be employed as a form of "peak rectifier".

Line pulses are fed to it through  $C_{141}$  and the resulting average direct voltage across it is fed to the control grid of  $V_{13}$  through  $R_{124}$ . The effect is rather similar to that of an a.g.c. voltage, for should the amplitude of the line pulses tend to reduce, due to low voltage, heavy loading or other reasons, the negative d.c. voltage at the grid falls also. This tends to increase the effective gain of the stage and to stabilise the line pulse amplitude. The nominal bias for the grid is set by the preset potentiometer  $P_{11}$ .

Note that the circuit provides a pulse output for the flywheel-controlled line sync circuit.

Another feature revealed in Fig. 35 is the switch-off spot suppression

circuit. The bottom of the brightness control is returned to the neutral side of the mains on/off switch. This means that when the set is switched off the tube control grid is caused to rise towards the full h.t. line voltage (since the chassis connection to the brightness control is broken). The resulting heavy beam current then speedily exhausts the residual e.h.t. charge held by the tube before a bright, harmful spot can appear on the screen.

The circuit also shows a connection between the vertical scanning coils and the tube control grid circuit. The circuit, which is an R-C potential-divider network, injects negative-going pulses into the tube grid during the vertical flyback, thereby cutting off the tube and suppressing the display of flyback lines.

*To be Continued.*

## RADIO TOPICS . . .

### by Recorder

**I**F EVER THERE WERE A COMMENTARY on our present times it must surely lie in our ready acceptance of the domestic television receiver, together with all the raw materials of which it is made and all the manufacturing techniques which go into its assembly. In a TV set, the list of insulating materials on their own is, to say the least, of considerable length, including as it does such things as mica (used in exactly the form in which it is quarried from the ground in Madagascar, Canada and India) and the whole family of man-made plastics. The metals range from cadmium-plated mild steel for chassis and frames to the cold-drawn tungsten alloy wire used in the valve heaters. At the same time, the techniques involved in making the various component parts extend from the winding of coils to the sintering of ceramic magnetic materials.

#### A Fascinating Case History

A case history which demonstrates the interdependence of different industries in TV manufacture is given by the development of the plastic materials for the K.B. "Featherlight" transportable tele-

vision set, model KV003. This receiver caused a minor sensation at last year's Radio Show due to its use of an 11-in screen and the breakaway design of its cabinet. There is always a story behind developments of this nature. The story behind the "Featherlight" has just been passed on to us by Imperial Chemical Industries Limited, who played a very important role in bringing the original design to fruition, and it represents one of those fascinating aspects of manufacture and production which never normally reach the public ear.

The account starts with an investigation, carried out by K.B., into the buying pattern in the TV and record playing industries. This brought to light the continuing popularity of moulded plastic units and the desirability of developing a design system that would permit the ready interchangeability of moulded components. In other words, mouldings had to be produced that were capable of "permutation" to make a specified number of different models. K.B. decided to follow up this investigation by producing, for the 1964 Radio Show, two new plastic-

housed projects based on the interchangeability of moulded units. The projects were a record player and the "Featherlight" television receiver. The designs were originated at K.B., after which the work of tooling and producing the mouldings was assigned to Injection Moulders Limited of Kingsbury, London.

The choice of plastic material gave rise to a great deal of experimental work, and it was finally decided to use polypropylene because of its lightness, toughness and superior heat resistance, this last being a very important technical advantage so far as the TV set was concerned. A further requirement which particularly occupied the styling department was the ability of the plastic chosen to accept a simulated leather grain on its surface, and polypropylene came through with flying colours here.

Once the designs for the models were off the drawing board, Injection Moulders Limited immediately started the intricate and highly exacting job of mould design, in which some 28 separate moulds valued at many thousands of pounds had to be made in time to meet the critical dead-line date of the Radio Show. The main housings for both the TV set and the record player were to be moulded in I.C.I. "Propathene" brand of polypropylene.

Subsidiary mouldings were to be in various thermoplastic materials such as high impact polystyrene, acrylic, polythene and cellulose acetate butyrate.

The engraving of the housing moulds to produce the leather grain finish, a vital sales factor, was undertaken by J. Martin & Sons of Salford, who specialise in engravings of this nature.

#### Colour Matching

In addition to the production of the moulds and other preparatory work in readiness for the actual moulding, there was the problem of colour matching. Here the Technical Service Department of I.C.I. Plastics Division came to the fore. New polypropylene colours had to be produced and accurately matched to K.B. specifications, and I.C.I. even produced experimental mouldings incorporating a leather grain finish to make certain that the finished units would be fully up to standard. These experiments

were of the utmost importance, as the colour rendering of the grained moulding is markedly different from the plain surface moulding in the same material.

By now the drawing office capacities at both K.B. and Injection Moulders Limited were stretched to their utmost as dozens of components, mould and general assembly drawings were being produced. A serious crisis occurred after fire broke out in the drawing offices at K.B. and destroyed many of the component drawings; but it was possible, by close co-operation between the two firms, to overcome this problem in time. Pressure on the tool makers was exceptionally high, and teams of engineers were working all round the clock to meet the Radio Show dead-line.

Also in the midst of this feverish activity were the planning engineers, who were spending every available minute on the design of jigs and fixtures to facilitate finishing and assembly operations on the mouldings.

When the final tooling work was completed, only 14 days were available for sampling the mouldings, seeing that all the pieces in the "jigsaw" fitted perfectly, and securing final approval from K.B. Only then could actual production start. In their factory at Kingsbury, Injection Moulders Limited made use of their full range of equipment—from 800 ton Buhler presses down to 2oz machines—to produce the components needed for the new K.B. products. And everything, down to the last tiny detail, was finally completed in time.

At the Show the "Featherlight" and record player were an outstanding success, much of this being due to the styling and design of their plastic housings. As you can see from the accompanying illustrations, the most impressive part is the grilled component which forms the outside housing for the "Featherlight", and which enables an exceptionally attractive presentation to be given.

It is a credit to all the firms concerned that the work was done in time and done so well. And the story emphasises only too strongly how wide-ranging are the requirements, in terms of industrial research and manufacture, which are involved in the production of just one section of a domestic television receiver.

#### Masterly Diagnosis

During the recent gales I was dragged out of my comfortable den to inspect the domestic TV receiver, which had obstinately refused to provide any ITV signal all evening, despite the fact that B.B.C.-1 was belting through at its usual strength. (B.B.C.-2 hasn't made its way to our outlandish parts yet.) I waggled the turret tuner knob and found that, as I eased it slowly towards the I.T.V. channel indent, noise on picture and sound suddenly increased perceptibly as the contacts made to the I.T.V. channel biscuit. At the same time, there was not a vestige of transmitted signal. It seemed pretty safe to assume, on this evidence, that at least the oscillator coil was making proper contact, and that some form of connection was being made to the aerial and band-pass coils. So I



(I.C.I. LTD.)

Clean, neat and modern design. The K.B. "Featherlight" transportable 11in TV receiver in its plastic cabinet



announced loftily to a manifestly disbelieving family circle that the local I.T.V. transmitter was off the air, and made my departure.

I must confess I was a little relieved to read in the daily paper next morning that, due to a breakdown in the public electricity supply caused by the bad weather, that transmitter had been off the air all evening!

#### "Electrons In Picture Tubes"

I have just received a copy of a new educational booklet entitled *Electrons In Picture Tubes*, which is published by Mazda. This is an excellent little publication for anyone who wants to learn the basic facts of television cathode ray tube operation, and its 24 pages cover all the important details from electrostatic focusing to aluminising. The approach is completely non-mathematical, with a liberal number of very clear illustrations.

The booklet is written by B. Eastwood, B.Sc., A.M.I.E.E., Chief Engineer of the Thorn-A.E.I. Applications Laboratory, and is specifically intended for Apprentice Technicians and other students interested in television.

*Electrons In Picture Tubes* is the fifth publication in the Mazda "Electron" series, previous booklets having dealt with the functioning of valves under the titles:

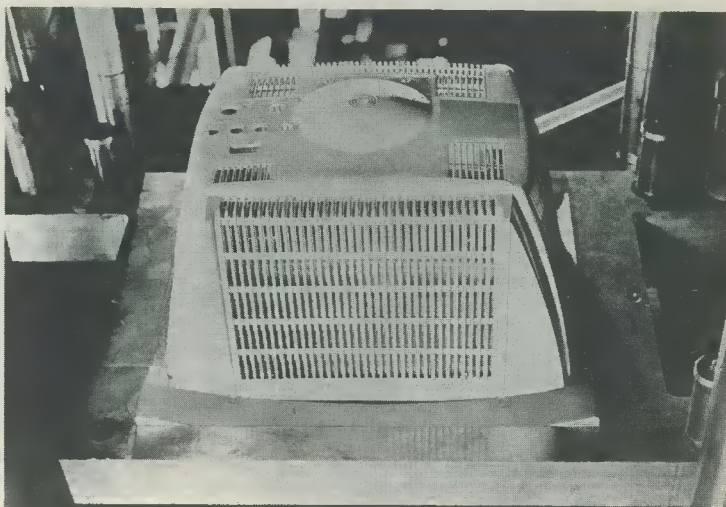

(I.C.I. LTD.)  
An impressive moulding, which illustrates how careful attention to detail and finish can produce a plastic component which combines strength with attractive presentation. This moulded unit forms the main housing for the K.B. "Featherlight" transportable TV receiver model KV003, and it incorporates a simulated leather finish on the outer surface. The moulding material is I.C.I. "Propathene"

*Electrons In Diodes,*  
*Electrons In Triodes,*  
*Electrons In Screen Grids and*  
*Pentodes,*  
*Electrons In Beam Tetrodes.*  
Any of the "Electron" booklets

are available, free of charge, to electronics students and television service technicians on application to Thorn-A.E.I. Radio Valves and Tubes Ltd., 155 Charing Cross Road, London, W.C.2.

## RADIO CAROLINE

# OUR CONTRIBUTOR VISITS (And Broadcasts From) RADIO CAROLINE

F. C. JUDD, A.INST.E., G2BCX

MUCH HAS ALREADY BEEN SAID AND MUCH has been written on the subject of offshore pirate radio stations. It is not, therefore, the object of this article to condemn or condone the operation of unlicensed radio broadcasts from ships outside the three mile limit but, rather, to describe for the sake of interest how one of them operates and the kind of equipment that is used.

To visit Radio Caroline involves a 2-hour journey by sea from Harwich, where customs and passport formalities must be completed. Radio Caroline is operated from a small ship called the *Mi Amigo*, registered in Panama. Visitors such as myself are, therefore, on Panamanian territory when on board the ship.

Radio Caroline, or *Mi Amigo*, lays at anchor about five miles out, almost due east of Frinton, and the tender vessel takes out food supplies,

spares, water, records and visitors almost every day. The journey is pleasant when the sea is calm, but life on Caroline can be quite hectic when a North Sea gale is in operation at around Force 8.

#### Pirates With A Personality

Caroline may not fly the "Jolly Roger" but, like the rest of the offshore stations around this country and abroad, it commands the attention of a multi-million audience. Perhaps this is indicative of the necessity for commercial or local broadcasting, or non-stop music programmes with or without advertising. But mine is not to reason why, so let us return to the ship and to its equipment.

The ship is a happy and comfortable one except, perhaps, when the weather is very rough, whereupon anything can happen! Pick-ups jump the record grooves, the transmitter relays trip out and the disc jockeys go off their food.

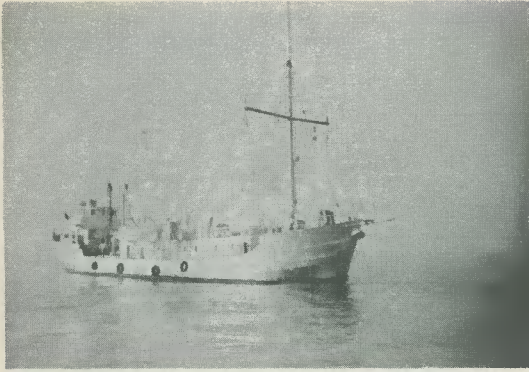

*A broadside view of Radio Caroline as she lays at anchor 5 miles out at sea. The vertical transmitting aerial is 140ft high, nearly equal to the length of the ship. Clever rigging design gives the aerial maximum efficiency with sufficient strength to withstand the full force of North Sea gales*

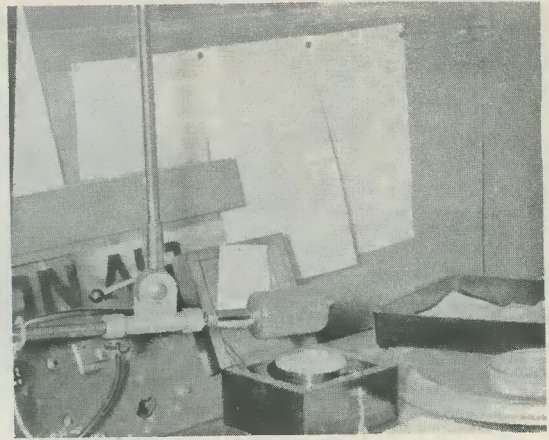

*Studio space on Radio Caroline tends to be cramped and conditions informal, as is illustrated by this view of the announcer's studio*

I was shown around the ship, invited to lunch, and was even allowed to announce a request record of my own. The control room and announcer cubicles are quite small and, surprisingly enough, tape recording is used very little. Nearly all the record announcements and much of the sponsors' material is given directly over the microphone. The disc jockeys write their own scripts and build up most of the programmes from the record library on the ship.

#### **10kW Transmitters**

There are two transmitters of 10kW each (one used on standby) and the entire equipment is run from specially installed generators. The aerial is a vertical unipole, and is a masterpiece of rigging and supports. It is 140ft high, which is more or less the same as the length of the ship, and its entire structure has to withstand the full force of North Sea gales.

Radio Caroline is, to say the least, a well organised

and compact radio station, and it may not be generally known that it has a sister ship which operates off the coast by Liverpool. At the time of writing, yet another offshore station has been put into operation, namely Radio City. This is a 50kW transmitter on an ex-American mine-sweeper somewhere off the Thames Estuary. I shall be visiting Radio City very soon, together with Bob Danvers Walker the Radio and Newsreel commentator. And, of course, Britain's first officially licenced commercial radio station, namely Radio Manx, is already on the air.

Does this situation represent the thin end of the wedge? Well, there are already hundreds of newspapers and other concerns with registered names for local radio stations which they will sponsor. The unlicensed offshore stations have no wish to operate for ever out in the open sea; they would, instead, much rather function in comfortable onshore studios and with the full blessing of the licencing authorities.

---

**Queries.** We regret that we are unable to answer queries other than those arising from articles appearing in this magazine nor can we advise on modifications to equipment described. Queries should be submitted in writing.

**Correspondence** should be addressed to the Editor, Advertising Manager, Subscription Manager or the Publishers, as appropriate.

**Opinions** expressed by contributors are not necessarily those of the Editor or proprietors.

**Contributions** on constructional matters are invited, especially when they describe the building of particular items of equipment. Articles should be written on one side of the sheet only and should preferably be typewritten, diagrams being on separate sheets. Typewritten articles should have maximum spacing between lines. In handwritten articles, lines should be double-spaced. Diagrams need not be large or perfectly drawn, as our draughtsmen will re-draw in most cases, but all relevant information should be included. Sharp and clear photographs are helpful, where applicable. If negatives are sent, we usually work from these rather than from prints. Colour transparencies normally reproduce badly—black and white photographs are very much better. Details of topical ideas and techniques are also welcomed and, if the contributor so wishes, will be re-written by our staff into article form. All contributions must be accompanied by a stamped addressed envelope for return, if necessary, and should bear the sender's name and address. Payment is made for all material published.

**Production.**—Letterpress/contact litho.

# LEARN ELECTRONICS AS YOU BUILD 25 CIRCUITS ... EXPERIMENTS ... TEST GEAR ...

including

## ● CATHODE RAY OSCILLOSCOPE

- VALVE EXPERIMENTS
- SQUARE WAVE GENERATOR
- SIGNAL TRACER
- BASIC AMPLIFIER
- SIMPLE TRANSMITTER
- BASIC COMPUTER CIRCUIT
- BASIC RECTIFIER
- TRANSISTOR EXPERIMENTS
- BASIC RADIO RECEIVER
- PHOTO ELECTRIC CIRCUIT
- BASIC OSCILLATOR
- MORSE CODE OSCILLATOR
- TIME DELAY CIRCUIT
- ELECTRONIC SWITCH
- ETC. ETC.

This complete practical course will teach you all the basic facts of electronics by making experiments and building apparatus. You learn how to recognise and handle all types of components—their symbols and how to read a circuit diagram. You see how circuits are built and how they work **BY USING THE OSCILLOSCOPE PROVIDED**. Applications of all the main electronic circuits are

demonstrated—radio reception and transmission; photo-electrics; computer basics; timers; control circuits; etc.; including servicing techniques. **NO MATHS USED OR NEEDED. NO THEORY NEEDED. NO PREVIOUS KNOWLEDGE OR EXPERIENCE NEEDED.** Tutor service available. No extras needed—tools provided. Send now, for *Free Details* without obligation, to address below

**POST NOW**



To **RADIOSTRUCTOR**, Dept. K3, READING, BERKS. Please send free details of your electronics kit set to:

NAME .....

ADDRESS .....

## SMALL ADVERTISEMENTS

Use this form for your small advertisement

To: The Advertisement Manager, Data Publications Ltd., 57 Maida Vale, London, W.9  
Please insert the following advertisement in the ..... issue of **THE RADIO CONSTRUCTOR**

16 words at 9d.  
= 12/-

**ALL WORDING  
IN  
BLOCK LETTERS  
PLEASE**

I enclose remittance of ..... being payment at 9d. a word. **MINIMUM 12/-**.  
Box Number, if required, 2/- extra.

NAME .....

ADDRESS .....

*Copy to be received four weeks prior to publication. Published on the 1st of every month*

COMPONENTS FOR THE

**"ALL BAND COMMUNICATION RECEIVER"**

as featured on page 699 in the May 1964 issue

**MAXI-Q**

**"BASIC SUPERHET FOR BEGINNERS"**

as featured on page 688 in the May 1964 issue

**COIL TURRET CT.7/B**

This turret is the basic portion of the CT.7. It comprises cadmium plated steel frame (5½" deep x 4½" high x 3½" wide), silver plated contacts, polystyrene insulation and rotary turret movement, incorporating Aerial, Mixer and Oscillator Coils for the three bands 1.5-4 Mc/s, 4-12 Mc/s and 10-30 Mc/s. Price 75/-

Coil strips for the long and medium wavebands may be purchased separately for incorporation in the turret. Price 10/6 each

The turret requires a 315pF tuning capacitor. A suitable 3-gang component with ceramic insulation is available. Price 19/-

Air spaced concentric trimmers 3-30pF Price 3/6 each

**I.F. TRANSFORMER IFT.11/465 kc/s**

A miniature I.F. Transformer for 465 kc/s giving excellent performance at low cost. Coils are litz wound and permeability tuned with high-grade iron-dust cores and silver mica capacitors. Screening Can 1¾" x 1¾" square. Price 6/6 each

Also available for 1.6 and 10.7 Mc/s.

**BEAT FREQUENCY OSCILLATOR COIL BFO.2/465 kc/s**

These compact coils are wound on a bakelite former complete with adjustable iron-dust cores enclosed in an aluminium screening can measuring 1¾" x 1¾" square. Price 5/- each

Also available for frequencies of 85 kc/s, 100 kc/s and 1.6 Mc/s.

**COIL PACK CP.3/F**

This 4-waveband coil pack is for use with a 500pF 2-gang condenser and covers the standard Long, Medium and Short Wavebands with the addition of the band 50-160 metres (1.85-6 Mc/s). It comprises of Aerial and Oscillator coils with iron-dust tuning cores, wavechange switch and mica compression trimmers mounted on an aluminium plate measuring 4½" x 2½" x 1" (not including spindle). Price 49/- plus 8/2 P.T.=Total 57/2

Two-gang 315pF Tuning Condenser Price 14/8

General Catalogue covering full range of components, send 1/6 in stamps

**STOP PRESS** 3 Pole 3 way Bank Switch 7/6 each. 1 Pole 8 way 4/3 each.

**PLEASE SEND S.A.E. WITH ALL ENQUIRIES**

**DENCO (Clacton) LTD**

(DEPT. RC), 357/9 OLD ROAD  
CLACTON-ON-SEA, ESSEX



**MIDLAND AGENTS FOR**

- ★ **EDDYSTONE RECEIVERS & COMPONENTS**
- ★ **NATIONAL RECEIVERS & TRANSCEIVERS**
- ★ **GREEN & DAVIS EQUIPMENT**
- ★ **KW EQUIPMENT**
- ★ **MOSLEY AERIALS**
- ★ **WITHERS**

- **H.P. FACILITIES AVAILABLE**
- **PART EXCHANGES**

**AERIAL EQUIPMENT**

**TWIN FEEDER.** 300 ohm twin ribbon feeder similar K25, 6d. per yard. K35B Telecon (round), 1/6 per yard. 75 ohm twin feeder, 6d. per yard. Post on above feeders and cable, 1/6 any length.

**COPPER WIRE,** 14G, H/D, 140ft, 22/6; 70ft, 11/6. Post and packing 2/6. Other lengths pro rata.

**FEEDER SPREADERS.** 6" Ceramic type F.S., 10d. each. Postage 1/6 up to 12.

**CERAMIC CENTRE PIECE** for dipoles, Type AT, 1/6 each. P. & P. 1/-.

**2 METRE BEAM, 5 ELEMENT W.S. YAGI.** Complete in box with 1" to 2½" masthead bracket. Price 49/-. P. & P. 3/6.

**SUPER AERIAL,** 70/80 ohm coax, 300 watt very low loss, 1/8 per yard. P. & P. 2/-.

**TOUGH POLYTHENE LINE,** type MLI (100lb), 2d. per yd. or 12/6 per 100 yds. Type ML2 (220lb), 4d. per yd. or 25/- per 100 yds., ML4 (400lb), 6d. per yd., post free. Ideal for Guys, L.W. Supports, Halyards, etc.

**ABSORPTION WAVEMETERS.** 3.00 to 35.00 Mc/s in 3 Switched Bands. 3.5, 7, 14, 21 and 28 Mc/s. Ham Bands marked on scale. Complete with indicator bulb. A MUST for any Ham Shack. ONLY 22/6 EACH. Post free.

**BANDCHECKER MONITOR,** 3.00-35.00 Mc/s in 3 switched Bands. 0-1mA Indicator. Monitor Socket. Very sensitive, £3.13.6. P. & P. 2/6.

**VARIABLE CONDENSERS.** All brass with ceramic end plates and ball race bearings. 50pF, 5/9; 100, 6/6; 160, 7/6; 240, 8/6; and 300pF, 9/6. Extension for ganging. P. & P. 1/-.

**RACK MOUNTING PANELS:** 19" x 5½", 7", 8½", or 10½", black crackle finish, 5/9, 6/6, 7/6, 9/- respectively. P. & P. 2/-.

**GELOSO VFO UNITS.** 4/102 with new dial and escutcheon. Outputs on 80, 40, 20, 15 and 10. For 2-807 or 6146 Tubes. Only £8.15.3, valves to suit, 24/-. ALL POST FREE.

**SHADED POLE MOTORS,** 230V or 110V operation, ideal for fans, blowers or models. Single Unit 12/6, plus 2/- P. & P., or Pair £1, plus 2/6 P. & P.

**PARMEKO TRANS.** 200/200 40mA, 6.3V, 3A. New, not ex-W.D. Only 12/6. P. & P. 2/6.

**CHAS. H. YOUNG LTD**

**170-172 Corporation St., Birmingham 4**

Please print your address. No C.O.D. under £1. 'phone CEN 1635

# SMALL ADVERTISEMENTS

Rate: 9d. per word.

Minimum charge 12/-.

Box No. 2/- extra.

Advertisements must be prepaid and all copy must be received by the 4th of the month for insertion in the following month's issue. The Publishers cannot be held liable in any way for printing errors or omissions, nor can they accept responsibility for the *bona fides* of advertisers. (Replies to Box numbers should be addressed to: Box No. —, *The Radio Constructor*, 57 Maida Vale, London, W.9.)

**THE INCORPORATED PRACTITIONERS IN RADIO AND ELECTRONICS (I.P.R.E.) LTD.** Membership conditions booklet 1s. Sample copy of I.P.R.E. Official Journal 2s. post free.—Secretary, Dept. D, 32 Kidmore Road, Caversham, Reading, Berkshire.

**SERVICE SHEETS, 1925-1964.** From 1s. Catalogue 6,000 models, 1s. 6d. S.A.E. enquiries.—Hamilton Radio, 13 Western Road, St. Leonards, Sussex.

**S.E.S. SERVICE SHEETS** for all Television, Radio, etc. Lists 1s. 6d. plus S.A.E.—Sun Electrical Services, 38 St. George's Road, Hastings, Sussex.

**METALWORK.** All types cabinets, chassis, racks, etc., to your specifications.—Philpott's Metalworks Ltd., Chapman Street, Loughborough.

**HAMMER FINISH PAINT.** The modern finish for electronics. Can be brushed or sprayed. Blue or silver. 2½ oz. tins 3s. 6d., ½ pint 7s. 6d., 1 pint 15s. Post 6d. on any order. Trade supplied.—Finnigan Speciality Paints, (RC), Mickley Square, Stocksfield, Northumberland.

**CONVERT ANY TV SET INTO AN OSCILLOSCOPE.** Instructions and diagrams 12s. 6d. *Electronic Experiments* for the enthusiast and student 20s.—Redmond, 42 Dean Close, Portslade, Sussex.

**FOR SALE.** Television Sets—not working. For callers only. 17in, £1 10s.; 21in, £3 10s.; 14in mains portables, £2 10s.—Telephone: Bournemouth 26849.

**GOVERNMENT SURPLUS** electrical and radio equipment. Our new illustrated catalogue No. 16 ready early March. 2s. 6d. Post Free, cost refunded on purchase of goods over £2.—Arthur Sallis Radio Control Ltd., 93 North Road, Brighton, Sussex.

**FOR SALE.** Mohican receiver in good order. £25, or will exchange Pye Solent. Perioli, 1 Garfield Road, Felixstowe, Suffolk.

**FOR SALE.** New grey cabinet, length 12in, height 7in, back to front 7in, £2 post paid. Black crackle cabinet, length 16½in, height 7½in, back to front 7½in, £1 post paid. Crystal mic. in G.P.O. type desk stand, 15s. post paid.—Box No. F225.

continued on page 573

# BENTLEY ACOUSTIC CORPORATION LTD

38 CHALCOT ROAD CHALK FARM LONDON NW1

THE VALVE SPECIALISTS Telephone PRIMROSE 9090

IL4	2/3	6X5	4/6	DK96	6/6	EF41	6/9	HABC80	9/3	U25	8/6
IR5	4/-	6/30L2	9/-	DL96	6/-	EF80	4/-	KT66	12/3	U26	7/6
IS4	5/-	9BVV6	9/6	DM70	5/-	EF83	9/9	N339	15/-	U31	7/-
IS5	3/6	10C1	8/9	DY86	6/9	EF85	4/6	PABC80	6/9	U191	9/6
IT4	2/3	10C2	12/3	DY87	8/-	EF86	6/6	PC86	10/3	U282	12/3
2D21	5/6	10F1	10/-	EB8CC	10/-	EF89	4/-	PC88	9/6	U301	11/6
3D6	3/9	10F18	9/9	EABC80	5/9	EF91	3/-	PC95	6/9	U329	9/-
3Q4	5/3	10LD11	9/6	EAF42	7/6	EF92	2/6	PC97	6/9	U404	6/-
3Q5	7/-	10P13	8/3	EB91	2/3	EF97	10/-	PCC84	5/6	U801	16/3
354	4/6	10P14	11/6	EBC33	6/-	EF98	10/-	PCC85	6/9	UABC80	5/-
3V4	5/3	12AH8	10/9	EBC41	6/6	EF183	7/-	PCC88	10/6	UAF42	7/-
5Y3GT	4/9	12AT6	4/6	EBC81	5/9	EF184	7/-	PCC89	8/6	UBC41	6/3
5Z4	7/6	12AU6	5/9	EBF80	5/9	EL33	6/9	PCC189	10/6	UBC81	6/3
6AQ5	5/9	12AV6	6/6	EBF83	7/3	EL34	8/6	PCF80	6/6	UBF80	5/9
6AT6	3/9	12BA6	5/9	EBF89	6/-	EL36	8/9	PCF82	6/3	UBF89	6/9
6AU6	5/3	12BE6	4/9	EBL21	10/6	EL41	7/3	PCF84	8/6	UBL21	10/9
6AV6	5/6	12BH7	6/-	EC92	6/6	EL42	7/6	PCF86	7/9	UC92	6/3
6BA6	4/6	19AQ5	7/3	ECC40	7/-	EL83	6/9	PCF801	10/6	UC84	8/9
6BE6	4/9	20D1	10/-	ECC81	3/6	EL84	4/6	PCF802	10/-	UCC85	6/6
6BH6	5/3	20F2	11/6	ECC82	4/6	EL85	7/6	PCL82	6/6	UCF80	8/9
6BJ6	5/6	20L1	12/6	ECC83	4/6	EL86	7/3	PCL83	7/9	UCH21	8/-
6BQ7A	7/6	20P1	12/6	ECC84	5/6	EL95	5/6	PCL84	7/6	UCH42	8/-
6BR7	8/9	20P3	12/-	ECC85	5/9	ELL80	13/6	PCL85	7/6	UCH81	6/6
6BR8	8/-	20P4	13/6	ECC88	8/9	EM34	11/6	PCL86	8/9	UCL82	7/9
6BV6	8/9	20P5	12/3	ECC189	11/6	EM71	15/6	PL36	9/-	UCL83	9/-
6CD6G	18/-	30C18	10/6	ECF80	6/6	EM80	6/3	PL38	16/-	UF41	6/9
6CH6	5/-	30F5	5/9	ECF82	6/3	EM81	7/-	PL81	6/9	UF42	4/9
6CI1	9/6	30L15	9/3	ECF86	11/6	EM84	6/9	PL82	5/3	UF80	6/3
6J7G	4/6	30P4	12/3	ECH21	9/-	EM85	8/9	PL83	6/-	UF85	6/9
6K7G	1/3	30P12	7/6	ECH35	6/3	EM87	7/6	PL84	6/6	UF86	9/-
6K8G	3/3	30P19	12/3	ECH42	8/-	EY51	5/9	PM84	9/3	UF89	6/-
6L1	10/-	30P11	8/6	ECH81	5/9	EY91	7/3	PY33	8/9	UL41	7/3
6L6GT	7/-	35W4	4/9	ECH83	6/6	EY83	9/3	PY80	5/-	UL84	6/-
6L18	10/-	B5A2	6/6	ECH84	9/6	EY84	9/6	PY81	5/-	UM80	8/3
6LD20	5/6	5763	7/6	ECL80	6/-	EY86	5/9	PY82	4/9	UY21	7/9
6Q7G	4/-	AZ31	6/6	ECL82	6/6	EY88	8/9	PY83	5/9	UY41	5/-
6S17	5/3	AZ41	6/6	ECL83	9/6	EZ40	5/3	PY88	7/3	UY85	5/-
6SN7	4/-	DAF96	6/-	ECL86	8/9	EZ41	6/3	PY800	6/-	VP4B	12/-
6V6G	3/9	DF96	6/-	ECP37A	6/-	EZ80	3/9	PY801	6/3	X41	10/-
6X4	3/9	DK92	8/-	EF40	8/9	EZ81	4/6	U24	12/6	X78	20/6

Terms of business: Cash with order or C.O.D. only. Post/packing 6d. per item. Orders over £3 post free. C.O.D. 3/6 extra. All orders despatched same day. Complete catalogue including transistor section and components with terms of business 6d. Any parcel insured against damage in transit for 6d. extra. We are open for personal shoppers 8.30-5.30 Saturdays 8.30 a.m.-1 p.m.

# JACKSON

the big name in **PRECISION** components

Precision built radio components are an important contribution to the radio and communications industry.

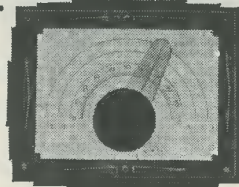

**No. 6/36 DRIVE**

Incorporating the Dual Ratio Ball Drive providing 36-1 Slow drive and 6-1 Fast drive under one knob with co-axial control. Scale is calibrated 0-100 and an extra blank scale is provided for individual calibration.

The unit consists of aluminium back plate, drive unit, scale, spare scale, transparent cover, hair-line pointer, escutcheon and knob. Fits in front of panel which may be any thickness up to ½" (or more by providing longer screws).

**STAND 267 R.E.C.M.F. EXHIBITION**

**JACKSON BROS. (LONDON) LIMITED**

Dept. RC, KINGSWAY-WADDON, CROYDON, SURREY  
Phone Croydon 2754-5 Grams Walfilco, Souphonne, London

# SOLON GETS THINGS TOGETHER FOR GOOD



SOLON ELECTRIC SOLDERING IRONS are made by AEI. Seven models suitable for all soldering jobs. The 15 and 25 watt for radio work, the 65 watt for heavier duties. All parts are replaceable. Prices from 24/8.

**SOLON**  
TRADE MARK

*From your radio or electrical supplier.*

## MARTIN F.M. TUNER

From 3 easy to assemble units

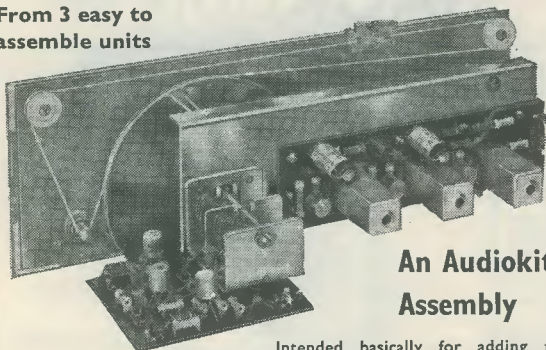

An Audiokit Assembly

**UNIT 15.** F.M. Head complete with tuning condenser **£5.12.6d.**

**AMPLIFIER 16.** 1.F. Amplifier Strip **£5.7.6d.**

**UNIT 17.** Escutcheon, drive and controls assembly **£1.17.6d.**

Intended basically for adding to existing Martin Audio assemblies, this new F.M. Tuner can also be used with other high quality amplifiers. It combines three new prefabricated Martin Units which when assembled make a modern, all-transistor F.M. Tuner with A.F.C. For 9 volt operation via dropper supplied, or battery. The on-off control provides switch-through facilities for recorder, etc. A well-styled bevelled perspex escutcheon is included in Unit 17. These units are individually tested and available boxed separately.

MARTIN ELECTRONICS, 154 High St., Brentford, Middlesex

Details please of Recordakits  and F.M. Tuner  (Tick as required)

Name .....

Address .....

RC.25 .....

**FREE** *inside every copy!*

## 24 - PAGE PRACTICAL WIRELESS POCKET GUIDE

Packed with invaluable at-a-glance data. You'll use it again and again. It includes:—

- **ELECTRICAL QUANTITIES, UNITS AND SYMBOLS**
- **WIRE AND METAL GAUGE DATA AND COMPARISONS**
- **FREQUENCY AND WAVELENGTH DATA with Conversion Table**
- **DECIBEL CALCULATIONS**

Plus Multiples and Sub-Multiples—Greek Alphabet Symbols—Conversion of Units and Constants—Eureka Resistance Wire Data—Copper Wire Data—Transformer Matching—Time Constants.

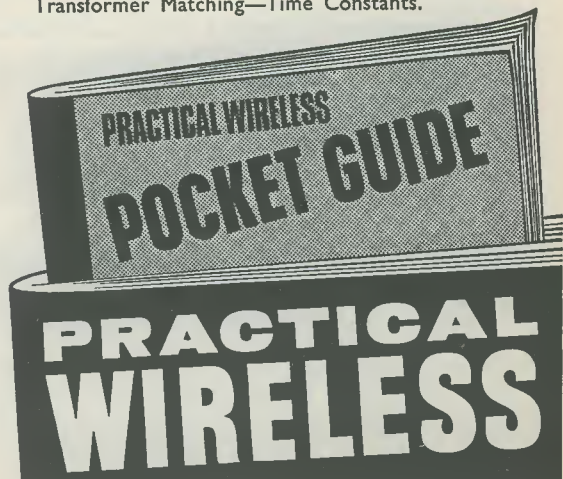

**APRIL ISSUE** on sale March 4th—2/-  
**BIG DEMAND! MAKE SURE OF YOUR COPY!**

## SMALL ADVERTISEMENTS

continued from page 571

**FOR SALE.** Heathkit OS1 oscilloscope, Jason W11 wobullator, as new £30. Hallicrafters SX53A communications receiver, 550 kc/s to 54 Mc/s. 230V a.c. Perfect. £18 o.n.o.—Mitchell, 65 Cants Lane, Burgess Hill, Sussex.—Telephone: 3851.

**FOR SALE.** Garrard AT6 de-luxe autochanger, Ronette stereo cartridge, £6 10s. Little used.—Box No. F230.

**FOR SALE.** Light sensitive transistors for the experimenter, 5s. each with circuit for light operated switch. P. & P. 6d.—Meadows, 10 Heol-Y-Llan, Barmouth, Merioneth.

**FOR SALE.** Elliot transistor curve tracer with handbook £60. Leak 10W amplifier and control unit £11 10s.—3 Hydefield Close, London, N.21.

**FOR SALE.** Moving to Australia. Modified CR100 £25. Stereo amplifier £15. Jason VHF/MW receiver £15. Many valves, transistors, etc. S.A.E. enquiries.—Peter Burton, 18 Manor Way, Purley, Surrey.

**INTERESTED IN AMATEUR RADIO TELEPRINTING?** Then join the British Amateur Radio Teletypewriter Group. Details from Hon. Sec., G3LLV, 15 Havelock Square, Broomhill, Sheffield 10.

**JOIN THE INTERNATIONAL S.W. LEAGUE.** Free Services to members including Q.S.L. Bureau. Amateur and Broadcast Translation. Technical and Identification Dept.—both Broadcast and Fixed Stations, DX Certificates, contests and activities for the SWL and transmitting members. Monthly magazine, *Monitor*, containing articles of general interest to Broadcast and Amateur SWLs, Transmitter Section and League affairs, etc. League supplies such as badges, headed notepaper and envelopes. QSL cards, etc., are available at reasonable cost. Send for League particulars. Membership including monthly magazine, etc., 21s. per annum.—Secretary, ISWL, 12 Gladwell Road, London, N.8.

**THE INTERNATIONAL HAM HOP CLUB** is a non-profit-making organisation open to RADIO AMATEURS AND SHORT WAVE LISTENERS. OBJECT: to improve international relationships through an organised system of hospitality. MEMBERS offer overnight hospitality to visiting members, subscription 10s. per annum. ASSOCIATE MEMBERS invite radio amateurs to visit their stations. Associate membership 5s. per annum. FAMILY EXCHANGE holidays arranged, also FRIENDSHIP LINKS between radio clubs. The Club's official journal is free to both Full and Associate Members.—Hon. Gen. Secretary: G. A. Partridge, G3CED, 17 Ethel Road, Broadstairs, Kent.

continued on page 575

## BOOKS NEW TITLES FOR 1965

### JANUARY

	<b>CLOSED-CIRCUIT TELEVISION HANDBOOK</b> by Leon A. Wortman	288 pages	42/- Net
Demy 8vo	<b>ELECTRONIC ORGAN HANDBOOK</b> by H. Emerson Anderson	272 pages	35/- Net
Demy 8vo	<b>TAPE RECORDERS—HOW THEY WORK</b> (New, Enlarged Edition) by Charles G. Westcott and Richard F. Dubbe	224 pages	26/- Net
Demy 8vo	<b>PRACTICAL TRANSISTOR SERVICING</b> by W. C. Caldwell	192 pages	24/- Net
Demy 8vo	<b>101 MORE WAYS TO USE YOUR VOM &amp; VTVM</b> by Robert G. Middleton	128 pages	20/- Net
Demy 8vo	<b>101 WAYS TO USE YOUR SWEEP GENERATOR</b> by Robert G. Middleton	144 pages	20/- Net

### FEBRUARY

	<b>TRANSISTOR SUBSTITUTION HANDBOOK</b> (Fifth Edition)	128 pages	12/6 Net
Demy 8vo	<b>SCIENCE PROJECTS IN ELECTRONICS</b> by Edward M. Noll	144 pages	24/- Net
Demy 8vo	<b>RADIO SERVICE TRAINING MANUAL</b> by Edward F. Rice	288 pages	30/- Net
Demy 8vo	<b>MATHEMATICS FOR ELECTRONICS ENGINEERS &amp; TECHNICIANS</b> by Norman H. Crowhurst	256 pages	42/- Net
Demy 8vo	<b>HANDBOOK OF ALGEBRAIC &amp; TRIGONOMETRIC FUNCTIONS</b> by Allan Lytel	160 pages	30/- Net
Demy 8vo	<b>TECHNICAL WRITER'S &amp; EDITOR'S STYLEBOOK</b> by Rufus P. Turner	208 pages	28/- Net
Demy 8vo	<b>UNDERSTANDING TRANSFORMERS &amp; COILS</b> by Edward J. Bukstein	96 pages	16/- Net

### MARCH

	<b>HANDBOOK OF TRANSISTOR CIRCUITS</b> by Allan Lytel	224 pages	35/- Net
Demy 8vo	<b>101 WAYS TO USE YOUR OSCILLOSCOPE</b> by Robert G. Middleton	180 pages	21/- Net
Demy 8vo	<b>TRANSISTOR RADIO SERVICING MADE EASY</b> by Wayne Lemons	128 pages	18/- Net
Demy 8vo	<b>RADIO RECEIVER SERVICING</b> by John T. Frye	224 pages	25/- Net
Demy 8vo	<b>SHORT WAVE LISTENERS GUIDE</b> by H. Charles Woodruff	70 pages	12/6 Net
Demy 8vo	<b>HI-FI STEREO HANDBOOK</b> by William F. Boyce	288 pages	32/- Net

Recently Published—**BASIC ELECTRICITY/ELECTRONICS**  
Programmed Learning

	<b>1. BASIC PRINCIPLES &amp; APPLICATIONS</b>	320 pages	35/- Net
Demy 8vo	<b>2. HOW AC &amp; DC CIRCUITS WORK</b>	304 pages	35/- Net
Demy 8vo	<b>3. UNDERSTANDING TUBE &amp; TRANSISTOR CIRCUITS</b>	224 pages	35/- Net
Demy 8vo	<b>4. UNDERSTANDING &amp; USING TEST INSTRUMENTS</b>	256 pages	35/- Net
Demy 8vo	<b>5. MOTORS &amp; GENERATORS—HOW THEY WORK</b>	224 pages	35/- Net

From Booksellers or, plus 8d postage, from the Publishers

Write for complete catalogue

### FOULSHAM — SAMS TECHNICAL BOOKS

Dept. ARC, Yeovil Road, Slough, Bucks, England

# THE MODERN BOOK CO

**Radio Amateur Handbook, 1965**  
By A.R.R.L. 40s. Postage 2s.

**Inter: GEC Transistor Manual.**  
7th Ed. 18s. Postage 1s 6d.

**Electronic Organ Handbook**  
By H. E. Anderson. 35s. Postage 1s.

**101 More Ways to Use Your VOM and VTVM.**  
By R. G. Middleton. 20s. Postage 1s.

**Analogue Computing for Beginners.**  
By K. A. Key. 25s. Postage 1s.

**Basic Theory and Application of Transistors.**  
By U.S. Dept. Army. 10s. Postage 1s.

**Aerial Handbook.**  
By G. A. Briggs and R. S. Roberts. 8s. 6d.  
Postage 8d.

**Radio Valve Data.**  
7th Ed. Compiled "W.W." 7s. 6d. Postage 10d.

**World Radio TV Handbook, 1965**  
26s. Postage 1s.

**Beginner's Guide to Colour Television.**  
By T. L. Squires. 15s. Postage 8d.

**Closed Circuit Television Handbook.**  
By L. A. Wortman. 42s. Postage 1s.

**Transistor Ignition Systems Handbook.**  
By B. Ward. 20s. Postage 1s.

**Tape Recorders—How They Work.**  
By C. G. Westcott and R. F. Dubbe. 26s.  
Postage 1s.

**Practical Transistor Servicing.**  
By W. C. Caldwell. 24s. Postage 1s.

**Worked Radio Calculations.**  
By A. T. Witts. 15s. Postage 8d.

**Wireless for Beginners.**  
By C. L. Boltz. 18s. Postage 1s.

Complete Catalogue 1s.

We have the Finest Selection of English and American Radio Books in the Country  
**19-21 PRAED STREET (Dept RC) LONDON W2**

Telephone PADdington 4185

## WIRECOMP ELECTRONICS

BARGAINS  
FOR THE HOME  
CONSTRUCTOR

### SINCLAIR SUPER MINIATURES

**THE SLIMLINE.** The new 2-transistor pocket radio, size only 2 3/4" x 1 3/8" x 1 1/2". Micro alloy transistors and printed circuit. Easy to assemble. **CAN BE BUILT FOR 49/6**

**THE MICRO-6.** Self-contained pocket radio. Size only 1 4/5" x 1 3/10" x 1 1/2"—truly amazing performance. Complete with earphone. **CAN BE BUILT FOR 59/6** Mercury cell 1/11 extra

**THE X10.** 10 watt power amplifier with integrated pre-amp. Requires only 1mV for an output of 10 watts undistorted. Size 6" x 3" x 2", weight 5 oz. Operates from 12V d.c. at 75µA quiescent. Circuit uses 7 MATs and 4 r.f. power transistors. **KIT PRICE £5.19.6 AVAIL. READY BUILT £6.19.6.** 3 pots. for volume, bass and treble, 7/6 the three extra.

**SUB-MINIATURE TRANSISTORISED AMPS.** British made, these sub-min. transformerless amplifiers come to you fully built and ready for immediate use. All use NPN-PNP circuit powered by 9V battery.

**PC1,** input 50mV, output 150mV at 40Ω, size 2" x 1" x 2". **PRICE 29/6**  
**PC2,** input 1mV, output 400mV at 15Ω, size 2" x 2 1/2" x 2". **PRICE 37/6**  
**PC3,** input 5mV, output 400mV at 15Ω, size 2 1/2" x 1 1/2" x 2". **PRICE 37/6**  
**PC4,** input 150mV, output 400mV at 15Ω, size 2 1/2" x 1 1/2" x 2". **PRICE 37/6**  
Add 1/- P. & P. on each.

**VEROBOARD** is a high grade laminated board with copper strips bonded to it, pierced with a regular matrix of holes. Ideal for experimental circuits and "one off" constructions.

BOARDS		ACCESSORIES	
42/1503	2 1/2" x 5" ...	3/8	Terminal pins—packet of 36 ...
43/1504	2 1/2" x 3 1/2" ...	3/-	Spot face cutter tool ...
45/1507	3 1/2" x 5" ...	5/2	Pin inserting tool ...
46/1508	3 1/2" x 3 3/4" ...	3/8	
44/1505	3 1/2" x 17" ...	13/6	

P. & P. 6d. per item extra

**TRANSISTORS** GET.S1, GET.S5, GET.S6—2/6; 873A, 874P—3/6; OC.45, OC.71, OC.81D—4/6; OC.44, OC.70, OC.76, OC.81—5/6 (matched pair 10/6); AF.117, OC.75, OC.200—6/6; OC.42, OC.43, OC.73, OC.82D—7/6; OCP.71—9/6; OC.201, OC.204—15/-; OC.205, OC.206—19/6; OC.28—24/6.

**TRANSFILTERS** by BRUSH CRYSTAL CO.  
TO-01B 465 kc/s ±2 kc/s TO-02D 470 kc/s ±1 kc/s  
TO-01D 470 kc/s ±2 kc/s TF-01B 465 kc/s ±2 kc/s  
TO-02B 465 kc/s ±1 kc/s TF-01D 470 kc/s ±2 kc/s

**6/6** each  
P. & P. 6d.

323 EDGWARE ROAD, LONDON, W.2. AMBASSADOR 7115  
378 HARROW ROAD, LONDON, W.9. CUNNINGHAM 9530  
Both branches open all day Sat. Early closing Thurs. Mail orders to Harrow Rd.

TO DESIGNERS & CHIEF ENGINEERS

# OSMOR

SPECIALISE IN WINDING MINIATURE COILS, TRANSFORMERS, ETC. OF INTEREST TO BULK MANUFACTURERS IN THE INDUSTRIAL FIELD.

MANUFACTURERS USING UP TO 50 S.W.G. WOULD FIND OUR SERVICE ECONOMICAL AND RELIABLE. ENQUIRIES APPRECIATED.

LARGE CAPACITY AVAILABLE

PLEASE TELEPHONE CRO 5148  
FOR SWIFT ACTION

OSMOR RADIO PRODUCTS LTD.

540 PURLEY WAY (PARKING FACILITIES)

(Nr. AIRPORT) CROYDON

CRO 5148/9



## SMALL ADVERTISEMENTS

continued from page 573

### SITUATIONS VACANT

**NATIONAL INSTITUTE FOR MEDICAL RESEARCH, MILL HILL, LONDON, N.W.7.** A junior technician/engineer is required in the Engineering Division for the production, initially under supervision, of prototype electronic equipment. Some experience in assembly, testing or servicing in this field is desirable. Salary dependent on age and experience. Application should be addressed to the Personnel Officer.

### Electronic Technicians

Cambridge Works Limited, a member of the Pye (Cambridge) Limited Group of Companies, require technical staff for their Industrial Television Department. If you are seeking an interesting job covering a wide field in electronics this could be it. The work consists of the construction of special television equipment for industrial applications.

Basic knowledge of AC and DC theory, ability to read circuit diagrams, plus common sense in good measure are the qualifications required.

Please apply to Personnel Manager,  
Cambridge Works Limited,  
Haig Road, Cambridge.



**PYE TELECOMMUNICATIONS LTD**

Have vacancies in  
CAMBRIDGE.

## VHF ENGINEERS

Experience of A.M. and F.M. Transmitters and Receivers essential. Some transistor circuit experience desirable. Men who have had training in the Services may be suitable. Excellent rates of pay and good prospects for promotion. Applicants who wish to seek a career with Europe's leading Radiotelephone manufacturers should apply to:

**Personnel Manager**  
Pye Telecommunications Limited,  
Newmarket Road,  
Cambridge.  
Telephone Teversham 3131

**REJECTOR UNITS 1.2-10 Mc/s** in 4 switched ranges. Ideal for Harmonic suppression of TX, or as a station rejector for RX's, just plug aerial into one socket and connect to other socket, large tuning knob and dial, in small grey case. **BRAND NEW, only 35/-, post 5/-.**



### CHECKING RADIATION ?

**SCINTILLATION COUNTER 1093 (B)** using 6097B tube, plus 10 other valves, magnetic counter with lens. Each unit in case but made for 19" rack mountings x 8 1/2".

**POWER UNIT 1093 (B)** for above, 200-50 A.C. input, output stabilised adjustable (1) 0-2kV, (2) 300V 120mA. Meter for checking output voltages, same size as above using 10 valves, made by Ferranti. These two units are the complete counter, and checked complete, but as we know very little of this type of equipment no enquiry can be answered. £12.10.0 B.R.S. 10/- or either unit £7.0.0. B.R.S. 10/-.

### SCALING UNITS 1009 A X B S.A.E.

### 50-75 WATT TANNAY AMPLIFIER

200-50 A.C. input, using 6 valves, circuit and handmike also 2 spare 6L6 and 2 FW4/500 Valves. **BRAND NEW £10.0.0 B.R.S. 10/-.**

**12 VOLT-150 Vibrator pack** made for 52 Set. **BRAND NEW** in Sealed Cartons, less 6 x 5 Rectifier, 15/- Post 2/6.

### AERIAL MATCHING TUNING UNITS

Latest American release bulk purchase of 3,000

These well-made tuning units, made for the American 19. T.X.-R.X. are housed in a metal case, green or brown, using a large precision calibrated scale, are an essential piece of equipment for the serious T.X. or R.X. operator. This unit will match an untuned wire or whip aerial to almost any short wave receiver or transmitter, exceptionally good for mobile Top Band use. This American version being well noted as far superior to any other. **GUARANTEED BRAND NEW, only 20/-, post 7/6.** Instructions supplied.

**U.H.F. RADIO RECEIVER R10 Fx 4840 Mc/s-4475 Mc/s (6.2-6.7 cms).** These recently made sets are supplied in two units:

1. Receiver. This is manual or auto-tuned, by an internal motor, using a total of 18 valves, osc. mixer CV90, IF 45 Mc/s, aerial input via ordinary Pye co-axial plug (supplied).

2. Power unit & output stage. Contains 300V H.T. and -50V bias supplies, also Receiver auto-tune supply.

Both units housed in matching metal cases sizes 17 1/2" x 8" x 10". Supplied in first-class order, complete with circuit and connecting cable from power unit to set. Mains 230V input. Offered at a fraction of cost £4.10.0 per unit. Carr. 10/-.

19" RACKS 5ft and 6ft high, 50/- each, carr. 10/-.

**J. T. SUPPLY (Dept. F), 38 MEADOW LANE, LEEDS 11**

## TESTED TRANSISTORS

1/- each Red or White Spots. OA81, OA202.

2/- each XA101, XA102, XA111, XA112, XB103, NKT122, OA90, OC430.

3/- each OC44, OC45, OC81, OC81D, OC200, GET16.

4/- each AF114, AF115, AF117, OC170, OC171, SX658, XV611.

5/- each OC72, OC139, OC140, OC204, GET8, ORP60, BY100.

10/- each OC35, OC26, OC28, AFY19, 2S013, ORP12, GET571.

**ZENER DIODES 4.7 volt to 33 volt 1/4 watt, 3/6 each, 1.5 watt, 5/- each, 7 watt, 6/- each.**

Send 3d. stamp for Full Price List, and Free Equivalent Chart

## B. W. CURSONS

78 BROAD STREET, CANTERBURY, KENT

# CHASSIS and CASES by



287/9 Edgware Road  
London W2  
TELEPHONE  
PADDINGTON 5891/7595

**BLANK CHASSIS—Same Day Service**  
Of over 20 different forms made up to YOUR SIZE.  
Order EXACT SIZE you require to nearest 1/16th.  
(Maximum length 35", depth 4")  
Specials dealt with promptly.

**SEND FOR ILLUSTRATED LEAFLETS**  
or order straight away, working out total area of material required and referring to table below which is for four-sided chassis in 18 s.w.g. (for 16 s.w.g. add 1/6th).  
48 sq. in. 4/- 176 sq. in. 8/- 304 sq. in. 12/-  
80 sq. in. 5/- 208 sq. in. 9/- 336 sq. in. 13/-  
112 sq. in. 6/- 240 sq. in. 10/- 368 sq. in. 14/-  
144 sq. in. 7/- 272 sq. in. 11/- and pro rata  
P. & P. 2/6 P. & P. 2/9 P. & P. 3/-  
Discounts for quantities. Finishes arranged for quantities of 25 or over.  
**FLANGES** (1/2" or 3/8"), 6d. per bend.  
**STRENGTHENED CORNERS**, 1/- each corner.  
**PANELS**  
Any size up to 3ft at 4/6 sq. ft. 18 s.w.g. (16 s.w.g. 5/3).  
Plus postage and packing (orders over £2 Post Free).

## CASES

ALUMINIUM, SILVER HAMMERED FINISH			Type W		
Type	Size	Price	Type	Size	Price
U	4 x 4 x 4"	9/6	Y	8 x 6 x 6"	25/-
U	5 1/2 x 4 1/2 x 4 1/2"	14/6	Y	12 x 7 x 7"	39/-
U	8 x 6 x 6"	20/-	Y	13 x 7 x 9"	44/-
U	15 x 9 x 9"	42/6	Y	15 x 9 x 7"	46/-
W	8 x 6 x 6"	19/6	Z	17 x 10 x 9"	63/-
W	12 x 7 x 7"	32/6	Z	19 x 10 x 8 1/2"	67/6
W	15 x 9 x 8"	42/-		* Height	

Type Z has removable back and front panels.  
Type Y all-screwed construction.

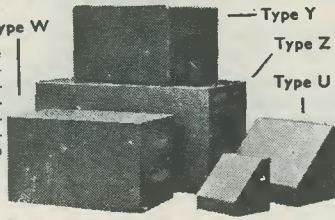

**NYLON P.T.F.E.**  
**ROD BAR SHEET TUBE STRIP WIRE**  
*No quantity too small List on application*  
**BRASS COPPER BRONZE ALUMINIUM LIGHT ALLOYS**  
**STAINLESS STEEL**  
**H. ROLLET & CO LTD**  
HOWIE STREET, LONDON, S.W.11 BATTERSEA 7872  
Also at Liverpool, Birmingham, Manchester, Leeds, Glasgow

the unique **PANL** black crackle paint  
4/-d. per 1/8 pt. Can  
(We regret we can only supply on cash with order basis)

**BRUCE MILLER LTD.,**  
219 Coastal Chambers,  
Buckingham Palace Road, S.W.1.

**YUKAN** Get this Air-drying Grey  
**HAMMER FINISH NOW—**

IT'S SUPERB . . . . . THE PUSHBUTTON WAY!

YUKAN Aerosol spraykit contains 16 ozs. fine quality durable easy instant spray. No stove baking required. Available in Grey Hammer at 14/11 at our counter or 15/11 cart., paid, per pushbutton self-spray can. **SPECIAL OFFER:** I can plus optional transferable snap-on trigger handle (value 5/-) for 18/11. Please enclose cheque or P.O. for total amount to:



**YUKAN**  
Dept. RC/2 307a EDGWARE ROAD LONDON W.2  
(Closed Thursday afternoons, open all day Saturdays)  
Choice of 13 self-spray plain colours and primer (motor car quality) also available

## YOUR CAREER IN RADIO?

Big opportunities and big money await the qualified man in every field of Electronics today—both in the U.K. and throughout the world. We offer the finest home study training for all subjects in radio, television, etc., especially for the **CITY & GUILDS EXAMS** (Technicians' Certificates); the Grad. Brit. I.R.E. Exam.; the **RADIO AMATEUR'S LICENCE**; P.M.G. Certificates; the R.T.E.B. Servicing Certificates; etc. Also courses in Television; Transistors; Radar; Computers; Servomechanisms; Mathematics and Practical Transistor Radio course with equipment. We have **OVER 20 YEARS'** experience in teaching radio subjects and an unbroken record of exam. successes. We are the only privately run British home study Institute specialising in electronic subjects only. Full details will be gladly sent without any obligation.

SEND FOR FREE BROCHURE TO:  
**BRITISH NATIONAL RADIO SCHOOL**  
DEPT 4, RADIO HOUSE · READING · BERKSHIRE

## WE SPECIALISE

In Quality TRANSISTORS & COMPONENTS

... for last month's constructional articles ...  
Goodmans Audiom 61 and 81 loudspeakers  
Parts for Bass Guitar 17 watt amplifier  
... or for Transistor equivalent  
also available GEX541, OC36, SX68, 2S712, 2G304, OC44,  
OC83, OC75, 5000uF 25V.  
and voltage dependent resistors.

For details of these, please send 3d. stamp for March List or one shilling (stamps) for our Transistor Reference Catalogue

**J. WILLIAMS & CO.** 208 HAGLEY ROAD  
BIRMINGHAM 16

## THE RADIO CONSTRUCTOR—BOUND VOLUMES

Volume 17, August 1963 to July 1964 Price £1 10s 0d Postage 3s 0d

Where all issues are returned : Price £1 Postage 3s 0d

We regret Volumes 13, 14, 15 and 16 are now sold out

Send for our latest brochure containing details of our other publications

**DATA PUBLICATIONS LTD 57 MAIDA VALE LONDON W9**

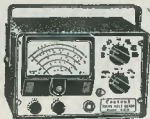

### VALVE VOLTMETER

AC/DC (+ and -) Resistance.  
AC/RMS and PK/PK.

Detailed leaflet on request.

- ★ AC RMS and DC Voltage 0/1½/5/15/50/150/500/1,500 volts. DC IMP. 11 meg. A.C SENS 7.33 meg/volt.
  - ★ AC PK to PK 0/4.2/14/42/140/420/1,400/4,200 volts.
  - ★ Resistance from 0.2 ohm to 1,000 Meg. In 4 ranges. AC/DC Probe, DC to 4 Mc/s, High Stability and Accuracy. Size 7½" x 4½" x 5". Mains operated. Fully guaranteed.
- Price £13.19.6. P.P. 2/6  
(Probe to extend to 100 Mc/s, 40/- extra)
- ★ TRANSISTOR TESTER £9.17.6. P.P. 3/6

### BUILD A QUALITY TAPE RECORDER

- ★ Pre-Built Equipment—6 Valves—Collaro Studio Decks—Portable Cabinet
- ★ Cabinets with 8" x 5" Speakers

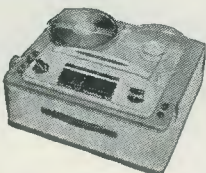

- ★ LEAFLET ON REQUEST

### TWO TRACK Total Cost £26

P.P. 8/6

OR Deck 10 gns. P.P. 5/-; Amplifier 11 gns. P.P. 3/6. Cabinet with Speaker 5 gns. P.P. 3/6.

### FOUR TRACK Total Cost £30

P.P. 8/6

OR Deck £13.19.6. P.P. 5/-; Amplifier 12 gns. P.P. 5/6. And Cabinet with Speaker 5 gns. P.P. 3/6. All complete in every detail. Illustrated leaflets on request. Ideal for portable or domestic equipment.

### GARRARD 2-TRACK BATTERY TAPE DECK



9V operated, 2 track, 2 speed. Brand new, fitted heads, etc. Supplied complete with cassette and manual. Brand New. £10.10.0. P.P. 3/6.

### FM VHF TUNING HEART

Printed circuit construction, fully tunable 85 to 105 Mc/s. Completely screened. Requires UCC85 (8/6), R.F. stage and osc./mixer stage. With circuit. Brand new in maker's cartons 15/-, P.P. 1/-

### MULTI METERS

#### BRAND NEW FULLY GUARANTEED

- PT34 1kΩ/volt 39/6
- CABY11 2kΩ/volt 49/6
- THL33 2kΩ/volt 75/- (illustrated)
- EP10K 10kΩ/volt 79/6
- IT12 20kΩ/volt 82/6
- TP55 20kΩ/volt £5.19.6
- 500 30kΩ/volt £8.19.6
- EP30K 30kΩ/volt £5.10.0
- EP50K 50kΩ/volt £8.10.0
- EP100K 100kΩ/volt £9.19.6

Post and Packing 2/- any model



## TRANSISTORS, CRYSTALS, VALVES AND COMPONENTS

### THE LARGEST RANGE OF THE ABOVE ITEMS IN THE COUNTRY

We stock far too many types to list here. See our Catalogue for full range LET US QUOTE FOR PARTS FOR YOU RETURN OF POST SERVICE

### A SELECTION FROM OUR STOCKS

See Catalogue for full details

- Sinclair X10 Amplifier (Kit) ... £5.19.6
- (Build) ... £6.19.6
- Sinclair Micro-6 (to build) ... 59/6
- Sinclair TR750 Amplifier (to build) ... 39/6
- Sinclair Micro Injector (to build) ... 27/6
- Tape Jack Tuner (Full Med. Wave) ... 29/6
- 10-Watt Horn Tweeter ... 27/6
- 20-Watt Super Tweeter ... 69/6
- Two-channel Mixer for Mics/Pu's 1 to 200 Mc/s Field/str. Meter ... 15/-
- 5-hole Chassis Punch Kit ... 49/6
- Stereo Stethoscope Headset, 8+8 arm Resistor Substitution Box ... 14/6
- Crystal Mono Stethoscope Headset ... 25/-
- Magnetic Mono Stethoscope Headset ... 32/6
- Transistor Signal Injector ... 10/6
- Fully Disappearing Car Aerial ... 12/6
- Test Lead Kit with Pouch ... 35/-
- Capacitor Substitution Box ... 8/6
- De Luxe Stereo Headsets with junction box ... 22/6
- PP3 9V Batt. Eliminator ... £6
- Transistor Telephone Amplifier ... 18/6
- 8+8Ω Stereo Headphones ... 59/6
- Crystal Contact Microphone ... 62/6
- MCI Crystal Mic. Insert ... 12/6
- Earphones, Crystal or Magnetic Complete with Jack and Socket. ... 5/-
- Telephone Recording Attachment ... 9/6
- 50-0-50μA Edgewise Meter ... 25/-
- 6/12V Min. 212w Relay ... 12/6
- Transistor Coil Set With Tuner, Ferrite Aerial and Circuit ... 20/-
- Complete Test Lead Kit ... 8/6
- 30W Pocket Mains Solder Iron ... 14/6
- 8" Hi-Fi 15/16 ohm Speaker ... 69/6
- 100 kc/s Quartz Crystal ... 15/-
- Twin Crystal 1 Mc/s and 100 kc/s ... 22/6
- 1 Mc/s B7G Glass Crystal ... 28/-

### RECORD/REPLAY/ERASE TAPE HEADS

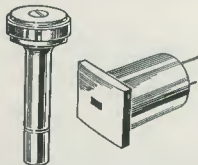

Marriot Type R/RP/3 ½ track record-replay head and Mullard type TS erase head with mounting post. Ideal for transistor circuits. Bargain Offer, 15/- Pair. P.P. 1/-

### ★ 700Ω IMPEDANCE ★

### CRYSTAL MICROPHONES



- (See Catalogue for details and for Dynamic Mics)
- Acos 39-1 Stick Microphone ... 32/6
  - Acos 40 Desk Microphone ... 15/-
  - Acos 45 Hand Microphone ... 19/6
  - Lapel/Hand Microphone ... 12/6
  - Acos Stick Microphone ... 15/-
  - 100C Stick with Stand ... 32/6
  - BM3 Stick with Stand ... 49/6
  - Lapel/Hand Magnetic ... 8/6
  - MM71 2k Mag. Mic ... 12/6
  - MC70 Studio Mic ... 42/-

Trade and Export Enquiries Invited

### NOMBREX TEST EQUIPMENT

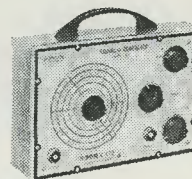

LEAFLETS ON REQUEST FULLY GUARANTEED

All transistor portable units supplied with full instructions.

- ★ 150 kc/s to 350 Mc/s generator. RF Mod., AF, 8 ranges. Leads, batt., instructions, £9.10.0.
- ★ Resistance/Capacitance Bridge, £8.5.0.
- ★ Transistorised Power Supply, £6.10.0.
- ★ Audio Generator, £16.15.0.
- ★ Inductance Bridge, £18.

### TRANSISTOR PORTABLE WALKIE-TALKIES

9-Transistor Portable Trans-receivers. Supplied complete with leather cases, batteries, aerials, etc., in presentation case. Range up to 5 miles in favourable conditions. Sizes 6½" x 3" x 1½". Superhet crystal controlled on transmit and receive. Price £21 per pair. P.P. 3/6

### ★ DUAL IMPEDANCE

(50 ohm-50k-ohm) or 600 ohm /50k-ohm dynamic professional quality microphone. Size 7½" long x 1½" diam. 40 c/s to 15 kc/s. Price 82/6. P.P. 2/6



### POCKET RADIOS

All complete with battery, earphone, carry case and fully guaranteed. 6 and 7 transistor superhet designs.

- ★ 6-Transistor Med. Wave, 69/6. P.P. 2/-
- ★ 7-Transistor Med. Wave, 79/6. P.P. 2/-
- ★ 6-Transistor Med./Long Wave, 5 gns. P.P. 2/6
- ★ 7-Transistor MW/LW/SW, £12. P.P. 3/6

### MAINS AND BATTERY RECORD DECKS

ALL COMPLETE with ARM and CARTRIDGE

- ★ BSR UA14 4-speed ... £5.19.6
  - ★ BSR UA15 4-speed ... £6.19.6
  - ★ Garrard Autoslim 4-speed ... £6.10.0
  - ★ Unpluggable Head Version ... £6.19.6
  - ★ Stereo Version ... £7.19.6
  - ★ 6-9 volt version ... £8.19.6
  - ★ SRP10 4-speed or BSRGUT... £5. 0.0
  - ★ Garrard AT6 with Stereo Cartridge, 4-speed ... £10.19.6
  - ★ AT6 with Mono Head ... £10.10.0
  - P. & P. 3/6 any type above
  - ★ AT6 with EV26 or Sonotone ... £11.19.6
  - ★ 9V Star, 45 r.p.m. ... £1.19.6
  - ★ 45 and 33 r.p.m. Star, 9V ... £4.12.6
  - ★ 45 r.p.m. Garrard 6V ... £1.15.0
  - ★ 4-speed B.S.R., 9V or S.R.P.10 9V ... £5. 5.0
- P. & P. 2/6 any of above

## HENRY'S RADIO LTD

303 EDGWARE ROAD LONDON W2

PADDINGTON 1008/9

Open Monday to Sat. 9-6. Thurs. 1 o'clock PLEASE TURN TO BACK PAGE

# FIRST AND BEST PROVED & TESTED DESIGNS, QUALITY COMPONENTS & UNITS

## ● TRANSISTOR HI-FI AMPLIFIERS

MONO or STEREO

10 WATTS and 20 WATTS

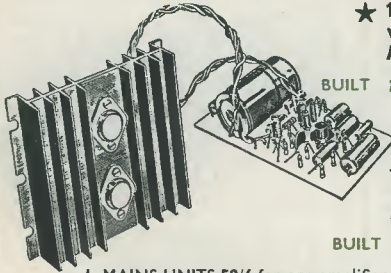

★ 15 to 16 ohm 10 watt Power Amplifier

BUILT £5-19-6 P.P. 2/6

★ 3 to 4 ohm 10 watt Power Amplifier

BUILT £5-10-0 P.P. 2/6

★ MAINS UNITS 59/6 for one amplifier, or 69/6 to power 2 amplifiers.

★ Mono full function pre-amplifier with 8 input positions. Low noise, high quality and sensitivity. Gives 10 watts with one power amplifier or 20 watts with two amplifiers. Size: 9" x 2½" x 2".

BUILT £5-10-0 P.P. 2/-

## ● PRE-AMPLIFIERS

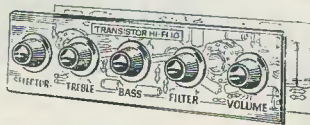

★ FRONT PANEL PLATE 8/6

## ● STEREO PRE-AMPLIFIER



Two Channel version of above. For use with two power amplifiers for 10+10 watts. Size: 9" x 3½" x 1½".

PRICE BUILT £10-19-6 P.P. 3/6

★ BROWN with Gold Front Panel 12/6.

## ● MULTI-INPUT PRE-AMPLIFIER

Simplified pre-amplifier for use with one or two power amplifiers, 8 inputs.

PRICE BUILT 65/- P.P. 1/6

★ Front Panel Plate 6/6.

All the above pre-amplifiers can be used with any valve or transistor power amplifier requiring 250mV for full output. They can be operated with two 9 volt batteries in series or from the power amplifiers. High gain, low distortion, excellent quality designs, combined with value for money.



## CIRCUITS AND DETAILS ON REQUEST

Demonstrations of above equipment and VHF FM Tuner can be heard during normal shop hours. All units are fully guaranteed.

## TWO PACKAGED TRANSISTOR QUALITY AMPLIFIERS

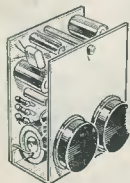

★ 6-Transistor printed circuit designs. Push-pull output for 3 to 5 ohm speakers. Can be battery operated. 6mV into a 1 kΩ sensitivity. Response 40 c/s to 12 kc/s.

Can be used with above pre-amplifiers for mono or stereo in any amplification requiring a low distortion low cost amplifier. Overall sizes: 2½" x 2" x 1½".

★ 4 watt version operates PRICE 79/6 P.P. 1/6

★ 1½ watt version from 9 to 12 volts. PRICE BUILT 65/- P.P. 1/6

★ CIRCUITS AND DETAILS ON REQUEST ★

1½ watt and 4 watt

LATEST 5th EDITION  
90-PAGE CATALOGUE

Fully detailed and illustrated.  
Price 2/6 post paid.

HENRY'S RADIO LTD.,

303 EDGWARE ROAD LONDON W2

PADDINGTON 1008/9

Open Mon to Sat. 9-6. Thurs. 1 p.m.

## ● FOR THE HOME CONSTRUCTOR

### "REGENT-6"

New!

★ MEDIUM and LONG WAVE POCKET SUPERHET RADIO. A new 6-transistor printed circuit designed with full coverage on both wavebands. Features "Cleartone" push-pull speaker output, geared tuning and complete set of 1st grade components. Moulded two-tone cabinet size 5" x 3" x 1½". Easy to follow building details. All parts sold separately.

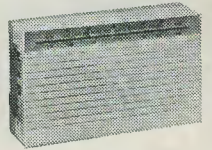

★ Total cost of all parts 85/-

P. & P. 2/- (Battery 2/6 extra)

## All Transistor Car Radio

★ ONE HOUR TO BUILD WITH FACTORY ASSEMBLED CHASSIS AND PANELS

6-transistor 3 diode Med. and Long Wave Superhet Design. Features double tuned IFT's, AVC, Permeability tuning with geared drive, push-pull car filling volume. Full tuning of both wavebands. A high sensitivity design on printed circuits to fit any type of vehicle. 12 volt positive earth only. All parts available separately. After sales service and guarantee.



THE "ROADSTER"

★ Total Cost to Build £8-19-6 P.P. 3/6

★ 7 x 4 inch. hi-flux speaker with baffle and car fixing kit 20/- extra.

★ Circuit and details on request.

## VHF TRANSISTOR HI-FI FM TUNER

★ HIGH STABILITY — HIGH SENSITIVITY ★

Features 5-Mullard transistors with 4 diodes, compact printed circuit, high gain, low distortion, superhet design. Full tuning from 87/105 Mc/s with geared tuning. AVC and AFC. 9 volt 9mA operation. 50dB S/N. Output up to 1 volt audio. Easy to build and align. Overall size in cabinet 3½" x 2½" x 4". All parts sold separately and guaranteed.

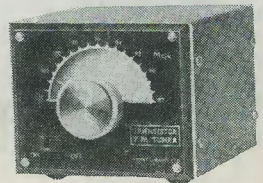

Total Cost with Front Panel

★ £6-19-6 P.P. 2/6

(Cabinet Assembly 20/- extra)

AFTER SALES SERVICE  
★ CIRCUIT AND DETAILS ON REQUEST

## "CONVAIR" PUSH BUTTON PORTABLE CAR RADIO

★ UNBEATABLE FOR PERFORMANCE AND DESIGN ★

Printed circuit 6-Transistor 2-Diode superhet radio with full tuning on medium and long wavebands. Push-pull output up to 1 watt. Attractive portable cabinet, size 10" x 7" x 3½" with horizontal slow motion tuning dial and push button wave change. Easy to build with superb performance. All parts sold separately. After Sales Service and Guarantee.



★ Total Cost of All Parts

£7-19-6 P.P. 3/6

(Batteries 6/- extra)

★ The Finest Portable Available

★ CIRCUIT AND DETAILS ON REQUEST

## NEW! VHF FM TUNER



New 6-transistor superhet design. Factory built and aligned units.

Covers 88 to 108 Mc/s. Horizontal tuning scale.

Total Cost £12-17-6 Leaflet on Request