

The

RADIO CONSTRUCTOR

for the Radio and Television Enthusiast

Volume 7
Number 4
NOVEMBER
1953

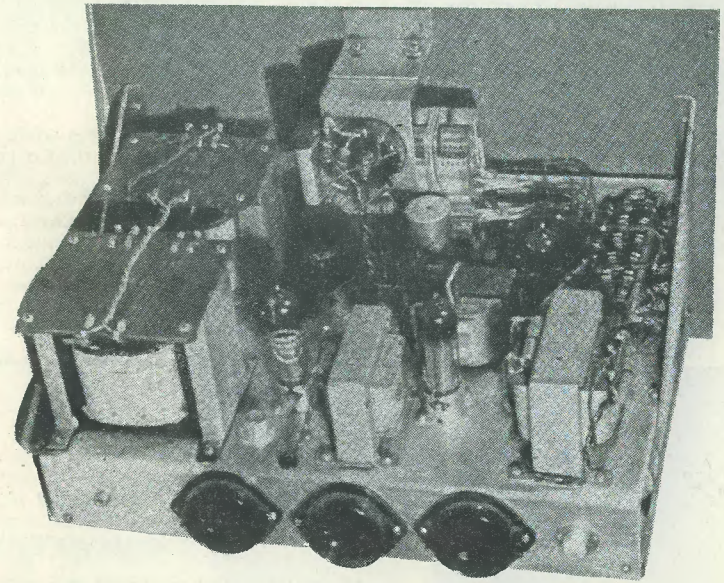

A HIGH FIDELITY AND RECORDING AMPLIFIER

ALSO IN THIS ISSUE

THE "PATTERN-MASTER" TV PATTERN GENERATOR

PART 2

EASILY CONSTRUCTED BASIC VALVE VOLTMETER . OVERLOAD
PROTECTION FOR MOVING COIL METERS, Part 2 . RE-FORMING
ELECTROLYTIC CONDENSERS . RADIO FEEDER UNITS
RF VOLTAGE INDICATOR FOR SIGNAL TRACER PROBES etc. etc.

16

SCOTTISH INSURANCE CORPORATION LTD.



62-63 CHEAPSIDE LONDON, E.C.2

TELEVISION SETS AND SHORT WAVE TRANSMITTERS

Television Sets and Short Wave Transmitters/Receivers are expensive to acquire and you no doubt highly prize your installation. Apart from the value of your Set, you might be held responsible should injury be caused by a fault in the Set, or injury or damage by your Aerial collapsing.

A "Scottish" special policy for Television Sets and Short Wave Transmitters/Receivers provides the following cover:—

- (a) Loss or damage to installation (including in the case of Television Sets the Cathode Ray Tube) by Fire, Explosion, Lightning, Theft or Accidental External Means at any private dwelling house.
- (b) (i) Legal Liability for bodily injury to Third Parties or damage to their property arising out of the breakage or collapse of the Aerial Fittings or Mast, or through any defect in the Set. Indemnity £10,000 any one accident.
- (ii) Damage to your property or that of your landlord arising out of the breakage or collapse of the Aerial Fittings or Mast, but not exceeding £500.

The cost of Cover (a) is 5/- a year for Sets worth £50 or less, and for Sets valued at more than £50 the cost is in proportion. Cover (b) (i) and (ii) costs only 2/6d. a year if taken with Cover (a), or 5/- if taken alone.

Why not BE PRUDENT AND INSURE your installation—it is well worth while AT THE VERY LOW COST INVOLVED. If you will complete and return this form to the Corporation Office at the above address, a proposal will be submitted for completion.

NAME (Block Letters)
 (If Lady, state Mrs. or Miss).....
 ADDRESS (Block Letters)

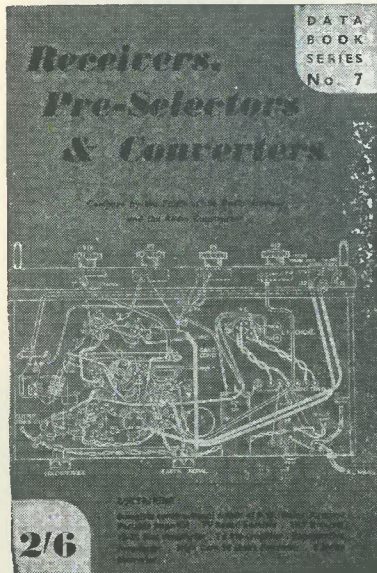

Data Book No. 7

"Receivers, Pre-Selectors & Converters"

The book for which you have been waiting!

Containing complete constructional details of:

- S.W. Mains Receiver . Portable Superheterodyne
- TV Sound Receiver . TRF Receiver
- 13-31 Mcs Pre-selector . TV Pre-amplifier
- Regenerative Pre-selector . High Gain
- 10 Metre Converter . 2 Metre Converter

PRICE 2/6 Postage 2d

Available immediately from:

Data Publications Ltd.

57 Maida Vale . London . W.2



20,000 ohms per volt plus
AUTOMATIC Overload Protection

Produced in response to a demand for a high sensitivity version of the world-famous Universal AvoMeter, this model incorporates the traditional design features of its predecessors, so highly valued for simplicity of operation and compact portability. It has a sensitivity of 20,000 ohms per volt on all D.C. voltage ranges and 1,000 ohms per volt on A.C. ranges from 100 V. upwards. A decibel scale is provided for audio frequency tests. In addition, a press button has been incorporated which reverses the direction of current through the moving coil, and thus obviates the inconvenience of changing over test leads when the current direction reverses. It also simplifies the testing of potentials both positive and negative about a common reference point. A wide range of resistance measurements can be made using internal batteries, separate zero adjustment being provided for each range.

Sizes: 8½in. x 7½in. x 4½in.
 Weight: 6½ lbs. (including leads).

£23 : 10s.

It is of importance to note that this model incorporates the "AVO" automatic cut-out for protection against inadvertent overloads.

D.C. VOLTAGE		D.C. CURRENT		A.C. VOLTAGE		A.C. CURRENT		RESISTANCE	
2.5 V	50 uA	2.5 V	100 mA	2.5 V	100 mA	10 A	1 A	First indication 0.5 Ω	} using internal batteries
10 V	250 uA	10 V	1 A	10 V	1 A	2.5 A	2.5 A	Maximum indication 20M Ω	
25 V	1 mA	25 V	2.5 A	25 V	2.5 A	10 A	10 A	0-2,000 Ω	
100 V	10 mA	100 V	10 A	100 V	10 A			0-200,000 Ω	
250 V	100 mA	250 V		250 V				0-20 M Ω	} using external batteries
1,000 V	1 A	1,000 V		1,000 V				0-200 M Ω	
2,500 V	10 A	2,500 V		2,500 V					

THE AUTOMATIC COIL WINDER & ELECTRICAL EQUIPMENT CO. LTD.
 WINDER HOUSE · DOUGLAS STREET · LONDON S.W.1. Telephone VICTORIA 3404-9



BUILD A TAPE RECORDER THAT REALLY WORKS WELL!

Designed by the man who gave us the "VIEW-MASTER" Home-constructed Televisor and shown stage-by-stage in the same clear fool-proof manner—send to:—

Smith's
of
EDGWARE ROAD

For Flack's 26 page Soundmaster booklet with 6-stage construction sheets, amplifier circuit, price lists, etc.

6/6 post free

H. L. SMITH & CO. LTD

287/9 Edgware Road London W2

Telephone Paddington 5891

Hours 9 till 6 (Thursday 1 o'clock)

Nr. Edgware Road Stations, Metropolitan & Bakerloo

ARTHURS HAVE IT!

LONDON'S OLDEST RADIO DEALERS
LARGE VALVE STOCKS

AVOMETERS IN STOCK
Avo Test Meters and Signal Generators
and Taylor Meters
Leak Point One Amplifiers and Tuning Units.

Chapman Tuning Units.
Crystal and Moving Coil Mics.
Decca Replacement Heads and Pickups.
Goodman's Axiom 150 Speakers.
Partridge Output Transformers for Williamson Amplifier.

All Components for the Radio Constructor's 16" Televisor.

Weare & Wright Tape Deck £35.

LATEST VALVE MANUALS
Mullard, Osram & Brimar No. 4 5/- each
Mazda 2/- each Postage 6d extra

TELEVISION SETS, WIRE AND TAPE
RECORDERS ALWAYS IN STOCK
Goods offered subject to price alterations
and being unsold.

Arthurs first

Est.
1919

Proprietors: ARTHUR GRAY LTD.

OUR ONLY ADDRESS Gray House

150-52 Charing Cross Road

London, W.C.2.

TEmpLe Bar 5833/4 and 4765 WRITE FOR LISTS

THESE STANDARD
WIDE ANGLE
COMPONENTS ARE
USED IN THE
"TELEKING"
AND
"SUPERVISOR"

Also for the conversion
to 14" or 17" C/R Tube
of all popular home-built
televisors.



From all leading stockists.

**ALLEN
COMPONENTS
LIMITED**

Crown Works
Lower Richmond Road
Richmond Surrey

Telephone Prospect 9013

Send 9d. and stamped
addressed envelope for
Circuit Diagram.

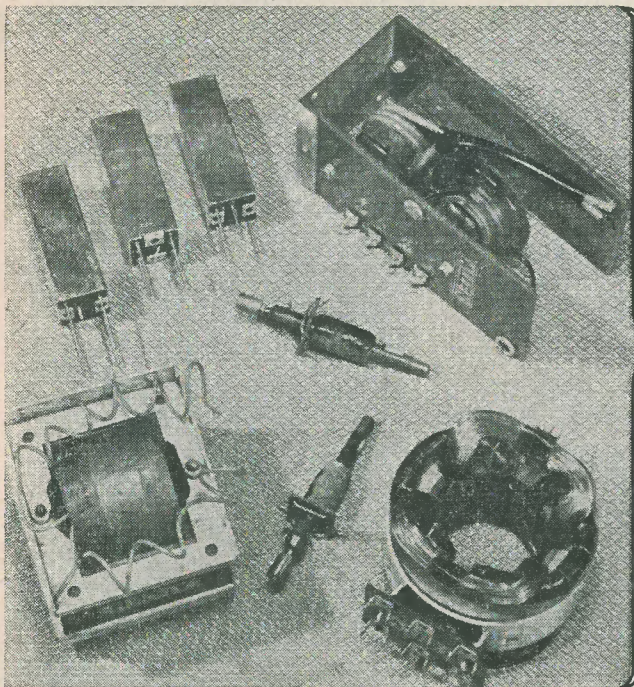

OUTSTANDING SCIENTIFIC BOOKS AT ONLY A
FRACTION OF THE NORMAL PUBLISHED PRICES!

Join The SCIENTIFIC Book Club

You BUY Books published at 10/6, 12/6, 15/-
for ONLY 3/6

Each month, the Scientific Book Club brings to its members the fascinating story of the march of modern science, told in thoroughly dependable books by the front-rank scientific writers of our time—vivid, vital, constructive contributions to Man's unceasing struggle to solve the problems of the Universe. And although the ordinary editions of these books are sold to the general public at 10/6, 12/6 or 15/-, THE PRICE TO MEMBERS OF THE SCIENTIFIC BOOK CLUB IS ONLY 3/6. Remember, too, that Scientific Book Club selections are full-length, and unabridged. They are printed on good quality paper, well bound, with an attractive picture jacket. These are, we say with certainty, books that you will be glad to read, proud to own. The Scientific Book Club brings these great books to you each month; helping you to build up, at remarkably low cost, a first-class collection of scientific books. Now is the time to join!

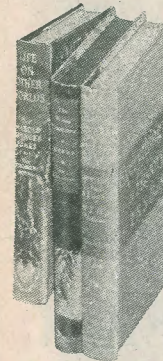

RECENT & FORTHCOMING SELECTIONS

—at only 3s 6d to members—include: BIRDS AS INDIVIDUALS by Frank S. Stuart (12s 6d); THE STRANGE WORLD OF NATURE by Bernard Gooch (10s 6d); PROFILE OF SCIENCE by Ritchie Calder (16s); LIFE ON OTHER WORLDS by Sir Harold Spencer Jones (12s 6d). All wonderful value!

FILL IN THIS ENROLMENT FORM TODAY

To the Scientific Book Club, 121 Charing Cross Road, London, W.C.2.

I wish to become a member of the Scientific Book Club and agree to purchase the special edition of the selected book issued each month to members at a cost of 3s 6d (postage 6d). I agree to continue my membership for a minimum of six books and thereafter until countermanded.

You may enrol through your usual bookseller if he is a member of Associated Booksellers.

* I will pay for selections on receipt.
Or if you wish to save time, postage and postal-order costs, you may send an advance subscription. Six books 24s. 0d. twelve books 48s. 0d.

* I enclose 24s./48s. (strike out amount not applicable).
* Place ✓ in the space above, as required

NAME.....
(Block Letters, please)

ADDRESS.....

Overseas enrolments must be accompanied by an advance subscription

STOP PRESS! WE PROUDLY INTRODUCE OUR LATEST HIGH STANDARD LOW PRICED INSTRUMENT WHICH WE KNOW WILL BECOME A PRIZED AND INDISPENSABLE POSSESSION IN EVERY CONSTRUCTORS SHACK

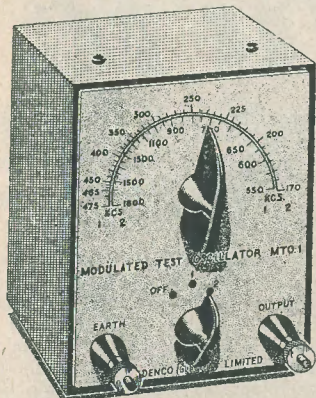

MODULATED TEST OSCILLATOR MTO.1

- ★ Provides a modulated signal suitable for I.F. alignment also trimming and tracking R.F. circuits.
- ★ Frequency is continuously variable from 170-475 Kc/s and 550-1600 Kc/s.
- ★ Operates from a single 9 volt grid bias battery which is housed within the unit.

Price £3.15.0 obtainable from all reputable stockists or in case of difficulty direct from works. Send for our General Catalogue (9d. post free).

DENCO (Clacton) Ltd 357/9 Old Road Clacton-on-Sea
ESSEX



CONDENSERS

The abbreviated ranges of two popular types given here are representative of the wide variety of T.C.C. Condensers available

"VISCONOL CATHODRAY" CONDENSERS (Regd).

Cap. Range: .0005mfd. to 1 mfd.

Voltage Range: 750 to 25,000 at 60°C.

Cap. in μ F.	Max. Wkg. at 60°C.	Dimens. (Overall)		Type No.
		Length	Dia.	
.0005	25,000	5 $\frac{1}{8}$ in.	1 $\frac{1}{2}$ in.	CP.57.HOO
.001	6,000	2 $\frac{1}{2}$ in.	1 $\frac{1}{4}$ in.	CP.55.QO
.001	12,500	3 in.	1 $\frac{3}{8}$ in.	CP.56.VO
.01	6,000	3 in.	1 $\frac{3}{8}$ in.	CP.56.QO
.1	7,000	6 $\frac{1}{2}$ in.	2 in.	CP.58.QO
.25	5,000	5 $\frac{3}{8}$ in.	2 $\frac{7}{8}$ in.	CP.59.MO

SUPER TROPICAL MINIATURE "METALMITES" (in Aluminium Tubes)

Capacity μ F.	Wkg. Volts D.C.		Dimensions		Type No.
	at 71°C.	at 100°C.	Length	Dia.	
.0002	500	350	.8 in.	.2 in.	CP110S
.0005	500	350	.8 in.	.2 in.	CP110S
.001	350	200	.8 in.	.2 in.	CP110N
.002	350	200	.8 in.	.22 in.	CP111N
.005	200	120	.8 in.	.22 in.	CP111H
.01	350	200	.8 in.	.34 in.	CP113N

THE TELEGRAPH CONDENSER Co Ltd.

Radio Division: North Acton, London, W3 Tel: Acorn 0061

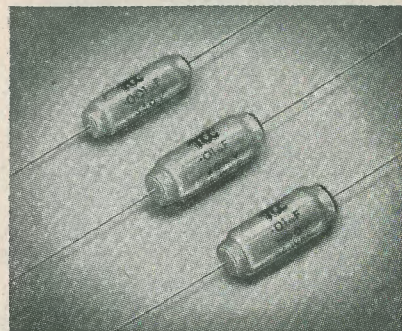
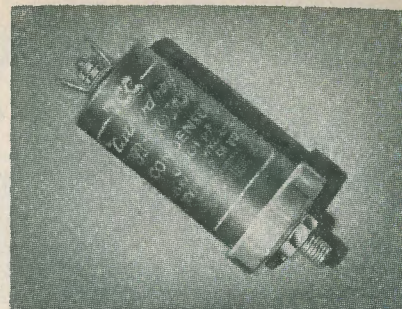

IKOPATENTS

LTD.

Managing Director
E. G. O. ANDERSON

Consultants

- RADIO
- TELEVISION
- ELECTRONICS

17 CRISP ROAD W6
RIVERSIDE 2678

TELEVISION CABINETS

All Sizes up to 16" Tube

Specially Designed for 'The Radio Constructor' 'MAGNAVIEV' TV Receiver.

Price £18:10 Carriage £1

SEND FOR ILLUSTRATED LEAFLET

H. ASHDOWN

98 HERTFORD ROAD
TOTtenham 2621 EDMONTON N9

TELE-RADIO (1943) LIMITED

BRAND NEW GUARANTEED METAL RECTIFIERS

Volts	Amps		£. s. d.
6	2	BRIDGE	8 9
6	3	"	10 6
6	4	"	12 6
6	6	"	15 0
12	1.5	"	8 9
12	2	"	11 3
12	3	"	12 6
12	4	"	15 0
12	6	"	18 6
12	10	"	1 15 0

TRANSFORMERS

ELLISON T68 0-4-6.3v. 4A	19 6
ELLISON SP70 0-6.3v.-12v. 3A	21 0
DOUGLAS 30v. 2A	22 6
TAPPED 3, 4, 5, 6, 8, 9, 10, 12, 15, 18, 20 and 24v.	
ELLISON CT109 0-4-9-18v. to charge 2, 6 and 12v. at 2 amps	21 0

POSTAGE & PACKING EXTRA. C.W.O. OR C.O.D.

189 EDGWARE ROAD LONDON W2

Shop Hours
Mon.-Sat. 9 a.m.-6 p.m.
Thursday 9 a.m.-1 p.m.

Telephone
PAD. 4455/6

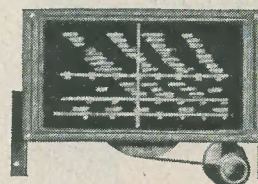

The
S. L. 8.
Spin Wheel
Drive

Complete with 3-band glass scale
9"x4 1/2" — 27/6

The S.L.8. Spin Wheel Drive gives easy control through a ratio 24-1. Fitted with constant velocity coupling, it eliminates strain on the Condenser, providing mechanical and electrical isolation from vibration and noise.

S.L.5, similar but fitted with reverse vernier drive, gives ratios of 18-1 search and 50-1 reverse vernier. 26/6.

Please write for our list of Condensers and Drives

JACKSON BROS. (London) Ltd.

KINGSWAY · WADDON · SURREY
Telephone CROYDON 2754-5
Telegrams WALFILCO, SOUPHONE LONDON

NEW! RADIO, TELEVISION AND ELECTRONICS



LEARN THE PRACTICAL WAY Instruction and Equipment

Here at last is the only real way of making home study really successful. Actual equipment is supplied thus combining theory and practice in the correct educational sequence. Whether your need be for career, hobby or general interest, here is the ideal method for acquiring the knowledge in the most efficient way possible.

QUICKER - BETTER - MORE INTERESTING

This equipment specially prepared and designed remains your property and it provides thoroughly sound basic sets which can easily be expanded to meet your growing knowledge.

PRACTICAL COURSES IN MANY OTHER SUBJECTS INCLUDING: Draughtsmanship, Carpentry, Chemistry, Photography, Commercial Art



POST THIS COUPON TODAY

Please send me your FREE book on *Practical Courses*
To: E.M.I. INSTITUTES, Dept. 179x,
43 Grove Park Road, Chiswick, W.4.

NAME

ADDRESS

We will not worry you with personal visits.

EMI INSTITUTES

*The only Postal College
which is part of a world-wide
Industrial Organisation.*

IC20

The RADIO Constructor

Vol. 7. No. 4

Annual Subscription 18/-

November 1953

Editorial and Advertising Offices—57 Maida Vale London W9
Telephone CUNingham 6518

Editor: C. W. C. OVERLAND, G2ATV
Advertising Manager: F. A. BALDWIN

Contents

	PAGE
SUGGESTED CIRCUITS: RF VOLTAGE INDICATOR FOR SIGNAL TRACER PROBES, by G. A. French	188
IN YOUR WORKSHOP: A CONDENSER-FORMING POWER PACK, by J. R. D..	190
A STABILISED POWER SUPPLY UNIT, by D. W. Easterling	193
OVERLOAD PROTECTION FOR MOVING COIL METERS, PART 2, by W. E. Thompson, A.M.I.P.R.E.	195
RADIO MISCELLANY, by Centre Tap	200
A HIGH FIDELITY AND RECORDING AMPLIFIER, PART 1, by Hans Marhauer, OZ5HM	202
THE "PATTERN-MASTER," A VERSATILE TV PATTERN GENERATOR COVER- ING 40-70 MC/s, PART 2, by D. Allenden, Grad.I.E.E.	208
QUERY CORNER—A RADIO CONSTRUCTOR SERVICE FOR READERS	219
AN EASILY CONSTRUCTED BASIC VALVE VOLTMETER, by T. W. Dresser.	222
RADIO FEEDER UNITS, by D. Nappin	226
BOOK REVIEW	232

NOTICES

THE CONTENTS of this magazine are strictly copyright and may not be reproduced without obtaining prior permission from the Editor. Opinions expressed by contributors are not necessarily those of the Editor or proprietors.

THE EDITOR invites original contributions on construction of radio subjects. All material used will be paid for. Articles should be typewritten, and photographs should be clear and sharp. Diagrams need not be large or perfectly drawn, as our draughtsmen will redraw in most cases, but relevant information should be included. All Mss must be accompanied by a stamped addressed envelope for reply or return.

Each item must bear the sender's name and address. TRADE NEWS. Manufacturers, publishers, etc., are invited to submit samples or information of new products for review in this section. ALL CORRESPONDENCE should be addressed to *Radio Constructor*, 57 Maida Vale, Paddington, London, W.9. Telephone CUN. 6518.

A COMPANION JOURNAL TO THE RADIO AMATEUR

Suggested Circuits for the Experimenter

The circuits presented in this series have been designed by G. A. FRENCH specially for the enthusiast who needs only the circuit and essential relevant data.

No. 36: RF Voltage Indicator for Signal Tracer Probes

THE INTRODUCTION OF THE NEW Mullard subminiature tuning indicator type DM70 has caused some comment amongst technicians, not only on account of its novel method of operation but also because of its extremely low current consumption and its very small size.

The DM70 has a tubular glass envelope, its dimensions being 10mm in diameter and approximately 35mm in length. It has a filament consumption of 25mA at 1.4

may therefore be used as a tuning indicator by connecting the grid to an AVC line or to the signal diode load of a receiver.

Voltage Indication

In this month's circuit the DM70 is used as a voltage indicator mounted in the probe of a signal tracer. Its very small size allows this to be done quite easily, and the indicator is then capable of giving comparative peak readings of any RF voltage to which the probe is connected. The ability to mount

Voltage indications given by this method are approximate only, but they will be found to be of considerable help in evaluating the gain offered by an amplifying stage, or the losses given by an IF transformer or similar component. Other applications will at once suggest themselves to the keen experimenter. The addition of the indicator does not detract in any way from the performance of the signal tracer itself.

The Signal Tracer

It is assumed that the equipment to which the probe is to be connected will consist of a conventional AF amplifier capable of bringing the signals obtained from the probe diode up to phone or speaker strength, as the case may be. A typical amplifier for this purpose was described by J.R.D. in the July issue. It is immaterial whether the amplifier used by the experimenter is run from mains or battery supplies, as the DM70 is capable of operating in either application.

Fig. 1 illustrates how the indicator may be connected to a signal tracer amplifier which runs from dry batteries. The figure references at the DM70 envelope indicate the valve pins to which connection is made.

Using the circuit of Fig. 1, the DM70 will show a fluorescent column some 11mm long at zero voltage, and complete extinction of the column at a peak RF voltage of approximately 12.

The probe components illustrated in Fig. 1 may all be of very small physical size. For instance, all resistors may be eighth-watt, and the capacitors may be miniature mica. It will be noticed that the negative HT and filament supply to the DM70 is carried by the outside conductor of the screened lead.

Mains Supplies

Fig. 2 illustrates the power supply arrangements needed at the signal tracer amplifier if a mains power supply is used. The probe circuit itself remains unaltered, with the exception that the value of R3 should now be increased to 470kΩ. The HT supply circuit consists quite simply of two resistors in series giving a voltage of approximately 100 at their junction. If the HT voltage is higher than 200, the value of R4 should be adjusted accordingly. Thus, for an HT voltage of 250, R4 should be changed to 75kΩ.

The filament supply to the DM70 is obtained from the 6.3 volt heater supply in the amplifier via a series resistor, (R6), of 220Ω. This assumes that one side of the heater winding is connected to chassis. If the heater winding is centre-tapped, the 3.15 volts appearing at either end of the

winding may be dropped by a resistor of 82Ω. A heater voltage of 4 will need a series resistor of 120Ω. All these resistors should be plus-or-minus 5% and have a rating of ½ watt.

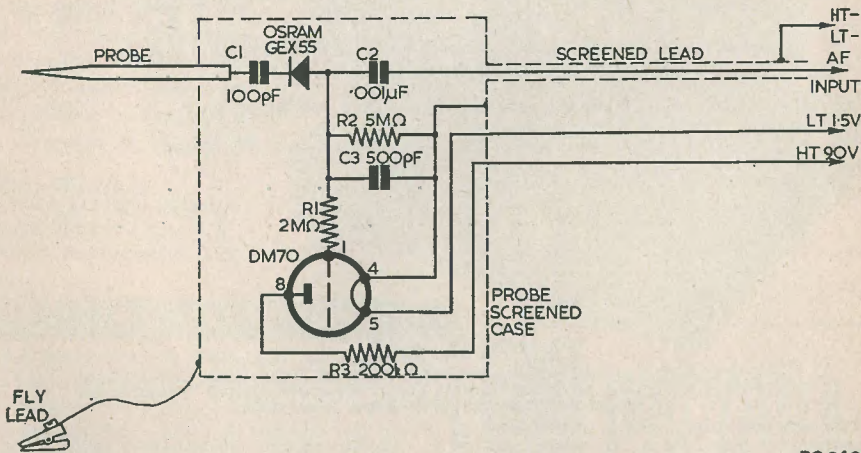
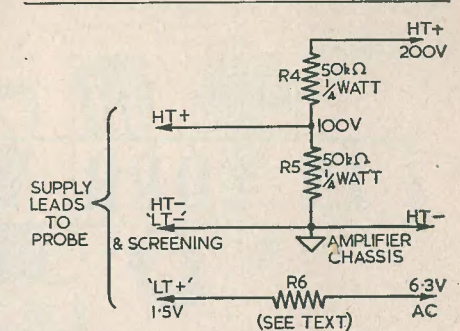

Fig. 1

RC 360

volts and an anode current of, at most, 170μA at 90 volts. It gives an indication of the negative voltage (with respect to filament) applied to its grid by means of a fluorescent column of varying length. It

the indicator in the probe itself confers a considerable advantage, since the user does not then have to raise his eyes from the probe, as is necessary with a conventional valve voltmeter, in order to read the voltage.



RC361

Fig. 2

Using the arrangement shown in Fig. 2, the maximum peak RF voltages capable of being read by the indicator will be approximately 15 volts.

Practical Details

The fitting of the indicator to a signal tracer probe will present few problems to the experienced constructor. A simple method of construction is suggested in Fig. 3. This diagram shows a probe that is relatively long and slender, the cut-out for the indicator being near the probe terminal itself. Such a design will allow the probe to be held

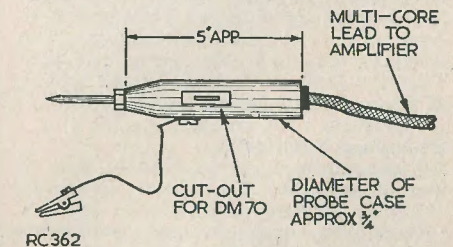

RC362

Fig. 3

comfortably in the hand without the fingers obscuring the indicator.

A few words concerning the DM70 itself may also be of help. As will be obvious, care should be taken to ensure that the maximum filament voltage of 1.4, and the maximum anode voltage (without series resistor) of 90 are not exceeded. The filament does not give a noticeable glow when

the supply is connected to it. Increasing the anode voltage will not cause any useful increase in the brightness of the fluorescent

column. Even with an anode voltage as low as 70, the column is still readily visible in strong sunlight.



In which J. R. D. discusses Problems and Points of Interest connected with the Workshop side of our Hobby based on Letters from Readers and his own experience

I HAVE RECENTLY RECEIVED quite a few letters from readers concerning the treatment of electrolytic condensers; especially after a period of shelf-life. Most of the queries which have reached me have been concerned with the procedure of re-forming these components. I have also been asked to give a circuit for a power-pack capable of carrying out such a process.

Unfortunately, the more popular radio "literature" does not give a great deal of information on this point. I decided, therefore, to write to the Telegraph Condenser Co. Ltd., for their advice. This company has kindly sent me one of their Technical Bulletins dealing with the subject, as well as a reply giving specific answers to the questions I had raised.

Re-forming Electrolytics

I can hardly do better than to start by quoting from the T.C.C. letter. This reads: "It is definitely necessary to 're-form' electrolytic condensers, and the Services are now doing this on all stores equipment. The period at which 're-forming' is carried out depends largely on storage conditions, such as temperature, and in this country a shelf-life of six to twelve months is permitted before re-forming becomes necessary; whereas in hotter climates the period may be only from three to six months.

Your question as to whether 're-forming' is more important on some types than on others is also of importance, since the

energy required to 're-form' a high voltage condenser is very much greater than that required to 're-form' a low voltage condenser. There is, therefore, a far greater chance of overheating and subsequent breakdown with the high-voltage condenser than there is with the low voltage condenser.

The important point always to bear in mind when 're-forming' condensers of any voltage or capacity is to keep the current as small as possible so as to reduce the effects of overheating, since if a heavy current were to be passed through the condenser this would cause heating which would then cause an even heavier current to flow, thereby creating even greater heat. Once this vicious circle was started it would lead to the breakdown of the condenser."

The points mentioned in the letter are amplified in the Technical Bulletin (No. 33 Series 2, The Telegraph Condenser Co. Ltd.). This states:

"One of the inherent characteristics of the electrolytic condenser is its leakage current. When a DC voltage is applied to a discharged condenser a high leakage current is passed initially, and this drops quite rapidly to a normal value and decreases still further when the condenser is in circuit for long periods.

The leakage current varies with the applied voltage, with temperature, and with the duration of the idling period.

Storage and Reforming.

If an electrolytic condenser has been in store for a long period, the leakage current will take rather longer to drop

For polarised dry electrolytic condensers (Plain Foil or Etched Foil) Leakage in $\mu\text{A}=0.15\text{ CV}$.
For reversible electrolytic condensers Leakage in $\mu\text{A}=0.3\text{ CV}$.

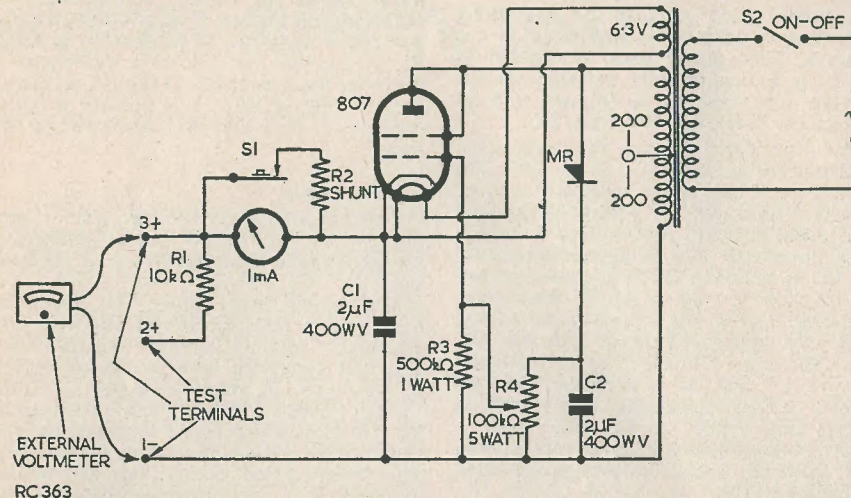

A power-supply circuit with variable output which is suitable for re-forming electrolytic condensers

to its normal steady value when it is first put into circuit than would be the case with a new condenser, or one recently in use. This is of no importance, however, unless the storage time has been so long that the leakage current does not decrease rapidly enough to prevent over-heating of the condenser. Broadly speaking, condensers should be 're-formed' every 12 months if stored under good, cool conditions. Where, however, storage is doubtful, or where the temperature is at all high, then 're-forming' should be done at intervals of not more than six months. "Re-forming" may best be carried out by applying the working voltage to each condenser in series with a resistor of value large enough to limit the initial current to a safe value. For an $8\mu\text{F}$ 450 volt unit, 10,000 ohms will be found satisfactory for the series resistance. Naturally, a cool place should be chosen for storage whenever possible.

Leakage Currents.

The value of leakage current for electrolytic condensers can be calculated from the following formulae:—

For wet electrolytic condensers Leakage in $\mu\text{A}=0.35\text{ CV}$.

Where C is the capacity in microfarads, V is the working voltage, and μA is microamps.

For example, the leakage current for an $8\mu\text{F}$ 350V Condenser should be 0.42 milliamperes.

For an $8\mu\text{F}$ 450V Condenser it should be 0.54 milliamperes.

For a $32\mu\text{F}$ 450V Condenser it should be 2.16 milliamperes.

The figures specified for the leakage current of a condenser are given for the purpose of determining whether the condenser has been sufficiently re-formed before placing in service, and must not be regarded as a limit for the rejection of the condenser. If the leakage current is falling at the end of one hour, but has not dropped to the calculated figure, then the re-forming process should be continued until the calculated figure is obtained or until a steady reading is reached. If the leakage current increases during the application of a steady voltage and at a constant ambient temperature, it is usually an indication of internal overheating. The voltage should be reduced until the

leakage current has fallen, and after a suitable period the volts should be raised slowly. If the condenser still shows signs of excessive leakage it should be replaced."

A Power Pack

A power pack suitable for re-forming electrolytic condensers is illustrated in the diagram. This power pack is capable of supplying a continuously variable voltage between approximately 40 (or less with an appreciable load) and 400 volts DC.

The "rectifier" feeding the electrolytic condenser being re-formed is an 807 with its screen-grid and anode strapped together. A second source of HT voltage is supplied by a metal rectifier, this causing a voltage of approximately 400 to appear across R4 and C2 in parallel. R4 is a potentiometer, and its slider is used to tap off the voltage appearing across the track; this voltage being then applied to the grid of the 807. The 807 acts, therefore, as a cathode-follower as well as a rectifier, and the rectified voltage appearing at its cathode follows that applied to its grid. Thus, a continuously variable voltage appears between Test Terminals 1 and 3, this voltage being controlled by R4.

A limiting resistor, R1, is connected between terminals 3 and 2. This resistor is included to reduce any tendency towards overheating in the condenser being re-formed. If the value of R1 is not sufficiently large for any particular condenser, an additional resistor may be connected in series externally.

A series milliammeter is also shown. This meter should have a full-scale deflection of 1mA. A shunt, R2, is connected across the meter, the value of the shunt being such that the meter reads 10mA. This shunt is taken out of circuit whenever push-button S1 is pressed.

Operation

The operation of the power unit is quite simple. The condenser being re-formed is connected to Test Terminals 1 and 2, observing correct polarity. An external voltmeter, switched to read 400 volts, is next connected between Test Terminals 1 and 3. R4 is then set to give a minimum voltage and the power unit is switched on.

When the 807 has warmed up, the external voltmeter will give a reading between zero and the cut-off grid voltage of the 807. R4 is then carefully turned up. This will cause the milliammeter in the power unit to give an indication of increased current. Whenever this current reading rises above a safe value R4 should be left alone until the current has dropped again. If, however,

the current continues to rise R4 should be turned down until a safe reading is obtained.

The re-forming of the condenser will be complete when the external voltmeter indicates the working voltage of the condenser being re-formed, and the milliammeter shows the correct leakage current. If the leakage current is below 1mA, a more accurate reading may be obtained by pressing S1, whereupon the full-scale deflection of the meter becomes 1mA. S1 should, of course, only be pressed when it is obvious that the current is small and will not damage the meter.

Further Points

Apart from the outline just given, there are one or two further points concerning the power unit which merit a little explanation.

The mains transformer, for instance, may need a little care in its selection. Its secondary winding should be 200-0-200, and it is connected here to give an output of 400 volts. A winding having a current rating of 50mA will be more than adequate. To prevent cathode-heater breakdown, the heater of the 807 is connected to the cathode. This method of connection necessitates ensuring that the insulation between the 6.3 volt heater winding and the frame and other windings of the transformer is capable of withstanding 400 volts.

If desired, the metal rectifier used for supplying the control voltage may be replaced by a valve rectifier (assuming that the rectifier heater winding on the transformer is adequately insulated). The current taken by R4 is approximately 4mA.

Reservoir condensers (C1 and C2) are shown for both rectifiers. These condensers should be paper, with a working voltage of at least 400.

A resistor, R3, is connected permanently between the slider of R4 and the negative end of its track. This is a protective device, its purpose being to bring the voltage applied to the condenser being re-formed back to zero if ever the slider of R4 should make poor contact to its track. It is essential, of course, that R4 be always set to its minimum position before the power unit is switched on. If desired, R4 may be roughly calibrated in terms of the voltage appearing across Test Terminals 1 and 3.

An 807 is suggested in the circuit for the re-forming "rectifier" not because it is capable of passing a heavy anode current at a high voltage, but because its internal construction should allow it to withstand the fairly high peak inverse voltages appearing across its electrodes. It can, however, be replaced by any other pentode, tetrode or triode judged suitable for the purpose.

A STABILISED POWER SUPPLY UNIT

by D. W. EASTERLING

ARTICLES ON POWER SUPPLY UNITS have appeared from time to time in the wireless press, most of them providing for a wide range of outputs with extensive means of control and metering, and calculated to satisfy even the most unorthodox requirements in the experimenter's workshop. The power unit to be described, however, provides only a series of fixed but constant outputs at voltages usual in mains equipment.

Various designs were considered, but the final circuit, shown in Fig. 2, has proved to be the most economical, reliable and compact. Heater current is obtained in the usual way, while a 5U4G full-wave rectifier and normal smoothing circuit provides the main HT of about 450 volts when the components specified are used. To obtain HT supplies other than the above, however, an ex-WD Stabilivolt type VS68 (Marconi Wireless Telegraph Co. STV280/40) was used. The completed unit therefore provides heater current at 6 and 4 volts, and high tension current at 450, 280, 210, 140 and 70 volts.

The latter four outputs remain constant up to loads of 55mA. The stabilivolt requires an ignition voltage greater than its normal working voltage; actually resistor R1 controls the ignition, since until the tube is operating very little current is drawn and consequently very little voltage drop occurs. Once the tube is operating, R1 prevents the tube from passing current above its rated maximum of 60mA. Resistor R1 equals:—

$$1000 (\text{supply voltage} - \text{max. tube operating voltage}) \Omega$$

Tube operating current in mA

The final choice of 3k Ω is a convenient value and allows a slight safety margin.

It should be noted that the current through R1 will not fall below the operating current of the tube. Switch S2 puts the stabilisor out of circuit when it is desired to use the full HT at 120mA.

Resistors R2, R3 and R4 specified at 250k Ω ½ watt aid ignition of the VS68 while capacitors C3, C4, C5 and C6 bypass noise generated by the tube.

The metering circuit controlled by switch S4 is a luxury and enables an output to be selected and the current readily measured. Unless a multi-range meter is used, meter M1 should have a maximum reading of 200mA. Switch S3, biased in the "short" position, shunts the meter until a reading is actually made. The meter may be used separately via terminals M- and M+.

Two fuses are installed; fuse f1 rated at 1A in the input circuit protects the mains, and gives a degree of protection to the transformer should the heater winding be inadvertently shorted; fuse f2 rated at 200mA protects the HT circuit.

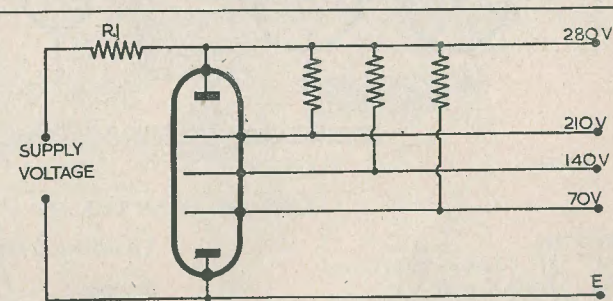

FIG. 1
BASIC CIRCUIT OF STABILIVOLT

The actual layout is not important, but should be so arranged that wiring is kept short and those components which dissipate heat, in particular the 5U4G, VS68 and resistor R1, are given plenty of ventilation.

other shunt across the meter. As he points out, for certain purposes this facility of being able to measure fairly heavy currents without

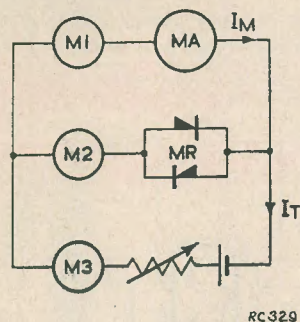

FIG. 6.

having to worry about which range the meter is switched to can be an advantage, under conditions which enable one to use a milliammeter with a relatively high resistance.

The basic circuit for a rectifier-protected

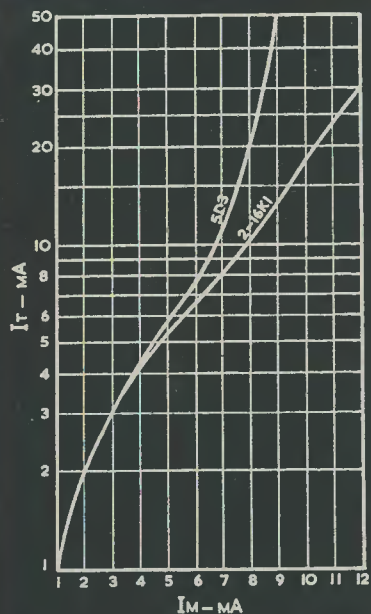

FIG. 7.

meter is given in Fig. 5. By connecting two elements back-to-back as shown, protection is automatically given against reversal of the test current. This arrangement does not materially affect the operation, for when one rectifier is conducting the other is cut off; that is, its reverse resistance is very much higher than the forward resistance of the other, so the shunting effect on the conducting rectifier is negligible.

The 1mA meter used for the tests had an internal resistance of 75Ω. Two Westinghouse rectifiers, types 16K1 and 5D3, were connected as shown in Fig. 6, and a range of measurements taken. The result is shown in the graphs, Fig. 7. It should be noted here that the type 16K1 is a single-element type, so two separate rectifiers were wired together with their senses reversed. The 5D3 is actually two elements in series, with soldering tags for each end and a centre-tap, so the two outers are strapped together to connect the elements back-to-back. The centre-tap is wired to one side of the meter, the wire strapping the two outers of the rectifier being taken to the other side of the meter. It can be seen from the graphs that some measure of protection is given without anything more than just connecting the rectifier across the meter. With the 5D3, for instance, if the total circuit current IT is 10mA, a current IM of 6.7mA actually flows through the meter, the remaining 3.3mA being shunted by the rectifier. For heavier currents than this, the characteristic of the rectifier changes steeply; for a total current of 50mA the meter current IM is 9mA, or a further increase of only 2.3mA in meter current for a rise in main current of 40mA. The shunting effect of either type of rectifier for total currents up to about 3.5mA is very small, so the linearity of the meter is barely affected up to its normal full-scale deflection.

However, even with circuit currents up to 10mA the meter is still taking quite a large proportion of it, and actually is well overloaded.

Similar tests with SenTerCel rectifiers types D25-1-1W and D35-1-1W produced the curves shown in Fig. 8. The characteristic of the D25-1-1W is very similar to that of the Westinghouse 5D3. The D35-1-1W has a steeper characteristic, especially over the range from 10mA to 50mA, the meter current changing only 1.1mA for a total circuit current change of 40mA. Again, the linearity of the basic meter is altered very little for currents up to about 2mA. Like the 5D3, these rectifiers are two elements in series with a centre-tap, so the same method of connection is used.

An interesting circuit arrangement becomes possible if some resistance is inserted in

series with the meter, and the rectifier shunted across the two, as shown in Fig. 9. This really comes back to what *Cathode Ray* did when he toyed with a 5mA movement, and the conditions which he stipulated regarding the accuracy of readings apply equally when using the present author's arrangement for a 1mA meter. A surprising range of currents can be applied to the meter with impunity, using the same rectifier types that were mentioned above. The graphs in Figs. 10, 11, 12 and 13 show families of curves for each rectifier. In order to take these measurements, the series resistor RS was adjusted so that the total resistance of this in series with the meter resistance RM gave the value shown against each curve. The considerable increase in range of the meter for a relatively small increase in the value of RS is noticeable. The parts of the curves shown dotted in Figs. 12 and 13 were actually obtained with the rectifiers taking the overload continuously. It is felt that this is a fairly stiff test, so similar currents of a transient nature could be expected to have no harmful effects on the rectifiers.

The Westinghouse type 5D3 shows up well in this test, and its small size makes it particularly attractive for use in this way, for it is only $\frac{3}{8}$ " diameter by $\frac{1}{2}$ " long. Not that the other rectifiers tested are cumbersome things; none of them are very large, but the 5D3 was the smallest of them. Note that with a series resistance of 625Ω (making $RS+RM=700\Omega$) a current of 22mA can be passed when the meter is on full-scale, so 21mA is being shunted off by the rectifier. With the normal full-scale current flowing in the main circuit, i.e., $IT=1mA$, the meter reads 0.54mA, or a little over half-scale. Increasing the value of RS widens the range of IT that can be accepted by the circuit, so it is mainly a matter of choosing the curve you want.

The curve for 700Ω using the SenTerCel D35-1-1W, Fig. 13, seems a particularly useful one, for between the range of IT from 1mA to 60mA, a change of 59mA, the meter current IM changes only 0.52mA, from 0.48mA to full-scale.

A small alteration to the circuit of Fig. 9, suggested by Mr. E. A. Richards, of S.T. and C. Ltd., gives the circuit of Fig. 14. With the "Press-to-read" key in the normal position shown, the meter is fully protected, as it is in Fig. 9. Depending on the type of rectifier and the value of $RS+RM$, a certain value of current will be shown on the meter if more than its full-scale current is applied. Should less than 1mA be applied, the meter will read something less than the critical value, which of course can be marked by a red line on the scale if desired. If the

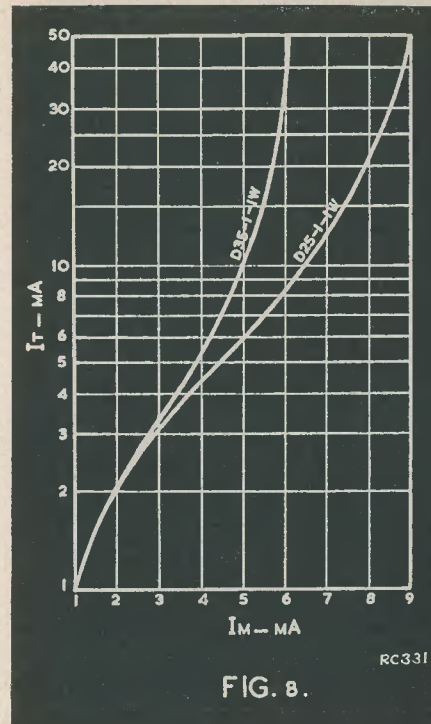

FIG. 8.

critical figure is not reached, the key can be pressed and the actual current read on the meter. As an instance of this, if, when using the 5D3 rectifier (Fig. 11) on the 800Ω curve, the main current IT is 1mA the meter reads only 0.49mA. A red line at 0.49mA will enable the user to see at a glance whether or not it is safe to press the key, for if the

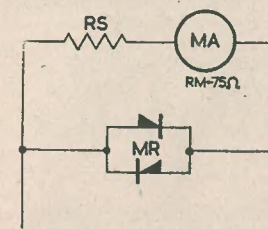
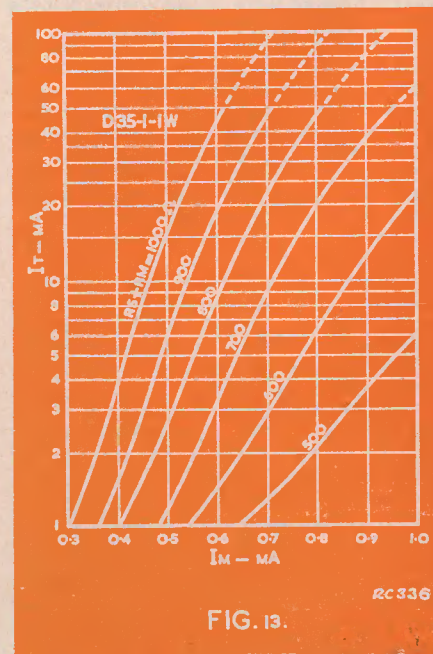
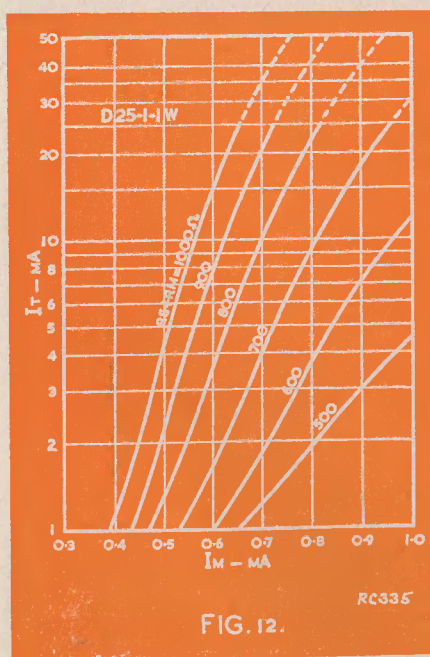
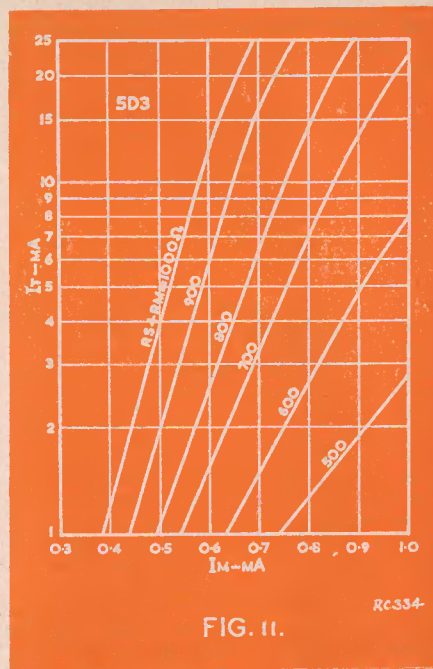
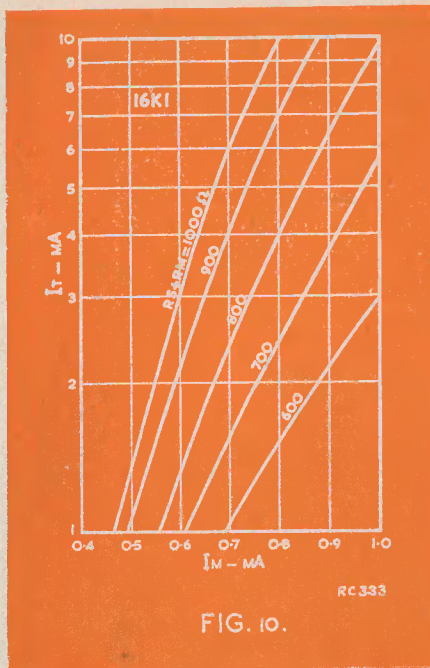

FIG. 9.

meter reads below the red line the main current must be less than 1mA. Pressing the key will enable the actual current to be read off.



It is possible, under certain conditions, to interpret from the curve a rough value for the actual current if the meter reads above the red line with the key normal. If the meter reads 0.72mA, reading up to the 800Ω curve shows an intersection with a value of I_T of about 7mA. Multiply this by the range to which the meter is set, and an approximate value is obtained. It should be remembered, however, that this can only be done if the insertion of the meter with its inflated value of resistance does not materially affect the circuit being tested. It would not matter much, for instance, if used in this way in series with an anode load resistor of several thousand ohms, for then the 800Ω of the meter circuit is of little import, but if placed in series with a cathode resistor of, say, 470Ω the meter resistance will alter considerably the circuit constants, and so give an erroneous reading.

It can, of course, be argued that the use of a key in this circuit introduces a fault liability, and the author would be the last to deny the fact. As with the possibility of contact-resistance mentioned previously in connection with the relay circuits, the key contacts could become dirty or oxidized, thereby setting up a high resistance which could (a) increase the shunt path resistance of the rectifier circuit and divert more current through the meter, (b) fail to short out fully the series resistor R_S when the key is depressed and cause an erroneous reading to be given, or (c) give a complete disconnection in either position with increased error of reading. Such conditions can occur with any electrical contact, as the reader possibly knows only too well. The remedy is fairly clear—a check up now and again by giving the contacts a burnish with a slip of thin steel; a feeler gauge is just the thing for doing this. A few seconds giving attention of this sort to contacts now and again undoubtedly pays dividends, and certainly puts one's mind at rest.

The simplicity of the circuit shown in Fig. 14 is attractive and lends itself to inclusion in an existing instrument, since it needs only a resistor, a small rectifier and a suitable key with a change-over contact. A non-locking action key should be used so that the circuit is restored to the protective position when the key is released. Although it is not possible to give details of how the circuit should be incorporated in a particular make of meter, it can be stated that in general the modification affects the moving-coil circuit only. Current shunts already existing in the meter, together with their associated range switch, should be connected between points X and Y in Fig. 14. Series resistors for voltage ranges, again with their range switch, will normally be connected between

one Test terminal and point X, though they would be equally effective if wired between point Y and the other Test terminal.

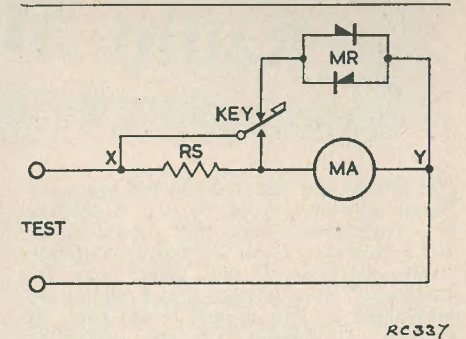

FIG. 14.

It is to be noted that this protective circuit is effective on AC ranges as well as DC. Being wired across the moving-coil, which for AC measurements is connected across the DC branch of a bridge-connected rectifier, it encounters the same conditions as when used on DC ranges. In this respect the protective circuit is an added attraction, for it is perhaps on the AC ranges that one is apt to need it more.

The author desires to acknowledge the valuable assistance given to him by Mr. S. A. Stevens, Joint Chief of Research Laboratory, Messrs. Westinghouse Brake and Signal Company, and Mr. E. A. Richards, Chief Rectifier Engineer, Rectifier Division, Messrs. Standard Telephones and Cables Ltd., who devoted much of their time to providing replies to some of his queries, and furnishing technical information concerning suitable rectifiers for use in his experiments.

Errata. On page 137 of the October issue, column 2, the relay dimensions in the first part of this article were inadvertently given as "millimetres." They should have been "mils," or thousandths of an inch.

THREE TYPES OF VALVE DISCONTINUED

The General Electric Co. Ltd. has discontinued the production of the following three types of Osram valves; the VMS4, the VMS4B and the VMP4G, in both clear and metallised forms. No further stocks of these valves are now available.

Radio Miscellany

SOME OF THE POINTS I touched upon last month have given rise to a number of questions, particularly the references to the Austrian pirates. Perhaps the question "What happens if, and when, they are found out?" is so obvious that I might have anticipated it. The answer is not easy. It depends, I suppose, on the occupying Power. Quite what would happen behind the Iron Curtain is anybody's guess, but then has anyone ever heard of a "pirate" in those parts? The only rarer bird there could be would be a *licensed* Austrian National in the Russian Zone. He would probably finish up with a life sentence in Siberia.

In the non-Iron Curtain zones, the cases of detected Pirates of which I have heard seem to have got away with sharp warnings. They came to light through interference caused by their transmissions in local broadcast receivers. Thus, no BCI—no trouble, would appear to be the rule. The warning by the authorities in each case was sufficient to silence the amateurs concerned, but I wouldn't be sure whether it was fear of drastic measures following a second offence, or the fact that their positions, when transmitting licences are re-issued, would be prejudiced, which proved the greater restraining influence. Probably a bit of each.

Consequently, there is a great interest in harmonic suppression at the transmitting end, which is all to the good for everybody concerned. At the time of writing it seems that the Russians are still intent on using Austria as a counter in a bargaining wrangle, so the restoration of OE amateur transmitting licences is very much around the corner.

No liberty-loving British subject can remain unsympathetic to Austrian amateurs—or to those of countries whose Governments forbid them to work with stations beyond their own boundaries. Currently under either of these headings are numbered, among others, the amateurs of Indonesia, Thailand, Iran, Viet Nam and Laos. For myself, I am old-fashioned enough to think that rules should be made to fit people; not people made to fit the rules.

Interference

Interference by Amateurs with both radio and television reception is far less common than is generally supposed. The last analysis of complaints received by the Post Office divides the forms of interference into 183 different sources and causes. Amateur transmitters were responsible for barely one per cent of the trouble. In fact, sewing machine motors gave rise to three times as many complaints as amateurs. Even so, most of the amateur trouble was TVI rather than BCI, so with reasonable precautions Austrian amateurs stand an excellent chance of getting away with it. At least they have no TV to bother about.

TV Pirates

A few readers were surprised at my references to UKW (UHF) broadcasting in Germany and Austria and the big lead they have over us in this field. In fact, I understated the case. In Germany alone they have ninety such transmitters already working. We have only one, at Wrotham, and you have to go a long way to find anyone who has heard it, if you disregard a few enthusiasts.

To a considerable extent 3-metre broadcasting was forced on Western Germany by the Copenhagen agreement. They have certainly made a good job of it. The improved quality and freedom from interference comes as quite a shock to those of us accustomed only to AM medium and long-wave broadcasting. The short-wave broadcast listeners seem to put up with a lot worse than the ordinary broadcast listener who is content with his local station.

German TV is also VHF, in the region of 1½ metres. Despite the fact that it is technically somewhat better than ours, there is a surprising lack of interest in it. Perhaps they prefer to spend their evenings in the beer gardens, and one can hardly blame them for that. The programmes are no better than ours; not so good, in fact. There are seven TV stations in Western Germany from which programmes are radiated for about two hours each day, and four hours on Sundays. Commercial TV receivers, with screens up to 21 inches, are

available in the shops. The prices for comparable models are about 20 per cent dearer than our own.

Like our own TV service for many years, theirs is hard-up. Harder-up than ours, I should imagine, at least during the early post-War years. The German Post Office says that the number of licences taken out is less than 3,500. In informed quarters, the number of unlicensed viewers is estimated to be over double that figure. An infinitely bigger ratio than we ever had. The Germans call them "black viewers," which leaves the term "pirates" free to describe the unlicensed amateur and thus avoid confusion.

Literal Translations

Quite apart from "UKW" broadcasting, there is a very lively amateur VHF interest in the German-speaking countries, and some very good books (which for some strange reason have no English or American equivalents) have consequently achieved wide popularity. Particularly Hans Dominick's booklet, and *Der Ultra-Kurzwellen Amateur* by Karl Schultheiss, both very practical and amply illustrated. They are sometimes seen over here and eagerly "read" by non-German-speaking VHF fans.

Centre Tap *talks about* TVI PIRATES LANGUAGE DIFFICULTIES

The diagrams and layouts can easily be followed. In fact the only difference in the circuitry from that to which we are accustomed in British publications, is the resistor. This is always shown as an elongated rectangle. Thus German circuits have the advantage of looking far less strange to British eyes than those found in American books and periodicals. Most of the technical terms, too, are similar, just as are many normal words. Those seeking some very practical VHF designs would do well to borrow copies if they have access to them, especially as at least one good German-English Radio Dictionary is readily available.

Would-be readers are warned not to guess at similar words too recklessly. *Gift* for instance, might seem obvious, but it means POISON. Make sure, also, that you get the right sense. Once with my school-boyish German I murmured *Danke* on being offered a second helping at table. To them this meant I was declining. I soon learned to use *Bitte* for acceptance!

I need hardly add that if a resistor is depicted as an elongated rectangle, one with an arrow stuck through the middle is a variable resistor.

Friendly Relations

In the early days of broadcasting a happier relationship between nations was confidently expected to result. Indeed, the BBC used the motto "Nation shall speak unto Nation." They did, and still do; usually with abuse and propaganda. Then the BBC added the word "Peace" to their motto—perhaps as a gentle reminder that they meant the word "speak" to be interpreted in the best sense.

In the amateur world, however, much international good-will has been fostered, and many lasting friendships have been formed. Often they result in the exchange of family photographs, presents and reciprocal visits. Whenever I have been abroad I have received much practical help and good fellowship from overseas amateurs, including those of ex-enemy countries. A Portuguese YL operator, CT1YA, writing recently in the *Radio Amateur*, said "when we travel we never feel alone, we have friends everywhere who receive us in the kindest way." Many others will warmly endorse that.

Language is no barrier. In fact I would say a knowledge of the language is a slight disadvantage. They would far rather you

talked in English and helped them to practise theirs, than have you talk an Exercise-book version of their native tongue. After all, the pens of your aunt and the pencils of your uncle have a rather limited conversational value.

Harking back to the previous paragraph, the guessing at apparent equivalents, I once became the centre of a misunderstanding that way in Germany. I went swimming and sun-bathing with a party of local amateurs and their friends in one of the lakes. They very nearly worship the sun, but that has nothing to do with it. The story concerns the loss of my socks when it came to the matter of re-dressing. I duly announced, in bad German, "*Ich habe verloren meine hose.*" I felt most flattered at the anxiety everyone showed to help. They seemed most disconcerted that the *Englisch amateur* should have lost or had something stolen.

As the news spread, two or three of the girls looked at one another and giggled. I didn't wonder when I discovered that *hose* meant trousers, not socks. The thought of me going home with a towel wrapped round my middle, was too much for them.

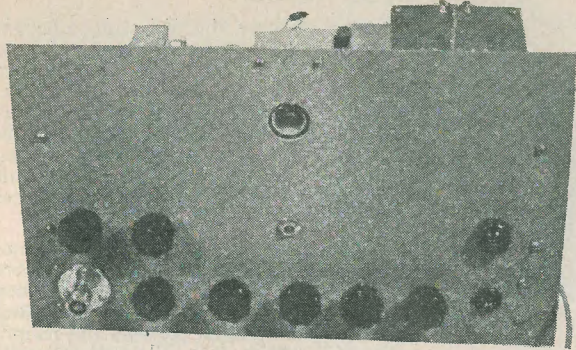

By
HANS MARHAUER
 OZ5HM

A High Fidelity and Recording Amplifier

IN RECENT YEARS, developments of recording technique have extended the range of frequencies that an audio amplifier of good quality must be able to reproduce without noticeable linear distortion. Thus, today an audio amplifier must have a frequency response which is flat from some 30-15,000 c/s, and it also must include ample means of adjusting the response curve, in order to compensate for different recording characteristics and—of course—the individual ear.

Linearity is secured mainly by careful design of the entire circuit, by correct calculation of the components and by introducing negative feedback. Careful wiring is also a great asset—as usually!

Tone compensation is maintained by two different circuits, each of which serves a special purpose. One circuit, the equalizer, compensates for the different recording characteristics. Most gramophone records attenuate the lower frequencies. The equalizer compensates for this, so that the reproduction 'technically' is a true copy of the original. 'Technically,' because to give the listener a true copy of the original it is necessary that the loudspeaker be placed in a room similar to the one where the recording microphone was placed.

Also, the characteristic of the listener's ear and his personal taste make additional tone compensation necessary. This com-

pensation is undertaken by means of two independent tone controls, one for the bass and the other for the treble. Also the loudspeaker contributes to the quality of the reproduction, so in this amplifier a dividing network has been designed for use with two quality loudspeakers.

Several problems arose when the present amplifier was first planned, as the author intended to keep the cost as low as was practicable, yet keeping the linear frequency range as close to the ideal 30-15,000 c/s as possible. It was, therefore, decided to use only one valve in class "A" in the output stage; used with a high-quality output transformer, the linear frequency range will be 50-13,000 c/s.

The Circuit

This amplifier may be used either for reproduction of gramophone records and tape or wire recordings, or in conjunction with a microphone or a radio. As a 35 kc/s oscillator and an output level indicator are included it can also be used for recording on tape or wire. 01 is the record/playback switch, here shown in playback position. 02 permits either the recording-head of the recorder, a gramophone pick-up, a microphone or a radio to be connected to the control-grid of the first valve. In this valve the input voltages are amplified, and from the anode led through C3 and the volume

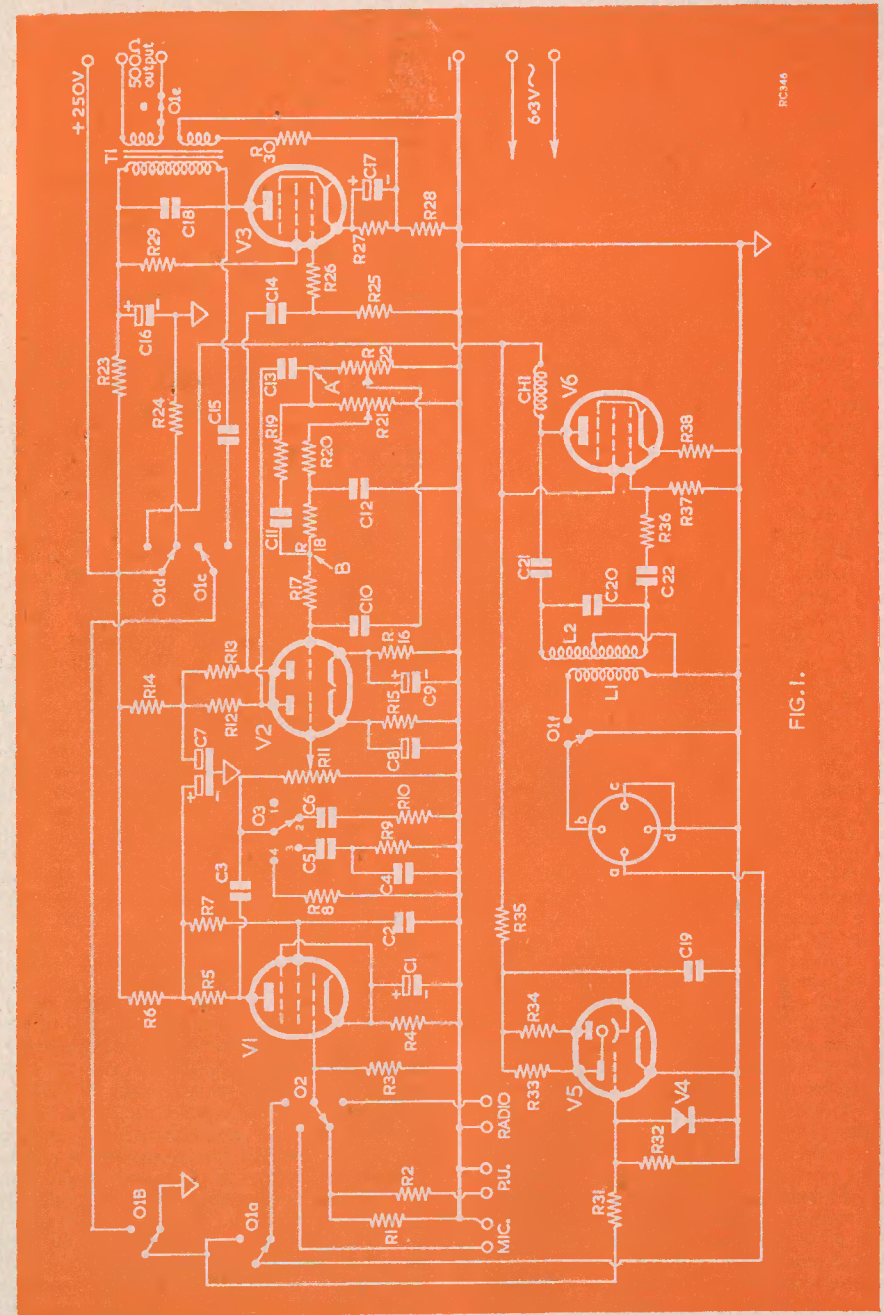

FIG. 1.

control R11, to the control-grid of the first section of the twin-triode, V2. The volume control is here placed between the first and the second amplifying stage, and not in the control-grid of the first valve as it is usually done. This was so arranged because of the microphone input, but it has, on the other hand, made a fixed potentiometer, R1 R2, necessary in the gramophone input, as the comparatively high voltages from the pick-up (of the order of 1 volt) far exceed the allowed maximum input voltage on the control-grid of the valve.

The Equalizer

It will be seen that, by means of the switch 03, different capacitance-resistance networks may be switched in or out between the control-grid of the first triode of V2 and earth. These are the equalizing networks.

With the switch in position 1, no additional network is switched into the circuit. This position is used when a microphone or a radio is connected to the amplifier, and maximum amplification is obtained in the first stage. In position 2, a capacitor C6 and a resistor R10 are connected in series between the control-grid of the second valve (or anode of the first valve if you wish) and earth. It is known that the gain of an amplifying stage is proportional to the parallel combination of the internal resistance of the valve, the anode resistor and the grid leak of the following valve. Let us now see what happens when C6 R10 is switched into the circuit. At low frequencies (up to some 20 c/s) the reactance of the capacitor is of the same order as the combination of the internal resistance of V1, the anode resistor R5, and the grid leak of the first section of V2 (R11), and will not have any noticeable influence on the amplification. As the frequency is increased, the reactance of the capacitor decreases and for each octave (the interval between a given frequency and twice the frequency or half the frequency) by which the frequency is increased the reactance of the capacitor falls to half its original value, causing also the amplification to fall to a half—6db. In other words, the amplification falls 6db/octave as the frequency is increased. This will continue up to some 300 c/s, when the reactance of C6 has fallen to a value which is of the same order as R10, and at all higher frequencies the reactance will be much smaller than R10, so that it will no longer influence the amplification, which is then determined by R10 alone, as this is much smaller than both R5, R11 and the internal resistance of V1. Fig. 2 curve c shows the frequency response of the amplifier with this network switched in. This curve is the 'reverse'—or image—

of the recording characteristics used by the EMI firms except for a slight attenuation of the extreme high frequencies, and of the recording characteristic used by DECCA and associated firms except for a slight lack of attenuation of the extreme high frequencies. So when playing 78 rpm records made by any of these firms, with the C6 R10 network switched into the circuit, the reciprocal distribution of the amplitudes of the various frequencies will be exactly as in the original before being recorded.

The recording characteristics used by other firms for recording 78 rpm records do not differ substantially from the DECCA or EMI characteristics, as efforts have been made, during the last few years, to establish a standard also in this field.

When the switch is moved to position 3, the network consisting of the capacitors C4 and C5 and the resistor R9 is switched into the circuit. Up to some 300 c/s the effect of this network on the amplification will be exactly the same as in the case of the network C6 R10. But at frequencies above 300 c/s the reactance of C4 will be much smaller than the resistance of R9, so that it will be essentially this reactance that determines the over-all amplification. When the reactance of C4 has decreased sufficiently, the resistance of R9 is no longer of any significance to the amplification which, therefore, will fall 6db per octave above 1,000 c/s. Curve b in Fig. 2 shows the frequency response of the amplifier with the switch in position 3, and this curve is the 'reverse' of the average recording characteristic used for recording long-playing records. So the correct reproduction is secured, if the switch 03 is placed in position 3 when using long-playing records.

Equalizing networks for use in connection with tape or wire recorders has not yet been included in the amplifier, though the characteristics of both recording head and recording medium shows that considerable boost of both bass and treble is required. Satisfactory reproduction levels can be obtained if, during the recording process, switch 03 is set to position 1, bass-control (R21) is set mid-way and treble-control (R22) at maximum. During playback, switch 03 is set to position 2 and the bass and treble controls set according to taste.

When any of the equalizing networks are switched in, the amplification is only a small percentage of the maximum of amplification obtained with the switch in position 1. If, therefore, the switch is suddenly moved from position 2 or 3 to 1, the control-grid of V2 will be overloaded, causing heavy distortion and possible damage to the valve. To avoid this, position 4 on the switch 03 has been included. In this posi-

PARTS LIST	
Resistors	0.1μF electrolytic 16 + 16μ F450 volts
R1	62kΩ
R2, R3, R32, R33, R34	1MΩ
R4, R15, R16	2.2kΩ
R5, R18	330kΩ
R6, R8, R9, R10, R35	10kΩ
R7	1.5MΩ
R12, R13	220kΩ
R14	5.1kΩ
R17, R31	390kΩ
R19, R20	1.2MΩ
R23	1kΩ 3 watts
R24	10kΩ 10 watts
R25	680kΩ
R26, R29, R36	1kΩ
R27	160 Ω
R28	180 Ω
R30	30 Ω
R37	50kΩ
R38	300 Ω
Potentiometers	
R11	1MΩ
R21	2MΩ
R22	5MΩ.
Capacitors	
C1, C8, C9, C17	electrolytic, 50μF 50 volts
C2, C19	0.5μF
C3, C13, C14, C15	0.02μF
C4	0.01μF
C5, C6	
C7	0.1μF electrolytic 16 + 16μ F450 volts
C10	150pF
C11	270pF
C12, C18, C22	1,000pF
C16	electrolytic 8μF 350 volts
C20	2,000pF
C21	4,000pF
C23	electrolytic 16 + 16μF 450 volts
C24, C25	See text.
Switches	
01	6 sections, 2 positions (see also text)
02, 03	1 section, 4 positions.
Transformers	
See text.	
Chokes	
Ch1, Ch3, Ch4	See text
Ch2	filter choke, 300 ohms, 125 mA.
Valves	
V1	Philips EF40, Mullard EF40, Brimar 6BR7, EF37, 6SJ7.
V2	Philips ECC40, Mullard ECC40, Brimar 12AU7, B65, 6SN7.
V3	Philips EL41, Mullard EL41, Brimar 6BW6, KT66, 6F6, 6L6.
V4	Philips OA50, 1N34.
V5	Philips EM4, Mullard EM34, 6U5.
V6	Philips EZ40, Mullard EZ40, Brimar 6X4, 5R4, 5U4.
NOTE! In the model PHILIPS valves were used, which are all-glass miniatures. If alternative valves are employed, the HT and LT current consumption will differ from the values given in the article.	

tion a resistor, R8, is switched in between the grid of the first section of V2 and earth. This resistor has the same value as R9 and R10, so that in position 4 the over-all amplification will be of the same order as in position 2 or 3, thus eliminating the possibility of shocks to valves, the listeners' ears and the recording head and medium in the case of recording. Curve a in Fig. 2 shows the over-all frequency response of the amplifier, excluding the output transformer, with the switch in position 4.

The Tone Control

The voltages are now amplified by the first section of the twin-triode and are then led on to the control-grid of the second

section, passing on the way the tone control network, which has separate controls for bass and treble. The tone control system was suggested by PHILIPS and published in a book by this firm, as part of an amplifier. Finding it suitable and uncomplicated, the author included it in the present amplifier, having altered only the value of a single resistor, thus improving the performance of the circuit to some extent.

The tone control operates as follows:

Assume that the connections to the sliding contacts of the potentiometers R21 and R22 are interrupted. Then the voltage on the grid of the second section of V2 is equal to that of point B in the circuit diagram. This voltage is determined by the voltage

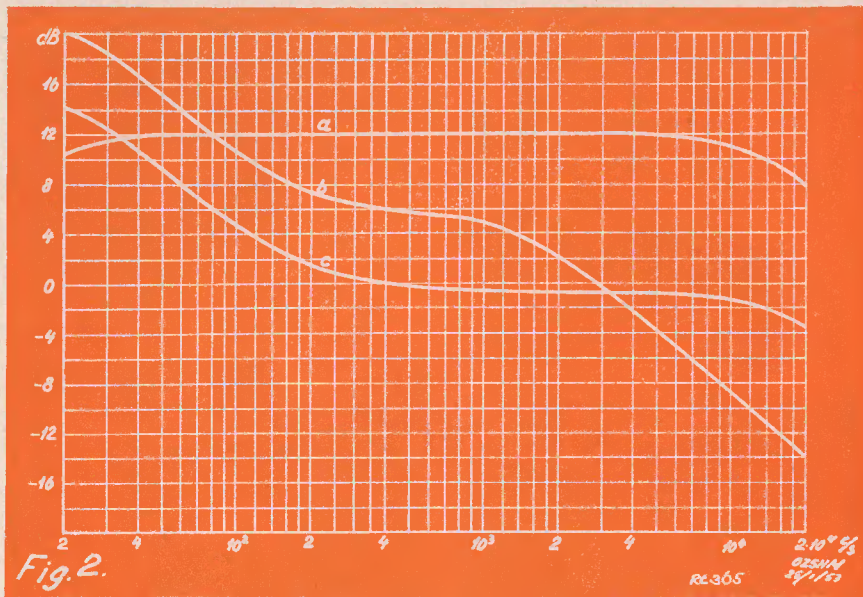

divider formed by R19-C11 and R18-C12 and also by the voltage at point A. The RC products in both parts of the voltage divider being practically equal, the division

is independent of the frequency and the voltage at point B is about one third of that at A. When the connections to the sliding contacts of the potentiometers R21 and

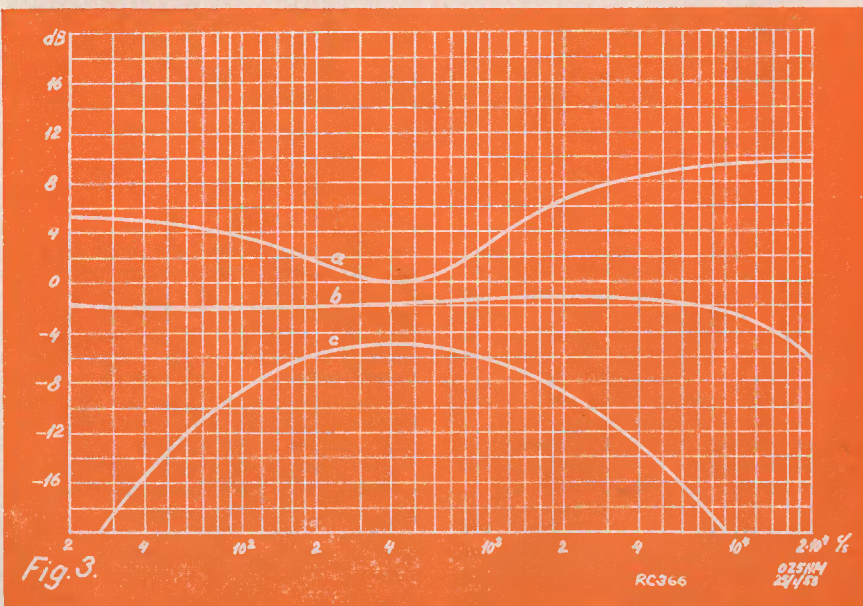

R22 are closed, then it can be seen that this voltage division can be influenced by the potentiometers. With the sliding contact of R22 in the upper position, at high frequencies more voltage is passed via the capacitor, C10, to the grid of the valve than when the sliding contact is in the lower position. In the latter case there is an additional attenuation via R17 and C10. Thus with the potentiometer R22 either a rising or falling frequency characteristic can be obtained for the upper register. The potentiometer R21 has the same effect upon the frequency characteristic for the lower register. In the upper position at low frequencies a higher voltage passes via R20 and C12 to the grid of the valve than in the lower position. In the latter case, the capacitor C12 is shunted by the resistor R20 so that at point B the low frequency voltages are reduced.

In Fig. 3 are shown different frequency characteristics obtainable with this tone control system. Curve (a) shows the characteristic with both potentiometers in the upper position, curve (b) when they are in a central position, and curve (c) shows the characteristic of the system when the potentiometers are in the lower position.

Further amplification is obtained in the second section of V2, from where the voltages are taken to the control grid of the output valve, where R26 and R29 are introduced to avoid possible parasitic oscillations. This is also the purpose of C18, the value of which should be kept as low as possible so that it should not cut off the higher end of the frequency range. The output transformer, which will be discussed later on, has two secondary windings. One is the 500 ohms output, the other being the negative feedback winding which, through the voltage divider formed by R28 and R30, delivers the necessary voltage for feedback.

The HF Oscillator

Let us now take a look at the arrangement which makes recording on tape or wire possible. This arrangement includes an HF oscillator, a form of output level indicator and a switching network. In the circuit diagram of Fig. 1, V6 and associated components constitute the HF oscillator, the function of which is to supply the necessary

voltage for the erasing process or to ensure sufficient 'bias' when recording. This oscillator is easily made to work, but the values of the capacitors C21 and C22 are rather critical as they determine the output voltage,

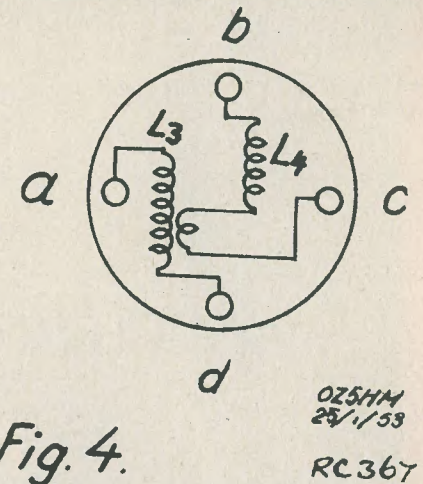

which must be of a certain value and varies with the type of recording head employed. In connection with the amplifier described here was used a wire deck of Danish design, and the recording head had the following characteristics, which I believe are typical:

- Impedance of record/playback coil (L3 in Fig. 4): 16,000 ohms.
- Maximum recording level: 7 volt eff.
- Impedance of erase coil (L4 in Fig. 4): 9 ohms.

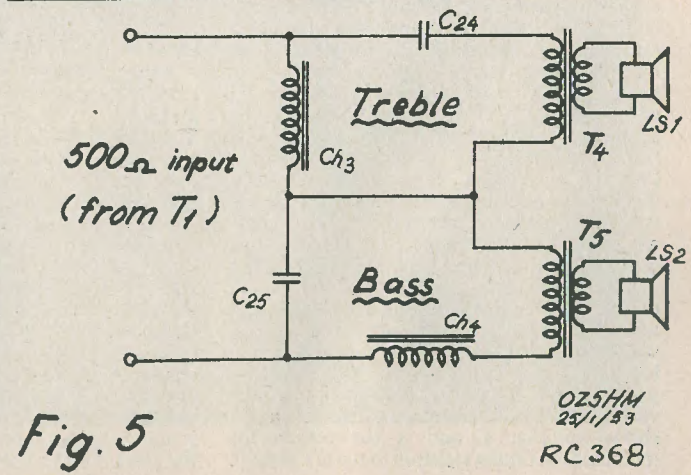

Optimum input voltage (erase and bias): 6 volts at 35 kc/s.

The coils L1 and L2 (Fig. 1) are supplied with the deck by the manufacturer. The RF choke, Ch1, has 2,250 turns of 38 swg enam. copper wire, wound on a former about 3/8" in diameter and fitted with iron core (open, dust). This should give an inductance of 35mH.

All Rights for the Scandinavian Countries reserved by the Author.

The Switch, O₁

The heart of the switching arrangement is the switch O₁. This has 6 sections, each with 2 positions. To avoid undesirable feedback each of the sections has been removed as far from the others as possible. The amplifier input and output connections have been separated further by connecting to sections of the switch, namely O_{1a} and O_{1b}, in series. In the circuit diagram the switch, O₁, is shown in playback position.

[To be continued]

The "PATTERN-MASTER"

1. A versatile TV Pattern Generator for serious work, covering 40-70 Mc/s.

PART 2

By D. ALLENDEN, GRAD.I.E.E.

The Frame and Audio Circuits

The circuit of this unit is given in Fig. 7. The main multivibrator is in this case symmetrical, and produces a square wave at 500 c/s. To improve the frequency stability, the grid timing resistors are returned, not to earth, but to HT+. One of them is made variable to permit the operating frequency to be precisely adjusted, to some multiple of the frame frequency; not necessarily 10 times: if, by virtue of normal component tolerances, 500 c/s cannot be achieved, one or two multiples above or below 50 c/s can be tolerated, provided that the succeeding stage is set to divide down in the appropriate ratio. The frequency is stable because the frequency of a multivibrator depends primarily on (1) the time constants of the grid circuits. These are passive elements. (2) Ratio of V_f to V_i (See Fig. 8 Waveforms). Since these voltages are all derived from the single HT source, variations affect them equally, so resulting in some error cancellation. (3) Precision with which the onset of conduction in the valve can be determined. This is again shown in Fig. 8, and is the reason for returning the timing resistors to the HT supply.

The valve used is a Brimar 12AT7 twin triode, with low values of anode load (10kΩ) so that a fairly low impedance output is obtained. The output square wave is taken from V6A anode, and is used both as an audio modulating signal and also for frame video modulation, when it provides horizontal black and white bars.

The square wave is also fed to the 'staircase' waveform generator consisting of V7 and V8 and their associated components. The action of this circuit is best understood by reference to Fig. 8. Consider V6B to be conducting, with its anode at about 100 volts positive, and assume C19 to be initially uncharged, so that its upper end is at earth potential. The lower end of C18 is also at earth potential, so C18 is charged to 100 volts. Now let V6B be cut off by the normal multivibrator action. The upper end of C18 rises to +250V, and the anode of V7A is carried positive so that V7A becomes conducting, and C18 and C19 are effectively in series. Thus C18 and C19 together become charged to 250 volts. Since C19 is much larger (about 20 times) than C18, the final distribution of voltage is such that

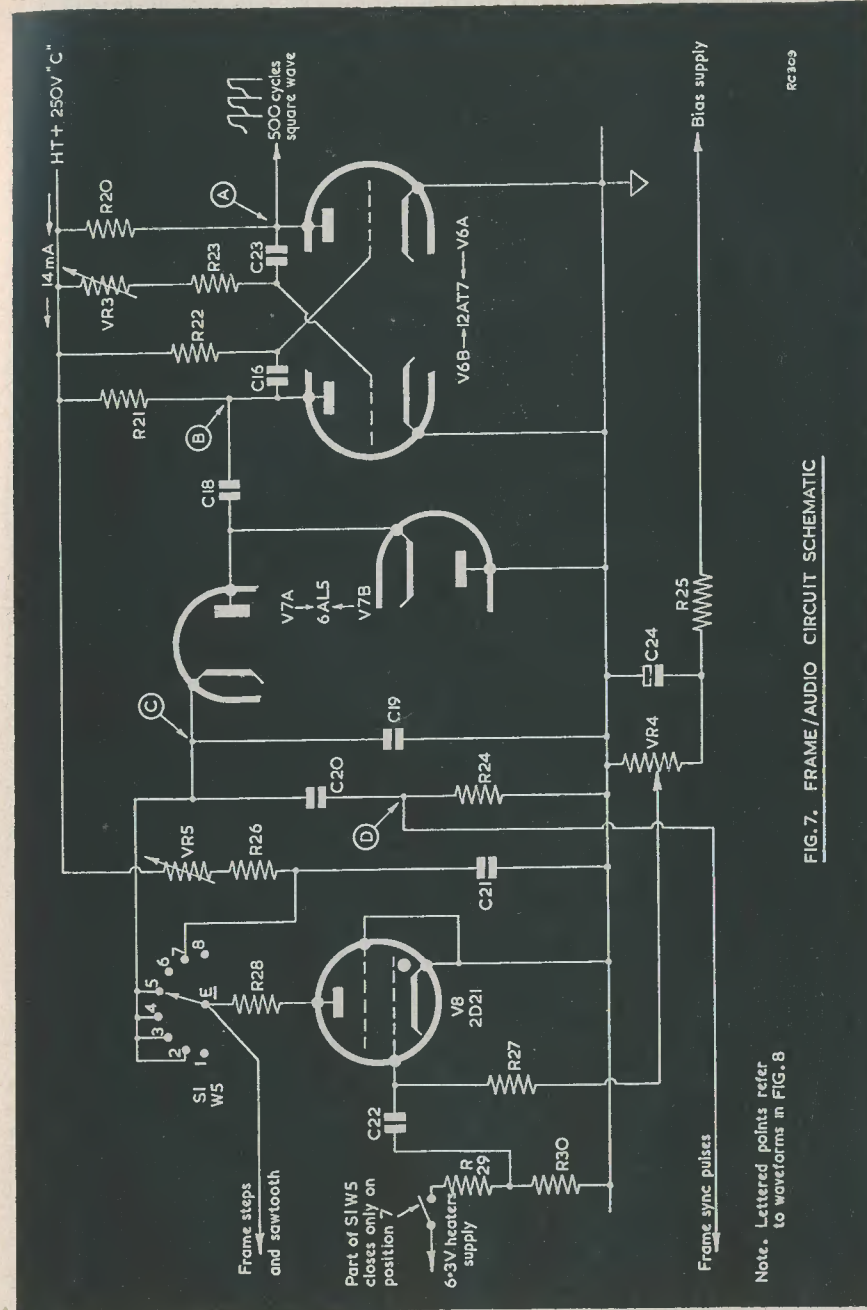

FIG. 7. FRAME/AUDIO CIRCUIT SCHEMATIC

Note. Lettered points refer to waveforms in FIG. 8

C19 is charged to 12.5 volts, the rest of the 250 volts being across C18. Now let V6B anode again fall to 100 volts as V6B conducts again. V7A anode is driven negative and V7A is thus non-conducting. C19 cannot therefore lose the 12.5 volts it has acquired. However, the cathode of V7B now becomes negative with respect to its anode, which is earthed, and V7B conducts, allowing the lower end of C18 to discharge to zero voltage. On the next cut-off of V6B, the process is repeated, except that C19 is initially charged to 12.5 volts, and so this time acquires a second (slightly smaller) increment of charge. This process is repeated each cycle, so that the voltage across C19 rises in a number of steps each slightly smaller than the preceding one. There is, of course, a limit to the possible voltage that can be acquired by C19, but, long before this limit is reached, the voltage across C19 becomes high enough to initiate conduction in the thyatron V8 which is connected across this capacitor. After a definite number of steps the thyatron anode voltage overcomes its bias, and the valve fires, thus discharging C19. When C19 is discharged, the thyatron de-ionises, allowing the grid once more to take control, and the whole cycle commences again. By suitable adjustment of the bias of V8, effected by R21, the number of steps per cycle may be adjusted, and is in fact adjusted until the division ratio of the circuit is equal to the ratio F_m/F_f , where F_m and F_f are the multivibrator and frame frequencies respectively. Thus if the multivibrator runs at 450 c/s, the staircase waveform must have 9 steps.

The valves used for V7 and V8 are, respectively, Brimar 6AL5 and Brimar (S.T.C.) 2D21. (4G/280K).

A differentiating circuit C20-R24, across the staircase output, produces a negative pulse each time the staircase wave returns to zero. This pulse is used for frame sync purposes. The staircase wave itself is fed to the grid of V2 as a modulating voltage to produce the graduated horizontal bars.

By means of very simple additional switching, the thyatron may be used to produce a 50 c/s sawtooth sweep. Switch SIW5, which is actually part of the main selector switch, disconnects the thyatron from the staircase generator, and reconnects it to the junction of R26 and C21. At the same time a 50 c/s sync voltage is introduced into the grid circuit. VR5 is so adjusted that the thyatron produces a sweep of sufficient amplitude. Whilst it is true that this sweep is far from linear, it is still useful for testing purposes. If desired, a second switch position could be added here so that a line sweep is also available.

Note the resistor R28 in the thyatron discharge path, whose function is to limit the current through V8 to a safe value.

Mixing Circuit and Cathode Followers

The previous units described produce all the necessary modulating waveforms. The manner in which these waveforms are fed to the modulator is controlled by a multi-position, multi-bank selector switch, and a pair of cathode followers, V9A and V9B (see Fig. 9). The selector switch has 8 positions, as follows:

- 1 Unmodulated RF
- 2 Line sync and video
- 3 Frame sync and video (bars)
- 4 Frame sync and video (steps)
- 5 Line and frame sync and video (steps)
- 6 Audio
- 7 Timebase 50 c/s (not available for modulation)
- 8 External mod.

In order to preserve the modulating waveforms, and also to allow them to be fed into relatively low impedance external circuits, a Brimar 12AU7 is used as a pair of cathode followers of conventional design. V9A handles the sync waveforms and feeds them to the suppressor of V2, and V9B handles video and audio waveforms via a gain control VR6 and feeds them to the control grid of V2. Thus VR6 is used as a modulation depth control for RF, and as a straight gain control for video output. No similar provision is made for the sync cathode follower, since, provided the sync amplitude is sufficient to cut off V2, this is all that is required. Note how in position 5 of the selector switch provision for mixing the line and frame voltages is provided by the additional wafer W3. This was not part of the original switch, but was salvaged from a scrap unit. Note also that the fourth wafer of this switch is that shown in Fig. 7 of the frame/audio unit.

In position 8 the input to the cathode follower V9A is grounded, and that of V9B connected to a front panel terminal at which external modulation voltages may be fed in.

A terminal on the front panel also allows the output of each cathode follower to be used externally, the actual voltage available at each terminal depending on the position of the main selector switch. When combined sync-and-video waveforms are required externally, these may be obtained by strapping terminals A and B and using them as a single terminal.

The front panel controls, apart from those mentioned, viz. tuning, selector and video gain, consist of only mains off-on switch and carrier off-on switch. This latter switch

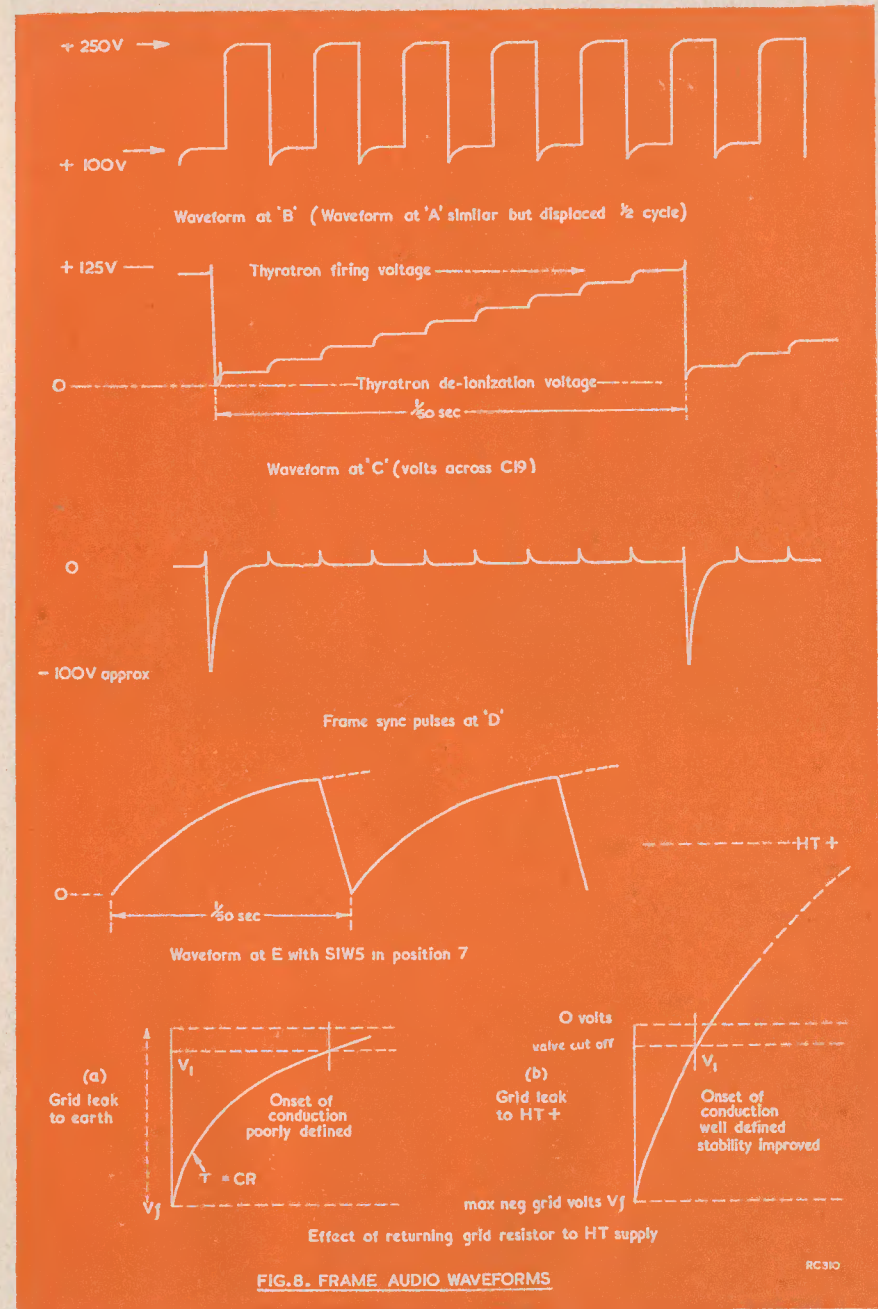

FIG. 8. FRAME AUDIO WAVEFORMS

RC310

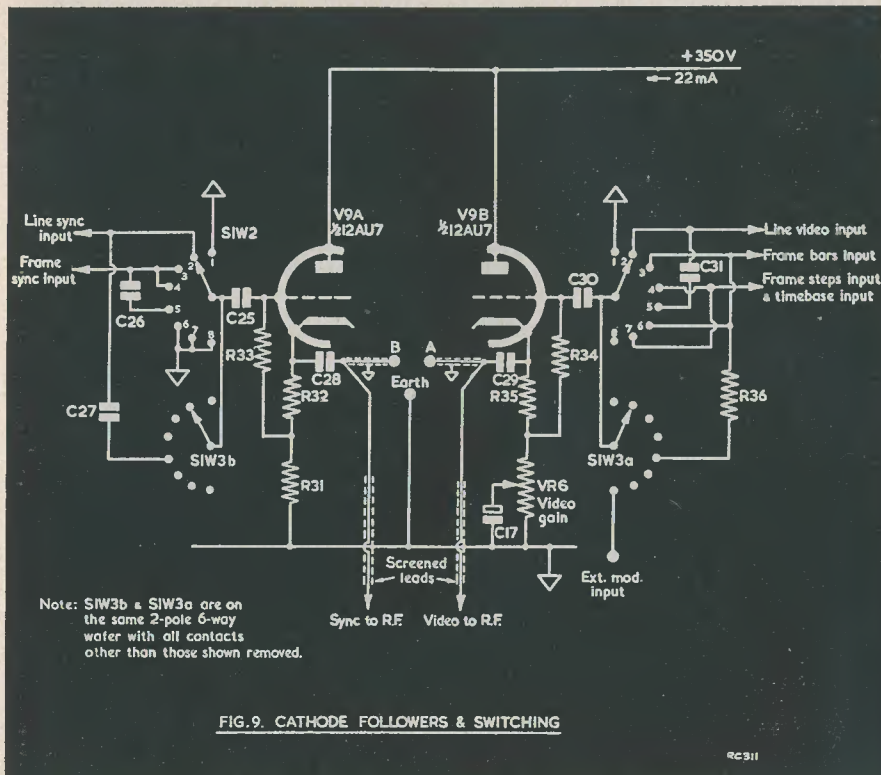

FIG. 9. CATHODE FOLLOWERS & SWITCHING

(S3 in Fig. 10) disconnects HT from the oscillator section, but substitutes a dummy load to enable the power pack loading to be kept constant.

Other panel fittings are RF output socket, Video output terminals, Modulation input terminal, and pilot lamp.

The Power Pack

This is largely of conventional design, but is very liberally smoothed and filtered to prevent waveforms from one unit being fed into another. The transformer is rated at 350-0-350 Volts, 80mA; 6.3 Volts, 1A (rectifier); and 6.3 Volts 5A heaters. The somewhat unusual rating necessitated a special transformer which was made by Electrovoice Products and supplied by H. L. Smith and Co. Ltd. of 287 Edgware Road, W.2. The smoothing choke, rated at 80mA, was obtained from the same source. A Brimar 6X4 miniature rectifier V10 was employed, with 32 μ F smoothing and reservoir capacitors. The smoothing capacitor C33 feeds three C-R decoupling-

filtering circuits, each of which supplies one of the major units. R38-C35a feeds the RF oscillator unit via switch S3 already mentioned. R37-C34 feeds the line video system, and R39-C35b the frame/audio system. The cathode follower stage V9 runs at the full 350 volts. The dial lamp is fed from the heater supply, which feeds all heaters except that of V4 and V10.

Negative bias voltage is provided by a metal rectifier MR1 and resistance capacitance network R40-R41-C36-VR7.

Construction

The mechanical construction of the RF unit has already been described. A good idea of the layout adopted for the whole instrument can be gathered from Figs. 2 and 11, showing above and below chassis views during construction, and the complete instrument. The instrument has been designed to fit into an Imhof type 1054B Case, which requires a panel dimension of 17 $\frac{1}{4}$ " \times 9".

A dimensioned, exploded view of the chassis and panel construction is given in Fig. 12, which is largely self explanatory, whilst Fig. 13 shows above- and below-chassis layouts of the main components. Since the majority of the valves are upside down in normal operation, retainers should be fitted, or, preferably, lock-on screens.

The components are mostly mounted on the group boards attached to the transverse screens associated with each row of valves. The switch S1 is fixed to the second screen, but its shaft passes through the front screen and front panel. An exceptionally long shaft is therefore required, or a coupler can be used. The wafer W5 of the switch is carried on the rear screen, whilst all the other wafers are carried on the centre one.

The tuning and selector controls are each fitted with large knobs, and 5" diameter perspex dials backed with aluminium. A stiff card sandwiched between the dial and backing carries the scale markings in Indian ink, and perspex cursors are fitted. The

video gain potentiometer is mounted on an outrigger bracket close to the cathode follower with which it is associated, and a long extension shaft brings the control through the front panel. It will be noted that all the pre-set controls are fitted with knobs, but this is not strictly necessary; it merely makes adjustment easier. Feeds from the cathode followers V9 to the RF unit and to the panel terminals are in screened lead.

The RF unit is screwed down to the chassis proper by means of 6-BA screws and milled head terminals. It may thus be quickly and easily removed. Its power cable should be long enough to permit it to be operated outside the instrument; this is necessary for setting up. No RF Attenuator is at present fitted, but it is hoped to fit a calibrated piston attenuator in the future. RF output at a 75 ohm level may be taken either from the socket via a co-axial lead, or a short aerial may be fitted into the socket.

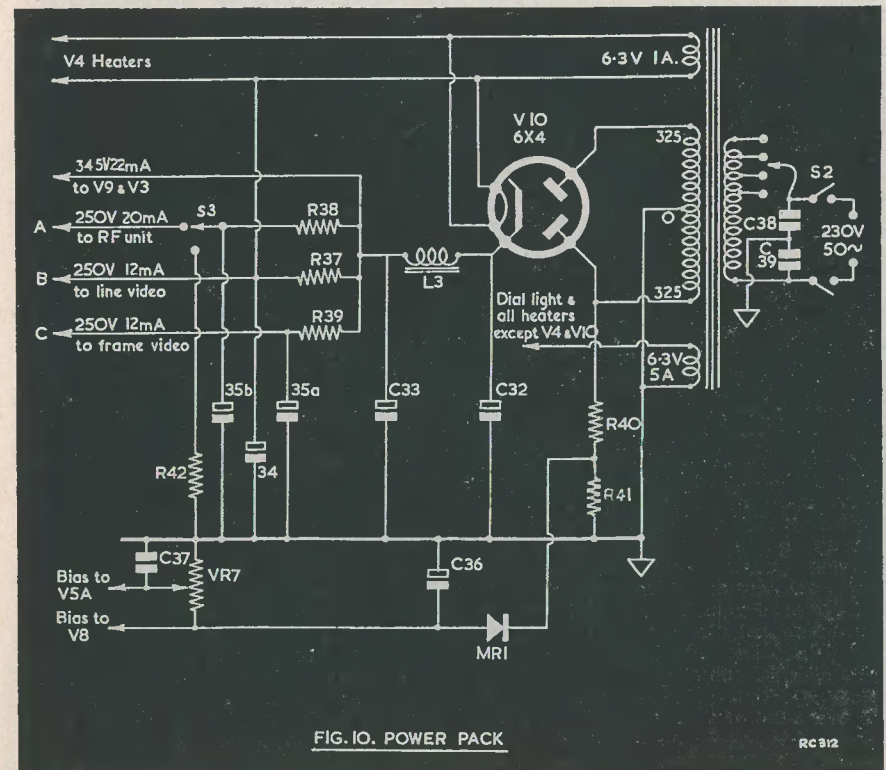

FIG. 10. POWER PACK

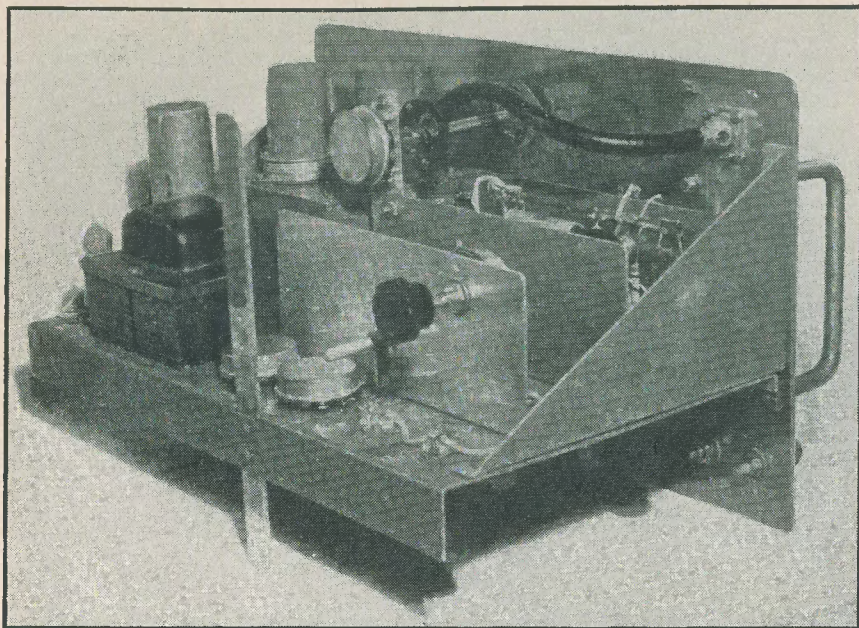

Fig. 11a. Above-chassis view of Instrument during construction

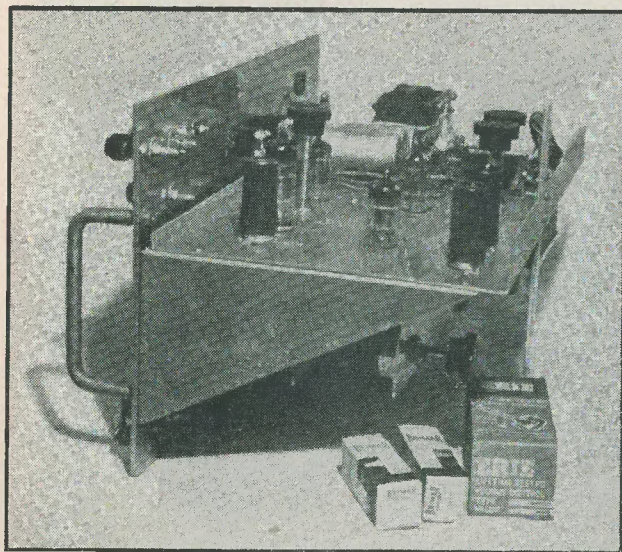
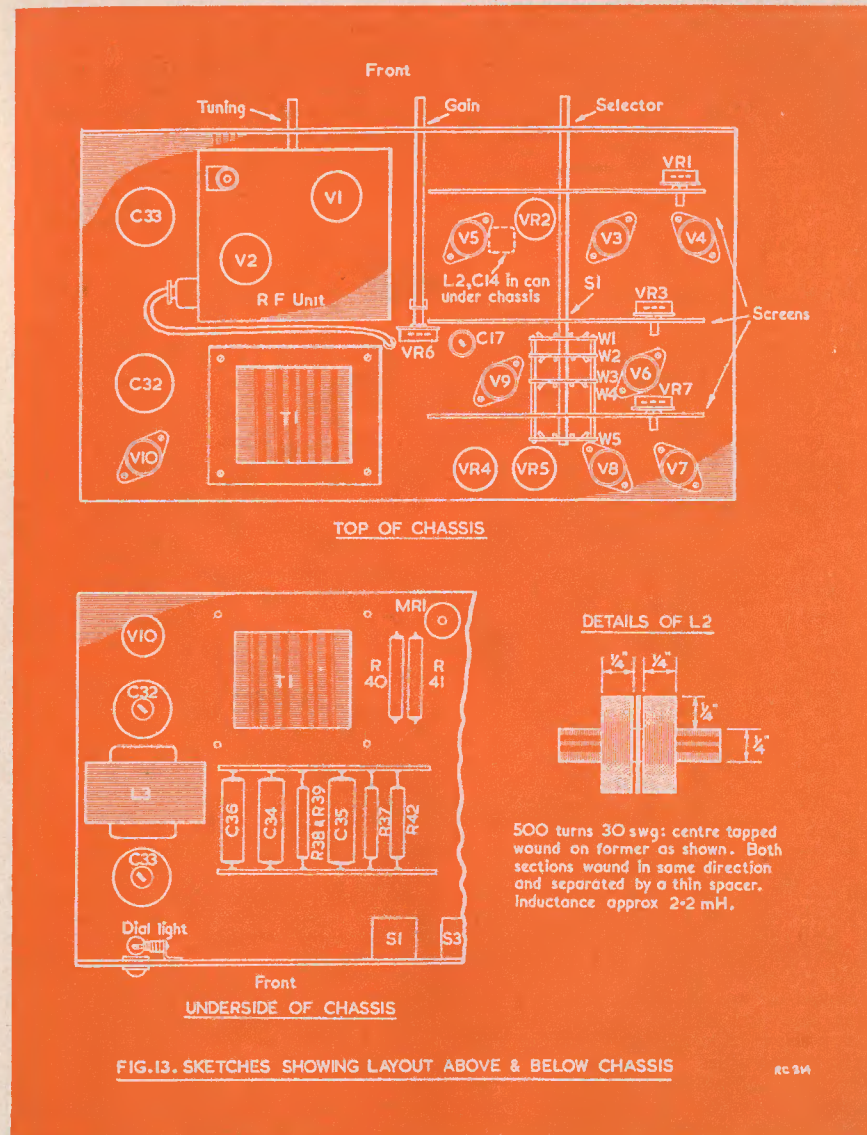

Fig. 11b. Below-chassis view at same stage as Fig. 11a.



Calibration and Setting Up

Some frequency standard is necessary to calibrate the frequency control, and to set the band limits, although quite a lot can be achieved without calibration. The method of calibrating an oscillator by reference to a standard, using the heterodyne method, will be familiar to most readers, and will

not be discussed in detail. The upper and lower frequency limits of the band are set respectively by adjustment of C2 and by squeezing or opening the turns of L1. It should be possible to adjust so that the range is 40-70 Mc/s approx.

For setting up the video circuits the ideal instrument is an oscilloscope, but quite a

satisfactory job can be done using only a TV receiver.

The line PRF control, VR1, can be adjusted by tuning the TV set to a station, turning the contrast down and the brilliance up, setting the selector switch to line video, RF off, and feed the voltage at terminal 'B'

may not appear, or appear with insufficient contrast. If excessive they will not be rigidly locked to the sync pulses, and the bars will move or jitter. This is because excessive bias prevents V5A being turned "on" by the sync pulse, and a continuous oscillation is then produced by L2C and V5B.

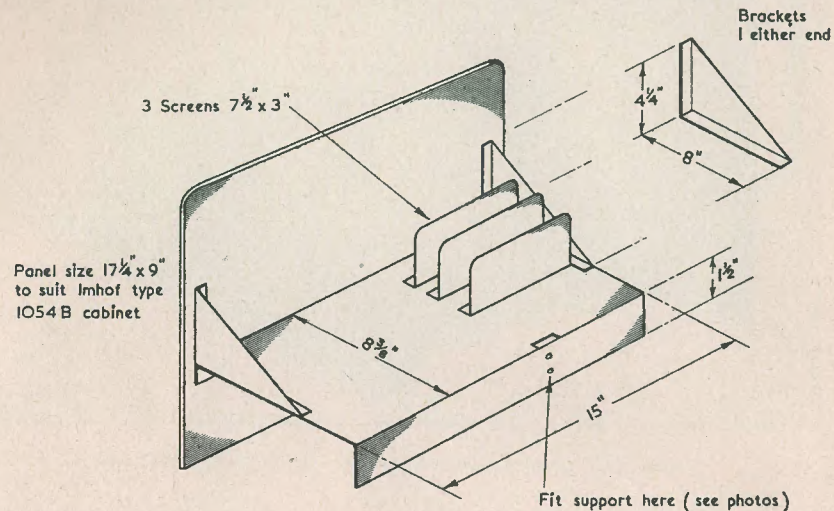

FIG. 12. CHASSIS DETAILS

to the CRT grid. The sync pulse will produce a vertical black bar on the screen. Adjust VR1 until this bar is stationary, and adjust C11 until the width of the black bar is about 1/10 of the screen width. It is advisable to disconnect the signal feed to the CRT grid during this process, but the sync circuits of the receiver must be left working so that line sync is obtained.

The next adjustment is VR2, the line regeneration control. Switch to line video, set the video gain control to about 3/4 max., RF off, and feed line video output to CRT grid under the same conditions as before, except that the generator itself now provides sync pulses. Vertical bars should appear on the screen. If VR2 is insufficiently far advanced, the bars will fade out towards the righthand side of the screen. Adjust VR2 so that this just does not occur. This setting is by no means critical. The oscillator bias control may also be adjusted at this point. If the bias is insufficient the bars

As far as the frame circuits are concerned the first step is to adjust the frequency of the frame multivibrator. Set selector switch to audio, RF off, tune the set to a signal, and disconnect the CRT grid lead as before. Feed the square wave to the tube grid and adjust VR3 until there are about 10 stationary horizontal bars on the screen. Then switch to frame video (steps) and observe the pattern. The same number of bars should be there, but in different tone levels. Adjust VR4 until the whole screen contains a single range of tones, and under these conditions the number of steps generated by the staircase generator will be exactly equal to the number of bars produced by the square wave.

Finally set selector to timebase, and feed the video output to the grid of the output valve, the frame oscillator having been put out of action. Horizontal sweep should return, and its amplitude should be adjusted to a suitable value by means of VR5.

Using the Instrument

A final word may be added about uses of the instrument OTHER than its specific function as a TV signal generator. One such use has been mentioned above. If the set under test has no frame sweep, apply frame timebase voltage to the frame output valve grid; if sweep returns, frame oscillator circuit is faulty; apply to Frame oscillator valve grid; if sweep returns, valve is OK, components are faulty.

The line sync pulses are very useful for checking when a set has no EHT. Apply line sync pulses to line output stage grid; if EHT returns the line output stage and EHT are OK, but line sweep oscillator is at fault. The steps are useful when checking for video distortion since if the gradations of tone are not uniform, there is distortion which can be traced by moving the video feed through the video amplifier.

LIST OF COMPONENTS REQUIRED TO CONSTRUCT THE GENERATOR

Valves	C13 0.1μF 500V "Metalpack" type CP46S
V1 EF50 or Brimar 6AM6 for miniature version	C14 200pF Mica SMWN
V2 EF50 or Brimar 6AM6 for miniature version	C15 0.01 "Metalmite" CP33S
V3 Mullard ECL80 (or alternatives as discussed in text)	C16 0.01 "Metalmite" CP33S
V4 Brimar 6AL5	C17 16μF 350V CE19L
V5 Brimar 12AU7	C18 .005 "Metalmite" CP33S
V6 Brimar 12AT7	C19 0.1μF 500V "Metalpack" type CP46S
V7 Brimar 6AL5	C20 100pF Mica SMWN
V8 Brimar (S.T.C.) 2D21 (4G/280K)	C21 0.1μF 500V "Metalpack" type CP46S
V9 Brimar 12AU7	C22 0.001μF Mica M3U
V10 Brimar 6X4	C23 0.01 "Metalmite" CP33S
MR1 Brimar RM1.	C24 50μF 12V.W., CE32B
	C25 0.1μF 500V "Metalpack" CP46S
	C26 .001μF Mica M3U
	C27 .001μF Mica M3U
Inductors	C28 0.5μF 350V "Metalpack" CP9IS
L1 6 turns 16 swg, length 7/8", tapped 3 1/2 turns.	C29 0.5μF 350V "Metalpack" CP9IS
L2 500 turns on former as shown in Fig. 13. 30 swg. Centre Tapped. Both Sections in same direction, separated only by thin spacer. Inductance 2.2mH, approx.	C30 0.1μF 500V "Metalpack" CP46S
L3 Smoothing choke 80mA 10H (H. L. Smith and Co. Ltd., 287 Edgware Road, W.2.). (Electrovoice type 101F).	C31 100pF Mica SMWN
	C32 32μF 500V, CE32P
	C33 32μF 500V, CE32P
	C34 16μF 350V, CE19L
	C35 8+8μF 350V, CE34
	C36 16μF 350V, CE19L
	C37 0.1μF 500V, CP46S
	C38, 39 0.1μF "Metalmite" CP33S
	Resistors
	All resistor types specified refer to Eric Resistors.
	R1 22kΩ, type 9
	R2 10kΩ 1/2 watt, type 8
	R3 1kΩ 1 watt, type 2
	R4 100kΩ, type 8
	R5 220Ω 1/2 watt type 8
	R6 100kΩ, type 8
	R7 470kΩ, type 8
	R8 1kΩ, type 9
	R9 75Ω 1/2 watt, type 8
	R10 10kΩ 1 watt, type 2
	R12 10kΩ 1 watt, type 2
	R11 220kΩ 1/2 watt, type 9
	R13 100kΩ 1/2 watt, type 9
	R14 220kΩ 1/2 watt, type 9
	R15 47kΩ 1 watt, type 2
	R16 10kΩ 1 watt, type 2
	R17 220kΩ 1/2 watt, type 9
	R18 1kΩ 1/2 watt, type 8
	Transformers
	T1 Primary 200/15/30/45 50 c/s Sec. 325-0-325 80mA 6.3V 1A 6.3V 5A Electrovoice (H. L. Smith and Co. Ltd.).
	Capacitors
	C1 50pF microvariable (Polar)
	All other capacitors are types made by T.C.C. Ltd., and type Nos. quoted refer to T.C.C. catalogue.
	C2 3-30pF trimmer, ceramic type TCK
	C3 20pF type SMWN
	C4, C6, C9 0.001μF Mica type M3U, also C40, C41
	C5, C7 5pF ceramic type SCT11
	C8 50pF type SMWN
	C11 45pF ceramic trimmer, type TCK1545
	C12 0.001μF Mica, type M3U

- R19 4.7kΩ ½ watt, type 8
- R20 10kΩ 1 watt, type 2
- R21 10kΩ 1 watt, type 2
- R22 220kΩ ½ watt, type 8
- R23 220kΩ ½ watt, type 8
- R24 10kΩ ¼ watt, type 9
- R25 100kΩ ½ watt, type 8
- R26 100kΩ ½ watt, type 8
- R27 22kΩ ¼ watt, type 9
- R28 470kΩ ¼ watt, type 9
- R29 1kΩ ¼ watt, type 9
- R30 47Ω ¼ watt, type 9
- R31 10kΩ 1 watt, type 2
- R32 820Ω ½ watt, type 8
- R33 220kΩ ¼ watt, type 9
- R35 820Ω ½ watt, type 8
- R34 220kΩ ¼ watt, type 9
- R36 47kΩ ¼ watt, type 9
- R37 6.8kΩ 2 watt, type 1
- R38 4.7kΩ 2 watt, type 1
- R39 6.8kΩ 2 watt, type 1
- R40 47kΩ 2 watt, type 1
- R41 20kΩ 1 watt, type 2
- R42 10kΩ 6 watt, type SKC2400-Z
- VR1 250kΩ preset, type SKC2061A
- VR2 10kΩ preset, type SKC2061A
- VR3 100kΩ preset, type SKC2061A

- VR4 10kΩ preset, type SKC2061A
- VR5 100kΩ preset, type SKC2061A
- VR6 10kΩ Mod. Depth Control, type SKC2061A
- VR7 50kΩ preset, type SKC2061A

Switches

- S1 8 position 5 Bank Yaxley type made up in accordance with details given in text
- S2 Mains on-off, 2A 230V
- S3 RF on-off, Single-pole 2-way tumbler switch

Miscellaneous

- 1 Panel light. Bulgin List No. D180
- 3 Terminals, Insulated, Belling Lee type, 2BA, 2 red 1 black
- 1 Sockets insulated
- 4 Valveholders with screens B7G type
- 4 Valveholders with screens B9A type
- 2 Valveholders with retaining rings B9G type
- 1 Miniature 6-way Jones or similar plug and socket
- 3 Instrument Knobs.

NOTE: Readers will see that the current measurements given in the various circuits in the power supply diagram above are, in fact, lower than those given in the section circuits concerned. The reason for this is that the mains transformer specification has been modified in order to make certain that the 6X4 rectifier is not over-run. The transformer should be as specified above and in the Components List.

**SEVENTH ANNUAL R.S.G.B.
AMATEUR RADIO
EXHIBITION**

November 25th - 28th, 1953

THE SEVENTH ANNUAL AMATEUR RADIO Exhibition, organised by the Incorporated Radio Society of Great Britain, will be held at the Royal Hotel, Woburn Place, W.C.1, from Wednesday, November 25th to Saturday, November 28th, both dates inclusive. The Exhibition will be opened at 12 noon on the 25th by Mr. Rene Klein, Founder-Member and Vice-President. Mr. Klein, who is Managing Director of McMichael Radio, founded the Society (as the London Wireless Club) 40 years ago last July.

As in past years the Exhibition will be supported by a number of companies who specialise in the provision of valves, apparatus, equipment and publications for the radio amateur. In addition, the Services will be represented.

Members of the R.S.G.B. will exhibit a wide range of home constructed equipment of modern design, whilst the British Amateur Television Club will again display Amateur Television equipment.

The following have reserved stand space:—
Air Ministry; Automatic Coil Winder and Electrical Equipment Co. Ltd.; Denco (Clacton) Ltd; General Electric Co. Ltd.; Iliffe and Sons; Panda Radio Ltd.; Philipotts Metalworks; Salford Electric; Siemens Electric Lamps and Supplies Ltd.; Short Wave Magazine Ltd.

**OSRAM VALVE MANUAL
Part II
TRANSMITTING AND
INDUSTRIAL
VALVES ENGINEERING
DATA**

THE GENERAL ELECTRIC CO. LTD. has now issued Osram Valve Manual Part II. This part of the Manual gives full technical data and characteristic curves on current transmitting and industrial valves, with tabulated information on maintenance types.

In addition, sections on the design of RF oscillators and amplifiers, on the interpretation of ratings, and operating precautions make it a useful reference book for the engineer, as well as a complete catalogue of Osram transmitting valves.

The Manual is available through dealers, price 10s 0d each, or from the General Electric Co. Ltd., Magnet House, Kingsway, W.C.2., price 10s 0d each plus 9d postage and packing.

Query Corner

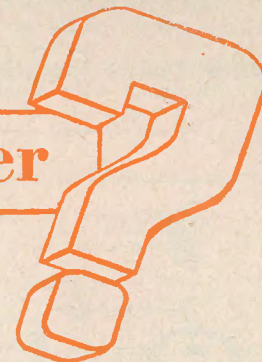

**A Radio Constructor Service
for Readers**

Double Superhet

Some communications type of short wave receivers employ the double superhet principle which involves the use of two different intermediate frequencies. One IF is usually of a fairly high value whilst the other is of the more standard 465 kc/s or 110 kc/s: does it matter which of the two is used after the first frequency changer?

F. Owens, Hull.

This question is best answered by a brief consideration of the principles involved in the double superhet receiver. Figure 1 is a block schematic of such a set, from which it will be seen that two independent frequency changing stages are employed. The first one is tunable in the usual manner and is followed by an IF amplifier of a relatively high frequency, 1.6 Mc/s being a common choice. The second frequency changer is fixed tuned and simply converts the first IF to one of

times known, is the effect which allows the same signal to be tuned in at two points on the dial. These two points are remote from each other by twice the intermediate frequency of the receiver, and if the tuned circuits are correctly aligned the signal when the dial is correctly tuned will be stronger than when it is tuned to the image. The effect is reduced as the selectivity of the RF stages is increased or as the IF of the set is increased. If the reduction of this interference were the only consideration, all SW superhets would have high intermediate frequencies, but unfortunately as the IF is increased so the selectivity of the receiver is reduced, so that in the standard superhet a compromise has to be made. The difficulty is overcome in the double superhet because the second channel interference is prevented by the first high IF, whilst the second or lower IF contributes most of the selectivity

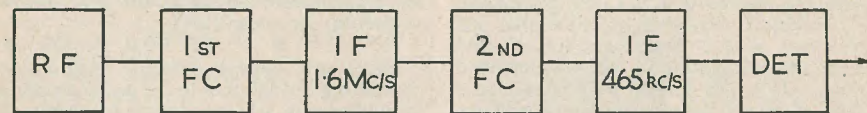

**FIG.1
BLOCK DIAGRAM OF THE HIGH FREQUENCY
STAGES OF A DOUBLE SUPERHET**

RC 382

lower value, 110 kc/s sometimes being chosen. The main advantage of the double superhet is that second channel interference is virtually non-existent because of the high first IF. It will be recalled that second channel, or image interference as it is some-

and gain to this part of the set.

Grid Resistors

I see that in valve manufacturers' published data a maximum value is usually specified for grid resistors. Surely the choice of values

for these components is governed by circuit considerations and not by the valve makers?
J. Peterson, S.E.22.

The choice of value for the grid leak of a valve is determined only within certain

high compared with the impedance in the grid circuit. If this were not the case the gain of an amplifier stage might well be dependent upon the input impedance of the valve following it. There are, of course,

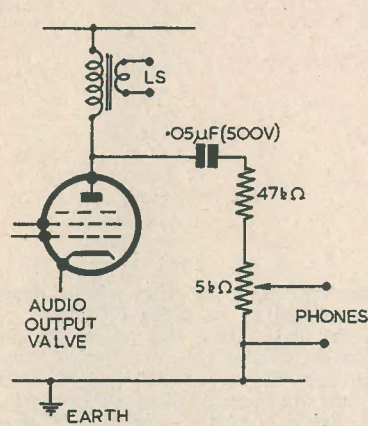

FIG. 2a

RC 383

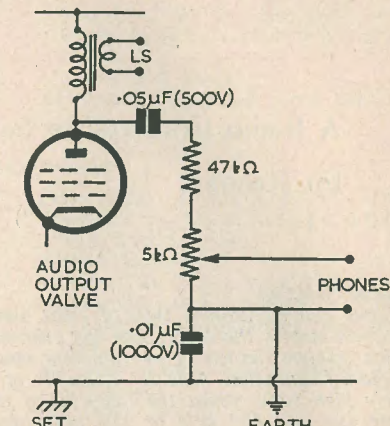

FIG. 2b

limits by circuit considerations. For example, consider an audio output pentode which is driven from an R-C coupled amplifier having a high value of anode load. It is obviously important that the grid resistance should be as high as possible if it is not to seriously shunt the load resistor of the previous valve. So in this circuit the designer would wish to use the highest possible value of grid resistance, and his choice is governed by the valve makers who specify a maximum value for this component.

Now the reasons that this limit is imposed are twofold; firstly, it is possible that the valve may pass a small amount of grid current when operating in the recommended manner. This grid current may be due to a variety of causes such as insulation leakage, grid emission or a trace of gas within the bulb. But whatever the cause, the current may entirely upset the operation of the valve by altering the bias if it is allowed to flow through a very high resistance grid leak. Thus the valve maker can determine from his experience of any one type the grid current which is likely to be present and can accordingly specify the maximum value of grid resistance which, at this current, will not seriously alter the bias.

The second factor which is considered when setting the limit for grid resistance is that the input impedance of the valve should be

exceptions to the above generalisation, perhaps the one most generally encountered being that of the grid current biasing arrangement found in the early stages of some audio amplifiers. This is, however, a rather different problem which we hope to deal with at some future date.

Headphones with TV

I wish to connect a pair of headphones to the audio side of my television receiver in order that a deaf person can better enjoy the programmes. What is the best method of making the connection?

F. West, Birmingham.

There are several different methods of connecting headphones to the audio amplifier in a television set, the choice depending on the type of receiver circuit which is employed. There is, however, one arrangement which, with minor modifications, is applicable to all types of set and it is this which we are recommending. The only connection made to the receiver circuit is to the anode of the output valve. The phone circuit is of sufficiently high impedance to prevent it upsetting the loading of the output valve, so that no reduction in either audio quality or sensitivity of the sound channel will result from its use. The signal is taken from the anode via a blocking capacitor and limiting resistor to an additional volume control. This

enables the deaf person to adjust the level independent of the main control. The phone circuit for use with an AC type of television receiver in which the chassis is isolated from the mains by means of a double-wound transformer is shown in Fig. 2a. In an AC/DC set, or one in which an auto type of mains transformer is employed, the chassis will be live to one side of the mains and a further isolating capacitor must be employed as shown in Fig. 2b. This is most important, because should the mains plug be inadvertently connected so that the chassis is joined to the unearthed side of the mains a very severe shock might be obtained. A further safety precaution is obtained by connecting one of the phone leads to the earth socket on the set, which in turn should be either joined up to an external earth or to the earthed pin of a three-pin mains plug. It will be remembered that in the AC/DC type of receiver the earth socket is not joined directly to the chassis but is taken via a capacitor.

The two arrangements described are suitable for use with high impedance phones; that is, those having an impedance in the region of 2,000 ohms. If low impedance phones are to be employed a matching transformer must be used. The most popular

Query Corner

RULES

- (1) A nominal fee of 2/6 will be made for each query.
- (2) Queries on any subject relating to technical radio or electrical matters will be accepted, though it will not be possible to provide complete circuit diagrams, for the more complex receivers, transmitters and the like.
- (3) Complete circuits of equipment may be submitted to us before construction is commenced. This will ensure that component values are correct and that the circuit is theoretically sound.
- (4) All queries will receive critical scrutiny and replies will be as comprehensive as possible.
- (5) Correspondence to be addressed to "Query Corner," Radio Constructor 57 Maida Vale, Paddington, London, W.9.
- (6) A selection of those queries with a more general interest will be reproduced in these pages each month.

low impedance phones are the ex-Government 8 ohm moving coil type, which require a transformer having a turns ratio in the region of 25:1.

THE INSTITUTE OF PRACTICAL RADIO ENGINEERS

Midlands Section

PROGRAMME SEASON 1953-54

- Monday, December 7th, 1953
Mr. F. WILD, of Cruickshanks Ltd.
MODERN INDUSTRIAL METAL FINISHING.
- Monday, January 4th, 1954
Mr. P. SILVERMAN, of Ferguson Radio Ltd.
FERGUSON TELEVISION RECEIVERS.
- Monday, February 1st, 1954
Mr. H. G. TRAPP, of Ultra Electric Ltd.
ULTRA TELEVISION RECEIVERS.
- Monday, March 1st, 1954
Mr. A. C. ROTHERHAM, of the British Inter-Planetary Society.
THE FIRST MOON JOURNEY.
- Monday, April 5th, 1954
TO BE ANNOUNCED.
- Monday, May 3rd, 1954
Mr. C. W. SHEFFIELD, of Sobell Radio Ltd.
SOBELL TELEVISION RECEIVERS.
- Monday, June 14th, 1954
ANNUAL GENERAL MEETING.
In the event of the scheduled speaker being unable to attend, one of the following will be submitted.
Mr. G. W. JONES, M.I.P.R.E.
INSTRUMENTS AND TESTING.
Mr. J. S. KENDALL, M.I.P.R.E.
NOTES ON ELECTRONIC ORGANS.
Non-Members are invited to attend any of these meetings.
Meetings will commence at 7.30 p.m. prompt
All Meetings will be held at the
CROWN HOTEL, BROAD STREET, BIRMINGHAM.

THE TELEVISION SOCIETY

Lecture Programme 1953-54.

All meetings, unless otherwise specified, are held at the Cinematograph Exhibitors' Association, 164 Shaftesbury Avenue, W.C.2., and commence at 7.0 p.m.

Non-members are admitted by ticket only, to be obtained from a member or from the Society's offices at 164 Shaftesbury Avenue, W.C.2.

- Friday, November 13th
Discussion on **COMPETITIVE TELEVISION**
- Thursday, November 26th
CONVERTERS FOR VHF or UHF TELEVISION
- Thursday December 17th
INFORMATION THEORY AND TELEVISION
Dr. E. C. Cherry (Imperial College).
- Wednesday, January 6th
THE MARCONI TELEVISION O.B. UNIT
C. Carrington (Marconi's W.T. Co.)
This is a Joint Meeting with the British Kinematograph Society at Film House, Wardour Street, commencing at 6.45 p.m.
- Thursday, January 21st 1954
AMERICAN TELEVISION
J. Sieger (formerly of Scopphony Ltd.)
- Thursday, January 29th—Saturday, January 31st
THE SOCIETY'S ANNUAL EXHIBITION
(Admission by ticket).
- Thursday, February 12th Thursday, February 25th
The Fleming Memorial Lectures on COLOUR TELEVISION
Given by G. G. Gouriet, B.Sc., at the Royal Institution, Albemarle Street, W.1., at 7.0 p.m. Admission by ticket only.
- Thursday, March 12th
TRICK EFFECTS IN TELEVISION PRODUCTION
D. R. Campbell (B.B.C. Television).

AN EASILY CONSTRUCTED BASIC VALVE VOLTMETER

By T. W. DRESSER

THE INCREASING COMPLEXITY of modern radio equipment and TV receivers has, among other things, spelt the doom of many of the old-fashioned instruments with which the average service shop technician and amateur got along not so many years ago. In their place there has come to the fore such things as the VVM, the square wave generator, and many others which are as much a necessity now as the ability to judge the HT voltage by splashing it to the chassis was in the old days. Unfortunately, whereas the latter merely called for a reasonable amount of sagacity and a little previous experience of splashing, the purchase of modern equipment of the type I have mentioned requires something more than that. It demands the layout of a considerable sum in hard earned cash if one is to buy a commercial instrument, and most of us are not overburdened in that respect nowadays. Nor can we always solve the difficulty by purchasing a kit set, although such things are common enough in the United States. It follows that our only alternative to paying, perhaps, forty or fifty pounds for a commercial instrument is to build our own—and here again, as far as the writer can see, it is not all plain sailing. Of the designs published in technical journals, the majority are far too elaborate, the circuit diagram alone being sufficient to frighten off any self-respecting amateur unless he has a heart like a lion! Where these designs go wrong, in the writer's opinion, is that they have far too extended an Ohms range for amateur purposes and in addition they are somewhat cluttered up with built-in diode rectifiers and separate voltage dividing networks for use on AC and DC inputs. Such refinements as these and voltage regulators are all very well for highly accurate lab or works use, but most of us dabblers would be well content with a simpler instrument at a correspondingly lower price, particularly as some of us will already possess a good multi-range meter, or may be contemplating the construction

of such an item, which will do all that is required in the way of resistance measurements.

Some time ago the writer was faced with the need for a reasonably accurate VVM for use in checking some figures on a communication receiver, and it was as a result of that need that the instrument to be described was developed. As will be seen from the circuit diagram of Fig. 1, it is neither a highly elaborate version nor the simplest of its kind. It is, however, a reasonably accurate compromise between them and is extremely easy to construct, as well as being easy on the pocket. With the exception of resistance measurements it will do all that the very elaborate models will do. The resistance side of the meter was omitted deliberately, for a number of reasons. There was already a high accuracy multi-range meter available for one thing, and for another it was felt that the occasions on which it would be necessary to take very high resistance readings would be few in number, and below twenty MΩ or so the multi-range meter could very well handle them. Moreover, the additional components needed to include resistance ranges would undo all we set out to do—to keep the thing simple.

The instrument was built in an aluminium case bent to the dimensions given in Fig. 2 and drilled as shown. The bottom, front and top are bent from one piece, and the sides and back are screwed on to it by means of Parker-Kalon self-tapping screws after wiring is completed. The back is drilled with a large number of holes immediately behind the valve for ventilation purposes; this is of some importance as, otherwise, heat may affect the accuracy of the readings. The valve used in the original model was a 12AU7 miniature type, but there is no reason why a 12AT7 or a 6SN7 should not be pressed into service if it is available. Either of them will function just as well as the original, and as 6SN7's are cheap and plentiful on the surplus market and are probably more robust than the miniature

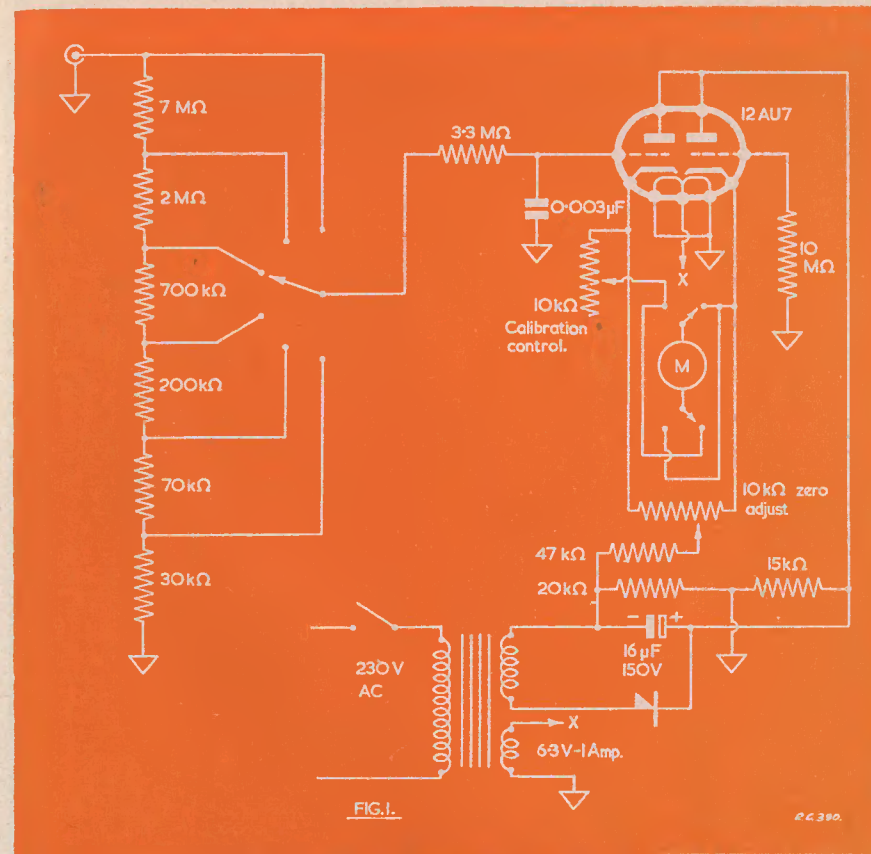

COMPONENT LIST

- | | |
|---|--|
| 1 Mains Transformer, Secondaries 0-120V 40mA; 6.3V 1A, midget size. | 1 Single-pole single-throw toggle switch (Bulgin). |
| 1 Minipak 16µF 150V wkg electrolytic (wire ends). | 1 6-way single-pole miniature wafer switch. |
| 1 Metal Rectifier 120V 40mA. | 1 2-way 2-pole miniature wafer switch. |
| 2 10kΩ pots (preferably wire-wound). | 1 Meter (see text). |
| 1 Valveholder. | 1 Length shielded cable (2'6"). |
| 1 Valve, 6SN7, 12AU7 or 12AT7. | 1 Belling-Lee socket type 6045. |
| Fixed resistors, Fixed condensers, as in Figs. 1 and 4. | 2 Belling-Lee plugs type 642F. |
| | Aluminium for case, 16 swg. |
| | Parker-Kalon screws, strip-back wire, etc. |

types it may even be good policy to use one of them. The physical layout is given in Fig. 3 and needs little additional explanation. The mains transformer, a miniature type on an output transformer core, which can be wound at home to the specification given in the components table or bought readily enough from any of the larger dealers, is mounted immediately below a

stand-off bracket carrying the valveholder, the metal rectifier and the midget smoothing condenser. The remainder of the components are controls and are mounted on the front of the case, with the exception of the calibration control which is attached to the valveholder bracket and is adjusted from the rear of the instrument. It will be noticed that the transformer secondaries are rated

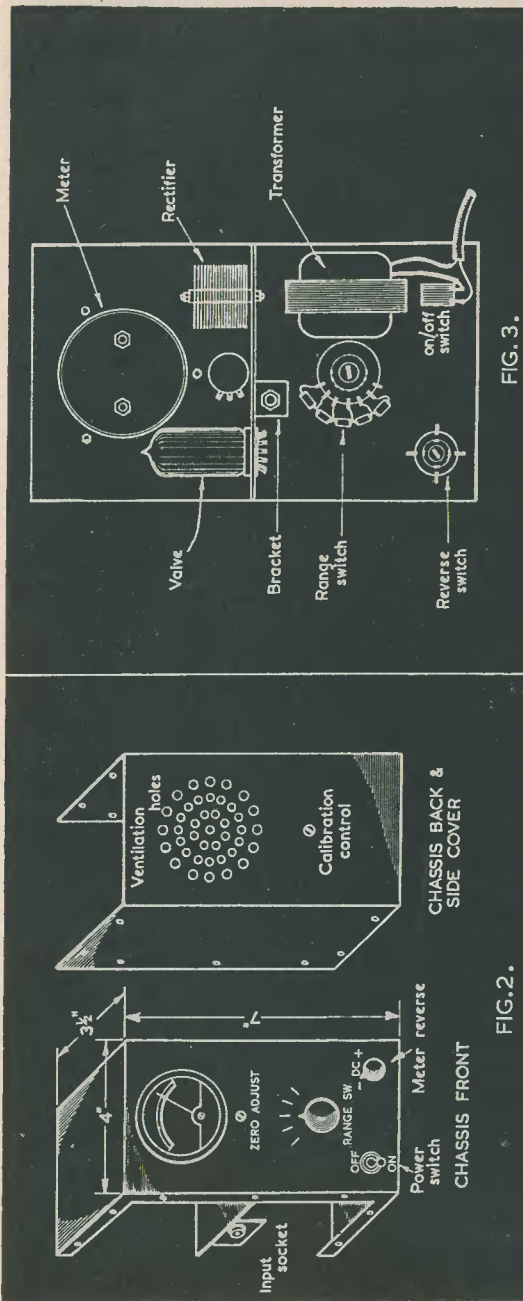

FIG. 2.

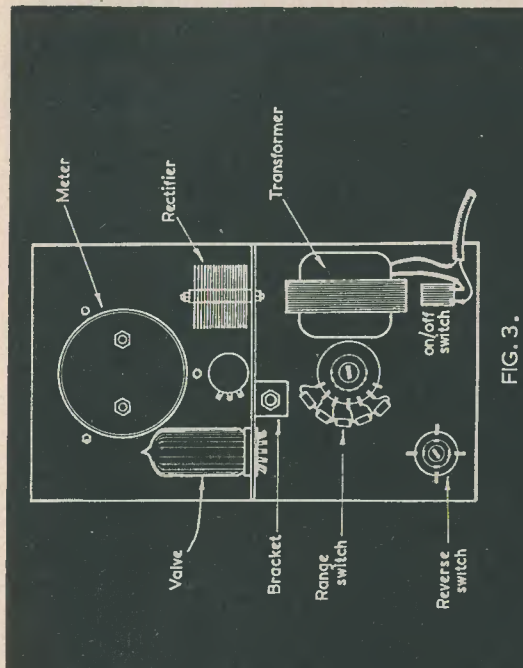

FIG. 3.

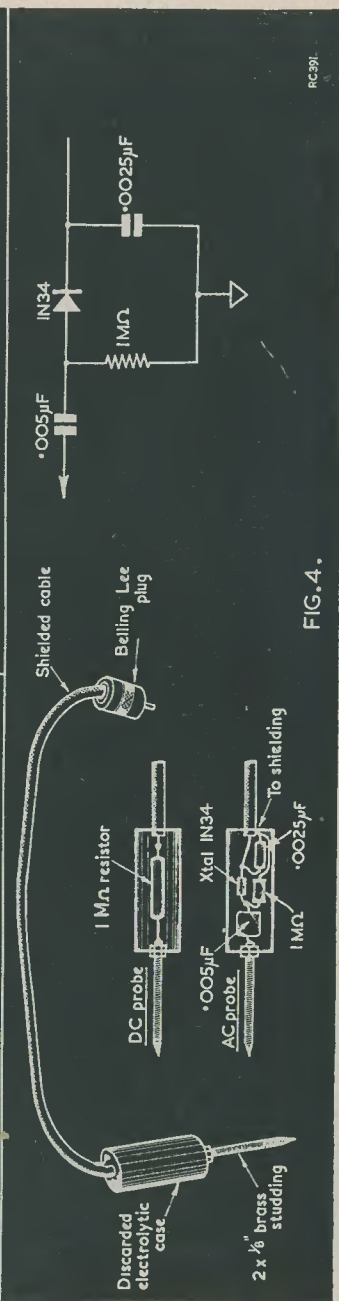

FIG. 4.

RG391

at 115-120V at 40mA and 6.3V at 1 Amp. These supplies were found adequate for the purpose, and the low HT also meant that a small and cheap metal rectifier could be used instead of the bulkier 230 volt variety. A line cord could have been used and the supplies taken directly from the mains, but it is felt that all and any AC/DC supplies are far from being safe, though, if a reader wishes, the conversion is a simple matter.

The original meter used was a 200μA movement, scaled 0-10, 0-100 volts, and came from ex-service gear, but any similar meter up to 1mA may be used—although it must be remembered that the lower the current the greater the accuracy. A 50μA movement would be ideal if one can be obtained at a reasonable price. The scaling of the original meter made it very convenient to fit in the ranges required, which are 0-3, 10, 30, 100, 300 and 1,000 volts AC and DC. The voltage divider network is made up of standard 1/2 watt resistors, chosen with care for the sake of close tolerance (thanks to an obliging dealer); the values are 30kΩ, 70kΩ, 200kΩ, 700kΩ, 2MΩ and 7MΩ, and they should be as close to these as it is possible to get.

The circuit is a balanced one, and the purpose of the calibration control is to ensure that both halves of the double triode draw such a current that the potential at both anodes is identical. Under such conditions a change in the grid voltage of one half of the valve will upset the balance and cause the meter to indicate the imposed voltage.

The front panel, shown in Fig. 2, shows the operating controls which are:—power on-off switch, meter reverse switch, zero set, and range switch. The diagram is self-explanatory.

For efficient operation two probes are needed; one for DC, and the other, which includes a rectifier, for use on AC. Both are made up from a fifteen inch length of shielded cable with an old electrolytic case as the actual probe shield, as in Fig. 4.

The probe cable is fitted at the end which connects to the instrument with a Belling-Lee co-axial plug, a similar socket being mounted on a bracket on the instrument case. Quite apart from simplifying the construction of the unit, these probes are of advantage in other ways. The shielding reduces hand capacity to negligible proportions, and in the case of the AC probe it is a definite advantage to bring the rectifier right up to the source being tested. Incidentally, there is some inaccuracy when the meter is used on AC—approximately 6%—but this can be compensated for by marking an error factor on the meter scale or by simply taking the readings on a comparative basis. It could, of course, have been entirely eliminated by other means, but this would have involved considerably complicating the instrument.

In this connection it may be necessary to make some small changes, such as adding 2,000Ω cathode resistors, one in each leg if 6SN7's are used, and possibly reducing the value of the right hand grid-to-earth resistor to about three or four MΩ. But otherwise no changes are involved, and none at all with a 12AT7.

Calibration is simple. All that is necessary is to apply a known voltage such as that from a battery or low voltage AC source and adjust the control until the meter reads that figure. With a meter differing greatly from that used in the original it is possible that a new dial scale may be necessary, but with a shaped and clean piece of white paper glued to the dial, and using a variable source of AC and DC, it is not a difficult matter to mark in the required voltage points.

In conclusion, this instrument should not cost more than two pounds or so with judicious buying, and possibly less if a well-stocked junk box is at hand. While it will not provide laboratory results, it will prove well worth the little trouble involved in building it, and will save many hours of otherwise fruitless labour.

From Our Mailbag . . .

Dear Mr. Overland, Upon reading the article *Something New* in the October issue of *Radio Constructor* (page 158) we feel we must quarrel in a friendly way with your contributor J. S. Kendall, who states, apropos a M and L.W coil that is apparently air-cored, "As there is no core of magnetic material the "Q" is quite high."

The obvious inference a reader will draw from this, is that coils with iron-dust cores have a lower "Q" — and as makers of

iron-dust-cored coils we are naturally a little concerned at this misleading statement.

As you are no doubt aware, size for size, a MW or LW coil with a suitable core has a higher "Q" compared with an air-cored coil, not lower, as a Q-meter will soon prove.

We hope that you might raise this point with Mr. Kendall, and if he disagrees with what we say we should be interested to hear the explanation.—Yours faithfully, Osmor Radio Products Ltd., P. MOSELEY, Director.

RADIO FEEDER UNITS

By D. NAPPIN

BEFORE IT IS POSSIBLE TO BEGIN a description of the circuitry involved in radio feeder units it is necessary to define the term 'Radio Feeder Unit.' In this article it is taken to mean an apparatus for the purpose of converting radio frequency signals into low level audio signals so that the audio output is a faithful reproduction of the modulation present on the radio frequency signal as transmitted.

It thus differs from a normal receiver in having no output stage, being designed to drive, via a pre-amplifier, a quality amplifier such as the unit already described by the writer.

As it is necessary to exclude spurious noises from the receiver output, or at least to maintain a high signal to noise ratio, it follows that such a unit may only be used for the reception of local stations on the medium and long wavebands.

In Britain such stations will normally be the BBC transmitters—the Continental stations being, as a rule, subject to much fading and interference.

The Input Signal

Input to the unit, if derived from a BBC transmitter, may be modulated with frequencies up to 10 kc/s, thus producing sidebands of $f_0 + 10\text{kc/s}$ and $f_0 - 10\text{kc/s}$, where

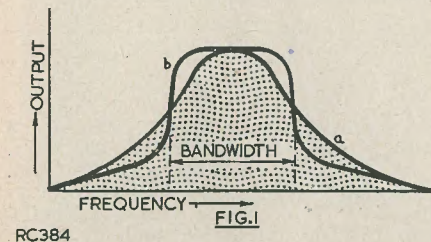

f_0 is the carrier frequency. Thus to preserve this signal without distortion it is necessary to provide a channel 20kc/s wide in the RF

or RF and IF circuits, depending upon whether the unit is of the superhet or TRF design.

Again, modulation of up to 100% may be encountered, although the BBC usually limit peak modulation to about 85%. It is thus necessary to have a demodulator stage capable of handling high modulation percentages without introducing non-linearity distortion (Ref. 1).

Spurious signals may be present if the receiver is sited in an electrically noisy area or at a great distance from the transmitter, as in certain coastal towns. Such signals are of two kinds—the untuned impulsive form of interference from electrical gear which is best suppressed at the source, and interference from stations on adjacent frequency channels giving rise to 9 kc/s whistles. The latter may be best removed by means of the controls of the pre-amplifier.

The former kind of interference is, over a certain frequency range, uniformly distributed in energy per unit frequency interval. Thus the noise contributes to the output proportionally to the square root of the bandwidth, as multiplying the energy of the noise by a factor n increases the voltage by \sqrt{n} .

The bandwidth of the receiver must thus be no greater than necessary.

Interference may, of course, be minimised by suitable siting of the aerial clear of interference fields, or by employing one of the commercial anti-static aeriels.

Design of the Feeder Unit

A radio feeder unit may be either straight or superhet design and the points for and against each will be considered.

As a bandwidth of 20 kc/s is required, it will be seen that if a straight receiver is employed, little discrimination will be offered to signals outside the pass band, due to the broad resonance curve as in Fig. 1 (curve (a)). At the most, three or four tuned circuits will be employed, and thus difficulty may occur in tracking the circuits, if staggered to give greater skirt selectivity. The

position is improved by the use of switch selected inductors or capacitors tuning pre-selected stations, although here screening must be thorough.

With the superhet, however, five or more tuned circuits are available, of which four are pre-set at the IF. Thus it is possible to stagger tune these four circuits to give a square pass band as in Fig 1 (curve (b)) while the remaining tuned circuits are broadly tuned at signal frequency to accept all the signal. Alignment is difficult in the absence of a wobulator and oscilloscope; however, if a strong signal is available and a tuning indicator or meter fitted it is possible to obtain a fair approximation with patience. This method cannot be used with switch tuning. One disadvantage to the superhet is that the bandwidth of 20 kc/s must be obtained at a lower frequency, where the percentage bandwidth is correspondingly greater. However, at 465 kc/s, 20 kc/s is a 4.3% bandwidth and easily obtainable. Gain not being a controlling factor in such design due to reception of only strong signals, it may be sacrificed to improve the shape of the pass band by shunting some of the IF tuned circuits with resistors to broaden their bandwidth.

It is possible to obtain such a bandwidth at 110 kc/s, where it represents a percentage bandwidth of 18%.

This compares favourably with some IF strips produced for radar gear and television applications with, for example, bandwidths of 3 Mc/s at 13.5 Mc/s, a percentage bandwidth of 22.2%, with considerable gain.

The superhet is sometimes said to be productive of spurious whistles; however, if ordinary care be taken in construction no trouble should be experienced from this cause.

It may hence be seen that for those situated in an area of high signal strength it is possible to employ a straight circuit, whereas a superhet is more suitable in more distant areas or areas prone to interference. The circuit should always be designed so as to provide sufficient input to the demodulator, as most demodulators tend to be non-linear at low inputs.

Many opinions exist upon the best form of detector to use for demodulating the signal with least distortion. However, as most detectors reduce to either the series or shunt diode detector, the diode often being formed by the grid and cathode of a triode or pentode, there appears to be little cause for argument.

The simple diode possesses two inherent faults; firstly, it loads the tuned circuit feeding it, thereby increasing its bandwidth; and secondly, at high modulation percentages distortion may occur. The second fault

may be minimised by suitable choice of component values.

However, the simple diode, and its derivative the grid leak detector to a lesser degree, load their inputs, as current must flow through the diode to establish a voltage across the load resistor or grid leak.

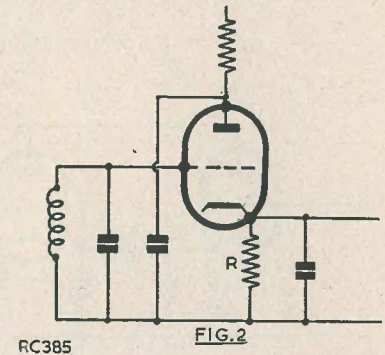

This loading is eliminated in the anode bend detector, and its derivative the infinite impedance detector in which the input impedance is further increased by degeneration across the cathode load resistor R (Fig. 2).

The lack of handling capacity for deep modulation remains if the AC and DC loads of the detector are unequal. However, if the output from the infinite impedance detector be fed to a further cathode follower, which may be direct coupled, an almost distortionless demodulator will result. The functions of these two valves may be combined in a double triode such as the 6SL7 or 12AX7 on octal and noval bases respectively. Such a circuit with appropriate component values is shown in Fig. 3. The circuit is self-balancing, and the voltage developed across the 47kΩ cathode load of the demodulator serves to back off the bias on the cathode follower, thus enabling a reasonable mutual conductance to be maintained. No further amplifier stages need be incorporated as the output from the cathode follower may be fed direct to the pre-amplifier.

Due to the low output impedance of this stage, which is $\frac{1}{g_m}$ where g_m is the mutual conductance of the valve, it is possible to feed the signal over a considerable length of cable without severe loss of the upper frequencies on account of cable capacitance.

It will be noted that no mention has yet been made of Automatic Volume Control (AVC). This is partially due to the fact

that it is difficult to derive an AVC voltage from the infinite impedance detector. As the receiver is being used only for the reception of powerful signals it will be seen that AVC is unnecessary in most cases. If the signal level is too great from any

the cathode follower will be present so as to operate the detector on a linear region of its characteristic, noise and hum may not be troublesome and hence an economy may be made by employing a normal valve for the cathode follower, such as the 6J5 or 6C4.

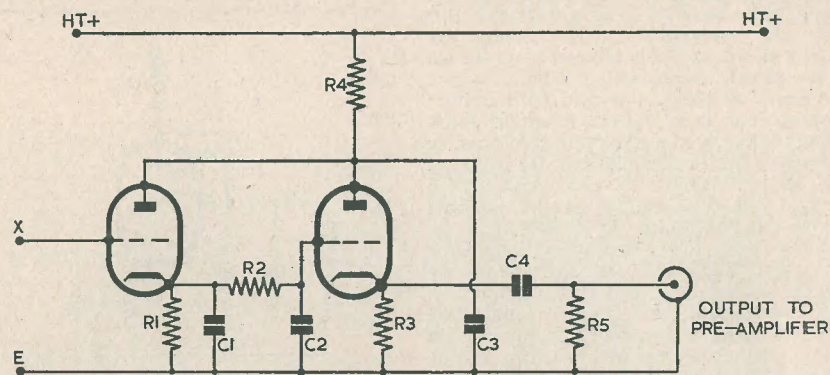

RC 386

FIG. 3

Component Values

C1	100pF ceramic	R1	47kΩ ¼W
C2	100pF ceramic	R2	100kΩ ¼W
C3	0.1μF 350V paper	R3	10kΩ ¼W
C4	0.1μF 350V paper	R4	22kΩ ¼W
		R5	1MΩ ¼W

particular station it should be possible to provide switched damping resistors across the first tuned circuit in the set. In areas where severe fading is prevalent a measure of AVC may prove beneficial; it should, however, be applied only to RF and IF stages as if applied to mixers it is liable to cause trouble by driving the valve into a non-linear regime and hence cause cross modulation of adjacent carriers. Some non-linearity is introduced in RF amplifiers when heavily biased back, but it is not as serious as in mixers and hence can be tolerated. For AVC to be provided a diode must be introduced, and thus it will be as well to employ here a diode detector, as small distortions will probably be introduced in any case due to the AVC bias. If the diode be directly coupled to a further cathode follower, the AC and DC loads may be made equal and only damping of the input circuit will remain. Such a circuit is shown in Fig. 4 with suitable values. Valves for use here may be, in the octal range, EB34 and EF37A strapped as a triode, or in the miniature range, 6AL5 and strapped 6BR7. Due to the fact that a large input signal to

Further Notes

Suitable circuit diagrams for straight and superhet RF circuitry for radio feeder units are shown in Figs. 5 and 6. In each case the point X is to be connected to the corresponding point X on Figs. 3 and 4. The choice of RF section and demodulator depends upon the factors of site and distance from the transmitter, as previously discussed. If the demodulator of Fig. 3 is employed, the line marked AVC upon the RF sections may be earthed and the capacitor between it and earth removed. A note on this capacitor C5 in Fig. 5 and C9 in Fig. 6 is not inopportune. It will be seen that this capacitor completes the tuned circuit feeding the controlled valve, and hence it must have good RF characteristics and present a low impedance with good power factor. The most suitable type, if obtainable, is the paper feed-through capacitor such as the Sprague 'Hypass' type (Ref. 2); however, a good quality paper capacitor mounted adjacent to the inductor concerned should prove suitable. Mica capacitors cannot be obtained in sufficiently large values not to affect tracking. Almost any coils should

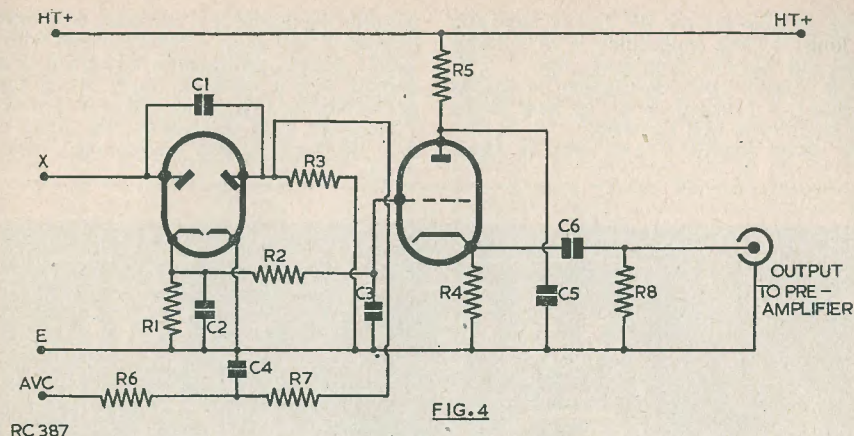

RC 387

FIG. 4

Component Values

C1	47pF silver mica	R2	100kΩ ¼W
C2	100pF ceramic	R3	470kΩ ¼W
C3	100pF ceramic	R4	10kΩ ¼W
C4	0.1μF 350V paper	R5	33kΩ ¼W
C5	0.1μF 350V paper	R6	2MΩ ¼W
C6	0.1μF 350V paper	R7	1MΩ ¼W
R1	270kΩ ¼W	R8	1MΩ ¼W

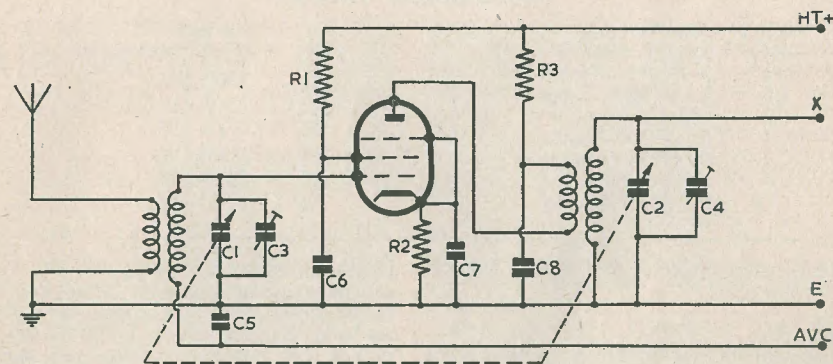

RC 388

FIG. 5

Component Values

C1, 2	500pF 2-gang	C7	0.1μF 350V paper
C3	3-30pF trimmer	C8	0.1μF 350V paper
C4	3-30pF trimmer	R1	82kΩ ¼W
C5	0.1μF 350V paper	R2	330Ω ¼W
C6	0.1μF 350V paper	R3	3.3kΩ ¼W

prove suitable for the RF tuning inductors so long as their inductance is of suitable value and they have iron dust cores.

The manner of construction is chiefly a matter of personal choice so long as the RF circuitry is well screened.

A power supply of 250 volts at 25mA

monitor the output it is necessary to connect between X and earth a diode in series with a 270kΩ resistor and monitor either the diode current with a meter or apply the voltage across the load to a tuning indicator as above.

However, with the straight set lining up may be done by ear. Assuming a wave-

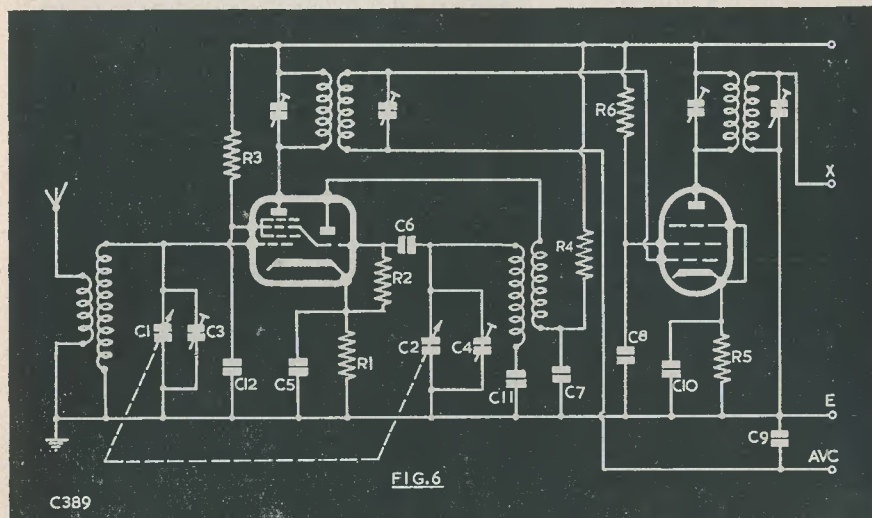

COMPONENT VALUES

C1, 2	500pF 2-gang	C11	see text
C3	3-30pF trimmer	C12	0.1μF 350V paper
C4	3-30pF trimmer	R1	330Ω ¼W
C5	0.1μF 350V paper	R2	47kΩ ¼W
C6	100pF ceramic	R3	47kΩ ¼W
C7	0.1μF 350V paper	R4	15kΩ ¼W
C8	0.1μF 350V paper	R5	330Ω ¼W
C9	0.1μF 350V paper	R6	82kΩ ¼W
C10	0.1μF 350V paper		

should prove ample if well filtered for RF as well as hum.

Lining Up

Suitable stations for lining up on are the high and low frequency Third programme if variable tuning is incorporated.

With the diode detector an output indicator may be employed if a sensitive microammeter be placed in series with the diode load. If this be not available, a tuning indicator such as the EM34 may be connected to the AVC line in the usual manner, this wire being broken to allow of the RF grids being unbiased by AVC.

With the infinite impedance detector, to

length calibrated dial to be attached to the capacitor and assuming the tuning inductors to be fitted with dust cores, the straight set may be aligned as follows:—Set the dial to 194 metres and adjust C3 and C4 for maximum output. Set dial to 464 metres and adjust coil slugs for maximum output. Repeat these adjustments until both hold together and these stations are accurately tuned.

Alignment of the superhet is carried out in three stages. If no signal generator is available the procedure is as follows:—Swing the tuning dial until a signal of some sort is received. Adjust C3 for maximum output. Then adjust the IF trimmers for

maximum output. If these trimmers are well towards the limit of their travel, alter the tuning until they peak in the middle of their range. Having peaked the IF's, the RF circuits may next be adjusted. Here the procedure is exactly as for the straight receiver, except that where the padder C11 is variable it may be varied instead of the dust core in the oscillator coil. This capacitor C11 has a value dependent upon the coils in use and the intermediate frequency. For a 465 kc/s IF it is usually in the range 300-500pF.

Alignment of the IF transformers is more difficult without a signal generator; however, as long as a tuning indicator is available this may be accomplished thus—Take a strong signal, say the Home Service on 908 kc/s. If the IF is 465 kc/s a bandwidth of 20 kc/s is required, i.e., 455-475 kc/s. A signal at any position within this range may be derived by swinging the tuning dial from 898 kc/s to 918 kc/s, when the oscillator frequency swings from (898+465) kc/s to (918+465) kc/s. However, the signal frequency remains constant at 908 kc/s. Thus the mixer output varies from (898+465)-908 kc/s to (918+465)-908 kc/s=455-475 kc/s. Points corresponding

to these frequencies are marked on the dial in pencil and the IF coils detuned in such a way that when the dial is swung between the two marks the output is sensibly constant and falls off rapidly beyond them. The IF transformers should be detuned so as to give each a symmetrical pass band. The first IF transformer should be detuned to a greater extent than the second, by increasing the capacitance of one trimmer and decreasing the other or screwing in and out the corresponding dust cores. Damping may be added if necessary. Alignment is facilitated by a signal generator or preferably a wobblator and oscilloscope.

If the IF transformers have variable coupling, the first IFT should be set to loose coupling, aligned for maximum signal, and then set to close coupling giving the doubled humped response curve. The sag between the humps is filled in by the second IFT, giving a square pass band.

References

- (1) COCKING, W. T. Diode Detector Distortion, *Wireless World*, May 1951.
- (2) DAVIDSON, R. R.F. Characteristics of Capacitors, *Wireless World*, August 1952.

PORTABLE 20 MILLIWATT TRANSISTOR TRANSMITTER

A MINIATURE FOOL-PROOF crystal controlled portable radio transmitter using two GEC crystal triodes or transistors has been designed and constructed by Mr. Douglas Walters (G5CV) of Godalming, Surrey.

This is believed to be the first no-valve and probably the lowest power transmitter yet used in this country.

The transmitter, which is completely self-contained with its own battery, is housed in a cast aluminium case measuring 4½"×2"×3½". There are no switches or tuning controls except for one recessed pre-set control. The transmitter is switched on by the press-to-talk switch on the carbon microphone, which is connected to the transmitter by a short length of three-way cable.

The sole power supply is a miniature 22½ volt deaf aid type battery. The power of the transmitter, on CW (excluding the modulator) varies between 10-20 milliwatts—that is to say, between 1/100 and 1/50 of a watt.

At present, the transmitter is crystal

controlled on 3608 kc/s and the aerial is a 4ft "whip." Despite this low frequency and the fact that the aerial is non-resonant, clear speech was received from the transmitter at a distance of half-a-mile from a well-known radio factory in Essex, when it was demonstrated a few days ago. The set was held in the hand so that the aerial was only a few feet above ground.

During the test with G6BZ of Guildford, CW (by keying the press-to-talk switch of the microphone) was received over a measured distance of over ¾ mile, with much screening in between.

This transistor transmitter has been demonstrated to high officials from Scotland Yard and several radio firms are interested. Enquiries have also been received from the entertainment world.

Within the next three months it is intended that a VHF version will be ready for field tests.

In view of the lilliputian size and power of this little set, reports of reception of signals from G5CV/P would be greatly appreciated (address them to Radio G5CV, Godalming, Surrey).

BOOK REVIEWS

BASIC ELECTRONIC TEST INSTRUMENTS by Rufus P. Turner. 254 pages, 39 illustrations, 131 diagrams. Price \$4.00. Published by Rinehart Books Inc., New York and Toronto.

Obtainable in England, price 32s, from The Modern Book Co. (Dept. RC), 19-23 Praed Street, Paddington, London, W.2.

There are few books of this type available in this country. Even though this one is of American origin, it contains a wealth of information about many useful pieces of test equipment that will be of interest to English readers. A prominent feature is the large number of circuit diagrams that are complete in every detail, and the copious notes concerning calibration and use of most of the test instruments described.

Containing sixteen chapters, the book covers quite a wide field. The author has succeeded in presenting a large amount of subject matter from pointer instruments to specialized laboratory equipment in a manner that makes delightful yet informative reading. The first two chapters are concerned with the principles and practical considerations of pointer instruments for measuring voltage, current and resistance, and multi-range meters for both AC and DC.

In the next chapter there are details of various types of valve-voltmeter. This is followed by a short section on testers for power output measurement. Next come a few pages on impedance meters. The two ensuing chapters deal with capacitance and inductance bridges, the latter containing also some details of Q-meters.

In the eighth chapter are several pieces of specialized equipment such as precision resistance bridges, skeleton R-C-L and impedance bridges, a signal source oscillator, and high-gain null indicators with and without peaking-amplifiers. There is also a short note on the use of the CRO as a null indicator.

General-purpose and wide-band oscilloscopes are covered in the next chapter, which also contains information on their uses for servicing and alignment of AM, FM and TV receivers. An electronic switch for producing two displays on the CRO, and a voltage calibrator, are also described.

Signal generators with amplitude and frequency modulation, a frequency marker and a TV pattern generator appear in the next chapter. Following this, audio signal generators are discussed. In the twelfth chapter, devoted to the measurement of radio frequencies, such items as absorption wavemeters, grid-dip oscillators, frequency sub-standards and heterodyne frequency meters are included. The measurement of audio frequencies is discussed in the following chapter.

Devices for testing audio amplifiers, discussed upon in the fourteenth chapter, include distortion meters, wave analyzers and square-wave generators. The measurement of inter-modulation distortion is also mentioned. The penultimate chapter embraces signal tracers, while a short discussion on the principles of operation of valve-characteristic testers forms the subject of the sixteenth and last chapter. A useful Index is included.

This book impresses the reader favourably in many ways, and is considered good value for money. Not the least of its virtues is that very few errors exist; the most noticeable is the shunt rectifier in Fig. 1-11, drawn so that it conducts in the wrong direction, while in Fig. 11-3 the switch contact joined to the junction of C1-C3 should be drawn so that it touches the moving arc of the Range switch, S1. The clear type, neat diagrams and needle-sharp photographs are in keeping with the quality of the paper and binding. It should command a place among one's reference books, for without it a collection of technical data would be incomplete.

NORMAN CASTLE

UHF ANTENNAS, CONVERTERS AND TUNERS. Published by Howard J. Sams and Co. Inc., and exported by Ad Auriema, Inc., 89 Broad Street, New York 4, N.Y., U.S.A.

With the much discussed sponsored and alternative BBC TV transmissions to ponder on, the arrival of this book may be said to be very timely. Technicians and amateurs alike will at this time be devoting a lot of thought to the subject of UHF and its attendant difficulties.

In the United States, sufficient time has elapsed since the inauguration of these TV frequencies for any teething troubles to be satisfactorily overcome. It would seem reasonable to suppose that if television of this nature ever opens up in this country, technicians are likely to take advantage of the pioneering undertaken across the Atlantic.

This book will provide much useful information. A great many types of aerials, such as the Helical, the Horn, and the Rhombic, are described. Adequate data is provided to enable experiments to be undertaken.

Transmission Lines and Matching Networks for accurate connection of the aerial to the converter are also described. Tuned Lines, Butterfly Tuners, and descriptions of ten commercially made converters are included.

Undoubtedly a most useful book, it is available in this country from the Modern Book Co., 19-23 Praed Street, London, W.2., price 12s 6d.

A S T

THE RADIO CONSTRUCTOR

DATA publications

LIMITED

57 MAIDA VALE LONDON W9

Telephone CUNningham 6518

ORDER FORM

Please supply the following

	Price	Postage	Qty.
DATA BOOK SERIES			
D.B.4. INEXPENSIVE TELEVISION	2/6	2d	<input type="checkbox"/>
D.B.5. T.V. FAULT FINDING	5/-	3d	<input type="checkbox"/>
D.B.6. THE RADIO AMATEUR OPERATOR'S HANDBOOK.	2/6	2d	<input type="checkbox"/>
D.B.7. RECEIVERS, PRESELECTORS AND CONVERTERS	2/6	2d	<input type="checkbox"/>
D.B.8. TAPE AND WIRE RECORDING	2/6	2d	<input type="checkbox"/>
MISCELLANEOUS BOOKS			
WORLD RADIO HANDBOOK (Johansen)	8/6	3d	<input type="checkbox"/>
HOW TO LISTEN TO THE WORLD (Johansen)	1/9	2d	<input type="checkbox"/>
RECEIVERS (R.S.G.B.)	3/6	2d	<input type="checkbox"/>
SIMPLE TX EQUIPMENT (R.S.G.B.)	2/-	2d	<input type="checkbox"/>
T.V. PICTURE FAULTS (T.V. Times)	3/6	3d	<input type="checkbox"/>
THE RADIO AMATEUR'S REPORT PAD (Data Publications)	3/6	3d	<input type="checkbox"/>
MAGAZINES			
THE RADIO CONSTRUCTOR monthly	1/6	2d	<input type="checkbox"/>
" " " 6 months sub.	9/-	paid	<input type="checkbox"/>
" " " 12 months sub.	18/-	paid	<input type="checkbox"/>

PLEASE TICK SUBSCRIPTIONS REQUIRED AND STATE FIRST ISSUE BELOW

Enclosed find Cheque/Postal Order/International Money Order £.....

NAME PLEASE
USE
ADDRESS BLOCK
CAPITALS

ALL OUR PUBLICATIONS ARE AVAILABLE THROUGH
YOUR LOCAL NEWSAGENT

TRADE TERMS AVAILABLE ON REQUEST



POST THE COUPON TODAY FOR OUR BROCHURE ON THE LATEST METHODS OF HOME TRAINING FOR OVER 150 CAREERS & HOBBIES

PRIVATE AND INDIVIDUAL TUITION IN YOUR OWN HOME

City and Guilds Grouped Certificates in Telecommunications: A.M. Brit. I.R.E. Examination, Radio Amateur's Licence, Radio and Television Servicing Certificates, General Radio and Television Courses, Radar, Sound Recording, etc. Also Courses in all other branches of Engineering and Commerce.

The advantages of E.M.I. training.

★ The teaching methods are planned to meet modern industrial requirements. ★ We offer training in all subjects which provide lucrative jobs or interesting hobbies. ★ A tutor is personally allotted by name to ensure private and individual tuition. ★ Free advice covering all aspects of training is given to students before and after enrolling with us.

Courses from £1 per month

EMI INSTITUTES

The only Postal College which is part of a world-wide Industrial Organisation.

POST THIS COUPON TODAY

Please send without obligation your FREE book. E.M.I. INSTITUTES, Dept. 179K, 43 Grove Park Road, London, W.4. Phone: Chiswick 4417/8.

NAME _____
ADDRESS _____
SUBJECT(S) OF INTEREST _____

IC18

Benson's Better Bargains

VALVES: IS4, IT4, IS5, IR5, at 9/-; VR65, VR66, VUI11, 9004, 9006, VR21, CV6, VUI20, CV54, 6H6, at 3/6; 6AG5, 6BBM, 6J5M, (GT), 6N7M, 12S17, 12SR7, KT44, 12A6, EF54, EC52, CV66, AC6/Pen, SG215, Pen 46, 1625, ATP4, 9002, 6K7, SP4, KT2, 6L7M, 12SC7, EBC33, EK32, PM256, 721A, VS10A, NGT1 at 7/6; 6B7, CV181, 210VPT, VR150/30 at 8/6; 12SK7, 954, 955, 956B, 9D2, EF39, EF50, ARP12, 6SH7, 9001, MH4, ML6, 77, 78, RK34, NT37, VS70, 6C4, 12SH7, 717A at 5/6; EA50 7193, 12H6, EB34 at 2/6; UCH42, ECL80, PM240, 6SN7, 6A6G, KT33C, MUI2/14, 6Q7G, 6F6G at 10/-; 12AT7, 6AK5, PT15 at 12/6. NEONS, SBC/DCc. 100v. 2/-. Coilformers 2in.x1in. 4 for 1/- VHF Rx. Ex-Police. 10x8x7ins. Grey enamel case, with 10 valves, 45/- (carr. 5/-). Chassis only, 10/-, plus carr. less xtal and power supplies. **IF AMP. No. 178** with 5/IFTs. 7/VR65, EA50, 27/-, **R161A**, VHF converter, with 2/VR136, CV66, VR137, 22/-.

NEW TRANSFORMERS: 250-0-250v. 80ma. 6v. and 5v., 18/6; 350v. similar, 19/-; fully shrouded (Woden, Varley) 350v. 21/-.

VITREOUS Resistors 21k 15w. 3k 30w. 30k 25w. 400u 25w. 500u 5w. 7K tap 2k 25w. 15k 25w. 2.7k. 10w. 30Ω. 30w. 20k 50w. 350u 60w. at 1/-, 1k 100w. 16+2+2μ 120w. 20k 120w. at 2/- Var. wirewound 8u 50w. 500u 15w. 100u 5w. 1,850u 10w. 20k 10w. at 3/6, 1K30w. 6/6. **METAL RECTIFIERS, HW** 270v 80ma. 6/-, 560v. 100ma. 7/6; 600v. 30ma. 6/-; meter type bridge, 5/6. **FW** 75v. 80ma. 5/-, 30v. 60ma. 3/-.

GENERATORS: hand: driven, geared, 300v. and 28v. outputs, 9/-.

DYNAMOTORS: 9v. DC to 450v. 8/6, TR1196 Rx-type 24v. 7/6, 6v. DC to 250v., 10/6. **Vibrapacks:** 12v. DC to 150v. 30ma. 13/6. **CERAMICONS** at 5/- doz. 2.2, 3, 5.6, 6.8, 10, 12, 15, 22, 27, 33, 39, 40, 47 and 100pfs.

YAXLEYS: 3P3W2B, 2P4V4B, 1P6V2B, at 2/9; 4P2W at 1/3. **BOXES,** Test, with 0/10ma 31in. Fl, Mc Meter Grey metal 11/6. **CHOKES, RF** 4 pie,

Bulgin, 9d.; RF 1.5mH 250ma (Eddystone type). 1/3. **CONDENSERS (Variable),** 75pf. Twin Ceramic, 4/-; 75pf. Double spindle (as RF26), 2/-; or long spindle, 1/6; 500 pf. 4 gang, 8/6; 500pf. twin, 5/6.

Scale	FSD	Size	Type	Fitting	Price
5mA	...	2in.	MC	Square	7/-
10mA	...	2½in.	MC	Flush R.	10/6
30mA	...	2in.	MC	Proj. R.	8/-
100mA	...	2½in.	MC	Flush R.	8/-
300mA	...	2½in.	MC	Flush R.	9/-
300mA (100ma)	...	2in.	MC	Square	7/-
500mA	...	2½in.	MC	Flush R.	9/-
1A	...	2½in.	TC	Fl. or proj.	8/-
3	...	2in.	TC	Square	7/-
6A	...	2½in.	TC	Flush R.	8/-
20A	...	2½in.	MI	Flush R.	10/6
30A	...	2½in.	MC	Proj.	8/-
50A	...	6in.	MI	Proj. Met.	30/-
20-0-20A	...	2in.	MC	Square	8/-
Freq. 45-55c	...	7in.	230v.	Proj. Met.	75/-
500uA (6ma)	...	2½in.	MC/TC	Flush R. Met	17/6
15v.	...	2½in.	MI	Flush R.	10/6
15-0-15v.	...	2½in.	MC	Flush R.	10/6
150v.	...	2½in.	MC	Flush R.	10/6
2,500v.	...	2½in.	EI.	Flush R.	30/-
3,500v. (5mA)	...	3½in.	MC	Proj.	17/6

CHOKES RF 4 pie Rx, 9d.; Tx 250mA, 1/-.

MOTORS. Collaro AC37 Gram. 110/250v. A.C. var. speed, ½in. dia. spindle, 30/-.

R.F. UNITS type 24, 21/-; 25, 25/-; 27, 40/-.

List and enquiries, S.A.E. please!
Terms Cash with order. Postage extra.
Immediate delivery

Callers and Post Callers only
W. A. BENSON (RC), SUPERADIO, LTD.,
308 Rathbone Rd., 116 Whitechapel,
Liverpool L3 5TO 1604. Liverpool ROY 1120

THE MODERN BOOK CO.

Communications Receiver Manual: CR2. Price 27s. 6d. Postage 1s.

Audio Anthology: Parts I & II. Compiled by *Audio Engineering.* Price 16s. 0d. each. Postage 9d.

Wireless World Television Receiver: Model 2. Price 3s. 6d. Postage 3d.

Radio Designer's Handbook. By F. Langford-Smith. Price 42s. 0d. Postage 1s.

The Radio Amateur's Handbook. By A.R.R.L. Price 30s. 0d.. Postage 1s.

Remote Control by Radio. By A. H. Bruinsma. Price 8s. 6d. Postage 4d.

The Williamson Amplifier. By D. T. N. Williamson. Price 3s. 6d. Postage 3d.

Sound Reproduction. By G. A. Briggs. Price 17s. 6d. Postage 6d.

TV Fault Finding: Data Book No. 5. Price 5s. 0d. Postage 3d.

Tape and Wire Recording: Data Book No. 8. Price 2s. 6d. Postage 2d.

Receivers, Pre-Selectors and Converters: Data Book No. 7. Price 2s. 6d. Postage 2d.

Radio & Television Valve Equivalents Manual. By B. Babani. Price 3s. 6d. Postage 3d.

Osram Valve Manual: Part II. Price 10s. 0d. Postage 6d.

Radio Valve Data. By *Wireless World.* Price 3s. 6d. Postage 3d.

The Amateur's Guide to Valve Selection. By Mullard. Price 1s. 6d. Postage 2d.

Introduction to Valves. By R. W. Hallows and H. K. Milward. Price 8s. 6d. Postage 6d.

Magnetic Recording. By S. J. Begun. Price 25s. Postage 9d.

Magnetic Recording. By M. L. Quartermaine. Price 4s. 6d. Postage 3d.

Sound Recording and Reproduction. By J. W. Godfrey and S. W. Amos. Price 30s. Postage 9d.

Magnetic Tape Recording. By P. A. Tarry. Price 6s. 6d. Postage 6d.

The Recording and Reproduction of Sound. By O. Read. Price 64s. Postage 1s.

Practical Wireless Encyclopaedia. By F. J. Camm. Price 21s. Postage 9d.

Amplifier Circuits. By N. H. Crowhurst. Price 2s. 6d. Postage 2d.

Amplifiers. By G. A. Briggs and H. H. Garner. Price 15s. 6d. Postage 6d.

Amplifiers. By N. H. Crowhurst. Price 3s. 6d. Postage 3d.

Loudspeakers. By G. A. Briggs. Price 7s. 6d. Postage 4d.

Television Engineers' Servicing Manual. By E. Molloy (Ed.). Price 42s. Postage 1s.

Radio Engineers' Servicing Manual. By E. Molloy (Ed.). Price 42s. Postage 1s.

We have the finest selection of British and American radio publications in the Country. Complete list on application.

19-23 PRAED STREET (Dept. RC) LONDON W2

Telephone PADDINGTON 4185

ELECTROLYTIC CONDENSERS

8 mfd. 450 v.w.	1/9	16+16 mfd. 500 v.w.	4/6
8 mfd. 500 v.w.	2/3	16+32 mfd. 450 v.w.	4/9
16 mfd. 350 v.w.	2/3	32+100 mfd. 450 v.w.	7/6
16 mfd. 500 v.w.	3/3	60+100 mfd. 350 v.w.	7/6
32 mfd. 500 v.w.	5/11	BIAS	
50 mfd. 350 v.w.	4/6	25 mfd. 25 v.w.	1/6
60 mfd. 350 v.w.	3/6	50 mfd. 12 v.w.	1/3
250 mfd. 350 v.w.	4/11	50 mfd. 50 v.w.	1/9
8+8mfd. 450 v.w.	3/11	75 mfd. 12 v.w.	1/-
8+16 mfd. 500 v.w.	4/6		
12+12 mfd. 350 v.w.	2/6		

ALL BRAND NEW AND GUARANTEED (NOT EX-GOVT.)

All other types, Paper, Tubular, Waxed, etc., in stock

SPECIAL C.R.T. OFFER

Brand new and unused 12in ion trap cathode ray tubes, 6.3 volt heater, 7-9 Kv. E.H.T. 35 mm. neck. Black and white picture.

By Famous Manufacturer
PERFECT £12/19/6
Carriage and insurance 15/- per tube extra.

GERMANIUM CRYSTAL DIODES

1/6 each

DINGHY AERIALS

Wire mesh construction with reflector. Ideal for T.V. and V.H.F. reception, also transmitting.

LASKY'S PRICE 6/-
POST FREE

VCR97 C.R. TUBES

New unused, 35/- Carriage 5/-

EHT Transformer

For VCR97, 45/-

SCREEN ENLARGER

For VCR97. Filter type, 17/6. Postage 2/6.

E.H.T. Condensers

1 mfd. 3Kv. 3/6
1 mfd. 2.5 Kv. 2/6

MICROPHONE STANDS

Table model. 2-section chrome plated. Crackle finish base . . . 17/6
Floor model, 2-section. Brass, heavily chrome plated . . . 59/6
Carriage 2/6 extra

SOLON SOLDERING IRONS

220-250 volts. Latest model instrument iron . . . 19/8
Standard model . . . 19/-

SPECIAL BRAND NEW T.C.C. T.V. CONDENSERS

32+100 mfd. 450 v.w. Type CE15PE . . . Price 7/6
.04 mfd. 12.5Kv. Type CP59VO Visconol . . . Price 7/6

LARGE SCREEN T.V.

Every component in stock for the Magnaview, Tele-King, Viewmaster and Universal television receivers, including all cathode ray tubes and valves.

9 INCH TABLE T.V. CABINETS

Medium shade mahogany finish. Complete with back safety glass, speaker-fret. Internal dimensions: 19 1/2 in high, 16 in wide, 14 in deep. LASKY'S PRICE 39/6. Carriage 7/6 extra. Adaptor frame available for 6in c.r. tubes. The aperture can easily be enlarged for 12 or 14in c.r. tubes.

A.C. MAINS GRAM MOTORS—Synchronous Shaded Pole. For use on 200-250 volts, 50 c.p.s. Rim and belt drive type. 9/6 each. MANY USES.

PORTABLE TAPE RECORDER CABINETS

Strong wood construction, finished in attractive cream covering, with carrying handle and two chrome plated locks. Hinged lid. Internal dimensions: 15in long, 10in wide, 7in high. Soiled condition. LASKY'S PRICE 25/-, Carriage 5/- extra.

THE "UNIVERSAL" LARGE SCREEN AC/DC TELEVISOR

by A. S. Torrance, A.M.I.P.R.E., A.M.T.S. A 28 page booklet giving full instructions for building a large 17 inch screen televisor. *AC & DC Mains. *PM focusing. *Mullard Valves and CR Tube *Five-channel Superhet *Table Model *Convertible into Radio-gram console *Incorporates all latest developments. Reprinted from the Radio Constructor 3d post free.

I.F. TRANSFORMERS

Midget. 465Kc/s. Iron dust cores. In can size: 1 x 1 1/2 x 2 1/2 in high. 9/6 pair. Wearite type 500. 450-470 Kc/s. Dust core compression trimmer tuned. In can, size: 1 1/2 in sq. x 3 1/2 in high. 10/- pair. Wearite type 550. 445-520 Kc/s. Permeability tuned. In can, size as for 500 type. 10/- pair.

CRT Rr. neck protectors 2/6

R.I132A RECEIVERS

With all valves. Brand New . . . 79/6
Store Soiled . . . 49/6
Second Hand . . . 39/6
Carriage 10/- extra.

TAPE RECORDER AMPLIFIERS

Fully assembled, with 6 valves: 2 6V6, 2 6J7, 1 6J5, 1 5Z4. Also 5-inch p.m. speaker. Although brand new, these amplifiers are untested. LASKY'S PRICE £7/15/0. Carriage 10/- extra.

SAVE CASH ON RECORD CHANGERS

No. 1 3-speed, twin head Collaro automatic record changers. Brand new in maker's original cartons. Fully guaranteed. Complete with two high quality crystal heads. Lasky's price £9/19/6. Carriage 3/6 extra. No. 2 Famous name 3-speed automatic record changers. Turnover pick-up head. Brand new in maker's original cartons. Plays mixed 7, 10 and 12 inch records. Listed £16/10/0. Auto-change on all speeds. Lasky's price £11/10/0. Carriage 3/6 extra.

TANNOY PRESSURE UNITS

10 watts. 7.5-ohms impedance. Last few only. Price 59/6. Carriage 3/6 extra.



CATHODE RAY TUBES MASKS

New aspect ratio.

9in cream	7/-
10in Double D	7/6
12in	15/-
12in Flat face	15/-
12in Old ratio	9/6
14in Rect.	21/-
16in Double D	25/-
17in Rect.	21/-
12in Soiled	7/6
12in Soiled. Cream, with safety glass	11/6
12in Soiled. Black, with safety glass	8/6

15 INCH CATHODE RAY TUBE MASKS

Cream rubber. Latest aspect ratio. Overall dimensions: 17in wide, 13in high. Price 17/6. Postage 2/- extra.

ARMOUR PLATE GLASS

9 x 8 x 1/4-inch	3/-
13 x 10 x 1/4-inch	4/-
16 x 13 x 1/4-inch	6/11
17 1/2 x 15 1/2 x 1/4-inch	7/11

DARK SCREEN FILTERS (LATEST TINT)

18 x 14 1/2 in	25/-
14 1/2 x 12 1/2 in	19/6
13 1/2 x 11 in	14/11

PERSPEX

13 1/2 in x 10 1/2 in x 1/8 in. Natural shade, slightly marked. 4/11 per piece.

SMALL ADVERTISEMENTS

Readers' small advertisements will be accepted at 2d per word, minimum charge 2/- . Trade advertisements will be accepted at 6d per word, minimum charge 6/- . If a Box Number is required, an additional charge of 1/- will be made. Terms: Cash with order. All copy must be in hand by the 5th of the month for insertion in the following month's issue.

PRIVATE

EXCHANGE Pilot "Blue Peter" Receiver, 4 waveband including Trawlers, 6 months old for Communication Receiver to value of approx. £25. Box No. C141.

R1116A Battery Communication Receiver covering 172 kcs to 20 mcs, complete with power pack and loud speaker, £8 o.n.o. Moore, 33 Jackson Road, Clacton-on-Sea, Essex.

HAMMARLUND HQ-129-X post-war Rx, separate bandspread on ham bands, built in 100 kcs calibrator, speaker, mint condition, bargain, £45. Box No. C143.

AMATEUR SELLING UP. 1155 modified with S meter, noise limiter, power pack output stage and speaker. Realigned, fine appearance, £15. R103A with internal AC power pack with S meter and speaker. All new Mullard valves, £10. BC342N chassis complete with valves and xtal but without front panel and power pack. Needs some re-wiring, £5. 100-1000 kcs mains Xtal Oscillator, can be fitted to any radio. Spot on, £2/10/0. If desired —£30 the lot or offers. Chapman, 62 Tagwell Road, Droitwich Spa, Worcs.

EDDYSTONE S640, perfect condition, Instruction book. 41 Appleton Street, Northwich, Cheshire.

FOR SALE Eddystone 680 receiver, mint condition. Reeve, 6 Manor Mount, Forest Hill, London. Telephone FOR 0231.

RX R107, 28 mcs converter, speakers, Radiocraft Dx2 Rx, phones. Offers, lot or separate. H. James, 448 East Prescott Road, Liverpool.

FOR SALE Eddystone 740 with S meter. Tx, CO/PA, 160/80 CW, in TUB case with internal power pack (Woden transformer) and built in volt and mA meters. All in excellent condition. Inspection welcomed. Offers—G3GYR, 6 Council Houses, Rode Heath, Stoke-on-Trent, Staffs.

WIRELESS SET 48, Transmitter/Receiver, good condition, covers 33-50 metres. Complete equipment for Phone/CW plus ten spare valves, hand generator. Ideal for Field Days. Benton, 11 Paines Lane, Pinner, Middlesex.

WAVEMASTER 34" Cabin Cruiser Kit, ideal for radio control—unwanted gift, £2/10/0. Mrs. Carter, 25 Inglis Road, Ealing, London, W.5.

EXCHANGE Surplus Equipment for record player, receiver, anything. SAE. Box No. C142.

WANTED Short Wave News January-June 1950 (inclusive); March 1952. Monitor January 1952. Short Wave Listener January 1951. Prices to Coppel, 540 Antrim Road, Belfast.

WANTED 2 RF Coils for R1155A, 16-40 metres Nos. 10D/1643 and 40-100 metres Nos. 10D/955. Rowe, 136 Hillfoot Avenue, Liverpool 19.

SALE. Service Sheets 2/- each plus SAE. List 1/- plus SAE. Ratel, 171 Norris Street, Preston, Lancs.

Kendall and Mousley

Electronic Engineers and Laboratory Equipment Manufacturers

99 DUDLEY PORT, TIPTON, STAFFS.

Instrument cases in 18G steel, complete with light alloy front panel Colours Black (Red and Green 10 per cent extra). Back punched for ventilation. 8"x9"x8" at 18/-, 10 1/2"x12"x10 1/2" at 21/- . Chassis to suit 7" square by 2 1/2" deep (16G Light alloy, four sides) 7/6. Chassis to suit 10" square by 2 1/2" deep (16G Light alloy, four sides) 10/6. Heavier steel case in 20G steel complete with 18G alloy front panel, finished in Black (Red or Green 10 per cent extra). Back punched for ventilation, 9"x12"x9" at 30/-, chassis for same 10"x8"x2 1/2" (reinforced corners) at 10/6 each. Case complete with chassis and panel £2.0.0 Meter stands, ends only, 2/6 per pair, panel for same 6" square at 1/9, 9"x6" at 2/6 and 12"x6" at 3/3. Meters can be mounted at extra cost if required. A full range of components, by well known manufacturers, are stocked, Mullard, Brimar, Cossor, T.C.C., Dubilier, Erie, R.E.P., Wearite, Elstone, Morganite, etc. High stability 1, 2 and 5 per cent resistors available from stock or to order.

Just Released . . .

"TAPE & WIRE RECORDING" DATA BOOK No. 8

A selection of articles from the Radio Constructor and the Radio Amateur COVERING BOTH THEORY & PRACTICE

48pp. • Price 2/6 • Post 2d.

Available at your Bookstall or direct from:
DATA PUBLICATIONS LTD.,
57 MAIDA VALE, LONDON, W.9

VALVES—OVER 3,000 IN STOCK

12E1, 85A1, 85A2, 15/- . CV284, 2D21, VR150, 10/-
12AU7, 12AT7, 6SN7, 807, EC91, 6V6, 6BW6,
6CH6, 9/- . 616, EF91, 6S17, 12AX7, 6SL7, EL91,
6F33, EY91, 7/- . 6AL5, 6CA, EF92, EAC91, 6/-

SKILLMAN STREET WEYMOUTH

LASKY'S RADIO

Lasky's (Harrow Road) Ltd. 370 HARROW RD PADDINGTON LONDON W9

(Opposite Paddington Hospital) Telephones CUNningham 1979 and 7214. All Departments. Hours Mon. to Sat. 9.30 a.m. to 6 p.m., Thurs. half day 1 p.m.

MAIN ORDER & DESPATCH DEPARTMENTS 485/487 Harrow Road Paddington London W10
Terms Pro Forma, Cash with Order, or C.O.D. on post items only. Postage and packing on orders value £1—
1/- extra, £5—2/- extra, £10—3/6 extra. Over £10 carriage free. All goods fully insured in transit.

[continued on page 239]

ADCOLA (Regd. Trade Mark) SOLDERING INSTRUMENTS

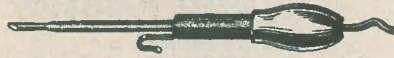

Reg. Design No. 860302 (British, U.S. and Foreign Patents)

Designed for wireless assembly and Maintenance

Supplied for all volt ranges from 6/7v to 230/250v 3/16" Dia. Bit Standard Model 25/6

Sole Manufacturers **ADCOLA PRODUCTS LTD.**

Sales Office and Works Cranmer Court, Clapham High St. London SW4 (MAC 4272)

VALVES NEW TESTED AND GUARANTEED

IR5	7/9	6F6g	8/6	6SA7	7/6	6V6g	8/6
IS5	7/9	6F12	7/6	6SG7	6/6	6V6gt	8/6
IT4	7/9	6G6	5/9	6SK7	6/9	8D3	7/6
IS4	7/9	6J5g	4/6	6SL7	8/6	12AT7	7/9
3S4	7/9	6K7g	4/6	6SQ7	7/6	12AX7	5/9
3V4	7/9	6K7	6/6	6X4	8/6	57	6/9
5U4g	8/6	6K8gt	8/6	6X5	7/6	954	2/-
5Z4g	8/9	6K8g	8/9	7C7	7/9	2C34	2/-
6AM6	17/6	6Q7g	8/9	7H7	6/9	EB91	6/6

MATCHED PAIRS 6V6g and gt 17/-; 6F6G 17/-; 807 15/6; 6G6 12/-; 6J5g 9/6 per pair P. and P. 6d per valve

R. COOPER

32 SOUTH END CROYDON SURREY
Telephone CROYdon 9186

COLLARO 3-SPEED RECORD CHANGER

RC3/521. Complete with 2 Crystal Heads. £9/19/6. Carriage paid.

PYE 45 Mc/s STRIP. Type 3583 Units. Size 15" x 8" x 2". Complete with 45 mc/s Pye Strip, 12 valves 10 EF50, EB34 and EA50, volume controls and hosts of Resistors and Condensers. Sound and vision can be incorporated on this chassis with minimum space. New condition. Modification data supplied. Price £5, carriage paid

PHOTO-CELLS

25/- each
G.E.C. CMG.25 90 volts
BAIRD GS18 90 volts
U.S.A. 71A 90 volts
Brand New and Boxed

INDICATOR UNIT

TYPE 182A. This unit contains VCR517 Cathode Ray 6" Tube, complete with Mu-Metal Screen, 3 EF50, 4 SP61 and 1 5U4G valves, 9 wire-wound volume controls and quantity of Resistors and Condensers. Suitable either for basis of Television (full picture guaranteed) or Oscilloscope. Offered BRAND NEW (less relay) in original packing case at 67/6. Plus 7/6 carriage.

VCR517C Blue and White 6 1/2 in. Tube.

This Tube replaces the VCR517 and VCR517 without alteration and gives a full Blue and White picture. Brand new in original crates, 35/-, carriage free.

HENRY'S

We have over 20,000 American and B.V.A. valves in stock.

ALL VALVES NEW AND GUARANTEED

OE4A	7/-	6Q7GT	8/6	9001	6/-	U17	10/-
IG6	6/6	6S17GT	8/6	9002	6/-	U19	10/-
IR5	8/-	6R7	8/6	9003	6/-	Y63	8/6
IS4	8/-	6X5G	8/6	9004	6/-	P2	4/-
IS5	8/-	6SA7GT	8/6	9006	6/-	MU14	8/6
IT4	8/-	6SQ7GT	8/6	954	6/-	PX25	12/6
1A7GT	10/-	6SG7	7/6	955	6/-	KT33C	10/-
IC5	8/-	6SH7M	7/6	956	6/-	KT66	12/6
ILN5	8/-	6SK7GT	7/6	1299A	7/6	GU50	12/6
2X2	5/-	6SL7GT	9/-	TZ40	37/6	XP(2v)	4/-
3V4	8/-	6SN7GT	9/-	931A	5/0	XH(1.5)	4/-
3S4	8/-	6SC7	10/-	EA50	2/-	VU111	4/-
5Z3	8/6	6SS7	7/6	EF54	4/-	VU133	4/-
5U4	8/6	6V6GT	7/6	(VR)316	6/-	VU120A	4/-
5Z4	8/6	7C5	8/6	EF55	12/6	CV54	5/-
6A7G	8/6	7A7	8/6	EB34	3/6	S130	7/6
6AC7	6/6	7C7	8/6	EBC33	8/6	7475(VS70)	
6AG5	7/6	7H7	8/6	EF36	6/6	CV66	6/-
6A8G	8/6	7B7	8/6	EF39	6/6	VR150/308	6/-
6AM6	9/-	7S7	10/-	EK32	6/6	CK510AX5	-
6B8	7/6	12A6	7/6	EF91	9/-	DI	2/-
6C4	8/6	12C8	7/6	EL32	7/6	AC6PEN	6/6
6C5GT	5/-	12H6	8/6	EF50	8/6	AC5/	
6C6	6/6	12K7GT	8/6	EF50 (Red.)		PENDD	12/6
6D6	6/6	12K8GT	8/6	EF50 (Syl.)	10/-	PEN25	6/6
6F6G	8/6	12Q7GT	8/6	EF50		PEN46	7/6
6G6G	6/6	12SA7GT	8/6			QP25	6/6
6H6MT	5/-	12SQ7GT	8/6	(Ex-Units)		QP230	8/-
6H6M	8/6	12SG7	7/6	SP2	8/6	SP61	4/-
6J5MT	5/-	12SH7	7/6	VP2	8/6	SP41	4/-
6J5M	8/6	12SJ7	8/6	TDD2A	8/6	HL23/DD6	6/-
6J6	9/-	12SK7	8/6	DK40	9/-	TP25	5/-
6KA5	9/-	12SR7	7/6	UL41	9/-	VP23	6/6
6J7M	6/6	14A7	8/6	UY41	9/-	VP41	7/6
6K6	9/-	25Z6GT	8/6	4D1	4/-	U22	8/6
6K7G	6/6	25Z5	8/6	8D2	4/-	ATP4	4/-
6K7M	7/6	35Z4GT	8/6	9D2	4/-	TP22	8/6
6K8G	9/-	25A6	8/6	15D2	10/-	TH233	10/-
6K8GT	9/-	35L6	8/6	R3	8/6	41MP	7/6
6L6G	8/6	50L6GT	8/6	D41	5/-	42SPT	6/-
1622	11/-	43	8/6	D42	5/-	2155G	4/-
6U5	7/6	75	8/6	D63	5/-	MS/PENB	
6U5G	7/6	78	8/6	KT2	5/-		
6L7	7/6	80	8/6	KT61	8/6		
6N7GT	7/6	866A	15/-	KTV61	7/6		
				U52	8/6	VT501	7/6

SETS OF VALVES

Ten EF50 (Ex-Set Brand New Units)
5/- each ... 45/-
6K8G, 6K7G, 6Q7G, 5Z4G, 6V6G (or KT61) ... 37/6
IR5, IS5, IT4, IS4 or (3S4 or 3V4) ... 30/-
TP25, HL23/DD, VP23 PEN25 (or QP25) ... 25/-
6K8G, 6K7G, 6Q7G, 25A6G, 25Z5 or 25Z6G ... 27/6
12K8GT, 12K7GT, 12Q7GT, 35Z4GT, 35L6GT or 50L6GT ... 37/6
12SA7GT, 12SQ7GT, 12SK7GT, 12S7GT, 35Z4GT, 35L6GT or 50L6GT ... 37/6
PX25, KT33C, Each KT66, GU50 ... 12/6
PX25's Matched Pair Pairs ... 25/-
TEN 6AM6 (EF91), 80/-

RECEIVER R1355.

As specified for "Inexpensive Television." Complete with 8 valves VR65 and 1 each 5U4G, VU120, VR92, Only 29/-, carriage 5/- Or Brand New in original packing case, 55/-, plus 5/- carriage.
RF24, 25/-; RF25, 25/-; RF26, 59/6; RF27, 59/6.

SHADED POLE MOTORS.

200/250 v. AC Ideal for Tape Decks, etc. ... 10/6

25/73 TR 1196 RECEIVER UNIT.

Complete with 6 valves. 2 EF36, 2 EF39, 1 EK32, 1 EBC33. In new condition. Circuit and Conversion Data Free. 25/-, carr. paid.

SMALL ADVERTISEMENTS

continued from page 237

PREMIER 6" TV, with pre-amp, polished oak console cabinet. Holme Moss working, guaranteed perfect. Free delivery £17/10/0. Ekco Eliminator 15/-, Atlas with trickle charger 20/-, Young, 94 Liquorpond Street, Boston, Lincs.

UNUSED. VCR511, 12" screened, 70/- VCR97, N.C.O., 25/- VCR138A, 15/-, 38 Sandiways Avenue, Netherton, Liverpool.

FOR SALE Haynes quality tuner, amplifier and power pack, £18. Epoch 12" energised speaker £5. Barker 148A £9. Inspection by appointment. Fisher, 51 Bemsted Road, Walthamstow, London, E.17.

FOR SALE Premier electrostatic Telescope, complete and working, VCR97 tube, requires slight adjustment for excellent picture. Owner built Viewmaster. Seen Croydon. £10 or offer. Box No. C139.

FOR SALE Electronic Keyboard (3-Octave) with Tone generator and circuit diagram, (less amplifier), £24. Cash, exchange or instalments. Box No. C140.

FOR SALE Magnaview timebase, specified components good working order, £15. Robinson, 2 Coteford Close, Loughton, Essex.

FOR SALE Portable Tape Recorder, Lane deck (3 Collaro motors) fitted with Burgoyne heads, amplifier incorporating Magic Eye and earphone monitoring, complete with Xtal mike and housed in grey rexine covered cabinet. £30 or near offer. Box No. C144.

FOR SALE Oscilloscope, all metal black crackle finish with unbreakable glass inspection window. Usual X plus Y amplifier shift and expansion—ten controls—made by Henrys of Harrow Road—new last Easter—cost £14/14/0 accept £10 or offer. Goodmans 12" speaker—15" ohm voice coil, £8 or near offer. Laminated one inch wood ten inch reflex cabinet fitted speaker—accept £6. Many Rotary Converters, American and British Hoover—cheap—offers. Fine console model three speed (Bristol Magnetic Recording Company) Tape recorder (Practical Wireless design). Double amplifier, separate power pack, eleven watts output. Wharfedale speaker, cost £125 would accept £80. Apply by letter or call Mon., Thurs., or Fridays after 6 p.m. to Ernest Wain, 39 Kensington Gardens Square, Bayswater, London, W.2.

TRADE

I.P.R.E. PUBLICATIONS. 5,500 Alignment Peaks for superhets 5/9. Sample copy *The Practical Radio Engineer* 2/-. Membership examination particulars 1/-. Syllabus of TV and radio courses free and post free. Secretary, I.P.R.E., 20 Fairfield Road, London, N.8.

OAK SWITCH SERVICE. Multi-way switches made to specification. Approx. cost—Ceramic Wafer 5/-, Paxolin Wafer, 2/-, Clicker Plate 2/6. Box No. C117.

JOIN THE ISWL. Free services to members including QSL Bureau, Translation, Technical and Identification depts. Dx certificates, contests and activities for the SWL. Monthly magazine 'MONITOR' duplicated, containing articles of general interest to the SWL and League member, 10/6 per annum, post free. ISWL HQ, 86 Barringer Road, London, N.10.

BLUEPRINTS. High Gain 10 Meter Converter, with a de-luxe circuit comprising EF91 RF stage, ECC91 double triode mixer and oscillator, EF92 IF amplifier, with stabilised voltage supply via a 7475. Is 8d post free with full instructions. A.S.W.P., 57 Maida Vale, London, W.9.

TRANSFORMERS.—Manufactured to our specification and fully guaranteed. Normal Primaries. 425 v. -0.425v. 200 m.a., 6.3 v. 6 a., 6.3 v. 6 a., 5 v. 3 a., 0.2-4-6.3 v. 3 a., ONLY 72/6. 425 v. -0.425 v. 200 m.a., 6.3 v. 4 a., 6.3 v. 4 a., 5 v. 3 a. ONLY 50/-, 350 v. -0.350 v. 160 m.a., 6.3 v. 6 a., 6.3 v. 3 a., 5 v. 3 a. ONLY 42/6. 250 v. -0.250 v. 100 m.a., 6.3 v. 6 a., 5 v. 3 a. ONLY 32/6. The above are fully shrouded, upright mounting, Universal Mounting 350 v. -0.350 v. 80 m.a., 0.4-6.3 v. 4 a., -0.4-5 v. 2 a. ONLY 18/6. Top shrouded, drop through 260 v. -0.260 v. 70 m.a., 6.3 v. 3 a., 5 v. 2 a. ONLY 16/6. The following are upright mounting. EHT for VC97 Tube 2,500 v. 5 ma., 2, -0.2 v. 1.1 a., 2 v. -0.2 v. -0.2 v. 2 a. ONLY 37/6. EHT 5,500 v. 5 ma., 2 v. 1 a., 2 v. 1 a. ONLY 72/6. EHT 7,000 v. 5 ma., 4 v. 1 a. ONLY 82/6. PLEASE ADD 1/6 PER TRANSFORMER POSTAGE.

TRANSFORMER, for use on trains, models, etc., giving outputs of 3 v., 4 v., 5 v., 6 v., 8 v., 9 v., 10 v., 12 v., 15 v., 18 v., 20 v., 24 v., 30 v., at 2 amps from normal mains input. ONLY 17/6 (postage 1/-).

TRANSFORMERS.—Ex. W.D. and Admiralty, built to more than 50 per cent. safety factor, with normal A.C. Mains Primaries. All Brand New and Unused. 300 v. -0.30 v. 200 m.a., 5 v. 3 a., 6.3 v. 5 a., C.T., 20 v. 750 m.a., 70 v. 100 m.a. Weight 12 lb. ONLY 42/6 (postage, etc., 2/6). 330 v. -0.330 v. 100 m.a., 4 v. 3 a. Weight 7 lb. ONLY 22/6 (postage 1/6). L.T. 5 v. -0.5 v. 5 a., 5 v. -0.5 v. 5 a., 5 v. -0.5 v. 5 a. By using combination of windings will give various voltages at high current. Weight 11 lb. ONLY 35/- (postage, etc., 2/6). L.T. 6.3 v. 7.7 a., 4.2 v. 2.5 a., 4 v. 1 a. ONLY 19/6 (postage 1/6). EHT 1,400 v. 2 ma., 520 v. 10 ma., 300 v. 10 ma. 2 v. 1.5 a. ONLY 21/- (postage, 1/6).

Cash with order, please, and print name and address clearly. Amounts given for carriage refer to inland only **U.E.I. CORPORATION**

The Radio Corner

138 Gray's Inn Rd. LONDON WCI
Open until 1 p.m. Saturdays. We are 2 mins. from High Holborn (Chancery Lane Stn.) and 5 mins. by bus from King's Cross.

BARGAINS CLEARANCE

SALVAGE & EX. W.D. VALVES. Guaranteed All at 8/9. 20F1, 20F2, 6AB8, 807, EAF42, 5X4, 5Y4, 5Y3, 6BE6, 6B8, 6G6, 6BV6, 6V6, 6D3, 10P13, 6A7, EF80, X65, KT8, 35Z4, 1A3, 1A5, 11C6, IT4, IS4, IS5, IF5, 5U4, 5V4, 6B4, 6F6, 6F15, 6L18, 6Q7, 10F1, 3A4, ECC91, EF36, EF50, EL91, EY51, KTZ63, KTW61, X66.

MAINS PORTABLE CHASSIS. New, Universal, 5 valve superhet. Frame aerial included. Price £5.19.6, plus 3/6 carriage.

MICRO SWITCHES. Latest American midgets. 250 volt 3A. 1/2" x 1/2" x 1 1/4". Price 3/6 post 6d.

RELAYS. New and boxed. G.P.O. pattern, break one make three. 1,000 ohms. 3/9 each, post 1/-.

I.F. TRANSFORMERS. 465 k/cs. 3/9 each, post 6d.

METAL RECTIFIERS. Guaranteed. Salvage, 300v-250 m/a. Ideal T.V. 11/9. Also new, 180v-40 m/a. 3/9. Post 6d.

T.V. TUBES. £3 9/-; £5 12/- Shown working. Personal callers only.

100 MICRO-AMMETERS. New by Westons. 2 1/2" scale square, 28/6. Also used working 12/9. Full scale or centre reading. Post 1/6.

SPEAKERS. 2/9, Post 6d. M/coil. Ideal quality microphone or personal speaker.

O.P. TRANSFORMERS. 1/9. Guaranteed. Store soiled. Post 9d.

CAR RADIO TRANSFORMER. Unused, store soiled. Either 6v. or 12v. prim. Standard sec. 7/9, Post 2/3.

DUKE & CO.

621 Romford Road LONDON E12
Money back guarantee GRA 6677

[continued on page 240]

CLYDESDALE *Prices Slashed*

INDICATOR UNIT TYPE 62A with EF50's Containing VCR-97 Tube and Valves. 12-VR91 (EF50) 4-VR65-CV118 (SP61) 3-VR92 (EA50) 2-VR-54 (EB34), etc., etc., in metal case 18x18½x11½ins. Used, good condition.

ASK FOR **79/6** Each CARRIAGE PAID
B/H868

INDICATOR UNIT TYPE 62
Used, good condition.

ASK FOR **49/6** Each CARRIAGE PAID
B/E774

IF/AF AMPLIFIER UNIT R1355
In transit case. With valves, IF frequency 7.5 mcs. Dim., 18x8½x7½ins. Used good condition.

ASK FOR **37/6** Each CARRIAGE PAID
B/E770A

ALSO STILL AVAILABLE

R1355 as above but loose stored.
ASK FOR **22/6** Each CARRIAGE PAID
B/E770B

R.F. Unit Type 24.
Switched tuning 20-30 Mc/s with valves, etc.

ASK FOR **22/6** Each CARRIAGE PAID
B/H850

R.F. Unit Type 25.
Switched tuning 40-50 Mc/s with valves, etc.

ASK FOR **22/6** Each CARRIAGE PAID
B/H847

Order direct from: Telephone SOUTH 2706/9
CLYDESDALE SUPPLY CO. LTD.
2 BRIDGE STREET GLASGOW G.5
Branches in Scotland, England and North Ireland

SMALL TRANSMITTERS for 27mcs band (Model Radio Control). These units have been built by us from surplus equipment for operating radio controlled boats, etc., and are supplied complete with valve and working instructions. Price 18/6. Postage 1/6.

SMALL DC MOTORS. Size 2¼" long by 1½" wide by 1½" high, grey, fitted ⅜" shaft, operates from 6-12V., weight 11oz. As new 15/6. Postage 1/3. 12-24v., 9/6. We have sold many of the 12v. type to model boat builders, for use in boats up to 3ft 6in long.

SECTOR SWITCH BOXES. Containing 16 Chromium Plated on/off Toggle Switches. Slide Switch and Terminal Box. Enclosed in Metal Box 7 x 4 x 2". Price 10/-. Postage 1/6. These are ideal for Model Railway Signal Switches, etc.

TELESCOPIC MASTS. 4 section each 3ft long ⅜"-¾" dia. 2 aerials fitted in 3ft canister. Price 7/6. Carriage 3/6.

4FT TELESCOPIC AERIALS. Weight 2oz Price 2/-. Postage 8d.

INDICATOR LAMPS take screw in type bulbs, set of 3 mounted on Paxolin panel, coloured red, green and amber, with 2ft of 4-way lead. Price 2/-. Postage 11d.

OUR NEW LIST NOW AVAILABLE. LIST NO. 10
26 PAGES. PRICE 6d. INLAND, 2/- OVERSEAS
AIRMAIL

A. T. SALLIS

93 NORTH ROAD BRIGHTON SUSSEX
Telephone BRIGHTON 25806

SMALL ADVERTISEMENTS

continued from page 2391

FREE! Brochure giving details of Home Study Training in Radio, Television, and all branches of Electronics. Courses for the Hobby Enthusiast or those aiming at the A.M.Brit.I.R.E. City and Guilds Telecommunications R.T.E.B., and other professional examinations. Train with the College operated by Britain's largest Electronic Organisation. Moderate fees. Write to E.M.I. INSTITUTES, Post Division, Dept. RC28, 43 Grove Park Road, London, W.4. (Associated with H.M.V.).

METALWORK. All types cabinets, chassis, rack etc. to your own specification. Philpott's Metalworks Ltd. (Dept. R.C.), Chapman Street, Loughborough.

KENDALL AND MOUSLEY. Manufacturers of Laboratory Equipment, chassis and instrument cases, also suppliers of B.V.A. valves, Radio & T.V. components. 99 Dudley Port, Tipton, Staffs.

RADIO CONTROL THAT MODEL. Practical circuits, simple, cheap, easy to construct. Applications—Boats, A/C, Trains and Domestic Radios. Handbook 3/6 post free with unlimited advice. Carter, A.M.I.E.T., 101 High Street, Harlesden, N.W.16.

MANY DEALERS now Stock PANL, the air-dry black crackle. If there is no Stockist in your district send 4/6 to L. Miller, 8 Kenton Park Cresce, Kenton, Middlesex.

OSMOR—for efficient coils, coilpacks, etc. Send stamp for FREE circuits and lists. Dept. RC Osmor Radio Products Ltd., Borough Hill, Croydon, Surrey. Telephone Croydon 5148/9.

"GLOBE KING" (Regd.) Miniature Single Valve Receiver gets real Dx. Amateur Radio enthusiasts should send for free copy of interesting literature and catalogue (enclose stamp for postage). Write to makers: Johnsons (Radio), 46 Friar Street, Worcester.

BOOKBINDING. Volumes of *Radio Construction* and *Radio Amateur* fully bound, imitation leather gold lettering, 7s. 6d post free. Prices for other publications on application. Jerome Alcock, CHEADLE, Stoke-on-Trent.

1 MA METER RECTIFIERS 6/- MICRO-SWITCHES 2/- OBSOLETE VALVES, SELENIUM RECTIFIERS 6-12V 1A 7/6, 6-12V 3A 14/-. Transformers to match 12/6 and 16/-. All carry extra. S.A.E. stating requirements, for bargain LAWRENCE, 134 Cranley Gardens, London N.6, CLI 6641.

BASS REFLEX CABINETS. Many designs. 1 for 12" Speaker Models, 97/6. Goodmans Ax 150 MK.II Corner Reflex from £11/0/0. Cabinet made to order. A. DAVIES and Co. (Cabinet Makers), 3 Park Hill Place, off Parkhill Road, London N.W.3. GULLIVER 5775.

WIRELESS STATION SUPERINTENDENT required by the NIGERIA GOVERNMENT Post and Telegraphs Department for one tour of 18 to 24 months in the first instance. Commencing salary according to experience in scale £864 rising to £1,392 a year. Gratuity £100/£150 a year. Outfit allowance. Free passages for Officer and wife and assistants towards cost of children's passages or their maintenance in the U.K. Liberal leave on full scale. Candidates must have had wide practical experience of modern radio techniques and equipment, particular V.H.F. equipment, and preferably V.H.F. multi-channel equipment. Write to Crown Agents, 4 Millbank, London, S.W.1. S age, name in block letters, full qualifications experience and quote M2C/28927/RN.

"YOU CAN RELY ON US"

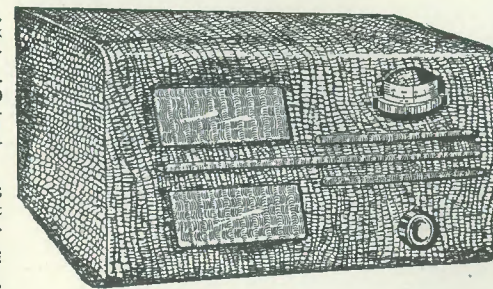

COILS
Wearite "P" Coils. All types in stock including AF.1. RF.1. Price 3/-
Midget I.F. Transformers Type 800 21/- per pair. Standard Type 500/501 (465Kc/s) 20/- pair
HIGH IMPEDANCE HEADPHONES
NewEx-Government Price 12/6 per pair.
SCOTCHBOY TAPE
1200ft Reels 35/-
Spare Reels 4/3

COILS
Osmor Midget iron-cored "Q" Coils 4/- each. Leaflet on request.
Coilpacks Type H.O. 52/-, LM 43/4, MTS 54/2, TRF 43/4, all including Tax.
TRIMMERS
All new Postage Stamp Ceramic. 4-70pf Bd. 40-100pf 10d., 20-150pf 1/- 100-550pf 1/3.
LINECORD
3-way .3a at 60 ohms, per foot 6d ft., .2a at 100 ohms per ft 8d ft.

The "MAXIMITE" AC/DC SUPERMIDGET SUPERHET — Full Plans 1/-

CATALOGUE No. 12 now available

70 pages 250 Illustrations Price 1/-

NOTE OUR NEW ADDRESS

RADIO SERVICING COMPANY

DEPT. K 82 SOUTH EALING ROAD LONDON W.5

Telephone EALing 5737

SOLIDAS LTD.

4 PRAED STREET
LONDON W2

**DEFINITELY
THE CHEAPEST RADIO SHOP IN
TOWN**

Telephone AMB 4670

32+32 mfd 275V 4/-, 16 mfd 425V-wet-screw fitting, 4/-, 8 mfd 500 screw, 1/6, 8 mfd 600 V/W, screw 2/-, 8 mfd 450 midget, 2/6, 30+30 350, 2/6. 10 mfd paper 600V, 4/-, 4-way Fuse holder, 6d. Continuity tester in nicely polished box can also be used for Morse practice, 5/-; 10 watt push-pull output Trans., 15/-; 4 gang .0005, 2/6; Slow motion drive with 2" drum, 1/6. L.T. Trans., 6.3, 2 amps, 7/6. Polythene stand-off insulators, 9d. WX6 W.I. detectors, 1/-; L.T. Trans., 3V, 1A, 2/6; Box of 10, 3.2, 0.2 pilot bulbs, 2/6. Tube neck support fits 9", 12", 15", 2/- Wire wound pots. 1000Ω, 500Ω, 2/- Miniature 2 amp plug and socket, 1/- pair. L.T. Trans., input 110-250V, output 2-0-2V, 3.3A, or 4V, 6.6A, 12/6. Bush All Wave chassis, 5 valve S/Het., less speaker, reconditioned, £6.10.0, has gram. sockets; 5.5 KV EHT Trans. with U22

Rectifier, 45/-, MV4=MH4 4/-; 878A 10/-; Z62 10/-; 807 10/-; Z77 10/-; EF22=7H7 6/-; 3D6 2/6; 1LD5 4/-; APR12 2/6; VUI11-VUI33 2/6; 6SS7-6SJ7 5/-; 12Y4 0.3 Rect. 5/-; 6L6M 10/-; VT25 5/-; H30 5/-; HHLD6-6Q7 A.C. 6/-; 6SL7 10/-; 6SN7 10/-; ML4 5/-; TP25 7/6; VR55=EBC33 8/-; VP41 10/-; 5U4G=US2 10/-; 6F6G 8/6; 6C6-6D6 5/-; 12CB 10/-; Y63 7/6; 6G6 6/-; 7DA 10/-; 12SH7 5/-; 12SK7 7/-; 117L7 10/-; VR56=EF36 6/6; 6AG5 6/-; CU188 V/Regulator 6/-; VR137, EC52 4/6; 9D2 4/-; VR116 4/6; KTZ73=Z66 10/-; 6AK5 10/-; 6SK7 7/-; VR126=VP48 10/-; MS/PEN 6/-; 5Z1 8/6. Special offer AZ31 less locating pin 6/-; CY31 less locating pin 6/-; KT44 7/6; AC6PEN 6/-; 12SA7 10/-; 5Y5 6/6.

NO MAIL ORDERS — CALLERS ONLY

URGENTLY WANTED

COMMUNICATIONS RECEIVERS.

TEST EQUIPMENT.

RADIO—and TELEVISION SETS,

TAPE RECORDERS.

BEST PRICES GIVEN

Phone or Call

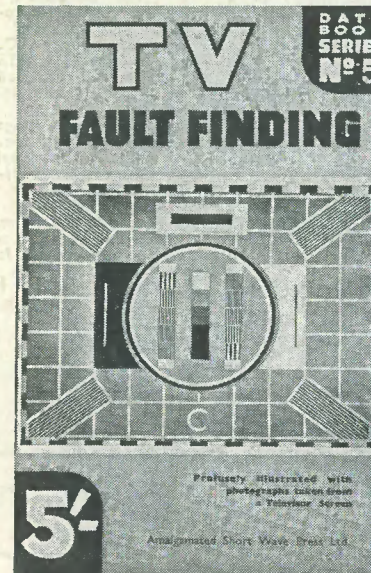

“ . . . A book that should be in every television dealers service workshop, and in every home-constructor's, for that matter.”

Journal of the Television Society

“ . . . The book will undoubtedly be of value to TV service engineers, particularly those who are not fully experienced in translating the appearance of faulty pictures into the necessary adjustments or receiver fault location.”

Wireless and Electrical Trader

TV FAULT FINDING

Data Book Series No. 5

This is a completely new production—not a reprint—and is unique in that it is lavishly illustrated by photographs taken from the screen of a television exhibiting the faults under discussion. A handy fault-finding guide is incorporated, and this is cross-referenced to the book itself.

100
Illustrations and Diagrams

80
pages, high quality paper with heavy art board cover

PRICE 5 SHILLINGS, Postage 3d.

Available from your usual supplier, or direct
(Trade enquiries invited)

DATA PUBLICATIONS LTD.
57 MAIDA VALE LONDON W9

Telephone CUN 6518

Printed in Great Britain for the Proprietors and Publishers Data Publications Ltd., 57 Maida Vale, London W9, by A. Quick & Co. Ltd., Oxford House, Clacton-on-Sea, Essex. "The Radio Constructor" is obtainable abroad through the following: Collets Subscription Service, Continental Publishers & Distributors, Ltd., William Dawson & Sons Ltd. Australia and New Zealand: Gordon & Gotch Ltd. South Africa: Central News Agency.

