

Vol. 4
Number 6
JANUARY
1951

RADIO CONSTRUCTOR

for the Radio and Television Enthusiast



IN THIS ISSUE . . .

A VERSATILE OSCILLOSCOPE • TV SOUND RECEIVER
USEFUL TEST SET • Capacitance Bridge
Magnetic Recording, Part 2 • Aerials • TV Picture Faults
Query Corner

etc., etc.

13

THE MODERN BOOK CO.

- Sound Reproduction. By G. A. Briggs. 2nd Edition. 10s. 6d. Postage 6d.
 Testing Radio Sets. By J. H. Reyner. 22s. 6d. Postage 9d.
 The Radio Amateur's Handbook, 1950 Edition. By A. R. R. L. 20s. Postage 9d.
 Questions and Answers on Radio and Television. By E. Molloy. 5s. Postage 3d.
 Television Servicing Manual. By E. N. Bradley. 4s. 6d. Postage 2d.
 Radio Engineers' Handbook. By F. E. Terman. 50s. Postage 9d.
 A Portable Televisor. By E. N. Bradley. 3s. Postage 2d.
 The Technique of Radio Design. By E. E. Zepler. 25s. Postage 9d.
 Recent Advances in Radio Receivers. By L. A. Moxon. 18s. Postage 6d.
 Magnetic Recording. By S. J. Begun. 42s. 6d. Postage 9d.
 The Electronic Musical Instrument Manual. By A. Douglas. 18s. Postage 6d.
 Radio Engineering. By E. K. Sandeman. Vol. 1, 45s. Vol. 2, 40s. Postage 9d.
 Radio Communication at Ultra High Frequency. By J. Thomson. 21s. Postage 9d.
 Personal Portables. By E. N. Bradley. 2s. 6d. Postage 2d.

We have the finest selection of British and American radio books in the Country. Complete list on application.

19-23 PRAED STREET, (DEPT. RC) LONDON, W.2

PADDINGTON 4185



FOR ALL TYPES OF
**Television and VHF
 AERIAL INSTALLATIONS**

Maintenance to
 VHF Transmitting and
 Receiving Equipment

Agents for B.M.C. Lightweight
 Television Aerials

TRADE ENQUIRIES INVITED

Send for prices and details to:—

**5, PROBERT ROAD, BRIXTON
 LONDON, S.W.2.**

OP-AID

Printed on good heavy paper, with durable stiff cover, the "Op-Aid" gives you the latest revised information about Distances, Amateur Codes and Abbreviations, Zone Boundaries, QSL Bureaux of the World, International and Amateur Prefixes, Call Areas, the Amateur Transmitting Licence, Morse Code, International Q and Z Codes, Standard Frequencies and Local Time Conversion

PRICE **1/6** (post 2d.)

from your local supplier or direct from

**AMALGAMATED
 SHORT WAVE PRESS Ltd.**

**57 Maida Vale, Paddington
 London, W.9**

'Phone: - - CUN. 6518

METAL WORK

with a difference!

If you want a well-made, attractive and robust cabinet for that receiver or transmitter; if you need a chassis for a modulator, amplifier or converter; in fact, if you need any metalwork at all for your ham requirements

**YOU CAN DO NO
BETTER THAN TO
WRITE US FOR AN
ESTIMATE**

All metal work "made to measure"

For full details and address of nearest agent, contact—

L. J. PHILPOTT (G4BI)

(E. J. PHILPOTT)

Chapman St., Loughborough

Telephone: 2864

Come to **SMITH'S** of **EDGWARE ROAD**
the friendly shop for all radio components

We stock everything the constructor needs—our 25 years experience of handling radio parts and accessories enables us to select the best of the regular lines and the more useful items from the surplus market in:—

Loudspeakers and Phones	Valves and CR Tubes
Transformers and Chokes	Cabinets and Cases
Meters & Test Equipment	Capacitors and Resistors
Pickups and Turntables	Coils and Formers
Switches and Dials	Plugs and Sockets
Metalwork and Bakelite	Aerials and Insulators
Books and Tools	Motors and Generators
Valve Holders and Cans	Wires and Cables
Metal Rectifiers	Panel Lights and Fuses
Sleeving, Nuts and Bolts, Tags, Clips, Grommets and all other bits and pieces	

NOTHING TOO LARGE—

NOTHING TOO SMALL

Everything you need under one roof—including all the parts specified for the popular "Viewmaster" Home-built Televisor, both London and Birmingham models. Send for list of our "Electro-Voice" range of Transformers and Chokes—"As good as the best, yet cost little more than the cheapest!" (No general catalogue available).

H. L. SMITH & CO. LTD.

287/9 Edgware Road, London, W.2

Telephone: Paddington 5891

Hours 9 till 6 (Thursday, 1 o'clock)

Near Edgware Road Stations, Metropolitan and Bakerloo

WHAT IS THE I.S.W.L.?

- (1) The International Short Wave League is an organisation of short wave listeners, amateur transmitters, and others interested in short wave radio communication.
- (2) Its objects are to encourage, in every way possible, friendly intercourse and understanding between peoples of every country, through the medium of a common interest in their hobby.
- (3) Membership is open to anyone, of whatever race, creed, or colour, provided there is a genuine interest in short wave radio and a desire to further the aims of the League.
- (4) The membership fee consists of an annual subscription of 2s. 6d., or its equivalent. There is no entrance fee.
- (5) Contests, Set Listening Periods and Dedicatory Broadcasts are regularly arranged, in order to further the aims of the League.
- (6) Organisation consists of an HQ staff, Country, County and Town representatives, and local I.S.W.L. Groups. These latter are the essential units of I.S.W.L. activity, as they stimulate and keep together local I.S.W.L. members.
- (7) Many free services are available to help members to get the best out of their hobby. Amongst these is a QSL Bureau which is unique in that it handles both amateur and broadcast 'veries.'
- (8) A section of 'Short Wave News' is devoted each month to I.S.W.L. affairs, and carries news of contests and Group activities. The purchase of 'Short Wave News' is **NOT** a condition of membership.
- (9) The address of HQ is 57 Maida Vale, Paddington, London, W.9., and the telephone number is CUNningham 6518.

IF YOU ARE A

SHORT WAVE ENTHUSIAST

—JOIN US NOW



Radio Constructor

Vol. 4, No. 6

Annual Subscription 16/-

January, 1951

Editorial Office—57, Maida Vale, Paddington, London, W.9:

Tel.: CUNningham 6518

Advertising—Radio Constructor, 15, Charterhouse St., London, E.C.1. Tel.: HOLborn 8655

Edited by: C. W. C. OVERLAND, G2ATV

CONTENTS

Suggested Circuits: Useful Capacitance Bridge, by G. A. French - - -	186
RC Quiz, conducted by W. Groome - - -	187
Modern Receiver Alignment, Pt. 2, by W. G. Morley - - -	188
Radio Miscellany, by Centre Tap	191
Magnetic Sound Recording, Pt. 2, by E. Kaleveld, PAØXE - - -	195
A Useful Test Set, by A. E. Thornton - - -	197
Practical Aerials, Pt. 5, by Aetherium - - -	201
A Versatile Oscilloscope, by G. Boston - - -	204
Query Corner - - -	207
Jones and the Electronic Thief Taker, by C. Noall - - -	210
A Television Sound Receiver, by Centre Tap - - -	212
Television Picture Faults, Pt. 10, Interference - - -	216
Your Workshop - - -	219
From Our Mailbag - - -	221
Panel Sheet No. 7—Oscilloscope Controls (1) - - -	Y

Editorial

The commencement of the series on *Magnetic Sound Recording* in our last issue has met with general approval. There is no doubt that it will 'catch on', for it has possibilities outside the immediate attraction to the radio constructor.

Both tape and wire recordings have the advantage over discs in that the playing time of a spool is so much longer, so obviating annoying breaks at inopportune moments. Moreover, wear and tear is infinitely less, and 'hiss' is practically absent even in the cheaper mechanisms.

A radio and film artiste of our acquaintance has become intrigued, and now merrily rehearses away at home. For he can hear himself as others will after the microphone has been at work, and can make alterations to his delivery accordingly.

We understand, too, that tape recorders are becoming popular in the medical profession, for the purpose of lectures to students. Again, a doctor or surgeon carrying out a delicate operation can chatter away making comments as they occur to him, knowing that afterwards he will not need to rely on memory for his reactions, but will be able to study his own statements made at the time.

A more commercial use also occurs to us. Apart from the obvious employment for office dictation purposes, it would often be valuable to have an actual recording of company meetings, business conferences, and particularly occasions when verbal agreements are made. This does not exhaust the possibilities by any means—make up your own list, it can be very amusing!
G2ATV.

NOTICES

THE CONTENTS of this magazine are strictly copyright and may not be reproduced without obtaining prior permission from the Editor. Opinions expressed by contributors are not necessarily those of the Editor or proprietors.

THE EDITOR invites original contributions on construction of radio subjects. All material used will be paid for. Articles should be clearly written, preferably typewritten, and photographs should be clear and sharp. Diagrams need not be large or perfectly drawn, as our draughtsmen will redraw in most cases, but relevant information should be included. All Mss must be accompanied by a stamped addressed envelope for reply or

return. Each item must bear the sender's name and address.

COMPONENT REVIEW. Manufacturers, publishers, etc., are invited to submit samples or information of new products for review in this section.

ALL CORRESPONDENCE should be addressed to *Radio Constructor*, 57, Maida Vale, Paddington, London, W.9. Telephone: CUN. 6518.

Suggested

CIRCUITS *for the* **EXPERIMENTER**

The circuits presented in this series have been designed by G. A. FRENCH specially for the enthusiast who needs only a circuit and the essential relevant data.

No. 2 A Useful Capacitance Bridge

Range

Range:—50 pF (or less) to greater than 2 μ F in two ranges. With careful design, values of capacitance down to 10 or 15 pF can be measured.

The Oscillator

The oscillator is intended to function mainly as a multi-vibrator, in order that it may deliver a rich band of audio frequencies to the bridge. The capacitor C1 should be experimentally chosen to give the output a large proportion of high audio frequencies, these being audible as a "hiss". (The "hiss" may be drowned by the lower audio frequencies present until it is used for testing purposes). The value of C1 will lie between 100 pF and 0.01 μ F.

The purpose of having such a strong "hiss" content is to enable capacitors below 200 pF or so to be tested, a facility not always available with an audio bridge. Whereas such low value capacitors offer a very high impedance to the usual audio frequencies, they allow sufficient "hiss" to be passed to enable the bridge to be balanced for values down to and below 50 pF.

Any two reasonably-chosen valves may be employed in the oscillator. V1 should be a triode, (6J5, etc., etc.), and V2 an output pentode or tetrode, (6V6, EL32, etc.). If desired, 2-volt battery valves could be employed instead of the mains type.

The output choke in the anode circuit of V2 may consist of any choke available which can carry the appropriate anode current. The primary of a speaker transformer would do quite well.

The Bridge

It may be found convenient to make the bridge a separate unit. Care should be taken to ensure that the earthy lead of the oscillator output corresponds to the appropriate terminal on the bridge unit.

The wiring in the bridge unit should be stiff and short. If a metal panel or chassis is used, this should be earthed to the earthy lead from the oscillator.

The transformer coupling the bridge proper to the headphones may consist of any "intervalve" transformer whose ratio is smaller than 4:1. It should be connected as shown in the diagram. ("I.P." stands for Input Primary; "O.P." for Output Primary; "I.S." for Input Secondary; and so on.).

The 10 k Ω potentiometer, R7, acts as a volume control. High impedance headphones should be used.

The 50 k Ω potentiometer, R6, should be a high-grade, wire-wound component, its spindle being fitted with a pointer and scale. For maximum accuracy, the indicating part of the pointer should trace an arc whose diameter is at least four inches.

Calibration

Calibration is carried out by checking the position of the potentiometer for various known values of capacitance; then completing the scale to cover all types which may be encountered. (Point of balance will correspond to minimum AF in the headphones).

The bridge should be used with its own oscillator only, as the use of other oscillators, after original calibration, may cause slight discrepancies.

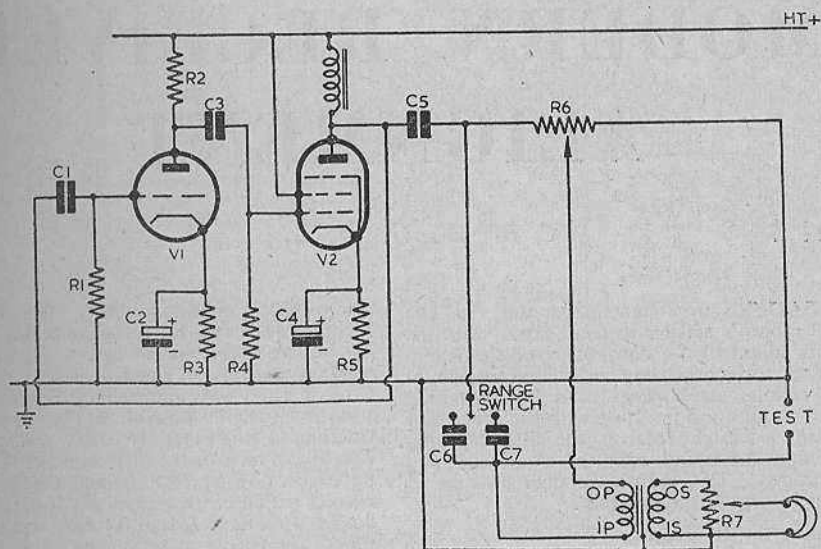

C150

Circuit of Oscillator and Bridge

C1, see text.
 C2, 25 μ F.
 C3, 0.01 μ F.
 C4, 25 μ F.
 C5, 0.1 μ F.

Component Values
 C6, 0.1 μ F.
 C7, 500 pF.
 R1, 250 k Ω .
 R2, 100 k Ω .

R3, 1 k Ω .
 R4, 250 k Ω .
 R5, 400 Ω .
 R6, 50 k Ω pot.
 R7, 10 k Ω pot.

"RADIO CONSTRUCTOR" QUIZ

Conducted by W. Groome

(1) Mr. Brain was astonished to find, when trying out a new TV set, that the picture was negative—in other words, parts which should have been black were white, and white were black. The effect was just the same as the familiar photographic negative. Explanation, please.

(2) Why is it often wise to use a small loudspeaker having limited frequency response with equipment which is known to be of poor quality?

(3) When calculating the effective baffle size of a loudspeaker, would you include the sides, top and bottom, or only the front?

(4) A 12-in. cathode ray tube gives a picture which is double the size of that given by a 6-in. tube. Right or wrong?

(5) Which gives a positive sawtooth output—the transitron generator or the blocking oscillator?

(6) Why do most line output stages for magnetic scanning use a valve with a top cap anode connection?

Answers on P.218.

Please !

MENTION THIS MAGAZINE
 WHEN
 WRITING TO ADVERTISERS

MODERN RECEIVER ALIGNMENT

Part 2

By *W. G. Morley*

READERS may remember that, in last month's article, we dealt briefly with the points raised in the April issue of the *Radio Constructor*, continuing with a discussion of the various components used for trimming tuned circuits and finishing with the process of aligning a straight receiver, the latter bringing out important points common to all trimming operations. This month we shall pass on to the alignment of the superhet.

Aligning the IF Stages

Whenever a superhet is being aligned, the IF stages must be accurately trimmed before anything else is attempted. This is because the oscillator and signal tuned circuits should be adjusted to pass only signals of the correct frequency to the IF stages; and it is therefore pointless to touch the other circuits until one is sure that the IF's are working on their proper frequency.

There are two main points to observe when IF transformers are being aligned. First of all they must be lined up to the correct frequency; and secondly they must be trimmed not only to offer the greatest amplification at that frequency but also to give a sufficiently acceptable response curve for the receiver as a whole.

The Frequency of the IF Stages.

The frequency to which the IF's are aligned has a great deal to do with the final results given by the receiver. There are several reasons for this. In the first place it is, of course, obviously desirable to use the IF transformers on or near the frequency for which they were designed. Added to this is the fact that, in some receivers, alignment of the IF's on the wrong frequency may cause instability owing to feedback. Instability can also be caused if the frequency of the IF stages happens to fall on or near the frequencies covered by the signal and oscillator tuned circuits.

Another very important reason for using the correct frequency lies in the fact that, should the IF's be trimmed incorrectly, it may prove difficult, or even impossible, to get the signal

and oscillator circuits to track. The effects of incorrect IF will be most noticeable on the lowest frequency bands of the set, such as the long wave band of a domestic receiver. When a set is fitted with adjustable padding capacitors, it is usually possible to obtain accurate tracking so long as the IF remains within about 3 to 4% of its proper value; although this does not excuse no attempts at making the frequency correct within narrower limits. If the receiver has fixed padding capacitors (or is permeability-tuned) the IF's must be aligned as near to the original frequency for which the set was designed as is possible.

Finding the Correct Frequency

Should it prove impossible to find the correct frequency for the IF stages from the manufacturers' literature, it will probably be necessary to use a little guesswork. In this case the reader may find the following figures helpful. Most English domestic receivers use IF's of 456 and 465 kcs, usually the latter; whilst American receivers (or American-style receivers built in Britain) appear to favour 450, 456, 460, and 465 kcs. Occasionally, with English receivers, one finds that certain models use slightly different IF's for different parts of the country in order to overcome the effects of interference from local stations, but this practice appears to have been discontinued many years ago. There is also, of course, the old-fashioned 110 kcs which was used in the earlier superhets. Specialised sets, such as communications, service receivers and so on, use IF's which are often very different from those found in domestic receivers, but we shall deal with these in a future article.

When the IF of a receiver is unknown, one may often get a good guide by finding the frequency to which it is already trimmed. If the set has been tampered with (and, incidentally, the service work carried out by some radio "experts" is nothing short of tampering) then the frequency to which the IF's are tuned cannot be taken for granted; and it is often

necessary to retrim them to 465 kcs or to whichever frequency is adjudged to be the correct one. Should this frequency be incorrect, the results will soon be apparent when the long wave, or lowest frequency band, of the receiver is tackled—and it is found that either the dial calibration is badly out or that it is impossible to track the receiver. One must then, of course, line the IF stages up to another frequency.

A word of warning, however, is necessary here. The writer has never yet come across a domestic receiver which uses an IF (apart from 110 kcs) which lies outside the range 440—480 kcs; but there is still nevertheless the chance that such receivers exist. (We believe an early Decca Battery/Mains receiver had an IF of around 380 kcs—Ed.). Therefore, when an unfamiliar receiver whose IF is found to be well away from these figures is encountered, a note of the frequency to which it is trimmed should always be made before it is re-adjusted to the more conventional figure.

The Process of Alignment

Having duly considered the snares and pitfalls accompanying the adjustment of the IF transformers to the wrong frequency, let us now discuss the actual process of alignment itself.

This is usually carried out, in the first place, by breaking the connection to the signal-grid of the frequency changer and then applying the output of the signal generator between that grid and chassis. It is advisable, in this case, to switch the set to a high frequency band to prevent the oscillator in the receiver from beating with, or otherwise affecting the output of the signal generator.

However, for several reasons, this direct connection is not always useful. To begin with, not all frequency changer valves have their signal-grid connections brought out conveniently to the top-cap, and it would be ridiculous to start chopping and changing the wiring to the valve holder simply for purposes of alignment; and, furthermore, not all signal generators are capable of being attenuated sufficiently to give the very weak signal required when the IF's are really accurately lined up.

It is therefore sometimes advantageous to use a looser coupling. This may be done by connecting the signal generator to the signal grid (via a 0.01 μ F capacitor to avoid a possible short circuit of the AVC line) without breaking the lead from the signal grid tuned circuit. This latter will then provide heavy attenuation of the output of the signal generator. Alternatively, the signal generator output lead may be held near the wire to the signal grid, or loosely twisted round it, the receiver then being switched to, say, the medium-wave band so as

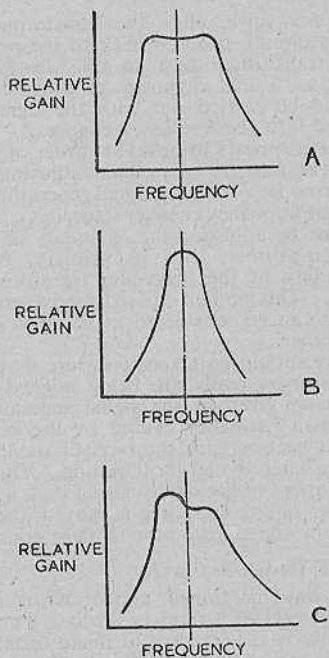

CI49

Fig. 4. In this diagram (a) represents the ideal response curve given by IF transformers working as band-pass filters; whilst (b) shows the effect given by loosely coupled transformers. (c) illustrates the result sometimes obtained when a receiver is unstable. The dotted central lines represent the frequency to which the transformers are aligned.

not to entirely attenuate the signal obtained from the now very loose coupling existing. Or again, if the connections to the frequency changer are all below the chassis and are difficult to get at, the signal generator may even be connected between the aerial and earth terminals. Unless an IF filter or an RF stage is included in the receiver, the signal generator should then, in most cases, break through to the IF stages, particularly so if the receiver is switched to the medium or long-wave bands.

If, however, the receiver is very badly out of alignment it may be necessary to commence with the direct connection, reverting to the looser coupling when the IF's have become more sensitive or if it is found that the signal generator cannot be sufficiently attenuated. It may even prove necessary, if the IF's are very badly out of alignment, to connect the signal generator to the grid of the last IF

amplifier valve, align the transformer in its anode circuit, proceed back to the next valve and transformer and so on. In this case, however, a final alignment of all the trimmers should be carried out with the signal being passed into the frequency changer.

There appears to be no set order of aligning the transformers when final adjustments are being made. With the signal generator feeding into the frequency changer stage, it is customary to start by adjusting the secondary of the last IF transformer, then its primary, then the secondary of the preceding transformer and so on. This method is used by most servicemen and it can be considered as being as good as any other.

Care should be taken to ensure that the IF transformers really are being aligned on the frequency given by the signal generator, and not on a frequency caused by the generator output beating with the receiver oscillator or with a heterodyned local station. This point may easily be checked by seeing that, when the receiver tuning capacitor is moved, the signal from the signal generator remains constant.

The IF Response Curve

As was mentioned above, when the IF transformers of a receiver are being lined up, not only is it necessary to make certain that they are accurately trimmed and therefore capable of offering the greatest amplification to signals of the correct frequency, but also that they are not adversely affecting the audio response of the receiver.

Fig. 4 (a) shows a typical response curve such as could be offered by the IF stages of an average domestic receiver. It will be seen that the response is symmetrical, falling rapidly at points removed from the central frequency by an equal amount on either side. The width of the response curve (in terms of frequency) varies with different receivers, most domestic models having a bandwidth of about 8 kcs, (i.e., they receive sidebands up to 4 kcs).

Fig. 4 (a) illustrates the double-humped curve which is offered by a band-pass circuit. Nearly all domestic receivers employ band-pass filters for their IF transformers, a fact which considerably assists in the process of alignment. Occasionally, however, one may come across receivers fitted with variable selectivity circuits, the IF response curves of these receivers sometimes being similar to that shown in Fig. 4 (b), where the sharp peak is obtained by using loosely coupled IF transformers. The selectivity is varied by switching resistors across the tuned circuits in the transformers, thus flattening the response curve and so allowing the reception of a wider range of sidebands.

After the IF's have been primarily trimmed up, all that is then necessary is to finally adjust each trimmer for maximum resonance. If the receiver is fitted with a variable selectivity control it should be set for maximum selectivity; i.e. sharpest tuning. In case of any slight alterations in capacitance in the second detector circuit owing to changes in position of the volume control, this should be turned to "full."

When a receiver is well designed and is working properly, alignment for maximum sensitivity should automatically ensure that a good response curve (similar to that of Fig. 4 (a)) is obtained. After trimming, the response may be roughly checked by slowly swinging the signal generator backwards and forwards across the IF frequency, whereupon the signal received from the generator should fall off at points above and below the control frequency and which are removed from it by equal amounts. This check is, of course, only capable of giving approximate results but it still enables one to obtain a very good idea of the efficiency of the IF transformers.

Unfortunately, it will be found in quite a few cases that aligning the IF's for maximum signal does *not* result in the curve shown in Fig. 4 (a). Instead one obtains something like that illustrated in Fig. 4 (c) in which the signal falls off sharply on one side of the central frequency and trails off slowly on the other side. This effect is nearly always caused by slight instability in the receiver: not enough to cause oscillation, but sufficient to allow a small amount of regeneration. The shape of the curve of Fig. 4 (c) points to something in the nature of a tuned anode-tuned grid oscillator; and it often helps if the screen-grid decoupling capacitors of the IF amplifiers are thoroughly checked. Feedback of any nature may, however, be causing the trouble and so all decoupling components should be suspect, particularly the electrolytic capacitor which usually decouples all the anode returns in the receiver. Unhappily, one or two of the cheaper receivers which suffer from this defect do so owing to inherent faults in their design and little can be done to cure them—apart from fitting additional decoupling circuits, if this should be considered worth the trouble.

If it is impossible to improve a poor IF response curve by replacing defective components, it may sometimes be made better by judicious adjustment of the trimmers. The best method of doing this is to set all trimmers to their optimum position, and then adjust one of them to a frequency slightly removed from the central frequency and on the opposite side of that part of the curve which falls off

Continued on P.218

Radio Miscellany

NO doubt readers interested in the fourth Annual RSGB Exhibition will look elsewhere for detailed reports. Possibly I have had a surfeit of Radio Exhibitions and have become a little blasé. They are almost invariably repetitions of what they had last time. This is, of course, unavoidable, but as Exhibitions their primary appeal is to the newcomer to the hobby, and what to the old timer has become almost a repeat performance is to him a great event.

With the RSGB show the old-timers are always well in evidence. They go to see each other rather than the exhibits, unless there are some startling novelties. In this way, I enjoyed myself immensely, but there were also quite a few items I found to be of especial interest.

Happily, I don't have to report on the Exhibition. Perhaps I am getting past the stage where I could warm up with the requisite enthusiasm. Perhaps, too, I see things too much from behind the scenes to adequately share the effect on those who view it from the stalls.

And the high-spots? Well, I had no end of fun playing with the Reaction Timer on the GPO Stand. It's nothing to do with tickler coils; it's just a device to measure how quickly one responds to a visual signal. Any friends I have left will be pleased to know that I am still a shade quicker than the average. In case some of those present did not believe it I took them across with me to prove it. It's nice to be able to show people how good you are at something—but it doesn't make them

Appearance

While you don't judge radio gear by its case any more than you judge a book by its covers, a handsome case (or a beautiful binding) is a permanent source of joy to its owner.

Philpotts Metalworks, as usual, had a nice range of metal cabinets etc., on show, at very reasonable prices. By the way, any doubters of the "made to measure" claim can take it from me that it is not exaggerated. I did feel their stand would have attracted still more attention if 4BI had added an eye-catcher. Why not fix up a cabinet where Archie Andrews' head pops up when you raise the lid next year, O.M.? People would then be sure to look and find out for themselves that the inside is as good as the outside.

The Widney-Dorlect cabinet system, from which simple metal boxes or elaborate rack-and-panel housings can be assembled, seems to have everything—rigidity, strength, lightness, appearance and expandability. Perhaps later they will devise an equally ingenious system by which ordinary blokes like me could work out the price of one just the size they want, without the aid of a stump of pencil and an exercise book.

The BATC closed circuit 300 line 50 frame TV demonstrations were good, and aroused considerable interest. G2CVO stood up to the photoflood heat magnificently, and gave excellent imitations of the friend in the shack who has the microphone thrust in his hand for the first time. The cameramen, however, missed their vocations. They should have

CENTRE TAP *talks about*
RSGB EXHIBITION — BOOKS AND MORSE

any friendlier!

The device consists of a meter, the slow-moving needle of which is arrested as soon as you press the "Stop" button after being warned by a flashing light. A rough model could be knocked up at home, when you can find out for yourselves just how easy it is to become thoroughly unpopular if you happen to be good at it.

been machine gunners. They swung the camera round just as if they were mowing down a mass attack of advancing infantry. The subject was only steady and properly centred for very brief periods. Not that it mattered much for an audience interested chiefly in how well it worked technically, but normal viewers might think it was the fault of the transmission—not the cameramen.

The BATC are otherwise to be congratulated on an excellent job providing one of the highlights of the exhibition.

It was pleasing to see how well the RC stand was supported by our many readers. It is encouraging for those on the Editorial side to have visible evidence of the feeling of accord that grows up between the reader and the living entity HIS magazine represents to him. One buys many things more strictly personal, but unlike a magazine they never become anything more than mere merchandise. Quite a few of our visitors spoke of their pleasure at the brightness and friendliness of the stand as if they, too, shared in the satisfaction that RC was keeping its end up so well.

Those in Favour

From time to time I am asked by beginners to recommend to them which books I consider to be most suitable for a pleasant and helpful start to "learn something more about radio". While the position is certainly much easier to-day when there is a very wide range of books available compared to the mere handful of pre-War days, it is no easy matter to give advice on this point. It is essential to know quite a bit about the person to whom you are commending them.

By beginners' books, one reader might mean only those which treat with the practical side and completely skip fundamental theory. For him, the inclusion of mathematics and formulae immediately condemns the book as being too advanced. Another feels that a book about components and circuits, and just the bare minimum of theory, is what he wants. Others want a really simplified exposition of theory, feeling that practical design is already amply covered by various periodicals. All of them, however, are emphatic in that they don't want ordinary text books which they allege concern themselves with far too much "light, heat and sound".

While I try to advise each according to whatever I judge to be most suited to his needs, I never feel very easy about it. The best advice I can give is for them to contact their local club, most of which run a members' library, and to choose for themselves. They probably will not find the more advanced-looking books quite so formidable once they get really interested.

For lone workers in country areas with no Club facilities there is, of course, the public libraries—most of which seem to have a fair selection of radio books. In any case, either of these courses is best for all beginners as many books, once the edition is sold, are unobtainable from booksellers or the publishers. However well suited I consider

a book to be for any particular reader's needs, it is quite pointless for me to tell him to try books which he might not be able to buy, while all the time a copy is available either in a local Club or public library where he might have found it for himself in the first instance.

Despite this, I readily agree there is need for some sort of guide to radio literature. Possibly, if enough readers are interested, the Editor might arrange a list of the better known books with brief details as to their scope, up-to-dateness, price, whether still in print and whether the primary appeal is to the hobbyist, student or technician.

Wag

A correspondent in a letter published in a national Sunday newspaper claims to waggle his ears independently. It is not just a simple case of the right ear not knowing what the left ear is doing. Apparently, even if one wags while the other stays put they can still work in co-operation. He writes, "During the First World War I could send morse code signals by using my left ear for a dot, right for a dash."

Such an accomplishment might make its performer the life and soul of the party, but to those who know nothing of the use of the morse code it does seem to perpetuate that silly notion that messages are passed by reading dots and dashes (or watching which particular ear is wagged).

Morse is made up of GROUPS of rhythmic sound, and it is perhaps the unfortunate way of putting it on paper that makes it harder for the beginner to learn than it ought to be. Until he clears his mind of what it looks like, or how it would sound if read from print, he simply becomes confused when he hears it. From that, disheartenment sets in and he becomes another who finds he "couldn't get on with it". Once he clears his mind of the unfortunate 'appearance' conception and learns it as sound in its proper grouping, the signals soon begin to 'speak' to him.

I have long believed it would be far quicker for someone who could neither read or write to learn code than for those who can. The non-reader would not have anything to unlearn first!

To simply know that you ought to disregard wrong conceptions before you become proficient isn't enough. You have to condition yourself to it—and it often takes a long time.

It is recorded that Plato regarded the use of writing as an artificial support, which gradually became indispensable to those who used it, so that the exercise of the intellect became less necessary and thus weakened. Whether it is true or not of writing, it certainly seems true of reading morse. It takes the average man quite a little time to forget what it looks



Our Stand at The Amateur Radio Exhibition

like on paper (or the movement of wagging ears should anyone fancy learning it that way). Once it comes to you as rhythmic sound, you suddenly discover yourself reading it—not trying to think it out.

Boomerang

It is reported that Professor A. M. Low advised a Birmingham audience of an effective way to deal with the nuisance of bad-mannered neighbours who keep their radio on at full blast. He suggests the use of an electric fan, preferably an old one with a rough commutator, placed against the dividing wall as close as you can to the point where they keep their radio. You just switch it on when you have had just about as much of their radio as you can stand, and the set next door will give out the most appalling noises.

True. Very true! But what if the neighbour doesn't notice the difference? You have then to put up with the added noise yourself, as well as a beastly draught from the fan!

Off the Record

Some months ago I mentioned that the B.B.C. Studio engineers might be suspected of turning up the wick to provide an apparently noisy applause for some of the third-rate

turns. The term includes some of the so-called stars.

Sorry, gentle reader, to return to the subject once again but a listener (even after allowing for friends and grateful seat recipients in the studio) refused to believe much of the applause was genuine. In fact he went so far as to suggest that it must have been supplied by the Effects Dept.

As no doubt many others are likely to have come to a similar conclusion, the B.B.C. have recently announced that recorded applause is never used.

DESPITE THE FACT

that we are now printing and distributing many more copies of this magazine, we are still receiving letters from readers informing us that they have difficulty in obtaining regular copies. If details are sent to us, then we can take up the matter with the people concerned. Should this prove ineffective, then we shall be glad to supply copies direct, on either 6 or 12 month subscriptions.



spells Quality in
Tape & Wire Recording

**RECORD, PLAYBACK and ERASE HEADS
RECORD-PLAYBACK AMPLIFIERS
OSCILLATOR COILS and UNITS
TAPE and SPOOLS**

**TAPE MECHANISMS AND COMPLETE
RECORDERS READY SHORTLY**

Constructor's Envelope:

Complete Amplifier Equipment
Price 4/3 Post Free (G.B.)

"Magnetic Tape Recording".

By P. T. A. TARRY, A.M.Br.I.R.E.
Fourth Edition revised and enlarged
Price 7/- Post Free (G.B.)

WRITE FOR LATEST PRICE LIST

AUDIGRAPH
LTD.

DEPT. MR8, 74 Gt. Hampton St., Hockley, 5460/D
Birmingham 18

ADCOLA

(Regd. Trade Mark)

SOLDERING INSTRUMENTS



Reg. Design No. 860302

(British, U.S. and Foreign Patents)

Designed for wireless assembly and maintenance. Supplied for all volt ranges from 6/7v to 230/250v. **High Temperature, Quick Heating, Low Consumption, Light Weight.**

3/16" Dia. Bit Standard Model 22/6

1/4" Dia. Bit Standard Model 25/0

3/16" Dia. Detachable Bit Type 30/0

Sole Manufacturers: **ADCOLA PRODUCTS LTD.**

Sales and Service:

50 Clapham High St., London S.W.4. (MAC 4272)

THE BASIC SUPERHET

This book describes the construction of a simple superhet receiver. "Centre Tap" also describes suitable extensions, such as Adding an RF Stage, A Preslector, and a BFO, by means of which the performance can be enhanced to approaching that of a communications type receiver. Coil Data is included. Price 1/-. Postage 2d.

Amalgamated Short Wave Press Ltd.

57 Maida Vale, Paddington,
London — W.9

Telephone: CUNningham 6518

Magnetic Recording Aids . . .

for the Home Constructor

TAPE DRIVE MECHANISM—Sub-assembled kit, finished in an attractive mottled silver grey. Kit includes motor, EMI tape, spare reel, head kit **£14-0-0.**

AMPLIFIER KIT—Designed for tape and wire recorders. The kit may be purchased complete or just those components needed by the constructor. Complete kit
... .. **£9-15-2**

45Kc OSCILLATOR UNIT—If you have an amplifier with a high gain first stage, our oscillator unit will give you the necessary bias. Ready made ... **£2-0-0.**

HIGH GAIN FIRST STAGE PREAMP — This preamp and the oscillator unit makes any amplifier suitable for magnetic recording. Ready made ... **£2-5-0.**

RECORD/PLAYBACK AND ERASE HEAD KIT—Consists of necessary "gen" and parts to construct the heads ... **7s. 6d.**

E.M.I. TAPE AND SPARE REELS IN STOCK. E.M.I. tape, **£1-5-0** a reel; spare reels 4s. 6d. Recording Wire with spools to fit British and American wire recorders, half hour lengths ... **£2-8-6.**

CONSTRUCTIONAL DATA—Wire and Tape recorders, **5s.**; Make Your Radiogram Earn Its Keep, **1s.**; Wire Recorder Manual, **2s. 6d.** Simple Loop Tester, free with stamped, self-addressed envelope.

Write today for price list. Enquiries answered as carefully as possible. Demonstrations given Ask for appointment.

JUDGE INDUSTRIES

783 ROMFORD ROAD Phone ILF 2066 LONDON, E.12

MAGNETIC Sound Recording

Magnetic sound recording is enjoying increasing popularity, and the fact that a number of firms are now supplying kits of parts, components, wire, tape, recording heads, etc., enables the radio constructor to build all or much of the gear himself at reasonable cost. Our contributor has had considerable practical experience of home constructed recording equipment.

The second of a series of articles by E. KALEVELD,
PAØXE

The construction of a Record-Playback Head for tape recording.

THE principle of the head is, as we have seen in part 1 of this series, very simple. However, its construction may offer some difficulties to the reader not equipped with laboratory precision tools, and it was not until many unsuccessful attempts had been made that the writer finally hit on the method described here. First of all, let it be noted that there are two types of head; low impedance, of about 15 Ω , and high impedance of 2000 Ω or above.

Both types have their merits. The low impedance head needs a microphone transformer to couple it to the grid of the input valve in the playback position, whereas it can be connected directly to the secondary of the amplifier speaker transformer when recording. It is less susceptible to hum pickup in the strong magnetic field of the electric motor, but the microphone transformer is very sensitive in this respect, so precautions will be needed with it—though these are easier to apply to the transformer than to the head. Hum pickup is the worst offender when playing back.

The high impedance head can be coupled directly to the grid of the first valve, but is much more susceptible to hum pickup. It will therefore need to be used with a well-screened motor, screening the latter is generally better than screening the head, and should preferably be done with mu-metal. This type of head, in the recording position, should be connected with a series capacitor in the anode circuit of one of the pre-amplifier stages. RF bias injection with the low impedance head is generally done by a separate winding which is connected in series with the rest of the turns

for playing back. RF injection with a high impedance head is usually done capacitively.

In this article, both types of head and suitable amplifiers will be described, together with a bias oscillator. (Both types of head can be purchased in this country by those readers who wish to save themselves the task of construction.—Editor).

Construction of a High Impedance Head

A high impedance head must of course have a bobbin with a great many turns of fine wire on it. To overcome the task of winding thousands of turns of hair-like wire onto a core, use can be made of the bobbins from an old headphone. There are generally two of these in each earpiece, but only one is needed for our purpose.

The next thing required is a piece of mu-metal. We have mentioned this metal before, when we discussed the screening of the motor, and a few words about it may not be out of place. It is an alloy with a very high magnetic permeability, so it is ideally suited to screening parts from magnetic fields. One well known application is for screening cathode ray tubes. It is particularly useful for constructing the core of a head, as it does not retain its magnetism after being magnetised. It consists of 20 per cent. iron, 73 per cent. nickel, 5 per cent. copper, 0.5 per cent. manganese and 1.5 per cent. chromium. Another similar alloy is *permalloy*, consisting of 21 per cent. iron, 78 per cent. nickel, 0.1 per cent. copper, 0.2 per cent. manganese and 0.7 per cent. cobalt. The laminations of several types of microphone transformers consist of mu-metal or permalloy, (e.g., the microphone transformers from No. 19 sets are permalloy). A simple way to test if the metal is one of these

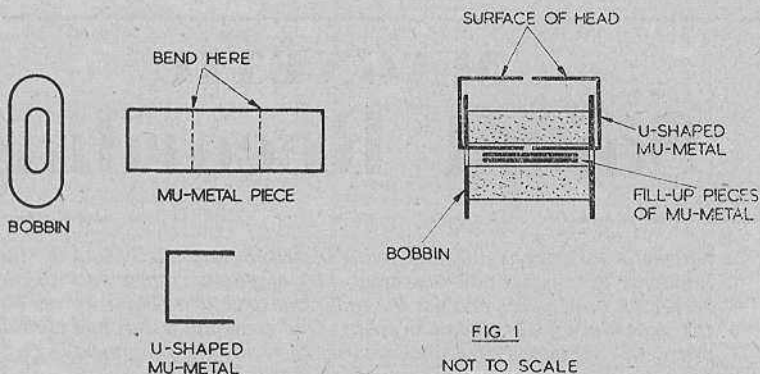

FIG. 1
NOT TO SCALE

C133

Details of Head Construction

suitable laminations is to see whether it rusts! To do this quickly, dip a cleaned strip into a mixture of 10 parts methylated spirits and one part vinegar. Leave in this solution for five minutes and then remove. If the metal is still bright and clean, it is one of these alloys. If not, it will corrode a yellowish red.

To continue with the construction of our head. . . Two pieces of mu-metal, cut to size depending on the dimensions of the bobbin, are folded as shown in Fig. 1. Push into the bobbin, one each side, and fill up the space between with more strips of mu-metal until the bobbin is full. The diagram shows how the strips are arranged. Care must be taken to make the folded pieces as alike as possible, so that the surface of the head is flat. The two folded pieces must be arranged so that a small gap is left between them, as shown, and this gap must be kept as narrow as possible.

The size of the gap has already been discussed in our first article, but no practical dimensions were then given. A good value for amateur work, which can be easily achieved, is 20 micron (a micron is one-thousandth of a millimetre, and 20 micron is the thickness of a cigarette paper). During the construction of the head, push the two 'U' shaped pieces together with a piece of cigarette paper between the two, taking care that the surfaces are flush and the edges parallel. Once the 'U's are lined up squarely, and the bobbin cavity filled with the other pieces of mu-metal, put the whole assembly into the drawer of a matchbox and pour in melted wax. When this has set solid, break off the sides of the box, and cut away the surplus wax. The piece of cigarette paper can be pulled out of the gap, just before

the wax sets. It may be necessary to polish the surface of the head a bit with very fine emery paper, as this surface must be perfectly smooth.

Construction of Low Impedance Head

The writer has found that, in some cases of very obstinate hum, the cure has been to use a low impedance head, so some information on the way to make up one of these may be useful.

The construction is essentially the same, and the details outlined above apply equally well. The only difference, in fact, is in the bobbin. The writer used an empty telephone earpiece bobbin, on which 150 turns of 30 swg enamelled copper wire were wound. A tap was taken off at the 30th turn, the smaller section being used as the voice coil. The remaining 120 turn section was used for the RF bias coil. When playing back, only this latter winding is employed.

The writer has made up many heads in the manner described, and he can state with confidence that the method is absolutely foolproof when reasonable care is taken. The gap is the important item, and every care must be taken to get it true and symmetrical. Examination with a magnifying glass may reveal irregularities not apparent to the naked eye.

So much for the construction of the head. Next month we shall consider the question of suitable amplifiers which may be used with either home made or professionally built heads.

To be Continued.

A Useful . . .

TEST SET

by A. E. Thornton

ONE of the essential parts of any serviceman's or amateur's equipment is, of course, the multi-range meter. The second most useful item is the signal generator. Though the former is comparatively easy to construct, the latter is a totally different proposition; both construction and calibration offer numerous difficulties, while to guarantee stability of calibration over a long term is even more difficult.

The instrument described in the following article has been designed with a view to ease of construction, and at the same time every effort has been made to keep the cost down. If the capacitors, resistors, etc., are available, and only the main items need be purchased, its cost should be well under £4.10.0.

While the signal source in no way supplants a calibrated signal generator for 'lining up' a modern superhet, it has been found invaluable for trouble shooting, providing a check on distortion as well as on short and open circuits.

Ranges

In actual fact, the ranges covered are:—

DC Volts 0—10, 0—250, 0—500.

DC mA 0—1, 0—10, 0—100.

AC Volts 0—10, 0—500.

Capacitor leakage test (not electrolytics).

Radio frequency output.

Audio frequency, both high and low impedance.

Switching

Switching is effected by one eleven-way one-pole switch, and one two-way three-pole switch.

No higher current ranges than 0—1 mA are included, because varying contact resistance makes these unstable. They can be included, however, by running a lead and wander plug from the positive side of the meter to the shunt sockets.

S1 is for selecting individual ranges, and S2 differentiates between AC and DC measurements.

Construction

Construction is fairly simple. All components were included in a crystal monitor case size $7\frac{1}{2}'' \times 5\frac{1}{2}'' \times 5''$, weighing $7\frac{1}{2}$ lb. when finished, though any case of sufficient size could be used. An aluminium chassis was used. As all components are light no special strength is needed here. The layout can be seen from Fig. 2, and the main points to notice are that the $1\frac{1}{2}$ V cell used for the ohms range must be isolated from chassis, as must be the smoothing capacitor C1. The tag board with R's 1, 2, 3, 4, 5, must be mounted far enough away from V to be unaffected by heat dissipated by this valve. Current shunts must carry their maximum current without warming up, as any change of temperature causes a change in resistance value.

All controls are mounted on the front panel and this in turn is bolted to the chassis, making it easy to withdraw the unit from the case for any servicing required.

The actual layout is not critical, and can be adapted to suit individual preference.

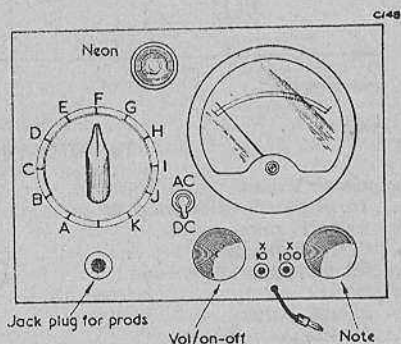

FIG 1

FRONT VIEW

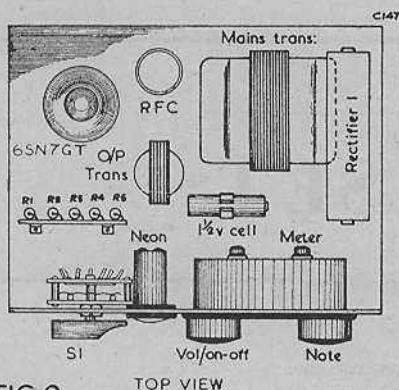

FIG 2

TOP VIEW

Multimeter

This follows standard practice, and presents no real difficulty. The resistors R's 1, 2, 3, are ± 1 per cent., R's 4, 5, are dependent on the rectifier used, and are best made by selecting wire-wound components that give slightly less than FSD on the meter, with full scale voltage

for the given voltage range, and removing a few turns so that the meter registers exactly the voltage applied. Here again they must not warm up or accuracy will suffer.

The current shunts are best wound with high grade resistance wire to give a reading somewhat higher than the true one, and then shorting part of the wiring out by running solder along it until correct deflection is obtained.

Signal Source

This is the part of the test set that is likely to be unfamiliar to many, and though it is so simple, it can be of great assistance in every day servicing. As can be seen from the circuit it is merely a back-coupled, double-triode valve, with a suitable filter net-work across the output.

This circuit, though the fundamental frequency of its oscillations may be low, say 500—1000 cps, has the advantage (in this case) of a wide range of harmonics, reaching well into the radio frequencies. It is these harmonics that we make use of when fault finding in RF and IF circuits.

The variable note control's action is to alter the time constant of the circuit, and this appears as a change in frequency at the output, useful when testing AF stages for distortion.

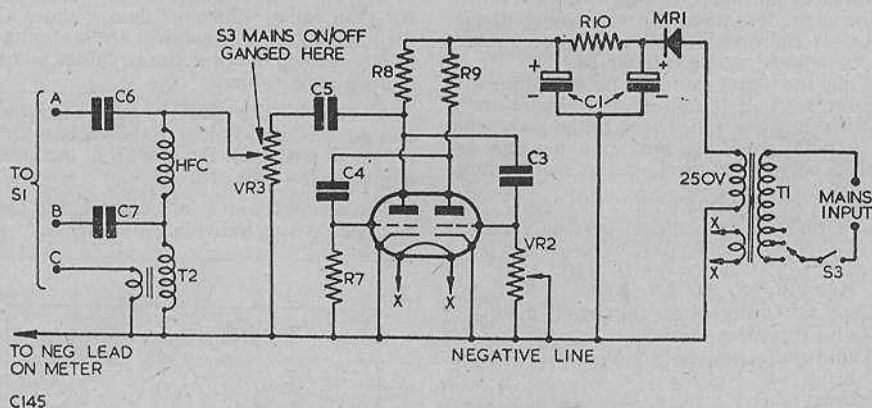

The Multi-Vibrator Signal Source

Component Values

- C1, 16 + 16 μ F, 350V wkg.
- C3, 0.01 μ F, mica.
- C4, 0.01 μ F, mica.
- C5, 0.1 μ F, paper.
- C6, 50 pF.
- C7, 0.1 μ F, paper.
- R7, 3.3 k Ω $\frac{1}{2}$ W.
- R8, 33 k Ω $\frac{1}{2}$ W.
- R9, 33 k Ω $\frac{1}{2}$ W.

- VR2, 50 k Ω pot.
- VR3, 100 k Ω pot.
- V, 6SN7GT.
- MR1, 250V 30 mA.
- T1, Sec: 250V 30 mA, 6.3V 1A.
- T2, Speaker trans.
- HFC, High freq. choke.
- "A", HF output.
- "B", AF output, high impedance.
- "C", AF output, low impedance.

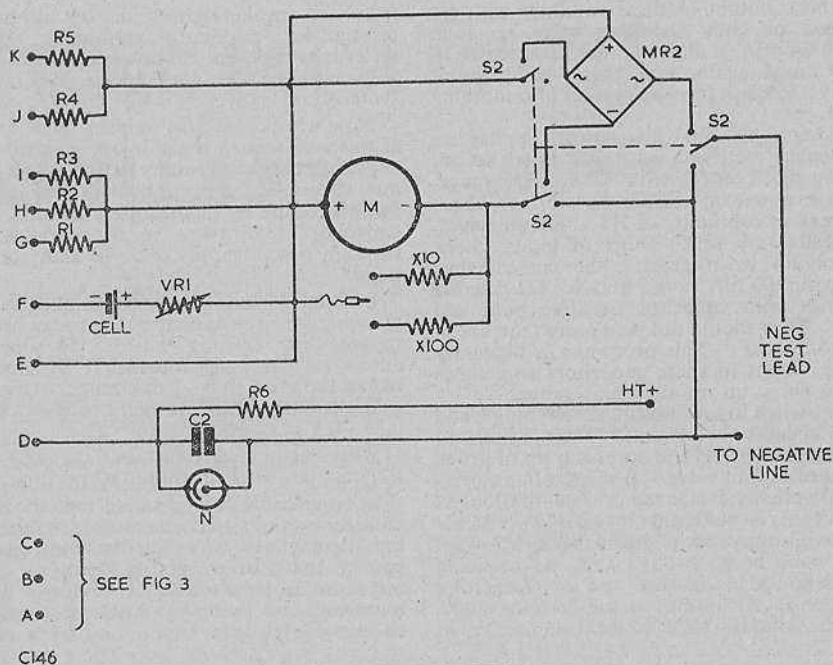

Circuit of The MultiMeter

Component Values

R1, 10 kΩ—Rm, $\pm 1\%$ C2, 0.1 μ F.
 R2, 250 kΩ, $\pm 1\%$. MR2, 1 mA meter type.
 R3, 500 kΩ, $\pm 1\%$. M, 1 mA FSD meter.
 R4, 10V AC range, S1, 11 way, single pole.
 to suit rectifier. S2, 2 way, three pole.

R5, 500V AC range, Letters on left refer to
 to suit rectifier. the contacts of S1.
 R6, 3 MegΩ The positive prod is
 x 10, } Current shunts, taken to the wiper
 x 100, } see text. contact of S1.
 VR1, 2 kΩ.

Leakage Test

This test is intended for paper or mica capacitors, NOT ELECTROLYTICS.

The action of the circuit is this: C2 charges up through R6 until the striking voltage of the neon is reached. The neon then ionises and forms a discharge path for C2. As the neon takes some time to de-ionise, C2 is nearly discharged before it extinguishes, and the whole cycle starts again.

When switch S1 is on 'neon range' and a faulty capacitor is placed across the prods, it forms a leakage path across C2, and prevents the striking voltage being reached. The neon ceases to flicker, and thus provides an indication of the capacitor insulation.

The values given in the diagram are for a neon of 125V striking voltage, and either R6 or C2 may be varied to suit other neons.

Operation

In use, the advantage of having all the ranges available at the turn of a switch soon becomes apparent, but for those unfamiliar with normal fault finding technique it is proposed to give a brief summary of the usual procedure when confronted with a "dead" receiver.

Switch to ohms range, and check primary of mains transformer for continuity. The resistance of this winding varies, of course, with individual transformers, but is usually in the region of 100 ohms. If this is OK check secondary windings. Switch to AC ranges,

and check output of these windings with set switched on, but rectifying valve removed. Switch set off. If all is in order here, switch to ohms range again, and check HT+ point for short to earth from both sides of smoothing choke.

Having ascertained that power supplies are OK, replace rectifying valve, and switch set on, keeping check on HT with 500 volt DC range. If it rises above input from transformer, check for break in continuity of HT+ line to valves. If it falls very much short of input, check electrolytics by measuring the current they pass with 100 mA range, and 4.7 k Ω inserted in series with capacitor negative pole and earth. They should not pass more than about 0.5 mA per μ F. This procedure is necessary because faults in these capacitors sometimes do not show up on the ohms range.

Now switch to low impedance AF range, and check speaker voice coil. Then switch to high impedance AF and approach tip of probe to grid of output valve. It is not often necessary to actually touch the grid connection, as the output is sufficient to give an audible signal while the probe is still an inch or so away. Now work back through the set, touching anodes and grids in turn and not forgetting to switch to RF output at the detector stage.

When a faulty stage is located, (no signal

from the speaker) check the circuit by first testing for grid/earth continuity (leakage tester is useful here if grid resistor is too high to be checked with ohms range. Set must be switched off, however, if this range is used).

Now check HT on screens and anodes. If this is absent or much lower than would be expected, check continuity to HT+ and check any decoupling capacitors with leakage test, but make sure by unanchoring one end of the capacitor, that there is no parallel path through power supply, etc., to short out the neon.

Proceed to check bias across cathode resistor, allowing for drop caused by the meter being in parallel with existing resistor. In superhets, check oscillator for operation by inserting meter, switched to 0-1 mA range, to measure grid current. This is usually of the order of 0.25-0.5 mA.

When making any test but the AC ones, S2 must be switched to the DC position.

In conclusion, it is repeated that the multi-vibrator type of signal generator is *not* intended for aligning new IF or oscillator circuits. It can be used for correcting "strayed" IF's, but input must be to the RF circuits. Additional uses are lining up TRF receivers, and checking for "dead" spots on tuning ranges

BOOK REVIEW

SHORT WAVE RADIO and the IONOSPHERE. By T. W. Bennington. Published for "Wireless World" by Iliffe and Sons, Ltd. Price 10/6d.

This book, which is an entirely re-written and revised edition of "Radio Waves and the Ionosphere," is a *must* for every radio amateur's bookshelf. We thoroughly recommend that all aspirants for the R.A.E., read this book before commencing the examination. It is written with both the professional and amateur uses in mind, and has succeeded, we feel, in successfully tackling the vagaries of ionospheric behaviour in such a way that the beginner can

comprehend, and the more experienced reader will find much to add to his existing knowledge. The presentation is clear and straightforward with a minimum of mathematical treatment. The whole subject is dealt with in simple language, and covers both the fundamentals as well as practical applications. We recommend this book to all interested in the short waves. It will add greatly to the understanding of the media through which our hobby is made possible. A.C.G.

RADIO CONTROL FOR MODELS. By G. Honnest-Redlich. Published by Harborough Publications. Price 8/6d.

The newcomer to radio control will find a useful introduction to the subject in this book. It is written primarily for aeromodellers, but the principles outlined apply equally to any type of model. Radio enthusiasts will no doubt think of many ways of improving the radio equipment described in this book, which goes to prove what we have said before, that this aspect of radio construction work can best be done by liason between keen radio fans and aeromodellers. The book is well produced and beautifully illustrated and will, we are sure, introduce many to a fascinating aspect of our hobby which has been somewhat neglected in this country. A.C.G.

Correction

We must apologise for a mis-statement in the last instalment of 'Query Corner'. The circuit of the TV Frequency Changer was not complete, as given. The EF91 local oscillator should, of course, have been fed from HT+ via a tap on L3, through a resistor (22k Ω) and decoupling capacitor (0.001 μ F).

Did you have Fun and Games?. In Fig. 1, the valve should be supplied with HT. An RF choke will do the needful.

PRACTICAL AERIALS

by "AETHERIUM"

Part 5

Relative Gain

The Flat Top Beam

Tuning Simple Beams

Relative Gain

The multi-element (or Yagi) beams previously described each have a certain theoretical gain figure over that of a di-pole. To this figure must be added the additional efficiency due to a maximum of low angle radiation. This latter value is an unknown quantity, so the quoted gain figures should be taken as the minimum. Figs. 1 and 2 show the two most important benefits obtained from even a simple beam—very little wasted radiation at high angles and a more concentrated, although much narrower, beam. The gain figures for the beams previously described are approximately as follows:—2-element using reflector and tuned for maximum forward gain, 5.5 dB or approximately 3.5 : 1 (it must be remembered that the gain figures are expressed in a power ratio, therefore the simple 2-element beam gives an improvement equal to raising the power input about $3\frac{1}{2}$ times).

2-element using director tuned for maximum forward gain = 5.7 dB or approximately 3.9 : 1

(nearly 4 times the power).

As additional elements are added, the gain figure rises and for a 3-element with 0.1 spacing, it is approximately 7.5 dB or approaching 5 times the power and the 4-element 0.2 spaced beam gives approximately 10 dB of gain, nearly $6\frac{1}{2}$ times the power. Additional directors will give an increase of about 1 dB per element, so theoretically a 12-element Yagi beam would provide something like 18 dB of gain, which is equivalent to raising the input from a 100 watts to $1\frac{1}{2}$ KW.

The beginner is not advised to attempt the construction of such a beam, however, as the procedure for tuning up is very involved, and as additional directors are added the lengths of all other elements are affected.

"Flat Top" Beams for 14 and 28 Mcs

As distinct from the Yagi beam, the Flat Top type contains no parasitic elements. These beams may be used with either a matching stub as shown in Fig. 3 or by tuning the feeders. For the beginner, the tuned feeder

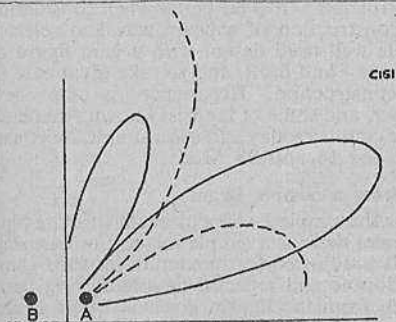

FIG 1 Simple dipole "A". Radiation shown by dotted line. Adding reflector "B" improves angle as indicated by thick lines

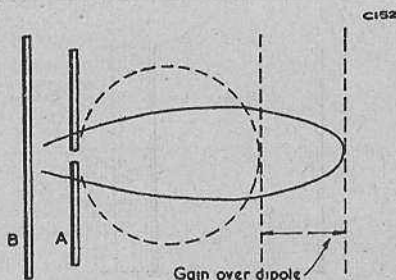

FIG 2 Dipole "A". Dotted line shows horizontal pattern. Adding reflector "B" gives increased toward gain a narrower beam

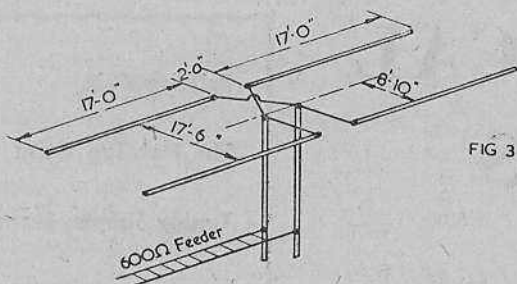

FIG 3 Flat top beam for 14 & 28 Mcs. Stub may be omitted & feeders directly connected.

method is recommended. (Tuned feeders will be discussed later).

The single section flat top beam has a bi-directional radiation pattern broadside to the flat top on both the fundamental and 2nd harmonic, which makes it an interesting aerial for dual operation on 14 and 28 Mcs. The dimensions given are for fundamental operation on 14 Mcs. and/or 2nd harmonic operation on 28 Mcs. The bi-directional gain to be expected is in the order of 4 dB.

As a vertical rotary beam, end feeding is recommended (Fig. 4).

The radiation resistance of these aerials is approximately 600 ohms, but if no 600 ohm feeder is available we may, if we wish, use a matching transformer consisting of 0.8 of a $\frac{1}{2}$ wavelength of 300 ohm ribbon feeder to which is connected the main 80 to 100 ohm balanced feeder. This arrangement will not be quite as good as the stub or tuned feeder method, but will provide a good workable arrangement.

The transformer method also limits the use of the beam to one band, as tuned feeders are necessary for harmonic operation.

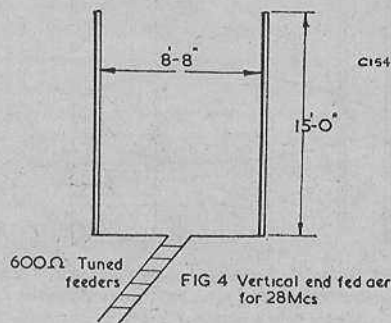

FIG 4 Vertical end fed aerial for 28 Mcs

Rotary Beams for 14 Mcs

On 28 Mcs the rotary beam attains proportions which are just about manageable. For 14 Mcs work, however, we are faced with elements approximately 33 feet long. The problem of supporting such a structure is one thing and having the necessary space to rotate it is another.

Fig. 5 shows how a 14 Mcs beam may be bent and so take up approximately the same rotating space as a 28 Mcs beam. The turned down length of Dural tube will be self supporting, but it is a good plan to strengthen the angle by the method shown in Fig. 6. This will prevent any tendency for the element to whip and break off in a high wind.

Freak Aerials

Many strange aerials have been described from time to time in various journals. One recently was fitted with coils of wire on the ends of the elements reminiscent of a spring mattress. Avoid these like the plague.

Extraordinary claims of efficiency have been made for some of these aerials, but all are Chinese copies of standard types and in the main are not worth the trouble involved in their construction. It is far better when considering the construction of a beam aerial to select a simple well tried design with a gain figure of between 4 and 6 dB, and to take great care in its construction. Experience is the best teacher, and some of the best known Amateurs in the country today still use a simple 2-element beam for 14 and 28 Mcs.

Adjusting a Simple Beam

For the simple 2-element beam (di-pole plus reflector) there is a simple method of ensuring that it is adjusted for maximum forward gain. The di-pole and reflector lengths having been chosen from the figures given in Table 1, are prepared for mounting at the correct spacing, but before doing so the reflector is cut 2" shorter than the figure given and is then cut exactly in half. A spacing of 1" is left between

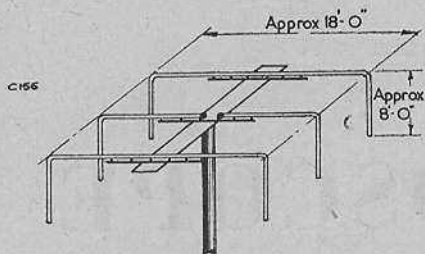

FIG 5 14 Mcs beam with bent elements. See fig 6 for method of strengthening the angles

each half and each piece of tubing is drilled near the end to take a 3" length of 2 BA brass studding (Fig. 7). The two pieces of studding are bridged with a short piece of wire by means of crocodile clips and the beam is then installed in a temporary position as far from the ground as possible, but within reach from a pair of steps or short ladder. An output meter extension should be run from the receiver with the leads long enough to reach to the beam position.

A steady local or semi-local signal is now required. Tune this in correctly on the receiver to give approximately half scale reading on the output meter. Carry output meter to the beam and adjust position of the crocodile clips on the 2 lengths of studding until maximum signal is indicated on the output meter. With the beam, of course, facing the direction of the received signal. (NOTE: If output meter goes off scale do not rotate the

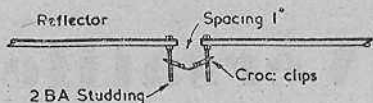

FIG 7 Tuning a reflector (see text)

beam to give less signal indication but reduce the RF gain on your receiver). Having obtained point of maximum signal, a permanent length of stout wire may be soldered across the studding and your 2-element beam is tuned.

Exactly the same procedure may be adopted for a 2-element radiator and director, also for a 3-element beam. In the latter case, however, the operation will take much longer, but if you can enlist the aid of an Amateur friend to produce the necessary steady carrier, this will simplify the operation.

Never attempt to tune a beam on DX signals, as a slight fade or an increase in field strength will give a false reading of the result of an adjustment.

The performance of a beam aerial should never be assessed after only a few days' trial. Conditions change rapidly and it may well be that a period of poor conditions sets in from the day the beam is installed.

An aerial should be given a fair trial for a month or two before any attempt is made to assess the relative efficiency.

(To be continued).

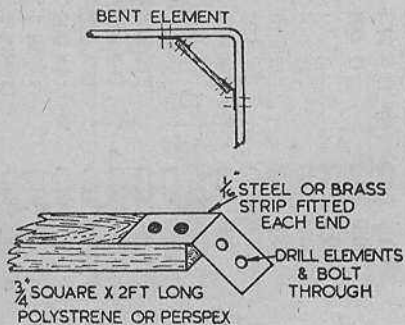

FIG 6 BENT ELEMENT SUPPORT

C156

T.C.C. "PICOPACK" Electrolytics— Improved Connections

A modification has been made to the connections on T.C.C. "Picopack" Miniature Electrolytics.

The outer soldering tag has been replaced by a tubular eyelet to which is fitted a headed and soldered tinned wire. This arrangement offers two advantages:—

- (1) Complete shrouding of the clamped connection in the aluminium lead-out wire, thus preventing the ingress of solder flux which can cause high resistance joints.
- (2) More convenient wire leads for connection into the chassis.

A

Versatile OSCILLOSCOPE

by G. Boston

SOME time ago I realised that, to carry on experimental work on television time bases, an oscilloscope would be necessary. As, like most experimenters, I had to study costs very carefully, it was decided that the cheapest way out was to build one.

There are a number of units on the surplus market which can be very easily adapted, but as the price of these was above the figure which I could afford, other methods had to be found.

The first purchase was the chassis and case of an Indicator BC929A. This unit used a 3BP1 tube, so one of these was also purchased, at a cost of 10s. The chassis of the unit contained a mains transformer wound for 115V 400 cps supply, so this was stripped out and a 250V transformer fitted instead. Some anxiety was felt as to the position of this, as it was fitted near to the base of the tube and to one side of it. Luckily, no deflection of the

LIST OF COMPONENTS

R1, 1 Meg Ω pot.	R34, 2 Meg Ω	C18, 32 μ F
R2, 1 Meg Ω	R35, 2 Meg Ω	C19, 16 μ F
R3, 500 Ω	R36, 500 k Ω pot.	C20, 0.1 μ F 2 kV
R4, 5 k Ω	R37, 250 k Ω	C21, 0.1 μ F 2 kV
R5, 40 k Ω	R38, 250 k Ω	C22, 0.03 μ F 2 kV
R6, 200 k Ω	R39, 200 Ω	C23, 0.1 μ F 2 kV
R7, 40 k Ω	R40, 10 k Ω	C24, 0.25 μ F 2 kV
R8, 100 Ω	R41, 100 Ω	C25, 0.1 μ F
R9, 22 k Ω	R42, 1 Meg Ω	Cf1-8 :
R10, 100 k Ω	R43, 200 Ω	Cf1, 0.25 μ F
R11, 500 k Ω	R44, 10 k Ω	Cf2, 0.05 μ F
R12, 250 k Ω pot.	R45, 10 k Ω	Cf3, 0.02 μ F
R13, 50 k Ω	R46, 1 k Ω	Cf4, 0.006 μ F
R14, 1 Meg Ω pot.	R47, 100 Ω	Cf5, 0.002 μ F
R15, 100 Ω	R48, 1 Meg Ω pot.	Cf6, 500 pF
R16, 1 k Ω	R49, 250 k Ω	Cf7, 200 pF
R17, 10 k Ω	C1, 0.2 μ F	Cf8, 100 pF
R18, 20 k Ω	C2, 10 pF	V1, 6AC7
R19, 200 Ω	C3, 0.1 μ F	V2, 6AC7
R20, 1 Meg Ω	C4, 10 pF	V3, 6AC7
R21, 200 Ω	C5, 0.1 μ F	V4, 6AC7
R22, 100 Ω	C6, 32 μ F	V5, 6AC7
R23, 20 k Ω	C7, 32 μ F	V6, 5Z4
R24, 50 k Ω pot w/w	C8, 0.2 μ F	V7, 3BP1
R25, 500 k Ω pot.	C9, 0.1 μ F	L1, 10H, 60 mA
R26, 2 Meg Ω	C10, 0.1 μ F	MR1, 350V, 40 mA
R27, 500 k Ω pot.	C11, 0.1 μ F	MR2, 600V, 2 mA (J50)
R28, 1 Meg Ω	C12, 0.1 μ F	MR3, 600V, 2 mA (J50)
R29, 1 Meg Ω	C13, 0.1 μ F	MR4, 350V, 40 mA
R30, 1 Meg Ω pot.	C14, 0.1 μ F	(250-0-250V 60 mA,
R31, 2 Meg Ω	C15, 0.2 μ F	TI, { 6.3V 3A
R32, 2 Meg Ω	C16, 0.1 μ F	{ 5V 2A
R33, 2 Meg Ω	C17, 32 μ F	T2, 6V 1.5A

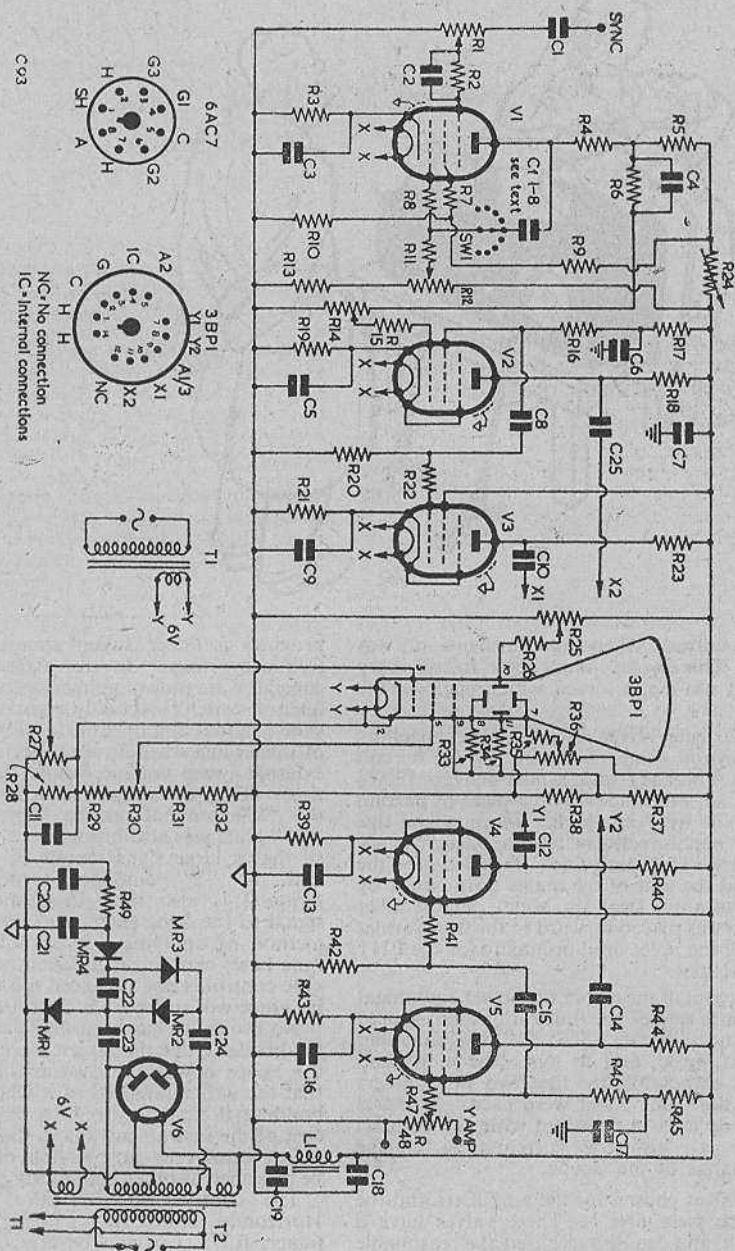

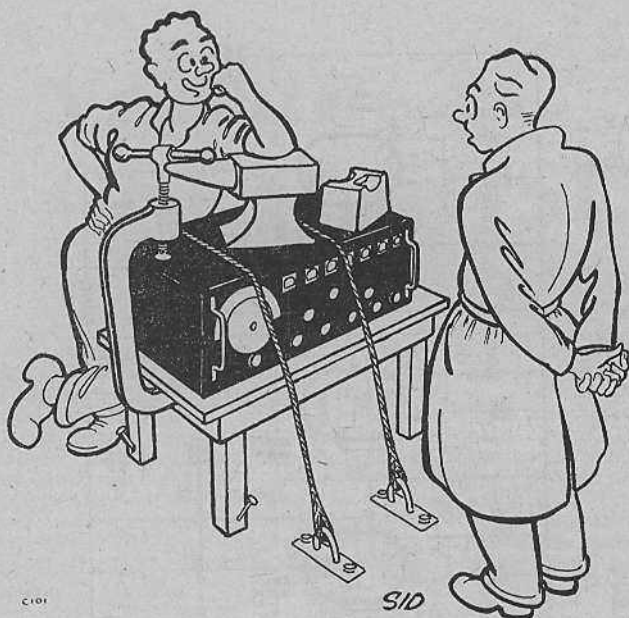

*"With VR91's so cheap,
I put in ten RF stages and
fourteen IF stages!"*

spot occurred when the instrument was tested. This is no doubt due to the very excellent mu-metal screen which encloses the tube.

The next step was to remove all the capacitors and resistors, and to rewire to the circuit shown. The EHT unit, which delivers 1200V to the tube, was made up on a piece of paxolin $3\frac{1}{2}$ ins. wide by $5\frac{1}{2}$ ins. high. Mounted on this are the metal rectifiers and a $0.03\mu\text{F}$ 2 kV capacitor. This unit was fastened to the chassis at the rear of the mains transformer by a piece of angle steel $\frac{1}{2}$ in. wide. The rectifier valve V6 was placed forward of the transformer in one of the holes used originally for the EHT valve rectifier.

The layout of the rest of the power equipment is shown in one of the illustrations and should present no difficulty. The "Y" axis amplifier was next wired, and to make the input lead as short as possible the first two valveholders nearest the front panel were used. The grid and anode leads were wired with $\frac{1}{4}$ in. co-axial cable to save any stray currents affecting the performance of the 'scope.

The valves chosen for the amplifiers and the time case were 6AC7. These valves have a high gain, and can be purchased at a reasonable price from dealers in surplus equipment.

The time base is of quite a simple type, and

provides a linear sweep over quite a wide frequency range. In the diagram only one capacitor is shown going to the coarse frequency switch. Actually eight were used, as shown in the component list. The last position of this switch was left unconnected, in case an external sweep voltage should be used at any time. This, of course, would be applied via the "X" terminal on the front panel. The "Y1" plate was also brought out to a terminal, so that a large signal could be applied there and the "Y" amplifier turned off. This terminal is also used to connect the Sync signal to the Sync terminal. When using this method of applying a sync potential to the time base, care must be taken to see that the sync control is not advanced too far, otherwise the trace will suffer from distortion.

No provision has been made at the moment for blanking out the return trace. At present the 'scope is working overtime, and doing all that the writer required of it when the idea of building it first occurred to him. The total cost of the instrument was in the region of £4, which cannot by any stretch of imagination be reckoned as other than pretty reasonable!

The controls are: Vertical Shift, R36. Horizontal Shift, R25. Focus, R30. Brilliance, R27. Coarse Frequency, Sw1. Sync, R1. "X" Gain, R14. "Y" Gain, R48. Fine Frequency, R12. Amplitude, R24.

QUERY CORNER

A "Radio Constructor" Service for Readers

Sync. Separator

I recently built the *Inexpensive Television receiver*, and, although the results are reasonably satisfactory, I do experience some trouble with the frame time base slipping. Some of the circuit constants have been modified in an attempt to obtain a more positive picture hold, but no appreciable improvement has been obtained to date. Can you provide me with some data on the sync. separator circuit as I believe that is where the fault lies?

D.WHYTE, Chatham.

Most certainly the synchronising pulse separator, to give it the full title, can be blamed for some of the most annoying faults which occur in a television receiver. Among these faults the following are the most frequently encountered.

- (1) Line slipping
- (2) Frame slipping
- (3) Poor interlace
- (4) Line pulling after whites.

The exact causes of these different troubles will be considered later, but first let us take a look at the circuit of the sync separator which is used in the *Inexpensive Television*; this is reproduced in Fig. 1. In order that the circuit should operate satisfactorily it must perform the following functions.

- (a) Separate the video signal from the synchronising pulses.
- (b) Restore the DC component to the input signal.
- (c) The frequency response of the input circuits must extend up to at least 1.5 Mcs.
- (d) Separate the line synchronising pulses from the frame pulses.

This list of requirements may appear to be asking a lot for such a relatively simple circuit but it is most important that each one is fulfilled, and the manner in which this is achieved is most easily demonstrated by means of a number of diagrams.

The waveforms which appear at the different parts of the circuit are shown in the inset circles of Fig. 1, and it will be seen that the sync pulses at the grid of the valve are positive going. If therefore the valve can be maintained at a steady grid bias which is just sufficient to cut off the anode current, the pulses will drive the grid in the positive direction causing anode current to flow in a similar series of pulses, whilst at the same time completely suppressing the video signal. This is of course the most important requirement, that of separating the sync pulses from the composite video voltage, but it cannot be

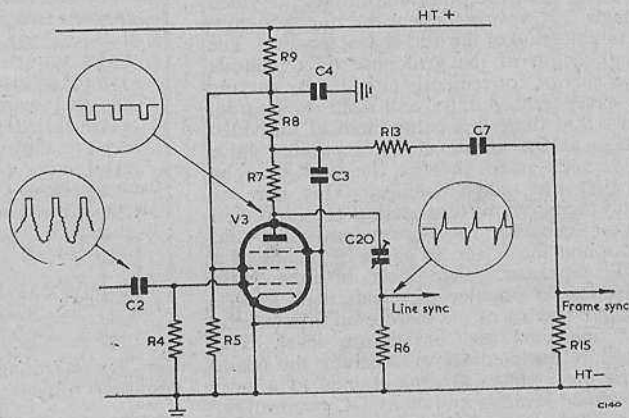

Fig. 1: Circuit of a typical sync separator. The circuit references are those used in the original *Inexpensive Television*.

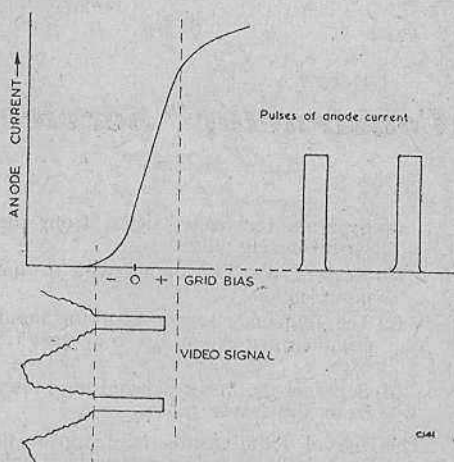

Fig. 2: Showing method of separating the sync pulses from the video signal.

achieved efficiently unless the grid bias is set at an optimum voltage. Now this bias may be obtained and automatically adjusted by arranging that the valve passes grid current on the peak of each sync pulse, this current charging the earthy plate of the capacitor C2 slightly negatively. The time constant of this capacitor and its associated grid leak must be long compared with the interval between pulses, otherwise the charge on C2 will leak away between successive pulses. This automatic adjusting action of the bias maintains the peaks of the sync pulses at approximately the same voltage regardless of their amplitude so that, providing the grid base of the valve is shorter than the pulse amplitude, the video voltage will always appear on the non-conducting portion of the grid characteristic. The actual length of the grid base of a pentode valve may be conveniently adjusted by varying the screen grid voltage, and if an oscillogram shows that there is a component of the video voltage at the anode of the separator valve the remedy is to shorten the grid base by reducing the screen voltage. This may be simply achieved by connecting an additional resistor between the screen and R9, and decoupling the screen to earth by means of a $0.5\mu\text{F}$ capacitor. The effect of inadequate separation in practice manifests itself mainly as severe tearing of the picture on interference or sudden changes in picture level. The procedure outlined above, whereby the peaks of the sync pulses are maintained at a predetermined level, is known as DC restoration.

Turning now to point 'c' in the list of requirements, this calls for a frequency response of the input circuit of the separator extending up to at least 1.5 Mcs. The need for this response will be appreciated from consideration of Fig. 3, which shows the video waveform during one white scanning line. In order that the sync pulse can commence at the correct instant, it is necessary for the signal to change from white to black in less than half a microsecond. If the change is slower than this, the leading edge of the pulse will be masked as indicated by the dotted line in the diagram. This will cause the time base to trigger late and produce the effect known as "pulling after whites". Provided that the vision channel is correctly aligned and has an adequate bandwidth, the fault can occur due to excessive stray capacitance between components in the detector, video or sync'd separator stages and earth. Much of the stray capacitance may be attributed to the coupling capacitors (C1 and C2) which should be mounted well clear of the metal chassis.

The only remaining part of the circuit which has to be considered is that part which separates the line and frame synchronising pulses. The circuit is designed to differentiate between the two types of pulses by virtue of their different duration. The line pulses are fed to the time base oscillator via a differentiating circuit consisting of C20 and R6. This circuit responds to sudden changes in signal level and is therefore capable of passing on the short-duration line pulses. The frame pulses on the other hand are passed by an integrating circuit which consists of C3 and R13; this combination responds only to the relatively long frame pulses and merely absorbs any line pulses which may reach it.

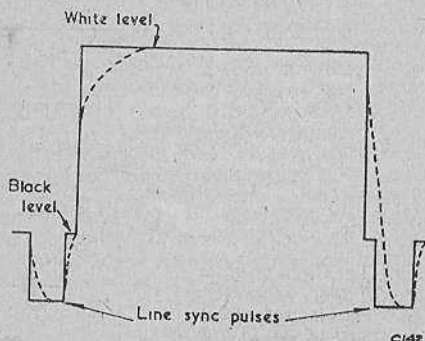

Fig. 3: Indicating the effect of inadequate frequency response in stages prior to the sync separator.

Should it be found that the time bases do not lock-in positively but tend to slip occasionally, and this may be particularly noticeable at low contrast levels, the amplitude of the sync pulses which are fed to the time bases may be increased slightly by the following means. Provided that the stray capacitance in the anode circuit of the separator valve has been reduced to a minimum, the gain of the stage may be raised by increasing the value of R7 to 10,000 Ω and that of R8 to 30,000 Ω .

The only fault not already mentioned is that of poor interlace. This trouble may appear as a continual movement of the line structure of the picture or it may simply take the form of line pairing; that is, the line formation instead of being regularly spaced is divided into pairs of lines. This type of fault is usually due to unwanted coupling between the two time bases, which may occur as a form of backwash via the sync separator or may be due to stray capacity between components. A diode is sometimes included in the frame sync pulse line to prevent the frame time bases upsetting the operation of the line oscillator; however, trouble of this nature has not been experienced with the Inexpensive Televisor. It is, however, very necessary to take precautions against stray capacity coup-

ling, and this may be achieved by the careful positioning of components and the use of metal screens.

QUERY CORNER

"Rules"

- (1) A nominal fee of 2/- will be made for each query.
- (2) Queries on any subject relating to technical radio or electrical matters will be accepted, though it will not be possible to provide complete circuit diagrams for the more complex receivers, transmitters and the like.
- (3) Complete circuits of equipment may be submitted to us before construction is commenced. This will ensure that component values are correct and that the circuit is theoretically sound.
- (4) All queries will receive critical scrutiny and replies will be as comprehensive as possible.
- (5) Correspondence to be addressed to "Query Corner," Radio Constructor, 57, Maida Vale, Paddington, London, W.9.
- (6) A selection of those queries with a more general interest will be reproduced in these pages each month.

Short Wave News

is a monthly journal which deals with all aspects of short wave radio. The constructional side describes short wave receivers, transmitting equipment, aeriels, test apparatus, etc. The amateur and broadcast bands are covered in separate articles, each contributed by an enthusiast in each sphere, and there is usually an illustrated description of an amateur or commercial station. International Short Wave League activities are exclusively recorded in this magazine, and a number of competitions are run for the benefit of readers. Now in its fifth volume, Short Wave News is obtainable from local booksellers at 1/6, or may be subscribed for at 19/- annually.

*The Amalgamated
Short Wave Press Ltd.*

57, Maida Vale, London, W.9

1000's and 1000's
of "VERIES" and
SWL/QSL CARDS

have been supplied for Hams in
many Countries by:

G 6 M N

who knows your requirements

Printer of QSL'S
since 1925

Send for Samples to

G 6 M N
CASTLEMOUNT,
WORKSOP, NOTTS.

Jones and the . . . Electronic Thief Taker

by CYRIL NOALL (ISWL G3479)

WHEN I met Jones at the club the other evening he was in a simply frightful temper.

"Some blighter," he raged, "has been breaking into my workshop and stealing my things! Last week it was the signal generator; last night the test-meter! If only I could get my hands on him!"

Now, Jones is a forgetful fellow—a very forgetful fellow indeed. Remembering this, I said, placatingly:

"Sure you haven't put 'em away in some odd corner. OM? It's very easy to mislay things, you know!"

"Nonsense!" snorted Jones. "I never forget *anything*! They've been stolen, I tell you!"

"Well," I shrugged, "you should know best. Have you called in the police?"

"I have. They checked for fingerprints and found nothing. The fellow must have used gloves. And they've refused to post a guard to catch him when he calls a third time. Say they're too busy. What do we pay taxes for, I'd like to know?"

"Why not sit up for him yourself?"

"On these cold nights?" sniffed Jones. "Think again, brother! But I'll cook his blithering goose—you see! I'm going to instal a burglar alarm of my own design in the workshop. You know the kind of thing—infra-red rays operating a selenium cell coupled to an electric buzzer in my bedroom."

"Jones!" I exclaimed, not concealing my disappointment. "We expect better things of you than this! There's no originality in your suggestion at all! The typical Jones touch is quite lacking, if I may say so! Goodness knows how many existing patents your burglar alarm would violate! What's more, the thing would prove quite impracticable in your case!"

"How so?" snapped Jones. "Why shouldn't an ordinary simple burglar alarm serve my purpose quite well?"

"Because," I retorted, "you're such an infernally sound sleeper that Big Ben himself wouldn't wake you; and, furthermore, the workshop is situated so far from your house that you could never get there in time even if you were aroused. So what, my dear Jones?"

Jones stroked his chin thoughtfully.

"Maybe you're right," he conceded. "I'll have to think up a better device. Call round this evening, and perhaps I'll be able to show you something."

"Good man!" I cried, clapping him on the shoulder. "I knew you wouldn't let down your own great traditions!"

Well, when I dropped in on him at about eight o'clock, I found him putting the last touches of solder to one of the craziest contraptions I've ever seen.

"What on EARTH is this?" I gasped, staring at it in amazement.

Jones smirked with satisfaction.

"It's the Jones Thief-Taker," he said proudly. "This is how it works. When the burglar drops in, he is seized immediately by this old-fashioned steel man-trap. (I borrowed it from the County Museum; the curator is an old friend of mine.) the jaws of the man-trap were pretty sharp, being guaranteed to inflict severe bodily damage, so I've masked them with rubber to mitigate their effect somewhat. After all," he added unctuously, "I don't want to be *too* vindictive towards the fellow—though it was a really super meter he stole!"

"Go on!" I said weakly. "What next?"

"Ah!" said Jones. "This is where the really *clever* part comes in! You see, it occurred to me that our light-fingered friend might also be something of a mechanical genius. In that case he could, if he had a file handy, cut himself out of the trap or, alternatively, unlock the spring and so make his escape. Well, I've made certain that, whilst in the trap, his mind will be so fully occupied with other matters that he'll have no opportunity for planning escapes of that sort."

He pointed to a piece of electrical mechanism.

"Know what that is?" he asked.

"Looks like some kind of timing device to me," I replied.

"It's the Venner Remote Contactor, No. 4. During the War it was used to switch on a transmitter for fourteen seconds in each minute. I've connected it up now to a mains transformer; and so for fourteen seconds out of every sixty, it permits 250 volts at 30 mils

to pass into the fellow seized by the trap! Neat and simple, eh? I don't think he'll have time, in between doses, to get up to any mischief! In fact, he'll be so busy counting his pulses to know when to expect the next shock that he won't be able to think of escaping!"

"You can't do this, Jones!" I gasped. "It's fiendish — devilish! Besides, if the chap has the wrong kind of body-resistance, he may be electrocuted!"

"I don't think so," replied Jones. "He should *just* be able to stand it. Well, what do you think of the idea?"

"It's certainly brilliant — If it doesn't get you hung!" I declared. "Of course, you'll come down and let the thief out as soon as you know he's been caught?"

"What?" cried Jones. "Not likely! I intend him to be well punished for his folly! Let him stay there till morning!"

"You may live to regret it!" I exclaimed. "He could quite possibly be held in the trap for twelve hours or more — long enough to drive him nuts! Look here, OM," I added, "I shall be going to work very early tomorrow — around four. I have to pass your way, as you know; and if I should find anyone in the Thief-Taker —"

"Don't you meddle with this!" roared Jones. "By George, if I find you've switched off the juice or let the thief out — I'll never let you borrow any of my gear again!"

This was, indeed, a frightful threat, for I rely absolutely upon Jones for all my spare parts.

"All right," I said hastily. "It shall be just as you wish, old chap. After all, it's your neck that will get stretched — not mine."

"See that you don't forget, then," growled Jones. "And now I'd be obliged if you'd buzz off. I've still got to test the thing out and make any necessary adjustments. 73's, OM."

The weather was wild and stormy as I passed down Jones' avenue in the wee, sma' hours of the following morning; but above the roaring of the wind I could hear quite another kind of roaring altogether proceeding from the famous Jones workshop.

I stopped outside the door and listened.

"Ooooooh — aaaaaah — oooooow!" came a horrible yell from within. Clearly, the Thief-Taker had gone into action! I pulled back my cuff and began timing the shrieks by the second hand of my luminous wrist-watch.

Yes; for fourteen seconds out of every sixty the air was blue with howls of pain and simply shocking bad language; during the remaining forty-six there reigned a grim, tense, expectant silence!

No doubt about it — the timing device was working like a dream!

I couldn't help grinning at first. Perhaps I'm a bit sadistic by nature, but it always gives me a lift to find that a wrongdoer has been paid out for his crimes with some really fitting and appropriate punishment. But then I began to reflect on how long a time the wretched man had already probably spent in that electrified trap and how much longer he was likely to remain there before obtaining his release; and my feelings changed somewhat.

"Poor beggar!" I muttered, wincing at a particularly purple oath. "It's too bad of Jones — really it is! The thief has suffered quite enough for his depredations, surely"

My hand went to the door-handle. I had fully made up my mind to release him from his misery when I suddenly recalled Jones' dreadful threat.

Yes — to my shame let it be confessed — self-interest caused my kind humanitarian feelings to vanish as suddenly as a W station at fade-out time; and, closing my ears to the frantic yells from within, I hastily turned on my heels and fled.

I almost relented at the bottom of the avenue. A telephone kiosk stands there and I was strongly tempted to slip inside and summon the police. But then I thought again of the plenteous supply of free valves, condensers and resistances that would inevitably dry up if I followed such a course; so I hardened my heart and continued on my way.

It was not till that evening that I learned what had really happened.

It seems that Jones had his Thief-Taker completely wired up and tested by 9.30 p.m. He then went back to the house to get a cup of coffee and glance at the paper. Somewhere around ten, however, he found he had left his cigarette-case in the workshop and went down to retrieve it.

You remember I said Jones is a *frightfully* forgetful fellow? Yes! I knew you'd guess the rest! He rushed into the workshop, completely forgetting the Thief-Taker which he had rigged up just inside the doorway — and got caught in his own electrified trap! It was almost noon on the following day before he was released! You can just picture the state of mind he was in by that time!

But the worst part of his sufferings that night was caused neither by that cruel-jawed trap nor the regular doses of H.T. mils, but by the taunting sight of his "stolen" generator and test meter brilliantly spotlighted by the full moon upon the top shelf where he had put them for greater safety!

Yes, I'll say it once more — Jones has a simply *shocking* memory!

A *Television . . .*

SOUND RECEIVER

by *Centre Tap*

THE extensive number of amateurs successfully undertaking the home construction of television receivers has greatly increased the beginner interest, and it is for this class of reader that the construction of a sound strip on the lines described is intended.

Chassis dimensions are given, but a reduction might well be made after a little thoughtful planning by the more experienced reader, and further reference to this will be made later.

The Circuit

From a quick perusal of the circuit it will be readily appreciated that all the components and valves are commonly to be found in dismantled ex-WD apparatus or on the surplus market. Several of the circuits described for home-built TVs use a similar line-up, but this is hardly surprising when we consider their inexpensive availability and their almost ideal suitability for the purpose. Rarely do circumstances combine so favourably in the constructor's interest! It would seem virtually impossible to plan a layout more straightforward and compact from any widely obtainable gear even if a search outside surplus supplies was made—when the cost would be at least four times as much.

SP61s (or Service type VR65) would serve in place of the EF50s (VR91), but the construction and layout would become a more difficult problem, as the former are "double-ended" with the control grid brought out to the top cap. The sub-chassis screening used with the latter types makes complete isolation of the grid and anode circuits easily possible.

Use of the popular small Aladdin iron-cored coils ensures that unwanted capacitances are kept to a minimum, and liability to unstable operation completely eliminated. Care in securing the windings is essential, as even a small movement will put the receiver off tune.

The Coils

The Aladdin formers may be taken from stripped-down ex-WD gear, but in any case

they are readily and cheaply available from most component stockists. Their winding is straightforward, and 32 swg silk covered wire is used throughout. Each of the three formers has two windings, L1 and L2 being accommodated on the first, L3 and L4 on the second and L5 and L6 on the third. As will be seen from the drawing, the coils are mounted beneath the chassis, large holes being made so that trimming can be done from the top. In each instance, the tuned winding is at the base of the former.

Coils suitable for use on the London TV Sound Transmissions on 41.5 Mcs. are wound as follows:

L1—2 turns L2—7 turns L3—6 turns
L4—7 turns L5—9 turns L6—11 turns

L2, 3 and 5 are the tuned windings and, as previously mentioned, these are wound nearest the base of the formers. The space between the windings on each former is equal to the width of one turn. It will be found best to put a spare turn in this position and then to remove it after both windings are complete.

Flanges can be fitted on the formers to secure the ends of the windings, but it will be perfectly satisfactory to keep the ends in position by a smear of Certofix. It is not important which way round the ends are connected in circuit.

Construction

The chassis and screens are made from 25 swg tinplate, with a top measurement of 12 ins. by 4 ins. It is necessary to solder the chassis return leads to the chassis, so aluminium should not be used. Copper would be otherwise satisfactory, but it is difficult (and requires more heat) to solder. To make perfect joints for all earth return leads to the chassis, a large bit must be used, capable of storing sufficient heat and shaped so that as large an area as possible makes heat contact with the chassis. This is particularly important if copper is used for the chassis, on account of its high heat conductivity. In any case it will take quite a few seconds for the solder to become really molten, and then a slight

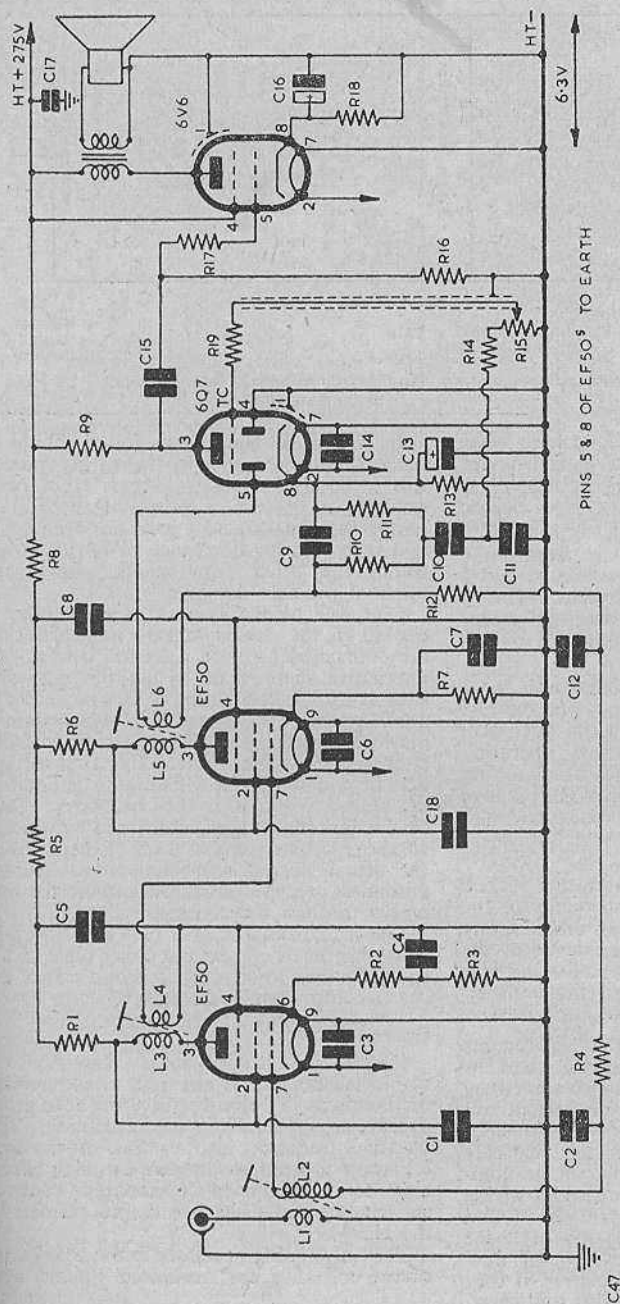

Fig. 1: Circuit of the TV Sound Receiver

COMPONENT VALUES

- | | | | |
|------------------------|---------------|----------------|----------------|
| C1, 4, 5, 7, 8, 11, 18 | 0.001 μ F | R1, 6, 10 | 4.7 k Ω |
| C2, 3, 6, 14 | 500 pF | R2 | 30 Ω |
| C9 | 50 pF | R3, 7, 18 | 270 Ω |
| C10 | 0.1 μ F | R4, 12, 15, 16 | 1 Meg Ω |
| C12, 15 | 0.02 μ F | R5 | 2.7 k Ω |
| C13 | 25 μ F | R8, 13 | 2.2 k Ω |
| C16 | 50 μ F | R9, 11, 14, 17 | 100 k Ω |
| | | R19 | 1 k Ω |

PINS 5 & 8 OF EF50'S TO EARTH

C47

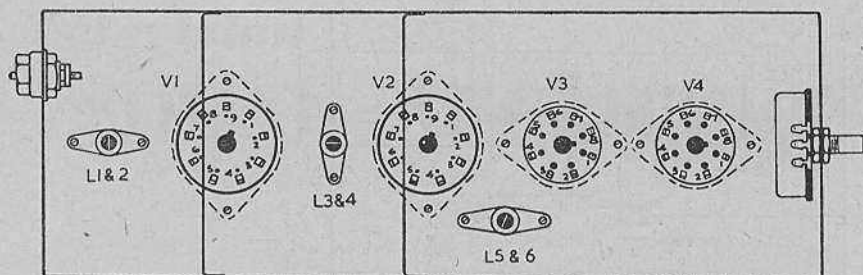

C48

Fig. 2: Underneath view of receiver showing layout of main components.

"rubbing" with the iron will help it to take.

Personally I prefer to use a plain iron for joints of this type, or else a little supplementary heating for a normal domestic type electric iron.

The sub-chassis screens pass across the valveholders V1 and V2, and sockets 5 and 8 of each are soldered to these screens. This in effect is a continuation of the internal screens of the EF50s, isolating the input and output circuits.

Holes must be drilled in the chassis large enough to clear the coil slugs—not only in order that tuning adjustments can be made, with the chassis in its normal operating position, but also because their final setting may require them to protrude slightly above the chassis surface.

Small Dimensions

All the resistors may be $\frac{1}{2}$ watt rating, indeed even 1/10 watt types will be adequate for the great majority and still leave an ample safety margin. All the capacitors should be of the mica postage-stamp type, except for the bias smoothing of V3 and V4 and the 0.02 μ F coupling and 0.1 μ F decoupling capacitors.

The small dimensions of the components will enable the more experienced constructor to reduce the size of the chassis to something very much smaller than that suggested, but the less experienced will do well to keep to the dimensions given. Even so, great care will be needed not to damage other components with the soldering iron when wiring up. A pencil-pointed bit will be found essential, and to make a neat job of it the constructor should acquire a pair of fin-nosed pliers and a pair of sidecutters. If they are not already to be found in his tool-chest.

In wiring, all the chassis joints should be made first—the earlier in the wiring process this is done, the better. Apart from being quicker, it enables a proper inspection to ensure that a satisfactory joint has been made, and it avoids the hindrance of having to get round the other components with consequential possible damage.

One side of the heaters of each valve is carried via the chassis, and the non-earth sides are connected up with screened wiring. An alternative method of wiring the non-earth sides is to pass the wiring from one holder to another *above* the chassis, in which case it may be unscreened. Where it is intended later to add a video receiver, the latter method is to be preferred, as it will simplify the addition of chokes should it be necessary. Such chokes (air cored) are best formed by winding 10 turns close-spaced of $\frac{1}{4}$ in. diameter, using the actual sleeved connecting wire. Rubber grommets are, of course, used where the wire passes through the chassis.

The lead from the grid of V3 to the gain control is screened and the cover plate of the control joined to chassis, as is one side of the speaker transformer secondary.

Operation

It will have been noted that AVC is employed, but this is not used to compensate for fading as in normal receivers, but to avoid overloading in areas of strong reception. The negative feedback in the bias of the first RF stage is used to prevent detuning effects and to maintain a reasonably constant capacitance and resistance despite changes in the bias.

The only tuning necessary is the adjustment of the coil slugs for maximum volume, and

contd. on P.218

FOR

INEXPENSIVE T.V.

RECEIVER R.1355 as specified for "Inexpensive Television". Complete with 8 valves VR65, and 1 ea. 5U4G, VU120, VR92, and a copy of "Inexpensive TV". ONLY 55/- (carriage, etc. 7/6). Copy of book only 2/6.

I.F. STRIP 194. Another of the units specified as an alternative for the above. A first class strip giving tremendous amplification, and well recommended for constructors who have built televisions, but have come unstuck in the vision or sound receivers. Complete with 6 valves VR65, and 1 ea. VR53 and VR92, also a copy of the book which gives simple mod data for both TV stations. ONLY 45/- (post 2/6).

"PYE" 45mcs I.F. STRIP. Ready made for London Vision channel. Complete with 6 valves EF50 and 1 EA50, also mod data. ONLY 60/- (Postage, etc. 2/6).

RECEIVER R.3547. This contains the "PYE" Strip as above, which is easily taken out if desired, and also 15 valves EF50, 3 of EB34, 2 of SP61, and 1 ea. EA50, EBC33, EF36, also shoals of condensers, resistors, etc. An ideal chassis for building up. BRAND NEW IN MAKERS CASES. ONLY 120/- (carriage 7/6). Mod data supplied.

RECEIVER R.3084. A very sensitive unit containing 7 valves EF50, 2 EF54, and 1 ea. VU39A, HYR2, EA50, and also a 30mcs IF Strip with 4mcs bandwidth. Well known to "long distance" constructors already. BRAND NEW IN MAKERS CASES. ONLY 75/- (carriage 7/6).

RF UNITS TYPE 25 for use with R.1355 for London TV. ONLY 17/6 (postage 1/6).

RF UNITS TYPE 26 for use on Sutton Coldfield channels are now all sold but we can supply one of the other RF Units with full details of modifications to cover the TV. BRAND NEW ONLY 25/- (Postage 1/6).

INDICATOR UNIT TYPE 6 as specified for "Inexpensive TV". Complete with VCR97 tube, 4 valves EF50 and 3 EB34. ONLY 67/6 used but good condition, or BRAND NEW IN MAKERS CASES ONLY 90/- (Carriage on either 7/6).

INDICATOR UNIT TYPE 62. Another unit containing the VCR 97 tube, and 16 valves VR65, 2 EB34, 2 EA50, and shoals of components. ONLY 75/- (Carriage, etc. 12/6).

MAGNIFYING LENS for 6in. tube. First grade oil filled. ONLY 25/- (Postage 1/6).

TV PRE AMPLIFIER for really weak areas can be easily made from the ex-RAF amplifier 6046/6050 containing 2 valves EF50, and giving very high signal to noise ratio. Full mod data for both stations supplied. ONLY 22/6 (Post 1/-).

RECEIVER 25/73. Part of the TR 1196. Covers 4.3—6.7 mcs, and makes an ideal basis for an all wave superhet as described in this journal. Complete with 6 valves; 2 ea. EF36 and EF39, and 1 ea. EK32 and EBC33. ONLY 22/6 (Postage, etc. 2/6). Osmor all wave coil pack specified for this conversion 40/4.

Cash with order please, and print name and address clearly.

U.E.I. CORPN.

The Radio Corner, 138 Grays Inn Road, London, W.C.1 (Phone: TErminus 7937)

Open until 1 p.m. Saturdays, we are 2 mins. from High Holborn, 5 mins by 'bus from King's X

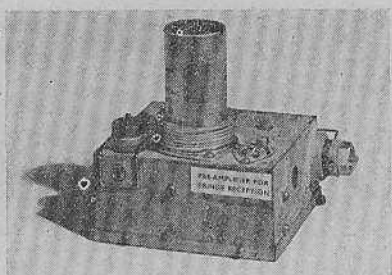

TELEVISION PRE-AMPLIFIER

Just the thing you have been looking for. This Ex-Govt. 1-valve pre-amplifier is extremely sensitive and stable. It makes an amazing improvement in both vision and sound reception in all fringe areas. Now available for both London (type A) and Birmingham (type B). Very small dimensions. Length 4in. Width 3½in. Chassis depth, 1½in. Overall depth to top of valve 4½in. Fitted with EF50 valve. Ready for use. Power requirements 6.3 v. L.T. 200/275 v. H.T. Coax. Input and Output sockets. Ideal for "The Viewmaster", "The Inexpensive Television Set." Electronic Engineer's Television, and any commercial set with suitable power supply. Unique value at the price of

15/- (Post 1/-)

All Tested and Guaranteed before despatch. Prompt Delivery. Obtainable only from

H.P. RADIO SERVICES LTD.

Britain's Leading Radio Mail Order House

55, COUNTY ROAD, WALTON, LIVERPOOL, 4
Tel.: Aintree 1445

CLYDESDALE

Bargains in Ex-Services Radio & Electronic Equipment

TELEVISION CONSTRUCTORS

Indicator Type 62	£3 7 6
Indicator Type 6H	£3 19 6
R1355 IF/VIDEO Ampl.	£3 7 6
R3515 IF/AF Ampl. Unit	£3 7 6
I2.25 Mc/s. I.F. Strip	17 6
R.F. 24 (& R.F. 25) Unit	12 6
VCR 97 6 inch Elect. CRT	£1 15 0
3BP1 3 inch Elect. CRT	£1 2 6

RADIO CONSTRUCTOR

Walnut Wooden Cabinets	£1 5 0
Glass Dials for Above	1 3
Control Knobs	...	Ivory 9d.	Brown 8d.
W/Glass Switch 2w. 3P. 4W.	4 6
.0035 Mfd. 2 gang Tuner	7 6
Loudspeaker 8 in. P.M.	17 6

MISCELLANEOUS

Hand Driven Generators	13 6
P.40 VHF Superhet Rx.	£3 19 6
ET—4336 Transmitter with Sp. Amli.
Mic. Key—Everything	£120 0 0

Order Direct from:—

CLYDESDALE SUPPLY CO., LTD.

2, BRIDGE STREET, GLASGOW, C.5.

Visit our 'Phone: SOUTH 2706/9

Branches in Scotland, England & Northern Ireland

TELEVISION

Picture Faults

*Part ten of a series, illustrated by photographs
from a Televisor screen by courtesy of*

Mr. John Cura.

Part 10 - Interference

INTERFERENCE effects may be classified under two main headings; those caused by intermittent electrical contacts, and those produced by radiated signals from electronic equipment. The former group is the result of short pulses of energy occurring at irregular intervals, and is usually associated with sparking at contacts or switches.

The obvious examples are car ignition interference and radiation from electrical appliances such as vacuum cleaners and electric bells. These are experienced to a greater or lesser degree by all television viewers, and their effects are well known. The distance that this form of interference travels varies with the conditions under which reception is carried out.

The effects will obviously be more noticeable

when the signal strength is low and the receiver has to be operated at high gain. The bandwidth of the receiver has some bearing here as the wider the bandwidth, the more likely is interference to be picked up. This, unfortunately, does not justify a reduction in the bandwidth in an attempt to eliminate the interference, as a very great reduction would have to be made if it were to produce a noticeable decrease. The result would be a serious diminution of the picture quality, and it is therefore not a practical solution to the problem.

The bandwidth of a sound receiver being very much narrower than that of a vision receiver and interference from cars more noticeable, the statement in this case would seem to be contrary to the facts, but is not so. The reason is that a much greater amount of



*Fig. 1: 'Snowstorm' effect
caused by car ignition interference.*

(John Cura 'Tele-Snap')

Fig. 2: Interference caused by an electric motor of the brush type as used in vacuum cleaners, electric drills, etc. Note loss of interlace on this occasion.

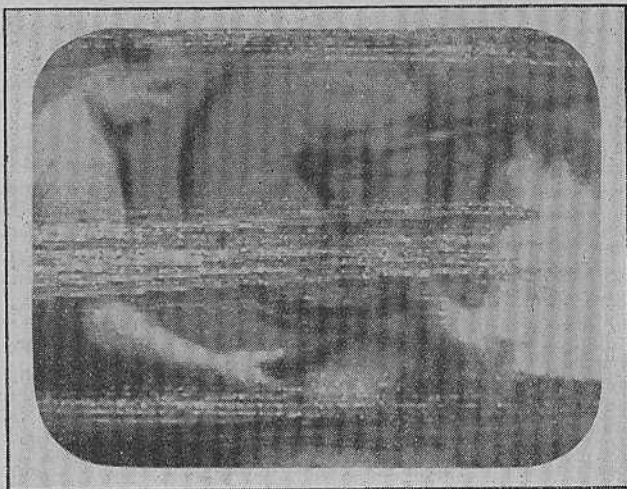

(John Cura 'Tele-Snap')

interference can be tolerated on a picture than the ear will stand. When one considers the wide variations in bandwidth and response of a vision receiver that will give a passable picture, which if applied in proportion to a sound receiver would give very poor quality, this point is easily understood.

Effective elimination of pulse type interference can only be carried out at the source, and in the case of cars complete suppression can be achieved by fitting suppressors. Electrical appliances which radiate noise require a different technique, and complete suppression generally means considerable trial and error in order to find a satisfactory method. This usually consists of capacitors to bypass the noise pulses, RF chokes to prevent the noise passing into the power leads, and resistor and capacitor combinations to reduce sparking at contacts and brushes. A considerable amount of information on interference suppression is available elsewhere, so will not be reproduced here.

Reduction of pulse interference at the receiver may be carried out by applying some of the many noise suppressor circuits which have been published. These generally use diodes or rectifiers arranged so that they bypass pulses which exceed the amplitude of the incoming signal. Another method, very effective on vision receivers, is to apply heavy negative feedback to the video stage during noise pulse periods. This produces black "splash" on the screen, which is much

less noticeable than the bright "splash" which is still passed by other types. It is not easily adaptable to sound receivers.

If the radiation comes from a definite direction, some improvement may be made by arranging the aerial system so that it gives low gain in the direction of the source of interference. This can be quite effective if the signal strength is high, but will be of little use in remote districts as every microvolt of signal will be needed, and rotation of the aerial system will not produce a sufficient change in signal to noise ratio to justify this method.

To be Continued

Many thanks

..... to the numerous readers,
 from home and overseas,
 who sent Christmas Greetings and kind wishes for
 the future.

ANSWERS TO QUIZ

(1) Mr. Brain was either feeding a negative-going signal to the grid, which should have a positive-going input, or was applying a positive-going signal to the cathode, which should be negative-going. Among other causes, perhaps the most likely is reversal of the diode detector. In most cases of negative picture, sync. is erratic or missing.

(2) This is one case where a good component may make a poor performance seem worse. A high grade speaker will reproduce very faithfully everything which is applied to its speech coil within a range of perhaps 30 to 15,000 cps. If the input is beyond reproach the results will be superb, but the ability to reproduce everything will rapidly draw attention to the deficiencies of poor equipment. Heterodyne whistles, valve noise, needle scratch and high harmonic distortion will be delivered with ruthless efficiency by the excellent top response; down at the bass end will be mains hum, motor rumble and the unpleasant effects of overload of the output stage on bass notes.

A small speaker with narrow response functions as a filter by its inability to reproduce the top and bottom frequencies. Where cheapness is essential, this makes it possible to cut the smoothing and permit some of the high AF slush, the removal of which would lead to circuit complication and expense. A most lamentable procedure.

On the other hand, the foregoing will show that it is a waste of money to buy a top-grade

speaker unless one is prepared to make the rest of the equipment of comparable quality.

(3) Everything which increases the distance to be travelled by sound from the front to the back of the cone counts as baffle. With a box, the sides, bottom, and top form an extension of the distance and are therefore to be included.

(4) Wrong. Using the simple formula for area, πR^2 , we have for a 6-in. screen $3.1414 \times 3^2 = 28.27$ sq. in. For 12-in. diameter, the area is $3.1414 \times 6^2 = 113.09$ sq. in. Something like four times the area.

Again, using the old aspect ratio for simplicity, the picture size is 5-in. \times 4-in. = 20 sq. in. for a 6-in. tube, and for a 12-in. tube is 10-in. \times 8-in. = 80 sq. in. — four times the area.

(5) The blocking oscillator. This explains its popularity in magnetic circuits, where the output valve requires a positive-going sawtooth. The transitron, excellent though it is in many respects, delivers a negative-going sawtooth which requires an extra valve to reverse its phase for application to the output valve.

(6) The high voltage during the flyback is likely to bridge the gap between the anode and other tags and pins where the usual base arrangement is used. Furthermore, the internal spacing in many such valves is insufficient to prevent flash-over. These difficulties are avoided by bringing the anode lead out at the top.

TV SOUND RECEIVER

contd. from P.214

when adjusted the slugs are secured against movement by pouring in a small quantity of molten wax. An ample supply of wax can be obtained from an old discarded capacitor. The usual vertical TV dipole aerial should be used. It is best made from dural rod or tube of 1-in. diameter, the length of each arm being 5 ft. 3 ins.—a compromise between the video and audio signals of the London transmissions.

The receiver will give very strong signals within 30 miles of Alexandra Palace at the average location. At greater distances, a reflector should be added behind the dipole, this being 10 ft. 9 ins. long. It is, of course, not connected in any way to the dipole, and is placed approximately one half-wave (5 ft. 6 ins.) behind it. Should the constructor at greater ranges wish, an additional RF stage

could be added before V1. The circuit for such a stage would be exactly the same as that of V1.

MODERN RECEIVER ALIGNMENT

Contd. from P.193

slowly. The response should then be checked. If there is any improvement then the chosen trimmer should be experimentally adjusted until an acceptable response is obtained. All the trimmers should be tried, as it is sometimes found that the slight alteration of a particular one yields dramatic improvements. The trimmers must never be so far detuned that they cause a heavy fall in sensitivity, only a slight alteration being needed in practice.

Next Month

In next month's article we shall leave the subject of aligning the IF transformers and pass on to the signal frequency and oscillator circuits.

YOUR WORKSHOP

In which J. R. D. Discusses Problems and Points of Interest connected with The Workshop side of our Hobby, based on Letters from Readers and his own Experiences.

HERE we are again! Now that this series of articles has got under way it is possible for the writer to assess more easily the requirements of his readers and to quote extracts from their letters in order to spread further a few of the good ideas which they have utilised in their workshops.

For instance, R.H.J. of Gloucester, sends an interesting wrinkle with regard to those useful little things which are found in most workshops—razor blades. He says:

"In company with most constructors I have often left a few razor blades in my shop for odd jobs but found that I was continually losing them. Once or twice, coming upon one accidentally, I have also cut myself. Hardly a satisfactory state of affairs!

"I got over the trouble by mounting an old permanent magnet above the bench; the razor blades being stuck onto it. Whenever I have finished using a blade, I just throw it in the direction of the magnet, whereupon it is attracted to it and stays ready for the next time I need it, out of harm's way."

Yes, a good idea, R.H.J. A permanent magnet now adorns the wall of this writer's shack! It also comes in useful for odd nuts and bolts, equalising files, and all the other small impedimenta which so easily lose themselves.

AC/DC Receivers

Do you do much servicing work in your shop? From the letters received it seems that quite an appreciable amount is carried out by amateurs, and a certain amount of apprehension is felt with regard to working on AC/DC receivers. This is very understandable since these sets are quite definitely capable of giving nasty shocks.

The method adopted by the writer is to make certain that, should he touch the chassis of an AC/DC set whilst it is switched on, he is himself free from earth and cannot therefore receive a shock. A wooden floor helps to ensure this, and to make doubly certain he usually sits on a bench stool with his feet off the ground.

Apart from the normal precautions against

shock, it is also worth while taking care to see that no earthed object touches the set whilst it is connected to the mains. For instance, when a signal generator is used to align an AC/DC receiver, its test leads should not be connected to earth. Or again, when an earthed soldering iron is used, the receiver should be entirely disconnected from the mains before the iron is applied to any part of it.

It must be remembered that the on-off switch in the receiver cannot be relied upon

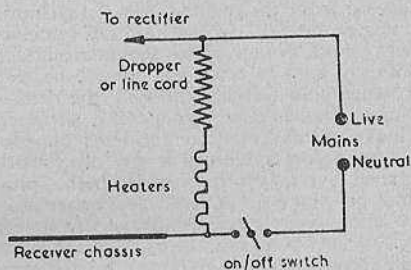

FIG 1a

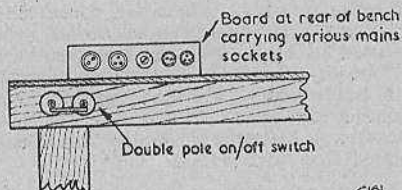

FIG 1b

Fig. 1 (a) Illustrating the fact that the on-off switch of an AC/DC receiver does not necessarily isolate its chassis from the live side of the mains.

Fig. 1 (b) To ensure complete isolation from the mains a double-pole switch may be fitted at an easily accessible position on the front of the bench.

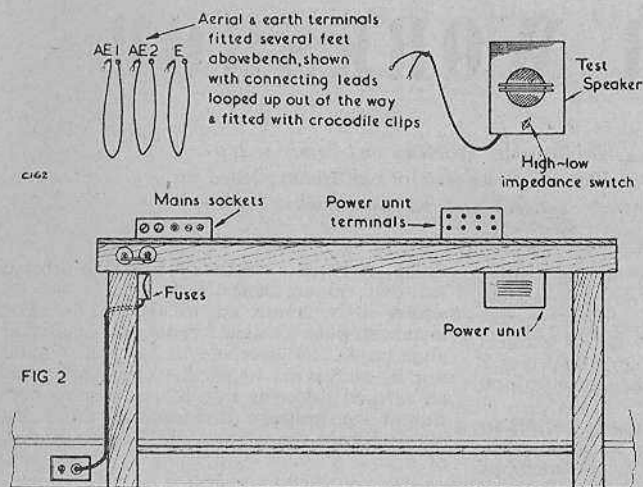

Fig. 2 A layout showing the electrical services which may be fitted to the workshop bench.

to ensure that the receiver chassis is disconnected from the mains. Fig. 1 (a) shows the heater circuits of an AC/DC receiver whose on/off switch is in the neutral lead (as often occurs in practice). It will be seen that, when this switch is opened, the chassis becomes live via the heaters and dropper. To make certain that no accidents happen, therefore, before soldering or any other work is carried out in the receiver its mains plug should be removed entirely. A better way of ensuring complete disconnection from the mains is shown in Fig. 1 (b). At the back of the bench is fitted a board with several different types of sockets which are used to take the mains plugs of the receivers which are being serviced. These are connected to the mains via a double-pole on/off switch mounted in an easily accessible position at the foot of the bench, this switch breaking both mains leads, live and neutral. Thus, whenever any work in the receiver proves necessary it may be instantly and reliably isolated from the mains.

Bench Electrical Facilities

The writer mentioned just now the fitting of a row of different sockets to the rear of the bench for testing the various receivers which are encountered. This definitely proves to be a useful asset and overcomes the somewhat Heath Robinson lash-ups which may otherwise occur when a quick connection to the mains is needed.

Whilst on the subject of bench facilities,

there are other arrangements which may also be fitted up in one's shack. Fig. 2, for instance, shows a layout which should meet the requirements of most amateurs. It will be seen that the board carrying the various sockets is mounted at the rear of the bench. These individual sockets could consist of a two-amp two-pin, a five-amp two-pin, a five-amp three-pin, a fifteen-amp three-pin and a bayonet socket; in addition to a small pilot lamp, if desired, which would show when they are switched on. Local fuses for these sockets are also fitted to the bench, the whole being supplied from a normal power point in the workshop. A separate socket or sockets could be mounted elsewhere on the bench to feed signal generators, soldering irons and so on.

Two aeriels and an earth connection are also provided, these being brought to terminals several feet above the bench. Flexible leads with crocodile or bulldog clips are fitted to these terminals so that they may either be quickly applied to the equipment under test or clipped out of the way.

A test speaker is also available, this being fitted with a switch that allows it to offer either a high or a low impedance, (see Fig. 3). This speaker is fitted with test leads as well, and these also may be hung out of the way when not required.

If a lot of experimental work is being carried out, it is helpful to fit a permanent power pack to the bench; this being used to provide

heater and HT voltages for the experimental rigs. A series of heater voltages such as 4, 6.3 and 12.6 AC, plus HT voltages of 150, 200 and 250 at about 100 mA or more, would prove extremely useful if brought out to terminals on a board at the back of the bench, as shown in Fig. 2.

A Service for Readers

And so we come to the end of another month's article centred around the amateur's workshop. The reader is reminded that, if he has a workshop problem, if he has used any novel or original dodges, or if he has equipped his workshop in any manner which might prove of interest to other readers, we are only too pleased to hear from him. In all cases and in all matters appertaining to the workshop the reader is cordially invited to drop a line and so join in these monthly discussions.

It is desired to make this series into a really useful service for readers in which the regular interchange of ideas and opinions assists all of us not only to find out how "the other fellow" solves his problems but also to realise

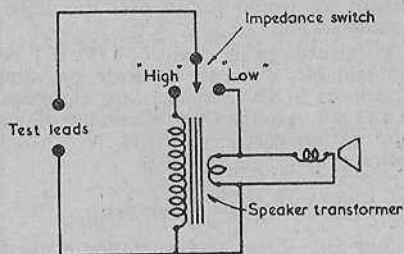

FIG 3

C165

Fig. 3 Showing how a "high-low" impedance switch may be fitted to the test speaker.

the facilities with which he works. It should be remembered that it is in ways like this that the fascinating hobby of amateur radio construction is continually being built up by mutually helpful people. And, of course, even the smallest point is of interest and will be properly dealt with, or the information will be passed on in the articles themselves

"from our

MAILBAG"

Using RF26 Unit

Dear Ed.—Re letter by Mr. T. Walker in "Mailbag". Cannot understand reason for background noise with RF 26 Unit as stated in fault No. 1. Think I can help our friend with fault No. 2. IF Breakthrough.

I have had this trouble with both RF 26 and 27 Units, the RF 24 and 25's are O.K. This may be due to the locality or because I am still using a London H type aerial. I have not found the cause of the trouble, but have cured the breakthrough by means of a wave trap made from a spare 1355 IF transformer. These transformers are advertised in various magazines quite cheaply. A 15 pf capacitor is to be connected across the coil. Any other components that are fitted are removed. The coil is connected in series with the coax. lead from the aerial. I am using a switch unit, type 10H/528 and this unit switches the aerial to either vision or sound or both. The IF can was fitted on the lid

of this and connected across the input socket and switch. By adjusting the iron dust core I can cut out Moscow which seems to be the biggest culprit. Previously Moscow could be heard all over the dial when S.C. was not on the air.

With regard to fault No. 3, I have found that by decreasing the value of C.9. (DB4 page 16) with a corresponding increase to R16, I can improve the linearity. No fixed values can be given as I find that one time base will differ from another.

I also find that by increasing the value of one of the high voltage capacitors to the Y plates and leaving the other capacitor at its original value will help to correct this fault. The side to be increased can be determined by results shown on the screen. In the event of a bright line at the bottom of the picture, increasing the value of C13 will cure this. Non-linearity on the X plates can usually be overcome by adjusting R23. All values of course are found by experiment. Thought

perhaps you would like to pass this dope on to your readers.

By the way, in the event of 1355 IFT being unobtainable, one can be made by winding 30 turns of 36 SWG enamel wire, close wound on a 11 mil. Aladdin Coil former, but of course must be screened.—Vy73. H. W. Arundel, (Birmingham).

Magnetic Sound Recording

Dear Sir,—I was very interested in the first of the series of articles on Magnetic Sound Recording by E. Kaleveld, and I am looking forward to the continuation of the series. There is one statement I would like to correct, however, and that is "The frequency response is good, being better than with normal gramophone records (60—7,000 cps at normal speeds). In actual fact, the frequency response of normal discs is far superior, being from 30—14,000 cps and this includes long-playing which have virtually no surface noise, are unbreakable, play up to 25 minutes and from a commercial aspect are very easy to mass produce in thousands, at the same time I would like to point out that both E.M.I. and Decca's are using tape for recording the actual studio performance, which is then transferred to discs, showing what can be achieved with tape recording when using really good equipment under studio conditions. Yours faithfully, J. A. McCarthy, (Kingston-on-Thames).

Intermittent Heater Supply

Dear Sir,—Recently, whilst experimenting with a mains receiver, I had occasion to disconnect the heater supply while the H.T. was still applied to the valves. I was very surprised to find that the receiver continued to play for a considerable time.

I therefore carried out some experiments and found that it was possible to keep an average 6.3 volt valve working (after it had warmed up) with the heater connected to its supply only for half the time the valve was being used. For instance, if the heater were disconnected for 15 seconds the cathode would still continue to give full emission, it being necessary to connect it up again for another 15 seconds to enable it to maintain its temperature. Thus, the valve would function quite normally although its heater supply were connected only for 15 seconds out of every 30.

The advantage of this seems to me to be immediately obvious when such things as car-radios and other such battery-driven sets are considered. As the heaters are only con-

nected for half the time, the drain on the battery caused by the heaters would at once be halved.

A timing circuit to switch the heaters would be quite simple to fit to a battery-driven radio. For example a 1.5 volt battery valve connected to a simple 15 second timing circuit could operate a relay, whilst the additional drain on the batteries occasioned by such an arrangement would be very small indeed.

I wonder if any of your readers have investigated the possibilities of such an arrangement. Yours faithfully, P. J. Jackson, (Swansea).

EHT for 7/6

Sir,—I have been using an EHT supply upon the lines detailed by your contributor H. W. Arundel, (Oct. and Nov., 1950 issues), and have had every satisfaction. However, the second notice of the non-availability of these EHT transformers is incorrect. My source of supply was Messrs. C. Marks and Co., of 30, Commercial Road, Newport, Mon., and these items are still available at the original price of 3/6d. As your article indicates, they are good and practical value for money.—I am, Sir, Yours faithfully, James R. Cook, GW3AAA, (Cardiff).

Dear Sir,—When reading through the December issue of "Radio Constructor", I came across two circuits, which are worthy of comment. These are for two ways of connecting an EHT rectifier valve in such a way as to remove the need for a highly insulated heater winding.

The first circuit is correct and the rectifier cathode is at earth potential all the time. Actually as drawn the heater winding on the transformer is in series with the EHT output and so will contribute some AC component that must be removed by the smoothing. The percentage ripple introduced by this means is of course very small, with an EHT voltage of the usual magnitude.

The second circuit is, however, decidedly wrong and what is more is very dangerous. The reason for this should be immediately apparent if the conducting and the non-conducting cycles of the rectifier are considered separately.

(a) Conducting

The cathode of the rectifier has negative regard to the anode, and so the live end of the EHT winding of the secondary of the transformer is positive relative to earth. Assuming that no load is taken, or a very small load, the smoothing condensers are charged to a PD of $\sqrt{2} \times \text{RMS}$ voltage of the transformer. If some current is being drawn, the mean PD across the condenser during both

conducting and non-conducting cycles is somewhat less than this value. During this conducting cycle, the rectifier heater winding is slightly above earth potential, by the drop across the valve, perhaps some 50—100V.

(b) *Non-Conducting Cycle*

During this cycle, the PD across the condenser, or more accurately the mean PD is the output voltage, the live side being positive with regard to earth. The lower end of the EHT secondary is positive with regard to the other end, which is connected to the live side of the condenser. This lower end of the secondary is connected to the rectifier heater winding, which is thus at a potential of the output voltage *plus* the peak voltage of the EHT secondary above earth. This potential under light load conditions is thus equal to approximately $2 \times \sqrt{2} \times \text{RMS EHT voltage}$ or nearly 3 times the output voltage. To make matters worse this high voltage is not steady as it would be with the normal connection of the heater winding, but is pulsating sharply at a frequency of fifty times per second. This means that the stress on the insulation of the heater winding is very great indeed.

As this circuit has been tried and proved to be satisfactory in this one case, Mr. Jenks must consider himself very lucky that his transformer stood up to this treatment. It also reflects great credit on the manufacturer of the transformer. If the insulation of the heater winding had gone down, the result would most certainly have been a damaged heater winding and a burnt out EHT secondary.

Yours faithfully,

J. T. HYMAN (Bexleyheath).

Radio, Television and Society

The publication of the Beveridge report on broadcasting is certain to heighten public interest in radio and television. Therefore it is of special interest that the Oxford University Press are publishing, on the 4th of January, Charles Siepmann's *Radio, Television, and Society*. The author worked for twelve years in high administrative positions with the B.B.C., and has done considerable work on radio in Canada and the United States. In his book Mr. Siepmann examines the whole problem of Sound broadcasting in America, Great Britain, and Canada. His purpose is to demonstrate the far-reaching effects of radio and television upon our tastes, opinions and values, and to consider broadcasting in relation to propaganda, free speech, and our relations with the rest of the world. His thorough examination of this whole subject is particularly pertinent at the present time, when the future of our own broadcasting system is under review.

DANGER — HIGH VOLTAGE?



IT MIGHT HAPPEN TO YOU!

COULD you meet your commitments on the National Insurance Benefit?

An accident or period of illness can cause serious financial embarrassment. A "SCOTTISH" policy will protect you at a very low cost.

A quotation will be sent on receipt of details of your age exact occupation and the weekly benefit required.

**Scottish Insurance Corporation
Ltd.**

62/63 CHEAPSIDE LONDON E.C.2

Inexpensive Television

The fourth in our popular Data Book Series, this publication describes the construction of television receivers from ex-Govt. surplus equipment, which is cheap and easily obtainable. This book was published in its original form some twelve months ago, and sold 40,000 copies. With its aid, television sets were built which operated far outside the normal service areas, and in all parts of the country.

The new edition, which is double the size, gives a much wider choice of equipment suitable for conversion, and will be equally popular with all television constructors.

PRICE 2/6 (post 2d.)

from your local supplier or direct from

**AMALGAMATED SHORT
WAVE PRESS LTD.**

**57 Maida Vale, Paddington, London
W.9**

'Phone: CUN. 6518

RADIO CONSTRUCTOR

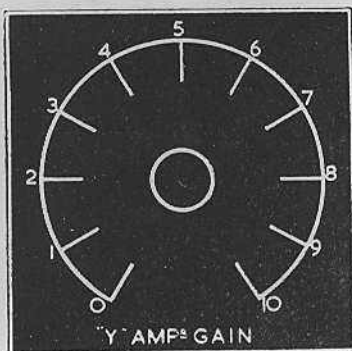
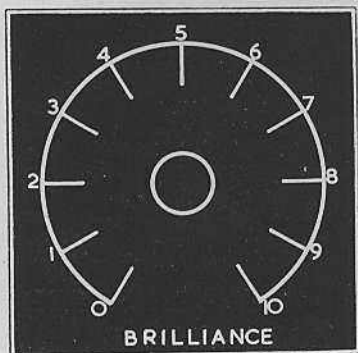
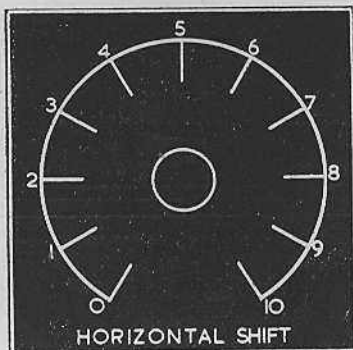
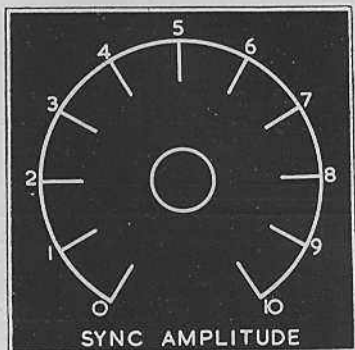
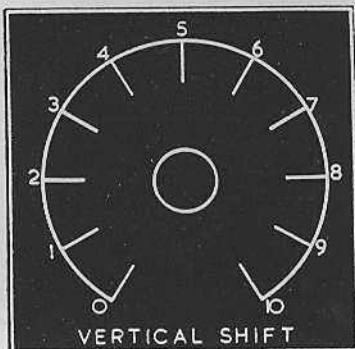
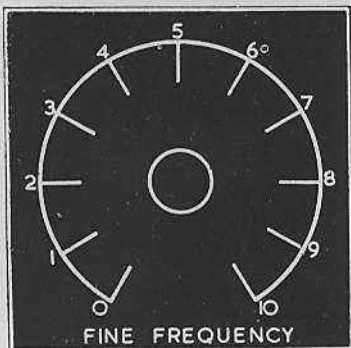

Panel Sheet No. 7

Oscilloscope Controls (1)
Protect with Sellotape or Clear Nail Varnish