



Radio Constructor

Vol. 2, No. 8

Annual Subscription 16/-

March, 1949

(Waiting List)

Editors:

ARTHUR C. GEE, G2UK

W. NORMAN STEVENS, G3AKA

Technical Editor:

LIONEL E. HOWES, G3AYA

Advertisement & Business Manager:

C. W. C. OVERLAND, G2ATV

Editorial

“Walk Before You Try To Run.”

EVERY so often we receive a letter from a reader asking for instructions on how to get such and such a piece of gear going, or for further details of how to construct one of the designs published in these, or other magazines. And then, too, we get letters asking how to tune up complicated pieces of ex-Service gear. When one comes to sort out the real difficulties of these readers, one finds that they are attempting to use elaborate equipment or build to designs far in advance of their previous experience or ability.

Prior to the war, when every piece of equipment in an amateur station—other than the receiver—had to be home built, the average amateur worked up from simple gear to the more complicated in easy stages. On the transmitting side he started with a simple crystal controlled oscillator—probably a 6L6. When he had sorted out the difficulties to be found with even such a simple rig—when he had got the aerial coupled properly, got the crystal peaking nicely, and a nice clean, readily keying note—then he went a step further and added a triode RF amplifier. He had to learn to neutralise this, an experience of use even nowadays with our 807 and 813 tetrodes which the instructor tell us do not need neutralising! The difficulties of a triode amplifier solved, a doubler stage was added, and then finally phone work was tried and he had to start learning how to solve another set of problems.

Similarly on the receiving side, our pre-war SWL started with an O-V-1, to which he eventually added a tuned RF stage. Then perhaps a further audio stage was added, so that by the time he tried his hand at a very elementary superhet, he really was beginning to know how to set about solving the little, inevitable, snags himself.

But nowadays we start into ham radio with a BC348 or 1155. We get a TU5B unit and convert one—or try to—into a VFO. We wade in to an elaborate TX with two doubler stages so that we can be “one of the boys on ten,” and when the whole thing becomes one mass of untameable parasites—well, we blame the bloke who drew up the original circuit design!

May we plead for a return to the natural process of learning anything, i.e., start with the really simple and work upwards slowly. You will get much more fun out of your hobby that way, and when eventually you do get that 150 watt cw/phone, all band VFO/CO rig, you will be much prouder of it than if you've acquired it by getting all the neighbouring hams in to iron out your difficulties for you. Start with something simple, learn all about it, and then go on to the next stage. No one need be ashamed of being a “learner.” We all have to go through it. The war may have given us the impression that there are short cuts to acquiring most forms of knowledge, but there is still nothing which can surpass the value of experience as a means of acquiring knowledge and particularly is this so in the realms of amateur radio.

A.C.G.

NOTICES

THE EDITORS invite original contributions on construction of radio subjects. All material used will be paid for. Articles should be clearly written, preferably typewritten, and photographs should be clear and sharp. Diagrams need not be large or perfectly drawn, as our draughtsman will redraw in most cases, but relevant information should be included. All MSS must be accompanied by a stamped addressed envelope for reply or

return. Each item must bear the sender's name and address.

COMPONENT REVIEW. Manufacturers, publishers, etc., are invited to submit samples or information of new products for review in this section.

ALL CORRESPONDENCE should be addressed to *Radio Constructor*, 57, Maida Vale, Paddington, London, W.9. Telephone: CUN. 6579.

AUTHENTIC AND UP-TO-THE-MINUTE INFORMATION ON VHF, BROADCAST BAND AND AMATEUR ACTIVITIES IS GIVEN IN OUR MONTHLY PUBLICATION “SHORT WAVE NEWS.” TELEVISION FANS — READ “TELEVISION NEWS” MONTHLY

PUSH PULL AMPLIFIER using PX4's.

By A. J. DULEY.

THIS amplifier was built for a medium power output combined with quality. The consideration of quality decided the writer to use triodes in push-pull for the output stage, and PX4's were the valves finally chosen.

From the circuit diagram it will be seen that a resistance capacity coupled stage feeds the driver stage which is transformer fed to the output.

Many argue that transformer feeding causes distortion and hum pick-up, but the present system was found as good, if not better, than a paraphase circuit which was tried with the same output.

Power supply in the writer's case was a separate unit. The supplies needed are 300 volts HT and two 4-volt heaters centre-tapped.

The amplifier chassis was made of 18 SWG sheet-iron. Power is led in via a 7-pin valve holder at the rear, and input and volume control are at the front. The output is led away to the speaker from sockets at the right-hand side.

The MH4 is decoupled as shown, and the heater is common to MH4 and ML4, biasing being obtained in each case by a resistance in the cathode circuit.

A miniature 2-pin plug was used for the input circuit, one side being earthed and the live side going via a screened lead to the volume control. The lead from this component to the MH4 grid leg is screened also.

In the driver stage, the transformer was obtained from an old circuit incorporating a Corsor 240B Class "B" valve. If no transformer is available with a centre-tapped secondary, an ordinary transformer can be used as shown in diagram No. 2. Two 200,000 ohm resistors are joined across the secondary and the junction is taken to earth.

The output stage is fed by two leads from the secondary to the valve grids via 1,000 ohm resistor secondary to the valve grids via 1,000 ohm resistors, these latter components being soldered on to the valve holder leg.

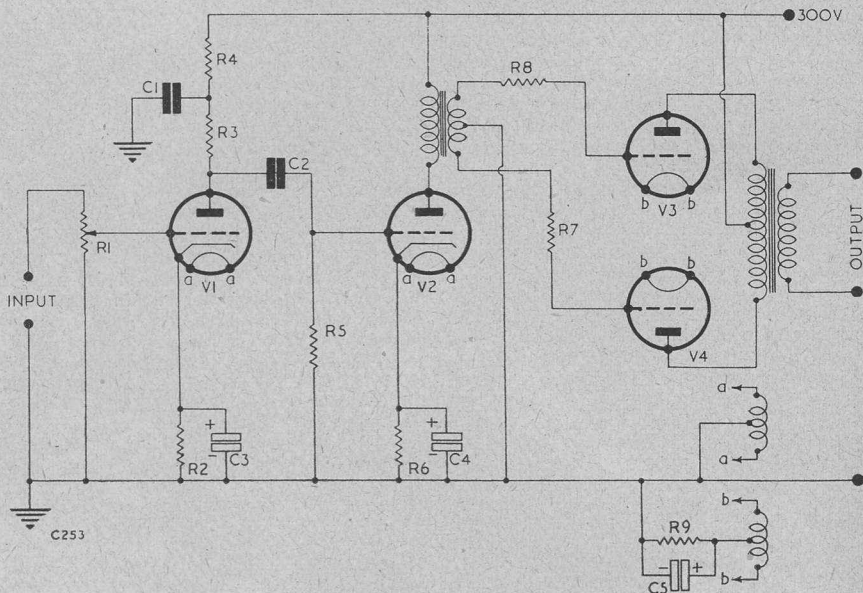

Resistors	
R1, 500,000 Ω	R5, 1 M Ω
R2, 750 Ω	R6, 1,000 Ω
R3, 40,000 Ω	R7, 1,000 Ω
R4, 10,000 Ω	R8, 1,000 Ω
	R9, 500 Ω , 5 watt.
(All resistors $\frac{1}{4}$ -watt except R9)	

Component Values

Capacitors	
C1, 4.0 μ F	C4, 50 μ F, 12V
C2, 0.1 μ F	C5, 12 μ F, 50V
C3, 50 μ F, 12V	

Valves

V1, V2, ML4
V3, V4, PX4
"a-a" is 4V heater supply for V1 and V2
"b-b" is 4V heater supply for V3 and V4

Biassing is obtained for this stage from the centre-tap of the heater winding feeding it. The method of calculating this resistor may incorporate a factor which is not familiar to the reader. Using ohms law as usual we start

$$\frac{\text{volts}}{\text{current}} = \text{resistance}$$

The bias volts is 42, and the current flowing in the PX4 is 50mA but as each valve is fed from the same heater, the total current flowing in the resistor is 100mA. Therefore, the resistor's value is given by

$$R = \frac{42 \times 1,000}{100} = 420 \text{ ohms}$$

In the amplifier as built, a 500 ohm resistor was used. The wattage of this resistor is 5 as a minimum for

$$\text{Power} = \frac{\text{volts} \times \text{amps}}{42 \times 100} = \frac{1,000}{42} = 4.2 \text{ watts}$$

Micropack capacitors were used throughout, and $\frac{1}{4}$ watt resistors except for the biasing components already discussed.

TELEVISION STANDARDS AGREEMENT.
Partial Adoption of British System.

DETAILS of the television standards agreed upon by five leading manufacturers in Britain and Holland for use on the Continent of Europe are now known in London.

The five firms (Philips, of Eindhoven, E.M.I., G.E.C., Marconi and Pye) have agreed to standardise equipment for the Continent on 625-line picture definition, and what is known as "positive modulation" for the vision signal.

Positive modulation is already used in Britain with 405-line definition and in France where a system on 819-lines is projected, but negative modulation is used throughout the U.S.A. and the Dutch were proposing to use it before the present agreement was reached.

Other technical standards agreed upon are 25 frames per second, interlace 2 to 1, vestigial side-band operation, and 6 megacycle total channel-width. There is no recommendation for the method of modulating the sound signal.

A British radio industry representative returning to London to-day from the negotiations in Holland said that the agreement on positive modulation was of vital importance and very satisfactory from the point of view of the British manufacturer. "If negative modulation had been adopted on the Continent," he said, "the manufacture of sets with different forms of modulation for home and abroad would have presented difficulties which do not arise in making receivers for a different line definition. An advantage of positive modulation to the user is

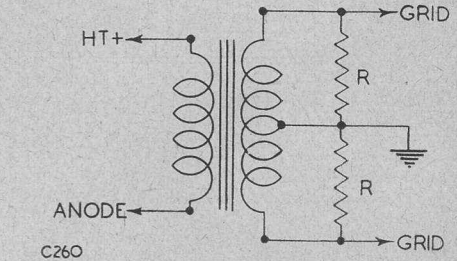

Showing modification of Intervalve transformer. Resistors R are 200,000 Ω each.

The anodes of the PX4's were taken to an output transformer with a centre-tapped primary; the secondary of this component was taken to a socket strip in the side of the chassis.

A mains energised 8" m/c speaker was used, as also was a 12" Goodmans P.M. Both gave excellent results, and the volume was more than enough for a large room with the speaker mounted on a four-foot baffle. Quality was found to be good enough to dispense with a tone control system, and linearity showed up well on applying the amplifier output to a scope.

that receivers are cheaper than those made for negative modulation."

The British radio industry has been strongly in favour of adoption of its own 405-line system with positive modulation as the standard for Europe and has not changed its view that it is the most efficient system in relation to cost and to other space occupied. It became evident recently, however, that some countries abroad might want to take advantage of Britain's unique experience of television in all its aspects—studio and transmission technique and receiver manufacture—while wanting a line definition nearer to or higher than the American one. It is now accepted by leading British manufacturers that uniformity on the Continent, especially with the British system of modulation, is of more value to them than the partial acceptance of 405-lines, although the 405-line system will continue to be used and extended in Great Britain.

With regard to the choice of 625-lines, which is a higher definition than is used in the U.S.A.; it is already favoured by Sweden and Germany, where television development work is recommencing and it is believed that other Scandinavian countries and Belgium and Switzerland may also favour it. Apart from the advantage of being able to exchange programmes and so sharing the major cost of television, these countries would benefit by economies in the manufacture of transmitters and receivers arising from standardisation.

British manufacturers, it is stated, will at once begin planning production of sets suitable for the Continent.

TRADE NOTES

A NEW RADIO FREQUENCY ALLOCATIONS CHART

A new wall chart showing the Frequency Allocations decided at the Atlantic City Conference of the International Telecommunications Union has just been issued by Standard Telephones and Cables Limited.

The keynote of the Chart is simplicity. It does not rely on complicated colour systems, but a simple black-and-white scheme which is easily readable. Three additional colours are, in fact, used, but only to identify the regions across the chart, lining up with the coloured regional map of the world.

The various services are arranged in separate columns and the frequencies of any particular service are shown as black blocks. It is a matter of seconds to run the eye down a column to find all the frequencies allocated to that particular service, or to look across the columns to find the services associated with any particular frequency. This arrangement of the chart leaves considerable free areas, designed to facilitate ready reference and also to allow users to add notes or changes which may be issued at a later date.

The blocks carry paragraph numbers identical with the Handbook reference numbers, and as these references are reproduced in full at the foot of the chart, the information presented is comprehensive.

Size 40" x 25", the chart is obtainable, 3/9 post free, from Standard Telephones and Cables Limited, Connaught House, 63, Aldwych, London, W.C.2. All orders should be accompanied by remittance.

NEW MULLARD WALL CHART FOR DEALERS.

The 1949 edition of the Mullard wall catalogue is the most comprehensive yet produced by the company. Quite apart from its actual contents it is produced of much more substantial material and will stand constant and hard usage by service departments.

The catalogue is a comprehensive record of current equipment and maintenance valves in the Mullard range. In addition to prices, information includes operating data and characteristics, base connections and diagrams.

It has complete equivalent lists and recommendations for the substitution of obsolete types by modern valves. The arrangement of data has been slightly changed to facilitate speedy reference.

Previously it was customary to include prices and purchase tax alongside technical data. In the new issue prices are placed opposite the valve type in the index.

"INEXPENSIVE MODULATOR."

Reference was made in this article (last issue) to "accompanying photographs" — but no photos were shown. This was due to the fact that the blocks were lost in the post and the paragraphs affected were not modified. The valve pin connections were also omitted in error. Apologies are extended for any inconvenience caused.

Valve Base Connections (looking at underside of valve holder).

Pins are numbered in a clock-wise direction, starting with pin 1 located on the left of the keyway on the spigot.

6V6, 6F6.

Pin 1-Shield, 2-H, 3-A, 4-G2, 5-G1, 6-NC, 7-H, 8-C.

6N7.

Pin 1-GT2, 2-AT2, 3-CT2, 4-GT1, 5-AT1, 6-CT1, 7-H, 8-H.

6J7.

Pin 1-Shield, 2-H, 3-A, 4-G2, 5-G3, 6-NC, 7-H, 8-C, TC-G1.

BRITISH TELEVISION TO TELL THE WORLD

Export Drive is Planned at Radiolympia Services to Exhibit

TELEVISION, as perfect technically as it can be demonstrated in all stages from studio to receiver, will be a feature of the 16th National Radio Exhibition ("Radiolympia") to be held at Olympia, London, from September 28th to October 8th.

It is expected that considerable improvements will be noticed in the quality of the television picture since the last Radiolympia in 1947. New cameras, improved studio and control technique, a new aerial on the roof of Olympia and better arrangements for the public to view both the studio and the screen picture will contribute to the most ambitious demonstration yet staged by the British radio industry and the B.B.C. whose experts, it is claimed, still lead the world in television technique.

Other features of Radiolympia announced by the Radio Industry Council are an enlarged section for communications equipment, navigational aids and electronics in industry and exhibits for the first time since the war by the Royal Navy, the Army and the Royal Air Force. The Ministry of Supply, the Department of Scientific and Industrial Research and the G.P.O. will also exhibit.

Overseas visitors, who will be welcomed by the Director of the Radio Industry Council in rooms set apart for them in the Grand Hall, will be given special facilities for watching studio performances, camera and transmitter control and finally reception in private demonstration rooms. They will also have access to the control room for the elaborate system of sound distribution throughout the exhibition buildings.

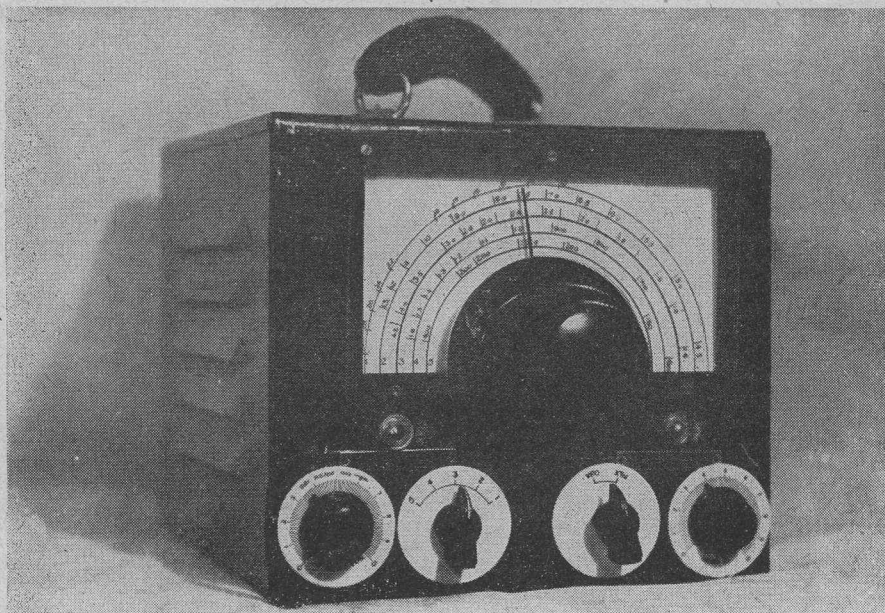

The Keeley-Webb Signal Generator

A versatile instrument built and described
by S. E. KEELEY and N. F. WEBB.

A SIGNAL generator is a "must" to any constructor who has progressed beyond the 0-v-1 stage and wishes to obtain optimum performance from his gear. Professionally-built signal generators are very expensive, and the only way most of us will ever come to possess a signal generator is by "rolling our own."

We perused many circuits with this end in view. We built up one using a 6A8 pentagrid with built-in switching coils, which covered 105 Kcs to 15 Mcs. It worked okay, but had one snag: It had to be set to the required frequency visually, and an error of as much as 30 Kcs can creep in on the higher frequencies just by reading the wrong side of the pointer! Also, we felt that a 'sig genny' should work down to at least 30 Mcs.

A crystal oscillator, using a one megacycle crystal and tuning to the harmonics, works too. But suppose you are aligning a newly-built set which has not yet been calibrated. How can you identify the correct harmonic on which to line up the set?

We thought about it for some time and then hit upon what we think is a neat solution: Why not use the 6A8 VFO and the crystal oscillator, setting the VFO as near as possible to the required frequency visually, and then switching to the

crystal oscillator and using its one megacycle harmonics to check that we were "spot on" the required frequency?

And so was born the signal generator shown in circuit form at Fig. 1, and illustrated in the accompanying photographs. It was built entirely from Government surplus stuff except for the small mains transformer and the metal rectifier.

It is enclosed in a metal case. This is most important, as it is essential that no signal be allowed to enter the set you are aligning except through the shielded output leads.

For the tuning dial, we were fortunate to acquire (for a bob!) an R.A.F. type slow motion dial. Using a piece of Perspex for the window, and mounting on a small metal panel a piece of white card at the back of the window, on which to mark the calibration, we were able to make a reasonable facsimile of the R1155 dial that everyone likes so much!

If you use small black pointer knobs, and ivorine discs marked with the appropriate legend—"MODULATION," "ATTENUATOR," etc., a really professional job can be made. As you can see, we even went to the extent of putting on a handle from an old suit case, to make the job fully portable!

The Circuit.

It will be seen that the signal generator divides itself into four parts:—

- the one megacycle crystal standard (Fig. 1a),
- the 6A8 VFO (Fig. 1b),
- the 6J5 audio oscillator (Fig. 1c),
- the power pack (Fig. 1d).

One megacycle crystals are rather expensive, but you can build the VFO and audio oscillator sections and use them for lining up, etc. while you are waiting for the xtal. A few line-ups should soon pay for the "rock"!

The crystal oscillator.

This was "lifted" from Short Wave News, hoping G2UK does not mind!

The one megacycle crystal is connected between earth and the control grid of an EF50. For the little "tank" circuit connected to grid 2, SWN recommends an RFC and a padding capacitor. We used a 465 Kcs bobbin from an IF transformer, stripped down to 1 Mcs and slipped over a former with an iron dust core for tuning.

The output from this oscillator is taken, via C2, to the master switch, about which we shall have more to say later.

The VFO

The valve is a 6A8 pentagrid in a transitron circuit. Five switched coils and a .0005μF capacitor form a tuned circuit covering from 150 Kcs to 30 Mcs. This tuned circuit is connected to grid 4 of the valve.

The modulation from the 6J5 audio oscillator is fed, via the master switch, to grid 1.

The output transformer in the anode of the 6A8 consists of a modified RF choke taken from the 1155. (There are three of them in the compartment at the back of the BFO box.) The choke has six pies. Five are used as the primary and connected between anode and HT+. The other pie forms the secondary. One end is earthed; the other side is shielded and taken, via the master switch, to the attenuator. This choke has a neat little screening can, which, incidentally, should be individually earthed, as it is a little shorter than the choke former, and does not make contact with the chassis.

The coils.

Four of the five coils are mounted on a little sub-chassis. The other coil, the 12-30 Mc coil, is mounted as near to the wavechange switch as possible.

Range.	Turns.
400—150 Kcs	Two pies from the same type of choke from the 1155 as was used for the output transformer of the VFO.
1600—600 Kcs	About 100 turns of about 34 SWG on a three-quarter inch former.
4.2—1.4 Mcs	About 40 turns of 34 SWG on a three-quarter inch former.

12—4.5 Mcs	13 turns of 22 SWG, single spaced, three-quarter inch former.
30—12 Mcs	4½ turns of 22 SWG, single spaced, three-quarter inch former.

The instructions for the coils may seem a little vague, but they are essentially "cut and try" jobs. The average constructor will use what wire he has by him, rather than dash out and buy a specified gauge. The only test is whether the coils give the required coverage. So keep winding, testing, stripping, adding till you get them right.

The modulator.

This consists of a 6J5 and a small AF transformer, T1. One side of the transformer secondary is connected to the grid of the valve via the usual grid-leak capacitor combination. The other side is earthed. This is, to all intents and purposes, the grid winding of an ordinary short wave coil. For the "tickler" winding, the primary of the transformer is used. It is connected between anode and, through a voltage dropping resistance, HT+. (*Practical Note:* If, when you come to test the 'sig genny,' the modulator doesn't "sing" right away, try reversing *either* the primary or secondary leads of the transformer. As you know, if the energy fed back from anode to grid is not in phase, no oscillation takes place.) The switch across the secondary windings is to short out the modulation if you should wish to line-up a receiver using the receiver's BFO.

Output from the modulator is taken via C10 and R11 to the master switch, so that it can be switched either to the oscillator grid of the VFO or the suppressor grid of the xtal oscillator. The HT to the 6J5 is not switched.

The master switch.

This is a three-pole, two-way Yaxley. It has to do three things:—

1. Feed the HT to *either* the VFO or the xtal oscillator (section a, b, c in the diagram).
2. Feed the output of the modulator to *either* the VFO or the crystal oscillator (section g, h, f).
3. Feed the output of *either* the VFO or xtal oscillator to the attenuator, which is the boss-class name for the 500 ohm potentiometer connected so as to present a constant impedance to the receiver (section d, e, f).

This may seem to be a bit tricky, at first glance, but it isn't. We hope the diagram makes it easy.

The power pack.

Because the current drain is so small, a metal rectifier is preferred to a valve rectifier, especially as the metal rectifier will not generate heat. Only one side of the secondary windings of the mains transformer need be used, since half-wave rectification and the 16μF of smoothing is ample.

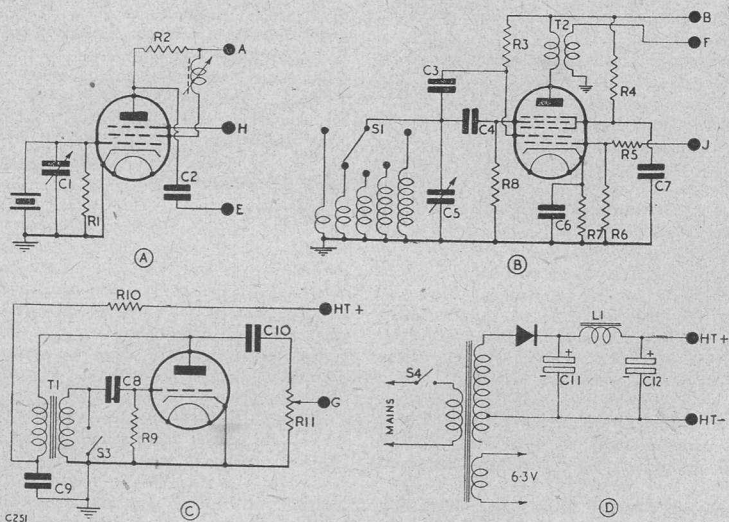

Fig. 1

- (A) Crystal Oscillator (1 Mcs crystal standard)
- (B) Variable Frequency Oscillator
- (C) Audio Oscillator
- (D) Power Supply

Component Values

Resistors	Capacitors
R1, 1 M Ω	C1, 5-100 μ F
R2, 100,000 Ω	C2, 100 μ F
R3, 27,000 Ω	C3, 0.01 μ F
R4, 68,000 Ω	C4, 100 μ F
R5, 47,000 Ω	C5, 500 μ F
R6, 300,000 Ω	C6, 0.01 μ F
R7, 300 Ω	C7, 0.1 μ F
R8, 100,000 Ω	C8, 0.005 μ F
R9, 100,000 Ω	C9, 0.1 μ F
R10, 47,000 Ω	C10, 0.001 μ F
R11, 20,000 Ω	C11, 8.0 F
R12, 500 Ω	C12, 8.0 μ F

Switches	Valves
S1 Single Pole 5-way Yaxley	(A) EF50
S2 3 pole 2-way Yaxley	(B) 6A8
S3 on/off toggle (modulator)	(C) 6J5
S4 on/off toggle (mains)	

(N.B. The terminal marked "J" in the VFO should read "I")

The midget choke and the capacitor are, of course, standard.

It is felt that anyone who has progressed far enough in his constructional activities to feel the need for a signal generator will not have the least difficulty in building this one. It divides itself into four parts. If you build one part at a time and do a neat job of it, you can't go wrong.

Calibration.

We calibrated our 'sig genny' with the aid of our 1155. This receiver had been re-aligned on 100 per cent correct broadcast signals and checked

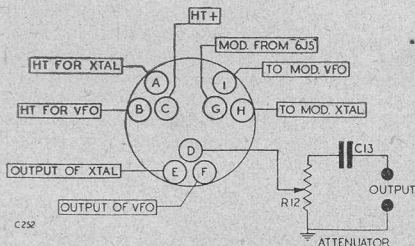

Fig. 2

Showing the connections to S2, the Master Switch

with WWV, so we were confident that our 'sig genny' would be calibrated to within working limits of accuracy.

The drill went like this:—

1. We connected the output leads of the 'sig genny' to the input of the 1155 and switched both on.
2. We tuned the 1155 to 18 Mcs and switched the 'sig genny' to the correct frequency range, to VFO, and with the modulation "on." We then tuned round the dial of the 'sig genny' praying for a modulated note at about dial reading 10 degrees, as it were. We emitted an ecstatic sigh when we heard it.
3. We switched modulation off, switched to crystal oscillator, put the BFO of the 1155 on, and tuned down to whistle to silent point. The 1155 is now bang on 18 Mcs.
4. We switched back to VFO, MOD "on" and re-adjusted the VFO so that the modulated note was again heard in the speaker. We put a dot on the calibration card, confident that we had our 'sig genny' as near to

18 Mcs as we could wish for practical purposes.

5. We repeated the process with the 1155 adjusted to 17 Mcs, 16 Mcs, 15 Mcs, etc., each time switching to crystal oscillator with the Rx BFO on, to check that the Rx is "bang on" before we adjusted the VFO to that setting, and made the dot on the card.

This way, you can get complete coverage from 18 Mcs down.

For 1.5 to 3 Kcs, which is not covered by the 1155, we used the first harmonic of the signal generator itself, i.e., set the generator at 1500 Kcs and logging the fundamental, we then retuned the 1155 to the first harmonic (3 Mcs) and then pressed on to 4 Mcs (for 2 Mcs) 5 Mcs (2.5 Mcs) 6 Mcs (3 Mcs) and intermediate hundreds.

For signals up to 30 Mcs we used the harmonics, as above, i.e., 15 Mcs for 30 Mcs, 14 Mcs for 28 Mcs and so on, using a Type 24 Converter (R.A.F. type, much modified!) to extend the range of the 1155.

NOTE: When you are doing the calibrating, make sure you know which is the fundamental and which the harmonic. This is especially important when you start calibrating each new wave band. The way to recognise a fundamental from a harmonic is (a) the fundamental should be louder; (b) to check, note what frequency you think you have set your signal generator to, divide by two, and try to find a signal on the 1155 at that frequency. For instance: You think your

coil will get down to 18 Mcs. You set the 'sig genny' to 18 Mcs as you think. You then divide by two, giving you 9 Mcs. Now, leaving the 'sig genny' where it is (at what you hope is 18 Mcs), tune the 1155 to 9 Mcs. If you get a modulated note up there, I am afraid that *that* is your fundamental; your coil does not go down to 18 Mcs as you hoped. So get stripping a few turns off and try again . . .!

Operation.

On frequencies between 150 Kcs and 2 Mcs simply set the 'sig genny' to the required frequency on the dial and inject the resultant signal into the set you are working on. As a check, tune in to the LIGHT PROGRAMME (200 Kcs) on your receiver, and *tune the 'sig genny' to beat with it.* The 'sig genny' will then generate harmonics *exactly* on 400, 800 Kcs and so on.

From 2 Mcs to 30 Mcs, where alignment on megacycle points at each end of the band is the desired procedure, work this way: (1) Switch to VFO, set the dial to the required frequency as near as you can visually, and search for the signal on the receiver. (2) Switch to crystal—this will generate a harmonic spot on the frequency you wish. (3) Make final adjustments to the set you are servicing, using this harmonic as your guide.

If you wish to work on frequencies between 30 Mcs to 60 Mcs, set the VFO to half the required frequency, and use the first harmonic, i.e., 21 Mcs for 42 Mcs, etc., and so on, and switch to crystal for final check-up.

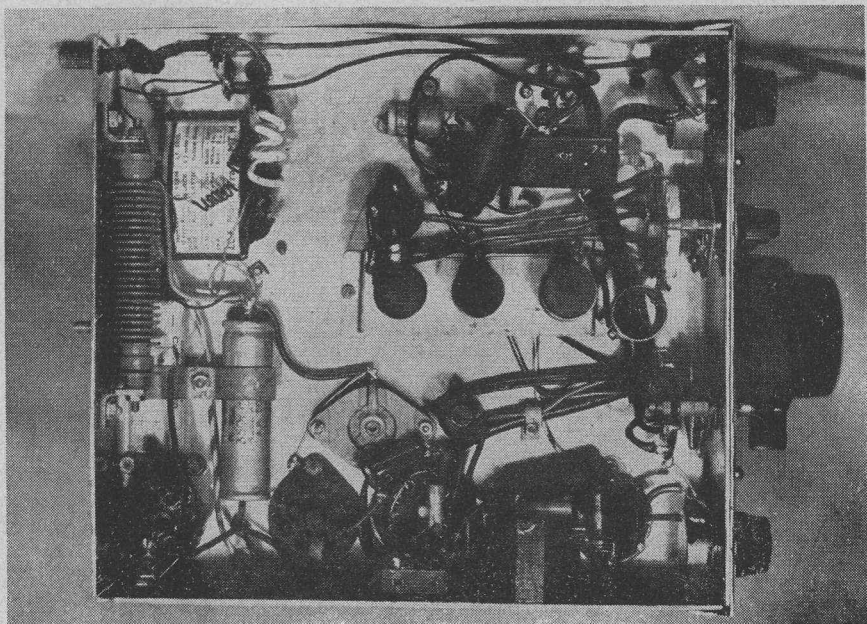

The Unchallengeable Voice

Centre Zap

MOST readers give more time to the technical aspects of radio than to broadcast listening, and still less time to considering the effects of broadcasting. Yet a few moments reflection will suffice to see the profound effects it has made, and continues to make in our daily lives.

It is reasonably certain that the Nazi creed could never have infected, and later dominated, Europe if it had not been able to overwhelm those opposing voices who lacked its penetrating power. The controlling of the broadcast word, intruding into nearly every home, persuading, insinuating, was a deciding factor. The spoken word coming to you by your fire-side with its power of suggestion and inflection have a far greater influence than the cold print of reasonable argument.

To-day in Europe, although the actual fighting has ceased, "cold war" continues, and the microphone is perhaps one of the principal weapons. Those in power jealously keep the iron fist of monopoly clutched over their ether, nor are they content with internal propaganda, but use it as a means of "softening up" or promoting discord externally. Radio, like many other of the blessings of scientific progress seems to be increasingly used to enslave mankind. What a travesty of our early hopes for a permanent Peace "when Nation shall speak unto Nation."

Impartiality.

Happily in this country, although broadcasting has always been a monopoly, it has been scrupulously conducted on the most impartial lines, and even the highest members of the Government have at times been refused it's unconditioned use. Whatever faults can be laid at the door of our B.B.C. no one could deny it has always shown an admirable sense of responsibility and independence. Indeed, in its anxiety to do the "right thing" it has given the listeners a poorer service rather than have the faintest suspicion of "bias" or "preference," or even allow the discussion of strongly controversial issues. At least one ace broadcaster was temporarily rested because it was feared his influence was becoming too great!

Brightening Up.

At various times there has been strong agitation for some measure of controlled commercial broadcasting in this country, but the possibility of seeing it materialise rather daunts the imagination. Before the last War in a great many European countries broadcasting was at least partly privately owned and paid for by advertising, but in the rest of the world commercial stations are commonplace. In the United States it is big business having, after an early open-to-

anybody scramble, settled down in the main to domination by a few interests, but there is a competitive element, and it must be admitted many of our own programmes are modelled on lines they exploited much earlier than we did. The short wave listener will well remember how in pre-War years the novelty of the speed and pep of American radio with which he became familiar, contrasted strongly with the heavy slowness of the B.B.C.—the programmes were not only often dull and poorly presented, but there were far too many intervals filled with the ghostly ticking of a metronome or ringing of bells.

During the War years the listening public had the chance to hear something of America's lighter radio entertainment, and to note its speed and sparkle. The contrast between that and many of our own programmes was so marked that B.B.C. apologists excused it by reminding us that we should not try to draw comparison with what they called the cream of American radio.

There is certainly a very strong case for the introduction of some measure of "rival" broadcasting in this country. That extra effort stimulated by the incentive of competition, giving a real opportunity to those with initiative and new ideas, would be beneficial to all parties and shake the complacency out of some of the B.B.C.'s senior staff.

Disheartening.

Perhaps one of the most unfortunate aspects of monopoly broadcasting is that, with only one employer of radio talent, the programme maker, whether he be script writer, producer, commentator, artiste, impressario, or permanent staff, cannot take himself elsewhere, to try out new ideas. He must do the bidding of the officials who engage him, and officials always play safe. Can we expect enterprise under such circumstances? With a single unenterprising employer hedged in with a mass of restrictions, the innovation is strangled and promising young talent too often rebuffed and discouraged. The free-lance knows that if his work is rejected it is completely wasted—he cannot take it elsewhere. Broadcasting as a career is far too forbidding to newcomers, and the listener too often suffers by having to put up with the same old gang dishing him up with the same old stuff with slightly different dressing, without much promise of any future improvement.

Nor is there any scope for serious broadcasters with unorthodox ideas—a first-class man will not readily submit to tedious inhibitions and restrictions—so again we have been denied men of the Wells, Shaw, class.

The Need for " Ideas " Men.

No one who remembers the pre-war Sunday programmes can have any doubt of the effect of competition. The B.B.C.'s were so dull and stodgy that even the second-rate recorded stuff put out by Luxembourg and Normandy wooed the listeners away in their thousands, until an overhaul and brightening-up took place at Broadcasting House. There is no doubt that given the freedom of choice, thinking listeners would overwhelmingly plump for controlled commercial broadcasting, if only for the sake of stimulating the effect of rivalry.

Despite the mediocrity of its general average, British broadcasting has produced a number of names which have become household words, and in every instance their success was founded on their understanding of the technique of the microphone. In the many tributes paid to the late Tommy Handley, only the " popular " side of the radio comedian was noted. His success did not simply happen by accident of voice or mannerism; it was the essence of careful planning, and the understanding of the effect produced, appealing to the broad average of the masses. Surrounded by other well-defined characters, Handley became far more than a voice in a studio. His achievement in radio entertainment was not simply giving enjoyment to millions of listeners; he raised the general standard of comedy programmes by developing a technique. Others learned from his methods. Who is there to improve upon them? And will the pundits of Broadcasting House give them the opportunity?

Unequaled.

" Itma " was Britain's greatest popular programme, and was equal to America's best. I remember a Poll taken by the British Institute of Public Opinion. Tommy Handley simply romped to the top. He received nearly double the percentage of votes as the next five in order of popularity put together.

Maybe some readers will feel I have exaggerated the importance of the Handley & Co. technique. If so, I would remind them that the technique was always improving, and after years of regular appearances it was *gaining* in popularity. Think of as many programmes, past and present, as you can, and find another that has not gone stale after a single season.

Opinion.

I seem to have wandered from the theme supporting those who would like to see some opportunity afforded to controlled commercial broadcasting in this country. Having used B.I.P.O. figures to support my assessment of the Handley influence, I suppose I have laid myself open to having the same token thrown back at me on the question of competitive broadcasting. I believe the last voting on this issue was :—

- B.B.C. only 47 per cent
- Commercial Broadcasting 40 per cent
- Do not know 13 per cent

The value of those figures to bolster the pro-Monopolist argument is greatly undermined when it is realised the same poll revealed that 38 per cent did not know that U.S. radio was *free* to the listener, and 45 per cent were afraid commercial broadcasting might be used to exert political influence. We all know figures can be used to justify any argument ; a view with which I readily concur, especially when 18 per cent said they considered the B.B.C. News bulletins were already ' biased.'

**MASS TESTING OF VALVES
IN MULLARD FACTORY**

The vast progress made in the production of electronic equipment to enable mass testing of thousands of valves in a matter of a few hours, was stressed by Mr. C. H. Gardner, an executive of Mullard Electronic Products Ltd., when he spoke to members of the Institute of Practical Radio Engineers in Reading on February 24th.

Mr. Gardner dealt with methods of mass testing valves as they come off production belts, the individual testing of valves from the point of view of quality control, and finally explained what happened to a valve which was returned to the manufacturer to see if it could be replaced.

" The function of a factory test," he said, " is to ensure that the valves coming off assembly benches are free from defect. The test gear must be such that it will deal with large quantities of valves in a short space of time. In fact thousands of valves—for housewives, radio, television and industrial use—are tested nowadays in a few hours by the finest electronic equipment ever devised."

Mr. Gardner declared that the examination and testing of valves returned as faulty was of prime importance to engineers. Every one of these valves was exhaustively tested and reported on.

" Special techniques have been developed for each type of alleged fault," he added. " Every endeavour is made not only to confirm or otherwise the existence of fault—often a difficult matter if the fault is intermittent—but also to ascertain the cause."

" This may involve a post-mortem examination, perhaps under a microscope. The results of these examinations not only determine the matter of replacement but provide data which is of the greatest value to the technical and production departments."

Q.R.P. 7 Mcs Transmitter

Improved Modulation System suggested

By W. OLIVER, G3XT

THE article on a "QRP Transmitter for 7 Mcs" in the January "Constructor" shows how a pentode (or tetrode) CO can be modulated by a triode.

In this design, G. Pennington employs an anode modulation system which is commonly used in other transmitters, for modulating a PA stage; except that it is usual to insert a suitable resistor and large capacitor in the PA anode circuit (as shown in Fig. 1), to drop the voltage to the PA and thus enable the modulator to get a better "grip" on it, so to speak.

former (capable of carrying the anode currents of the modulator and oscillator valves through its primary and secondary windings respectively) for the LF choke shown in Mr. Pennington's circuit diagram.

The resistance of the transformer secondary serves to drop the voltage to the CO, so there is generally no need to add an external resistor in this case. Further, the step-up effect of the transformer helps to give adequate depth of modulation with a low-power modulator such as Mr. Pennington specifies.

Fig. 1.

Resistor R2 drops the anode voltage to V1.

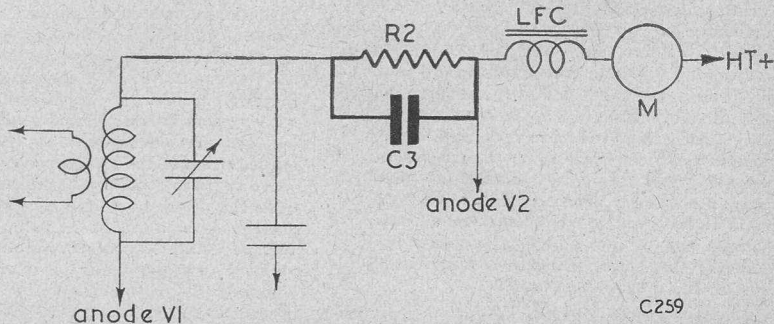

While it is true that this system can be applied to a CO, it is generally deprecated as unwise, since the practice of modulating an oscillator is liable to introduce unwanted frequency modulation where only amplitude modulation is required.

A far better method, which I (and other experimenters) have used successfully, is to introduce the modification shown in Fig. 2. It will be seen that this consists of substituting a suitable trans-

I think that any readers who build the transmitter described in the January issue will find that the substitution of transformer for choke will give greatly improved results. Moreover, in the case of an ultra-low power transmitter such as this, the transformer need not necessarily be a costly one; I have had quite successful results with a cheap 5-1 ratio intervalve transformer of pre-war vintage in this position.

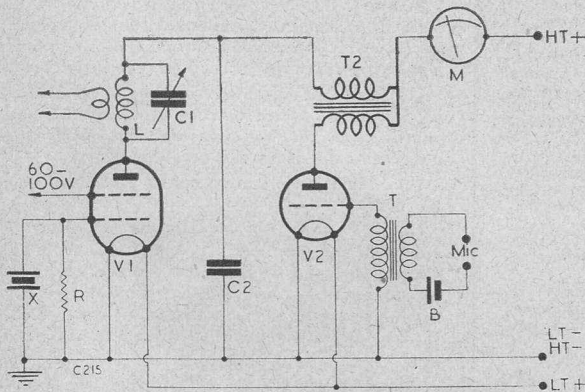

Fig. 2. Showing how a transformer T2) is substituted for the LF Choke.

Query Corner

A "Radio Constructor" service for readers

Mercury Vapour Rectifiers.

"My transmitter requires a power supply whose output exceeds the ratings of the largest vacuum type rectifier which I can find listed in my valve catalogues. I require about 750 volts at 250 m.A. Have you any suggestions for obtaining this supply?"
J. Riley, Pinner.

There is no single high vacuum rectifier which is capable of providing the output power which is required for this transmitter. The solution to the problem therefore, lies in the use of either two high vacuum rectifiers of the full wave type with the sections strapped in parallel, or two mercury vapour rectifiers connected in a standard full wave circuit. On the face of it, it would seem that the former system is the most economical but the possibility of an increase in power being required in the future should not be overlooked. With the vacuum rectifiers working on their limit such an increase would mean the construction of an entirely new power pack; with mercury vapour rectifiers however, it would only be necessary to increase the input voltage. Provision may be made for this contingency by arranging suitable taps on the mains transformer.

Mercury vapour rectifiers are simple to use, reliable in operation and have an extremely low internal resistance. This latter feature enables good voltage regulation to be obtained, which is an asset in preventing instability and provides maximum operating efficiency.

The voltage drop across a mercury vapour rectifier is normally about 16 volts and is independent of the rectifier current.

The action of a mercury vapour rectifier is briefly as follows: When the cathode attains the working temperature the globule of mercury within the rectifier is vapourised. Thus, when the anode voltage is applied electrons will be attracted towards the anode and will ionise the vapour. The positive ions travel towards the cathode where they will neutralize the field produced by the electrons leaving the cathode. This means that the presence of the positive ions has the same effect as that of reducing the space between the anode and cathode, hence the low impedance and low voltage drop which characterizes this type of rectifier. When the anode voltage is negative with respect to the cathode, no electrons travel between the electrodes and the vapour is de-ionised. Thus, the peak inverse voltage which the valve will stand without flashing over is dependent upon the spacing between the electrodes. As the presence of ions within the valve will ensure a low voltage drop during conduction the spacing between electrodes may be relatively large, thus enabling the rectifier to withstand a high peak inverse voltage.

In the foregoing, the advantages of the mercury vapour rectifier have been discussed, but needless to say there are disadvantages. The major disadvantage lies in the fact that the mercury must be vapourised before the anode voltage is applied; this means delayed switching of the latter. This delay, which should be about half a minute, is preferably obtained by means of a thermal delay switch, but manual switching may be employed if desired.

It must, however, be stressed that unless the delay is provided the rectifiers will almost certainly be ruined. Other points worthy of note when employing this type of rectifier, are listed below.

(1) Fuses of suitable rating should be included in the anode circuit of each rectifier, this safeguards both the rectifiers and associated components in the event of a breakdown.

(2) The rectifiers must not be placed in strong RF fields.

(3) RF must not be allowed to reach the anodes of the rectifiers. If the two latter points are not observed trouble may be experienced due to flashover within the rectifiers. However, normal screening in the transmitter together with HT decoupling is generally adequate in preventing this.

(4) Free circulation of air must be allowed around the rectifiers for cooling purposes.

"Query Corner" Rules

- (1) A nominal fee of 1/- will be made for each query.
- (2) Queries on any subject relating to technical radio or electrical matters will be accepted, though it will not be possible to provide complete circuit diagrams for the more complex receivers, transmitters and the like.
- (3) Complete circuits of equipment may be submitted to us before construction is commenced. This will ensure that component values are correct and that the circuit is theoretically sound.
- (4) All queries will receive critical scrutiny and replies will be as comprehensive as possible.
- (5) Correspondence to be addressed to "Query Corner," Radio Constructor, 57, Maida Vale, Paddington, London, W.9.
- (6) A selection of those queries with the more general interest will be reproduced in these pages each month.

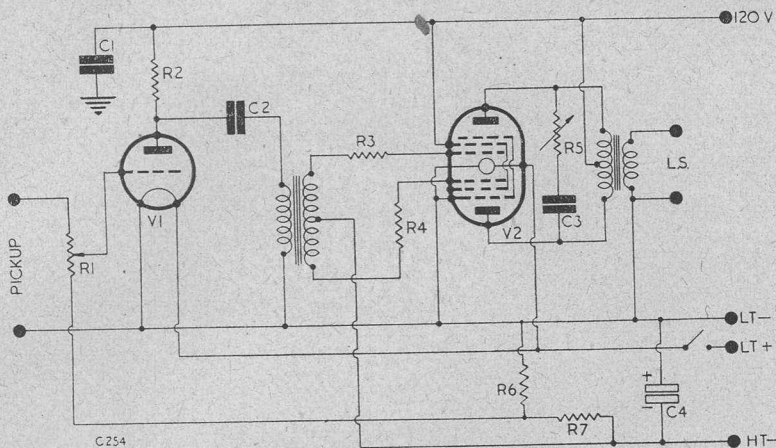

BATTERY OPERATED AMPLIFIER

Component Values

- R1, 1 M Ω
- R2, 50,000 Ω
- R3, 1,000 Ω
- R4, 1,000 Ω
- R5, 50,000 Ω
- R6, 150 Ω
- R7, 700 Ω

- C1, 1.0 μF
- C2, 0.05 μF
- C3, 0.005 μF
- C4, 50 μF , 25V

Transformers :

Push-pull Input Transformer, ratio 1:4 centre tapped.

Output Transformer. Optimum load of QP25 is 16,000

- V1, HL23
- V2, QP25

Battery Powered Amplifier.

"As I live in a district in which there are no electric main supplies we are compelled to rely upon batteries for the source of power. Up to the present I have used a sound-box type of gramophone, but I would like to construct a battery-powered amplifier for use with a gramophone pick-up. This should provide increased volume and a much improved tonal response. Can you recommend a suitable amplifier circuit?"

G. Drake, Basingstoke.

There will be many readers in similar circumstances who will find the following details of a two-stage battery-powered amplifier of interest. Such an amplifier may be built into a small case together with its associated loudspeaker and a clockwork gramophone motor. A gramophone of this type is entirely self-contained and is capable of combining good quality reproduction with an output power that approaches 1 watt on peaks.

The circuit consists of a triode amplifier which parallel-feeds a push-pull input transformer, which, in turn, drives a quiescent push-pull double pentode. This form of output valve is a development of the class "B" double triode which was so popular about fifteen years ago. The double pentode operates with a DC grid bias which approaches the anode current cut-off value, thus providing a maximum economy in HT current consumption. It has the advantage over the

class "B" valve in that the maximum output power is obtained without grid current, thus avoiding the use of a special driver transformer. The grid bias is obtained by means of a resistor connected in the negative HT lead; this resistor is shunted by a high capacity. The time constant of this circuit is such that the bias is held reasonably constant during transients in speech or music. This is not the case however, if the amplifier is required to provide constant output when driven by a pure tone. For applications of this nature the use of battery bias is essential. The overall gain of the amplifier is sufficient to allow an output power of about 1 watt peak to be obtained when it is driven by a standard moving iron or crystal pick-up.

THE EDITORS INVITE . . .

● **Constructional articles suitable for publication in this journal. Prospective writers, particularly new writers, are invited to apply for our "Guide to the writing of Constructional Articles" which will be sent on request. This guide will prove of material assistance to those who aspire to journalism and will make article writing a real pleasure !**

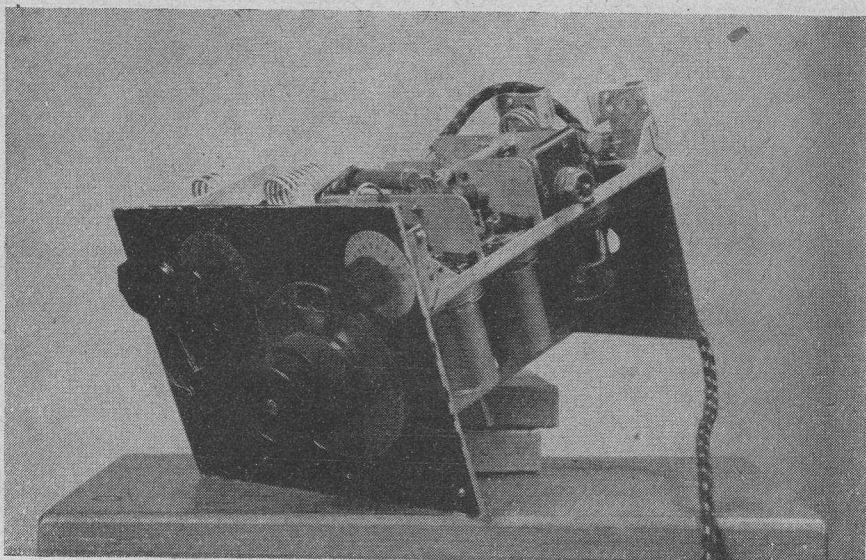

RF27 UNIT

Conversion to plug-in coils
and Earthed Grid RF Stage

By J. TAYLOR

THE 27 unit is apparently being very extensively used by a great number of "hams" for 5-6 metre working, and is proving very successful. These units are also cheap and easy to obtain. Its original use was as a plug-in unit to the 1355 IF amplifier and CRT unit, with which the 24-25-26 units were also used in the Gee system.

The complete original circuit is given in Fig. 1, and as will be seen, the capacitors are in series with the coil, giving improved results on VHF with larger tuning inductors.

It is necessary to modify the oscillator stage to the circuit as shown in Fig. 2. This incorporates a VR150/30 stabiliser, a very desirable refinement on weak signals and variable mains. The modifications to the oscillator are as follows:—An Eddystone, or similar VHF choke is inserted in place of R13, R9 being also removed. HT+ to

the anode of the EC52 is obtained through R16 and the choke. R16 is a 5 watt type, and becomes quite warm in operation; it has been left well clear of the coil to minimise possible frequency drift.

The IF of this unit is about 7.7 Mcs., but it can be varied between 6 to 8 Mcs. by adjustment of the iron core (L6), the wax being first removed. This should be replaced once a suitable spot has been found, preferably one free of QRM. It has been found with the writer's unit that no pick-up of unwanted signals was noticed, this being due in a large measure to the use of a very short co-axial cable between the unit and main receiver, the 604—with a good earth on the outer screening of the cable.

To commence reconstructural details of the unit, first of all slacken the coupling between the dial and first RF stage, and loosen the screw

Another "Radio Constructor" surplus gear conversion article

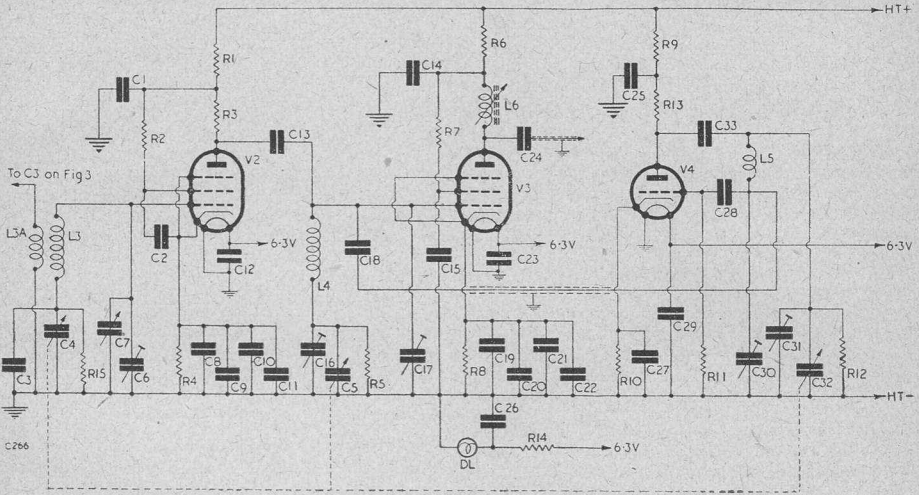

Fig. 1. The Original Circuit.

Component Values

- R1, 6, 2,200 Ω
- R2, 3, 11, 10,000 Ω
- R4, 150 Ω
- R5, 47,000 Ω
- R7, 12, 100,000 Ω
- R8, 1,000 Ω
- R9, 470 Ω
- R10, 100 Ω
- R13, 5,600 Ω
- R14, 56 Ω

- C1, 2, 8, 9, 10, 11, 12, 14, 15, 18, 19, 20, 21, 22, 23, 25, 26, 27, 29, 34, 500 μ F
- C3, 16, 30, 15 μ F
- C4, 5, 32, 3-gang, 75 μ F each section.

- C6, 13.5 μ F
- C7, 6.5 μ F
- C13, 33, 100 μ F
- C17, 31, 7.5 μ F
- C24, 10 μ F
- C28, 20 μ F

- V1, 6X6 (RL37)
- V2, 6AV6 (EF54)
- V3, 6AV6 (EF54)
- V4, 6AV6 (EC52)

Coils for 5-metres

- L3, 4 turns
- L5, 3 turns
- L6, Existing Coil
- L3A, see Fig. 5

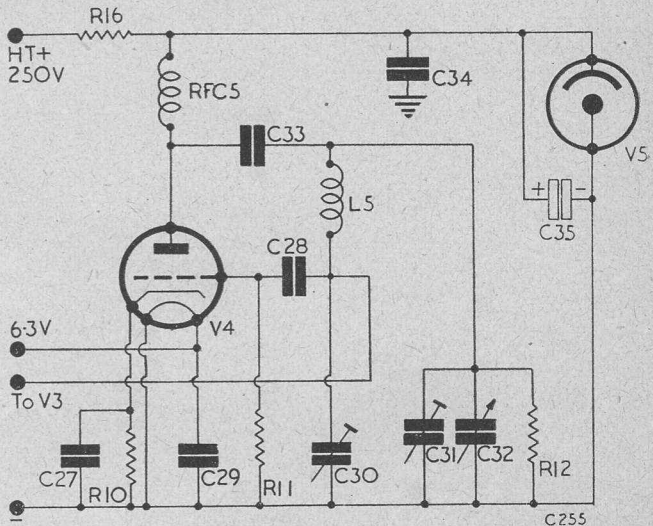

Fig. 2

Oscillator Modifications

Additional components are V5 (VR1503/0-), C35 (8 μ F electrolytic), RFC5 and R16 (10,000 Ω , 5 watt).

holding the dial on. It will then slide off through a hole in the side.

The handle must be removed, also the co-ax socket, the small trimmer capacitor, and several screws which secure the panel. A new panel was next cut and drilled to suit the dials, etc. This operation must be left to individual requirements for those who wish to utilise components to hand. The writer could suggest the use of a really good slow-motion dial in the absence of bandspread.

We come now to the coil modification, and commencing with the oscillator stage, remove the coil, noting the original connections. Next drill two $\frac{1}{8}$ " holes, their centre being 1" apart, as are all the coil holes, with the far hole, looking at the unit from the front, being as close as possible to the trimmer C30 (Fig. 1). All other component positions will be given as viewed from the front.

Before proceeding further, all the solder tags, except the one on the first EF54 RF stage, must be removed from coil bases, put on the coil-holder screws, and then bent up to a vertical position. (Fig. 6), to clear sides of the holes. The original connections should be left on the tags.

Next the mixer stage coil is removed, and the two original bolt holes enlarged to $\frac{1}{2}$ " dia., also the punched-out earthing point, which is directly under and in the centre of the original coil, must be bent up and cut off with a pair of side cutters. The wide end of the hole thus left is used to pass a bolt through in order to hold the coil base in place. It will be found just possible to fit this base in after first removing the two valve retaining rings. A solder tag is fitted under the bolt before finally fixing the base, and the earth wire from the mixer tuning capacitor transferred to this tag.

Now follows the RF stage, when again the coil is removed as before. A tip here—if the nuts in

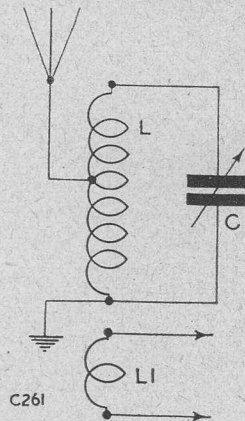

Fig. 4. Circuit for use with end-fed aerial. L is 8 turns on $\frac{3}{8}$ " diam. L1 is 2 turns on $\frac{3}{8}$ " diam. and C is 100 μ F

your unit are difficult to move, a hot soldering iron applied to each one will quickly loosen them. This system is used with all dismantling of surplus units. Here again, the earth tag is cut out, and the hole utilised to hold the coil base, and another solder tag placed under the nut, and the earth wire transferred to it as before. The one original solder tag left on the coil base here is the left hand one, again looking from the front. This goes to the stator of the RF tuning capacitor.

The other coil in this stage is removed, and not used, and a one-way solder tag bar is fitted above the position occupied by this coil, and bolted to the nut holding the paxolin panel in place on the preceding screen. C3 is soldered to this tag—the photos show the general position of this com-

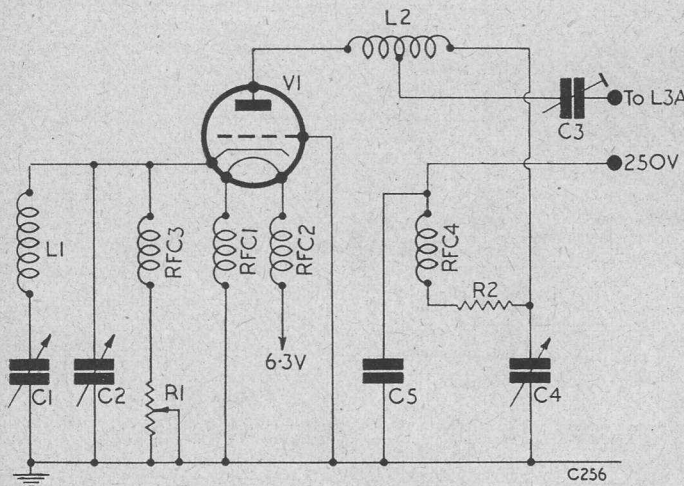
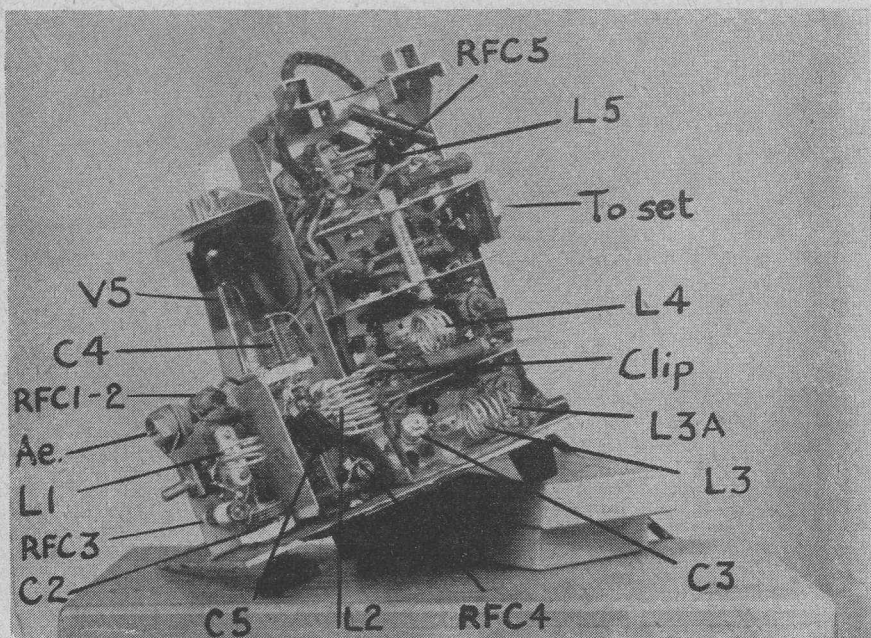

Fig. 3. Earthed Grid RF Stage

- R1, 150 Ω
- R2, 4,700 Ω
- C1, 200 μ F
- C2, 15 μ F
- C3, 30 μ F
- C4, 100 μ F
- C5, 100 μ F
- L1, 3 turns, with $1\frac{1}{2}$ turn link for 80 Ω feeder (not shown)
- L2, 8 turns
- V1, CV66
- RFC1-4, see text

Pin connections for CV66:

- (1) Heater, (2) Grid,
- (3) Grid, (4) Anode,
- (5) Anode, (6) Grid,
- (7) Grid, (8) Cathode,
- (9) Heater



Top view of the modified unit.

ponent. To complete the modification to this RF stage, a piece of paxolin or other rod of $1\frac{1}{8} \times \frac{3}{8}$ " is drilled at each end, or right through would be better, with a $\frac{1}{8}$ " drill. Next, one end is tapped, and this end bolted to the right angle end of the unit on the extreme right. Here, again, the photos show this clearly. A hole drilled and tapped is required at the side of the other end; this serves to make the coupling coil L variable both up and down, and from left to right, to accommodate all sizes of coil. A detailed drawing of this is shown in Fig. 6.

is in the way of the larger oscillator coils when on the television band, etc. It is just possible to reach 30 Mcs. with a 13 turn coil, which would have to be made up.

As there will be variation in the wiring of readers units, no definite dial readings can be given. The five metre band on the writer's unit occupied about a quarter of the dial in the centre.

For those who do not wish to make these extreme modifications, an alternative to re-winding the original coils is to insert an iron core.

A co-ax socket is fitted in the mixer stage, and soldered to C24 from which the original co-ax cable to the six-pin plug is removed. Incidentally, this plug is also removed, HT and LT connections going straight to their respective points. This plug

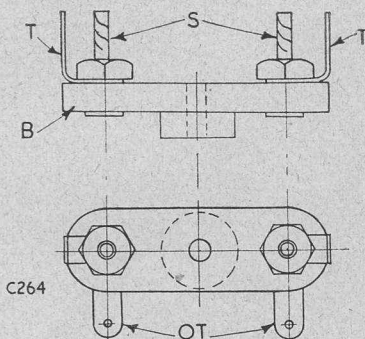

Fig. 6.

B = Coil Base T = New tags
S = Sockets OT = Original tags

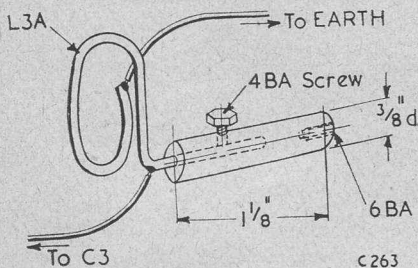

Fig. 5.

The EGT RF stage (Fig. 3), has been found to give very considerable gain with less increase in noise over several other types of RF stage. The circuit as shown in Fig. 3, requires the use of an 80 ohm feeder from a 5 metre dipole or beam.

For an end-on type of aerial, Fig 4 must be used; about 8 turns of 16 SWG tinned copper wire tuned by a 100 μ F capacitor will be suitable.

The CV66 valve, or RL37, has an amplification factor of 98. If this is not available, the EC52 could be used, or the CV6 horned triode, both of which perform quite well in this circuit. For those interested in the 144 Mcs. unit described in May Short Wave News (Vol. 3, No. 5), it is noted that the TR 3566 trans-receiver contains both the EGT stage described here, and the valves and other components for the 144 Mcs. oscillator.

To return to the EGT stage, it is very important to include the heater chokes RFC1 and 2, as these maintain the correct input capacity. They are both wound with 24 SWG wire, and of about 50 turns on a $\frac{1}{4}$ " dia. rod, the two being interwound. The two VHF chokes, 2 and 4 also are $\frac{1}{4}$ " x $1\frac{1}{2}$ " and wound with about 60 turns of 24 SWG. They are drilled and tapped at the end and fixed in an upright position, the bottom of RFC3 going to the cathode, and the stator on the C2, and one end of the 3 turn coil, L1. The top of RFC4 supports the 100 μ F capacitor C5, the other end of which is soldered to the rotor of C4. HT+ is applied to the top of RFC4. The resistor R1, it will be seen, is made variable. This is a 500 ohm midget type, and

was used to get the optimum value, its normal value being 150 ohms. Should it not be required to use the RF stage in its inverted form, the coils can be used by drilling two holes to pass their connection through the chassis in the ordinary way. The connection between the EGT stage and the first RF stage of the 27 unit is via a Philips concentric 30 μ F capacitor C3, mounted on an Eddystone insulated tag bolted to the screening between the first two stages.

A clip of two $\frac{3}{4}$ " lengths of 16 SWG copper wire soldered together on a short length of flex serves as a means of selecting the best tapping on L2. This has been found to be near the capacitor end. The setting of C3 is best carried out with a non-metallic instrument, and will be found to be critical, the best indication being given on the S metre with a signal tuned in.

A slow-motion dial is not essential for C4. The writer used a 6-1 epicyclic type for finer adjustment. An 8 turn coil will bring in 5 metres at about 30° on the dial, resonance being indicated by an increase in the noise level.

Acknowledgement is due to Mr. G. Elliot for his modifications to the oscillator, which have been used in this unit, also to G3AAT for his help in the supplying of the base connections and operating conditions of the CV66.

The writer would like to point out from experience that one needs great patience to receive that first signal on 5, after which it seems simple.

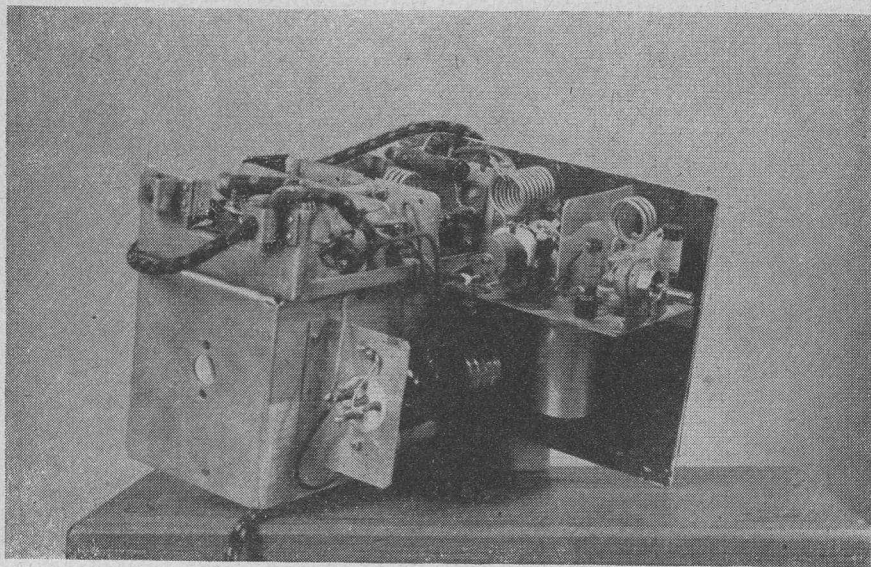

The modified unit viewed from underneath.

LOGICAL FAULT FINDING

The second in a series of articles to assist the home constructor in tracing and curing faults

By J. R. DAVIES

Modulation Hum.

WHAT causes modulation hum? I think that the best method of describing the cause is to say that at some point in the RF section of the receiver, (usually where non-linear amplification takes place such as in a detector, frequency change or in correctly biased IF or RF amplifier), an RF field becomes affected by some conductor nearby carrying a 50 cycle, (or 100 cycle, after full-wave rectification), current or ripple, thereby causing a form of modulation. The effect may be caused occasionally by the aerial lead being in close proximity to mains wiring. Usually, however, the cause lies in the chassis itself, combined with a peculiar set of circumstances in the house in which the set is being used. (Very often a set with bad mains modulation works perfectly when the set is put on the servicing bench in another building.)

The cure for mains modulation is usually not to decouple any RF components to by-pass the mains voltages (a difficult task), but rather to decouple any mains voltages so as to by-pass RF currents.

The remedies are usually very simple and consist mainly of adding $0.01\mu\text{F}$ capacitors at what may be described as certain strategic points of the circuit.

Fig. 4 shows the circuits and procedure to adopt. First of all, we should try connecting a $0.01\mu\text{F}$ capacitor between one side of the mains input and the chassis of the set, preferably using the side of

the mains that is switched. See Fig. 4(a). (If an AC/DC set is used, the $0.01\mu\text{F}$ capacitor may be connected across the mains input.)

If this does not succeed in eliminating the mains modulation, we try *two* capacitors, as shown in Fig. 4(b). Should this not work, capacitors should be connected as shown in Fig. 4(c), between the anodes of the rectifier and chassis.

Finally, as a last resort, an $0.01\mu\text{F}$ capacitor can be connected between the cathode of the rectifier and chassis. See Fig. 4(d).

It must be pointed out that, of the cures mentioned above and shown in the diagrams in Fig. 4, only *one* is necessary, and not a combination of two or more of the circuits shown.

The capacitors used in Figs. 4 (a)–(c) should have a working voltage of at least 750 volts, preferably 1,000 volts, owing to the strain under which they work.

These remedies should shift the most obstinate of modulation hum troubles. It may happen, however, that with a tightly coupled aerial circuit, mains modulation may be caused at “the other end” of the receiver. In this case, a filter circuit for the aerial should be tried as in Fig. 4(e) or (f), using the circuit of Fig. 4(f) only after that of Fig. 4(e) has been tried.

The cures for mains modulation represent some of the very few cases in which the circuit of a commercial receiver should be altered in any way so as to effect a repair.

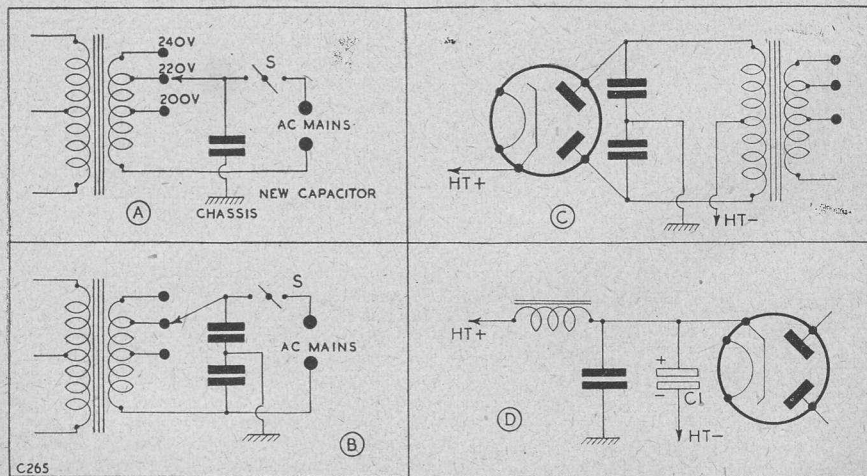

Fig. 4. (a-d) Methods of adding capacitors to power unit circuits to combat modulation hum. Those capacitors shown in (a) to (c) should have a working voltage of at least 750, preferably 1,000 volts. The value of the additional capacitors is $0.01\mu\text{F}$.

"Oscillator Wobble."

"Oscillator wobble" is caused, quite simply, by a slight ripple in the HT line, unnoticeable as a hum in the speaker, but of sufficient intensity to cause the oscillator of a superhet to change its frequency at the frequency of the ripple. It usually occurs on the short-wave bands, because a small change in oscillator frequency makes a large difference in signal strength on these bands. It occurs mainly in a set where the smoothing components have become somewhat inefficient. It sometimes shows up as a "gurgle," instead of a hum, as though the person speaking needed to clear his throat. The effect is more pronounced when the set is slightly off tune.

The cure is to increase the efficiency of the receiver smoothing circuits, or to add extra decoupling to the oscillator anode, Fig. 5, using whichever is the simpler course.

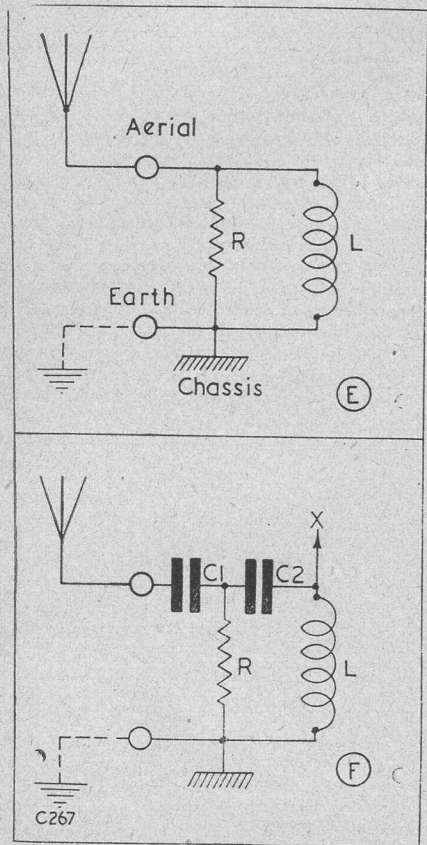

Fig. 4. (e-f) In the very occasional cases where mains modulation is caused in the aerial circuit, the addition of components as shown in (e) and (f) will cure the trouble. Value of R is 5,000 Ω . L is the aerial coupling coil. "X" is the lead originally connected to aerial terminal.

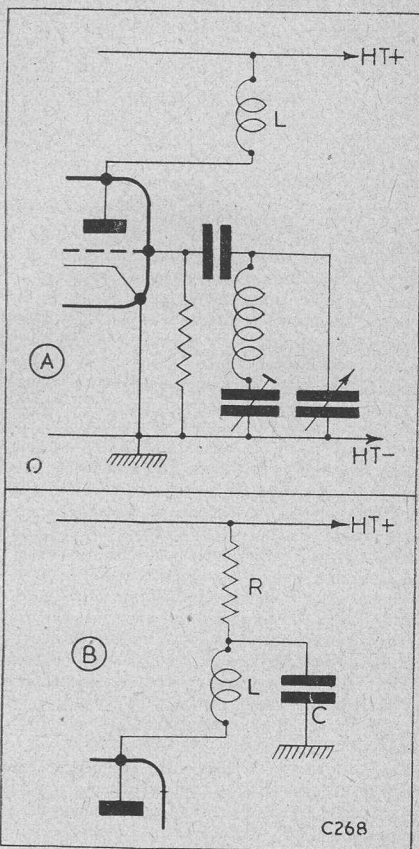

Fig. 5. (a) A typical circuit, often used in practice, wherein may lie the cause of "oscillator wobble" (see text). (b) The addition of an extra smoothing circuit for the oscillator anode. The additional capacitor may be an electrolytic component if of good quality. (L is the Feedback Coil and R is approx. 20,000 Ω).

Hum Due to Stray Magnetic Fields.

This is a fault that will cause little trouble in domestic receivers, except in the rare cases where an iron-cored inter-valve transformer is used, yet which can be very troublesome in high gain AF amplifiers. The magnetic field causing the trouble is found around the mains transformer and smoothing choke (or speaker field). All other transformers, except the speaker transformer, should have their axes at right angles to these first two components; and they should also be at some distance from them. The transformers may be shielded by soft-iron or "mu-metal" covers, if necessary.

A magnetic pick-up will occasionally be sensitive to alternating magnetic fields, these coming

sometimes from the gramophone motor itself! A steel motor-board mounting, or steel turntable, will usually effectively "screen" these two components from each other, however.

Hum Induced Mechanically.

When the laminations of a mains transformer become loose they usually make themselves heard as a 100 cycle note, the sound being easily located. The author has, however, come across a case where a transformer has been vibrating *silently* (at 50 cycles) and has caused the tuning capacitor to vibrate also, giving the symptoms of "oscillator wobble." This last case is very isolated. The cure for loose or vibrating laminations is to thoroughly tighten the lamination-mounting bolts of the transformer, and, as a last resort, insert little wooden wedges between the laminations as they enter the centre hole of the winding, and the inside edge of the bobbin. It is not advisable to apply shellac varnish to the bobbin of the transformer.

A loose speaker field or hum-bucking coil may occasionally cause an irritating hum. The remedy is, of course, obvious.

SUMMARY

Hum.

1. Hum Due to Bad Smoothing.

- (a) Check electrolytic capacitors.
- (b) Check rectifier.
- (c) Check smoothing choke or speaker field.

2. Hum Due to Grid or Cathode Pick-up.

- (a) Locate grid on which hum is picked up, by means of shorting grids to chassis, starting at first AF amplifier.
- (b) Check screening and grid returns at point discovered in (a) above.
- (c) Check cathode by-pass capacitors.

3. Modulation Hum.

- (a) Add capacitors to receiver circuit as shown in Fig. 4 (a—d), to find which application gives relief.
- (b) Add filter circuit to aerial stage as shown in Fig. 4(e) and (f).

4. "Oscillator Wobble."

Increase efficiency of receiver smoothing or add decoupling components to oscillator anode feed as shown in Fig. 5.

5. Hum Due to Stray Magnetic Fields.

This may be picked up by transformers or magnetic pick-up from mains transformer or smoothing choke, etc.

6. Hum Induced Mechanically.

This is caused by loose laminations in the mains transformer, or, occasionally, by a loose speaker field or hum-backing coil.

To be continued.

EXAMINATIONS IN TELEVISION SERVICING.

A new examination in the Servicing of Television Receivers has been drawn up and adopted by the City and Guilds of London Institute and the Radio Trades Examination Board.

The first examinations under this new scheme will be held in 1950 and arrangements are similar to those for the Radio Servicing Certificate Examination which is also conducted jointly by the City and Guilds of London Institute and the Radio Trades Examination Board.

"INEXPENSIVE TELEVISION"

Some general remarks.

Wiring Diagrams.

Several readers have written in asking if we could supply a complete wiring diagram of the televisor. This is impossible and is, in any case, not necessary. The modifications to the receiver unit have been explained clearly in the series of articles and as far as the time base unit and tube network is concerned, the only question which might arise is that of the layout. This, however, is not critical and possibly the best method is to arrange the valves in positions as shown on the theoretical circuit diagram. Should the reader not be capable of reading the theoretical diagram then we would respectfully advise him that in our opinion he would not really be wise to embark on its construction.

The Tube Network.

Now a word about the VCR97 tube network. Some readers have advised us that they find difficulty in getting the focus control (R6) to function correctly. This would appear to be due to variations in the tube or to the effects of component tolerances. R6 should be adjusted for the sharpest possible focussing and an additional resistor of some 250,000 ohms inserted between R6 and R5 (or R6 and R7) as indicated by the position of the moving contact of R6.

Whilst on the subject of the network it may be mentioned that some readers have had difficulty in obtaining sufficient brilliance. In this case R9 in the VCR97 network or R1 in the 5CP1 network should be reduced in value.

The 5BP1 Tube.

Another frequent query concerns the 5BP1 tube. This can be satisfactorily used with the network shown for the 5CP1, ignoring the intensifier connections (SC). Also, of course, the pin connections differ.

"Negative Rail."

In the circuit diagram of the R1355 receiver, the negative rail connection shown has caused some confusion. Many readers have taken this connection to HT centre tap on the HT transformer. The negative rail supply was used originally for anti-jamming purposes and should be completely ignored for television purposes as it is earthed through the ZYXN switch when on position N. The HT centre tap or mains transformer should be taken to chassis as in normal practice.

THE TR1196

Modifying the Receiver section to amateur Requirements

By J. SIMMONDS, G3BSW.

IN the opinion of the writer, one of the best "buys" in the surplus market at the present time is the receiver section of the TR1196 or the TR1196A. This is a 6 valve super-heterodyne and is known as receiver unit Type 25 (not to be confused with the RF Unit!). This unit can be obtained quite easily, complete with valves, in the region of 35/-.

The beauty of the unit is that it needs so very little conversion to amateur requirements. The frequency range covered by the receiver is 4.3 to 6.7 Mcs, but this can be extended by the insertion of an "all-wave" coil pack or by plug-in coils. For easy conversion, first remove the existing coils and four preset capacitors which are mounted on the top of the chassis. If an all-wave coil pack with variable capacitors is to

be built in, proceed to do this conversion ahead of V2, which is a VR57 (an Octode Frequency Changer) removing V1, the RF stage valve, and wire in as shown in Fig. 1 or 2, or to the instructions given with the coil pack. It is necessary to disconnect the wiring from grids 1, 2 and 4 as these connections are taken to the coil pack.

For those who wish to retain an RF stage, it will be necessary to obtain three additional coils covering the same ranges as the coil pack. Also, of course, an additional section to the variable capacitors will be needed, making it 3-gang instead of 2-gang (see diagram). For the little extra trouble involved, the retention of the RF stage will be found to be well worth while.

The IF transformers in the unit are set at 460 kcs and these can be easily reset to 465 kcs.

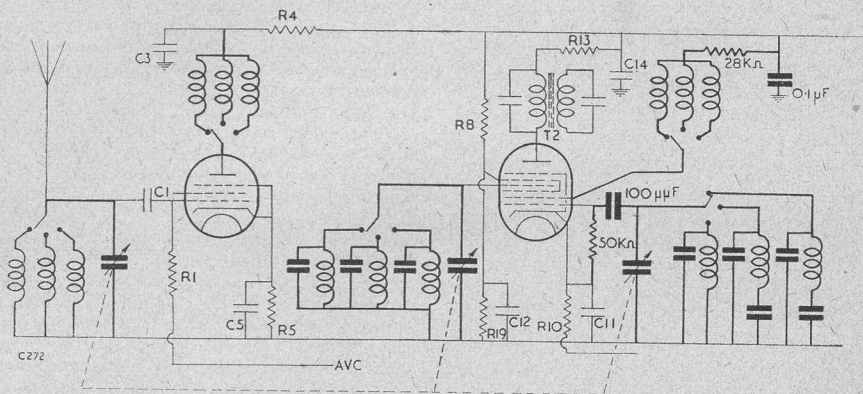

Fig. 1. Using RF stage. Existing portion in light outline. New components and wiring in heavy line.

"RADIO CONSTRUCTOR" SURPLUS GEAR CONTEST

The announcement of our contest for articles on converting surplus radio gear has been followed by some very interesting articles. It has also brought forth requests that the time limit be extended to allow more scope for building gear and getting the text on paper.

We feel, therefore, that we can with advantage make some concession in this respect and hereby amend Rule (9) to read :—

"The closing date of the Contest is April 30th, 1949."

The time definitely cannot be extended further, so go to it and let us have your manuscripts !

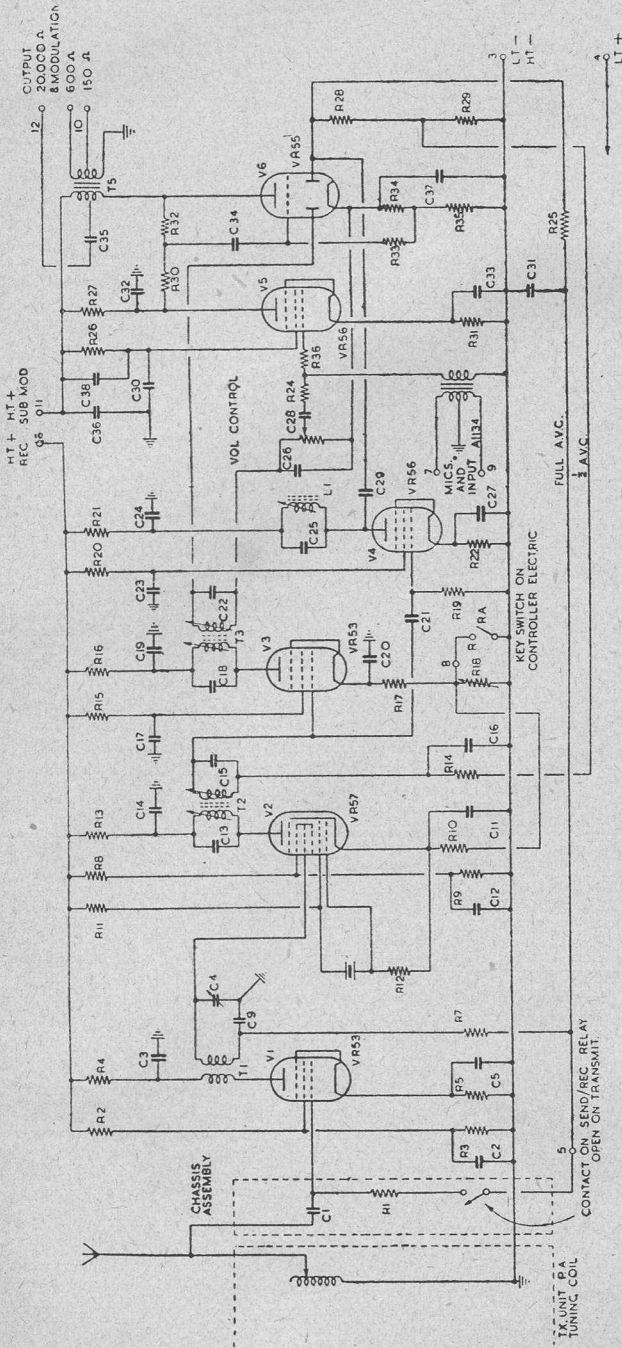

COMPONENT VALUES RECEIVER PORTION TR1196

- Capacitors**
 C1, 50 μ F
 C2, 3, 5, 9, 11, 28, 34, 0.01 μ F
 C3, 8, variable
 C12, 14, 16, 17, 19, 20, 23, 24, 27, 30, 31, 33, 37, 36, 38, 0.1 μ F
 C13, 15, 18, 22, 150 μ F
 C21, 29, 100 μ F
 C25, 26, 200 μ F
 C32, 0.5 μ F
- Resistors**
 R1, 7, 14, 25, 28, 29, 33, 1 M Ω
 R2, 8, 9, 15, 23, 30, 0.1 M Ω
 R3, 20, 0.2 M Ω
 R4, 13, 16, 2 M Ω
 R5, 10, 400 Ω
 R19, 24, 32, 36, 0.5 M Ω
 R31, 34, 35, 600 Ω
 R17, 200 Ω
 R18, 21, 5,000 Ω
 R11, 12, 50,000 Ω
 R22, 500 Ω
 R26, 0.25 M Ω
 R27, 60,000 Ω

“INEXPENSIVE TELEVISION”

PICTURE FAULTS

Illustrated by photographs taken from a television in which these faults were deliberately introduced, and photographed, by
JOHN CURA

6. Frame non-linearity. Indicates non-linear output from the frame time base or its amplifier. Only cure is to experiment with the valves which may vary in characteristics, or with the component values in these stages.
7. Frame Slip showing fly-back lines and also loss of interlace. Picture slips either upwards or downwards due to faulty synchronising. Also occurs at wrong setting of frame frequency control.
8. Line Non-linearity. Indicates non-linear output from line time base or its amplifier. Investigate components associated with these valves.
9. Line Slip. Shows portion of picture—which may be elsewhere than shown—pulling out to one side. May be due to incorrect adjustment of line frequency control or line hold control. May pay to investigate synch separator circuits.
10. Showing result of incorrect setting of the line frequency control, or insufficient or absent synchronisation.



6



7



8



10



9

COULPHONE RADIO

"The Return of Post Mail Order Service"

Phone :—
ORMSKIRK
496

58, DERBY STREET, ORMSKIRK,
LANCS.

Grams :—
COULPHONE
ORMSKIRK

Sole Proprietor:- Cliff Coulborn G3AJM

COULPHONE RADIO, apart from being the fastest **MAIL ORDER SERVICE** with **SOUND GOODS** is a **PERSONAL SERVICE** well appreciated by over 20,000 clients in all parts of the world—including America. All orders over 5/- are post free. Terms C.W.O. or C.O.D.

MAINS TRANSFORMERS

Why buy surplus Mains Transformers when you can buy a brand new fully guaranteed job at a lower price. Standard size, drop through chassis type with top shroud. Screened, primary tapped 200/230/250v. Interleaved and impregnated windings.

- (a) 250-0-250v 60ma 6.3v 3a, 5v 2a 16/6
- (b) 250-0-250v 60ma 4v 4a, 4v 2a 16/6

Following types have **UNIVERSAL LT WINDINGS 0-4-6.3v 4a CT** and **0-4-5v 2a** enabling either 4v or 6.3v valves and 4v or 5v rectifier to be used.

- (c) 250-0-250v 80mA 19/-
- (d) 300-0-300v 80mA 19/-
- (e) 350-0-350v 80mA 19/-
- (f) 250-0-250v 100mA 22/-
- (g) 300-0-300v 100mA 22/-
- (h) 350-0-350v 100mA 22/-
- (i) 350-0-350v 150mA 0-4-6.3v 6a, 0-4-5v 3a 39/-

10,000 VALVES IN STOCK AT B.O.T. PRICES

Send 2½d stamp for 32 page Catalogue and valve list. If interested in EX-GOV'T. SURPLUS, please include extra 2½d stamp for illustrated surplus catalogue, it will save you £s.

SELECTED EX-GOV'T. SURPLUS GEAR

In response to many requests from clients in all parts of the U.K. I have decided to stock carefully selected items of ex-Gov't. Radio Surplus—**NO JUNK**—only equipment in sound condition being considered—equipment which is also of the most value to radio enthusiasts. Prices? The lowest of any—I invite you to compare, remembering that there are no further charges for packing cases or carriage. **ROTHERMEL "TORPEDO" CRYSTAL MICROPHONES.** Brand new in maker's boxes. List price £18/18/0. My Price £3/18/6. Post paid. **INDICATOR UNIT TYPE 6A/APN/4.** The ideal unit for conversion into a super C.R.O. or TELEVISION RX. 26 VALVES including 14 6SN7 (double triodes) and 5 in. C.R.T. A gift at £4/19/6. Carriage Paid.

T1154 TUNING PANELS. Two single and one 2-gang condensers with reduction drives. Three coloured knobs. Only 3/6. Post Paid.

T5B Tuning Units. Brand New. 25/- . Carr. Paid. **Type BC456 40 Watt MODULATOR UNITS** with 1625, 12J5 valves and VT150 stabiliser. 19/6. Post paid.

—LASKY'S RADIO—

Let Lasky's help you Build your "Inexpensive Television" for even less money. Data Book giving full details, using Ex. Government equipment available. Price 1/6

INDICATOR UNIT TYPE 62.

Containing 20 valves and a 6 in. cathode ray tube type VCR97 (short persistence). Valve line up: 16 SP61, 2 EA50, 2 EB34. Dozens of useful components, condensers, resistances, coils, 117 Mcs. crystal, 16 pot/meters, etc. Totally enclosed in metal case. Size: 18 x 8½ x 11 ins. Weight 40 lbs. Enamelled grey with coloured control knobs. LASKY'S PRICE 59/6. Carriage 7/6 extra.

The cathode ray tube is tested before despatch. The ideal Indicator Unit at the Lowest possible Price for conversion to Television.

INDICATOR UNIT TYPE 62A.

Contains 21 valves, 117 Mcs., crystal and 6in. cathode ray tube type VCR97, 6in. (short persistence). Valve line up: 12 EF50, 2 EB34, 4 SP61, 3 EA50, also condensers, resistances, switches, pot/meters, and hosts of other useful components. Totally enclosed in metal cabinet. Size: 18 x 8½ x 11 ins. Weight 40 lbs. LASKY'S PRICE 99/6. Carriage 7/6 extra.

BRAND NEW TYPE 1355 RECEIVERS.

In original Wood Transit Case. Supplied complete with 11 new valves. LASKY'S PRICE 42/6. Carriage 5/- extra. As Above, but used, type 1355 30/- . Carriage

5/- extra. R.F. Units, for use with the 1355 receiver, extra.

New Manufacture.

E.H.T. TRANSFORMERS.

For the VCR97 cathode ray tube. Specifications: Primary 200/250 volts, 50 cycles. Secondary: 2,500 volts at 4 ma., 4 volts at 1.1 amps, and 4 volts (centre tapped) at 1.5 amps. LASKY'S PRICE 35/- . Post 1/6 extra.

BRAND NEW AND UNUSED SETS OF VALVES. 1 6K8G, 1 6K7G, 1 6Q7G, 1 6V6G, 1 5Z4G. LASKY'S PRICE for the 5 valves 35/- . Post 1/- extra.

Ex. U.S. AIR CORPS RECEIVER TYPE BC966. Contains 13 valves: 7 6SH7, 3 6H6, 3 7193, 3 relays. Also dozens of components, resistances, condensers, Unit built on two chassis. Also contains dynamotor with 18 volt input and 450 volt output. Totally enclosed in metal case. Size: 12½ in. high, 12½ in. wide, 8½ in. long. Black crackle finished. The motor can easily be converted to run off 230 volts AC/DC. LASKY'S PRICE 30/- . Carriage 4/6 extra.

10 YARD LENGTHS OF TWIN RUBBER COVERED CABLE.

Circular section. Fine quality. LASKY'S PRICE 2/6. per length. Post 9d. extra.

Send a 2½d. stamp for a copy of our current Bulletin giving full details of our Ex. Government stocks. Please write your name and address in block letters.

LASKY'S RADIO

370 HARROW ROAD, PADDINGTON, LONDON, W.9

(Opposite Paddington Hospital).

Telephone : CUNningham 1979.

Hours : Mon. to Sat. 9.30 a.m. to 6 p.m. Thursday half day.

EQUIPMENT OF TOPICAL INTEREST

RF27 Unit.

As featured in this issue of the Constructor. Coverage is 65 to 85 Mcs and supplied complete with 2 EF54 and 1 EC52 valves. The Unit is of the tuneable type. Priced at 17/6 and available to callers only.

Receiver Units types 25 or 73 (portion of TR1196).

Another popular item in great demand is the Receiver Unit 25/73. Actually the receiver portion of the TR1196, they make an ideal medium wave superhet by fitting two coils. Valves incorporated are 2 EF36, 2 EF39, 1 EK32, 1 EBC33; also included are one pair of 460 Kcs I.F. Transformers, resistors and condensers. Suitable coils for superhet adaptation are the Wearite "P" which we have available at 6s. per pair. Moderately priced at 19/6 plus 3s. carriage and packing, it is little wonder that the Receiver Unit 25/73 is proving so resounding a success.

Receiver R1124.

Frequency range is 30.5 to 40.5 Mcs switched by 5 bank 6 way Yaxley switch, thereby proving eminently suited for conversion to the Television sound channel. Valve line-up: 1 10D1, 1 15D2, 3 9D2, 1 8D2, all with screening cans. Among the host of components are 30 condensers, 30 resistors and 3 pot/meters all enclosed in a robust metal case the size of which is 16 x 10 x 16 in. Brand new and unused. Astonishingly cheap at 17/6, plus 2/6 carriage.

Ex-Govt. Valves at keen prices.

Output Valves. EL32 7/6, 6V6 7/6, 12A6 6/6, 807 6/-, 6N7 8/6.

R.F. Pentodes. EF50 (new and boxed) 6/-, slightly soiled 4/-. EF39 6/6, EF36 6/-.

Rectifiers. 5U4G 7/6, 5Z4 7/6, 6X5 6/6.

High Voltage Rectifiers. VU133 (V960 Mazda) 7/6, VU111 (V1907) 7/6, VU120 7/6.

Miscellaneous Types. EBC33 4/6, 6J5 3/-, 6SN7 6/-, EA50 2/6, D1 2/6, 6B4 7/6, IT4 5/-, Y63 6/-.

ALL VALVES GUARANTEED

Special Multimeter Offer.

For only 17/6, post free, we are proud to offer a portable M.C. test meter in bakelite case. Ranges: 0-1.5v., 0-3v., 0-6 m/a., 0-5 ohms. Can be speedily modified to make a superb general purpose test meter. Order early. The demand will be huge and consistent.

Postscript for all potential TV Constructors. Because RF25 Units are becoming increasingly difficult to procure, do not be alarmed into purchasing these for exorbitant prices. We are pleased to announce that we can supply the RF24 at 10/6, post free, accompanied by concise and simple to follow instructions for rapid conversion to 45 Mcs reception. These Units in brand new condition are also in stock, at 16/6 each.

SHOP HOURS: 9 a.m.—6 p.m. Thursday to 1 p.m. Open all day Saturday.

BEST BUY AT BRITAIN'S

CHARLES BRITAIN (RADIO) LTD.,

11, Upper Saint Martins Lane, London, W.C.2.

Phone: TEMple Bar 0545.

3 mins. from Leicester Square—up Cranbourne Street.

Henry's Radio Component Specialists

We have the most comprehensive range of Radio Components of every nature.

Our reputation is your guarantee.

If unable to call, please send stamp for current price list.

(Dept. RC)

5 HARROW ROAD, W.2

PADDINGTON 1008/9

(Opposite Edgware Road Tube)



We have the finest stock of British and American radio books in this country.

Write or call for complete list—

THE MODERN BOOK COMPANY (Dept. RC)

19-23 Praed Street, London, W.2



SOUTHERN RADIO AND ELECTRICAL SUPPLIES

85, Fisherton Street Salisbury, Wilts. Telephone: Salisbury 2108

BELLING-LEE PRODUCTS

L336 80 ohm Twin Feeder 7½d. per yard. L600 Co-axial cable, ¼in. diam. 1/6 yd. L1221 Screened twin cable 1/9 yd. L604P Co-axial plug for ¼in. cable 1/9. L604S Co-axial socket 1/6. L333 Aerial T strain insulator 3/3. Y7713 Hard drawn Cadmium Copper Aerial wire. Per 80ft. coil 9/-. L609 Amateur Aerial Kit. Comprising T strain insulator 80ft. cadmium copper aerial wire, 80ft. 80 ohm twin feeder, two pyrex

aerial insulators and full instructions for erecting efficient di-pole aerial suitable for reception or transmission. Complete Kit 35/9.

L308/K Complete "Eliminoid" Anti-Interference Aerial Kit for all-wave reception. Comprises 60ft. aerial wire, two transformers, 50ft. screened feeder, earth wire and insulators. Complete with instructions. £6/6/0.

L501T U.H.F. Di-pole with wall-fixing bracket. Suitable for television use. £2/12/6.

L502/L Television Aerial with reflector, cross arm and chimney lashings. £6/6/6.

MULTI-CONNECTORS—L550 5-way cable sockets 2/3, L551 5-way chassis plug 2/3. L1258 5-pin flex plug with cord grip 4/6. L331 5-way socket with shield panel 1/9. L530 7-pin flex plug 4/3. L531 7-way chassis socket 1/9. L1244 10-pin flex plug 6/-. L332 10-way chassis socket 2/9. Many other Belling-Lee products in stock.

Please include postage on orders under £2.

SMALL ADVERTISEMENTS

Readers' small advertisements will be accepted at 3d. per word, minimum charge 3/-. Trade advertisements will be accepted at 6d. per word, minimum charge 6/-. If a Box Number is required, an additional charge of 1/6 will be made. Terms: Cash with order. All copy must be in hand by the 10th of the month for insertion in the following month's issue.

PRIVATE

MCRI. Complete with power pack and all coils. New and unused, £8.—G. Fagan, Elliott House, Molyneux Street, London, W.1.

C.R. Oscilloscope, using 3 in. tube (and spare). With metal carrying case. 200-250v. AC. Perfect. £4/10/0. Avominer Universal, boxed as new, £7, 1947 ARRL Handbook (10th Edition—Cloth) 6/-. Box 124.

Hallicrafters. SX18. 500 kcs to 38 Mcs. with manual. "S" meter and spare tubes, £15. Matched Hallicrafter, 12 in. speaker in case, £3. VFO (Converted TU5B) metered, with valves and stabiliser. Perfect performance, £2/10/0. Box 125.

FOR SALE; R 1116/A Receiver, 8 valve double S/Het, 15-2000m., with Amplion Corvette for A.C. mains, Phones, Circuit Diagrams. £10 or offers. Warwick, 19, Church Road, Roffey, Horsham, Sussex.

EXCHANGE. 150 Watt Transmitter for good miniature camera. Leica preferred. Offers to "Stonehaven," Horncastle Road, Boston, Lincs.

FOR SALE; Valves, new and unused, 832 double-beam tetrode VHF transmitting valves, 15/-. Used but OK, PT15's, 10/-; 1625's, 7/6; ML6's, 2/6. Also 100 kcs. Billey standard xtal, with base and mounting, £1.—E. J. Clarke, 39 Boston Park Road, Brentford, Middx.

LOOK! Prices Slashed! No. 74 Indicator, 9 inch CRT, Mag. with focus and deflector coils, RF osc giving 4Kv 3 DET19, 2 6V6 etc. £3/17/6. No. 6F Indicator, as 6A, VCR97, etc., slight use £3/5/0. R1132A Receiver, 10 valve, mains types, 100-125 Mc/s., convertible for 144 Mc/s. £5/0/0. S27 Hallicrafters, one only 27.8 to 143 Mc/s. £24 or offer. All carriage paid. A. C. Steadman, 230, Chellaston Road, Derby.

TRADE

G6MN for the "best" QSL's and approved log books, send for samples: G6MN, Bridge Street, Worksop, Notts.

COMPONENTS for all circuits in this Journal. Eddystone, Raymart, Wearite stockist. Send for lists. Smith, 98, West End Road, Morcambe. Order now '640' Rx £27/10/0 Westeht units £7/15/0, "P" Coils 3/-. etc. Quick Service.

QSL's and G.P.O. Approved Log Books. Samples free.—Atkinson Bros., Printers, Elland.

CHASSIS, Panels, Racks and Metal Cabinets stock sizes or made to specification in steel or aluminium: Wrinkle finishes available.—Reosound Engineering & Electrical Company, Coleshill Road, Sutton Coldfield.

American Receiver BC603, 10 valve FM receiver, 20-28 Mcs., with built-in speaker, 24v dynamotor, 10 push buttons and manual tuning. Valves are:— 2 x 12SG7, 3 x 6AC7, 1 x 6J5, 2 x 6SL7GT, 1 x 6H6, 1 x 6V6GT. Green and chrome finish. Dimensions 11½ x 6½ x 12½ in. Ideal for mod. as car radio. £5.5.0 (plus 7/6 carr). Whip Aerials. 7 section extending to 13½ feet, with base. 4/6 (plus 1/- carriage).
RDPI VHF Receivers. 5 x SP61, 2 x P61, 3 x VR92, 1 x 5Z4, 1 x VR137, 1 x CV83, 450v pencil rectifier, etc., etc., 25/- (plus 7/6 carriage).

GARLAND RADIO, Dept. RC
4 Deptford Bridge, London, S.E.8
Phone: TIDeway 3965

No Shop keeps all you want—we keep more than most. That's why people say—

"You'll probably get it at
SMITH'S
of Edgware Road"

Pay us a visit and see for yourself
H. L. SMITH & CO. LTD.
287-9 EDGWARE ROAD, LONDON, W.2
Near Edgware Road Met. and Bakerloo
Phone PAD. 5891 :: Hours 9-6 (Thurs. 1 o/c.)

THE RADIO & ELECTRICAL MART (G3BSW) of 253, Portobello Road, LONDON, W.11. Park 6026

Take pleasure in offering the following:—
BC453A or B. If you own one of these excellent receivers, we can supply you with a MW Coil Pack specially designed by us for use with this set. You will be delighted with the results. Price including circuits 17/6.

T.R. 1196. These 6 valve Super-Hets are the best buy of the day. Just fit a 2 Gang Variable Condenser and All Wave Coil Pack. Requires only 5 connections to Frequency Changer valve and set is ready for use. Price with circuit 27/6.

Mains Supply Unit. This neat and handy unit in black enamelled case 9 x 6 x 6 ins., contains heavy duty transformer, Rectifier valve, smoothing choke, condensers, fuses, panel light and switch. Input 200/260v AC. Output 6-3v at 3-5 amps. HT 350v at 80 ma. Larger output available by changing rectifier valve. Price £3/5/0.

250 watt Double Wound Transformers. 230v/110v. Made by G.E.C. with steel shroud. New, each £2/7/6.

R.1132A. This grand 10 valve Super-Het, covering from 100 to 126 Mcs., is easily adapted for 144 Mcs. band by simply moving connections on tuning coils. Large Slow Motor Dial. S Meier, etc. Case measures 20 x 12 x 12 ins. Price £5/10/0.

Test Set, Type 46. We still have a few of these excellent battery operated frequency meters covering from 2 to 23.5 Mcs. Made by Marconi Instruments. Can be adapted to all wave by inclusion of MW and LW Coils. Circuit supplied, each 40/-. Aluminium Rods Aerials for use with same, extra 3/6.

2 Metre Oscillator or Signal Generator. We still have a few left of this most useful and interesting piece of equipment. Uses a CV1197 UHF Triode. Requires only LT6-3v and HT120v supply to work. Complete with circuit, each 16/6.

Type BC347. U.S. Signals Mike Amplifier. Small and Compact. Case measures 5½ x 2½ x 4 ins. Price 10/-. Write for Lists—hundreds of items in short supply. Remember money back guarantee.