

PRACTICAL WIRELESS

51. New

JANUARY
1967

216

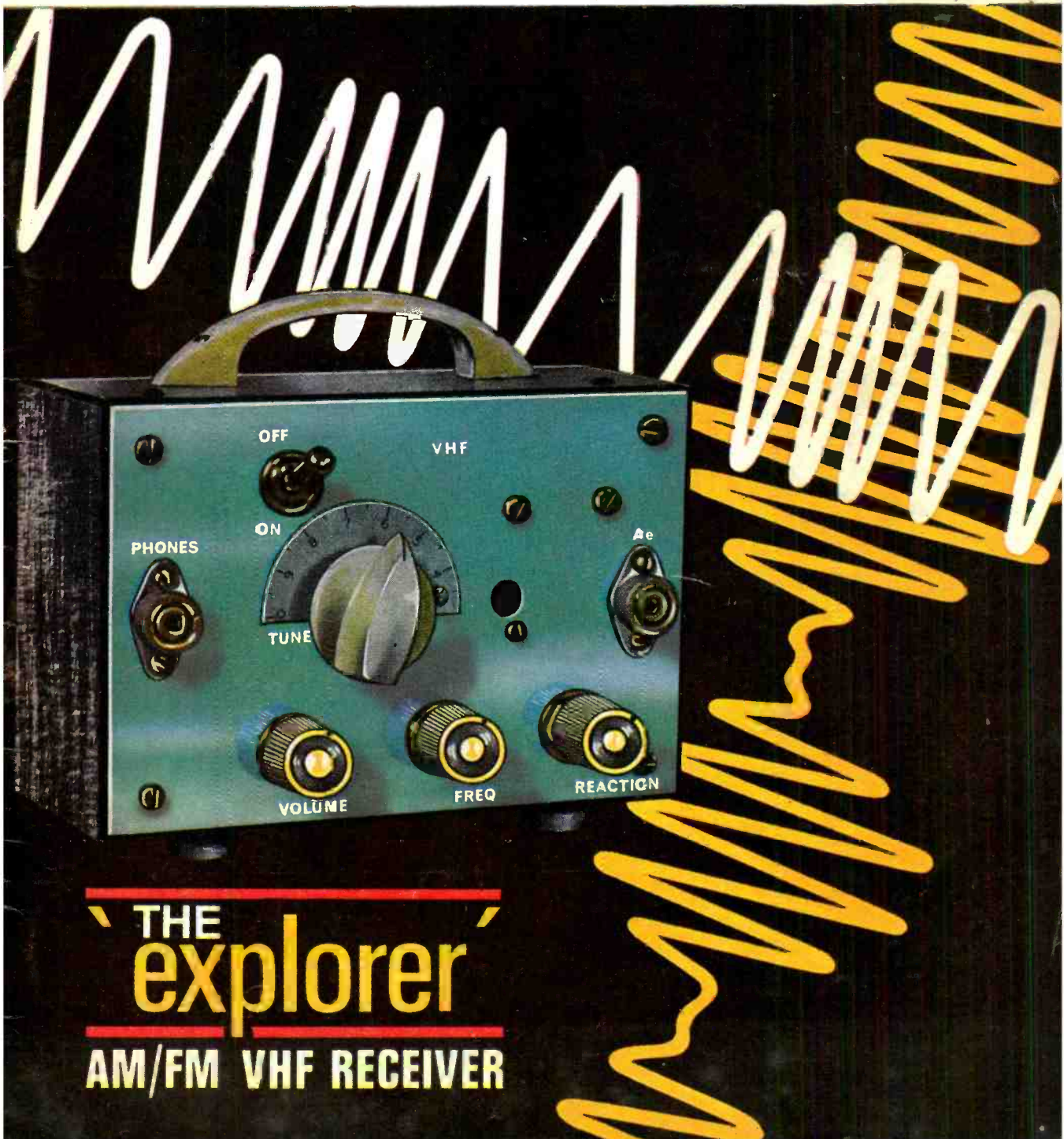

THE
explorer
AM/FM VHF RECEIVER



SOLDERING EQUIPMENT

FOR
THE
RADIO
CONSTRUCTOR

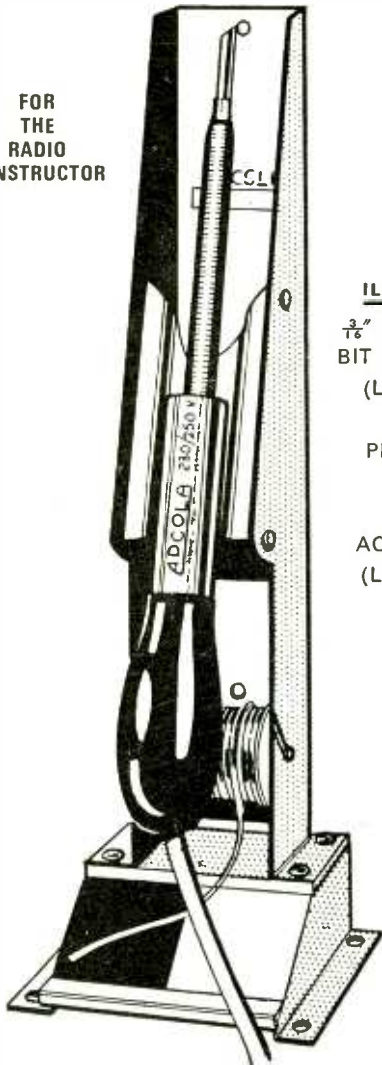

ILLUSTRATED
 $\frac{3}{16}$ " DETACHABLE
BIT INSTRUMENT
(List No. 64)
IN
PROTECTIVE
SHIELD
WITH
ACCESSORIES
(List No. 700)

FOR CATALOGUES APPLY DIRECT

ADCOLA PRODUCTS LTD.
ADCOLA HOUSE
GAUDEN ROAD,
LONDON, S.W.4

Telephones:
MACaulay 0291/3

Telegrams: "SOLJOINT" LONDON SW4

NOMBREX INSTRUMENTATION

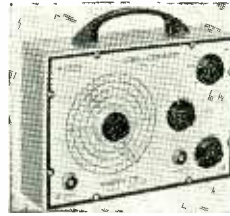

WIDE RANGE TRANSISTORISED SIGNAL GENERATOR MODEL 27

- ★ Range 150Kc/s-350Mc/s
- ★ Direct Calibration
- ★ Mod. or Unmod. output
- ★ Accuracy better than 2%
£10.18.9.

ALSO AVAILABLE

Audio Generator 63	..	£17.3.9
Inductance Bridge 66	..	£18.8.9
Power Supply Unit 61	..	£6.16.6

WIDE RANGE TRANSISTORISED C.R. BRIDGE—Model 62

6 Ranges: 1Ω to 100MΩ
1pF to 100μF

- ★ Visual null indicator
- ★ Power factor check
- ★ Electrolytic leakage test
- ★ Battery operated
£9. 8. 9.



All prices include battery, post and packing

S.A.E. for Leaflet Trade & Export Enquiries Invited Prompt Delivery

NOMBREX LTD INSTRUMENTS DIVISION

Estuary House, Camperdown Ter., Exmouth, Devon

For quick, easy faultless soldering



Easy to use and economical. Containing 5 cores of non-corrosive flux, instantly cleaning heavily oxidised surfaces. No extra flux required. Ersin Multicore Savbit Alloy reduces wear of copper soldering iron bits.



**SIZE 5
HANDY SOLDER
DISPENSER**
Contains 12 ft. of coil 18 s.w.g. Ersin Multicore Savbit Alloy on a plastic reel. 15/- each (Also available in other sizes) 2/6 each



NEW SIZE 15
21 ft coil of 60/40 Alloy, 22 s.w.g. in a dispenser. Ideal for small components, transistors, diodes, etc. 3/- each



SIZE 12
Ideal for home constructors. Contains 102 ft. of 18 s.w.g. Ersin Multicore Savbit Alloy on a plastic reel. 15/- each (Also available in other sizes)



**BIB MODEL 3
WIRE STRIPPER
AND CUTTER**
Strips insulation without nicking the wire, cuts wire and splits plastic twin flex. 4/- each

From Electrical or Hardware shops. If unobtainable write to:
MULTICORE SOLDERS LTD., Hemel Hempstead, Herts. M29 A

HI-FI AMPLIFIERS — TUNERS — RECORD PLAYERS

20+20
STEREO
AMP.
AA-22U



GARRARD
PLAYER
AT-60



TRANSISTOR MIXER. Model TM-1. A must for the tape enthusiast. Four channels. Battery operated. Similar styling to Model AA-22U Amplifier. Kit £11.16.6. Assembled £16.17.6

20+20W TRANSISTOR STEREO AMPLIFIER. Model AA-22U. Outstanding performance and appearance. 5 stereo inputs each channel, 20 transistor, 10 diode circuit. Kit £39.10.0 Assembled £57.10.0 (Cabinet £2.5.0 extra).

GARRARD AUTO/RECORD PLAYER. Model AT-60, less cartridge £14.12.10. With Decca Deram pick-up £19.7.4 incl. P.T. Many other Garrard models available, ask for Lists.

HI-FI MONO AMPLIFIER. Model MA-5. A general purpose 5W Amplifier, with inputs for Gram., Radio. Modern functional appearance. Kit £11.9.6 Assembled £15.15.0

10W
POWER
AMP.
MA-12



9+9W
STEREO
AMP.
S-99



HI-FI MONO AMPLIFIER. Model MA-12. 10W output, wide freq. range, low distortion. Use with control units. Models UMC-1 (Mono) or USC-1 (Stereo). Kit £12.18.0 Assembled £16.18.0

3+3W STEREO AMPLIFIER. Model S-33. An easy-to-build, low cost unit. 2 inputs per channel. Kit £13.7.6 Assembled £18.18.0

DE LUXE STEREO AMPLIFIER. Model S-33H. De luxe version of the S-33 with two-tone grey perspex panel, and high sensitivity necessary to accept the Decca Deram pick-up. Kit £15.17.6 Assembled £21.7.6

HI-FI STEREO AMPLIFIER. Model S-99. 9+9W output. Ganged controls. Stereo/Mono gram, radio and tape inputs. Push-button selection. Printed circuit construction. Kit £28.9.6 Assembled £38.9.6

POWER SUPPLY UNIT. Model MGP-1. Input 100/120V, 200/250V, 40-60 c/s. Output 6-3V, 2-5A A.C. 200, 250, 270V, 120mA max. D.C. Kit £5.12.6 Assembled £7.2.6



Make the most of your leisure time..

Hear the BBC Stereo FM Programmes on the TRANSISTOR STEREO FM TUNER

Elegantly designed to match the Stereo Amplifier, AA-22U



Many special features including:—

- ★ Pre-assembled and aligned RF tuning unit.
- ★ 4 stage IF amplifier, Automatic freq. control.
- ★ Printed circuit board, 14 transistor circuit.

Available in two units, sold separately, can be built for a **TOTAL PRICE KIT (STEREO) £24.18.0** incl. P.T. Kit (MONO) £20.19.0 incl. P.T. can be converted to stereo with adaptor, optional extra. Cabinet, optional extra £2.5.0. Send for details.

TRANSISTOR RADIOS

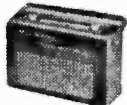

Oxford

"OXFORD" LUXURY PORTABLE Model UXR-2. Specially designed for use as a domestic or personal portable receiver. Many features, including solid leather case. Kit £14.18.0 incl. P.T.



UXR-1

TRANSISTOR PORTABLE. Model UXR-1. Pre-aligned I.F. transformers, printed circuit. Covers L.W. and M.W. Has 7" x 4" loudspeaker. Real hide case. Kit £12.11.0 incl. P.T.

JUNIOR EXPERIMENTAL WORKSHOP Model EW-1. More than a toy! Will make over 20 exciting electronic devices, incl.: Radios, Burglar Alarms, etc. 72 page Manual. The ideal present! Kit £7.13.6 incl. P.T.

HIGH PERFORMANCE CAR RADIO, CR-1. Superb LW/MW entertainment, wherever you drive. For 12v pos. or neg. earth systems. Tastefully styled to match any car colour scheme. Many special features. Send for details. Kit (less speaker) £12.17.0., L/S £1.4.5 extra. Prices incl. P.T.

WELCOME TO OUR LONDON HEATHKIT CENTRE

233 Tottenham Court Road, W.1

We open MONDAY-SATURDAY 9 a.m.-5.30 p.m.

THURSDAY 11 a.m.-2.30 p.m.

Telephone No: MUSEUM 7349

WHEN YOU ARE IN TOWN, WE HOPE YOU WILL VISIT US THERE

TEST INSTRUMENTS

Our wide range includes:

3" LOW-PRICED SERVICE OSCILLOSCOPE. Model OS-2. Compact size 5" x 7½" x 12" deep. Wt. only 9½lb. "Y" bandwidth 2 c/s-3 Mc/s. ±3dB Sensitivity 100mV/cm. T/B 20 c/s-200 kc/s in four ranges. fitted mu-metal CRT Shield. Modern functional styling. Kit £23.18.0 Assembled £31.18.0

5" GEN.-PURPOSE OSCILLOSCOPE. Model 10-12U. An outstanding model with professional specification and styling. "Y" bandwidth 3 c/s-4.5 Mc/s ±3dB. T/B 10 c/s-500 kc/s. Kit £35.17.6 Assembled £45.15.0

DE LUXE LARGE-SCALE VALVE VOLTMETER. Model IM-13U. Circuit and specification based on the well-known model V-7A but with many worth-while refinements. 6" Ernest Turner meter. Unique gimbal bracket allows operation of instrument in many positions. Modern styling. Kit £18.18.0 Assembled £26.18.0

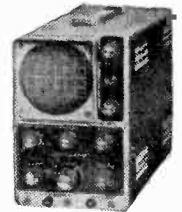

OS-2



VVM, IM-13U

AUDIO SIGNAL GENERATOR. Model AG-9U. 10 c/s to 100 kc/s, switch selected. Distortion less than 0.1%. 10V sine wave output metered in volts and dB's. Kit £23.15.0 Assembled £31.15.0

VALVE VOLTMETER. Model V-7A. 7 voltage ranges d.c. volts to 1,500. A.C. to 1,500 r.m.s. and 4,000 peak to peak. Resistance 0.1Ω to 1,000MΩ with internal battery. D.C. input resistance 11MΩ. dB measurement, has centre-zero scale. Complete with test prods. leads and standardising battery. Kit £13.18.6 Assembled £19.18.6



V-7A



RF-1U

MULTIMETER. Model MM-1U. Ranges 0-1.5V to 1,500V a.c. and d.c.; 150μA to 15A d.c.; 0-2Ω to 20MΩ 4½" 50μA meter. Kit £12.18.0 Assembled £18.11.6

R.F. SIGNAL GENERATOR. Model RF-1U. Up to 100 Mc/s fundamental and 200 Mc/s on harmonics. Up to 100mV output. Kit £13.18.0 Assembled £20.8.0

SINE/SQUARE GENERATOR. Model 1G-82U. Freq. range 20 c/s-1 Mc/s in 5 bands less than 0.5% sine wave dist. less than 0.15μ sec. sq. wave rise time. Kit £25.15.0 Assembled £37.15.0



1G-82U

TRANSISTOR POWER SUPPLY. Model IP-20U. Up to 50V, 1.5A output. Ideal for Laboratory use. Compact size. Kit £35.8.0 Assembled £47.8.0

Prices and specifications subject to change without notice

TAPE AMPLIFIERS — TAPE DECKS — CONTROL UNITS



**FM
TUNER
FM-4U**

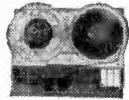

**STUDIO-
MATIC
DECK**

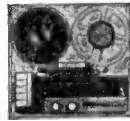

**TRUVOX
DECK**



**AM/FM
TUNER**

HI-FI FM TUNER. Model FM-4U. Available in two units. R.F. tuning unit (£2.15.0 incl. P.T.) with I.F. output of 10.7 Mc/s and I.F. amplifier unit, with power supply and valves (£13.13.0). For free standing or cabinet mounting. Total Kit £16.8.0 (Multiplex adaptor available, as extra).

HI-FI AM/FM TUNER. Model AFM-1. Available in two units which, for your convenience, are sold separately. Tuning heart (AFM-T1—£4.13.6 incl. P.T.) and I.F. amplifier (AFM-A1—£22.11.6). Printed circuit board, 8 valves. Covers L.W., M.W., S.W., and F.M. Built-in power supply. Total Kit £27.5.0 (Multiplex adaptor available, as extra).

STUDIOMATIC "363" TAPE DECK. The finest buy in its price range. Operating speed: 1 7/8", 3 3/8" and 7 1/2" p.s. Two tracks, "wow" and "flutter" not greater than 0.15% at 7 1/2" p.s. £13.10.0 With TA-1M Tape Pre-amplifier kit £31.5.6

TRUVOX D-93 TAPE DECKS. High quality stereo/mono tape decks. D93/2, 1/2 track, £36.15.0 D93/4, 1/2 track, £36.15.0

TAPE RECORDING/PLAYBACK AMPLIFIER.
Mono Model TA-1M Kit £19.18.0 Assembled £28.18.0
Stereo Model TA-1S Kit £25.10.0 Assembled £35.18.0

HI-FI CABINETS. A wide range available for example:—
Malvern Kit 18.1.0 incl. P.T.

MONO CONTROL UNIT. Model UMC-1. Designed to work with the MA-12 or similar amplifier requiring 0.25V or less for full output. 5 inputs. Baxandall type controls. Kit £9.2.6 Assembled £14.2.6

STEREO CONTROL UNIT. Model USC-1. Push-button selection accurately matched ganged controls to ±1dB. Rumble and variable low pass filters. Printed circuit boards. Kit £19.19.0 Assembled £27.5.0

Enjoy building a Heathkit model



SPEAKER SYSTEMS



SSU-1



Berkeley

HI-FI SPEAKER SYSTEM. Model SSU-1. Ducted-port bass reflex cabinet "in the white". Two speakers. Vertical horizontal models with legs, Kit £12.12.0, without legs, Kit £11.17.6 incl. P.T.

The BERKELEY SLIM-LINE SPEAKER SYSTEM, fully finished walnut veneered cabinet for faster construction. Special 12" bass unit and 4" mid/high frequency unit. Range 30-17,000 c/s. Size 26" x 17" only 7 3/8" deep. Modern attractive styling. Excellent value. Kit £19.10.0 Assembled £24.0.0

COTSWOLD SPEAKER SYSTEMS. Outstanding performance for price.
MFS: Size 36" x 16 1/2" x 14" deep. Kit £25.12.0 Assembled £33.17.0
STANDARD: Size 26" x 23" x 14 1/2" deep. Kit £25.12.0 Assembled £33.17.0

MULTIPLEX DECODER SD-1

For receiving Stereo FM. Convert your existing FM Mono receiver to stereo with this low cost, self powered unit. Fully transistorised. Kit £8.10.0 Assembled £12.5.0 Styled to match British Heathkit models.

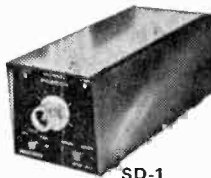

SD-1

"AMATEUR" EQUIPMENT

80-10m TRANSMITTER, DX-40U. Power inputs 75W. C.W., 60W peak CC phone. Output 40W to aerial. Provision for VFO. Kit £29.19.0 Assembled £41.8.0

SSB ADAPTOR, SB-10U
Kit £39.5.0 Assembled £54.18.0

AMATEUR BANDS RECEIVER Model RA-1. To cover all the Amateur Bands from 160-10 metres. Many special features, including: half-lattice crystal filter; 8 valves; signal strength "S" meter; tuned R.F. Amp. stage. Kit £39.6.6 Assembled £52.10.0

160-10M TRANSMITTER. Model DX-100U. Careful design has achieved high performance and stability. Completely self-contained. Kit £81.10.0 Assembled £106.15.0

COMMUNICATIONS TYPE RECEIVER. Model RG-1. A high performance, low cost receiver for the discriminating listener. Frequency coverage: 600 kc/s-1.5 Mc/s and 1.7 Mc/s-32 Mc/s. Kit £39.16.0 Assembled £53.0.0

REFLECTED POWER METER and SWR BRIDGE. Model HM-11U. Indicates reliably but inexpensively, whether the RF power output of your TX is being transferred efficiently to radiating antenna. Kit £8.10.0 Assembled £10.15.0

OUTSTANDING "AMATEUR" EQUIPMENT
A wide range of American Amateur SSB equipments is now available in the U.K. Why not send for full details of range, for example:

FILTER TYPE SSB TRANSCEIVERS
Models for 80, 40 or 20 metre bands.
Model HW-12 (80M) £67.10.0 Kit.
Model HW-22 (40M) } £66.0.0 each kit.
Model HW-32 (20M) } price inc. duty, etc.



DX-40U



RA-1



HM-11U



80M Transceiver
HW-12

**SEND FOR THE LATEST
FREE CATALOGUE**

Deferred terms available in UK over £10
Prices quoted are Mail Order prices

DAYSTROM LTD Dept. P.W.—1
GLOUCESTER

Without obligation please send me (Tick here)

FREE BRITISH HEATHKIT CATALOGUE.....

FULL DETAILS OF MODEL(S).....

(Please write in BLOCK CAPITALS)

NAME

ADDRESS

DEPT. P.W.1

BSR MONARCH UA16 with FULL-FI HEAD

4-speed, plays 10 records, 12in. 10in. or 7in. at 16, 33, 45 or 78 r.p.m. Internixes 7in., 10in. and 12in. records of the same speed. Has manual play position: colour, brown. Dimensions: 12 $\frac{1}{2}$ x 10 $\frac{1}{2}$ in. Space required above base board 4 $\frac{1}{2}$ in. below baseboard 2 $\frac{1}{2}$ in. Fitted with Full-Fi-turn-over crystal head.



£4.19.6
P. & P. 9/-

Complete Amplifier Kit comprising E.C.L. 82 Mains transformer, metal rectifier, volume control, smoothing condenser, metal chassis, speaker, etc. To the purchasers of the above changer only 19/8 plus 3/- P. & P.



POCKET MULTI-METER

Size 3 $\frac{1}{2}$ x 2 $\frac{1}{2}$ x 1 $\frac{1}{2}$ in. Meter size 2 $\frac{1}{2}$ x 1 $\frac{1}{2}$ in. Sensitivity 1000 O.P.V. on both A.C. and D.C. volts. 0-15, 0-150 0-1000 D.C. current 0-150mA. Resistance 0-100k Ω . Complete with test leads, battery and full instructions. 42/6 P. & P. 3/6. **FREE GIFT** for limited period only. 30 watt Electric Soldering Iron value 15/- to every purchaser of the Pocket Multi-Meter.



"MAYFAIR" 5-Transistor TAPE RECORDER

Capatan-driven, battery operated 7 $\frac{1}{2}$ and 3 $\frac{1}{2}$ l.p.s. Precision made. Push-button controls. High quality 2 $\frac{1}{2}$ in. speaker. Push-pull circuit. Output 400mW. Frequency response: 200-7,000 kc/s. Fast rewind. Up to 1 hour twin track playing time. Automatic erasing for re-recording. Dimensions: 8in. x 11in. x 3 $\frac{1}{2}$ in. Weighs only 7lb. Takes 5in. spools. plus 9/- P. & P.

£11.10.0

40W FLUORESCENT LIGHT KIT



Incorporating GEC Choke size 8 $\frac{1}{2}$ in. x 1 $\frac{1}{2}$ in. x 1 $\frac{1}{2}$ in. 2 bi-pin holders, starter and starter-holder. P. & P. 5/6. **11/6**
Similar to above: 80W. Fluorescent Light Kit incorporating GEC choke size 11 $\frac{1}{2}$ in. x 1 $\frac{1}{2}$ in. x 1 $\frac{1}{2}$ in. 2 bi-pin holders, P. & P. **17/6**
starter and starter holder. 6/6

Twin 40W Choke instant start for 2 x 2ft. tubes 17/6. P. & P. 5/6.

THE MOTORIST'S REV COUNTER

FULLY TRANSISTORISED



Suits 4 or 6 cyl. engines. Would cost at least £8 to buy. Kit contains moving coil movement and all parts including transistors, a circuit diagram and full instructions. Maximum reading 8,000 r.p.m. Send P.O. for 22/-, which includes 2/6 postage.

MUSETTE 6 TRANSISTOR SUPERHET PORTABLE RADIO

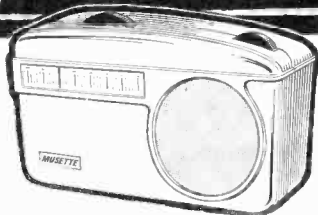

39/6

P. & P. 3/6.
Circuit diagram 2/6.
Free with parts.

INCLUDING CARRYING STRAP

- 2 $\frac{1}{2}$ " Speaker.
- 6 Transistors Superhet Output 200mW.
- Plastic Cabinet in red, size 4 $\frac{3}{8}$ " x 3" x 1 $\frac{3}{8}$ " and gold speaker louvre.
- Horizontal Tuning Scale.
- Ferrite Rod Internal Aerial.
- IF 470 kc.
- All components, Ferrite Rod and Tuning Assembly mount on printed board.
- Operated from PP3 Battery.
- Full comprehensive instructions and point-to-point wiring diagram.
- Printed Circuit Board.
- Tunable over medium and long waveband. Car aerial and ear piece socket.

RADIO & TV COMPONENTS (ACTON) LTD
21C HIGH STREET · ACTON · LONDON · W.3

MULTIPLEX DECODER

For receiving Stereo FM

Now is your chance to benefit in full from the new B.B.C. stereo transmissions with our Multiplex Decoder. Design features: Highly efficient; Mullard vinkor pot cores. Two semi-conductor diodes. Double purpose valve. Printed circuit type construction high input impedance. Specification: Cross talk minus 26 dB at 1 kc/s. Input requirements 0.5-1.5 RMS. Stability plus or minus 0.1%. Voltage requirements H.T. 190-250 volts. D.C. at 5 mA. heaters 6-3 volts. A.C. at 300 mA. Self powered unit shortly available, price to be announced. Size 5 $\frac{1}{2}$ " x 3 $\frac{1}{2}$ " x 1". Fully built and tested.

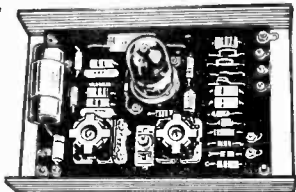

Price **£4.4.0** P. & P. 3/-

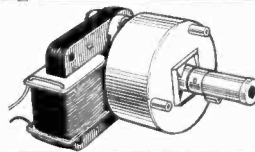

Type E MOTOR

Small A.C. mains motor 230/250 volts complete with gearbox. 6 r.p.m. Price 15/- plus 4/- P. & P.
Similar to above motor but without gearbox. Price 9/6 plus 3/- P. & P.



FIRST QUALITY P.V.C. TAPE

5 $\frac{1}{2}$ in. Std.	850ft.	9/-	5in. L.P.	850ft.	10/6
7in. Std.	1200ft.	11/6	3in. T.P.	600ft.	10/6
3in. L.P.	240ft.	4/-	5in. T.P.	1800ft.	25/6
5in. L.P.	1200ft.	11/8	5 $\frac{1}{2}$ in. T.P.	2400ft.	32/6
7in. L.P.	1800ft.	15/6	7in. T.P.	3000ft.	42/6
5 $\frac{1}{2}$ in. D.P.	1800ft.	15/6	4in. T.P.	900ft.	15/-

P. & P. on each 1/6, 4 or more post free.

MAGNAVOX COLLARO



Set of three Tape Deck Motors 240V. A.C. Three motors 49/6. P. & P. 6/-.

CYLDON U.H.F. TUNER

Complete with PC88 and PC86 Valves. Full variable tuning. New and unused. Size 4 $\frac{1}{2}$ x 5 $\frac{1}{2}$ x 1 $\frac{1}{2}$ in. Complete with circuit diagram. plus 3/6 P. & P.

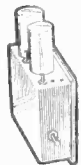

SILICON RECTIFIERS

250 v. P.I.V. 750 milliams. Six for 7/6 post paid.

3 to 4 WATT AMPLIFIER KIT

3-4 watt Amplifier built and tested. Chassis size 7 x 3 $\frac{1}{2}$ x 1 $\frac{1}{2}$ in. Separate bass, treble and volume control. Double wound mains transformer, metal rectifier and output transformer for 8 ohms speaker. Valves ECC81 and 6V6. £2.0.0 plus 5/6 p. & p.
The above in Kit Form, 29/8 plus 5/6 p. & p.

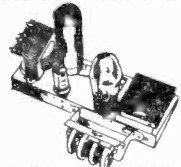

POWER SUPPLY KIT

A.C. MAINS 200-250V
Incorporating "C" core type mains transformer, full wave metal rectification and smoothing condenser. Smooth output 250 v. 250 mA and 6-3 v. 4 amp. for Heaters. **25/-** P. & P. 9/6

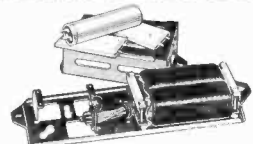

NEW Transistorised SIGNAL GENERATOR

Size 5 $\frac{1}{2}$ " x 3 $\frac{1}{2}$ " x 1 $\frac{1}{2}$ ". For IF and RF alignment and AF output 700 c/s frequency coverage 460 kc/s to 2 mc/s in switched frequencies. Ideal for alignment to our Elegant Seven and Musette. Built and tested.

39/6 P. & P. 3/6

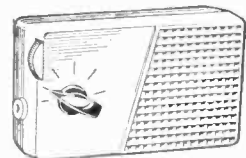

★ Our new branch at
323 EDGWARE ROAD, LONDON, W.2.
IS NOW OPEN

ALL ENQUIRIES STAMPED ADDRESSED ENVELOPE
OPEN 9 a.m.—6 p.m. INCLUDING SATS. EARLY CLOSING WED.
GOODS NOT DESPATCHED OUTSIDE U.K. TERMS C.W.O.

Elegant Seven Mk II

COMBINED PORTABLE *and* CAR RADIO

SPECIAL OFFER

7" x 4" P.M. Speaker at no extra charge

Buy yourself an easy to build 7 transistor radio and save at least £10.0.0. Now you can build this superb 7 transistor superhet radio for under £4.10.0. No one else can offer such a fantastic radio with so many de luxe star features.

- ★ De luxe grey wooden cabinet size 12½" x 8½" x 3½"
- ★ Horizontal easy to read tuning scale printed grey with black letters, size 1½" x 2"
- ★ High 'Q' ferrite rod aerial.
- ★ I.F. neutralization on each separate stage.
- ★ D.C. coupled push pull output stage with separate A.C. negative feedback.
- ★ Room filling output 350 mW.
- ★ Ready etched and drilled printed circuit board back printed for fool proof construction.
- ★ Fully comprehensive instructions and point-to-point wiring diagrams.
- ★ Car aerial socket.
- ★ Fully tunable over medium and long wave. 168-535 metres and 1250-2000 metres.
- ★ All components ferrite rod and tuning assembly mount on printed board.
- ★ Full after sales service.
- ★ Parts list and circuit diagram 2s. 6d., free with parts. Price £4.4.0 — 7s. 6d. postage and packing.

ONLY **£4.4.0**

Plus 7/6 P. & P. Parts List and circuit diagram 2/6 FREE with parts.

POWER SUPPLY KIT

To purchasers of 'Elegant Seven' parts, incorporating mains transformer, rectifier and smoothing condenser, A.C. mains 200/250 volts. Output 9v 100mA. 7s. 6d. extra.



RADIO & TV COMPONENTS (ACTON) LTD
21C HIGH STREET · ACTON · LONDON · W.3

ALL ENQUIRIES STAMPED ADDRESSED ENVELOPE
OPEN 9 a.m.—6 p.m. INCLUDING SATS. EARLY CLOSING WED.
GOODS NOT DESPATCHED OUTSIDE U.K. TERMS C.W.O.

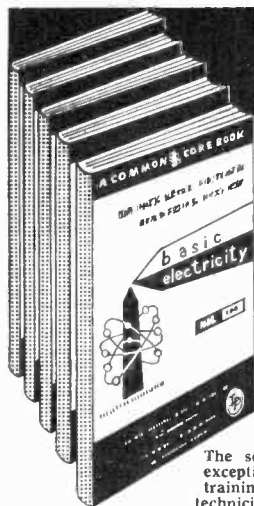

YOURS FREE FOR 7 DAYS

The New 'Picture - Book' way of learning

BASIC

ELECTRICITY (5 Vols)
ELECTRONICS (6 Vols)
ELECTRONIC CIRCUITS (2 Vols)
INDUSTRIAL ELECTRICITY (2 Vols)
SYNCHROS & SERVOMECHANISMS (2 Vols)

You'll find it easy to learn with this outstandingly successful new pictorial method—the essential facts are explained in the simplest language, one at a time; and each is illustrated by an accurate cartoon-type drawing.

The books are based on the latest research into simplified learning techniques. This has proved that the Pictorial Approach to learning is the quickest and soundest way of gaining mastery over these subjects.

The series will be of exceptional value in training mechanics and technicians in electricity, Radio and Electronics.

WHAT THIS MONTH'S ENTHUSIASTIC READERS SAY

"After reading section on Filter Circuits once, I understood more about them than in a whole year from the obscurities of other manuals." L. G. West Wickham. "I must say they are the best books on the subject as they explain in simple language what other books make hard going of." C. B. Hartlepool. "They have a wonderful system of imparting the subject to the beginner." H.O.L. Leicester. "What a contrast to the mangy text books I have attempted to struggle through." J.G. Rugby.

TO SELRAY BOOK CO.

60 HAYES HILL, HAYES, BROMLEY, KENT

Please send me Without Obligation to Purchase, one of the above sets on 7 Days Free Trial. I will either return set, carriage paid, in good condition within 7 days or send the following amounts. Basic Electricity 70/- Cash price or Down Payment of 15/- followed by 4 fortnightly payments of 15/- each. Basic Electronics 82/- Cash Price or Down Payment of 15/- followed by 5 fortnightly payments of 15/- each. This offer applies to UNITED KINGDOM ONLY.

Tick set required (only ONE set allowed on free trial).

BASIC ELECTRICITY 70/- BASIC ELECTRONICS 82/-
BASIC ELECTRONIC CIRCUITS 40/-
BASIC INDUSTRIAL ELECTRICITY 40/-
BASIC SYNCHROS & SERVOMECHANISMS 38/-
ALL PRICES INCLUDE POSTAGE

Signature (If under 21, signature of parent or guardian)

NAME

FULL POSTAL ADDRESS BLOCK LETTERS BELOW

POST NOW FOR THIS OFFER!

NEWMART

Telephone: 33 Withy Grove Manchester, 4 Deansgate 7710

introduce their down-to-earth exceptional values with the offer of a **FREE GIFT** of a genuine E.M.I. "Fisk" Solariscope, value £2.2.0 with every order value £5 and over. The "Fisk" is a boon to short wave listeners, showing clearly & easily hours of daylight and darkness at all hours each month of the year.

MICROPHONES—A selection from our range—**SLIM**—High impedance, for stand, chest or hand use. Satin-chrome finish with desk stand and two interchangeable holders, switch and lead. 33/9 P. & P. 1/3.

LAPEL/HAND Mike—1½ in. diameter, lapel clip, ideal for tape recording &c. Very sensitive with lead—7/6 P. & P. 1/-.

CRYSTAL HAND microphone—robust and sensitive, ideal for tape recorders, cream plastic case, 8/6 P. & P. 1/6.

FLOOR STAND aluminium, heavy base, smooth telescopic action standard threads. 49/6 Carr. 2/6.

TELEPHONE PICK-UP COIL for recording or amplifying both sides of conversations—suction cupfitting to phone, with lead. 7/6 P. & P. 1/-.

Many other types of crystal, dynamic, carbon mikes in stock.

TRANSRECEIVERS really excellent results with intermediate model. Complete with batteries, extending aerials, instructions. Per pair £6.15.0. P. & P. 5/-.

Including free gift. *These cannot be operated in U.K.*

TRANSISTORS—Some popular types from our range:—

OC44 and OC45—3/6 each. OC71, 2/9. OC72, 3/6. OC81 and OC81D—3/- each. OC169, 3/9. OC170, 3/6. AF117, 4/-.

OC26, 7/6. GE18, 5/9. Gen. Purpose (approx. OC71) 1/- each. Postage 6d for 3; over 12 sent post paid.

METERS. POCKET SIZE MULTI-TESTER—Type PT34, 1000ΩAV. 0/10-50-250-500-1000 volts AC and DC. 0/1-100-500mA. 0/100,000 Ω. Complete with battery, leads, instructions. 37/6. P. & P. 2/6.

MINI-METER Perspex front, 1000Ω P.V. 0-12, 120, 1200V. AC/DC 0/1 and 0/120mA. 0-200Ω, with battery, leads, instructions. 35/-.

P. & P. 2/6.

PANEL MOUNTING 0/1 mA—1¾ in. square front, black numerals on silver dial. 20/- each. P. & P. 2/-.

2½ in ROUND SPEAKERS, 8%, as used in many transistor sets, inter-coms, baby alarms—ideal replacement. 4/- each. P. & P. 1/-.

CAR/AERIAL In-Wing fitting, anti-vandal, 2 keys, 4 extensions, lead, plug. 36/-.

P. & P. 2/-.

GARRARD RECORD-PLAYING DECKS

SRP12	3 speed single player	4	5	6	} Carriage on all types 5/-.
1000	4 speed auto-change	5	19	6	
AT6, MkII	4 speed de-luxe auto	9	19	6	
SP25	4 speed superb single-player	8	19	6	

All above fitted mono cartridge—stereo 10/- extra. free gift.

XMAS SPECIAL—Ideal gift for either sex—attractive permanent chargeable (plug into A.C. mains outlet). **POCKET FLASHLIGHT 18/9.**

P. & P. 1/3.

Finest quality U.S.A. RECORDING TAPE—fully guaranteed.

3½ in 600ft. Mylar	10/-	7in. 1200ft. acetate	12/6
5in 600ft acetate	8/6	7in 1800ft acetate	15/-
5½ in 1800ft mylar	22/6	7in 2400ft mylar	25/-

Post &c. 1/- per reel extra. 4 reels and over post paid. Most other popular sizes in stock.

SPECIALLY SELECTED VALVE OFFER THIS MONTH

1S4	4/9	6X5G	4/-	ECC82	4/6
1S5 (DAF91)	3/-	807	8/6	ECC83	4/6
1T4 (DF91)	2/3	10F3	7/9		
5U4G	4/6	10L1	7/-		
5Z4G	6/9	12SJ7	3/9		
6AM6	3/9	12SK7	3/6		
6CH6	5/9	ECC85	4/6		
6F11	5/9	L63	5/9		
6K8G	3/-	PCF80	5/9		
6X4	3/6	UU7	9/6		

R.F. FIELD INDICATOR: Checks radiation from an existing antenna. Tunes 1 to 250Mcs in 5 bands. Sensitive 200μA meter movement.

5 section plug-in antenna—phone jack for monitoring. Crystal earpiece and instructions supplied. Ideal for use with radio controlled models. No battery required. Powerful magnet for attaching to metal surfaces. 47/6

P. & P. 2/6

The above represent only a few of the many hundreds of lines available at prices which stand any comparison.

TERMS: Cash with order—No C.O.D. Orders totalling £5 and over carr. paid (except Garrard Decks and transreceivers where carriage is as shown) guaranteed money refund if goods returned perfect within 7 days of despatch. **REMEMBER THE FREE GIFT!**

Callers Welcome—Open All Day Mon.—Sat. 9.30 a.m.—6 p.m.



RECORD HOUSING



Schubert Equipment Cabinet 37 gns.

Housing Hi-Fi is our business . . . turntables, tape recorders, loudspeakers, tuners, amplifiers, records, tapes . . . there's a RECORD HOUSING cabinet to suit your equipment. Send for illustrated catalogue giving full details of over 20 different cabinets, plus stockists' list (U.K. only) to:

RECORD HOUSING (Dept. PW1)

Brook Road, London, N.22. Tel.: BOWes Park 7487

RADIO CONSTRUCTOR

4 STAR FEATURES

★ BEGINNERS POWER PACK

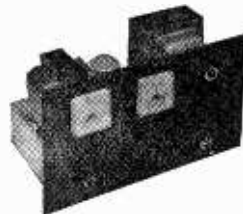

★ 7 SILICON PLANAR TRANSISTOR CIRCUITS

★ SQUARE WAVE GENERATOR

★ SIMPLE CAPACITANCE METER

ALL IN DECEMBER ISSUE
buy your copy now — 2/6

from your newsagent or 3/- post paid from

Data Publications Limited
57 MAIDA VALE LONDON, W9

INCREASE YOUR KNOWLEDGE



RADIO TELEVISION ELECTRONIC ENGINEERING

MEMBER OF THE ASSOCIATION
OF BRITISH CORRESPONDENCE COLLEGES

CHOOSE THE RIGHT COURSE FROM
RADIO AND TELEVISION ENGINEERING,
INDUSTRIAL TELEVISION, RADIO AND
TELEVISION SERVICING, ELECTRONICS,
COMPUTERS AND PROGRAMMING,
ELECTRONIC TECHNICIANS, SERVOMECH-
ANISMS, TELEMTRY, CLOSED CIRCUIT TV,
INSTRUMENTATION, AND PRINCIPLES OF
AUTOMATION.

ALSO EXAMINATION COURSES FOR:

Inst. of Electronic and Radio Engineers
C. & G. Telecommunication Techns'. Cert.
C. & G. Supplementary Studies
R.T.E.B. Radio/TV Servicing Cert.
P.M.G. Certificates. Radio Amateurs' Exam.

LEARN AS YOU BUILD

Practical Radio Courses: Gain a sound knowledge of Radio as you build YOUR OWN 5-valve superhet Receiver and Transistor, Portable Signal Generator and High Quality Multitester. At the end of the course you have valuable practical equipment and a fund of personal knowledge and skill. ICS Practical Radio Courses open a new world to the keen amateur.

THERE IS AN **ICS** COURSE FOR YOU

Whether you need a basic grounding, tuition to complete your technical qualifications, or further specialised knowledge, ICS can help you with a course individually adapted to your requirements.

There is a place for you among the fully-trained men. They are the highly paid men—the men of the future. If you want to get to the top, or to succeed in your own business, put your technical training in our experienced hands.

ICS Courses are written in clear, simple and direct language, fully illustrated and specially edited to facilitate individual home study. You will learn in the comfort of your own home—at your own speed. The unique ICS teaching method embodies the teacher in the text; it combines expert practical experience with clearly explained theoretical training. Let ICS help you to develop your ambitions and ensure a successful future. Invest in your own capabilities.

FILL IN AND POST THIS COUPON TODAY

You will receive the FREE ICS Prospectus listing the examinations and ICS technical courses in radio, television and electronics. PLUS details of over 150 specialised subjects.

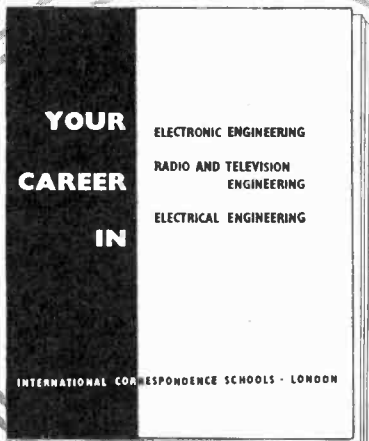

PLEASE SEND FREE BOOK ON.....

NAME

ADDRESS

.....

OCCUPATION..... AGE.....

INTERNATIONAL CORRESPONDENCE SCHOOLS
Dept. 170, INTERTEXT HOUSE, PARKGATE ROAD, London, SW11
1/67

LASKY'S RADIO

FOR THE FINEST VALUE AND

We wish all our customers old and
AND CORDIALLY INVITE YOU TO SELECT YOUR

TRANSISTOR PORTABLES

SPECIAL PRE-CHRISTMAS OFFER!

£1 reduction off the Skyrover De Luxe for cash customers.

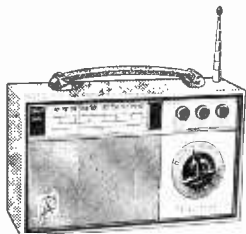

THE SKYROVER De Luxe

7 transistor plus 2 diode superhet, 6 waveband portable receiver covering the full Medium Waveband and Short, Waveband 31-94M and also 4 separate switched bandspread ranges, 13M., 16M., 19M., and 25M., with Band Spread Tuning for accurate Station Selection. The coil pack and tuning heart is completely factory assembled, wired and tested. The remaining assembly can be completed in under three hours from our easy to follow, stage by stage instructions. Superhet, 470 Kc/s. All Mullard Transistors and Diode. Uses 4 U2 batteries. 5m. Ceramic Magnet P.M. Speaker. Easy to read Dial Scale, 500 MW Output. Telescopic Aerial and Ferrite Rod Aerial. Tone Circuit is incorporated, with separate Tone Control in addition to Volume Control. Tuning Control and Waveband Selector. In a wood cabinet, size 11½ x 6½ x 3in. covered with a washable material, with plastic trim and carrying handle. Car aerial socket fitted.

Can now be built for **£8.19.6** Post extra

H.P. Terms: 45/- deposit and 11 monthly payments of 14/2. Total H.P.P. £10.0.10

★ LONG WAVEBAND COVERAGE IS NOW AVAILABLE FOR THE SKYROVER

A simple additional circuit provides coverage of the 1100/1950M. band (including 1500M. Light programme). This is in addition to all existing Medium and Short wavebands. All necessary components with construction data.

Only 10/- extra Post Free.

This conversion is suitable for receivers that have already been constructed.

Data 2/6 extra: Refunded if you purchase All components available separately.

TAPE RECORDERS

MAGNAVOX 363 TAPE DECKS

The very latest 3 speed model—1½, 3½, 7½ ips, available with either ½ track or ¼ track head. Features include: pause control; digital counter; fast forward and rewind; new 4 pole fully screened induction motor; interlocking keys. Size of top plate 13½ x 11in. x 5½in. deep below unit plate. For 200/250v. A.C. mains, 50 cps operation. New, unused and fully guaranteed.

Lasky's Price ¼ track model **£10.10.0**

Lasky's Price ½ track model **£13.9.6**

Carriage and Packing 7/6 extra.

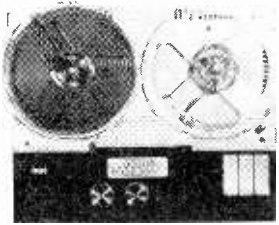

NEW MARTIN TAPE RECORD/REPLAY AMPS.

Now available from stock—for use with the Magnavox 363 Tape Deck.

¾ track model..... LASKY'S PRICE **£14.19.6** Carriage and ¼ track model..... LASKY'S PRICE **£15.19.6** Packing 4/6 extra.

Optional extra: Control panel escutcheon to tape deck and amplifier controls.

LASKY'S PRICE 12/6 Post & Packing 2/6.

INTERNATIONAL TAPE

Famous American Brand—Fully Guaranteed

3in. Message tape, 150ft.	2 6	5½in. Long play, 1200ft. Acetate	12 6
3in. Message tape, 225ft.	3 9	5½in. Standard play, 850ft. PVC	11 6
3in. Message tape, 300ft.	7 6	5½in. Long play, 1200ft. Mylar	15 0
3½in. Triple play, 600ft. Mylar	10 0	5½in. Triple play, 2400ft. Mylar	45 0
4in. Triple play, 900ft. Mylar	17 6	7in. Standard play, 1200ft. Acetate	12 6
5in. Long play, 1200ft. Mylar	15 0	7in. Standard play, 1200ft. Mylar	12 6
5in. Long play, 900ft. Acetate	10 0	7in. Long play, 1800ft. Mylar	19 6
5in. Standard play, 600ft. PVC	8 6	7in. Double play, 2400ft. Mylar	25 0
5in. Triple play, 1800ft. Mylar	35 0	7in. Long play, 1800ft. Acetate	15 0
5½in. Double play, 1800ft. Mylar	22 6	7in. Triple play, 3600ft. Mylar	50 0

P. & P. 1/- extra per reel, 4 reels and over Post Free
Full range of Philips prerecorded cassettes—send S.A.E. for list.

MICROPHONES

THE VERY LATEST MARVELS OF ELECTRONIC MINIATURISATION

THE TTC MODEL B4002 FM WIRELESS MICROPHONES

Highly sensitive—suitable for either static or mobile use. Signals can be picked up by any FM radio or tuner which receives frequencies between 96—104 Mc/s over several hundred yards. Size only 3 x 2½ x 1in. (in leather case). Operates in one PP3 type battery. Complete with neck cord, clip on dynamic extension mike (1 x ½ x 3/16in.) and battery. LASKY'S PRICE 10 Gns. Post Free anywhere in world.

THE TTC MODEL 13/500. More powerful version of above—size 4 x 1 x 1in. Operates on one PP3 type battery. LASKY'S PRICE 12 Gns. Post Free anywhere in world.

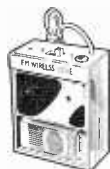

CONSTRUCTORS BARGAINS

SPECIAL PURCHASE—UHF/VHF TV TUNERS

Well known British makers surplus stocks. Now available for the first time to the Home Constructor. Add 2/6 Post and Packing on each.

TRANSISTORISED UHF MINIATURE MODEL 1
Shielded metal case only 3½ x 1½ x 3in. Fully tunable—complete with two AF139 transistors. LASKY'S PRICE 39/6

TRANSISTORISED UHF MODEL 2
Metal case size 3½ (plus spindle) x 2½ x 1½in. Fully tunable with slow motion drive. Complete with two AF186 transistors. LASKY'S PRICE 25/6

VALVE UHF MODEL (illustrated)
In metal case size 4 x 6 x 1½in. Fully tunable—complete with PC86 and PC88 valves. LASKY'S PRICE 29/6 Without valves 12/6

TRANSISTORISED VHF TUNER

Sub-miniature turret type fitted with 12 sets of coils and 3 Mullard AF102 transistors. In metal case size 3 x 1½ x 2½in LASKY'S PRICE 37/6



SURPLUS TV IF AMPS.

35 Mc/s. Contains a large number of components, IF transformers, resistors, capacitors etc., and the following valves: 2 x PCF80, 1 x EB91, EF80, EF183 and EF184. Overall size 11½ x 3½ x 4in. deep. Ideal for servicemen and experimenters. This IF amp. when used with the valve model UHF tuner (above) provides a suitable conversion for BBC2. No circuit available. LASKY'S PRICE 39/6 Post 2/6

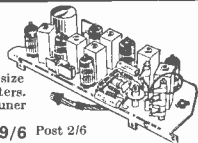

SPECIAL PACKAGE BARGAIN OFFER!

Free standing table cabinet, size 19½ x 9 x 5½in. finished in medium Mahogany. Scale marked 21 to 68 (UHF band). Designed to accept the above IF Amplifier with space for a Valve UHF Tuner.

CABINET ONLY 27/6 Post 3/6

Special Package Offer: IF Amplifier, UHF Tuner with valves and Table Cabinet



PACKAGE PRICE 89/6 Post 6/-

NEW—LASKY'S MINIATURE TRANSISTOR AMPLIFIER MODULES

Incorporating the very latest circuitry to provide high sensitivity and good quality in conjunction with extreme small size and compactness. High quality Newmarket transistors used throughout. All designed to operate on 9v. miniature battery.

Add 1/- on each for Post and Packing.

TYPE LRPC 1. 3 transistor. Input sens. 50mV, output 150mW, output imp. 40Ω, 2 x 1 x 1½in. PRICE 27/6

TYPE LRPC 2. 5 transistor. Input sens. 1mV, output 330mW, output imp. 15Ω, size 2½ x 1½ x 3½in. PRICE 22/6

TYPE LRPC 3. 5 transistor. Input sens. 5mV, output 400mV, output imp. 15Ω, size 2½ x 1½ x 3½in. PRICE 25/6

TYPE LRPC 4. 5 transistor. Input sens. 150mV, output 330mW, output imp. 15Ω, size 2½ x 1½ x 3½in. PRICE 22/6

TYPE LRPC 5. 6 transistor. Input sens. 8mV, output 3W, output imp. 3Ω, size 6½ x 1½ x 1in. PRICE 59/6

TYPE LRPC 6. Tape record/playback amp. (for use with self oscillating erase head). Output 750 mW, output imp. 8Ω. Size 4½ x 2 x 1in. PRICE 39/6

FULLY ENCAPSULATED MODULES

Special function modules—all one size 1½ x 1 x 1½in. Complete with detailed function and installation instructions. Send S.A.E. for specification sheets.

TYPE PA-1. Public address amp. for use with carbon, crystal or Dynamic microphones. 3Ω output imp. PRICE 30/-

TYPE GR-1. Gramophone amp.—provides sufficient power to fill average room. 3Ω output imp. PRICE 30/-

TYPE CO-1. Morse code practice oscillator—for use with morse key and 3Ω speaker. PRICE 20/-

TYPE MT-1. Metronome module—provides audible and visual beat from 30 to 240 beats per minute (for use with 3Ω speaker or indicator lamp). PRICE 22/6

GORLER UT 340 FM/VHF TUNING HEART

Permeability tuned—covering 87 to 108 Mc/s. For use with one ECUS8 valve. In metal case, size 3 x 2½ x 1½in. Circuit supplied.

LASKY'S PRICE 15/11 Post 2/-, ECC85 valve 9/- extra.

TRANSISTORS

ALL BRAND NEW AND GUARANTEED

GET 81, GET 85, GET 86 2/8; 878A, 874F 8/8; OC45, OC71, OC81D 4/8; OC44, OC70, OC76, OC81 5/8; (match pair 10/8); AF117, OC200 8/8; OC42, OC43, OC73, OC82D 7/8; OC201, OC204 15/-; OC205, OC206 19/8; OC28 24/8; OC75 8/-.

TRANSFILTERS

by BRUSH CRYSTAL CO., Available from stock.

TO—O1B 465 kc/s. ± 2 kc/s. | TO—O2D 470 kc/s. ± 1 kc/s. 9/6 each
TO—O1D 470 kc/s. ± 2 kc/s. | TP—O1B 465 kc/s. ± 2 kc/s. Post 6d.
TO—O2B 465 kc/s. ± 1 kc/s. | TP—O1D 470 kc/s. ± 2 kc/s.

NOW AVAILABLE—OUR NEW BARGAIN BULLETIN. 24 foolscap pages packed with hundreds of bargains for the "ham" and service man—exclusive to Lasky's—plus full list of regular stock items. PRICE 6d. POST FREE.

LASKY'S RADIO FOR FINEST VALUE AND COURTEOUS SERVICE

CODAR — QUALITY

ANOTHER CODAR TRIUMPH!

THE NEW 1966 CR.70A COMMUNICATION RECEIVER.

This completely new receiver sets a new high standard for performance and finish unequalled at the price, and is a worthy addition to the outstanding range of **CODAR** quality communication equipment. Frequency range: 580 Kc/s-30 Mc/s (540-10 metres) in four ranges; 560 Kc/s-1.5 Mc/s; 1.5 Mc/s-4.2 Mc/s; 4.2 Mc/s-11.5 Mc/s; 11.5 Mc/s-30 Mc/s. Slide rule scales for each band calibrated in frequencies plus an additional logging scale in degrees. Two speed vernier tuning control with reverse slow tune action. Unique aerial input stage exclusive to the CR.70A employing High 'Q' Air-spaced **CODAR-COIL** inductor giving extremely high gain with low noise level. Panel aerial trimmer for peaking weak signals. Double tuned I.F. Iron cored transformers, 470 Kc/s with EF183 frame grid valve for maximum gain and selectivity. 5 valves (including two twin triodes) giving 7 valve line-up. Separate B.F.O. stage for CW and SSB reception. Calibrated signal strength 'S' meter, illuminated. Automatic Volume control. Panel phone jack for 'private' listening, 2-3 ohm output for external speaker. (Matching unit optional extra.) Superb styling, metal cabinet in the new Organosol Satin lustre finish. Size: 13" x 5 1/2" x 7 1/2". For A.C. 200/250v. Ready built. Not a Kit at the fantastic low price of £19.10.0. Carr. 7/6.

CODAR R.F. PRE-SELECTOR MODEL P.R.30. Considerably improves the performance of any superhet receiver over 1.5-30 Mc/s. Uses EF183 Frame Grid Valve, and provides up to 20dB gain plus substantial image rejection, improved signal/noise ratio and selectivity. Selector switch for either dipole or single wire antenna. Power requirements 180-250 volts 12mA H.T. 6.3 volts, 3 amp L.T. Size 8 1/2 x 5 x 4 1/2 in. Ready built, complete with cables, plugs and instructions, £5.10.0. Carr. 4/6. **MODEL P.R.30X.** Self powered model for 200-250v. A.C. Also provides 25mA at 200v, H.T. and 6.3v. 1 amp L.T. for other accessories £7.4.0. Carr. 4/6.

CODAR "Q" MULTIPLIER MODEL R.Q.10. For use with any superhet receiver with an I.F. between 450 and 470 Kc/s. Provides considerable increase in selectivity for either peaking or rejecting a signal on AM, CW, or SSB, BFO. Size 8 1/2 x 5 x 4 1/2 in. Power requirements 180-250v, H.T. at 5mA 6.3v. 3 amp L.T. Ready built complete with cables, plugs and instructions. £6.15.0. Carr. 4/6. **MODEL R.Q.10X.** Self powered version for 200-250v. A.C. and also provides 25mA at 200v, H.T. and 6.3v. 1 amp. L.T. for other accessories £8.8.0. Carriage 4/6.

CODAR A.T.5, 12 WATT 2 BAND TRANSMITTER. The newest most compact transmitter for fixed or mobile use on 160-80 metres. "The tiny TX with the BIG voice". Size only 8 1/2 x 5 x 4 1/2 in. (Base area is less than two-thirds of this page!) High stability new type calibrated VFO, 1.8-2.0 Mc/s and 3.5-3.8 Mc/s (up to 4 Mc/s export). Air-spaced **CODAR COIL** Pi-net output, P.A. Plate current meter plus neon indicator. Plate-Screen modulator. AM/CW switch and Panel key jack. Plug change over for 6 or 12 volts heater supply. Ready built £16.10.0. Carr. 4/6. **A.T.5 POWER SUPPLY UNITS.** For 200-250v. A.C. and 12v. Solid state for Mobile use, complete with all Transmit/Receive changeover switching available.

CODAR-KIT CR.45K MAINS T.R.F. SHORT-WAVE RECEIVER. World wide reception—North and South America, Russia, India, Australia, Far East, Amateurs, Shipping, etc. ★ Separate electrical bandspread. ★ 3 slow motion vernier drives. ★ Low loss polystyrene plug-in coils, factory aligned ★ Dials calibrated in frequencies and degrees. ★ Power output 3 watts for 2/3 ohm speaker. ★ Valve line-up: ECC81, EL24, EZ80. Size 12 x 5 1/2 x 7 1/2 in. **CODAR-KIT CR.45K** complete with valves, 3 coils (10-28, 25-75, 60-176 metres) and 11 page instruction manual, £9.10.0. Carr. 6/-. Extra coils 5/- each. Instruction manual only 4/- (credited on order). (Can also be supplied ready built—price on request).

CODAR-KIT MINI-CLIPPER—OUR FAMOUS SHORT-WAVE RECEIVER. ★ Can be built in one evening ready to switch on and bring the World to your fingertips at very low cost. ★ Supplied complete with valve, one coil 25-75 metres and 4-page instruction manual. PRICE 39/6. Carr. 3/-. Extra coils 5/- each. Instruction manual only 2/- (credited on order). Electrical bandspread available. Provision to add 2 transistor amplifier.

Send 6d. in stamps for illustrated leaflets of the Codar range

H.P. terms available

World-Wide Mail Order Service

CODAR

CODAR RADIO COMPANY
BANK HOUSE, SOUTHWICK SQUARE
SOUTHWICK, SUSSEX. Tel. 3149
G3IRE G3HGO

Canada: Codar Radio of Canada, Tweed, Ontario

SENSATIONAL COLLECTION OF BARGAINS

ONLY 49/6

New Lunar TELESCOPE

Giant Power 40 x 40

Scoop Purchase of Limited Stock. 800 only at fraction of the true value. Special Grade A.1. (de-luxe model—passed by Japanese Board of Inspection. All Metal Construction in white enamel finish with chromium plated parts. Special polished optical lens gives astounding magnification power of 1600-1 areas. Single draw focusing tube enables you to study the MOON, PLANETS & STARS. Focus on subjects miles away or just across the road. Brand new complete with collapsible tripod at unbelievable price of only 49/6 plus 5/- post and SAFE PACKING. Money back guarantee.

Large Bulk Purchase—Thus Large Cash Saving 1967 Model ALL TRANSISTOR CAR RADIO

7 Semi-Conductors
5 Push Buttons
2 Full Wavebands

including Extras **£11.19.6** INCREDIBLY SLASHED PRICE

NORMALLY COSTS DOUBLE THIS PRICE

Leading manufacturers high specification—Full 2 watts output, superb tone from dynamic 6" x 4" elliptical speaker, uncannily sensitive, latest drift transistor, full med. & long waves, all-metal construction—not plastic, exquisite black and silver finish, precision slide rule tuning brings in all B.B.C. & dozens of Continentals WITHOUT FADING. Utterly simple to install in any 12 volt system. Complete with all accessories. WRITTEN GUARANTEE. Simple instructions, size 6 1/2" x 6 1/2" x 2". Amazing price, cash £11.19.6 + 6/8 registered post/safe packing. Order confidently, your money back immediately if not 100% satisfied.

Miraculous Scoop from Swiss Manufacturer Limited Shipment NEW 21 JEWELLED DIVER'S WATCH

with Rotating Timing Bezel Staggering price reduction—compare prices at 97/6 locally, 950 only at 97/6

Make a genuine LARGE CASH SAVING on this high-quality watch, 200 vacuum tested for depth. 21 Jewelled movement. Shock-proof, electronically timed, lum. dial and hands. Ideal for skin-divers, sailing, motoring, research work for accuracy. FULLY GUARANTEED. Send only 97/6 plus 4/6 p. & p. TEST AT HOME. Money back g'tee. STAINLESS STEEL expanding bracelet 12 1/2 ex.

SAVE YOUR LEGS! INTERCOM OUTFIT & BABYALARM Ready Built Only 49/6

Robustly made, brand new current model. You get 2 separate fully transistorised intercommunicating sets—each can speak or listen to the other—complete with 60ft. connecting wire. Fired in a flash. Ends baby crying worries. Ideal for Workshop to House, Sickroom, hundreds of uses! Hangs on wall or stands up. Our price 49/6, battery 2/6 ex. Post, etc. 4/6. Money back guarantee.

Profit from the credit squeeze Importers stock bought at miles below actual value

WIDE RANGE HIGH POWER MICROSCOPE only 37/6

not a penny more to pay. Grade A.1 De Luxe model, all metal construction in black crackle with plated parts. Accurate rack and pinion focusing gives crystal clear definition. 3 optically polished lenses on revolving turret, giving 100x, 200x and 300x magnification powers. Adjustable mirror light, reflector and tilting joint. Ideal for students, hobbyists, nature study, etc. Should last a lifetime—Passed by Japanese Board of Inspection. Brand new in box, complete with set of slides at fraction of real worth—ONLY 37/6 plus 3/6 post & safe packing. Money back g'tee. Demonstrations daily.

Frustrated Import Shipment OFFERED BELOW HALF PRICE TO CLEAR 500 only ALL TRANSISTOR PERSONAL TRANSCIEVER SETS

OUR PRICE £5.19.6

You've heard about them—You've read about them. NOW'S YOUR CHANCE TO OWN THEM. Highly sensitive two-way transistor transceiver sets have individual volume control and talk-listen switch. Telescopic aerial pulls in the voice from the other set over tremendous distances—no wires—a genuine transceiver as used by official bodies and forces. 500 sets only at £5.19.6 plus 5/6 p. & p. (Batteries, leather cases, etc. 10/6 extra). Money back if not delighted with the performance. These cannot be operated in U.K.

3500 Bought at "Rock Bottom" Off Leading British Maker REAL EPISCOPÉ PROJECTOR

ONLY 45/-

No more to pay! Projects FULL SIZE Magnified PICTURE onto your wall or screen in BLACK & WHITE OR COLOUR with CRYSTAL CLARITY ANY PHOTOGRAPH, DOCUMENT, picture, drawing, stamp etc. Entertaining and educational—hundreds of uses in home, office, schoolroom, etc. A FULL SIZE precision made scientific instrument WITH REAL GLASS REFLEX LENS. Sturdy, reliable. So simple even a child can use it—plugs into standard mains. BRAND NEW complete with cable, lamp, etc. Offered at fraction of real worth at 45/- plus 5/- p. & p. Satisfaction or money back.

This is truly a wonder purchase. Limited quantity only of FABULOUS EVER-GOLD POCKET WATCHES

Now at the lowest ever price. **ONLY 25/-**

No More To Pay 25/-

Now offered at well below clearance price these remarkably reliable EVER-GOLD pocket watches. Designed to withstand years of constant use with high resistant unbreakable glass. Luminous face markings—so easy to see the correct time at a glance. Fully guaranteed DON'T MISS THIS ONCE IN A LIFETIME BARGAIN. Send only 25/- plus 3/6 p. & p. for 7 days' free home trial. Money back if not your best ever bargain.

Super Long Range COMMANDO Pattern BINOCULARS 40 m.m. (o.g.) Lens

45/-

NO MORE TO PAY

Amazing magnification of 16 areas. Brand new, contracted by leading optical manufacturer. Full size, metal construction, lightweight, precision ground and polished optical lenses for needle sharp definition. Extra large Telescopic draw tubes with smooth action centre focusing and inter-pupillary pivot. Larger optical system gives higher luminosity for night viewing—takes you to the moon or just across the road. Limited quantity only at 45/- inc. lux. real pigskin case with shoulder strap, plus 4/6 p. & p. Money back guarantee.

Make 5 different TRANSISTOR RADIOS for 39/6

No Experience Necessary

No soldering. Only 8 connections for first radio to work. Just look, you get Easy ABC Plans Cabinet, Loudspeaker (alone 17/6), Earphone, 4 Semi-conductors, Coils, Condensers Resistors, Tuner, Switch, Screws, etc. YES—EVERY THING! Loud clear English and Foreign reception. As supplied to Educational Authorities, H.M. Forces, etc. TESTIMONIALS GALORE. Complete course—originally 26. Now only 39/6 + 4/6 Post etc.

NO SOLDERING AMAZING CIGARETTE RADIO

ONLY 25/-

Yes a perfectly ordinary packet of cigarettes! But watch your friends' astonishment on hearing it fetch in station after station, loud and clear! Still holds 10 cigarettes yet cleverly conceals highly sensitive, fully transistorised circuit (including tiny battery). Even a young boy can assemble it under 2 hours. No soldering. No experience necessary. Only 16 connections to make. Ideal for taking to work with you. From our bulging testimonial file Mr. D. B. of Huddersfield, writes: "... I have fitted the parts in it and it is working wonderfully..." ALL PARTS including Semi-Conductors, ABC Plans, etc. ONLY 25/- plus 2/6 post, etc. Parts Available Separately.

Test this SELF-WINDING WATCH on your wrist for 7 days—FREE! 1,000 purchased at miles below actual value. Our amazing discount price £5.7.6

YOU NEVER WIND IT! Famous Thimery—the ultimate in Swiss Automatics. Unbeatable. Specification: 1967 Gents Slimline 21 jewels, diamond cooled, automatic date-change, unbreakable mainspring, waterproof, electronically timed, luxurious gold finish, screw back, triple sealed, shockproof, mathematical hairspring gives uncanny accuracy. Brand new with guarantee. Send £5.7.6 + 4/6 p. & p. (bracelet 17/6 ex.) for TRIAL—Refund in full without question, if not delighted!

NEW RADIO No soldering VOLKSRADIO ANYONE CAN BUILD IN 2-3 HOURS ONLY 25/-

EVEN THE OLDER CHILDREN BUILD THEM! ... no soldering—only 16 connections! then hear it reach out bringing in station after station, loud and clear. Palm-of-hand size 4 1/2 x 2 1/2 x 1 1/2 in. Many Testimonials: M.H. of Bradford writes: "... I have just completed one of your sets successfully, it is the first time I have ever tackled anything like radio, and I must state here and now, I am amazed how easy it is to a layman like me. Your instructions and plan have obviously been very carefully thought out so that even the most dim can follow them..." Direct from Manufacturers to You. Send 25/- plus 3/6 post, etc. PARTS AVAILABLE SEPARATELY.

Scoop purchase, save £££ NEW DOUBLE LENS REFLEX CAMERA ONLY 19/6 Plus 3/6 P. & P.

You'll never get another bargain like this! Advantageous purchase from distressed importer offered at fraction of real worth—unrepeatable once this batch is sold. Full size double lens reflex camera that even a child can use. Takes 12 full size 127 pictures in Full colour or black/white. You'll marvel at your professional pictures. Beautifully made and finished, size 4 1/2 in. high (6 in. high with focusing hood raised) x 3 1/2 in. x 3 1/2 in. Speeds 1/30th sec. F8. Should last a lifetime. Brand new in makers' cartons—our five-away price 19/6 + 3/6 p. & p.

Undoubtedly our finest ever Radio Offer 9 TRANSISTOR A.M./F.M. 2 WAVEBAND PORTABLE

Crazy price ONLY £7.10.0

We invite you to test it at home for 7 days & guarantee your money back in full if not 100% delighted. This FULL SIZE Electronic Marvel even plugs in private broadcasts and interesting stations you wouldn't dream of getting plus B.B.C., Lux, Finances and Continentals. The multi-angle, swivel, telescopic aerial ensures finest directional reception in all regions. The Hi-Fi quality and tone, coupled with its high sensitivity tuning, guarantees perfect clarity. FULLY GUARANTEED. Don't miss this limited period offer.—Send £7.10.0 for 7 days' home test plus 5/6 p. & p. (Leather carrying case, earpiece, batteries, etc., 8/6 extra).

CONCORD ELECTRONICS LIMITED (P.V.35) 87-89 TABERNACLE ST., LONDON, E.C.2. CALLERS WELCOME—DEMONSTRATIONS DAILY

JOYSTICK

VFA ONLY 7' 6" LONG



AERIAL PROBLEMS SOLVED!

The revolutionary JOYSTICK AERIAL SYSTEMS presents a satisfactory solution to all the problems of restricted space receiving (and transmitting) aerials. A completely new range of tuning units have been designed to allow the maximum possible efficiency with absolute simplicity of tuning and operation. For reception on all amateur bands from 1.8 Mc/s to 30 Mc/s, for general short wave and broadcast reception including the medium wave band. This variable frequency aerial system has been acknowledged as the most successful solution to a host of aerial problems. Over 5,500 are in use all over the world (as at July 1966). Hundreds and hundreds of terrific testimonials may be seen at the Joystick Office—the selection shown here will prove the point.

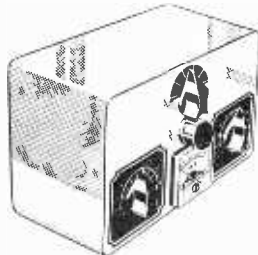

Above: One of the new JOYMATCH 'EASY-TO-USE' units with built-in RF indicator

OUTSTANDING SIGNALS FROM THE JOYSTICK VFA CAN BE HEARD EVERY DAY ON THE AMATEUR AND MARINE BANDS. START THE SEASON WITH A SUPER AERIAL.

James C. Cox—Hull "I find it successful in all ways . . . am an avid SWL."

John Cramb—Eastbourne "Have indoor Joystick . . . am getting excellent results on my Codar CR45."

B.B. St. V. Moullin—Guernsey "Truly satisfied . . . GC-1U Mohican Rx performs with greater selectivity."

Raymond F. Bence—Cardiff "Joystick system certainly does its stuff."

UK AGENTS: G. W. Smith & Co. (Radio) Ltd., 3 Lisle Street, London, W.C.2; Brian J. Ayres & Co., 8 Hartfield Road, Wimbledon, London, S.W.19; Stephens-James Ltd., 70 Priory Road, Liverpool, 4; Chas. H. Young Ltd., 170/172 Corporation Street, Birmingham, 4; R.S.C. (Manchester) Ltd., 326 Argyle Street, Glasgow, C1; or ask your local dealer.

France: Vareduc-Comimex, 2 Rue Joseph-Riviere, Paris, Courbevoie, France.

West Germany: Ing. Hannes Bauer, 86 Bamberg, Hornthalstrasse 8,

West Germany: Dressing GmbH, 45 Osnabruck, Bohmter Str, 32,

West Germany: Stotz & Goessl, 8 Munchen 15, Bayerstrasse 3,

AND WORLD WIDE AGENCIES

U.S. Patent No. 3274600

THIS BROCHURE GIVES YOU THE FACTS AND ONLY THE FACTS!

SEND TODAY

PARTRIDGE ELECTRONICS LTD.
CAISTER HOUSE, PROSPECT ROAD, BRADSTAIRS, KENT

NAME..... CALL/BRS No

ADDRESS.....

.....

..... 1



R.S.C.
HI-FI CENTRES LTD.

MAIL ORDERS TO:
102 Henconner Lane
Bramley, Leeds 13

No C.O.D. under £1. Terms C.W.O. or C.O.D. Postage 3/9 extra under £2. 5/9 extra under £5. Trade Supplied. S.A.E. with all enquiries please. Our HI-FI Catalogue is now available price 3/3 post paid. — Personal shoppers welcome at the following branches. Open all day Sats, except High Holborn branch.

- BRADFORD** 10 North Parade. Tel. (Half-day Wed.) 25349
- BRISTOL** 14 Lower Castle St. Tel. (Half-day Wed.) 22904
- BIRMINGHAM** 30/31 Gt. Western Arcade, opp. Snow Hill Station. CENTRAL 1279. No half-day
- DERBY** 26 Osmaston Rd., The Spot (Half-day Wed.) Tel.: 41361
- DARLINGTON** 13 Post House Wynd (Half-day Wednesday) Tel.: 68043
- EDINBURGH** 133 Leith Street (Half-day Wed.)
- GLASGOW** 326 Argyll St. Tel.: (No half-day) CITY 4158
- HULL** 91 Paragon Street (Half-day Thursday) Tel.: 20505
- LEICESTER** 92 High Street (Half-day Thurs.) Tel.: 56420
- LEEDS** 5-7 Bunby (Mecca) Arcade (No Half-day) Tel.: 28252
- LIVERPOOL** 73 Dale St. (No half-day) Tel.: CENTRAL 3573
- LONDON** 238 Edgware Road, W2 (Half-day Thurs) Tel.: PAD 1269
- MANCHESTER** 96 High Holborn, WC1 Tel.: HOL 9874 (Half-day Sat)
- MIDDLESBROUGH** Large walk round store (No half-day) 60A-60B Oldham St. Tel.: CENTRAL 2778 (Half-day Wednesday) Tel.: 47096

- NEWCASTLE** 41 Blackett Street Opp Fenwick's Store Half day Wed. Tel.: 21469
- UPON-TYNE** (Half-day Thursday) Tel.: 20716
- SHEFFIELD** 13 Exchange Street Castle Market Bldgs. (Half-day Thursday) Tel.: 20716

ALL LEADING MAKES OF HI-FI EQUIP. STOCKED Cash or Terms

15 watt HI-FI TRANSISTORISED AMPLIFIER TYPE A15

with integral pre-amp tone control stages. Output for 3, 7.5 and 15 ohm spkrs. Kit includes printed Circuit and all parts including 9 Mullard or Newmarket, latest **£5.19.11** Post type semi-conductors 5/- Heat sink and full wiring instructions or with printed circuit fully wired and tested **30/-** extra. Frequency Response: ± 1dB 20-20,000 cps. Harmonic Distortion: 0.1% measured at 1000 c.p.s. Hum and Noise: —80dB. Sensitivity: 2mV. Bass Control: +9dB to —14dB at 40 c.p.s. Treble Control: +9dB to —13dB at 10 Kc/s. Subst. 9.4 ohms. Power Pack Kit 39/6 or ready built 59/6.

JASON VHF/FM TUNER Complete kit with valves **£6.19.11**
Total cost of parts with detailed wiring diagrams and instructions. Carr. 10/- **12 1/2 Gns.**
Or factory built 15f Gns. Or in Teak finished cabinet as illustrated 19f Gns. Terms: Deposit 25 and 9 monthly payments 39/- Total £22.11.0.

LONDON-NEWCASTLE

New branches now open — see addresses

HI-FI LOUDSPEAKER ENCLOSURES

All types of pleasing modern "slimline" design acoustically lined and ported and in finishes of light Teak or medium Walnut.



SE8. For optimum performance with any Hi-Fi 8in. speaker. **£5.17.9** Size 22 x 15 x 7in. Carr. 7/6

SE10. For 10in. Hi-Fi speaker with provision for tweeter. Carr. **£6.19.9** Size 24 x 15 x 8in. 10/-

SE12. For outstanding performance with any 12in. Hi-Fi speaker. Cut for tweeter. Size 24 x 20 x 8in Or Deposit 27/- and 9 monthly payments of 18/2 (Total £9.10.6.) Carr. 10/-

FHEs. Folded Horn type. Size 27 x 16 x 10in. Designed for high flux 8in. speaker with exceptional quality can be obtained. Terms Deposit 21/- and 9 monthly payments 21/- (Total 10 Gns.) Carr. 10/-

AUDIOTRINE HI-FI 'SPEAKER SYSTEMS

Consisting of matched 12in. 12,000 line, 15 ohm high quality speaker; cross-over unit and Tweeter. Smooth response and extended frequency range ensure surprisingly realistic reproduction. Standard 10 watt rating. Or **5 Gns.** 12/10 speaker 7 Gns. Carr. 7/6. Carr. 5/9 Or Dep. 21/- and 9 mthly pmts of 15/4 (Tot. £719.0).



AUDIOTRINE HIGH FIDELITY 'SPEAKERS

Heavy cast construction. Latest high efficiency ceramic magnets. Dial Cone for extended frequency range. Plastic treated surround giving low fundamental resonance. Response 35-20,000 c.p.s., Impedance 3 or 15 ohms. Carr. 5/6.

HF11D 8 in. 10 WATT 4 Gns.
HF10D 10 in. 15 WATT 25.15.0
HF12D 12 in. 20 WATT 26.15.0
HF17D 12 in. 30 WATT 26 Gns.

TWEETERS R.A. 3 ohm 25/9. 15 ohm 25/9



R.S.C. STEREO/TEN HIGH QUALITY AMPLIFIER

A complete set of parts for the construction of a unit giving 5 watts high quality output on each channel (total 10 watts). Sensitivity is 50 millivolts. Suitable all crystal or ceramic stereo heads. Ganged Bass and Treble Controls. Provision is made for use as straight (monoaural) 10 watt amplifier. Valve line-up ECC83, ECC83, EL84, EL84, EZ81. Outputs for 2-3 ohm speakers. Point to point wiring diagrams and instructions supplied. Send S.A.E. for leaflet.

Or supplied factory assembled with 12 months' guarantee for 11 Gns. **£8.15.0**
Terms: Dep. 38/- and 9 monthly payments 25/5 (Total £13.4.9). Carr. 11/6

R.S.C. STEREO/20 HIGH FIDELITY AMPLIFIER

PROVIDING 10/14 WATT ULTRA LINEAR PUSH-PULL OUTPUT ON EACH CHANNEL. SUITABLE FOR "MIKE", GRAM, RADIO OR TAPE. Employing valves ECC83, ECC83, ECL86, ECL86, ECL86, E27L. Frequency Response: ±2dB 30-20,000 c.p.s. Hum Level: 65dB down. Sensitivity: 5 millivolts maximum. Harmonic Distortion: (each channel): 0.2%. ★ Four-position tone compensation and Input Selector Switch. ★ Stereo/Mono switch. ★ Will amplify direct from Tape Heads. ★ Neon panel indicator. ★ Handsome Perspex Frontplate. ★ Separate Bass "Lift" and "Cut" and Treble "Lift" and "Cut" controls. Output transformers are high quality sectionally wound to reject spurious tones. Output matching on springs. Carr. 12/6 **14 Gns.**



Or factory assembled, tested and supplied with our usual 12 months guarantee. Or Deposit 23 and 9 monthly payments 43/2 (Total £22.4.6). Send S.A.E. for leaflet. Carr. 12/6 **19 Gns.**

R.S.C. TFM1 TRANSISTORISED VHF/FM TUNER

★ High-sensitivity ★ 200-250v. A.C. Mains operation. ★ Sharp A.M. Rejection. ★ Drift-free reception. ★ Output ample for any amplifier (approx. 500 mv.). ★ Simple alignment instructions. ★ Output available for feeding tuning meter. ★ Output for feeding Stereo Multi-plexer. ★ Tuner head using Silicon Planar Transistors. ★ Designed for standard 80 ohm co-axial input.

Made to visually match our Super 15 and 30 amplifiers and of the same high standard of performance and reliability. The pre-wired tuning head facilitates speed and simplicity of construction. Printed circuitry. Only first grade transistors and components used. Our latest product giving you the best at half the cost of comparable units.

R.S.C. SUPER 15 HI-FI AMPLIFIER

FULLY TRANSISTORISED 200/250v. A.C. Mains. OUTPUT 10 WATTS R.M.S. cont. into 15 ohms. Input: ±15dB to ±13dB R.M.S. cont. into 9.4 ohms. Maximum instantaneous Peak power output 28 watts. **PRINTED CIRCUIT CONSTRUCTION. LATEST MULLARD TRANSISTORS.** AD149, AD149, OC12Z, OC81Z, OC44, OC44, OC81Z, OC44, AC107. **5 POSITION INPUT SELECTOR SWITCH. EQUALISATION to Standard R.I.A.A. and C.C.I.R.** Characteristics for Gram and Tape Heads. **FULL TAPE MONITORING FACILITIES. SENSITIVITIES:** Magnetic P.U. 4 mV. Crystal or Ceramic P.U. 400 mV. Microphone 4.5 mV. Tape Head 2.5 mV. Radio/Aux or Ceramic P.U. 10 mV. **FREQUENCY RESPONSE:** ± 2dB 20-20,000 c.p.s. **TREBLE CONTROL:** +15dB to —14dB at 10 Kc/s. **BASS CONTROL:** +12dB to —15dB at 60 c.p.s. **HUM LEVEL:** —75dB. **HARMONIC DISTORTION** at 10 Watts R.M.S. 1,000 c.p.s. 0.25%. **NEGATIVE FEEDBACK:** 52dB. Complete kit of parts with full constructional details and point to point wiring diagrams. Carr. 11/- **11 Gns.** Supplied factory built 15 Gns. Carr. 12/6. Terms: Deposit 49/- and 9 monthly payments 33/9 (Total £17.12.9). Or fitted in beautiful Walnut or Teak veneered cabinets as illustrated. 4 Gns. extra. **ALL COMPONENTS ETC. ARE OF A HIGH STANDARD AND SUPPLIED BY LEADING BRITISH MANUFACTURERS.**

TECHNICAL SPECIFICATIONS COMPARE MORE THAN FAVOURABLY WITH SIMILAR AMPLIFIERS AT TWICE THE COST



R.S.C. SUPER 30 STEREO AMPLIFIER

A DUAL CHANNEL VERSION OF THE SUPER 15. Employing Twin Printed Circuits. Close tolerance Ganged Pots. Matched Components. **CROSS TALK:** —52dB at 1,000 c.p.s. **CONTROLS:** 5 position Input Selector. Bass Control, Treble Control, Volume Control, Balance Control, Stereo/Mono Switch, Tape Monitor, Mains Switch. **INPUT SOCKETS (Matched Pairs):** (1) Magnetic P.U. (2) Ceramic or Crystal P.U. (3) Radio/Aux. (4) Tape Head/Microphone. Operation of the Input Selector Switch assures appropriate equalisation. Rigid 18 s.w.g. Chassis. Size approx. 12in. Wide, 3in. High and 8in. Deep. Neon Panel Indicator. Attractive Facia and Spun Silver Matching Knobs. Above facilities, etc., except for Ganging and Balance Control, apply also to Super 15. **THESE UNITS ARE EMINENTLY SUITABLE FOR USE WITH ANY MAKE OF PICK-UP OR MICROPHONE (Crystal, Ceramic, Magnetic, Moving Coil, Ribbon) CURRENTLY AVAILABLE. SUPERB SOUND OUTPUT QUALITY CAN BE OBTAINED BY USING WITH FIRST RATE ANCILLARY EQUIPMENT.** All required parts, point to point wiring diagrams and detailed instructions. Carr. 13/9 **18 Gns.** Unit factory built 25f Gns. or Deposit 83/9 and 9 monthly payments 56/9 (Total £29.14.6). Fitted cabinet as Super 15 29f Gns. Carr. 15/- or Deposit 24.14.9 and 9 mthly pmts 65/10 (Total £29.7.3). Send S.A.E. for leaflet.



Why

NOT BUILD ONE OF OUR PORTABLE TRANSISTOR RADIOS...

FIRST FOR PERFORMANCE, QUALITY & PRICE!

BACKED BY OUR SUPER AFTER SALES SERVICE

"A wonderful range of transistor radios using first grade components for guaranteed results."

NEW ROAMER SEVEN Mk IV

7 WAVEBAND PORTABLE OR CAR RADIO

Amazing performance and specification ● Now with **PHILCO MICRO-ALLOY R.F. TRANSISTORS**

FULLY TUNABLE ON ALL WAVEBANDS

● 9 stages—7 transistors and 2 diodes

Covers Medium and Long Waves, Trawler Band and three Short Waves to approx. 15 metres. Push-pull output for room filling volume from rich toned 7 x 4in. speaker. Air spaced tuned tuning condenser. Ferrite rod aerial for M. & L. Waves and telescopic aerial for S. Waves. Real leather-look case with gilt trim and shoulder and hand straps. Size 9 x 7 x 4in. approx.

The perfect portable and the ideal car radio. (Uses PP7 batteries, available anywhere.)

★ **EXTRA BAND FOR EASIER TUNING OF PIRATE STATIONS, etc.**

Total cost of parts now only

£5.19.6

P. & P. 5/6



Parts Price List and easy build plans 3/- (Free with kit)

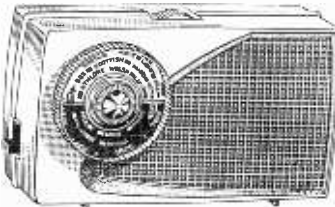

NEW MELODY MAKER SIX

3 WAVEBAND PORTABLE

8 stages—6 transistors and 2 diodes

Covers Medium and Long Waves and **EXTRA BAND FOR EASIER TUNING OF PIRATE STATIONS, etc.** Top quality 3in. Loudspeaker for quality output. Two RF stages for extra boost. High "Q" 6in. Ferrite Rod Aerial. Approx. 350 milliwatts push-pull output. Handsome pocket size case with gilt fittings. Size 6 1/2 x 3 1/2 x 1 1/2in. (Uses long-life PP6 battery.) Carrying strap 1/6 extra.

This amazing receiver may be built for only

£3.9.6

P. & P. 3/6

Parts Price List and easy build plans 2/- (Free with kit).



NEW TRANSONA FIVE

Now with 3in. Speaker!

"Home, Light, A.F.N., Lux. all at good volume." G.P., Durham.

● 7 stages—5 transistors and 2 diodes

Fully tunable over Medium and Long Waves and Trawler Band. Incorporates Ferrite rod aerial, tuning condenser volume control, new type fine tone super

dynamic 3in. speaker, etc. Attractive case. Size 6 1/2 x 4 1/2 x 1 1/2in. with red speaker grille. (Uses 1289 battery, available anywhere.)

Total cost of all parts now only

42/6

P. & P. 3/6

Parts Price List and easy build plans 2/- (Free with kit)

POCKET FIVE Now with 3in. Speaker!

● 7 stages—5 transistors & 2 diodes

Covers Medium and Long Waves and Trawler Band, a feature usually found in only the most expensive radios. On test Home, Light, Luxembourg and many Continental stations were received loud and clear. Designed round supersensitive Ferrite Rod Aerial and fine tone 3in. moving coil speaker, built into attractive black and gold case. Size 5 1/2 x 1 1/2 x 3 1/2in. (Uses 1289 battery available anywhere.)

Total cost of all parts now only

42/6

P. & P. 3/-

Parts Price List and easy build plans 1/6 (Free with kit)



STOP PRESS! Pocket 5 med. and long wave version with miniature speaker.

29/6 P. & P. 3/-



NEW ROAMER SIX

NOW, WITH **PHILCO MICRO-ALLOY R.F. TRANSISTORS**

● 6 WAVEBAND !!

● 8 stages—6 transistors and 2 diodes

Listen to stations half a world away with this 6 waveband portable. Tunable on Medium and Long Waves, Trawler Band and two Short Waves. Sensitive Ferrite rod aerial and telescopic aerial for short waves. Top grade transistors. 3-inch speaker, handsome case with gilt fittings. Size 7 1/2 x 5 1/2 x 1 1/2in. (Carrying strap 1/6 extra.)

★ **EXTRA BAND FOR EASIER TUNING OF LUX., etc.**

Total cost of all parts now only

£3.19.6

P. & P. 3/6

Parts Price List and easy build plans 2/- (Free with kit)

TRANSONA SIX

● 8 stages—6 transistors and 2 diodes

This is a top performance receiver covering full Medium and Long Waves and Trawler Band. High-grade approx. 3in. speaker makes listening a pleasure. Push-pull output. Ferrite rod aerial. Many stations listed in one evening including Luxembourg loud and clear. Attractive case in grey with red grille. Size 6 1/2 x 4 1/2 x 1 1/2in. (Uses PP7 battery available anywhere.) Carrying Strap 1/- extra.

Total cost of all parts now only

59/6

P. & P. 3/6

Parts Price List and easy build plans 1/6 (Free with kit)

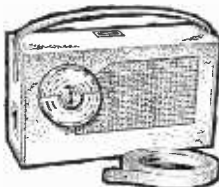

MELODY SIX

● 8 stages—6 transistors and 2 diodes

Our latest completely portable transistor radio covering Medium and Long Waves. Incorporates pre-tagged circuit board, 3in. heavy duty speaker, top grade transistors, volume control, tuning condenser, wave change slide switch, sensitive 6in. Ferrite rod aerial. Push-pull output. Wonderful reception of BBC, Home and Light, 208 and many Continental stations. Hand-some leather-look pocket size case, only 6 1/2 x 3 1/2 x 1 1/2in. approx. with gilt speaker grille and supplied with hand and shoulder straps.

Total cost of all parts now only

£3.9.6.

P. & P. 3/6

Parts Price List and easy build plans 2/- (Free with kit)



SUPER SEVEN

● 9 stages—7 transistors and 2 diodes

Covers Medium and Long Waves and Trawler Band. The ideal radio for home, car, or can be fitted with carrying strap for outdoor use. Completely portable—has built-in Ferrite rod aerial for wonderful reception. Special circuit incorporating 2 RF Stages, push-pull output, 3in. speaker (will drive large speaker). Size 7 1/2 x 5 1/2 x 1 1/2in. (Uses 9V battery, available anywhere.)

Total cost of all parts now only

£3.19.6

P. & P. 3/6

Parts Price List and easy build plans 2/- (Free with kit)

Callers side entrance
Barratts Shoe Shop.

RADIO EXCHANGE CO.

Open 9—5 p.m.
Saturday 9—12.30 p.m.

61 HIGH STREET, BEDFORD Telephone: Bedford 52367

LOOK!

PRACTICAL!

VISUAL!

EXCITING!



a new 4-way method of mastering

ELECTRONICS

by doing — and — seeing . . .

1 ▶ **OWN and HANDLE** a

complete range of present-day **ELECTRONIC PARTS** and **COMPONENTS**

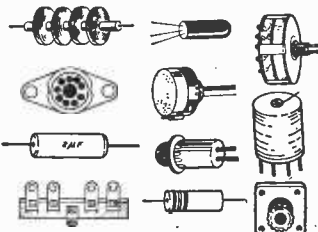

2 ▶ **BUILD** and **USE**

a modern and professional **CATHODE RAY OSCILLOSCOPE**



3 ▶ **READ** and **DRAW** and

UNDERSTAND **CIRCUIT DIAGRAMS**

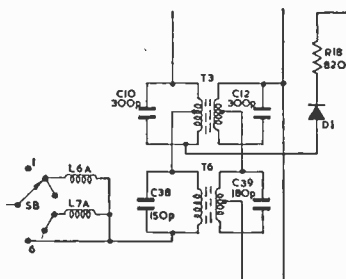

4 ▶ **CARRY OUT OVER 40 EXPERIMENTS ON BASIC ELECTRONIC CIRCUITS AND SEE HOW THEY WORK . . . INCLUDING . . .**

- VALVE EXPERIMENTS
- TRANSISTOR EXPERIMENTS
- AMPLIFIERS
- OSCILLATORS
- SIGNAL TRACER
- PHOTO ELECTRIC CIRCUIT
- COMPUTER CIRCUIT
- BASIC RADIO RECEIVER
- ELECTRONIC SWITCH
- SIMPLE TRANSMITTER
- A.C. EXPERIMENTS
- D.C. EXPERIMENTS
- SIMPLE COUNTER
- TIME DELAY CIRCUIT
- SERVICING PROCEDURES

This new style course will enable anyone to really understand electronics by a modern, practical and visual method—no maths, and a minimum of theory—no previous knowledge required. It will also enable anyone to understand how to test, service and maintain all types of Electronic equipment, Radio and TV receivers, etc.

FREE POST NOW
for
BROCHURE

or write if you prefer not to cut page

To: **BRITISH NATIONAL RADIO SCHOOL, READING, BERKS.** Please send your free Brochure, without obligation, to: *we do not employ representatives*

NAME BLOCK CAPS

ADDRESS PLEASE PW1

PRACTICAL WIRELESS

VOL 42 No 9

issue 719

JANUARY 1967

TOPIC OF THE MONTH

Flights of Fancy?

It is much easier to fly off into a hypothetical future of some vaguely distant time than to visualise what is going to happen in the immediate months ahead. This becomes depressingly clear to an editor about to write a seasonal leader on what 1967 holds for his readers. In fact, he will probably evade the issue by a few general observations!

For instance, amateur construction and activity will doubtless continue to follow industry, for the days when amateurs could lead with major developments are gone. The trend in commercial and military radio and communications is an inexorable march to tinier circuit elements; microminiaturisation.

Semiconductors and the scaling down of component sizes already determine the pattern for home constructors. And complete modules, like the spring, are acumin' in, taking things another step forward.

But the most spectacular event of recent times is the development of the microcircuit and it is significant that RCA in America is already using an integrated circuit unit in domestic TV sets. The unit has the equivalent of 12 transistors, 12 diodes and numerous resistors all contained on a single match-head size chip of silicon and housed in a transistor case. It performs the functions of 4.5Mc/s amplifier, limiter, noise rejector, f.m. demodulator, audio preamplifier and regulated power supplies!

Microcircuits cannot be repaired or altered; the cure for a defective unit is complete replacement. So that with a combination of ready-assembled units, modules and microcircuits, will the radio enthusiast of the future become a mere assembler needing little ability other than green fingers and a watchmakers' glass?

At this point it is perhaps as well to return to the present. And get back to those old-fashioned transistors!

NEWS AND COMMENT

Leader	643
News and Comment	644, 672
On the Short Waves	
<i>by John Guttridge and David Gibson, G3JDG</i>	650
Practically Wireless	
<i>by Henry</i>	658
BBC V.H.F. Sound	
Broadcasting Stations	671
Club Spot—Peterborough & District Amateur Radio Society	693

CONSTRUCTIONAL

The Explorer	
<i>by W. E. Bardgett</i>	646
Simple Electronic Organ	
<i>by J. M. Watt</i>	657
The Ten-Five Transmitter	
<i>by A. S. Carpenter, G3TYJ</i>	661
Tape Recorder Monitoring	
System <i>by L. McNamara, B.Sc.</i>	666
High-Z Sub-Min. Amplifier	
<i>by F. L. Thurston</i>	685

GENERAL ARTICLES

Set Manufacturing in the 20's	
<i>by C. H. Gardner</i>	652
Transfilters for I.F. Coupling	
<i>by Gordon J. King</i>	668
Power Supplies <i>by H. T. Kitchen</i>	676

FEBRUARY ISSUE WILL BE PUBLISHED ON
JANUARY 6th

Merry Christmas and a Happy New Year

from the staff of Practical Wireless

W. N. STEVENS

D. L. Gibson, G3JDG

L. E. Howes, G3AYA

C. R. Riches

D. C. Rolfe

All correspondence intended for the Editor should be addressed to: The Editor, "Practical Wireless", George Newnes Ltd., Tower House, Southampton Street, London, W.C.2. Phone: TEMple Bar 4363. Telegrams: Newnes Rand London. Subscription rates, including postage: 36s. per year to any part of the world. © George Newnes Ltd., 1966. Copyright in all drawings, photographs and articles published in "Practical Wireless" is specifically reserved throughout the countries signatory to the Berne Convention and the U.S.A. Reproductions or imitations of any of these are therefore expressly forbidden.

Oh it Hertz!

As a humble student of the noble science of electronics may I raise my voice in protest against your leader in the December issue.

The Hertz takes a fraction of a second to say, as compared with probably two or three seconds for "cycles-per-second". The symbol Hz is accomplished with a single sweep of the pen as compared to a staccato thundering of 30-odd ball points as a lecturer shouts "c/s".

No, I am a firm believer of this information and I am lucky in the fact that according to a brand new meter, the local Electricity Board is already supplying 50Hz mains to our laboratories.

May I add that though I agree with the retention of the term r.p.m. (mainly because there is no more easily pronounceable alternative) I like the term of i.p.s. for tape speed and would prefer the use of the B.S. term mile/h to the outdated and now unofficial m.p.h. or the imagination-inspiring idea of Fords.

This last term could be confusing in that the gentleman to be remembered to posterity by the expression had the Christian name of "Henry" and the devices that he manufactured had, amongst their controls, one called the "choke". I will leave you to reconsider the wisdom of such a term.

Bob Covington.

University of Southampton.

Pop on the Light

WITH reference to the Government's plan to abolish the pirates and use the BBC wavelength of 247m for an advertising station, this wavelength (Light Programme) cannot be heard in the West Country. If they are going to do this, they should use a frequency that can be heard in all parts of the country.

E. H. C. Terry. Paignton, Devon.

[*Editor's Note*] In the BBC annual report recently published, the Corporation says it is willing to run a round-the-clock programme of "pop" music and similar entertainment on 247m to replace pirate stations. The report points out, however, that since they would be obliged to honour "needle time" requirements it could not broadcast unlimited pop music. The BBC further states that it will not accept any advertising whatsoever.

These matters, however, and other related factors will not be finally settled until the publication of the Government White Paper on Broadcasting which has still not appeared at the time of going to press.

NEWS AND..

INTERNATIONAL RADIO COMMUNICATIONS EXHIBITION

After the opening of the Exhibition on Wednesday, October 26th, at 12 noon, H.R.H. Prince Philip, The Duke of Edinburgh, was able, for the first time, to hear his opening speech broadcast to the world, on radio amateur wavelengths, and hundreds of thousands of radio enthusiasts were able to listen to him, through the Radio Society's transmitting station in the exhibition on the call-sign "GB3RS", by kind permission of the GPO. The GPO were also showing colour television pictures, relayed by micro-wave link direct from the Post Office Tower. This was arranged in conjunction with the BBC. The Post Office research station was showing to the public, for the first time, developments from the laboratories on satellite reception and low-noise receivers and semiconductor equipment.

The Manufacturers' Award this year went to Contactor Switchgear (Electronics) Ltd., for their solid state transmitter and receiver types CSE2A10 and CSE2AR (see opposite).

The Horace Freeman Trophy went to M. H. Emmerson, G3OQD, for a transistorised s.s.b./a.m./c.w. transceiver covering 160-10 metres, and the Thorogood Plaque to S. F. Weber, G8ACC, for a 7W Transistorised Transmitter for 432Mc/s.

NEW PLESSEY 3in. SPEAKER



The Plessey Components Group have introduced a new 3in. loudspeaker for use under severe climatic conditions. The more common applications of this speaker will be in taxi, ambulance and police radios, where the unit is exposed to conditions of high temperature and humidity.

Investigations indicate that temperatures of up to 80°C are found in these applications during the summer months in the U.K. These high temperatures are frequently accompanied with conditions of high humidity, and can be followed by periods of low temperature and high humidity.

The new speaker has been designed to withstand these conditions without any loss of sensitivity. Chassis height is 0.6in. and when fitted with the 6.500 line motor unit the total height becomes 1.22in.

POP PROTESTS

The Postmaster General recently revealed that the Post Office had received 40 representations from Belgium, Czechoslovakia, France, Germany, Eire, Italy, Holland, Sweden and Yugoslavia concerning interference to local stations by pirate broadcasters operating around the UK. Trouble is not necessarily confined to fundamental channel interference since we have notes of at least one case where a pirate station is radiating spurious signals falling in the shipping band. (Radio 270, on 1672.5kc/s.)

As we go to press, the first prosecution of a pirate broadcaster (Radio 390 at Canterbury) began on November 24th. Also, the much heralded White Paper on Broadcasting had still made no appearance.

...COMMENT

CSE TYPE 2AR RECEIVER

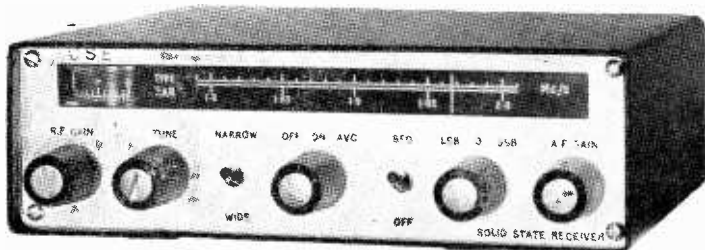

A new silicon, solid state, 12V, 2Mc/s receiver complementary to the 2A10 transmitter has recently been marketed by Contactor Switchgear (Electronics) Ltd. Like the transmitter it is suitable for operation in mobile, fixed or portable locations from car or dry battery supply.

Specification: Supply, 12V d.c. at 120mA, quiescent, 280mA on a.f. peaks; Supply, may be + or — earthed; no adjustment necessary; supply reversal protection; Signal to noise ratio $1\mu\text{V}$ for 10dB $\frac{S+n}{n}$ measured at 80Ω ; Signal input, fast multiple diode r.f. protection; Image rejection, better than 50dB ; Selectivity, switched, 4kc/s and 8kc/s ; Shape factor, 2.5:1 from 3dB down to 50dB down; Intermediate frequency, 511.5kc/s ; AVC, fast attack 100m/sec , fast decay 400m/sec ; AVC, will control 150mV at 80Ω input; AVC, delay switched in with B.F.O.: 1.5 sec; BFO, locked to ceramic resonator; and switched $\pm 2\text{kc/s}$, lower sideband—centre—upper sideband; single control s.s.b. resolution by "Tune"; S. meter presentation of a.m.—c.w.—s.s.b. signals; Audio, transformerless; Output impedance, $1-10,000\Omega$; Audio output, 1.5W into 3Ω speaker; Size, identical to C.S.E. 2A10 transmitter, $8\frac{1}{2} \times 2\frac{1}{2} \times 6\text{in.}$; Supply input connector, Painton 4 pin retained—Audio connector, miniature jack, Aerial connector and standard Belling Lee 80Ω coax are supplied. Price £44 U.K.

WHAT THEY SAY!

Talking about girls wearing skirts so short that they could teach the birds and bees a few things, Sir Miles Thomas said in Birmingham recently "It's the day of the hi-fi and thigh-high."

Mini skirts are certainly commonplace, but is hi-fi; we doubt it?

MOVING COIL HAND MICROPHONE



Amplivox Ltd., Beresford Avenue, Wembley, Middlesex, announce the release of their new high fidelity moving coil microphone—the Elite.

This microphone has been introduced to meet a wide variety of applications in the fields of recording and communications. The Elite is available with or without switching arrangements and a variety of circuits are available to suit customers' requirements. The microphone has a response of from $50-15,000\text{c/s}$.

Further details may be obtained from Amplivox at the above-mentioned address.

Issues for Disposal

I HAVE the following issues of PRACTICAL WIRELESS for disposal: May, Sept., Oct., 1951; Mar., April, May, June, July, Aug., Oct., Nov., Dec. 1952; Jan., Feb., April, May, June, July, Aug., Sept., Oct., Nov., Dec., 1953; Jan., Feb., April, May, June, Aug., Oct., Nov., Dec., 1954; Sept., Nov., Dec. 1955; Jan., Feb., Mar., June, Sept., Oct., Nov., Dec. 1956; Jan., Feb., Mar., April, May, July, Aug., Sept., Oct., Nov., Dec. 1957; Jan., Feb., Mar., May, June, July, Aug., Sept., Oct., Nov., Dec. 1958; Jan., Feb., Mar., April, Nov. 1959; Sept. 1960; Feb., Mar., April, May, July, Aug., Sept., Oct., Nov. 1961; Jan., Feb., Mar., April, May, June, July, Aug., Sept., Oct., Nov., Dec. 1962; Jan., Mar., April, May, June, Oct., Nov., Dec. 1963; Jan. 1964.

If any readers are interested, would they please contact me.

E. L. Lewin.

8 The Knoll,
Hayes, Bromley, Kent.

Mobile Registration

PERHAPS C. P. Finn (Mobile Registration, September issue) would be interested in the registration number I saw recently. It was 1003 PF and on a Ford 105E van. Possibly a service van?

D. K. Agar.

Loughton,
Essex.

Wanted!

YOUNG radio enthusiasts willing to form a club in South London for young people (up to about 20). Meetings will be made as interesting and varied as possible with outings, competitions, etc. and always at least one Ham station on the air.

Will anyone interested let me know (write or phone ADD 6866). If the turn-out is reasonably large, the Sir Philip Game Boys' Club—near E. Croydon station—will let us use part of their premises.

If you are unable to come yourself, please tell your friends. All letters will be answered giving details of meetings when known.

A. D. A. Hansen, G3VLJ

(aged 16).

99 Stretton Road,
East Croydon, Surrey.

R1155 Information

I THINK Mr. Preston seems to have misread my R1155 information. It was meant to be helpful to anyone who could get back numbers.

If he would get the O.K. from W.W., S.W. Mag. and yourselves, he can have my information to copy.

John Tye.

Dereham.

More News and Comment on Page 672

THE explorer

AM/FM VHF RECEIVER

By W.E. BARDGETT

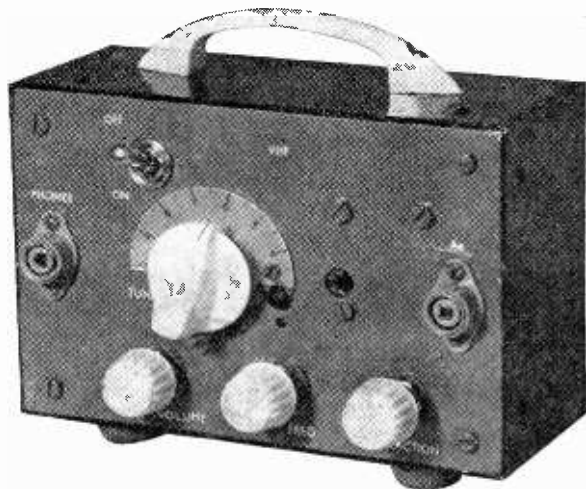

A Four Transistor unit covering 65-170 Mc/s

A NUMBER of readers have indicated in recent correspondence an interest in constructing receivers which will explore the v.h.f. ranges, including the 2 and 4 metre amateur bands. A valve receiver employing inexpensive surplus valves was described in the June, 1964 issue, and one advertiser offers a simple kit for a mains valve super-regenerative receiver employing the Flewelling circuit which requires few components, yet provides a means of exploring the v.h.f. bands at low cost. These receivers are, however, dependent upon mains power supplies. Very high frequency transistors are now available at reasonable cost which permit the construction of a tuner/receiver which can be entirely portable or can be used in a motor car feeding into the amplifying stages of a car radio. The receiver described may be fitted with coils of various

sizes allowing coverage of the 2 and 4 metre amateur bands, the B.B.C. Band II f.m. transmissions and many others. The v.h.f. Explorer is a detector of amplitude modulated signals but can also receive f.m. transmissions although not at hi-fi quality.

SKILL REQUIRED

The construction of the receiver described should not be attempted by the absolute beginner, as the building requires a certain amount of skill. V.H.F. circuits must be leadless in the signal circuits, so that the components have to be soldered directly to each other with the shortest possible connections. The layout of the components must facilitate this lead-less construction and the proximity of the components concerned must take precedence over any

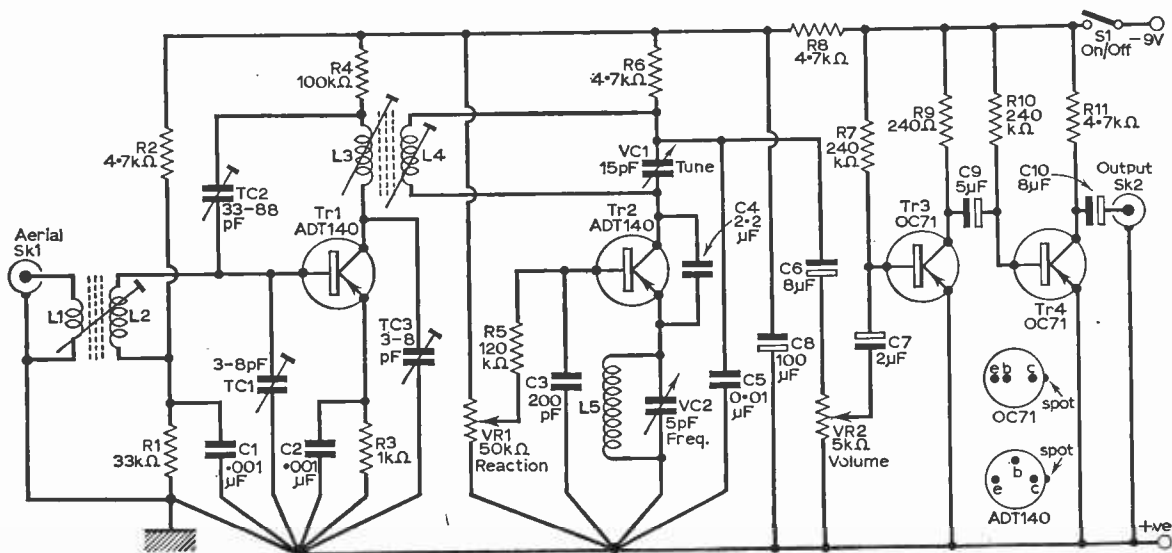

Fig. 1: Circuit diagram of the "Explorer" receiver.

claims for symmetry, or even accessibility. The need for this ultra short wiring cannot be too strongly stressed: without it, the losses in the signal circuits would be so great that the receiver would not work at all. To achieve successful results demands intricate construction, good soldering, patience and persistence, as well as an electric soldering iron with a small bit and pair of tweezers. On the other hand, the sense of achievement when results are finally obtained at v.h.f. is akin to that experienced by earlier generations when it was an event to receive radio transmissions at all.

V.H.F. transmissions have a relatively short range, and the amount of traffic picked up on a receiver of the type described will vary considerably between different parts of the country.

These are the two main warnings to those considering the construction of the receiver.

THE CIRCUIT

The receiver circuit is shown in Fig. 1. It consists of a tuned r.f. stage Tr1, with a neutralising capacitor and a self-quenching super-regenerative detector (Tr2); both employing alloy diffused transistors capable of operation up to 200Mc/s in the circuits shown. These two stages are followed by two conventional stages of audio amplification with an output capable of driving headphones. This is also suitable for feeding into a transistor or valve amplifier for loudspeaker reproduction. Whilst a sensitive pair of headphones may be driven directly, much improved results are obtained if the output is fed into a package transistor amplifier such as many advertisers offer, or into the amplifying stages of a car radio. The author has fitted a jack and socket before the amplifier section of his *Practical Wireless* "Autocrat" car radio (described in the November 1964 issue), so that the v.h.f. tuner can be fed into this.

CONTROLS

The aerial input socket Sk1 is a television-type co-axial socket for use with a dipole aerial. The second socket Sk2 is the output to headphones or amplifier. The on/off switch is of the toggle type. This was preferred to the type incorporated in the volume control as it is possible to see at a glance whether the tuner is switched on or not. The main tuning capacitor requires a 180° scale and knob/pointer, but as tuning is fairly broad a reduction drive is not necessary. The other controls consist of a volume control VR2, especially important if the output is to be fed into a transistor package amplifier without its own volume adjustment, a base bias potential adjuster VR1 which controls the regeneration of the super-regenerative detector and a quench frequency control VC2.

CONSTRUCTION

As super-regenerative detectors are radiators which would cause illegal interference if connected directly to an aerial or operated unshielded, an r.f./buffer stage must be used and the receiver must be contained in a metal case. All components, controls and sockets are fitted directly or by means of flanged panels to the front panel; of aluminium measuring 6 x 4in. This is then housed in a commercially pro-

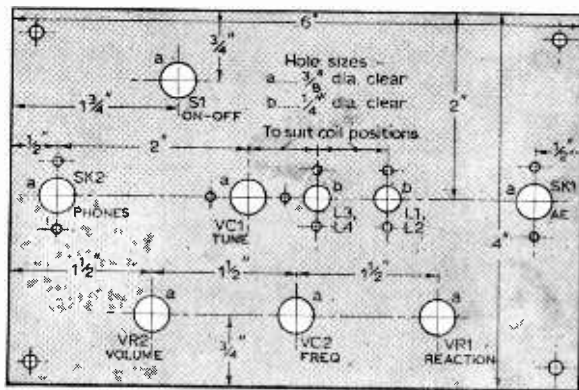

Fig. 2: Drilling dimensions of front panel.

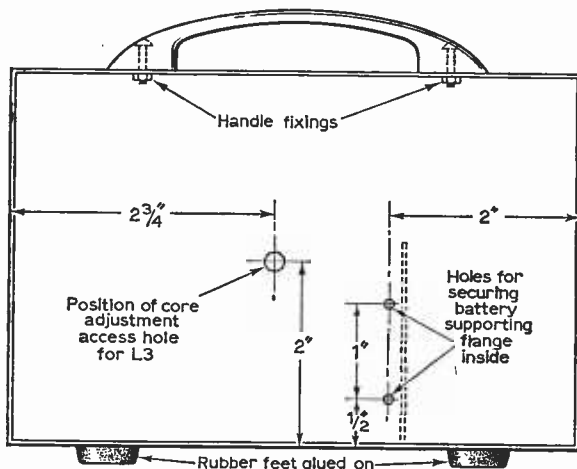

Fig. 3: Rear view of screening box.

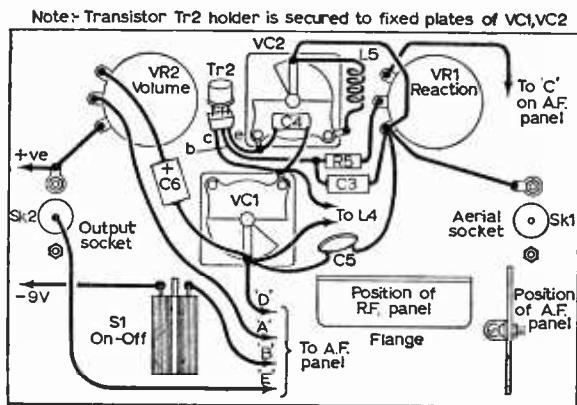

Fig. 4: Layout of components on rear of front panel.

duced metal screening box measuring 6 x 4 x 2 1/2 in, being attached to it by four self-tapping screws which go into the corner flanges on the box. The layout of controls and sockets on the front panel is shown in Fig. 2. The r.f. stage is not merely a buffer: it improves the signal/noise ratio sufficiently to make listening pleasant and makes selective what would otherwise be very broad band reception.

COILS

Details of the coils are given in Table I. They are positioned and permeability tuned by two Aladdin plastic coil formers with dust cores. Coils L3 and L4, although on the same former, each have a separate dust core entering the former from opposite ends. A hole may be drilled in the rear of the screening box opposite the coil former of L3 and L4 as shown in Fig. 3, to permit adjustment of L3 core by means of a plastic trimming tool. The cores of L1, L2, and L4 may be adjusted in a similar way through the holes opposite the Aladdin formers on the front panel.

The positioning of the main components at the rear of the front panel is shown in Fig. 4, which also shows the wiring of the super-regenerative detector stage. The r.f. stage is constructed on a 2 x 1½ in. paxolin shelf, held at right angles to the front panel by a narrow aluminium flange. The wiring and connection of components for the r.f. panel is shown in Fig. 6. All wiring should be completed on the shelf before it is fitted close to the Aladdin formers mounted on the front panel. The coils on these formers should be cut to give, by trial, the shortest and most direct connections to the transistor holder of Tr1 and to the variable capacitor VC1. Thick wire is highly desirable for v.h.f. and 16 s.w.g. is suggested. As the v.h.f. signals flow on the outer surface of the wire, tinned copper wire should be chosen. The tuned choke L5 is space-wound and self supporting being mounted directly on the quench frequency variable capacitor VC2. It should be at right angles to the other coils. The usual v.h.f. practice is followed of bringing all earth connections of each signal stage to a common point.

The a.f. stages are constructed on a 12 position tag board (two lines of 6 tags), which in turn is mounted on the front panel by means of an aluminium bracket in the position shown in Fig. 4. The wiring of the a.f. panel is shown in Fig. 5. Transistors Tr3 and Tr4 mounted on the tag board are bent back on their leads (which should be covered in p.v.c. sleeving), so that they are close to the board, and so permit the easy insertion of the receiver into its screening box. A heat sink must be used when soldering leads of transistors Tr3 and Tr4 to their tag connections: a pair of pointed nosed pliers will suffice. Transistors Tr1 and Tr2 should not be inserted in their transistor holders until all soldering is completed, and they must be

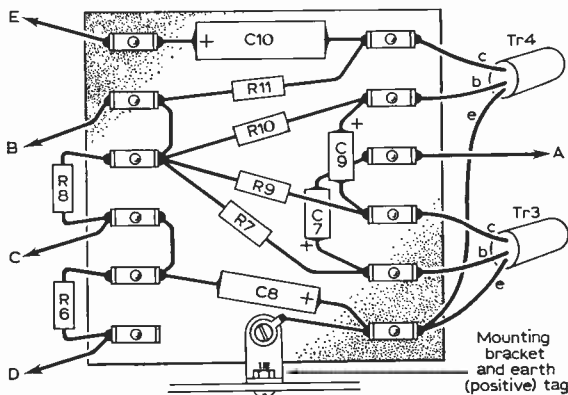

Fig. 5: Wiring of the a.f. panel.

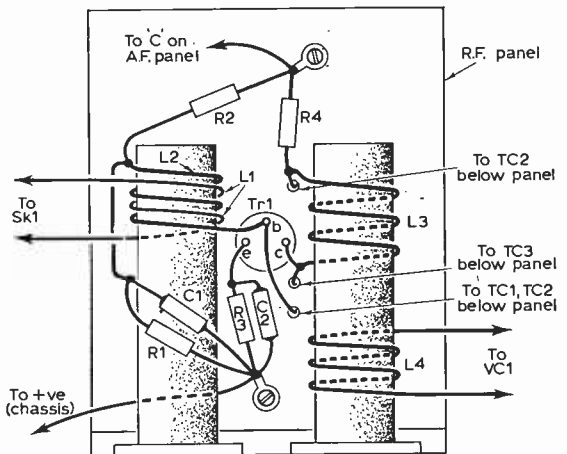

Fig. 6. Wiring of the r.f. panel. Below—Coil winding data.

Table I—Coil Details

Range 1 110 to 170Mc/s	<p>L1. 2 turns 22 s.w.g. tinned copper p.v.c. covered on ¼ in. Aladdin former with dust core (without screening can) interwound with L2.</p> <p>L2. 3 turns 16 s.w.g. tinned copper on same ¼ in. Aladdin former with dust core and interwound with L1.</p> <p>L3 and L4. 3 turns each of 16 s.w.g. tinned copper adjacent to each other on same ¼ in. Aladdin former with 2 dust cores, 1 to each coil, without screening can.</p> <p>L5. 28 turns 30 s.w.g. enamelled copper, self-supporting wound in screw thread of OBA bolt and then removed.</p>
Range 2 65 to 120Mc/s	<p>L1. As in Range 1.</p> <p>L2. 5 turns 16 s.w.g. tinned copper on same ¼ in. Aladdin former as L1 and interwound with L1 with dust core, without screening can.</p> <p>L3 and L4. 5 turns each of 16 s.w.g. tinned copper adjacent to each other on same ¼ in. Aladdin former with 2 dust cores, 1 to each coil, without screening can.</p> <p>L5. As in Range 1.</p>

removed when any subsequent soldering (e.g. for coil changing) takes place.

AERIAL

The usual long wire domestic aerial is virtually useless at v.h.f. Plugging in the home television aerial will probably give some results, but it is advisable to construct a half-wave dipole aerial for the frequency range to be explored. The length across both arms of the dipole in inches is found by dividing 5616 by the frequency in megacycles. A telescopic quarter wave whip aerial may be connected as an alternative to a tapping point about the centre of L2.

TESTING AND OPERATION

All wiring should be checked carefully against the theoretical circuit diagram before a battery is connected to the receiver. A PP7 battery supplying 9 volts fits neatly into the case and is held in position by an aluminium flange bolted to the rear. Ensure that the correct battery connectors are fitted to the appropriate leads, as reversal of the battery polarity could ruin all the transistors.

Connect a dipole aerial to the aerial socket and a pair of headphones to the output socket or alternatively connect the output, preferably by a short length of co-axial cable, to the input of an amplifier. Switch on the receiver and advance the volume control VR2 as required. Rotate the regeneration control VR1 until the characteristic super-regenerative hiss is heard. If regeneration does not take place, adjust VC2 and/or move coils L3 and L4 a little further apart. Search for signals with the set just regenerating. The dust core of L3 and L4 should at first be well out towards opposing ends of the coil former in order to avoid increasing the the coupling and damping the regeneration. Set the trimmers and cores initially as follows, and adjust for best results when a signal is heard.

TC1 just fully out; TC2 just fully out; TC3 quarter closed; L1 and L2 core fully into coil; L3 core almost fully into coil; L4 core end just entering coil.

All final adjustments should be made on signals found by rotating VC1 slowly, and if necessary adjusting the core of L4.

By installing the coils for L1, L2, L3 and L4 of the size given for Range 1 in Table 1, it is possible on the prototype to pick up taxis and other mobile transmissions in the 165 to 174Mc/s allocation and even Band II television sound transmissions, but at this height in the frequency scale the receiver is approaching its limit and regeneration may be difficult to obtain over the full range of tuning of VC1. In appropriate areas there should be no difficulty, however, in hearing on Range 1 coils, the air to ground transmissions between 118 and 136Mc/s as well as the 2 metre amateur band

★ components list

Resistors:

R1 33k Ω
R2 4.7k Ω
R3 1k Ω
R4 100 Ω
R5 120k Ω
R6 4.7k Ω
R7 240k Ω
R8 4.7k Ω
R9 240 Ω
R10 240k Ω
R11 4.7k Ω

Capacitors:

C1 0.001 μ F ceramic
C2 0.001 μ F ceramic
C3 200pF ceramic
C4 2.2pF ceramic
C5 0.01 μ F ceramic
C6 8 μ F electrolytic
C7 2 μ F electrolytic
C8 100 μ F electrolytic
C9 5 μ F electrolytic
C9 5 μ F electrolytic
C10 8 μ F electrolytic

Variable Capacitors:

VC1 15pF air spaced bolt fixing insulated from panel
VC2 5pF air spaced spindle fixing

Transistors:

Tr1 ADT140 (Sinclair)
Tr2 ADT140 (Sinclair)
Tr3 OC71 (Mullard)
Tr4 OC71 (Mullard)

Trimmer Capacitors:

TC1 3-8pF beehive trimmer
TC2 3-8pF beehive trimmer
TC3 3-8pF beehive trimmer

Potentiometers:

VR1 50k Ω VR2 5k Ω

Miscellaneous:

6 x 4in. aluminium front panel, 6 x 4 x 2 $\frac{1}{2}$ in. metal screening box, 2 x 1 $\frac{1}{2}$ in. paxolin panel, 1 $\frac{1}{2}$ x $\frac{3}{4}$ in. aluminium for panel flange, 2 x 2in. aluminium for battery flange, 1 $\frac{1}{2}$ x 1 $\frac{1}{2}$ in. 12 position tag board, 1 single pole toggle switch, 1 aluminium bracket, wire, nuts, bolts, etc., 2 co-axial sockets, 2 transistor holders (Eagle Products), 2 battery connectors, 2 coil formers $\frac{1}{2}$ in. Aladdin, 3 dust cores for formers, 3 small knobs, 1 tuning pointer knob with scale, 4 rubber feet, 1 carrying handle.

(144Mc/s). Range 2 coils as described in figure 7 will allow the BBC f.m. band to be heard with mobile radio allocations on either side of it. The lower one between 71 and 87Mc/s is easily recognisable by the frequent Motoring Association transmissions about vehicle breakdowns. Not far from this on Range 2 is the 4 metre amateur allocation. Initial success is more likely if Range 2 coils are tried first.

CONCLUSION

When signals are tuned, they should quench the super-regenerative hiss, so that the background is clear of noise. Super-regenerative receivers have the advantage of possessing built-in automatic volume control and noise limiting action, whilst the relatively broad tuning characteristics make band spread or reduction drives unnecessary. The gain of this type of receiver appears to be proportional to the frequency, so that at v.h.f. levels its performance can be quite phenomenal. ■

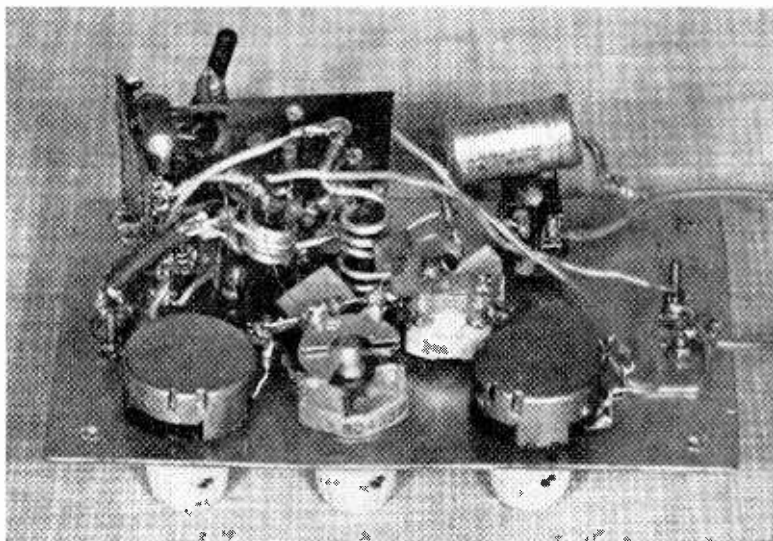

Rear of front panel, showing Range 1 coils fitted.

ON THE SHORT WAVES

MONTHLY NEWS FOR DX LISTENERS

Times in GMT
Frequencies in kc/s

THE BROADCAST BANDS

by JOHN GUTTRIDGE

Rumania: *Radio Bucharest* (P.O. Box 111, Bucharest) now transmits in English as follows: 1500—1530 15,380/11,940/11,810/11,900; 1930—2030 9,655/9,510/7,225; 2230—2300 7,195/6,190/155 (longwave); 0130—0230 11,810/9,750/9,660/6,190/6,150/6,080; 0300—0330, 0430—0500 as 0130 with the addition of 6,095. The station has also been reported outside the international broadcast bands on 10,650 with French at 1830 and 2030, Arabic 1900 and English 1930.

Sweden: *Radio Sweden* (Box 955, Stockholm) has changed the frequencies for some English transmissions, viz.:—1100—1130 (Far East) 11,765; 1400—1430 and 1445—1515 (East North America) 17,840; 2345—0015 (Far East) 11,765; 0145—0125 (East North America) and 0315—0345 (West North America) 9,705.

Switzerland: *Swiss Broadcasting Corporation* (CH3000, Berne 16) is now on its winter schedule and has extended all its English transmissions by 15 minutes to 75 minutes. In addition there is a new experimental non-directional transmission at 0700 on 6,165 using a 250kW transmitter. Times and frequencies for beamed English transmissions are 0700 (Far East) 9,670/11,775/15,320; 1300 (India/Pakistan) 15,305/17,845/21,520; 0900 (Australia/S.E. Asia) 15,305/17,800/21,520; 1500 (Middle East) 9,655/9,665/11,715/15,305; 0900 (Africa) 17,770/21,460; 0115 (East North America) 5,965/6,120/9,535; 0500 (West North America) 5,965; 1500 (West North America) 15,130; 1100 (U.K.) 9,665/11,865; 1845 (U.K.) 6,045/7,220. Reception reports are requested particularly for the 0700 transmission. Full schedules may be obtained free of charge on application to the above address.

U.S.S.R.: *Radio Kiev* (Ukrainske Radio, Radio Centre, ul. Khreshchatik 24, Kiev) again using 6,020 for its English transmission at 1900—1930 on Mondays, Thursdays and Sundays. This transmission interferes with Radio Nederland on the same channel.

Radio Moscow has a new English transmission at 0000—0030 on 998 (medium waveband).

Radio Vilnius (Lieutvas TSR Radijas, ul Kanarskio 49, Vilnius) may be heard in English at 2230—2300 Sundays and Fridays on 1106 (medium waveband) under AFN Munich.

Vatican: *Vatican Radio* (Vatican City) uses the new frequency of 11,705 for Arabic at 1640 and French at 1720. These transmissions are additionally on 15,135.

Yugoslavia: *Radio Belgrade* (2 Hilendarska, Belgrade) now uses 6,100/7,200/9,505 for the 1830—1900 English transmission.

AFRICA

Algeria: *Radiodiffusion-Television Algerienne* (21 Boulevard des Martyrs, Algiers) now transmits as follows: French 0630—0830, 1700—2300 6,175; 1100—1430 11,835; Arabic 0600—0830 529/548/980 with the

addition at 1200—2400 of 9,510/11,810; Kabyle 0600—0830 6,080/6,270; 1200—1430 9,685/11,715; 1700—2300 5,970/6,080/6,270/7,170/9,685. The new medium wave frequency of 529 is the same as that used by the Swiss Broadcasting Corporation and has caused considerable interference. As protests have been of no avail S.B.C. is planning to increase the power of its transmitter to at least 500kW.

Egypt (U.A.R.): *Cairo Radio* (P.O. Box 1186, Cairo) now uses the new frequency of 11,965 in parallel with 9,475 for its European Service between 1745 and 2315. English is from 2145—2315.

Ghana: *Ghana Radio and TV Corporation* (Broadcasting House, P.O. Box 1633, Accra) now uses 6,130/4,980 for its 1400—2215 English transmission.

Guinea (Portuguese): *Emissora Provincial da Guire* (Avenue da Republica, Brissau) has replaced 5,017 by 5,044. Has been heard 2100—2400.

Guinea (Spanish): *Emisora da Radiofusion Santa Isabel* (Apartamento 195, Santa Isabel, Fernando Poo) has English 1900—1945 on 6,250.

Liberia: BBC West African Relay Station (C.E.X.B., Bush House, London, W.C.2., England) can be heard around 1800 on 9,555 under Radio Finland.

Morocco: *Radiodiffusion Television Marocaine* (1 Rue Pierre Parent, Rabat) has dropped its evening English, French, Spanish programme over 11,735/15,408. These frequencies are now used from 1900—2300 for a relay of the French home service.

Nigeria: *Nigerian Broadcasting Corporation* (Broadcasting House, Lagos) has English at 1500—1600, 1700—1900, 2100—2200 on 7,275/9,690/11,915/15,215. The 19m.b. transmitter has a temporary power of 10kW, the other outlets are all 100kW. Announcements incorrectly give 11,915 as 11,900. Around 2200 the home service on 4,990 may be heard.

South Africa: *Radio South Africa* (P.O. Box 8606, Johannesburg). According to this station's schedule its European English transmission at 2200—2255 is on 11,900/9,690. Numerous reports give the frequencies used as 9,720/11,785/15,205 however.

Sudan: *Sudan Broadcasting Service* (P.O. Box 572, Omdurman) is reported back on 4,990 with a good signal from 2000 onwards.

NORTH AMERICA

Canada: *Radio Canada* (P.O. Box 6000, Montreal) has replaced 15,320 by 15,365 for European service transmissions between 1100—1830. A new QSL is now being issued.

Thanks go this month to Roy Patrick, Swiss Broadcasting Corporation, A. B. Thompson, Brian Burling, D. J. Chandler and the International Short Wave Club for sending in information.

WE start this month with one minute's silence, all heads reverently bowed, please. Twenty metres has passed on to greener pastures—alas. Very few reports for 14Mc/s arrived and it looks like the band has been deserted, certainly by the s.w.l. fraternity.

Where have all the s.w.l.'s gone, well you'd be surprised. Some 80% went all l.f., 5% cast a critical earhole on 15 metres and the remainder succumbed to tales of treasure trove on—yes, twenty-eight megacycles.

Topband is still quite good with the VO stations still at it on c.w. together with the odd W. Your scribe logged a GM3 on phone at 5 and 5 too. Didn't work him though (curses, foiled again).

On eighty, the usual sideband round tables, but a little careful listening produced half the States. Don't forget that the W's are permitted to squirt r.f. out right up to 4Mc/s.

Forty has been really good at times, just take a peep at the logs of the real s.w.l.'s who ventured forth and see what goodies you missed.

Fifteen, wide open at times and nearly always something of interest happening. A good band to watch now that ten is opening up.

Ten metres. Well I said all along it would happen and it has. One or two really terrific openings this month. Those lovely 'ole sunspots are doing us proud. Lets start with 28Mc/s this month and see what sort of things are about up there.

28 Megacycles

First log out of the hat comes from **A. Dorrough** (Berks), Eddystone 730, 68 ft. l.w., all c.w.—CR61V, CR7ER, CT10Z, CT3AM, CX8CZ, DJ4SS, EL2AR, FH8CD, IT1ALG, K5HLP, LU4EK, LU5XE, OD5FC, OH2SB, OK1AHZ, PJ2AP, PY2CK, VS9AJC, VQ8BJ, WA2SEP, ZE1BP, ZS2OM, ZS9G, ZD8ARP, 5A3TN, 5N2AAF, 9J2VX, 9H1AF.

Paul Baker (Monmouthshire), HE30, 45 ft. l.w., a.m. and s.s.b.—CR6DX, CR7FM, CX2DB, EA8EV, LZ1UF (using 10 watts), many PY's and UA's, UG6AZO, UW3IN, W1, 2, 3, 4, W5LDH, W8AOU, WAØFIX, ZC4KF, ZS1JH, ZS2OM, ZS9G, ZE3JJ, 5A1TK, 5N2AAF, 9G1DM, 9H1X and hoards of VE's.

F. Simpson (Hull), SR550, 80 ft., l.w., IT1JR, K4RLO, KØORR, KP4CPE, MP4TBO, PY2CK, SV1BH, VK6RU, VS9AJC, W5HWR/VP9, VE3NB, W3MSK, W4ZXI, W5VY, W8LYO, ZB2AM, ZC4MO, ZS8L, ZS6IW, ZE1AA, 5Z4AA, 9J2DT.

R. Iball (Nootts) says, "28Mc/s really gone mad—terrific QRK from all modes, c.w., a.m., s.s.b.—all W districts heard except W6 and 7 on 24th." Bob's log included—CE6CA, ET3WH, KV4CI, LU4DM, OA4PF, PY2DTV, SVØWL, UM8AP, VE3AIU, VO1AW, VP7NX, W5PTG, W5FTD, WØKFL, YV5AXT, ZC4MO, 9J2FK. The receiver is an AR88, antenna 80ft. l.w., with 72Ω co-ax feed!

C. Peel (Staffs), S750 with PR30 pre-selector, 20-metre dipole in the loft, writes, "Things are

looking up, some of these were on a.m. and very loud." Chris logged—HK1PAR, KV4CX, LU4EZ, LU2DIN, W4ZXI, W5KGT, W5GQG, W5IJQ, W7QFL, WØBAA, YV5ANF. This was between 1730 and 1830.

We could see many more logs for ten metres, but let's look down the other end and see what's new l.f.

Eighty and Forty

I was going to sneak in my own log for 7Mc/s but **N. Hembrey** (Sussex) heard twice as much from twice as far so I'll let him tell it instead. Using a 20-metre dipole into an EA12 Norman logged—CN8AW, CR6IV, JA2BAY, JA4BJO, JA6—AK, BZI, YB (yes, it's 7Mc/s), MP4BEU, OX3BX, OY7ML, PY3AVA, UB5UN, UD6BR, VK2AVA, VK2BLR, VK3MO, VK4EQ, VK7SM, VP6KL, ZC4MO, ZL1KG, 4X4BL, 9M2DW. Other periods of listening raised—CN8AW, HI8XAL, K1DTA, K2ISP, VE1ABZ, VE1AU, VP9DL, W1AQH, W1FZJ/P/KP4, W2GO, W3BMS, W4SIB, W5KFD, ZL3FT, ZL3GS, ZL4BO, ZL4LM. It's no good, I'll have to put an aerial up!

F. Simpson (Hull), again, heard—OX3LP, VO1FG, VE1IE, VE2PA/P2, VE3FUX, W1HKK, W2ZPO, W4SIB, W4IHK, WA2SFP, W1FZJ/KP4, YV5BTS, ZL3GS, ZL4LM, ZL4CH (Campbell Is.), all on 80, while a peep at 40 produced—K1PQT, PY1MIN, PY4ND, PY7AOT, UA3KBO, VK2AVA, WA2MMY, WB2GBL, ZL2AAG, 5N2ABF.

Fifteen Metres

Peter Elliott (South Africa), 1950 Pye radiogram, 50 ft. l.w. heard this bunch on a.m.—CX—5AAM, 8XD/MM, DL—8HD, 5CG, ET3USA, F—3OX, 5RV, II—MSG, NIC, ZM, LU—2DJT, 8BS, MP4BBA, PY—2DBB, 4AP, VK6—BS, QL, WA4—LNS, TJC, W—2AFV, 2DYZ, 5PMZ, 8HRV, 8PHJ, 9SOM, YA5RG, ZC4KF, ZP5JB, 4X4—BS, QA, 5N2AAR, 9L1TL, 9U5CB.

Chris Peel (Staffs), again plus S750 and PR30 sends a fantastic log for 21Mc/s—BV1USA, CE—3DM, 8A, CP1DR, CP6CC, CR6HG, CR7GF, CX3BBD, DU1—AP, BA, RA, EP3RO, EL2A, ET3WH, FK8CK (New Caledonia), FH8CD (Comoros Is.), FO8AB, HC1FF, HI8XAL, HKØAI (San Andres), W9WNV/HKØ (Baja Nuevo), HS1CB, HC4AK, JA2CJB, JA6DCE, JA8CE, KA8HC, KB6CZ (Baker Is.), KC4USP, KP4BKB, KV4XA, KZ5UR, KC6BO (Caroline Is.), KM6BI (Midway Is.), KJ6BZ, KG6ALW, KH6BB, KR6KS, KS6BH, KX6BQ, KW6EJ (Wake Is.), KL7BZO, LU1ACO, MP4TBM, PJ3CI, PYØXA (St. Peter and St. Paul Rocks), TF2WJF, 9LINM/MM/TR8 (Gabon), VE4AO, 7G1ND, VE8AA, VK2EK, VK3IP, VK4DD, VK5ON, VK6KK, VK7PR, VK8AN, VK9DJ (some 57 VKs in all, too numerous to mention!), VP3HAJ, VP8IK,

—continued on page 694

C.H.GARDNER

Set manufacturing in the 20's

THE manufacture of radio and TV receivers is now big business dominated by the "big boys", who have a tendency to merge into still "bigger boys" with capital of astronomical amounts and facilities beyond the comprehension of the uninitiated.

Very different was the situation some 40 or more years ago. Many of the manufacturers of that period were enthusiastic amateurs who, convinced that they could produce better receivers than those already available, turned professional and entered the industry.

The emphasis was on quality rather than reduction of price. Eagerness from action came largely from technical rather than commercial considerations. At a later time, when the rapidly growing market seemed to offer the possibilities of considerable future riches, which by no means always eventuated, the more commercially inclined gentlemen were stirred into action, but that is a story of another period.

In the meantime the possibility of becoming the "Rolls Royce" of receiver producers became the target of many an enthusiast with little commercial experience and still less capital to put the idea into practical operation.

Up to the time of which we are writing, the home wireless receiver had generally consisted of a number of so-called "units". Each unit, which did just one job, consisted of a wooden box on which was mounted an ebonite panel. The necessary components were mounted on the underside, and the valves and control knobs on the top of the panel.



This early set looks more like a laboratory instrument than a receiver.

Numbers of terminals were provided for leads to batteries and to other "units".

This mass of boxes and flexible wires complete with batteries had to stand on the grand piano or large table and was not necessarily looked upon with favour by the lady of the house. The efficient operation of this conglomeration required considerable skill and, to put it mildly, the results were pretty awful!

So, until the matter was looked into a little more deeply, the task of designing something more suitable did not appear to offer any considerable difficulty. It was only when he really got down to matters that the designer realised that snags arose like the prickles on a hedgehog.

The earliest receivers had to rely for their sensitivity on their being operated on or near the point of self-oscillation. This resulted in reception being accompanied by grunts, howls and whistles to an extent which made the P.M.G. find it necessary to issue an edict that all future receivers must be incapable of feeding oscillations back into their

Wiring a 1924 six-valve receiver. Actual line-up was as follows: two h.f. stages, a detector, two low frequency and an audio output stage. Note the large pre-heat soldering iron used by the young lady and the large variometer aerial tuning unit.

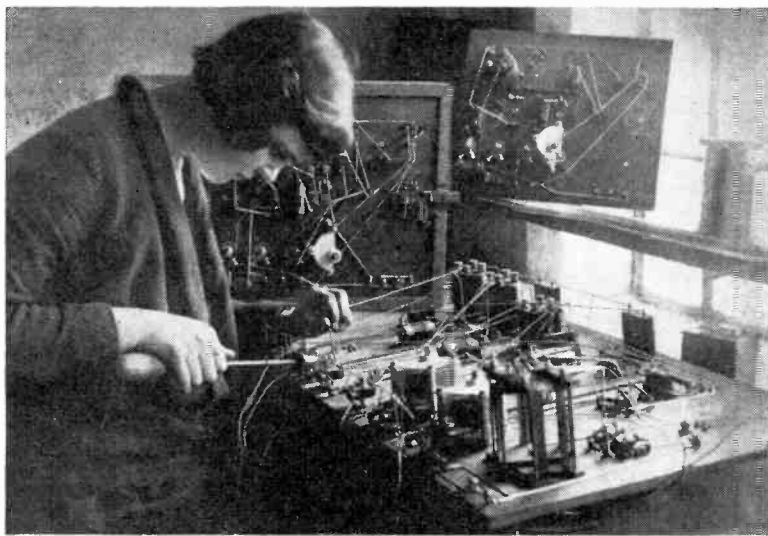

aerials. In order to ensure this, a prototype of every new receiver to be put on the market had to be sent to the G.P.O. for test. If satisfactory it would be tied up with tape, sealed, and placed in their archives. Dire penalties awaited the manufacturer who departed from the design of the sealed model in his production run.

Here arose snag number one. The receiver had to operate with l.t., h.t., and bias supplied from batteries, the voltage of which varied considerably in use. Each valve had a rheostat in its filament circuit and "reaction" was obtained by the adjustment of the coupling of a pair of coils. Sensitivity also required the use of individually tuned aerial and h.f. circuits which varied the propensity of the receiver to go into oscillation by the accuracy of their settings. If the circuitry was so arranged that oscillation was impossible even when the set was in use by a ham-handed user, its general sensitivity was pretty dreadful.

You may well wonder why a high degree of sensitivity was required. The answer was that the user of that period had a strong DX complex and the performance of a receiver was measured by the number of transmissions it could receive, even if such transmissions had little or no entertainment value.

It was the desire of every designer of this period to produce a receiver which could be operated by "Grandma". In point of fact, few sets could be correctly adjusted even by *Pater Familias* unless he was a wireless enthusiast, a matter which was realised by many potential purchasers. Any advance in this direction was a major breakthrough and cause for considerable excitement for the designer. It was possible to allow one's enthusiasm to extend too far, as when the author presented a receiver to his company chairman with the suggestion that any fool could operate it and that he should try it and see!

It would be misleading to suggest that there was an entire lack of interest in good quality reproduction, but good reproduction was judged more from the angles of clarity and absence of discordant harmonics than from the ability to reproduce an extended scale. But even this simple requirement had conflicting interests.

The use of a suitable output valve meant a heavy drain on the h.t. battery and indicated the use of large capacity cells with a consequent appreciable increase in bulk and in cost of replacement. Frequent replacement of an expensive h.t. battery was a matter which soon told against the popularity of any receiver. It was not unusual to provide a switch in order that the final stage could be cut out at will and reception obtained from headphones or at a reduced loudspeaker level.

The loudspeakers available at the time suffered from a defect well described as "tinniness", a defect which could be to some extent reduced by a suitable loading of the intervalve transformer with capacitance and resistance. Variations of the loading allowed of a switch labelled "Speech" "Music" and "Mellow" to be provided on the panel. It is perhaps unnecessary to mention that, without this switch, speech was inclined to give the impression that the speaker had left his teeth at home or had



A common practice for early designers was to house their "babies" in shiny oak or mahogany cabinets such as this.

hurried to the studio with his mouth still full of porridge.

Until broadcasting had really got going, "wireless" had been almost entirely a male hobby and even often thought of as a bit of a nuisance by the rest of the family, but when father, on rare occasions, could be prevailed upon to stop knob twiddling, and leave the dials set on a BBC station, sufficient interest was aroused to engender an idea that a broadcast receiver might well be a welcome addition to the home providing it would "fit in" with the general room furniture.

No matter how much knobs, dials and switches might appeal to papa and enable him to impress his-friends by his skill in adjusting them, they could not be considered as an attribute in the drawing-room. Construction of the receiver had still remained on the general principle of mounting valves and controls on one side of an ebonite panel, the wiring and components being mounted on the other.

It was not difficult to arrange for the panel to be held upright in a cabinet with folding doors which could shut away the controls when not in use. The batteries could be contained in an additional compartment, thus doing away with the necessity of unsightly wires.

For those conversant with modern methods of manufacture of TV and radio cabinets an extract from a catalogue of 1924 may be amusing: "All our cabinets are hand made by skilled cabinet makers out of genuine seasoned oak or mahogany and undergo a french polishing process by experts, which requires three weeks to complete".

In the same catalogue of receivers the manufacturer asks the potential purchaser if he "would like to have his drawing room carpet ruined by acid accidentally spilled from an accumulator for

which no proper provision has been made". It will be seen that it was still advisable to provide arguments in favour of self-contained receivers.

Highly polished ebonite panels were in favour. One supplier, without warning the set manufacturer, used a process which entailed the use of tinfoil on the surface, the tinfoil later being removed leaving a very high gloss indeed. It also left an invisible conducting surface on the panels which accounted for the production of a quantity of sets which entirely failed to function on test, and, incidentally some headaches in the test department before the cause was discovered!

Wiring of the receiver was by means of uninsulated tinned copper wire. This was somewhat of a work of art as not only must wires cross at different levels but it was thought necessary that adjacent wires should cross at right angles in order to avoid undesirable coupling. The result was beautiful to behold but not always as expected. Shorter cuts often proved to be more effective. For a reason which it is difficult to recall, square sectioned wire came into use. One's chief recollection of this wire was the difficulty experienced in making good soldered joints when using it.

Components such as intervalve transformers, resistors, capacitors and valves were usually purchased from specialist manufacturers by the smaller set manufacturer, but many other components were produced by themselves, often being of their own design and providing greater individuality for their own sets. This gave an opportunity for ingenuity, not always successful.

The standard type of filament adjustable rheostat was apt to be rough and noisy during adjustment. One manufacturer evolved an ingenious design for this component in which the variable contact was made by a curved strip made to rock over the turns of resistance wire by the movement of a cam turned by the adjusting knob.

This operated noiselessly and the movement was velvety but, alas, the designer had omitted to remember that some frictional contact was essential to keep the track clean. As this particular receiver carried with it a two-year guarantee, the final result was by no means in the manufacturer's favour.

The quality, performance and finish of many of the receivers produced by these small manufacturers was exceptional. They were designed and made by craftsmen who loved their work, but their demise was almost inevitable. A few survived to be taken over by larger concerns with more practical ideas concerning mass markets and more capital available to put such ideas into operation. Some were unable to survive the more difficult times and closed their doors, but for many years one came across samples of their products the owners of which contended that they remained superior to the later mass-produced receivers which had become available.

But technical development of a major nature soon took place and the only monument that remained could sometimes be spotted by the knowing in the shape of a cigar cabinet or medicine chest in which, alas, on opening the doors no highly polished ebonite panel could any longer be seen. ■

NEXT MONTH

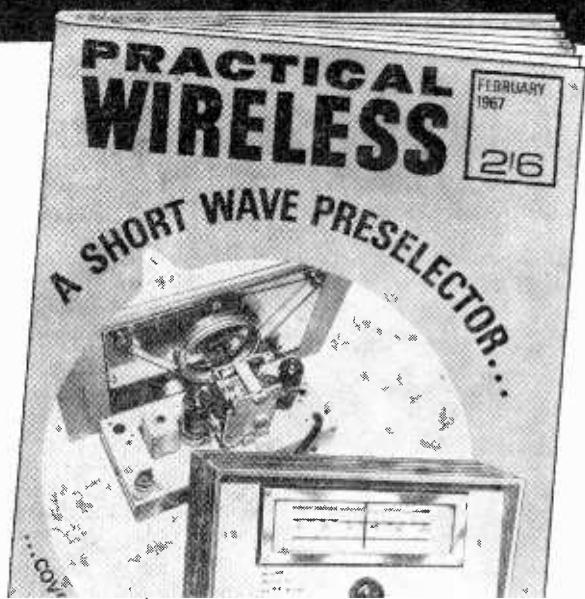

SHORT WAVE PRESELECTOR

Hot up your receiver with this easy-to-build 2-stage preselector. Continuously tunable over 14-30Mc/s, it takes in 10, 15 and 20 metre amateur bands, also 13 and 19 metre bands. Provides better selectivity and sensitivity, and improves signal-to-noise ratio.

THE HOME WORKSHOP

An article intended for the beginner who needs some idea of how to set out his space and equipment before actually beginning to build his own, and also for the established amateur who feels that perhaps he is not using the area at his disposal to the best advantage.

WIDE-RANGE SIGNAL GENERATOR

Full constructional details. Covers 95kc/s to 85Mc/s in 6 switched bands. Has facilities for c.w., modulated c.w. and audio outputs. Cabinet 10 x 8 x 3 inches.

PULSE COUNTER DISCRIMINATOR

For f.m. fans. A front end of practical simplicity, using pulse counter techniques for detection of f.m. signals.

PRACTICAL WIRELESS

FEBRUARY ISSUE
ON SALE JAN. 6th

Make sure of
your copy — order now!



*I should like a copy of the Electronics Hobbies Manual.
Enclosed is a cheque/P.O. for 10/6.*

NAME _____

ADDRESS _____

P.W.T. _____

**Available now!
The enthusiasts' greatest-ever components guide!**

Over 600 pages packed full of tips, kits and details of over 11,350 different parts from 85 leading manufacturers!

Whatever your particular interest in electronics, you'll find the Electronics Hobbies Manual a first-class investment.

It saves you time. No searching around for the parts you need. Every type of equipment—from stock components to sophisticated professional items—is here. Supplied by over 85 leading manufacturers, this equipment is *all* available by mail order on fast despatch.

It aids your projects. Complete designs, and details of kits available for beginners and experts, are all contained in the Manual. Inside, too, there's a wealth of technical data, practical tips and formulae to help you build with confidence.

It costs just 10/6 post free. And it puts the whole electronic industry at your service, including the specialised knowledge of Electronics. Behind this brilli-

ant new venture are the vast resources of STC and ITT, so you're assured of a first-class service!

Be sure of your Electronics Hobbies Manual. Clip the coupon, and send today—while stocks last!

Electronics (Prop. STC Ltd.)
Edinburgh Way, Harlow, Essex.
Telephone: Harlow 26777.

High-grade components for amateur communications





PRECISION SOLDERING EQUIPMENT

Instant-heat Soldering Gun

Solders in seconds ... heats immediately ... cools quickly. Long reach ... built-in spot-light. Perfectly balanced, lightweight, comfortable to use. Two position trigger for dual-heat control.

EXPERT Dual-Heat Gun. 8200D 57/6.

EXPERT Soldering Kit. 8200D-PK 72/6.

Kit contains: Expert Gun; resin-cored solder; cleaning brush; soldering aid tool; spanner; 2 spare bits. In fully fitted polypropylene carrying case.



The MARKSMAN Soldering Iron

Compact, lightweight, highly efficient, gives full 25 w. heat at tip. Screw-in tips and long reach for tight space working. Handle always cool.

MARKSMAN Soldering iron SP25D 25w. 240v. 29/-.

MARKSMAN Soldering Kit SP25D-K. 38/- . Kit contains: Marksman Iron; resin-cored solder; soldering aid; 2 spare tips.

Manufactured by the world's largest makers of quality soldering tools.

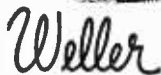

ELECTRIC CORPORATION • HORSHAM • SUSSEX • TEL: HORSHAM 60807

WEYRAD

COILS & TRANSFORMERS FOR CONSTRUCTORS

Special versions of our P50 Series are now available for AF117 or OC45 Transistors. They can be used in the standard superhet circuit with slight changes in component values, details of which are given in the latest edition of the Constructors' Booklet priced at 2/-.

Oscillator Coil	P50/1AC (For OC45)	P50/1AC (For AF117).....	5/4
1st I.F. Transformer	P50/2CC (For OC45)	P51/1 (For AF117).....	5/7
2nd I.F. Transformer	P50/2CC (For OC45)	P51/2 (For AF117).....	5/7
3rd I.F. Transformer	P50/3CC (For OC45)	P50/3V (For AF117).....	6/-
Rod Aerial	RA2W		12/6
Driver Transformer	LFDT4/1		9/6
Output Transformer.....	OPT1		10/6
Printed Circuit.....	PCA1		9/6

I.F. TRANSFORMERS & COILS FOR VALVE CIRCUITS

Production of Tuning Coils (Type "H") and I.F. Transformers is being continued and details of these and our other components are given in an illustrated folder which will be forwarded on request with 4d. postage please.

WEYRAD (ELECTRONICS) LIMITED
SCHOOL STREET, WEYMOUTH, DORSET

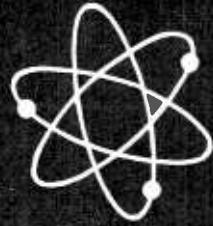

SIMPLE ELECTRONIC ORGAN

J. M. WATT

THE first problem in this project was to find an oscillator capable of producing a pleasant sounding note, and whose pitch could be varied easily over a suitably wide range.

After experimenting with capacitive/inductive oscillators it was decided that they were unsuitable for two reasons. They were difficult to adjust when their pitch was varied, and the finished unit would be rather large due to the size of suitable inductances, chokes and transformers, etc.

Attention was then concentrated on the ever-popular multivibrator, and although this type of

circuit did produce a satisfactory range of approximately one octave, the notes produced were very harsh and unmusical.

It was finally decided to try the phase-shift oscillator. This seemed promising since the output waveform approaches a pure sine wave if the transistor is not driven too hard. A circuit for such an oscillator appeared in *PRACTICAL WIRELESS*, August, 1962.

The note produced by this circuit was both musical and easily variable, but since this circuit was originally designed to give a frequency of 1kc/s,

it had to be modified to produce notes in the 200—500c/s range. This was achieved by increasing the capacity in the phase-shift network as shown in Fig. 1.

The 25k Ω potentiometer VR1 proved capable of varying the note over a limited range. If a greater range is required then a switch must be employed to vary the value of one or more of the components in the phase-shift network.

The oscillator in the form shown produces a continuous note which, although variable, is not interrupted. This can be remedied by introducing a bell press type switch to break the battery supply.

The amplifier used for the completed organ was a two-stage circuit, using the final two stages (driver and class B output), of a transistor radio. The circuit used was, in fact, taken from a *PRACTICAL WIRELESS* Blueprint for a transistor superhet.

Using simple capacitive coupling between oscillator and amplifier, it was found that a very much harsher note was produced than had been obtained when the oscillator was tested using a tape recorder as an amplifier. It was then discovered that if the oscillator and amplifier were supplied from different batteries, and a large value resistor and a capacitor were introduced between the positive line of the two units, this note could be considerably mellowed.

The final circuit is shown in Fig. 2. Although it uses OC72 transistors, red spot surplus types can be substituted in the first two stages. The final stage could also employ surplus transistors as the distortion

produced, due to these devices being unmatched, etc., should not prove objectionable. Also, there seems no reason to suppose that other surplus items should not be used.

Constructional details have been purposely omitted as the constructor may wish to vary the size of the instrument and include a keyboard instead of the variable resistor. The prototype was built on a piece of perspex 6 x 2½ in.

If a keyboard is required, then a small perspex key may be used which will press down on to a hairgrip.

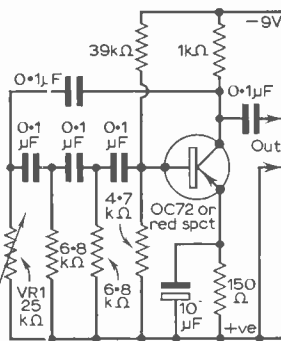

Fig. 1: Sine wave generator.

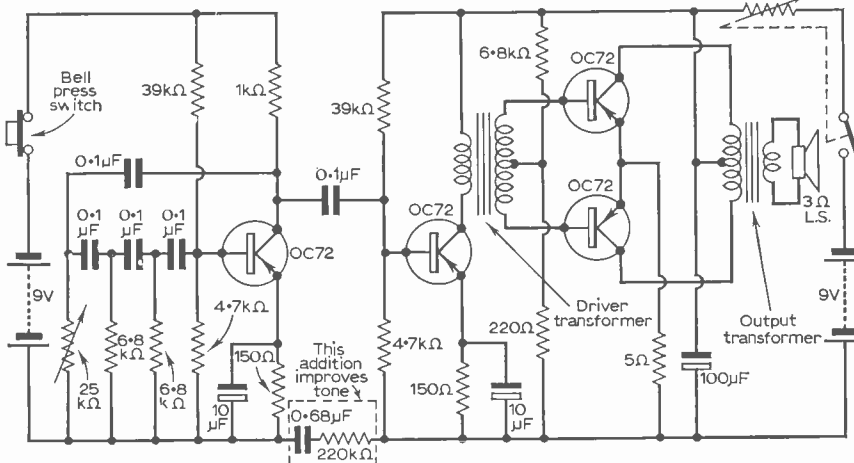

Fig. 2: Complete circuit of the organ.

practically wireless

commentary by **HENRY**

Look out
ahead!

JAN. 1: Made a few resolutions, just to be in the fashion. Keep my solder bit bright, always check component colour coding before snipping the end-wires, never switch on until I've re-checked the drawing, file my PRACTICAL WIRELESS copies in order . . .

Jan. 2: Decided to make a start on constructional projects. Sorted through blue-prints. Found interesting trouble-shooting chart. Pinned on workshop wall. Not a bad day for a Monday.

Jan. 3: More back copies than I thought, but some puzzling gaps. Must look up diaries for 1963. Don't know how I came to miss the *Malvern* that summer. Must try a few transistor designs. Noted that F-E-T circuits are promised—time that breakthrough broke through. In the meantime, must classify building projects.

Jan 4/5: Too busy to enter log last night. Uncle Joe called. Very interested in shack, especially 12W transmitter under bench. Wanted to dust it off and get on the air. Had to explain PMG requirements. Dare not swamp neighbours with TVI just as we have settled the car-parking controversy.



Everyone is entitled to a rest

Jan. 6: Commenced multi-purpose pre-amp. Lucky, project just fits baby-alarm unit. Pity to have discarded that one because of a little feedback problem. Women just do not understand these things. Still, suppose Junior will not be needing it, now he is going to school.

Jan. 7: Unfair to wife yesterday. Very interested in projects. Wants door-answering intercom. Suppose pre-amp could be adapted. Would speaker/mic signal be OK for input. Must ask John Law . . . *Memo, look up current issue for Query Coupon.*

Jan. 9: Unable to enter log yesterday, owing to domestic strife. Wife no right to lend PRACTICAL WIRELESS to Uncle Joe. We still haven't had the garden-hose returned. Trouble patched up, however, but had to promise early completion intercom. Decided against P-C board, will use support-wire method. Crude, but good enough for some equipment makers.

Jan. 12: Good progress with intercom. Decided against bootstrap input—not quite sure how it works. Must write Darlington—or was it the G.M./E.C.D. pair who dealt with semiconductors? Check when index complete. Had to use pair OC72 in Georgie's radio—should' get away with OC71 in intercom circuit though—cheap enough, anyway.

Jan. 16: Hopeless task. Wife has practically sold intercom idea to neighbours. Never get five made by Valentine's Day. Job lot of parts arrived today. Spent two hours sorting and identifying resistors.

Jan. 17: Mysterious note from Uncle Joe. CQ HPE U HRD RPT OM. BCNU. Not if I can help it! Must look up issues with R.A.E. lessons. Forgotten most of



Please close the betting shops

my Ham Code. Was it a year ago the S.W. Pocket Guide came out in P.W.? Time flies.

Jan. 18: Flies indeed! Must concentrate on prototype intercom. Mass production out of question—quite apart from expense. Problems with power supply. Chassis not big enough, not her's—intercom's.

Jan. 20: Wonder if Wagner power supply would do. July '66. He says he knocked it up from his "bits box". Wish he could see mine—full of unusable oddsments. I need two OC26, two OA85, two silicon diodes, two meters . . . pity I hadn't kept up the no smoking resolution a bit longer.

Jan. 27: Scrapped intercom.

Jan. 28: Memo—look up transistorised mixers. Memo—check address intercom suppliers. Can't imagine how they produce the things so cheaply. Wonder how Uncle Joe got hold of the address?

Jan. 30: Must check index. Must look up *Practical Television* copies—may be closed-circuit design for visual intercom. Could perhaps modify the old transmitter. That should knock Uncle Joe for six!



PEAK SOUND

Cir-kit

THE WORLD'S MOST VERSATILE CIRCUIT BUILDING SYSTEM

ENABLES YOU TO BUILD THIS SUPERB

8 + 8 WATT STEREO AMPLIFIER FOR ONLY £12.19.6

What you should know about Cir-Kit

"Cir-Kit" is supplied in conveniently prepared packs to enable the home constructor as much as the lab. or industrial user to make single or prototype circuit boards quickly and very cheaply. "Cir-Kit" also provides the ideal way to repair existing conventional printed circuits. It comprises strip and sheet in 99.5% pure copper lacquered with corrosion resist on the rear and backed with an exclusively developed powerful self-adhesive which actually strengthens with age. "Cir-Kit" is quick, clean and instant in application, and easily modified. Nothing could be simpler or more efficient in making circuits as constructors as well as leading industrial organisations are finding to their advantage. "Cir-Kit" cuts costs too, as will be seen in the first Peak Sound Design pack offered here.

PEAK SOUND CIR-KIT PACK 3 comprising 6 x 12in. Bakelite Laminate E.10 board, 6 x 4in. Cir-Kit adhesive sheet and approx. 15ft. of 1/4in. adhesive Cir-Kit strip—enough for about 10 separate circuits, complete in sealed polythene pack with instructions.

15/-

NO CHEMICALS, ETCHING, HEAT, SPECIAL TOOLS OR LAYOUT RESTRICTIONS

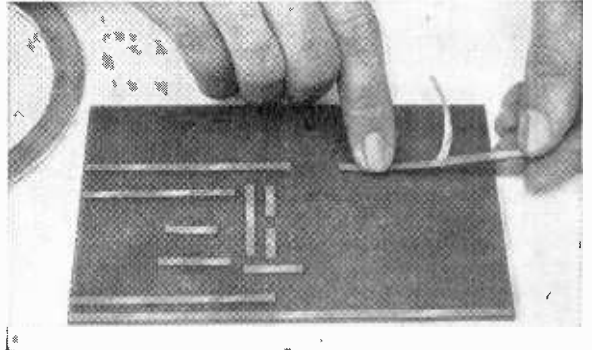

Peak Sound Design Pack SA. 8-8 WITH CIR-KIT, UNIQUE PEAK SOUND SHADOW TEMPLATE, CIR-KIT BOARD DRILL AND SOLDER

An outstandingly fine amplifier using circuit designed by A.E.I. to bring the best out of modern high-quality ceramic pick-up cartridges. With a total output of 16 watts into two 3.5 ohm loudspeakers, the SA. 8-8 has more than enough power for all domestic listening. Because YOU do all the building (and get all the satisfaction that comes from this) WE can offer this amplifier at a fantastically low price for quality equipment. Building with Cir-Kit is something new and stimulating in kit construction. When finished you will have a compact, powerful instrument to delight all who hear and see it—and anyone can build the SA. 8-8 even without previous experience!

CIR-KIT—THE SYSTEM THAT ENSURES UNBEATABLE VALUE WITH EXCITING NEW BUILDING TECHNIQUES

- ★ Specially developed circuit by A.E.I.
- ★ With 2 sets of 7 factory-matched transistors (14 in all)
- ★ Output—8½ watts into a 3.5 ohm speaker per channel.
- ★ Frequency response—20 c/s to 20 Kc/s ± 3dB.
- ★ Input sensitivity—180 m/v—ideal for high quality ceramic P.U.s.
- ★ Power requirement—25V. d.c. at 0.6A at peak load current.
- ★ Controls—separate volume on each channel for perfect stereo balance; treble; bass; separate on-off.
- ★ Chassis serves as heat-sink.
- ★ Size 10in wide x 3in. deep x 2½in. high. Easily fits under motor board.
- ★ Kit includes: Cir-Kit supply of unique Shadow Template for easy layout and component mounting and free Cir-Kit drill and solder.

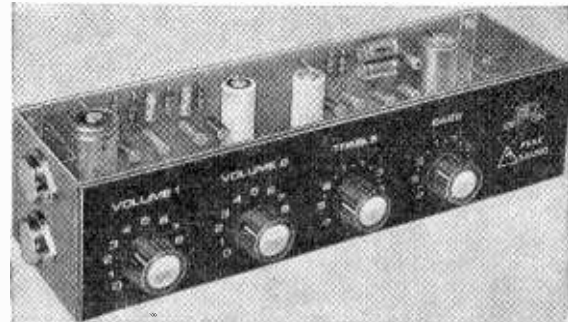

Anyone can build this fine amplifier with complete success by using the ingenious self-checking Shadow Template and simple instructions. FROM YOUR USUAL DEALER, OR DIRECT IN CASE OF DIFFICULTY.

10 STAR STEREO VALUE

COMPLETE KIT AS DESCRIBED WITH INSTRUCTIONS

£12.19.6

Peak Sound Mains Power Pack 75/-



Designed and manufactured by **PEAK SOUND (HARROW) LTD.**, 10 Asher Drive, Mill Ride, ASCOT, Berks. Phone: Winkfield Row, 3217 (S.T.D. Code 0EH47) Distributors to the Wholesale and Retail Radio Trade in U.K. **TECHNICAL SUPPLIERS LTD.**, 63 Goldhawk Road, London, W.12 Phone: 603-2581; 603-4794

★ IN CASES OF DIFFICULTY, USE THIS DIRECT ORDER FORM

To **PEAK SOUND, 10 ASHER DRIVE, MILL RIDE, ASCOT, Berks.** Please send AT ONCE Cir-Kit Pack 3 at 15/-, Peak Sound Design Pack SA.8-8 at £12.19.6, Peak Sound Power Pack £3.15.0

Herewith please find £.....s.....d. cash/cheque/money order.

NAME

ADDRESS

BLOCK LETTERS PLEASE

P.W.671

the TEN-FIVE TRANSMITTER



THE "Ten-Five" transmitter is a two-band affair which may be used with the "Ten-Five" transistorised communications-type receiver described earlier in these pages. Small in size, the transmitter would, if stood on a single page of "P.W.", fail to cover it completely!

Valves are used throughout, for although transistorised transmitters are entering the amateur sphere, these do tend to be expensive to construct. The "Ten-Five" transmitter weighs $3\frac{1}{2}$ lb., is virtually of sandwich box proportions, and is intended for use on the "80" and "160" metre amateur bands for a.m. phone working.

Arrangements are such that the transmitter may be used under "Fixed Station" conditions, requiring 300V d.c. @ 100mA and 6.3V a.c. @ 3A. Alternatively a 12V d.c. car battery plus d.c.-d.c. transistorised converter may be connected whereupon portable, mobile, etc., working becomes feasible. The mode of powering required may be selected at will, it merely being necessary to exchange a pair of Noval plugs, the intention being to allow the transmitter to be moved from shack to car, or *vice versa*, as required. It must be emphasised, however, that at the time of writing only "fixed station" tests have been carried out using a mains-powered p.s.u. and 6.3V a.c. heaters.

The "Ten-Five" transmitter may be loaded comfortably to the 10W maximum input permitted on "Top Band" whilst on "80", 12W input is possible.

R.F. Stage Circuitry

As may be seen from Fig. 1 no trick circuitry is employed, the aim being reliability. Valve types other than specified may be used in certain cases, *provided* basing differences are noted. A 5763 has been used for V2 and a EL84 for V4 quite successfully; the specified types are preferred, however.

A Clapp v.f.o. is arranged around the triode section of V1, L1 in conjunction with VC1 tuning over the frequency range 1.75—2.0Mc/s. The band edges are adjusted at the setting-up stage, using the

dust core of the coil, VC1 and trimmer TC1. Tuning is accomplished mechanically by means of a vernier reduction drive located on the front panel, the intermediary being a *flexible* insulated coupler.

The v.f.o. output is extracted from the cathode circuit of the triode and injected into V1B which functions as a buffer stage on "Top Band" and a frequency doubler for "80" metre working.

Selection of the fundamental or second harmonic frequency is carried out automatically, depending on the position of the panel-fitted band switch, S3. Fixed tuning is applied to L2 in each case, and this is adjusted at the setting-up stage and thereafter requires no alteration.

The output frequency selected from the anode of V1B is fed to V2, the p.a. stage via C11, tank coil L3 also being switched automatically via S3b.

Metering the cathode circuit of the p.a. permits grid drive current to be read when the function switch is set to "Net". On "Transmit" the meter reads cathode current and is used for tuning-up operations. Approximately 2mA of grid drive is obtained at band centre and falls off slightly at band edges.

Modulator Stages

A crystal microphone may be plugged into Sk1, V3 operates as a conventional two-stage speech amplifier, values of resistor and coupling capacitor combinations being selected to favour voice frequencies. Decoupling and smoothing for the speech amplifier stages, plus the screen circuit of V4, is by means of R17 and C22, R19 being included to offer a discharge path for electrolytic capacitor C22 which would otherwise be left in a charged state each time the function switch was moved from "Transmit".

The valve specified for the speech amplifier stages has an amplification factor of 100 and it is thus desirable to include the modulation gain control VR1. Some trouble was experienced in the prototype due to parasitic oscillation which was finally traced to V3. The inclusion of R13 and C17 proved beneficial but normally these two items

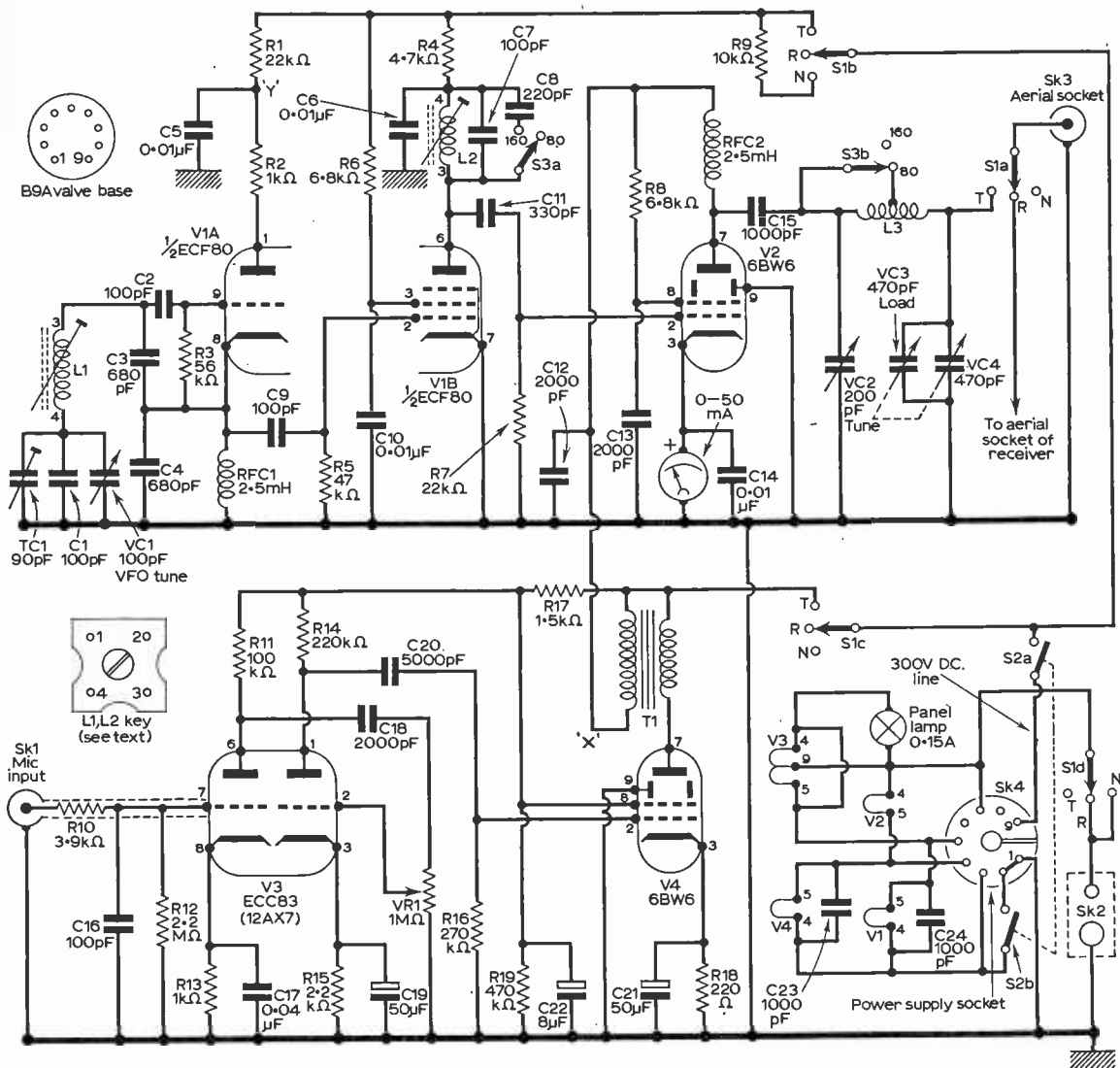

Fig. 1: The complete circuit of the transmitter.

would not be needed. T1 is a half-wave type mains transformer, the low voltage windings being ignored. It is possible to make use of a push-pull (or centre-tapped) output transformer in this position if it is of generous physical and electrical proportions. Such a transformer should be connected as shown in Fig. 2, the secondary winding(s) being ignored; if this circuit is analysed, however, it will be found to be identical with that of T1, Fig. 1.

Operation Switching

The function switch S1 permits three operations, viz., "Receive" (or "Stand By"), "Net", "Transmit", whilst for "On/Off" purposes S2 does duty, this being ganged with VR1.

With the function switch at "Receive" and S2 closed, h.t. is normally present but is not applied to the transmitter valves. The valve heaters are "On" together with the panel lamp and the aerial

is connected to the receiver. By moving the function switch to "Net", h.t. is applied to the v.f.o. and buffer, whereupon the panel meter reads one subdivision, i.e., 2mA approximately. Subsequent setting of the function switch to "Transmit" enables h.t. to be supplied to the p.a. and modulator stages. If a 15W lamp "load" is now connected to Sk3, this will glow quite brightly if VC2 and VC3 are correctly adjusted. Speaking or whistling into the microphone should then cause the lamp to brighten slightly on peaks.

Resistor R9 is included to maintain the potential at point "Y" identical in both "Net" and "Transmit" positions of the function switch.

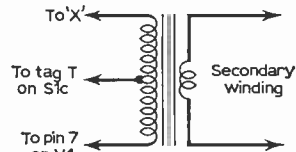

Fig. 2: Alternative modulation transformer connections.

Socket Sk2 is intended for use when the transmitter heaters are in 12V d.c. connection. The wiring of the plug associated with Sk4 decides whether the valves have their heaters in 6V or 12V connection—and Sk2 is associated with Sk4 via S1D. In the “Receive” and “Net” positions of the function switch, 12V d.c. (assuming use of a car battery), is thus available at Sk2 for feeding a transistorised unit—the “Ten-Five” Receiver, for example, although such receivers must be protected during “Transmit” periods!

Power Supply Plugs

The wiring of the two plugs—*looking at the pins*—for either 6.3V or 12V heaters is shown in Fig. 3 *a* and *b* respectively. Plug “A” inserted, arranges the valve heaters in parallel as shown at *a*, whilst Plug “B” results in parallel-series connection as indicated at *b*, the panel lamp being placed across V3 automatically. If no lamp is used a 47Ω resistor should be wired in its place to compensate for the dissimilar heater current rating of V3; it is also necessary to use a lamp holder that allows complete isolation from chassis. It is advisable also to use dissimilar plugs at the p.s.u. ends of the two cables so that the incorrect unit cannot be accidentally connected.

Mechanical

Only two pieces of aluminium are required, one for the panel, the other for the chassis. Panel dimensions and necessary data are given in Fig. 4. Constructors may use suitable items already to hand for VC2 and VC3, receiver-type items being satisfactory. Both of these capacitors are fitted to the panel direct.

A combined chassis/layout diagram is shown in Fig. 5. The chassis is bolted to the panel, its rear being supported by a 1in. deep flange carrying sockets Sk2, Sk3 (which should be a flush mounting item) and Sk4.

The v.f.o. is separated from the other items by a metal screen, and small brackets are required to support VC1 and L3. Skirted valveholders are used in the V1 and V3 positions. The insulated flexible coupler used between the drive mechanism and VC1 is essential, not only to eliminate hand effects, but also to simplify a minor angle problem that exists due to the slight backward slope of the panel. Care is required in connection with the v.f.o. components and short lengths of stiff copper wire should be used.

Any windings associated with tags 1 and 2 on L1, L2, should be carefully removed prior to fixing. The tank coil is centre tapped and consists of 65 turns of 24 s.w.g. enamelled copper wire close wound on a former 1in. diameter and 2in. long. It is essential to use high-grade modern miniature components since space is at a premium to some extent. Commence construction wiring by completing the heater circuits and do use screened cable from Sk1 across to V3. Rigidity of all components and wiring must be aimed at.

Conventional tests consist of checking all wiring thoroughly and using an ohmmeter to ensure that no short circuits exist between the h.t. line and the chassis but that a return circuit does exist to chassis

★ components list

Resistors:—10%, ½W

R1 22kΩ
R2 1kΩ
R3 56kΩ
R4 4.7kΩ
R5 470kΩ
R6 6.8kΩ
R7 22kΩ
R8 6.8kΩ 1W
R9 10kΩ 1W
R10 3.9kΩ
R11 100kΩ
R12 2.2MΩ
R13 1kΩ
R14 220kΩ
R15 2.2kΩ
R16 270kΩ
R17 1.5kΩ 1W
R18 220Ω 1W
R19 470kΩ
VR1 1MΩ (log.)

Capacitors:

C1 100pf silver mica
C2 100pf silver mica
C3 680pf silver mica
C4 680pF silver mica
C5 10,000pF ceramic
C6 10,000pF ceramic
C7 100pF silver mica
C8 220pF silver mica
(see text)
C9 100pF silver mica
C10 10,000pF ceramic
C11 330pF silver mica
C12 2000pF ceramic
C13 2000pF ceramic
C14 10,000pF ceramic
C15 1000pF ceramic
C16 100pF ceramic
C17 0.04μF paper
C18 2000pF ceramic
C19 50μF, 6V electrolytic
C20 5000pF ceramic
C21 50μF, 25V electrolytic
C22 8μF, 350V electrolytic
C23 1000pF ceramic
C24 1000pF ceramic
VC1 100pF variable, type C804
VC2 200pF variable } see
VC3 470pf } text
twin-gang
TC1 100pf postage stamp type trimmer

Coils:

L1 QO8 } Osmor
L2 QA4 }
L3 See text

Valves:

V1 ECF80
V2 6BW6
V3 ECC83
V4 6BW6

Switches:

S1 4-pole, 3-way Miniature rotary type
S2 2-pole On/Off, ganged with VR1
S3 D.P.D.T. Toggle (or slide) type

Sockets:

Sk1 Surface mounting type TV coaxial socket
Sk2 Miniature non-reversible insulated 2-pin socket
Sk3 Flush mounting type TV coaxial socket
Sk4 Noval valve holder

Drive:

Vernier Dial, ratio 8 : 1, calibrated 0–100 over 180°, 2-in. diameter—T502

Chokes:

RFC1 } 2.5mH Ferrite cored type CH1 (Alpha Radio
RFC2 } Supply Co., 103 Leeds Terrace, Wintoun
Street, Leeds)

Panel Lens and Bush:

Type D149, Bulgin (Red) plus lamp, 0.15A, 6V and insulated holder

Miscellaneous:

Insulated flexible coupler, Four valve holders (B9A), two with skirts and screening cans. Transformer T1 See text. Miniature Plastic panel meter, 0–50mA. Four control knobs. Coil former, 1in. diameter x 2in. Oddments aluminium for brackets and screen, Grommets, 6BA nuts and bolts, wire, solder tags, tag strips, etc.

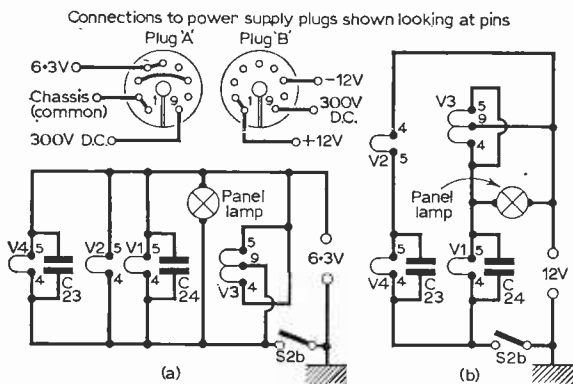

Fig. 3(a): Power supply plug wiring for 6-3V a.c. heaters; (b): power supply plug wiring for 12V d.c. heaters.

from all valve grids and cathodes. Particular care should be taken regarding the function switch wiring to see that it is correct.

Coil L1 should receive attention next, the aim being to adjust it via its dust core and in conjunction with TC1 and VC1 so that the maximum tunable range of frequencies is 1.75-2.0Mc/s. With TC1 set to about half capacitance and the vanes of VC1 fully closed, a g.d.o. is adjusted to 1.75Mc/s and coupled to L1. The core of the coil is then rotated slowly until a sharp dip is indicated by the g.d.o. meter. The g.d.o. is then returned to 2.0Mc/s and VC1 rotated until the appropriate dip is again noted. On inspection the vanes of VC1 should be almost fully disengaged, otherwise the inductance value of L1 is incorrect. Repeat the procedure again, although after a short time it will be found possible to obtain the exact frequency swing required when VC1 is moved from maximum to minimum capacitance. Should excessive frequency coverage result it may be necessary to "pad" the circuit a little, i.e., by inserting a fixed capacitor of approximately 100-300pF in series with VC1. When the required coverage results, the core of L1 should be lightly sealed together with TC1.

The transmitter may now be connected to a p.s.u. after adjusting the function switch to "Receive" and checking that S2 is "open". With power applied to the p.s.u. the panel lamp and valve heaters should light when S2 is closed. No attempt at putting out a signal should be made at this stage for the v.f.o. may be inoperative. To check the v.f.o. lift the "earthy" end of R5 and insert a meter set to read 0-5mA. Move the function switch to "Net" and observe the meter reading. Using the blade of a screwdriver, momentarily short-circuit tags 3 and 4 of L1 whereupon the current reading should increase sharply, returning to a low value immediately the screwdriver is removed. If no change

in the meter reading occurs the v.f.o. is not functioning and it is useless proceeding further until the fault has been cleared. Likely faults are a low-emission triode section of the valve, incorrect or faulty capacitor or resistor values or an open-circuit r.f. choke, etc.

The buffer/doubler may be checked by transferring the external meter to the "earthy" end of R7 and reconnecting R5 to chassis. The 50mA panel meter can be used instead and R7 left *in situ* but a more positive indication results from inclusion of an external meter adjusted to read 0-10mA.

VC1 should now be adjusted for 1825 kc/s output, set S3A to "80" and adjust the core of L2 carefully to give the highest possible meter reading; this should be about 2mA. The core of L2 is now sealed and S3 closed, whereupon a similar reading should be obtained on "Top Band". The value of C8 is fairly critical and experiment is likely in this connection—or a trimmer may be fitted instead.

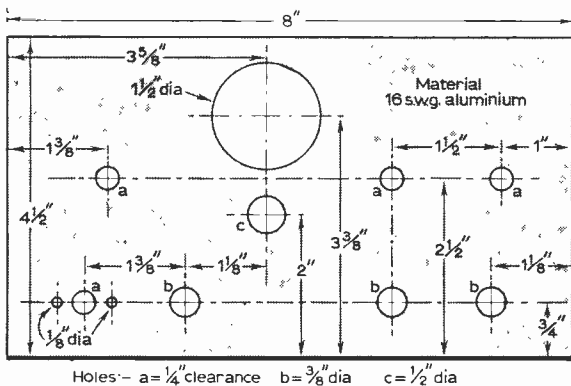
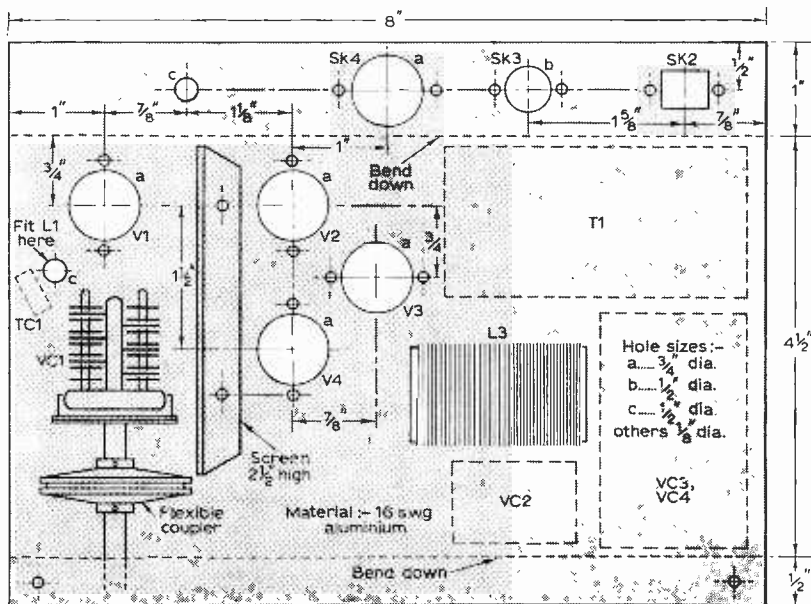

Fig. 4: Main panel dimensions and drilling details.

Fig. 5: Chassis dimensions and main component locations.



Checks should be finally made with a wavemeter to prove that L2 is in fact tuned to 1825 kc/s and 3650 kc/s when S3a is in its "closed" and "open" positions respectively.

With the external meter removed and R7 chassis-connected again the panel meter should indicate —2mA— at either position of the band switch when the function switch is at "Net".

Further Tests and Checks

The modulator may be checked by setting the function switch to "Receive", removing V2, plugging in a crystal microphone and connecting a pair of high impedance headphones across the secondary winding of T1. With the function switch rotated

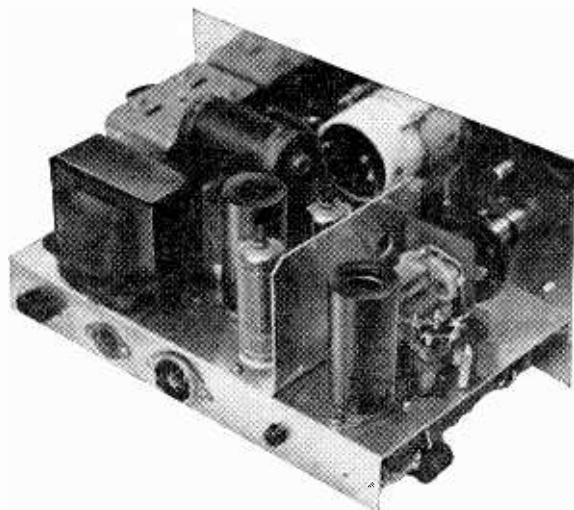

Photograph showing positioning of major components. Note screen shielding V1 and v.f.o. components.

to "Transmit" speech should sound crisp and clear when VR1 is suitably adjusted. If high pitched whistles are heard at any setting of VR1 suspect parasitic oscillations; these are very likely to occur if V3 is not fitted with a screening can, for example. Grid "stopper" resistors of approximately 10kΩ are usually a cure for parasitic oscillations.

The transmitter function switch may now be returned to "Receive", the phones removed, V2

replaced, a 15W lamp "load" connected to Sk3 (an aerial must not be connected) and VC2 plus VC3 so set that their vanes are each fully enmeshed. Move the function switch to "Net" to check that drive is present then go over to "Transmit". The panel meter should now show an almost full scale deflection if the valves are healthy, therefore *quickly* rotate VC2 until the meter reading dips to a low value, say, 10-15mA. Now open up the vanes of VC3 a little until the meter reading increases, immediately retuning VC2 to lower it as far as is possible. Again open VC3 and again readjust VC2 as before until the *dipped* meter reading is approximately 30mA. The lamp "load" will be glowing quite brightly now and should visibly brighten further on speaking into the microphone.

Air-Testing the "Ten-Five"

The transmitter may now be considered ready for air testing and some form of r.f. indicating device (a Wavemeter for example) will be found useful at this stage to monitor radiated signals and confirm that they are within the appropriate Amateur band. Tests with the prototype were made using a G5RV dipole with a 102ft. top, the feeders being strapped together at the station end for "Top Band" working.

The transmitter tuning and loading controls will normally need readjustment when an actual aerial is connected in place of the dummy "lamp load". Find a quiet spot on the band selected set the transmitter function switch to "Net" and tune the v.f.o. to the receiver frequency, at the same time checking grid current on the panel meter. The receiver is next silenced, or partially muted, the transmitter function switch rotated to "Transmit", small tuning adjustments made and a call sent.

Thereafter it is merely necessary to go through the normal formalities and generally get the "feel" of the transmitter whilst learning from reports received how well, or otherwise, that it works.

When optimum results have been achieved and any small adjustments required made, the v.f.o. and buffer/doubler stages should be rechecked frequency-wise; the cores and trimmer(s) sealed firmly; a graph drawn relating scale readings to frequency for each band preferably by means of a crystal frequency marker/receiver/transmitter combination; and all nuts and bolts given a spot of varnish. ■

PRACTICAL NEW YEAR THOUGHT . . .

If you've forgotten a friend who's a fellow radio enthusiast, you can still send him the ideal New Year gift . . . in a few moments . . . a year's subscription to PRACTICAL WIRELESS.

Simply send your friends' names and addresses, together with your own and remittance to cover each subscription to: The Subscription Manager (Z2), PRACTICAL WIRELESS, Tower House, Southampton Street, London, W.C.2. An attractive greetings card will be sent in your name to announce each gift.

RATES (INCLUDING POSTAGE FOR ONE YEAR (12 ISSUES):
U.K. AND OVERSEAS £1.16.0. U.S.A. \$5.00.

To make sure of your own copy why not place a regular order with your newsagent?

PRACTICAL ELECTRONICS

JANUARY ISSUE

REMOTE TEMPERATURE MEASUREMENT
TAPE RECORDER CONTROL UNIT
INTEGRATED STEREO AMPLIFIER-2

SPECIAL SERIES

THE ELECTRONIC ORGAN-2

ON SALE DECEMBER 15—2/6

TAPE RECORDER MONITORING SYSTEM

L. McNAMARA, B.Sc

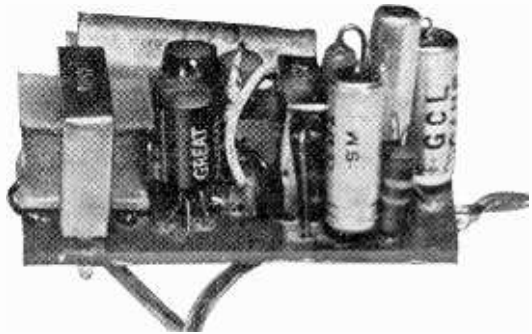

SOME time ago, the writer assembled the tuner unit described in the September 1965 issue of PRACTICAL WIRELESS for use with his tape recorder, a Phillips model 3541. The results were highly satisfactory—well up to the author's claims—and it provided pleasant listening and clear recordings. However, with this recorder it is impossible to record and listen simultaneously without the use of monitoring headphones. It was therefore decided to investigate the possibility of a modification to permit this.

The Amplifier

The amplifier incorporated in the recorder uses three valves and a rectifier. With switching, the audio output valve, an ECL82, functions as the erase oscillator when the machine is set to record. Very extensive changes would be called for if audio output and oscillator functions were required at the same time. It is possible to employ either a transistorised erase oscillator or to provide an auxiliary audio amplifier. The first option would require modification of the switching in the recorder, as well as some unusual components, such as a new oscillator coil matched for transistor use, whereas the parts for an audio amplifier were to hand. Fig. 1 shows a common-emitter driver stage followed by a transformer-coupled push-pull output pair. This type of amplifier was chosen in preference to the more recent transformerless style, since the latter requires a high-resistance loudspeaker, rather than the 3Ω type employed with valve circuits.

Fig. 2 displays the layout of the printed circuit board, which was produced by the now-familiar method of painting the required pattern on a copper-clad paxolin sheet and removing the unprotected areas of copper by etching in ferric chloride (Fe Cl₃) solution.

On completion, the unit can be tested using a battery power supply. The input to the amplifier is taken from the sockets provided on the tape recorder, with the output going to the extension speaker sockets. The amplifier will then reproduce the monitored signal through the internal loudspeaker of the recorder. However, as one of each pair of sockets is earthed, care must be taken to ensure that the earth side in each case is taken to the positive line of the amplifier, in order to avoid undesirable feedback effects. Those who have completed the project in last September's issue will already have a power supply able to provide the low voltage d.c. built into their machines. As readers will remember, that writer recommended the use of

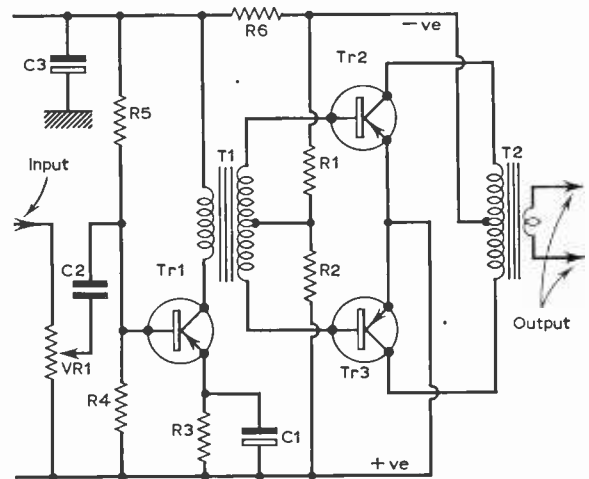

Fig. 1: The circuit diagram of the auxiliary audio amplifier.

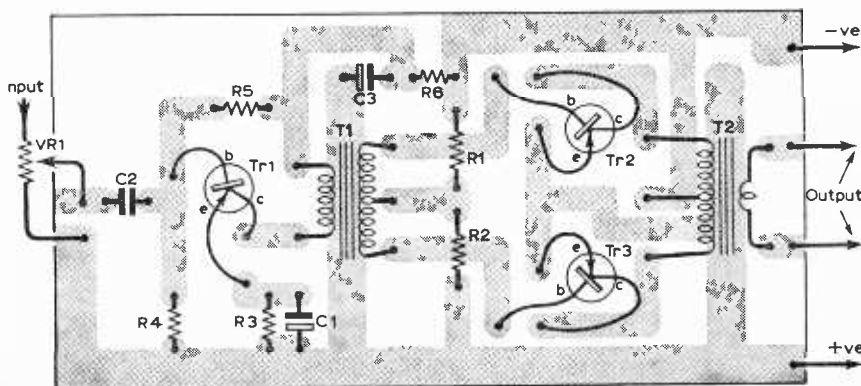

Fig. 2: The printed circuit board with components shown as seen through the panel.

a silicon diode to rectify the 6.3 volt a.c. heater supply. Due to the lower voltage, however, the output of the amplifier will be slightly lower than that obtainable with a 9V supply. Since the current required by the 3-valve amplifier of the recorder is considerably greater than that required by the transistorised units to be added, there is no reason why the latter should not be put in series with the former, with a resistor in parallel to cope with the extra current. All the h.t. from the rectifier must flow through the earthed centre tap of the secondary of the mains transformer in the full-wave rectifier system regularly employed. A d.c. voltage will therefore appear across a resistor inserted between this centre tap and earth. This arrangement also has the advantage, when used to power transistorised apparatus, that the earth is positive with respect to the transformer tap.

Value of R7

The current required by the valve amplifier is first measured by inserting a milliammeter in the circuit between the transformer centre-tap and earth; in the recorder the current was approximately 50mA, and the add-on units 25mA at 9 volts full volume. Therefore (50-25)=25mA must flow through the by-pass resistor. Ohm's Law is used to determine the value of this resistor. $\frac{9}{25 \times 0.001} = \frac{9,000}{25} = 360$ ohms. The power dissipated in this resistor = $I^2R = (0.025)^2 \times 360 = 0.225$ watts. A $\frac{1}{2}$ watt component of the nearest pre-

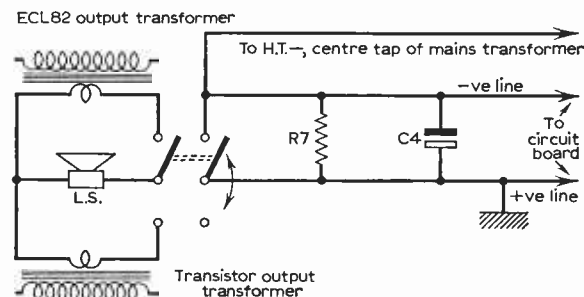

Fig. 3: H.T. and output transformer switching.

★ components list

Resistors:

R1	4.7kΩ
R2	100Ω
R3	1kΩ
R4	10kΩ
R5	47kΩ
	(39kΩ for 6v operation)
R6	680Ω
R7	370Ω 1 watt

Capacitors:

C1	50μF
C2	0.01μF
C3	100μF
C4	320μF 12v working

Transistors:

Tr1	OC81D
Tr2	matched pr.
Tr3	OC82
T1	driver trans
T2	output trans

Miscellaneous:

5kΩ potentiometer. 2 pole 2 way slide switch. Repanco type TT45, TT46 are suitable.

ferred value (330Ω), would suffice; however, as failure would leave the amplifier to carry the full 50mA, a more conservative rating of at least 1 watt should be used. A very large smoothing capacitor must be used across this resistor in order to eliminate hum, and also to provide for the large variation in current drawn by the output transistors of the amplifier which operates in class B.

Class B

In this mode the current drawn depends on the volume level. Details of the mounting in the recorder are not given, but a volume control and a separate 2-pole 2-way slide switch must be used. One pole of the switch is used to bring the secondary of the ECL82 output transformer, or the transistor transformer into circuit when required; the other switches off the unit by connecting the centre tap of the mains transformer to earth. The input to the unit is now taken internally from the monitor socket; it is quite simple to solder the screening and core of a length of mike cable to the earth and signal sockets respectively.

The amplifier greatly increases the scope of the tuner, and it is now much easier to tune the station one wishes to record. Finally, the amplifier, when switched off, leaves the circuitry of the recorder unchanged for normal microphone work, and of course the facility to monitor with headphones remains. ■

COMBINED TV TEST UNIT

If you service or instal TV sets you will want to read the January issue. The main feature is another constructional article of importance:

||| A COMPACT COMPOSITE TEST UNIT INCORPORATING A BAR AND PATTERN GENERATOR, AERIAL RIGGERS INTERCOM SYSTEM, MAINS POWER SUPPLY ETC. |||

Also in this issue is a description of a sync line selector which can be added to any standard oscilloscope as an aid to diagnosing those elusive sync circuit faults. There is also an article describing a circular TV aerial and the start of a new series "The World of Service"—Part 1 describes the experiences of the outside engineer.

JANUARY PRACTICAL TELEVISION IS OUT ON DECEMBER 22nd — only 2s.
The only magazine devoted entirely to the interests of the TV enthusiast!

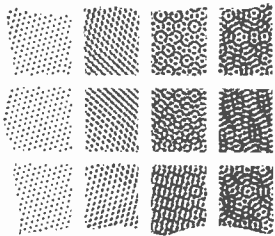

transfilters for

IT is conventional practice to couple i.f. amplifiers through tuned couplings which, of course, are the i.f. transformers. These are resonated to the intermediate-frequency by adjustments either to the inductance of the coupled windings, using dust-iron tuning cores, or to the parallel capacitance across them, using trimmer capacitors, as shown respectively at (a) and (b) in Fig. 1.

THE TRANSFILTER

With the development of piezoelectric ceramics, an entirely new type of i.f. coupling has appeared in recent years. This is sometimes called the *transfilter*, so called because it uses piezoelectric "filter" elements arranged in a kind of electromechanical coupling between the coupled stages. However, before we can understand how these operate and how they are applied in circuit, we shall have to learn a little about the subject of piezoelectricity and modern piezoelectric ceramics.

Piezoelectricity is not a recent discovery. It has been known since the start of radio itself, and it is the nature of electricity produced by crystal pick-ups, crystal microphones and other crystal transducers. Early devices of this kind employed water soluble crystals, such as Rochelle salt, which were easily damaged by excessive pressure and by temperature and humidity effects. The latest devices use more robust man-processed crystals, based on ceramics, as we shall see.

Years ago it was discovered that when a certain type and cut of crystal is subjected to mechanical stress there occurs an electric charge across two selected faces. This charge is piezoelectricity. It was also discovered that by applying an electric charge or voltage across the two faces a mechanical movement takes place in the crystal. This is sometimes called the *motor effect*.

Naturally formed crystals are possessed of crystal sections, making up the whole crystal, arranged in a definite pattern relating to a specific cut, and the direction of piezoelectric activity is related to a certain axis. This crystalline make-up is created by

nature during the growth of the crystal.

Ordinary, unprocessed ceramics, however, do not exhibit strong piezoelectric activity because the material is composed of randomly orientated crystal sections, by the application of a strong electrostatic field during the manufacturing process, the individual crystal sections are caused to reorientate along a common axis in the required direction. This process gets the whole crystal mass, as it were, to act as a single, polarised crystal. The crystal as a whole then develops strong piezoelectric tendencies, which remain when the electrostatic polarising field is removed.

The greater physical strength of piezoelectric ceramics, coupled with their greater resistance to temperature and humidity, give them considerable advantage over the water soluble crystals, and as a consequence they are now taking over many of the jobs held formerly by the earlier crystals. We now have the so-called ceramic pick-up, ceramic microphone, and so forth. In pick-ups and microphones, the sound vibrations are coupled to the faces of the ceramic insert in such a manner that the insert is put under mechanical stress in sympathy with the vibrations, and an audio voltage (signal), varying in accordance with the stresses, is developed across the terminals.

Crystal and ceramic loudspeakers (tweeters) work the other way round. The crystal insert is caused to impart its vibrations to a diaphragm, the vibrations resulting, of course, from the application of an audio voltage to the insert. Ceramic elements of this kind are sometimes called *transducers*, and are found at either end of PAL colour television delay lines, in audio echo devices and so on. The action is that the applied signal causes a crystal vibration at the sending end, which is translated back again to signal voltage at the receiving end, a time delay being given by the nature of the mechanical coupling between the two elements.

Like any mechanical structure, a piece of piezoelectric ceramic when cut to certain dimensions will exhibit specific modes of vibration directly related to those dimensions. This, indeed, is how quartz crystal controls the frequency of an oscillator. It is

Fig. 1 (below): Conventional i.f. transformer; (a) dust-iron core tuning and (b) trimmer tuning.

Fig. 2 (right): A ceramic filter as the final i.f. coupling to the detector.

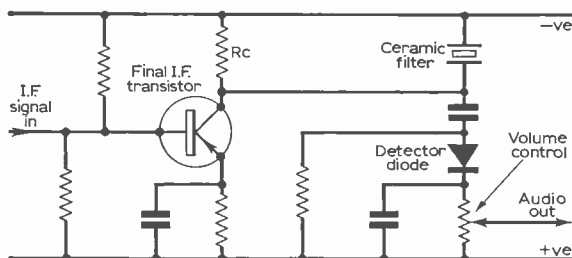
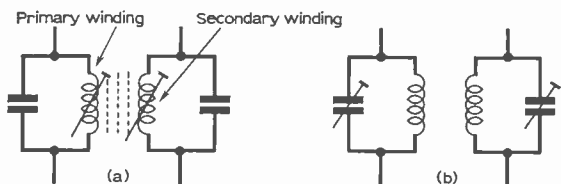

F. coupling

critically dimensioned by grinding to vibrate at the required controlled frequency. A tuning fork is the same.

CERAMIC FILTER

We now have sufficient information fully to understand the application of ceramics to i.f. couplings. Suppose that a disc of piezoelectric ceramic is dimensioned to "vibrate" at 470kc/s, the standard i.f., and that it is connected in place of the i.f. transformer between the final i.f. stage and the detector, as shown in Fig. 2.

Clearly, if the i.f. signal applied to this final stage is also 470kc/s, the ceramic disc will be subjected to a voltage across its face of frequency equal to its own resonant frequency. The ceramic disc will thus set up a vibration, and it will act very much like an ordinary tuned circuit at that frequency. It will effectively amplify the i.f. signals in the collector of the i.f. amplifier, and reject signals that are outside its response range.

The sharpness of the response curve will depend on the nature of the ceramic filter and associated circuit parameters. High "Q" values can be obtained if required, and the filter can be analysed into equivalent components of inductance, capacitance and resistance, just like any ordinary L-C tuned filter.

Now, by the use of two ceramic filters arranged in such a manner as to be mechanically coupled, a ceramic transformer action can be obtained. The first element, corresponding to the primary of an ordinary transformer (see Fig. 1), is caused to vibrate, due to the signal, and this vibration is transmitted directly into the second element, corresponding to the secondary of an ordinary transformer. The practical arrangement of this is shown in Fig. 3.

Here the ceramic element is in the form of a small disc, previously polarised to suit the requirements. One face is completely metallised, while the opposite face (that shown in Fig. 3) carries a metallised inner area and a metallised outer ring, the two being isolated from each other.

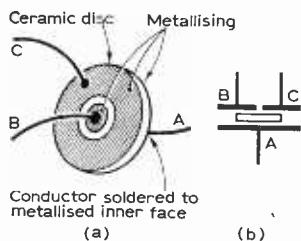

Fig. 3: The nature of a disc transfilter (a) and its symbol (b)

Fig. 4: (extreme right) A transfilter i.f. coupling, using the piezoelectric transformer principle.

The primary filter section consists of the piezo action between the fully metallised face and the metallised inner area on the opposite side of the disc, while the effective secondary is between the fully metallised face and the outer metallised ring.

TRANSFORMER ACTION

The ceramic is dimensioned to be mechanically resonant to the i.f. Thus, in the presence of an i.f. signal the primary section of the filter will vibrate, and similar vibrations will be incited into the secondary section, across the faces of which will develop the "transformed" i.f. signal. It will be understood, of course, that the secondary section vibrations are translated into corresponding signal voltage by the piezoelectric effect.

Apart from tuning the amplifier, conventional i.f. transformers also serve as matching devices between, say, the collector of one transistor and the base of the subsequent stage. Ceramic transformers, or transfilters, can also satisfy this matching requirement. This is because the mechanical impedance, and consequently the electrical impedance, of the primary can be made different from that of the secondary. Transfilters are generally employed in transistor circuits, and are thus designed to have collector-to-base matching impedances.

Figure 4 shows the circuit of a transfilter coupling between two transistor i.f. amplifiers. Ordinary transformer windings, of course, possess d.c. continuity, but since transfilters fail to have this attribute, collector resistor R_c is necessary. In the base circuit connection is direct, along with the base potential-divider resistors. This is also seen at the collector in Fig. 2. To an extra matching artifice, it is sometimes necessary to introduce a little capacitance in the base circuit, between the transfilter and transistor.

OVERTONES

Like quartz crystals, ceramic filter elements have so-called secondary modes of vibration or resonance, termed *overtones*. In filter applications these can cause trouble by creating unwanted i.f. responses, but a practical way of overcoming this problem is to make the first coupling a conventional i.f. transformer, say, between the frequency changer and the first i.f. stage. This provides unwanted signal rejection in the order of 60dB, sufficient for most purposes.

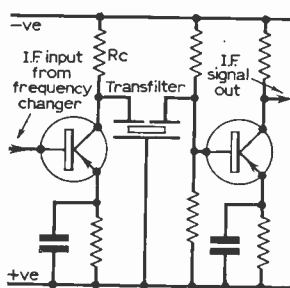

It is not uncommon, incidentally, for the filter elements to be dimensioned for the main resonance to fall at half the required i.f. The first overtone is then used to give the nominal i.f. For example, the filters may be cut to resonate at 175kc/s, giving the first overtone at 470kc/s.

The reason for this is that a filter cut for a fundamental resonance of 470kc/s would be only one-eighth of an inch in radius, which is rather small and difficult to handle. By reducing the fundamental frequency to 175kc/s, the radius is increased to about a quarter inch, which is more reasonable.

Another style of construction is shown in Fig. 5. A bar of ceramic is here used instead of a disc, and

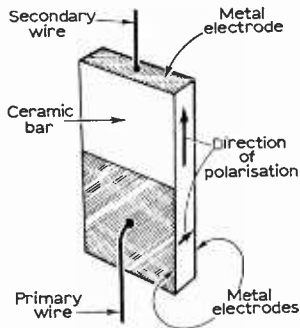

Fig. 5—An alternative method of ceramic transformer construction when a high, critical, step-up ratio is required.

its two major faces are metal coated over half their length. The third electrode is plated at the end edge of the other half of the ceramic. The section of ceramic sandwich between the two large electrodes is polarised in the thickness direction, while the uncovered section is length polarised.

This nature of construction has certain advantages for applications where large, critically valued step-up ratios are needed, having in mind that the voltage and impedance ratio bears a direct relationship to the dimensions of the effective primary and secondary sections of the ceramic.

In conclusion, it is interesting to reflect that piezoelectric ceramics are being used in applications requiring high voltage generation. One firm already holds a patent for ceramic car ignition systems, while ceramics are already being used for producing a large spark for lighting gas fires, the ceramic being stressed by advancing the gas regulator!

There is reason to believe that one day we may see piezoelectric ceramics as the prime element in television e.h.t. systems, especially in colour sets demanding 25kV or so of e.h.t. One thing about it, ceramic is a very good insulator! ■



||| MICROWAVE VALVES.
By C. H. Dix & W. H. Aldous. Published by Iliffe Books Ltd.
275 pages. Size 8½ x 5½. Price 55s.

MOST books on this subject have been directed at advanced students, but this time we have something intended for those educated to graduate or HNC level. It follows the predictable (and perhaps inevitable) pattern of discussing first principles and developing into an examination of the various types of microwave valves and their construction and applications. The authors keep well in mind the level for which they are writing and restrict mathematics only essential to an understanding of the principles involved. This is a welcome addition to radio literature, in particular to one of the few remaining fields in which the thermionic valve still reigns supreme.—*LB.*

||| TRANSISTOR BIAS TABLES.
By E. Wolfendale. Published by Iliffe Books Ltd. 71 pages.
Size 9½ x 7½. Price 21s.

THIS is actually a collection of accurately computed tables for those engaged on designing transistor amplifiers. The tables can be used either directly, to provide the values of the three resistors required for the conventional bias circuit, or as a starting point for more detailed bias circuit analysis. Six introductory pages outline the aims of the tables and describe their use. Eleven values of collector current are given and for each there are five values of supply voltage each occupying a full page. Other data includes the values of transistor parameters in conventional bias circuits and the

range of junction temperatures over which the transistor is required to operate. The complex calculations were achieved using a digital computer. A great time saver for the designer.—*WNS.*

||| QUESTIONS AND ANSWERS ON AUDIO.
QUESTIONS AND ANSWERS ON TRANSISTORS.
QUESTIONS AND ANSWERS ON ELECTRONICS.
QUESTIONS AND ANSWERS ON RADIO AND TELEVISION.
Published by George Newnes Ltd. Price 8s. each.

THIS set of four volumes are compact pocket books, size 6½in. x 4½in. in stiff covers, running to around 100 pages or more. The format is identical in that each chapter consists of set question followed by explanatory text. While the reviewer is not particularly enamoured of the Q and A approach, it must be admitted that the style does not jar so much as usual, probably because the Q's are single-line only.

The first three volumes are written by Clement Brown and the fourth by H. W. Hellyer. In all cases the material does what it sets out to do in providing an easily readable account of the subject matter by packing in a considerable amount of very useful information in the space provided. Although the approach in general is for the lesser experienced reader, no one need feel ashamed to be seen dipping into these pages for the level of writing is commendably high. But undoubtedly these pocket books are ideal for those just embarking on the subjects and can be thoroughly recommended. The price, too, is commendably cheap.—*NWS.*

BBC V.H.F. SOUND BROADCASTING STATIONS

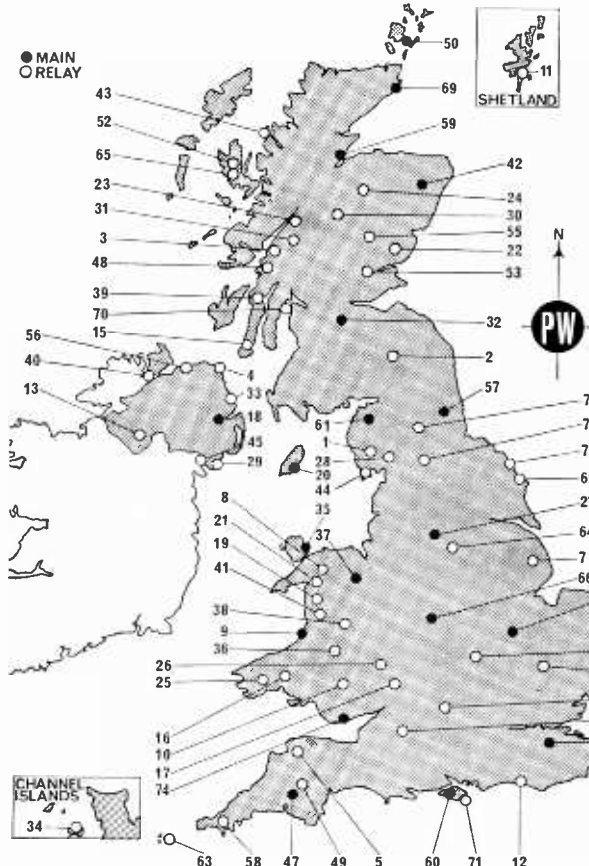

Location	Version of Home Service	Frequencies (Mc/s)			Max. ERP †
		Home	Light	Third	
27 Holme Moss	North	93.7	89.3	91.5	120kW
28 Kendal	North	93.1	88.7	90.9	25W*
29 + Kilkeel	N. Ireland	93.2	88.8	91.0	25W*
30 + Kingussie	Scottish	93.5	89.1	91.3	35W*
31 Kinlochleven	Scottish	94.1	89.7	91.9	2W
32 Kirk o' Shotts	Scottish	94.3	89.9	92.1	120kW
33 Larne	N. Ireland	93.5	89.1	91.3	15W*
34 Les Platons	West	97.1	91.1	94.75	1.5kW*
35 Llanddona	Welsh	94.0	89.6	91.8	12kW
36 Llandrindod Wells	Welsh	93.5	89.1	91.3	1.5kW
37 Llangollen	Welsh	93.25	88.85	91.05	10kW*
38 + Llanidloes	Welsh	92.5	88.1	90.3	5W
39 + Lochgilphead					
40 Londonderry	N. Ireland	92.7	88.3	90.55	13kW*
41 Machynlleth	Welsh	93.8	89.4	91.6	60W*
42 Meldrum	Scottish	93.1	88.7	90.9	60kW
43 Melvaig	Scottish	93.5	89.1	91.3	22kW*
44 Morecambe Bay	North	94.4	90.0	92.2	4kW*
45 Newry	N. Ireland	93.0	88.6	90.8	30W*
46 + Northampton	Midland	93.3	88.9	91.1	60W*
47 North Hessary Tor	West	92.5	88.1	90.3	60kW
48 Oban	Scottish	93.3	88.9	91.1	1.5kW
49 Okehampton	West	93.1	88.7	90.9	15W*
50 Orkney	Scottish	93.7	89.3	91.5	20kW*
51 Oxford	{ Midland West	{ 93.9 95.85	89.5	91.7	22kW*
52 Penifiler	Scottish	93.9	89.5	91.7	6W*
53 Perth	Scottish	93.7	89.3	91.5	15W*
54 Peterborough	Midland	94.5	90.1	92.3	20kW*
55 Pitlochry	Scottish	93.6	89.2	91.4	200W*
56 + Portrush					
57 Pontop Pike	North	92.9	88.5	90.7	60kW
58 Redruth	West	94.1	89.7	91.9	9kW*
59 Rosemarkie	Scottish	94.0	89.6	91.8	12kW*
60 Rowridge	West	92.9	88.5	90.7	60kW
61 Sandale	{ Scottish North	{ 92.5 94.7	88.1	90.3	120kW
62 Scarborough	North	94.3	89.9	92.1	25W*
63 + Scilly					
64 Sheffield	North	94.3	89.9	92.1	60W
65 Skriaig	Scottish	92.9	88.5	90.7	10kW*
66 Sutton Coldfield	Midland	92.7	88.3	90.5	120kW
67 Swingate	London	94.4	90.0	92.4	7kW*
68 Tacolneston	Midland	94.1	89.7	91.9	120kW
69 Thrumster	Scottish	94.5	90.1	92.3	10kW*
70 Toward	Scottish	92.9	88.5	90.7	250W*
71 + Ventnor					
72 Weardale	North	94.1	89.7	91.9	100W*
73 + Wensleydale/Swaledale					
74 Wenvoe	{ Welsh West	{ 94.3 92.125	89.95	96.8	120kW
75 + Whitby	North	94.0	89.6	91.8	40W*
76 Wrotham	London	93.5	89.1	91.3	120kW

Location	Version of Home Service	Frequencies (Mc/s)			Max. ERP †
		Home	Light	Third	
1 + Ambleside					
2 Ashkirk	Scottish	93.5	89.1	91.3	18kW*
3 + Ballachulish					
4 Ballycastle	N. Ireland	93.4	89.0	91.2	40W*
5 Barnstaple	West	92.9	88.5	90.7	150W*
6 + Bath	West	93.2	88.8	91.0	35W*
7 + Belmont	North	93.1	88.8	90.9	15kW*
8 + Betws-y-Coed					
9 Blaen-plwyf	Welsh	93.1	88.7	90.9	60kW
10 Brecon	Welsh	93.3	88.9	91.1	10W*
11 Bressay	Scottish	92.7	88.3	90.5	10kW*
12 + Brighton	West	94.5	90.1	92.3	25W*
13 Brougher Mountain	N. Ireland	93.3	88.9	91.1	2.5kW
14 Cambridge	Midland	93.3	88.9	91.1	20W*
15 + Campbelltown					
16 Carmarthen	Welsh	92.9	88.5	90.7	10W*
17 Churchdown Hill	Midland	93.4	89.0	91.2	25W*
18 Divis	N. Ireland	94.5	90.1	92.3	60kW
19 + Dolgellau	Welsh	94.5	90.1	92.3	
20 Douglas	North	92.8	88.4	90.6	6kW*
21 + Ffestiniog					
22 Forfar	Scottish	92.7	88.3	90.5	10kW*
23 Fort William	Scottish	93.7	89.3	91.5	1.5kW
24 Grantown	Scottish	94.2	89.8	92.0	350W*
25 Haverfordwest	Welsh	93.7	89.3	91.5	10kW*
26 Hereford	Midland	94.1	89.7	91.9	25W*

* Directional aerial.
 + Station not in service at date of issue of this sheet; where frequencies or ERP are not shown, these are not finalized.
 † ERP figures given are the same for each programme.

A Question of Phonetics

THANK you for publishing my letter in the November issue. I would like to mention, however, that the NATO alphabet is uniform, whereas that used by amateurs varies considerably. For instance, I heard a Ham on 80m using very different phonetics when repeating his call sign in the same transmission.

Charles Mitchell. Oxford.

I SHOULD like to point out that amateurs do not use a definite phonetic alphabet. It seems to me that they use the first word that comes into their heads. The phonetic alphabet contained in the Geneva Radio Regulations 1959 has been very carefully compiled to reduce ambiguity to a minimum, and I think it would be wise policy for Hams to adopt this alphabet.

E. R. Lisle. Maidstone, Kent.

I WOULD like to make it clear that the NATO code is used by all Marine radio operators, both on ship and on shore stations, throughout the non-Communist area of Europe. When you include all the fishing vessel skippers who use the M.F. R/T channels, those in favour of Mr. Mitchell's theory are considerably in excess of your estimate. Surely, it would be fairer to do as Mr. Mitchell suggests and have the amateurs fall in line and use the NATO code. It is, after all, a very good, easily understood one and at least has the advantage of being "standard" and not subject to local or regional variations.

G. M. Christie. Orkney, Scotland.
2nd Engr. Officer.

WITH reference to your comment on Mr. Mitchell's letter, another quick count would reveal that most Hams use numerous words for the same letter. For their own benefit, I suggest they start using the officially recognised handbook.

N. Farrand. Mansfield, Nottinghamshire.

I WAS amazed by your comment on Mr. Mitchell's letter. The differentiation of letters by phonetics is by sound. Many different letters have a similar phonetic sound and vice-versa. The purpose of the NATO system is to minimise ambiguity of sound. The phonetics were chosen by people who knew what was necessary to achieve the object: (a) no phonetic can be confused with another of this system; (b) the choice of words is such that each is intrinsically clear.

R. W. Goulden. Harrogate, Yorkshire.

NEWS AND..

TOOL KIT FOR TRANSISTORISED CIRCUITS

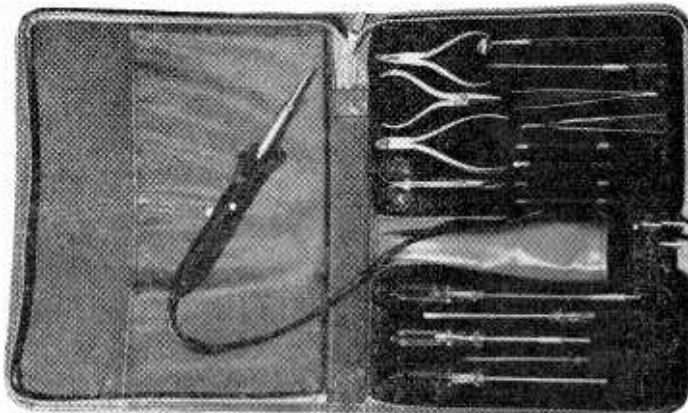

This Transistor Tool Kit 1900 TR contains 18 tools held in cut-out plastic foam to eliminate retaining straps. The selection includes a 14 mm magnifying contact mirror, a 30W soldering pencil, a flexible screwdriver, a screw-positioner, hook tweezers for removing excess solder and a special side cutting nipper. Amongst the more conventional tools are miniature screwdrivers in five sizes, 2 sizes of grub screw screwdrivers and one for Phillips screws, a crown shear and two pairs of specially shaped electrician's pliers.

The complete kit weighs just over 2lbs. and measures 10 x 13 x 1½ in. A large pocket is provided for documents and there is ample room for small additional accessories. The price is 10 guineas, from Henri Picard & Frere, Ltd., 34/35 Farnival Street, London, E.C.4.

STC ENTERS HOBBIES MARKET

Standard Telephones and Cables Limited, has acquired the business patents and other assets of Electroniques (Felixstowe) Limited, and has incorporated this enterprise into a new fully comprehensive electronic component/equipment supply service.

Operating under the name Electroniques (proprietors STC Ltd.), this service is part of Electronic Services Division—STC, the "same-day despatch" organisation formed in January 1965 which supplies industry with components by return of post.

A logical development of this industrial venture, Electroniques offers to hobbyists a similar service covering a vast selection of equipments, test sets, modules, components, tools and accessories.

The address for enquiries regarding the Electroniques hobbies supply service is: Electroniques (proprietors STC Ltd.), Edinburgh Way, Harlow, Essex.

STEREO DECODER FROM HEATHKIT

From Daystrom Ltd. of Gloucester comes the Heathkit f.m. stereo decoder SD-1. Audio frequency response is $\pm 2\text{dB}$ 50c/s to 15c/s. Output impedance (each channel) 20k Ω . Output voltage (each channel) 250mV. Input signal voltage 0.4V min. from discriminator output of f.m. tuner. Channel separation (1kc/s) 30dB. Hum and noise level—55dB. Transistor complement 7 x 2N2712. Dimensions 3½ x 3½ x 9in. Power requirements 105–125 and 210–250V a.c. 50–60c/s 10W. Price is £8 10s. (kit) or £12.5s.

...COMMENT

THOSE JAP TWO-WAY RADIOS

"At last, the P.M.G. has been able to initiate a successful prosecution of a user of a Jap walkie-talkie outfit. Though the defendant got away with a magisterial admonition and the payment of costs, the point was finally established that the operation of these sets—which work in the 27 Mc/s band—is illegal. The case gained wide publicity, which might have the effect of warning dealers not to sell them to the general public. Indeed, dealers are well aware that their use is prohibited—except by licensed amateurs in our 28Mc/s band—so that anyone prosecuted in future could almost certainly sue the dealer who sold him the thing, and recover damages and costs."—"Short Wave Magazine" November, 1966.

NEW TAPE RECORDER FROM ELIZABETHAN

The LZ 612 tape recorder, made in Britain by Elizabethan Electronics has an output of 5W. Mic. input impedance is 400Ω at 200μV. Radio input 100kΩ, 80mV, Pickup input 330kΩ, 300mV. Monitor output 10kΩ, 300mV. Power output 5 watts—push-pull Class "B" output stage. Semiconductors used are BC109+3, AC128+6, OC81, AC127, AD161, AD162, OA81 diode for the tape and power amplifier unit and BC113, BC115, BZX17 diode for the power supply unit (mains).

Playing time is 2 x 30 mins. with C.60 Cassette, 2 x 45 mins. with C.90 Cassette. Loud speaker is a 10in. Goodmans. Hi flux 11,000 lines/sq.cm. Bass Res., 55c.p.s. Geon damped curvilinear cone. Dimensions are 17½ x 12½ x 7½in. deep. Weight is 18lbs. less battery. The LZ612 retails at 45 guineas.

SIMPLIFIED SOLDERING

Multicore Solders Ltd. have published a new booklet entitled "Hints on Soldering". The purpose of the booklet is to demonstrate to handymen and others that soldering is straight forward and not a difficult operation providing a few simple basic rules are followed. It is distributed to the public through the trade.



TRANSMITTING STATIONS FOR BELGIUM

Two 30 kilowatt h.f. Marconi Self-Tuning (MST) radio transmitters are to be installed at Belgium's advanced communications centre at Ruiselede. These self-tuning transmitters are fully automatic and will be remotely controlled over land lines from a centre three kilometres away.

An Offer to Readers

BACK in 1918 my late father became interested in radio, and as much as a later generation of amateurs did after the last war, he acquired a considerable quantity of World War I ex-WD radio material—field receiving sets, transmitters, valves, and so on. A fair amount of this stuff has been stored in my attic for many years.

I shall shortly be moving to a smaller house and the attic must be cleared. I am writing therefore to ask if you could suggest a club, institution or other body likely to be interested in acquiring this old material. I am not expecting money for this material, but would be very happy to donate it to a suitable recipient.

W. Lloyd-Thomas.

South Wales.

[If any organisation is interested in any of this equipment for their museums, etc., would they please write to me so that suitable applicants may be put in touch with Mr. Lloyd-Thomas—Editor.]

Great Circle Calculations

REGARDING the article by W. E. Rigg. 9J2AA, in the August issue, I have been able to secure the Weir Charts mentioned in the article. They are obtainable from any Admiralty chart dealer and are numbered: 5000. Modified Weir 0° to 65° and 5001. Modified Weir 65° to 80°. Both these charts are large, but smaller ones can be obtained viz., 5000A and 5001A. Also a description on page 97 of "The Admiralty Manual of Navigation" Vol. III.

F. A. Connop Behenna,
B.R.S. 20042.

Swansea,
S. Wales.

19 Set for V.H.F.

From recent correspondence in our magazine, I understand several readers are interested in the v.h.f. frequencies. I also understand that most surplus gear for v.h.f. is crystal controlled. But these people can buy, for a small sum, the old 19 set and obtain wonderful results from the "B" set. On such a rig I have used plug-in coils—yes on v.h.f.!—and had marvellous results, with no other mods other than the changing of the little coil at the front of the set. I have also had this set down to the radio control bands, and very good it was, too.

T. Heslop.

Brandon,
Co. Durham.

POWER SUPPLIES

by H. T. Kitchen

ALL electronic equipment requires a source of power without which it cannot function. It is not proposed to cover battery operation in this article, it is proposed instead, to examine mains power supplies in some detail because these can vary from the very simple to the very complex. There are also several fundamental requirements that are not always appreciated, or are overlooked, when designing a power supply.

Where valves are concerned, the power supply will have to provide a low voltage for the filaments, usually 6.3V. It may have to provide the voltage in one of several ways; floating, i.e. neither side connected to chassis; centre-tapped, i.e. the winding is in two halves, the centre being connected to chassis; or simply with one end connected to chassis and the other used to feed the filaments. If a filament winding has no centre tap it is possible to provide an artificial centre tap by connecting two 47Ω or 100Ω resistors across it in series, using their junction as the centre tap. A potentiometer can fulfill the same purpose with its wiper connected to chassis, in which case the "centre tap" can be varied so that either end of the winding can be earthed at will, or it can be set at any intermediate position desired. This potentiometer is known as a "humdinger" and can be used to minimise hum signals flowing in the circuit. A leakage from heater to cathode or heater to grid would allow these hum signals to flow, as would siting of the heater wires near a low signal level grid. The humdinger minimises hum by introducing a voltage of opposite phase, to cancel out the original offending signal.

Valves also require a source of high tension voltage which must be rectified by means of a valve or metal rectifier (in this context the term "metal" includes selenium, silicon and germanium, fed from a suitable high voltage winding on the mains transformer. (Universal or a.c./d.c. power supplies which do not use a transformer will be covered later in the article.) The primary requirements of this rectifier is that it should be able to handle the voltage fed into it, and supply the current demands of the circuit it supplies. There are three main ways of converting the AV fed to the rectifier into the DV required by the circuits (1) half wave (2) full wave and (3) bridge; see Fig. 1. The circuit configuration is independent of the type of rectifier, apart from the heater supply required by the valve. In all cases the output from the rectifier is positive, though it can if necessary, be reversed so that its output is negative. Its action is to remove one of the peaks of the alternating voltage fed into it, leaving us with a pulsating DV output, that is in its present form, totally unsuited to feeding the majority of electronic equipment. This can be readily appreciated from Fig. 2 which shows the raw rectified AV input/output waveforms from a half wave rectifier.

Figure 3 shows the action of the full wave rectifier, from which it will be seen that the rectifiers conduct twice per cycle instead of once as in the half wave circuit. Consequently the output will consist of twice as many positive (or negative) peaks. The rectifiers do not conduct simultaneously, but conduct in anti phase, i.e., MR1 conducts when MR2 is non-conducting and vice versa. With the normal 50c/s mains the output from MR1, MR2 will pulsate at 100c/s.

VALVES OR METAL RECTIFIERS

The choice between a valve rectifier and a metal rectifier requires careful consideration as both have their advantages and disadvantages. For normal amateur usage, their voltage and current ratings can be regarded as being identical, so that the difference has to be resolved in terms of instantaneous current supply *at the moment of switching on*. The valve rectifier has a heater which requires a certain warming up time, which in the case of indirectly heated valves is quite appreciable, before the valve will conduct. The valves which form the load will also have been warming up at roughly the same rate, so that the output voltage at the rectifier's cathode will not differ very greatly at any given moment.

The metal rectifier does not have to be heated and conducts immediately the power is switched on. The valves forming the load will not have warmed up, so that the current drawn will be negligible, resulting in the h.t. voltage rising not to its working level but to a level of $AV \cdot \sqrt{2}$ which in the case of a 300V AV input will be 425V, until such time as the valves warm up and start drawing current. This is not the only disadvantage of the metal rectifier, for at the moment of switching on, the following reservoir capacitor will be discharged and will therefore act as a virtual dead short across the rectifier. The initial current surge will be limited only by the total series resistance as presented by the transformer winding, necessitating the inclusion of a surge limiting resistor either immediately preceding or following the rectifier. This current surge will take place with a valve rectifier if the power is switched off and then immediately switched on again, before the cathode has time to cool down. Failure of rectifiers is often accelerated by continual switching off and on without allowing adequate cooling down time.

Directly heated valve rectifiers fall midway between the metal and the indirectly heated valve types as far as current surges are concerned, and are more prone to failure with continual switching off and on as the DV power output is obtained from the heater itself, which will thus go open circuit.



Armstrong

TUNER-AMPLIFIERS WITH STEREO RADIO



- 227M MONO TUNER-AMPLIFIER £40 1 6
(illustrated)
- 127 STEREO TUNER-AMPLIFIER £40 1 6
(excluding stereo radio decoder)
- 127M MONO TUNER-AMPLIFIER £29 18 9
- OPTIONAL CASE teak and vinyl hide £3 10 0

Three tuner-amplifiers, identical in size and similar in styling, each with the same high performance AM-FM Tuner incorporated.

The 227M provides 10 watts power output whilst the 127M, with 5 watts output, is designed for those whose power requirements are more modest.

The 127 is the stereo version of 127M, having two amplifiers, each of 5 watts output.

All three have similar facilities; pickup and tape inputs, tape recording output, bass and treble tone controls.

M5 STEREO RADIO DECODER £14 10 0
Enabling any of our current stereo tuner-amplifiers and tuners to receive the BBC's new stereo broadcasts.

For full details and technical specifications of all models, plus list of stockists, post coupon or write mentioning 1 PW67.

ARMSTRONG AUDIO LTD
WALTERS ROAD, LONDON N7
telephone North 3213

NAME

ADDRESS

1PW67

Make Your Ability

PAY

UNLIMITED OPPORTUNITIES exist today for "getting on" . . . but only for the fully trained man. Let ICS's tuition develop *your* talents and help you to success.

STUDY IS EASY with ICS guidance. The courses are thorough. Printed manuals, fully illustrated, make study simple and progress sure.

YOUR ROAD TO SUCCESS can start from here—today. Complete this coupon and post it to us, for full particulars of the course which interests you. **MODERATE FEES INCLUDE ALL BOOKS.**

Take the right course now . .

ADVERTISING & ART
Copywriting, Cartooning
Layout and Typography
Commercial Illustrating
Oil & Water Colour

BUILDING & CIVIL ENG'NG
Architecture, Bricklaying
Building Construction
Builders' Draughtsman
Builders' Quantities
Interior Decoration
Quantity Surveying
Heating & Ventilation
Carpentry & Joinery

COMMERCE
Book-keeping
Accountancy & Costing
Business Training
Office Training
Purchasing, Storekeeping
Secretaryship
Shorthand & Typing
Computer Programming
Small Business Owners

DRAUGHTSMANSHIP
Architectural, Mechanical
Drawing Office Practice

ELECTRONICS
Computers
Electronic Technicians
Industrial Electronics

FARMING
Arable & Livestock
Pig & Poultry Keeping
Farm Management & Accounts

GENERAL EDUCATION
G.C.E. subjects at Ordinary & Advanced Level
Good English
Foreign Languages

HORTICULTURE
Home Gardening
Park Gardening
Market Gardening

MANAGEMENT
Business Management
Hotel Management
Industrial Management
Office Management
Personnel Management
Public Relations (P.R.)
Transport Management
Works Management
Work Study
Foremanship

MECHANICAL & MOTOR ENG'NG
Engineering Maths.
Diesel Engines, Welding
Industrial Instrumentation
Workshop Practice
Refrigeration
Motor Mechanics, etc.

POLICE
Entrance Examination
Police Promotion

PHOTOGRAPHY
Practical Photography

RADIO, TV & ELECTRICAL
Servicing & Engineering
Radio Construction (with Kits)
P.M.G. Certificates
Telecommunications
Electricians
Electrical Contractors

SELLING
Company Reps.
Sales Management
Marketing

WRITING FOR PROFIT
Television Scriptwriting
Short-story Writing
Free-lance Journalism

INTENSIVE COACHING for all principal examinations—G.C.E., Secretaryship, Accountancy, Engineering, Work Study, Management Radio, and Surveying. Special courses for G.C.E. French, German Oral Tests.

Member of the Association of British Correspondence Colleges

Start today the I.C.S. way!

INTERNATIONAL CORRESPONDENCE SCHOOLS
(Dept. 172)
Intertext House, Parkgate Rd., London, S.W.11

Send FREE book on.....

Name

Address

Occupation

1.67

INTERNATIONAL CORRESPONDENCE SCHOOLS

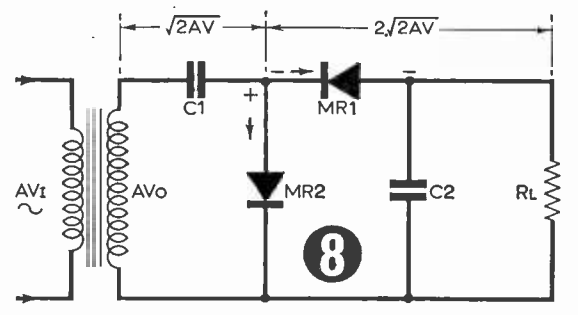
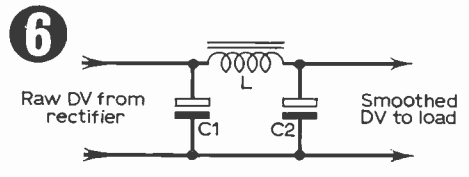
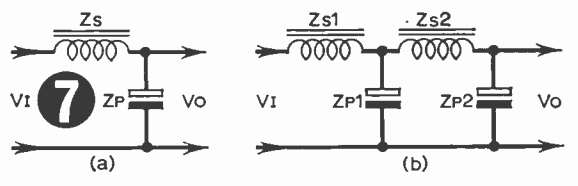
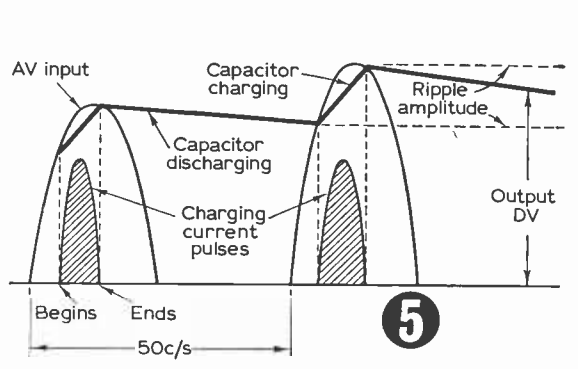
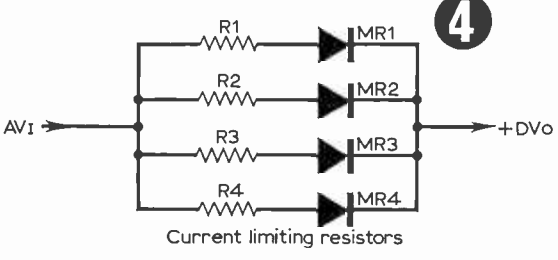
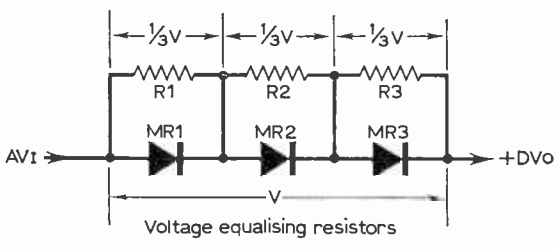
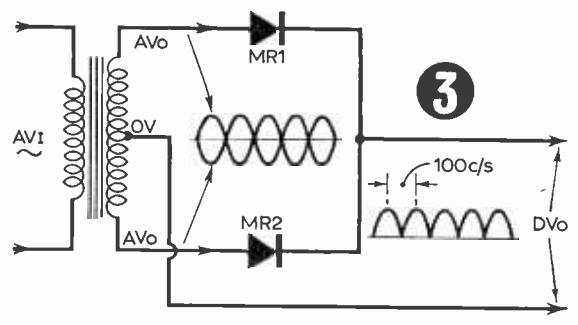
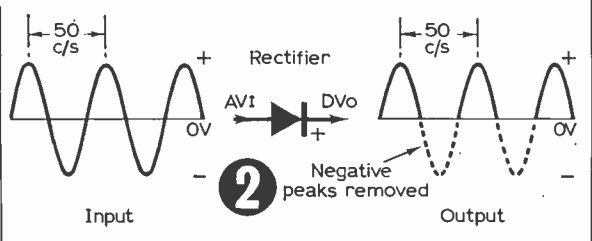
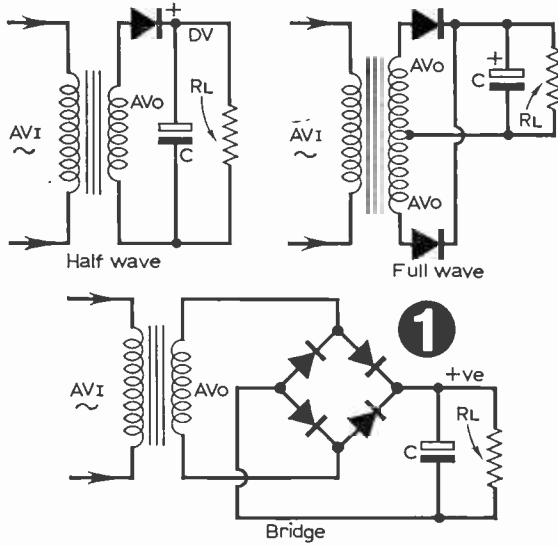

Fig. 1: Rectifier configurations.
 Fig. 2: Before and after with a diode in the line.
 Fig. 3: Ripple frequency after full-wave rectification is twice the original frequency.
 Fig. 4: Rectifiers in series and parallel.
 Fig. 5: Action of the reservoir capacitor.
 Fig. 6: Conventional π smoothing section.
 Fig. 7: Impedance considerations for the single section (a) and for the double section (b).
 Fig. 8: Simple voltage doubler.

Valve rectifiers are somewhat critical as regards siting and positioning unlike metal rectifiers, unless of the finned variety, which require proper positioning with the fins in a vertical position. The magnetic field from a mains transformer can be quite strong, and valve rectifiers are averse to being in a strong magnetic field. It is inadvisable to mount some types in a horizontal position as the internals can expand when hot, allowing parts to come into contact which would normally be kept apart if mounted correctly. If in doubt the maker's literature should be consulted.

SERIES OR PARALLEL

Rectifiers can be connected in series or parallel providing some simple precautions are taken to equalise the loading so that it is shared equally between the total number of rectifiers. With series connection, each rectifier should be shunted by a moderately high value resistor so that differences in forward/reverse resistances are minimised. With parallel connection each rectifier should have a series resistor carefully chosen to have negligible effect on the current drawn. By this means the current is distributed more evenly, the resistor serving to limit the current passed by any rectifier whose forward resistance may be lower than its fellows.

SMOOTHING

Whatever rectifying configuration we use we are still left with a DV that pulsates between its positive peak value and zero. In order to provide a more acceptable DV we may connect a capacitor across the output from the rectifier. This is C in Figs. 1 a,b,c, and its effect upon the pulsating voltage is illustrated in Fig. 5 in which the capacitor is charged to a value of $\sqrt{2} \cdot AV$ or to the peak value of the AV input during which time the rectifier passes current. The rectifier will not pass any current until such time as the instantaneous AV value exceeds the DV across the capacitor. This is where the resistor RL, representing the external load, comes in by discharging C, and sets into motion the following cycle of events. C is charged by every positive peak from the rectifier. On the negative swings the voltage starts to fall due to the lack of the charging pulses. The capacitor now starts to discharge into RL at the normal exponential discharge rate, so maintaining the DV at an average value less than its peak, but appreciably greater than zero, the actual value depending on the value of C and the current demands of RL. By making C very large or reducing I. RL and DV can be maintained at a level approaching the peak voltage. As the AV falls below the voltage across C, the rectifier current diminishes until it ceases completely when $AV = 0$.

The voltage across the rectifier differs appreciably when C is connected across the output. Without C, the maximum voltage across the rectifier is equal to AV but with C in circuit this increases to $2AV \cdot \sqrt{2}$ which is the sum of the DV and AV components, and is due to the fact that without C the

rectifier passes current during the positive peaks, but with C in circuit the current flows for only a short portion of each peak. During negative going peaks the current is supplied by C discharging into RL until it is met by the next positive peak which charges C again. Since the transformer supplies the current demands of RL it is necessary for the average value of the current pulse in each cycle to equal the mean current output, which requires a very large peak current value in relation to the mean current. All these effects are illustrated in Fig. 5.

IMPROVING THE SMOOTHING

We now have a partially smoothed pulsating DV supply which varies from the PK value of the AV input, to a value determined by CI where C is the reservoir capacitor and I the current drawn by RL. This is the amplitude of the ripple voltage, as the variations are termed, with the charge/discharge portions having a saw tooth appearance. Whilst this partially smoothed DV is obviously preferable to raw or unsmoothed DV for most applications, it is, as a rule unacceptable even in its present form, particularly when used to power equipment that handles low level signals. Stages that handle signals in the mV region obviously require an h.t. supply having a correspondingly lower level of ripple voltage if the output is not to contain a large percentage of h.t. induced hum. This additional smoothing can be provided in one of two ways. At one time the standard, if not only method, was by inserting an iron cored choke in series with the h.t. supply with a capacitor following, these components forming with the capacitor already present, a low pass π section filter which will be recognised as forming the conventional smoothing circuit. The operation of these components Fig. 6 is quite simple. C1 and C2 are made sufficiently large in capacity to present the ripple voltage with a low impedance path to earth, whilst the choke presents a fairly high series impedance to the same signal, having a very low ZF (zero frequency, i.e. d.c.) resistance in order to minimise the voltage dropped across it. LC smoothing can be very effective but it has the disadvantage that the current passing through the coil has a tendency to create a strong magnetic field in the vicinity of the choke. Although this may be of little consequence in some applications, there is a very real danger that nearby inductors may be within the range of the magnetic field which will not only have a steady state due to the passage of the ZF current, but also a field varying at 50c/s or 100c/s (depending whether half wave or full wave rectification is being employed). This field, which will be somewhat weaker than the steady state field, may react inductively with other inductors, such as tape replay heads, bass or treble boost coils, etc., and result in hum being introduced into the signal. The steady state field is not without its dangers since it can magnetize tape record replay heads with an attendant increase in the general noise level. Where such a choke is mounted close to the c.r.t. of an oscilloscope or TV receiver, the magnetic field can play havoc with the display. Care is therefore necessary when choosing the site for such a choke.

EXTRA SMOOTHING SECTIONS

It is possible to connect several such π sections in series where a really pure DV output is required, each section being considered as a divider network where a high impedance (the choke) is connected in series with a low impedance section (the capacitor) the ripple being reduced approximately by $\frac{1}{n} = \frac{Z_P}{Z_P + Z_S}$ where $\frac{1}{n}$ is the reduction factor and Z_p and Z_s the high and low or parallel and series impedance sections of Fig. 7. If two sections are placed in series with identical components, the degree of filtering afforded is given by $\frac{1}{n^2} = \frac{Z_{P_1}}{Z_{P_1} + Z_{S_1}} \frac{Z_{P_2}}{Z_{P_2} + Z_{S_2}}$. This process can be carried on indefinitely, in which case the degree of filtering will be equal to $\frac{1}{n^x}$ where x represents the number of sections.

When magnetic fields cannot be tolerated and the current demands are not excessive, the choke can be replaced by a resistor. Since the steady state DV and the ripple voltage are affected equally by such a resistor, it will be obvious that either the current drawn by the load will have to be limited or the value of the resistor will have to be kept as low as possible. Some compensation for a low value R can be had by making C_1 and C_2 larger in capacity when compared to the original LC configuration. The calculation of the reduction in ripple is complicated by the fact that the resistive and capacitive reactances are 90° out of phase and so we have to use vectors to arrive at an answer. For the curious, $\frac{1}{n}$ is equal to $\sqrt{\frac{\frac{1}{\omega C}}{R^2 + (\frac{1}{\omega C})^2}}$, though my own crude but effective method is to select R so that not too much voltage is lost and then pile on the capacitors! RC smoothing is free from magnetic fields but can generate much heat if an appreciable current is passed through R , and for this reason is mostly used on high voltage low current applications, such as smoothing out oscilloscope e.h.t. supplies where voltages are in the kV region and currents in the μA or mA region. Resistances are measured in $100k\Omega$ values and capacitors in $\frac{1}{10^5}$ of a μF .

VOLTAGE DOUBLER

We come now to an application where rectifiers not only provide DV from an AV input, but increase it as well, to twice the input voltage or even higher, but usually at the expense of a reduction in the amount of current that can be drawn from the input. The application concerns the voltage doubling, trebling, quadrupling, etc. configurations, of which the simplest, the doubler, is shown in Fig. 8. The operation of this circuit which rectifies the AV input voltage and increases it by a factor of $2\sqrt{2}AV$ is quite simple, and can be commenced at the moment the input to C_1 becomes positive. At this instant MR_2 conducts, placing a virtual short across C_1 which is charged to a voltage of $\sqrt{2}AV$. As the polarity to C_1 is changed to negative, MR_2 cuts off or does not conduct. MR_1 however is "facing" the right way and does conduct. Since C_1 has already been charged up by the

previous pulse, the output from MR_1 will consist of this voltage plus the transformer secondary voltage so that the final charge across C_2 is $2\sqrt{2}AV$. It must be remembered that C_1 is charged to the peak value of the AV, not to its RMS value.

The current output from a voltage doubler is limited not only by the transformer and MR_1 , MR_2 , but also by the value of C_1 and cannot therefore compare with voltage increases obtained by a straightforward voltage step up transformer. The idea can be extended indefinitely but, as would be expected, the increase in voltage is accompanied by a corresponding decrease in current. Assuming 100% efficiency (needless to say this cannot be achieved), the current is halved every time the voltage is doubled, thus keeping the wattage constant.

WATCH CURRENT AND VOLTAGE RATINGS

Although voltage doublers are most commonly employed in providing high voltage low current outputs, such as the e.h.t. supply for an oscilloscope where V is in the 1 to 3kV region and I around a mA, it is possible to use a voltage doubler to supply, say, 450v from the normal mains, at a current ranging from a few mA to 100mA or more. The value of C_1 can range between $0.1\mu F$ and $1.0\mu F$ for the oscilloscope e.h.t., to $100\mu A$ or more for the high current power pack. The capacitor used in this position must be rated at least $2\sqrt{2}$ the input voltage, so that a secondary having an output of 300V RMS would require C_1 to have a working voltage of at least 840V. It is not a bad idea to rate all components rather more conservatively than is absolutely necessary, as this improves the safety margin and leads to a longer and more reliable working life for the equipment as a whole. Thus a 1kV component for the previous example would be preferable to the bare minimum of 840V, whilst a 1.5kV component would double the safety margin.

The same remarks apply to the two rectifiers which should have adequate voltage ratings as well as the more obvious current ratings. During its conducting state MR_2 has to withstand the full peak voltage applied to it and during its non-conducting state the peak voltage, plus the voltage across C_1 . During its conducting state, the voltage applied to MR_1 is the PK.AV input plus the voltage across C_1 and during its non conducting state it has to withstand the PK.AV input until C_1 is charged up. Again, the principle of conservative rating is well worth applying.

The design of low voltage power supplies can be carried out along similar lines, as long as we bear in mind that the series impedance as represented by the choke or resistor must have a very low ZF resistance in order to minimise the voltage dropped across it. As a general rule, RC smoothing is uneconomical when applied to low voltage, high current, supplies because the DV dropped across it is "lost" as far as the terminal voltage is concerned. Where such a voltage loss is unacceptable resort must be made to LC smoothing. If the choke is

stern-clyne

ELECTRONIC CENTRES

MEMBER OF THE PANTIYA GROUP OF COMPANIES

LONDON:
18 Tottenham Court Road, W.1.
23 Tottenham Court Road, W.1
309 Edgware Road, W.2
109 Fleet Street, E.C.4.
182 Holloway Road, N.7.

MUS 5929/0095
MUSEUM 3451
PADdington 6863
FLEet Street 5812/3
NORTH 7941

DEPT. FW. 3-5 EDEN GROVE, HOLLOWAY, LONDON, N.7 Tel. NORTH 8161/5.
9 Camberwell Church Street, S.E.5. RODney 2875
220 Edgware Road, W.2. PADdington 5607
CROYDON: 12 Suffolk House, George Street, MUNICIPAL 3250
BRISTOL: 26 Merchant Street, Bristol 1. Bristol 20261

LIVERPOOL: 58 Lord Street.
MANCHESTER:
20/22 Withy Grove, M/c 4.
SHEFFIELD: 125 The Moor.
NOTTINGHAM: Eastown House, Lincoln St.

Royal 7450
Blackfriars 6379/5248
Sheffield 29993
Nottingham 45898

stern-clyne's NEWEST, GREATEST KIT... THE SULTAN solid-state integrated Stereo amplifier ★ 13 WATTS PER CHANNEL



The most advanced design in brilliant new kit form—so simplified you can build it to professional standards without specialized knowledge and with simple tools. Designed for kit builders from the beginning with a system of wiring that enables you to complete each solder joint as you proceed; nothing is soldered twice and there are no unfinished joints left waiting to be overlooked!

SULTAN performance is a natural result of superb design incorporating the most advanced fully proved semi-conductors, and modular substage construction that permits searching quality control and precise matching at every stage of assembly. Particular attention has been given to the provision of all the additional input, output, and power take-off facilities ever likely to be required. The compact sized, craftsman finished teak cabinet and restrained styling ensures unobtrusive, harmonious matching with almost any decor.

BRIEF SPECIFICATION:

13 watts per channel. Frequency response 30-20,000 cycles. Harmonic distortion less than 0.25% at full output. Crosstalk—better than 50 db at 1 kc/s. Hum and noise 52 db below full output. For 200/250 volts AC mains. Output suitable for 8 to 16 ohm speakers. Finished with Black/Silver mirror edge panel and complete in teak veneered case, size overall: 13 x 11 x 5 1/2 in. H.P. available.

Sultan kit of parts

£29.80

Carr. & Ins. 8/6

Assembled & tested

£39.18.0

Carr. & Ins. 8/6



57/6

Carr. 2/-

TEST 8 MULTIMETER

Compact all purpose tester with 12 specially selected ranges for all home and motor car wiring and servicing, amateur radio, TV fixing, electronic hobby work, etc. Extremely robust construction employs rugged large scale meter movement and plus in range selection to obviate switch wear defects and ensure trouble-free life. In tough metal backed impact resisting case. Ranges: 0-10-250-500-1,000v. A.C. and D.C. (sens. 1,000 ohms per volt) 0-1-250 mA D.C. current. 0-10,000-100,000 ohms resistance. Size only 4 1/2" x 3 1/4" x 1 1/2". Complete with test leads and battery.

stern-clyne's TREMENDOUS PRICE BREAKTHROUGH IN NEW UNIVERSAL RECORDING TAPES

- TENSILIZED, prestretched, extra strong
- Fully frequency spectrum response
- Guaranteed playing times

STERN-CLYNE make huge bulk purchases of recording tapes from the world's biggest manufacturers—and hand on the enormous price advantage to their customers. The quality is unequalled: Tensilized to ensure the most permanent type of base. Highly resistant to breakage, moisture, heat, cold or humidity. Highly polished, splice-free finish. Smooth output throughout entire audio range. Ideal for your most treasured recordings, cheap enough to use all the time. Double-wrapped—distinctively boxed. Available in both P.V.C. and Polyester qualities.

TENSILIZED P.V.C.	
3in. 250ft. Long Play	5 6
5in. 600ft. Standard	8 6
5in. 900ft. Long Play	10 0
5 1/2in. 1,200ft. Long Play	12 6
7in. 1,200ft. Standard	12 6
7in. 1,800ft. Long Play	15 0

TENSILIZED POLYESTER	
3 1/2in. 600ft. Double Play	11 6
5in. 1,200ft. Double Play	15 0
5 1/2in. 1,800ft. Double Play	22 6
5 1/2in. 2,400ft. Triple Play	37 6
7in. 2,400ft. Double Play	25 0
7in. 3,600ft. Triple Play	50 0

TRIPLE BARGAIN OFFER
3-Reel packs of 3in. Professional quality tape in self mailing boxes with fill-in address label on reverse. Works on all tape recorders. 200ft. per reel. Famous Audio Magnetic brand. P. & P. 1/6d. **13/6**

SEND FOR CATALOGUE

A 1/- P.O. brings new 100-page Sound & Science Catalogue packed with unique items; profusely illustrated.

★ FABULOUS microphone bargain!

TWO MICROPHONES, TWO STANDS
PLUS ACCESSORIES, COVER EVERY
MICROPHONE OCCASION

LOOK WHAT YOU GET

for only **£4.10.0** Carriage 7/6d.

1 STICK MICROPHONE

Superlative 5 in., wide-range crystal type in beautifully styled housing finished in black and gleaming chrome. Complete with braided neck cord, stand adaptor, and shielded lead.

2 LAPEL MICROPHONE

Super-slim, highly sensitive crystal microphone with gold anodized grille. Fitted with spring clip and complete with 40 in. lead and phono plug.

3 FLOOR STAND

Three-section heavily chromed tubular steel telescopic type with heavy cast base. Fitted with friction locks and threaded end for stand adaptor.

4 DESK OR TABLE STAND

Black crackle finish horseshoe base carries heavily chromed flexible swan-neck stem and fixed tube.



MONOGRAM AMPLIFIER & ACCESSORIES

Superb space and cost economy design specially developed by Mullard Research Laboratories and quality constructed by Stern-Clyne. Actually uses only one multivalve but provides an undistorted output from any standard xtal pick-up. Plus features include Bass Boost and Treble Cut controls, panel illumination and specially wound output transformer. Size only 10 x 2 1/2 x 4 1/2 in. High. Silver hammer chassis finish satin silver finish engraved panel.

Kit of parts **£4.10.0**

Carr. 4/6

Assembled and tested **£6.0.0**

Carrage 4/6

ACCESSORIES ONLY: Specially designed PCS Carrying case takes Monogram Amplifier, 8 x 5 Elliptical Speaker (illustrated) and any standard turntable or Autochanger. Size overall 18 x 16, 1/2 x 8, 1/2 in. Handsomely finished in dark grey fabric weave. PCS Case £3.5.0. Carriage 6/6d. 8 x 5 Speaker £1. Carriage 2/6d.

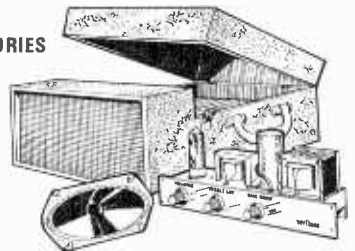

the versatile VERITONE 30 high power amplifier

- ★ for discriminating Hi-Fi
- ★ brilliant guitar reproduction
- ★ crystal clear P.A. for meetings, fetes, all outdoor activities



A magnificent professional instrument ● 30 WATT with a performance to satisfy the Hi-Fi enthusiast, plus superbly engineered construction and facilities that fulfil every amplifier need. Veritone 30 is packed with clean distortion-free power and a host of features found in amplifiers costing 3 times as much. It combines main amplifier, giving a true 30 watts output, preamplifier with two separately controlled mixer inputs. Volume, Bass and Treble controls, speaker impedance selection (3 or 16 ohms), and extra power supply outputs of 300 volts at 40 mA and 6.3 volts at 2A to drive auxiliary equipment. Veritone 30 is both an excellent rugged service PA amplifier, and the heart of a superlative Hi-Fi system. It makes an ideal basis for a guitar amplifier with inputs for 2 guitars.

£16.10.0

Carr. & Ins. 10/-

BRIEF SPECIFICATION

Inputs 10 mV and 100 mV for 60 watts at 1 kc/s. Response 25-20,000 c/s. Noise level -65 db at full output. Bass +11 db to -13 db. Treble +5 db to -15 db. Output imp. 3 and 15 ohms. Valves 2 x EF96, 2 x EL134, ECC83, C334. Power cons. 125 watt. Size 14 x 8 x 6 1/2 in. (7 1/2 in. with cover). Weight 21 1/2 lb. Silver grey hammer finish with silver perspex control panel carrying indicator lamp.

Optional top cover £1.15.0
H.P. available
Send for details

SUPERB NEW STERN-CLYNE FMI VHF TUNER

Specially designed for the Amateur builder, a new sensitive tuner unit that provides stable, interference-free reception of BBC FM transmissions. High quality output

signal ensures optimum performance from any Hi-Fi audio system; superb styling makes for harmonious installation with tuned equipment. Reliable easily altered circuit employs RF stage, tuning anode tuned grid frequency changer, 2 IF's Noise Limiter and Ratio Detector. Input sens. 100mV for 40 db. Distortion less than 1% at full deviation. Power req. 200v at 20mA and 6.3v at 1.8A. Panel black and silver grey, size 8 x 5 in.

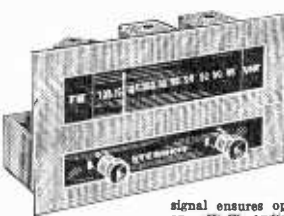

FM Kit of parts

£7.9.6

Assembled and tested

£10.9.6

Carriage 4/-

Optional Power Pack

Type D Kit of parts £2.15.0

Optional Power Pack

Type D Assembled £3.10.0

Carriage 3/6



39/6

Carr. 2/-

TEST 7 POCKET MULTIMETER

A really versatile instrument that makes a handy pocket-size tool. Measures AC or DC voltage in three ranges of 0-15-150-1000v. Resistance 0-1000,000 ohms, and Current 0-150 mA. DC. Size only 8 1/2 x 2 1/2 x 1 1/2 in., with ingenious dial design providing a clear, easily read scale. Complete with battery and test leads.

R.S.T. VALVE MAIL ORDER CO.

144-146 WELLFIELD ROAD, STREATHAM, S.W.16

Mon.—Sat. 9 a.m.
—5.45 p.m.
No Early Closing
Open Daily to Callers
Tel. STR 0199, 1649

All valves
brand new
and boxed

0A2	5/3	6BE6	4/8	6K6GT	5/-	7R7	18/6	19AQ5	7/6	50L6GT	6/-	DF96	6/-	ECF80	7/-	EM81	7/-	PCC189	10/-	S130	12/6	UM80	7/-
0C3	5/-	6BH6	7/-	6K7M	5/-	787	17/9	20D1	10/-	75	5/-	DH77	7/6	ECF82	7/6	EM84	7/6	PCC80	6/6	SP4	9/6	UC6	13/6
1A7	7/9	6BJ6	7/-	6K7G	1/3	7Y4	7/6	20F2	11/-	78	4/6	DK32	3/9	ECJ21	19/-	ESU150	27/6	PCP82	8/6	SP41	1/6	UU7	13/6
1D5	6/-	6BQ7A	7/-	6K7GT	4/6	9BW6	8/-	20L1	13/-	80	6/6	DK91	5/6	ECJ85	11/-	EY51	7/6	PCP84	8/6	SP41	1/6	UU9	8/6
1E5	7/6	6BR7	10/6	6K8M	8/6	10C1	9/6	20P4	12/6	85A2	9/6	DK92	8/6	ECH42	9/6	EY86	6/6	PCP86	8/6	SU25	19/6	UY21	7/6
1LD5	5/-	6BR8	7/6	6K9G	3/-	10C2	12/6	20P5	12/6	150B2	14/6	DK96	6/6	ECH81	5/3	EZ35	4/9	PCP81	9/9	SU2150	12/6	UY41	6/3
1N5GT	8/-	6BS7	16/6	6K9GT	8/3	10P1	12/6	25A6	6/6	150C4	12/6	DL70	7/-	ECH83	7/-	EZ40	7/-	PCF802	9/9	T41	9/-	UY85	5/-
1R5	5/-	6BW6	7/6	6K25	20/-	10P3	12/6	25L6GT	4/6	801	5/6	DL92	4/8	ECL80	6/6	EZ41	8/6	PCF805	10/9	T41D4	7/6	VPM49	17/-
184	5/-	6BW7	8/6	6L1	9/6	10F9	9/9	25Y5	6/-	807	7/9	DL93	3/6	ECL82	6/6	EZ80	5/6	PCF806	12/-	U14	7/6	VR105	30/-
185	3/3	6C4	1/9	6L6G	9/6	10L18	9/6	25Z4	8/3	813	80/6	DL94	5/9	ECL83	9/-	EZ81	5/6	PCF808	11/6	U19	30/-	VR150	30/-
174	2/6	6C5G	4/9	6L18	7/6	10L1	10/-	25Z6	11/-	954	4/-	DL96	6/-	ECL86	8/6	EZ86	8/6	PCL82	7/6	U19	30/-	VR150/30	5/6
3A4	8/6	6C6	3/6	6Q7G	5/6	10L11	10/-	25D7	5/-	1625	5/6	DM70	5/-	EF36	8/3	EZ87	8/6	PCL83	8/3	U25	9/6	VR150/30	5/6
3Q5	6/6	6C8G	6/-	6Q7GT	9/-	10P13	12/6	30C1	6/6	4022AR	15/-	DY86	6/6	EF37A	7/6	EZ88	8/6	PCL85	8/6	U25	9/6	VT25	29/-
384	4/6	6CH6	5/6	6S7	7/-	12A8H	15/-	30C15	9/9	5763	10/6	DY87	7/6	EF39	6/6	EZ89	8/6	PCL86	8/6	U25	11/6	VT31	59/-
3V4	5/9	6CW4	12/-	6SC7	6/6	12AT6	4/6	30C17	12/-	7193	1/6	ES8CC	12/-	EF41	8/6	EZ90	8/6	PEN44	20/-	U25	11/6	VU111	6/-
5E4G	8/6	6D6	2/6	6S7T	2/6	12AT7	3/3	30C18	10/6	7475	2/6	EAS2	2/6	EF42	8/6	EZ91	8/6	PEN45	20/-	U30	12/6	VU120	12/6
5L4G	4/-	6E5	5/9	6S7T	2/6	12A8T	2/9	30FL1	10/6	ATP4	1/6	EACB0	5/9	EF80	5/6	EZ92	8/6	PEN46	20/-	U30	12/6	VU508	30/-
5V4G	8/-	6E5	5/9	6SK7GT	4/9	12A8U	5/9	30L15	11/-	ATP5	7/6	EAF42	7/6	EF85	6/6	EZ93	8/6	PEN47	20/-	U403	6/6	VU508	30/-
5Y3GT	5/-	6F1	9/9	6SL7GT	4/9	12AX7	5/9	30L17	11/-	ATP7	4/8	EBA1	4/6	EF86	6/3	EZ94	8/6	PEN48	20/-	U801	18/6	W81M	5/6
5Z4	8/6	6F5G	4/-	6SN7GT	4/9	12BA6	6/6	30P12	8/6	AU2	30/-	EB91	3/6	EF89	5/6	EZ95	8/6	PEN49	20/-	U802	18/6	X79	41/-
6/30L2	9/9	6F8G	4/-	6SQ7	6/6	12C86	5/3	30P19	14/6	AU5	8/6	EBC33	6/6	EF91	3/3	EZ96	8/6	PEN50	20/-	U803	18/6	XB1-5	5/6
6A7	15/-	6R8G	4/6	6U4GT	10/-	12CB8T	7/6	30PL1	11/6	AZ1	8/6	EBC41	3/3	EF92	2/6	EZ97	8/6	PEN51	20/-	U804	18/6	XP1-5	5/6
6ASG	12/6	6F11	12/6	6U5G	7/6	12E1	19/6	30PL3	12/6	AZ31	7/9	EBC90	3/9	EF98	9/6	EZ98	8/6	PEN52	20/-	U805	18/6	XSG1-5	10/-
6AC7	3/-	6F13	5/6	6V6M	8/6	12F5GT	2/3	30PL4	12/6	CBL31	15/6	EBF80	6/6	EF99	9/6	EZ99	8/6	PEN53	20/-	U806	18/6	Y63	7/6
6AK5	4/6	6F14	12/6	6V6G	3/6	12G7GT	7/3	35A5	17/-	CK502	5/6	EBF83	7/6	EF98	9/6	EZ99	8/6	PEN54	20/-	U807	18/6	Y63	7/6
6AL5	3/-	6F23	10/6	6V6GT	7/6	12K7GT	3/6	35L5	5/9	CL33	12/6	EBF89	6/6	EF99	9/6	EZ99	8/6	PEN55	20/-	U808	18/6	Y63	7/6
6AM5	2/6	6G6	2/6	6X4	3/6	12K8GT	8/6	35W4	4/6	CY31	10/6	EBL1	17/6	EL33	17/6	EZ99	8/6	PEN56	20/-	U809	18/6	Y63	7/6
6AM6	3/6	6H6	1/3	6X5G	4/9	12Q7GT	3/6	35Z3	10/6	DAC32	7/6	EBL21	10/6	EL34	9/6	EZ99	8/6	PEN57	20/-	U810	18/6	Y63	7/6
6AQ5	5/6	6J5M	6/6	6X5GT	7/6	12RA7	8/6	35Z4GT	3/9	DAC91	3/3	EBL31	27/6	EL41	8/6	EZ99	8/6	PEN58	20/-	U811	18/6	Y63	7/6
6AST6	19/6	6J5G	2/6	7B6	11/-	12R87	6/6	35Z5	5/6	DAF96	6/6	ECC81	3/9	EL42	7/6	EZ99	8/6	PEN59	20/-	U812	18/6	Y63	7/6
6AT6	3/9	6J5GT	4/8	7B7	7/6	12SH7	2/9	37	5/6	DCC90	8/6	ECC82	4/9	EL43	4/6	EZ99	8/6	PEN60	20/-	U813	18/6	Y63	7/6
6AUB	6/-	6J6	3/6	7C5	10/6	12S17	3/9	42	4/6	DF3	8/6	ECC83	5/9	EL90	5/6	EZ99	8/6	PEN61	20/-	U814	18/6	Y63	7/6
6BR3	2/-	6J7M	8/6	7C6	6/6	12SK7	2/9	50B5	6/6	DF70	5/6	ECC84	5/6	EL95	6/6	EZ99	8/6	PEN62	20/-	U815	18/6	Y63	7/6
6B4G	10/-	6J7G	4/3	7D5	8/6	12SR7	5/6	50C5	5/9	DF91	2/6	ECC85	5/6	EL94	12/6	EZ99	8/6	PEN63	20/-	U816	18/6	Y63	7/6
6BA6	4/6	6J7GT	8/6	7H7	5/-	1287	20/-	50C6G32	6/6	DF92	2/6	ECC88	7/-	EM80	7/6	EZ99	8/6	PEN64	20/-	U817	18/6	Y63	7/6

SPECIAL 24 HOUR SERVICE

OBsolete TYPES A SPECIALITY

QUOTATIONS FOR ANY VALVE NOT LISTED

Postage 6d. per Valve C.W.O. No C.O.D.

Send S.A.E. for list

Manufacturers and Export Inquiries Welcome

Special 24 Hour
Express Mail
Order Service

SETS OF VALVES
DAF96, DF96, DK96, DL96 Set of 4, 24/6

BRAND NEW TRANSISTORS							
AC127	8/-	OC25	11/6	OC71	4/8	OC82D	6/-
AF11	7/-	OC28	16/-	OC72	4/8	OC83	6/-
AF115	7/-	OC35	9/6	OC75	6/6	OC170	7/6
AF116	7/-	OC44	4/6	OC76	6/6	OC171	7/6
AF117	5/-	OC45	3/6	OC77	8/6	OC280	8/-

PLEASE NOTE OUR NEW ADDRESS

PUBLICATIONS for the Radio Amateur & Short Wave Listeners

RSGB Publications

Radio Data Reference Book	..	12/6	(14/- post paid)
Technical Topics for the Radio Amateur	..	10/-	(10/8 " ")
Amateur Radio Call Book 1967	..	6/-	(6/6 " ")
Guide to Amateur Radio	..	5/-	(5/7 " ")
Radio Amateurs Examination Manual	..	5/-	(5/9 " ")
SSB Equipment	..	3/-	(post free)
Communication Receivers	..	3/-	(" ")

Log Books

RSGB Standard Log	..	6/6	(7/3 post paid)
Listeners and Observers Log	..	5/6	(6/3 " ")
Mobile Mini-Log	..	2/9	(3/3 " ")

Magazine Subscriptions (Monthly)

CQ	44/-	per annum
QST	43/6	" " "
73	30/-	" " "

Trade enquiries invited

Further details of other RSGB Publications, and information about membership of the RSGB including a free copy of the monthly RSGB Bulletin, may be obtained on request from the Society:

Other Technical Publications

Radio Amateurs Handbook 1966 (ARRL)	..	40/-	(44/- post paid)
Radio Amateurs Handbook 1966 Buckram bound	..	47/6	(52/- " ")
Transistor Radio Handbook (Editors and Engineers)	..	40/-	(42/- " ")
Outline of Radio and Television (Hawker-Newnes)	..	30/-	(34/6 " ")
Antenna Roundup Vol. II (Cowan)	..	28/6	(30/- " ")
Shop and Shack Shortcuts (Cowan)	..	28/-	(29/6 " ")
Antenna Roundup Vol. I (Cowan)	..	22/-	(23/6 " ")
Single Sideband for the Amateur (ARRL)	..	22/6	(23/6 " ")
Antenna Book (ARRL)	..	17/-	(18/6 " ")
Radio Amateurs VHF Manual (ARRL)	..	17/-	(18/6 " ")
Understanding Amateur Radio (ARRL)	..	17/-	(18/6 " ")
Parametric Amplifiers (73)	..	14/6	(15/- " ")
Radio Valve Data (Iliffe)	..	9/6	(10/6 " ")
Ham's Interpreter	..	8/-	(8/6 " ")
Guide to Broadcasting Stations (Iliffe)	..	6/-	(6/6 " ")
Radio Amateurs Operators Handbook (Data)	..	5/-	(5/6 " ")

RADIO SOCIETY OF GREAT BRITAIN

Dept. P.W., 28 Little Russell Street
London, W.C.1. HOL. 7373.2444

wound with heavy gauge wire, the ZF resistance can be made negligible whilst still maintaining a high inductive reactance to AV. Capacitances are generally much higher with low voltage supplies, values up to 5000 μ F are common. The rectifiers used for low voltage supplies are almost without exception of the metal variety, arranged either in a full wave or bridge configuration. The latter has the advantage that there are always two rectifiers in series at *any one instant*, and the maximum inverse voltage across any one rectifier out of a series pair is only half the terminal voltage. This makes it possible to use lower voltage rectifiers having correspondingly higher current ratings than would be possible with the normal full wave or half wave configurations.

REGULATION

The voltage output of a power supply is not fixed, but varies with the current drawn from it, the voltage falling with increasing current, until a limit is reached when no more current can be extracted *even if the output is short circuited to earth*. Since the output terminals of the supply are s/c to earth, it will be obvious that the resistance limiting the flow of current cannot be external to the power supply but must be integral with, or contained within, the power supply itself. This resistance is made up of the resistance of the transformers windings in series with the internal resistance of the valve. Although the overall internal resistance is more of academic than of practical interest, it is worth pursuing a little further because it affects the regulation of the power supply (which is the variation in terminal voltage caused by varying current) and that is one aspect that is of interest to many people, particularly those who are of an experimental turn of mind.

CALCULATING INTERNAL RESISTANCE

The internal resistance of a power supply can be considered as a resistance in series with the terminal voltage and can be calculated by a number of means. The obvious method of short circuiting the output terminals and measuring the flow of current is used for the low voltage batteries but is impractical and possibly destructive when applied to mains powered supplies. In any case it smacks of the "brute force and ignorance" technique and as such need not concern us further.

An alternative and more elegant way is to measure the terminal voltage for any given current drawn, and then measure it again at a different current. If we call the first voltage and current readings E^1 and I^1 and the second voltage and current readings E^2 and I^2 , the internal resistance will be given by the simple equation $\frac{E^1}{I^1} \times \frac{E^2}{I^2} = R$ (internal) where IR is the internal resistance. Let us take an example from a simple power pack the author uses for non critical applications. At a current output of 25mA the terminal voltage is 250V falling to 230V at

60mA. Substituting for E^1 I^1 and E^2 I^2 we have $\frac{250}{25} \times \frac{60}{230}$ or R (internal) = 38 Ω , to the nearest round figure.

Yet another method is to measure the open circuit terminal voltage with a low consumption voltmeter and then connect a load into circuit and measure, if possible, the instantaneous change in voltage. The voltmeter must have no overshoot and must respond very quickly if the reading is to have any pretensions

to accuracy. In this case R (internal) = $\frac{E^1 - E^2}{E^1} \times RL$

where RL is the external load resistance, and E^1 and E^2 the "before and after" voltages. In my own view the method is inferior (from the amateur's point of view, and excluding professional establishments) to the previous method since it relies on the operator having a very swift—and sure—hand and eye when reading and noting the voltage change, as well as on a suitable voltmeter.

CONSTANT VOLTAGE

If it is essential to maintain the output terminal voltage constant, irrespective of varying current demands, recourse will have to be made to a stabilised or regulated supply. A very simple and crude form of this would be a variable resistor in series with the output voltage which could be manually adjusted to maintain the terminal voltage reasonably constant. Such a device would be wasteful of power since the excess voltage has to be dropped across it, but even more serious is the fact that this device would be useful only if the rate of current change was slow enough to enable human mind and muscle to keep in step with it, quite apart from the fact that some means of indicating the varying voltage (or current) would be required. There is also the tedium of continually adjusting such a resistor to be considered, as well as the fact that human eye, mind and muscle can no longer be able to keep up with the rate of change should it become excessively fast.

A comparatively simple, but more effective and completely automatic means of maintaining a reasonably constant output voltage can be provided by a gas filled diode in series with a resistor, with the input applied across both and the output extracted across the neon Fig. 9a. If the unstabilised input voltage increases, the diode passes more current whilst the resulting voltage increase is dropped across R1. If the current output increases, the diode passes correspondingly less current, thus maintaining a reasonably constant output voltage.

There are a number of inherent disadvantages. The output voltage is fixed and cannot be varied, except by substituting another diode having a different working voltage. The maximum working voltage of a single diode is only about 150V (VR150/30 diode) though this can be increased by connecting a number of diodes in series, in which case parallel, voltage equalising resistors, across each diode are desirable, rather in the fashion of series connected rectifiers. The working voltage is usually lower than the igniting voltage, about 115V with a working voltage of 85V, so that sufficient voltage

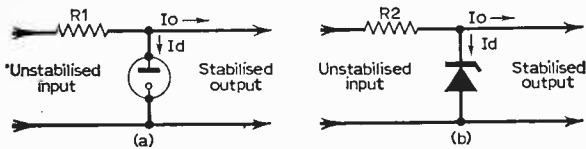

Fig. 9: Simple stabilisers: (a) thermionic or gas filled device; (b) Zener diode.

must be available, though this is not usually a serious matter. The lowest working voltage is in the region of 55V (Ferranti G55/1K diode) and there is no way of countering this. Finally, the range of control is somewhat limited by the minimum and maximum currents the diode can pass. Exceeding the maximum life will seriously impair the diode's working life and efficiency, whilst the effect of under running the diode will again impair its efficiency. If, as is common practice, the diode is decoupled by a capacitor, the effect of current starvation will probably cause the pair to act as a relaxation oscillator. A popular reference diode is the Mullard 85A2 with a working voltage of 85V and min. and max. currents of 1mA and 10mA respectively, between which the voltage change is 3V from the nominal. If the voltage change is to be kept within very close limits the current through the diode must be also closely maintained. For instance, at a steady tube current of 6mA. The voltage will remain constant with 0.5% for the whole of its working life.

LOW VOLTAGE STABILISATION

For the stabilisation of low voltages use can be made of Zener diodes. These are operated the "wrong way round", beyond the breakdown point, so that they pass very little current until the breakdown point is reached, after which they conduct heavily. Unlike gas diodes, Zeners do not require a higher igniting voltage, their igniting and working voltages are one and the same. In other respects, they can be dealt with in a similar manner to the gas filled diodes by selecting the series resistor to pass the appropriate current through the Zener and extracting the stabilised output from across it. Like gas filled diodes they do not permit any voltage variation, though a number can be connected in series.

It is possible to increase the regulated current output from both the gas filled diode and the Zener diode by replacing the former with a valve cathode follower and the latter by a transistor emitter follower. The stabilisation ratio, however, is comparatively low, commonly less than a factor of 10, with an output impedance in the case of the valve cathode follower of $\frac{1}{gm}$. The stabilisation factor can be increased greatly, by as much as several thousand times, and the output impedance reduced to less than an ohm by interposing a high gain error amplifier between the reference voltage and the output voltage variation. The differences between the two voltages are then amplified, and fed into the grid of the cathode follower valve, or, in the case of the transistor emitter follower, into the

base. Fig. 10 illustrates the basic valve regulator in which V1 is the series cathode follower or regulator valve, V2 is the high gain error amplifier and V3 the reference voltage diode. The operation of the circuit is quite simple and is as follows. The voltage across V1 controls the terminal or output voltage and is itself controlled by the negative grid bias derived from R1 which is the anode load of the error amplifier V2. The cathode of V2 is held at a constant potential by the voltage

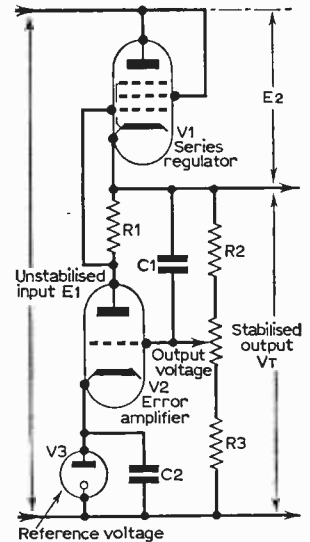

Fig. 10: Basic stabiliser circuit.

across the reference diode V3. The grid bias for V2 is derived from a potentiometer across the output voltage and is variable about the cathode potential. As the wiper of the potentiometer is rotated towards R3 the grid is made more negative than the cathode with a corresponding decrease in the anode current. A decrease in anode current is accompanied by a decrease in the voltage dropped across R1 which is passed to the grid of V1 as a positive bias voltage which causes the valve to pass an increased voltage. Conversely as the wiper is rotated towards R2 the grid of V2 is made more positive with respect to cathode, the valve passes more current, and the voltage dropped across R1 increases. The decrease in V2 anode voltage is passed to V1 grid as a negative bias voltage which causes the anode current to fall. Thus we can arrange for the terminal voltage to be varied within moderately wide limits.

VARYING CURRENT DEMANDS

The variation of terminal voltage with varying current demands is compensated for in a similar manner. Suppose that from a state of no load, the power supply is called upon to supply a sudden load. The terminal voltage will begin to fall, and a portion of the voltage change will be passed to the grid of V2 via the potentiometer. The valves bias will undergo a change as already described, resulting in a changed bias for V2 which will therefore pass an increased current to compensate for the sudden load. And, of course, the reverse will apply if a load is suddenly disconnected from circuit.

Since the circuit operates by amplifying changes in the output voltage, it will become apparent that this output voltage is continually varying, and that 100% regulation is never realised. If we call the voltage applied to the regulator valve E1 and the voltage dropped across the regulator valve E2 and the terminal voltage VT, the gain of the error amplifier n, we can calculate the correction voltage

—continued on page 690

MARTIN RECORDAKIT

designed specially for the MAGNAVOX 363

3 WATTS OUTPUT

3 SPEEDS: 7" REELS
OUTLET FOR HI-FI AMP

SOLDERING NOT
NECESSARY

SEPARATE RECORDING
LEVEL AND VOLUME
CONTROLS

You need a MARTIN RECORDAKIT to do full justice to this excellent deck. With it, you will have a 2 or 4 track instrument of outstanding quality and dependability. MARTIN RECORDAKITS consist of basic Martin units assembled and tested, making it necessary for you simply to fit and connect in accordance with the detailed instructions book supplied. When built, your 3 speed Martin Recorder appears as shown here. The lid is detachable. Case with speaker, and deck also available. Details on request. MARTIN RECORDAKITS have long been famous for their high performance standards, quality of materials, simplicity and dependability. The latest is the best yet.



AMPLIFIER 8328-A, with 5 valves in position, plus "magic eye" controls, switches, transformers, all leads, etc., with instructions FOR TWO TRACK OPERATION. £14.19.6

AMPLIFIER 8328-4A, Track Switch Assembly 7217-A and valves, etc., as above FOR FOUR TRACK OPERATION. £15.19.6

M2-M4 CONVERSION KIT
For converting two Track amplifier system used with a FOUR TRACK DECK to FOUR TRACK OPERATION. (Part 7217-A). £1.2.6

DE-LUXE CASE ASSEMBLY
Elegant 2-tone leatherette covered wooden case (type 6664-A) with high-quality acoustically mounted 8 in. x 5 in. speaker (to take two or four Track Deck). £7.7.0

COMPLETE RECORDAKIT M2
Assembly with Magnavox two Track deck and case ready for building. £34.6.0

COMPLETE RECORDAKIT M4
Assembly with Magnavox deck and case for four Track operation. £38.0.0

MARTIN AUDIOKITS FOR HI-FI

The uniquely reliable kits with "Add-on-ability"

No other system allows you to enlarge your installation stage by stage as Audiokits do. They comprise a wide range of very well made prefabricated transistorised units in which connections are standardised throughout and from which anything from a simple straight amplifier to an elaborate hi-fi stereo amplifier with F.M. tuner can be built. The Recordakit described above can be combined with your Audiokit assembly if you wish.

- 5-stage input Selector £2.7.6
- Pre-amp/vol. control £1.17.6
- Pre-amp/tone controls £3.2.6
- 10 watt amp. (3 ohms) £5.12.6
- 10 watt amp. (15 ohms) £6.12.6
- Mains power supply £2.15.0

THE UNITS THAT ENABLE YOU TO BUILD BY STAGES FROM PRE-AMP TO A HI-FI STEREO/FM ASSEMBLY

And now add F.M. radio to your MARTIN AUDIOKIT ASSEMBLY

with only 3 easy-to-assemble prefabricated units

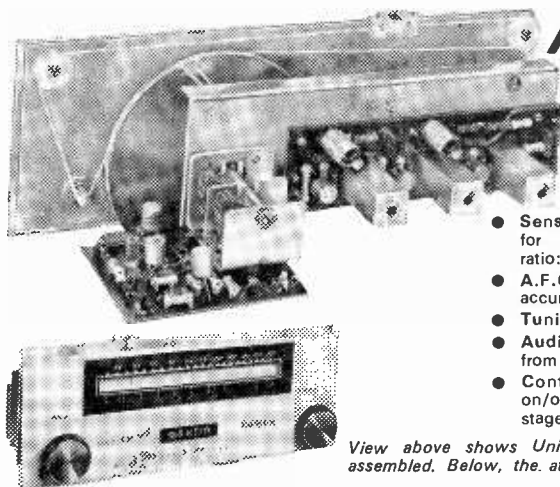

- Sensitivity—2 micro-V for 20dB signal/noise ratio: 5 micro-V for 40dB
- A.F.C. — ensures easy accurate tuning
- Tuning—88 to 108 Mc/s
- Audio Response—Flat from 30 to 15,000 c/s
- Controls—Tuning, and on/off with switch through stage for recording, etc.

View above shows Units 15, 16 and 17 assembled. Below, the attractive escutcheon.

UNIT 15
F.M. Head
& tuning
condenser
£5.12.6
plus 1/9
surcharge

UNIT 16
I.F. Amp. £5.7.6

UNIT 17
Mounting drive
escutcheon &
controls £1.17.6

SUPERB QUALITY FOR VERY MODEST OUTLAY

From Radio and Hi-Fi Stockists

Trade enquiries invited

MARTIN ELECTRONICS LTD. 154/5 HIGH STREET, BRENTFORD, MIDDLESEX. ISLWORTH 116112

The unique and outstandingly successful system developed by Martin Electronics whereby prefabricated transistorised units can be assembled to make your own choice of hi-fi now brings 3 further Units, No. 15, 16 and 17 to enable you to build a modern F.M. Tuner of exceptionally good design and performance. Intended primarily for those who have chosen an Audiokit hi-fi set-up, the Tuner may also be used with other good amplifiers if desired. With a few simple connections, you will have a tuner of excellent appearance to please the most critical ear, yet it is surprisingly inexpensive.

MARTIN ELECTRONICS

154 High Street, Brentford, Middlesex
Please send Recordakit/F.M. Tuner/Audiokit
Hi-Fi Leaflets. (Strike out items not wanted)

Name

Address

P.W.17

HIGH-Z SUB-MIN AMPLIFIER

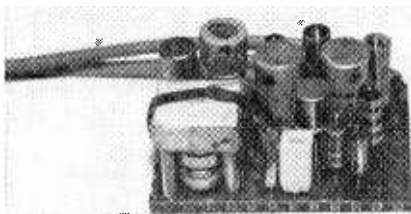

by F. L. THURSTON

ONE of the major disadvantages of the crystal microphone is that, if it is to give good reproduction at the lower audio frequencies without undue loss of signal strength, it must feed into a very high impedance load, preferably in the order of several megohms. At these high impedances, feeder lines, from the microphone to the amplifier, are very prone to stray signal "pick up" from unwanted sources, such as the mains, etc. To overcome this trouble, it is normal practice to use screened cable as the feeder, but, even so, trouble is still experienced, and the feeder lines have to be kept reasonably short, and the versatility of the crystal microphone is thus restricted.

If a low impedance load and feeder line can be used, however, very little trouble with unwanted pick up will be experienced, and very long cables can be used. Thus, one way of overcoming the disadvantage of the conventional crystal microphone is to build an impedance converter into the feeder line, preferably as near as possible to the crystal microphone, or, better still, in the actual microphone case. In this latter instance, the converter must be complete with batteries and on/off switch, and the whole unit must be exceptionally compact. The unit that forms the basis of this article meets this requirement very well.

This unit, shown in the photograph against a half-crown for size comparison, is complete with three miniature batteries and an on/off switch, but measures a mere $1\frac{1}{2}$ in. x $\frac{7}{8}$ in. x $\frac{3}{8}$ in., giving a volume of less than 0.7 cubic inches! A three transistor circuit is used, and the unit gives an input impedance of approximately 8M Ω .

Circuit Theory

As shown in Fig. 1, the equivalent circuit of a crystal microphone can be shown as a voltage generator in series with a small capacitance, usually in the order of 1,000pF. When the microphone is connected to a resistive external load, the resistance and this capacitor are effectively in series, and thus act as a potential divider network, but, as one

arm of this potential divider is reactive, the attenuation factor will vary with frequency, being greatest at the low end of the frequency spectrum. To give a reasonably linear response over the entire audio band, therefore, the impedance of the external load must be kept high, relative to the output impedance of the crystal microphone, at all operating frequencies. In practice, this means that the input impedance of the external load must be very high, in the order of 5M Ω or greater.

Having cleared up this point, we can now consider the means of obtaining this high impedance. Quite clearly, because of size limitations, transistor circuitry must be used; unfortunately, however, the transistor is basically a low impedance device.

The most basic way of obtaining a reasonably high input impedance, using transistors, is to employ the emitter follower mode of operation, as shown in Fig. 2a. Here, the input is applied to the base of the transistor, and the output is taken from the emitter: R1 is simply a base-bias resistor, while R2 forms the emitter load. The input impedance of this circuit is equal to the emitter load, R2,

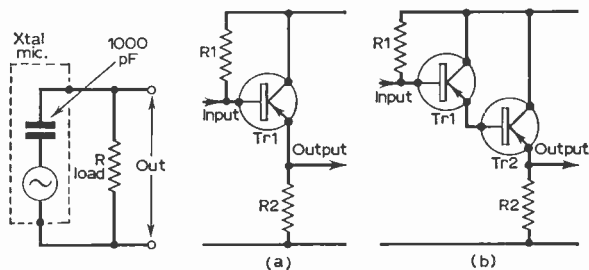

Fig. 1 (left): Equivalent circuit of crystal microphone feeding a resistive load.

Fig. 2a (centre): Emitter-follower circuit for high input impedance.

Fig. 2b (right): Super-Alpha pair for very high input impedances.

multiplied by the current gain of the transistor. Thus, with R2=10k Ω , and current gain=100, an input impedance 1 M Ω may be achieved.

In practice, the value of the emitter load has to be kept within reasonable limits, and the actual current gains of transistors are rarely greater than a few hundred, so that impedances of greater than a couple of megohms can rarely be obtained with this type of circuit. If greater impedances than this are required, the effective current gain of the transistor must be increased by artificial means, and the most popular way of doing this is shown in Fig. 2b.

Super-Alpha Pair

Here, two transistors are used, with the base of one connected directly with the emitter of the other, and the two collectors joined together. The resulting assembly forms a three terminal network, and can be regarded as a single transistor in which the effective current gain is the product of the two individual transistor gains, i.e., if both transistors have gains of 100, the effective gain of the pair is equal to 10,000. Because of the very high current gain that is obtained with this connection, the circuit is often known as the "Super-Alpha Pair". The only real snag with both the emitter follower

and the Super-Alpha pair is that the voltage gain of each circuit is very slightly less than 1; the power gain, however, is high.

In the two circuits that have been discussed so far, "ideal" conditions have been assumed as far as the input impedances are concerned, so as not to confuse the issues too much. In practice, of course, conditions are far from ideal, and matters are complicated by such details as the need for base-biasing networks, leakage impedances of the transistors, etc. These difficulties are made clear in Fig. 3a, which shows the effective input circuit of a practical emitter follower of Super-Alpha pair.

Here, Z_T = the transistors input impedance as calculated by the simple formula outlined above; unfortunately, this impedance is shunted by Z_B , the impedance of the base-bias network, and also by

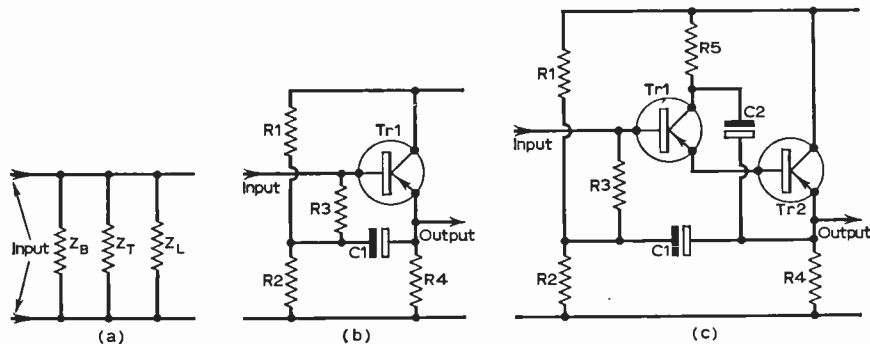

Fig. 3a: The effective input circuit of an emitter follower. Fig. 3b: "Bootstrapping", applied to the base-bias network. Fig. 3c: "Bootstrapping", applied to both Z_B and Z_L .

the internal leakage impedance, Z_L , of the actual transistor. Thus, the actual input impedance to the transistor input is equal to the value of all three individual impedances in parallel. To obtain really high input impedances, therefore, it is necessary to eliminate the effects of Z_B and Z_L .

Dealing first with Z_B , the method of overcoming the unwanted shunting effect of the base-bias network is shown in Fig. 3b. Here, the method is shown applied to an emitter follower circuit, although it can be applied equally well to the Super-Alpha pair. R_1 and R_2 are the base-bias resistors, using the potential divider method of bias, and R_3 is an isolating resistor interposed between the R_1 - R_2 junction and the base of the transistor. The signal input is applied directly to Tr_1 base. The output of the circuit is taken from across R_4 , the emitter load.

Circuit Action

When an input signal is applied to Tr_1 base, the output signal appears at the emitter in the same phase and at almost the same amplitude, so that, for practical purposes, it can be accepted that the two signals are identical in form. In Fig. 3b, the signal from Tr_1 emitter is fed, via the large capacitor, C_1 , to the junction of R_1 and R_2 ; thus, the same a.c. signal appears at each end of the isolating resistor, R_3 , and no a.c. current flows in that resistor. It follows that since no current flows

in R_3 as the result of the applied a.c. signal, that resistor must represent an infinitely large impedance to a.c., although to d.c. it appears as its normal value, and the shunting effect of Z_B is effectively overcome.

In practice, the isolating resistor will not appear as an infinitely large impedance, as the voltage gain of the emitter follower is slightly less than one. The impedance of the resistor is, however, increased by a substantial amount, and if, for example, the voltage gain of the emitter follower is 0.99 and the value of $R_3=100k\Omega$, the effective impedance of R_3 will equal $10M\Omega$, i.e., its effective value is increased by 100 times. This technique of increasing the apparent impedance of a component is known as "Bootstrapping".

A similar "Bootstrap" technique can be used to overcome the shunting effect of the leakage impedance, Z_L , as shown in Fig. 3c. Here, the effect of leakage is minimised by ensuring that, as far as a.c. is concerned, there is no voltage difference between the collector of Tr_1 and the emitter of Tr_2 , and an infinite impedance is thus represented between these two points. This is achieved

by connecting resistor R_5 between the collector of Tr_1 and the negative supply line, and feeding the a.c. signal from the emitter of Tr_2 to Tr_1 collector via capacitor C_2 . In this case, of

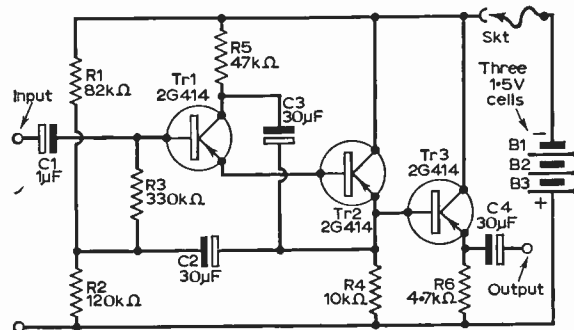

Fig. 4a: Circuit diagram of the complete unit. See text and Fig. 4c for details of Skt and battery holder.

course, the leakage impedance is normally high (in the order of a couple of Megohms) even without bootstrapping, so that effective leakage impedances in the order of hundreds of megohms can be obtained with little difficulty. In Fig. 3c the base-bias network is also shown Bootstrapped, and a super-alpha pair is used, so that the effective input impedance is virtually that obtained from the simple "emitter load x current gain" formula.

The Circuit

The circuit diagram of the sub-miniature high impedance amplifier is shown in Fig 4a, and con-

TRS

BARGAINS IN QUALITY KITS AND COMPONENTS



ANOTHER TAPE RECORDER BARGAIN

New re-designed contemporary Cabinet

Famous Manufacturers end of production Surplus Offer

A 24 gns. Tape Recorder offered at the fabulous bargain price of only 15 gns. + 12/6 Carr. Supplied in 3 Units already wired and tested—only simple inter-Unit connections necessary. A modern Circuit for quality recording from Mike, Gram or Radio, Incorporating the latest BSR Twin Track Monardeck Tape Deck Type TD2. Housed in attractive two-tone Cabinet of contemporary design, size 14" x 13 1/4" x 7 1/4" complete with Tape and Mike storage pockets.

Valve line up—EF86, ECL82, EM84, EZ80 and Selenium Diode.
Comprehensive facilities available:—

- ★ Straight through Amplifier provision.
- ★ Mike, Radio/Gram inputs.
- ★ Superimpose Recording.
- ★ Low level O/Put Socket for ext. Amp. Ext. Speaker Socket.
- ★ Conversion to 4 Track.
- ★ Monitoring facilities.

- Cabinet and 7" x 4" Speaker £3. 5.0 + 5/- Carr.
- Wired Amplifier complete with Record/Play-back Switching, 4 Valves, front Panel, Knobs etc. £6. 5.0 + 3/6 Carr.
- BSR Monardeck Type TD2 £7. 7.0 + 4/6 Carr.
- Accessories—Mike, Tape, empty Reel, screened Lead and Plugs, Instructions etc. £1. 0.0 + 2/- Carr.

**COMPLETE KIT comprising items above BARGAIN PRICE 15 gns. + 12/6 Carr.
ANY ITEM AVAILABLE SEPARATELY**

DE-LUXE RECORD PLAYER KIT

Incorporating 4 Sp. Garrard Auto-Slim unit and Mullard latest 3 watt printed circuit amplifier (ECL 86 and EZ 80), vol. bass and treble controls, with 8" x 5" 10,000 line speaker.
Contemporary styled 2-tone cabinet, charcoal-grey and off-white with matching blue-relief. Size 17 1/2" x 16" x 8". A stylish unit capable of quality reproduction. Circuit and const. details 2/6 (free with kit).



COMPLETE KIT £13.19.6
Carr. and ins. 12/6.
Ready wired 30/- extra. Illuminated perspex control panel escutcheon. 7/6 extra. Four contemporary mounting legs, 6in. 10/6; 9in. 11/6; 12in. 12/6 extra.

RECORDING TAPE SYNCHROTAPE

Bulk buying from a famous British Manufacturer has at last made possible the marketing of a superior grade Recording Tape at greatly reduced prices. Leader and Stop Foils on all types (except 3" size) Brand new, Factory fresh and attractively cartoned. Suitable for all Twin, 4 track or Stereo recordings. Unconditionally Guaranteed.

	Standard (PVC Base)	Long Play (PVC Base)	Double Play (Mylar Base)
3 in.	150 ft. 3/9	225 ft. 4/9	300 ft. 6/6
4 in.	—	450 ft. 9/6	600 ft. 13/9
5 in.	600 ft. 11/6	900 ft. 15/-	1200 ft. 23/6
5 1/2 in.	850 ft. 14/6	1200 ft. 17/6	1800 ft. 29/6
7 in.	1200 ft. 17/6	1800 ft. 22/6	2400 ft. 37/6

Triples Play—3 in. 450 ft. 12/6 4 in. 900 ft. 25/-
Post and Packing 3 in. Reels 6d. Each additional Reel 3d.
4 in. to 7 in. Reels 1/- Each additional Reel 6d.

EMPTY TAPE REELS (Plastic)
3 in. 1/3, 4 in. 2/-, 5 in. 2/-, 5 1/2 in. 2/-, 7 in. 2/3.
PLASTIC REEL CONTAINERS (Cassettes)
3 in. 1/3, 5 in. 1/9, 5 1/2 in. 2/-, 7 in. 2/3.

TRS STEREO DECODER KIT

Based on a Mullard design

Six Transistors, Printed Circuit size 5 1/2" x 2 1/2". Two stage transistor Stereo Beacon Indicator incorporated. 12v supply. Neg. Earth. Basic Kit supplied suitable for Transistor Tuner input and Transistor Amplifier output. With simple mods (data supplied with Kit) easily adapted for Valve Tuners and Valve Amplifiers. Kit and assembly instructions, complete with Mullard specified Inductors, Type WF2949 and WF2951. **Bargain £4.19.6d. Carriage 2/6.**

GOERLER CONTINENTAL STEREO DECODER

A ready built and aligned factory Unit 6 transistor plus 5 diodes designed to connoisseur standards. Size 4 1/2" x 3" ready for connecting to existing transistor tuner Multiplex O/P. 12v—18v supply. Full technical specification details S.A.E. **Price £9.10.0, plus 3/6 carriage.**

SINCLAIR KITS

We are Specialists, we carry full stocks of these world-famous all-British designs as advertised and give prompt delivery.

- MICRO-6 six stage vest-pocket rcvr. (kit) 59/6
- MICRO-FM seven transistor FM tuner-rcvr. (kit) £5.19.6
- Z.12 combined 12w. amp. and pre-amp. built 89/6
- STEREO 25 de luxe pre-amp/control unit (stereo) built £9.19.6

6 VALVE AM/FM TUNER UNIT

Med. 190 m., 650 m., V.H.F.—86 Mc/s-103 Mc/s., 6 valves and metal rectifier. Self-contained power unit. Magic-eye, 3 push-button controls, on/off, Med., V.H.F. Diodes and high output sockets with gain control. Illuminated 2-colour perspex dial 1 1/2 x 4in., chassis size 1 1/2in. x 4in. x 6 1/2in. Strongly recommended for use with Mullard amplifiers below. For A.C. mains 200/250 v. Unbeatable value. Complete kit, inc. Power Pack as illustrated, 11 gns. Carr. 7/6. Ditto less Power Pack 10 gns. Carr. 7/6. Circuit and Const. details 4/6. Free with kit.



ENAMELLED COPPER WIRE—2oz. reels, 14g-20g, 2/-; 22g-28g, 3/6; 36g-38g, 4/9; 39g-40g, 5/- etc.
TINNED COPPER WIRE, 16-22g., 4/- 2oz. **VALVE HOLDERS**—Int. Oct. 6d. Nylon or Ceramic, B7G, B9A unskirted, 9d. B7G, B9A skirted 1/- each. B7G with Can 1/6; B9A with Can, 1/9 etc.
KNOB—Modern Continental types:—Brown or Ivory with Gold centre. 1in. dia. 9d. ea., 1 1/2in. 1/9. Conc. knobs, ivory with gold centre, 1 1/2in. dia. 2/9 per pair. Matching ditto. 2/8 ea. **LARGE SELECTION AVAILABLE.**

STYLUS REPLACEMENTS, Diamond Stylus for L.P. or Stereo, for all pop. types, BSR, Collaro, Garrard, etc., 11/3 ea. Gt. 12 mths. **SAPPHIRE** ditto, 5/3 ea. Comp. range in stock.

We manufacture all types Radio Mains, Transf. chokes, Quality O/P Trans., etc. Enquiries invited for specials, prototypes for small production runs. Quotation by return.

MULLARD "3-3" & "5-10" HI-FI AMPLIFIERS 3 OHM AND 15 OHM OUTPUT

"3-3" Amp. 3-valve HI-FI quality at reasonable cost. Bass Boost and Treble controls, quality sectional output transformer. 40 c/s-25 kc/s ± 1dB. 100 mV. for 3W, less than 1% distortion. Bronze escutcheon panel. Complete kit only £7.10.0. Carr. 7/6. Wired and tested. £9.10.0.
MULLARD "5-10" AMPLIFIER—5 valves 10W, 3 and 15 ohms output. Mullard's famous circuit with heavy duty ultra-linear quality output tfr. Basic amplifier kit price £9.19.6. Carr. 7/6. Ready built 11 1/2 gns.
2-VALVE PRE-AMP. UNIT. Based on Mullard's famous 2-valve (2 x EF86) circuit with full equalisation with volume, bass, treble, and 5-position selector switch. Size 9in. x 6in. x 2 1/2in. Complete kit £6.12.6. Ready built £5.10.0. Carr. 6/6.

Only a few items are listed from our comprehensive stock. Write now for full bargain lists. 3d.

Terms: C.W.O. or C.O.D. post and packing 1/6. 1/-, 1lb. 1/9, 3lb. 3/-, 5lb. 3/9, 8lb. 4/6 etc.



RADIO COMPONENT SPECIALISTS
Established 1946

70 BRIGSTOCK ROAD, THORNTON HEATH, SURREY
Tel: THO 2188 Hours 9 a.m.—6 p.m. 1 p.m. Wednesdays



**USE
A WHARFEDALE SPEAKER**

... IT SOUNDS BETTER

SUPER 8/RS/DD

Undoubtedly the best and most popular 8" unit ever made in this Country.
Frequency range 40 c/s — 20,000 c/s
Impedance 10/15 ohms.
Power handling capacity 6 watts (12 watts peak).

£7

(inc. 20/- p.t.)

In your next system use world famous Wharfedale Super Range Loudspeakers — there's no better value for money — anywhere. Each is fitted with roll surround for low resonance and double diaphragm assembly for extended H.F. response.

Send today for further details of these units plus free cabinet construction leaflets to enable you to build a top quality Hi-Fi loudspeaker system.

RANK WHARFEDALE LTD
IDLE, BRADFORD,
YORKSHIRE
Tel Bradford 612552/3
Grams 'Wharfedale' Bradford



**FREE
CONSTRUCTION LEAFLETS**

Complete this coupon for 8 page booklet on Wharfedale Speaker units plus FREE CABINET CONSTRUCTION LEAFLETS for your own Hi-Fi system. (Dept PW.1.)

NAME _____
ADDRESS _____
TOWN _____
COUNTY _____

THE ELECTRONICS & SCIENTIFIC CENTRE

**MAGNAVOX-COLLARO
363 TAPE DECKS**

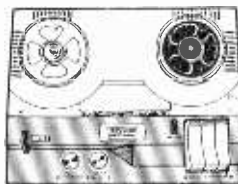

The very latest 3-speed model—1, 3 $\frac{1}{2}$, 7 $\frac{1}{2}$ i.p.s. available with either 1 track or 2 track head. Features include: Pause control; digital counter; fast forward and rewind; new 4 pole fully screened induction motor; interlocking keys. Size of top plate 13 $\frac{1}{2}$ x 11 x 5 $\frac{1}{2}$ in. deep below unit plate. For 200/250 v. A.C. mains 50 c.p.s. operation. New unused and fully guaranteed.

LIND-AIR PRICE

1 track model **£10.10** 2 track model **£13.96**

Carriage and Packing 7/6 extra.

**FANTAVOX STEREO
AMPLIFIER
MODEL MG 333**



The Stereo MG-333 is a compact and handsomely designed dual channel amplifier for use with stereo record players and AM or FM tuners. The amplifier operates from a power source of 105-125 (or 200-240) volts, 50/60 cycle AC, and is equipped with individual volume controls for each channel, a continuously variable tone control, and a stereo-monophonic mode switch. Price **£8.19.6**. P. & P. 6/6.

**BRAND NEW GRAM
DECKS FROM STOCK**

(With Cartridge unless stated)

- BRS**
UA 14, **£4.9.6**. UA 16, **£5.8.6**.
- GARRARD**
1000 (Mono or Stereo) 6 gns.
3000 (Stereo) 8 gns.
SP25 **£9.19.6**
AT60 **£9.19.6**
401 (less cartridge and arm) **£28.19.6**
1A850 (less cartridge) **£24.19.6**
WB1 Base **£3.19.6**
WB2 Base **£5.10.3**
Postage and Packing 5/- on each.

MULTIMETERS

- C.1001 (see illus.)
20,000 Ω /volt **£3.12.6**
P. & P. 3/6. D.14
1,000 Ω /volt **£2.2.0**
P. & P. 3/6. CABY
NH.200 20,000 Ω /volt
£6.0.0. P. & P. 5/6.
CABY B.40 10,000 Ω /volt
£6.2.6. P. & P. 6/-
TAYLOR TMK.500
30,000 Ω /volt **£5.19.6**. P. & P. 6/6. New
AVO Meters from Stock. MINILAB 71
Tester **£8.19.6**. P. & P. 6/6.

FIELD TELEPHONES



Operate up to 17 miles. Built-in 100 v. hand generator for ringing current, 2 standard 1.5 "D" torch cells for talking current. Complete with sturdy carrying case and strap. 11 x 8 x 4in. Weight 14lb. Simple screw adjustment for use with common battery system.

PRICE £6.19.6 per pair. P. & P. 10/-.
200 Hand Drums of TWIN PLATE 75/-.
Other quantities available on application.
Also: Portable hand sets operated by two "S" cells, with hand generator in metal cases with webbing slings.
TELE-1: Price 69/6 per pair. P. & P. 10/-.
TELE-2-P: Price **£8.19.6** per pair. P. & P. 10/-.

**SELECTOR
DRIVE**

A very interesting item with numerous applications consisting of an electro-magnet and brass tooth wheel. A switch wafer and contacts are coupled to this and are arranged to be on for 10 pulses and off for the next 15. An auxiliary contact is normally on, but off for one in every 25 pulses; complete with suppressor resistors and a series contact to facilitate continuous operation. Absolutely ideal for window displays, switching lamps or models, 12 or 24 v. D.C. Brand New and Boxed. 12/6, inc. P. & P.



Ideal for model makers, home repairs, electronics, radio, TV etc. Unique features include interchangeable tips, extension barrels, comfortable grip with trigger control. "U" shaped 3/4in. bit to minimise wear. Light beam is automatically directed onto end of bit when ON/OFF trigger is in use, 85 watt element with special ventilation. Complete with 2-pin, 5 amp. plug, 230-250 volts. Spares **49/6** P.P. available.

**SYNCHRONOUS
CLOCK MOTORS**

Geared for 40 revolutions per hour, 230 v 50 cycles. With mounting flanges. 29/6 P. & P. 1/6.

MODEL MAKER'S

Miniature D.C. Motor. Ideal for driving a gear system or can be used as a Techo-meter. Speed 10,300 r.p.m. at 230 mA, 0.3 v. D.C. Housed in black ebonite case size 1 1/2in. x 1in. dia. Spindle 1/2in. long x 3/64in. dia. Two for 15/- P. & P. 2/6.

**LIND-AIR
Electronics
Ltd. DEPT. PW.4**
53 TOTTENHAM COURT ROAD, LONDON W.1.
LANgham 3653

MANY MORE INTERESTING BARGAINS AVAILABLE AT THE SHOP

sists of Tr1 and Tr2 wired as a super-alpha pair, with the base-bias network R1-R2 Bootstrapped via C2, and the leakage impedance Bootstrapped via R5 and C3. To prevent the emitter resistor, R4, from being shunted by an external load, an additional emitter follower is interposed between Tr2 emitter and the output of the unit, this emitter follower, Tr3, having its base direct coupled to Tr2 emitter. The input impedance measured on the prototype was $8M\Omega$.

Construction

The constructional details of the unit are made clear in Fig. 4b and in the photograph. Being so compact, the unit is somewhat "fiddly" to build, and construction is thus best carried out "by numbers", as follows:—

(1). Cut the Veroboard panel to size and break the copper strips as shown, using either a small drill or the special tool that is available for the job. Now drill the two 1/16th inch diameter holes, as indicated. Note that this Veroboard uses 0.1in. hole spacing, which is a far smaller matrix than that normally used. In the case of difficulty, this size of Veroboard can be obtained from the address shown in the components list.

(2). Solder the shorting link in place from 7H to 7E, using sleeved wire. Solder R2 in place between 8A and 8F, with the resistor flush on the face of the panel.

(3). Now solder the remaining components in place, mounting them all vertically and as close to the panel as possible, in the following order: C3, Tr1, R4, C2, C1, R5, R1, R3, R6, Tr2, Tr3 and C4.

(4). Take a Radio Spares 3-pin transistor holder and carefully modify it as shown in the inset, cutting away the body with the aid of a fret saw and file until only a single socket remains, then solder it in place in hole 6H on the Veroboard panel. This socket, in conjunction with a lead from the battery supply, then acts as an on/off switch.

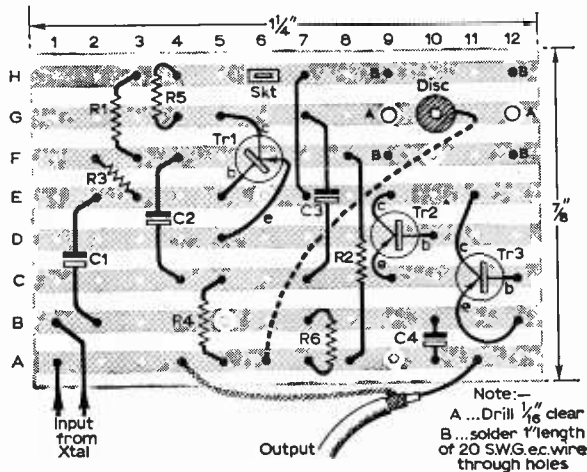

Fig. 4b: Wiring details of the Veroboard. Care should be taken when soldering transistors directly in circuit.

(5). Take four 1in. lengths of 20 s.w.g. enamelled copper wire and, after baring $\frac{1}{16}$ in. of one end, solder one wire into each of the following holes, keeping the wire vertical; 9F, 9H, 12F and 12H. Now cover these wires, except the one in hole 12F, with sleeving, and temporarily fit the three sub-miniature $1\frac{1}{2}$ volt cells in place in the resulting "cage", and cut off the top of the 4 wires just below the top of the upper cell. Now remove the three cells from the cage.

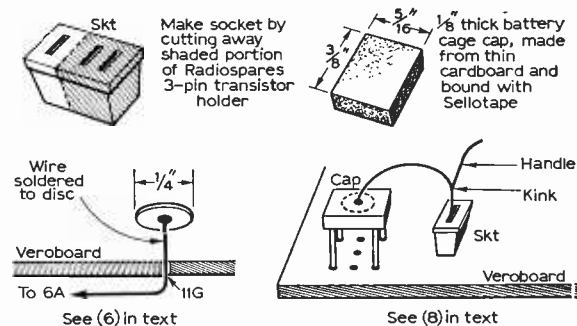

Fig. 4c: Details of battery "cage" and switch. The transistor holder (top right) is cut to resemble the miniature switch Skt (bottom left). See text for full details.

(6). Take a small piece of tin or copper sheet, and cut it into a disc a little less than $\frac{1}{4}$ in. diameter. On the prototype, a piece of metal strip taken from the inside of a PP3 battery was used. Solder the disc to a length of fine gauge sleeved copper wire, and thread the wire through hole 11G in the Veroboard, with the disc on the component side of the panel; apply a dab of Bostik to the underside of the disc and then glue it in place on the panel. Take the free end of the wire and solder it in hole 6A.

(7). Make the battery cage cap from thin cardboard, in the form of a 4-sided tray, as shown in the inset, first cutting and folding the cap and then binding it in shape with Sellotape. The cap should be a close fit over the top of the cage.

(8). Cut a small disc from sheet tin, etc., the disc being slightly over $\frac{1}{4}$ in. diameter, and solder it to a length of fine copper wire. Make a small hole in the top of the cardboard cap with a pin, and thread the wire through the hole, with the disc on the inside of the cap. Apply a drop of Bostic to the underside of the disc and glue it in place on the cap, taking great care not to smear the face of the disc, which acts as the negative battery contact, with glue. Take the free length of wire and bend it as shown, the 'kink' fitting into the socket of the modified transistor holder and thus acting as an on/off switch.

(9). With the cap in place on top of the cage, thread a length of rubber band through the two 1/16th holes in the Veroboard panel and hook the band over the cap; from the underside of the panel, pull the elastic band reasonably tight and tie the two ends into a knot, thereby ensuring that the cap is held firmly in contact with the batteries.

(10). Remove the cap and fit the three batteries in place, one on top of the other and with the negative terminals uppermost. Now replace the cap and secure it in place with the rubber band. Solder the units output lead with its core to hole 11A and its screen to hole 4A. Connect the crystal microphone between holes 1A and 1B. Now connect the lead from the battery cap into the small socket, and carry out a simple functional test of the unit. The unit is now ready for use, and can be fitted into the microphone case, where it can be secured in place either with adhesive or with cotton-wool packing.

It may be noted that, for the sake of miniaturisation, 2G414 type transistors have been used in making the unit, and these happen to be v.h.f. types. Because of this, the unit will give a linear frequency response up to a couple of Megacycles, and thus makes a very useful high impedance buffer for use with test equipment, etc., where signal levels are less than approx 2 volts peak-to-peak. The input impedance of the unit is, of course, much higher than that of most 'scopes, V.T.V.M.'s, etc.

★ components list

Resistors:

R1 82kΩ
R2 120kΩ
R3 330kΩ
R4 10kΩ
R5 47kΩ
R6 4.7kΩ
all $\frac{1}{2}$ watt. carbon

Capacitors:

C1 1μF } sub-miniature
C2 30μF } electrolytics
C3 30μF } 6V wkg.
C4 30μF }

Semiconductors:

Tr1 2G414 }
Tr2 2G414 } (Texas)
Tr3 2G414 }

Miscellaneous:

Veroboard with 0.1in. hole spacing, transistor holder 3-pin (Radio Spares). 3 Mercury cells type 312, wire, sleeving, etc.

Note.—In case of difficulty, all components may be obtained from Newbury Radio (Forest Gate) Ltd., 274 Romford Road, Forest Gate, London, E.7.

POWER SUPPLIES

—continued from page 682

that will oppose the variation in VT. This will be equal to n.VT, whilst $VT = E1 - E2 = E1(1 + n)$

$\frac{E1}{n}$ since the gain of the error amplifier n is considerably greater than unity. This is really another way of saying that any mains input variations together with the ripple voltage remaining after initial smoothing are reduced by a factor of $\frac{1}{n}$.

In a well designed circuit, the output impedance at ZF will be under one ohm, with ripple voltages of only a few mV and output variation of 1% or better between no load and full load conditions for a mains input variation of up to 15%.

Up to now we have ignored the two capacitors in Fig. 10. C from the output voltage to the grid of V2 serves to feed back any ripple voltages or signal voltages that may be flowing into the power supply from equipment being run from it. These are therefore subject to the same degree of attenuation as are the surge voltages caused by the switching on or off of external loads. Typical values are from 0.1μF to 0.5μF.

Capacitor C2 across the neon serves to short circuit the internally generated noise that all neons are subject to, to varying degrees. A point to watch is that the neon is not suffering from current starvation, as it very easily can if R1 is made very high in value in an attempt to increase the gain of

the error amplifier. A current starved neon and a capacitor in parallel could very easily act as a relaxation oscillator, thereby defeating the very object of including the capacitor. A very common dodge is to feed the neon with current by means of a resistor from the unstabilised h.t. line.

TRANSISTOR ERROR AMPLIFIERS

Low voltage power supplies utilise transistors for the error amplifier and series emitter follower regulator with a Zener diode for the reference voltage. The principle of operation is exactly the same as for valve stabilisers. Although the basic circuitry is quite simple it is possible that the ultimate circuit will be considerably more complex. The single series regulator valve of Fig. 10 can be replaced by a number of valves in parallel to increase the current capacity of the supply and the triode error amplifier can be replaced by a single pentode or a twin triode arranged as a cascode amplifier. This is often adopted because a single triode is incapable of supplying the large amplification factor necessary for adequate stabilisation. The voltage gain of a pentode is greater than a triode but the internal noise level is also greater so that what one gains on the swings one loses on the roundabouts. A circuit that can supply a very high gain with a low internal noise level is the cascode where two triodes are used, one acting as the anode load of the second.

CONTINUED NEXT MONTH

'Q' MULTIPLIER

We have been informed by Electronics that the reference given for L1 in the components list for the 'Q' multiplier for the R1155 is incorrect. The correct part number is QL4 and the price is 7s. 6d., plus postage. Since Electronics has been acquired by Standard Telephones and Cables Ltd., sales enquiries should be sent to the Sales Office, Edinburgh Way, Harlow, Essex.

INDEX

No more frantic searching for that particular article which appeared in that past issue. For 1/6d. you can be the proud possessor of a *Practical Wireless* index to volume 40. This price includes postage, and the index is available from our Post Sales Department, George Newnes Limited, Tower House, Southampton Street, London, W.C.2.

RADIO • HI-FI • COMPONENTS • TEST EQUIPMENT

ALL ITEMS SENT POST FREE

TT.144 DYNAMIC TRANSISTOR TESTER

Tests in-circuit or out of circuit. Identifies PNP and NPN types. Indicates electrode open circuits, short circuits and current drain. Complete with instructions. **£4.10.0**



TT.145 DE-LUXE TRANSISTOR RIDGE TESTER

MULTI METERS

TK.20A 1,000 o.p.v.	£2.15.6
TK.25 1,000 o.p.v.	£2.15.6
EP.10K 10,000 o.p.v.	£4.17.6
EP.10KN 10,000 o.p.v.	£5.3.0
EP.20K 20,000 o.p.v.	£5.19.6
EP.20KS 20,000 o.p.v.	£6.8.0
EP.30K 30,000 o.p.v.	£7.19.6
EP.30KN 30,000 o.p.v.	£9.0.0
EP.50KN 50,000 o.p.v.	£11.19.6
EP.100KN 100,000 o.p.v.	£14.19.6



TE-188. RF SIGNAL GENERATOR
A stable wide range signal generator with a range of 120 Kc/s-280 Mc/s on 6 bands. Features a large 4 1/2 in. vernier tuned, etched circular dial for easy accurate frequency adjustments. Complete with instructions. **£20.15.0**

TE190. SINE SQUARE WAVE AUDIO GENERATOR

SINE WAVE: 20-200,000 cps in four bands.
SQUARE WAVE: 60-30,000 cps. Input impedance 0-5,000 ohms. Especially designed for HI-FI Radio and TV Service men who require a dependable instrument. **£21.19.6**



LA9P. AC ELIMINATOR
with a double wound step down transformer to operate 9v Radios, etc., from AC Mains. **£18.6**

FSW1. FOOT SWITCH



Snap action foot switch with skid proof rubber base pad. Plugs into your Tape Recorder remote control system but special adaptor supplied enables this to be used with all other Tape Recorders. **24/-**

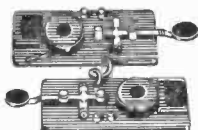

MCK.2. MORSE CODE KIT
Two station morse code kit supplied with instructions, 50ft. of connection wire and morse code charts. **£2.2.0**

REIDA RADIO LTD



SR165. ALL BAND COMMUNICATION RECEIVER

This entirely new professional type communication receiver features frequency coverage of 535 Kc/s-30 Mc/s for complete general coverage. In particular ham bands are arranged in the same calibration scale, so that the band switching can be accomplished rapidly. **£48.0.0**

UD40H CARDIOD DYNAMIC MICROPHONE



Features a pop-proof diaphragm and superior anti feedback properties, reduces feedback and room reverbation. O/p: -42 db. Response: 60-12,000 cps; 50K ohm impedance 26.0.

DM31C. CARDIOD DYNAMIC MICROPHONE

Superb quality with ball head for distributed cardiod frontal pick-up. Output: -52db. Response: 40-15,000 cps. Impedance 50K ohm. **£7.7.0.**



DM24HL

A goose-neck dual impedance microphone 600 ohm - 50K ohm. Response: 60-11,000 cps. **£6.8.0.**

27 other microphones available.

EAGLE SA100. 10W INTEGRATED STEREO AMPLIFIER



A compact, versatile integrated unit for monaural or stereophonic reproduction from record player, tape recorder and tuner. Power output 6 watts per channel. Frequency response 40-20,000 c.p.s. **£18.0.0**

EAGLE AFM100. AM-FM TUNER

Combines a host of advanced features that easily make it the finest AM-FM tuner in its class. A tuned RF stage on FM, AFC circuit and a heavy flywheel giving smooth but effortless tuning, built in AM Ferrite aerial. FM.88-108Mc. **£29.0.0**

MS80. 20W ROSEWOOD SPEAKER SYSTEM

The perfect answer for the music lover who wants full range fidelity in a compact system. Features an 8in. full range high compliance speaker with an output capacity of 20 watts RMS. Frequency response: 30-20,000 c.p.s. Resonant frequency: 30-40 c.p.s. Sensitivity: 97 db/w. Flux density: Over 12,000. Impedance: 16 ohm. Size 14 1/2 in. high x 10 1/2 in. wide x 8 1/2 in. deep. **£14.14.0**

As well as this beautifully designed speaker there are two other models MS65 10 watts RMS at £12.12.0 and MS40 5 watts RMS £8.10.0. All three speakers are finished in magnificent rosewood and the entire cabinet filled with acoustic damping material.

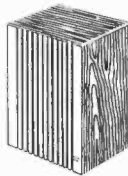

EAGLE PRODUCTS

MAGNETIC STEREO CARTRIDGES

M1007G. GOLD Response: 20-20,000 cps Output: 5MV at 1Kc/Sec./Sec.
M1007F. SILVER Response: 20-18,000 cps Output: 10MV at 1Kc/Sec./Sec.
Stylus: 0.6 Mil diamond
Tracking Pressure 1-2.5 grams **£6.12.6**
Stylus: 0.7 Mil diamond
Tracking Pressure 2-4 grams **£5.14.6**

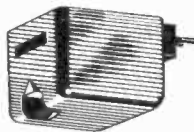

Both feature singularly smooth reproduction and incisive separation of stereo channels

ALL TRANSISTOR PUBLIC ADDRESS AMPLIFIERS

Two new models offering the last word in P.A. amplification. All transistorised circuit, negative feedback circuit reduces distortion to a minimum. Two mike inputs high and low with individual controls. Plus inputs for TAPE, TUNER and RECORD PLAYER. PA540 35 Watts **£36.0.0**
PA541 50 Watts **£56.0.0**

SC10F. RECTANGULAR REFLEX HORN SPEAKER

An outstanding combination of reflex horn and driver unit for car mounting, to deliver wide angle high quality reproduction. Weatherproof, waterproof and shockproof. Output 10 watts. **£7.15.0**

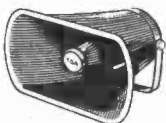

Also available SC5F: 5 watts, £4.2.6 and SC15F: 15 watts £14.12.6.

FOR FULL DETAILS OF THESE AND MANY OTHER ITEMS SEND FOR FREE COMPREHENSIVE CATALOGUE, EAGLE NEWS AND ORDER FORM. ALL ITEMS AVAILABLE POST FREE AND COVERED BY 12 MONTHS' GUARANTEE.

CALLERS WELCOME AT OUR HI-FI SHOWROOM

(Dept. P.W.13)
87 Tottenham Court Road, London, W.1.

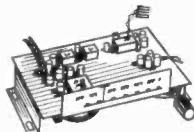

EAGLE FMT41. FM TUNER

Sub-miniature 6 transistor 3 diode F.M. Tuner. Covers 88-108 Mc. Operates from 9-volt battery, micro miniature circuit giving brilliant FM reception. Ready to use, simply connect to your Hi Fi Amplifier. Instructions supplied. **£8.10.0**



EG304

Sub-miniature 3 watt transistorised push-pull radio amplifier on printed circuit. Ideal unit for Intercoms, Baby Alarms, Radio Tuners, etc. Complete with circuit and instructions. **£3.12.6**
Also available EG104. **£3.2.6**
One Watt **£2.5.0**
and EG2004 250 mW **£2.5.0**



CSK.10 Self-powered crystal set kit with private earphone. Supplied complete with instructions. **18/6**

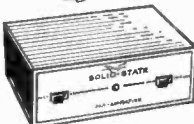

ALL TRANSISTOR MONO & STEREO PRE AMPLIFIERS

Provide extra stage of amplification for use with magnetic cartridges, tape and microphone inputs. Both models feature wide band pass range, 30-30,000 cps. PRE 301 MONO **£4.12.6**
PRE 302 STEREO **£5.15.0**



WI-2. TRANSISTORISED WIRELESS INTERCOM

No wires, no installation needed, simply plug them into AC power point and talk. Units have pre-to-talk lock switch and on-off volume control. Ideal Intercom or Baby Alarm for home, office. **£14.12.0** Complete.

DP303. DOOR PHONE INTERCOM

Ultra sensitive transistorised intercom designed so that you may answer the door from within for greater convenience and safety. **£4.12.6** Other Intercoms available.

WIRELESS MICROPHONES

WM909 (as illustrated) Pocket FM Wireless transmitter complete with tie-pin microphone. Transmits clearly up to 100 yds. and is fully tunable over the entire FM band. Simply used with an FM radio or tuner. **£14.0.0**

Also available WM808 **£21.0.0**
Professional stick type FM Wireless Microphone. These cannot be operated in U.K.

THE *Adamin* DE-SOLDERING TOOL

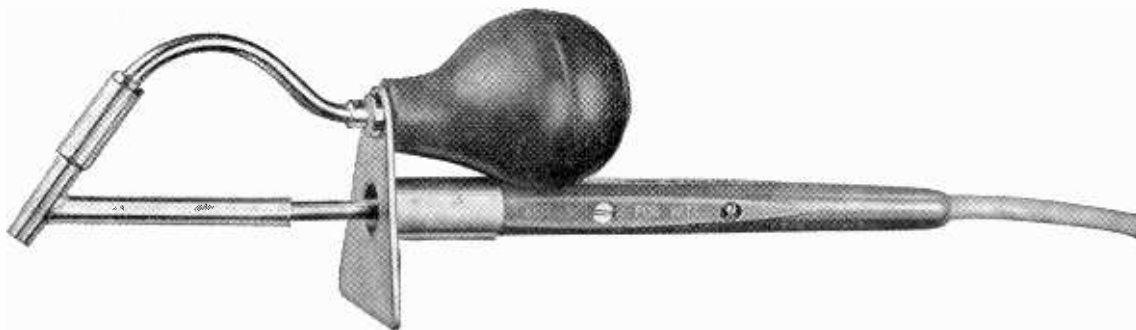

- Self-contained—does NOT require the use of air-lines or pumps
- Simple, light and inexpensive
- PERMABIT nozzle will not wear or become eroded by the solder
- Standard nozzle, $\frac{5}{64}$ in. bore. Alternative, $\frac{3}{64}$ in. bore
- Mains or low voltages

Please ask for free catalogue S.P.11

LIGHT SOLDERING DEVELOPMENTS LTD. 28 Sydenham Road, Croydon, Surrey
Tel: CRO 8589, 4559

AMATEUR RADIO
CHAS. H. YOUNG LTD.

The Sensational
ALL-TRANSISTOR
Communications Receiver



EDDYSTONE
EC10

for use in the home, caravan, car or boat,
H.P. facilities. Only £48 Part exchanges

Write for brochure

170-172 CORPORATION STREET
BIRMINGHAM 4
Telephone: 021-236-1635

VIKING STEREO 4 + 4 HIGH QUALITY AMPLIFIER

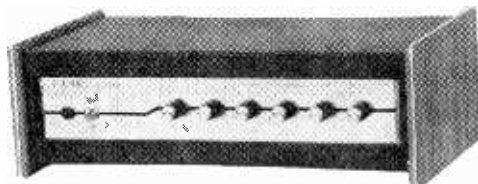

A high quality stereo amplifier, built to meet the requirements of budget HI-FI. Elegant styled cabinet in black resins and wood grained ends. Brushed aluminium panel, black and silver knobs. Quality components throughout. Ganged Bass and Treble controls, separate volume controls for each channel. Valves (Standard Model) 2 x ECL86 (De-Luxe Model) 1 x ECC83 (2) x ECL86. Output 3 ohms matching, suitable A.C. mains 230-240 volt. Cabinet size, 16 1/2 in. wide, 5 1/2 in. high, 8 1/2 in. depth. Full instructions and guarantee. Send for leaflet.
STANDARD MODEL (amplifier only)..... £11.11.0 plus 12/6 P. & P. and Ins.
DE-LUXE MODEL (amplifier only)..... £12.12.0 plus 12/6 P. & P. and Ins.
CABINET extra if required..... £1. 5.0
CABINET separately..... £1.15.0 plus 7/6 P. & P. and Ins.

VIKING 10-12. A twelve watt amplifier for use on 230-240 volt A.C. mains. Inputs suitable Microphone, Record Player, Tuner, Tape Recorder, etc. Printed circuitry. Five Mullard valves, reliable components. Front panel contains 2 Input Jacks, 2 Volume Controls, 1 Tone, Neon and On/Off switch. Designed to fit into same type and size cabinet as Stereo. Fully guaranteed. Send for leaflet.
Price (amplifier less case) £7.19.6 plus 12/6 P. & P. and Ins.

VIKING X.P.15. A frustrated order offered at a fraction of cost (original price 39 gns.). 15 watts output. Suitable for 210-240 Volt A.C. mains. Attractive Black Chassis with slotted Chromed steel top cover, size 15 x 7 1/2 x 7 in. 4 Input Jacks. 2 volume controls, 2 tone. 5 Mullard valves. Fully guaranteed. Send for leaflet.
Price Complete £12.19.6 plus 12/6 P. & P. and Ins.

Famous VIKING P.A. BASS AMPLIFIERS. 15, 30, 40, 60 and 100 Watts. Send for leaflet.

SPEAKER-ENCLOSURES — SPEAKERS — MICROPHONES — RECORD PLAYERS and TAPE DECKS. Send for leaflets.

Terms: C.W.O.. C.O.D. Money back guarantee.

VIKING (ELECTRONICS) LTD. 37 HILLSIDE,
STONEBRIDGE,
LONDON N.W.10

Telephone: ELG3644



No. 13

PETERBOROUGH AMATEUR RADIO SOCIETY

RADIO Clubs are noted for having their headquarters in somewhat peculiar premises, but perhaps the Peterborough & District Amateur Radio Society is the only one in the world to have its "home" in a 100-year-old windmill.

Visitors are always welcome on Club nights (Fridays) at the mill, which is behind the Peacock Inn on the London Road, and they will see the Club's own station G3DQW in operation—on all bands from Top to Two.

There is a 200 feet long-wire aerial for the high-frequency bands, whilst for 146Mc/s, an 8-over-8 slot-fed beam is mounted high above the mill, well over 70 feet from the ground, and free from all man-made static.

The mast goes right down through three floors to the shack, and is rotated bodily by the hand-draulic or "Armstrong" method—two brawny members pull on a car steering wheel, and set the beam accurately in any direction by watching compass-bearings painted on the floor . . . Rather unusual, yes, but it works well—as the many v.h.f. contacts from '3DQW will confirm!

The gear includes a mint HRO senior, which was kindly donated to the Club, and a CR100 and LG50 as well as much other equipment loaned by various members.

Latest interest is in Amateur Television, and junior members are busy building a multi-element array for 420Mc/s—cutting down old TV aeri-als.

Well-situated from every point of view, the Mill is only a few minutes' walking distance from the centre of Peterborough, near the bus station, and next to a large car park. It is immediately behind a public house, and only a stone's-throw from the Posh football ground—in fact, members can have a free grandstand view from the top of the mill.

The Peterborough A.R.S. is also unique in having its own private riverside site on the banks of the Nene, with plenty of mooring space for boats, grassy banks for picnicing, and a boat-house, changing-room and even a power-house. A large punt and a small rowing-boat have been given to the Club. Members can swim, sunbathe, or picnic to their heart's content, and the site makes an ideal venue for barbecues and Field Days—there's no t.v.i.

During the summer months, members spend weekends camping by the river, as well as taking part in both National Field Day and v.h.f. Field Day. Direction-finding contests are organised, and a "Bucket and Spade" party was held at Hunstanton for several summers.

For the past two years, a Mobile Rally has been

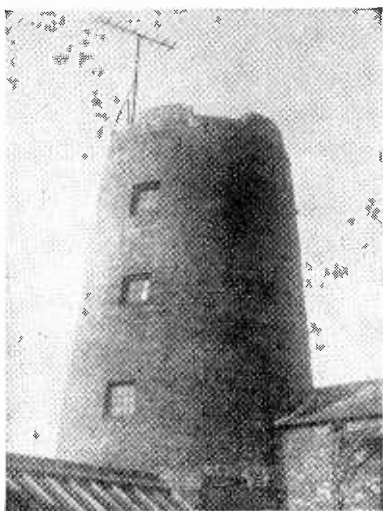

The Club house is an old windmill. The fact that it is next to a pub is pure coincidence. On the right is the Club station G3DQW. On the key G3HXR, logging G3KPO.

run at Peterborough on August Bank Holiday, attracting hundreds of visitors from all over the East Midlands. A popular feature this August was a free trip down the river by motor launch—repeated over and over again, with Jack and Leslie at the helm.

During the winter months, lectures and demonstrations are held at Peterborough Technical College, where the Society members are granted every facility—including the use of the electronics laboratory, lecture hall and cinema for technical film shows.

An eighty-metre dipole aerial has been erected by members above the College, which holds its own transmitting licence and callsign composed of its initials—G3PTC. Demonstrations of the latest amateur and professional radio equipment have been given at regular intervals, including those on single sideband transceivers, teleprinters, radio-astronomy, direction finding, and amateur television.

Classes for the Radio Amateur Examination are held annually, and this winter G3KPO has 17 in the class—by a coincidence, the same number as last winter. Incidentally, one of that class, Colin Whyles, is already “on the air” as G3VRS.

[Congratulations, Colin—Ed.]

The Society endeavours to provide “something for everyone”, from veteran old-timer to youngest shortwave listener. This is borne out by the number of visits which have been paid to local places of interest, such as the electricity generating station, the automatic telephone exchange, and the local



Making a 420 Mc/s beam for amateur TV work. Enthusiasts left to right are Michael Bond, Bill Yeomans, Mervyn Carver, and Barry Ellery

television transmitting station.

Club junk sales have also been very popular, as well as the bulk purchase of ex-government surplus radar equipment. A quantity of this was stripped down into individual components by the members, and re-distributed in handy plastic bags.

The present Peterborough A.R.S. began in quite a small way in March 1960, when a few enthusiasts gathered one evening at the home of the Hon. secretary and decided to go ahead with its formation. From the outset, every assistance was given by the principal and staff of the Technical College, and this proved a tremendous advantage to the Club.

Its chairman is “Gus”, Mr. C. J. Guscott G3HXR, and vice-chairman Ted Barnes G2BYI, whilst the “Hon. sec.” is Douglas Byrne, G3KPO, who is also

Area Representative of the RSGB. Incidentally, Douglas is endeavouring to get together a “Radio Museum” of old wireless gear, books and magazines from the twenties or early thirties, and would appreciate a postcard from any reader who could help. His address is—“Jersey House”, Eye, Peterborough.

At this summer’s three-day Agricultural Show at Peterborough, the Club were invited to operate a Transmitting Station—and put GB3PAS on the air, using a Swan 350 and KW2000 as well as a.m. gear. A Mosley tri-band beam was erected on an iron tower specially constructed for the show by s.w.l. Jack Warrington and Leslie Critchley, G3EEL. As might have been expected, contact was established with all parts of the globe—and thousands saw “amateur radio” in operation for the first time. The inclement weather was no handicap—for the station was snug and dry in a large wooden garage, loaned by a local firm.

After lengthy negotiations by the Society’s officials, who pointed out the great publicity value of amateur radio, the Town Council agreed to supply local radio amateurs with QSL cards free of charge, as well as for Club use with G3DQW and in connection with special exhibition stations.

These fine QSL cards are printed on glossy paper, and show a photograph of Peterborough Cathedral and the City coat-of-arms on one side, with the usual report data and space for remarks on the reverse. All the individual amateur has to do is to overprint his callsign, and name and address.

THE AMATEUR BANDS

—continued from page 651

VS9ARV, VQ9HP (Seychelles), VR6TC (Tom Christian on Pitcairn Is.), VU2TX, all W districts 1—Ø, XW8BS, YA1DXE, ZD8ARC, XD9BE, ZL1AXB, plus many others including ZL4CH, ZL5AA (Scott Base Antarctica), 3A2CP, 5H3AC, 5U7AK (Niger), 5X5UW, 5Z4IR, 5R8AS, 5W1AZ (Western Samoa), 6O1PK, 6Y5AR, 7Q7LC, 9J2VX, 9K2AM (Kuwait), 9M2BO, 9M6MQ, 9N1BJ (Nepal), 9V1GH.

Finale

That’s it for this year, and vy fb it’s been too, especially this last month. 28 and 21 really starting to come into their own. Watch 28 next year, things will really start to hum. DX on 80 and 40 for the stalwarts. Twenty and 160 dying out?

Contests for December. The only one in my diary is the 70Mc/s c.w., and that was on the 4th. January is not much better. The Affiliated Societies contest on January 14—15th, and on the 29th, is the 144Mc/s c.w. contest. Anyone listen higher than 30Mc/s? No excuse now that the v.h.f. Explorer circuit is on show. (See page 646).

Your scribe is still at it on topband with a 5763 and 10 watts to 140ft., endfed. Reports welcome, both phone and c.w. Careful, the phone may be a.m. but will probably be f.m. (B.F.O. out, a.v.c. off).

Many thanks for the fine logs, a very MX (Merry Christmas in c.w.) and a real cool yule to the way out cats. (Like endsville man). Hpe cu next yr. 73 from G3JDG.

P.S.—Deadline for festive keen types is 26th.



SINCLAIR MICRO FM

POCKET SIZE COMBINED FM
TUNER/RECEIVER

THE ONLY SET OF ITS
KIND IN THE WORLD

- 7 TRANSISTORS
2 DIODES
- LOW I.F. ELIMINATES
NEED FOR
ALIGNMENT
- OPERATES FROM
STANDARD SELF CON-
TAINED 9v BATTERY
- ONE OUTPUT FOR
AMPLIFIER ONE FOR
PERSONAL LISTENING

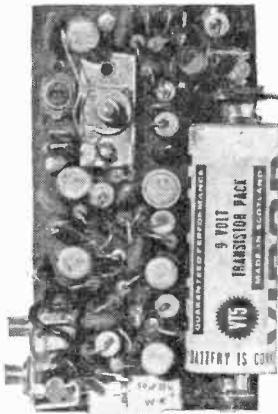

Anyone can build it!

This is a marvellous set to build and use. It has so many unique, original features that it is years ahead of any FM design ever produced for the home constructor. It is so professional in its appearance and performance too. With the Sinclair Micro FM there are simply no problems of alignment, so it is ready to use just as soon as you have built it, and unlike any other FM Set in the world, the Micro FM is a double purpose unit which you can use both to feed to a hi-fi system or tape recorder and as a self-contained pocket FM portable. The sensitivity of the Micro FM is such that it will operate satisfactorily using its own telescopic aerial in all but the very poorest reception areas. Quality is outstandingly good because of the system of pulse counting discrimination used, and although this set is no bigger than a packet of 10 cigarettes it uses a standard 9 volt self contained battery. Powerful A.F.C. makes tuning simple. Backed by Sinclair service facilities and the Sinclair guarantee, anyone can go ahead and build the Micro FM straight away and with assured success.

Complete kit including transistors, telescopic aerial, case, earpiece and instructions.

£5.19.6

TECHNICAL DESCRIPTION

Self-contained double-purpose FM superhet using 7 transistors and 2 diodes. The R.F. amplifier is followed by a self-oscillating mixer and three stages of I.F. amplification which dispense with I.F. transformers and all problems of alignment. The final I.F. amplifier produces a square wave which is detected to produce the original modulation exactly. The pulse-counting discriminator ensures better audio quality. Two outputs are provided—one is for feeding to amplifier or recorder and the other enables the Micro FM to be used as an independent self-contained pocket portable. A.F.C. "locks" the programme tuned in. The telescopic aerial included is sufficient in all but the worst signal areas.

- ★ Size: $2\frac{1}{2} \times 1\frac{1}{2} \times \frac{1}{2}$ in.
- ★ Pulse counting discriminator
- ★ Low I.F. completely eliminates alignment problems
- ★ Tunes from 88 to 108 Mc/s
- ★ Audio response: 10 to 20,000 c/s ± 1 dB
- ★ Signal to Noise Ratio: 30dB at 30 microvolts
- ★ Plastic case with brushed and polished aluminium front and spun aluminium tuning dial

sinclair world pace-setter in electronics

SINCLAIR MICRO-6

The kit that builds into the world's smallest radio

This is the kit that builds into a M.W. set against which a matchbox looks enormous. Yet it is completely self-contained, including aerial and batteries and virtually plays anywhere. Its clever six-stage circuit (2 R.F., double diode detector, 3 A.F.) ensures all you want in a radio today—power, range, quality and selectivity. A.S.C. counteracts fading, bandspread brings in Luxembourg like a local station. There is great pleasure to be had in building the Micro-6, and it makes a highly acceptable gift with its white, gold and black case and amazing performance.

- Size $1\frac{1}{2}$ in. x $1\frac{1}{2}$ in. x $\frac{1}{2}$ in.
- Weight: One Ounce
- Easily built in an evening



Complete kit with earpiece, case and instructions.

59'6

ORDER FORM AND MORE SINCLAIR DESIGNS ON FOLLOWING PAGES

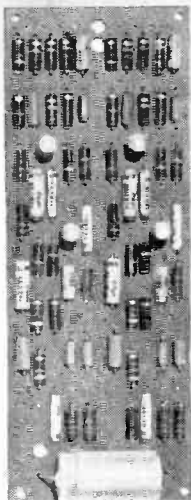

SINCLAIR STEREO 25

ALL-PURPOSE DE-LUXE PRE-AMP/CONTROL UNIT

Using only the finest possible matched components in circuitry developed specially by Sinclair Radionics own research laboratories, the SINCLAIR STEREO 25 Pre-amplifier and Tone Control Unit is for use in any stereo system where it is intended to take fullest advantage of today's best amplifier and auxiliary equipment systems. When used for feeding into two Z.12's, there is even greater advantage for there is appreciable saving also in what you have to spend to get first class hi-fi. In appearance, the Stereo 25

reflects the professional elegance which characterises all Sinclair designs. The front panel is in solid aluminium brush finished and polished in horizontal sections. Solid aluminium knobs are fitted. Mounting the unit is simple and it will enhance any hi-fi furnishing scheme in which it is used. A PZ.3 is recommended for powering the Stereo 25 and two Z.12's stereo assembly. For complete hi-fi coverage a Sinclair FM should be used for the radio section of your installation.

Performance figures obtained with the Stereo 25 fed to two Z.12s all powered by a PZ.3 mains power supply unit.

- **SENSITIVITY** for 10 watts into 1.5 ohms load per channel.
Mic.—2 mV into 50K ohms.
Pick-up—3 mV into 50K ohms.
Radio—20 mV into 4.7K ohms.
- **FREQUENCY RESPONSE** (Mic. and Radio)—25 c/s. to 30 kc/s. ± 1 dB extending to 100 kc/s ± 3 dB.

TECHNICAL DESCRIPTION

- **EQUALISATION**—Correct to within ± 1 dB on RIAA curve from 50 c/s to 20 kc/s.
- **TONE CONTROLS**
Treble + 12dB to -10dB at 10 kc/s.
Bass + 15dB to -12dB at 100 c/s.
- **SIZE**—6½ in. x 2½ in. x 2½ in. overall, plus knobs.
- **FINISH**—Front panel sectioned in brushed and polished solid aluminium with solid aluminium knobs. Black figuring on front panel.

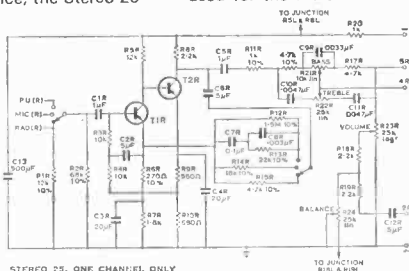

BUILT,
TESTED AND
GUARANTEED
£9.19.6

Circuit Diagram shows one channel of the Stereo 25 pre-amp and Control Unit.

sinclair world pace-setter in electronics



"Does all you claim"

So writes V.C.W. of London S.W.17 who is a keen and critical enthusiast for building unusual designs. He says:

"Micro FM assembly instructions are complete and plain, and when finished the set is truly amazing and does all you claim. Reception up and down the country proved strong, signal quality is very good and station "locking" excellent. Recording programmes through a good quality machine was all one could wish for, and I continue to be amazed at the performance the set puts up".

"I have received your Z.12 amplifier. I am extremely pleased with its performance, and it is well worth the cost. Thank you for your prompt delivery."

B.R.L., Howick, Auckland, N.Z.

"Much to my delight, the tuner (Micro FM) performs splendidly, fully justifying the modest outlay called for. The tuner picks up all the F.M. programmes. I am now anxious to purchase two Z.12 amplifiers."

P.E.R., Florida, Transvaal

WE ARE LOOKING FOR PHOTOS showing Sinclair equipment in use in any interesting or unusual way anywhere in the world. £3.3.0 will be paid for each picture we publish. A brief story should accompany each one. All photos received will be posted back.

sinclair

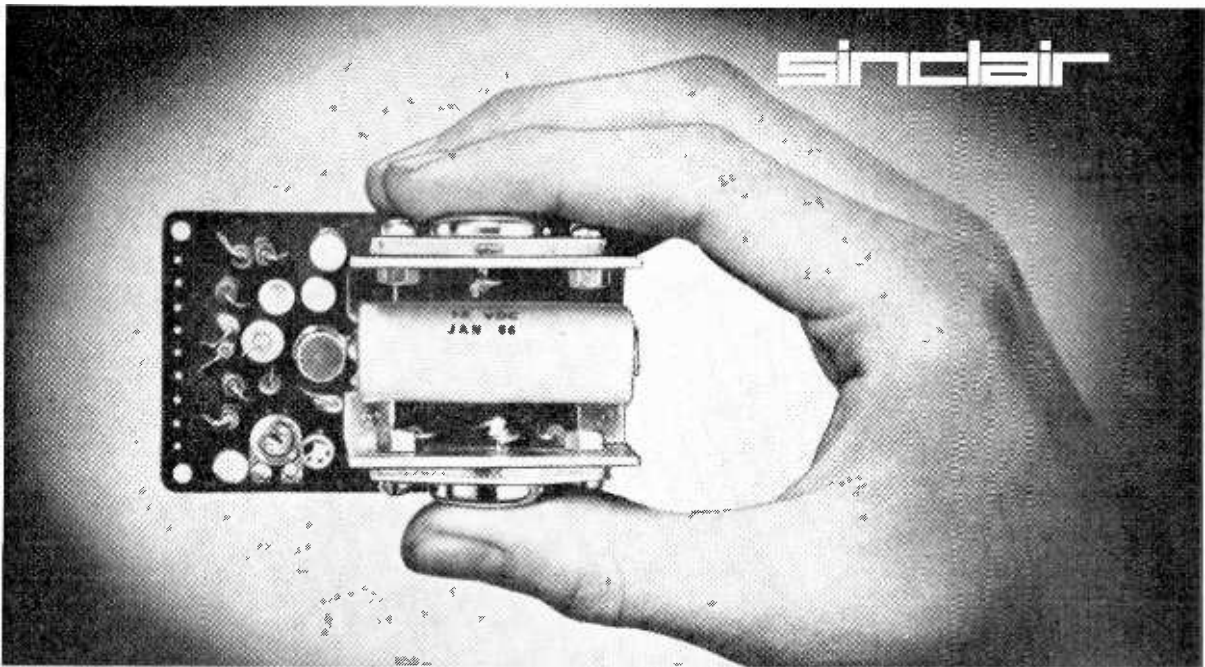

SINCLAIR Z.12

COMBINED 12 WATT HI-FI AMPLIFIER AND PRE-AMP FOR OPERATING FROM 6-20V. D.C.

The amazing adaptability and rugged construction of this very powerful and exceptionally compact amplifier make it possible to use just one type of unit with outstanding success in an unusually wide variety of applications. Eight special H.F. transistors are used in a highly original circuit to achieve the characteristics demanded of any quality amplifier irrespective of price, yet this Sinclair unit costs only 89/6 and includes its own integrated pre-amplifier. The Z.12 accepts radio, microphone

and pick-up inputs. Detailed instructions for connecting these, matched for mono and stereo are given in the manual supplied with every unit. Where it is required to run the Z.12 from mains supply, the PZ.3 is recommended. Those wishing to have a ready made pre-amp control unit can feed inputs via the Stereo 25, which, with two Z.12s will provide the finest stereophonic hi-fi possible—and the saving in cost is considerable.

USE IT FOR HI-FI ELECTRICAL GUITAR, CAR RADIO, P.A. INTERCOM, INSTRUMENTATION, ETC.

- SIZE 3in. x 1 3/4in. x 1 1/4in.
- FANTASTIC POWER! 12 WATTS R.M.S. CONTINUOUS SINE WAVE (24 W. PEAK); 15 WATTS R.M.S. MUSIC POWER (30W PEAK)
- REQUIRES FROM 6 TO 20V. OPERATING POWER
- HI-FI PERFORMANCE AT A FRACTION OF THE USUAL COST

READY BUILT, TESTED AND GUARANTEED, WITH MANUAL

If you prefer not to cut this page, please refer to P.W.167 when writing your order.

89/6

SINCLAIR PZ.3 POWER SUPPLY UNIT

Transistorised techniques are used to achieve phenomenally good smoothing, thus assuring ideal operating conditions. Ripple is a barely measurable 0.05 V. Will power two Z.12's and the Stereo 25 with ease.

79/6



THE SET THAT STOLE THE SHOW

THE SINCLAIR MICROVISION POCKET TV RECEIVER provided a world wide sensation when shown for the first time at the recent 1966 Radio and TV Exhibition. This fantastic British set tunes over 13 channels or bands 1 and 3, operates from six self-contained "Penlite" batteries and measures only 4in. x 2 1/2in. x 2in. Despite the minute proportions of this 30 transistor receiver, quality from the exclusively designed tube and loudspeaker is superb. This amazing Sinclair triumph will be available early in 1967 at a cost of 49 gns.

SINCLAIR MICROVISION
The world's only pocket T.V.!

sinclair world pace-setter in electronics

YOUR SINCLAIR GUARANTEE

Should you not be completely satisfied with your purchase when you receive it from us, your money will be refunded in full and at once without question.

FULL SERVICE FACILITIES AVAILABLE TO SINCLAIR CUSTOMERS

sinclair

SINCLAIR RADIONICS LTD.,
22 NEWMARKET ROAD, CAMBRIDGE
Telephone 52996 (STD CODE OCA3)

To: SINCLAIR RADIONICS LTD., 22 NEWMARKET ROAD, CAMBRIDGE
Please send items detailed below:

.....
.....
.....
.....

For which I enclose cash/cheque/money order

NAME

ADDRESS

.....

PW.167

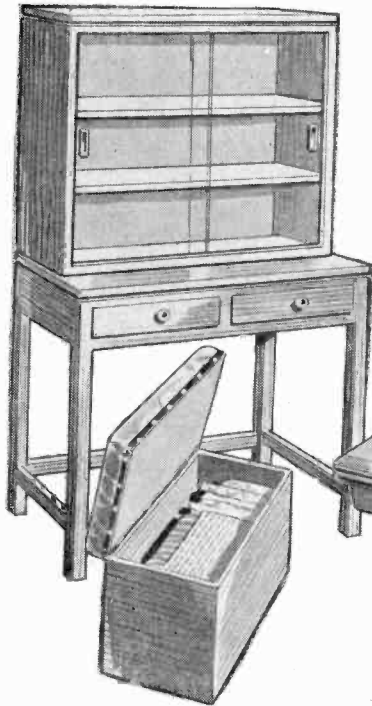

MAKE THESE FOR YOUR HOME!

Month by month PRACTICAL WOODWORKING brings the handyman just the know-how he needs on a wide range of useful woodworking jobs. Here are some of the attractive additions to the home fully covered in the January issue.

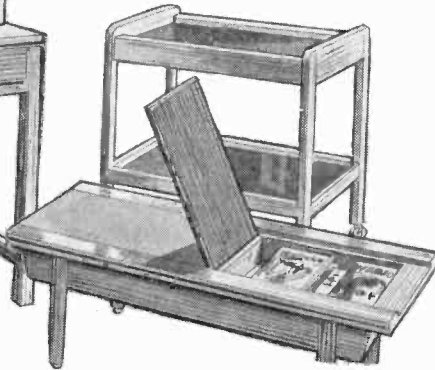

TELEPHONE DESK & SEAT

A handsome desk to house your telephone . . . a cupboard for directories . . . a cushioned seat for comfort . . . all easy to make from full constructional details.

CABINET, TABLE & TROLLEY SUITE

A space-saving 3-piecer.

OCCASIONAL TABLE

Modern, low-line in appearance and specially designed to store books and magazines.

BLANKET BOX

To store blankets when winter's over. Also makes a handy seat.

UTILITY DISPLAY SHELVES

Simple to make for those odd corners.

CLOAKROOM MIRROR

Framed in Wood, with a generous shelf for clothes-brushes.

Plus PLAN SHEET for SINGLE-LIGHT, FULLY-GLAZED EXTERIOR DOOR.

JANUARY ISSUE OUT NOW — 2/6
MAKE SURE OF YOUR COPY!

PRACTICAL Woodworking

17 in.—£11.10.0 TWO-YEAR GUARANTEE EX-RENTAL TELEVISIONS

Channels all areas
Carr., Ins. 30/-

FREE ILLUSTRATED LIST

17" — 19" — 21" — 23"

WIDE RANGE OF MODELS
SIZES AND PRICES

DEMONSTRATIONS DAILY

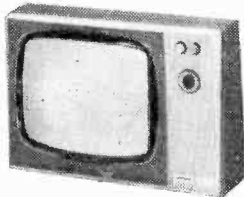

TWO-YEAR GUARANTEED TUBES

14 in. 59/6

17 in. 79/6

21 in. and all Slimline Tubes 99/6



100% REGUNNED
Add 10/- or old tube.
Carr. 10/6.

Ex-Maintenance Tested Tubes

17" 35/- 14" 15/-
Most makes and Types (Not Slimline) Carr. 5/-

LATEST RADIOGRAM CABINETS £9.10.0

Brand new long low design in veneered English walnut, dia. 40 x 16 x 15½ in. Carr. 30/- . Also Small Cabinets £6.19.6. Radiogram/Cocktail Cabinets (Personal Shoppers.) Free List.

TV Turret Tuners, 2/8. New lens valves. Slim models, 5/- . Press button models, 19/8. P & P. 2/6.
VALVES, £1 per 100. Assorted TV and Radio. Surplus ex-rental dismantled receivers. Post 4/6. Send for list.

RECORD PLAYER CABINETS, 49/8. Latest designed covered cabinets. Takes any modern Autochanger.
TRANSISTOR CASES 19/6 9½" x 6½" x 3¼" P. & P. 2/6.

DUKE & CO. (LONDON) LTD.
621/3 Romford Road, E.12 ILF 6001-2-3



Richard Allan
HIGH FIDELITY

Module

SPECIFICATION—Bass Unit: Natural resonance 40 c.p.s. Flux density 14,000 Gauss. Total flux 56,000 Maxwells. **Tweeter Unit:** Flux density 6,000 Gauss. Total flux 9,000 Maxwells. **Overall:** Height 11in. (28 cm), width 8½in. (21.5 cm), depth 2½in. (6.4 cm), weight 5 lb. (2.3 kg). Power handling 10 watts in recommended enclosure. Impedance 5, 8 or 15 ohms.

TECHNICAL DETAILS:

The unit is a compact and self contained loudspeaker system which only needs to be fitted into a simple cabinet of the recommended design to produce a high fidelity loudspeaker of the highest quality.

The unit consists of a 5in. bass unit, 4in. tweeter and crossover network mounted on a duralumin plate which forms the front panel of the complete enclosure.

The method of assembly of the module is unique in that the cone and synthetic rubber surround of the 5in. bass unit are mounted directly on to the duralumin front panel and the ceramic magnet is supported on substantial pillars attached to the panel. The conventional chassis with all its disadvantages is thus eliminated.

The tweeter is a special version of the 460T unit with a doped cambric surround and extremely light suspension system.

The crossover network is a five element circuit using ferrite cored inductors and reversible electrolytic capacitors mounted on a printed circuit board.

Free constructional details of the recommended cabinet are readily available from us.

Where larger power handling is required several units may be mounted in a larger cabinet, multiple units may also be mounted in a column enclosure to form a high power handling, high quality line source. The unit may also be mounted directly into existing equipment or in cavities in walls etc.

The unit forms the drive system of the 'Minette' enclosure, for details see separate leaflet. Patents applied for.

Price £8 plus £1.8.3 tax

For further details contact:
RICHARD ALLAN
RADIO LIMITED
Bradford Rd, Gomersal,
nr Leeds, Yorks.
Tel: Cleckheaton 2442/3

Richard Allan

HIGH GAIN 4 TRANSISTOR PRINTED CIRCUIT AMPLIFIER KIT Type TA1

- Peak out in excess of 1 1/2 watta.
- All standard British components.
- Built on printed circuit panel, size 6 x 3in.
- Generous size Driver and Output Transformers.
- Output transformer tapped for 3 ohm and 15 ohm speakers.
- Transistors (T1T 114 or S1 Mullard OC81B) and matched pair of OC81 a/p).
- 9 volt operation.
- Everything supplied, wire, battery clips, solder, etc.
- Comprehensive easy to follow instructions and circuit diagram 1/8. (Free with Kit). All parts sold separately.

SPECIAL PRICE 45/- P. & P. 3/-
 Also ready built and tested, **52/6**, P. & P. 3/-
 A pair of TA1s are ideal for stereo.

STEREO AMPLIFIER

Incorporating 2 ECL86s and 1 EZ80, heavy duty, double wound mains transformer. Output 4 watta per channel. Full tone and volume controls. Absolutely complete.

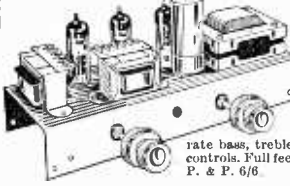

ONLY **£4.19.6**
 P. & P. 6/6

Super Deluxe version with ECL86 valves separate bass, treble and balance controls. Full feedback. 8 gns. P. & P. 6/6

6 TRANSISTOR AND DIODE SUPERHET

A first-class 3 waveband transistor superhet. ● Printed circuit, panel (size 8 1/2 x 2 1/2in.) ● 3 pre-aligned IF transformers. ● High-gain Ferrite Rod Aerial. ● All First-grade transistors. ● Car aerial winding. ● Push-pull output ● All parts supplied with simple instructions. All parts sold separately. Set of parts if purchased at one time ONLY **£4.5.0**, P. & P. 2/6 (Circuit diagram 2/-, Free with set of parts.)

35 OHM SPEAKERS

Suitable for use with above. 2In. Goodmans' Ideal replacement for most pocket portables, 8/8; 3sdn. 12/6; 7 x 4in., 21/-; P. & P. 2/- per speaker.

Portable CABINET

Size approx. 9 1/2 x 6 1/2 x 3 1/2in. Suitable for above using 3 1/2in. speaker. P. & P. 2/6.

COIL AND TRANSFORMER SET FOR TRANSISTOR SUPERHET

3 IF transformers one oscillator coil one driver transformer and wound Ferrite aerial (med. long and car aerial coupling). 52/6 complete post 2/-. Transistor printed circuit board to match 8/8. Post 1/-. Circuit diagram 1/8 extra.

MINIATURE PRECISION AIR-SPACED TWO GANG TUNING CONDENSER. 176 + 176 p.f. size 1 1/2" x 1/2" x 1 1/4" with vanes open. Built in trimmers 5/-, P. & P. 1/-

BRAND NEW TRANSISTOR BARGAINS
 GET 15 (Matched Pair) 15/-; V16/10P, 10/-; OC71 5/-; OC76 6/-; AF117 7/6.
 Set of Mullard 6 transistors OC44, 2—OC45 OC81D matched pair OC81 25/-, ORP12 Cadmium Sulphide Cell 10/6.

* EDISWAN MAZDA

PXA101 6/6; XAI03 6/6.
 R.F.1. Pack: 1—PXA102 Mixer; 2—PXA101 I.F. Amp. (Equiv. OC44 and OC45) 10/6
 R.F. 2 Pack: 2—PXA101 I.F. 1—PXA102 Osc. 12/6
 PXA102 Mixer 10/6
 L.F. 6 Pack: Consisting of FXB113 Driver Matched pair, PX171 mounted complete with heat sinks (Equiv. OC81D and OC81) 12/6
 ALL TRANSISTORS POST FREE

TAPE DECKS

B.S.R. MONARDECK (single speed) 3 1/2in. per sec., simple control, uses 5 1/2in. spools. 26.15.0 plus 7/6 carr. and ins. (Tapes extra)
LATEST COLLARO MAGNAVOX 363 TAPE DECK DE LUXE. Three speeds, 2 track, takes up to 7in. spools. 10 gns. Plus 7/6 Carr. & ins. on each (Tapes extra).

PORTABLE TAPE RECORDER CASE

Beautifully made and expansively finished in dark grey heavy grade rexine. Satin Chrome metal grille front and chrome fittings. Speaker aperture 9" x 4". Overall size 15 1/2" w. x 15" d. x 7 1/2" h. Will take any standard tape deck or single record player. Limited number only. Worth at least 25/- OUR PRICE 49/6. P. & P. 6/-, Brand new and unused.

AGOS CRYSTAL MIKES. High imp. For desk or hand use. High sensitivity. 15/6. P. & P. 1/6
TEL CRYSTAL STICK MIKE. Listed at 45/-. Our price 18/6. P. & P. 1/6.

QUALITY RECORD PLAYER AMPLIFIER

A top-quality record player amplifier. This amplifier (was used in a 29 gns. record player) employs heavy duty double wound mains transformer, EOC83, EL84, EZ80 valves. Separate Bass, Treble and Volume controls. Complete with output transformer matched for 3 ohm speaker. Size 7in. w. x 2 1/2in. d. x 5 1/2in. h. Ready built and tested. PRICE 69/6. P. & P. 4/9.
 ALSO AVAILABLE mounted on board with output transformer and 6in. speaker ready to fit into cabinet below. PRICE 89/6. P. & P. 5/9.

QUALITY PORTABLE R/P CABINET

Uncut motor board. Will take above amplifier and B.S.R. or GARRARD Autochanger or Single Record Player Unit. Size 18 x 14 x 8 1/2in.
 Price £3.9.6. Carr. 7/6.

4-SPEED PLAYER UNIT BARGAINS

All brand new in maker's original packing.
SINGLE PLAYERS
 B.S.R. TU/12 £3.9.6 Carr. 5/6
 GARRARD SP25 De Luxe £12.10.6 Carr. 5/6
 B.S.R. GU7 with unit mounted pickup arm. £4.18.8 Carr. 5/6

AUTO CHANGERS

Latest B.S.R. UA25 Super slim £6.2.6
 GARRARD 1000 with special Hi-Fi cartridge. £6.19.6
 GARRARD AT6 £9.10.0. Carr. 6/6 on each.
 All the above units are complete with t/o mono head and sapphire styl or can be supplied with compatible stereo head for 12/6 extra.

BRAND NEW CARTRIDGE BARGAINS!

ACOS GP67-1. Mono complete. List price 21/-. Our price 13/8. P. & P. 1/-.

BRAND NEW 3 OHM LOUDSPEAKERS

5in., 12/6; 6 1/2in., 15/-; 8in., 21/-; 10in., 25/-; 7in. x 4in., 15/-; 10in. x 6in., 26/-.
 E.M.I. 8" x 5" with high flux ceramic magnet. 23/6.
 E.M.I. 13 1/2" x 8in. with high flux ceramic magnet. 42/- (15 ohm. 45/-). P. & P. 5/6 2/6; 6 1/2" x 8 1/2" 10" & 12 3/6 per speaker.

SPECIAL OFFER!

Limited number of 12in. 10 watt "R.A." Speakers: 3 ohm 25/-; 15 ohm, 27/6, P. & P. 3/6.

E.M.I. PLASTIC CONED TWEETERS. 2 1/2" 3 ohm. Limited number 12/6 each. P. & P. 1/6.
BRAND NEW HEAVY DUTY 12in. SPEAKERS Response 45 c/s-13 Kc/s. 1in. voice coil. Available in 3 or 15 ohms. Guaranteed full 15 watta British rating. Heavy cast aluminium frame. These are current production by world famous maker and as they are offered well below list price we are not permitted to disclose the name. LIMITED NUMBER ONLY. UNREPEATABLE at 59/6. P. & P. 5/6. Also 25 watt Guitar Model available at £5.5.0. And 35 watt Guitar Model £8.8.0.

VYNAR AND REXINE SPEAKER AND CABINET FABRICS.

Approx. 5 1/2in. wide. Usually 35/- yard. OUR PRICE 13/6 per yard length. P. & P. 2/6 (min. one yd.) S.A.E. for samples.

SPECIAL OFFER!

GENUINE HIGH QUALITY TYGAN FABRIC. 48in. wide. Our price 10/- per foot run. P. & P. 1/6. 30/- per yard run. P. & P. 2/6.

SEMI SHROUDED DROP THRO' MAINS TRANSFORMER. Tapped pri 200/250 v. at 110mA and 6.3 v. at 3 amp. (E/B screen). Stack size 3 1/2 x 3 1/2 x 1 1/2in. 30/-, P. & P. 3/6.

MAINS TRANSFORMER. For transistor power supplies. Pri. 200/240v. Sec. 0-0-9v. at 500mA. 11/-, P. & P. 2/6.

MAINS TRANSFORMER. For transistor power supplies. Tapped pri 200-250v. Sec. 40-0-40 at 1 amp (with electrostatic screen) and 6.3v. at 5 amp for dial lamps etc. Drop thro mounting. Stack size 1 1/2" x 3 1/2" x 3 1/2" 27/6. P. & P. 4/6.

SMOOTHING CONDENSER. 2800 mfd. 25v. 1 1/2" dia. x 3" high 3/-, P. & P. 1/6.

MATCHED PAIR OF 2 1/2 WATT TRANSISTOR DRIVER AND OUTPUT TRANSFORMERS. Stack size 1 1/2 x 1 1/2 x 1 1/2in. Output trans. tapped for 3 ohm and 15 ohm output. 10/- pair plus 2/-, P. & P. 2/6.

7-10 watt OUTPUT TRANSFORMERS to match pair of ECL 86's in push-pull to 3 ohm output. ONLY 11/-, P. & P. 2/6.

7-10 watt ULTRA LINEAR OUTPUT TRANSFORMERS to match pair of ECL 86's in push-pull to 3 ohm output. ONLY 16/-, P. & P. 2/6.

WELL-KNOWN MAKERS SURPLUS! ONE TRANSISTOR PRE-AMP

Suitable for use with Medium or High Impedance mikes, guitars, gram pickups, tape decks etc. For operation from 200/300 volt H.T. rail or 9 volt battery. Gain approx 14:1. Fully insulated input by Mu-Metal screened transformer. Size 4 1/2" x 1" x 1". Ready built complete with full circuit diagram and instructions. ONLY 15/-, Post free.

Dual Purpose Bulk Tape Eraser and Tape Head Demagnetiser, 35/-, P. & P. 3/-.

SPECIAL HARVSON OFFER! FM/AM TUNER HEAD



Beautifully designed and precision engineered by Dormer and Wadsworth Ltd. Supplied ready fitted with twin 0005 tuning condenser for AM connection. Prealigned FM section covers 86-102 Mc/s. I.F. output 10.7 Mc/s. ECL 86 valve and full circuit diagram of tuner head. Another special bulk purchase enables us to offer these at 27/6 each. P. & P. 3/-, Order quickly! Limited number also available with precision geared 3:1 reduction drive, 30/-, P. & P. 3/6.

MATCHED PAIR AM/FM I.F.'S

Comprising 1st I.F. and 2nd I.F. discriminator (465kc/s/10.7Mc/s). Size 1 x 1 1/4 x 2 1/4in. Will match above tuner head. 11/- pair. P. & P. 2/6.

SPECIAL PURCHASE! TURRET TUNERS

By famous maker. Brand new and unused. Complete with PCC84 and PCF86 valves 24-35 Mc/s I.F. Resists for Channel 1 to 5 and 6 and 9. Circuit diagram supplied. ONLY 25/- each. P. & P. 3/6.

GORLER F.M. TUNER HEAD

88-100 Mc/s 10.7 Mc/s I.F., 15/-, plus 2/- P. (EOC85 valve 8/6 extra).

3-VALVE AUDIO AMPLIFIER MODEL HA34

Designed for Hi-Fi reproduction of records. A.C. Mains operation. Ready built on plated heavy gauge metal chassis, size 7 1/2in. w. x 4in. d. x 4 1/2in. h. Incorporates EOC83, EL84, EZ80 valves. Heavy duty, double wound mains transformer and output transformer matched for 3 ohm speaker, separate Bass, Treble and volume controls. Negative feedback line. Output 4 1/2 watta. Front panel can be detached and leads extended for remote mounting of controls.

The HA34 has been specially designed for us and our quantity order enables us to offer them complete with knobs, valves, etc., wired **£4.5.0** and tested for only P. & P. 6/-.

HSL 'FOUR' AMPLIFIER KIT

A.C. Mains 200/250v., 4 watt, using EOC83, EL84, EZ80 valves.

● Heavy duty double-wound mains transformer with electrostatic screen.
 ● Separate Bass, Treble and Volume controls, giving fully variable boost and cut with minimum insertion loss.
 ● Heavy negative feedback loop over 2 stages ensures high output at excellent quality with very low distortion factor.
 ● Suitable for use with guitar, microphone or record player.
 ● Provision for remote mounting of controls or direct on chassis.
 ● Chassis size only 7 1/2in. wide x 4in. deep. Overall height 4 1/2in.
 ● All components and valves are brand new.
 ● Very clear and concise instructions enable even the inexperienced amateur to construct with 100% success.
 ● Supplied complete with valves, output transformer (3 ohms only), screened lead, wire, nuts, bolts, solder, etc. (No extras to buy.) PRICE 79/6, P. & P. 6/-.
 ● Comprehensive circuit diagram, practical layout and parts list 2/6 (free with kit).

This kit although similar in appearance to HA34 employs entirely different and advanced circuitry.

10/14 WATT HI-FI AMPLIFIER KIT

A stylishly finished monaural amplifier with an output of 14 watta from 2 EL84s in push-pull. Super reproduction of recorded music and speech, with negligible hum. Separate inputs for mike and gram allow records and announcements to follow each other. Fully shrouded section wound output transformer to match 3-15 ohm speaker and 2 independent volume controls, and separate bass and treble controls are provided giving good lift and cut. Valve line-up: 2 EL84s, EOC83, EF86, and EZ80 valves. Simple instruction booklet 1/6. (Free with parts). All parts sold separately. ONLY 27.9.6. P. & P. 8/6. Also available ready built and tested complete with std. input sockets, 29.5.0. P. & P. 8/6.
 Carrying case for above 25/6. P. & P. 7/6.

NEON A.C. MAINS INDICATOR. For panel mounting, cut out size 1 1/2 x 3 1/4in. deep inc. terminal. White case with lens giving brighter light. For mains 200/250v. 2/6 each. P.P.d. (6 or more post free).

Open all day Saturday
 Early closing Wed. 1 p.m.
 A few minutes from South Wimbledon
 Tube Station.

HARVSON SURPLUS CO. LTD.
 170 HIGH ST., MERTON, S.W.19 CHerrywood 3985
 SEND STAMPED ADDRESSED ENVELOPE WITH ALL ENQUIRIES

(Please write clearly)
 PLEASE NOTE: P. & P. CHARGES QUOTED APPLY TO U.K. ONLY P. & P. ON OVERSEAS ORDERS CHARGED EXTRA.

10/-

BARGAIN SALE

10/-

- 10/- PISTOL-GRIP SOLDERING IRON (USUALLY 25/-)
- 10/- 20 well assorted TRANSISTOR ELECTROLYTICS
- 10/- 3 Television Smoothing Condensers, 200/200 μ f., 200/100 μ f., 300/125/50 μ f., 275 volt
- 10/- 50 assorted $\frac{1}{4}$ watt 5% Resistors (Long leads)
- 10/- 100 $\frac{1}{4}$ to $\frac{1}{2}$ watt mixed resistor types, values
- 10/- 100 $\frac{1}{2}$ to 3 watt Close Tolerance types
- 10/- 100 Silver Mica/Ceramic/Polystyrene Condensers
- 10/- 50 assorted paper condensers .001 to .5 μ f
- 10/- 100 miniature paper condensers (Mixed values)
- 10/- 50 untested TRANSISTORS (excellent value)

- 10/- 6 NPN or PNP Switching Transistors (min. 200 mc/s)
- 10/- 10 Transistor Holders
- 10/- ACOS MONO PICK-UP HEAD COMPLETE WITH NEEDLES
- 10/- 3 Miniature earpieces complete with plug and lead
- 10/- 20 Diodes. Very high quality
- 10/- Magnetic Lapel Microphone with plug and lead
- 10/- 3", 4" or 5" Low impedance LOUD-SPEAKER
- 10/- SIGNAL INJECTOR R.F./I.F./A.F. parts and circuit
- 10/- Car Rev. Counter, Parts and Circuit (excl. meter)
- 10/- 12 pre-set potentiometers mixed

10/- FREE!
10/- FREE!

10/- FREE!
10/- FREE!

ANY ELEVEN ITEMS FOR £5!

10/- FREE!
10/- FREE!

10/- FREE!
10/- FREE!

Rush your order now! These prices cannot be repeated!

G. F. MILWARD

17 Peel Close, Drayton Bassett, Nr. Tamworth, Staffs. Phone: TAMWORTH 2321 POST ONLY

FREE TO AMBITIOUS ENGINEERS

—THE LATEST EDITION OF ENGINEERING OPPORTUNITIES

Have you sent for your copy?

ENGINEERING OPPORTUNITIES is a highly informative 156-page guide to the best paid engineering posts. It tells you how you can quickly prepare at home for a recognised engineering qualification and outlines a wonderful range of modern Home Study Courses in all branches of Engineering. This unique book also gives full details of the Practical Radio and Electronic Courses, administered by our Specialist Electronics Training Division—the B.I.E.T. School of Electronics, explains the benefits of our Employment Dept. and shows you how to qualify for five years promotion in one year.

SATISFACTION OR REFUND OF FEE

Whatever your age or experience, you cannot afford to miss reading this famous book. If you are earning less than £30 a week, send for your copy of "ENGINEERING OPPORTUNITIES" today—FREE

BRITISH INSTITUTE OF ENGINEERING TECHNOLOGY

344B, Aldermaston Court, Aldermaston, Berks.

WHICH IS YOUR PET SUBJECT

Mechanical Eng.,
Electrical Eng.,
Civil Engineering,
Radio Engineering,
Automobile Eng.,
Aeronautical Eng.,
Production Eng.,
Building, Plastics,
Draughtmanship,
Television, etc.

GET SOME LETTERS AFTER YOUR NAME

A.M.I.Mech.E.
A.M.I.C.E.
A.M.I.Prod.E.
A.M.I.M.I.
A.I.O.B.
E.So.
A.M.I.E.R.E.
City & Guilds
Gen. Cert. of Education
Etc., etc.

PRACTICAL EQUIPMENT

Basic Practical and Theoretic Courses for beginners in Radio, T.V., Electronics, etc. A.M.I.E.R.E., City & Guilds Radio Amateur's Exam R.T.E.B. Certificate P.M.C. Certificate Practical Radio Radio & Television Servicing Practical Electronics Electronics Engineering Automation

INCLUDING TOOLS!

The specialist Electronics Division of B.I.E.T. NOW offers you a real laboratory training at home with practical equipment. Ask for details.

B.I.E.T. SCHOOL OF ELECTRONICS

POST COUPON NOW!

- Please send me your FREE 156-page "ENGINEERING OPPORTUNITIES"
- (Write if you prefer not to cut page)

■ NAME.....
■ ADDRESS

■ SUBJECT OR EXAM THAT INTERESTS ME..... 344B



THE B.I.E.T. IS THE LEADING INSTITUTE OF ITS KIND IN THE WORLD

DANE Electronics

39 Barrack Rd. Northampton

GUARANTEED SOUND BARGAINS

GARRARD TURNTABLES

LAB.80

Transcription Player, less cartridge
£26.0.0

SP.25

Non-Auto Player, wired for stereo,
less cartridge £10.19.6

AT.60

Auto-Changer, heavy cast turn-table
less cartridge £11.12.6

3000

Auto-Changer, less cartridge
£8.12.0

2000

Auto wired for stereo including cartridge
£7.15.0

1000

Auto wired for stereo including cartridge
£7.5.0

CARTRIDGES

EV.26 shell cartridge, sapphire stylus 21/6
Sonotone 9TA HC Stereo 25/6
ACOS GP.83 Stereo 12/6
ACOS GP.67/1 with shell mono 12/6
ACOS GP.91/1 less shell mono 17/-
GARRARD GC.8 with shell mono 14/-
GARRARD GC.2 with shell mono 17/-
RONETTE DC.284P with shell
and diamond stylus 23/6

SPECIAL

AMERICAN VERITONE P.V.C.
TAPE—PROFESSIONAL QUALITY

SP.7 1200 ft. 13/6 7" reels
LP.7 1800 ft. 19/6
LP.5 900 ft. 11/6 5" reels
DT.5 1200 ft. 16/-
5½" reels LP.6 1200 ft. 14/-

CAR RADIOS

"Royal" Push Button 2 wave transi-
storised complete with speaker and
fitting kit £14.15.0
"Burleigh" 2 wave transistors complete
with speaker and fitting kit £11.7.6

AMPLIFIERS

15 watt Stereo Amplifier £31.15.0
10 watt Stereo Amplifier £18.0.0
8 watt Stereo Amplifier £11.19.0
"Minette" 2 valve Gram Amplifier £4.5.0

All above prices including
post and packing

DANE ELECTRONICS
39 Barrack Rd. Northampton

SLEEP LEARNING

Make use of your tape recorder to learn scripts,
languages, songs, speeches etc. etc. the modern
way.

Send S.A.E. for details and price list of time
switches, pillow speakers, tapes and complete
sleep learning outfits

MAINS POWER PACKS

The ideal economical and safe way of running
any Transistor Radio, Record Player, Tape
Recorder, Amplifier etc. from A.C. Mains.
The MAJOR "Power Plus" for 9v.; 39/6
6v.; 4½v.; Single Output. P. & P. 2/6
For 9v. + 9v.; 6v. + 6v.; 4½v. +
4½v. Two separate outputs. P. & P. 2/6 42/6

Please state outputs required

The BIJOU "Power Plus". For the smaller
set using PP3 type battery. Supplied complete
with special adaptor enabling you to reactivate
your existing PP3 type battery. 17/6
P. & P. 2/6

All units are completely isolated from mains by
double wound transformer ensuring 100%
safety.

LISTEN TO THE WORLD ON TELSTAR our

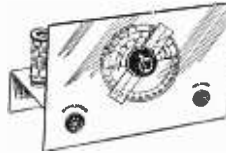

1-VALVE
SHORT WAVE
RADIO

Receives speech and music from
all over the
world. Price includes valve and one coil covering
40-100 metres. Can be extended to cover 10-100
metres. Can be converted to 2 or 3 valve and all-
mains speaker use. 35/- P. & P. 2/-
Total building costs 35/- P. & P. 2/-
All parts available separately.

R.C.S. PRODUCTS (RADIO) LTD.

(Dept. P.W.), 11 Oliver Road, London, E.17

NEW EDITION

RADIO VALVE DATA

CHARACTERISTICS OF 7,000 VALVES
TRANSISTORS • SEMICONDUCTOR
DIODES AND RECTIFIERS • CATHODE
RAY TUBES

Compiled "WW" 8th edition. 9/6
Postage 1/-

OUTLINE OF RADIO AND TELEVISION

by J. P. Hawker. 30/- Postage 2/-.

1966 WORLD RADIO TV HANDBOOK

28/- Postage 1/-.

TRANSISTOR TRANSMITTERS FOR THE AMATEURS

by D. L. Stoner. 21/- Postage 1/-

TRANSISTOR POCKET BOOK

by R. G. Hibberd. 25/- Postage 1/-.

RADIO CIRCUITS

by W. E. Miller revised E. A. W. Spreadbury.
25/- Postage 1/-.

RADIO AND TELEVISION TEST INSTRUMENTS

by G. J. King. 25/- Postage 1/6.

RADIO AND AUDIO SERVICING HANDBOOK

by G. J. King. 25/- Postage 1/6.

THE MODERN BOOK CO.

BRITAIN'S LARGEST STOCKISTS
British and American Technical Books
19-21 PRAED STREET
LONDON, W.2

Phone: PADDINGTON 4185
Closed Saturday 1 o'clock

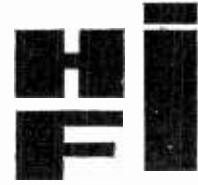

EQUIPMENT CABINETS OF DISTINCTION



Imperial

- Illustrated in this advertisement are two fine cabinets from the Lewis Radio Range.
- These cabinets are just two of a really extensive range.
- Each one carefully made by British Craftsmen and soundly constructed from the best materials available.
- Fill in coupon below to obtain FREE catalogue showing this wonderful range of cabinets.



Lowflex

FREE THE NEW LEWIS RADIO CATALOGUE

Designed to assist your choice of
Cabinet.
The New Lewis Radio Cabinet Cata-
logue—the most comprehensive ever
prepared. Sent absolutely FREE!
Please send your FREE cabinet catalogue.

NAME

ADDRESS

..... (Dept. P17)
Capitals please

LEWIS radio

100 Chase Side, Southgate, London N.14.
Tel.: Palmer's Green 3733 9666

Practical Wireless Classified Advertisements

The pre-paid rate for classified advertisements is 1/6d. per word (minimum order 18/-), box number 1/6d. extra. Semi-displayed setting £4. 12s. 6d. per single column inch. All cheques, postal orders, etc., to be made payable to PRACTICAL WIRELESS and crossed "Lloyds Bank Ltd." Treasury notes should always be sent *registered post*. Advertisements, together with remittance, should be sent to the Advertisement Manager, PRACTICAL WIRELESS, George Newnes Ltd., Tower House, Southampton Street, London, WC2, for insertion in the next available issue.

METAL WORK

METAL WORK: All types cabinets, chassis racks, etc., to your specifications. PHILPOITTS METAL WORKS LTD. Chapman Street, Loughborough.

SHEET METAL PUNCH (Pat. App. No. 309050/66), with Punch and Die for one size 19/6. P. & P. 4/-. Clearance sizes available, $\frac{1}{8}$ " to $\frac{1}{4}$ ". Send for leaflet. J. MOIR (TOOLS), 81 Oldham Street, Hyde, Cheshire.

SITUATIONS VACANT

TV and Radio, City & Guilds, R.T.E.B., Certs., etc. on 'Satisfaction or Refund of Fee' terms. Thousands of passes. For full details of exams and home training Courses (including practical equipment) in all branches of Radio, TV, Electronics, etc. write for 132-page handbook—FREE. Please state subject. BRITISH INSTITUTE OF ENGINEERING TECHNOLOGY, (Dept. 137K), Aldermaston Court, Aldermaston, Berks.

RADIO TECHNICIANS

A number of suitably qualified candidates are required for permanent and pensionable employment in various parts of the UK, including London, but primarily Cheltenham. There are also opportunities for service abroad.

Applicants must be 19 or over and be familiar with the use of Test Gear. They must have had Radio/Electronic workshop experience and offer at least "O" level GCE passes in English Language, Maths and/or Physics, or hold the City and Guilds Telecommunications Technician Intermediate Certificate or equivalent technical qualifications.

Pay according to age, e.g. at 19 £747, at 25 £962 (highest age pay on entry) rising by four annual increments to £1,104.

Prospects of promotion to grades in salary range £1,032-£1,691. There are a few posts carrying higher salaries.

Annual Leave allowance of 3 weeks 3 days, rising to 4 weeks 2 days.

Normal Civil Service sick leave regulations apply.

Application forms available from:
Recruitment Officer (RT/37)
Government Communications
Headquarters
Oakley, Priors Road
CHELTENHAM, Glos.

SITUATIONS VACANT

(continued)

ALDERMASTON COURT POSTAL TRAINING for B.Sc. (Eng) Part 1, A.M.I.E.R.E., A.M.S.E., City & Guilds, G.C.E., etc. prepares you privately for high pay and security as Technician or Technologist. Thousands of passes. For details of Exams & Courses in all branches of Engineering, Building, Electronics, etc. (including latest information on C.Eng.), write for 132-page handbook—FREE. Please state interest. BRITISH INSTITUTE OF ENGINEERING TECHNOLOGY, (Dept. 169K), Aldermaston Court, Aldermaston, Berks.

RADIO & TV Exam. and Courses by Britain's finest Home-study School. Coaching for Brit.I.R.E., City & Guilds Amateur's Licence, R.T.E.B., P.M.G. Cert., etc. FREE brochure from BRITISH NATIONAL RADIO SCHOOL, Russell Street, Reading.

RADIO TECHNICIAN

with a sound knowledge of at least three of the following types of equipment is required immediately for Meteorological Office Ocean Weather Ships:

Single Side-Band Transmitter
Radar (Navigational)
Radar Height Finding
Echo Sounders and Radio Receivers
Automatic D.F., V.H.F. and
M.F. Low Voltage Servo Recorders.
Digital Telemetering Equipment.

Salary scale £678-£1104 per annum, according to age, plus £120 per annum overtime allowance. Free food and accommodation provided on board ship.

Applicants must be natural born British subjects.

Full details from

SHORE CAPTAIN
Ocean Weather Ship Base
Great Harbour, Greenock
Telephone: Greenock 24291.

EDUCATIONAL

TRAIN FOR SUCCESS WITH ICS

Study at home for a progressive post in Radio, TV and Electronics. Expert tuition for I.E.R.E., City & Guilds (Telecoms and Radio Amateurs') R.T.E.B., etc. Many unique diploma courses incl. Colour TV, Electronics, Telemetry & Computers. Also self-build kit courses—valve and transistor.

Write for FREE prospectus and find out how ICS can help you in your career.

ICS DEPT. 541 PARKGATE ROAD
LONDON, S.W.11.

EDUCATIONAL

(continued)

RADIO OFFICER training courses. Write: Principal, Newport and Monmouthshire College of Technology, Newport, Mon.

RADIO OFFICERS see the world! Sea-going and shore appointments. Trainee vacancies during 1967. Grants available. Day and Boarding students. Stamp for prospectus. Wireless College, Colwyn Bay.

"BECOME "Technically qualified" in your spare time, guaranteed diploma and exam. home-study courses in radio, T.V. servicing and maintenance. T.T.E.B., City and Guilds, etc. highly informative 120-page Guide—free. CHAMBERS COLLEGE (Dept. 857K), 148 Holborn, London. E.C.1."

CITY & GUILDS (electrical, etc.) on 'Satisfaction or Refund of Fee' terms. Thousands of passes. For details of modern courses in all branches of electrical engineering, electronics, radio, T.V., automation, etc., send for 132 page Handbook—FREE. B.I.E.T. (Dept. 168K) Aldermaston Court, Aldermaston, Berks.

BOOKS & PUBLICATIONS

A GUIDE TO SURPLUS COMMUNICATION RECEIVERS

A detailed guide to thirty-one receivers, including the HR0, AR88, CR100, R107, R1155, PCR, 52 set, etc.

7/6. P. & P. 1/-. Mail order only to:
ADKINS, 72 Courtenay Ave, Harrow
Middlesex.

SURPLUS HANDBOOKS

19 set Circuit and Notes	4/6 p/p 6d.
1155 set Circuit and Notes	4/6 p/p 6d.
H.R.O. Technical Instructions	3/6 p/p 6d.
38 set Technical Instructions	3/6 p/p 6d.
46 set Working Instructions	3/6 p/p 6d.
88 set Technical Instructions	5/- p/p 6d.
BC.221 Circuit and Notes	3/6 p/p 6d.
Wavemeter Class D Tech. Instr.	3/6 p/p 6d.
18 set Circuit and Notes	3/6 p/p 6d.
BC.1000 (31 set) Circuit and Notes	3/6 p/p 6d.
CR.100/B.28 Circuit and Notes	8/6 p/p 6d.
R.107 Circuit and Notes	5/- p/p 6d.
AR.88D Instruction Manual	15/- p/p 1/6
62 set Circuit and Notes	4/6 p/p 6d.
Circuit Diagrams 3/- each post free, R.1116/A, R.1224/A, R.1355, R.F. 24, 25 and 26, A.1134, T.1154 (all models), BC.312, BC.342, BC.348J, BC.348 (E.M.P.), BC.624, 22 set.	
52 set Sender and Receiver circuits 8/- post free	

Resistor colour code indicator, 1/6 p/p 6d.

S.A.E. with all enquiries please.

Postage rates apply to U.K. only.

Mail order only to:

INSTRUCTIONAL HANDBOOK SUPPLIES

DEPT. PW. TALBOT HOUSE,
28 TALBOT GARDENS, LEEDS 8

BOOKS & PUBLICATIONS

(continued)

AUDIO, America's foremost journal. Year's subscription 43/-, specimen copy 4/-. All American radio journals supplied—list free. WILLEN (Dept. 40), 61a Broadway, London, E.15.

MISCELLANEOUS

CONVERT ANY TV SET into an Oscilloscope. Diagrams and instructions 12/6. REDMOND, 42 Dean Close, Portslade, Sussex.

ELECTRONIC MUSIC?

Then how about making yourself an electric organ? Constructional data available—full circuits, drawings and notes! It has 5 octaves, 2 manuals and pedals with 24 stops—uses 41 valves. With its variable attack you can play Classics and Swing. Write NOW for free leaflet and further details to C & S., 20 Maude Street, Darlington, Durham. Send 3d. stamp.

SERVICE SHEETS

SERVICE SHEETS for all makes. Radio, T.V. Tape Recorders, 1925-1966. Prices from 1/-. Catalogue 6,000 models 2/6d. Free fault-finding guide with all Sheets. Please send stamped addressed envelope with all orders/enquiries, HAMILTON RADIO, Western Road, St. Leonards, Sussex.

SERVICE SHEETS, Radio TV, 5,000 models, List 1/-. S.A.E. inquiries. TELRAY 11 Maudland Bank, Preston.

SERVICE SHEETS (75,000) 4/- each. Callers welcome. Always open. 5 South Street, Oakeshaw, Bradford.

SERVICE SHEETS

4/- each, plus postage

We have the largest display of Service Sheets for all makes and types of Radios and Televisions, etc., in the country. Speedy service.

To obtain the Service Sheet you require please complete the attached coupon.

Name:

Address:

To: S.P. DISTRIBUTORS

30 Baker Street, London, W.1

Please supply Service Sheets for the following

Make:

Model No. Radio/TV

Make:

Model No. Radio/TV

Make:

Model No. Radio/TV

I require the new 1967 List of Service Sheets at 1/6 each plus postage.

(please delete items not applicable)

I enclose remittance of (which includes postage)

MAIL ORDERS ONLY (Jan.) PW

RECEIVERS & COMPONENTS

Unique Stereo/Mono Hi-Fi systems and record players, with components of your choice, at far less than shop prices! Systems from only 23 gns, (less than many players), players from only £8.1½. For details, please state requirements, enclose 4d. S.A.E.—SINCLAIR, 4 Southover Way, Hunstno, Chichester, Sussex.

MULLARD TRANSISTOR BARGAIN

Brand new first grade—fully guaranteed. OC44, OC81D, OC81, OC73, any 5 pieces 10/- post paid. Matched Output Set OC81D + pair OC81 7/- post paid. Matched RF Set OC44 + pair OC45 8/6 post paid.

100 pIV 750 mA Silicon Rectifiers 8 pieces 10/- 2N2926 Planars gain spread 150-300 3 pieces 11/- KS31W Thermistors 8 Kohms at 20°C 2/- each. 1500+2000 MFD at 25V WKG. Capacitors 3/- each. CATALOGUE. Our 16 page list contains prices of hundreds of Semiconductors, circuits and handy reference section—Send 1/- stamps. Postage. 9d. per order.

L.S.T. COMPONENTS

23 New Road Brentwood Essex

COMPONENTS, transistors ex-W.D. and surplus. Call at ROGERS, 31 Nelson Street, Southport. (List 6d stamp.)

VALUE IN TRANSISTORS

Germanium high gain, amplifier (up to 5 Mc/s) 2N1304, NPN, 4/3; 2N1305, PNP, 4/3. Silicon high gain, amplifier (up to 100 Mc/s) 2N2926, NPN, 4/-; 2N3702, PNP, 4/9. Matched pairs available 6d. extra. Many other high gain types stocked. Cat. 6d. Cadmium Sulphide Photoconductive Cells Similar to ORP12, brand new 5/3. Top line in Resistors, brand new ½W 5% 4-7Ω to 10MΩ 2/3 doz, 17/3 100. Electrovalve (PW) 6 Mansfield Place, Ascot, Berks

RECEIVERS & COMPONENTS

(continued)

TRANSISTORS, UNMARKED, UNTESTED, 40 for 10/-, p. and p. 1/-, 4 packets post free. Relays, thousands of types, special catalogue free. General catalogue of Mechanical and Electrical Gear, Tools, etc. (5,000 items), free. K. R. WHISTON (Dept. PRW), New Mills, Stockport.

WELL-KNOWN ARMY TRANS-RECEIVER MK III Range 2-8 Mc/s R.T. M.C.W. and C.W. approx. size 17 x 7 x 1 1/2 in. Power required 12 VLT. Receiver H 275 V. T.X. 500 V. set only 45/- or with 235 Mc/s U.H.F. Tx/Rx. Section 15/- extra. Carr. both 10/-. Every set checked complete and in reasonable condition. Air tested 10/- 12 V.D.C. P.U. 15/- New 30/-, Carr. both 5/- Brand new 200/250 V.A.C. Power Unit for Receiver. In louvered metal case 12 V. and 275 V. complete with 12 pin plug to set only 70/- post 5/-. Similar P.U. for T.X. and R.X. supplying 12 V.D.C. 275 V. and 500 V. 27.10.0. post 5/- Brand New Headset and Mike which plug straight into set (specially made) 22/6. Brand New Sets available at £6.10.0. New Aerial tuning units at 20/-. Post 7/6. All circuits of units supplied.

TOWNEND RADIO (DEPT. E) 288 Wakefield Road, Bradford 4, Yorks.

NEW COMPONENTS

- * TRANSISTORS—Matched Output Kit: OC81D and 2-OC81 9/6 R.F. Kit: OC44 and 2-OC45 9/6 OC44, 45, 70, 72, 81 and 81D Equivalents, each 3/-
- * RESISTORS—5% Hi-Stab Carbon Film 75Ω to 1MΩ (½ watt); 10 off, one preferred value 4/-
- * CAPACITORS—Polyester Foil: 180 VDC/100 VAC. 33 pF to .1µF: 5 off, one preferred value 9/6 .1µF to .47µF: 5 off, one value 5/-
- * ASSORTED CAPACITORS—New. Paper, Polyester, Electrolytic etc.: 100 off 9/6
- * ASSORTED RESISTORS—Hi-Stab. 300 off (5% or better, worth 25). 15/- (P. & P. 1/6 per order, C.W.O.)

ELMBRIDGE INSTRUMENTS LTD.

Island Farm Avenue, West Molesey, Surrey

(continued on next page)

BI-PAK SEMICONDUCTORS

8 RADNOR HOUSE 93/97 REGENT STREET LONDON, W.1

LOW COST SILICON CONTROLLED RECTIFIERS (THYRISTORS) FACTORY TESTED

1 AMP (20-5 can) PIV EACH	7 AMP (STUD) PIV EACH	16 AMP (STUD) PIV EACH	Free SCR Literature including Circuit Diagrams for Light Dimmers, Speed Controllers, AC Power Switch, etc., with SCR order or on request.
50 8/6	100 10/8	100 16/6	
100 9/6	400 30/-	400 35/-	
200 22/6	600 45/-	600 55/-	
400 22/6	25 PIV Power SCR 50 Amp, Special Price 35/-		

FREE One 10/- Pack of your own choice free with orders valued £4 or over **FREE** Logic Modules and/or Gates, Memory Units, Timer Units, etc., details free **FREE**

VALUE PAK 50 TRANSISTORS MIXED UNTESTED 10/- 10 SCR'S UNMARKED, UNTESTED VOLTAGE RANGR 1 Amp 20/- 50-400 PIV

3 OC139 Trans. NPN Mullard	10/-	3 High vit. AF Trans. PNP ACY17	15/-
2 Drift Trans. 2N1295 100 M/Cs	10/-	8 Sil. Rect. 750mA 100 PIV TEXAS	15/-
6 Matched Trans. OC44(45/81/81D)	10/-	3 BS95A Sil. Trans. STC	15/-
4 OA10 Diodes Mullard	10/-	3 Sil. Trans. OC200 Mullard	15/-
15 Red Spot AF Trans. PNP	10/-	2 Sil. Power Rect. 6 Amp. 200 PIV BVZ13	15/-
15 White Spot RF Trans. PNP	10/-	1 AF139 GERM. Trans. 1600 M/Cs	15/-
4 Sil. Rects. 3A 100/600 PIV	10/-	1 Sil. Power Trans. 100 M/Cs STC BU111	15/-
4 NPN Trans. OC139 2N1308, ETC	10/-	6 Zener Diodes 3-15vIts. Mixed 400mW	15/-
2 10 Amp. Sil. Rect. 50/100 PIV	10/-	5 OAS Gold Bonded Diodes Mullard	10/-
8 Diodes 4 OA70, 4 OA79	10/-	1 2N1132 PNP PLANAR Trans. Sil	15/-
1 3 AMP SCR 100 PIV	10/-	2 2N697 NPN PLANAR Trans. Sil	15/-
3 Sil. Trans. 28303 PNP	10/-	4 GERM. Power Trans. eqvt. OC16 Mullard	15/-
5 2G34A Trans. Eqvt. OC44	10/-	1 UNIJUNCTION Trans. 2N2646 G.E.	15/-
10 Assorted Computer Diodes	10/-	2 Sil. Trans. 60VCB 200 M/Cs. TZ83/84	15/-
4 Zeners 5, 6.8, 10, 12 VIts	10/-	1 Sil. PLANAR Trans. BSY25 NPN 1000M/Cs	15/-
4 2G417 Trans. Eqvt. AF116/7	10/-	1 Sil. Trans. IS104 160 M/Cs HFE 200 NPN	15/-
2 200 M/Cs 8 I. Trans. BSY26/7	10/-	2 SCR's 50 PIV 1 Amp. TO-5 can	15/-
2 Bi-directional Trans. AS766	10/-	1 Tunnel Diode IN376 (TD-5) G.E.	15/-
4 High Current Trans. OC49	10/-	1 2N2160 UNIJUNCTION Trans. TO-5 can.	15/-
2 Power Trans. OC26/35	10/-	2 Sil. Rect. 5 Amp. 400 PIV Stud	15/-
5 Sil. Rect. 400 PIV 250mA	10/-	1 Tunnel Diode JK 19B ETC. 1200 M/Cs	15/-
3 OC71 Trans. Mullard	10/-	2 GERM. Power Trans. OC28/29	15/-
3 OC78 Trans. Mullard	10/-	1 2N174 Power Trans. 150W PNP Ic 1A	15/-
3 NPN Sil. Trans. 70 M/Cs	10/-	6 Sil. Rect. Type BY100 800 PIV 550mA	20/-
1 Power Trans. OC20 100 VIts	10/-	8 Sil. Rect. 400 PIV 200/600mA	20/-
5 OA47 Gold Bonded Diodes	10/-	1 Transistor Manual by G.E. 648 pages	30/-
4 OA202 Sil. Diodes Sub-Min	10/-	1 Silicon Controlled Rect. Manual G.E.	30/-
3 OC77 Trans. Mullard	10/-	25 Mixed Sil. & GERM. Trans. New Marked	30/-
8 OA31 Diodes Sub-min	10/-	40 Mixed Semiconductors New Marked	40/-
8 Sil. Rects. 400 PIV 500 mA	10/-	1 Logic Module Handbook & Catalogue	17/6

Our vast stocks change daily with hundreds of Semiconductor bargains becoming available. Just send 2/6 to cover 3 months mailing of our latest stock lists, eqvt. charts, circuits, etc.

Minimum Order 10/-. CASH WITH ORDER PLEASE. Add 1/- postage and packing per Order. GUARANTEED by return postal service. Overseas add extra for Airmail.

RECEIVERS & COMPONENTS

(continued)

**BRAND NEW
MULLARD
TRANSISTORS
OC83**

Output Transistors can be used in place of OC81 with better results. 4/6 each, 7/6 for 2, 42/- a dozen.

C.W.O. p. and p. 2/6d in the pound

Trade Enquiries Welcomed

**NEW ERA, 70 Baring Road,
London, S.E.12
Kip. 7978**

CQ ALL HAMS Telephone sets "L." Mk. 1 with batteries 36/- each or 58/6 pair. Carbon hand mikes No. 4 7/6. Remote control units No. 2 13/6. No. 10 padded moving coil head phones & mike 12/6. 3 gang 500 Pf tuning capacitors new & boxed 8/6. 19 set morse keys 7/6. 6V6 & 807 valves 5/-. Post paid. SAE lists. G. WEBSTER (ELECTRICAL) 9a Greyfriars Road, Coleham, Shrewsbury, Shropshire.

31 Set WTs. complete with 15 valves and 2 crystals. Operate up to 48 MEG tunable with circuit and details. No rear case 25/- each. Part post 5/-.
Spare Set Valves and Crystals. 12/6.
Chassis less valves. 12/6. P. & P. 5/-.
No other spares available.
Assorted High Stab Resistors. 7/6, 100.
Assorted Syntex P.P. Condensers. 7/6, 100.
Paxolin Sheet. 1/16" x 12" x 12". 3/-.
Thin Paxolin Sheet. approx. 1/64" x 12" x 12". 6 sheets for 5/-.
White Plastic Sheet. approx. 1/32" x 6 1/2" x 24". Suitable dials, insulation, case fronts, etc. 4 sheets for 5/-.
Small E.M. Counters, 5 digit, 500 ohm. 6/6.
Bulgin Extra Sensitive Micro Switch. 5/-.
P.O. Relay 2000 ohm. 1B. 8 1/4". 1B. 8/-.
Key Switches, 4 pole, 2 throw, 3/6. 3 position DP+DP centre off. 5/-.
3 c/o+4 c/o centre off. 6/-.
DP+DP 2 for 5/-.
Plessey Plugs and Sockets. 12 way, 3/- pr. 6 way, 5/- pr.
6 or 12 way screened cable to match. 3/- yd.
Breast Mjke. 6/-.
Carbon Inserts. 1/6.
Battery Ever-Ready. 90v+7iv. 4/6, 12 for 30/-.
Small Component Boxes. 12/6, for 60 samples 6d.
M.L. Metal Screen for 5uP7 with fittings 6/6.
250mA Fuses 1 1/2". 5/-, 100.
100 volt Hand Generator. 7/6.
Rheostat WW Rotary. 15 ohms. 3.6 amp. 12/6.
Details of Instrument Case Assembly. Free, send large addressed envelope.
Elac Speakers. 5". 5/-, 7" x 4". 7/-, 8". 8/-.
Rotary Transformer. Input 12 volts, output 490v at 65mA. 9/-.
Rotary Transformer. 12v input, 300v output, at 0.2 amp. 35/-.
Modern lightweight Breast Mjkes, Polythene fittings. New. 7/6, spare insert 2/6.
Ernest Turner meter 2 1/2" fitting (round) 1-0-1M/A. Centre zero. 12/6.
Carpenters relay type 3SE1. 250 ohm + 200 ohm each side. Fitted with plug in base. 17/6 each.
Type 3000 F.O. relay. New 6000 ohm coil. 2 sets of change-over. 3/6.
Printed circuit board. 11" x 5 1/4" ideal for reuse with 28 diodes CV448 plus some high stab resistors. 10/- post paid.
A new range of instrument cases ready send for free list. S.A.E. please.

E. R. NICHOLLS

Mail Order and Retail Shop
46 LOWFIELD ROAD
OFF SHAW HEATH, STOCKPORT
CHESHIRE

RECEIVERS & COMPONENTS

(continued)

'BY 100 rectifiers 4/- each any quantity. Post Paid. BLAKE, 52A Runcorn Road, Birmingham 12.

A.I. POST FREE BARGAINS

SPECIAL OFFERS ALL BRAND NEW

V/controls w/wound s.p. switch 25k or 50 k 4/9
V/controls carbon less switch all values 3/6
V/controls carbon D.P. switch all values 5/9
Mixed resistors per 100 7/6
Wearite "P" coils PA1-PA3-PA4-PA5 3/6 each
Wearite "P" coils PO3-PO4-PO5-PO7 3/6 each
2-way socket panels 9d. each. 4/9 dozen.
Recording TAPE
3in. 300ft. 4/9 3in. 150ft. 3/3
5 1/2in. 1800ft. 20/- 5in. 900ft. 12/-
7 in. 1800ft. 19/- 7in. 3600ft. 57/8
3in. 600ft. 12/6 3in. 225ft. 3/9
5in. 600ft. 8/3 5 1/2in. 1200ft. 14/6
7in. 1200ft. 14/3 4in. 900ft. 14/6
3 Reels and over 5% discount.

S.A.E. All enquiries. Satisfaction guaranteed.

A.I. RADIO COMPONENTS

14 The Borough Canterbury Kent

MARCONI CANADIAN RECEIVER No. 52



Shipping Amateur, & Broad-cast. Magnificent 10-valve receiver in three switched wave-bands covering 1.75-16 Mc/s (19 - 170 metres), plus 3 valve crystal calibrator, employing dual crystal to provide marker check at 10-100-1000 kc/s. One RF and two IF stages. Other refinements: valve, HT, and signal check meter. Internal 3in. speaker and two H/Gain, Noise Limiter, Filter, BFO, Heterodyne pitch control. Wide and Narrow Bandwidth Man. or AVC on CW & RT. Fast and Slow tuning with lock. Additional OSC Tuning (plus & minus). Size 15 x 14 x 12in. Fully tested and working. A.C. Mains 200/240v. £14. Carr. £1

No. 52 GROUND-STATION comprising Receiver, Transmitter and 12v. D.C. Power Unit. £27.10.0. Carr. £2.10.0. (Mainland only).

**NATIONAL H.R.O. SENIOR RECEIVERS
5T MODEL**



In excellent tested condition. Complete with 9 coils 50 Kc/s-30 Mc/s and Power Unit. £31.10.0. Carr. 30/-.

REFLECTOR UNITS 1.2-10 Mc/s
Switched, 4 ranges. Primarily designed as station reflector for R.C. Suitable for harmonic suppression and many other uses with slight alteration. Tuning dial with lock. Aerial in and out sockets. Brand New 25/-, P. & P. 5/-.

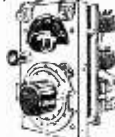

4 VALVE 4 WATT AMPLIFIER



"C" Core transformers A.C. Mains 110/230 volts 600 ohms of high impedance input. Output 3 or 6W ohms (state choice) Controls: On/Off switch Gain control. Indicator light. Valve inspection panel. 19 x 7 x 7in. Brand New in maker's carton. 79/6. Carr. 10/-.

32ft. TELESCOPIC AERIAL MASTS

Comprising 20ft 4 section tubular steel telescopic mast and 12ft. folding whip; can be erected in less than 5 minutes. Closes to 5ft. 9in. Weight 21 lbs. Must have cost well over £20. Price 70/-, Carr. 5/-.

ROTARY TRANSFORMER. 12v. D.C. input, 250v. D.C. output at 125 mA. Size 3 1/2 x 5 1/2in. Brand new 17/6. P. & P. 5/-.

Also **AMERICAN DYNAMOTOR UNIT. 12v. D.C. input 240v. output, 150 watts approx. Suitable for Universal A.C./D.C. equipment, 45/-, Carr. 5/-.** Many other types.

R.F. ANTENNA TUNER (A.T.U.) Calibrated scale, Ideal 160/50/40 metres. Limited number only. Brand new with instructions. 17/6. P. & P. 7/6
ALL 19 SETS & PARTS AVAILABLE
Complete list of other bargains. 1/-.
S.A.E. all enquiries. Credit Terms Available.

A. J. THOMPSON (Dept. P.W.)

"ELLING LODGE", CODICOTE, HITCHIN, HERTS.
Phone: CODICOTE 242

RECEIVERS & COMPONENTS

(continued)

**JOHN'S RADIO (Dept. B)
OLD CO-OP, WHITEHALL ROAD,
DRIGHLINGTON, BRADFORD**

EXCLUSIVE OFFER
Radio Telephone Type T.R.101. MK 2 Medium Power



These sets cover the range of 2-8 mcs. in two switched bands, using R/T and C.W. incorporating netting control, internal speaker and internal P.U. for 200/250 V.A.C. A. 12 volt D.C. version available. A meter is used for checking the set while in operation, using 13 valves, (3 EL32 in final transmitter output) transmitter automatically tunes to the same F.X. as receiver, which uses one R.F. and two I.F. stages, being extremely sensitive and selective. Each set supplied fully tested, complete with mike, headset, spare valves, handbook, in carton, brand new. £17.10.0. carr. 30/-
(Manufacturing price alone cost around £100 each)
These sets have been made to stand up to the hardest of wear and working conditions.
T.R. 101 MK 1 R/T M.C.W., C.W.
This set is practically identical to the above, but being an earlier version, using:
11 valves (one large valve in final output instead of three). Main difference external power unit for 200/250 V.A.C. or 12 V.D.C., or 12 and 24 V.D.C. Also no Internal Speaker. Size of Mk. 1 and 2 approx. 18 x 8 x 12 ins., supplied complete with mike and headset, handbook, fully tested in carton, BRAND NEW. Set with mains P.U. £14.10.0. 12 and 24 V.D.C. £12.10.0. 12 V.D.C. £10.10.0. Carriage all 30/-.

**STELLA NINE
RANGE**

A new range of instrument cases including most of the designs used in Practical Wireless and Practical Electronics, from September 1966 issues.

These will be made for stock, ready for return-of-post service.

Send now for free photostats and price lists.

Money back guarantee on all goods if not satisfactory.

E. R. NICHOLLS

46 Lowfield Road, Stockport,
Cheshire.

(continued on next page)

RECEIVERS & COMPONENTS
(continued)

R & R RADIO & TV SERVICE

Dept. P.W.
MARKET STREET, BACUP, LANCs.
Telephone 465

SALVAGE VALVES		Tested before despatch					
6F13	4/6	U329	5/-	30P11	4/-	20P4	6/6
6L18	4/6	10P14	5/-	PL36	6/-	PC084	4/-
EP80	1/8	20P5	6/6	PL82	3/6	PY81	8/6
ECC82	3/-	30P	7/-	U801	7/6	U301	6/-
ECL80	3/6	6P16	5/-	10F1	1/6	10P13	5/6
30F5	5/-	EP91	1/-	30P14	5/-	20D1	2/-
PCF80	4/-	EP85	5/-	PY32	6/-	30P12	5/-
PL81	5/-	6/30L2	4/-	6U4GT	5/-	PY83	5/-
PZ30	5/-	20P3	6/-	EY86	4/-		

Speakers. Ex.T.V. 5in. round 6 x 4in., 3/6; 8in. round 6/-; post 2/-.

Line Output Transformers available. State set model No. Turret Tuners, 8/-, post 2/-.

Scan Coils, etc. Quote set model No. with all enquiries and S.A.E. for prompt reply. All goods subject to satisfaction or money refunded.

POST EARLY FOR CHRISTMAS!

and get 40 semiconductors for £1 in my £5 value package containing:—8 Si & Ge transistors, 2 thyristors, 18 Si & Ge signal diodes, 6 zeners, 6 Si rectifiers. Money-back guarantee.

J. C. WOODWARD

94 Great Brickkiln St., Wolverhampton

**POCKET SIZE
Transistor Testers**

Tests Transistors in or out of set
Test both P.N.P. and N.P.N.
Price 30/- Battery and Post Free

Personal shoppers welcome

BROOK & HILL ELECTRONICS
695/697 Seven Sisters Road,
London, N.15
(50 yds. from Wards Corner)

FOR SALE

FIVE-TON FACTORY CLEARANCE: Radio TV Electrical Components in mixed parcels. Example: 22lb. mixed parcel £1, p.p. 7/6. Speakers, grilles, valves, bases, i.f.s. covers, condensers, etc. Hundred other items. S.A.E. list and postal order to P. NEWTON, 16 Shalcross Crescent, Hatfield, Herts.

ELECTRIC SOLDERING IRON



**FANTASTIC
BARGAIN OFFER**

Lightweight Pistol Grip handle 40 watt. 240/250v. A.C. Detachable handle forms cover for iron when not in use. With 4ft. Safety 3-core flex. Indispensable for every home handyman. A boon to model makers and a necessity for every wireless enthusiast. Offered to you at this new amazing price.

**ONLY
10/-
Post
Free**

C. H. SERVICE (Dept. P.W.)
Lusted Hall Lane, Tatsfield, Kent.

FOR SALE
(continued)

Pair of new column speakers, each containing 4 x 10" Goodman's speakers. Overall size 50" x 12" x 10". £16 the pair, or £10 each. 'PHONE HALIFAX 21796.

SPECIAL OFFER

GEVAERT TAPE. New, Boxed, 5 $\frac{1}{2}$, 600ft. with Stop and Leader Tapes 9/- or 6 for 50/-, post paid.
GRUNDIG MA1. 2 Transistor Pre-amps for Tape Monitoring or Microphone Boosters, 57/6, post paid.
LIST PRICE 4 GNS.
LEE ELECTRONICS
400 Edgware Road, Paddington 5521
Send for Free Lists and details of above

PCR modified as PW less case £12. 53 Ingatestone Road, Woodford Green, Essex.

MANUFACTURERS varied surplus, experimenters send for list. HATFIELD, 7 St. George Bungalow, Hildenborough, Kent.

MORSE MADE EASY!

The Famous RHYTHM RECORDED COURSE cuts the practice time down to an absolute minimum.

One student, aged 20, took only 13 DAYS, and another, aged 69, took under a week to read 18 wpm. If you wish to read Morse easily and naturally please enclose 8d. in stamps or two international reply coupons for full explanatory leaflet to: G3CHS/P, 45 Green Lane, Purley, Surrey, UPLands 2896

Linstead audio frequency signal generator, new condition, £15. E. RILEY, 1 Boulton Square, West Bromwich, Staffs.

**TRANSISTORS
SPECIAL OFFER**

1 watt S.T.C. 300 mc/s N.P.N. Silicon Planar, Transistors limited stocks £1 for 6.
WITH DATA

3/- each. OC44, OC45, OC70, OC71, OC81, OC81D, OC200, GET16, GET20.

4/- each. AF114, AF115, AF116, AF117, OC170, OC171.

5/- each. OC139, OC140, GET7, GET8, GET9, XC141, BY100, OA211.

BSY27 7/6 each OC20 10/- each

ZENER DIODES

All volts between 3.9v. and 26v.
 $\frac{1}{2}$ w 3/6 each, 1.5w 5/- each, 7w 6/- each.

Send 6d. for full lists:—
inc., S.C.R., Zeners.

CURSONS
78 BROAD STREET
CANTERBURY, KENT

FOR SALE
(continued)

"PRACTICAL WIRELESS" and "PRACTICAL TELEVISION" back numbers. Details, 77 Merrion Avenue, Stanmore, Middx.

HAMMERITE HAMMER PATTERN BRUSH PAINT FOR PANELS, METALWORK

3/8 TIN • JUST BRUSH ON •
WITHSTANDS 150°C. OIL, WATER ETC.
2 $\frac{1}{2}$ oz. tins ... 3/6 $\frac{1}{2}$ gallon ... 35/-*
 $\frac{1}{2}$ pint ... 7/6 1 gallon ... 58/-*
Carriage: Orders up to 5/-, 9d.; up to 10/-, 1/9; over 10/-, 3/-. Colours: blue, silver, black or bronze. Return of post service, Monday to Friday.
From your component shop or direct from the manufacturer:
FINNIGAN SPECIALTY PAINTS (PW)
Mickley Square, Stockfield, Northumberland.
Tel. Stockfield 2280.

WANTED

VALVES WANTED, brand new popular types boxed. DURHAM SUPPLIES (C), 175, Durham Road, Bradford 8, Yorkshire.

WE BUY New Valves and Transistors. State price. A.D.A. MANUFACTURING CO., 116 Alfriton Road, Nottingham.

DAMAGED AVO METERS wanted. Models 7 and 8. Any condition. Any quantity. HUGGETTS LTD., 2-4 Pawson's Road, West Croydon.

WANTED: Popular Brand New Valves. R.H.S. Stamford House, 538 Great Horton Road, Bradford 7.

WE BUY New Valves for cash, large or small quantities, old types or the latest by return. Send details. Quotations by return. WALTON'S WIRELESS STORES, 15 Church Street, Wolverhampton.

**WANTED NEW
VALVES ONLY**

Must be new and boxed
Payment by return

WILLIAM CARVIS LTD
103 North Street, Leeds 7

SOUND RECORDINGS

A UNIQUE TAPE BUY! Top brand 7in. 2,400ft., 25/-; 5 $\frac{1}{2}$ in., 1,200ft. 15/- P. and P. 1 at 2/-, 2 at 2/9, 3-6 at 3/6. Bargains in all sizes. S.A.E. for list. E.C. KINGSLEY AND CO. LTD., 93 Tottenham Court Road, London W.1., EUSton 6500.

TAPE RECORDERS, TAPES, Etc.

TAPES TO DISC—using finest professional equipment 45 rpm—18/-. S.A.E. leaflet. DERBY, High Bank, Hawk Street, Carnforth, Lancs.

Please mention
"Practical Wireless"
when replying to
Advertisements

H.A.C. SHORT-WAVE KITS

NEW RELEASE: MODEL "DX"



Famous for over 30 years for Short-Wave Equipment of quality, "H.A.C." were the original suppliers of Short-Wave Receiver Kits for the amateur constructor. Over 10,000 satisfied customers—including Technical Colleges, Hospitals, Public Schools, R.A.F., Army, Hams, etc.

IMPROVED 1967 RANGE

One-valve model "DX", complete kit—price 56/6 (Post 3/6).

Customers say: "Definitely the best one-valve S.W. Kit available at any price." This kit contains all genuine short-wave components, drilled chassis valve, accessories and full instructions. Ready to assemble, and of course, as all our products—fully guaranteed. Full range of other kits still available, including the famous model "K". Before ordering, call and inspect an assembled receiver, or send for a descriptive catalogue and order form to:—

"H.A.C." SHORT-WAVE PRODUCTS
29 Old Bond Street, London W.1

PADGETTS RADIO STORE

OLD TOWN HALL
LIVERSEDEGE, YORKSHIRE
Telephone: Cleckheaton 2866

Motors, Single Phase, 240v., 1/2 H.P. 26/- each. 1,400 revs. Fully guaranteed, ex washing machines, Carr. 8/6.

Special Offer. Garrard Record Players. Auto Changers. Model AT6 £8.2.6. Model 1,000 £5.12.0.

Single Player. Model S.P.25 £8.2.6. Model 1,000 £5.12.0.

Single Player. Model S.P.25 £8.2.6. Carriage and Insurance on any Model, 10/- . All complete with cartridge and maker's guarantee. 19 Set with outer case. Receiver section complete with valves.

Parts Removed. 500 micro-amp meter, all transmitter parts. Relay and 807 valve. Condition fair. No dry rot 10/- . Carr. 10/- . Bush TV53 14in. 13 Channel TV Set. Perfect working order 26. Carriage 10/- . N.Z. £4.0.0.

Part VT4 14in. 13 channel, fitted with new tube and in good working order. Condition of Cabinet, far, £5.10.0. Carriage 10/- . N.Z. £4.0.0.

Reclaimed Tubes. Six months' guarantee. AW43/80, 30/- . MW43/80, 30/- . MW43/69, 30/- . CRM172, 30/- . CRM142, 17/- . 12in. Tubes 10/- . 17in. Tubes perfect but without guarantee, 17/- each. Carriage on any Tubes in G.B. 10/- . Specially Selected Nearly New Valves. 6 months' guarantee.

PF33	6/-	AP212	1/8	EL38	5/-
PCC84	5/6	ECL80	3/6	5U49	4/-
PCF80	5/6	ECC83	5/-	6K7	1/9
PL81	5/6	ECC82	4/3	6V6	1/9
807	5/-	EP91	2/-	185BT	8/6

Single Valves. Post 7d.

VALVE LIST

Ex. Equipment. 3 months' guarantee.

Single Valves. Post 7d.	EF80	1/6	PCF80	2/-	10P13	2/6
	ECL80	1/6	PCC84	2/-	10P1G	5/-
	EF91	9d.	PCL82	4/-	20D1	3/-
	EB91	9d.	PCL83	3/-	20L1	5/-
	EBF80	3/-	PCL85	3/-	20P1	4/-
	ECC81	3/-	P230	5/-	20P4	8/6
	ECC82	3/-	PY81	1/6	U329	5/-
	ECC83	4/-	PY82	1/6	U801	8/6
	EL84	5/-	PL81	4/-	U301	5/-
	EF50	1/-	PL36	5/-	U191	5/-
	EY86	5/-	PY33	5/-	U281	5/-
	6K25	5/-	6B8	1/6	U282	5/-
	6U4	5/-	6F1	1/-	U25	5/-
	6P25	5/-	6F14	5/-		
	KT36	5/-	10C2	3/-		

Breaking up 19 Sets.

Relays 100 Ohm Coil 2/- . Post 2/6. 1 Doz. 26/- . Post Paid. Jack Sockets, 7/6 doz. Post Paid.

Torric Switches 7/6 doz. Post Paid.

Pointer Knobs 7/6 doz. Post Paid.

Top Grade Diodes 3/6 doz. Post Paid. No duds.

Perfect Speakers. Removed from TV sets. Goodmans 7 x 4, 5/- . Goodmans 8 x 5, 7/6. 6 x 4 and 5 ins., 3/- . Plus Post on any Speaker, 4/- .

TRANSISTOR

SPECIFICATIONS & SUBSTITUTION

HANDBOOK, NEW 1967 ED. BY TECHPRESS
PRICE 22/6 PLUS 1/3 P.&P.

New Sideband Handbook by Stoner a "CQ" publication. 24/- . P. & P. 1/3.

Radio Valve Data new 8th ed. by Wireless World. 9/6. P. & P. 1/- .

Radio Amateur Examination Manual 1967 ed. 5/- . P. & P. 8d.

Questions and Answers on Transistors by Brown. 8/6. P. & P. 9d.

ABC's of Silicon Controlled Rectifiers by Lytel. 16/- . P. & P. 1/- .

ABC's of Computers, new ed. by Lytel. 16/- . P. & P. 1/- .

How to Build Proximity Detectors and Metal Locators by 20/- . P. & P. 1/- .

Where possible 24-hour service guaranteed.

UNIVERSAL BOOK CO.

12 LITTLE NEWPORT STREET,
LONDON, W.C.2

(Leicester Square Tube Station)

Please mention

"Practical Wireless"

when replying to

Advertisements

4-STATION INTERCOM



£6/9/6

Solve your communication problems with this new 4-Station Transistor Intercom (1 master and 3 Subs), in de-luxe plastic cabinets for desk or wall mounting. Call/talk/listen from Master to Subs and Subs to Master. Ideally suitable for Business, Surgery, Schools, Hospital, Office and Home. Operates on one 9v battery. On/off switch. Volume control. Complete with 3 connecting wires each 66ft. and other accessories. P. & P. 3/6.

INTERCOM/BABY ALARM



Usually £10.00

Our Price ONLY

49/6

Modernise business or home with this new two-way Portable Transistor Intercom. Consisting of Master and Sub, in strong plastic cabinets, with chromium stands. Designed as a two-way instant communication system. Call/talk/listen from Master to Sub and Sub to Master. Operates on one 9v battery. Complete with 60ft. wire. Battery 2/6. P. & P. 2/6.



Transistor TELEPHONE AMPLIFIER

Usually £5.00

Our Price Only

55/-

Why not boost business efficiency with this incredible De-luxe Telephone Amplifier. Take down long telephone messages or converse without holding the handset. A status symbol! Yes, but very useful one. On/off switch. Volume Control. Operates on one 9V battery. P. & P. 2/6. Battery 2/6 extra. Full price refunded if returned in 7 days.

WEST LONDON DIRECT SUPPLIES (PW/1)
168 KENSINGTON HIGH STREET, LONDON, W8.

FIRST-CLASS RADIO AND T/V COURSES... GET A CERTIFICATE!

After brief, intensely interesting study—undertaken at home in your spare time—YOU can secure a recognised qualification or extend your knowledge of Radio and TV. Let us show you how.

FREE GUIDE

The New Free Guide contains 120 pages of information of the greatest importance to both the amateur and the man employed in the radio industry. Chambers College provides first rate postal courses for Radio Amateurs' Exam., R.T.E.B. Servicing Cert., C. & C. Telecoms., A.M.I.E.R.E. Guide also gives details of range of diploma courses in Radio/TV Servicing, Electronics and other branches of engineering, together with particulars of our remarkable terms of

Satisfaction or refund of fee

Write now for your copy of this invaluable publication. It may well prove to be the turning point in your career.

FOUNDED 1885—OVER
150,000 SUCCESSES

CHAMBERS COLLEGE

(Incorp. National Inst. of Engineering)

(Dept. 849F), 148 HOLBORN

LONDON, E.C.1

LOOK! AT OUR PRICES

OC71 TRANSISTORS
or 27/6 doz. P. & P. 6d. **2/6** EACH P.&P. 4d.

LATEST WIRELESS WORLD VALVE AND SEMICONDUCTOR DATA BOOK
Data on 7,000 types 9/6. P. & P. 1/-

GERMANIUM RECTIFIERS
GJ7M 24v 1/2 amp. **2/6** EACH P.&P. 6d.

or 24/- doz., post 1/- .

MINIATURE GERMANIUM DIODES Postage 6d. **6/-** Doz.

SILICON RECTIFIERS
800v. P.I.V. 500 mA. **5/-** EACH P.&P. 6d.

TRANSISTOR HOLDERS
3 or 5 Pin. **11/6** dozen. P. & P. 6d.

1/- each, post 4d.

VEROBOARD
2 1/2" x 5" 4/- 2 1/2" x 3" 3/4

3 3/4" x 3 3/4" 4/- 3 3/4" x 5" 5/8

Postage 6d. each extra.

TANK AERIALS
6 Section. Total Length 10' 10". Perfect for Vertical Aerial or Fishing Rod.

10/6 each 1/6 P. & P.

PETHERICK'S RADIO SUPPLIES
Dept. P.

22 HIGH STREET, BIDEFORD, N. Devon
Tel.: Bideford 3217

BROADWAY ELECTRONICS

92 MITCHAM ROAD · TOOTING BROADWAY · LONDON S.W.17 · Tel: BALham 3984

(four minutes from Tooting Broadway Underground Station)

GARRARD 4 SPEED DECKS ALL WITH MONO

Autochangers: AT6 MK II, £8.19.6. AT60 with heavy turntable, £10.19.6. 3000, £8.8.0. 2000, £6.19.6. 1000, £5.19.6. Autoslim de luxe with Plug-in-head, £5.15.0. Autoslim £5.5.0. A.T.5 £6.10.0 cartridge, stereo 10/- extra. P. & P. all changers 6/-.
Last chance to purchase famous Garrard RC.210 quality changer. Mono, £5.10.0 with stereo head/diamond Stylus 15/- extra. P. & P. 6/-.
EDE Plinth for above changers size 16½" x 14½" x 3¼", 45/- P. & P. 3/6.

SINGLE PLAYERS:

SP 25 with cartridge stereo or mono, £9.19.6. SRP 12, £5. P. & P. 6/-.

CARTRIDGES: Ronette, Stereo, 25/-, Acos GP67, 15/-, Garrard EV26, 25/-, GC2 or GC8, 15/-, A.T.6 shells 5/- P. & P. all 6d.

SPEAKER ENCLOSURES

TONY Corner Cabinet 20" x 10" x 7" takes 10" x 6" speaker covered in Rexine and Vynair, 45/- P. & P. 5/-.

BLAKE De LUXE, veneered with woodgrain formica and standing on smart 6" legs, cabinet size 18" x 24" x 9½" £6.5.0. P. & P. 10/-.

HAYDON 16½" x 15" x 7½" fabric covered suitable for 12" speaker. 45/- P. & P. 7/6.

Corner Ext. speaker complete with volume control, covered woodgrain fabric, 45/- P. & P. 4/6.

Ext. speaker complete with 8" speaker and volume control. Size 13" x 10" x 6" covered woodgrain formica, £3. P. & P. 4/6.

SPEAKERS

ELAC Heavy Duty Ceramic Magnets 11,000 line. 10" round 10" x 6". 3 ohm or 15 ohm, 42/6. P. & P. 3/6. 8" round 15 or 3 ohm, 38/6. P. & P. 3/6. E.M.I., 13½" x 8" 15 or 3 ohm, 42/6. P. & P. 3/6. E.M.I. Tweeter, 12/6. P. & P. 1/6. R.T.C. 12" 20 watt 15 ohm, Ceramic magnet, £5.5.0. P. & P. 3/6. 8" x 4" Elliptical 30 ohm, 30/- All other speakers supplied—Goodmans, Bakers, W.B., Wharfedale, Eagle, Tripletone.

BARGAINS IN TRANSISTORS.

AC127, AF114, 115, 116, 117, 118, 119, OC169, 170, 171, 172, 202, 203, 204, 5/6. OC72, 75, 82, 83, 3/6. OC71, 81M, 3/-.

R.F Packs 1 OC44, 2 OC45, 8/6.

AF Packs 1 OC81D, 2 OC81M, 6/6. 1 OC81D, 2 OC81 (Mullard), 8/6.

AF Pack 1 GET118, 2 GET119, 5/6. GET113, Red Spot, 2/-.

OC26, 28, 29, 9/6. ORP12 Light Cell, 8/6.

Diodes OA81, 2/3. OA91, OA95, 1/9. P. & P. on above 6d.

AAZ12, BCY38, BCZ11, 3/6.

TRANSISTOR ELECTROLYTICS.

1, 2, 4, 5, 8, 16, 25, 32, 50, 100 mfd 15 volt working, 1/3. P. & P. 6d.
250 mfd 25v DC, 3/- 1,000 mfd 50 v DC, 5/6.
500 mfd 12v DC, 3/- 1,500 mfd 10v DC, 4/6.
500 mfd 50v DC, 5/- 5,000 mfd 12v DC, 6/6. P. & P. 1/-.

RESISTORS. ¼ watt 10% from 3.3 ohm to 10 meg 5d. each. 4/- doz. P. & P. 6d.

EARPIECES WITH CORD AND 3.5 mm. plug. 8 ohm magnetic, 3/- 250 ohm, 4/- 180 ohm with clip, 6/6. Xtal 4/- P. & P. 6d.

TRANSISTOR SPEAKERS 8 ohm 2" 8/6; 3" 10/6; 3½" 12/6. P. & P. 1/-.

PANEL LIGHTS. Neon 200-250v, 2/6. 6v Red, Blue, Green, Yellow, White (uses Lilliput bulbs) 3/- each. P. & P. 6d.

Paper Condensers for Cross-Over Units, 2 mfd, 2/6. P. & P. 6d.

MAKE YOUR OWN PRINTED CIRCUITS.

Complete kit, Hayato P.K.1, 22/6. P. & P. 1/- (with full instructions).

ROTARY SWITCHES

2 pole Mains Switch, 3/-.
1 pole 12 way, 2 pole 6 way, 2 pole 2 way, 3 pole 3 way, 3 pole 4 way, 4 pole, 3 way, 3/6 each. P. & P. 6d.

MICROPHONES.

Xtal Hand Mikes.
BM3 and 200C, 30/- P. & P. 2/- Stand for same 9/6 & 12/6. P. & P. 1/9.
ACOS Mike 45, 21/- ACOS Mike 40, 18/6. Dyn. Mike DM-391, 22/6.
CM21 Xtal, 12/6. CM20 Xtal, 9/6. Magnetic Hm 63C with remote control switch, 15/- Telephone Pick-up 10/6. P. & P. 1/-.
XTAL LAPEL MIKE, 7/6. GUITAR MIKE, 12/6. P. & P. 6d.

PUSH BUTTON SWITCHES, 4 button. 2 banks of 6 S.P.C.O. 1 bank of 5 S.P.C.O. 1 off button, 5/6. P. & P. 6d.

BATTERY CHARGER KITS.

6 volt and 12 volt with circuit.
4 amp. GEC Rect., 15/- Heavy Duty Transformer, 25/- P. & P. 3/6.
3 amp. Westinghouse Rect., 10/6. Heavy Duty Transformer, 20/- P. & P. 3/6. 1 amp Westinghouse contact cooled rect., 7/6. Transformer 12/6. P. & P. 3/- Large Croc. Clips, 2/6 per pair. P. & P. 6d.

Stockists for Eagle Products, Goodmans, W.B., Wharfedale, Bakers, Tripletone, Linear, all makes of amplifiers and speakers supplied. S.A.E. please. Trade terms to bona fide dealers.

HOME RADIO LTD. 187 LONDON ROAD, MITCHAM, SURREY 'Phone: MIT 3282

A MERRY XMAS TO YOU ALL!

Have You Got a Little List?

I don't mean the KOKO variety! That is, a list of people who would be of no great loss if he chopped their heads off; after all it is Christmas! I'm referring to the list of presents you are going to buy. If you have a husband, brother, uncle, son or boyfriend you might find what you—and they—want in the Home Radio Catalogue. As you know it lists some 6,000 items ranging from twopence to £185; or you might give the catalogue itself, the price is modest, only 7/6 plus 1/6 postage and packing and each copy contains 5 vouchers each worth 1/- if used as directed.

SHUSH! If you happen to be a husband, brother, uncle, son or boyfriend, why not leave the magazine open at this page, where the little woman, sweetheart, aunt, mother, etc., can't miss reading the advertisement! *What have you got to lose?*

REMEMBER! Send your 9/- P.O. or cheque with coupon and solve your present problem.



Please write your name and address in block capitals

NAME

ADDRESS

HOME RADIO LTD., Dept. PW, 187 LONDON ROAD, MITCHAM.

OLRUS ELECTRONICS LTD. PAD 1515
9 Norfolk Place (off Praed St.) London, W.2

FACTORY NEW FULLY GUARANTEED

Valves		Transistors—Diodes—Zener			
DAF91 4/6	GZ34 10/-	68N7GTB	AF199 15/-	0AZ202 8/6	OC59 18/6
DAF96 6/8	PC86 11/-		AF196 19/6	0AZ203 8/6	OC60 17/6
DF91 3/-	PC88 11/-	6V6GT 6/6	AFY19 22/6	0AZ204 8/6	OC65 22/6
DF96 7/-	PC97 7/6	6X5GT 6/-	AFZ11 17/-	0AZ205 8/6	OC66 25/-
DK91 5/6	PC84 6/-	25L6GT 6/6	AFZ12 12/6	0AZ206 8/6	OC70 4/-
DK92 8/-	PC89 11/-	30C15 10/-	ASY26 6/6	0AZ207 9/6	OC71 4/-
DK96 7/-	PC189 11/-	30FL2 10/6	ASY28 6/6	0AZ208 6/6	OC72 5/-
DL92 5/-	PCF80 7/-	30FL14 11/-	ASZ20 7/6	0AZ209 6/6	OC73 7/6
DL94 5/6	PCF86 8/6	30L15 11/-	GET20 10/-	0AZ210 6/6	OC75 6/-
DL95 7/-	PC182 7/-	30P12 9/-	GET102 6/-	0AZ211 6/6	OC76 5/-
DY86 6/4	PC183 8/6	30P19 13/-	GET103 4/6	0AZ212 6/6	OC77 7/-
EBC41 7/6	PC184 7/6	30P12 10/6	GET108 8/6	0AZ213 6/6	OC78 5/-
EBC81 6/6	PC185 9/-	30P13 12/-	GET113 5/-	0AZ222 9/6	OC78D 5/-
EBC90 4/3	PC186 8/6	35L6GT 6/-	GET114 4/-	0AZ242 4/6	OC81 5/-
EBF89 6/8	PL36 9/-	35Z5GT 5/6	GET115 9/-	0AZ245 4/6	OC81D 5/-
ECC81 4/-	PL81 7/-	50L6GT 6/6	GET11612/6	0AZ246 4/6	OC81M 5/-
ECC82 5/-	PL82 6/6	AC107 10/-	NKT213 6/-	0AZ247 4/6	OC81DM 5/-
ECC83 5/6	PL83 6/6	AC126 6/6	NKT216 7/6	0AZ290 9/6	OC81Z 9/-
ECC85 5/-	PL84 6/6	AC127 7/6	NKT261 5/-	0AZ291 9/6	OC82 6/-
ECF80 7/-	PL500 13/6	AC127Z 9/6	NKT255 6/6	0AZ292 9/6	OC82D 5/-
ECH35 10/9	PY32 8/6	AC128 6/6	NKT304 8/-	OC16 20/-	OC83 5/-
ECH42 9/-	PY81 6/-	AC176 7/6	NKT403 17/6	OC19 7/6	OC84 6/-
ECH81 5/2	PY82 5/6	ACY17 8/6		OC22 10/-	OC122 15/-
ECH84 8/10	PY83 6/-	ACY18 6/6	OA5 4/-	OC23 12/6	OC128 7/6
ECL80 7/-	PY88 7/3	ACY19 6/6	OA7 4/-	OC24 17/6	OC140 9/6
ECL82 6/3	PY88 7/3	ACY20 5/-	OA10 3/-	OC25 9/6	OC169 5/-
ECL86 9/-	UBC41 7/6	ACY21 6/-	OA47 3/-	OC26 7/6	OC170 5/-
EF80 5/-	UBC81 7/6	AD140 16/-	OA70 2/-	OC28 12/6	OC171 6/-
EF86 6/3	UCC85 6/6	AD149 16/-	OA73 2/6	OC29 15/-	OC200 7/6
EF183 6/4	UCL42 8/6	AD161 11/-	OA79 2/6	OC35 12/6	OC201 11/6
EF184 6/4	UCH81 6/3	AD169 11/-	OA81 2/6	OC36 12/6	OC202 13/6
EL34 9/6	UCL82 7/3	ADT14015/-	OA85 3/-	OC41 6/-	OC203 10/6
EL41 8/6	UL41 8/6	AF102 18/-	OA86 4/-	OC42 5/-	OC204 15/-
EL44 4/9	UL84 8/3	AF114 8/6	OA90 2/6	OC43 9/-	OC205 15/-
EM84 7/-	UY85 5/6	AF115 6/-	OA91 2/6	OC44 5/-	OC206 28/6
EY51 7/-	U25 9/6	AF116 6/6	OA95 3/6	OC44M 5/6	ORP12 8/6
EY86 6/6	U26 8/6	AF117 5/-	OA200 3/3	OC45 4/-	ORP60 5/-
EZ40 7/6	5U4GD 8/6	AF118 12/6	OA202 4/3	OC45M 4/-	18202 4/6
EZ80 5/-	5Y3GT 5/-	AF124 9/-	OA210 7/6	OC46 5/6	28O12 20/-
EZ81 5/-	5Z4GT 8/-	AF125 8/6	OA211 9/6	OC47 7/6	28O12A 25/-
EZ90 4/-	6X23 10/-	AF126 8/-	0AZ200 11/-	OC57 16/-	28O13 20/-
GZ32 10/-	6L5GC 7/6	AF127 8/-	0AZ201 10/-	OC58 17/6	

C.W.O. only P. & P. 2/- in £ 1/- minimum
METAL WORK—PANELS—CHASSIS
For P.W. P.E. Constructional Projects

ELECTRONICS GALORE! IN THE NEW dca CATALOGUE

THE CONVENIENT WAY TO SHOP FOR ALL YOUR ELECTRONIC NEEDS. EVERYTHING FROM SINGLE COMPONENTS TO COMPLETE EQUIPMENT ALL AT BEST VALUE PRICES.

SEND 1/6d. NOW FOR YOUR COPY TO—
Dept. PW/1

dca ELECTRONICS LIMITED
28 UXBRIDGE ROAD, EALING, W.5

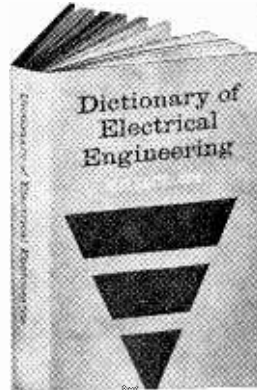

DICTIONARY OF ELECTRICAL ENGINEERING

Compiled by K. G. Jackson

This comprehensive and well-illustrated dictionary covers terms that are of general use among electrical engineers and includes a selection of the more important terms from related subjects such as electronics, lighting and constructional materials. Mathematical principles also are described if they are of importance in electrical calculations. Appendices provide a considerable amount of additional and useful data on abbreviations, and letter and graphical symbols. 380 pages, over 200 line illustrations. 45s.

NEWNES Tower House,
Southampton Street, W.C.2.

AROUND THE WORLD
GO A.F.N. PAT. APP. FOR
396
POST FREE

On your own
TRANSISTOR PORTABLE!

- * Boosts Pirate and distant stations.
- * No Plugs—No Connections! Just place Dewtron Wave Trap near radio.
- * Extends Battery life — reduces 'fading'.
- * Use in car, caravan, without aerial.

With PP3 battery (life several months).
D.E.W. LTD., Dept. P.W., Rinswood Road,
FERNDOWN, Dorset.

2 METRES 4

The thrills of VHF Amateur Radio! Complete Kit, 70-150 Mc/s, costs only 42/6 (by post, UK, 3/3 extra) also now available new transistor Short-Wave kit model TR2 10-180 metres, ideal for beginners to Ham radio via simplified "Easy-Build" step-by-step instructions from 79/6. Write today enclosing a stamped addressed envelope for literature and full details. Overseas enthusiasts note we despatch to all parts of the world—local stamp OK for literature. "GLOBE-KING" (Regd.) precision standard products tried and trusted by Amateurs everywhere.

JOHNSONS (Radio)
St. Martins Gate, Worcester

NEW CIRCUITS

- Football Pool Computer
- Multiplying/Dividing Computer
- Simultaneous Equation Solver
- Quadratic Equation Solver

The above analogue computer circuits, all based on the Wheatstone Bridge, are not expensive to build and all parts are available. Circuits, wiring diagrams, instructions, price lists, 4/6 post free.

Multimeters at new reduced prices. TK20A, 33/- post 3/-; EP10K, 67/6 post 3/-; EP20K, 85/- post 3/-; EP30K, 105/- post 4/6; EP50K, 145/- post 4/6. Further details on request.

1% High Stab Resistors, 1/2W, 2/- Stock list on request.

PLANET INSTRUMENT CO.
25 (W) Dominion Avenue, Leeds 7

SOLDERING?—the complete answer!

Made by ANTEX—makers of the finest precision soldering irons in the world, this Soldering Kit contains everything you need for successful soldering. Unique plastic "tool-box" format (with space for iron stowage with plug) keeps everything where you want it.

ANTEX LTD. GROSVENOR HOUSE, CROYDON, SURREY. MUNICIPAL 2774/5

**BRAND NEW AM/FM (V.H.F.) RADIOGRAM CHASSIS
AT £15.15.0 (Carriage Paid)**

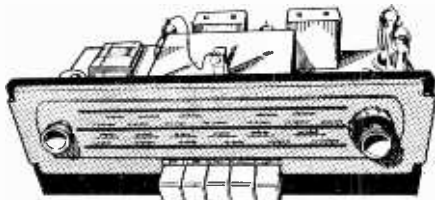

Chassis size 15 x 6½ x 5½in. high. New manufacture. Dial 14½ x 4in. in 2 colours, predominantly cream. 200-250v. A.C. only. Pick-up Ext. Speaker. Ae., E. and Dipole Sockets. Five push-buttons—LW, MW, SW, FM and Gram. Aligned and tested. O.P. Transformer Tone control 1000-1900M: 200-550M: 38-98 Mc/s. E280 rect.; ECH81, EP89, EABC80. EL84, ECC85, 3-ohm speaker required.

TERMS: (Chassis). £5.5.0 down and 5 monthly payments of £2.5.0. Total H.P. price, £16.10.0. Cheap Room Dipole for V.H.F., 12/6. Feeder 6d. per yard. Circuit diagram, 2/6. Carriage to N. Ireland, 20/- extra.

BATTERY ELIMINATOR. 5¼ x 4¼ x 2½in. for 90 v. H.T. at 20mA and 1.5 v. at up to 250mA. Fully built. 55/- carriage paid.

NEW 6 PUSH-BUTTON STEREOGRAM CHASSIS. M.W.; S.W.1; S.W.2; V.H.F.; Gram; Stereo Gram. Two separate channels for Stereogram with balance control. Also operates with two speakers on Radio. Chassis size: 19 x 7 x 6½in. high. Dial cream and red. 15 x 3in. 190-550M; 18-51M; 60-187M; VHF 96-100 mcs. Valves: ECC85, ECH81, EP89, 2 x ECL86, EM84 and Rect. Price £19.19.0, carr. paid or £18.13.0 deposit and 5 monthly payments of 56/6. Total H.P. price £20.15.6. Cream moulded escutcheon included.

**TAPE AMPLIFIER FOR MAGNAVOX
TAPE DECKS — 2 or 4 TRACK**

Chassis 12½ x 5¼ x 4½in. high. Plastic front panel "gold" finish—12½ x 4½in. 200-250 A.C. Record/Playback amp. switch; On/Off-Tone; Vol/Mic; Vol/Gram; Mic. Input; Gram. Input; Monitor; Speaker Sockets. Valves 6BR7; 12AX7; EM84; EL84; 6X4 Separate power pack. Complete amp. and power pack, £8.17.6, (10/- P. & P.). Rexine covered cabinet (tan) 15½ x 17 x 3½in. high with sloping front for amp; complete with two tweeter speakers and special adapting brackets for Magnavox Deck—55/- (8/- carr.). 3 speed Magnavox 2 track tape deck £10.17.6; 4-track £12.15.0. Complete Recorders (with speed compensation) 2-track £28; 4-track £32 (carr. 25/-). Worth £10 more on normal retail prices.



**4 TRANSISTOR
MINIATURE PUSH-PULL
AUDIO AMPLIFIER
HIGH IMPEDANCE**

PRINTED CIRCUIT. 4in. x 2½in. x 1½in. over transformers. Output transformer. Suitable for record player and intercom. 9 volt battery required. Frequency range 100 cps. to 25 Kcps. Push-pull output class B. Instruction sheet provided. Fully wired ready for use. Three types 200mW, 35/-; 500mW 41/-; 1.2W 57/6. (P. & P. 2/6 each).

CRYSTAL MICROPHONES

With 3.5 mm. Jack plug, 12/6 (Post 1/6). Moulded case. With std. Jack plug, black or chrome. Beautifully finished with adaptor 39/6. (Post 3/-) Stand 10/- (Post 3/- or 4/6 both items).

The
SUPER 6
**LONG & MEDIUM WAVE
TRANSISTOR RADIO**



A quality radio available as a kit or ready-built. The sparkling performance and superb finish of the completed receiver give you value equivalent to a £12.18.0 commercial model.

★ All new parts. ★ 6 transistors and diode. ★ 350mW output. ★ Superhet circuit ★ Ferrite rod aerial. ★ Weymouth Radio printed circuit board. ★ Component positions and references printed on back of board. ★ Nicely styled wooden cabinet 11 x 7½ x 3½in. ★ Vinyl covered in various colours. ★ 6 x 4in. speaker giving good bass and treble response. ★ Full instruction booklet, 2/-. Free with kit. ★ I.F. frequency 470 kc/s. ★ Lining up service if required. ★ All parts supplied separately. Write for list, S.A.E. **COMPLETE KIT ONLY £4.0.0** P. & P. 5/- **OR FULLY BUILT £6.7.6. Tax and Carr. Paid.**

**8 WATT PUSH-PULL O.P.
AMPLIFIER £5.5.0. (6/- Carr.)**

200-240 A.C. mains. Bass treble and vol. controls. E280, ECC83 and 2-EL84's. Chassis 12 x 3½ x 3½in. With o.p. trans. for 2-3 ohm speaker. Front panel (normally screwed to chassis) may be removed and used as flying panel. With cream/black control panel whole length of front chassis.



STEREO-AMPLIFIER 2 x 4 WATT

Valves ECC83, 2 x EL84, on printed circuit approx. 4 x 4in. Neg. feed back. Controls (vol. tre. bass) on separate panel. Separate power pack with rect., double wound mains trans., connection socket etc. Supplied fully wired and tested with two O.P. transformers for 3-ohm speakers, only £6.10.0 (7/6 P. & P.). Two speakers, 3in., 3-ohm for 50/- each, post paid, if ordered with above Amp.

DECCA Deram Stereo Cartridge (latest type Blue Tip). £3, (List £4.4.16). Post 2/-. ORP12 Cell, 5/- (post 1/-).

GRAMOPHONE AMPLIFIERS AND PLAYERS

1½ watt type. With 6in. x 4in. speaker. Baffle 13½ x 7½in. 200-240v. A.C. ECL82 and Rectifier Tone and Volume On/off switch. Two knobs. Ready to play, 49/6, post 5/-.

4 watt type. Valves UY85, UF80 and UL84. 200-240v. A.C. Covered baffle 13½ x 7½in. (6in. speaker), 3 front controls; bass, treble, on-off/vol. 60/-, post 5/-. Double wound mains transformer.

TAPE RECORDER AMPLIFIER

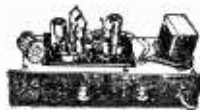

Type TR3. Fully built, high gain, low noise, printed circuit. Attractive grey and gold front panel 13 x 1½in. Height 5½in. overall. Front to back 5½in. Vol. and on/off tone, Mike, radio and ext. speaker jacks. Valves, magic eye, FCC83, ECL82, E280. Mains trans. Ready to bolt to B.S.R. Deck. Complete with switch packer wired. Our Price ONLY £8.15.0 (6/- carriage and P.). Also available for Colliaro Deck at 5/- extra.

HEATER TRANSFORMER

Mains input giving 6.3v. 2 amp. Size 2½ x 2½ x 1in. (2½in. over winding), 5/6 ea. Less 10% for 12, or 20% for 50. P. & P. 2/- for 1 to 6, post free more than six.

GLADSTONE RADIO

66 ELMS ROAD, ALDERSHOT, Hants. Aldershot 29240
(2 mins. from Station and Buses)
CLOSED WEDNESDAY AFTERNOON
CATALOGUE 6d.
Bulk enquiries invited for Export.

with the NEW Antex

PRECISION SOLDERING KIT

This is what the ANTEX Kit contains:

- Model CN240 15W Precision Iron with 3/16" bit, (used in electronic workshops and factories all over the world)
- Two spare Interchangeable Bits (5/32" and 3/32")
- Reel of resin-cored Solder
- Handy Heat Sink
- Cleaning Pad

PLUS

36-page booklet on "How-to-Solder"—a mine of information for amateur and professional.

BRING YOUR WORKSHOP UP-TO-DATE with the new ANTEX KIT

*Obtainable from
radio and electrical
shops everywhere.*

49/6

ANTEX LTD. GROSVENOR HOUSE,
CROYDON, SURREY. MUnicipal 2774/5

1/2 PRICE SPECIAL RADIO CHASSIS OFFERS

HI-FI CONTINENTAL
STEREOPHONIC RADIOGRAM CHASSIS



Magnificent 'Continental' Stereophonic Radiogram Chassis with piano key switches, built-in ferrite rod aerial. Comes complete with two 10" elliptical loudspeakers, plus a mono/stereo 4-speed automatic record changer. Complete £29.19.6. (Units available separately if required. Chassis only 19i gns.)
Special terms available of £10.00 deposit followed by 18 monthly payments of £1.6.5 (total H.P. of £33.15.6)+15/- P. & P. Send £10.15.0 now.

IMPERIAL HI-FI STEREOPHONIC RADIOGRAM CHASSIS



The Imperial Stereophonic 4 waveband chassis has the most advanced specifications yet offered in this country. There is a built-in ferrite rod aerial, seven piano key buttons, controlling mono/stereo selection, Gram-Long-Medium-Short-FM-ON/OFF. The unit comes complete with two 10" elliptical loudspeakers plus a mono/stereo 4 speed automatic record changer. Complete £41.9.6. Chassis only 29i gns.

Special terms available of £13.16.6 deposit followed by 24 monthly payments of £1.8.10 (total H.P. £48.8.6)+17/6 P. & P. Send £14.14.0 now.

EMPRESS HI-FI AM/FM STEREOPHONIC CHASSIS



This most advanced radiogram chassis with automatic push button selection covers short, medium and long wavebands plus V.H.F./F.M. Offered complete with 2 10 x 6 speakers 4 speed Stereo/Mono autochanger only £35.19.6. Chassis only 25i gns. Special terms available of £12 deposit followed by 18 monthly payments of £1.11.7. (total H.P. £40.8.6)+15/- P. & P. Send £12.15.0 now.

All Lewis Radio equipment including valves are fully guaranteed for one year free of charge. Send your cheque or P.D. today while stocks last to Dept. P.17.

LEWIS radio
LEWIS RADIO, 100, CHASE SIDE, SOUTHGATE
LONDON, N.14. Telephone: PAL 3733/9666

EXCLUSIVE TO BOTHWELL ELECTRIC SUPPLIES (GLASGOW) LIMITED

Due to a massive purchase from abroad, we can still offer you at the fantastic price of 3/6 (P. & P. 1/- per horn) a miniature high frequency horn, suitable for use as a burglar and fire alarm; motor cycle alarm and all warning devices. Demand for this unique offer has been great, so order now and avoid disappointment. 1.6.4 5V. D.C. only.

CAPACITORS:

1. Yet another snip from Bothwells—Plessey 100 x 400 MFD. 300V. W.K.G. 1 1/4 in. dia x 3 in. long approx. Only 6/6 each +1/- P. & P.
2. Transistor Capacitors: 10, 15, 32, 50, 100 MFD all 15V. D.C. W.K.G. Any three, 4/- + 6d. P. & P.

MAGNETIC EAR PIECES: Prices are down—YOU benefit. Complete with 3.5mm. jack plug, only 2/6 each + 6d. P. & P.

AERIAL WIRE: Pure copper, insulated; still available in 76ft. reels at excellent price of 5/- + 1/- P. & P.

CAR BATTERY CHARGERS: An elegant yet robust 4A. charger with fitted ammeter. 6/12V. Guaranteed 1 year—58/6 + 5/- P. & P.

RELAYS:

1. Miniature Plug-in with 2 light duty c/o contacts. Coil 185 Ohms. 4 1/2/18V. D.C. 15/-.
2. Miniature Plug-in with 4 light duty c/o contacts. Coil 130 Ohms. 9/15V. D.C. 18/6.
3. Heavy duty car alarm relay 6/12V. D.C. 3 heavy duty c/o contacts 27/6.
Postage and packing on above items 1/- each.
4. Base for item (2). 3/9 P. & P. 6d.

SEMICONDUCTORS: We carry a wide range of transistors, diodes, rectifiers and other devices to meet your every need at competitive prices, e.g.:

1. Transistors OC44, 45, 71, 72, 81, 81D. 2/6 each + 6d. P. & P.
2. 10D1 miniature rectifier diode. 100V. P.I.V. 1A invaluable in all low-voltage power supplies 5/- each + 6d. P. & P.

LOUDSPEAKERS: We carry a range of speakers to suit every application. Typical examples are:

1. Westwell 0.2W.; 8 Ohm; 2 1/2 in. dia. 7/9.
2. Westwell 0.2W.; 5 Ohm; 3 in. dia. 9/6.
3. Richard Allen 12in. 3 Ohm. with tweeter. 37/6 + 3/- P. & P.

TEST METERS: General purpose test meter. IT1-2. 20K/Ohms per Volt. 78/8 + 3/- P. & P.

Write or call now for our components list

BOTHWELL ELECTRIC SUPPLIES (Glasgow) LTD.
54 EGLINTON STREET
GLASGOW, C.5. Tel. 041 South 2904
Member of the Lander Group

NEW VALVES !

Guaranteed Set Tested
24-HOUR SERVICE

1R5	4/-	DK91	4/-	EF86	6/6	PY33	3/9
1R5	3/9	DK96	6/3	EF89	4/9	PY80	4/9
1T4	2/9	DL33	6/6	EL33	6/3	PY81	5/-
384	4/3	DL35	4/9	EL41	8/-	PY82	4/9
3V4	5/-	DL92	4/3	EL84	4/3	PY83	5/3
5V4G	7/6	DL84	5/-	EV61	5/11	PY800	5/11
5Y3GT	4/6	DY86	5/3	EY86	5/3	R19	6/6
6F1	6/3	DY86	6/3	EZ40	5/6	U25	8/6
6K7G	1/3	DY87	6/9	EZ80	3/6	U26	8/6
6K8G	3/3	EABC80	5/6	EZ81	4/-	U191	10/-
6L18	7/3	EAF42	7/-	GZ32	8/9	U301	11/6
6Q7G	5/6	EBC41	6/6	KT61	6/3	U801	16/-
6V6G	3/-	EBF80	5/9	N78	14/6	UABC80	5/-
10F1	9/6	EBF89	5/9	PCC84	5/3	UAF42	6/11
10P13	8/3	ECC81	3/3	PCC89	9/9	UBC41	6/6
20P1	8/9	ECC82	4/6	PCF80	6/3	UBF80	5/6
20P3	8/9	ECC83	4/6	PCF82	5/9	UBF89	5/9
20P4	12/6	ECC85	5/3	PCF805	3/-	UCC86	6/-
30F5	9/3	ECH35	5/9	PCL82	6/3	UCH42	8/9
30P4	11/6	ECH42	8/9	PCL83	3/9	UCH81	6/-
SOP19	11/6	ECH81	5/6	PCL84	7/3	UCL82	7/3
DAC32	6/9	ECL80	5/9	PCL85	7/9	UCL83	8/6
DAF91	3/9	ECL82	6/3	PL36	9/3	UF41	7/9
DAF96	5/11	ECL86	7/6	PL81	9/6	UF89	5/6
DF33	7/6	EF33	5/6	PL82	5/-	UL41	7/9
DF91	2/9	EF41	5/9	PL83	5/11	UL84	5/3
DF96	5/11	EF80	4/3	PL84	6/-	UY41	4/9
DK32	7/-	EF85	5/-	PY32	8/9	UY85	4/9

Postage on 1 valve 9d. extra. On 2 valves or more, postage 6d. per valve extra. Any parcel insured against damage in transit 6d. extra. Office address, no calls.

GERALD BERNARD

83 OSBALDESTON ROAD
STOKE NEWINGTON
LONDON N.16

A concise guide for only 6s. 6d.

BEGINNERS GUIDE TO ELECTRONICS by T. L. Squires

This book provides a "short-cut" for those wishing to obtain a quick acquaintance with modern electronics. It describes as simply as possible the basic concepts in electronic engineering. No prior technical knowledge is assumed, mathematics being avoided and emphasis placed on numerous illustrations.

6s. 6d. paperback—Limited supplies only
By post 7s. from Newsnas, Tower House,
Southampton Street, London, W.C.2

NEW RANGE U.H.F. AERIALS FOR BBC 2 (625) line transmissions

All U.H.F. aerials now fitted with tilting bracket and 4 element grid reflectors.
Loft Mounting Arrays, 7 element, 35/-, 11 element, 42/6, 14 element, 50/-, 18 element, 57/6, Wall Mounting with Cranked Arm, 7 element, 60/-, 11 element, 67/-, 14 element, 75/-, 18 element, 82/6. Mast Mounting with 2in. clamp, 7 element, 42/6; 11 element, 55/-; 14 element, 62/-; 18 element, 70/-, Chimney Mounting Arrays, Complete, 7 element, 72/6; 11 element, 80/-; 14 element, 87/6; 18 element, 95/-. Complete assembly instructions with every unit. Low Loss Cable, 1/8 yd. U.H.F. Preamps, from 75/-, State clearly channel number required on all orders.

BBC • ITV • F.M. AERIALS



BBC (Band 1). Telescopic loft, 21/-, External S/D, 30/-, "H" £2.10.0

ITV (Band 3). 3 Element loft array, 25/-, 5 element 35/-, Wall mounting, 3 element, 35/-, 5 element, 45/-.

Combined BBC/ITV. Loft 1+3, 41/3; 1+5, 48/3; Wall mounting 1+3, 58/3; 1+5, 63/3; Chimney 1+3, 63/9; 1+5, 71/3.

VHF transistor pre-amps 75/-.

F.M. (Band 2). Loft S/D, 12/6, "H", 30/-, 3 element, 52/6. External units available. Co-ax cable, 3d. Yd. Co-ax plugs, 1/3. Outlet boxes, 4/6. Diplexer Crossover Boxes, 12/6. C.W.O. or C.O.D.P. & P. 5/-, Send 6d. stamps for illustrated lists.

Quotations for special arrays available on request

K.V.A. ELECTRONICS (Dept. P.W.)
27 Central Parade, New Addington
Surrey
LOD 2266



SUPPLIERS OF ELECTRONIC EQUIPMENT TO ...

- * UNIVERSITIES
- * COLLEGES OF TECHNOLOGY
- * COLLEGES OF FURTHER EDUCATION & SCHOOLS
- * ALL RADIO ENTHUSIASTS

OFFICIAL SUPPLIERS TO MANY
EDUCATION AUTHORITIES
Usual Educational Discounts

OUR NEW 1966/67 illustrated catalogue NOW AVAILABLE

(send 1/- in stamps
for your copy)

INCLUDES

Valves, Transistors, Transformers, Loudspeakers, Recording Tape, Coils, Resistors, Condensers, Potentiometers, Chassis, Rectifiers, Test meters, Microphones, Tools, Solder etc.

ALPHA RADIO SUPPLY CO

103 Leeds Terrace,
Wintoun Street, Leeds 7
Telephone 25187



(14)

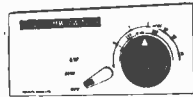

(12)



(10)

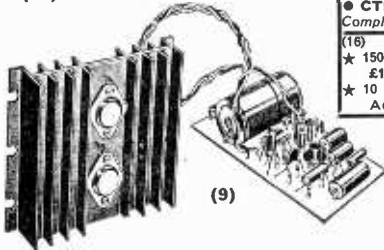

(9)

HENRY'S RADIO LTD.
303 EDGWARE RD., LONDON, W.2
PADdington 1008/9 (STD 01-723-1008)
Open Mon. to Sat. 9-6. Thurs. 1 p.m.
Open all day Saturday

10 AND 20 WATT MONO AND STEREO TRANSISTOR AMPLIFIERS

(9) **POWER AMPLIFIERS.** 10 watts RMS output. 100mV input. 30 c/s to 20 kc/cs — 1dB. 6-Transistor Push-pull. Panel size 4 x 2½ x 1 in. H/S 4 x 4in.
TPA10/3 3-5 ohm spkr. £4.10.0, pp. 2/6.
TPA10/15 12-16 ohm spkr. £5.5.0, p.p. 2/6 (Mains unit 1 or 2 amplifiers, 59/6, p.p. 2/6)

The Finest High Fidelity at Unbeatable Prices

25 WATT AMPLIFIER

New 8-Transistor design. Push-pull output for 7½ to 16 ohm speaker. 150mV input. 30c/s to 20kc/cs — 1dB. For use with valve or transistor pre-amplifiers as item (10) above
PRICE BUILT £7.19.6 P.P. 3/-
AND TESTED (Mains unit 79/6, p.p. 2/6)

(13) MULTI-METERS SCOPE

PT34 1kV 39/6 EP30k 30kV £6.10.0
TP10 2kV 75/- EP50k 50kV £8.15.0
1T1-2 20kV 69/6 500 30kV £8.17.6
TP55 20kV £5.19.6 EP100k 100kV £10.10.0
● **CT52** Scopes £22.10.0 P.P. 10/-
Complete range of test equipment in stock

(16) NOMBREX TEST UNITS

★ 150 kc/s—350 mc/s RF Generator £10.10.0. All Transistor.
★ 10 c/s—100 kc/s Transistor. £16.19.6 Audio Generator.

(15) GARRARD BATTERY 2-SPEED TAPE DECK

Brand New with R/P head, erase/osc. head, tape cassette Specifications and osc. circuits. 2 speed 2-track 9 volt operated. List Price 13 gns.

PRICE £8.19.6 P. & P. 3/6

COMPONENTS AND EQUIPMENT. The largest range in the country. 6/- buys 150-page catalogue with discount vouchers.

(10) **PREAMPLIFIERS.** 8 input selector. Treble, bass, volume, filter controls. 1½mV to 100mV inputs. Battery operated or from Mains Unit. Output up to 150mV RMS.

MP2 Mono 9½ x 2½ x 2in. £5.10.0, p.p. 2/6 (grey and gold front panel 8/6).
SP4 Mono/Stereo, 9 x 3½ x 1½in. £10.19.6, p.p. 3/6 (front panel plate 12/6)
● **ALL UNITS BUILT AND TESTED**

(12) MW/LW QUALITY TRANSISTOR RADIO TUNER

Fully tunable superhet with excellent sensitivity and selectivity. Output up to ½ volt peak. Complete with front panel, etc. 9 volt operated. For use with any amplifier or tape recorder.
TOTAL COST £3.19.6 P.P. 2/6
TO BUILD

(14) VHF FM TUNER

Supplied as 2 Preassembled Panels, plus metal work Superhet design. 88-108 Mc/s. 9 volt operated. 6 Mullard Transistors. Total cost to assemble £12.17.6, p.p. 2/6

STABILISED POWER SUPPLY

Two outputs. 3.6 volt and 7.6 volt up to 250mA each. Transistorised and tuner stabilised. 110 to 250 volt mains input in case with leads. **PRICE 67/8**, p.p. 2/6.

(17) 5 WATT AMPLIFIER

6- Transistor Push-pull, 3 ohms. 6mV into 1K. 12/18V supply, 2½ x 2 x 1½in.
BUILT AND TESTED 69/6 P.P. 2/-
(optional mains units 54/-)
1½ watt version 59/6.
Matching Preamplifier, 6 inputs, treble/bass/selector/volume controls. 6-10mV o/p. 9-18V supply. 79/6, p.p. 2/-.
For use with any Transistor Amplifier

(18) **FMT41 FM TUNER.** 6-transistor 3 diode design. Com-£8.10.0 p.p. 2/-
pletely built and tested

(19) **AMT31.** Med. Wave Tuner Built ready to use. 79/6, p.p. 2/-.

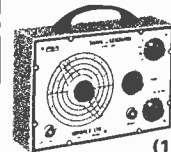

(16)



(17)



(13)



(15)

SEE BACK COVER FOR MORE ITEMS OF INTEREST

YOUR CAREER in RADIO & ELECTRONICS ?

Big opportunities and big money await the qualified man in every field of Electronics today—both in the U.K. and throughout the world. We offer the finest home study training for all subjects in radio, television, etc., especially for the **CITY & GUILDS EXAMS** (Technicians' Certificates); the Grad. Brit. I.R.E. Exam.; the **RADIO AMATEUR'S LICENCE**; P.M.G. Certificates; the R.T.E.B. Servicing Certificates; etc. Also courses in Television; Transistors; Radar; Computers; Servo-mechanisms; Mathematics and Practical Transistor Radio course with equipment. We have **OVER 20 YEARS'** experience in teaching radio subjects and an unbroken record of exam. successes. We are the only privately run British home study College specialising in electronic subjects only. Full details will be gladly sent without any obligation.

To: **British National Radio School, Reading, Berks.**

Please send **FREE BROCHURE** to:

NAME Block

ADDRESS Caps.

1 67

BRITISH NATIONAL RADIO SCHOOL

SURBITON PARK RADIO

MARTIN RECORDAKITS

NEW MAGNAVOX 363 DECK. Two Track Cash £11.19.6
6 Valve amplifier complete 2 EL84 Cash £14.19.6
Complete recorder, Case, Tape, Mic Cash £36.0.0
Or Dep. 180/- and 12 m. pymts. 49/6 (H.P. Price £38.14.0)
FOUR TRACK MAGNAVOX 363 DECK Cash £14.14.0
FOUR TRACK AMPLIFIER as above Cash £15.19.6
Complete recorder, Case, Tape, Mic. Cash £40.0.0
Or Dep. 200/- and 12 m. pymts. 55/- (H.P. Price £43.0.0)
These recorders are very well made. The amplifier is on a printed circuit and all components are mounted and tested. Can be built in 2 to 3 hours.

MOTORS PICK-UPS Selection

GARRARD Model 1000 Mono Cash £7.10.0
Or Dep. 37/6 and 8 m. pymts. 16/3 (H.P. Price £8.7.6)
GARRARD Model 2000 Mono. Large table Cash £8.10.0
Or Dep. 42/6 and 8 m. pymts. 18/6 (H.P. Price £9.10.6)
GARRARD Model 3000 Stereo 9TA/HC Cash £11.11.0
Or Dep. 58/6 and 9 m. pymts. 21/5 (H.P. Price £12.11.3)
GARRARD Model AT60 Less cart. Cash £13.0.0
Or Dep. 65/- and 9 m. pymts. 23/11 (H.P. Price £14.0.3)
GARRARD Model SP25 Single player, less cart. Cash £12.10.0
Or Dep. 62/6 and 9 m. pymts. 23/1 (H.P. Price £13.10.3)

AMPLIFIERS-TUNERS Selection

ARMSTRONG 221 10-10 watts Stereo Mag PU and Filter Cash £25.10.0
Or Dep. 177/6 and 12 m. pymts. 48/10 (H.P. Price £38.3.6)
ARMSTRONG 222 10-10 watt Stereo Deram. Cash £28.15.0
Or Dep. 147/6 and 12 m. pymts. 39/3 (H.P. Price £30.18.6)
ARMSTRONG 224 FM Tuner Powered Cash £24.15.0
Or Dep. 135/- and 12 m. pymts. 33/7 (H.P. Price £26.18.0)
ARMSTRONG 225 AM/FM Tuner Powered Cash £31.0.0
Or Dep. 155/- and 12 m. pymts. 42/6 (H.P. Price £33.7.0)
ARMSTRONG 127 Mono 5W with AM/FM Cash £23.10.0
Or Dep. 147/6 and 12 m. pymts. 40/7 (H.P. Price £31.14.6)
ARMSTRONG 127 Stereo as above Stereo amp. Cash £29.10.0
Or Dep. 197/6 and 12 m. pymts. 54/4 (H.P. Price £42.9.6)
ARMSTRONG 227 Mono 10 watt with AM/FM Cash £29.10.0
Or Dep. 197/6 and 12 m. pymts. 54/4 (H.P. Price £42.9.6)
Teak Cases for all Armstrong Units £3.10.0
TERMS: C.W.O. or C.O.D. **ALL ITEMS CARRIAGE FREE**
Leaflets available upon receipt of 6d. stamp

48-50 Surbiton Road, Kingston-on-Thames, Surrey
Phone **KIN. 5549** Hours 9 a.m. to 6 p.m. daily (1 p.m. Weds.)

The following blueprints are available from stock. **Descriptive text is not available but the date of issue is shown for each blueprint. Send, preferably, a postal order to cover cost of the blueprint (stamps over 6d. unacceptable) to Blueprint Department, Practical Wireless, George Newnes Ltd., Tower House, Southampton Street, London, W.C.2.**

The Strand Amplifier }	(Oct. 1962)	5/-	The Celeste 7-transistor Portable Radio }	(June 1963)	5/-
The PW Signal Generator }			The Spinette Record Player }		
The Berkeley Loudspeaker Enclosure }	(Dec. 1962)	5/-	Transistor Radio Mains Unit }	(June 1964)	5/-
The Luxembourg Tuner }			7 Mc/s Transceiver }		
The PW Troubadour }	(June 1962)	7/6	The Citizen (December 1961) }		5/-
The PW Everest Tuner }			The Mini-amp (November 1961) }		5/-
The PW Britannic Two }	(May 1962)	6/-	The PT Multimeter (October 1961) PT }		5/-
The PW Mercury Six }			The Beginner's Short Wave Superhet (Dec. 1964)		5/-
Beginner's Short Wave Two S.W. Listener's Guide }	(Nov. 1963)	5/-	The Empire 7 Three-band Receiver (May 1965) }		5/-
Beginner's 10-watt Transmitter Transmitting and Aerial Data }	(Dec. 1963)	5/-	Electronic Hawaiian Guitar (June 1965) }		5/-
PW "Sixteen" Multirange Meter Test Meter Applications Chart }	(Jan. 1964)	5/-	Progressive SW Superhet (February 1966) }		5/-
			Beginners' 5-Band Receiver }	(Dec. 1966)	5/-
			Home Intercom Unit }		

★ PLEASE NOTE THAT WE CAN SUPPLY NO BLUEPRINTS OTHER THAN THOSE SHOWN IN THE ABOVE LIST. NOR ARE WE ABLE TO SUPPLY SERVICE SHEETS FOR COMMERCIAL RADIO, TV OR AUDIO EQUIPMENT. ★

Before using the query service it is important to read the following notes:

The PW Query Service is designed primarily to answer queries on articles published in the magazine and to deal with problems which cannot easily be solved by reference to standard text books. In order to prevent unnecessary disappointment, prospective users of the service should note that:

(a) We cannot undertake to design equipment or to supply wiring diagrams or circuits, to individual requirements.

(b) We cannot undertake to supply detailed information for converting war surplus equipment or to supply circuitry.

(c) It is usually impossible to supply information on imported domestic equipment owing to the lack of details available.

(d) We regret we are unable to answer technical queries over the telephone.

(e) It helps us if queries are clear and concise.

(f) We cannot guarantee to answer any query not accompanied by the current query coupon and a stamped addressed envelope.

QUERY COUPON

This coupon is available until 6th January, 1967 and must accompany all queries in accordance with the rules of our Query Service.

PRACTICAL WIRELESS, JANUARY 1967



BUILD THE WORLD'S FIRST ALL TRANSISTOR PORTABLE ORGAN KIT

MAYFAIR PORTABLE ELECTRONIC ORGAN

ACCLAIMED BY EVERYONE!



Designed by L. W. ROCHE

TO BUILD YOURSELF IN EASY STAGES, ALL PARTS SOLD SEPARATELY and FULLY GUARANTEED

Latest 4-page Illustrated Catalogue Supplement. Free on request.

- ★ EASY TO BUILD WITH PRINTED CIRCUITS AND FULLY COMPREHENSIVE HANDBOOK
- ★ CIRCUITS USE 170 TRANSISTORS AND DEVICES
- ★ 10 SELECTED TONE COLOURS PLUS VIBRATO
- ★ PORTABLE TWO COLOUR CABINET WITH DETACHABLE LEGS, MUSIC STAND, SWELL PEDAL
- ★ THE ONLY COMPLETE KIT AVAILABLE IN THE WORLD
- ★ FOR GROUPS, CLUBS, HOBBYISTS, HOME ENTERTAINMENT

SPECIFICATIONS:

- TONE COLOURS (ROCKERTABS) 10 DIFFERENT TONES CAN BE SELECTED
- SWITCHED VIBRATO. ● CABINET SIZE 30½ x 15½ x 9 in. ● WEIGHT 35 lb.
- 49 NOTE C-C FULLY SPRUNG KEYBOARD ● 6 OCTAVES OF GENERATORS
- PRESET VOLUME CONTROL ● TONE COLOUR BLEND CONTROL
- FOOT SWELL PEDAL ● OUTPUT UP TO ½ VOLT ● 110/250 VOLT MAINS OR 18 VOLT BATTERY ● FULLY POLYPHONIC OPERATION
- PLUG-IN PRINTED CIRCUIT PANELS ● SIMPLE LOCKED-IN TUNING
- DETACHABLE LEGS WITH STOWAGE
- FULLY DETAILED INSTRUCTION HANDBOOK, PHOTOS AND CIRCUITS

UNBEATABLE FOR PRICE PERFORMANCE AND QUALITY

- COMPLETE KIT WITH CABINET, ALL COMPONENTS AND HANDBOOK
- ALL PARTS AVAILABLE SEPARATELY
- HP AVAILABLE FOR COMPLETE KIT
- HANDBOOK SEPARATELY, 20/- post paid

99 GNS. (CARRIAGE AND PACKING 30/- EXTRA)

DETAILED LEAFLET FREE ON REQUEST CALL FOR DEMONSTRATION

TRANSISTORS
Latest 14-page Transistor/Rectifier catalogue now ready. Many new devices—plenty of price reductions. Send 3d. stamp for free copy. The Largest Range available.

TUNNEL DIODES

1mA 22/8; 5mA 15/-; 15mA 12/8; brand new at fraction of normal price. Full specs supplied.

(1) REGEN'S MW/LW SOCKET RADIO TO BUILD

6-Transistor superhet. Geared tuning. Push-pull speaker output. Moulded cabinet 5 x 3 x 1½ in. FM Tuners, P.U.'s, etc. O/P 4 to 16 ohms. Mains oprtd. **£15.15.0** P.P. 2/- Full tuning on both bands

SCR'S (THYRISTORS)

● 1 AMP SERIES WIRE LEADS
50 PIV .. 7/6 100 PIV .. 7/6
200 PIV .. 12/6 300 PIV .. 15/6
400 PIV (280V Rms) .. 17/6
100 PIV, 3 Amp Stud Type .. 9/6
400 PIV, 7 Amp (280V Rms) .. 25/-
400 PIV, 3 Amp .. 20/-

(3) DEAC RECHARGEABLE BATTERY.

Your last chance for this offer. ● 9.6 volt 225mA/H ... 20/- pp. 1/8

DEAC CHARGER **45/-**
To charge 3.6 volt and 9.6 volt packs. Fully mains isolated in case. P.P. 2/-

(2) HI-FI EQUIPMENT

Complete range in stock. Send list of requirements for special price quote. Hi-fi demonstration room open.

VALVE AMPLIFIERS AND TUNERS IN CABINETS

● SA100. 5 + 5 watt Stereo. 300mV Input FM Tuners, P.U.'s, etc. O/P 4 to 16 ohms. Mains oprtd. **£27.10.0** P.P. 7/6
● SA200. 7½ + 7½ watt version. Also Inputs for Mag. Mic. Mag. P.U.'s, etc. self-powered mains. **£23.10.0** P.P. 5/- (AFM100 and 200 may be used with any amplifier)

● AFM 200. AM/FM tuner to match SA200. P.P. **29 gns.** 7/6
● AFM100 and 200 may be used with any amplifier

Also from stock: ARMSTRONG QUAD GOODMANS LEAK ROGERS TRUVOX

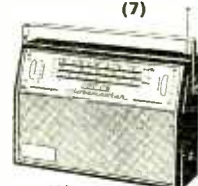

(7)



(2)

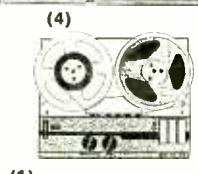

(4)



(1)

FM STEREO DECODER
7 Mullard Transistors. Printed Circuit Design with Stereo Indicator. For use with any valve or transistor FM. Uses pot cores to Mullard design and ger. and silicon transistors. Complete **£5.19.6** P.P. 2/-

(4) BUILD A QUALITY 2 OR 4 TRACK TAPE RECORDER

New 3-speed version using new '363' decks
● TWO-TRACK. Deck **£10.10.0**. Martin Amplifier **£14.19.6**. Cabinet and speaker 7 gns. Complete kits with FREE 7in. 1200ft. tape, spare spool. **27 gns** P.P. 15/-
Today's Value **£45**
● FOUR-TRACK. Deck **£13.10.0**. Martin Amplifier **£15.19.6**. Cabinet and speaker 7 gns. Complete kits with FREE 7in. 1200ft. tape, spare spool. **30 gns** P.P. 15/-
Today's Value **£50**

TSA90. Transistor Stereo Amplifier in Case. 4½ + 4½ watts. 8 to 16 ohms O/p. Input 80mV Tuner and P.U.'s. Mains operated. **£9.19.6** P.P. 6/-

(5) VHF FM TUNER TO BUILD

87/105 Mc/s Transistor Superhet. Geared tuning. Terrific quality and sensitivity. For valve or transistor amplifiers. 4 x 3½ x 2½ in. Complete with dial plate, 5 Mullard Transistors (FM Decoder Kit **£5.19.6**, P.P. 2/-). **TOTAL COST £6.19.6** P.P. 2/6
(Cabinet Assembly 20/- extra)



(8)



(5)

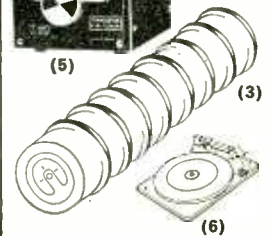

(6)

GARRARD DECKS—BRAND NEW FULLY GUARANTEED			
1000 mono	£5 13 6	SP26 stereo	£10 10 0
AT5 mono	£6 9 6	SP26 Deram	£12 19 6
2000 mono	£6 9 6	AT6 less cart.	£10 10 0
2000 stereo	£6 10 6	AT6 mono	£10 19 6
3000 1m stereo	£7 10 0	AT6 stereo	£11 10 0
SP26 less cart.	£9 10 0	AT6 Deram	£13 19 6
SP26 mono	£9 19 6	LA380 less cart.	£27 0 0

All other makes of decks and cartridge in stock
(F. & P. 5/- any type)

(7) GLOBEMASTER MW/LW/SW PORTABLE RADIO TO BUILD

Full 3-waveband tuning. Pushbutton wave-change. Superhet printed circuit. Black-chromed cabinet 11 x 7½ x 3½ in. (SW 17-50 metres). Ear/Recorder sockets. 1 watt Push/Pull output. 6 Mullard Transistors. **TOTAL COST £7.19.6** P.P. 3/6

(8) TOURMASTER TRANSISTOR CAR RADIO

7-Transistor MW/LW Car Radio. 12 volt operated. 3 watt output. Push-button wave-change. RF stage. Supplied built, boxed, ready to use with Speaker and Baffle. Car fixing kit and manufacturers' current guarantee. Special Bargain offer. Buy Now! List Price **15 gns.** **£9.9.0** P.P. 3/6

WE CAN SUPPLY FROM STOCK MOST OF THE PARTS SPECIFIED ON CIRCUITS IN THIS MAGAZINE. SEND LIST FOR QUOTATION. ASK FOR NEW 4-PAGE CATALOGUE SUPPLEMENT ALSO LIST OF SPECIAL HIGH FIDELITY EQUIPMENT DISCOUNTS AVAILABLE.

HENRY'S RADIO LTD.

303 EDGWARE RD., LONDON, W.2
PADdington 1008/9 (STD. 01-723-1008)
Open Mon. to Sat. 9-6, Thurs. 1 p.m.
Open all day Saturday

LATEST 1966 CATALOGUE

Have you a copy? Fully detailed and illustrated. 150 pages of components, equipment, etc. Over 5,000 stock items. PRICE 6/-, post paid. Free discount vouchers with every catalogue. You cannot afford to be without a copy of this catalogue

SEE PAGE 711 FOR MORE ADVERTS

FULL DESCRIPTIVE LEAFLETS ON ALL ITEMS ON REQUEST