

THE LEADING HOME-CONSTRUCTORS' WEEKLY!

# Practical Wireless

3<sup>D</sup>.

Published every Wednesday by  
**GEORGE  
NEWNES  
LTD.**

Vol. 2. — No. 31.

APRIL 22nd, 1933.

Registered at the G.P.O. as a Newspaper.

## The SELECTONE A.C. RADIO-GRAM TWO



VOLUME CONTROL  
ADDING A VALVE  
MAKING COIL FORMERS  
WIRING EFFICIENCY  
THE DOUBLE-DIODE-  
TRIODE  
OPERATING THE BETA  
FOUR Etc., Etc.



MONARCH OF THE MAINS.

### HEAYBERD MAINS TRANSFORMER

AGAIN—EXCLUSIVELY SPECIFIED! For the 'A.C. Twin'

Send for 36 page Handbook to: 10, FINSBURY ST., LONDON, E.C.2.

Write name in margin and send, with 3d. stamps—NOW!

# WHY TROUBLE?



The Utility Bakelite Condenser with the disc dial.

You may think "Why should I trouble to buy a Utility Bakelite Condenser when I can get a dozen others all the same." But there is as much difference between a good and bad bakelite condenser as between chalk and cheese. We believe that a bakelite condenser justifies care in design and in construction, that it should be accurately rated, that H.F. losses should be kept as low as possible. We may be wrong, but a check is easily applied; substitute a Utility for the bakelite condenser you are using for reaction control. We feel sure that you will prove that we are right.

Coupled with the famous Utility disc dial, the condenser costs **4/6** in the following sizes:— .0002, .0003, .0005. The condenser can be purchased separately for 2/-.

If your dealer cannot supply write direct to:—

**WILKINS & WRIGHT LIMITED**

Utility Works, Hollyhead Road, Birmingham

London Agent: E. R. Morton, Ltd., 22 Bartlett's Buildings, Holborn Circus, E.C.4

## Utility BAKELITE CONDENSER

Belmont

### STRONGLY RECOMMENDED

Innumerable specifications of Lewcos Components by experts for the most successful sets of the year indicate that these renowned units are recognised as the most modern and efficient obtainable.

*fit* Lewcos Radio Components transform even the most indifferent receivers into instruments of outstanding brilliance.



Radio Components

A Lewcos Band Pass Filter (Ref. B.P.F/R) is exclusively specified by the

designer for the "A.C. Twin" described in this issue.

THE LONDON ELECTRIC WIRE COMPANY AND SMITHS LIMITED, CHURCH ROAD LEYTON LONDON E.10

### THE VALVE OF THE MOMENT!

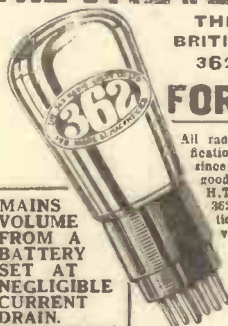

THE BRITISH 362

**CLASS B**

FOR IMMEDIATE DELIVERY

All radio journals agree that "Class B" Amplification is a great and revolutionary development, since this new valve gives tremendous volume and good quality for insignificant expenditure of H.T. Send direct to the makers for a British 362 "CLASS B" Valve with full instructions—you will be delighted with the marvellous results obtained.

Price

**9/**

POST FREE

If you also require a "driver" valve, send for the British 362 "P.2." price 4/6, post free. For full list of British 362 FULLY GUARANTEED VALVES see our advt. on page iii of cover.

Cash with order. Cheques and P.O.'s must be crossed and made payable to The 362 RADIO VALVE Co., Ltd. (Dept. W.7), 415, Mare St., Harkney, London, E.8.

### 'SMITHCRAFT' LYRIC CABINETS

Exclusively specified for the

### A.C. TWIN

PRICE £2 : 18 : 6  
SMITH'S CABINETS LTD.

18-20 HERTFORD RD., N.1



AN EXAMPLE OF 'SMITHCRAFT'

# IGRANIC T.24.B TRANSFORMER SPECIFIED FOR THE A.C. TWIN

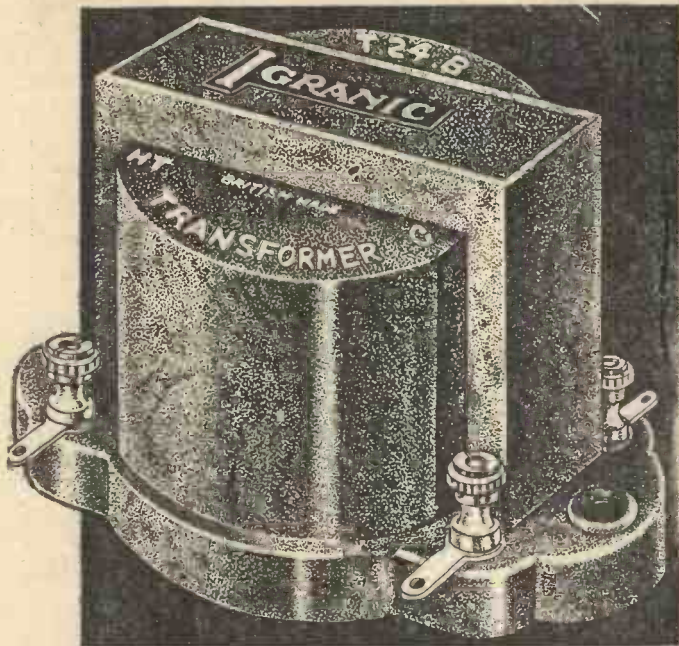

"I do not know what the life of a transformer is supposed to be, but this one has been in constant use for 7 years and has given about 10,000 hours' actual performance and is still going strong."

J.A.L., Liverpool. Extract from letter.

Through long experience of wireless construction, Igranic have evolved the perfect general purpose transformer—specified to-day for the A.C. Twin. The Igranic T.24.B Transformer reproduces over the whole scale of musical frequencies. Ratios 3-1 and 5-1. Price only 5/6.



Write to-day for fully-illustrated Catalogue No. J.1248 of complete new range of Igranic Quality Components.

Igranic Electric Co., Ltd.,  
149, Queen Victoria Street, London, E.C.4.

**IGRANIC COMPONENTS WILL  
BE THE MAKING OF YOUR SET**

CVS-72



# EDISWAN

The name that means 'EXCELLENCE'

## Convert your radio into a RADIO- GRAM

PRICE  
**25/-**

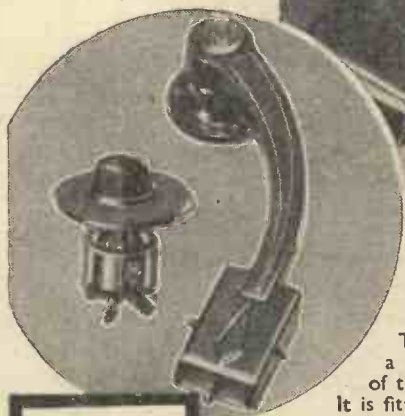

The B.T.H. Pick-up has, since pick-ups were first used, always been acknowledged as the finest obtainable. The "Minor" model is a worthy representative of the latest B.T.H. range.

It is fitted in a highly finished tone-arm moulding. A volume control of the correct value is incorporated in the tone-arm pillar. It is supplied complete with rest and fixing screws. For the connoisseur in radiogram reproduction, the "Senior" model is ideal. It is finished Florentine bronze and supplied complete with separate volume control.

PRICE  
**42/-**



## PICK-UPS and TONE ARMS



The Edison Swan Electric Co. Ltd.  
155 Charing Cross Rd., London, W.C.2

GOOD RADIO DEALERS RECOMMEND EDISWAN

W.207

The First Completely Practical-Completely Safe—  
**ALL-ELECTRIC RECEIVER**  
 for the Home Constructor!

KIT COMPLETE WITH FOUR VALVES

£7.19.6



The **ALL-ELECTRIC A.C. SAFETY SKYSCRAPER**

Now, at last, you can equip your home with ALL-ELECTRIC RADIO, SELF CONSTRUCTED. Here for the first time is a complete All-Mains Kit for the Home Constructor which is at once completely practical and completely safe. You build the "All-Electric Skyscraper" yourself, and by a few hours of fascinating home construction you will have a powerful receiver, complete with every modern reception device—bringing you in every receivable station at full moving-coil volume.

UNIQUE SAFETY FUSE PLUG



No harmfully powerful current can possibly flow from your mains to your A.C. Skyscraper. The special safety fuse plug completely protects you by introducing a small valve fuse into each lead.

FOUR MATCHED HIGH POWER VALVES

The four valves of the A.C. Safety Skyscraper are matched to each other and to the rest of the special circuits to give the utmost power, utmost range, utmost fidelity of reproduction.



The "All-Electric Skyscraper" works from A.C. Mains. It is a self-contained receiver, with provision for Mains Aerial. You simply plug in and switch on. Unique to this A.C. "Skyscraper" is the special Safety Power Unit and Safety Fuse Plug giving the fullest possible protection, and making this the first really SAFE A.C. Constructor's Kit, AS SAFE TO HANDLE AS A BATTERY SET! Lissen has published a beautiful and practical coloured Chart which gives you plans and photographs and exhaustive descriptions of every single point in the construction, operation and enjoyment of this receiver. Matched Valves. Pentode Output. Variable Mu Screened Grid H.F. Stage. Drives Moving Coil Speaker at full volume. Metal Chassis. One Dial Tuning. Ganged Reaction, and Volume Control. Walnut Console Cabinet which you assemble yourself and so save money. Power Pack an integral part of the chassis. Heavily insulated Mains Lead. Every refinement of the most expensive All Mains Receiver is incorporated in the All-Electric "Skyscraper"—and SUCCESS IS CERTAIN WHEN YOU FOLLOW THE GREAT LISSEN CHART.

**MOST COMPLETE AND DETAILED CHART EVER PUBLISHED**

Obtainable from all Lissen Dealers at the following prices:  
 "All-Electric A.C. Skyscraper" Chassis Kit, complete with Power Unit, 4 Matched Valves and Mains Lead with special Power Unit and Safety Fuse Plug. Price £7 19s. 6d.  
 "All-Electric A.C. Skyscraper" Kit, as above, including valves, with Table Model Walnut Cabinet. Price £8 15s. 0d.  
 "All-Electric A.C. Skyscraper" Kit, as above, including valves and with Walnut Console Cabinet, as illustrated, and full power MOVING COIL LOUDSPEAKER. Price £10 12s. 6d.

**LISSEN**

**AC SKYSCRAPER SAFETY**

To LISSEN LTD., Publicity Dept., Isleworth.  
 Please send me FREE copy of the Chart of "All-Electric Safety A.C. Skyscraper."

Name .....

Address .....

..... PRACT. A.C. 2

**POST THIS COUPON**



EDITOR:  
 Vol. II. No. 31 || F. J. GAMM || April 22nd, 1933  
 Technical Staff:  
 H. J. Barton Chapple, Wh. Sch., B.Sc., (Hons.), A.M.I.E.E.  
 W. J. Delaney, Frank Preston, F.R.A., W. B. Richardson.

# ROUND *the* WORLD of WIRELESS

### Good News for Battery-Set Users

A CELL that will hold its charge for a longer period has been the dream of accumulator experts for years past. At last that desirable goal has been realized by the introduction of the new Edison "Extralife" accumulator. In developing the new cell, Ediswan have made use of a new principle. It is called by them "balanced capacity." By special designing of the plates, an exact electrical balance is maintained between the positive and negative elements of the cell. This has the effect, not only of conserving the charge, but also of prolonging the life of the cell, even under adverse conditions. A range of these trouble-saving accumulators has recently been placed on the market at the same prices as ordinary accumulators.

### Two Stations for Christmas Island

THE value of wireless communications to highly-developed countries has been so widely demonstrated in recent years, during which a vast network of radio telephone and telegraph services has been established between practically all the principal nations of the world, that, paradoxically enough, the special value of wireless to isolated communities is less emphasized to-day than in the earliest period of Marconi's inventions. Yet modern wireless apparatus has attained a degree of efficiency and reliability, combined with simplicity of operation, that renders it an essential part of the equipment of any settlement that is outside the world's established communications systems.

A typical example of such a community, and the utility of wireless to its members, is the small British settlement on Christmas Island, in the Indian Ocean. Christmas Island lies some 800 miles south of Singapore and 1,000 miles north-west of the Australian continent. It is served by no cables, and it is far from the regular shipping routes.

Without wireless, its inhabitants would be isolated from contact with the outside world, except through the medium of trading ships.

### Pentode Output Stage

THERE are a number of circuits about showing a pentode output stage coupled by means of a choke fed trans-

former. While this circuit undoubtedly gives excellent results we wonder how many listeners realize the danger of using such an arrangement. Should the detector-valve heater suddenly break, which it must at some time, the following set of events takes place. The anode current, which was passing through the choke to the valve, suddenly stops, with the result that the magnetic field round the choke suddenly collapses, which sets up an abnormal voltage across it, say, 10 volts.

**HAVE YOUR COPIES OF  
 VOLUME 1 OF  
 "PRACTICAL WIRELESS"  
 BOUND!**

SEE THE

**SPECIAL  
 BINDING OFFER  
 ON PAGE 200**

**NEXT WEEK:  
 SOMETHING ENTIRELY  
 NEW IN LIGHTWEIGHT  
 CLASS B PORTABLES**

Assuming a 3 to 1 transformer, this 10 volts will become 30 across the secondary. Allowing the pentode moderate magnification of 40, the 30 volts will become 1,200 volts between anode and cathode of the pentode. Granted this voltage will only be present for an infinitesimal part of a second, it is often long enough to blow every condenser in the power pack. To prevent such an unhappy occurrence, a resistance should be connected across the choke. The value may be anything between 50,000 and 200,000, and will not alter the quality of reception if the value is chosen with some regard to the inductance of the choke.

### New German Interval Signal

TO commemorate the Potsdam celebrations in connection with the re-opening of the German Reichstag on March 21st last, the Königs Wusterhausen (Deutschlandsender) has adopted as an interval signal the first bars of the patriotic hymn, *Ueb' immer Treu und Redlichkeit*, played on the carillon of the Potsdam Garrison Church. As the sounds are reproduced by a musical box of the barrel-organ type, they do not sound like bells but closely approximate the tones of a piano.

### Radio Luxembourg and Istanbul

MANY readers have been puzzled by a call from the super-power Luxembourg station, which has led them to believe that they were also hearing a broadcast from Istanbul (Constantinople) on a neighbouring wavelength (1,200 m.). There should be no confusion between these two transmitters; the announcement given in a feminine voice is not *Ici Radio Istanbul*, but *Ici Radio Luxembourg*—the last word being pronounced *Lix-am-boor*. The Turkish studio does not possess a woman announcer.

### Hungary's Seven Transmitters

CONSIDERABLE developments have taken place during the past few months in the Hungarian broadcasting system which now comprises a network of seven stations. The Budapest main programme is broadcast through the Lakihegy 18.5 kilowatt transmitter on 550.5 metres, and also through three 1½ kilowatt relays installed at Magyarovar, Pecs and

Miskolc which work on a common wavelength (209.8 metres). In addition, the same wireless entertainments are taken by Nyiregyhaza (6.25 kilowatts) on 267.2 metres. An alternative programme for the Hungarian capital is now transmitted through the old Csepel station on 840 metres, with a power of 3 kilowatts. For experimental purposes only tests are made with a small mobile plant at Craciunelu on 2,000 metres.

### A Royal Birthday Broadcast

TO celebrate the birthday anniversary of Princess Juliana of Holland on April 30th, a special programme will be broadcast by the A.V.R.O. association

# ROUND the WORLD of WIRELESS (Continued)

through Hilversum station on 296.1 metres on May 1st. As this date in previous years was always conceded to the V.A.R.A. Socialist Clubs for their Labour Day wireless entertainments, these celebrations will be postponed to the following week.

## Atlantic Ice Patrol

**F**OLLOWING the sinking of the s.s. *Titanic*, on her maiden trip in April, 1912, when she collided with an iceberg, the United States coastguard service instituted a regular iceberg patrol in the North Atlantic. As the movement of these bergs from the Polar regions has already begun, special vessels from New York and Norfolk are already patrolling the international shipping routes to locate the icebergs, the positions of which are wirelessed at regular intervals throughout the day and night.

## The Strasbourg German Programmes

**P**ITT STRASBOURG since its installation has always broadcast in both French and German in view of the mixed population in the Alsace province. In view of the fact that complaints by listeners are made regarding anti-French propaganda put out by the neighbouring German stations, the authorities are considering a suggestion to make Radio Strasbourg an all-French studio, and to cut out German entertainments and announcements.

## Listen to West Regional

**T**HE new West Regional transmitter at Washford Cross is now ready to operate and listeners may hear the station testing from April 24th, when from that date it will be on the air daily between 11.10 and 11.50 a.m. The B.B.C. also proposes to broadcast the late dance music through this station. The wavelength is the one at present used by Cardiff, namely, 309.9 metres.

## The Awakening of the Orient

**C**OMPLETE re-organization of the French broadcasting system in Northern Africa is to take place during the next eighteen months. Radio Algiers will be completely rebuilt in order to house a 75-kilowatt transmitter and a 60-kilowatt plant will also be installed at Tunis. Radio Maroc (Rabat) may also see its energy considerably increased by next autumn and plans have been drawn up for the erection of two further relay stations. According to reports, work on an official Egyptian transmitter at Cairo is making good progress and a second station may be built at Alexandria. Even Jerusalem in the near future will broadcast wireless programmes, with a short-wave relay transmitter at Tel-Aviv, to make the entertainments available to the New World.

## Bringing the Orient to Italy

**I**N order to give listeners an impression of native life in the Italian-African Colonies, the E.I.A.R. intends to relay running commentaries from the native "souks" in Tripolitania. A well-known

## INTERESTING and TOPICAL PARAGRAPHS

journalist and two radio engineers have been sent to the capital, Tripoli, to study ways and means. The relays would probably be carried out by short-wave transmission to Rome and then re-broadcast over the Italian net.

## HOW IT IS DONE!



The Columbia van at Marble Arch recording an organ recital from inside the cinema.

## The Moscow Foreign Broadcasts

**O**N 1,000 metres (300 kc/s) and 50 metres (6,000 kc/s) broadcasts in foreign languages are carried out by the Moscow

# SOLVE THIS!

## Problem No. 31.

A rather peculiar fault had developed in Smith's three-valve set. This employed a grid leak rectifier, resistance-coupled to the next valve which was in turn transformer-coupled to the output valve. When the set was switched on it gave good signals for about one minute and then the strength fell to about one-third of normal, at which it would remain constant for the rest of the evening. When, however, Smith was looking for the fault and testing the soldered joints he suddenly touched the grid terminal of the second valve and signals were immediately restored to full strength. What was wrong with the set? Three books will be awarded for the first three correct solutions opened. Address your solutions to The Editor, PRACTICAL WIRELESS, Geo. Newnes, Ltd., 8-11, Southampton Street, Strand, London, W.C.2, and mark your envelopes "Problem No. 31." Do not enclose any other correspondence with your solution.

## SOLUTION TO PROBLEM No. 30.

Blackman should have inserted the S.G. valve into the detector socket (ignoring the anode connection), and connected the aerial, via a small fixed condenser, to the junction of coil, tuning condenser and grid condenser. The following three readers received books in connection with Problem No. 29.

A. Feakins, 37, Rosebery Road, Brixton Hill, S.W.2; M. H. Hayton, 11, Park View, Harton, South Shields; W/O L. H. Metz, Fighting Area H.Q., R.A.F., Usbridge.

(Old Komintern) transmitter according to a regular time schedule as under:— From 8.0-9.0 p.m. B.S.T., in German, on Sundays, Mondays, Thursdays and Saturdays; from 10.0-11.0 p.m., in Dutch, on Fridays; and between 8.0-9.0 p.m. on Tuesdays; from 10.0-11.0 p.m. on Thursdays and Saturdays in Swedish; in Spanish (Sundays); Magyar (Tuesdays) and in Czech (Wednesdays and Fridays). Moreover foreign talks are also transmitted by the

Trades' Union station in English on Monday, Wednesday, Friday, Saturday and Sunday, and in French on Tuesday, Thursday and Saturday, between 9.0 and 11.0 p.m. B.S.T. These are also relayed on the short-wave transmitter working on 46.6 metres.

## Man-Made Statics?

**A**USTRIAN papers report that in order to prevent German listeners from hearing the Polish broadcasts, the German authorities have deliberately jammed the Warsaw transmissions. Interference on the Moscow wavelength is also said to be due to the same cause. Similar complaints have been levelled against Italy by the Jugo Slavian studios and in particular by Ljubljana, of which the transmissions on several occasions were destined for the Trentino districts. All quiet on the ether front!

## The Monte Ceneri Tests

**O**WING to an unforeseen "technical hitch" the first broadcasts to be carried out by the new Tessin station on 680 metres may be postponed for another three weeks. The wavelength has been temporarily adopted and may be changed for a more favourable channel at a later date.

## Regular Night Programme from Zeesen

**A**S already stated in these columns, DJC, Zeesen, is now carrying out a nightly broadcast between 1.0 and 3.0 a.m., B.S.T., on 49.83 m. (6,020 kc/s). This special transmission is destined to German residents in North and South America and in order to favour reception beam aerials will be used. The station will no longer act as a short-wave relay for Berlin or other German studios, but will put out original programmes of special overseas interest.

## The Ether Controllers

**I**N addition to the special station designated by the International Union of Broadcasters to check the wavelengths of all European transmitters, there exist other "listening posts" acting for individual States, such as Tatsfield (England), the Telegrafentechnisches Reichsamts (Berlin), Csepel (Hungary), Mojauk (U.S.S.R.); Sesto Calende (Italy), Noiseau (France) and recently-opened radio laboratories at Madrid, Warsaw and Stockholm. Officials appointed for the purpose measure the transmissions at regular intervals during the broadcasts with a view to assisting the transmitters to maintain their allotted positions in the waveband.

# ADDING A VALVE TO YOUR SET

By W. B. RICHARDSON

If you are Thinking of Altering Your Receiver to Include Another Valve You Should First Read This Article. It Tells You When the Alteration Would be Advisable and Gives the Pros and Cons of the Various Possible Arrangements.

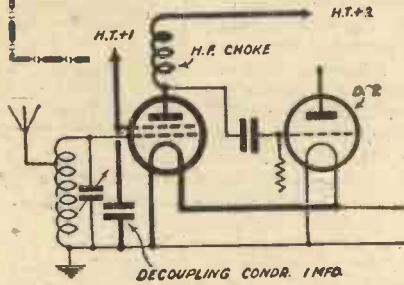

Fig. 1.—Adding an untuned H.F. stage. Heavy lines indicate the new parts required.

SOMETIMES the home constructor possessing a two-valve or three-valve set feels he could do with a little more "punch," or with rather greater range. Must he scrap his present receiver, he asks, and make or buy a more powerful one, or can he add another valve to it and thus achieve the desired result without any great additional expense?

The answer to such a question depends on a variety of things. Perhaps the most important is the type of set. If it is a commercial receiver it is usually practically impossible to alter it; but if it is home-constructed it may be possible. The amount of space available will probably be the deciding factor.

### H.F. or L.F.?

The first thing to decide is whether the valve is to be an H.F. or L.F. amplifier. Broadly speaking, adding a screen-grid valve will give increased selectivity and greater range, while an L.F. valve will increase the volume.

similar to L.F. amplification. However, it differs from the latter in that it is able to increase the range of the set. This is due solely to the imperfections of the detector.

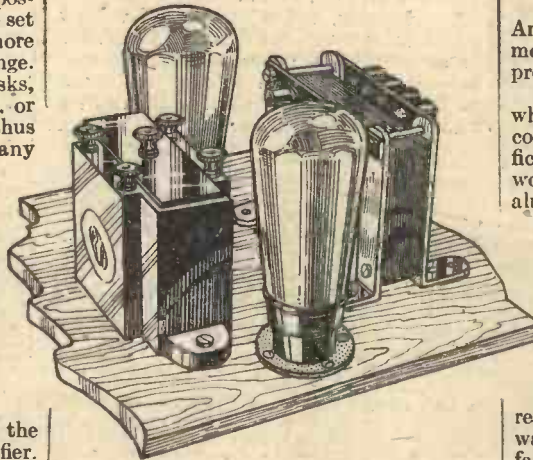

Fig. 6.—One way of adding a valve is to connect it in push-pull with the existing output valve. The lay-out for such an arrangement is shown here.

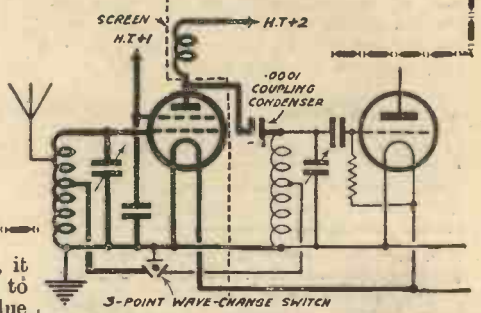

Fig. 2.—Circuit showing how to add an S.G. valve.

An L.F. valve on the other hand cannot do more than amplify what the detector provides it with.

From the foregoing it is easy to see in what circumstances the addition of a choke-coupled or untuned stage of H.F. amplification would be desirable. Briefly, it would be useful where the selectivity is already quite sufficient, but where the sensitivity is poor. Such conditions might be found where a small indoor aerial was in use, or where the receiver was situated many miles from the nearest broadcasting station. One fact which recommends its use with a short aerial is that it gives better amplification on the long waves, thus compensating for the naturally poor response of such an aerial on the upper wave-band. Other strong points in its favour are its cheapness and simplicity—no extra coils or condensers are necessary and thus no extra tuning is involved.

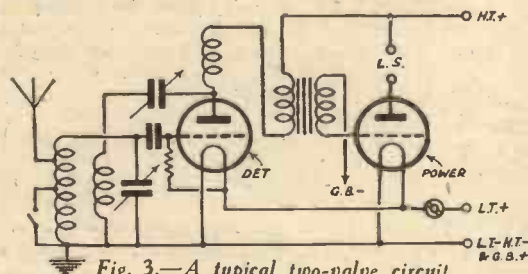

Fig. 3.—A typical two-valve circuit.

The average detector is unresponsive to very weak inputs. This means that weak or distant transmissions provide only the most feeble rectified outputs, while powerful stations give signals out of all proportion louder.

The screen-grid valve in Fig. 1 being placed before the detector amplifies the feeble H.F. currents set up by the distant stations so that they are made powerful enough to be properly rectified.

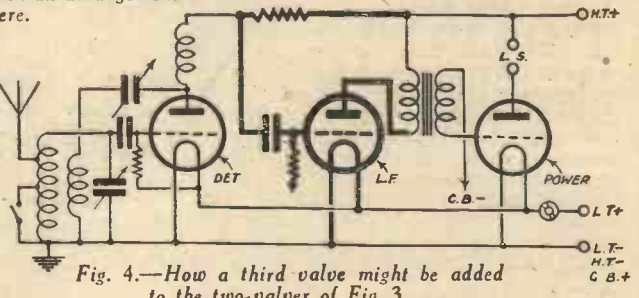

Fig. 4.—How a third valve might be added to the two-valver of Fig. 3.

Before dealing with the practical side of the problem it will be just as well to have a look at the theory of the thing and find out the pros and cons of the two possible arrangements, for needless to say, there are many subsidiary points which need consideration.

Taking the question of H.F. amplification first, we find that there are two possible ways of coupling the additional valve. An H.F. choke can be used as in Fig. 1, or an extra tuned circuit as in Fig. 2.

### Increasing Sensitivity

The first method is the simplest, but suffers from the drawback that it does not increase selectivity. In fact, owing to the increase in sensitivity the selectivity may appear to be actually worse than without it, since both the wanted and any unwanted stations are amplified alike. In this respect it is

### Adding a Tuned H.F. Stage

Owing to the great power of the local stations, it is not often that the selectivity of a set is more than sufficient. It is usually the reverse, and it is here that the addition of a stage of tuned H.F. amplification is useful. The circuit is shown in Fig. 2. The thin lines represent the original circuit, and the heavy ones the additional part.

The advantages are as follows: First, there is the increase in selectivity. This is due to the extra tuned circuit. Each additional tuned circuit in a receiver provides an additional barrier against the unwanted stations. Next, there is the increase in sensitivity. This is greater than with the choke coupled arrangement, especially on the medium waves.

Effects of an Extra L.F. Valve  
Now for L.F. amplification. This is (Continued overleaf.)

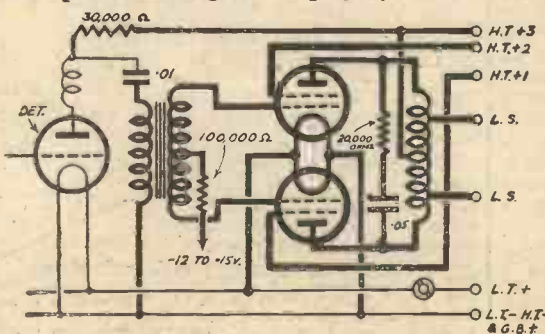

Fig. 5.—Circuit for pentodes in push-pull.

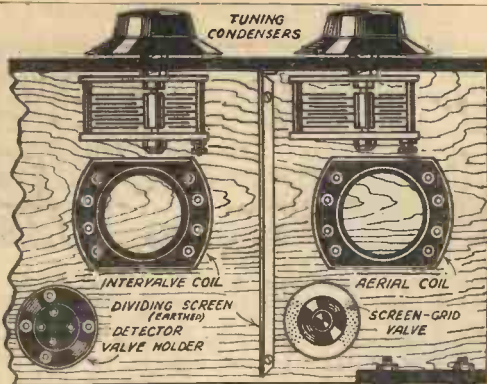

Fig. 7.—How to arrange the lay-out when adding an S.G. valve to a EARTH receiver.

(Continued from previous page.)

undoubtedly the best method of increasing the volume from the loud-speaker. It will not increase the selectivity for the reasons already mentioned, nor will it mean a great increase in the volume of the very weak stations, but it will certainly add plenty of "punch" to all others. The extra parts necessary to make the conversion are comparatively cheap and do not require a lot of extra room, or any special positioning or screening as with H.F. amplification. This means that in quite a large number of cases the same panel and baseboard can be used by altering slightly the position of the present components to accommodate an extra valve and transformer, and possibly a decoupling condenser.

Now let us take one or two examples of typical receivers and see how and where the extra valve should be added. First of all there is the popular two-valver, consisting of det. and power valve, or pentode. If it has a power valve, undoubtedly the cheapest conversion is to add an additional resistance-coupled stage between the detector and the output valve. The extra parts required will be an anode resistance of about 100,000 ohms, a .01 coupling condenser, a ½ or 1 meg. grid leak, a valve holder, and an L.F. type valve. The original circuit is shown in Fig. 3 and the conversion in Fig. 4. The heavy lines represent the new part of the circuit.

**The Extra Valve in Push-Pull**

Adding a valve in this way although cheap to fix up, and unlikely to introduce any howls or other unforeseen accompaniments, has its limitations. It will increase the volume from all stations, but it must be remembered that the maximum volume depends on the capacity of the last valve. If the transmission from the local station already loads this to the limit, the addition of an intermediate valve will not increase the volume beyond this limit but will merely overload the last valve. Therefore, if it is more power from the local which is required, not only must an intermediate valve be added but the output valve must be replaced by one capable of handling more power. Of course, if it is found with a two-valve set that the output valve is more than fully loaded by the local transmissions, and it is desired to increase its power handling so that the full volume may be turned on without fear of distortion,

then the best way to add another valve is to connect it in push-pull with the output valve. Adding a valve in this way, unlike the method shown in Fig. 4, will not give any increase in the volume of the weak and medium powered transmissions but will allow full volume to be obtained from the local station for a very modest consumption of H.T. current. Instead of having to keep the volume of the local throttled down to avoid distortion it will now be possible to turn it right up. When adding a valve in push-pull it must, of course, be identical with the one at present in the set and with which it will be used. The circuit in the case of two pentodes is shown in Fig. 5, while a view of the usual lay-out showing the disposition of the input transformer and the output choke is given in Fig. 6.

Incidentally, where the output valve of a two-valve set of the det. and 1 L.F. type is a pentode, the push-pull arrangement is the only practical way of adding an additional L.F. valve, since to interpose an additional stage between the detector

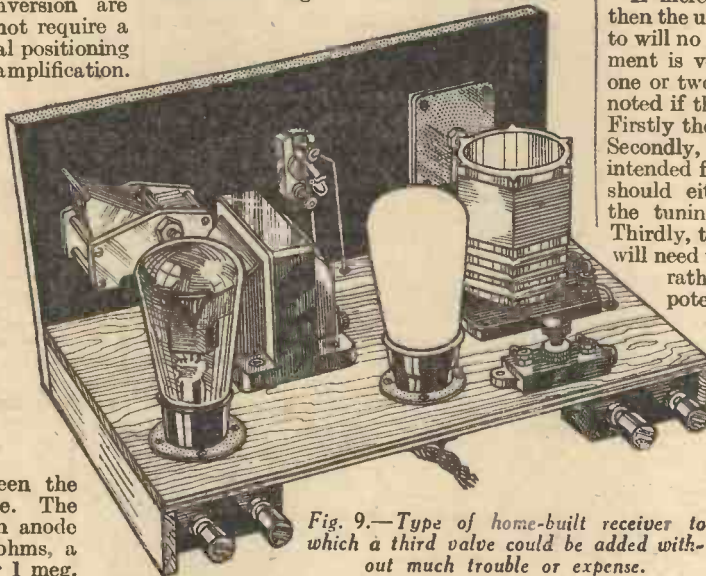

Fig. 9.—Type of home-built receiver to which a third valve could be added without much trouble or expense.

and the pentode would almost certainly overload the latter.

**How to Get More Stations**

Many users of two-valve sets find the volume quite sufficient for domestic purposes, but desire an increase in range. They wish to receive a few "foreigners" at full loud-speaker strength. In this case the only possible solution is to add a tuned screen-grid stage. Without doubt this will mean a larger panel and baseboard to accommodate the extra valve, coil, tuning condenser and choke, etc. Fig. 2 shows the circuit, with the additional part in heavy lines. Fig. 7 shows how the high-frequency end of the receiver should be arranged. The new baseboard and panel should be long enough to accommodate another tuning condenser and tuning coil each of the same make and type as the ones already employed. It will be noticed that a single metal screen is erected between the two coils and condensers, so as to

completely separate the two tuned circuits. This screen is, of course, earthed. The coils should both be the same distance from either side of the screen. In the case of two-inch coils, this should preferably be not less than 2in. The screen-grid valve, which should be metallised, is placed on the aerial coil side of the screen. If the wave-changing with the particular coils used is carried out by shorting the long-wave turns, then a single three-point switch will suffice to operate both coils.

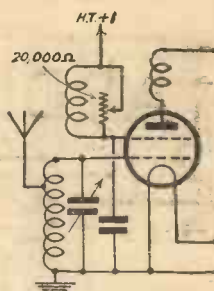

Fig. 8.—Reaction from the screening grid.

Of course, if the original coil in the set is of the screened type, then another similar one should be purchased and the dividing screen will be unnecessary, also they may be placed as close together as desired.

**A Simple Way of Adding an H.F. Valve**

If increased sensitivity is only required, then the untuned H.F. stage already referred to will no doubt fill all needs. This arrangement is very easy to fix up, but there are one or two practical points which should be noted if the best results are to be obtained. Firstly the S.G. valve should be metallised. Secondly, the H.F. choke must be one intended for use with screen-grid valves and should either be placed well away from the tuning coil or else screened from it. Thirdly, the voltage on the screening-grid will need to be only about 30 volts. Being rather critical it is best to use a potentiometer control, unless the H.T. can be tapped at intervals of not more than three volts round about the 30-volt mark. Fourthly, it is usually better to take the reaction from the plate of the S.G. valve than from the detector. Another method is to take it from the screening grid. A circuit using this method is given in Fig. 8. It is that employed by the Ferranti Co., Ltd., in one of their designs and being the subject of a patent must not, of course, be used on a set intended for re-sale without their consent.

**Converting a Three-Valver to a "Four"**

When it comes to adding another valve to a three-valve set, the decision as to its position depends chiefly on the circuit. (Continued on page 204.)

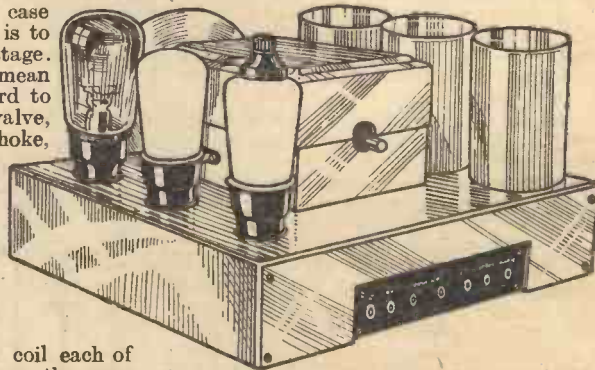

Fig. 10.—The compact type of commercial receiver which does not lend itself to any additions or alterations.





# Forms & Methods of Volume Control



**C**ONTROL of volume may be effected in a dozen or more different ways, but each system of control has its good and bad points. The reason for volume control is either to prevent overloading in one of the valve stages, or to permit the listener to vary the sound emanating from the loud-speaker to suit his own particular taste. In either case

Simple and effective means of obtaining it are briefly described in this article by J. B. SKETCH.

when it is used in sets having ganged circuits; it will be found that when the pre-set condenser is varied, it upsets the ganging of the circuits and alters the tuning of the set. It then becomes necessary to retune the set slightly.

distortion. This form of volume control also varies the high-frequency amplification.

### Control of Volume by Variable Mu Valves

The most successful of all methods of volume control is made possible by the use of variable mu valves, which have only been introduced within the past few years. The method used is to vary the amount of grid bias applied to the grid of the vari mu valve.

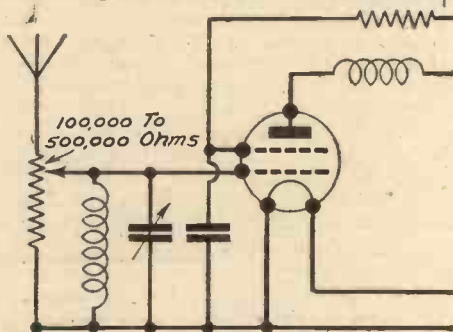

Fig. 1—Control of volume by potentiometer in aerial-earth circuit.

volume may be controlled by limiting the high-frequency signal input to the first stage of the receiver or by adjusting the degree of amplification in one of the high or low-frequency stages.

### Limiting High-frequency Signal Input

The high-frequency signal voltage applied to the grid of the first valve, which is usually a screen-grid, may be controlled by the adjustment of a potentiometer connected between the aerial and earth as in Fig. 1. The value of the potentiometer depends upon the strength of the local transmissions, but it will be found that any potentiometer with a value

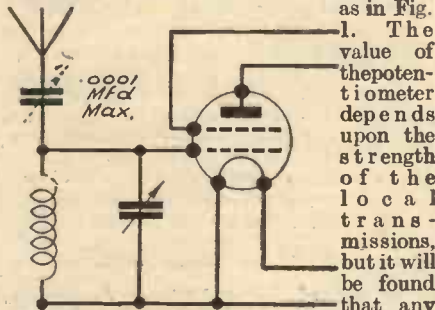

Fig. 2—Control of volume by pre-set condenser in the aerial circuit.

ranging between 100,000 and 500,000 ohms will be found quite satisfactory. Another important point concerning this type of volume control is, it is preferable to use a wirewound potentiometer as the carbon or other form of resistance element becomes very erratic in operation after a certain amount of use.

### Control by Pre-set Condenser

The next form of volume control is obtained by inserting a pre-set condenser (.0001 mfd. max.) in the aerial input circuit, in Fig. 2. This is a similar form of control as the previous one (i.e., limiting H.F. signal input), its disadvantage is noticeable

### Control of High-frequency Amplification

The third form of volume control is effected by varying the temperature of the filament of the screen-grid valve by inserting a variable resistance of about 20 or 30 ohms in the filament circuit of the valve, Fig. 3. When the temperature of the valve is lowered the sensitivity of the valve is reduced, which in turn reduces the high-frequency amplification or stage gain. This type of control is very fierce in operation and is not to be recommended before other methods to be described.

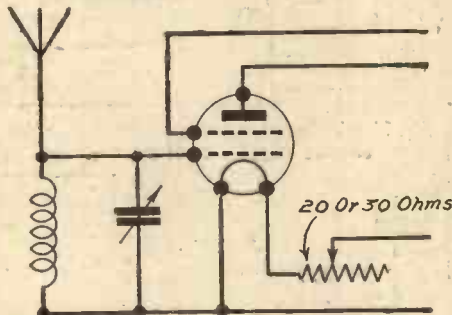

Fig. 3—Control of high-frequency amplification by filament control.

### Variation of Screen Voltage

A system of control which possesses a much smoother variation of volume is by varying the voltage applied to the screen of the screen-grid valve. The connections for a battery set may be seen in Fig. 4, and the mains set in Fig. 5. The constructor will not encounter any difficulties with this arrangement in general practice, but if too big a voltage variation is used even this type of control will produce its disadvantages, such as self oscillation, and possibly become unstable in operation and produce

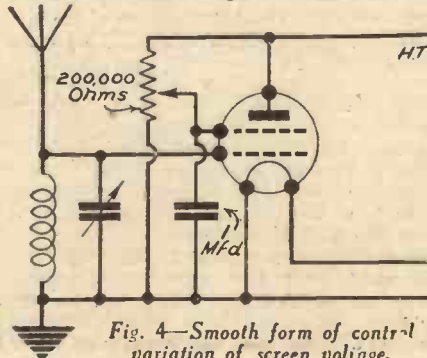

Fig. 4—Smooth form of control variation of screen voltage.

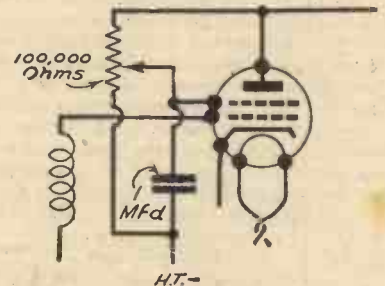

Fig. 5—Variation of screen voltage mains connections.

The amount of variation is from 0-15 volts in the case of a battery set, and from 1.5-40 or 50 volts in the case of a mains set. It may be well to insert here a brief description of the working of the variable mu valve. The variable mu valve is a new and special form of screen-grid valve. The special feature of the valve is that it is possible to vary its mutual conductance (which in simpler terms means its amplification). To vary the mutual conductance of a valve we vary the grid bias applied to its screen grid. If we wish the valve to amplify to its maximum, we must reduce

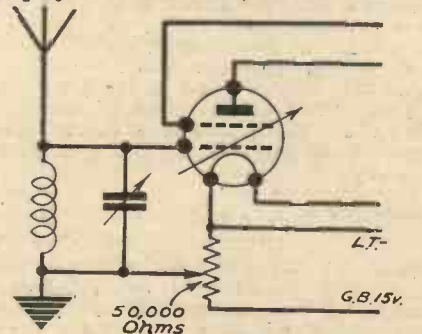

Fig. 6—Control of volume by battery variable mu valve.

the grid bias to nil or to a very low value. As we gradually increase the value of the grid bias applied to the valve, its amplification is reduced until when the maximum grid bias has been applied, no signals will be heard from the receiver. The connections for the battery set will be seen in Fig. 6. The value of the potentiometer is about 50,000 ohms.

### A.C. Variable Mu Valves

The arrangement of the mains variable mu volume control is a little more complicated. It is to be seen in Fig. 7. It has been stated that the amount of grid bias

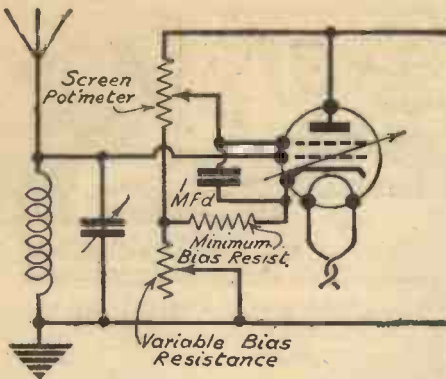

Fig. 7—Connections for A.C. variable mu valve.

required for a mains variable mu is about 40 or 50 volts, thus it would be impracticable to supply this from batteries as in the battery arrangement of the variable mu. The easiest method of obtaining this voltage is to use automatic grid bias, by connecting a resistance between the high tension negative and the cathode of the variable mu valve. The anode current of the valve passes through this resistance and a voltage drop is set up across it, making the

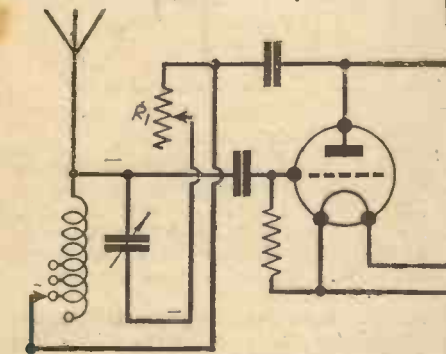

Fig. 10—Special form of volume control, reaction controlled by a resistance.

potential of the cathode higher than that of the grid by the amount of the voltage drop across the bias resistance.

To avoid grid current in the variable mu valve it is essential not to lower the grid bias voltage lower than 1.5 volts, and to do this it is necessary to have the bias resistance in two separate units, one of permanent value calculated to allow the minimum bias value (1.5 volts) and the other variable to allow control above this limit. It is difficult to give any definite values for

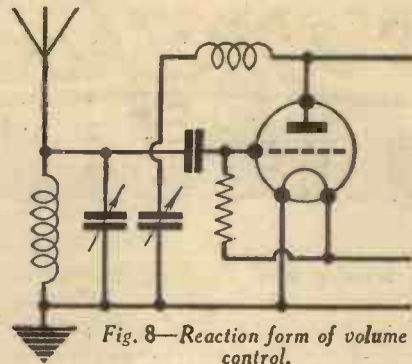

Fig. 8—Reaction form of volume control.

these resistances as they vary with the many characteristics of the various valve makers. However, most valve makers state on the operating slip the best values to use.

**Control of Volume in Detector Stage**

The simplest way of controlling volume in this stage is by reaction. Only two forms are shown (Figs. 8 and 9), as reaction is not a good form of volume control, for if it

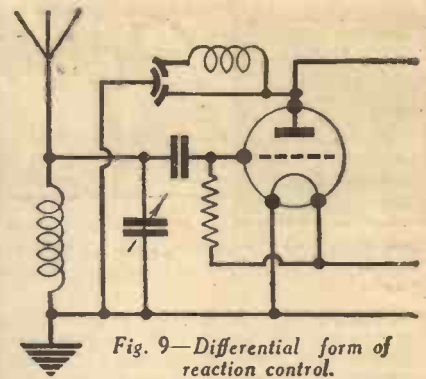

Fig. 9—Differential form of reaction control.

is improperly used it will oscillate and cause interference and distortion. Another method of volume control in the form of reaction control is shown in Fig. 10. The control is effected by variation of the resistance R1. Both these forms of reaction volume control are quite satisfactory in operation and are only included for the sake of completeness.

**Control of Volume in Low-frequency Stages**

One of the most common methods of volume control in low-frequency stages is

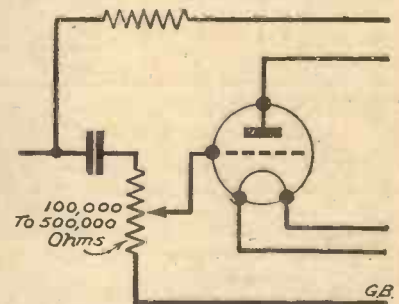

Fig. 12—The same method is used here as in Fig. 11. Resistance capacity stage.

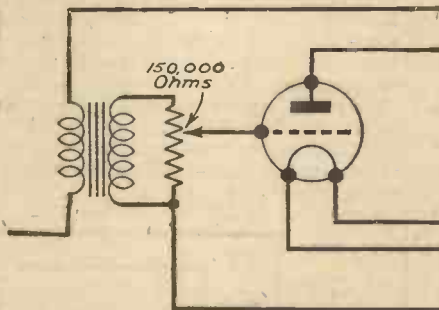

Fig. 11—Volume controlled in the transformer coupled stage by a potentiometer.

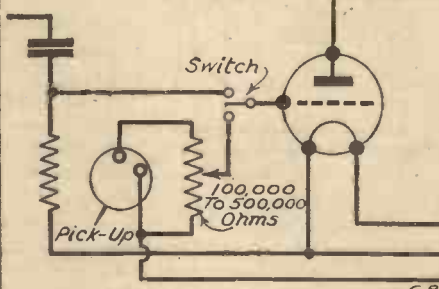

Fig. 13—Control of input from pick-up by a potentiometer.

shown in Fig. 11, which is a transformer coupled stage. Control is effected by variation of the potentiometer connected across the low-frequency transformer, the same idea being used in the resistance capacity coupled stage in Fig. 12. In Fig. 13 the input from the gramophone pick-up is controlled by the potentiometer connected in parallel with the pick-up.

In all three cases the input to the grid of the valve, thus effecting the amplification or stage gain, is controlled by the potentiometer.

**T**ELEVISION for the Amateur Constructor, by H. J. Barton-Chapple, Wh. Sch., B.Sc., etc.; 12s. 6d. net; Demy octavo; 234 pages. Sir Isaac Pitman and Sons, Ltd., Parker Street, Kingsway, W.C.2.

Television, which is now on the threshold of success, is a subject on which literature is all too scanty. The author of "Television for the Amateur Constructor" has already covered the general principles, the history, and the development of television in a companion volume entitled "Television—To-day and To-morrow," which was recently reviewed in these columns. The present volume is essentially practical. The first chapter forms a brief but complete introduction to the general theory of television, but from that point the author plunges straight away into the practical avenues of his subject. The cohesion

**BOOKS RECEIVED**

of the chapters and the scheme of the book may be gauged from the following list of chapter headings:—

A Workshop in the Home; The Vision Wireless Receiver—H.F. and Detective Stages; The Importance of the L.F. Side; Suggested Experimental Circuits; H. T. Power for Television; A Wireless Set for Television Reception; Further Practical Details of Wireless Apparatus for Television Reception; Building the Television Apparatus; and Making Vision Apparatus. The last chapter deals practically if prophetically with future developments. The extremely lucid and simple style adopted in the text is rendered

even more understandable by the generous proportion of excellent illustrations in half tone and line which punctuate it at almost every page. This is not a work for the highbrow; it gets down to the level of the man who wishes to build television apparatus at small cost and with limited income, and I can thoroughly recommend it. A word of congratulation to the publishers for the attractive manner in which they have presented the book. It is similar in size, style, and binding to "Television—To-day and To-morrow."

**HAVE YOUR COPIES OF VOLUME 1 OF "PRACTICAL WIRELESS" BOUND. SEE SPECIAL OFFER ON PAGE 200.**

# MORE ABOUT— INTERFERENCE

A Practical Article Explaining the Various Causes of Interference and the Best Means for Dealing With It.

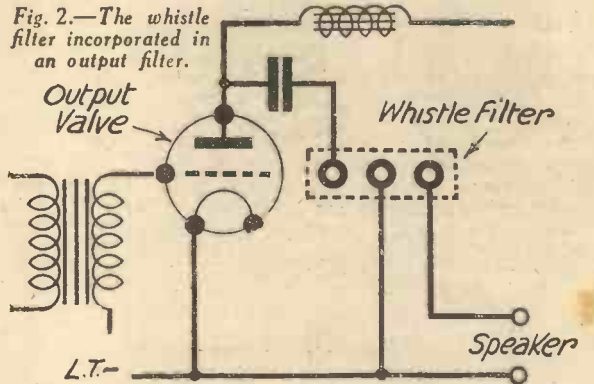
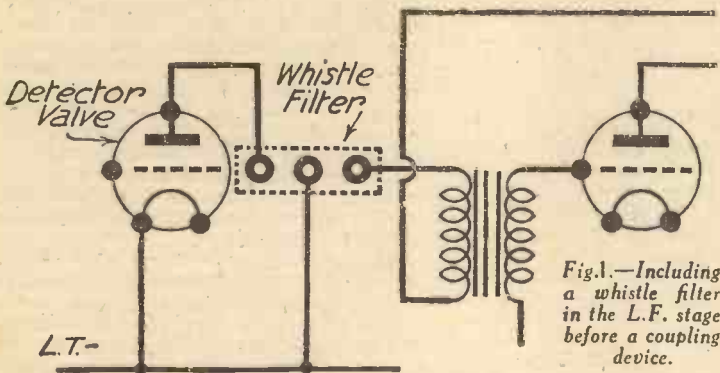

THE modern wireless receiver, in conjunction with a good moving-coil speaker, is capable of giving clear and faithful reproduction of the broadcast, with almost complete absence of background noise. Interference with reception is unpleasant under any circumstances, but when a high level of quality has been attained, interference due to local disturbances is still more annoying and unpleasant, as the effect of the interference seems to be accentuated by contrast with the quality and clarity of the reception obtained.

Interference may come from three sources—from the set itself or its associated components, from natural static charges known as atmospheric, and from artificial static charges sometimes termed "man-made statics." The latter may be divided into two categories, distant and local.

At the present time, the prevention of interference from natural atmospheric provides an insoluble problem. Although they are practically untuned, atmospheric are usually found to be less troublesome on the medium than on the long wave-band. Fortunately, reception in this country is not seriously marred by atmospheric disturbances, this form of interference being generally confined to short periods during the summer months. A type of this interference only experienced very occasionally, is that set up by electrically charged raindrops, falling on the aerial. This is due to the rain having recently passed through an electrically charged atmospheric area and, on precipitation, carrying with it small individual static charges.

**Heterodyne Whistles**

Distant interference is usually caused by Morse from broadly tuned transmitters, or heterodyne whistles produced by stations' carrier-waves overlapping each other. The Morse trouble can generally be removed by sharper tuning of the receiver, but even the sharpest tuning may not completely

eliminate the heterodyne whistle. It can, however, be fairly effectually cured by fitting a whistle filter to the set. The filter can

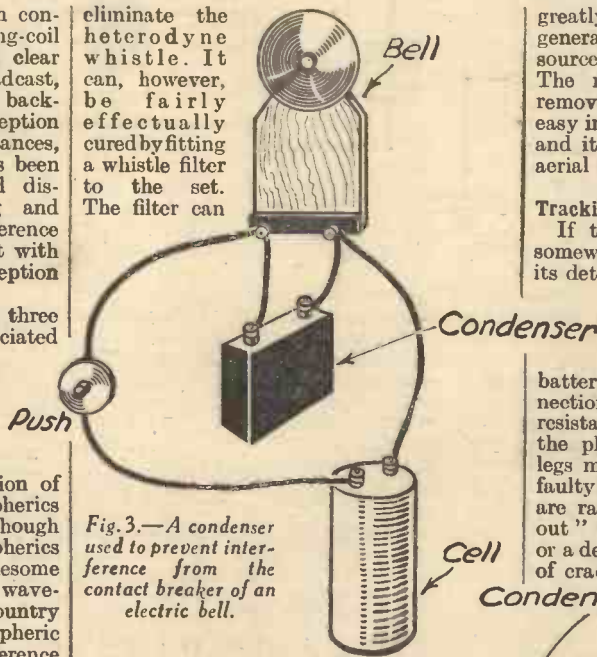

Fig. 3.—A condenser used to prevent interference from the contact breaker of an electric bell.

be purchased as a complete unit, and is best connected to the detector circuit, so that the low-frequency stages do not have to handle the high notes unnecessarily. Fig. 1. If, however, difficulty is experienced in connecting it to the detector circuit, it may be connected to the output stage, in the speaker circuit, Fig. 2. Heterodyne whistles are usually more pronounced on moving-coil speakers, owing to their better response to the upper register.

When persistent or recurring interference exists, the first step in its elimination is, of course, to discover its cause or origin. The aerial connection to the set should be removed, and, if the trouble ceases or is

greatly reduced in intensity, it may generally be taken for granted that the source of the trouble is outside the set. The method of testing by temporarily removing the aerial connection, is not as easy in the case of sets with built-in aerials, and it is better to short circuit the frame aerial rather than disconnect it.

**Tracking Internal Causes of Crackling Noises**

If the trouble is found to be located somewhere in the set, the best method for its detection is by a process of elimination. That is, taking each circuit or component in turn and testing for faults in the usual way, beginning with the H.T. battery if the receiver is battery operated. Loose terminal connections, badly soldered joints, faulty resistances, intermittent contacts between the plates of a variable condenser, valve legs making bad contact in their holders, faulty switches (some push-pull types are rather prone to give trouble), "burnt out" low-frequency transformer winding, or a defective grid leak, are possible sources of crackling noises.

(Continued overleaf.)

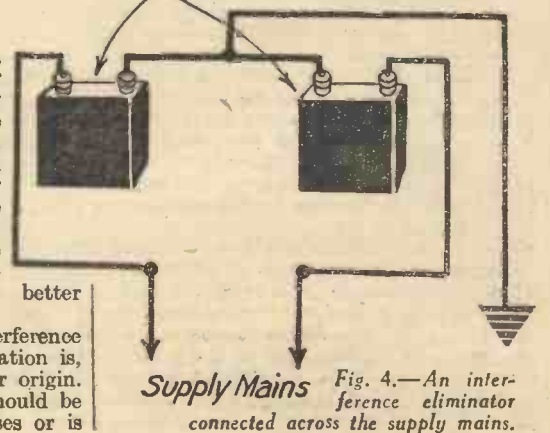

Fig. 4.—An interference eliminator connected across the supply mains.

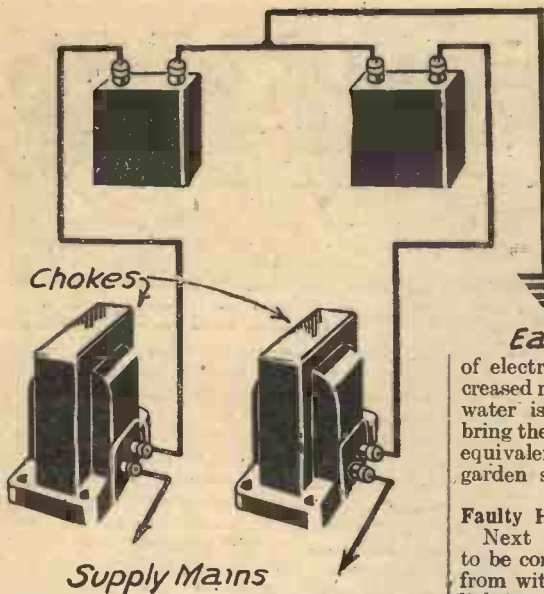

Fig. 5.—To prevent interference from machinery, etc., special chokes may be used as shown here.

(Continued from page 181.)

Other possible causes of noise from within the set are interaction between components through bad layout, over-loaded mains unit, or insufficient decoupling of the high-tension feeds to the valves. Either of these causes may result in what is known as "motor-boating." A run down H.T. battery causing feed-back may also give this trouble. Motor-boating or low-frequency instability, is not usually difficult to overcome. Microphonic noise is often more difficult to cure owing to the difficulty of definitely locating the cause, particularly in the case of receivers with powerful built-in speakers. The usual cause is through lack of rigidity in the electrodes of the detector valve. The sound waves from the speaker impinging on these electrodes set up vibrations which produce a singing noise in the speaker, which in turn causes sympathetic vibration of the valve electrodes, and so a cycle is established which results in the building up of a ringing volume of sound which eventually blots out the programme.

Placing two rubber bands round the bulb of the valve, or binding a jacket of cotton wool round it by means of rubber bands will often effect a cure. Caution is advised, however, in using this method in the case of mains valves, owing to temperature rise which may cause scorching of the cotton wool, and internal damage to the valve due to overheating. It is sometimes found necessary to mount each of the valves on sponge rubber feet, or else to fit rubber pads under that part of the receiver upon which the valves are mounted. Microphonic noises may also be produced by other causes such as vibrating condenser vanes, or even the walls of the cabinet containing the set may be the cause of the trouble.

**Defective Earths**

A defective earth is a prolific source of crackling in a receiver. If the earth lead is a long one, interference may be caused by induction in the wire from the house-lighting mains. The lead should be carefully soldered to the earth tube, and not just bound round it. Unless the wire is

soldered, the surface of both the tube and the wire becomes oxidized and sometimes corroded, which results in a high resistance earth with consequent losses. The lower the resistance to earth the greater will be the efficiency of the receiver.

The earth tube or plate should also, if possible, be placed in a situation where it will be maintained in a moist condition. Recent tests carried out by the National Physical Laboratory, indicate that while dry soil is a poor conductor of electricity, the conducting power is increased more than one thousand times when water is added in sufficient quantity to bring the moisture content of the soil to the equivalent of that usually found in normal garden soil.

**Faulty House-lighting Fittings**

Next in the order of interfering noises to be considered are those which may come from within the home itself. Faulty house-lighting switches may cause trouble, and this can be ascertained by operating each of the switches in turn. If a faulty switch is found it can be corrected by removing the switch cover, and slightly closing the switch contacts with a wooden

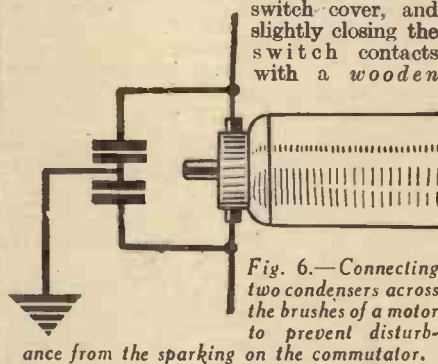

Fig. 6.—Connecting two condensers across the brushes of a motor to prevent disturbance from the sparking on the commutator.

handled screwdriver. Another possible source of trouble is the electric light bulbs. When these have been in use for some time and are approaching the period for replacement, the filament sometimes becomes defective and produces intermittent cracklings in the receiver when the bulb is in use. Trouble from this cause can be located in the same manner as in the case of the faulty switches.

Electric vacuum cleaners, refrigerators, heat regulators, hair driers and fans, are also probable offenders, and in purchasing household electrical apparatus of this description, a definite guarantee should be obtained from the supplier that interference with wireless reception will not be caused by their use. Trouble from electric bells may be cured by connecting a 1 mfd. condenser in the bell circuit, in the manner shown in Fig. 3.

Stray high-frequency currents find their way into the supply mains from outside sources and may cause H.F. trouble in the receiver, especially if it is operated from the mains. This form of interference is difficult to definitely identify, but if the presence of H.F. currents in the mains is suspected, two 2 mfd. condensers (400 working voltage type) should be connected across the mains supply, with the centre point earthed, as in Fig. 4. Where

serious high-frequency interference is experienced it may be necessary also to connect chokes in series with each of the supply mains leads, Fig. 5.

**Interference from Electrical Equipment**

Turning next to interference from external sources, an opinion was recently expressed in the technical Press to the effect that owners of electrical equipment which caused interference should not be called upon to take any steps for its elimination, as wireless users, being the last comers, should so arrange their apparatus as to render it unsusceptible to unwanted influences. This view, however, is a debatable one.

External interference is generally of an intermittent nature, and varies in character from humming or buzzing of differing pitch and strength, to crackling or tearing noises, or even loud cracks reminiscent of the sounds of minor explosions. The nature and intensity of the interference reproduced by the speaker depends upon the character of the equipment from which the trouble emanates and upon the type of receiver which is subjected to its influence. It is often possible to identify the character of the offending equipment from the nature and recurrence of the interference.

Interference from another wireless receiving set in the immediate neighbourhood is inexcusable in these days of high power broadcast transmissions and sensitive receivers. This form of disturbance consists of a high-pitched howl, or if the set is working very close to the oscillation point without actually breaking into oscillation, the result is a low-pitched moaning noise. The interference is caused by the use of excessive reaction, which converts the receiver into a miniature transmitter. Fortunately trouble from this source is becoming much less prevalent.

Electrical equipment which may be the cause of considerable interference includes electric trams and trolley buses, flashing signs both ordinary and of the Neon lamp type, automatic traffic signals, violet ray apparatus, arc lamps used as spot lights for cinema or theatrical purposes, sparking at the commutator of accumulator charging sets or of motors or generators in workshops and factories, and leakage currents from the earth return system on tramway and trolley bus routes. With the exception of emanations from tram and bus overhead wire conductors, and earth leakage currents, the other sources of interference do not usually extend beyond a radius of 250yds.

High-frequency emanations are caused every time an electrical circuit is broken, and sparking is not necessarily an accompaniment of their production, but in the case

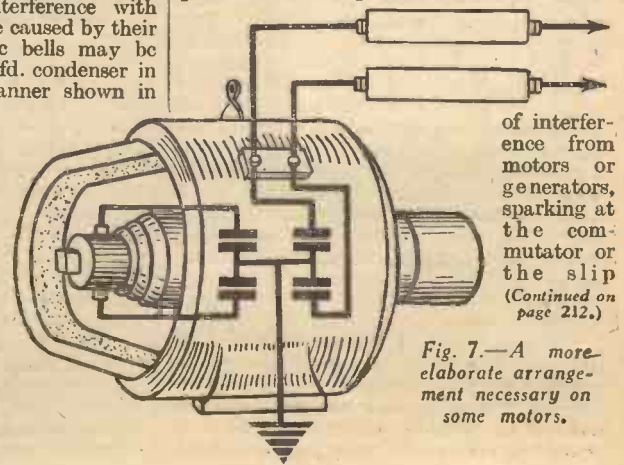

of interference from motors or generators, sparking at the commutator or the slip (Continued on page 212.)

Fig. 7.—A more elaborate arrangement necessary on some motors.

# SELECTONE A.C. RADIO-GRAM TWO



It has often occurred to me that there must be hundreds of mains users who would like to have a really good all electric radio-gramophone, but who are debarred from such a luxury by reason of the expense of the normal instrument of this type. Most radio-gramophones on the market, as well as those which have hitherto been described in the Radio Press, are multi-valve models, designed essentially as "de-luxe" articles and, in consequence, costing upwards of £25. For the latter reasons I have enjoyably spent not a little time designing the simple all-mains radio-gramophone which I am about to describe. As the name implies, it is a 2-valve job, which is comparatively inexpensive to build and of simple construction. This instrument has been designed for a definite and special purpose, which it fulfils in what I consider an ideal manner. The purpose is to give really fine quality of reproduction from more or less local stations as well as from gramophone records. It can be used either with or without an external aerial, and in both cases will give sufficient volume for all ordinary purposes. I am not going to describe the "Selectone Two" as a long distance set, although it will most certainly afford excellent reception of a good number of stations when operated with care, and after a little experience of tuning.

**Selectivity**  
Selectivity is of a high order, but is not so great as to make tuning at all difficult, even to the entirely inexperienced user. Moreover, the degree of selectivity can be varied over wide limits to meet the demands of all average requirements.

**Tone Control**  
The receiver embodies a refinement which I consider a necessary part of any modern receiver, namely, the provision for varying the tone of reproduction from deep bass (often referred to as "mellow") to the highest treble, or "brilliance." The tone control is of great value, not only because it enables the reproduction to be adjusted to a suitable pitch in any room, and permits of the elimination of most forms of heterodyne interference, but because it makes possible the easy elimination of record needle scratch, and allows extra amplification to be given to the lower frequencies which are necessarily somewhat curtailed in the recording process.

**No Mains Hum**  
"Hum," which is often considered an unavoidable source of trouble with receivers taking their power supply from the electric lighting mains, has been almost completely cut out by the use of a very ample H.T. smoothing system. Indeed, hum is quite

### A HIGH-CLASS AND EFFICIENT INSTRUMENT AT A REASONABLE PRICE.

By FRANK PRESTON, F.R.A.

inaudible when the weakest transmission is tuned-in, whilst, when the set is "off tune," only the very slightest amount can be detected. This latter statement applies particularly to the A.C. supplies upon which the set has been tested, but as some of these have been notoriously "rough" I can safely say that interference from this source is most unlikely to present itself when the set is used on any mains supply in any part of the country.

### Cost

It can be seen from the list of components that the "Selectone Two" when made up either as a broadcast receiver pure and simple, or as a complete radio-gramophone, is not expensive. At the same time it does not come under the heading of a cheap set, nor would I like it to, for it is unquestionably a "quality" instrument using first-rate and fully guaranteed components throughout. It is a very unwise practice to employ any but the very best parts for an instrument which is to be connected to A.C. mains, since inferior quality in this direction is bound to lead to trouble and possible breakdown sooner or later. In making this set the constructor may rest well assured that it will perform with every satisfaction, not only for the next few months but for many years to come.

### Current Consumption

One point which has not yet been mentioned, and which is frequently overlooked, is in regard to current consumption. This is extremely low in the present case, being in the region of 12 watts per hour for the receiver itself and well under 50 watts for the gramophone motor. In other words, the receiver will give over 80 hours service per unit of electricity,

whilst the combined radio-gramophone can be used for over 10 hours continuously on the same amount of current—I think these figures speak for themselves.

### Simple Lay-out

Matters of appearance and simplicity of lay-out have not been forgotten, and the whole instrument is decidedly handsome. The cabinet is very robust and of such pattern that it will harmonize with any existing furnishing scheme, and yet it is compact and neat. A symmetrical arrangement of panel controls makes for ease of operation, whilst a further improvement in this respect has been obtained by combining

(Continued on page 186.)

### A "PRACTICAL WIRELESS" GUARANTEED CIRCUIT

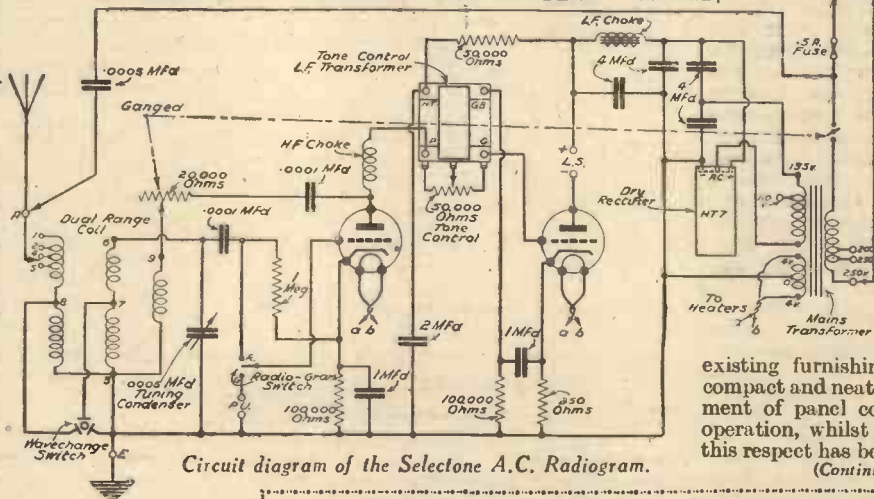

Circuit diagram of the Selectone A.C. Radiogram.

### COMPONENTS FOR THE SELECTONE A.C. RADIOGRAM

- |  |  |
|--|--|
| <ul style="list-style-type: none"> <li>1 Polished Plywood Panel, 10in. by 7in. (supplied with Cabinet specified).</li> <li>1 5-ply Baseboard, 15in. by 14in. (supplied with Cabinet specified).</li> <li>1 Utility "Mité" .0005 mfd. Condenser with disc drive.</li> <li>1 "Wearite" 3-point Wavechange Switch (Type G.W.C.).</li> <li>1 "Wearite" Changeover (Radiogram) Switch (Type G.C.O.).</li> <li>1 "Wearite" 20,000 ohm volume control with combined Mains Switch.</li> <li>2 Lotus 5-pin Valve Holders.</li> <li>1 Colvern Type "T.D." Coil.</li> <li>2 Dubilier .0001 mfd. Fixed Condensers.</li> <li>1 Dubilier .0005 mfd. Condenser.</li> <li>1 Graham Farish Ohmite 1 megohm Grid Leak.</li> <li>1 Graham Farish Horizontal Grid Leak Holder.</li> <li>1 Wearite Screened H.F. Choke (Type H.F.P.).</li> <li>1 Lissen "Hypernik" L.F. Transformer.</li> <li>1 Lissen "Tone Compensator."</li> <li>3 Belling-Lee Terminal Mounts.</li> <li>6 Belling-Lee, Type "R" Terminals, 2 marked "Pick-Up" and 1 each marked "A," "E," L.S., L.S.</li> <li>1 Heayberd, Type W.25 Mains Transformer,</li> </ul> | <ul style="list-style-type: none"> <li>giving outputs of 135 volts, 70 mA. and 2—0—2 volts, 4 amps.</li> <li>1 Heayberd, Type 751, Smoothing Choke.</li> <li>1 Westinghouse, Style H.T.7 metal Rectifier.</li> <li>4 Dubilier (400 volts D.C. working) 4 mfd. Condensers.</li> <li>1 Dubilier (400 volts D.C. working) 2 mfd. Condenser.</li> <li>2 Dubilier (400 volts D.C. working) 1 mfd. Condensers.</li> <li>1 Belling-Lee Fuseholder with .5 amp. fuse.</li> <li>1 Graham Farish Ohmite 100,000 ohm, 1 watt Resistance.</li> <li>1 Graham Farish Ohmite 50,000 ohm, 1 watt Resistance.</li> <li>1 Graham Farish Ohmite 1,000 ohm, 1 watt Resistance.</li> <li>1 Graham Farish Ohmite 250 ohm, 1 watt Resistance.</li> <li>1 Heayberd Mains Flex with Lamp Adaptor.</li> <li>2 Coils Glazite, screws, short length flex.</li> <li>1 Mazda A.C.2 H.L. valve metallized.</li> <li>1 Mazda A.C.P. Valve.</li> <li>1 Simpsons Electrical Turntable.</li> <li>1 Becker Q.M.B. On-Off Switch.</li> <li>1 B.T.H. "Minor" Pick-up.</li> <li>1 Celestion "Soundex" Speaker Chassis.</li> <li>1 "Camco" Selectone-Tablegram Cabinet.</li> </ul> |
|--|--|

# MAKING COIL FORMERS WITH CARDBOARD

A Practical Article Describing the Construction of a Highly Efficient Set of Low-loss Band-pass Coils

By F. THORNE

**T**O the average constructor, the making of these formers, and the winding of the coils, will present very little difficulty and, as the whole thing can be made and finished off in a couple of nights at a total cost of less than 2s. 6d., it will provide the practical man of modest means with a ready solution of how to bring his wireless set up to date. The first step is to procure some pieces of pliable cardboard, the actual thickness used in the model about to be described was about  $\frac{1}{8}$  in. and was part of a large carton.

### Constructional Details

After procuring your cardboard, cut a piece  $6\frac{1}{2}$  in. by 5 in., and carefully bend it into a tube  $5\frac{1}{2}$  in. long by  $2\frac{1}{2}$  in. outside diameter, leaving an inside diameter of 2 in. Something which is about 2 in. diameter on which to bend the tube will readily be found knocking about the house. A washing stick or rolling pin will just about suit the purpose.

After making the tube, do not stick the edges of it together, but cut another piece of cardboard  $1\frac{1}{2}$  in. by  $6\frac{1}{2}$  in., and bend this around the tube to shape it, and then Seccotine or glue it in the position shown in Fig. 2. A piece of wire wrapped around near the top and bottom edges of this piece will keep it in position till set. The next operation is to cut two rings  $2\frac{1}{2}$  in. outside diameter and  $2\frac{1}{2}$  in. inside diameter; slip one of them over the top and one over the bottom of the tube so that they rest, Seccotined, against the edges of the last piece put on, as in Fig. 3.

Two pieces are now cut  $1\frac{1}{2}$  in. wide, and these are built on to the tube one at the top, and one at the bottom, flush with the ends. The joints of these should face the same way as the centre piece previously put on, and should be opposite the joint of the tube. A space of  $\frac{1}{4}$  in. should now exist between the rings and the pieces just fixed on. Another two  $1\frac{1}{2}$  in. pieces are now cut and put on at top and bottom of the tube as before, but with the joints the opposite way round; again, two  $1\frac{1}{2}$  in. pieces are cut and put on in a

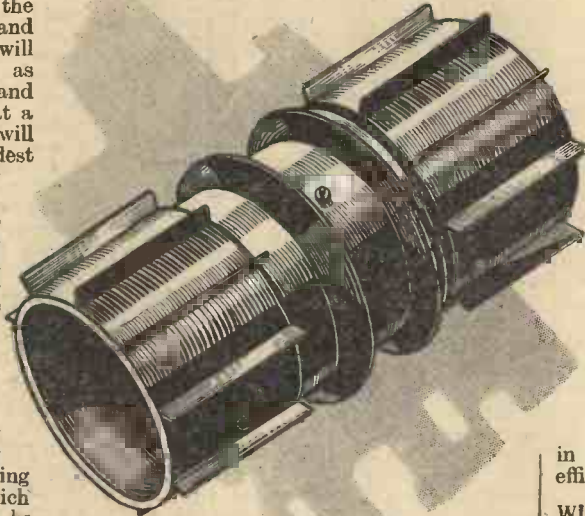
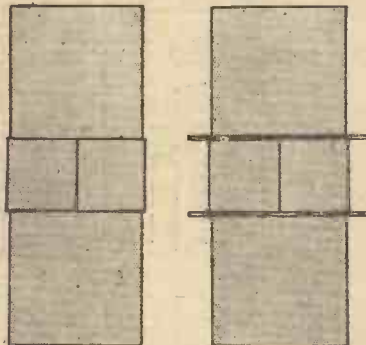

Fig. 1.—The complete dual former.



Figs. 2 and 3.—The method of building up the former.

similar manner to the last two pieces, the joints again being put opposite. The former should now appear as shown in Fig. 4, having the dimensions indicated.

Now cut a few lengths of card, of such a width that when stood on edge along the biggest diameters of the former, and running parallel with the centre of the tube, they will be level with the top of the rings already in position; this width will be about  $\frac{1}{4}$  in., according to the thickness of cardboard and the amount of adhesive used in the previous operations. The strips are now cut into eighteen pieces  $1\frac{1}{2}$  in. long and fixed with adhesive, nine at the top of the former, the ends being level with the top of the former, and nine at the bottom, the ends again being made flush. All these pieces are to be equally spaced around the larger diameters of the former as shown at Fig. 4. Do not cut these pieces with scissors or they will bend in cutting, in fact a sharp

knife and the use of a straight edge is the way that all the cardboard should be cut, if flat edges and straight lines are to result.

The formers are completed by making a tube  $2\frac{1}{2}$  in. long by  $1\frac{1}{2}$  in. outside diameter, from a piece of board  $2\frac{1}{2}$  in. by 6 in., Seccotined along the joint and kept in position until set, by pieces of wire; any surplus adhesive showing on the outside of the tube after setting should be removed with sandpaper. The formers can now be well coated with shellac varnish, but, should it be the constructor's idea to use cotton-covered wire to wind them, this operation can be deferred until after winding the coils, when the wound formers can be rotated in a shallow bath of shellac varnish and completely saturated, after which a good baking (not burning)

in an oven will result in a very highly efficient set of low-loss band-pass coils.

### Winding the Coils

Winding the coils by hand is not difficult, and a start on this part of the job is made by first piercing an anchoring hole  $\frac{1}{4}$  in. from the ring end of a rib at each end of the large former. These anchoring holes, by the way, should be made near to where the ribs are fixed on to the former so that the tension exerted in winding the wire will not pull the rib over. After threading the wire through one of the holes to the length of 6 in. or so, make a half-hitch to fix it, then, in the direction indicated in Fig. 5, wind on 38 turns of 26 or 28 D.S.C. or D.C.C. wire. Before going further, it is advisable to point out that D.S.C. wire is to be preferred on account of the silk having greater resisting powers to the absorption of

(Continued on page 186.)

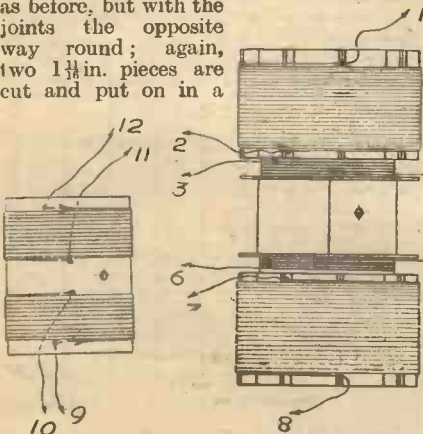

Fig. 5.—The long-wave coil.

Fig. 6.—The connections.

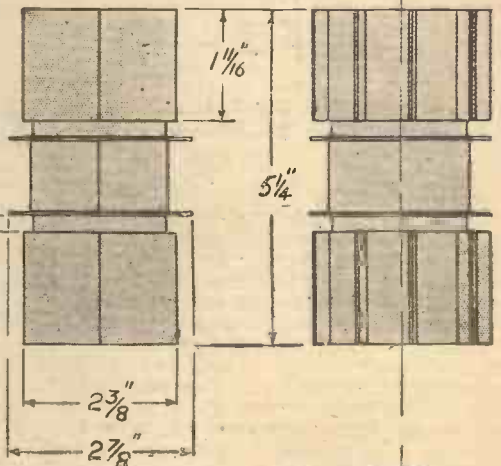
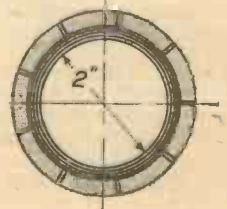

Fig. 4.—The principal measurements.



# COSSOR 240B

—the new valve  
for



## CLASS "B" AMPLIFICATION

Filament volts 2.0; Filament amps 0.4;  
Anode volts 150 max.; Max. Anode  
Current Swing 50 mA.; Max. Peak  
Applied Signal (Grid to Grid) 40 volts;  
Static Anode Current at  
 $V_a=100, V_g=0$  (each half) **14/ =**  
1.5 mA. Price

Full instructions for the use of this remarkable  
new valve, including circuit diagrams will  
be supplied on application to our Technical  
Service Department.

Volume equal to that of the average Mains Receiver is now obtainable from Battery Sets with this new Cossor Valve, and with this remarkable output, the H.T. Current demand of the Cossor 240 B. is lower than that of a small power valve. Thus, a really large output is obtainable without in any way over-stressing the average H.T. Dry Battery.

Anode and Grid Current/  
Anode volts curves of  
Cossor Class "B" Valve  
Type 240 B.

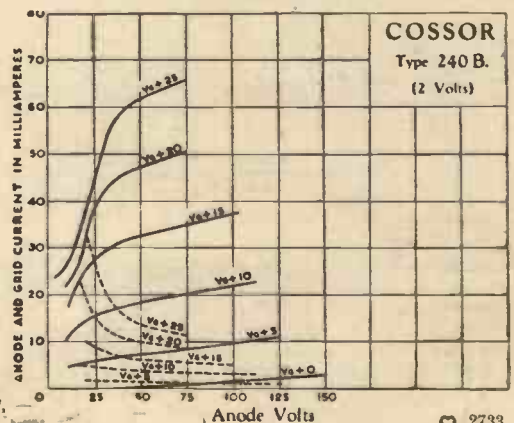

(Continued from page 184.)

moisture. Keep the wiring close and uniform, finishing off by making another anchoring hole and passing through about 6in. of wire and half-hitching it as before. The other end of the former is wound with the same gauge wire, having exactly the same number of turns, and is wound in the direction shown in Fig 5. This completes the medium-wave sections.

**The Long-wave Section**

The long waves are catered for by winding on 130 turns of 34 gauge D.S.C. or D.C.C. wire in each of the slots or grooves at the bottom of each section of the medium-wave windings, and in the direction shown in Fig. 5.

Anchor the ends in any convenient manner, again leaving 6in. or 7in. at beginning and ends of both windings. A start is now made on the small tube, and two separate coils of 36-gauge wire, one of 50 turns and one of 70 turns, are wound on it, each commencing 1/2 in. from opposite ends of the tube and in the direction shown in Fig. 6, leaving about 8in. or 10in. of wire at the beginning and end of each winding.

After completing the winding of the short tube, a central hole is made through it, then a corresponding hole is made through the centre of the large former, and, after

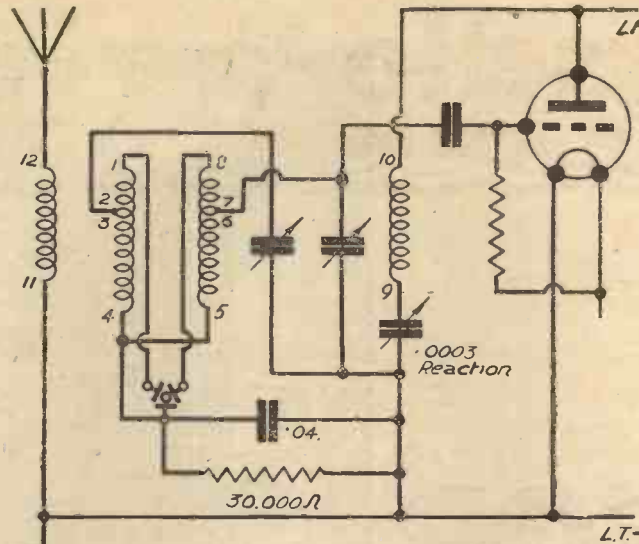

Fig. 8.—The circuit connections of the complete coil.

are 4 and 5, and also 6 and 7. That is, we now have only five ends of wire on the large former instead of the eight as shown at Fig. 5. Plenty of room has been left between the ribs for terminals to be inserted, either at the top or bottom, or both, but of course the small former must be fixed in position before any terminals are thought of. A thin ebonite or fibre base can be fixed on the bottom with a 3-point switch mounted in the centre, and this would make the coils panel mounting. However, these and other refinements are left to the discretion and ingenuity of the constructor, as all the wire ends can be taken direct to their respective positions as shown in Fig. 7.

With regard to Figs. 5 and 6, the coils are shown here in the position that the small former will occupy when placed inside the large former, that is, the reaction coil of 70 turns will be towards the bottom, the other or top coil of 50 turns is the aerial coupling coil. After trying the coils out, connected as shown, a reversal of the aerial coil connections can be tried, leaving it connected in whichever way the constructor thinks he gets the best results.

Ganged condensers of .0005 capacities are ideal for tuning these coils, thus providing a one knob tuning arrangement, but of course two separate .0005 condensers can be used if desired.

carefully sliding the small tube into position inside the large former, a bolt is pushed through the holes from the inside, and the two formers clamped together by putting a nut on the bolt from the outside and lightly tightening up.

Fig. 7 shows the coils connected in a detector band-pass circuit, and it will be noted that the wires numbered 2 and 3 are twisted, or soldered, together, so

coupling coil. After trying the coils out, connected as shown, a reversal of the aerial coil connections can be tried, leaving it connected in whichever way the constructor thinks he gets the best results.

Ganged condensers of .0005 capacities are ideal for tuning these coils, thus providing a one knob tuning arrangement, but of course two separate .0005 condensers can be used if desired.

the on-off switch and reaction control in a single instrument. The constructional work involved is particularly straightforward, and can successfully be tackled by the veriest novice. One large baseboard accommodates both the receiver and power supply units, so that wiring between the two is easy and direct. It might be thought by some that this form of construction is somewhat out-of-date, but it has been followed with the idea of attaining utmost simplicity, combined with maximum efficiency.

**"Quality" and "Punch."**

Quality of reproduction is particularly good and will meet with the approval of the most fastidious music lover. This has been ensured by employing a sound circuit design and also by the efficient loud-speaker "baffle" provided by the comparatively large and rigid cabinet. At the same time an ample volume is available, since the maximum undistorted output is in the region of 1,250 milliwatts. Actually an output of this order can easily be obtained from gramophone records with the volume control a little more than "half-on." The same power can be obtained on "radio" when the set is used within ten miles or so of a B.B.C. transmitter, but even at a hundred miles the volume is more than ample for a very large room.

**The Circuit.**

Having run over the main features it will be interesting to study the circuit diagram shown in Fig. 1. The dual range tuner has a tapped aperiodic aerial winding, so that by connecting the aerial to any one of four tapings selectivity can be varied over wide limits. Instead of using an external aerial the mains leads can be employed as a source of pick-up by connecting the aerial terminal, through a .0005 mfd. fixed condenser, to one side of

**THE A.C. SELECTONE RADIOGRAM TWO**

(Continued from page 183.)

the A.C. supply. The first valve is a detector working on the leaky grid principle, and provision is made for connecting a pick-up in its grid circuit as required. The wiring is so arranged that when the pick-up is brought into action a suitable bias voltage is automatically applied to the detector valve by the voltage drop across a 1,000 ohm resistance connected in its cathode lead.

Reaction is controlled in a rather unusual manner by means of a 20,000 ohm variable resistance, connected between the anode of the detector valve and the reaction coil, a .0001 mfd. fixed condenser being inserted in the reaction lead to prevent a short circuit of the high tension supply. A tone control transformer feeds the audio frequency output from the detector to a three-electrode power output valve. The grid circuit of the latter is decoupled by means of a 100,000 ohm resistance connected between terminal G.B. on the transformer and earth. Grid bias is obtained automatically across a 250 ohm fixed resistance.

The power supply circuit is arranged on conventional lines, a metal rectifier being connected on the full wave principle to convert the A.C. to direct current. The smoothing system consists of a suitable choke and a pair of 4 mfd. condensers, whilst H.T. is fed to the detector valve through a 50,000 ohm. resistance. A .5 amp. fuse included in the mains lead safeguards against damage in case of an accidental short circuit. The mains Q.M.B. switch is ganged with the reaction control resistance.

**The Components**

A full list of the necessary components is given elsewhere, and I would add the customary warning that this should be duplicated exactly if maximum efficiency is to be obtained. I would further point out that the parts have been chosen with care, not only in regard to their suitability for the circuit, but also bearing in mind their cost. It is especially important that the types of condenser are as specified, since, if they were of lower working voltage, there would be a serious danger of their breaking down whilst in use. Incidentally, condensers used in any A.C. mains receiver should always have a peak working voltage of at least twice the maximum supplied by the rectifier under normal conditions of operation. The mains transformer is of a new pattern which has recently been brought on to the market, and consequently, constructors should see they are not supplied with one of the old type when obtaining the parts from a local dealer. The mains switch which is ganged with the reaction potentiometer may be obtained with either soldering tag, or terminal contacts; the choice will depend upon your own ideas and inclinations in regard to soldering.

As a space of only 7in. is available for the loud-speaker it is essential that the unit specified should be obtained, unless some modification is made to the set. When a slightly larger unit is on hand it might be possible to accommodate it by reducing the panel height to 6in.; in any case the question of space should be borne in mind. Little need be said of the other components, except that they are all standard models which are readily available.

Next week I shall give full constructional details, so you may order the components now in readiness.



THE HALF-GUINEA PAGE

Radio Wrinkles FROM READERS

Fixing Terminal Tops to S.G. Valves

MANY readers probably have on hand an S.G. valve from which the top has been accidentally screwed off. To make a serviceable repair is not such a formidable job as one would at first think.

BROKEN S.G. VALVE TO BE REPAIRED

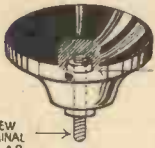

RECESSED TO 1/4" AND FILLED WITH MERCURY

Repairing the terminal top of a screen-grid valve.

This is one way to effect it: Make a cup-shaped recess in the underside of top by drilling with a rather large bit (about 3/16 in.), to a depth of about 1/4 in. If, when this is done, the terminal pillar still holds fast, proceed to cement that part of the top which

contacts with glass of bulb with either celluloid cement or white wax. Now, holding the top—carefully gripped upside down in a vice—perfectly upright, fill the recess to its utmost capacity with mercury, and replace bulb in as near its original position as possible. If sufficient mercury has been put in the glass bulb it will displace the superfluous quantity when pressure is made on it. This will ensure a perfect metallic connection between terminal pillar and the broken wire protruding from glass. Should the terminal pillar be damaged or slack, obtain a short length of threaded rod and place through the top, securing with a nut on either side, as shown in the illustration. Celluloid cement can be made by dissolving some clippings of celluloid in amyl acetate. If white wax is used, the whole job will require warming when making the final fixing. This method has been adopted with success when the wire of the bulb was broken flush with glass.—R. E. BEALL (Plymouth).

Making a Box Spanner

A HANDY box spanner to reach awkward corners, or places where terminals are close together, can be made by drilling a hole 1/8 in. diameter, in a piece of 3/8 in. or 1/2 in.

Extending a lay-out without increasing the size of the baseboard.

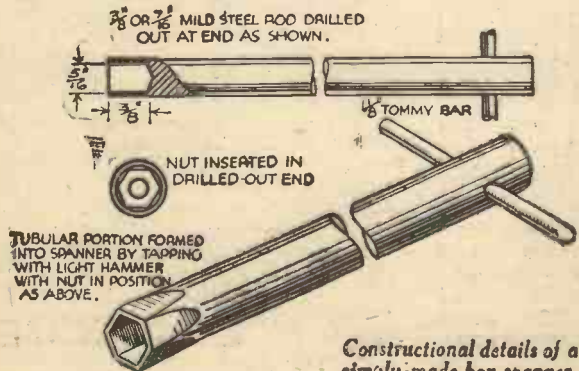

Constructional details of a simply-made box spanner.

THAT DODGE OF YOURS!

Every reader of "PRACTICAL WIRELESS" must have originated some little dodge which would interest other readers. Why not pass it on to us? We pay £1-10-0 for the best wrinkle submitted, and for every other item published on this page we will pay half-a-Guinea. Turn that idea of yours to account by sending it in to us, addressed to the Editor, "PRACTICAL WIRELESS," George Newnes, Ltd., 8-11, Southampton Street, Strand, W.C.2. Put your name and address on every item. Please note that every notion sent in must be original. Mark envelopes "Radio Wrinkles." Do NOT enclose Queries with your Wrinkle.

round mild or silver steel, or just large enough to take a terminal nut, and about 1/2 in. deep. Put the nut in the edge of the hole and, with a light hammer, tap the steel rod on the flats of the nut, thus closing the metal in and forming a hexagonal opening. An 1/4 in. hole drilled through the other end of the rod will accommodate a handle, as shown in the sketch. Where nuts are close to the side of components file off two sides, thus forming a kind of "claw foot" spanner.—T. URWIN (Monkseaton).

Mounting Additional Components

SOMETIMES at the L.F. end of a set it is desired to fit a filter or add an extra stage. It may be that there is no

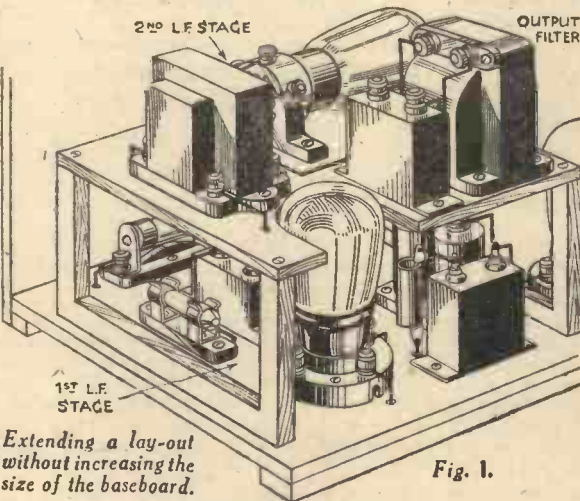
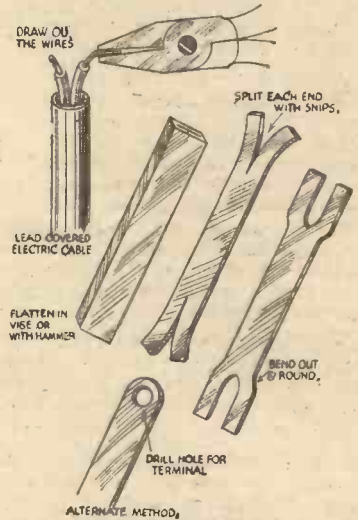

Fig. 1.

which in turn are screwed down on the baseboard. Part of the platform can be cut away to clear a valve underneath, if necessary.—G. D. BRUCE (Edinburgh).

Useful Accumulator Connectors

THE lead covering on ordinary household electric cable is very convenient for making strip connectors or terminal



Some useful types of accumulator connectors.

lug extensions for accumulators. These can be made quite easily by flattening the lead covering after first removing the twin wires as shown in the illustration, then snipping off to the required length. Cut down the centre of each end for about 1 in. and then bend round, as shown. The ends can of course be drilled, provided the terminal is not of too great a diameter. A word of warning might be in order here as to connecting up accumulators. These, unless of the same make and capacity, should not be joined up in parallel.—R. GRAPER (St. Albans).

(Continued overleaf)

room on the baseboard, but this can easily be overcome by placing the additional components on a raised platform in the accompanying sketch. Valves can be mounted horizontally so that they will not project above the panel. First get two pieces of plywood, about 8 in. by 3 1/2 in., and cut them to the shape shown in Fig. 2. The platform, which measures 8 in. by 6 in., can also be cut from a piece of plywood. The platform is screwed to the upturned ends of the brackets,

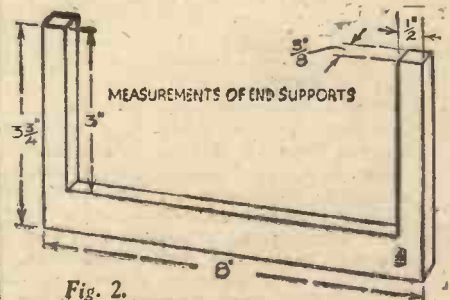

Details of the supports for the baseboard.

(Continued from previous page.)

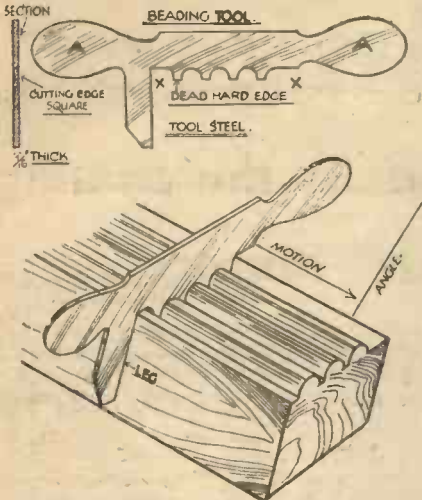

A simple beading tool made from sheet metal.

**A Handy Beading Tool**

THIS simple tool will be found very useful for making beadings, as shown in the illustration. It can be filed to shape out of  $\frac{1}{16}$  in. tool-steel or mild steel, case-hardened. The edges for cutting should be left square and then the scraper can be used in both directions. The bead produced, if started gently until a groove is formed, is equal to any produced by machine. The tool is held in the fingers at A-A, pressing the leg to side of the wood. Depth is regulated by X-X, and the bead is left smooth when finished, requiring no sandpapering whatever.—G. W. BARRATT (Whetstone).

**A Cheap Eliminator**

SOME experimenters may not be aware of the fact that a very simple H.T. eliminator may be constructed at very little cost by the use of a couple of ordinary bell transformers, as shown in the accompanying illustration. These should be of a type which delivers 12 v. at two of its terminals, with a third connection at 6 v. The plate current requirements of a small receiver will be met if an ordinary 6 v. detector valve is used as a rectifier; its plate and grid being linked together, as shown. The output voltage for the output valve is the direct connection marked 150 v. plus; two additional, lower potential leads may be obtained through the use of a fixed resistor of about 15,000 ohms at R1 to deliver about 90 v., and resistor R2, variable between 0 and 5 meg., may be used to adjust the detector plate potential to exactly the correct voltage.

As illustrated, the choke coil shown may be the secondary winding of a "Ford" spark coil; the fixed condensers from these coils may be connected in parallel to form

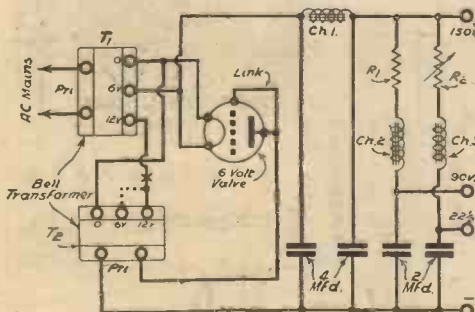

A cheap H.T. Eliminator using bell transformers.

the required filter capacity shown by the 4 and 2 mfd. condensers.

Tracing through this circuit, we find that the m/r/n supply fed into the primary of transformer T1 is stepped down; 6 volts output from part of the secondary drops to a little over 5 v. when it is applied to the filament of valve.

The 12 v. output of this secondary may be connected as shown by the solid lines, resulting in output voltages not exceeding the line potential; by connecting transformer T2, as shown by the dotted line, breaking the 12 v. lead at X, the output voltage may be doubled at a sacrifice in output current.—F. R. (Manchester).

**Extending Condenser Spindles**

IN some short-wave sets, and especially in adaptors, where hand capacity gives trouble, it is not always possible to mount the condensers back from the panel, owing to the proximity of coils, valves, etc. The diagrams show how extension handles may be made from old discarded lead-in tubes about 6 in. long. They are quite efficient, and cost very little. The two adaptors A and B are cut from wood, and are quite simply made. Care must, of course, be taken to keep the two sections and the spindle hole concentric, and the wood chosen must be capable of

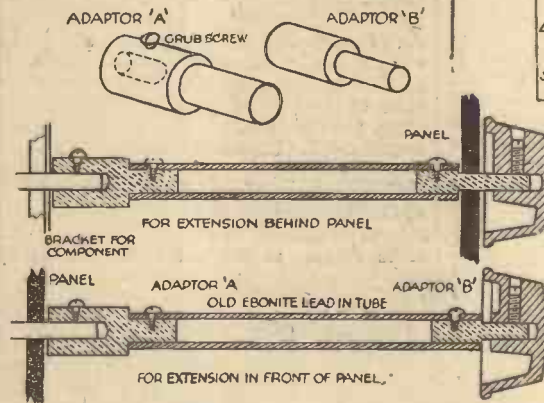

Method of making extension handles for condensers in S.W. sets.

being bored easily, and taking a screw through a small thickness without splitting. The two holes in the ebonite tube may be burnt out with a hot bradawl.—R. NYE (Southampton).

**Novel Lightning Arrester**

A NOVEL lightning arrester which not only protects the set but indicates the approach of thunderstorms some distance away can easily be rigged up as

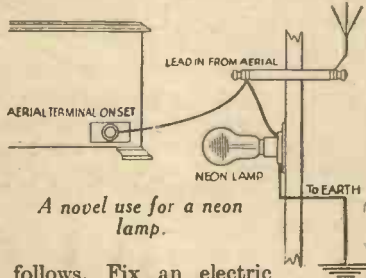

A novel use for a neon lamp.

follows. Fix an electric lamp holder beside the aerial lead-in tube and connect up as illustrated. One terminal of the holder is joined to the aerial and the other is earthed. Insert a standard 240-260-volt neon lamp into the holder; most electrical dealers can supply these for about 3s. each. When a thunderstorm

draws near the neighbourhood the lamp will indicate the fact by emitting dull red flashes corresponding to each flash of lightning. This is due to the aerial receiving oscillatory waves which are radiated by the lightning. The lamp will also glow if charged raindrops strike the aerial. Should a storm break overhead and the aerial be struck by lightning, the current, like the oscillatory waves, will pass between the electrodes of the lamp and direct to earth, this being the shortest path.—J. K. HOLMES (Gosforth).

**Switch for Two Loud-speakers**

A LOUD-SPEAKER switch for one or two speakers, either single or

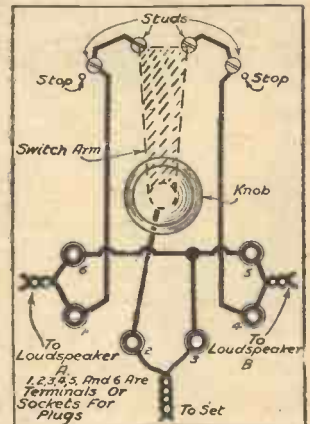

A switching arrangement for two loud-speakers.

coupled, can easily be made as shown in the accompanying sketch. The parts required, which are usually to be found in the scrap-box, consist of a piece of ebonite, 4 studs, 2 stops, and a switch arm from an old crystal set, together with terminals or banana plugs and sockets.—D. C. TOY (Ickenham).

**Cutting Ebonite Tubing**

HERE is a simple dodge for cutting ebonite tubing squarely. A metal rod, B, is held firmly in the vice, and is used as a guide for the tubing, while another rod, on which the saw rests, can be adjusted to the length of tubing to be cut off.—A. G. PEACOCK (Southbourne).

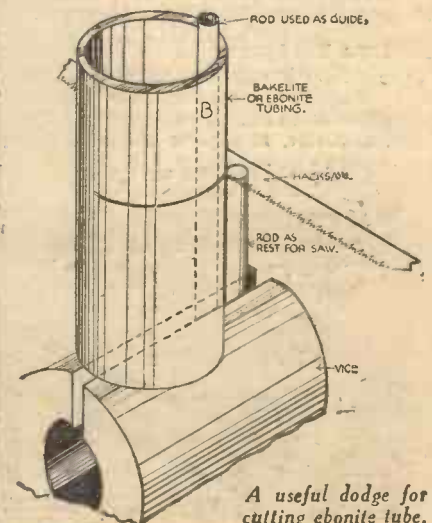

A useful dodge for cutting ebonite tube.

# CLASS B PUSH-PULL

## NEW VARLEY PRODUCTS

for a modern need—a range of tested components ensuring maximum results from Class B amplification.

The Input Transformer, DP 40.

- (1) gives good amplification of low notes because of its high primary inductance.
- (2) prevents grid current distortion by employing a low resistance secondary.
- (3) permits accurate matching of the Class B and "Driver" valves by means of alternative ratios.

The Output Choke, DP 42, gives a choice of three ratios making the matching of the Class B valve and loud-speaker an easy matter.

Write for free illustrated literature.



DP 40

### CLASS B INPUT TRANSFORMER

Ratios, 1.5:1 and 1:1. Primary inductance 28 Henries with 2 m/a D.C. Maximum primary current 6 m/a. Secondary resistance 100 ohms on the 1.5 to 1 ratio and 145 ohms on the 1:1 ratio. Price 15/-

### CLASS B OUTPUT CHOKE

Ratios, 2.5:1, 2:1, and 1.5:1. Inductance, 10 Henries per half primary with 33 m/a D.C. D.C. Resistance 350 ohms. Price 16/6

All prices include Royalty.



DP 42



**A** revolution as wonderful as the coming of " $\frac{1}{2}$  watt" lamps



Do you remember when " $\frac{1}{2}$  watt" lamps appeared—giving twice the light for the same electric current? They changed the faces of our cities. To-day there is a revolution, no less startling, in accumulators—

## double capacity accumulators

- ① No weight-wasting plates—just a core inside a cylinder (itself the acid container.)
- ② Far more thorough action (the plate-grids used to cause interference.)
- ③ Total result—twice the capacity per lb. weight!

AT present you use a 40 a.h. accumulator? Now you can have one that lasts twice as long per charge, for little more. And instead of a lumbering glass case—just a neat cylinder of lovely bakelite! See your dealer at once!

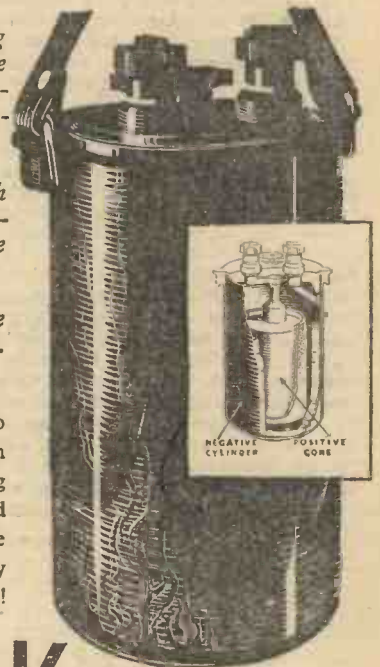

## BLOCK plate-less accumulators

2. 80 AMP. 11/6<sup>D</sup>.  
v. HRS.

**T**HE first essential in a detector valve is that it should be a good detector. This sounds a very obvious statement, but it is a fact which is very often lost sight of because we have become so accustomed to the three electrode detector valve, which does other things besides detecting, that we are rather apt to neglect the detecting action proper.

In essence, the process of detection is simply that of half-wave rectification. Let me explain. Fig. 1 is the familiar representation of a modulated radio signal. The little waves vibrate at radio frequency—some hundreds of thousands or even several millions of times a second—and it is the variations in strength, as shown by the varying height of the waves, which constitutes the audio frequency signal. Now the "positive" and "negative" half waves follow each other so rapidly that, from the mechanical point of view they cancel each other out, so that, were they applied directly to a pair of telephones, the nett effect on the diaphragm would be nil, and no sound would be forthcoming.

**Suppressing the Negative Half Cycles**

If, however, we apply the incoming signal to a device which allows current to pass in one direction but not in the reverse direction (see Fig. 2) the "negative" half cycles will be suppressed, and the so-called "rectified" signal will then appear as shown in Fig. 3. The signal is now in a form suitable to operate a telephone instrument or, after further amplification, a loud-speaker.

It is just that phrase, "further amplification" which makes efficient detection so difficult. The original Fleming two electrode valve, and the crystal detector, are purely half-wave rectifiers, and give no amplification whatsoever. Under the most favourable conditions, the output of such a detector can only operate headphones, and that only on fairly strong signals. Moreover, this output generally is not sufficient to operate a power valve or pentode, so that if a loud-speaker is required to be used, two low frequency amplifying valves must be employed.

When the three electrode valve was developed, it was found possible to employ it in such a way that it acted both as a detector and as an amplifier at the same time. Two methods are available. In the anode bend detector the valve is biased to the bottom bend of its characteristic. It amplifies the positive half-waves of the high frequency signal fully, but the negative half-waves are amplified very little. The valve thus acts as a high frequency amplifier and detector combined.

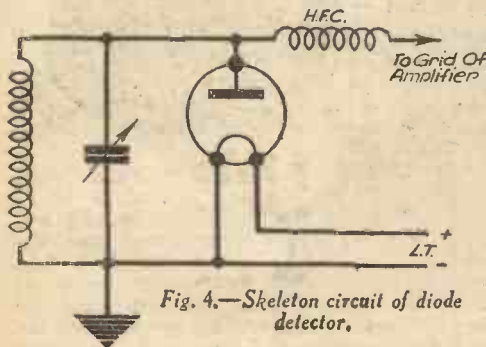

Fig. 4.—Skeleton circuit of diode detector.

# About the Double-Diode-Triode

The Latest Development in Detection

By H. J. BARTON CHAPPLE,

Wh.Sch., B.Sc. (Hons.), A.C.G.I., D.I.C., A.M.I.E.E.

Alternatively, in the leaky grid detector, the grid and filament act as a half-wave rectifier, suppressing or partially suppressing one half of each signal wave, after

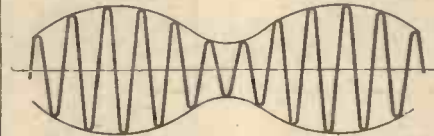

Fig. 1.—Modulated H.F. signal.

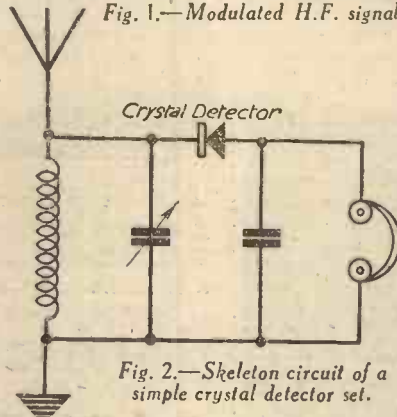

Fig. 2.—Skeleton circuit of a simple crystal detector set.



Fig. 3.—The result of half-wave rectification—the "negative" half-cycles have been suppressed.

which all three electrodes come into play to amplify the signal at audio frequency.

**Not Perfect**

Although this sounds very satisfactory and efficient, it must be admitted that the arrangement is not perfect. Neither arrangement gives 100 per cent. rectification, so that the result is something less than perfect undistorted reproduction. The reason, of course, is that the conditions for good amplification are not ideal for perfect rectification. It is true that in a well designed wireless receiver, carefully adjusted as to operating conditions, detection with a three electrode valve can reach a high standard of excellence, but it is equally true that in many sets, more care has been taken to obtain a big degree of amplification in the detector stage than in ensuring distortionless rectification. Recently more attention has been paid to detection proper. Owing to the increased sensitivity of modern valves, a high degree of amplification in the detector stage is not quite so vitally important, and in a certain number of sets the designer has referred to the "diode" or two electrode valve as detector. Fig. 4 shows this principle. The "anode" of the diode rectifier may be, and usually is, the grid of a normal three

electrode valve, the anode of which is not used in this circuit. (Then again we have the recently developed Westector unit whose action I have recently described in the columns of this paper).

A diode valve is merely a rectifier, and if it is employed, all amplification in a receiver must be obtained from high frequency and low frequency stages. For greater efficiency, two diodes are sometimes used to give a species of push-pull detection. The principle of full-wave detection can be seen from Fig. 5.

**Saving Space and Cost**

But diode rectification, although giving wonderful freedom from distortion, does necessitate the use of an additional stage of low frequency amplification. This means, in the usual way, an additional valve and associated circuits, and results in increased low tension current consumption, and extra baseboard space, all of which cost money. What is required, therefore, is a method of combining diode detection with low frequency amplification in one valve, thus saving space and cost, and at the same time it is desirable to avoid the unsatisfactory features of the three electrode detector in which one set of electrodes have to serve the dual purposes of detection and amplification. For it is due to this double use of one set of electrodes—this compromise between two sets of conflicting conditions, that the triode detector just falls short of perfection.

The solution of the problem has now been found and will, before very long, be available to listeners generally. Valve designers have now succeeded in developing a valve which combines in one bulb one or two diode elements for detection, and also either a triode or tetrode (four electrode valve) for use as a low frequency amplifier. Not only this, but the two parts, although enclosed within one bulb, act entirely separately, so that working conditions for each part can be adjusted independently so as to ensure the highest efficiency for both functions.

**Valve Details**

So far, British valve manufacturers in general have not made known full details of their programmes with regard to these new valves, but it is probable that indirectly heated valves for use on A.C. electric

(Continued on page 207.)

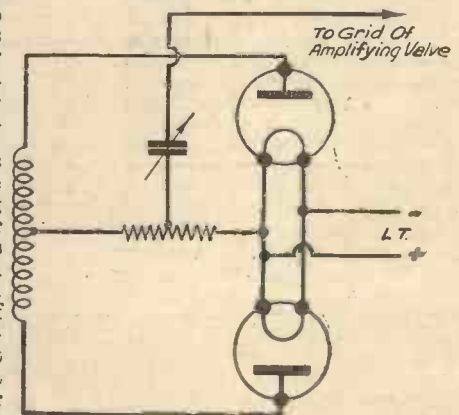
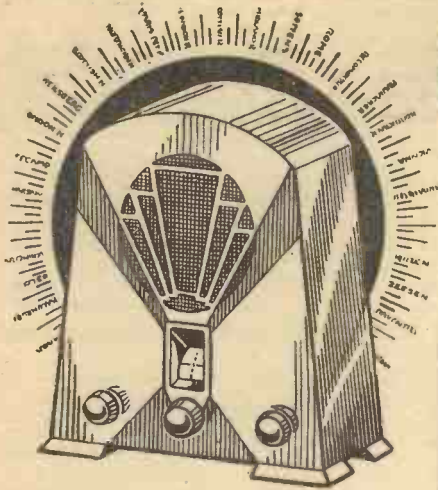

Fig. 5.—Push-pull diode detection. Instead of two diodes two triodes may be used, their grids being employed as the diode anodes and their anodes left disconnected.

# OUR VIEWS ON RECEIVERS



**T**HE original Lissen Skyscraper is too well known to need any reference in these pages, and this receiver has now made its appearance in an all-electric form under the title of the A.C. Skyscraper. This is an all-mains (A.C.) receiver with the mains portion of the set separately contained in a metal box. It is put up in two cartons, one of which contains all the parts for building the receiver, with the addition of the four valves, each separately boxed. The second carton contains the complete mains unit, which you do not have to assemble. This method of separating the parts ensures that no damage will be done to some of the more delicate parts of the complete apparatus. To prevent some of the smaller parts from being lost or mislaid when unpacking the carton, some are fastened to a card, whilst others are enclosed in six separate envelopes. This shows a certain amount of care in putting up this attractive kit and gives no cause for complaint from the customer.

### The Circuit

The circuit consists of a variable- $\mu$  screen-grid stage followed by a power detector which is in turn transformer-coupled to a pentode valve. The first two valves are of the indirectly-heated type, and the pentode is directly heated. A biasing resistance is included in the cathode lead of the detector valve and comes into operation when the gramophone pick-up is inserted in the sockets provided at the rear of the chassis. The standard Lissen screened dual-wave coils are used with a substantial two-gang condenser for tuning. This is provided with a concentric trimmer. The coupling between S.G. and detector valves is of the parallel-fed tuned anode arrangement with capacity-controlled reaction. To prevent parasitic oscillation in the output valve a resistance of 100,000 ohms is inserted in series with the grid lead. Three alternative aerial connections are provided, two being *via* small fixed condensers and one direct to the aperiodic aerial coil. In addition a plug is fitted to enable a mains aerial device to be employed.

### Assembling the Kit

The Kit is extremely simple to assemble, the large chart which is supplied having very complete instructions tabulated into a number of Steps. Thus under Step 1 you are told how to assemble the metal

## THE LISSEN A.C. SKYSCRAPER

chassis and mount the condensers, etc. In Step 2 you are instructed how to assemble the components on the upper side of the base and so on. In this way, and



with the special connecting wires supplied, it does not take long to make up the receiver.

The mains unit is bolted to the chassis after the principal assembly is completed. An interesting point in the wiring is that you are told how long to cut the wires, and a rule is printed on one edge of the chart. It would appear, therefore, that everything has been thought of to assist the constructor in putting this receiver together in the easiest and most efficient manner possible.

### Results

The receiver is remarkably efficient, and if you had any experience with the original Skyscraper (battery version) you will have some idea of what to expect in a mains operated version of the set. The sensitivity of the H.F. stage is very high indeed and stations simply roll in. The quality, due to the power rectifier, is very good, and is characterized by that crispness and good response to transients. The output from the pentode is ample and when used with a moving coil loud-speaker, correctly matched, the tone of reproduction is very

good indeed. The number of stations which can be received on the receiver will, of course, depend on the locality, but with the mains aerial in use, in the heart of London a dozen stations could be easily tuned in at really good loud-speaker strength. When used with an outdoor aerial the range is vastly increased, and there are many stations to choose from. When used with a gramophone pick-up the reproduction is also of a high order, the detector valve having very good characteristics as an L.F. valve. It was found with the particular pick-up which we used, that a volume control was necessary across the pick-up input, and this fact is mentioned in the Lissen chart. The price of the Kit, with 4 valves is £7 19s. 6d. With table cabinet the price is £8 15s. For those who require a complete outfit, a console cabinet, with permanent magnet loud-speaker is obtainable, and this, with the complete kit costs £10 12s. 6d.

### Special Features

It is always interesting to examine these commercial kits for points of interest and there are one or two small features included in the Skyscraper which we should like to mention before concluding. Firstly, the particular form of automatic volume and reaction control. This consists of a bakelite moulding carrying a circular resistance on one edge. Mounted on a central point is a small variable condenser of the bakelite dielectric type. Rotation of the control knob varies the setting of the reaction vanes as well as adjusting the grid bias on the screen-grid valve. Consequently as the sensitivity of the H.F. stage is reduced, the sensitivity of the detector stage is increased and this results in a very fine form of control over both volume and selectivity. A further interesting feature is the inclusion of a special fused combination output plug from the



mains unit. This is of bakelite and

in each lead from the mains unit is a fuse forming the connection from wire to pin. The two wires are enclosed in a single rubber covering and the plug has the usual 5-amp. wall socket pins



Compact, quickly assembled, and cheap—  
a star performer.

**SINCERELY** hope that the preliminary notes which I gave you last week filled you with ambition to build this interesting two-valve set. I am certain there are hundreds of readers who will find that this receiver fills a long felt want. I will not go over again the essentials of the circuit, but will start right away on the instructions for building the set, a task which, while not difficult, is a little more complicated than the ordinary type of receiver. But as the finished product will bear the hall-mark of the factory-built receiver, this extra work will be well justified. Well then, the first operation is to purchase the cabinet, and this will be fitted with the side rails to take the shelf and the main baseboard. It will be noticed, by the way, that there are actually two baseboards, one which I will call the main base, upon which the principal parts of the receiver proper are accommodated, and the second, which is the upper shelf, upon which the mains portion of the set is built. As with all PRACTICAL WIRELESS receivers, the sub-baseboard of mounting is employed, and this is a most valuable feature as it enables the component parts of the receiver to be divided into two parts with wiring also split up. If you have never built a receiver on this principle you will find that it is a novel idea which greatly simplifies the wiring. The hole for the escutcheon will also be cut out of the front.

**Commencing Construction**

First of all, take the main baseboard and rule a line across the centre so that you can correctly position the Polar gang condenser. With the template which is supplied with this component, mark *very carefully* the position of the screw holes. If this condenser is mounted even slightly out of line the control knob will be found to set awkwardly outside the cabinet and the ivory scale will not fit neatly behind the window of the escutcheon. Next mark out the positions for the valve-holders and the small cut-out on the right of the

baseboard to accommodate the various leads. Next take the upper shelf and mark the position of the valve (on the centre line), and also the cut-out on the right, which is similar to that on the main base. If you wish to use a light behind the dial (a feature which I would definitely advise you to do), you will have to cut out a small section from the edge of the upper shelf to clear the bulb and its holder. This latter is held in position by the escutcheon bolts. A further piece is cut from the rear of the upper shelf to clear the small Clix socket mount. The holes for the valve-holders are 1in. clearance. Three holes will be found on the side of the cabinet, and these are for the on-off switch, the reaction condenser, and the wave-change switch.

**Mounting the Components**

With the wiring diagram of the under-side of the main base before you (or the full-size blue print, which is obtainable for 1s.), carefully position the fixed condensers and the L.F. transformer. Now turn the base over and screw on the two valve-holders and the gang condenser. Measure a line 1½in. from the right hand side of the base, and with the switch rod on the centre line fit the Lewcos coil. The switch rod may then be withdrawn and placed on one side for the time being. The .0001 fixed condenser, and the .01 condenser should then be attached in their respective positions, and finally the H.F. and L.F. chokes. This completes the main base, and you may proceed to the upper shelf. The first part to attach here is the aerial and earth strip, and this is simply held in position with small wood screws. The two 4 mfd. condensers are next fitted, after which the .01 condenser should be attached close to the valve-holder. Fit the valve-holder, and then place the mains transformer on the right. The Bulgin mains plug and its mounting is the final component to be fitted to the shelf, and you can therefore attach the on-off switch and the reaction condenser to the side of the cabinet.

**The Wiring**

The constructional work so far carried out will have been found extremely simple, and the wiring, whilst not difficult, is a little complicated, and the following instructions should therefore be carefully carried out. First of all, attach a short length of Glazite from the terminal marked E on the Lewcos coil to one side of the .01 mfd. condenser, putting one wire of the 10,000 ohm resistor under the terminal head before tightening it up. Attach the other end of the resistor to the other terminal on this condenser, and at the same time connect a length of wire to the terminal and take this down through hole No. 1 in the base and join it to the .001 mfd. fixed condenser on the under-side of the

# Building "A.C.T."

Complete Constructional Details of Receiver which was Introduced L

base. From this terminal take a short lead to the nearest terminal of the 1 mfd. fixed condenser, and a further wire to the central terminal of valve-holder V.1. A wire must also be taken from this condenser terminal to terminal H.T. on the L.F. transformer, and this terminal is also joined to the G.B. — terminal on the transformer. From the latter terminal a wire runs to a terminal on the 1 mfd. fixed condenser on the left of the base, and this is in turn joined to the 2 mfd. condenser. A short wire is next attached to the terminal

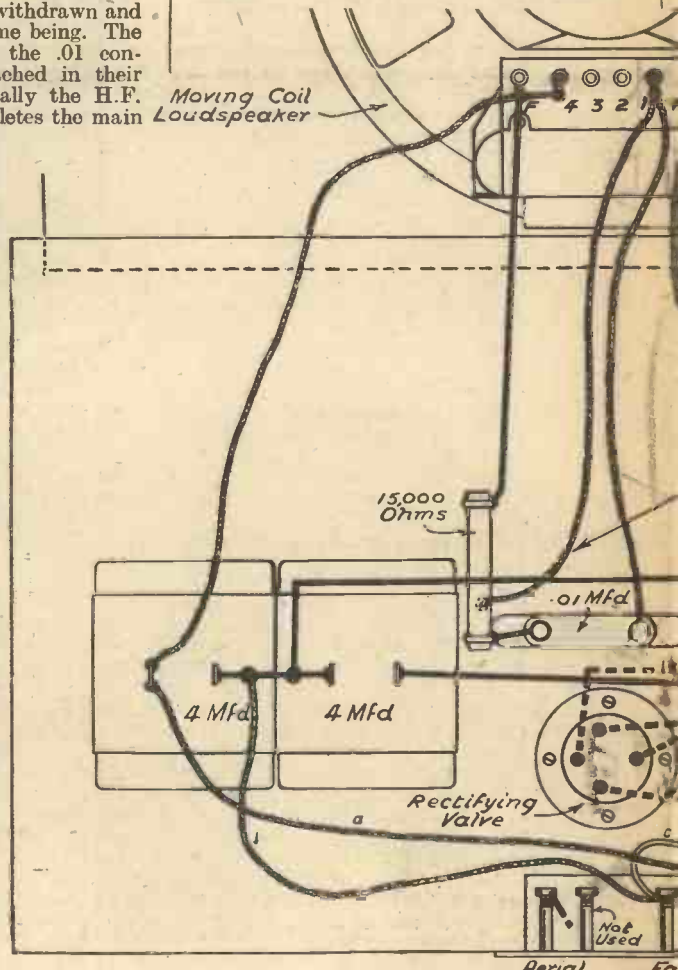

Wiring diagram of the power section of the A

# the TWIN

## FIRST AGAIN! The First Two-Pentode Receiver

or Making Up the Ingenious  
Last Week by W. J. DELANEY

on the rear of the gang condenser, and this is passed down through hole No. 4 and joined to the G.B. — terminal on the L.F. transformer. Now join the 400 ohm resistor across the 2 mfd. condenser, and connect the right-hand terminal of this condenser to the central terminal of valve-holder V.2. Two and a half inches of wire will join terminal G of the transformer to the grid terminal of this latter valve-holder, the normal plate terminal of which is joined to the 1 mfd. condenser, which is close handy. Before tightening this nut, attach one end of the 2,500 ohm resistor to the terminal. The 30,000 ohm resistor is joined

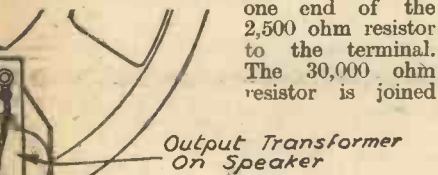

by one end to terminal H.T. on the transformer, and by the other end to terminal P on the transformer, and a wire from this point is taken to the 1 mfd. condenser which is situated under the L.F. choke. From the other terminal of this condenser, a wire is joined to terminal 4 on the choke, whilst a 12,500 ohm resistor is joined from the same point to the normal plate terminal of valve-holder V.1. Now turn the base over and join terminal 4 of the L.F. choke to the rear terminal of the H.F. choke, and to the remaining terminal on this latter choke attach a 3in. length of flex, a 9in. length of flex and a 4in. length of Glazite. The Glazite is passed down through hole No. 3 and joined to the remaining terminal on the .001 fixed condenser, whilst the short length of flex is bared at its end for subsequent connection to the anode terminal on top of the valve. The longer piece of flex will be attached to the reaction condenser when the base is placed into its position. A similar remark applies to the short length of flex which is attached to terminal R on the Lewcos coil. An inch or so of Glazite is now used to connect together terminals 2 and 3 on the Varley choke, and a short length of wire is joined to terminal 1 on this choke for connection to the free end of the 2,500 ohm resistor. This connection may be made by soldering, or using one of the Erie special connectors.

### Completing the Wiring

Only one or two wires remain, and the next to attach is that from terminal C on the Lewcos coil to the terminal on the gang condenser which is just below the trimming wheel. From terminal G on the Lewcos coil a wire is taken down to the nearest terminal on the .0001 mfd. condenser, and a further wire joins this terminal to the remaining terminal on the side of the ganged condenser. The remaining terminal on the .0001 fixed condenser is now joined, via hole No. 2, to the grid terminal on valve-holder V.1, attaching at the same time one end of the .25 megohm grid leak. The other end of this leak is joined to the terminal of



the .001 condenser, which already has two wires on it. Before tightening this up, attach a 2ft. length of flex, and in order to identify this, strip off the cotton covering, so exposing the rubber. Now tighten up the terminal, and this part of the wiring is finished, and the base may be put on one side whilst the shelf is wired up.

### The Mains Unit

Join together the two centre terminals of the two 4 mfd. condensers, and attach at the same time a 9in. length of flex and a similar length of Glazite. The flex should be attached to the earth socket on the Clix

(Continued overleaf.)

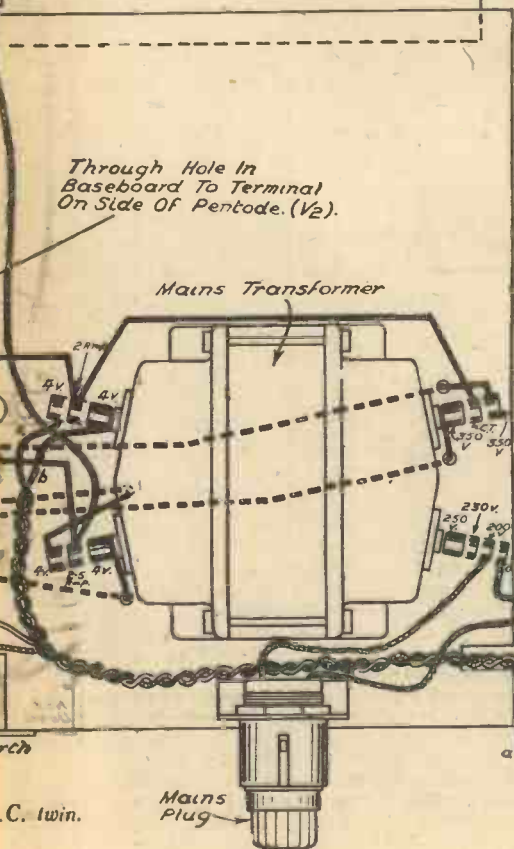

### COMPONENTS FOR THE A.C. TWIN

- One Lewcos Band-Pass Filter, Type 51, B.P.F./R.
- One Polar Uniknob 2-Gang Condenser, .0005.
- One Irganic Transformer, Type T/24/B.
- One Lotus .0003 Reaction Condenser.
- One Bulgin Standard H.F. Choke (H.F.9).
- One Varley 300 Henry L.F. Choke (D.P.16).
- One .0001 fixed Condenser (Type S), T.C.C.
- One .001 fixed Condenser (Type S), T.C.C.
- Two .01 fixed Condensers (Type 34), T.C.C.
- Three 1 mfd. fixed Condensers (Type 50), T.C.C.
- One 2 mfd. fixed Condenser (Type 50), T.C.C.
- Two 4 mfd. fixed Condensers (Type 84), T.C.C.
- Two 5-pin valve-holders (Clix Chassis type).
- One 4-pin valve-holder (Clix Chassis type).

- One 1/2 megohm Erie Resistor.
- One 12,500 ohm Erie Resistor.
- One 400 ohm Erie Resistor.
- One 2,500 ohm Erie Resistor.
- One 30,000 ohm Erie Resistor.
- One 10,000 ohm Erie Resistor.
- One 15,000 ohm Erie Resistor.
- One Heayberd Mains Transformer (Model A.C. Twin).
- One Grampian Energized Speaker, Type E.1.
- One Bulgin Mains Toggle Switch, Type S.80.
- One Bulgin Small Mains Connector, Type P.21.
- One Clix Terminal Strip.
- Two Clix Wander Plugs (One black and one red).
- One Cossor 442 B.U. Rectifying Valve.
- One Cossor MS-PEN-A (H.F. Pentode Valve).
- One Cossor MP-PEN (Pentode Output Valve).
- One Smith Lyric Cabinet.
- One coil Glazite, 3 yards red and black flex, screws, bulb for panel light, etc.

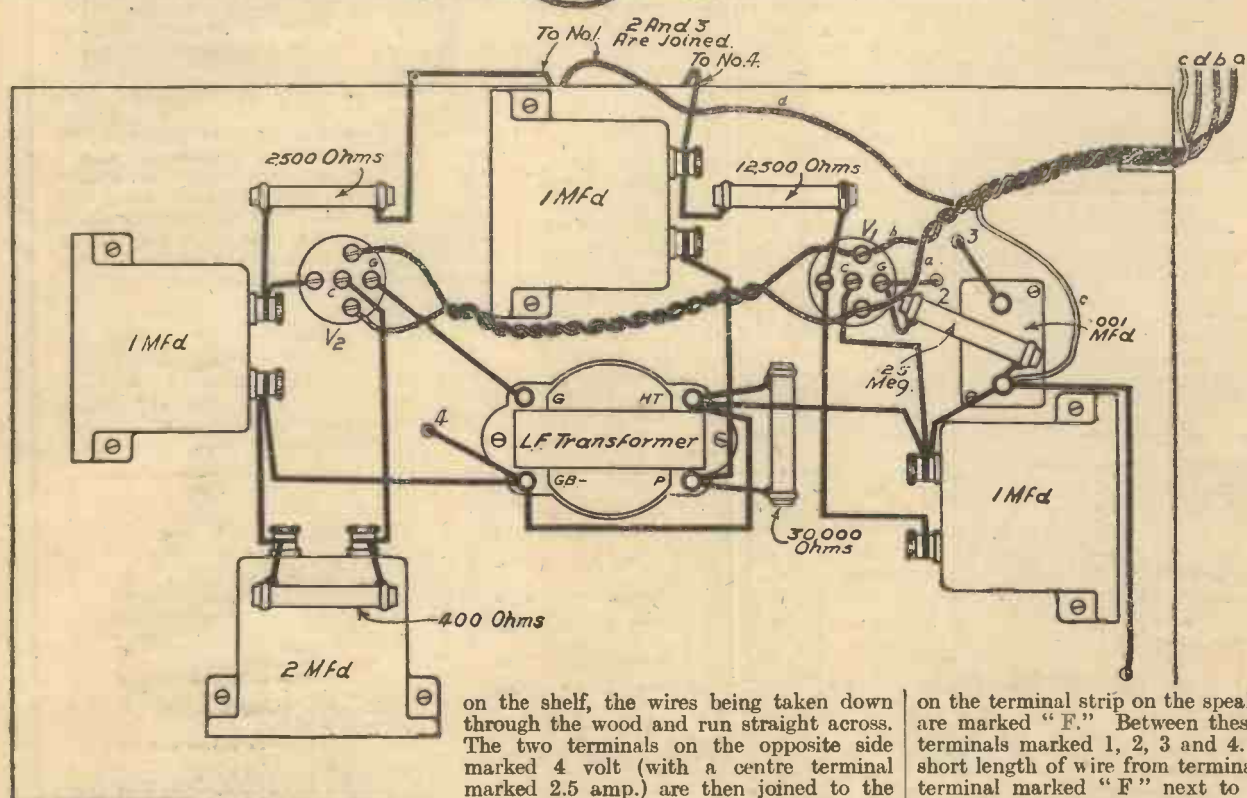
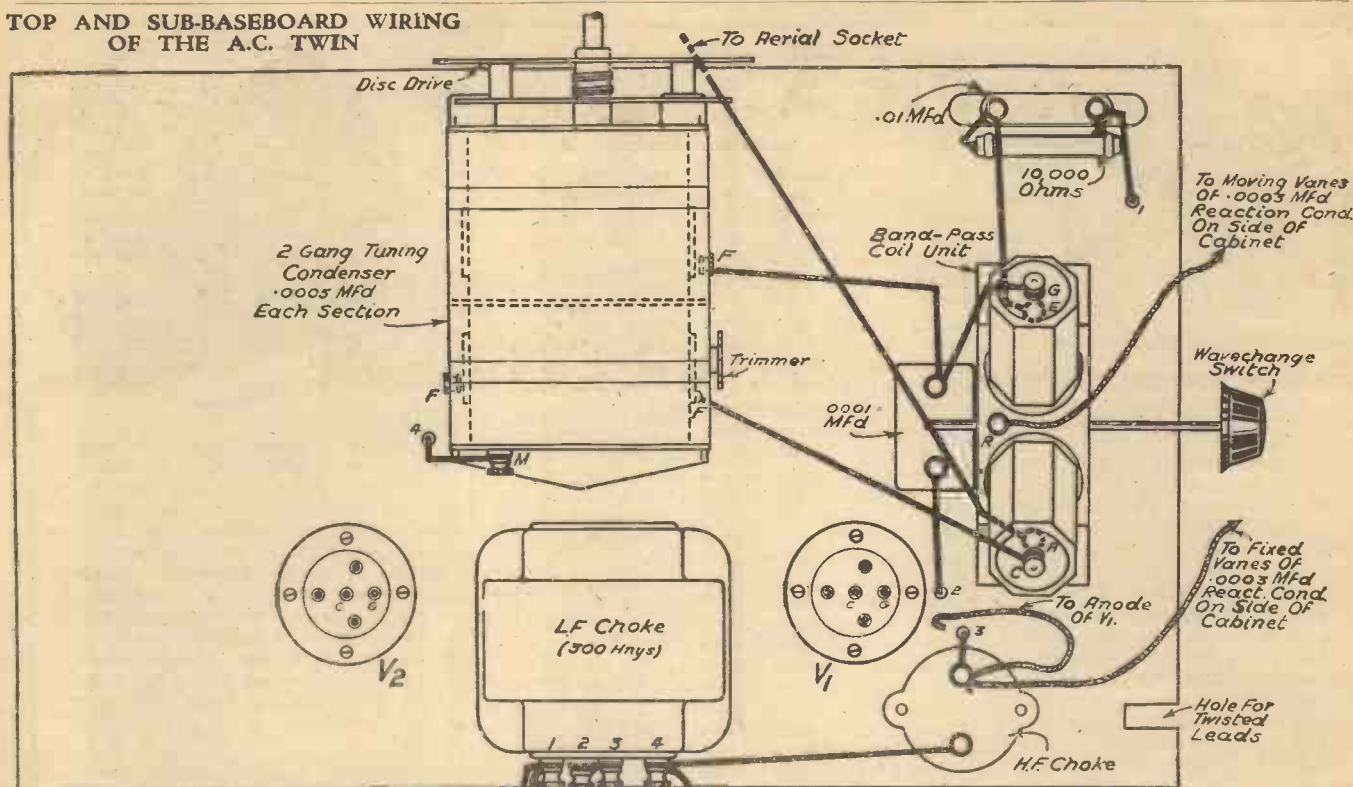
TOP AND SUB-BASEBOARD WIRING  
OF THE A.C. TWIN

(Continued from previous page.)

strip, whilst the Glazite is joined to the centre terminal of the group of three on the mains transformer marked 4 volts 2 amps. From this latter terminal a wire is run round the transformer and joined to the centre terminal on the opposite side, marked CT. The terminals on each side of this latter, marked 350, are now joined to the normal grid and anode legs of the valve-holder

on the shelf, the wires being taken down through the wood and run straight across. The two terminals on the opposite side marked 4 volt (with a centre terminal marked 2.5 amp.) are then joined to the filament terminals of the valve-holder, and the centre terminal joined to the nearest terminal on the 4 mfd. condenser. Two 6in. lengths of flex are now connected to the terminals on the Bulgin mains connector, and the shelf may be placed on one side whilst the loud-speaker is prepared.

As has already been pointed out, the speaker field acts as the smoothing choke for the mains unit, and it will be seen that there are two terminals (one at each end)

on the terminal strip on the speaker, which are marked "F." Between these are four terminals marked 1, 2, 3 and 4. Solder a short length of wire from terminal 4 to the terminal marked "F" next to it, at the same time attaching a 7in. length of flex and one end wire of the 15,000 ohm resistor. To terminal 1 attach a 12in. length of flex and a 4in. length, whilst to the remaining "F" terminal a 6in. length of flex should be soldered. Now position the speaker behind the baffle and screw it into place. Fix a 2in. length of flex to one terminal on the on-off switch and attach this to the side of the cabinet. Now attach the ends of a

(Continued on page 201.)



# The BEGINNER'S SUPPLEMENT

Conducted by F.J. CAMM

THE EASY ROAD TO RADIO



**Coulomb**

THE name given to the unit of quantity of electricity. It is the amount of electricity conveyed in a second by a current of one ampere. To take an example: suppose the accumulator of a multi-valve set were supplying current to the filaments of the valves at the rate of exactly one ampere as measured by an ammeter connected in the circuit. How many coulombs of electricity would

**THE BEGINNER'S ABC OF WIRELESS TERMS**

(Continued from April 15th issue, page 156.)

the aerial, porcelain insulators and a lead-in tube being used.

**Coupled Circuit**

In a receiving set this term is used to refer to two circuits, which by means of inductance, capacity or a resistance are able to influence one another, so that electric currents fluctuating in the one circuit induce currents in the other. The two circuits thus combined or "coupled" together are spoken of as a *coupled circuit*. The aerial circuit of a receiver, that is, the circuit which receives the incoming wireless waves, is often a coupled circuit. The reason in this case is that the coupled circuit gives greater selectivity than a single circuit.

**Coupling**

Coupling is the connection between two circuits, by means of which the energy is transferred from one to the other. There are three methods of obtaining coupling, namely: directly, inductively, or capacitatively.

Direct coupling simply means that there is a metallic connection between the two circuits. A modification of this method employs a resistance, and is accordingly called resistance coupling.

Inductive coupling, which is the form most commonly met with in wireless, is obtained by arranging the two circuits (Continued overleaf.)

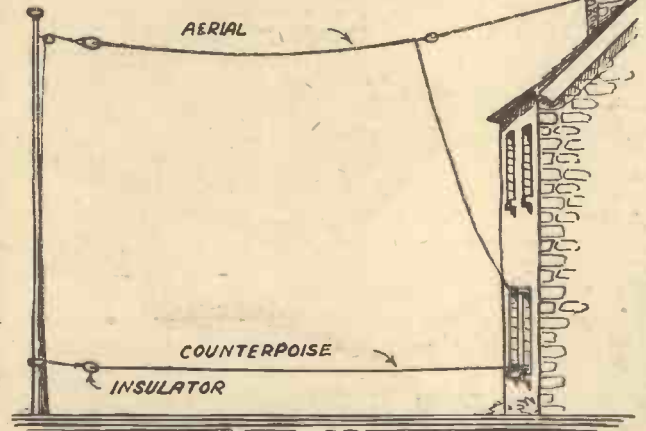

Fig. 1.—How to fix up a simple counterpoise earth.

be used in, say, ten minutes? Well, as the rate of flow is one amp., therefore one coulomb must flow every second (See "AMPERE"). Thus, in ten minutes, six hundred would be used. If the current used were half an amp. for five minutes then the quantity of electricity consumed would be half a coulomb every second, that is, one hundred and fifty coulombs in five minutes.

**Counterpoise**

A wire or network of wires suspended a foot or so above the ground which is used as the earth connection to a wireless or transmitting station, instead of making direct connection with the earth itself. A proper counterpoise earth is insulated in the same way as the aerial, and is usually placed directly under it. It has certain advantages over the ordinary type of earth connection. For one thing it gives more consistent results and is less affected by the seasons, change in temperature, dampness of soil, etc. It sometimes helps towards the reduction of interference caused by atmospherics. An example of how simple a counterpoise can be fixed up by the amateur is shown in Fig. 1. This arrangement is worth trying where disturbance of reception is caused by near-by electrical machinery. It is insulated in exactly the same manner as

in dry weather, they function almost entirely by virtue of the capacity effect. A piece of wire netting spread on the ground is a good example of this type of "earth."

**Countersinking**

The act of making a conical recess to a screw hole, so that the head of the screw may sink in to the wood, ebonite or other material, and thus lie flush with the surface. Countersinking gives a much better finish to a job than is obtained by just boring a plain hole for the screw. It should always be resorted to when fixing brackets to ebonite panels and such-like jobs. The usual method of carrying out the work is to first drill the hole for the screw and then to countersink it by means of a special countersinking drill or bit. The process is shown in Fig. 2. The inset shows a typical drill used for this purpose, which may be obtained for a few pence. The fixing holes of many components supplied to the constructor are already countersunk but where they are not this should either be done by hand or else roundheaded screws should be used. To screw an ordinary wood screw down really tight into a bakelite flange when the hole is not recessed may split off the flange. Thus, you see, there is a structural reason for countersinking beside the question of appearance.

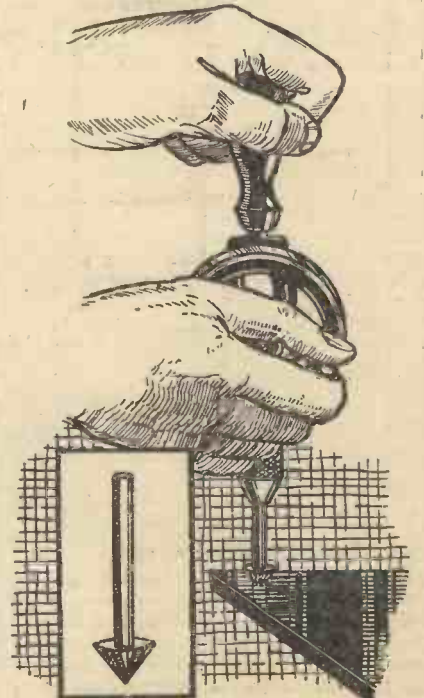

Fig. 2.—Countersinking an ebonite panel. Inset, countersink drill.

(Continued from previous page.)

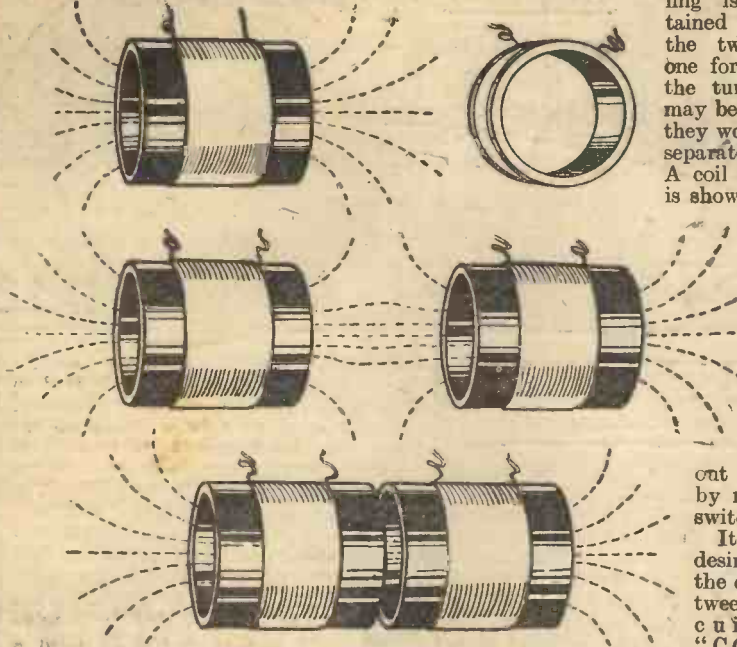

Fig. 3—Illustrating various degrees of coupling between two coils.

so that the magnetic fields around them interact. This is illustrated in Fig. 3, which shows two coils coupled together in varying degrees.

When a current is passed through a coil a "magnetic field" is produced round the coil, that is to say, the space round the coil exhibits magnetic properties. A compass held near the coil will point in different directions, according to where it is held. The direction of this magnetic force round a coil is represented by the dotted lines in Fig. 3. Now, when two coils are placed near together their respective fields will interact and some of the lines of force will join up so that they are common to both circuits. The amount to which they do this depends not only on the nearness of the coils to one another, but also on their relative positions. If you look at the top coils in Fig. 3 you will see that they are at right angles to one another. In this position there is little or no interaction. In other words, there is no coupling, or else it is very loose. The

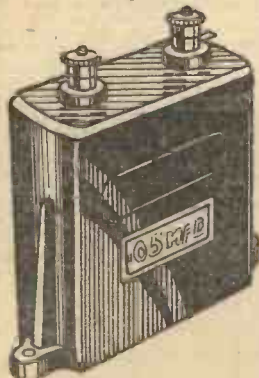

Fig. 7—A fixed condenser as used in coupling circuits, particularly band-pass circuits.

centre coils are shown end-to-end some little distance apart. Here there is more linking up and the coupling is said to be tighter. In the third position the coils are placed as close as possible. This ensures the maximum transference of energy from the one end to the other and the coupling is tight. Tight coupling

is often obtained by winding the two coils on one former so that the turns of wire may be closer than they would be if on separate formers. A coil of this type is shown in Fig. 4.

It is a commercial short-wave coil with three windings. Two of these are used at a time, the third one being cut out of circuit by means of a switch.

It is often desirable to vary the coupling between two circuits (See "COUPLED CIRCUIT" and "SELEC-

TIVITY," etc.), and so various methods have been devised to accomplish this. Fig. 5 shows one of them. Here one coil is made smaller than the other and is mounted on a spindle so that it can be rotated inside the larger one.

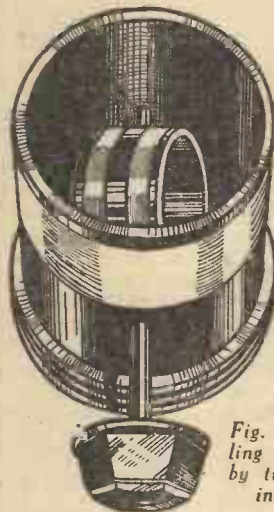

Fig. 5—How coupling may be varied by turning one coil inside another.

Coupling by means of capacity means that the two circuits are joined with a condenser. According to the way the condenser is connected up, a large condenser will give tight coupling and a small one loose coupling, or vice versa. The method of connecting, which gives the latter effect, is shown diagrammatically in Fig. 6 (right-hand sketch).

Two coils of wire may be either in-

ductively coupled, capacitatively coupled, or both. Examples of the first method are shown in Figs. 3, 4 and 5. In the second method the coils are either so far apart as to have no inductive coupling, or else are screened from one another by means of a sheet of metal to attain the same object. They are then joined by a condenser, such as the one in Fig. 8. The coupling is then purely capacitive. If the coils are allowed to have some magnetic interaction as well as being joined by a condenser, then the coupling is not pure but mixed. The three different methods all have their various merits and drawbacks with which we need not concern ourselves here.

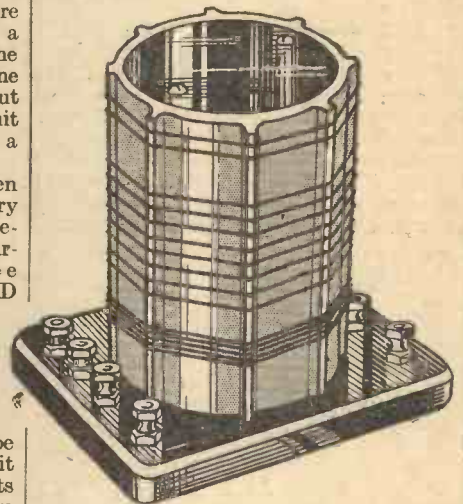

Fig. 4—Shows three windings on the same former. The coupling here is fairly tight.

Intervalve coupling, which refers to the method of joining together the various valves in a set, may be divided into three classes, namely, Resistance-capacity, Choke and Transformer coupling. They are dealt with under their respective headings, which see.

Have Your Copies Bound

REGULAR readers of PRACTICAL WIRELESS should carefully peruse the announcement on page 200 of this issue. It is a tedious task to have to wade through twenty-six issues of a paper to find a particular article. Every reader should collect his issues together and have them bound in the attractive binding case, together with the title page, and index, which we have had prepared as a service to the reader. This can be done at a special bargain price of 5s. 6d., and the completed volume will provide you with a remarkable work of reference.

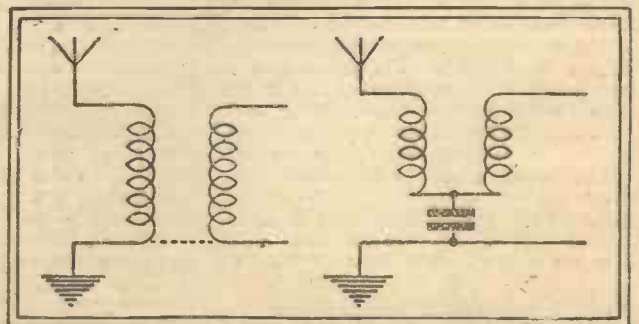

Fig. 6.—Diagrams showing inductive coupling (left) and capacitive coupling (right).

# FOR EVERY SET — there's a PILOT AUTHOR KIT

CASH — C.O.D. — or H.P.

**TELSEN "SUPER" 6.** Complete Kit of Telsen Parts in Sealed Carton. Cash or C.O.D. Carriage Paid, £5/18/6. Balance in 11 monthly payments of 10/10, only (Set of valves add 7/8 to each of 12 payments.) **Send 10/10**

**JUST RELEASED**

**LISSEN ALL-ELECTRIC SKYSCRAPER 3**

Complete with 4 valves and constructional chart in sealed Lissen carton. Cash or C.O.D. Carriage paid, £7/19/6. **Send 14/8** only  
Balance in 11 monthly payments of 14/8.

**BLUE SPOT UNIT AND CHASSIS.** Type 99 P.M. Including matched transformer. Cash Price, £2/19/6. **Send 5/6** only  
Balance in 11 monthly payments of 5/6.

**ROLA PERMANENT MAGNET MOVING-COIL SPEAKER F.6.** With Universal tapped input transformer. Cash Price, £2/9/6. Carriage Paid. **Send 4/6** only  
Balance in 11 monthly payments of 4/8.

**SEND 2/6 ONLY**

Just pay a further 2/6 on delivery and balance in 5 monthly payments of 5/6 for **PETO-SCOTT GUARDIAN Q.P.P. MOVING-COILSPEAKER** specially designed for Q.P.P. output. Extremely sensitive, and gives perfect quality. Cash or C.O.D., Carriage Paid, 29/6.

Just pay a further 2/6 on delivery and balance in 5 monthly payments of 5/6 for **PETO-SCOTT PERMANENT MAGNET MOVING-COIL SPEAKER**, ideal for all sets except Q.P.P. Cash or C.O.D. Carriage paid 29/6.

**NEW BLUE SPOT PERMANENT MAGNET MOVING-COIL SPEAKER 29 P.M.** With input transformer. Cash or C.O.D. Carriage Paid. £1/12/6. **Send 5/2** only  
Balance in 6 monthly payments of 5/2.

**SNIP BLUE SPOT 100U**

Special Bargain Offer to "Practical Wireless" Readers. Speaker and Chassis. For high or low-powered sets. Original Price £1 12s. 6d. Our Price (for a limited period only) **19/6** CASH or C.O.D.

**ATLAS ELIMINATOR.** Type A.C.244. Three Send 5/6  
tappings, S.G., Detector and Power. Output 120 volts at 20 m/A. Cash Price, £2/19/6. Carriage Paid. only  
Balance in 11 monthly payments of 5/6.

**GARRARD INDUCTION GRAMOPHONE MOTOR.** For A.C. Mains. Model 202. Mounted on 12-inch nickel motor plate with fully automatic electric starting and stopping switch. only Cash Price £2/10/0. Carriage Paid. **Send 4/7**  
Balance in 11 monthly payments of 4/7.

Send 1/- for splendid **SHORT-WAVE BOOK**, written and edited by Mr. G. T. KELSEY, the world-famous short-wave expert. Describes four efficient receivers with full building and operating instructions; 48 pages, 4-colour cover. Amply illustrated. **FULL SIZE BLUE PRINT WITH EVERY COPY.** Obtainable from all shops and branches of W. H. Smith and Sons.

**A.C. TWIN** As described in this week's issue

**KIT "A"** Author's Kit of first specified parts less valves, cabinet, panel, baseboard and speaker, CASH or C.O.D. Carriage Paid, £7/1/6.

Delivered, Carriage Paid on first payment of **13 -** Balance in 11 monthly payments of 13/-.

**KIT "B"** As Kit "A" but with valves only. Delivered, carriage paid, on first payment of **17/5**  
Balance in 11 monthly payments of 18/-.  
Cash or C.O.D. Carriage Paid, £9/16/6.

**KIT "C"** with valves, cabinet, panel, and baseboard, but less speaker, Delivered, carriage paid, on first payment of **21/3**  
Balance in 11 monthly payments of 21/3.  
Cash or C.O.D. Carriage Paid, £11/11/6.

If specified speaker required, add £1-10-0 to each Kit Cash Price or 2/8 to each monthly payment. Selected C.O.D. Items. You pay the postman. We pay post charges over 10/-.

- KIT-BITS**
- |   |       |   |        |
|---|-------|---|--------|
| 1 Polar Uniknob 2-gang .0005 Condensers with disc drive | 19 6  | 1 Leweos B.P.F./R Coil                  | 12 0   |
| 1 Heayberd Mains Transformer, Model A.C. Twin           | 1 9 6 | 3 Specified Valves                      | 2 15 0 |
|   |       | 1 Smith Lyric Cabinet                   | 1 15 0 |
|   |       | 1 Gramplan Energised Speaker, Model E.1 | 1 10 0 |

**SEND DIRECT to AVOID DELAY**

**FURY FOUR**

**BATTERY MODEL**

**KIT "A"** Author's Kit of specified parts, including ready drilled panel, but less valves and cabinet. Delivered, Carriage Paid, on First Payment of **12/-**. Balance in 11 monthly payments of 12/-.  
CASH or C.O.D. Carriage Paid, £6/10/0.

**A.C. RADIOGRAM**

**KIT "A"** Author's Kit of specified parts, including Motor, Pick-up and Speaker. CASH or C.O.D., Carriage Paid. £10-0-0. Delivered, Carriage paid, on first payment of **18/4**. Balance in 11 monthly payments of 18/4.

**KIT "B"**

As Kit "A" but with valves, less cabinet. Delivered, Carriage Paid, on First **17/3** Payment of **18/6**. Balance in 11 monthly payments of 17/3. CASH or C.O.D., Carriage Paid, £9/7/6.

**KIT "C"**

As Kit "A" but with valves and Peto-Scott American Type Cabinet with lift-up lid. Delivered, Carr. Paid. **18/6** on First Payment of **18/6**. Balance in 11 monthly payments of 18/6. Cash or C.O.D., Carriage Paid, £10/2/6.

- ESSENTIAL ACCESSORIES**
- 1 Simpson Electric Turntable, £1/19/6
  - 1 Amplion Pick-up with Volume Control, 25/-
  - 1 W.B. Permanent Magnet Moving-Coil Speaker, £2/2/0.

**EXCLUSIVELY SPECIFIED PETO-SCOTT 1933 ADAPTAGRAM** Cash or C.O.D. Real Inlaid Walnut. With Motor Board and ready for Set. Or send 8/3 deposit and 11 monthly payments of 5/9. Carriage Paid **65/6**

**CASH, C.O.D. or EASIWAY**



**PILOT GUARDIAN Q.P.P. 4-VALVE KIT**

**KIT "A"** Complete Kit of Parts, including ready-drilled panel, but less Valves and cabinet. CASH or C.O.D., Carriage Paid, £3/19/6. 7/6 Deposit and 11 monthly payments of 7/3. **7/6**

**KIT "B"** As Kit "A" but with Valves, less cabinet. CASH or C.O.D., Carriage Paid, £6/18/0. Delivered, Carriage Paid, **12/6** on First Payment of 12/6. Balance in 11 monthly payments of 12/6.

**KIT "C"** As Kit "A" but with Valves and Table Cabinet. CASH or C.O.D., Carriage Paid, £7/13/0. Delivered, Carriage Paid, **14/-** on First Payment of 14/-. Balance in 11 monthly payments of 14/-.

**KIT "D"** As Kit "C" but with Console cabinet less meter and speaker. CASH or C.O.D., Carriage Delivered Carriage Paid, on First Payment of **15/-**. Balance in 11 monthly payments of 15/-.

Send for Full Size Blue-Print and Constructional Chart. Usual price 1/- Sent FREE to "Practical Wireless" Readers.

**IMPORTANT** Parts, Kits, Miscellaneous Components, Finished Receivers or Accessories for Cash, C.O.D., or H.P. on our own system of Easy Payments. Send us a list of your wants. We will quote you by return. C.O.D. orders value over 10/- sent carriage and post charges paid.

**PETO-SCOTT CO. Ltd. 77, City Road., London E.C.1.**

Telephone: Clerkenwell 9406/7. West End Showrooms: 62, High Holborn, London, W.C.2. Phone: Holborn 3248. Dear Sirs, Please send me CASH/C.O.D./H.P. ....

for which I enclose £.....s.....d. CASH/H.P. Deposit.

NAME .....

ADDRESS .....

Pr. W. 22/4/33

**STRICT PRIVACY GUARANTEED — WE DEAL WITH YOU DIRECT**

## OPERATING



How the Beta Should Be Handled to Bring You Music from all Parts of Europe, with Any Tone You Desire

**B**EFORE we give detailed instructions for handling this interesting four-valve receiver, there are one or two points which may be explained at more length than was done last week. First of all, the coil L.3 (see page 154 of last week's issue) should be earthed, and owing to a draughtsman's error this was not shown on this diagram. Therefore, a wire must be joined to terminal 6 on this coil, and the other end of the wire taken across to the earth terminal. It is also preferable, in some cases, to connect the switch rod and the cans of the coils to earth, and for this purpose a bare wire should be attached to this terminal (No. 6 on coil 3), and the end of the wire placed below the metal base of the coil before tightening up the screws. As the switch rod bears on a small spring which is in contact with the case, the remaining two screening cases will also be automatically "earthed." This point should not be overlooked, as it prevents hand-capacity effects and also assists in ganging.

## Connecting the Batteries

The battery connections are simple, as stated last week, but to assist those who are new to wireless, the following detailed hints are given. The Lissen battery is marked with a minus sign at one end and a plus sign at the other. The two battery leads carrying the plugs marked H.T. — and H.T. + should be inserted in these two sockets, the H.T. — plug being inserted in the end marked with the minus sign, and the H.T. + plug in the other end of the battery. The grid-bias battery will have three plugs inserted in it normally, and a fourth when the pick-up is employed. The lead from the potentiometer is inserted in the negative end of the grid battery, that is, the 16-volt tapping. The lead joined to the filament leg of valve-holder V.1 is inserted in the opposite end of the grid battery, and the lead from the Multitone transformer should be inserted in the socket marked 7.5 volts. The L.T. leads

are joined to the accumulator, the L.T. — lead being joined to the black terminal and the positive lead to the red terminal. Before the receiver will work, a fuse bulb must be inserted in the special holder on the on-off switch on the panel. It is important to note that unless this bulb is in position no high-tension supply is in circuit. Do not use an ordinary flash-lamp bulb for the purpose, as there is a risk that this will not blow before the valve filaments in the event of a short-circuit occurring. Obtain one of the special Belling-Lee, or Bulgin fuses, and obtain one of the correct rating, which is .150 amps. On the transformer fitted to the speaker will be found three soldering points, and lengths of flex should be attached to these. The centre lead must be joined to the battery plug H.T. +, and the remaining two leads are then joined to the L.S. terminals on the receiver base-board. The inclusion of the lead to the centre terminal is most important, as the set will not work without this.

## Testing Out

Now, before switching on, turn the knob of the potentiometer half-way between its maximum and minimum positions, and set the reaction control so that the vanes of the condenser are all out. That will be with the knob turned to the left as far as it will go. The knob immediately above the reaction knob should also be set to a

mid-way position, although this control is not important at the moment. If you now examine the rear of the aerial-series condenser (above the potentiometer) you will see a small arm, which rotates with the control knob, and the knob should be set so that this arm is touching the lower contact on the condenser. In this position the condenser is short-circuited, and maximum signal strength (but minimum selec-

Note the tidy arrangement of the components.

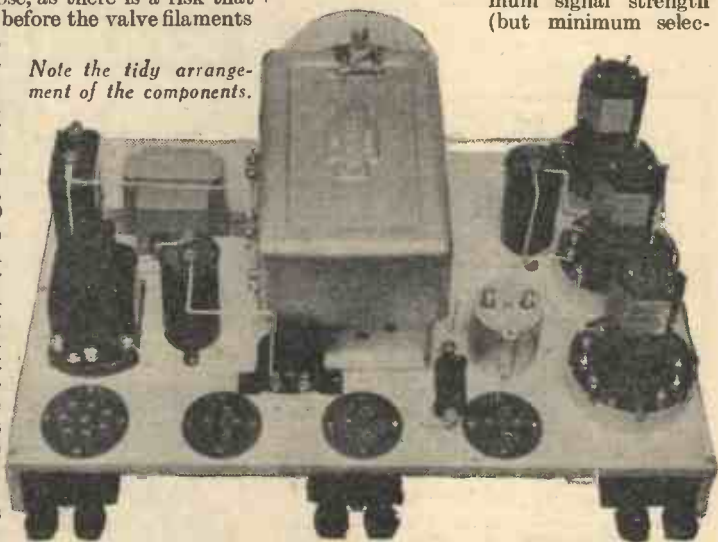

tivity) will be obtained. Now pull out the switch, and you should hear a certain amount of rushing noise from the loud-speaker. If there is no sound at all, rotate the reaction knob, and if nothing at all happens, switch off, as some connection is faulty, or the set is not correctly wired up. Check over, therefore, and get everything correct so that this rushing is heard when the switch is pulled out. Now rotate the dial until the wavelength corresponding to your local station is in line with the pointer, and you should hear the station

(Continued on page 201.)

## LIST OF COMPONENTS FOR THE BETA UNIVERSAL FOUR.

One Pair Telsen Band Pass Coils (Type W.290).  
One Telsen Single Matched Coil (Type W.216).  
One Telsen Three-gang Condenser with Disc Drive.  
One Telsen Aerial Condenser with shorting switch.  
Three 4-pin chassis-type valveholders, Clix.  
One 7-pin chassis-type valveholder, Clix.  
One .02 Dubilier fixed condenser, type 9200.  
One .001 Dubilier fixed condenser, type 670.  
One .002 Dubilier fixed condenser, type 670.  
One .05 Dubilier fixed condenser, type 9200.  
One 1 mfd. Dubilier fixed condenser, type BB.  
One .0002 mfd. Dubilier fixed condenser, type 670.  
One .1 mfd. Dubilier fixed condenser, type 9200.  
One 10,000 ohm spaghetti resistance, Lissen.

One 20,000 ohm spaghetti resistance, Lissen.  
One 30,000 ohm spaghetti resistance, Lissen.  
One Bulgin H.F. Choke, Type H.F.9.  
One Lissen standard H.F. Choke.  
One .0005 mfd. reaction condenser, Lissen.  
One Multitone Toco 1-4 L.F. Transformer.  
One Multitone Graded Potentiometer.  
One Benjamin Class B Driver Transformer.  
One Busco three-point switch with fuseholder.  
One Lewcos 20,000 ohm Potentiometer.  
One Becol Ebonite Panel, 15in. by 7in.  
One 1 megohm Lissen Grid Leak with wire ends.  
One Lissen 16-volt Grid Bias Battery.  
One Lissen 120-volt H.T. Battery.  
One Lissen 2-volt Accumulator.

One Rola Loud-Speaker, Type F.6/PM/O1/Class B.  
One 5-Ply Baseboard, 15in. by 10in.  
One Cabinet, Peto-Scott.  
One Coscor 220 VSG valve (metallized).  
One Coscor 210 Det. valve (metallized).  
One Coscor 215 P. valve.  
One Coscor 240 B. valve.  
Three Belling-Lee Terminal Mounts.  
Six Belling-Lee Type B Terminals (Aerial, Earth, Pick-up, Pick-up, Loud-Speaker, Loud-Speaker).  
One Belling-Lee Four-Way Battery cord.  
Three Wander Plugs, G.B.+ , G.B.1 and G.B.2.  
Sundry Screws, Fuse Bulb, Coil of Glazite, Flex, etc.

# A.C. TWIN

*The Grampian again the Designer's Selection*

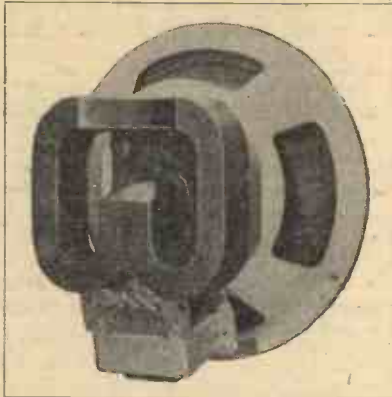

The Nipper  
Type P.C.2. Price 27/6

A MOVING COIL SPEAKER  
FOR EVERY SET TO  
SUIT EVERY OUTPUT

Grampian Speakers are used by wide world manufacturers, one of whom says: "The reproduction from the Loudspeaker is quite exceptional—no less than sheer delight."

*All Speakers are fitted with Multi-Ratio Transformers and are guaranteed for Two Years.*

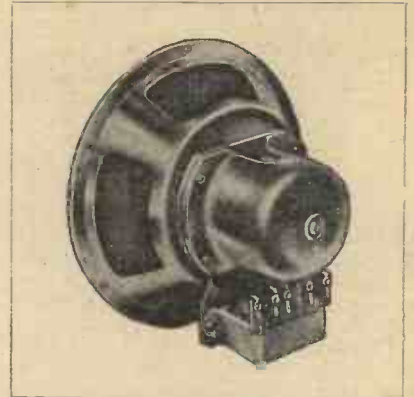

Specified for the "A.C. Twin."  
Type E.1. 2,500 ohms, 6" cone. Price 25/-  
Type E.8. 2,500 ohms, 8" cone. Price 37/6

Write for Catalogue K.1.

**GRAMPIAN REPRODUCERS LTD.**  
KEW GARDENS, SURREY

# A TRIUMPH OF PRECISION

● Gives extremely fine tuning. Similar in construction to the J. B. "NUGANG" Condensers, but the trimmer of front section is operated independently from the receiver panel by means of a second knob concentric with the main tuning knob. Rigid one piece chassis, very robust construction. Trimmer to each stage. Heavy gauge wide spaced aluminium vanes. Special bearings to rotor ensure permanent accuracy. Capacity .0005.

Matched to within  $\frac{1}{2}$  mmfd. plus  $\frac{1}{2}$  per cent.  
Complete with disc drive and bakelite escutcheon plate.  
2 gang - 18/6      3 gang - 27/-

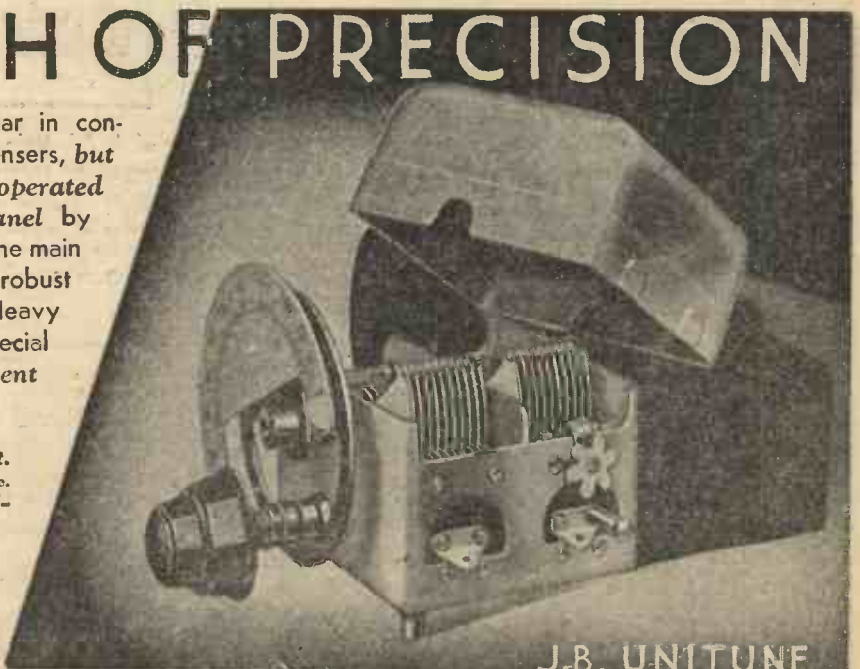

J.B. UNITUNE

**PRECISION INSTRUMENTS**

Write for Complete Catalogue.

Advertisement of Jackson Bros. (London) Ltd., 72, St. Thomas' Street, London, S.E.1.  
Telephone: Hop 1837.

**THE EDITOR RECOMMENDS this Simple Way of having Your Parts of "Practical Wireless" Bound in Convenient Volume Form.**



*The Bound Volume of "Practical Wireless."*

This illustration shows the exceptionally attractive style of binding case supplied. It is of Rich Royal Blue art book cloth, boldly lettered on the shelf and front side with Peerless Silver Leaf. These binding cases and semi-annual indexes have been produced for the convenience of the reader so that he can readily turn up the particular article to which he wishes to refer.

**FILL IN AND POST THIS ORDER FORM**

**TO-DAY**

with your copies of "Practical Wireless"

No. 1 (dated Sept. 24th, 1932) to No. 26 (dated March 18th, 1933).

To **A. W. BAIN & Co., Ltd.,**  
17-19, Bishop's Road,  
Cambridge Heath,  
London, E.2



Don't hesitate, don't delay—bound immediately, before copies are lost or damaged, "Practical Wireless" in convenient Volume form will find a place on your bookshelf ready for immediate reference at any time. Do not waste the money you have spent in purchasing your copies of "Practical Wireless" by omitting to have the first Volume bound in the Publishers' authorised covers. For utility, lasting service and good appearance these handsome binding cases in Rich Royal Blue Cloth with Silver lettering and design are ideal.

**IMPORTANT**

The Binding House of A. W. Bain & Co. Ltd., have arranged to receive and bind each volume of "Practical Wireless" in the Publishers' authorised Covers. Missing parts can be obtained at post free rates from the Publishers.

**URGENT**

So that you shall not miss this opportunity of having your parts bound at this special inclusive price, forward your copies (dated Sept. 24th, 1932, to Mar. 18th, 1933) of Volume One for binding TO-DAY, using the order form below.

**INCLUSIVE BARGAIN PRICE OFFER**

**The cost of the Case and Binding, including Title Page, fully cross-referenced Index and Return Carriage is 5'6.**

**ALL YOU HAVE TO DO**

Send your 26 copies, clearly marked with your name and address (use order form), to A. W. Bain & Co., Ltd., 17-19, Bishop's Road, Cambridge Heath, E.2, together with P.O. or cheque for 5/6.

Return carriage is paid on all orders in U.K. If parcels are not clearly marked, the binder cannot accept responsibility for delay or loss. Payments acknowledged and orders executed in strict rotation. Average time—three weeks.

To A. W. BAIN & Co., Ltd.,  
17-19, Bishop's Road,  
Cambridge Heath, London, E.2.

Please find P.O. (or cheque) attached for 5/6 to include cost of Cover, Binding, Title Page, Index, and Return Carriage for Volume I of "Practical Wireless" in Rich Royal Blue Art Cloth.

Name .....

Postal Order Address.....

No ..... enclosed.

Please cross / & Co/ .....

**BETA UNIVERSAL FOUR**

*(Continued from page 198.)*

if it is working. If not, rotate the potentiometer control, and also the reaction control, until you hear the station. Now carefully turn the series-aerial condenser knob and see if any increase in signal strength is obtained. If so, then the small star-wheel on the variable condenser nearest the panel should be carefully turned with a long, thin piece of wood. Now, with one hand holding the main tuning-knob, swing the condenser backwards and forwards over a few degrees, and at the same time rotate the other two star-wheels in order to gang the three circuits. This is a tedious business, but must be carried out carefully, if you are going to receive distant stations, as two or three degrees difference on two sections of the condenser will result in a weak station not being heard at all. The idea is to get the three wheels adjusted so that the movement of any one wheel, either forwards or backwards, results in a weakening of the station. When you have carried out this operation, turn the dial to a reading at the other end of the scale and try and pick up a station there, and see if any further adjustment is needed. If not, the receiver is ganged, and may be now installed in the position it is to occupy.

The method of handling all the knobs is really quite simple and should be carried out in the following manner. Suppose you wish to try and receive Rome. From Data Sheet No. 15, or other source, you see that the wavelength of Rome is approximately 441 metres. The first thing to do,

therefore, is to set the dial to give this reading. Now take the reaction knob in the right hand and the potentiometer knob in the left hand and turn the two together until you hear the station (if it is transmitting at the time). You will find that as the reaction is increased probably Stockholm also can be heard, but then by reducing the potentiometer setting the two stations will fade away. An increase of the reaction condenser will bring back the Rome station, but the Stockholm signal will be weaker. When these two controls have been juggled to get the very best, without oscillation, the Rome station should be received quite clear of interference. It may happen,

however, that you are situated in such a position, or your aerial is arranged in such a way that it is impossible to get rid of Stockholm. In this case, and in other cases where an interfering station cannot be got rid of, the following procedure is carried out. The reaction and potentiometer are adjusted for maximum results as just described, and when the best setting has been found the left hand should be transferred to the knob above the potentiometer, and this should be slowly turned anti-clockwise. At the same time, the reaction should be increased to make up for the loss in signal strength. If it is found that the condenser value has to be so reduced that the H.F. valve oscillates, the potentiometer should be turned back a degree or so. You will find, however, that these three controls may be handled quite easily, and it is possible to get most stations clear of interference. Naturally, the series-aerial condenser only requires adjusting when interference is experienced, and the reaction is only wanted when a distant station is required. When the station is received at its best, the tone control may be called into use to vary the reproduction, but it will probably be found that for most types of reception, the knob may be turned to a midway position, where it gives a practically uniform response. If a heterodyne whistle is heard or a soprano is screeching away, the top may be removed by turning the control towards one end. On the other end, if a violin lacks "bite," due to, perhaps, an excessive use of reaction, the knob may be turned the other way to remove some of the lower notes and give brilliance.

**BUILDING THE A.C. TWIN**

*(Continued from page 194.)*

length of twin flex to the filament terminals of valve-holder V.2 on the main base, connecting them also to the filament terminals on valve-holder V.1. Take a length of flex with red cotton covering and attach this to terminal No. 1 on the Varley choke and plait together the twin filament leads, this red-covered lead and the plain rubber lead which you attached to the .001 mfd. condenser. Pass them up through the slot on the right of the base and carefully slide the base into the cabinet. When right home, attach the two leads (from H.F. choke and R terminal on coil) to the terminals on the reaction condenser, and push the wave-change rod through the hole into the coil base. Attach the condenser knobs to the spindle.

**WEARITE COILS**

are SPECIFIED  
for the  
SUPERSONIC SIX

Again and again Wearite features as exclusive specification for Oscillator and I.F. Transformers in Superheterodyne Sets. The "Supersonic Six" uses Wearite. Only by following the designer implicitly can you obtain the results he intended—and the coils are the more important components.

BEFORE YOU START—SEND for BOOK No. G.N:

**The SPECIFIED COILS**

- 1 .011/8 Dual Range Oscillator with switch Price 10/6
  - 2 .0T2 Bandfilters .. Price 10/6 each
  - 1 .0T1 Bandfilter .. Price 10/6
- ALSO SPECIFIED
- 1 Wearite Q.V.C. Volume Control, 25,000 ohms .. Price 4/6

The WEARITE  
Centre-Tapped  
Frame Aerial

Suitable for the "Supersonic Six."  
Super Model (as illustrated) .. Price 42/-  
Popular Model .. .. .. 32/8



WRIGHT & WEAIRE LTD., 740, High Road, Tottenham, N.17. Telephone: Tottenham 3847-8-9

# RADIO RAMBLINGS

By JACE

*Gettings from my Notebook*

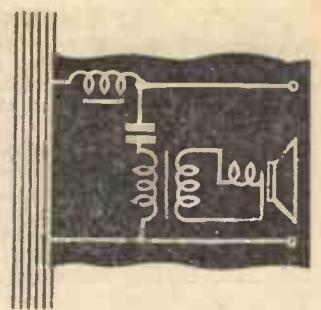
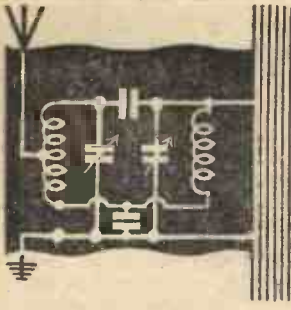

### H.T. Current and Volume

IT is surprising to find how mistaken ideas, especially in regard to wireless matters, manage to circulate so freely before they are corrected. I make this remark after being entertained to tea by some friends who have owned a battery-fed radio receiver for the past seven years. The "wireless" was switched on after tea and I was rather horrified at the very poor volume and "thin" tone. On tactfully making reference to this, however, I

The reason is that the ear is less responsive to both high and low notes, especially at low sound levels; as a result the "middle frequencies" are heard quite well, but the high and low ones can scarcely be detected. Under such conditions music seems to lack all "punch" and "vigour," so that most of the enjoyment in listening is lost. This effect is so noticeable that one or two American receivers are fitted with what is called an "Acoustically Compensated Volume Control." The name is something of a mouthful, but the principle of operation is perfectly simple and can easily be tried in any set fitted with a potentiometer volume control. A circuit diagram showing how the idea is applied is given in Fig. 1, where the extra components required are enclosed by a broken line. P is the usual potentiometer volume control and R is an additional variable resistance. When the potentiometer is set to "full volume" the tone compensating circuit has no appreciable effect, but it comes into play as volume is reduced. Since the choke and condenser "tune" to the middle frequencies they allow these to "leak away" to a certain extent and emphasis is thus given to the higher and lower notes. By experimenting with the setting of resistance R a position can be found with which the tone is automatically balanced for any setting of the potentiometer. You might care to try this idea for yourself if you have the necessary parts on hand.

side by side with the set instead of being above or below it as is more usual; this gives a particularly pleasing and business-like appearance.

### The 1933 Portable

TALKING of summer time and portables reminds me that I have not yet finished working out the final design for my 1933 model (portable, I mean). This I am sure of, it will have "Class B" L.F. amplification and in all probability one of those small permanent-magnet moving-coil speakers. I would also very much like to use Ferrocart coils because of their high efficiency and compactness, but at the time of writing I understand that they are only available in sets of three, whereas only one, or possibly two, would be required. A portable designed on the above lines and fitted with an H.F. pentode should make an almost perfect outfit for, unlike most sets of this type, it would provide really ample volume for open-air and picnic use. I am afraid it would be rather on the heavy side, but it need not be much worse in this respect than many

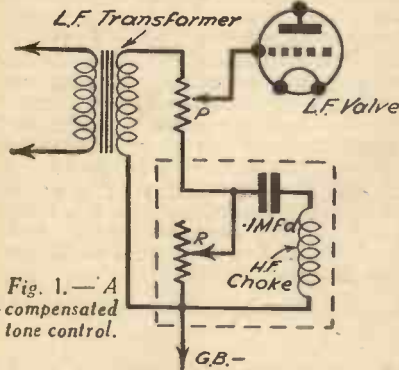

Fig. 1.—A compensated tone control.

was told that the set was certainly capable of much better things but that the batteries were rather low and might not last the night out if the volume was turned full on. It was a little difficult to see the meaning of this statement at first, but I gathered that my host was under the impression that the set's current consumption depended upon the signal strength obtained from the loud-speaker.

The time was not an opportune one for correcting this wrong impression, but if by chance any new readers are under the same misapprehension I would like to emphasize the fact that, with most sets at any rate, the consumption of either H.T. or L.T. current is scarcely affected by the volume of reproduction. The only slight difference which does occur is that the H.T. current to a leaky-grid detector falls as the signal strength applied to it is increased. Thus when the programme is made louder by increasing reaction the set consumes rather less H.T. current than otherwise.

When a variable-mu valve is employed the H.T. current consumption certainly does rise when volume is increased by reducing the V.-M. grid bias, and in that case there is some justification for keeping down the volume in the interests of economy. The same thing applies to a set using a Q.P.-P. output stage—H.T. current consumption is then almost proportional to the volume level.

### Compensated Volume Control

THIS reminds me of another effect of reducing the loud-speaker volume below certain limits. You have probably noticed yourself that when the strength is turned down "quality" becomes worse.

### S.W. Superheterodynes for the Colonies

IN view of the previous references on this page to the dearth of battery-operated S.W. superheterodynes suitable for Colonial listeners, it is interesting to note that two such instruments have recently been put on the market by two well-known firms. Both of these instruments are exceptionally well made and specially designed for the conditions under which they are likely to be used. One model has a zinc-plated chassis which is proof against all climatic variations, whilst both employ a special insulating material for the coil formers, etc., which has been found to withstand the disintegrating effects of heat and humidity.

The other set is interesting in that it has a built-in moving-coil speaker arranged

of the sets which are already very popular. It would at least be trans-portable and could easily be carried into the garden or stowed in the car.

### A Suggestion for a Lightweight Portable

THIS brings us back to the old question: "When is a portable portable?" I must confess that I do not know of any set on the market which I should care to carry for more than a few hundred yards—at least, not for pleasure. But I have just rigged up a simple two-valve receiver which I think could be made up in portable form at an inclusive weight of 16 pounds or so. It uses a pentode detector, followed by a pentode output valve and really does give quite good loud-speaker volume up to 30 or 40 miles of the Regional stations when used on a small frame aerial. Should

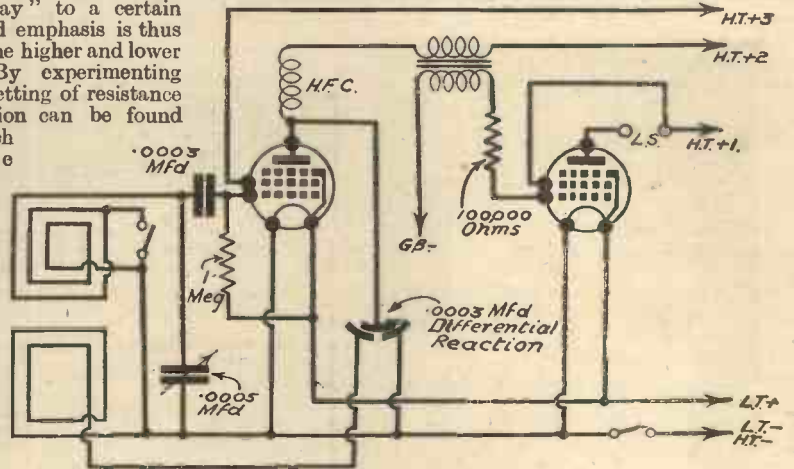

Fig. 2.—A novel portable circuit.



you care to try this excellent arrangement for yourself I give the circuit diagram in Fig. 2. As can be seen, it is straightforward enough and entirely devoid of "frills." The frame aerial contains two windings, one for tuning and the other for reaction, and is wound in the manner described on page 950 of PRACTICAL WIRELESS No. 20. Three separate H.T. tappings are provided to save the necessity for decoupling resistances and condensers; these should receive voltages approximately as follows: "H.T. +1," 100 volts; "H.T. +2," 70 volts and "H.T. +3," 30 to 50 volts. Using two pentodes of the high efficiency type (such as Cossor 220 HPT) the total H.T. current consumption is only about 6 milliamps and can economically be derived from the smallest size of high-tension battery.

**Detector Overload**

**I** DARESAY that very much of the distortion found in the average S.G.—D.P. receiver is due to the detector valve being overloaded, and yet this source of trouble is very rarely suspected. The point is that if a power valve is to be fully loaded the detector must supply a large output or else be coupled through a fairly high ratio transformer. When the transformer is not of high step-up the detector is liable to overload long before the power valve. If the latter fault is suspected it can be checked fairly easily by tuning in a foud station and observing the effect of increasing and decreasing reaction; if this makes practically no difference you can be fairly certain that overloading is taking place. The cure is to fit an aerial-input volume control or to increase the detector H.T. voltage. Maximum volume will naturally be reduced when the former method is employed, but it can be brought back to its previous level by using a higher ratio L.F. transformer or changing over to resistance-fed transformer coupling.

**Excessive Oscillation**

**E**VERYONE who handles a wireless receiver should be able to recognise the signs of self-oscillation, as H.F. instability is still the most fruitful source of trouble in receivers with H.F. amplification.

For instance, in some cases, when the potentiometer volume control of a set is advanced to "maximum" the signal strength drops considerably. This is almost a certain indication that, when loading is removed from one of the tuned circuits, the H.F. valve passes into a state of violent self-oscillation, with the probable result that the succeeding detector-grid circuit is choked.

**Summer-Time Reception Conditions**

**W**ITH the advent of "Summer Time" we can expect to find conditions for long-distance reception considerably worse than they have been during the last few months. I give this timely hint because about this season every year for the last decade I have been inundated with questions such as "What can be wrong with my set? I used to be able to get scores of foreign stations and now I can hear nothing of them." If this is your present trouble I can only make three suggestions. One is that you add an extra H.F. valve, another is that you build a new set specially designed for long-distance reception (you can't beat the "Fury Four") and the third is that you try the short-waves.

**BUY THE  
RESISTANCE  
OF  
PROVED  
PERFORMANCE  
TEMPERATURE**

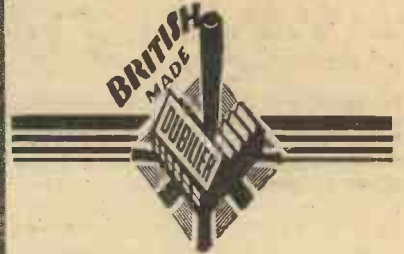

**DUBILIER TESTS**

**COEFFICIENT**

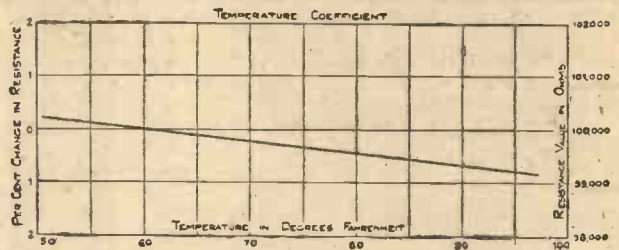

For every one degree centigrade rise in temperature the change in resistance value of a Dubilier resistance is only .04%. The small effect of this change in the resistance value under normal working conditions is emphasised by the curve shown herewith, the right-hand scale of which gives the actual resistance values of a 100,000 ohm resistance at various temperatures; while the left-hand scale gives the average percentage changes.

Dubilier resistances are made according to value and rating to cover every requirement—insist on Dubilier make when buying resistances and be certain of absolute satisfaction.

Have you seen the new Dubilier Component Booklet, "Choosing your Resistances and Condensers"? Ask your dealer for a copy or write to us.



1 watt type 1/-, 2 watt type 2/-, 3 watt type 3/-

**DUBILIER  
METALLISED  
RESISTANCES**

DUBILIER CONDENSER CO. (1925) LTD.,  
Ducon Works, Victoria Road, North Acton, London, W.3.

# A Great NEW Valve

New principles of construction have made possible the HIVAC Valves at specially low prices—from 4/6 upwards.

There is a HIVAC Valve for every wireless requirement which will save you money and give you longer service.

Write to us for our Comparative Valve Guide and state the set you have or the set you propose to make.

ALL HIVAC VALVES ARE BRITISH MADE



Telephone CLERKENWELL 7587

The HIGH VACUUM VALVE CO. LTD.

113-117, FARRINGDON R.  
LONDON, E.C.



## ADDING A VALVE TO YOUR SET

(Continued from page 178.)

already employed. If it is a det. and 2 L.F. circuit, then the most obvious addition is a screen-grid stage. The only exception might be in the case where the receiver was used chiefly for local reception and gramophone records, from which extra volume was required, when the extra valve could with advantage be used in push-pull with the existing output valve.

With the S.G.-det.-pentode type of receiver, the position of the additional valve is not quite so obvious. As with a two-valver, there are again two possible positions, namely, before and after the detector. However, there are certain difficulties which would not be met with in the case of the two-valver. These are chiefly connected with the pre-detector arrangement. First of all, the addition of another screen-grid stage would make the input to the detector rather large, with the consequent risk of overloading it on the loud stations. There are two ways of avoiding this. One is to use a variable-mu valve as the additional amplifier so that large inputs can be reduced by using the usual grid bias volume control employed with these valves, and the other is to adjust the working characteristics of the detector so that it will handle larger signals than with the normal arrangement. This is, of course, power grid detection and consists of using instead of a 2 meg. leak and .0003 mfd. condenser, a .25 or .5 meg. leak and a .0001 mfd. condenser, together with a high anode voltage.

If there are already three tuned circuits in the set, namely, band-pass input and a tuned intervalve circuit, then another tuned H.F. stage is unlikely to be necessary except in the very worst cases of interference and will in any case add to the tuning difficulties, so that the best use for the extra valve is either as a choke-coupled H.F. amplifier between the present S.G. valve and the detector, or as an extra L.F. amplifier. In the former case it will add to the sensitivity of the receiver and also assist the ganging, since the third tuned circuit will now form the grid circuit of the new valve instead of that of the detector. The removal of the damping imposed on this circuit by the detector will mean sharper tuning and better ganging.

### Pros and Cons

On the face of things the inclusion of the additional valve after the detector has much to recommend it. For instance, there is no likelihood of H.F. instability, there is no need for extra tuning and no possibility of detector overload. On the other hand, however, adding an L.F. stage, either R.C.C. or transformer coupled, means replacing the pentode output valve with a power or super power type. To retain the pentode as the last valve would mean overloading it. Again the additional L.F. stage would most likely call for extra decoupling, especially where the high tension current is derived from the mains.

A method of adding an extra L.F. valve which will appeal to many, especially those using battery sets from which a large undistorted output is desired, is to connect it in push-pull with the existing pentode, as suggested for the two-valver. Of course, there will be the added expense of the necessary push-pull transformers or chokes, but against this must be reckoned the fact that only one extra valve will be needed and no extra decoupling. Of course the push-pull method is not confined to pentodes. Triodes may be used equally well.

## A Complete Range KNOBS

**MATCH UP!**  
... that odd assortment of knobs on your panel by making a selection from our range.

**POINTER KNOBS**  
Black.  
K.3. 1 1/2" dia. x 3-16" bore 6d.  
K.4. 1 1/2" " x 1/2" " 6d.  
K.5. 1" " x 3-16" " 4 1/2d.  
K.6. 1" " x 1/2" " 4 1/2d.

**WALNUT KNOBS**  
K.11. 1 1/2" dia. x 3-16" bore 6d.  
K.12. 1 1/2" " x 1/2" " 6d.  
K.13. 1" " x 3-16" " 4 1/2d.  
K.14. 1" " x 1/2" " 4 1/2d.

**OCTAGON KNOBS**  
Black.  
K.7. 1 1/2" dia. x 3-16" bore 6d.  
K.8. 1 1/2" " x 1/2" " 6d.  
K.9. 1" " x 3-16" " 4 1/2d.  
K.10. 1" " x 1/2" " 4 1/2d.

**RIBBED KNOBS**  
Black.  
K.15. 1 1/2" dia. x 3-16" bore 4 1/2d.  
K.16. 1 1/2" " x 1/2" " 4 1/2d.

**ARROW LINE**  
Black.  
K.17. 1 1/2" dia. x 3-16" bore 4 1/2d.  
K.18. 1 1/2" " x 1/2" " 4 1/2d.  
Delivery ex. stock.

**BULGIN**  
SEND FOR 80 PAGE CATALOGUE & MANUAL  
Enclose 2<sup>d</sup> Postage.  
(Dept. N)  
A. F. BULGIN & Co., Ltd.,  
ABBEY ROAD, BARKING, ESSEX.

## EASY TERMS

Everything Wireless supplied on lowest terms.  
Prompt Delivery Guaranteed.  
Price List Free on request.

**JUST RELEASED**  
New Lissen All-Electric Sky-scraper Kit. Complete Kit, incl. valves, for building this outstanding new receiver.  
Cash Price £7/19/6  
And 11 monthly payments of 14/4.  
Lissen Sky-scraper, Battery Model.  
Cash Price £4/9/6.  
And 11 monthly payments of 8/6.

With order **14/4**  
With order **5/-**

**NEW BLUE SPOT UNITS**  
inst. released by the manufacturers.  
NEW BLUE SPOT 99 P.M. MOVING-COIL UNIT.  
Cash Price £2/19/6  
And 11 monthly payments of 5/6.  
NEW BLUE SPOT PERMANENT MAGNET MOVING-COIL SPEAKER 29 P.M. With input transformer.  
Cash £12/6.  
Balance in 6 monthly payments of 5/2.  
NEW BLUE SPOT PERMANENT MAGNET MOVING-COIL SPEAKER 45 P.M. With input transformer.  
Cash £2/8/0.  
Balance in 9 monthly payments of 5/- only.

With order **5/-**  
With order **5/-**  
With order **5/-**

ATLAS ELIMINATOR A.C. 244. Three H.T. tappings. 20 M/A output.  
Cash Price £2/10/6.  
And 11 monthly payments of 5/6.  
All carriage paid. Quotations sent by return.  
(Dept. P)

With order **5/-**

**The LONDON RADIO SUPPLY COMPANY** ESTD 1925  
11, Oat Lane, Noble St., LONDON, E.C.2  
Phone NATIONAL 1977

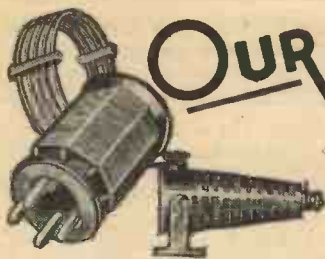

# OUR SHORT WAVE SECTION



SHORT-WAVE work has always excited a great deal of interest, and in many people a sort of awed wonder, by reason of the remarkable long-distance reception that is possible with quite reasonable consistency, and since the opening of the new Empire transmitters it has been more in the limelight than ever. Incidentally, it is curious that, since short-distance signals are seldom strong on short waves, the new Daventry transmitters should have caused such a burst of activity in this country, since they will probably be heard worse in England than in Dominions five thousand miles away! In spite of their possibilities, however, many people fight shy of short waves for no better reason than that they believe them to be "tricky sort of things," as they put it, having the impression that anything under 200 metres cannot possibly obey the same laws as govern the action of longer waves. Yet these same people will cheerfully tackle the construction of a super-het., complete with band-pass tuning, provided that there is no suggestion of short waves about it! Personally, I would never think twice about building an ordinary short-waver, but the complications of ganged tuning and band-pass filters on ordinary broadcast waves do cause me to "gang warily," literally as well as figuratively!

At the same time, one is bound to admit that a certain percentage of those bold enough to try short-wave work do find it tricky, and in some cases give up in despair. It is my purpose in this article to diagnose one of the principal causes of this complaint and prescribe a remedy. Before going on to specific circuit details, let me mention one or two effects that occur in short-wave work and are responsible in part for its reputation for devilry. In the first place, the signal strength of any station working on short waves will vary enormously more during a period of twenty-four hours than it would if the station was operating on either the 2,000 or the 200-550 metre band.

### Elusive S.W. Transmissions

Consequently, if, say, W8XK is heard R8 on its 19-metre transmission when the set is first tested one Saturday afternoon and later the set is tried on the same station in the evening, the listener will almost certainly blame the receiver, valves, batteries, and general perverseness of short waves, severally and collectively, when he finds not so much as a whisper of the American, although he knows that he is on the air. And yet this is quite in order, at any rate, in the winter, when the fade-out may occur as early as four o'clock in the afternoon, although in the summer the same station may be audible at midnight. Then again, not only is there a very great daily variation in signal strength, but conditions for reception vary much more from week to week and month to month on short waves than on

## SIMPLIFYING TUNING ON THE SHORT WAVES

A Practical Article Explaining the Band-Spread System and How to Improve Reception.

By K. E. BRIAN JAY

long, so that while one week you may be able to listen day after day to a certain station, a week later you can hardly hear him, even at the most suitable time of the day. As an example of this, quite recently

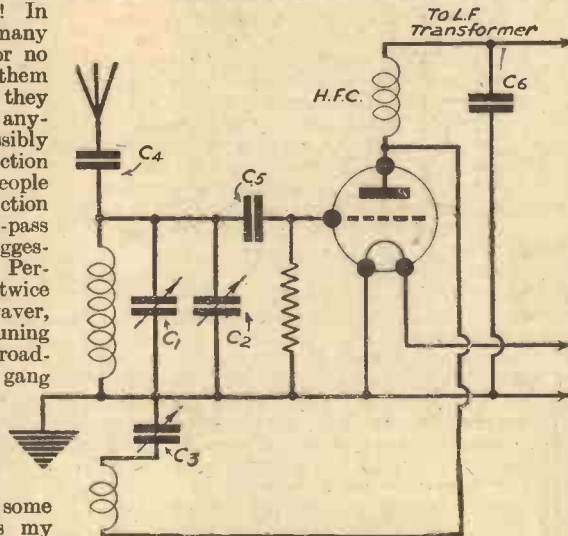

Fig. 1. Circuit.

American amateur transmitters were audible on the 40-metre band as early as 6.30 in the evening, and by nine o'clock there were so many that it was difficult to separate them enough to read their call-signs; but a week later, on listening at 9.30 p.m., not a single one was heard; the band was as quiet as a graveyard.

It is effects like these, then, that give short waves their name for trickiness, although actually, the same thing happens to some extent on long waves, but because, generally, one does not listen to stations more than a few hundred miles away, the variations are not so noticeable. Unfortunately, however, many constructors and designers add to their difficulties by a wrong choice of apparatus in their receivers, and especially is there a tendency to choose a variable condenser for tuning that is much too large for the job. Let me illustrate what I mean.

A certain, commercially-produced, dual-range short-wave coil is supposed to cover, approximately, from 19 to 80 metres on the two ranges, when used with a .0003 mfd. variable condenser. By way of a test, a few rough measurements were made on the lower range of one of these coils, using a .0003 mfd. condenser, and it

was found to cover from rather below 19 metres to 50 metres, approximately. Superficially, this seems very nice; most of the principal stations lie in this range, and the rest are covered by the long-wave winding, the total range appearing to be quite small compared with the usual 200 to 550 metres. But let us compare these ranges, not in terms of wavelengths, but of frequencies. Take the 200 to 550 metres band; this, in terms of frequency, is from 1,500 kilocycles to 545 kilocycles, i.e., a range of 955 kilocycles. Now 19 metres is the same as 15,790 kilocycles, and 50 metres as 6,000 kilocycles; that is to say, the short-wave range is equivalent to 9,790 kilocycles, over ten times as great as the range of the broadcast band. In short, tuning on the short waves will be ten times as sharp as tuning on the long waves. Suppose, on the long waves, you use a slow-motion dial with a ratio of 10 : 1, by no means a high ratio for comfortable tuning; in order that tuning shall be equally easy on short waves, a ratio of at least 100 : 1 will be needed, and only a very good dial will provide this ratio without backlash. Furthermore, even if such a dial is obtained, tuning will be a very weary process, because broadcasting stations are not distributed evenly over the whole band as on long waves, but are in little groups placed at intervals. Consequently, although a high ratio will be needed when a group is reached it will be a great nuisance when tuning from one group to the next.

### Reception of Amateur Transmissions

This trouble arises in a very much more acute form in the reception of amateur transmissions which take place in very small bands of frequencies, the most popular being from 7,000 to 7,300 kilocycles and 14,000 to 14,400 kilocycles. Consider, for example, the case of anyone chiefly interested in amateur transmissions on the latter band. This band lies in the 19 to 50 metre range of our coil, and was found actually to occupy little more than 5 degrees on the dial, into which space there may be crowded as many as a hundred stations all working together, a prospect calculated to appal the most expert operator!

A similar state of affairs would exist on any of the other bands and clearly something has to be done about it. The simplest thing to do is obviously to use a smaller variable condenser, but this alone is not sufficient to spread each band over 180 degrees of the dial, and so various methods of band spreading have been devised. Of these only one is of interest to listeners to short wave broadcasting stations, because all the others require the use of plug-in coils, or tapped coils of non-standard sizes, and their band spreading is so effective that the frequency range is more limited.

(Continued on page 206)

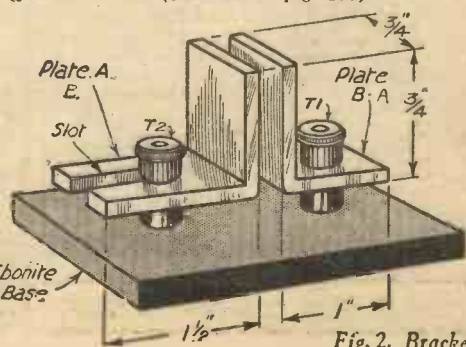
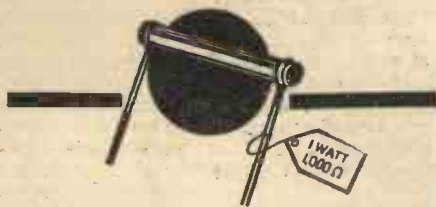

Fig. 2. Bracket



SPECIFIED again & again  
ESSENTIAL for SAFETY

# ERIE RESISTORS

NECESSARY for the  
"A.C. TWIN"

Notice how Erie Resistors are specified for one set after another. That's because they are indispensably safe—positively Guaranteed against breakdown! Seven of them are essential for the "A.C. Twin." You need them for every set. They save money too!

**1/-** PER WATT IN ALL VALUES  
50 ohms to 5 megohms, in  
1 to 5 watts. Tag identified  
and colour coded.

At all dealers. Ask firmly for Erie  
Resistors. WRITE FOR LEAFLET  
AND COLOUR CODE CHART.

THE RADIO RESISTOR CO.

1, Golden Square, Piccadilly Circus,  
London, W.1.

## EASY TERMS PROMPT DELIVERY

Any Amplion, Blue Spot, Baker, Celestion, Epoch, R. & A. Rola, Sonochorde, or W.B. Moving Coil Speaker supplied.

Send 5/- only

and pay the balance by monthly instalments. No references. Entirely private and confidential.

KITS, PARTS, SETS, ELECTRIC CLOCKS ON EASY TERMS.

Write for Catalogue and details to:

TURNADGE & PARTNERS, LTD.  
Ludgate House, Fleet Street, London, E.C.4.  
Telephone: Central 1903.

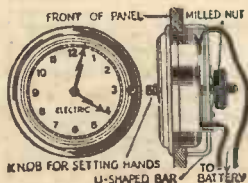

## FIT THIS ELECTRIC CLOCK

TO YOUR SET!  
NO MAINS NEEDED!  
KEEPS CORRECT TIME!  
NO WINDING!

Works off small battery lasting 12 months, or can be plugged into G.B. battery without affecting reception. Uses practically no current. Fits into hole 3/4 in. dia. in any panel up to 1/2 in. thick. Easy to fix—no screws required. Only 1/2 in. from front of panel to back of case. Swiss movement. Hands set from front. Nickel-plated bezel. Useful addition to any set.

RIVERSIDE MFG. Co., Ltd.,  
Dept. 21, Crisp Road,  
Hammersmith, W.6.  
Telephone: Riverside 6392.

**12/6**

COMPLETE WITH BATTERY

POSTAGE 6D

Genuine AMPLION Units. Limited number. Over 75 per cent. reduction. Guaranteed. To clear, 2/3 each, carr. paid.—G.E. Pioneer Radio, Copth St., W.C.1.

## SHORT WAVE SECTION

(Continued from previous page.)

### Band Spread System

The method referred to is absurdly simple and consists merely in using two variable condensers in parallel, one being smaller than the other. These condensers are marked  $C_1$  and  $C_2$  in Fig. 1, and may be respectively .00005 and .0002 mfd. capacity;  $C_1$  should never be more than .00005 mfd., but  $C_2$  should be chosen so that the total capacity of the two condensers together is equal to that recommended by the makers of the coil. Thus, for example, if the wavelength range of a coil is specified as being obtained with a .0002 mfd. condenser,  $C_2$  should be .00015 mfd. when  $C_1$  is .00005 mfd.  $C_1$  is the main tuning condenser, but because of the band spreading effect a slow motion ratio of no more than 16:1 is quite satisfactory.  $C_2$  is called the band spreading condenser and need not be fitted with a slow motion dial at all.

Before describing the *modus operandi* of this band spread system (not to be confused with band pass) let me say a word in answer to those who may think, and say, that this is a lot of fuss about nothing, and the same effect could be obtained merely by using a smaller condenser. Within limits this criticism is justified, but let us consider a concrete case. Using the same coil a .0001 condenser was substituted for the .0003 mfd. instrument and the frequency range was now found to be from 15,790 kilocycles to about 8,000 kilocycles (37.5 metres). We have, therefore, lopped about 2,000 kilocycles off the range, which is a little help, though not very much, but has introduced the further complication that we shall need at least one extra coil to tune down to our previous lowest frequency of 6,000 kilocycles. On the longer wave range the difference would be a little greater, but still not very much better, and another extra winding would be required. We shall, incidentally, find that the amount of spread available on  $C_1$  will be greater the longer the wavelength, that is to say that stations will be more crowded on the dial of the small variable condenser on the shortest wavelengths than on the longest. In this respect  $C_1$  might well be as little as .000025 mfd. on 20 metres, but this capacity would be found inconveniently small on 50 metres; the size suggested is therefore in the nature of a compromise.

The band spread system is quite simple in use.  $C_1$  is set to the middle of its scale and  $C_2$  is tuned until a station is heard; fine tuning is then completed on  $C_1$ . Since the broadcast stations are grouped together at intervals over the short-wave spectrum several other stations will be found nearby and tuned in on  $C_1$  only, and the much greater ease of tuning will be at once appreciated. Even with a band spread arrangement, however, always obey the golden rule in short-wave reception and tune slowly. When each group of broadcasting stations has been located the dial reading for  $C_2$ , which places the centre of the group in the middle of the dial of  $C_1$ , should be noted so that the receiver can be retuned quickly to any group. This is another point in favour of the band spread arrangement, since each group can be found quickly without the laborious dial twisting which the use of a high ratio dial involves in getting from one reading to another some distance away.

As a matter of fact, with a modification of this method I have been able to use an ordinary direct drive dial on both condensers quite comfortably down to 18 metres.

### S.W. Station Groupings

The principal groups of broadcasting stations on short waves are located at:—

- from 17,750 to 17,780 kilocycles, or 16.90 to 16.87 metres.
- from 15,075 to 15,330 kilocycles, or 19.90 to 19.56 metres,
- from 11,180 to 11,905 kilocycles, or 26.83 to 25.20 metres
- from 9,500 to 9,860 kilocycles, or 31.58 to 30.43 metres
- from 6,000 to 6,667 kilocycles, or 50.00 to 45.00 metres

with a number of odd stations scattered between them and on wavelengths up to 80 metres (frequencies down to 3,750 kilocycles).

### Condenser Capacities

Now a word about the kind of condensers to use. The points to look for in any short-wave tuning condenser are rigidity of bearings and frame, small physical dimensions, absence of dielectric material, good, well-insulated pigtail connection, smoothness of action, and low minimum capacity with reasonably well-spaced vanes. If you do not possess a .00005 mfd. condenser for  $C_1$ , try reducing the size of one you have by you. Remember, double spacing reduces the capacity to one-quarter of its nominal maximum, since you are both doubling the spacing and halving the number of plates; if plates are removed and the spacing kept the same, the approximate resultant capacity will be:—

$$\text{Original maximum capacity} \times \frac{\text{Number of plates left in}}{\text{Original number of plates}}$$

For  $C_2$  any good air dielectric condenser can be used, and in order to save panel space midget condensers may be preferred; this condenser should be mounted close to  $C_1$ .

In choosing the reaction condenser  $C_3$ , the chief thing to look for is, as before, good bearings, in order that the condenser shall be noiseless. For this reason air dielectric instruments are preferable to the small bakelite or mica dielectric type. The capacity may be from .0001 to .0003 mfd., and a slow-motion dial with a high ratio, say, about 8:1 is helpful, but not essential.

With regard to the other condensers in the diagram there are a few points worth noting. The aerial series condenser  $C_4$ , for example, must be quite small, or the damping of the grid circuit will be so great as to prevent the receiver from oscillating. Quite often even a .0001 mfd. pre-set condenser has too large a minimum capacity for use here, since actually something of the order of .00001 mfd. is required. A semi-variable condenser suitable for this position can be made very easily from two 1/4 in. or 1/2 in. wide strips of brass or aluminium in the manner indicated in Fig. 2.

The grid condenser  $C_5$  should be smaller than the standard value of .0003 mfd. used with leaky-grid rectification; .0001 mfd. is ample for  $C_5$ , and it should preferably be of small physical dimensions. The value of the grid leak may often be increased to five megohms or more with considerable improvement.

(Continued from page 190.)

light systems will be among the first to appear. For the sake of economy in low tension supply, a single cathode will be employed and will be shared in common by all the elements of the valve. For the diode portion—whether one or two diodes are incorporated—the anode for each will consist of a metal ring or rectangle surrounding but not touching the cathode. Above the diode anodes a metal screen will be fitted, to shield the triode portion from the diode. The amplifying section of the valve will consist of a grid and anode, arranged very similarly to the electrode system of the ordinary indirectly-heated three electrode valve. Those valves in which the amplifying element is of the four electrode variety will have, of course, two grids instead of one. Some little uncertainty recently existed, also, regarding the type of valve base which will be employed. It now appears that seven terminals are required for each valve, and how the pins are arranged was shown in last week's issue.

There are several different ways in which valves of this type may be employed, and some of these are indicated below. It is, of course, not possible at present to give full practical circuits, as the actual characteristics of the valves have not yet been published. As the double-diode-triode type of valve seems the one most likely to be adopted, the diagrams reproduced in Figs. 6 and 7 refer to this class of valve.

**Fundamental Circuits**

In the first diagram, the valve is employed as a full wave rectifier and a low frequency amplifier. The drawing is self explanatory and it is easy to trace the detector arrangement and the way in which the combined output of the two diodes is led to the grid of the amplifying portion. Possibly a more useful way of applying the double-diode-triode, however, is that shown in Fig. 7, where only one of the diodes is employed for detection (as a half wave rectifier). The second diode is used for applying the automatic gain control or volume control biasing voltage to previous high frequency stages fitted with variable-mu valves. Several variants of this automatic volume control

circuit are possible, some of which are capable of adjustment so that a delayed action occurs, whereby no extra biasing voltage is applied to the variable-mu valve or valves until the signal has reached a predetermined minimum strength. In another circuit the triode portion also plays a part in the automatic volume control, for the biasing voltage itself is amplified so that a small variation in signal strength will give a comparatively large control voltage.

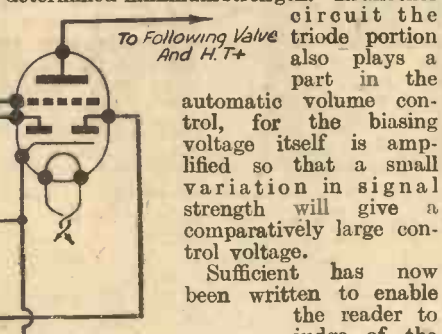

Fig. 6.—Fundamental circuit for using double-diode-triode as full-wave detector and L.F. amplifier. For the sake of clearness all decoupling components have been omitted.

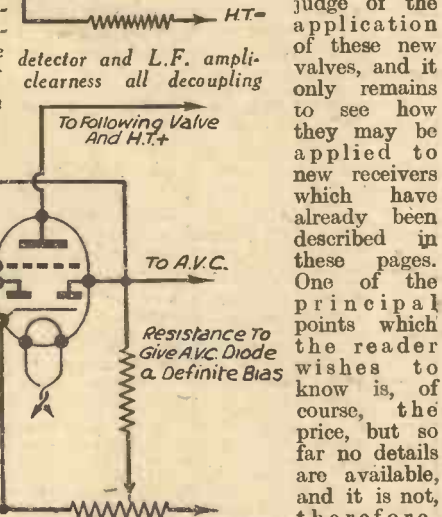

Fig. 7.—Fundamental circuit for using double-diode-triode as half-wave rectifier, L.F. amplifier and delayed automatic volume control valve.

is hoped, however, that the valve manufacturers will see their way to produce these valves cheaply.

**HANDY BOOKS FOR HOME CONSTRUCTORS**

By **F. J. CAMM**  
(Editor of "Practical Wireless.")

**Twenty-five Tested Wireless Circuits.**  
**Accumulators: Charging, Maintenance and Care.**  
Each 98 pages, fully illustrated, 1/- each or 1/2 post free.

**Modern Wireless Sets and How to Make Them.**  
80 pages 6d. or 7½d. post free.

**Make Your Own Wireless Set.**  
80 pages 6d. or 7½d. post free from:

**Geo. Newnes, Ltd., 8-11, Southampton Street, Strand, W.C.2.**

**FOR BETTER RECEPTION WITHOUT INTERFERENCE**

The selectivity of every set can be improved by fixing a PIX in the aerial lead-in. Even if a pre-set aerial condenser is fitted inside the set, a PIX will give better and sharper tuning. With a PIX in your aerial you can cut out the local station and get foreign concerts.

**2/- WITH CLIP 2/9**

Why suffer the inconvenience of dual and mixed programmes; fix a PIX and separate them and enjoy pure reception. A PIX can be fitted to any set, crystal, battery, or all mains, and will improve the reception of any set. No skill is required to fix a PIX. For 2/- any set can get super-het selectivity. From your local dealer, or send postal order to manufacturers:—

**OVER A MILLION AERIALS LEAD DOWN TO A PIX**

**FIX A PIX IN YOUR AERIAL**

The British Pix Co., Ltd. (Dept. 504), 118/28, Southwark Street, London, S.E.1.

**SET CRACKLING IS ANNOYING!**

**IF IT'S YOUR SWITCH**

**FIT THE "BUSCO" SWITCH**

**1/0**

each 1/3 Post Free. Patented.

and ensure perfect switch contact! There is no contact point to turn round, and when you "switch on" you have contact like a power switch. They are as cheap as the inferior type, but far superior in operation.

From your local dealer or **BUSBY & CO., LTD. (Patentees)** Dept. P.W., PRICE ST., BIRMINGHAM

**M.P.R. BATTERY CHARGER**

Send for particulars of complete Charging Equipment for A.C. Mains to charge 100 2-volt Cells weekly.

**Price £4:4:0**

**MAINS POWER RADIO LTD., ROMFORD, ESSEX**

**LOUD SPEAKERS REPAIRED 4/-**  
(Blue Spot a Speciality, 5/-)

Transformers 4/-, all repairs magnetised free. Eliminator Repairs quoted for. 24 Hours Service. Discount for Trade. Clerkenwell 9069.

**E. C. MASON, 44, EAST ROAD, LONDON. N.1.**

**THE IMPROVED "TONIC"**

self-generating trickle-charger kit keeps 2-volt accumulators fully charged. Electric mains and charging stations unnecessary. Ideal for remote places. 7/- each, postage 9d. Particulars, testimonials, with pleasure.

**WILLIAMS, Netherend, Cradley, Birmingham.**

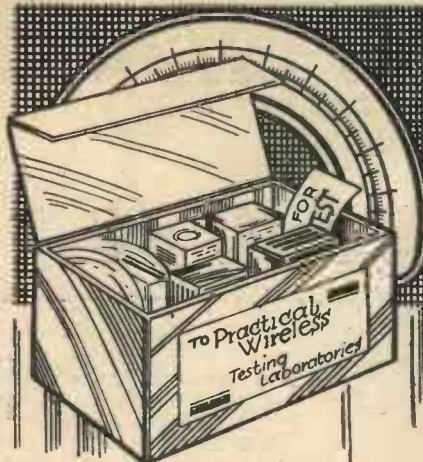

**BULGIN HETERODYNE WHISTLE FILTER**

THE filter illustrated is of great value where the annoying whistle which accompanies some transmitting stations is so marked as to spoil reception. There are many whose hearing prevents them noticing the higher notes in the musical scale, but to others, especially in the younger generation, the heterodyne whistle can prove a real nuisance. The inclusion of a filter in the circuit results in all frequencies above a

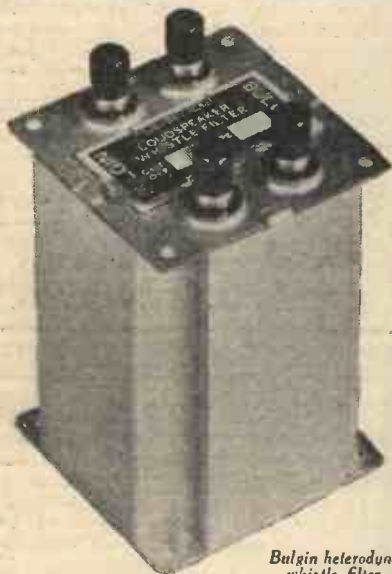

Bulgin heterodyne whistle filter.

certain value being cut off, and Messrs. Bulgin have developed two different types of filter, one cutting off at 3,250 cycles and the other at 4,750. As the normal moving-iron loud-speaker is not so sensitive at the higher parts of the scale the former is recommended for use with that type of speaker, whilst the latter should be used on receivers employing moving-coil loud-speakers, and having circuit arrangements which do not cut off the top notes. The now standard Bulgin universal type of case is used for the filter which is about 4in. high. The provision of fixing holes at top and bottom enables the filter to be mounted on the top of a baseboard, or beneath a metal chassis, with the terminals protruding through four specially-drilled holes in the chassis.

Four terminals are provided, two of which are to be joined to the L.S. terminals on the receiver, and the loud-speaker then joined to the other two terminals on the filter. Inside the filter is a special tuned series circuit, with parallel paths, and it therefore forms the link between the receiver and the speaker. In use it is very effective indeed, and by fitting a double-pole change-over switch it is possible to demonstrate quite clearly the effect of this component, which really does do the job it is intended to. The price, for either type, is 10s. 6d.



"Fotos" nipper transformers.

# Facts and Figures

Components Tested in our Laboratory

BY THE PRACTICAL WIRELESS TECHNICAL STAFF.

**NEW CLIX WALL PLUG**

NO doubt the majority of readers are familiar with the ordinary type of 5 or 15 amp. wall plug, intended for connecting apparatus to the two-pin sockets fitted in the house. The majority of these plugs are not too easily fitted up, the method of connecting the ends of the flex, and of reassembling the plug, being anything but simple. The new Clix plug is a most marked advance in the design of this type of plug, and possesses several remarkable features. First of all, it is finished in neat black bakelite and only one retaining screw is employed. This is mounted between the two pins, and to take the plug to pieces to wire it up takes but a second or two. In place of the usual small screws with a small diameter hole in which to force the flex, Messrs. Lectrolinx have included an enlarged version of their wander plug for this particular plug. This is, as we have mentioned before in these pages, in the form of a large split, or lynch-pin, and it forces down through a hole in the bakelite plug base. To anchor the ends of the flex they are simply passed through the large loop in the top of the pin, and the pin then pressed home. A small brass fitting then locks the wire in the loop. To prevent strain on the leads they are fed round through a circular groove in the base and given a turn round a bakelite pin, after which they are passed out through a side slot. The circular groove is amply proportioned, and will take the thickest of flex, and the cover does not prevent any number of leads being used with the plug. The particular type of split pin enables it to give perfect contact in practically any sort of wall socket, and there is a very sound contact with the wire when the cover of the plug is drawn down by means of the retaining screw. Finally, the price is only 9d., and it marks one of the most interesting developments in electrical equipment that we have seen for some time.



The new Clix wall plug.

**SIEMENS BATTERIES FOR Q.P.-P. SETS**

IN the various descriptions of the Quiescent and Class B amplification which we have given, we have explained how the current rises on the arrival of a strong signal, and we also gave figures in the case of one of our receivers showing the maximum current taken. It will be appreciated that the maximum current taken will be quite large in the case of a very strong signal, and furthermore, as a current is a fluctuating value all the time the signals are being received, there is a great necessity to use one of the triple capacity, or specially-designed batteries for the purpose. Messrs. Siemens manufacture a very suitable H.T. battery for this purpose in the Power Type, which costs 12s. for the 90-volt size, and 20s. for the 100-volt size. The capacity of this type of battery is more than double that of the standard type, but it costs less than double, and therefore, is a very economical line. For those who intend to use the larger types of pentode or super-power valve on the Class B principle, there is a still larger battery obtainable in the Super Radio battery, which costs 20s. for 45 volts. This will stand up to the very largest of valves and may be depended upon for really hard wear.

**BELLING-LEE FUSE-HOLDER**

THE illustration shows one of the neat fuse-holders made by the Belling and Lee Company. This is obtainable in two types, a single fuse-holder and a twin fuse-holder. As the names show, one takes a single fuse, which is included in one lead, whilst the other takes one fuse in each lead. The base is of neat moulded bakelite, and inside at either end is a standard wire attachment. This is of the "telephone terminal" type, with a small pillar having a transverse hole, and a screw tapped down into the top of the pillar: The side of the case is drilled with a hole in line with the hole in the side of the pillar. The end of the lead is, therefore, pushed through the pillar from the outside of the case, and the screw tightened down on the wire. In this manner no bare wires are accessible outside the fuse-holder. The lid, as can be seen in the illustration, has two clips at the extreme ends, and two smaller clips are raised from the same piece of metal a little



Belling-Lee fuse-holder, showing how the cartridge fuse is held.

**FOTOS "NIPPER" TRANSFORMER**

THIS is a particularly neat and cheap transformer, costing only 4s. 6d., and being obtainable in ratios of 3:1 or 5:1. It is of extremely small dimensions; the base being less than 1 1/2 in. wide by about 2 1/2 in. long, and the overall height being 2 in. The performance is quite large compared with its size, and it gives very good results for a component of the cheap type. The overall response is quite good, and the resonant points are not so marked that they detract in any way from its reproduction. The bass is quite clear, and the higher notes are reproduced without screech. We passed up to 10 mA. through the primary without noticing any ill-effects, although naturally this small type of transformer is not intended for such loads. For the builder of a really cheap set, where price is a consideration, this transformer will be found to satisfy all normal requirements, and can thoroughly be recommended for this purpose. We have also received a series of valves made by the same firm, and we shall have more to say about these in a later issue.

Have Your Copies Bound,  
See page 200.

nearer the centre. The latter two clips accommodate the standard Belling-Lee fuse, and the outer clips fit over the metal pillars at the end of the base. Therefore, when the lid is pressed into place the fuse makes connection from one end of the lead to the other, and removal of the lid breaks the connection. It is thus possible to remove the lid to replace a fuse without having to disconnect any leads. The twin fuse-holder inserts a fuse in each lead, and at least one of these holders should form part of the equipment of all mains apparatus. The single holder costs 1s. 6d., complete with 1 amp. fuse, and the twin holder costs 2s. 6d., fitted with twin 1 amp. fuses. The particular fuses which are fitted may be exchanged at the time of purchase for any other value. Readers should note that if the holders are purchased without fuses the above prices are increased by one-third.



# Practical Letters

from

# Readers.

The Editor does not necessarily agree with opinions expressed by correspondents.

### Readers Abroad and Advice Bureau Coupon

SIR,—I am pleased to have your free gift Handy Metal Gauge given with the January 28th issue of your valuable journal, for which I thank you. Your paper furnishes all the necessary information for amateur wireless enthusiasts. May I bring to your notice that the time you allow for free advice bureau coupon is too short for people in India, as the post takes more than fifteen days to reach London? Under the circumstances, I trust you will be in a position to extend the time stipulated, especially to your Indian readers? I am reading every issue of PRACTICAL WIRELESS with great interest, and wish it every success in the future.—P. V. RANGAM (Madras, India).

[The correct extension of time for receiving Advice Bureau coupons from readers residing abroad is always allowed.—Ed.]

### A Wonderful Volume

SIR,—Being a regular and satisfied reader of PRACTICAL WIRELESS, allow me to thank you for the Encyclopædia, which is a wonderful volume. It is certainly packed with the good things we amateurs enjoy. More power to PRACTICAL WIRELESS.—E. F. ASHTON (Romford).

### A Fine Book

SIR,—Permit me, as a regular reader of PRACTICAL WIRELESS, to thank you for the Wireless Constructor's Encyclopædia. After even a brief examination it is obvious that it is a fine book.—Wishing PRACTICAL WIRELESS every success.—R. SQUIRES (Rotherham).

### Of Great Value

SIR,—It is a really splendid book, both with regard to the reading matter and the binding. The book will be of great value to the amateur wireless constructor.—E.B. (Leeds).

### A Store House of Information

SIR,—I have been so interested that I have not had time to write before. It is a store house of wireless information, those who have not subscribed do not know what they have missed.—E. W. C. (Birmingham).

### The Development of Tuning Coils

SIR,—I am somewhat surprised at Mr. Barton Chapple's reply to my letter re "Coils." May I point out that with regard to his plea that he intended his remarks to be construed as meaning that the new coils are "New," inasmuch as they are only

now "commercially possible" is entirely wrong. Had he read the paragraph in the book to which I referred him he would have discovered that not only is the idea not new, but on the page facing the description of the coils "tuned with a core of finely divided iron," he would have seen the photograph of a "Commercial" receiver (Marconi Co.) employing this idea. As I pointed out, a visit to the Air Port (GED) would have shown one in use.

How about a really good short-waver in the near future. (Not a converted medium-long-wave, please!)—ALBERT L. BEEDLE (Balham, London, S.W.).

### A Scottish Reader's Appreciation

SIR,—Many thanks for answering my queries re suitable values of resistances and condensers in connection with my three-valve short-waver, employing a S.G. valve as detector.

I have followed your suggestions and the result is that I now have a really "hot stuff" S.W. receiver. My first turn round the dial brought in W3XAL on 16.87 m.

CUT THIS OUT EACH WEEK.

## DO YOU KNOW?

—THAT a temporary small value fixed condenser may be made up by twisting two short lengths of ordinary flex together.

—THAT the readings of a meter may be increased but they cannot be reduced.

—THAT Luxembourg now provides high-power programmes on a wavelength of 1,191 metres.

—THAT Class B amplification renders the design of a portable more efficient.

—THAT portable receivers may now be fitted with moving-coil loud-speakers in view of the above.

—THAT long-distance reception is not so reliable in the longer summer days.

—THAT the cause of the falling off in signal strength is the absorption effect of the sun's rays.

—THAT the new Ferrocart coils should be fitted where they are well away from high-power valves or other sources of heat.

—THAT we may expect great things from a "three-valve set" next autumn.

### NOTICE.

The Editor will be pleased to consider articles of a practical nature suitable for publication in PRACTICAL WIRELESS. Such articles should be written on one side of the paper only, and should contain the name and address of the sender. The Editor does not hold himself responsible for manuscripts, every effort will be made to return them if a stamped addressed envelope is enclosed. All correspondence in regard to the Editor should be addressed: The Editor, PRACTICAL WIRELESS, Geo. Neufnes, Ltd., 8-11, Southampton Street, Strand, W.C.2.

Owing to the rapid progress in the design of wireless apparatus and to our efforts to keep our readers in touch with the latest developments, we give no warranty that apparatus described in our columns is not the subject of letters patent.

on a moving-coil speaker. I have the set fully decoupled, and even on such a low wavelength there is no hand capacity. Of course, I have my panel backed with tinfoil. I found the set gave best results with the reaction circuit connected to the screening grid. I can vary the current at will by means of a potentiometer, and I have also a 400 ohms potentiometer between L.T.+ and grid leak. This, in conjunction with a variable condenser, gives me perfect reaction control.

When I first put the set together I used two high-class transformers of well-known make. The first one was parallel fed, and when I switched on I got the finest imitation of a motor-cycle race that one could have wished for. I had the cores at right angles and the metal cases were earthed. Well, I replaced the first transformer with an old "Hedgehog," and the set at once behaved like a gentleman. I made no other alteration to the circuit. Perhaps you will find space sometime to explain the reason for this. It has puzzled me.

For a short-waver I could wish nothing better, and on some nights the 49-metre Yankees come in at R7 to 8 on the loud-speaker. Zeesen on 31 metres, and Moscow on 50 metres usually wipe out everything in their immediate vicinity. In fact, I could tune in Zeesen on good phone strength without any aerial at all. In concluding, I would just like to say how much I appreciate PRACTICAL WIRELESS. It is practical in every sense of the word, and although I have made about a score of sets in my time, there's not a week passes but I learn something new from your columns.

I was very much struck with the "Fury Four," but as I expect some startling developments in radio before another winter, I will "wait for it."

Wishing PRACTICAL WIRELESS continued success.—ALEX. HENDRY (Longside, Aberdeenshire).

### Exceeds Anything I Expected

SIR,—Please allow me to thank you for the Wireless Constructor's Encyclopædia, just received. It far exceeds anything I expected, and I am more than delighted with it. I am looking forward to some really pleasant hours reading.

It's a pity every amateur constructor cannot possess one. I am very grateful for mine.

Wishing PRACTICAL WIRELESS and its staff every success.—A. HUDSON (Erdington).

### Another Reader's Appreciation

SIR,—Allow me to express to you my appreciation of the Wireless Encyclopædia, safely to hand. It has far exceeded my expectations and will, I am sure, be the most useful book of reference I possess.

(Continued in col. 2 overleaf)

# HEAYBERD MAINS TRANSFORMER

Exclusively Specified for the  
"A.C. TWIN"



Constructed to the designer's specification, the Heayberd Mains Transformer is exclusively specified for the "A.C. Twin"—you can therefore be fully confident that you have the very best transformer for the job. Time and time again the technical experts of "Practical Wireless" and other radio papers, specify Heayberd mains components for their most important receivers—convincing testimony to the sound design and high quality of these sterling components.

Remember—the mains transformer is the heart of an A.C. mains receiver, unless that heart is sound the whole receiver is rendered weak and ailing. Technical experts ensure the efficiency of their sets by specifying Heayberd.

The transformer described below is made by craftsmen from the finest British materials. Windings are adequately protected by special metal end-plates, and the insulation will withstand even tropical conditions. Excellent voltage regulation, with negligible temperature rise.

## HEAYBERD "A.C. TWIN" MAINS TRANSFORMER.

### SECONDARY OUTPUTS:

350+350v. 60 ma.  
2+2v. 2 amps.  
2+2v. 2.5 amp.

**29/6**

Complete

Guaranteed Twelve Months.

If you have any difficulty in obtaining supplies locally please write to us direct.

**F. C. HEAYBERD & CO.,**  
10, Finsbury Street, London, E.C.2.

### —POST COUPON TO-DAY—

I enclose 3d. in stamps for 36-paged Handbook and Catalogue of Radio mains equipment. Packed with hints and diagrams.

Mr. ....

Address .....

Prac.



## PRACTICAL LETTERS

(Continued from previous page.)

May I conclude with the following lines: An excellent "volume" with perfectly "controlled" "output," which no amount of "amplification" can do justice to. It is an "accumulator" of facts which requires no "re-charging." In which you can "switch" over from query to query and run them all to "earth."—A. R. WOTTON (Altringham).

### A Useful and Interesting Book

SIR,—Very many thanks indeed for your splendid Encyclopædia just received. It is a very useful and interesting book, which, with your Data Sheets, enable amateur wireless enthusiasts to successfully tackle jobs they could not otherwise do without professional help. Wishing your-

paper every success.—F. J. FREEGARD (Bishop's Stortford).

### "More than Satisfied"

SIR,—Just a few lines to say I have received the Encyclopædia quite safe and am more than satisfied with it. Of course I have not been able to fully explore it yet, but from what I have read I find there the same consideration for beginners as given in PRACTICAL WIRELESS which I have taken from No. 1. I have found this journal most helpful in explaining to me a lot of what was to me the mysteries of wireless. Apart from this I think the Encyclopædia, by its external appearance a welcome and pleasing addition to any bookcase or shelf. I will close wishing your publications the success they deserve.—C. SHEMELD (West Wittering).

# RADIO CLUBS & SOCIETIES

Club Reports should not exceed 200 words in length and should be received First Post each Monday morning for publication in the following week's issue.

### ILFORD AND DISTRICT RADIO SOCIETY

On March 23rd a talk and demonstration was given by Mr. R. M. Weston on "Meters and Measuring Instruments." Practical details were given which would enable members to construct their own instruments, and to adapt their meters for other purposes. The acquisition of a good standard instrument to start with was advised.

Mr. Weston had brought a large array of apparatus and meters, and with these before him was able to explain their construction and use, and they included micro-ammeters, a valve voltmeter, and many types of A.C. and D.C. meters, complete with multipliers. A pick-up was measured for output, and the signal from constant frequency records was measured through an amplifier showing stage gain and voltage output. A Dynatron modulated oscillator was demonstrated, also. On March 30th a sale of apparatus was held.—Hon. Sec., C. E. LARGEN, 16, Clements Road, Ilford.

### THE SOUTHALL RADIO SOCIETY

The winter session of this society closed with the Annual General Meeting. The session has been one of the most successful in the life of the society, and the retiring officers expressed their appreciation of the interest shown in the society's winter activities. During the summer it is proposed to arrange social events and visits to places of technical interest. Intending members are cordially invited to communicate with the Hon. Secs., Mr. G. Lee, 261, Beaconsfield Road, Southall, and Mr. A. J. Stephens, "Buena Vista," Pole Hill Road, Hillingdon.

### THE CATFORD AND DISTRICT RADIO AND TELEVISION SOCIETY

At a meeting of this society held recently, Mr. Radford gave an interesting lecture on the "Acoustic Side of Radio Reproduction." This difficult subject was very simply explained and illustrated by means of lantern slides. Many problems which hitherto puzzled the wireless enthusiast were admirably explained. Various studios at Broadcasting House were put on the screen and their points of interest explained, also a studio at Budapest was shown. The discussion that followed all went to prove that the members had been following the subject with close interest.—Hon. Secretary, Mr. H. W. FLOYD, 38, Como Road, Forest Hill, S.E.23.

### MERSEYSIDE AMATEUR TRANSMITTERS' SOCIETY

This society have now acquired premises in a central position in Liverpool which are being prepared as a club-room in which a transmitter and receivers will be installed, and also a workbench for the use of members. Further particulars of the society can be obtained from the Hon. Sec., J. DAVIES, 13, Exeter Road, Wallasey.

### THE CROYDON RADIO SOCIETY

Mr. H. Bevan-Swift, President of the Radio Society of Great Britain, presided over a recent meeting, the occasion being a lecture-demonstration entitled "The Output Stage," by Mr. F. Youle. He discussed, firstly, harmonic distortion, and explained very clearly why second harmonic distortion came in the triode valve and the third in pentodes. Measuring the permissible distortion was also very fascinating, it being seen how its percentage was derived, using load lines and a valve's characteristic curves. He said much about

quiescent push-pull, ordinary push-pull, and Class B amplification. Finally the lecturer's special amplifier was demonstrated, using quiescent push-pull.—Hon. Sec., E. L. CUMBERS, Maycourt, Campden Road, Croydon.

### BLACKPOOL AND FYLDE RADIO SOCIETY

The inaugural meeting of this society was held at the Café Suisse, Queen's Square, Blackpool, on Friday, March 24th, at 8 p.m., and eighteen prospective members were present. Mr. Gray taking the chair. The offices of President and Treasurer were left in abeyance until a more representative meeting could be held, but Mr. Howard was elected Secretary and a committee consisting of five members, together with the Secretary, was formed. Subscriptions were fixed at 10s. 8d. per annum for senior members (that is, over eighteen years of age) and 5s. per annum for junior members. An interesting programme is being compiled by the committee and will be published in due course, and the society will welcome any new members who may be interested. All communications should be addressed to Mr. Howard, 43, Cumberland Avenue, Blackpool.

### SLADE RADIO

A recent meeting of the above society was devoted to "How you can win the D.F. (Direction Finding) Cup." Mr. G. T. Peck gave some very interesting details covering the procedure to be adopted from the commencement to the finish of a test. These were based on his own experiences in past tests, and as he has been successful on several occasions some very useful information was given. Details of the types of sets which can be used were given, and also a number of questions were dealt with. Anyone who is interested in D.F. work is invited to write to the Hon. Sec., who will be pleased to give details of the society's activities in this particular branch. Address: 110, Hillaries Road, Gravelly Hill, Birmingham.

### SUGGESTED RADIO CLUB FOR SOUTHPORT AND BIRKDALE (LANCS)

All amateurs residing in these districts who are interested in radio, television or gramophones are invited to communicate with C. H. TURNER, 62, Zetland Street, Southport, sending stamped envelope for reply concerning the first meeting, which will be arranged as soon as enough members can be got together.

### WIRELESS TERMS TRAVESTIED—6.



Resistance Feed.



LET OUR TECHNICAL STAFF SOLVE YOUR PROBLEMS

REPLIES TO



If a postal reply is desired, a stamped addressed envelope must be enclosed. Every query and drawing which is sent must bear the name and address of the sender. Send your queries to The Editor, PRACTICAL WIRELESS, Geo. Neumes, Ltd., 8-11, Southampton St., Strand, London, W.C.2.

QUERIES and ENQUIRIES by Our Technical Staff

The coupon on this page must be attached to every query.

SPECIAL NOTE

We wish to draw the reader's attention to the fact that the Queries Service is intended only for the solution of problems or difficulties arising from the construction of receivers described in our pages, from articles appearing in our pages, or on general wireless matters. We regret that we cannot, for obvious reasons—

- (1) Supply circuit diagrams of complete multi-valve receivers.
(2) Suggest alterations or modifications of receivers described in our contemporaries.
(3) Suggest alterations or modifications to commercial receivers.
(4) Answer queries over the telephone.
Please note also, that all sketches and drawings which are sent to us, should bear the name and address of the sender.

DIODE AND REACTION

"I have recently been trying out the diode method of detection, and whilst I heartily endorse all claims made for its purity, I find there is a sad loss of volume. The diode is preceded by a variable-mu valve, and followed by a pentode, but the distant stations are now lost to me. Is there any way of boosting the strength of this form of detector so that I can get a few foreigners? I do not want to add another L.F. stage if I can help it, as I am using a mains unit and it is already fully loaded."—(W. D., Edgware.)

We presume that you are using the valve which originally served as the detector for your diode, and this may be used to provide signals quite as loud as previously. The grid of the valve should be used for the diode, and the anode ignored. We do not know whether this is the arrangement you are using, or whether you have bonded the grid and anode or are using the anode alone. However, use the grid as above-mentioned, and then connect the anode to the reaction condenser (which we presume you previously used). A further H.F. choke will, of course, be required to connect the anode to the H.T. supply, but the reaction will act as with an ordinary valve and will give you the advantage of distant reception. The quality does not appear to suffer from this method of using a diode.

CLASS B.

"My receiver is a bit ancient, but has stood the test of time. It employs a neutrodyne H.F. stage, anode bend detector, and three resistance-capacity stages. Would you think the addition of a Class B-stage in the last socket would be an improvement? I get very pure signals, but not much punch, and I think the Class B arrangement would be worth while, but I should like your advice first."—(U. C. B., York.)

It is not very easy to give you a reply to this question, U. C. B. Presumably, from the circuit arrangement, you have gone all out for quality, irrespective of high stage gain. Therefore, the input to your third L.F. stage is quite small. Class B requires a fairly strong signal to be passed through the primary of the driver transformer, and it is probable that even now, after all your R.C. stages, the output valve does not handle a sufficiently large signal. We think, therefore, that probably the best arrangement would be to scrap the two last L.F. stages, fit a really high-class L.F. transformer with high ratio between the detector and the first L.F. valve, and to follow this by the Class B stage driver. This would give you the punch, and would not give bad quality. In view of the three stages you are now using, however, we would hesitate to recommend you to add the Class B and driver after the present set, as there would be a great risk of L.F. instability.

AERIAL INSULATION

"I have just moved from a flat into a house, and have now for the first time got the chance of building an outdoor aerial. I am not clear as to the best arrangement of the insulators for an outdoor aerial, and I notice from a catalogue that there two types of china

insulator, one like a reel and the other called the 'egg.' Which is the best, and would I want more than one at each end? They seem to be rather small to me."—(A. L., Weston-super-Mare.)

The principal consideration in arranging aerial insulation is to provide a long leakage path. Therefore, you may use either of the types of insulator you mention, but more than one is required. The best arrangement is to obtain a dozen insulators, and to wire them in two chains of six. The wire which you use for the aerial may be used to join them together, and the space between each insulator should be about 3 or 4 in. Pass the joining wires through opposite holes so that there is no metallic connection from one insulator in the chain to the next. Then fit one chain to the aerial pole and the other to the chimney or house end of the aerial, and suspend the aerial between the two chains. The aerial should be lowered periodically and the entire chain thoroughly washed in warm soda water and brushed with a wire brush to remove the sooty deposit which coats it.

TRIPLE RANGE COIL

"I like making my own coils, and have used for some time now a very efficient dual range coil. I also have a spare set which is wound for short waves, and I like to listen on the 10 metre band now and then.

DATA SHEET No. 31

Cut this out each week and paste it in a Notebook

UNITS AND THEIR EQUIVALENTS

Table listing units and their equivalents: One foot-pound, One B.Th. Unit, One H.P. hour, One kW hour, One H.P. ...

Could I wind a coil to take me over the whole range and so save myself the trouble of d'sconnecting one set when I wish to change the range? I should like winding data, if this is possible, and to receive your valued advice."—(A. I., Wood Green.)

It is quite possible to make up a coil of the type you mention, but it is not very efficient. As you have probably found, the short waves require very careful treatment, and the use of a three-range coil means that the medium and long-wave coils have got to be short-circuited when listening on the short waves. This may introduce losses which will prevent the maximum efficiency being obtained. A much better arrangement is to build a complete short-wave detector stage in one part of your cabinet, and to arrange a switch in the anode circuit of the valve. This should connect to the L.F. coupling arrangement so that the short-wave detector or the ordinary detector could be coupled to the L.F. stages. A separate filament switch would also be advisable to switch out the unused valve.

SCREENING A LEAD

"I am afraid I am getting hum from the pick-up leads in my set and should like to try the effect of screening them. As I am not sure that it is this which is causing

the trouble I do not want to buy screened leads until I have found out the actual fault. I think I could carry out screening by winding some copper wire round and round the rubber covering of the pick-up leads and connecting this to earth. Is this so?"—(W. J., Crystal Palace.)

You could screen the wire by this means, but there is one serious snag. If you wind the wire round and round (and use ordinary covered wire for the purpose) you will have an inductive covering over the wire and this may give rise to even worse troubles. You could overcome this by using bare wire and winding it so that each adjacent turn touched and so short-circuited the inductance, but it would tend to open and when the lead was bent the turns would not be in contact and this would lead also to trouble. It does not cost much for the screened cable and it is a much more satisfactory arrangement. You can get three feet of cable, with all clips and earthing tags for 1s., and this is therefore the better course to adopt.

WOODEN PANEL

"I have just finished my radio-gram, and I want to fit the set into it. I have fretted out a neat vignette in the front of the cabinet, but as this is of walnut I do not like the look of a sheet of ebonite inside it. Could I mount the panel controls on a piece of the walnut so as to match the cabinet, or is there any reason why wood is not good enough for the purpose?"—(B. H., Highbury, N.)

A great deal depends upon what controls are mounted on the panel. If only components which are connected to earth, or which have an ebonite fitting are attached to the panel, then wood may certainly be employed. In some parts of the circuit it is still possible to use wood, provided it is quite dry and that metallic bodies in contact with the wood are separated by a good space and are in parts of the circuit where there is little risk of inter-action. You will, therefore, have to study your circuit and note what controls are mounted close together. An alternative, of course, is to use a very thin ebonite panel and mount the components on that, with a facing of walnut veneer with clearance holes cut in it.

AUTOMATIC GRID BIAS

"I have read all your articles on grid bias and I am now going to build up a set employing this method of biasing. Which method, however, do you recommend me to adopt? There are several methods, apparently, and I am not sure which is best."—(P. R. V., Manchester.)

This is a question which it is not possible to answer. First of all, you do not state what circuit arrangement you are proposing to use. Secondly, you do not say whether battery-operated or mains valves are in use. As you know, the bias resistance may be inserted in the cathode lead of an I-H valve, or in the common negative lead. You must, therefore, study the articles again and adopt the method which best suits your circuit arrangement.

D.C. MAINS SETS

"I have built a circuit shown in your book, and am using it with a home-made D.C. mains unit. When I switched it on at first it sounded all nice and clear, but when I went to adjust the loud-speaker after a few minutes I found it was almost red-hot. I switched off and examined the output choke arrangement, and this appeared to be O.K., but after switching on again the same thing happens. What can be the reason of this? The unit is a good one and the circuit seems all right."—(W. G., Kentish Town.)

As you have made up an ordinary circuit and connected it to an ordinary D.C. mains unit, you have probably overlooked one point. The receiver should not be joined direct to earth. It should be earthed via a large fixed condenser, say 2 mfd. It is also advisable to fit a 2 mfd. fixed condenser on each side of the loud-speaker if this is fed from an ordinary output choke arrangement. These remarks only apply, of course, to D.C. mains receivers.

FREE ADVICE BUREAU COUPON

This coupon is available until April 29th, 1933, and must be attached to all letters containing queries. PRACTICAL WIRELESS 22-4-33.

# CATALOGUES RECEIVED

To save readers trouble, we undertake to send on catalogues of any of our advertisers. Merely state, on a postcard, the names of the firms from whom you require catalogues, and address it to "Catalogue," PRACTICAL WIRELESS, Geo. Newnes, Ltd., 8/11, Southampton St., Strand, London, W.C.2. Where advertisers make a charge, or require postage, this should be enclosed. No other correspondence whatsoever should be enclosed with applications for catalogues.

### THE COSSOR MP/PEN

WE have received a leaflet giving full particulars and curve diagrams of the new Cossor A.C. mains pentode valve which has several advantages over an output valve of the triode type, including improved bass response, higher power sensitivity and larger output. The valve is designed for a heater voltage of 4 at 1 amp. and a maximum anode voltage of 250. A copy of the leaflet can be obtained from A. C. Cossor, Ltd., Highbury Grove, London, N.5.

### BRYCE POWER PACK

IN a leaflet issued by W. Andrew Bryce and Co., details are given of this useful unit for converting a battery set to all-mains working and supplying the field current for a moving-coil speaker. The pack consists of a mains transformer, L.F. smoothing choke, valve holder, fixed condensers, and sheet steel chassis, complete with sockets clearly marked with input and output voltages. Two models are obtainable, one giving a smoothed H.T. output of 350 v. 80 mA. and L.T.-A.C. 4 v. 3 amps, the other giving 500 v. H.T. at 120 mA. and L.T.-A.C. of 4 v. 2-3 amps. The address is Woodfield Works, Bury, Lancs.

### MAGNACORE COMPONENTS

FULL particulars of a Quiescent Push-Pull Transformer and a Q.P.P. Output Choke, are given in a folder we have just received from Magnacore, Ltd., 57, James Street, London, N.W.1. The transformer has a ratio of 8.5 to 1, with a D.C. primary resistance of 950 ohms, each half of secondary having a resistance of 525 ohms. The choke, which has a total primary D.C. resistance of 840 ohms, can be obtained with a ratio of either 1 to 1, 1.8 to 1, or 2.9 to 1, for matching, to any ordinary type of speaker. Both components are priced at 7s. 6d., with an additional 1s. 6d. royalty on the transformer.

### GRAHAM FARISH COMPONENTS

A COMPLETE range of the latest components made by Graham Farish, Ltd., is given in a booklet issued recently by this firm. A new potentiometer volume control, the "Megite," has an element of fine nickel-chrome wire embedded in bakelite. The action is through a slipper plate, giving a smooth, silent operation. Among the other components listed are a new H.F. choke, grid leaks, "Ohmite" resistances fixed and variable condensers, valve holders and "Filt," the new percolative earth. The address is Masons Hill, Bromley, Kent.

### FERRANTI POWER UNITS

THE construction of mains units calls for a certain amount of technical knowledge and experience. Messrs. Ferranti, of Hollinwood, Lancs, have specialised in such apparatus for years, and have prepared an interesting and useful folder, No. Wa. 522. This contains constructional details for several different types of mains units, with theoretical diagram, wiring diagram, chart of D.C. output, list of components, and valuable technical details. In addition there is a chart showing at a glance the value of resistance required to drop practically any voltage at any current. Copies of this folder may be obtained by readers by sending threepence in stamps to Messrs. Ferranti at the address given above.

### Replies to Broadcast Queries.

DIGGER (Leicester): Ship telephony on about 200 m. M. SYMANS (W.12): (1) Norddeich (Germany) calling S.S. Cap Ancona; (2) regret, cannot trace; (3) possibly W2XA, New York, on 48.9 m.; (4) DJA; Zeesen, on 31.381 m. F. G. CHARITON (Southgate), (1) GSA, Empire Broadcaster on 49.586 m.; (2) DJC, Königs Wusterhausen, on 49.83 m. Two VALVE (Jedburgh): G6YJ is the call sign of Mr. F. R. Canning, "Crindan," Newport (Mon); he would like your report on his transmission. Pop (Birmingham); (1) W2PP is the call sign of W. F. Scott, 207 N. 11 St., Newark (N.J.); (2) G51S; call sign of P. Johnson, 49, Carson Road, Dulwich, S.E.21; (3) cannot trace; (4) this would be the call sign of a coastal station, but we cannot trace it in lists.

### MORE ABOUT INTERFERENCE

(Continued from page 182.)

rings is usually the cause. Sparkless commutation is the first thing to be aimed at by careful bedding of the brushes, and condensers should be connected in series across the brushes, with their centre point earthed, Fig. 6. In obstinate cases a heavy duty choke, capable of carrying the full current of the machine, should also be connected in each of the mains leads, together with condensers, in the manner shown in Fig. 7.

Interference from overhead conductors of trams and trolley buses is now being dealt with by some municipal authorities, and although at present it has not been found possible to completely eliminate the trouble, a great reduction of the annoyance has been brought about by the fitting of protective devices on each vehicle.

### Earth Leakage Currents

All the sources of interference already enumerated, with the possible exception of earth leakage currents, may be quietened down without much difficulty, if suitably dealt with, each case requiring its own particular treatment, and in cases where the interference has been reduced, but not completely removed by this treatment, altering the direction of the aerial so that it is at right angles to the direction from which the interference is coming will usually have the desired effect.

Earth leakage currents present a more difficult problem. They may cover a wide area, and although regulations are laid down for their control, these are not always effective from the wireless user's point of view. Where this type of interference is experienced, the most effectual remedy is the use of a counterpoise in place of the usual earth. This, however, is not always to be recommended, as in the case of mains operated receivers the use of a counterpoise may introduce hum, which may possibly be as unpleasant as the interference which it is desired to cure.

The B.B.C., in collaboration with the Post Office engineers, has carried out a great deal of research, and has done much valuable work in the investigation of problems connected with interference to wireless reception, and over 10,000 cases of complaints from listeners are being dealt with annually.

Where reception is suffering due to the influence of outside electrical disturbances, the origin of the trouble should be located if possible and the owner of the offending apparatus approached with a view to its cure. If difficulties arise, the complainants may with confidence look to the B.B.C. and the P.O. engineers for assistance.

No actual or legal responsibility for correcting the trouble rests with the owner of the apparatus, however, and whether he takes any steps in the matter is entirely a question of good will. The onus of responsibility in the future should really fall upon manufacturers of electrical equipment which is likely to cause interference, and the introduction of legislation to this effect is desirable. A decree on these lines has already been passed and is being enforced by the Belgian Government.

## Filtron

THE EARTH THAT GROWS A ROOT

● FOR SENSITIVITY. ● AND SILENT BACKGROUND. PRICE OF ALL DEALERS 2/-

### THE MOTOR-CYCLISTS' REFERENCE YEAR BOOK, 1932-1933.

*The Motor-Cyclists' Encyclopaedia.*

Edited by F. J. CAMM (Editor of "Practical Wireless").

The Only Year Book relating to Motor-Cycles (Fourth Year of Issue).

Complete and comprehensive information relating to Machines, details, facts, and figures regarding records, legal matters, overhauling, Classified Buyers' Guide, etc. etc.

128 pages, 1/- net or 1/2 by post from George Newnes, Ltd., 8-11, Southampton Street, Strand, London, W.C.2.

Famous Maker's Offer? **£5** Radio-Gram CABINET for **65/-** SEVEN DAYS' FREE TRIAL (OR 10/- MONTHLY)

Polished Oak! and Piano built! The acoustic tone brings a fine thrill. Makers to Radio-Press, B.B.C. 3,000 clientele.

MODELS FROM 35/- to £15 Photographs and List FREE.

**PICKETTS** Piano-Tone Cabinets, (P.R.), Albion Road, Bexleyheath.

FOR DE-LUXE RADIO-GRAMS **PICKETTS CABINETS**

*Recommended for Best Results!*

## ADVERTISEMENT INDEX

	Page		Page
Block Batteries, Ltd. . . . .	189	Jackson Bros.; Ltd. . . . .	199
British Pix Co., Ltd. . . . .	207	Lissen, Ltd. . . . .	174
Bulgin, A. F. & Co., . . . . .	204	London Electric Wire Co.; & Smiths, Ltd.	
Busby & Co. . . . .	207	<i>Inside Front Cover.</i>	
Columbia Graphophone Co., Ltd.	<i>Back Cover.</i>	London Radio Supply Co. . . . .	204
Cossor, A. C. Ltd. . . . .	185	Mains Power Radio . . . . .	207
Crafts, Ltd. . . . .	<i>Inside Back Cover.</i>	Mason, E. C. . . . .	207
Dubilier Condenser Co., Ltd. . . . .	203	Newnes "Modern Motor Repair."	
Edison Swan Electric Co., Ltd. . . . .	173	<i>Inside Back Cover.</i>	
Filtron! . . . . .	212	Newnes "Home Movies" <i>Inside Back Cover.</i>	
Grampian Reproducers, Ltd. . . . .	199	Newnes "Practical Wireless" Binder	200
Heyberd, F. C. & Co. <i>Front Strip and</i>	210	Peto Scott, Ltd. . . . .	197
High Vacuum Valve Co. . . . .	204		
Igranic Electric Co., Ltd. . . . .	173	Picketts . . . . .	212
		Pioneer Radio . . . . .	206
		Radio Resistor, Ltd. . . . .	206
		Riverside Mfg. Co., . . . . .	206
		Smith's Cabinets, Ltd. <i>Inside Front Cover</i>	
		The 362 Radio Valve Co., Ltd.	
		<i>Inside Front Cover and Inside Back Cover.</i>	
		Turnadge & Partners, Ltd. . . . .	206
		Varley, Ltd. . . . .	189
		Wilkins & Wright, Ltd. <i>Inside Front Cover.</i>	
		Williams, T. . . . .	207
		Wright & Weaire, Ltd. . . . .	201

## The Gentle Art of Cine Faking!

AN interesting feature of the April issue of *Home Movies* is a section dealing with "HOW IT'S DONE!" in film production, which includes some remarkable "Behind-the-Scenes" shots of the wonderful film *Cavalcade*, and striking pictures from a British Production.

*Other features include:*

CINE FILMS FROM MOVING VEHICLES  
ADRIAN BRUNEL ON TITLING  
SOUND ON FILM EXPLAINED  
NEW PRIZE COMPETITIONS  
AMONG THE AMATEUR SOCIETIES

# HOME MOVIES

and HOME TALKIES

## SIXPENCE

Obtainable at all Newsagents, Bookstalls, and Dealers, or post free, 7d. (Subscription rates: Inland and Abroad 7s. 6d. per annum. Canada 7s. per annum) from George Newnes, Ltd., 8-11, Southampton Street, Strand, London, W.C.2.

**BUY A COPY TO-DAY!**

Geo. Newnes, Ltd.

## A Remarkable New Work

**WILL SAVE YOUR TIME AND YOUR MONEY**

If you are interested in cars there can be no question that you will find this work wonderful value for money. It shows the best and quickest methods of overhauling, dismantling, and repairing the most popular types of cars now on the road. The articles are written by experienced men in the industry, and they are illustrated by hundreds of photographs showing actual methods of working.

You will be specially interested in the clear explanation of the new Daimler Fluid Flywheel which is given in Part 2. The operation of this wonderful invention is explained in a manner that all can understand. GET A COPY FROM YOUR NEWSAGENT TO-DAY.

**DEALING WITH**

*The Overhaul and Repair of—*

AUSTIN MORRIS ROVER RILEY TRIUMPH STANDARD WOLSELEY  
M.G. HILLMAN B.S.A. FORD JOWETT SINGER

**PART 1 NOW ON SALE**  
**PART 2 ON SALE APR. 21<sup>ST</sup>**

# MODERN MOTOR REPAIR 1!

Obtainable from all Newsagents and Bookstalls, or Post Post 1s. 3d., from GEORGE NEWNES, LTD., 8-11, Southampton Street, Strand, London, W.C.2.

Geo. Newnes, Ltd.

# AERIALS

## NO LONGER NECESSARY



Amazing new radio instrument eliminates indoor and outdoor aerials. No alterations to Set—just plug in to Aerial and Earth Socket. Fixed in a moment. No sticky tape. Increases selectivity and range. Reduces mains hum and statics and obviates all lightning risk.

Your dealer stocks the VEGA Aerial Eliminator, or send direct to—

**CRAFTS (Pr.W.), LTD.,**  
7, DUKE STREET, ADELPHI,  
LONDON, W.C.2.

Telephone: Temple Bar 1693

# VEGA

AERIAL ELIMINATOR

*Satisfaction Guaranteed... Or money returned*

Buckingham

## WHY PAY EXORBITANT PRICES FOR VALVES?



Direct from the Actual Makers  
POST FREE

SEND DIRECT TO THE MAKERS FOR

# BRITISH 362 VALVES

Compare the prices of British 362 Valves. They are FULLY GUARANTEED to have as high, or higher, characteristics as any valve (British or foreign), equal to any, better than most. Non-microphonic. Buying direct by post from the makers SAVES YOU 50%. Post your order to-day. Immediate delivery of all types

THE "CLASS B" 9/-

For further details see our advt. on inside front cover.

R.C. H.F. L.F. & DETEC.

POWER

SUPER POWER

SCREENED-GRID or VAR-MU.

PENTODE TYPE

3/6

4/6

4/6

7/6

10/6

All Post Free. In 2v., 4v., or 6v. Metallised 3d. extra.

If valves of a certain make have been specified for your Set, send the name and type with your order and we will send you 362 Valves of similar characteristics. Cash with order. Cheques and P.O.'s must be crossed and made payable to:—

The 362 RADIO VALVE Co., Ltd. (Dept. W. 6), 415, Mare St., Hackney, London, E.8.

A Six-valve . . . . a Portable . . . .  
and a **SUPERHET**

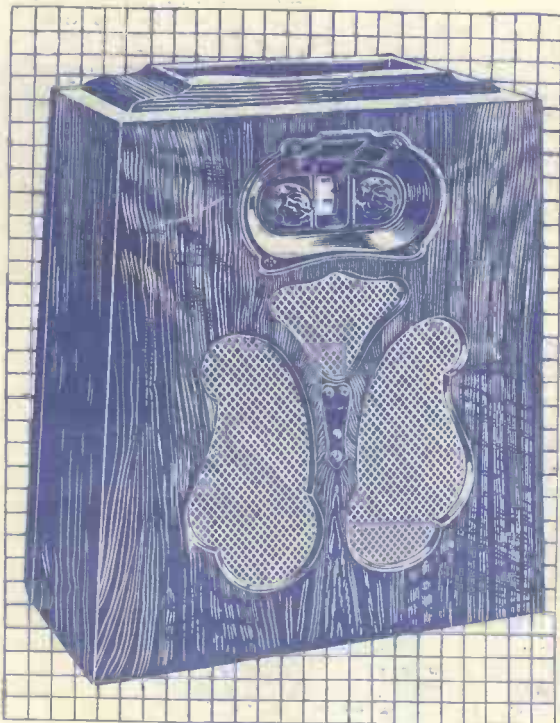

Buying radio to-day calls for extreme caution. Broadcasting conditions are changing but you certainly cannot afford to change your set from time to time. *Better be sure!* This six-valve portable battery superhet in polished walnut is definitely the set of the future. It will keep ahead of every possible broadcasting development for years yet. Test it at home—in every room—you'll be delighted!

**17 gns. cash** or delivered on first payment of **£1. 16s.**

**TWICE** as many stations!

Running costs **HALVED!**

**No aerial—no outside wires!**

# Columbia

Use the  
**COLUMBIA DEALER SERVICE**

Expert advice on local radio conditions  
and service after sales.



**CUT OUT AND POST TO-DAY!**

Please send me fullest particulars of Columbia Model 380 and other Columbia instruments from £4 7. 6 to 90 gns.

NAME.....

ADDRESS.....

Prac. W 22/4/33

(write in block capitals). Columbia, 98, Clerkenwell Rd., E.C.1