

MAINS WORKING ON SHORT WAVES—See Page 182

Practical and Amateur Wireless

3^D
EVERY
WEDNESDAY

Edited by F.J. CAMM

a GEORGE
NEWNES
Publication

Vol. 10, No. 242.
May 8th, 1937.

AND PRACTICAL TELEVISION

UNSUSPECTED CAUSES of TROUBLE

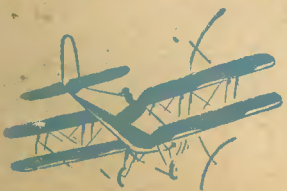
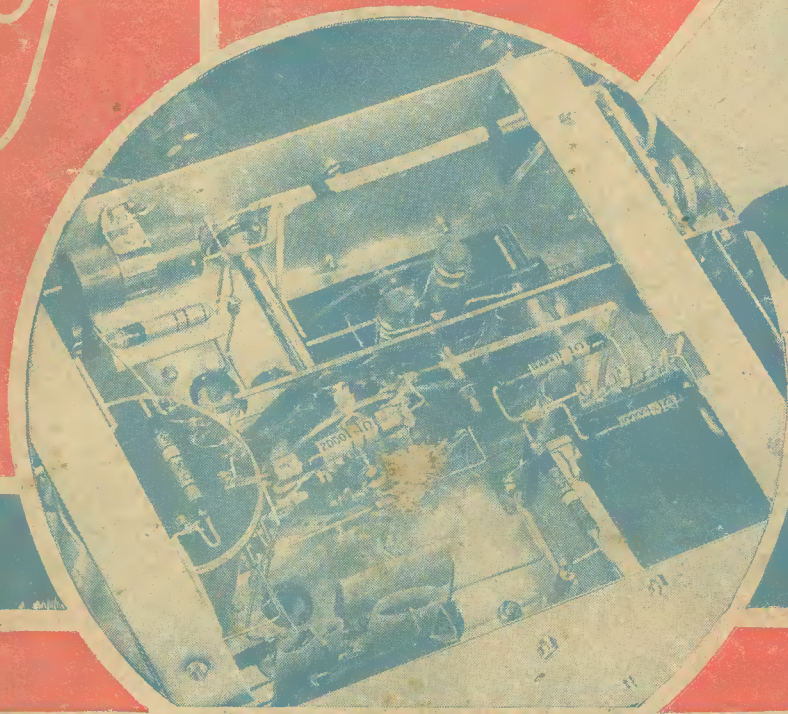

A Unique Book for the Air-Minded—

“ACE OF THE BLACK CROSS”

**Ernst
Udet**

The memoirs of Germany's greatest living air ace. Ernst Udet tells an unparalleled story of an enemy's heroic campaign: "A great tale it is!"—*Evening News*.

Get it from Your Library—6/- net Newnes : London.





Jim Mollison

WRITES ON

NOW FOR THE ATLANTIC

JIM MOLLISON holds the record for direct Atlantic crossings, so he knows more than any other man living the sort of conditions Atlantic pilots are likely to meet. If you are air-minded, read this article—and you will be able to talk on the coming Atlantic Air Service with authority!

* * * *

Other Special Contents of the May "POPULAR FLYING" include:

WHAT I SAW IN SPAIN. By Nigel Tangye.
THE ATLANTIC AIR RACE. By Wm. Ccurlenay.
FLYING IN THE WEST INDIES.

By Joanna Railton.

ABYSSINIAN ADVENTURE. By C. F. Hayter.

Profusely Illustrated.

POPULAR FLYING

THE NATIONAL AVIATION MAGAZINE
Of all Newsagents and Bookstalls, or by post 8d. from the Publisher, C. Arthur Pearson, Ltd., Tower House, Southampton Street, Strand, London, W.C.2.

6^d.
MAY

C. Arthur Pearson, Ltd.



SPECIAL

CORONATION

NUMBER

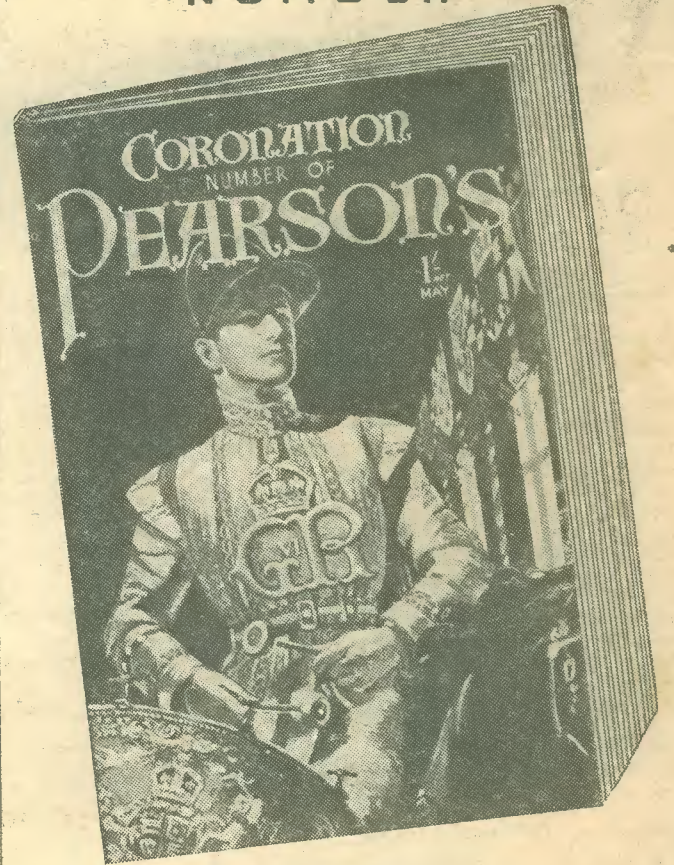

Principal Contents Include—

**H.M. THE KING
THE MAN—AND THE MONARCH**

By W. J. MAKIN
Illustrated in colour

The Story of Coronation Pageantry
By Sir Gerald Wollaston (Garter Principal King-at-Arms)
Illustrated in colour

THE EMPIRE'S SHRINE
A History of Westminster Abbey.

DRAMA IN THE ABBEY
By Dr. Jocelyn Perkins (Sacrist of Westminster Abbey)
Fiction in this number by E. PHILLIPS
OPPENHEIM, H. M. RALEIGH, HORACE
ANNESLEY VACHELL, etc.

PEARSON'S MAGAZINE 1/-

On sale at all Newsagents and Bookstalls, or by post 1/3 from the Publisher, C. Arthur Pearson, Ltd., Tower House, Southampton Street, Strand, London, W.C.2.

MAY NUMBER

C. Arthur Pearson, Ltd

THE VALVE AS RECTIFIER See page 171.



Practical

and Amateur

Wireless



Edited by **F. J. CAMM**

Technical Staff:
W. J. Delaney, H. J. Barton Chapple, Wh.Sch.,
B.Sc., A.M.I.E.E., Frank Preston.

VOL. X. No. 242. May 8th, 1937.

ROUND *the* WORLD of WIRELESS

Fault Finding

THE first step in locating a fault in a receiver is to measure the current or voltage at various points in the circuit, but, as every service man knows, it is often very difficult to locate some types of fault by this means. Such difficulties as broken tuning-coil windings, short-circuited transformer windings and so on, are not revealed by preliminary tests as above described, and there are other faults which will not be revealed at all by a meter of the usual kind. Short-circuited turns in such components as transformers are revealed by special types of apparatus which the average experimenter does not possess, and there are other faults which will only be located when a systematic substitution of components is carried out. In this issue we deal with such details, and even if you have not at the moment experienced such troubles you should study this article in order to be prepared against the time when one of these unforeseen difficulties arises.

Brighton Television Pioneer

THE range of reception of the Alexandra Palace transmitter has been the subject of much controversy, and it is now stated that no definite limit can be placed upon the range. Rumours that listeners on the Continent have picked up the vision transmission and that even American experimenters can get some sort of signal, show that we do not yet know all that is to be known of the peculiarities of the ultra-short-wave transmissions. Mr. S. R. Burbidge, a well-known television pioneer of Brighton, was recently televised from the B.B.C. television transmitter in a talk on how he regularly receives the programmes at Brighton, a distance of 50 miles.

Loudspeaker Traffic Control

THE General Electric Company has received an order for a loudspeaker announcing system for installation on Kincardine-on-Forth Bridge, for the purposes of traffic control. It is hoped by this means to direct traffic by loudspeakers at either end of the swing span, and thus greatly reduce delays caused by congestion. The engineer will have a microphone at his control desk, which is situated at the crown of the swing bridge, and he thus has maximum visibility. The amplifier is rated at 50 watts.

Empire Day Broadcast

THE B.B.C. announces that on Empire Day (May 24th) listeners will hear broadcast on the National wavelength for half an hour a programme from India, with a contribution from Ceylon. Devised by All-India Radio, the programme continues the policy of fostering radio exchanges between various units of the British Empire. The series of this type of Empire Day broadcast began in 1933, when the programme, "News of Home," was provided by the United Kingdom. In the following years,

Binding Cases for Vol. IX

May now be obtained from the address below
Price 3s. 6d. complete
 with Title Page and Index.

The Index alone costs 7d. by post.

Applications to be sent to

The Publisher, George Newnes, Ltd.,
 Tower House, Southampton Street,
 Strand,] W.C.2.

the principal broadcasting organisations of the Empire have collaborated with the B.B.C. in the provision of a special programme on May 24th; in 1934 Australia, in 1935 Canada, and last year South Africa.

Television Lectures

A SPECIAL course of four lectures on Television is to be given at the London Polytechnic, Regent Street, commencing on May 31st next. These lectures, delivered by Mr. H. J. Barton Chapple, will commence at 7.30 p.m., and will last for one hour and a half. Demonstrations of high-definition television, including the reception of the B.B.C. programmes, will be given at each lecture.

A Coronation Lesson

BENDIGEIDVRAN, in the Mabinogion, making his body into a bridge so that his men could cross over a river, is reputed to have said: "A fo ben did bont," which, translated into English means: "Who would be foremost, let him serve." A special Coronation lesson on this subject will be given to Schools in the Welsh programme by Alun Oldfield Davies, on May 10th.

Summer Programmes

THIS year it is proposed to provide alternative programmes during the summer months, instead of a single programme as in previous years. During July, August and September, these alternatives will be radiated on the National and Regional wavelengths between 6.30 p.m. and 8 p.m. It is emphasised that this arrangement is experimental, and its resumption in future years is likely to depend largely on its welcome by the public.

Coronation Route in Music

THE B.B.C. announces that three days before the Coronation a description in music of the route that the Royal procession will take to and from Westminster Abbey will be broadcast by the B.B.C. Variety Orchestra, directed by Charles Shadwell. The programme will be heard on the National wavelength during the afternoon of Sunday, May 9th.

Modern composers have written many famous and popular works around "the sights of London" and most of the important thoroughfares in the metropolis have been portrayed in music.

The programme will thus be able to cover all the important parts of the route, and it will include a Coronation march, "Royal Cavalcade," specially written by Albert Ketelbey; two movements from Eric Coates' London Suite, "Westminster" and "Oxford Street," and "Massed Bands of the Guards," by Michael North.

"Scotland Calling"

GOVAN BURGH BAND, conducted by Gregor J. Grant, will broadcast on May 6th. The programme will include the March Medley "Steps of Glory," Selection from "Oberon," and a Fantasia, "Scotland Calling."

THE VALVE AS RECTIFIER See page 171.



Practical

and Amateur

Wireless



Edited by **F. J. CAMM**

Technical Staff:
W. J. Delaney, H. J. Barton Chapple, Wh.Sch., B.Sc., A.M.I.E.E., Frank Preston.

VOL. X. No. 242. May 8th, 1937.

ROUND *the* WORLD of WIRELESS

Fault Finding

THE first step in locating a fault in a receiver is to measure the current or voltage at various points in the circuit, but, as every service man knows, it is often very difficult to locate some types of fault by this means. Such difficulties as broken tuning-coil windings, short-circuited transformer windings and so on, are not revealed by preliminary tests as above described, and there are other faults which will not be revealed at all by a meter of the usual kind. Short-circuited turns in such components as transformers are revealed by special types of apparatus which the average experimenter does not possess, and there are other faults which will only be located when a systematic substitution of components is carried out. In this issue we deal with such details, and even if you have not at the moment experienced such troubles you should study this article in order to be prepared against the time when one of these unforeseen difficulties arises.

Brighton Television Pioneer

THE range of reception of the Alexandra Palace transmitter has been the subject of much controversy, and it is now stated that no definite limit can be placed upon the range. Rumours that listeners on the Continent have picked up the vision transmission and that even American experimenters can get some sort of signal, show that we do not yet know all that is to be known of the peculiarities of the ultra-short-wave transmissions. Mr. S. R. Burbidge, a well-known television pioneer of Brighton, was recently televised from the B.B.C. television transmitter in a talk on how he regularly receives the programmes at Brighton, a distance of 50 miles.

Loudspeaker Traffic Control

THE General Electric Company has received an order for a loudspeaker announcing system for installation on Kincardine-on-Forth Bridge, for the purposes of traffic control. It is hoped by this means to direct traffic by loudspeakers at either end of the swing span, and thus greatly reduce delays caused by congestion. The engineer will have a microphone at his control desk, which is situated at the crown of the swing bridge, and he thus has maximum visibility. The amplifier is rated at 50 watts.

Empire Day Broadcast

THE B.B.C. announces that on Empire Day (May 24th) listeners will hear broadcast on the National wavelength for half an hour a programme from India, with a contribution from Ceylon. Devised by All-India Radio, the programme continues the policy of fostering radio exchanges between various units of the British Empire. The series of this type of Empire Day broadcast began in 1933, when the programme, "News of Home," was provided by the United Kingdom. In the following years,

A Coronation Lesson

BENDIGEIDVRAN, in the Mabinogion, making his body into a bridge so that his men could cross over a river, is reputed to have said: "A fo ben did bont," which, translated into English means: "Who would be foremost, let him serve." A special Coronation lesson on this subject will be given to Schools in the Welsh programme by Alun Oldfield Davies, on May 10th.

Summer Programmes

THIS year it is proposed to provide alternative programmes during the summer months, instead of a single programme as in previous years. During July, August and September, these alternatives will be radiated on the National and Regional wavelengths between 6.30 p.m. and 8 p.m. It is emphasised that this arrangement is experimental, and its resumption in future years is likely to depend largely on its welcome by the public.

Coronation Route in Music

THE B.B.C. announces that three days before the Coronation a description in music of the route that the Royal procession will take to and from Westminster Abbey will be broadcast by the B.B.C. Variety Orchestra, directed by Charles Shadwell. The programme will be heard on the National wavelength during the afternoon of Sunday, May 9th. Modern composers have written many famous and popular works around "the sights of London" and most of the important thoroughfares in the metropolis have been portrayed in music.

The programme will thus be able to cover all the important parts of the route, and it will include a Coronation march, "Royal Cavalcade," specially written by Albert Ketelbey; two movements from Eric Coates' London Suite, "Westminster" and "Oxford Street," and "Massed Bands of the Guards," by Michael North.

"Scotland Calling"

GOVAN BURGH BAND, conducted by Gregor J. Grant, will broadcast on May 6th. The programme will include the March Medley "Steps of Glory," Selection from "Oberon," and a Fantasia, "Scotland Calling."

Binding Cases for Vol. IX

May now be obtained
from the address below
Price 3s. 6d. complete
with Title Page and Index.

The Index alone
costs 7d. by post.

o o o
Applications to be sent to

The Publisher, George Newnes, Ltd.,
Tower House, Southampton Street,
Strand, W.C.2.

the principal broadcasting organisations of the Empire have collaborated with the B.B.C. in the provision of a special programme on May 24th; in 1934 Australia, in 1935 Canada, and last year South Africa.

Television Lectures

A SPECIAL course of four lectures on Television is to be given at the London Polytechnic, Regent Street, commencing on May 31st next. These lectures, delivered by Mr. H. J. Barton Chapple, will commence at 7.30 p.m., and will last for one hour and a half. Demonstrations of high-definition television, including the reception of the B.B.C. programmes, will be given at each lecture.

ROUND the WORLD of WIRELESS (Continued)

A Coronation Musical Acrostic

WE are informed that Reginald Foort's contribution, at the B.B.C. Theatre Organ, to the programmes of Coronation Week will include a novel arrangement of songs, entitled "A Musical Acrostic in Melody and Rhythm."

He will be accompanied again by Phil Park and Ivor Dennis at two pianos, Styx Gibling, of the B.B.C. Variety Orchestra,

INTERESTING and TOPICAL NEWS and NOTES

Variety from Bristol

A VARIETY programme will be broadcast from the Prince's Theatre, Bristol, on May 14th, the artists including Stainless Stephen, Nora Williams (the Piccolo Pete Girl) and Frank Wilson in a musical comedy act.

"Geisha" Broadcast for Soviet Listeners

THE "Comintern" radio station has recently given the first broadcast of the popular English operetta "The Geisha," composed in 1897 by Sydney Jones. A new text for the operetta was written by the Soviet poet J. Galitsky. George Martin Fuchs conducted.

Coronation Party of Radio Favourites

ON May 12th, listeners to the National programme will hear "Coronation Party," which will represent radio's contribution to the day's celebrations. The producer, Charles Brewer, has included on his invitation list the names of famous broadcasting acts. There will be Elsie and Doris Waters ("Gert and Daisy"), Jeanne de Casalis ("Mrs. Feather"), Clapham and Dwyer, The Two Leslies, Leonard Henry, Davy Burnaby, Michael North and Wynne Ajello, in addition to the Revue Chorus and the Theatre Orchestra.

Brian Lawrance, Jan van der Gucht, Raymond Newell and Stuart Robertson, four vocalists well known to listeners, will also feature in the Party. As a quartet, they will "put over" humorous part-songs.

In addition, Ashley Sterne, the well-known writer, who has already created much delightful microphone humour, has been engaged to provide some topical material for the show, which will run for seventy-five minutes, in the National programme.

Coronation Music in Braille

FOR the guidance of blind musicians during the Coronation period, the National Institute for the Blind has issued a list of fifty appropriate musical compositions—vocal and instrumental—that are available in Braille notation. Only five of these works are by non-British composers.

British Light Overtures

FOR the National programme at the lunch-hour on May 11th the B.B.C. Midland Orchestra, conducted by Reginald Burston, will play works by five British composers—Sir Arthur Sullivan, Roger Quilter, Leigh, Eric Coates, and Ansell.

Concert from Torquay

A NOTHER popular concert by the Torquay Municipal Orchestra will be broadcast in the Western programme on



Tuning-in a Coronation week broadcast on the new Cossor mains receiver Model 348.

at the drums, and by Esther Coleman and Bert Yarlett.

He has so arranged the programme, which will be broadcast on the Regional wavelength on May 14th, that the initial letters of the titles of the songs will, together, form an appropriate acrostic.

All British Variety

THE Empire Theatre, Belfast, has arranged a brilliant programme of All-British Variety to celebrate Coronation Week, and on May 14th a broadcast from this Theatre will be included in the Northern Ireland programme. The popular comedians, Hazell and Day, who broadcast from Belfast during the special week after the opening of the Lisnagarvey transmitter in March, 1936, are returning to Belfast, and among the other artists at the Empire will be Alex Findlay and Lou Redford with his xylophone. This should prove an outstanding variety programme, and it will be compered, as usual, by Raymond Glendenning.

Salisbury Cathedral Organ Recital

ON May 10th, in the Western programme, Sir Walter Alcock will give an organ recital from Salisbury Cathedral. He has been organist of the Cathedral since 1916.

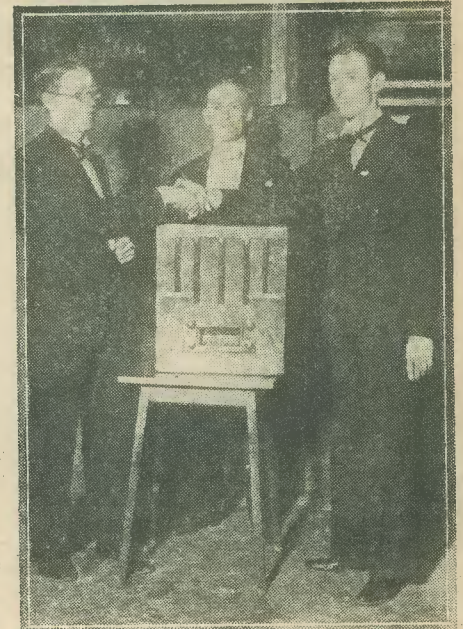

At a recent Charity Press Ball in Cambridge, a Pye T.20 A.C. Portable was offered as a special prize. Tommy Fields, the famous comedian, is here seen presenting the set to the lucky winner.

May 11th. Stanley Pope (baritone) will be the vocalist.

Light Entertainment from the Midlands

THREE Midland theatres will be visited by the microphone on May 14th to obtain an example of the light entertainment provided during the week of popular celebrations. These are all independent theatres, namely, the Theatre Royal, Hanley, where Arthur White and his Road Show will be the chief attraction; the New Theatre, Northampton; and the Coventry Hippodrome. All three contribute regularly to the broadcasts of theatre variety. The commentators will be David Gretton, who is charge of Midland Outside Broadcasts; Cedric Johnson, and Kenneth Harvey.

SOLVE THIS!

PROBLEM No. 242

Robertson's set suddenly stopped functioning, but when the low-impedance extension speaker was plugged into the extra L.S. sockets of the receiver satisfactory results were obtained. Where was the fault? Three books will be awarded for the first three correct solutions opened. Address your solutions to the Editor, PRACTICAL AND AMATEUR WIRELESS, Geo. Newnes, Ltd., Tower House, Southampton Street, Strand, London, W.C.2. Envelopes must be marked Problem No. 242 in the top left-hand corner and must be posted to reach this office not later than the first post on Monday, May 10th, 1937.

Solution to Problem No. 241

The hum and high readings were due to shorted turns on the field winding of the energised speaker. The following three readers successfully solved Problem No. 240, and books are accordingly being forwarded to them: J. M. Robertson, 16, Bank Street, Aberfeldy, Perthshire; D. A. Castle, 45, High Street, Winchester, Hants.; R. Le Grove, 128, Hailey Road, Forest Gate, London, E.7.

The Valve as Rectifier

This Article, which Explains the Functions of Valve Rectifiers, is Specially Written for Beginners By RADIO ENGINEER

BEFORE one can consider using alternating current supplies for the purpose of providing the necessary high-tension for a receiver or transmitter, it is essential to arrange some means whereby the alternating current can be "rectified" so that a steady current, flowing in one direction only—*direct current*—is obtained.

The process is known as "rectification," and in this article it refers to alternating currents of low frequency—the standard frequency of commercial supplies in this country being 50 cycles per second—and not, as in the case of rectification or detection in a wireless receiver, to alternating currents of radio or high frequency.

When dealing with batteries or D.C. supplies, the potential can be considered to be steady, while the polarity is always constant, one side of the circuit being negative and the other side positive. With A.C., however, the state of affairs is very different, as the polarity alternates between a positive and negative maximum value.

It is possible to represent the difference between the two supplies graphically, and "x," Fig. 1, indicates the wave form of a direct current, while "y" shows that produced by an alternating supply, the change

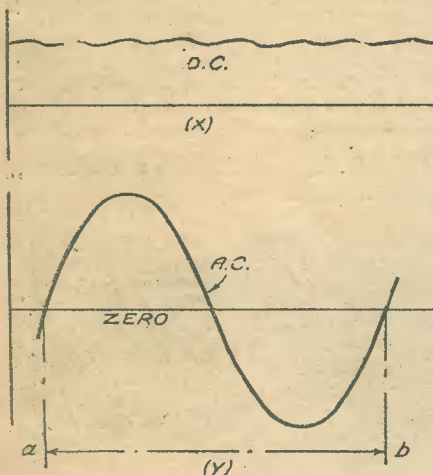

Fig. 1.—Graphical representation of a D.C. and A.C. supply.

in polarity being clearly indicated. The distance between the two points "a" and "b" represents a complete cycle, during which the current passes from zero to positive maximum, back to zero and on to negative maximum, finally completing the cycle by returning to zero. This cycle is repeated very frequently, and it is the number of times per second that it takes place which determines the periodicity or frequency of the current.

If the two curves are given a little consideration, it will be appreciated that to obtain the required results the alternating current has to be stopped from flowing in alternate directions, i.e., above and below the zero line; therefore, various methods have been devised to do this, but in this article we are only concerned with the thermionic valve as a rectifier.

The Valve Rectifier

The original thermionic valve (Fleming) employed two electrodes only (diode valve), a filament and an anode, as indicated in Fig. 2. For its operation it depended on the filament, when heated, emitting electrons which passed across the intervening space to the anode, providing

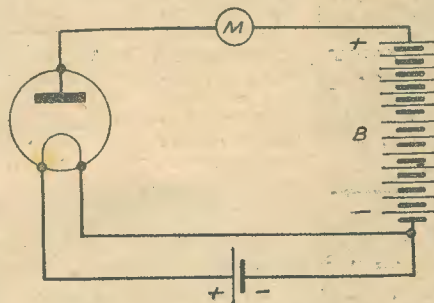

Fig. 2.—Simple or basic rectifying circuit.

the anode was maintained at a positive potential, with respect to the filament. The flow of electrons constitutes an electric current, and the milliammeter M will indicate its presence when the required operating conditions are in force.

The rectifying valve of to-day is fundamentally the same, though, of course, vast improvements have been made as regards design, construction and efficiency.

The modern rectifying valve can be of the directly or indirectly heated type; it can be fitted with one or two anodes for half or full-wave rectification, while larger electrodes are employed to allow the necessary output and life to be obtained.

One of the main considerations in design is the reduction of voltage drop across the valve, perfect insulation, and a filament which is capable of giving a generous emission without excessive loss of life. The placing of the anode in relation to the filament is very important, as the distance between them has a direct bearing on the voltage drop.

Operation

Referring again to Fig. 2. If the battery "B" is replaced with a source of alternating current, it follows that the anode will be alternately positive and negative; therefore, in view of the previous remarks concerning the Fleming valve, it also follows that current will flow only during the positive half-cycle, i.e., when the anode is positive. During the negative half-cycle, no current flow will take place, so what really happens is: a *unidirectional* current is set up, but it is of a *pulsating* nature due to the time between successive positive half-waves.

This can best be understood by examining Fig. 3, in which curve "A" shows the wave form of the rectified output, and it will be appreciated—by comparison with "x," Fig. 1—that the D.C. thus produced is still far from perfect.

The system described deals with only half of the A.C. wave, it being the most simple method possible, and it is usually known as half-wave rectification.

Full-wave Rectification

If two half-wave rectifiers are connected as shown in Fig. 4 it will be possible to utilise the complete A.C. cycle and obtain a greatly improved output wave form.

The source of alternating current is obtained from the mains via the transformer "T," which can be so designed that the voltage output of the secondary windings is greater or less than the actual mains supply.

The secondary "S" is provided with a tapping at its dead electrical centre, and it is essential that the voltage across "s," and "s.l." is equal to twice the voltage required by the anode of each rectifier, thus giving between "c.t." and "s" and "c.t." and "s.l." a voltage equal to that required by each valve.

When the secondary is positive at "s," current will flow through the rectifier "R," but "R1" will be inoperative. As soon, however, as the polarity of the secondary changes, "s.l." will become positive and the current flow will be through rectifier "R1," while "R" will cease, as that end of the winding is then negative.

By adopting this method, and it is the one most widely used, both half-cycles of the A.C. wave are rectified, and the resultant output is considerably smoother or, in other words, the big gaps between the pulses "A," Fig. 3, have been filled in, as shown by "B" of the same diagram, by the rectification of the additional half-wave.

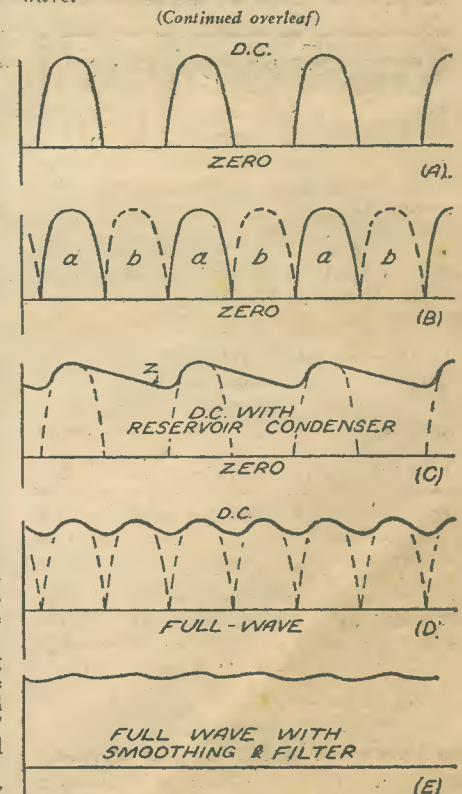

Fig. 3.—Graphical representation of the effects of rectification and smoothing of an A.C. supply.

THE VALVE AS RECTIFIER.

(Continued from previous page)

It is not usual, for average amateur work, to use two separate half-wave rectifying valves to obtain full-wave rectification, as full-wave rectifying valves, containing two sets of electrodes within one bulb, are standard products of the various valve manufacturers.

Smoothing

It has been agreed that the outputs obtained so far are still far from perfect

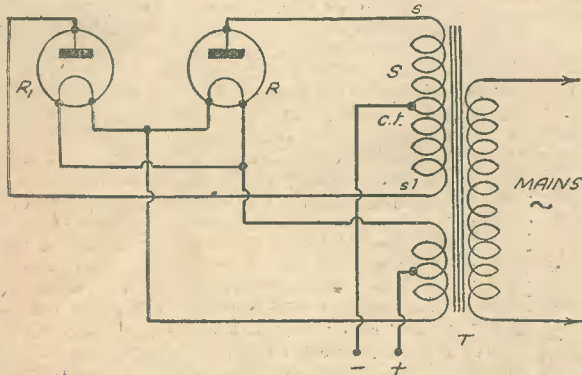
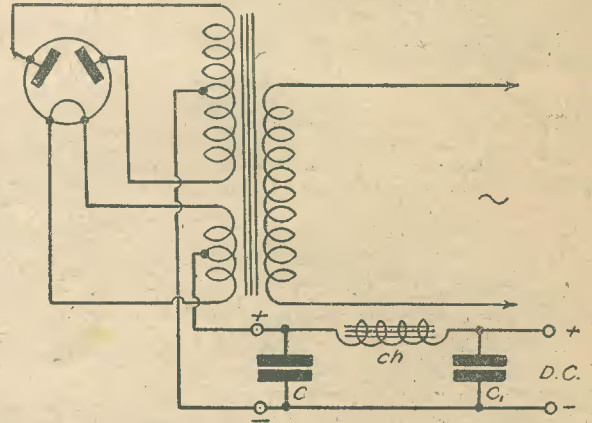

Fig. 4 (left).—Method of using two half-wave rectifiers to obtain an improved output waveform, and Fig. 5 (right).—Full-wave valve rectifier circuit.



and quite unsuitable to feed the anodes of the valves in a receiver or transmitter, therefore some smoothing arrangements must be employed.

For simplicity's sake, consider the half-wave output first. Quite a high degree of smoothing can be obtained by simply connecting a suitable fixed condenser across the output. In fact, such an arrangement also has a marked effect on the output voltage, tending to raise the value; therefore, although the capacity is not exactly critical, it is advisable to follow the rectifier makers specification. If the condenser has too high a value, damage can be caused

negative half-cycles, thus, as the curve shows, filling in, so to speak, the gaps between the pulses or peaks, the part "z" being condensed voltage.

For the average amateur working voltages a capacity of 4mfd. is quite satisfactory, but it will be found that half-wave rectification requires more smoothing than full-wave.

The unevenness of curve "C" is due, to a great extent, to the presence of "ripple" voltages superimposed on the direct current, and if such are allowed to remain it is highly probable that pronounced "hum" will be experienced, so a simple filter circuit

has to be embodied to remove all traces of them. A good L.F. choke and another fixed condenser are all that is necessary, at least, in the majority of cases, and they are introduced into the circuit as shown in Fig. 5, which shows the complete full-wave rectifier arrangement.

With the output of the full-wave circuit, the condenser smoothing has an even greater effect than in the previous case, the resultant curve being shown as "D"

(Fig. 3), where it will be seen that the output is no longer a series of heavy pulses, but a fairly steady supply.

The filter circuit is still, however, essential, and its effect can be seen by examining the curve "E" (Fig. 3), which represents a reasonably good D.C. supply.

The choke "Ch," Fig 5, should have an inductance of at least 20 to 25 henries when carrying the maximum current output of the rectifier concerned, while "C.1" should be 4 mfd. to 6 mfd., and, for safety's sake, it is advisable to see that it is made for a "working" voltage of, say, 50 per cent. higher than the rectified output.

SOUTHAMPTON'S WIRELESS COLLEGE

THE increasing interest which is being taken in radio and television technique has led to an increased demand for training centres. The Wireless College at Colwyn Bay has specialised in radio training for many years, and on April 14th a branch was opened at Calmore, Southampton. The opening ceremony was performed by Sir Ambrose Fleming, M.A., D.Sc., F.R.S., who was presented with a gold key for the purpose by Miss Pamela Whale, aged three years. A tablet is mounted in the Hall to commemorate the occasion and an address was given to the guests by a representative of the Marconi Company. A tour of inspection of the college, its grounds and equipment was made, and the proceedings terminated in the evening with a concert given in the College Theatre by the students. Full details of the training provided at the college

may be obtained on application to the Principal, Gordon S. Whale,

A.M.I.R.E., M.A.A.A.S., at Calmore, Southampton.



Sir Ambrose Fleming, with the principal of the Wireless College, Mr. Gordon S. Whale, reading a tablet he unveiled at the opening of the college recently.

Practical Television

May 8th, 1937 Vol. 3. No. 49.

TELEVISION IN CORONATION WEEK

The B.B.C. Announces the following Plans for Television Programmes During Coronation Week

THE outstanding event will, of course, be the televising of the Coronation procession at Apsley Gate, Hyde Park Corner, on the return journey from Westminster Abbey. The broadcast, which is expected to last one hour, will open at 2 p.m. with views of the Park and crowd scenes between Stanhope Gate and Hyde Park Corner. Telephoto lenses will pick out the head of the procession a quarter-of-an-hour later as it approaches down the East Carriage Drive, and from then until the last horsemen have passed through Wellington Arch to Constitution Hill the whole of the two-mile procession will be shown on the television screen. A descriptive commentary will be given by Frederick H. Grisewood, who will be stationed at a microphone beside the cameras at Apsley Gate.

As mentioned in a recent issue, three Emitron cameras will be used. Two will be mounted on a special platform at Apsley Gate and will be fitted with telephoto lenses for obtaining distant and mid-shots of the procession and the crowds to the north and south of the gate. A third camera, installed on the pavement to the north of the gate, will give close-range views of the Royal Coach and other important parts of the procession passing through the gate.

The cameras will be connected by some fifty yards of cable to the new mobile television unit behind the park-keeper's lodge, whence the sound and vision signals will be conveyed by cable to Broadcasting House and Alexandra Palace. The mobile television unit comprises three vans; one contains the control apparatus and scanning equipment, one the power plant, and the third an ultra-short-wave radio-link transmitter of 1 kilowatt power, which on May 12th will be used as a stand-by for conveying signals to the television station.

The Week's Programmes

Outstanding among the studio programmes in Coronation Week will be the appearance of Alicia Markova and Anton Dolin on Tuesday, May 11th, with members of their company in a Pas de Quatre and Tchaikovsky's "Blue Bird" suite. Special Coronation editions of "Picture Page," television's topical "magazine," will be presented in the afternoon and evening, and it is expected that many of the visitors will have been directly concerned with the Coronation preparations. On the same day, Gerald Cock, Director of Television, will give an illustrated account, both in the afternoon and evening, of the arrangements for televising the Coronation Procession. Films and photographs will be used and, through the co-operation of Scotland Yard, special plans will show how London traffic will be controlled on Coronation Day.

A "Music-hall Cavalcade," which will be the main feature in the evening television programme on Coronation Day, will be presented in a novel manner. An elderly couple who recall the grand old days of

Victorian and Edwardian music-hall will see their reminiscences take form and substance as the favourites of yesterday and to-day reappear on the television screen. The artists will include Albert Whelan, entertainer at the piano; Ada Cerito, singing her celebrated "widow" song; Tom Costello, singing "At Trinity Church I met my Doom"; Marie Lloyd, junior, who will be heard in her mother's great number, "One of the Ruins that Cromwell Knocked Abaht a Bit"; and Ida Barr, singing "Oh, you Great Big Beautiful Doll." The studio will be decked out as an old-time music-hall and the traditional chairman and the sellers of bath buns and sweetmeats will be very much in evidence.

Harry Roy's Band will be televised, with Princess Pearl, in the afternoon programme on May 13th. In the evening transmission Clapham and Dwyer will be featured in

evening programmes will be devoted to a tour of the London Television Station. The guide will be Leslie Mitchell, television announcer, and the visitor none other than George Robey, who will accompany the roving camera to the reception hall, to rehearsal, the sound and vision transmitters, the make-up and dressing-rooms, production shop, film projection room, control room and studios. During the "tour" viewers will meet C. H. Middleton, the gardening expert, and the Television Orchestra.

Another Historical Film

PRIOR to the official opening of the Alexandra Palace station the B.B.C. staff prepared a film entitled "Television comes to London" and televised it several times in the initial programmes. It traced some of the early history of television but dealt more specifically with the building and installation of the television equipment, together with the very considerable structural alterations in the Palace building itself. It is now learned that a more ambitious effort is to be made, for plans are already well in hand for an elaborate production which aims at portraying the historical development of television from the earliest work of the pioneers right up to the advanced equipment now in daily use. Not only will this serve as a record for posterity but it will be employed for propaganda purposes by being radiated in television signal form in the new hourly morning sessions which are being planned. These additional daily periods from 11 a.m. to noon are for the benefit of dealers so that



This illustration shows the camera in action televising a horse-riding demonstration for a recent Alexandra Palace broadcast.

"Starlight." The first performance of a new modern rhapsody by Ord Hamilton, "Rhythm in the Dawn," will be given by the Television Orchestra in the same programme.

On Friday, May 14th, Jack Hylton will bring his band to the television studio. The instrumentalists and vocalists number nearly forty—the largest musical combination yet televised, and as was the case on the Band's previous appearance, a special rearrangement of the studio will be necessary.

Television will televise itself on Saturday, May 15th, when both afternoon and

they can demonstrate sets to prospective purchasers, and to enable manufacturers to test their new models and designs under strict service conditions before going into big production. Both the production and direction of the film will be in the hands of the B.B.C. television producer, Dallas Bower, while the late chief cameraman of Baird Television, Ltd.—Allan Lawson—will be in charge of the photographic side. This move on the part of the B.B.C. is an admirable one, and serves as additional evidence of the determination of the television staff to put its service right on the map at a very favourable period.

THE TELEVISION O.B. VAN

Advance Details of the Special Mobile Control Room Which will be Used when Televising the Coronation Procession

FOR the purpose of televising the Coronation procession, the B.B.C. have purchased from the Marconi-E.M.I. Television Company a special mobile control room in which the various incidental pieces of machinery are housed. The complete installation is incorporated in a large motor vehicle about the size of a Green Line coach, and this will be parked on the grass on the west side of Apsley Gate, behind the park-keeper's lodge. The apparatus itself is mounted on two rows of racks along the sides of the vehicle, with a small central aisle along which the operators can walk when inspecting and operating the equipment. The racks, of which there are six on each side, measure 7ft. 6in. in height and 19½in. in width, and the total weight of the vehicle is 8½ tons. A monitoring receiver is fitted in a compartment over the driver's head, and thus the operators can see the televised picture and make the necessary adjustments by means of the controls provided for the purpose.

Sound Control Room

In addition to this section, there is a small sound control room incorporated in the vehicle, with all the necessary faders and amplifiers to deal with four microphones which will pick up the voice of a commentator and local sounds associated with the scene being televised. Three special multiple cables will run from the vehicle to the top of Apsley Gate, across which they will pass, concealed, to drop down behind a pillar at the point where the three television cameras are mounted. These cables are about 1½in. in diameter, and contain 27 insulated conductors, two of which are of a special low-capacity type designed to

carry the very high-frequencies involved in a television picture transmission.

A Stand-by Transmitter

A special stand-by transmitter vehicle will be parked alongside the main van, and

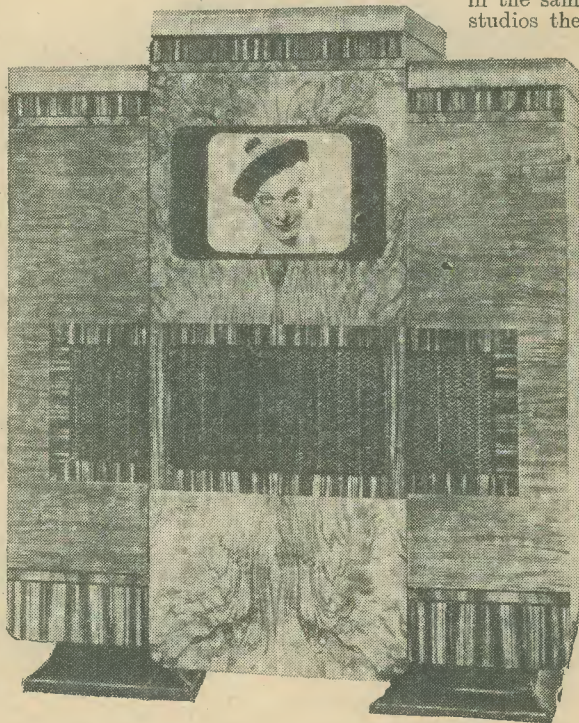

this will radiate the vision signal from a small highly-directional aerial which is mounted on two low wooden masts close to the scene of operations. This aerial is arranged to provide the maximum signal in the direction of the Alexandra Palace, where another special receiving aerial will be arranged to intercept the signal from Hyde Park. This receiving aerial is being mounted on top of the main transmitting mast at the Alexandra Palace, and a special shielded high-frequency feeder is to be carried down to a special receiver in the transmitting room, where the signal will be fed into the standard television transmitter in the same way as with signals from the studios there. To avoid any troubles from breakdowns, duplicate circuits are being arranged and special care has been taken to avoid interference from cars and other electrical equipment, which may be in the vicinity of the cameras and vans. No doubt the experience

The H.M.V. Television Autodiagram, a de-luxe television plus all-world radio receiver, incorporating an automatic record changer, playing eight 10in. or 12in. records. The radio controls are beneath the right-hand lid, the television controls beneath the left-hand lid, and the automatic record changing mechanism is in the centre section. The price of this elaborate receiver is 120 guineas, which includes the necessary television aerial, free installation and maintenance for one year.

gained with this particular equipment at the Coronation procession will provide valuable data for subsequent television broadcasts of important events which take place from time to time.

Spare Equipment

IN an effort to prevent the breakdowns in the television service from Alexandra Palace the B.B.C. is taking steps to install duplicate equipment. The system of oscillators, correctors, modulation amplifiers, and so on, now in operation is very complicated, and even the failure of a small component is capable of wrecking the whole chain. No doubt the Baird radio transmitter could be adapted to suit the B.B.C. picture standard, and this would then provide an admirable standby in case of a transmitter fault. It would be very serious for the popularity of the service if picture failures occurred when many of the proposed ambitious outside broadcasts were scheduled to take place, for it is known that many receiver purchases have been made for these events alone.

A Similar Characteristic

REGARDING cathode-ray tubes, it is possible that many readers have failed to realise that one of the characteristic curves resembles very much that of the familiar family of characteristic curves about which so much was said in the earlier days of radio. If a graph is made showing the relation between the negative voltage bias applied to the control electrode of the C.R. tube (horizontal ordinate), and the brightness (beam current) of the spot observed as fluorescence on the screen, it will be identical in shape and nature to a

TELEVISION NOTES

valve curve plotting anode current against grid bias for a steady anode voltage condition. The beam current will be zero for a certain negative potential on the modulator anode (similar to the valve grid)—some value between 50 and 90 volts—and after a sharp curve will rise steadily with reduced negative bias until a certain maximum value is reached corresponding to the saturation anode current condition of a valve. The shorter the bias range between black (zero beam current) and white (maximum beam current), the greater the sensitivity of the tube, but this characteristic has to be designed to match in with all the other features and operational data of the tube to ensure that good pictures materialise. If the picture is too bright a well-modulated signal will extend the voltage beyond the zero bias condition, rendering the modulator electrode positive and spoiling the picture. The static bias condition must be comfortably within the normal signal voltage range if the full black to white brightness variation is to show correctly.

American Receiver Design

SOME of the objections levelled against American television receivers included the small size of the picture—it seldom was greater than 10in. wide and more frequently

was less—its colour, since the designers showed a marked preference for green, and the total number of valves employed, generally in excess of thirty. Apparently these have been taken to heart, for in the later designs now being prepared by some of the more important companies the total number of valves is about two dozen, while there is a diminution in the number of external controls which the user can handle. Steps are being taken to increase picture size and improvements made in both the estimated life and performance of the cathode-ray tube which still features as the prime picture reproducer. Few, if any, of the companies show any partiality towards mechanical reproducers. On the programme side a close watch is being kept on the efforts of the B.B.C., a very unusual factor as far as anything connected with American radio is concerned. As in this country controversies still rage between the cinema and television interests, but signs of a spirit of co-operation seem to be emerging and this is a favourable factor. The two industries must be interdependent for some time to come and a merging of ideas will operate for the benefit of both sides.

Everyman's Wireless Book

2nd Edition
3/6, by post 3/10 from George Newnes, Ltd.,
Tower House, Southampton St., London, W.C.2.

YOU HAVE BEEN WARNED BY RADIO

Professor Hilton, on November 19th, 1936, from the B.B.C. broadcast a warning. The warning was to the effect that while there are many really good and reliable Colleges teaching by correspondence, there are many others which are colleges by name only. He said some so-called colleges rented a couple of rooms in a large building in a well-known street. Some made great promises which they did not intend to fulfil. Some claimed successes they could not prove. In some cases the names of prominent men were quoted who were in no way connected with the working of the College.

NOW BE ADVISED BY ME

The big name of a College is no proof of its national standing. The Bennett College has been established over 30 years and our entire building is devoted to Bennett College work. No other business of any kind is either on or attached to The Bennett College. We have seating accommodation for over 10,000. We have a permanent staff of over 190 people on the College premises. Our Professional Staff have all passed their examinations, and our tutors are all experts in their own specialised work. We do not send out any homework to be corrected by tired, spare-time tutors. All students' homework is corrected on the College premises the same day that it arrives, and is returned by evening post. This College is Technical, Scientific, General and Commercial, thus enabling us to cater for all requirements; this is important to Cost and Works Accountants, and all who have to deal with rate-fixing, machining-allowance, and it is also of great importance in many of the Civil Service Examinations. This is an entirely British College. Most of our textbooks are written on the College premises by our professional staff, especially for tutorial purposes. Our tutors specialise in teaching students for the examinations they themselves have already passed.

THERE IS NO OTHER COLLEGE IN THIS KINGDOM THAT CAN CLAIM ALL THE ABOVE ADVANTAGES.

It is not necessary for students to attend the College; we can send exactly the same tuition to you by post for a reasonable fee payable monthly. Anyone who reads the journals knows that there are many things advertised that one can study, and any kind of study is good. It is training for the brain, but the best thing to study, surely, is a course specially prepared to teach

your own vocation, or prepare you for the examination which you have in view.

Knowing that you are master of your job gives you self-confidence and personality, but a Diploma from a College is absolute proof of your efficiency. We have agencies in all English-speaking corners of the world. The nature of our business makes us keep in touch with employment requirements in all parts of the world, therefore we specialise in preparing students for the good positions which we know exist, and for all worth-while examinations.

THE ABOVE VAST ORGANISATION CAN HAVE BEEN CREATED ONLY BY THE SUCCESS OF OUR STUDENTS

There is a tide in the affairs of man which, if taken at the flood, leads on to fortune and success. There are three things which come not back: the sped arrow, the spoken word and the lost opportunity—this is your opportunity. If it is your desire to make progress and establish yourself in a good career, write to us for free particulars on any subject which interests you, or if your career is not decided, write and tell us of your likes and dislikes, and we will give you practical advice as to the possibilities of a vocation and how to succeed in it. You will be under no obligation whatever. It is our pleasure to help. We never take students for courses unless we feel satisfied they are suitable. Do not forget that success is not the prerogative of the brilliant. Our experience of over 30 years proves that the will to succeed achieves more than outstanding brilliancy.



J. Bennett

DO ANY OF THESE SUBJECTS INTEREST YOU?

- | | | |
|---|--|------------|
| Accountancy Examinations | Matriculation. | Metallurgy |
| Advertising and Sales Management | Mining, all subjects | |
| A.M.I. Fire E. Exam. | Mining, Electrical Engineering | |
| Applied Mechanics | Motor Engineering | |
| Army Certificates | Motor Trade | |
| Auctioneers and Estate Agents | Municipal and County Engineers | |
| Aviation Engineering | Naval Architecture | |
| Banking. | Pattern Making | |
| Boilers | Police, Special Course | |
| Book-keeping, Accountancy and Modern Business Methods | Preceptors, College of Pumps and Pumping Machinery | |
| B.Sc. (Eng.) | Radio Service Engineering | |
| B.Sc. (Estate Management) | Road Making and Maintenance | |
| Building, Architecture and Clerk of Works | Salesmanship, I.S.M.A. | |
| Cambridge Senior School Certificate | Sanitation | |
| Civil Engineering. | Secretarial Exams. | |
| Civil Service | Sheet Metal Work | |
| All Commercial Subjects | Shorthand (Pitman's) | |
| Commercial Art | Shipbuilding | |
| Concrete and Structural Engineering | Structural Engineering | |
| Draughtsmanship. | Surveying | |
| All branches, subjects and examinations | Teachers of Handicrafts | |
| General Education | Telephony and Telegraphy | |
| G.P.O. Eng. Dept. | Transport Inst. Exams. | |
| Heating and Ventilating | Weights and Measures Inspector | |
| Industrial Chemistry | Welding | |
| Insurance. | Wireless Telegraphy and Tele-Works Managers | |

If you do not see your own requirements above, write to us on any subject. Full particulars free.

LET ME BE YOUR FATHER
Let me tell you how to make a success of your career. If your future is undecided or appears unsatisfactory, let us talk it over together. I want to help, and it will cost you nothing to get my help, you will be under no obligation whatever.

We are prepared to produce, on demand, over 10,000 unsolicited testimonials from successful students, or in default we will hand over £100 to charity.



CAN YOU CHANGE MY EXPRESSION?

IF SO, YOU MAY BE THE ARTIST THAT COMMERCE IS WAITING FOR

Just try for yourself, trace or draw the outline and then put in the features.

There are hundreds of openings in connection with Humorous Papers, Advertising Drawing, Posters, Calendars, Catalogues, Textile Designs, Book Illustrations, etc., etc. 60% of Commercial Work Art is done by "Free Lance Artists" who do their work at home and sell it to the highest bidders. Many Commercial Artists draw retaining fees from various sources; others prefer to work full-time employment or partnership arrangement. We teach you not only how to draw what is wanted, but how to make buyers want what you draw. Many of our students who originally took up Commercial Art as a hobby have since turned it into a full-time paying profession with studio and staff of assistant artists—there is no limit to the possibilities.

Let us send full particulars for a FREE TRIAL and details of our course for your inspection. You will be under no obligation whatever.

Jim Duck Art Dept. 104.

YOUNG MEN

Young men physically fit and whose careers are not definitely fixed should join the Police Force. We have special Courses for Entrance and Promotion. 1s. per week brings success. Full particulars Free.

Address: POLICE DEPT. 104

ENGINEERS

Engineers, now is your chance to dig yourselves into a Key position, and make your future solid. It needs Technical Training, we can give you that by post. Full particulars free, Dept. 104.



THE MOST SUCCESSFUL AND MOST PROGRESSIVE COLLEGE IN THE WORLD.

SIGNS OF THE TIMES

ARMAMENTS
means
MASS PRODUCTION
means
JIGS, TOOLS, FIXTURES, ETC.

Our extended course on DRAUGHTSMANSHIP teaches the Design. Our PRACTICAL ENGINEERING teaches the manipulation.

THE AIR FORCE
is to be increased. All branches of **ENGINEERING MUST DEVELOP**

CIVIL SERVICE
Suitable to both sexes. Ages 15½ to 24. Pay Cuts have been restored.

G.P.O. ENG. DEPT.
CUSTOMS AND EXCISE: INSP. OF TAXES, Etc. NO EXPERIENCE REQUIRED. OPEN EXAMS.
TELEPHONY, RADIO and MOTOR ENGINEERING are expanding rapidly. There are lots of vacancies.

MATRICULATION
There are many ways of commencing a career, but Matriculation is the jumping-off board for all the best ones. We prepare Candidates for all

INSTITUTE EXAMS.
TECHNICAL, ACCOUNTANCY, SECRETARIAL, INSURANCE, Etc.

HOW TO STUDY

In your spare time when it suits YOU. You fix your own time, you do not GO to your studies—the postman brings THEM TO YOU. There is nothing that a class-room teacher can show on a blackboard that we cannot show on a white paper. The lesson on a blackboard will be cleaned off, but our lessons are PERMANENT. A class-room teacher cannot give you a private word of encouragement but a Correspondence Tutor can do so whenever your work deserves it. On the other hand, he can, where necessary, point out your mistakes PRIVATELY.

NOTE ADDRESS: DEPT. 104, BENNETT COLLEGE, LTD., SHEFFIELD

Constructional Details of "Practical Wireless" Receivers—3

FOR good long-distance reception, two H.F. stages are essential, and many amateurs prefer a "straight" receiver of this type to one of the superhet designs. There are, of course, the advantages of absence of whistles and the avoidance of tricky ganging and trimming adjustments, and in the Fury Four receiver greater simplification is introduced by utilising separate tuning condensers. The two H.F. stages are tuned by means of a two-gang condenser, the flatness of tuning of the aerial coil rendering it unnecessary to make use of any panel trimming device. The detector tuning coil is then tuned by a separate tuning condenser, and the only disadvantage of such a scheme is that it is possible to find two adjustments for certain powerful stations. However, if the trimmers mounted on the condensers are adjusted carefully, and the series aerial condenser also set to a certain position, it may be found in most cases that the dial readings of the two tuning controls will coincide, thus facilitating the tuning process.

Modifications

To bring this particular receiver up to date, modern iron-core coils are recommended in place of the original air-core variety, and the Varley combination will be found ideal. A set of three type BP.50 coils should be obtained, and the attached diagram shows the wiring to the coil unit, the majority of the wires in this diagram being placed in the same position as on the blueprint, which may be obtained for this receiver. For tuning purposes, we now recommend the J.B. "Nugang" type condensers, the make originally specified no longer being on the market. To keep in line with the original design, the J.B. drive Type A should be specified when ordering these condensers. Of the remaining components in the original specification, the aerial-series condenser, output choke, and volume control are now unobtainable, and for these, substitutes are given in the list of components which is attached.

One of Our Most Popular Early Receivers Was the Fury Four, and This Article Gives the Main Constructional Details and the Modifications Necessary to Bring It Up to Date

Construction

The receiver is assembled on a baseboard 16in. by 10in. with 2in. runners along two sides, and a panel 16in. by 8in. carries the controls and tuning dial escutcheons. Although not essential, the baseboard could be covered with a sheet of metal foil, either copper or aluminium. The former would enable various earth return leads to be connected to it by soldering. In wiring a receiver of this type it is preferable to do as much of the work as possible before the condensers and coils are mounted as by this

means the weight of the receiver is kept to a minimum, and it may be more easily handled.

It will be noticed that certain slight alterations now have to be carried out to the under-chassis wiring in order to enable the new coils to be used correctly. These are provided with a special change-over tapping on the coils, joined to terminal No. 3 on each coil unit. Therefore, the present connections from the grid line of each of valves V2 and V3 to the H.F. circuit of the preceding stages must be broken in order to enable this to be done. Condenser C5 (.0003 mfd.) is now joined to the grid of V2 and through hole No. 4 to the anode of V1. This lead must be left intact, but the lead which goes from the grid of V2, through hole No. 5, to the tuning condenser must not come into contact with the .0003 mfd. fixed condenser. The tag shown joined to this line should be connected to terminal No. 3 on the centre coil, another hole being drilled in the chassis to enable this lead to pass from one side to the other. The other condenser, C10, is joined in the blueprint to a lead running from hole No. 10 in the chassis, and accordingly it is necessary to

(Continued on page 184)

THE FURY FOUR

(Blueprint No. P W 11)

LIST OF COMPONENTS

- One three-gang coil assembly (B.P.50) (Varley).
- One two-gang "Nugang" condenser with type A drive (J. B.).
- One single gang "Nugang" condenser, with type A drive (J. B.).
- One Formodenser, type J (Formo Products).
- One Wearite S.G. choke, type H.F.P.A. (Wright and Weaire)
- One S.G. choke, type H.F.4 (Bulgin).
- One screened H.F. choke (B.T.S.).
- One L.F. transformer, ratio 3 to 1 (B.T.S.).
- One Pentode output choke, type D.P.9 (Varley).
- Three 1 mfd. fixed condensers, type B.B. (Dubilier).
- Two .0003 mfd. fixed condensers, type 665 (Dubilier).
- One .0002 mfd. fixed condenser, type 665 (Dubilier).
- Two .1 + .1 C mfd. fixed condenser, type BE.31 (Dubilier).
- Four Clix chassis mounting valveholders, three 4-pin and one 5-pin (Clix).
- Four 1,000 ohm 1-watt type Resistors (Erie).
- One 100,000 ohm 1 watt type Resistor (Erie).
- One 5,000 ohm 1-watt type Resistor (Erie).
- One 2 meg. grid leak with wire ends (Erie).
- Three terminal mounting blocks (Belling-Lee).
- One 4-way battery cord (Belling-Lee).
- Six terminals: A, E, Pick-up (2) and L.S. (2) (Belling-Lee).
- One fuse-holder, type F5 with fuse (Bulgin).
- One 50,000 ohm potentiometer, type VG.47 (Bulgin).
- One .0003 mfd. differential reaction condenser (B.T.S.).
- One three-point switch, type GWC (Wright and Weaire).
- One ebonite panel, 16in. by 8in. (Peto-Scott).
- One chassis, 16in. by 10in., with 2in. runners (Peto-Scott).
- Four valves: Type 220 S.G., 220 S.G., 210 H.F., and 220 PT (Cossor).

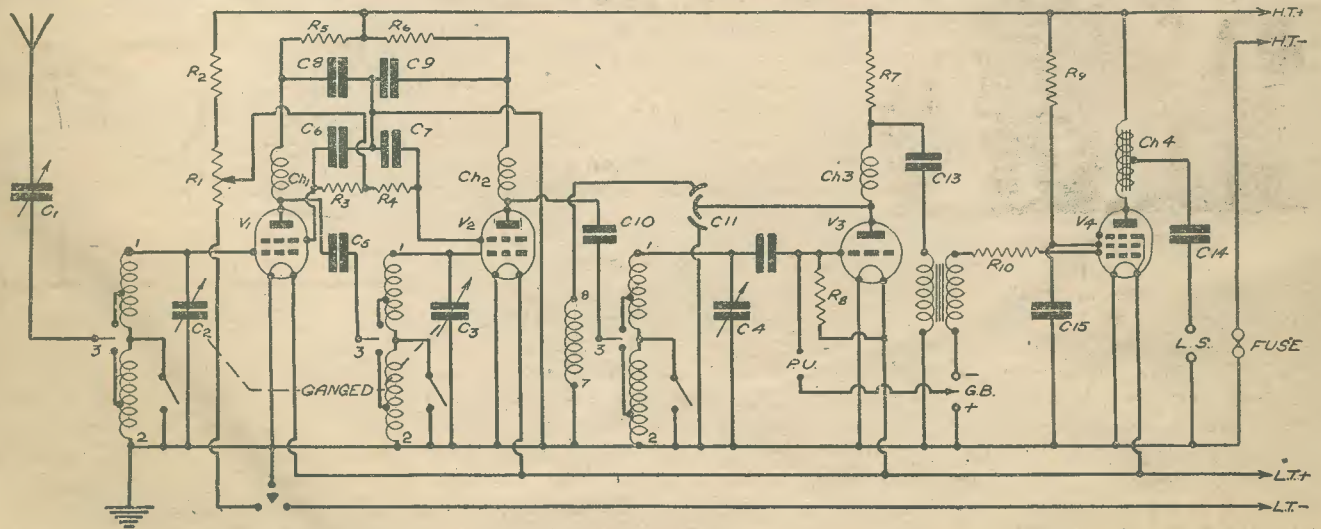

Complete theoretical circuit diagram of the Fury Four showing the terminal connecting points for the new coils.

On Your Wavelength

By THERMION



A Jam in the Studio

THE B.B.C. we must admit is bright and breezy and up-to-date in its outlook. Further evidence of this was provided by the recent jam session in which a room full of highly-paid musicians extracted from the leading bands in London were invited to broadcast themes on certain popular tunes without previous rehearsal. The result was better imagined than listened to—it was certainly easier imagined than described. I was left speechless, tongue-tied, and my usually prolific vocabulary with its rich store of appellations, execrations, objurgations, and expletives, entirely broke down in my effort to find suitable words with which to describe it. I can only tamely say that it was the greatest insult to the ear that the B.B.C. had yet broadcast. Or is it? After all, why shouldn't the B.B.C. do what the

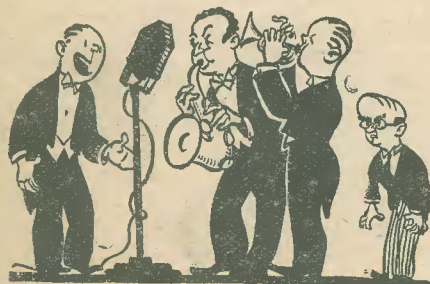

Money for jam.

Minister of Transport is allowed to do and is paid to do? I expect many members of the B.B.C. arrive at Portland Place by means of their Rolls-Royces—a vehicle, I understand, which even the most lowly paid luminary employed in that ugly building is wont to use. They must always be on the alert for ideas for new programmes. In travelling through London they must, as I do, become simply frantic at the muddle and the

chaos which has been created by Hore-Belisha. When they arrive at the office their nerves must be frayed to tatters, and on the grounds that after the night before you want the hair of a dog that has bitten you to effect a cure, they plan this cacophony to assuage their trembling nerves and bodily torments. The world is a mad place nowadays anyway, where rules of decorum and the proprieties are relegated to the limbo of bustles, harpsichords, antimacassars, and the cult of dirt in which it was considered unclean to wash every day. A world which can tolerate jazz and crooners can tolerate anything. Therefore, I congratulate the B.B.C. on having created the Big Din, and thereby set an example to America. The interlarded remarks such as "Yeah, Sir," "Swing it, Boys," "Gee, that's meller," or "Atta Baby, that's a hot one," add to the lunacy.

New Use for Crooners

I LEARN that the General Electric Company are installing a speech amplifying system on the Kincardine-on-Forth Bridge which is to be used for controlling traffic. The Control Engineer will be able to speak into a microphone from his cabin situated at the crown of the swing span, and when he wants the traffic to stop I suggest that he puts on a record of a crooner when the motorists will just fade away.

Good News for Norfolk?

I HAVE had a number of letters from readers in Norfolk and district who have bemoaned their lot for years. It appears that reception conditions there are very bad, and even the experts who have visited Norwich and its surroundings have been unable to say just why conditions should be so bad. On the long waves signals are received fairly well, but on the medium band even London does not provide a good signal. Apparently

the complaints have also been sent to the powers that be, for it is now announced that a station is to be built at Norwich by the B.B.C. So perhaps now the residents in that part of the country will rest content—or will they? I forgot to mention that the station will not be in operation until 1939!

Songs You've Never Heard!

Some time ago the B.B.C. had another bright idea—namely, to broadcast songs that had not been accepted by various music publishers. We were told that these songs had been submitted to the publishers who had either refused them, or placed them on their shelves as unsuitable for public consumption. What has happened now? I called in at our local bazaar yesterday, and the gramophone on the music counter was blaring out one of the songs in question. When I switched on the radio at home, the band which was playing at the moment was also playing the same tune. During the evening I heard it no less than five times. Does this mean that the song is so popular, or that plugging still takes place? Incidentally, the question of adver-

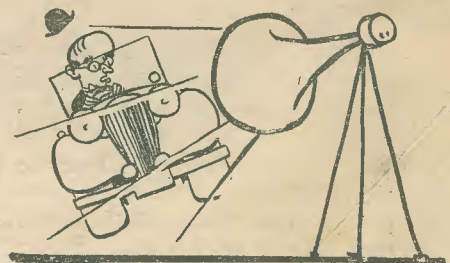

Loudspeaker traffic control.

tising in this particular series seems to have cropped up again, and although it is stated that no advertising is permitted I have noticed many instances lately where blatant infringements of this rule have taken place—even to an artist being permitted to state the hotel at which he is going to stay when he comes to London.

Radio Alarms

IN a recent issue some details were given concerning a new automatic call device to be introduced by the American shipping authorities, and these details seem to have raised the ire of a reader who sends the following epistle:—

"Produced in America, a country always regarded as very 'go-ahead,' one is led to believe that this device is something new and remarkable. Mr. Pannell, President of the Radiomarine Corporation of America, also seems to think it something to shout about. A considerable portion of my life has been spent at sea as a Marine Operator, and for eight years of that period I have worked on ships fitted with just such a device as is described in your paper. In America, the Safety Device was not recognised, nor would they even consider it as an effective aid in British ships, and, in consequence, they compelled all foreign ships trading on their coasts to carry, in addition to the Wireless Operator, a 'watcher'; that is, a person capable of receiving the distress call only. Apparently they have now come to appreciate the efficiency of the British instrument they have for so long scorned.

"In closing, I would like to mention that the Marconi Automatic Device is a beautiful piece of work, as delicate as the finest wrist watch, and worthy of more publicity than it has ever received in the past."

Of course, it should be unnecessary to state that the information was not given to belittle the British product, but merely to acquaint readers with the latest development in this direction. The policy of this paper is to give readers all the information which comes to hand of radio developments, and this particular item was only released in April.

America Again!

I HAVE called attention before to the way things are done "in the States" and in the latest news-sheet issued by a popular station I find the following: "The announcer was giving a sound-demonstration, while the narrator was describing a bombing and gun battle between thugs and police. The sound effects included automobiles, trains, crashing buildings, fires, sirens, etc. No synthetic stuff was employed here, and to simulate the gun battle the announcer was using two revolvers, one in each hand. As he blazed away he suddenly felt a burning sensation in the calf of his left leg, and after the show he found that he had shot himself. At least, the gun had gone off so close to his



Notes from the Nest Bench

M.B. Contacts

IT has previously been mentioned in these notes that the metallised surface of a wooden baseboard must not be used for conducting heavy currents such as valve filament current. Whilst conducting tests on the ultra-short-wave bands we have also found that the metallised coating of baseboards is not a good conductor of very high-frequency currents. If the metallising is used as a path from tuning coil to tuning condenser it is sometimes found that reaction cannot be obtained, but when heavy gauge connecting wire is used reaction is easily obtainable.

Limit and Vitesse All-Wavers

SOME readers who have constructed the Limit All-Wave Four have found that reaction cannot be obtained on the lowest short-wave band unless the M.B. bolt is connected direct to the bolt holding the gang condenser chassis to the baseboard. Constructors who are having poor results on the lowest band should therefore try this connection. When a metal chassis is used, as in the Vitesse All-Waver, it should be carefully ascertained that the M.C. bolts are making good contact with the metal. The metal is generally painted and therefore the paint should be carefully scraped off underneath the M.C. bolt in order to ensure good contact.

Improving Smoothing

CONSTRUCTORS who are troubled with L.F. instability on the short-wave band of their receivers when supplied from A.C. mains units should try the effect of connecting a high-capacity electrolytic condenser across the H.T.+ and H.T.— terminals of the unit—the T.C.C. type 80g condenser is very suitable for this purpose. Its high capacity of 32 mfd. ensures effective smoothing of the H.T. supply voltage from the unit and it has been found that it eliminates L.F. instability in the majority of cases. When using an electrolytic condenser in this manner in receivers supplied from batteries or a D.C. mains unit, great care should be taken to see that the polarity of the supply is not reversed. Polarity reversal will damage the condenser and may consequently cause damage to other components in the D.C. unit.

NEWNES' TELEVISION AND SHORTWAVE HANDBOOK

By F. J. CAMM

3/6, or 4/- post free from
George Newnes, Ltd., Tower House,
Southampton Street, Strand, London, W.C.2.

calf that he was severely burned and had to visit a nearby doctor to have surgical treatment. When he returned to the studio for a repeat of the item in a later programme, he took good care to fire the revolvers farther away from his body."

Receiver Developments

I HAVE often wondered what the radio set of the future will look like, and the various interesting cabinet designs which have been produced from time to time have given no indication of the ultimate trend. But a receiver is shortly to be put on the English market which may well be a welcome indication of the set which will eventually grace our homes—assuming that television takes on some new principle. This new receiver is built as a mantel clock and is, in fact, very little larger than the standard marble timepiece which our forebears used. It is, at any rate, sufficiently narrow to enable it to be stood comfortably upon the modern narrow fire surround. The entire front of the cabinet is in the form of a clock face, the centre portion acting as a speaker grille and the hands and chapters being arranged round the rectangular opening. Three controls are fitted just below this, and the receiver is an all-mains model with a novel built-in aerial and tuning system. Thus, where a power point is fitted by the builders in the centre of the mantel, this particular receiver may be placed in position and no wires of any description can be seen. The clock is mains operated and the makers guarantee 50 to 60 stations at full entertainment value.

Retaliation

AN interesting Court case in Denmark recently gave me quite an amusing five minutes. The owner of a stationery shop was charged with an offence against the Danish Broadcasting Act by using a receiver without a licence. He pleaded justification, and when asked for his reasons stated that the Post Office authorities were guilty of infringing another section of the same Act which forbids broadcast advertisements. He said that the Post Office, by continually using the radio to advertise their special "greetings" telegram, were undermining his business in birthday and similar cards, and as a protest he refused to take out a wireless licence. The magistrate was sufficiently impressed to inflict a relatively small penalty, and gave him permission to appeal to a higher court.

A PAGE OF PRACTICAL HINTS

SUBMIT YOUR IDEA

READERS WRINKLES

THE HALF-GUINEA PAGE

A Novel "Bug" Key

THE accompanying illustration shows a method I have adopted for making a simple but efficient "Bug" type key. The movement is light and definite, and

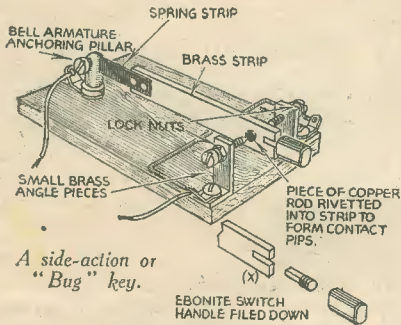

although some experimenters prefer the ordinary type of sender, speed may be improved since the length of the dots and dashes is more fully calculated, and consequently, when going back to the old key, more care is exercised when sending. Contact movement is adjusted by two screws with lock nuts, and correct air gaps must be maintained, otherwise impulses will vary. A piece of brass rod is filed down and made to fit the recess in the brass strip (X) after which soldering should complete the fitment. The ebonite finger control handle was procured from an old key switch, but numerous ways will suggest themselves to suit the conditions of operation.—L. R. MORRIS (Leicester).

A Simple Counter

THE easily constructed counter shown in the sketch can be made from odds and ends in a very short time. When

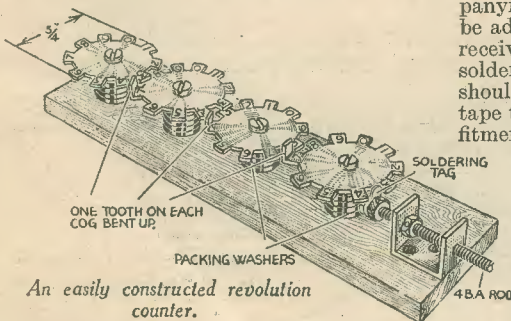

winding coils or transformers it saves much wearisome counting and ensures accurate results. The four cogs are best cut from sheet brass or stout tin-plate with a pair of snips, and then filed up in the vice together. Note that one tooth on each is longer than the others, and should be bent up as shown. The cogs are then given a coat of white enamel and mounted on a piece of wood with a screw through the centres. Washers are placed underneath to prevent them fouling. The driving spindle is a piece of 4 B.A. studding with

THAT DODGE OF YOURS!

Every Reader of "PRACTICAL AND AMATEUR WIRELESS" must have originated some little dodge which would interest other readers. Why not pass it on to us? We pay £1-10-0 for the best wrinkle submitted, and for every other item published on this page we will pay half-a-guinea. Turn that idea of yours to account by sending it in to us addressed to the Editor, "PRACTICAL AND AMATEUR WIRELESS," George Newnes, Ltd., Tower House, Southampton Street, Strand, W.C.2. Put your name and address on every item. Please note that every notion sent in must be original. Mark envelopes "Radio Wrinkles." Do NOT enclose Queries with your wrinkles.

a soldering tag nutted on the end and arranged so as to drive the first cog one tooth per revolution. The numbering of the teeth is best left till last, when it is easier to see the direction of rotations. As shown, the device will count to 9999, but, of course, more or less wheels can be arranged as desired.—D. BESSANT (Mitcham).

Anchoring Multiple Leads

THE anchoring of a number of parallel leads in a receiver may be neatly accomplished by the aid of passe partout picture hangers, as shown in the accom-

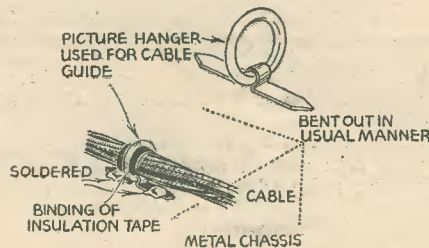

A method of anchoring multiple leads.

panying sketch. The leads should first be adjusted to the required positions in the receiver and the loops fitted and finally soldered into position. The cable or leads should be bound when possible by insulation tape to prevent wear, and also to make the fitment more secure, thus obviating any tendency towards slipping.—J. R. OLIVER (Taunton).

A Valve-lifting Device

AFTER loosening several valves from their bases when pulling them out of their holders, I made the simple lifter shown in the accompanying sketch, which is self-explanatory. In operation, the valve is shifted slightly to allow the lifting edge of the device to fit under the valve base, and pressure is applied to the hand-rest and below the finger grip. By this means the valve pins are easily withdrawn from their sockets without the possibility of loosening the valve bulb.—L. HENSHAW (Ilkeston).

Mounting S.W. Coils

I HAVE found that losses in efficiency of S.W. Coils can be minimised by mounting them on the glass pinch of an old valve, which in its turn is mounted on a cork screwed to a baseboard. The pinch is pushed over the cork and mounted on a small ebonite square. The whole assembly looks very attractive. A slider can be fitted to the side of the ebonite to vary the coupling, and small holes are made through the ebonite for the connecting leads, as shown in the sketch.—A. T. WARD (Edgware).

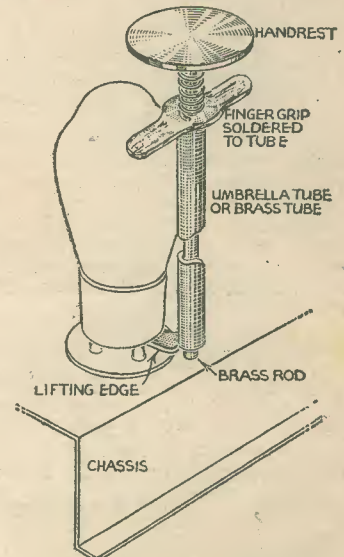

A simple valve-lifting device.

THE WIRELESS CONSTRUCTOR'S ENCYCLOPÆDIA

By F. J. CAMM 4th Edition 5/- net (Editor of "Practical and Amateur Wireless") Wireless Construction, Terms, and Definitions explained and illustrated in concise, clear language. From all Booksellers, or by post 5/6 from George Newnes, Ltd., Tower House, Southampton Street, Strand, London, W.C.2.

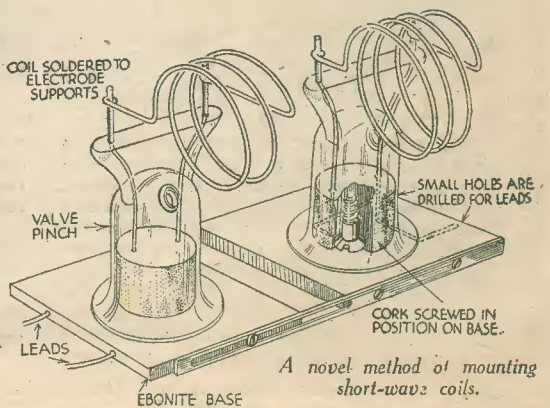

A novel method of mounting short-wave coils.

THE return of the warmer weather and longer hours of daylight leads to a diminution of the hours of listening in the case of many listeners, but there is no reason why this should be so. Apart from the fact that it is possible to make use of any receiver out of doors just as easily as in the house, the B.B.C. have this year decided to cut out their original arrangements regarding the provision of summer-time programmes. In previous years the hours from 6 p.m. to 8 p.m. have been utilised to radiate only one programme from both National and Regional transmitters, but they have now realised that listeners require to make use of these hours just as much as at other times, and accordingly will this year provide the usual alternative programmes, thus giving to those who have not previously taken advantage of outdoor radio, an added incentive to do so. In many cases one requires to listen in the garden, and in this case there are two alternative schemes. Either the receiver may be left in its original position in the house and an extension loudspeaker connected for use in the garden, or the receiver may be taken out of doors. There are advantages and disadvantages in both cases. In the former, one has to return to the house in order to make adjustments of volume or tuning, and in the latter the aerial and power supply leads may introduce some difficulty. It must, of course, be emphasised that when making use of the radio in the garden it is essential to keep the volume down to such a level that it is not audible in the next garden, otherwise, apart from the annoyance this may cause, you may be breaking a local by-law concerning the use of loudspeakers in such a manner that they cause a nuisance to other residents.

Separate Speaker or Set

When adjustments have to be made at the house end, it may be necessary for one listener to go into the garden and indicate to the operator in the house just when a suitable volume is reached. If the adjust-



A range of Portables described in past issues of "Practical and Amateur Wireless."

ment is carried out without assistance it may easily be made so that the next house also can hear the signal. In most cases, therefore, it will be preferable to take the receiver into the garden, running an extension lead from the aerial lead-in, or erecting a temporary one along the fence, for instance. In many cases this will not lead to much difficulty other than the problem of transport where the domestic receiver is of large dimensions. Many

OUTDOOR R

How to Make the Best of Radio in the Open Air
Reference to Suitable Receivers - - - - By

modern extension speakers are provided with a volume control and this will, of course, remove one of the drawbacks to an extension listening point in the garden. There still remains, however, the problem of changing from one station to another, and

low-tension accumulator used for the car lighting is employed to deliver the various voltages required for the radio receiver, the usual scheme being to employ a special type of rectifier which changes the accumulator supply to A.C. It is then stepped up by means of a transformer and rectified. This device can also be employed to build a small H.T. unit to operate a multi-valve set in the garden, or even when on a hike, provided that the separate sections are included in individual cabinets or cases for portability. A good 6-volt accumulator will be found lighter than a combined 2-volt battery and 120-volt H.T. battery and thus will enable much better results to be obtained from a receiver with only a very small aerial. A further important point is that the majority of modern receivers now include a short-wave band which will provide more alternative programmes, and a very small aerial will be found adequate for good reception of short-wave stations—providing the right time of day or night is chosen when selecting the stations.

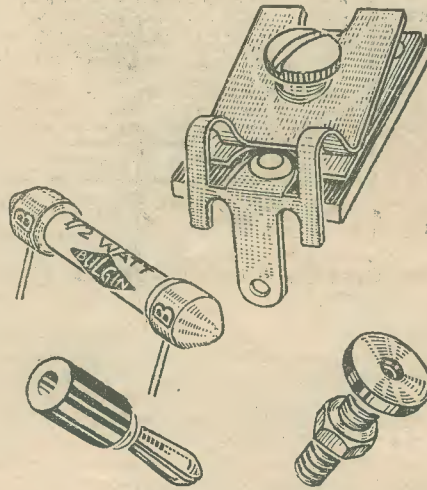

Midget components such as these may be used in constructing lightweight portables for outdoor use.

Aerials and Earths

The all-important aerial may take many forms in the open air, and it is important to remember that it is unnecessary in many cases to erect any form of mast. A length of good flex may be thrown over the branch of a tree (using a stone tied to the end to act as a weight when casting the aerial, and which will enable the end to drop within reach when the aerial has to be taken down). Alternatively a wire fence will often be productive of splendid results. In certain parts of the country wire fences will be found in which three or four wires are supported on wood or wood and concrete posts, and if these are very dry it may be found that the lowest wire may be connected to the earth terminal of a receiver and the top wire to the aerial terminal in order to give much better results than are obtained when a proper earth connection is employed. Normally this latter connection may most easily be

thus a small portable will be found the ideal solution to this particular form of listening.

Car Radio and Hikers

The user of a car already has facilities for radio when making journeys into the country, and the cyclist and hiker can build a very neat type of receiver which will provide entertainment with the crudest aerial system. It is, therefore, obvious that a good portable is an investment which returns one hundred per cent., as it may be utilised under so many different conditions. In our blueprint list will be found various types of receiver of the portable variety, from the smallest midget suitable for a hiker to the larger multi-valve receiver which includes a frame aerial and will provide many alternative programmes.

Overcoming H.T. Problems

For the car, one can also make use of receivers of this type, although as will be seen from the many car advertisements in these days a car radio fitment is now included in most good makes of car. The

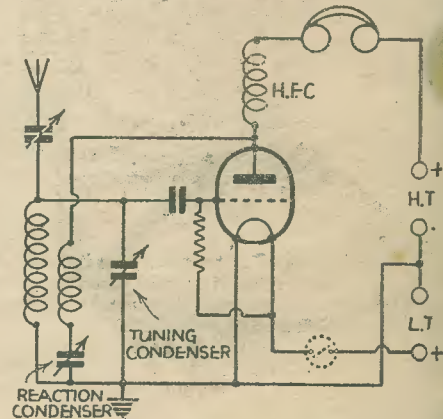

The simplest circuit for a small portable—ideally suited for the hiker.

ADADIO

with Particular
J. DELANEY

made by sticking a meat skewer or other metal object into the earth, pressing a piece of bare copper wire in with it, and attaching the other end of the wire to the earth terminal. If a small brook or stream



is adjacent to the place where you decide to camp or picnic, then the earth wire may simply be dropped into the water. If the weather is at all stormy and atmospherics are bad (due to the sensitivity control having to be turned up in order to reach out sufficiently far to obtain a strong signal), it will often be found desirable to ignore the customary earth and to use a wire stuck into the earth and connected to the aerial terminal. A few feet of flex coiled round a lin. diameter tube of some insulating material and then enclosed in an ordinary cocoa tin or some similar object, and the tin pressed into the earth by the mere process of treading on it, will often provide a splendid anti-static aerial connection, the wire being insulated where it passes through the lid and connected to the aerial terminal without any connection to the earth terminal. Where it is desired to obtain really long distance reception

with a small receiver and the best possible aerial is required, remember that a kite forms an admirable method of elevating the wire. Attach it to the bridle on the kite at the point where the normal kite string is attached and let the kite rise as high as desired, tuning the signal whilst the kite is rising, and making use of the desired amount of aerial. For this purpose again, ordinary thin flex will be found simplest to use, as it may be coiled round a suitable reel and will not easily break. It also has the added advantage of lightness.

H.T. Generator

If the special H.T. generator previously mentioned is to be built in order to dispense with the H.T. battery, the correct type of unit should be obtained, and this, together with the associated transformer, should be built into a metal box to avoid hum or induction with the wiring or other components in the receiver. It will be found that the entire unit may be made very compact indeed and up to 250 volts may be obtained. This, of course, overcomes one of the great difficulties of the portable receiver, where in many cases a very small H.T. battery is employed in order to reduce weight. Another method of avoiding the weight difficulty is to build the receiver from midget parts, and to use the Hivac Midget valves. Not only does this reduce the weight of the receiver itself, but a much smaller H.T. battery and L.T. accumulator may be used to operate it.

Additional Details

The above remarks cover the general principles of outdoor listening, and there

remain only the incidental details which will, of course, vary in each individual case. The majority of commercial receivers now provide an extension loud-speaker panel or socket strip and this may be employed to supply a speaker used in the garden, for instance. If a switch is fitted in the receiver to silence the built-in speaker this should be operated in order to keep within the desired volume range necessary to avoid disturbing neighbours. If no extension arrangement of this type is fitted, the simple filter circuit consisting of a 2 mfd. or 4 mfd. fixed condenser joined to the anode may be added. In this case the built-in speaker acts as an L.F. choke, and if the speaker is then to be silenced a switch of the ordinary on/off type must be inserted in one of the leads to the speech coil. If it is not thought desirable to modify the speaker in this way, then a good output choke should be obtained in order to provide the correct matching impedance. The special Clix loudspeaker switching panel will prove of great value if a permanent line into the garden is to be used, and to avoid difficulties due to dampness, such a line should be of the lead-covered type such as is now used for ordinary electric light wiring. The cab-tyre (rubber) cable is also suitable, and may be tacked along a fence, or run just beneath the soil. If a plug-in point is fitted at the distant end of such a lead (in a garden shelter, for instance) some type of damp-proof cover should be arranged to prevent corrosion of the sockets, and a good tip is to obtain a spare plug, well smear with vaseline and insert this into the sockets when the speaker is not in use. Remember that a single lead will suffice for an extension lead of this type, with the return path via earth—for which purpose a short wire from the plug point inserted in the ground will prove adequate.

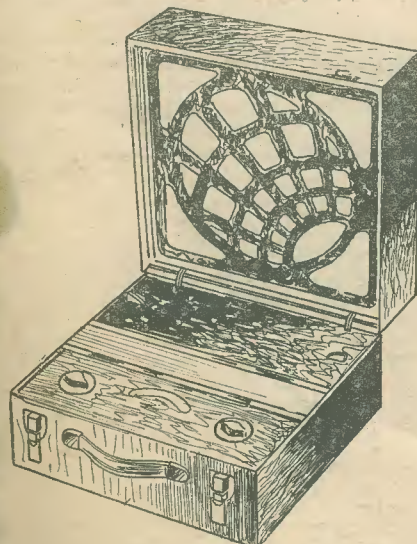

A typical portable of the attaché case type. This has the advantage that controls are hidden when the set is not in use.

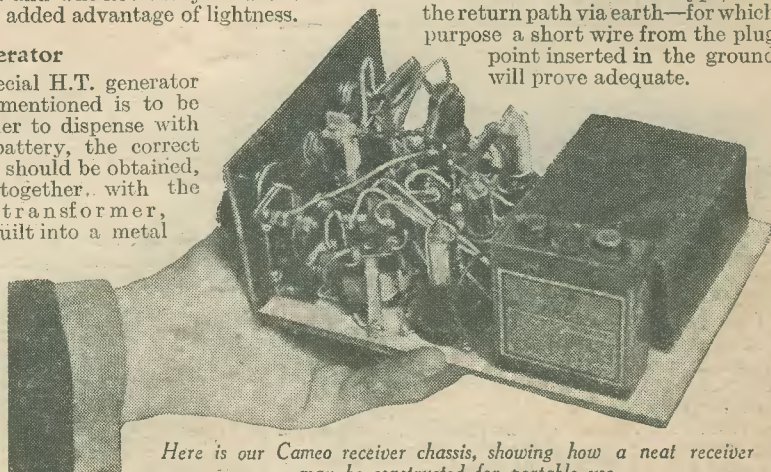

Here is our Cameo receiver chassis, showing how a neat receiver may be constructed for portable use.

When using a car-radio at a picnic it may often be found that the car has to be parked on the roadway or in a cart-track some distance from the point where you desire to picnic, and again the extension speaker arrangement may be brought into use, following the above details. Obviously, however, as weight is of minor importance when using a car for transport, a good portable will prove of great utility as it will avoid journeys to the car to change from one station to another, to switch off or to control the volume. If an extension speaker such as the W.B., provided with the built-in control, is employed, the question of controlling volume will be avoided.

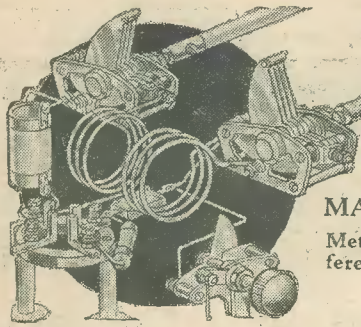

Short Wave Section

MAINS WORKING ON SHORT WAVES

Methods of Avoiding Mains Hum and Induced Interference : Precautions Which Should Be Taken : Extra Decoupling : Mains Filters.

ALTHOUGH it is by now no means unusual to build mains-operated short-wave receivers, there are several points which should be watched when designing such a set. One reason for this is that electrical interference and mains hum are far more likely to be troublesome than is the case with a normal broadcast set fed from the mains. That such trouble can be entirely overcome is well proved by the receivers which have previously been described in these pages, and also by the

—not power—type will give an excellent degree of amplification, and an output which is generally sufficient for operating a loudspeaker at modest volume.

Four-valve Superhet

Should it be desired to construct a four-valve superhet which will be simple to build and operate, a circuit similar to that shown in Fig. 2 will often suit. Here, again, there is an untuned aerial circuit, followed by a pentagrid frequency-changer

by replacing the triode output valve by a pentode. The latter method is satisfactory if reasonable precautions are taken to decouple the screening grid by means of a 2,000-ohm resistor and a 2 mfd. fixed condenser. The same advice applies when using a pentode in a "straight" circuit, but a good deal of care must then be taken with regard to the layout.

The Aerial Circuit

When designing any kind of set with tuned aerial circuit for mains operation, it is found worth while to employ an inductively coupled aerial winding, for this tends to minimize mains interference picked up by the aerial system. It is better still, of course, to employ a dipole aerial system, the two aerial wires being connected to the ends of the inductively-coupled winding. With this arrangement, any interference picked up by the aerial lead-in (which might run comparatively near to mains leads in the walls of the house) tends to be cancelled out due to the capacity existing between the two twisted leads. For the benefit of those readers who are not conversant with the dipole aerial system it might be mentioned that an article on this subject appeared in the issue of PRACTICAL AND AMATEUR WIRELESS dated September 19th, 1936.

Heater Connections

In the case of an A.C.-operated receiver a good deal of potential interference from the mains can be eliminated by connecting a fixed condenser between each heater terminal of the detector valve-holder and the earth-line, as shown in Fig. 3. The condensers may each have a capacity of about .002 mfd., and they should be placed as near as possible to the valve-holder. It is sometimes worth while to repeat this arrangement with the L.F. valve, using condensers of about .005 mfd. capacity. These condensers balance out the A.C. potential developed across the heater winding.

With the same object, it is often better to disregard the centre tapping on the 4-volt A.C. winding, used to supply the heater current, and to fit a "humdinger" or 30-ohm pre-set potentiometer, so that the exact "electrical" centre can be found by experiment. The idea is illustrated in Fig. 4.

When the set is of the A.C./D.C. type it is usually wise to arrange the heater connections so that the detector heater is

(Continued overleaf)

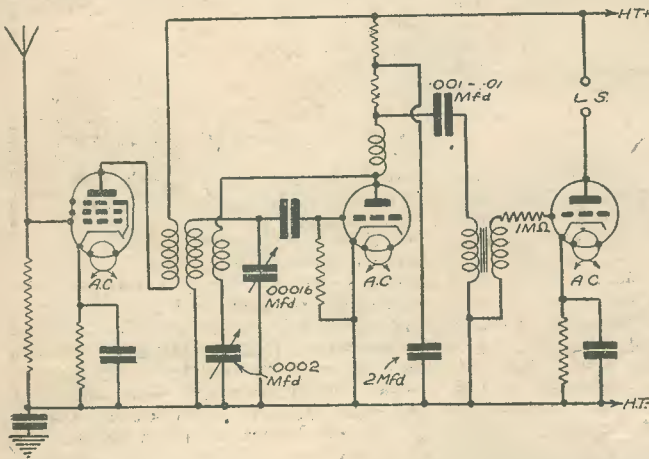

Fig. 1.—Skeleton circuit of a three-valve H.F. short-waver for A.C. operation, with an untuned aerial circuit.

many commercial sets which are designed for all-wave working.

Valves and Circuit

When the constructor proposes to make a receiver to other than a complete, published design, however, he must be prepared for difficulties which might possibly be encountered. With regard to the general form of the circuit, it is generally found that immunity from hum is most easily ensured by using a fair number of valves, each working well within its capacity. If maximum sensitivity is demanded from every valve in the set there is far more likelihood of interference troubles presenting themselves. Some readers may feel inclined to disagree with the statement that a well-designed superhet, even of very simple pattern, is more likely to be free from "mains" troubles than is a Det.-Pen. two-valver.

If the constructor does not feel disposed to go to the expense of a superhet, he would be well advised to include an H.F. stage—even if this is untuned. A circuit on the lines of that shown in skeleton form in Fig. 1 nearly always proves very satisfactory. It will be seen that there is an H.F. pentode, which follows an aperiodic aerial circuit, followed by a tuned-transformer type of inter-valve coupling, a triode detector and a triode output valve. Increased output can be obtained by using a pentode in the output stage, but this is more prone to give trouble in the way of mains interference. A triode of the L.F.

L.F. stage, triode second detector and triode output valve. Tuning is carried out by means of the single .00016 mfd. condenser. An intermediate-frequency of 465 kc/s should be used for preference, and the "oscillator" coil might be one of the normal type designed for aerial tuning, the reaction winding being included in the anode circuit of the oscillator portion.

If greater output were required it could be obtained by using two L.F. stages or

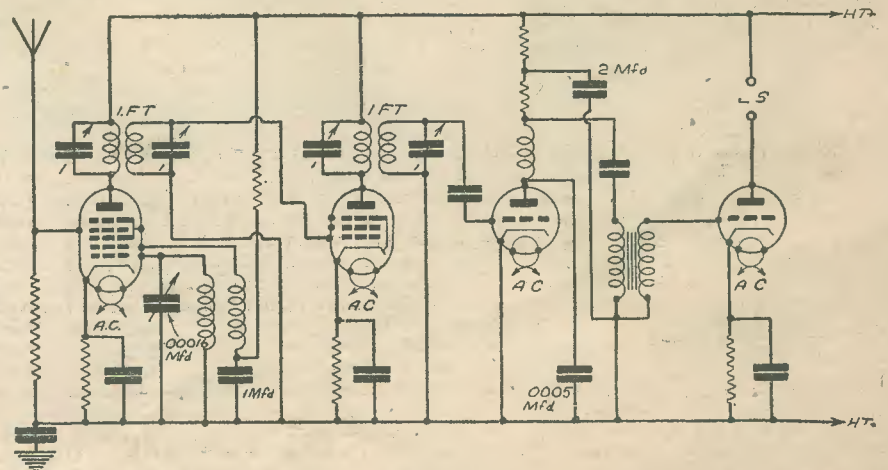

Fig. 2.—This skeleton circuit refers to a simple and effective type of A.C. superhet with single tuning circuit.

SHORT WAVE SECTION

(Continued from previous page)

returned to the earth-line, as in Fig. 5. If the detector heater is not at earth potential it frequently happens that pronounced hum is noticed, and that this cannot be eliminated by the usual means. Modulation hum, in particular, is likely to be troublesome. This manifests itself in the form of a pronounced, and often comparatively high-pitched, hum which is present only when the receiver is tuned to a fairly powerful signal. In many cases it has been found that a re-arrangement of the heater circuit has cured troublesome hum which could not otherwise be obviated.

Adequate Screening

Screening is always important in a sensitive receiver, but it is more than usually so in a mains-operated short-waver. In many instances it is found that it is insufficient simply to use screened coils and chokes, and to isolate the mains-supply portion of the set. Apparently-trivial things like unscreened anode connectors can cause a considerable amount of trouble. To guard against this it is worth while to

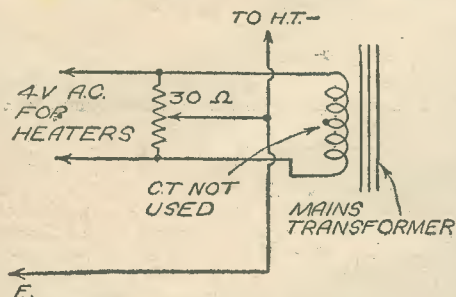

Fig. 4.—It is sometimes better not to use the centre tap on the heater winding, but to obtain the exact "electrical" centre by means of a 30-ohm pre-set potentiometer.

use valve anode connectors for H.F.-type valves which are provided with a small copper or aluminium cap designed to enclose both the connector and the portion of the valve which is not metal-coated.

Although decoupling is not usually considered in connection with mains hum, it does play an important part in this respect. Thus, if the detector valve is inadequately decoupled, interference is likely to be far more pronounced. Moreover, when reaction is employed, any tendency to instability and interference is increased. In most cases it is sufficient simply to include a decoupling resistance of between 25,000

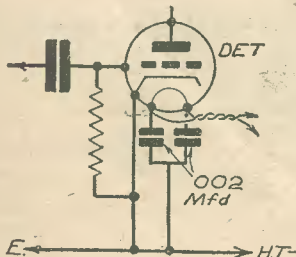

Fig. 3.—Hum can often be obviated by connecting a pair of fixed condensers as shown here.

and 50,000 ohms, along with a 1 to 2-mfd. fixed condenser, but in exceptional cases it is better to have two decoupling resistances in series, connecting a fixed condenser between each and earth. This double-decoupling also provides additional smoothing for the detector valve, which is most susceptible to the effects of mains irregularities.

Impaired Low-note Response

Another "trick" which has often been found useful is to reduce the efficiency of the L.F. amplifier at very low frequencies. This does not introduce any undesirable effects in most cases, because the quality of reproduction is rarely so good that the difference in tone can be recognised. One method of doing this when using R.C. or parallel-fed transformer coupling is to reduce the capacity of the coupling condenser to about .001 mfd. It might even prove worth while to experiment with a few different condenser capacities. Another method is to connect a condenser of between .0003 mfd. and .001 mfd. between the grid of the L.F. valve and earth.

With regard to the component lay-out, one of the most important points to watch is that the aerial and/or grid leads do not run close to the output valve or to the heater connections. Similarly, the speaker leads should be isolated from the mains and H.T. leads. Again, if the components are placed fairly close together, it is generally desirable to use twin, screened connecting wires for the 4-volt A.C. (heater) supply. The metal-braid covering should be earthed at a number of points, care being taken that the earthing wires are well soldered to the braid.

H.F. Pick-up

It might appear unimportant, but it is not so, that the wires from the rectifier to the various H.T. points should not be any longer than necessary. These have a tendency to act as a miniature "aerial," and so to pick up high-frequency currents, with the result that the set shows signs of instability. If the leads must be long it might be well to "break" them at intervals by inserting 250-ohm resistances, taking care that a good by-pass condenser is placed between the "set" end of these and earth.

Should hum be troublesome after taking the above-mentioned precautions it might be necessary to include a filter in the supply leads from the mains. Generally, a double

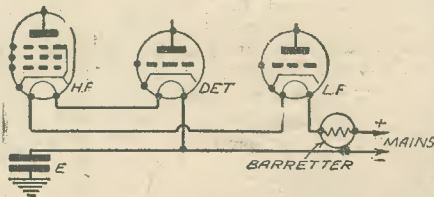

Fig. 5.—The detector heater should be connected to the earth line in an A.C./D.C. set.

.01 mfd. fixed condenser is sufficient. The centre tapping of this should be connected to earth, the other two ends being joined to the mains leads. In particularly troublesome cases it will also be necessary to include mains filter chokes—large H.F. chokes of high current-carrying capacity—between the mains leads and the set; the double condenser should be used in addition.

THE ONLY STANDARD WORK!
WIRELESS CONSTRUCTOR'S
ENCYCLOPEDIA.
 5/- or 5/6 by post from
 George Nawnes, Ltd., Tower House, Southampton St.,
 Strand, London, W.C.2.

BARGAINS!

Below are 3 only of the scores of amazing bargains N.T.S. have to offer. Send for complete lists of wonderful offers in Receiver Chassis, Kits, and Components at astonishingly low prices.

BARGAIN 1-valve S.W. KIT
 LIST PRICE 35/- BARGAIN **19/6**
 12-94 METRES Cash or C.O.D.

Kit comprises Metaplex base-board, condensers, switch, valve and coil holders, H.F. choke, terminals, slow-motion drive, 3 coils, wire, and FULL WIRING DIAGRAM. Less valve. **2/6 DOWN**

Carrriage Paid, 19/6 or 2/6 down and 8 monthly payments of 2/6. If headphones and valve required with Kit, deposit 2/6 and 11 monthly payments of 3/4.

S.G.3 CHASSIS
 with 3 BRITISH VALVES
 LIST PRICE £4:4:0 BARGAIN **42/-**
 CASH OR C.O.D. Carr. Paid.

Complete with 3 Valves.

- LATEST SCREENED-GRID CIRCUIT. Comprising
- Screened Grid, H.F., Detector and Pentode Output Valves.
- Screened wave-wound coils.
- 2-Gang Air Dielectric Condenser.
- Metal Chassis.
- Only 9 m.a. H.T. consumption.
- Illuminated and Wavelength Calibrated Dial.
- Wave range 200-2,100 metres.
- Complete with Valves, black escutcheon and all knobs.

This wonderful chassis will bring you a wide choice of English and foreign programmes with amazing purity of tone and remarkable volume. Available at this astonishing bargain price only from N.T.S. Secure yours while they last. 2/6 down secures; balance in 12 monthly payments of 4/-. Also available with 3 Cosor Valves at 45/-, or 8/- down and 12 monthly payments of 4/3.

2/6 DOWN

HALCYON AUTODYNE
 SHORT WAVE CONVERTER
 Instantly attached to your present A.C. Mains set and makes it an efficient All-Wave Receiver
 LIST PRICE £3:3:0 BARGAIN **29/6**

With Mullard 354V Valve. Stand your set on this amazing unit and hear the whole world through your present familiar receiver. Only from N.T.S. is this famous converter obtainable at this astounding bargain price. Secure yours now!

- FOR A.C. MAINS SETS ONLY
- 14-60 metres.
- No alterations to your set.
- Simply attach, and your set is an all-waver, a special switch enabling short-wave or broadcast reception to be enjoyed at will.
- Tuning and Sensitivity controls.
- Dial calibrated degrees.
- Walnut finished cabinet. Complete with plug-in adaptor and instructions.
- For A.C. mains sets only. 2/6 down secures; balance in 10 monthly payments of 3/-.

2/6 DOWN

FREE! Write to-day for free Booklet describing in full, with actual photographs, 5 entirely new N.T.S. Bargain Short-Wave Kits, and range of Short-Wave Components.

Postal Orders must be crossed and currency registered.

New Times Sales Co.
 56 (Pr.W.18), Ludgate Hill, London, E.C.4
 EST. 1924

HOME RECORDING !!

Electradix Radios' Wonderful Bargains. Electradix Home Recording with the all-gear-ed FEIGH Electric Recorder. Ball-bearing centre gear box and traverse rod; is the lowest-priced electric home recorder that will fit any gramophone. The set with tracking gear, pick-up and tone-arm with 37/6 diamond.

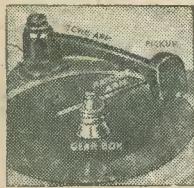

(Gear only, 21/6. **TELEPHONES** for House, Office, Garage and Field Sports. Table, wall, and waterproof portable from 10/-. **Headphones** for short-wave radio, 2/9 pair. **CRYSTAL SETS** (for crystal-pure reception. Table type "A," 7/6. Double circuit type "B," 10/6.

HEADPHONES, with cords, 2,000 and 4,000 ohms, 4/6. Single high res. earpieces, 2/6. Sullivan 120 ohms, 2/9.

WHY NOT LEARN MORSE? Cheap home learner's set, complete with battery and buzzer, on walnut base, 4/6. Large range of Keys, Buzzers, Sounders and Recorders.

X-RAY TUBES. As illus. previous issues. Brand-new W.O. Hospital Surplus, 7" dia. bulb, big tungsten electrodes. Full emission. Cost £5. Sale 10/-. Packing, 2/6.

PHOTO CELLS. R.O.A. UX867. Talkie model, 25/-; few Oram C.M.G., 35/-. Selenium Cells, 5/-, 7/6 & 10/-.

ALL-WAVE CRYSTAL SETS for plug-in coils, 2 tuning condensers, semi-perm. Detector, 5/6. Why bother to make one when cheaper to buy ours?

BELL PUSHES in porcelain and brass. Big Stock, all types, from 6d. English Bells, 2/-.

THIS BATTERY SUPERSEDER provides H.T. from your L.T. 2-volt battery, rectified and smoothed. 3 tappings. A boon to those who are not on the mains. Reduced from £3 15s. New and Guaranteed, 37/6.

SPARK COILS. 1 in., 1/2 in. spark transmitters for boat model control, 17/-.

SPEAKERS and MIKES cheap. "Radio Electrical" Scientific Illus. List "N." Free.

ELECTRADIX RADIOS

218, Upper Thames Street, London, E.C.4.

Engineers' Guide To Success

AMBITIOUS MEN Write TO-DAY for this great Guide, containing world's widest choice of home-study courses in engineering covering all branches, including Radio, Television, etc., and which alone gives the Regulations for Qualifications such as A.M.I.E.E., A.M.I.R.E., A.M.I.W.T., C. & G., etc. Training until Successful Guaranteed.

Free! THE TECHNOLOGICAL INSTITUTE OF GREAT BRITAIN, 42, Temple Bar House, London, E.C.4. (Founded 1917. 20,000 Successes.)

EASY TERMS

WE OFFER THE LOWEST TERMS FOR ALL RADIO SETS. Radiograms, Loudspeakers, Valves, and all accessories. It will pay you to secure our quotation—send list of requirements and we will quote by return. Prompt Delivery. Cash and C.O.D. Established 1925 (Phone National 1977).

THE LONDON RADIO SUPPLY CO., 11, Oat Lane, Noble St., London, E.C.2.

EARN EXTRA MONEY by hiring out the M.P.R.7 Watt Amplifier to dances, socials, etc. Complete with Four Valves, Speaker, and Volume Control. Push-Pull output. Will Reproduce Gramophone Recordings or Radio at full Band strength. Supplied ready for connecting to pick-up or microphone. For C mains only. Price 25-5-0 net, or 10/- monthly. Send for full particulars. Phone Romford 328. M.P.R. Electrical Co., 252, Victoria Road, Romford, Essex.

FREE ADVICE BUREAU COUPON This coupon is available until May 15th, 1937, and must be attached to all letters containing queries. PRACTICAL AND AMATEUR WIRELESS, 8/5/37.

LEAVES FROM A SHORT-WAVE LOG

Radio Servicio Santiago THE broadcasts from CEB, Santiago (Chile) on 24.23 m. (12.381 mc/s), recently reported in these columns, are now very well heard in the United Kingdom. The call given out at frequent intervals in both Spanish and English makes the identification an easy one. The studio, as an interval signal, appears to be using four chimes.

An Unpleasant Interference During the past few days the W2XAF, Schenectady, transmissions have been marred occasionally by a background of a South American broadcast. It is stated that the trouble is due to the change made by HJ4ABH, Armenia (Colombia), which moving from 31.51 m. or 10 kc/s above G.S.B. to 31.47 m. (9.532 mc/s) is now inconveniently wedged between W2XAF, Schenectady, and JZI, Tokio. The Colombian may be identified not only by its call-sign, but by its 5-chime signal sometimes alternating with 2 strokes on a gong,

and the fact that at G.M.T. 0245 it closes down with the playing of the *Indian Love Call* from "Rose Marie."

Another French Colonial Broadcaster At Fort de France, in the island of Martinique, the French colonial authorities have installed a 250-watt transmitter for the broadcast of wireless entertainments; the wavelength is 32.05 m. (9.36 mc/s). The daily schedule is: G.M.T. 1630-1730; 2315-0015 and from 0100-0200; on Thursdays the intermediate broadcast is devoted to a Children's Hour. All announcements are made in the French language.

Messages to the Far North If you care to tune in to W8XK, relaying the KDKA, Pittsburgh (Pa.), broadcasts on 48.86 m. (6.14 mc/s) on any Sunday morning at B.S.T. 06.00, you may eavesdrop on the private messages which are transmitted to trappers and settlers dwelling in the North-West provinces of Canada, Alaska and the Polar circle. It is the only practical means by which these temporary exiles are given the opportunity of hearing from their relatives and acquaintances. On most occasions a special programme of music and news bulletins is also compiled for their benefit.

CONSTRUCTIONAL DETAILS OF "PRACTICAL WIRELESS" RECEIVERS.

(Continued from page 176)

disconnect this condenser from that lead. Thus the condenser will still be joined to the lead passing through hole No. 11 and the other end of this condenser must be joined to terminal No. 3 on the coil farthest from the panel—again another hole being drilled for the purpose. An examination of the blueprint, in conjunction with the coil wiring diagram reproduced herewith will enable these points to be clearly seen and no difficulty should be found in building this receiver from the modern components specified.

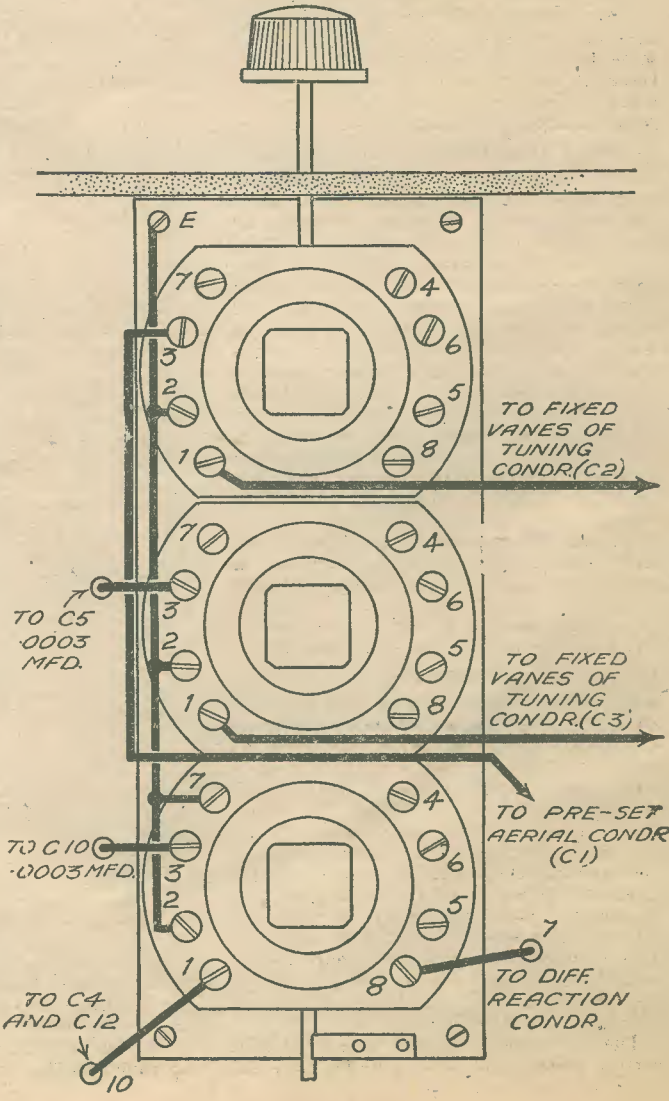

Diagram of connections for the new coils required for the Fury Four.

UNSUSPECTED CAUSES OF TROUBLE

A Few Unusual Defects Described and Explained : Aerial Faults :
 Damaged Coil : Condenser Drive : Speaker Distortion : Pick-up
 Trouble : No Reaction - - - - - By FRANK PRESTON

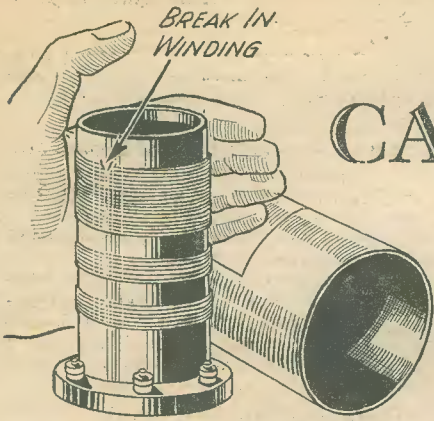

Fig. 1.—Signals could be received only when a hand was held near the coil—because of a break in the winding.

THE experienced constructor generally adopts a systematic method of tracing faults in a receiver, and by using suitable meters it is rarely difficult to locate the source of trouble. This does not always follow, however, whilst the constructor who does not possess very much equipment must rely on more "rule-of-thumb" tests.

But whether test gear is available or not, there are various forms of trouble which are very difficult to trace, due to the fact that the fault is of an obscure nature, and is one which a meter would not normally reveal. One such case was revealed a short time ago, when an amateur found that at some periods the signals of even the local transmitters became abnormally weak, whilst those from more distant stations could scarcely be heard at all.

Erratic Operation

The wiring was carefully checked, battery leads were tested, measurements of anode and L.F. current revealed no faults, and there were found to be good connections between valve pins and sockets. It was found that the periods of weak signals did not occur at regular intervals, nor at any particular time of day. It was only by accident that it was discovered eventually that the rubber-covered lead-in wire was fractured inside the insulated covering. Sometimes the contact was fairly sound, and at others it was broken, so that only the lead from the window to the set could serve as a source of pick-up. As this lead was fairly long, it provided quite a respectable "aerial."

Cutting off the end of the lead-in wire and re-making the connection immediately set matters right. In the majority of cases a fault such as this would have resulted in crackling noises being heard, but there was no such clue in the instance mentioned.

Wave-change Switching

In another case it was noticed that, although tuning was sufficiently sharp on long waves, it was so flat on the medium-waveband that a considerable amount of interference was in evidence. The receiver in use was of the H.F.-Det.-Pen. type, tuned-anode coupling being used between the H.F. and detector stages. It had operated perfectly well for several months after construction, and the fault developed suddenly. The wave-change switches for the two coils were of the Q.M.B. type, and were mounted on the panel. There was no doubt that these were operating, and the leads to them were making good contact with the coil terminals.

The owner went so far as to test the coils with a meter, and it was found that the

D.C. resistance of each was similar on both wavebands. There was no fault with the tuning condensers, and different valves did not make any difference. Despite these tests it was discovered that one of the wave-change switches was not making proper contact in the "on," or medium-wave position, and thus one coil was not being set for the lower waveband.

This seems impossible from the details given above, but it transpired that the contact was sufficiently good when a current was being passed through the switch, although insufficient to short-circuit the coil when only the H.F. signal currents were being handled. The D.C. test was insufficient chiefly due to the fact that it was made by using a battery of too high a voltage in conjunction with an ammeter. If a milliammeter had been used, in series with a resistance and 1½-volt cell, the fault would probably have been revealed.

"Listening Back"

Another example of a tuning fault was amusingly (and rather amazingly) described by a new constructor. He said that he could not receive the programmes from the local station when the tuning condenser was suitably adjusted; in fact, the set normally appeared to be completely "dead." But if the coil screen was removed from the aerial coil, and the windings grasped firmly,

Receiver Service

A reader sent in his receiver to the PRACTICAL AND AMATEUR WIRELESS laboratories. The set had been made to a design published in these pages, and was a super-het. A screened gang tuning condenser was employed, and although there was a very slight background noise no signals could be heard on medium waves, and only a very faint background of music on long waves. Furthermore, the faint signals which could be heard were at equal strength over the whole of the tuning scale.

The sender of this set was rather indignant, because he explained that he had followed the published design implicitly, had checked all the components, and had had the set in the hands of a "reliable" service engineer; the latter gentleman had been unable to find any fault, or to obtain any reception.

Would you believe it? The condenser drive had not been properly tightened on the condenser spindle, with the result that the condenser vanes did not move a fraction of an inch, despite the repeated turning of the knob on the tuning control. The matter was made more difficult of solution due to the fact that the spindle of the slow-motion drive was rubbing against the panel, so that there was a normal amount of resistance to turning; additionally, the rotor of the tuning condenser was fairly stiff, due to the end adjuster being tighter than usual. Anyhow, the application of a small screwdriver to two small grub screws immediately put the receiver into very satisfactory working order.

A rather similar kind of fault was experienced by a constructor who had been less careful in following the published design. A metalised baseboard was specified, but this constructor has used a plain plywood chassis. In the original design the frame of the tuning condenser was automatically earthed through the metallising, but when using a wooden chassis no such connection was obtained or

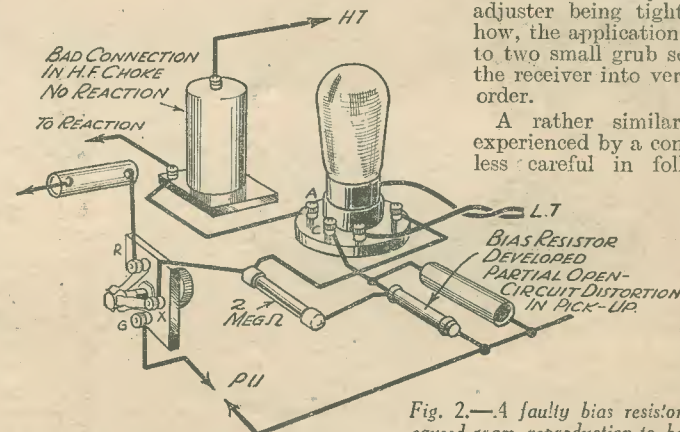

Fig. 2.—A faulty bias resistor caused gram. reproduction to be weak and distorted, whilst a defective H.F. choke made the reaction circuit inoperative.

yesterday's programme could be heard at fair strength. "Impossible," you will say. But the fact remained that signals could be received if the hand were held close to the coil, when reception was out of the question otherwise. A break in the winding of the coil explained the matter. The break was near to the "aerial" end, and gave the same result as if the aerial were disconnected. By holding the hand near to the coil, the pick-up of the body was employed, and this, quite by accident, had the effect of bringing in the Regional transmission when the set was tuned to the National.

provided for. In consequence, the condenser might just as well have been omitted.

Earth-lead Peculiarity

Another fault which frequently puzzles readers is indicated by the fact that signal strength is greater when the earth lead is not connected to the set. This can be due to the occurrence of a slight amount of instability, resulting in "automatic reaction" when the earth lead is removed. In that event, a certain amount of distortion

(Continued on next page)

UNSUSPECTED CAUSES OF TROUBLE

(Continued from previous page)

is generally present when the earth lead is not used. The proper remedy is to pay more attention to screening, and perhaps to re-arrange a few of the components in the H.F. circuits. On the other hand, the fault can be caused by a slight leakage between the aerial lead-in and earth. This in turn can be because a bared portion of the lead-in wire touches the window frame or masonry.

Distortion

A case of distortion, especially on loud signals, recently gave a fair amount of trouble. Grid-bias voltages, anode currents and anode voltages were tested and found correct; the output valve was tried in another receiver; another output valve was tried in the set which gave trouble; tuning was checked and found to be normally sharp. Not until another speaker was tried did it become evident that the fault was in this component. Even then it was not due to incorrect matching, a faulty transformer or a defect in the magnetic system, but to the speech coil touching the magnets when a strong signal was applied to it. In order to overcome the trouble it was necessary only to slacken the nut in the centre of the spider, insert slips of paper at two or three points round the speech-coil former between it and the magnet pole and re-tighten the spider screw. This, of course, centred the speech coil, so that it was prevented from touching the magnets.

Although this particular fault could immediately have been traced by means of proper instruments, it passed undetected for a long time. The four-valve A.C.

superhet operated perfectly satisfactorily on radio, but results on gram. were distinctly disappointing; they had previously been very good. Not only was the record reproduction of low volume level, but it was badly distorted. A new pick-up was tried without there being any change, and then a measurement was taken of the anode current passed by the detector—which was acting as an L.F. amplifier on gram. This showed that the valve was passing only 1 mA, whereas the current should have been almost three times this figure. That gave a clue. The bias resistance was defective, so that the valve was considerably over-biased when the pick-up was in use. On test, the resistance was found to have developed a partial open-circuit, although it was not "dis." Thus, the H.T. was being applied to the valve, although the voltage was a good deal lower than it should have been, whilst the bias voltage was so high that the handling capacity of the valve was considerably reduced.

A Reaction Fault

A fault of a somewhat similar nature was observed in a Det.-L.F. battery set, but in this case there was no provision for gram. Reception of the local station could not be called poor, despite the fact that signal strength was below normal, and the reaction condenser had practically no effect. In this case it was found that there was a poor connection inside the H.F. choke in the detector anode circuit. In consequence, the voltage being applied to the anode was less than 10 volts. The valve was able to rectify in a fairly satisfactory manner, but was incapable of oscillating or providing sufficient feed-back for reaction to be effective.

ROBED BRILLIANCE OF BRITISH HISTORY

Cavalcade of Coronation Splendours

THE glamour of British State Pageantry is reflected in an admirable and dignified work of reference which Messrs. John Player & Sons have just prepared in the form of an album specially planned to take the new Coronation series of 50 cards issued with Player's "Medium" Navy Cut Cigarettes. It is a portfolio of pageantry which is obtainable for 3d. from most tobacconists.

The aim has been to make this series of permanent value to the collector and due attention has been given therefore to ensure accuracy of text and detail.

So well selected are the series that a complete album constitutes a really handsome souvenir and an attractively useful addition to the home library. Do you know the work for which an Elder Brother of the Trinity House shares responsibility and how he dresses? What shape is the distinctive hat of a High Constable of Holyroodhouse? The interesting answers to these and many more ceremonial dress questions are recorded by building up this unusual album.

TO FIND THAT FAULT!

THE WIRELESS CONSTRUCTOR'S ENCYCLOPEDIA

5/- or 5/6 by post from

George Newnes, Ltd., Tower House, Southampton St., Strand, London, W.C.2.

How to make a Silence SPEAK for itself



BRITISH MADE

SHOULD your set become obstinately silent and your loudspeaker won't even whisper, it will readily confide the cause of the trouble to the AvoMinor.

Trouble-tracking with the D.C. AvoMinor is fascinatingly simple with the help of the illustrated instruction booklet included with the instrument; and the AvoMinor gives you accurate readings in milliamps, volts and ohms. It enables you to test valves, circuits, components, batteries and power units with the ease and precision of the radio engineer. The AvoMinor is a permanent investment in a trouble-free radio. It's time YOU had an AvoMinor in the house.

45/-

Deferred Terms if desired.

Write for descriptive pamphlet and details of Easy Terms.

THE AUTOMATIC COIL WINDER & ELECTRICAL EQUIPMENT CO., LTD., Winder House, Douglas St., London, S.W.1. Vic. 2404/7.

The D.C. **AVOMINOR** REGD. TRADE MARK

EVERY TEST

Current

- 0.6 m/amps.
- 0.30 m/amps.
- 0.120 m/amps.

Voltage

- 0.6 volts
- 0.12 volts
- 0.120 volts
- 0.240 volts
- 0.300 volts
- 0.600 volts

Resistance

- 0.10,000 ohms
- 0.60,000 ohms
- 0.1,200,000 ohms
- 0.3 megohms

For All Cyclists, Motorists and Hikers—

NEWNES

ROAD MAP of LONDON

and Surrounding Country

only 2'6 net

This is really 2 maps in one, showing on the first side the Central London Area with the principal thoroughfares and new by-pass and arterial roads, and on the other side the main roads to the country and coast with their suburban connections.

It is complete, showing, besides all the main and second-class roads, adjacent railways, stations, golf courses, places of interest and sports grounds.

It is a map at last drawn to a reasonably large scale (Map 1, London Area, 1 mile to the inch; Map 2, Surrounding Country, 4 miles to the inch).

It incorporates a complete index key with a quick reference explanation and colour guide.

From all booksellers, or 2/9 post free from Book Dept., Tower House, Southampton Street, Strand, W.C.2.

NEWNES : LONDON

'THE EMPIRE'S HOMAGE' on CORONATION NIGHT

Mr. Stanley Baldwin, The Viceroy of India, the Prime Ministers of the Dominions and representatives of other units of the Empire will be among those taking part in the Coronation Night broadcast entitled "The Empire's Homage."

For forty minutes, from 7.20 p.m. (British Summer Time), listeners not only in the United Kingdom but throughout the Empire and in other parts of the world will be taken by radio westwards round the world till the Prime Minister of Great Britain in his closing address leads up to a message from King George VI to his peoples.

The King will himself speak into a special microphone at Buckingham Palace, and as his father talked to "my beloved people" in the memorable Christmas Day broadcasts of the past, so will the new monarch speak to his Empire.

It will be a unique and historic occasion; the first on which a king, by the power of broadcasting, has ever spoken to his subjects in all parts of the world only a few hours after his Coronation.

It will be the first time, too, that the Dominion Prime Ministers have taken part in such a programme.

Mr. W. L. Mackenzie King, Prime Minister of Canada; Mr. J. A. Lyons, Prime Minister of Australia; Mr. M. J. Savage, Prime Minister of New Zealand; and General J. B. M. Hertzog, Prime Minister of South Africa, all of whom will be present at the Coronation as representatives of their Dominions, will speak from London. Southern Rhodesia will be represented by its Prime Minister, Dr. G. M. Huggins, and Newfoundland by a member of its Commission of Government, Mr. W. R. Howley, both speaking from London.

The Viceroy will broadcast from India.

With its impressive list of names, the roll of members of the Colonial Empire will be called, and this part of the Empire will also have its direct representation in a message to be broadcast from Bermuda by Lieutenant-General Sir Reginald Hildyard, Governor of the Colony.

The programme will also embody some of the features which have become customary in the Christmas Day broadcasts. For instance, in addition to the official greetings, representative citizens will be heard speaking from Canada, New Zealand, Australia, and South Africa, as well as spokesmen for the King's people in England, Scotland, Wales and Northern Ireland.

From beginning to end, the programme, in which the B.B.C. has the co-operation of the British Post Office and the various broadcasting authorities overseas, will be recorded, so that afterwards it may be repeated from Daventry and so be made available to any parts of the Empire where it has not been possible to hear the original broadcast.

LOCAL STATION QUALITY SETS

(Concluded from last week's issue)

A HIGH impedance detector valve has been chosen with values for the grid leak and condenser to give a good compromise between sensitivity, selectivity and quality. The leak is connected to the cathode which is returned to earth via a biasing resistance shunted by a 50 mfd. electrolytic condenser. The biasing arrangements provide the necessary grid bias when the valve is used as an amplifier for gramophone work.

With regard to the coil a suitable one would be the Bulgín type C7.

Why certain values have been given the various components will be apparent from the points discussed last week. In practice such a receiver will give exceptionally good quality from the local station and, with careful handling, should receive one or two of the more powerful foreigners, although, of course, it is not intended for the latter.

From our discussion of a quality receiver, it is apparent that a large set is necessary for faithful reproduction, but this does not necessarily mean that a battery user, or a constructor with A.C. mains at his disposal, cannot obtain quality above the average without being very ambitious. Perfect quality means a set similar to that given in Fig. 1, but the two-valve mains receiver, shown in Fig. 2, will suit all but the most fastidious of quality enthusiasts. Its fidelity curve would be equal to that of the larger set but, of course, it would not have the power-handling capacity, and would not be able to reproduce transmissions at the same strength as they would appear to a listener were he in the actual concert hall. It must, therefore, fall short of our ideal, but it would certainly give a quality of reproduction which could not be approached by any set with a selective H.F. stage.

A Set for Battery Users

Battery set users are limited at the outset by the H.T. supply necessary for valves capable of giving a reasonable undistorted output. In Fig. 3, however, is shown a receiver suitable for use from H.T. accumulators, a Milnes Unit or an eliminator. Dry battery operation is not permissible, but one of the new Bulgín Electronic H.T. Vibrator Generator Rectifiers would enable the set to be worked entirely from a six-volt accumulator, and dispense with H.T. batteries, in which case it would be greatly advantageous to use Cossor six-volt valves in the output stage—either the type 610XP or the 625P. This would give a greater undistorted output and would allow the set to have greater power-handling capacity. For anyone limited to battery operation, and who is in search of real quality, the circuit can be confidently recommended.

No doubt many readers using batteries will say immediately that they are able to get good quality and plenty of volume with a Class B or Q.P.P. output stage, but there is no doubt, at least from the author's experience, that both these systems contain a large percentage of harmonic distortion in their output. This distortion is, of course, strongly emphasised with a good loud-speaker, and directly the H.T. volts drop below 120, the distortion is so pronounced as to render reproduction, to anyone at all musically inclined, unbearable. Such systems cannot, therefore, be recommended for a quality battery receiver.

One thing stands out from the above remarks—and that is that quality of reproduction must be paid for.

IMPORTANT BROADCASTS OF THE WEEK

NATIONAL

Wednesday, May 5th.—Running commentaries on the Chester Cup, from the Roodey Racecourse, Chester.

Thursday, May 6th.—Variety programme, from the Union Cinema, Kingston.

Friday, May 7th.—Scrapbook for 1902, presented by Leslie Baily and Charles Brewer.

Saturday, May 8th.—A running commentary on the second half of the Rugby League Cup Final, from the Empire Stadium, Wembley.

REGIONAL

Wednesday, May 5th.—Empire Exhibition, a talk.

Thursday, May 6th.—Paradise Isle, a musical picture of the South Seas, by Sonny Miller.

Friday, May 7th.—King's Health, feature programme.

Saturday, May 8th.—Scrapbook for 1902, presented by Leslie Baily and Charles Brewer.

MIDLAND

Wednesday, May 5th.—English Song Writers, Holst: vocal and instrumental programme.

Thursday, May 6th.—Cricket Interval, stories and verse.

Friday, May 7th.—Midland Composers: choral programme.

Saturday, May 8th.—The Roving Reporter, a feature column in sound.

WESTERN

Wednesday, May 5th.—Opening Overs: Hampshire v. Gloucestershire, a recording of some of the match and an eye-witness account of the day's play.

Thursday, May 6th.—Cider Tasting at Long Ashton, feature programme.

Friday, May 7th.—A Novelty Instrumental programme.

Saturday, May 8th.—Town Tour, Bourne-mouth, a talk.

NORTHERN

Wednesday, May 5th.—Variety programme, from the Royalty Theatre, Chester.

Thursday, May 6th.—God Save the King, a musical tribute to Coronation Year in which the original development of our National Anthem is portrayed, from the Town Hall, Manchester.

Friday, May 7th.—Farming Fundamentals, a talk.

Saturday, May 8th.—Orchestral programme.

SCOTTISH

Wednesday, May 5th.—Robert Burns, a play by Joe Corrie.

Thursday, May 6th.—Band programme.

Friday, May 7th.—Gaelic Concert.

Saturday, May 8th.—Scottish Dance Music.

NORTHERN IRELAND

Wednesday, May 5th.—Orchestral programme.

Thursday, May 6th.—Pianoforte recital.

Friday, May 7th.—Young Farmers' Debate.

Saturday, May 8th.—Round the Albert, a panoramic view of Belfast Life, written by Ruddick Millar and Harry S. Gibson; music by Gerald Morrison.

A New 40-Page Booklet—Free



This booklet, which is yours for the asking, gives particulars of the many opportunities open to trained men engaged in the Radio industry. It also gives full information about the specialized instruction offered by the I.C.S.

The industry is progressing with amazing rapidity. Only by knowing the basic principles can pace be kept with it. I.C.S. Instruction includes American broadcasting as well as British wireless practice, and provides ambitious men with a thoroughly sound training.

Here are the I.C.S. Courses:
Complete Radio Engineering
Complete Radio
Radio Servicemen's
Elementary Radio
Radio Service and Sales
Television

Preparatory Courses for:
I.W.T. Associateship and Associate Membership Exams.
City and Guilds Exams. in Radio Communication.
P.M.G. Certificates in Wireless Telegraphy.
I.E.E. Graduateship Exam.

The Complete Radio Course covers equipment and radio principles as well as practice.

Efficient Servicing is of first importance to every wireless dealer and his assistants.

In addition to inculcating the art of selling, the Service and Sales Course provides that knowledge which enables the salesman to hold his own with the most technical of customers.

Television will soon be a tremendous branch of the industry. Our Course deals adequately with this subject.

SEND FOR OUR BOOKLET TO-DAY
 And, if you wish, ask for our free advice.

Our standard fees are substantially reduced during the summer months.



Dept. 94, International Buildings,
 Kingsway, London, W.C.2.

RADIO CLUBS AND SOCIETIES

Club Reports should not exceed 200 words in length and should be received First Post each Monday morning for publication in the following week's issue.

Exeter and District Wireless Society

AT the last meeting of the above society a lecture and demonstration was given by Mr. Mays, consisting of the illustration of various forms of electrical interference as experienced in radio reception. A full selection of gramophone records was given showing the types of interference received from almost every imaginable source, and as each was illustrated the method of cure was explained. Electric vacuum cleaners, Neon signs, and ultra-violet ray apparatus were illustrated. Lectures are held every week at 8 p.m. at No. 3, Dix's Field, Exeter, and intending members should communicate with the Secretary, W. J. Ching, 9, Sivell Place, Heavitree, Exeter.

Torrington and District Short-wave Club

THIS club, which is now enjoying increased membership, is fortunate in having excellent facilities available which include A.C. Mains Power supply, powerful mains driven amplifier, and efficient testing apparatus, etc. A successful Field Day took place recently on a prominent landmark of the district, the object being the practical application of various Aerial systems. Experiments are being conducted on the application of super-regeneration to ultra-short-wave reception.

Meetings will be held as usual throughout the summer session, and anyone interested will be given a cordial welcome. Particulars may be obtained from the Secretary, Mr. A. E. Cornish, 1, Halsdon Road, Torrington.

Radio Society of Northern Ireland

THE above society's new H.Q. are now the City of Belfast Y.M.C.A. Radio Club (G16YM) and meetings are held on the first Wednesday of the month at 8 p.m., when new members are also welcome. The society held a very successful dance recently, and over 200 members and their friends attended. Two of the club's members have recently obtained their full licences and may be heard on the air with the call-signs G18LF and G18ML. Great enthusiasm is shown by the members at the Morse class, which is held every Wednesday night in the club room, and the club now possesses 12 operators. Many of the members have also obtained their A.A. licences. Some of the transmitting members held a QSO party every Saturday night at 24.00 G.M.T., on 20 metres, and the following call-signs may be heard on telephony: G15QX, G15JN, G15OY, G16TK, G18GK, and G18MI; reports on these transmissions will be very much appreciated.

Two of the club's transmitting members have obtained their W.A.C. telephony and await their QSL cards; also, the club's station transmitter will be in operation

within the next few days after being completely overhauled. The R.S.N.I. Leonard Trophy contest is to be held during the week-ends in May, and the club's receiving contest is in full swing. A large entry is expected. New members are gladly welcomed and full particulars may be had from the Hon. Secretary: F. A. Robb (G16TK), 46, Victoria Avenue, Sydenham, Belfast, N.I.

Knutsford Amateur Radio Club

MEETINGS of this newly formed club are held at Room 4, The Liberal Club, Brook Street, Knutsford, every Monday at 8 p.m. There is a Morse class, and the G.P.O. have accepted our application for an A.A. Licence. The Hon. Sec. is J.

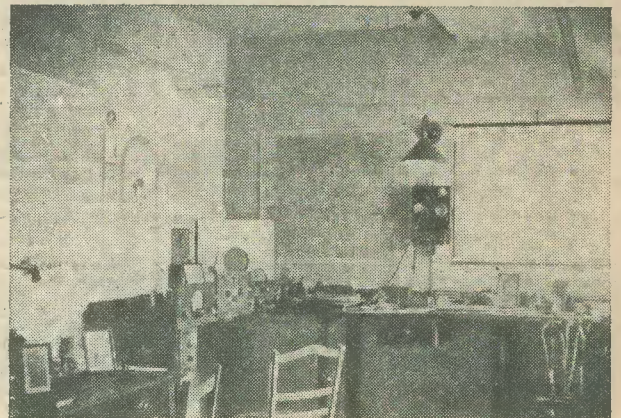

Experimental receiving station operated by Mr. M. L. Hunt, treasurer of the Knutsford Amateur Radio Club.

McDermott (2AHH), Shaw Heath Cottages, Moberley Road, Knutsford.

Peterborough and District Short-wave Radio Society

AT a meeting of the above society, held at the "Bird in Hand" on April 20th, the second result of the Boyce Cup DX receiving competition was announced, the winner being W. S. Cornwell (total distance 26,670 miles), with J. W. Parmer, of Whittlesey (9,650 miles), runner up. Each received replicas given by Mrs. H. Lyon and the donor Mr. C. Boyce.

As the winter session is now drawing to a close the last meeting will be held at 7.30 p.m. on Tuesday, May 4th, when a supper will be given at the "Bird in Hand." Anyone wishing to attend is asked to advise the Hon. Secretary.

During the summer, meetings will be held at the "Bird in Hand" the first Tuesday in the month at 7.30 p.m. and a prize will be given each month for the best QSL received. Results will be judged by the distance divided by the square of the wattage, and this will give all members an equal chance as G stations will be included.

It is expected of members, that when reporting G stations for this competition, that postage is included, and also that the report will be of some use to the station concerned. W. S. Cornwell (2ACP), Jt. Hon. Sec., 80, Elmfield Road, Peterboro.

The Liverpool S.W. Radio and Transmitting Club

THE first meeting of this club was held recently at the premises of the chairman, Mr. J. E. Crabtree, at 11, Wavertree Road, Liverpool, 7, when various matters relating to the future of the club were

discussed. Any person who is interested should write to the Hon. Secretary, Mr. C. E. Cunliffe, 368, Stanley Road, Bootle, Liverpool.

The Kingston and District Amateur Radio Society

A MEETING of the 5-metre group of the above society was held at Ashford, Middlesex, on Tuesday, April 14th. The meeting was very well supported, and after members had presented their individual fortnightly reports, a most instructive talk was given by Mr. J. Stuart Williams (G5JW) on "The Design of 5-metre Receivers." During this talk Mr. Stuart Williams exploded the popular notion that in a super-regenerative receiver a large amount of quench noise is unavoidable.

Hon. Sec: R. K. Shergold, "Reculver," Manor Lane, Sunbury-on-Thames.

Bideford and District Short-wave Society

IN view of the interest being shown in amateur transmission, it has recently been decided that alternate meetings of this society, which are held fortnightly, should be devoted to this subject.

A large attendance of members witnessed the first transmitting demonstration by the chairman on April 5th last, when a transportable low-power mains set produced satisfactory contacts with four amateur stations on the 1.7 mc/s band.

Interested prospective members are invited to apply to the Secretary, Mr. E. K. Jensen, 5, Fufzebeam Terrace, East-the-Water, Bideford, for particulars. The subscription has been fixed at 1s. per fortnight.

Clackmannanshire Short-wave Club

THE annual general meeting was held on Sunday, April 18th, and proved very interesting. The date has now been fixed for the annual field day, which will be held on Sunday, June 13th. The members will be divided into three sections, each one having its particular site, and the contest will be run on a competitive basis, points being allowed at the rate of one per thousand miles. A big membership is predicted when the club opens again on Sunday, October 3rd, and an interesting programme is promised: Prospective members can obtain full particulars from the Hon. Secretary, David McIntosh, 10, Cobblecrook Gardens, Alva, or from the Chairman (GM6TF), 12a, Erskine Street, Alloa.

The Golders Green and Hendon Radio and Scientific Society.

MEMBERS of this society recently visited the television demonstration theatre of Messrs. Marconiphone Co.

Six stages of T.R.F. are used having a gain between 40,000/100,000 times, rectified to give a variable voltage between 0/10 volts D.C. Unfortunately the various circuits used were only briefly dealt with, and this rather limited the scope of the discussion.

The meeting closed with a full programme demonstration on three different models all working at the same time. The pictures were remarkably bright, steady, and clear, and it was noted that the apparatus required very little attention, and that local interference was much more noticeable on the sound side than in the pictures. Full details of the society will be sent on application to the Secretary, 60, Pattison Road, N.W.2.

REPLIES IN BRIEF

The following replies to queries are given in abbreviated form either because of non-compliance with our rules, or because the point raised is not of general interest.

Y. A. (Mosul). The Radiolab tester would probably suit your requirements. Write to Everett Edgcombe, Colindale Works, Hendon; N.W.9.

E. H. (Ossett). We regret that we could not insert your request in the paper. You could, if you desired, take a small advertisement in our advertisement columns for the purpose.

I. S. (N.8). We regret that there is no blueprint of a unit of the type mentioned, and the only issues in which these units were described are now out of print.

E. J. R. (Norwich). It is impossible to guarantee reception of the countries mentioned on a two-valver. Under good conditions, it should be possible, but local conditions vary and no guarantee can be given even with a more powerful receiver.

A. G. S. (Edinburgh). In most cases it is only necessary to enclose postage. An International Reply Coupon, obtainable from your local post office, will overcome the difficulty of sending the remittance.

A. P. (S.W.19). As the receiver is a commercial model the reaction arrangements must have been correctly designed in the first case, and therefore we suggest that the trouble is due to some fault. It would be desirable to have the receiver overhauled by a local service agent of the makers.

A. R. (E.15). The issue is still available (5.12.36), and the coil may be obtained from Messrs. Bulgin, price 8s. 9d.

R. A. P. (Southend-on-Sea). The unit should be suitable, but some difficulty may be experienced due to hum. A circuit of your receiver would be desirable to advise definitely.

T. V. B. (Fishponds). Messrs. Electradix Radios, whose advertisement appears in this issue, can supply the gramules. The price varies according to the grade.

W. M. (Helensburgh). The chemical mentioned is suitable and is dropped into the vent hole until the desired degree of jellification has taken place.

B. M. C. (Montrose). The trouble is due to the peculiar action of the ultra-short radiation. Reflection and absorption also enter into the problem. The medium waves cannot be used, as the frequency band employed is so wide that the whole of the medium-wave band would be occupied and interference would result.

R. C. S. (Heavitree). The device consists of inductance, resistance and capacity equivalent to an ordinary aerial and is used to provide an artificial load to prevent signals from being radiated during experiments.

J. P. R. (Rugby). We regret that the issue in question is now out of print.

E. M. (Liverpool, 20). We have not described a receiver of the type mentioned by you. The converter would probably be suitable, but we have not tried it with this particular unit, and there may be insufficient current available.

M. S. (Leeds, 7). The S.W. Converter, blueprint P.W.48A, would be suitable for your requirements. It would be desirable to use this as a converter, connected in front of the set, rather than as an adapter in the detector stage, as by that means greater amplification will be obtained.

J. N. (Leeds). The books in question are now out of print.

S. M. (Beckenham). We do not recommend the procedure in view of the difficulty of accurately reproducing the circuit now employed. This will, of course, govern the output and you may find difficulty from hum.

J. L. (E.4). We regret that the issue and the blueprint are no longer available.

D. F. (Llanelly). We regret that we are not familiar with the servicing difficulties of individual commercial receivers and suggest that you have the set examined by the makers.

D. S. (Bromley). The coil in question is no longer on the market, and we suggest you use a Wearite Unigen coil in its place. A diagram of connections will be supplied with the coil.

J. L. (S.E.17). A list of the type you mentioned is to be found in the "Wireless Constructor's Encyclopaedia."

S. R. C. (St. Ives). The trouble may be due to a number of things. Reduce the H.T. on the valve, and if this does not stop it, disconnect the reaction winding. If it then ceases you will know that the wiring is too large and turns should be stripped off until normal conditions are obtained.

G. F. W. (Fulham). We believe a condenser of the type referred to may be obtained from Messrs. S. Bird and Son, Cydon Works, Cambridge Arterial Road, Enfield.



You must
LOOK UNDER THE SHELL WHEN JUDGING A CONDENSER

One condenser may look like another, but appearance does not make performance. So look under the shell—investigate what gives the performance, and how.

Strip open any T.C.C. condenser—see the "finish" inside. Take the paper type... see the purest linen tissue, that not only stands up to heavy flash tests but lasts a lifetime. See too, the finest foil, so carefully positioned... Note the heavy soundly soldered leads that connect the tags... fine workmanship all of it! A pity you cannot see the 28 years' specialized research that has led up to the design of these condensers. But you can accept the verdict of the country's leading set makers, they are prepared to take T.C.C. condensers on trust. Why? Because they have never been let down... For safety's sake use T.C.C.

T.C.C.
ALL-BRITISH
CONDENSERS

The Telegraph Condenser Co. Ltd., Wales Farm Road, N. Acton, W.3.

Ideal for the Beginner
F. J. CAMM'S
EVERYMAN'S WIRELESS BOOK
2nd Edition.
288 Pages and over 200 Illustrations. Now 3/6, or 4/- by post, from George Newnes, Ltd., Tower House, Southampton St., Strand, London, W.C.2.



LETTERS FROM READERS

The Editor does not necessarily agree with the opinions expressed by his correspondents. All letters must be accompanied by the name and address of the sender (not necessarily for publication).

Advanced Radio Theory

SIR,—I have been an ardent supporter of your valuable paper since the publication of your 2-valve superhet, at which time I knew absolutely nothing about radio, and consequently your "Beginner's Supplement" was most valuable. I constructed such sets as the "Monitor" and have, during the past five months, designed a self-contained four-valve superhet portable, and have also had five "Wrinkles" published. Surely any average beginner could now do the same, as I am only 16. I think, therefore, that many readers would welcome a section on more advanced work, such things as more complicated formulæ, to find inductances of coils, etc., and articles in the latest developments of this very progressive science.

There has been much comment on the delivery of components lately. Actually, I never have any trouble dealing direct with manufacturers. It is the shops which disappoint me. I have to spend at least 9d. on fares to reach Liverpool, where I can obtain out-of-date components, as there are no good firms stocking a good range of modern components. I have a solution which I hope comes to the notice of the R.M.A. If a second-rate shop can produce profit to provide flashing signs, surely a good shop would be capable of doing the same. Such shops could be established by the R.M.A., profits being shared by the manufacturers according to sales. Instead of four or five smooth-tongued, incompetent men, two or three skilled assistants would suffice, with obvious advantage to both constructor and manufacturer.—A. M. WILDING (Wallasey).

[What do other readers think of the suggestion concerning articles of the type mentioned in this reader's letter?—Ed.]

Back Numbers Wanted

CAN any readers let us have a copy of AMATEUR WIRELESS, dated October 27th, 1934, in which details of the 20 station one-valve receiver were given? We have several requests from readers for this particular issue.

We also have a request for a copy of the *Wireless Magazine*, dated February, 1934.

Band Spreading

SIR,—Referring to the article in the April 24th issue of PRACTICAL AND AMATEUR WIRELESS on Band Spreading and how a bandspreader can be made out of a midget .0001 condenser, I would like to state that I made a similar bandspreader, using two fixed and two moving plates, the spacing being four washers between the moving plates, and likewise for the fixed. Tuning from 0 to 180 degrees on this spreader gives a spread of between 5 to 7 degrees on the setter, which is a .00016. I have had this in use for about a fortnight, obtaining good results.

Further, I enclose a log of stations received, as I have not seen one from this district. My receiver is an 0-v-1, and antenna 45ft. long and 25ft. high.

Incidentally, could you give me the QRA of SV1MK, as there are no SV stations given in my call-book.

Thanking you for the very fine articles, and wishing PRACTICAL AND AMATEUR WIRELESS continued success.—C. DRAKLEY (Mansfield, Notts.).

[We were very interested in your fine log, which, however, was rather too long for publication. SV1MK is a Greek station.—Ed.]

Logged at Stockport: Correspondent Wanted

SIR,—Having been a reader of PRACTICAL AND AMATEUR WIRELESS from No. 1, and being interested in short-wave reception, I am enclosing the best out of my log for this year as follows: LU2CA, 6KE, 7BK; FT4AI, 4AL, 4AA; K4ENY; VO1T, 4Y, 1P; YV5AA, VP6VR, PY2CK, 2EJ; VE2IT, 2EE, 2AA; CT2AB, and quite a large log of W stations from seven different states. In one of your past issues one of my fellow readers was asking if W2UK QSL'd. I sent him a report about three months ago, enclosing reply coupon, but have not received reply yet. He was also inquiring about VE3CK. I think he must have mistaken the call for VE3ACK,

CUT THIS OUT EACH WEEK.

Do you know

—THAT English-made valves may now be obtained as replacements for all of the American types.

—THAT it is essential to watch carefully the connection to the top cap of those valves which are provided with this form of top cap.

—THAT the reason for the above precaution is that in some valves the cap is an anode connection and in others a grid connection.

—THAT a dipole aerial for the television signals should be constructed from heavy gauge tubing, and not from ordinary stranded aerial wire.

—THAT if an open type of lightning arrester is employed it should be cleaned periodically to avoid loss of signal strength.

—THAT care should be taken, when making up a multi-cable for use between separate units in a receiver, to avoid wide differences of potential between adjacent leads.

The Editor will be pleased to consider articles of a practical nature suitable for publication in PRACTICAL AND AMATEUR WIRELESS. Such articles should be written on one side of the paper only, and should contain the name and address of the sender. Whilst the Editor does not hold himself responsible for manuscripts, every effort will be made to return them if a stamped and addressed envelope is enclosed. All correspondence intended for the Editor should be addressed: The Editor, PRACTICAL AND AMATEUR WIRELESS, George Neveles, Ltd., Tower House, Southampton Street, Strand, W.C.2. Owing to the rapid progress in the design of wireless apparatus and to our efforts to keep our readers in touch with the latest developments, we give no warranty that apparatus described in our columns is not the subject of letters patent.

who was on the air quite a lot about the same time as W2UK. I have cards from VE1CR, VE2DC, VE2EE, VE2BG, VE3ACK, WIDAY, W2IXY, W3CJA, W4CBY, VO1L, VK3LR, SM5SI, LA1G, F8MM, and HB9T. All stations were received on the 20-metre amateur band. I have only been sending reports out during the last four months, giving a good detailed report, and I have received QSLs from all reports, so far. I have been interested in short-wave work now for two years, and I have done quite a lot of set-building, thanks to PRACTICAL AND AMATEUR WIRELESS. I should be very pleased if you could put me in touch with a fellow reader and S.W.L. in my district through your paper. I have three receivers, one of them being a one-valve detector circuit taken from your journal, coupled to a three-valve amplifier (push-pull), also from your pages. My aerial is an inverted-L type, 60ft. long, 30ft. high, pointing direct north.—A. NEWALL (33, Ladysmith Street, Shaw Heath, Stockport).

The "Simplest Short-waver"

SIR,—Having made the "Simplest Short-waver," I decided to add another valve. I was astonished at the reception, as my set was really only flung together. No components are of the low-loss type, but the coil unit is just as specified. In addition to sixteen G stations I have also logged EI6J, I2RO, F8MI, TPA3, OLR3E, and DJP. Many other stations are easily received, but being only a "new hand" at short-wave reception, I cannot identify them.

Wishing PRACTICAL AND AMATEUR WIRELESS every success.—H. E. CHAMBERLAIN (Shoreham-by-Sea).

A Good Log from Cambridge: Back Numbers Available

SIR,—May I add my log to those you have been publishing each week. I started listening on the short waves nearly three years ago with an adapter made from junk parts, and now have a three-valve (0-v-2, R.C.C. and Trans.), which receives below 10 metres.

Since June, 1934, I have received over 2,000 amateurs as well as broadcast stations, all on 'phones, 569 of them W stations on 10, 20, and 80 metres. I have heard 57 countries altogether.

During the last month I have also logged the following stations: CE3DW, CN8MB, CN8AG, CO2KL, CO2MA, CO2WZ, CO6OM, CT2AB, CX1CC, FT4AI, HAF8N, HI7I, HK3JA, K4UG, K4ENY, KA1MD, KA1KY, LU7DK, LU6KE, LU4AW, LU1DA, LY1HB, LY1AA, OH2ME, SU1RO, SU5NK, SU8MA, PY2AC, PY2ER, PY2CK, SV1NK, SV1KG, VO2Z, VO4A, VO6L, VP6TR, VP9G, VP9R, VS2AK, YN1NS, YV5AA, YV1AD, YR5AA, and ZP2AC, besides numerous American and Europeans.

I have just received programme sheets from Radio Podedbrady for May, and they state that they will send them to anyone for one year on receipt of six international reply coupons or six months for three coupons.

I have all numbers of PRACTICAL AND AMATEUR WIRELESS from No. 60, and will be pleased to send any one the numbers they require if they send a stamp for postage.

Congratulating you on the excellence of your paper, which gets better every week. I hope you will publish more on Amateur Transmitting, but don't cut "Thermion's" space down, as his pages are always interesting and amusing.—B. A. LANSDELL (Clock House, Balsham, Cambridge).



QUERIES and ENQUIRIES

The Westector

"Could you please let me know the makers of the Restector Type W6?"—F. N. B. (Brighton 7).

WE presume that you refer to the Westector, which is a high-frequency rectifier manufactured by the Westinghouse Brake and Signal Company, Ltd., of 82, York Road, London, N.1. The type W6 is a half-wave unit suitable for use on frequencies from 100 to 200, and is therefore most applicable to superhets in which an I.F. of 110 kc/s is employed.

2-H.F. Receivers

"Have you in the past described any 2-H.F. receivers for battery operation? I should also like details for winding a Droitwich wave-trap on a 2in. former. I have a 4-gang Radiophone condenser with oscillator section. Does this tune to 110 kc/s or 465 kc/s, and have you a circuit using this particular component?"—J. C. (Nottingham).

THE Fury Four and Fury Super both employed 2 H.F. stages, and you will see from our Blueprint Service list that we have several other receivers employing this arrangement. You can no doubt make a selection from these—they are included in the four and five-valve sections. The Droitwich suppressor may be wound on your former by using 26 D.C.C. wire and winding 100 turns. The condenser referred to employed an I.F. of 110 kc/s so far as we can trace, but you may be in possession of a manufacturer's surplus model in which some other intermediate frequency was employed. In view of this we cannot recommend any of our receivers in which to incorporate the condenser.

Converting a Battery Set

"Please let me know how I can convert my battery set into a D.C. mains set and thus discard my L.T. and H.T. batteries. What valves must I use if the supply is 230 volts?"—S. T. (Londonderry).

ALTHOUGH you could replace the present valves there may be some difficulty on the score of instability, as the mains type of valve is more efficient than the battery valve. The H.T. could be supplied direct from the mains, using a series resistor to drop the 230 volt supply to 120 or so, according to the previous voltage which you employed. For the heater supply, the valves should be wired in series and a special resistance (obtainable from Messrs. Bulgin) connected between the mains and the heaters. These resistances are supplied according to the current taken by the valves, and these may take .1, .18, .2 or .3 amps.

A Simple One-valve Set

"I am only a beginner, and in your issue I saw two sets, the All-Wave Unipen, PW 31A and the B.B.C. One-valver, AW387. Which set would be the cheapest and easiest to construct? I have only just commenced taking your paper."—P. I. (East Barnet).

THE first set employs a pentode valve as detector and a special all-wave tuner. The second employs a home-made tuning coil (covering the broadcast wavelengths only) and a simple triode detector valve, and is consequently cheaper to build. The first set has the advantage that the short waves may be tuned in, in addition to the standard broadcast stations. Unfortunately, both the issues describing construction are now out of print.

a blueprint available?"—N. R. (Stockport).

THE current delivered by your mains unit is probably 30 mA at the most. This is .03 amp., and thus you will see that to charge an accumulator you would have to leave the cell on for weeks to replace even the drain of a two-valve set. The average trickle charger delivers .5 amp., and therefore your present unit could not be used for charging purposes. A blueprint for making an A.C. charger may be obtained from this office, price 6d., and the number is AW462. It was fully described in the issue of *Amateur Wireless* dated January 5th, 1935.

An All-wave One-valver

"In a recent issue you replied in the Briefs column to W. J. A. C. regarding the ranges of a one-valve set. I would like to know the name of this set and in what issue of the paper the constructional details were given. Is it possible to obtain a blueprint for it?"—H. J. W. (Ash Vale).

THE receiver in question was the All-wave Unipen, blueprint number PW31A. It was described in the issue dated October 14th, 1933, but this is now out of print.

The Westector for A.V.C.

"Referring to a back number of one of your magazines I found an A.V.C. unit which can be built into an ordinary battery set. I wish to incorporate this in a set I am building, but I am puzzled by one thing only, and that is, what component is represented by the box-like figure marked plus and minus. I thought I knew most theoretical signs, and this is a new one on me. Does the potentiometer in the diagram control the volume or the amount of grid bias?"—S. M. (Parkhead, Glasgow).

THE symbol in question is a pictorial representation of the Westector. This is a high-frequency rectifier, sometimes referred to as a cold valve. The theoretical symbol is exactly the same as a standard crystal detector, and therefore the pictorial symbol is often used in preference, to avoid confusion. The polarity must be observed, and that accounts for the plus and minus sign. You will find that the component has red and black end caps to enable this to be done. The potentiometer in question governs the delay voltage, and is, of course, connected across the G.B. battery.

I.H. and D.H. Valves

"I have a directly-heated pentode which I require to use in conjunction with an indirectly-heated detector in a two-valve straight set. I have a mains transformer which has only two four-volt heater windings, and I wish to use a valve rectifier. I understand that it is possible to run both I.H. and D.H. valves off the same winding and should be glad to know how."—A. C. (Wimbledon).

AS the detector is indirectly heated the cathode will be joined direct to earth, and therefore an automatic bias resistor may be inserted between the centre tap of the heater winding and the H.T. negative line to bias the output valve. Even if the detector is used for pick-up work and has to be biased, the necessary resistor may be inserted in the cathode lead of that valve and no difficulty will therefore arise.

RULES

We wish to draw the reader's attention to the fact that the Queries Service is intended only for the solution of problems or difficulties arising from the construction of receivers described in our pages, from articles appearing in our pages, or on general wireless matters. We regret that we cannot, for obvious reasons—

- (1) Supply circuit diagrams of complete multi-valve receivers.
- (2) Suggest alterations or modifications of receivers described in our contemporaries.
- (3) Suggest alterations or modifications to commercial receivers.
- (4) Answer queries over the telephone.
- (5) Grant interviews to querists.

Please note also, that queries must be limited to two per reader, and all sketches and drawings which are sent to us should bear the name and address of the sender.

Requests for Blueprints must not be enclosed with queries as they are dealt with by a different department.

If a postal reply is desired, a stamped addressed envelope must be enclosed. Send your queries to the Editor, PRACTICAL AND AMATEUR WIRELESS, George Newnes, Ltd., Tower House, Southampton Street, Strand, London, W.C.2.

The Coupon must be enclosed with every query.

Repairing a Speaker

"My loudspeaker vibrates on the outer edges, where it is crinkled, when I put my volume on to full strength. This causes a rattling, blurring sound. Could this be stiffened by painting with any solution to stop it, or is there any other means of preventing the trouble? There is also a crackling sound in my set which is very slight on short waves, louder on the broadcast band, and very loud on the long waves. Can you suggest the cause and a remedy, please?"—C. S. M. O'H. (Moascar).

IF the speaker cone is fractured at the corrugated surround it could be repaired by using some cellulose cement. This material is now marketed for loudspeaker repairs, together with a special thinning medium. It may be obtained from Messrs. Holiday and Hemmerdinger, of Dolefield, Manchester, at 2s. 6d. for the two, or 1s. 6d. for the cement and 1s. for the thinner. The cause of the crackling noises is, in our opinion, something outside of the receiver, and this may be confirmed by removing aerial and earth. If the noise then ceases you will know that the set is not responsible and will probably find some electrical apparatus in the vicinity which is causing the trouble.

Trickle Charging

"I have in my possession a mains unit which gives an output up to 120 volts. Would it be possible, either by resistance or step-down transformer, to charge a 2-volt accumulator from this? If this is not possible, has there been an A.C. trickle charger described in your paper or is there

The coupon on page 184 must be attached to every query.

Miscellaneous Advertisements

Advertisements are accepted for these columns at the rate of 3d. per word. Words in black face and/or capitals are charged double this rate (minimum charge 3/- per paragraph). Display lines are charged at 6/- per line. All advertisements must be prepaid. All communications should be addressed to the Advertisement Manager, "Practical and Amateur Wireless," Tower House, Southampton Street, Strand, London, W.C.2.

RECEIVERS, COMPONENTS AND ACCESSORIES

Surplus, Clearance or Secondhand, etc.

RADIOMART

SHORT-WAVE MANUAL

Packed with short-wave information and circuits of mains and battery receivers, including straight, superhet and 5-metre transmitters, modulators, etc. Information on transmitting licences, aerials, Class B amplifications, neutralizations, superhet alignment, etc. The most comprehensive manual published, written by practical engineers, price 6d., post free, 7d. including catalogue.

1937 Short-wave Catalogue only (3 times enlarged) price 1½d., post free.

44, HOLLOWAY HEAD, BIRMINGHAM 1

CONVERSION UNITS for operating D.C. Receivers from A.C. Mains, improved type, 120 watts output at £2/10/0. Send for our comprehensive list of speakers, resistances and other components.

WARD, 46, Farringdon Street, London, E.C.4. Telephone: Holborn 9703.

REPAIRS to Moving Coil Speakers, Cones and Coils fitted or rewound. Fields altered. Prices Quoted including Eliminators, Loudspeakers Repaired, 4/- L.F. and Speech Transformers, 4/- post free. Trade invited. Guaranteed. Satisfaction. Prompt Service. Estimates Free. L.S. Repair Service, 5, Balham Grove, London, S.W.12, Battersea 1321.

SHORT WAVE on a crystal set. Full building instruction and crystal 1/2 post paid.—Radio-mail, Tanworth-in-Arden, Warwickshire.

ALL lines previously advertised still available.

RADIO CLEARANCE, 63, HIGH HOLBORN, W.C.1.

ALL goods previously advertised are standard lines, still available. Post card for list free.

VAUXHALL UTILITIES, 163a, Strand, W.C.2. Over Denny's the Booksellers, Temple Bar 9338.

BANKRUPT Bargains. List free. Decca 6v. Superhet A.C. radiograms, 12 gns. Decca 6v. A.C. superhets, £6/5/-. Ditto all-wave, £7/5/-. Halcyon A.C. S.W. converters with valve, 25/-. Ormond 3v. H.F. battery sets with valves, 59/6. Many other receivers and large stock components, valves, etc. All new goods. Butlin, 6, Stanford Avenue, Brighton.

ALCO ELIMINATORS AND CHARGERS.—4 H.T. taps, 120v/150v. 20/30 m.a., 18/-. With ½ amp. charger, 25/-. Charger alone, 7/6. ¼ amp., 11/-. Year's guarantee. Details free. P. & D. Radio, 1, Goodinge Road, N.7.

VARIABLE Directional Aerials. 3 models available. As used at home, India, South Africa, etc. New Semi-variable Model, 12s. 6d. P.F. Send 1½d. stamp for Leaflet.—A. W. Mann, 62 Costa Street, Middleborough, Yorks.

SOUTHERN RADIO'S Wireless Bargains. All lines advertised in previous issues of "Practical and Amateur Wireless" still available.—Southern Radio, 323, Euston Road, London, N.W.1 (near Warren Street Tube). Phone: Euston 3775—and Branches.

HEADPHONES. Guaranteed. Brown, Sterling, B.T.H., G.E.C., Brandes, etc. 2,000 ohms, 2/6; 4,000, 5/-; postage 6d. **SPECIAL**. Ericsson, 4,000 ohms, as new, 7/6. Telefunken, adjustable, lightweight, 7/6. **CRYSTAL SETS**. Burne-Jones. Complete. Guaranteed. 5/6. Ditto, double circuit, 8/-. Sensitive permanent detectors, 1/6. Crystal detectors, complete parts, 1/-. Crystal with whisker, 6d.; postage 1½d.—Post Radio, 133, Caledonian Road, London, N.1.

PREMIER SUPPLY STORES

All goods guaranteed perfect; carr. paid over 5/-; under 5/- postage 6d. extra.

ALL POST ORDERS TO JUBILEE WORKS, 167, LOWER CLAPTON RD., LONDON, E.5. Phone: Amherst 4723.

CALLERS, AS USUAL, TO 165 & 165a, FLEET ST., E.C.4 (Next door to Anderton's Hotel), Central 2333. **New Branch: 50 HIGH ST., CLAPHAM, S.W.4** (Macauley 2381).

Have you had our **GIANT ILLUSTRATED CATALOGUE AND VALVE LIST?** Send 4d. in STAMPS FOR THIS BARGAIN LIST.

SHORT-WAVE COILS, 4- and 6-pin types, 13-26, 22-47, 41-94, 78-170 metres, 1/9 each, with circuit. Special set of 3 S.W. Coils, 14-150 metres, 4/- set, with circuit. Premier 3-band S.W. Coil, 11-25, 10-43, 38-86 metres. Simplifies S.W. receiver construction, suitable any type circuit, 2/6.

COIL FORMERS, in finest plastic material, 1½in. low-loss ribbon, 4- or 6-pin, 1/- each.

SUPER CERAMIC CONDENSERS, S. L. F., .00016, .0001, 2/9 each; double-spaced, .00055, .000225, .00015, 3/- each. All brass with integral slow motion .00015 tuning, 3/9; .00015 reaction, 2/9. **S.W. H.F. CHOKES**, 9d.

MAINS VALVES, famous Europa 4 v. A.C. types, 4/6 each. H.L., L., S.G., Var.-Mu.-S.G., H.F. Pens., Var.-Mu.-H.F. Pens., 1, 3 and 4-watt A.C. directly heated output Pentodes. Full-wave rectifiers, 250 v. 60 m.a. A.C./D.C. types. 20-volt .18 amp. S.G., Var.-Mu.-S.G., H.L., Power and Pen. Following types all 5/6 each. Full-wave rectifiers, 350 v. 120 m.a. and 500 v. 120 m.a. 2½ watt indirectly-heated Pentodes. Octode Frequency Changers.

BATTERY VALVES. 2 volts. H.F., L.F., 2/3. Power, Super-Power, 2/9. S.G., Var.-Mu.-S.G., 4- or 5-pin Pentodes, H.F. Pens., V.-Mu.-H.F. Pens., 5/-, Class B, 5/-.

AMERICAN VALVES. Genuine American HYTRON and TRIAD first-grade Valves. 3 months' guarantee. All types in stock, 5/6 each. 210 and 200, 8/6 each. New Metal-Glass Valves, all types, 3/6 each. Genuine American DIOTRON Valves, all types, 3/6 each. Valve holders for all above types, 6d. each. **OCTOL** bases, 9d. each.

3-WATT A.C. AMPLIFIER, 2-stage for mike or pick-up. Complete kit of parts with 3 valves, 40/-.

7-WATT A.C./D.C. AMPLIFIER, 3-stage high-gain, push-pull output. Complete kit of parts with 5 specially matched valves, 24 4s. Completely Wired and Tested, 45/5/0.

COSMOCORD PICK-UPS, with tonarm and volume control. 10/6 each. **PICK-UP HEADS** only, 4/6 each.

PREMIER MAINS TRANSFORMERS, wire-end type with screened primaries, tapped 200-250 v. Centre-tapped Filaments. Guaranteed one year. **H.T. 8 & 9 or H.T. 10** with 4 v. 4 a. C.T. and 4 v. 1 a. C.T., 8/6. 250-250 v. 60 m.a., 4 v. 1 a., 4 v. 2 a., and 4 v. 4 a., all C.T., 8/6. 350-350 v. 120 m.a., 4 v. 1 a., 4 v. 2 a., and 4 v. 4 a., all C.T., 10/6. Any of these transformers with engraved panel and N.P. terminals 1/8 extra. 500-500 v. 150 m.a., 4 v. 2 a. 4 v., 2 a. 4 v., 2 a. 4 v., 2 a. 4 v., 2 a. 4 v., all C.T., 17/6. **SPECIAL OFFER PHILIPS MAINS TRANSFORMERS**, 250-250 v. or 300-300 v. at 80 m.a., 4 v. 5 a., C.T.; 4 v. 1 a. Tapped Primary 100-250 volts, 6/11. 450-450 v. at 150 m.a. or 500-500 v. 100 m.a., 4 v. 4 a. C.T. 4 v. 4 a. and 4 v. 3 a. Screened Primary. Tapped input 100-250 v., 12/6. **AUTO TRANSFORMERS**, step up or down, 60 watts, 7/6; 100 watts, 10/-. **SMOOTHING CHOKES**, 25 m.a., 2/9; 40 m.a., 4/-; 60 m.a., 5/6; 150 m.a., 10/6. 2,500 ohms, 60 m.a. Speaker Replacement Chokes, 5/6.

Electric SOLDERING IRONS, 200-250 v., A.C./D.C., 2/3.

SPECIAL OFFER. LISSÉN TWO-GANG SCREENED ALL-WAVE COILS, 12 to 2,000 Metres, complete with switching and wiring diagrams, 6/11 per set.

Special Offer BTH Energized Moving Coils, 10½in. diam. 1,650 ohms field. Power or Pentode transformer (state which), 14/6.

ROLA latest type P.M.s, 15/- **GOODMANS'** Sin. mains energised 1,000 ohms field, 10/6 each; Jensen P.M.s, 10/6.

TRANSFORMERS, latest type Telsen R.C.4 (list 12/6), 2/9. Lissen Hypernik Q.P.P. (list 12/6), 3/6.

OUTPUT TRANSFORMERS for Power or Pentode, 2/6; Multi-Radio, 4/6.

TUBULAR CONDENSERS, non-inductive, all values up to .5 mfd., 6d. each.

Wire-end RESISTORS, any value, 1 watt, 6d.; 4 watts, 1/-; 8 watts, 1/6; 15 watts, 2/-; 25 watts, 2/6 each.

Reliable MORSE-KEYS with Morse Code engraved on bakelite base, 2/- each.

Bakelite case **BUZZERS**, 1/6; Walnut case "Loud-tone," 2/6 each.

Super Quality lightweight **HEADPHONES**, 3/9 pair.

Telsen DISC DRIVES, W 184, 1/- each.

W.B. 1938 STENTORIAN SPEAKERS. Standard model (list 32/6), 22/6. Senior model (list 32/6), 28/6. Brand new in original sealed cartons.

GRAMOPHONE MOTORS. Collaro Gramophone Unit consisting of A.C. motor, 100-250 v., high quality pick-up and volume control, 45/-; Collaro motor only, 30/-; Collaro Universal Gramophone Motor, 100-250 v. A.C./D.C., 49/6; Edison Bell double-spring motor, including turntable and all fittings, 15/-; Cosmocord Gramo. unit, comprising A.C. motor, pick-up and volume control (list 55/-), 35/9.

NEW RECEIVERS, COMPONENTS AND ACCESSORIES

ROLA SPEAKERS, BRAND NEW BOXED. 8", 1,000 ohms, with matching transformer, 6/6. Postage 6d. Linecords, 2/-.

POWER TRANSFORMER, 6.3v 2½ amp., 5v 3 amp., 350-0-350, 100 MA, 8/6. Postage 6d. Radiographic, Ltd., 66, Osborne Street, Glasgow, C.1, Bell. 848.

SITUATIONS VACANT

WANTED.—Ambitious young men to prepare for well paid posts in TELEVISION, the great career of the future. Apply for free booklet from BRITISH INSTITUTE OF ENGINEERING TECHNOLOGY, 18P, Stratford Place, W.1.

MISCELLANEOUS

"INTERESTING." P. & A.W. New Detection Theory. Experiments, Circuits, Book. Post anywhere, 1/1d. D'Arcy Ford, Gandy Street, Exeter.

CORRESPONDENCE TRAINING COURSE for Service Engineering. Low fees. Easy payments.—Tutor, 150 Central Avenue, Hounslow.

WANTED. Modern used Short-Wave sets, parts, Eliminators, Speakers, Meters, Motors, and Pick-Ups, etc. Bring or send. Spot cash paid.—University Radio, Ltd., 82 Hampstead Road, Euston, London, N.W.1.

GRAMOPHONE attachments for Radio, electric motors, 25/-; pick-ups, 9/6; portable gramophones, 12/-; spring motors, 4/6; dozen, 36/-, 100 £12/10/0, 1,000 £100; walnut pedestal Anaxagram, £5; soundboxes, tone-arms, horns, cabinets, needles, gears, springs, accessories, cheapest. Quantity buyers obtain lower prices. Catalogue free.—Regentam, 120, Old Street, London, E.C.1.

"NEWNES TOURIST ATLAS of Great Britain and Route Guide." Edited by John Bartholomew & Son, Ltd., 120 pages of fully coloured contour maps for the whole of England, Scotland, Ireland and Channel Islands, with index to the principal Motoring and Cycling centres and distances, 2s. 6d. from all Booksellers.—George Newnes, Ltd., Tower House, Southampton Street, Strand, London, W.C.2.

VISITORS TO LONDON should get Newnes Handy Pocket Atlas and Street Guide to London. Edited by John Bartholomew & Son, Ltd., 18 coloured Maps, General Index to Streets and Railway Stations, 2s. from all booksellers.—George Newnes, Ltd., Tower House, Southampton Street, Strand, London, W.C.2.

"WIRELESS FOR THE MAN-IN-THE-MOON," by Columbus and Decibel, 2s. 6d. net.—Writing about the book the "Midland Daily Telegraph" says: "It is both good fun and sound theory."—At all Booksellers and Libraries, or from George Newnes, Ltd., Tower House, Southampton Street, Strand, London, W.C.2.

"THE OUTLINE OF WIRELESS," by Ralph Stranger. Fifth edition, 8s. 6d. net.—This book, which covers the subject from A to Z, is to be recommended to all who desire to master the theory of Modern Wireless. At all Booksellers and Newsagents.—George Newnes, Ltd., Tower House, Southampton Street, Strand, London, W.C.2.

A DICTIONARY OF WIRELESS TERMS, by Ralph Stranger. A Wireless Work of Reference that should be on the bookshelf of every keen amateur. Compiled by a master of lucidity, it gives the meanings of all Technical terms in general use. Price 2s. 6d. from all Booksellers and Newsagents.—George Newnes, Ltd., Tower House, Southampton Street, Strand, London, W.C.2.

FIFTY TESTED WIRELESS CIRCUITS, by F. J. Camm, 2s. 6d.—This handbook contains every modern circuit, complete with instructions for assembling, component values, and notes on operation. Obtainable at all Booksellers and Newsagents.—George Newnes, Ltd., Tower House, Southampton Street, Strand, London, W.C.2.

THE PRACTICAL MOTORIST'S ENCYCLOPEDIA, by F. J. Camm, 3s. 6d. net. A lucid exposition of the principles, upkeep and repair of every part of the car. 442 illustrations. From booksellers everywhere.—George Newnes, Ltd., Tower House, Southampton Street, Strand, London, W.C.2.

EVERYMAN'S WIRELESS BOOK, by F. J. Camm, 3s. 6d. net. An invaluable book of reference explaining the operation, upkeep and overhaul of all types of wireless receiver. 200 illustrations. From all Booksellers and Newsagents.—George Newnes, Ltd., Tower House, Southampton Street, Strand, London, W.C.2.



A wireless constructional chappie
Was always notoriously snappy
Until he made bubbles
Of all of his troubles
With FLUXITE... he's
now nicknamed
"Happy."

See that FLUXITE is always by you—in the house—garage—workshop—wherever speedy soldering is needed. Used for 30 years in government works and by leading engineers and manufacturers. Of Ironmongers—in tins, 4d., 8d., 1/4 and 2/8.
Ask to see the FLUXITE SMALL-SPACE SOLDERING SET—compact but substantial—complete with full instructions, 7/6.
Write for Free Book on the art of "soft" soldering and ask for Leaflet on CASE-HARDENING STEEL and TEMPERING TOOLS with FLUXITE.

TO CYCLISTS! Your wheels will NOT keep round and true, unless the spokes are tied with the fine wire at the crossings AND SOLDERED. This makes a much stronger wheel. It's simple—with FLUXITE—but IMPORTANT.

THE FLUXITE GUN

is always ready to put Fluxite on the soldering job instantly. A little pressure places the right quantity on the right spot and one charging lasts for ages.
Price 1/6.



ALL MECHANICS WILL HAVE

FLUXITE

IT SIMPLIFIES ALL SOLDERING
FLUXITE LTD. (Dept. W.P.) DRAGON WORKS, BERMONDSEY STREET, S.E.1.

**ENGINEERS!
ARE YOU EARNING
LESS THAN £10 PER WEEK?**

If so, you cannot afford to carry on without reading our 268-page Handbook. The book explains clearly and definitely many ways of carving out a successful career. Among other things it explains the Services of our unique Appointments Department, outlines Home-Study Courses in all branches of Civil, Mechanical, Electrical, Motor, Aero, Wireless, "Talkie," Engineering, Building, Govt. Employment, etc., and gives details of B.Sc., A.M.I.C.E., A.M.I.E.E., A.M.I.Mech.E., A.M.I.A.E., A.M.I.W.T., A.M.I.R.E., G.P.O., Matric, and all Exams. We Guarantee—NO FASS—NO FEE! Whether you be an old hand or a budding apprentice get this book to-day—FREE and POST FREE, BRITISH INSTITUTE OF ENGINEERING TECHNOLOGY.



409, Shakespeare House, 17/19, Stratford Place, London, W.1.

ADVERTISEMENT INDEX

Automatic Coil Winder and Electrical Equipment Co., Ltd.	186
Bennett College, Ltd.	175
British Institute of Engineering Technology	Inside Back Cover
Electradix Radios	184
Fluxite, Ltd.	Inside Back Cover
International Correspondence Schools, Ltd.	188
London Radio Supply Co.	184
M.P.R. Electrical Co.	184
McCarthy Radio, Ltd.	Inside Back Cover
New Times Sales Co.	183
Premier Supply Stores	192
Technological Institute of Great Britain	184
Telegraph Condenser Co., Ltd.	189

When writing to Advertisers please mention "Practical and Amateur Wireless"

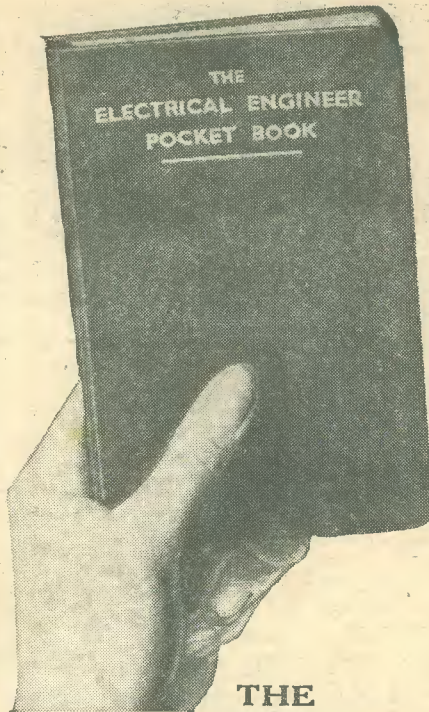

THE ELECTRICAL ENGINEER POCKET BOOK

Some of the Contents:

- | | |
|-------------------------|--------------------|
| ACCUMULATORS | RECTIFIERS |
| A.C. THEORY | TABLES |
| BATTERY CHARGING | (MATHEMATICAL) |
| FUNDAMENTALS | TRANSFORMERS, A.C. |
| LIGHTING | TRANSMISSION |
| MAGNETISM | SPACE HEATING |
| MOTORS | WATER HEATING |
| POWER-FACTOR CORRECTION | WIRING TABLES |

An essential everyday reference book—handy, practical, and up-to-date.

Illustrations: This handy pocket volume contains a profusion of diagrams and sketches together with graphs. Also included for convenience is a small section of blank pages for notes, calibrated pages for graphs, so that the Pocket Book can contain information of a particular or personal nature as well as being a reference book of general facts.

The Book Itself: The Pocket Book is strongly bound in durable art, leather—deep red, richly grained, and embossed in gold. The book measures approximately 6 1/2 x 4 inches, and has rounded corners, so that it is in the truest sense of the word a pocket book. The paper has been specially chosen to give the minimum bulk consistent with good printing, again making for convenience in handling.

★ The Electrical Engineer Pocket Book can be obtained from all good newsagents and book-sellers at 3/6 net, or in cases of difficulty direct from the publishers, George Newnes, Ltd., Book Dept., Tower House, Southampton Street, Strand, London, W.C.2, at 3/8 post free.

NEWNES : LONDON



MCCARTHY

NEW BATTERY ALL-WAVE SUPERHET

£7

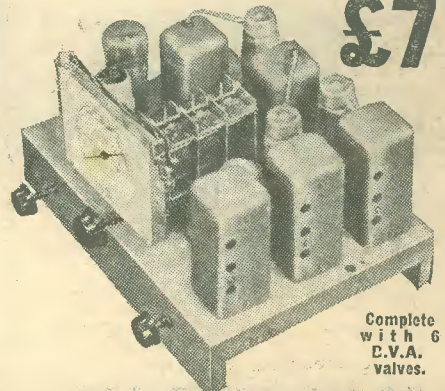

Complete with 6 C.V.A. valves.

The only receiver of its type now on the British market. Results on all 3 wavebands equal to mains receivers of equivalent type. Latest technical developments incorporated in circuit. Latest types valves, transformers, tuning coils, switches, etc.
Specification in brief: radio frequency amplifier, first detector with separate triode oscillator, I.F. amplifier, double diode detector, I.F. amplifier, low consumption pentode output. D.A.V.C. volume control and tone control both operative on gramophone. Illuminated dial with station names. Wave-ranges: 16-52, 200-550, 900-2,000 metres.

ALL-MAINS ALL-WAVE SIX with radio frequency stage

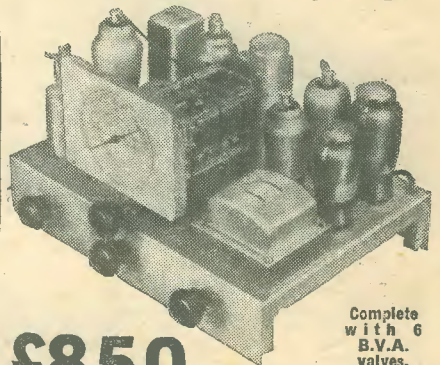

Complete with 6 B.V.A. valves.

£8.50

"De luxe" 6 valve receiver, with 8 valve performance (specially recommended for tropical and foreign reception conditions). Built on special cadmium-plated 16 gauge steel chassis. Varley iron-cored I.F. coils. Litz-wound tuning coils. 3 wave-ranges—16.5-2,000 metres. Illuminated "Airplane" dial with principal station names.
Circuit comprises: Pre-selector radio frequency amplifier (operative on all wavebands), triode-hexode frequency changer, double band-pass coupled I.F. amplifier, double diode detector, D.A.V.C. applied to 3 preceding valves. I.F. amplifier and pentode output. Variable tone control and volume control operate on radio and gramophone.

Important!
The prices at which McCarthy Chassis are advertised include Marconi Royalties.
Readers should, for their own protection, make sure before purchasing any receiver that the quoted price includes the Royalty payment.

All McCarthy receivers supplied complete with valves, knobs, pilot lamps, leads, mains cable and plug. 12 months' guarantee. Cash with order on 7 days' approval.

Deferred terms on application, or through London Radio Supply Co., 11, Oat Lane, E.C.2.

Write for catalogue of complete range of McCarthy receivers.

MCCARTHY RADIO LTD.
44a, Westbourne Grove, London, W.2

Telephone: Bayswater 3201/2.

Build this



FOLDING OUTBOARD MOTOR BOAT

A Portable Speed-boat, which is easy to construct and costs little.

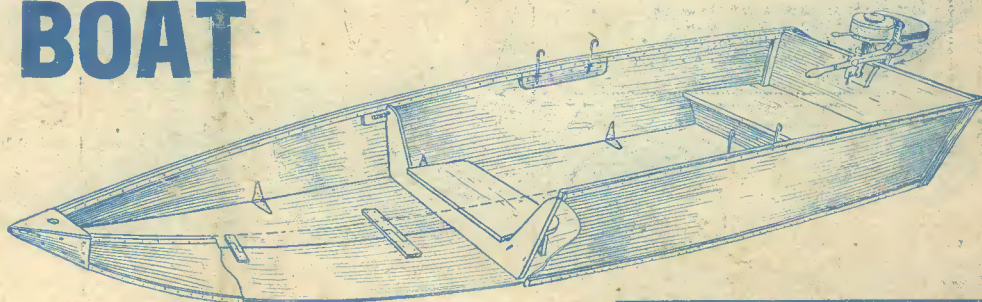

NOW is the time to get to work on this splendid Portable Speedboat. A folding boat, it has been specially designed for simplicity in construction—you and a friend should be able to put it together in a week-end! In this month's "PRACTICAL MECHANICS" you will find constructional details for part of it, together with diagrammatic sketch of the finished boat. It's just the thing for the long summer days ahead.

IN THE MAY

PRACTICAL ^{6^p} MECHANICS

THE MAGAZINE OF MODERN MARVELS

Other Special Contents of the May "PRACTICAL MECHANICS" include:

FLYING FOR ALL. The Development of one of the Newest Light Aeroplanes, the Luton "Minor."

BUILDING A WORKSHOP.

GREAT MODEL AIR-CRAFT CONTEST. 1st Prize £50.

A "MIDGET SUN." Wonders of a Mercury Arc which produces a temperature Twice that of the Sun.

THE MECHANICS OF VANISHING TRICKS. By Norman Hunter (The Well-known Conjuror).

Of all Newsagents and Bookstalls, or by post 8d. from The Publisher, George Newnes, Ltd., Tower House, Southampton Street, Strand, London, W.C.2.

George Newnes, Ltd.

Published every Wednesday by GEORGE NEWNES, LIMITED, Tower House, Southampton Street, Strand, London, W.C.2, and Printed in England by THE NEWNES & PEARSON PRINTING CO., LTD., Exmoor Street, London, W.10. Sole Agents for Australia and New Zealand: GORDON & GOTCH, LTD. South Africa: CENTRAL NEWS AGENCY, LTD. Practical and Amateur Wireless can be sent to any part of the World, post free, for 17s. 8d. per annum; six months, 8s. 10d. Registered at the General Post Office as a newspaper and for the Canadian Magazine Post.