

To be Completed in about 32 weekly parts.

# NEWNES PRACTICAL ELECTRICAL ENGINEERING

## IN THIS PART

THE DESIGN OF  
MAINS UNITS

TIME SWITCHES AND  
PROGRAMME CLOCKS

MAINTENANCE OF  
AN ELECTRICALLY  
EQUIPPED STORES

FURTHER NOTES ON  
ELECTRO-PLATING

ILLUMINATION OF  
OFFICE BUILDINGS

ELECTRICAL  
MEASURING  
INSTRUMENTS

1/-

PART  
23

A PRACTICAL WORK WRITTEN BY EXPERTS

STUDY  
AT  
HOME

FOUNDED 1900.

32 YEARS OF SUCCESS.

IN  
YOUR  
SPARE  
TIME

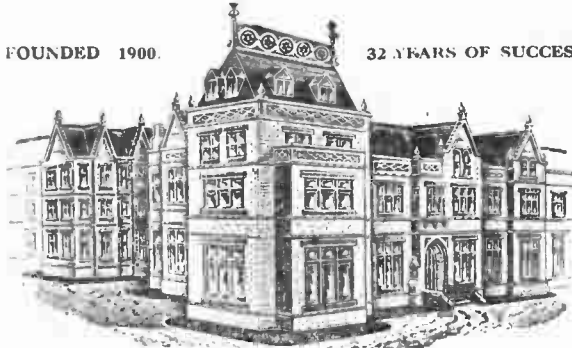

**THIS IS THE BENNETT COLLEGE - - ALL OF IT**

The Bennett College is not a Rented Room in a well-known street—it is a *College*. Over 31 years ago the Founder took as his motto what has now become a household slogan:

**LET ME BE YOUR FATHER**

In many trades and professions there are more vacancies than trained men to fill them. We do not profess to act as an employment agency, but our gigantic organisation certainly does tell us where the demand exists, thus enabling us to give **FATHERLY ADVICE ON ALL CAREERS AND THE POSSIBILITY OF EMPLOYMENT, FREE.**



*J.H. Bennett*

WE TEACH ALL BRANCHES OF THE FOLLOWING VOCATIONS AND SPECIALISE IN ALL EXAMINATIONS CONNECTED THEREWITH.

**THE MOST SUCCESSFUL AND MOST PROGRESSIVE CORRESPONDENCE COLLEGE IN THE WORLD**

- Aviation Engineering.
- Boiler Engineering.
- Boiler Making.
- B.Sc. (Engineering).
- Civil Engineering :  
A.M.I.C.E.
- Quantities—Specifications.
- Commercial Art

- Concrete and Steel.
- Draughtsmanship :  
Electrical or  
Mechanical.
- Electrical Engineering :  
A.M.I.E.E.  
City and Guilds.
- Engineering Mathematics.
- Foundry Work.
- Heat Engines.

- Heating, Ventilating and Lighting.
- Internal Combustion Engines.
- Machine Designs :  
Theory of Machines.
- Marine Engineering :  
Motor.  
Steam.
- Mechanical Engineering :  
A.M.Inst.B.E.  
A.M.I.Mech.E.  
City and Guilds.
- Pattern Making.

- Mechanics.
- Metallurgy of Steel.
- Mine Electrician :  
A.M.E.E.
- Mining (all examinations).
- Motor Engineering :  
A.M.I.A.E.
- Municipal and County Engineers :  
M. and C.E.
- Naval Architecture
- Pumps and Pumping Machinery.
- Radio Reception.
- Ship Building.
- Structural Engineering.
- Telegraphy and Telephony.

IF YOU DO NOT SEE YOUR OWN REQUIREMENTS ABOVE, WRITE TO US ON ANY SUBJECT.

IT COSTS NOTHING TO ENQUIRE.

Also ask for Our New Book (FREE OF CHARGE)

**THE HUMAN MACHINE**

SECRETS OF SUCCESS

WE TEACH BY POST IN ALL PARTS OF THE WORLD

Note Address Carefully :

The BENNETT COLLEGE, Ltd., Dept. 119, Sheffield



stamping, such as that illustrated in Fig. 18 for transformers.

### Bobbin for Smoothing Choke.

We first proceed to make a bobbin in a similar manner to that described for the transformer. The bobbin is then wound full of wire as evenly as possible. The wire may be either enamelled insulated or cotton insulated, or, if expense is no object, silk covered. Of the three insulated wires, the writer prefers the cotton covered as this gives a much better choke and on test has proved to give the best results.

copper wire should be used and will mean approximately 6,000 turns.

### Voltage Drop of Different Types of Wire.

The D.C. resistance of the choke wound with double cotton-covered wire will naturally be a little higher, but this will not matter at all. For instance, in a 30 hys. choke, one wound with cotton-covered wire and passing 50 milliamps. will have a voltage drop of approximately 15 volts, whereas that wound with enamelled wire would have a voltage drop of 10 volts, and as 5 volts will make so little

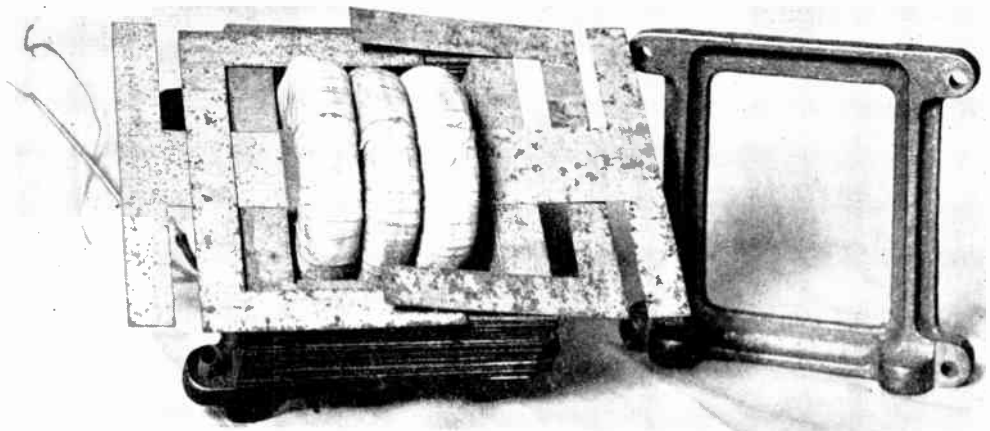

Fig. 16.—ASSEMBLING THE STAMPINGS FOR A TRANSFORMER.

These are assembled in a manner so as to interlace each other. Strong clamping end plates prevent core hum.

This is due to the lower self capacity of the winding. While it is true that cotton-covered wire takes up a little more space, it is nevertheless compensated. Also, cotton-covered wire will be found more easy to wind as it is more docile and will easily take the form of the core and can be laid side to side without any difficulty.

For the 20 hys. choke the bobbin should be wound full of No. 34 double cotton covered or No. 32 enamelled wire. This will be approximately 4,000 turns. Avoid looseness and bunching in winding as this will lead to a waste of space and there will not be room to accommodate the required number of turns.

For a 30 hys. choke No. 32 double cotton-covered wire or 30 enamelled

difference in the H.T. supply, it is not necessary to give it any serious consideration.

### Placing the Stampings and Assembling the Core.

After the bobbin is wound and finished off the next step is to place the stampings and assemble the core. With the choke, the stampings are assembled in a different manner to the transformer, for with a choke we require an air gap. Therefore all the stampings are assembled in one way, not alternately as in the case of a transformer, and between the stampings a small air gap is allowed. This should be approximately 10, 1000 inch or, approximately, the thickness of a visiting card. A small piece of this insulated card

A

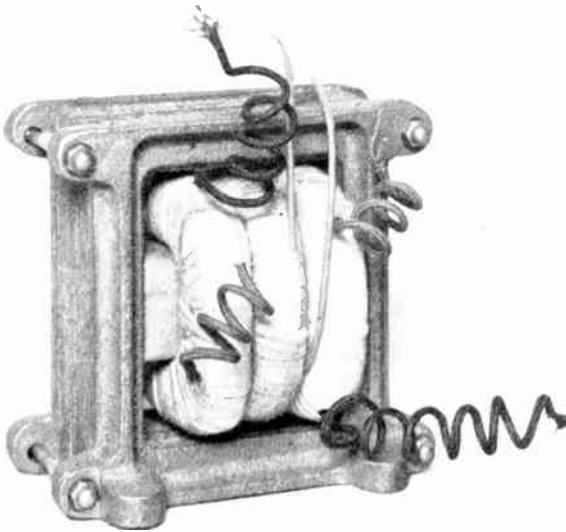

Fig. 17.—ANOTHER STAGE IN THE ASSEMBLY OF THE STAMPINGS.

The primary winding is placed in the centre and the two secondaries each side. The filament windings would be placed at the side. Note the insulation round the core.

is placed between the points of the stampings, as photo, and clamped down hard together. End plates similar to those used for the transformer are then clamped on each side of the stampings to hold them securely together. With a choke it is important that as many stampings as possible should be forced into the core of the bobbin so as to prevent

any movement of the stamping inside, for as we cannot interlap the stampings, it is essential that they should be very tightly packed to prevent movement or hum.

#### Fixing a Terminal Board.

Finally, a terminal board is secured to one of the brackets carrying the terminals for connecting the wires leading from the bobbin.

#### Coating the Edges of the Stampings With Enamel.

The exposed edges of the stampings in both the transformers and smoothing choke should be given a coating of enamel, as otherwise these will quickly rust. Any quick-drying black enamel will be quite satisfactory.

#### Choke for Higher Inductance.

If we require a choke of a higher inductance than these mentioned, we increase the size of the core and the number of turns. For instance, for a choke of 50 hys. approximately 8,000 turns of wire will be required. This should not be smaller than No. 30 gauge wire, as otherwise the resistance of the choke will be high. Alternatively, two chokes can be connected in series, and often this method is to be preferred, as one choke in each lead of the eliminator sometimes adds to the smoothing, and, of course, it is

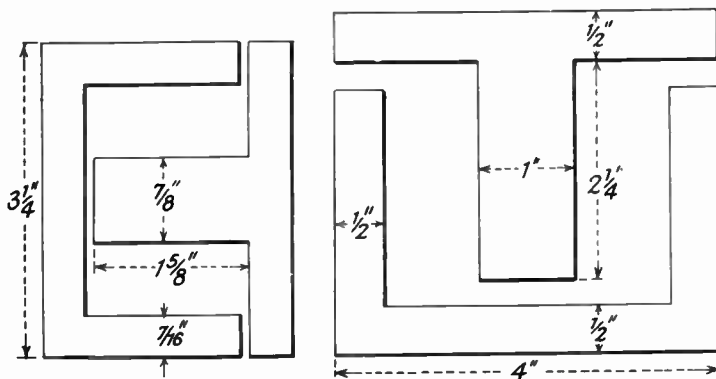

Fig. 18.—SUITABLE SIZES FOR STAMPINGS.

The stampings on the left are suitable for 20 Hys. choke, and those on the right for a transformer to operate either metal or valve rectifiers.

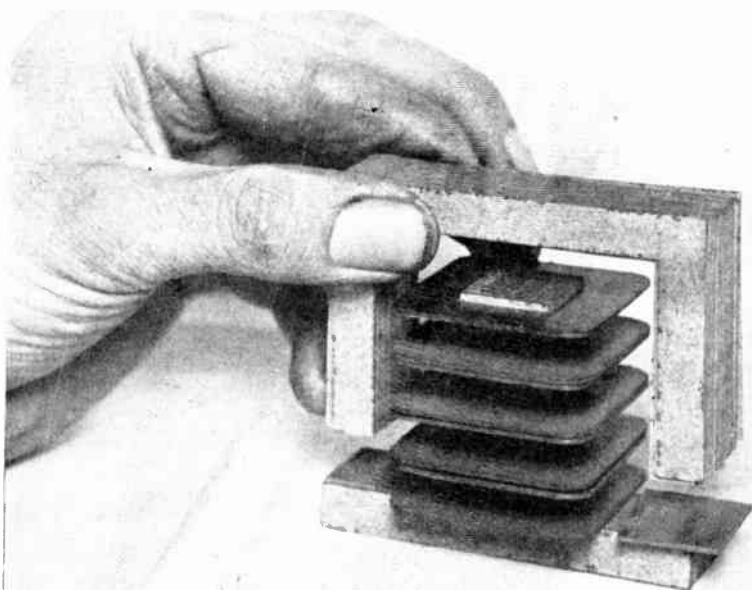

Fig. 19.—ASSEMBLING THE CORE FOR AN L.F. IRON CORE CHOKE.

**SERVICE NOTES FOR H.T. UNITS.**

**No H.T. current.**

Main switch not making contact.

Flex from main broken.

Fuse broken.

**Supply to H.T. unit O.K. but no output.**

Valve burnt out or faulty.

Transformer breakdown.

Test all windings of transformer.

Metal rectifier breakdown (very rare unless overloaded.)

**Rectifier valve or unit and transformer O.K. but no H.F. output.**

Examine all connections for broken joint.

**Transformer winding overheating.**

Breakdown of smoothing condensers or rectifier.

**No voltage on one tapping.**

Faulty resistance or smoothing condenser.

**Heavy hum in receiver.**

Breakdown of smoothing choke.

**Humming in H.T. unit.**

Loose core of transformer smoothing choke.

**Low output.**

Faulty valve or rectifier.

**Low output on one tapping.**

Faulty resistance or broken lead wire.

**H.T. unit overheating.**

Unit overloaded or supply voltage not correct.

**Intermittance or crackling.**

Faulty smoothing condenser shorting resistance.

Shorting turns in winding of smoothing choke or transformers.

Flexible leads partly broken.

Bad fitting plugs.

absolutely important in the case of D.C. supply units, and two 30 hys. chokes are the smallest that should be used for smoothing this type of supply mains.

TABLE OF PRIMARY WINDINGS.

Supply Voltage.	Turns of Wire.	Wire Gauge and Covering.
100	600	24 D.C.C.
110	660	24 D.S.C.
120	720	24 enamel S.C.
130	780	26 D.S.C.
200	1,200	28 D.S.C.
210	1,260	28 D.S.C.
220	1,320	28 enamel S.C.
230	1,380	28 enamel S.C.
240	1,440	28 enamel S.S.
250	1,500	28 enamel S.S.

H.T. SECONDARY WINDINGS.

Output Voltage.	Turns of Wire.	Wire Gauge and Covering.
230	1,380	32 enamel S.C.
135	820	32 enamel S.C.
45	270	36 enamel S.C.

FILAMENT WINDINGS.

4 volts	26 turns	16 D.C.C.
---------	----------	-----------

# TIME SWITCHES AND PROGRAMME CLOCKS

By KENELM EDGCUMBE, M.Inst.C.E., M.I.E.E.

**T**HE function of both these devices is to open and/or close a circuit at predetermined times. Both the time switch and the programme clock consist of two distinct parts, the timing mechanism and the switching mechanism.

## Timing Mechanism.

In the past a one-day, eight-day or, more rarely, a 15 or 30-day clock has been employed and the trouble of winding has sometimes been obviated by the fitting of an electrical rewinding device, which may consist of a small induction motor or of a reciprocating mechanism, either operated by a trembler contact or vibrated in step with the supply frequency (Venner). Although such devices reduce the labour of winding, their value is largely discounted by the fact that the timing of the clocks cannot be perfect, and the error being cumulative, attention at fairly frequent intervals is essential.

## Using a Synchronous Motor.

More recently, owing to the rapid extension of A.C. distribution at an exactly

time-controlled frequency, it has been possible in a large number of cases to operate the timing mechanism by means of a synchronous ("Synclock") motor, which, running in step with the controlled frequency of the system,

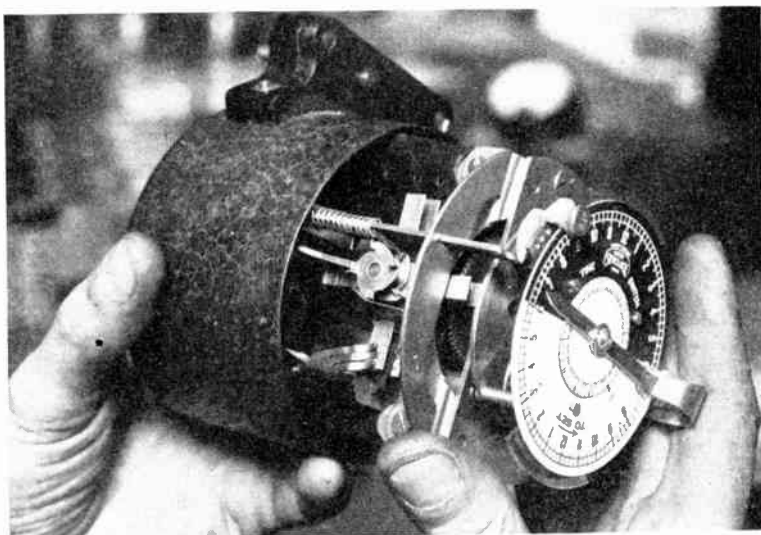

Fig. 1.—STREET LIGHTING TIME SWITCH, FITTED WITH SOLAR CORRECTION DIAL. (Ercott, Edgcumbe.)

The mechanism has been half withdrawn from the case to show the double break "knife switch" contacts. The "on" rider is just commencing to depress the switch operating plunger. The three depressions seen to the left of the rider-clamping screw enable switching to take place before or after sunset or sunrise, as may be desired. The small dial in the centre is graduated in months and days of the month. Note that from 6 p.m. to 6 a.m. is coloured black, so as to indicate the night period.

keeps exact time and, moreover, gives large working forces for the operation of the contacts.

## Time Switches for Street Lighting.

When time switches are used for street lighting, frequent resetting is required, particularly in spring and autumn, owing to the rapidity with which the time of

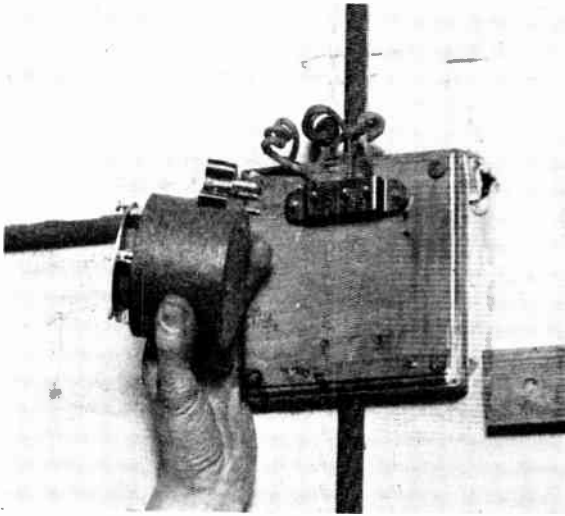

Fig. 2.—STREET LIGHTING SYNCLOCK MOTOR-DRIVEN TIME SWITCH WITH COVER REMOVED.

Provided with pin contacts which also serve to support it in the lamp pillar. The third pin is required for leading the current to the synchronous timing motor.

sunset and sunrise changes at certain periods of the year. For example, in September there is a change of nearly a quarter of an hour each week. Unless, therefore, the street lights are to be switched on and off too early or too late, very frequent attention is necessary, and

more owing to the unavoidable and cumulative errors in the time-keeping of the clock. Here, again, the "Synclock" or other synchronous motor drive solves the difficulty. A time switch

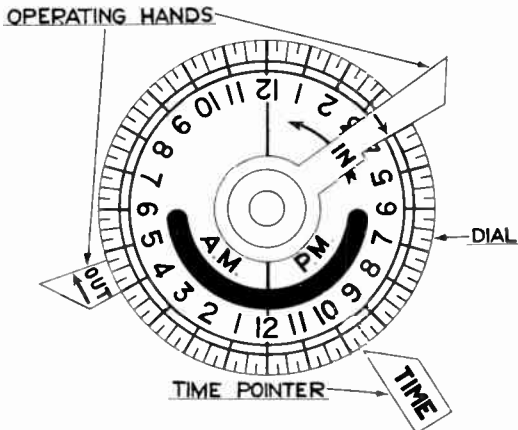

Fig. 3.—ANOTHER TYPICAL TIME SWITCH DIAL. (Venner.) (See also Fig. 1.)

to obviate this the so-called solar or astronomical dial has been introduced.

**The Solar Dial.**

This usually consists of a specially shaped cam which makes one revolution per year and which moves the timing lever progressively forward or backward at a rate based upon the daily change in the hour of sunset. This rate differs widely according to the latitude, so that the cam must be differently shaped for various parts of the country. If the hour of switching off is also to be varied according to the changing times of sunrise, another suitably shaped cam operates the "off" lever. Fig. 1 shows a time switch fitted with solar dial.

Unfortunately, it is not possible to take full advantage of this device with a spring-driven time switch, owing, first, to the necessity for rewinding, but still

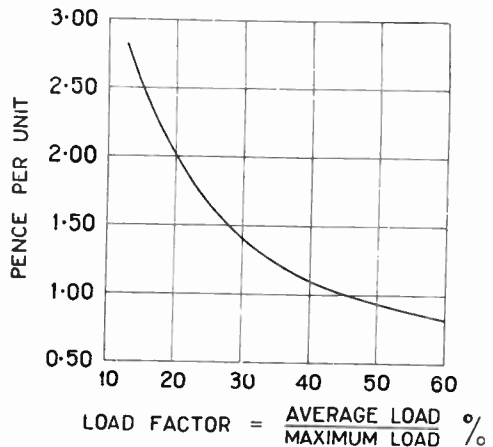

Fig. 4.—CURVE CONNECTING THE ECONOMICAL PRICE PER UNIT WITH THE "LOAD FACTOR" OF THE STATION.

This shows how great an economy may be effected by reducing the maximum load for a given average load.

so operated and provided with a solar dial can be left entirely without attention throughout the year; in fact, it may almost be said that if a solar dial is fitted no form of drive other than the synchronous motor should be used. Unfortunately, on direct current systems, this is impracticable and spring-driven clocks are essential.

#### Contact - making Systems.

In the majority of cases, the dial revolves once in 24 hours and mounted upon it are either pins or cams capable of being fixed in any appropriate position, so as to cause the contacts to open or close at the desired times. Care must be taken that the operating members are correctly set and firmly secured in place. The contacts themselves may be of the button pattern (usually of platinum, silver or tungsten) or, better, of the rubbing type, on the lines of a small knife switch (Fig. 1). Button contacts are usually suitable up to, say, 10 amperes, blade contacts up to 15 amperes. For heavier currents, mercury contacts in vacuo are to be preferred (Fig. 5) and will deal with currents up to 50 amperes at 250 volts for A.C. or D.C.

#### Marking of Time Switch Dial.

Fig. 3 shows to a larger scale the marking

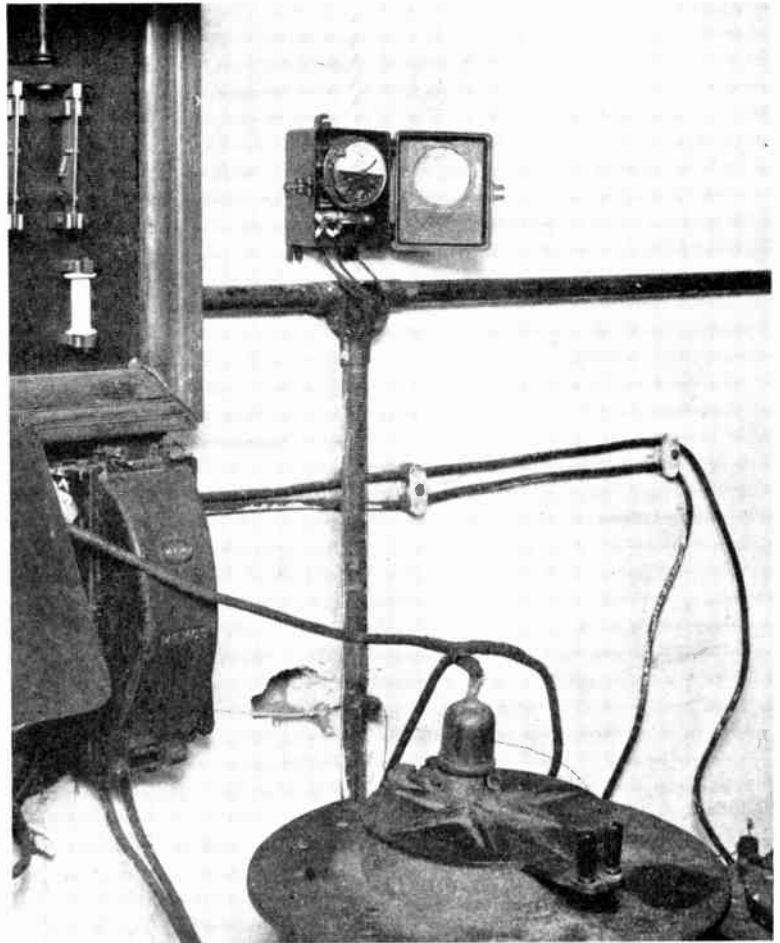

Fig. 5.—A 50-AMPERE TIME SWITCH CONTROLLING AN ELECTRIC ANNEALING FURNACE.

The contacts in this case are of mercury in vacuo.

of a time switch dial (Venner). In order to avoid confusion it is usual to mark the night hours (that is, 6 p.m. to 6 a.m.) in black (see also Fig. 1) so as to distinguish them from the daylight hours. The dial in Fig. 3 is also marked "p.m." and "a.m." to avoid any possible confusion. The operating hands, marked "in" and "out" respectively, have to be clamped at the required times on the dial and, finally, the dial should be set to the correct time, as shown by the "time" marker. In some time switches, the operating pins, although marked "on" and "off" or "in" and "out," will perform



either operation and in use merely reverse the existing state of affairs. This is an unsatisfactory arrangement, since the operations are likely to get out of step, resulting in a dial being switched on when it should have been switched off, and *vice versa*.

### FORMS OF TIME SWITCH.

For *street lighting purposes*, time switches have usually to be fixed in an unventilated lamp post or pillar, where they are exposed to damp and are often somewhat inaccessible. For the former reason the switch should be enclosed in a tight-fitting case of its own, and for the latter reason should be readily removable from the pillar for inspection. Fig. 2 shows such

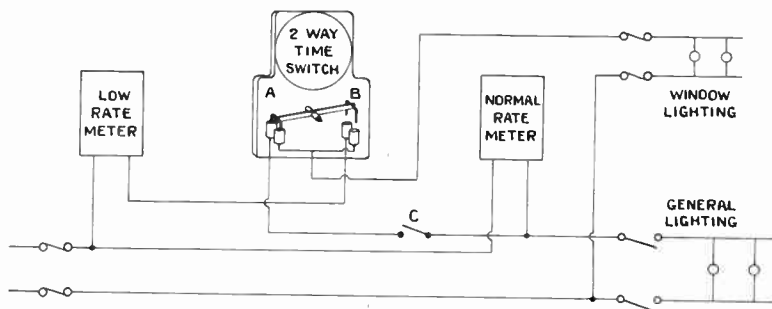

Fig. 6.—CONNECTION DIAGRAM FOR "AFTER HOURS" SHOP WINDOW LIGHTING, SUPPLIED ON A TWO-RATE TARIFF.

Switch C enables the window lighting to be switched on at any time.

a time switch in which the circular case  $3\frac{7}{8}$  inches in diameter has a tight fitting lid, secured by a bayonet catch, and the whole switch is simultaneously supported and connected in circuit by three pins, which enter three fixed sockets. The reason for three pins and sockets instead of two is that this time switch is driven and timed by a synchronous ("Synclark") motor. A press button is provided which will short circuit the time switch contacts, thus enabling the attendant to test a lamp without it being necessary to close the main contacts or to interfere with the setting of the dial.

### Time Switches for Domestic Water Heating.

Another direction in which the use of time switches is rapidly growing is in connection with domestic water heating and

their value arises as follows. The possibility of supplying electrical energy at a low price depends upon obtaining a steady demand, so that the generating and distributing plant may be run as nearly fully loaded as possible throughout the 24 hours. This question is illustrated by the curve of Fig. 4, which shows for a given maximum load how rapidly the cost decreases as the average load increases.\* A purely lighting load is obviously unsatisfactory in this respect and a cooking load is little better, since both are of short duration. A water heating load, on the other hand, approximates to a constant demand throughout the 24 hours, but necessarily overlaps the lighting and cooking loads. The function of the time

switch, then, is to cut off the water heater during the times of lighting and cooking loads. For example, the water heater may be switched on at 11 p.m. and switched off again at 7 a.m., when the load tends to come on. The cooking load usually falls off about 1 p.m., so that the water

heaters are often switched on again from 1 to 3 p.m., after which, in winter, the lighting load is likely to be of importance.

### Mercury Switches.

Water heating time switches are usually required for fairly heavy currents and a vacuum mercury switch is the most satisfactory for the purpose. Fig. 5 shows a time switch so fitted. When mercury switches are used, great care must be taken that the case is properly levelled, or the mercury may flow over owing to vibration and thus close or open the circuit when it should not do so.

### Switches for Shop Window Lighting.

Time switches are also much used in

\*C. S. Davidson, *Electrician*, April 17th, 1931, p. 588.

connection with "after closing" shop window lighting. Since this occurs largely after the time of peak load many supply authorities are ready to furnish the current at a lower rate, and the consumption is measured either by a two-rate meter (see page 1053) or by two separate meters, the lower price applying after a certain hour, say, 6 p.m. Fig. 6 shows a convenient method of connecting up for such a purpose. By day the time switch keeps the contacts A closed, so that the normal rate meter is in circuit. The switch C enables the window lights to be switched on at any time, but the higher rates will be charged until the time switch changes over to the lower. The time switch may also cut off the window lighting at a given time, say, 10.30 p.m.

#### **PROGRAMME CLOCKS.**

Most of the foregoing remarks apply

equally to programme clocks, which are generally similar to time switches, although being commonly intended to operate more frequently and for shorter periods, they necessitate a finer setting.

They may be required for a variety of purposes, from the ringing of school bells at certain hours to the timing of a complete cycle of industrial operations. (See also page 498.)

The timing dial is usually larger than that of the corresponding time switch, say, 6 inches or 8 inches in diameter, but the whole travel may be divided between two or even three distinct dials, the one rotating, for example, once in seven days, the next in one day and the next in three hours. The contact arrangements are similar to those already described and likewise vary according to the loads to be dealt with.

---

## QUESTIONS AND ANSWERS

### **What is the purpose of a time switch or programme clock ?**

To open and/or close a circuit at pre-determined times.

### **What method is generally used to-day to control time switches ?**

Owing to the rapid extension of A.C. distribution at an exactly time-controlled frequency, the timing mechanism is frequently operated by a synchronous ("Syn-clock") motor, which, running in step with the controlled frequency of the system, keeps exact time.

### **What is a solar dial ?**

This usually consists of a specially shaped cam which works one revolution per year and which moves the timing lever progressively forward or backward at a rate based upon the daily change in the hour of sunset.

### **What is a solar dial used for ?**

When time switches are used for street lighting, frequent resetting is required owing to the rapidity with which the time of sunset and sunrise change at certain periods of the year. The use of a solar dial obviates the necessity for resetting.

### **What are the chief applications of time switches ?**

- (1) Street lighting ;
- (2) Domestic water heating ;
- (3) Shop window lighting ;
- (4) Controlling electric furnaces ;
- (5) Electric signs.

### **How does a programme clock work ?**

A large drum is made up of a series of brass discs with slots at interval spaces of one minute each. Metal pins are inserted into these slots according to the programme schedules. The insertion of metal pins into a series of smaller discs decides the day on which signals are to be obtained.

# MAINTENANCE OF AN ELECTRICALLY EQUIPPED STORES

By H. W. JOHNSON

**T**HE modern stores is equipped with almost every conceivable type of electric light fitting and power appliance. An extensive knowledge and wide experience of electrical installation work and practice is therefore necessary to maintain successfully the electrical equipment.

The lay-out of the stores is arranged so that all the goods for sale may be easily inspected by the general public.

Such an arrangement makes it imperative that the electrical installation must always be in good working order. The wiring and appliances must be fireproof and shockproof. All lighting pendants must be securely hung and there should be no danger from falling glass in the event of a glass reflector, diffusing panel, etc., cracking.

## THE LIGHTING EQUIPMENT.

### Window Lighting.

The equipment will include the lighting of all the shop windows and display cases, with special arrangements for flood and spotlighting.

Colour changing devices will often be

installed for special displays, and these will require motor-driven flashers to operate them.

### Entrance Halls and Doorways.

Entrance halls and doorways will be illuminated with fairy-strip lighting fixed round the architraves of doors, and round the extreme edges of canopies. Special ceiling fittings and cove lighting for recesses will be used.

### Staircases.

Staircases well lighted with strip lighting fixed behind cornices and special bracket lights fixed to the walls.

### General Floor Lighting.

The general lighting of the various departments will be carried out with high C.P. fittings of various types and designs. Where considerable overhead clearance is required, recessed ceiling fittings will be used.

Floor standards will be extensively used for localised lighting and a liberal supply of plugs and sockets will be installed to supply the current to them.

### Counter and Showcase Lighting.

These will be illuminated with concealed

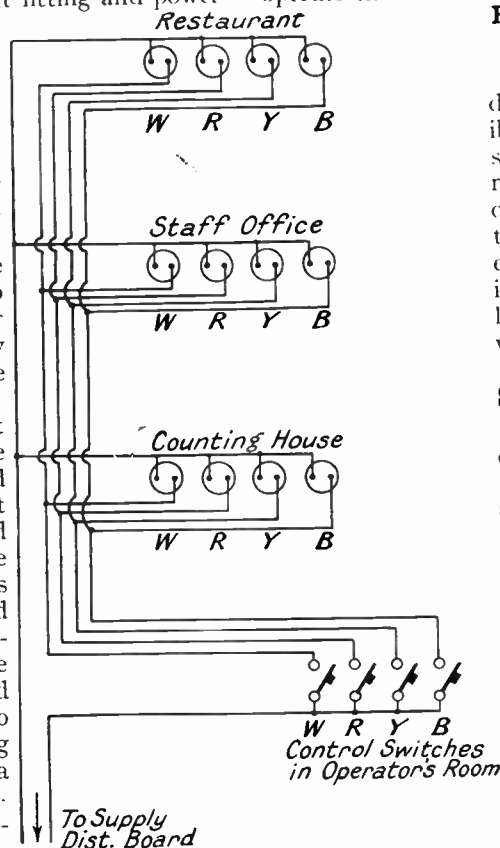

Fig. 1.—A SIMPLE DIAGRAM FOR FOUR SIGNALLING LAMPS OF DIFFERENT COLOURS TO ENABLE MEMBERS OF THE EXECUTIVE TO KEEP IN TOUCH WITH THEIR STAFF.

When switch W is closed in the operator's room, white lights are shown on the signalling boards in all the departments, indicating that the attendance of executive officer W is desired in his department. Similar indications are given when switches R, Y and B are closed, to the respective executive officers.

strip lighting fitted with suitable reflectors, and often an arrangement of mirrors will be used to reflect the light in any desired direction.

### Ladies' Saloons and Hairdressing.

These will have special treatment. Here the lighting will be designed to give artistic effects and a considerable amount of cove lighting with strip light will be used.

Adjustable lighting fittings will be installed for the use of the hairdressing

pendant fittings will generally be installed to produce an artistic effect and a soft light free from shadows and contrasts.

### The Ventilating and Air-washing Plant.

Motor-driven fans and pumps will be installed with suitable control switchgear, fixed in convenient positions in the air ducts.

### Air-Compressor Plant.

Motor-driven air compressors will be used for supplying compressed air to the pneumatic cash tube system installed throughout the stores, and for closing the gates of lifts.

### Passenger Lifts, Escalators and Goods Hoists.

A battery of passenger lifts will be installed for the use of the general public. These lifts will be electrically driven and generally operated by an attendant from the car. Push-button control may also be fitted to them, so that they may be used without the lift attendant, when required. A number of lifts will also be installed for the use of the staff. These lifts will generally have push-button control.

Electrically driven escalators will be installed to deal with the rapid transit of the public to the various floors of the stores.

Electrically driven goods hoists will be used to transmit the goods to and from the various departments from the receiving and dispatch department.

### Heating and Cooking Appliances.

The restaurant and lunch buffet will be fully equipped with electric heating and cooking appliances. Hot water for the various lavatories, etc., may be supplied from electrically heated water-tanks, which will be thermostatically controlled.

### The Telephone Installation.

In addition to the G.P.O. telephone installation with extension lines to the various departments and call boxes, a private intercommunication telephone system will be in use between the various departments and the offices of the executive.

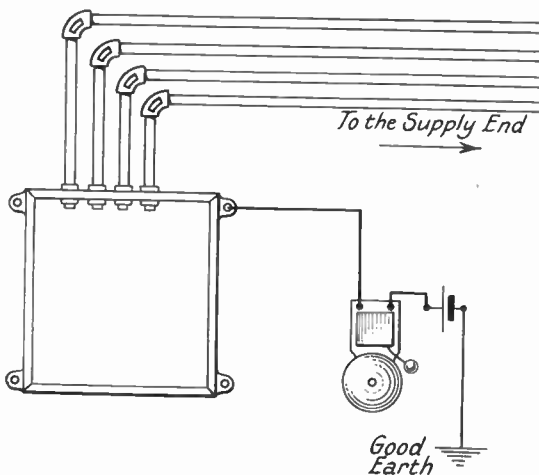

Fig. 2.—TESTING RUNS OF CONDUIT AND AN IRON-CLAD DISTRIBUTING BOARD FOR AN EFFICIENT EARTH.

The resistance of the conduit system between the supply end and any other point must not exceed 2 ohms. The bell should ring vigorously with one Leclanché cell in the circuit.

staff, and various kinds of hairdressing and toilet appliances will be installed.

### The Materials, Dress Fabrics and Carpets Departments.

In addition to the general lighting of these departments, daylight and colour matching lighting fittings will be installed.

### Sign and Flood Lighting.

The exterior of the building may be illuminated with flood lighting units and various kinds of electric signs will be installed.

### The Restaurant, Lunch Buffet, and Rest Rooms.

Concealed strip lighting and artistic

**The Signalling Lamps.**

A system of signalling with coloured lamps will be in use, whereby the executive and the staff may always be in touch with each other, no matter in which department of the stores one or the other may be. The signalling lamps will be operated with a series of switches fixed in the telephone operator's room.

**The Bell Installation.**

The stores will be equipped with an installation of electric bells. The bells will be used for indicating closing times and for giving special signals.

**The Pilot Lighting.**

A special pilot lighting circuit will supply a system of pilot lights fixed in all parts of the stores, to enable the public to leave the stores in comfort in the event of a breakdown of the ordinary lighting installation, or a failure of the supply.

**The Supply.**

The supply of current to the installation may be obtained from the public supply company or, in certain cases, the current will be generated by a plant operating in the premises of the stores.

**The Switchboard.**

The switchboard will distribute and control the whole of the electrical energy from the supply company's cables, or the generating plant, to the installation.

The installation will be split into a number of main circuits. Each main circuit will be controlled by a main switch and circuit breaker or fuses, which are fixed on one of the panels of the switchboard.

Lighting circuits will be kept distinct from the power circuits.

Electricity meters will be connected in the various circuits to record the energy consumed by the various departments.

The switchboard will be situated in a separate room, and access to it will only be allowed to the members of the electrical staff. A member of that staff should be held responsible for the efficient operation and clean condition of the switchboard.

A working bench fitted with a vice and suitable tools could with advantage be fixed in the switchboard room. Here

repairs to defective appliances and fittings could be conveniently carried out.

**The Distribution Boards.**

These will be fixed in convenient positions in the stores and will be supplied from the switchboard circuits.

The various sub-circuits to the lighting and power appliances will be taken from the distribution boards.

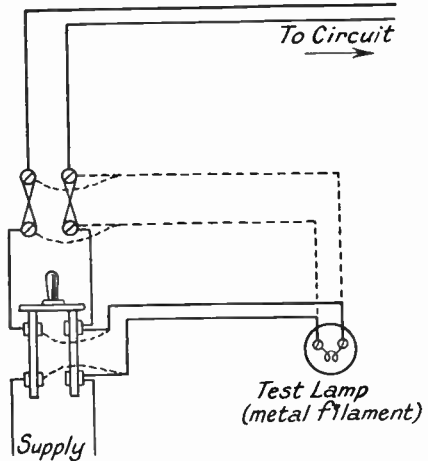

Fig. 3.—TESTING SWITCH AND FUSES FOR BAD CONTACTS.

When a circuit does not appear to be getting the full pressure, test across the various switch and fuse contacts with a test lamp. The lamp should be able to take the full supply pressure. A bad contact will be indicated when the lamp glows. If the lamp does not appear to glow the fault is of comparatively low resistance and a low reading voltmeter may be substituted for the lamp.

**THE MAINTENANCE WORK.**

**General Organisation.**

The whole of the work will be under the supervision of the Chief Engineer and Superintendent of the building. He will have the services of an electrical foreman and a staff of electricians and their mates. The foreman will receive instructions from the Chief Engineer, when any alterations to the installation are to be made, or any special display required by a department.

The ordinary routine work will be under the direct control of the foreman, and he will divide out this work among the staff of electricians.

Each electrician will be responsible for

a certain section of the maintenance work.

Reports of failures and defects will be given by the heads of the various departments to the Chief Engineer each day, so that they may be remedied without delay.

It is advisable to give the maintenance of the telephone and bell installations to an electrician who has had special experience in this work.

### **The Switchboard.**

Examine the switches for making good contact—a bad contact will heat up. Clean the switch blades and contacts with fine glass-paper and adjust the contacts; lubricate with a trace of mineral oil.

Renew the fuses regularly with the correct size of fuse wire and adjust the fuse contacts so that the fuse bridges are held firmly.

Examine the tripping gear of the circuit breakers and make sure they are working smoothly.

Inspect the cable connections frequently and tighten up any which are loose.

Examine the earth wires of ironclad switchgear for good connection.

Clean the panels regularly with a soft dry cloth.

### **The Distribution Boards.**

The fuses should be inspected frequently and any which show signs of corrosion should be renewed.

The panels must be kept clean. Any traces of metal which may have been deposited on the panels when a fuse has blown on a "short circuit" must be carefully removed.

The circuit switches are often fixed inside the distributing boards and they should be examined for bad contact, faulty make-and-break action, loose fixings and bad cable connections at the terminals.

Examine the "earth" wire for efficient connection.

### **The Wiring.**

The wiring will generally be protected with steel conduit. Examine the runs of conduit for good joints at the junction boxes, inspection T's, etc. Where there is a doubtful joint test the run of conduit for a good "earth."

The outlet points of the conduit should all be bushed. Conduit which is run in exposed positions should be watertight and examined frequently for signs of rusting.

Make an insulation test of all the circuits frequently. Should any circuit show a low test, it should be split up by disconnecting at the various loops and the faulty length of wiring traced and renewed. Examine the connections of the wiring at all light and switch positions, the insulation of the wiring at exposed positions is liable to damage and deterioration.

Particular attention must be given to the wiring of signs. The H.T. side of Neon signs will be wired with heavy insulated cable; keep these cables clear of all inflammable material. The loops from one tube to another should be enclosed in glass tubes, and V-shaped bell glasses fitted over the terminal connections. Where it is possible for water to enter these bell glasses, they should be provided with drainage holes.

Examine the main D.P. (pull-down type) switch which is fixed outside the building for cutting off the current to the signs, in case of fire or breakdown.

The metal troughings of strip lighting should be kept well painted, and frequently examine the earthing connections to them.

### **Strip Lighting.**

Examine the lampholders of strip lighting for signs of corrosion and contact plungers sticking. Wiring for strip lighting fixed at the extreme edges of entrance halls and canopies may be exposed to "drip." Examine frequently to see that the circuits are water-tight. Considerable condensation of moisture may occur between the strip lighting and the glass diffusing panels, when there is a sudden fall in temperature. The panels should be taken out and the interior of the strip lighting troughs and reflectors carefully dried. Make a test of the circuit for low resistance between poles, having removed the lamps, and for insulation resistance.

### **The Lighting Fittings.**

Switch on the lights and note any which show signs of blackening of the bulbs, or fail to light.

Examine the lampholders and screw up any parts which have worked loose.

Carefully clean the reflectors and diffusing panels and bowls with a soft dry cloth.

Any cracked reflectors, panels, or bowls should be replaced immediately.

### Examining the Spot-lights.

Examine the connections to spot-lights and the insulation of the cables where they pass into the case. Test the beam of light for correct focus and adjust if necessary. Clean the lenses carefully with a soft cloth. Flood-lighting units should be examined. Those which are exposed to wind and weather, should be kept painted and the fixing nuts and bolts covered with a little oil. Examine carefully the insulation of the wiring in the flood-light cases, and the terminal connections for signs of corrosion.

The earth wire should be making good connection with the case.

The motor flashers which are used for colour changing lighting schemes and for signs should be frequently overhauled.

Examine the brush gear of the motors if they are of the D.C. type. Inspect the condition of the lubricating oil and change if required. The contacts and the drum must be kept perfectly clean. Adjust the contact fingers if necessary. The contact fingers of animated signs are subjected to very severe service and they should be frequently inspected.

### Pendant or Bracket Fittings.

The fixings of all pendants and bracket fittings must be secure and they should be examined from time to time. Examine all supporting chains for signs of corrosion, and renew any which appear to be unsafe.

Concealed strip lighting fixed behind cornices should be examined for deterioration, especially if the heat produced by the lamps cannot readily be dissipated.

Particular care must be taken when cleaning delicate glassware of artistic fittings and brackets. Always allow for expansion of the glass inside their metal frames and do not tighten up the binding screws, when replacing the glassware after cleaning.

### The Ventilating Fan, Air-Compressor Motors and Switchgear.

The fan motors for the ventilating plant must be examined each morning, the

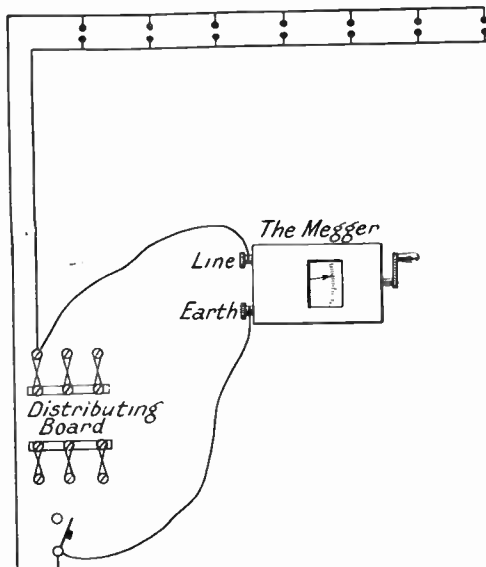

Fig. 4.—TESTING STRIP LIGHT WIRING FOR LOW INSULATION BETWEEN POLES.

The lamps are removed from their holders, the switch in the D.B. opened, and the fuse on the other pole taken out. The ends of the circuit are connected to the live and earth terminals of the Megger and the value of the resistance obtained. This test should be taken if there is excessive condensation of moisture where strip light is fixed in exposed positions.

brushgear and lubrication of the bearing should be in good condition. Clean the commutator with a soft cloth and lubricate with a trace of mineral oil to prevent chattering of the brushes. If the motors are supplied with A.C. they will generally be of the slip-ring type. Inspect the rotor slip rings and brushgear and the lubrication of the bearings. Contactors will be used for starting and accelerating the speed of the motors. These should be regularly inspected. Examine the contacts and the armatures. The contacts should be cleaned if necessary, and the movement of the armatures be quite free. Test the operation of the time limit relays for accelerating the motors, frequently. The solenoid plungers should be kept free from dirt and the pistons attached to the

lower end of the plungers must work smoothly in the oil dashpot.

The operation and running of the air-compressor motors will be controlled with a relay which will start the motor when the air pressure is reduced below a certain point, and stop it when the maximum value is attained. Examine the windings of the relay and note that the connections are tight. Clean the contacts and adjust them if necessary.

The air compressor motors must be regularly cleaned and the brushgear maintained in good condition. The operation of

act promptly when the current is switched off.

(4) The car gate and landing gate switches should be in good working order.

(5) The locking device attached to the landing-gate switch must prevent the gate being opened, unless the car is at the correct level.

(6) The over travel limit switches in the car, and operated by the cams fixed to the side of the lift shaft, must be in good order and open the circuit if the car overruns its appointed travel.

(7) The over-speed governor switch must open the circuit when the speed of the car exceeds the safe limit.

(8) The car controller must be in good working condition and the contacts on the drum and contact fingers clean and correctly adjusted.

### Winding-Gear Motors.

The motors which drive the winding gear will generally be of the D.C. type, even if the supply is A.C., because the Ward Leonard system of speed control will be used. Motor generators for the conversion of the A.C. supply current to D.C. will be installed. The motors will be started and accelerated and reversed with contactors which are controlled from the car controller.

The contactor gear must be regularly cleaned and kept in good working order.

The motors must be regularly cleaned, brush gear kept in good condition, and the lubricating oil in the motor bearings changed at regular intervals. Frequently examine the connections of the car trailing cables in the connection box fixed in the lift shaft. The direction indicator lamps fitted on each floor at the lift landings should be inspected from time to time. Examine the wiring to the lamp-holders and screw up tightly any loose connections which are found.

### The Escalators.

The motors are coupled to a worm shaft

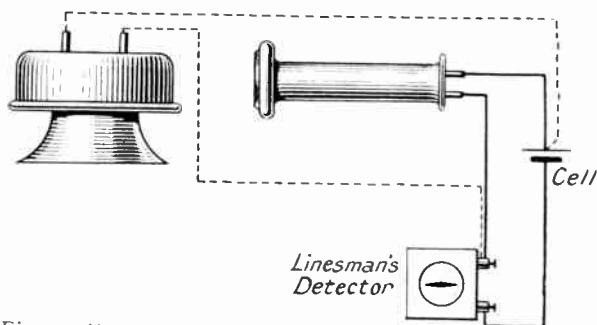

Fig. 5.—TESTING A TELEPHONE TRANSMITTER FOR "OPEN" CIRCUIT OR SHORT CIRCUIT.

The connections to the receiver or transmitter are disconnected and a linesman's detector and a cell are connected to their terminals. If the instrument has an open circuit, there will be no deflection on the detector. Now connect the detector and cell in circuit with an instrument which is in good condition and note the deflection on the detector. Compare the deflection obtained with the one obtained when the detector is connected to the one suspected of "short circuit." A large deflection, probably over to the extreme edge of the scale, will be obtained if the instrument is short circuited. This test may be applied to test an induction coil of a telephone set for open and short circuits.

the contactors used for starting and accelerating the motors must be tested frequently.

### The Passenger Lifts.

The correct and safe operation of the passenger lifts is perhaps the most important of the maintenance work. Each lift should be tested every morning before the public are admitted to the stores.

The examination and testing of the lifts should include the following details:—

(1) The steel suspension cables to be in good condition.

(2) Their attachment to the lift car and to the counterweight to be secure.

(3) The electric solenoid brake should



which drives the sprocket wheel of the escalator through a spur-gear wheel.

Each worm shaft may be coupled to one or the other of two motors, which are fixed on either side of the shaft. This arrangement avoids stoppages of the escalator if one of the motors breaks down.

The motors should be regularly cleaned, the brush gear and commutator inspected and kept in good condition.

Heavy duty starters or controllers will be used to operate the motors. The contact studs and starter arm contact must be cleaned regularly and adjusted to prevent arcing when the arm of the starter is in operation.

The gearing should be efficiently lubricated and inspected for signs of wear and incorrect alignment.

**The Staff Lifts.**

These will generally be push-button controlled, and in addition to the necessary daily inspection of their efficient and safe operation, and the general maintenance to the driving motors and contactor control gear, the relays which are operated by the various push-buttons will require regular inspection and cleaning.

The mechanism which operates the selecting switches must be inspected regularly. The mechanism will be driven from the winding shaft. The chain driving the striker arm spindle should be lubricated regularly and examined for correct alignment, excessive wear and stretching.

**The Goods Hoists.**

These will be fitted with hand and push-button control. Special attention should be given to their winding gear and the steel cable attachments to the cars on account of the heavy loads they have to deal with. The maintenance of the control gear and wiring will be on similar lines to that for the staff lifts. The gates and their opening and closing gears will be subjected to severe conditions and the condition of the gate locks on the car and at the landings should receive special attention.

**The Telephone Installation.**

The operation of the switchboard for the departmental telephone system will generally be done by the person who answers

and puts through to the various departments the calls from the G.P.O. system. Complaints of failures should be reported to the foreman at the earliest moment.

The general faults which may exist will be :—

- (1) Can hear the station called speak, but this station cannot hear the caller.
- (2) The signalling bells operate, but neither station can hear or speak.
- (3) Cannot call up a station.

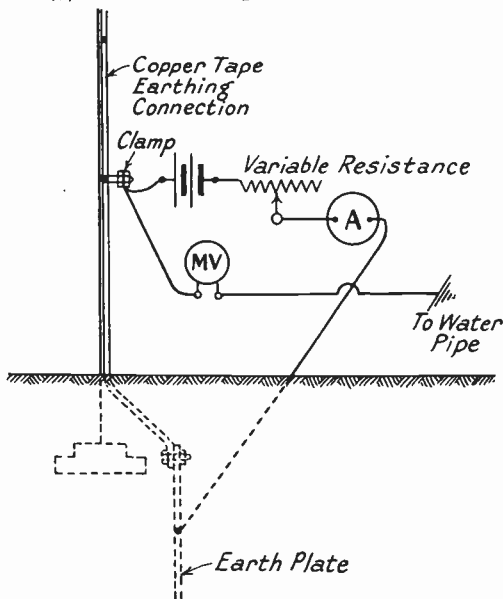

Fig. 6.—TESTING AN EARTH PLATE FOR EFFICIENT EARTHING.

An earthing plate is used for earthing a lightning conductor. Its resistance to earth may be obtained by sending a suitable current through it from a battery of accumulators and testing the pressure drop between the copper tape connection to it and a water main, with a milli-voltmeter. The reading on the instrument should be small.

- (4) Cannot get attention from the operator.

In addition to the above faults, line wires may be broken or in contact. Indicators fixed on the switchboard sticking, bad contacts in the jack springs, bad joints due to defective soldering, and batteries require recharging.

When a station can hear, but cannot be heard, the local microphone circuit is faulty, or the secondary wires from the induction coil are short-circuited.

Examine the receiver for a cracked diaphragm, the wire gauze pressing on the diaphragm, or the carbon granules packing together.

Test the induction coil secondary for short-circuit and open circuit. Examine the transmitter circuit for bad connections.

If the signalling bells are working, but neither station can hear or speak, the secondary or the main line speaking circuit is defective.

Test the receiver for short circuit and open circuit, buckled diaphragm, insufficient clearance between magnet poles and the diaphragm. Examine the switch hook contacts, and all the connections in the circuit. When the station cannot call or get attention from the switchboard operator, the magneto generator, the bell, or some part of the line circuit is defective. The line terminals of the bell should be short circuited with a piece of wire, and the bell cut-out on the generator be prevented from acting by inserting a piece of paper between the contacts. If now the bell does not ring when the generator is turned, there is either an open circuit or short circuit in bell or generator coils. A short circuit will be distinguished by the fact that the generator runs heavily.

If the bell does not ring, but the generator works heavily, and then works easily when the short circuit is removed from the line terminals, the bell coils are short circuited; but if no change occurs, it is probable that the generator is itself short circuited.

### **The Bell Installation.**

The bell installation will require periodical inspection. Examine regularly the contact springs and screws and clean them if they are corroded. The contact screws should be locked tightly in the bell contact pillars.

The signalling switches and pushes must be examined for good contact and tight connections.

If the supply is A.C., a bell transformer will be used. The connection should be tight and the insulation of the wiring close up to the terminal connections should be in good condition. Give the windings an occasional coat of shellac varnish. The

fuses which protect the transformer should only be of small carrying capacity.

If accumulators are used to supply the installation, a spare set will be required to supply the circuits when recharging the set which is run down. The discharge must never be continued after the voltage of each cell is 1.8. Keep the level of the electrolyte always above the top of the plates and always use pure or distilled water in making up the level to the correct height. The terminals of the accumulators must be covered with a little vasoline and the containers must be kept perfectly clean and dry.

### **The Pilot Lighting.**

The pilot lighting circuit will be totally independent of the main generating plant, or the supply companies cables which supply the main installation. In some cases it may be supplied from the mains of another public supply company.

The circuit must be switched on each morning before the stores is open to the general public and all lights examined, failures should be made good immediately. The fuses must be renewed regularly.

### **Small Current Appliances.**

There will be numerous small power motors driving various appliances in different parts of the stores. These must be regularly inspected and cleaned. When the supply to them is through a plug and socket, always examine the condition of the flexible cable and the connections to the plug. Renew the flexible if it shows signs of deterioration and make sure that the earthing connection to the appliance is efficient.

### **Heating Appliances.**

Examine the fuses of cookers and stoves regularly for corrosion and loose connection, and make them good without delay.

Test the earthing connections for good contact with the cooker or stove cases.

### **Insulation Test of the Wiring.**

A complete insulation test of the whole of the wiring should be made at the main switchboard once a week, and a continuous record of the results obtained should be preserved.

# FURTHER NOTES ON ELECTRO-PLATING

## DEALING WITH ZINC, CADMIUM, TIN AND BRASS, BARREL PLATING AND STRIPPING

By W. MERRY

### ZINC AND CADMIUM PLATING.

**Z**INC and cadmium are the metals which are to be preferred above all others where the intention is to preserve iron and steel against corrosion. They offer no advantage over any other metal when applied to any non-ferrous base. But both, by reason of their position in the electro-chemical series, do protect iron in an additional manner beyond mere mechanical shielding, since any electrical action that occurs between them and the base metal in the presence of moisture, is at their expense and not to the detriment of the iron.

Cadmium is slightly better than zinc as a protection for iron and steel. Other points of comparison are briefly: Cadmium is softer than zinc, tends to stain when handled, and is definitely poisonous if associated with food stuffs. It, however, resists the action of alkaline liquids (lyes, caustics, soap solutions, etc.) much better than zinc does, and is, in consequence, much used for washing machines and for all iron parts likely to be exposed to caustic liquids or vapours.

### Electro Zincing.

Electro-galvanizing is a perfectly simple process and presents no more difficulty than any other electrical metallic deposition.

The solution used may be either an acid

or cyanide one following the types given under acid and cyanide copper solutions.

Since for perfect protection the deposited metal should be of the highest order of

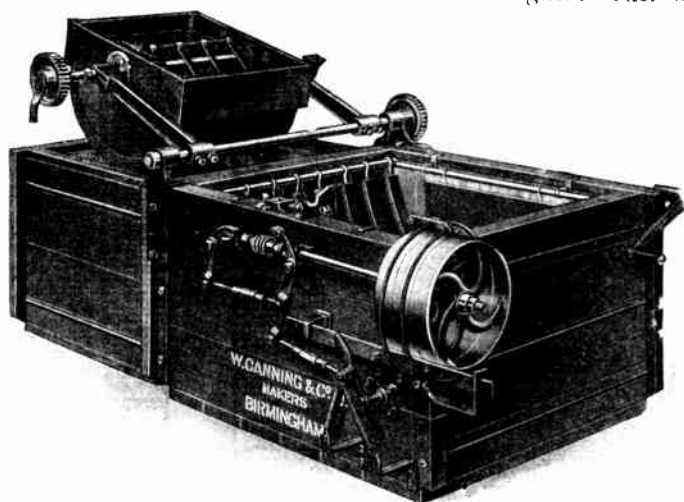

Fig. 1.—ELECTRO-GALVANIZING CRADLE.

The solution used for electro-galvanizing may be either an acid or cyanide one. Every effort should be taken to preserve the solution from contamination and only anodes of the highest purity of zinc should be used.

purity, every effort should be taken to preserve the solution from contamination (especially the cyanide solution) and only anodes of the highest purity (99.9 per cent.) of zinc should be used.

### The Equipment.

Acid zinc solutions should be contained in a wooden vat, lined with chemically pure lead and matchboarded inside. If an old vat is used which has been previously used for another solution, strip out the old matchboard, thoroughly clean down the lead and re-line.

B

Cyanide zinc solutions should be contained in plain welded iron tanks fitted with a wood top surround to carry the insulators and rods.

**The Solution.**

A reasonably good acid zinc solution may be made with the following formula as a basis :—

- Zinc sulphate .. 3 lbs.
- Boric acid .. .. 2 ozs.
- Salt .. .. . 2 ozs.
- Aluminium sulphate 3 ozs.
- Dextrine .. .. . 1 oz.
- Water to 1 gallon.

The boric acid acts as a "buffer" acid and prevents a high ionization. The function of the dextrine is to condition the grain size of the deposit.

Sometimes a little mercury sulphate is added to the solution, and this, besides tending to whiten the deposit, promotes even and good anode corrosion.

The working acidity of a zinc solution is considerably higher than that of a nickel solution and usually stands from 2 to 3 on the pH scale.

**Working Conditions.**

The bath should be worked at from 2½ to 3 volts, a pressure which will give about 10 amps. per square foot of cathode surface.

The temperature of the solution should never fall below 60° F. and may be raised to 100° F.

**Preparation of the Work.**

All work should be prepared and cleaned as previously recommended (see page 445). Cast-iron should be freed absolutely from casting sand and scale. Sand is best removed by immersing in a pickle of :—

- Hydrofluoric acid .. 1 part.
- Water .. 9 parts.

This pickle should be

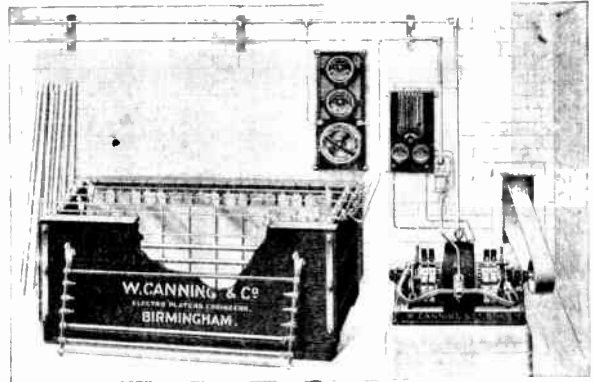

Fig. 2.—ILLUSTRATION OF OUTFIT FOR ELECTRO-ZINCING TUBES.

contained in an oak tub, a gutta-percha tank, or a solid lead vessel. *Never in stoneware or earthenware.* Castings will need from 10 to 40 minutes in this solution according to their state.

ZINC BATH TROUBLES.

APPEARANCE OF WORK, ETC.	CAUSES.	REMEDIES.
Deposit rough, hard and brittle.	Too high current density.	Lower voltage.
Deposit dark.	Low current density.	Raise voltage.
Bad "throw" into recesses.	Low acid content.	Add pure sulphuric acid ½ fl. oz. per gallon.

Scale may be removed by immersion in a pickle of :—

- Sulphuric acid (oil of vitriol) 1 part.
  - Water .. .. . 9 parts
- used either hot or cold.

It is, however, cleaner and in many ways safer to sandblast in preference to pickling if this course is practicable.

After plating, articles should be well swilled in cold water, dried after immersion in clean hot water, or with hot box-wood sawdust. They may then be lightly scratchbrushed for a bright finish or left matt.

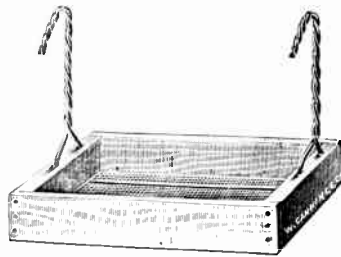

Fig. 3.—A TYPICAL PLATING BASKET.

This may be used for plating small articles such as pins, fish hooks, or hooks and eyes.

**Cadmium Plating.**

As already explained, cadmium is probably the best metal to deposit on iron and steel purely from the protective point of view. It has, moreover, distinct decorative properties and when scratch-brushed and lacquered retains its lustre as long as the lacquer stands.

Only solutions of the cyanide salts are at present employed, and a typical formula would run thus :—

Cadmium oxide	..	6 ozs.
Potassium cyanide	98/100 <sup>o</sup>	14 ozs.
Water	.. ..	1 gallon.

The cyanide should be dissolved first in the water (warm), and the cadmium oxide slowly stirred in till it has all dissolved.

The product is double cadmium cyanide, sodium cyanide (free) and caustic soda.

The vat should be of plain iron, mounted in the usual way with wooden surround, insulators and anode and cathode rods.

Current conditions: 2—2½ volts will be suitable for the still vat (use 6 volts for barrelling). The current density will be about 15 amperes per square foot of cathode surface.

**Notes.**

The work should be cleaned as for zinc, and where possible *sandblasting* should be recommended in preference to pickling, since the pickling acid has a decided tendency to "spot out," especially from castings, and cause unsightly stains.

If the solution works sluggishly and the anodes become coated with slime, add ½ to 1 oz. of potassium cyanide 98/100<sup>o</sup>. Articles may, after plating, be scratch-brushed bright or left matt. Swilling should be very stringent and drying out is best done in hot boxwood sawdust.

**TINNING.**

Electro-tinning is a powerful rival to "pot tinning" in modern industrial practice, and a brief account of the process is desirable. Tinned iron is used largely in many articles and tinned brass and copper are employed in the arts. Much "oxidised silver ware," especially of the cheaper sort, is iron sheet electro-tinned

and subsequently "bronzed" with suitable chemicals.

Electro-plating solutions of tin may be made readily and cheaply, and a good formula is :—

Hydroxide of potash	..	8 ozs.
"Tin salts" (stannous chloride)	.. ..	2 ozs.
Water	.. ..	1 gallon.

The potash should be dissolved first (avoid spitting and overheating when adding the caustic to the water), then the tin salts should be added little by

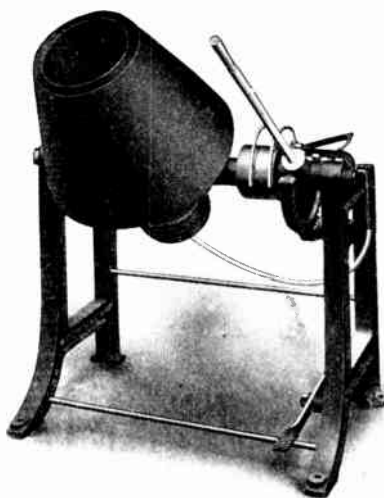

Fig. 4.—HOT SAWDUST DRYING-OUT BARREL.

Used for drying articles after plating.

little with constant stirring. *Don't let it get too hot.* Finally a little glue size—about one-tenth of an ounce per gallon, should be dissolved in the solution.

This last ingredient is quite important, since without it, the deposit will "tree"—that is, grow pronounced whiskers round the edges of the work!

A plain or enamelled iron vat with the customary wooden frame on top is used. Cleaning of the work is carried out as usual but need not be so stringent as for nickel plating, since the powerful caustic solution itself tends to remove the last traces of grease. The anodes should be of pure cast tin and should be removed

from the solution and cleaned when work ceases for the day.

### Voltage.

One half of a volt is the correct voltage for plating, with an anode distance of about 7 in. The work should be "struck" at about 1 volt but as soon as the surface has covered, the voltage should be reduced to that stated above. Temperature of solution about  $140^{\circ}$  Fah.

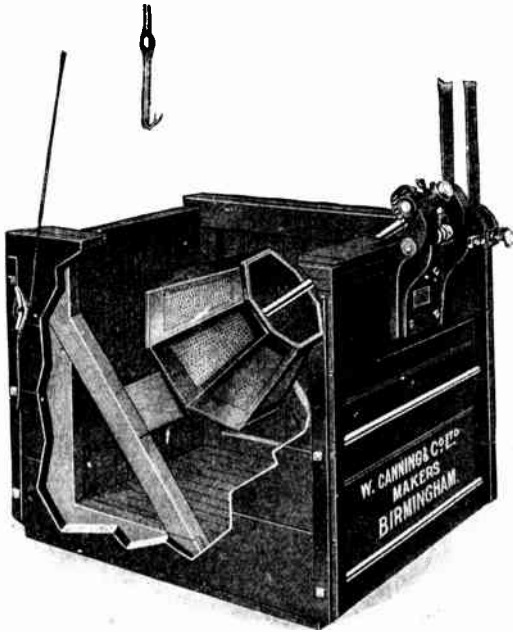

Fig. 5.—PLATING AND BURNISHING BARREL, SUB-MERGED TYPE.

Suitable for nickel, copper, brass, zinc and cadmium plating. No anodes are shown in the above illustration.

### Plating Small Articles.

Small articles such as pins, fish hooks, hooks and eyes are generally polished in a shaking barrel, then put straight into the tin solution without any other cleaning or preparation. They may be barrel-plated or plated in a basket similar to that in Fig. 3. Such a basket is made with wood sides, gauze of metallic meshed bottom and conductors running to it as shown. When work is basket-plated it should be frequently turned over with a wooden fork or stick. A really good

deposit should be obtained in 30 mins.—45 mins. and the articles should then be swilled in clean water, dried out in clean boxwood sawdust and then polished in a barrel containing dry bran.

*Replating and renovating* old cooking utensils, baking pans, etc.

These are first cleaned in the alkaline cleaner (see page 445) preferably with the current. After cleaning, they are pickled in a solution of:—

Sulphuric acid .. 1 part.  
Water .. 10 parts.

(Always add the acid to the water, and *never* the water to the acid.)

Use this pickle hot (about  $180^{\circ}$  F.) and keep the work in till all rust is removed from it—a few minutes should suffice.

Swill in clean water, scour with sand and a stiff brush. Then tin in plating solution for 10 minutes. Swill and either scratch brush or scour with sand till bright.

*Cold solutions* may be used compounded much as the previous formula but of higher concentration of salts. Generally speaking these solutions should be worked at lower voltages, from one-fifth to two-fifths of a volt being the extremes of the permissible current pressure.

### Tinning Iron Dress Pins.

These are generally given a preliminary coating of brass, polished highly in a hot sawdust barrel. They are then tinned by the well-known "boiling white process." This process, though not strictly electrical, must be included here not only for completeness sake, but because it is often used in electro-plating works.

The solution may be prepared as follows:—

Dissolve:—

Tin chloride .. ..  $4\frac{1}{2}$  ozs.  
Cream of tartar .. ..  $2\frac{1}{2}$  ozs.  
Water .. .. 1 gallon.

Use boiling.

The articles, with a few pieces of granu-

lated zinc are either placed loose in the containing vessel or hung in by a muslin bag. They should be left in the solution for about 2 minutes, then taken out and swilled and replaced for another 2 minutes.

After tinning the work is swilled and dried out as before.

TIN BATH TROUBLES.

APPEARANCE OF WORK, ETC.	CAUSE.	REMEDY.
Solution works sluggishly. Anodes dirty.	Conductivity low and solvent absent.	Add $\frac{1}{2}$ oz. of potash for every gallon of solution.
Solution works sluggishly. Anodes bright and crystalline.	Too little metal and too much solvent.	Add 1 oz. tin salts per gallon. Dissolve these salts in a bucketful of hot solution and return to vat.
Deposit, uneven, and feathery.	Too high current density. Deficiency of colloids.	(A) Reduce current density. (B) Add 1-20th oz. of dextrine per gallon of solution.

**BRASS PLATING.**

Brass, of course, is an alloy of copper and zinc and its colour largely depends on the relative proportions of its two constituents. It is possible to deposit both metals in any required proportions from their cyanide salts by suitable adjustments of concentration, voltage and temperature. But it is practically impossible to plate anything but copper from an acid solution of the combined salts. Hence acid solutions of copper are used from the electrolytic refining of that metal from adulterants and cyanide solutions for the deposition of alloys.

**Making the Solution.**

Brass solutions are preferably worked warm (at about a temperature of 100° F.)

and at any fixed voltage a considerable variation of colour can be obtained by alterations of temperature. The solution itself can be readily prepared by mixing a gallon of cyanide copper solution with half a gallon of cyanide zinc solution, if these are available.

Failing these a good solution may be made by the following formula:—

- Potassium cyanide .. 16 ozs.
- Copper carbonate .. 8 ozs.
- Zinc carbonate .. 8 ozs.
- Sodium bicarbonate .. 2 ozs.
- Sodium bisulphite .. 3 ozs.
- Water .. .. . 1 gallon.

Dissolve the cyanide first in warm water and stir in the other ingredients in the

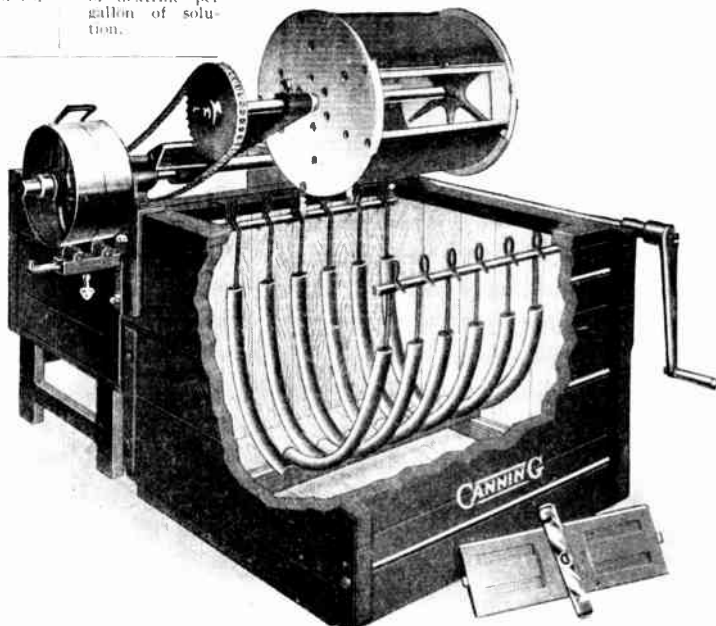

Fig. 6.—THE "QUICKPLATE" PLATING BARREL WITH DEPOLARISED (DEPASSIVE) NICKEL ANODES. Showing anodes in position and swill trough at back.

order given. The solution (when cold) should register 23 Tw. (or 15° Be.).

A little ammonium chloride may be advantageously added, especially if there be any difficulty of obtaining a good brass colour over a fair range of voltage.

The vat should be of plain welded iron and (if possible) fitted with a steam coil, or a stand with gas burners.

The usual insulated rods are, of course, required.

The anodes should be of good quality brass, and as many should be used as possible. The smaller the anode surface the greater the tendency for them to slime up, with consequent rise of resistance and poverty of deposition.

### Conditions of Working.

Articles are prepared for plating in the usual manner. The point in the actual operation of the process that calls for special attention is the control of the colour. Zinc requires a higher voltage for its free deposition than copper does, so



Fig. 7.—"MIDGET" PLATING APPARATUS.  
Suitable for mixed loads of work.

that *other things being equal*, a low voltage will deposit a brass high in copper and low in zinc—therefore *red*; a higher voltage will deposit more and more zinc in proportion to the copper and therefore pale. Only actual experiment will determine the best plating conditions and this, when determined, will vary as the internal conditions of the bath changes.

As more brass baths are worked warm, a gradual and steady disintegration of the cyanide is certain, and this must be replenished periodically. A certain sign of lack of cyanide is the state of the anodes; if and when they become coated with

slime an addition of cyanide is indicated. Add  $\frac{1}{4}$  oz. of potassium cyanide 98/100 per cent. per gallon of solution and note the effect.

Even more may be required.

### BRASS BATH TROUBLES.

SYMPTOMS. (Appearance of Articles, Solution, etc.)	CAUSE.	REMEDY.
Work blisters, deposit breaks and peels on scouring or scratch-brushing.	(1) Bad cleaning. (2) Oxide on base metal. (3) Temperature too low.	(1) Clean as directed on page 115. (2) Dip in cyanide dip, 10 per cent. solution, swill. (3) Warm a portion and replace.
Colour of deposit too red, i.e., too much copper deposited in proportion to zinc.	(1) Too low current density.	(1) Increase voltage. If this fails: (2) Cool solution. If this fails: (3) Add $\frac{1}{4}$ fluid oz. of liquid ammonia per gallon (1.5 cc. per litre). If this fails: (4) Add zinc salts, $\frac{1}{2}$ oz. to 1 oz. per gallon.
Colour of deposit too pale, i.e., too much zinc deposited in proportion to copper.	(1) Too high current density. (4) Insufficient copper in solution.	(1) Decrease voltage. If this fails: (2) Warm solution. If this fails: (3) Boil to dispel excess ammonia and cool again. If this fails: (4) Add $\frac{1}{4}$ oz. to $\frac{1}{2}$ oz. per gallon copper salts.
Solution "gasses" excessively. Solution gives good deposit, but work stains on standing.	Working solution past its capacity.	(1) Add brass salts. (2) Add $\frac{1}{4}$ oz. to $\frac{1}{2}$ oz. potassium cyanide per gallon.

NOTE.—Anodes should look a DULL brass, and should be cleaned often. If slimy green or black, add  $\frac{1}{4}$  oz. to  $\frac{1}{2}$  oz. potassium cyanide (1.5 to 3 grammes per litre). If very pink add copper salts.

### Redness of Deposit.

Sometimes brass baths produce red deposits very obstinately, and however much the current density and the general conditions are varied. This is generally due to the inferior insolubility of the zinc salts. They are, however, readily soluble in ammonia or ammonium salts, and the addition of either liquid ammonia or solid ammonium carbonate will often aid the deposition of a true brass. Very small additions of these chemicals are advised ( $\frac{1}{4}$  to  $\frac{1}{2}$  oz. per gallon).

Should this treatment fail, as it sometimes does, an actual deficiency of zinc



in the solution is suggested and zinc cyanide (or zinc carbonate) should be cautiously added.

**Paleness of Deposit.**

A pale deposit, even at the lowest current compatible with good plating, indicates that the solution is deficient in copper, and copper salts should be added, either as copper cyanide, or copper carbonate.

Both the zinc and copper salts should never be added *directly* to the solution, but should be prepared as follows:—

Add a little potassium cyanide to a bucket full of the brass solution (*not* a galvanised bucket!); now stir in the metallic salts, and warm till dissolved; if they will not dissolve add more cyanide, little by little, till they do. Now pour this concentrated solution into the original vat through a filter of muslin or linen.

**BARREL PLATING.**

“ Barrel ” plating is generally employed by the electro-platers for all such small parts (nuts and bolts, washers, pins, etc.) that are not convenient or economical to wire up. The apparatus consists essentially of a revolving container for the work and provision for the necessary anode and cathode connections. Great ingenuity is exhibited in the best type of barrels to secure good sliding connection and to obtain rapid and easy handling of the loads.

It should be noted that the work must always be in contact with the cathode connections and that the load should always be sufficiently large, so that it does not scatter and lie isolated in the container.

Several types of barrel are shown in Figs. 5 to 9.

**How the Barrels are Constructed.**

A type of barrel suitable for nickel, copper, brass, zinc and cadmium plating is shown in Fig. 5.

It consists of a central container of octagonal form made of perforated celluloid panels fixed to a teak base. A trunnion on the barrel acts as a support while the barrel revolves, the driving

end being carried in an iron bracket secured to the vat.

A suitable contact device is fixed inside the barrel at its base, the insulated centre shaft being fixed into this.

To allow the barrel to be emptied, the shaft is pivoted on the vat bracket, fast and loose pulleys are fitted together with suitable moving gear.

The barrel runs practically submerged in the solution and this permits a large quantity of work to be plated in one load.



Fig. 8.—THE “ MINIK ” PLATING BARREL.

The barrel illustrated has the following specifications:—

Diameter at top	..	13 inches.
Depth	..	13½ inches.
Capacity	..	3 gallons of articles.
Horse-power drive	to ..	½ h.p.

**Other Types of Barrels.**

A somewhat different type of barrel possessing several advantages is shown in Fig. 6, while Fig. 7 shows a small and economical unit very suitable for mixed loads of work and it has the advantage that it can be quickly attached to any existing vat.

The container is of Nylonite, except when used for tinning or cleaning when a stoneware container is fitted.

**Specifications.**

Inside width of vat needed .. ..	2 feet.
Capacity of barrel .. ..	$\frac{1}{2}$ gall. articles.
Max. speed of barrel .. ..	20 r.p.m.

Still another design is shown in Figs. 8 and 9. This apparatus permits the central container to be lifted away and the work swilled without removing the solution from the apparatus.

**Specifications.**

Size of container .. ..	1 or 2 galls.
Speed of container .. ..	20 r.p.m.
Horse-power required to drive .. ..	$\frac{1}{2}$ h.p.

**Notes on Barrelling.**

One of the chief virtues of barrel-plating is that the process polishes or burnishes as the plating proceeds. To obtain the best results the speed of rotation should be carefully regulated.

**Shape of Articles.**

Sometimes it is best to mix the load; work all of one shape (e.g., flat washers) often lie close together and steel balls or scrap will often break up the mass.

**Cleaning.**

All work should be cleaned before barrelling exactly as for still plating. Barrel polishing often precedes the actual barrel plating.

**Voltage and Current.**

The internal resistance of all barrel systems is higher and the voltage must be adequate to obtain the necessary current density. Some solutions work at 6 volts, but it is generally necessary to work from a 10 to 18-volt supply.

The use of a resistance board and an ammeter are essential, because if too high a current be used a good burnished appearance is not obtained.

For nickel plating use all current possible during the first half of the time; then reduce to about two-thirds, and leave the articles plating until they have a sufficient coat on and a good bright appearance.

**STRIPPING DEPOSITS.**

When electro-plating is proposed for articles that have already received a

deposit (replating of worn parts, repair work generally, etc.) it is sometimes advisable to remove all the old deposit before attempting a new one. In some cases—nickel for an outstanding example—all the old deposit must be most carefully stripped before replating with the *same* metal. If for any reason it is impracticable to strip nickel, it may be copper plated after careful preparation and the copper polished and nickel-plated.

Stripping electrolytically is, of course, only the converse to electro-plating, and might in general be performed in the same solution used for the metal deposition. The article, of course, would be made the *anode* of the circuit and the usual anodes be connected to the negative pole of the current supply.

However, special solutions are invariably used for stripping, and the electrical conditions are adjusted accordingly.

**Nickel.**

Nickel may be cleanly and expeditiously removed from its base metal in the following manner:—

A solution of sulphuric acid  $2\frac{1}{2}$  parts by measure, is carefully added to water, 2 parts. (Always pour acid to water, and never vice versa.) This solution should be contained either in a lead lined tank or in a stout earthenware container.

The usual insulated brass rods are fitted to the tank, but the central rod in this case is made the anode and the two outer rods are cathodic.

Lead sheets are hung upon the cathode rods, and it is best to bend them over the rods as shown in the illustration; this method ensures better connection than would be obtained by hooks—especially after some days running.

Rolling the sheet completely round the rod is better still because it preserves the brass from the corrosive fumes and spray sent up from the acid.

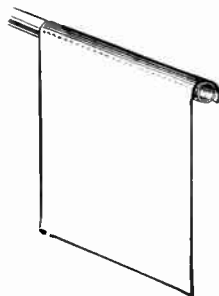

**Current Conditions.**

A pressure of from 5 to 6 volts at the vat terminals is used and the amperage is varied according to the load. A resistance board should be fitted in the circuit, and a 6-volt meter should also be incorporated.

**The Care of the Solution.**

The solution must be maintained at a density of from 50-53° Beaume, by the periodical additions of sulphuric acid. In time, of course, large accumulations of metal will "kill" the free acid and give a misleading density (the density due to dissolved nickel sulphate, iron sulphate, etc.); when this occurs the bath is best emptied and a new solution made up.

**The Procedure.**

Old work is wired up and cleaned exactly as for plating except that several strands of copper wire should be used in order to take the higher current employed.

After swilling, the work should be well drained so that the acid solution shall not be diluted.

The work should be periodically inspected and immediately all the nickel is removed it should be taken out, swilled, passed through a solution of washing soda (about 8 ozs. per gallon), swilled again and dried out.

**Stripping Nickel Without Current.**

Mix together in an earthenware vessel:—

- Nitric acid .. .. 1 part.
- Sulphuric acid .. .. 2 parts.
- Water .. .. 1 part.

(Add acid to water and not vice versa.)

Small articles can be placed in a perforated porcelain basket and dipped into this solution till clear. Since this mixture



Fig. 9. - "NOVAT" BARREL, SHOWING METHOD OF SWILLING.

attacks most base metals the process must be very carefully done if the article itself is to escape irreparable damage. Die-castings and zinc articles generally can never be done in this way.

**Silver and Gold, Etc.**

The electrolytic method is most suitable for stripping silver or gold deposits from table ware, etc., and may be advantageously used for removing old brass, copper, tin or zinc deposits from iron. The solution consists of:—

- Potassium cyanide .. 1 lb.
- Caustic soda .. .. ½ lb.
- Water .. .. 1 gall.

A suitable vat (plain iron, enamelled iron, or earthenware) is fitted with the usual rods. The articles to be stripped are made the anodes and hung on the centre (positive) rod, sheet iron cathodes are suspended on the two outer rods which are connected to the negative pole of the dynamo.

A resistance and voltmeter should be incorporated as usual. The pressure used is about 6 volts and at this pressure the work should strip cleanly and quickly.

The articles are cleaned and wired as for electro-plating and the process should be

carefully watched less any undue attack takes place on any bare patches of the underlying metal.

When the deposited metal is all removed the work should be carefully swilled in cold water, then in hot, and finally dried out in hot boxwood sawdust. It is then ready for repolishing.

This method is the best and cleanest for removing the metals specified.

The silver in the stripping solution may be recovered when concentration justifies it, by several processes.

Either add hydrochloric acid (caution!) little by little, and throw down silver chloride; or reverse the whole process and deposit loose silver on a silver sheet hung in the solution as cathode, using a carbon or steel plate as anode.

### Stripping Copper from Steel.

When it is necessary to strip a copper deposit from steel or iron without injuring the base metal, the following method should be used:—

Dissolve 1 lb. of sodium cyanide in 1 gallon of water and pour this into a plain iron or stoneware tank.

Make the article the anode and a sheet of iron the cathode, using a pressure of 6 volts.

After stripping, swill and dry out as usual.

### Removal of Brass after Bronzing.

The excess brass round bronzed joints can be most economically removed by electrolytic stripping methods. Use a solution made as follows:—

8 ozs. nitrate of soda.

1 oz. nitrite of soda.

$\frac{1}{2}$  oz. nitric acid.

1 gallon water.

This solution should be contained in a plain wood vat.

The articles to be treated should be first sandblasted to remove the borax flux and then it should be wired up with fairly stout wires and hung in the solution as anode. Steel sheets are convenient cathodes. 6 volts across the vat terminals should be ample, and this on an ordinary cycle frame will give an amperage of from 50-60 amps.

The process should take about half an hour if reasonable precautions have been taken to avoid wasteful lumps of brass in the bronzing process.

When the article is clean it should be well swilled and dried out in the usual manner.

## QUESTIONS AND ANSWERS

### Why is cadmium so useful for protecting iron and steel?

Because owing to its position in the electro-chemical series, any corrosion which takes place is at the expense of the cadmium. Also, it has distinct decorative properties and when scratch-brushed and lacquered retains its lustre as long as the lacquer stands.

### How should an electro-plating solution of tin be prepared?

(1) Dissolve the potash (taking care to avoid spitting and overheating when adding the caustic to the water).

(2) Add the tin salts little by little with constant stirring, taking care not to let it get too hot.

(3) Dissolve a little glue size in the solution (about one-tenth of an ounce per gallon).

### What is barrel plating?

Barrel plating is the method generally employed by electro-platers for all small parts, such as nuts and bolts, washers, pins, etc. The apparatus used consists essentially of a revolving container for the work and provision for the necessary anode and cathode connections.

### What is the most suitable method for stripping silver or gold deposits from table-ware, etc.?

The electrolytic method, a suitable solution being potassium cyanide, 1 lb.; caustic soda,  $\frac{1}{2}$  lb.; water, 1 gallon. The article to be stripped is made the anode. A piece of the metal which is to be recovered should be used as the cathode.

# ILLUMINATION OF OFFICE BUILDINGS

By E. H. FREEMAN, M.I.E.E.

## OFFICES.

**T**HE design of a lighting installation for a block of offices involves problems which, whilst they must be solved on the main principles already

formulated, yet require special consideration. As regards any individual office, whether large or small, the problem is usually simple and must be dealt with on standard lines, but with due allowance for the views of the tenant as to the methods of lighting to be adopted. Some banks, for example, insist on general lighting adequate for all work in their main banking halls, without the use of any local desk standards, whilst others prefer less general lighting combined with local lamps for each clerk. There is much to be said in favour of each scheme, and the decision must

rest in most cases with the tenant, particularly if this is an institution such as a bank or insurance office with much past experience in their own requirements.

## General Lighting and Local Lighting.

The great advantage of general lighting, designed to provide adequate illumination over the whole area to be lit, is that desks, etc., can be moved at any time without any need for alteration to the lighting. This is of great importance in buildings where floors are occupied by separate tenants, thus making it impossible, as a rule, to obtain access to the floor above. If alterations are required the work must thus be run on the surface, and this is usually considered objectionable.

The first cost of installation should also be appreciably lower with large general lighting units and also possibly in running cost, providing the entire area is in use.

On the other hand, local lighting provides the maximum of light where it

is most required and may be very much cheaper to run if the office area is only in partial use. With general lighting all the lights might be required at times to give sufficient illumination for a few clerks,

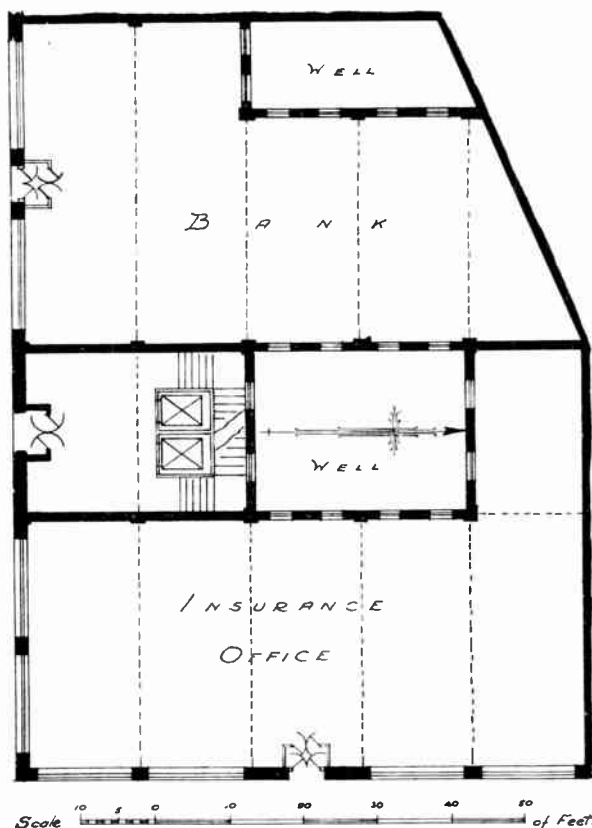

Fig. 1.—GENERAL PLAN OF GROUND FLOOR FOR IMAGINARY OFFICE BUILDING DESCRIBED IN THE ARTICLE.

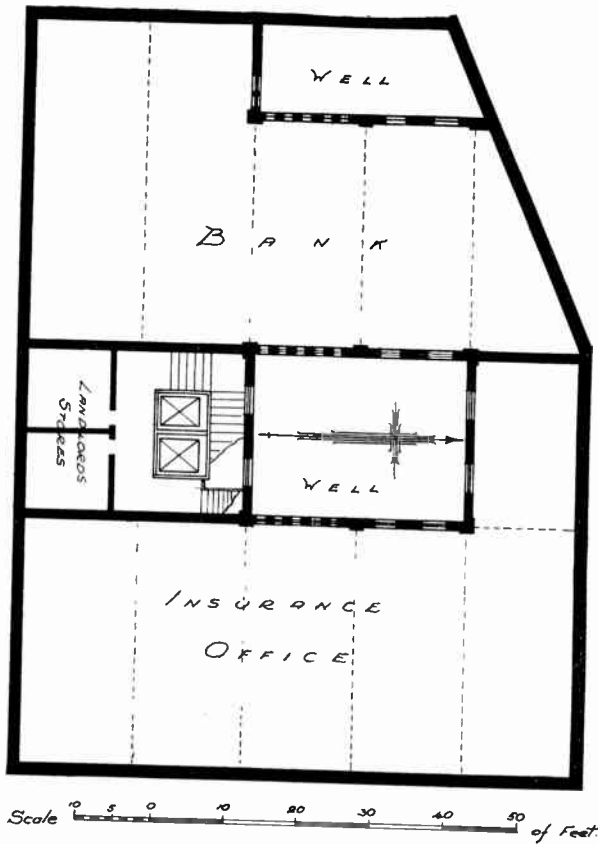

Fig. 2.—BASEMENT—GENERAL PLAN.

whereas with local lighting each would use only his own small local light.

Obviously, the decision in favour of one or other scheme must depend on the conditions, which would include such points as :—

(1) The likelihood of any rearrangement of desks and tables.

(2) The prospects of part of the staff being required to work during irregular hours.

(3) Cost of installation.

(4) Cost of current.

If, for example, current is cheap and the staff is so inter-connected in its work that if any of them are at work they must all be working, there is little doubt that general lighting would be advisable.

On the other hand, if each clerk can work independently of others and if current is expensive, there is a strong

argument in favour of local lighting.

### Other Problems.

Apart from this general principle, which must be decided independently for each of the larger office areas, there are many other special questions that must be considered before the design of an office building such as that shown can be completed.

These include :—

Nature of lighting to be provided for unknown tenants' requirements on lettable floors.

Probable arrangements for metering these tenants' areas.

Whether and what provision should be made for landlord's lighting on lettable floors.

Method of control of landlord's lighting.

These and other questions can best be considered by working out in detail the design for such an imaginary office block as is shown in Figs. 1, 2 and 3, which show respectively the ground floor, basement and a typical upper floor of the building.

### TYPICAL BUILDING.

For the purposes of the design the following data can be assumed :—

*Sub-basement.*—Occupied entirely by landlord for boiler-house, lift gear rooms and similar purposes with sundry stores, which can be hired by tenants, including the use of light. Fig. 13.

*Basement and ground floor, west side.*—To be occupied by bank, details of planning all being decided as shown in Figs. 5 and 6. The bank requires local lighting for all desks in main banking hall.

*Basement and ground floor, east side.*—To be occupied by insurance company, details of planning also being decided, as shown in Figs. 8 and 9. The insurance company will also occupy the east side of the first floor, as Fig. 10.

Unlike the bank, the insurance company prefers general lighting with local lamps only at a few special positions, including desk lamps in private offices.

## SCHEDULE I.—BANK.

Area.	No. of Points.	Fitting.	No. of Switches.	Position of Switch.	Watts per Fitting.	Total Watts.
<i>Ground Floor.</i>						
Main office, general lighting .. ..	8	Pendant	16	Near waiting room	400	3,200
Cashier's desk .. ..	6	Standards	6	On standards ..	60	360
Front desks .. ..	8	Standards	8	On standards ..	60	480
Back desks .. ..	8	Standards	8	On standards ..	60	480
	6	Standards	6	On standards ..	60	360
Waiting room .. ..	1	Pendant	1	Door .. ..	100	100
Manager .. ..	1	Pendant	1	Door .. ..	100	100
	1	Plug	1	Near plug .. ..	60	60
Assistant Manager ..	1	Pendant	1	Door .. ..	100	100
	1	Plug	1	Near plug .. ..	60	60
Store .. ..	1	Pendant	1	Door .. ..	25	25
By stairs .. ..	1	Pendant	1	Near .. ..	60	60
Porch .. ..	1	Pendant	1	Near .. ..	100	100
Messengers .. ..	2	Plugs	2	Near .. ..	60	120
<i>Basement.</i>						
Near stairs .. ..	1	Pendant	2 D.C.	Top and bottom ..	60	60
Typists' office .. ..	6	Pendant	6	Door .. ..	60	360
Filing .. ..	2	Pendant	2	Door .. ..	60	120
Lobby .. ..	1	Pendant	1	Door .. ..	40	40
Ladies' lavatory .. ..	6	Pendant	6	Doors .. ..	40	240
Cloaks .. ..	1	Pendant	1	Door .. ..	40	40
Men's lavatory .. ..	6	Pendant	6	Doors .. ..	40	240
Cloaks .. ..	1	Pendant	1	Door .. ..	40	40
Corridor .. ..	2	Pendant	1	Near stairs .. ..	40	80
Messengers .. ..	1	Pendant	1	Door .. ..	60	60
Messengers' lavatory ..	2	Pendant	2	Door .. ..	40	80
2 stores .. ..	2	Pendant	2	Door .. ..	40	80
Strong room .. ..	4	Pendant	2	Inside door .. ..	60	240
	1	Pilot lamp	1	Control switch	20	20
				outside door ..		
Promenade corridor ..	4	Pendant	1	Outer door .. ..	40	160

*Upper floors, including first floor west.*—All left for letting off to tenants. In order to maintain the character of the building it has been decided by the landlord that the first, second and third floors will be let off in areas not less than about one half of the total floor area, whilst the fourth, fifth and sixth floors may be let off in separate rooms or other areas to suit tenants.

*Seventh floor.*—All occupied by lavatories and cloak-rooms, as in Fig. 14, but with a caretaker's flat, attached to which is a kitchen to enable the caretaker to provide teas for the tenants.

Other details that affect the lighting scheme will be ascertained as the design for each area is worked out.

### BANKING PREMISES.

#### General Description.

The entrance to the bank is independent

of the main entrance and opens, as usual, direct into the public space at the back of which is a range of cashiers' desks with another row of clerks' desks behind. Beyond this on the east side are several private offices and a further area for clerical work. A staircase at the back leads to the basement, where there are offices for typists and filing and messengers; men's and women's lavatories; stores and strong room.

#### Ground Floor—General Lighting.

The whole general office area and public space can be considered as one unit area, and can be divided into two sections: one at the front to include the public space and cashiers, etc., measuring 30 feet by 44 feet, and the other at the back for a general office measuring 36 feet by 18 feet. The total floor area will thus be about

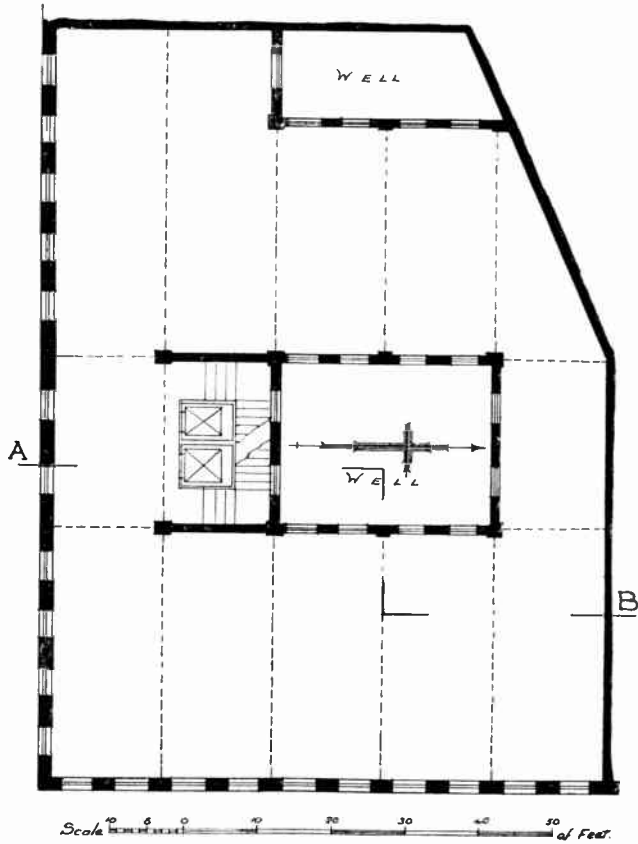

Fig. 3.—TYPICAL LETTABLE FLOOR PLAN.

1,320 + 648 or 1,968 square feet in all.

As desk lamps will be used in addition to the general lighting, there is no need to allow for more than 5 ft. candles or a total of about 9,840 lumens. On the other hand, allowance must be made for possibly inefficient fittings, as in a large banking hall appearance rather than efficiency will be studied. Fittings with an efficiency as low as 40 per cent., or even less, might be used so that the lumens to be allowed from the lamps should be 24,600.

#### Arrangements for Spacing.

Accurate spacing will also probably need to be sacrificed to appearance and must be arranged to suit the beams which project well below the ceiling, as indicated by the dotted lines. The height from

floor to ceiling, as taken from the sectional drawing of the building, is 14 feet, so that the working height from fitting to desk level will be not more than 9 or 10 feet, and fittings should be spaced about 14 to 16 feet apart or one and a half times this at most. To suit the beams three fittings in each bay of the front section will suit this spacing admirably and will then be 14 feet 6 inches apart in one direction—east to west—and 15 feet apart in the other—north to south. In the back section a single row of fittings will also suit the arrangement of the beams, and the scheme for general lighting will be as shown in Fig. 6. To allow for reduced lighting for cleaning, etc., it would be advisable to put each fitting on two switches.

It will be seen that there will be eight of these general lighting fittings in all, so that each should carry lamps giving

$$\frac{24,600}{8}$$

or 3,100 lumens. A single 300-watt lamp will suit, giving 4,140 lumens, but to

allow for the use of fittings requiring several lamps it would be advisable to allow for four 75-watt lamps at each, which will give  $4 \times 780$  or 3,120 lumens per fitting. If it is possible to obtain a decision on the design of the fitting at an early stage of the scheme so much the better, but otherwise it would be inadvisable to cut the loading below this, and it would be safer to allow for four 100-watt lamps per fitting.

#### Desk Lighting.

For the desk lighting a lamp will be required for each cashier as shown, i.e., for six lamps along the front desk. On the general office area one lamp for each 5 feet run of desk should be allowed, i.e. :

For long desk in front area,  
40 feet long . . . . . 8 lamps  
For desk facing wall, 38 feet



long . . . . . 8 lamps  
 For central desk, back area,  
 32 feet long . . . . . 6 lamps  
 All of these should be wired for 60-watt lamps.

For each of the private offices a central pendant and desk lamp will be wanted, and these can be taken as 100/150 watts for the pendant and 60 watts for the plugs. No plug will be necessary in the waiting room, but a plug in each front corner of the public space will be desirable for messengers' tables. A small lamp (60-watt) over the stairs down and one in the porch entrance will complete the ground floor lighting.

**Basement.**

There will be no need to calculate the lighting details of the basement area with any great accuracy. Taking the rooms as they appear on the plan, the requirements can be met as follows:—

*Near stairs.*—Pendant for general lighting—60 watts.

*Typists.*—Several pendants to suit arrangement of machines. The number and location will be known and provision for six machines should be ample.

*Filing.*—Two pendants will suit—one for a desk by the window and the other for a central table.

*Lavatories.*—The lighting of these will depend on the manager's instructions, i.e., whether there is to be one light per w.c. or only general lighting. A suitable scheme is shown on the plan.

*Strong room.*—Only general lighting is required, sufficient to locate particular books, boxes, etc., and four 60-watt lamps will be sufficient with a control switch and pilot light outside. The promenade corridor round the strong room will require

a light at each corner all on one switch at the entrance.

*Stores and messengers.*—One light in each will be suitable.

*Corridor.*—Two lights will be ample.

This completes the scheme for the bank, and the lighting schedule can now be made out (see page 1093).

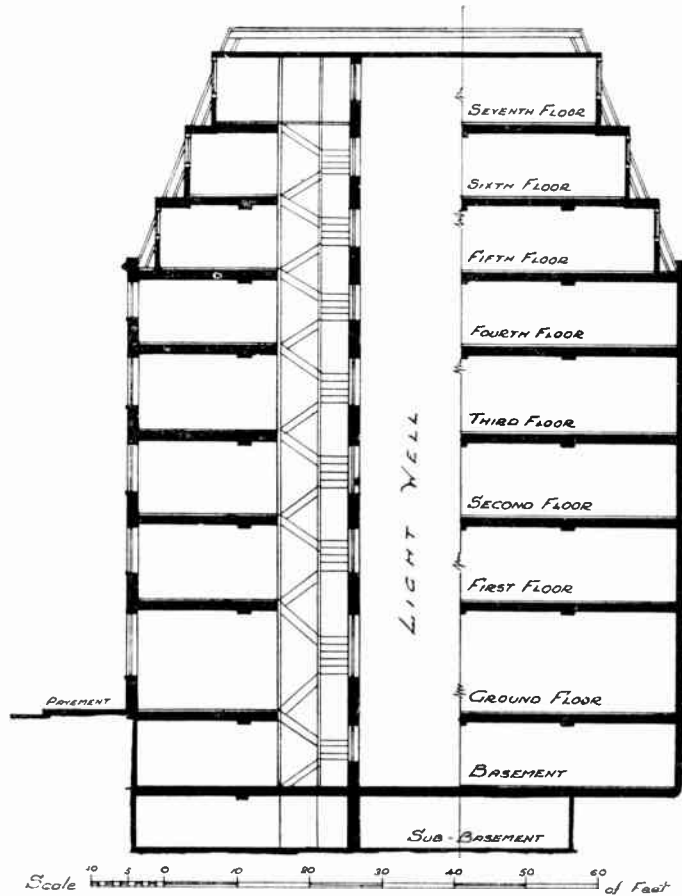

Fig. 4.—SECTION THROUGH BUILDING. (SECTION AB, SEE FIG. 3.)

**Distribution Scheme.**

The wiring distribution scheme will be quite simple. The loads on the floors, as will be seen from the schedule, are:—  
 Ground floor 5,605 watts or 25 amps., at 230 volts.  
 Basement . . 1,860 watts or 8 amps., at 230 volts.

The supply may be an independent

## ILLUMINATION OF OFFICE BUILDINGS

## SCHEDULE 2.—INSURANCE COMPANY.

Area.	No. of Points.	Fitting.	No. of Switches.	Position of Switch.	Watts per Fitting.	Total. Watts.
<i>First Floor.</i>						
Board room .. ..	2	Pendants	2	Door .. ..	150	300
	4	Brackets	2	Door .. ..	60	240
	4	Plugs	1	Door .. ..	60	240
Secretary .. ..	1	Pendant	1	Door .. ..	150	150
	1	Plug	1	Door .. ..	60	60
General manager ..	1	Pendant	1	Door .. ..	150	150
	1	Plug	1	Door .. ..	60	60
General office .. ..	18	Pendants	6	Near stairs ..	150	2,700
Manager, No. 3 ..	1	Pendant	1	Door .. ..	100	100
	1	Plug	1	Door .. ..	60	60
Assistant Manager, No. 3 .. ..	1	Pendant	1	Door .. ..	100	100
	1	Plug	1	Door .. ..	60	60
Typists .. ..	5	Pendants	5	Door .. ..	150	750
Stairs .. ..	1	Pendant	2 D.C.	Ground and first floor.	100	100

Area.	No. of Points.	Fitting.	No. of Switches.	Position of Switch.	Watts per Fitting.	Total. Watts.
<i>Ground Floor.</i>						
General office .. ..	6	4-light pendants	12	Near stairs ..	700	4,200
Messengers .. ..	2	Plugs	2	Near plugs ..	60	120
Manager, No. 1 ..	1	Pendant	1	Door .. ..	100	100
	1	Plug	1	Near plug ..	60	60
Assistant Manager, No. 1 .. ..	1	Pendant	1	Door .. ..	100	100
	1	Plug	1	Near plug ..	60	60
Waiting room .. ..	1	Pendant	1	Door .. ..	100	100
Manager, No. 2 ..	1	Pendant	1	Door .. ..	100	100
	1	Plug	1	Near plug ..	60	60
Assistant Manager, No. 2 .. ..	1	Pendant	1	Door .. ..	100	100
	1	Plug	1	Near plug ..	60	60
Manager's lavatory ..	6	Pendants	6	Doors .. ..	40	240
Cloaks .. ..	1	Pendant	1	Door .. ..	40	40
Stairs .. ..	1	Pendant	1	Near stairs ..	100	100
Porch .. ..	1	Pendant	1	Near .. ..	100	100
<i>Basement.</i>						
General office .. ..	11	Pendant	2	Near stairs ..	150	1,650
North end .. ..	1	Pendant	1	Near stairs ..	100	100
Strong room .. ..	4	Pendants	2	Outside .. ..	60	240
	1	Pilot lamp	1	Control switch ..	20	20
	2	Pendants	1	Door .. ..	60	120
Book store .. ..	2	Pendants	1	Door .. ..	60	120
Men's lavatory and cloaks .. ..	6	Pendants	6	Doors .. ..	40	240
Filing .. ..	2	Pendants	2	Doors .. ..	60	120
2 private offices ..	2	Pendants	2	Doors .. ..	100	200
	2	Plugs	2	Near plugs ..	60	120
Foot of stairs .. ..	1	Pendant	2 D.C.	Basement and ground floor ..	60	60
Ladies' lavatory and cloaks .. ..	7	Pendants	7	Doors .. ..	240	280

service from the street taken to some such position as the front store or may be taken from the main supply in the sub-basement to a position in the basement corridor. In either case the runs of mains and circuits will not be long enough to give more than a small voltage drop and cables rated up to I.E.E. standard, will be large enough,

The fuse board circuits can be arranged as follows:—

General lighting pendants, ground floor .. .. .	4 circuits
Desk lamps, one circuit per desk .. .. .	4 circuits
Other lamps, ground floor ..	2 circuits
<b>Total .. .. .</b>	<b>10 circuits</b>

Basement.—Circuits as convenient with not more than eight lights per circuit.

Total, say, 6 circuits.

The distribution scheme would thus be:—

Main switch and fuses .. .. .	40 amps.
Main cables .. .. .	7/.052 (for a total load of 33 amps.)
Main fuse board ..	2 ways, 25/30 amps.
Sub-mains to ground floor ..	7/.044 (for 25 amps.)

Allow. . . . .	7/.029 (for 8 amps.)
Sub-fuse boards:	
Ground floor ..	12 ways (including 2 spares)
Basement ..	6 ways, each with spare capacity

The scheme is shown diagrammatically in Fig. 7.

**INSURANCE OFFICE.**

**First Floor.**

The first floor of the insurance company's offices is devoted mainly to a large general office and, as stated earlier, the lighting of this is to be designed for general lighting only without any local desk lamps.

The area is 34 feet by 50 feet, or a total of 1,700 square feet. The illumination provided should be eight to 10 candle feet, so that a total of 1,700 × 10 or 17,000 lumens must be obtained. In such a general office fittings can be used of an efficient character providing they are free from glare, i.e., of the usual enclosed unit type having an efficiency of 50 per cent. or more. The total output from the lamps must thus be about 34,000 lumens.

**How Fittings Should be Spaced.**

The height from floor to ceiling (see Section Fig. 4) is 10 feet 6 inches, so that with lamps 1 foot down and desks 3 feet from floor the working height will be 6 feet 6 inches, and the spacing distance about 10 feet to 11 feet, i.e., 1½ to 1¾ times the working height. Although appearance will not be of great importance (as it will be on the ground floor), it will certainly be desirable to space the fittings on some plan that

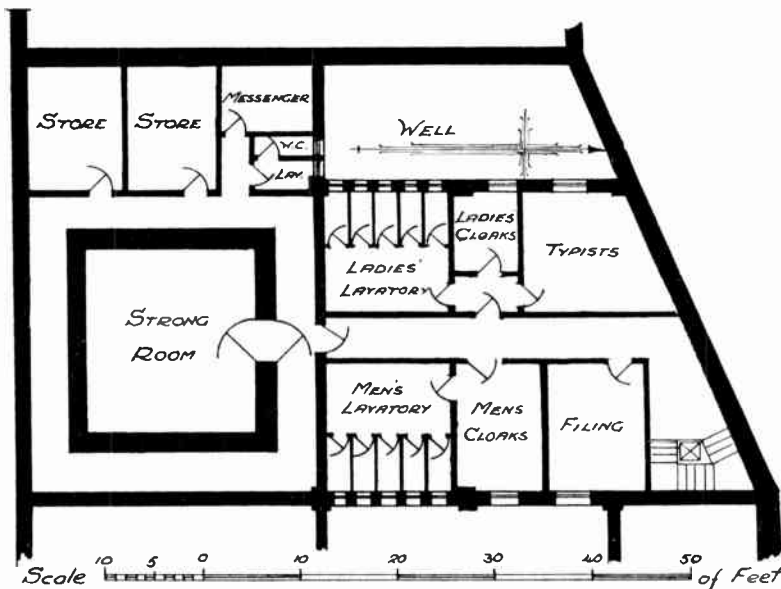

Fig. 5.—BASEMENT PLAN—BANK SECTION.

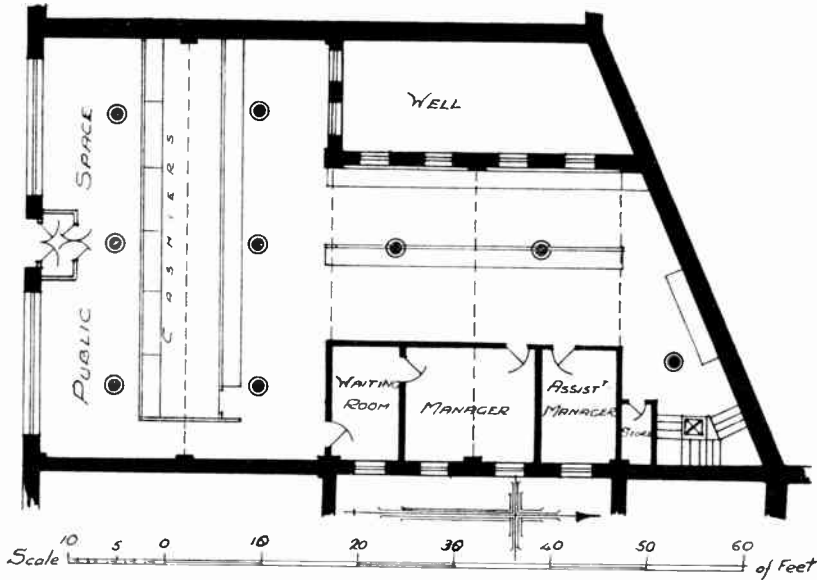

Fig. 6.—GROUND FLOOR PLAN—BANK SECTION.  
Showing general lighting points.

higher than those in Fig. 11C, but still well below the theoretical distance.

This last scheme will probably be the best, but it may be criticised as extravagant.

The two small sections of the ceiling at the north and south ends can be ignored, as the floor space below must be left for gangways, which will

will correspond with the beams that project below the main ceiling area. These are 15 feet apart in one direction, the whole ceiling being divided into bays 34 feet by 15 feet, as shown in Fig. 10.

It will be seen that a scheme arranged symmetrically with the beams involves some difficulty and alternative arrangements are shown in Figs. 11A to 11D.

Fig. 11A has three fittings in each bay, which will be at 15 feet and 12 feet spacing, i.e., decidedly too far apart.

Fig. 11B has additional fittings on the beams. This is much better, but involves the difficulty of taking the wiring below the beam, which is an awkward wiring problem to be avoided if possible. It may also mean lowering all the fittings 6 inches to 12 inches, making the spacing less satisfactory than before.

Fig. 11C has eight fittings in each bay with spacing about 7 feet 6 inches by 8 feet 6 inches, i.e., closer than necessary.

Fig. 11D has six fittings in each bay with an average spacing rather

receive ample lighting; in fact, the effective floor area to be lit might be reduced on this account to 34 feet by 45 feet, corresponding to a reduction in the total lumens from the lamps down to 30,000.

With the layout in Fig. 11D the total number of fittings will be 18, so that each must give  $30,000 \times \frac{1}{18}$ , or about 1,660 lumens, and 150-watt lamps giving 1,876 lumens will be suitable. Lamps of 100 watts giving only 1,130 lumens would be too small.

**Private Offices on First Floor.**

The remainder of the first floor consists of private offices, which will only require the usual pendant and plug for each, and the board room, which will require two pendants and two or three plugs, and possibly some brackets for decorative

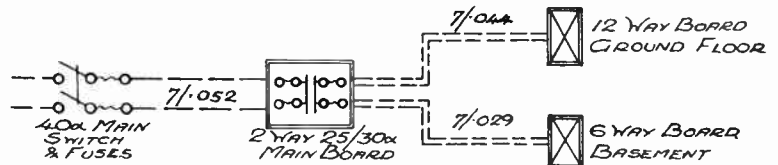

Fig. 7.—DIAGRAM OF CONNECTIONS FOR BANK.

effect rather than illumination.

**Typists' Room.**

Finally, there is the typists' room, for which local or general lighting may be required, according to the views of the management. Typists, as a rule, undoubtedly prefer local lighting, and certainly need very good general lighting if this is provided, copying as they usually do from possibly blurred pencil notes. If general lighting is used not less than five pendants each of

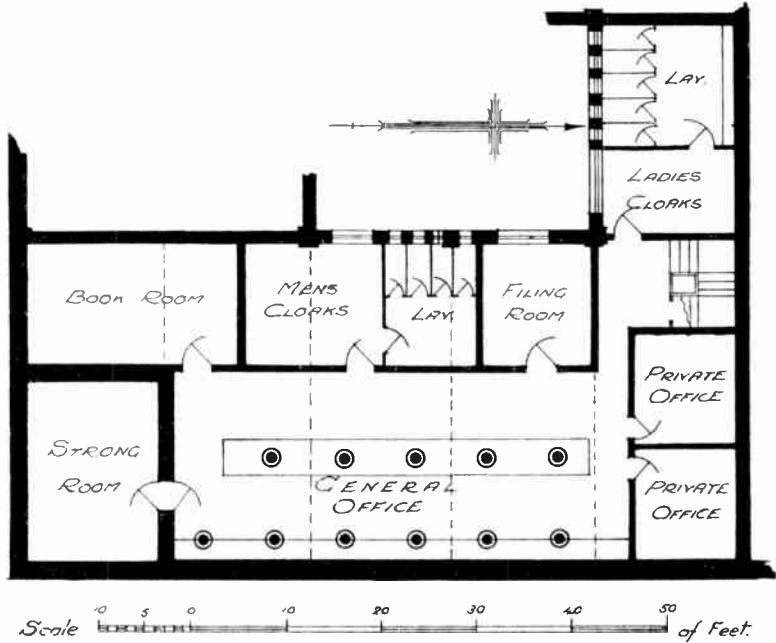

Fig. 8.—BASEMENT PLAN—INSURANCE SECTION. Showing arrangement of general lighting points.

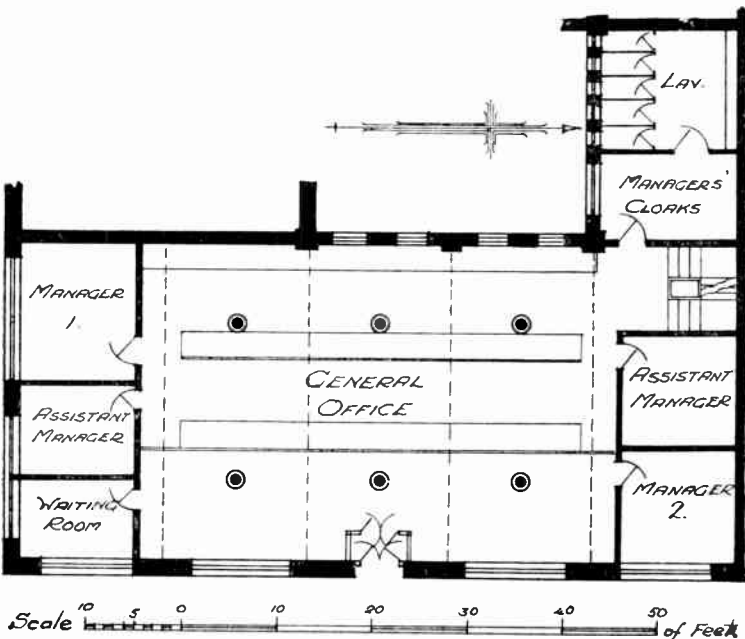

Fig. 9.—GROUND FLOOR PLAN—INSURANCE SECTION. Showing arrangement of general lighting points.

150 watts should be provided.

**Ground Floor.**

In the main hall of the ground floor appearance will no doubt be more important than efficiency in the lighting units, and proper spacing in the ceiling panels will be essential. Of these there are three each 15 feet wide by 34 feet, and obviously two units in each will be a satisfactory scheme. The height is 14 feet, as in the banking hall, with a working height of 9 to 10 feet, and this corresponds very well with the

spacing required to suit the ceiling panels.

The total area is 50 feet by 34 feet or 1,700 square feet, requiring 17,000 lumens nett or about 42,500 lumens from the lamps, allowing 40 per cent. efficiency, which is as high as can be allowed for fittings which may be designed for appearance more than efficiency. The lamps per fitting must thus give  $42,500 \times \frac{1}{4}$  or about 7,100 lumens. One 500-watt lamp (7,500 lumens) would be suitable, or,

square feet in all. The height is 9 feet from floor to ceiling, giving a working height of 5 feet and a spacing distance of 8 to 9 feet. This indicates two rows of fittings with two in each bay, and as the rows correspond to the desks these might with advantage be moved rather to one side and be fixed over the desks. The fact that this will leave the west side slightly less well lit will not matter as this is all corridor. Any re-arrangement of the desks is unlikely, as there is obviously

not room for an extra row. The north end light can with advantage be moved opposite the gangway space, as the desk cannot extend as far as the front desk if gangway space is to be provided.

For an area of 1,000 square feet, and an illumination of 10 foot candles, 10,000 lumens nett will be required, and 20,000 lumens from the lamps. There are 11 fittings, so that each must give about 1,800 lumens, and 150-watt lamps

giving 1,875 lumens each will be suitable.

The schedule for the insurance company's premises can now also be completed.

**Distribution Scheme.**

The loadings on the various floors as taken from the schedule are as follows:—  
 First floor . . 5,070 watts or about 22 amps.  
 Ground floor 5,540 watts or about 24 amps.  
 Basement . . 3,150 watts or about 14 amps.

Total load 13,760 watts or about 60 amps.

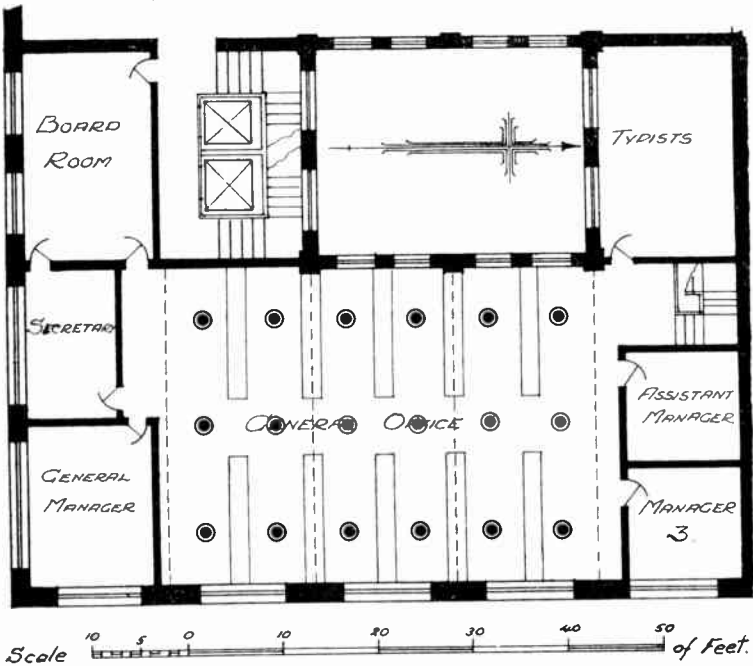

Fig. 10.—FIRST FLOOR PLAN—INSURANCE SECTION.  
 Showing arrangement of general lighting points.

according to the design of the fittings, three 200-watt lamps (total 7,800 lumens) or four 150-watt (total 7,500 lumens) or seven 100-watt (total 7,010 lumens). In any case two switches per fitting would be desirable.

The remaining areas do not require any special design and the lighting details can be as given in the schedule.

**Basement.**

Only the general office area in the basement needs any special consideration. This area is 50 feet by 20 feet or 1,000

The cables required for these loadings at I.E.E. ratings would be:—

To first floor..	..	7/.036 (maximum loading 24 amps.)
To ground floor ..	..	7/.044 (maximum loading 31 amps.)
To basement..	..	7/.029 (maximum loading 18.2 amps.)
Main cable for total load ..	..	19/.052 (maximum loading 64 amps.)

It will be as well to check the voltage drop, as the switches all being at the north end, remote from the supply position, the fuse boards should also be placed thereabouts. The measurements for the first floor are approximately 120 feet run for the main cables to the fuse board and about 100 feet run to the worst circuit—that supplying the board room, etc.

For 7/.036 main cables the voltage drop at the maximum loading is 1 volt per 33 feet of conductor, so that the drop for 120 feet run or 240 feet of conductor will be:—

$$\frac{2 \times 120}{33} \times \frac{22}{24} \text{ or } 6\frac{1}{2} \text{ volts.}$$

For the circuit to the board room the drop at maximum loading (7.8 amps.) with 3/.029 conductors is 1 volt per 30 feet of conductor. The current with a load of 800 watts is  $3\frac{1}{2}$  amps., so that the voltage drop will be:—

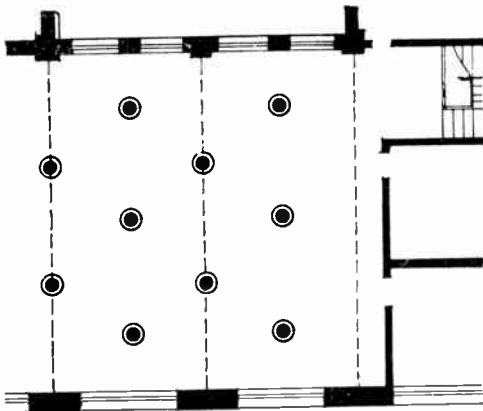

Fig. 11B.—SHOWING ARRANGEMENT WITH ADDITIONAL FITTINGS ON THE BEAMS.

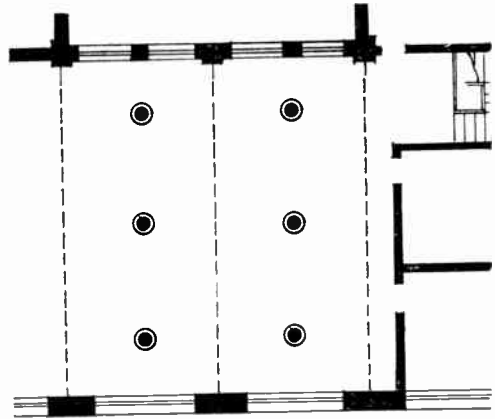

Fig. 11A.—ALTERNATIVE ARRANGEMENT OF FITTINGS FOR FIRST FLOOR. With three fittings in each bay.

$$\frac{2 \times 100}{30} \times \frac{3.5}{7.8} \text{ or } 3 \text{ volts.}$$

The length of conductor required for a drop of 1 volt is given in the I.E.E. Tables, and the voltage drops obtained on any circuit can be calculated from these figures. The drop will vary directly with the length of conductor and inversely with the current carried, i.e., it will be increased in proportion to the length of the conductor and reduced if the current carried is less than the I.E.E. maximum.

### Total Voltage Drop.

The total drop on sub-main and circuit would thus be about  $9\frac{1}{2}$  volts without any allowance for losses in the main cables, switch contacts and fuse boards and flexible cords. This considerably exceeds the I.E.E. allowance of 3 per cent. + 1 volt or 7.9 volts, and some reduction must be made. This might be effected by:—

- (1) Increasing the size of the sub-main.
- (2) Reducing the load on the few long circuits below 800 watts.
- (3) Increasing the circuit wiring on these circuits to 3/.036.

Of these alternatives either (2) or (3) would be the cheapest as the voltage drop on circuits supplying lights near the fuse boards will be well below the maximum in any case, but as the drop

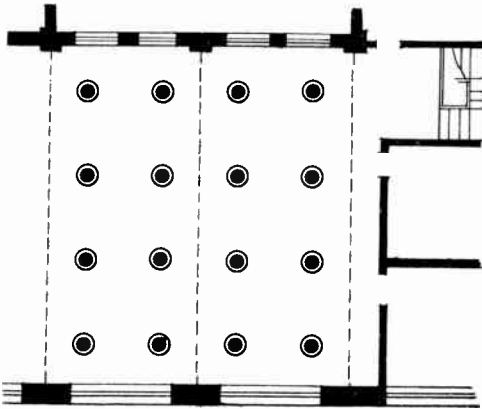

Fig. 11C.—SHOWING ARRANGEMENT WITH EIGHT FITTINGS IN EACH BAY.

on the sub-main cable is as high as  $6\frac{1}{2}$  volts, it would be advisable in any case to increase the size of this so that there is some spare capacity available.

#### Cable to Use.

Cables of 7/.044 section will carry 31 amps., and give a voltage drop at this rating of 1 volt per 39 feet. The actual drop would thus be:—

$$\frac{2 \times 120}{39} \times \frac{22}{31} \text{ or about } 4\frac{1}{2} \text{ volts.}$$

If two or three of the longest circuits are wired with 3/.036 conductors this will be satisfactory.

For the ground floor a similar change can be made also and the voltage drop here will then not be excessive as the run is shorter than for the first floor.

#### Fuse Boards.

The arrangements of the fuse board circuits can now be decided, a convenient scheme leaving spare capacity on all circuits being:—

#### First Floor.

Board room and front offices .. .. .	2 circuits
General office .. .. .	5 circuits
Back private offices .. .. .	1 circuit
Typists and stairs .. .. .	1 circuit
Spare .. .. .	1 circuit
<b>Total .. .. .</b>	<b>10 circuits</b>

#### Ground Floor.

General office .. .. .	6 circuits
Front offices .. .. .	1 circuit
Back offices .. .. .	1 circuit
Lavatory and stairs .. .. .	1 circuit
Spare .. .. .	1 circuit
<b>Total .. .. .</b>	<b>10 circuits</b>

#### Basement.

General offices .. .. .	3 circuits
Strong room and book store .. .. .	1 circuit
Lavatory and filing .. .. .	1 circuit
Back offices and stairs .. .. .	1 circuit
Lavatory .. .. .	1 circuit
Spare .. .. .	1 circuit
<b>Total .. .. .</b>	<b>8 circuits</b>

The distribution scheme is thus completed, and the wiring diagram can be made out as in Fig. 12.

### LANDLORD'S LIGHTING.

In such a building as this there must be a separate system of lighting in the areas used for the general service of the building; i.e., for such areas as the boiler house, lift gear rooms, main switchboard room, etc. These are all controlled by the landlord for the general convenience of

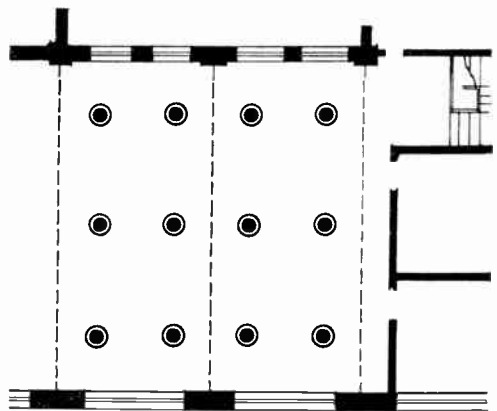

Fig. 11D.—SHOWING ARRANGEMENT WITH SIX FITTINGS IN EACH BAY.



the whole building, and lighting must be supplied independently of the tenants.

The landlord must also provide for the lighting of the staircases which are for the common use of the various tenants, although not, of course, for those in separate tenancies, such as those in the bank and insurance offices.

### Lavatories.

Lavatories used in common by various tenants also must be included in the landlord's system and also the caretaker's quarters.

All these sections can easily be arranged and do not need special consideration. The requirements can easily be seen from the plans. Figs. 13 and 14 show the arrangement of the sub-basement and the seventh floor, and the lighting scheme is detailed in Schedule No. 3.

### Staircases.

The staircases require a light in each landing and half-landing, and these are also given in the schedule as are also the two lights for the lift cages for which wiring must be run to a point half-way up the lift well to which the trailing cables attached to the lift cage can be connected.

### Corridor Lighting.

The only question involving any difficulty is that of providing for corridor lighting on lettable floors. In the case we are considering this will not arise on the first, second and third floors, where it is decided that only half floors will be let without sub-division. This means that any corridor lighting required must be provided by the tenant and will not be connected to the landlord's system.

On the fourth, fifth and sixth floors, however, this condition does not apply, and corridor lighting may need to be provided by the landlord, although this will not be known until the floors are let.

Even then the arrangements made will not be final, as alterations of tenancies may make it necessary to alter the corridor lighting.

In the present case the problem is fairly simple. With a single staircase the only points of entry to the lettable area on each floor are at A and B (see Fig. 15). Corridors must run from these points at first west and east to C and D. It may be necessary to extend them still farther in these directions to E and F, but this need not affect the lighting, as points at C and D will give sufficient light for corridors between C and E or between D and F.

From C and D corridors might run north as shown—C G J and D H K. It is most unlikely that any other planning of

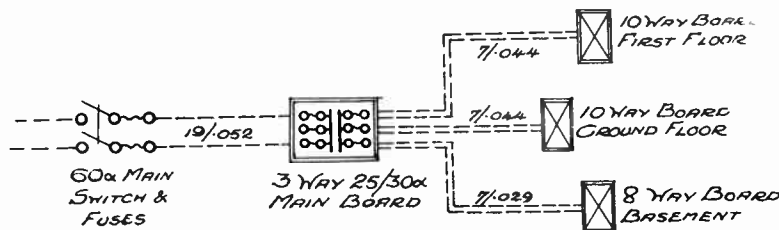

Fig. 12.—DIAGRAM OF CONNECTIONS FOR INSURANCE SECTION.

the corridors will be adopted as the office areas will naturally be arranged to give them the maximum daylight from the light wells and other windows. The landlord's corridor lighting need thus only be continued along these lines. It may easily be stopped short of J or K if a large area at the back is let to one tenant, but it need not be continued along the short ends at J L and K M (which might be required as a landlord's corridor to give access to the area north of the central well). These short corridors, if required, will be sufficiently well lit from points at J and K.

The landlord's lighting might thus consist of points placed at C, G, J, D, H and K, and provision must be made on each of these upper floors for these lamps. Each should be 60-watt and one switch should be provided on the landing for each side of the building, i.e., two per floor.

More complicated schemes are occa-

sionally required, but if the plan of the building makes such necessary it is usually sufficient to make provision on the main cables supplying the landlord's lighting, and to leave the circuit wiring to be run on the surface to suit the planning of the lettable areas.

In the present case it would be advisable to run a tube from the landings to points G C J and to draw in the wires as necessary when the areas are let. If a large area is let to one tenant the landlord's corridor lighting can be omitted where it is not required—due to the corridors being included in the tenant's area.

The schedule of landlord's lighting can now also be made out and should include for all the corridor lighting that may be necessary.

**Distribution Scheme.**

From Schedule 3 it will be seen that the loadings on the various floors are as shown in the table on page 1110.

The whole load can go on one main switch, but there are many alternative schemes for sub-dividing the load; probably the most convenient will be to provide a main board in the sub-basement sub-mains feeding sub-fuse boards for various sections somewhat as follows:—Circuit 1—To supply sub-basement and basement.

Total load 1,660 watts, 7.4 amps.

Sub-main Allow 7/.020

Sub-board 5 ways fixed in sub-basement  
Circuit 2—To supply ground floor and lettable floors up to sixth floor.

Total load 2,320 watts, 10.2 amps.

Sub-main Allow 7/.020

Sub-board 6 ways fixed on ground floor  
Circuit 3—To supply seventh floor.

Total load 2,020 watts, 9 amps.

Sub-main Allow 7/.020

Sub-board 8 ways fixed on seventh floor  
The main board should be 3 way, 10/15 amps., and the main cables supplying it of 7/.044 section.

It will be seen that the mains and

boards have ample spare capacity, but this will be desirable in view of the possible use of inefficient fittings on landings, etc., which may involve the use of larger lamps than would otherwise be necessary. The extra cost will be very small and it must be remembered that the whole of the staircase and corridor lighting is likely to be in use, so that

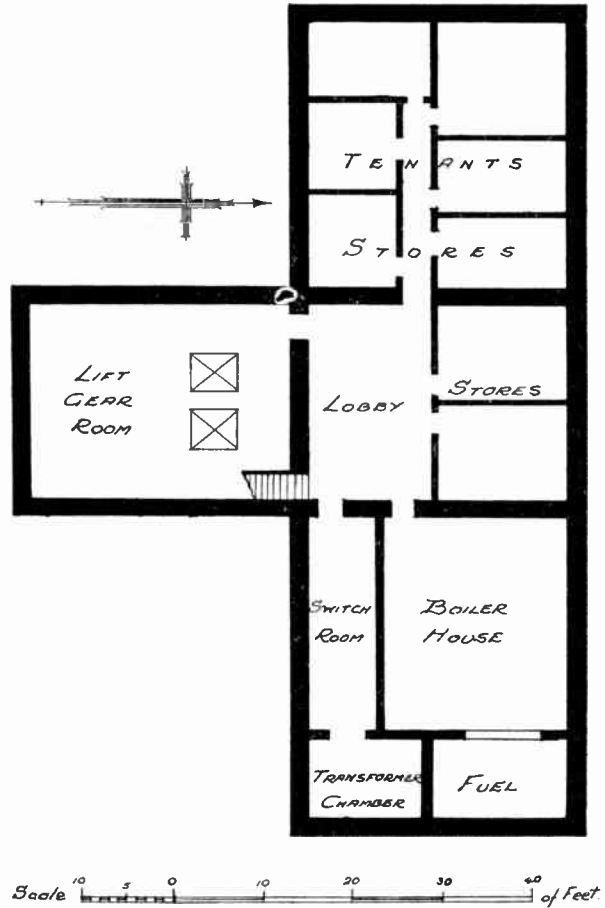

Fig. 13.—SUB-BASEMENT PLAN.

allowance must be made for maximum lighting.

If a sub-meter is required for the caretaker's flat, the bus bar of the seventh floor board can be split and the meter connected between the two sections of the bus bars.

The wiring diagram for the landlord's lighting is shown in Fig. 16.

### Staircase Lighting.

It will be noted that the staircase lighting is all arranged with two-way switch controls, thus allowing the caretaker to have light all the way up and yet leave all lights off as he makes his final tour of the building at night. Tenants on any floor can also then switch on their lights as they wish. Objection is sometimes made to this, the landlord preferring to have the whole of the staircase lights controlled only by the porter. If this is required, a master switch must be fitted at the ground floor and the distribution scheme modified to suit. In such a case this switch can, if desired, be of an automatic type arranged so that the caretaker can switch it on or off by push-button control from the seventh floor or the ground floor. There are many other variations that can be adopted, but it is always desirable to leave the caretaker with control at the top in any case so that he can have ample light for going up and down stairs after the offices are shut.

### LETTABLE AREAS.

The provision to be made for the lighting of the lettable areas remains to be considered, and in designing this section of the installation at the commencement of the scheme the difficulty arises of deciding what allowance must be made for the requirements of unknown tenants. Obviously the only thing to do is to make a suitable allowance in watts per square-foot of floor area and to calculate the probable loading on this basis.

### Location of Building.

In forming an opinion on this point two methods are practicable—one to work out the wattage required for a specimen area on an assumed standard of illumination and the other to base the loading on the requirements in similar buildings in the same neighbourhood. Both methods should be adopted as a check.

The second question—the location of the building—may be of very considerable importance. Higher standards of illumination or, alternatively, less efficient designs due to the use of special fittings will be required in very important areas, such as the heart of the City, than in outlying districts. In certain districts, also, it may be necessary to make allowance for special showroom lighting

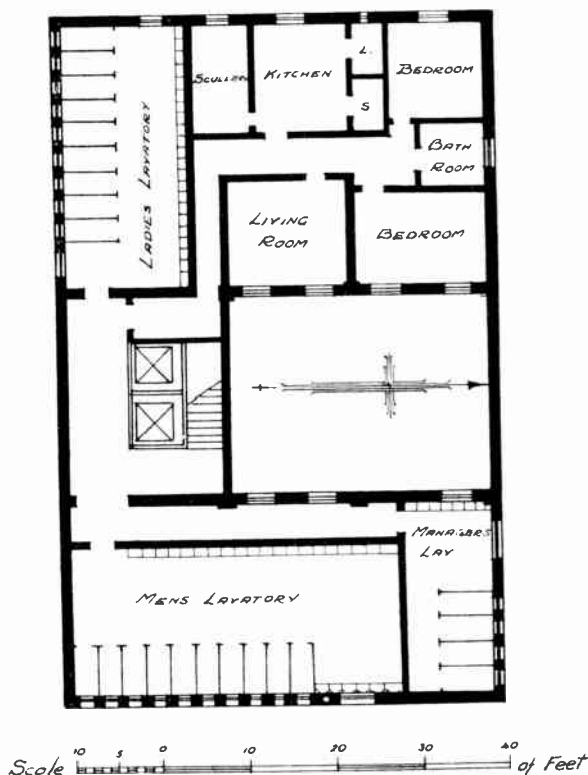

Fig. 14.—SEVENTH FLOOR PLAN.

with special fittings in display cases.

### Calculated Results.

If results are calculated, only rough approximations can be made. For example, the area west of the west corridor in Fig. 15 of the typical floor measures 14 feet by 76 feet or about 1,050 square feet. This might need illumination up to 8 candle feet, i.e., a total of 8,400 lumens. The class of fitting to be used is unknown, so that an efficiency of over 50 per cent. cannot be expected with certainty, thus

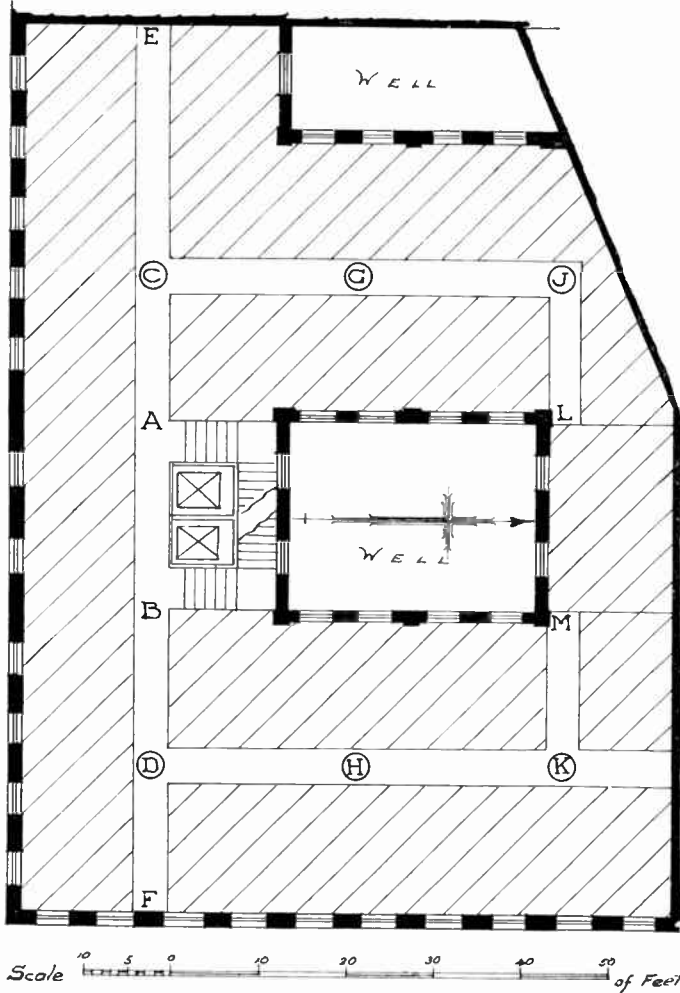

Fig. 15.—TYPICAL LETTABLE FLOOR. Showing arrangement of corridors.

The first scheme would certainly be impracticable, as the large lamps could not be spaced satisfactorily for effective lighting, whilst the second would also be unsuitable if only on account of the high cost of installation.

Some scheme between these two extremes would be adopted, whilst if the areas were sub-divided into private offices a much lower loading in watts per square foot would be sufficient. Unless it is anticipated that special lighting for showrooms or some similar purpose may be required, it should be safe to allow the loading per floor at the rate of 1½ watts per square foot.

The area of the typical floor shown in Fig. 3 is about 6,000 square feet, excluding the light wells and the space occupied by the lifts and staircases, and the allowance for tenants' requirements would thus be 9,000 watts or, say, 40 amps.

making the total lumens required about 17,000. So far the calculation is straightforward and fairly reliable, but the main difficulty arises in deciding how this total load is to be obtained from the lamps. It might be obtained from seven lamps each 200 watts and giving 2,600 lumens each, in which case  $7 \times 200$  or 1,400 watts would be sufficient or about 1.4 watts per square foot.

On the other hand, if small units of 40 watts were used, each giving only 316 lumens, the number required would be about 55 and the total watts,  $55 \times 40$  or 2,200, requiring well over 2 watts per square foot.

**Cable Sizes.**

The size of cable required for this load on I.E.E. rating would be 7/.064, which will carry 46 amps., but this must be checked for voltage drop. The voltage drop at 46 amps. is 1 volt for every 55 feet of conductor, whilst the length of the main up to the fourth floor is about 30 feet on plan to the pipe duct by the staircase and about 90 feet vertical.

The voltage drop will therefore be :—

$$\frac{110 \times 2}{55} \times \frac{40}{40} \text{ or under } 3\frac{1}{2} \text{ volts.}$$

This would leave about  $3\frac{1}{2}$  volts drop for the circuit wiring, etc., which will be

sufficient, so that 7/.064 mains will be suitable.

The slightly increased length of mains to the fifth and sixth floors will be more than balanced by the reduced areas which will be noticed from the section Fig. 4.

The cables would be run up to each floor and, on the three lower floors, connections taken across the landing to positions just inside the lettable areas through a two-way main fuse board, which must be sealable by the supply company.

On the upper floors similar main connections must be made, but provision must also be made for extending the wiring to the various separate tenancies into which the area may be divided. Probably the best method of arranging for this would be to extend the mains along the prospective corridor, leaving access boxes at suitable intervals so that connections can be made to suit the tenants. All such boxes must also be sealable by the company. The alternative to this is to run these tenants' services as required on the surface.

**Distribution System.**

The distribution system for the lettable areas can now be designed, and this should be considered with that for the landlord's. The whole installation must be balanced on the company's three-phase supply, so that the total load for the building must be considered. The details as calculated above are :—

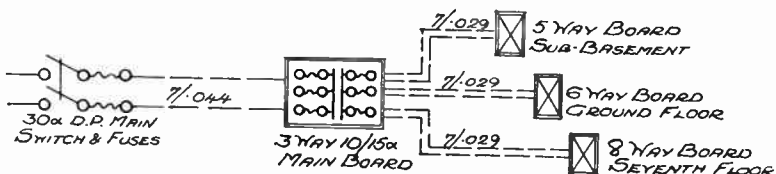

Fig. 16.—DIAGRAM OF CONNECTIONS FOR LANDLORD'S LIGHTING.

- Bank area—
- Total load .. .. 33 amps.
- Insurance company's area—
- Total load .. .. 60 amps.
- Landlord's lighting—
- Total load .. .. Allow 30 amps.
- Tenants' areas—
- First floor (half floor) Allow 20 amps.
- Second floor .. .. Allow 40 amps.
- Third floor .. .. Allow 40 amps.
- Fourth floor .. .. Allow 40 amps.

SCHEDULE 3.—LANDLORD'S LIGHTING.

Area.	No. of Points.	Fitting.	No. of Switches.	Position of Switch.	Watts per Fitting.	Total. Watts.
<i>Sub-basement.</i>						
Lift gear room ..	2	Pendants	2	Door .. ..	60	120
	2	Plugs	2	Near plug .. ..	40	80
Stairs up .. ..	1	Pendant	2 D.C.	Top and bottom ..	40	40
Switchboard room ..	2	Pendants	2	Door .. ..	60	120
	2	Plugs	2	Near plug .. ..	40	80
Transformer room ..	2	Pendants	2	Door .. ..	60	120
	1	Plug	1	Near plug .. ..	40	40
Boiler house .. ..	2	Pendants	2	Door .. ..	60	120
	2	Plugs	2	Near plug .. ..	40	80
Fuel .. ..	1	Pendant	1	Door .. ..	40	40
Lobby .. ..	1	Pendant	1	Door .. ..	60	60
8 stores .. ..	8	Pendants	8	Doors .. ..	60	480
Corridor .. ..	1	Pendant	1	End .. ..	40	40
<i>Basement.</i>						
Main landing .. ..	1	Pendant	2 D.C.	Top and bottom ..	100	100
Stores .. ..	2	Pendants	2	Doors .. ..	60	120

(Continued overleaf.)

## ILLUMINATION OF OFFICE BUILDINGS

SCHEDULE 3.—LANDLORD'S LIGHTING (*continued*).

Area.	No. of Points.	Fitting.	No. of Switches.	Position of Switch.	Watts per Fitting.	Total. Watts.
<i>Ground Floor.</i>						
Entrance hall .. ..	1	Pendant	1	By lift .. ..	300	300
Lobby .. ..	1	Pendant	1	By lift .. ..	100	100
Over entrance .. ..	1	Sign	1	By lift .. ..	100	100
<i>First Floor.</i>						
Landing .. ..	1	Pendant	2 D.C.	Ground and first floor .. ..	100	100
<i>Second Floor.</i>						
Landing .. ..	1	Pendant	2 D.C.	First and second floor .. ..	100	100
Lift well .. ..	1	Points for Lifts	—	—	60	120
<i>Third Floor.</i>						
Landing .. ..	1	Pendant	2 D.C.	Second and third floors .. ..	100	100
<i>Fourth Floor.</i>						
Landing .. ..	1	Pendant	2 D.C.	Third and fourth floors .. ..	100	100
Lettable corridors* ..	6	Pendants	2	Landing .. ..	60	360
<i>Fifth Floor.</i>						
Landing .. ..	1	Pendant	2 D.C.	Fourth and fifth floors .. ..	100	100
Lettable corridors* ..	6	Pendants	2	Landing .. ..	60	360
<i>Sixth Floor.</i>						
Landing .. ..	1	Pendant	2 D.C.	Fifth and sixth floors .. ..	100	100
Lettable corridors* ..	6	Pendants	2	Landing .. ..	60	360
<i>Seventh Floor.</i>						
Landing .. ..	1	Pendant	2 D.C.	Sixth and seventh floors .. ..	100	100
Manager's lavatory ..	7	Pendants	7	Doors .. ..	40	280
Men's lavatory .. ..	16	Pendants	16	Doors .. ..	40	640
Corridor .. ..	1	Pendant	1	End .. ..	40	40
Women's lavatory ..	13	Pendants	13	Doors .. ..	40	520
Corridor to caretaker ..	2	Pendants	2 D.C.	Ends .. ..	40	80
<i>Caretaker's—</i>						
Living room .. ..	1	Pendant	1	Door .. ..	60	60
	1	Plug	1	Door .. ..	40	40
2 bedrooms .. ..	2	Pendants	2	Doors .. ..	40	80
Bathroom .. ..	1	Pendant	1	Door .. ..	40	40
Kitchen .. ..	1	Pendant	1	Door .. ..	60	60
Scullery .. ..	1	Pendant	1	Door .. ..	40	40
Passage .. ..	1	Pendant	1	Door .. ..	40	40

\* Provision to be made on main cables.

Fifth floor .. .. Allow 40 amps.  
 Sixth floor .. .. Allow 40 amps.

Total for entire building .. 343 amps.

Phase B.—Second, third and fourth floors. Total = 120 amps.

Phase C.—Fifth and sixth floors and landlord's lighting. Total = 110 amps.

Very accurate balancing is not necessary and is, in fact, impossible with the scanty knowledge of the tenants' requirements that is available, and a satisfactory scheme would be:—

Phase A.—Bank and insurance company and first floor area. Total = 113 amps.

The scheme involves a complication that needs careful attention, viz., that the corridor lighting on the landlord's supply will be connected to phase C, whilst the general lighting in the lettable areas will be on phase B. In wiring great care must be taken to avoid the circuits being run so that two phases will be in proximity.

conductors being required only a four-core cable is necessary. Another is that if one tenant makes an excessive demand for current this may be balanced by a reduced demand from another. With a separate main to each floor no such adjustment is possible between various floors.

This is not of great importance for an ordinary lighting scheme, but if the mains also supply heating and power there may be very great advantage in this alternative.

**Complete Scheme for the Building.**

The complete scheme of distribution cables, etc., for the building can now be made out:—  
Main switches. — 3 (one per phase) each, say, 150 amps.

- Main cables.— $37/064$  for each phase suitable for about 130 amps.
- Main circuit switches—
  - Phase A 40 amps. for bank.
  - 60 amps. for insurance company.
  - 20 amps. for first floor lettable area.
  - Phase B 40 amps. for second floor do.
  - 40 amps. for third floor do.
  - 40 amps. for fourth floor do.
  - Phase C 40 amps. for fifth floor do.
  - 40 amps. for sixth floor do.
  - 30 amps. for landlord's lighting.
- Main cables, etc.—
  - For bank, as detailed in bank section above.
  - For insurance company, as detailed in insurance company's section above.

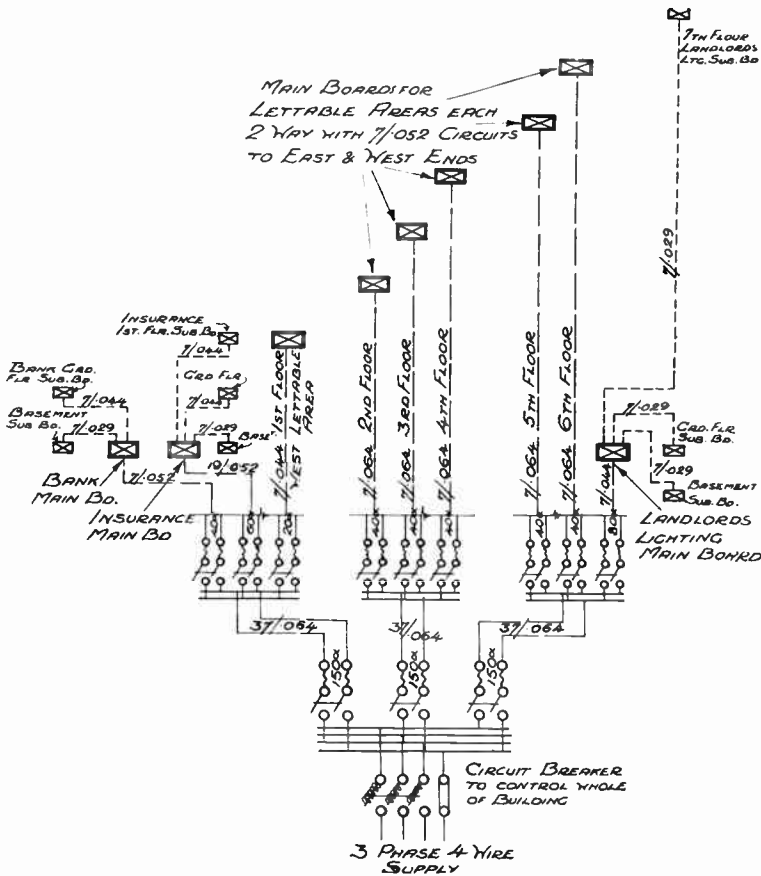

Fig. 17.—COMPLETE WIRING DIAGRAM FOR WHOLE OF BUILDING.

If the landlord's supply is kept in a separate tube and the switches fixed on the landings outside the lettable areas there is little risk of danger.

An alternative scheme would be to divide the landlord's lighting into separate sections, but this is probably not necessary if suitable precautions are taken in arranging the tube run for the circuits and in labelling or marking the phases for the various sections.

**Alternative Scheme for Tenants' Mains.**

Another alternative is to run the whole of the tenants' supply from a three-phase main. This has definite advantages. One is the saving in cost in that a common return on the neutral is provided so that, for example, instead of three pairs of

For first floor lettable area, 7/.044 cables, terminating in main switch inside area.

For other lettable floors, 7/.064 cables to each supplying two-way (scalable) main fuse board with sub-mains each 7/.052 into the two sections east and west of the building.

For landlord, as detailed in landlord's section above.

TABLE SHOWING LOADINGS ON VARIOUS FLOORS.

Floor.	Points.	Total.
Sub-basement	27	1,420 watts = 6.2 amps.
Basement	3	220 watts = 1.0 amps.
Ground	3	500 watts = 2.2 amps.
First	1	100 watts = .5 amps.
Second	3	220 watts = 1.0 amps.
Third	1	100 watts = .5 amps.
Fourth	7	460 watts = 2.0 amps.*
Fifth	7	460 watts = 2.0 amps.*
Sixth	7	460 watts = 2.0 amps.*
Seventh	40	2,020 watts = 9.0 amps.
Total	..	5,960 watts = 26.4 amps.

\* Including corridor lights.

### Wiring Diagram.

The complete wiring diagram can now be made out as shown in Fig. 17.

## QUESTIONS AND ANSWERS

**What two systems of lighting are generally employed in banks ?**

(1) General lighting adequate for all work in their main banking halls.

(2) Less general lighting combined with local lamps for each clerk.

**What is the great advantage of the first of the above systems ?**

Desks, etc., can be moved at any time without any need for alteration to the lighting; also the first cost should be appreciably lower.

**Under what conditions would the second system be better ?**

When there is a prospect of part of the staff being required to work during irregular hours.

**How many lamps should be provided for desk lighting ?**

One lamp for each 5 ft. run of desk should be allowed if 60-watt lamps are to be used.

**How would you effect a reduction if you found that the total voltage drop exceeded the I.E.E. allowance ?**

Either by reducing the load on the long circuits, or by increasing the size of wires used for circuit wiring on these circuits.

**Why should greater illumination be allowed for in basements which are to be artificially lighted during daylight ?**

Because they have to stand the contrast with direct daylight. People entering an artificially lighted basement from daylight require a high intensity of illumination to enable them to see reasonably well. For this reason from 25 per cent. to 50 per cent. extra illumination should be provided in rooms which are to be artificially lighted during daylight.

**What is the maximum current which can safely be carried by the following sizes of cables : 1, 7/.036 ; 2, 7/.044 ; 3, 7/.029 ; 4, 19 .052 ; 5, 3 .029 ?**

The above cables should have a maximum loading of :—

1, 24 amps.; 2, 31 amps.; 3, 18.2 amps.; 4, 64 amps. ; 5, 7.8 amps.



# ELECTRICAL MEASURING INSTRUMENTS

## AND THEIR USES

By KENELM EDGCUMBE, M.Inst.C.E., M.I.E.E.

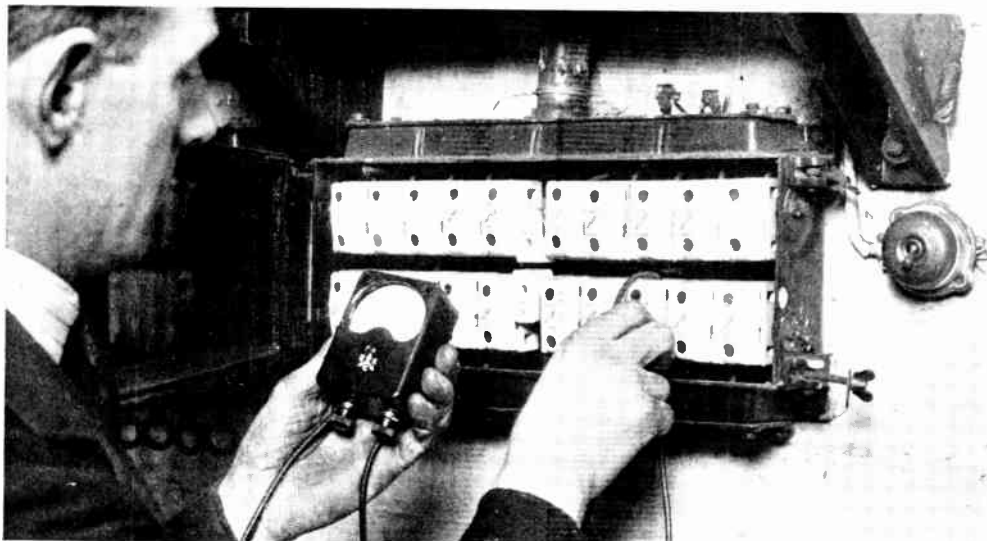

*Fig. 1.*—MEASURING THE CURRENT IN A BRANCH CIRCUIT.

The tester has removed the fuse from a fuse carrier and connected the ammeter across the two fuse terminals. This provides a rapid means of testing each circuit in turn.

**I**N the vast majority of cases the best answer to the question "How shall I repair this instrument?" is undoubtedly "Don't." Electrical measuring instruments are so delicate and their operating principles so diverse that their repair is in most cases work for the specialist, and it is far better (and in the long run, far cheaper) to return them to the makers for any necessary repair. At the same time, unless the engineer has a good knowledge of the internal construction of the instruments under his care, he cannot make the best use of them.

### Moving-Iron Ammeters and Voltmeters.

Fig. 2A shows the working parts of a typical 100-ampere moving-iron ammeter. The iron vane A, attached to the spindle, is, when in position inside the coil, opposite

a small fixed vane. The current flowing in the winding (of heavy copper strip) magnetises these two pieces of iron in such a way that they repel one another with a force which increases rapidly with the strength of the current. This repulsion causes the spindle to rotate against an opposing force exerted either by weight (gravity control) or by a flat spiral spring (spring control as shown at D). The reading, therefore, depends upon the value of the current, and the scale is marked off in amperes.

### Construction of a Voltmeter.

The construction of a voltmeter is similar, except that in place of a winding consisting of a few turns of comparatively large cross-section (Fig. 2A), it has a very large number of turns of fine wire

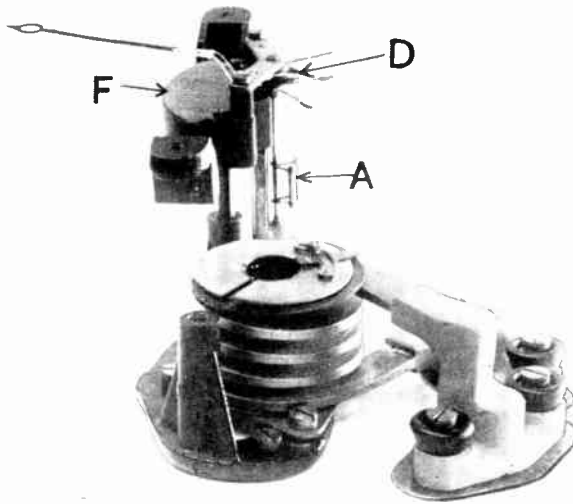

Fig. 2A.—A 100-AMPERE "SUPERSCALE" AMMETER WITH MOVING IRON WITHDRAWN.

(Fig. 2B), so that the same deflecting force is obtained with a current of perhaps 1/20 ampere (50 milliamperes). The form of coil shown in Fig. 2B is one which is employed particularly in "Precision" moving-iron instruments in which a flat iron vane is drawn into an oval coil. Whatever form of coil is used, an idle resistance is connected in series with it so that if the current flowing is 50 milliamperes at full scale, the total resistance of a 250-volt voltmeter would be 20 by 250 = 5,000 ohms. The idle resistance (or "swamp") must not vary with temperature, should have a resistance many times that of the copper coil, since otherwise the total resistance of the voltmeter will vary with temperature, and its accuracy will be impaired. In the voltmeter shown in Fig. 2B the idle series resistance represents 90 per cent. of the total, which is a very satisfactory proportion.

When the current or voltage changes rapidly it is most inconvenient if the pointer swings about violently, and the instrument should be "damped," as it is called, by a light paddle attached to the spindle and moving in an air-tight box (F in Fig. 2A).

Modern moving-iron instruments are extremely satisfactory and are largely replacing other types, not only for switch-

board mounting, but also for precision work.

**Moving-Coil Ammeters and Voltmeters.**

Fig. 3 shows a typical moving-coil instrument. The horseshoe permanent magnet A produces a strong magnetic field in the narrow gap between the pole pieces BB and the cylindrical core C, all of which are of soft iron. In this gap swings the rectangular coil W, which carries the current to be measured, and which is urged to turn round the pivot D with a force which, with a given magnet, is precisely proportional to the strength of the current. This twisting force is opposed by that of the spiral spring E, so that the deflection of the pointer P over the scale depends upon the current flowing through the coil W. The moving-coil arrangement is equally applicable to the construction of voltmeters, a resistance being then connected in series with the coil W in the same way as shown in Fig. 2B.

**When "Shunting" is Necessary.**

It is evident that only a very small current can be led into and out of the moving-coil W, since extremely flexible connections are essential. Consequently, if the current to be measured exceeds about 1/2 ampere, the instrument must be "shunted" as shown in Fig. 4, which is self-explanatory. For currents exceeding 30 amperes or thereabouts such shunts

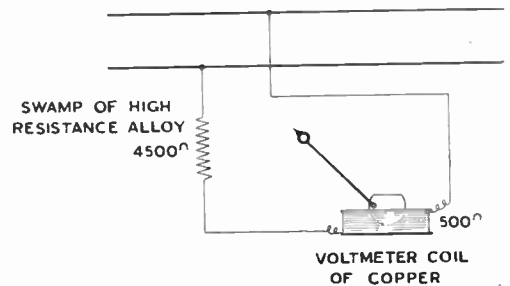

Fig. 2B.—CONNECTION DIAGRAM OF MOVING-IRON VOLTMETER.

Note the high ohmic resistance of the "swamp."

# RALPH STRANGER'S WIRELESS BOOKS

*The Wireless Library for the  
Man in the Street:*

MATTER AND ENERGY  
ELECTRONIC CURRENTS  
ELECTRIFIED MATTER  
MAGNETISM AND ELECTRO-  
MAGNETISM  
THE MATHEMATICS OF WIRELESS  
BATTERIES AND ACCUMULATORS  
SEEING BY WIRELESS (TELEVISION)  
MODERN VALVES  
WIRELESS COMMUNICATION AND  
BROADCASTING  
WIRELESS WAVES  
HOW TO UNDERSTAND WIRELESS  
DIAGRAMS  
SELECTION OF WIRELESS SIGNALS  
DETECTION OF WIRELESS SIGNALS  
AMPLIFICATION OF WIRELESS SIGNALS  
REPRODUCTION OF WIRELESS SIGNALS  
WIRELESS RECEIVING CIRCUITS  
WIRELESS MEASURING INSTRUMENTS  
THE BY-PRODUCTS OF WIRELESS

**SOME PRESS OPINIONS:—**

"The new shilling library aims at giving the wireless enthusiast a sound theoretical and practical grip of his subject. The author employs clear and simple language, and starts practically from zero."—*The Broadcaster*.

"These books deal with a highly technical subject in the simplest language which enables those who have no scientific training to grasp the wonders of wireless, and assist the listener to get the best possible results from a receiving set."—*Railway Review*.

**ONE SHILLING EACH**

By Post 1/2 each.

## THE MATHEMATICS OF WIRELESS

This book is essential for the wireless amateur who desires to gain a fuller knowledge of his subject. Written by one who has the gift of explaining abstruse matters in a simple fashion, it will enable its readers to attempt research and experiments which at one time were far beyond their powers. Fully illustrated.

**3/6, by post 3/9**

## WIRELESS: THE MODERN MAGIC CARPET

Fourth and Revised Edition

If you know nothing about wireless and do not even possess a receiving set, this book will show you how to provide yourself with an interesting and absorbing hobby. If you are a listener, but rather weak on the technical side, it will save you much unnecessary worry and expense. If you wish to experiment, this volume will provide you with valuable experimental data. If you are an expert and have to lecture, it will give you some useful lecture material.

**3/6, by post 3/9**

On sale at all Newsagents, Bookstalls and Bookshops, or by post from **GEORGE NEWNES, Ltd., 8-11, Southampton Street, Strand, London, W.C. 2.**

Geo. Newnes, Ltd.

*This article on Electrical Measuring Instruments is continued in Part 24. Ready March 22nd. Order your copy to-day.*

---

# Save Money

---

## BY GROWING YOUR OWN FOOD

Owing to the new import duties it will be almost impossible for foreign produce to sell in our markets, and home-grown produce must take its place. Home-grown vegetables, fruit and home-produced eggs and poultry are far nicer than bought. You can make room in your garden to raise a plentiful supply. Every week **THE SMALLHOLDER** is full of suggestions for all who would save money with home-grown produce. It not only tells you what to do but how to do it by simple action photographs. Be sure to get this week's

# THE SMALLHOLDER

**GARDENER & POULTRY KEEPER**

*Now on Sale . . . . . Twopence*