

To be Completed in about 32 weekly parts.

NEWNES PRACTICAL ELECTRICAL ENGINEERING

DEALING WITH
ALL PRACTICAL
APPLICATIONS OF
ELECTRICITY IN
EVERYDAY LIFE.

INTENDED FOR
ELECTRIC LIGHTING
and
POWER ENGINEERS.
ELECTRICIANS AND
WIREMEN.
WIRELESS DEALERS
STUDENTS,
APPRENTICES AND
IMPROVERS IN ALL
BRANCHES OF
THE ELECTRICAL AND
WIRELESS INDUSTRIES.

1 1/2

PART
10

A PRACTICAL WORK WRITTEN BY EXPERTS

STUDY
AT
HOME

FOUNDED 1900.

31 YEARS OF SUCCESS.

IN
YOUR
SPARE
TIME

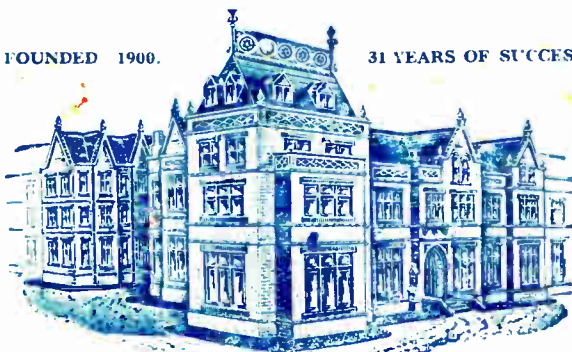

THIS IS THE BENNETT COLLEGE - - ALL OF IT

The Bennett College is not a Rented Room in a well-known street—it is a College. Over 30 years ago the Founder took as his motto what has now become a household slogan :

LET ME BE YOUR FATHER

In many trades and professions there are more vacancies than trained men to fill them. We do not profess to act as an employment agency, but our gigantic organisation certainly does tell us where the demand exists, thus enabling us to give FATHERLY ADVICE ON ALL CAREERS AND THE POSSIBILITY OF EMPLOYMENT, FREE.



J. Bennett

WE TEACH ALL BRANCHES OF THE FOLLOWING VOCATIONS AND SPECIALISE IN ALL EXAMINATIONS CONNECTED THEREWITH.

THE MOST SUCCESSFUL AND MOST PROGRESSIVE CORRESPONDENCE COLLEGE IN THE WORLD

Aviation Engineering.
Boiler Engineering.
Boiler Making.
B.Sc. (Engineering).
Civil Engineering :
A.M.I.C.E.
Quantities—Specification.
Commercial Art

Concrete and Steel.
Draughtsmanship :
Electrical or
Mechanical.
Electrical Engineering :
A.M.I.E.E.
City and Guilds.
Engineering Mathematics.
Foundry Work.
Heat Engines.

Heating, Ventilating and Lighting.
Internal Combustion Engines.
Machine Designs :
Theory of Machines.
Marine Engineering :
Motor.
Steam.
Mechanical Engineering :
A.M.Inst.B.E.
A.M.I.Mech.E.
City and Guilds.
Pattern Making.

Mechanics.
Metallurgy of Steel.
Mine Electrician :
A.M.E.E.
Mining (all examinations).
Motor Engineering :
A.M.I.A.E.
Municipal and County Engineers :
M. and C.E.
Naval Architecture.
Pumps and Pumping Machinery.
Ship Building.
Structural Engineering.
Telegraphy and Telephony.

IF YOU DO NOT SEE YOUR OWN REQUIREMENTS ABOVE, WRITE TO US ON ANY SUBJECT.

IT COSTS NOTHING TO ENQUIRE.

Also ask for Our New Book (FREE OF CHARGE)

THE HUMAN MACHINE

SECRETS OF SUCCESS

WE TEACH BY POST IN ALL PARTS OF THE WORLD

Note Address Carefully :

The BENNETT COLLEGE, Ltd., Dept. 119, Sheffield



with all shunt-wound dynamos having outputs of 50 amps. and upwards.

CONNECTIONS TO THE DYNAMO.

It will be noticed that there are three terminals on the dynamo—positive, negative and neutral. The relation of the neutral to either of the other two is always opposite: i.e., neutral is always negative to the positive and positive to the negative.

How the Barrels are Connected.

The barrels are connected across the *outer* terminals—that is, directly to positive and negative, thus getting the maximum voltage of the two armatures in series.

Position of the Still Vats.

The still vats are connected between the neutral and the positive and between the neutral and the negative, care being taken to see the load is balanced as near as possible on both sides.

How to Connect the Armatures of the Dynamos in Series.

Assuming that the load is equally balanced it will easily be seen that no current will pass along the centre lead or conductor, but as this happy state of affairs is rarely attained, it is usual to have the neutral conductor with a cross sectional area equal to half that of the outer or main conductors. Any double-commutator machine can be connected up in this manner, but it may be necessary to alter the dynamo connections, because, in many cases, the dynamo is connected

to give the output of its two armatures in parallel, whereas for the three-wire arrangement, it must have its two armatures connected in series; the alteration is a very simple one—one brush rocker must be moved one pole forward or backward, and the field coils must be connected across one armature only.

THE PLATING VATS.

Plating vats vary according to the solutions they are intended to hold. Generally for nickel, silver, cold brass, cold copper, and cold zinc solutions, wooden vats are used, lined with chemically pure lead, with burnt joints, and except for silver again lined with matchboarding to protect the lead lining from mechanical damage. For larger quantities of silver solution welded iron vats can be used lined with cement or lead (with no matchboarding), whilst for small quantities, iron vats lined with a special enamel are suitable. For hot solutions of brass, copper and tin, welded iron vats are used.

When an iron vat is used, a wooden frame should be fitted on the top to carry the insulators and prevent contact with the vat.

Tubes and Rods for Vats.

Plating vats are fitted with brass tubes or rods for carrying the anodes and the articles to be plated. These tubes must rest on earthenware or porcelain insulators, screwed to the vat at equal distances to prevent leakage due to the wood becoming saturated with solution.

These may be fitted either lengthwise or across the vats.

When Three Rods are Used.

If three rods are used the two outside are generally used for the anodes, and the centre one for the articles to be plated. If five rods are used, the two outside and the centre one carry the anodes and the other two carry the articles. Any number of rods may be used, however, so long as the articles to be plated have sufficient room, and the anode area and bulk of solution and dynamo power are suitable.

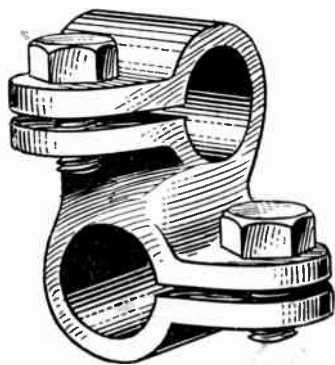

Fig. 13.—A HEAVY ROD CONNECTOR.

The connections to the vat from the main leads are usually made by means of insulated cable. The cable should be capable of carrying the quantity of current taken by the vat when fully loaded.

The cable is connected to the vat rods by means of brass connections clamped to the rods. The connections shown in Fig. 13 are suitable for currents up to 100 amps.

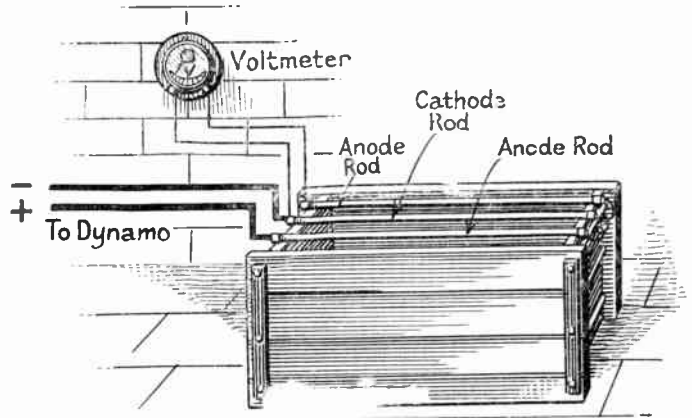

Fig. 14.—How to Connect a Voltmeter to a Vat.

Resistance Boards.

Place the resistance board close to the vat, so that the lever is easily accessible, but choose a position where it will not be subjected to steam if hot solutions are used. One terminal of the board should be connected by cable to the cathode rod of the vat, and the other terminal should be connected to the negative lead rod (see Fig. 2).

Voltmeters.

Where several vats are used a voltmeter should be provided for each, and fitted close to, or on, the resistance board, so that it can be easily read by the operator.

As shown in Fig. 14, the terminals of the voltmeter should be connected by thin insulated wire, 24 to 26 S.W.G., to the positive and negative cables, at the vat terminals. This is important, as, if connected in any other way, the voltmeter will not indicate.

Using One Voltmeter for Several Vats.

One voltmeter can be used for measuring the voltage at the terminals of any number of vats. The number of studs must at least equal the number of vats, of which readings are to be taken. The voltmeter placed near the dynamo registers the voltage at the dynamo terminals, but this is not necessarily the same as the voltage at the vat terminals, as the resistance board and conductors cause a certain drop or loss.

For small plants with one nickel and one copper vat, it is better to place the

voltmeter above the nickel vat, as the voltage at the copper vat is not so important. A pocket voltmeter is a very useful instrument in the plating shop; being of the watch type it is very convenient for rapidly testing vat voltages.

What an Ammeter Shows.

Ammeters measure the quantity of current in amperes flowing in a circuit. It is advisable to have one of these instruments connected to each vat, to show the quantity of current which is flowing through the vat, the voltage being no guide to this.

The ammeter only indicates the quantity of current being actually consumed; thus, if a dynamo with an output of 100 amperes is the source of the current, but only 50 amperes are being used in the circuit in which the ammeter is connected, the ammeter will only register 50 amperes.

Unlike the voltmeter, the ammeter is a very low resistance instrument, and is connected as in Fig. 15, so that the whole current in the circuit passes through it.

The ammeter and resistance boards are usually connected in the negative lead, merely for the sake of uniformity in fitting up.

THEORY, FACTS AND FIGURES FOR THE PRACTICAL MAN.

The craft of the electro-plater is based on the laws of electrolysis and at least a little knowledge of these is desirable

in any electrician before he can usefully intervene in the plating shop.

What the Electro-Plater Does.

The electro-plater's task may be put thus :—

It is to separate a particular metal from the solution of one of its salts by the aid of the electric current, and to deposit it, in a firmly adherent form, upon a selected article.

The work of Michael Faraday in 1831 made this feasible and the invention of the low-voltage dynamo made it practicable.

Properties of Conductors.

Chemical substances can be divided into classes according to the electrical conductivity. Copper, silver and iron may for example be called conductors even though they differ in degree of conductivity. Sulphur, glass, rubber, may be termed non-conductors though their insulating properties are graded.

The conductors again are capable of sub-classification ; some conduct with no chemical change in their constitution (e.g., copper, mercury) and others suffer actual decomposition or change of state as and because they carry a current.

The latter substances are of particular interest to the electro-plater.

An Experiment Showing Effect of Electric Current on Metal.

A single experiment may make things clearer :—

One oz. of metallic copper may be

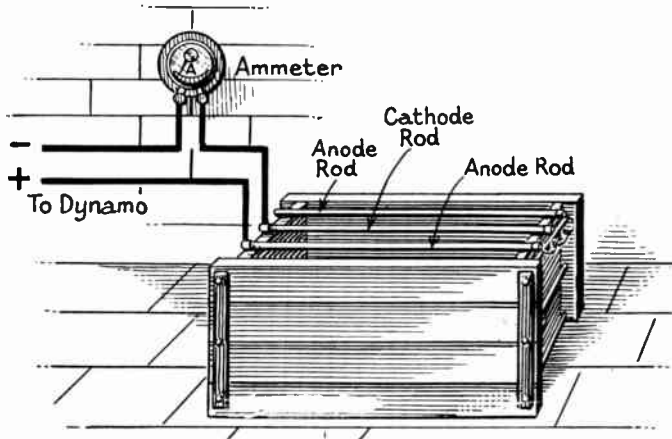

Fig. 15.—HOW TO CONNECT AN AMMETER TO A VAT.

converted (with difficulty) by the use of sulphuric acid into the blue crystalline substance called "Copper Sulphate." This chemical, supremely unlike either copper or sulphuric acid, contains nothing else but these materials and a definite amount of water. It has lost both the characteristic "metal" appearance, texture and colour of copper and the acid reactions of the sulphuric acid. It dissolves readily in water.

We have now dissolved our ounce of copper in the form of copper sulphate in a pint of water, and hold the blue liquid in a jar. The wires from the two terminals of a 2-volt accumulator or battery can be attached to two suitable pieces of metal—say a tea-spoon to the negative wire, and a copper disc to the positive wire. If these articles are hung in the prepared solution it will be observed that the spoon becomes immediately covered with copper.

Several other things, not so obvious, happen too. Not only is copper deposited at the negative pole of the circuit (the cathode) but sulphuric acid, hitherto combined with the copper is released at the copper disc at the positive pole (the anode).

This acid attacks the copper, and if conditions are suitably adjusted, dissolves it to exactly the degree required to keep the copper sulphate content of the solution constant.

If an insoluble anode be used—carbon or platinum for example instead of a copper one, the process of elimination of the copper can be continued until *all* the copper is deposited, the solution becomes water-white, being in fact, only water and sulphuric acid. In this case exactly the 1 ounce of metallic copper will be recovered with which the experiment started.

What Happens When a Plating Bath Becomes Impoverished in Metal.

The latter case is of

great practical importance to the electro-plater because of its implications. When a plating bath becomes impoverished in metal, as it may for several causes, the current is partially carried by the acidulated water and that, too, is split. The component hydrogen—which is a metal from the electro-chemist's point of view—is liberated at the cathode with very disastrous results to the appearance and physical properties of the deposit.

What a Well-balanced Plating Solution Does.

A well-balanced plating solution, working under the correct current conditions should, however, decompose the minimum of the solvent and liberate the minimum of gas. The ideal solution deposits on the cathode *a weight of metal directly proportional to the strength of the electric current used and the time.*

This last is a paraphrase of Faraday's first law.

Weight of Metal Deposited.

The actual weight deposited varies, of course, with the actual metal in question and below are a few representative ones :—

Metal.	Weight deposited per hour with a current of 1 ampere.
Copper (from a sulphate solution) ..	1.1832 grammes.
Silver	4.025 ..
Gold	7.356 ..
Nickel	1.094 ..
Tin	2.218 ..
Zinc	1.22 ..

Thus from an acid copper solution 10 amperes will deposit $1.1832 \times 10 = 11.832$ grammes of copper in one hour.

Or 5 amperes will deposit the same weight of metal in 2 hours.

Importance of Current Voltage.

Not only, however, does the amount

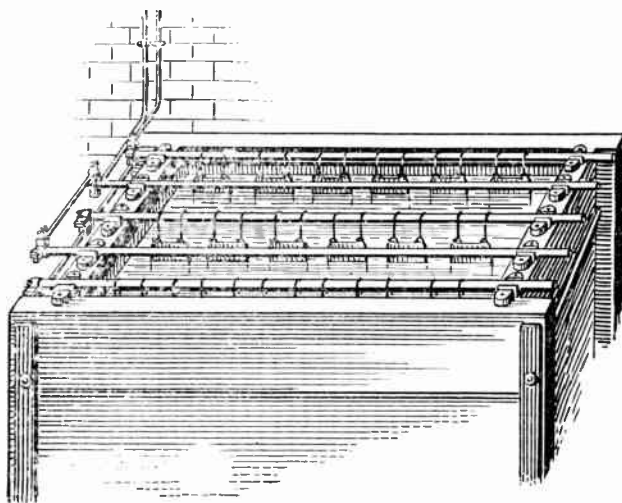

Fig. 10.—A LEAD-LINED WOOD VAT.

Showing the method of fitting rods, connections and insulators.

of the current passing directly affect the amount of the metal deposited, but the pressure, measured in volts, greatly affects the nature of the deposit. The majority of electro-plating is carried on at low voltages which need to be critically adjusted. Below are a few typical cases :—

Type of Solution.	Average Voltage.
Brass (Cyanide solution) ..	3 —4
Copper (Cyanide solution) ..	2 —3
Copper (Sulphate)	1 —2
Gold (Cyanide)	2 —6
Nickel (Sulphate)	1 —2½
Silver (Cyanide)	¾ —1
Zinc (acid)	2½ —3

All these figures are for solutions working at the normal temperature and conditions, but it is possible and often desirable to depart from them considerably. The temperature modifies profoundly the conductivity of the solutions and also the permissible current (measured in amperes) for a unit surface. Agitation, too, affects the current conditions, because it ensures that no portion of the solution, and especially that lying immediately between anode and cathode, is impoverished of metal. In general, warmed

and agitated solutions can carry a higher current density (amperes per square foot of cathode) than still and cold solutions of the same type.

Voltage for Barrel Plating.

Barrel plating, too, demands special voltage conditions. "Barrels" are in general types of apparatus often selected for the plating of small articles such as nuts, screws, rivets, etc., which cannot be profitably wired to the cathode rods. The work is placed in a receptacle and makes its contact with the negative pole of the current supply by its own weight. The barrel is then rotated so that every portion of the work is exposed to the anode.

This motion in many cases has the secondary purpose of burnishing the surface as it is plated.

The voltages demanded for barrels are generally much higher than that required for "still" vats, mainly because of the higher resistance (due to the indifferent contact and nature of the container) of the internal circuit. Typical barrel voltages are:—

Solution.	Voltages.
Brass	6—10
Copper	6—10
Nickel	6—8

ELECTRO-PLATING PROCESSES DESCRIBED IN DETAIL.

Before any article comes into the plating shop it has to be properly prepared. The drastic pickling, grinding, polishing, etc., that may be necessary is outside the function of this work. It is necessary to emphasise this point: the success of the actual plating operation, the beauty, lustre and adherence of the deposit depend almost entirely on the thoroughness and success of the preliminary treatment of the metal. In general, the polish of the finished article will never be better than the polish of the base metal.

After the work has been polished it enters the plating shop. There it is "wired up," i.e., attached to one or two strands of copper wire (22 gauge) about 18 inches long. By means of this wire the work is manipulated, and finally

suspended in the plating solution. After cleaning the work the surface should never be allowed to be touched by the hands or clothes of the operator.

Cleaning.

The cleaning apparatus is very simple, but very important. When the electrician finds cases of bad adherence between the deposit and the base metal, it may, in the vast majority of cases, be traced to inefficient cleaning.

The cleaner is best contained in a plain welded iron tank which is heated over gas. The solution may be made by dissolving about 8 oz. of "brown potash" per gallon of water; but better and less harsh proprietary cleaners are now readily obtainable. They are all of the same nature. They are all alkaline and obtain their results by changing the animal and vegetable greases on the work to a water-soluble soap.

The electrician can immensely improve his client's cleaning process by a simple device. The iron tank may be wired direct to the open positive main of the plating dynamo (6-10 volts). An insulated brass rod over the tank should be connected through a single-throw knife switch to the negative lead. Any work now hung from the rod in the cleaner becomes cathode in the circuit and the gas generated freely on the surface sweeps away any grease and dirt very rapidly and effectively.

Whether worked electrolytically or not, the cleaner should be used as near boiling as possible.

After the articles have been immersed in the cleaner for some minutes they are taken out and quickly swilled in a suitable trough of clear running water, carefully inspected for grease, and if not perfectly clean, rapidly mopped with a cotton mop and returned to the cleaning tank.

A Test for Cleanliness.

An accurate measure of the cleanliness of the metal is the *wetting* of the article by the water; that is, the water should be a continuous unbroken film all over the surface, and in no place should it run dry.

Special precautions must be taken when the metals treated are zinc, aluminium,

lead and tin, since all these metals are attacked by the alkaline cleaner, and the polish may be impaired. In extreme cases the metal dissolves away completely.

An Electrical Cleaning Process for Iron and Steel.

Modern practice submits iron and steel to another electrical cleaning process before nickel-plating. In this process the vat itself—which is of wood, lead lined—is made the cathode and the work of the anode of the circuit. The open circuit of the plating dynamo is used exactly as for the alkaline cleaner. The current used is at the onset rather considerable, but the amperage rapidly falls and in a couple of minutes drops to nearly zero. This is an indication that the operation is finished. The work is then taken out, rapidly and thoroughly swilled and immediately transferred, while still wet, to the nickel bath.

The special advantages of this process are as follows: It removes all traces of rust, of the incipient oxide formed after the alkaline cleaner, and it lightly etches the polished surfaces, thus providing a key for the deposition of nickel.

This operation eliminates any necessity for scouring and practically ensures that the nickel will be closely adherent.

The solution used for this process is best made of:—

Sulphuric acid	..	60° B.
Chromic acid	..	1 oz. per gallon

After cleaning, non-ferrous metal should in general pass through the proceeding operations:—

1. Swill.
2. Dip for a few seconds in a weak solution of potassium cyanide.
3. Swill.
4. Dip in a solution either of weak sulphuric acid or in a solution of cream of tartar, 1 oz. to a gallon of water.
5. Swill.
6. Direct to nickel solution.

Iron and steel, if acid cleaned (see above), will not need this process. It *will* need the acid dip (Item 4) if the acid cleaning is omitted.

NICKEL-PLATING.

Plant Necessary.

The vat used is invariably of wood, lead lined, with burnt joints and again lined with matchboarding, to protect the lead from mechanical injury. Very modern equipments include agitating units, automatic filtration and heating by electric heaters.

Solutions.

The solutions used differ very considerably in details. Years ago a simple solution of double nickel salts (nickel ammonium sulphate), 12 oz. per gallon of water, was the standard one. Now it is generally accepted that a mixture of single nickel salts with a small quantity of sodium chloride and boric acid is far superior to the older formula.

How to Test the Nickel Bath.

The acidity of a nickel bath must be carefully controlled. When correct it should turn a blue litmus paper a sullen red and not affect a red litmus paper at all. The acidity is best checked with a "comparator," that is, an instrument that gives the "*pH*" (hydrogen ion concentration) directly by colour changes. However determined, sulphuric acid should be added to the solution if it reacts alkaline. About 1 oz. of pure acid should be added to every 20 gallons of solution, and this repeated until the acidity is correct.

If, on the other hand, the acidity of the bath is excessive, nickel carbonate is best added to the solution, or, failing this chemical, pure liquid ammonia. All these alterations should be made with the greatest care, since the smallest additions have considerable effect.

Electrical Conditions for Successful Nickel-plating.

Still nickel vats work generally at from 1½ to 2 volts. Agitated baths can be worked at higher voltages. The amperage per square foot of work surface varies considerably with the type of solution employed, and its conditions as to temperature, agitation, etc.

With the old double nickel solution, cold, a current density of about 3 amperes per square foot could never be exceeded, and this produced a thickness of nickel of about 0.00015 inch of nickel per hour. The modern single nickel solution, warmed and agitated and filtered, works at from 30-40 amps. per square foot, and attains about .001 inch of nickel in 30-40 minutes.

Nickel-plate that is intended to be the undercoat of chrome-plate should have a minimum thickness of .001 inch.

Faults in Nickel Solutions and How to Correct Them.

The following charts should enable the electrician to give some assistance to the plater. These observations are based as far as possible, not on chemical analysis, but on the appearance of the imperfect work, the behaviour of the anodes, etc.

Appearance of Work, etc.	Causes.	Remedies.
Nickel strips away from base metal.	(a) Bad cleaning. (b) No acid dip used. (c) Current interrupted. (d) In repair work previous nickel coat not completely removed. (e) Bath too acid. (f) Bath too alkaline.	Clean out cleaning tank, examine water swills, etc. Do not handle work. Supply one (see page 431). Test all connections, look to cleanliness of anode hooks, etc. Test dynamo belt. All old nickel must be removed before replating; or copper-plate over. Add nickel carbonate (see page 431). Add sulphuric acid, (see page 44b).
Deposit very dark.	(a) Too high current density. (b) Contamination of solution with zinc or copper	Reduce voltage. Neutralise acidity of bath. Then work <i>hard</i> for some days on scrap metal as cathode.
"Pinholes."	Bath too acid.	See above.
Nickel not deposited.	Current reversed.	Correct connections and then work on scrap as above.

CHROME-PLATING.

The important commercial applications of this process make it necessary to deal with it in some detail.

The Nickel Undercoat.

The best practice is to deposit chromium on a preparatory deposit of nickel, and this nickel coat should be of the best quality, firmly adherent, of good texture,

free from pinholes or porosity, not less than .001 inch thick, and highly polished. If this undercoat complies with the above conditions, most of the troubles often experienced in the actual chrome deposition will be eliminated.

Board of Trade Regulations.

Since chrome-plating solutions give off a noxious vapour while working, Board of Trade regulations demand a very efficient exhaust system. This is most readily obtained by ducts placed round the plating vat at a height of not more than 8 inches above the surface of the solution. These ducts lead into a liquid trap, which in turn is exhausted by a fan placed as high as possible with a vertical discharge pipe rising at least 6 feet clear of the roof. The ducting should be made of 18 gauge sheet iron and all joints should be well packed with asbestos, white and red lead and gold size.

The Vat.

The vat itself is of iron, lined with hard lead (lead alloyed with 8 per cent. anti-mony). The anodes used are of the same alloy. The vat is glass lined in order to shield the work from the anodic influence of the metal lining.

Many chrome tanks are water-jacketed, the better to maintain the constant temperature (95-98° Fah.) which is conceded to be the most favourable for a bright deposit.

Plating Solutions for Chromium-plating.

Chrome solutions work at voltages of from about 4 to 5 volts, and take a rather high current—from 60 to 80 amps. per square foot. This means, of course, a rather large capacity motor generator to supply current to the larger vats, and every care must be taken to ensure that all conductors and leads are massive enough to take the current required (see page 432).

No hints as to the care of the solution are possible, since it should be the subject of the attention of specialised chemists, but it will be found that most of the trouble experienced with the process is either electrical or mechanical. On the electrical side little remains to be said:

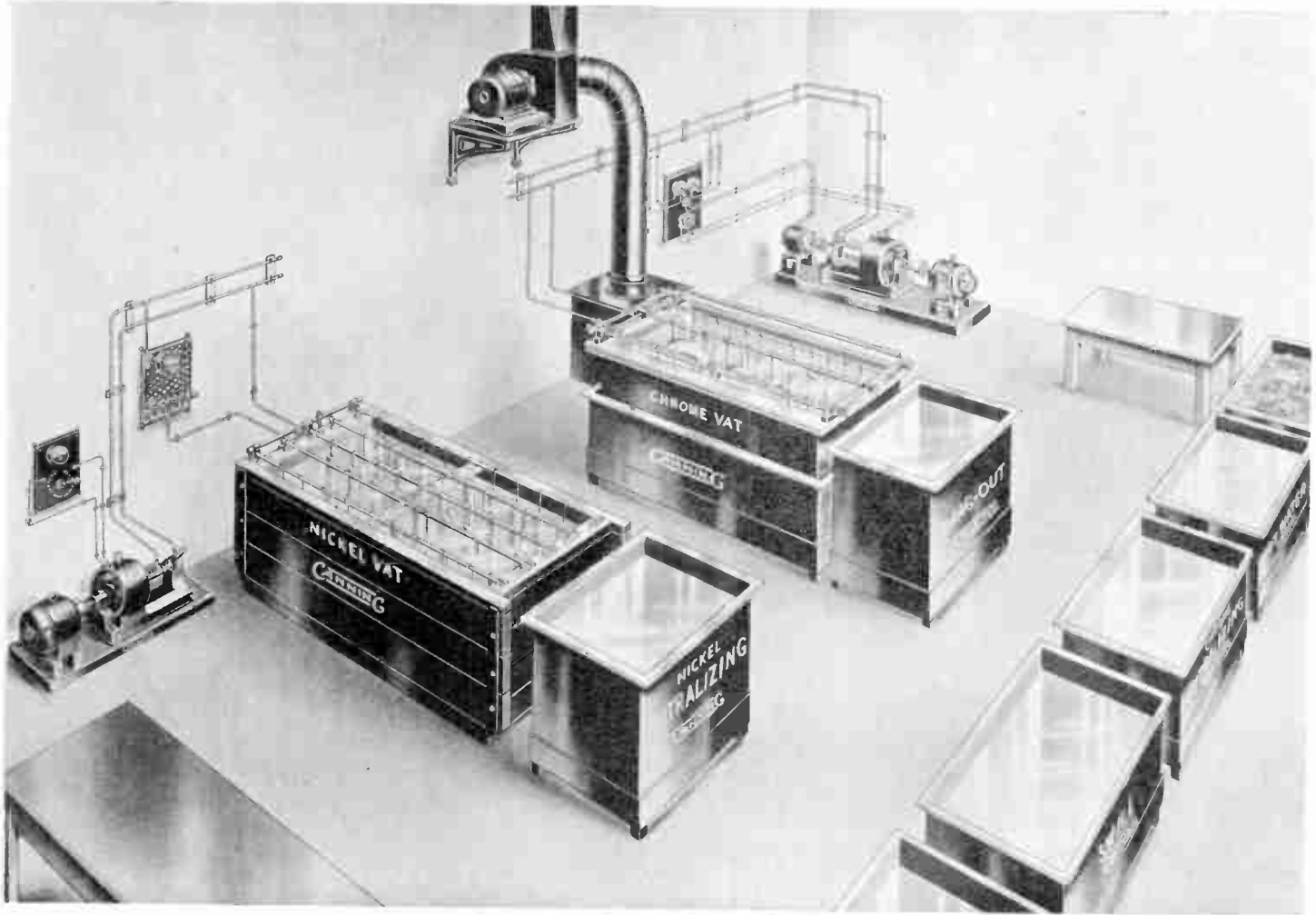

Fig. 17.—CHROME AND NICKEL PLANT.
Showing arrangement of auxiliary tanks, swills, etc.; also the position and fixing of resistance boards and meters.

a voltage should be used sufficient always to maintain a fairly vigorous gassing round the work. Nickel-plated work when polished and finished with dry lime can be taken into the bath without cleaning, but should be allowed to remain in the solution with a low applied current at about 2 volts pressure for a minute or so; the voltage then being raised for the full plating time (generally for from 10 to 20 minutes) to the proper pressure that experience proves best for that particular shape and size of article.

When brass, copper or nickel silver is to be plated direct, the full normal voltage is applied at once and maintained for the full duration of the plating—about 30 to 40 minutes in the absence of the nickel undercoating.

The chief mechanical problems presented come intrinsically from the comparatively low "throwing power"—that is, its capacity for plating in recesses is small in even the best solution.

Awkwardly shaped articles have to be surrounded with anodes, so that as far as possible they follow its contour, and bring all parts of the plating surface under their influence. In most cases this is best done by the use of suitable cross rods from which anodes can be hung.

A considerable amount of gas is liberated in the operation of plating, and if the gas is retained in any "pocket" of the article no chromium will be deposited in or around the pocket. The work should be so hung that there is no opportunity for gas-locked pockets.

All open joints of the work from which gas may be forced should be closed. This is best done by wood plugs; cork, plastic wood or plasticine being used as the case demands.

Intimate contact of the article with the cathode rod is of the greatest importance.

Wherever possible, the connecting wire or (better) copper rod should be actually screwed into any convenient hole in the work. Special racks for repetition work are very desirable.

COMMON FAULTS IN CHROME-PLATING AND HOW TO AVOID THEM.

Fault.	Cause.	Remedy.
Stripping of deposit.	All cases of stripping are the parting of the under-coat of nickel from the base metal. The nickel is under strain after chroming.	See to cleaning of metal before nickelling (see page 445). Reduce current density in chrome.
Missed and patchy deposits.	Too high a temperature.	Adjust.
	Too low a current.	Raise the current a little, but avoid burning on the high parts. Clean and test connections.
	Dirty connections. Articles shielding one another. Anodes too far from one portion of the work.	Space out on cathode rod. Arrange anodes.
Dull and burnt deposits.	Too low a temperature or too high a current.	Adjust these conditions.
	Anodes too near.	Adjust.
Dull patches only.	Grease left on work.	Avoid touching work after it is polish d.

COPPER-PLATING AND ELECTRO-TYPING.

When it is desired to deposit copper electrolytically direct on to iron and steel, a cyanide solution of the metal is always used, but certain non-ferrous metals can be plated directly with copper to any desired thickness by the following solution:—

Copper sulphate	2 lb. 2 oz.
Potash alum	2 oz.
Sulphuric acid	5 fluid oz.
Water	1 gallon

All the chemicals used must be of the best commercial quality, and particularly free from arsenic.

The solution should be contained in a similar vat to the one described for nickel, and the connections and general conditions of working are identical, except that, of course, copper anodes are used instead of nickel.

Current conditions: an applied voltage of 2 volts across the anode and cathode rods will give a current density of 10-15 amps. of cathode surface when the bath is worked as a still solution.

If, however, agitating devices are fitted to the solution, very much higher current densities may be safely used and consequently much time may be saved.

Troubles in Copper-plating.

Fault.	Cause.	Remedy.
Rough deposits: anodes very bright.	Excessive acid. Too low a temperature.	Warm some of the solution with copper carbonate and return to vat. Repeat until acidity is sufficiently reduced. Warm bath.
Bad throwing power, i.e., poor deposit on recessed parts.	Insufficient acid or insufficient copper sulphate.	Add pure sulphuric acid, 1 fluid oz. per gallon. Check density of solution. It should be 19° Be. (30° Tw.); if seriously below, add copper sulphate till correct.

Electrotyping.

One of the most important applications of copper-plating is in the electrotyping industry, where it is very largely used for the reproduction of steel and copper etched plates, for line and half-tone blocks, etc.

Briefly described, the method used in the printing trade is as follows:—

The original plate is pressed by means of a toggle press into a suitable mixture of wax and plumbago held in a lead case.

A typical mixture is as follows:—

Genuine beeswax	18½ oz.
Venice turpentine	1 oz.
Plumbago	1 oz.

The operation of pressing is rather delicate, and every care is taken to get a perfect impression. The case is now trimmed and redundant wax removed, after which small sprigs are driven through the wax at selected places (not printing surfaces) into the lead case at the back.

These sprigs are to convey the current and are spaced as near as possible to the surfaces to be covered. The back and sides of the case are covered with ungraphited wax in order to prevent growth of copper in unwanted places.

The wax surface is now blackleaded either by means of a fine brush, or by a spray. This is to render it conductive, and it will be readily appreciated that any portion missed by the graphite (plumbago) will miss in the plating.

Surplus graphite is washed off by a jet of water and holes in the top of the case are scraped clean to receive the hooks.

When the case is ready it is suspended in the copper solution in the usual manner and gradually builds up a complete shell of copper.

The sensitising of the wax surface can be accomplished in several ways, but the method given above—though one of the oldest—is still largely practised and when properly carried out is capable of very beautiful results, and is of wide application.

Bas-reliefs, hammered work, etc., are accurately reproduced and a large number of “antiques” and “native work” are manufactured in bulk by electrolytic copper deposition methods.

Many modern printers now press into lead, and lead impressions have certainly this advantage that no graphiting (and consequent blurring of the impression, to say nothing of actual damage) is necessary. The lead mould can go direct into the plating bath—and this generally is a nickel bath. Nickel direct on to lead with a subsequent heavy backing of copper has the advantage of presenting a very hard printing surface.

Reproductions of Medals, Plaques, etc., which are Undercut.

The moulding composition is as follows:—

Gutta percha	2 lb.
Lard	1 lb.
Linseed oil	½ oz.

Melt together and well mix.

This composition can be either warmed till it is just plastic and then pressed as before, or it may be heated till fluid and then poured over the article, which in both cases should be well brushed with graphite before this operation—to prevent sticking.

When cold, the impression is separated from the original, sensitised with graphite, and copper wires imbedded round the prepared surface to take the current. It is then plated as usual.

Stripping and Cleaning the “Shell.”

When the shell is of sufficient thickness the case is removed from the plating bath and the shell carefully removed from the composition by means of hot water. It is then cleaned—often by means of paraffin—and backed. This is

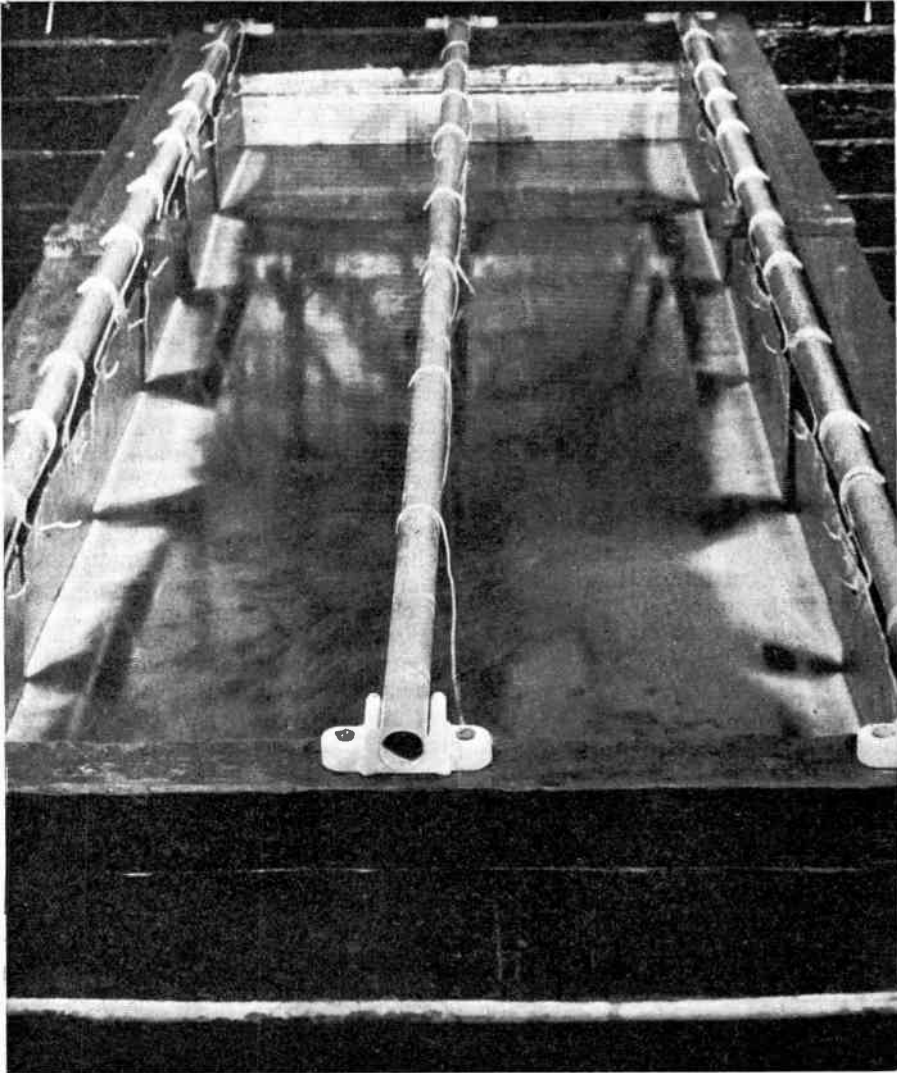

Fig. 18.—CLEANING NICKEL PLATING FROM METAL.

The articles to be cleaned are used as the anode, and hung on the centre rod (connected to the positive lead). Note the froth on the sides of the lead plates.

done by tinning, and then the shell is placed face down in a heated tray and on to it is poured the molten backing metal.

Backing.

Backing metal is usually made with 6 parts antimony, 92 parts lead and 2 parts tin, and is bought in ingot form ready for use.

Nickel or Steel Facing.

After backing, electros are often nickel or steel faced to give extra life and sharpness. Chrome facing is becoming increasingly important. Medallions and plaques may be silver-plated, bronzed and relieved as taste and demand require.

It will be readily appreciated that this process of copper-plating non-conductors (wax, etc.) by means of graphite is both of almost unlimited application and at the same time of considerable difficulty.

Personal skill in manipulation counts for a great deal and these notes can do little more than familiarise the electrician with the plating problems involved.

The prime electrical demand is for steady current, often for protracted periods, and for this reason accumulators may be recommended.

Electro-coppering for Case-hardening Mild Steel.

When any steel parts are required to be case-hard in certain sections only it is a good practice to copper-plate the parts that are to remain soft.

The work should be first cleaned in the usual manner (see page 445), passed through a 10 per cent. sulphuric acid dip and swilled. The parts to be hardened are then "stopped off" with a suitable medium—copal varnish, enamel or lacquer, and the bare parts lightly nickel-plated for a few minutes only. The work is then swilled and placed in the agitated acid copper bath for 20-30 minutes, working at 50 amps. per square foot at a pressure of 3-3½ volts. It is then swilled in cold water, then in hot and finally dried out.

After the stopping off varnish has been removed the steel is case-hardened in the usual way.

Cyanide Copper Solutions.

As already explained, the acid copper solutions are inappropriate for plating directly on to iron or steel. This is primarily due to the fact that loose non-adherent metallic copper is precipitated from such solutions on to the iron by simple chemical interchange. Solutions of the double cyanides of copper and potash (or soda) do not have this disability, and are often used for general work (coppering prior to "oxidising," etc.).

The essential salt in these baths is copper potassium cyanide ($\text{CuCN} \cdot \text{KCN}$), and an additional essential ingredient is an alkaline cyanide whose functions are to dissolve the anodes, to keep them free from the insoluble single copper cyanide formed on them and to act as a conducting agent.

Cyanide copper solutions are usually contained in a plain iron tank and gas heated to about 140° Fah. Two to three volts are generally employed. The electrician will have no difficulty with this type of solution, provided this simple chemical fact is borne in mind: The solution must contain a small amount (at least 1 oz. per gall.) of free cyanide, and as this is an unstable salt, always degenerating to a more stable (and useless) compound, it must be periodically replaced. Potassium cyanide (98/100 per cent.) should be added daily for this purpose.

The signs of the need of this chemical are very plain.

(1) Dirty anodes covered with greenish slime.

(2) (In extreme cases.) The solution changing from amber to green.

In the latter case 1½ oz. of potassium cyanide per gallon of solution should be recommended—and it will probably need more.

If the solution has been worked for some days with a deficiency of cyanide, it will be deficient in copper, and this should be added in the form of (a) copper potassium cyanide; (b) copper cyanide dissolved in potassium cyanide or in "copper salts." Failing any of these, copper carbonate dissolved in a warm solution of potassium cyanide is a good substitute.

SILVER AND GOLD PLATING.

Both these "precious" metals are electro-deposited from solutions of their cyanide salts, and the electrician would be well advised to leave the actual compounding of them to expert hands. In any case, it should be remembered that *all* cyanide solutions are in the highest degree poisonous, and when electrical adjustments have to be made, every precaution should be taken against accidental poisoning.

A Good Silver Solution.

A good silver solution contains at least 2 oz. per gallon of metallic silver in the form of the double cyanide (AgCN KCN) and beyond this about 1 oz. per gallon of the single salt potassium cyanide to dissolve the anode and keep it clean from the insoluble silver cyanide (see notes of copper cyanide) that would otherwise tend to form and insulate it. Wooden vats lined with chemically pure lead are recommended for silver solutions, though plain iron tanks, earthenware or enamelled iron are quite good.

A Warning.

Note at this point that *no tinned or galvanised vessels should be employed in the plating shop at all*. They are fatal for the majority of solutions for acid dips, and for cleaning tanks, and are better out and kept out. Wood linings to silver baths, too, are highly undesirable, and the electrician who finds one should recommend that the wood lining be ripped out—the cyanide of the solutions attacks the wood and the solution becomes contaminated with resins. A sure sign of this contamination is the appearance in the plated work of yellow stains and patches which cannot be polished out.

The anodes should be of fine silver. They should hang from the rods by silver hooks, or by bent strips cut from their own sides.

Plating.

After cleaning the work in the usual way (see page 445) the metal is lightly scoured with lime, swilled, and cyanide dipped. Iron, steel, tin and lead should

then be coppered in the cyanide copper solution (which see).

Articles, when perfectly clean, are "quicked" in an amalgamating solution of either:—

"Mercury salts" $\frac{1}{4}$ oz.
Water 1 gallon

Or, alternatively:—

Double cyanide of mercury
and potassium $\frac{1}{2}$ oz.
Potassium cyanide $\frac{1}{4}$ oz.
Water 1 gallon

The work is left in this solution till they have a faint whitish appearance—a matter of seconds only.

After quicking, the articles are well swilled and then carried to a special "striking vat."

This is a silver solution kept for the purpose and is generally low in silver content, but with as much as 4 oz. to the gallon of free potassium cyanide. The anodes in this solution should be as large as possible and a pressure of 6-8 volts should be applied before the articles enter the bath and maintained for about 15 seconds. In this time the articles should be coated all over with silver and then swilled and lightly scratch-brushed with a small wire brush mounted on a lathe shaft. If the deposit is sound and does not strip, the articles are then transferred to the main silvering bath.

This solution should be worked at a much lower voltage, from about $\frac{1}{2}$ to 1 volt being all that is necessary. In about 15 minutes the work should be a fine porcelain dead white and this film should be allowed to build up till it is of the desired thickness.

If the work is slightly bluish in tint, it is a sign that potassium cyanide is required in the solution, and $\frac{1}{4}$ oz. of this chemical should be added to every gallon of solution.

After plating, all work is well swilled and dried out, embossed and filigree work is scratch-brushed and plain surfaces are mopped up with rouge compo applied to a revolving cloth mop, finally being "finished" on a swansdown mop with rouge powder mixed with methylated spirit and water.

“ Doctoring ” Silver Plate.

Articles that are defective in localised patches or that are required to be treated *in situ* can sometimes be renovated in the following manner:—

The defective part should be well polished and then cleaned with a soft rag and a mild cleaning agent. After swilling well, the colouring process may be performed.

A small rod of silver, if obtainable (if not, a piece of arc carbon), should be mounted between two pieces of rod to form an anode.

Connect length of copper wire to the anode and the positive pole of a 6-volt accumulator. Wire the defective work to the negative pole. The silver rod should now be swathed in cotton cloth and tied round with it. If this cotton mop is now soaked in a little of the ordinary silver-plating solution and swabbed gently on to the defective part of the work, a real silver coat can be built up that will stand subsequent polishing and wear.

Silver-plating Troubles.

Appearance of Work, etc.	Causes.	Remedies.
Deposit blisters or strips.	Bad cleaning. Bad amalgamating (quicking). Base metal unsuitable.	Rectify (see page 445). Make up fresh “quick” (not too strong). Copper before silvering if metal suspect.
Deposit dark and loose in texture.	Too high a current.	Lower voltage.
Anodes very bright and crystalline.	Too much cyanide.	Add single silver cyanide (½ oz. per gall.).
Deposit bright—your anodes encrusted, voltage high and amperage low.	Too little cyanide.	Add ¼ oz. per gall. pot. cyanide.

Gilding.

A gilding solution may be prepared by dissolving ½ oz. of gold chloride in a solution of 3 oz. of potassium cyanide in

1 quart of water, boil vigorously and make up to 1 gallon with distilled water.

The solution should be contained in a good enamelled iron jar, and should be worked warm about 140° Fah.

If insoluble anodes are used—as they may be—the gold deposited is not replaced by the anode, and so the solution is quickly impoverished of metal. Should the anode become dark, potassium cyanide should be cautiously added.

A pressure of about 3 volts is required. The colour of the deposit can be largely controlled by the voltage employed. Higher voltages give darker shades and lower voltages lighter shades.

Inside Gilding.

Articles such as sugar basins and egg cups may be rapidly gilded inside without damaging the outside finish.

The inside is polished, or burnished, well cleaned and swilled. The gold solution is then carefully poured into the vessel to the required height, the vessel itself wired to the negative lead and the gold anode (corrected, of course, to the positive pole) introduced into the solution and moved gently about for the time required to obtain the desired thickness of deposit.

The anode should now be removed, the gold solution returned to stock, the article well swilled—*very* well swilled—and the inside scratch-brushed or burnished.

Articles with a frosted appearance are either sand-blasted or scratch-brushed and, after gilding, scratch-brushed again.

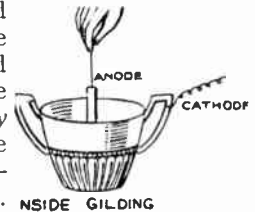

Gilding Troubles.

Appearance of Work, etc.	Causes.	Remedies.
Colour too pale.	Excess of cyanide.	Boil for an hour or so, and then make up volume with distilled water.
Deposit brownish red.	Too high a current or too slow a temperature. Too little metal.	Add ¼ oz. pot. cyanide, or raise temperature. Make new solution, or add “Gold Salts.”

FAULT-TRACING CHART FOR ALL TYPES OF RADIO SETS

By H. E. J. BUTLER.

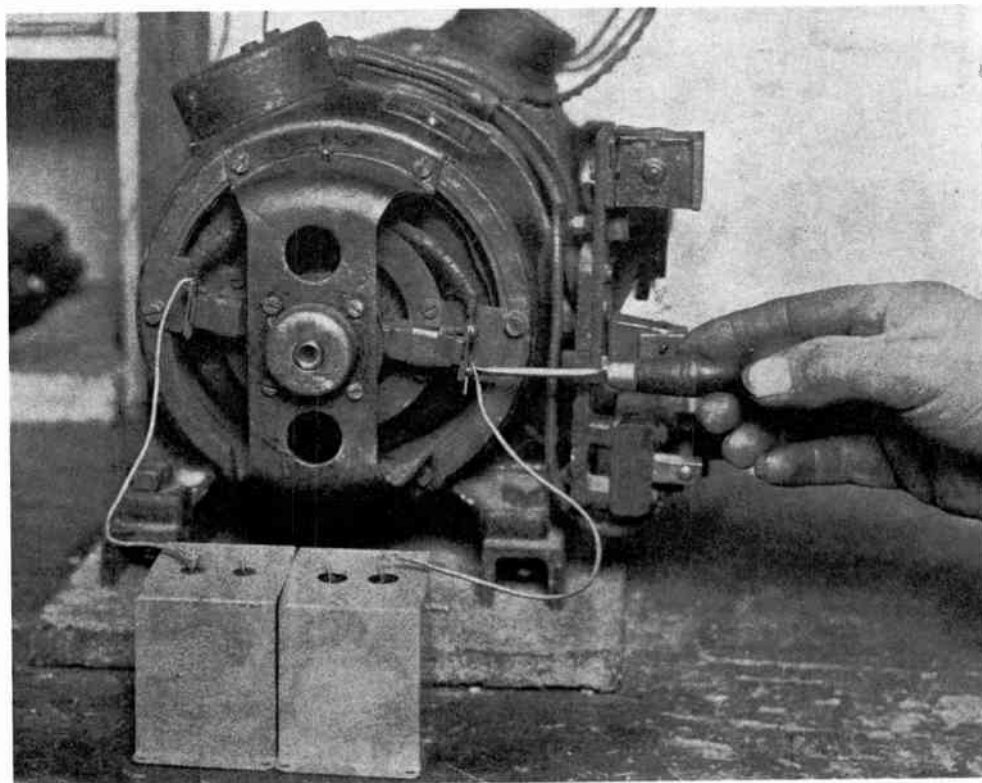

Fig. 1.—HOW TO CURE INTERFERENCE FROM AN ELECTRIC MOTOR (1).

Static interference from adjacent electric motors is a frequent cause of intermittent crackling noise in wireless sets. This interference can be cured by earthing the centre of two condensers connected in series across the motor brushes. This illustration and Fig. 2 show how the condensers should be connected.

Faults and Causes.

Two or more stations are heard at the same dial setting.

(1) Set not sufficiently selective to deal with the large number of stations now on the ether.

Remedy.

(1) When a set is situated close to a broadcasting station, and it is found that it is impossible to eliminate the local station while listening to another, a wavetrap should be attached to the set. A condenser of .0001 microfarad capacity in series with the aerial will improve the selectivity. Where reaction is employed, an increase of the reaction will improve

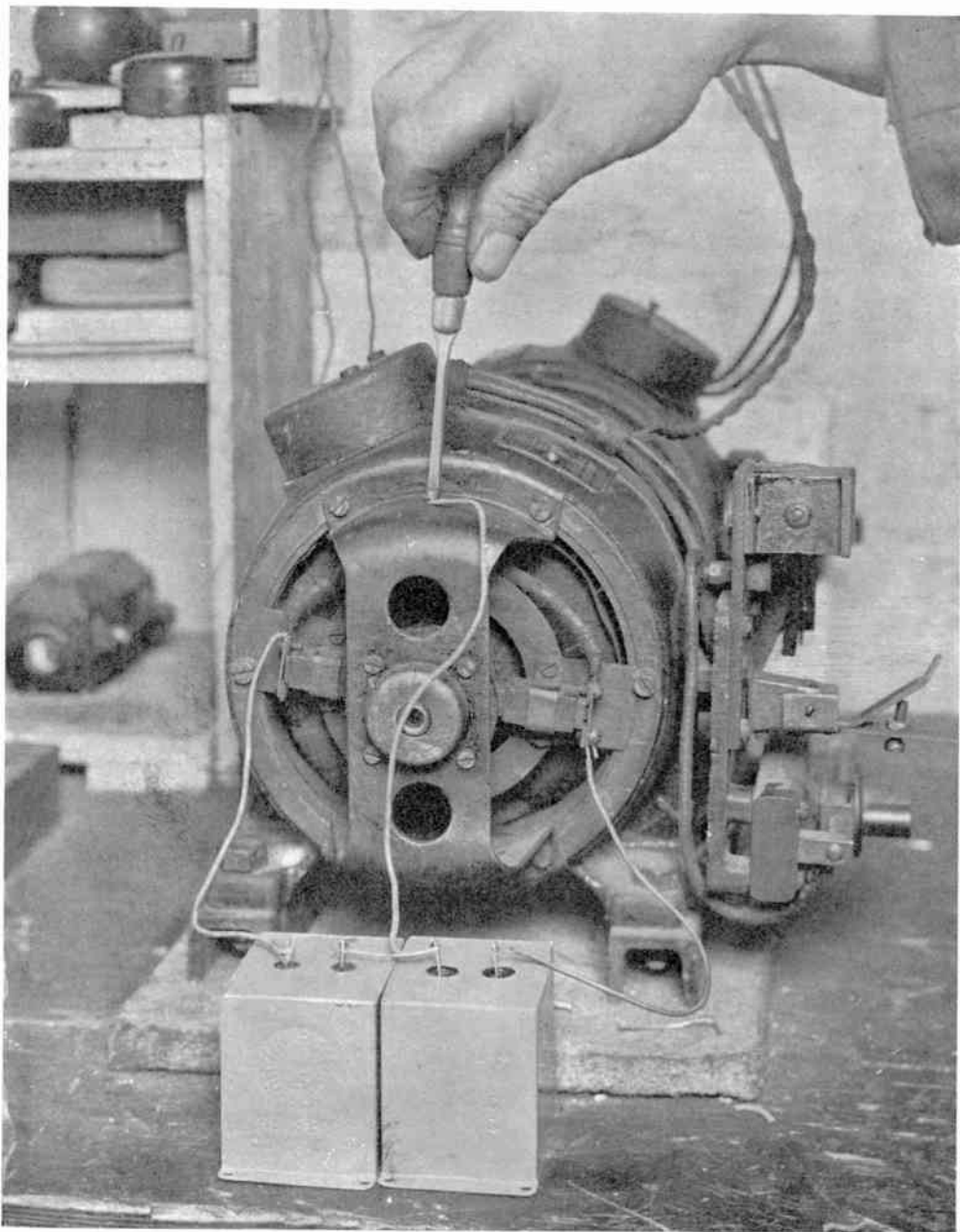

Fig. 2.—HOW TO CURE INTERFERENCE FROM AN ELECTRIC MOTOR (2).

The method shown here and in Fig. 1 depends, of course, on the users of electric motors, trains and sparking coils, whose apparatus is responsible for causing interference.

Faults and Causes.

(2) Where ganged tuning is employed, the condensers may be out of line.

High-pitched whistle on some stations.

This is partly due to the chaotic condition of the ether and partly to the receiver. It is caused by the heterodyning of two stations' carrier waves which are very close in wavelength.

Intermittent crackling noises, especially on the long-wave band.

Atmospheric or man-made static interference.

Crackling persists when aerial and earth are disconnected.

Fault in the set or attached accessories, which may be a loose connection of any wire, joint improperly soldered, dirt or moisture on terminal strip due to the use of corrosive soldering fluid.

Crackling not due to a bad connection or outside interference.

Valve legs not making efficient contact to holder, especially where the valve legs are solid and the valve sockets are solid also.

Remedy.

the selectivity. Where the set has an obsolete single circuit tuner, the set should be redesigned to include a modern highly selective tuning arrangement.

(2) Loosen the screw which holds each set of moving vanes of the variable condenser assembly after tuning in to a weak station. Now rotate each set of moving vanes separately until the loudest result is obtained and lock them in position. Where trimming condensers form part of the condenser assembly, the correct alignment is obtained by setting these.

A frame aerial will largely eliminate this trouble if the two interfering stations lie in different directions. The fault is not usually serious and the whistle heard from this cause should be noticeable only when no music or speech is being received. The adoption of a highly selective system of super-heterodyne reception will eliminate it.

Choose a time when this trouble is fairly persistent and, with the set switched on in the normal way, disconnect the aerial and earth. If the noises cease, the trouble is due to outside interference. There is at present no remedy for atmospheric disturbances. The elimination of static interference from adjacent electric motors, trains and sparking coils rests with the users of these. Interference from an electric motor may be cured by earthing the centre of two condensers connected in series across the motor brushes.

Examine all connections to terminals first. If these are secure, examine the soldered connections in the set to ensure they are mechanically sound. Where the set is wired with bare conductors, see that no two wires are nearly touching. If the crackle still persists, examine the surface of the ebonite between the terminals. If the surface appears greasy or has any deposit of foreign matter on it, fit a new panel or terminal strip.

Remove the valves from the holders and give a little extra set to the contact springs where it seems to require it. As the majority of modern valves have solid pins, it is essential to have a type of valve-holder with spring contacts. In older sets where the sockets are solid, fit new valve-holders.

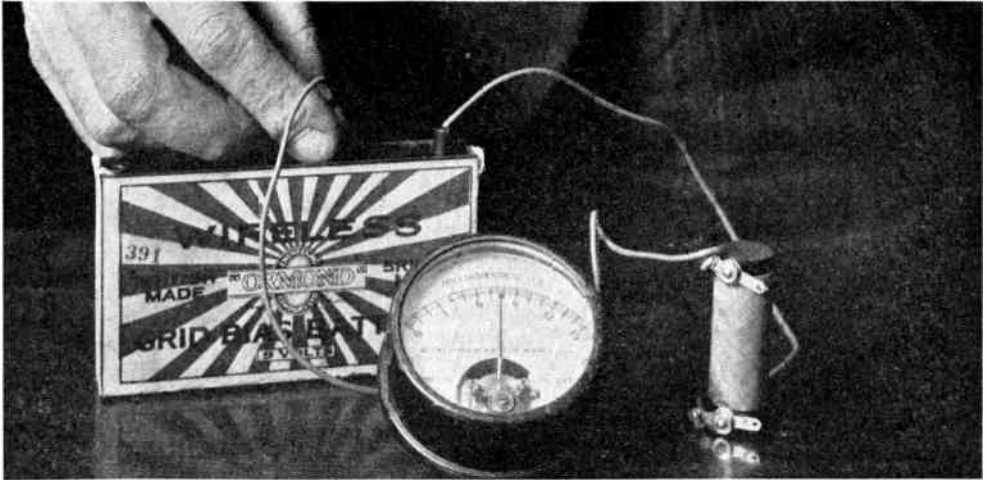

Fig. 3.—TESTING A HIGH FREQUENCY CHOKE FOR CONTINUITY WITH BATTERY AND MILLIAMPERE METER.

A faulty high frequency choke may be the cause of reception suddenly stopping.

Faults and Causes.

Crackling not due to outside interference, bad contacts or connections.

Breakdown of a component in the set. Most likely to be an anode resistance, intervalve transformer, choke or condenser.

Loud scratching and crackling noises when tuning in.

- (1) Moving vanes of variable condenser touching the fixed vanes.
- (2) Dust or metal filings between the two sets of blades.
- (3) Bad connection to moving vanes.

A metallic ring is heard in the loud-speaker when the set is lightly tapped.

Transference of mechanical vibration to the metal electrodes of the valves.

Whistling noises varying in pitch while tuning in.

Set in a state of oscillation. Reaction

Remedy.

Disconnect the batteries (or mains) from the set. Large condensers are tested by charging them up from a D.C. supply of, say, 100 volts, leaving them for five minutes, then bridging the terminals with a screwdriver. A spark should be obtained. No spark indicates a leaky condenser. Test anode resistances, chokes and transformer primaries by connecting them in series with a battery and a milliamperemeter to give a current comparable with that under operating conditions. A steady current indicates the component in order. Preliminary tests can be made without unwiring the components.

Examine the air space between the fixed and moving vanes and clean out any foreign matter between them. Rotate the condenser spindle slowly until a scratch is heard, then see if the blades touch at any point. If so, adjust. Examine the connection to the moving vanes if the two foregoing remedies are ineffective.

Fit a set of anti-microphonic valveholders which will prevent mechanical vibrations reaching the valve electrodes.

Where variable reaction control is fitted, reaction must not be increased so that the receiver oscillates or interference

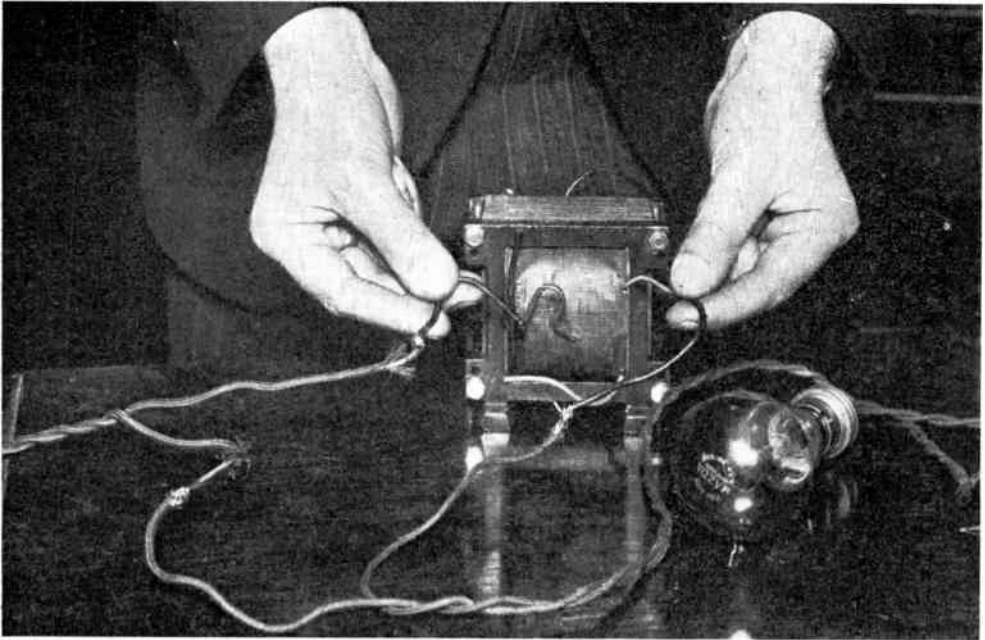

Fig. 4.—HOW TO TEST THE PRIMARY WINDING OF A MAINS TRANSFORMER BY PUTTING A LAMP IN SERIES.

If the lamp glows, the primary winding is continuous.



Fig. 5.—TESTING THE CONDITION OF A VALVE WITH A MILLIAMPERE METER IN THE ANODE CIRCUIT.

The test should be made in the anode circuit of each valve in turn. A large increase, or fall to zero, of anode current when signals cease will be indicated if a low frequency valve is faulty. A smaller change will be indicated in the anode circuits of the other valves if one of these is at fault.

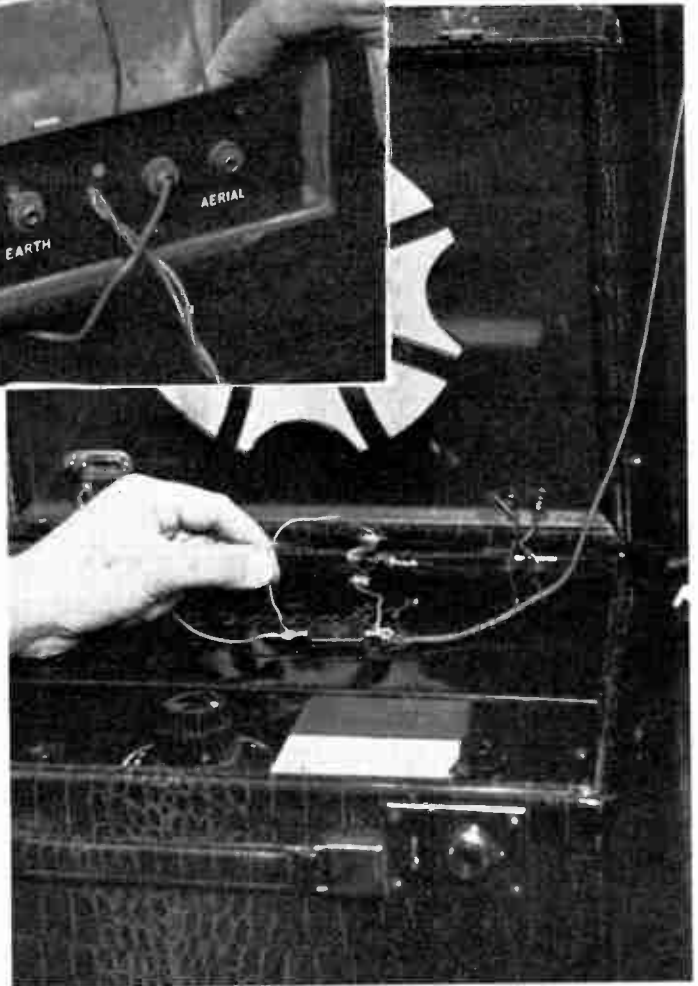

*Fig. 6 (left).—*PLACING A FIXED CONDENSER INSIDE THE SET FROM THE AERIAL TERMINAL.

Greater selectivity is obtained by placing a .0001 condenser in series with the aerial.

*Fig. 7 (right).—*ANOTHER METHOD OF PLACING A FIXED CONDENSER IN SERIES WITH THE AERIAL.

In this case the condenser is connected to the aerial lead-in, while a switch is also shown which short-circuits the condenser when selectivity is not required.



Faults and Causes.

control increased too far. Screen grid voltage too high.

When reaction control is increased, volume is less.

- (1) Connections to reaction coil reversed.
- (2) Reaction increased too far, so that the set is in a state of oscillation.

When set is switched on, reception lasts only a few seconds. If the set is put off, then switched on again after a minute or so, the same happens again.

Faulty valve. As the valve warms up, one of the electrodes becomes disconnected inside the valve, causing a complete stoppage of signals.

Reception perfect on short wave, no reception on long wave band, or vice versa.

Break in windings of long wave coils, or wave-change switch not making proper contact.

Reception weaker than usual on all stations.

Aerial or earth connections corroded. Valves wearing out. 'Phones or loud-speaker requires remagnetizing.

FAULTS PARTICULAR TO BATTERY RECEIVERS.

Reception fades off slowly.

One of the batteries, most probably the low tension, run down.

Remedy.

may be caused to neighbouring receivers. Where the sensitivity of a receiver is controlled by varying the screen grid voltage, the set may oscillate when the voltage is increased to its maximum limit.

(1) By referring to a circuit diagram of the receiver, find which is the reaction coil and reverse the connections to it.

(2) This is verified by resetting the reaction to a minimum, then increasing slowly. The volume increases up to a point, then suddenly diminishes with a pop.

The fault may lie with any of the valves, so that to determine which one is at fault, connect a milliamperemeter in the anode circuit of each valve in turn and notice its behaviour on cessation of signals. A large increase or fall to zero of anode current will be indicated if a low frequency valve is faulty. A smaller change will be indicated in the anode circuits of the other valves if one of these is at fault. Test the output valve first.

Test the long wave sections of the coils for continuity and examine the wave-change switch contacts to see if they are making proper contact and are free from dirt.

Examine the connection of the lead-in wire to the aerial. If this is just twisted round, the aerial wire should be soldered to the lead-in to ensure permanent contact. Examine the earth connection and if possible solder this to the earthing point if not already done. The condition of the valves is tested by inserting a milliamperemeter in the anode circuit of each valve in turn. Assuming the high tension and grid bias to be in order, a worn valve is indicated by a low reading on the meter. The correct anode current is found by referring to the manufacturers' chart.

Test the voltage of the batteries while the set is working. Do not test the high tension battery with a meter of resistance less than 200 ohms per volt, 1000 ohms per volt if possible, or a false reading will be obtained. First test the safety fuse for continuity.

*Faults and Causes.***Reception stops suddenly and no other station can be picked up.**

Valve burned out. Fuse blown, if any, in high tension circuit. Aerial disconnected or broken. Low frequency transformer or anode feeding resistance burned out. The corrosion of a wire under the low tension battery terminal will sometimes cause a sudden breakdown. Loud-speaker, when connected in anode circuit of output valve, may be burned out.

Crackling noises in 'phones or loud-speaker. (See also under general faults.)

High tension battery running down. Low tension battery may cause this fault when fully charged owing to the evolution of gas bubbles.

Set will not oscillate and reception not as good as usual.

Either low or high tension battery run down.

Whistling noise or low frequency oscillation of steady pitch, which does not vary much on altering the tuning.

High tension battery has developed a high resistance due to being run down.

Low frequency valves or output valves run very hot ; distortion on loud passages.

Grid bias battery not functioning, grid bias voltage too low, or bias battery disconnected.

Remedy.

The condition of the valves is verified by connecting an ammeter or voltmeter in series with the valve filaments. If the valves are in order, a burned-out component in the set is looked for. The most likely is a low frequency transformer primary winding. Transformers, chokes and anode resistances or voltage regulating potentiometers are tested for continuity by connecting them in circuit with a milliamperemeter and a suitable battery.

Inspection of the high tension cells by tearing away the side of the box will reveal the zinc pots eaten through. If the low tension is suspected, agitate the cells to assist the dispersing of the gas and allow the battery to stand for a while before using.

Where the reception does not fade much after the set has been working half an hour or so, the high tension is at fault. Test it with a high resistance voltmeter.

Where decoupling arrangements are insufficient this may occur when the battery has much useful life left in it, so that it is better to design the receiver with anode feeding resistances and decoupling condensers, rather than take tapplings off the high tension for the different voltages.

Test the voltage of the grid bias battery with a high resistance voltmeter. If in order, refer to the manufacturers' recommendations of bias voltage for the high tension voltage at which the valve is being run. If this is correctly adjusted, examine the wander plugs to see if they make good contact.

FAULTS IN ALL-MAINS RECEIVERS.**No reception when set is switched on. All valve filaments glow.**

Some part of high tension equipment at fault ; such as high voltage winding on transformer burned out, choke or anode resistance burned out or disconnected.

Test each valve anode circuit with a milliamperemeter. The anode currents of the screen grid valves may be tested by removing the flexible connection to the valve cap and inserting the meter at this point. If the anode currents of detector and low frequency valves are in order, but there is no anode current to the high frequency valves, the screen grid feeding resistances may be disconnected or



Fig. 8.—TESTING THE HIGH-TENSION BATTERY WHILE THE SET IS IN OPERATION.

A high-resistance voltmeter should be used.



Fig. 9.—HOW TO TEST THE ANODE CURRENT OF A SCREEN-GRID VALVE.

Remove the flexible connection to the valve cap and insert the meter at this point.

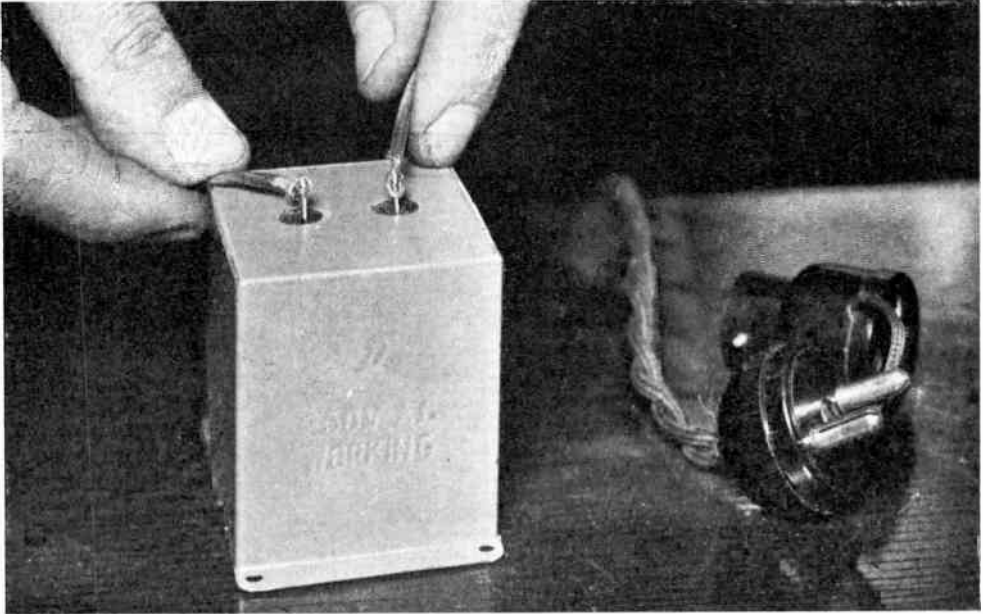

Fig. 10.—TESTING A LARGE CAPACITY CONDENSER (1).

A faulty large capacity condenser may be the cause of crackling that is not due to outside interference, bad contacts or connections. To test the condenser it should be charged up from a D.C. supply, of say, 100 volts, leaving it for five minutes and then bridging the terminals with a screwdriver (see *Fig. 11*). A spark should be obtained, otherwise a leaky condenser is indicated.

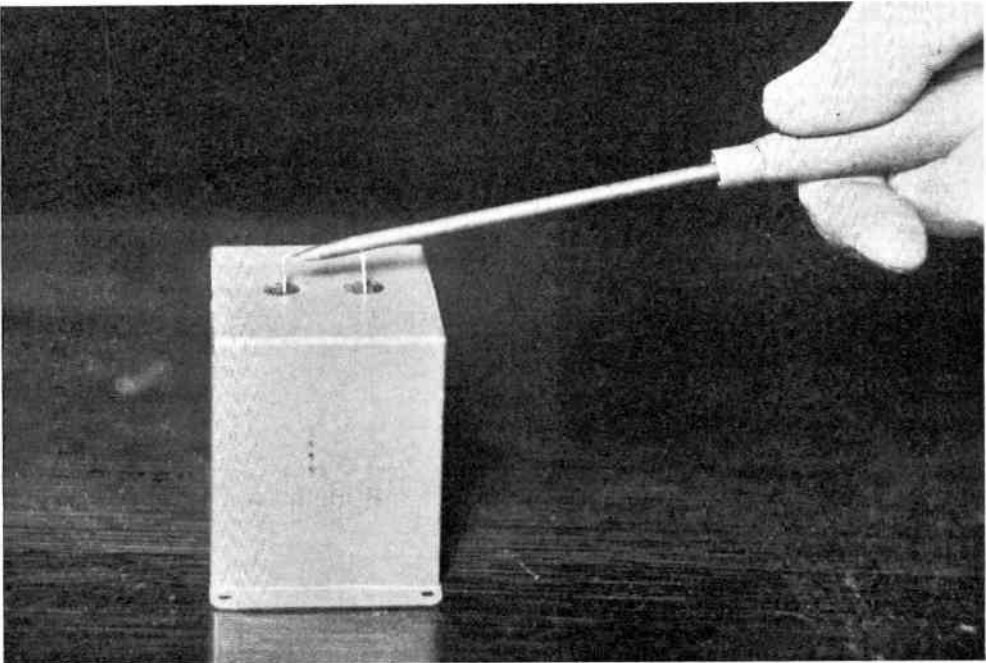

Fig. 11.—TESTING A LARGE CAPACITY CONDENSER (2).
Showing method of bridging the terminals when testing for a spark (see *Fig. 10*).

Faults and Causes.

Valves do not glow when set is switched on, or do not glow when reception stops suddenly.

In an A.C. receiver, broken connection to mains transformer or mains transformer primary winding burned out. In a D.C. receiver, the resistance between the mains and the filaments is to be suspected.

Reception stops suddenly. (See also under battery sets.)

Any part of mains transformer (A.C. set) or voltage absorbing resistance (D.C. set) burned out.

Crackling noise in loud-speaker. (See also under general faults.)

One or more smoothing condensers punctured. Noisy high frequency valves. Faulty connection to grid bias resistances or grid bias resistances themselves faulty.

Steady hum, previously non-existent.

Earth disconnected. Loud-speaker moved too near to an unshielded mains transformer. Short circuit of smoothing choke. Grid bias resistance disconnected or burned out. Breakdown of smoothing condenser. Anode current increased by using type of valve for which the set was not designed.

Mains hum only when gramophone attachment is used.

Inadequate screening of pick-up leads. Motor not earthed, scratch filter, when fitted, is not screened.

Valves burn out quickly after being replaced.

Mains connected to wrong tapings on set. Mains transformer wrongly wound.

Output valve gets very hot.

Incorrect value of bias resistance, or bias resistance short-circuited.

Remedy.

burned out. Try all soldered connections, and test all components for continuity in those anode circuits showing no current.

Test the primary winding of the mains transformer by inserting a lamp in series with it and the mains. If it glows, the primary winding is continuous.

If the valve filaments are still glowing, the procedure is the same as for no reception when switching on.

Test the smoothing condensers as previously described. If these are in order, try replacing the high frequency valves and the grid biasing resistances.

Verify the earth connections and any screen connections. There are usually several earthing points in a mains receiver and the disconnection of one of them may give rise to hum. Test the smoothing chokes and smoothing condensers.

Both the pick-up arm and the gramophone motor case must be earthed. Pick-up leads must be run with metal braided wire when mains induction is present. A scratch filter must be screened if it is found that on cutting it out of circuit the hum is less or ceases altogether.

Verify the connections to the set and the mains voltage. Test the filament windings of the mains transformer with an A.C. voltmeter.

Check the value of the bias resistance and replace if faulty or incorrect.

TRAFFIC PROBLEMS OF TELEPHONE ENGINEERING

By COLONEL SIR THOMAS F. PURVES, M.I.E.E.



Fig. 1.—INSIDE A TYPICAL TELEPHONE EXCHANGE.
This is a section of the Victoria Exchange switchboard, showing B positions with operators.

WHEN calculating the amount of switching plant required for the interconnection of circuits in telephone exchanges, whether of the manual or automatic type, it will be obvious that provision must be made for dealing with the *maximum* number of conversations which may be expected to be in progress at any one time.

In practice it is found that the percentage of subscribers using their telephones simultaneously is usually comparatively small; for example, in the case of a large London exchange of 10,000 lines, the number of calls in progress may reach 1,000, but will not often exceed this figure. From the nature of the case, it is to be expected that the use of the telephone will vary from hour to hour during the day and to a less extent from day to day throughout the year.

How the Traffic at an Exchange Varies.

Figs. 2 and 3 show how the traffic at an exchange varies during the 12-hour period from 8 a.m. to 8 p.m. In Fig. 2 a representative business exchange in London is compared with a representative business exchange in New York, and in Fig. 3 representative residential exchanges in the two cities are compared. The ordinates show the number of calls handled during each half-hourly period, and the scales are so adjusted that the curves of morning traffic for the two exchanges have approximately the same maximum height. It will be seen that in the case of the business exchanges, both in London and New York, there is a high traffic peak in the morning, followed by a similar but lower peak in the afternoon, and that the traffic falls to a very low figure quite early in the evening.

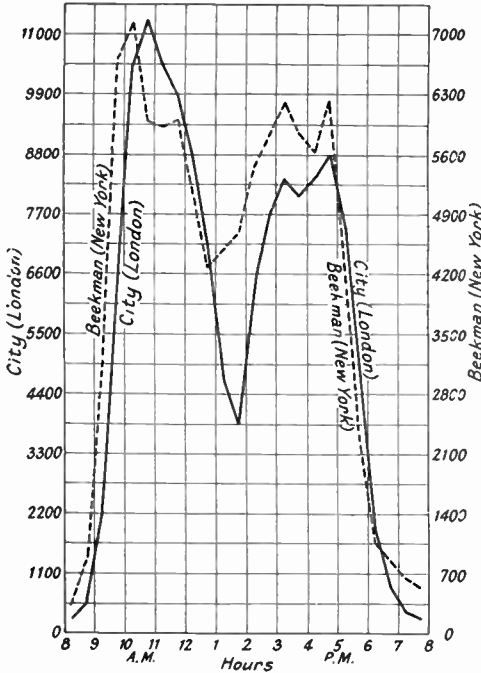

Fig. 2.—HOW TRAFFIC VARIES (1).
This shows a business exchange in London compared with one in New York.

Where Evening Traffic is Heaviest of the Day.

In the case of the residential exchanges, however, the incidence of the traffic has quite a different character, and there is also a marked difference between the conditions in London and New York. In the former case, after a fairly heavy hour in the morning, the traffic falls off very rapidly and remains low throughout the remainder of the day, whereas in the case of the New York exchange it is well maintained throughout the afternoon, with a very high peak of "social" traffic in the evening, the evening traffic being actually the heaviest of the day.

Providing for the Maximum Demand.

As switching plant has to be provided in sufficient volume to cater for the maximum demand of the peak period, and lies idle at other periods of the day, it will incidentally be noticed that revenue earning conditions are much more favourable in New York than in London exchanges. In other words, much more sustained use is made of the telephone plant in America than in Great Britain.

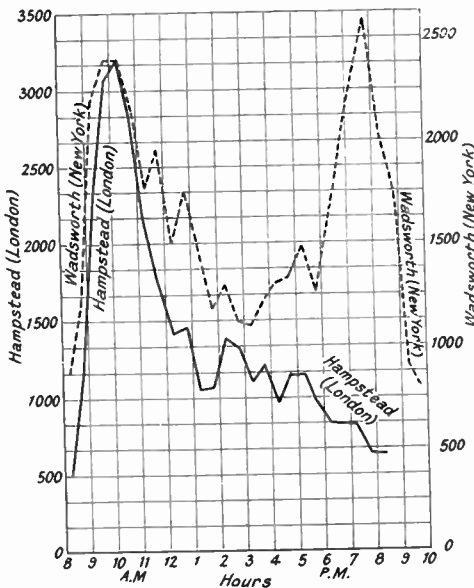

Fig. 3.—HOW TRAFFIC VARIES (2)
This shows the difference in traffic between representative residential exchanges in London and New York.

"Busy Hour" Traffic.

The hour during which the traffic is heaviest is called the "busy hour," and this period is usually used in designing the lay-out of an exchange. It will be found that similar but less intense variations occur in the traffic from one period of the year to another, and therefore account must also be taken of the probable demands of the busiest season of the year when the exchange is designed.

When considering the way in which the anticipated traffic affects the design of an exchange, it is desirable to consider manual and automatic exchanges separately.

How a Manual Exchange is Planned.

Taking the manual case first, it will be clear that the number of operators' positions required must be based on the busy hour traffic. The number of positions will, of course, depend on the amount of traffic which an operator can handle, because it is impracticable to provide more than one operator per position.

Determining the Load an Operator can Carry.

Now the load which an operator can carry will depend on the amount of time she has to spend on each call. With a simple call, such as a local call on an ordinary common battery exchange, the amount of time involved is only a few seconds. With a more complicated type of call, such as a junction call where two or more operators may be involved, or a call from a call office where the collection of money has to be supervised, the time involved is greater and the number of such calls which the operator can handle is less. It is the practice to take one of the simple types of call as a unit and to express all others in relation to that unit. The value of a call so equated is thus approximately proportional to the operating time involved. As calls do not come in at a uniform rate, allowance must be made for busy and slack periods within the busy hour itself, otherwise calls occurring during short rushes will be unduly delayed.

Points to Consider.

Making allowance for this, it is found that an operator can handle about 200 unit calls during the busy hour, the proportion of the busy hour during which she is effectively occupied being approximately 45 minutes. Thus to estimate the number of positions required in a manual exchange, it is necessary to estimate the numbers of each type of

call which will be received, to express these in terms of the unit call, according to their relative values, and then to divide by 200 in order to obtain the number of positions to be provided. Generally speaking the incoming and outgoing traffic have to be considered separately, and there will, in addition, be a number of special types of call, service calls and others, to be taken into consideration.

Junction Circuits.

When further we consider the number of junction circuits required from one exchange to another, it is obvious that, since a junction is in use throughout the period of the call, the number of junctions required will depend on the average duration of the calls as well as on their total number. This point is referred to in more detail under automatic working.

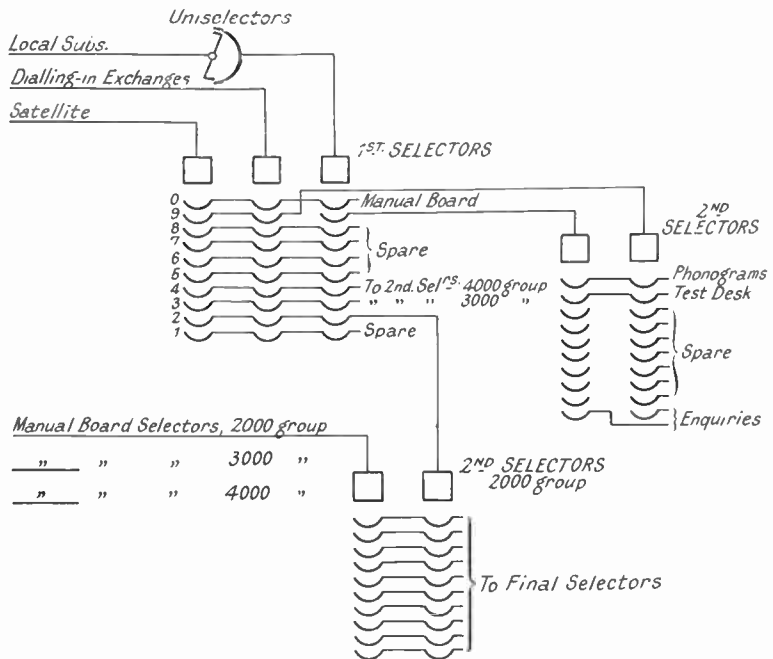

Fig. 4.—How AN AUTOMATIC EXCHANGE WORKS.

It will be seen that when the subscriber lifts his receiver to initiate a call the first result is that the "uniselector" corresponding to his wire will hunt for a disengaged first selector. When he dials the first digit, the connecting brushes of the first selector will be lifted to the level corresponding to this digit and will then proceed to hunt automatically among the circuits on that level, for one providing an outlet to a second selector. Similarly, the second selector will respond to the second digit, and so on.

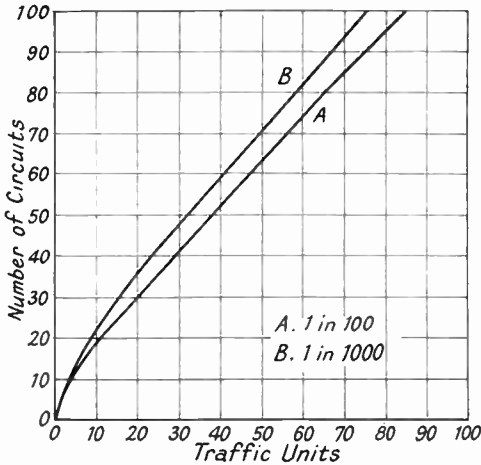

Fig. 5.—THIS SHOWS THE RELATION BETWEEN TRAFFIC UNITS AND THE NUMBERS OF CIRCUITS REQUIRED TO CARRY THEM FOR GRADES OF SERVICE OF 1 IN 100 AND 1 IN 1,000.

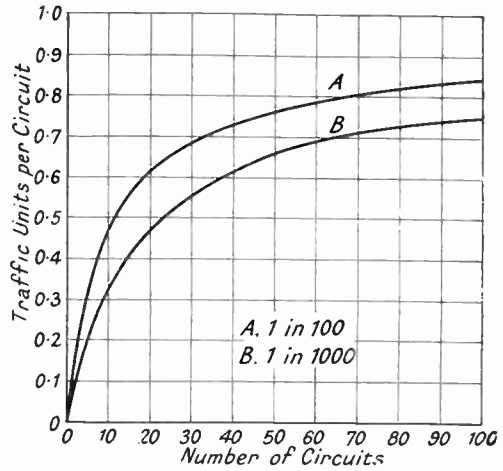

Fig. 6.—THIS SHOWS THE RELATION BETWEEN NUMBERS OF CIRCUITS AND THE AVERAGE TRAFFIC PER CIRCUIT FOR THE SAME GRADES OF SERVICE AS IN Fig. 5.

The Working of an Automatic Exchange.

It has been mentioned that the amount of junction plant required between two manual exchanges depends on the average duration of a call as well as on the number of calls. In an automatic exchange, the same principle is true for nearly every item of the plant. Thus, from Fig. 4.

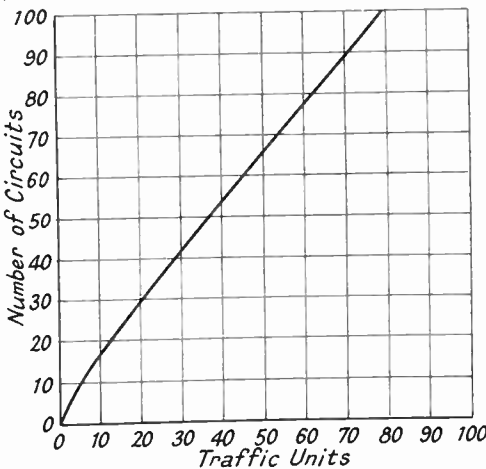

Fig. 7.—METHOD OF ESTIMATING THE NUMBERS OF JUNCTION CIRCUITS BETWEEN MANUAL EXCHANGES.

This does not correspond with a fixed grade of service, but gives a better grade of service on large groups than on small ones.

which represents a typical exchange trunking diagram, it will be seen that when the subscriber lifts his receiver to initiate a call the first result is that the "unselector" corresponding to his line will hunt for a disengaged first selector.

What Happens When a Number is D'aled.

When he dials the first digit, the connecting brushes of the first selector will be lifted to the level corresponding to this digit and will then proceed to hunt automatically among the circuits on that level for one providing an outlet to a disengaged second selector. Similarly, the second selector will respond to the second digit and hunt for a disengaged "final" selector which will then receive the last two digits and complete the connection to the called subscriber.

Why a Call May Fail.

At each of these hunting operations, three in number, there is a chance that the call may fail because the search for a disengaged outlet is unsuccessful. In such cases, the usual practice is to arrange that the "busy" signal shall be given to the calling subscriber and that the failure of the call shall be registered on a special meter called an "overflow" meter. The immediate problem is to

determine what number of selectors at any stage should be provided in order that this busy condition may not arise too often. It will be clear that if the exchange were designed so that there will always be sufficient plant available for any demands made upon it, the provision would be extravagant and uneconomical.

Proportion of Calls Liable to Fail.

A reasonable limit has therefore to be set to the proportion of times a call may fail for the want of an available outlet. This is expressed as the "grade of service," which is defined as the proportion of calls which are liable to fail at any switching stage owing to the limitation for economic reasons of the amount of plant. In the British Post Office, the grade of service at each stage is generally one lost call out of 500, with the added condition that if the traffic should increase temporarily by 10 per cent., the grade of service shall not fall below one lost call in 100.

How the Amount of Plant is Determined.

Although the amount of plant depends on the number of calls and on their duration, it will be clear that it also depends on the number of simultaneous calls at any time. These two ideas are related under the term "traffic unit," or unit of traffic flow, which is defined in the following way:—In the first place, traffic flow is defined as the number of simultaneous communications in progress at any instant. The number of traffic units carried by a group of circuits during an hour is the average number of simultaneous calls during that hour. This can be shown to be the same as the number of calls originating during the hour multiplied by the average duration of these calls expressed in hours. For automatic working, the idea of traffic flow as consisting of simultaneous calls is the most useful one. The number of selectors provided must be in excess of the average number of calls because the actual number fluctuates from one moment to another. The actual amount in excess of the average which must be provided depends on the grade of service and on the size of group considered.

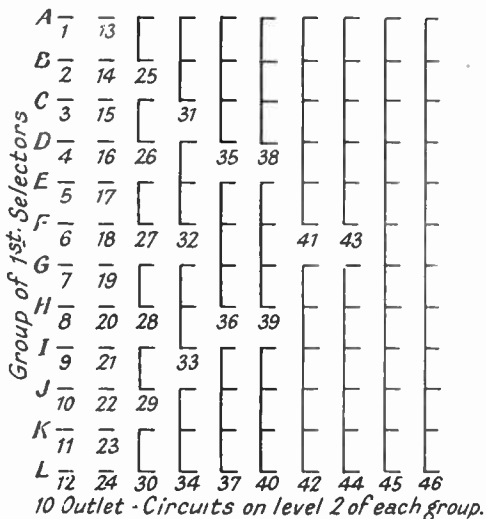

Fig. 8.—THE "GRADING" METHOD USUALLY EMPLOYED IN THIS COUNTRY.

It is assumed that 12 groups of first selectors, each having a common "multiple" of outgoing circuits, need to be connected on one of their levels to 46 circuits leading to second selectors. The different groups of first selectors are designated by the letters A to L; the row of short lines after each letter indicates the 10 circuits coming from, say, level 2 of that group of selectors.

" Full Availability " Condition.

If we make the assumption in the first place that any call can reach any disengaged circuit—this is termed the " full availability " condition—then the conditions in this country are best met by a theory which is the work of Dr. Erlang, of Copenhagen. Fig. 5 shows the relation between traffic units and the numbers of circuits required to carry them, for grades of service of one in 100 and one in 1,000, while Fig. 6 shows the relation between numbers of circuits and the average traffic per circuit for the same grades of service. It will be seen that the average traffic per circuit is greater for the lower grade of service and that for the same grade of service it is greater for large groups than for small groups.

Carrying an Overload.

Fig. 7 shows the design curve usually employed in estimating the numbers of junction circuits between manual ex-

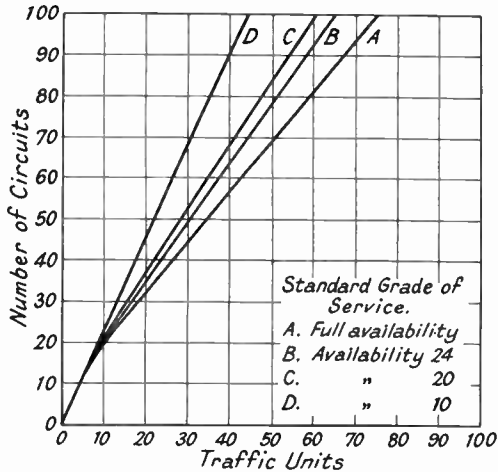

Fig. 9.—THIS SHOWS THE TRAFFIC CAPACITY OF THE ARRANGEMENTS GENERALLY USED IN POST OFFICE PRACTICE FOR THE STANDARD GRADE OF SERVICE.

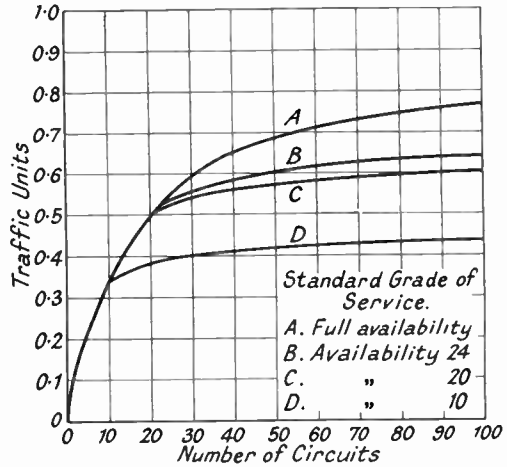

Fig. 10.—THIS SHOWS THE AVERAGE TRAFFIC PER CIRCUIT FOR THE SAME ARRANGEMENT AS SHOWN IN FIG. 9.

changes. This does not correspond with a fixed grade of service, but gives a better grade of service on large groups than on small ones. The reason for this is that, since the available margins are more fully absorbed on large groups, a small group of circuits will carry an overload with less deterioration of service than a large group.

When Availability is Limited.

The foregoing remarks apply to the full availability condition. Generally speaking, in automatic working, availability of choice is limited by the design of the plant. Thus, if we consider the circuits outgoing from, say, level 2 of first selectors to second selectors, any given call can only hunt for a disengaged outlet among a number of circuits equal to the number of contacts in the selector bank; this is usually 10 or 20 in Post Office practice. It will be clear that the amount of traffic which a given number of circuits will carry will be less when the availability is limited than when it is full, because the busy signal will be given when all the circuits in an available group of 10 or 20 circuits are engaged, although circuits in other groups may be disengaged. When availability is limited, the problem arises as to how the

total circuits provided can best be distributed among the circuits which are hunting for them.

The "Grading" Method.

In British Post Office practice, the method usually adopted is that termed "grading," which is illustrated in Fig. 8. In this figure, it is assumed that 12 groups of first selectors, each having a common "multiple" of outgoing circuits, need to be connected on one of their levels to 46 circuits leading to second selectors. The different groups of first selectors are designated by the letters A to L; the row of short lines after each letter indicates the 10 circuits coming from, say, level 2 of that group of selectors. It will be seen that the two circuits representing the first and the second choice of each group are individual to that group and cannot be reached from any other group. The third choice is shared between two groups, the fourth choice is shared among three groups, and so on, until the ninth and the tenth choice (outlet circuits 45 and 46) are made accessible from any of the 12 groups. Thus a total of 120 circuits coming from the banks of level 2 on these selectors is reduced to 46 circuits leading forward to second selectors. The availabilities

generally used in Post Office practice are 10, 20, and 24 and the traffic capacity of these arrangements (using grading) as compared with the full availability case is shown in Fig. 9 for the standard grade of service.

Fig. 10 shows the average traffic per circuit for the same arrangements.

Traffic Measurement.

The foregoing briefly outlines the main principles which govern the traffic design of an exchange, and upon which measurements of traffic are made in working exchanges in order to provide for the design of extensions, and other similar

matters. The basis of traffic measurement throughout is the traffic unit applied to groups of circuits, or, in other words, the average number of simultaneous calls over those circuits. This may be obtained by actual counting, but automatic means of obtaining the same information have been developed. Overflow meters, which measure the number of calls which fail to mature owing to shortage of plant, have already been mentioned. In practice a great many other points require to be considered and provided for, in order that the volume of plant provided may suffice to carry the traffic satisfactorily without wasteful over-provision.

THE USES OF SHUNT, SERIES AND COMPOUND-WOUND DYNAMOS AND MOTORS

Direct current electric machines may be divided according to the method of field excitation into four main classes, namely, shunt, series, compound and over-compounded.

Shunt-wound motors are used for driving factory machinery where a 5 per cent. decrease in speed between no load and full load can be tolerated. Thus a shunt-wound motor is quite suitable for driving drilling machines, lathes, grinders, blanking presses, guillotines, planers, shapers and milling machines.

Shunt-wound dynamos are used for charging accumulators and supplying current for lights and other purposes where a 5 per cent. decrease in voltage output between no-load and full-load does not vitally matter.

Compound-wound dynamos are used in the transmission systems of petrol-electric vehicles in conjunction with a series-wound motor where a decrease in output voltage with increase of output current is necessary. A series-wound dynamo is not suitable for charging accumulators.

Series-wound motors are chiefly applicable to traction where a strong starting torque, not characteristic of the shunt motor, is necessary. The speed of a series-wound motor decreases considerably with an increase of load and a large motor will race dangerously if the load is entirely removed. Series-wound motors are also used for small electric tools and vacuum cleaners, on account of the ability of a series motor to work on alternating current. This type of motor is used for car starters.

Compound excitation is a combination of series and shunt windings whereby it is possible to obtain a perfectly constant output speed in a motor and a constant voltage output in a dynamo. An over-compounded dynamo is used for supplying power to traction systems where an increase of voltage with an increase of load is desired. An over-compounded electric motor is applicable to rolling mills where an increase of speed is necessary as the load increases with the cooling of the metal being rolled.

HAIRDRESSERS' EQUIPMENT

FROM THE ELECTRICIAN'S POINT OF VIEW

By I. B. CALVETE, F.R.S.A.

A VALUABLE sideline that might profitably be explored by the enterprising electrician is the installation of electrical apparatus in hairdressers' shops. The modern hairdresser has found it necessary to make use of many electrical machines and appliances, such as electrical hair-dryers, permanent-waving apparatus, and haircutting and shaving apparatus.

Not only can much useful work be obtained in the fitting and repair of this apparatus, but where a hairdresser has not already the facilities for their use, it is possible that quite a fair amount of work may be obtained from fitting additional points for plugs and switches.

This article gives some practical advice regarding the maintenance of electrical apparatus for hairdressers, while the illustra-

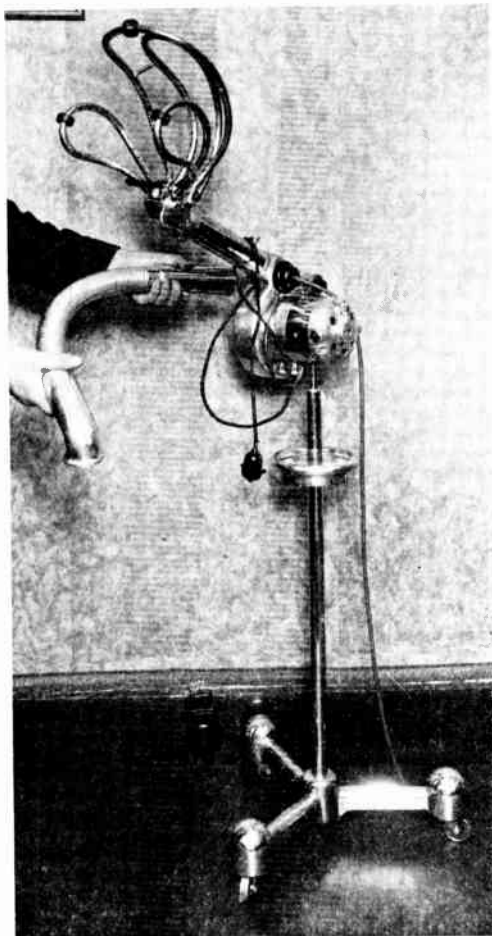

Fig. 1.—PEDESTAL HAIR-DRYER WITH TUBULAR HOOD IN POSITION.

The hood is removable and a flexible tube adapted instead when required. The drum swivels round and up and down to take any convenient position. There is a triple-action switch to give hot, cold and off, also a pear switch giving high and low heat, which is controlled by the customer.

tions show various methods of adjustment.

The Electric Hair-dryer.

The most useful machine in ladies' saloons is the hair-dryer. In conjunction with permanent waving or water waving, or even an ordinary shampoo, the hair-dryer is called upon to do its work as quickly as possible. In the process of permanent waving, the hair has to be shampooed before and after the operation and the hair-dryer is used for nearly an hour on each customer. Bearing this in mind, it has been the aim of manufacturers to produce hair-dryers of great efficiency, capable of reducing the required time by half. Fig. 1 shows a pedestal hair-dryer with the tubular hood in position. This hood is removable and a flexible tube adapted instead when required. The drum



Fig. 2.—HIGH FREQUENCY APPARATUS.

Showing, in the foreground, from left to right, the kicking coil, the condenser and the resonator or oscillating coil.

swive's up and down to take any convenient position. There is a simple action switch to give hot, cold and off; also a pear switch giving high and low heat, which is controlled by the customer.

Double Windings for D.C. and A.C.

The hair-dryer is provided with special double windings for use in D.C. or A.C. supplies. Fig. 6 shows the two pairs of

terminals, one for D.C. and the other for A.C.

The Fan Turbine.

In the hair-dryer the fan turbine is held in position by means of a concentric chuck and nut. (See Fig. 7.)

Removing the Heating Element.

It is quite a simple matter to remove

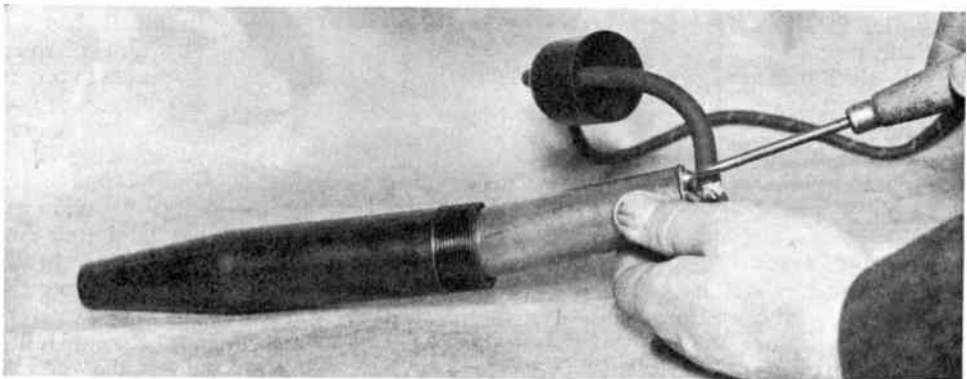

Fig. 3.—HIGH FREQUENCY APPARATUS.

Removing the connection from the resonator which is contained in the bakelite handle.

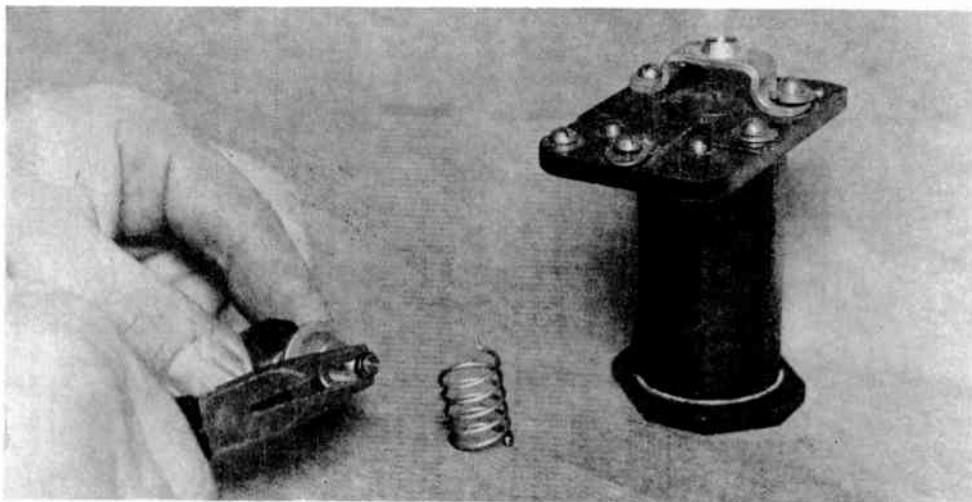

Fig. 4.—THE KICKING COIL OF THE HIGH FREQUENCY APPARATUS.

This has a trembler blade and a bridge which receives the controlling knob. The spark takes place between two tungsten contacts. This illustration shows how the tungsten contact is removed from the knob.

the heating element of the hair-dryer. All that is necessary is to give it a pull and it will come off the nozzle as shown in Fig. 8.

Portable Hairdryers.

Another popular form of hair-dryer is the portable type. Should it be necessary

to replace the carbon brushes, clean the commutator or replace the heating resistance, the cover and nozzle can be removed to obtain access to the motor.

Apparatus for Permanent Waving.

Permanent waving has now been adopted



Fig. 5.—PORTABLE HAIR-DRYER.

Showing the cover and the nozzle removed to obtain access to the motor when it is necessary to replace the carbon brushes, clean the commutator or replace the heating resistance.

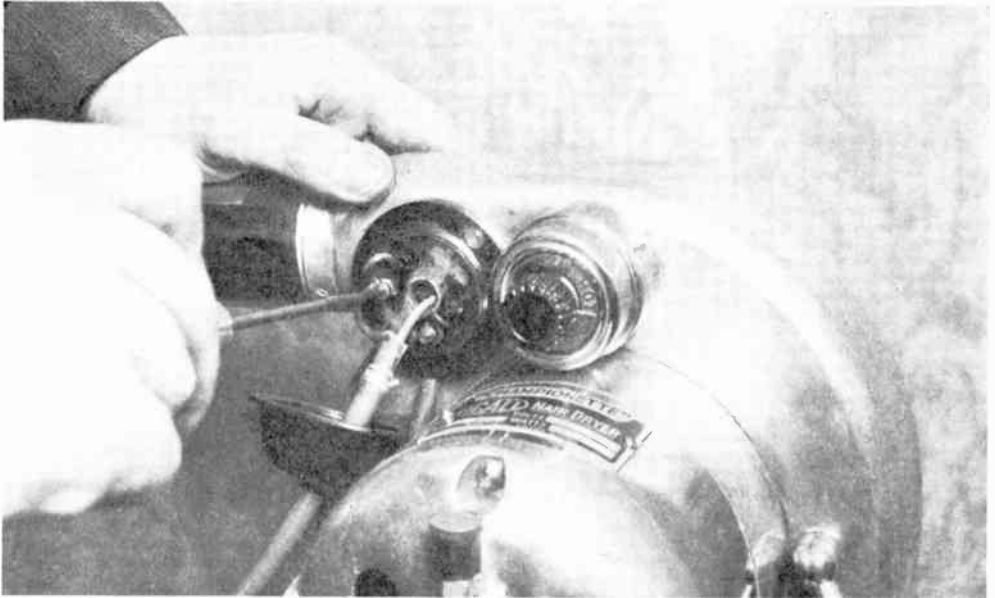

Fig. 6.—PEDESTAL HAIR-DRYER.

This is provided with special double windings for use in D.C. or A.C. supplies. The illustration shows the connecting box with two pairs of terminals, one for D.C. and the other for A.C.

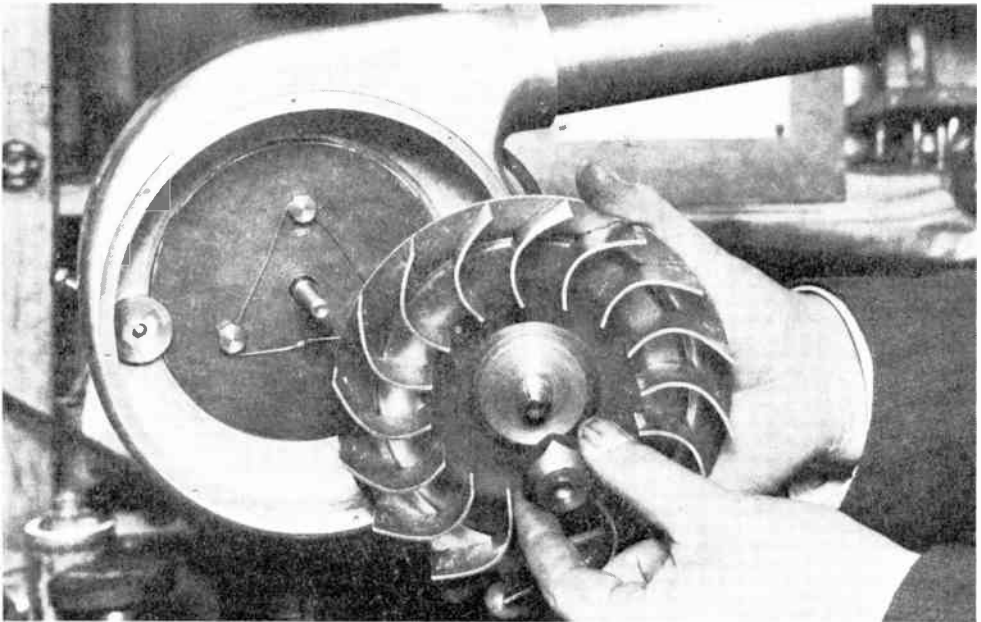

Fig. 7.—PEDESTAL HAIR-DRYER.

The fan turbine is held in position by means of a concentric chuck and nut. The interior of the drum shows the swivelling arrangement with a locking device (on the left, inside the drum).



Fig. 8.—HOW TO REMOVE THE HEATING ELEMENT.
All that is necessary is to give it a pull and it will come off the nozzle.

by most ladies' hair dressers. The process is rather elaborate and requires reliable electrical apparatus and calls for special attention in installing.

The Heaters.

A permanent-waving outfit consists of the machine and a number of heating units called heaters. (See Fig. 9.) All the heaters must generate exactly the same amount of heat and must be well insulated. By removing the cover of the chandelier, the connections to the plugs and switches are exposed. (See Fig. 10.)

Fig. 11 shows the cover removed from one of the heaters, showing the heating element in position and also after being removed for re-winding. The heaters are fitted to the machine by means of the suspender shown in the photograph.

Heating Appliances.

Other machines used by hairdressers are electrical stoves for curling irons and electro-medical apparatus.

Violet and Heat Ray Apparatus.

Fig. 12 illustrates a

typical high frequency apparatus in which the voltage can be changed from 100 to 220 by turning a knob. Various parts of the apparatus are shown in Fig. 2. The kicking coil (shown in Fig. 4) has a trembler blade and a bridge supports the controlling knob. The spark takes place between two tungsten contacts. The method of adjusting these is illustrated in Fig. 4, while Fig. 3 shows the method of removing the connection from the resonator which is contained in the bakelite handle.

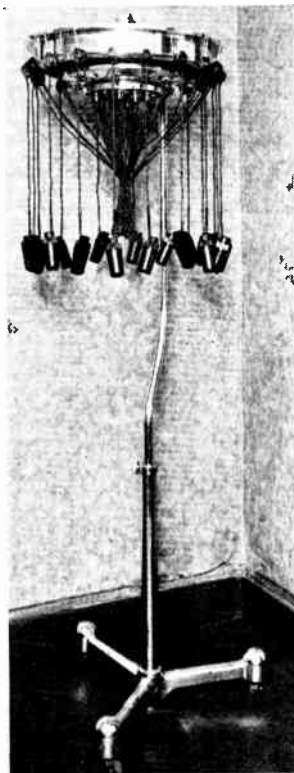

Fig. 9.—PERMANENT-WAVING MACHINE.

This apparatus has 18 heaters, which are fitted to the machine by means of the suspender shown in Fig. 11.

High-frequency electric current — usually called violet ray—is not to be confused with ultra-violet ray or artificial sunlight. The high-frequency current is produced by conducting the ordinary lighting current through a series of special coil—containing miles of fine wire—causing such tremendous rapidity of electrical oscillation that human nerves are insensitive to it. Science has demonstrated that the sensory nerves are capable of feeling pain from electric waves or oscillations up to 100,000 per second.

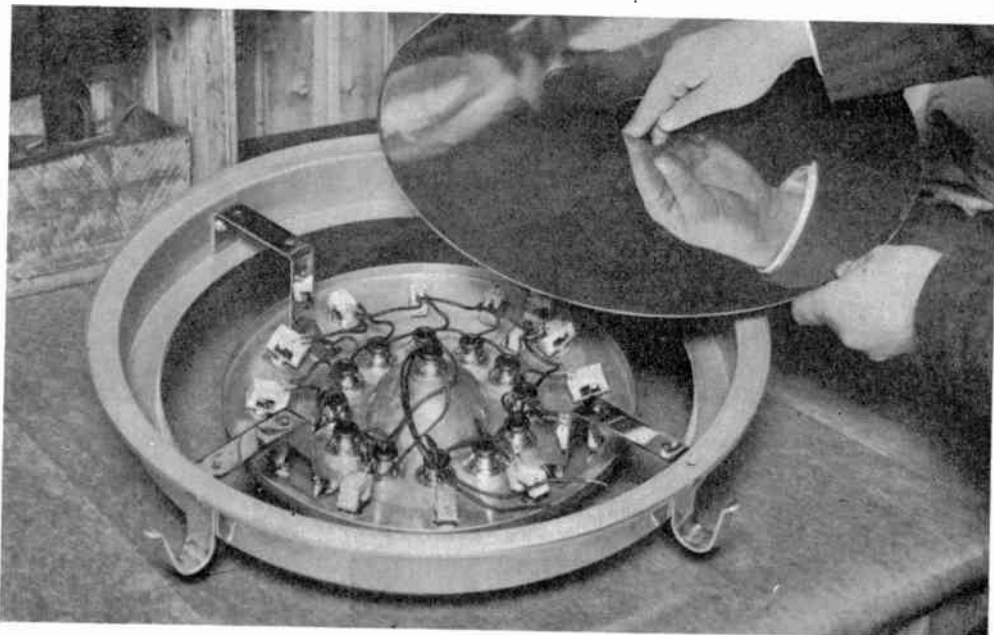

Fig. 10.—PERMANENT-WAVING MACHINE.

The chandelier with the cover removed shows the connections to the plugs and switches.

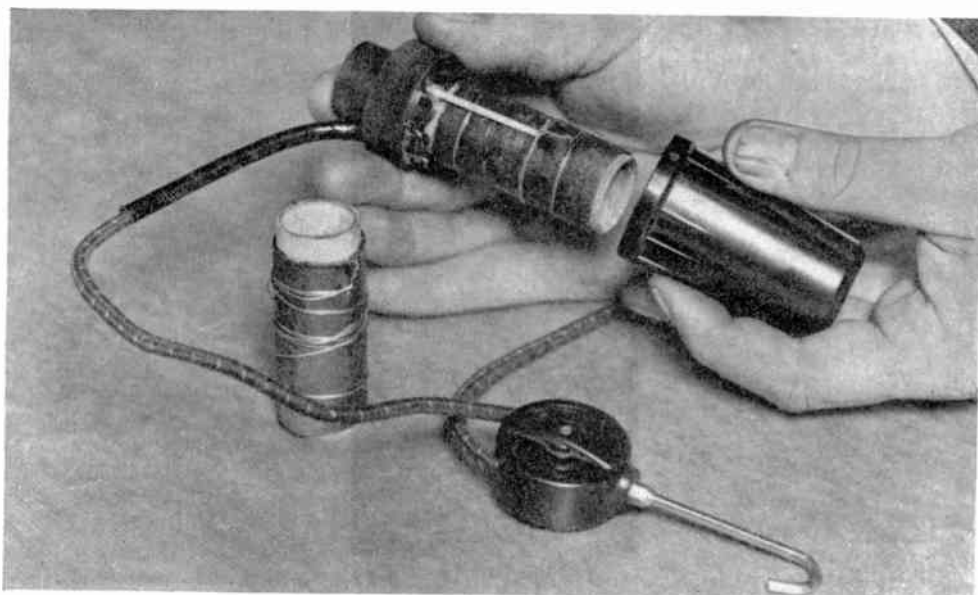

Fig. 11.—HEATER OF THE PERMANENT-WAVING MACHINE.

With the cover removed, showing the heating element in position and also after being removed for rewinding. The suspender in the foreground is used to keep the heater in any desired position.

Therefore, when we produce a current with oscillation higher than this, we can apply it to the human body without fear of causing discomfort.

A high frequency generator produces a current with oscillations running into millions per second, thus causing no pain or unpleasant sensation whatever; but, on the contrary, giving an immensely

smooth discharge and producing an agreeable and refreshing effect.

Ultra-Violet Ray.

Earlier articles in this work have dealt

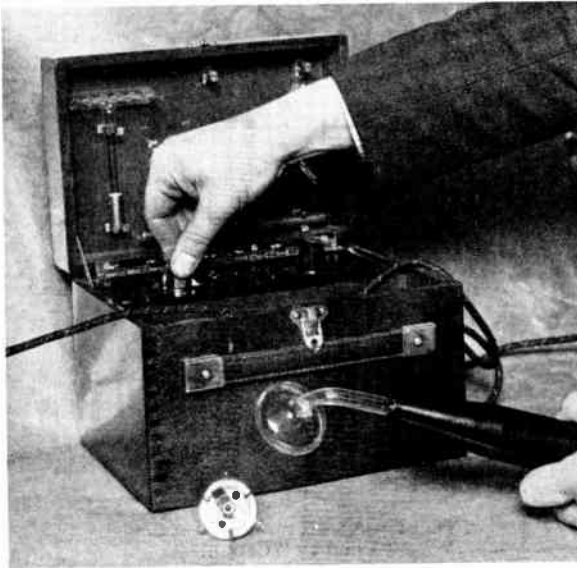

Fig. 12.—HIGH FREQUENCY APPARATUS.

Operating the knob to change the voltage from 100 to 220. A special 3-way switch, shown in the foreground, is employed.

with the subject of ultra-violet ray apparatus. It will be realised by the reader that this is quite distinct from the violet ray which is really very high frequency current. Sunlight is, of course, the most powerful source of ultra-violet radiations, especially when the sun's rays can reach the body before the ultra violet radiations have been filtered out by impurities in the atmosphere.

It is worth remembering that ordinary window glass is opaque to these beneficial rays although it is transparent to ordinary light rays. Quartz glass allows ultra-violet rays to pass through.

WHY CABLES ARE STRANDED

Electric cables have stranded conductors for two reasons. First, to increase the current-carrying capacity of the cable. A cable consisting of many strands of copper wire has a larger capacity than a cable made from a solid conductor, for although the area of copper is the same in both, the stranded conductor has a larger heat-radiating and conducting surface and so permits a higher current density for the same temperature rise.

The second reason for stranding is to give flexibility. Flexibility is necessary

not only for electric light pendants, but for large cables which have to be wound and unwound from drums and frequently bent round corners. The property of flexibility of a wire also permits continual bending with less chance of breaking. Where extreme flexibility is necessary, as for the telephone receiver cords, wireless loud-speaker and headphone cords, a different kind of flexible conductor is used. This consists of very thin copper wires wound on silk or cotton threads, known as tinsel, which is covered with cotton or silk braiding.

ELECTRIC CLOCKS

THERE are four main types of electric clocks, namely, self-wound clocks, synchronising clocks, A.C. motor clocks and master-clock circuits.

(1) *Self-wound clocks* measure time by means of an escapement controlled by a balance wheel or a pendulum, electricity being solely used to provide the motive power.

(2) *Synchronising systems* assume a central time station which sends out electrical impulses—at each hour, or once a day—to correct the hands of complete clocks having an independent life of their own, whether key-wound or self-wound.

(3) *Continuously running synchronous A.C. motor clocks*, plugged into the electric light supply, are really not clocks at all, since they have no escapement, and do not measure time but merely indicate on a clock dial the time kept by the alternators in the generating station.

(4) *Circuits of electrically propelled dials* consist of a "transmitter," "controlling pendulum," or "master clock," which sends out electrical impulses at short intervals—usually every half-minute or minute—to propel the hands of "receiver," "indicator," or "impulse" dials.

Self-wound Clocks.

The first named, *self-wound clocks*, are numerous and interesting, because they "go without being wound up" and do nothing to secure uniformity. They have the defect of their merit. Since they require no winding, they are apt to be neglected and allowed to run wildly out of time.



Fig. 1.—A MODERN ELECTRIC "PLUG-IN" CLOCK.

It is only necessary to connect this clock to a convenient plug, set it to the correct time, and start the motor. The motor is not self-starting, so should there be any interruption of the current there is no danger of the clock starting up and registering the wrong time (*Smith's English Clocks, Ltd.*).

Synchronising Systems.

The second, *synchronisation*, is a system that has to be undertaken by owners of large networks of wiring, such as the Post Office. At present it is thought that the cost of such a network, if devoted exclusively to the purpose, is for practical purposes too great compared with its earning power. The only service available in England is that of the Standard Time Co., Ltd., established in London fifty years ago.

A.C. Motor Clocks.

The third, *A.C. motor or "plug-in" clocks*, were first commercially introduced in America under the name Telechron about the year 1920, and

have since become popular in the U.S.A. They were based upon the Warren frequency meter, in which a very small motor running at 3,000 r.p.m. has shading rings of copper on its poles whereby the A.C. current produces a rotating magnetic field which ensures synchronous running of a small steel disc and makes it self-starting.

The recent tendency towards the adoption of A.C. supply throughout the British Isles, and its standardisation of voltage and periodicity by the Electricity Commission under the grid system, creates conditions favourable to this method of time-keeping, and when the phase frequency of the generators is maintained precisely, against really accurate clocks in the central stations, there should be a considerable demand for A.C. motor clocks, particularly for domestic use.

The idea of being able to "plug-in" a clock of this kind on one's house supply is as alluring to the householder as is the

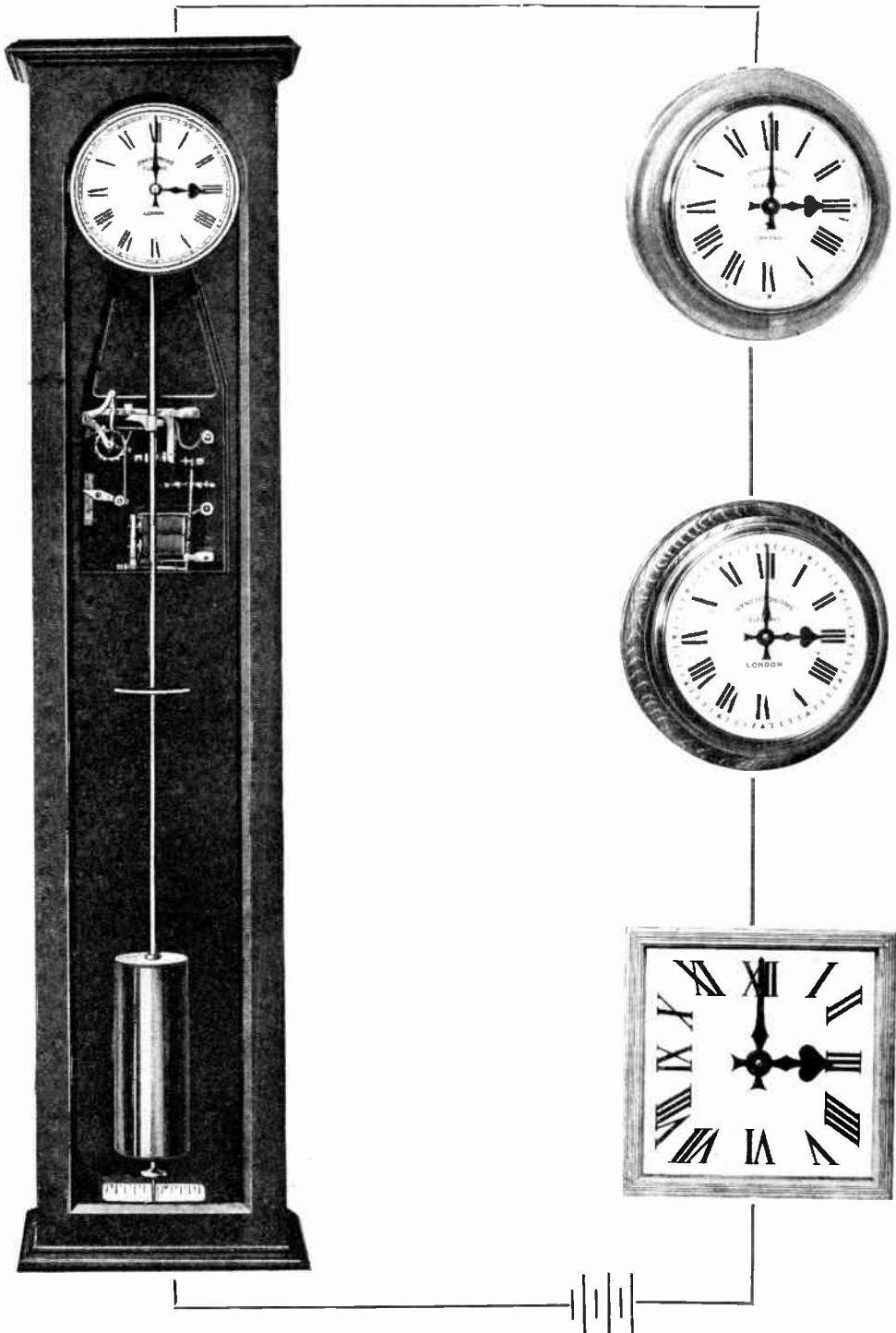

Fig. 2.—How the SYNCHRONOME ELECTRIC CLOCK SYSTEM IS WIRED.
The master clock and the secondary clocks are connected in series with a battery.

prospect to the shopkeeper of selling over the counter an electric clock which does not require installation, but it cannot truthfully be said that no wiring is required, since if you monopolise a two-pin plug intended for a reading lamp or a radiator you will presumably require another. And the liability to stoppage owing to the blowing of a fuse must not be ignored, whilst the possibility of a station or mains breakdown must always remain.

Fixing a Clock in Position.

The mantelshelf will usually be considered the best place for a clock of this type, and if there is a plug at the side of the chimney breast, the easiest way to wire for it is to loop out a 2-amp. wall socket through a fuse with flex. In offices where a dial with a circular frame is required on the wall, a position may be selected over the door within reach of the switch by the side of the architrave, but it must be looped in between positive and negative and a negative wire is not always available at a switch. Temporary makeshifts of this kind will be inevitable unless and until these clocks come into such general use

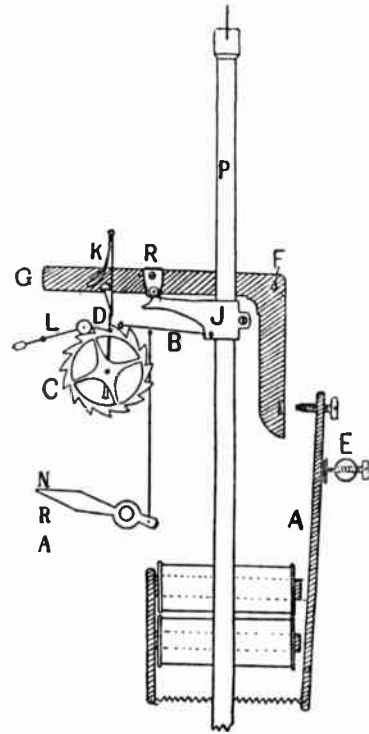

Fig. 3.—SWITCH MOVEMENT OF A SYNCHRONOME ELECTRIC CLOCK.

The gravity arm G which is held up in the catch K is released by the vane D once every half-minute when the wheel C has been pulled round one revolution by the gathering click B. The gravity arm is pivoted at F and carries a little roller R which falls upon the bracket J and gives a push to the pendulum P. When the gravity arm touches the contact screw E set in the top end of the armature A, the electro-magnet throws the gravity arm up on to its catch again.

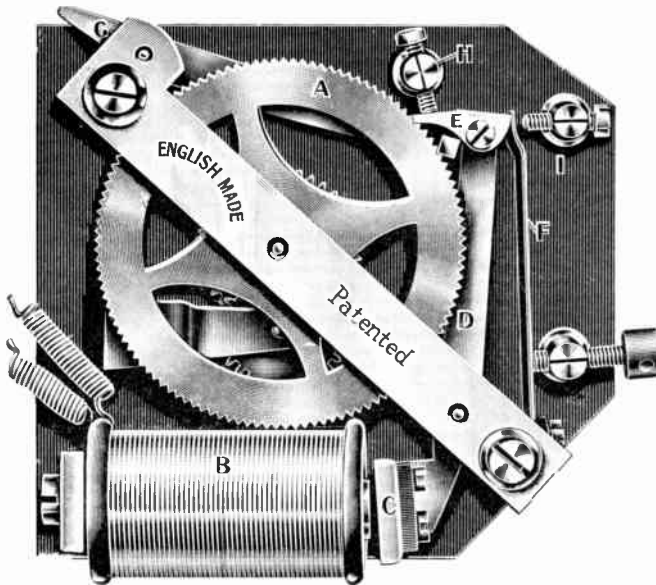

Fig. 4.—DIAL MOVEMENT OF SYNCHRONOME SYSTEM.

A—Ratchet wheel. B—Electro-magnet. C—Armature. D—Actuating arm. E—Pawl. F—Pawl spring. H.—Pawl stop.

that special wall socket points are habitually provided for them.

What Happens when the Current is Cut Off.

It must not be taken for granted that it is an advantage for these little synchronous

motors to be self-starting, since in the event of a temporary interruption of the supply they would be found going again and indicating the wrong time. The Warren Company provide a window in the dial behind which a red disc appears if the current has been cut off, as a warning that the clock is wrong and requires resetting.

A type which can be strongly recommended is known as Synchrono-Mains, in which the motor, which is British made, is of a comparatively slow speed and is not self-starting. Since it is always necessary to set each individual clock to time after an interruption, a setting device is provided which automatically starts the motor immediately after use.

THE SMITH SYNCHRONOUS ELECTRIC CLOCK.

The motor essentially consists of two parts—(a) the stator and (b) the rotor.

(a) The stator is clamped in a substantial bakelite housing and consists of two pressed steel cups enclosing the energising coil. The coil is wound on a cellulose acetate moulding which effectively protects the winding from mechanical damage. The poles are arranged on the inner periphery so that the whole unit is robust and the rotor is protected from accidental damage.

(b) The rotor consists of a star-shaped cobalt-

chrome permanent steel magnet mounted between two brass discs and fixed to a steel spindle. The properties of this type of magnet are practically unlimited life without appreciable demagnetisation and considerably greater strength than for any other type.

Specially ground and polished bearings are employed which ensure silent and smooth running. These are self-lubricating and, therefore, do not require either oiling or cleaning.

Setting and Starting the Clock.

The motor is not self-starting and the clock is, therefore, free from the serious objection that, in the event of a temporary cessation of the supply, it will start up indicating the wrong time, and remain so. The setting to time and starting up are performed by the simple operation of a single lever, and one cannot be done without the other.

The motor runs at the comparatively low speed of 200 r.p.m. when connected to a supply of 50 cycles (commonly known as frequency). The power consumed by this motor is only in the order of 1 to 1.5 watts. The motor provided for an ordinary 3½-in. drum clock has ample power to operate clocks with 12-in. diameter dials.

Master-Clock Systems—

The fourth system of electric clocks is that of

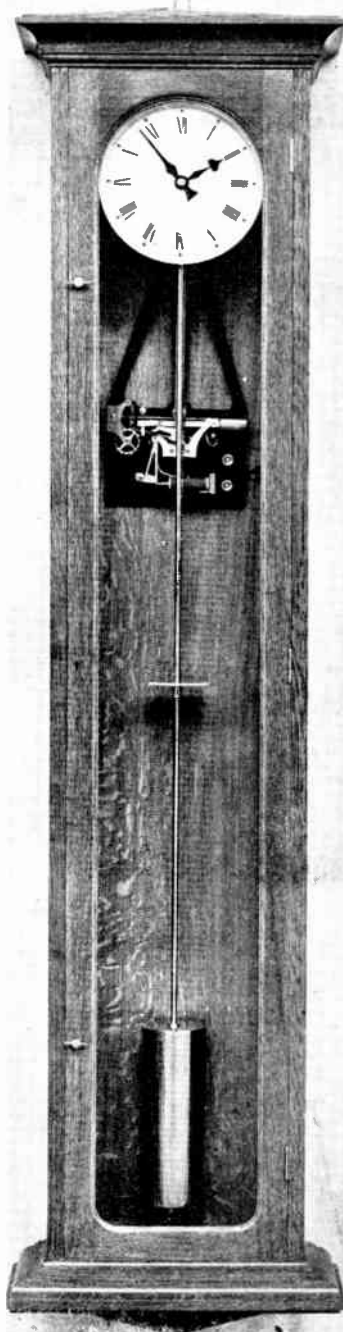

Fig. 5.—THE GILLETT-JOHNSTON MASTER CLOCK.

The distinctive feature is the patent swinging armature.

the *circuits of electrical impulse dials*, and time service installations of this kind have been adopted to a growing extent during the first thirty years of this century, and have reached a high standard of automatic accuracy.

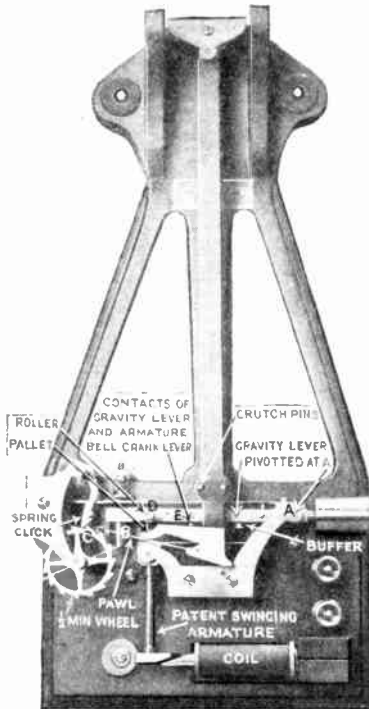

Fig. 6.—How THE MASTER CLOCK WORKS.

In this illustration the pendulum has been removed, but it normally suspends from the rod located between the two crutch pins. (Gillett & Johnston.)

—And How They Work.

The *synchronous propulsion of groups of clocks* dispenses with ordinary clock work and substitutes "dial movements" which propel the hands, usually by means of an armature lever pulled by a magnet and replaced by a spring. Hence the name "electrical impulse dials," the impulses being transmitted by a master clock. All attempts to produce such impulses by the application of contacts to the wheelwork of ordinary clocks have

proved more or less unsatisfactory owing to the small power available and to a want of precision in the make and break. Where such contacts are used, the only safe thing to do is to reverse the direction of the current at each impulse and use polarised mechanisms in the dials. Broadly speaking, this is the Continental method, and is represented by such systems as Grau-Wagner, Siemens & Halske, Peyer-Favarger and Aron. Intermittent or "splashy" impulses can then do no harm because they can only rock the armature in one direction.

Overcoming Failure of Battery and Contact.

The "Magna" induction system claims to overcome troubles due to failure of battery and contact, more or less inherent in foreign practice. Polarised dial movements are employed, and the master clock consists of a weight-driven dynamo whose armature makes a revolution once a minute. This is a great improvement on the induction system of Wheatstone. A master clock capable of operating a large circuit of small dials, or even a small circuit of large dials, must be both costly and cumbersome compared with one which has only to operate a switch, and will require frequent winding.

THE SYNCHROME SYSTEM.

At the British Horological Institute in 1895, and at the Institution of Electrical Engineers in 1899, Mr. F. Hope-Jones introduced a simple method of obtaining in connection with a pendulum a non-intermittent impulse perfectly clean in the make and break, and of a duration which automatically adjusts itself to the requirements of the dial movements in series with it. It forms the basis of the "Synchrone" switch. It may be described as a switch so combined with a pendulum that it operates every half-minute, the action of the switch being cleverly arranged to impart an impulse to the pendulum to keep it swinging for the next thirty seconds.

How the Switch Works.

The switch consists of two moving parts: (1) the right-angled lever G (see

Fig. 3) centred at F and normally supported on the spring catch K. Once every half-minute the lever is let down (in the act of giving an impulse to the pendulum P) upon (2) the armature A. Current from any available source then passes through the series circuit of dials and the magnet, which attracts the armature A and throws up the lever G on to its catch again.

How Impulses are Imparted to the Pendulum.

The pendulum releases the switch by means of the 15-toothed wheel C, which carries a vane D engaging with the catch K at each revolution. The hook B pivoted upon the pendulum P turns this wheel once every thirty seconds. At the moment of its release the little roller R on the gravity arm G is just above the curved end of the pallet J, down which it runs, giving an impulse to the pendulum *at the moment when it passes through its zero or central position.* Thus the pendulum is free at all times except in the middle of its swing; not only is the escapement detached, but it operates at zero, a combination which horologists have always been aiming at, but had not hitherto attained.

An important development of this invention (described at the Royal Society of Arts in 1924) is the free pendulum designed by Mr. W. H. Shortt, M.Inst.C.E., which has taken all the world's records for accuracy of time measurement at Greenwich and other Observatories.

How Failure of the Battery is Indicated.

Indication of impending failure of battery is clearly given by the prolonged duration of contact which results from the switch magnet being unable to replace the weighted lever without the assistance of the pendulum, which is so arranged to render that assistance when necessary. This duration is normally about the twentieth part of a second, but is increased to a whole second when the battery is insufficient, yet the circuit will

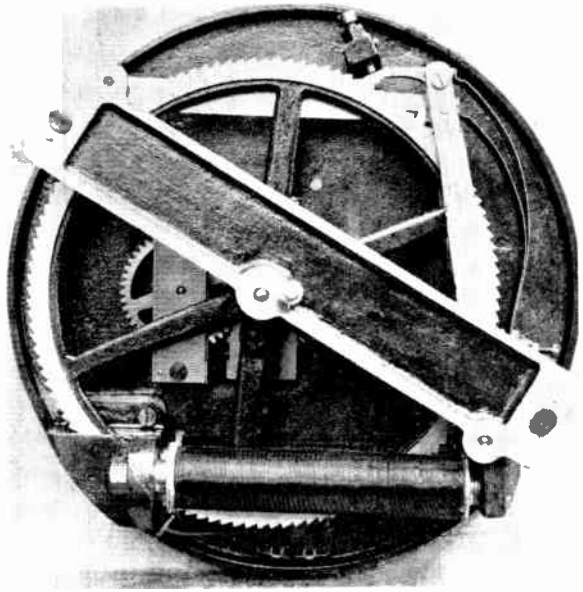

Fig. 7.—SECONDARY CLOCK MOVEMENT. The minute hand is driven direct by the 120-toothed ratchet wheel and the hour hand is geared down 12 to 1 in the usual manner. (Gillett and Johnston.)

continue to run perfectly for some days before finally stopping. If this warning is neglected and the system is allowed to stop, the pendulum will hold the switch open, thereby preventing the battery from completely exhausting itself.

Using a Bell or Lamp.

If desired, a single-stroke bell or small carbon filament lamp may be included in the series circuit, so adjusted that the normal impulses of the short duration will not affect it, but the weaker the current and the longer the contact, the more loudly will the bell ring, or the more brightly will the lamp flash.

Dial Movement for Existing Clocks.

The dial movement of the Synchronome system (Fig. 4) is readily applicable to existing clocks of all kinds, from those on the mantelshelf with 3-inch dials to those in a turret with 10-foot dials. When the latter are illuminated the movements are fixed to the opal centres of the dials and are relatively so small as to be covered by the bosses of the hands,

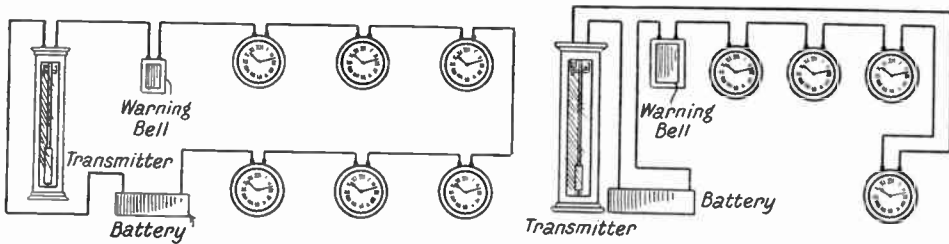

Fig. 8.—How the PUL-SYN-ETIC MASTER CLOCK AND IMPULSE CLOCKS SHOULD BE WIRED. The diagram on the left shows the principle of "series wiring." Where it is not possible to arrange them in a complete ring the alternative method shown on the right should be used, and this still follows the principle of "series wiring."

consequently the clock chamber is entirely empty and available for illumination, no shadows being thrown.

Inspecting the Hands.

The central panels of the dials can be made detachable, enabling them to be drawn inwards for the inspection of hands; the facility thus afforded for access to the outside faces of turret dials is invaluable in church steeples and towers where costly scaffolding would otherwise have to be erected whenever the dials were cleaned.

Setting the Dials to Time.

Convenient means of setting all the dials to time is provided by the lever on the left-hand side of the controlling pendulum switch (see Fig 3.) When this lever

is at *N, B* releases the switch once every half-minute. This is *normal* position. When depressed to *R* the switch will be put out of action altogether and the dials *retarded* for as long as may be necessary. When the lever is further depressed to *A*, the dials will be *accelerated*, because the switch will be released at every other swing of the pendulum.

This device was invented in 1909 to assist the late Mr. William Willett in his campaign for Daylight Saving by demonstrating the ease with which large numbers of clocks could be set forward or backward.

Why the Circuits are Wired in Series.

Circuits of electrical impulse dials are wired in series in order to secure the benefit of the Synchronome principle, which uses self-induction to dictate the duration of the contact.

Why Electric Light Wire Should be Used.

Substantial wiring is therefore demanded both on the grounds of conductivity and mechanical strength; 3/.036-inch electric light wire is recommended, and though ordinary electric bell wire of 18 gauge is electrically sufficient both for conductivity and insulation, a triple conductor should always be used in order to minimise the risk of disconnection and ensure respect for the line. All instruments being in series, care should be taken to avoid

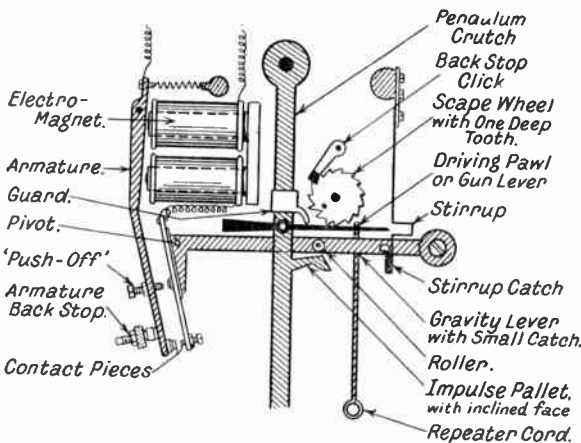

Fig. 9.—TRANSMITTER SYSTEM OF THE PUL-SYN-ETIC ELECTRIC CLOCK.

loose connections, and the terminals should invariably be screwed up with pliers.

Fitting Non-inductive Shunt Coils.

In the best systems, non-inductive shunt coils are fitted in the dial movements in parallel with the electro-magnets to absorb the spark at the break, and since the strength of a chain is that of its weakest link, these serve also as an extra path for continuity in parallel with the magnet wires which are necessarily small and weak.

Operating Series Circuits in Parallel.

The Synchronome switch can be used to operate a number of such series circuits in parallel. An outstanding example of this is the large head offices of the Imperial Chemical Industries at Millbank, where upwards of

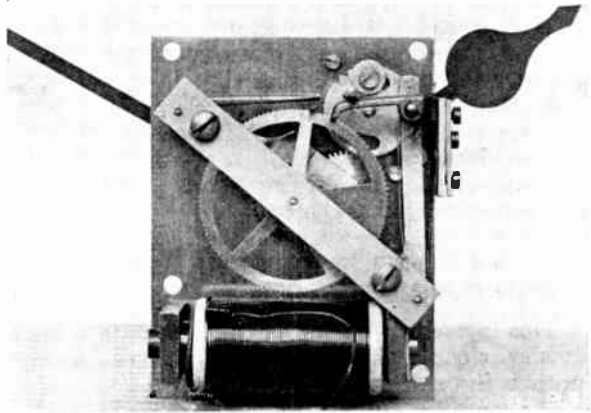

Fig. 10.—IMPULSE OR SECONDARY MOVEMENT OF PUL-SYN-ETIC ELECTRIC CLOCK SYSTEM.

600 dials are driven by one master clock in six series loops of about 100 on each.

Supplying Current from Batteries.

Any convenient source of electrical supply may be used for systems of this type, a primary battery, a set of storage cells, or electric light supply, and the current consumed is so small as to be practically negligible. Ordinary wet Leclanche cells are the least suitable on account of their high and fluctuating internal resistance, but they may be used if two series sets are provided and joined up in parallel. A good dry cell is better. A reserve battery of dry cells should never be provided, since the current consumption is so small that you are only concerned with the "shelf" life of the cells and an idle set would last no longer than those in use.

Using A.C. or D.C. Mains Supply.

An ideal arrangement for a large circuit of great responsibility is to install two sets of storage cells, one in reserve with a charging board and change-over switch. Half an hour's attention once a month will then suffice. Alternatively, they may be

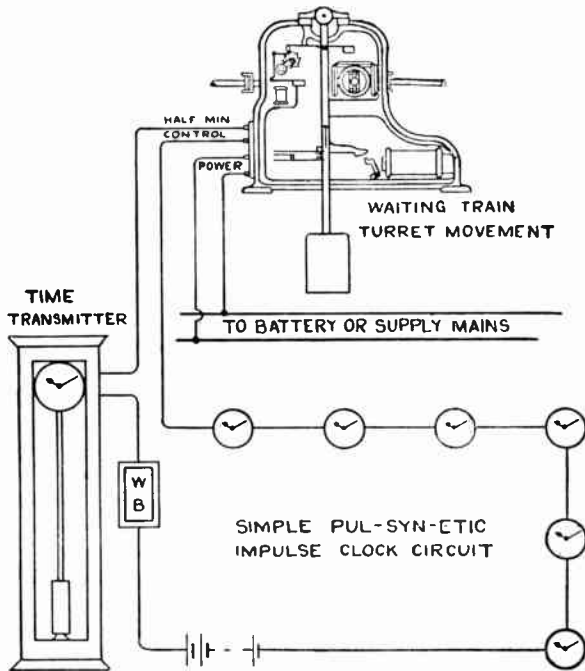

Fig. 11.—HOW THE "WAITING TRAIN" TURRET CLOCK WORKS.

This movement is designed specially for driving the hands of large clocks that are exposed to the full force of the weather.

connected to the service mains through a carbon filament lamp in the case of D.C. and through a transformer and rectifier in the case of A.C., but it is of the utmost importance that the time circuit wiring and all the instruments are well insulated from earth, if the source of supply is also connected to other metallic networks in the building.

GILLETT AND JOHNSTON'S SYNCHRONISED ELECTRIC CLOCK SYSTEM.

This system consists of an accurate master clock, which is electrically connected through independent battery (or other source of supply) to any number of secondary clocks, all wired in series.

Every half-minute this master clock, or, strictly speaking, master *pendulum*, transmits an impulse current to each secondary clock dial, through a simple magnetic coil and jawl-and-ratchet mechanism, thus putting forward the dial hands.

Master-Clock Movement.

The distinctive feature of the Gillett and Johnston master clock is the *patent swinging armature* (see Fig. 5), which eliminates noise and gives a remarkably smooth action, all contributing to accuracy and general reliability.

A reference to Fig. 6 will explain the action, and in this illustration the pendulum has been removed, but it normally suspends from the top of the casting and the rod locates between the two crutch pins indicated on the photograph.

The pawl C, engaging with the ratchet wheel E, causes the latter to revolve

once every half-minute. At each revolution the horizontal gravity lever A, pivoted at B, is released from its catch F, and, in falling, the following sequence of operations takes place:—

(a) The roller G drops on to the crutch pallet H, thus giving an impulse to the pendulum as it swings to the right.

(b) The gravity lever contact J touches that on the swinging armature bell crank lever K, thus closing the battery circuit, and

(c) Energises the coil, causing the armature L to swing over, thus breaking the circuit just made, then

(d) From the "tail end" of the armature bell crank lever the gravity lever A is clicked back into position, ready for the next half-minute's impulse.

This movement is practically silent; there is no actual contact of armature with pole piece; all parts are buffered against shock, and there is ample time-contact for safe working of the largest clocks.

Secondary Clock Movement.

The minute hand is driven direct by the 120-toothed ratchet wheel, and the hour hand is geared down 12 to 1 in the usual manner. Fig. 7 shows the secondary clock movement.

Every time the master clock makes electrical contact, the current energises the magnet, which then attracts the armature, thus allowing the pawl to fall into the next tooth of the ratchet wheel.

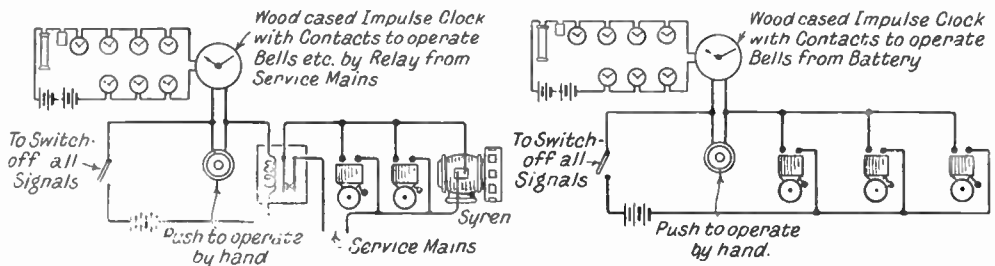

Fig. 12.—How a CLOCK CAN BE USED TO OPERATE SOUND SIGNALS.

On the left an impulse clock is shown connected up to operate bells and sound signals by relay from the service mains. On the right the clock is shown connected up to operate bells from a battery. (*Pul-syn-etic.*)

The Best Gifts for Children



128 pages
Fully Illustrated

3/6

THIS Annual is devoted to simple and practical descriptions of working models of every type, including electric motors, model aeroplanes, submarines, printing machines, theatres, steam engines, etc. No elaborate equipment is necessary to make the articles described.

Special Design Sheet

and Three Fine Cut-out

Cardboard Models Inside

HOBBIES NEW ANNUAL



All kiddies will enjoy this fine new bumper Annual full of fun and frolic. The adventures and misadventures of Punch, Judy, Baby and Dog Toby are a constant source of amusement.'

128 pages

Fully
Illustrated

2/6

each

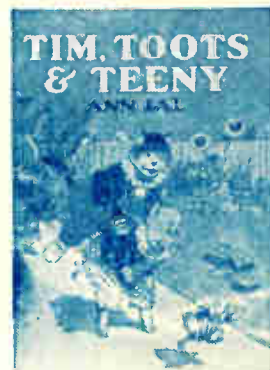

Full of new amusing adventures and comic antics of Tim the cat, Toots the pig, and Teeny the duck, a queerly assorted trio, who will give the children plenty of fun and enjoyment.

On sale at all Newsagents and Bookstalls, or at post free rates from

GEORGE NEWNES, LTD.,

8-11, Southampton Street, Strand, London, W.C.2.

Geo. Newnes, Ltd.

**This article on Electric Clocks will be continued in Part 11.
Ready December 23rd.**

Inexpensive Books for Christmas

NEWNES'
Home Mechanic
BOOKS

OF VALUE TO EVERY HANDYMAN

Clearly written and fully illustrated

each book contains 96 pages

TOY MAKING FOR AMATEURS

Tells how to make clockwork toys, model aeroplanes, model locomotives, model boats, ingenious toys operated by sand, wooden models and toys, electrical toys, steam toys, guns, kaleidoscopes, acrobats, etc. Abundant illustrations and simple text. Every principle and mechanical movement known in toy manufacture is included.

TWENTY-FIVE TESTED WIRELESS CIRCUITS

A book for the modern wireless enthusiast. All the sets described have been designed to meet modern needs. They range from simple crystal receivers to a seven-valve super-heterodyne, and all the sets have been made and tested before inclusion.

SIMPLE ELECTRICAL APPARATUS

An excellent little book for those who wish to make simple and useful electrical appliances, such as galvanometers, electric motors, dynamos, and Leyden jars. All these may be made by anyone with the aid of a few tools and some inexpensive materials. Clear instructions are given in every case.

MODEL BOAT BUILDING

There are few more fascinating hobbies than Boat Building. In this book there are designs for a battleship, a speed boat, a paddle steamer and yachts, from which excellent models may be built with the help of the simple directions and diagrams that are given. No elaborate tools are needed, and each model can be made at small cost.

Other Titles

THE HANDYMAN'S ENQUIRE WITHIN

THE HOME WOODWORKER

25 SIMPLE WORKING MODELS

MODEL AEROPLANES AND AIRSHIPS

One Shilling each

On sale at all Newsagents and Bookstalls, or by post 1/2 each from George Newnes, Ltd., 8-11, Southampton Street, Strand, London, W.C.2.

George Newnes, Ltd.