

- Integrated CD player
- Integrated amplifier
- Tuner
- Power amplifier
- DSP Surround sound processor
- 5 Channel AV amplifier

Finish: silver or matt black

MODE CD TUNER VIDEO LINE 1 LINE 2 TAPE

ROKSAN

Caspian
whichever way you look at it....

...its award-winning

Roksan Caspian system – January '99
Best Buy
CD player/amplifier/speakers



Caspian – '98 winner
Best Buy
Integrated/Power amp
from £1000



Caspian – '97 winner
Best amplification
component up to £1000



Roksan was formed in 1985 to offer sound reproduction systems of the highest quality for the most discerning of music lovers.

Today... nothing has changed, except of course the products... same standards – but now more affordable.

ROKSAN
ROKSAN Audio Limited
15B Atlas Business Centre
Oxgate Lane London NW2 7HJ
Tel: +44 (0)181 830 7722 / 7733
Fax: +44 (0)181 830 7744
Email: info@roksan.co.uk
www.roksan.co.uk

Well, it's been a long time coming but at last it's here and it could transform the way many people buy and listen to music, especially tunes on the move. Is it Super Audio CD or 24-bit, 192kHz Pulse-Code Modulation we're talking about here? Nope, it's that hot topic amongst computer audiophiles and record company lawyers - MP3 music down-loaded from the Internet.

While such heavily-compressed songs have been flowing over phone lines and into PCs for a few years now, it's the emergence of portable machinery for replaying them which has really set the cat amongst the pigeons. Record companies fear piracy and loss of revenue on a massive scale as PC-equipped consumers simply visit web sites instead of their local record shops to obtain their music.

As well as the major questions as to the future of today's software distribution chain, lovers of hi-fi have been

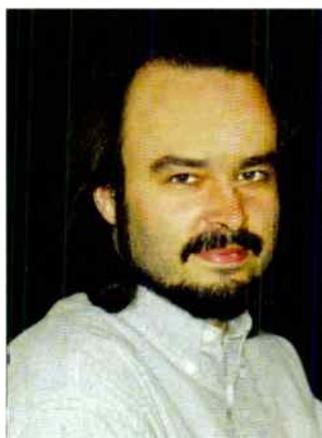

JON MARKS

asking themselves how MP3 portables such as Diamond Multimedia's Rio actually sound. After all, with no moving parts surely these tiny players could be something worth waiting for? Turn to page 13 and you can find out if they threaten conventional tape and MiniDisc machinery.

Equally portable but less likely to change the face of hi-fi as we know it is Sony's PBD-V30 portable DVD player. This cunning piece of miniaturisation is just as comfortable playing video discs as it is CDs, and it makes

a surprisingly sweet sound whether on the move or in a more domestic setting.

Of course, if you're an analogue Luddite like HFW's staff, vinyl is probably the main format in your system. The ways of spinning LPs are many and varied, and one of them involves the superbly-engineered and aptly-named 2001 from Basis. Cheap it ain't but when it comes to sound quality this is truly a turntable to take black plastic into the next millennium.

Hewn from thick, precision-machined slabs of perspex, this belt-drive with its out-board motor and silicone-filled suspension pods has a solid, purposeful look mirrored in a sound quality best described by words like "effortless" and "natural".

Whatever the replay medium of your choice, with so much happening in the world of hi-fi, especially the new digital super-formats on the horizon, these are indeed interesting times we're living in.

HOW WE TEST THE PRODUCTS

- *Hi-Fi World* has its own advanced test laboratory and acoustically treated listening room. No other hi-fi magazine has the benefit of such facilities.
- *Hi-Fi World* has a dedicated in-house team of experienced listeners, and uses selected freelance professionals. We review thoroughly by extensive auditioning, rather than by quick-fire group listening tests.
- *Hi-Fi World's* engineering team designs a wide range of products in-house. No other hi-fi magazine is so expert and dedicated.



WORLD VERDICT



OUTSTANDING - Superb sound, something we'd use ourselves.



GOOD - Has strong merit. Well worth an audition.



ADEQUATE - Mediocre in several areas. May be worth auditioning.



POOR - Seriously flawed. Not worth considering.

Contents

20...
VERITAS MODEL 7



Reviews

Solid-State Portable

13... DIAMOND MULTIMEDIA RIO

Noel Keywood spreads his Net for MP3 tunes to fill this revolutionary solid-state portable.

Amplifiers

28... MVL INTEGRAL A2+ VS PAPWORTH MVH-200

It's survival of the fittest as Jon Marks goes head-to-head with high-tech £1200 integrations.

Compact Disc

17... HARMAN/KARDON HD740

You can lavish £300 of your digital budget on the H/K's dual 20-bit Burr-Brown DACs.

31... CREEK OBH-14 DAC

Can Creek's tiny converter threaten the mighty Flying Calf? Jon Marks provides the transport.

37... GOODMAN'S 901 CMD

Digital compilations have never been easier thanks to this combined CD/MD recorder.

57... SONY PBD-V30 PORTABLE DVD PLAYER

If it's a mobile disco for one you're after, check out Sony's petite pocket-filler.

Loudspeakers

20... VERITAS MODEL 7

With its box-within-a-box design, the 7 sets out to eliminate cabinet pollution.

33... YAMAHA MPS5 ACTIVES

Simon Pope finds the diminutive MPS5s offer membership of the active club for a mere £450.

59... ARKAYDIS ASC

Richard White discovers the charms of Arkaydis' £400 stand mounters.

Vinyl

53... BASIS 2001 TURNTABLE

Looking for a record deck to last a life-time? The £3000 perspex Basis could be the one.

Tuner

39... DENON TU-260L MKII

The king is dead, long live the king! We review the classic TU-260L's eagerly-awaited replacement.

28...
PAPWORTH MVH-200
INTEGRATED



37...
GOODMANS 901 CMD



53...
BASIS 2001 TURNTABLE



26... ONE THING STEREO DECODER

Whatever the model, a mono tuner can blossom into full stereo with One Thing's Stereo Demodulator.

Features

22... THOSE BARMY ARMIES

David Price presents a top tone-arm guide for those buying second-hand.

41... WIRED ONCE MORE

This month, Jon Marks mainly listens to mains cables.

99... DIY SUPPLEMENT

Not so much a feature as a landmark, June's DIY Supplement has come in from the cold.

118... MUSIC, MAESTROS

Simon Pope and Richard White introduce more of their favourite recordings.

Regulars

7... NEWS

HFWorld's roving reporters scour this green and pleasant land for the freshest of industry and component news.

11... NEXT ISSUE

Four weeks is not a long time to wait, but we wouldn't recommend holding your breath.

34... COMPETITION

This month's bonanza includes Copland's CDA 266 CD player, Musical Fidelity's X-LP phono stage, Mission's 772 loudspeakers and a Dynavector DV20X-H MC.

42... READERS' LETTERS

Are you plagued by problems or terrorised by treble? World's gurus provide the solutions.

50... HI-FI WORLD KITS

If you believe irons are for use on resistors and capacitors, not shirts and blouses, have a peek here.

55, 61, 63, 65... COLUMNS

The editorial team air their opinions on this thing called hi-fi.

66... MEET YOUR MAKER

For more information on your prized audio possessions, go straight to the horse's mouth.

68... HI-FI WORLD LIBRARY

Fancy a spot of tome-raiding? This is just the place you're looking for.

70... SPECIALIST HI-FI DEALERS

If you're in need of direction, turn to the dealers listed here for help.

79... DIAL-A-DEALER

Once you've whittled your shopping list down to one, you'll have to speak to these people.

83... HI-FI WORLD BUYING GUIDE

Putting a system together? First-time buyer or upgrading? You need to check out the components in our brand new buying guide.

127... MEASURED PERFORMANCE

Electro-surgeon Noel Keywood gauges the ear-worthiness of our reviewees this month.

139... CLASSIC BUYING GUIDE

Don't feel left out if your finances won't stretch to new components. Here we list some of the best used buys.

141... OLDE WORLDE

David Price goes back in time with STD's 3055 turntable.

143... READERS' CLASSIFIEDS

It's bargain time in our monthly six-page bonanza.

154... ADVERTISERS' INDEX

Music Reviews

73... ROCK AND POP

RECORD OF THE MONTH: Public Image Ltd, Plastic Box.

76... CLASSICAL

RECORD OF THE MONTH: Shostakovich, The Film Album.

77... JAZZ

78... DANCE AND AMBIENT

RECORD OF THE MONTH: Orbital, The Middle Of Nowhere.

Hi-Fi WORLD

HI-FI WORLD

IMEX HOUSE,
THE PARK BUSINESS CENTRE,
KILBURN PARK ROAD,
LONDON, NW6 5LF

WEB SITE

www.hi-fiworld.co.uk

MAIL ORDER

Tel: 0171-266 0461
(24 hour answerphone)

SUBSCRIPTIONS

See page 97 or our web site.

CONTACT NUMBERS

10am - 6pm

Editor

Jon Marks

0171 625 8074

Email: edit@hi-fiworld.co.uk

Editorial Assistants

Richard White

Simon Pope

0171 328 8627

Fax: 0171 328 1844

Individual queries cannot
be answered by telephone.

Contributors

David Price

Dominic Todd

Haden Boardman

Timothy Liu

Music Reviewers

Jon Clarke

Sara Davis

Stuart Lenz

Ian Nicolson

Design & Production

Editor

Fredrick Dittlau

Advertising Designer

Faiza Chunara

0171-625 8033

Fax 0171 328 1844

Photography

David Noble

Sales and Marketing

Manager

Amanda Sweeney

0171-328 2213

Advertising Sales

Executive

Sarah Wrenn

0171 328 4892

Technical Manager

Nick Lucas

Tel/Fax: 0171-625 8032

wad@hi-fiworld.co.uk

Accounts

Michael Ogazi

0171 328 1711

Fax: 0171 328 1844

Credit Control Manager

Louise Palfrey

0171 328 1711

Publisher

Noel Keywood

Distributed by:

Marketforce Ltd, 245

Tottenham Court Road,

London, W1P 0AU

Tel: 0171 261 5555

Printed by:

Southernprint, Dorset.

Tel: 01202 622226

All unsolicited submissions are
made at the owner's risk. We
accept no responsibility for such
submissions, nor do we undertake
to return them.

No material may be reproduced
from this magazine without the
publisher's written permission.
© Audio Publishing Ltd

ABC
LONDON
CONSUMER PRESS

Natural Beauty

Loudspeakers from Vienna Acoustics

Turntables from Pro-ject

Music from Austria

Distribution by Henley

Your Hi-Fi system should be as pleasing to the eye as it is to the ear.
Spoil yourself with the latest affordable masterpieces from Austrian craftsmen



MAHLER



CLASSIC CHERRY



PERSPECTIVE



CLASSIC



BACH

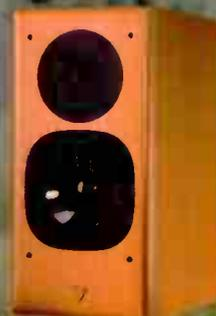

HAYDN

Distributed in Great Britain by HENLEY DESIGNS LTD
The Old Coach House, The Street, Crowmarsh Gifford, Wallingford, Oxfordshire, OX10 6EH
TEL: 01491 834700 Fax: 01491 834732

PAP MUSIC

Papworth Audio Technology, noted for their high-power valve amplifiers, are expanding their list of models. The three newcomers in the MOSFET Series are two integrals, the MVH-200 and MIA-200, and a power amp, the MPA-200.

As the initials suggest, MVH-200 (reviewed on p29 this month) is a MOSFET/valve hybrid while the MIA-200 is pure solid-state. Both are priced at £1200, with an infra-red remote control as a £100 option. And if you already have a pre-amp, the MPA-200 (again, no valves here) will set you back £1100. The power output common to all three is, you've guessed it, 200watts.

In addition to the above, the valve range has been extended to include the M300 monoblocs with their KT88s and the PPA6 pre-amp, which now includes remote control.



Papworth Audio Technology
1 Cambridge Court,
Papworth Everard,
Cams. CB3 8RG
Tel: 01480 831666

KEEP TAKING THE TABLETTES

ProAc's new loudspeaker duo was recently unveiled at the Bristol Sound And Vision show. Smaller of the two was the £649 Tablette 2000. 50% larger than the existing Tablette 50, it has a bigger mid/bass driver and an upgraded crossover and tweeter.

Joining the 2000 is an entry-level (£999) floor stander, the Studio 125, with its 6.5in. mid/bass driver and soft-dome tweeter. Both models are magnetically shielded so they can be used close to TV sets.



DNA Marketing
New Street,
West Sussex
GU28 0AS
Tel: 01798 343414

AR RETURN IN STYLE

The name Acoustic Research has been absent from these shores for some time now. However, Recoton UK have announced details of their impending return in the shape of the Phantom on-wall 'speakers, none of which is thicker than 4in.

Whereas all of the Phantoms have 1in. titanium tweeters, only the two top models use low-mass MagAlloy driver technology in their dome midrange units to help lift sensitivity to 88dB-90dB levels. Prices range from £400 per pair for the 5.2 to £1200 for the 8.3.



Recoton UK
Towngate Bus. Centre,
Lester Road,
Walkden,
Manchester M38 0PT
Tel: 0161 702 5001

FAST CONNECTION

Not content with their recent releases of hi-fi and A/V electronics, TAG McLaren are now turning their hand to the world of wire with their Cables AvantGarde.

First to be launched are the F3-10-ANA analogue interconnects, the F3-10-DIG S/PDIF digital interconnect and a 'speaker cable, the F3-10-SPK. Again, the boffins at TAG claim to have looked to their motor racing experience to "examine the influence of directionality" through extensive testing.

The interconnect consists of a twisted pair of screened, 9mm-diameter solid-core conductors made of 99.99% pure copper. A 1m set will cost you £145, with each additional metre at £44.

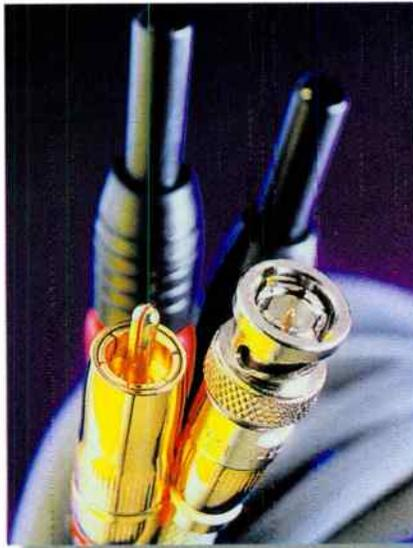

The digital cable carries a price tag of £90 when terminated with RCA connectors (£110 if it's BNCs) and comes covered in a PVC and protective mesh covering.

F3-10-SPK can be supplied with a variety of connectors - spade/spade, BFA/spade and BFA/banana plug, all of which are available in gold-plated versions. Prices are £180 for a 1m pair (spade/spade), £250 (BFA/spade) and £270 (BFA/banana plug). Additional metres are charged at £72 a pair.

TAG McLaren Audio
Ermine Business Park,
Huntingdon,
Cams. PE18 6EY
Tel: 0800 783 8007



The world's finest sound systems don't come cheap
BUY NOW, BUT DON'T START PAYING UNTIL THE NEXT CENTURY!
but they do come easy at branches of KJ West One

Visit any branch of KJ West One and you'll discover a truly exciting range of the most desirable hi-fi and audio-visual equipment.

Stay awhile, and listen to some fabulous systems, like those featured above, alongside many others from the world's most highly regarded specialist manufacturers.

Relax in the knowledge that all of these superior products are so easy to own. We are always keen to accept older hi-fi equipment in part-exchange, and we offer a wide range of convenient payment options.

So, before simply buying hi-fi, think about investing in a real hi-fi system, at KJ West One.

FEATURED SYSTEMS

Audio Analogue Paganinni CD	£750	Musical Fidelity X-Ray CD	£800	Krell 250CD CD Player	£2490
Audio Analogue Puccini SE Amp	£635	Musical Fidelity X-P100 Pre	£800	Krell 300i Integrated Amp	£2495
Sonus Faber Signum Skrs	£1249	Musical Fidelity X-AS100 Pwr	£800	Martin Logan Aerius i Spkrs	£2199
		Wilson Benesch Orator Spkrs	£2900		
System Price	£2634	System Price	£5300	System Price	£7184
Minimum Deposit	£264	Minimum Deposit	£530	Minimum Deposit	£724
Maximum Balance	£2370	Maximum Balance	£4770	Maximum Balance	£6460

Defer Payments for 12 Months
then it's just £98.75 per month!

Defer Payments for 12 Months
then it's just £199 per month!

Defer Payments 12 for Months
then it's just £269 per month!

Deferred Payment Interest Rate 2.2% per month, 29.8% APR. Many other very competitive repayment plans available. Full details on request.

kj WestOne

IN PETERBOROUGH

THE HI-FI COMPANY

42 COWGATE PETERBOROUGH
TEL: (01733) 341755

kj WestOne

IN LONDON

THE WORLD'S FINEST HI-FI

26 NEW CAVENDISH STREET W1M 7LH
TEL: 0171 486 8262/3

kj WestOne

IN NORTHAMPTON

THE HI-FI SPECIALISTS

32, GOLD STREET NORTHAMPTON
TEL: (01604) 637871

BERLIN WALL OF SOUND

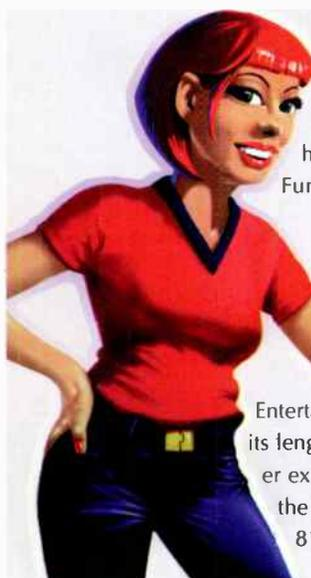

From the 28th of August to the 5th of September Berlin plays host to the 75th Internationale Funkausstellung (IFA), otherwise

known as the International Trade Fair for Consumer Electronics, Communications And

Entertainment. As you might guess from its lengthy title, this show gathers together exhibitors from all four corners of the electronics globe in a union of 816 exhibitors from 35 countries.

Statistics for 1997 show that well over 400000 visitors attended, and the organisers are expecting even more eager audiophiles to attend this year. These high hopes are partly due to the fact that the emphasis in IFA '99 is on the convergence of entertainment systems with the world of information technology. So, for the first time, visitors from the world of IT will be attending as well.

The whole shebang takes place at the Berlin Trade Fair And Exhibition Grounds. Further information is available from the sources below.

Tel: +49 30 3038 2066/+49 30 3038 2087

e-mail: ifa@messe-berlin.de

web: www.ifa-berlin.de

BIG NEWS FROM DOWN UNDER

What springs to mind when you think of New Zealand? Rugby, Kiwi fruit, glaciers? Well, now you can add high-fidelity to the list, as NZ's Plinius high-end amplifiers are available in the UK.

Absolute Analogue are currently bringing in seven of Plinius' models, which include two integrateds, two pre-amplifiers (one phono) and three power amps.

All three of the SA power amps are class A designs built after apparently 13 years of research. The company's bold claim is that the amps are capable of "driving and controlling any loudspeaker on the market". They also say that, in their quest to deliver "the very essence of music", the topology of the circuits closely

resembles the behaviour of "real musical waveforms", a goal achieved through the use of asymmetrical circuit building blocks.

All models feature audio-grade parts and short signal paths - apparently the layout involves virtually no wiring. Prices range from £995 for the 2100i integrated to £5850 for the SA250/3 power amp.

Absolute Analogue

PO Box 1532,

Fordingbridge,

Hants. SP6 1BU

Tel: 01425 654488



MYRYAD HIT THE BIG TIME

With the current slump in the hi-fi market and speculation of the beginning of the end of specialist high-fidelity as we know it, it's good to receive some news to the contrary. Hampshire-based Myryad Systems have announced a 300% increase in turnover from 1997-1998 on their hi-fi and AV components.

Myryad Systems

2 Piper's Wood,

Waterberry Drive,

Waterlooville PO7 7XU

Tel: 01705 265508

FIRING ON ALL EIGHT

These sizeable loudspeakers are the product of Von Schweikert Research of the USA, who are now distributed in the UK by The Disc Emporium. Albert Von Schweikert began his professional life as a musician, playing with the likes of Sonny And Cher and the Yardbirds. Only later did he turn his hand to audio design, forming his present company in 1995. Prices start at £1395 for the VR-1100 and finish at £19000 for the VR-8s. Pictured are the VR-6s at £12500.



The Disc Emporium

144 London Road,

Knebworth,

Herts. SG3 6EY

Tel: 01438 816699

another world-first.

hi-tech home cinema for the audiophile

1 Latest DSP Technology

World premiere in an audio product of the 32-bit 60MHz Analog Devices ADSP-21065L SHARC™ Digital Signal Processor; decodes, as standard, all current movie formats with capacity to cope with the future.

2 Powerful 16-Bit Microcontroller

The 16-bit Siemens C161RI microcontroller controls the AV32R and its Set-up Wizard provides most comprehensive on-screen user interface, making set-up extremely simple, without printed manuals.

3 96kHz/24-bit DACs

With its multiple 96kHz/24-bit DA-converters, the AV32R is equipped to handle the finer resolution and more spacious sound recordings of DVD Audio.

4 Minimal Jitter/ TAGtronic™ Sync Link

The precision twin phase-locked loop reduces jitter to an absolute minimum, while the unique TAGtronic™ Sync Link sends a signal to products designed for this advanced technology (e.g. the forthcoming DVD32R) to synchronize its clock to the master reference within the AV32R. DVDs will sound better than ever before.

5 Future-Proof

All software is stored in Flash Memory and is entirely user upgradable, with upgrades downloadable from the Internet via a PC and the TAGtronic™ Communications Bus. This bus also allows the easy transfer and sharing of information for multi-room installations and powerful communication between components.



Five-channel amplifier 100x5R
(launch summer '99)



6 Learning Remote Control

The powerful backlit remote control operates all our home cinema products. It can also be user-programmed to control almost any product that uses an infra-red remote, such as our audio products, so just this one handset will control your whole system.

7 Gold-Plated Multi-Layer PCBs

The gold-plated multi-layer printed circuit boards control return currents, provide controlled impedances and minimize couplings, with the ground planes split between audio and digital processing.

8 Mixed Technology Construction

Surface mount components for fast digital circuitry and leaded components for perfect audio signals, to optimize performance, requiring both reflow and wave soldering production techniques. Anything less would be inferior.

9 Broadcast-Quality Video and Premium Grade Audio Components

No-compromise broadcast-quality video components and premium grade audio components for maximum clarity and transparency.

6 TAG McLaren Surround Sound

An audiophile processing mode for listening to stereo and mono sources in surround mode. TMS-Surround is capable of processing 24-bit/96kHz recordings without artefacts.

www.tagmclarenaudio.com - freephone: 0800 783 8007

TAG McLaren Audio Ltd., Ermine Business Park, Huntingdon, Cambs PE18 6XY.

"Dolby", "ProLogic" and the double-D symbol are trademarks of Dolby Laboratories • "DTS" and "DTS Digital Surround" are trademarks of Digital Theater Systems, Inc • The "THX" name and logo are trademarks of Lucasfilm Ltd. and trademarked. All rights reserved. Used under authorization • The "MPEG" logo is a trademark of Royal Philips Electronics • "SHARC" is a registered trademark of Analog Devices, Inc •

World Radio History

TAG McLaren
audio



DAB VIBES

After nigh on 12 years since the launch of the Eureka 147 project the waiting is, at long last, over. The race to release the first DAB tuner has been won by Arcam. The Alpha 10 Digital Radio Tuner was launched on Monday 15th March and is now available from dealers.

Inside the 10 DRT, after the digital signal decoding, D/A conversion is carried out by a Crystal Semiconductors IC. This is fed from a mains transformer with multiple secondary windings followed by eight supplies for the various analogue and digital circuits.

Alongside the large rotary tuning knob and selection of presets is a display which shows the transmitter ID, data rates and the signal strength. All of this brings the price of the Alpha 10 DRT up to £799.99

A&R Cambridge
Pembroke Avenue,
Waterbeach,
Cambridge CB5 9PB
Tel: 01223 203200

FOUR!

American cable specialists Nordost describe their Quattro Fil as "a cable of true aerospace, state-of-the-art technology". This bold statement is based on a design which incorporates a Teflon microfilament wound around the conductor to support an extruded Teflon tube. The result is a predominantly air dielectric that ensures fast signal propagation at a velocity of over 93% of the speed of light. Keeping out interference nasties is a dual-layer, floating ground shield.

All this could be yours for a meagre £1250 (1 metre terminated pair). Additional half metres are £250, with balanced XLR terminations carrying a £30 premium.

Nordost UK Ltd
First Floor, Unit 7,
Aber Park Industrial Estate,
Aber Road,
Flintshire CH6 5EX
Tel: 01352 730251



NEXT MONTH'S ISSUE

This is merely a thin cross-section of the audio wonders to be unveiled in four weeks:

MUSICAL FIDELITY X-P100/X-AS100

Can this pre/power combo match the sonic achievements of the rest of the respected X series?

ALCHEMIST KRAKEN CD

This new two-box from Alchemist arrives from outer space and lands in our dock-

ing port for the attention of our Spock-like ears. Will its dynamic looks be matched by a dynamic sound?

CASTLE INVERSION 15 LOUDSPEAKERS

Something slightly different from the Yorkshire loudspeaker stalwarts. These stand mounts incorporate unusual

tapered cabinets and Castle's in-house carbon-fibre drivers.

DENON DRM-555 CASSETTE DECK

Manufacturers continue to produce cassette decks amidst talk of MiniDisc's rise to stardom. The DRM-550 proves there's fight in the old tape yet.

WORLD'S BEST AMPLIFIER UNDER £1,000?



MVL INTEGRAL A2

FEATURES

- **GREATER CLARITY AND REALISM** achieved through patented circuitry and extremely low distortion. All instruments and voices sound real and whatever warmth or coldness was originally recorded is revealed.
- **3 DIMENSIONAL SOUND STAGE** brings every performance into the room.
- **CONSISTENT SOUND QUALITY** regardless of volume quality remains constant, whether at 0.5 Watt or at maximum rated output.
- **CONSTANT CONTROL** speaker drivers are both pushed and pulled, never allowed to float, minimising back EMF effect.
- **EASY COMPONENT MATCHING** due to high tolerance to source components, leads, speaker impedance and sensitivity.
- **NO 'BURN IN' OR WARM UP REQUIRED** sound is correct from first turn on, with no degradation of sound for the life of the unit.
- **5 YEAR WARRANTY** provided free of charge.
- **100 Watts per channel RMS** (8 ohms, both channels driven).
- **SS² FREQUENCY CONTROL.** Improves speaker performance by adjustable matching of frequency response.
- **SS³ PHONO STAGE.** Improves sound quality from Vinyl whilst reducing surface noise and rumble.
- **Built in total mains conditioning.**
- **Built in temperature compensation.**
- **Custom built Toroidal mains transformer.**
- **Headphone socket.**
- **Nine line inputs. Five record outputs. (All switchable)**

WORLD VERDICT



An excellent performer with any music. At present, it would be hard to imagine the A2 being beaten at the price.

HI-FI WORLD MAY 1999



PLUS A RANGE OF OPTIONAL FEATURES NOT AVAILABLE ON ANY OTHER AMPLIFIER

SS² OPTION PACK

- **SS¹ TAPE** Eliminates tape hiss on analogue cassette/tape whilst increasing frequency range.
- **SS⁵ CD** Enhances playback quality of CD by removing 'digital edge' yet retaining original attack.
- **SS⁶ CD** Enhances playback from and recording to CD. Improves recordings, particularly from vinyl records.
- **SS⁷ MINIDISC** Improves quality of record / playback on MD from all sources.
- **SS⁸ FM** Improves quality of FM / AM receivers.
- **SS¹⁰ DAB** Improves quality of Digital Radio.
- **SS¹³ NICAM** Improves quality of NICAM receivers.
- **SS¹⁵ DAT** Improves quality of record / playback on DAT.

MVL A2: £895 inc. VAT Option Pack: £354 inc. VAT. For more information ring 01953 850800

MVL

MVL Technology Limited, Northfield Mill, Wymondham, Norfolk NR18 0DF
Tel: +44 (0) 1953 850800 Fax: +44 (0) 1953 851022

Sound Sentinel[®] manufactured under licence from Sound Sentinel Systems. Sound Sentinel[®] is a registered trade mark.



SOUND SENTINEL
SYSTEMS

RIDING *the* RIO



One of hi-fi's major headline-makers is Diamond Multimedia's Rio MP3 portable. Noel Keywood puts the Rio under the measurement microscope and then assesses its sonic strengths.

Since a US court injunction attempting to restrain its sale, the Rio must be the most controversial personal stereo ever; some even claim it spells the end of the music industry monopoly. But does it offer decent sound for £180, or is MP3 music a joke? Would you actually be better off ignoring all the hype and buying a portable MiniDisc recorder instead?

Possibly. Wherever the Rio (or similar machines from Saehan and Pontis) comes up for discussion, people inevitably compare it with MiniDisc, so that's what I want to do here, looking at performance rather than politics.

The Rio attracted the wrath of the Recording Industries' Association of America (RIAA) because it was the first stereo of its type to be introduced to the US market by a US company, Diamond Multimedia, maker of computer sound cards and such like.

The concept of an MP3 portable originally came from Korean company Saehan a year or so earlier and wasn't new. But Diamond got all the publicity and the Rio is the only

player we could find on sale in London, within a few stores, in early 1999. Expect to see models from Samsung and Saehan of Korea, Pontis of

Germany, Creative Sound Labs of the USA and many more introduced through the course of this year.

Prices will doubtless fall, but the 32-64MB of computer flash memory these stereos use to store music does not come cheap, so they may not fall as much as you might hope or expect.

THE RIO UNWRAPPED

Open the box and inside you find the Rio, tucked into a restraining holder. It's small and light, measuring 92mm high, 70mm wide and 20mm deep and weighing a mere 70gms. Accessories include earphones, a PC serial-port adaptor, an umbilical lead that runs from this adaptor to the Rio, a single AA-size battery and a slim owner's manual.

The Rio can only be loaded with music from a host PC. It cannot be connected up to a hi-fi system, so there are no phono

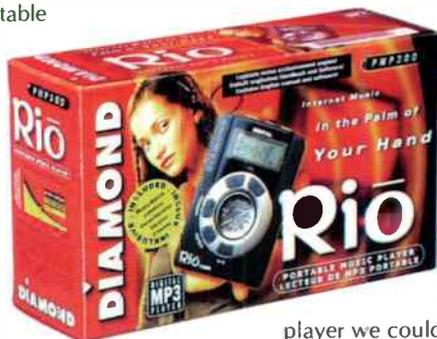

leads. You do get a couple of CDs, though, one with Diamond's own Rio management software, plus MusicMatch Jukebox which loads data-reduced music into the Rio, and contains MP3 songs. Both are destined for a computer's CD-ROM drive; the songs disc will not play in a conventional audio CD player. Connection to PC is via a flat, multi-pin connector; the headphone outlet is a normal 3.5mm jack socket, like any Walkman's.

READY FOR REPLAY

There are normal Start, Pause and Stop controls, but Fast Forward/Reverse and Skip are combined. Trying to nudge the sound forward caused the player to skip to the next track, a minor nuisance. By the way, fast forwarding is silent - you do not hear the music speeded up.

The top of the player carries a useful Menu function that shows how much of the internal memory has been filled (or the external memory, if fitted). Various equalisations can be selected to offer different tonal balances; Normal and Classic were acceptable while Jazz sounded muffled and Rock obviously had a lot of bass boost applied.

The Rio can repeat a track section, the whole track or all the tracks in its memory. There's a random shuffle mode too, and you can even get it to play short intros from each tune. A small LCD display gives track number, playing time, volume level, data rate (128/80/60 kbps) and battery life (12 hours).

Diamond warn that the Rio consumes power even when switched off - in effect it goes into stand-by mode. To preserve the battery it should be removed, which is a nuisance. The memory retains its contents however.

THE MATTER OF MEMORY

External memory cards are available for the Diamond, but not in pre-recorded

form. You cannot at present buy pre-recorded media for these players, although Pontis of Germany plans to offer it and Saehan of Korea suggest music could be down-loaded from a docking station that looks a bit like a vending machine. But the cost of memory makes even pre-recorded Minidisc at £16 a shot look cheap.

A 16MB external flash-memory card for the Rio, offering just 17minutes' extra storage time, is likely to cost around £40 on the UK high street. Pre-recorded memory cards burdened by artists' fees, recording costs, etc, would therefore cost at least £45, so I can't help feeling pre-recorded software is a long way off. You can certainly forget about buying such things at a station or airport to pass the time during a long journey: the Rio needs to be close to a computer to get its fix. Of course, you could dump down from MP3 files stored on a laptop, or from the Internet through it.

The Rio comes with 32MB of flash memory as standard, enough for 34 minutes' replay at the maximum data rate of 128kbps, which gives the best sound. This is often described as being of "CD quality" but that's what you might call 'optimistic' by audiophile standards, as I will explain later. Playing time can be doubled by halving the MP3 file data rate to 64kbps with a consequent loss in quality. Although playing time can be extended by using external memory it is not only expensive but also adds to the Diamond's bulk.

NETTING THE SOFTWARE

I had no problems loading Multimedia's own Rio management software or MusicMatch Jukebox into my PC.

The manual supplied is brief and explains only the Rio's controls, saying little about the software. Diamond's management software was poor in my view - it has peculiarly small visual representations of equipment



The Rio comes with earphones, a PC serial-port adaptor and umbilical cord for downloading songs.

fascias, tiny active buttons and obscure operating procedures. Luckily, the Jukebox software worked well once I'd grasped its modus operandi.

The MusicMatch programme acts as a database of MP3-encoded music files, from which can be assembled a playlist that is then dumped down into the Rio. Music in MP3 form can be added direct to the database from the Internet or from a CD-ROM of MP3 songs such as that supplied with the Rio. It can be "ripped" from a conventional music CD loaded into the computer's CD-ROM drive as well. This means there are plenty of ways of getting music into the Rio and, in spite of the fact that it is, technically, illegal to copy your own CDs to a personal or car stereo for your own use, nowadays the music industry is not prepared to make an issue of it (remember the "Home Taping Is Killing Music" campaign?)

There's no shortage of MP3 songs on the Internet - they run into hundreds of thousands, and a large number of them are quite legal since they're promotional freebies from unknown bands trying to get recognised and sell their music direct. Try www.mp3.com which claims to have 1000 songs available, as well as

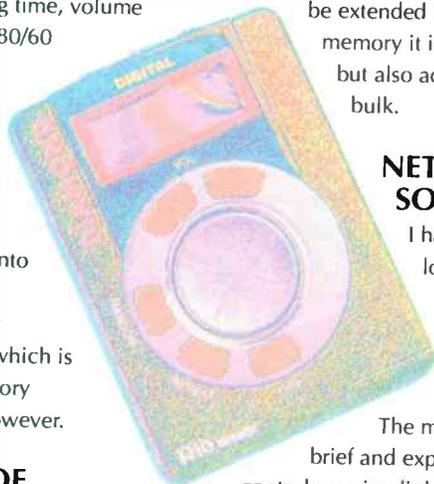

information on players, MP3 technology and a lot more.

Ripping songs from music CDs takes a little time. Exact speed depends upon the computer used but a 10-minute track should take around five minutes to complete on a Pentium II running at 233MHz. However, downloading can be slow, depending upon how busy the Internet is, the state of your own connection and other factors. A five-minute track recorded at 128kbps took me around 20 minutes to download, at local call rate, running at a slow 3-5kbps download rate. A typical file size is 4MB.

ON THE TEST BENCH

Does the Rio measure up to its main rival, MiniDisc, which uses ATRAC data-reduction to give excellent sound quality and an impressive set of measured performance figures? ATRAC reduces files to one-sixth of their uncompressed size; MP3 nearly doubles this to one-tenth, so it throws out considerably more information which will obviously have a greater impact upon sound quality. But this is a test of how the Rio handles MP3, not of MP3 itself.

Bear in mind that the Rio is one of the first portable MP3 players to become widely available. It's an early example of a new technology and generally such things have a few rough edges.

I hit the Rio with a set of standard CD test tones from CD-ROM and it ran into trouble immediately. It objected to reproducing full-level tones in both channels at once (L+R, which gives a centre-stage, mono image) and the outcome looked dire. Playing the MP3 test files through the computer's sound card showed the problem came from the software, not the Rio.

Two other coders I tried suffered the same problem, but not CDCOPY by Markus Barth. This piece of software was difficult to configure and slow (track time x0.3 or thereabouts) and buggy (it could



A circular control panel rocks about its centre to provide CD-style control functions such as Fast Forward, Fast Reverse, Track Skip, Stop, Play, Pause and Power Off. Touch pads control volume, Track Repeat and other functions. Along the top are buttons for EQ and Menu to show memory state.

only see one of my CD drives and hung up if asked to find the other) but it encoded perfectly.

Whilst a full-level tone on both channels is a standard test signal, it is not a common condition for music on disc.

Although music is often compressed up to the top of the dynamic range of CD, peaks run close to 0dB but do not hit it. And peaks may approach full level but they are short-term in nature. Average music levels run from around -15dB down to -40dB; at these levels the Rio worked well and looked impressive in many ways, even if it wasn't perfect. From -3dB downward there was minimal distortion, good channel separation and low noise (-94dB). Providing music does not hit full level, there should be little sign of roughness in the sound, good stereo imaging and no audible hiss using the software supplied.

Frequency response displayed a smooth treble fall above 1kHz, output reaching 16kHz before dropping like a stone. However, employing the tight parameters used to gauge CD, the Rio returned a frequency response of 10Hz-3kHz when fed a signal from the MusicMatch software supplied. The treble droop (-4dB at 16kHz) gave the player an innately warm sound, which at least ensured the Rio did not sound sharp or tizzy. It also suited the earphones supplied, compensating for their innately bright, sharp presentation.

The Rio's performance figures might not reach the standards set by CD or MD, but they aren't so bad either. The absence of distortion and quantisation products looks good and means that clean recordings from CD stay clean in MP3, avoiding digital harshness and glare. This puts the Rio well ahead of cassette, if not the now-defunct Digital Compact Cassette (DCC), which behaved like MiniDisc.

LETTING RIP

Since there is so much room for tweaking the ripping software in terms of bit-rate,

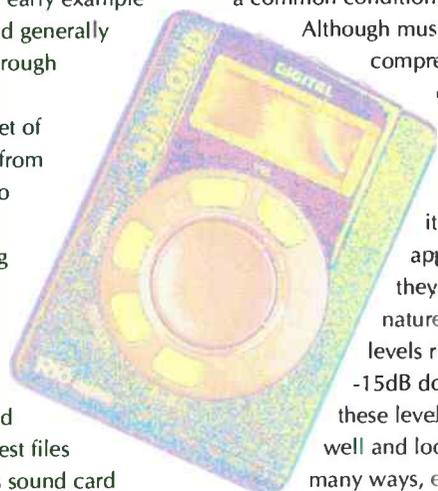



rip speed and such, MP3 is a bit of a moving target in performance terms. For proof, just take a look at the "Definable Parameters" of AudioCatalyst, from Xing Technology Corporation (www.xingtech.com) -

- Variable Bit-Rate Encoding: 32, 48, 56, 64, 80, 96, 112, 128, 160, 192, 224, 256, 320kbps
- Encoding up to 20kHz
- Down-sampling
- Naming Convention
- Leading/Trailing Silence
- Rip Offset, Start and End (Windows version only)
- ASPI or MSCDEX ripping (Windows Macintosh version utilizes the AppleCD driver)
- Rip method (burst and jitter-corrected rip methods)
- DAE speed
- Normalizing volume using a file or straight percentage (Windows version only)"

Rippers/encoders like AudioCatalyst are for propeller heads as they make just about every recording parameter available for adjustment. Note that Xing claim their ripper reaches 20kHz, higher than the 16kHz limit imposed by Bravura Software's Jukebox (www.musicmatch.com).

MP3 ripping/encoding software falls into two categories: easy to use, all-in-one solutions like MusicMatch and highly-technical and flexible alternatives that are more focussed, lacking a database and play-list construction for example. Compilation and loading of files into the

Rio from the latter must be carried out through the Rio's management software.

SOUND QUALITY

In use, how the Rio sounded depended upon the level of the signal being fed to it. I noticed a 'swimmy' quality and vague image positioning from many CDs. At times it seemed not to want to reproduce stereo, but this was due to the presence of strong centre-stage information, our spectrum analyser showed. At other times, with lower levels from a CD, music sounded fairly clean and well defined, with solid image positioning right across the sound stage, left to right.

Measurement showed the Rio, together with its software, possessed wide channel separation when it was not overloaded by strong centre-stage signals; this was the deciding factor in stereo performance.

All this changed with CDCOPY software. Highly-compressed Rock tracks with heavy centre-stage bass, like Billy Idol's 'White Wedding', hung together perfectly. Images were steady and well defined, bass clean and solid. The MusicMatch software supplied with the Rio auto-configures, works first time and is very flexible. In my view Diamond made the right choice in supplying it. CDCOPY is for PC-heads and I had to fight to make it work on my computer, but it offers superior sound quality and measured performance.

With the MusicMatch software there wasn't much detail to be heard, nor a lot of atmosphere, because low-level signals (below -70dB) don't get coded. This hardly matters when using the Rio with headphones in a busy environment, but it does become apparent when it's hooked up to a hi-fi system. I assessed the Rio using Sennheiser headphones as well as working through a system connected to the Rio's headphone output. Since it will deliver 900mV at full volume there's sufficient signal to drive any amplifier's Aux or CD inputs. The earphones supplied were poor, giving virtually no bass; expect to replace these if you're after decent sound.

So how does the Rio compare with a MiniDisc player? In sound quality, it doesn't - not at present. MiniDisc uses less compression, has a wider, flatter frequency response on a par with CD, possesses better clarity, more dynamic range and is freer from minor coding artifacts. But it takes only a minute or two on the Internet to uncover a torrent of data on MP3, plus alternatives like Yamaha's VQF (<http://www.vqf.com>). With this level of interest, and with thousands of files to download, the Rio obviously has access to a world of software MiniDisc can only dream about. You must own a PC to



Version 2.5 supplied with the Rio had a clearer interface than this later 3.1 version. Price is \$29.99 from www.musicmatch.com.

access it, of course, which will exclude many people. By the way, although there's plenty of software for Macs at present, the Rio will operate with PCs only.

The Rio has some teething problems,

there's no doubt about that. It is every bit an early example of a new technology in this respect. MiniDisc has better sound quality, and MP3 - at least through the Rio - is not exactly CD-like. But unlike MD and CD, MP3 is an open technology, not a proprietary one. It might be a little uneven now but tomorrow, in the fast-moving world of computers and the Web, it will be different, very different - and certainly much better. In the meantime, the Rio - its headphones apart - offers fair sound that anyone used to cheap, portable cassette should be happy with.

Diamond Multimedia PMP300 Rio £160-£180
Diamond Multimedia
610 Wharfedale Road,
Berkshire RG41 5TY
Tel: 0118 944 4400
www.diamondmm.com

WORLD VERDICT



Promising start for a technology in its infancy. Presently no threat to MD in sound quality.

OUT OF HARM'S WAY

Simon Pope plays host to the new HD740 CD player from harman/kardon.

Unbeknown to many, American outfit harman/kardon have a couple of spots allocated to them in the hi-fi hall of fame. Founded way-back-when in the design-obsessed Fifties, the company was the first to manufacture a hi-fidelity receiver in 1954. This was followed in 1971 by the first cassette deck with Dolby B and the first 'high-current' amplifier in 1980. There's been a lull in electronic milestones since then but h/k are keeping their hi-fi hand in with a new range of components. This consists of three integrations, a receiver, a twin cassette deck, two CD multi-players and three single CD machines, the middle-priced of which is the HD740 at £300.

Cosmetically, harman have traditionally never strayed very far from the inoffensive and so it remains with the '740, surprisingly the replacement for the HD730 reviewed back in August '96. There has been little change on the plentiful feature side too, and there are some commendable internals to boot. Behind the metal fascia are dual 20-bit Burr-Brown PCM1802K DACs with 8x oversampling which can be side-stepped with the coaxial digital output.

Having wired up the '740 to loudspeakers from Heybrook and Veritas (with amplification from Musical Fidelity, Crimson and Audio Analogue), my initial impressions were that this wasn't the most neutral of players. It has an extremely rich and sophisticated character, especially with Classical as I discovered with Bach's Mass in B Minor and Shostakovich's Tenth Symphony. The lengthy string phrases that are the bread and butter of the Bach were beautifully



relayed and the violins' middle and lower registers had a full, almost valve-like tonality.

The Bach is a close mic'd recording of a smallish group, which contributed to detail and imaging. For example, the two voices in the Domine Deus were positioned nicely to each side of the sound stage to create a vivid sense of width. Their long, exquisite phrases were carried through smoothly with little veiling of the voices. This refinement extended into the treble where strings and flutes were bright but not harsh. In addition, the sharp tone of the Baroque trumpets, which can take your sideburns off with certain equipment, was here well controlled.

Shostakovich's Tenth includes modern percussion which this player reproduced as sparkling and clean, albeit with a slight sheen which resulted in a somewhat processed sound. The much larger orchestra showed up another chink in the HD740's armour too, one lurking in the low frequencies. There wasn't enough oomph on tap, so large-scale recordings such as

this lost out on impact and weight.

Moving on to more studio-based fare with some Rock and Dance, I found the '740 picking up points for its rhythm. Beck's 'New Pollution' had a driving momentum which, together with the aforementioned smoothness, confirmed that the h/k can be quite a musical performer.

The guitar Rock of Radiohead's The Bends didn't make such a sweet match, the Achilles' heel of the '740, a lack of midrange transparency, making its presence felt. As a result, the opening track sounded compressed, the guitars swamping the vocals and the kick-drum failing to propel the music along as it should have done. Still, the h/k kept a tight reign on rhythms so this album never became loose or flabby.

The HD740 is definitely an improvement on its predecessor in the involvement stakes - nothing that I played sounded boring or laboured, and its mixture of drive and smoothness will win this machine fans, especially on Classical. If you want neutrality and intricate detail, however, it's less likely to hit the spot ●

harman/kardon HD740
£299.99

Gamepath
25 Heathfields,
Milton Keynes,
Bucks. MK12 6HR
Tel: 01908 317707

WORLD VERDICT



A smooth, musical and rhythmic player, but its closed midrange means it's better suited to Classical than Rock.

Sensational Selection at



PLEASE NOTE NOT ALL PRODUCTS ARE STOCKED AT ALL OUTLETS. PLEASE TELEPHONE TO VERIFY PRICE AND AVAILABILITY BEFORE TRAVELLING.

CD PLAYERS

Arcam Alpha 7 CD £ CALL
 Arcam Alpha 8 CD £ CALL
 Arcam Alpha 8SE CD £ CALL
 Arcam Alpha 9 CD £ CALL
 Cyrus DAD1 £ CALL
 Cyrus DAD3 £ CALL
 Cyrus DAD3Q £ CALL
 Denon DCD435 £ CALL
 Denon DCD635 £ CALL
 Denon DCD835 £ CALL
 Denon DCD1550 AR £ CALL
 Exposure CD £ CALL
 Marantz CD48 £ CALL
 Marantz CD671I £ CALL
 Marantz CD671IOSE £ CALL
 Marantz CD631KI Signature £ CALL
 Marantz CD17KI Signature £ CALL
 Meridian 506 20 Bit £ CALL
 Meridian 508 24 Bit £ CALL
 Musical Fidelity X-Ray £ CALL
 Myryad T10 £ CALL
 Myryad T20 £ CALL
 Myryad MC100 £ CALL
 Myryad MCD500 £ CALL
 Naim Audio £ CALL
 Pioneer PD5505 Precision £ CALL
 Roksan Caspian £ CALL
 Rotel RCD951 £ CALL
 Rotel RCD971 £ CALL
 Sony CDPXE310 £ CALL
 Sony CDPXE520 £ CALL
 Sony CDPXB920 £ CALL
 TAG McLaren CDT20R £ CALL
 Yamaha CDX493 £ CALL

CD MULTIPLAYERS

Arcam Alpha MCD £ CALL

CD TRANSPORTS

Meridian 500 £ CALL
 TAG McLaren CDT20R £ CALL

DACS

Meridian 566 24 Bit £ CALL
 Musical Fidelity X24K £ CALL
 TAG McLaren DAC20 £ CALL

MINI DISC/CD RECORDERS

Denon DMD1000 £ CALL
 Kenwood DM3090 £ CALL
 Marantz DR700 £ CALL
 Philips CDR760 CD Recorder £ CALL
 Philips CDR765 CD Recorder £ CALL
 Pioneer PDR555RV CD Recorder £ CALL
 Sharp MDM5702 MD Portable £ CALL
 Sharp MDM5722 MD Portable £ CALL
 Sony MZR35 MD Portable £ CALL
 Sony MZR50 MD Portable £ CALL
 Sony MDSJE520 £ CALL
 Sony MDSJB920 £ CALL
 Sony MDSJA20E5 £ CALL

CASSETTE DECKS

Denon DRM550 £ CALL
 Denon DRV585 Twin £ CALL
 Pioneer CT5550 Precision £ CALL
 Yamaha KX393 £ CALL
 Yamaha KX580SE £ CALL

TURNABLES

Michell Gyrodec inc RB300 £ CALL
 Project 0.5 £ CALL
 Project 1 £ CALL
 Technics SL1210 £ CALL
 Thorens TD280/IV inc AT95E £ CALL
 Thorens TD166/VI inc RB250 £ CALL

TUNERS

Arcam Alpha T7 £ CALL
 Arcam Alpha T8 £ CALL

Creek T43 £ CALL
 Cyrus FM7 £ CALL
 Denon TU260L MK2 £ CALL
 Denon TU215RDS £ CALL
 Denon TU1500RD £ CALL
 Marantz ST48 £ CALL
 Marantz ST17 £ CALL
 Meridian 504 £ CALL
 Myryad T30 £ CALL
 Myryad MT100 £ CALL
 Pioneer F504 Precision £ CALL
 Roksan Caspian £ CALL
 Sony STSE500 £ CALL
 Sony STSB920 £ CALL
 TAG McLaren T20 £ CALL

AMPLIFIERS

Arcam Alpha One £ CALL
 Arcam Alpha 7R £ CALL
 Arcam Alpha 8R £ CALL
 Arcam Alpha 9 £ CALL
 Arcam Alpha 10 £ CALL
 Cyrus SL £ CALL
 Cyrus MR3 Multiroom £ CALL
 Cyrus III i £ CALL
 Denon PMA250SE £ CALL
 Denon PMA350SE £ CALL
 Denon PMA1500R £ CALL
 Exposure Super 10 £ CALL
 Exposure Super 20 £ CALL
 Exposure Super 15 £ CALL
 Exposure 25 £ CALL
 John Shearne £ CALL
 Marantz PM57 £ CALL
 Marantz PM66SE £ CALL
 Marantz PM66KI Signature £ CALL
 Marantz PM17KI Signature £ CALL
 Meridian 551 £ CALL
 Musical Fidelity X-A1 £ CALL
 Myryad T40 £ CALL
 Myryad MI 120 £ CALL
 Naim Audio £ CALL
 Pioneer A300R Precision £ CALL
 Roksan Caspian £ CALL
 Rotel RA921 £ CALL
 Rotel RA931 £ CALL
 Rotel RA971 £ CALL
 Sony TAF248E £ CALL
 Sony TAFB920R £ CALL
 TAG McLaren 60i £ CALL
 TAG McLaren 60iRv £ CALL

PRE AMPLIFIERS

Arcam Alpha 9C £ CALL
 Cyrus AEQ7 Phono £ CALL
 Cyrus ACA7 Phono £ CALL
 Exposure 13 £ CALL
 Exposure 17 £ CALL
 Exposure 21 £ CALL
 Meridian 501.2 £ CALL
 Meridian 502 £ CALL
 Myryad MPI100 £ CALL
 Musical Fidelity X-Pre £ CALL
 Naim Audio £ CALL
 Rotel RC971 £ CALL
 TAG McLaren PA10 £ CALL
 TAG McLaren PA20R £ CALL
 TAG McLaren PPA20 £ CALL
 TAG McLaren PPA20 Phono £ CALL

POWER AMPLIFIERS

Arcam Alpha 8P £ CALL
 Arcam Alpha 9P £ CALL
 Arcam Alpha 10P £ CALL
 Cyrus XPA £ CALL
 Cyrus PSXR Power Supply £ CALL
 Cyrus Power £ CALL

Cyrus APA7 Mono (each) £ CALL
 Exposure Super18 £ CALL
 Exposure Super18 Mono (pair) £ CALL
 Meridian 556 £ CALL
 Meridian 557 £ CALL
 Myryad T60 £ CALL
 Myryad MA120 £ CALL
 Musical Fidelity X-A50 Mono (pair) £ CALL
 Naim Audio £ CALL
 Roksan Casplan £ CALL
 Rotel RB971 £ CALL
 Rotel RB981 £ CALL
 TAG McLaren 60P £ CALL
 TAG McLaren 100P £ CALL
 TAG McLaren 125M Mono (each) £ CALL

LOUDSPEAKERS (Pair)

Acoustic Energy Aegis One £ CALL
 Acoustic Energy AE100i £ CALL
 Acoustic Energy AE105SE £ CALL
 Acoustic Energy AE109 £ CALL
 AVI NuNeutron £ CALL
 B&W DM601 £ CALL
 B&W DM602 £ CALL
 B&W DM603 £ CALL
 B&W CDM1SE £ CALL
 B&W CDM2SE £ CALL
 B&W CDM7SE £ CALL
 Castle Isis (Deluxe Extra) £ CALL
 Castle Tay (Deluxe Extra) £ CALL
 Castle Kendal (Deluxe Extra) £ CALL
 Castle Severn 2 (Deluxe Extra) £ CALL
 Castle Avon (Deluxe Extra) £ CALL
 Castle Harlech (Deluxe Extra) £ CALL
 Epos ES12 £ CALL
 Epos ES15 £ CALL
 Epos ES22 £ CALL
 Epos ES30 £ CALL
 Heybrook Optima £ CALL
 Kef Q15 £ CALL
 Kef Q35 £ CALL
 Kef Q55 £ CALL
 Kef Reference £ CALL
 Mission 700 £ CALL
 Mission 701 £ CALL
 Mission 703 £ CALL
 Mission 705 £ CALL
 Mission 771 £ CALL
 Mission 772 £ CALL
 Mission 773 £ CALL
 Mission 774 £ CALL
 Mission 750LE £ CALL
 Monitor Audio Silver 53 £ CALL
 Monitor Audio Silver 55 £ CALL
 Monitor Audio Silver 57 £ CALL
 Monitor Audio Silver 59 £ CALL

Ruark Epilogue (Deluxe Extra) £ CALL
 Ruark Icon (Deluxe Extra) £ CALL
 Ruark Templar II (Deluxe Extra) £ CALL
 Ruark Sceptre (Deluxe Extra) £ CALL
 Ruark Talisman II (Deluxe Extra) £ CALL
 Ruark Prologue One (Deluxe Extra) £ CALL
 Tannoy Mercury M1 £ CALL
 Tannoy Mercury M2.5 £ CALL
 Tannoy Revolution R1 £ CALL
 Tannoy Mercury M3 £ CALL

SYSTEMS

Denon DM3 ex tape ex spks £ CALL
 Denon DM5 ex tape ex spks £ CALL
 Denon DM7 ex tape ex spks £ CALL
 Denon DF88 ex spks £ CALL
 Denon System 6.5 ex spks £ CALL
 Pioneer N55 ex tape inc spks £ CALL
 Pioneer N57 ex tape inc spks £ CALL
 Sony MDT333 inc spks £ CALL

Sony CMTED1 inc spks £ CALL
 Sony CMTMD1 inc spks £ CALL
 Teac Ref 300 ex spks £ CALL
 Teac Ref 500 ex spks £ CALL
 Technics SCHD55 inc spks £ CALL
 Technics SCHD81 inc spks £ CALL

DVD & LASER DISC PLAYERS

Denon DVD3000 £ CALL
 Panasonic DVDA150 £ CALL
 Panasonic DVDA350 £ CALL
 Pioneer DV515 £ CALL
 Pioneer DV717 £ CALL
 Pioneer DVL919 £ CALL
 Samsung DVD907 £ CALL
 Sony DVP5315 £ CALL
 Sony DVP5715 £ CALL
 Yamaha DVDS700 £ CALL

SURROUND AMPLIFIERS

Arcam AV50 £ CALL
 Yamaha DSPA592 £ CALL
 Yamaha D5PA2 £ CALL
 Yamaha D5PA1 £ CALL
 Yamaha D5PA1 Gold £ CALL

SURROUND RECEIVERS

Denon AVR1100RD £ CALL
 Denon AVR1700 £ CALL
 Denon AVR2700 £ CALL
 Sony STRDB925 £ CALL
 Yamaha RXV393 £ CALL
 Yamaha RXV592 £ CALL
 Yamaha RXV795 £ CALL

SURROUND PROCESSORS

Meridian £ CALL
 Yamaha D5PE492 £ CALL
 Yamaha DDP2.AC3 Decoder £ CALL

CENTRE SPEAKERS

Acoustic Energy AE107C £ CALL
 B&W CC6 £ CALL
 B&W CDMCSE £ CALL
 Kef Q95C £ CALL
 Mission 70c1 £ CALL
 Mission 70c2 £ CALL
 Mission 77C £ CALL
 Monitor Audio Silver Centre £ CALL
 Mordaunt Short T1000 £ CALL
 Ruark Dialogue One £ CALL
 Tannoy MC £ CALL
 Yamaha NSC60 £ CALL
 Yamaha NSC105 £ CALL
 Yamaha NSC150 £ CALL

SURROUND SPEAKERS (Pair)

Acoustic Energy AE101 £ CALL
 Boston £ CALL
 Mission 70 £ CALL
 Yamaha N5E60 £ CALL
 Yamaha N5E105 £ CALL

SUB WOOFERS

Acoustic Energy AE1085 £ CALL
 Rel Q50 £ CALL
 Rel Q100E £ CALL
 Rel Strata II £ CALL
 Rel Storm £ CALL
 Rel Stadium II (Blk) £ CALL
 Rel Stentor II (Blk) £ CALL
 Yamaha Y5T5W40 £ CALL
 Yamaha Y5T5W80 £ CALL

SPEAKER PACKAGES

Boston Micro 90t £ CALL
 Mission Cinema I £ CALL

Advertisement valid until at least 15th May, 1999 E&OE

GREAT VALUE

Outlets Nationwide



SEVENOAKS HI FI OUTLETS NATIONWIDE

- **SEVENOAKS**
01732 459555
109-113 London Road
- **ABERDEEN**
(LATE NIGHT THURSDAY)
01224 587070
491 Union Street
- **BEDFORD**
01234 272779
29-31 St Peters Street
- **BIRMINGHAM**
0121 233 2977
12 Queensway Arches,
Livery Street
- **BRIGHTON**
01273 733338
57 Western Road, Hove
- **BRISTOL**
0117 974 3727
92b White Ladies Road,
Clifton
- **BROMLEY**
0181 290 1988
39a East Street
- **CAMBRIDGE***
Due to open in late April
- **CARDIFF**
01222 472899
104-106 Albany Road
- **CARLISLE**
01228 590775
3 Earls Lane
(Next to Bus Station)
- **CHELSEA**
0171 352 9466
403 Kings Road, SW10
- **CHELTENHAM**
01242 241171
14 Pittville Street
- **CROYDON**
(LATE NIGHT THURSDAY)
0181 665 1203
373 London Road
- **EDINBURGH**
Apologies - Opening Delayed
- **ESSEX**
01376 501733
1 The Grove Centre,
Witham
- **EXETER**
01392 218895
28 Cowick Street
- **GUILDFORD**
01483 536666
73b North Street
- **HOLBORN**
(OPEN UNTIL 7PM EXCEPT SAT)
0171 837 7540
144-148 Grays Inn Rd
- **HULL**
(OPEN SUNDAYS)
01482 587171
1 Savile Row, Savile Street



Mail Order 01732 458985
Apologies ~ Marantz products cannot be supplied by mail order

*Cambridge due to open in late April subject to legal completion

- **IPSWICH**
01473 286977
12-14 Dogs Head Street
- **KINGSTON**
(LATE NIGHT THURSDAY)
0181 547 0717
43 Fife Road
- **LEEDS**
(OPEN SUNDAYS)
0113 245 2775
112 Vicar Lane
- **MAIDSTONE**
01622 686366
96 Week Street
- **NEWCASTLE**
0191 221 2320
19 Newgate Street
- **NORWICH**
01603 767605
29/29a St Giles Street
- **OXFORD**
01865 241773
41 St Clements
- **PETERBOROUGH**
(LATE NIGHT THURSDAY)
01733 897697
36 Park Road
- **PLYMOUTH**
01752 226011
107 Cornwall Street
- **PRESTON**
01772 825777
40-41 Lane Street
- **READING**
0118 959 7768
3 & 4 Kingswalk
- **SHEFFIELD**
(OPEN SUNDAYS)
0114 255 5861
635 Queens Rd, Heeley
- **SOUTHAMPTON**
01703 337770
33 London Road
- **SOUTHGATE**
0181 886 2777
79-81 Chase Side, N14
- **SWANSEA**
01792 465777
24 Mansel Street
- **SWISS COTTAGE**
(OPEN SUNDAYS)
0171 722 9777
21 North Ways Parade
- **TUNBRIDGE WELLS**
01892 531543
28-30 St Johns Road
- **WATFORD**
(OPEN SUNDAYS)
01923 213533
478 St Albans Road
- **WORCESTER**
01905 612929
2 Reindeer Court

At Sevenoaks Hi Fi you will find a wide range of products on show with the emphasis on quality combined with unbeatable value for money.

Everything in stock is on display and available for audition in our dedicated Hi Fi and Home Cinema demonstration rooms.

Our friendly and experienced staff will be happy to assist you through every step of your purchase and will, when appropriate, deliver and install your equipment to ensure total listening satisfaction.

Sevenoaks Hi Fi - there is no better place to buy.

**UK
TOP TEN
CD Albums
only £9.99
each**

Participating outlets only.
Offer subject to availability.
Personal callers only. E&OE.



NATIONWIDE

THE TRUTH & NOTHING BUT

Veritas are new kids on the loudspeaker block. Simon Pope checks out their pedigree.

Before turning his hand to audio design, the co-founder of Veritas, John Hullah, spent 20 years as a respected acoustic guitar maker. Seeing as acoustic guitars and loudspeakers are both basically wooden boxes that emanate sound waves, there is a fairly close relationship between the two, no strings attached (ouch!)

To find out what a switch from one end of the musical production chain to the other means in hi-fi terms, we selected a pair of Veritas' 7s, the company's entry-level, two-way stand mounters at £1245. Finished in a classy piano black, the 7s come with a pair of snazzy dedicated stands on slate plinths. An extra £200 buys you the same 'speakers supplied with external crossovers built into the stands.

When it comes to build there is no questioning the Veritas' calibre. Each cabinet is constructed with a core of 18mm MDF completely encased within an outer box of 10mm solid hardwood. They look very stylish indeed and the 28mm enclosure walls do a good job of reducing cabinet coloration. Any remaining doubts as to rigidity can be rapidly dispelled by a quick knuckle-rap on the side, which will result in a bout of swearing followed

by a few days of swelling. Presumably Mr. Hullah's guitars didn't weigh in at anywhere near this amount unless his clients had the fore-arms of Popeye!

There appears to be no scrimping when it comes to the bits that make the music in the cabinets, either. The crossovers are all made with polypropylene capacitors and air-core coils hard-wired to the twin terminals. The two drive units are a specially-made Morel 5in. DPC cone (with a 3in. voice coil) and a Seas 1in. textile-dome tweeter.

After the first few days' running the Veritas in I got to know a few of their characteristics and traits before starting the serious listening. With the help of a Roksan Caspian CD player as source and amplification from Musical Fidelity, Crimson and Audio Analogue, the scene was set.

From preliminary auditioning it was obvious that the Veritas' fortes were in neutrality and detail rather than out and out power. With their relatively low sensitivity they need a bit of pushing on the amplification front but when this is duly sorted you are greeted with an engaging sound that manages to mix detail and subtlety with musical involvement.

Spinning Leftfield's awesome Leftism CD the Veritas 7s showed

their love of a wide, well-mixed recording. They managed to tease apart the two stereo channels but still maintain that vital sense that what was occurring in the left channel was very much connected with the goings on of the right.

It can be a fine line between neutral and clinical for some 'speakers but the 7s had the knack of staying on the right side. 'Afro-left' was bristling with detail, tiny additions to the main electronic percussion brought to my attention as an integral part of the artists' canvas of colours. The Veritas revelled in the lean, dry production of Leftism, producing a very clear and articulate sound.

When it came to the all important bottom-end, the curtailed extension you'd expect from the smallish cabinet failed to materialise. On tracks where there was a genuinely deep, pumping bassline the Veritas literally showed what they were made of. Their construction made for substantial (if not truly thunderous) bass that was as tight as a convention of accountants. With more lightweight floor standers, for example, you tend to get plenty of bass, but it almost invariably lacks the control, speed and impact which are so vital to musicality.



No such difficulties here.

With vocal and guitar-based Rock courtesy of American boppy-Punk trio Green Day, the 7s confirmed a slightly bright top-end which I had previously suspected in cymbals and vocals. In fact, with Rock recordings there was a definite emphasis in the treble and midrange but, as is the case with Jamo's Concert 8s, it wasn't obtrusive because of the quality of the drivers.

Further proof of the 7s' calibre came in the deft handling of the drum kit; everything from the thudding kick-drum to the close-mic'd toms and shimmering ride cymbal was as pure as the driven snow. Lead vocals were just as pristine as they emerged from between the 'speakers to the rear of the sound stage, establishing an acoustic with a satisfying sense of depth.

My weakness for large Austro-Germanic Classical compositions meant the Veritas were in for a tough time when it came to faithfully representing the scale and depth of an elephantine orchestra. The predominantly string and wind

opening of Mahler's Ninth Symphony (played by the Gustav Mahler Youth Orchestra under James Judd) was reproduced with plenty of detail, the phrasing and vibrato in the strings and woodwind impeccable.

Disappointingly, on this recording the Veritas failed to flesh out the sound stage width fully due to their tight, dry bass. The situation improved with the first climax, where the cymbal crash opened things up spatially, but I was still left feeling it could have been broader. Counterbalancing this was the way the 7s relished the tonal colour and character of each instrument.

With this in mind I probed the Veritas' resolution of the subtle differences between the voices of an unaccompanied choir and a string quartet. The modal melancholy of Herbert Howells' Sing Lullaby performed by the Cambridge Singers had a life-like vibrancy and transparency. The bulk of the sounds in choral music are located in the middle of the frequency spectrum and again the insight of the Veritas was without fault apart from a little

thinness in the upper ranges of female voices.

Ravel's string quartet played by the Alban Berg quartet yielded much the same results as had choral works - chords were rich and rounded and individual melodies very easy to follow. All the instruments had natural tonal signatures and the loudspeakers' clarity coupled with a realistic sound stage gave the impression of almost being in the Wigmore Hall, without the coughs and dropped programmes of course.

If you're looking to invest in a small pair of stand mounts which major on detail, control and freedom from cabinet coloration, the Veritas 7s are appealing newcomers. Yes, they are fairly expensive for the size (Opera manufacture hardwood loudspeakers for less), but the build is excellent (as are the matching stands) and they work very well in small rooms. Another plus point is their even-handedness - Rock or Classical, the Veritas are happy with either. The only flies in the ointment are the lack of bass depth and that occasional midrange thinness. Otherwise, full marks all round.

Veritas 7 £1000

Veritas Horn Systems
2 Manor Farm Barns,
Glandford,
Holt,
Norfolk NR25 7JP
Tel: 01263 741417

WORLD VERDICT



The Veritas 7s combine neutrality and detail with fluidity and sophistication.

Measured Performance
see page 127

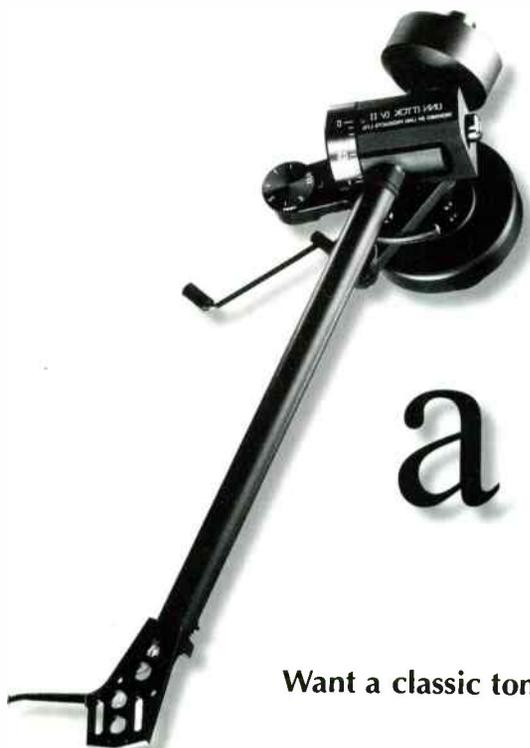

ick-up a bargain

Want a classic tone-arm on the cheap? David Price looks at four potential golden oldies.

LINN ITTOK LVIII

By many people's reckoning the Ittok was the world's first super-arm. Originally manufactured for Linn by the Denon Parts Company of Japan (no relation to the electronics brand), it was designed by a certain Mr Ito to Linn's specification back in the late Seventies. The Tik-Tok (as fans called it) evolved over the years with various detail changes (such as a new counterweight), until it reached its LVIII incarnation in 1989. This last version of the Ittok was undoubtedly the best, featuring Ekos-style glued arm-tube joints. By this time, the price had risen from the original £230 to over £450.

Arguably the first arm to espouse the maximum rigidity principle, the Ittok is built for strength. Its large-bore alloy arm tube is glued to a perforated magnesium headshell and a robust bearing assembly which houses standard ball-races plus a tool-steel central shaft. Very finely aligned, these bearings offer a single, rigid coupling right through to the arm pillar with its three-point fixing.

The sliding brass counterweight is decoupled from the rear end-stub by hard rubber bushes; thumbwheels set the spring-

applied tracking force and bias. Cabling is very low capacitance and inductance copper, terminated with gold-plated Linn phono plugs. With an effective mass of 12gms, the Ittok is in the medium to high-mass category, meaning it will work well with most MCs and MMs alike.

One of the Ittok's best platforms is Linn's own LP12, with which it enjoys a real synergy. But it's actually extremely effective on any decent turntable, suspended sub-chassis or not. Its slightly forward, lively character tends to complement most smooth-sounding, capable belt drives. After hearing designs from a previous generation such as Grace's G707, the Ittok's unusually tuneful and very powerful bass articulation is immediately apparent. Later super-arms like the Zeta

Linn's Ittok is never less than a highly musical performer.

bettered it in the latter respect but never the former. Moving up the frequency scale, the midband is detailed and open with good depth perspective. It images well too - far better than the LP12 it usually partners - but is still a touch

vague about the centre compared to the Syrinx PU3 or Zeta. The Ittok's real strength is its musicality. To this day it's one of the most enjoyable non-unipivot designs around, investing anything it plays with a sprightly bounce. Dynamics are also strong, and although quite a way behind the likes of the SME V in absolute terms, the Ittok always manages to sound more expressive than its peers.

This isn't the world's most perfect arm though. Treble could ideally be more refined - it's rather forward and splashy compared to the best of the rest, but still does the job well enough. The maxim about not partnering the Ittok with bright moving coils

(such as Audio Technicas, for example)

holds as true as ever. Bass, although very fluid, can be lumpy and lacks the clout of the Zeta or SME V. Detail retrieval isn't a forte either, tending to be cloudy in the midband and fuzzy in the treble. The Linn is such an involving listen, however, that most people simply don't notice.

The Ittok is readily available second-hand and prices are low. Unfortunately, due to it being relatively delicate it's easy to buy a pig in a poke. The very last LVIII is undoubtedly the one to have, but is difficult find - pay up to £300 for a mint

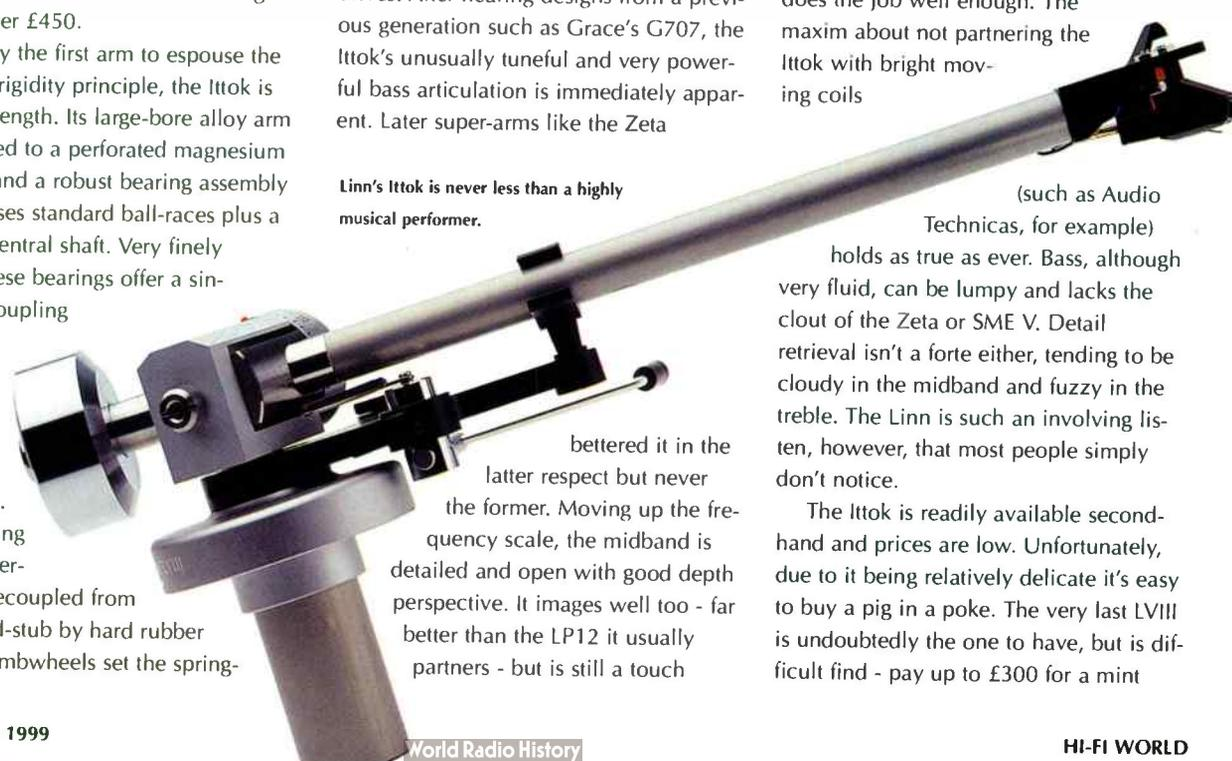

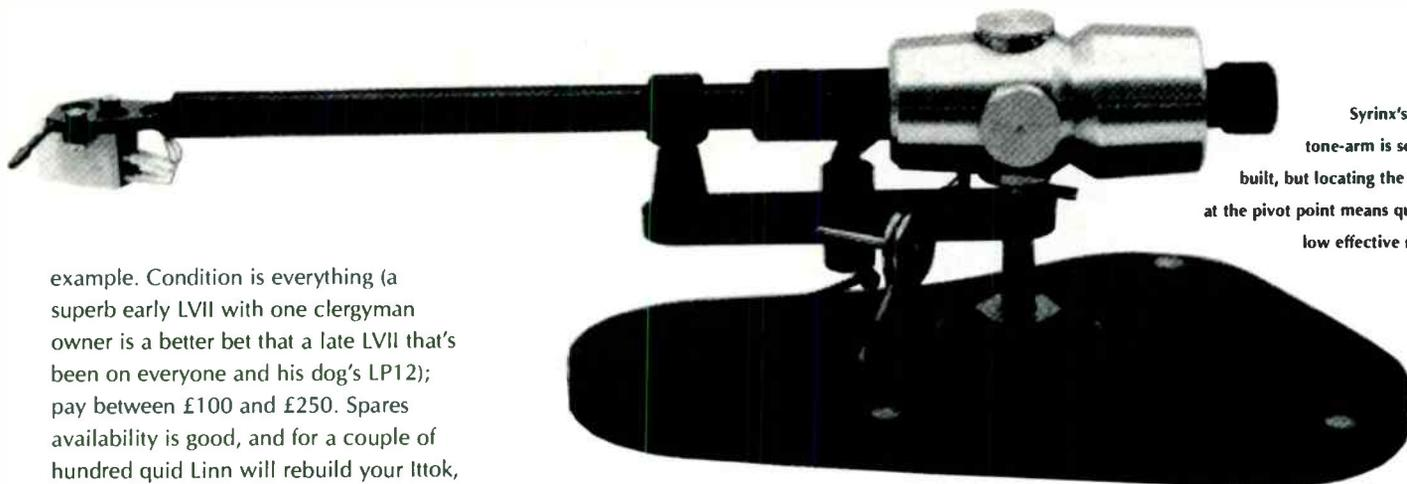

Syrinx's PU3 tone-arm is solidly built, but locating the mass at the pivot point means quite a low effective mass.

example. Condition is everything (a superb early LVII with one clergyman owner is a better bet than a late LVII that's been on everyone and his dog's LP12); pay between £100 and £250. Spares availability is good, and for a couple of hundred quid Linn will rebuild your Ittok, a very worthwhile option.

WORLD VERDICT



Extremely musical but hardly the last word in refinement. Market oversupply keeps prices low and makes for some superb used bargains.

SYRINX PU3

Back in late 1981, Scot Strachan unveiled his Syrx PU2 to an unsuspecting world. In spite of its promise it was flawed in several important areas such as resonance characteristics, ease of use and build quality. Enter the PU3 in 1983, substantially redesigned to achieve ultra-low resonance and simple set-up. At £291 it wasn't cheap, but its performance and flair were such that it seemed a bargain.

Aesthetically a bit of an odd one, the PU3 is reckoned to be the first tone-arm to feature a cigar-shaped arm-tube to reduce resonances. Strachan once lamented the fact that few people gave him credit for this bright idea even when someone pointed out that Isambard Kingdom Brunel had actually used it in his bridges a while before! Despite the beefy looks it has a surprisingly low effective mass of 9gms which will get the best out of higher compliance moving magnets as well as most moving coils. Cartridge weight range is 4gms to 12gms.

Off-set adjustment is accomplished by unclamping the arm-tube at its boss and moving the whole assembly fore and aft on a screw. Tracking force is set via a threaded counterweight and then locked with a concentric thumbwheel; bias is the common weight and thread on a falling lever. And in

the best traditions of tweaky kit, neither adjustment is calibrated! Bearings are tightly-toleranced items, internal wiring high-purity copper with a PVC dielectric.

Sound quality is extremely good overall, with a particularly lucid and organic midband. Whereas arms like the Zeta give epic versions of every record you play on them, the PU3 is altogether more subtle and cohesive. By contrast, bass is lighter and slower with less energy and articulation. Although extremely detailed, the Syrx is never 'in your face'; instead it conjures up instruments in all their tactile, vibrant glory.

Critics of the PU3 might call it warm and coloured, with a slightly fat, over-blown sound; from where I'm standing it's a true star. The PU3 is a great way to unlock the music in the groove rather than the merely cerebral. Eminently natural, it draws the listener in rather than making them focus on the song's recording quality or the disc's surface noise.

The Syrx PU3 is a fine used buy providing the example you choose has been carefully kept. Pay £200-£250 for a well-preserved specimen, much less for a clunker. The PU2 Gold is another possibility as it's the most developed incarnation of the 3's predecessor, but they're fiddly to set up and use, and often drift out of tune. Pay £80 for a good PU2g.

WORLD VERDICT



Weird but loveable arm with a quintessentially 'analogue' performance. Questionable spares availability and age make for low prices.

ALPHASON HR100S

Just when it seemed that every super-arm worth the name had thick, straight arm-tubes like Linn's Ittok, Alphason's HR100S appeared in 1983 sporting classic S-shape geometry. And this wasn't the only departure from fashion as the HR100 used titanium in its arm-tubing for maximum strength and rigidity, as SME had done with the Series III and Technics with the EPA500H five years earlier. Even more unusual was its thin, flat-plate headshell which was ingeniously formed from the end of the arm tube.

The Alphason's concentric gimbal bearings are of hardened tool steel. The counterweight system is more flexible than many, with a balance weight sitting on a carrier that can be screwed forward or backward on a hard nylon carrier and then locked by a small screw. As one complete forward rotation of the carrier applies 0.25gm, the system obviates the need for a stylus balance to set the tracking weight.

Three counterweights are available to cope with a wide range of cartridges. In standard guise, the HR100S will accept 4gms to 12gms. Bias is by the old SME-style thread and weight, and is also calibrated. The effective mass is quoted at 11gms, making this a medium-mass arm capable of handling most cartridges. Early

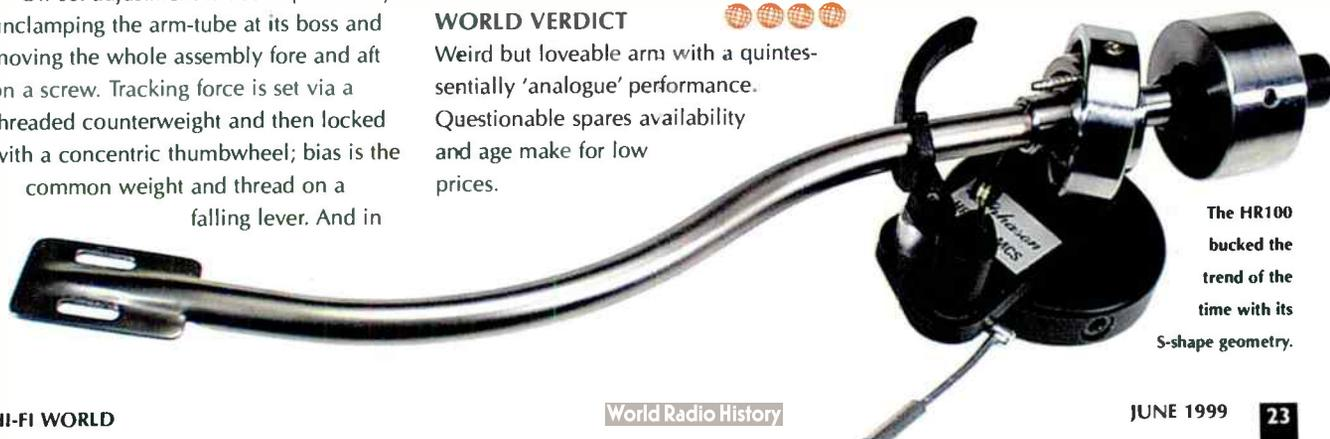

The HR100 bucked the trend of the time with its S-shape geometry.



The Alphason's gimbal bearings look old-fashioned but work very well.

arms were wired with decent, low-capacitance (95pF) copper; from 1985 the MCS version came with the worthwhile option of Mono-Crystal Silver wire for a small price premium.

The Alphason's sound is a bit of a conundrum. In some respects it's absolutely superb, in others sadly lacking. In terms of detail, focus and refinement it will run rings around an Ittok or a Syrinx. Midrange neutrality is another high point, instruments reproduced with a master tape-like solidity. Sound staging is naturally proportioned, with no restrictions to either width or depth perspectives. Likewise, bass is punchy and even, never sounding leaden like a Zeta or lightweight like the Grace.

In so many ways the Alphason is a real class act. The problem is that it isn't so gifted at music making - vocals lack power and projection, rhythms are deconstructed rather than visceral and dynamics lack impact. Everything on the record is there in the listening room but it never really sparks the imagination or gets the feet tapping. The Alphason is just a touch too smooth, a teensy bit bland. In fairness, many will value the Alphason's strengths more than, say, the Ittok's. Lovers of Classical and choral music, for whom the ability to recreate a recorded acoustic is paramount, will prefer it to the lumpy, splashy Ittok or the euphonic Syrinx. But boogie merchants, be they into Jazz or Rock, should look elsewhere.

Second-hand Alphason prices are keen these days. Build was patchy on the very early models, but generally to a high standard after 1984. Construction materials are far more robust than many rivals, meaning you don't need to be quite as paranoid as when buying an Ittok, for

example. Prices range from £150 for an early non-MCS to £300 for a mint MCS with all its original accessories.

WORLD VERDICT

Beautifully-engineered arm with a very refined sound, but not as musical as some.

ALPHASON ZETA

If ever there was a battleship tone-arm, the Zeta is it. Launched in 1982 at £399, build was heroic, with a huge arm pillar housing top-class bearings, large-diameter arm-tube cut from 20-gauge alloy and a solid, one-piece alloy headshell with a milled-flat underside. The counterweight comprises an alloy housing with three mild-steel weights inside, a removable insert allowing a total cartridge weight range of 17gms. Wiring is copper Beyer microphone cable, although later Zetas came with the option of vdH MCD502 for a £90 premium. Physically, the arm resembles the Mission 774SM, which happened to be made in the same London engineering works, GB Tools.

A classic example of a heavyweight tone-arm, its 16gm effective mass makes it best suited to low-compliance moving coils. Setting up is a tad fiddly as there's no spring-applied tracking force adjustment. This is good news for sound quality since there are no extra bits of metal inside the bearing housing to vibrate. Unfortunately, it also makes setting the tracking weight a more fussy business requiring a decent stylus balance. The counterweight is locked in place by a grub screw. Likewise the arm height adjustment, while bias is applied by a

thumbwheel on the arm pillar which is uncalibrated.

On audition the Zeta is a gem. It's a great all-rounder with a very strong, even and taut bass, superb midband performance and clean, extended treble. Dynamics are superb, with a tremendous feeling of power and grip. The Zeta's resolution is class-leading too, letting the listener focus on a single strand in the mix and follow it effortlessly right through the song. This, plus its superb dynamics and commensurate rhythmic ability, mean it's always a compelling listen.

The Zeta has few weak points. You could say it lacks the tonal richness and warmth of some rivals - in fact, detractors call it dull. There's a sense that its upper midband is a touch coarse, and its critics draw attention to its overlarge bearing housing as a source of unwelcome resonances. They also claim, wrongly in my opinion, that it has an artificial way with music. True, it's big and butch and pulls no punches, but it's also a real music maker, if not quite as beguiling as the best unipivots.

The Zeta is popular second-hand, its robust construction doing no harm at all to used values. This, plus the fact that it was one of the most expensive around until the advent of mega arms like the SME V, means it's pricey. Early samples go for around £250, but sample consistency was patchy in those days. Although the vdH wiring does little extra for its sound quality, these later versions are the ones to go for. Pay £350-£450 depending on condition.

WORLD VERDICT

Superbly dynamic, powerful sound. Fiddly to set up though, and too heavy for some decks.

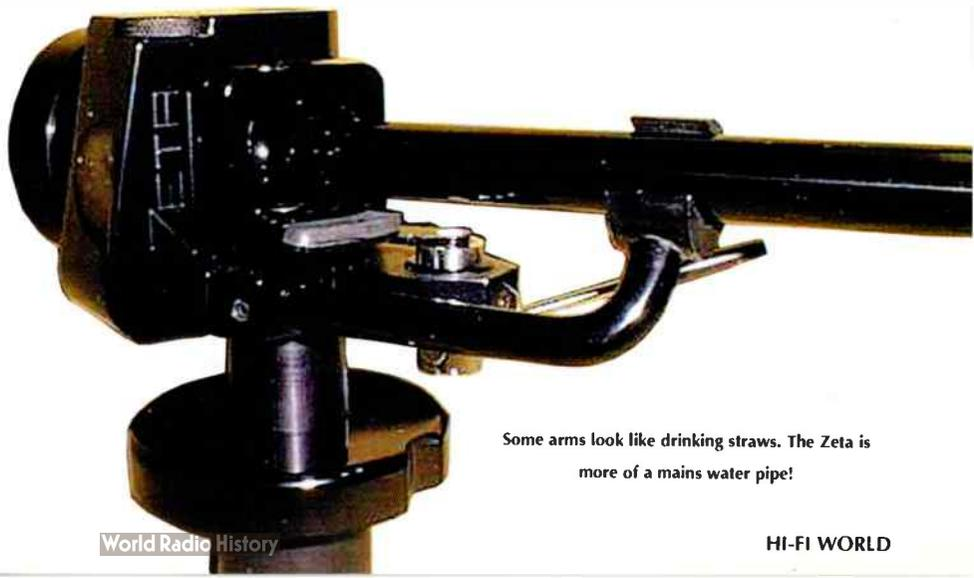

Some arms look like drinking straws. The Zeta is more of a mains water pipe!

ultimate



One Thing at a Time

Richard White goes all cryptic with One Thing's stereo decoder.

The Leak Troughline tuner is excellent; the stereo decoder is not. Solve this problem and any high-quality mono tuner (Leak; Rogers; Pye; Quad) can get a whole new lease of life. Not only but also, many stereo tuners have 'standard' decoders fitted almost as an afterthought. These too can benefit hugely from a better-specified modern decoder. One Thing's Stereo Demodulator sustains an honourable line and is available in an outboard version as illustrated, in kit form for DIY, or as a 'factory-fitted' upgrade to your own tuner.

For newcomers to the tuner scene, multiplex is a method for combining two or more signals in such a way that they can be unravelled again when required. The technique was developed as being the most retro-compatible when FM stereo broadcasting standards were set years ago.

A simple analogy (fig.1) shows the basis of the idea. So long as the two sets of points are correctly synchronized, the two groups of trucks can be sent along the single line alternately and re-switched at the other end with no-one any the worse off. A great part of the secret of successful operation is making sure that the points switch at the right time: if this gets out of synch, it is easy to see that the separation which is the object of the exercise might degenerate into an



unseemly mixture or a series of pile-ups, resulting in no signal/trucks getting through at all.

Whatever refinements are adopted, the 'switch' synchronization is governed by a pilot tone transmitted (by the broadcaster) with the encoded stereo signal.

Because the basic requirements were decided long ago, modern-day decoder designers are more concerned with ensuring that the technology gives the best possible performance within the given limits: low noise is an important factor, as is stability of separation.

One Thing's decoder is unusual inasmuch as it does not amplify the incoming signal before decoding it, so the overall gain is less than unity (or 1x). The manufacturer says that this hasn't been an issue so far: most

tuners are capable of pushing out the requisite 320mV multiplex signal without needing an additional amplifying stage and the effect that can have on the sound. If there is insufficient signal for decent stereo, the beacon fails to light and you have the options of switching to mono for lower noise or maybe using the handy Blend control to pick an optimum in-between point.

Tuning in to Radio 3 for what is probably the least meddled-with signal on the dial, I was astonished at how good the broadcast was. Everything from chamber works to full orchestra to plays to news leapt into life. A gloriously rich spread of crisp, clear stereo sound wafted forth whichever way the dial was pointed. Even the ultra-compressed commercial stations sounded vaguely human for a change.

In use, I found that I simply forgot about the One Thing - ungrateful I know! My admiration tended to settle on the tuner and (gasp!) the programmes. Given the steady improvements in stereo broadcasting over the last 30 years, I don't think my tuner has sounded better in its life.

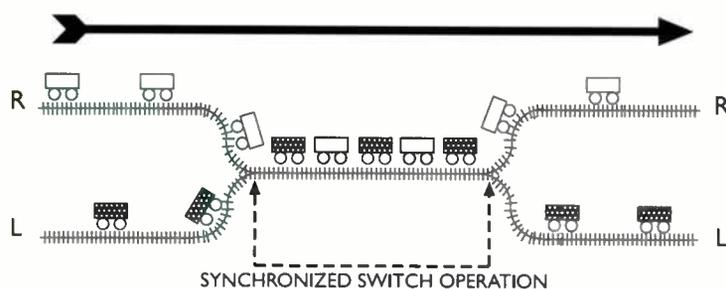

One Thing Stereo Demodulator £150

One Thing
Classique House,
61 Aylestone Drive,
Aylestone,
Leicester LE2 8QE
Tel: 0116 283 5821

WORLD VERDICT



Lets a tuner speak for itself, simple as that.

Measured Performance see page 127

statement



Full 4 way system • 5th generation Uni-Q® technology • 15" dual suspension LF driver
individually selected crossover components • 3 dedicated separate enclosures • 25mm
braced MDF construction • bespoke gold plated hardware • fine veneer and lacquer finish

Designed on computer • fine tuned by ear • hand built by music lovers

REFERENCE SERIES MODEL 109
THE MAIDSTONE



For details on the Reference Series please contact KENT AUDIO LTD LIMITED DEPT HFW33, FREEPOST MA1332, ECCLESTON ROAD, OVINGDEAN, MAIDSTONE, KENT ME15 6BR. FREEPHONE 0800 7315620
KENT and Uni-Q are registered trademarks. Uni-Q is protected under GB Patent 2 276929, U.S. Pat. No. 5,548,657. Worldwide patents pending. www.kent.com

WorldRadioHistory

BOX FOR 2

Jon Marks quizzes Papworth's MVH-200 and MVL's A2+ in the search for a top integrated amp.

One of the toughest questions facing audiophiles on the upgrade path is where should one box become two? This can apply to CD replay, but in this instance it's amplification under examination as we decided to test the mettle of two top £1200 integrations to find out if your money is better spent on single chassis or double. The contenders are Papworth's classy MVH-200 and MVL's A2+.

same manufacturer, only this time there are six and they're rated at 100V. Alps is the name on the volume pot again. Where the Papworth

was Natacha Atlas' *Gedida*, with its mix of Arabic rhythms, synthesizers and Drum 'n' Bass. Its production isn't the smoothest ever stamped into



The MVH-200 is very well built, its lacquered heatsinks and gold knobs lending it an air of class.

WE'RE GOING IN

The Papworth's inputs run to four line-levels, two Tape in and a Tape out. Loudspeaker terminals number a pair per channel. Turning to the MVL, I discovered a real socket-fest - there are loops for CD-R, MiniDisc, Tape and DAT. The rest cater for Phono, CD, DAB, FM, VCR and Line In/Out for bi-amping. Each of these has been treated to MVL's Sound Sentinel stages, tailored to boost the sound of their respective sources.

UNDER THE BONNETS

Making up a large part of the MVH-200's mass is a chunky Talema toroidal. Supplying the ECC88 valve in the input stage (which is mounted hard up against the source sockets) is a second, small E/I transformer. The Alps Blue volume pot and selector are both shaft-driven from the glass front panel to keep signal paths short. Finally, the two pairs of 10000uF 80V reservoir caps are soldered directly onto the power stage boards to ensure short supply lines.

The MVL A2+ uses caps from the

has very large fins on its heatsinks (which are fairly microphonic), the A2+'s are extremely short, suggesting a high-efficiency mode of operation. Like Crimson Electric's amps, ribbon cabling is widely used for point-to-point wiring. One unusual feature was the mystery black box stuck to the right side wall of the chassis, which presumably contains some of MVL's to-be-patented circuitry.

SOUND QUALITY

When it came to putting the A2+ and MVH-200 to the test, the system consisted of a clocked Kenwood '9010 transport feeding Pink Triangle's latest Cardinal DAC. The MVL's phono stage was partnered with a Trio L-07D and a DNM RICA MM. Loudspeakers were Magneplanar's SMGa panels.

Over the course of a long weekend, the Papworth made itself a welcome addition to my system as it turned out to be a musical, dynamic and involving amp. One disc where these traits were especially obvious

a CD, a fact which the MVH-200 made no attempt to conceal. However, rather than dwelling on the brash percussion and occasionally lumpy bass, it got on with making the most of the music. The result was tapping feet on tracks that ranged from the up-lifting 'Ezzay' with its energetic fiddles and hand claps all the way through to the final number, 'One Brief Moment', with its orchestral intro followed by a laid-back bassline which comes perilously close to limping along on most amplification.

Musicality is a vitally important part of hi-fi's recipe but something which gets the pulse racing only to yield sound staging of beer-mat dimensions and imaging so soft-focus that all you're left with is an amorphous blob probably isn't going to last long in anyone's system. The Papworth was granted a long-stay visa thanks to its insight and transparency, both of which gave recordings plenty of spread and depth, especially relatively unprocessed acoustic ones.

A very prime example of the above was Whistler's eponymous guitar Indie. 'If I Give You A Smile' came through with an impressive realism which didn't dissolve into confusion as things got busier towards the end of the song, the Papworth having no trouble keeping a firm grip on the individual instruments. And, as 'Closing Time' with its acoustic guitar and vocal intro proved, it did this without compromising delicacy or small-scale dynamics - this isn't an amp which turns everything into a massive crash-bang performance regardless of whether it's Dance or Chamber music.

Ironically, it was the Paladin Ensemble's Trios For Four on Linn Records which started to uncover a few hiccups in the MVH-200's presentation. As our measured performance had hinted at with its distortion spectrum, there was a slight extra brightness to the Papworth's sound which tended to bring Rock

spread. To be fair, this is what happens through most amps, but there is a little more to be squeezed from this disc.

MVL's A2 basic integrated reviewed last month left the right impression on everyone who heard it, and it even managed to knock Audio Analogue's outstanding Puccini SE off its No1-below-£1000 perch (although the A2 has the advantage of a £250 price premium). The question now was, could that amp with the addition of the whole range of Sound Sentinel inputs rise to the challenge of its £1250?

Returning to Natacha Atlas' Gedida was once again an enjoyable experience - 'Ezzay' had a spaciousness, vibrancy and drive which had me prodding the Repeat button on the Kenwood transport's remote a fair few times. Image focus was also well up there with the best at this price, each strand of the mix clear in itself but woven homoge-

nudges up the volume at this point. Strangely, this isn't all that noticeable through a lot of amplification.

Whistler found the A2+ in equally fine form. Despite a measured performance for the MVL which suggested loads of distortion and a commensurately hard, sharp sound, it had a natural smoothness and lucidity that made this disc an addictive listen. The sweetly-sung but bitter lyrics never suffered any undue sibilance or harshness, and there was an almost tangible sense of space between images that set up the sort of warehouse sound staging you'd expect from pricier integrations or pre/powers.

This theme continued into the Paladin Quartet and the Elgar, where strings were incisive but not excessively brash. And the 3-D presentation of both orchestra and quartet proved the MVL was just as competent with depth perspectives as width, not a combination solid-state is renowned for. Other feathers in the cap included an appealing ebb and flow to the Elgar along

with a scale and sense of lack of strain - the A2+ never sounded as if it was struggling to keep up on crescendoes.

HEAD TO HEAD

These two integrations both have considerable strengths, particularly when it comes to musicality. The MVH-200 adds a touch of emphasis at both ends of the spectrum to enhance detail and weight, a trick which worked a treat on Dancier, Rockier numbers; on Classical it didn't gel quite as well, violins picking up a slight steely edge and cellos losing some of their speed and focus.

MVL's A2+ had a more subtle impact on the music flowing through it. Compared with a battery-powered DPA 50S and a pair of Musical Fidelity X-A200 monoblocs, there was some marginal dynamic compression, but then this three-box outfit costs over twice as much as the MVL. If you're after a genuinely transparent, natural and effortless performer, the A2+ is currently at the top of the pile●



The A2+'s front-panel controls include treble and bass adjustment.

percussion and Classical strings (and recorder for that matter) up towards the front of the sound stage while instruments with less high-frequency output stayed further back.

This explained a suspicion I'd had that this amp's depth perspectives, good though they were, weren't entirely natural. Confirmation came in Elgar's violin concerto. Now, this isn't the most open or ebullient of recordings anyway, but through the MVH-200 it had a faint air of mugginess as the orchestra stayed put well behind the Magneplanars and missed out on its full front-to-back

neously into the whole within a sound stage which was properly layered front to back. And in spite of the overall electronically-processed feel of this album, the A2+ demonstrated a winning way with harmonics as it did an excellent job of allowing through those of strings plucked and bowed.

Evidence of the MVL's adept handling of dynamics came just after two minutes into 'Ezzay'. Maybe he'd had a hard day, perhaps it was that spicy pizza and seventh can of Red Stripe at 4am, but for some reason it sounds as if the engineer gets a bit fader-happy and accidentally

Papworth MVH-200

£1200

Papworth Audio
Technology

1 Cambridge Court,
Papworth Everard,
Cambs. CB3 8RG
Tel: 01480 831666

MVL A2+

£1250

MVL Technology

Northfield Mill,
Wymondham,
Norfolk NR18 0DF
Tel: 01953 850800

WORLD VERDICT



MVH-200

Very solid, enjoyable amp but not the smoothest top-end or most open sound staging.



A2+

Seamless, natural and very open, the A2+ sets the pace at the price.

Measured Performance
see page 127



X-A RANGE.
MACHINED, MIL-SPEC ALUMINIUM
FRONT PANEL.

MILLED METAL KNOBS.

RUGGED, NON-RESONANT
METAL CASEWORK.

JUST IMAGINE HOW GOOD
THE ELECTRONICS MUST BE.

MUSICAL FIDELITY

INTEGRATED AMPS, PREAMPS, POWER AMPS, TUNER, AND CD PLAYER. FOR DETAILS OF YOUR NEAREST STOCKIST RING 0181 900 2866.

CREEK IN THE

BOX

Jon Marks discovers the attractions of Creek's OBH-14 combined DAC and passive pre-amp.

As the millennium closes, some forward-thinking audiophiles are raising an eyebrow to the increasingly rare newcomers on the outboard budget DAC scene; after all, Super Audio CD and 24-bit, 192kHz are due to arrive as the 1s on all the calendars change to 2s. Surely, anything that decodes measly 16/44.1 is an electronic has-been which should be gathering dust in a junk shop? Labelling CD museum fodder is jumping the gun a wee bit, though. Neither of the new formats is here yet and there's a hell of a lot of CDs out there in addition to older players whose innards are a fair way from the cutting edge.

Unlike most of the breed, the small, black box which houses Creek's £239 OBH-14 convertor doesn't just exist to crunch the numbers from a transport or integrated player. It hosts a volume potentiometer and single analogue source input too. While others have been here before - Monarchy's Model 18 DAC has more inputs as befits a pricier product - I doubt any have done it so discreetly.

"Tiny" didn't describe the size of this project's finances judging from the parts quality, however. Inside the case are Philips polystyrene caps, Os-Cons (albeit not the audio-grade types) and Elna Sarget electrolytics. Op amps are that trusty stalwart, the 5532, and the DAC Crystal's 4390 24-bit sitting downstream of the 8412 interface receiver.

Teaming up with the OBH-14 was one of Kenwood's venerable



but heavyweight DP-X9010 transports (clocked to bring it up to date). Amplification was MVL's A25 Integral amp driving Magneplanar's SMGa panel loudspeakers. Giving the Analogue/Digital button on the Creek's fascia something to do was a modified Pioneer DV-505 DVD player.

Fired up straight out of the box, the OBH-14 had a rather bright but plodding presentation which proved to be quite hard going for my ears. I duly left it plugged into the Kenwood on repeat for a couple of days, periodically checking that it was loosening up. After 48 hours of burn-in, the Creek was sounding considerably more fluid and musical; where Beck's Mellow Gold album had been a real battle before, now the man's mad genius ("Get crazy with the cheese-whizz!") made some sort of weird sense in spite of the fact that, on most of the tracks, he seems to be trying to eat a cardboard box and sing through a breeze-block wall at the same time.

If electronics can hack it with Mellow Gold, they can hack it with just about anything, so I wasn't

surprised to hear the OBH-14 sail through dEUS' The Ideal Crash with no problems. Again, this album isn't what you'd call easy listening but at least it has some clear, crisp production to its credit, a fact which the Creek highlighted with its stable, expansive sound staging and accurate imaging. 'One Advice, Space' had its lilting bassline intact, above it vocals and cymbals unmarred by the grain

and lack of tonal colour for which some players have given CD a bad name. The only area in which the Creek lagged slightly was the bottom end - a tad more speed, extension and definition would really have iced the cake.

Bringing the pre-amp side of the OBH-14 to bear, I was greeted by a presentation not too dissimilar from that of another OBH, the '12 passive pre. Along 30cms of interconnect (keep it short with passives) the music flowing from the Creek had evidently lost some of its space, detail, dynamics and control over the fixed output. The bonus is not having to splash out on a separate pre - as long as you only have a single analogue source and don't want to make recordings from it, that is.

Seeing as its £239 includes the beefier of Creek's two PSUs, the OBH-2, a passive pre and an extremely able DAC, the OBH-14 has a lot going for it. If you've got a budget transport or an older CD player that could do with a breath of fresh air in the convertor department, it pulls ahead of even Midiman's killer Flying Calf

Creek OBH-14/OBH-2
£239

Creek
2 Bellevue Road,
Friern Barnet,
London N11 3ER
Tel: 0181 361 4133

WORLD VERDICT



At the money, this multi-talented DAC has no competition.

Measured Performance
see p127

Unique [you-neek]

..alone, exceptional, peerless, rare, single, sole, unmatched, one of a kind, unusual, unparalleled.



...and that's just the looks!

The Opal-25i SE Integrated Class 'A'

6 inputs incl phono of pure class A operation.

See it!.. Hear it!.. Want it!.. Own it?

For further details, Please contact:-

Sound Management Consultants Ltd



Tel/Fax 01709 579 010

Email:smcsimpson@compuserve.com

jT HORN LOUDSPEAKERS

Musicality with Emotion

Listening to JT HORN LOUDSPEAKERS gives the enjoyment of sheer musicality, with stunning dynamics and a life size natural mid and treble plus a fast bass which only efficient horn loudspeakers can offer.

To optimise the musicality of our horn loudspeakers all the models are made from birch-ply which has excellent acoustical properties.

Each horn loudspeaker is fitted with the superb Lowther DX3 drive unit.

Cabinets are finished in real wood veneers of the buyers choice.

JT Horn Loudspeakers to be partnered with quality valve or solid state amplifiers with audiophile front-end sources.

Retail price per pair:

JTH50 £2300:

JTH40 £2700:

JTH30 £3900:



4 Datchet Close, Littleover, Derby DE23 7SQ

Tel/Fax: 01332 512 510



epos

**HAPPY
BIRTHDAY
SWEET 16!**

**16 YEARS OF:
TECHNOLOGY...
BEAUTY...
MUSICALITY...**

Under new management:

EPOS ACOUSTICS

2 Bellevue Road, Friern Barnet
London N11 3ER, England

Tel: 00 44 + (0)181 361 8864

Fax: 00 44 + (0)181 361 4136

E-mail: epos-acoustics@ibm.net

Internet: www.epos-acoustics.com

ACTIVELY ENGAGED

Simon Pope is on a mission to find the best affordable active loudspeakers. Next stop, Yamaha's MSP5s.

In the world of domestic audio more and more people are taking a lesson from the professional side of things and going active. Of course, domestic active loudspeakers have been around for a long time, but only ever in limited numbers due to their cost. Now, the growing flood of such designs intended for home-studio and multi-media use means the situation's changing.

As converts will know, the benefits of going active can be numerous. Fabulous midrange and treble clarity alongside bass slam like a fore-arm smash from Giant Haystacks (God rest his soul) are just some of the tasty attributes attainable in the best packages. Unfortunately, a three-way cabinet packed with expensive drivers and six-channels of amplification doesn't come cheap. On the other hand, Yamaha's MSP5s are inexpensive two-ways intended for a life as monitors in home studios.

Some may find the MSP5s look a little spartan for the front room. The sturdy enclosure is punctuated by a titanium-dome tweeter peeking from behind a plastic phase plate and metal grilles cover the mid/bass drivers. Round the back, the input connections are either XLR (balanced) or 0.25in. jack (unbalanced). For lowest signal degradation, I plugged the source directly into the unbalanced sockets via a length of The Chord Company's Chameleon with appropriate terminations.

Powering up Roksan's Caspian CD player, I started with a selection of beefy Rock recordings (lucky neighbours!) Having checked that the volume controls on each monitor were matched I pressed Play and was confronted by a punchy, forward sound with sharply-focused imaging. With the Foo Fighters' 'Colour And The Shape', the various

instruments were precisely located in the sound stage. Vocals were very clear and powerful as they emerged from centre stage front, just the right spot in a typical mix.

The Yamahas proved that, with an active set-up, small boxes needn't automatically mean small bass - kick-drums were firm and very fast, not boomy or sluggish. This theme continued into the midrange where it was less welcome, guitars and vocals 'in-your-face' and unnaturally loud. And thanks to the metal tweeter, treble wasn't the sweetest. Reaching for the level adjusters on the rear panels (+1dB/-1.5dB for either driver) improved matters slightly and took a bit of the razor-edge off the sound. One point worth remembering is that it is not always preferable for professional gear to make everything sound good since the prime purpose of monitors is to expose any flaws so that they can be corrected.

Mahler's Seventh Symphony, incorporating DG's '4-D' digital recording technology, actually had a surprising elegance to it through the MSP5s. The third movement's ghostly flickers of strings and stark timpani strikes showed a degree of control which was not always present with Rock. Once again, the sound stage was commendably deep and imaging accurate, but despite this I somehow got the feeling that Classical wasn't the Yamahas' cup of tea; their cool tonal balance robbed the orchestra's



playing of some of its innate vibrancy.

Photek's skeletal Drum 'n' (a little) Bass was next in line and, with their domestic hat on, the Yamahas responded better to the inherently clinical character of this music. Not searching out the phrasing of voices or fingerwork, they had the chance to concentrate on the notes and rhythm alone. The bass drum pounded away meatily whilst the other intricacies in the music flitted about in the mix, creating a barren sound that left goose pimples on my goose pimples.

As a pair of domestic loudspeakers Yamaha's MSP5s could cause system hiccups with their hard midrange and treble if your cables and source come from the same school. Link them with laid-back cabling and a warm source which better suit their professional roots, however, and you'll discover they're transparent, powerful little bruisers that would do the job very nicely at a rave of about 40 people. Party on!

Yamaha MSP5 £449

Yamaha Kemble,
Sherbourne Drive,
Tilbrook,
Milton Keynes MK7 8DL
Tel: 01908 366780

WORLD VERDICT



The Yamahas are ruthless to poorly-produced material and can sound cold, but their detailing is impressive.

Measured Performance
see page 127

WIN A CD PLAYER, LOUDSPEAKERS, CARTRIDGE OR A PHONO STAGE WORTH £1900

This month's prizes are a Copland CDA 266 CD player, Mission 772 'speakers, a Dynavector DV20X-H cartridge and a Musical Fidelity X-LP.



At long last it seems spring is finally here - and so are the prizes for this month's big give-away! Variety is the key to June's competition - there's something for everyone whether they be CD-lovers or digi-phobes.

If it's the silver disc that spins your world you could be in with a chance of winning Copland's £1200 CDA 266 player. This Scandinavian's minimalist fascia bears a drawer (with its matching Open button), a discreet display and just two knobs, one for On/Off, the other for Play, Pause and Skip. To reduce front-panel clutter, more complex procedures are controlled from the remote.

As well as looking good the Copland sounds pretty impressive. This much was evident in February 1999's issue

where we discovered that this player has a rare ability to let music speak for itself. The bottom-end came in for special praise, Jon Marks commenting that the double-bass on Blues tracks "had a pungency and twang that came as breaths of fresh aural air". Since the CDA 266 is fitted with Pacific Microsonic's PMD-100 HDCD filter, its upper frequencies and transparency were equally class-leading. Playing both Eric Bibb and Stravinsky, it produced "delicacy and tonal colour married to scale and power."

The winning performance doesn't stop at HDCD as the



Copland is equally at home with standard CDs. Whatever the fare, it responds with powerful bass and control plus a clear, pure treble.

The next two prizes are a double-treat for vinyl-spinners. Dynavector's DV20X-H Black is a high-output moving coil designed by Prof. Noburu Tominara, who first broke the low-output MC mould back in the Seventies with the Ultimo 10X.

Aluminium features prominently in the DV20X-H's construction - the body is milled from a solid billet and the cantilever formed from a pipe. David Price was converted from the out-set, commenting "As soon as its stylus hit the groove, I was struck by how different the Black was to most moving coils".

MC cartridges have built up a reputation for their imaging and dynamics, both of which the Dynavector has in abundance. The Black also possesses an addictive musical richness reminiscent of Goldring's evergreen 1042 allied to the unmistakably crisp, fast top-end typical of an MC. David summed up by putting the Dynavector at the top of its class since it often sounded as musical as many high-end moving coils.

Where there's a cartridge you'll find a phono stage, in this instance Musical Fidelity's X-LP. This switchable MM/MC equaliser is housed in the trademark X series cylindrical chassis and powered from a wall-plug. As far as sound quality is concerned, the X-LP came up trumps after Richard White found it very hard to fault in the May issue whatever the music.

Shifting from sources to 'speakers, our loudspeaker candidates are the new 772 stand-mounters from Mission. The key to the success of these elongated stand mounters is the quality of the drive units fixed to the sculpted front baffle. The 130mm mid/bass boasts an Aerogel cone with a stylish silver phase plug at its centre while the tweeter is a 25mm silk-dome unit whose face-plate has leaf-springs moulded into it to isolate it from cabinet vibration.

We encountered the 772s back in April 1999's issue where we discovered that one of their strengths was striking 3-D imaging. Combined with a talent for sound staging, this managed to bring a real sense of life to good acoustic recordings. Another forte was the smooth, natural tonal quality which silk and Aerogel drivers are renowned for.

Unlike the majority of small stand mounters, the 772s don't suffer from anaemic bass because of restricted enclosure dimensions. The narrow front baffle is matched by greater depth than normal, which also reduces midrange coloration due to reflections off the rear wall. The icing on the cake is bi-wirability, which opens up the 772s' sound even further.

If you wish to bag one of the above, simply answer the questions below correctly and complete the tie-breaker in no more than 30 words. Stick the form (or a photocopy) on the back of a sealed



envelope or postcard and send it to the address below by June 4th:

June Competition
Hi-Fi World Magazine,
Suite 29, Imex House,
Kilburn Park Road,
London NW6 5LF

COMPETITION ENTRY QUESTIONS

- Which digital filter does the CDA 266 use?
 A. ACDC C. HDCD
 B. EIEIO D. ABBA
- What material is used in the mid/bass cones of Mission's 772s?
 A. Hair gel C. Kevlar
 B. Paper D. Aerogel
- From which country does the DV20X-H cartridge originate?
 A. Denmark C. UK
 B. Japan D. USA
- Which metal is used in the Dynavector?
 A. Brass C. Titanium
 B. Aluminium D. Steel
- What is Musical Fidelity's X-LP?
 A. A phono stage C. A CD player
 B. A DAC D. A turntable

COMPETITION VERSE (obligatory)

Complete the following in less than 30 words
*If a lady cares to scribble for our bumper prizes deal,
 Then a Miss might find a Mission quite a catch,
 Else a Copland to be coped with, or a shiny X-LP'll
 Keep the Dynavector's needle up to scratch...*

COMPETITION WINNERS

April's lucky winners of the VPI record cleaner and Clearaudio turntable are: D. Cattrell of Bridport, Dorset and R. Browne of Fleetwood. Congratulations!

ex display clearance



sevenoaks ex display clearance

Only limited quantities of these products are available from the Peterborough and North London outlets below, see numbers in brackets, and once sold are generally unrepeatable - so be quick! All are complete with packing, accessories & full warranty. Please confirm availability before travelling.

		Previous Price	Ex Display Price			Previous Price	Ex Display Price		
Acoustic Energy	AE100i	(3) Speakers	£199	£129	Mission	701	(1) Speakers	£159	£129
	AE109	(1) Speakers	£349	£249		771	(6) Speakers	£169	£129
	AE120	(1) Speakers	£499	£299		772	(3) Speakers	£229	£159
	AE107	(1) Centre Speaker	£149	£119		773	(4) Speakers	£349	£199
	AE505	(5) Speakers	£849	£399		752FPV	(1) Speakers	£648	£449
	AE509	(5) Speakers	£999	£499		753FBK	(1) Speakers	£798	£549
	AE520	(2) Speakers	£1199	£599	Monitor Audio	703PMC (Rosemah)	(1) Speakers	£899	£499
	AE1	(1) Speakers	£795	£499		Monitor 1	(1) Speakers	£249	£159
	AE2	(1) Speakers	£1095	£599		Studio 2SE (Rose)	(1) Speakers	£699	£449
Arcam	Alpha MCD	(4) CD Multiplayer	£449	£299	Musical Fidelity	X-ACT	(1) DAC	£129	£79
	Alpha T7	(1) Tuner	£229	£179		T10	(9) CD Player	£399	£249
	Alpha T8	(1) Tuner	£279	£229	Myriad	T20	(9) CD Player	£599	£349
	Alpha One	(2) Amplifier	£229	£179		T30	(6) Tuner	£399	£249
	Alpha 10	(1) Amplifier	£799	£639		T40	(7) Amplifier	£399	£249
	Alpha 10P	(1) Power Amplifier	£599	£479		T60	(8) Power Amplifier	£299	£199
	AV50	(2) AV Amplifier	£699	£459	Neat	Petite	(1) Speakers	£799	£599
Audiolab	8000C	(2) Pre Amplifier	£579	£399		Gravitas	(1) Sub Woofer	£1249	£999
B&W	DM302	(3) Speakers	£149	£99	Panasonic	DVDA350	(2) DVD Player	£549	£379
	DM601 (Not S2)	(7) Speakers	£199	£149	Pioneer	PDS505 Precision	(9) CD Player	£459	£299
	DM602 (Not S2)	(9) Speakers	£299	£199		A300R Precision	(8) Amplifier	£399	£249
	DM603 (Not S2)	(8) Speakers	£499	£349		F504 Precision	(9) Tuner	£299	£179
	CC3	(2) Centre Speaker	£149	£99		PDR555RW	(1) CD-RW Recorder	£479	£399
	CC6	(9) Centre Speaker	£229	£149		CTS550 Precision	(4) Cassette Deck	£339	£199
	P4	(1) Speakers	£674	£499		MJD707	(1) MiniDisc Recorder	£249	£199
	Solid S100	(1) Speakers	£129	£89		DVL909	(9) DVD/Laser Disc	£899	£699
	Solid C100	(1) Centre Speaker	£129	£89		SDT50W1	(1) Television	£3299	£2499
	Solid PB100	(1) Sub Woofer	£349	£249		SPD07	(1) Processor	£399	£299
Castle	Isis	(1) Speakers	£249	£159	Poik	CS275	(1) Centre Speaker	£249	£179
	Harlech	(2) Speakers	£879	£499	REL	Q50	(1) Sub Woofer	£374	£299
	Kendal	(2) Speakers	£399	£249		Strata II	(4) Sub Woofer	£594	£399
	Severn II	(1) Speakers	£579	£399		Storm	(3) Sub Woofer	£694	£499
	Avon	(2) Speakers	£729	£429	Roksan	Caspian CD	(1) CD Player	£894	£699
	Howard II	(1) Speakers	£1199	£799		Caspian Int Amp	(1) Amplifier	£694	£499
	Eden	(1) Speakers	£499	£299	Rotel	RB971	(1) Power Amplifier	£199	£169
	Keep	(1) Centre Speaker	£249	£159		RB981	(3) Power Amplifier	£299	£249
Cyrus	AV Master	(3) AV Processor	£697	£449		RC971	(3) Pre Amplifier	£149	£129
	SL	(2) Amplifier	£399	£299		RC972	(4) Pre Amplifier	£225	£199
Denon	AVC2800	(1) AV Processor	£799	£559		RC9930AX	(2) CD Player	£179	£149
	DRM550	(1) Cassette Deck	£159	£129		RC9950	(1) CD Player	£249	£179
	DRW580	(1) Twin Cassette	£199	£129	Ruark	Crusader II	(1) Speakers	£1649	£999
	DRM650S	(1) Cassette Deck	£199	£149		Epilogo	(1) Speakers	£239	£199
	TU260L	(6) Tuner	£119	£89	Shearpe	Phase 2	(1) Amplifier	£689	£499
	TU215RD	(2) Tuner	£149	£99		Phase 2 Ref	(1) Amplifier	£799	£599
	TU425RD	(2) Tuner	£199	£149	Sony	DVPS315	(1) DVD Player	£499	£379
	DCD-S10/II	(1) CD Player	£1299	£849		DVPS715	(5) DVD Player	£599	£449
	PMA-S10/II	(1) Amplifier	£1399	£899	Talk Electronics	Storm 1	(1) Amplifier	£499	£389
	AVR2700	(3) AV Receiver	£599	£499		Tornado 2	(1) Power Amplifier	£599	£389
	DVDS2000	(1) DVD Player	£599	£399	Tanney	MC	(1) Centre Speaker	£99	£59
	DVD3000	(2) DVD Player	£699	£549		Mercury M2	(1) Speakers	£139	£99
	DMDM7	(1) MiniDisc Recorder	£329	£249		Mercury M3	(2) Speakers	£229	£169
	DM7/DRR	(2) Mini System ex spks	£579	£529	Teac	AH500	(1) Amplifier	£279	£239
	DF88	(1) Mini System ex spks	£569	£499		MDH500	(1) MiniDisc Recorder	£349	£299
Epos	ES12	(5) Speakers	£549	£449		PDH500	(1) CD Player	£239	£189
	ES30	(1) Speakers	£2549	£1499		Reference 300	(1) Mini System ex spks	£599	£499
	Z5	(1) Amplifier	£999	£799		Reference 500	(1) Mini System ex spks	£799	£599
	Super 20	(2) Amplifier	£799	£489	Tsunami	TS200	(1) Sub Woofer	£299	£199
	Super 15 (MC)	(1) Amplifier	£899	£589	Yamaha	DPSA492	(9) AV Amplifier	£249	£199
KEF	Q95C	(2) Centre Speaker	£199	£129		DSPA592	(9) AV Amplifier	£329	£249
	Q35	(1) Speakers	£349	£199		DSPA1 (Black)	(2) AV Amplifier	£1599	£1249
	60S	(1) Surround Speakers	£199	£129		DSPE492	(2) AV Processor	£249	£149
	Ref Model 1	(1) Speakers	£1199	£799		RXV392	(1) AV Receiver	£249	£199
Marantz	Layla	(2) System Inc spks	£499	£379		RXV592	(8) AV Receiver	£399	£279
	Arch 2	(2) System Inc spks	£599	£449		AX492	(5) Amplifier	£219	£149
	PM57	(1) Amplifier	£199	£139		TX492RDS	(1) Tuner	£129	£99
	CD48	(1) CD Player	£199	£139		APD1	(1) Demodulator	£99	£79
	SR47	(1) Receiver	£249	£199		DDP2	(4) Decoder	£349	£269
	ST48	(1) Tuner	£119	£79		DVD5700	(9) DVD Player	£599	£499
Micromega	Solo	(1) CD Player	£2499	£1749		YSTSW40	(2) Sub Woofer	£139	£99
Mission	73C	(2) Centre Speaker	£149	£89		YSTSW80	(2) Sub Woofer	£179	£129
	700	(1) Speakers	£129	£99		YSTSW150	(2) Sub Woofer	£279	£199

Please Note - Speaker prices quoted are for Black or Standard Finishes unless stated otherwise

Valid until at least 9th June 1999 E&OE



PETERBOROUGH

36-38 PARK ROAD
PETERBOROUGH
CAMBRIDGESHIRE
PE1 2TG
☎01733 897697
OPEN MON-SAT
9.15-5.15

NORTH LONDON

79-81 CHASE SIDE
SOUTHGATE
LONDON
N14 5BU
☎0181 886 2777
OPEN MON-SAT
10.00-6.00

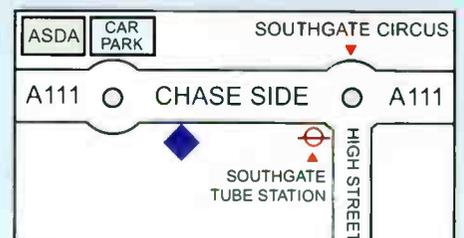

DELTA *winning* HAND?

How do the cards stack for Goodmans' Delta 910 CMD combined CD/MD recorder? Fairly-Young Maverick Richard White to deal. . .

Well, it was bound to arrive sooner or later and it's come from Goodmans in the form of the Delta 910 CMD, a replay-only CD deck and MiniDisc recorder all in one. What is perhaps more surprising is the very reasonable £199 price of this novel combination, although it's fair to remark that earlier mixes like tuner-amplifiers, compact systems and music centres tended to be mid-fi as regards both price and specification.

Possibly not since the heyday of cassette have the gods smiled so brightly on home compilers. Goodmans' little number is a standing temptation to run off a quick few compilations for listening to on your portable, delighting friends and acquaintances alike with the acuteness of your taste. No sooner have their feet ceased tapping to a couple of Russ Conway hits than, what a surprise, the strains of melodious Mrs Mills are wafting earwards. . .

Let's hold back those lazy, hazy, crazy days for a mo' while we examine the CMD 901's vital statistics. 'Oblong off-black box with buttons on the front' just about tells you all you need to know about the front layout. There is a little wheel for track hopping, a powered drawer for CD and a 'push-in, eject-out' slot for MiniDisc. Moving round the back, there are only two pairs of phono sockets; one each for play and record. As is quite common with kit at this price, the mains lead is not detachable, nor will lifting the machine's 10lbs cause undue stress, unless you're feeling particularly feeble.

Although CD playing will not necessarily be the primary reason for



buying the Delta 901, once it's made itself at home it will doubtless have to double as a second player in addition to being an MD recorder. With this in mind, I gave the CD player a fairly thorough work-out before trying any recording.

Having thus established the level of the playing-field and found the player 'warm' but otherwise unobjectionable, I decided to try a test recording of Conifer's rather jingly Rameau collection with the Philharmonia Baroque Orchestra.

There are ways and means of doing this: the '901 is a machine designed for convenience. In the usual case where you might want to record a CD in batches of complete tracks, the procedure is at its simplest. Select said CD track, press the Synchronization button and, when you release Pause, the MD will record the CD starting at your chosen tune. Starting up in the middle of a CD track is a little more awkward, but a few experiments and you'll pick up the knack fairly swiftly. The complete handbook for the machine has some Awful Warnings about using scratched source CDs: apparently, in the case of a 'fatal scratch' (sic), you're best off not even trying.

Back to the Rameau and a quandary: what's the best technical

way of saying 'scarce a hap'orth of difference'? Given that the Delta's CD player has a less-than-crystalline sparkle you can't expect to pin-point all the subtleties of digital-to-digital transfer loss. With ears positively glued to some Klipsch Heresies, I could make out a slight increase in paperiness, but I really had to listen for it.

A bigger sound yielded much the same result. Although Cab Calloway was woefully past-it by the time he made this (last) recording, his final contribution to Porgy and Bess transferred to MD without losing a jot of his tortured laryngeal efforts.

Of course, a combined machine like this has a 'my bat, my ball' self-definition. Only on recordings not on CDs in the Goodmans' own drawer were the effects of the format really noticeable. A good, full-range DGR Direct Metal Master of Romeo and Juliet lost a bit of life once recorded. Then again, vinyl can be difficult for the best of domestic recording machinery.

Having given the Delta 901 a tough grilling, I found it more than fulfilled its terms of reference. Out and out audiophile it ain't, but as a convenient recorder with CD and MD playback it rates as very good value indeed●

Goodmans
Delta 901 CMD £199

Goodmans Industries Ltd.
Units 2 & 3,
Mitchell Way,
Portsmouth,
Hants. PO3 5PR
Tel: 01705 391000

WORLD VERDICT



Well-tailored CD/MD pairing and a doddle to use. Sound quality is spot-on for the price.

Measured Performance
see page 127

Jecklin float and Ergo headphones ... a revolution in sound



Sonically quite exceptional, for my money these are the best headphones in the review. (Hi-Fi choice, England)***

Distinguishing the Ergo AMT from my reference AKG 1000 (costing twice as much) was an extremely difficult task. (Audio USA) ***

Ergonomic headphone without any pressure, ideal for long term listening. Exceptional clean and transparent sound. (Sound Switzerland) ***

Their lightweight comfort and effortless sound make the Float 2 a joy to use (What Hi-Fi, England).

The Ergo AMT can be viewed like the best combination between a dynamic headphone and electrostatic, with a total absence of distortion and a complete balance in its timbre. (Audio Review Italy), **

Hours of listening pleasure for everyone without the typical headphone fatigue. (New HiFi Sound, Australia) ***

The balanced advantages and excellent sound image make the JF Float 2, without question, the headphone I would like for myself. (Audio Ideas, Canada) **

Ergo and Float headphones present a natural soundfield to the ear, the unique construction ensuring no direct contact with the ear, unlike conventional headphones that can deprive the human of its natural function by pressing on and distorting the outer ear.

Outstanding performance and comfort at affordable prices. From £79.00

May Audio

Box 27, Skipton

North Yorkshire, BD23 1YE

Tel: 01756 793777 Fax: 01756 793999

SUGDEN audio products



Masterclass from the original CLASS A company

New products from Sugden

Wide-bandwidth d.c coupled high current class A power amplifier and matching pre-amplifier. Available as a stereo power amplifier you can upgrade or balanced monoblocks.

Handcrafted from the finest materials and components, Sugden guarantee to add an extra dimension to your listening pleasure. Our superior wide-bandwidth designs will increase the dynamic range and sonic accuracy of your audio system - without fatigue.

With over thirty years experience in design and manufacturing Sugden has become a reference for reviewers, musicians and audiophiles around the world. Prices start at £549.00 for the Audition series so why settle for anything less?

J. E. Sugden & Co Limited
Valley Works, Station Lane, Heckmondwike,
W. Yorks. WF16 0NF
Tel. 01924 404088 Fax 01924 410069
Email jesugden@compuserve.com

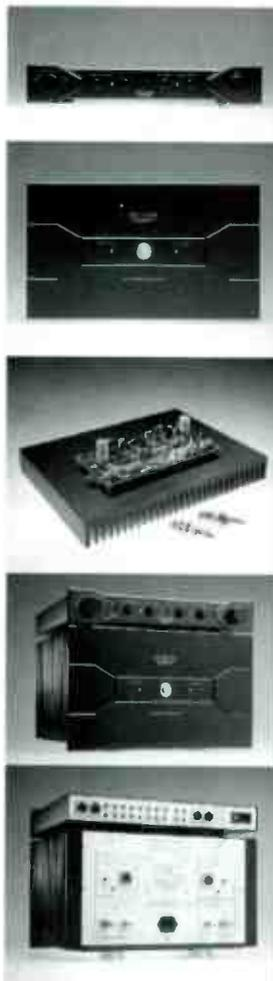

Play that Tuner Gain

Denon's original TU-260L tuner lasted nine years in dealers' windows. Can its successor carry on the tradition asks Simon Pope.



The hi-fi business' apparent confidence in radio listeners means that there has been no deceleration in the production of analogue tuners, in spite of the fact that DAB is just around the corner. This means there is an abundance of keenly-priced tuners around, the good ones offering excellent sound and a constant variety of quality music and information.

Over the years a few budget tuners have become audiophile household names, one of them Denon's long-lived TU-260L (1990-1999, RIP). Replacing such a popular component is always a headache, so Denon have put a great deal of thought into the innards (rather than the name) of its successor, the TU-260L MkII.

The MkI was known for its gently rolled-off treble that created a warm, very listenable presentation with a scale and atmosphere that many tuners couldn't match at the price. The MkII is designed to keep the tonal character of the MkI but attention has been paid to improving the frequency response and stereo separation.

Back in a 1992 group test we noted that the Denon had the edge in the beauty stakes but the MkII is certainly more pleasing to eyes in the late Nineties. The display has been relocated in the centre of the fascia next to the analogue-style

rotary tuning knob and 12 small function buttons. These cover a shed-load of functions including RDS, EON and Radio Text facilities which allow you to search for broadcasts by programme type. To finish off, you can preset no less than 40 stations.

Unlike other budget tuners, the MkII doesn't come with a copper 'bootlace' 300ohm aerial. Denon recommend a proper indoor 75ohm aerial is connected to the co-axial socket on the tuner's rear. Hooked up to the outside world, I duly hit the airwaves and tuned into Radios 3 and 4.

An interview interspersed with music from the Labeque sisters (pianists) was on 3, the close mic'd voices very clean and unpolled by boom or excessive chestiness. In a Mozart concerto that followed, the pianos which opened the piece had a smoothness easily on a par with the MkII's predecessor. Clarity was also impressive and the attention lavished on digging out more detail paid dividends, as the orchestral image was wide (if not especially deep). This broadcast, like many other BBC Classical transmissions, also lacked a little bass weight, the Denon picking up on this in double-basses and cellos which couldn't muster the oomph necessary to fill out the orchestra.

The TU-260L MkII rendered Radio 4 in a similarly detailed and

transparent manner. An interview with three 'throat singing' Eskimos (!) gave the Denon the opportunity to show off its separation. With bizarre sounds emerging from the Eskimos seated far left to far right, what came out of Heybrook's Optima loudspeakers was altogether very weird and very life-like.

Unfortunately the same was true of the subsequent location report from an Alaskan seal-skinning contest, the background sounds being all too realistic for my weak stomach. I decided to tarry no longer and moved on to the less esoteric delights of Capital FM.

It was on more commercial and processed stations such as Capital that the Denon's slight response roll-offs worked best. Bass was bouncy and tight whilst the relaxed treble reduced the sibilance and sizzle mandatory with these sorts of broadcasts. On both AM and LW as well the Denon maintained its control and clarity, with stations tuning in precisely without added birdie effects.

The TU-260L MkII does everything a well-engineered budget tuner should. It has all the best traits of the MkI plus superior separation, detailing and facilities. There are fuller sounding tuners about, such as the function-starved Cambridge T500 at £50 more, but at £130 it would be hard to better the Denon

Denon TU-260L MkII
£129.99

Hayden Laboratories
Chiltern Hill,
Chalfont St. Peter
SL9 9UG
Tel: 01753 888447

WORLD VERDICT



With its smooth, inoffensive sound and abundance of facilities the MkII is a worthy addition to the tuner line-up.

Measured Performance
see p127

replay

Panton Road
Hoole
Chester
CH2 3HX
Tel: 01244 401290

ALCHEMIST
AUDIO ANALOGUE
AUDIO PHYSIC
AVI
CREEK AUDIO
CRIMSON
DNM/RESON
HEYBROOK
JAMO
LFD
MERACUS
MUSICAL FIDELITY
NEAT
ORIGIN LIVE
PINK TRIANGLE
PROJECT
ROKSAN
ROYD
SONNETEER
TEAC
TRICHORD
TRILOGY
UKD
YAKAMURA CHURCHILL

EMAIL replay@dial.pipex.com
WEB SITE <http://dialspace.dial.pipex.com/replay>
TEL: 01244 401290
contact us for a copy of our product guide, newsletter
or a list of our clearance items.

reson®
the real sound experience

reson mica

MM Cartridge £185.00
Trade-in price *£135.00



reson etile

MC Cartridge £455.00
Trade-in price *£345.00



reson aciore

MC Cartridge £299.00
Trade-in price *£215.00

reson lexe

MC Cartridge £1300.00
Trade-in price *£975.00



reson reca

MM Cartridge £250.00
Trade-in price *£190.00

*Trade-in any cartridge to qualify for the special offer price.

Virtual Reality Audio Systems Ltd
P.O. Box 383, Brentwood, Essex, CM14 4GB
Tel: 01277 227355 Fax: 01277 224103
E-mail: info@virtualr.demon.co.uk

We put the
"Impact" into
Compact

AVS-Series MicroSystem

Home theater is all about putting the "big" sound of the movies into a relatively small viewing room. So the objective of our design engineers has always been two-fold - to maximise speaker performance while minimizing speaker size.



AUDIO
ILLUSION

23 Langley Broom
Langley
Berkshire SL3 8NB

TEL: 01753 542761 FAX: 01753 772532

Now, from the minds at Mirage, comes the all-new AVS-Series MicroSystem - a perfectly balanced blend of front and rear surround satellite speakers and matching center channel, that is winning rave reviews both for the power of its performance and the compactness of its componentry.



cable main-tenance

Jon Marks goes cable-hunting with three specialist mains leads from Campaign Audio Design and LAT International.

LAT INTERNATIONAL AC-2

£69/4ft.

One point to note about this cable is that the lengthy recommended burn-in of 80-100 hours for the three silver-plated OFC conductors and their shield isn't an exaggeration. The LAT was feeding MVL's Integral A2s for a good two or three weeks before its sound quite suddenly opened up.

Replacing the AC-2 with a standard mains lead produced a clearly audible effect on the sound, as Nick Drake's guitar playing on Pink Moon took a step back in

a shrunken sound stage. Imaging was fuzzier too, his guitar less well defined in the space between Magneplanar's SMGa loudspeakers. Swapping to dEUS' The Ideal Crash album, I found the differences even more evident. Electric bass was a lot slower and muddier, and complex tracks had a habit of tripping over themselves.

Returning to the AC-2 with Whistler's eponymous CD restored the sense of spaciousness, harmonic richness and dynamics, especially in the bottom-end. For the money, that's no mean feat.



CAMPAIGN AUDIO DESIGN CONQUEROR

£44.50/1m

Hidden away beneath the Conqueror's black outer sheath are silver-plated OFC conductors within a PTFE dielectric, a recipe not dissimilar from the AC-2's. And as had been the case with the LAT, the Conqueror's impact on the sound wasn't subtle.

After a week-long burn-in, removing the CAD in favour of a normal cable I discovered that a superficially beefier bottom-end was actually attributable to waffle which slowed the rhythm section

down. The outlook was bleaker in the treble as well, as cymbal crashes became cymbal splashes and vocals showed an unwelcome return to sibilance.

Slotting the Conqueror back into the system I relaxed as clarity and musicality both improved. Strings and voices were now more natural thanks to a broader spread of tonal colour, and bass gained definition and drive. The overall result was once again more involving and wasn't a million miles from the LAT in spite of its lower cost.



CAMPAIGN AUDIO DESIGN CANDOUR

£14.64/1m

More basic in its construction than the Conqueror, the Candour goes lighter on the wallet as well. The braided outer shield protects standard copper conductors from the worst effects of RFI.

While this lead took a while to settle sonically, its sound didn't change as much as had the Conqueror's. And where that cable lost a touch of treble fizz and bass boom as it mellowed, these two traits didn't disappear entirely from the Candour.

Going back to a give-away mains lead proved that the cheaper CAD was still having a positive influence on what was emerging from a modified Pioneer DV-505 DVD player. Music was generally cleaner, more detailed and better controlled - a good dose of the 'hash' that's otherwise present had been removed.

Compared with the Conqueror, the Candour lacked finesse at the frequency extremes and wasn't tonally as sweet but what it does do is worth checking out at the price.



Letter of the Month

The writer of the 'Letter of the Month' wins a free subscription to Hi-Fi World.

I MUST PROTEST!

I refer, of course, to your shameful and partisan promotion of the breakthrough allegedly made by Vector Developments (April 1999). I fail to see how a group of audio bastions such as yourselves could be unaware of my own work in this field. The true cognoscenti are often heard to comment that Vacuum Audio Technology (VAT) really sucks. I feel the least you can do in reparation is to allow me space to describe my own, infinitely more advanced system.

As with most great discoveries, this came about almost by accident. I noticed that the sound from the right

channel of my system had straighter bass definition, more treble depth, perceptibly louder ambience and mirror-like silences. The fact that my all-valve system is ranged along the right wall as seen from my listening seat set me to thinking, especially as a similar but more localised effect appeared halfway down the left side, where the TV is located.

I removed all valves from the amps and the TV from the room. Lo! And Behold! When I switched on I no longer perceived the same sound improvements. As a side effect, I found that TV sound had assumed a distant quality and the picture was very poor. I noted this for future investigation.

However, I was now certain that the presence of vacuum tubes in the room was affecting the loudspeaker/room/psycho-acoustic interface. What I am describing is a physical effect, hitherto unrecognised and unrelated to the acknowledged electronic properties of valves. I surmised, but have yet to empirically prove, that the vacuum devices induce a sort of negative room damping effect, probably by the generation of random plasma-flux turbulation, preventing the formation of the vacuum equivalent of standing waves (horizontal troughs).

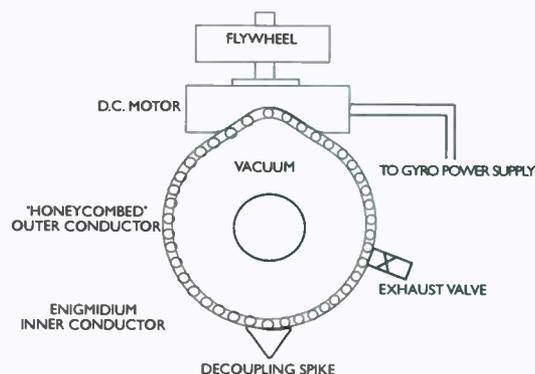

It seems that the radical concepts embodied in Vector's Enigmidium cable are no longer at the forefront of conductor technology.

This deeply interesting phenomenon is not capable of measurement by any normal test equipment being hardly, if at all, related to impedance, capacitance or even reluctance. I finally gained some measurements using a modified Fast Fourier Transform. My version is faster, considerably furrer and measures what I have termed repugnance.

I quickly dismissed the Vector Developments approach as totally inadequate. They were on the right track but clearly lacked the vision and commitment to see things through. Moreover, their attempts at superconductivity through cooling are totally spurious techno-babble. It doesn't

WRITE & WIN WITH HI-FI WORLD!

Every letter we print wins a superb prize! On offer are The Chord Co. interconnects, Audio Electronics books, Ringmat Statmats, DNM Licon contact enhancer, DNM Reson 'speaker cable, and a FREE subscription to Hi-Fi World for the best letter of the month! Please write, fax or E-mail to Hi-Fi World Mail, Suite F29, Imex House, Kilburn Park Road, London NW6 5LF. Fax: 0171 328 1844 E-mail: edit@hi-fiworld.co.uk

take a Degree in Cryogenics to know that the conductor will contract as it cools, reducing its cross section and increasing its resistance in proportion. What was needed was the most complete vacuum possible for all components.

I started by having my entire system vacuum-packed at a local bacon factory. This made everything transparent but my loudspeakers, although clearer, were considerably quieter, as well as unfamiliar in shape. It was only at this point that I fully realised the sacrifices I would have to make in my quest for perfection. The whole system and listening environment must be subject to total vacuum!

After some months' working to install positive vacuum reinforcement beams and other counter-implosion devices, I was ready to begin testing. For safety reasons I started by listening via a high-quality Rozenkrantz And Gildenstern measuring mike from outside the room. I started the military-surplus, turbine-

powered vacuum pumps and listened enchanted as the sound improved by leaps and bounds as the room pressure dropped.

Then, disaster! The sound slowly faded, becoming more beautiful but less perceptible, until it was gone. I wept bitterly at the realisation that I had overlooked one crucial factor - sound cannot travel through a vacuum! Undaunted and armed with the knowledge that all engineering is compromise, I set about devising my solution, the intermittent-vacuum process.

I reasoned thus. If I could cause the room to oscillate between total vacuum and atmospheric pressure at a rate of 25kilocycles per second, I could gain all the advantages of vacuum without the downside. The silence effect would be inaudible, due to the widely acknowledged 20kHz upper-limit to human hearing. By developing a system of multiple-frequency, parallel-reactive resonators, controlling double-acting reed valves, I was able to achieve the desired

intermittent vacuum, with only a ten-fold increase in power requirements. Provided that I wear the specially-developed, carbon-reinforced kevlar suit, I am now able to listen to the world's ultimate system in complete safety.

The suit is equipped with resonant valves over the body orifices, working contra-phase-wise with the main reed valves in the evacuation system, thus preventing accident and/or embarrassment. My system is now perfect and, when fully evacuated, conveys immense atmosphere. Every evening after dinner, I go upstairs and sit in the control seat to commence evacuation. Only when evacuation is complete can I sit in comfort and listen. Those who doubt my achievement of perfect Vacuum Audio Technology (VAT) need only ask my many friends. Any of them will tell you that VAT really sucks.

Colin Berresford
Zero Atmospheric Pressure Projects (ZAPP)

QUAD SQUAD

Thanks for your recent Quad electrostatic articles which have filled some gaps in my knowledge. I've owned ESL 57s for the past 36 years, servicing them myself when funds were short, and presently possess a stacked pair which have all been given the Classique Sounds treatment. Thankfully, none of them needed as much work as your review pair, even though one of them is serial number 611, so the cost for all four was about half your bill.

I am very pleased with the performance of my stack now. They needed servicing because I had blown two treble panels in spite of clamps being in circuit; I think some damage had been done before they were fitted. Apart from



Properly serviced, it's not hard to hear why many regard Quad's original '57 electrostatic as a true reference.

the treble panels it was mainly work on the PSUs that was needed and the results were beyond all my expectations.

The Hayden Boardman/Russ Andrews comment about multiple PSUs is interesting because I came to the same conclusion. However, according to Classique's engineer, if all the panels are up to specification one good PSU per 'speaker is all that's necessary. Multiple PSUs only compensate for below-par panels.

P.H. Jones
Shropshire.

For more on loudspeakers and electronics, turn to John Linsley Hood's Audio Electronics.

JAMMING WITH JAMO

The valve versus transistor debate rages on! The fact of the matter is that neither comes close to the experience of attending a live concert, that anticipation of a performance by a great artist, the whole sense of occasion. The sound is also radically different!

I am fortunate enough to attend regular concerts at the Symphony Hall in Birmingham which is renowned for its

excellent acoustics. Nonetheless, from a hi-fi standpoint stereo imaging is imprecise, bass is waffly, treble can be rolled off or screechy depending on audience size, depth perspective is variable and dynamic range is way beyond the capability of even the best system.

I regret to say that at best we are producing an acceptable reminder of a great performance. I must say at this

point that I am an avid CD and LP collector and am constantly trying to improve the sound of my system, which leads to my system query.

My source components are a Linn LP12 with all the modifications, Manticore MB6 power supply, Magician tone-arm, Gregory cartridge and a Teac P700 CD transport with custom-built, 20-bit DAC. I also have a Leak Troughline with HFW decoder. The pre-



THE SOUTHWESTS PREMIER RETAILER

CONTACT NIGEL ON:- 01326 221372

AUDITION THE FOLLOWING PRODUCTS HERE:-

AMPLIFIERS:- ALCHEMIST * AUDIO ANALOGUE * AUDIO NOTE * BORDER PATROL * ELECTROCOMPANIE * GRAFF * MUSICAL FIDELITY * PARASOUND * PRIMARE * SONIC FRONTIERS * SUGDEN * UNISON RESEARCH

SPEAKERS:- AUDIO NOTE * AUDIO SPECTRUM * BOSTON ACOUSTICS * J.M LABS * KELLY * MAGNAT * MONITOR AUDIO * REL SUBWOOFERS * TOTEM * TRIANGLE * TSUNAMI

C.D. PLAYERS:- ALCHEMIST * AUDIO ANALOGUE * AUDIO NOTE * MUSICAL FIDELITY * PARASOUND * SONIC FRONTIERS * TEAC * TRICHORD

ANALOGUE:- AUDIO NOTE * HENLEY DESIGNS * MICHELL * MUSICAL FIDELITY * ORTOFON * PROJECT * SME * THORENS * VOYD

ANCILLARIES:- ATACAMA * AUDIOQUEST CABLES * CABLE TALK * ELEMENTAL AUDIO * PHILOSOPHY CABLES * SONIC LINK * STANDS * UNIQUE * STRAIGHT WIRE * TARA LABS CABLES * TARGET

WE HAVE THESE SECOND HAND PRODUCTS

SALE

Kef Reference 4 spks mint Rosette	£2850
Audio Note AN-E SE Silver speakers mint boxed	£3995
Jamo Concert 11 boxed new (unused gift)	£1695
Jamo Concert 8 with STD(unused gift)	£1095
Pink Triangle ANNV/PSU/SME 309/MC10Supreme	£1395
Electrocompaniet EC 4.6 pre-amp ex-dem	£1349
Parasound CBP 2000 boxed	£795
Audio Note OTO SE phono ex-dem (new valves)	£995
Rel Stadium II (upgrade) black	£895
Electrocompaniet AW60FTT power amp	£795
Pink Triangle Tarantula/Rega RB300/MC1 Turbo	£495
Teac P700 transport/Trichord clocked	£495
Parasound PLD 1500 pre-amp	£425
Electrocompaniet ECI2 amp ex-dem	£749
Kinshaw Perception DAC (2 units)	each £249
JPW Ruby 2 speakers	£295
Heybrook HB100 speakers boxed	£149

**CONTACT US FOR
UP TO THE MINUTE PRICES OF
SECOND-USER EQUIPMENT
AND SPECIAL OFFERS**

****FULL WEB SITE SOON AVAILABLE ON GLOBAL ****

**FOR FRIENDLY ADVICE AND 7 DAYS A WEEK
8AM to 10 PM**

MAIL ORDER THROUGHOUT UK

VISA/ACCESS/SWITCH

NEW PRODUCTS

from the designers of RINGMAT and STATMAT

**The RINGMAT
SUPPORT SYSTEM**

*a complete, modular system to help you
achieve the perfect sound from your LPs*

The RINGMAT SUPPORT SYSTEM comprises four components, including the long awaited RINGMAT Spacers, the LP version of STATMAT, RINGCAP and a RINGMAT for those who do not already have one.

STOP PRESS...STOP PRESS...

FIRST SYSTEM REVIEWS

Jimmy Hughes, Hi-Fi Choice, March 1999

Richard White, Hi-Fi World, April 1999

Prices:

Full System with RINGMAT MkII XLR £160.00
Full System without RINGMAT (for existing users) £115.00
P&P £4.50 within UK; £10.00 outside UK

Prices are available for modules of the complete System, platter inserts for Roksan Xerxes & Garrard 401 turntables and other products

A MkII version of



for an even better sound from your CDs

Prices:

STATMAT MkII £19.95
MkII replacements, exchanges & upgrades £12..50

P&P £1.95 within UK; £5.05 outside UK
Replacements, etc., post free within UK; £3.00 outside UK

RINGMAT and STATMAT have been extensively reviewed around the world. Extracts and copies of the reviews are available on request, as well as brochures and price lists.

Information on our products and other services can be found on our website:

www.ringmat.com

Our products can be obtained through good hi-fi retailers. Also available on mail order with moneyback guarantee.

**For further information, or to place an order, contact:
RINGMAT DEVELOPMENTS
PO BOX 200 BRENTWOOD ESSEX CM15 9FB GB
T: +44 (0)1277 200 210 F: +44 (0)1277 201 225**

amp is a custom-built version of your own active line/phono pre-amp using Vishays, paper-in-oils, Panasonic pot and silver wire. This out-performed a Michell Argo HR I used to own. Speakers are Jamo Concert 11s with DPA IS19 cable.

I am looking for ideal matching power amps. I have recently been getting good results from a rebuilt Dynaco Stereo 70. This is preferable in all respects to my Naim 160 or a Meridian amp I borrowed. I was contemplating purchasing two of your PSE amps to monobloc. My room is 20ft. by 12ft.

Anthony Parkin
Aylesbury.

Given the fact that the Concert 11s can be bi-wired and you've had good results with the Dynaco, bi-amping is surely one option worth pursuing. By using the valve amp to drive the tweeter and midrange, you could leave all the hard work of controlling the woofer to a beefy solid-state power amp like your own 160. Of course, the age-old



Jamo's Concert 11 floor standers are capable of outstanding transparency but they really need to be bi-amped to give of their best.

Dynaco and Naim are putting out the same levels. A simple potentiometer in front of the more sensitive of the two should do the trick.

From past experience we know that the Concert 11s require plenty of current and control to keep them from loosening up in the bass. A pair of monobloc'd PSE valve amplifiers alone would not have sufficient grip and power to do this, the result being boom at the bottom-end. They could replace the Dynaco in a bi-amp system, though.

As you say, the disparity between live and reproduced sound is always massive, regardless of how much money you spend on components - you only have to walk past a busker and you'll hear just how far hi-fi still has to go in areas like detail and dynamics. Getting more realistic sound is as simple as going to listen to live music, as you've discovered. JM

problem is how to ensure that both

A set of free Chord Company Siren interconnects will lighten the cost of bi-amping.

SOURCE OF INSPIRATION

Nearly a year ago I went shopping for a new CD player. I was looking to spend £200-£300. I came home with a Quad 77 pre/power/CD and matching 10L 'speakers single-wired with Ixos Gamma 102 on Atacama SE24 stands.

I'm now looking for a tuner and cassette deck but I cannot afford anywhere near the same prices. What's the least I need to spend to approach the same quality? What interconnects would you recommend? I wouldn't be averse to second-hand kit if it's robust enough.

Nick Mawson
Blackburn.

One impressive but highly affordable cassette deck is Yamaha's KX-580SE at £250, which we reviewed back in September 1997. This has a very stable, transparent presentation and makes fine recordings. Alternatively, there's JVC's excellent TD-V662 for

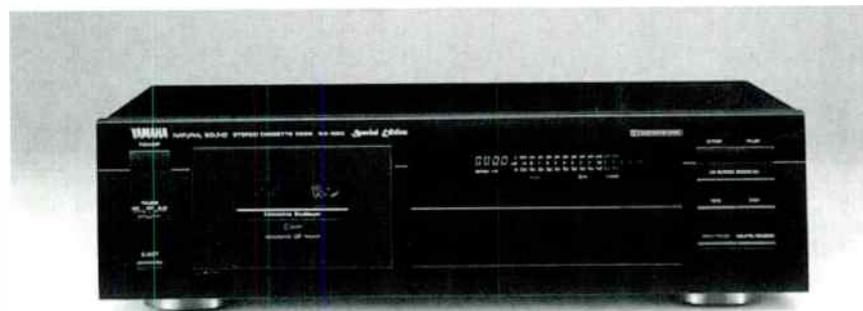

Proving budget cassette is still a viable format is Yamaha's KX-580SE

an extra £50. Tuner-wise the choice boils down to Cambridge's T500 (£180) or Creek's T43 (£400).

When it comes to cabling, Nordost's Black Night (reviewed September 1997, £55 per metre) should suit your Quads well as it has a slightly cool edge which will balance their warmth. It is also very revealing. If your budget won't stretch quite that far, DPA's Slink 2 (September 1997 again, £41 per

metre) is another option.

One bi-wire loudspeaker cable which has stood the test of plenty of competition is Pentacone's Plain Soft Copper (August 1997, £176 for a 3m bi-wire set). Otherwise QED's Profile Silver 12 at £15/metre is dependable wire. JM

One of your wire worries is easily dealt with thanks to a free set of DNM Reson bi-wire loudspeaker cable.

e-mail

Visit our website at
<http://www.hi-fiworld.co.uk>
 or send your e-mails to
edit@hi-fiworld.co.uk

THIS MORTAL COIL

I have Lowther Fidelio loudspeakers fitted with PM5A drive units. I read with interest in a recent issue some information on how, in Japan, it is hot news to earth loudspeaker drive units to remove Radio-Frequency Interference from the voice coil.

How exactly do you do this? Where do you connect the wire to the drive unit? Do you run to earth via the 'speaker cables, which I guess would need to have 'spare' wires like bi-wire cables? Do you use the house earth or is a separate earth rod best? Is there a chance of getting unwanted earth loops? I am desperate to experiment.

Chris Valder
Christopher_E_Valder@sbphrd.com

The problem is the same in all Western countries where frequencies between 75kHz and 200kHz and beyond are used for communications, time signals and machine-control purposes.

A quick look on a VLF RF spectrum analyser using a pair of 'speakers with connecting cables as the aerial will confirm that there are some surprisingly large signals around. These are picked up in the 'speaker leads, can be subsequently fed back into the output stages of the power amplifier and can easily find their way through to the feedback loops where they cause many spurious effects. Of course the degree of interference depends on the topology and design of the power amplifier, but not necessarily on the degree of RF/EMC screening as the 'speaker terminals provide direct connection to the inner circuitry through the screened metal case.

A way around this problem is to make the 'speaker cable 'earthy' at each end to inhibit RF pick-up. Screened cable is not recommended as it can impose a capacitive load

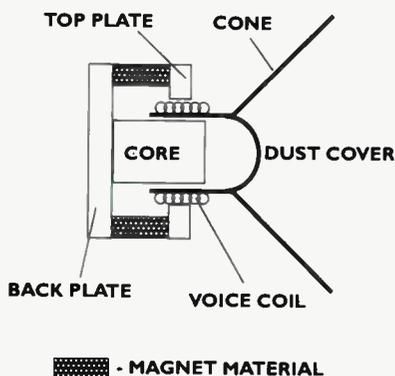

The best places to earth a loudspeaker drive unit are the back and top-plates of the magnet, as shown in the diagram above.

on the power amplifier which can generate further spurious problems including spontaneous oscillation triggered by fast transients.

Tannoy has performed experiments which show that earthing the magnet and chassis of a drive unit effectively forms an RF-proof shield around the voice coil. Taking a connection from the chassis and magnet assembly back to the screening or 'ground' connection of the power amp is very effective in 'cleaning up' the sound of a good system. Grounding the whole system to a good, low-impedance RF earth (usually not the mains earth) is also most effective, but this can only be done with Class 2 or Double-Insulated equipment supplied without a mains earth connection. Many Marantz items use this mains connection. All the latest Tannoy Prestige range from the Stirling HE up to the mighty Westminster Royal HE now have a connection on the rear terminal panel which provides grounding of the 'speaker system to the amplifier.

Both the top-plate and pole

piece of the 'speaker magnet need to be connected to the grounding point as they are usually separated by a ferrite magnet which is electrically non-conducting. Connecting to the chassis as well is desirable but not essential. The grounding cable can be a part of the 'speaker cable (such as a bi-wire cable) or running alongside it.

The degree of improvement is dependent on the amount of RF interference in the location and the susceptibility of the power amp to RF interference, so no guarantees can be made for improving everyone's system in this way. Generally, though, it's better to ground than not to ground.

Do not be tempted to create your own earth by using either a gas or water pipe or a metal rod sunk into the ground unless you have electrical equipment which does not need a mains earth. If you do, then you run the risk of carrying large circulating currents from your equipment back to the electricity supply sub-station via your external grounding point.

The mains supply neutral and earth cables are connected together at the sub-station and therefore it is possible for the mains earth to be at a slightly different potential voltage to true 'ground' outside your house, especially if the phases are not balanced along your street. Although the voltage differences are usually small (less than 5V), large currents can flow if the impedances are low and very dangerous conditions can occur under faults, which may be in other people's houses!

Alex Garner
 Technical Director, Tannoy.

For more information on amplifiers and RF, look into a free copy of John Linsley Hood's Audio Electronics book.

If you do not want your e-mail address published, please let us know.

GOING FOURTH TO MULTIPLY

My system is ageing, rather like me. It contains a 17-year-old NAD 3020 integrated, equally old AR18 loudspeakers and a slightly younger NAD 5120 turntable with an Audio Technica 110 cartridge. CD comes courtesy of a Marantz CD-60SE and tape from a Kenwood KH-550. The interconnects are AT LCOFCs and 'speaker cable is from Exposure. The ARs sit on Partington stands.

What changes would you make if you had £500 to play with? I listen predominantly to CDs, hardly any records and barely any tapes. My gut feeling tells me that its goodbye amp and 'speakers, but what is your opinion?

Name and address withheld by request.

Seeing as the 3020 has a Pre Out socket, it might be worth getting

DOING THE TWO-STEP

My set-up is an Arcam Alpha 6 CD player (actually an upgraded Alpha 5), Creek OBH-12 passive pre-amp, Sugden A51P power amp and Accoustat 'speakers (I'm not sure of the model, but they're 5ft. tall, full-range electrostatics).

Tonally the system sounds quite warm but suffers from 'wandering' bass which leads to ill-defined rhythms. By way of explanation, on something like the Byrds' 'Sweetheart Of The Rodeo', the Country two-step is lost at times as the bass fades into the background of the mix. The sound is also faintly harsh at high volumes.

I went down to a dealer the other day and he was demoing a Pink Triangle Numeral. This seemed to have better definition of isolated sounds, but what I'm looking for is a rhythmic entity - think Linn in the Eighties and the ideas they were promoting. I'm not too bothered by extra

A QUESTION OF PURITY

My system is a Meridian 506 (20-bit) CD player, Linn Axis, Quad 34/306 amps, Monitor Audio Studio 20 SE 'speakers and a single run of Kimber 4TC cable.

I'm experimenting with interconnects at the moment. I'm happy with my system but I suspect that there is more to be had from it (maybe a touch of warmth). I was also thinking of

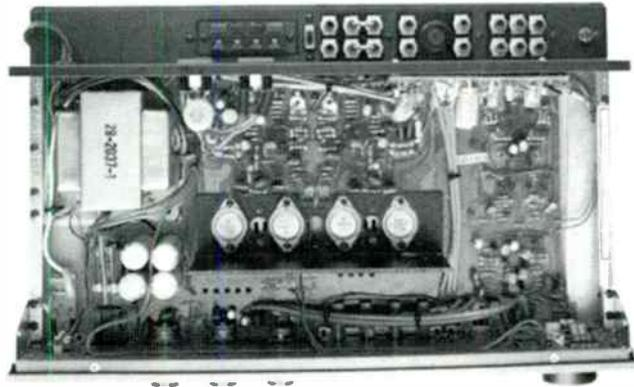

NAD's 3020 might not be the youngest amp on the block, but its Pre Out sockets make it a prime candidate for bi-amping.

hold of a second one, which shouldn't cost more than about £40. You could then bi-amp whatever loudspeakers stepped in to replace the Acoustic Researches, say KEF's Q35 floor standers.

This leaves you with £100 plus whatever you can raise from the

sale of the Partingtons and ARs, which should cover the cost of a Cambridge CD4SE CD player at £200. JM

A free pair of The Chord Company's Siren interconnects will sit nicely between your two NAD amplifiers.

detail so much as the music making sense.

Any suggestions as to a suitable player? I'm assuming this is what's at fault, though of course it could be the amp and 'speaker combination. I would prefer to change the CD player as, if there is extra information on those little silver chappies, I might as well have it. But rhythm is the king. . .

Bill Adair
adairb@it.postoffice.co.uk

They say it takes two to tango, and the partners in this dance are your Arcam CD player and Creek passive pre-amp - both are a little loose at the bottom end.

Audio Analogue's Paganini CD player would clean up the bass as well as allowing through more of the detail and music on your discs.

upgrading my amplifier but want the same build quality as my Quads. What's your advice? What will a Chord 1800/400 or 2200/600 pre/power do in my system?

The mains and all its problems intrigue me. As a regular reader I can't remember reviews on power conditioners. Do they produce better results than just cables?

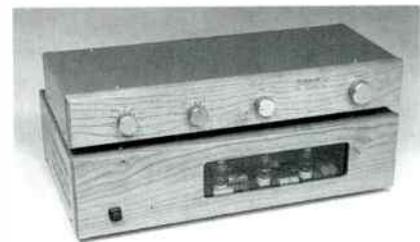

If your pre-amp is letting the side down, Rothwell's Indus stepped attenuator passive pre is one alternative.

If you want to remain passive when it comes to pre-amplification, Rothwell's Indus stepped attenuator, reviewed in last month's issue, would fit the bill nicely as it has taut, fast bass. JM

One of Ringmat's Statmats will help sweeten the sound of digital.

Charles Veggel
c.veggel@prv.gelderland.nl

The Chord amplification would certainly better your Quads given what we heard when we reviewed the 1800/400 back in March 1998. However, what they won't do is add warmth to your system.

I think you'll find that the

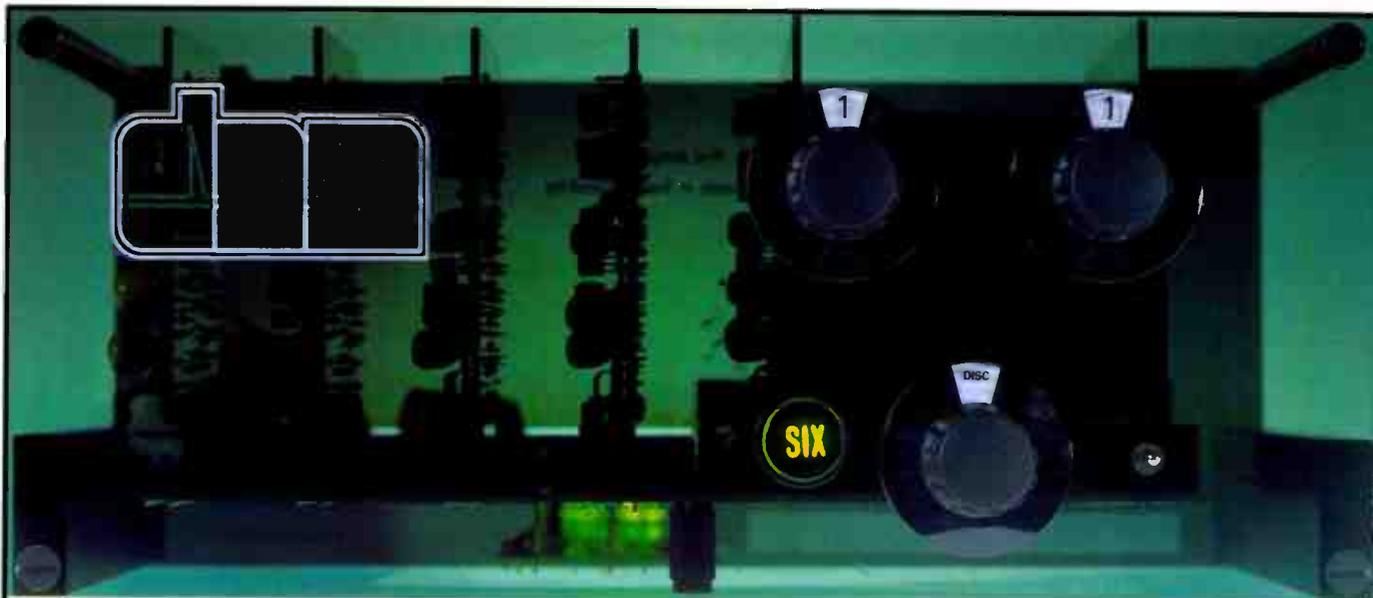

Thinking different...

Virtual Reality
Audio Systems Ltd.

P.O. Box 383
Brentwood CM14 4GB
Tel: 01277 227355
Fax: 01277 224103
email: info@virtualreality.co.uk

Audio Scene
Chesterfield
01246 204005

Hazlemere Audio
High Wycombe
01494 437892

The Right Note
Bristol
01225 874728

Progressive Audio
Near Gillingham
01634 389 1044

The Music Mill
Edinburgh
0131 555 3963

Walrus Systems
London
0171 724 7224

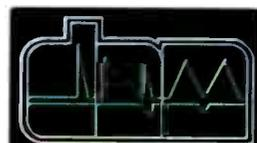

high-tech for music
British amplifiers handmade in Switzerland

RELEASE *the* FULL POTENTIAL *of* YOUR SYSTEM

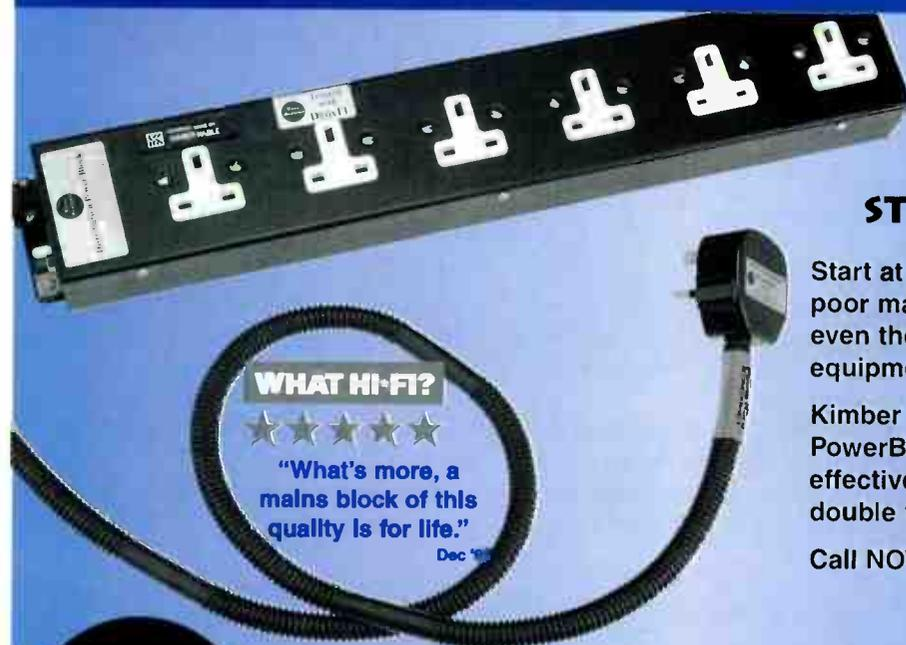

WHAT HI-FI?



"What's more, a
mains block of this
quality is for life."

Dec '97

STEP 1: YOUR MAINS

Start at the beginning! The truth is that poor mains quality ruins the sound of even the best equipment. The better the equipment, the bigger the difference.

Kimber PowerKords and Distribution PowerBlocks remove mains pollution so effectively that they can more than double the performance of your system.

Call NOW for your free brochure.

*Russ
Andrews*

"They've now taken up permanent residence in our system!"



Hi-Fi World Dec '97

MAIL ORDER *direct* 0800 373467 (UK ONLY)

Russ Andrews Accessories Ltd., Edge Bank House, Skelsmergh, Kendal, Cumbria LA8 9AS
Tel: +44 (0)1539 823247 Fax: +44 (0)1539 823317 E-mail: ahw699@russandrews.com www.russandrews.com

combination of warm Quads and cold Monitor Audios still gives a slightly cool overall balance. Swap the 34/306 for the Chords and it will get cooler still. Interconnects can push the sound in the right direction but a replacement for the MAs would be a better idea - try BKS' 107 Mk2 floor standers at £1500.

Mains cables can reduce Radio-Frequency Interference along their length thanks to shielding or capacitance added through their construction but they won't have



If your system is suffering from polluted mains, Accuphase's PS-500 is one possible answer.

any effect on the distortion caused by other equipment on the mains.

Most active mains conditioners work fairly well but, as we discovered last month, Accuphase's PS-500 with its innovative waveform-correction technology has a major impact on mains purity and therefore sound quality. I have to say that our experience with passive conditioners has been disappointing as they have almost invariably just changed matters rather than improving them. JM

Another link in the hi-fi chain - a set of Siren cables from The Chord Company.

TRANSFORMING AMERICA

I now live in the US and would like to bring my system from the UK to use it here. I have a Systemdek turntable, Arcam Alpha amplifier and CD player with Rogers 'speakers. I assume I will need to change the mains transformer on the turntable. Do you have an e-mail address for Systemdek in Scotland? Will I have to do the same for the Arcam components? And will there be any frequency problems since the mains in America is 110V at 60Hz.

Alan Reoch
areoch@nassco.com

The commonest way around the problem of different mains voltages is a step-up or step-down transformer between the wall socket and your equipment. One

point to watch out for is this transformer's power rating. Check the total power consumption figures which are normally printed on the rear of a component's case.

Likely to be more costly is having your Arcam gear modified by a dealer in the US. Both the CD player and amplifier have split primaries on their internal transformers that can be arranged in series for the UK or in parallel for countries where the national grid is 110V.

More of an obstacle to system happiness is your record player. The speed of the motor is dictated by the frequency of the mains, which is 50Hz in Britain. Going up to 60Hz in the States will cause the motor to run fast and noisy unless you have one of Systemdek's electronic PSUs



Turntables built to work on the UK's 50Hz mains frequency, like Systemdek 2X2, will run fast if used in countries where 60Hz is the standard.

which will also require a step-up transformer. JM

Whatever the location, a free bottle of DNM's Licon contact enhancer will open up the sound of your system.

CROSS THAT BRIDGE

I will be moving into a new house with my partner and plan to combine our two systems into one, with my power amps driving her 'speakers.

The problem we have is that my Rotel amps run in bridged mode and the minimum impedance they can handle is 8ohms. Unfortunately, the 'speakers have an impedance of 4ohms. Is there any way of increasing the overall impedance of the 'speakers or would it be easier to run the amps in normal mode and convert the 'speakers to make them bi-wired?

Stuart Holt
Stuart.Holt@mcs.co.uk

Running amplifiers in bridged

mode is normally a way of squeezing more power out of a stereo chassis to drive demanding loads, so I suspect Rotel's 8ohm advisory limit is possibly aimed at near-deaf head-bangers with 80dB sensitive loudspeakers.

Finding out if your amps will suit your loudspeakers is as simple as putting the two together and giving it a test. Fire up the system at a low level with something like chamber or a-cappella music and gradually turn the volume up. If that's OK, move on to Rock and follow the same steps.

Even if the bridge method is successful, you're more likely to achieve better sound quality through bi-amping. The effort of

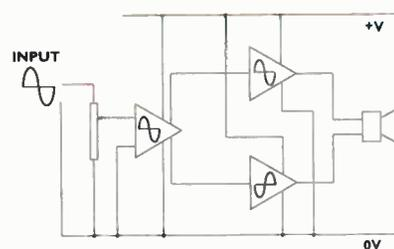

In bridged mode, each channel of a stereo amplifier handles half of the input voltage swing.

making the appropriate 'speaker changes would be well worth it as there is no way to alter the impedance of a 'speaker short of re-designing it. JM

Another link in the hi-fi chain - a set of Siren cables from The Chord Company.

KITS HAVE NEVER

NEW!



£315

KEL34 E&I VALVE INTEGRATED AMPLIFIER KIT

The KEL34 E&I version is our second generation budget stereo integrated valve amplifier, utilising E&I output transformers, providing a massive 40 watts of pure valve sound. With 4 line level inputs and one tape output, fully controllable from the front panel, the KEL34 E&I is a simple and elegant circuit design using a 6AU6 pentode input valve, an ECC82 double-triode phase splitter and a push-pull pair of Tesla, JJ branded EL34s. The result is a typically sweet, open valve sound with atypical bass control and power. The KEL34 E&I will work its magic into 'speakers of average sensitivity too. Jon Marks says, "tonally the KEL34 E&I is a bit of a smoothie compared with the original toroidal version, a major upgrade in every area of performance. It has a fast, dynamic sound, plucked guitar strings and bass drum enjoy crisp leading edges and great impact. Clear imaging and spacious sound staging meant voices and instruments really jumped out of the loudspeaker boxes. Overall the KEL34 E&I is a beautiful power amp." At the price, this kit is second to none and will open up the benefits of valve amplification to a whole new class of audio nuts! Weight 12kg. External dimensions with valves: 33cm(w) x 27.5cm(d) x 18cm(h).

HD83 VALVE HEADPHONE AMPLIFIER KIT

The HD83 is our new headphone amplifier, a beautifully simplistic design using Mullard ECL83 valves, a triode and power pentode housed in the same envelope. It works directly from any source be it a CD, tape, tuner etc., or from an amplifier's tape out or pre-amp sockets. The circuit utilises high specification output E and I output transformers that will drive any headphone load from 16 ohms to over 300 ohms depending on how the secondaries are wired up. The HD83 is a single ended design with the power pentode wired up in triode configuration for that added purity and is as quiet as a mouse. For sound quality Jon Marks says, "The bass is punchy and controlled without becoming artificial, while treble has the crispness of the best solid-state, with the tonal purity, delicacy and speed associated with valves. External dimensions 18cm(w) x 30cm(l) x 8cm(h) weight 4kg.

Please note that we are selling the full range of Sennheiser headphones at discounted prices when purchased in combination with our HD83. Please ring 0171 625 8032 for further details.

NEW!



£175

K5881 MkII VALVE AMPLIFIER KIT

MkII with SRPP input stage!



£395

A 20watt, Class A power amplifier that uses reliable Russian 5881 output valves, a military version of the American 6L6, designed for low distortion audio work. Now with a super shunt regulated push-pull (SRPP) input stage K5881 offers amazing sound quality. It can be used with a simple passive pre-amp or one of our own pre-amplifiers, and it matches modern loudspeakers well. Weight 15kg external dimensions with valves 40cm(w) x 32.5cm(d) x 17cm(h).

K5881 MkI Upgrade kit

Upgrade your pre November 1996 K5881 amplifier to MkII status. The kit converts your amplifier to the new 7025 double triode input stage in place of the original EF86 pentode input.

£35

300B VALVE AMPLIFIER KIT

£850



This is a specialised 28watt amplifier based on the highly linear 300B triode valve. Our 300B runs in Class A, giving one of the most sweet, open and neutral sounds possible today. Matched with good loudspeakers, it is unsurpassed. All parts are included in the kit, except valves since different 300B makes are available. Weight 26kg, external dimensions with valves 44cm(w) x 35cm(d) x 20cm(h).

KLPP1 VALVE PHONO PREAMPLIFIER

KLPP1 has five line inputs, a tape input with monitor, and a unique low noise valve MM/MC phono stage. There is a switchable subsonic filter to prevent output transformers of valve amplifiers saturating. The line stage has gain, so it will drive any power amplifier. Audio grade components are used and many parts are custom made for highest quality. KLPP1 has a super clear sound, sweet and detailed through line and phono inputs. Weight 6.5kg external dimensions 28.5cm(w) x 23cm(d) x 8cm(h).

£495

KLPP1 & KLP1 use the same chassis



£345

KLP1 VALVE LINE PREAMP

The KLP1 line level preamp uses one an elegant cathode follower line drive circuit to give a sound of remarkable clarity and detail. The components are all high quality and include Alps volume control, Sovtek valves, silver plated wire etc. With a gain off x1, it matches our sensitive power amplifiers. Beautifully built, with solid machined alloy fascia and gold anodised knobs, it looks compact and elegant in the home. Weight 5kg external dimensions 28.5cm(w) x 23cm(d) x 8cm(h).

K5881PSE VALVE AMPLIFIER KIT

£650

An audiophile parallel-single-ended valve amplifier at an affordable price. K5881PSE uses the reliable Russian 5881 output valve. Its 17watts is enough to drive most loudspeakers, making high-end sound quality and design available to everyone. Can be easily monoblocked to give 32watts. Weight 17kg external dimensions with valves 40cm(w) x 32.5cm(d) x 17cm(h).



BEEN SO GOOD!

NEW!



£394

KLS10 HIGH TECHNOLOGY COMPACT MONITOR

Want high technology loudspeakers, without a high cabinet high price? You couldn't do better than build KLS10, our latest mini-marvel. Using an Audax carbon fibre bass/midrange unit, married to the world's most advanced tweeter, the piezo-electric gold dome HD3P from Audax, KLS10 offers high performance from a small package. The main 'speakers are designed to work alone, or with a dedicated subwoofer to extend their bass. Alone, they are suited to near-wall mounting and can be tuned by port adjustment to suit personal taste and location. They are easy to drive and need just 30-60watts. Those who want the bass of a big loudspeaker can build our inexpensive dedicated subwoofer at a little extra cost or intrusion into the room, this custom designed addition offers big loudspeaker performance. KLS10 is unique. Technically advanced, yet compact and relatively inexpensive. There is little to match it. Sensitivity 89dB 1W/1m, 15mm MDF, internal volume 9Ltrs, external dimensions 19cm(w) x 31cm(h) x 23cm(d).

DRIVE UNITS & CROSSOVER KIT £394.00
DRIVE UNITS ONLY £358.00

KLS10 GOLD SUBWOOFER

Our new KLS10 Gold subwoofer was designed to compliment KLS10 Gold stand mounters by providing a deep and open bass. The subwoofer is inexpensive, easy to build, comprising a simple crossover network to a high quality 8 inch Aerogel, dual voice coil bass unit. A must for all KLS10 Gold customers. Sensitivity 89dB, volume 25 litres, external dimensions 28cm(w) x 43cm(h) x 34cm(d).

Drive unit and crossover £149.95 GBP
Drive unit only £71.00GBP

NEW!



£149.95

KLS9 TWO WAY FLOOR-STANDER

Here's a storm for you - KLS9, with its BB4 alignment bass cabinet and Audax High Definition Aerogel 8in bass/midrange unit. Designed by Noel Keywood to possess optimal bass damping and a clean step response. Aided by a teensy bit of bass lift, KLS9 really thunders; it will rearrange your furniture. But it does not waffle, falling silent when there's no bass in the music. Aided by a high power 1in fabric dome tweeter, KLS9 is detailed, evenly balanced and images superbly. It is an easy 12ohm load and is 88dB sensitive. For amps up to 60W. Easy to build and great for beginners. Internal volume 70Ltrs, 18m MDF external dimensions 25cm(w) x 93cm(h) x 40cm(d).

DRIVE UNITS & CROSSOVER KIT £230.00
DRIVE UNIT PACK £160.00



£230

KLS3 Gold Mk II ADVANCED TECHNOLOGY THREE WAY LOUDSPEAKER

KLS3 Gold uses the latest version of Audax's innovative oval gold dome piezo electric tweeter, giving it the sweetest and most extended treble. Married to a 4in. carbon fibre cone midrange driver for neutral and clear reproduction, and a powerful 8in. bass driver for superb depth, this is our top-of-the-line reference 'speaker. Sensitivity 90dB at 1W/1m, 25mm MDF, internal volume 60Ltrs, external dimensions 26cm(w) x 100cm(h) x 35cm(d).

DRIVE UNIT & CROSSOVER KIT £575.00
DRIVE UNIT PACK £450.00

Upgrade your KLS3s to Gold status. Includes latest oval gold dome piezo tweeter and all components.

£330



£575

KLS3 THREE WAY CARBON-FIBRE DRIVER LOUDSPEAKER

KLS3 uses extremely light and stiff carbon fibre cone drive units for a fast, accurate sound. A dedicated 4inch carbon-fibre midrange drive unit provides the clean, smooth and detailed midrange characterised by superb projection. Its high 90dB sensitivity and near flat 8ohm impedance make it one of the easiest loudspeakers to drive. An ideal loudspeaker for high-end valve amplifiers. 25mm MDF, internal volume 60Ltrs, external dimensions 26cm(w) x 100cm(h) x 35cm(d).

DRIVE UNIT & CROSSOVER KIT £350.00
DRIVE UNIT PACK £230.00



£350



NEW!

£595

KLS11 3 WAY DESIGN

Our newest design is a wonderful three way bass reflex enclosure stand mounter. Another star performer, featuring the superb gold dome tweeter, the HD3P. This, married perfectly to a HM100ZO midrange unit and utilising the deep full sound of the 10 inch PR24OZO bass unit. All units are from Audax. As both these units use high definition Aerogel cones they have similar sonic signatures, providing a deliciously gelled sound. Our KLS11 is a quality three way, with powerful bass and midrange driver that ensures vocals are handled with high fidelity. The treble is both smooth and sweet. Sensitivity 88dB Volume 45.5 litres External dimensions 31cms (w) x 37.3cms (d) x 64cms (h)

DRIVE UNIT & CROSSOVER KIT £595.00
DRIVE UNIT KIT £470.00

KLS4 TWO WAY CARBON-FIBRE DRIVER LOUDSPEAKER

A two way standmounter using stagger-tuned reflex loading for good bass, plus light and fast carbon-fibre drivers. Sensitivity 86dB at 1W/1m, 18mm MDF, internal volume 15.3 Ltrs, external dimensions 21.6cm(w) x 42cm(h) x 25.8cm (d).

DRIVE UNIT & CROSSOVER KIT £230.00 **DRIVE UNIT PACK £120.00**

KLS7 TWO WAY CARBON FIBRE DRIVER FLOORSTANDER

Compact and affordable two way reflex loudspeaker KLS7's slim dimensions make it easy to accommodate, but it uses top quality carbon fibre drivers so performance isn't compromised. An audiophile bargain. Sensitivity 86dB at 1W/1m 12mm MDF, internal volume 18Ltrs, external dimensions 15cm(w) x 80cm(h) x 22cm(d).

DRIVE UNIT & CROSSOVER KIT £195.00
DRIVE UNIT PACK £110.00

KLS8 TWO WAY HIGH SENSITIVITY

With a sensitivity of 94dB, KLS8 needs very little power. Its 10in. professional bass driver and horn loaded tweeter give it a BIG sound. Ideal for low power amplifiers. Internal volume 50.5Ltrs, external dimensions 29cm(w) x 65cm(h) x 36cm(d).

DRIVE UNIT & CROSSOVER KIT £260.00 **DRIVE UNIT PACK £175.00**

WAP SURPLUS VALVE TOROIDAL MAINS TRANSFORMER

For 230V/240V operation: join windings in series, join black & white together and isolate. Brown is 230V/240V and blue is 0V.

For 110V/120V operation: join brown & white together, becoming 110V/120V and join black & orange together, becoming 0V.

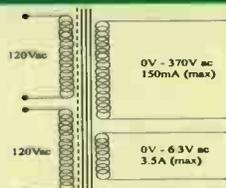

Perfect for kit valve amp builders, a quiet 77VA mains transformer, versatile use, will provide 500Vdc HT line, can be used for Mullard 5-10 and many others. Price includes 1 x 20mm fitting metal washer, 2 x 70mm rubber washer and M5 x 50 fixing screw. Physical size 95mm diameter, 50mm height, weight 1.5kg, 2200mm leadouts

Order code - TRANS1
 Price-25.00GBP + 6.00GBP

WARNING

THESE ARE EXPERT KITS, NOT FOR THE INEXPERIENCED. YOU MUST BE ABLE TO SOLDER AND READ A CIRCUIT DIAGRAM. THE VALVE KITS CONTAIN LETHAL VOLTAGES. WE CANNOT BE HELD RESPONSIBLE FOR ANY ERRORS ARISING FROM THE CONSTRUCTION OF THESE KITS.

ORDER FORM

Please send your completed order form to: **WORLD AUDIO PUBLISHING LTD, Suite G4, Imex House, The Park Business Centre, Kilburn Park Road, London, NW6 5LF Tel/Fax: 0171 625 8032 e-mail: wad@hi-fiworld.co.uk**
 240/120 option - delete the voltage NOT required. If you wish for a built item, please phone for a quote.
 Valves included except where otherwise stated.

IF YOU WOULD LIKE A DATA SHEET ON ANY OF THE KITS, PLEASE WRITE A 'D' IN THE QTY BOX

WARNING - World Audio Publishing Ltd accept no responsibility for kits, parts or modifications made or supplied by third parties.

DESCRIPTION	ORDER No.	QTY	UK (inc VAT & carriage)	OVERSEAS (exc. VAT)
AMPLIFIER KITS				
HD83 Valve headphone amplifier kit.....	HD83-K240/120	<input type="checkbox"/>	£175	£150
HD83 Transformer set.....	HD83-K240/120(T.set)	<input type="checkbox"/>	£105	£90
KEL34 Upgrade Kit.....	KEL34 Upgrade Kit)	<input type="checkbox"/>	£150	£125
KEL34 E&I 40W push-pull integrated amplifier.....	KEL34 E&I -K240/120(withvalves)	<input type="checkbox"/>	£315	£270
KEL34 E&I (without valves)	KEL34 E&I -K240/120(No valves)	<input type="checkbox"/>	£270	£230
KEL34 E&I Transformer set (1 main & 2 outputs)	KEL34 E&I -K240/120(T. set)	<input type="checkbox"/>	£130	£110
KEL34 E&I Output Transformer (pair).....	KEL34 E&I -K240/120(OPT)	<input type="checkbox"/>	£80	£68
K5881 MkII 20W push-pull valve amplifier.....	K5881-K240/120	<input type="checkbox"/>	£395	£350
K5881PSE 17W single-ended amplifier.....	K5881PSE-K240/120	<input type="checkbox"/>	£650	£555
300B 28W valve power amplifier (Not inc. Valves)	300B-K240/120	<input type="checkbox"/>	£850	£725
KLP1 line level pre-amplifier.....	KLP1-K240/120	<input type="checkbox"/>	£345	£295
KLPP1 valve phono pre-amplifier.....	KLPP1-K240/120	<input type="checkbox"/>	£495	£425
WAP surplus toroidal valve mains transformer.....	TRANS1	<input type="checkbox"/>	£31	£21

LOUDSPEAKER KITS

KLS11 3-way aerogel standmounter loudspeaker with piezo gold tweeter				
Drive Units + Crossover kit etc.....	KLS11-C	<input type="checkbox"/>	£595	£505
Drive Units.....	KLS11-D	<input type="checkbox"/>	£470	£400
KLS10 2-way carbon-fibre standmounter loudspeaker with piezo gold tweeter				
Drive Units + Crossover kit etc.....	KLS10-C	<input type="checkbox"/>	£394	£343
Drive Units.....	KLS10-D	<input type="checkbox"/>	£358	£311
KLS10 SUBWOOFER Drive Unit + Crossover Kit etc.....	KLS10-SubC	<input type="checkbox"/>	£149.95	£130
KLS10 SUBWOOFER Drive Unit.....	KLS10-SubD (1 x HM210Z2)	<input type="checkbox"/>	£71	£61
KLS3 3-way carbon-fibre driver floorstanding loudspeaker				
Drive Units + Crossover kit etc.....	KLS3-C	<input type="checkbox"/>	£350	£300
Drive Units.....	KLS3-D	<input type="checkbox"/>	£230	£200
KLS3 Gold 3-way carbon-fibre driver floorstanding loudspeaker with piezo tweeter				
Drive Units + Crossover kit etc.....	KLS3-C	<input type="checkbox"/>	£575	£500
Drive Units.....	KLS3-D	<input type="checkbox"/>	£450	£392
KLS4 2-way carbon fibre driver standmounting loudspeaker				
Drive Units + Crossover kit etc.....	KLS4-C	<input type="checkbox"/>	£230	£200
Drive Units.....	KLS4-D	<input type="checkbox"/>	£120	£105
KLS7 2-way carbon fibre driver floorstanding loudspeaker				
Drive Units + Crossover kit etc.....	KLS7-C	<input type="checkbox"/>	£195	£170
Drive Units.....	KLS7-D	<input type="checkbox"/>	£110	£95
KLS8 2-way high sensitivity standmounting loudspeaker				
Drive Units + Crossover kit etc.....	KLS8-C	<input type="checkbox"/>	£260	£225
Drive Units.....	KLS8-D	<input type="checkbox"/>	£175	£150
KLS9 2-way HDA driver floorstanding loudspeaker				
Drive Units + Crossover kit etc.....	KLS9-C	<input type="checkbox"/>	£230	£200
Drive Units.....	KLS9-D	<input type="checkbox"/>	£160	£140

AUDAX DRIVE UNITS

Carriage and packaging please add £6.00 for one unit or a tweeter pair, otherwise add £15.00 for 2-6 units * Not applicable to overseas prices

High Definition Aerogel Drivers

3inch midrange, 93dB.....	HM100Z0	<input type="checkbox"/>	£35	£30*
4inch midrange, 92dB.....	HM130Z0	<input type="checkbox"/>	£47	£40
6.5inch bass/mid, 91dB.....	HM170Z0	<input type="checkbox"/>	£53	£45
8inch bass, 91dB.....	HM210Z0	<input type="checkbox"/>	£64	£55
10inch bass, 90dB.....	PR240Z0	<input type="checkbox"/>	£76	£65

Carbon Fibre Drivers

4inch midrange, 90dB.....	HM130C0	<input type="checkbox"/>	£41	£35
6.5inch bass/mid, 90dB.....	HM170C0	<input type="checkbox"/>	£47	£40
8inch bass, 90dB.....	HM210C0	<input type="checkbox"/>	£58	£50

Paper Cone Drivers

10inch paper cone bass, 95dB.....	PR240M0	<input type="checkbox"/>	£67	£55
13inch paper cone bass, 97dB.....	PR330M0	<input type="checkbox"/>	£147	£125

Fabric Dome Tweeters

25mm 92dB for 2 way systems.....	TW025M0	<input type="checkbox"/>	£15	£13
25mm 92dB for 3 way systems.....	TW025M1	<input type="checkbox"/>	£16	£14
25mm horn loaded 97dB.....	PR125T1	<input type="checkbox"/>	£25	£21
34mm 93dB - powerful sound.....	TW034X0	<input type="checkbox"/>	£26	£22
Oval Gold Piezo electric dome tweeter, 89dB.....	HD-3P	<input type="checkbox"/>	£130	£110

(Please telephone for further details regarding other Audax Drive Units).

CREDIT CARD ORDERS TEL: 0171 266 0461 (24 hours)

NAME: _____ I enclose cheque/postal order for £ _____ made payable
 ADDRESS: _____ to World Audio Publishing Ltd. I wish to pay by Mastercard / Visa
 _____ /Switch/ Solo.
 Please debit my account no: _____

POST CODE: _____

COUNTRY: _____

TEL. (DAY): _____ Expiry Date: _____

Signature: World Radio History

OVERSEAS PRICES & DETAILS

Please allow for your own local import taxes (customs duties) and for carriage charges, which must be added to the net price.
 Telephone or Fax for a quote.
METHODS OF PAYMENT
 International money order in Sterling, Mastercard or Visa.



BASIS INSTINCT

Timothy Liu takes the Basis 2001 turntable for a spin.

On the subject of hi-fi, few components ever reach the same level of cult nostalgia as the turntable. If you've seen the film *Clockwork Orange* you might remember glimpsing in the background a Michell Transcriptor, which in later years metamorphosed into the GyroDec, a design for vinyl junkies with a carriage-clock fetish.

Riding the wave of the recent mini vinyl revival, Basis of America have introduced the 2000 series to lure new disciples to the LP-playing fraternity. Believing the main bearing to be the area most critical to performance, Basis have taken the same high-tolerance parts as used in the Ovation and Debut Standard Gold and incorporated them into the scaled-down, more cost-effective 2000.

Fixed to the 1in. black acrylic base-plate are the bearing (with its 0.5in. stainless steel shaft) and the acrylic platter, both machined to super-fine tolerances of 0.0001in. The out-board, Swiss-made AC synchronous motor is housed in a heavy aluminium enclosure to help reduce its vibration, the flat drive belt being the only link between it and the turntable. Speed change to 45rpm is accomplished by simply flipping the belt onto the larger pulley diameter. Fit and finish in all areas is impeccable.

Our review sample came supplied with suspension feet, which bump up the original asking price of £1995 by a grand, changing the 2000 into a 2001 in the process. These ingenious items are sprung, fluid-damped affairs which can be locked tight prior to transit to avoid spilling the silicon fluid they're filled with.

The 2000 series can be bought with a Rega RB300 modified to include adjustable VTA and built exclusively for Basis. To this I fitted my own Koetsu Red Signature car-



tridge followed by a Jeff Rowland Cadence phono stage, Coherence pre-amp, Jeff Rowland Model 2 battery power amp and Sonus Faber Electa Amator 2 'speakers.

Having just sampled and become accustomed to some recent digital delights, my first encounter with the 2001 left me in a spin! The opening grooves of Blondie's 'Dreaming' had me gob-smacked at the sheer speed, attack and rapid-fire delivery of Clem Burke's drumming. Deborah Harry's gutsy vocals were well projected and controlled, highlighting the openness and punchy dynamics of the Basis.

The superb resolving power and separation of this acrylic deck unlocked musical colours and textures lurking deep in those black grooves. The Dukes Of Stratosphere (aka XTC) continued to raise vinyl replay levels with 'You're My Drug' from their Psonic Pspot album. The intricacy of Colin Moulding's bass guitar playing was unravelled intact, allowing the notes to bop along unfettered, maintaining the drug-free listening high.

Whatever the music, the Basis always remained tonally neutral, revealing but not ruthless. The treble, although sweet, was more in the speed and dynamics camp, with fine extension giving hi-hats detail and shimmer beyond many decks'

abilities. Down in the two-digit frequencies, the 2001 had the welly and extension you normally associate with bigger, more expensive high-mass turntables without the loss of speed and immediacy they often suffer from.

The talent that really elevated the Basis into the super-deck league was imaging, palpable, 3-D instruments and performers locked into a life-size sound stage. The track 'Sorrow' from David Bowie's *Pin Ups* album had DB and co. emerging from an inky-black background, the velvety tones of the cello intro warm and sumptuous. Gently-strummed acoustic guitars in the background had a fresh, airy quality, and were easily picked out without being smothered by surrounding instruments.

With 24-bit 192kHz as well as SACD on their way, it seems quite ironic that Basis have now chosen to construct a turntable with the Midas touch to sway people back to their records. Despite the Basis offering excellent sound, its £2995 price tag (without arm) in basic guise will make many think long and hard. However, pride of ownership, a 10-year warranty and the flexibility to upgrade make the 2001 an ideal proposition for those who are willing to take the plunge and head for audio Nirvana●

Basis 2001 £2995

RT Services
118 Mendip Heights,
Didcot,
Oxon. OX11 7TG
Tel: 01235 810455

WORLD VERDICT



It's not cheap, but the 2001 shows just why vinyl is still a sonically viable format.

Measured Performance
see page 127

Walrus Systems = High Fidelity

If you're only interested in hi-fi (not AV or Multimedia),
and you want a system(that's been set up properly)
to give you lasting enjoyment,
and you're looking for a shop which is patient,
and listens to what you want (and understands what you don't),
where you can feel at home
and stay as long as you need to make a decision,
a shop which understands turntables as well as CDs,
transistor amps as well as valves, and which is able to make
your system sound exactly how you want it to sound
(most of the time - we're not perfect)
and a shop you can turn to when you have hi-fi problems
(and sometimes other problems too)
come on in and see Les or Pete.

Ps. Sorry 'bout the waffle: we didn't have time for anything better
this month!

Amazon ARS Acoustica ATC Audio Physic Audio Synthesis Avantgarde Balanced Audio Technology Clear Audio DNM EAR Yoshino
Eggleston Works Electrocompaniet Final Graaf Hales Helios JM Lab Living Voice Morch Musical Fidelity NotePerfect Nordost
Pass Labs Rega Rehdeko Stax Sugden Trilogy Unison Research Van den Hul Yamamura Churchill



Walrus Systems

11 New Quebec St, London W1 0171 724 7224

fax: 0171 724 4347
e-mail: mail@walrus.co.uk
Web: www.walrus.co.uk

PAPWORTH AUDIO TECHNOLOGY



Our new range of mosfet products have been designed to give you a lifetime of listening pleasure

The MVH 200 is a six input, mosfet valve hybrid, integrated amplifier, producing two hundred watts per channel. Our combination of a built in valve preamplifier controlling a mosfet power amplifier produces musical bliss with any loudspeaker.

All products from Papworth Audio Technology, are designed, hand built, and individually tested with a care and attention to detail that sets new standards of quality and craftsmanship.

UK Distribution by Elm Audio, Telephone/Fax (01744) 604578
Visit our Website at www.papworthaudio.demon.co.uk

Papworth Audio Technology, No 1 Cambridge Court, Papworth, Cambridge, CB3 8RG
Telephone (01480) 831666 Fax: (01480) 830606

After all the hype I don't know whether to be impressed by Diamond Multimedia's Rio MP3 portable or not. Using computer memory to store music in a personal stereo that is small, light and insensitive to movement (because it has no moving parts) is an idea with natural appeal - it seems so much more elegant than a box full of cogs and wheels. And since it's computer-based as well as Internet-friendly, the Rio makes MiniDisc look a little out-dated. Or does it?

When you investigate further, the picture changes. A blank MiniDisc nowadays costs as little as £1.50 and

will store 160MB of information - that's around 1p per MB of recording capacity. Solid-state memory for the Rio costs £40 for 16MB if you buy it separately, which amounts to £2.50 per MB. Now I've always

thought that one day we will be recording into solid-state memory and I am as enthusiastic about the idea as anyone, yet at the same time these figures cannot be ignored. The simple truth is that no matter how fast memory prices may fall, they have a long way to go to catch up with the sort of costs offered by MD storage.

IBM think the same and have good cause. They recently released their new Microdrive, a miniature magnetic storage disc drive that measures about one inch square (see pic), works from 3.3V and could well end up in portable music players since it can store 170MB or 340MB. This raises the question: why didn't Sony produce a 160MB MiniDrive for computers six years ago? Anyway, IBM say specifically that "Microdrive technology takes storage far beyond flash-memory cards", suggesting again that solid-state memory might seem like a good idea but it remains impractical.

MiniDisc offers excellent recording quality now that its ATRAC data-reduction system has been honed, and Sony are going to launch higher-density MiniDiscs in the future. The discs are small, easy to store and robust. Viewed as a recording medium MiniDisc makes

the Rio, and forthcoming rivals, look inadequate in so many ways it would be easy to dismiss them as poor infants of the computing world.

That might be to miss a crucial point, however. Very soon we will witness a flood of rivals to the Rio - there are around 16 different makes and models due out in 1999 and knowing how the computer business works - for this is not a product of the audio industry - there may well be many more. Unlike MiniDisc, which is a proprietary technology developed and controlled by Sony, anyone can contrive an MP3 personal stereo. The whole world and

its dog will be beaver away trying to produce something better than Rio, all hoping to be the next Bill Gates. Can Sony defend MiniDisc against such an onslaught?

In theory at least the Japanese giant has plenty

of leeway. MiniDisc is not only vastly cheaper as a recording medium but it could also be hooked up to a computer to load MP3s just like the Rio. In this case, since an MP3 music file is typically 4MB, one disc could hold 40 songs of around 3minutes' playing time apiece, giving nearly 2hours' playing time total. But to do this Sony would have to make use of their own ATRAC data compression system optional, which might stick in their throats. Would such a device be MiniDisc? It might have to be re-christened MiniDrive to emphasise its open architecture and usage as a computer accessory.

By doing this Sony could trump the one ace Rio holds up its sleeve: Internet connectivity. Buy a Rio and suddenly you have a world of music literally at your fingertips. A few taps at the computer keyboard gets you on line and into a site like www.mp3.com which claims to list 1000 songs. There are scores of Indie music companies like www.goodnoise.com who put out promotional MP3s and you can even buy CDs full of MP3 songs via the Internet.

This is where MiniDisc is cru-

cially weak. Learning from the problems of DAT, Sony ensured MD could be produced easily and cheaply in pre-recorded form by a stamping process. In spite of this, after six years or so in the marketplace, pre-recorded MiniDiscs are not exactly plentiful and there's no doubt they are over-priced by a music industry that treats them as a "premium product". Also, Sony's music industry rivals would prefer not to support this potential monopoly by allowing chart hits to appear on MiniDisc, which is another block on growth. I suspect pre-recorded MDs will never replace the pre-recorded cassette, even though they were designed to do so and are ideal for the role.

I wasn't impressed by the Rio so much as hooked by it! Once I got the hang of the software, downloading and compiling a playlist is quite addictive. Very soon I was listening to bands I had never heard before and enjoying new music. The Rio itself isn't as attractive and sexy as MiniDisc; quite the reverse - it is little more than an inert black box. But it is a brilliant marketing tool for the music business in a way that MiniDisc is not, and this is likely to be a crucial advantage MD will never overcome.

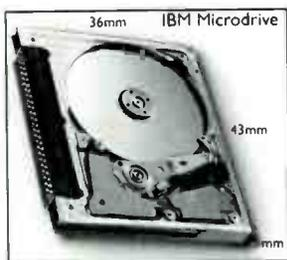

Noel Keywood

Trichord Research Limited

CD UPGRADE

CLOCK 3

CD PLAYER UPGRADE FROM £132

From the designer of the original Clock 2 upgrade
A new generation of Master Clock

"Significantly better than anything else I've experienced to date."

- Jimmy Hughes.

"Superior Clarity & Imaging - Irresistibly foot-tapping."

- Clive Meakins - Hi-Fi News - June '98

- High accuracy (5ppm) low jitter performance master clock.
 - Up to five times reduction in date related jitter
 - Increased transparency, resolution and sound staging
 - Greater dynamics and sheer listening pleasure
 - Can be fitted to most players or transports regardless of price
- The level of improvement is just as significant with expensive transports as it is with inexpensive players.

These modifications can be carried out by Trichord Research Ltd, or by your local Trichord dealer. Also available in kit form with instructions for the technically competent.

Pulsewire Digital + Analogue Cable
Major Credit Cards Accepted

Tel: (01684) 573524 Fax: (01684) 577380
6 Woodlands Close, Malvern Wells, Worcs,
WR14 4JD



ORANGES & LEMONS

Juicy fruit from
London's freshest
hi-fi / home cinema retailer.
Free home installation + credit cards,
0% credit finance available
(subject to status).

ARCAM, B&W, CABLETALK, CAS-
TLE, CHORD CO, DENON, EPOS,
KEF, MARANTZ, MICROMEGA,
NAD, NAIM, NEAT, QUAD, REGA,
ROKSAN, ROTEL, ROYD, RUARK,
SOUNDSTYLE, STANDS UNIQUE,
YAMAHA

Now in our fifth flamboyant year
THE INNOVATIVE
AUDIO RETAILER
0171-924 2040

61/63 WEBBS ROAD, CLAPHAM, SW11

Are you getting the Maximum from your System

D102II Hybrid Interconnect cable

£69.99/0.8m pair

Best Interconnect Cable - What Hi-Fi?
Award Winner 1998

★★★★★ "...a wiry wonder" What Hi-Fi? May '98

★★★★★ "...this is pretty much as good as cable gets"

Best Buy Hi-Fi Choice March '98

CS122 Hybrid Loudspeaker Cable

£11.99/m

Highly Recommended - What Hi-Fi? Awards 1998

★★★★★ "Buy with confidence" What Hi-Fi? Oct '98

The Teatrack Hybrid Bi-Wire (£21.99/m)

Insist on Cables by

van den Hul

The Link Between Technique and Emotion

For details of our extensive range of cables and cartridges please contact

van den Hul UK, Imex House, 6 Wadsworth Road, Greenford, Msex, UB6 7JJ. Tel:0181 997 4280

pear audio

presents

Shahinian DYNAVECTOR Well Tempered

Stockists and Information from
Pear Audio Ltd. 7 Prospect Place,
Alnmouth, Northumberland, NE66 2RL
Tel: 01665 830862 Fax: 01665 830051

S'ONY MUSIC

If you're after a player that cuts the mustard at home or outdoors, Jon Marks reckons Sony's PBD-V30 DVD portable should be on your shopping list.

While many audiophiles bemoan the passing of the age of valves and their sweet sound, there is one major benefit that the transistorisation of the world brought with it - miniaturisation. Before valves vanished almost entirely from everyday electronics, some of them (like the Nuvistor beloved of Musical Fidelity) had shrunk to the size of the tip of your little finger. By thermionic standards that's seriously small, but when you need the processing power of a small computer in a package not much larger than three or four CD jewel cases, truly microscopic is what's needed. Without transistors, portable DVD players such as Sony's PBD-V30 wouldn't exist.

Like Panasonic's DVD-L10 (reviewed in November 1998), the Sony is one of a growing band of multi-format portables. It may not be pocket-sized but it weighs not much more than a kilo with its 7.2V Lithium-Ion battery pack. Desirable Feature Number two after the petite dimensions is the damped lid which rises smoothly at the touch of a button. Number three is the lid-mounted controls. Number four is the flip-up battery socket on the rear where the pack slots in.

Under the bonnet is a twin-laser mechanism which makes for easier reading of the differing disc types. After the signal has been read and decoded it interfaces with the outside world via an optical digital out (for both audio and Dolby Digital), an S-Video socket, an AV out (mini jack) and a headphone stage with volume control. Where the PBD-V30 scores over the

Panasonic is the fact that these sockets are always accessible. On the DVD-L10, clicking the battery pack into place covers the S-Video as well as audio and video line outs.

Seeing as the real reason for creating a portable DVD player is so



that it can be used on the move, I wasn't raising my hopes over the Sony's sound quality with it running from the mains. The wall-plug PSU is the usual lightweight affair and produced a sound in keeping with its mass. A swift switch to the Lithium lump yielded much more promising results.

Located on a Perfect Pitch Sound Absorber platform and feeding MVL's Integral A2S amplifier, the 'V30 got stuck into Red Snapper's Making Bones album. As it revved the disc up to speed, and music started to flow from Magneplanar's SMGas, it was obvious the Sony was far happier operating from pure DC.

Opening track 'The Sleepless' showcased the same sort of musicality which had made the Panasonic an appealing prospect, the menacing basslines rendered with satisfying weight and drive. Up

in the treble cymbals had an attractive shimmer and sweetness while vocals were free from sibilance and grain. Imaging was fair, if not particularly sharply focused, and sound staging wasn't as spacious as you'd get from a static machine at a similar price, but the enviable forte of the 'V30 was a tunefulness that kept me pinned to the listening seat. And as it warmed up, dynamics and clarity gradually improved.

A stiffer test was provided by Elgar's violin concerto. In spite of an initial sneaking suspicion that the Sony might struggle to tease apart the orchestral strands or give a coherent overall account of this disc, I was pleased to find that everything was present and correct after a little judicious tweaking of the MVL's tone controls.

More points were picked up when the Sony replayed the Palladian ensemble performing trios for four (on Linn Records), where its slightly rolled-off top-end helped counter a little of the sharpness in this disc. Harmonically the archlute and violin were limited but enjoyability was the main theme once more.

With cassette soldiering gamely on and CD portables available for considerably less than the PBD-V30, the Sony might appear to be merely an expensive indulgence. When you consider it will play DVD-Video in addition to CD and higher sampling-rate, uncompressed music, it doesn't seem quite so expensive. Most important of all, it puts out music instead of background noise which makes it a worthy competitor for Panasonic's DVD-L10.

Sony PBD-V30 £699.90

Sony
The Heights,
Brooklands,
Weybridge,
Surrey KT13 0XW
Tel: 01932 816000

WORLD VERDICT



The Sony is an engrossing performer in a sturdy and attractive design.

Measured Performance
see page 127

Crimson
AMPLIFIERS WITH ATTITUDE

Virtual Reality

P.O. Box 383 Brentwood Essex CM14 4GB
Tel: 01277 227355 Fax: 01277 224103 email: info@virtualdemon.co.uk

Mains quality and power supplies in equipment are crucial to the sound you hear. It's this power, not the music signal, that drives the speakers.

Power...

and glorious sound

Anything done to improve the mains will give your whole system more **CLARITY AND AMBIENCE**. A direct spur reduces noise and interference from your own computers, TVs fluorescents, etc but does not cut spikes, surges and mains-borne "grunge" from outside which harden the sound.

MAINS CABLES make a huge difference by screening and filtering the last link. We offer DNM, Nordost and Yamamura Churchill, to suit systems from moderate to massive.

Try Yamamura Churchill M-Tubes and mats to screen **RF INTERFERENCE** at all sockets and between components.

Probably the ultimate source is an Accuphase PS-500 or -1200 **CLEAN POWER SUPPLY** which re-constitutes a pure 50Hz sine wave, free of all interference.

Customers say we make some of the best sounds they have ever heard, so you know we can do the same in your home.

Our advice will take account of your best components and guide you where change is needed, in stages you can afford.

You **AVOID EXPENSIVE MISTAKES**, enjoy music along the way and save money in the long run.

JUST LISTEN AND YOU'LL KNOW

The Right Note

Music in the home

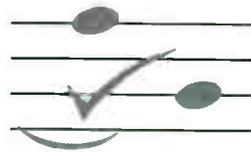

BATH

01225 874728

CD: ACCUPHASE, ADVANTAGE, AUDIO SYNTHESIS, BALANCED AUDIO TECHNOLOGY, dCS ELGAR, MERACUS, PASS, WADIA, XTC. **VINYL:** BASIS, CROWN JEWEL, DNM, GRAHAM, LEHMANN, MICHELL, STRATOSPHERE, SUMIKO BLUE POINT SPECIAL, TRANSFIGURATION. **AMPLIFIERS:** ACCUPHASE, ADVANTAGE, BALANCED AUDIO TECHNOLOGY, CAT, DNM, LUMLEY, NAGRA, PASS, SIEMEL, SIRIUS, SONNETEER, XTC. **LOUDSPEAKERS:** AUDIO PHYSIC, BKS, CHARIO, ETHOS, HALES, HARBETH, LUMLEY, MAGNEPLANAR, MIRAGE, NEAT, TOTEM. **TUNERS:** ACCUPHASE, FANFARE, MAGNUM DYNALAB. **CABLES:** ARGENTO, CHORD CO., DNM, NORDOST, YAMAMURA CHURCHILL ETC. **SUPPORTS:** DH CONES, STANDS UNIQUE, VIBRAPLANE ETC.

campaign audio design

Getting a better, more involving sound often means spending a lot of hard earned money. It's such a waste, because every system can benefit from our cables and accessories. at a fraction of the cost of some new "black box". Here are some of the ways we can help.

We have Linear Crystal Oxygen Free Copper interconnects (£12.48) up to High Purity Silver cables (£89.00) and high definition loudspeaker cables in Silver Plated Copper or Pure Silver. Our mains cables add weight, power and scale. and with non-inductive RF filtering (£10.00) and over-voltage protection (£3.00) enhance performance still further. Gold plated AV cables, both RF (£17.95) and OFC Scart (£19.21), help bring picture quality in line with NICAM sound resolution. Valves, capacitors and transistors are all microphonic. They cannot perform optimally if vibrated. Our set of three brass isolation cones are worth their weight in gold - revealing low level resolution and dynamics hitherto hidden beneath electronic noise. We also have a cure for your noisy fridge or central heating motor (£3.50), enabling you to throw away your big mains noise suppressor, which has been giving you that "sat upon sound" for years. There's lots we can do to bring you closer to the emotion and energy of the performance. So confident are we, that we offer a 14 day money back guarantee.

Ring or write for details:-

CAMPAIGN AUDIO DESIGN
Llandudno Road (HW)
Cardiff CF3 8PG
Tel:- 01222 779401

Website: <http://business.virgin.net/cad.cables/>

Trade and International Enquiries Welcome. **VISA**

Arcaydian Scenes

Are Arcaydis' new ASC 'speakers a one-way ticket to hi-fi heaven? Richard White calls at the travel bureau.

Their striking wedge profile almost qualified Arcaydis' latest loudspeakers for our 'radical design' group test last month. Although the footprint measures 6.25in. by 11.75in., the front baffle is angled backwards at about 60°, leaving the top roughly six inches square - not much room for flower pots there. It's nice to see a ported two-way that breaks the box mould, though.

One pleasant change from some of the loudspeakers we've dealt with recently is the lack of back-break factor. By no means flimsy, the cabinets can be handled with ease, which ensured equable tempers during set-up. The manufacturer recommends that the ASCs be placed on short stands where the benefits of the crossover optimisation and angled front baffle can do their work. As the review progressed, I found that even placing the units on the floor could have benefits in certain acoustic environments; bass reinforcement from the floor helped to give a broad, even spread of frequencies which was something of a surprise given the small cabinet size.

Happily installed and fired up, the Arcaydis' first encounter was with Radio 3 fluting out Debussy's well-worn Golliwog's Cakewalk. Perhaps it's because the sound of a piano is so widely known that our ears are quick to find fault with this instrument if there's a problem with the loudspeakers. No such worries with the ASCs and their natural delivery. The announcer at the end of the piece also showed no evidence of chestiness or nasality.

To check the tonal integration of the 'speakers with rather more complex music I tuned into Beethoven's



Sixth. As they had hinted when fed with piano music, the ASCs had a pleasantly realistic touch with midrange dwellers like the brass section's horns. Bass extension on the other hand was controlled in a lean way, which at least avoided any danger of one-note waffle. Indeed, when the big guns had stopped thundering, a performance of Max Reger's final clarinet sonata demonstrated that these boxes had quite a winning way with small-scale works.

The same thing can't be said of the amplification needed to drive the ASCs when given an arduous symphony to handle. The size of the port was perhaps a limiting factor; great for intimate, low-key compositions but a design approach which could lead to dynamic compression. Because the cabinet is commendably solid, the woodwork is self-effacing but on larger orchestral works there was still some confusion

to imaging which was otherwise pretty solid.

Jazz chanteuse Diana Krall on CD re-inforced the impression that the ASCs needed a firm hand at the amplification helm of around 40watts, so they're not natural partners for valves. Driven properly, they produced comfortably clean, precise imaging of the accompanying quartet. Actually, thanks to the very deep sound stage, the result was rather schizophrenic since the singer in the front and the pianist at the back were one and the same. Doubtless a bad day at the mixing desk!

On smaller-scale recordings the Arcaydis ASCs made a name for themselves against some stiff competition and the distinctive but discreet styling blended in unobtrusively with a variety of decors. If your listening room is petite and you seek a natural, controlled loudspeaker which won't cause bass boom, the ASCs are one for the wish-list●

Arcaydis ASC £399

Arcaydis
Unit 4,
19 Lisle Avenue,
Kidderminster,
Worcs. DY11 7DF
Tel: 01562 865788

WORLD VERDICT



The ASCs have natural warmth and good imaging. Inclined to be a little power-hungry.

Measured Performance
see page 127



Sounds Of Music

◆ The best range of Hi Fi separates anywhere ◆

◆ 1 months home trial exchange system ◆

◆ Free delivery and installation ◆

◆ 6 demonstration rooms and easy parking ◆

◆ Interest free credit & most credit cards ◆

FOR SERVICE AND ADVICE - WE CAN'T BE BEATEN !

Agencies include:

Avantgarde, Argento, Audio Synthesis, Advantage, Audio Physics, Apollo, Audion, Audio Note, Audio Research, Audio Analogue, Anthem, Altis, AVI, ATC, Alon, Acoustic Energy, Atacama, Artemis, BCD, Base, Balanced Audio Technology, Bow, Bose, Convergent Audio Technology, Chord, Copland, Cadence, Cable-Talk, Churchill, Copulare, Dunlavy, DAC, Eggleston-Works, Electrocompanient, Eikos, FM Acoustics, Genesis, Graham, Graff, Goertz, Goldring, Gershman, Hales, Harbeth, Helios, Hovland, Jamo, J M Labs, Koetsu, Krell, KEF, Klipsch, Lumley, Lyra, L.A.T, Lavardin, Musical Technology, MIT, Magnum, Magnum Dynalab, Micromega, Marantz, Martin Logan, Mitchell, Musical Fidelity, Neat, Nordost, Nottingham Analogue, Opera, Optimum, Ortofon, Orelle, Orchid, Osborn, Plinius, Promenade, PAD, Passlabs, Pro-ac, Pink Triangle, Primare, QED, Quad, Reference 3A, Rockport, Ruark, Rel, Roland, SME, Shure, Sequerra, Sennheiser, Sonic Link, Soundstyle, Sonic Frontiers, Spendor, Sonus-Faber, Stands Unique, Target, Trilogy, Tannoy, Totem, Talk, Transparent, Transfiguration, Triangle, Unison Research, VAC, Woodside, Wisdom, Wilson, Wilson Benesch, Wadia, XTC, XLO, YBA, Zingali.

10-12 Chapel Place, Tunbridge Wells, Kent TN1 1YQ

Tel: 01892 547003 / 616383 Fax: 01892 616517

Web site: <http://www.sounds-of-music.co.uk>

“ Let no one imagine that in owning a recording he has the music” states the latest advertisement from a well-established hi-fi manufacturer. This is actually an ambiguous quote from the late John Cage, an American avant-garde composer whose most (in)famous piece is, ironically, ‘4min 33sec’, a “silence for any instrument(s)”.

The idea behind the advert brings us into the very grey (and oft-discussed) area of recorded versus live performance. It would seem that, on the one hand, John Cage is saying that ‘the music’ only exists in performance and, on the other hand, the manufacturer is trying to tell us that by purchasing their equipment we can bring ourselves a little closer to actually experiencing ‘the music’. Regardless of the components, what is important is the point they are trying to raise.

“Dear Sir, only the other day I took myself to see a concert. . . and I didn’t think the Tchaikovsky sounded as good as it does through my hi-fi . . .” is a classic hi-fi anecdote. It seems to me that it’s simply not possible to compare a flesh-and-blood performance with a recording, even a live one (which often involves overdubbing and other studio work). They are two very separate entities.

Something no one can deny is that every live performance of any piece of music is, like it or not, different - even the aforementioned ‘silence’. But then this ‘piece’ was conceived to emphasize exactly this difference in performances. The artist takes to the stage and looks at his or her watch whilst the ‘music’ is created from events in the venue - the creaking of seats, coughs, sneezes, passing ambulances, dropped programmes, stifled sniggers, etc. As a result, every Cage ‘silence’ is unique. It’s this very unpredictability that can make a concert special. Sure, you may know the music, but you never know quite what to expect in the performance.

As a keen concert-goer and one-time performer, I can honestly say that all my most memorable musical experiences (so far!) have been in live performance situations. The acoustics of certain venues may resemble singing into a damp duvet, and you may not hear that all-so-important triangle stroke at bar 43 that’s as clear as clear at home, but there is a frisson and excitement that is incomparable. For example, there is nothing quite like hearing a live symphony orchestra. A realistic relay of the space, depth and dynamics cannot be

“ Dear Sir, only the other day I took myself to see a concert. . . and I didn’t think the Tchaikovsky sounded as good as it does through my hi-fi.

recreated by any audio equipment, full stop. And no rack upon stack of domestic audio amplifiers will reproduce the wall of sound produced by, say, Rage Against The Machine.

You may well be thinking at this stage, “Why does this bloke work for a hi-fi mag, if he apparently feels there’s no place in the world for recorded music?”. Well, there is a place for both live performance and recorded music in our lives.

In certain live situations, purely musical edification is sometimes sacrificed for the experience of it seeing it in the flesh - fluffs, cracked horn notes, etc. In addition to bad acoustics, your position in the venue may not be the best, further lowering your chances of catching what the performers want you to hear.

This is where recordings and home listening triumph. At home the “cheap seat” phenomenon should be minimal, unless your preferred listening position is sideways-on to the ‘speakers with a stone column in the way! Also, the detail that you can get from a studio record-

ing and a quality hi-fi system is near-impossible to recreate live.

It’s not just sonic benefits either, there are many more ways in which hi-fi listening can be preferable to live performance. For starters, you choose the programme. If there’s a song or piece that you really don’t like, you simply move to the next track. You can’t exactly shout out “er, do you mind skipping this one old chap, I never did care for it” in the Festival Hall or the Shepherd’s Bush Empire. And unless you’re conducting, you won’t get an orchestra to repeat your favourite theme.

From Cage’s emphasis on the experience of performance, we can assume that ‘the music’ referred to in the quote he regards as a live presentation of the score. The struggle of hi-fi companies to reach ever-closer to the goal of the ‘live experience’ seems to me a bit like flugging a horse long dead. Deep, muscular bass, smooth treble, imaging and detail are not really the hallmarks of a concert or a gig. Trying to recreate a live experience in a domestic situation is often - like meeting your heroes - a bit of a let-down. When someone comes up with a system that will magically transport Leonard Bernstein and the Vienna Philharmonic into your front room (and supply the interval drinks), then we might start taking claims as to genuinely like-like reproduction seriously!

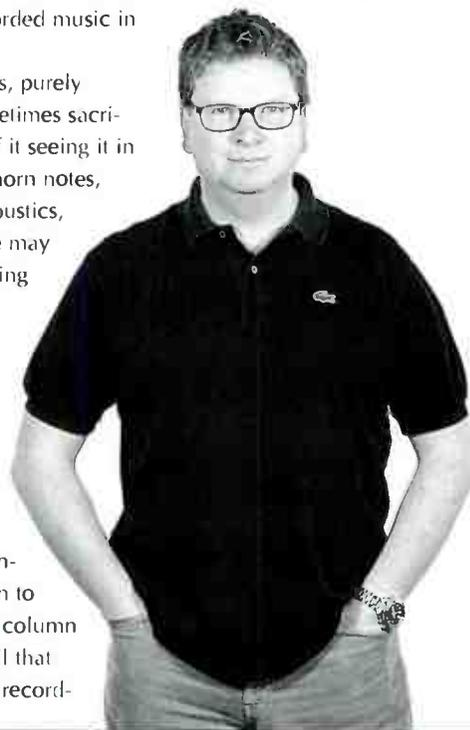

Simon Pope

PURITY of form

PURITY of function



ARIA S2

by Unison Research

Combining styling of classic elegance with a sound both pure and natural, ARIA S2 has an unbeatable pedigree. Electronic design to reference standard is by Giovanni Sacchetti, and includes pure silver circuitry throughout. Appearance design is by Italy's top audio stylist Claudio Chiarello. Made for the serious music-lover, the S2 gives you the enchanting sound of a fine single-ended valve amplifier in a sensibly-powered and sensibly-priced package. Check it out soon at your nearest UKD stockist. You'll be enthralled.

Thoroughbred Audio Products

from

UKD

23 Richings Way, Iver, SL0 9DA, Bucks, England

Tel: 07000-853443 (UKD HIFI) Tel: 01753-652669: Fax: 01753-654531

or visit our website: www.ukd.co.uk

This time of year is usually when things quieten down a little in the world of hi-fi. Manufacturers, distributors and retailers pause after a (hopefully) busy winter before their new models are launched in autumn. So a synopsis of what sold best last year and who and what the money is on this time around seems appropriate.

The amplifier market saw NAD showing a return to form with the highly-rated 312. The company had no problem shifting every one it could manufacture and has already begun to consolidate the range with the 314 and new, high-end SilverLine range. I see no reason for their success not to continue into the season, although fresh components from Marantz and Cambridge Audio may scupper any grand plans of budget amp domination.

Further up the price ladder Arcam

Where Mission have scored over both their rivals is in their consistency. The Huntingdon-based outfit has received critical acclaim and decent sales right across their 700 and 770 range, and the 75 Freedom are far from obsolete.

Away from the ruthless budget market, the ones to keep an eye out for are Mordaunt-Short and Epos, both under new ownership (Audio Partnership and Mike Creek respectively). New loudspeakers are promised for later on this year.

Not so loudspeaker lucky were Rodgers and Goodmans (GLL). In spite of the latter continuing to make in-car 'speakers, neither will be making domestic transducers again. On a lighter note, this could be the year of the active, with the powered version of Wharfedale's Diamond now finally on the market.

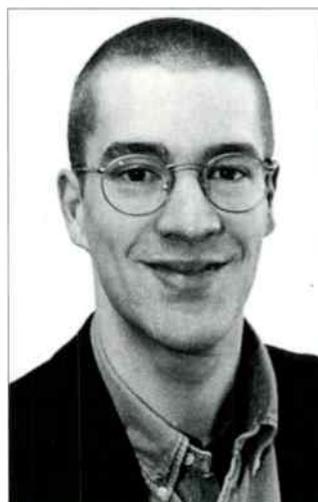

Dominic Todd

"DVD has captured everyone's attention and split opinion across the industry"

proved to be the leaders yet again thanks to the steady and continuous improvement of their Alpha line-up. Their 10 and 10P amps took them into the realm of the £1000+ price category too, a frightening prospect for many smaller manufacturers, especially with TAG McLaren's arrival on the scene. This domination is likely to continue throughout the year, although I'd be surprised to see such luminaries as Cyrus and Naim prepared simply to sit back and watch.

Anybody who has had even merely a passing interest in hi-fi over the past 20 years will still be familiar with 1998's best-selling 'speaker. Now in its seventh generation, the Diamond continues to be the real bread winner for Wharfedale. As ever, though, it was far from being without competition. Mission's 700 and Tannoy's M1 both proved extremely popular budget boxes. Expect to see modifications to all three as we go into the autumn.

Only time will reveal the public's reaction to the concept this time around.

Although DVD has captured everyone's attention and split opinion across the industry, it's still too early for it to have any real impact on budget to mid-priced CD players. MiniDisc, on the other hand, has made a much bigger splash as sales rocketed skywards during '98. As a consequence, any budget CD player without a digital started to look inadequate. No problems for Technics and Sony then, who made sure their entire range of machines were so equipped last year. Expect to see others following suit.

Slightly further up market, the NAD 522, Kenwood DPF-3010 and Cambridge CD4SE all proved deservedly popular. Look out for the Cambridge D500 which will feature a Crystal DAC (like the CD4SE) and jitter-reduction circuitry.

With the exception of the Linn Sondek CD player (£12000), the upper

echelons of CD replay were fairly quiet. Mind you, with Sony having already launched four new DVD players, the future of £400+ CD machinery appears decidedly shaky. We'll have to wait to see exactly what effect SACD and DVD-Audio have.

As well as being at the forefront of DVD, Sony continued to dominate the MiniDisc market. Their MDS-JE520 was last year's top MD purchase. More telling was the fact that sales of the '520 pretty much blitzed any opposition from cassette. Keep an eye out for new MD recorders from Sony, Kenwood and Sharp and don't be surprised to see some new faces in the world of MiniDisc next year. As an aside, the choice of blank discs should increase with the likes of TDK and Maxell already adding to their wares.

It's hard to believe that Denon's leading TU-260L tuner is now over eight years old. It comes as no surprise this issue to hear that its replacement, the TU-260MkII, has been equally well received. A few tweaks and the addition of an RDS circuit might not see it through the next eight, but it will certainly do for now.

Arcam are still (at time of writing) the only major player with a Digital Audio Broadcasting tuner on sale. Others will no doubt go the same way, but tuners are likely to continue to be a low priority for many manufacturers involved in a range of formats.

Whatever may or may not happen over the coming months, one thing's for sure - the industry definitely can't be accused of becoming stagnant. These are exciting times for the hi-fi enthusiast.

VIVANTE

Unit 4, 60 High Street,
Hampton Wick, Surrey KT1 4DB
Tel: 0181 977 6600 Fax: 0181 977 4445
E-Mail: vivantelondon@compuserve.com

TWO FEMALE VOCALISTS TWO AUDIOPHILE FAVOURITES

It gives us great pleasure to introduce two incredible albums from two incredible artists. Patricia

Barber, famous for her excellent album *Cafe Blue*, delights once again this time with the excellent *Modern Cool*. *Modern Cool* builds upon her visionary musical landscape discovered by *Cafe Blue*. *Modern Cool* is available on 180g LP and CD priced £19.95 and £12.95 respectively. From the critically acclaimed DCC Compact Classics audiophile label we have an audiophile favourite. Joni Mitchell's *Blue*, a sad, spare and beautiful reflection on Mitchell's growing sense of disenchantment and disillusionment with the world in general and love in particular. *Blue* is available on 24ct gold CD £19.95



On The Record

The UK's leading bi-monthly audiophile news letter is free to Hi-Fi World readers. Simply give us a call and we'll be glad to forward the latest issue to you.



ADVANTAGE



"THE MOST AMAZING
NEW RANGE TO HIT
THESE SHORES FOR
DECADES."

Single ended class A driver stage.
Fully balanced or single ended input.
Integral mains filtering and regulation.

Models available:

- * I200 Integrated Amplifier *
- * P I Pre-Amplifier *
- * A 300 Stereo Power Amplifier *
- * M 300 Mono Block Amplifiers *
- * T I CD Transport *
- * CD I Integrated CD Player *
- * CDS S.O.A. Integrated CD Player *

"GIVE YOURSELF AN ADVANTAGE - AN
ABSOLUTELY STUNNING RANGE"

CALL FOR YOUR NEAREST DEALER TO:-

ZENTEK MUSIC LTD

Distributors of fine music products

PASSLABS • EGGLESTON WORKS • HALES •
CORULARE • BALANCED AUDIO TECHNOLOGY •
HOVLAND • WISDOM • REFERENCE 3A •

T: 01892 530595 F: 01892 616517

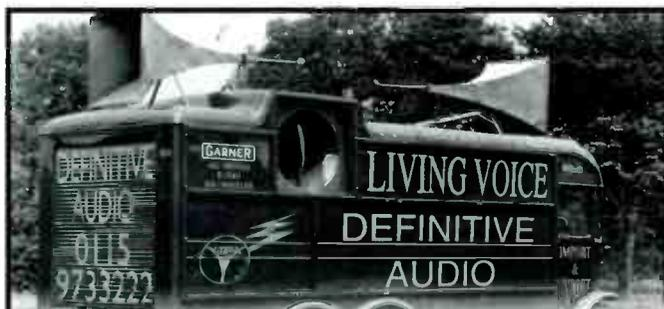

DEFINITIVE AUDIO

You may be a newcomer to Hi-Fi, bewildered by choice. You may be a seasoned audiophile, tired of hype and marketing. Perhaps you should give us a call.

Our range of equipment moves from modest to exotic, from mainstream to unusual. All of it serious. We have a system based approach that achieves results far greater than the sum of the parts. Our starter system, featured in 'Hi-Fi Choice' last year was praised as "One of the best systems I have heard. At any price."

If you share our passion for music and have the urge to hear something a little bit different, ring for an information pack or make an appointment to visit our new listening rooms. We are situated in a fabulous Victorian mill just off junction 25 M1., 10 minutes from East Midlands Airport.

Part exchanged items for sale:

	Sale	New
Audio Innovations S.500 Int. Excellent	£ 550	(£1200)
Audio Innovations L2 Line Pre	£ 500	(£ 750)
Audio Innovations S100 Pre	£ 500	(£1350)
Audio Innovations Series 800 Mk1	£ 400	
Sugden SDT 1 CD Player	£ 400	(£1000)
Ariston RD 80 Turntable (no arm)	£ 100	
AudioNote DAC3 Sig.	£1850	(£ 2850)
AudioNote ANV i/c 2 metres	£ 250	(£ 500)
Border Patrol 300B SE 'Blue'	£1500	(£2500)
Denon Transport and DAC	£7000	(£15000)
Pass Labs X600 Monos	£15000	(£23000)
Border Patrol PSU	£ 495	(£ 595)
Orchid Precision PLL 1 loudspeakers	£3900	(£7900)
Kelly KT3 loudspeaker (new)	£1200	(£1850)
Impulse H2 loudspeakers Mahogany	£1500	(£2500)
Impulse Ta'us	£1900	(£3100)
Naim CDS	£2250	(£3940)
Naim 72 pre-amp	£ 400	(£ 745)
Naim CD2	£1200	(£2000)
Naim 82 pre-amp	£1500	(£2225)
Naim NAP 250 power	£1200	(£1705)
Naim Hi-Cap	£ 450	
Naim A5 Speaker cable 5 & 7 metre sets	£ 50 & 60	

AMEX - VISA - MASTERCARD

Tel 0115 973 3222 Fax 0115 973 3666

• Living Voice • Border Patrol • Art Audio • SJS Electroacoustics • Wadia •
• Vitavox • Lowther • Helios • MF • Kelly • Nott'm Analogue • Mystic Mat • SME • WB Ortofon •

VINTAGE VIRTUES

By Haden Boardman



Off the wall - plenty of ventilation is necessary with the red-hot Class A A1.

Musical Fidelity's boss, one Mr Anthony Michaelson, has always had a keen eye for style in his hi-fi. The current X range components are sound bargains, and the company's earlier big power amplifiers such as the P270 and A370 have built up almost cult followings. Even the first MF product, the aptly named The Preamp, was a stylish beast. Not much bigger than a cook's matchbox and sporting the minimum of inputs and a light-up fascia, this little device won over lots of ears with its clean sound.

However, the device which really put

the company on the map was a little integrated amplifier of modest output power housed in a crazy case. Enter the mould-breaking A1, a Class A, 20watts per channel integrated amplifier. Not since the Sugden A21 Series Two had audiophiles been able to buy an affordable, one-box, Class A hi-fi amplifier.

The A1 looks like no other amp on the planet; the top-plate doubled as the heat-sink and the distinctive, angled-off fascia complete with flush-fitting knobs meant it resembled something milled out of a solid block of aluminium. Musical Fidelity must have become sick and tired of having

their new baby compared to Bang and Olufsen gear, especially as they spent £100000 to style and develop it.

As mentioned above, the most unusual feature was the heat-sink. The A1 runs extremely hot, so hot that in some service departments it has been affectionately nick-named the waffle maker. Feature-wise, five inputs, a tape monitor and a half-decent moving-magnet and moving-coil phono stage is your lot.

Some of the A1's fans argue that it's the only hi-fi amplifier most music-lovers would ever really need. Sonically it is a real peach; its designer is more famed for valve circuits than transistor stuff and this shows through clearly. Instead of the normal quasi-complementary push-pull circuit with plenty of negative feedback, by transistor standards this amp uses little feedback and few output devices; no fancy MOSFETs, just basic silicon bi-polars.

Launched in late 1985 (I am now feeling very old!) at the exceedingly cheap price of £189, the A1 proved to be an instant success; even the Japanese loved



Included with the five-level inputs is a decent phono stage.

A REFERENCE GUIDE TO BRITAIN'S MANUFACTURERS AND DISTRIBUTORS.

ALCHEMIST PRODUCTS Call us and allow us to transform your life with products from an acclaimed range of Amplifiers, CDs and Pre/Power combinations including models as Kraken and 'Forsetti' right through to our award winning 'The Alchemist' range (Winners 1996 C.O.T.Y. Japan) Unit 1, Furzewood House, Cranbourne Ind Est, Potters Bar, Herts. EN6 3JN. Tel: 01707 664607 (for enquiries). Tel: 01753 889949 (for UK Sales). Fax: 01707 664207 (for enquiries). Fax: 01753 889636 (for UK Sales).

ALEMA LTD 103 South Street, Lancing, BN15 8AS. Tel: 01903 750755/6. **"AUDION"** **"EDISON"** **"DAC"** **"AMP"** Europe's Leading Brands. Gold Medal Winners 'A' Rated in Stereophile, Best of Year (Taiwan). Buy the Best Full Remote Valve And New Transistor Range. Tube Amps £599 - 115,000. Kits From £399. Check the Latest at www.hi-fidelity.co.uk.

APOLLO The UK based designers and manufacturers of high quality speaker stands and equipment range of hi-fi products. We offer a comprehensive range of modular systems ideal for housing audio visual products and CD storage. Please send for our free brochure to Zenith Crown Ltd Tipton Rd, Dudley, West Midlands, DY14 Tel: 0121 520 5070. Fax: 0121 522 2055. All export trade enquiries welcome.

ARCAM Pembroke Ave, Denny Industrial Centre, Waterbeach, Cambridge, CB5 9PB. Tel: 01223 440964 or Fax: 01223 863384. Manufacturers of the Delta 290 Amplifier and the Delta 280 Digital FM Tuner. The two together produce a sound that has been described as 'subtle and intriguing' and that provide 'real clout' - discover this for yourself. For information on not only these products but also the Arcam CD Players, Speakers, Cassette Decks etc., *Phone or write in to request a brochure - The pleasure is all yours!

AUDIOPHILE FURNITURE LTD The Square, Forest Row, East Sussex RH18 3ES. Tel: 01342 826262. Fax: 01342 824845. Manufacturers of the patented **BASE VIBRATION CONTROL PLATFORMS AND THE MODULAR AUDIO SUPPORT SYSTEM.** These products are endorsed by Hi-Fi World, and are now being introduced as the **RESONANCE CONTROLLED HI-FI CABINETS** which are multi level modular design and available in various sizes and wood finishes. Please telephone for more details and a product portfolio.

AUDIOLAB Cambridge Systems Technology Ltd, Spitfire Close, Epsom Park, Huntingdon, Cambs. PE18 6XJ. Tel: +44 (0)1480 415600. Fax: +44 (0)1480 52159. The Audiolab amplifiers, CD players and tuners are internationally acknowledged for their sophisticated, modern design, combined with outstanding sound quality and flexibility. There are now 10 Audiolab models which range from the famous 8000A integrated amplifier through to the new 8000CD Integrated CD Player. For full information and details of your Audiolab dealer, please phone or write.

AUDIO SYNTHESIS Manufacturers of the the outstanding AX-1 digital Hi-Fi analogue converter, components, DAC's, a new Hi-end reference converter able to dig deeper into the digital source than ever before! A new addition to the superb PASSION series of all Vishay controllers has just been introduced in the form of PASSION 8, a fully remote controlled uniquely transparent passive preamplifier, the perfect match for DESIRE. By word of mouth our DESIRE power amplifier is rapidly convincing listeners, whether passive or active! Now for 1997 it's TRANSCEND a state of art CD transport with AES, coaxial, AT&T glass and Toslink outputs. Audio Synthesis, PO BOX 50, Nottingham, NG9 1DZ. Tel: +44 (0)115 922 4138. Fax: +44 (0)115 922 9701.

BORDER PATROL 63 Berriedale Avenue, Brix 410. Tel/Fax: 01273 276716. Manufacturers of **Power Supply Units** for valve amplifiers, **Single-Ended Power Amplifiers** and high quality **Transformers.** The **Border Patrol PSU:** valve-recified choke input filter power supply units which dramatically improves the sound of valve amplifiers; models available to suit Audionote, Audio Innovations, Audion, Art Audio, Cary, Unison Research, World Audio Designs. The **Border Patrol 300B SE** single-ended valve amplifier featuring interstage driver transformers and valve rectified choke input filter power supplies. **Border Patrol transformers:** high quality output (PP and SE), interstage and pre-amp output transformers and high valve inductors.

CABLE TALK Unit 12, Farnborough Business Centre, Elmloo Road, Farnborough, Hampshire, GU14 7XA. Tel: 01253 372434. Fax: (0)1252 371818. Designers and manufacturers of British made high quality, value for money, interconnect and speaker cables. Phone or fax for a free full colour brochure on our What Hi-Fi? 5 star rated products.

CAMPAIGN AUDIO DESIGN Llandudno Road, Cardiff CF3 8PC. Tel: 01222 795 401. Supplies / manufactures mailorder, high purity silver interconnects, loudspeaker cables, internal wires and bespoke mains cables. Generous two week trial period.

CANFORD AUDIO PLC Crowthor Road, Washington, Tyne & Wear, NE38 0BW. UK Sales 0191 415 0205. Fax: 0191-416-0392 E-Mail: mbc@canford.co.uk. Internet: www.canford.co.uk The UK's leading manufacturer and distributor of professional audio equipment, specialists in cabling & connectors. Canford invite interested parties to call for one of their FREE 850 page bi-annual catalogues which details over 12,000 products. Canford have offices and distributors world-wide.

CHORD ELECTRONICS LIMITED 3 Bower Mount Road, Maidstone, Kent. ME16 18AX. Telephone: 01622 648774. Fax: 01622 888480. We have recently complemented our highly acclaimed SMP range of power amplifiers with 2 super pre-amps: the CPA 2800 + CPA 4000s well as the BBC qualified L5S1/2A loudspeaker & LFS1/2 bass extension system. Call us for copies of reviews that will leave you wanting details of your nearest retailer.

CREEK AUDIO LTD 2 Bellevue Road, Friern Barnet, London N11 3ER. Tel: 0181 361 4133. Fax: 0181 361 4136. E-mail: mcreeek@bms.net. Internet: www.creekaudio.co.uk Creek Audio build stylish Hi-Fi products in the UK, combining state of the art electronic design with fully balanced, accurate and musically rewarding sound. Our standard size products come in two award-winning ranges, the

entry level 43 series and higher priced S2 series. These include: CD43 - CD player with 24 bit resolution DAC, T43 AM/FM Tuner, Integrated Amps - S230, S230SE and 4320 (described by Stereophile Magazine as the best amp under \$1000). Our A43, AS2 and AS2SE Power Amps range from 50 to 250 Watts and both P43 and P52 Pre-Amps offer passive and active operation with remote control. In addition we have an award winning OBH range of small products: OBH/80SE PHM and OBH/90 Phonostyle Amplifier. OBH-11 and 11 SE Headphone Amplifiers, OBH-10 and 12 Remote Control Passive Pre-Amps and OBH-14 - 24 bit DAC. See our home page for further details or call us for leaflets.

DBS AUDIO P.O.Box 91 Bury St Edmunds, Suffolk, IP28 6RY. Phone: 01284 818191. Fax: 01284 611791. E-mail: DBSaudio@AOL.COM. Superior sound with our self-built loudspeakers, featuring quality components and novel technologies. True high-end on a budget - £269 floor-standing DBS7 would cost over £1600 retail. Save £££s with stand-mount DBS8, DBS8-S, DBS4/3 and DBS57. CLIO Line electronic-acoustic measuring system with mic. only £455. Also Neotrac, Boxcast and Boxdraw speaker CAD software.

EMINENT AUDIO Distributor of Croft Valve Amplification. Tel: 01902 656157. Fax: 0121 681 8772. Mobile: 0956 912740. UK. Stocks are: Classic sounds (Leicester) GT Audio (London NW) Ringham Analogue, Purist Audio, The Cartridge Man (Len Gregory - Croydon), call for overseas distributors.

FALCON ACOUSTICS LTD Labor House, Norwich Road, Mulbarton, Norwich, Norfolk, NR14 8JT. Tel: (01508) 578272. U.K. distributors of FOCAL drive units and SOLEN (chateauroux) polypropylene capacitors and the largest inductor manufacturer in the UK. Comprehensive range of DIY Speaker Parts and Kits, Sub-Bass and Electronic Filters. Everything but the wood! Enquiries should be accompanied by a 38p stamped addressed envelope.

FULLERS AUDIO 20 Tunbridge Road, Southend on Sea, Essex SS2 6LT. Tel: 01702 612116. Fuller's audio produce a range of innovative products. Amplification - a10 single ended class A semiconductor power amplifier - £1200. b70 a mosfet power amplifier of high standard - £599. pre1 and pre1 + matching pre-amplifiers - £599/£649. gen1 phono stage for mm and mc cartridges £299. Loudspeakers - Pharoah system, upgradeable from 1 pair of cabinets to 3 pairs for full extended bass, passive/active options £649-£2499. Sphinx a 3 way floor standing unit £849. Sultan HE. 98dB sensitivity £439. matching Sub Woofer £559. Sultan, 91.5dB sensitivity £309.

JAN EDWARDS The Old Chapel, 282 Skipton Road, Harrogate, Yorks. Tel: 01423 500442. Some of our customers must make better choices for CDs, Music, LPs, HiFi, Books, etc. than Jan Edwards. BUT until he appears, why not send for the brochure showing a selection of HAND MADE units. To do this please send 3 x 2nd class stamps.

JPL ACOUSTICS are a long established supplier of high quality speaker kits, components and PTFE Silver cables. Our kit range includes 6 Transmission Lines and Kits for A.V. use, available with or without flat-pack cabinets (Plain or veneered). Our latest Transmission Line has a spun aluminium bass unit and a superb new ribbon tweeter. For details send large 30p S.A.E. - JPL Acoustics, 2 Laverton Road, Westbury, Wiltshire, BA13 3RS. Tel: 01373 823333

JAMO UK LTD Jamo House, 5 Faraday Close, Drayton Fields, Daventry, Northants. Tel: 01327 301300

JEM DISTRIBUTION (FI) RAX Springfield Mills, Spa Street, Ossett, Wakefield, WFS OHW. Tel: 01924 277626. Fax: 01924 270759. Fi-Rax offers a new dimension in audio visual racking. High quality aluminium construction. Finishes available to your choice. Fully adjustable 6mm glass shelving, sound insulation on shelf/feet. Custom created to suit your system. Free delivery throughout the UK. For further information or a free brochure contact JEM Distribution.

JORDAN WATTS ACOUSTICS LTD Centre Place, 201 Mariner Street, Hackney, London E8 3QE. Tel: 0181 985 1646. Jordan Watts Acoustics for Sight AND Sound.

KESWICK AUDIO RESEARCH 54 Coach Road, Outwood, Wakefield, W Yorks, WF1 3EX. Tel: 01484 876066. "I'd say that the Figaro is the best miniature speaker." "I'd say that the Audiophile March 1993. Write or call for details on our full product range and your nearest stockist.

KRONOS DISTRIBUTION 7 Scotch Street Centre, Dungeness BT70 1AR. Tel: 01868 753606. Fax: 01868 753006. Kronos is the UK distributor of some of the finest Hi-Fi products in Europe. These include Audiomeca digital products and turntables; Lieder silver speaker and interconnect cables; Project turn-tables and amplifiers; Triangle speakers and electronics; and YBA amplifiers. We also handle Frameworks equipment tables; Arson valve amplifiers and mains filters and Essex Audio digital products from the UK. Please telephone or write for product details and dealer lists.

LANGREX SUPPLIES LTD 1 Mayo Road, Croydon, Surrey. CR0 2OP. Tel: 0181 684 1166. Fax: 0181 684 3056. One of the largest distributors of electronic valves, tubes and semi-conductors in the UK, and USA manufacturers stock. We specialise in obsolete types including original UK and USA made audio valves. Telephone or fax for an immediate quotation.

LORICRAFT AUDIO "Vintage DIY". 4 Big Lane, Green, Lambourn, Berks. RG17 8XQ. Tel: 01488 72267. Specialist restoration of Garrard 301's and 401's using genuine spares and re-manufactured parts to original pristine standards in our newly built work shops designed primarily for these purposes. Wanted.Goldring.GL25

MARSTON AUDIO 17, Queens Avenue, King's Lynn, Norfolk, PE30 5LR. Tel: 01553 727875. Fax: 01553 767988. email: marston@planetweb.co.uk website: www.planetweb.co.uk/marston. Manufacturers of the Silhouette and Silhouette Elite Digital to Analogue Converters and the new "Marston Silhouette" CD Player, engineered to produce stunning dynamics, impeccable timing and a

beautifully transparent sound. Telephone for stockists and future developments.

MAY AUDIO MARKETING U.K. LTD Ardele Mills, Thornaby, Kesteven, West Yorkshire, BD20 1BL. Tel: 01353 632700. Fax: 01353 632887. Distributors of High Quality audio products from LFD amplifiers, Totem Loudspeakers, Reference Recordings, Jecklin Float Headphones, Sequence Loudspeakers, Sonnetter amplifiers and quality recordings from Proprius. IF ITS MUSIC YOU LOVE, TELEPHONE OR WRITE FOR LITERATURE.

MICROMEGA distributed by Surrey Sounds, 32-33 Enterprise House, Terrace Road, Walton On Thames, Middlesex. KT12 2SD. Tel: 01932 254297. Fax: 01932 230174. For dealer and product info on the fantastic Minimum complete system, up to the Solo and Data and Dialog. Also the new 24bit audio and video DVD player and the outstanding new premium range of CD players. All Micromega CD players play CDs like Vinyl!

MORGAN AUDIO SYSTEMS LTD A range of equipment hand built in the UK, consisting of a CD player / D.A. converter / integrated amp & pre/power amplifiers. The integrated amplifiers are designated 12S/2SD/600. Priced at £249/£399/£999. Pre-power versions of the 2S0/600 are priced at £799/£899. The CD player @ £579 + DAC @ £399 offer astounding performance and complete the 3 ring range. For further info. please call: 0151 236 7667.

NORTON TECHNOLOGIES LTD Manufacturers of the acclaimed AirPower LP12 Power Supply, 14 Rothesay Avenue, Chelmsford CM2 9JH. (01245) 283125

NOTTINGHAM ANALOGUE STUDIO LTD (01773 762947). Design and manufacture of quality analogue audio. We're in the business because we realise how important music is. Our turntable arms and cartridges sell the world over a commitment to providing all our customer's with the best of analogue. we love music.

OPUS/PENTACON. Natural Acoustical Music recorded on CD & LP. Three Dimensional, Dynamic and Live. SYSTEM HARMONISING: A service to extract the full potential of your hi-fi equipment by careful and innovative methods of Synergy Tuning. **WE WERE AT THE RECORDING SESSION!** Because we record live music we know what it sounds like. 4, Cross Bank Road, Batley, W Yorks. WF17 8PJ. Tel/Fax: 01924 445039. E-Mail: opus@pentacon.com. WWW: <http://dspcpe.dial.pipex.com/nim>

PLATFORM 7 High density marble ISOLATION PLATFORMS for all makes of equipment RACKS/STANDS. An elegant way to UPGRADE. Improves clarity, better BASS control. 3 Abbots Drive, North Wembley, Middlesex HA0 3SB. Tel: 0181 907 2646. Also NEALGAR DISTRIBUTION Tel/Fax 01296 2475.

P.M. COMPONENTS LTD Are the specialist component company for high end audio enthusiasts. Also carbon tubes/audio valves. Major stockists for Golden Dragon, Mullard, GEC & Technic valves plus a vast archive of vintage tubes

PRISM ACOUSTICS LTD Prism House, Duncan Street, Banff, Aberdeenshire. AB45 1EQ. Tel: 01261 818444. Fax: 01261 818555. <http://www.primis-acoustics.com> E-mail: enquiries@primis-acoustics.com Prism Acoustics Ltd. HiFi home audio system of Reflexion HiFi Technology (RWT) in the design of all our loudspeakers. Contact to find out more!

PREMIER MARBLE LTD Uncover the true sound quality and potential of your system. Use the natural beauty of granite and marble. These natural materials offer better bass definition, clarity, and natural sound staging capabilities. CD/Turn-table platforms, custom made stands, shelves or anything you desire cut and polished to any shape or size required. Tel: 01603 721995

REL ACOUSTICS North Road, Bridgend Ind Est, Bridgend, Mid Glamorgan, CF31 3TP, UK. Tel: 01656 768 777. International +44 656 768 777. Fax: 01656 766 093. international. +44 656 766 093. E-mail: contact@relnet.com Web: <http://rel.net> The UK's only specialist sub-bass speaker manufacturer. "The only one that works". Get your dealer to give you a home demo and find out what the fuss is all about.

RDE TANDBERG HI-FI SERVICES Holly Tree House, The Green, Full Sutton, YORK YO4 1HW. Tel: 01759 372795. The service, overhaul and re-conditioning of all Tandberg hi-fi products regardless of age.

ROTHWELL ELECTRONICS Specialist amplification for discerning audiophiles. Valve power amps and pre-amps with stepped attenuation controls. 40 Pennington Road, Great Lever, Bolton, BL3 3BR. Tel/Fax 01204 654614.

SHEARNE AUDIO P.O. Box 22, Stevenage, Hertfordshire SG2 8HF, England. Tel: 01438 740953. Following the highly acclaimed Phase 2 integrated, by adding the Phase 3 power amplifier and bi-amping, Shearne Audio are continuing their design philosophy of an upgradable system through the range. Introducing the Phase 6, a superbly musical, specialised pre-amplifier allowing owners of the Phase 2 or 3 or both to upgrade their systems to highly specialised levels, also the introduction of the Phase 9, 100 watt Monoblock. These along with the phase 6 pre-amplifier can be used via Phono inputs or balanced mode giving even greater versatility.

SONIC LINK The Derwent Business Centre, Clarke Street, Derby. DE1 2BU. Tel: 01332 361390. Fax: 01332 200698. "Makes the World's Finest Hi-Fi Cable From the Highest Quality Materials" SonicLink BLACK RHODIUM interconnect uses Rhodium plated wire, VERMIION USA uses pure Titanium wire. S-GOLD mains cable improves the picture quality in TV, computer monitors and home cinema as well as sound in hi-fi systems. Best selling products include RED, SILVER PINK AND VIOLET interconnects, AST75x2 AST200x2 and S130x2 BiWire loudspeakers cables and GREEN digital 75 ohm interconnect.

SOUND BYTES 72 Novar Drive, Hyndland, Glasgow, G12 9TZ. Tel: 0141 339 7595. Fax: 0141 339 7592. e-mail bytes@colloquium.co.uk. We specialise only in mass loading material. After hours exhaustively testing SOUND BYTES with various

types of speakers, we know it works and so do you - we have never had a single complaint. Call us for advice on how much to add to your equipment for the best performance and the location of your nearest dealer.

SOUND IMAGE UK LTD 52 Milton Road, London SW14 8JX. Tel: 0181 255-6868. Importers and distributors of the finest audio equipment, featuring the stunning Boulder 2,000 series and the complete range from Norwegian manufacturer Electrocompaniet.

J E SUGDEN & CO LTD Valley Works, Station Lane, Heckmondwike, West Yorkshire, WF16 0NF. Tel: 01924 404088. Email jesugden@compuserve.com. Superb amplifiers and compact disc players from the original class A Company. Our unique wide-bandwidth Masterclass series sets new standards in sound reproduction and can be upgraded to 180 Watt balanced monoblocks. Prices start from £549.00 for the incredible Audition-T and £649 for the legendary A21a. Contact us now for Brochures, reviews and purchase details. British owned - British built.

TALK ELECTRONICS Unit 12, Farnborough Business Centre, Elmloo Road, Farnborough, Hampshire, GU14 7XA. Tel: 01252 378383. Please ring for details

TARGET AUDIO PRODUCTS PLC Britannia House, Leagrave Road, Luton, LU1 1RJ. The Audio equipment, rack and speaker stand specialist. For information on our products please telephone or write.

TECH-LINK distributes some of the best performing hi-fi and avx accessories currently available in the UK. These include: Puresonic, best known for its range of high performance interconnects and connectors, cable adapters for a wide variety of hi-fi and avx applications in its range; Tech-Link's own brand Switch Boxes are the perfect solution to multiple applications - for example, its highly acclaimed TAS-1 is a very practical and inexpensive way of switching your speakers between hi-fi and home cinema systems; and Shark - a range of very exclusive high quality cables, interconnects and connectors. For more information, contact: Tech-Link at Units 1/2, 76a Farnley Road, Luton, SE25 6NX. Tel: 0181 771 8388. Fax: 0181 771 1840.

TEAC 5 Marlin House, The Croyley Centre, Watford WD18 1YA. Tel: 01923 819630. Fax: 01923 236290. Teac has already established a virtual world-dominance in the manufacture of precision recording equipment and data storage products and the company is now turning its attention to its core hi-fi and audio related products. The Tokyo Electro-Acoustic Company (hence TEAC) was formed in 1956. Over the years TEAC has produced some of the world's most outstanding recording equipment, including many excellent affordable home cassette decks (for which the name TEAC became almost synonymous) and by the time of the dawn of the digital age at the beginning of the 1980's it was internationally acknowledged as a world leader in audio technology with a string of high fidelity firsts to its name. 1997 saw a significant turning point for TEAC with the launch of a superb new mini-system, a newly designed VRDS mini CD player and a British designed CD player.

TRICORD RESEARCH LTD Following on from the highly acclaimed CD clock oscillator modification known as the Pulsar Star One digital to analogue converter. This unique design is part multi-bit and part bitstream to give absolute linearity over an extremely wide dynamic range. Switchable between 18 or 20 bit resolution this converter will become the standard for CD replay. For details telephone 01684 573524.

VADIS AMPLIFIERS Kirkland, 32 Head Street, Both, Ayrshire KA15 2EU. Tel: 01505 504128. A new manufacturer in Scotland producing a very different valve power amplifier. The DIRECT OUTPUT (Patent applied for) design, after two years of development, has resulted in a power amplifier which dispenses with the output transformer, yet has an output impedance of only 0.2 ohm! Distortion is low at about 0.05%, and because there is no output transformer the bandwidth is very wide with no loss of power or increase in distortion. The result is astonishingly clear and natural sound. Two versions hand made to order, the SLS giving 15w per channel stereo, the MS0, 50w mono. Black or colour finish.

WILMSLOW AUDIO, 50 Main Street, Broughton Astley, Leicester LE19 6RO. Tel: (01455) 286603. Fax: (01455) 286605. "Extensive range of Drive Units and over 30 different designs of self-assembly kit. Drive units include those from KEF, Dynaudio, Audax, Seas, Peerless, Scanspeak and Morel. Everything required for the loudspeaker Builder, and facilities to listen to the kits in built up form."

SERVICES & CONSULTANTS
RIF AUDIO VISUAL tel 01209 612260/0170777 Fax 01209 711935. A.K.G., Atacama, Audioquest, Audio Technica, Beyer, Charko, Denon, Goldring, Harmon Kardon, Henley Designs, JBL, Klipsch, Magnat, Micromega, Musical Technology, NAD, Neat Acoustics, Onkyo, Orifon, Primare, Project, QED, Quad, Revco, Rowland, SME, Sonus Link, Soundscape, The TDL, Teac, Thorens, Trichord Research. Service and repair to most high end Hi-Fi and studio products, including open reel and multitrackers modifications including CD re-clocking and laser disc AC3. Valve, transistor, analogue and digital specialists, PA and studio equipment supplied (new & used)

MUSONIC UK LTD Specialist manufacturer & supplier of replacement & original stylus for more than 40 years. Over 600 types stocked with many obsolete - 78 records available. Also pick up cartridges, record, tape, CD accessories. Why not try us & hear the difference!! Trade-Export enquiries: welcome. Tel/Fax/e-mail your requirements to: Unit 13, Wentz Business Centre, Colne Way, Watford, Herts. WF14 8PD. Tel: 01923 34424 Fax: 01923 213355. e-mail: musonic@compuserve.com

To advertise in Meet Your Maker call Amanda or Sarah on 0171 328 2213/0171 328 4892

them despite a retail price about 2.5 times the UK cost. Reviews were rave, and nobody dared say anything against this baby. Well, a few people did question the claim that the amplifier was 100% true Class A1 as stated by its designer and manufacturer. They pointed out that the heat-sink was possibly not big enough to dissipate the necessary minimum of 80 watts of heat. (Push-pull Class A is 50% efficient, so for a rating of 20 watts per channel, each channel will consume 40 watts of power, which is all dissipated as heat when no music is playing.) Still, there's no denying the A1 runs red hot so I for one am going to give it the benefit of the doubt.

Like valve amps, this little 20watter does need reasonably sensitive loudspeakers (or a small, well-ventilated room!) However, unlike most valve amps it actually has a good stab at putting out some current and is not scared of low impedances. A natural match would therefore be the BBC LS3/5a, for instance, but 'speaker choice is only limited by how loud you want, or need, to go.

In certain ways this MF could be looked on as the amp for the would-be valve aficionado who is put off glowing bottles by their reputation for patchy reliability and often idiosyncratic styling. The A1 is transistor and it behaves like a transistor amp, but in addition it has that unique fluidity that only the very best transistor amps even manage to hint at. If I am failing to get the message across here, then may I suggest you listen to a well-engineered transistor amp, contrast it to a competent valve amp and let your ears note the rather large differences.

Reliability wise, well, there have been one or two hiccups but most were pretty well sorted. Musical Fidelity were report-



For those lucky few - this two-box Collector's Edition of the A1 was supplied in a flight case and limited to 20 examples.

ed to have had the odd problem with a batch of PCBs but all of those would have been fixed long ago under warranty. All you have to keep an eye out for are warped top-plates and peeling paint, neither of which should put you off an amplifier in good working condition. And make sure the volume is at zero when switching on and off or changing input.

Intermittent sound can usually be traced to the input sockets on the back. Because these are screwed to the back panel and soldered to the PCB, as the amplifier warms and cools the top-plate can flex, taking the PCB with it. Dry joints along the input sockets bear the brunt of this movement and can work loose. The answer is to re-solder all of the input ter-

minals and not over-tighten the input sockets' screws on the rear.

Partnering the A1 was a rare tuner fitted in a matching case and going by the name of the T1. Good it was too but finding one second-hand can be tough.

If you liked the case of the A1 but just couldn't get away with only 20watts, later on you could buy the B200, a Class B 60watter. Unfortunately, this doesn't scale the same sonic heights as the A1.

When it comes to handing over the ready, around £100-£130 should net you a clean A1. Once it's in your system, enjoy it - it's an exceptional performer with either digital or analogue. Even the phono stage is better than most (it's remarkably similar in its sound to the current X-LP, so work that one out). It responds well to decent supports and tweaky wiring, although solid-core 'speaker cable should be avoided; for some strange reason the A1 sounds distinctly odd with it.

The new X-A1 sounds good but very different from the original A1 - it is not designed along similar circuit lines to its predecessor and you can hear it. The later Musical Fidelity A2 was another product that went its own way. Stick to the classic A1 and you're unlikely to go wrong; it combines great performance with fine styling, not something you can say of much British hi-fi from the mid-Eighties.



The Collector's Edition A1 boasts an out-board power supply to lift its performance far above that of the standard amp.

WORLD LIBRARY

OVER 40 TITLES ON OFFER!!!

LOUDSPEAKERS

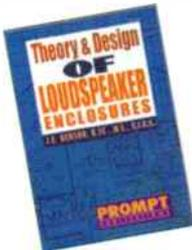

Theory and Design of Loudspeaker Enclosures
J. E. Benson
 Covers infinite baffle, reflex, passive radiator etc. in great detail with a highly mathematical approach making it unsuitable for beginners but highly authoritative to experienced designers.
244pp 6" x 9"
Paperback Code: 1140
£23.95 + £2.50 P&P (UK)

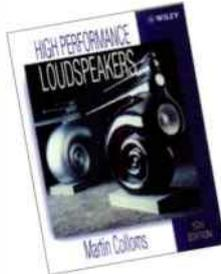

High Performance Loudspeakers 5th Edition
by Martin Colloms
 An up to date high performance reference book. Ideal for professionals and students. Covering reviews of CAD packages, digital loudspeaker design, new results in loudspeaker distortion, new developments in short path, low order crossover network design, bending wave panel speaker technology, hybrid loudspeakers and more.
478pp 7 1/8" x 9 1/2"
Paperback Code No 1350
£27.50 + £3.50 P&P (UK)

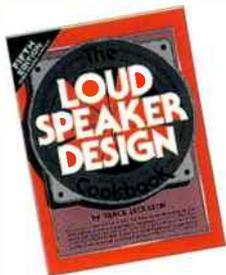

The Loudspeaker Design Cookbook, 5th edition - Vance Dickason
 This best seller offers up-to-date design information for the home constructor. It uses modern Thiele-Small theory and parameters.
185pp 8 1/4" x 11 1/2"
Paperback Code No. 1090
£22.95 + £3.25 P&P

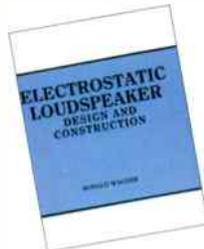

Electrostatic Loudspeaker Design and Construction
Ronald Wagner
 Step by step guide to the design and construction of a full range electrostatic loudspeaker, including basic operating principles. Strongly recommended for those wanting to either build, repair and/or restore or who are just interested in electrostatics.
243pp 7" x 9 1/8"
Paperback Code No. 1080
£16.95 + £3.25 P&P (UK)

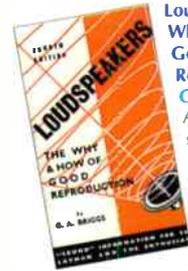

Loudspeakers: The Why and How of Good Reproduction
G.A. Briggs
 An easy to understand book on building loudspeakers, using empirical techniques that pre-date computer analysis. Strong recommendation for beginners.

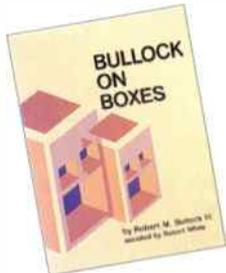

Bullock On Boxes
Robert M. Bullock III.
 Using Thiele-Small parameters clearly, it offers lots of helpful tables and graphs to get to grips with the sizing of the box and port of a reflex loudspeaker.
72pp 8 1/2" x 11"
Paperback Code No. 1100
£12.95 + £2.00 P&P (UK)

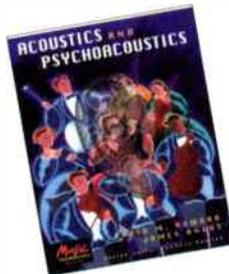

Acoustics & Psychoacoustics
by David M. Howard & James Angus
 This book provides an introduction to acoustics, including the principles of human perception of sound, notes and harmony, musical dynamics, timbre of musical instruments, acoustic model for musical instruments, hearing music in different environments, deceiving the ear and processing sound electronically.
224pp 244 x 189mm
Paperback Code No. 1370
£25.00 + £3.25 P&P (UK)

88pp 5 1/2" x 8 1/2"
Paperback Code: 1070
£10.95 + £1.50 P&P (UK)



Testing Loudspeakers+
by Joe D'Appolito
 The authoritative book on the subject of loudspeaker testing! Joe D'Appolito, loudspeaker designer and consultants, has written the definitive text on testing loudspeakers.

Loudspeaker and Headphone Handbook

Second Edition
by John Borwich
 This book brings together in a single volume every aspect and practice in sufficient depth to equip students and professionals alike with a solid working knowledge of the subject.
592pp 234 x 156mm Paperback Code No. 1360
£50.00 + £4.25 P&P (UK)

Electronic Circuits Student Handbook

by Michael Tooley
 This book provides the knowledge necessary to appreciate the operation of a wide range of basic electronic circuits including amplifiers, logic gates, power supplies, timers and pulse generators. The coverage is ideal for students following formal courses.
240pp Paperback Code No.1450 £14.99 + £2.75 P&P (UK)

Dr. D'Appolito brings his expertise to the subject and provides you with a hands-on discussion of testing drivers and systems. He brings you the theory and physics behind loudspeaker testing in this volume.
Paperback Code No. 1580
£24.95 + £2.50 P&P (UK)

AUDIO ELECTRONIC THEORY BOOKS

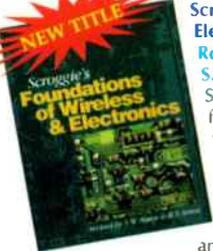

Scroggie's Foundation of Wireless and Electronics
Roger Amos B.Sc. B.D., M.I.T.S.C. & S.W. Amos
 Scroggie's Foundations is a classic text for anyone working with electronics, who needs to know the art and craft of the subject. Based on experience since the dawn of the electronic age, and updated in regular editions over 60 years, it covers both the theory and practical aspects of a huge range of topics from valve and tube technology, and the application of cathode ray tubes to radar, to digital tape systems and optical recording techniques.
400pp 234 x 156mm Paperback
Code No. 1590 £19.99 + £3.00 P&P (UK)



High Performance Audio Power Amplifiers
by Ben Duncan
 Power Amplifiers and their performance lie at the heart of audio engineering. This handbook is the distillation of the state of the art. Linking analog electronics, acoustics, heat and music technology; high-end hi-fi and professional PA and recording studio use; theory, modelling and real-world practice; design and repair; the old and the new, the mainstream and the specialised.
288pp, 234x156mm, Hardback Code No.1460
£40.00 + £3.25 P&P (UK)

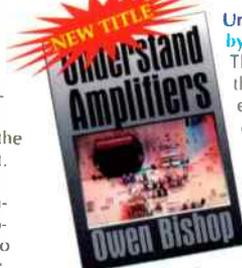

Understand Amplifiers
by Owen Bishop
 This is a readable introduction for those with little previous knowledge of the subject. The theme of amplification is central to many branches of electronics. Consequently there is a large and confusing array of amplifier types; intended for a wide range of applications. This book describes amplifier types, how they work, their properties, advantages and disadvantages, and applications. Amplifiers are treated with the minimum of mathematics and lots of illustrations.
Paperback Code No. 1560
£16.99 + £2.50 P&P (UK)

Electronics made Simple

by Ian Sinclair
 This books covers the basic theory and principles of electronics. A good read for the beginner.
Code No 1420 £12.99 + £2.00 P&P (UK)

Build your own High-end Audio Equipment

by Electkor
 Build your own High-end equipment contains construction projects for solid state and valve preamplifiers and power amplifiers, active cross-over filters, and active subwoofer, a mono/stereo compressor and a headphone amplifier.
Code No. 1390 £14.95 + £2.25 P&P (UK)

Build your own Electronic Test Instruments

by Electkor
 This book contains designs for 17 measuring instruments, seven generators and analysers; ten miscellaneous instruments and a number of test ancillaries and auxiliaries. The designs range from a simple multicore cable designs contain a special printed circuit, drawing of which are given in an appendix.
Code No. 1400
£15.95 + £3.25 P&P (UK)

Practical Electronic fault-Finding and Troubleshooting

by Robin Pain
 This book explains the basic techniques needed to be a troubleshooter, using only the basic equipment: a digital multimeter and an oscilloscope. Simple circuit examples are used to illustrate principles and concepts fundamental to the process of fault finding.
240pp 2 1/4" x 156mm
Paperback Code No. 1430
£19.95 + £2.25 P&P (UK)

VALVE BOOKS

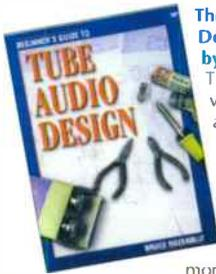

The Beginner's Guide to Tube Design

by Bruce Rozenblit

The best beginner's guide on vacuum tube audio is now available. This book takes a comprehensive look at tube audio design. For the beginner, the author starts by explaining how vacuum tubes work and how to design with them. For the more experienced constructor,

Rozenblit has provided chapters on subjects including stabilisation and testing, a description of 13 famous and classic amps and preamps and how to work effectively as a designer. A hands-on guide to construction techniques, tools and choosing components and tubes is provided. 1997, 132pp., 8 1/2" x 11" Paper back Code No. 1340 £15.50 + £2.25 P&P (UK)

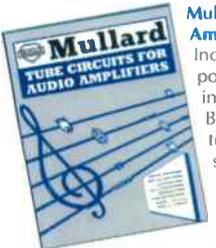

Mullard Tube Circuits for Audio Amplifiers

Includes full designs for eleven power and control amps, including 5-20, using valves. Begins with a four chapter tutorial on getting the best sound from valve amplifiers.

142pp 8" x 10" Paper back Code 1030 £13.95 + £1.50 P&P (UK)

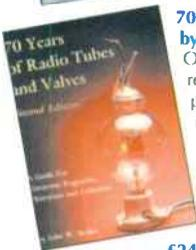

70 Years of Radio Tubes and Valves

by John W. Stokes.

Outlines the evolution of radio receiving tubes and the part they played in the domestic radio receiver. A reference for those interested in the history and development, and collectors alike.

256pp "8 1/2" x 11" Paper back Code: 1050 £24.95 + £3.50 P&P (UK)

An Approach to Audio Frequency Amplifier Design

Seventeen circuits from 5 to 1100watts - General Electric Co. High quality amp. designs using KT66s, KT88s, DA100s etc. Includes two valve pre-amps complete with phono stages. 126pp 6" x 9" Paper back Code No. 1020 £19.95 + £1.75 P&P (UK)

RADIO DESIGNER'S HANDBOOK

4th Edition
Fritz Langford-Smith

This is a classic, comprehensive reference handbook for all who are interested in the design and application of audio amplifiers and radio receivers, and deals with basic principles and the practical design of all types of classic audio amplifiers, radio receivers and record-producing equipment up to the invention of the transistor.

This reprint of the classic fourth edition, first published by Iliffe in 1953 and revised in this edition in 1967, provides information that is not available from any other source. It will therefore be invaluable to anyone working with valves, and provides a definitive guide to the valve and other components, audio and radio frequency technology, rectification, regulation, filtering, hum, complete receivers and sundry data.

This book is the work of 10 authors and 23 collaborating engineers, under the editorship of F Langford-Smith. The enormous amount of data included in the book has been made readily accessible by means of a fully detailed list of contents and a very complete index. The main subjects are: valves, valve testing, general theory and components; audio and radio frequencies; power supplies, design of complete AM and FM receivers, and reference information.

1498pp 216mm x 138mm Hard back Code No. 1600 £35.00 + £6.00 P&P (UK)



Saga of the Vacuum Tube

by Gerald E.J. Tyne

This book covers the history of the evolution of the thermionic vacuum tube, tracing its complex genealogy, and presenting essential facts to assist in the identification of sub tubes made prior to 1930. Bell Labs News, March 29, 1974, "Today Tyne probably knows more about the history of tubes than anyone else in the world". As reviewed in

August Supplement 1998

Paperback 494pp, 5 1/2" x 8" Code No. 1540 £16.95 + £2.50 P&P (UK)

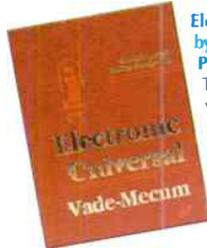

Electronic Universal Vade-Mecum

by Piotr Mikolajczyk & Bohdan Paszkowski. This Data book comprises 5693 valves divided into 442 groups. A comprehensive book which contains connection details, operating parameters, load lines and example circuits.

Hard back Code 1060 £49.95 + £ 8.50 P&P (UK)

Build your own Audio Valve Amplifiers

by Rainer Zur Linde

This book is intended for a broad cross-section of the public: apart from construction projects for preamplifiers, power amplifiers and two amplifiers for musical instruments aimed at the practical audio/hi-fi enthusiast, it offers much information on the operation of electron tubes, while the first chapter gives a short history of the thermionic valve.

Code No.1320 £14.95 + 2.25 P&P (UK)

Valve Amplifiers

Morgan Jones, Audio Engineer

This book allows those with a limited knowledge of the field to understand both the theory and the practice of valve audio amplifier design, such that they can analyse and modify circuits, and rebuild an amplifier. Constructional techniques are also provided so readers can build from scratch designs that actually work.

374pp 6" x 9 1/2" Paper back Code No. 1330 £25.00 + 2.75 P&P (UK)

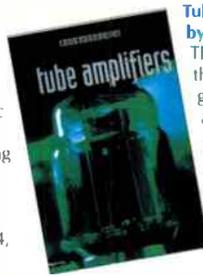

Tube Amplifiers

by Kavsek & Kavsek

The most beautiful tube amp book in the world. No specs, no test, just 215 gorgeous four colour photos of 65+ amps with a short description of each. Including a 12 page explanation of the history of tubes and tubeamps. Appendix with addresses with tech. data.

167pp 9 1/2" x 12 1/2" Hard back Code No. 1310 £47.95 + £5.50 P7P (UK)

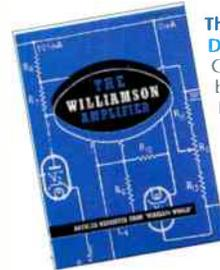

The Williamson Amplifier

D.T.N. Williamson.

Offers practical advice on how to build and set up the amplifier for best results.

40pp 8 1/2" x 11" Paper back Code No. 1040 £9.95 + £1.50 P&P (UK)

Electronic Valves in Audio Frequency Amplifiers

by E. Rodenhuis

Originally published in 1954 by Philips, this book encourages amp. builders to experiment with design elements. Discussing the use of valve data, the function of different amplifier stages and includes detailed descriptions of eight designs. A wealth of practical data, measurements and interesting features will be found. A very good read.

Paperback 147pp Code No. 1520 Price £12.95 + £2.00 P&P (UK)

Audio Amateur Power Amp Projects

by the editors of Audio Amateur

This profusely illustrated handbook features 26 of the best articles on power amps published in Audio Amateur from 1970-89. Authors from six countries offer an array of designs to provide almost any level of high-quality audio power needed by the resourceful amateur who prefers the pleasure of building his or her own equipment.

205pp., 8 1/2" x 11" Paper back Code No. 1300 £14.95 + £2.25 P&P (UK)

Principles of Electron Tubes

Herbert J. Reich.

A textbook for beginners starting with the basics of how a vacuum tube actually works. Shows how a simple circuit is designed including amplifiers, transformers and power supplies. A must for both enthusiasts and hobbyists.

398 pp 6" x 9" Paper back Code No. 1010 £27.95 + £3.00 P&P (UK)

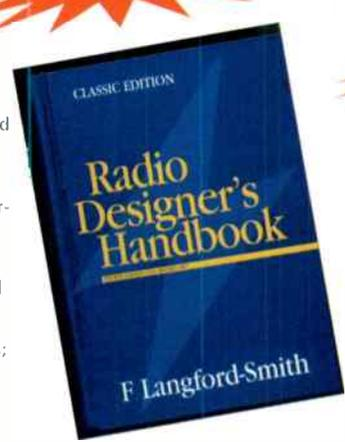

Valve & Transistor Audio Amplifiers

by J L Hood

This is J L Hood's greatest work yet, describing the milestones that have marked the development of audio amplifiers, from the earliest valve amps to the latest solid state design. This book is the complete world guide to audio amp design. Other contents: active & passive components, amplifiers, pre-amplifiers and power supplies.

As reviewed in June 98 Supplement Paperback 250pp., 156mm x 232mm Code No. 1530 £19.99 + £2.50 P&P (UK)

ORDER FORM

Please send (Code No.) _____ (enter codes clearly)

Pay: World Audio Publishing Ltd. £ _____ or debit my Mastercard/Visa card (Card No): _____

Expiry date: _____ Name: _____ Signed: _____

Delivery Address: _____

Tel: (Day) _____ Please return to: W.A.P.Ltd, Suite G4, Imex House, The Park Business Centre, Kilburn Park Road,

London NW6 5LF, ENGLAND TEL/FAX: 0171 625 8032 OR 24 HOUR ANSWERING MACHINE: 0171 226 0461 E-Mail: wad@hi-fiworld.co.uk Tick if you do not want to be added to our mailing list

Please contact us for overseas P&P charges. Allow 28 days for delivery. All orders subject to availability. If further space is required please attach separate sheet.

LONDON



0171 384 3030

think audio think...

Auditorium

THE HI-FI SHOP 112 NEW KINGS ROAD LONDON SW6



INSTANT 0% FINANCE AVAILABLE SERVING LONDON FROM BATTERSEA

ORANGES & LEMONS

Juicy fruit from London's newest, freshest hi-fi/home cinema retailer. Telephone demonstrations or just pop in. All the usual, i.e. friendly and efficient service, free home installation + credit cards.

THE INNOVATIVE AUDIO/VISUAL HI-FI RETAILER. ARCAM, CABLETALK, CHORD CO, DENON, EPOS, MARANTZ, NAD, NAIM, REGA, ROKSAN, ROTEL, ROYD., RUARK, SOUNDSTYLE, STANDS UNIQUE, YAMAHA

NOW IN OUR FIFTH FLAMBOYANT YEAR.

0171- 924 2040

61 / 63 WEBBS ROAD, SW11

O'Brien Hi-Fi



MARTIN LOGAN COPPAND

ARCAM • ANTHEM • AUDIOGRAM • AUDIO RESEARCH • AUDIO TECHNICA • BEYER • CABLETALK • CHORD • CREEK • OFNON • DENSEN • JADS • JECKLIN • MICHELL • MUSICAL FIDELITY • NAD • NAIM • OPERA • PRECIOUS METALS • QEO • REGA • ROGERS • ROYD • SENHEISER • SILTECH CABLES • SME • SONNETER • SONUS FABER • TEAC • THORENS • TRANSPARENT CABLES • UNISON RESEARCH • WILSON

Clearance • Second Hand • Ex Dem Equipment • Details on request

0% Instant Finance Available

New Demonstration Room • Free car parking • Major Credit Cards
Personal Export • Mail Order • Installation Service • Repair facilities
5 mins walk Raynes Park BR • 20 mins Waterloo
5 mins from A3 (Raynes Park B28 exit) • 25 mins M25 Junction 10

60 Durham Rd, West Wimbledon, London SW20 0TW
Est. 1966
Tel. (0181) 946-1528 Fax (0181) 946-0331

AUDIO CONCEPT

27 BOND STREET, EALING
LONDON W5 5AS
TEL. 081 - 567 8703

Audio Analogue, Art Glass, Ash Designs, Avik, B&O, B&W, Cabletalk, Chord Company, Creek, Denon, Epos, Harman Kardon, Infinity, KEF, Lat, Marantz, Musical Fidelity, NAD, Nakamichi, Nordost, Orelle, Onkyo, Primare, Quad, Roksan, Rotel, Ruark, Sennheiser, SonicLink, Sound Style, Stands Unique, Straightwire, Supra, Tag McLaren, Target, Teac, Thorens, van den Hul.

10 - 6 pm Mon., Tues., Friday, & Sat.
Late night Thur., closed Wed.

Two demonstration rooms.
Free local delivery and installation.
Repairs and Services

**TO ADVERTISE IN
SPECIALIST HI-FI DEALERS
PLEASE CALL
AMANDA or SARAH ON 0171
328 2213/0171 328 4892**

SOUTH

SPALDINGS
THE SOUTH EAST'S LEADING HI-FI COMPANY

3 DEM ROOMS A.V.
HOME DEMS., 0% CREDIT
FREE INSTALLATION

**LINN • NAIM • MISSION • KEF
DENON • TAG MCLAREN
MARANTZ • MUSICAL FIDELITY
CASTLE**

MON TO SAT 9.00 to 6.00, TUE 9.00 to 8.00 Closed
WEDNESDAYS

SEVICE DEPT

325-354 Lower Addiscombe Road, Croydon, Surrey CRO
7AF
Telephone: 0181 654 1231/2040 Facsimile: 0181 655 3922

WORTHING AUDIO

20 Treville Gate, W Sussex BN1 1UA
(01903) 212133

The friendly shop with the best sound system in the South.
Talk Electronics - Friendly Advice - 3 Year Guarantees
Easy Parking - Open Mon-Sat. 10am-6pm.
Late Night Wed 7.30pm.

Agencies include: Arcam, Exposure, Kinshaw, Naim, Audio, Marantz, Ruark, Audio Technica, Target, Tripod, JPW, TDL, Orelle, and many more.....

UNILET
Sound & Vision

Best place in town for Hi Fi and Home Cinema

- * Three demonstration rooms
- * All leading brands
- * Interest Free Credit
- * Good parking facilities

UNILET SOUND & VISION
24-26 UNION STREET, MAIDSTONE ME14 1ED
Tel: 01622 626703 Fax: 01622 626723

MIDDLESEX & SURREY

Front End Problem?
contact
The Cartridge Man

It doesn't have to cost an arm and a leg to get the best - listen to my Koetsu - and Decca -eater.

Also agents for Croft, Hadcock, Real Music Co, Michell & Moth.

plus cartridge re-tipping service

0181 - 688 6565

Stockists of: ARCAM • CREEK • EPOS • LINN • MERIDIAN • NAIM AUDIO • NAUTILUS 800 • NEAT • REGA • ROTEL • ROYD • SHAHINIAN • STAX • YAMAHA •

Infidelity
indecently good hi-fi

9 High Street, Hampton Wick, Kingston upon Thames, Surrey KT1 4DA. Tel: 081-943 3530
Open Tues - Sat 10.30am - 7.00pm.

UNILET
Sound & Vision

Best place in town for Hi Fi and Home Cinema

- * Six demonstration rooms
- * All leading brands
- * Interest Free Credit
- * Free Parking
- * Open 10-4 every Sunday

UNILET SOUND & VISION
35 HIGH STREET, NEW MALDEN, SURREY, KT3 4BY
Tel: 0181 942 9567 Fax: 0181 336 0820

AudioVenue
Brussels Radio Visual Co-ordinators

Components from £80 - £72,000

0% Credit available
Whether you choose to repay! Subject to status.

- ▶ Hi-End Audio & Home Theatre ◀
- ▶ Home Demonstrations ◀
- ▶ Export Orders Welcome ◀
- ▶ Part Exchange Available ◀
- ▶ Unbiased Advice & Support ◀
- ▶ Multi-Room Design & Installation ◀

Fulltime - 04 2080 727 4549 24hrs - 44 20970 475 426
email: audiovenue@btinternet.com

▶ Other Leading Components & Accessories

specialist hi-fi dealers

NORTH

THE hi-fi ROOM

50 BRIDGE STREET, MANCHESTER M3 3BN. TELEPHONE: 0161-832 0888/0161-835 1366

An Oasis of Sound

EXCLUSIVE HI-FI AND AUDI VISUAL SYSTEMS

GLASGOW
0141 248 2857

EDINBURGH
0131 220 0909

NEWCASTLE
0191 230 3600

LEEDS
0113 242 7777

SERIOUS KIT

The finest range of Hi-Fi in the north. Stockists of Audionote, Sugden, Impulse, Pro-Ac, Harbeth, Stemsfoot, Target, Neat, Trichord, Systemdek, Lyra, Proceed, SME, Michell, Heart, Keswick etc etc
Open 10-6pm Mon-Fri
10-5pm Sat
10-2pm Sun

Phone: 0161 793 6742
Fax: 0161 727 7042



Soundcraft

INSTALLATIONS

VISIT THE LEADING HI-FI DEALER
IN THE SOUTH EAST
"SEE & HEAR THE DIFFERENCE
REAL HI-FI MAKES"

LINN NAIM ARCAM REGA
HELPLINE: 01233 624441



Basically Sound

NORWICH • NORFOLK

Arcam, Audio Analogue, Cabletalk, Chario, Chord Co., Denon, Epos, Naim Audio, ProAc, Rega, Royd, stax, Talk Electronics, Teac, UKD Opera, Audio Note and many others

The Old School
School road, Bracon Ash
Nr Norwich, Norfolk, NR14 8HG
Tel (01508) 570829

NORTH WEST

Demonstrating some of the worlds
finest HI-FI
Home Demonstrations a speciality
(see Dial-A-Dealer for complete
product range)

Tel/Fax 0161 304 7494 Mobile: 0402 268490
Evening calls welcome

For The
of Music

MIDLANDS



FRANK HARVEY HI FI EXCELLENCE

The Midlands Largest Choice
of Specialist Hi Fi & Home Cinema

163 Spon Street, Coventry
Tel: 01203 525200
Web: <http://frankharvey.co.uk>

For real choice and the largest range of Hi Fi & Home Cinema products in the Midlands

Acoustic Energy - Atacama - Arcam - Audio Quest - Alphason - Apollo - Bang & Olufsen - B & W - Castle - Cable Talk - Celestion - Chord - Cyrus - Definitive Technology - Denon - DCS - Kef - Marantz - Meridian - Monitor Audio - Miller & Krause - Mission - Michell Gyrodek - Musical - Fidelity - NAD - Optimum - Panasonic - Pioneer - Quad - QED - REL - Rega - Rotel - Sennheiser - Sharp - Tag McLaren - Target - Teac - Tannoy - Tonesans - Van Den Hul - Yamaha

Much more in store on 3 Floors with 3 dedicated Hi Fi demonstration rooms of the very best Hi Fi.
Plus our new Home Cinema Room Very nice Staff and excellent coffee. Appts Req.
Opening Hours 9-30 to 5-30. Tues to Sat. Closed all day Monday



INVEST IN OUR EXPERIENCE

MUSIC
MATTERS



LATEST ARRIVALS...

CHORD SPA3200 & SPML200B PRE-POWER, MERIDIAN DSP6000 SPEAKER SYSTEM, 565AC-3 SURROUND PROCESSOR, 557 POWER AMP, 518 DIGITAL PROCESSOR AND 566 20-BIT DAC.,

ALCHEMIST MAXIM, NEMESIS AND FORSETI AMPLIFIERS, DYNAUDIO RANGE OF SPEAKERS, EPOS ES22, SPENDOR AND PRO-AC SPEAKERS, ROYD SQUIRE & DOUBLET SPEAKERS, QUAD 77 RANGE....

CLEARANCE & SECOND HAND SALE

OUR VERY SUCCESSFUL SALE NOW
MEANS WE HAVE A NEW LIST.
PLEASE SEND A N.S.A.E. FOR AN
UPDATE OF THE NEW BARGAINS
AVAILABLE.

PLEASE NOTE OUR NEW OPENING TIMES
TUESDAY TO SATURDAY 10am TILL 5.30pm,
LATE NIGHT THURSDAY TILL 7pm.

Branches at:

- Birmingham : 363 Hagley Road, Edgbaston, Tel: 0121 429 2811
- Solihull : 93-95 Hobs Moat Road, Tel: 0121 742 0254
- Stourbridge : 9 Market Street, Tel 01384 444184

~Demonstrations By Appointment~

CYMBIOSIS

AUDIO & VISUAL
SOLUTIONS



WE MAKE IT HARD TO GET ON THIS LIST...

ARCAM · ACOUSTIC ENERGY · CASTLE · CHARIO · CURA
CHORD CO. · DENON · LINN HI-FI & KNEKT · LOEWE
LUTRON · MUSICAL TECHNOLOGY · NAIM · NORDOST
REGA · REVOX · ROTEL · TAG MCLAREN · WADIA

6 HOTEL STREET
LEICESTER

TEL: 0116 262 3754
e-mail: shop@cymbiosis.com

...TO MAKE YOUR
CHOICE EASIER!

www.cymbiosis.com

THE LEAMINGTON HI-FI COMPANY THE LEADING HI-FI SPECIALIST

ARCAM AUDIOLAB QUAD MERIDIAN MARANTZ DENON PIONEER
YAMAHA NAD MICROMEGA MISSION KEF CELESTION ATACAMA
TECHNICS TRICHORD TDL RELIENS
SINGLE SPEAKER DEM ROOM WE DO NOT USE ANY COMPARETORS
WE ALSO HAVE FULL DEMONSTRATION OF PROJECTION TV WITH
LASERDISC AND FULL PRO LOGIC SYSTEMS
PART EXCHANGE WELCOME
PLEASE PHONE OR E MAIL FOR PRICES
WE HAVE IN STOCK OVER 300 LASERDISCS
CALL FOR OUR LATEST CATALOGUE

THE LEAMINGTON HI-FI COMPANY
23a Regent Street, Leamington Spa, Warwickshire CV32 5RJ
Phone: 01926 895641 Fax: 01926 387486 E-mail: L.browne@hbcnca.org.uk

NORTH WEST

audio excellence

WHERE THE MUSIC MATTERS
CHESTER PRESTON
86-90 Boughton, 131 Friargate
Chester CH3 5AQ Preston, PR1 2EE
(01244) 345576 (01772) 253057

TUESDAY - SATURDAY 9.00 - 5.30
CLOSED MONDAY

REPAIR & DIY

TECHNICAL & GENERAL

THE ORIGINAL TURNTABLE SPECIALIST

for the Great Classical Turntable, Arms, Cartridges, Styli

CONNOISSEUR • GARRARD • GOLDRING •
LENCO • ORTOFON • SHURE • S.M.E •
THORENS • WATTS

All available Genuine spares and our own
re-manufacture of obsolete parts

NO ILLUSORY 'IMPROVEMENT' NO
DUBIOUS OR HARMFUL 'MODIFICATIONS'

Cartridges and styli, correct radius diamonds, for early
recordings - 78s & Lps

TECHNICAL & GENERAL

P.O.Box 53 Crowborough, East Sussex TN6 2BY
Tel: 01892 65 45 34

VALVES & TUBES



Buy CVC PREMIUM HI FI valves direct from us.
All valves processed for improved performance.
We also have stock of MAJOR BRAND types inc.
MULLARD, GEC, BRIMAR, RCA, GE, PHILIPS, etc.

130, New London Road, Chelmsford Essex CM2 0RG
Tel. 01245 265865/355296 Fax: 01245 490064
e-mail :- sales@chelmervalue.com

VINYL

MUSONIC STYLTM
SPECIALIST MANUFACTURETM &
SUPPLIER FOR MORE THAN 40 YEARS
REPLACEMENTS & ORIGINALS
MANY OBSOLETE/78 VERSIONS
PICK-UP CARTRIDGES
& RECORD ACCESSORIES

For prices to Email to:
MUSONIC (UK) LIMITED
Unit 13 The Wentu Business Centre Colne Way
Watford Hertfordshire WD2 4NJ
e-mail: musonic@compuserve.com
Tel: 01923 213344 Fax: 01923 213355



WEST & WALES

audio excellence

WHERE THE MUSIC MATTERS

Bristol

65 Park Street
Bristol BS1 5PB
(01179) 264975

Cardiff

134/6 Crwys Road
Cardiff CF2 4NR
(01222) 228565

Gloucester

58 Bristol Road
Gloucester GL1 5SD
(01452) 300046

Swansea

9 High Street
Swansea SA1 1LE
(01792) 474608

Exeter

156 Sidwell Street, Exeter, EX4 6RT
(01392) 491194

TUESDAY - SATURDAY 9.00 - 5.30
CLOSED MONDAY

EIRE

Hearing is Believing

CLONEY
Audio

55 Main Street,
Blackrock,
Dublin.

Tel: (01) 2889449/2888477
Open Tues - Sat 10 am to 6 pm.
Thur - Fri 10 am to 6 pm.

Arcam
B&W
Tag McLaren
Castle
Meridian
Classé
Copland
Marantz
Jadis
Naim Audio
Sony
REL

TO ADVERTISE IN

SPECIALIST HI-FI

DEALERS

PLEASE CALL

AMANDA or SARAH ON

0171 328 2213

0171 328 4892

SERVICES & CONSULTANTS

STUDER REVOX

SALES, SERVICE, SPARES

SERVICE & REPAIR OF

A77, B77, A700, PR99 &

36 SERIES

HI-FI SPARES TO ORDER

SERVICED MACHINES IN

STOCK

APPROVED CONVERSIONS

E.M.A.S.

TEL: 01246-275479

FAX: 01246 550421

atv

- Service & Repairs
- Valve & transistor amplifiers
- Vintage valve Radios
- Hi-Fi VCR's
- Valves Tested

ATV SERVICES
LEATHERHEAD
01372 456921

TO ADVERTISE IN
SPECIALIST HI-FI DEALERS
PLEASE CALL
AMANDA or SARAH ON 0171
328 2213/0171 328 4892

MAIL ORDER

YOUR

Russ
Andrews

MAIN
problem

COULD BE YOUR

MAINS
problem!

Call now for the Russ Andrews
essential guide
to upgrading your mains.

0800 373467

Russ Andrews Accessories Ltd, Kendal, Cumbria, LA8 9AS
Tel: +44 (0)1539 823247 www.russandrews.com
E-mail: ahwb699@russandrews.com

ref: AHWB699

specialist hi-fi dealers

ROCK & POP

by Jon Clarke & Stuart Lenz



BLACK CROWES
BY YOUR SIDE

It's good to see that some things never change. Clinging defiantly to their Bluesy Rock roots, the Black Crowes maintain a proud and total disregard for all new musical forms with this, their fifth LP.

Since their Shake Your Money Maker debut of 10 years past, it is safe to say that this Atlanta-based band have not strayed, either in fashion or music, from the late Sixties or early Seventies. However, having spent the last few years producing comparatively tedious, meandering Psychedelic jams which reached their nadir with 1994's *America*, the Black Crowes now find themselves renewed if not necessarily reborn in *By Your Side*.

What this comes down to is a return to the source, and thank goodness! So it's back to those high-calibre influences The Stones and Small Faces, the latter always easy given lead singer Chris Robinson's vocal delivery in the manner of Rod Stewart. In fact, *By Your Side* is probably the best record The Stones never did (since 1983, anyway) with at least five songs sounding like Stones' cover versions.

To get a shot of this album's butt-kickin' contents you only have to listen to 'Go Tell The Congregation' and 'Then She Said My Name', tunes with such liberal doses of Rock, steel guitar, Soul and Southern-country pepper that you could be forgiven for reaching for your grits and sourmash.

Cohabiting with the above are Gossypily hell-raisers like their famous 'Remedy' (reworked here as 'Horsehead') and the swaggering title track (uncannily like the earlier 'Jealous Again'). It's all in a good cause, though, and the display of genuine Seventies tribute material is a far cry from mere retro-puppetry.

By Your Side may be chock full of up-beat Rock grooves ('Go Faster' aside), but it cannot hide one sad fact; when all is said and done, it does have, dare I say, Dad-Rock pretensions. And if the boys don't like me saying that, they can just get back to their palatial Georgian mansions and Marshall stacks. Rebellion is, and always has been, for the youth.



DAVID SYLVIAN
DEAD BEES ON A CAKE

David Sylvian always was a contemplative and sensitive

sort. Uneasy with success, adulation and external pressures, he prematurely terminated the one great achievement in his life. When Japan's erstwhile frontman - once the acclaimed 'beautiful man' of Pop (not hard with his ridiculous, Lady Di wedge cut) - split the band in 1982 at the very height of their fame, he brought to an end one of that decade's great, white hopes. And now things have come to this, *Dead Bees On A Cake*. Hmm? Do you smell a rat?

I'm afraid Dave, as I'm gonna call him, should have stayed behind his fringe. He is undoubtedly a highly talented and eclectic musician, but nothing quite adds up here. He has, of course, achieved a fair amount since 1982, his collaborative ventures with such luminaries as Ryuichi Sakamoto and Holger Czuckay (avant-garde bassist with Kraut Rockers Can) to name but two.

Those familiar with albums such as *Brilliant Trees*, *Secrets Of The Beehive* and *Gone To Earth* won't be too surprised by *Dead Bees* with its highly textural, finely-wrought and personal songs framed by Sylvian's warm but mournful monotone. Which is mostly fine, if occasionally it borders on Bryan Ferry aboard a sinking ship.

The songs are occasionally daring with their Jazz simplicity and often rely on strange Eastern instrumentation. They are helped immensely by the extraordinary contributions from Sakamoto, Marc Ribot and man of the moment,

Talvin Singh. In spite of this, the results remain patchy outside of high points such as current single 'I Surrender', a haunting ballad in the epic mould of Japan's 'Nightporter', and 'Midnight Sun', an Eastern Blues number, gift-wrapped as usual in top-grade production.

Unfortunately, while Sylvian has gone for high-quality studio work with interesting Oriental inserts, he is largely going nowhere special at the moment.

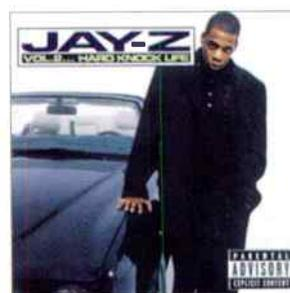

JAY-Z
VOLUME 2, HARD
KNOCK LIFE

Last seen having a major falling-out with Puffy (omni-present) Coombes on his *No Way Out* tour and a close mate of Notorious BIG (RIP), despite his dodgy associations Jay-Z is beginning to flourish in his own right. With help from his huge 1996 single, a duet with Foxy Brown entitled 'Ain't No N-G-A (Like The One I Got)', Brooklyn's Sean Carter, aka Jay-Z, managed to get a contract with the Priority label and release his debut, *Reasonable Doubt*, all in the same year.

12 months later he resurfaced with *In My Lifetime, Volume 2*, a generally fraught

ROCK & POP

RECORD OF THE MONTH

PUBLIC IMAGE LTD
PLASTIC BOX

"By the time I started Public Image Limited I knew that nobody was going to stop me taking things to the Nth degree," John Lydon, aka Johnny Rotten, stated for the record last year. This four-CD box-set, stylishly crafted and including just about every cough and spit produced in the career of Britain's finest irritant, demonstrates exactly what Lydon means by Nth degree.

From the brilliant opening bars of 1978's 'Public Image' to the BBC Sessions of 1992, there can be no better journey into the mind of a madman/genius, nor better lesson in the ways of British music's wild and experimental hinterland. For Mr Lydon consistently pushed back the borders through the late Seventies and Eighties without jeopardising his image as a colourful caricature left over from the heyday of Punk. But while his former Sex Pistols band mate Sid Vicious died in abject squalor, his life collapsing around him c/o the needle, John Lydon continued to make cutting-edge music and got rich in the process.

and slushy affair. Hard Knock Life is the follow-up, and thankfully it's a vast improvement. This is reflected by its staggering five weeks residing at Number One in the US charts, a record for a Rap album.

The opener on Volume 2, 'Hand It Down', lays down the

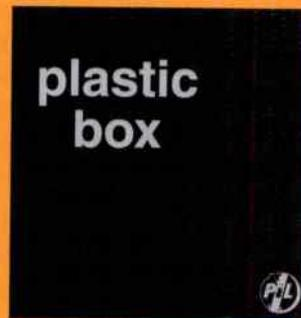

Moving to America on the proceeds (he claimed the change of address was due to his refusal to live under a monarchy), he occasionally returned to pop up on British TV music shows to snarl, spit vitriol and, often the case, walk off in disgust. Still, the music kept coming as Plastic Box delightfully demonstrates.

It was in the wake of the Sex Pistols' disastrous and fatal US tour in 1978 that PIL first came together. An amalgamation of Lydon (who'd split up the Pistols, insisting they could go no further), bassist Jah Wobble, a mate of his and Sid's, and guitarist Keith Levine, who'd just been sacked from the Clash, the band got into the studio and started to jam together. They were soon joined by former Kings Road Punker Jeanette Lee and,

gauntlet to his critics. Relying on an assortment of guest vocalists (DMX, Timbaland and Kid Capri all provide meaty contributions) some might say it couldn't fail. But the definite highlights are 'Paper Chase' with bad-ass diva Foxy Brown, and 'Money Ain't A Thing', a phat Rap

within months, the debut Public Image was in the shops.

The album upset many die-hard Pistols fans, but at least it showed Punk had a future. With its striking singles 'Death Disco', a spooky anthem written for Lydon's mum who was suffering from cancer, and the thrusting 'Public Image' with its poignant opening line "You never listened to a word I said", it was always going to be a memorable debut. These, however, weren't the only top tracks of note - 'Poptones', 'Careering' and 'Religion' proved as much and they are all here.

Next up was the difficult, experimental Metal Box whence Plastic Box got its packaging. More guitar-based, it was a violent and evil affair - Levine was truly on fire and Lydon warbled on in his inimitably manic style. Also on Disc Two are crunching and intense tracks like 'Flowers Of Romance' and another 10 or so highly experimental numbers like 'Banging The Door' which showcases Lydon's scary singing.

Disc Three is the album everyone will know and it's

suited only to loud stereos.

Much of the rest of the album is not quite so tough, and bangs on about the customary Rap subjects of money, other niggaz and hoes. In fact on 'Money, Cash and Hoes' he manages to Rap about all three without realising he's slipped up a bit

PIL at their most commercial. Including the series of hit singles 'This Is Not A Love Song', 'Round', 'Rise' and 'Home', it highlights the band at their most fruitful, but that's not to say either weak or Poppy. The final disc is, well, just about everything since.

Far from a relaxed, chill-out, Plastic Box is easily the most challenging album of the year yet. It's worth the effort, though; angry, aggressive and bass-heavy, it really is the Nth degree. From the political anthem 'Religion' to the inspiring 'Rise' (based on South African torture methods), there is rarely a dull moment.

If there was one defining moment in the career of John Lydon and PIL, it must have been during the recording of their most successful LP, *Album*, in the mid-Eighties. While in the studio one day, Jazz maestro Miles Davis, impressed with what he was hearing next door, simply dropped in and started playing his trumpet in the background. He later told Lydon he sang like he played the trumpet. A fitting compliment from another man who liked to take things to the Nth degree.

with the title.

All in all, this is a surprisingly straightforward album probably not quite deserving of its huge US success. That Public Enemy's *A Nation Of Millions*, a clearly far superior album, got nowhere near as many sales is, well, a travesty.

UK SUBSCRIPTION £27 ONLY !!!

GET THOSE CLASSIFIED ADS EARLY AND GRAB A BARGAIN !!!
SUBSCRIBE TO HI-FI WORLD !!!

INTERNET
Visit our site
www.hi-fiworld.co.uk



*News; DIY; valve amps/pre-amps; speaker kits; reviews
+ lots more information
not published in the magazine.
www.hi-fiworld.co.uk*

OVERSEAS SUBS RATES

Surface Mail	£40
Airmail Europe	£50
Airmail Middle East & South-East Asia	£60
Airmail USA, Canada, Australia, Japan, Korea and China	£70
<input type="checkbox"/> Airmail	
<input type="checkbox"/> Surface mail	

- ★ 1 year's subscription only £27 (£2.25 per issue!), and we mail it to you free.
- ★ Get to our amazing classified ads first and grab a bargain.
- ★ Run by dedicated hi-fi engineers and enthusiasts, Hi-Fi World has become famous for its informative reviews and radical kit designs.

Missed an issue?

Back issues also available at a cost of £3.00 only (includes P&P), payment by cheque only - overseas please contact for details.

By telephone: Contact Faiza Chunara
Credit card hotline 9.30AM - 12.00 NOON: (44) 0171 625 8033
Fax: (44) 0171 328 1844 (Please fax form below)

By post: Make cheque or postal order payable to Audio Publishing Ltd, sent in an envelope marked Hi-Fi World, FREEPOST LON3478, LONDON, W9 1BR

HI-FI WORLD SUBSCRIPTION CARD

PLEASE REGISTER ONE YEAR'S SUBSCRIPTION FOR HI-FI WORLD

I WOULD LIKE TO PAY BY CHEQUE MADE PAYABLE TO AUDIO PUBLISHING LTD CREDIT CARD

DEBIT MY MASTERCARD/ACCESS/VISA ACCOUNT NO:

EXPIRY DATE: SIGNATURE _____ DELIVERY ADDRESS IF DIFFERENT _____

NAME _____

ADDRESS _____

DAYTIME TEL NO _____

HI-FI WORLD

CLASSICAL

by Stephen Priest & Frank Blake

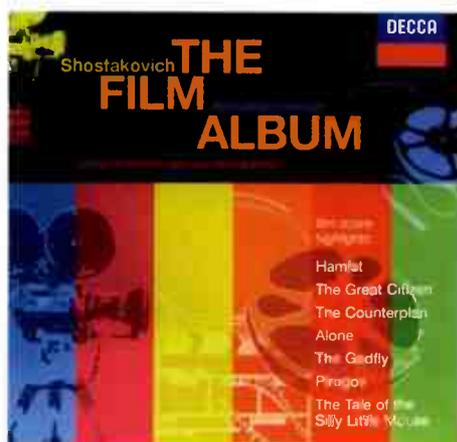

SHOSTAKOVICH
THE FILM ALBUM
Royal Concertgebouw
Orchestra, conductor
Riccardo Chailly
DECCA 460 792-2

Shostakovich is undoubtedly recognised today for his life-long contribution to the symphonic repertoire. Unbeknown to many, however, is the influence that the moving picture had on his creative output. Indeed, from the outset of his career, to supplement his income as a student he tickled the ivories in cinemas.

After the success of his First Symphony, he was asked to write a 'live' score for the 1929 film *New Babylon* by Grigori Kozintsev and Leonid Trauberg, which was followed the next year by a commission from the same duo for a score to their film *Alone*, the earliest piece featured on this recording.

Concert-goers will probably know of his scores for the 1963 film of *Hamlet* and *The Gadfly* dating from 1955, excerpts from both of which are featured on this disc. The remainders are various gems

from his cinematic output spanning the years 1930-1967, including a beautifully-crafted Funeral March (with echoes of the *Eroica*) from *The Great Citizen* (1940), plus an arrangement by Andrew Cornall of *The Tale Of*

The Silly Little Mouse (prepared especially for this recording).

The Concertgebouw are no strangers to the music of Shostakovich - during his time with the orchestra, Haitink was a resolute champion of the symphonies, as their catalogue verifies. Chailly demonstrated his interest in Shostakovich's less familiar works with his earlier recordings, *The Jazz Album* and *The Dance Album* (with the Philadelphia Orchestra). Consequently, both of them take to *The Film Album* like ducks to water, displaying with a blend of tonal richness and rhythmic grip the bleakness, wit and sarcasm that are the compositional stamps of Shostakovich.

Whilst much of the music on this record lacks the gravity and depth of say the 5th, 8th or 10th Symphonies, it is none the worse for it. It merely demonstrates his mastery of the cinematic genre. Indeed, musical picture-painting is never far from the surface with most of Shostakovich's output.

Since it was recorded in the main hall of the

Concertgebouw's Amsterdam home which has one of the best orchestral acoustics on the planet, the sound quality is near spot-on. Balance is excellent, as is the playing and it all contributes to a refreshing 78minutes of rarely-heard music from a master of musical animation.



AIRS DE COUR
Catherine King, Jacob
Heringman And
Charles Daniels
LINN CKD 089

The literary convention of Courtly Love blossomed anew at the end of the Sixteenth century and many of the mainly anonymous verses set by the eight composers on this disc are veritable bridges of sighs. On occasion, the two lovers are even caught sighing unrequitedly while in each other's company; perhaps the course of true love in those days needed as many self-made obstacles as possible to prove itself worthy.

Taken in bulk, the musical settings for these out-pourings have considerable charm without being particularly distinguishable. The effect is rather like Gregorian chant: if you like it, one minute of it is

as good as another. This makes for a soothing hour or so but not, it must be confessed, one that is particularly challenging.

This sensation of 'mood' rather than high art is perhaps helped along by the chosen performance style. Radio 3 fans have long been familiar with the 'two-performer' format which makes for such an economical Lunchtime Concert. Catherine King and Jacob Heringman are manifestly seasoned in this vein, Heringman's mastery of the lute an object lesson in making the difficult sound both easy and natural.

Charles Daniels (tenor) contrasts sufficiently well with Miss King to give an agreeable effect on the duets. The very nasality of the French language does not always make for beauty but the vocalists keep things in perspective without being too didactic.

'Baroque' voices are a bit of a niche market at the moment. Catherine King not only sings in tune but also manages to avoid the 'what a good girl am I' inflection which can make the effusions of some better known 'early music' singers so nauseating. Unfortunately she does follow the current fashion for a rather 'bloodless' sound which contrasts oddly with the suppressed passion of the verses.

Linn's recording is crystal clear but the pressing features a rather lop-sided balance. With intimate music of this sort, however, this is by-the-by and does not detract from a very pleasant and melodious performance.

JAZZ

by Ian Nicolson

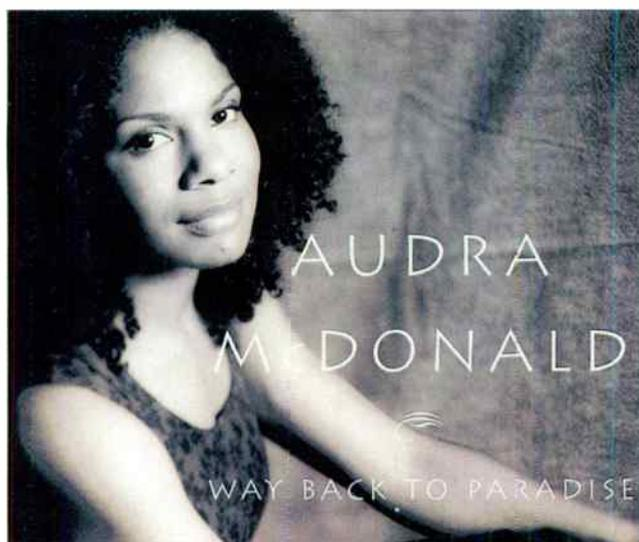

AUDRA MCDONALD
WAY BACK TO PARADISE
NONESUCH 79482

If it hadn't been for a minor accident last month, you'd have seen a lot more column inches for this celebrated young Broadway diva. Delaying her first singing dates in the UK, although not the release of her first Nonesuch set, the interruption could yet prove useful to her career outside her native USA. For hers is not the kind of art that makes for easy marketing, although it will certainly make reviewers and listeners talk - and word of mouth has worked just fine for class acts like Jeff Buckley and the David Matthews Band.

Many might not have heard of Audra but the stage community certainly has: three Tony Awards for Broadway performances, *Carousel* (1993), *Master Class* (1996) and *Ragtime* (1998) make her a celebrated part of the revival that has made Broadway intensely profitable again in the Nineties.

For 30 years the stage musical has struggled to win back the Pop mainstream from less theatrical competition. And for most of her career, the 29-year-old McDonald has fought just as hard to establish her right to sing Classical like Pop and vice versa.

Born in Berlin to a musical family, she grew up in California where five of her aunts still tour as a gospel act, fell in love with musical theatre after joining a dinner theatre company at the age of nine, battled her way through Juilliard as a student of Classical singing and then took her magnificent mezzo-soprano and startling emotional range to a succession of nightmare auditions (at the Lincoln Centre call for *Carousel* she even managed to faint on stage in mid-song but still got the part). She has effortlessly perfect pitch and diction, a distinctive vibrato, an intimidating range and the ability to infuse all her material with a Gospel sincerity and fervour that make her unique.

This debut album is also a

primer to the new generation of US stage composers: Michael John La Chiusa, Jenny Giering, Adam Guettel and Jason Robert Brown songs are the core of her debut album. And her astonishing, seemingly instinctive musicality lifts their post-Sondheim modern mixture of traditional Gershwin-esque show tune, pungent social or political observation and eclectic 'concert art' into a spell-binding collection that remembers the past but is firmly rooted in the magpie, ironic and sophisticated Nineties.

There can't be many first-timers who can carry off inviting guests like Dawn Upshaw and Theresa McCarthy to duet with her. Nor many who can pull the composers of her chosen tracks to play piano for her, or conduct the orchestra. And if you think that there's just no way a Broadway diva is going to be singing jazz, remember Anita O'Day and Barbra Streisand, and try a listen first.

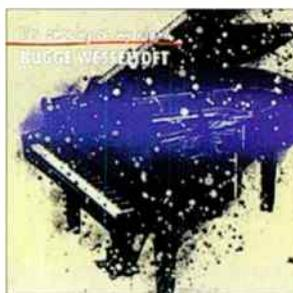

BUGGE WESSELTOFT
NEW CONCEPTION OF JAZZ SHARING
JAZZLAND/EMARCY 538 278

Which brings us to Norwegian Grammy-winning pianist and composer Wesseltoft's latest

for his own Jazzland label. Halfway between the lounge-lizard irony of Dimitri From Paris and the lyrical quartet settings of Dave Brubeck or the acoustic Herbie Hancock, Sharing is one of those mould-breaking sets that tends to outlast the vagaries of musical fashion.

Wesseltoft is as much producer and soundscape artist as composer and star of this double-CD, and he's shipped in intensely catchy elements from Hip-Hop, Rap, House and Acid Jazz by the bucketload, sampled his way past artistic oblivion and made it back intact and funky. If you like your music pure, this may not be for you, but if you're convinced by the 'mongrels are smarter and healthier than pure-breds' argument, this is some argument to lean on.

Sometimes the feel is Jimmy Smith with a bourbon on the B4 next to his hand, sometimes the iceberg cool of Jan Garbarek, or conveying subtle echoes of the biting romanticism of Massive Attack or the intense, percussive texture of Drum 'n' Bass. Then again, sometimes it's like a soothing, seductive Robert Miles (only with balls and a few more ideas).

If you know the adventure ECM's Nils Petter Molvaer has embarked on by interleaving House rhythms and mixing attitudes with his skeletal Jazz, Wesseltoft's approach to his own music will strike home as well. It would take an exhaustive run-down of the nine tracks that comprise *Disc One* to convey the shifting horizon of mood, style and setting on *Sharing*, but I'm convinced.

DANCE & AMBIENT

by Sara Davis

RECORD OF THE MONTH

**Orbital
The Middle
Of Nowhere**



ORBITAL
THE MIDDLE OF NOWHERE
FFRR LC7654

Orbital's fifth album was always going to be massive. The brilliance of both the untitled brown and green albums defined Electro-Ambience as we know it and raised the amount of uplift

10-fold in tunes such as the legendary 'Chime' and 'Belfast'. Then came the eccentric Snivilisation, the least inspiring Hartnoll collaboration yet strangely the biggest. Many will recall the single 'Are We Here?' which showcased the mature and more up-beat side of Orbital whilst distracting attention from the awful 'Technology'

(which sounded like the theme tune to a late-night science programme).

In Sides took the album count to four with an altogether more laid-back sound scape; In Sides was a great Ambient soundtrack but lacked those funky, synthesised chord patterns which were so, er, Orbital.

The Middle Of Nowhere could have marked Orbital's decline into an old-age of low-tempo musical mush; after In Sides it was looking like Techno's own pair of frank-talking Grant brothers were ready to fade into the background. Thankfully, this was not to be! The Middle is a truly awesome explosion of Orbital as we once knew them.

From the opening chords of 'Way Out', the quirky samples and pummelling beat herald a brilliantly original yet strikingly familiar sound. By 'Know Where To Run', the pace of the album has risen to Olympic levels - this tune is a

contender for album track of the decade thanks to its deep bass and storming beat. 'I Don't Know You People' carries on from where In Sides stopped with its experimental, Thrash Metal riffs and repetitive Rock beat.

'Spare Parts Express' features more of the Snivilisation-style innovations, mainly by lifting from the Pop charts and putting the transplants under the Hartnoll scalpel for experimentation. This monster blends Gothic church organs and the odd sample from John Craven's Newsround. 'Nothing Left: Parts 1 & 2' is a hands-in-the-air marathon and ready-made classic set to replace 'Impact' as a new live highlight, a no-messing Electro session with vocals melted on top. And finally there's 'Style', weaving its fabric from simple melody and bleeps into rising waves of haunting theme - Orbital at their peak and a great tune to close with.



VARIOUS
SYMPATHY IN CHAOS, VOL 3
MATSURI PRODUCTIONS MPCDP 25

The Matsuri slow-beat

collection crosses the border into trilogy-land with ease thanks to a solid wall of respect from the music press to date. Sympathies In Chaos volumes 1 and 2 took Trance to the mainstream under a banner of rave reviews and even featured on the snooty designer catwalks of fashion Issey Miyake.

The laid-back beats of Sympathy 2 set the tempo for this third episode, which opens on a pure and smoochy tip that Seb Taylor

(in his Digitalis guise) can lay claim to. Despite having previously built a name for rare Trance, Matsuri then pilot the album through a diverse selection of apprentices old and new, including Gabriel Le Mar on an Electro-Dub tack ('Bob') and kooky Bristol funksters Moloko.

Mid-way through the proceedings the menacing spectre of deep Trance rears up in the form of Tsuyoshi's 'Joujouka' project remixing of

Japanese Rock band Walrus, a fine sample of invigorating beats mashed-up with funky studio post-production.

As Sympathy 3 continues to evolve it dips into the underground Japanese sound which is probably going to explode into fashion soon. Dub Squad's squelchy, big-beat tune 'Enemy Or Friend?' is definitely worth checking out, as is Drum 'n' Bass act Something Wonderful's gorgeously raw 'Kyoumei' number.

BEDFORDSHIRE

RICHARD'S AUDIO VISUAL 4 Greyfriars Bedford. Tel: 01234 365165. Stockists of: Arcam, Audioquest, Beyer, B&W, Bose, Cable Talk, Celestion, Cyrus Denon, Heybrook, Marantz, Mission, Moth, Nakamichi, Ortofon, Pioneer, Pro-Ject, Quad, REL, Rotel, Royd, Ruark, Sennheiser, Sound Style, Systemdek, Target, Teac, Thorens, van den Hul & more! Expert friendly service : Listening room. Pioneer Reference Point. Visa / Access.

BERKSHIRE

SEVENOAKS HI-FI 3 & 4 Kingswalk Shopping Centre, 19-23 King Street, Reading, Berks. RG1 2HG. Tel. 0118 9597768. A specialist Hi-Fi store with two demonstration rooms. The audio visual room is complete with Meridian Digital Surround Sound. Major brands stocked are: Arcam, Audiolab, Cyrus, Denon, Marantz, Meridian, Rotel, Yamaha, Acoustic Energy, Castle, B&W, Kef Reference, Monitor Audio & Ruark.

BRISTOL & BATH

THE RIGHT NOTE Tel: Tel.No. (01225) 874728. Just think: most audiophiles listen for most of the time to systems that are 'not quite right'. Are you happy with yours? Forget the reviews and trying to put together a system like a patchwork quilt with the 'best' bits around. Its our job to do the assessing, you judge our results. We'll help you to plan a system for the future, even if you spread the purchases. Leave the 'up-grade-itis' behind, save money and enjoy music all the time. Just listen, and you'll know. CD: Accuras, Audio Synthesis, Classe, DCS, Enlithened Audio Design, Meracur, Orelle, Wadia, XTC. Vinyl: Basis, Crown, Jewel, Graham, Michell, Sumiko, Transfiguration. Amps: Accurus, Audio Sculpture & more. Speakers: Audio Aristry, Audio Physics & more. Tuners: Fanfare, Magnum Dynalab & many more. Cables: Chord, DNM, Silver Sounds & more. (Credit Cards Accepted).

BUCKINGHAMSHIRE

HAZLEMERE AUDIO CONSULTANTS To hear how realistic music can sound please call for an appointment (day or evening). Objective advice, comfortable listening, home demonstrations, free installation, part exchange, repairs and superb service. Acoustic Precision, Air tangent, ATC, Audiomeca, Basis, Classe, EAD, Fanfare, Henley, Magnaplanar, Mirage, Monrio, Muse, Nottingham Analogue, Opera, Ortofon, SD, Sirius, Straightwire, Tice, Triangle, Trilogi, VPI. Based in High Wycombe. Please call: 01494 437892.

TECHNO SOUND/AUDIO INSIGHT 7 Granville Square, Willen, Milton Keynes, MK15 9JL. Tel. (01908) 604949. Audiophile Hi-Fi and Home Cinema Specialists. All major brands stocked from Arcam to Yamaha. Meridian Digital Home Theatre dealer. Custom home cinema and multi room installation. 4 dem rooms and expert advice. Audiophile CDs, LPs and LaserDiscs to buy. Open late on Fridays.

NORTHWOOD AUDIO 98 Cambridge St, Aylesbury, Bucks HP20 1BA. Tel. 01296 428790. Selected sounds from Acoustic Energy, Alchemist, Arion, Audio Meca, Audio Note, Boston, B & W, Cabeltalk, Castle, Celestion, Chord Co, DNM Virtual Reality, Denon, DPA, Epos, Exposure, Gyrodek, Harman Kardon, Heybrook, Kef, Klipsch, Marantz, Micromega, Monitor Audio, Moth, Musical Technology, Myrrad, NAD, Nakamichi, Neat, Pioneer, Proac, Rega, Rel, Rose, Rotel, Ruark, Stax, Tannoy, Teac, Talk Electronics, Thorens, TDL, Triangle, Tube Technology and a range of quality pre-used equipment. Export orders welcome. 2 Dem rooms. Credit facilities available.

CAMBRIDGESHIRE

THE AUDIO FILE 41 Victoria Road, Cambridge. Tel. 01223 368305. 'For the best in British Hi-Fi and Home cinema entertainment'. Visit or call to arrange a dem with products from: Audiolab Arcam, Mission, Linn, Naim, Rega, Cyrus, Absolute Sounds, Kef, Sony, Yamaha, Rel, Quad, Ruark, Denon.

THE HI-FI COMPANY PETERBOROUGH The region's largest range of enthusiast hi-fi. Arcam, Audiolab, B&W, Cyrus, Denon, KEF, Kenwood, Krell, Marantz, Martin Logan, M&K, Meridian, Mission, NAD, NAIM, Pioneer, Quad, REL, Rotel, Yamaha and many more. Excellent hi-fi and A/V demonstration facilities. Part exchange welcome. Huge selection of top quality, carefully used equipment, telephone for mailing list, 35-42 COWGATE, Peterborough. Phone: (01733) 341755 Fax: (01733) 358141.

CHESHIRE

ACOUSTICA 17 Hoole Rd., Chester CH2 3NH Tel: 01244 344227. All that's best in hi-Fi from Epos, KEF, Teac, Royd, Linn, Rega, Naim, Arcam, Audiolab, Ruark, Rotel and many more. Multi room systems from Linn Knekt. Superb demonstration facilities, home demonstrations and installation a pleasure. We offer the best products, the best service and the best sounds. Open Tuesday to Saturday, evenings by appointment.

ACTON GATE AUDIO 4 Ruabon Road, Wrexham, North Wales. Tel. 01978 364500. Audio Visual Specialists. Arcam, Audio Analogue, Bose, B&W, Celestion, Castle, Denon, Harmon Kardon, Jamo, Marantz, Michell, Mission, Onkyo, Pro-Ject, Musical Fidelity, NAD, Micromega, Myrad, QUAD, Radford, Rotel, Ruark, Tannoy, TDL, Teac, Thorens, UKD, Unison Research, Yamaha, DSP Club Member, Demo Room, installation service. Easy Parking and Motorway access. All major credit cards accepted. 9.30 - 5.30 daily. Closed Weds pm.

INPUT AUDIO Dukinfield, Cheshire. Tel/Fax: 0161 304 7494. Mobile: 0402 268490. We have the time, we have the patience, we have the desire, and we have the products to help you reach your musical goals. featuring: Adyton, Altis, Art, Audiogram, Audio Analogue Puccini, Audiomeca, Audio Physics, Audio Vector, Base, B.C.D., Chord, Diapason, Graaf, Insert Audio Immedia, Meracur Monrio, Neat, P.A.D., Siemel Silver Sounds, Stands Unison, System Audio, Triangle UKD Opera, Unison Research, Yamamura-Churchill, YBA. And much more arriving soon, specialising in home demo's. Please phone for more information or friendly chat. All usual facilities. Input for the pleasure of music

DOUG BRADY HI-FI Kingsway Studios, Kingsway North, Warrington, WAI 3NU Tel. 01925 828009 Fax 01925 825773. Visa, Mastercard, Lombard Tricity. 2 dem rooms, home trial; Agencies include: Arcam, Tag McLaren, AVI, B&W, Castle, Caspian, Chord Electronics, Exposure, Harbeth, Heybrook, Krell, LFD, Michell, Meridian, Musical Fidelity, Monitor Audio, Naim, Nautilus 800 series, Pink Triangle, ProAc, Roksan, SME, Wilson Benesch, XTC and many more.

PRACTICAL HI-FI 88 Bridge Street, Warrington, WAI 2RF. Tel: 01925 632179. See our main entry under Preston, Lancs.

REPLAY AUDIO CONSULTANTS Tel/Fax Chester (01244) 401290. Cheshire's alternative hi-fi specialists. Honest advice and personal service. We can demonstrate Alchemist, AVI, Henly, Heybrook, LFD, Michell, Moth, Musical Fidelity, NAD, Neat, Origin Live, Ortofon, Pink Triangle, Royd, Sonneteer, Totem, Trichord. Demonstrations by appointment in Chester or in your own home. Delivery & installation available. Mastercard, Visa, Switch, Delta

SWIFT HI-FI St. Annes Parade, Wilmslow. 01625 526213. Aura, B&W, Denon, Kenwood, Marantz, Nad, Pioneer, Rotel, Systemdek, Tannoy, Revolver, J.P.W., M. Short, Mission, Celestion, Technics, Audiolab, Castle. Open 9.30-6. Dem room. No pressure. BADA member.

CORNWALL

SOUNDS PERFECTION Cornwall's most exclusive Audio retailer'. Agencies include: Audiomeca, Analysis, Audio Spectrum, Audionote, Cadence, Harmon Kardon, Impulse, Konnekt Cables, Michell, Ortofon, Parasound, Project, Phylosophy Cables, Rel and SME. Home Demonstrations by Appointment. Tel/Fax. 01326 221372 Mobile 0468 754353

CUMBRIA

MISONS SOUND & VISION Viaduct House, Victoria Viaduct, Carlisle, CA3 8AN. Tel (01228) 22620. Exposure, Heybrook, Aura, Bang & Olufsen, B & W, Castle, NAD, Quad, Rotel, Sony, Sugden, Yamaha, Demo Suite. No appts nec. Home trial facilities. Free installation. Service Department Mon - Sat. 9 - 5.30

PRACTICAL HI-FI 106 English Street, Carlisle, CA3 8ND Tel: 01228 44792 See our main entry under Lancaster.

DORSET

MOVEMENT AUDIO 588 Ashley Road, Poole, Parkstone, Dorset BH14 0AQ. Tel: (01202) 730865. Arcam, Audiolab, B&W, Castle, Cyrus, Denon, KEF, Marantz, Meridian, Michell, Micromega, Pioneer, Ruark, Shearpe Audio. 2 Dem rooms. Listen to the available choice and decide at your leisure - no pressure, no obligation. Our staff enjoy music, with our choice of products, you can too! Service Department. Free installation. Home trial facilities. Access, Visa, Amex, Diners Card. Credit facilities available. Open Mon-Fri 10-6. Sat 9-6

MOVEMENT AUDIO 336 Wimborne Road, Winton, Bournemouth, Dorset. BH9 2HH. Tel: (01202) 529988/520066 Arcam, B&W, Denon, KEF, Marantz, Meridian, Mission, Pioneer, Sony, Yamaha. Full dem facilities available, also home dem. Friendly expert advice. Service Department. Free installation. Home trial facilities. Access, Visa, Amex. Open Mon-Fri 9-5.30

DAWSONS OF WESTBOURNE Home Cinema Specialists. Main agents for Bang & Olufsen, Harman Kardon, JBL, REL, Mordaunt Short, Sony, Technics and TDL. Demonstration facilities include our unique Dolby pro-logic system comparator for the ultimate way to choose the perfect system. Also on demonstration large screen televisions from Thomson, sony and Ferguson with video projectors from Sharp and Seleco. Dawson's, 23 Seamoor Road, Westbourne, Bournemouth 01202 764965

SUTTONS HI-FI 18 Westover Road, Bournemouth, Dorset. Tel: 01202 555512. You will find the very latest in superb Hi-Fi facilities with stocks to include: Arcam, Cabeltalk, Celestion, Denon, DTS, KEF, Linn, Marantz, Meridian, NAD, Pioneer, QED, Rotel, Sennheiser, Sony, Sound Organisation, Tag McLaren, Target, Teac, Technics, Yamaha, and many more. If you're serious about Hi-Fi you've probably heard of all these brands and probably heard of Suttons too! We've been around for over 45 years. Please call for expert knowledge and friendly advice.

WEYMOUTH HI-FI 33-35 Maiden Street, Weymouth, Dorset DT4 8BA. Tel (01305) 785729. Arcam, Aura, B&W, Denon, Kenwood, Marantz, Micromega, Musical Fidelity, Panasonic, Quad, Sony, Technica, Yamaha. Dem room. Friendly professional advice. Only quality hi-fi dealer in Weymouth area. Service Department. Free installation. Home trial facilities. Access, Visa, Amex, Switch, Delta Mastercard. Interest free credit. Instant credit. Open Mon-Fri 9.30-5.30 Sat - 9.30-5.30

ESSEX

GRAYSTON SOUND & VISION 33 Sir Isaac's Walk, Colchester. (01206) 577682. Akai, Arcam, B&W, Boston Acoustics, Denon, Grundig, Infinity, KEF, Linn, Loewe Opta, Meridian, Nokia, Philips, Pioneer, Quad, Rotel, Ruark, Sennheiser, Spendor, Thorens. Superb demo rooms, free regional delivery and installation. Regular musical and surround evenings, home demonstrations. Excellent credit facilities.

GLOUCESTERSHIRE

THE RIGHT NOTE - BATH For specialist advice and home demonstrations. See Bristol & Bath.

HAMPSHIRE

HAMPSHIRE AUDIO LTD. 2-12 Hursley Road, Chandlers Ford, Hants, SO53 2FU. Tel Southampton (01703) 252827/265232. 3 Hi-Fi and 2 Home Cinema/Dolby Surround Sound Demonstration Rooms, one with Projection TV and an 8' wide screen. Brands

stocked include ARCAM (incl. Xeta), Audiolab, Audioquest, Celestion, Cyrus, Denon, Gradient, Infinity, KEF, Marantz, Meridian, Mission, Polk, Quad, Rotel, Seleco, Sennheiser, Soundstyle, Tannoy, Target Audio, Thorens, & Yamaha. Established 1969, we offer a 2-year Guarantee covered by our own well-equipped Service Dept. We have a large FREE car parking facility and we are located within 3 miles from Junction 14 (M3/M27 Interchange) and Junctions 13 (M3) and 5 (M27). Closed Mondays, except in December. Late Night: Thurs to 8pm. BADA Founder Member. All deposits fully covered by BADA Bonding.

NOW THATS HI-FI 32 Arundel Street, Portsmouth Tel: (01705) 811230. Pioneer, Yamaha, Marantz, Kenwood, Mission, TDL, REL, Attacama and much more. Laserdisc and AC3 specialists. Accessory center at 24 Arundel Way, Portsmouth. Tel: (01705) 811618

SOUTH COAST SPEAKERS LTD 326 Portsmouth Road, Southampton, Hampshire. Tel: 01703 559312. Hand made Loudspeaker Systems! Tailored to your individual tastes. Many real wood veneers. Any colour finish available. U.K. suppliers of Driver Units for: SEAS, VOLT, MOREL, VISATION, RCL, SCAN-SPEAK & MORE. Home builder kits always on demo. High quality accessories/components, comfortable listening area, ample free parking, friendly advice.

HEREFORDSHIRE

ENGLISH AUDIO 37 Whitecross Road, Hereford, HR4 0DG. (01432) 355081. Arcam, A.T.C., B&W, Castle, Cyrus Centre, Denon, Dynaudio, Heybrook, KEF, Magnat, Marantz, Mission, Musical Fidelity, Naim, ProAc, Pink Triangle, Pioneer, Project, REL, Rotel, Ruark, John Shearpe, Stax, System Audio, Tag McLaren, Teac, Wadia, and Yamaha. Single speaker dem room, home trial facilities, free installation, service dept. Access/Visa, Credit arranged. Open Mon-Sat. 9.30-5.30pm. BADA members.

HERTFORDSHIRE

ACOUSTIC ARTS LTD 101 ST. Albans Road, Watford, Herts. Tel: (01273) 245250. Fax: (01923) 230798. Audio Research, B&W, Boston, Castle, Celestion, Chord, Copland, Denon, Densen, DPA, Jadis, KEF, Krell, Marantz, Martin Logan, Michell, Micromega, Rel, Roksan, Ruark, SME, Sonus, Faber, Theta, Thorens, Wilson. 4 demonstration rooms. Purpose built AV studio. Credit available. 100 yards from Watford Junction station. Open Tues-Sat 10-5.30 (Thursday open by appointment until 8pm).

AUDIO FILE (THE) 27 Hockerill Street, Bishops Stortford, Herts. Tel. (01279) 506576. Please see main ad under Cambridgeshire.

AUDIO FILE OBJECTIVE 37 Tower Centre, Hoddesdon, Hertfordshire. EN10 8UD. Tel: 01992 478666 Fax 01992 440431. Selected British and specialist brands. New, Ex-dem, and S/H. Mail order Hi-Fi Purchased. Free Parking.

DARBY'S OF ST. ALBANS. 6 Market Place, St Albans, Herts. Tel: (01727) 851596. Hertfordshire's premier Hi-Fi/Audio Visual specialists established 1946. Full Home Cinema demonstration suite. Whether your needs are large or small, we stock it all: Arcam, Yamaha, Quad, Denon, Sony, Bang & Olufsen, Pioneer, REL, KEF, Mission, Ruark, Celestion, Polk, and many more. Free planning service. Free Delivery and basic installation. Full workshop facilities. Open 9-6 Mon-Sat.

KENT

ASHFORD SOUNDCRAFT HI-FI 40 High Street, Ashford. Seeking music lovers, male or female, any age, to share common interest in musical Pro-aktiv Hi-Fi Systems, Multi Room of Home Cinema. Attractive unusual equipment in unusual setting, your place or ours, we guarantee lasting pleasure. Open Mon-Sat. Appointment Service or just pop in. Tel (01233) 624441

dial-a-dealer

DOVER HI-FI 43 High Street, Dover. Tel: 01304 207562. Suppliers of quality hi-fi equipment including; Arcam, Akai, B&W, Denon, Jamo, Mordaunt Short, NAD, Panasonic, ProAc, Quad, Rotel, Ruark, TDL Technics, Tannoy. Part exchange. Listening room. Service and repairs. Credit facilities. Access/Visa. Open 6 days 9-5.30.

THE LINN STUDIO Sondek LP12* knekt* Karik* Kairn* Klout* Kremlin* Keltik* Kaber* Keilehd* Numerik* Tukan* Wakonda* Majik* Mimik* LK100* Ekos* Kudos* Arkiv* Brilliant* Lingo* Valhalla* Sekrit* Aktiv*... Dream systems for everyone from £2,000 to £30,000+. A new dealership from a specialist family business, established in 1948. Outstanding service and facilities. Multi-room specialist. 123 Snargate Street, Dover, Kent. CT17 9AP. Tel: 01304 201525, Fax: 01304 240135.

KIMBERLEY HI-FI 193 Broadway, Bexleyheath, Kent. Tel: 0181 304 3272. Sep dem rooms, Denon, Technics, Kenwood, Aiwa, NAD, Dual, Wharfedale, Mission, Marantz, Tannoy, Castle, Monitor Audio, Heco, Jamo, Cerwin Vega and many more.

PROGRESSIVE AUDIO 2, Maryland Ct, Rainham, Kent, ME8 8QY. Tel: 01634 389004. Agencies include: Audio Innovations, Audion, Audionote, Audio Mecca, Audio Systems, Audio Static, Audio Technica, Chord Amps, Cogan Hall, Conrad Johnson, Convergent, Denson, Goldring, Impulse, Koetsu, Levinson, LFD, Lyr, Moth, Nordost, Origin Live, Pink Triangle, Proac, SD Acoustics, Silversounds, SME, Sugden, Sumiko, Systemdek, Snell, Target, TDL, Transfiguration, Townshend, Tube Technology, Unison Research, UKD., Voyd, VPI, etc. Demos by appointment.

UNILET SOUND & VISION 24-26 Union Street, Maidstone, Kent. Tel: (01622) 676703. Fax: (01622) 676723. The best place in town for Hi-Fi and Home Cinema. * Three superb dem rooms * Interest Free Credit * All leading brands * Also Open Sundays 10 - 4.00pm.

LANCASHIRE

CLEARSTONE 235 Blackburn Road (1/2 mile from city center on the A 666 Blackburn Road) Bolton, Lancs BL1 8HB Tel: (01204) 531423. Bolton's biggest Hi-Fi superstore. Every top brand & all the best buys at guaranteed unbeatable prices. Aiwa, Akai, Arcam, Audioblab, B&W, Bose, Castle, Celestion, Denon, Hitachi, Infinity, JBL, JVC, KEF, Kenwood, Marantz, Meridian, Mission, Mordaunt Short, NAD, Panasonic, Pioneer, Rotel, Sony, Tannoy, TDL, Technics, Toshiba, Yamaha. 2 dedicated Hi-Fi Demo rooms and 2 A/V Demo rooms, no appointments necessary. Service department, free installation, home trial facilities, free parking, Access, Visa, Amex, Dinners. Interest free credit. Open Mon-Wed 10.00-6.00. Thurs-Fri 10.00-7.00. Sat 9.00-6.00. Sun 11.00-5.00

MARTON MUSIC 5 Masterson Ave. Read, Burnley, BB12 7PL. For audition of the best stereo and surround sound equipment from BRYSTON (20 yr guar.), MYRYAD, PMC, RUARK, YAMAHA, and the latest WILMSLOW-HART electronics, in a comfortable demonstration room through commercial and custom-built speakers including Transmission Line, Open Baffle and Reflex designs. Home demos encouraged for complete satisfaction. Also main agent for Liberty Audiosuite loudspeaker/audion measurement system, ETF4.0 room measurement system and LspCAD room/box design/crossover package. Call Tony Seaford anytime for an appointment, a chat or free advice on 01282 773198 (fax 776413), or e-mail 106505.251 @compuserve.com.

ORPHEUS AUDIO Tel: 01257 473175 See our main entry under Greater Manchester.

PRACTICAL HI-FI 43 Friargate, Preston. Tel: 01772 883958. The audio visual specialist, expert advice, instant demonstrations, best prices, instant free credit, part exchange welcome. Extended warranty. Stockists of Yamaha, Castle, Teac, NAD, Lexion, Arcam, Kenwood, Denon, Sony, Technics, Onkyo, Marantz, Pioneer, Mission, Kef, Celestion, B&W.

PRACTICAL HI-FI 84 Penny Street, Lancaster, LA1 1XN Tel: 01524 39657 - See our main entry under Lancaster.

PRACTICAL HI-FI 33/35 Knowsley Street, Bolton, Lancs Tel: 01204 395789 - See our main entry under Lancaster.

PRACTICAL HI-FI 81 Whitegate Drive, Blackpool, FY3 9DA Tel: 01253 300599. See our main entry under Lancaster.

ROMERS HI-FI, 94-96 High Street, Rishton, BBI 4LQ. Suppliers of quality hi-fi equipment including: Linn, Arcam, Cyrus, Quad, Yamaha, Mission, Ruark, Sony, Monitor Audio, NAD, Onky, Bose, Castle, Nordost, Straightwire, Panasonic, Pioneer, Loewe, TDL, JVC, Target, Stands Unique. Specialists in multiroom installations. Access/Visa/Dynalab. Credit facilities. Open 9.00 - 5.30 Mon-Sat (5.00pm Wed & Sat). Tel: 01254 887799 Fax: 01254 876866

LEICESTERSHIRE

ZOUCH AUDIO Suppliers of quality Hi-Fi, Apollo, Audio Analogue, AVI, Bow Technologies, C.A.T., Celestion, Chord Electronics, Creek, D.C.S., Dynalab, Graham, John Shearn, L.A.T., Lumley, M.I.T., Magnum, Munro, Musical Fidelity, Musical Technology, Neat, Opera, Orchid, Orelle, Sirius, Stands Unique, Sumiko, Teac, Tice, Townshend, Transfiguration, Unison Research, Wilson Benesch, X.T.C. Open 10.00-5.30. Closed Monday. Zouch Audio, The Old Coach House, off South Street. Ashby De La Zouch, LE65 1AN. For further information call Michael on 01530 414128 or 0976 571875

CYMBIOSIS 6 Hotel Street, Leicester, LE1 5AW. Tel: (0116) 2623754. Email: shop@cymbiosis.com. Arcam, Acoustic Energy, Cable Talk, Castle, Chario, Chord Company, Cura, Denon, Linn Hi-Fi, Linn Knekt, Loewe Televisions, Lutron Lighting, Musical Technology, Naim, Nordost, Projekt Furniture, Rega, Revox, Rotel, System Audio, Tag McLaren, and Wadia. Multi room design & Installation Service. 4 listening lounges, Installation Service. Finance Available. Open 10-5.30 Monday to Saturday.

LEICESTER HI-FI 6 Silver Walk, St Martins Square, Leicester LE1 5EW. Tel: (0116) 2539753. Fax: (0116) 2626097. Arcam, B&W, Nautilus, Mission, Cyrus, Marantz, Pioneer, Quad, Tannoy, Copland, Pink Projects, Michell, Technics, Rotel, Rogers, Yamaha, Acoustic Energy, Chord Electronics, Teac, Miller & Kreisel, DPA, Talk Electronics, Greig Loudspeakers, E.T.C. 4 Listening areas over 3 floors. We can demonstrate, deliver and install. Including A.V. and Multiroom. Credit Facilities. All cards taken, open 6 days 9.30-5.30.

STEREO SHACK 1-3 Guildhall Lane, Leicester. Tel: (0116) 2530330. Fax: (0116) 2626097. Yamaha, Kenwood, NAD, Mission, Teac, Aiwa, Cerwin Vega, Pioneer, TDL, Thorens, JBL, Rotel, Celestion, Jamo & many more. We are A.V. specialists, 2 dem rooms. We can demonstrate, deliver and install. Credit facilities and all cards taken. Open 6 days 9.30-5.30

LONDON

AUDIOJOY LIMITED For equipment that sounds natural and musical, ring for friendly advice, demos and price deals. Professional Monitor Co., Trichord, Michell, Bryston & Laverdin, VPI, ClearAudio, Moth, Stands Unique, Target, Nordost, etc. 7 Days, 10am til 10pm. Telephone 0181 363 4963. Mobile 0966 231557. E-Mail: audiojoy@demo.co.uk www.audiojoy.demon.co.uk

BABBER ELECTRONICS SERVICE CENTRE 158 Uxbridge Road, West Ealing, London, W13 8SB Tel: 0181 579 6315 Akai, Aiwa, A&R, Celestion, Dual, Goodmans, Harman Kardon, JBL, JVC, Kenwood, Marantz, Panasonic, Sennheiser, Sony, ES range, Tannoy, Technics, Wharfedale, Yamaha and many more. Auth. Service Dept. Credit Facilities, Open 10.30 - 5.30 Mon-Sat.

BILLY VEE SOUND SYSTEM 248 Lee High Road, Lewisham, London SE13 5PL Tel: 0181 318 5755/0181 852 1321. Arcam, Denon, Marantz, Linn, Mission, Naim, Tag McLaren, Pioneer-DVD, Rega, etc. 2 domestic style listening lounges. Apts required, service dept, home trial facilities. Interest free credit, Access, Visa, Amex cards

accepted. Opened Mon-Sat 10-6.30, Closed Thursday.

CHOICE HI-FI Tel: 0181 392 1959. Specialist dealers in high end quality second-hand equipment. All main brands in stock including Krell, Audio Research, Wadia, Mark Levinson, Sonus Faber, Linn, Naim, SME & many more. Generous price given on trade-in. Part exchange welcome. Also dealers for Trichord, SME, Gamma, Trilogy, Lumley, Boulder & many more.

INFIDELITY 9 High Street, Hampton Wick, Kingston-upon-Thames. Tel: (0181) 943 3530. for full details see entry under SURREY

HIFI EXPERIENCE 227 Tottenham Court Road, London W1. 0171 580 3535. Arcam, Audioblab, Mission, Cyrus, Quad, Celestion, Kef, Meridian, Rogers, Tannoy, Yamaha, TDL, Thorens, Marantz, Nakamichi, Musical Fidelity and many more. Open 10.00-7.00 Mon-Fri. 9-6 on Sat. Service dept, Credit facilities, delivery and free installation.

K J WEST ONE 26 New Cavendish St., London W1M 7LH. 0171 486 8262/63. Fax 0171 487 3452. Two hi-fi & two home cinema dem studios. Apts pref. Home trial. Installation by arrangement. Service dept. Major credit cards. Interest free credit on selected items. Major brands stocked: Arcam, Audio Alchemy, Audion, Audioblab, Audio Research, B&W Castle, Chord, Copeland, DPA, Epos, Graaf, Harbeth, KEF, Klipsch, Krell, Lexion, Marantz, Martin Logan, Meridian, Michell, Micromega, Mission, Musical Fidelity, Nitty Gritty, Pink, ProAc, Quad, Regl, Rotel, Orelle, Sonus Faber, Stax, Tannoy, Theta, Unison Research, Wilson Benesch. Open 6 days.

THE LISTENING ROOMS 161 Old Brompton Road, London SW5 0LJ. (0171) 244 7750/59. Fax: (0171) 370 0192. Linn, Quad, Meridian, Nakamichi, Arcam, Audioblab, Acoustic Energy, SME, Audio Research, Krell, Wadia, Theta, Apogee, Martin Logan, Pioneer, Tannoy, Systemdek, Stax, Pink Triangle, Michell, Monitor Audio, Yamaha, Marantz, KEF, Bose, Celestion, Epos, Mission, Denon, Neat Petite. Mon-Sat 10-6pm.

ORANGES AND LEMONS 61-63 Webbs Road, Battersea, sw11. Tel: 0171 924 2040. Juicy fruit from London's freshest Hi-Fi / Home Cinema retailer, now in our second year. Telephone demonstrations, or just pop in. All the usual, i.e. friendly and efficient service, free home installation, credit cards, 0% credit finance available (subject to status), plus...all the very best from Arcam, Cable Talk, Castle Acoustics, The Chord Co., Denon, Epos, Kef, Marantz, Micromega, NAD, Naim Audio, Neat, Quad, Rega, Roksan, Rotel, Royd, Ruark, Soundstyle, Stands Unique, Yamaha and more.

THOMAS HEINITZ LTD 35 Moscow Road, Bayswater, London, W2 4AH. Tel: 0171 229 2077. Fax: 0171 727 9348. Email: info@thomasheinitz.com. Web site: www.thomasheinitz.com. Established in 1956 Thomas Heinritz has a long history of installing the best music and visual systems available. We continue to offer the highest standard of service in the most relaxed atmosphere. If you require multiroom, Av systems or just a high quality audio system then we can supply systems that are tailored to your exact requirements. For more information contact Rufus or Alester.

TIME & TUNE For T.V, video, Hi-Fi, and in-Car Hi-Fi, we are dealers of: Aiwa, Bose, Hitachi, Jamo, Kenwood, Marantz, Mitsubishi, Nad, Pioneer, Pioneer, Sony, Technics. For these and more come and see us at Time & Tune, 218-220 Whitechapel Rd, London, E1 1BJ. Or call 0171 377 2000.

GREATER MANCHESTER

ORPHEUS AUDIO...Passion for Total Fidelity... Authorised Dealer for: Acoustic Precision, Art Audio, Audio Analogue, Audiomeca, Audio Physic, Audio Synthesis, Boulder, Burmester, Cabasse, Conrad Johnson, Croft, DPA, E.A.R., Electrocompaniet, Forsell, Gamma Acoustics, Golden Tube, Graaf, Klipsch, Living Voice, Louther Voigt, Magnum, Meracous, OCM, Oracle, Orelle, Ortofon, Papworth, Project, Pentachord, Pink Triangle, Purist, QED, Sequence, Stax, Teac, Triangle, Trichord Research, Totem, Unison Research, VPI, Yamamura Churchill, YBA and others. Free

delivery/installation. Call for list of part ex. bargains. Demonstrations by arrangement in Standish (J27 of the M6), or in your own home without obligation. Tel: 01257 473175 (evening calls welcome).

PRACTICAL HI-FI 65 Bridge Street, Manchester M3 3BQ Tel: 0161 839 8869 See our main entry under Lancaster

SWIFT OF WILMSLOW, 4-8 St. Annes Parade Wilmslow. Tel: (01625) 526213. Aura, B&W, Denon, Kenwood, Marantz, NAD, Pioneer, Rotel, Tannoy, Revolver, JPW, Open 9.30-6.00pm. 2 dem. rooms. No pressure!

MERSEYSIDE

ACOUSTICA 17 Hoole Rd., Chester CH2 3NH Tel: 01244 344227. See our main ad under Cheshire.

MIDDLESEX

MUSICAL IMAGES 45 High Street, Hounslow, Middlesex. Tel: (0181) 569 5802. Fax: (0181) 569 6355.

MUSICAL IMAGES 173 Station Road, Edgware, Middlesex. Tel: (0181) 952 5535. Fax: (0181) 952 5535. Most brands available - see full page advert. Interest free credit, ask for details. Demo rooms. Repairs & Service. Sunday opening - Open all week. A Home Cinema Specialist. Mail order. Part exchange.

OPAL DESIGNS LTD. Rockware Business Centre, 5 Rockware Avenue, Greenford, Middlesex, UB6 0AA. Tel: (0181) 930 7972. Fax: (0181) 930 7976. Email: jas@opal.co.uk. Home Page: www.opal.co.uk. High-end Audio & Home Theatre Consultants. Authorised dealers: Mark Levinson, Proceed, Linn Hi-Fi, Linn Knekt, Runco Projectors, Finouga, Stewart Film Screen, Revel Loudspeakers, Stax, Wilson Audio, Martin Logan, Sonus Faber, MIT, Transparent, B & W. Mail order welcome. Credit cards accepted. Phone for latest brochure.

RIVERSIDE HI-FI 422 Richmond Road, East Twickenham, Middlesex, TW1 2EB. Tel: 0181 892 7613 Fax: 0181 892 7749. www.riversidehifi.co.uk Arcam, Bose, B&O, Castle, Copland, Denon, Krell, Marantz, Martin Logan, Michell, Monitor Audio, Musical Fidelity, NAD, Pioneer, Project, Rel, Sonus Faber, Sony, Tag McLaren Audio, Tannoy, Teac, Theta, Wilson. Finance available. Subject to status. Written details available on request. Export orders welcome. UK mail order available. 3 demonstration rooms. All major credit cards. Open 10am-5.30pm Mon-Sat.

NORFOLK

BASICALLY SOUND The Old School, School Road, Bracon Ash (Nr Norwich), Norfolk, NR14 8HG. Tel: (01508) 570 829. Stockists of the following leading Hi-Fi: Arcam, Audio Analogue, Beyer, Denon, Dynavektor, Epos, Grado, Naim, ProAc, Rega, Royd, Sennheiser, Talk Electronics, Teac and more. Bada members, 2 comprehensive demo rooms.

NORTHAMPTON

CLASSIC HI-FI At Classic Hi-Fi we cover the best in quality sounds. Be it a question of taste, a question of balance or a question of price, we're the ones to help. We stock: Marantz, Nad, Pioneer, Roksan, Yamaha, Heybrook, LFD, Sugden, Rotel, Kenwood, B & W, Kef, Rogers, Monitor Audio, Musical Fidelity, Tannoy, Shearpe Audio, Royd, Audio Alchemy, Teac and many more. For more details call: 01536 310855

LISTEN INN 32 Gold Street, Northampton, NN1 1RS. Tel: (01604) 637871 Making Music with help from Linn, Naim, Rega, Myryad, Arcam, Denon, Rotel, Yamaha, Marantz, Castle, Shahinian, Epos, KEF, Mission, Tannoy, Chord Company, Cable Talk, Dynavektor, Sumiko and others. 2 listening rooms, Open 10am-5.30pm (closed Thursdays).

NOTTINGHAMSHIRE

CASTLE SOUND & VISION 48-50 Maid Marian Way, Nottingham, NG1 6GF Tel: 0115 958 4404. Nottingham's leading hi-fi, multi room and home cinema store, serving the whole of the East Midlands. Brands

stocked include: Alchemist, Audio Valve, Bose, Boston Acoustics, Castle Acoustics, Chord Electronics, DMP, Denon, Jolida, KEF, Klyne, Linn, Linn Knekt, Lexicon, Loewe, Monarchy, Musical Fidelity, Naim, Nordost, Pink Triangle, Pioneer, Project Turntables, Precious Metals, REL, Rega, Revox, Seleco Projectors, Sheffield Lab, Solidsteel, Sony, Stand Unique, Stereophile, Talk Electronics, TEAC, Wavac, Wilson Benesch and XLO. Large showroom including purpose built home cinema room as well as three demonstration rooms. Home demonstrations and a full installation service available, including multiroom systems. Open 10.00 am - 6.00 pm Tuesday, Thursday, Friday and Saturday; 11.30am - 7.30pm Wednesday. Appointments out of normal shop opening hours can also be arranged.

NOTTINGHAM HI-FI CENTRE 120-122 Alfreton Road, Nottingham. Tel: 0115 9786919. Multi-room specialists. Hi-Fi, Home cinema. All leading brands stocked. Three superb demonstration areas. Two year parts and labour guarantee. Home trials. On site service facility. Full delivery and installation service. Easy free parking. BADA Dealer. Established 1968. Mon-Sat 9.00-5.30

OXFORDSHIRE

HI-CAM Buy/Sell Part Exchange. Good Quality Audio Products. Equipment includes: Naim, Linn, Audiolab, Kef, Mission, Krell, Meridian, Rel, Epos, Also Prologic Equipment. Open Mon-Sun 10.00am - 8.00pm. For genuine & friendly service Tel/Fax 01844 260182 Mobile 0973 233380.

OVERTURE HI-FI, 3 Church Lane, Banbury, OX16 8LR. Tel (01295) 272158. Email sales@overturehifi.demon.co.uk. Arcam, Bose, B&W Solid, Denon, KEF, Linn Products, Miller and Kreisel, Mission, NAD, Naim Audio, Yamaha. For sensible unbiased advice, call Oxfordshire's audio experts. Superb demo facilities. No appts. necessary, service dept. free install, home trial. Access/Visa, instant credit. Mon-Fri 10-6, Sat 9.30-5.30.

SHROPSHIRE

ADAMS & JARRETT Hi-Fi and Home Cinema Specialist. Phone or visit us at 6-18, Norman Road, St. Leonards-on-Sea, E.Sussex. (01424) 437165/432398. Stockist of quality equipment including: Audio Innovations, Meridian, KEF, Ruark, Marantz, NAD, JBL, Royd, Dali, Jamo, Onkyo, Rel, Traget, Cable Talk, Technics, TDC, Yamaha, Kenwood. Air conditioned listening rooms, on site service and repair facilities

MID SHROPSHIRE AUDIO 24 Peveril Bank, Dawley, Telford, Shropshire, TF4 2BU. Telephone: 01952 502097 OR mobile: 07930 913536. E-mail: roygagott@hotmail.com Used and ex-dem Hi-Fi equipment, call for current list. Also agent for Audionote, Alchemist, Appollo, Henley Designs, Michell, Ortofon, Project, SME, etc. I will give you top part/ex allowance against any new product. Home dems always a pleasure (I will travel any reasonable distance). **STRICTLY APPOINTMENT ONLY.**

SHROPSHIRE HIFI St Michael Street, Shrewsbury. Shrops. SY1 2ES. Tel. 01743 232065. Stockists of Musical Fidelity, Mordaunt Short, Sony, Kenwood, Pioneer, Rotel, Denon, B&W, Proac. Audio Visual. Products available. Open 9.30 - 5.30pm Mon-Sat.

SOMERSET

SOUTH WEST ANALOGUE Quality British and European Hi-Fi. SME specialist. Mk 2 turntable on demonstration. Michell, Garrard, Project, Ortofon, Tube Technology, Tesseract, Castle, Ensemble Cables. 01643 851351 anytime.

STAFFORDSHIRE

SOUND OF MUSIC The alternative Hi-Fi shop. 01270 214143. A.K.G., A.V.I., Alchemist, B.C.D., Blueprint, Castle, Chord Co., Deva, Dynaudio, Dynavector, Electrocompaniet, John Shearn, Kef, Lexicon, Linn, Loewe, Michell, Myrrad, Nordost, Ortofon, Project, Projekt Stands, Q.L.N., Restek, Roksan, Stands Unique, Teac.

SUFFOLK

AANVIL AUDIO, Tel/Fax 01359 240687 Mobile 0467 404874 Music from the Sound Foundry! Suppliers of: [Audio Physic]: Loudspeakers, Adyton: amplifiers, Meracus: CD transports, players, DAC's pre and power amplifiers, Yamamura Churchhill: cables and accessories, ART: Accessories Mail Order Accessories/CD's Cable/Amp Stock Clearance: Phone or fax for further details and ex-demo hardware offers. Most major credit cards accepted

ANGLIA AUDIO The Street, Hesseset, Bury St Edmunds, Suffolk, IP30 9AZ Tel. 01359 270212. "Hi-Fi and speaker centre dedicated to quality hi-fi since 1971. Open 10-6. Closed Weds and Sundays. Evening and Sunday Demos by appointment.

AUDIO IMAGES 128 London Road North, Lowestoft, Suffolk, NR32 1HB Tel: 01502 582853. Arcam, Acurus, Castle, Rotel, Moch, Triangle, QTA, Sugden, Denon, Yamaha, Mirage, M&K, Definitive, Musical Fidelity, plus the incredible Rothwell range. Refreshingly different selection. Dem Room. Professional AV installer's from budget to high end. Full credit facilities. 9.30 to 5.30 Mon & Sat - 9.30 to 6.00 Tues to Fri.

EASTERN AUDIO 41 Bramford Road, Ipswich, Tel. 01473 217 217. Fax 01473 215705. Quad, Arcam, Audiolab, Meridian, Mission, Denon, Rotel, Marantz, NAD, Sony, Rogers, Nakamichi, Systemdek, Technics, Celestion, B&W, Tannoy, Morel Thorens and Top Tape. Also stock a wide range of accessories. usual credit facilities. A BADA dealer.

STOWSOUNDS audio consultants, Stone Farm, Borough Lane, Great Finborough, Stowmarket. Tel: 01449 675060. We offer genuine impartial advice and demonstrations of quality audio equipment, racks and accessories. Demonstration by appointment here or in your own home. Some ex-demo and second-hand equipment. Phone for a consultation, demonstration, or price lists and product information.

SURREY

INFIDELITY 9 High Street, Hampton Wick, Kingston upon Thames, Surrey. KT1 4DA. Tel. 0181 943 3530. Stockists of: Arcam, Creek, Epos, Linn, Meridian, Naim Audio, Nautilus 800, Neat, Rega, Rotel, Royd, Shahinian, Stax, Yamaha. Open Tues - Saturday. 10.30am - 7.00pm.

SPALDINGS HI-FI 352-4 Lower Addiscombe Rd., Croydon, Surrey, CR0 7AT. 0181 654 1231/2040. 3 dem rooms and home dem. Free installation/credit. Meridian, Linn, Naim, Quad, Arcam, Audiolab, Mission, Denon, Tannoy, Marantz, Ruark. Mon-Sat 9-6, Tues 9-8, . Service dept. (3 Dem rooms incl. A.V. 0% credit).

UNILET SOUND & VISION 35 High Street, New Malden, Surrey. Tel (0181) 942 9567 or Fax. (0181) 336 0820. Six superb dem rooms, Interest free credit on all leading brands * Also Open Sundays 10 - 4.00pm.

SUSSEX (EAST)

ADAMS & JARRETT For the best Audio Visual Specialist with friendly helpful staff phone or visit us at 6-18 Norman Road St. Leonards-on-sea, East Sussex. Tel. 01424 437165/432398. Meridian, Kef, Ruark, JBL, Marantz, NAD, Dali, Jamo, Onkyo, Rel, Target, Technics, Yamaha, Kenwood, Musical Fidelity, Dynaudio, Denon, Tannoy, B&W, Rotel, Thorens. Interest free credit available subject to status. Visa, Mastercard.

THE POWERPLANT "Brighton's Leading Hifi Shop", 66 Upper North Street, Brighton, Tel. 01273 775978. Fax. 01273 748419. email@powerplant.co.uk. Open 10am-6pm Tues-Sat. Comfortable listening rooms. Experienced and friendly staff. ATC, Arcam, B&W, Cyrus, Rega, Linn, Pro-Ac, Tag McLaren, and much more.

SUSSEX (WEST)

AUDIO DESIGNS 26 High Street, East Grinstead, West Sussex RH19 3AS. Tel/Fax (01342) 314569. Hi-Fi, Home cinema + multi

room specialists. Authorised specialists of: Arcam, Audiolab, Castle, Cyrus, Epos, KEF, Linn (inc AV51), Marantz, Mission, Naim, Pioneer (inc LaserDisc), Quad, Rel, Rotel, Sony, Soundstyle, Stands Unique, Target, Thorens, Yamaha & more. 3 dedicated demonstration rooms - Hi-Fi & Home cinema. Service dept 0% finance available 9.30-6.00 Mon-Sat. Late by appointment.

WARWICKSHIRE

LEAMINGTON HI-FI CO 23a Regent Street, Leamington Spa, Warks. CV32 5EJ. Tel: 01926 888644 Fax: 01926 887486 E-mail: thehificompany@dial.pipex.com. Web: <http://www.hi-ficompany.co.uk> Arcam - Quad - Marantz - Denon - Pioneer - Yamaha - NAD - Mission - KEF - Celestion - Atacama - Technics - TDL - REL - Ixos Single speaker dem room. Permanent Dolby Digital Demonstration with rear projection televisions + DVD laserdisc hardware and software in abundance. Part exchange and credit available - subject to status.

SOUNDS EXPENSIVE 12 Regent St, Rugby, Warwks CV21 2QF. Tel: 01788 540772. Agents for: Arcam, Audiolab, B&O, Castle, Celestion, Denon, Dual, Kef, Mission, Marantz, Meridian, Pioneer, Quad, Rotel, Sony, Tannoy, Yamaha & many more. 2 year warranty on all hi-fi separates. 2 Demonstration rooms, Home Trials, All Major Credit Cards Accepted, Mail Order Welcome. Ring Now For Keenest Prices. Open Monday - Saturday 9.5-3.0. Closed Wednesday. If We Haven't Got It It's Probably Not Worth Having.

STRATFORD HI-FI 10a Chapel Street, Stratford upon Avon, Warwickshire. Tel: (01789) 414533. Arcam, B&W, Bose, Cyrus, Denon, KEF, Marantz, Micromega, Mission, Monitor, Audio, NAD, Panasonic, Onkyo, Pioneer, Rotel, Sony, Technics, Yamaha. Demonstration room. Service facilities. Mail order, Interest free credit. Open 9.30-5.30 Monday to Saturday. all major credit cards.

WEST MIDLANDS

MUSIC MATTERS Birmingham - 363, Hagley Road, Edgbaston, B17 8DL. Tel. 0121 429 2811.

Soihull - 93-95, Hobs Moat Road, B92 8JL. Tel. 0121 342 0254.
Stourbridge - 9, Market Street D48 1AB. Tel. 01384 444184.
Sutton Coldfield - 10, Boldmere Road, B73 5TD. Tel. 0121 354 2311.

Arcam, Alchemist, Apollo, Audioquest, Audio Research, B&W, Cable Talk, Castle, Celestion, Chord, Copland, Cyrus, Denon, DPA, JBL, Kef, Krell, Marantz, Martin Logan, Meridian, Musical Fidelity, Panasonic, Pioneer, REL, Rotel, Ruark, SME, Sennheiser, Sonus Faber, Tag McLaren, Teac, Theta, Yamaha etc. Classical CD's available at Birmingham only. Demonstration rooms, service and installation. BADA member. VISA / MASTERCARD / AMEX / SWITCH. Open: 10-5.30 Tuesday to Saturday. Late night Thursday till 7.00 (not Stourbridge).

FRANK HARVEY HI FI EXCELLENCE 163 Spon Street, Coventry, CV1 3BB. Tel: 01203 525200. Web Site: <http://www.frankharvey.co.uk>. Much more in store on 3 floors with 3 dedicated Hi-Fi demonstration rooms of the very best Hi-Fi. Plus our new Home Cinema Room. Appts Req. Open 9.30 to 5.30, Monday to Saturday. Authorised agencies include: Acoustic Energy, Atacama, Arcam, Audio Quest, Bang & Olufsen, B&W, Castle, Cable Talk, Celestion, Chord, Cyrus, Definitive Technology, Denon, KEF, Marantz, Meridian, Monitor Audio, Miller & Kreisel, Mission, Michell Gyrodek, Musical Fidelity, NAD, Optimum, Panasonic, Pioneer, Quad, QED, REL, Rega, Rotel, Sennheiser, Sharp, Tag McLaren, Target, Teac, Tannoy, Thorens, van den Hul, Yamaha. Interest free credit and part exchange. Wide screen TV, Projection and Multi room specialists.

GRIFFIN AUDIO 94 Bristol St., Birmingham, B5 7AH Tel. 0121 622 2230 Fax 0121 666 6795. Tues-Sat 10 a.m.-6 p.m. Enjoy music at home with a system from Griffin Audio. We demonstrate and install

the very best hi-fi, with systems from £500 to £25 000. Ask for Bob, Tim or Alex. Stockists of Arcam, Denon, Linn, Musical Technology, Naim, Quad, Rega, Shahinian, Stax.

SOUND ACADEMY For the Midlands. The Parade, Sutton Coldfield, Tel. 0121 321 2445 & High Street, Bloxwich, Nr Walsall, (sharing the ASDA shopping centre) Tel 01922 493499. Hosts 4 private studios plus a Home Theatre Cinema with Tube & LCD Projectors. The best in hi-fi from Naim, Arcam, Audiolab, Chord, Meridian, Monitor Audio and many more. So... if you've taken time to read this, please let us make you welcome. Phone 0121 321 2445 for Sutton or 01922 493499 for Walsall. Call in and to browse our exciting display of hi-fi and home cinema equipment. Mail order available. interest free credit S.T. Status. Open 6 days, 9am to 5.30pm. Please call for late night. Expert Advice, Cable Dressing and Installation.

WILTSHIRE

SALISBURY HI-FI LTD, 15 Catherine Street, Salisbury, Wiltshire SP1 2DF. Tel (01722) 322169. Arcam, B&W, Celestion, Denon, KEF, Kenwood, Marantz, Meridian, Micromega, NAD, Ruark, Sony, Yamaha, 2 Dem rooms. Friendly, relaxed atmosphere. Professional advice. Home dem available. Service department, Free installation. Home trial facilities. Access, Visa, Amex. Interest free credit. Instant credit. Open Mon-Sat 9-5.30.

THE RIGHT NOTE - See under BATH & BRISTOL heading.

WORCESTERSHIRE

MAX - MIDLAND AUDIO X-CHANGE 181 Franche Road, Kidderminster, Worcs. DY11 5AD. Phone: 01562 822236 • Mobile: 0421 605966 • e-mail: john.roberts20@virgin.com Analogue Hi-end specialist • Open Monday to Saturday 9.30 to 6.00 • Part exchange always welcome • Evening demos arranged by appointment • Service facilities • Free delivery. Suppliers and installers of high quality audio systems, including: Audio Note • Basis • BAT • Densen • Dpa • Electrocompaniet • Mark Levinson • Michell • Nagra • Pass • Primare • ProAc • Rega • Revel • Roksan • SPM • Sugden • UKD • Unison Research • Wadia. Access, MasterCard, Visa and Switch.

YORKSHIRE (EAST)

THE AUDIO ROOM 38 St Augustines Gate, Hedon, Nr Hull HU12 8EX. Tel: 01482 896166. Superb 1st floor showrooms and demonstration rooms are open. We are authorised agents for Accurus, Alchemist, Atacama, Audiovector, B&W, Base, CR Developments, Classé, Cable Talk, Chord Co., Dali, Denon, Grado, Helios, Jamo (concert only), Lavardin, Marantz, Monrio, Musical Fidelity, NAD, Neat, Opera, Onkyo, Ortofon, Pioneer, Pro-Ject, QED, Quad, Sonic Link, Sennheiser, Soundstyle, Stands Unique, Talk Electronics and more. Open Mon-Sat 9am-7pm. Credit facilities, home demonstrations available. Friendly, unbiased, personal service guaranteed.

ZEN AUDIO 35 George Street, Hull Tel. 01482 587397. "Comfortable listening rooms: Home dems; Personal, friendly service; Free installations. Agencies include: Arcam, Audiolab, Atacama, Audio Innovations, Audio Note, Audion, Alchemist, B&W, Cable Talk, Chord CO, DPA, Densen, Denon, DNMM, EAR, Exposure, Fi-Rax, Harbeth, Heybrook, Impulse, KAR, KEF, Michell, Micromega, Monitor Audio, Musical Technology, Myrrad, NAD, NAIM, Pioneer, REL, Rehdeko, Rotel, Royd, Ruark, Shearne Audio, Stands Unique, Sugden, Spondor, Sonic Link, TEAC, TDL, Tube Technology, Vivanco and many others.

YORKSHIRE (SOUTH)

HIFI STUDIOS DONCASTER Hi-Fi Studios. Sunnyfields, Doncaster, DN5 8SA. Tel: (01302) 781387. Fax: (01302) 391193. Alchemist, Audio Analogue, Audio Physic, AudioQuest, Blueprint, Castle, Celestion (A Series only), Densen, Electrocompanion, Exposure, Harbeth, Impulse Horns, John Shearpe Amplifiers, Living Voice, Michell Turntables, Monitor Audio, Musical Fidelity, Nottingham Analogue Studios, Opera, ProAc, Rell Acoustics Subwoofers, Ruark, Tag McLaren, TEAC, T&A, Unison Research. Home Cinema and multi-room experts. Demonstrations available. Audio Technica, Nordost, Ortofon, Stands Unique, Stax Electrostatics, Goldring, Listening Rooms. Home Trial, Free delivery, and installation. 2 years Guarantee. Access & Visa. 10-8pm Tues - Fri, 10-6pm Sat. Closed Monday. Phone for further information and FREE fact-pack.

MOORGATE ACOUSTICS 8 Westgate Chambers, Rotherham Tel: 01709 370666, 184 Fitzwilliam Street, Sheffield Tel: 01142 756048 - Audio Alchemy, Atacama, Arcam, Audio Lab, Audio Quest, Beyer, Bose, Canon, Castle, Cyrus, Celestion, Denon, Jamo, John Shearn (Amplifiers), Linn, Marantz, Mission, REL (Sub Woofers), Rogers (Speakers & Amplifiers), Royd, Sennheiser, Spendor, Tannoy "D", T.D.L., Technics, Yamaha. Demo rooms (6), Home Cinema, Access, Visa, Switch, Interest free credit (details available upon request), up to 5 years guarantee.

SOUNDWAVE AUDIO 22 Lord Mayor's Walk, York, YO3 7HA. Tel: 01904 646309. Hi-Fi sales incl. NAD, Onkyo, Dali, Cerwin Vega, Teac, Kenwood, Ortofon, Alchemist, Jamo and many others. In-house workshops for repairs and svcs. on all makes. Dem-room incl. Home Cinema. No pushy sales staff! Just good equipment and a friendly atmosphere.

SOUND ORGANISATION YORK, 2b Gillygate, York YO3 7EQ. Tel (01904) 627108. Carefully chosen Hi-Fi and AV equipment includes Arcam, B&W, Denon, Linn, M&K subwoofers, Naim, Rega, Rotel, Royd, etc 3 dem rooms incl. Home Cinema and Multi-room facilities. Service Department. Home installations. Instant Credit and major credit cards. Closed Mondays. Phone for chat and more details.

YORKSHIRE (WEST)

HUDDERSFIELD HI-FI CENTRE 4 Cross Church St, Huddersfield. (01484) 544668. B&W, Cyrus, Kenwood, Denon, Rotel, Arcam, Musical Fidelity, Quad, Audio Lab, Marantz, Mission, etc. Dem facilities - appointment reqd. Mon-Sat 9-5.30, Thurs 9-8. Closed Wed. Free installation, credit facilities. Access, Visa

PREMIER AUDIO Wakefield (01924) 255045. A brand new company offering a range of exciting Audiophile products carefully selected and professionally demonstrated. Equipment includes Audio Synthesis, Chord Company, Classé, cable Talk, DPA, EAD, Exposure, Harbeth, Korra, Mirage, Myryad, Orelle, Trichord and many others. demonstration facilities, Home demonstrations & Free installation. Part Exchange & used equipment Available. telephone for details and opening offers.

—SCOTLAND—
CENTRAL

COLIN MACKENZIE'S HIFI CORNER 52 Gordon Street Glasgow 0141 248 2840. Rose St Edinburgh 0131 220 1535, 1 Haddington Place, Edinburgh 0131 556 7901 and 44 Cow Wynd, Falkirk 01324 629011. Audiolab, Cyrus, Sound-Bytes, Meridian, etc. Most major Brands stocked. Free five year guarantee on all loudspeakers, keen prices. **JAMES KERR & Co.**, 145 Bath St, Glasgow 0141 226 5711. Glasgow's oldest established hifi specialist, now at new larger premises.

LOTHIAN

COLIN MACKENZIE'S HIFI CORNER 52 Gordon Street Glasgow 0141 248 2840. Rose St Edinburgh 0131 220 1535, 1 Haddington Place, Edinburgh 0131 556 7901 and 44 Cow Wynd, Falkirk 01324 629011. Audiolab, Cyrus, Sound-Bytes, Meridian, etc. Most major Brands stocked. Free five year guarantee on all loudspeakers, keen prices.

JAMES KERR & Co., 145 Bath St, Glasgow 0141 226 5711. Glasgow's oldest established hifi specialist, now at new larger premises

MUSIC MILL 72 Newhaven Road, Edinburgh EH6 5QG. Tel: 0131 555 3963 Fax: 0131 555 3964. Audio Research, Copland, Naim Audio, Krelli, Roksan, Rotel, DNM, Marantz, AVI, Martin Logan, Pro-Ac, Wilson Audio, Wilson Benesch Theta Digital, Transparant Audio, Alchemist, Quadraspire, Stands Unique. Listening Rooms, Free Parking, Full Workshop, Delivery and Installation. Open Mon-Sat 10-6.00 pm. Please phone for a map or contact Raoul, John, Mark, or Mike.

GRAMPIAN

HOLBURN HI-FI 441 Holburn Street, Aberdeen. Tel: 01224 585713. Arcam, Audiolab, B&W, Celestion, Denon, Dual, Epos, Heybrook, ION, Kenwood, Creek, Marantz, Meridian, Mission, Cyrus, M.S., NAD, Nakamichi, Pioneer, QED, Quad, Revox, Rotel, Ruark, Tannoy, Technics, Wharfedale, Yamaha. 9.30-5.30 Mon-Sat.

STRATHCLYDE

COLIN MACKENZIE'S HIFI CORNER 52 Gordon Street Glasgow 0141 248 2840. Rose St Edinburgh 0131 220 1535, 1 Haddington Place, Edinburgh 0131 556 7901 and 44 Cow Wynd, Falkirk 01324 629011. Audiolab, Cyrus, Sound-Bytes, Meridian, etc. Most major Brands stocked. Free five year guarantee on all loudspeakers, keen prices.

KEVIN GALLOWAY AUDIO, Audio Physic, Accuphase, Audion, Basis, DCS, JM Lab, Pink Triangle, Electrocompanion, Sugden, Nagra, Tara Labs. Nationwide delivery and installation. Demonstration by appointment. Tel: 01563 574185. Fax: 01563 573207.

JAMES KERR & Co., 145 Bath St, Glasgow 0141 226 5711. Glasgow's oldest established hifi specialist, now at new larger premises

LOUD & CLEAR 520 St Vincent Street, Finnieston, Glasgow G3 8XZ. Tel: (0141) 221 0221 or visit us at www.loud-clear.co.uk. Glasgow's finest and friendliest Hi-Fi store, combining knowledgeable advice with specially selected products and the best of service. Three comfortable demonstration rooms, full service and installation facilities, interest free credit on selected products. Product lines include Naim Audio, Exposure, Alchemist, Rega, Tag McLaren, Musical Fidelity, Marantz, Denon, Rotel, Acoustic Energy, KEF, KEF Reference, Monitor Audio, Tannoy, ProAc, VdH, Chord Co., DNM, Ash Design, Stands Unique. Open Tues-Sat 10am-6pm, Thurs till 7pm. Complimentary parking at PC World, Finnieston Street.

STEREO STEREO 278 St Vincent Street, Glasgow, Tel: 0141 248 4079 E-mail Stereo@cix.compulink.co.uk We will supply the most musical sound for your budget and if you take the time to visit us we will take the time to return the compliment with free installation of your chosen equipment. Open 10-6.00pm closed Sunday, Tuesday Installation Nationwide Interest free credit available

—WALES—
NORTH WALES

ACOUSTICA 17 Hoole Rd., Chester CH2 3NH Tel: 01244 344227. See our main ad under Cheshire.

ACTON GATE AUDIO 4 Ruabon Road, Wrexham, North Wales, Tel: 01978 364500. See our main ad under Cheshire.

GLAMORGAN (SOUTH)

SOUND DR. JULES SWANSEA, 01792280 061. Call now for price list, UK or overseas. Hi end new and pre-owned hi-fi at an affordable price. Home trial prior to purchase. Reliable courier service and repair service. Friendly and enthusiastic advice, day or evening seven days a week. A service to suit you.

—IRELAND—

AUDIO AUDIO HIFI SPECIALISTS 15 Mansfield Heights, Portglenone, Co. Antrim, N. Ireland BT44 8JR. Telephone 01266 822128/ Fax 01266 822128. Products include

Totem, Sugden, Denon, Ortofon, Project, Alchemist, QED, Chord Co., Arcam, Quadraspire, Audioquest, Rega, Soundstyle, Apollo, Grado, Ixos, Sonace, Optimum, Acoustic Energy, Tangent, Mighty Mighty, Sound Organisation, Jamo, Free installation. Please ask about our **FREE** customer care package.

CLONEY AUDIO 55 Main Street, Blackrock, Dublin, Tel. 2889449/2888477 Fax. 2834887. Products include: Arcam, Classe, Phillips, B&W, Naim Audio, Meridian and others. Open Tues/Sat 10am-6pm. Thurs/Fri 'till 9pm Closed Mondays.

DUBLINN HI-FI 38 Aungier Street, Dublin 2. Tel: (00 353) 1 4785205. Fax: (00 353) 14785219. We all have two ears and one mouth - use them accordingly. We only stock the best products, based on performance and reliability - not reviews or sales patter. Call Mark or drop in for a listen. Three single speaker demo rooms. Free delivery and installation. Full service department. Open Mon-Fri 10-7, Sat 10-6

-----NORTHERN IRELAND-----

KRONOS HI-FI 7 Scotch Street Centre, Dungannon, BT70 1AR. Tel: (01868) 753606. Fax: 753006. Email: David@KronosHi-Fi.demon.co.uk, website <http://www.KronosHi-Fi.demon.co.uk> We have one of the largest ranges of quality Hi-Fi in Ireland. Our agencies include Absolute Sounds, Apogee, Audion, Audiomeca, Blueprint, BOW Technology, Cadence, Copeland, Denson, Frameworks, Harman Kardon, Helios, JBL, Kelly, Kimber, Klipsch, Living Voice, Lyra, LFD, Marantz, Michell, MIT, Musical Fidelity, Nottingham Analogue, Oracle, Orelle, QL, N. Rogers, Roksan, Rotel, Ruark, Silver Sounds, SME, Triangle, Trichord, Unison, UKD, Wilson Benesch, YBA and much more. Demo rooms for Hi-Fi and A.V. Free installation, home demos and home trial. Access and Visa. Credit including instant and interest free. Multi-Room specialists. Open Mon-Fri 9.30-5.30. Closed Wed. Sat 10-5. We are also open any evening by appointment.

VINYL / RECORD MAIL ORDER

AUDIOPHILE UK LTD 214 Station Road, Addlestone, Surrey, KT15 2PH. Specialists in high quality, new and used vinyl & CD. Telephone order: 01932 701248 Fax order: 01932 701162. E-mail order: sales@audiophile.co.uk. Order your copy of our free monthly flyer and get the most up to date information on new releases plus the thousands of mint used LPs we hold in stock. As well as this we stock interconnects, record cleaning materials, isolation feet and many more accessories. Callers welcome by appointment. Hours Mon - Fri 9.30am 5.30pm and occasional Saturdays.

ABERGAVENNY MUSIC 23 Cross Street, Abergavenny, S. Wales. NP7 5EW Tel: 01873 853394. 9am - 5pm Monday-Saturday. E-mail: abermusic@compuserve.com. All major credit cards accepted. Abergavenny Music is a specialist classical music shop carrying a wide stock of CDs & Tapes. We regret we do not stock vinyl. Please phone for prompt personal service. Any item in stock can usually be posted on same day. First class free p&p. We welcome any enquiry or order.

DIVERSE MUSIC 12 Upper Dock Street, Newport, Gwent. NP9 1DF. 9am-5.30pm Mon-Sat. Internet site <http://www.diverse-music.co.uk>. Phone/fax 01633 259661 / 256261. E-mail: sales@diverse-music.cix.co.uk. Catalogues available. Mastercard, Visa, Amex, Switch, JCB. New and forthcoming releases: Blue Note 180gm LPs - re-issued on 14th April (very limited) also large current and back catalogue stock selection. P&P £1.00 1st LP, additional LPs 50p each (max £3.50) Please contact us for more details and catalogues.

SILVERNOTE PO Box 158, Cheshunt, Herts, EN7 6UH Always wanted: Vintage and

Modern Equipment, Records & CD's. Telefax Steve on 01992 620905.

VINYL DEMAND Stockists of VPI record cleaning machines and the widest range of audiophile vinyl in the UK - at the best prices. Living Stereo, Verve, Mobile fidelity, Decca, Absolute Analogue, Testament, MCA, DCC. Also a vast range of analogue accessories. Phone 01425-654545 or Fax 01425-654400 for orders or catalogues.

VIVANTE - Unit 4, 60 High Street, Hampton Wick, Surrey KT1 4DB. Tel: 0181 977 6600. Fax: 0181 977 4445 One of the UK's largest importer and distributor of audiophile and conventional vinyl is now operating a mail order service specialising in jazz and classical reissues. Labels include Decca, London, Deutsche Gramophon, Archiv, EMI, Telefunken, Testament, Verve, MPS, Milestone, Fantasy, Pablo and more. Extensive catalogue available. Access/Visa accepted.

CHRISTMAS TREAT - From the region's largest vinyl stockist: Spend £30.00 or more in store, cash or cheque, during December and get a whopping 15% discount. **WOODSTOCK RECORDS**, 22 Heritage Close, St. Albans, Herts AL3 4EB Tel/Fax 01727 846 907. Shop opening Mon 9.30-1.00 *Tues-Sat 9.30-5.30.

-----VINTAGE-----

AUDIO CLASSICS, 18/20 Chapel Green Road, Hindley, Wigan, WN2 3LL. Tel: 01942 257525. Fax: 01942 207089. Mobile: 0585 476574. Hi-Fi bought, sold, repaired and renovated. Mail order and vintage specialists. Please see our main ad (look under the ad index to find) for further information.

-----EX DEMONSTRATION-----

AFFORDABLE AUDIO (Northampton) Pre-Owned Hi-Fi Specialists. 168 Wellingborough Road, Northampton, NN1 4DU. Tel: (01604) 231261/845138. Mobile: (0370) 877893 Urgently required: compact disc collections, hi-fi separates, especially Linn products, Naim Audio, Cyrus Electronics, Musical Fidelity, Quad Electronics, almost anything British/American. Cash waiting, part exchange welcome. We also stock lots of audio accessories, compact discs, vinyl, Naim video recorders, DAT players. Single speaker dem room. All equipment is sold with warranties. All Credit Cards accepted. Please phone anytime for stock update.

AUDIO CLASSICS, 18/20 Chapel Green Road, Hindley, Wigan, WN2 3LL Tel: 01942 257525. Fax: 01942 207089. Mobile: 0585 476574. Hi-Fi bought, sold, repaired and renovated. Mail order and vintage specialists. Please see our main ad (look under the ad index to find) for further information.

CHOICE HI-FI/Hi-Fi Exchange Open 10am-8pm, 7 days by appt. Tel: 0181 392 1959/1963. Fax: 0181 392 1994. Agents for Acoustic Energy, Alon, ATC, Boulder, Bryston, Chord, Forsell, Gamma, Van den Hul, Lumley, Rockport, SME, Soundstyle, Straight Wire, Target, Trichord, Trilog, VPI, XLO and many more. We offer: generous part exchange, your equipment purchased, show room/dem room, single speaker dem room, trade in policy, credit card facilities, mail order, export service, finance available.

HAZELMERE AUDIO. To hear how realistic music can sound, please call for an appointment, (day or evening). Objective advice, comfortable listening, home-demonstration, free installations, part exchange, repairs and superb service. Acoustic Precision, Air Tagent, ATL, Audiomeca, Basis Classe, EAD, Fanafare, Henley, Magneplanar, Mirage, Monrio, Muse, Notts, Analogue, Opera, Ortofon, SD, Sirius, Straightwire, Tice, Triangle, Trilog, VPI. High Wycombe (01494) 437892.

TO ADVERTISE IN
DIAL A DEALER CALL
AMANDA SWEENEY ON 0171 328 1711
SARAH WRENN ON 0171 328 4892

HI-FI WORLD

Buying Guide

Our comprehensive new guide contains over 1000 hi-fi components, all tried and tested by Hi-Fi World's listening team. Backing up each one is our performance verdict to help you select the perfect upgrade or first purchase. Happy reading!

Contents

Loudspeakers	84
Integrated amps	87
Pre-amps	88
Power amps	89
CD players	90
Turntables	93
Phono stages	94
Cartridges	94
Tone-arms	95
Tuners	95
Cassette decks	97
DVD players	98
Headphones	98
CD transports	98
Classics	139

Loudspeakers £ Year Verdict

Under £300

Acoustic Energy AE100	£200	Jan 96	Reasonably neutral but ultimately lacklustre. Control of treble and mid-range poor.
Audio Gem Opals	£240	Dec 97	Partner the Opals with warm ancillaries and you get an involving sound. Avoid bright amps and sources.
Aura LSB-627M	£230	Aug 98	Energetic, bold and highly detailed, the Aura is one to consider for the budget-conscious.
Aura LST-627	£299	Oct 98	Like Aura's matching stand mounters, the 627Ms are lucid and controlled. Treble is brightish.
B&W 601	£200	Jan 96	Unrestricted and clean sound with satisfying musicality. An engaging subtlety not common at the price.
B&W DM302	£130	Apr 96	Clear open and detailed sound but balance too forward and weak bass.
B&W DM602	£250	Nov 96	Excel with taut hard-hitting bass with dynamic and uncoloured midrange. Metal dome tweeter bleaches out the treble.
Boston CR6	£150	Sep 98	With simple music, the CR6s work well, but not quite as well as the best of the competition.
Castle Isis	£230	Jan 96	A lively little animal, well worth the money.
Celestion 12i	£119	Feb 98	The 12is' powerful, confident sound belies a rather poor measured performance.
Celestion Impact 15	£200	Jan 96	Big presentation but a rather distant quality. Could sound boomy and confined.
Celestion Impact 23	£299	Nov 96	Sterling performance in the bass with speed and control. Good midrange projection.
Eltax Liberty 3+	£150	Jan 98	A lot of loudspeaker for the money. Punch and slam in the bass but sometimes thin in the treble.
Eltax Symphony 6	£240	Nov 96	Although bright, the Symphony 6s score for clarity and power. Bass is fast and accurate.
Gale 2i	£140	Feb 97	Smooth, balanced performers that do a good job on any genre. Free from the nasties that afflict many at the price.
Gale Mini Monitor	£50	Apr 97	Not the last word in midrange or bass clarity, but gives real hi-fi results for a paltry £50.
GLL ICT100	£170	Nov 95	For their size and price they offer some super qualities, especially stable imaging.
Heybrook Heylette	£270	Jun 98	A mini monitor with more precision and dynamism than the size and price tag would suggest.
Heybrook Optima	£259	Oct 98	Capable all-rounders, the Optimas combine smoothness, insight and control to great effect.
Heybrooks HB1 S3	£269	Nov 96	Excellent imaging with clear treble and midrange. Bass slightly dry and boxy but would suit a smaller room.
Jamo CS5 Actives	£200	Oct 98	In spite of a few colorations, the Jamos are fine examples of budget active operation.
JPW ML510	£130	Jan 98	With greater transparency and a bit more get-up-and-go, the 510s could be leaders of the budget pack.
Kef 60S	£200	May 96	The 60S is open and detailed but coloured too.
Kef Coda 7	£129	Apr 95	Rhythmic push and tuneful bass are the plus points of these small standmounts.
Kef Coda 8	£200	Jan 96	Breezy presence, good dynamics and a sense of fullness. Not the utmost in clarity, some box colouration.
Kef Coda 9	£299	Jul 96	Strong bass can get out of control, as can treble. This tends to overpower the midrange.
Kef Q15	£199	Feb 97	Impressive bass and a sweet clarity make the Q15s' speakers that'll put a smile on any audiophile's face.
Kenwood LS90UK	£129	Jul 98	The LS90UKs have dry bass and limited tonal colour, but staging and imaging are superb.
Linn Sekrit	£298	Apr 96	Well-behaved and with a decent tonal quality.
Linn Mission 700	£130	May 98	The 700s are easily outclassed by Mission's own superb 731 Pros at a £10 premium.
Mission 731	£129	Apr 95	An initially impressive, upfront sound but ultimately a little uninvolving.
Mission 731 Pro	£139	Jul 97	Music makers with a clean, punchy sound. Real value for money.
Mission 731i	£130	Nov 96	Mission's babies are a truly worthwhile improvement on the original 731s.
Mission 731LE	£150	Nov 95	Excellent sound puts the competitors in the shade. Well built and pretty too!
Mission 732i	£200	Aug 97	If you've got £200 with 'loudspeaker' written on it, then the 732i should be on your shopping list.
Mission 750LE	£250	Mar 98	The 750LEs with their combination of Aerogel clarity and budget cost are hard to resist.
Mission 771	£170	Jul 98	Superb stand mounters of real refinement and musicality. A touch bass light.
Mordaunt-Short MS20i	£200	Jan 96	Very tight bass and an all-round big sound. Some sharpness in the treble but assertive and clear.
Nad 801	£100	Jun 97	Impressive bass extension and midrange clarity are pluses. Prominent treble stops the 801 from challenging the best.
Paradigm Mini Monitors	£230	Aug 97	The Paradigms have a generally enjoyable sound but treble is sharp and midrange recessed.
QLN 122	£270	Jun 96	Solid bottom end will drive a large room well, but they're a bit bright too.
RDL RA Labs Mini Ref	£99	Jul 95	Engineering is not tip-top, but with a smooth system they will produce a clear and open, if bright, sound.
Revolver Purdey	£200	Jan 96	Rather small sound for a big cabinet. Absence of deep bass hard to forgive.
Rogers LS1	£149	Feb 96	Clear, bright and open but with weak bass. Best used close to or against a wall.
Rogers LS33	£250	Nov 96	Detailed and clear with a forward midrange. Could be a little rough on vocals, bass extension is limited.
System Audio 1005	£299	Aug 96	Excellent all-rounder that provides a real open window into almost every genre of music.
Tangent Monitor 11	£200	Nov 97	The Tangents' bass has attractive speed and impact, matched with smooth treble and open midband.
Tangent Monitor 2	£60	Jul 96	Good imaging as well as control. Tweets a bit too much but more than fine for the money.
Tannoy Mercury m1	£120	Jun 98	The best at the price and capable of embarrassing many more expensive speakers.
Tannoy Mercury m2	£140	May 97	For £140, you get a speaker with transparency and enjoyability unmatched at the price.
Tannoy Mercury m3	£240	Nov 97	Even overall balance and taut secure bass, if not the deepest ever. Slightly lightweight and uninvolving.
Tannoy R1	£199	Nov 98	Worth an audition if you need to balance a bright source and amp, but treble lacks clarity.
TDL NFM 1	£120	May 97	Bright treble is partially balanced by taut, well integrated bass, but outclassed by the competition.
TDL Nucleus 1	£60	Apr 97	Clean, incisive, detailed and revealing, especially in the bass.
Wharfedale Valdis 300	£150	Jul 96	Can work well if partnered to give weighty bass and smooth treble.



Blue Room Mini Pod.



Aura Speakers.

Loudspeakers £ Year Verdict

£300-£799

B&W CDM1SE	£600	Apr 98	Tuneful and confident, these 'speakers are well suited to Pop and Dance music.
B&W DM305	£350	Mar 97	All the ingredients for listening fun are mixed into the DM305. Overall presentation could be more cohesive though.
B&W P4	£600	Mar 95	Good-looking solid 'speakers with great spirit and tenacity but with a dry treble. Not fans of classical music.
Blue Room Minipod	£400	Jan 97	Arresting style allied to an engaging sound makes the Minipods attractive. Best partnered by smooth amps and source.
Carlsson OA 50.2	£585	Dec 98	Acoustic music gels nicely. More artificial pieces sometimes don't work so well.

BEFORE YOU INVEST
IN HI-FI
MAY WE SUGGEST
YOU INVEST
IN ONE OF THESE?



At Arcam we believe that buying hi-fi is a serious business. Before splashing out, we believe that you should sit back and consider just what you expect for your money. Quality of sound, reliability, value for money, technical excellence...these are standards by which Arcam hi-fi is judged...and is found to excel.

But don't just take our word for it. A glance through any hi-fi magazine will reveal that our efforts are applauded more than

almost any other manufacturer. To find out why, complete the coupon opposite and tell us which products you're considering. We'll send you independent reviews of suitable Arcam equipment. (We'll give you our own views by including a colour brochure with details of our whole range).

But neither we nor the critics are the final judges. You are.

So we'll also send you a list of dealers where you can sample the Arcam experience for yourself.

ARCAM

Simply complete the coupon and post it to:

Arcam, Pembroke Avenue, Waterbeach, Cambridge CB5 9BP. Or telephone: (01223) 203203

Please send me independent reviews of: (please tick box)

- Arcam Amplifiers
- Arcam CD players & DACs
- Arcam Tuners
- Arcam Home Cinema
- AudioQuest cables

Title _____ First Name _____

Surname _____

Address _____

Postcode _____

Loudspeakers £ Year Verdict

£300-£799

Castle Avon	£699	Dec 96	Taut, dry bass and lucid midrange but need matching to warm ancillaries to avoid sounding bright.
Castle Eden	£450	Mar 97	Impressively vice-free 'speakers that offer great transparency and involvement. Should be at the top of the list.
Castle Harlech	£799	Aug 96	Bass power and extension will impress but overall sound is uneven and rather sterile.
Castle Kendal	£450	Mar 98	The Kendals have great clarity but need coupling to warm ancillaries.
Castle Severn II	£579	Jul 98	Apart from some hardness in the tweeters, the Severn 2s are accomplished all-rounders.
Chario Hiper 1	£399	May 95	Music makers through and through with a great feel for rhythm and dynamics.
Dali 450	£700	Feb 96	A powerful and rich sound from these competitively priced floorstanders makes them worth a recommendation.
Epos ES12	£495	Oct 96	Strong, punchy bass allied to detailed and articulate midrange and treble.
Heybrook Heylios	£339	Mar 97	The Heylios stand out for their bass depth, dynamics and sound staging. Overall balance prefers Classical to Rock.
Heybrook Heylo	£389	Oct 95	Posses a neutral, fast and dry sound. A good match for soft sounding systems.
Jamo 307	£300	Apr 95	Delicate, detailed sound, albeit with rather imprecise imaging. Will work well on a bookshelf.
JPW ML910	£300	Nov 97	The 910s aren't perfect but they make music fun. Quality, power and extension, the Milleniums are worth a listen.
JPW Ruby 2	£395	Oct 98	Once allied to warm electronics, the Ruby 2s mix insight with plenty of involvement.
Kef LS3/5A	£599	Jul 95	Partnered with the Rogers AB1, this is a substantial marriage.
Kef Q35	£350	Nov 97	Very accomplished midrange and treble but the dry in the bass. For Rock fans the upper bass speed is appealing.
Kef Q55	£499	Aug 97	The Q55s look rather expensive at £500 with their 'boom and tizz' presentation.
Kef RDM1	£499	Oct 97	The RDM1s soundstage well thanks to their Uni-Q drivers. Can be uninvolved because of a lack of scale and impact.
Linn Tukan	£389	Dec 95	Highly musical standmounters that give similarly priced floorstanders a great deal to worry about.
Meridian A500	£750	May 95	Very polite and many will appreciate their civility. Deep powerful bass.
Mission 733	£300	Apr 95	Captivating floorstanders that bring music to life - what good hi-fi should do.
Mission 734	£430	Sep 95	Engineered for low price and showroom appeal rather than absolute sound quality.
Mission 751 Freedom	£350	Apr 97	Charming little stand-mounters with a sweet, warm, musical sound.
Mission 752 Freedom	£578	Jan 97	Dynamic, punchy, and musical yet refined like few at the price. Bass lacks a little depth.
Mordaunt-Short MS25i	£300	Nov 96	Sweet sounding metal dome tweeter although the dry bass and rather plasticky midrange work against it.
Musical Technology PM15	£474	Jan 99	Sophisticated, neutral sound and fine musicality put the PM15s near the head of the class.
Near 10M	£500	Jan 96	A thin and hard sound but precise with it!
Nmat Critique II	£445	Jan 99	Deserving 'speakers with good looks and build. Can fail to shine with over-polite equipment.
NHT 1.3	£389	Aug 95	Very crisp sounding 'speakers best suited to smaller rooms.
Ortofon ConCorde 6	£329	Oct 95	Good value floorstanders with clean enjoyable sound - not quite supersonic, though.
Polk PSW150	£500	Jul 97	The PSW150 adds depth to a system but can sound obvious at times.
Proac Tablette	£600	Aug 98	Amp-sensitive and slightly boxy in the lower treble, the ProAcs are still highly musical.
Rel Q Bass	£350	May 96	Needs care in setting up but this subwoofer offers serious quality bass for not a lot of money.
REL Q100E	£500	Apr 98	Another capable sub from REL that boosts bass and improves sound staging.
Rogers AB 1	£499	Jul 95	When used with the Kef LS3/5a this sub delivers the goods, beyond a doubt.
Roksan RokOn	£595	Feb 97	Musically involving 'speakers that many will enjoy, but a little unrefined at times.
Sequence 400	£329	Apr 96	Good at orchestral scale but coloured in the midband.
Soundcraft Absolute 4P	£799	Oct 97	The Absolute 4Ps excel in all areas except for the rather bright, hard treble. Bass is exceptional.
Spendor 2030	£599	Jun 96	Smooth, focussed and coherent in their delivery with deep and taut bass extension. Not the most spacious sound.
Systemdek 165	£400	Feb 96	Dry and clean sound, but can become hard and confused when pushed.
Tannoy Precision P10	£300	May 98	Though very even in their performance, the P10s lack ultimate clarity and punch.
Tannoy Profile 633 plus	£300	Nov 96	Weighty bass and rhythmic detail work well on dance. Less satisfying with classical music. Firm imaging.
Tannoy Profile 637	£500	Jun 95	With a rich sounding source you could well discover they're what you've been waiting for.
TDL RTL 4	£650	Feb 95	Easy going with plenty of detail and timbral richness. Better with classical fare.
TDL T-line 2	£550	Jan 97	Midrange and treble have good tonal colour, detail and speed. Bass is slow and blurred.
Technics SB-M300	£350	Nov 95	A great sound with solid bass from a compact and well priced 'speaker.
Technics SB-M500	£450	May 96	Clean, dry and taut with good imaging and sound staging. More neutral than Mission's 752s but less euphonic.
Triangle Comet TZXe	£475	Jan 95	Quite pleasant, inoffensive sound but others costing less can offer more.
Wharfedale Valdus 500	£300	Oct 95	Good for adding scale and power to a weak system or budget separates.



JPW Ruby 2.



Soundcraft Absolute 4P.

Loudspeakers £ Year Verdict

£800-£1499

Audionote E	£1450	Mar 95	Big, bulky and ultra-sensitive with quick pace and a well balanced sound, but not without flaws.
Audiovector M1 Sig.	£1479	Aug 98	The M1 Sigs may be a little laid-back, but they have a pleasant and involving sound.
Audiovector M2	£1499	Jun 98	The M2s are marred by a boom 'n' tizz presentation that suits Heavy Metal but not much else.
B&W CDM7	£999	Feb 98	With warm ancillaries the CDM7s produce a weighty, open sound. Bass could be faster.
Castle Howard S2	£1099	Mar 96	Fantastically deep and tight bass but some treble sharpness requires careful matching.
Celestion A2	£1499	Jun 98	Focus is not a strength, but bass extension and even tonality are. Metal tweeter can be bright.
Chario Academy One	£1199	Dec 95	Musical realism and a great real-wood finish make these speakers enjoyable, if not perfect.
Epos ES22	£1185	Jun 98	Aside from a slightly cool balance, the ES22s shine. Dynamics, bass depth and control are tops.
Event 20 20BAS	£829	Sep 98	Warm, detailed and well-endowed in the bass, the Events lack only a touch of overall control.
Harbeth DPM1 Active	£849	Sep 98	Now HHB's Circle Actives, these loudspeakers mix the best of pro and domestic to produce first-class results.
Harbeth HL Compact 7	£1329	Jun 96	Dry and analytical but truthful with it. A first class monitor ideally suited to acoustic or classical music.
Harbeth HL K6	£975	Dec 96	Clean, musical and classy - Harbeth have done themselves proud again!
KAR Torino	£895	Jan 97	The Torinos' stylish sound won't shame any system. That powerful bass does need space to breathe properly though.



RELEASE the FULL POTENTIAL of YOUR SYSTEM

STEP 1: YOUR MAINS

Start at the beginning! The truth is that poor mains quality ruins the sound of even the best equipment. The better the equipment, the bigger the difference. Kimber PowerKords and Distribution PowerBlocks remove mains pollution so effectively that they can more than double the performance of your system.

Call NOW for your free brochure.



They've now taken up permanent residence in our system! Dec 97

MAIL ORDER direct 0800 373467 (UK ONLY)

Russ Andrews Accessories Ltd., Edge Bank House, Kendal, LA8 9XZ
 Tel: +44 (0)1539 823247 Fax: +44 (0)1539 823317 www.russandrews.com E-mail: hw@art@russandrews.com

WHAT HI-FI? ★★★★★
 "What's more, a mains block of this quality is for life"
 Dec 97

audio

EXCELLENCE
WHERE THE MUSIC MATTERS

audio T

Great Value Sound & Vision

AUDIO T & AUDIO EXCELLENCE - probably the two best specialist retailers of hi-fi and home cinema equipment - give independent advice, excellent deals and a level of after sales service that keeps customers returning year after year.

We select products which offer high quality performance and value for money whatever your budget. We back this up with staff who have the knowledge that only comes from being genuine enthusiasts. We are not just the same as other dealers, so why not test our claims for yourselves soon at a town near you.

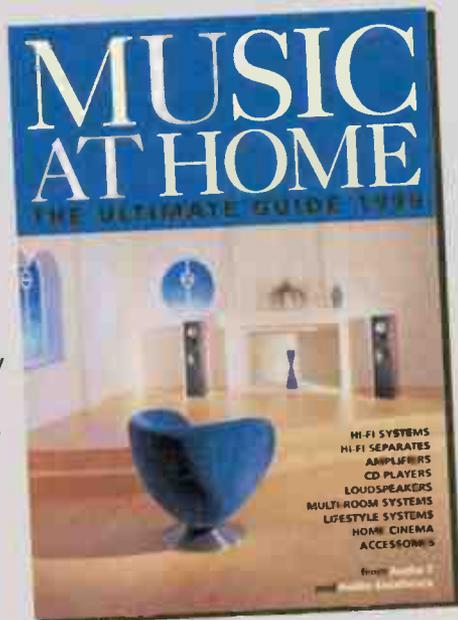

Ask for your free copy of **MUSIC AT HOME** The Ultimate Guide 1999

FREEPHONE 0500 101501

8am - 10pm 7 days a week (UK only. Please quote HFW2)
Or return the FREEPOST coupon below

- 49 years of experience ● fully authorised dealers
- full demonstration facilities ● 10 day exchanges
- 30 day no penalty upgrades ● interest free option on all sales over £250 (Subject to status. Written details on request)
- 3 year guarantee on hi-fi separates and systems ● home loans and home dems ● custom installation



Please send me my **FREE** copy of **MUSIC AT HOME - The Ultimate Guide 1999** (UK only)

NAME

ADDRESS

POST CODE

Music at Home HFW2, Freepost LV1747, Abingdon, OX14 4YQ

AT BASINGSTOKE
4 Feathers Lane
Tel: 01256 324311
Tues - Sat 9am - 5.30pm
Eve dems by appointment

AT BRENTWOOD
30 Crown Street
Tel: 01277 264730
Tues - Sat 9.30am - 5.30pm
Thurs eve open late until 8

AX BRISTOL
65 Park Street
Tel: 0117 926 4975
Tues - Sat 10am - 6pm
Thurs eve open late until 8

AT CAMBERLEY
173-175 London Road
Tel: 01276 685597
Tues - Satur 10am - 6pm
Thurs eve open late until 8

AX CARDIFF
134/136 Crwys Road
Tel: 01222 228565
Tues - Sat 9am - 5.30pm
Eve dems by appointment

AT CHELTENHAM
40/42 Albion Street
Tel: 01242 583960
Tues - Fri 9.30am - 6pm
Sat 9.30am - 5.30pm
Eve dems by appointment

AX CHESTER
88/90 Boughton
Tel: 01244 345576
Tuesday - Friday 10am - 6pm
Saturday 9am - 5pm
Thurs eve open late until 8

AT ENFIELD
159a Chase Side
Tel: 0181 367 3132
Tues - Fri 9.30am - 6pm
Sat 9.30am - 5.30pm
Eve dems by appointment

AT EPSOM
15 Upper High Street
Tel: 01372 748888
Tues - Sat 10am - 6pm
Thurs eve open late until 8

AX EXETER
156 Sidwell Street
Tel: 01392 491194
Tues - Sat 9am - 5.30pm
Eve dems by appointment

AX GLOUCESTER
58 Bristol Road
Tel: 01452 300046
Tues - Sat 9am - 5.30pm
Eve dems by appointment

AT HIGH WYCOMBE
30-32 Castle Street
Tel: 01494 558585
Tues - Sat 10am - 6pm
Thurs eve open late until 8

AT LONDON WEST HAMPSTEAD
190 West End Lane
Tel: 0171 794 7848
Tues - Sat 10am - 6pm
Thurs eve open late until 8

AT OXFORD
19 Old High Street, Headington
Tel: 01865 765961
Tues - Sat 10am - 6pm
Thurs eve open late until 8

AX PRESTON
131 Friargate
Tel: 01772 253057
Tues - Sat 9am - 5.30pm
Eve dems by appointment

AT READING
4 Queens Walk, Broad Street Mall
Tel: 0118 958 5463
Tues - Sat 9am - 5.30pm
Eve dems by appointment

AT SOUTHAMPTON
2-12 Hursley Road Chandlers Ford
Tel: 01703 252827
Tues - Sat 9am - 5.30pm
Thurs eve open late until 8

AX SWANSEA
9 High Street
Tel: 01792 474608
Tues - Sat 9.30am - 5.30pm
Wed eve open late until 8

AT SWINDON
60 Fleet Street
Tel: 01793 538222
Tues - Sat 9.30am - 6pm
Thurs eve open late until 8

AX WORCESTER
Independence House The Trinity
Tel: 01905 619059
Tues - Sat 9am - 5.30pm
Eve dems by appointment

All shops are closed on Mondays.

For the very latest information please check our web sites:
www.audio-t.co.uk
www.audio-excellence.co.uk
www.music-at-home.co.uk

PRICE PROMISE

- ★ You won't find better service.
- ★ You won't find better sound.
- ★ But if you find a better deal, let us know and as long as we can verify it we'll be happy to match it.

MAIN BRANDS STOCKED:

ACOUSTIC ENERGY
ALCHEMIST
ALPHASON
APOLLO
ARCAM
ATACAMA
AUDIO TECHNICA
AUDIOPHILE FURNITURE
AUDIOQUEST
AVI
B&W
CABLE TALK
CASTLE
CELESTION
CHORD
CHORD ELECTRONICS
CREEK
CYRUS
DENON
DENSEN
DYNAUDIO
DYNAVECTOR
EPOS
GOLDRING
GRADO
HEYBROOK
KEF
LINN
LOEWE
MARANTZ
MAXELL
MERIDIAN
MICHELL
MILLER & KREISELL
MISSION
MIT
NAD
NAIM
NORDOST
ONKYO
ORTOFON
PANASONIC
PARTINGTON
PIONEER
PRIMARE
PROAC
PRO-JECT
QED
QUAD
QUADRASPIRE
REGA
REL
ROTEL
RUARK
SENNHEISER
SHAHINIYAN
SONANCE
SONIC LINK
SOUND STYLE
STANDS UNIQUE
SYSTEMLINE
TAG McLAREN
TALK ELECTRONICS
TANNOY
TARGET
TDK
TEAC
TECHNICS
THORENS
VAN DEN HUL
YAMAHA

Not all products are stocked by every shop so please check with your local branch before travelling

Loudspeakers £ Year Verdict

£800-£1499

Model	Price	Year	Verdict
Kef Reference 1	£995	May 95	Beautifully fluid and integrated mid band and treble but can be slow, with a little loss of bass control.
KEF Reference 2	£1499	Jan 95	Handles rock and classical with equal aplomb, with the ability to reproduce detail that flummoxes many other models.
Kelly KT3	£1199	Apr 98	The KT3s go very loud very easily but they don't possess the most even response.
KRK V8	£995	Sep 98	Ultra-detailed and revealing, the V8s are true pro more than domestic transducers.
Magneplaner MG 0.6 SE	£1370	Mar 95	Very clear detail and separation, but just fails to produce a fully 3-dimensional sound.
Mirage 890i	£1075	Oct 95	An easy going, open and natural sound makes the mirages an attractive proposition.
Mission 754 F5	£1299	Sep 96	Articulate and informative sound with fine imaging and tight, deep bass.
Mordaunt Short 860	£1450	Dec 95	Fast, tight and informative, but a poor tweeter casts a grey shadow.
Musical-Tech. Falcon	£955	May 96	Give a big sense of scale on rock and jazz but not subtle and even enough for the critical classical listener.
NEAR Soundmast	£1199	Aug 95	An interesting, musical floorstander that's good value even at this price.
Origin Live Sovereign	£1225	Jun 98	The OLs have transparency and detail in considerable amounts. Bass can be loose though.
PT Ventricle	£896	Aug 95	Smooth and refined floorstanders that some listeners will find captivating.
QLN Signature	£1499	Mar 96	Super sound staging, openness and detail. Well worth seeking out.
REL Stadium 2	£995	Aug 95	Excellent bass performance means that this subwoofer is no toy.
Roksan Ojan 3	£1000	Jan 98	Unusual 'speakers with great rhythmic capabilities and bass. Could be more transparent.
Ruark Paladin	£1099	May 95	The Paladins possess a detailed and expansive soundstage but also a rather dry character.
Spendor 2040	£899	Oct 96	The tweeter works well but a recessed midband and one-note bass are the Achilles heels.
Spendor FL8	£1275	Jun 98	The FL8s are warm, mellow performers which prefer Classical to Rock.
Tannoy D300	£1000	Apr 97	Impressive bass extension and control go hand in hand with precise imaging to make the D300s a snip at £1000.
Tolem Model 1 Sig.	£1250	Sep 97	Imaging and sound staging are good but the move from standard to Signature has taken speed and punch out of the Model 1s.
UKD Callas Gold	£995	Jun 96	A rich and open sound, extremely musical if not strictly accurate. Great bass extension for their size.
UKD Divina	£1390	Jun 95	Not the most neutral 'speakers but they are extremely smooth with an overall coherence to the sound.



Jamo Concert 8.

Loudspeakers £ Year Verdict

£1500-

Model	Price	Year	Verdict
Audiovector 6	£4600	Jun 95	If you have enough room and money the 6s are capable of a highly musical, involving performance.
BKS 107 MkII	£1500	Dec 98	The 107 Mk2s may look slim but they have a solid sound and are fabulously revealing.
Cadence ES	£3500	Sep 95	Interesting design that incorporates an electrostatic tweeter. An impressive sound but an inconsistent performer.
Celestion A3	£1800	May 97	The A3s are quite simply superb. All you'll need to enjoy them is a large enough listening room.
Epos ES25	£1505	May 95	An extremely coherent and focussed sound; these are true audiophile speakers. Captivating with classical music.
Harbeth HLS8	£1999	Mar 97	Glassy clarity, bright treble, with bass that comes alive when given welly. Expensive though.
Heybrook Octet	£1800	Jul 98	The Octets are smooth, laid-back floor standers. Lack speed and transparency.
Jamo Concert 11	£2000	Dec 97	A worthy bigger brother for the Concert 8s, with a fast, transparent and even sound.
Jamo Concert 8	£1500	Jun 97	The Concert 8s are superbly clean and transparent. Their nature will show up any source shortcomings.
JBL S2600	£3500	Jul 96	Smooth, detailed and spacious with great scale, dynamics and imaging. Capable of producing a real performance.
Kef Reference 3	£2000	Nov 95	For superb reproduction within large rooms, the 3s are a force to be reckoned with.
Kef Reference 4	£3099	Oct 96	Superb bass and near-electrostatic soundstaging make these involving 'speakers a bargain.
Spendor SP7/1	£1970	Jan 95	Gorgeous looking. Listening becomes an enjoyable experience, full of surprises from subtleties.
Spendor SP9/1	£3400	Apr 96	One of the clearest and most expressive loudspeakers you'll ever find for a large room. Easy to drive, too.
Tannoy AMS8	£2702	Aug 96	Bold and powerful sound with solid bass, clearly focussed midrange and delicious treble. Well worth tracking down.
Tannoy D900	£3999	Sep 97	£4000 may be a lot to pay for a pair of 'speakers, but the Tannoys deliver to great effect in all areas.
Technics SB-M1000	£1500	Nov 96	Materially excellent value. Sound clean and extended but can lack involvement.
Th. Transducers Accelerando	£6600	Sep 96	Very sensitive, easy load. Convey great dynamics, but uneven sound and rather uninvolved feel make them look expensive.
Thomas Transducers Brio	£4750	Feb 95	Capable of producing a captivating performance of lifelike proportions with a great air of naturalness.
Thomas Virtuoso Gold	£3395	May 98	Impressive horns that combine lightness of touch with power and clarity.



Audio Analogue Bellini.

Integrated £ Year Verdict

Under £300

Model	Price	Year	Verdict
Alchemist Maxim	£299	Mar 96	Fluid and musical but upper bass is a little dry. Useful phono stage with but with a little sibilance and ringing.
AMC 3025	£150	Nov 96	A lot for very little money - sweet sound and good build make the AMC 3025 a great starter amp.
AMC 3050A	£170	Feb 98	Offers plenty of power for the money but sound quality is not class leading.
Arcam Alpha 5 plus	£250	Oct 96	Good with efficient loudspeakers but generally needs more power and control.
Arcam Alpha One	£230	Jan 99	In a smooth system with a warmish bias the Alpha One makes a strong case for itself.
Aura VA80	£279	Apr 95	Excellent value for money and will get the best from any component. Needs a separate phono stage.
Aura VA80 SEx	£250	Mar 96	The Aura has a smooth, civilized sound with fine detail. Bass punch really rolls along. Good phono stage.
Cambridge A1 MkIII integ	£100	Jul 98	Involving and finely detailed, the Cambridge pushes forward the boundaries for inexpensive amps.
Denon PMA 250SE	£160	Feb 97	A mix of control, delicacy and detail allows it to excel with any music.
Denon PMA 425R	£230	Sep 96	Good drive, punch and an open soundstage, but suffers from confusion plus a thin midrange and treble.
Denon PMA 450SE	£280	Oct 96	Big and brutish but unfortunately bland with it. Something of a blast from the 1970s-80s past!
Harmon Kardon HK610	£180	Jun 95	Thorough-going down to earth liveliness. Bright but clean which gives appealing vivacity.

AUDIO ANALOGUE

In just a short while, Audio Analogue has won plenty of admirers. When Hi Fi World tested the *Puccini* Special Edition, they gave it their top star rating with the words

"Excellent sound quality ensures the *Puccini* S.E. outstrips the competition at up to £1,000". And the influential USA magazine *Stereophile* (Dec.98) praised its "harmonic richness, stunning purity of tone and sheer musicality". To top that,

the basic £475 *Puccini* won Hi Fi Choice's Best Buy for amplifiers in an up-to £1,000 group test (Feb. '98). In their words: "This is a first-rate budget amplifier that looks and sounds like an altogether more costly model. Check it out". The *Bellini* preamp and *Donizetti* power amp fared equally well. Ken Kessler in *Hi Fi News* (Jan. '98) had this to say. "A new benchmark in the value for money stakes". Now, we're proud to introduce you to the

latest member of the family: the *Paganini*. It's a real music-lover's CD-player. For more details contact:

UKD

23 Richings Way, Iver, Buckinghamshire SL0 9DA, England
 Telephone: 01753 652669 - Telephone: 07000 UKD HIFI (853 443) - Fax: 01753 654531
 Or visit our website: www.uk.co.uk

Integrated £ Year Verdict

Under £300

Harman Kardon HK620	£280	Oct 95	Not quite a giant killer, the Harman is nevertheless a good solid budget buy.
Kenwood 3020SE	£200	Nov 94	Budget virtues and budget failings, too. Good with CDs but phono stage makes vinyl sound a little brutal.
Musical Fidelity E11	£299	Feb 98	A very capable integrated with a smoothness and warmth predisposed to classical rather than rock.
NAD 304	£239	Apr 95	Fine quality bass but rather lackadaisical as regards timing. Phono stage moderate. Needs careful matching.
NAD 310	£130	Jan 95	Good detail and a spacious open sound gives acoustic music and the majority of rock superb clarity.
Pioneer A103	£130	Mar 95	Luxuriant presentation doesn't compensate for the tendency to un-rhythmic effects. MM phono stage.
Pioneer A300X	£230	Apr 95	Another highly capable all-rounder although a touch sterile sounding for some tastes.
Pro-ject 7	£259	Apr 95	On a budget, the Pro-ject has strong merit, including an excellent phono stage. Not for all systems.
Rotel RA 970BX	£250	Oct 96	Fresh sound with sharp attack. A slight midrange emphasis can make certain music sound rather forward.
Rotel RA 931	£150	Dec 98	For the money there's no faulting such a gifted performer.
Sony TAF446E	£250	Aug 95	bright clear and detailed, but needs a touch more refinement to prevail.
Technics SU A700 mk3	£250	Jan 97	A smooth unassuming sound misses out on the subtlety which brings music to life.

Integrated £ Year Verdict

£300-£799



MVL A2+.

Alchemist Axiom	£300	Sep 95	Musically rewarding; deserves serious audition. Great British hi-fi on a budget.
AMC 3150A	£329	Nov 98	Not the most musical amp ever but good value. The tone controls and balance adjustment will appeal to some.
Arcam Alpha 6+	£350	Jan 96	Full and smooth sound, unfortunately with loose bass.
Arcam Alpha 9	£500	Dec 96	Excellent value. A detailed and open sound gives great atmosphere to all types of music.
A. A. Puccini SE	£595	Dec 97	All the main ingredients like rhythm and dynamics present and correct. Natural smoothness and transparency.
Audio Analogue Puccini	£595	Sep 97	Excellent sound quality outstrips the competition at up to £1000.
Audiolab 8000A	£500	May 95	Manages the rare feat of sounding powerful and lithe at the same time. Bass taut but not the last word.
Audiolab 8000S	£700	Dec 97	Powerful hefty sound which doesn't blanch when driving awkward loads. Perspective and tonal colour ultimately limited.
Benchmark Roynon SIA 1	£680	Aug 96	Too thin and crisp which makes prolonged listening fatiguing.
Cyrus 3	£500	Oct 96	Highly refined and detailed performance with a clear well-proportioned soundstage.
Cyrus Straight Line	£398	Nov 98	A good, honest bit of kit with a fine musical sound and no glaring vices.
Densen Beat	£650	Dec 97	If a musical adrenaline rush is what you seek, fine. Listening in bulk, rather clinical and cold sounding.
DPA Renaissance	£595	Dec 94	Rated very highly for serious listening. Richness of timbre, purity of sound and impressive concise imaging.
Holfi Audis	£750	Jun 98	Powerful and refreshingly pure; a sound investment.
Kenwood KA-7090R	£400	Apr 98	Excels with sound staging but lacks subtlety and tonal colour.
LFD Mistral	£499	Jun 97	An extremely enjoyable, lucid little amplifier that really gets to the heart of the music.
Marantz PM-66 KI-S	£400	Nov 97	An enjoyable and rhythmic sound but may be too lean for some bass-light speakers.
Monno MJ	£695	Jan 97	An engaging musical performance, sweet overall sound. Doesn't cope with difficult loads so well.
Moth 30 Integrated	£320	Jul 95	A big open sound sets the Moth apart at this price. Low powered, though. Distinctly amateurish looks.
Musical Fidelity X-A1	£480	Dec 98	Two boxes don't form a pre and power in the X-A1 but the result is nevertheless a winning combination.
Myryad T-40	£399	Nov 98	Couple the Myryad with a warm system and enjoy. Possibly a little lightweight on the Reggae & Rap side.
Nad 317	£470	May 97	With 80 watts on tap the NAD has power aplenty but is rather dynamically limited and ultimately uninvolved.
Naim Nait	£500	May 95	Rather monochromatic with midband emphasis and slightly dry bass. Good imaging but smallish soundstage.
Orelle SA 100	£449	Jul 96	Clean, open, active sound. Smooth and detailed with good punch too. One of the best at the price.
Pioneer A-300R Precision	£400	Aug 97	A bargain at £400 pure and simple. Outclasses the competition in every area.
Pioneer A400X	£300	Oct 96	Complements all sorts of music with power and confidence. Outstanding value for money.
Quad 77	£595	Feb 95	Although classically orientated, the Quad will rock too. Precise and stable imagery and fidelity to tonal values.
Roksan Caspian	£695	Jun 97	Mixes the best of solid state and valve worlds (without valves!) to produce a seductive sound.
Rose Scion	£615	May 97	Great packaging and super sound make the Scion a winner.
Sonneteer Champion	£579	Jan 96	Highly detailed and smooth sound. Worth searching out.
Teac ABX7R	£700	Jun 96	Big and powerful sound, but a little unsubtle with it.



Audio Analogue Puccini.

Integrated £ Year Verdict

£800-

Audionote Soro Se	£1999	Mar 95	Needs the right loudspeaker but a good musical presentation is in there somewhere. High sensitivity speakers essential.
Copland CSA 14	£1099	Apr 96	A sweet and subtle sound. Fine midrange; transparent and open with vocals.
Densen DM 10	£1299	Jun 95	Dual mono construction gives strong stereo separation. Brutal resolution of detail but not the clearest ever.
Exposure Super XV	£800	Oct 95	A stringy-sounding transistor amp for rock. Build and finish could be better and price lower.
Gamma Rhythm	£2499	Jul 96	Partnered with sensible loudspeakers of good bass depth, the Rhythm is capable of impressive performance.
McIntosh MA6800	£3735	Sep 95	A mighty confection of power, facilities and style, and it sounds good to boot.
Musical Fidelity A1001	£2499	Jun 98	Awesome power and seismic bass. A very good all-rounder with super-clean sound.
Shearpe Phase 2	£800	Apr 97	Even-handed performer deals confidentially with music regardless of genre. Not as smooth as the best.
Sonic Fronteers Anthem	£1295	May 98	A characteristically competent and musical integrated. Prefers fairly efficient loudspeakers though.
Sonneteer Alabaster	£900	Oct 97	Excellent high-end integrated with a real love of music and plenty of poke.
Teac AB X10	£1000	Sep 95	Very strong all round performer with excellent build and finish. Verging on the expensive though.
Unison Res. Simply 845	£2950	Mar 98	Allied to all the right speakers will handle all musical genres with smoothness and power.
Unison Simply 4	£1495	Oct 95	With a sweet, detailed and open sound the Simply 4 is unusually musical. Sensible facilities too.

Pre-amps £ Year Verdict

Under £300

Creek OBH-12	£200	Jul 98	Only poor cosmetics mar the Creek. Sonically it's a gem.
Musical Fidelity X-Cans	£130	Mar 98	If you haven't yet experienced the world of quality headphone listening, the X-Cans is the way to start.
Musical Fidelity X-Pre	£200	Jan 98	A smooth, sweet and musical performer.
Project 7	£259	Feb 95	Immensely enjoyable and listenable, a rare mixture of sophistication and fun.
Technics SU-C1000MkII	£299	Apr 98	Needs slightly more taut bass and a less grainy midrange to bring it up with the best.

To advertise in the Buying Guide

Please contact Amanda Sweeney on 0171-328 2213
or Sarah Wrenn on 0171-328 4892

Or email us on edit@hi-fiworld.co.uk

Pre-amps £ Year Verdict

£300-£799

Audio Analogue Bellini	£475	Apr 98	Organic and transparent. Free from transistor hardness.
Aura CA200	£749	Mar 97	A smooth and sweet sound devoid of roughness.
Crimson CS610C	£440	Nov 98	The phono stage is the main area of weakness. Can sound a touch muddled at times.
Croft Epoch	£600	Jun 96	A fine sounding preamp, but the phono stage is weak in the bass.
Cyrus Pre	£650	Feb 96	Pre-amplifier has plenty of facilities, but sounds a little unexciting and 'conventional'.
PM Audio Lab L1S	£650	Dec 95	This valve pre-amp is very good value indeed.
Sumo Athena II	£767	May 96	More valve-like than transistor in sound; highly competent if not spectacular.
Talk Hurricane 1	£500	Jun 97	Flexible with a strong controlled sound, but won't suit all tastes.
Technics SU C1000	£350	Feb 97	Good when mains powered, even better running on its batteries. One to consider at the price.
Thorens TTA2000	£550	Jul 95	Poor sound quality and engineering let this pre-amp down. Pricey too.
Unison Res. Feather 1	£795	Aug 98	Warm but still exciting, it is only let down by a slightly recessed midrange.
Heybrook Signature II	£549	May 97	Impressive smoothness and tonal colour, transparent as well.

Pre-amps £ Year Verdict

£800-£1499

Alchemist Freya	£1020	Oct 94	Quite gentle, yet controlled, the smoothness suits classical.
Etalon Preamp	£1095	Feb 98	Smooth, even and transparent. Well worth the outlay.
John Shearne Phase 6	£895	Sep 96	Matched with a smooth amp and speakers the Phase 6 is capable of a transparent and rewarding performance.
Linn Wakonda	£900	Apr 98	In terms of musicality and involvement it falls short.
Meridian 502	£1295	Dec 96	Transparent, detailed sound with good tonal range and very natural presentation.
Musical Fid. Nu-Vista	£1200	Sep 98	A truly competent pre-amp whose high-end sound comes with a very reasonable price tag.
Naim NAC102	£999	Apr 97	This even-handed performer images well and deals confidently with music regardless of genre.
Quad 7741	£850	Jul 96	Bright and detailed, but phono stage is inadequate at this price.
Shearne Phase 1	£1099	Oct 94	Very good all-rounder with clarity and a strong treble.
TAG McLaren PA10	£850	Nov 98	Justifies its price with a very musical and revealing performance.
Tube Technology Prophet	£1310	Jun 94	Beautifully built and finished, it will attract attention in any home.
XTC Pre-1	£1000	Nov 96	This pre-amp is highly detailed and spacious.



Chord CPA-1800.

Pre-amps £ Year Verdict

£1500-

Audiovalve PPP30	£1995	Mar 95	A bright and lean approach to the valve sound.
Chord CPA 1800	£1774	Mar 98	Has it all - detail, transparency, slam and rhythm. In a word excellent.
Focusrite Red 4	£2345	Feb 96	Smooth and detailed sound. Not as clinical as some professional amps can be.
Galactron Pre	£1630	Nov 95	Smooth, but dull balance makes it suitable for bright systems.
Marantz 7	£3500	Mar 97	Superb, combines delicacy and power, especially with a vinyl source.
Michel Orca	£1650	Oct 98	With its Panasonic pot, the Orca reaches new standards of transparency and involvement.
Unison Res. Mystery 2	£1750	May 98	Offers finesse, control and clarity for a very reasonable outlay.



Monarchy SM-70.

Power amps £ Year Verdict

Under £800

Arcam 9P	£400	Dec 96	A detailed and open sound gives great atmosphere to all types of music.
Arcam Alpha 10P	£600	Jul 98	This power amp lags behind the best of the competition, and the build is flimsy.
Audio Analogue Donizetti	£575	Apr 98	As smart as an Armani suit, they sound powerful in a natural, organic manner.
Aura PA100	£749	Mar 97	A smooth, sweet powerful sound free from the rough brightness that afflicts many solid-states.
Cyrus Power	£449	Feb 96	The Cyrus Power is simply impressive in all respects.
Linn LK100	£650	Apr 98	Well built, but judged purely on a musical basis they fall short.
Linn LK240	£750	Aug 97	The LK240 plays tunes exceptionally well, tonal colour and image precision are not its fortes though.
Meridian 505	£795	Aug 97	Crisp, clear images are set in a broad spread between the speakers but the 505 lacks stage depth and grunt.
Monarchy SM-70	£595	Jan 99	The Monarchy is a smooth, warm amp most at home with speakers that are easily driveable.
Moth Stereo 60	£549	Dec 95	This power amp unfortunately suffers from sharp sounding treble and poor depth.
Musical Fidelity X-A50	£500	Jan 98	Very smooth, sweet and musical performers, not over-analytical but very involving.
PM Audio Lab 211SE	£2750	Dec 95	The MP 211A power amplifiers are detailed and open with great bass.
Quad 77/67	£600	Jul 96	With good punch, speed and attack its not bad at all but can be a little uninspiring.
Rose RP-190	£495	Nov 93	An amplification system with a wide range of facilities, easy upgrade path and a smooth and relaxing sound.
Shearne Phase 3	£689	Apr 97	The Phase 3 possesses impressive clarity, detail and dynamics.
Talk Tomado 1	£500	Jun 97	A flexible power amp with a strong, controlled sound, but won't suit all tastes.
Technics SE-A1000	£400	Feb 97	Smooth, warm sound has plenty of grunt when needed and is very enjoyable to listen to.
Thorens TTP 2000	£500	Jul 95	Its best feature is the key on/off switch, otherwise its a case of poor sound quality and engineering.



HEATHERDALE AUDIO LTD.



202 FINNON ROAD, WORTHING, WEST SUSSEX, BN14 0EJ
 TEL: 01903-872288 OR (AFTER HOURS) 0860 660001 FAX: 01903-872234
 e-mail: heatherdale@hifi-stereo.com http://www.hifi-stereo.com

HEATHERDALE PRE-OWNED GUARANTEED EQUIPMENT EXPORT FACILITIES AVAILABLE

PASSLABS X 600	£1195	NEW
CONRAD JOHNSON MP11	£950	NEW
GOLOMUNO REFERENCE	£900	NEW
MARK LEVINSON M2	£1000	NEW
AUDIO RESEARCH SP15	£1100	NEW
GRAHAM M 2	£1100	NEW
VAC	£1100	NEW
AUDIOLAB	£1100	NEW
ROTEL RT 100	£1100	NEW
KLH R	£1100	NEW
ACCUPHASE	£1100	NEW
HAKAMICHI 1010	£1100	NEW
TECHNICS S1	£1100	NEW
TRIEL	£1100	NEW
SOLISTICE AAD	£1100	NEW
ALDIS CDT III	£1100	NEW
ACCUPHASE	£1100	NEW
AERIAL A	£1100	NEW
AUDIOWIDE P2SE P	£1100	NEW
AUDIOWIDE P4	£1100	NEW
AUDIOWIDE N	£1100	NEW
AUDIOWIDE 10	£1100	NEW
AUDIOWIDE 20	£1100	NEW
AUDIOWIDE 40	£1100	NEW
MONITOR AUDIO	£1100	NEW

B & W MM250	£1100	NEW
MIRAGE M Ls	£1100	NEW
EXPOSURE 25	£1100	NEW
EXPOSURE 21	£1100	NEW
EXPOSURE 18 S	£1100	NEW
JVC 7050 P	£1100	NEW
SYNERGISTIC	£1100	NEW
1.5 MP	£1100	NEW
QUAD NEW	£1100	NEW
QUAD NEW	£1100	NEW
TEAC A 14	£1100	NEW
LUXMAN MC3000	£1100	NEW
LUXMAN S 700	£1100	NEW
MARTIN LOGAN	£1100	NEW
PASS LABS	£1100	NEW
ORCHID	£1100	NEW
MIT	£1100	NEW
ROKSAN	£1100	NEW
ARAGON AURIUM	£1100	NEW
ARAGON PALLADIUM	£1100	NEW
KINERGISTIC SUBWOOFERS	£1100	NEW
LUXMAN M2000	£1100	NEW
NEAT	£1100	NEW
MARK LEVINSON	£1100	NEW
MARK LEVINSON	£1100	NEW
MARK LEVINSON	£1100	NEW
MILLER & KREISAL	£1100	NEW
MISSION 782	£1100	NEW

QUAD ESL 63	£1500	NEW
VOYD	£1395	NEW
CELESTION	£850	NEW
BURMESTER	£990	NEW
VP119	£720	NEW
FORSELL	£695	NEW
FINESTRA	£1195	NEW
MERIDIAN	£1195	NEW
RUARK	£1195	NEW
KEF	£1195	NEW
REVOX	£1195	NEW
VOYD T	£1195	NEW
MIT	£1195	NEW
HELLIUS	£1195	NEW
MARANTZ	£1195	NEW
TARA	£1195	NEW
AUDIO MECA	£1195	NEW
AUDIO INNOVATIONS	£1195	NEW
IMPULSE H5	£1195	NEW

WE NOW OFFER 0% FINANCE * PLEASE PHONE FOR DETAILS

(Subject to status)

MAIN UK DEALERS FOR TRIEL SPEAKERS
 MARK LEVINSON, ABSOLUTE SOUNDS, & MUCH MORE
 EX-DEM EQUIPMENT AVAILABLE PHONE LIST
 FOR AN UP-TO-THE-MINUTE LIST VISIT OUR WEB SITE
<http://www.hifi-stereo.com>

VISA - SWITCH - MASTER CARD - AMEX - DINERS CLUB WE COME
 WE TAKE PART EXCHANGE ON NEW & USED STOCK AND BUY IN FOR CASH

Power amps £ Year Verdict

£800-£1499

Malbarry S508	£850	Aug 92	All the makings of a budget high-end classic. Sweet and warm if slightly soft at the top end.
Audio Innovations 800	£849	Feb 94	Very worthy valve amp with a silky smooth response and plenty of grunt when called for.
Audiolab 8000Q	£999	Jun 95	Highly recommended for its blend of operational sophistication, build and sound quality.
Chameleon Ruby	£995	Jan 96	Well specified and powerful, but dry and short of life. Suits Rock on bass-heavy speakers.
Chord SPM 400	£1325	Mar 98	This amp has it all - detail, transparency, slam and rhythm. In a word, excellent.
Crimson CS630C	£800	Nov 98	These monoblocs have a tonal richness and bass speed rare amongst powerful amps.
Croft Series V	£800	Jun 96	Fast, clear and detailed sound will win friends in both the transistor and valve camps.
Delph Da Capo	£1469	May 95	Quality bass and a clear midband but the treble can be harsh at high volume.
DPA 200S	£1245	Jul 93	Serious audiophile product at an affordable price. Well constructed, pleasant to use and fine sounding.
Galactron Power	£1200	Nov 95	Smooth sound but dull balance make the Galactron suitable for bright systems.
HD Audio Duo	£1185	May 95	Not dissimilar to the Audiolab monoblocs, the sound has a sweet top and amazing clarity.
Heybrook Signature II	£1051	May 97	Not quite as transparent as it could be but impresses with its smoothness and tonal colour.
Meridian 557	£1400	Dec 96	Great control and dynamics allied to seductive smoothness. A rare combination of power and delicacy.
Musical Fidelity X-A200	£1000	Aug 98	Hugely powerful and controlled, the X-A200s are still superbly musical.
MVL Integral A2	£895	May 99	An excellent performer with any music. It is hard to imagine the A2 being beaten at the price.
Myryad MA120	£1000	Apr 96	The sound is a somewhat acquired taste and a little rough in places.
Omak Jewel One	£899	Jul 95	A lot of amplifier for the money. Big, warm, sweet sound places it ahead of most.
Quad 707	£800	Jul 97	The 707 embodies a rare blend of grace and power in its sleek grey casework.
Sugden 41P	£899	Apr 93	A good balance between detail and fullness without serious compromise.
Sumo Polaris III	£898	May 96	More valve-like than transistor in sound, highly competent if not spectacular.
TAG McLaren 60P	£850	Nov 98	Fully justifies the cost with a very musical and revealing performance.
VRR Adur	£1495	Jun 95	Lovers of light piano-based fare and Baroque music will appreciate this amp's delicacy.



Final Music-6.

Power amps £ Year Verdict

£1500-

Audiovalve LC8	£1995	Mar 95	Eschews the traditional lavish tube sound for a brighter and leaner approach.
Canary 301	£3055	Nov 98	The 301 puts the 300B's traditional virtues to good use in a push-pull design that will drive most loudspeakers.
Cary 300B SE	£3975	Feb 98	Cary have a winning amplifier that is a prime example of how a 300B can sound.
Etalon Ampli	£2925	Feb 98	Very natural, substantial presentation with lots of power on tap.
Final Music-6	£1500	Feb 99	This battery-powered power amp has a convincing three-dimensional sound and scale.
Focusrite Red 5	£2057	Feb 96	Powerful, smooth and detailed sound. Not as clinical as some professional amplifiers can be.
Gamma Aeons	£4999	Apr 97	Sound quality of these monoblocs is impressive but marred by a rather obvious hum. Build could be better.
Mirantz 9	£8000	Mar 97	These monoblocs are superb, producing a beguiling performance of great control and verve.
Marantz MA22	£2199	Apr 93	Sound is certainly not too hard, in fact it's rather warm. There are more dynamic outfits around however.
Michell Alecto	£1989	Oct 98	The new Alecto is crisper, cleaner and more controlled than earlier incarnations.
Orchid RC750	£6600	Aug 96	A powerful grip on music, but articulate and detailed too. A rare combination.
Shearpe Phase 1	£1999	Oct 94	Good sound quality and an impressive tonal balance.
Sugden Symetra	£1550	Oct 96	The Symetra monoblocs impress with their grip. They run hot and sound warm.
Tube Technology Genesis	£2599	Jun 94	Valve monoblocs that produce explosive bass, midrange as clear as a bell and shimmering treble.
Unison Res. Smart 300B	£4250	May 98	Powerful, neutral sounding amps thanks to their modified 300B valves, but a little expensive for the same reason.
Unison Res. Power 35	£1525	Aug 98	A great compromise between delicacy, power and practicality. Very musically satisfying, too.
Vadis S15	£2350	Jul 98	The S15's purity and clarity are impossible to beat for the money. Bass is not brilliant, but still better than most.
XTC POW-1	£2000	Nov 96	This power amplifier is smooth and seductive, although a little pricey.



Cambridge CD4SE.

CD Players £ Year Verdict

Under £300

AMC CD8	£150	Oct 97	The CD8 is free from grain but can sound too polished at times.
Cambridge CD4SE	£200	Feb 98	Natural and very life-like - the CD4SE embarrasses many pricier players.
Denon DCD-315	£150	Jan 96	Great box of tricks which gets all of the basics right. A bargain.
Denon DCD-425	£150	Apr 97	Crisp, up-beat player which is inconsistent in its overall presentation.
Denon DCD-635	£180	Feb 98	Rhythmically slick and dynamic, the Denon errs to the cool side of neutral.
Denon DCD-835	£280	Nov 98	Warm and smooth - the 835 is laid-back rather than in-your-face.
Grundig CD3	£240	Sep 94	Great for simple Jazz and Folk, but soft bass slows things down.
JVC XL-V230	£157	Jan 99	Slightly muddled in the bass, the '230 isn't the most rhythmic of players.
JVC XL-Z574	£250	Apr 95	Light in the bass and methodically mechanical, the JVC prefers sparse tracks.
Kenwood DP-3080II	£180	Feb 98	One of the best budget all-rounders there is. A shade treble-heavy.
Kenwood DP-5050	£250	Aug 93	Waffly bass and enthusiastic treble mean the Kenwood prefers Classical to Rock.
Kenwood DPF-3010	£180	Jan 99	A fine performer. Lacks only some of the spirit of its predecessors.
Marantz CD-63	£249	Jun 94	Upholds the Marantz tradition of lively CD players.
Marantz CD-67	£270	Nov 96	Fine vocal projection and treble. Bass is deep if not that light.

WORLD'S BEST AMPLIFIER UNDER £1,000?

WORLD VERDICT

An excellent performer with any music. At present, it would be hard to imagine the A2 being beaten at the price.

HI-FI WORLD MAY 1999



MVL

For more information ring 01953 850800 (See our main ad)

MVL Technology Limited, Northfield Mill, Wymondham, Norfolk NR18 0DF. Tel: +44 (0) 1953 850800 Fax: +44 (0) 1953 851022
Sound Sentinel® manufactured under licence from Sound Sentinel Systems. Sound Sentinel® is a registered trade mark.



CD Players £ Year Verdict

Under £300

Model	Price (£)	Year	Verdict
NAD 510	£200	Oct 95	Hard to criticise at the price, with a typically smooth, fluid NAD sound.
NAD 522	£170	Jan 99	Warm and smooth, this is a cultured player. Can be over-civilised at times.
Philips CD721	£130	Feb 96	Not the most accurate machine, but holds its own at the price.
Pioneer PD-103	£140	Feb 95	Rolled-off treble limits detail. Light bass retains foot-tapping ability.
Quad 67	£?	May 93	One of the top players at the price with great speed and grip.
Rotel RCD-940BX	£230	Oct 94	Controlled and invigorating player albeit a touch sterile.
Teac CD-P3450SE	£200	May 97	Refuses to become flustered. Can lack emotion as a result, though.
Teac CD-P4500	£249	Nov 92	Like many of its contemporaries, the Teac is too smooth to shine
Technics SL-PG490A	£100	Jan 99	In spite of a bias towards bass and treble, this machine remains a bargain.
Technics SL-PS570D	£200	Feb 98	Typical Technics' bright and bassy sound. Prefers Dance and Rock
Yamaha CDX-480	£200	Mar 95	Mature, laid-back machine drops points for inferior timing and imaging.
Yamaha CDX-590	£230	Feb 98	Detailed, refined but not particularly engaging or exciting
Yamaha CDX-593	£180	Jan 99	Lean and up-front, the Yamaha is involving on Rock but can sound rough.

CD Players £ Year Verdict

£300-£799

Model	Price (£)	Year	Verdict
AMC CDM7	£340	Jun 96	Very musical outfit which gains sweetness with optional valve output stage.
AR-07	£300	Jan 92	The '07 is even-handed but has no real fortes.
Arcam Alpha 5+	£480	Sep 96	Old-style Arcam warmth mixes with fine imaging. Not the fastest sound.
Arcam Alpha 6	£600	Jan 96	Seamless most of the time, although there is a touch of coarseness.
Arcam Alpha 7	£320	Jan 97	Superbly-designed, instinctively musical player destined for success.
Arcam Alpha 8SE	£599	Jun 98	The 8SE builds on the strengths of the standard 8 with HDCD filtering.
Arcam Alpha 9	£799	Dec 98	Apart from its tonal brightness, the Alpha 9 is a very capable machine.
Audio Innovations Alto	£449	May 96	Grainless treble is detailed but the Alto misses that vital emotional spark.
Aura CD50	£450	Jul 93	High measured distortion mars the treble and bass is dry.
Creek CD43	£499	Oct 98	A competent player with a musicality that will seduce any music-lover.
Cyrus dAD3	£598	Dec 96	Lacklustre with Classical, dramatic and lively on Dance and Rock
Denon DCD-1015	£350	Apr 95	Warm and slightly loose, the '1015 is a good match for bright ancillaries.
Denon DCD-1550AR	£350	Jul 98	Clean and precise, the Denon lags only in warmth and openness.
Harman/Kardon HD730	£300	Aug 96	Strong on dynamics and drive, but lifeless treble can dampen music.
Kenwood DP-7060	£380	Dec 94	With more weight, sweetness and pace, the Kenwood could be a winner.
Linn Mimik	£798	Apr 95	Tonally hard but possesses many, if not all, of the Linn rhythmic strengths.
Marantz CD-63 KI-Sig.	£500	Sep 96	This is a rare player, greater than the sum of its parts
Marantz CD-63SE	£350	May 95	Taken as a whole, the CD-63SE is one hell of a CD player. No digital nasties.
Mission DAD5	£499	Dec 92	Enjoyable deck with beefy bass. Not the ultimate detail retriever.
Myryad T20	£600	Dec 98	With its brightness balanced by warm ancillaries the T20 will win friends.
Onkyo DX-750	£350	Dec 94	Lean in the midrange but otherwise well-rounded and highly enjoyable.
Orelle CD100e	£650	Mar 97	Clean and tidy on electronic music. Not so good with acoustic material.
Orelle CD480	£400	Mar 94	Uneven and forward, the Orelle doesn't really cut the mustard.
Pioneer PD-S904	£400	Sep 96	Fluid midrange leads a dry bass and tonally-limited treble.
Rotel RCD-965BX Discrete	£375	Dec 94	Fast, clean sound verges on the clinical at times.
Rotel RCD-971	£350	Sep 98	Refinement is a plus point, but lack of vitality holds the Rotel back.
Rotel RCD-975	£450	Sep 96	Tuneful, pungent bass are the pros, flat sound staging and tone the cons.
Sony CDP-X3000ES	£500	Mar 98	Neutral, dynamic and stylish but not quite up with the best.
Sony CDP-XE900E	£300	Mar 97	In spite of fine sound staging and clarity, the Sony fails to involve.
Teac CD-5	£350	Jan 96	Clean and dry, the Teac is rather sterile compared to the competition.
Teac VRDS-7	£599	May 94	Honey of a transport outperforms the tonally-restricted convertor section
Technics SL-PS840	£450	Sep 95	Not the last word in bass control. Midrange is more persuasive.
Trichord Genesis	£549	Sep 96	Warm and bassy, but extremely natural. Not the most consistent player.
Trichord Revelation	£799	May 97	When it's good, it's very good indeed. Can get confused on dense mixes.
Yamaha CDX-880	£340	Dec 94	Easy-listening Yamaha is fine if you want to relax rather than Rock.



Sony CDP-XE300ES.



Marantz CD-63 KI-S.

CD Players £ Year Verdict

£800-£1499

Model	Price (£)	Year	Verdict
Audiolab 8000	£1000	Dec 96	Sweet treble and full midrange give the 8000CD a lucid sound.
Cymbal CDP12	£1279	Dec 97	Its warm, musical sound plus HDCD compatibility are a strong combination.
Cyrus dAD-7	£899	Jan 95	Up with the best at the money, the Cyrus simply sounds 'right'.
DPA Renaissance	£895	Jun 95	Breathtaking imagery and dynamics. Not strictly accurate, but who cares?
Harman/Kardon HD7725	£800	Jan 94	Construction is price-correct, but not the excessively relaxed sound.
Heybrook Signature	£989	Oct 97	The Heybrook loses out because of its rough treble and lack of clarity

Wide range of popular, classic, vintage, rare Electron Tubes from STOCK.

E.T.O.L.S

Electronic Tube On Line Shopping

Division of **HALFIN**
50 years of experience.
We ship worldwide.

Free membership gives access to the gateway of the world.

Web site

www.halfin.com/shop

37/39
Quai aux
Pierres de Taille
B-1000 Brussels
BELGIUM

VISA
EUROCARD

Phone: +32.2.218 10 11 Fax: +32.2.218 69 98
E-Mail: etols@halfin.com

marantz®



Sunglasses by Ray-Ban,
suit by Cerruti,
watch by Cartier,
Hi-Fi by Marantz.



Telephone: 01753 680868 Internet: www.marantz.com

because music matters

CD Players £ Year Verdict

£800-£1499

Holfi Xara	£950	May 98	It's not cheap but the Xara scores for firm bass and exciting presentation.
LFD Mistral	£999	Nov 97	The Mistral is outclassed in areas like pace and bass depth.
Marantz CD-17	£800	Mar 96	The CD-17 has a presentation which excels in musicality and lucidity.
Marantz CD-17 KI-S	£1300	Sep 97	The KI-S has a valve-like smoothness and clarity.
Meridian 506	£875	May 95	Characteristically dry Meridian balance which could do with more emotion.
Pink Triangle Numeral	£1099	Apr 98	This very natural one-box fully justifies its £1000 price tag.
Quad 77	£850	Nov 95	Competent, entertaining machine with neat styling and remote.
Quad 7712	£850	May 96	The 7712 takes a mellow view of tunes marred only by loose bass.
Roksan Caspian	£895	Aug 97	The Caspian is a gifted player well worth its asking price.
Sugden SDT-1	£850	Mar 93	A superb all-rounder with particularly convincing rhythms.
Teac VRDS-10SE	£850	Apr 96	Draws you into the music. Soundstaging fine but treble is a little bright.
Teac VRDS-25	£1300	Aug 96	Solid build doesn't make up for sound which lags in integration and detail.
XTC CDP-1	£1250	Dec 97	Rhythmically satisfying, but can sound hard in the wrong system.

CD Players £ Year Verdict

£1500-

Anthem CD1	£1600	Mar 98	Sweet sound and numerous features make the Anthem fine value for money.
Burmester 937	£5460	Sep 94	Amongst the best with its belt-drive transport.
McIntosh CDM-7009	£2635	Dec 95	Unmatched quality from CD at a high but fair price.
Meridian 508.24	£1995	Jul 98	The 508.24 is one of the top performers at its price.
Naim CD2	£1998	Apr 97	CD2 excites at the expense of subtlety. More at home in a Naim system.
Pink Triangle Litaural	£2099	Feb 98	One-box player with sound capable of mixing it with the best.
Teac CD-X1	£2300	Jun 92	You'll either love or hate this machine's great flair and confidence.

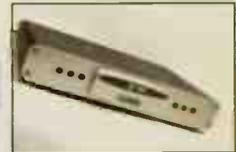

Roksan Caspian CD.

Turntables £ Year Verdict

Under £300

Linn Basik	£400	Sep 94	Definitely a turntable for devotees of attack and strong bass lines. Not strong on imaging.
NAD 533	£200	Nov 94	Based on a Rega Planar 2. Both pleasant to use and look at with a mature sound, all for £200.
Project 1.2	£200	Jun 97	A bargain at £200 with its substantial and involving sound.
Project 6.1	£435	Sep 94	The 6.1 gives a very full, strong sound. A very exciting deck.
Systemdek IIX900	£415	Sep 94	Detailed sound stage and broad imaging with a good, even range of tonal colour.
Systemdek IIXE	£450	Jan 93	Combined with an SME 309 it achieves great results, with a massive sound stage.
Thorens TD166 Mk6	£405	Sep 94	Tonally smooth with a warm midrange, but a little too laid back.
Thorens TD180	£180	Feb 95	A good, basic budget bargain.
Thorens TD280 Mk4	£199	Jun 93	Superbly lucid and clear midrange, but lower reaches are a little lightweight.



Pink Triangle Tarantella.

Turntables £ Year Verdict

£300-£799

Michell Mycro	£539	Jan 94	Silent and beautifully made, with transparent reproduction.
Opus 3 Continuo/Cantus	£900	Oct 95	Solid as a rock and almost as heavy, it's a satisfying performer, but not quite the best.
Pink Triangle Tarantella	£575	Oct 97	Simply the best at the money. Combines PT's customary transparency with real authority.
Project 6	£350	Dec 93	Involvement and rhythm are priorities. Highly recommended.
Systemdek 2X2	£500	Aug 96	Clear and precise sound through midrange and treble puts it up with more expensive rivals.
Townshend Rock 3	£799	Feb 94	Capable of deep, solid bass and precise imaging. The unusual trough makes cartridges track like trains.
Virtual Reality Reson rs1	£600	Nov 95	With fine detail resolution, transparency and a neutral balance the Reson rs1 represents super value.
VPI Junior	£500	Oct 97	The Junior is a very good deck indeed, with an assured and involving sound.

Turntables £ Year Verdict

£800-£1499

Origin Live Oasis-A	£950	Dec 98	Nice looks and a good sound, but can be bettered on price.
Pro-ject Perspective	£900	Aug 98	Aesthetically, the Perspective is a winner, but better sound can be had from cheaper decks.
Roksan Xerxes X	£1295	Jan 97	An undoubted bargain and class leader in all areas with a precise, confident and well-balanced sound.

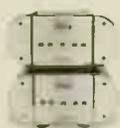

Nu-Vista 300
power amplifier



X-PI00
X-AS100
pre power amplifiers



X-A50
also available
X-A200
monoblock power amplifiers



X-A1
also available
X-A1000
integrated amplifiers



X-RAY
24 bit integrated
cd player



X-24K
digital analogue
converter



X-UP
phono stage

Hi-End Audio & Home Theatre

Multi-Room Design & Installation

Home Demonstrations

Export Orders Welcome

Unbiased Advice & Support

Part-Exchange Available

0% credit available. Written quotations on request. Subject to status.

Tel/Fax: +44 (0)181 707 4849 • Mobile: +44 (0)973 471 426 • email: info@audiovenue.co.uk

Other ranges available... Audio Analogue • Boston • Bow Technologies • Chario • Diapason • Graaf • Michell • Monitor Audio • MRS • Opera • Proceed • Project • OED • Straight Wire • Stax • Target • Unison Research & other leading components & accessories

MUSICAL FIDELITY

X SERIES
at

AudioVenue

Bespoke Audio Visual Consultants



Van den Hul Grasshopper.

Turntables £ Year Verdict

£800-£1499

Technics SL-1200 LTD £1000 Apr 97 Looks expensive at £1000, but don't let that put you off the capable standard version.

Turntables £ Year Verdict

£1500-

Alphason Symphony £1860 Nov 92 The Symphony has to be one of the best the British can offer. It's expensive, but a true sophisticate.
 Michell Orbe £1950 Apr 95 Fast and detailed with crisp sheer treble and clean, deep bass.
 Origin Live Oasis-S £2250 Oct 98 The Oasis-S is a cool, lean but very transparent performer thanks to battery power. Up against strong competition.
 PT Anniversary £2390 Oct 96 With its battery supply and ultra-quiet DC motor, the Pink displays great accuracy and neutrality. A top-flight deck.
 SME Model 20 £2500 Oct 92 This is a deck for those with a substantial record collection who demand the best. Exemplary sound.
 Wilson Benesch £1775 Jul 96 Gives a technically excellent rendition but fails to really communicate the emotion in music.
 Wilson Benesch Full Circle £2000 Mar 98 Offers clarity in abundance with a natural ease. Looks gorgeous too.

Phono Stages £ Year Verdict

Under £300

Creek OBH-8SE/OBH-2 £160 Nov 97 The best MC phono stage on the market at the price
 Creek OBH-9/OBH-1 £110 Nov 97 Smooth and truly musical, exceedingly worthy entry-level phono stage.
 LFD Mistral £299 Sep 97 The most lucid and musical budget phono stage around - a true audiophile bargain.
 NAD PP1 £40 Sep 98 At this price the NAD is an accomplished all-rounder. Slowish bass will suit leaner systems though.
 QED Discsaver £35 Jan 97 A bargain. Beguilingly musical presentation, with more than enough detail and power for a mere £35.
 Rotel RQ-970BX £130 Nov 94 Combine with a good cheap line level integrated and it will show you how good vinyl can be.



Hadcock 228 SE.

Phono Stages £ Year Verdict

£300-£799

Audio Innovations P2 £749 Feb 96 Fantastic bass and super insight make this one of the best phono stages around.
 Densen DP Drive/DP-02 £350 Sep 97 A beautifully made, fine sounding device that looks great too
 DPA DSP 200SD £495 Oct 94 Could be too forceful for some, but with excellent detail and extremely powerful bass.
 EAR 834P £340 Oct 94 Very fine phono stage with precise imagery and a bargain at the price.
 Henley HMC100 £450 Jul 97 Clean, powerful sound makes it a strong contender. Bright cartridges should be avoided.
 Kinshaw Perception £525 Oct 94 Extremely impressive results, especially with MM cartridges.
 Lehmann Black Cube £395 Oct 98 Capable of involvement, neutrality and insight usually the preserve of stages three or four times the price.
 Michell Iso £528 Oct 94 Gives a thoroughly cohesive picture of a recording with a very tight and rhythmical bass.
 Sonneteer Sedley MC/MM £399 May 98 The Sedley combines transparency and fine dynamics with excellent rhythmic ability.
 Unison Simply Phono £495 Mar 96 Liquid sound with great dynamics, but a little hissy and muddled too. Beguiling, but not perfect.

Phono Stages £ Year Verdict

£800-

Anthem Pre 1P £899 Aug 98 Despite a sizeable price tag the Anthem offers a smooth, lucid sound and superb build quality.
 Audiolab 8000PPA £800 Oct 94 Instruments can have a somewhat flat perspective, but excellent clarity
 Linn Linto £850 Oct 97 Marries beautifully into the Linn family, but not too hot with other components.
 Michell Iso HR £850 May 93 Perhaps too good for some record collections. Extremely revealing.
 Roksan Artaxerxes/DS5 £945 Oct 97 Doesn't worry about genre, it just gets on with the job of making music in an enjoyable way.
 Sonic Frontiers Phono 1 £2000 Apr 98 Expensive, yes, overpriced, no. The Phono 1 is a superb all-round phono stage.

Cartridges £ Year Verdict

Under £200

Denon DL103M £110 Aug 97 First manufactured in 1963, it sounds mature and sure-footed rather than over the hill.
 Denon DL110 £? Mar 94 May be a little soft-natured for some. Splendid dynamics and an even tonal balance.
 Denon DL304 £199 Sep 92 The DL 304 offers superb neutrality at a comparatively low cost.
 DNM Mica £185 Feb 98 Better Goldring's 1042 without difficulty. MC quality from an MM.

Sound Investment

If you have invested expertise and money in building up a sound system to your own unique specifications, then why compromise with indifferent housing units?

Fi-Rax offers a new dimension in audio visual racking - from a range of standard designs to the flexibility to custom create a unit to suit your particular sound system and lifestyle.

- *High quality aluminium construction.
- *Finishes available to your choice.
- *Fully adjustable 6mm glass shelving
- *Sound isolation on shelving/feet.
- *Custom created to suit your system.
- *Free delivery throughout the UK.

Fi-Rax - a sound investment for those who want the best from their equipment.

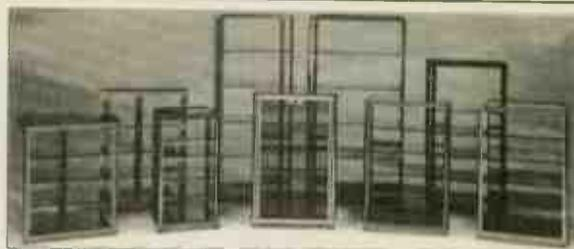

Audio Visual Furniture

For further information or a free brochure contact JEM Distribution, Springfield Mills, Spa Street, Ossett Wakefield WF5 0HW
 Tel: 01924 277626 Fax: 01924 270759

Cartridges £ Year Verdict

Under £200

Goldring 1042	£90	Jan 93	One of the best MMs at the price with strainless delivery.
Goldring 1012GX	£60	Jul 93	Great with Rock music, the 1012GX is the best value MM.
Grado Prestige Silver	£119	Apr 97	Good tracking and inoffensive sound, but somehow lacks sparkle in any department.
Linn K9	£7	Sep 94	Rhythmic bite compensates for a lack of vibrancy in music (MM).
Ortofon 520	£50	Jan 92	At the price they keep well up with the rest of the competition (MM).
Ortofon 540	£100	Jan 93	Smooth operator and very good value for money (MM).
Ortofon MC15 Super II	£110	Mar 95	In the right system, can be masterful with its dry and accurate response.
Ortofon MC25E	£170	Sep 95	A considerable achievement that adds true verve a pizzazz to the MC15 Super II
Roksan Corus Black	£120	Jan 93	Light and dry presentation with good presentation (MM).
Slate Brazen MM	£185	Sep 97	If you like the V15 you'll love the Brazen. Works well with an SME 3009.
Sumiko Blue Point	£100	Oct 92	Excellent value for money. It does its job of transcribing the information on the disc without fuss or bother.

Cartridges £ Year Verdict

£200-

Cartridge Man Music Maker	£549	Feb 99	Good price, high output and a winning musicality make this Moving Iron cartridge the one to beat.
DNM Aclore MC cartridge	£255	Jul 97	Oynamism ad subtlety mix i the Aclore to produce very enjoyable results.
DNM Lexa	£1300	Jan 99	A Goldring make-over that tracks well and sounds good. Pricey, though.
DNM Rica MM Cartridge	£255	Jun 98	This betters the Mica, has super-MM virtues.
EMT HST6	£850	Oct 96	Solid bass and smooth, musical sound make this rare MC cartridge worth the money.
Goldring Excel VX	£495	May 97	Has fine midrange clarity, but is bettered in other areas by cheaper competitors.
Linn Arkiv	£1200	Dec 97	Linn fans will love it but it's up against strong competition.
Linn Klyde	£489	Jun 95	Sumptuous sounding cartridge that borders on the bass heavy but has a good feel for music.
Lyra Lydian	£649	Jun 95	Extremely smooth, civilised MC with no obvious weaknesses.
Ortofon MC25F	£225	Sep 95	Delightfully sweet, musical sound with added refinemet on FL that takes some beating.
Ortofon MC30 Supreme	£450	Jun 95	Involving yet refined presentation but some could feel it's slightly coloured.
Ortofon MC7500	£2000	May 94	Conveys the full gamut of emotion from A-Z with the fervour of a live concert. Expensive, but the business.
Ortofon Rohmann	£1000	Apr 96	A top quality MC with superb tonal quality and excellent imagery.
Shure V15VxMR	£295	Mar 97	Warm, dynamic rendition of music with great detail and impact (MM).
Transfiguration Spirit	£1000	Jul 98	A balanced all-rounder that misses out only on the last ounce of detail and bass weight.
Van Den Hul MC10	£840	Jun 95	The MC10 is very hard to fault. A honey, pure and simple.
VDH Grasshopper IV	£3750	Dec 95	Allows music to flow with superb fluidity and reveal things which were previously unheard - at a price!



SME Model 20.

Tone-arms £ Year Verdict

Hadcock GH 228 SE	£595	Dec 98	Construction won't worry SME but its sound quality will unsettle a lot of the competition.
Origin Live RB250/RB300	varies	Nov 97	These modified arms are a considerable improvement on the originals
SME 309	£689	Jan 93	Tight, neutral sound with good tonality, but lacks the IVs pace and precision.
SME IV	£828	Mar 92	Sexy chassis and staggering engineering along with potent performance earn it a place in audio history.



Sonic Frontiers Phono 1.

Tuners £ Year Verdict

Under £300

AMC T7	£130	Jul 97	Although it has a tempting price, its sound quality is poor compared with its rivals.
Arcam Alpha 7	£230	Mar 97	An attractive, smooth sounding tuner that won't break the bank.
Cambridge T500	£180	Feb 99	The T500 is one of the most gifted tuners under £200
Harman/Kardon TU 950	£200	Jul 96	Sound quality is generally impressive. Let down by a rather constricted sound stage, but still good value.
Kenwood KT-2080	£130	Feb 97	Smooth, even balance allows the KT-2080 to convince with whatever it's receiving. £130 well spent.
Marantz ST-57	£150	Oct 97	The ST-57 is a smooth, warm tuner but lacks a little clarity and transparency.
Mission Cyrus FM7	£299	Apr 94	Musical, communicative and extremely detailed and a steal at the price.
NAD 412	£190	Jun 96	A remarkably musical and natural sounding tuner. Unbeatable at the price, or even twice the price for that matter.
Onkyo T401	£160	May 94	A competent machine, but time has taken its toll on the sound quality.
Pioneer F-504RDS	£300	Dec 98	One sole mark against the class-leading transparency is its slightly dry character.
Rega Radio	£230	Jan 95	Sounds on the whole more than its price, but in other respects it isn't especially competitive.
Rotel RT-930AX	£175	Aug 94	The RT-930AX is a glowing little bargain, real quality at a very realistic price.

Are you making the right connections?

Send for Britain's biggest catalogue of specialist cable and connections.

All available by mail order.

Phone 0181-942 9124 or clip the coupon for your Free copy

CUSTOM CABLE SERVICE

PO Box 4007, London SW17 8XG

Please send me your FREE Custom Cable Catalogue

Name _____

Address _____

Postcode _____

NO FURTHER INFORMATION REQUIRED

Send to: Custom Cable Service
PO Box 4007
London SW17 8XG

HFW 06/99





100% value

A supremely elegant, neat and complete, CD music system combining power, performance and style.

a **classik** by Linn®



LINN
the only sound®

Linn is available from the very best hi-fi retailers and Linn at Harrods. For further information simply see our website on www.linn.co.uk or call 0500 888909

PAPWORTH AUDIO TECHNOLOGY



Our new range of mosfet products have been designed to give you a lifetime of listening pleasure

The MVH 200 is a six input, mosfet valve hybrid, integrated amplifier, producing two hundred watts per channel. Our combination of a built in valve preamplifier controlling a mosfet power amplifier produces musical bliss with any loudspeaker.

All products from Papworth Audio Technology, are designed, hand built, and individually tested with a care and attention to detail that sets new standards of quality and craftsmanship.

**UK Distribution by Elm Audio,
Telephone/Fax (01744) 604578
Visit our Website at
www.papworthaudio.demon.co.uk**

**Papworth Audio Technology,
No 1 Cambridge Court, Papworth,
Cambridge, CB3 8RG
Telephone (01480) 831666
Fax: (01480) 830606**

Tuners £ Year Verdict

Under £300

Sony ST-SA3ES	£250	Apr 97	The Sony is worth every penny of its asking price. If you're a fan of radio this is one to go for.
Sony ST-SE700	£180	Aug 97	The ST-SE700 is one of the best at this price. LW reception is a welcome bonus.
Technics ST-GT-350L	£140	Jun 95	Not a bad buy at all and a very good fit for budget and mid-price systems.
Yamaha TX580 RDS	£200	Feb 95	If you want something for casual listening with superior aesthetics, this might be the one for you.

Tuners £ Year Verdict

£300-

Adcom GFT 555.2	£399	May 93	Quite musical but does not rejuvenate the waves! Good solid performance but less than luxurious.
Creek T43	£399	May 98	A great little tuner. This is the one in the price bracket.
Denon TU-S10	£400	Mar 98	A stylish, well-built tuner which has a detailed sound but needs careful partnering
Kenwood KT-6050L	£300	Oct 95	A good value, excellent sounding rds tuner, but lacks full EON facilities
Magnum Dynalab FT101A	£749	Apr 92	Worth auditioning but bass rather dry and light.
Meridian 504	£660	Mar 96	A clear, natural sound with good punch. Has strong rivals at the price, but acquits itself well.
Micromega Tuner	£700	Jul 95	An unusual design from Micromega that's well built but sonically unrewarding and expensive.
NAD 702	£330	Jul 94	Well worth auditioning, even if you've never previously considered a receiver.
Naim NAT 03	£499	Sep 93	Soft and pure, especially across the midband. Speech very well reproduced plus solid weighty bass.
Nakamichi ST3S	£350	Dec 94	Looks good, but the sound quality isn't really worth the asking price.
Pioneer F-504RDS	£350	Nov 95	Well engineered and competent tuner, but a little uninspiring.
Rotel RT-990BX	£500	Apr 95	The price of twenty concert tickets, and for that you can listen as if you were there. A bargain.
Thorens TRT-2000	£500	Dec 97	An otherwise competent tuner is let down by a rather processed character.
Burmester 931	£4347	Nov 94	This is not a cheap tuner, but its cheaper than buying a radio station, which is the only possible alternative.
Fanfare FT 1	£1350	Mar 95	Whether it's sweaty disco or symphony hall, the Fanfare comes up to scratch.
Linn Kremlin	£1645	Mar 92	Commendable basic performance but, considering the price there are limitations
Rotel Michi RHT10	£895	Mar 94	This classy looking tuner can hold its head up high amongst the best tuners at the price.
TAG McLaren T20	£1100	Mar 99	Extremely well built with a lucid if slightly dry sound. The only set back here is the price.



Rotel Michi Tuner.

Cassette £ Year Verdict

Under £300

Aiwa AD-F810	£200	May 94	Impressive on playback, the '810 really hits its stride when recording.
Aiwa AD-F580	£150	Apr 98	No Dolby S, but three heads and two capstans make the Aiwa a bargain.
Denon DRM-550	£160	May 96	Good enough for the price and no worse than the competition.
Denon DRM-650S	£230	Aug 96	Top sound quality with ferric and chrome makes this deck a steal.
Denon DRW-580 (twin)	£200	Feb 96	Good value and performance, but bettered by Denon's own single decks.
Grundig CF4	£250	Jan 95	Fair on pre-recordeds, OK when recording, but speed stability isn't great
JVC TD-V662	£300	Sep 98	Only the lack of Dolby S conspires against the otherwise excellent JVC.
Kenwood KX-5080S	£200	Jan 97	Stable transport gives fine results on metal and chrome. Rough on ferrics.
Nad 613	£230	Jan 96	Decent playback and good recording when used carefully.
Nad 602	£200	Mar 94	Respectable on pre-recordeds but bass-light on recordings.
NAD 614	£270	Sep 95	Excellent electronics are let down by a low-grade transport.
Rotel RD-960BX	£230	Oct 95	A solid, competent machine which is reasonable value for money.
Sony TC-K311	£150	Dec 93	Auto-tuning is mediocre and the general results are unexceptional.
Sony TC-K490	£170	Jan 93	A mix of average heads and electronics doesn't make for happy taping.
Teac V-610	£100	Apr 97	The V-610's performance matches its price well, but audiophile it isn't.
Teac V-600	£150	Sep 94	Satisfactory for in-car recordings, but the low price shows.
Yamaha KX-580 SE	£250	Sep 97	The '580 lives up to its SE tag with a fine performance in all areas.
Yamaha KX-650	£260	Feb 94	The Yamaha offers a fine blend of performance and facilities.



Nakamichi DR1.

Cassette £ Year Verdict

£300-

Aiwa AD-S950	£300	Feb 95	Vice-free playback is mirrored by impressive recording.
Denon DRS-810	£300	Jan 92	On the right tapes, the Denon repays with delightful sound quality.
JVC TD-V1010	£400	Sep 92	Disappointing on replay but recording is another kettle of fish altogether.
Kenwood KX-7060S	£330	Dec 94	Convincing all-rounder except for heavy-handed noise reduction.
Nakamichi 1.5	£500	Jan 92	The Cassette Deck 1.5 has no rivals in its ability to recreate a realistic performance.
Nakamichi DR-1	£780	Jun 93	Not perfect but as close as you can get for the money.

SUPERCLOCK....a new concept in digital master clock design

Simply the Ultimate CD upgrade

The latest in CD master clock development, using a completely new unique design resulting in a much greater accuracy in data retrieval and conversion processes. Features comprehensive circuit topology using push-pull techniques and series mode oscillation, and the sine-square converter utilises a very high speed IC to provide a precision square wave clock signal.

- ⇒ Greatly improved resolution and detail
- ⇒ Extended accurate bass with real weight, control and presence
- ⇒ High frequencies have less glare and hardness at all listening levels.
- ⇒ Greater dynamics, and detail at all frequencies.
- ⇒ Spacious 3-D presentation of vocals and instruments.

The SUPERCLOCK is available *exclusively* from AudioCom (UK) and can be fitted to any CD players/ transports using the following frequencies: 11.2896MHz, 16.934MHz & 22.5792MHz. Modifications are carried out at AudioCom (UK). A kit is also available with instructions for the technically competent.

Specialist Upgrade Service

Professional modifications using leading edge components. Modifications are carried out by engineer with 30 years experience in the field of analogue and digital electronics. Upgrades available to all types of audio equipment.

- CD Players/ Transports & D-A converters
Analogue stage, digital stage, master clock, power supplies
- Pre & Power amplifiers,
Power supplies, signal de-coupling, volume control

For further information on SUPERCLOCK and other products request a copy of our FREE catalogue. (Overseas: £3.50)
Tel 01834 842803 Tel/Fax 01834 842804 E Mail audiocom@scotnet.co.uk



Cassette £ Year Verdict

£300-

Nakamichi DR-3	£300	Mar 93	Unfortunately keeping the price down keeps performance below Nak's norm.
Onkyo TA250	£350	Oct 94	Top transport but the electronics aren't on a par.
Pioneer CT-S740S	£430	Jun 96	Complex but superb in every important area.
Sony TC-K611S	£330	Feb 94	Muffled on pre-records but pulls out all the stops on recordings.
Teac V-6030S	£550	Nov 97	Solid build and solid sounds. Top-notch at the price.
Teac V-8000S	£699	Jun 92	With decks like the Teac, cassette deserves to live beyond the year 2000.
Teac V-8030S	£650	Aug 95	One of the highest quality Dolby S decks available.
Technics RS-AZ7	£300	Jul 96	Excellent bass but mid and treble lack dynamics. Auto-tunes poorly on metal.
Pioneer CT-95	£1000	Mar 97	On chrome and ferric, the '95 is smooth and natural. Not so good with metals.

DVD Players £ Year Verdict

£700-



Panasonic DVD.

Denon DVD-3000	£700	Aug 98	The Denon is a fine performer with CD and better still with 24/96.
Denon DVD-5000	£1500	Mar 99	Build is second to none. Sound is very solid convincing, but not as musical as the 3000.
Panasonic DVD-A350	£700	Jul 98	The A350 wipes out the CD-only competition at the price and threatens players up to £2000
Panasonic DVD-L10	£1000	Nov 98	Isn't cheap, but it's an outstanding portable and a capable domestic device.
Sony DVP-S715	£700	Aug 98	The Sony is warm and smooth but lacks clarity and precision.

Headphones £ Year Verdict

£20-

Ergo Model 2	£140	Mar 99	Wonderfully lucid and transparent panel-like sound.
Jecklin Float 2	£100	Mar 99	Clarity and openness are their traits, rather than slamming bass, but still good value.
Sennheiser HD-433	£20	Mar 97	Whatever genre tickles your fancy, these will reproduce it with an ability which belies their price tag.
Sennheiser HD-455	£50	Nov 95	The HD-455s offer a civilized and refined performance and are easy on the pocket.
Sennheiser HD-580	£200	Nov 98	In the company of a smooth, warm system the 580s can shine.
Sennheiser HE60/V70	£1000	Feb 95	Electrostatic design that set a class standard and can put a case for chucking out your power amp and 'speakers.
Vivanco FMH-6800	£80	May 98	Have a lot of potential but basic operating problems have to be cleaned up first.
Vivanco SR850	£50	Nov 95	Excitement that is rarely heard in headphones, but have a little trouble with heavy orchestral loads.

CD Transports £ Year Verdict

Under £799



Sonic Frontiers 3.

DPA Enlightenment	£695	Mar 95	Solid and lifelike sound with Rock music and full bodied on Classical.
Kenwood DP-X9010	£530	Feb 92	Superb build for the money and a very musical sound. Benefits greatly from clocking.
Rotel RDD-980	£450	Jul 96	Good, clean dynamic sound with a neutral and pure midrange tone.
Teac VRDST1	£499	Feb 95	Enjoyable player with good insight. Good finish and keen pricing make it a thoroughly good buy.

CD Transports £ Year Verdict

£799-

Audiolab 8000 CDM	£1249	Aug 94	Distinguished by a wide array of facilities, Thoughtfully designed and high quality.
Cyrus Disc Master	£1800	Jul 94	Smooth and cohesive. The Disc Master looks good and comes with the Dac Master within the price.
Micromega Duo	£3435	Apr 93	Excellent build quality and a sound quality to match.
Monarchy DT-40A	£1595	Jun 94	Isn't cheap but has a solid dependable sound with a big, powerful presentation.
Parasound C/BD-2000	£1695	Jun 97	The belt drive is an interesting idea but the Parasound is bettered by cheaper transports.
PT Cardinal	£1440	Feb 95	Heart-stopping speed and impact contribute to what is an exceptionally good machine.
Roksan Atessa	£1295	Apr 94	Fascinating player but a little flawed when compared with the competition.
Sonic Frontiers SFT-1	£2295	Aug 96	Top flight machine with an easy, musical and enjoyable sound, for those that can afford it.
Sonic Frontiers 3	£6999	Sep 98	A handsome machine both sonically and aesthetically. We love the camera aperture-style loading system.
Teac P-30	£2500	Jun 97	Costs a lot of money and sounds nothing short of superb.
Thorens TCD 2000	£900	Jun 96	A soft and warm sound will please vinyl lovers, but it's not the last word in detail.
XTC CDT1	£1200	Apr 96	A warm and musical sound with a taste of high-end refinement and detail.

To advertise in the Buying Guide

Please contact Amanda Sweeney on 0171-328 2213
or Sarah Wrenn on 0171-328 4892

Or email us on edit@hi-fiworld.co.uk

D.I.Y. Supplement

Contents

All rights to the designs are reserved by World Audio Design Ltd. They are published for single use by private individuals. They are not to be used for commercial gain without prior permission from World Audio Design Ltd.
Audio Publishing Ltd and World Audio Design Ltd accept no responsibility for accident or injury arising from the construction or use of any of the designs published.
All of the projects in this supplement have gone through rigorous listening and test procedures. The performance and specification of these projects can only be guaranteed on kits bought directly from World Audio Design Ltd.



KEL34 - THE UPGRADES

New E/I transformers and audio-grade parts boost the performance of our valve integrated.

101

DIY LETTERS

Puzzle no longer as we answer all your kit-build and tweak queries.

111

Watford Valves

7 DAYS A WEEK 9AM - 9PM THE AUDIOPHILES CHOICE

All output valves multi-tested and digitally matched

Full no quibble guarantee. Expert advice on all valve amps

ECC81	Philips	4.50	EL519	E.I	12.00
ECC82	RFT	4.50	EM84	R.F.T.	4.50
ECC82	R.T.	7.00	EZ80	Mullard	5.00
ECC83	Philips	6.00	EZ81	Tesla	6.00
ECC83	G.E.	7.00	GZ32	Harma	9.00
ECC84	R.F.T.	4.50	GZ34	Harma	6.00
ECC85	R.F.T.	4.50	KT66	G.E.C.	80.00
E88CC	Tesla	6.00	KT88	Sovtek	20.00
ECC807	Brimar	28.00	KT88	Tesla	25.00
ECF80	Mullard	3.50	PL509	Tungstram	8.50
E182CC	Mullard	12.00	5687WB	Philips	5.00
E188CC	Philips	8.00	5881	Sovtek	5.00
ECL82	Siem/Telefun	14.00	6072	R.C.A.	9.00
ECL83	Mullard	6.00	6550C	Svetlana	16.00
ECL85	Polam	4.00	6550WE	Sovtek	16.00
ECL86	Harma	5.00	6CG7	G.E.	12.00
EF804S	Siemens	24.00	6CZ5	USA	10.00
EF86	Siemens	7.00	6GK5	USA	7.00
EL34WXT	Sovtek	6.00	6SL7WGT	Sylvania	8.00
EL34	Svetlana	8.50	6SN7GTB	G.E.	8.00
E34L	Tesla	8.50	7044	G.E.	8.00
EL84M	Sovtek	5.00	7591A	Harma	16.00
EL84	Philips	12.00	12AY7	Mixed	9.00
EL86	Siemens	7.00	12BH7A	Brimar	9.00



300B JJ/Tesla

This superb 300B features 24 carat gold plated control grids. The core is made from nife alloy and is copper coated which improves plate dissipation and sonic performance. The W.E. style grey coated plates are housed in a heavy grade glass envelope with structure supports, which results in less microphony than other types. The base is glazed ceramic with finely finished pins. Jon Marks commented 'The upper registers are cleaner and less fizzy and the bass is faster and meatier. Image, precision and sound stage are of the warehouse variety'. The valve is covered by a unique warranty and comes with its own test report. It will be the best upgrade you will ever make at only £68.00 each.

WATFORD VALVES 3 RYALL CLOSE,
BRICKET WOOD, ST ALBANS, HERTS AL2 3TS

Fast mail order/next day delivery/World Wide shipping
1000's more valves stocked. Prices exclude VAT and carriage.



01923 893270

Fax: 01923 679207



ACTIVE CROSSOVER MODULES

● A true reference for other active crossovers.

● Individually calibrated in our workshop for your loudspeaker.
Analogue phase linear.

● User adjustments
- Instructions supplied.

● More accurate than the best loudspeaker computer software.

● Built using audiophile components.

● Fully alterable for future loudspeakers.

● Available for 2 way, 3 way, satellite and subwoofer systems.

● Specifications:
<0.0002% Distortion
>110dB S/N Ratio
<0.5µs Rise Time
0Hz to 450kHz Bandwidth

Available exclusively from

AUDIO LINKS

7 Fairmont Crescent, Scunthorpe, North Lincolnshire DN16 1EL.
TEL (+44) 01724 - 870432 FAX (+44) 01724 - 875340

TECHNICAL & GENERAL

SOME NECESSITIES - FROM THE ORIGINAL CLASSIC TURNTABLE SPECIALISTS

CONNOISSEUR			P&P
BD1/2 Drive Belt		£10.55	£1.85
BD1/2 Motor Suspension kit		£13.95	£2.45
SAU.2 Headshell		£16.75	£2.55
SAU.2 Connecting Lead		£15.95	£3.55
GARRARD Standard Models			
Wired arm tubes	from	£12.75	£2.50
Cartridge carriers (sliders)		£10.55	£1.85
Idler wheels		£9.85	£2.25
301/401 Transcription models			
Original Thrust pad assembly		£10.85	£2.25
Original Idler tension spring		£2.95	£1.85
Original Brake pad		£2.20	£1.85
Xerocopy Owners Manual 301 incl. full size mounting template		£8.85	£1.85
		401	£6.70
Replacement 301 control knobs On-Off/Speed select	pair	£20.25	£2.55
Replacement 301 suppressor unit		£5.65	£2.25
Replacement 301 motor pulley (-2%), (-1%), (Std), (+1%)	each	£15.65	£2.25
Replacement 301 Chrome plated mounting bolts	set	£6.60	£2.25
Recommended Lubrication set - early 301 or 301/401	(specify)	£5.60	£1.85
GOLDRING/LENCO			
Idler wheel (lock-nut or clip fixing)		£19.95	£2.85
Arm pivot bearings with instructions		£8.55	£1.85
Spindle/Main bearing assembly complete		£24.85	£3.85
Headshells	from	£21.95	£2.55
Instruction books	from	£4.20	£1.85
THORENS			
TD.124 series			
Idler wheel original		£27.50	£2.85
Idler wheel our redesigned replacement		£15.35	£2.55
Drive belt		£15.25	£1.85
Chassis spring suspension (replaces 'mushrooms')		£15.85	£2.55
TD.150/160			
Drive Belt		£12.50	£1.85
Suspension springs (-1%), (Std), (+1%)	set	£12.85	£2.55
Suspension bushes	(set of 3)	£12.50	£2.55
Armboards for most models	from	£16.90	£2.55
CECIL WATTS			
Dustbugs/Parastats/Spares - incl. Preener wicks			

Cartridges and styli for 78s and Mono LPs in addition to current Stereo LPs

TECHNICAL & GENERAL

PO BOX 53, CROWBOROUGH, EAST SUSSEX, TN6 2BY
TELEPHONE: (01892) 654 534

PARTS POWER

Nick Lucas and Jon Marks outline our upgrade kit for the popular KEL34 valve integrated.

To complement the release of our KEL 34 E/I version (I thought some of you KEL 34 original owners might feel a little left out), HFW's 'Mod Father', our beloved editor Jon Marks, has devised a highly effective upgrade kit which was enforced by 'Tech Tarzan' myself, Nick Lucas. The result is a serious collection of audiophile components for the budget price of £150. Getting them into your amp is pretty straightforward but here are a few pointers just to help you on your way.

1) As soldering to both sides of the PCB is necessary, it is important that you can gain easy access to the board.

Desolder all the wires attached to the volume potentiometer as these restrict board movement. To avoid having to pass the PCB over the front panel, undo the mains transformer fixings and then lift and tilt it to provide more elbow room.

While you are working, avoid moving the PCB back and forth too often as this can weaken external joints to the PCB or even break them, causing problems later. You may like to go the whole hog and remove the PCB from the chassis completely. This will obviously be more time consuming, though.

2) Remove the pre-upgrade components carefully. At this stage it is a good idea to use a desoldering pump or solder braid to soak up all the dead solder. Make sure you clean up all the remains as stray solder strands are little devils and can cause problems later. I always use a tooth

brush to clear off any loose debris; just be certain not to put it back in your toothbrush holder! You may like to

30mm (dia). Ensure that they are well away from the large cathode resistors R13 and 16 as they do generate heat which can affect the performance of the capacitors.

These capacitors have inner and outer-foil leads. The outer is denoted by the black, exposed-resin end and should be soldered to the 'earthiest' potential of the circuit to exploit the inherent screening capabilities of these types of capacitors. The orientation in situ is thus important and is marked in the diagram.

4) When fitting the Panasonic volume potentiometer (an old favourite of ours) it is necessary to enlarge the chassis hole as the

original pot in the kit has a diameter of 7mm; 9mm is required here. I used a reamer, but a drill bit used carefully will do the job adequately. Make sure that you still have enough exposed metalwork internally as this is the chassis earth point. You will have to open up the M6 solder tag to fit the shaft by cutting into it.

5) It is a good idea to use rubber sleeving on the component leads to reduce the risk of a short-circuit. A short can also be created through the metal cases of the Stargets.

6) The diodes used for the bridge rectifier upgrades are static sensitive and some measures have to be taken to prevent damage. My workshop is full of static and shocks are common place; a dry atmosphere together with a synthetic carpet is not a happy combination. An



KEL 34 upgrade kit contains all parts in labelled, sealable bags and a full set of instructions.

temporarily remove C3 to facilitate the upgrading of BR3 at this stage.

3) Once the board has been made ready, a dummy run is a good idea for confirming component location. Bear in mind that the Stargets are built up of smaller value capacitors in parallel and will take up more room than a single cap. We had to do this as Stargets do not come in the values required. Incidentally, this arrangement has the added bonus of lowering the overall ESR (equivalent series resistance) and ESL (equivalent series inductance) of the capacitors, improving bass and treble in the process. With the C17 upgrade, take note that the selector sits just above this point so its positioning is critical.

The aluminium-foil and impregnated-paper dielectric capacitors (C7, 8, 15, 16) are extremely chunky at 55mm (l) by

BILLINGTON

EXPORT LIMITED



α

Billington

Gold

Ω

COMPETITIVE WHOLESALE PRICES BILLINGTON EXPORT LTD

The minimum order requirement is £400.00 for all prices in this advertisement.

Orders under £400.00 are welcomed, please enquire for prices.

To qualify for the "100 pieces" price, please ensure your order is both over £400.00 and for 100 pieces.

	Unit Price For 01 piece	Unit Price For 100 piece		Unit Price For 01 piece	Unit Price For 100 piece
4HA7/PC900 Russia/East European	£1.15 each	£0.90 each	85A2 Mullard	£3.00 each	£1.00 each
5Z4GT Russia	£2.30 each	£1.60 each	5670W GE USA	£1.50 each	£1.00 each
6AL5 Mullard UK/CV4025	£1.00 each	£0.75 each	5751 GE/JAN USA	£4.00 each	£2.80 each
6AU6WC USA	£0.95 each	£0.95 each	5965 GE USA	£0.99 each	£0.99 each
6BQ5 (EL84 Billington Gold Russian)	£2.40 each	£2.00 each	6550B Russia	£8.00 each	£6.00 each
Extended guarantee. NFD			E88CC Tesla. gold pin 1962. OB	£5.90 each	£4.20 each
6BQ5/6CH6 Brimar UK - these 6CH6 are similar to 6BQ5 but have different pin out. Data on request	£1.95 each	£1.40 each	EB91 - SEE 6AL5		
6DJ8/ECC88 Tesla 1962. OB, NFD	£2.00 each	£1.45 each	ECC81/83 - SEE 12AT7/12AX7		
6DJ8/ECC88 Tesla 1962. Unboxed, NFD	£1.75 each	£1.20 each	ECL86 - SEE PCL86 similar item - data on request		
6SG7 GE USA	£1.80 each	£1.60 each	EL34 Tesla, clear glass	£5.40 each	£4.80 each
6SL7GT Russia, Unbranded	£1.60 each	£1.40 each	KT88 - SEE 6550B		
6V6GT Russia	£2.95 each	£2.10 each	PCL86 Russia	£0.37 each	£0.37 each
12AT7/12AT7WC Phillips	£1.65 each	£1.65 each	PL509/19 Tungram	£5.60 each	£3.95 each
12AT7 Tungsol	£2.80 each	£2.80 each	SV572-30 Svetlana	£32.00 each	-
12AU7 Thermionic. NFD	£2.40 each	£2.20 each	SV811-10 Svetlana	£15.16 each	-
12AX7/12AX7WA Sylvania USA	£4.50 each	£3.20 each			

1 million valves in stock, please enquire for retail or wholesale prices including Billington Gold, Mullard, GEC and many others.
Major Credit Cards, Switch and Delta accepted.

BILLINGTON EXPORT LTD IE GILLMANS INDUSTRIAL ESTATE

BILLINGSHURST SUSSEX RH14 9EZ

TEL: (0)1403 784961 FAX: (0)1403 783519 email: billingtonexportltd@btinternet.com

VISITORS BY APPOINTMENT ONLY PLEASE

MARTON MUSIC SPRING SALE NEW and EX-DEMO EQUIPMENT

Product	status	new	sale
ATC EC23 3-way Electronic Crossover	ex-demo	(1085)	£645
AVI S2000MT FM tuner	ex-demo	(550)	£250
AVI S2000MD DAC	new	(450)	£150
AVI S2000 INTEGRATED	ex-demo	(2000)	£450
BRYSTON BP20 preamp 20yr guarantee	ex-demo	(1125)	£695
BRYSTON 4BST poweramp 250w/ch	ex-demo	(1755)	£1095
KELVIN LABS Class A Integrated	ex-demo	(405)	£225
KELVIN LABS Absolute Zero Integrated	ex-demo	(685)	£325
YAMAHA DSP A2070 Surround Amplifier	ex-demo	(1099)	£450
YAMAHA DSP A592 Surround Amplifier	new	(329)	£195
YAMAHA MX2 Poweramp 150w/ch	ex-demo	(749)	£495
YAMAHA C110 Centre Speaker	ex-demo	(165)	£65
AUDIO PHYSICS Monoblock amps (pair)	ex-demo		£400
MYRYAD MP 100 Stereo Preamp	ex-demo	(599)	£345
MYRYAD MI 120 Stereo Integrated Amp	ex-demo	(599)	£345
MYRYAD MA 120 Stereo Poweramp	ex-demo	(479)	£295
MYRYAD MC 100 CD Player	ex-demo	(699)	£395
SONY SA-VA3 Surround System	new	(699)	£395
SONY 557 ES CD Player	ex-demo	(1099)	£395
A & R CAMBRIDGE A60 Amplifier	ex-demo		£80
MIRAGE M890mdli Bipolar Speakers	ex-demo	(1049)	£495
MIRAGE BPS 150 Bipolar Subwoofer	ex-demo	(785)	£345
CANON S50 Surround Speakers	ex-demo	(220)	£85
SEQUENCE 30D Surround Speakers	new	(265)	£115
TDL Studio 3 Transmission Line Speakers	ex-demo	(995)	£395

Plus numerous other finished speakers, Transmission Lines, Open Baffle.
Ported and Infinite Baffle designs, from small to large

Call Tony Seaford on 01282-773198 for further information

Falcon Acoustics Ltd

Falcon Electronics, Basically Sound

<http://www.falcon-acoustics.co.uk>

DRIVE UNITS: by FOCAL & SEAS, and a pick of the best from other manufacturers.

100+ CROSSOVER NETWORKS: - Active & Passive, Components, Accessories, COMPONENTS

SOLEN Polypropylene capacitors. 0.1mFd. to 100mFd.

Polyester and Polycarbonate Film Capacitors. 0.1mFd. to 10mFd.

ALCAP Reversible Electrolytic Capacitors (Non-Polar): 50v, 100v & Low Loss. 2mfd. to 600mFd

NEW CAPS:-

VTA PRO-CAP: Silver Foil/Paper in Oil A feast for the ears. 650v range for valve amps.

FALCON Custom-wound Inductors.

FERRITES:- Standard, High Power, Super Power, Super Super Power + AIRCORED 0.56 - 1.25mm wire

NEW IRON DUST. 1mm wire

TAPPED INDUCTORS:- 0-10mH in 1mH steps & 0-1mH in 0.1mH steps

AUDIO AMATEUR PUBLICATIONS

NEW- Valves for Audio Frequency Amplifiers from Philips Technical Library plus lots in PL.

Back year sets of Speaker Builder, Audio Amateur & Glass Audio, plus the Audio Anthology Set.

Altogether 50+ books and 50+ Audio Amateurs magazine year sets. 1998 sets available.

FOCAL®

'State of the Art' Kit Designs

ARIA 5

15 Litre

2 way

90 dB/watt system

-3dB. point of 62Hz

2 PolyKEVLAR 5" bass/mid units

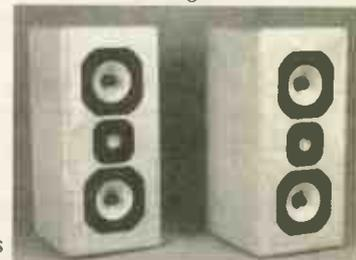

From a wide range of High-Tech Loudspeaker units

SUPPLIERS TO THE TRADE SINCE 1972

Send for our FREE price list PL28: Just send a large S.A.E. (40p stamp) or US\$2 bill overseas, Europe US\$1 bill or 3 International Reply Coupons (IRC) to: (Dept HFW) Tabor House, Norwich Road, MULBARTON, Norwich, Norfolk. NR14 8JT Tel (0)1508 578272

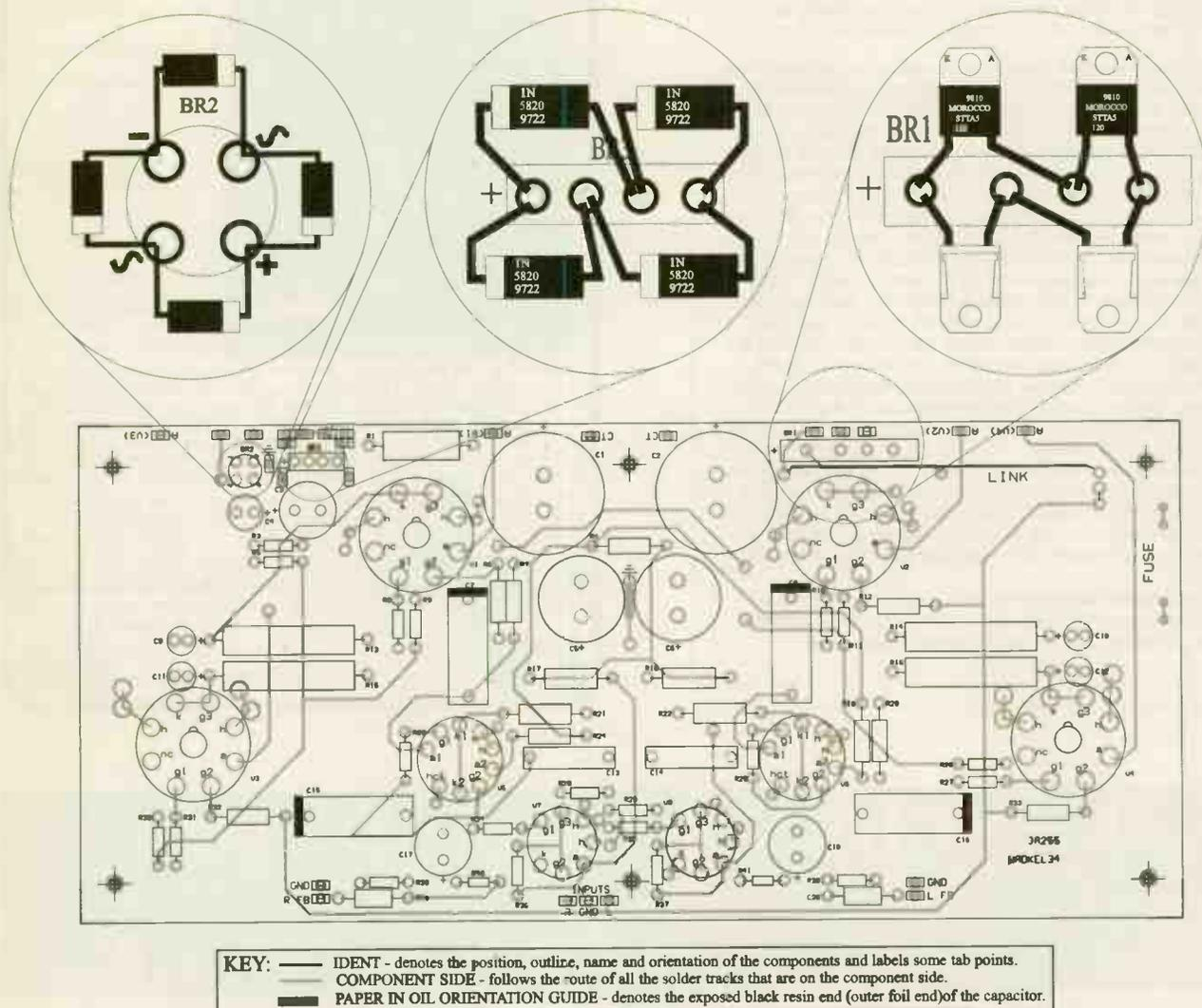

This PCB diagram shows the position and orientation of the upgrade components.

anti-static wrist band with its lead attached to KEL34's chassis is a solution. Personally, I made sure I was static-free by discharging myself to the earthed metal case of a light switch. On top of this, I made sure all the equipment I needed was ready on my work bench so I didn't have to move around, creating static. To be extra sure I only touched the components with insulated pliers.

7) Fitting the diodes is a bit of a fiddle. I made life easier by using terminal pins as the leads of the diodes are thicker than the holes in the PCB. Pay careful attention to the diagram above as an incorrectly-oriented diode can cause a major mess.

8) Please note that available to those who purchased the original KEL34 is the option of obtaining a pair of new E/I output transformers for £80 including

VAT and postage. These will come with a template for fixing-hole location. The transformers will be of the upright, double-shrouded variety.

AND FINALLY...

Double-check your handiwork a couple of times just to be sure. Refit the PCB, reconnect any external connections and fire her up. You should notice an immediate change in the sound, but it does not stop there. Components need to be burned in to their new living quarters for at least 50hours, during which period the sound will keep getting better.

INTRODUCING THE PARTS

VR1 Panasonic Pot
 An encapsulated black and grey, alloy-bodied pot of exceptional quality and accuracy. Laser-trimmed conductive plastic/carbon track. Silver internal

contacts. Gold-plated lead-outs. Channel accuracy <0.5dB guaranteed.

C7, 8, 15, 16 Paper-in-oil, 0.47uF 600V British-made by Ampohm. An aluminium-foil and impregnated paper audio capacitor of very high quality, ideal for valve audio.

BR1 STTA512D4
 TurboSwitch ultra-fast diodes (4)

BR2 MBR160RL4
 Schottky diodes (4)

BR3 1N5820RL4
 Schottky diodes (4)

All the diodes above have a very fast switching time and are quiet in operation.

C9, 10, 11, 12 Elna Targets
 2 x 100uF paralleled with 2 x 22uF 35V



M. WALTHER
AUDIO ELECTRONICS
 HIGH GRADE AUDIOPHILE COMPONENTS
 APPLIED AND TESTED PERFORMANCE

ALPS AUDAX FOCAL WIMA SCR RELOAP BHC-AEROVOX ELNA RUBICON EVOX-RIFA NIPPON-CHEMICON SICOCEL SANYO PANASONIC ICEL SIEMENS SVETLANA BURR BROWN (OPA ICS) HARRIS IR (FAST RECT-MOSFETS) TOSHIBA BC (HIGH BETA) DALE VITROHM ROEDERSTEIN BI

TOROIDAL transformers wound to our spec using top grade big cores and copper wire, CE approved, give fast & dynamic sound: Power (VA): 50-100-200-300-400-500-630-800-1000-1500-2000.

Prices in EURO: 15-20-31-41-65-68-76-118-154-164-224.

ELNA STARJET electrolytics (microfarad/Volt): 2200/16-1000/16-470/16-470/35-100/35-47/35-22/35-10/35-100/50-22/50-10/50-4,7/50.

Prices in EURO: 6,3-4,4-2,8-4,4-1,9-1,3-0,8-0,7-2,1-1,1-0,7-0,7.

ALPS special order conductive plastic pots, close tolerance 1,5% gang error, 46Vac, 100mw (blue) and 150 mw (black), specified to avoid overload from digital sources with 30,000 cycles rotational life and specially positioned brushes to our spec again. BLUE VELVET logs: 10K-50K-100K for 21,2 EURO. 10K motorized for 36,4 EURO. BLACK BEAUTY logs: 10K-50K-100K for 36,4 EURO.

GOLD plated TEFLON insulated female chassis mount RCAs are 2 EURO each. GOLD plated serious RCA males are 4,3 EURO each. SILVER plated isophase ribbon double speaker wire is 3,6 EURO per 1 metre. You won't believe its sound at the price.

SVETLANA 6550C latest model valves are 36 EURO each, 33 for 5 pieces+, 31 for 10 pieces+. — The above are just a sample of our complete list of thoroughly auditioned and logically priced components. All prices include 18% taxes. Cheques payable to "M.WALTHER", MASTERCARD and VISA are accepted. For orders, complete price list and info about upgrading standard equipment or building new audio projects please contact us at:

M. WALTHER AUDIO ELECTRONICS, 98 KOLOKOTRONI STREET, 18838, PIRAEUS, GREECE. TEL: +30-1-4134234, +30-1-4133905, FAX: +30-1-4129642, (prefer) E-MAIL: walther@otenet.gr



50 WATT STUDIO
Loudspeaker Amplifier
Panel. PP50



- FEATURES:-**
- ★ 50W R.M.S. into 8 ohm
 - ★ 775mV I/P for rated O/P
 - ★ Toroidal Transformer
 - ★ Short Circuit Protection
 - ★ D.C. Speaker Protection
 - ★ Balanced I/P (readily unbalanced)
 - ★ Link through XLR sockets for daisy chaining more than one Speaker
 - ★ Indented gain control
 - ★ I.E.C. fused mains inlet
 - ★ Compatible with HiFi Amps CD Players, Studio Mixers and Computers etc.

The PP50 Studio Loudspeaker Amplifier is designed to meet the exacting demands of the professional market but has the quality of sound reproduction normally associated with Highend Audio. Although having a small footprint, it has a full 50W R.M.S. output that makes a useful addition to an existing loudspeaker cabinet or custom made loudspeaker enclosures. The panel is designed to fit flush through a cutout approximately 170mm x 150mm in the rear of a Loudspeaker cabinet. Individual artwork available for OEM users.

SPECIFICATION: ★Power 50W R.M.S. @ 8 ohms ★B/W 20-25KHz -1dB
 ★Damping Factor >200 ★Distortion 0.05% ★S/N A Weighted >100dB
 ★Supply 230V. A.C. 50-60Hz ★Weight 1.4Kg ★Size H205 W165 D85mm

The above item may be ordered by post, fax, e-mail or phone and payment is welcome by cheque or credit card. **PRICE: £59.00 + £5.00 P&P Incl VAT**

B.K.ELECTRONICS
 UNIT 1 COMET WAY
 SOUTHEND-ON-SEA
 ESSEX SS2 6TR

Web: <http://www.bkelec.com>
 E-mail: Sales@bkelec.com
 TEL: 01702-527572
 FAX: 01702-420243



LANGREX SUPPLIES LTD

DISTRIBUTORS OF ELECTRONIC VALVES, TUBES AND SEMI-CONDUCTORS AND I.C.S.

1 MAYO ROAD • CROYDON • SURREY CR0 2QP

24 HOURS EXPRESS MAIL ORDER SERVICE ON STOCK ITEMS

PHONE
 0181 684 1166

E-MAIL: LANGREX@AOL.COM

FAX
 0181 684 3056

A selection of our stocks of **New Original Valves / Tubes.**
 Many other brands available

STANDARD TYPES			SPECIAL QUALITY TYPES			AMERICAN TYPES			OTHER TYPES		
ECC88	BRIMAR	4.50	A2900/CV6091	GEC	17.50	6L6GC	GE	15.00	ECC81	RFT	3.00
ECC88	MULLARD	6.00	E88CC/CV2492	BRIMAR	4.50	6L6WGB	SYL	10.00	ECC82	RFT	3.50
ECH81	MULLARD	3.00	E88CC/CV2492	MULLARD	8.50	12AX7WA	SYLVANIA	6.00	ECC83	RFT	5.00
ECL82	MULLARD	5.00	ECC81/CV4024	MULLARD	6.00	12BY7A	GE	7.00	EF86	USSR	5.00
ECL86	SIEMENS	5.00	ECC81/M8162	MULLARD	7.50	5687WB	ECG	6.00	EL84	USSR	2.25
EL36	MULLARD	5.00	ECC81/6201	MULLARD	8.50	6072A	GE	6.00	EL34G	SOVTEK	6.00
EL84	RCA	5.00	ECC82/CV4003	MULLARD	6.00	6146B	GE	15.00	E34L	TESLA	8.00
EZ81	MULLARD	3.50	ECC82/M8136	MULLARD	7.50	6336A	RCA	35.00	6SL7GT	USA	5.00
EZ80	MULLARD	3.50	ECC83/CV4004	BRIMAR	6.50	6550A	JAN GE	25.00	6SN7GT	USA	5.00
GZ33/37	MULLARD	6.00	ECC83/M8137	MULLAD	15.00	7027A	GE	25.00			
5Z4G	BRIMAR	5.00				7581A	SYL	15.00			
6V6GT	BRIMAR	4.25									
12E1	STC	10.00									
13E1	STC	85.00									
807	HYTRON	7.50									
811A	RCA	25.00									
6080	MULLARD	10.00									

THESE ARE A SELECTION FROM OUR STOCK OF OVER 6000 TYPES. PLEASE CALL OR FAX FOR AN IMMEDIATE QUOTATION ON ANY TYPES NOT LISTED. WE ARE ONE OF THE LARGEST DISTRIBUTORS OF VALVES IN THE UK.

SAME DAY DESPATCH VISA/ACCESS ACCEPTABLE. OBSOLETE TYPES A SPECIALITY.

CREDIT CARD MIN ORDER £10.00.

OPEN TO CALLERS MON.-FRI. 9AM - 4PM. CLOSED SATURDAY

U.K. P&P 1-3 VALVES £2.00, 4-6 VALVES £3.00 ADD 17.5% VAT TO TOTAL INC P+P. O'SEAS P & P PLEASE ENQUIRE



C17, 18 Elna Stargets
 2 x 2200uF 16V paralleled with
 2 x 100uF 35V
 Stargets are constructed using a 50µm cathode foil and a specially-formulated electrolyte that minimises internal defects which produce distortion. The leads are of Oxygen-Free Copper.

Fitting Parts
 PCB terminal pins, small 12
 PCB terminal pins, large 12
 Rubber sleeving 50cms
 NL

SOUND QUALITY

By far the easiest way to judge how well a set of upgrades is working is to take out the audiophile parts one by one after they've all had a good time to burn in (in this case, about three weeks). Before Nick began wielding the soldering iron, however, I put our standard KEL34 head-to-head with the turbo-charged version.

KEL34 with the full revamp proved to be much smoother, faster and more open than its non-tweaked cousin. The latter lacked definition in the bass which slowed rhythms down and sapped some of the enjoyment from music. The midrange was coarser too, brass and strings as well as vocals sounding harsh by comparison. Cymbals were also fizzier and less natural and following the separate instruments in a tune was tough.

The high-grade parts had a major impact on sound staging and imaging. With Classical, orchestras spread in a much wider arc between the loudspeakers, their individual sections better delineated spatially and tonally. The news for front-to-back perspectives was just as good, bands becoming fully fleshed-out in three dimensions rather than two.

Seeing as the specialist caps, resistors and diodes were obviously paying their way, it was time to find out exactly what each was doing. First to be replaced were the paralleled Starget feedback caps.

POSITIVE FEEDBACK

Into the boots of the Stargets came single Nover 4700uF electrolytics. Plying the KEL34 with a spot of Shostakovich and then some Brazilian Jazz, I discovered that the cap swap had taken the clarity and sparkle of the overall presentation down a notch or two, thickening the

vocals in the process. While music was still very enjoyable, it had lost some of its vivacity and drive, bass loosening up on drums and guitars.

More extended listening showed up a couple of other shortfalls. For example, tonal colour was more limited whether the music was Classical, Jazz or Blues, and there was a suspicion of dynamic compression. Together, these made orchestral sections more difficult to tell apart as the musical pace hotted up.

POST PAPER

Now it was time to revert to the 0.47uF polyester coupling capacitors after the paper-in-oils. It came as no surprise to hear that the sound shrank back towards the loudspeakers and became duller and less ebullient. Instead of the addictively foot-tapping rhythms in evidence before the parts removal commenced, tunes were beginning to plod along in a less involving fashion.

As above, imaging and sound staging both suffered from a veiling of detail which meant that singers as well as instruments were smaller between the 'speakers and more closely confined to their enclosures.

Previously, KEL34 had had an enviable tonal richness next to the thin, hard sound of a lot of solid-state gear. Now, however, piano sound slightly 'plinky, plonky' and strings had an artificial edge to them. Tweakers often encounter the same problem when stuffing an amp full of metal-film resistors in place of carbon films. The former might often be more detailed but they are usually brighter, harder and less natural as well.

TAKING THE BY-PASS

As more Stargets exited the amplifier (in this case those paralleled up as 220uF cathode by-pass caps), the sound stage dropped back into the loudspeakers' cabinets once more, orchestral music losing out in terms of scale, dynamics and weight. Imaging was now fairly two-dimensional next to the life-like presentation of the full upgrade kit. Strings also picked up a metallic edge to their upper registers and lost some of their signature harmonics. As had been the case with the tweaks to our 300B power amplifier, tonal richness continued to suffer as the good (but not audiophile) parts were soldered back onto the PCB.

CALLING THE SCHOTTKIES

There's no doubting the superiority of Schottky and fast-recovery diodes over normal types - they seem to work their magic whatever the component they're fitted to. Removing them from KEL34 I found the result was an additional layer of muddiness to the bass and brittleness to the treble and midrange. The change wasn't night and day, but it did make for more tiring long-term listening as subtle detailing was obscured and the music sounded less natural.

PAN POT

The last part to come out was also the most expensive, Panasonic's For Audio potentiometer. We know from plenty of past experience how much better this is than the customary (and admittedly cheaper) Alps Blue and Black units. KEL34 sans Panasonic was a much less open, lively amplifier as cymbals tended to splash and pianos had a wooden coloration to them. Where KEL34 packed with top-notch parts had possessed a vibrant, convincingly musical and realistic way with recordings, the non-mod alternative sounded flat and processed by comparison. This isn't meant as condemnation of the base model, but it's surprising how much more can be squeezed out of favourite albums with money spent on the right parts in the right places. JM

The upgrade parts listed above are available as a kit from Hi-Fi World.

KEL34 Upgrade Kit
UK (inc VAT and P+P) £150
Overseas
(exc VAT and P+P) £125

KEL 34 E/I output transformer pair
UK (inc VAT and P+P) £80
Overseas
(exc VAT and P+P) £68
For order form see p52.

The Tube Preamp Cookbook

30 years of hi tech valve preamp development and philosophy discussed in depth—phono, line and P/Supply stages, overall topologies, balanced and SE schematics, and two complete state of the art designs for you to build.

"I was delighted to see that there is something more than just the same old schematics and principles over and over again" EW

"SOUNDS FABULOUS! More 'grins per spin' than I dared to hope for.

Thank you so much for making your design available. It has been a positively uplifting experience to build and listen through this stellar device" WG

The SuperCables Cookbook

As it suggests: DIY super cables—analogue & digital interconnects, speaker and AC cables, theory and practice. Super sonics at some very un—super prices...

"Transcendence in interconnects" CJ (Positive Feedback Magazine)

"I tried the AC cord and the result was really good. I used it on my pre-amp. The music has more energy and is more lively" AC

"More music, more sense that the performers were living breathing humans—less hi-fi. No spit, grain nor fizz...rave ravel!" RF

Precious Metal-Beautiful Music...

Four 9's pure silver foil to make the very best interconnect & speaker cables. Or use for superb low impedance, wide bandwidth interconnect wiring in electronics and speakers.

3mm x 0.05mm DM 12/\$8 per linear meter
25mm x 0.05mm DM 72/\$48 per linear meter

Silver foil and Teflon I/C kit: 1st meter pair DM 177/\$100—extra meter pairs for DM 158/\$90 This is the best I/C anywhere! The books are DM60 (approx £23) or \$US40 each. P&P for a book or kit is DM14 in EU, \$5 in USA—worldwide it's DM26/\$US10.

Special offer: Both books for DM130/\$80 including p&p in EU or USA—elsewhere please add an extra DM12/\$8

VISA/MC welcome

USA: Ph (415) 492 0728 Fax (415) 499 8441 (FSpiritEd@aol.com)

Asia: Octave Ph + 60 3 793 7939 Fax ...7929 (octavele@tm.net.my)

Australia: Joe Rasmussen Ph+ 61 (0) 417 414475 (joeras@acay.com.au)

Europe and all other areas, please contact Allen Wright:

Einsteinstr.129, 81675 Munich, Germany. Ph/Fax: + 49 89 477415

(vacuumstate@compuserve.com) www.acay.com.au/~joeras/vacuum.htm

VACUUM STATE ELECTRONICS

CRICKLEWOOD ELECTRONICS

ANSAR SUPERSOUND
Audio Polypropylene 400VDC±5%

The secret's in the metallised film!



Manufactured specifically for high end audio, these polypropylene capacitors offer exceptional value for money as they use a specially imported high purity metallised polypropylene film, ensuring smooth, detailed and transparent sound quality and extremely low distortion, whether they are placed directly in the signal path such as in crossovers or for decoupling etc. Ideal for replacing old, stale and leaky capacitors.

Part No	Value	Price
CW100N	CAP PROPYL 100nF	£1 25
CW150N	CAP PROPYL 150nF	£1 25
CW220N	CAP PROPYL 220nF	£1 25
CW330N	CAP PROPYL 330nF	£1 25
CW470N	CAP PROPYL 470nF	£1 25
CW680N	CAP PROPYL 680nF	£1 25
CW100M	CAP PROPYL 1µF	£1 25
CW150M	CAP PROPYL 1.5µF	£1 50
CW220M	CAP PROPYL 2.2µF	£1 50
CW330M	CAP PROPYL 3.3µF	£1 85
CW470M	CAP PROPYL 4.7µF	£2 00
CW680M	CAP PROPYL 6.8µF	£2 50
CW100N	CAP PROPYL 10µF	£3 50
CW150M	CAP PROPYL 15µF	£4 50
CW220M	CAP PROPYL 22µF	£6 50
CW500	CAP PROPYL 50µF	£9 95
CW1000	CAP PROPYL 100µF	£20 00

Low value capacitors are extensively used in amps & preamps (especially in tone control, bass & treble etc). By changing to polypropylene you can enjoy an enhanced lighter - brighter sound especially in the treble and mid bass range and a transparent lower bass improvement. Close tolerance & high stability ensures that both channels can be very closely matched.

Part No	Value	Voltage	Price
CPP47P	CAP PROPYL 47pF	250V	£0 35
CPP100P	CAP PROPYL 100pF	250V	£0 35
CPP150P	CAP PROPYL 150pF	250V	£0 35
CPP220P	CAP PROPYL 220pF	250V	£0 35
CPP330P	CAP PROPYL 330pF	250V	£0 35
CPP470P	CAP PROPYL 470pF	250V	£0 35

Low Impedance High Temperature (105° C) Radial Electrolytics ± 5%

Superior electrolytics at affordable prices. The low impedance end resistance maximises signal purity whilst the superior temperature characterisation allow the capacitor to remain very stable under the most varying conditions.

Part No	Value	Voltage	Price
1M50	LO Z HI TEMP 1µF	50V	£0 25
2U2M50	LO Z HI TEMP 2.2µF	50V	£0 25
4U7M63	LO Z HI TEMP 4.7µF	63V	£0 25
10H63	LO Z HI TEMP 10µF	63V	£0 25
22H63	LO Z HI TEMP 22µF	63V	£0 30
47H63	LO Z HI TEMP 47µF	63V	£0 35
100H63	LO Z HI TEMP 100µF	63V	£0 50
220H50	LO Z HI TEMP 220µF	50V	£0 75
470H63	LO Z HI TEMP 470µF	63V	£1 25
1000H35	LO Z HI TEMP 1000µF35V		£1 50
2200H50	LO Z HI TEMP 2200µF50V		£2 25
4700H25	LO Z HI TEMP 4700µF25V		£2 50

Trobo Solder Lug Reservoir Capacitor 10,000µF 80V

Choosing the right electrolytic for power supply use is very important in keeping down hum whilst allowing maximum current flow for good transient & bass response. Elma capacitors are respected the world over for their exceptional audio attributes.

Part No	µF/Voltage	Price
10000C80	CAL ELNA1000µF/80V	£11 00

Monacor Air Cored Inductors.



A range of professional air cored inductors for 8Ω or 4Ω crossovers/filters for use up to 300W. 1.2mm enamelled copper wire wound on air spaced plastic bobbins.

Part No	Specification	Price
P15	150µH 0.15Ω 8x19mm	£2 00
P22	220µH 0.15Ω 8x19mm	£2 50
P33	330µH 0.2Ω 8x19mm	£3 00
P47	470µH 0.25Ω 59x19mm	£3 50
P68	680µH 0.35Ω 59x19mm	£4 50
P100	1mH 0.4Ω 59x19mm	£5 50
P150	1.5mH 0.5Ω 70x30mm	£6 50
P220	2.2mH 0.6Ω 70x30mm	£8 00
P330	3.3mH 0.75Ω 70x30	£10 00

Monacor Ferrite Inductors



A range of professional high efficiency ferrite cored inductors with very low ohmic losses for 8Ω or 4Ω crossovers or filters for use up to 400W. 1.4mm enamelled copper wire (1.3mm on F1000) wound on plastic bobbin.

Part No	Specification	Price
F220	2.2mH 0.15Ω 400W	£6 50
F330	3.3mH 0.2Ω 330W	£9 50
F470	4.7mH 0.25Ω 140W	£11 00
F680	6.8mH 0.35Ω 120W	£12 00
F1000	10mH 0.45Ω 100W	£13 50

High Quality Valves

Part No	Description	Price
6550C	OUTPUT VALVE	£26 00
6L5GT	OUTPUT VALVE	£4 50
6SN7GT	OUTPUT VALVE	£4 50
6V6GT	OUTPUT VALVE	£3 95
EC081	TRIODE	£4 50
EC082	TRIODE	£4 50
EC083	TRIODE	£4 50
EF86	LOW NOISE PENTODE	£9 90
EL34	OUTPUT VALVE	£8 50
EL84	OUTPUT VALVE	£3 50
GZ34	RECTIFIER	£6 50
KT88	OUTPUT VALVE	£20 00

Valve Holders - High quality valve bases. Chassis mounting with screw fittings.

Part No	Description	Price
B9AC	B9A VALVE HOLDER CERAMIC	£1 50
CC	SCREENING CAN	£2 25
OCTC	OCTAL VALVE HOLDER CERAMIC	£2 00
OCTP	OCTAL VALVE HOLDER PHENOL	£1 50

Fully Gold Plated Phono (RCA) Plugs with spring coil cable grip.



Part No	Description	Price
PPG5A2	PAIR GOLD PLUGS for up to 5mm CABLE	£1 50 pair
PPG8A2	PAIR GOLD PLUGS for up to 8mm CABLE	£1 50 pair

Very High Quality Phono (RCA) Plugs



Very high quality satin grey metal with heavy gold plated connections. Top collet cable grip & PTFE insulators. Very low noise.

Part No	Description	Price
PPG6H2	GOLD PTFE PLUGS for up to 6mm CABLE	£3 50 pair
PPG8H2	GOLD PTFE PLUGS for up to 8mm CABLE	£3 50 pair

Extra High Quality Gold Plated Phono Oxygen Free (RCA) Leads (pairs)



Available in 2 colours & 3 lengths. Highly flexible oxy.

gen free cable with extra moulded-in control / ground wire

Part No	Length/Colour	Price
LPG10Q	0.8 Metres/Green	£5 50
LLP10V	0.8 Metres/Violet	£5 50
LPP20G	1.5 Metres/Green	£6 50
LPP20V	1.5 Metres/Violet	£6 50
LPP50G	5 Metres/Green	£11 00
LPP50V	5 Metres/Violet	£11 00

Bass Reflex Tuning Ports

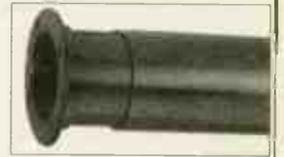

A range of adjustable plastic ports for use in various sizes of loudspeaker cabinets. d=diameter L=adjustable length (mm)

Part No	Dimensions	Price
R35	d=35L=110-210	£2 50
R50	d=50L=150-280	£3 00
R70	d=70L=128-245	£3 50
R100	d=110L=160-122	£5 50
R85	d=85 angled 45° for narrow cabinets L=210-310	£6 50

Super Monacor loudspeaker cabinet design book with many interesting new designs £6.00 (no VAT) + £1.00 P&P

High Quality Components at the right price. Please add £2.00 carriage + VAT to all orders. Credit Card phone orders accepted.

Howard Dawson Audio Hand-Crafted Loudspeaker Units for Music Lovers

Let your craving for that elusive tweeter upgrade end

HERE !

Howard Dawson Audio
16 Copeman Road,
Aylsham,
Norwich NR11 6JL.
U.K.
Tel (01263) 734361

Design-in the HRL-1 audiophile tweeter/supertweeter and sit back for a lifetime of listening pleasure.

The HRL-1 is a 'traditional' hand-made ribbon transducer for the discerning audiophile. A very low inertia all-aluminium membrane is used in conjunction with a massive Alcomax III cobalt magnet system to provide effortless clarity and presence. Sine wave response is specified as 3kHz to 30kHz, but useful output is available to beyond 50kHz.

Benefits include substantial improvements in location and identification of sources containing significant energy above 10kHz. These are mainly voices and 'acoustic' instruments. Metallic percussion, for example, is reproduced with scalp-tingling precision and presence, while simultaneously there is no trace of harshness or 'listener fatigue'.

Units are supplied in pairs with templates and comprehensive applications guidance, including crossover section design, and are intended to last a lifetime. Spare ribbon elements are available at low cost in case the unthinkable should ever happen.

HRL-1 Ribbon Tweeter/Supertweeter £300.00 per pair

Replacement ribbon insert for HRL-1 £10.00 each

Remanuf. inserts for Kelly/Decca ribbon units ... £16.00

or your own inserts rebuilt (new ribbon + tags) £13.50

U.K. p&p : ribbon inserts free, HRL-1 pair .. £10.00

HRL-1 overseas at cost (6kg parcel) - ribbon inserts .. £5.00

Write/phone for further information or see our website

WWW :: <http://www.argonet.co.uk/business/hsdawson>

E-mail :: hd-audio@argonet.co.uk

E/I, 'ERE WE GO!

Designer Gary Devon and World's Nick Lucas introduce the latest incarnation of our KEL34 valve integrated with E/I output transformers.

Following the success of our KEL34 integrated amplifier featured in the October and November '98 DIY Supplements, we decided it was time for a few improvements to the original. The result is KEL34 E/I.

The suffix denotes the major change to the amplifier, which is the replacement of the first-generation toroidal output transformers with more expensive E/I laminated, iron-core output versions. We enlisted the assistance of our boffin in the white coat, Gary Devon, to design these quality devices and explain the pros and cons of not just toroidals and E/Is but C-cores as well.

TRANSFORMER LORE

At one time there was only one type of transformer, the E/I, with the laminations which give it its name. Nowadays, audio-frequency transformers come in three main groups: E/I, C-core and toroidal. Each type has its advantages and weak points.

E/I and C-core transformers come in two varieties, "shell" and "core" winding, the two being topographical inverses of each other. Typical E/I transformers (shell types) have one bobbin with the laminations passing through and around it to form the magnetic circuit. With a core winding there's a pair of bobbins and one rectangular loop of magnetic material, one bobbin on each long side of the rectangle. The toroidal is an extension of this principle with a circular core and the winding around it.

The E/I is probably the most common output transformer mainly due to its cost effectiveness and because many of today's amps just rely on rehashes of old technology. The single bobbin used in the shell construction means that excellent layering and interleaving of the E/I sections can be used to obtain a good high-frequency response, but there are some problems.

The best steels are grain-orientated, which means that sub-optimal performance results from a magnetic flux which travels across the grain; this happens in the central 'bar' of the 'E' in



The new KEL34 proudly displaying its E/I transformers.

the E/I laminations. Also, the bobbin is generally quite squat to achieve good electrical efficiency, but this aspect ratio is not ideal from the point of view of leakage inductance.

Since laminations are relatively inexpensive and readily available it is possible to spend a little more on them and make a larger transformer, thereby improving performance without equalling the extreme price of a C-core. However, no matter how well you put the laminations together, a small air gap remains where they butt up. In an output transformer this is no problem because, although it lowers the effective permeability of the core, it reduces the effect of imbalanced valve currents as well.

The almighty C-core is a thin metal tape wound into a rectangular loop. The core is then bonded and cut before the cut faces are ground to a high tolerance and mated so there is virtually no gap.

And as the core is wound from a tape, the grain always points in the preferred direction, optimising the material's characteristics.

C-cores can be made from much higher grade material than E/Is where the better material would be wasted. C-cores are often seen with the 'core' type of construction too, which can improve performance as well as reducing the amount of expensive core needed.

To eliminate the air gap completely a continuous loop is used in the toroidal. As with the C-core, the grain of the metal is correctly aligned for good magnetic performance. Extremely compact and efficient mains transformers can be made with toroidal cores. Another plus is that since the two ends of the winding which appear in the bobbin are joined together, leakage inductance should be low. There are drawbacks, however.

The way our universe is put together means that the greatest volume is

SPEAKER KITS FROM IPL ACOUSTICS

Over a 10 year period I.P.L. ACOUSTICS have developed a range of high quality speaker kits, using the best units from SEAS, MOREL, AUDAX, and I.P.L. and have produced a comprehensive range of speakers which will compete with the most expensive of commercial designs.

All speakers have biwired crossover kits containing high quality components and terminals.

**S5TL
TRANSMISSION LINE**



PLUS KIT£382.00
TOTAL KIT£506.00

**FIVE TRANS-
MISSION LINE
KITS**

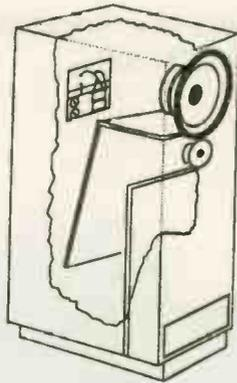

TRANSMISSION LINE
PLUS KITS£177.00 -
.....£382.00

**M3TL
TRANSMISSION LINE**



PLUS KITS£177.00
TOTAL KIT£241.00

**A2 H.D.A.
AEROGEL KIT**



PLUS KIT£187.50
TOTAL KIT£259.00

**S3TLM METAL
TRANSMISSION LINE**



PLUS KIT£233.00
TOTAL KIT£311.50

PRE-VENEERED CABINET KITS NOW AVAILABLE. Carriage charge extra on all kits.

If you would like further details please send large SAE with 38p stamp for SPEAKER BUILDING CATALOGUE, comprising VALUABLE ADVICE on DESIGNING, BUILDING, and TESTING speakers and full technical specifications including response curves of eight kits, drive units, and details of SPECIALIST CABLES and ACCESSORIES. KITS FOR A.V. USE NOW AVAILABLE.

I.P.L. Acoustics, Chelsea Villa, Torrs Park, Ilfracombe, N.Devon, EX34 8AY Tel:01271 867439

Pro-Cap

Silver Foil Paper in Oil Capacitors
*Precision Engineered Professional Grade Audio
Signal Capacitors*
MADE IN UK

These capacitors are the very best available anywhere in the world and are sonically superior to all others irrespective of price. Silver Foil Paper in Oil Pro-Caps are perfect for single end triode amplifiers, push-pull power amplifiers, tube preamp, power supplies and premium loudspeaker designs. You will hear superior detail in your music, but none of the harshness, only deliciously liquid, sweet and rich music.

Available in the following values

Silver Foil Paper in Oil Capacitors (650 V)

0,005µF - 0,01µF - 0,02µF - 0,05µF - 0,1µF - 0,22µF - 0,47µF
1µF - 2µF - 4µF - 8µF - 16µF - 32µF

Low Voltage Speaker Crossover Silver Foil Paper in Oil Capacitors

1µF - 2µF - 4µF - 8µF - 16µF - 32µF

Contact Audiolamp for further information and pricing.
Audiolamp is the sole distributor for Pro-Cap capacitors for all countries that are members of the European Community (excluding Germany).
Fax: +39 0974 984477

E-Mail: audiolamp@pisucane.edinet-gdp.com
<http://www.edinet-gdp.com/audiolamp>

Audiolamp

Audiolamp, via Nazionale 41, 84067 Policastro B., Sa. Italy



**SERVICE
FOR
ENTHUSASTS**

High quality Push-Pull or single ended Output, Mains, Chokes, Interstage, Input and Cartridge Transformers



Choose from our catalogue or specify a custom design at no extra charge. Range of package options: full or half shrouded or open frame. Encapsulation, as illustrated for our popular size "P+" for output or mains. All transformers built to order by our craftsmen. Usually 3-4 weeks delivery. Free technical support for all our products (Phone, Fax or internet). Free catalogue. Visa, Mastercard, JCB etc.

E A Sowter Ltd
PO Box 36 IPSWICH
IP1 2EI England
Tel: (+44) (0) 1473 252794
Fax: (+44) (0) 1473 236188

E-Mail: sales@sowter.co.uk
techsupport@sowter.co.uk
Catalogue and overseas agents on our Website:
<http://www.sowter.co.uk>

enclosed within a cube, so a toroidal shape is not the most space efficient. With a reasonable-sized core, the inside diameter is substantially less than the outside, which leaves the windings in a bit of a mess.

Their totally-closed magnetic circuit means that toroids have very good theoretical bass performance. Unfortunately, when presented with a super-imposed DC current, that performance rapidly drops away. Theoretically, the toroid is the ideal shape; in practice it doesn't deliver. The C-core comes out as the best but is very expensive. The good, old E/I still holds its own as an affordable, down-to-earth design. **GD**

RINGING THE CHANGES

The overall KEL34 circuit hasn't altered, nor have the chassis' dimensions. What have changed are the following:

- 1) The PCB has been altered to incorporate terminal pins so that the populated board can be fixed into position and from there the PCB-to-external connections made. This makes the amplifier less fiddly to build.
- 2) The mains transformer has been relocated to the centre of the rear of the chassis.
- 3) More ventilation slats have been added to the top of the chassis to improve heat dissipation.
- 4) The tape/source switch has been moved to the front panel for easier access.
- 5) Due to the current unrest in Yugoslavia, where the Ei 6CA7 valves are manufactured, there is a supply problem into the UK. Hopefully this will only be short-term. However, as a result the KEL34 E/I version will feature Tesla's JJ-branded EL34s, valves that Gary Devon recommended first time round.

This is a very popular EL34 in the valve industry, as it's very rugged, looks good and has a pure sound. These valves are made in the Slovak republic.

6) The price. Owing to the added expense of the E/I output transformers there has been a slight price increase of £20 for EEC member countries.

To those who purchased the original KEL34 we are offering the option of obtaining a pair of new E/I output transformers for £80 including VAT and postage. These will be supplied with a template for fixing-hole location. The new transformers will be of the upright, double-shrouded variety.

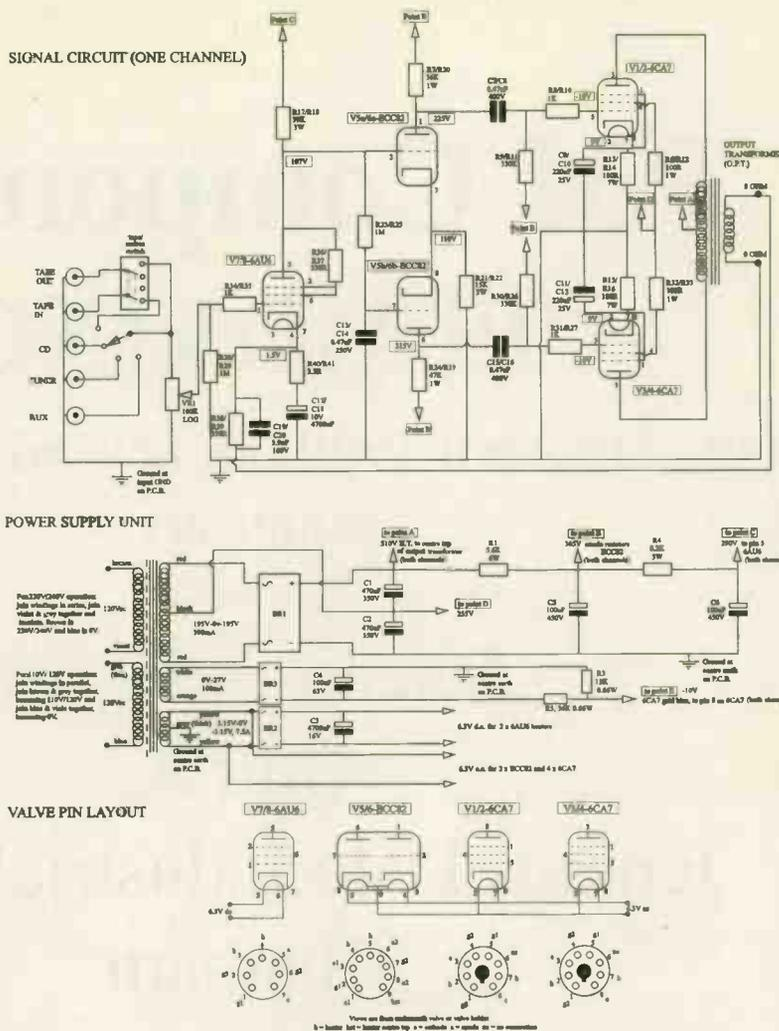

KEL 34 E/I circuit diagram.

SOUND QUALITY

Just as caps, resistors and diodes can radically alter the sound of a piece of equipment, so it is with transformers too. Replacing the standard toroids with our new E/Is turned out to be a major upgrade in every area of performance. The biggest bonus was in imaging and sound staging, both of which were far clearer and more spacious than before - voices and instruments really jumped out of the loudspeaker boxes.

Tonally, KEL34 E/I was a bit of a smoothie compared with the toroidal version, as lower levels of grain and 'hash' all the way from lower bass to upper treble proved. It was faster dynamically as well, plucked guitar strings and bass drum having crisper leading edges and more impact ●

Measured Performance see p127

KEL34 E/I is available as a kit from HFW

KEL34 E/I PCB	
UK (inc VAT and P+P)	£65
Overseas (exc VAT and P+P)	£57
KEL34 E/I transformer set	
UK (inc VAT and P+P)	£130
Overseas (exc VAT and P+P)	£110
KEL34 E/I K240/120 (no valves)	
UK (inc VAT and P+P)	£270
Overseas (exc VAT and P+P)	£230
KEL34 output transformer, pair	
UK (inc VAT and P+P)	£80
Overseas (exc VAT and P+P)	£68
KEL34 E/I K240/120 (with valves)	
UK (inc VAT and P+P)	£315
Overseas (exc VAT and P+P)	£270

PM Components Ltd

Selectron House, Springhead Enterprise Park, Gravesend, Kent, England. DA11 8HD
FAX:01474 333762 TEL: 01474 560521

PM Components IS MOVING

As from 16th April 1999 our new address and contact points are:

Selectron House
Unit A
Jenkins Dale Industrial Estate
Chatham
Kent
ME4 5RT

Telephone: 01634 848500

Fax: 01634 848676

E-mail: 101650,2424@compuserve.com





DIY

Letters

THE SENSITIVE SORT

I should like to upgrade my Leak Stereo 20 and decrease the input sensitivity. Have you any suggestions for both these queries? Your help would be very much appreciated.

Chris Gould
CGould2640@aol.com

To begin with, all the upgrades in the world will still leave you with a Stereo 20 when all's said and done; that is, it will be an elderly, low-power amp. You can certainly improve on things like the decoupling capacitors, assuming they have already been replaced with cheap polypropylene types. Several firms are offering paper-and-foil types which are better than the original metallized paper ones and much less harsh than metallized plastic. Money spent here is arguably the most cost-effective upgrade, so long as you keep the values no more than, say, 25% over the original. It can be a mistake to put grossly over-value capacitors in the signal path: old circuits used coupling caps for more than just DC blocking - they also prevent low-frequency signals from setting off 'motor-boating' oscillations, so keep by and large to the specified values.

The sonic benefits of this or that type of resistor are endlessly chewed over in certain circles. Acquaintances of many seem to be fairly unanimous in condemning the 1% metal film

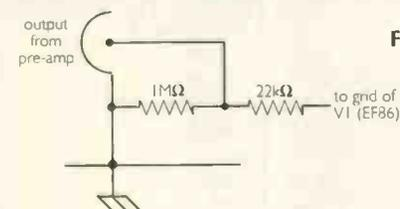

Fig 1

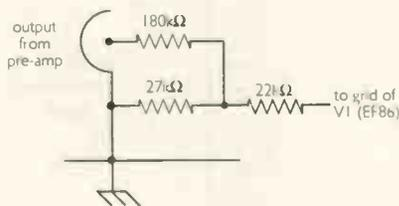

Fig 2

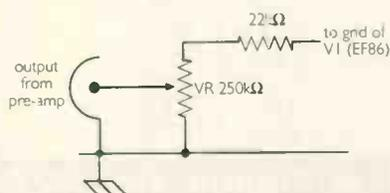

Fig 3

types which are the mainstay of most retail outlets. My own experience is that they are certainly bright sounding and if you can find carbon types these give a 'kinder' sound. Holco 1watt non-inductive resistors can sound good in vintage gear. Which you decide on obviously depends largely on your taste and the depth of your pockets.

It is not desperately difficult to convert the heater circuit to DC although poor component placement can nullify the benefits of this by increasing hum pick-up from the mains transformer. Morgan Jones' book 'Valve Amplifiers' (World Library) is very hot on DC heater

supply and HT smoothing, giving a lot of tips and worked examples on both subjects. Do bear in mind that DC heaters mean shorter valve life.

For trimming the input sensitivity Leak used to employ the network shown in fig 2 (one channel only shown). Fig 1 is the standard set-up for comparison. The fig 2 arrangement reduces the input sensitivity to about 1 volt with 200kΩ impedance. A cruder method is shown in fig 3, where a 250kΩ pot replaces the individual resistors. Leak used this in their TL50 monobloc; it has the advantage of variable control but the input is never the ideal place for a pot! RMW

PRICE VALIDITY TO END JUNE 1999 - ASK ABOUT ANY TYPES NOT ON THIS LIST



CHELMER VALVE COMPANY

for High Quality Audio Tubes

Everybody in the tube business knows that the justly famous Brand names of yesteryear like BRIMAR, GEC, MULLARD, RCA & TELEFUNKEN Etc. Etc. are scarce and often very expensive.

Although we supply all major brands when available (and have many in stock) our policy is to offer a range of tubes, mostly of current manufacture, the best we can find from factories around the world, which we process specially to suit audio applications. The result - CVC PREMIUM BRAND.

Our special processing includes selection for LOW NOISE, HUM & MICROPHONY and controlled BURN-IN on all power tubes to improve STABILITY and select out tubes with weaknesses Etc.

A selection of CVC PREMIUM Audio Tubes

PRE-AMP TUBES	POWER TUBES	POWER TUBES	SOCKETS ETC.
ECC81 5.20	EL34G 7.70	(continued)	B9A (Chassis or PCB) 1.60
ECC82 5.20	EL34 (TESLA) 8.20	6336A 46.00	B9A (Ch or PCB) G/Plated 3.00
ECC83 5.20	EL34/6CA7 (Large Dia.) 10.70	6550A 11.00	Octal (Ch. or PCB) 1.80
ECC85 6.00	EL84/6BQ5 4.80	6550WA or WB 13.50	Octal (Ch. or PCB) G/Plated 4.20
ECC88 5.00	EL509/519 13.00	7581A 11.00	4 Pin (For 2A3, 300B etc.) 3.30
ECF82 5.00	E84L/7189A 6.50	807 9.00	4 Pin (For 2A3, 300B etc) 5.00
ECL82 5.20	KT66 9.50	811A 11.00	G/ Plated 11.00
ECL86 5.20	KT66R 22.00	812A 34.00	4 Pin Jumbo (For 211 etc.) 15.00
EF86 5.60	KT77 12.00	845 30.00	4 Pin Jumbo (For 211 etc.) Gold Plated 3.00
E80F Gold Pin 10.00	KT88 (Standard) 12.50		5 Pin (For 807) 4.50
E81CC Gold Pin 6.80	KT88 (Gold Special) 21.00	RECTIFIER TUBES	7 Pin (For 6C33C-B) 5.00
E82CC Gold Pin 8.00	KT88 (GL Type) 30.00	EZ80 4.20	9 Pin (For EL, PL509, Ch. or PCB) 2.00
E83CC Gold Pin 7.50	PL509/519 9.00	EZ81 4.70	Screening Can (For ECC83 etc.) 1.50
E88CC Gold Pin 8.00	2A3 (4 or 8 Pin) 14.50	GZ32 12.00	Anode Connector (For 807 etc.) 1.70
6EU7 6.00	300B 50.00	GZ33 10.00	Retainer (For 6L6WGC etc.) 2.00
6SL7GT 8.50	6C33C-B 27.00	GZ34 6.70	
6SN7GT 4.60	6L6GC 6.50	GZ37 8.70	
6922 5.50	6L6WGC/5881 8.00	5U4G 5.50	
7025 6.50	6V6GT 5.00	5V4GT 4.70	
	6080 11.50	5Y3GT 4.20	
	6146B 10.50	5Z4GT 4.70	

and a few "Other Brands" (inc. Scarce types).

5R4GY FIVRE 7.00	6B4G / SYLVANIA 27.00	6SN7GT BRIMAR 10.00	13E1 STC 110.00
5R4WGY CHATHAM USA 10.00	6BW6 BRIMAR 5.00	12AT7WA MULLARD 5.00	805 CETRON 50.00
5U4GB RCA or GE 12.00	6BX7 GT GE 8.50	12AY7 GE-SYLVANIA 7.75	5842A GEC 15.00
5Y3WGT SYLVANIA 5.00	6CG7/6FQ7 SYLVANIA 7.50	12AZ7 GE 7.50	6080W TUNGSTOL 12.50
6AS7G RCA or SEIMENS 12.00	6CL6 RCA or GE 5.00	12BH7A GE or RCA 13.00	6550A GE 23.00
6AU6WC SYLVANIA 3.50	6CW4 RCA 11.00	12BY7A GE 9.00	6146B GE 17.00
	6SL7GT STC 8.50	12E1 STC 12.50	

ALL PRICES IN U.K. POUNDS £

Please note carriage charge extra + VAT (EEC Only) - When ordering state if matching required (add £1.00 per tube).

Payment by CREDIT CARD (ACCESS, VISA, MASTERCARD) or BANKERS DRAFT, TRANSFER or CHEQUE (UK ONLY).

FAX or POST your ORDER - We shall send PROFORMA INVOICE if necessary.

Valve Amplifiers sound better still fitted with CVC PREMIUM Valves!

Chelmer Valve Company, 130 New London Road,
Chelmsford, Essex CM2 0RG. England.

☎ 44 (0)1245 355296 Fax: 44 (0)1245 490064

HEADING FOR SUPERIOR SOUND

I promised a letter on my upgrading results when I bought the HD83kit, so here it is.

Firstly, note that the components supplied with HD83 have an excellent price/performance ratio, so it takes more than a few quid to obtain significant improvements. Secondly, all trials have been with Sennheiser HD580 'phones, so my observations are based on these. This is a good quality headphone, though, and I suspect that after the upgrades listed below, I'll have to go electrostatic for the next upgrade.

UPGRADE PARTS

Upgrades in order of maximum cost-effective improvement:

- 1) Replace C4, C7, C5 and C8 with Black Gates. If you do nothing else, this is the upgrade to go for. I tried Elna Cerafines in the C5/C8 position and, although worthwhile, it's definitely worth the extra for the BGs.
 - 2) Replace R9/R16 with Vishay VSRJs. This is purely a rule of thumb from experiments with transistor gear but it seems to work here, too. Always put the very best components in the negative feedback loop. If on a budget, I would use Audio Note 0.5watt tantalum-film resistors here.
 - 3) Replace R5-R12 with Audio Note tantalum-film resistors starting at the input stages and working backwards. Do the cathode circuits first and use low-noise resistors (carbon films can hiss here). The anode circuits are next.
 - 4) C6/C9 is a fine-tuning element for the deep of pocket. The supplied polyester cap is the carbon resistor of the coupling-cap world - the sonic performance for the money is unbeatable. Like carbon films, though, this is not because of super performance or resolution but because the distortion it adds is sonically benign.
- I have listened extensively to two upgrades here. Infinitap Setis give superb resolution and detail freaks will love them. Personally, I find the bright, lively nature of the '580s is a poor match for the bright, lively nature of the Infinitaps. Although the presentation is sweet and clean, I find it tiring after an hour or so and couldn't stand a whole evening of it.
- Audio Note paper-in-oils are my favourites. I can listen to these all night

HD83 Headphone amplifier

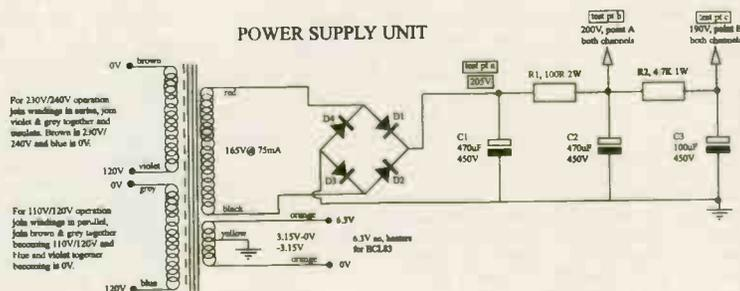
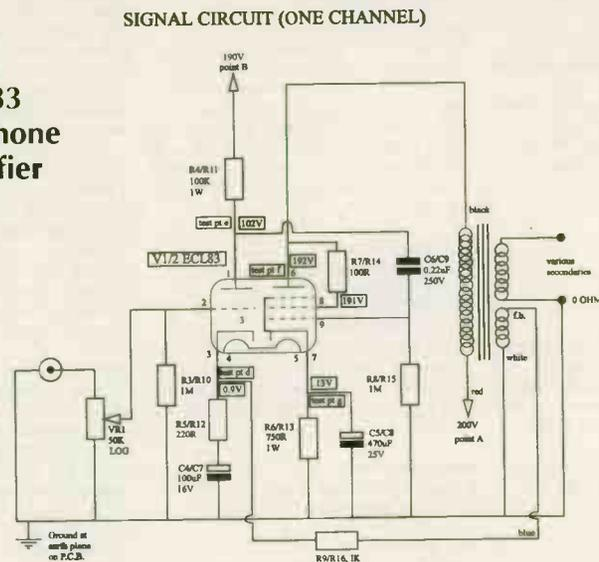

VALVE PIN LAYOUT

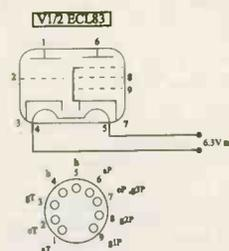

Notes are from underneath valve or valve holder
b = heater hot = heater centre tap = cathode = anode ac = no connection T=triode Protoprods

and still not want to switch off and go to bed. I can only fit the 400V aluminium foils in the HD83 case, however. The copper foils only come in 630V and won't fit on the board. I intend to try some off-board.

I'm sure that anyone who tries these upgrades will be as bowled over by the improvements as I was. This will give you an amp/transducer combination better than most and bettered by few (and definitely not at the price!)

ASSEMBLY TIPS

- 1) It's worthwhile using extra terminal pins in the positions of all the components listed above and soldering the stock components to them. Then, if upgraditis strikes, components can be

changed from above without having to remove the PCB and all its many peripheral wires.

- 2) Unless you live alone, solder dummy-load resistors across the output socket which 'switch in' when the phones are removed. This keeps the outputs loaded when the phones are un-plugged. My spouse hit the wrong button on the remote one evening while I was out and started the CD player. Irritated by the cans playing flat out, they were unplugged for the best part of a whole Rock CD. The output trannies seem OK but the valves have gone unusably noisy (what a waste!) Be warned.

John Spriggs

john.spriggs@wollaton25.swinternet.co.uk

KIT & COMPONENT SUPPLIERS

LOUDSPEAKER KIT SUPPLIERS

**Wilmslow Audio, 50 Main Street,
Broughton Astley, Leicestershire LE9 6RO**
Tel: (01455) 286603
Fax: (01455) 286605

UK distributors of Drive Units from ATC, COLES, DYNAUDIO, KEF, MOREL, PEERLESS, RCL, SEAS, SCANSPEAK AND VOLT. Comprehensive range of high quality crossover components, acoustic damping products, connectors and veneers. Over 20 different D.I.Y. loudspeaker kits on demonstration, including ATC 50 & 100.

Audio Note (UK Ltd)
Unit C, Peacock Ind. Est.
125-127 Davigdor Road
Hove, East Sussex BN13 1SG
Tel: 01273 220511
Fax: 01273 731298

Suppliers of a large amount of components for the Audiophile Kit builder. Valve amplification data and vintage circuits also available. See the double page spread in the back section of the main issue for extra & more detailed information.

European Precision Mouldings Ltd
Highwyh, Sawbridgeworth,
Herts, CM21 0JS
Tel: 01279 600428
Fax: 01279 723846

Manufacturers of the Red Scorpion range of loudspeaker terminals and binding posts.

Falcon DIY Speakers
Falcon Acoustics Ltd., Tabor House,
Norwich Road, Mulbarton,
Norfolk NR14 8JT.
Tel: 01508 578272

UK distributors of FOCAL drive units & Kits, plus SOLEN (SCR - Chateauroux) polypropylene capacitors and the largest specialist Audio inductor manufacturer in the UK. Stocking Audio Amateur Publications and Audio Computer Software. Comprehensive range of D.I.Y. Speaker kits, Parts, Accessories and Books. Please send large SAE (38p) for free price list. "Everything but the wood"

**IPL Acoustics, Chelsea Villa, Torrs Park
Ilfracombe, N.Devon EX34 8AY.**
Tel: 01373 823333

IPL supply a range of eight speaker kits using drive units from SEAS, Morel, Audax, Visaton etc. including four transmission lines to suit all room sizes. We also supply a full range of drive units, capacitors, and cabinet accessories as well as silver plated P.T.F.E. insulated cables.

South Coast Speakers Ltd
326 Portwood Road,
Southampton, Hampshire.
Tel: 01703 559312

UK suppliers for High-Quality Driver Units from: SEAS VOLT VISATON SCAN-SPEAK also MOREL RCL & many more. Accessories/Components all of the Highest Quality inc. ProAudio MKT Capacitors, Inductors wound to order for any values. Many DIY Kits always on demonstration in our comfortable listening area. Custom design services & friendly advice!

VALVE AND OUTPUT TRANSFORMER SUPPLIERS

**Wilson Valves, 28 Banks Avenue,
Golcar, Huddersfield,
West Yorks HD7 4LZ.**
Tel: 01484 654650
Fax: 01484 655699

E-mail: wilsonvalves@surfink.co.uk
We stock over 2,500 different types of valves, N.O.S. and New. Please send a S.A.E. for full list. No charge for matching. Most major credit cards accepted

Chelmer Valve Company
130 New London Road,
Chelmsford, Essex CM2 0RG.
Tel: 01245 265865 Fax: 01245 490064.

Supplier of premium range of audio valves, other valves and components also available. (Please see our main advertisement in this supplement).

Billington Export Ltd.
IE Gillmans Trading Estate,
Billingshurst,
West Sussex RH14 9EZ
Tel: 01403 784961
Fax: 01403 783519

Billington Export Ltd. holds large stocks of audio valves including many obsolete brands such as Mullard, GEC, Brimar etc. as well as Sovtek, Thermionic Gold Brand and the recently introduced Billington Gold range. Also Cathode Ray Tubes (eg. used in Marantz tuner 10B). 50 page catalogue available, tel or fax for a quotation. Minimum order £50.00 UK, £100 export

Langrex Supplies Ltd
1 Mayo Road, Croydon,
Surrey RO2 2QP
Tel: 0181 684 1166
Fax: 0181 684 3056

One of the largest distributors of electronic valves, tubes and semi-conductors in the UK by original UK and USA manufacturers. Obsolete types are a speciality. Telephone or fax for an immediate quotation.

Watford Valves
3 Ryall Close, Bricket Wood,
St. Albans, Herts AL2 3TS
Tel: 01923 893270
Fax: 01923 679207

Specialist in new old stock and current production valves. Sole UK distributor of the Harma Diamond range selected for their superior performance. Huge range held, stockists of Mullard, GE, Phillips, National, Brimar, Sylvania, Telefunken, RCA, MOV and many more. All valves are new boxed and guaranteed. For free price list and specialist advice call or fax Derek Rocco, Watford Valves.

PM Components
Springhead Enterprise Park,
Springhead Road, Gravesend,
Kent DA11 3HD
Tel: 0474 560521

P.M. Components Ltd are the specialist component company for High End Audio enthusiasts. We have a design and manufacturing base for audio valves and associated products and have a capability to produce custom tubes for major manufacturers. Our 70 page catalogue is available at £2.50 including U.K. postage. P.M. Components are major stockists for Golden Dragon, Mullard, GEC and Teonex valves and have a vast archive of vintage tubes gathered from every manufacturer in the world.

Woodside Sound Engineering,
Arfryn, Llanbaldy, Whitland. SA34 0EY
Tel: 01994 448271 Fax: 01994 448665
E-Mail: woodside@tesco.net

As well as producing transformers for our own products, we can now offer an expanding range of audio transformers for new ventures and Renovations. We can wind transformers for most RADFORD amplifiers to original specification. Contact us with your requirements or a list of standard items is available on request.

CLASSIC TURNTABLES

Technical & General
P.O. Box 53, Crowborough,
East Sussex TN6 2BY.
Tel: 01892 65 45 34.

The original specialist source of spares, replacements and expertise for the classic turntables. Years of actual experience and comprehensive range of parts (originals and re-manufactures), manuals, ancillaries, No dubious 'improvements' - no harmful 'modifications'. Our specialities: Connoisseur; Garrard; Goldring; Lenco; S.M.E.; Thorens; Watts; Ortofon; Shure; Cartridges and styli for 78s, Mono LPs, Stereo LPs.

COMPONENT SUPPLIERS

**PV Tubes, 108 Abbey Street, Accrington,
Lancs BB5 1EE. Tel: 01254 872500. Fax:
01254 872166.** Large range of electronic and TV components, satellite and aerial equipment. Call today for efficient service.

Avondale Audio,
The Hollius, Avondale Road
Chesterfield S40 4TF
Tel: 01246 200096
Fax: 01246 207240

Audio Engineers: upgrades, Improvements & servicing to both static and moving parts of the hi-fi chain. (amps as well as turntables). Also bespoke range of own equipment and an extensive range of parts & components available.

Audio-Links
7 Fairmont Crescent, Scunthorpe,
North Lincolnshire DN16 1EL
Tel: 01724 870432 Fax: 01724 875340

Large range of specialist audiophile components for solid state and valve enthusiasts. Mail order and a friendly service. Monday to Saturday, 9am - 6pm. 30 Page Catalogue - £2.00.

AudioCom (UK),
Unit 4 & 6, Tindle Centre
Warren Street, Tenby
Pembrokeshire, SA70 7JY
Tel: 01834 842803
Fax: 01834 842804

E-Mail: audicom@scotnet.co.uk
AudioCom are international suppliers of premium grade components. We stock a range of specialist parts including: Elna CERAFINE & SILMIC electrolytics, Sanyo OS-CON SA,SC & SG electrolytics, MIT MultiCap self-bypassed film capacitors, 99.99% Long-grain pure silver wire, Danish Audio Connect CT1 attenuators., OFC inductors & RCA connectors. For a copy of our 1998 audiophile parts catalogue, mail, phone or fax the above. (overseas £3.50).

Hart Electronic Kits Ltd
Penylan Mill, Oswestry,
Shropshire SY10 9AF
24 Hr sales/enquiries Tel: 01691 652894

A range of Audiophile kits for 80 watt Power Amplifiers, Tuners, Pre-Amps and Moving Coil/Moving Magnet RIAA Pickup Preamps. All kits are fully engineered, with our thirty years design experience, for easy constructions from circuits by John Lindsey Hood, the most respected designer in the field. Send for lists.

AP Electronics
20 Derwent Centre, Clarke Street,
Derby, DE1 2BUT
Tel: 01223 811 716

Check out the AP ELECTRONICS catalogue. It's free with every order of over £40.00 or can be purchased for a £4.95 cheque payable to 'AUDIOKITS'. Over 80 pages include pre and power amplifier kits, high grade audiophile resistors, capacitors and semiconductors, audio and mains cables, gold and rhodium plated connectors and COMPONENT NOTES on using high grade parts. A quarterly newsletter 'AP PERFORMANCE AUDIO' has been recently launched and your first issue is free.

Cambridge Scientific Supplies
12 Willow Walk,
Cambridge CB1 1LA.
Tel: 01223 811 716
Fax: 01223 501 833

Specialist wire products for the knowledgeable audiophile including:- Silver wire (>99.99% purity, stress free) unique quadruple PTFE insulated Silver wire, Silver loaded solder, PTFE sleeving and Nylon braid sleeving, premium Gold plated connectors and plugs. Custom assembly available. Call Peter Bullock for a catalogue and application note.

Kopperae
PO Box 6884, Dundee, DD5 1YB
Tel: 07970 - 654356

E-mail: wkopp@taynet.co.uk
Kopperae manufacture unique anti-resonance and anti-interference hi-fi accessories that dramatically cut transistor harshness and background noise. These products include the highly effective anti-RF, anti-resonance CD Roof: an attractive medite-copper-damping pad slab that sits on TOP of your CD player. For the DIY enthusiast, we have the Cu Pad, a copper backed self-adhesive damping pad that can be used in a variety of applications, including cutting panel vibrations and lining chassis. We also supply plain 0.6mm sheet copper. Build chip, transformer and DAC

shields, or clad casings, and get the significant benefits that RF shielding brings. ALL products are available custom sized. Contact us now for a free brochure

RESTORATION

Audio Laboratories (Leeds)
3, Kildare Terrace, Whitehall Road,
Leeds, LS12 1DB
Tel: 0113 244 0378

Have your pet hi-fi project professionally done. With over 20 years experience in factory-grade kitbuilds and overhauls, to both valve and solidstate equipment, our good reputation stems from meticulous engineering coupled with superb measurement facilities.

White Noise
11 Station Road, Bearsden
Glasgow G61 4AW
Tel: 0141 942 2460

Specialist supplier of the highest quality, solder masked, silkscreened, PCBs and kits for audiophile grade, solid state power amplifiers, power supplies, MM/MC phono stages, and active crossovers, with many more to come. We also supply a wide range of top quality audiophile passive and active components, specialising in the latest high performance Japanese transistors and UK lateral power mosfets. Write for a free catalogue. Mail order only.

VINTAGE DIY

Loricraft Audio
4 Big Lane, Goose Green,
Lambourn, Berks RG16 7SQ.
Tel: 01488 72267

Specialist restoration of 301's and 401's using genuine spares and re-manufactured parts to original pristine standards in our newly built workshops designed primarily for these purposes.

WELDING

N.Clark Welding & Fabrications
14 Redhills Road
Easton Industrial Estate
Southwoodham Ferrers
Essex CM3 5UP

Tel: 01245 323336
Precision welding and sheet metal work TIG/MIG welding, CNE Punch and Press Milling and Turning Fine Limit and General Engineering Prototype work and batch work undertaken.

SPECIALIST UPGRADE SERVICES

AudioCom (UK),
Unit 4 & 6, Tindle Centre
Warren Street, Tenby
Pembrokeshire, SA70 7JY
Tel: 01834 842803
Fax: 01834 842804

E-Mail: audicom@scotnet.co.uk
Professional modifications using leading edge components. Modifications are carried out by engineer with 30 years experience in the field of analogue and digital electronics. Upgrades available to all types of audio equipment including CD players, Transports, D-A converters, Pre & Power Amplifiers. Call us today for more information.

**TO ADVERTISE IN
KIT & COMPONENT
SUPPLIES
CALL AMANDA OR
SARAH ON
0171 328 2213 &
0171 328 4892**

Previously Cherished Items, Or something new from Choice

Clearance Items

	Choice Price	Original Retail Price
Audio Research D240 mk II	£ 1395.00	£ 3500.00
Exposure V Active x over	£ 295.00	£ 995.00
EAD 7000 Transport	£ 895.00	£ 2495.00
Tesserac Tala pre-amp	£ 695.00	£ 1495.00
Magnum P200 pre-amp	£ 895.00	£ 1895.00
Sonus Faber Gravis Sub woofer + X-over + power amp	£ 1250.00	£ 3200.00
Kenwood 9010 CD Transport	£ 195.00	£ 500.00
Alon Adriana	£ 3500.00	£ 10000.00
Alon PWT Subwoofer (Passive)	£ 295.00	£ 750.00
Gale 401	£ 250.00	£ -
Kinshaw Overture Phono	£ 195.00	£ 395.00

New in This Month

	Choice Price	Original Retail Price
POWER AMPLIFIERS		
AVI 2000 Monoblocks (As New)	£ 895.00	£ 1400.00
EAR 519	£ 2695.00	£ 4699.00
VTL 225 Monoblocks	£ 2250.00	£ 5000.00
Audio Note Kassi	£ 12995.00	£ 30000.00
Audio Note Kagon	£ 29500.00	£ 80000.00
Exposure Dual Reg IV	£ 795.00	£ 1800.00
Unison Research Simply 2 (As New)	£ 650.00	£ 995.00
Unison Research Smart 845	£ 2200.00	£ 3250.00
Krell 50S	£ 2250.00	£ 3690.00
PRE AMPLIFIERS		
Boulder L5AE	£ 2000.00	£ 3500.00
Exposure XIV pre IX psu	£ 1500.00	£ 3000.00
Unison Research Mystery One pre	£ 1195.00	£ 2000.00
Krell KRC2	£ 2200.00	£ 4190.00
Krell KRC HR	£ 4995.00	£ 7000.00
SPEAKERS		
Roksan ROK 1	£ 295.00	£ 600.00
Sonus Faber Concerto Grand Piano + Stone base (Piano Black)	£ 1700.00	£ 2200.00
Wilson System V (Black)	£ 12000.00	£ 18000.00
Rogers LS3/5A Black (NEW)	£ 575.00	£ 798.00
Rogers AB1 Sub (NEW)	£ 395.00	£ 598.00
Monitor Audio Studio 50SE (Black Laquer)	£ 3500.00	£ 4799.00
Linn Khelids (Oak)	£ 395.00	£ 750.00
Ruark Accolades Passive/Active	£ 1495.00	£ 2699.00
JM Lab Spectral 909.1 (External Damage)	£ 595.00	£ 1375.00
C.D PLAYERS & DACS		
Theta Data Basic II (S/E)	£ 1295.00	£ 2400.00
Meridian 203 dac	£ 225.00	£ 500.00
Sony C.D.P/D.A.S R1	£ 2295.00	£ 8000.00
Krell KPS 20I	£ 6995.00	£ 12000.00
Pink Triangle de Capo/Cardinal	£ 1495.00	£ 2331.00
DPA Renaissance C.D.	£ 495.00	£ 800.00

Power Amplifiers

Copeland CSA 14 Integrated (Silver)	£ 795.00	£ 1195.00
Restek Extract Monoblocks (180 watt)	£ 2495.00	£ 3500.00
Mark Levinson 331	£ 3395.00	£ 5000.00
Krell KAS 2 Monoblock	£ 9000.00	£ 18000.00
Michell Alecto Stereo	£ 995.00	£ 1500.00
Jadis JA500	£ 7995.00	£ 21000.00
Boulder 102 AE	£ 2650.00	£ 3400.00
Boulder 500 AE	£ 2995.00	£ 5000.00
Audio Note P1 SE	£ 500.00	£ 950.00
Jadis JA 80 Monoblocks	£ 4995.00	£ 10000.00
Audion Golden Knights	£ 1995.00	£ 4000.00
Audion Silver Knights (Gold)	£ 995.00	£ 2250.00
Jadis Defy 7 mk III	£ 3250.00	£ 4790.00
Micromega Tempo 2 Integrated	£ 550.00	£ 900.00
Krell FPB 600	£ 8995.00	£ 12900.00
Krell KSA 250	£ 2750.00	£ 6700.00
Audio Note Ankoru Monoblocks	£ 8500.00	£ 14500.00
Micromega amp	£ 695.00	£ 1295.00
Micromega Tempo P	£ 695.00	£ 1250.00
FM Acoustics 611X Resolution Power	£ 14995.00	£ 22000.00
Audio Research M300	£ 4995.00	£ 12000.00
Naim NAP 250	£ 1150.00	£ 1800.00
Lamm M1 Monoblocks (100W)	£ P.O.A.	£ P.O.A.
2 x Arcam Alpha 10 power amps	£ 450.00	£ 600.00
Quad 77 Integrated (Quadlink)	£ 495.00	£ 700.00

Pre Amplifiers

Jeff Rowland Consumate+Phono	£ 3995.00	£ 8000.00
McCormack Micro Line Drive	£ 350.00	£ 595.00
Audio Research LS3	£ 1095.00	£ 1900.00
Audio Research LS5 mk II	£ 2495.00	£ 5700.00
Meridian 541 Dolby Surround	£ 650.00	£ 1095.00
Audio Research LS7	£ 1095.00	£ 1620.00
Audio Note M2	£ 650.00	£ 950.00
Naim 52	£ 2200.00	£ 3100.00
Conrad Johnson PV10AL	£ 795.00	£ 1195.00
FM Acoustics 266 Resolution	£ 10995.00	£ 17000.00
Arcam Alpha 9 pre amp	£ 295.00	£ 400.00
Audio Research LS2 (£1500 upgrade)	£ 2250.00	£ 3300.00+

Quality Speakers

Acoustic Energy AE1	£ 550.00	£ 795.00
Alon V mk II Blk	£ 2500.00	£ 5000.00
Wilson 3/2 (Black)	£ 5995.00	£ 15000.00
Alon Lotus SE	£ 2500.00	£ -
Sonus Faber Extrema + Stands	£ 4250.00	£ 7000.00
Wilson 5.1 (Piano White)	£ 11500.00	£ 19000.00
Thiel CS1.5	£ 1595.00	£ 2700.00
B & W 801 Series 2 (Black Ash)	£ 1895.00	£ 4000.00
Apogee Stage	£ 995.00	£ 3000.00
Quad ESL 63 Black	£ 1895.00	£ 3200.00
Sonus Faber Guarneri	£ 4500.00	£ 6500.00

CD Players & DACS

Krell MD-10 CD Turntable	£ 3495.00	£ 7990.00
Krell Studio Dac	£ 1995.00	£ 4500.00
Theta Pro Basic III (Balanced)	£ 1695.00	£ 2990.00
Cambridge Dac Magic	£ 150.00	£ -
Mark Levinson No 39	£ 4250.00	£ 5000.00
Audio Alchemy DDE V1.0 + psu 1	£ 150.00	£ 300.00
P.S. Audio Ultralink	£ 795.00	£ 2390.00
McCormack DAC-1	£ 450.00	£ 995.00
Forsell Air Ref Transport mk II	£ 4995.00	£ 8000.00
Forsell Air Ref dac	£ 2995.00	£ 5800.00
Mark Levinson 30.5/31	£ 11500.00	£ 24000.00
Meracrus Transport	£ 1500.00	£ 3995.00
Meridian 566 DAC (20 Bit)	£ 895.00	£ 1095.00
DPA PDM 1 mk III	£ 550.00	£ 1000.00
Marantz CD94/94A	£ 595.00	£ 1600.00
Audio Alchemy DDS II Transport	£ 395.00	£ 900.00
Naim CDS	£ 2250.00	£ 3600.00
Naim CD2	£ 1695.00	£ 2200.00
Krell KPS 25s	£ 13995.00	£ 19995.00
Krell KAV 300 CD	£ 2500.00	£ 3500.00
Marantz CD17 KI Sig (Black)	£ 795.00	£ 1195.00
Quad 77 CD Player (Quadlink)	£ 495.00	£ 700.00
Genesis Digital Lens	£ 1095.00	£ 1900.00

Turntables & Analogue

Voyd Reference/Reference Power supply/	£ 11500.00	£ 22000.00
Helios Cyalene/Audio Note 10 limited + P/S	£ 650.00	£ 1200.00
Roksan Xerxes/Linn Akito/PSIII/DSU	£ 150.00	£ 300.00
Musical Fidelity T1 FM Tuner	£ 450.00	£ 650.00
Ortofon MC30	£ 750.00	£ 1400.00
Linn LP12/Lingo/Cirkus	£ 1500.00	£ 4500.00
Piere Lume J1/SL5	£ 11995.00	£ 25000.00
Forsell Air Force One	£ 195.00	£ -
Quad FM3 Tuner	£ 450.00	£ 600.00
Linn Klyde	£ 850.00	£ -
Pink Triangle PT Too Ref Bearing, platter, clamp	£ 1000.00	£ 2200.00
Transparent Musiclink Reference (RCA-RCA)	£ 1600.00	£ 3300.00
Transparent Musicwave Ultra Bi-Wire 3.6mtr	£ 750.00	£ 1200.00
Naim Nat 02	£ 2500.00	£ 4000.00
Linn LP12/ARO/Armageddon/Prefixed/Hi Cap/17 DII	£ 550.00	£ 900.00
LFD MC1 Phono mm/mc	£ 1200.00	£ 2000.00
Lyra Parnasus (NEW)	£ 8995.00	£ 16000.00
Clear Audio Master Reference/Clear Audio Insider Reference (Wood) Basis	£ 7500.00	£ 12500.00
Debut Gold/Graham Model 2.0 (Ceramic)		

- STOCKIST OF:**
- Acoustic Energy, Pass
 - Alon, Rockport,
 - ATC, SME,
 - Audible illusion, Soundstyle,
 - B.A.T. Stand Unique
 - Boulder, Tara Labs,
 - Bryston, Target,
 - C.A.T., Totem,
 - Chord, Trichord,
 - ClearAudio, Trilogy,
 - Elemental Audio, van den Hul,
 - Graham, VPI,
 - Helios, XLO,
 - Lavardin,
 - Michell,
 - Musical Fidelity,
 - Oracle analogue and digital,

DVD Players now available from Sony, Panasonic and Pioneer, and many more.

- In-depth experience on high end new and used equipment
- Best prices paid for top quality equipment
- Generous part exchange
- Show room/dem room
- Long term trade in policy, to allow continual upgrading
- All credit cards inc. Amex
- Mail order
- Export service
- Finance arranged subject to status
- Widest range available
- Unbiased advice
- Unique 'Hi-Fi Exchange' - a computerised database of sales and wants - will put you in touch

Choice hi-fi make it easy for you to fulfil your sonic dreams. Quality hi-fi is not just about expensive brandnames, it's about aspiring to the very best sound, about choosing your ideal system from the widest selection in the country, in a unique no-pressure environment. It's about taking advantage of our unrivalled knowledge and being given the freedom to choose and upgrade the audio equipment you want, when you want. Others may sell you hi-fi, Choice hi-fi will sell you solutions.



tel **0181 392 1959 & 0181 392 1963**

fax 0181 392 1994 e-mail choice_hifi@msn.com open from 10am to 8pm by appointment
All previously cherished items in mint, second hand or as new condition - guaranteed

THE FINEST SELECTION OF PREVIOUSLY OWNED HI-FI IN THE COUNTRY - AND ALL GUARANTEED!

TURNTABLES / ARMS

AR Legend No arm	£148
Audio Synthesis APS + ADF	
MC Phono Stage + PU	£795 £498
Linn LP12 + Grace + AT (MM)	£425
Linn LP12 (Ex dem)	£1750 £993
Linn LP12 (black) + Ekos - Valhalla	£2600 £1198
Linn LP12 + Lingo + Ittok LVII + K9	£2300 £1150
Linn LP12 + Basic Plus	£1600 £595
Linn LP12 + Lingo + Ittok LVII + ATOC9	£2500 £1250
Linn LP12 + Ittok LVII + Sumiko	
Blue Point Special	£2250 £950
Luxmun PD300 + SME III (Vacuum platter)	
Belt Drive - Accepts 2 arms - 33/45/78	£1468
Lyra Parnasus	£878
Michell Focus One/Hadcock 228/Dynavecator 20a	£220
MicroSeiki DDX 1000 + SME3009/Ortofon MC20	
Direct Drive/PSU/2 arm mounts	£550
Nottingham Analogue Hyperspace with mentor arm	£2300 £1298
Oracle Delta II/Linn Ittok LVII	£1395
Oracle Alexandra MKIII (cut for SME)	£748
Ortofon T-300 Transformer	£900 £495
Pink Triangle PT2 Teak (SME cut)	£348
Revolver / Helius Scorpioin / P77	£249
Roksan Xerxes + Artemiz + AT OC5	£1700 £758
Roksan Xerxes + ALRE Tangent 16+	£3500 £1995
SME 'W' arm Ex-dem - Mini	£1467 £POA

AMPLIFIERS - SOLID STATE

Technics SL150 + SME3009 + Shure V1511	£228
Adcom GTP500Mk2 + GFA545Mk2 Pre/Pwr	£695
Arcam Delta 90 Integrated 70 wpc	£195
Albarray M 1008 Series II Monoblocks	£698
Arcam Zeta I (Ex-dem)	£999 £597
Arcam Alpha 9 Power	£400 £295
Arcam delta 110 Pre	£700 £195
Audiogram MB1 (Integrated) Ex-dem	£495 £359
Audiogram MB2 (Integrated) ex-dem	£599 £429
Audiolab 8000A	£500 £365
Audiolab 8000C Pre (old style)	£550 £245
Audiolab 8000 LX	£470 £378
Audiolab 8000S	£700 £495
Audiolab 8000Q	£1249 £895
Audio Synthesis Passion (passive pre)	£2000 £1295
Aura VA50 Integrated	£299 £175
AV1 S2000 Integrated	£999 £692
Chameleon 900S 2 x 300w pwr	£1000 £495
Chord 1200b Power (Ex-dem)	£3790 £POA
Chord 1200C Power (Ex-dem)	£4710 £POA
Chord CPA 2200 Pre (Ex-dem)	£2530 £POA
Classe 30 Pre-amp Balanced/Remote	£695 £450
Copland CTA301 Pre (Ex-dem)	£1249 £849
Copland CTA401 Integrated (Ex-dem)	£1698 £1069
Copland CTA501 Power (Ex-dem)	£1420 £999
Copland CTA504 Power (Ex-dem)	£1999 £1389
Counterpoint Solid 1 Pwr	£1495 £675
Cyrus One	£150
Cyrus Two	£185
Cyrus Straight Line (Integrated)	£398 £298
DPA DSP200 Line Pre (Ex Dem)	£499 £397
DPA Renaissance (Ex-dem)	£595 £447
Dynaco ST120 (Classic circa '76)	£278
Exposure VIII (Mono's)	£1300 £898
Exposure X (Int)	£195
Exposure XXI RC (Pre)	£999 £625
FM Acoustics A800 (2,500 watt)	£12,000 £4298
Goldmund 6B (Ex-dem)	£3124 £1799
Harmon Kardon AVP1a Processor	£2000 £495
Harmon Kardon HK620 remote	£250 £165
Krell KR-1 + KRSP (4 box pre)	£2245
Leak delta 30	£75
Leak Delta 70	£275
LF LSB + PA2 (Pre/Pwr)	£3800 £1498
Linn Kairn Phono Pre	£1198
Linn Kairn Line (Ex-dem)	£1400 £1095
Linn Kairn Phono (Ex-dem)	£1700 £1493
Linn LK1 Pre	£250
Marantz SC22 (pre) + 4 MA22 (mono's)	£2800 £1795
Meridian 201 Pre	£760 £395
Meridian 501 Pre (Ex-dem)	£740 £597

Meridian 603 Pre/DAC	£1750 £794
Meridian 561 AC3/DTS/MLP (Ex-dem)	£2850 £POA
Michell Argo + Hera	£900 £595
Michell Engineering Alecto(mono power amps)	£2000 £1295
Musical Fidelity Elektra E100 (Int)	£750 £475
Musical Fidelity Elektra £20+E30	£900 £550
Musical Fidelity A100 (integrated)	£225
Musical Fidelity P172 Pre	£395
Musical Fidelity 3a Pre	£379 £248
Musical Fidelity 2a Pre	£299 £178
Myryad MPI00 Power (EX-dem)	£599 £443
NAD 2700 HX Power 140WPC	£449 £295
Naim NAC12	£165
Naim NAC32.5	£195
Naim NAC42.5	£220
Naim NAC62	£150
Naim NAC128	£95
Naim NAC22	£145
Naim NAC42	£195
Naim NAC72	£498
Naim NAC82(Ex-dem)	£2225 £POA
Naim NAC92	£POA
Naim NAP90 (new Style)	£460 £370
Naim NAP110	£200
Naim NAP140 (Old Style)	£750 £450
Naim NAP250 (Old Style)	£1705 £828
Naim NAP250 (Ex-dem)	£1705 £POA
Naim NAP135 Mono's (Ex-dem)	£3410 £POA
Naim NAIT 2	£298
Naim Hi-Cap (Ex-dem)	£720 £POA
Nakamichi 1 A-3 (Int)	£150
Nakamichi 420 Pwr	£220
Nakamichi 603 Pwr	£290



NVA

EX-FACTORY SPECIAL PURCHASE

TDS Second State Mono	
Power amps	Pair £6400 £3200
Probably the most beautiful solid state amplifiers we have ever seen!	
TSS Second State Stereo Pwr	£3700 £1800
TSS Second State Stereo Pre amp	£1000 £500
TSS Integrated State Int-amp	£1500 £800
EMOTIVE STATEMENT	
integrated CD player	£2120 £1100
EX-FACTORY STOCK DUE TO DOWNTURN IN FAR-EAST EXPORT MARKETS - SO STRICTLY LIMITED AVAILABILITY	

NVA P50 (Passive Pre)	£250 £150
NVA A7- (Mono's)	£448
Onex A30 Series 2 mm Integrated	£170
Pink Triangle PIP Pre (3 box)	£2400 £1398
Pioneer C-90 Pre	£295
PS Audio PS IV (Pre)	£298
PS Audio 6.1 Pre (Ex-dem)	£799 £499
PS Audio 6.2 Pre (Ex-dem)	£899 £599
PS Audio 4.6 Pre (Ex-dem)	£998 £649
PS Audio 5.6 Pre (Ex-dem)	£998 £649
PS Audio Delta Power (Ex-dem)	£1499 £999
QED A270 Integrated	£225
QED Systemline Kit + Mods (Ex-D)	£3000 £1897
Quad 33/303 Pre/Power	£POA
Quad 405 Power-amp	£195
Quad 33 Pre	£65
Quad 34 (Grey & Beige)	£220
Quad 44 Pre (Beige)	£265
Quad 77 Pre	£450
Quad 606	£495
Rappaport Pre I (pre)	£275
Rappaport Amp I (Pwr)	£550
Roksan LI Pre + PSU	£1100 £758
Rotel RC972 Pre	£225 £173
Rotel RB971 Power	£225 £173
Rotel RB981 Power	£325 £273
Sonograph SC1 Pre	£1250 £450
Sugden Optima 10 (2X70w Intgd)	£770 £448
Thorens TTP2000 Mk1 Pre (Ex Dem)	£499 £397
Thorens TTA2000 Pwr (Ex Dem)	£599 £497

URGENTLY REQUIRED
ALL TYPES OF QUALITY HI-FI
WE BUY OR PART-EXCHANGE

AMPLIFIERS - VALVE

Thule PR200 (Pre) + 2 X PA200 (pwr)	£2700 £1598
Arion Tycho (Power) + Passive Pre	£1895 £1095
Audio Innovations L1 (Pre)	£369 £269
Audio Innovations Second Audion Mono's	£3299 £1995
Audio Innovations Series 800	
10th Anniversary Edition	£898
Audio Note P3 (300B Power)	£1298
Audio Note Meishu	£2750 £1895
Audio Research V70 Pwr (Ex Dem)	£4480 £2487
Audio Research D70 Pwr (Ex Dem)	£2800 £1395
Audio Research V140 (Mono-blocks)	£9000 £3998
Audio Research SP14 Pre (silver)	£3300 £195
Audio Research D200 Power (Ex dem)	£3248 £1997
Audio Research D240 Power	£1848
Audio Research D250 Power	£2498
Audio Research LS7 (pre amp)	£1550 £1095
Audio Research SP14 (black) (pre amp)	£3200 £1495

AUDIO VALVE Baldr

(200+200 watt mono-blocks) RRP £10,000

AN UNWANTED PRIZE

Make us a sensible offer!

Audion Sterling Integrated	£595 £398
Avantic SPA II Vintage Valves	£168
Beard P505 (Pwr) + P100 (pwr)	£995
Beard P505 MkII (pre amp)	£495
Beard P100 (power amp)	£650
Crof Series 5 (Power)	£495
Conrad Johnson PVII	£2000 £1398
EAR 549 (mono block power amps)	£6220 £3998
Grant G100AS (Pwr) + G100PB (Pre)	£2000 £650
Jadis DA30 DeLuxe Int (Black) Ex dem	£3490 £2699
Jadis DA60 Int (Black) Ex-dem	£4483 £3759
Jadis JJP200VT Pre Ex-dem	£4778 £3759
Luxman LX33 (Integrated)	£698
Luxman CL32 (Pre) + 3600 (Pwr) 50+50 watts	£1498
Muse Model 300 (Mono powers)	£4400 £2898
Papworth Audio M100 monoblocks	£3600 £2600
Papworth Audio M200 monoblocks	£5200 £3998
Sonic Frontiers Assemblage L1 Pre	
Built and reviewed by Hi-Fi World with extensive upgrades	£798

WE'LL SELL ON COMMISSION

So that you get the Best Price without any of the hassle!

TAPES AND TUNERS

Tube Technology Prophet/Genesis	£4800 £2398
A & R Cambridge Alpha Tuner	£75
Arcam Alpha Tuner	£75
Avantic BM611 Valve Tuner Circa 1960 (no dec)	£148
Leak Delta FM Tuner	£65
Leak Delta AM/FM Tuner	£75
Kenwood KX-4520 3 Head HX-Pro	£135
Magnum Dynalab FT11	£550 £328
Myryad T/40 (ex demo)	£399 £294
Naim NAT02 (Ex-dem)	£1130 £POA
Naim NAT03 (Ex-dem)	£615 £POA
Nakamichi 630 Tuner/Pre-amp	£500 £295
Pioneer RTU11 1/4" & 1/2" track 10" R to R	£598
Pioneer F91 Tuner	£395
Quad FM3	Choice from £95
Revox A77 1/2" track	£POA
Revox B77 Mk's 1 & 2 (Call for details)	£POA
Sony TCK 611S	£330 £218
Tandberg 3034 (silver)	£278
Technics RS-BX404 (cassette)	£90
Theta Lynx Tuner	£500 £324
Yamaha 800 AM/FM Tuner	£175

VERY HIGH SPEC

DIGITAL PROCESSOR + LASERDISC
(24ct gold plated)
Call MATT 01733 341755

After twentyfive years, and with three specialist stores, we know that thousands of satisfied customers prefer to shop this way!

CD PLAYERS - DACS

Accuphase DP75 CD Player	£5995	£3998
Accuphase DP65 CD Player		£2998
Alchemist Nexus APD32A Cd Player	£600	£425
Arcam Alpha 8 CD	£450	£350
Arcam Delta Black Box (DAC)		£148
Arcam Delta Black Box 5 (DAC)		£248
Arcam Delta 170 (Trans)		£198
Audiolab 8000DAC	£1000	£450
Audio Alchemy Drive 3	£695	£498
Audio Alchemy DACMAN (Ex dem)	£149	£117
Audio Alchemy DAC-IN-BOX (EX dem)	£229	£177
Audio Alchemy V1 DAC		£238
Audio Research DAC1 20 bit (Ex-dem)	£3740	£2199
Audio Research DAC3 MK2 (As new!)	£3999	£3269
Audio Research DAC5 (ex-dem)	£2335	£1999
AVI 2000MC Reference CD	£1300	£898
AVI S2000 DAC		£225
California Audiolabs Delta DAC (Ex-dem)	£1100	£859
California Audiolabs Sigma 2 DAC (EX-d)	£995	£789
California Audiolabs Alpha CD Trans	£1800	£1359
California Audiolabs Aria 3 CD Player XDE	£2489	£1599
California Audiolabs Icon 2 CD Player X	£1197	£899
Copland CDA266 (Ex-dem)	£1200	£POA
DPA Little Nit 2 (DAC)	£250	£148
Denon DCD1650 (CD Player)	£600	£295
Denon DCD1500 Mk 2 CD Player	£500	£195
Jadis JD2 CD Trans (Ex-dem)	£4490	£3299
Kinergetics KCD30 CD Player (EX-dem)	£1900	£1059
Kinshaw Overture DAC		£195
Krell KPS 201/ CD/Pre (Breathtaking!)	£11,000	£5995
Marantz CD80		£230
Marantz CD17		£538
Marantz CD95 Transport	£1500	£845
Mark Levinson No.39	£5000	£3998
Meridian 200	£818	£425
Meridian 203 DAC	£560	£195
Meridian 206	£995	£495
Meridian 263DAC	£650	£395
Meridian 500 Transport (Old Style)	£1025	£793
Meridian 506 CD Player	£1100	£650
Meridian 508 20 Bit (Ex-dem)	£1650	£1293
Meridian 508 24 Bit (Ex-dem)	£2150	£POA
Meridian 563 DAC	£865	£468
Meridian 563 DAC (Ex-dem)	£865	£693
Meridian 606 DAC	£1500	£795
Meridian 207 CD Player-pre	£1400	£495
MicroMega Satge 5 (Ex-dem)	£750	£597
MicroSeiki CD-M2	£2800	£1445
Mission PCM II CD		£150
Monarch DIP Jitter Buster	£345	£188
Musical Fidelity Digilog DAC		£98
Musical Fidelity E61 CD (Ex-dem)	£299	£247
Pink Triangle Da Capo	£1500	£975
Pink Triangle Digital Package - Cardinal transport		
de Capo DAC + battery psu	£4500	£call
PS Audio Digital Link 2 DAC (Ex-dem)	£599	£399
PS Audio DC 3 DAC (Ex-dem)	£777	£499
PS Audio SL 3 DAC (Ex-dem)	£1449	£899
PS Audio Reference Link PRF/DAC		
Balanced (Ex-dem)	£4500	£2899

CALL THE 'FI' FINDERS

Can't find what you want?
Rare, Classic, Special...even New!
Whatever you want, we'll find it
for you...and at the best price!

PS Audio Lambada CD Trans (ex-dem)	£2250	£1439
QED Digit Reference	£450	£284
Quad 66 CD Player		£440
Rega EXS (Ex-dem)	£599	£444
Roksan DAC1		£250
Rotel RCD971 CD	£400	£293
Rotel RCD930AX CD	£200	£143
Sugden SDA-1	£800	£528
Yamaha CDX-390A CD Player		£85

LOUDSPEAKERS

A FEAST OF APOGEE

Apogee Centaur Minor	£1345	£847
Apogee Centaur (Ex-dem)	£2300	£1399
Apogee Column (As new)	£1900	£1199
Apogee Mini Grand (Mint)	£7598	£4499
Apogee On Wall (Mint)	£3000	£1999
Apogee Slant 6 (Mint)	£7598	£4499

Apogee Full Range (Ex-dem)	£17,000	£8999

QUITE LITERALLY A 'WALL' OF SOUND

Technics SL-PS-670A CD Player		
Theta TLC	£230	£178
Theta Data Basic - Transport	£2397	£1398
Theta Pro Gen V a - bal Dac	£6200	£3198
Theta Cobalt 307 DAC (New!)	£699	£539
Theta ProPrime DAC (Ex-dem!)	£1449	£1249
Theta Basic 11 CD Trans (Ex-dem)	£2307	£1689
Audiostatics ES100	£2400	£1698
B & W 2000IFS Centre	£220	£108
B & W P5 (Rose) Ex-dem	£875	£593
B & W DM 580 (Black)		£150
B & W Silver Signature Fabulous!	£6000	£2498
Cambridge Auto R50 (Trans Line)		£495
Castle Chester (Yew)	£770	£495
Castle Durham (Inc stands - R/wood)		£245
Castle Harlech (Ex-dem/Yew)	£995	£879
Castle Howard (Rosewood)	£1399	£878
Castle Pembroke (Black Ash)		£200
Celestion CS7		£195
Celestion 3000 (black)(ribbon hybrid)		£495
Diesis Solitaire		£150
DCM Time Windows		£245
Duntech PCL500	£5250	£2699
Epos ES11 Rosewood		£368
Epos ES12 Walnut + stands	£500	£375
Epos ES14 Ex-dem	£675	£474
Epos ES14 Black + stands		£428
Epos ES11 Black (veg)		£248
Gale 301 (Black)	£250	£159
Gale GS301		£155
Heybrook HB200 (teak)		£140
IMF Professional Monitor MKIV (Teak)		£798
KEF 103/4 (Mahogany)	£1299	£748
KEF 104/2 (Teak)	£2200	£1098
KEF Q70 (Black)	£750	£498
KEF Q50 (Black)	£349	£195
KEF 104/2 (Teak)	£2200	£1098
KEF 105 (Walnut)		£378
KEF Coda (black)	£130	£80
Linn Tukan (black)	£300	£175
Magna Planar SMGA (Blk 7 Chrome)		£450
Magna Planar SMGA (Wood/Brown)		£450
Magna Planar SMGA (Ex-dem)		£POA
Magna Planar MG2.5 (New)	£1998	£1199
Meridian A500 (Rosewood)	£875	£595
Meridian M30 Active (Black)	£900	£525

MAIL ORDER

All items Fully Insured
and Guaranteed

Meridian A500(rosewood)	£875	£555
Mission 707 (Walnut)		£100
Mission 727 (Teak)		£158
Mission 733 (Black)		£155
Mission 770 (Mahogany + stands)		£225
Mission Argonauts (black)		£395
Monitor Audio R352 (Teak)	£395	£248
Monitor Audio Studio 60SE New/Blk/Rose	£5000	£2995
Musical Fidelity MC2		£150
Naim Intro (Ex-dem)	£680	£574
Naim SBL - Cherry (Latest)	£2030	£1378
Note Perfect Virtuoso (Ex-dem)	£2750	£1497
ProAc Tablette 50 Signature (Ex -dem)		£899 £POA
ProAc Response 3.5 (Ex-dem)	£4250	£2997
ProAc Response 3.5 (Cherry)	£4250	£2800
ProAc Studio Towers (Black)	£2595	£1395
ProAc Studio 150 (Cherry)		£1399 £POA
ProAc Response Two (black)	£1700	£995
Quad ESL57		from £395
Quad ESL63	£3449	£1698
Quad ESL63 (Ex-dem)	£3449	£1997
Rega Ela (walnut)	£299	£198
Rogers LS33/AB33 (Black Ash)		£1428
Rogers Studio 1a (Teak)	£600	£348
Rogers LS1 (Black)		£120
Royd Minstrel (Walnut/Black)	£240	£168
Royd Sintra	£330	£230
Ruark Equinox Light Oak (Updated)		£POA
Snell K II		£288
Sonus Faber Electa (Black) Ex-dem	£1790	£1299
Spendor PS2/3	£1195	£775
Tangent RS2 + Stands	£400	£225
Tangent Monitor 2 (Rosewood)	£200	£140
Tangent 607 MkII		£185
Tannoy 638 Plus (Rosewood)	£750	£498
Tannoy 605 (black) + stands		£185
TDL Nucleus 1 (black)		£85
TDL RTL2 (black)	£300	£175
Thomas Transducers Virtuoso Gold		
with silver wired Lowther drive units	£3400	£2398
Wharfedale Harewood + stands		£POA
Wilson Witt Mk1 (Ex-dem)	£8888	£6497
Wilson Witt Mk1	£8888	£5998
Yamaha NS1000M		£975
Yamaha NS1000M (Black)		£898

MISCELLANEOUS

Audio Alchemy Clearstream digital Lead	£200	£128
DBX228		£98
Essex Digital Correction for Celestion SL700	£750	£375
Harmonix TU812 LP Record Clamp	£220	£170
Helios Orion arm		£548
Micro-Seiki MA707 arm		£98
Siltech 560 Balanced cables 1 mtr pr	£1600	£600
Stax SR Lambada SIG+SRMI Mk2		
Electrostatic Headphones	£1695	£995
XLO Signature 2.1 Balanced Interconnects		
1.0m pair: (£675) £448	0.5m pair	£485 £398
Rotel RN560 Dolby Noise Reduction System		£75
Target R1 stands		£228

BUSINESS HOURS: TUESDAY - SATURDAY 9.30am - 5.30pm

CLOSED MONDAYS

VISITORS WELCOME AND DEMONSTRATIONS BY APPOINTMENT

35 COWGATE
PETERBOROUGH PE1 1LZ
(01733) 555514

FAX(01733) 358141

TRADING STATION

The HiFi Company

ESTABLISHED 1974

ALL MAJOR CREDIT/DEBIT CARDS ACCEPTED

ALWAYS
a Large Selection of
Budget Hi-Fi Bargains!

HERE ARE JUST A FEW EXAMPLES

NEW		
Ex-demonstration		
Denon DM03 system	£459	£389
Denon DM5 system	£279	£239
Denon DM7 system	£429	£369
Marantz Venus system	£700	£475
Teac 500 system	£799	£649
Audiolab 8000A amplifier	£500	£375
Audiolab 8000LX amplifier	£470	£350
Cyrus Pre-amplifier	£648	£548
Cyrus aPA7 mono blocks	£2000	£1600
NAD 208 HX power amplifier	£1200	£850
Pink Triangle Litaural CD Player	£2200	£1700
Copland CDA 288 CD Player	£1998	£1698
Quad 77 (Bus) CD Player	£699	£499
Monitor Audio PMC 700 loudspeakers	£500	£400
Pro-ac Tablette 50 (cherry) loudspeakers	£600	£450
Castle Severn II (walnut) loudspeakers	£580	£475
Mission 773 (cherry) loudspeakers	£350	£280
Meridian DSP6000	£10000	£7500
Pass Aleph 5 (class A amplifier)	£3150	£2500
Wilson Benesch Orator cherry no grilles	£2900	£1900
Naim CDX CD Player	£2265	£1800
Naim Credo loudspeakers ebony	£1250	£950
M + K MX150 Subwoofer	£1500	£1150

AMPLIFIERS-S/H

A & R Cambridge A60		£75
A & R Cambridge C200/SA150 Pre/Pwr		£250
Audiolab 8000A (DNIN)		
Fully upgraded to current spec		£295
Aura VA80SE-X		£198
Beard P100 100wpe Pwr amp		£695
Cyrus 1 and 2 amps	Several from	£145
Kenwood KA540R	£320	£175
NAD 3020A Integrated		£85
NAD 1000pre		£145
NAD 3240 Power Envelope Integrated		£145
Naim Nait 1		£138
Nytech CPA602/CP122 Pre/pwr		£300
PS Audio Elite		£450
Rotel BX935		£170
Yamaha DSPe200 Processor		£149

CD PLAYERS - DACS S/H

Arcam Delta Alpha CD	£250	£125
Arcam Delta Black Box		£175
Kenwood DP7060 CD	£360	£175
Marantz CD36		£110
Marantz CD52		£120
Marantz CD56		£70
Marantz CD65		£85
Mission daD 7000		£199
Mission PCM11		£140
Philips CD1 210		£95
Philips CD850 Mk2 (Trichord clock upgrade)		£195
Rotel RCD865	£300	£120
Rotel RCD965BX		£165
Yamaha CD3050		£178

LOUDSPEAKERS - S/H

B&W 2000HFS Centre Speaker		£95
Mission Argonauts		£240
Musical Fidelity MC2		£195
Gale 301		£125

**INSTANT CASH LOAN SCHEME
AGAINST QUALITY S/H EQUIPMENT
-ASK FOR DETAILS-**

The **HiFi** Company
**TRADING
STATION 2**

22a LINCOLN ROAD
PETERBOROUGH
Tel: 01733 343469

TESTING, TESTING

Simon Pope and Richard White reveal two more of their favourite recordings for grilling hi-fi components.



THE TEMPERANCE SEVEN

THE TEMPERANCE SEVEN 1961

PARLOPHONE

There are many reasons why this record, for all its advancing years, remains a firm favourite of mine. For a start, the music is good. The Temperance Seven shot to fame on a novelty ticket but, as this album demonstrates, there is real musicianship here, with a deep understanding of vintage Jazz which puts most of the offerings of the present Trad Boom to shame.

Aside from the excellence of the front-line men, the rhythm section - sousaphone, piano, banjo and (mostly) washboard - is fit to take its place with the all-time greats. If you think the combination ought to sound corny, listen to the band. If you still think it sounds corny, perhaps 'real' vintage Jazz is not for you!

If, as the sleeve note claims, the recording was achieved with 'single' mike techniques, there are lessons here for any would-be recordist wanting a natural sound: The Temperance Seven 1961 has some beautifully subtle stereo with seamlessly-integrated ensemble work. On an historical note, Parlophone's hard-pressed staff producer was soon to garner a hit or two with a rather different band and was, I believe, only too pleased to be shot of the 'novelty' market. A pity really - I mean, who on earth remembers The Beatles?! RMW



NEW ORDER

MOVEMENT (1981)

FACTORY RECORDS

Along with, perhaps, the ex-Stockhausen students Kraftwerk, it's probably safe to say that no one has influenced Dance/Rock hybrid music quite like New Order. Movement was their first album released just after the demise of Joy Division (their previous incarnation), so laugh-a-minute it ain't. They took the down-beat cosmos of Joy Division, added slightly to the synthesizers and drum machines they had previously clattered with and decided the guitarist, Bernard Sumner, could sing marginally more in tune than the late Ian Curtis. They also managed to get shot of that slightly tiresome "I'm really depressed - honestly" aspect to the music. The result was this barren and emotionless masterpiece of a record.

Martin Hannet's claustrophobic production separates each and every component of the music and mixes it together with superbly clinical results that seem to match the detached feel of the songs and, indeed, the record cover.

The first track, 'Dreams Never End', tries so hard to sound slightly happy but, fortunately, fails. From here it's onwards through seven more songs - all as good as each other - that appear to have no structure (and you never remember their titles) but are curiously addictive. Best kept for an overcast Sunday afternoon and taken with a neutral, clean-sounding system. SP

AUDIO ILLUSION

23 Langley Broom
Langley

Berks SL3 8NB

TEL: (01753) 542761 FAX: (01753) 772532

OPENING HOURS:

10am - 8pm Monday - Saturday (By appointment)

BARGAINS GALORE

*Mail Order Service * Export Facilities: * All Major Credit Cards Accepted

**CLASSÉ AUDIO
BARGAINS
AND MUCH MUCH MORE !!!!**

SPRING SALE

		NEW	SALE
ACURUS DIA 100 Integrated Amplifier	Mint Ex. Demo	£1100	£699
ACURUS A100 100w Stereo Power Amplifier	Mint Ex. Demo	£650	£425
CLASSÉ CP 50 including Phono. Fully Balanced Remote Pre-amplifier (Black)	Mint Ex. Demo	£3190	£1995
CLASSÉ CA-100 100w/350w Balanced Stereo/Mono Switchable Power Amplifier (Black)	Mint Ex. Demo	£2000	£1195
CLASSÉ CA-200 200w/500w Balanced Stereo/Mono Switchable Power Amplifier (Black)	Mint Ex. Demo	£3000	£2195
CLASSÉ CA-300 300w/1100w Balanced Stereo/Mono Switchable Power Amplifier (Silver)	Mint Ex. Demo	£4250	£2995
COUNTERPOINT SA 20 220w Valve Hybrid Power Amplifier	Mint. S/Hand	£3000+	£995
EAD CD 1000 20 Bit HDCD CD Player	Mint S/Hand	£2000	£1195
KORA D30 30w Pure Class A Integrated Line Tube Amplifier	Mint Ex. Demo	£1850	£1295
KORA D50 50w Pure Class A Integrated Line Tube Amplifier	Mint Ex. Demo	£2700	£1950
KORA 100SB Pure Triode Monoblocks + Bal & S/E Inputs & Resonance Tuned Chassis	Min Ex. Demo	£5350	£3950
LINN INTEK Integrated Amplifier	VGC S/Hand		£195
MARK LEVINSON no. 27.5 Power Amplifier - Still under warranty - As new -	Mint S/Hand	£5400	£2650
MIRAGE:			
M-290 2-Way Audiophile Compact Monitors	Mint Ex. Demo	£400	£235
M-390s 2-Way Tuned Vent Floorstander (Black Ash)	Mint Ex. Demo	£550	£295
M-490s 2-Way Tuned Vent Magnetically Shielded Floorstander (Piano Black)	Mint Ex. Demo	£650	£395
BPS-100 Active 100w Subwoofer (Black Ash)	Mint S/Hand	£600	£375
REGA Planet CD Player with Remote Control	Unused	£500	£399
TEAC VRDS 10 CD Player	Mint S/Hand	£770	£425
HOME CINEMA			
CLASSÉ CAV-150 Multi Channel Switchable Power Amplifier, 3,4,5 or 6 Channells (6x150w - 3x300w) Balanced and S/E Inputs (Silver)	Mint Ex. Demo	£3600	£2495
EAD Theater Master Encore AC-3 & DTS Processor/ Pre-amplifier (Silver)	Mint Ex. Demo	£3000	£2250
EAD Theater Vision Ultimate NTSC Laserdisc Player, AC-3 Output Finished in 2ct Gold. *No 1 of only 5 ever made in Gold - Unique*	Mint Ex. Demo	£6100	£2800
RCE 3001 CRT Projector	Mint Ex. Demo	£4000	£2650
LASERDISCS Various available - call for titles and prices	Mostly new sealed		

Information available on the following:-

acurus: AERIAL ACOUSTICS

Barclay: Cairn: Classé Audio

EUPHONIA ISOLATION DEVICES

RENAISSANCE AUDIO

KORA MIRAGE

For your nearest stockist contact AUDIO ILLUSION

LAT INTERNATIONAL

World Class Cables Made in USA

AC-2 Power cable - Silver clad, Teflon insulated at 10awg; this is the largest gauge of power cord we know of. The design of our shielding system effectively eliminates interferences from RF and EMI sources. 2ft £49, 3ft £59, 4ft £69, 6ft £89. 4, 6 and 8 way all steel distribution boxes also available. Analogue Interconnects, IC-50, IC-80, IC 100, IC, 200.
Speaker cables - SS800, BIWIRE, SS1000



Gershman Acoustics

Avante Garde RX20 - a mere 36" tall and 12" x 12" at the base - Absolute Sound review - "a true torture test with a bass line that's big, super fast and continuous - the Gershman's handled it beautifully, servo driven infinity RS1 towers have more power but are way too slow. The Magnepan MG3.5's, can't match the low bass impact of the Avant Gardes, only the Thiel 3.6 can handle this track with aplomb and even they don't sound quite as fast. Unquestionably, the Avant Gardes are a tremendously musical loudspeakers".
X-1, Specter, Enigma 500-X, GAP-520X

Sunfire Corporation

Janet and Saul of Bob Cover

TUBE PRE AMP, POWER AMPS 300 & 600
wpc, FIVE CHANNEL AMP 200 wpc, TRUE
SUB-WOOFER 11 INCH CUBE 18 HZ



*Taperwire
flat speaker cable*

418 Biwire *****What Hi Fi,
also 420, 212, 215, 218, 222

AUDUSA & Co

Vampire Wire

Analogue, Digital & Video Interconnects,
Speaker Cable continuous cast copper, OFS, OFC
4 Arundel Road Kingston Upon Thames
Surrey KT1 3RZ
Tel: 44 (0) 181 241 9826
Mobile: 0956 230056
Fax: 44 (0) 181 241 0999
E-Mail: cweere @mcmail.com

AUDIO MATTERS

**NEW EX-DEM & PART EXCHANGE
EQUIPMENT FOR SALE
0181 225 0572/0973 436135**

	LIST	SALE
Alchemist Forsetti pre + power	£2398	£POA
Alchemist Kraken Anniversary MkII	£579	£POA
Anthem CD player (5 star What Hi-Fi)(ex/d)	£1699	£1250
Apogees ribbon monitors (new & ex/d)	£999	£699
Audiomeca Mephisto CD transport	£2400	£1250
Audio Research SP14 pre (boxed)	£3300	£1095
Audion Black Shadows 845 valve monoblocks	£4000	£POA
Audion Silvernight 300B monoblocks	£2250	£POA
Chario Academy 1 solid walnut (ex/d)	£1299	£800
Chario Academy 2 solid walnut (ex/d)	£1649	£1100
Chario Academy 3J (ex/d) floor standing solid walnut speakers	£5999	£2699
Conrad Johnson MV55 valve amp	£1995	£1195
Ear 859 pwr	£1700	£750
Ear 834L pre	£449	£235
Genesis Gen 500 spks in built active bass (ex/d) SUPERB	£11000	£6499
Genesis Amp1 spk (ex/d)	£9000	£3999
Krell Kav 300I	£2495	£POA
Krell Kav 250A	£3149	£2149
Macintosh C26 pre	-	£395
Macintosh 2100 (looks like 275)	-	£450
Micromega T drive & T DAC & XLO cable	£2150	£999
Nakamich 1.5 cassette	-	£200
Nakamich LX5 cassette	-	£350
Quad 77 Int. Carbon	£700	£450
Restek 6ch pwr amp	£900	£595
Revoic H1 cassette	£1150	£650

Wazoo integrated amp from Bow Technologies now on Dem

**A NEW RANGE OF AUDION AMPS ON DEM - THE BLACK SHADOWS 845
TO THE GOLDEN DREAMS - WITH CADECE ES MK II'S -
LISTEN & BE PERSUADED**

**ON DEM - Alchemist, Anthem, Audiomeca, Audion Valve Amps, Cadence Spks.,
Chario, D.P.A., Monarchy, Ortofon, Pink Triangle, Project T-T, Sonic Frontiers,
Triangle Spks., Trilogy Valve Amps, Vand den Hul.**

VISA/MASTERCARD ACCEPTED

Audio Note Kit Amplifiers -

Power-Amp Kit

The Audio Note Kit One (illustrated)

Based around the justly famous 300B directly heated triode, we see this kit as the introduction to real Audio Amplification, as it covers all the important aspects of design necessary, Single Ended, No-Feedback, Class A, Directly Heated Triode, to become a member of this exclusive club of amplifiers.

Kit One has one 300B per channel running at 420 volts with 75mA current giving 8-9 watts of the cleanest power you will ever hear, the input stage consists of a 6SN7GT with a 5687 double triode driver stage running in SRPP. The power supply is capacitor-choke-capacitor configuration with a 5U4G HT rectifier, the 300B's have a DC filament supply for hum-free operation whilst the other valves are AC heated. Component quality is similar to our Level 2 finished products, **Audio Note** paper in oil signal capacitors, Beyschlag 1 watt 1% metal film resistors, good quality electrolytics (sorry NO Black Gates!) and a simple, attractive stereo chassis in black paintwork. We have several component and cosmetic upgrades available for **Kit One**, please ask for details.



The Kit One has recently been awarded the title "The Greatest Audio Bargain of the Twentieth Century" by Dick Olsher (ex-Stereophile) in a review on the Internet - this is just one of many rave reviews, copies of which we can supply on request.

Price: £799 incl. VAT, which includes ALL parts & valves (yes, also the 2 x 300B's needed) but not postage/packing which to UK customers is £12.00.

KIT ONE ORDER CODE: AN-KIT-001

Audio Note is happy to provide a wide range of complete kits, output and mains transformers, chokes, paper in oil, aluminium, tin, copper or silver foil signal capacitors, Black Gate, Cerafine or standard electrolytic capacitors, tantalum, carbon and metal film resistors, silver wires, interstage and driver transformers, switches, balance controls, potentiometers, attenuators, chassis's and fittings for the quality oriented DIY'er, whether you are a beginner or hardened experimenter, male or female, we have the best (and not always most expensive) parts for most projects.

Audio Note Loudspeaker Drivers & Kits

We shall be offering the speaker drivers that we use in our own loudspeakers for general sale from now on. You can buy the drivers individually or together with matched and tested cross-overs, cabinet drawings and reflex ports.

Audio Note Circuits, Valvedata & Basic Technical Information

If you would like some suggestions which to base a future project around, then we shall be happy to provide you with a circuit pack containing good circuits like ONGAKU, KEGON/KASSAI, NEIRO, GAKU-ON plus several other power amplifier circuits and the M7Tube & M10 pre-amplifiers, which are the best sounding pre-amplifier circuits we have come across.

Audio Note Quality Output Transformers

We are in the process of building up four separate ranges of **Audio Note** output transformers, in order to offer the best possible outputs at different pricepoints, they will fall into four categories.

Economy range Selected to ensure quality audio in a price efficient package.

Mid-price range Top quality with specially selected components.

High Quality range Double C-core outputs for single-ended circuits exclusively.

Super High Quality range All-silver wired outputs of the best possible quality.

Audio Note offer a design, prototyping and production service, where we can supply for almost any requirement. Please telephone for details.

Audio Note Mains Transformers

Available for most popular designs. We shall continue to expand the range as opportunities become available.

The Audio Note Kit Two

Kit Two features a single 6550 tetrode running in Single-Ended mode, yielding some 12 watts of pure Class A. With a valve rectified HT for the output stage, stereo chassis, and 6SN7GT input and 12AX7/ECC83 SRPP driver stage, componentry and chassis as Kit One.

Kit Two costs \$599 incl. VAT, includes valves, but not postage/packing.

KIT TWO ORDER CODE: AN-KIT-002

The Audio Note Kit Three

Kit Three features 2 x 300B's per channel running in single-ended parallel yielding 16/17 watts in pure Class A. This kit is on two mono chassis with valve rectified HT supplies, no signal feedback, it uses a 6SN7GT double triode as input valve and a pair of 5687 double triodes running in SRPP as drivers. The **Kit Three** is essentially a mono version of the **Kit One** with double the power, the same component choices and on two chassis' instead of one.

The **Kit Three** costs £1,550 incl. VAT but excluding delivery.

KIT THREE ORDER CODE: AN-KIT-003

The Audio Note Kit Four

The **Kit Four** is really our introduction to valve amplifier kit building, the circuit and power supply being mounted on a single printed circuit board. The high-quality push-pull output and mains transformers are all mounted in a small aluminium chassis covering everything so nobody will be able to see that you have succumbed to the lure of the valve amplifier which is sweeping the world. The circuit consists of two 6V6GT tetrodes running in Push-Pull class A, yielding about 10 watts, driven by a 6SN7GT and a 12AX7/ECC83 input stage. Easy to build, even for the beginner. Visually **Kit Four** matches the **Audio Note** Pre-amplifier shown here but with a single chrome-plated volume control. As with all **Audio Note** kits everything (except solder) is included.

The **Kit Four** costs: £279 incl. VAT but not delivery.

KIT FOUR ORDER CODE: AN-KIT-004

Audio Note Driver, Interstage & Pre-Amplifier Output Transformers

Here is a product group that you do not see advertised every day! As usual we start small with the intention to grow quickly.

Audio Note Paper In Oil Signal Capacitors

These handmade signal capacitors are sonically superior to any of the plastic or other paper types we have come across. If you have never experienced the difference that a really good paper / oil capacitor can make in a valve amplifier, then you really should try.

Audio Note Paper In Oil Tin Foil Signal Capacitors

The tin foil is better than alu-foil for most applications, we recommend you try them.

Audio Note Paper In Oil Copper & Silver Foil Signal Capacitors

These copperfoil paper signal capacitors are considerably better than both the standard offerings and the tin foils. To start with there will be a few values / voltages of each available and we shall expand as fast as we can to cover all the popular values.

Audio Note Acid & Chloride Free Silver Solder

The best solder available, used in all our amplifiers from OTO to the mighty GAKU-ON.

Audio Note Cables & Wires

Audio Note manufacture a range of high quality copper and silver coax, speaker and wiring cables, which, depending on the overall price of the project, will do justice to any hifi system, regardless of price. Please call for prices and details.

Audio Note High Quality Stepped Attenuators & Switches

These handmade attenuators and switches are manufactured by a friend of Mr Kondo of **Audio Note**. They are the best you can buy.

Audio Note High Quality Valve Bases

All of our valve bases are of the highest possible quality materials. Ceramic, Teflon and gold and silver plated. If you want the best look no further - they are the ultimate!

Audio Note Resistors

Audio Note endeavour to stock the entire E12 range of all the different makes of resistor, since most are used in our products stock is generally available within four weeks.

BEYSCHLAG - HOLCO - SHINKOH Tantalum Film Resistors

AUDIO NOTE 1/2 Watt Tantalum Resistors

AUDIO NOTE 1 Watt Tantalum Resistors

AUDIO NOTE 2 Watt 1% Tantalum Resistors

AUDIO NOTE Precision Carbon Film Resistors

ALLEN BRADLEY 1 Watt 5% Carbon Film Resistors

Components & Valves

Pre-Amp Kit

The Audio Note Pre-Amplifier Kit (illustrated)

A complete kit loosely based on the Audio Note M7Tube pre-amplifier circuit is now available. The moving-magnet compatible phono stage consists of a cascode input, with passive RIAA equalisation and anode-follower output using the 12AX7/ECC83. Line buffer/amplification for the four line inputs consists of an ECC82 configured in parallel anode-follower mode. For the power supply a valve rectifier and choke-input filtering are employed. All circuitry is housed in a non-magnetic aluminium chassis giving the very best sound quality.

Both phono and line stages are built on 'track-less' pcbs allowing easy construction but with the sonic benefits of hard-wiring.

The standard-quality version of the pre-amp kit includes Roederstein polyester film capacitors, Beyschlag 1 watt 1% metal film resistors, Noble open-frame style potentiometers and all pcbs, valves, wire etc. Various component upgrades are available, details upon request.

Cost of The Pre-Amplifier Kit is: £299
Incl. VAT but not delivery.

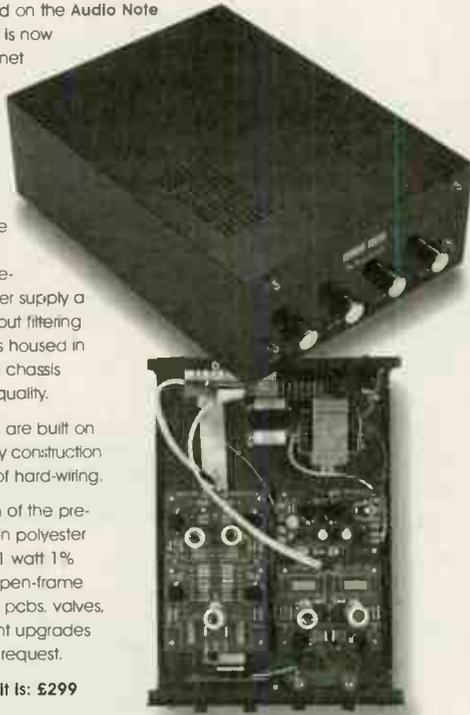

Audio Note Black Gate Electron Transfer, High Performance, Graphite Foil Capacitors

Audio Note is currently the sole source in Europe that holds any significant range of values in stock, we use literally 1000's in production, as we were the first company to realise the tremendous benefits that Black Gate capacitors offer, and we are to date the only high-end audio company in the world to incorporate Black Gate capacitors consistently in our finished products.

There are very few audio parts that promise a guaranteed improvement when replacing practically any other part, but this is what the BLACK GATE capacitors actually do. Exchanging any electrolytic capacitor anywhere in the circuit of an amplifier or in the crossover of a speaker will greatly improve sound quality. We are working on some guidelines as to where, how and which types of Black Gates to use in different circuits, the first such technical guideline is available now and is called "Improving your CD-Player" and can be obtained by sending a stamped addressed envelope to us requesting this leaflet. All AUDIO NOTE Level 2 Signature products use Black Gate Electron Transfer in critical signal / power supply junctions.

Audio Note Cerafine Powdered Ceramic Electrolytic Capacitors

We have at long last secured a reliable source for these fine power supply filter capacitors, a must in any single-ended project. The Cerafines really cover many of the Black Gates values and where the prices for the BG's are prohibitive the Cerafine is a fine sounding alternative. We have increased the range of Cerafines we stock quite recently, and strongly recommend all the Cerafines as a far superior replacement or substitute for ordinary electrolytics, and at the prices offered that should be within most budgets. All power supply Cerafines are supplied with a capacitor clamp and are upright mounting.

Audio Note Potentiometers

The best available from a sound quality / price viewpoint, made by Noble in Japan, utilising high quality conductive plastic film. However a better alternative is the KO-ON volume controls which are used in pre-amplifiers like the M7 Tube, M7Line, and in a mono version on the input in the NEIRO, KASSAI, KEGON and GAKU-ON, these are very good sounding pots by any standard.

Audio Note also carry large quantities of STANDARD TYPE SWITCHES, STANDARD ELECTROLYTIC CAPACITORS (good quality industrial types), RCA, BNC, BANANA, PLUGS, RCA SOCKETS, SPEAKER & GROUND TERMINALS & LOUDSPEAKER SPADES.

Audio Note Moving Coil, CD Line & Input Matching Transformers

Audio Note now offer moving coil, CD and Input matching transformers for general sale. Common to all of these small signal transformers is that they come in a mumetal screening can with a threaded spindle with a nut for mounting.

Stock Clearance SALE

In anticipation of the arrival of the new in-house made Audio Note copper foil paper in oil signal capacitors, we are pleased to offer a **60% discount on current list price** on all Tobias Jensen made paper in oil aluminium, tin and copper foil signal capacitors.

Offer strictly limited to availability, while stocks last.

Minimum Order
4 pcs single or mixed values or £20.00.

Audio Note Selected Audio Valves

Our valves are selected from the best available sources and are tested to the same stringent standards that we apply in the production of our own amplifiers. They fall into two categories, standard production items and rare, mostly NOS (*New Old Stock*) valves which are no longer in production. We have compiled a special list of the NOS items, which is available against a stamped self addressed envelope, if you live outside the UK, send US \$2. You should be aware that the valves on this list are NOT cheap, but we have stock of original GE, RCA and United Electronics 211, both standard versions and reinforced anode type for the US airforce, 845 Westinghouse, VT25/10/10Y, VT62/801A, WE300B, STC4300A, Mullard GZ34/CV1377, Tungsol 5U4G (best sounding 5U4G we have ever heard!), Chatham 5R4WGY and many others.

Audio Note Recommended Magazines

Listener

Review based music & hi-fi magazine that contains some of the best considered & well written articles in print. A very good read £4 per copy.

The Audio Adventure

Glossy, well produced publication that provides a good alternative to the established magazines. Not afraid to be controversial. £4 per copy.

A full list of available issues on request.

FOUNDING SPONSOR

masterprize

Call us today for more information.

Ask for a full components catalogue or see our web page.

Audio Note now has a dedicated division to keep pace with the growing demand for amplifier kits and specialist components. **Music's Finest Conductor Limited** will now be able to provide a specialist service to DIY enthusiasts and record collectors.

Please direct all enquiries to the contact numbers below:

Audio Note

Music's Finest Conductor

Music's Finest Conductor Limited
25 Montefiore Road, Hove, East Sussex BN3 1RD

Tel: +44 (0)1273 770778

Web: www.audionote.co.uk

A selection of our ever changing offers for sale (all fully guaranteed)

AMPLIFIERS

Arcam Delta 60 inc. (g.c.) s/h	300.00	169.95
Chameleon Ruby power amp (2x200 watts) (vgc) s/h	1200.00	449.95
Exposure XV inc. c/w MC/MM	750.00	399.95
Leak Stereo 30 int. (vgc) s/h	-	45.00
Lamley YTP 1000 valve line pre-amp (vgc) s/h	1000.00	399.95
Mosden PMA inc. amp (min. module) (vgc) s/h	-	199.95
Mission Cyrus One (late black version) (g.c.) s/h	300.00	129.00
Musical Fidelity X-Pre valve pre-amp (new)	575.00	400.00
Naim Mast 3 inc. (mint) s/h	700.00	299.95
QED C300/P300 pre/power amps (f.c.) s/h	180.00	149.95
Rotel RB 9608X (2x60watts) power-amp (vgc) s/h	130.00	89.95
Rotel RB 9708X II (2x60watts) power-amp (vgc)	180.00	149.95
Rotel RC 9708X pre-amp (vgc) s/h	loads	169.95
SAE Mark IV CH 2x100Watts American power amp (g.c.) s/h	loads	89.95
Suggden CS1 pre-amp (vgc) s/h	450.00	249.95
Technics SLA90 Mk II 2 x 70 Watts integrated (vgc) s/h	1150.00	795.00
Union Research Simply Two Valve Integrated (mint) s/h	200.00	169.95
Marantz PM 55SH 2x55 Watts/Full Remote Inc. (mint) s/h	200.00	169.95
Mission Cyrus One 2x25 Watts (Original Version) (MC) s/h	650.00	299.95
P.M. Components PP LIS Mk. II Valve Pre-amp (MC) s/h	150.00	99.95
Technics SU Y300 2x25 Watts Int. (Mint/as new) s/h	-	-

TURNTABLES/ARMS/CARRIDGES PHONO-STAGE ETC

Audio Technica AT630 step-up transformer (vgc) s/h	-	30.00
Audio Technica AT PS/OC moving coil (vgc) s/h	100.00	50.00
Hybrook TT 2 / Formula Four / Grado TK + (vgc) s/h	500.00	249.00
Hybrook TT-2/Mission 774/Grado T5 (walnut) (vgc) s/h	500.00	249.95
Linn LS cartridge (vgc) s/h	70.00	30.00
Linn LP12 (walnut) /Bask arm k9 (vgc) s/h	1500.00	845.00
Linn LP12 /Bask Plus /Track H.C. (vgc) s/h	2000.00	549.95
Mission TBS SH774 arm/VPS 206 (vgc) s/h	loads	399.95
Monozor SP16 PH Photo Stage/PSD (Silver Value) New	£26.95	-
Musical Fidelity X LP (The One At This Price) H/M/MC NEW	-	130.00
Q.E.D. R232 /arm/MIA RP 20 (vgc)	200.00+	109.95
Q.E.D. Disc Saver Phono Stage PH (vgc) s/h	35.00	20.00
Revolver Helix/chr arm/V.T. cart (mint) s/h	-	149.95
STD 305H c/w Mayware Unipol/Galdring Ebn cart (vgc) s/h	loads	199.95
Thorens Blue Point High Output MC Cartridge (Mint Boxed 30 hours) s/h	120.00	80.00
Thorens TD.280 IV / A.T. cart (mint) s/h	200.00	129.95
Linn Aus/Bask Plus/R.9 (mint/as new) s/h	500.00	299.95

LOUDSPEAKERS

Acoustic Energy AE1/dedicated stands (vgc) s/h	1250.00	595.00
Apogee Caliper (piano black) with bases (Restoration project/need finishing) (g.c.) s/h	3500.00	500.00
Canon S.35 inc. stands (vgc) s/h	300.00	169.95
Canon SU.15 mini monitors (mint) s/h	110.00	74.95
Castle Durham Bi-wire (black) (vgc) s/h	200.00	119.95
Celestion SL-600 (Bi-wire Conversion) (vgc) s/h	800.00	349.95
Celestion SL 65 (black) (f.c.) s/h	400.00	169.95
Dali S05 floorstanders (mint) s/h	300.00	199.95

Equivalent New Price Sale Price

A selection of our ever changing offers for sale (all fully guaranteed)

Epos ES12 (Light Ash) (Mint) s/h	550.00	375.00
Epos ES14H Bi-wire (Black) inc. stands (Mint) s/h	675.00	429.95
Foundation Heavy 18" stands (vgc) s/h	80.00	59.95
Gale 301 (black) (vgc) s/h	300.00	169.95
Heybrook Point 5 Bi-wire (black) (vgc) s/h	179.00	89.95
IPW Monitors s/w stands (black) (vgc) s/h	250.00	139.95
Ref 102/4 Uni-Q Floorstanders (black) (vgc) s/h	1300.00	599.95
Linn Helix LS 150 (vgc) inc. stands (black) s/h	280.00	179.95
Monitor Audio R300 MD (black) (vgc) s/h	300.00	159.95
Monitor Audio R852 MD (gold) (vgc) s/h	450.00	189.95
Ruark Paladin (Dark Walnut/Soundbytes) (vgc)	1100.00	599.95
Spendor SP.2 (walnut) (vgc) s/h	450.00	229.95
Tannoy T185 Dual Concentric (Walnut) (vgc) s/h	loads	249.95
Rega Ela Floorstanders (black) (mint) s/h	500.00	299.95
Celestion T II (black) (mint) s/h	250.00	149.95
Rogers LS 55 Floorstanders (rosewood) (mint) s/h	600.00	269.95

lots of LS. stands in stock including Target/Alphason etc.

Equivalent New Price Sale Price

A selection of our ever changing offers for sale (all fully guaranteed)

Rotel RCD.9708X Remote CD Player (Mint/As New) s/h	350.00	249.95
Rotel RCD.9708X Remote (another one)(Mint/As New) s/h	350.00	249.95
Sony CDP 35 HiFi player (mint/as new) s/h	-	65.00
Technics SL P550 remote (vgc) s/h	-	129.95
Technics SL P777 remote (vgc) s/h	350.00	129.95
Teac VRDS.7 (mint) s/h	600.00	379.95
Marantz CD67 S.E. Remote (mint/as new) s/h	350.00	199.95
Marantz CD67 S.E. Remote (Number power cable) (mint/as new) s/h	350.00	229.95
Technics SL PD 888 S.Disc Remote Multi-Player (vgc) s/h	180.00	129.95
Sony CDP.X339ES Remote (Battleship) CD Player (vgc) s/h	500.00	249.95

OTHER ITEMS OF INTEREST

Alphason Glass 4 shelf mini stand (ideal for X Series) (mint) s/h	100.00	69.95
Horizont Short Decoder One (Dolby Pro Logic Processor) (Inexpensive route to home cinema) (mint) s/h	400.00	149.95
Yamaha DSP A492 remote Pro Logic amp (mint) s/h	250.00	169.95
Yamaha DSP-E1000 remote pro-logic processor/amp I (mint) s/h	700.00	249.95
Horizont Platine 4 Bi-wire Cable 2 x 2m (vgc) s/h	£120.00	£59.95
Puresonic 9010A Psocc Interconnects (New)	£100	£39.95
Rega IS Cable s/h	loads	phone loads
Naim NAC A4 Cable s/h	loads	phone loads

PRODUCT OF THE MONTH
ARCAM DELTA 100 CASSETTE DECK
VERY RARE BRITISH TAPE DECK WITH DOLBY S
IN VERY GOOD CONDITION
UK NAKAMICHI?
NORMALLY 990.00 AA PRICE 499.95

TAPE DECKS/TUNERS ETC.

Arcam Delta 100 Dolby S Cassette Deck (g.c.) s/h	loads	499.95
Denon D4M 650S Dolby S etc (Mint) s/h	230.00	149.95
Denon D4M10.HX cassette deck / 3 motor / HX.Pro etc (vgc) s/h	-	119.95
Rega Radio FM Tuner (Mint/As New) s/h	250.00	189.95
Technics SLG350 FM Digital Tuner (New)	150.00	119.95
Denon D4M 550 HX.Pro etc (mint/as new) s/h	160.00	139.95
Technics RS-TR313 Twin/Auto-REV/HX.Pro etc (vgc) s/h	180.00	109.95
Kenwood KX-S080S Dolby S etc (vgc) s/h	200.00	119.95

COMPACT DISC PLAYERS/TRANSPORTS/D.A.C.S.

Arcam Delta 250 transport/black Box 50 DAC (mint) s/h	1250.00	795.00
Cambridge Discmagic 1/ Dacmagic 1 (vgc) s/h	500.00	269.95
DPA little bit 3 DAC (vgc) s/h	350.00	199.95
Marantz CD.42 (f.c.) s/h	250.00	119.95
Micro Mega CD3 top loader transport (Acrylic) (vgc) s/h	1500.00	795.00
Musical Fidelity X-Ray 24/96 player (superb player) (new)	799.00	-
Musical Fidelity X-Act DAC (new)	-	300.00
Musical Fidelity X-100 DAC (new)	-	130.00
Musical Fidelity X-100 missing Link Line Buffer (Mint) s/h	120.00	90.00
Philips CDI 210 (interactive) (mint) s/h	400.00	109.95
Pioneer PD-102 Basic CD Player (g.c.) s/h	150.00	89.95
Pioneer PDS 703 (stable platter) remote (vgc) s/h	450.00	179.95

*** GOOD HIFI SEPARATES WANTED ***

Phone anytime with your wants, stock changing daily. All equipment is sold with warranties. We welcome part-exchange on any of the above.

Don't forget we can offer mail order. All major credit cards accepted.

Affordable Audio is always keen to buy, (or part-exchange) Good quality Hi-Fi separates in good condition. Especially top British manufacturers products!

We can also sell your equipment for you on a commission basis. (Lowest rates/best return) (Please phone Paul for details!)

71 HIGH STREET,
NEW MALDEN,
SURREY, KT3 4BT.
ENGLAND.

TEL: 0181 336 0012
FAX: 0181 336 2703

Grandix
Sound & Vision
HI END CLEARANCE SALE

0% CREDIT
(SUBJECT TO STATUS)

2 DEMONSTRATION ROOMS
FREE PARKING
WIDE RANGE OF PRODUCTS
OPEN 9.00-6.00 MON - SAT

MARK LEVINSON



USA ESOTERIA

UNISON RESEARCH



	WAS	NOW
ATC A7 R/W	£ 749	£ 525
ATC 20TSL R/W	£ 3055	£ 1999
ATC 20ATSL CH	£ 4250	£ 2995
ATC SCA2 inc. rem.	£ 2800	£ 1990
ATC 100SL R/W	£ 5450	£ 3549
AVI S2000 Amp	£ 999	£ 599
AVI S2000 Pre	£ 949	£ 549
Diapson Adamantes III inc. stands	£ 2500	£ 1999
EPOS ES22	£ 1350	£ 949
Linn Majik L	£ 650	£ 455
Linn Kairn Pre	£ 1700	£ 1199
Mark Levinson No. 332	£ 6500	£ 4499
McIntosh MC7100 Power	£ 1575	£ 999
Musical Fidelity X-ACT	£ 130	£ 99
Musical Fidelity X-PRE	£ 200	£ 149
Musical Fidelity X-P100 & X-AS100	£ 1600	£ 1249
Musical Fidelity X-A100R	£ 1000	£ 789
Proceed CDP	£ 3400	£ 2390
Tannoy P20	£ 399	£ 199
Teac VRDST/DTI	£ 1050	£ 699

EXCLUSIVE AREA DEALERSHIP FOR...
● ACOUSTIC ENERGY ● AUDIO ANALOGUE ● ATC ● AVI ● CASTLE ● CHORD ● COPLAND ● DIAPASON ● EPOS ● GRAAF ● JAMO CONCERT ● LINN ● MARK LEVINSON ● MUSICAL FIDELITY ● PROCEED ● RESTEK ● SONUS FABER ● TEAC ● UNISON RESEARCH ● AND MANY OTHERS

"MAIL ORDER WELCOME"

NEW ARRIVALS AUDIO ANALOGUE ● COPLAND ● ROTEL ● SONUS FABER

CHORD

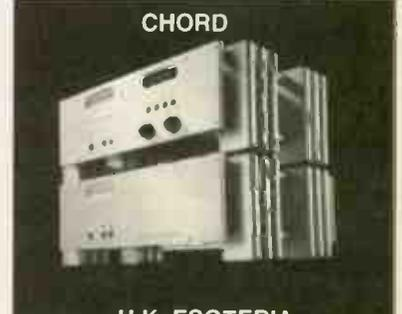

U.K. ESOTERIA

SONUS FABER





BorderPatrol

Valve Amplifier Power Supply Upgrade £595.00

Off board valve rectified, choke input filter power supply for Valve Amplifiers. This upgrade reduces distortion, increases resolution and strengthens bass performance and dynamics. If you like the sound of your valve amplifier but would like to tighten the bass and strengthen the overall dynamics this is what you need. Versions available to suit everything from vintage Leaks to modern Audio Innovations, Audio Note and Art Audio designs. If you are unsure about the suitability for your amp please telephone us.

'In every instance the Border Patrol effect was nothing short of a transformation. Bass solidified, imaging became significantly more three-dimensional and substantial, and the power supplied amp made the regular version sound, quite literally, a mess.'

'With the Border Patrol back on the music regained its composure: instruments not only sounded more natural and realistic, but seemed much more musically coherent. In many respects it was like taking the good things about transistor amps and adding them to the natural strengths of valves - a remarkable blend.'

..Jason Kennedy Hi-Fi Choice April 97

Check out the full range of BorderPatrol activities: power supplies, power amps, components, used equipment etc at www.borderpatrol.demon.co.uk

BorderPatrol Tel/Fax Brighton 01273 276716

Rothwell



Valve Amps of Distinction

This pre/power combo has been winning admiration and praise from satisfied customers throughout Britain and abroad for over five years. Many are so impressed with the performance that they have invested in a second Rubicon, running the two amps as monoblocks. To find out for yourself why these music lovers are so dedicated to Rothwell, contact your nearest dealer for a dem.

The Rubicon is a stereo valve power amp using triode configured EL84s to give a remarkably delicate sound, guaranteed to captivate. Bridgeable for monoblock operation **£949**

The Indus is the ultimate passive pre-amp, based on Rothwell's unique stepped attenuator. This precision device has fine and coarse volume controls to give 132 volume settings and unbeatable sonic accuracy. **£499**

Audio Images Lowestoft, Suffolk 01502 582853
 Kronos Hi-Fi Dungannon, N.Ireland 01868 753606
 Serious Kit Prestwich, Manchester 0161 798 9649
 Sounds Perfection Helston, Cornwall 01326 221372
 Shadwell Hi-Fi Studios Leeds, Yorkshire 0113 237 1019
 Input Audio Dukinfield, Cheshire 0161 3047494
 Kevin Galloway Audio Kilmarnock, Ayrshire 01563 574185
 Romers Hi-Fi Rishton, Lancashire 01254 887799
 Hazlemere Audio Consultants High Wycombe, Bucks 01494 437892
 Audio Illusion Langley, Berkshire 01753 542761
 Mid Shropshire Audio Telford, Shropshire 01952 502097
 Rothwell Electronics 60 Pennington Road, Great Lever, Bolton BL3 3BR
 Tel/Fax 01204 654614

HICAM

GOOD QUALITY PRE OWNED HI-FI EQUIPMENT PLUS PHOTOGRAPHIC EQUIPMENT - NIKON, CANNON A.F. BOUGHT SOLD PX (SOLD ON COMMISSION)

Cable Talk Concert 4 2x5 metres	£80
Cable Talk Improved 2, 1 metre	£20
Castle Chester Mahogany marked hence	£350
Denson Beat 100 amp	£395
Cnord Rumour 2x4 metres	£60
Keif Q55 black (ideal for home cinema)	£350
Linn Basik plus amp	£50
Linn Index/Stands	£125
Linn Kaim pre/phono	£750
Linn Majik/phono	£500
Linn Wakonda/phono	£475
LP12 valhalla Basic plus K9	£495
M+K 125 THX active sub	£495
Mark Levinson 28/29 + psu, balanced	£2750
Meridian 563 uprated to 566 spec	£475
Mission 753 black	£395
Musical Fidelity 3A pre/phono	£150
Musical Fidelity E200 pre/phono/E300 power	£795
Musical Fidelity E624 CD player latest 24 bit	£395
Musical Fidelity MVT pre/270 Mk2 power	£1200
Naim 140 old style	£350
Naim 250 power amp	£850
Naim 32.5 phono	£195
Naim 42.5 phono	£195
Naim 90 old style (recased)	£195
Naim 90.3/92 pre/power	£695
Naim cables various	£POA
Naim CD 3.5	£695
Naim Hicap old style	£375
Naim intro speakers black	£475
Naim Nait 2	£250
Naim Nait 3	£395
Naim phono boards	£40
Naim SBL black latest	£850
Naim Snaps psu	£100
Neat Petite Mk3 cherry	£450
Revolver T/T complete	£80
Roksan Rok1 transport	£250
Sonic Link Violet 1 metre	£45
Sony 540 int. amp	£100
Soundstyle 4 shelf rack blue	£150
Technics SUA 900 Mk2 amp	£175
Transparent The Wave 2X3 metres	£80

DVD
PLAYERS
ALSO
WANTED

5 miles from either J6/BA M40

Mon-Sun 10am - 8pm VISA Switch = Mastercard

For further details Phone/FAX 01844 260182

Mobile: 0973 233380 E-mail: HICAM@GLOBALNET.CO.UK

DANISH AUDIO CONNECT

Made in Denmark



CTI Audio Attenuator / Volume Control

Improve the sound quality of your amplifiers by changing to the CT1 volume control.

CTI offers you a more effortless sound, more details, better dynamics, lower distortion and improved bandwidth. CTI has the ability to "disappear" and not influence the enjoyment of the music. The tracking between stereo channels and the attenuation is within the range of professional equipment. Besides, CTI is very compact for easy build-in.

How do we obtain this?

- 24 step precision switch
- All contacts and conductors are gold plated
- Use of low noise, non inductive, non-magnetic SMD resistors.
- Five times shorter signal path than conventional designs

Key CT1 specifications

Bandwidth: 50 kHz
 Attenuation accuracy: $\pm 0.05\text{dB}$
 Tracking between channels: $\pm 0.1\text{dB}$
 THD: $< 0.0001\%$
 Dimensions: 52mm diameter, 45mm length

CT1 versions

Standard impedances: 10, 20, 50, 100 and 250 kohm
 Available with:
 • 1 meter (single ended mono)
 • 2 meters (single ended stereo or balanced mono)
 • 4 meters (balanced stereo)

Danish Audio Connect (Thailand) Ltd. Rm 150/3 Bin Chang Co. Road Bldg. 1 Sarnamit Road, Soi 22, Bangna, No. 11, Bangkok 107, Thailand. Tel: 66 2 260 6112 Fax: 66 2 260 6071 E-mail: info@danishconnect.com

UK distributor: www.danishconnect.com 8/20 Linn & Troels Exports, Centre Warsaw Street, Tenby, Pembrokeshire SA70 2JF, UK. Tel: 44 (0) 1323 811233 Fax: 44 (0) 1323 812024 E-mail: Audio_Con@danishconnect.com

AMPLIFIER BREAKTHROUGH !
Come and experience the amazing distortion free
purity of sound created by MVL Technology



FREE "PLAY AND LISTEN" DAYS

Bring your own test pieces
recorded on Cassette, Vinyl, DAT, Mini Disc or CD
and hear them as you've never heard them before!
READ JON MARKS' REVIEW - HI-FI WORLD MAY 1999

Join us at the following venues:-

CAMBRIDGE - Mumford Theatre, June 7

ALDEBURGH - The Cinema, June 24

BURY ST. EDMUNDS - Theatre Royal, July 12

Available for Sale: Small stock of MVL Integral 100 w.RMS
Amplifiers with/without Option Pack

For brochures and free tickets to any of the above venues
please contact Roger Williams at



The Long House, Haughley, Stowmarket, Suffolk IP14 3NT
Telephone: 01449 672222 Fax: 01449 677958

WANTED

HI-FI & accessories any make, any age

BUY · SELL · TRADE

NOTHING LEGAL REFUSED!

Please bring official ID with address & signature when selling or exchanging

MUSIC & VIDEO EXCHANGE

64 Notting Hill Gate, London W11
☎ 0171 792 3474

480 Fulham Rd (Broadway), London SW6
☎ 0171 385 5350

95 Berwick St, Soho, London W1
☎ 0171 434 2939

**MVE, Manchester Arndale Centre (near
High St entrance) ☎ 0161 839 0677**
OPEN 7 DAYS

LARGE SELECTION ON SALE

Hi-fi/camera expert wanted - ☎ 0171 727 3538

UNIVERSITY AUDIO SALE 3 Peas Hill Cambridge CB2 3PP SALE 01223 354 237

	WAS	NOW
AVI S2000 DAC	449.00	299.00
AVI S2000 Pre/Phono	1199.00	599.00
Arcam Xeta 2	499.00	299.00
Arcam Xeta 1	499.00	299.00
ATC SCA 2 Pre	2599.00	1999.00
ATC SPA-150 POW	2699.00	1999.00
ATC SC1A2/150	1984.00	1595.00
ATC SCM 10	999.00	799.00
ATC 20SL Tower Active	4249.00	3799.00
ATC 50SL Active	5875.00	4499.00
ATC Stands	350.00	249.00
Cyrus AV Master	698.00	299.00
Cyrus Disc/DAC Master	1790.00	950.00
Linn Kaber Active	3000.00	999.00
Linn Kairn Line	1400.00	799.00
Linn Kairn Phono	1700.00	999.00
Linn Majik Phono	800.00	499.00
Mission Active Sub	299.00	249.00
Monitor Audio Act Sub	499.00	299.00
Monitor Audio CC900	499.00	249.00
Yamaha DSP E1000	699.00	349.00
Yamaha DSPA 592	330.00	249.00

ALL ITEMS ARE EX-DEMONSTRATION
MAIL ORDER ADD £10.00

EX - DEMONSTRATION EQUIPMENT

	NEW	SALE
MARANTZ CD67E Integrated CD Player	£300	£225
PROJECT 6+MC15 Turntable with MC15 Super	£500	£350
ARCAM ALPHA 6 PLUS Integrated Amplifier	£400	£175
MARANTZ PM66ki Integrated Amplifiers	£400	£350
CYRUS IIIi Integrated Amplifier	£598	£450
CYRUS IIIi Integrated Amplifier	£598	£450
CYRUS PRE Pre Amplifier	£648	£400
MISSION 731 Pro Black finish	£140	£95
EPOS ES22 Speakers Cherry Finish	£1350	£899
SENNEISER HD455 Open Back Phones	£55	£40

QUALITY USED EQUIPMENT

MICROMEGA STAGE 1 Integrated CD Player	£550	£300
MICROMEGA STAGE 1 Integrated CD Player	£550	£300
MICROMEGA DRIVE 3 Transport	£1000	£600
MICROMEGA DAC	£750	£400
ROKSAN Turntable with stand	£750	£395
AUDIOLAB 8000C Pre Amplifier	£580	£350
AUDIOLAB 8000Q Pre Amplifier (line level)	£1200	£995
CYRUS PRE Pre Amplifier	£648	£350
AUDIOLAB 8000P Stereo Power Amplifier	£750	£350
CYRUS POWER Modular Power amplifier	£498	£350

SPECIAL PURCHASE NEW BOXED EQUIPMENT

MISSION 73C Centre Speaker	£150	£75
YAMAHA KX-690 3 Head Cassette Deck	£400	£295

Now playing at The Powerplant

The Rega Jupiter & Io

The Linn Keosa

The New Linn Kolektor Pre Amplifier

THE

power plant

66/67 Upper North Street Brighton BN1 3FL

Tele: 01273 775978 Fax: 01273 748419

Email: email@powerplant.co.uk

ATC, Audiolab, Arcam, B&O, B&W, Cyrus, KEF, Linn, Marantz, Mission, Mark Levinson, Pro Ac, Procel, Rega, Stax and other quality equipment.

Mail-order and Worldwide Export service available

THE EMPORIUM

28 St Nicholas Street, Diss, Norfolk IP22 3LB Tel/Fax: 01379 650744
emporium@dircon.co.uk

CD & DAC's

	Cost	Price
ALTS CD transport + DAC NEW	5500	1750
ARCAM Alpha 5	450	200
AUDIO NOTE DAC 1 signature		600
DPA little bit DAC		125
DPA the power		50
LINN KARIK CD Player	1500	750
PINK TRIANGLE ORDINAL DAC		500
PSAUDIO LAMBDA CD Transport	2700	1000
ROKSAN CASPIAN 3 months old	900	630
SUGDEN SDA1 DAC		650 275
SUGDEN audition cd ex dem		650 490
ARCAM 8se cd player		600 425
HELIOS stargate ex dem	2500	1875
MUSICAL FIDELITY x-24k dac		240
PRIMARE D20 cd player ex dem	700	525
MUSICAL FIDELITY x-ray ex dem	800	600
MERIDIAN 203 DAC	500	150
MARANTZ CD10	1200	450
MICROMEGA DUO B5	650	200

VALVE-AMPS

AUDION 2 Box Pre with Phono	1500	800
BEARD BBA100 line integrated	1500	600
BEARD P500A valve pre with phono		400
CROFT SERIES V power amp	650	300
COUNTERPOINT SA11 enormous line level valve pre has 17 valves!	9000	2500
GAINMA SPACE REFERENCE 300B single ended line integrated	4000	1500
HEATHKIT MA 12 valve monoblocks 12 watts pair		250
MORE FIDELITY German 300B amp	2000	900
ORANGE pre mm/line very smooth sound		300
SOUND AUDIO VP3A line valve pre		200
concordant exhilarant line pre		500
LUMLEY M75 MONOBLOCKS, big black and beautiful	1200	pair
AUDIO RESEARCH sp6		750
WOODSIDE radford sta 35 renaissance		700

LOUDSPEAKERS

ALIANTE MOD SPAZIO		400
AUDIO NOTE J		700
AUDIO TECH-NICA ATH9000 electret headphones	200	100
CADENCE ES hybrid electrostatic	3500	1500
CASTLE SEVERN MK1		325
DYNAUDIO AUDIENCE 5		280
EPOS ES 11 biwire		350
JR 149 round version of ls3/5a		175
ROGERS STUDIO 1		275
ROYD MINSTREL pair		120
RUARK SABRE		200
RUARK EQUINOX	2250	1200
SENNHEISER 580 JUBILEE HEADPHONES	250	150
SONUS FABER MINIMA FM2		600
SPENDOR S100	1650	600
STAX LAMBDA signature and SRM-T1 valve energizer		700
TANNOY little gold monitor		700
AUDIO physic tempos with Essex equalizer	4000	1750
DYNAUDIO audience 50 cherry ex dem	576	430
DYNAUDIO AUDIENCE 70 ex dem		
DYNAUDIO contour 1.1 cherry ex dem		
DYNAUDIO contour 1.3 cherry ex dem	1198	900
JAMO CONCERT 8 30th anniversary piano black special edition ex dem	1500	1150
DAU grand coupe, gorgeous stand mounter ex dem	2500	1750
ORIGIN LIVE resolution with dedicated stands	1250	650
ORIGIN LIVE sovereign floorstanders ex dem	1200	800

KLIPSCH la scala big horn loaded speakers	2200	1200
SPENDOR spl. bi wire	1000	500
MONITOR AUDIO 1200 gold	800	400
CADENCE arca, amazing looks and sound	10000	3000
REGA ELA8 ex dem		375
TANNOY IILZ		400
SONUS FABER MINNETOS	800	450
SONUS FABER SIGNUM	1250	1000
SONUS FABER CONCERTINOS NEW	600	450
PROAC TABLETTE 50 SE in ebony with target RI stands mint	1168	800

CASSETTE DECKS & TUNERS

DYNACO FM3 valve stereo FM Tuner		120
LEAK STEREO FETIC FM Tuner		40
McIntosh MAC1700 Hybrid valve/solid state receiver		400
MERIDIAN 104 FM tuner		120
MISSION CYRUS Tuner matches one and two amps		100
NAKAMICHI 480Z cassette deck		200
QUAD FM 2 stereo valve tuner		100
QUAD FM 66		400
REVOX B77 high speed one owner from new with service history		600
AKAI 4000d reel to reel		50
NAKAMICHI 600		100
TANBERG TCD	330	100

SOLID STATE AMPS

ALBARRY DMP1 pre with M408 monoblocks		650
ARCAM Delta 60 amp		300 160
ALCHEMIST FREYA/ODIN pre/power original budget high end designs		2100 1000
CHORD SPM 800B power amp		2200 1500
COPLAND CSA 28 integrated amp		1300 900
CYRUS straight line		400 275
CYRUS phonostage MM/MC		500 300
ELECTROCOMPANET ELCTRO 25 watt class A power amp		400
EXPOSURE XV integrated		800 400
KRELL KAV300I integrated		2550 2000
LAVERDIN IT		3200 2500
LFD PAL power amp		900 450
LFD MISTRAL integrated		500 300
LINN INTEK		200
LINN KAIRN remote pre	1000+	500
McINTOSH C28 PRE / MC2150 power amp Enormous beauties with wooden sleeves and they light up in blue!		900
McINTOSH MC250 classic early transistor power amp with output transformers		400
MARC LEVINSON 38 remote controlled	5000	2500
MOTH 60 watt stereo power amp with PSU	600	350
NAIM AUDIO ECLAT PSU		200
NAIM NAIT 3		400
NVA 50 watt stereo power amp old style		200
NVA P50 pre with mc input and two PSU old style		250
PIONEER spec 1/4 Pre/Power 150 Watts		400
PS AUDIO PLUS C power amps pair bridgable for 150 watts per channel pair		500
QUAD 33/PM2/303		250
SUGDEN OPTIMA 200 line integrated		450
DENSEN beat b-200/b-300 pre/power ex dem	2000	1500
DENSEN beat b-100 integrated es dem	650	480
ELECTROCOMPANET pre/power class a		500
DENSEN d20/d30 pre/power ex dem	2500	1850
SUGDEN audition T remote integrated	700	525
OCM 500 250watts per channel massive heatsinks, stereophile class b recommendation		2500 1200
MARANTZ ma24 class a monoblocks mnt boxed	2700	1500

EXPOSURE vii pre with custom built psu		250
SUGDEN p28 power amp		250
MUSICAL FIDELITY the preamp/typhoon power amp		300
MUSICAL FIDELITY a1000, class a beast with 600 spent on it at russ andrews		1000
REGA brio int amp ex dem	298	220
REGA luna " "		
REGA maia/cursa pre power ex dem	900	675
QUAD 50e monoblocks		250
HITACHI hma 7500 100 watt mosfet power amp		175
ARCAM alpha 9 integrated amp		600 400
PRIMARE a20 integrated ex dem		700 525
AUDIOLAB 8000A		500 275
MUSICAL FIDELITY pre8/ma65 monoblocks		700
MUSICAL FIDELITY a1		140
MUSICAL FIDELITY x-a100R ex dem	1000	750
MUSICAL FIDELITY x-a1		800 600
MUSICAL FIDELITY x-p100/x-as100 pre/power	1600	1200
QUAD 34 brown		150

TURNTABLES/ARMS/CARTRIDGES

CLEARAUDIO with parallel arm and BETA cartridge	2100	1400
GARRARD 401 in slate plinth		300
LINN LP12 EARLY MODEL no arm		250
LINN LP12 with avondale psu		350
MICHEL FOCUS, no arm crack in lid		90
ORACLE DELPHI MKII WITH WELL TEMPERED ARM & ONIX psu		1000
ORTOFON MC3000 light use since rebuild	1000	350
ROKSAN XERXES with XPSI II (SME cutout)		895 400
SLATE AUDIO PLINTH FOR THORENSTD	124	300
SYSTEMDEK IIX900 with RB250		200
THORENS td 160b/maymare arm		100
GOLDRING ELITE MC boxed		100
SUMIKO blue point special unused boxed		200
SYSTEMDECK IIX/900		225
VPI TNT MK III with base and jmw memorial arm cost 7000 mint and boxed for only		3500
THORENS TD124 MKII excellent		225

VINTAGE

JORDAN WATTS 4" Full range speaker modules pair		75
LEAK TL12+ player pair		350
LOWTHER PM4A with new silver voice coils pair		800
DECCA kelly ribbon tweeters		Pair 150
SHACKMAN electrostatic tweeters		Pair 150
TANNOY 12" blues		POA
TANNOY LANCASTERS with 15" gold		POA

CLASSICAL LPS

ask for our latest list

" looking for a good london dealer"
for new equipment by
CLEAR AUDIO, VPI, AUDION,
ABSOLUTE SOUNDS, ADVANTAGE,
AMP, PASS, CADENCE, AUDIO PHYSIC,
EGGLESTON, HALES,
SONIC FRONTIERS, VD.H, ELEMENTAL,
TRIANGLE, ORTOFON, LFD, NORDOST,
DAC, HELIOS, JM LABS,
ELECTROCOMPANET, LAVARDIN,
PLINIUS, ROCKPORT.

we recommend Audiocraft ask for Kevin Walker tel/fax 01895 253340 hours 10-8 home dems and loans a speciality, trade-ins welcome

Are you making the right connections?

Send for Britain's biggest catalogue of specialist cable and connections.

All available by mail order.

Phone 0181-942 9124 or clip the coupon for your Free copy

CUSTOM CABLE SERVICE

PO Box 4007, London SW17 8XG

Please send me your FREE Custom Cable Catalogue

Name _____

Address _____

Postcode _____

NO FURTHER INFORMATION REQUIRED

Send to: Custom Cable Service
PO Box 4007
London SW17 8XG

HFV 06/99



THE MIDLANDS
BEST USED EQUIP-
MENT
SPECIALIST

TEL/FAX 0121 783 8227



QUALITY USED
EQUIPMENT,
BOUGHT, SOLD, PART
EXCHANGE

URGENTLY REQUIRED
LINN, NAIM,
MERIDIAN, QUAD
CASH WAITING

Audio Alchemy DDS3
Audio Research LS7
EAR 509's Mk1 (full recent service)
JBL L80T
Jeff Rowland Model 1
Linn Kan Stands MkII
Linn Kans Mk1 plus stands
Linn Karik/Numank
Linn Lingo
Linn LP12 Cirkus Trampoline Lingo Aro
Linn Sara & stands
Meridian 203 DAC
Meridian 557
Meridian 601
Meridian 602
Micro Seiki CDM 2
Micromega Duo B/S
Naim 02 tuner
Naim 110
Naim 135's
Naim 140 old style x2
Naim 250 new style
Naim 250 old style (recent service)
Naim 32.5
Naim 42.5
Naim 82 plus phono
Naim 92
Naim Aro
Naim CDI
Naim Hi-Cap new style
Naim Hi-Cap old style
Naim IBL black
Naim Naxo 3/6 new style
Naim SBL black latest
Naim SBL walnut
Nuance Plentitude pre amp
Pink Triangle Export Rega RB300
Pioneer PD95
Proac Response 2 & stands
Quad 44
Roksan Xerxes Artemiz piano black
Rotel RB 981
Siltech HF6 0.5 metre
Syrinx PU3

RRP£ NOW£

700 250
1700 850
3699 895
1250 395
3000 995
n/a 50
n/a 195
3350 995
750 450
3500 1395
900 195
450 150
1600 895
2750 995
1750 595
2800 795
500 195
1130 695
n/a 250
3410 1595
770 350
1705 1095
1705 795
n/a 250
n/a 175
2307 1350
485 295
1070 695
1800 1095
720 450
720 350
1000 250
650 250
2200 1095
2200 895
n/a 295
1070 395
2500 795
2000 695
n/a 195
2500 795
300 195
100 35
n/a 150

OPEN MON-SUN 10.00 TO 8.00 RING FOR FURTHER DETAILS TEL/FAX 0121 783 8227



PROGRESSIVE
AUDIO

VISA

2 Maryland Court, Rainham, Kent, ME8 8QY
Telephone / Fax No. 01634 389004

We now have on permanent demonstration the following new products; PROAC Response 3.8 loudspeakers, the whole range of AUDIO SYNTHESIS products, the GRAAF GM 20 amplifier, the MUSIC FIDELITY NU-VISTA pre amp, the CADENCEARCA and latest CADENCE ES loudspeakers, DIAPASON loudspeakers, GOERTZ cables and TICE power conditioners and enhancers, the amazing INNERSOUND hybrids, PATHOS twin tower amp (stunning), PROAC Tablette 2000 and Studio 125 loudspeakers, AUDIONOTE Zero system, TUBE TECHNOLOGY CD players DNM pre and power amplifiers, Sugden MASTERCLASS CLASS A amplifiers and of course all our usual equipment. For any more information please call.

- Conrad Johnson NV55 Power amp £1,500.
- Proac Studio 150 Loudspeakers. Yew. Boxed. Mint. £1,025.
- Proac Response 2 Loudspeakers (Black) with Target R2 stands. Boxed. Mint. £995.
- Audionote SN 3 (Silver) MC transformer. Mint. £1,100.
- Mirage M3Si Loudspeakers. Boxed. Mint. £1,950.
- Pioneer Exclusive M6 300 Watt Class A mono blocks. Very rare. Boxed. Mint. Cost £8000 nine years ago. The pair £2,995.
- Tube Technology Prophet Pre amp and Genesis 100 Watt mono blocks. Boxed. Mint. £2,750.
- Genesis Digital Lens. Mint. £995.
- Monarchy 22 B DAC. 20 Bit Burr Brown. Mint. £475.
- SD Acoustics SD 1E Loudspeakers £1,995.
- Unison Research Mystery One Pre amp. Boxed. Mint. £1,350.
- Proac Response 3 Loudspeakers. (Mahogany) Boxed. Mint. £1,550.
- Proac Response 3.5 Loudspeakers. (Burnt Oak) Boxed. Mint. £2,850.
- Voyd Vald Turntable (Ash). RB300 Tonearm. Genz Micro Glider Cartridge. Absolutely Mint. £850
- Audionote CD 2 CD Player (One Year Old). £725
- Audio Innovations Series 1000 M/C Transformer. £185
- Audionote Level 5 E's. Ebony. Cost new £9,600. £2,995
- Densen DM10 Int. Amp. Boxed. mint. £750
- Audio Synthesis Desire Power Amp. Boxed. Mint. £1,295
- Audion Golden Knights 9W 300B. Boxed. Mint. £2,495
- Tube Technology Synergy 150W Integrated Amp (New) £5,250
- Harbeth HLP3ES (ExDem). Boxed. Mint. (Teak) £550
- Harbeth K6 (ExDem). Boxed. Mint. (Walnut) £725
- Acoustic Solutions "Eight" Loudspeakers (ExDem) Boxed. Mint. £795
- Muse Model 18 Active Sub Woofer (oak) mint condition £2250
- Gamma Aeon Mono Blocks very very latest specification. Mint Boxed 3 months old £3250 (new) £6000

TEL: 01428-651554

P.G. Hi-Fi

FAX: 01428-654592

Buying & Selling Vintage HiFi, Valves,
Classical LP Records & Spare Parts.

Quad

Acoustical (Quad) pre-amp very
early type (ECC35) £100
QA12P Amplifiers (Pair) £0ffers
QCII Pre-Amps (x8) for spares or
repair - the lot £100
33/303 £120
FM3 £75

Leak

TL12+ (Pair) £300
Stereo 20 £250
TL12.1 (Pair) £1300
TL25+ (single) Black £150
Troughline Stereo Tuner (mint) £100
Stereo 30 Amplifier £20

Valves (G E C Mullard etc.)

PX25, KT66, ECC81/84, EF80
Many Others.
Please Phone For Details.

Most Models Of Leak Mono + Stereo Pre-Amps In Stock.

Garrard 401 with S.M.E. 3012 MK II
+ Plinth £350
Garrard 301/Goldring Arm + Plinth
and cover £275
Radford SC2 pre amp £70
Shure V15 III cartridge £25
Nakamichi CR1E (mint) £175

VALVE ALERT

GENUINE MULLARD ECC83'S
LAST BATCH MADE IN UK
BLUE BOX - N.O.S.
£10 EACH INC P&P
FOREIGN ORDERS WELCOME
MINIMUM ORDER 10 VALVES

Servicing for Quad II + Leak
Amplifiers
Photocopies Of Circuit Diagrams +
Vintage Hi-Fi Literature
Spare Parts For Quad +
Leak - Transformers etc.
Garrard 301 spares

Quad II mains transformer £80
Quad II output transformer £80
Quad II choke £25

Please phone for details of other
Quad/Leak/Garrard spares

Speakers

Lowther Acousta's with original PM6
drive units £250
Tannoy 3LZ (cabinets only) very good
condition £40
Tannoy 12" Monitor red drive units and
crossover's (pair) £700
Sonab OA4 speakers (pair) £50
Tannoy speakers + drive units
for sale please phone for details

Wanted

Tannoy Speakers - Lancaster,
York, G.R.F. and Autograph.

definitive audio

We specialise in natural sounding dynamic audio systems
which use valve amplifiers and high efficiency loudspeakers.
If dynamic effortless sound appeals to you give us a ring. If
you prefer small trained wearing transistor sound don't
bother

Selected products from

ARCADIA AUDIO NOTE
BORDER PATROL GOLDRING
HORNING LIVING VOICE SME

AUDIO INNOVATIONS valve amplifier *repair, service and
spare parts* (most parts available including replacement
mains and output transformers): We can repair and service
most makes of valve amplifier both vintage and modern.

USED AND EX-DEMONSTRATION EQUIPMENT FOR SALE:

Audio Note DAC4 Signature	2995	9995
Teac P500	650	995
Voyd The Voyd split phase, light ash	650	2195
Audion Golden Night Single-ended 300B mono-blocks	2200	4500
BorderPatrol 300B SE 10W single-ended power amp	1495	2495
Helius Aureus tonearm	125	375
Selection of cables (Audio Note AN-B, AN-SPx, AN-V, AN-Vx etc)	please enquire for more details	

TEL/FAX:

Brighton 01273 276716

MEASURED PERFORMANCE

AMPLIFIERS

PAPWORTH MVH-200

The Papworth is massively powerful, delivering 200watts per channel into 8ohms and 225watts into 4ohms. This is enough to handle any loudspeaker in just about any room and make it go very loud. With good low-frequency extension down to 10Hz the amplifier should have plenty of bass oomph too.

Frequency response was wide and distortion fairly low, although there was some rise in non-linearity at high frequencies, yielding a distortion figure of 0.2%, with extended odd-order harmonics, as our analysis shows. This may result in a little sharpness or hardness to the treble.

Channel separation measured well and

noise was very low, unfortunately because the amplifier lacked gain, possessing an unusually low input sensitivity of 750mV on all inputs. Most amplifiers have a sensitivity of 200mV or so these days and 300mV is a minimum if old sources like cassette decks are to match. Nowadays, many sources still deliver no more than 500mV out, so the Papworth will not suit them. Apart from this peculiar feature, the Papworth measured well enough. NK

Power	200watts
CD/tuner/aux.	
Frequency response	10Hz-60kHz

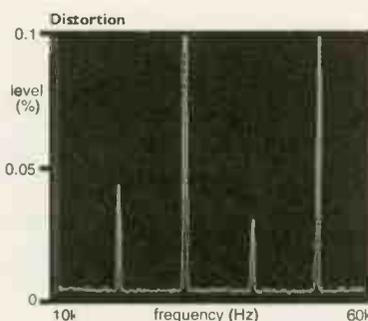

Separation	71dB
Noise	-107dB
Distortion	0.04%
Sensitivity	750mV
DC off-set	2.7/1.6mV

LOUDSPEAKERS

ARCAYDIS ASC

A small peak in frequency response around 1.5kHz may give these loudspeakers a degree of forwardness, perhaps a little brightness or spitch on vocals. Otherwise they should sound detailed and accurate, since frequency response was pretty even from 18kHz down to 100Hz. However, low bass rolled away, meaning the 'speakers are a little overdamped and best used near to a rear wall to augment lower-bass output.

Impedance did not drop below 6ohms and measured out at 9ohms overall, a relatively high value. In spite of this, sensitivity was good at 87dB from one nominal

watt of input, demonstrating good efficiency from well-made drive units. With gentle slopes to the impedance curve indicating low reactance, the Arcaydis will be an easy enough load for any amplifier. NK

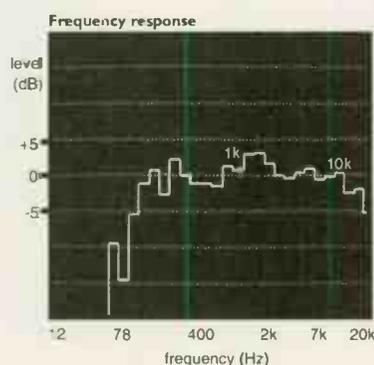

watt of input, demonstrating good efficiency from well-made drive units. With gentle slopes to the impedance curve indicating low reactance, the Arcaydis will be an easy enough load for any amplifier. NK

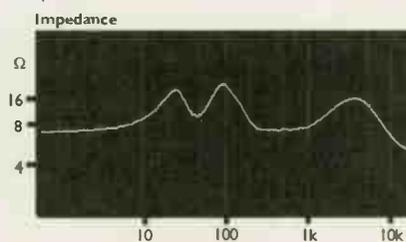

VERITAS 7

A +4dB bass peak around 200Hz will ensure the Veritas has plenty of upper bass, giving a good impression of 'speed' to drums. Lower bass output falls away steadily to become -6dB at 63Hz. The 'speakers will need to be used close to a rear wall to lift lower bass slightly.

Further up the range frequency response measured flat and phase matching between the drivers was quite good over a usefully wide forward angle, so seating position will not be too critical. The 'speakers are accurate and should sound detailed but smooth in their treble.

The impedance curve swings around 8ohms and measures out at 8ohms overall, using a music-like pink-noise test signal. Low curve slopes mean the Veritas

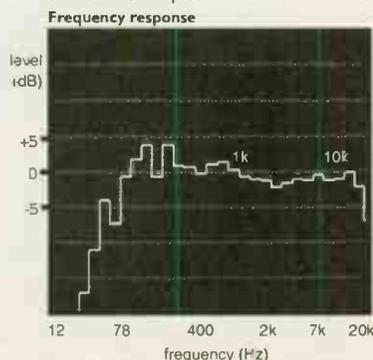

do not possess much reactance and will not be too difficult a load. However, sensitivity was low - just 84dB SPL was produced from a nominal watt of input (2.84V), relatively poor nowadays. To go loud these 'speakers will need a powerful amplifier of 60-100watts per channel. NK

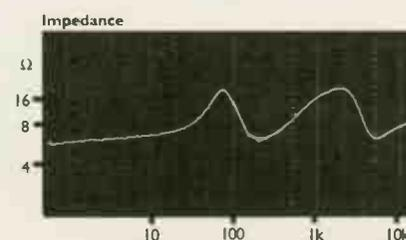

Audio Connoisseurs

Distributors of Fine Audio equipment

Introducing a world first.

You have seen the "outstanding review" of our CA601 Pre Amp, now wait until you hear our CA608 integrated valve amplifier.

35 watts per channel of class A power.

Utilising four 6CA7 (EL34) valves, Mallory capacitors. Alps black pot volume control, Teflon coated silver wire, oversized transformers, and a build quality second to none.

Now available in black to go with your existing boxes

Don't just take our word for it why not let your ears decide. We are happy to arrange fuss free demonstrations in the comfort of your own home.



Please call Steve or Peter for more details.

Happy listening

Stockists: Doug Brady HiFi, Sounds Perfection, Better HiFi

Call Audio Connoisseurs Tel/Fax: 0151 343 0007

VISA HEATHERDALE AUDIO LTD. VISA

202 FINDON ROAD, WORTHING, WEST SUSSEX, BN14 0EJ
TEL. 01903-872288 OR (AFTER HOURS) 0860 660001 FAX. 01903-872234
e-mail: heatherdale@hifi-stereo.com http://www.hifi-stereo.com

HEATHERDALE PRE-OWNED GUARANTEED EQUIPMENT EXPORT FACILITIES AVAILABLE

PASSLABS X 600 Monoblock Amps II (8 month old) £17000 new £11995
CONRAD JOHNSON Mofit MP11 Phono stage £850
GOLDMUND REFERENCE 7 (table/73F arm) £8995
MARK LEVINSON ML3 Power amp £2450
AUDIO RESEARCH SP15 revision A (black) Pre-amp £2495
GRAHAM Mofit 1 Tonearm (Spare wand) £1250
VAC Dac 22 1 (HDCC) £895
AUDIOLAB 8000A Integrated amp £245
ROTEL RT 850 AL Tuner £35
KLH Research Speakers £250
ACCPHASE DP70V Cd player (MINT/BOXED) £1995
NAKAMICHI 1000 ZXI Gold 'td edition' MINT/BOXED/MANUALS £3995
TECHNICS SU-V85A Stereo Integrated amp £95
THIEL 7.2 Speakers (Birds eye maple) EX DEM £10995
SOLSTICE AAD Speakers with Stands £495
ALDIS CDT III Cd Transport EX DEM £3500
ACCPHASE 80/81L CD Player £2995
AERIAL Acoustics Speakers (Piano Black finish) £3995
AUDIONOTE P2SE Power Amp MINT £895
AUDIONOTE P4 Monoblocks MINT £3395
AUDIONOTE Wiro amp MINT/BOXED (new £15400) £5495
AUDIONOTE 10 limited Cartridge & PSU £2750
AUDIONOTE Omega MINT £3495
AUDIONOTE ANE S-E Lspeakers (rosewood) F. venser £3995
MONITOR AUDIO Studio 50 Speakers (Rosewood) MINT £2500

B & W DM2A's (Teak) £150
MIRAGE M-Ls Speakers (Piano black) MINT/boxed £3995
EXPOSURE 25 Integrated with remote NEW £850
EXPOSURE 21 Pre-amp with remote NEW £890
EXPOSURE 18 Stereo Power amp NEW £720
JVC 7050 Power Amp Power amp £695
SYNERGISTIC research resolution ref MK2 blue balanced interconnect £695
1.5 MTR (cost £1300 NEW) £595
QUAD NEW 77 Integrated amplifier with remote (£850) £595
TEAC A3340s 4 TRACK TAPE RECORDER (£899) £595
LUXMAN M03600 KT88 Stereo Power amp £1295
LUXMAN ST10 Tuner £450
MARTIN LOGAN CLS IIz BOXED/MANUALS £2895
PASS LABS Aleph P remote controlled pre-amp new £3195 £1995
ORCHID speakers (pair) with stands 3 yrs old new £5006
MIT 750 PLUS SPEAKER CABLES 5MTR PAIR £495
ROKSAN Koros Turntable/azemiz arm £495
ARAGON AURIUM pre-amp boxed/manuals £895
ARAGON PALLADIUM monoblocks boxed/manuals (£3000 new) £1895
KINERGETIC SUBWOOFERS with X over boxed/manuals £2195
LUXMAN M2000 power amp MINT £495
NEAT Mystique Speakers (Veneer) £350
MARK LEVINSON 35 Dac EX DEM £3795
MARK LEVINSON 28 Pre-amp £1495
MARK LEVINSON 30 S/31 5 Cd transport & dac £12995
MILLER & KREISAL MX100 Subwoofer EX COM £795
MISSION 782 Loudspeakers with stands £250

QUAD ESL 63 Speakers £1495
VOYD Standard turntable MINT £1495
CELESTION Kingston Speakers with Stands £1395
BURMESTER 877 pre-amp £1495
VP119 M/C3 (dark oak) AVR Tangent/Koetsu Black £1800
FORSELL Cartridge MINT £795
FINESTRA Pre-amp (with psu) £395
MERIDIAN 203 DAC £195
RUARK Talisman II Speakers (Mahogany) 4yrs old £395
KEF 104 Loudspeakers £450
REVOK PR99 MK2 Tape Deck (Trolley mounted) £1495
VOYD Triable (upgraded psu & mtr) / Helius orion £1095
MIT M15 2 MTR interconnect £200
HELIUS Silver Wired tonearm £995
MARANTZ Cd 63SE (boxed) £175
TARA Labs 2 MTR RSC Master Interconnect cable Balanced £495
AUDIO MIECA Kreatura Cd Transport £595
AUDIO INNOVATIONS L2 Pre-Amp £395
IMPULSE H5 Speakers £895

WE NOW OFFER 0% FINANCE * PLEASE PHONE FOR DETAILS
(Subject to status)

MAIN UK DEALERS FOR THEIL SPEAKERS
MARK LEVINSON, ABSOLUTE SOUNDS, & MUCH MORE
EX-DEM EQUIPMENT AVAILABLE PHONE FOR LIST
FOR AN UP-TO-THE-MINUTE LIST VISIT OUR WEB SITE:
<http://www.hifi-stereo.com>

ALL USED CARTRIDGES ARE CHECKED UNDER A MICROSCOPE BEFORE BEING OFFERED FOR SALE.

VISA - SWITCH - MASTER CARD - AMEX - DINERS CLUB WELCOME.
WE TAKE PART EXCHANGE ON NEW & USED STOCK AND BUY IN FOR CASH

Sound Investment

If you have invested expertise and money in building up a sound system to your own unique specifications, then why compromise with indifferent housing units?

Fi-Rax offers a new dimension in audio visual racking - from a range of standard designs to the flexibility to custom create a unit to suit your particular sound system and lifestyle.

- *High quality aluminium construction.
- *Finishes available to your choice.
- *Fully adjustable 6mm glass shelving.
- *Sound isolation on shelving/feet.
- *Custom created to suit your system.
- *Free delivery throughout the UK.

Fi-Rax - a sound investment for those who want the best from their equipment.

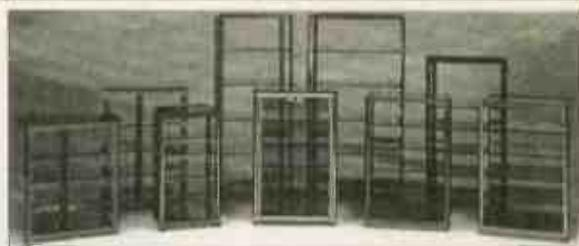

Audio Visual Furniture

For further information or a free brochure contact JEM Distribution,
Springfield Mills, Spa Street, Ossett Wakefield WF5 0HW.
Tel: 01924 277626 Fax: 01924 270759

YAMAHA MSP5

Measured frequency response of the small Yamaha MSP5 powered loudspeakers was not overly impressive. They have a forward midrange and some lift in their treble around 5kHz, both of which will result in brightness. Below 1kHz output dips down to 400Hz before rising up to peak at 160Hz. This will weaken any sense of fullness and body in the sound as well as producing peaky bass. Below 160Hz output falls slowly down to 60Hz, before rolling off rapidly below this fre-

quency, so downward extension was good for the size of the cabinet.

Integration between the drive units was tight: the 'speakers gave a consistent sound over a wide range of forward positions. Sensitivity was high too: just 50mV of sound would generate a loud 90dB sound pressure level one metre in front of the loudspeaker. This is more than enough for the Yamahas to go very loud working directly from the output of a CD player. **NK**

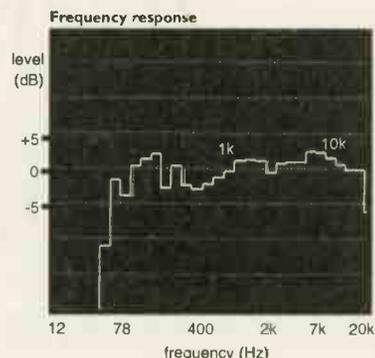

TUNER

DENON TU-260L MKII

The TU-260L gained a reputation for its warm sound coupled with good all-round performance at a low price. The MkII differs little. If memory serves, it had a greater response roll off than the MkII model tested here. However, some warmth will still be evident I suspect.

Channel separation was high right across the audio band, which is helpful in reducing distortion since crosstalk signals are often heavily distorted. Noise was reasonably low at -71dB, low enough not to be audible, but as always this does assume the tuner is receiving a strong enough signal of 1mV or more from the aerial and the TU-260L MkII is no different from usual here. Both sensitivity and selectivity were up to scratch too. Denon fit an effective pilot-tone filter to elimi-

nate signals at and above 19kHz, so the audio output is clean.

The TU-260L MkII measured very well and seems little changed in most areas, but it is likely to sound a little less warm than before. **NK**

Frequency response 3Hz-12.5kHz

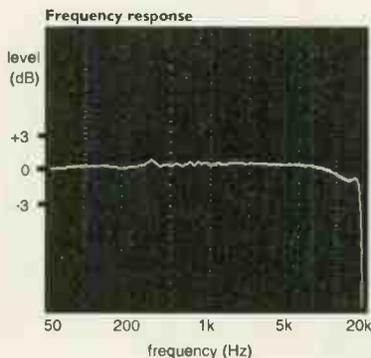

Stereo separation	53dB
Distortion (50% mod.)	0.2%
Hiss (CCIR)	-71dB
Signal for minimum hiss	1mV
Selectivity (at 0.4MHz)	80dB
Sensitivity	
mono	2uV
stereo	32uV
Signal strength meter:	none

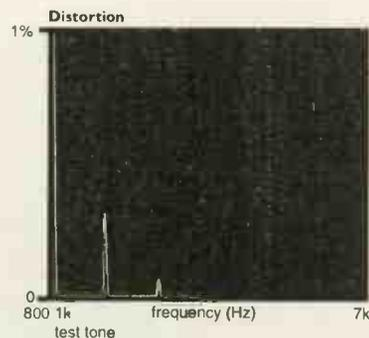

ONE THING DEMODULATOR

This decoder had accurate 50µS de-emphasis, so frequency response was flat and extended to 14kHz (-1dB), as our analysis shows. It will have a good balance to its sound quality as a result. Channel separation was high at 45dB in the mid-band and 31dB at 10kHz; these are very good figures. Distortion measured a miniscule 0.12% and noise was absolutely minimal. However, the excellent noise performance probably resulted from the lack of gain before the decoder chip, which in turn made it insensitive. A minimum of 300mV in is needed to trigger the stereo beacon, yet maximum input was 800mV, before overload distortion set in. The makers state most tuners offer more than 300mV MPX out but in my experience MPX out signals can be

quite weak - 50mV or so. Perhaps my experiences are unrepresentative. Whatever, it would help if this unit had under/over lights, a small amount of variable gain or some other way of coping. Users otherwise are best advised to measure output from their tuner to ensure compatibility.

This matter apart the One Thing mea-

sured very well and will do justice to high-quality tuners. **NK**

Frequency response	2Hz-14kHz
Stereo separation	45dB
Distortion (50% mod.)	0.12%
Hiss (CCIR)	-78dB
Trigger level	300mV
Max input	800mV

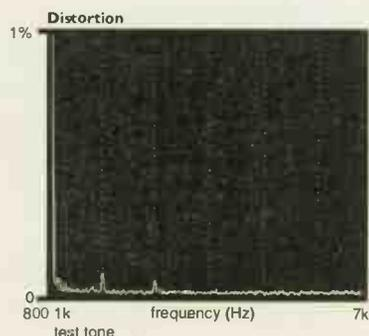
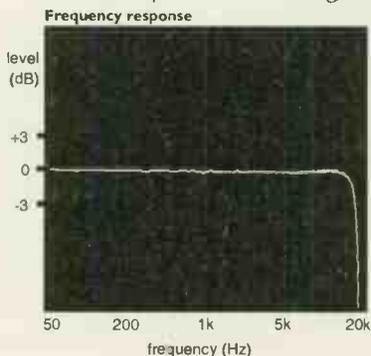

The Audio Experience

20th June 1999

Vintage Audio • Classic HiFi • Tuners • Turntables • Amplifiers • Loudspeakers • CD Players • Valve Equipment • Records • CDs • Cables • Accessories • Components

THE CORN EXCHANGE
CAMBRIDGE CITY CENTRE
10.00 - 4.30

A must for all audio enthusiasts!

(with plenty of local attractions for the rest of the family)
 Admission: £2.50 OAPs/Students £1.50 Children (under 16) free
 Further details: Audio Ex. Tel./Fax. 01279 792041
 E-Mail: audio.ex@virgin.net Web: freespace.virgin.net/audio.ex

AE
 Atacama
 Audiolab
 B&W
 Cable Talk
 Copland
 Cyrus
 Epos
 Hamman-Kardon
 JBL
 KEF
 Kenwood
 Krell
 Marantz
 Martin-Logan
 Meridian
 Michell
 Mission
 Monitor Audio
 Musical-Fidelity
 Pickering
 Pink Triangle
 Pioneer
 Quad
 REL
 Rogers
 SME
 Sonus-Faber
 Spondor
 Tannoy
 TDL
 Thorens
 Yamaha
 & lots more...

York...
a great place for...

- Widest choice in the area
- Independent advice
- Qualified staff
- Comfortable dem rooms
- Superb showrooms
- Main road location
- Major car parks nearby
- Insurance estimates
- Over 30yrs experience
- Service Dept
- Delivery & installation
- Part Exchange
- Open 10.30-5.30 6 days

**Up to 3 yrs.
 Interest Free
 Credit**

deposit only 20% of
 £500+ for 12 months
 £1500+ for 24 months
 £3000+ for 36 months
 subject to status

*PS if you're making a special trip...
 it's best to book, weekdays*



24 Gillygate, York
Tel. 01904 629659
High Fidelity Specialists est.1967

Cyrus

Audiolab

*The very best
 in Hi-Fi and
 Home Cinema...*

Martin-
 Logan

Krell

Monitor-
 Audio

X Dem. Sale...

	Was	Now
Acoustic Energy AE1 r/w	£995	£745
AE2 II r/w/wood inc stands	£2090	£1400
Audiolab 8000C	£580	£475
8000LX	£470	£395
8000CDM+DAC	£2300	£1725
8000DAC	£900	£650
8000MX pair	£1800	£1495
B&W CDM2 r/wood	£400	£320
Copland CDA288	£1999	£1599
Cyrus 111i	£598	£475
Commander remote	£100	£50
PSX-R	£328	£275
Power	£498	£395
SL integrated amp	£398	£325
JBL Aquarius S119 LSs	£1250	£625
KEF LS3/5a piano bk. LE	£1800	£895
Krell 250 Pre+power	£5195	£4650
KAV300 cd	£3550	£3195
Marantz CD17 bk.	£800	£650
PM17 gold	£900	£695
Meridian A500 r/wood	£875	£650
M60 r/wood	£2500	£1875
566.20	£1095	£750
500 CDT +566.20 DAC	£2420	£1795
Michell Argo pre.+Hera	£885	£595
ISO phono stage	£420	£320
Mission 753f oak	£898	£750
754f oak	£1498	£1125
Monitor Audio Studio 50SE		
r/wood piano laq.	£5000	£2995
Studio 12 r/w/wood	£1100	£825
Pink Triangle Litaural CD	£2099	£1675
Tarantella+RB+XLZ	£1054	£750
Pioneer CLD-D925	£800	£595
A300 Precision	£400	£300
PDS505 Precision	£460	£350
Quad 77 Power amp	£600	£450
77 Pre-Amp	£700	£525
77 Remote	£300	£150
77 CD bus (all carbon)	£700	£595
REL Q100E bk.	£495	£395
Yamaha DSP-A3090	£1500	£1125

Classic second-hand...

Acoustic Energy AE1 r/w	£495
Audiolab 8000C pre-amp	£375
8000A integrated amp	£350
Audio Innovations Series 1000 monoblox (were £1799)	£750
2nd Audio (was £3000)	£1000
Gale 401 chrome/black	£250
HK Citation 11/12 pre/power & 15 tuner the very first models, in walnut cases	£300
KEF 104/2 r/w (£2000)	£850
Marantz CD63 II K1-S	£275
CD85 (built like a tank)	£250
Mission 776/777 batt pre amp & 2 x 100w power amp	£950
Argonaut bk., big, twin bass	£325
Quad 22 pre & powers	£600
ESL57 pair bk latest spec.	£750
34 pre-amp	£150
44 pre (din)	£185
405 power amp	£200
FM4 tuner (din)	£150
Revox G36 1/2 track 10"	£195
B77 reel-reel 1/4 track, 7.5ips pro-nabs, op cover	£850
Rogers LS6 teak	£175
Ruark Sabre bk.	£250
SME original 3012	£175
3009 mk1 original box	£75
Tandberg TD20A	
1/4 track 7.5ips 10" reel	£650
Tannoy Cheviot 10"	
Dual Concentrics, walnut	£350
609 marble effect inc. stands	£195
Thorens TD124 mk2 +3012	£150
TD125 mk2 +3009	£200
TD150+3012 in SME plinth	£300
Vortexion Series 4 recorder	£100

COMPACT DISC

CREEK OBH-14

Fed a normal test signal, the Creek displayed a perfectly conventional performance. It has a smooth frequency response with a roll-off at the top-end that will soften and warm the sound just a little, helping to banish harshness.

There was little distortion on either channel. Our analysis shows a complete absence of distortion and quantisation products when fed a -30dB signal. Further down the dynamic range the Creek remained relatively linear, low distortion at -60dB yielding an impressive EIA) dynamic range of 110dB. With a normal output of just over 2V, plus good channel separation, the OBH-14 offers a fine measured performance. NK

Frequency response	4Hz-20.7kHz	
	left	right
Distortion (%)		
-6dB	0.01	0.01
-30dB	0.018	0.018
-60dB	0.4	0.37
-90dB	30	30

Separation (dB)	left	right
1kHz	89	97
20kHz	63	80
Noise		-105dB
with emphasis		-105dB
Dynamic range		110dB
Output		2.17V

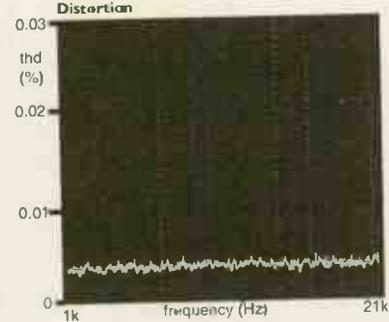
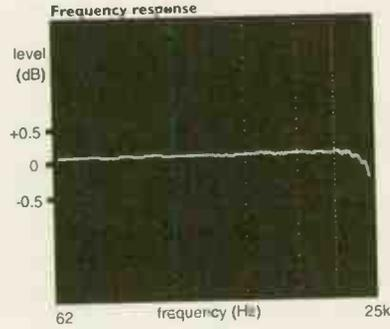

HARMAN/KARDON HD740

The HD740 has a slight rise in its treble above 5kHz, possibly enough to add a slight brightness to the upper midrange. It may well sound fast and detailed.

Distortion measurement through the dynamic range revealed a normal result. At -30dB there are harmonically-related products up to 13th, which is common for CD. At around 0.03% overall distortion levels on both channels were low right down the range.

Channel separation was wide and noise very low. Dynamic range was a healthy 106dB and output normal at 2.1V. The HD740 measured well in all areas, but it might be a little brighter in its sound than many players. NK

Frequency response	4Hz-21.5kHz	
	left	right
Distortion (%)		
-6dB	0.007	0.007
-30dB	0.027	0.035
-60dB	0.5	0.48
-90dB	26	27

Separation (dB)	left	right
1kHz	101	100
20kHz	78	77
Noise		-107dB
with emphasis		-107dB
Dynamic range		106dB
Output		2.1V

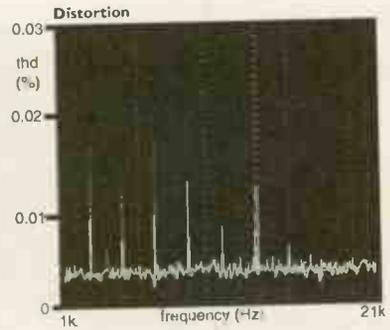
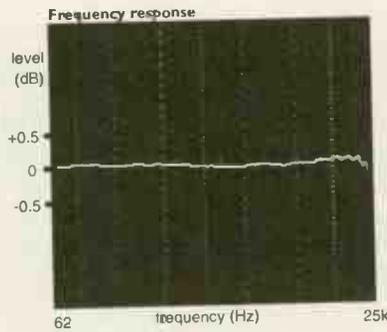

SONY PBD-V30

The Sony does not reach hi-fi standards for CD replay so much as offer good headphone listening. Our response analysis shows filter ripple affects performance above 1kHz, but as the trend is downward some warmth should result.

Distortion levels were higher than usual, with values of 0.12% at -30dB against 0.02% for a normal hi-fi player. Harmonics and quantisation products were extended. This sort of thing adds coarseness. All the same, the Sony still puts up a reasonable performance in absolute terms and will not sound obviously distorted in practice.

Low-level signals, below -60dB, were not well resolved: the player is ineffective here, but again it will only remove a little detail and subtlety from the sound and such properties aren't expected from

portables in any case. The noise level was higher than usual at -71dB, but low enough not to be an audible problem. This sort of performance is not great but it does look good against cassette. NK

Frequency response	4Hz-20.3kHz	
	left	right
Distortion (%)		
-6dB	0.02	0.02

-30dB	0.12	0.12
-60dB	3	4.7
-90dB	100	130
Separation (dB)	left	right
1kHz	70	70
20kHz	68	68
Noise		-71dB
with emphasis		-71dB
Output		0.6V

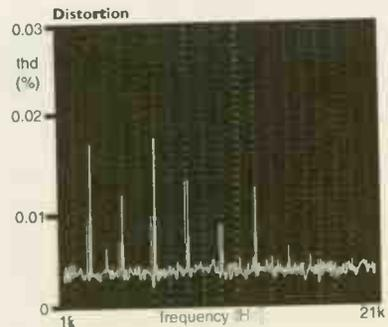
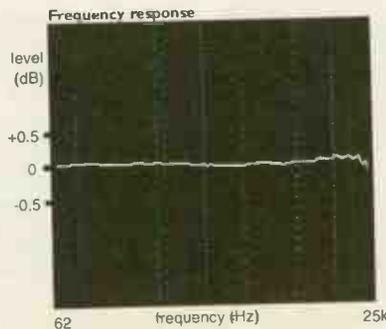

SONNETEER

A · U · D · I · O · P · H · I · L · E

Campion
Byron Dryden
Sedley
Alabaster

It's time for a change...

p.o.box 163c, esher, surrey, kt10 0yh, england.

tel: +44 (0) 1372 468676

fax: +44 (0) 1372 470053

www.sonneteer.co.uk

- amplifiers - CD player - phono stage - dac -

R.J.F.

84 PENDARVES ST,
TUCKINGMILL
CAMBORNE
CORNWALL
TR14 8NJ
TEL: 01209 710777

AUDIO VISUAL

NEW ITEMS

Denon AVD-2000, best buy for home cinema	£380.00
Denon DVD-3000, best buy for home cinema	£650.00
Denon - full range available	£POA
Neat Acoustics - full range available	£POA
Ortofon cartridges - full range available	£POA
Selec0 SVP 350, AWARD WINNING CRT PROJECTOR	£3,500.00
Sharp XV-C20E LCD projector	£1,350.00
SME 20/2 precision turntable	£POA
SME 20/2A as above with series V arm	£POA
SME series II model 3009 pick-up arm	£POA
SME series 300 model 309 pick-up arm	£POA
SME series IV pick-up arm	£POA
SME series V pick-up arm	£POA
TDL Loudspeakers - full range available	£POA

We are Dealers for a good number of audio brands including PA and studio equipment. Please contact us with your requirements.

DVD, LASER DISC AND PROJECTION SYSTEMS NOW AVAILABLE

Consult us for your high (or low) end repairs/mods, CD re-clocking, LASER DISC AC3 UPGRADES - PIONEER, SONY, PHILIPS, DENON. We are valve and transistor specialists. Specialist cables supplied and made to order.

DUE TO THE ADVENT OF TRICHORD CLOCK III WE NOW HAVE A NUMBER OF CLOCK II UNITS FOR DISPOSAL. WE CAN OFFER THESE FITTED TO YOUR CD PLAYER OR TRANSPORT AT £110.00 INCLUDING RETURN CARRIAGE.

ORIGIN LIVE TURNTABLE KITS Standard & Ultra

Now you can save money and build your own high performance deck. The standard kit version is offered at £145, and the ultra version at £279. Both decks come with a full set of drawings and guidance instructions. The kit allows for your creativity or there are optional parts that will enable you to assemble a tried and tested design within 1-4 hours. This is probably the easiest kit you will ever make.

"this Vinyl font end had my jaw heading towards the floor with the solidity and transparency of the music it was making"...
" the standard came up with crystal clear images set in a broad sound stage"... *"With all these goodies in place, the standard would give turntables at the £1200-£1400 mark a hard time."*
HI-FI WORLD SUPPLEMENT NOV 97

"is exceptionally easy to build and professional in both sound quality and appearance"
HI FI NEWS SUPPLEMENT NOV 97

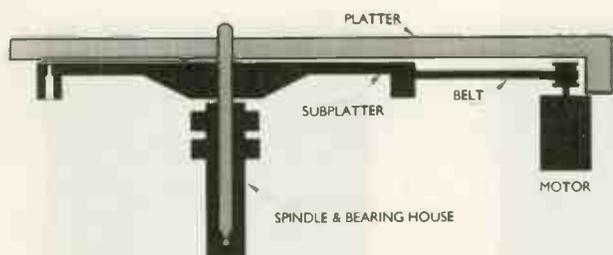

TURBOCHARGING YOUR REGA ARM

"Nothing less than total dynamite!"

HI-FI WORLD, FEB 1999

If you are the proud owner of any Rega arm, why not utterly transform it into the league of super arms with the Origin live structural modification:- £75 inc post & packing. This modification will enable your Rega to perform at a level exceeding that of arms costing over £1200. Internal rewiring with high grade litz cable is also offered at an additional £70.

"I have to say the Rega modifications turn this humble arm into a real Giant killer. Gone is the rather grey, sterile sound of the cooking Rega. Instead, tonal colour is fresh, dynamics have great speed and impact, and the sound stage is huge." HI FI WORLD SUPPLEMENT NOV 97 (structural modification only to a RB250) WHAT HI-FI Sept 98 gave this modification a 5 star rating.

For arm modifications we normally return your arm in 2-3 days

CROSS SECTION OF ARM END

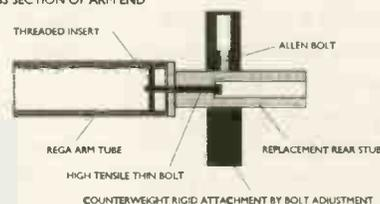

For further information contact:-

**Origin Live, 87 Chessel Crescent, Bitterne,
Southampton, SO19 4BT**

Tel: 01703 578877 / 442183 Fax: 01703 398905

Email: origin.live@virgin.net

web site: <http://www.originlive.com>

GOODMANS DELTA 901

A steadily falling frequency response, shown in our analysis, will give the Delta 901 CMD a warm sound. Distortion was double that normally encountered, but still not so high that it should be too intrusive. However, with no less than 1.35% at -60dB, against a common value of 0.5%, the 901 CMD obviously doesn't look too hot on paper and this result held dynamic range to 100dB. Top players manage 110dB. The player may well sound a little less smooth than lower distortion models, but differences will be small and the warm sound will help ameliorate the situation. Recording digitally to MiniDisc and replaying through the same D/A and analogue stages gave the same performance.

With good channel separation, normal

output and adequately low noise, the Delta 901 CMD measures well enough considering its price and facilities. **NK**

Frequency response	4Hz-20.5kHz	
	left	right
Distortion (%)		
-6dB	0.015	0.015
-30dB	0.04	0.04

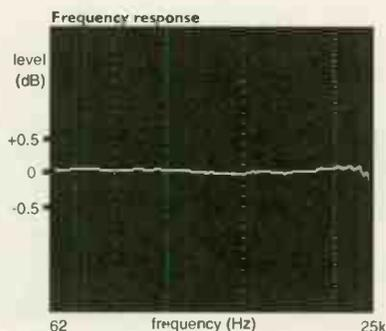

-60dB	1.3	1.35
-90dB	30	31
Separation (dB)	left	right
1kHz	83	87
20kHz	68	63
Noise		-91dB
with emphasis		-91dB
Dynamic range		100dB
Output		2.2V

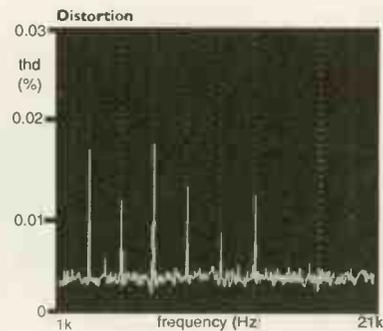

DIAMOND RIO

The test figures disguise the Rio's main problem, that of high-level signal compression on a full-level mono (L+R) signal ripped from CD. This induced low-rate amplitude modulation which introduced sidebands and compressed fundamentals. Our third-octave analysis of 16Hz, 1kHz and 16kHz L+R tones at 0dB clearly shows low-frequency hash and 10dB of signal compression at 16Hz. There was also 3dB of compression in the midband. It affected sound quality significantly, making it swimmy and ruining stereo. CDCOPY software overcame this problem, the drawback being significantly slower encoding speed.

Frequency response fell smoothly above 1kHz to become -4dB at 16kHz, above which it plummeted. Xing claim their encoder runs to 20kHz, so the upper response limit is software defined, rather than affected by the Rio itself.

Channel separation was high and noise very low. In spite of signal compres-

sion, there was little in the way of harmonic distortion from the Rio.

At full level the MusicMatch software supplied with the Rio had problems if asked to encode both channels, although it was fine encoding one channel to 0dB. From -3dB down though, it worked well, offering low distortion, good channel separation and very low noise. Frequency response could usefully be flatter; at present it gives a warm sound due to treble fall. **NK**

Frequency response	10Hz-3kHz	
	left	right
Distortion		
-1dB	0.1	0.1
-10dB	0.01	0.01
-30dB	0.014	0.016
-40dB	0.03	0.032

Separation	left	right
1kHz	89	88
10kHz	71	70

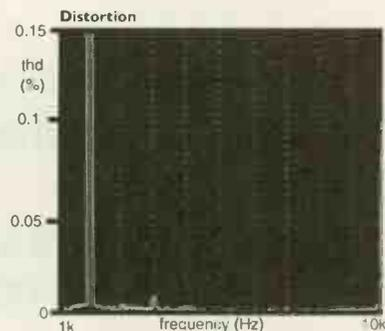
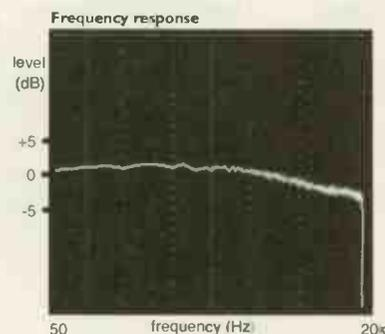

Noise	-95dB
Output	0.9V

KEL34 E/I

With sturdy output transformers KEL34 delivers 40watts per channel from one pair of EL34 valves. With this sort of power, considering around 5watts average is needed by reasonably sensitive loudspeakers, there is plenty of headroom for musical peaks. KEL34 can drive most modern loudspeakers without difficulty.

Frequency response is flat from 22Hz to 77kHz within 1dB limits. Distortion at 1kHz measured 0.08% at 1watt, rising to 0.8% at full output. Since most of this was second harmonic, it has little impact

upon sound quality. It's much the same at high frequencies, our distortion analysis showing second harmonic predominates.

Sensitivity is high enough for the amplifier to generate full output from most sources, measuring 280mV. Noise was low at -96dB and channel separation good at 62dB. **NK**

Power	40watts
CD/tuner/aux.	
Frequency response	22Hz-77kHz
Separation	62dB

Noise	-96dB
Distortion	0.08%
Sensitivity	280mV
DC off-set	none

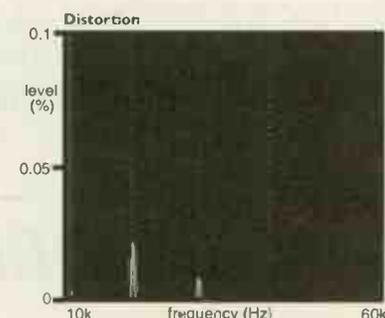

5 Rocks Lane Barnes
London SW13 0DB
Tel: 0181 876 3355
Fax: 0181 876 3399

THE
Hi-End



**Roksan Caspian Integrated
Amp + CD**

**£795 + £895 = £1690 or
£430 deposit and 9 x £140
(total payable £1690)**

**Sonic Frontiers
Anthem Integrated 2
£1799 or**

**£449 deposit and 9 x £150
(total payable £1799)**



AVI, ALCHEMIST, ANTHEM, BAYER, BOSE, BOULDER, CABLETALK, CASTLE, CHARIO,
CITATION, ELECTROCOMPANIET, EXPOSURE, FINAL, GAMMA ACOUSTICS, GENESIS,
HEYBROOK, JAMO, KEF, LINN, LUMLEY, MAGNUM DYNALAB, MARANTZ, MARSTON,
MCINTOSH, MERIDIAN, MICHELL, MICROMEGA, MONARCHY, MYRYAD,

MAIL ORDER HOTLINE 0181 878 0066

0%

- ▾ Interest Free Credit
- ▾ On Selected items
- ▾ Subject to status
- ▾ UK only



Hi-End

We specialise in:

- Audio visual interior design.
- Multi-room installations.
- 'Life-style' systems.
- Systems from £300 to over £30,000.

For your convenience:

- All Major Credit Cards Accepted.
- Finance Arranged.
- 2 Demonstration Rooms.
- Open 9.00 to 6.00 Mon to Sat.
- 10.00 to 5.00 Sundays

CLEARANCE BARGAINS EX DEMO

Hotline: 0181 878 0066

	<u>Was</u>	<u>NOW</u>
Thorens TD180	£199	£145
Micromega Microdac	£499	£199
Monarchy Audio D18B	£595	£399
Marston Silhouette	£899	£649
Linn Classic	£995	£849
Gamma Rhythm	£2500	£2300
Michell Gyrodec RB300/OC3/Gyropower	£1320	£1099
Michell ISO	£420	£299
Michell Argo	£730	£549
Meridian		huge savings

<u>STANDS</u>	<u>Was</u>	<u>NOW</u>
Alphason (5 shelf, black)	£470 £205	£250 £185

	<u>Was</u>	<u>NOW</u>
<u>SPEAKERS</u>		
Ruark Epilogues (cherry)	£280	£235
Lumley Monitor LM 2.5 (L. Oak)	£1750	£1500
Lumley Monitor LM 3.5 (Walnut)	£1050	£900
Totem mite 'T' (Mahogany)	£600	£550
Totem Rock (Mahogany)	£700	£650
AVI Bigatrons	£600	£560

PRECIOUS METALS, PRIMARE, PROJECT, ORTOFON, QED, QUAD, RESTEK, REVOX, ROKSAN, RUARK, SEQUENCE, SOUNDSTYLE, SONNETEER, SONICLINK, SENNHEISER, SONIC FRONTIERS, SME, STAX, TDL, TEAC, TOTEM, TRICHORD, TANNOY, TARGET, XANTEK.

WORLDWIDE MAIL ORDER + 44 181 878 0066

MUSICAL IMAGES

PRODUCT	LIST	NEW
AUDIOLAB 8000LX Int amp	NEW	£450 £300
AUDIOLAB 8000Q pre amp	NEW/EX DEMO	£1,250 £800
ANTHEM INTEGRATED AMP 1	EX/DEMO	£1,300 £800
ANTHEM CD 1	EX/DEMO	£1,700 £1,000
AVI S2000MC cd player	EX/DEMO	£1,400 £800
AVI S2000MP pre amp	EX/DEMO	£950 £600
ACOUSTIC PRECISION FRI green speakers	EX/DEMO	£800 £500
APOGEE-Centaurus Ribbon Monitor black spkrs	S/H	£1,000 £400
B&W-MATRIX 801 walnut speakers	EX/DEMO	£4,000 £2,800
B&W CDM1 speakers	S/H	£600 £300
CABASSE FARELLA 400 beech speakers	EX/DEMO	£1,000 £700
CHORD SPM 2000 6 channel power amp	S/H	£745 £350
DENON- PMA Q5 10I amp	EX/DEMO	£1,800 £1,100
DENON DF07 mini system	EX/DEMO	£650 £400
EXPOSURE- 17 pre-amp	S/H	£850 £250
KELLY KT2 speakers	S/H	£700 £500
LINN-KEILIDH walnut speakersE	X/DEMO	£850 £650
LUMLEY-VTP1000 pre amp	S/H	£1,000 £500
MARANTZ MM 500THX (pair) mono power amp	S/H	£500 £300
MERIDIAN-501V av pre amp	S/H	£875 £400
MICROMEGA PREMIUM 20 cd player	EX/DEMO	£850 £550
MICROMEGA TEMPO P pre amp	EX/DEMO	£1,250 £600
MICROMEGA AMP power amp	EX/DEMO	£1,250 £600
MISSION 754 - r/wood speakers	EX/DEMO	£1,500 £900
MONITOR AUDIO STUDIO20SE r/wood speakers	EX/DEMO	£2,400 £1,900
MONITOR AUDIO STUDIO 50 r/wood speakers	EX/DEMO	£3,300 £2,600
MUSICAL FIDELITY-3B pre amp	S/H	£380 £150
MUSICAL FIDELITY A1001 amp	EX/DEMO	£2,500 £2,000
NAIM NAC72 pre amp	S/H	£745 £350
NAIM NAP 140 power amp	S/H	£770 £400
PINK TRIANGLE-LTAURAL cd player	EX/DEMO	£2,100 £1,575
PINK TRIANGLE TARATELLA (no arm) T/Table	EX/DEMO	£680 £550
PROAC-STUDIO 150 cherry/walnut speakers	EX/DEMO	£1,400 £950
ROGERS- GS5 black speakers	EX/DEMO	£380 £190
ROGERS- GS6 black speakers	EX/DEMO	£430 £215
ROKSAN-S1.5 silver power amp	EX/DEMO	£1,495 £1,150
ROKSAN ROK1 black/r/wood speakers	NEW	£600 £250
SOUNDLAB-PRISTINE electrostatics speaker	S/H	£8,000 £2,000
TEAC MDH500 mini disc	EX/DEMO	£650 £450
TUBE TECHNOLOGY- PROPHET pre amp	EX/DEMO	£1,970 £850
TUBE TECHNOLOGY- GENESIS mono power amp	EX/DEMO	£4,700 £2,000
TUBE TECHNOLOGY- SEER phono pre amp	EX/DEMO	£1,000 £600
TUBE TECHNOLOGY-UNISIS power amp	EX/DEMO	£1,900 £1,000

PLEASE VISIT OUR SHOWROOMS OR
CALL OUR HOTLINE NUMBER FOR DETAILS.
HURRY, THESE ARE ONE-OFF ITEMS!!

SEE IT! HEAR IT! BUY IT!

**HOTLINE NUMBER:
0171 497 1346**

14-18 Monmouth Street, Covent Garden, London WC2H 9HB
E-Mail. sales@musical-images.co.uk

Beckenham Edgware Hounslow
0181 663 3777 0181 952 5535 0181 569 5802

NOT VALID WITH ANY OTHER OFFERS OR PROMOTIONS E&OE



MUSONIC STYLI

SPECIALIST MANUFACTURER &
SUPPLIER FOR MORE THAN 40 YEARS

REPLACEMENTS & ORIGINALS

MANY OBSOLETE/78 VERSIONS

PICK-UP CARTRIDGES

RECORD/TAPE/CD ACCESSORIES

WHY NOT TRY US AND HEAR THE
DIFFERENCE !!

See us at the NEC
National Vintage Communication Fair
9th May 1999

For prices tel/fax/e-mail to:-

MUSONIC (UK) LIMITED

Unit 13 Wenta Business Centre Colne Way

Watford Hertfordshire WD2 4ND

Tel: 01923 213344 Fax: 01923 213355

e-mail:musonic@compuserve.com

VISA Trade and Export enquiries welcome



IAN HARRISON HI-FI

TEL: 01283 702875

9am - 9pm

INCLUDING SUNDAYS

HI-FI AT DISCOUNT PRICES. FREE NATIONWIDE DELIVERY

TRADE IN YOUR OLD MOVING COIL CARTRIDGE & SAVE UP TO 45% OFF THE RRP.

CARTRIDGES & STYLI	TONEARMS	CASSETTE DECKS	COMPACT DISC
DENON SHURE AUDIO TECHNICA GOLDRING AUDIOQUEST TRANSFIGURATION LONDON (DECCA) ARCAM GRADO ROKSAN VAN DEN HUL ORTOFON AUDIO NOTE DNM CLEAR AUDIO	ROKSAN SME MOTH TURNABLES SME TECHNICS MICHELL CLEAR AUDIO HIFI FURNITURE APOLLO SOUND STYLE PROJEKT SOUND ORGANISATION CABLES SONIC LINK AUDIOQUEST AUDIO-TECHNICA VAN DEN HUL GOLDRING QED	PIONEER TEAC SONY DENON YAMAHA MARANTZ TASCAM BVA PIONEER TEAC TASCAM SONY FOSTEX MINI DISC SONY DENON CDR PIONEER REEL-REEL STUDER TASCAM	PIONEER TEAC SONY DENON YAMAHA MARANTZ PHILIPS CREEK TUNERS SONY DENON PIONEER YAMAHA MARANTZ PHILIPS AMPLIFIERS DENON MARANTZ PIONEER YAMAHA MARANTZ PHILIPS & OTHERS
HARBETH ATC SONY ROYD HEADPHONES SENNHEISER BEYER SONY AKG GRADO AUDIO-TECHNICA	LOUDSPEAKERS HARBETH ATC SONY ROYD		
TEST CASSETTES TEST CD'S TEST RECORD DEMO CD'S *PHONE OR WRITE FOR DETAILS	BLANK TAPES / DISCS TDK SONY MAXELL BASF AMPEX JVC SCOTCH FUJI	ACCESSORIES DISHWASHER MIXER OEN GOLDRING TUNER	MAXELL SONY PIONEER YAMAHA PHILIPS MOTELLI

*ALL GOODS ARE BRAND NEW & BOXED
WITH FULL U.K. GUARANTEES. NO
EX/DEM OR EX DISPLAY GOODS. NO
GREY IMPORTS.

PLEASE PHONE TO CONFIRM PRICE & AVAILABILITY PRIOR TO ORDERING. GOODS
ARE NOT SUPPLIED ON APPROVAL. SORRY, NO GENERAL CATALOGUES. PLEASE
PHONE OR WRITE FOR SPECIFIC REVIEWS, BROCHURES OR PRICES.

MAIL ORDER ONLY FROM: IAN HARRISON, 7 MILL HILL, REPTON,
DERBY, DE65 6GQ. TEL: 01283 702875. 9am - 9pm INCLUDING SUNDAYS.

SLATE AUDIO



Linking The Past, Present & Future



THE SPEAKERSTAND®

The best speaker supports in the world.

State of the art in performance and design, custom made to suit any loudspeaker. Solid slate, supremely rigid and totally neutral* (*One specific Slate was chosen after extensive testing on all other stones)

SPEAKER PLATFORMS ISOLATION PLATFORMS TURNTABLE PLATFORMS SHELVING SYSTEMS

"Immaculately finished, sublimely rigid, on a par with the best stands I've used." Ken Kessler, Hi-Fi News R/R. *"An astonishing degree of instrumental separation, stable and holographic, with great precision and remarkable poise. The ultimate in high fidelity supports."* David Praker, Hi-Fi Answers. *"Superbly finished, the sound quality was considered to be first rate."* Martin Colloms, Hi-Fi News R/R. *"The sound quality when using the Slate Audio stands proved to be a revelation, something special."* Paul Messenger, Hi-Fi Choice. *"The finish is excellent, the sound quality magnificent and breathtaking."* Tom Bryant, The Telegraph. *"The Slate stand is unusual and expensive, but if you are after an exceedingly neutral stand it's the leading contender. This stand offers an exceptionally neutral platform for speakers; highly transparent sound leads to musical performances with real insight."* SOUND QUALITY: ■■■■■■ Malcolm Steward Hi-Fi Choice.

SLATE AUDIO GARRARD 301 and 401

The best & most musical record players in the world.

Our researched Solid Marble Plinth System® brings the Garrards into the 21st century. All wooden Plinths produce unacceptably levels of coloration and feedback. No other Plinth system can claim to improve the performance of these superb players.

THE REVIEWERS

"The Slate deck defines what real instrument solidity should be, it's in a class of its own." Alan Sircom, Hi-Fi Choice. *"The build and performance of the Slate Audio 401 are the audio equivalent of the E type Jaguar."* Audiophile. *"I have never used a system like this one, it gets everything right. Peter Soper insists Garrards are best mounted on Marble or stone, and from my experience with this plinth I wouldn't disagree."* Noel Keywood, Hi-Fi World. *"The Garrards main problems are dealt with most effectively by three cures; correct set up, heavy plinth and appropriate mat. Peter Soper has mastered them all, the results are close to miraculous."* Ken Kessler, Hi-Fi News R/R. *"I have been using the fantastic Slate plinthed Garrard, the sound was nothing short of breathtaking. The basic Garrard without the Slate plinth is well engineered and pleasant sounding, but they only give exceptional results with the right kind of treatment."* Dominic Baker, Hi-Fi World.

OUR CLIENTS *"I have tested your 301, the sound quality as you know is excellent!"* G. Pyne. *"The results I get are really unbelievable and I have tried some of the best turntable around, (Linn LP12 Roksan Xerxes). Thanks again for a marvellous piece of art."* Mr Teilinger. *"I am delighted with my Slate Audio Garrard 301, it sounds fantastic. Well worth all the detailed work that went into the design."* R. Newham. *"When I first put up the Slate Audio 301 I must admit to having quite a shock, forever converted."* K. Van Green, Electric Eel Studios. *"I'm over the moon, the plinth looks and sounds superb, stunningly beautiful!! I would very highly recommend any of your customers to seriously consider this great combination."* J. Marsh.



Nothing sings like a diamond

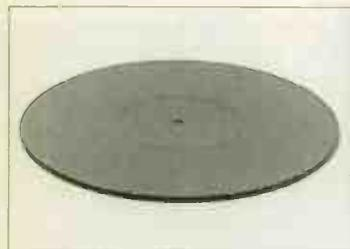

THE GLASSMAT®

The finest platter mat in the world.

The Glassmat® was developed to improve the performance of the Garrard 301 and 401 record players. However it also gives astonishing results when used on other turntables. So effective is its performance, we have now made it available as a universal replacement mat. In all cases other mats introduce colorations of their own, robbing the music of large amounts of detail and ambience. In order to achieve maximum information retrieval with optimum damping, a hard and unyielding material is required. Glass is ideal in every respect, damping is complete, the playing surface being quite simply sublime. In terms of detail resolution and sheer three dimensional ability, no other mat comes close. But then you still have to consider the absolute clarity, precision and solidity of the presentation. This is the ultimate platter mat.

THE POWERHOUSE OUR QUARTZ REFERENCED GARRARD 301/401 TD124 AND UNIVERSAL POWER SUPPLY. "KILLER" K.K.
THE TABLESTROBE QUARTZ REFERENCED STROBE GUN DESIGNED SPECIFICALLY FOR THE GARRARD 301 AND 401.
THE HANDSTROBE QUARTZ REFERENCED HAND HELD STROBE SUITABLE FOR ANY TURNTABLE WITH SPEED ADJUSTMENT.
STORMFORCE SOLID MARBLE ENCLOSURES® FOR ALL TANNOY DUAL CONCENTRICS. BEWARE... STRUCTURAL DAMAGE MAY OCCUR!
HUMDINGER ELEVATE YOUR EARLY SME 3009S2 TO 1997 STATUS. BREATHE NEW LIFE INTO A GREAT CLASSIC.
BACKLASH SUPERB SME 3009 & 3012 GOLD PHONO SOCKET CONVERSION. INCLUDING OFC LEADS; BRILLIANT? YES.
BRAZEN UPGRADE YOUR V15III WITH OUR ALLOY RE-BODY AND MICRO RIDGE STYLUS; INSANE? NO.
SOLID MARBLE PLINTH SYSTEMS® ALSO FOR EMT AND THORENS TD124.

SLATE AUDIO GARRARD 301 AND 401 ARE AVAILABLE COMPLETE OR MARBLE PLINTH SYSTEM® ONLY.
 SME CELEBRATION ARMS WITH SPECIAL GRAPHICS "SLATE AUDIO 301 OR 401 CELEBRATION" AND "SLATE AUDIO TD124 CELEBRATION" 309 • 312 • IV • V.
 THE TONEARM OUR SPECIAL VERSION OF THE FAMOUS REGA RB300. FITTED WITH GOLD PHONOS.
 SME 3009S2 (1997 VERSION) A PERFECT MATCH FOR OUR V15III BRAZEN AND THE NEW SHURE V15V x MR. "STILL CRAZY AFTER ALL THESE YEARS".
 THE SPIKEKIT SPECIALLY DEVELOPED TO FIT DIRECTLY TO FLOOR STANDING LOUDSPEAKERS OR ANY WOODEN SUPPORT ADJUSTABLE AND VERY SIMPLE TO FIT.

"COMPETITION IS HEALTHY, IT ENSURES WE STAY AHEAD"

SHURE STYLUS PRESSURE GAUGE • GARRARD 301 SWITCH SUPPRESSOR • TURNTABLE SERVICING • GARRARD 301 LEVER SET • GARRARD 301 FIXING BOLT SET
 STROBE DISC • GARRARD 401 CONTROL PANEL SET • GARRARD 301 MOTOR PULLEY • FULL RESTORATION OF GARRARDS TO ORIGINAL CONDITION

ALWAYS WANTED, GARRARD 401, GARRARD 301 AND THORENS TD124 RECORD PLAYERS, PLEASE PHONE

47 GEMINI CLOSE, LEIGHTON BUZZARD, BEDS, LU7 8UD.

TEL/FAX: 01525 384174 MOBILE: 0956 471601



DENYS TRICKETT'S HI-FI CURIOSITY SHOP

WE BUY & SELL VALVES!

*For all valve amp repairs;
overhauls, rebuilds.*

*The best workmanship at
the fairest prices*

Buy: Sell: Exchange:
Tannoys: Garrard 301/401
Thorens 124/224: Quad: Leak:
Radford: Williamson W.H.Y.

We ship abroad:-
Tel/Fax for a quote, No destination too far

0171 723 8545

Visit us at:
Unit 231
Webheath Community Workshop
London NW6



117 & 119 Regent Street
Rugby CV21 1JG

CODE KEY: - N = NEW X = EX DEM S = SECOND HAND

Make	Model	Description	Code	Stock	R.R.P.	Now
ARCAM	ALPHA	AMPLIFIER	X	1	£550.00	£375.00
BANG & OLUFSEN	AV - 5	TELEVISION - CD & RADIO	X	1	£4,650.00	£2650.00
BANG & OLUFSEN	BEOCENTRE 9300	CD/RADIO AND CASSETTE	X	1	£1,650.00	£1200.00
BANG & OLUFSEN	BEOLAB 2030	ACTIVE LOUDSPEAKER	X	1	£550.00	£350.00
BANG & OLUFSEN	BEOLAB 3500	HORIZONTAL ACTIVE LOUDSPEAKER	X	1	£900.00	£600.00
CASTLE	AVON	LOUDSPEAKERS - VARIOUS VENEERS	N	1	£730.00	£500.00
CASTLE	SEVERN	LOUDSPEAKERS - NATURAL OAK	X	1	£580.00	£480.00
CASTLE	HOWARD	LOUDSPEAKERS - ANTIQUE OAK	N	1	£1,400.00	£800.00
CASTLE	ISIS	LOUDSPEAKERS - MAHOGANY	N	1	£250.00	£210.00
CASTLE	TAY	LOUDSPEAKERS - WALNUT	N	1	£350.00	£300.00
CELESTION	100	LOUDSPEAKERS - MAHOGANY	N	1	£540.00	£300.00
CELESTION	SL 6 SI	LOUDSPEAKER - WALNUT	N	1	£450.00	£200.00
KEF	CODA 9	FLOORSTANDING LOUDSPEAKERS	X	2	£300.00	£200.00
LINX	OUJASAR	AMPLIFIER	S	1	£500.00	£200.00
MERIDIAN	500 & 566 DAC	CD TRANSPORT & 20-BIT DAC	S	1	£2425.00	£1400.00
MERIDIAN	565 7.1 AC-3	AC-3 DOLBY DIGITAL PROCESSOR	S	1	£2850.00	£1900.00
MERIDIAN	566	POWER AMP	X	1	£950.00	£760.00
MERIDIAN	557	POWER AMP	X	1	£1,580.00	£1,220.00
QUAD	77 AMP	AMPLIFIER - NEXTEL	N	3	£700.00	£390.00
QUAD	77 PREAMP	RE-AMPLIFIER + REMOTE CONTROL	N	2	£850.00	£575.00
QUAD	77 CD	CD PLAYER - MAINS + BUS POWERED	N	2	£900.00	£420.00
QUAD	ESL 57S	ELECTROSTATIC LOUDSPEAKERS	S	1		£390.00
QUAD	77 POWER AMP	POWERAMP - LIMITED STOCK	N	2	£600.00	£420.00
ROTEL	RB 956	SIX CHANNEL POWERAMP	S	1	£350.00	£225.00
SPENDOR	2040	FLOORSTANDING LOUDSPEAKERS	S	1	£900.00	£500.00
SYSTEMDEK	SYSTEM 165	FLOORSTANDING LOUDSPEAKERS	S	1	£300.00	£200.00
YAMAHA	AV 1	PROLOGIC SYSTEM	N	2	£650.00	£500.00
YAMAHA	DSPA 492	AV AMPLIFIER	N	3	£250.00	£140.00
YAMAHA	DSPA 592	AV AMPLIFIER	N	3	£330.00	£200.00
YAMAHA	DSPA 1	DOLBY DIGITAL/DTS AMPLIFIER	N	1	£1,600.00	£1,300.00
YAMAHA	DSPA 2	DOLBY DIGITAL/DTS AMPLIFIER	N	1	£1,000.00	£850.00
YAMAHA	DSPE 492	AV PROCESSOR	X	1	£250.00	£175.00
YAMAHA	DVDS 700	DVD PLAYER	X	2	£660.00	£475.00
YAMAHA	KX 580 SE	CASSETTE DECK	X	2	£250.00	£200.00
YAMAHA	RXV 582 RDS	AV RECEIVER	N	3	£400.00	£275.00

Wanted Items:-

Audiolab 8000 PX or SX
B & O Ouverture
Meridian 500 Series
QUAD 77 Series

Power-Amplifiers
& any B & O active loudspeakers
Any Meridian 500 Series
Any Quad 77 Series

RING

FOR
CASH
PRICES!

ALL HI-FI WANTED PLEASE RING FOR CASH PRICES

12 Regent Street, Rugby, Warwickshire, CV22 5LP
Tel: 01788 540772 Fax 01788 542170

Wide range of popular, classic, vintage, rare Electron Tubes from STOCK.

E.T.O.L.S

Electronic Tube On Line Shopping

Division of **HALFIN**
50 years of experience. We ship worldwide.



Web site

www.halfin.com/shop

37/39
Quai aux
Pierres de Taille
B-1000 Brussels
BELGIUM

Free membership gives access to the gateway of the world.

Phone: +32.2.218 10 11 Fax: +32.2.218 69 98
E.Mail: etols@halfin.com

Cassette

Verdict

Yamaha TC-800GL

Early classic in serious cassette. It's ski-slope looks got it a cult following once it had ceased to be simply ugly.

CD Players

Verdict

Meridian 207
Pioneer PD-91

Beautifully-built two-box with pre-amp stage. Very musical although not as refined as modern Bitstream gear. No digital output. Built-to-last player with easy upgrade routes for the modifier. Not knockout as it stands but get one cheap and have a go!

Amplifiers

Verdict

Leak Point One TL12 & TL10
Leak Pre-amps
Leak Stereo 20
Leak TL12+
NAD 3020
Quad 33
Quad II
Sugden A21
PA Technics SE-AS Mk2

Ancestors of Hi-Fi, consequently expensive nowadays. As with all vintage stuff, overhauling is de rigueur before use. Line of 'good for their time' pre-amps. Use of EF86 pentode for high gain rules out ultra performance. Not the highest-fi. Excellent workaday classic. In good order the 20 will not disgrace itself. Various upgrades are available from specialist repairers. Plentiful monobloc equivalent of Stereo 20. Reasonably inexpensive and a tweakers' dream. Genuine hi-fi on a budget. You can't argue with success! NAD's budget integrated gave thousands their first taste of hi-fi and remains great value. By no means a bad job and value for money. With its matching 303 pre-amp makes a good introduction to audio classics. One of the all-time classic mono amplifiers. Unusual circuit but it works beautifully. 22 pre-amp not up to today's standards. Seventies transistor integrated has an eminently likeable smoothness and musicality. Limited inputs via DIN sockets. Nice transformer and electronics, shame about the casework. With tweaking, this 150watter can sound sweet.



Leak TL12.

Loudspeakers

Verdict

Klipschorn
Leak Sandwich
Lowther PM6A
Magneplanar SMGa
Mission 770
Quad ESL57
Tannoy GRF & Autograph
Wharfedale Super 8 RS DD
Yamaha NS1000M
TannoyYork, Lancaster etc.

Not exactly plentiful or cheap but a splendid beast. For efficiency they have seldom been equalled. Space hungry! Rather warm sounding big infinite baffle but cheap with it. With reasonably powerful amp can sound quite satisfying. High quality full-range driver; still manufactured. High sensitivity, as fitted to many classic horn designs. Touch dry in the bass but a technological 'speaker with genuinely musical abilities. Usual warnings re: dipoles apply. Father of the 77 range which continues to this day. Well mannered with a warm sound and a kind load to amplifiers. Unrivalled. Properly serviced there is nothing like 'em. Their natural presentation may make them caviar to the general. Folded horn monsters which certainly sound good if you have the space. For Tannoy vintage see HFW November 1998. Ideal experimenters' driver. High sensitivity - 14,000 Gauss magnet and extended frequency range. Inexpensive too! HI-tech favourites of the Japanese and Americans. Viewed more warily in the UK but can give excellent results. Many similar models of infinite baffle or reflex design. Not the last word in tautness but the drivers work well in modern cabinet.

Vinyl

Verdict

Acos Lustre
Alphason HR100S
Ariston RD11
Garrard 301 & 401
Goldring Lenco 88 & 99
HadcocK 228
Linn Axis
Michell Focus One
Shure 75
SME 3009 IIS
Thorens TD124
Thorens TD150
Trio L-07D

Very honest piece of kit, well made and easily adjusted. Vinyl beginners could do very much worse. First class arm, up to present-day standards. Buy carefully, though, as there's no service available now. A one-time king of turntables very similar to the Linn LP12. Now deposited but worth a look at the right price. Legendary and fairly plentiful. Excellent back-up available; many different custom plinths available. High quality. Great deck for the kitchen table enthusiast. Garrard fans won't look at 'em but cheap and capable. Servicing available. Recently out-classed by HadcocK's updated 228 Special Edition but a proper hi-fi arm for all that. Makers still service. Uncomplicated, lower-price version of the famous Sondek. Considerably less expensive than some of its stablemates. 20 years and still going strong. Early runner in the 'modern' turntable cycle with a first class arm. Factory servicing available. Recent line-contact improvements have left the M75 behind but the wide range of needles make it a handy tool. Everlasting classic tone-arm. Spares permanently available from SME. No longer the last word but peanuts second-hand. Best classic deck ever? Judging by the prices they fetch it's possible - 78rpm too! Mid-price deck with a keen following. No real difficulty with servicing - novices may find the suspension system unnerving. Knockout heavyweight from 1980 with stainless bearing and 11lb platter! Not a give-away and beware! - spares scarce.



Thorens TD124.

Tuners

Verdict

Leak Troughline (original)
Leak Troughline II & III mono
Leak Troughline III Stereo
Marantz ST-8

Interesting ornament but no longer hi-fi. Bandwidth limited to 88MHz to 100MHz only. Arguably the best-sounding tuners ever. Adaptation for stereo easy via phono multiplex socket. Excellent tuner with indifferent stereo decoding circuit. Best when adapted to use modern outboard decoder. Possibly the ultimate Tardis console, including an oscilloscope for checking the strength of signal. Expensive even now.



HEATHERDALE AUDIO LTD.



202 FINDON ROAD, WORTHING, WEST SUSSEX, BN14 0JEJ
TEL: 01903-872288 OR (AFTER HOURS) 0860 660001 FAX: 01903-872234
e-mail: heatherdale@hifi-stereo.com http://www.hifi-stereo.com

HEATHERDALE PRE-OWNED GUARANTEED EQUIPMENT EXPORT FACILITIES AVAILABLE

PASSLABS X 600 Monoblock Amps II (8 month old) £17000 new	£11995
CONRAD JOHNSON Molif MP11 Phono stage	£850
GOLOMUNO REFERENCE T/Tab/e/T3F arm	£3995
MARK LEVINSON ML3 Power amp	£2450
AUDIO RESEARCH SP15 revision A (black) Pre-amp	£2495
GRAHAM Model 1 Tonearm (Spare wand)	£395
VAC Dac 22.1 (HDCC)	£245
AUDIO LAB 8900A Integrated amp	£95
ROTEL RT 850 AL Tuner	£250
KLH Research Speakers	£1995
ACCUPHASE DP70V Cd player (MINT/BOXED)	£3995
NAKAMICHI 1000 ZXL Gold Ltd edition MINT/BOXED/MANUALS	£395
TECHNICS SU-V85A Stereo Integrated amp	£10995
TRIEL 7.2 Speakers (Birds eye maple) EX DEM	£495
SOLSTICE AAD Speakers with Stands	£3500
ALTIM CDT III Cd Transport EX DEM	£2995
ACCUPHASE 80/81L CD Player	£3995
AERIAL Acoustic Speakers (Piano Black finish)	£395
AUDIO NOTE PS2E Power Amp Mint	£3995
AUDIO NOTE P4 Monoblocks MINT	£5495
AUDIO NOTE Nero amp MINT/BOXED (new £15400)	£2750
AUDIO NOTE 10 limited Cartridge & PSU	£34995
AUDIO NOTE Ongaku MINT	£3995
AUDIO NOTE ANE-S-E L Speakers (rosewood) F veneer	£2500
MONITOR AUDIO Studio 50 Speakers (Rosewood) Mint	

B & W DM2As (Teak)	£150
MIRAGE M Lsi Speakers (Piano black) Mint/boxed	£3995
EXPOSURE 25 Integrated with remote NEW	£950
EXPOSURE 21 Pre-amp with remote NEW	£890
EXPOSURE 18 Stereo Power amp NEW	£720
JVC 7050 Power Amp Power amp	£695
SYNERGISTIC research resolution ref MK2 blue balanced interconnect	£695
1.5 MTR (cost £1300 NEW)	£595
QUAD NEW 77 Integrated amplifier with remote (£850)	£595
QUAD NEW 77 Cd player (mains powered) (£699)	£595
TEAC A3340s 4 TRACK TAPE RECORDER	£1295
LUXMAN MQ3600 RT88 Stereo Power amp	£450
LUXMAN 5110 Tuner	£2895
MARTIN LOGAN CLS Iiz BOXED/MANUALS	£1995
PASS LABS Aleph P remote controlled pre-amp new £3895	£1995
ORCHID Speakers (pair) with stands 3 yrs old new £6000	£495
MIT 750 PLUS SPEAKER CABLES SMTR PAIR	£495
ROKSAN Xe zes Turntable/Arteniz arm	£895
ARAGON AURIUM pre-amp boxed/manuals	£1895
ARAGON PALLADIUM monoblocks boxed/manuals (£3000 new)	£2195
KINETIC SUBWOOFERS with X over boxed/manuals	£495
LUXMAN M2000 power amp MINT	£360
NEAT Mystere Speakers (White)	£5795
MARK LEVINSON 35 Dac EX DEM	£1495
MARK LEVINSON 28 Pre-amp	£12995
MARK LEVINSON 30.5/31.5 Cd transport & dac	£795
MILLER & KREISAL MK100 Subwoofer EX CON	£250
MISSION 782 Loudspeakers with stands	

QUAD ESL 63 Speakers	£1495
VOYO Standard turntable MINT	£1495
CELESTION Kingston Speakers with Stands	£1395
BURMESTER 877 pre-amp	£1495
VP119 MK3 (dark oak)/Air Tangent/Koetsu Black	£1800
FORSELL Cartridge MINT	£795
FINESTRA Pre-amp (with psu)	£695
MERIDIAN 203 DAC	£195
RUARK Taisman II Speakers (Mahogany) 4yrs old	£395
KEF 104 Loudspeakers	£450
REVOX PR99 MK2 Tape Deck (Trolley mounted)	£1495
VOYO T/Tab/e (upgraded psu & mtr) / Helius Orion	£1095
MIT M15 2 MTR Interconnect	£200
HELIUS Silver Wired Tonearm	£995
MARANTZ Cd 635E (boxed)	£175
TARA Labs 2 MTR RSC Master Interconnect cable Balanced	£495
AUDIO MECA Kreatura Cd Transport	£395
AUDIO INNOVATIONS L2 Pre Amp	£895
IMPULSE H5 Speakers	

WE NOW OFFER 0% FINANCE * PLEASE PHONE FOR DETAILS
(*Subject to status)

MAIN UK DEALERS FOR THEIR SPEAKERS
MARK LEVINSON, ABSOLUTE SOUNDS, & MUCH MORE
EX-DEM EXPOSURE EQUIPMENT AVAILABLE PHONE FOR LIST
FOR AN UP-TO-THE MINUTE LIST VISIT OUR WEB SITE:
<http://www.hifi-stereo.com>

ALL USED CARTRIDGES ARE CHECKED UNDER A MICROSCOPE BEFORE BEING OFFERED FOR SALE.

VISA - SWITCH - MASTER CARD - AMEX - DINERS CLUB WELCOME.
WE TAKE PART EXCHANGE ON NEW & USED STOCK AND BUY IN FOR CASH

**CLASSIQUE SOUNDS. (LEICESTER)
VINTAGE HI-FI & VALVE SPECIALIST**

Sugden A21A pure class A integrated £799 Sugden Audition CD player £649

**Now appointed agents for Sugden for the East Mids
FOR SALE. PRE/POWER AMPLIFIERS**

Quad 300 power amplifier. Good condition £195	Luxman L81 integrated amplifier. Absolutely mint. £125
Audiolab 800RM pre-amplifier. Mint. Boxed £695	Audiolab 800RM mono amplifiers. (pair) Mint. Boxed £895
T. Via. Line level valve pre-amplifier. Ex condition £350	Naim 42.5 pre-amplifier with MC board. Mint. Bsd £195
Sugden AUC1C pre-amp Mint. Boxed. Cost 1000 £550	Arcam Delta 60 amplifier. Mint. Boxed £150
Rocel 97093X pre-amplifier. Mint. Boxed £100	Sugden A21A power amplifier. Mint. £350
Auras S5503B pre-amplifier. Ex condition £70	Auras S5503B power amplifier. £80
Luxman MC33B power amplifier. Black. Ex condition £450	Sound Design SD2 pre-amplifier. Valve. Amazing. £495
Croft M60 S11 Valve pre-amplifier. Ex condition. £22	5Leak stereo 20 Refurbished. 12 months warranty £350
Quad 303 power amplifier. Good condition. £125	Croft integrated valve amplifier. Ex condition. £375
Pye HF 58 integrated valve amplifier. As new. Model £95	Audio Innovations L1 Valve pre-amp. Line level £195
Armstrong A10 mono valve power and pre-amp £195	Sugden CS1 pre-amplifier. Good condition £95
Audio innovations. Also integrated amplifier. Mint. £180	Beard BB100 integrated valve amp. Mint £400
Sugden A48 integrated amplifier. Good condition. £1180	Gamma Era Standard valve pre-amp with phono. £250
Creek 4040 MK1 amplifier. Excellent condition £75	Denon PMA350 amplifier. £75
Concordant modified Quad 22 pre-amplifier £75	T/Vac Model TA801 Int valve amp 50W. Cost £180 £695
Harman Kardon H1610 integrated amplifier £99	O.A.C. Mistral int amp 55W/C11. Cost £450 £199
Fisher X100A integrated valve amplifier. G/C £250	Rogers Colet 2 pre/power amplifier. Ex condition. £150
Fisher 400 valve tuner amplifier £195	Connoisseur/Sugden stereo pre/power amp. Very rare £195
Musical Fidelity E200 pre-amp with remote £299	Dynaco CA35 integrated valve amplifier. Ex condition £99
Quad 11s various conditions. From £350 pair £10A	Richard Allen class A integrated amplifier. £150
Quad 33 pre-amplifiers. Various from £75	Rogers cadet mono valve amplifiers. (Pair). Reduced £180
Leak Stereo 20 power amps. Various condition from £201	Leak TL 25 mono valve power amplifiers. From.. £150

TURNTABLES

Linn LP12 with Akito tone arm/Good condition £450	Linn LP12 with Linn Basik 4 tone arm. Good cond £350
Gramm 401 & 401 motor units. All Serviced. From £125	Thorns 124 motor units. Serviced. From £85 £210
Linn LP12/Black/Boxed. Near mint. £550	Thorns TD 150 chassis only. Good condition. £35
Rocel RP 960 turntable. Ex condition £75	Arison RD40 with Mission tone-arm. Ex condition £160
Thorns TD160 and Thorns arm. No lid. £65	Thorns TD160 and Thorns arm. Good condition. £95

SPEAKERS

Pair Dynastatic electrostatic hybrid speakers £100	Pair Linn Kan MK1 speakers in Teak. Mint. Boxed £195
Pair large corner units using Goodman drivers £110	Pair B&W DM3 loudspeakers. Good condition. £125
S225 12 speakers. Biwireable. Audionote wired Mint. £425	JR150 loudspeakers in excellent condition £200
Heybrook HB1 loudspeakers in good condition. BK £75	Rogers DB101 loudspeakers. Mint. Boxed. £75
Keil 105 loudspeakers. Boxed. Good condition £495	Pair Whiteley Electrical Stereovision corner speakers £175
Rogers Studio 5 speakers. Ex condition £350	Bose 901 speakers with equaliser. £250
DL RT12 speakers. Mint. Boxed £160	Ciate 301 speakers in black. Mint. Boxed. £150
Keil Coda 9 speakers. Ex condition. Boxed £125	Cyrus 781 speakers & stands. Mint £150
Pair Lowther Accusta speakers. Good condition £250	Keil 102Z speakers. Ex condition. Cost 750. Bvd £295
Gradient subwoofer for HL 563 BND. Cost £1700 £750	Richard Allen Monitor 80 speakers. Ex condition £175
Magnephaser SMC7B loudspeakers. Mint. Boxed £550	Quad Electrostatic speakers. From £400 pair £10A
Single Lowther accusta using PM6A Early style cab £150	Montauk Short MS600 with Decca Kelly Ribbons. £195

OTHER ITEMS

Linn K18 cartridge in excellent condition £95	Arcam Alpha 5 CD player. Mint. Boxed £250
Quad 104 stereo tuner. Mint. Boxed £250	Seibowr HD540 Ref gold headphones. Boxed £99
Pink Triangle DACapo Mint. Boxed £895	Pink Triangle Cardinal. Mint. Boxed £495
Linn Karma MC Cartridge. Ex order. Boxed £195	Pair original Quad H563 speaker stands. Black £75
Maranz CD3632. Mint. Boxed £100	Sine 3039 series 2 improved tone-arm. Mint. Boxed £100
Ortofon MC10 MC cartridge. Ex condition £49	Cambridge Audio Dacmagik 1 & silver matrix lead £95
Revox A77 2 track. 375K/7.5 psud condition £225	Revox A77 replacement wooden case. As new £50
Maranz CD675E cd player. Mint. Boxed £150	Quad FM3 tuner. Good condition. £195
VDR The First. Digital Interconnect. Cost £125 £65	Phillips CD960 Cd player. Cost 700. Make ex trans £199
Quad FM1 Mono tuner £20	Quad FM1. Mint. Boxed £40
Leak Truaffline 2 & 3 Mono/Stereo From £75	Maranz CD32 MK2. No remote £69
SME 3009 tone-arms. Various from £60	Sony CDP 561E. CD player £99
Audio Technica AT1005 tone-arm. Brand new. BND £35	QED Digit and Positiv power supply £75

QUAD ESL57 PANELS/SERVICING ETC

Rebuilt & soak tested treble panels. Fitted new dustcovers. Exchange £100
 Rebuilt and soak tested bass panels. Fitted new dustcovers. Exchange £120
 New high spec rectifier boards. Excellent quality and long lasting £ 40
 High spec rectifier block (rebuilt wax unit). Exchange. Price each £ 30
 Clamp boards. (price per pair). £ 45
 New dust covers bass or treble panels. Fitted £ 25
 Treble protection boards (before S/N 16800) price each £ 15
 Refurbish Grille with fabric overcover. Black or brown. Each £ 30
**Full servicing facilities available. 12 months warranty on all panels/parts
 WANTED. All Quad ESL speakers. Dead or alive regardless of condition.**

TRANSLUCENT *Something of a bargain. Hifi world, Jan 1999*

PURE SILVER INTERCONNECT CABLE

pure silver conductors. Quality gold plated RCA phono plugs.
 Half Metre terminated £60.00 one metre terminated £80.00
 Translucent Minor. pure silver conductors. Single screen. White finish.
 Half Metre terminated £40.00 One Metre terminated £55.00
 Translucent Digital. 1M £40.00 Half metre. £30.00

Please add £20.00 per additional Half metre. £15.00 Minor & £10.00 per half metre (digital)
 7 day money back guarantee if not better than existing cable. Regardless of price or quality. Ex. Minors.

99.99% pure silver wire 5mm (unsleeved). Only £4.95M

NEW EAR/YOSHINO EQUIPMENT

Pair 834P MM/MC phono stage with/without volume. Brand new. Boxed at only £499
Pair 834P MM phono stage. No volume control. Brand new. Boxed at only £350
Pair 834L. Line only valve pre-amplifier. Amazing. Brand new. Boxed at only £450

301/401/124 PLINTHS

Plinths @ only £199 unfinished or £299 finished (veneered). Awarded 4 Globes October 98 (HIFI WORLD)

WANTED VINTAGE & MODERN HI-FI EQPT.

Tel/Fax 0116 2835821 or 0802 213740 (Mobile). Callers by appt only.
 Opening times 10.00am-6.00pm Mon-Friday. 10.00am-2.00pm Saturday.
 Classique House, 61 Aylestone Drive, Aylestone, Leicester, LE2 8QE

cartridges

- denon
- dnm
- goldring
- lyra
- ortofon
- sumiko

cables

- audioquest
- cable talk
- chord company
- dnm
- heybrook
- ixos
- kontakt
- lfd
- nordost flatline
- ortofon
- qed
- sonic link
- trichord
- van den hul
- xlo

headphones

- beyer
- ergo
- grado
- jecklin
- sennheiser
- stax

stands

- alphason
- frameworks
- sound org'n
- something solid
- soundstyle
- stands unique
- target

accessories

- audioquest
- creek
- densen demagic
- discwasher
- earmax
- goldring
- ixos
- kontakt
- michell
- milty
- monarchy
- moth
- musical fidelity
- nordost
- pixall
- qed
- rms
- shure
- trichord
- zerostat

hardware

- atc
- audiomeca
- audio physic
- audio synthesis
- densen
- harbeth
- jm labs
- michell
- nva
- nordost
- qlh
- royd
- sequence
- sugden
- teac
- thorns
- totem
- trichord

audio,
cables and
accessories
available
by post
(post
haste)



phone, fax or

write for latest

price list / newsletter

**Second hand &
ex dem deals**

Arcam Alpha 7 CD player 18 months old, boxed, as new s/h (£325) **£185**
 Audiomeca Damnation "SE" CD transport. Fitted with tri-chord DOB board, AES/EBU, phono + BNC digital outputs, unmarked, dinky and novel. x/d (£1395) **£995**

Conrad - Johnson PV10 preamplifier with phono stage. Perfect. boxed, General Electric Mill Spec Valves. s/h (£1295) **£725**

Graaf 50-50 valve power amplifier. As new, (extremely pretty!) boxed s/h (£2300) **£1195**

Harbeth HL 58 tower loudspeakers. Normal price £2499 a few ex review samples in cherry veneer available @ **£1599**

Monarchy DAC Balanced digital input, volume control s/h very good condition (£800) **£399**

Maranz CD63 KI Signature CD Player. Boxed, perfect s/h (£399) **£225**

Pink Triangle Cardinal CD transport. S/H with R/Control **£395**

Quad 77-10L loudspeakers. Yew wood, boxed, excellent s/h (£399) **£340**

Quantum Minstrel hybrid amplifier S/H Boxed, (£999) **£349**

Sony CDP XE CD Player x/d (£140) **£70**



hi-fi for grown-ups



ipswich (01473) 622866
 signals martlesham heath
 ipswich suffolk IP5 3UA
 fax (01473) 631588
 email: enq@signals.uk.com
 www: signals.uk.com

Well Developed

David Price examines one of the best-kept secrets in turntable bargains, Strathclyde Transcription Developments' STD305S.

In hi-fi as in life, some good ideas just never catch on, and STD's 305 turntable is a case in point. Launched in 'the Linn era' back in the late Seventies, the space-age 305M was a capable design. A large and very heavy suspended-chassis belt-drive finished off in slinky brushed metal, it looked every bit the expensive piece of kit it was. The problem was that, such as the degree of Linn hysteria, no one really noticed.

This was a shame, because the STD was a damn fine deck. Thoroughly engineered, nicely finished and attractively styled, it was as good as all bar the best super-decks around at the time. Fitted with the SME Series III with which it was usually supplied (along with a moving magnet from the likes of AKG, Stanton or Shure) the 305M was an addictive music maker.

Although it was obvious that Strathclyde Transcription Developments knew how to assemble a decent disc-spinner, they proved less adept at the marketing side. Although the deck got a few good reviews, its £300 price put it far too close to the LP12, and as a result it struggled in the shops.

Next came STD's single-ended valve amplifier. Considering this was 1979, when glowing bottles were about as fashionable as The Brotherhood Of Man, you'd be justified in thinking them naive. The fact that it sounded great in a 'mouse that roared' single-ended sort of way simply wasn't enough when the only amps Britain's hi-fi press of the day were recommending were very large black boxes with Naim writ large on the front. Hell, it was a valve amplifier, which we all knew were rubbish because the mags said so!

STD's money-making scheme number three was considerably more intelligent. It was evidently best to abandon all



plans of competing with Linn and educating a transistor-loving world in the joys of thermionic amplification. Instead, why not produce a stripped-out version of the 305M without the chintz for about half the money? Basically, by putting their top deck's mechanicals into a plain plinth, they could offer near-identical sound at half the price. Bingo! Thus was born the STD305S. Selling for a trifling £149 in 1981 - not that much more than a Rega 3 - it well and truly put the feline amongst the feathery things.

A two-speed belt-drive with manual speed change mounted in a large (480mm by 365mm by 155mm) black plinth, it featured a four-point sprung sub-chassis with bituminous damping. The 2kg alloy platter had a thick rubber mat and sat on a large, precision-machined sub-platter with integral bearing spindle. This fitted into a bearing housing which wasn't a million miles from the original pre-Cirkus LP12 design. The motor was a beefy AC synchronous unit which made slightly more noise than it should have done,

although little of this seemed to be transmitted into the platter. In fact, all the critical parts of the drivetrain were made to a very high standard not out of keeping with a top deck of the day.

Even compared to current competition, the STD305S is an excellent way to play records. It certainly isn't going to scare the best modern decks but it's remarkably convincing in isolation.

Speed stability is very good - excellent in fact seeing as it doesn't have a fancy quartz-referenced mains supply - and rumble is impressively low. The sub-chassis gives it fine isolation too, and lets the quality of the main bearing shine through.

Most of the examples around today have SME cut-outs on their armboards, and most likely a 3009S2 already fitted. These make a nice enough noise - pretty fast, bouncy and musical if a touch rough around the edges - but the deck's easily good enough to house a modern SME 309. Better still would be to have a Rega armboard made and fit an Origin Live RB250 with a decent budget moving coil. Thus equipped, the STD's capable of whipping practically any CD player at any price, and gives the latest crop of sub-£1000 LP spinners a thing or two to worry about.

The great thing about this deck is its Seventies sound, which means tunes a go-go without fixating on stuff like pinpoint imaging and detail retrieval. It's also got a warm and fruity tone which makes all music sound so much more enjoyable. Best of all is the second-hand price - there are still quite a few around at between £50-£100. Given a new belt, a bearing oil-change and a suspension tweak, the STD305S should go on for another 20 years making sweet, analogue music. If only the same had been true of the company!

A MANTRA AUDIO

CARTRIDGE SELECTION	STYLUS	REPLACEMENT STYLI
Audio Technica		Swiss Copy Diamond Styli
AT 95 E	£22 £14	ADC XLM Mk III £14.00
AT 110 E	£27 £14	Akai AN 5, AN 60 £10.00
AT OC 9	£300 £226 EX	AN2, AN 70 £12.00
Denon		Dual ON 145 E, DN 165 E £14.00
DL 110	£75 £59 EX	Goldring G800 Super E £14.00
DL 304	£200 £170 EX	JVC OT 55, OT 60 £10.00
Goldring		National EPS 24 CS, P 30 D, P 33 D £10.00
1012 GX	£76 £50	Ortofon FF 15 E II, VMS 20 E II, OM 20 £14.00
1022 GX	£94 £62	Pioneer PN 210, PN 220, PN 240 £10.00
1042	£115 £76	Shure N 75 C, SC 35 C, N 75 ED T2, N 75 EJ T2 £12.00
Erolca (LX or H)	£102 £78 EX	N 95 ED, N 95 EJ, N 75 3 (78) £14.00
Elite	£200 £153 EX	VN 35 E £16.50
Excel VX	£446 £342 EX	N 95 HE, N 97 HE, VN 35 HE £22
Grado		Sony ND 142 G, ND 150 G, ND 155 G £10.00
Prestige Black	£44 £24	CN234 £12.00
Prestige Gold	£134 £74	*** OVER 500 STYLI TYPES STOCKED ***
Ortofon		ORTOFON DJ PACKS (CARTRIDGE + 2 STYLI)
510	£34 £22	Concorde Pro SSS Pack £52
MC 15 Super II	£120 £102 EX	Concorde Nightclub SSS Pack £74
MC 25 FL	£226 £190 EX	Concorde Nightclub EEE Pack £85
MC 10 Supreme	£283 £240 EX	Concorde DJ SSS Pack £57
MC 20 Supreme	£355 £300 EX	HEADPHONE SELECTION
MC 30 Supreme	£420 £358 EX	GRADO Prestige Series SR-40 £45
Rohmann	£779 £690 EX	SR-60 £75
Jubilee	POA POA EX	SR-80 £90
Shure		SR-125 £135
V 15 V XMR	£265 £178	SR-225 £180
SC 35 X	£32 £24	SR-325 £270
		Reference Series RS-1 £590
		RS-2 (new) £425
		RECORD/DISC CLEANER KIT REFILL
		Milty Permactan Record Cleaner £13.00 £9.00
		Permastat Anti-static Spray £13.00 £9.00
		DiscwasherCD Cleaner £15.00 £6.00

EX - Exchange price any MC cartridge
 Order direct from the full selection as shown on our Website
<http://www.mantra-audio.co.uk>

MAIL ORDER (1-10 DAYS) PRICES (INC P&P) ARE BEST WE CAN OFFER THROUGH COMPETITIVE SOURCING UK & MAINLAND EURO. * ALL ITEMS CARRY FULL MANUFACTURERS GUARANTEE - OVERSEAS CUSTOMERS PLEASE ADD £5.00 TO ORDERS OVER £50 IN VALUE TO COVER INSURANCE

Tel/Fax (01757) 288652 e-mail: enquiry@mantra-audio.co.uk
 MANTRA AUDIO (HFW), 22 GARTH AVENUE, NORTH DUFFIELD, SELBY, NORTH YORKS YO8 5RP



listening rooms

	RRP	SALE	
AMPS/PRE-AMPS/A.V.CONTROLLERS			
ARCAM ALPHA7	249.00	199.00	D
ARCAM ALPHA9 INC. PH/ST AS NEW		395.00	SH
ARCAM ALPHA9PAS NEW		250.00	SH
AUDIO RESEARCH LS 3 PRE AMP	1895.00	995.00	D
AUDIOLAB 8000LX	469.90	299.00	D+N
AUDIOLAB 8000A	499.90	379.90	D
AUDIOLAB 8000Q	1,249.90	799.00	D
KRELL KRC3	2,998.00	1,999.00	D
KRELL KSA 200S		3,499.00	S/H
LINN 5105 POWER	1,200.00	779.00	D/H
LINN 5103 AV Controller	4,850.00	2,999.00	D
MERIDIAN 555 POWER	695.00	449.00	D
MERIDIAN 501 PRE	695.00	489.00	D
MICHELL J.A. ALECTO stereo	1,150.00	849.00	D
MICROMEGA TEMPO2 int	899.90	599.00	D
QUAD 77 int	650.00	449.00	D+N
CD PLAYERS/TRANSPORTS/DACS			
AUDIOLAB 8000CDM	1,399.00	899.00	D
AUDIOLAB 8000CD	999.90	699.00	D
AUDIOLAB DAC	899.90	449.00	D
MARANTZ CD67	269.90	189.00	D
MARANTZ CD67 SE	349.90	269.00	D
MICROMEGA DAC 1	699.90	379.00	D
MICROMEGA STAGE 2	549.90	299.00	D
MICROMEGA STAGE 1	499.00	279.00	D
QUAD MODEL 77	595.00	359.00	D+N
TRICHORD RESEARCH PULSAR	1,400.00	599.00	S/H
TRICHORD GENESIS	549.00	349.00	D
TRICHORD REVELATION	799.00	479.00	D
SPEAKERS			
EPOS ES12	500.00	350.00	D
KEF CODA 7		59.00	D
KEF CODA 8	189.00	95.00	D
LINN KABER	2,000.00	995.00	D
MERIDIAN M1500 SUB	895.00	679.00	D
MISSION 753		349.00	D
D&H			
NEATE PETITE 3	800.00	519.99	Mint

D = EX DEMONSTRATION. N = NEW. S/H = SECOND HAND

THE LISTENING ROOMS LTD
 161 OLD BROMPTON ROAD LONDON SW5 0LJ
 TEL: 0171 - 244 7750/59 FAX: 0171 - 370 0192
 E-mail: tlr@dial.pipex.com
 Mon-Sat 10-6pm



Vacuum Tubes for Audio Are Back!

Glass Audio brings together yesterday's tube with today's improved components, voltage control, and the exciting new Soviet tubes, to make smooth sound in your livingroom possible again!

YES!

Please send my first issue of *Glass Audio*. I'll pay just \$45.00 for six issues (1 year); \$80.00 for 12 issues (2 years) of the best information on tubes to be found anywhere. I understand that my satisfaction is guaranteed!

Name _____
 Street & Number _____
 City _____ Postal Code _____
 Country _____

REMIT IN US \$ DRAWN ON A US BANK ONLY. PRICE GOOD THROUGH DECEMBER 31, 1995.

We Accept MC/VISA.

Glass Audio

PO Box 176, Dept. HFWS, Peterborough, NH 03458-0176 USA
 Phone: (603) 924-9464 or FAX 24 hours a day (603) 924-9467

HI-FI WORLD PRIVATE CLASSIFIED ADS

Dealers must not advertise in the Private Classified section. Monthly consecutive insertions will be considered Trade advertising. The Publisher reserves the right to judge submissions.

SPECIAL INTERNET OFFER SEE PAGE 154 FOR DETAILS

EARLY ACOUSTAS
(birch-ply) professionally renovated in matt walnut and fitted with Lowther's latest neodymium cored DX3s, (new & warrantied). Redesigned front panels. Style-2000 compliant. £1050. Tel: 01483 268 804 or Email: zno@zsizsi.demon.co.uk (Jun/I)

AUDIO RESEARCH SP9 MkII as new £900. Audio Research SP9. Black. As new £700. Audio Research Classic 60 £1350. Marston Silhouette DAC/PSU brand new £700 ono. Marston Silhouette CD player new £450. Electrcompanion EC4 - AV 100 DMB pre/power £1800 ono boxed as new. Quad ESL 63s Afro. Immaculate £1000. Tel: Jules 01792 280 061 (Jun/I)

ROTEL MICHI pre & Sugden DAC. Michi active pre amp RHA10 with remote (mint), absolutely stunning (boxed/manuals) £695, Sugden AU51 Reference DAC as new, superb (silver wired/crown DACs) £595 ono. Tel: 01492 580 201 (N. Wales) evs (Jun/I)

TEAC X-3 Reel to Reel tape deck. 7.5 ips, loads of good quality tape, little used, honest, vgc, sensible offers only. Or would exchange for 'Separate' DAT machine (Tascam or Sony DTC960 or like) WANTED: Arcam Delta 290 amplifier (integrated or power. Tel: 01275 858 156 (Nailsea) (Jun/I)

MERIDIAN 200, DPA PDM II (cost £3500). Musical Fidelity F22 preamp. Micro Seiki DDX1000 T/Table. Pioneer C73 & M73, all boxed & mint. Technics SLP1200 CD & remote. Teac X10 reel/reel & DBX unit. Kelly KT3. Celestion SL6i. Tel: 01992 718 265 (Jun/I)

CYRUS POWER amplifier £300, PSX-R power supply £220. Pioneer 400-X amplifier £150. Pioneer PDS-703 CD player £100. QED Profile 12 bi-wire cable, 2x6 ft., 3mm terminated £40. All boxed, mint, instructions. Tel: 01480 422 337 or 01480 412 464 (Jun/I)

KRELL FPB 200 power amp £3800. Krell KRC-3 preamp £1800. Both only one year old. Mint condition with boxes and manuals. Tel: 0161 941 4573. Email: mvh@netcom.ca (Manchester) (Jun/I)

MICROMEGA, T-DRIVE, T-DAC. £2000 new, fabulous sound, full demonstration, must be heard, excellent condition, instructions, remote, original boxes. First offer £695 secures (bargain) Tel: 0131 538 9073 (Jun/I)

MERIDIAN DIGITAL Theatre 565 (£2250) £1750. DSP5000C (£1650) £1250. CD200 transport £350. M2 active speakers £300. Soundstyle black X120 stand (£250) for Meridian, Linn etc £150. Tel: 0181 442 1547 (Jun/I)

APOGEE STAGE Speakers, mahogany sides £800. Tel: 01604 645 590 (Jun/I)

QUAD ESL 63 loudspeakers with Quadrapod spiked stands £1000. Tel: 0181 758 9210 (Twickenham) (Jun/I)

CRIMSON 510 pre-amp and dedicated power supply and 2 x Crimson monoblock power amps and associated cables. Recently serviced. £175 the lot. Tel: 01253 824 005 (Jun)

WANTED: QUAD ESL57, must be mint, also Trough for Townshend Rock Reference turntable. For sale: Leak Sandwich speakers (large) £25. Wharfedale panel speaker £30. Leak stereo valve tuner £50. Strange 1950s Ortophon arm and cartridge £40. Tel: Alan 01661 852 874 (Jun/I)

MARANTZ CD17-KI £850, Exposure 21 preamp £690, Exposure 18 super monoblocks £1350, Studio 2 SE 'piano lacquer' £450, REL Stentor II subwoofer 'Rosenut' £1390, Meridian 541 Analogue surround sound processor £450, all have boxes, manuals, guarantees. Tel: 0973 899 651 or 01622 844 556 (Aug/I)

MERIDIAN 206 ΔΣ 1993 £275, NAD 533 & RB250 + Rega cart. £125, Linn Axis, Akito, K18 £245, Linn Mimik Anniversary model £440, Linn Majik phono £365, Linn Keilidhs no stands, black £385. All P&P. Tel: 01369 702 358 or 07801 587407 (Jun/I)

NAIM EQUIPMENT for sale. 82 pre amp £1200. 250 power amps £700 each. High Caps £375 each. Naxo 3x6, 2x4 £375. SBL speakers in walnut £700. Tel: Brian 01904 490 796 (Jun/I)

SPECIAL 7 Tier isolation platform in walnut and black marble. Built specially for Naim active system, will fit other equipment £700. Tel: Brian 01904 490 796 (Jun/I)

MARK LEVINSON ML-3 power amplifier(s) x 2 available. Late model (& damping circuits) consecutive serial numbers, 'matched pair' for bi-amping. Enormous power reserves. True TAS super amps. Either £2500 each or £4000 the pair. Tel: Dave Burton 01895 274 001 (daytime & evenings) (Jul/I)

AERIAL 10T speakers plus stands, plus Audio-Point 'footers', plus hoods, plus piano-lacquer black finish. Stereophile 'product of the year'. 'Fi' 4-star rated. £3000 ono (over £7000 new). Tel: Dave Burton 01895 274 001 (daytime or evening) (Jul/I)

STRATOSPHERE Turntable upgrade. Standalone Reference power supply, plus independent motor unit. Make 'the best' better. £560. Tel: Dave Burton 01895 274 001 (daytime or evening) (Jul/I)

AUDIO ANALOGUE Puccini SE integrated amplifier. As new, boxed, £350. Excellent sound. A 'Hi-Fi World' favourite. Tel: Dave 01992 628 848 (Jun/I)

RETRO REPRODUCTION

Exclusive Scottish distributor for
E.A.R./Yoshino Equipment and Nottingham Analogue Turntables
V20 & MC3 and spacedeck now in stock.



The Outstanding V20 Integrated Amp

V20
Introducing Tim De Paravicini's latest masterpiece, the outstanding V20. Using no less than 20 ECC83 triodes operating in Class A with no overall feedback, the result is the most natural and uncoloured sound available today.
HI-FI NEWS: Ken Kessler 'What I think we're witnessing here is Tim De Paravicini's finest moment and that's scary, when you consider that even his disasters are better than most designer's triumphs!'
WHAT HI-FI: Verdict *****
Leading French magazine Diapason voted the V20 Amplifier of the year.
To hear what all the fuss is about phone now for a personal home demonstration

SPECIAL OFFER
E.A.R. Clear Kit comprising of MM stage 5 passive line stages housed in the E.A.R. 834 case work.
Simply stunning. £299.00

- Rodgers SL6 speakers £125.00
- Thorens TD150 turntable with thorens tone arm £85.00
- Michel QC P.S.U. unit as new boxed £295.00
- Mission DAD5 DAC boxed £75.00
- Meridian 506CD player 18bit £595.00
- Audiolab 8000A 7 months old as new £350.00
- Marantz SM10 class A monoblocks £595.00
- Meridian 605 monoblocks 200 watt £995.00
- Quad 34 with FM4 & 405 housed in Quad rack £495.00
- Tube Technology Genesis 100 watt monoblocks with 2 box pre as new £2750.00
- Fisher x 100 Integrated valve amp £195.00
- Rodgers Cadet III valve amp mint £145.00
- Marantz 5 x 72 Vinyl noise suppressor £175.00
- Quad II with Pre, AM.F, & multiplex decoder all original boxed £495.00



Small but perfectly formed MC3

MC3
Producing the very best from vinyl has long been a black art and it's no wonder with so many permutations involved. Most people agree that Moving Coil cartridge design is technically superior than the Moving magnet but demands much more from it's ancillaries, especially the phono stage.

E.A.R./Yoshino have just launched the MC3 Cartridge Transformer with a band width of 31hz-100khz, facilities for a wide range of quality cartridge outputs and twin isolated earth terminals for maximum noise reduction.

The MC3 captures all the subtleties from the most complex recording without resorting to thrusting or spitting it out. Its extreme clarity and grainless presentation makes for a superb vinyl experience.
ART DUDLEY: Leading American hi-fidelity critic.

'I'm impressed with the MC3, and from a musical point of view, I think it's worth every penny of the price. Those of you who have tube-based systems & can afford it should pester your local dealer until he lets you take one home and try out Value/Quality *****'

- Leak stereo 20 with Pre very good condition £225.00
- RB 300 tone arm £89.00
- Rodgers LS 35A BBC Monitors 15 ohm Walnut Boxed £350.00
- DNM Floor Stand For Turntables /Pre Amps / Denon DP 60 D/Drive Turntable Built Like A Tank £75.00
- Pioneer PL 12 D/Drive Turntable £295.00
- Garrard 401 Turntable £75.00
- Audio Innovations S200 Valve Pre with MC £95.00
- B & O Beolab 5000 Amp £229.00
- Revox A78 Amp MK II £95.00
- Meridian 500 Transport £625.00
- Musical Fidelity F22 valve pre amp, remote, class A balanced outputs, phono board. cost £1100.00 £495.00
- Sumiko Tone Arm £125.00
- Quad II pair various £300.00
- Leak TL12+ pair £300.00
- EAR 834P £235.00
- Meridian 206 Delta Sigma CD £295.00
- Michel Argo pre with Hera £295.00
- Audio Innovations L1 Pre £195.00
- Revox B77 Open Reel mint £495.00
- Stax head phones and engersigs various models (phone)

Used Equipment For Sale

- Audio Research Classic 30 power amp mint £995.00
- Audio Research D250 power amp 20x 6550 Awesome £1995.00
- E.A.R. V20 integrated amp 4 months old still under guarantee BARGAIN £1995.00
- JR 149 Spkrs original GRILL mint condition £175.00
- Rega Planar 3 with RB250 arm 4 yrs old £175.00
- OLN Signature Spkrs new £1500 £995.00
- Musical Fidelity XLP value phono stage ££95.00
- Concordant Excelsior valve pre with valve P.S.U. rosewood case superb sound £495.00
- Sondex integrated amp £75.00
- SME 309 tone arm £495.00
- Musical Fidelity Doctor Thomas power amp £195.00
- Tannoy III LZ 10" Monitor golds £350.00
- Meridian 100 series tuner, power amp & PSU £350.00

- Leak stereo 20 with Pre very good condition £225.00
- RB 300 tone arm £89.00
- Rodgers LS 35A BBC Monitors 15 ohm Walnut Boxed £350.00
- DNM Floor Stand For Turntables /Pre Amps / Denon DP 60 D/Drive Turntable Built Like A Tank £75.00
- Pioneer PL 12 D/Drive Turntable £295.00
- Garrard 401 Turntable £75.00
- Audio Innovations S200 Valve Pre with MC £95.00
- B & O Beolab 5000 Amp £229.00
- Revox A78 Amp MK II £95.00
- Meridian 500 Transport £625.00
- Musical Fidelity F22 valve pre amp, remote, class A balanced outputs, phono board. cost £1100.00 £495.00
- Sumiko Tone Arm £125.00

Due in:
Meridian 601, 602, 604, Proac Response 100, PX 25, KT 61, KT88 (valves new boxed), Quad boxed ESL57 mint, Thorens 124, Garrard 301, Revox G36, Radford STA15, SME 12" Tonearms (various models)

NOW DEMONSTRATING
CARY CAD S72 SE 20 WATT CLASS A MONOBLOCKS
SUPERB BUILD QUALITY AT A VERY COMPETITIVE PRICE

NEW SHOWROOM NOW OPEN
Phone/Fax 0131 553 4126 or 07801/288686

VALVE FRIENDLY SPEAKERS
NOW IN STOCK FROM B.C. ACOUSTIQUE & TRIANGLE 90
DB SENSITIVITY AND ABOVE. PRICES START AT £199.00

SUSSEX SURPLUS

13 Station Road Horsham, W. Sussex RH13 5EZ
Telephone: 01403 240257 Fax: 01403 270339

VALVES		T.C.C. AXIAL OIL-FILLED PAPER CAPACITORS BRASS CASED					
KT66	GEC	£65	.1 µF	1000V		£10	
KT61	GEC	£25	25 µF	350V		£5	
EZ80	Mullard	£8	5 µF	500V		£6	
EZ81	Mullard	£10	5 µF	350V		£5	
ECC33	Mullard	£25		500V		£8	
ECC35	Mullard	£25	OIL-FILLED CHOKES				
ECC81	Mullard	£6	45H	5mA	£10	15H	
ECC82	Mullard	£10	2H	300mA	£15	5H	
ECC83	Mullard	£12	16H	30mA	£10	5H	
EF86	Mullard	£12	6H	250mA	£20	10H	
EL84	Mullard	£12	10H	250mA	£30	120mA	
E88CC	Mullard	£15	OIL-FILLED TRANSFORMERS				£20
M8137	Mullard	£15	PARMEKO		PARMEKO		
EF37A	Mullard	£10	Primary 200-250V SCR		Primary 115-230V SCR		
EL84	RCA	£12	Secondary		Secondary		
A2900	GEC	£20	COM 4V 4V 3A		400-350-0-350-400 150MA £40ea		
EL37	Mullard	£20	COM 4V 6.3V 3A		Secondary 105-240V SCR		
ML6	Marconi	£25	COM 4V 6.3V 4A		Primary 1185-0-1185V		
KT88	GEC	£125	COM 4V 6.3V 4A		Secondary 200MA £50ea		
6SL7	STC	£8	350-300-0-300-350V		250MA £70ea		
6SN7	STC	£15	OIL-FILLED BLOCK PAPER CAPACITORS				
6SN7	USA	£5	8 µF	600V	£10	2 µF	
EF86	Brimar	£6	8 µF	1000V	£15	2 µF	
8D8	Brimar	£15	12 µF	350V	£8	1 µF	
6SN7	Brimar	£6	4 µF	600V	£6	.5 µF	
5Y3GT	Haltron	£5	4 µF	800V	£8	1000V	
5R4GY	USA	£8	4 µF	1500V	£15	1000V	
5R4GY	STC	£15				£10	
3A/110A	STC	£20	VALVE SOCKETS				PLUGS AND SOCKETS
3A/110B	STC	£20	Mc Murdo Octal	£1 each	Quad 2 pin mains	£4 each	
6072A	USA	£5	Mc Murdo B7g	£1 each	Quad 6 pin output	£4 each	
5751	USA	£5	Cinch Skirted B9A	£1 each	Bulgoin Octal plug	£3 each	
6B4G	USA	£35	P.T.F.E. Skirted B9A	£1 each	Bulgoin Free Octal SKT	£3 each	
5U4G	USA	£12	P.T.F.E. Skirted B7G	£1 each	Bulgoin Free 3 pin mains	£3 each	
			USA Ceramic Octal	£1 each	Bulgoin FXD 3 pin plug	£3 each	
			Mc Murdo Ceramic Octal	£3 each	Bulgoin Free 2 pin Spkr plug used for leak spkr output	£3 each	
			Marconi Ceramic Octal	£3 each			
			Marconi Ceramic B4	£3 each			
			Chinese 807 Ceramic	£3 each			
			Chinese Twist Loc Ux4	£3 each			
			Chinese Twist Loc 211	£3 each			
			R.C.A. Twist Loc 211	£3 each			
			R.C.A. Twist Loc Ux4	£8 each			
			Marconi Bacolite DA100	£30 each			

Silver plated P.T.F.E. wire various sizes and colours several different voltage ratings all 50p per mtr (ring for details)

P & P £5 per order, overseas carriage at cost.

CLASSIFIED ADS

6 PAGES OF BARGAIN HI-FI

SPECIAL
INTERNET
OFFER SEE
PAGE 154 FOR
DETAILS

MERIDIAN 541 AV processor £400. Meridian M60C Active Centre £600. Mission 754F Black £700. All less than 12 months. Boxed. Mint. Also Micromega Trio CD, Trio AL2 P/Supply, Duo BS2 DAC. £1450. Rotel RB991 (THX) power amp 6 months £400. Tel: Nik 0498 712 975 or 01509 551 736 (Jun/I)

CLASSIC CELESTION Ditton 44 loudspeakers three in-line drivers per enclosure. Spiked low stands included. Teak finish. In original boxes and packing. Superb, gift at £75. Tel: 01952 541 223 (Shropshire) (Jun/I)

TRUVOX PD86 quarter track stereo 7.5 & 1.875 three head valve recorder. Complete with original packing, manual, plinth, manual and circuit diagram. £50. Tel: 01737 843 064 (Surrey) (Jun/I)

AUDIO RESEARCH SPD1 audiophile surround processor, from two-channel sources. Like new, boxed, £700. Snell type J bookshelf speakers, walnut £250. Aiwa AF-810 cassette deck, mint. £90. Tel: 0181 878 5046 (Jun/I)

BRIGHT STAR audio rack of Gibraltar. Four tier, black, ultra-heavy duty, welded, sand fillable, mint. Plus four Big Rock sand boxes and Little Rock isolation pods £1400. Tel: 0181 878 5046 (Jun/I)

WANTED: PIONEER reel to reel mod. RT707 or similar. Also a 1970s-early 80s silver coloured separates system (Pioneer) with reel to reel and blue LED. Tel: 0181 864 9185 or 0973 425 109 (Jun/I)

FOR SALE Speakers - Spendor SP2/2 with stands black ash, vgc, reluctant sale £295. Tel: 01634 268 071 (Medway) (Jun/I)

B&W Nautilus 805 speakers in light cherry with matching HNE granite stands, purchased 8/1/99, immaculate condition with warranty and receipt. Cost £1900 sell £1400 no offers. Can demonstrate. Tel: 01279 420 603 (Jun/I)

AUDIOLAB 8000CD, mint condition, boxed with all original packaging £600. Audio Innovations Series 300 integrated valve amplifier, recently serviced with new valves fitted £250. Tel: 01708 347 466 (Jun/I)

MCINTOSH COMMEMORATIVE Edition C22 pre amp £1300. MC275 power amp £2500. Thorens TDA 2000 D/A converter £350. Sound Anchor B&W 802III speaker stands £350. Tel: 0117 956 5361 (Jun/I)

FOR SALE Quad 33 control unit excellent condition £65. Nikon zoom lens 70-210mm F/4 Series E £150 ono (mint). QED variable cartridge equaliser £10. SME CA1 carry arm for 3 arm £10. Tel: Mike 01758 613 790 (Jun/I)

NAIM 92/90.3 pre/power with moving coil phono board. 2 years old, excellent condition, boxed £550. Tel: 0113 287 6925 (Jun/I)

FOR SALE: Acoustat Model II full range electrostatic speakers cost over £2000+ asking £600. Teac two track A-4300SX reel to reel in mint condition £300. Wanted, Altec Langsing drive unit No.604/G or 604/H duplex. Tel: 01342 850 652 (Jun/I)

ART AUDIO Tempo monoblocks 30w Class A triode £995 ono (£2600 new). 8 VTL KT 90 tubes unused £25 each. Cartridge Man's Grado £140 (£550 new). Tel: Christos 0181 993 2006 (Jun/I)

QUAD ESL 63 oak/black with stands £1250, Naim pre-fix £175, Naim Hi-Cap £400, Linn LK140 £450, Link active boards (x3) for Keilidh £100, Linn Kairn pro £800, all excellent condition and latest spec. Tel: 01225 420 494 (Bath) (Jun/I)

GARRARD 401, SME 3009 Series II, silicon fluid damper, Goldring 1042 cartridge (30 hours use), piano black plinth, smoked glass hood, Lorricraft serviced, quality interconnects. £325 ono. Tel: 01235 535 695 (Jun/I)

CELESTION SL600 speakers, brown, very good condition £250. Target stands, black 18" £25. Tel: 01256 324 901 (Basingstoke) (Jun)

QUAD ESL 63's £950, CD67, £450. 33 pre & 303 amps conv. Academy Sound £300, Garrard 401 & Decca MkIII arm & two heads, £250. Two Leak Troughline tuners & one decoder (Tim de Paravacini) £400. Tel: 01247 667 347 (Jun/I)

TANNOY CHATSWORTH speakers, rectangular style, in excellent condition £390. Tannoy Devon speakers, excellent sound, a little tatty, hence £150. Heybrook HBS1 speaker stands £25. Tel: 01276 650 54 (Jun/I)

NAIM NAC 52 & PS. Mint condition, can demonstrate £2500. Tel: Colin 01293 416 022 (Crawley) (Jun/I)

SUMIKO BLUE Point special cartridge, Brand new, never used (£250 new) £175 ono. Audio Technica AT630 moving coil transformer £25. Tel: 01633 881 722 (Gwent) Email: andrews@magor3.freereserve.co.uk (Jun/I)

QUAD ELECTROSTATIC loudspeakers £300. Quad valve set original near mint condition. Systemdek IIX 900, Rega, £200. Audio Innovations First Audio Triode £500. Leak TL12.1 original components £450. Leak TL12+ £100. Tel: 01935 891 342 (Jun/I)

NAIM 250 power amp £800, Naim IBL loudspeakers, black £350, Lexicon CP2 digital surround processor £400, Rotel RB956AX 6 channel amp £200, Celestion MPI loudspeakers £75. All mint condition. Tel: 0116 271 5439 or 0116 289 9728 (Jun/I)

B&W DM7 Mk1 speakers £300. Exposure XX integrated amp £430. Marantz CD 80 with remote £325. Musical Fidelity MVT Mk3 preamp, excellent phono stage £325. Tel: 01273 605 310 (Jun/I)

LOWTHER TPI original PM3A mint £1600. Lowther Audiovector original PM4As + PM6As mint £1950, Vitavox 12" dualconcentric loudspeaker £280, Burmeister 785 preamp £290, Unison Research Smart 845 monoblocks mint £2100. Tel: 0802 431 172 (after 6pm) (Jun/I)

QUAD 405 power amplifier £160, Quad 306 power amplifier, Quad 34 control unit, £280 the pair, will split. Tel: 01302 859 095 (Jun/I)

Oxford Audio Consultants HI-FI SPECIALISTS

WE'VE MOVED RIGHT NEXT DOOR TO
MUCH BIGGER PREMISES WITH SUPERB
PURPOSE BUILT DEM ROOMS



NOW DEMONSTRATING

SONUS FABER AMATI HOMAGE - a sensational world-beating product from our favourite Italian company - a full scale floor standing GUARNERI that we've prayed for for ages - we've actually got them now and wow!!!

KRELL KPS25 CD PLAYER - THE NEW REFERENCE - we become more and more impressed as each day goes past; it is just outrageously good!

B&W NAUTILUS 800 SERIES - WE ARE VERY PROUD TO BE A PREMIER RETAILER OF THIS MOULD-BREAKING RANGE FROM £1400 TO £8500

NAIM AUDIO CDS MK 2 - a sensationally good CD PLAYER for the money - audition an absolute must!

KRELL 250 CD PLAYER & 150 POWER AMPLIFIER - JUST OUT & 'HOT'

VIDIKRON HELIOS PROJECTOR - PINAFARINNA LOOKS & PICTURE

WILSON AUDIO SYSTEM 5 - still our reference speaker; ours sound even better now!!

SONUS FABER SIGNUM - a replacement for the wonderful MINIMA AMATOR at £1249

MUSICAL FIDELITY X RAY CD, X-A1 AMP & ALL OTHER X SERIES
- superb value for money

AUDIO ANALOGUE PAGANINI CD PLAYER - staggering build quality and unrivalled sound; on dem at last after a long wait

THETA DAVID DVD PLAYER - superb results

YAMAHA DSP A1 - a stunningly good home theatre package

MARANTZ CD17/PM17/ST17 TUNER K.I. SIGNATURE SERIES - hear how good it is.

KRELL 250P PREAMP & 250A POWER AMP - incredible value for money - just ask for a dem

CABLES & ACCESSORIES FROM TRANSPARENT, SILTECH, CABLE TALK, GM AUDIO, SOUNDSTYLE, TARGET, KONTAK etc.

GM AUDIO EQUIPMENT TABLES - THE ELITE - now even better looking and superb value

COPLAND CD266/277/288 CD PLAYERS - all superb value for money from this very impressive company; now joined by the CSA28 amplifier

*******MAIL ORDER INTEREST FREE CREDIT NOW AVAILABLE*******

EX DEM & P/EX BARGAINS

AUDIO RESEARCH SP14 BLACK	995	SH
KRELL KSA100 MK2	£1195	SH
MARTIN LOGAN SL3 LOUDSPEAKERS	£2495	SH
NAIM 102 PREAMPLIFIER/NA-PSC PSU	£895	XD
MARANTZ CD15 CD PLAYER	£1500	SH
MERIDIAN 500 CD TRANSPORT	£695	SH
MUSICAL FIDELITY F16 POWER AMP	£1500	XD
KRELL FPB600 POWER AMP	£995	XD
DCS ELGAR DAC	P.O.A	
KRELL KRC2 PREAMPLIFIER	£2495	SH
NAIM CDI CD PLAYER	£1295	SH
EXPOSURE 17/18	£795	SH
COUNTERPOINT SA100 POWER AMP	£295	SH
MICROMEGA STAGE 1	£200	SH
CASTLE HOWARD SPEAKERS LIGHT OAK EX DEM	£795	XD
EPOS ES14 SPEAKERS	£250	SH
KRELL MD10/REFERENCE 64	P.O.A	
LINN LP12	P.O.A.	SH
NAIM 92R PREAMPLIFIER	£495	SH
ORELLE XTC PRE 1 PREAMP	£595	SH
THORENS PRE/POWER	£595	SH
YAMAHA DSPA590	£195	SH

0% INTEREST FREE CREDIT

Licensed Credit Broker

Agencies include: Audio Analogue, Air Tangent, Audiogram, Audioresearch, Audio Technica, B&W, Cable Talk, Castle, Copland, Denon, Goldring, Harmonix, Heybrook, Jadis, Koetsu, Krell, Lyra, Marantz, Martin Logan, Michell, Musical Fidelity, NAD, Naim, Onkyo, Ortofon, Opera, Pink Triangle, Pioneer, Proac, Proceed, Projekt, QED, QUAD, REL Subwoofers, Rotel, Sennheiser, SME, Sonus Faber, Stax, Target, T.D.L., TEAC, Theta, Thorens, Transparent Cables, Unison Research, van den Hul, Vidikron, Wilson, Yamaha.

TAX-FREE EXPORT SERVICE
MAIL-ORDER AVAILABLE ON MANY ITEMS
Open Mon-Sat 10am-6pm

Oxford Audio Consultants

Oxford Audio Consultants, Cantay House, Park End Street Oxford OX1 1JD
Telephone: Oxford (01865) 790879 Facsimile: Oxford (01865) 791665
E-MAIL: Oxford.Audio@btinternet.com

Art Audio

THE **QUINTET** IS NOW AVAILABLE IN
KIT FORM @ £935

ASSEMBLED KIT £1135

As recommended by Hi-Fi Choice

R.R.P WAS £1550

300B **KIT** @ £1232

ASSEMBLED KIT £1432

R.R.P WAS £2499

ALL PRICES INCLUDE VALVES & VAT

REVIEWS AVAILABLE

Art Audio (UK) Ltd
62 Vaughan Avenue
Hucknall

Nottingham NG15 8BT
Tel/Fax 0115 963 7795

[HTTP://WWW.AUDIO.NDIRECT.CO.UK/ART/](http://www.audio.ndirect.co.uk/art/)

Cable Talk

Interconnects & Speaker Cables

1994



Best Speaker Cable

1995



Best Interconnect & Highly
Recommended Speaker Cable

1996



Best Interconnect &
Best Speaker Cable

1997



Best Speaker Cable &
Highly Recommended
Interconnect

Interconnects Speaker Cables

Doesn't Your System Deserve The Best?

FOR FURTHER INFORMATION

Please telephone, fax or write to

Cable Talk,

Unit J, Albany Park, Camberley, Surrey, GU15 2PL

Tel (UK ONLY): FREEPHONE 0808 - 100 - 6868

TEL: (+44) (0) 1276 686717.

FAX: (+44) (0) 1276 686353

(CT HFV 06/99)

CLASSIFIED ADS

6 PAGES OF BARGAIN HI-FI

SPECIAL
INTERNET
OFFER SEE
PAGE 154 FOR
DETAILS

NAIM CD2 CD. 1 yr old mint, boxed with receipt £1200. Musical Fidelity MA65 monoblocks Class A c/w matching Pre 8 pre amp, immaculate, boxed, manuals £650. Tel: 01530 831 574 (Jun/I)

ARCAM ALPHA 8 CD player, Arcam Alpha 9 integrated amplifier, Arcam Alpha 9 power amplifier, B&W DM603 speakers. 4X6m Pure Sonic quality speaker cable and two sets of Cable Talk interconnect cable. Slight mark on integrated amplifier covered when stacked with CD player. Two years old, boxed with manuals, £1100. Tel: 01772 882 189 (Jun/I)

MERIDIAN 504 tuner mint £385, 204 tuner £250. Cyrus dAD3 CD player mint £385. Kenwood DPC981 portable CD player with headphones £85. Sony MDS37 midi MiniDisc recorder £85. Celestion SL600Si speakers with DLP unit £385. Kudos S100 50cm. speaker stands £75. Teac P700/D700 CD transport/DAC £650. No offers. Tel: 0181 871 2345 evenings. (Jun)

MISSION 752 Freedom loudspeakers in rosewood. Immaculate condition and sound/boxed. Best Buy in 'Hi Fi Choice' etc. (Cost £650) sell for £405. Tel: 01803 770 006 (evenings) (Devon) (Jun/I)

LOWTHER FIDELIO horns, teak £375, Chapman valve tuner £30. Infinity 100 watt subwoofer boxed £150. Audio Synthesis DSMX (DAX) DAC mint £400. Decca London re-tipped low use £75. Tel: 01827 261 082 (Tamworth) (Jun/I)

CYRUS I, £95; Target TT4 (2 full & 2 half-width shelves) £50; Interconnects - Audioquest Ruby (1m) £35, Chord Chrysalis (0.5m) £20. Wanted: Black Cyrus PSX. Tel: 01380 721 715 (Jun/I)

MUSICAL FIDELITY F22 remote valve pre with MC phono £400, mint & boxed. X-LP £50, X-Tone £50, X-PSU £50, X 10D £30, all mint and boxed. Tel: 0181 851 9198 (Jun)

QUAD IIs, new and original valves, £400 ono. Denon DRM700A 3 head cassette, little use, £150 ono. Tannoy 15" HPDs, custom boxes, perfect, offers or swap 12". Tel: 01494 874 381 (Jun/I)

GALE 401 loudspeakers, black with chrome ends and matching stands £275. Tel: 0181 977 6656 evenings) (SW London) (Jun/I)

NAKAMICHI 1000ZXL cassette deck original manuals, sep Dolby B&C unit, mahogany surround, excellent condition £1500 ono (all offers welcome) Revox B77 II high speed, mint £495. Tel: 0181 942 6553 (Jun/I)

ELECTROMANIET ECI-2 integrated amplifier, high end bargain. Bold and fluid, near mint. Nordic beauty. Any trial. £550. (£1000 new). Tel: 01308 868 044 (Jul/I)

WANTED: TANNOY Westminster loudspeakers, Cary 805 amp, SME20 T/T, Rogers LS3/5 loudspeakers (15ohm); Vintage: Quad I amp x1, Quad API 2x1, Tannoy GRF original x1, Tannoy Dual Concentric 15" silver drive units. Tel: 0802 431 172 (after 6pm) (Jun/I)

NAIM NAC82 with MM boards, about 18 months old, £1500. Hi-Cap old style serviced by Naim about 6 months ago £350. DPA Little Bit Three digital to analogue converter £150. Tel: 01453 511 279 (Jun/I)

TARA LABS Master Gen2 1m RCA £250, Wadia 21 CD player, digital volume control, £1995 (£5500 new), Wilson Watt 5/Puppy 2, gloss black, accessories, £6995, all equipment mint Tel: 01449 676 335 (Jul/I)

DYNACO PAT transistor preamp £75, Cambridge P50 stereo amp £55, Cambridge T55 stereo tuner £45, Technics SU600 stereo amp £60, QED MC preamp £30. Quad 34 MC module £15. Tel: 01372 467 264 (Jun/I)

NAIM 32.5 / HiCap rebuilt by hand to Avondale spec, to accommodate this stunning power supply, phono outputs leads £425. Eikos interconnect £50 ono. Tel: 0118 981 5681 (Jun)

TWO TANDBERG 300X reel to reel tape decks with some 50 tapes - both need attention - free to anyone willing to pay carriage - must be taken as one lot. Tel: Mr. Wood 01452 713 211 (Jun)

HI-FI CLEAROUT! Many cables, speaker, interconnect, digital, mains - call for details. Also Pink Triangle Cardinal/DaCapo (spare filter), LFD PA2 and Trichord Black Box mains filter. Tel: 0181 879 0364 (Jun/I)

NAIM NAP 250 power amplifier (old style) serviced Naim April 99 (guarantee transferrable) £825 or offers. Tel: 01273 58 3996 (Jun/I)

YAMAHA CT 7000 tuner. Excellent condition, recently serviced £300. Tel: Mr. Wood 01452 713 211 (Jun)

REGA PLANAR 3 with Origin Live fully modified silver wired RB250 (£175) £230. Linn Intek integrated amp, mint £180. Bose Acoustimas 5, brand new £320. A&R tuner £40, Denon tuner £40. Tel: 0181 952 2044 (Jun/I)

ARCAM BLACK Box 5 £140, Audioquest digital interconnect £15. WANTED: Exposure stereo 18, VDH First or Second. Tel: Steve 01954 718 038 (ansaphone) (Jun/I)

WANTED: CHORD 1200, 1200B, 1200C power amp, Quad FM4 tuner. Tel: 01993 883 523 (Jun/I)

AUDIO INNOVATIONS First Audio (6B4G) £500 (£1500), Audio Note Kit 4 (6V6GT) fully built £150 (£249), Rotel passive RCH-10 preamp £100 (£800). Krell KSA 80 power amp £1250 (£3500) Tel: 0181 203 3150 (Jun/I)

QUAD 707 power amplifier £575 ono. QED MA30 high definition headphone/speaker switch unit £25 (£50 new). Cable Talk Monitor 2 stereo interconnect £20 (£50 new). All mint. Tel: 01703 738 935 (Southampton) (Jun/I)

SUGDEN A25 MosFet amplifier & non working one for spares £75. Aiwa F770, three head cassette £75. Kenwood KA3020 amplifier £85. Kenwood KA 1060 £49. Radford HD250 amplifier £95. Tel: 01484 846 253 after 7pm (Huddersfield) (Jun/I)

diverse vinyl

12 Upper Dock Street Newport Gwent NP20 1DF 9am-5.30pm Mon - Sat.
 Internet site <http://www.diverse-music.co.uk>
 phone/fax 01633 256261 / 259661 E Mail : sales@diverse-music.co.uk
 -Mastercard - Visa- Catalogues available -Amex-Switch-JCB-

EMI Millennium Vinyl Collection - 19th April

David Bowie	Aladdin Sane	£13.90
Deep Purple	Book Of Tallesyn	£13.90
Frank Sinatra	Come Dance With Me	£13.90
Jethro Tull	This Was	£13.90
John Lennon	Wall And Bridges	£13.90
Queen	Day At The Races	£13.90
REM	Document	£13.90
Specials	Specials	£13.90
Talking Heads	Stop Making Sense	£13.90
The Band	Music From Big Pink	£13.90

Forthcoming Releases

Add N To X	Avant Hard (19/4)	£11.90
Cassandra Wilson	Travelling Miles - 2LP 180gm	£24.90
Catatonica (plus free 7")	Equally Cursed/Blessed (12/4)	£TBC
Small Faces (plus 7")	Small Faces - 180gm (26/4)	£16.50

New & Recent Releases

Beth Orton	Central Reservation	£13.90
Blur	13	£16.60
Bob Dylan - Classic Rec	'Royal Albert' Box Set	£44.95
Bruce Springsteen	Born To Run audiophile	£21.90
Deus	The Ideal Crash	£11.90
Erinerm	The Slim Shady	£18.50
Fela Kutl	Beasts Of No Nation	£10.90
Jason Crest	Radio Sessions 1968-69	£15.90
Jim O'Rourke	Eureka	£9.90
Jimi Hendrix	Live/Filmore East - 3LP	£22.90
Kula Shaker	Peasants Pigs etc	£12.50
Meters	Meters/Look-Pa Ky Ky	each £9.90
Morgan Heritage	Don't Haffi Dread	£9.90
Patricia Barber	Modern Cool audiophile	£19.90
Roots Manuva	Brand New Second	£11.90
Roy Budd-Soundtrack	Fear Is The Key	£16.50
Roy Budd-Soundtrack	Diamonds	£16.50
Sarah Vaughan	Sassy audiophile	£19.50
Skatalites	Meet King Tubby	£10.90
Skunk Anansie	Post Orgasmic Chill	£14.90
Squarepusher	Budakhan Mindphone	£9.90
Stan Getz/Joao Gilberto	Getz/Gilberto audiophile	£19.90
Trans Am	Future World	£8.90
Various (Ska/R. Steady)	200% Dynamite	£12.90
Wings/Paul McCartney	Band On The Run-25th 2LP	£16.50

ALL PRICES SUBJECT TO CHANGE

P and P £1.00 1st LP additional LP's 50p each (max £4.00)

English Analogue

Supplier of quality second hand classical records
 Reasonable prices for truly collectable original vinyl from
 the 1950s to the 1970s. Labels include:

DECCA -SXL, SDD, SET, RCS, SPA, PFS
HMV - ALP, ASD, SAN, SLS
COLUMBIA - 33CX, SAX
RCA - SB - 2000/6000, VICS, SER
DEUTSCHE GRAMMOPHON, PHILIPS
 etc, also available

If you are unfamiliar with classical music,
 recommendations are available of great recordings to
 enhance the enjoyment of your Hi-Fi and enter you into
 the vast world of Classical Music. Just as there are good
 recordings or Rock, Pop or Jazz, the same applies to
 Classical.

To increase your satisfaction, all the records sold are
 cleaned and audibly checked before being sold, free of
 charge, as well as a guarantee. The records are also
 supplied with a new innersleeve, as well as the old, to
 insure a high standard. In addition, if you have any
 Classical LPs or CDs you wish to sell or want a free
 catalogue, please write, phone or fax to:

3 Naseby Rise, Newbury, Berks, RG14 2SF, England
 Tel: 44 - (0) 1635 40242 Fax: 44 (0) 1635 524239
www.multiplex.co.uk/Records

audio *edge*

visual *edge*

174 Central Road,
 Worcester Park, Surrey
 0181 337 4455

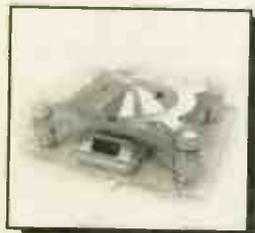

*For the ultimate in
 Sound & Vision*

NAD • HELIUS • LOWEW SYSTEMS • AUDIO AND TV'S PLIMIUS •
 AUDIO PHYSICS • JAMO • SONIC FRONTIERS • ROCKPORT •
 SPEAKERS & TURNTABLE • ORACLE CD PLAYERS & TURNATABLE •

OLD DAYS VINTAGE/AUDIO

Tel/Fax: 0171 349 9675 Mobile: 0958 607613
 E-mail: Olddays.vintageaudio@callnetuk.com



Vintage

Quad II amps +control unit/FM Tuner	£650
Quad II amps/manual	£500
Leak 12+ amps	£475
Leak Stereo 20 amplifier	£350
BBC Leak 12.1 amps	£POA
BBC Soundside Amps-LSM/10	£POA
BBC AM8/4a amps	£POA
Armstrong A10 Mk2 amps	£POA
Rogers Cadet Stereo pre	£200
Rogers Baby Delux mono	£225
EMI STD/373 amps + pre	£POA
Decca PX25 triode amp + psu	£POA
HMV PX25 triode amp	£POA
Western Electric amps	£POA
Etc	

Speakers

Tannoy 12" D/concetric units	£POA
Tannoy 12" Rec'd nits	£POA
Tannoy 15" Silver units	£POA
Lowther TP1 corner horn speakers	£POA

Audio

Krell KAV 300 CD	
4 mths old & boxed	£2550
Krell FPB 300 new/boxed	£POA
Krell FPB 600 new boxed	£POA
Krell KPS25s CD/DAC/pre	
new boxed	£18995
Martin Logan CLS II in pristine	
condition original boxes	£2000
Nakamichi ZK-7 3 heads professional	
cassette recorder in pristine	
condition	£650
Audio Research D400 MK II	£POA

Turntables

Garrard 301 + SME 21"	£POA
BBC Garrard 301/401	from £100-£300
Connoisseur Craftman III	£100

Valves

PX4/PX25/DA30/DA100/ KT66 etc etc	
--------------------------------------	--

CLASSIFIED ADS

6 PAGES OF BARGAIN HI-FI

SPECIAL
INTERNET
OFFER SEE
PAGE 154 FOR
DETAILS

CLASSIC HI-FI system.
Armstrong 626 tuner/amp.
Pair Celestion Ditton 44
floor-standing speakers.
Garrard DD75 turntable with
Shure head. All teak finish.
Offers? Tel: 01483 765 659
(eves) (Jun/I)

QUAD ESL63 electrostatic
speakers, natural ash/brown,
excellent condition £995.
Gradient active crossover,
£250. REL Strata II
subwoofer, as new, boxed
£325. Leak Troughline 3
Stereo tuner excellent
condition £125. Tel: 01978
780 580 (Jun/I)

NAIM CDX, 6 months old, as
new and boxed £1750. Quad
22/II booklets, original
(50s/60s) offers. Naim Aro
tonearm boxed £550. Tel:
01793 526 796 (Jun/I)

MERIDIAN 207 CD
player/preamp £340 or P/X
for Marantz CD 63MkII KI-S.
Tel: 01793 784 207 (Jun/I)

TANDBERG TD 20A SE reel
to reel, 2 track 15-7.5 ips.
Excellent condition, little use
with 2x7" and 3x10" tapes.
£300. Tel: 01179 565 894
(Bristol) (Jun/I)

MANA ACOUSTICS 6 shelf
amp stand, boxed £500. AVI
S2000 MP line level preamp
with remote. Boxed, late
spec model. £950 new, £450.
Tel: 01524 381 389 (Jun/I)

LINN SYSTEM. 4 Klouts,
Kairn phono Karik CD,
Numerik DAC, red
mahogany Keltik speakers.
Bought July 1993. All in
pristine condition. £8250. Tel:
01446 760 038 (Jun/I)

LEHMANN BLACK CUBE,
phono stage, as new, £280.
Tel: 01843 601 786 (Jun/I)

EXCELLENT B&O
Beomaster 6000, Beogram
8000, Beocord 8004, Beovox
S80 in good condition £110
ono. Also Garrard SP25
record deck £20 ono. Must
sell to make space. Tel:
01883 744 440 (Surrey)
(Jun/I)

AUDIO NOTE AN-J/B 523
speakers, rosewood with
Huygens dedicated stands.
Superbly responsive,
therefore compatible with
even very low output valve
amps. Mint condition, must
sell, bargain price £550. Tel:
01273 724 055 (Jun/I)

LEAK TL12 Plus amplifiers,
rebuilt, one black, one gold,
£125 each. Leak Stereo 20,
rebuilt, unmarked, £250.
Varislope 2 vgc, £40.
Troughline 3 stereo,
unmarked £115, mono
version £65. Tel: 01633 422
559 (Jun/I)

QUAD 2 power amplifiers,
22 control unit, tuner (fitted
decoder) excellent £450.
Quad 57 electrostatic
speakers £350. Kef 104s
original 1977 £350. Verdik
quality 10 monoblock and
controller £60. Tel: 01633
422 559 (Jun/I)

DECCA "PROFESSIONAL"
arm with Mk3 FFSS cartridge
£75. Lowther FM Mk2 tuner
with power supply £60.
Rogers Cadet 3 integrated
stereo valve amplifier £90.
Leak Stereo 70 £50. Tel:
01633 422 559 (Jun/I)

ALCHEMIST KRAKEN Class
A integrated amplifier, with
outboard power supply and
phono input. Boxed and in
excellent condition. £300.
Tel: 0115 982 5772
(Nottingham) after 7pm.
(Jun/I)

QUAD E50 monoblock
power amps £150 the pair.
Arcam Two loudspeakers on
Arcam stands £150.
Heybrook HB One speakers
£80. Marantz CD42 £75. Tel:
01495 350 677 (Jun/I)

£500 OFF! Reson Lexe MC
cartridge. Unplayed,
unmounted, absolutely brand
new (Hi-Fi World
competition prize). Top of
the outstanding Reson range
featuring rosewood/pocan
body, silver wiring and Gyger
5 stylus profile: 3 globe
"World" rating. £800
including p&p. Tel: Howard
Sherwood 01608 811 667
(Oxfordshire) (Jun/I)

REVOX A77 reel to reel tape
recorder 4 track 3.75, 7.5 ips.
Revox manual. £270. Pair
B&W DM2 loudspeakers £50.
Radio Designers Handbook
3rd Edition 1942 (approx).
Complete set 1933 "Wireless
World" (weekly). Offers. Tel:
01737 352 996 (Epsom) (Jun)

ARCAM ALPHA 9 & 9P
amplifiers as new & Ixos 100
03 studio interconnect (£150)
£500 the lot. Tel: Chris 0181
592 9797 after 6pm (Jun/I)

ROTEL RC960-BX preamp
(with phono stage) vgc £90
ono. Meridian 203 DAC vgc
£175 ono. Mission 751
speakers and Atacama SE24s
stands, both vgc £250.
WANTED: isolation platform
and anti-jitter equipment. Tel:
01865 716 503 or
iob@cheerful.com. (Jun/I)

MERIDIAN 557 power
amplifier £895. Quad
33/FM3/303 £220. Pair Quad
50D power amplifiers £170.
Quad 44 preamp £200.
Various Quad 44 input
modules some unused, call
for details. Tel: 0181 948
6250 (Jun/I)

MISSION 753 speakers in
real light oak finish, 18
months old £450, or swap for
good bookshelf size speakers
like Linn, A.E. Tel: 01702 331
931 (Jun/I)

TEAC D-TI DAC £300.
QED Digit £65. QED
Positron £35. Goldring-Lenco
GL75 original plinth, motor
idler, bearing vgc, £25. Tel:
Tony 0171 394 1271 (Jun/I)

QUAD ESL 57 loudspeakers,
bronze, treasured for over 20
years, must go now due to
total system upgrade, hence
only £180 pair. Tel: Jack
Richardson 01923 248 402
(Watford) (Jun/I)

MARANTZ CD63 MkII KI
Signature. 17 months old very
good condition boxed. A
touch of class from this
award winning player, yours
for £225. Tel: 01273 390 949
(Brighton) (Jun/I)

MICHELL GYRODEC, QC
PS, Tabriz Z, Corus Black,
Audio Innovations S200 pre
and two power amps,
Heybrook Solo, HSB1 stands.
Goldring 2&3 tier tables. All
cables. £1600 ono will split.
Tel: 01244 281 367 (Jun/I)

DENSEN BEAT 100
integrated amplifier, 60 watts,
6 inputs, pre out, bi-wire,
£450 ono. Chord Cobra 2,
phono to phono, 1m £40.
Tel: 01684 569 851
(Worcester) (Jun/I)

REGA RB300 arm, perfect.
Rega RB250 arm - Origin Live
mod, needs internal wiring,
otherwise perfect £200 pair
or split. Audio Alchemy
Power Station 2 £50. Buyer
collects. WANTED: 3
bladder seismic sink -
standard size. Tel: Brian 0181
841 5782 (Northolt) (Jun/I)

Midland Audio X-change

Suppliers and installers of High Quality Audio Systems

Audio Note • Basis • BAT • Densen • Dpa • Electrocompaniet • Mark Levinson • Michell • Nagra
Pass • Primare • ProAc • Rega • Revel • Roksan • SPM • Sugden • UKD • Unison Research • Wadia

S/hand and ex-demo clearance items - May '99

	Was	Now		Was	Now
Audio Innovations 1000 Passive Controller	199	99	Naim Audio 62 Preamplifier (old style)	N/A	159
Audio Innovations 200 Power amplifier	N/A	195	Naim Audio 72 Preamplifier M/C Boards	689	375
Audio Innovations 400 Integrated Valve Amplifier	1099	450	Naim Audio Hi-Cap New Style	780	450
Audio Innovations 800 Series III power amplifier	999	499	Naim Audio NAC 32mm/MC Preamplifier	N/A	149
Audio Note ANCD2 Valve CD player new boxed	1000	695	Orelle SA 100 Amplifier	449	299
Audio Note AN-VZ 1M Silver Interconnect	1520	750	Pink Triangle Cardinal / DeCapo 1307/HDCD	2500	1295
Audio Note IO 1v Moving Coil Ex-Demo	1295	650	ProAc Tablette 50 Cherry Loudspeakers	599	375
Audio Note M3RIAA Phono Stage	3950	1750	ProAc Tablette 50 Signatures Ebony Loudspeakers	900	695
Audio Note TTL/RB250/IQ1	750	495	Quad 33/303	N/A	175
Audio Research LS2 Hybrid Preamplifier	2850	1399	Radford/Woodside WS2 CD Player	1200	399
Audio Research LS3b Remote Volume/ black	2750	1495	Rega ELA Cherry Latest Spec	535	399
Audiolab 8000s Remote Amplifier	699	479	Rega HAL Pre Amp MM/MC Remote	998	599
Audion Premier 2.0 2 Box Preamp inc. Phono stage	1700	995	Revox A77 - fi Track 3fl - 7fi MK3 Reel to Reel	N/A	250
Basis2000 series Turntable /Air tangent 1B Tonearm	4000	2500	Revox B77 - fi Track 3fl - 7fi MK1 Reel to Reel	1600	595
Cary Audio CD955 valve compact disc player	1095	399	Roksan Artrexxerxes MK1 MC	599	195
Cogan Hall Intermezzo REF 0.5M	375	95	Roksan Attesa DP3T Transport	1295	699
Conrad Johnson PV10 AL SE	1299	750	Roksan Caspian CD Player	895	650
Decca London cartridge re built	N/A	199	Roksan DA2 DAC	595	449
DPA Little Bit III 4 months old	300	195	Roksan DS 5 Power Supply	549	429
Elemental Audio SCZ Custom Loudspeaker Stands	1399	750	Roksan DS1 Power supply Black	695	350
Epos ES 11 Loudspeakers Black	485	249	Roksan ROK-1	650	279
GM Audio Heavy Speaker Stands 24"	599	250	Roksan Shiraz 350hrs use	1000	375
Harbeth HL-K6 Cherry	1049	599	Roksan Xerxes SME cut/XPS2 Blk - (needs a paint job)	N/A	185
Heybrook TT2 Turntable Black	N/A	175	Roksan Xerxes Syrnix PU2 Supex 900 MkII	N/A	499
Impulse Lali Cherry Loudspeaker	1750	1295	Roksan Xerxes Tabrizi XPS 3.5/DSU	1650	699
Impulse Maya Loudspeaker	695	459	Roksan Xerxes XPS3.5/DSU/Tabrizi/Corus Black	1799	795
Impulse Moskito/RB300 Turntable New & Boxed	695	399	Rotel RC 970 BX Pre Amp (new)	175	99
Koetsu Tonearm	N/A	250	Ruark Talisman II Dark Oak	750	599
Krell KPS 20i/L CD/Pre	11,000	5999	Sonus Faber Extrema's	6500	3750
Krell KRC HR Remote Preamp	6950	4500	Stax Sigma Electrostatic Headphones/SRD 7	499	250
Linn Ekos MK1 Boxed Immaculate	1500	650	Sugden SDT-1 Special Edition CD Player	1499	895
Madrigal HPC Digital 0.5M RCA/RCA	N/A	50	Systemdeck 2X2 Cherry/RB250 Turntable	629	379
Meridian 203 DAC 7	499	169	Theta Pro Basic IIIa D/A Converter	2990	1795
Michaelson Audio Chronos 2 Box Valve Preamplifier	4700	1250	Transparent Music Wave Plus 2x2.44m	428	295
Michell Engineering Orca Pre amplifier 4 Months Old	1650	1195	Transparent Reference Balanced Music Link 1.5m	2895	1495
Micromega CD3/ Duo Pro DAC	3000	1195			
Naim Audio 110 Power amplifier (old style)	N/A	179			
Naim Audio 2/4 X-Over New Style	650	350			

Midland Audio X-change is looking for good used British & American Hi-fi, cash paid call John Roberts on 01562 822236

Michell Engineering Ltd

Those guys in Borehamwood have done it again; The Gyro SE takes the bull by the horns at the sub £800 turntable market. They have taken the Gyro off it's Perspex plinth and given it a stand alone motor, (this can be upgraded to a full gyro at a later stage) the price without tonearm and with a standard power supply - £775.00



Aria S2 a single ended triode valve amplifier, the sweetest little thing you ever saw with a superb sound quality to match. From the Unison Research factory in Italy this EL34 10 watt per channel amp has stunned everyone who has heard it. It's level of build quality is second to none - stainless steel and mated walnut meet in a heavenly combination and all for the angelic sum of - £1050.00

Accessories for the Vinyl Nutter

Audio Prism CD Black light	£39.95
Audiophile Record sleeves	£12.95
Decca CA2+2 Record cleaning brush	£9.95
Densen De-magic	£9.95
Discwasher D4 System	£18.00
Eco 2 Demagnetiser fluid/spray	£29.95
Einstein Octopus mains filter/conditioner	£199.00
Kontak Electrical contact enhancer	£14.95
Last All-purpose record cleaner	£19.50
Last Power cleaner for records	£32.50

Roksan

Xerxes X Special Offer - Limited numbers available.
Due to overstocking on Roksan Xerxes X Turntables, we have devised a special price on a complete package from this top turntable manufacturer:

Xerxes X in Rose/w or Black.	£1295.00
XPS 3.5/ D. S. U.	£320.00
Tabriz Tonearm	£320.00
Corus Black Cartridge	£130.00
Total Price	£2072.00
Our Price Complete	£1200.00

Vinyl

Alanis Morissette - Supposed Former	£17.95
Amanda McBroom - Midnight Matinee, 180 gm.	£21.95
Buena Vista Social Club Feat - Ry Cooder	£31.95
Charlie Hunter - Natty Drend	£15.95
DiMeola, McLaughlin, DeLucia - Friday Night	£19.95
Dr. John - Anutha Zone, 120 gm.	£14.90
Eric Clapton - Pilgrim	£15.90
Gomez - Bring It On	£15.90
Hank Mobley - Roll Call, 180gm	£21.95
J.J.Cale - Naturally, 180 gm.	£19.95
Janis Ian - Breaking Silence, 180 gm.	£24.95
Jewel - Pieces Of You (limited edition)	£15.90
Kebmo - Kebmo, 180 gm.	£19.95
Linda Ronstadt - Greatest Hits Vol 2 DCC, 180 gm.	£21.95
Lori Lieberman - Home Of Whispers, 180 gm.	£21.95
Massive Attack - Mezzanine	£15.99
Midnight Sugar - E B M 23, 180 gm.	£17.95
Mo-Fi - 200 gm. (Special Offer)	£19.95

A postage charge of £2.00 per consignment will be made

181 Franche Road • KIDDERMINSTER • Worcs • DY11 5AD
Ring John Roberts • Tel/Fax 01562 822236 • Mobile 0421 605966

CLASSIFIED ADS

6 PAGES OF BARGAIN HI-FI

SPECIAL
INTERNET
OFFER SEE
PAGE 154 FOR
DETAILS

CASTLE HOWARD loudspeakers, top of the range (Santos rosewood). What Hi-Fi 5 star rated, cost new £1400. £695 boxed. WANTED: active crossover kit for Linn Kabers. Tel: 0121 358 0459 (W Midlands) (Jun/I)

HEYBROOK QUARTET speakers walnut finish with matching stands, excellent condition £400. Ortofon T20 MkII step up transformer £110. Stax SR34 headphones £80. Soundstyle X053 stand £80. Tel: 01525 854 652 (Jun/I)

LINN KABERS. Active crossover cards. Granite stands. Walnut veneer, especially nice grain. £799 ono (£2500). LK100 £300. Genexxa LX5pro lineaeum £50. Excellent condition, boxed. Tel: (eve) 01256 896 870 (day) 0118 920 6137, Email:leigha@uvo.dec.com (Jun/I)

PHILIPS 544 speakers wanted at a reasonable price by experimenter. Buyer will collect or pay carriage. Tel: 0117 935 0239 Email: jst6@tutor.open.ac.uk (Jun/I)

AUDIOLAB TUNER 8000T, excellent, hardly used £550 ono. Linn Sara Nine speakers, vgc, c/w stands £375 ono. Naim 62K (MC) boards £30. Tel: 0973 406 305 eves (Hitchin) (Jun/I)

EPOS ES30 speakers, as new £1500, Myriad T40 amplifier £225, Rogers Avanti 625 speakers £250. Rogers 628 speakers £500. All items mint, also Audio Sythesis DSM DAC plus AP5-02 power module £500, Rogers Unique Prologic receiver £200. Tel: 01344 872 568 (Jun/I)

TEAC VRDS105E CD player, in mint condition, boxed. £425 ono (£850 new). Tel: 01582 758 049 (Luton) (Jun/I)

BRAND NEW Quad 99 series separates (mains) pre amp, power amp, CD player, tuner cost £2800, untouched, still in box with receipt, offers over £2200. Tel: 01203 459 009 (Jun/I)

LOWTHER TPI corner unit with rebuilt PM3A. Plus Thorens 124 with 12" arm, Quad valve amplifier and cabinet. £1100 only or may separate. Tel: 01932 821 563 (Surrey) (Jun/I)

NAIM SYSTEM CD1 CD player, NAC82/NAP180 pre/power, 2 Hi-Caps, SBL speakers (latest bass/midrange units). Half cost of units new £4200 ovno. Genuine reason for reluctant sale. Tel: David Freeman 01256 328 117 (Jul/I)

ARCAM DELTA 170 CD transport upgraded to 170.3 specification plus Black Box DAC 5 with sync lock. Mint condition with boxes and manuals (£1295 new) £450. Tel: 01264 359 346 evenings (Hampshire) (Jun/I)

CAT SL1 Mk2 phono valve pre, plus Counterpoint SA4 valve power amps (120W). Beautiful sounding combination, only £3500 all together. Tel: 01784 458 176 (Staines) or 0468 476 315 (Aug/I)

GARRARD 401 Turntable. Excellent original condition. No plinth. Acos Lustre arm with Shure M55E included £200 ono. Tel: 01483 726 254 evenings (Surrey) (Jun/I)

NAIM HI-CAP New style, Dec 96, boxed, excellent condition £500. Tel: 01473 785 659 (Jul/I)

MAGNUM IA-170 integrated amp with MM/MC phono, as new £225 (£330). Stax SR-84 electrostatic headphones plus SRE-15N extension cable, vgc £150 (£300). Tel: 01865 308 415 (Oxford) eves (Jun/I)

LINN LP12 Aro arm. Lingo, Cirkus, Trampoline. One owner, just serviced £1200 ono. Tel: 01482 641 261 before 7pm (Jun)

MARTIN LOGAN SL3 Hybrid electrostatic moving coil speakers £2250. Michell Gyrodec 'Bronze' Alphason HRS 100 MCS silver wired arm, Denon 304 cartridge, Gyropower supply/speed regulator £1100. Michell ISO Hera power supply £300. Tel: 0181 963 0851 (Jun/I)

ANALOGUE

Bellini/Donnizetti pre/power, 1 year old, £810. Linn Kairn, pre Brilliant, £620. Ruark Sceptre £390. HFW HD83 headphone amp £150. (Built, upgraded) Tel: 01530 831 357 or mobile 0831 565 010 (Jun/I)

SENNHEISER HD580 Jubilee headphones, £140, EARmax OTL valve headphone amp £230. KEF Reference 4 speakers, rosetta burr finish, £2500. All boxed, mint condition. Audio Analysis Epsilon ribbon speakers, £2300. Tel: 01474 743 326 (Gravesend)(Jun/I)

NAKAMICHI CASSETTE Deck 1, mint, boxed, instructions. Serviced Nakamichi (B+W) £425 ono. Tel: 01202 481 386 (Jun/I)

LEAK SANDWICH Speakers, teak, 15 ohm £100. Tel: 01903 208 552 (Jun/I)

MERIDIAN 551 Amplifier with MSR £440. Meridian 504 tuner £340. Both as new. Hardly used. Tel: 01642 559 204 (Jun/I)

YAMAHA NS 1000M (stands) £450. Quad 606 serviced £350. Croft Micro £75. Naim 42.5 pre £110. Audio Alchemy DDE VI DAC £190. May P/E. WANTED: Camax adaptors for Mark Levinson pre. Tel: 0191 422 3415 (Jun)

MAGNAPLANAR LARGE panel speakers MG2/CS, light oak/beige £800. Nakamichi preamp CA/5E, Nakamichi power PA/5E £550. Arcam Alpha Plus CD £150. Celestion Ditton speakers £35. Tel: 01202 721 555 (Poole) (Jun/I)

PAPER IN Oil reservoir capacitor clear out. NOS Dubilier 0.5µF at 2500V £5 each. Kenwood KA1000 integrated. 100 watts per channel, outboard power supply, dual mono with Sigma drive loudspeaker feed back, £185.ono. Meridian 207 CD player, vgc, £190 (cost £725). Ferrograph S1 monitors with stands, immaculate, £200. Aurex System vgc, pre/pwr/tuner/tape plus MiniMax speakers £175. WANTED: Trio L Series separates, working or not. Tel: Jon 0181 904 8023 (Jun/I)

GARRARD 401 Turntable chassis together with Audio Technica AT 1005 arm £120. Old Rogers valve amplifier chassis, working but need some attention £15. Tel: 01789 762 2201 (Warwickshire) (Jun/I)

Arcadia Valve Amplifiers



New Line Level Pre-Amplifiers

Two Models Available.

6 line inputs, 10dB of gain, zero feedback
finest quality components, musical results

Model 1 £995, Model 2 £1995

"There's none of the wispy airiness and soft, slow bass that one associates with the breed - just consistently fine tone, edge or goose-neck dynamics and effortlessness."

Jason Kennedy on the Model 1 in Hi-Fi Choice
Sept '97

OEM, TRADE AND RETAIL ENQUIRIES WELCOME

P.O. Box 21, Bramhall, Cheshire SK7 2FF

Tel/Fax: +44 (0)161 4390727

EMAIL [SJS@AUDIOPHILE.COM](mailto:sjs@audiophile.com)
[HTTP://WWW.NETFORWARD.COM/AUDIOPHILE/SJS](http://www.netforward.com/audiophile/sjs)



SJS Electroacoustics
HAND WOUND INTERSTAGE, OUTPUT AND MAINS TRANSFORMERS FOR VALVE AMPS

Billy Vee Sound Systems

Selected list of Pre-Owned and Ex-Dem Units

All with minimum 1 year warranty. Interest Free Option Available
We are authorised agents offering genuine reductions - call now

AVI S2000 Pre amp/phono stage E/D	(1199.00)	£799.00
AVI S2000 Mono power amps E/D	(1399.00)	£899.00
B&O Avant 28" inc Video Ex-Display	(3700.00)	£2495.00
B&O AV5 TV/Hi-Fi/CD Ex-Display	(4650.00)	£3249.00
B&O MX4002 21" T.V. Ex-Display	(1290.00)	£879.00
B&W P4 Speakers - Black E/D	(675.00)	£499.00
Linn KL1/280 Pre-Power Amp S/H	(1570.00)	£695.00
Linn Kudos (Sneaky) Module Tuner	(500.00)	£295.00
Linn Wakonda Phono Preamp S/H	(900.00)	£599.00
Linn Kan/2 Speakers S/H	(579.00)	£199.00
Linn Majik phono amplifier S/H	(800.00)	£479.00
Linn Karik/2 CD Player S/H	(1498.00)	£999.00
Linn Numerik DAC S/H	(1500.00)	£899.00
Linn Kairn Preamp - Line E/D	(1400.00)	£1095.00
Naim Nait 3 Amplifier S/H	(585.00)	£395.00
Naim 92/90 Pre/Power Combo S/H	(1110.00)	£849.00
Naim CDi Player S/H	(1800.00)	£995.00
Naim CDS Player S/H	(3900.00)	£2595.00
Pioneer PDR04 CD Recorder As New	(449.00)	£349.00
Pioneer PWR555 Re-Writable (NEW)	(449.00)	£349.00
ProAc Super Tablettles S/H	(599.00)	299.00
Pioneer CLD 2950 Laser Player S/H	(600.00)	£229.00
Rega XEL Monitor Speakers (blk) E/D	(1040.00)	£699.00
Yamaha CDX890 CD Player E/D	(349.00)	£199.00

Call (0181) 318 5755 or 852 1321

248 Lee High Road, Lewisham London SE13 5PL
10am-6.30pm Monday-Saturday (closed Thursday)

EVERY READER OF THIS MAGAZINE WILL HAVE HEARD OF LORICRAFT AUDIO AND OUR REVOLUTIONARY NEW GARRARD 501 TURNTABLE

MOST WILL KNOW OF OUR CLASSIC 301 AND 401 REMANUFACTURED UNITS AND OUR WORLD BEATING GARRARD PLINTHS.

MANY WILL KNOW OF OUR GARRARD POWER SUPPLIES FOR ALL FINE TURNTABLES AND SIGNAL SOURCES

SOME WILL EVEN BE AWARE THAT WE MAKE THE LORICRAFT PRC 2, SAID BY MANY TO BE THE WORLD'S FINEST VINYL CLEANING MACHINE.

BUT, DID YOU KNOW WE ARE THE U.K. & EUROPEAN

DISTRIBUTOR OF ART AUDIO VALVE AMPS? OR ABOUT OUR NATURAL FIBRE RECORD BRUSH.?

HOW ABOUT OUR SOUNDSTAGE ISOLATION PLINTH? TIMING STROBE AND DISCS? DAMPER RINGS?

IN FACT WE MAKE AND MARKET A WHOLE RANGE OF ACCESSORIES AND SPARE PARTS TO LET YOU GET THE MOST MUSIC FROM YOUR SYSTEM.

BECAUSE FOR US MUSIC IS A PASSION AND THAT'S WHY THIS YEAR WE HAVE HELPED AN ORCHESTRA TOUR, WE WILL BE PRESENTING LIVE MUSIC AND OPERA AT A HI-FI SHOW. AND WE HOPE, BE HELPING YOU GET THE BEST SOUND AND THE MOST MUSIC IN YOUR HOME.

LORICRAFT AUDIO we make music

FOR FURTHER INFORMATION ON OUR PRODUCTS SEND A LARGE S.A.E. TO LORICRAFT AUDIO, UNIT N, WAGON YARD, LONDON ROAD, MARLBOROUGH, WILTSHIRE, SN8 2LH., CALL OUR PRODUCT HOTLINE 01672 511401, E-MAIL US AT GARRARD@AUDIO.NDIRECT.CO.UK OR CHECK OUR WEBSITE:- WWW.AUDIO.NDIRECT.CO.UK/GARRARD/

GARRARD AND LORICRAFT PRODUCTS ARE ON SHOW AT
BYWORTH AUDIO, FARNHAM, SURREY +44(0)1252 717 784
AUDIBLE ELLAGANCE, WEST MERSEA, ESSEX +44(0)1206 384 247

HI-FI WORLD TRADE CLASSIFIED ADS

Dealers must not advertise in the Private Classified section. Monthly consecutive insertions will be considered Trade advertising. The Publisher reserves the right to judge submissions.

SPECIAL INTERNET OFFER SEE PAGE 154 FOR DETAILS

WANTED - EARLY HI-FI LOUDSPEAKERS
Tannoy, Lowther, Parmeko, Voigt, Vitavox, RCA WE etc
TURNABLES
Garrard, BBC301, EMT SME, Ortofon, Decca, etc.
VALVE AMPLIFIERS
AEI, EMI, Leak, Rogers, PYE-Quad, WE etc
AUDIO VALVES
DA30, KT66, KT88, PX4, PX25, PP3/350, VVE300
CLEAR CRYSTAL SYSTEMS
John Petrie-Baker
Tel: 0171 328 9275

VINTAGE & MODERN HI-FI
Bought, Sold, Exchanged.
FOR SALE: Quad II, Leak TL12.I-TL10. All Sonus Faber loudspeaker ex demo available.
WANTED: Valves: KT66, KT61, KT88, PX4, PX25, 300B - Any Garrard turntable (301/401) Lowther, Jadis, Conrad Johnson, Audio Note, Quad. Tel. 0790 1976 441
(Jun/I)

ROGERS SPEAKERS (new and ex-demo) still for sale, massive discounts. Studio 9 £550. Studio 7 £350. Studio 5 £250. BBC, Gold and LS ranges available. E40A valve amps £1000. Spares and servicing. Mitcham Loudspeakers Tel: 0181 648 0743 or 01344 872 568 (Jun/I)

CASTLE LOUDSPEAKERS
New. Discounts available. Deliver Anywhere UK. Please telephone for details. Five Ways Hi-Fidelity Ltd (Est 1972), 12 Islington Row, Edgbaston, Birmingham B15 1LD Tel: 0121 455 0667. Tues-Sat 10.30-6.00 (Jun/I)

OFFICIAL SUGDEN Service, repairs, and upgrades. Sales of new and reconditioned SUGDEN audio products. Prices from £150 including carriage for recons with guarantee. Full details available. Tel: Audio Synergy 01924 406 016 (Jun/99(I))

ANALOGUE ELECTRONICS design engineer Bsc (Hons) valve/transistor audio equipment designed, built to specification; stereo/monoblock amps, line and phono stages, power supplies. Also, repair, modification, restoration, technical writing. Tel: Theo 0181 881 1623 (Jul/I)

MUSIC IS ALL ABOUT TIMING
= YOUR MUSIC IS OUT OF TIME
CALL ME
I CAN HELP
PAUL HYNES
PHASE DESIGN
Tel/Fax: 01931 712 822
(Jun/I)

MOTIONAL FEEDBACK subwoofer! Clean deep powerful bass from a shoebox. As featured in 'Electronics World'. Improved version £695. Direct from the designer. Further details Tel: 01243 532 464, Email: russel_bredon@excite.com
(Jun/I)

DISPLAY CLEARANCE. Conrad Johnson PV10A £900, MV55 £1400. Premier 14 £3500, Premier 11A £2800, Golden Tube S150 £600, Pink Triangle Anniversary £1200, Proceed CDP £2400, Pre £1100, Mark Levinson 333 £5500, Audiostatic DCI £1700, Meridian DSP 5000C £1000. All boxed and fully guaranteed. Tel: 01473 286 977 (Jun/I)

IMF PROFESSIONAL studio monitor loudspeakers, (original flagship model) pair "004" £1000 ovna, Revox B77 recorder, two-track stereo, 3.75 & 7.5, fully serviced, calibrated Ampex 456, £400. Bay Electronics, Leeds 0113 270 1954 (Jun)

TECHNICS SP10 £260. Revox E36 £400. Studer B62 £500. Revox B77 £700, Studer A710 £500, Studer B67 £600, Studer A807 £850, Revox PR99 £600, EMT 950 £750, EMT 948 £450, Marantz CP230 £100, Uher RM £250. Tel: 01246 275 479 or Fax: 01246 550 421 (Jun/I)

HEYBROOK DUETS (£799) £599. Castle Howard MkII £799. Alchemist Kraken MkII pre/power £799. Neat Critiques (£399) £289. All above X/display. Audiolab 8000CDM & 8000DAC £899. Studio 12 Monitor Audio, piano rosewood (£1500) £859. DPA PDMII two box DAC (£2600) £699. Others available. Hi-Fi purchased. Objective Audio 01279 426 647 or 0973 452 368. objectiveaudio@cwcom.net
(Jun/I)

STUDIO 12 Stereo Decoder for Troughline tuner. Assembled and aligned PCB with instructions £18.50. Boxed, mains powered outboard unit ready to use £56.50. Tel: 01736 798 393
(Jun/I)

MIRAGE LOUDSPEAKERS, M5Si/M109i/MBS2/MC2/BPS1 50. Also M.I.T. MH 750II 25 foot bi-wire/M.I.T. 350 Proline balanced lead 20 foot. All are ex-dem and are open to serious offers. Please phone Audio Visual Concepts on 01628 440 873 anytime
(Jun/I)

1970's-80's HI-FI, over 100 units, (turntables, cassette decks, tuners, amplifiers, receivers, reel tape machines), shop comparator unit, test equipment, (prefer dealer/audiojumbler sale) For list: Tel/Fax. Roy 0113 270 1954, Leeds, (Jun/I)

EPOS ES22 (dark cherry) unused £900. Naim SBLs factory Mk2s £850. Naim Credo (ebony) as new £700. Quantum Minstrel valve amplifier £375. Arcam Alpha 7R amplifier £200. Alpha 7 CD £225. Tel: 01952 502 097 (Telford) (Jun/I)

NO VINTAGE! No New! But lots in between, 70's and onwards hi-fi. Phone for stock information: 0181 590 2890. Essex Sound & Vision, 762 High Road, Goodmayes, Ilford, Essex IG3 8SY. Mail Order Available. (Jul/I)

HI-FI WORLD CLASSIFIED ADS ORDER FORM

Dealers must not advertise in the Private Classified section. Monthly consecutive insertions will be considered Trade advertising. The Publisher reserves the right to judge submissions

classified ads form

Hi-Fi WORLD CLASSIFIED ADS ORDER FORM

Please type or write your advertisement copy in block capitals on a separate sheet of paper and return with this completed form.

SPECIAL OFFER

BOOK A PRIVATE OR TRADE CLASSIFIED AD. AND GET ONE MONTH'S FREE INTERNET AD.

RATES

Maximum length per advert is 30 words, each additional word is 50p extra. Telephone and model numbers are treated as one word.

MAGAZINE & INTERNET

- Private - Free Internet £10.00 per month
Private, Boxed - Free Internet £15.00 per month
Trade - Free Internet £10.00 per month
Trade, Boxed - Free Internet £15.00 per month

PLEASE TICK HERE IF YOU DO NOT WANT YOUR FREE INTERNET ADVERT

Name _____
Address _____

Post Code _____ Daytime Tel. No _____

I enclose cheque/postal order for £ _____ Made payable to:-
Audio Publishing Ltd.
Please debit my VISA/MASTERCARD card No. _____ Expiry Date _____



Send this form together with your payment to:



**Hi-Fi World Classified Ads.,
Audio Publishing Ltd., Suite F21,
Imex House, The Park Business
Centre, Kilburn Park Road,
London, NW6 5LF**

DEADLINE FOR JULY 1999 ISSUE IS FRIDAY 7TH MAY 1999

ADVERTISERS INDEX

Affordable Audio	122	Henley Designs	6	Rightnote	58
Arcam	84	Hicam	123	Ringmat	44
Art Audio	146	Hi-Fi Curiosity	138	RJF	132
Audio Com	123	Howard Dawson	106	Roksan	IFC
Audio Connoisseurs	128	Ian Harrison	136	Rothwell	123
Audio Illusion	40,119	IPL Acoustics	108	Russ Andrews	48,85
Audio Links	100	J T Loudspeakers	32	Sensonic	124
Audio Matters	119	Jem Distribution	128	Sevenoaks	18,19,36
Audio Note	120,121	KEF	25,27	Signals	140
Audio T	86	KJ West One	8	Sonneteer	132
Audio Venue	93	Langrex	104	Sound Image	IBC
Audusa	119	Linn Products	96	Sound Management	32
Billington Export	102	Listening Rooms	142	Sounds Expensive	138
Billy Vee	152	Loricraft	152	Sounds of Music	60
BK Electronics	104	Mantra Audio	142	Sounds Perfection	44
Cable Talk	146	Marantz	92	Sowter Transformers	108
Campaign Audio Design	58	Marton Music	102	SJS	152
Central Audio	126	May Audio Marketing	38	Sugdens	38
Chelmer Valves	112	Midland Audio Exchange	150	Sussex Surplus	144
Choice Hi-Fi	115	Mission	BC	Tag McLaren	10
Classique Sounds	140	Music & Video Exchange	124	Technical & General	100
Cricklewood	106	Musical Fidelity	30	The Hi-Fi Company	116,117,118
Custom Cable	125	Musical Images	136	Trichord	56
Definitive Audio	64	Musonic	136	Try Me & See	134,135
Definitive Audio (Brighton)	123,126	MVL Technology	12,90	UKD	62, 87
Disc To Disc Record Fair	130	Old Days Vintage Audio	148	Universal Audio	124
Diverse Music	148	Oranges and Lemons	56	Vacuum State Electronics	106
Emporium	125	Origin Live	132	van den Hul	56
English Analogue	148	Oxford Audio	146	Vickers Hi-Fi	130
Epos	32	Pear Audio	56	Virtual Reality	40, 48, 58
Falcon DIY	102	PG Hi-Fi	126	Visual Edge	148
Glaive	54	PM Components	110	Vivante	64
Glass Audio	142	Powerplant	124	Walrus Systems	54
Grandix	122	Progressive Audio	126	Walther Electronics	104
Halfin	138	Replay	40	Watford Valves	100
Heatherdale	128	Retro Repro	144	Zentek	64

advertisers index

STANDING OVATION

"For me, this is truly the ultimate desert island loudspeaker..."
Jack English, *Stereophile*, volume 19 no. 5.

"I am comfortable in saying that, to this point,
these are the best speakers I have ever heard. I love them..."
Johnathan Scull, *Stereophile*, volume 21 no. 4.



Sound Image UK Ltd ▪ 52 Milton Road ▪ East sheen ▪ London ▪ SW14 8JR
Tel 0181 255 6868 ▪ Fax 0181 255 6869 ▪ <http://www.focal.tm.fr>

*B*ehind beauty...



...lies technological elegance.



Real wood veneers:-

From sustainable european forests



Spring loaded tweeter:-

Ensuring clarity through isolation.



Sculptured 35mm Medite baffle:-

Maximum rigidity without reflective surfaces



Aerogel:-

Lightness with carbon fibre rigidity.

