

Hi-Fi WORLD

JULY 1991 £2.00



FOUR
RECEIVERS

NEW AIWA
CD PLAYERS

NEW
TDL STUDIO 4
TRANSMISSION
LINE MONITOR

NEW
CAMBRIDGE
CASSETTE DECK

OUR FAVOURITE
TEST DISCS

QUALITY
FERRIC TAPES
TESTED

NEW
GOLDRING
TURNTABLE



" THOSE MONITOR 14 SPEAKERS RIGHT,
THAT I JUST HEARD, PUT ME IN MIND, OF
THE FIRST TIME A CROTCHET. RIGHT,
CARESSED MY COCHLEA. I CAN FEEL IT
NOW, RISING AND FALLING IN A
CASCADING IRIDESCENT SPECTRUM, OF
AUDIO LIGHT AND SHADE, AND
CULMINATING IN A SONIC CATHEDRAL
OF SOUND... RAVE ON".

PRETENTIOUS MUSIC JOURNALIST.

"...But do they tingle the senses? They do."

- Value rating ★★★★★
- Sound rating ★★★★★

HIGH FIDELITY NOVEMBER 1990



MONITOR 14

RAM
RAM PROJECTS LTD



M O N I T O R
A U D I O

For further information contact:

RAM Projects Ltd, Unit 27 Stretford Motorway Estate, Barton Dock Road, Stretford, Manchester M32 0ZH. Tel: 061 866 8101 Fax: 061 866 8118



Cover Photograph by
Paul Hartley Studios

Contents

AMPLIFIERS

- ION SYSTEMS SAM 40:** Expandable three-box pre/power amplifier combination with class. 58
- ALPHASON APOLLO:** Wood-fronted integrated amplifier. Can good looks go with sound quality? 61
- MUSICAL FIDELITY CRPS:** We look at an unusual upgrade for the PI80 power amplifiers 62
- PENTODE vs TRIODE:** Reviving an old argument - which valve sounds best. 63

COMPACT DISC

- SONY'S NEW MIN DISC:** Hot news from Sony - a recordable mini disc for 1992. Full story. 8



- AIWA'S XC-500 AND XC-700:** budget CD players using different technologies We compare them. 36

CASSETTE TAPE

- CAMBRIDGE CT-50:** The 'first' British cassette deck 34
- TAPE TEST:** Up-market ferrics. Is there a clear winner? 44
- TAPE SPECS:** A simple guide to tape specs. 47

LOUDSPEAKERS

- TDL STUDIO 4:** The delights of a superb transmission line loudspeaker. 25
- TDL INTERVIEW:** how come such a big manufacturer is so little known? 28
- RUARK SWORDSMAN PLUS:** Mid-price loudspeaker with a craftsman finish. 41
- KELLY'S CORNER:** Quad Electrostatics for £50! Get sick by reading this!! 71

RECEIVERS

- FOUR RECEIVERS TESTED** 18
 Rotel RX-850AL NAD 7225PE
 Pioneer SX-757 Denon DRA-335R

TURNTABLES

- GOLDRING EXCELDA I:** Scoop review of a new budget turntable. 30
- THORENS TD-150:** More on reviving an old classic. 57

FEATURES

- DESERT ISLAND TEST DISCS:** A selection of our favourite test discs. 48
- INDOOR AERIALS:** Making the most of indoor dipoles and their brethren. 43
- FAMILY TREE:** An unusual look at movements in the UK Hi-Fi Industry. 54
- CHESTERFIELD DESIGN SHOW:** Our visit to a specialist small show. 74
- BOOK REVIEWS:** Two interesting tomes for the enthusiast's library. 77
- AUDIO EXCELLENCE RECORDS:** A novel idea. A hi-fi shop that sells music! 83

REGULARS

- NEWS:** All the news from around the hi-fi industry. 5
- LETTERS:** Yet more letters! We've worn out two postmen already! 10
- COLUMNS:** Out of the mouths of babes and hi-fi journalists... more columns than ever! 13
- TWEAKY CORNER:** Concluding last month's feature on component quality from Graham Nalty. 65
- QUERIES:** We try to find the answers to your hi-fi questions. 79
- NEXT ISSUE:** Some of the goodies gathered for our August issue. 83
- SPECIAL OFFERS:** Strange and wonderful hi-fi accessories that can be bought through the magazine. 84

MUSIC

- RECORD OFFERS:** Our own selection of good quality music is ever expanding and available on LP, CD and DAT by mail order. 97
- RECORD REVIEWS:** Our round-up of the latest releases you can't afford to miss!
 Rock from Malcolm Steward 94
 Classical from Peter Herring. 88

Editor
Noel Keywood

Deputy Editor
Alan Sircom

Production Editor
Philippa Steward

Advertising Manager
Damian McNamara

Marketing Manager
Akila Lingham

Contributors
Malcolm Steward
Peter Herring
Richard Kelly
Roy Gregory
Danny Haikin
Chris Binns
Richard Brice

Cartoonist
Freddy Ahmet

Computers:
Benchmark Press
0442 891151

Distributed by:
COMAG, Tavistock Road, West
Drayton, Middlesex, UB7 7QE
Tel: 0895 444055

Origination by:
Ebony Ltd., Heathlands Rd., Liskeard,
Cornwall. Tel: 0579 46880

Printed by:
Southernprint, Poole, Dorset.

HI-FI WORLD
is published monthly
on the 3rd Thursday
of the month preceding.

AUDIO PUBLISHING LTD.,
64 Castellain Road,
Maida Vale,
London W9 1EX.
Tel: 071-289 3533
Fax: 071-289 5620

Hi-Fi
WORLD

No material may be reproduced
from this magazine without
the publisher's permission.
© Audio Publishing Ltd

The TU 260L Tuned to perfection



As a leading manufacturer of equipment for broadcast and recording studios worldwide, Denon has applied its extensive knowledge in making marked advances in basic tuner performance.

The TU 260L is the first budget tuner in the Denon range, but it still offers the build and performance of its highly acclaimed brother, the TU 660L. Denon products may cover a wide range of prices but they represent a single standard of quality.

DESIGN FEATURES

FM, MW and LW wave bands • 20 station random preset memory • Auto/manual tuning facilities • Rapid FM station search

WHAT THE PRESS SAY

"...at the price it represents superb value and faces little immediate competition – an excellent first choice for the enthusiast on a tight budget."

WHAT HI-FI, SEPTEMBER '80

HOME HI-FI, LIFESTYLE PRODUCTS, CAR AUDIO, CD PORTABLES,
CD SOFTWARE AND PROFESSIONAL BROADCAST EQUIPMENT.

DENON

Enquiries to: Denon Freepost Enquiries, Chiltern Hill, Chalfont St Peter, Gerrards Cross, Buckinghamshire, SL9 9BS.

Hi-Fi World brings you all the latest news from the hi-fi industry



NEAT PETITE

Not only a misspelling of a classic Jackie Wilson song, Neat (North Eastern Audio Traders) Hi-Fi have announced the launch of their mini monitor loudspeaker, called the Petite. Priced at £525, the Petite features nothing new at all!

The designers behind the new loudspeaker suggest that traditional design methods can compete with the use of modern cabinet designs and materials. To this end, the Petite features a custom made 6.5" doped paper bass/mid unit and an Audax 1" soft dome tweeter, silicone mounted, hard wired and hand assembled.

Designed for use in high end systems, the Petite was originally unveiled at last year's Penta show.

MORDAUNT-SHORT UP A MOUNTAIN

Mordaunt-Short's new Classic loudspeakers are being launched in a novel way. Rather than using the usual press launch, M-S have opted to take their launch flag on expedition to Mount McKinley, the highest mountain in North America. This exercise, which is also designed to raise money for 'Save The Children' (M-S is sponsoring the venture), is said to be "the high point of the Hi-Fi year".

Joking aside, the Classic 20 and 40 loudspeakers themselves both feature a 25mm ferrofluid damped and cooled metal dome tweeter and 165mm bass/mid drivers (one in the Classic 20, two in the Classic 40) with injection moulded cones and surrounds. A simple crossover network is used to limit any distortion. Available in Black Ash, Walnut and Mahogany real wood veneers, both models will be launched at the June C.E.S. in Chicago and will be in hi-fi stores in July. The Classic 20 costs £395 (plus £105 for the optional stand) and the 40 will put you back £595.



NAD'S FLOORED

Following their successful venture into the field of loudspeakers with the 8225 mini-monitor, NAD have unveiled their new £299.95 floorstanding 8100 loudspeaker.

Finished in Black Ash vinyl, the 8100 is a two way reflex model that features a soft domed tweeter and a "Cobex" woofer with a massive magnet to produce deep, well controlled bass. This, combined with its high sensitivity (89dB/W at 1m), enables the 8100 to be partnered with a wide variety of amplifiers rated anywhere between 25 - 80W.

In addition, the 8100 features gold-plated 5-way binding posts that allow for either bi-amplification or bi-wiring. Finally, the 8100 comes with spikes to couple the loudspeaker directly to the floor, without the need for any supplementary stand.





BEST

Naim is committed to giving customers the greatest possible satisfaction from recorded music. We're very confident. We have the technology, the resources and the people.

Our product range extends from an acclaimed new state-of-the-art preamplifier, the NAC 52, to the famous little NAIT, the integrated amp with no fuss and the most music.

Our tuners are unassailably the best. You don't know how good radio can sound until you've heard them. Our award-winning loudspeakers, the SBL and IBL, set a completely new standard of design and manufacture.

Naim engineering is part care, part know-how, and part sheer love of music. Whatever your system, if music is a real part of your life, and you want the very best, come to Naim.

naim audio

SOUTHAMPTON ROAD SALISBURY SP1 2LN ENGLAND TELEPHONE 0722 332266



LINN PRODUKT

Linn Products are continuing their regular launch of products. This month sees the launch of the Kaber Aktiv active crossover for their Kaber loudspeaker and upgrades to the Kabers themselves and the long-standing lttok tonearm.

Since its launch in 1989, the Linn Kaber has been an obvious target for the development of an active crossover. The Kaber Aktiv crossover, a development of the existing Isobarik Aktiv, features a new power supply, developed for the Kaim preamplifier, and more efficient circuitry. This costs £992, with the crossover-less Aktiv Kaber loudspeakers at £998.

In the process of developing the Aktiv crossover Linn also looked to the loudspeaker and found that there were improvements to be made. The changes, which bring the cost of the Kabers up to £1198, involve a new ceramic coated treble unit, larger magnets and improved suspension for the mid/bass units and extensive use of Ku-stone within the mid-range and bass enclosures to aid damping. These improvements can also be fitted retrospectively to existing Kabers for £220.

Finally from Linn, improvements have been announced to their lttok tonearm, now called the lttok LVIII/2. The new arm, costing £560, uses the same lift/lower device and armrest found in Linn's top Ekos tonearm. These are said to eliminate resonance from the armboard. In addition, the lttok LVIII/2 also features a longer armtube with shorter headshell, to improve the rigidity of support for the cartridge.

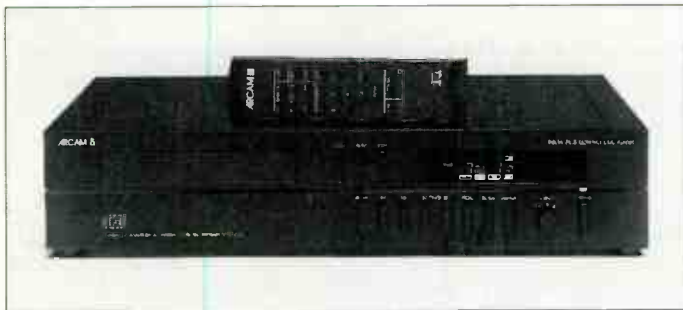

ARCAM'S NEW BITSTREAM CD PLAYER

Arcam's latest Compact Disc player, the £649.90 Delta 70.3, is the first CD player in their range to feature Bitstream. After nine months of rigorous circuit testing based around the Philips SAA-7350 chip, Arcam finally feel confident that their new Bitstream convertor is musically superior to its sixteen bit predecessor, the Delta 70.2.

Based around the earlier model, the 70.3 also features improvements to the digital CD decoder board. This board, featuring third generation decoding chips, is said to improve the playability of discs. In addition, the co-axial output, for connection to external digital-to-analogue convertors, is now supplied to Class 1 precision. This means far greater compatibility with other DACs.

Existing owners of Delta 70.2 players will be pleased to know that Arcam have honoured their promise of upgradability. Both the Bitstream and decoding board are available for the 70.2, priced at £180 and £120, respectively. Arcam are also honest enough to suggest that for most owners, the Bitstream board alone would suffice, stating that the £120 decoding board only adds about 10% to the overall sonic improvement.

IN BRIEF

IT'S SHOWTIME!

Congleton Hi-Fi are presenting a musical evening with Linn Products on the 24th June. Linn will be showing off their new Kaim preamplifier, the Aktiv Kabers (see Linn news story on left) and many other goodies. Admission is by ticket only and the evening, which starts at 7.30 pm, will be at Congleton's store at 1/1a Duke St., Congleton, Cheshire. For more details, contact Steve Cardell on 0260 297544.

A HIGH-END open day is planned for Saturday 6th July at the Guildhall in Cambridge. Featuring people such as Nottingham Analogue Studios, Bandor, Art Audio and Pentachord, the show is expected to run from 10.00 am until 5.00 pm and admission is free. Contact Oliver Brooke on 081 788 2288 for details.

AUDIOFILE of Bishops Stortford (0279 506576) are having a 4th of July Barbecue with an American theme. This will feature the new KEF 107/2, the Naim CD player and new amplifiers from Alchemist Products.

HARROGATE AUDIO AND VIDEO FAIR promises to be one of the biggest shows this year. Occupying five halls in the town's Exhibition Centre between November 7th and 9th, the show aims to cover the full range of consumer electronics including hi-fi, video, in-car and more.

AIWA have developed two new personal stereos, that can be made water and dust resistant when needed, without being cumbersome. The uni-directional £61.99 HS-RD5 and the auto-reverse £71.99 HS-RD7 feature Aiwa's new 'Radical' shell, which fits over the machine to keep it free from harm. It also uses a UV sensor that gives an early warning of excessive ultra-violet light levels - a good feature in these days of Global Warming.

B&W loudspeakers have announced their latest assault upon the mass market with new DM-600 and DM-610 loudspeakers, priced at £159.95 and £199.95 respectively. These new models, finished in 'Zelda' (!?) feature many of the innovations incorporated in B&W's more up-market designs, such as their metal dome tweeters.

MUSICAL FIDELITY are, according to a survey conducted by The Independent On Sunday and accountants Price Waterhouse, one of Britain's fastest growing privately-owned companies. Ranking 31 among the Top 100, MF's sales grew by 555% and their workforce by 443% over the past five years.

GOODMANS INDUSTRIES LTD. have moved. Their new address is Units 2&3, Mitchell Way, Portsmouth, Hampshire PO3 5PR.

BANDOR have announced the latest in their range of drive units. The new unit features a 4" spun aluminium anodised cone, with an aluminium former and a large magnet. Power handling is a maximum of 100W RMS and the unit is claimed to be humidity-proof. For details, contact Bandor direct on (0494) 714058.

HORN LOUDSPEAKER APOLOGY

Unfortunately, due to severe production difficulties (the saw wore out), we regret that we are forced temporarily to suspend Kit 2 of our Horn Loudspeaker. Kit 1 will still be available, however, and we are hoping to re-establish the full kit as soon as possible.



A prototype Sony MD recorder, with a CBS prerecorded disc (Mariah Carey - see p48 for review) and a Sony blank, recordable disc. Note that an MD recorder is bigger than an MD player.

lot of musical information. This is the reason it does not match the sound quality of a normal Compact Disc. A data rate of 1.4Mbits/second (Megabits, or millions of bits per second) compares with 2.4Mbits/second for the full size disc. The lower rate of MD means that roughly 40% of the encoded musical information is discarded. In this respect it is much like Philips Digital Compact Cassette (DCC) system, also due out in 1992. Both have to discard information to get enough playing time from a small and inexpensive carrier. The two new systems are direct rivals, both aiming to replace the ordinary cassette, which still comfortably outsells all other music formats.

To become as popular as cassette, certain difficult requirements have to be met by MD. It must be inexpensive, recordable, durable and portable. Conventional CD inadequately meets these requirements. Cassette sales - prerecorded and blank - have remained unaffected by its success.

SONY announce recordable mini-disc

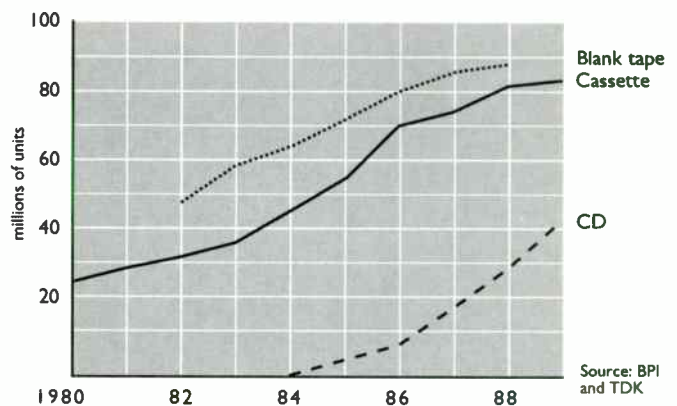

Cassette is overwhelmingly popular in Britain. Blank and prerecorded tapes had a combined sale of no less than 170 million units in 1988 (CD - 30million). Cassette is similarly dominant on the USA. These two markets alone are very valuable to the audio industry.

The race is on for a new digital recording medium to replace the cassette. Philips have announced Digital Compact Cassette (DCC). Now Sony have weighed in by announcing a rival - Mini Disc (MD). It is a small, recordable Compact Disc designed for use in a new breed of digital Walkman. Due for launch late in 1992, MD will hold up to 74 minutes of music.

Sony carefully state that sound quality of the new MD format "approaches" that of the full size disc; no claim is made to match it, since the new medium is meant to complement normal CDs, not replace them. "It is superior to the cassette, which it is designed to replace" we were told, "but it is not intended to replace either CD or DAT."

The disc itself is 2.5 inches in diameter (64mm) but it comes in a cartridge for protection, like a computer diskette. This is designed to make MD as durable as an ordinary cassette, so it can be carried in a handbag or pocket without becoming damaged or contaminated by dirt. The disc is not removable - the cartridge is inserted in a player. It measures little more than a disc alone, being almost square in profile (72mm x 68mm) and just 5mm thick.

Mini-Disc players will be very small - capable of fitting into the palm of the hand. They will be smaller than DCC players. However, because recording draws a lot of power, Mini-Disc recorders are likely to need large batteries, lessening any potential size advantage over DCC.

MD format uses a new adaptive coding technique that removes a

MD discs will cost little more than cassettes: prerecorded around £10 and blank around £4.50. They will have to compete with DCC tapes, which are going to be inexpensive.

Similarly, MD recorders must compete on price with DCC recorders. Since both Philips and Matsushita (Technics and Panasonic) intend to mass produce DCC, again prices will be low. Portable MD players will cost around £100, domestic recorders around £300.

Another battle Sony have to fight is with the Music Business. To be successful, a wide range of prerecorded material on Mini-Disc must be available in the shops from launch day onward. Philips have already dealt with this problem, getting big players like Virgin, EMI and Polygram to agree to release their music on DCC. Sony bought CBS to help them in this respect, but one company's catalogue will be insufficient. Whether Sony will successfully persuade the crucial UK music business to sign up for MD is open to question. But as a spokesman for EMI said, talking about his industry colleagues: "they'll do anything for money!" If Sony's pocket is deep enough, software should be a surmountable problem for them.

Digital Audio Tape (DAT) retains the quality advantage of CD, it is recordable and it is durable. High tape costs appear to have persuaded both Philips and Sony that it is unsuitable as a mass market product. DAT was euphemistically declared "a professional recording medium" by Philips, at the launch of DCC. In this manner, Philips

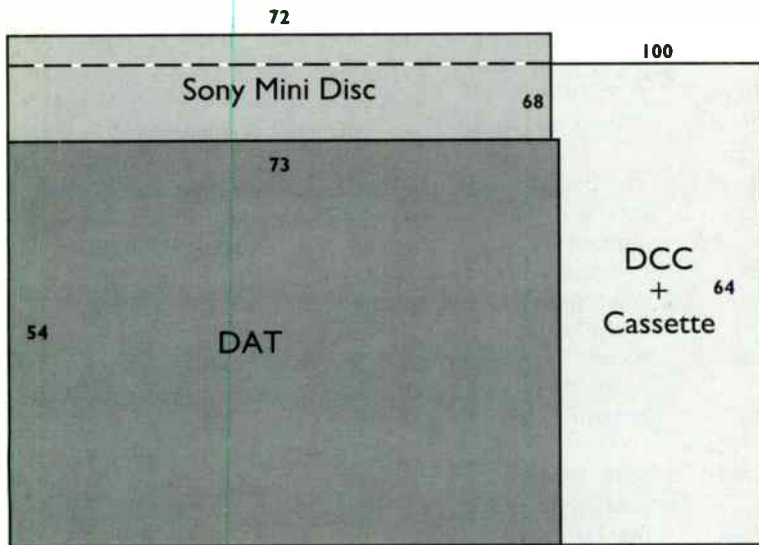

Left: Mini-Disc has a square profile and is just 5mm thick. But in outline it is not significantly smaller than cassette or DCC. DAT is smaller than Mini-Disc. Shown here actual size, in mm.

| Product | Units (Millions) | Value (£m) |
|--------------------------|------------------|--------------|
| Cassette Decks | 0.2m | £30m |
| Portable Recorders | 0.3m | £7m |
| Radio Cassette Recorders | 2m | £115m |
| Personal Stereos | 3.3m | £87m |
| Total | 5.8m | £239m |

Right: Sales of cassette related audio products in the UK totalled 5.8 million units in 1989, worth no less than £239 million. This is the sort of business Sony and Philips are chasing.

acknowledged that DAT gave superior recording quality, whilst pointing out that DCC would be more widely acceptable because of its lower tape costs. With Sony's announcement, DAT has been firmly shunted to one side as an expensive, high-end recording medium.

That cassette has been an inexpensive, portable, durable and recordable music carrier since 1963 is a tribute to Philips, its inventor. However, it was Japanese ingenuity that helped to popularise it, Walkmans and radio cassette recorders playing a major role in this process. Both Philips and Sony have benefited from cassette in the past. Now, each are struggling to find its successor.

To cram 74 minutes of music onto the Mini-Disc, Sony use a data compression system they dub ATRAC (Adaptive Transform Acoustic Coding). This is a particularly awkward name for a system that possesses strong similarities to Philips PASC (Precision Adaptive Sub-band Coding), used in DCC. Soft sounds are masked by nearby louder ones, making them inaudible. The coding process cuts them out. Very soft signals below the threshold of hearing are also removed. By this technique, a lot of unwanted information is discarded, relaxing coding requirements. In contrast, the linear non-adaptive coding system of CD and DAT encodes everything in a music signal, whether it is thought to be audible or not.

Sony are suitably cautious about ATRAC, slightly more so than Philips are about PASC, even though the latter discards more of a music signal (60%) in order to use ordinary chrome videotape. The trouble with both is that they stray into uncharted territory on psycho-acoustic masking effects. This is a highly complex and imprecise field currently being researched.

I have heard DCC and it sounds fine - in a noisy environment. Philips had the builders in at the time! Whether PASC and ATRAC will survive critical assessment under more rigorous conditions has yet to be determined. Sony simply acknowledge that DAT is the high quality recording medium; ATRAC is suitable for its intended purpose - use in budget audio products. Both ATRAC and PASC have a claimed dynamic range of 105dB.

More revolutionary and edifying than systems which throw the music away is the ability to record onto CD using a low power laser. Here, Sony's technology is impressively advanced. A laser heats a small spot on the disc's surface to 200 degrees Centigrade. A new type of highly efficient record head is used to apply a strong magnetic field, imprinting a digital signal that becomes permanent when the sur-

face cools. This magnetic recording alters the optical properties of the surface, allowing it to be subsequently read by an optical pickup, like a normal Compact Disc. This cleverly allows magneto-optical discs recorded on the player to be replayed, as well as normal prerecorded optical discs bought at a record shop.

The breakthrough here was in perfecting a low power recording system that would work from batteries. However, Sony say conspicuously little about power consumption, recording time and battery size of MD recorders. Their pictures clearly show that a recorder is larger than a player.

MD format lacks the compatibility of DCC. Whereas conventional analogue cassettes will play on a digital DCC recorder, MD is totally incompatible with CD.

When playing, the music from a disc is read into a three second memory. This fills in gaps caused by the player being joggled. How MD will react to continuous vibration, is open to question. This is a weakness tape does not suffer.

Although MD is a rival to DCC, Sony tell us that talks have been held with Philips about the medium. Meanwhile Matsushita, Japan's largest electrical company that sells under the Technics and Panasonic brand names, has announced it will support DCC. And guess what, Philips have just said that DCC will now be launched earlier - in the Spring of 1992, or about six months before Sony launch MD. The battle to replace the cassette is going to be a tough one. **NK**



A prototype MD player. It sits in the palm of the hand. Sony have provided readout of lyrics - also a feature of DCC.

● BADA representative, Mr Mike Lewin, said in a recent magazine article that in order "to maintain parity, UK manufacturers have to raise prices, and bring dealer margins more in line with the margins in Europe". BADA was also quoted as claiming that dealers in some parts of Europe make as much as 40 per cent profit, whereas UK dealers average 30 per cent. The implication is clear: British dealers should increase their prices to increase their own profits to the same level as Europe. In the same article, Mr Lewin also claimed that the increased profits would go towards better service in shops.

Well now, if you believe that, you'll believe anything, including the claim that the moon is made from blue cheese. In any case, having lived and worked in Germany for many years, I would say UK dealers would need to do a great deal more than raising their prices by 25% (to increase margins from 30% to 40%) to even approach, never mind equalling, the standard of service provided by the average German shop.

The Germans enjoy a far higher standard of living than we do and in consequence demand much higher standards of service, for which they are willing and able to pay. It has yet to be realized in the UK that good service is a question of attitude, rather more than a problem of cost. As long as the "Them and Us" and the "I'm as good as he is" syndromes remain paramount in this country, the ability to give really good service will never be learnt.

By British standards, I would say that our average Hi-Fi dealer does a good job. I suspect that 'by and large' most customers are reasonably satisfied. However, this latest statement by BADA (a lesson in lunatic PR) will needlessly annoy many of them and, I suspect, quite a number of dealers themselves. I suggest that dealers should consider leaving BADA and use the money they save to help their cash-flow.

Peter P.H.Rein, Devon.

● Your columns by Noel Keywood and Danny Haikin (May issue) were most interesting, for once telling the truth about the role of a reviewer. However, the articles don't go far enough. For the purpose of maintaining consensus, a minimum reference standard is necessary to make comparisons. But this is a non-starter; who determines the standard - assuming one exists?

Of greater importance is the content of the review and how it conveys its meaning. Products under scrutiny could be aesthetically acceptable, in terms of build quality, but too below standard in their basic task - the reproduction of music - to perform well. Yet often they receive an accolade towards the end of the review, presumably to soften the blow or for some other lame reason. The latter smacks of indecision and a lack of true conviction, which is unhelpful to the reader. I assume that reviewers are under pressure from outside influences for reasons best known to themselves and are prompted - or obliged - to adopt this particular stance.

As for how a system sounds, it virtually defies description. Danny Haikin expresses my view entirely: "How can I describe my taste in precise enough terms to allow another person full insight. I can't. And neither can anybody else." Surely, reviewers in these circumstances should inform readers that the advice they give is a guide, not an assurance.

We can go to a specialist dealer but here we are listening in a room unlike our own. The only alternative is to ask for a home demonstration. This presumably would increase costs considerably as there are few dealers willing to undertake this out of kindness.

Finally, it would be beneficial for Noel to visit the Tottenham Court Road. He may be fortunate enough to find there a system purporting to be hi-fi which actually is hi-fi. Reviewing such items would dispel any suspicion that the team only serve the

upper crust, reviewing expensive equipment, while those on income support (that's me) are relegated to 'Which Magazine' for cheaper products.

**A.T. Place,
Clevedon, Avon.**

The Editor writes: There is little consensus on reference systems and if you heard a few reviewers' personal references you'd be shocked at the differences between them!

Very heavy personal pressure is often put upon reviewers by manufacturers. Sometimes it takes an aggressive form (long argumentative phone calls), sometimes a more insidious passive one (home visits, hospitality, etc). There's enough argument and pressure to make all but the most convinced - or bigoted - to waver a bit. It might look lame, but bear in mind that unequivocally stated viewpoints, if controversial or potentially damaging, can attract fierce retaliation, including threats of Court action. Sometimes it is wiser to damn by faint praise.

Whilst we cannot convey sound quality with perfect accuracy, an approximate outline is often sufficient. Reviewers only need give their honest opinion, based upon experience. Most readers fully understand the limitations inherent in doing so.

● May I take this opportunity to clear up a few points regarding the Marantz PM-40SE and the Pioneer A-400.

My particular contribution to the A-400 was, apart from the major difficulty in persuading a company the size of Pioneer to commit to the project at all, the very careful specifying of the way in which the amplifier should be built and what priorities should be applied where. The straight-line circuitry, low negative feedback, three core mains cable, lack of tone controls and speaker switching, etc, were all in my original brief to the engineering team. Final

listening tests and component choice were carried out in my home, to my requirements on the basis of my own preferred sound. Can we now put an end to the belief that a British designer had anything to do with the A-400? Pioneer assigned three people to the project, with Mr Yamagishi being the chief designer.

When I later joined Marantz the first thing I looked at was the PM-40SE. Ken Ishiwata, in charge of Marantz audio design, came to my house, listened to what I had to say about the sound of the amplifier and came up with the changes that have been incorporated.

The two companies now offer alternatives to people, avoiding definitive statements about absolute merit. Most dealers should be able to build a system upon either amplifier that would allow this to happen. I am pleased to see this was the general conclusion of your article.

**Doug Randall,
Product Marketing,
Marantz.**

● I have enjoyed the articles in Hi-Fi World concerning tweaking and home construction. I firmly believe in trying to get the best value for the money I spend. One gripe that I do have: I wish the article in issue 2 (April issue) concerning the horn loud-speaker kit could have given some more in-depth information so as to encourage people to experiment with their own designs (rather than "buy the kit" and see), and explain the rationale behind the design as I am not totally convinced that it is a horn speaker in the usual sense. It has been stated that Hi-Fi World has its own test facilities - so why not put the horn in the anechoic chamber and give the readers some idea of its technical performance?

Finally, a request to Mr. Keywood. In the first two issues of the magazine there have been several mentions of his own Quad ESL 63 (modified) and sub-woofer

system, complete with active filters etc. I am sure many readers (including myself) would be very interested in details of his system appearing in the magazine in depth, e.g. modifications to ESL 63s, active filter design (maybe including circuit diagrams etc.) and final (measured) performance.

**Mike Croning,
Ware, Herts.**

The Editor writes: The horn loudspeaker became quite an organisational problem for us on the woodworking side so we have temporarily stopped Kit 2 in order to retrench, as it were. We have tested it and it has been in an anechoic chamber, but being tunable, there are many different possible responses. In the near future, a full set of specs will be published and, we hope, samples will be available in certain dealers for auditioning.

Quad Mods. and my crossover are on the agenda for a future issue. Some more information is to be found accompanying Mr Tilney's letter.

● Having been the owner of Quad equipment including ESL 63s for many years, and a lover of classical music, I was particularly interested to read in the March Kaleidoscope column that you use a Celestion SL-600 sub-woofer in your system.

I have often wondered whether a sub-woofer would be an improvement to my system but have usually concluded that the overall effect would not improve the sound quality of the Quads. However, in view of your own experience I would appreciate your views.

I deal with Bowers and Wilkins of Worthing who are an excellent firm and would arrange a trial for me if required and it would be helpful to know whether the Celestion sub-woofer is the one you would select for trial. I have had no experience of this item.

I would also be glad to

know whether the siting of the sub-woofer is important with the other speakers and how it is linked to the amplifier. You will no doubt realise that I am not a technical expert in these matters.

**T.V.J. Tilney,
Horsham, W.Sussex.**

The Editor writes: Using Quad ESL-63s with sub-woofers poses some interesting but difficult problems. They do benefit from sub-woofering because:

a) bass cancellation starts to occur below 270Hz, due to panel dimensions,

b) large bass excursions do not suit the diaphragm or the input transformers.

A better way to reproduce bass is needed. One way is to increase baffle size and therefore bass efficiency. Removing bass signals from Quad's by sub-woofering eases their load, giving a cleaner sound and allowing them to go appreciably louder.

The Quad's are difficult to subwoofer, so beware. You can use them with the Celestion SL-6000s, but in the end I found this arrangement unsatisfactory. The Celestion's sound big and they go very deep, but they also sound a bit slow. Subjectively, they don't marry up to the Quad's at all well, listeners noting a gap between them. This in fact really does exist and it cannot be removed, except by using various special equalisations that compensate for certain acoustic effects. This is why, in the end, I decided there was no solution other than to research the problems, find solutions and design a suitable crossover network. Sorry to be vague, but I'm sure you don't want to know about fourth order, stagger tuned Chebychev filters and such like, which are necessary, I found.

The Quad's have to be equalised and the SL-6000s also need a much better equalisation curve than that



readers' reply

in Celestion's own crossover. I am having ten prototypes built soon, mainly for experimental use, to assess the magnitude of room positioning difficulties with the SL-6000s.

As you might appreciate, this is a complex business, but a fascinating one all the same. It provides a system that works from sub-bass frequencies up to 20kHz, images superbly and actually improves the performance of the standard ESL-63. In the meantime, you may be interested to know that Philips use no fewer than fourteen pairs of ESL-63s with Celestion SL-6000 sub-woofers for studio monitoring at Polygram, Holland. The system is worth hearing, even if it is imperfect. Unfortunately, the SL-6000s have to be positioned by Celestion's computer at present, making home demo difficult. Speak to your dealer about the matter; he may be able to arrange something.

● I must air my views on modern audio equipment manufacturers and users and their constant push for 'perfection' in music. I feel that the industry must by now realise that they are not going to be able to keep on

**Send your letters to:
Hi-Fi World Letters
Page, 64 Castellain
Road, Maida Vale,
London W9 1EX.**

conning the consumer into thinking that new products are constantly better than the previous model on offer. I have been around many outlets listening to equipment on offer and I do not see how they will better the reproduction quality that is currently available. I think that a lot of improvements are thought to make equipment sound better through wholly psychosomatic interpretation of "they say it's better, therefore I must be able to hear it as better".

How close to perfection do you need to be? Come to that - what the hell is perfection anyway? In my view, hi-fi has got as close to it as it will ever get! The whole point of hi-fi is to recreate music for pleasure, not measure!
**Steve Whitt,
Gateshead, Tyne & Wear.**

● I have owned almost every piece of Quad equipment produced since 1960 and my comments may be of interest to your readers.

Firstly, do take Robin Marshall to task for some of his objections to panel speakers. He states that as sources, the panels are too large to produce the ideal point spherical sound source. He then goes on in some detail to elucidate the precise philosophy of design behind the Quad ESL 63s. Well, cone speakers are quite small but they seem unable to produce pin point accuracy in direction - the sound is very 'small' but totally 'unlocalised'.

Back to main theme: should sound systems be the 'closest approach to the original sound' or should they be 'musical instruments'? There are two types of listener: those who insist on Hi-Fi, and those who insist on Big-Fi.

Big-Fi first. Most pop, rock and some classical music is purely electronic in origin, hence the 'original' has little meaning since it depends on the particular equipment used. Also, many lovers of classical music have never (and will never) attend a live venue, and here again the correlation to original is meaningless. The aim seems to be a big, rather than lifelike sound.

Now Hi-Fi. This will appeal to people who attend live concerts and take their music seriously, possibly even listening with a score in front of them.

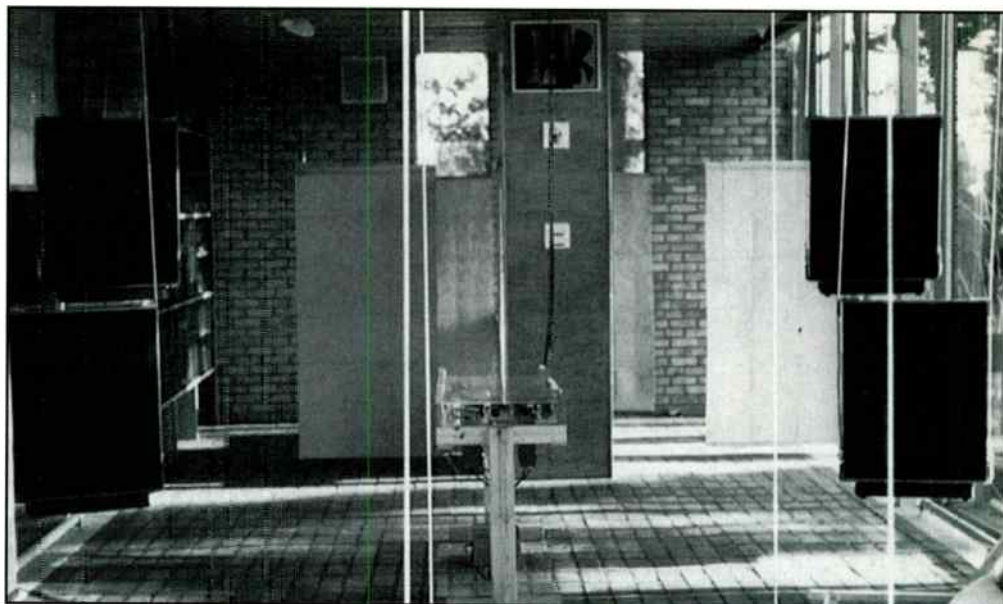

A brick and glass menagerie, or a shrine to Quad?

I admit to belonging to the second group, but I do not consider it necessarily superior - it's an acquired taste.

Now on to my experiences with the Quad ESL 63 electrostatic loudspeakers. I used to use a stacked pair of the original ESLs, but this arrangement is impossible with the '63s, owing to cancellation, etc. After some tortuous experimentation, I have arrived at the arrangement shown in the photograph above. I have a very large listening room (an L-shape of 63 by 43 ft, 16ft wide, 10 ft high). The surfaces are rather hard - brick or glass - but I did install a highly absorbent acoustic ceiling when I built the house. Looking back at my original design calculation: RT at 125Hz = 0.78, at 500Hz = 0.46, at 2000Hz = 0.42. I have no instrumenta-

tion to check these values, but they seem OK. I do have some 'flutter echo', ie when clapping hands, but this does not seem to affect the music to which I listen. I also have a pair of venerable box speakers wired across the positive terminals of the 606 (Hafler arrangement) and this is particularly good for organ music and orchestral climaxes.

So what about the final sound? Superb. Sufficient volume and excellent imaging. Well, there are just two organ pedal notes which can elicit a mild buzz when driven at maximum preferred volume. As a matter of interest, I was able to eliminate this problem by lowering the whole array so that the bottom speakers were 6in above floor level. In this position, I could obtain equal apparent volume by reducing the setting on my Quad 44 preamp by one notch. Regretfully, I was forced to raise the assembly to 18in above floor level - because we have three cats!

It may be slightly perverse, but I find that my system is most impressive with well recorded historic material - of which there is now a vast selection. The soloists/singers are precisely located and the orchestra seems to occupy a rather wider - although still undefined - space. A sort of pseudo stereo sound!

**Heino Anderson,
Leicester**

The Editor replies: OK, you win! Anyone that designs and builds his house to accommodate stacked ESL 63s has just got to get the prize for single minded dedication. I've heard some nutty Quad stories, but yours is number one.

You may be interested to know that the Quad recommended way of using two pairs of ESL 63s is to arrange them in L formation at either side. The main speaker faces you, the auxiliary sits at right angles to it. This increases maximum possible volume level, without compromising the point source property of a single '63. Anyone wanting to know more about this somewhat costly arrangement should contact Quad, who of course would be delighted to help!

I imagine that your own arrangement gives superbly large images and, firing downward, clearer treble, since Quad '63s sound best when you listen to them from beneath. But haven't you heard about the man who built bass horns under the floor? They'd make wonderful sub-woofers for Quads - you just need to re-design your house a bit!



I was taken aback by Sony's announcement of the Mini-Disc system (see p8). Philips DCC tape format seemed mildly unnecessary to me at the time of its launch, and it set a disturbing precedent for a hi-fi buff: quality compromised for the sake of cheapness. As far as hi-fi is concerned, DCC is a step backward, not forward, because it throws away more than 60% of the music. I have come to understand its role and accept its future presence, even if I don't exactly welcome the notion of a less than perfect medium. The idea that a similar rival system would be launched, however, was too fantastic to contemplate. Now we have two deliberately imperfect music systems.

Incredulity

Non hi-fi buffs - meaning most sane people - look at hi-fi with incredulity. The increasing number of formats and their innate complexity is quite the reverse of what the average man or woman really wants: namely ONE format that does everything. It must sound superb, be affordable, portable, durable and recordable. OK, so that's a tall order that can't be met with today's technology. It is an interesting set of requirements all the same, because it gives a clear idea of what the future is likely to hold.

By saying in effect "we can't make a high quality system that is cheap, so we'll make a lower quality one specially" both Philips and Sony have polarised the market in quality terms. This may have some interesting consequences. We now, for the first time, have 'officially' recognised lo-fi and hi-fi. Lo-fi is represented by DCC, and now MD. Hi-fi will be represented by CD and DAT. Cassette is being unceremoniously kicked out, after serving us all so well for so long. The future has to be digital; what a pity that retrograde digital is being proposed as a possible answer.

It may all go very wrong. But who for? If DCC or MD bomb, then so be it. I'll get to sleep at night and so will most hi-fi enthusiasts. But what if DCC or MD are successful? Could CD and DAT then become commercial victims? Were this to occur, then in 10 years time arguments about LP and CD will be looked at wistfully by music lovers. Both may have

succumbed to a second rate digital system. To work at all, both DCC and MD discard enormous quantities of musical information. This must be the first time the hi-fi industry has deliberately taken a step backward to make money.

But do people buy music systems they know are sonically inferior? The answer has to be yes, at least while there is a big price incentive to do so. Cassette has proven this point. Most people are at least vaguely aware that cassette is not a high quality medium, but that has not affected its sales one little bit. However, cassette has traditionally possessed some enormous advantages.

Until DAT arrived, cassette was unique in being durable, portable and recordable. DAT is now all those things, leaving cassette with just one main advantage - cheapness. Philips and Sony now propose to push DAT aside to come up with an acceptably cheap digital medium. But is the gap between DAT, and two systems that are by definition inferior, great enough to clearly swing the market one way or another? I would at least expect some hesitation and resistance on the part of consumers, made worse by the confusion of two new formats. Hopefully, they will not overwhelmingly choose DCC or MD.

Simple Truth

Perhaps the simple truth is that in spite of DAT's potential, it has been successfully stalled and will remain in a commercial backwater. The Music Business collectively decided CD was a tidy earner and DAT was a threat to that, something I unwittingly had a hand in by predicting DAT would wipe out CD. DAT got banned pretty damn quick. In retrospect, the B.P.I. and the I.F.P.I. - spokesmen for the Music Business - not only proved to be enormously powerful, they were very effective in their actions, too. DAT was declared unacceptable for widespread public use; that is how it has remained.

This incident showed Philips they have some useful allies in the UK music business. They have turned to them again for support with DCC and seem to have got it. Most of the majors, like EMI, Virgin and Polygram, say they intend to

support DCC. A spokesman for Philips told me that duplicating facilities for pre-recorded tapes are being installed in the UK at this very moment. When DCC is launched in around twelve months time (Spring 1992), the shops should be carrying good stocks of prerecorded tapes. They'll be 'inexpensive' at £8-£10.

This is the lead DCC has already built up - and I haven't mentioned the fact that Matsushita in Japan has agreed to mass produce DCC machines. Will the Music Business intervene again to ensure its success?

Whilst it seems that open



Reflections from Noel Keywood

kaleidoscope

commercial war is about to break out, behind the scenes it may be a bit different. The companies involved realise that failure could be bad for them. Both Sony and Philips have had their share of disasters (Elcasette, Betamax, Video 2000, Laservision); they don't want any more. Behind the scenes talks are being held about licensing, which must mean cross licensing. Each seems to be prepared to consider manufacturing and marketing the rival product.

Swallowing Pride

This new commercial pragmatism has developed out of necessity. Better to swap boats whilst your own is still afloat than wait until it is too late. Sony and Philips had to swallow their pride and take up VHS manufacture; they're getting prepared to do the same again with DCC and MD, whilst at the same time continuing to promote them individually.

Collusion? Not exactly, but there is a shared outlook. Both companies agree that a cheap, portable digital alternative to cassette is needed, they only disagree about what form it should take. I find this disturbing, for although neither Sony nor Philips would for one minute acknowledge that their actions pose any threat to

quality, in effect they do just that. For the first time ever, they appear to have agreed to move backward in order to move 'forward'.

It could well come to pass that either DCC or MD will become the hi-fi system of the future, especially if an interventionist Music Business steps in to adjust prices in one or other format's favour. This seems unlikely at present; I hope it is absurd! The distant possibility is one that worries me all the same, since DAT did set a disturbing precedent in this respect. It was successfully manipulated into touch without the buying public having much say in the matter. Could CD also get pushed aside in the race to foist a cheaper but superficially similar medium onto the market?

All the major manufacturers start to talk glibly about co-existence and harmony at this point in the argument. That multiple systems are confusing, unwanted and unnecessary to the public does not concern them at all. I still return to the view, however, that nobody really wants all this technology for its own sake. They want one system that does everything. Could it be DCC? Or MD? If the average perception is that one or the other fulfils every requirement, hi-fi will take a step backward ●

Danny Haikin
delivers



desperate dan

It is claimed by many that the CD versus LP argument is as unwarranted as it is unfruitful. They claim that the two mediums are at least equal in performance and that the success of CD is wholly justified. I have no argument with this. And neither with those who claim that CD is underdeveloped, offering mediocre performance and fooling the consumer through un-truthful advertising. The validity of each argument is gained solely on the subjective taste of its respective proponent. The point which I wish to discuss here is why they are so different: that is something which is not contested.

The idea to write on this subject came to me at a recent listening session at Hi-Fi World. Noel Keywood and I had spent some time listening to and discussing the merits of Meridian's new D6000 loudspeaker system. Using Meridian's own top of the range CD player, I felt that whilst it was not nearly as good as an LP system, it was one of, if not the best CD based system that I had heard to date. We also had a brand new Linn LP12 turntable to hand which, in both our opinions, was better still. Interestingly, it appeared to me that the turntable was better for all the same reasons that the system was better than

other CD systems. It was clearer, more articulate and better defined.

In a later conversation, Noel informed me that Bob Stuart of Meridian had put our preference down to LP being euphonically distorted. This is where my philosophizing starts.

Euphonically distorted. An odd con-joinment of words you might think. What is meant by this is that the nature of a distortion is such that it can give rise to a sound which is pleasing to listen to but, by definition, inaccurate. Through just listening this cannot be proven; it rather forms a subjective comment which must be proven in measurement. In other words, a perception of 'inaccuracy' is not necessarily the same as actual inaccuracy. Thus if a person were happily enjoying the sound of a hi-fi system and claiming it to be accurate, measurement may show it to be inaccurate. This is of course no reason to enjoy it any less, but as we are presently concerned with accuracy, it is discounted as being euphonically distorted. The question, then, is: this: are the things that people like about LP its own flaws. The things which I like about LP seem so un-like flaws that I am loathe to accept this.

Let us look at the problem from a slightly different angle. What would happen if a

record loving CD designer made a player which gave exactly the same measured performance as a good turntable? Would it sound exactly the same as a record player? In one sense this is a truism. Of course if we could measure every aspect of subjective performance then two things which measured the same would sound the same; there is no mystery. However, my impression of the current success of measurement is that it is not nearly this precise. Our LP-like-CD player would probably sound as good as neither. If this were the case, it could only be concluded that there are other aspects to measured perform-

ance which are also significant.

As these other aspects are not currently known of, it is impossible to gauge their importance. But to deny their potential influence would seem to similarly deny progress. Yet one major manufacturer, discussing its CD player, claims that digital either works or is broken; all competently designed players sound the same. I would guess that the statement was made for its polemic appeal, but this attitude of theory first is, in lesser forms, quite prevalent.

If something works in theory but not in practice, it is a tautology: it does not apply to the world. Conversely, if something works in practice but is not accountable in theory, it points to an inadequacy in reasoning. Science is carefully controlled empiricism.

Back to the point: did I prefer the LP sound because it was euphonically distorted? What I have tried to show is that as the LP sound was not patently distorted, and as I like it more because I perceive it as sounding more accurate, other factors have to be at work. The fact that a hi-fi component has an amount of distortion is proof that it is not wholly accurate; but the real point is just how inaccurate is it. Both CD and LP players produce at least some distortion, so neither can be regarded as truly accurate. We work from

the bottom up: we have no idea how far away we are from a perfect component as it would be impossible to recognise one if it ever existed.

If two components are under consideration, and both are imperfect in different ways, as there is no blue print of accuracy it would seem a subjective choice as to which measurements are notionally the better ones. And thus such concepts as euphonic distortion are tremendously complex value statements, and nothing more.

If someone could prioritise the measurements which are made of hi-fi and form a framework, that really would be interesting. They would effectively be measuring the measurements ●

BOB STUART OF MERIDIAN SAYS -

The tenets of linear theory underlie a great deal of our scientific work, and have traditionally been assumed to be valid for the purposes of performance measurement. This is now in question.

A problem we now face is that linear theory cannot be blindly applied to human auditory perception; the responses are quite different. Literature on psychoacoustics is rich with examples of non linear behaviour in human auditory perception. While we may characterise the human hearing system and our audio systems using tones, tone combinations and noises, these are not what we routinely perceive. Our auditory response is in terms of external sonic 'objects' - speech, echoes, musical instruments, etc. Some of the factors affecting our perceptions of them are -

- Language
- Amplitude
- Tone (frequency)
- Timbre
- Envelope patterns
- Onset disparities
- Correlated changes
- Attention
- Contrasts with earlier sounds
- Constancy
- Spatial location
- Rhythm
- Auditory streaming
- Similarity
- Continuation
- Common fate
- Closure

The back-print of the T-shirt says "Some find it early, some find it late and some never at all". I've found it later than most.

Yes, it's the Mana Reference table, again. I was sceptical about all the editorial coverage that this product got. Surely, I thought, it shows the press has run out of ideas when all it can do is devote its valuable column inches to a table.

Niggling in the back of what I laughingly call my brain was this feeling that all those reviewers must have seen something in this product to warrant such a tirade of praise. Malcolm Steward, Paul Messenger, Martin Colloms, Jason Kennedy and Peter Turner among others have all heaped compliments upon the Mana table; such consensus is rare in the hi-fi press.

Private Investigations

Since these reviewers have a myriad of different tastes in music and hi-fi, little alarm bells started ringing. Was I missing out on something? I decided to do some investigative work as to the quality of the table. First NVA, then Pink Triangle pointed to the Mana Reference table as the best partner for their turntables.

By now, the little alarm bells were becoming quite loud. Our cover photographer had also discovered the joys of the little sub-table and extolled its virtues to me, at some length. Finally, one evening, I ended up at Mana-ite Malcolm Steward's house. After hearing his system, I was determined to get one of these tables.

Not that I was totally convinced. I trust these people's values and was sure they heard improvements, but surely not to the level they spoke of. So I drove into the heart of deepest Pinner one evening to seek out John Watson, the man from Mana.

Demonic Grin

I had intended to collect the table and leave. Having been coffee'd, John Watson said: "Would you like to hear my system, then?", pointing to his Isobariks on specially made glass stands. He played a few tracks and then, with a demonic little grin, said he was going to "show what his system was really made of".

After a few seconds of Pink Floyd's 'One Of My Turns' I

could feel my head exploding. Its clean but incredibly powerful sound was little short of devastating. Several hours later, having peeled our respective eyes and ears from the ceiling, we left, highly impressed. The conversation in the car driving home was quite banal:

"Wow! No, I mean really, like wow!"

"Oh yes, very wow. Very wow indeed!"

At the end of this enlightening evening, my senses were in such disarray I walked into the wrong house, convinced that it had been re-painted in my absence.

When I sorted myself out, I attempted to put the table together. This is a painstaking process that should not be attempted by anyone in an excited state. After spending some time levelling the table, using Mana's own spirit level (itself worth its weight in gold), I compared the table against a solidly fitted and level Audio-tech wall shelf.

My disbelief at the comments levelled at the Mana table was soon replaced by disbelief at the improvement that it seemed make. My Linn had a life to it that I had never heard before. The Mana table improved the deck's dynamics - it went higher, with deeper bass and better control all round. The imagery improved, as did the solidity and the tonal qualities of the turntable.

Enjoyment

Strangely enough, the table also made me want to turn the system up very loud, as I felt that the deck was capable in ways not felt before. The Mana table basically injected large amounts of that indefinable factor, known as enjoyment. Previously, I felt that all tables were similar; no one table was drastically different. Mana's Reference table throws that theory out as it stands head and shoulders above the others.

One of the problems that people have with the Mana, is that it seems to cost a lot of money for just a table. We are all conditioned to accept that a turntable can cost hundreds, or even thousands, but there has been no such preconceptions with tables. In many ways this is the narrow-minded approach that I had, prior to hearing the table.

For anyone else still unsure about the Mana's value as a



manufacturers, some of which is highly desirable. Occasionally, a product turns up where the reviewer feels that he or she simply must own as a reference. This is one such product, as my colleagues listed above would agree. If you own an expensive system, I feel that, in most cases it is incomplete, without a Reference table.

I'm sure that there are some occasions where the Mana table will not be suitable. Mr. Mana himself suggests that a budget deck on his table will sound better than a more

Feedback from
Alan Sircom

sircom's circuits

table, consider it as an upgrade to the system. If you consider it in sound quality, instead of hardware terms, the Mana is a bargain. I have heard some voices of dissent, however. On questioning these people, the response has always been something like: "Well, I haven't heard it myself, but I have a friend who knows somebody that has a cousin who went to a dealer and they said it was RUBBISH!"

People with such a closed mind will always be the first to criticise and the last to understand.

I have subsequently tried the Mana table with a variety of products - turntables, tuners, cassette decks and even the odd Compact Disc player. I cannot explain why, but its magic seems to work on almost everything that rests upon its glass top. John Watson says he has a range of equipment tables that reap similar benefits throughout the system. If this is true, I can foresee a time when my entire system gets the Mana treatment. If it approaches the intensely dramatic sound that he can get from his own system, I'm sold already!

Reviewers receive products from a variety of different

expensive turntable on an alternative table. I have not had the chance to try this out, but I think he may be getting a little carried away!

Not 'Cricket'

I am still not enamoured of writers using their columns for promoting products, as it can be rather crass and not 'cricket'. In my defence, I feel the Mana table is something different. The changes that it brings to a system are difficult to describe, still harder to quantify. It is not a product that can be judged by conventional, empirical reviewing, as it defies categorisation. This is why it appears in my column, rather than in the review section.

Having now included the Mana Reference into my system, I can see why the other reviewers have raved about this humble product. I, too, appear to have gibbered on about it with foaming mouth. My non hi-fi friends learned to avoid me during the honeymoon period with the table. Try the table out for yourself, but do try not to get rabid about it ●

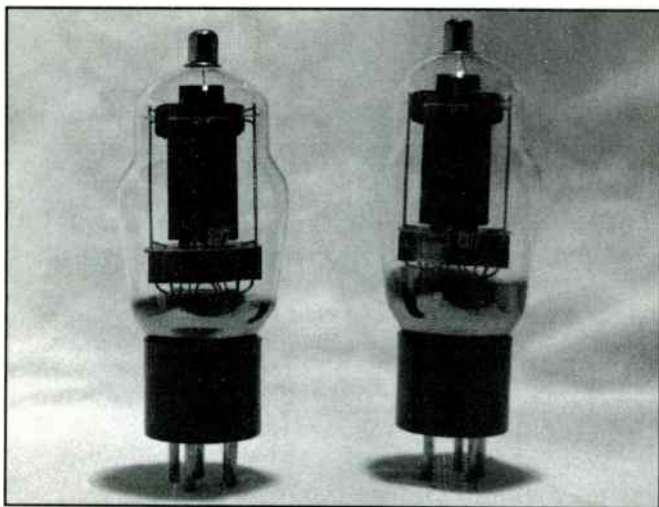

A representation of the author

recorded message

Left by Richard Brice

It's often said good movies are made in the cutting-room, not on the set. If you've ever watched a movie or video edit you'll know what a difference the director and editor make as they painstakingly piece together the finished article shot by shot. Mistakes, poor lighting and sloppy acting are edited out and consigned to the cutting-room floor.

Unfortunately, this practice has led to a belief in all sectors of the entertainment industry that performances can be fixed "post-production". Recorded music is no exception. It's a chastening thought to know that a classical Compact Disc may contain up to eight hundred edits. That's an edit about every five seconds!

There are several reasons for this state of affairs: Firstly, that it is possible at all. With the advent of digital recording and editing it's now feasible to stitch together one hundred 'takes' and seamlessly assemble them as an apparently complete musical performance. This has led to musicians, knowing the technical team can 'fix it in the edit' arriving at the recording session under-rehearsed. Also, record

reviewers, who have criticised recordings with comments like "It's a pity about the sour oboe tone in bar 65 of the scherzo", have made record companies loath to release recordings with even slight flaws.

But, what price Beethoven in the age of digital editing? Is it any wonder that, time after time, music lovers cherish 30 year old analogue performances over their modern digital

counterparts. At least the conductor knew, when he put down his baton 30 years ago, what the recording would sound like! Digital editing is doing for classical music recording what MIDI did for pop. The flawless, glossy and gutless is replacing the coherent, possibly blemished but sometimes inspired performance.

There is an energy - a vitality - well rehearsed live performances possess that a musical patchwork, no matter how beautifully or sensitively constructed, can never match. Nobody wants to hear dud notes, but a woodwind melody going slightly sharp at the climax of a musical phrase isn't a mistake, it's a natural part of a musical performance. The energy and fragility - it's human!

In pop and rock recording there is the beginning of a swing back to recording live. I know from rock recording sessions using MIDI sequencers in the past, that it was all too easy to fall into the trap of recording a sloppy keyboard part and then spending hours fiddling about with the technology, trying to fix bad timings and tunings. An attitude built up which was: "the technology is here to fix this and we'll do anything to avoid rehearsing and re-recording that piano part!!"

The trouble is, the technology gradually erodes the necessity and the inclination to put in a decent performance. This leaves the real job of shaping the music to the

people with their fingers on the computer mouse, rather than on the musical instruments.

I know it's one of the great patterns of history that technology replaces skill. I, for one, cannot remember the last time I had to fashion flint-tips for my spears or harvest my own wheat! But, at least with the necessities of life, they just need to be there, such is the nature of their importance. The arts are rather different, they're not a necessity. Take the "art" out of food production and you may take away an indefinable something, but not its innate value. Take the "art" away from music and you're left with a kind of industrial by-product, completely negating its *raison de'être*.

Of course, it's not as bad as that yet. There's plenty of skill left. Audiences still go to live performances and that has ensured good orchestras and fine conductors. But digital recording is breeding new skills: fine editors and fine producers and fine MIDI programmers too!

It's not that the skills have evaporated from the production of recorded music but that the important skills have changed. I wonder how long it will take before the record buying public cotton on. Will we walk into "Our Price" in five years time and see Beethoven Piano Concerto No.5 with credits for producer and editor on the front and a small credit on the back page of the pamphlet for conductor, orchestra and soloist? ●

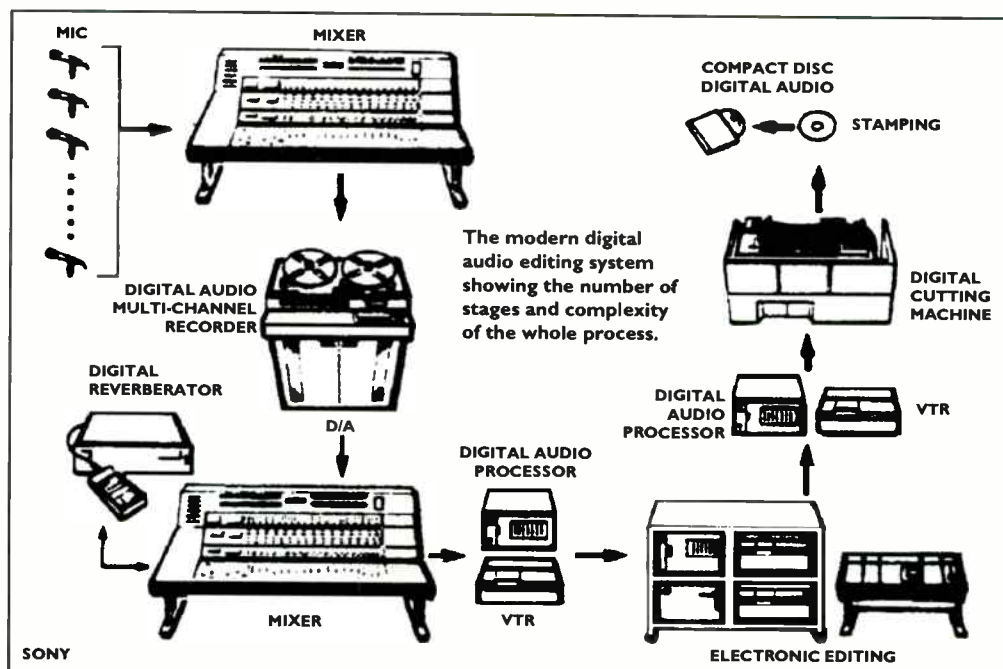

When you consider the plethora of hi-fi products on offer to the public, the cliff-like racks chock full of uniformly black boxes, is it surprising that the man in the street ends up confused? What does a phono stage do and does he need one? What about an equaliser and one of those dohickies with fins all over it?

That, of course, is why magazines exist, and why they in turn promote the ideal of specialist dealers. People want answers, the more straightforward the better. Faced with a quagmire of purchases, they want advice they can treat with confidence, a map which shows the quicksand in the right place.

Those maps are readily available. With shops and competing publications each offering their own 'solution', there's no shortage of guides. The problem, of course, is the quality of the advice. It is not exactly up to Ordnance Survey standards in all too many cases and the symptoms are surprisingly consistent. In a word: dogma. Dictionary definition - a point of view or tenet put forth as authoritative, yet without adequate grounds.

Fatal Attraction

With so much competition between outwardly similar products, the simple solution always takes on a fatal attraction, perhaps most obviously with Compact Disc players. Amidst the hype and hysteria of CD's launch, people were only too happy to cling to any security blanket on offer. The one on offer had the peculiar power that simple arithmetic can lend to an argument. Suddenly choosing (or selling!) a CD player was easy - count up the bits and compare the oversampling - the more the better. Fourteen bit four times oversampled gave way to sixteen bit two times oversampled, then four times, then sixteen times sixteen, and rapidly eighteens and twenties started to appear faster than the steps on an escalator.

As time went by, the realisation that there's more to a CD player than its specifica-

tion slowly dawned. Transport, power supplies, analogue stages and case work are all, in their own way, just as important. Of course this didn't help those who'd simply bought by numbers.

(Ironically, the most impressive new CD player I've heard is, of all things, the new Naim machine. Chip set? The lowly Philips TDA 1541 sixteen bit four times oversampling)

All change

Hindsight is a wonderful thing. Have we learnt from the experience? Of course not! Along comes bitstream and suddenly it's all change. Don't buy a CD player unless it's one bit and of course your old multi-bit machine is totally obsolete - not worth bothering with. Add into the cocktail time domain number crunchers from the USA (Wadia and Theta) and suddenly each technology has its own increasingly vociferous advocates. Sadly, magazines which should know better very often commit the same crime, with reviewers soapboxing their particular viewpoint.

Hopefully, the dangers of being seduced by such simplistic propositions are apparent, at least as far as buying equipment goes. 'Flavour of the month' technology is particularly common in the fast moving area of digital development.

Real Problems

The real problems with dogma occur in the 'Flavour of the Year' or even 'Flavour of the Decade' stakes. Something happens and suddenly, unless every product incorporates that idea, it becomes an also-ran. This is all very well if the 'dramatic advance' is genuine, but all too often it proves to be a case of new wine in old bottles. The result: a whole generation of perfectly good products which are either stillborn because they dared to buck the trend, or horribly mutilated to accommodate it.

Exaggeration? I don't think so. Let's look at a couple of examples. The first and most obvious has to be the metal

dome tweeter. Hot on the heels of Celestion's copper domed SL6 tweeter, Elac produced an aluminium driver which was made available to all comers. And suddenly, if your speaker wasn't 'metal domed', then you were wasting your time.

The rest is history. Each new product sporting the necessary glint merely added to the momentum, as did a flurry of redesigns. As a result, perfectly presentable speakers like the Rogers LS7 grew a 't' suffix and a titanium tweeter. Now the LS7 wasn't perfect, but the last place it had problems was in the treble. The new tweeter, and the inclusion of that other eighties 'must-have', bi-wiring, was actually detrimental, resulting in an exposed and disjointed top with a distinctly cold feel to it. Hardly an advance.

imaginative development, the kind of 'lateral' ideas which produce genuine advances.

Look around and you'll find dogma in every element of the Hi-Fi market place. Ever since Linn's LP12 fought its way to the top of a bloody heap, every turntable, in order to present a serious challenge, has had some variation on the theme of three springs and a subchassis. Oh, there have been other designs, but they just get ignored or laughed at because everybody 'knows' that the three spring approach is 'the only way' to build a quality turntable, an attitude which in this country enjoys total hegemony.

Ignored

High mass, high rigidity designs, air bearings and vacuum clamps, all have been ignored, and yet a product like the

R.G. Bary

Roy Gregory weighs in

In America, the long standing and well loved Vandersteen 2C now sports a metal dome, not through the designer's choice but because the original soft dome is no longer available! Perhaps the most ludicrous case of all is the JPW Sonata, an excellent little box which comprehensively trounces the more expensive metal domed and bi-wired Sonata Plus.

People have finally got over the hysteria. In fact, in certain quarters it's now de rigeur not to use metal domes. Is that any better? I doubt it. The lesson to be learnt is not to accept unquestioningly a single technological solution to a problem, to the exclusion of all others. I'm sorry, but life isn't that simple and nor is Hi-Fi. To pretend that it is leads to stagnation and the throttling of

Well Tempered turntable and arm proves conclusively that there's more than one way to play records. Unfortunately, so many people have got their heads buried so deeply in the sand that they can't see or hear alternatives anymore.

A new buzzword is currently emerging. Soon, unless a valve amp uses, and I quote "direct heated triodes", it will be inherently inferior. What a load of cobblers! Just like valves and transistors, Class A or AB, or even D, there is no 'right' way to build an amp. There are good and bad examples of most approaches. So do yourself a favour. Next time you are choosing a piece of hi-fi, remember that "it ain't what you use, it's the way that you use it - that's what gets results." ●



on the receiving end...

**Receivers often trade
sound quality for
convenience. Noel
Keyword gets behind
four models.**

Combining an amplifier and tuner seems highly sensible for convenience's sake, but it gets treated with some suspicion by hi-fi buffs. Directly items are combined like this, flexibility of choice is reduced. Say you choose the amplifier for its sound quality and power output. It might suit you perfectly in this area, but would the tuner then suit your aerial or your local reception conditions? It might not even have the wavebands you require. And if it did turn out to be unsatisfactory, the whole receiver would then have to be exchanged for something else.

So a receiver offers convenience and, being a single box, it also blends into domestic surroundings more adeptly. But by limiting choice, it possesses less appeal to choosy buyers. Realising this, some manufacturers place a slightly different emphasis on their design approach, choosing to extend convenience in particular. Acting on this principle, both Pioneer and Denon provide remote control with their models tested here. Their volume controls are motor driven, which is impressive to watch; they move as if turned by an invisible hand. Remote control signalling outputs are also fitted, to control auxiliary items like cassette decks. This cleverly adds to overall convenience and encourages brand loyalty. Rotel and NAD do not offer remote control.

Additional loudspeaker outlets are fitted to all four receivers, plus switching between them, a feature slowly disappearing from dedicated hi-fi amplifiers in order

to eliminate problems involved in high current switching. Rotel and NAD get around this by hard wiring in the main loudspeakers and switching in a secondary pair. If there are then switch contact degradations or other problems, most likely after a few years use, they will only affect the secondary loudspeakers. It's a clever compromise, sacrificing the convenience of full switching to retain sound quality.

The lessening of restrictions in UK broadcasting has brought many more radio stations onto the air, making preset tuning more useful than ever. All four receivers here have synthesiser tuning, which helps cope by providing a high level of tune accuracy and stability. This eliminates the problems associated with earlier push button station selection systems that relied upon Automatic Frequency Control for stability.

A feature to consider is the number of push buttons fitted; in some areas the five buttons of the NAD may not be adequate for ardent VHF radio listeners for example. In a similar vein, some UK models have Long Wave, the Japanese being diligent in providing this feature in order not to lose any sale. Manufacturers like NAD do not bother with such things. The VHF FM waveband carries all the major stations so Long Wave is hardly essential.

Being a bit non-audiophile, many receivers lack some of the little refinements you might find on amplifiers. Denon do not fit a tone control bypass switch for example and, surprisingly, only the Rotel tuner has a signal strength meter for its tuner. Since a good signal strength meter is important for aerial alignment and to warn of unsatisfactory reception conditions, the absence of this facility I view as a drawback. However, many budget tuners don't have one either, so its absence on the receivers puts them in the same league, rather than in a lower one.

With the accent on convenience rather than sound quality, I wasn't expecting too much from these receivers. As a product category, they are seen these days as being a bit lower on the sound quality ladder than separates, justifiably or unjustifiably. A ray of hope sprang from the good reputations of all four manufacturers. I hoped only that they would carry their knowledge and abilities over to these products. In the back of my mind I did fear that instead, to save costs, inferior circuits and short cuts would be resorted to. I am not sure they were not! Two of the units seemed far less than perfect. One manufacturer I quizzed closely insisted that everything was pukka, but a residue of doubt lingers in my mind. In the end, only one of the four models tested really struck me as a good buy. To the others I would say - goodbye.

Measured Performance

Power output measured 60 watts, plenty enough to make a big noise, if not enough to blow the roof off. There was a healthy increase into low loads, the figure increasing 50% to 90 watts.

The receiver has a design weakness, but subjectively it was not at all obvious. Frequency response varies with volume control position, a problem not unknown yet easily avoidable. At half volume, treble output reached just 10kHz (-1dB). This is low, but it did not produce dullness, only a certain degree of warmth that was not unpleasant.

Such a blemish, coming in the amplifier chain after the signal inputs affects all sources: CD, LP and tuner. At much less or more than half volume, frequency response did reach 20kHz. In use I found volume set to around one-third (10 o'clock), at which point the frequency response reached 20kHz. The precise half volume setting was too loud for me to be able to listen to it meaningfully!

The tuner measured well in all areas. It was very sensitive; hiss sank to a low level of -73dB with just 0.5mV of aerial signal. Channel separation was wide and distortion low. The analysis shows clearly a wide, flat frequency response trace, with some slight lift toward high frequencies. This ensured an even tonal balance was provided on VHF.

The phono input was satisfactory too. Distortion from the amplifier was well suppressed in the mid-band, measuring 0.005%. It rose at high frequencies, reaching 0.02% due to extended harmonics. This is less promising, but I detected no suggestion of a problem in listening tests. In fact, other less apparent properties must have prevailed, because in spite of small blemishes in measured performance, the DRA-335R had excellent sound quality.

AMPLIFIER

Power 60watts

CD/tuner/aux.

Frequency response 7Hz-10kHz
Separation 74dB
Noise -94dB
Distortion 0.005%
Sensitivity 180mV
dc offset 2/20mV

Disc

Frequency response 13Hz-10kHz
Separation -53dB
Noise -74dB
Distortion 0.006%
Sensitivity 3mV
Overload 180mV

TUNER

Frequency response 15Hz-10kHz
Stereo separation -30dB
Distortion (50% mod.) 0.3%
Hiss (CCIR) -73dB
Signal for minimum hiss 73mV
Sensitivity mono 1.2µV
stereo 20µV

TUNER FREQUENCY RESPONSE

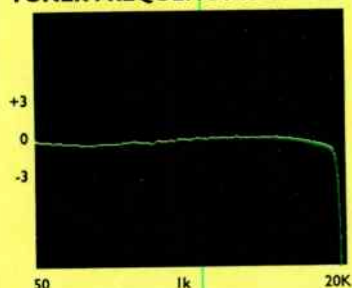

Slight treble lift improves clarity



DENON DRA-335R

This is a sturdy looking and well finished product, reflecting Denon's usual styling approach. They avoid using unnecessary legends and symbols, a regime that keeps the fascia looking clean and reasonably uncluttered.

Only a row of eight radio station selector buttons, each with three alternative store numbers marked on it, contravenes their design rules. This gives access to no fewer than twenty four stored stations, a front panel shift button being used to switch between the three option banks, identified as A, B and AB. With this arrangement, trying to find a particular stored station is none too easy.

Stations on either of the two wavebands, VHF and Medium Wave, can be freely allocated to any store, so the system Denon provide is very flexible. Keen VHF listeners could, for example use all eighteen stores to hold VHF stations. Others might want to put in some Medium wave stations.

Front panel ergonomics are less important than usual with the DRA-335R because it operates by remote control. Station selection is by up and down buttons. Scrolling through the twenty four channel numbers was quite fast, so I found no difficulties here. The blue fluorescent station readout numerals are large enough to be seen at a distance.

Large buttons on the remote control adjust volume - via a motor driven volume control. This moves eerily in response to commands from the hand held control unit - and very convenient such a facility is too. Input selection is remote controlled, but nothing else. The hand held unit carries buttons for Denon CD players, presumably for those who buy a complete Denon system. Inputs are provided for video (auxiliary by another name), LP and CD, plus one tape recorder. A co-axial panel plug (male socket) accepts a VHF download, but only with an adaptor if the lead is terminated with a standard plug.

Wire aerial terminals are fitted too though.

Tests showed the tone controls are well engineered in that they leave the mid-band unaffected. The amounts of lift and cut at spectrum extremes were large however, making their action more coarse than those of the Rotel, for example. Selector buttons control two sets of loudspeakers, connected via screw terminals at the rear.

Sound Quality

In spite of the Denon's limited measured treble extension, sound quality was little affected in practice. I was somewhat struck by its ability with CD, having previously listened to the Pioneer and the NAD. In contrast, the Denon offered a whole step up in refinement. There was a certain precision, coupled with delicacy that was missing with the others. I found myself listening to a complex and interesting musical performance with the Denon, so well integrated that matters such as bass and treble quality hardly seemed relevant. This is because neither were obviously out of character.

Much the same quality was evident with the tuner. I found it smooth and gentle, meaning it was very easy to listen to. There was fine stereo staging with plausible images across it that held my attention.

Heavier bass was evident from LP, due I suspect to good downward extension in the disc stages. This might lead to a ponderous sound with some loudspeakers, although there was no trouble with the big TDL Studio 4s or smaller Epos ES11s I should add. I loved the sense of mid-band clarity and relatively sweet and detailed treble, free from grain or roughness.

Summary

I was expecting limited treble response (at half volume only) to hamper this receiver. It didn't. Instead, I heard a smooth, refined delivery that captured my attention and provided pleasure in listening to music.

NAD 7225PE

A receiver from NAD is an interesting proposition. Whilst Denon and Pioneer appear to view their receivers as occupying a different niche from more dedicated 'separates', this route isn't really available to NAD; it would oppose the company ethos. Their problem is then how to combine an amplifier with a tuner at a very keen price, whilst at the same time keeping it clearly within the realms of true hi-fi. This may seem a trifle pedantic in terms of product positioning within a market place, but it is important in maintaining an appropriate image.

Part of the NAD image lies in their distinctive fascia style. Whilst not being dissimilar to Japanese products, it relies on an absence of visual trivia. The 7225 was the cleanest looking amplifier in the group. It is also well built and finished, but solid and utilitarian in appearance. Few NAD products could be rated as beautiful. The buttons tend to clank a bit when pushed, but the rotary controls move smoothly.

I found the amplifier was relatively powerful, delivering 55 watts under test. NAD put a Power Envelope legend and a PE suffix after the name, but I could detect no unusual circuit action at all during tests. Luckily, it hardly matters because actual output far exceeds that quoted. Similarly, the treble control did not work too well, even though claims to the contrary are made by NAD. Both failures would have been more annoying had they had much impact on overall results, but they did not.

Inputs are fitted to take CD, LP, tape and video. The tuner has VHF FM and Medium Wave bands, but no Long Wave. There are ten pre-sets, but they cannot be freely allocated to stations. Five are for Medium Wave and five for VHF FM. A bright red LED display reads station frequency but there is no signal strength indicator. Individual LEDs show tuning accuracy and the presence of a stereo transmission. Tuning is by a rocker switch, with automatic and manual tuning modes available.

NAD do not fit a co-axial VHF aerial socket, only spring terminals for bare wires.

They do however provide pre-amplifier output and power amplifier input sockets for external processors, bi-amping and such like.

I found the 7225 receiver easy to use and have no criticisms of the way it works.

Sound Quality

I noticed immediately that on CD the NAD sounded reasonably cohesive in contrast to many budget amps, including the Pioneer that went before it. As always, the characteristic NAD sound was there: a certain smooth but enclosed feeling surrounding the performance. Hand in hand with this effect goes perceived low distortion, little sign of coarseness or roughness being evident. I liked the stereo imaging too; it was quite precise and insightful. The 7225 was typical NAD - and very good for it.

Reproduction from LP was also enjoyable. My first and remaining impressions were of a fast, cohesive delivery with life and credibility. Marianne Faithful's guttural voice hung between the speakers in a lifelike fashion as she sang The Ballad of Lucy Jordan, giving me a strong feeling of her presence.

The tuner had a similar cohesiveness, but was warm and smooth in tonal delivery. It had a fine sense of insight and excellent stereo imaging. Weak stereo transmissions crackled and birdies from our resident Deltac PDM-1/II were heard, showing the NAD to be less resistant to this problem than the Pioneer.

Summary

This is a fine receiver in its ease of use and its smooth and cohesive sound. It has far fewer tuner pre-sets than are needed on VHF (in London at least), which is its main drawback. The NAD sound is well represented by the 7225.

Measured Performance

Power of the 7225 comfortably exceeded the 25 watts rating, hitting 55 watts. This was the short and long term power rating, Power Envelope only limiting output under arduous conditions.

The treble control was a poor one that when set to cut upset the entire audio band. NAD say that our sample may have been faulty.

The CD, tuner and video inputs are all band limited, having a frequency response of 15Hz-37kHz. This is NAD design policy, helping to prevent unwanted signals being amplified. Channel separation, noise and sensitivity figures were all satisfactory. There was just 0.008% distortion with miniscule amounts of second, third and fourth harmonic. NAD consistently achieve this result with their amplifiers and it does contribute to their clean sound.

As claimed, the disc stage is one of the quietest available. However, it was also less sensitive than many, needing 3.8mV for full output. A mild action warp filter limits low frequency response to 20Hz, too low to adversely affect bass strength. Distortion was negligible. The disc stage was a good one.

NAD have used a high performance mpx filter, properly terminated, to get extended high frequency response from the VHF FM tuner stage, whilst at the same time suppressing unwanted signals at and above 19kHz. Hiss sank to a very low value of -75dB with a strong aerial signal of 1mV or greater. Channel separation on stereo was very high at 49dB and distortion low at 0.3%, second harmonic only. Sensitivity wasn't as great as that of the Pioneer and Denon, but this is not of much importance in practice.

AMPLIFIER

Power 55watts

CD/tuner/aux.

Frequency response 15Hz-37kHz
Separation 72dB
Noise -89dB
Distortion 0.007%
Sensitivity 270mV
dc offset 6/2mV

Disc

Frequency response 20Hz-40kHz
Separation -70dB
Noise -82dB
Distortion 0.008%
Sensitivity 3.8mV
Overload 220mV

TUNER

Frequency response 16Hz-16kHz
Stereo separation -49dB
Distortion (50% mod.) 0.008%
Hiss (CCIR) -75dB
Signal for minimum hiss 1mV
Sensitivity
mono 2µV
stereo 32µV

TUNER FREQUENCY RESPONSE

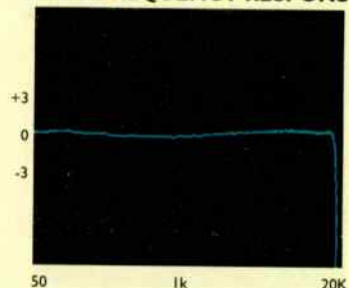

Extended treble due to good mpx filter

Measured Performance

I was surprised at the power this receiver produces: no less than 90 watts per channel. Low loads are handled respectably well, output increasing to 130 watts. For a comparatively compact unit, these are healthy figures, meaning the SX-757 will go very loud without strain.

The amplifier section has a wideband CD input, capable of amplifying right down to the lower limit of CD - 4Hz. The upper frequency limit was a sensible 34kHz. The tone controls worked well, although bass cut was peculiarly limited.

Separation between the channels was wide at 77dB and hiss very low at -90dB. Sensitivity was plenty high enough for CD, measuring 180mV for full output. As expected, Pioneer keep distortion down to around 0.01%. It is slightly lower in the mid-band and a bit higher at high frequencies. The CD input measured very well.

The disc input produced no surprises either. It possessed accurate equalisation, very low hiss and correct sensitivity for conventional moving magnet cartridges.

The tuner was also well engineered I found. It has an essentially flat frequency response with a slow treble roll off, as the analysis shows. Channel separation on stereo was adequate at 38dB and distortion low at 0.2% (an average value). Pioneer have made the unit sensitive. Most usefully this means that minimum hiss is achieved with a moderate strength aerial signal of 0.5mV, with which hiss sinks to an all but inaudible -73dB.

AMPLIFIER

Power 90watts

CD/tuner/aux.

Frequency response 6Hz-34kHz
Separation 77dB
Noise -90dB
Distortion 0.007%
Sensitivity 180mV
dc offset 6/2mV

Disc

Frequency response 15Hz-55kHz
Separation -65dB
Noise -82dB
Distortion 0.005%
Sensitivity 3mV
Overload 120mV

TUNER

Frequency response 5Hz -11kHz
Stereo separation -38dB
Distortion (50% mod.) 0.2%
Hiss (CCIR) -73dB
Signal for minimum hiss 0.5mV
Sensitivity mono 1μV
stereo 16μV

TUNER FREQUENCY RESPONSE

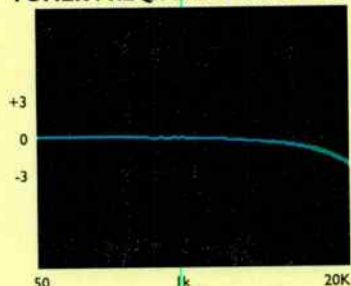

Slow fall in treble gives warm sound

PIONEER SX-757

Like the Denon receiver, this one has remote control, which includes remote control of volume. A motorised volume control is used, which turns slowly in response to up/down commands from the handset. The term 'handset' could however be a misnomer, unless Pioneer sell extensively to Gorillas; it was very large. Build quality of the receiver itself matched the usual standard of Japanese product, which is to say satisfactory. The front panel is an anodised extrusion and the cover a heavily vented steel pressing. Pioneer fit an attractive fluorescent display panel.

The remote control unit is covered in buttons, many devoted to CD and cassette deck use. Like the remote of the Denon, this is a general purpose Pioneer system unit, designed to operate a host of Pioneer products from the armchair. On the receiver it controls input selection, station selection with the radio, power on/off and a peculiar 'sleep' function, which appears to mean the receiver going to sleep, not the owner. Funny people, the Japanese.

All the buttons on the front panel are arguably a bit superfluous when remote control is provided, until the remote goes AWOL that is. Stations can be freely allocated to any one of thirty memories, VHF and Medium Wavebands being fitted. The tuner is inevitably a synthesiser type, like the others. It has no facilities, other than a mono/mute off button, which is obligatory. Going to mono mode reduces hiss.

Bass and treble tone controls are fitted, together with a balance control. Tests showed the tone controls worked well, except that there was little bass cut (-3dB). The tone controls cannot be operated by the remote control unit.

Pioneer build their products well enough, but the SX-757 is all the same a conventionally styled unit, which is to say it has the same level of finish and mediocrity of style as most products from Japan. The rear panel carries two sets of

loudspeaker sockets, each switchable from the front panel. They accept bare wires, but not 4mm plugs. A panel mounted coaxial plug (or male socket) is fitted for the VHF lead, in addition to bare wire terminals.

Sound Quality

I was not especially impressed by CD reproduction through the SX-757. Used with TDL Studio 4s, it failed to control the bass cones, producing a most unpleasant inflated 'boof...boof' type of bass. The NAD had no such problem, so although in real life the Pioneer would not be matched with such an expensive loudspeaker, this does underline its inability to apply cone control. In practice, I would suggest lightly damped reflex loudspeakers are not a good match. I switched to well damped infinite baffles, namely Goodmans Maxim's. The 757 has the muscle to drive these and they have enough inherent control to complement it. This improved the bass and brought it into line, but a brittle and forward treble quality remained. The Pioneer was not especially cohesive or engaging to listen to.

The tuner proved smooth, a bit warm but easy on the ear. There were no birdies on weak stereo signals, allowing distant stations to be received without being forced to switch to mono. Imaging was a bit vague, an overall impression being painted, with details missing. General listenability was good, only finesse was missing. Since budget tuners can sound unpleasant though, I rated the Pioneer's good.

The LP input managed fairly well, although again there was some bass and treble emphasis and a certain lack of cohesion. Neither hiss nor hum were audible.

Summary

The sound of this receiver was a disappointment. I found it crude in contrast to the other receivers - and to highly regarded Pioneer amplifiers as well.



ROTEL RX-850AL

Something about this Rotel receiver makes it look dated to me. They produced a popular range of receivers back in the seventies that appeared more modern in my view. However, Rotel have remained determinedly audiophile, at least in their UK destined products, and for this reason the RX-850AL receiver is an item to be considered with due care. Style matters less than content - a lesson that the company assimilated long ago.

The steel chassis and top cover gives the same hard clank to the controls that the NAD possesses - and for the same reason. Whereas the other receivers leave their frequency displays alight when other inputs are selected, Rotel switch theirs off. Since fluorescent displays generate a small amount of RF interference, this is a wise precaution.

As I explain in more detail in the Measured Performance section, Rotel fit superb tone controls to the RX-850AL, plus a bypass switch. The latter is useful for performing a quick A/B check of their action.

The tuner has a signal strength indicator, albeit one that lights fully with just 0.25mV of signal when four times as much is needed for optimum performance. Consequently, it is of limited use for judging whether the tuner is getting enough aerial signal to give of its best. Manufacturers are scared to fit an indicator that lights only at a high level, for fear of it portraying the tuner as insensitive.

There are sixteen station pre-sets, all of which can be freely allocated to stations on any waveband. So, for example, fourteen VHF stations and just two Medium wave stations could be stored, or vice-versa. Although our sample had a Long Wave band, one without is available.

Rotel provide LP, CD, tape and aux/video inputs. A co-axial aerial socket is provided, in addition to spring terminals

for aerials. The loudspeaker screw terminals will accept 4mm banana plugs.

Much like the NAD, I would describe this receiver as functional in appearance and feel, but entirely adequate. Styling and finish were satisfactory, but would set no standards.

Sound Quality

Reproduction of CD was characterised by a relatively forceful presentation, where the resolution of dynamics seemed especially well handled. Together with a certain pace - less evident in the other receivers - I felt that the Rotel was especially strong in its dynamic qualities and reasonably exciting as a result. I was a bit less taken by treble quality; a certain grain or greyness across the upper mid-range and treble was evident that my ears couldn't ignore. I wouldn't say that this was an especially endearing quality. The Rotel had powerful bass, but it was a bit fat also.

The tuner was unusually clear, more so than usual. This was its greatest quality - and an impressive one too. I found the imaging firmly spread between the speakers and Rock music in particular was delivered firmly and with pace. It was an impressive and enjoyable presentation that elevated the RX-850AL to best in the group, with the possible exception of the Denon.

Bass sounded a bit heavy and laboured from LP. I noticed a muted quality to the treble, plus some graininess too. Again, the sense of firmness and pace was maintained, but there was a lack of finesse - especially at spectrum extremes.

Summary

I would summarise the Rotel as sounding fast and dynamic. It had good, strong bass and quite good control as well. My only reservation was a certain character to its treble, often described as graininess.

Measured Performance

Tone control tests showed that Rotel have put some thought into this receiver. They work at extremes of the audio band, giving just 5dB lift and cut. Sound quality is altered by a fine but useful amount, I found.

The CD, tuner and tape inputs (i.e. flat inputs) all measured very well. Rotel do traditionally provide wideband working conditions and the RX-850L was no exception. It had a measured frequency response of 8Hz-60kHz, which suits CD in its low frequency extension, if not in its high frequency extension. Channel separation was wide at 73dB and noise as low as usual at -90dB. The input sensitivity value was normal and will give no problems, this also being the case with input overload level.

The disc stage had an even wider bandwidth than the CD/tuner/tape inputs, suggesting some rise in high frequency gain. Hiss levels were low-ish at -76dB and there was no sign of hum. An input sensitivity figure of 3.2mV suits moving magnet cartridges and the overload ceiling was plenty high enough at 180mV. All-in-all, the disc stage measured well enough, being essentially problem free.

Rotel have not bothered with mpX filtering in the VHF FM tuner stage. The frequency response analysis reveals this by extending smoothly right up to 20kHz. I expected to measure very strong pilot tone at 19kHz on the output (-30dB or so), but was surprised to find it was reasonably low at -51dB. The plus side is a clearer sound from VHF FM radio, free from tonal aberrations as well.

In almost every respect, the measured performance VHF FM tuner section of this receiver was better than that of its rivals. Rotel have obviously tried hard in this area.

AMPLIFIER

Power 50watts

CD/tuner/aux.

Frequency response 8Hz-60kHz
Separation 73dB
Noise -90dB
Distortion 0.008%
Sensitivity 200mV
dc offset 72/78mV

Disc

Frequency response 16Hz-107kHz
Separation -80dB
Noise -76dB
Distortion 0.008%
Sensitivity 3.2mV
Overload 180mV

TUNER

Frequency response 8Hz-17kHz
Stereo separation -52dB
Distortion (50% mod.) 0.4%
Hiss (CCIR) -78dB
Signal for minimum hiss 1mV
Sensitivity
mono 16µV
stereo 1µV

TUNER FREQUENCY RESPONSE

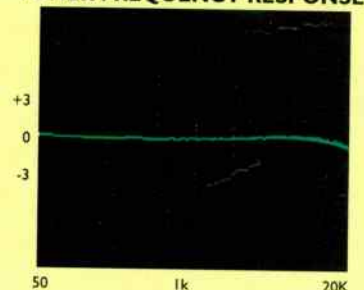

Extended upper treble gives clear sound

CONCLUSION

Power outputs of 50 watts to 90 watts do not greatly set these receivers apart, but having said that I have to admit that headbangers should look toward the latter and size up the Pioneer SX-757. Ironic that in my estimation, this was the least satisfactory of the models in terms of sound quality - but could the two be linked? Would Japanese Pioneer consider outright power more important than quality in a market viewed as less discriminating about sound quality? Or was the high power/low quality balance offered by the SX-757 just the way things turn out? It may have been due to unforeseen and obscure reasons like layout or earthing problems. The case is stuffed with a variety of differing circuits. It is too difficult to tell - and nobody's saying!

Sound quality apart, assuming it can be ignored for a moment, the SX-757 has a lot to offer. It will go very loud and it has plenty of heat sinking to keep everything cool. There are bass and treble controls and provision for two pairs of loudspeakers. I didn't like the shaky speaker terminals, but beauty is often less than skin deep on products like this one. I feel obliged to accept that Pioneer and others like them will always insist on using cheap hardware, to save pennies, just to be able to offer 90 watts of output at a low price. The power spec. will help sell this receiver, the quality of the loudspeaker outlets will not.

The SX-757 is powerful. It is also well equipped. Remote control has to be a big feature; few of us would deny that it can be gloriously useful. Traditionally, volume adjustment has been carried out by Voltage Controlled Amplifiers in remote controlled amplifiers. Early VCAs did nothing for sound quality however. Even though they have been replaced with more respectable designs dedicated to audio use, they remain unpopular. In their place we now commonly see the more visually arresting motor driven volume control. Pioneer fit one to the SX-757; it twiddles the volume control for you.

If the amplifier circuits were poor the tuner was a good one, offering thoroughly acceptable VHF quality. Again, I cannot rate it as the best I have heard. Acceptable is enough praise. Many budget tuners fall far below this categorisation. My main criticism is just the small one of slight congestion and blandness. Balancing this was a smooth and inoffensive delivery that was easy on the ear, if not especially engaging. In sheer practical terms, there was little to criticise. Pioneer fit plenty of presets and both sensitivity and selectivity were fine, giving the unit fine station grabbing ability.

For all the gadgets though, and the goodness of the tuner, the amplifier disturbed me. It made TDL Studio 4s sound quite awful, with disjointed bass and bright, sharp treble; the other

receivers did not. I had to bring in Epos ES11s and, most successfully, Goodmans Maxim IIs, before I could accept what I was hearing from the SX-757. And even then I was glad to move on to the other models. So it offers plenty of power, but you pay the price in quality. Quite what price will depend upon the loudspeakers selected for it however. I found well damped closed-box (infinite baffle) types best.

It says something for NAD that I chose their receiver to use as a comparative check when the Pioneer failed to drive the TDLs. Not unexpectedly, the 7225 had no problem with them and benefited from the partnership. At 55 watts output it is not a powerhouse, but it goes loud enough for many peoples' purposes. I do not listen at incredibly high levels (Quad electrostatic flat out levels!) so the NAD seemed fine to me in this respect. It is tidy and composed sounding, and very smooth too. There is that peculiar 'enclosed' quality that NAD amplifiers have, but it is always accompanied by fine imaging and an easy delivery. Bass output is provided in good measure with control over proceedings too. The disc stage and tuner were both very well engineered, offering fine sound quality. I had some reservations about treble quality that seemed a bit ragged at times.

Rotel's RX-850AL produced least power, but I had hoped that it would offer a useful alternative to the NAD. Quite often, Rotel can produce impressive sounding products, but they are not consistent in doing so. I feel the RX-850AL misses the mark a bit. It has a

wonderful tuner but the amplifier is less successful. It affects all sources of course, imparting its own character to them. Whilst I enjoyed its pace and dynamics, I was less attracted by its distinctive treble quality. Here the Rotel sounded a little bright and a touch 'grey' or grainy. It wasn't much, but it was enough to rank the RX-850AL below the NAD and Denon in my view. I couldn't openly criticise this receiver like the Pioneer, but I cannot honestly declare myself at all enthusiastic about its sound.

That leaves the Denon. Having tested these receivers first, before listening to them, I had expected to discard the Denon DRA-335R because of blemished performance. The problem of volume related frequency response is a simple, silly one Denon should not have let through the design process. At half volume, the DRA-335R has a treble response limited to 10kHz. This seemed potentially disastrous, but in practice it proved not to be. The main reason was that in use, only one-third volume was used, at which the response limit moves up beyond 20kHz. What I appreciated so much about this receiver was the finesse of its delivery. It is clean and lithe in its progress, but subtle and insightful too. I thought little about imbalances and colourations because they hardly existed. Instead, the Denon just sounded smooth, easy, delicate but quite natural. It was beautifully integrated, delivering a fine sense of performance free from the exigencies of hi-fi. With the DRA-335R I started listening instead of analysing. It was good enough for me ●

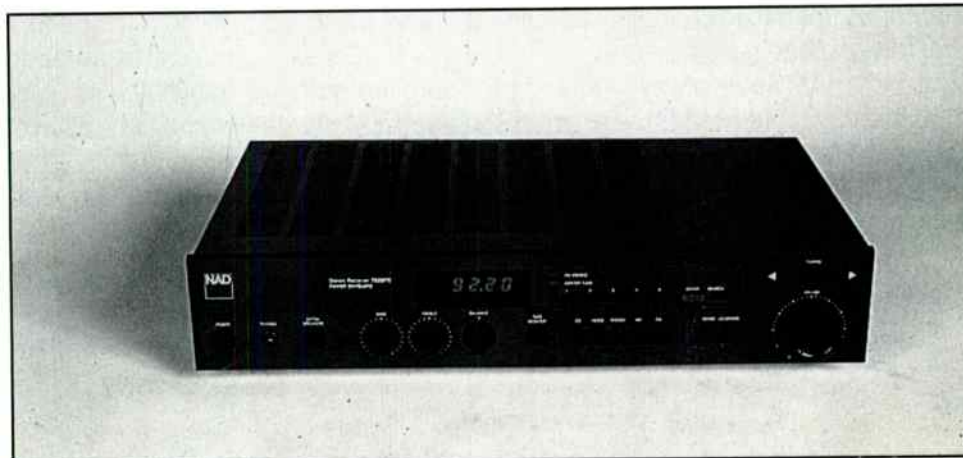



THE PROAC STUDIO 1 AND SUPERTOWER HAVE BEEN IMPROVED.

(THIS TIME WE'VE TAKEN THE SOFT OPTION).

Metal dome tweeters are good. In fact some of them are very good.

For the last three years we've even had one specially made for us, for use in our highly acclaimed Studio 1 and SuperTower models.

But at ProAc we're always looking for improvement and at the beginning of last year we discovered a very exciting new soft dome tweeter. This unit was so impressive that we spent a full ten months measuring, testing and modifying in order to integrate it into these two loudspeakers.

Radically revised crossover networks and improvements to cabinet damping, together with subtle modifications to the tweeter itself have produced exceptional results.

The new Mark II versions of The Studio 1 and SuperTower deliver a treble smoothness and overall transparency which is remarkable by any standards. We think you'll be impressed.

And as an added bonus, both these models are now available in such attractive finishes as Oak and Mahogany as well as the standard Teak, Walnut and Black Ash — at no extra cost.

Hear them at your nearest ProAc dealer or contact us for details.

 **ProAc**
CLEARLY MORE ACCURATE

130-132 THIRSK ROAD BOREHAMWOOD HERTFORDSHIRE WD6 5BA ENGLAND TELEPHONE 081 207 1150 FAX 081 953 8933

There are few products that make as bold a statement as the TDL Studio 4 loudspeaker. In its way, the Studio 4 is the Mont Blanc Diplomat fountain pen of the hi-fi industry; big, dramatic and implicitly suggesting a strong sense of purpose. A Diplomat pen is not bought for its convenience, but for pride of ownership, bestowing upon its owner the title of Writer of Important Documents.

The £1499 TDL Studio 4 has a similar air of authority about it. The implication is one of total dedication to music. With its imposing size and the sheer power of the sound it produces, the Studio 4 demands much of the listener; the faint of heart should not apply, as we are talking 'Maxell man' stuff here!

Almost all hi-fi enthusiasts speak of TDL loudspeakers with the reverence normally reserved for strategic weaponry. At hi-fi shows, TDL's room is easily identified by having the deepest, most intense bass of the exhibition. At home, their loudspeakers are given pride of place within the listening room. Never anything less than impressive, TDL's range of loudspeakers command a respect among the hi-fi fraternity that is born of solid, well engineered and consistently good sounding products, with a distinct TDL 'signature'. In producing products like the Studio 4, TDL are consolidating their reputation.

Transmission Line Theory

Before delving into the Studio 4 itself, a brief introduction into the world of the transmission line would be in order. The theory is simple; the 'line' (the name 'transmission line' is taken from an electrical term, used in communications electronics) is a long signal path, filled with absorbent material. Down this line travels the rear wave from the drive unit itself. This length of line, combined with its absorbent properties effectively cancels some of the distortion inherent in infinite baffle designs.

At the end of the line furthest from the drive units is a port, which allows the rear wave to escape into the listening room. This can either be a strong or weak wave, depending on the amount of absorbent in the line. Generally, a strong wave is used to enhance the signal from the front wave, at the cost of a rapid roll-off of bass. Alternatively, a weak signal is created that does not reinforce the front wave, but has a more relaxed roll-off.

Theory aside, what transmission line loudspeaker designs provide is the facility to extend the bass response below the norm. As TDL suggest in their literature, creating music in this manner can only be achieved by moving air, not just

moving speaker cones. In this respect, TDL loudspeakers are exceptionally capable of pressure-loading the room they work in, making truly deep bass felt rather than just heard. This is why people who speak of TDL loudspeakers usually mention the deep, powerful bass in the same breath.

Construction Quality

Returning to the Studio 4, we see that TDL are one of the few companies that successfully marry theory and practice into an attractive package. The Studio 4 has a constructional quality that many loudspeaker manufacturers can only aim for, its cabinet work specified with longevity in mind. While being far larger than most British loudspeakers, the Studio 4 is not too imposing when placed in a large room, simply because it is slim and visually unobtrusive as a result.

On the subject of room placement and interaction, the Studio 4 is not too fussy about room size and positioning. Its size (112cms high, 27cms wide and 44cms deep) demands that it be used in medium to large sized rooms, to avoid appearing too dominating. In a rectangular room, it is happiest firing down the room, rather than across it. Within reason, the Studio 4 is not especially room sensitive, but there is a position where the imagery



transmission power

improves and the entire portrayal becomes credible. Generally the loudspeaker works fine within the listening room (provided that the basic rules of positioning loudspeakers are adhered to - please do not blame myself or TDL if you cannot get the Studio 4 to sound good if it is placed on its side behind the sofa!).

A useful improvement is to be had from using TDL's own stands, costing £90. While only a few inches high, they do make a significant difference to the sense of authority that the sound can have. A few minutes of positioning can make the TDL sound good; a few hours can make it sound truly excellent.

TDL's new Studio 4

Transmission Line

loudspeakers reveal

their awesome power

to Alan Sircom.

THE SOUND REVOLUTION AND ALL THAT JAZZ . . .

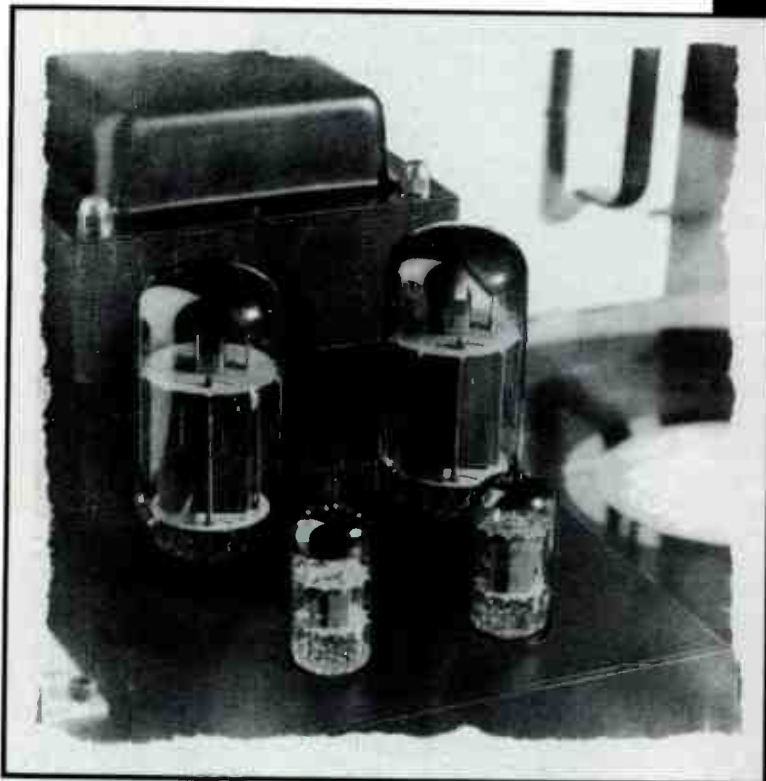

We are the only dealer in the UK to specialise in valve amplification and turntables exclusively.

This is because we firmly believe that vinyl records played through such systems come closest to the true sound of music.

The equipment we stock has been carefully selected to convey the emotion and vitality we feel is sadly missing on CD. But for those that need CD players, we find that valve amplification can help enormously.

Telephone us so that we can arrange a sensible demonstration and bring along your favourite records to hear how they should sound. You'll find no hard sell . . .

Just sound advice.

Professional record cleaning service now available. We are also happy to help you to track down original vinyl pressings.

VALVE AMPLIFICATION

Art Audio

Audio Innovations

Concordant Audio

Conrad-Johnson

Sound Design Studios

TURNTABLES

Kuzma Stabi

Rock Reference

Thorens

VPI

CARTRIDGES

Empire Scientific

London (Decca)

Lyra

Shure

CABLES

Chord

Kimber

Straight Wire

SPEAKERS

Camber

Pentachord System

SD Acoustics

Spendor

Townshend

VINYL TUBE AUDIO

where music matters

Specialists in Analogue Audio
& Valve Amplification

43-45 Fortress Road, London NW5 1AD
071-485 4854

Sound Stage

Once positioned correctly, the Studio 4 possessed a fine sound stage, especially when one considers how large it is. Imagery was well-formed, although not as precise as the leaders in this field. On tracks like 'Girlfriend Is Better' from Talking Heads' *'Speaking In Tongues'* LP, this sound stage was well outside the confines of the box from which it emanated. David Byrne's vocals were clearly delineated from backing singers. Synthesizer, guitar and bass appeared to be very definite instruments, with a sense of space around them.

David Byrne's vocals were clearly delineated from backing singers. Synthesizer, guitar and bass appeared to be very definite instruments, with a sense of space around them

The TDL excelled in its portrayal of instrument sound. In using a loudspeaker with so awesome a bass response, organ music has to be used. 'Cantate Domino', so beloved in hi-fi demonstrations because of its deep, powerful bass and good recorded acoustic, was called into play. Here, the TDLs behaved as one would expect, creating vast amounts of bass when needed, yet they also sounded both real and natural. Organ sounded full-bodied and rich, while the choir and the solo vocalist were easy to follow (especially if you can understand Swedish).

On playing 'You Can't Always Get What You Want' from The Rolling Stones' *'Let It Bleed'* LP, I felt that Mick Jagger's voice was a bit veiled and 'cuppy'. The rest of the performance was handled well, however. I did perceive an intensity to electric bass that was not apparent on classical pieces. This manifested itself as a minor earthquake with some bass notes. The room that took the Studio 4 was slightly too small and could account for its bass heavy sound. This compromised the performance a little, making the bass sound a bit ill-defined. In a larger room, I am convinced that this area would become far tighter.

One criticism that is levelled against transmission line loudspeakers

comes from the supporters of pace, rhythm and timing. They suggest that the transmission line cannot keep up with the pace of a standard Infinite Baffle loudspeaker, due to the length and convoluted nature of the line itself. Up to a point, I can agree with this argument, but this is not to say that the Studio 4 cannot keep time. With such a loudspeaker, its strengths lie elsewhere, but the sense of timing is nonetheless very good. Complex percussion rhythms, so popular in African and Latin American music, are not as well defined I have heard on other loudspeakers, but few can match the power of John Bonham's kick drum when played through the Studio 4, despite the timing involved. Unless most of your musical tastes are difficult rhythmically, the Studio 4 will cope more than adequately with whatever timing is thrown at it.

Classical Music

In the past I have felt that the transmission line loudspeaker design is best suited for playing classical music. One of my friends used TDL Monitor loudspeakers to play rock. I felt that, although impressive, the sound did not have that grip on the rhythm section that some loudspeakers have. On saying this however, he has developed a life-long love affair with these speakers, even going so far as exporting them to Canada when he emigrated. I can now see what transmission line loudspeakers have to offer the hardened rock fan and would now happily recommend them.

the TDL Studio 4 loudspeaker produced musically soulfully and effortlessly

I felt that the TDL Studio 4 loudspeaker produced musically soulfully and effortlessly. At no time did the Studio 4 disgrace itself, simply getting on with playing the music with the sort of intensity that forces people to listen. If you have the room; if you like bass; if you want to hear organ music the way it should be played, the Studio 4 should be high on the list. In many respects, the only alternatives to the Studio 4 lie within the rest of the TDL range. After playing a pair for some time, I can see why my friend took the time, trouble and expense of shipping his speakers after him. They have a quality about them that could be very addictive indeed.

The Editor writes: Like most big loudspeakers, you have to get back from the Studio 4s (by around 8ft minimum) before they sound 'right' - meaning integrated. I thought they sounded superb in being neutral, 'right' and free from major blemishes or peculiar effects. They are amongst the easiest loudspeakers to sit in front of that we have had in for review for a long time.

For me, this ease of listening embraces a lot of properties: I don't find 'easy' for example, an inaccurate loudspeaker because I constantly question it. I never questioned the performance of the Studio 4, but I do with 95% of loudspeakers. Interestingly, we ran a pair of Meridian D6000 active 'digital' loudspeakers at the same time (in another room!) and whilst they were more analytical and arguably more 'correct', they were not so relaxing as the Studio 4's (see our report in the next issue).

Being specific, mid-range clarity of this loudspeaker was extremely good, due I suspect to use of a high quality dedicated mid-range unit and to loss of rear energy down the transmission line, lessening time delayed reflections out through the cone. At times I detected a slight fluffy-sounding coloration here, but it was minimal.

TDL use a fine tweeter, allowing us to play fierce sounding CDs and poor recordings and yet still be able to enjoy the music, rather than cringe at the sound. In this respect I found the Studio 4s both refined and civilised.

Alan mentions an apparent lack of 'speed' and I don't disagree with him, but this is a psycho-acoustic effect. Where deep bass (i.e. below 40Hz) is present (not to be confused with large quantities of normal bass), the sound will appear slow. I encountered this whilst developing revised equalisation for my own Celestion SL-6000 sub-woofers. I was obliged to include a 10Hz LP warp filter (something Celestion unfortunately omit from their own crossover) and found that removing frequencies below this point made them sound faster. Discussing the D6000 loudspeaker, Bob Stuart of Meridian confirmed this point: true deep bass reproduction makes a loudspeaker sound slow and a bit ponderous. The TDL Studio 4 produces very deep bass and that is why it sounds 'slower' than other speakers.

Finally - and again like the D6000s - the Studio 4s go very loud with great ease. Connected up to a Musical Fidelity SA-470, the organ at the Basilica of Saint-Semin, Toulouse (Peter Hurford playing Cesar Franck, Argo 411710-2) had the foundations of the house fairly shaking. By any standards, the Studio 4s are a fascinating experience - and a very pleasant one ●

The TDL Story

The story behind TDL, manufacturers of transmission line loudspeakers, is little known. We speak to John Wright about the history of the company and its hopes for the future.

Where did your interest in audio start?

As a child, I was fortunate enough to live next to the South London record library. Like most hobbyists of the time, I built a gramophone with a magnetic pickup mounted on a wind up turntable, feeding a valve amplifier that I made out of ex-government parts. It was very much the way things were done then. The result enthralled me.

Quality of reproduction became an issue when I took a recording home from the library and found it was distorted. I took it back and said it was faulty, but they put it on their equipment and it was perfect. So I went home, took my equipment apart, found the fault and cured it.

Soon after, my father brought a long playing record and record player home and it was infinitely better than the one playing 78s. That sound quality could be improved like this intrigued me. It was these two events that got me interested in sound quality.

But you now specialise in loudspeakers. Did this come later?

I started designing loudspeakers in an ad hoc fashion, after a friend had produced speakers from published designs. These seemed to be less than successful. I found by trial and error that I could make a much more acceptable loudspeaker.

Did that stimulate you to start a business?

No. None of this was ever looked upon as a career. At the age of 18 I went to the University of Bristol to become a teacher. I was entrenched in education, following in my parents footsteps. Throughout this time, I kept my interest in hi-fi and found that it drained almost all the cash I had. So, to supplement paying for this hobby, I took in repair work from a local dealer. This generated enough cash to allow me to buy new equipment. I became ill through overwork because of this.

I was twenty five and newly married. I could see that on a teacher's salary alone I couldn't easily bring up a family, so I said to my wife that I would have a go in hi-fi. I went to work in the shop I was doing repair work for and ended up buying it with another person.

We had a fabulous time, because we were able to sell high end Quad and Leak equipment to a wealthy clientele at our leisure. We had a thriving business in Maidenhead. Then retail price maintenance was abolished and this spelt the end. People would come into our shop to listen; and go somewhere cheaper to buy.

How did you escape from that problem?

Like many small shops we had to diversify. I got involved in gramophone pickup arms, producing an Audio & Design unipivot arm that had mercury bath leadouts to reduce friction to the minimum. We took it to an Audio Fair at the Russell Hotel, together with a loudspeaker using Titanium cone drive units. Various people expressed an interest so we went into production with the arm and the loudspeaker. It got me involved with exporting and used to meeting people from overseas. The drive units had problems that I found I had to sort out and this got me more deeply involved with loudspeakers.

What happened then? Did the business turn out a success?

I did not go straight into loudspeaker systems manufacture from there. My interest in pick-ups brought me into contact with Goldring, who were making ceramic cartridges at the time. I helped them into magnetic car-

tridges, because when transistors came out they demanded a low impedance signal source. The magnetic cartridge provided this, whereas the ceramic did not. I helped design the G800 Series and enjoyed my time with them very much. I was also working as a reviewer at the time, writing for Hi-Fi Sound in the early seventies.

I remember you provided proper loudspeaker measurements, which was very sophisticated at the time. I was then editor of the sister magazine, Hi-Fi Answers.

Those measurements were made using test facilities set up to assess my early transmission line designs. I came across the transmission line principle in Wireless World. It was written up by a Doctor Bailey, who insisted that long haired wool was used as damping material inside!

I first heard a version that used KEF drive units and was fascinated by the sound, so I made a pair myself. We had a pair at Goldring too. This was around 1970 I believe. A person who took particular interest in them was Bud Fried, the American importer. He was going to demonstrate Goldring cartridges at a show in Philadelphia and wanted the loudspeakers there as well.

At the show, all people wanted to know about were the loudspeakers, because massive bass rolled down the corridors - and the Americans like bass. Everyone wanted to know their price, so Bud put what sounded to me at the time a silly price on them. The outcome was that I came home with orders!

I can't remember Goldring ever making a loudspeaker.

No, they didn't. I took the proposition to them, but they did not want to diversify. I got the speakers made by sub-contract and fulfilled the US orders. Because they were sent first to the States through Bud, we used his trading initials as the company name: IMF (Irving M. Fried). Within a few years I found myself exporting them to countries around the world, with Britain coming last on the list. The company did well: it was the right product at the right time. IMF continued successfully through the seventies, making a range of large transmission line loudspeakers.

IMF always looked to be a well founded and prosperous company.

Yes, however a problem that developed concerned the drive units. We had to use other people's and this, we felt, always put us at a disadvantage. Our suppliers all made

loudspeakers too and were therefore competitors. We could not get the best or latest designs from them.

My solution to this problem was to approach Elac, a company making drive units, mainly for cars and such like (this is Elac UK, not related to Elac Germany who made cartridges). Coincidentally, they wanted to get into hi-fi, so my proposition interested them.

Elac and IMF formed a separate company to make quality drive units and called it Transducer Developments Ltd, hence TDL. By the late 1970s, IMF was using TDL drive units and started selling these units more widely into the hi-fi market.

‘I came across the transmission line principle in *Wireless World*. It was written up by a Doctor Bailey, who insisted that long haired wool was used as damping material inside!

So what happened to upset this apparently happy situation?

For reasons not concerned with the company, I was getting disillusioned with the industry at this time, due to a range of outside causes. There was a lot of change taking place and I felt unsure about my future in IMF. Amicably, I sold out my share. I had the opportunity to make the right decisions - but I then made some wrong ones! I spent a number of years outside of, but close to the hi-fi business, working in related fields.

In June 1984 I received a phone call from the chairman of Elac. It turned out that IMF had got into trouble, with Elac as a major creditor. The upshot was that within about 24 hours I found myself back in the loudspeaker business, trying to sort matters out on behalf of Elac. It was such a mess that we decided not to intervene and let IMF go into receivership.

This presumably left IMF's customers without a supplier?

HI-FI WORLD JULY 1991

Yes. Elac were not happy with the outcome, so we started a new company with a better structure, using TDL. The first product was an entirely new transmission line called the Reference Standard loudspeaker. Being truly a part Elac, TDL was then used to provide greater credibility within the car loudspeaker business and generally act as a company flagship.

Elac were expanding successfully in the car loudspeaker business and had secured a factory in Wales. Their automotive business escalated, to the point where six hundred people were employed. Attention was drawn away from TDL and hi-fi became less and less important to them, representing 17% of turnover in the end.

This situation started to cause its own problems; for example outside customers, quite properly, got Elac drive units before TDL. I couldn't do much, because I was not in direct control; I was a consultant. Because TDL was wholly owned by Elac, but their attention was drawn away by rapid expansion of the bigger car speaker business, TDL was rather left to languish.

This is a long and tortuous tale I have never heard before.

That is because Elac, as a sub-contractor of some size, has traditionally exercised great discretion. They make parts for many, many people, all of whom do not want the fact known. Companies naturally like their customers to think they make and design vital parts themselves, when often Elac would be doing the job.

What brought Harman into the picture? I was surprised at the takeover, since Elac always seemed healthy.

Yes, Elac has always been a strong company. The takeover by Harman was by consent. In 1989 Audax in France got into trouble. Both Harman and Elac were interested and got talking to each other. Harman acquired Audax. Both companies realised that the Japanese posed a threat; they were interested in Audax for example. Harman needed to strengthen its European motive operation and Elac needed to gain some might. So both companies felt it was beneficial to form a larger unit.

Harman found that they had also acquired a hi-fi manufacturer at the bottom of the garden - called TDL! Harman are very sympathetic to TDL.

Harman rationalised the car speaker business by selling off Elac's North London works in Tottenham and moving the entire business down to this new factory in Bridgend, Wales. As you can see, TDL were

given generous new quarters. Our factory is one of Britain's biggest producing high quality loudspeakers. We have access to Elac's test facilities too, which includes a full sized anechoic chamber. However, because TDL exports most of its output, we are perhaps less well known in the UK than you might expect from the size of our business.

What do you hope TDL will go on to do in the future? Do you hope to diversify into electronics as well, for example?

Under Harman TDL has received more attention and it is flourishing. I would like to see TDL continue making really high quality loudspeakers of the stature of, say, Steinway pianos. This has always been our niche and it is what we do well. Our small transmission line models, the Studio 1 and 0.5 have been remarkably popular too. This suggests that perhaps we could reach a wider market also ●

What is a Transmission Line?

In loudspeakers it takes the form of a long, tapered tunnel damped to suppress the main resonant modes. The idea is to absorb all unwanted back radiation from the drive unit cone. This eliminates internal reflections, which in closed box loudspeakers pass back out through the drive unit cone after a delay, producing muddling and blurring of its sound.

Transmission lines add acoustic mass, lowering the resonant frequency of a drive unit and are noted for their very deep bass.

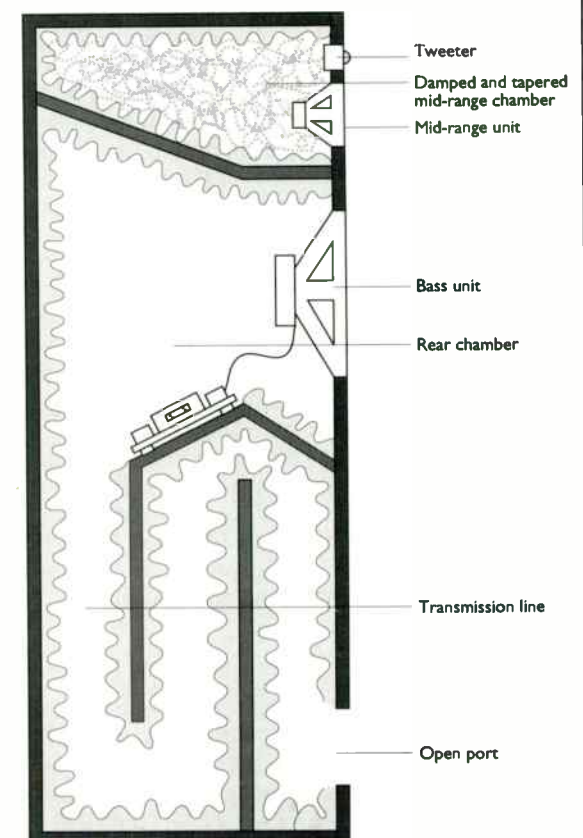

going for gold

After a fourteen year absence, Goldring are back in the turntable game with their new £149 Excelda I. Alan Sircom spins the discs.

Goldring are one of the last stalwarts of the vinyl cause. Manufacturers of cartridges and assorted turntable bits, many remember them for their classic Goldring-Lenco range of turntables. Now, in the autumn of vinyl, Goldring have returned with their first turntable since 1977.

Designed and built by Remy A. Thorens, the Excelda I comes fitted with a Thorens arm and a Goldring Elan cartridge, all for £149. The review model, complete with the original Thorens Pro-Ject I packaging and instructions, is a pre-production model, and as Goldring pointed out "may have a few rough edges, that will be smoothed out by the time it hits the streets."

There is not much left to smooth. The deck is finished with typical Thorens efficiency, leaving little for ham-fisted hi-fi reviewers to damage. The assembly manual is written in German, but with an English translation that is as thorough as to be expected from a collaboration of so prestigious a pair of companies. Packaging, although a bit crude, is well thought out and not too wasteful.

Reservations

Even though I use an Naim ARO tonearm, which appears flimsy to the untrained eye, I have grave reservations about spindly tonearms, like the model here. Its arm bearings appear quite free, especially for a model at this price, even though the arm switches the deck on and off semi-

automatically. In addition, I am a little concerned as to the general weakness of the arm support, but the armleads and Cinch phono plugs are very well specified.

The rest of the deck is diminutive. Barely larger than a record itself, the Goldring is only 41.5 cm wide by 32 cm deep by 11 cm high, with its dust cover on. The outer platter is quite weighty and needs a free main bearing to run. Fortunately, the deck's inner platter is one of the most free I've encountered to date, almost making a claim for perpetual motion. When fitted with outer platter, but without belt, the platter spun freely. With an uneven load, the platter rotated several times, which suggests that it should be less prone to speed fluctuations, as the platter will behave like a flywheel.

Setting up the turntable is a very simple operation and it's even easier to use. While we can take a purist line about semi-automatic turntables which start and stop at the touch of a tonearm, it has to be said they are popular and convenient. Speed changing is done by moving the belt on the motor. This can be done with the platter on (through two holes in the platter itself) and a device (an orange wing nut) is attached to the plinth to make speed changing easier.

I was very impressed by the deck's sense of stereo imagery. It produced a soundstage that was wide and deep, but had little height.

Through the Night

To give the turntable its best possible chance, I set it up and left it to tick through the run-out groove of a record overnight (the record was 'The Curse Of The Higsons' and it has the best sounding run-out groove around).

In assessing the deck, I used an Audio Innovations Series 500 amplifier and Snell Type K loudspeakers on Pirate stands. As it was very early when I did the bulk of the listening, I also used an elderly pair of Stax electrostatic ear-speakers (headphones, to you and me). These, although distinctly elderly, are remarkably able at resolving detail,

albeit with a somewhat soft and boomy bass. The deck was supported on a Mana Reference turntable support, which I consider to be the best available, although this does cost about twice as much as the turntable itself.

In overall terms, the sound quality was a bit of a curate's egg: good in parts. I was very impressed by the deck's sense of stereo imagery. It produced a soundstage that was wide and deep, but had little height. As if to justify the records listed on our test disc article, I used all my favourite tracks. On the obligatory Jane's Addiction LP, the track 'Summertime Rolls', the open staging, combined with its light, spacious sound provided a quality that was easy to listen to.

Separation

Its separation of musical instruments within a soundstage was very good for a deck of its price, giving the Goldring the appearance of creating solid instrument voices. Unfortunately, this was mere artifice, as I felt the deck was lacking in authority. By this, I mean that while an instrument is well placed within the soundstage and does not waver, the instrument voice itself cannot approach accuracy as it has no apparent power.

This was, I felt, due in part to the dynamic range of the turntable. On playing Rachmaninov's Symphonic Dances, the impact of the music was lost, as it sounded compressed and lacking in drama. Timpani had no intensity and the deck did not convey their explosive power. In addition, it lacked a fair amount of detail. Spatial information aside, subtle clues to timbre and pace were absent.

This lack in detail was noted when playing 'Pale Blue Eyes' from the eponymous 'The Velvet Underground' album. In losing the more delicate areas of this track (which only exist on an older pressing - later ones get this subtlety compressed out of the recording), Lou Reed's voice seemed to lose some of the emotion and depth of feeling that typifies his singing at the time.

When listening to vocals on 'Losing My Religion', from REM's 'Out Of Time' LP, it was surprisingly easy to follow Michael Stipe's lyrics. This led me to believe that the backing track was recessed, a feeling that was reinforced by the succeeding track, 'Low'. Here, vocals and guitar were both pushed forwards in the mix, leaving the backing band playing at a far lower volume than expected. The vocals themselves were very articulate and the guitar sounded suitably guitar-like.

Surface Noise

One area that did surprise me was the virtual absence of surface noise.

As the Goldring is set at such a low price, it will appeal to many who are looking to upgrade the turntable on their rack or midi system. Here, the deck would shine.

Many of my records are dusty, worn out and in poor repair - just like their owner. The surface noise the Goldring reproduced was far less than I would expect from a turntable of this price. In the case of 'Kind Of Blue' by Miles Davis, the surface noise almost disappeared altogether. Unfortunately, so did the bass player.

The Goldring could at best provide a sound that was polite, at worst, uninteresting. Mostly, however, it was capable of playing music with a restrained air that was pleasant and caused no offence.

As the Goldring is set at such a low price, it will appeal to many who are looking to upgrade the turntable on their rack or midi system. Here, the deck would shine. Its lack of

dynamics would be a boon, as it would not stress the phono stage of the amplifier. If one were looking at the turntable as an entry level audiophile model, competing with the likes of Dual and Ariston, it has virtues in relation to its competitors, but is still flawed in some respects.

Many people are now looking at buying their last ever turntable. The Goldring Excelda I may not be the budget option for everyone, but it is well built and should last. The turntable will appeal to those who enjoy good stereo imagery and like a polite sound. It will also be popular with owners of midi systems, for the reasons stated above. It has weaknesses, but at £149, it still represents good value for money ●



**THEY'VE TRAVELLED
10,000 MILES
JUST TO BUY OUR HI-FI.
DOES THAT SEEM
A LITTLE EXCESSIVE?**



In a modest building within sight of the twin towers of Wembley, a British company is quietly creating a revolution in hi-fi. The company is Musical Fidelity. Our hi-fi is revolutionary because it is designed for people who want to enjoy recorded music delivered through the cleanest, most elegant signal path possible. For the most realistic sound possible. No less an authority than What



Hi-Fi? Magazine thinks we are onto something. They say our B1 inte-

"This is the stuff of big amplifiers. The B1 is perfectly capable of emulating £1000 power stations."

What Hi-Fi Magazine

grated amplifier is "the very essence of a good budget amplifier" and it won their "Best Budget Amplifier" Award in

1989. When word of this revolution reached distant shores, overseas hi-fi buyers flocked



to our door. When they heard the open and natural sound of its low feedback circuit, they rejoiced. Further cries of delight

greeted the matching T1 stereo tuner which, says High Fidelity Magazine, is "informative and involving to listen to." As is our A200 integrated amplifier, which delivers 60 watts per



channel. In fact, we make a wide range of hi-fi separates and loudspeakers that are sold around the world, especially in the Far East where they know a thing or two about hi-fi. Our hi-fi is also available in the UK. To hear it for yourself, simply make the short journey to a Musical Fidelity stockist. Where you will discover why *hearing is believing.*

MUSICAL FIDELITY

FOR DETAILS OF YOUR NEAREST STOCKIST WRITE TO MUSICAL FIDELITY, 15/16 OLYMPIC TRADING ESTATE, FULTON ROAD, WEMBLEY, MIDDLESEX HA9 0TF OR TELEPHONE (081) 9002999.

Intelligence from Cambridge



Cambridge Audio's new CT-50 Cassette Deck has some intelligent aspects.

Noel Keyword spies its virtues.

Cambridge Audio now join NAD in bringing a cassette deck to the UK market - even though Cambridge cheekily claim the £250 CT-50, tested here, "is the first cassette deck to be offered by a major British hi-fi manufacturer". NAD might have something to say about that!

There'll be some hollow laughs in Taiwan, China and Japan too, 'cos they make all the important bits and throw the things together for us Brits. The CT-50 is made in Taiwan (NAD's cassette decks are made in China), using standard parts. The method of construction is that normally adopted in the East for products like this. The case and chassis beneath it are made of light sheet steel, sprayed Cambridge dark grey.

Neat Finish

The front panel is an aluminium extrusion, that is neatly finished. It is made distinctive by the addition of buttons and knobs finished in the Cambridge style, with bevelled edges and shallow depressions. Cambridge say the CT-50 is 'built to an exceptionally high standard'. I saw no sign of this; it is built to the usual standard, which is acceptable, but not high.

The lightweight steel cases common to products like this, which have to be built down to a very competitive price I should add, act as a sounding box, which can make the deck's operation

'clanky'. The CT-50 wasn't too bad in this respect. Its transport is logic controlled, which means that the transport buttons are in fact electrical switches. They had a short, firm action and the transport obeyed commands without hesitation. The transport clicks and clunks heartily, but there were no hollow, resounding clangs!

The controls move smoothly and give a good impression. Quality of detailing was fine, the knobs and buttons looking well finished and neatly aligned in the fascia cutouts, for example. Exceptions were the clear indicator panel, which needs to blend into the fascia a bit more harmoniously and the mechanical tape counter with its reset button, which looks and feels crude.

Cambridge have given the CT-50 a fairly comprehensive specification. Although the transport is a single capstan type, it has an independent capstan motor. A second motor drives the reels. I noticed that the left hub reel brake was slack, allowing a heavy, full reel of tape to overrun a little and spew out some loose tape. I felt generally, from other niggling problems identified later, that Cambridge will need to keep a close eye on alignment and quality control out of the factory to ensure an acceptable standard of performance is maintained. NAD are very interventionist in this respect. The brake problem was minor but at the same time both obvious and unsettling.

Dolby HX Pro has been included

and usefully increases treble overload headroom when recording. This results in cleaner, clearer treble at high recording levels. Dolby B and C type hiss reduction systems are included as well of course. Tape type selection is automatic, a green LED confirming whether a ferric, chrome or metal tape has been inserted. Similar indicators cover record or play modes and Dolby selection. The Play LED flashes when the machine is in music search mode - but Cambridge seem unaware the Taiwanese have incorporated this feature, for no mention is made of it in the owners handbook. This is the same sort of oversight as the one that resulted in Wharfedale, the company now behind Cambridge Audio, producing loudspeakers without the company name on! I found the search mode very effective, since it works in reverse as well as forward.

Tape Tuning

Variable bias for tape tuning purposes has not been included, which is a pity. Most decks now have it, in order to achieve tonally balanced recordings and lessen the chore of tape matching. Worse still, metal tape did not match the CT-50; there was too much treble lift, as the frequency response analysis shows. Adjustment for standard (IEC) ferrics and chromes was good, meaning that in practice the CT-50 matches TDK AR ferric tape and TDK SA chrome tape well. It will give a bright sound with

special ferrics like TDK AD, That's FX or Sony HF-S. Normal chromes like That's VX or TDK SA match too. So ferrics and chromes match in well, metals do not.

However, this deck is the third model available in the UK to offer Play Trim. NAD devised the idea in conjunction with Dolby Labs., Yamaha adopted it and now Cambridge offer it too, although it is called HF Trim. Like the NAD circuit, it trims treble level on playback by +/-3dB at 10kHz. This usefully makes prerecorded tapes sound brighter or duller, according to taste or their original condition. When a pre-recorded tape sounds clearer with Dolby out, HF Trim should be used to provide correction and Dolby B left in to suppress hiss. HF Trim will also make over-bright recordings on metal tape sound right, but they remain inherently bright of course and this will be obvious if they are transferred to a Walkman or car player. The CT-50 had been well enough aligned to play prerecorded tapes accurately with HF Trim set to zero. It does not sound dull or muffled.

The record level indicators use LEDs and have an adequate range, reaching +6 above 0VU. Cambridge have set the latter to coincide with Dolby (flux) level. Whilst +6 isn't much compared to say, a Nakamichi, it is just enough for the CT-50. TDK AR in particular can be taken up to +6, albeit with some degradation. Metals need to be kept to +4 or so.

Performance measurement showed that this deck has been generally well specified and set up. It has reasonable speed stability, but the review sample ran a bit fast. Some effort has gone into making sure prerecorded tapes do not sound muffled, which was once a common problem. Hiss was very low and there was no hum. The head records to satisfactorily high levels with ferrics, chromes and metals - except at low frequencies. Unfortunately, it suffers more bass distortion than is common these days. More details are provided in the Measured Performance section.

Sound Quality

Prerecorded tapes fairly sped along; I found the fast running obvious and a trifle irritating. Otherwise, the CT-50 sounded both clear and clean, with good, stable stereo imaging. It has a light, dry bass quality that helps towards its sense of tidiness and oneness. HF Trim worked very well, tonally equalising poor recordings effectively.

Recording right up to +6 with TDK AR worked well, some splash and smearing becoming obvious in the treble, which is only to be expected. Results were acceptable all the same, bass sounding good enough (i.e. not wallowy or plummy) in spite of high measured bass distortion. Backing off to +4 cleaned up treble and resulted in fine recording quality.

I got a bit of a shock with a recording on TDK SA of Vlado Perlemuter playing Chopin's Opus 48 No 1. Reasonably confident from measurement that it

would sound stable, the amount of tonal shake and jitter on sustained notes proved more painfully obvious than I expected. This is not a piano lover's deck. Its speed stability is satisfactory for Rock music, but not for Classical piano.

TDK MA metal tape sounded bright, but happily in this case less bright than expected! Recordings of a bright source do become over-bright and sharp. Otherwise, whilst a light, thin tonal balance was apparent, it proved tolerable.

Summary

Cassette recorders are difficult to get right. This is the first attempt by Cambridge and, to be frank, it just misses the mark. The CT-50 performs well in many areas and it shows promise. More attention is needed to detail however, notably speed accuracy, speed stability and metal tape recording quality. Then, the CT-50 could equal or start to outperform the competition, something it does not do at present ●

Measured Performance

Replay frequency response measured flat up to 18kHz with HF Trim set to zero. However, bass response drops off below 50Hz, which is higher than usual and this does result in bass lightness, both with prerecorded tapes and recordings. The head is poor at low frequencies, where it produces a lot of bass distortion. HF Trim produced a useful +/-3dB of treble adjustment at 10kHz in order to tonally equalise tapes and improve Dolby tracking accuracy.

Peak recording level, 0VU, has been set accurately to Dolby flux level. Hiss and hum in the replay amplifiers were low; at high volume I heard no motor drone at all. Replay speed was +1.3% fast and this proved clearly audible as raised tempo. Speed stability measured fairly well, except that wow hit 0.1%. Unfortunately, the rate of variation was around 6Hz and proved clearly audible.

Low flutter contributed to a good sense of clarity and basic speed drift was low also. These properties are seen respectively as lack of flutter spikes across the centre of the analysis picture and a sharp peak at right. Offence was caused by capstan wow (0.1%), seen as high 'shoulders' either side of the central test tone peak at right in the analysis.

Frequency response with blank ferric and chrome tapes measured flat by cassette standards, as can be seen in Fig 1. Bias was set properly for metal tape, but record equalisation was wrong, resulting in raised treble (Fig 2) with all brands. The internal bias adjuster was set to maximum I found, so there was no possibility of trimming here. In any case, the MOL/SAT balance was correct at +3.5dB/+1dB with TDK MA so, ideally, bias should not be increased. Record EQ. needs to be changed. Chrome bias (left and right channels) can be adjusted internally, but ferric is a single, slaved pot. Ideally, individual left and right channel bias adjustment pots. for all three tape types should be incorporated.

The head has good overload ceilings, except at low frequencies, where it is poorer than usual. TDK AR ferric gave 6% distortion at 0VU, That's MRX-PRO metal 12% (40Hz). Luckily, lack of bass humps and an early roll off keep bass quality dry and light. The CT-50 doesn't woof and wallow at low frequencies, like some recorders. Hiss and hum were very low and are not a problem.

REPLAY (prerecorded tapes)

Frequency response (-2dB) 50Hz-17kHz
Speed accuracy +1.3%
Hiss (70uS, Dolby out) -60dB

RECORDING (blank tapes)

Frequency response (IEC Primary Refs.)
ferric (IECI) 45Hz-15kHz
chrome (IECII) 45Hz-16kHz
metal (IECIV) 45Hz-15kHz
Separation (1kHz) -51dB
Distortion (315H) 1.4%
Hiss (70uS, Dolby out) -56dB
Speed variations (DIN total) 0.1%
Flutter energy (3-3.13kHz) -32dB
Modulation noise -40dB

MOL/SAT (IEC Refs) 315/10k
IEC I (ferric) +4dB/-7dB
IEC II (chrome) +2dB/-5dB
IEC IV (metal) +2dB/-1dB

Frequency Response

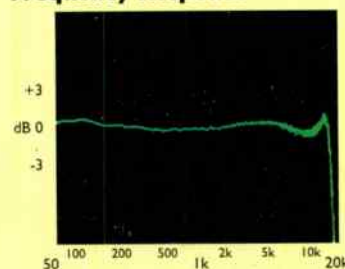

Fig 1 - Flat response, for cassette, with standard ferric and chrome tapes

Frequency Response

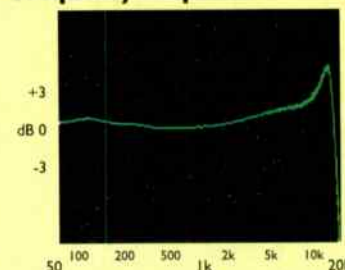

Fig 2 - Rising treble with metal tapes

Speed Stability

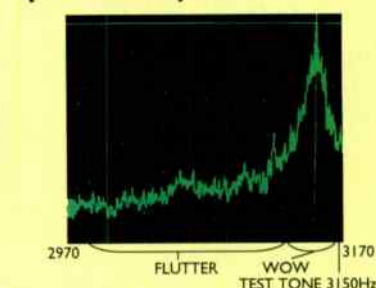

Fig 3 - Little drift or flutter, but capstan wow a problem - seen as shoulders to test tone spike at right



low bits on a low budget

**Aiwa's two new budget
Compact Disc players feature
competing low bit chip sets.
Noel Keyword reviews both.**

From the moment the press release landed on my desk I was intrigued. Why would a large Japanese company like Aiwa make two budget Compact Disc players, of similar price but differing chip technologies? Is it a fishing expedition to test the market place - and perhaps the Press - for its reaction? Or do they see some inherent merit in each system and feel a need to offer alternatives?

This report looks at both players in detail. The XC-500 uses Japanese digital convertor technology, known as the MASH system, and it costs just £150 - which includes remote control! The XC-700 uses Philips Bitstream technology and costs a little more at £170, again with remote control. By any standard, that's incredible value, assuming a reasonably competent performance, of course.

These players have some interesting competition. For example, Philips offer Bitstream with remote control in the CD-624, for £200, while NAD offer MASH in their 5420 player without remote for £170, or with remote control in the 5425 for £200. These two players are compared in the accompanying chart.

All these machines offer a good performance: let's face it - they have

to! The competition for the budget CD market in Europe is fierce, with Philips fighting to defend their position against the Japanese. Aiwa's release of a Bitstream model that undercuts Philips own CD-624 could be seen as aggressive marketing; I should imagine Philips will see it that way. The move looks even more disingenuous by another not so small detail - Union Jack stickers on the front!

Just when some Europeans are trying to get UK made cars from Nissan and Honda classified as Japanese, no matter what their local content is, Aiwa choose to bring out market-busting CD players with front panel stickers which say British Made, whilst on the rear is a permanent legend that says 'Made in the UK'. Subtle huh?

The XC-500 and 700 do not fit perfectly into this picture. They are assembled at Aiwa's Welsh factory using Japanese boards and components, arguably making them Japanese products masquerading as British hi-fi. That's how many people will see it, Philips included, I suspect. I neither welcome nor object to this; it's commerce at its liveliest or most fierce, depending upon your viewpoint. Bear in mind that NAD present us with a more complex situation by

using Japanese components, assembly in Taiwan, China and Japan - for designs brewed up in Finchley! So Aiwa are neither unique nor alone in sourcing and manufacturing in various locations.

Market Positioning

Being fastidious about market positioning, like all Japanese companies, Aiwa carefully distinguish these players in terms of facilities and rated performance. These equate exactly to the £20 price difference. Of course, this means that the cheaper one has less extravagant legends! An important difference in the eyes of Aiwa's Japanese marketing department, I should imagine. The XC-500 has only a '1 BIT D/A CONVERTOR' and Optical Digital Output, the XC-007 has both these things and an 'Eight times oversampling digital filter' as well. The extra £20 goes further, however. It also gets you a Quick Peak Search button and a 'CAL' button. So, for your 20 quid, you get two buttons and a few extra words with the XC-700, plus a Philips Bitstream chip inside of course!

Both the Peak Search and the Cal facility are fitted to assist tape recording. Peak search finds the strongest signal to be recorded, whilst Cal provides a fixed output tone at -10dB for record level setting purposes. Since musical peaks are aligned to hit around -5dB on CDs, using the Cal tone to set recording level to 0VU will result in the odd peak or two just going over 0VU, which is an acceptably conservative recording condition.

Operational Differences

Those are the main operational differences between the '500 and '700. They are small, but may be enough to persuade ardent recording enthusiasts to stump up an extra £20 for the XC-700. Looking more deeply I noticed a few other subtle differences. Most amusing, but very Japanese, were the ultra-fine differentiations in quoted performance. They are discussed in the Measured Performance Section. In every way Aiwa make sure the '700 reads better by the finest degree (e.g. 0.0005% distortion!) than the '500, even though in real life such small but tidy differences do not exist at all.

There were surprisingly few differences inside both players. They use the same transport mechanism, power supply and use circuit boards identical in size and composition. The circuits on them are different, of course, although not by much. Both use Sony digital filters and control chips (Aiwa are related to Sony). The circuit boards have to be removed to see the vital Digital to Analogue convertor chips, which cling like

spiders to their board's underside.

I wasn't impressed to find a piece of bare wire sticking to a track on the XC-700 board. It was close to shorting down to the metal chassis work below. I am surprised board cleaning for flux removal didn't remove this. Failing that, quality control or board inspection should have detected it.

Although both players cost little, they are well equipped all the same. Large blue fluorescent displays show track number, index number (very European), time and a calendar display of the tracks of a disc that is playing. This shows graphically how many tracks are left to be played. The current track number playing flashes on and off.

‘ So, for your 20 quid, you get two buttons and a few extra words with the XC-700, plus a Philips Bitstream chip inside of course!

Index Search

I was surprised to find an Index search function, almost certainly included for what Aiwa perceive to be European requirements. Index points were intended to mark out movements or breaks other than track breaks in Classical music. Nowadays it seems that Track Numbers are used instead, which is sensible enough.

Both players and their remote control handsets have numerical keypads for direct track number entry. The XC-700 handset has a few more functions on it, like A-B repeat (repeat playing between user preselected points A and B). I wouldn't say there were any significant differences between the two however. Neither has remote control of volume for example, but both have remote drawer opening.

In physical construction, the XC-500 and 700 are identical. They have a pressed steel base tray, sides, rear and cover. The fascia is a complex plastic moulding, finished to look and feel like brushed aluminium. These fakes are surprisingly good, mimicking an aluminium extrusion well - even down to poor end detail!

The cases are very large, measuring 430mm wide, 115mm high and

352mm deep. Inside there are large tracts of open space and bare base tray. The main circuit board occupies about 35% of the available area, the transport another 25% and the rest is free territory. This free space could be useful, as you could lease it out to a family of gerbils, for example.

There is little to say about construction and finish. The metal work just lies on the better side of flimsy, but it is mechanically adequate all the same. The front panels are reasonably well finished too, but they wouldn't win any prizes on this front. Headphone outlets are fitted, but without a level control.

Sound Quality

Without thinking about it, I was expecting these two players to sound very different. I also was not expecting too much. Lodged in my brain is the collective sound of at least half a dozen circa-£200 players of a few generations ago, that rated highly on the aural pain scale. Many percent of digital distortion isn't an experience that leaves you quickly!

This was not the case with the Aiwas. The XC-500 and '700 have a similar basic character. Since the two players share common power supplies, output amplifiers, analogue and digital filters and a host of other parts, they should sound similar. Both were, in essence, well balanced tonally, meaning they were neither unduly bright nor dull. Both were also free of gross blemishes - like many percent digital distortion! I sat in front of them in a relative state of relaxation, without much vexation. The XC-500 did start to become vexatious after a few hours and some swopping around. But it suffers from being a bit sloppy rather than being overtly unpleasant or unbearable, not a great crime as budget CD players go.

By accident rather than design I started listening to the XC-700 first, without prior conditioning by our reference Arcam Delta 170 transport (modified) and Deltec PDM-I MkII (we haven't got the PDM-II in permanently yet!). I simply enjoyed its open mid-range and good sense of imaging, only slowly becoming aware of some slight weaknesses at spectrum extremes (i.e. high treble and low bass).

Slight Muddling

As is so often the case with budget CD players, there was a slight muddling and lack of pin sharp differentiation between individual high frequency events. A close miked strummed guitar lost some of its fine detailing and character, becoming smeared and slightly compressed. This was most noticeable with the Mobile Fidelity recording of Tea for

STOP POWER POLLUTION

PURE SOUND **NEEDS** PURE POWER

POWER CONDITIONERS + MAINS PURIFIERS

You'll hear music like you've never heard it before with the Pure-Power Conditioners.



PC100
3 outputs,
1500W load
at £89

PC250
6 outputs,
2000W load,
at £129



Notice the huge improvement in sound quality when you run your system from a clean mains supply. How do you describe the difference? It's as if all this time your favourite artists have been playing and singing inside a wardrobe...and someone just opened the door and let them out. You could spend twenty times as much on special cables, plugs, mats etc. without achieving a tenth of the difference. Try it for yourself. The complete answer to mains conditioning, the sophisticated circuitry of the power conditioners eliminates all impulse spikes, smoothes away every trace of noise and interference.

VECTOR SCREENED MAINS CABLE

If you're using cheap cable, you probably don't realise how much better your system could sound, simply by changing to one of the VECTOR specialist mains cables.

VECTOR cables are the simplest, most cost effective way to dramatically improve your Hi-Fi's performance.

VECTOR is a three core multi-stranded cable, each conductor is fully insulated with high quality P.V.C. in standard mains colours of BLUE, BROWN and GREEN/YELLOW.

The fine stranding of the cores combined with the tinned copper screen braid produces a cable with the characteristics of a flexible mains cable, but with the screening properties of a screened signal cable.

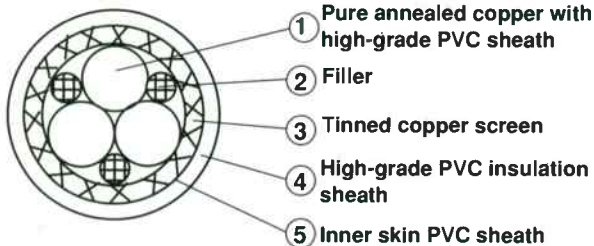

THE COMBINATION OF SCREENING, HIGH QUALITY CONDUCTORS AND INSULATION MAKES THE VECTOR CABLE AN ABSOLUTE MUST FOR ALL HI-FI ENTHUSIASTS

THE ULTIMATE TWEAK CATALOGUE

Features

- PHONO-STAGE
- CD ENHANCER
- CD POWER-SUPPLY
- PRO QUALITY SWITCHING UNITS
- 24 CARAT GOLD PLATED AUDIO CONNECTORS
- SURROUND SOUND DECODER
- CLEANING ACCESSORIES

and many more exciting tweaks!

NEW CATALOGUE AVAILABLE NOW!

PHONE OR WRITE FOR BROCHURES, CATALOGUE AND DETAILS OF 10 DAY HOME TRIAL

Tel: 0793 765256

FREE SAMPLE: If you would like to see a sample of the VECTOR cable then simply fill in the coupon below and return it to us. We would appreciate a first class stamp for the return package.

To: RADAR DEVELOPMENTS, 15 Sheep Street, Highworth, Wilts. SN6 7AA. Tel: 0793 765256
Please send me a sample of **VECTOR SCREENED MAINS CABLE.**

Name

Address

..... Post Code HFW

the Tillerman, by Cat Stevens (Gold Ultradisc, available from us). When I did go to our reference Deltec, the attack of the guitar strings was quite violent. Considering their price differences, this was no great problem though.

Generally, the XC-700 sounded tidy, unmuddled, quite clear and easily comprehensible. I found nothing annoying or irritating. It is not hard, glassy, clinical or rough sounding - or anything else similarly gruesome and commonly associated with budget Compact Disc. In fact, when I think about it, this must be quite a good CD player!

Generally, the XC-700 sounded tidy, unmuddled, quite clear and easily comprehensible.

Being similar in basic character, the XC-500 comes across initially as fairly benign in character and easy to listen to. It was only after some time and a few changes back to the XC-700, that I realised it was more slightly more muddled, sloppy sounding and, in particular, has a peculiarly heavy but wallowing bass. At times, bass lines seemed almost to career off out of control altogether, which was quite odd. I wondered whether servo correction or some similar erratic event might have been drawing sudden current and upsetting bass quality.

Summary

With time I found myself beginning to disregard the XC-500; the XC-700 was on the next level up for tidiness and togetherness and I always enjoyed it. Aiwa were right to pitch Bitstream above MASH, even though measured advantages are not clear cut between these machines, contrary to what the published specs would suggest. I still would not blow a raspberry at MASH however, it is just that the Japanese treat their own technology so badly. NAD MASH (available from the Finchley canteen) remains effective, with more bottom end drive and general finesse than typical JAP MASH.

But drawing back a bit. I have to say that both Aiwa players perform a remarkable job at the price. Audio-philos on a budget should take a close look at the XC-700. At £170 with remote control, it is a bargain ●

Measured Performance

I was keen to see how Aiwa would tackle certain problems involved in launching players using competing technologies, namely MASH and Bitstream. It would be foolish for Aiwa to launch the two players at the same price, so a price differential has been introduced. This could be seen as a political decision: but which is accorded most status - the Japanese or the European system?

Traditionally, the Japanese three and a half bit MASH system measures better than Philips proper one bit system - ignoring Philips latest DAC-7 super-chip which is intended for top end players only. Because Aiwa are Japanese and highly patriotic, I would have expected to see MASH in the more expensive XC-700 and Bitstream in the cheaper XC-500. Perhaps with some concern for European sensitivities, Aiwa do things the other way around - they put Bitstream in the '700 and MASH in the '500.

Because the distortion analyser I use deliberately ignores all signals except those harmonically related to the test tone (i.e. harmonic distortions), the measured distortion figure doesn't accurately reflect the differences between these players at normal music level. The cheaper XC-500 using Japanese MASH technology wins.

Or does it? At average music level, it does, but at other levels the issue becomes less clear. In truth, performance of both players varies both with level and between the channels, making any choice between them on the basis of distortion alone all but impossible. For example, MASH went a bit haywire on the left channel of the XC-500 at low levels, producing 72% distortion. MASH does not usually do this - look at the NAD figures. It is likely that Aiwa are using a lower grade of the MN6474 MASH chip in order to keep costs down, since the £150 price tag is almost absurdly low.

Whilst high quality Bitstream also commonly measures better than that in the XC-700, budget Bitstream does not. We have to be careful here. Aiwa use the new-ish SAA-7350 chip, but it looks like a budget, unselected version to me. I can tell by comparing the XC-700 with Philips own budget CD-624; they are much alike. High quality Bitstream, as in the Philips CD-850, gives better results. The comparative distortion figures below illustrate all this.

| Signal Level (dB) | Aiwa XC-500 | Aiwa XC-700 | NAD 5425 | Philips CD-624 |
|-------------------|-------------|-------------|----------|----------------|
| -6 | .005 | .006 | .003 | .004 |
| -30 | .023 | .023 | .02 | .03 |
| -60 | .7 | .7 | .4 | .9 |
| -90 | 50 | 30 | 28 | 55 |

Commercially aggressive and capable as we might imagine a company like Aiwa to be, or for that matter Philips, the simple truth is that little NAD show them the way with their implementation of Japanese MASH technology. And they achieve this performance at little extra price penalty. I make it 1 to Finchley and 0 to Eindhoven and Tokyo!

Frequency response of the XC-500 has a small treble lift, whilst that of the '700 has a small treble fall. Neither are as response tailored as an Arcam, NAD or Deltec however. I would not expect the fine differences visible in the response analyses to be easily audible. Both players were flat from 4Hz up to 21kHz, but the XC-500 MASH player extended upward further, hitting 21.2kHz compared to 20.8kHz (-1dB) for the XC-700. I am not trying to suggest that these fine differences are significant - they are not. The comparisons don't bear out Aiwa's quoted figures, you might notice.

The XC-700 did have wider channel separation than the XC-500, but it had higher noise and slightly lower dynamic range than the XC-500, seeming to be marginally inferior, in spite of Aiwa's own figures which suggest the opposite. Whilst I find this ambiguity interesting, I would not suggest it is likely to have much affect upon sound quality. The differences are, relatively, very small.

So what can we deduce from all these figures? Both players are fairly well engineered. Rotel, Arcam, Deltec and Micromega have all run into initial difficulties applying Bitstream. Aiwa have not. But both the Aiwa players use cooking grade convertors, as you might expect from their very low prices. Better performance is to be had from MASH and Bitstream, at higher price levels - or from NAD. You don't get something for nothing, but you get quite a lot all the same from these two players.

| Frequency response | XC-500 (MASH) | | XC-700 (Bitstream) | |
|--------------------|---------------|-------|--------------------|-------|
| | left | right | left | right |
| Distortion | 4Hz - 21.2kHz | | | |
| -6 | .005 | .005 | .006 | .006 |
| -30 | .025 | .022 | .023 | .024 |
| -60 | .96 | .57 | .67 | .74 |
| -90 | 72 | 31 | 29 | 31 |
| dithered | 2.3 | 2.3 | 7 | 8 |
| Separation | 4Hz-20.9kHz | | | |
| 1k | -98 | -90 | -107 | -120 |
| 20k | -76 | -78 | -78 | -86 |
| Noise | -106dB | | -103dB | |
| Dynamic range | 106dB | | 104dB | |
| Output | 2V | | 2.4V | |

XC-500

Frequency Response

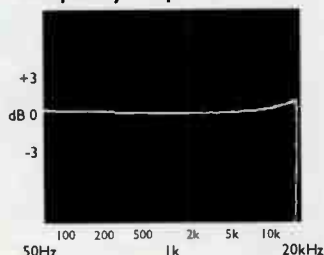

Small treble rise

Distortion

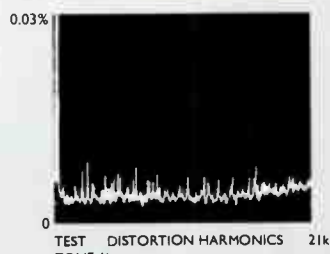

Very low distortion

XC-700

Frequency Response

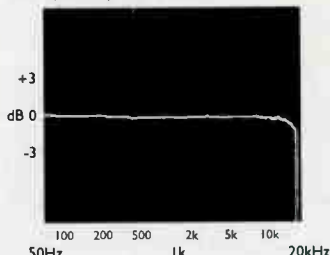

Small treble fall

Distortion

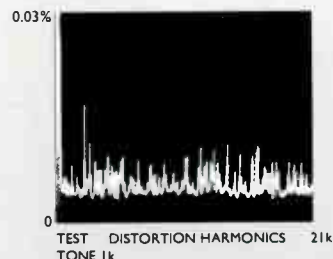

Quantisation noise spikes

Let us sit in your favourite chair

How well your system is set up is crucial to realise the best sound possible. We will come and sit in your favourite chair and make sure the system you choose sounds as good in your living room as it did in our shop. (But please have the kettle on).

All our shops have listening rooms where you can choose from a carefully selected range of the world's best hi-fi. You'll also find we have a range of essential accessories and an in-house service department.

So call in at Audio Excellence and enjoy the music in our favourite chair first.



audio excellence

WHERE THE MUSIC MATTERS

Tuesday - Saturday 9.00 - 5.30 CLOSED MONDAY

Hendrix? Sinatra? Beatles?

For collectable secondhand vinyl and re-issues **SPIKE WALTON** at Audio Excellence Records on Cardiff (0222) 664474. We're above the Sony Centre opposite Cardiff Castle.



Audio Excellence are leading members of BADA - the British Audio Dealers Association. Audio Excellence have 4 times been voted best dealer in the South West and South Wales in the Sony Hi-Fi News Awards.



BRISTOL

65 Park Street, Bristol BS1 5PB
Fax (0272) 251327
Telephone (0272) 264975



CARDIFF

134 6 Crwys Road, Cardiff
South Glamorgan CF2 4NR
Telephone (0222) 228565
Fax (0222) 398201



GLOUCESTER

58 Bristol Road, Gloucester
Gloucestershire GL1 5SD
Telephone (0452) 300046

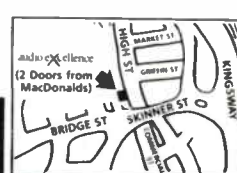

NEWPORT

37 High Street, Newport
Gwent NP9 1GF
Telephone (0633) 220012

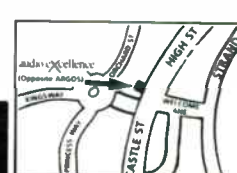

SWANSEA

9 High Street, Swansea
West Glamorgan SA1 1LE
Telephone (0792) 474608

ACOUSTAT, ACOUSTIC ENERGY, ARC, ARCAM, AUDIOLAB, AUDIO RESEARCH, CASTLE, CELESTION, DELTEC, DENON, DUAL, HEYBROOK, KEF, KOETSU, KRELL, LINN, MAGNEPLANAR, MARANTZ, MERIDIAN, MUSICAL FIDELITY, MISSION, NAD, NAKAMICHI, NAIM, PINK TRIANGLE, QUAD, REVOLVER, REVOX, ROTEL, SD ACOUSTICS, SME, SONY, STAX, TANNOY, WHARFEDALE, YAMAHA AND FULL RANGE OF ACCESSORIES.

Loudspeakers, possibly the most visual part of a hi-fi system, have been traditionally designed by engineers with little or no consideration for their appearance. By this, I do not mean that the designers themselves are unkempt, but that their loudspeakers look better on the drawing board than they do in the drawing room.

Ruark Acoustics are one of the few companies that are overcoming this, by producing more aesthetically pleasing loudspeakers. It seems strange then that most of Ruark's products are exported from this Green and Pleasant land of ours. Could it be that we British cannot equate hi-fi and good looks?

The latest model in their range, the revamped Swordsman Plus continues in the same vein as their existing models, combining a pleasing aesthetic with good sound. Replacing the existing Swordsman, the £279 Swordsman Plus was initially released for the export market, but has subsequently been launched back at home.

Master Craftsmen

Finished in walnut, the quality of cabinet construction is excellent. Fitted with gold plated Allen bolts to hold the drive units in place, the entire package looks refined and tasteful. At the rear of the loudspeaker is a small sticker saying that Ruark is a member of the Guild of Master Craftsmen and it shows in the build quality of this loudspeaker.

The cabinet itself has a narrow front, but is quite deep (its dimensions are 38.2 cm high by 20.2 cm wide and 27 cm deep). The box shape is a little odd, as it is a little too big to be classed as a bookshelf loudspeaker, but too small to be in the big loudspeaker league. Ruark favour stands of about 18 inches or so.

Moving aside from the build quality, the loudspeaker is an infinite baffle (closed box) unit featuring a 26mm ferrofluid-damped Polyamide dome tweeter and a 165mm bass/mid treated paper cone. Internally, the Swordsman Plus is wired using 56-strand cable and has a hard-wired crossover network, as opposed to using a circuit board that would lengthen the signal path. Finally, the Swordsman Plus has no bi-wire option. It uses flush mount connectors that can only take 4mm banana plugs.

Thirty Hours

Most loudspeakers need a significant amount of running in before they sound acceptable. Ruark recommend 30 hours to get them fully operative, a figure that I can agree with. When first fired up, the Swordsman Plus sound harsh and fierce. Given several hours with a signal running through them, they improve dramatically.

The speakers are reasonably efficient, at 87 dB (1W/1m), which, with their character suggests that they would be perfect partners for valve amplification. To this end, I listened to the Ruark Swordsman Plus using a Linn/Lingo/Ittok/Asaka and a Voyd Valdi/RB-250/Golding 1012 as turntable sources. For Compact Disc, I used a Marantz CD-

60SE Compact Disc Player with a Musical Fidelity Digilog digital to analogue converter. The Ion Systems SAM 40 pre/power amplifier combination reviewed elsewhere in the issue, along with the Audio Innovations Series 500 integrated amplifier, were also used. Finally, Linn Kan IIs and Snell Acoustic Type K loudspeakers were used as reference points.

After a suitable warm-up period, the Ruarks impressed me by the sheer amount of coherent detail that they produced, for a speaker in that price range. On playing 'Farmer John' by Neil Young on last year's 'Ragged Glory' LP, the guitars sounded gritty and nasty, but not lacking in detail; this information usually gets lost in the grunginess of the distorted guitar sound. This album, which features his part-time backing band Crazy Horse, has a great sense of a performance running throughout. If a piece of equipment fails to play music coherently, it begins to disintegrate into sounding like a rehearsal.

Watch-like Precision

The Ruarks never got in the way of the performance, making the individual members of the band come together with watch-like precision. Instrument voices were clear and well defined, without appearing as solid as I would like. Vocals were also quite easy to follow. I listened to 'Something I Learned Today' by Husker Du, on their 'Zen Arcade' LP. Even on the best of systems, it is virtually impossible to follow every word that Bob Mould shouts. On the Ruarks I could follow about one word in five or six, which is about average for a loudspeaker of this price.

Imagery was good from these speakers. While not able to pin-point instruments within the soundstage, at least there was a soundstage. Imagery was quite deep and high, but did not appear to stretch out of the box too much. On classical music, this created a somewhat claustrophobic orchestra, although passages designed for smaller troupes, such as Albinoni's Adagio in G minor for organ and strings sounded fine.

Timing

The speakers sense of timing was good, without being a leader in the field. Going back to the Neil Young album, I felt that I could follow the melody and tap my foot, but it was not as pacy as I have heard.

Overall, I felt that the sound quality of the Ruark was musical and, like the Alphason amplifier also reviewed this month, not very 'hi-fi' sounding. Their nature is detailed, articulate and refined, with very few rough edges, both sonically and visually. They are also a speaker for the Compact Disc fan; their character seems to show the detail inherent in CD, without portraying many nasties.

The biggest criticism I have toward the speakers concerns their treble performance. Even after a good deal of



blade runner

Stylish as ever, Ruark's revised

£279 Swordsman Plus loudspeakers

have much to offer. Reutger Hauer

**(alright, Alan Sircom) takes a few
fencing lessons.**

running in, the Swordsman still had a harshness about the treble. This, I found, made the speakers sound a trifle reedy and, as such, they never sounded full-bodied. Using the Series 500 amplifier helped to rectify this problem a fair amount, but even at its best, the speaker still exhibited this quality.

I feel that the Swordsman Plus suffered from a touch of the colorations. The box itself has a very definite resonance, which makes its presence felt throughout the performance. It is a pleasing coloration, however, if you can ignore my earlier reservations.

Criticism aside, the Ruark Swordsman Plus loudspeaker remains capable, particularly when partnered with sympathetic sources and amplifiers. I do have reservations about its brightness, although its detailed and coherent character gives it an attractive quality that would endear it to prospective owners ●

Your FM stereo radio choice is growing . . . and growing

It's all good news for listeners, because it means more choice of radio programmes broadcast to the highest standards. Already, many of us get the BBC national channels in superior FM stereo, and Radio 1 has extended its stereo reception nationwide. As well, there are already over a hundred local stations, BBC and Independent, and many of them are offering FM stereo quality.

Exciting new choice . . . Just a few years off

Latest government plans aim for a dramatic increase in your listening choice. At least one new independent national channel will be going out in FM stereo . . . and around two hundred new local and community stations will be catering for all kinds of special interests, from musical taste to ethnic background. It's a major explosion in scope for radio in the UK, with the exciting quality of FM stereo to bring it home to you.

The trend that demands a new aerial concept

But which aerial is best suited . . and why?

First consideration is bandwidth. To fit all the new stations in, more and more transmissions will be using the top end of the VHF/FM frequency band, right up to 108 MHz. So you will certainly need an aerial capable of giving optimum performance over all this extended FM radio band. Even now there are FM stereo transmissions coming from several stations within good reception range of you. Soon there will be even more. And while a conventional aerial is aimed straight at a single transmitter, deliberately designed not to pick up any other signals, radio choice calls for an aerial that will get good reception from any direction.

Now there is one,

we call it the **Antiference**  **ALLROUNDER**

Light and easy to install outdoors or in the loft. Will mount conveniently onto an existing 3/4" to 2" diameter mast . . . the one carrying your TV aerial for example.

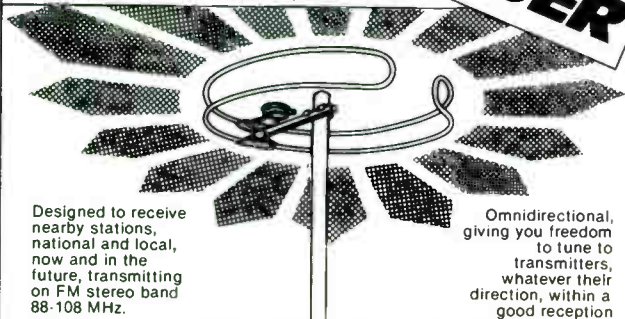

Designed to receive nearby stations, national and local, now and in the future, transmitting on FM stereo band 88-108 MHz.

Omnidirectional, giving you freedom to tune to transmitters, whatever their direction, within a good reception range.

all-round FM stereo choice

For further information contact:
Antiference Ltd.
Aylesbury, Bucks HP19 3BJ
Telephone: (0296) 82511

EXPENSIVE TUNER??

THEN HAVE THE AERIAL IT DESERVES

You spend many hours and quite a lot of money choosing that new tuner, so don't ruin the whole effect by fiddling with bits of wire or old aerials. Have the full benefit of the multipath-free, clean signal which only a well designed and properly installed unit can achieve. If D.X. is your scene, then go for the ultimate in rotating high gain narrow beam systems like our G.23 with 19dB forward gain, 38dB F. to B. and Acc. "one off" special built, up to 32 elements.

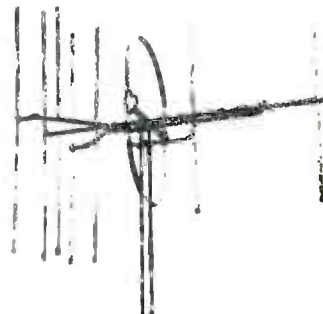

NEW ORION AERIAL

ORION 8 STEREO
GAIN 14dB F. to B. 25dB
WIND LOAD 30lb @ 100mph

WE DESIGN, MANUFACTURE, SUPPLY AND FIT

- ★ FM arrays from 4 to 23 Element. TV from 10 to 92 Element.
- ★ British-built and designed to withstand our weather.
- ★ Interested D.I.Y. advice freely given, backed by our complete range of masts, brackets, rotors, cables and aerials. Systems available for chimney, loft, wall, or through roof mounting.
- ★ Professional installation service available within a nominal 200-mile radius of LUTON. Full details of this service available on receipt of a large S.A.E. which will bring you our complete "Aerial Guide" which is more than just a list of our products and prices, and carries details of all our services, including MAIL ORDER and site surveys.

SEE THE REST, THEN FOR THE BEST, CALL

RON SMITH AERIALS

98 ASH ROAD, LUTON. BEDS.

Day: Luton 36561 9.00 to 6.00

Eve: Luton 29560 after 7.30pm

Shop Hours: 9.00 to 6.00 Closed Wednesday

5 Minutes from M1 Motorway. Turnoff No.11

10% DISCOUNT
ON PRODUCTION
OF THIS
AD

Peerless CC FORCE



Wilmslow Audio's NEW range of speaker kits from *Peerless*.

This new range of four kits utilise CC technology drive units for optimum performance.

The kit contains all the cabinet components (accurately machined from smooth MDF for easy assembly).

Pictured here the *Force 6*, a large floor standing design.

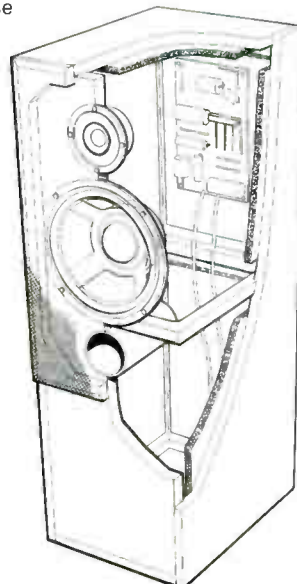

Dimensions:
800 x 275 x 335 mm
Response:
32 HZ-20 KHZ
AMP Suitability: 30-120w
Impedance: 8 ohms

| Price | carr./ins. | |
|----------------|-------------|----------------|
| Force 2 | £167 | £15 pr. |
| Force 4 | £190 | £15 pr. |
| Force 6 | £210 | £18 pr. |
| Force 8 | £265 | £18 pr. |

All kits are available in Plus and Basic forms.

Wilmslow Audio

Wellington Close,
Parkgate Trading Estate
Knutsford, Cheshire
WA16 8DX
Tel: (0565) 650605
Fax: (0565) 650080

D.I.Y. Speaker catalogue £1.50
post free (export £3.50)



Telephone credit card orders welcome



divining by dipole

The bit of wire that falls out of the box when you open it is an aerial. All tuners have them and most owners end up using them, pinned along the picture rail, into corners, under tables - and all sorts of other strange places. The outcome is usually the same: lots of hiss from radio, stereo that flickers on and off and a lot of crackling at times too.

The advice is: get yourself an aerial! For many people, this is difficult or impossible. Indoor aerials are the only answer, or lash ups such as an aerial sticking out of the window. Making the most of a bad job may be the only answer. Here's how to do it.

ALIGNING A WIRE DIPOLE

That piece of wire is known as a dipole. For best signal strength it has to be orientated so it faces sideways, as it were, to the transmitter (Fig 1). The next problem is: where's the transmitter? We explained how to find this in the June issue. To recap, the BBC or IBA have engineering departments that can tell you. Armed with knowledge of the location, you have to determine the compass direction from your house, a map being the pukka method.

Fig 2. The Magnum Dynalab ST-2 vertical whip aerial



That's the proper way of doing things. The other one is a bit more ad hoc. Stick your head out of the window, see which way other aerials are pointing and you should then know the rough direction of the transmitter.

Having determined the direction of the transmitter, you should now pin your wire dipole up to face it sideways on. Height is always the most important factor when trying to gain signal strength. If, say, your room has a high ceiling, try pinning the wire right up close to it. However, except at the ends which are pinned, the wires should be no closer than a few inches away from surfaces, or ground capacitance will start to influence matters.

Even worse are large metal objects, the usual horror quoted being the water tank. Keep any aerial well away.

Getting the aerial well positioned is likely to be frustrated by the length of the download. Most are just a few feet long. Since such aerials have a characteristic impedance of 300 ohms, an extension lead should be made up from special wire usually known 'flat twin feeder'. This consists of two wires running parallel to each other, spaced a few millimetres apart by a plastic web. It isn't so common in electrical or radio shops, but if possible use this to extend the lead between tuner and aerial, soldering the connections.

Experimenting with the position of a wire dipole should greatly improve signal strength. Quite often however, the best orientation cannot be used because there is no convenient wall, picture rail or parrot available for attachment purposes. In this case, consider the next alternative, which involves spending money.

THE ALUMINIUM DIPOLE

Get an aluminium dipole. We have one made by Maxview, which comes with a small stub mast and fixing clamp. It costs just £10 and, being self supporting, can be put up just about anywhere. Although this aerial is a dipole like the piece of wire that drops out of the box, it is better fashioned and more efficient. A characteristic imped-

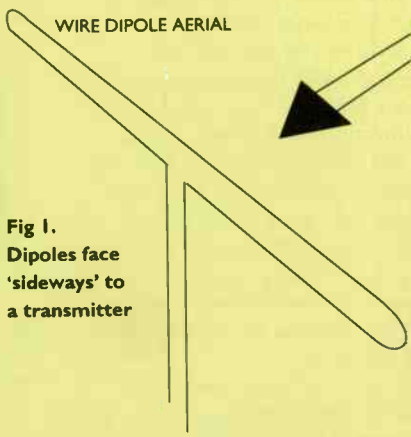

Fig 1. Dipoles face 'sideways' to a transmitter

ance of 75 ohms means it should be connected to the tuner with a length of co-axial cable. Such cable is used for TV aerial downloads, making it more commonly available than the flat twin feeder mentioned earlier. Again,

all connections should be soldered, since this minimises losses.

You'll have a lot of fun wandering around with an aluminium dipole, looking like a modern day water diviner. Suggested positions for it are at the top of a stair well, on top of a wardrobe in an upstairs bedroom, under the bed or in a loft, roof cavity or what have you. Height is usually most important in obtaining a strong signal.

ANTIFERRENCE ALLROUNDER AND RADIO ROD

Antiferrence make two aluminium dipoles intended for outdoor use. They can be used indoors however.

The Allrounder (FM1080) is a curved aluminium dipole that picks up signals from all directions (omnidirectional). It is very useful for getting local pirates, community stations and what have you, yet it costs just £12.80. Trouble is, the Allrounder doesn't have much gain, so it must be got up as

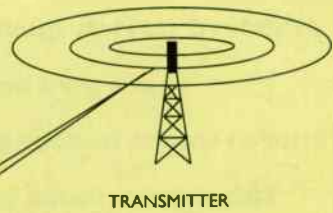

TRANSMITTER

high as possible. Mast mounting is used, so a stub mast or similar is needed.

Then there is the Radio Rod (FM1081), which again is omnidirectional. It is a vertical dipole, meant for loft or outdoor mounting, but again it can be used indoors. For best signal, the mounting position should be as high as possible.

The attachment point for a stub bracket is at its centre. Vertical aerials should only be used in areas where the polarisation of the radio signals are either vertical (rare), mixed or circular.

The latter are common, to provide better whip aerial reception for car radios. This aerial costs just £10.50.

MAGNUM DYNALAB

An aerial that is very easy to use indoors and provides a stronger signal than a dipole (+2.5dB approx.) is the vertical half wave whip (Fig 2). The Magnum Dynalab ST-2 has a loading coil at its base to terminate it and give a 75 ohm characteristic output impedance. It should be connected to a tuner through co-axial cable and can be moved around easily indoors when sitting on a DIY wooden base. Outdoor use is acceptable, high mounting points being best as usual. The ST-2 is 54in high and costs £55. Contributor Richard

Kelly whipped our review sample and tells us it's great.

Also from Magnum Dynalab is The Silver Ribbon, a high efficiency indoor FM antenna - as they put it. This sits on a base too, but looks like a TV set top aerial. It is smaller than the ST-2 whip and costs £17.50.

All these aerials will give the best possible results where indoor working is essential. They are mechanically simple and can often be got out of sight with a small amount of effort, plus a download to the tuner. The stronger signal will reduce hiss and give clearer stereo - all for a few quid ●

For details and suppliers, contact Antiferrence - Tel: 0296 825111
Magnum Dynalab - Tel: 0686 625266



quality ferric tapes

For a few pence more than standard ferrics, quality ferric tapes give an obvious improvement in sound quality.

This report looks at 'super-ferrics' to see what they offer and pick out a winner. Testing by Noel Keyword.

Between £1.10 and £1.50 lie a whole group of ferric tapes formulated to give far better results than standard cooking types (costing around £1). Some of these ferrics are so good that, in my view, they offer an alternative to metal tape as valid as most chromes. Whether you find this to be the case depends much upon your tape machine. However, consensus is beginning to appear it seems, since the tape I favour is enjoying excellent sales. But don't let me give you the impression that the outcome of this test is a foregone conclusion. Tapes are constantly being revised and different formulations suit different machines and purposes. Selection also depends upon taste: some listeners like a bright sound, while others prefer things a little more laid back. A tape can be chosen to suit. I will attempt to provide advice on all this later.

You may well find our typical prices far from the ones you encounter. They are pitched between the (very high) recommended price quoted by the importers and bargain basement Top Tapes prices, where these are available. As a result, our figures are only very approximate.

TDK AD £1.10

Always a popular tape, AD has deserved its success. It is characterised by a bright but clear sound, coupled with low hiss. TDK have now smoothed its surface, giving steadier treble and lower modulation noise. Use AD to improve clarity when budget ferrics sound dull.

Measurement shows rising treble sensitivity, seen in the frequency response analysis. Overload levels are good, especially at high frequencies, allowing a +5 or so record level to be used.

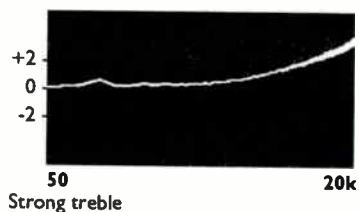

TEST RESULTS

| | | |
|----------------------|-------|--------|
| Treble level (10kHz) | | +1.6dB |
| Overload | | |
| mid-band (MOL315Hz) | | +3.4dB |
| treble (SAT10k) | | 0dB |
| Hiss | | -56dB |
| Modulation noise | | -40dB |
| Sensitivity | | 0dB |
| Dynamic range | | 59.4dB |

TDK AR

£1.20

Enormous overload headroom sets AR apart from all others. It even matches or betters some metal tapes. Recording levels of +8 can be used - if the tape machine can manage it! AR gives a very relaxed, easy sound due to this property.

Flat frequency response, seen in the analysis, means AR is tonally neutral or a bit dull sounding on most decks. Hiss is very low and dynamic range the highest of all ferrics. Treble overload occurs earlier than with most quality ferrics however.

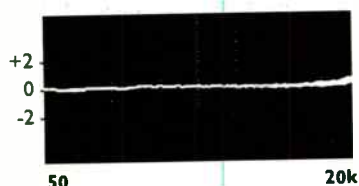

Flat frequency response

TEST RESULTS

| | |
|----------------------|--------------|
| Treble level (10kHz) |-0.4dB |
| Overload | |
| mid-band (MOL315Hz) |+6db |
| treble (SAT10k) |-1.7db |
| Hiss |-55.5db |
| Modulation noise |-38dB |
| Sensitivity |+1dB |
| Dynamic range |61.5dB |

Maxell XL-IS

£1.40

Maxell package this premium ferric well, using a resilient plastic that eliminates the hard, rattle quality of other tape shells.

XL-IS has high treble sensitivity, which gives it rising treble - as the analysis shows. Treble overload occurred at 0dB, comparable to that of its rivals. However, mid-band overload measured a low +1.8dB. This is below that of rivals. Hiss proved no lower than that of its rivals, giving XL-IS the second lowest dynamic range figure in the group as a result.

Maxell attain a consistent surface finish, resulting in very low modulation noise and a smooth, steady sound.

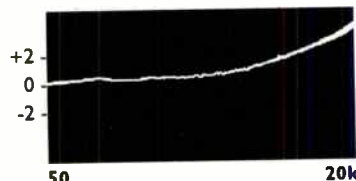

Rising treble gives a bright sound

TEST RESULTS

| | |
|----------------------|-------------|
| Treble level (10kHz) |+1.8dB |
| Overload | |
| mid-band (MOL315Hz) |+1.8db |
| treble (SAT10k) |0db |
| Hiss |-56db |
| Modulation noise |-43dB |
| Sensitivity |-0.8dB |
| Dynamic range |57.8dB |

Sony HF-ES

£1.45

The price positioning of this tape is unusual. It actually has less treble than its cheaper partner, HF-S, as comparison of their analyses shows. Sony have contrived to give 'ES more mid-range overload headroom however, increasing dynamic range up to 60.6dB. This only just gets them into contention with TDK, their main rival.

HF-ES accepts higher recording levels (+7) than HF-S and it is less bright. It is arguably better balanced than TDK AR-X in displaying such a balance of properties, even though dynamic range is lower.

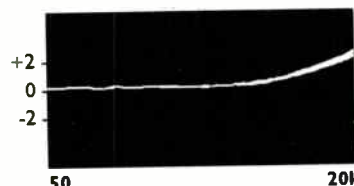

Less treble rise than HF-S

TEST RESULTS

| | |
|----------------------|--------------|
| Treble level (10kHz) |+1.2dB |
| Overload | |
| mid-band (MOL315Hz) |+4.8db |
| treble (SAT10k) |0db |
| Hiss |-55.7db |
| Modulation noise |-42dB |
| Sensitivity |+0.3dB |
| Dynamic range |60.6dB |

TDK AR-X

£1.40

This is a dual layer ferric tape. The thin top layer handles high frequencies, with the thicker under layer handling lows.

It has high treble sensitivity, as the peak in the frequency response analysis shows. This gives it strong treble, which only tape tuning can tame. Treble overload is high and hiss lowest of all ferrics, giving fine dynamic range right across the audio band.

AR-X gives a bright but clear sound and will take peaks at up to +7. It is best thought of as a bright sounding version of AR, even though its surface composition is entirely different. This is reflected in AR-X's higher cost.

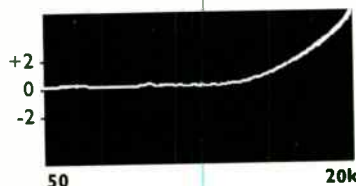

Very strong treble

TEST RESULTS

| | |
|----------------------|--------------|
| Treble level (10kHz) |+2dB |
| Overload | |
| mid-band (MOL315Hz) |+4.8db |
| treble (SAT10k) |+1.4db |
| Hiss |-56.5db |
| Modulation noise |-40dB |
| Sensitivity |+0.8dB |
| Dynamic range |61.3dB |

Sony HF-S

£1.10

Both Sony tapes in this group have hard plastic shells that rattle and fee' cheap. HF-S has a strong treble lift due to high sensitivity in the upper frequency ranges. This can be seen clearly in the frequency response analysis: it results in a bright sound as usual. The treble overload of HF-S (SAT10k) is correspondingly high which, in conjunction with a healthy mid-band figure, means the tape will take high-ish recording levels (+5).

Hiss was low, at -56dB measuring the same as its rivals. It results in a dynamic range of 59dB, which is about average, making HF-S a good all-rounder, but with very strong treble.

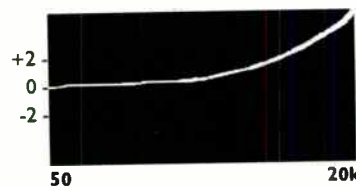

Very strong treble

TEST RESULTS

| | |
|----------------------|-------------|
| Treble level (10kHz) |+2dB |
| Overload | |
| mid-band (MOL315Hz) |+3db |
| treble (SAT10k) |+0.6db |
| Hiss |-56db |
| Modulation noise |-40dB |
| Sensitivity |-0.5dB |
| Dynamic range |59dB |

BASF Maxima I

£1.25

Like its high performance rivals, Maxima I has good treble sensitivity, giving it rising high frequency output and a bright sound. It has a shade less treble overload capacity than its main rival TDK AD, but performs satisfactorily in the vital mid-band, with an overload ceiling figure of +3.2dB. Recording levels can be pushed up to +5 as a result, which is on a par with its rivals.

Wide dynamic range depends both on a high recording level and low hiss. Maxima I performs averagely in terms of hiss, returning a measured result of -54.8dB, which is somewhat worse than most competitors.



Strong treble and a bright sound

TEST RESULTS

| | |
|----------------------|--------------|
| Treble level (10kHz) |+1.8dB |
| Overload | |
| mid-band (MOL315Hz) |+3.2db |
| treble (SAT10k) |-0.4db |
| Hiss |-54.8db |
| Modulation noise |-40.5dB |
| Sensitivity |-0.5dB |
| Dynamic range |57.8dB |

That's FX

£2.00

By combining high overload ceilings in the mid-band and treble regions with low hiss (-56dB), That's successfully provide FX with a wide and usable dynamic range of 60.2dB across much of the audio band. In this respect, FX matches or exceeds the performance of most of its rivals.

Like most super ferrics, FX has high treble sensitivity, giving it a rising frequency response, as seen in the analysis. It has a bright sound as a result. Consistency of its surface coating is good, yielding a low -42dB modulation noise figure. That's are close to Maxell in this respect. A sense of treble steadiness (lack of jitter) is the main benefit, but clarity is also improved.



Rising treble gives a bright sound

TEST RESULTS

| | |
|----------------------------|--------|
| Treble level (10kHz) | +1.5dB |
| Overload | |
| mid-band (MOL315Hz) | 60.2db |
| treble (SAT10k) | 0db |
| Hiss | -56db |
| Modulation noise | -42dB |
| Sensitivity | +0.2dB |
| Dynamic range | 60.2dB |

Scotch XSI-SX

£1.45

Scotch announced cessation of audio tape manufacture in their own plants some time ago. As a result, XSI-SX is now made under licence in Japan.

I mention this as the most likely reason for poor performance; the crucial and revealing dynamic range figure pushes XSI-SX to the back of the group. At 57dB it is 0.8dB below the next tapes up (Maxell and BASF) and no less than 4dB worse than the top ferrics in the group. This is a huge gulf by tape standards and it is due to hiss; XSI-SX is hissier than its rivals by a substantial degree.

Rising treble gives the tape a bright sound, but it is less bright than most rivals. Surface smoothness consistency was mediocre, resulting in a poor modulation noise figure of -38dB.

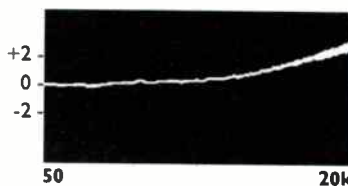

Moderate amount of treble lift

TEST RESULTS

| | |
|----------------------------|--------|
| Treble level (10kHz) | +1dB |
| Overload | |
| mid-band (MOL315Hz) | +4db |
| treble (SAT10k) | -0.5db |
| Hiss | -53db |
| Modulation noise | -38dB |
| Sensitivity | -0.3dB |
| Dynamic range | 57dB |

CONCLUSION

I'm a bit surprised to find that in super ferrics TDK are pulling ahead in tape technology. Their traditional Japanese rivals, Maxell and Sony look none too impressive in contrast.

That's, a back runner in sales volume but not in ability, make a good showing in this part of the market. BASF and Scotch must sharpen their research if they are to remain competitive. The Japanese are pulling ahead with alacrity.

From experience I still find TDK AR the ferric tape to beat. The test results show why: at 61.5dB it has the same dynamic range as metal tapes and confidently beats most chromes, plus all other ferrics. Yet this tape costs around £1.20! Note however that it has a flat (IECI) frequency response, which makes it a lot duller sounding than all its rivals. It should match most decks, but people do commonly report a warmer sound. I tune it in to avoid any such imbalance.

Before AR came along, TDK AD was the tape to beat. It has a bright sound, but very low hiss. TDK have kept it ahead in all areas, making AD fine value too.

TDK AR-X is a bright version of AR. Being a dual layer tape, AR-X is a pricey, which limits my enthusiasm a bit.

Sony have a good tape in HF-ES. It is less bright than most super ferrics, yet has a very wide dynamic range. Sony HF-S is good value, since it combines low price with good performance. It is obviously trying to be a TDK AD competitor and it gets very close. Similarly, That's achieve an excellent balance of properties with FX, but it costs around £2 we are told. This is unusually high and hardly squares with its ranking of fourth in the dynamic range chart.

Back runners are Maxell XL-IS (a real surprise), BASF Maxima I and Scotch XSI-SX, none of which I can recommend unless very cheap, by which I mean less than £1.10 ●

This chart puts the tapes into a rank order according to dynamic range, which is an accepted figure of goodness. TDK AR at right is best, Scotch XSI-SX at left, worst.

Also shown are the lower hiss floor and the upper overload (MOL315) limit. Low hiss is more important than high overload, but ideally both should be respectable.

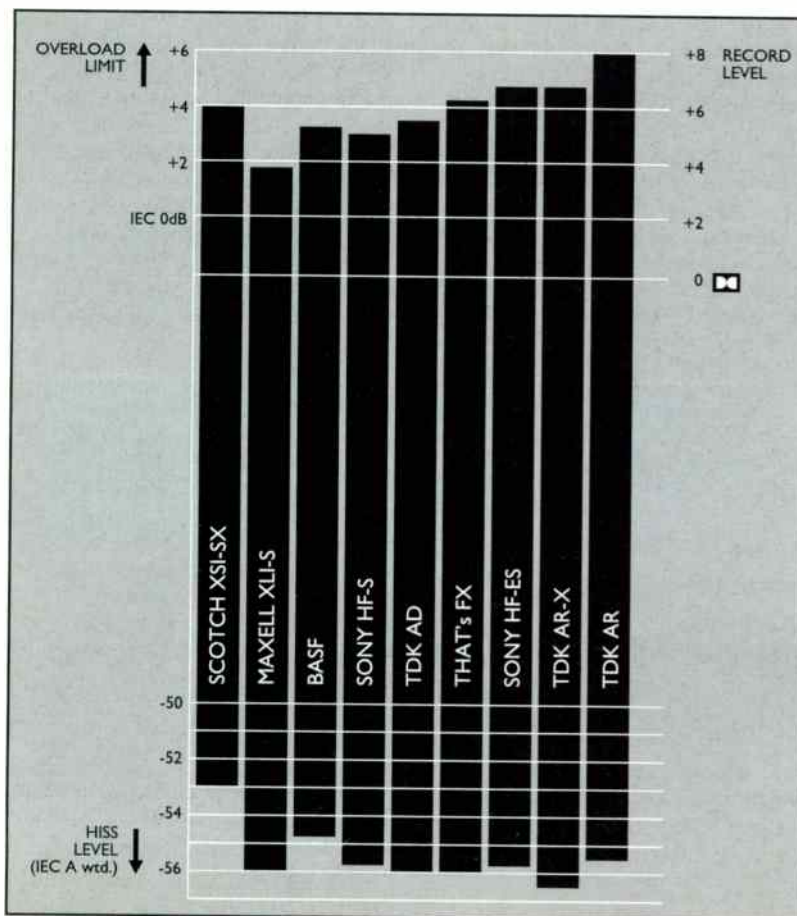

OVERLOAD CEILINGS

The overload ceiling of a tape sets its upper recording limit. It is a simple but crucial tape parameter, widely used in the tape world. As far as a user is concerned, it is the maximum recording level that can be used with any particular tape before a certain level of distortion sets in. Along with hiss, the upper recording limit in the mid-band also sets the dynamic range too and this is used as a simple but very revealing measure of quality. I have used it in the tape test graph (opposite) to show clearly how the different brands vary.

MOL315

In tape language, the overload ceiling in the middle of the audio band (at 315Hz) is known as the Maximum Output Level of the tape, or its MOL. This brings about the peculiar abbreviation 'MOL315' - for which simply read 'mid-band overload limit'.

Add +2dB to this value to find the upper recording limit in relation to Dolby level, as indicated by the Dolby symbol seen on many recording level displays. This enables you to translate the MOL315 value published in tape tests into an upper recording limit on a domestic recorder. For example, TDK AR has a MOL315 value of +6. Adding +2 gives an upper record level limit of no less than +8.

Remember that this value is very approximate. Tape tests are commonly carried out on expensive Nakamichis (I use a ZX-9) or open reel industrial machines with special heads. Domestic recorders rarely go as high, so in practice recording level may have to be reduced by a few dB, depending upon the quality of the recorder used.

SAT10k

This is another overload limit that is a measure of how much treble a tape will accept (at 10kHz) before it overloads (or saturates - hence SAT10k).

It is an important parameter, because cassette tapes are notoriously poor at high frequencies. Overload usually occurs way below OUV maximum recording level, resulting in muddled treble, or even dullness due to self-erasure.

You'll notice that metal tapes have much better SAT10k values than ferrics or chromes, which is why they sound clearer and more open. This is their main advantage.

HISS

Tape hiss is difficult to reduce, so hiss levels do not vary much between tapes. This is why tape manufacturers tend to concentrate on overload ceilings in order to improve dynamic range.

However, it is easier for a user to

exploit the benefits of a low hiss tape than it is to exploit one with high overload. The reason is that most decks cannot record to high levels, because their heads overload before the tape itself. So, a low hiss tape is preferable to a high overload tape, even though both have the same dynamic range.

This argument works in favour of chromes, which have very low noise, and against metals that have higher noise but much higher overload.

FREQUENCY RESPONSE AND TREBLE LEVEL

Tapes do not have a frequency response as such. However, in practice users want to know whether a tape has a bright or dull sound, which is determined by its high frequency sensitivity. By comparing tapes under test against reference standards (IEC Primary Reference Tapes) a relative frequency response can be established. These can be seen in the tape test as small graphs. A rise

understanding tape specs

Tape quality matters to users, yet it is little talked about.

Tape companies and magazines alike find the complex ideas and terminology impossible to translate.

To demystify tape specs, here's a very simple guide explaining the terms and relating sound quality and methods of use to our published performance figures.

Trouble is, the treble overload of chromes is inferior to that of metals, so it is not a simple choice that can be made between the two.

SENSITIVITY

For a fixed recording level, a sensitive tape will make a higher level recording than an insensitive one. Sensitivity used to be a selling point, but it isn't any more since the IEC insisted on the adoption of standard values, so Dolby noise reduction would work properly. Ideally, tapes should deviate by no more than 1dB or so above or below zero (zero being reference sensitivity as set by IEC Primary Reference tapes).

MODULATION NOISE

This is a form of hiss present only when a signal is recorded on a tape. The action of the tape bumping its way (microscopically) across the head randomly modulates any signal present, producing noise.

Mod. noise is minimised by consistent surface smoothness. With all tapes it lessens with usage, as the tape surface coating wears smooth.

at high frequencies (the right hand end!) means a tape is likely to sound bright, the degree of brightness depending upon the steepness of the rise.

Treble level is a spot measurement made at 10kHz that puts a figure on the degree of brightness. The higher this figure, the brighter a tape will sound. As a rough guide, +1dB will be just discernible, +2dB obvious, +3dB very bright or even excessively bright.

DYNAMIC RANGE

This is the recording range on a tape that is available for music. It is determined by the upper overload limit (MOL315) and the hiss floor. The wider the dynamic range, the better. However, as suggested earlier, low hiss tapes are preferable to high overload tapes. Our block diagram on the opposite page, showing the performance of ten premium ferrics, illustrates how tape dynamic ranges can vary in real life ●

Hi-Fi World will feature regular tape tests. The measurements we use are based on IEC recommendations. Remaining unchanged, they allow direct comparison of results between tests.

Desert Island test discs

We all have our favourite tracks. But for hi-fi reviewers, these recordings take on additional importance as they are often used as a reference to assess pieces of equipment. We asked some of the members of the Hi-Fi World team to list their favourite recordings, stating why they consider them useful.



ROCK & POP

MARIAH CAREY
Mariah Carey
CBS 466815 2 (CD)

There is nothing too special about this album, other than the range and flexibility of Mariah Carey's voice, which is remarkably similar to, but arguably more powerful than Whitney Houston's. The recording is good, however, and 'Vision of Love' - a number one in the States - places Ms. Carey centre stage and well forward. A good system will place her as an almost tangibly solid image between the loudspeakers. The degree of embodiment achieved with this disc is a good measure of the ability of a system in this respect.

Analysis shows some interesting properties. Track one is strong on mid-range energy but there's plenty of energy right up to 20kHz. Like most CDs however, other than the exceptions we mention, little output exists below 40Hz. Track four is an interesting real life test of dynamic impact. The start sounds violent and it is difficult to retain its impact when recording; analysis shows why. The introduction has an almost flat energy spectrum from 50Hz right up to 10kHz, harmonics above this frequency rolling off. This is an unusually strong treble output, but the track doesn't sound tonally unbalanced.
NK

BOB DYLAN
Desire
CBS 86003 (LP)

If this were 'Desert Island Discs', this would be top of my list. This record has followed me around for years, never losing its fascination and magic. Considered by many to be one of Dylan's best albums of the Seventies, along with cuts like 'Blood On The Tracks', it reminds me of events in my life long since past: drunken adventures in Oxford, travelling to Glas-tonbury Fayre and so on.

Aside from my great familiarity

with the recording, tracks like 'Hurricane' and 'One More Cup Of Coffee' are real orchestrated Rock recordings (I don't count 'Rock Operas' or 'Classic Rock'-type music, as it's far too pretentious). Consequently, there is a vast amount of information on the disc; information detail that can only be resolved by the finest of systems. Saturday afternoons will never be the same again. **AS**

DARYL HALL AND JOHN OATES
Daryl Hall and John Oates
RCA APLI 1144 (LP)

White Philadelphia Soul music from the good-looking duo. Yet more perfect pop songs with a very creditable list of session musicians and a production that threatens to stifle - but not quite. What saves this record from becoming sterile is the wonderful recording, which is absolutely razor sharp with superb dynamics. It also has a sense of coherence that has rarely been matched on LP or CD.
CB

BUDDY HOLLY
Legend
MCA MCMD 7003 (LP)

From the original master tapes, this is a double album of some of the greatest pop music ever. Digiphobes can't believe its been digitised, music lovers just lap it up. A lasting monument to Buddy Holly's talent and the world's loss, there's not a dud number here. For a real spooky view of a live studio take, try the inimitable 'True love ways'. **RG**

BILLY IDOL
Charmed Life
CHRYSALIS CCD1735 (CD)

The posturing might be indigestible, but the voice is fine and some of the tracks on this album, especially number three, are well recorded. It is track two that is of interest for a small joke inserted by the producer. At 2.32mins in from the start and to illustrate the line "I walk right through your door" a door crashes shut immediately afterward. This will pass unnoticed on many loudspeakers, even though measurement shows it is a full level event at 30Hz. Again, I was informed of this little trick by the Celestion SL-6000 sub-woofers, which issue a clap of deep, rolling thunder. Unfortunately, the trick is usually castrated by box speakers, in spite of its apparently high frequency.

Analysis also showed that kick drum (synthesised?) on this disc, plus

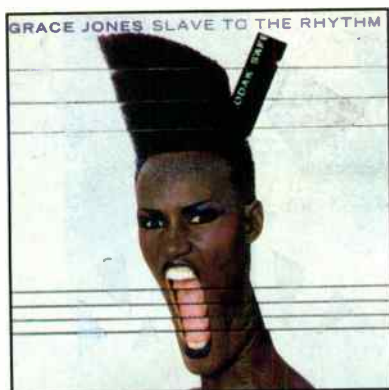
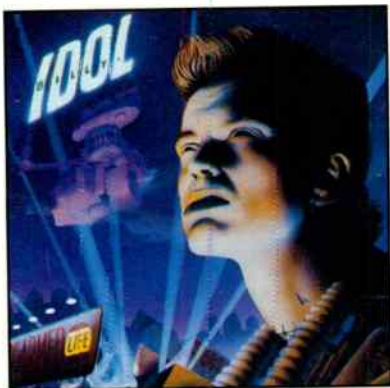

doesn't resort to Disco beats or thrashing drums. This music makes you want to move without really knowing why; it just works on you. And that's masterful. **CB**

REM Out Of Time

WARNER BROS. 7599-26496-1 (LP)

Probably REM's most commercial recording, 'Out Of Time' nevertheless loses none of the drive or meaning of the band's earlier discs. Although it moves away from REM's traditional field of political awareness, the poetic nature of Michael Stipe's intelligent lyrics still shines, particularly when partnered with people such as Kate Pierson of The B52's and rapper KRS-1.

In hi-fi terms, the sheer variety of style and tempo within the album makes 'Out Of Time' useful for assessing equipment on a number of levels. 'Low' for example, has a sparse, brooding tone, with a solid bass line that is excellent to check how well a system can resolve low level detail and spatial information, while 'Near Wild Heaven' and 'Shiny Happy People' put the equipment's sense of timing to the test. But, even more important - it's great to listen to! **AS**

MARTIN STEVENSON AND THE DAINTEES Gladsome, humour and blue

KITCHENWARE KW LP8; CD8 (LP & CD)

The second Daintees album and a more polished outing than the also excellent 'Boat to Bolivia'. A carefully crafted studio recording with genuine open spaces and deep, deep bass. Slight sibilance is a small price to pay for excellent songs offering an unusual blend of hard hitting lyrics and folk-rock roots, with Stevenson's personal and sardonic viewpoints. **RG**

THROWING MUSES The Real Ramona

4AD RECORDS CAD1002 (LP)

Somewhat less brash than their previous releases, 'The Real Ramona' is a wonderful mixture of pure, unadulterated pop songs and the more atmospheric tracks are reminiscent of the Cocteau Twins with a dictionary. Sparse production, clean recording and Doug Sax's mastering combine to produce a record that is full of energy. If that doesn't come through when you play it, there's something wrong with your system! **CB**

other effects, deliver energy into the system right down to 4Hz, which is the lower limit for CD. Energy levels below 20Hz are typically -30dB down, but they do all the same add a rumbling presence and an underlying sense of power when this album is played on a 'big' system.

Lots of fun, great voice and superb production - but I should finally add that this is Punk accommodated into mainstream Rock, so it may not suit those of a sensitive disposition. **NK**

JANE'S ADDICTION Nothing's Shocking

WARNER BROS. WX 216 (LP)

Perry Farrell, lead singer of Jane's Addiction, commands great respect among his following. Anybody who can withstand as much personal abuse as he can and yet still have the most impressive live act around, must be made of stronger stuff than the rest of us. Rather like a musical version of 'Less Than Zero', they sing the anthem for screwed-up Californian kids.

The recording itself is dense and complicated, especially when considering the powerful, driving nature of the music. As such, 'Nothing's Shocking' gives any equipment a real work-out. It's great for assessing how well a system images, particularly tracks like 'Summertime Rolls', while 'Mountain Song' tests dynamic ability and cohesiveness to the full. The highly charged 'Jane Says' establishes how equipment can affect emotions, as a good system will make me want to tear up the furniture! **AS**

GRACE JONES Slave to the Rhythm'

ISLAND CID 4011 (CD)

Ignoring the aching pretentious first track, this album is another well crafted Grace Jones performance, without Sly and Robbie but with Trevor Horn in charge of production. It is complex and varied in its arrangements - and very ingenious, too. The arrangements, the performance and the sound quality are all unusual and

make this disc a strong recommendation.

Recorded digitally on a Synclavier, some of the mixing and effects are dramatic. Track four has some thunderous bass and percussion but track seven in particular explores the use of extreme left and right instrument solos for effect, with gating between them. This track also contains an enormous low frequency event 40 seconds in from the start. It is a short, full level burst of a 20Hz tone with some undertones down to 6Hz. To date, only Celestion SL-6000 sub-woofers have reproduced it properly - which is just as well because it makes listeners hit the ceiling in fright!

This is a dramatic recording and a fine performance from Grace Jones, well worth having. **NK**

JOHN MARTYN Grace and Danger

ISLAND RECORDS ILPS 9560 (LP)

Definitely not for the broken-hearted, this collection of songs, written just after the break-up of his marriage, sees John Martyn in desperate form - the intense emotion of some of the songs will not leave you light of heart. The sheer honesty of his lyrics balanced with sensitive performances by Phil Collins and Jonn Giblin make listening to this record an almost painfully intimate experience. Combined with sympathetic production and recording technique, this is definitely not one for listening to alone. **CB**

THE NEVILLE BROTHERS Yellow Moon

A&M RECORDS 5420 (CD)

This is the disc that brought the Neville Brothers to everybody's attention after 30 years - and with some justification. The musical partnership with Daniel Lanois and Brian Eno works perfectly, giving some of the songs an almost eerie quality, but so rich and enveloping you want to just dive on in there. What really comes across, though, is the subtle rhythm of the songs, which

HEAR THE DIFFERENCE The dealers listed on this page are, in our opinion, the most experienced and knowledgeable in the U.K. They all offer excellent demonstration facilities and carry a wide range of systems at a wide range of prices. Linn dealers will give you sound advice and time to listen, so don't be afraid of a hard sell or a lot of gobbledegook.



S C O T L A N D

ABERDEEN
HOLBURN HI-FI LTD*
441 HOLBURN STREET 0224-585713

EDINBURGH
RUSS ANDREWS HI-FI*
34 NORTHUMBERLAND ST, 031-557 1672

GLASGOW
HI-FI EXPERIENCE,* 148 BATH STREET
041-226 4268
STEREO STEREO*
278 ST VINCENT STREET 041-248 4079

MONTROSE
ROBERT RITCHIE, 102 MURRAY STREET
0674-73765

WIGAN
CLEARSTONE HI-FI*
6 CROMPTON STREET 0942-323897

YORK
SOUND ORGANISATION,* 2B GILLYGATE
0904-627108

**C E N T R A L
E N G L A N D**

ALDRIDGE
MUSICAL APPROACH, 37 HIGH STREET
0922-57926

BIRMINGHAM
GRIFFIN AUDIO,* 94 BRISTOL STREET
021-692 1359

CAMBRIDGE
CAM AUDIO, 110 MILL RD. 0223-60442

COVENTRY
FRANK HARVEY,* 163 SPON ST, 0203-525200

IPSWICH
THE STEREO SHOP, 94 NORWICH ROAD
0473 233832

KING'S LYNN
MARTINS HI-FI,* 5 HIGH ST, 0553-761683

LEICESTER
LISTEN INN,* 6 HOTEL STREET
0533-623754

LOUGHBOROUGH
SOUND ADVICE, THE SOUND FACTORY
DUKE STREET 0509-218254

MILTON KEYNES
AUDIO INSIGHT,* 53 WOLVERTON ROAD
STONEY S'FORD 0908-561551

NORTHAMPTON
LISTEN INN,* 32A GOLD ST, 0604-37871

NORWICH
BASICALLY SOUND, OLD SCHOOL
BRACON ASH 0508-70829
MARTINS HI-FI,* 85-91 BER STREET
0603-627010

NOTTINGHAM
PARKER HI-FI, 70 LONG ROW, 0602-476377

ROYAL LEAMINGTON SPA
HI-FI EXPERIENCE,* 49 PARK STREET
0926-881500

ST IVES
AUDIO FILE,* 2 FOUNDRY WALK, MARKET HILL
0480-66123

SHREWSBURY
CREATIVE AUDIO, 9 DOGPOLE 0743 241924

STAFFORD
MUSICAL APPROACH, UNIT 7, WOODINGS
YARD, BAILEYS STREET, 0785-55154

STOKE-ON-TRENT
PURKISS HI-FI, 51-53 PICCADILLY, HANLEY
0782-265010

WOLVERHAMPTON
CLEARSTONE HI-FI,* 39 VICTORIA STREET
0902 772901

WORCESTER
WEST MIDLANDS AUDIO
158 OMBERSLEY ROAD 0905-58046

S . E N G L A N D

ASHFORD, KENT
PHOTOCRAFT HI-FI,* 40 HIGH STREET
0233-624441/2

BANBURY
OVERTURE LTD., 3 CHURCH LANE
0295 272158

BASINGSTOKE
AUDIO T,* 4 FEATHERS LANE, 0256-24311

BISHOPS STORTFORD
THE AUDIO FILE,* 40 HOCKERILL STREET
0279-506576

BRIGHTON
JEFFRIES HI-FI,* 69 LONDON ROAD
0273-609431

CHELMSFORD
RAYLEIGH HI-FI,* 216 MOULSHAM STREET
0245-265245

CHICHESTER
CHICHESTER HI-FI,* 7 ST PANCRAS
0243-776402

COLCHESTER
PRO MUSICA, 6 VINEYARD ST, 0206-577519

CROYDON
SPALDINGS,* 352-354 LOWER ADDISCOMBE
ROAD 081-654 1231

EASTBOURNE
JEFFRIES HI-FI,* 4 ALBERT PARADE
GREEN STREET 0323-31336

ENFIELD MIDDX.
AUDIO T,* 159A CHASE SIDE 081-367 3132

FARNBOROUGH HANTS
FARNBOROUGH HI-FI, 7 QUEENSMEAD
0252-520146

GUILDFORD
P J HI-FI,* 3 BRIDGE STREET 0483 504801

HARPENDEN
STUDIO 99,* 82 HIGH STREET 05827-64246

HARROW
HARROW AUDIO,* 27 SPRINGFIELD ROAD
081-863 0938

HIGH WYCOMBE
SOUND GALLERY, 65 CASTLE STREET
0494-31682

ILFORD ESSEX
AUDIO T,* 442/444 CRANBROOK ROAD
GANTS HILL 081-518 0915

LONDON N1
GRAHAMS HI-FI,* CANONBURY YARD
190A NEW NORTH ROAD 071-226 5500

LONDON N7
BARTLETTS HI-FI
175-177 HOLLOWAY ROAD, 071-607 2296

LONDON NW1
HI-FI EXPERIENCE*
2/4 CAMDEN HIGH STREET 071-388 1300

LONDON NW6
STUDIO 99,* 81 FAIRFAX ROAD
SWISS COTTAGE 071-624 8855
AUDIO T,* 190 WEST END LANE
WEST HAMPSTEAD 071-794 7848

LONDON SE1
SOUND ORGANISATION, 1 CATHEDRAL ST,
LONDON BRIDGE 071-403 2255

LONDON SE13
BILLY VEE,* 248 LEE HIGH ROAD, LEWISHAM
071-318 5755

LONDON SE19
AUDIO VENUE, 24 CHURCH ROAD
CRYSTAL PALACE 081-771 7787

LONDON SW5
THE LISTENING ROOM
161 OLD BROMPTON ROAD 071-244 7750/59

LONDON SW11
RPM, 2 BURLAND ROAD OFF WEBBS ROAD
071-585 0274

LONDON SW19
O'BRIEN HI-FI, 95 HIGH STREET
WIMBLEDON VILLAGE 081-946 1528

LONDON W1
DOUG BRADY HI-FI,* 18 MONMOUTH STREET
COVENT GARDEN 071-379 4010
HI-FI EXPERIENCE,* LION HOUSE, 227
TOTTENHAM COURT ROAD 071-580 3535
K J LEISURESOUND, 26 NEW CAVENDISH
STREET 071-486 8263

NEWBURY
NEWBURY AUDIO, 2 WEAVERS WALK
NORTHBROOK STREET 0635 33929

OXFORD
AUDIO T,* 19 OLD HIGH STREET,
HEADINGTON 0865-65961
WESTWOOD & MASON,* 46 GEORGE STREET
0865-247783

PORTSMOUTH
JEFFRIES HI-FI,* 29 LONDON ROAD,
NORTH END, 0705-663604

RADLETT
RADLETT AUDIO, 141 WATLING STREET
0923 856497

RAYLEIGH ESSEX
RAYLEIGH HI-FI,* 44A HIGH ST, 0268-779762

READING
READING HI-FI,* 4 QUEENS WALK
BROAD STREET MALL 0734-585463

SOUTHEND-ON-SEA
RAYLEIGH HI-FI,* 132/134 LONDON ROAD
0702-435255

TUNBRIDGE WELLS
TONBRIDGE HI-FI, 31 HIGH STREET
0892-24677

UXBRIDGE
UXBRIDGE AUDIO,* 278 HIGH STREET
0895-30404

WEST WORTHING
SOUND WAVES, 20 TEVILLE GATE
0903-212133

WINDSOR
RADFORD HI-FI,* 43 KING EDWARD COURT
0753-856931

S . W . E N G L A N D

BATH
RADFORD HI-FI,* 12 JAMES STREET WEST
0225-446245

BOURNEMOUTH
SUTTONS HI-FI,* 18 WESTOVER ROAD
0202-555512

BRISTOL
AUDIO EXCELLENCE,* 65 PARK STREET
0272-264975
RADFORD, HI-FI,* 52/54 GLOUCESTER ROAD
0272-428247

CHELTENHAM
AUDIO T,* 40/42 ALBION STREET
0242-583960

EXETER
RADFORD HI-FI,* 28 COWICK STREET
ST THOMAS 0392-218895

GLOUCESTER
AUDIO EXCELLENCE,* 58 BRISTOL ROAD
0452-300046

PLYMOUTH
RADFORD HI-FI,* 107 CORNWALL STREET
0752-226012

SOUTHAMPTON
HAMPSHIRE AUDIO,* 8 HURSLEY ROAD
CHANDLERS FORD 0703-252827
SOUND WAVES
1 HOLBURY DROVE PRECINCT, 0703-899131

SWINDON
AUDIO T,* 60 FLEET STREET 0793-538222

TORQUAY
RADFORD HI-FI,* 6 FORE STREET,
ST. MARYCHURCH, 0803-326723

TRURO CORNWALL
TRURO HI-FI AT ETS, 25 KING ST 0872-79809

YEovil SOMERSET
MIKE MANNING AUDIO, 110 MIDDLE STREET
0935-79361

W A L E S

CARDIFF
AUDIO EXCELLENCE,* 134 CRWYS ROAD
0222-228565

NEWPORT
AUDIO EXCELLENCE,* 37 HIGH STREET
0633-220012

SWANSEA
AUDIO EXCELLENCE,* 9 HIGH STREET
0792-474608

N . I R E L A N D

BELFAST
LYRIC HI-FI,* 163 STRANMILLIS ROAD
0232-381296

PORTADOWN
LYRIC HI-FI,* 84 BRIDGE STREET,
COUNTY ARMAGH, 0762-358059

E I R E

DUBLIN
CLONEY AUDIO, 55 MAIN STREET
BLACKROCK 889-449

I S L E O F M A N

MANX AUDIO, CLON VINE 0624 851437

J E R S E Y

ST HELIER
BASE HI-FI, 35 HILGROVE STREET
0534-58518

To find out more about Linn hi-fi and the Linn difference, please phone 041-644 5111, or post the coupon to Linn Products Ltd, Floors Road, Eaglesham, Glasgow G76 0EP. *Denotes Member or Associate Member of BADA (British Audio Dealers Association).

Please send me a Linn information pack by return of post.

Name _____

Address _____

Postcode _____

My present system is _____

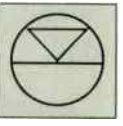

LINN
HFW7

clearly define the trumpet and saxophone as distinct tonal entities, then you know you've got a good system. **AS**

THOMAS LANG
Scalliwag Jazz
EPIC 4509961 (LP)

Beautifully crafted, if somewhat moody songs with impeccable jazz-tinged backing, this is one of those records that seems almost unwilling to relinquish the wealth of detail that lurks within its grooves upon first playing. Subsequent listening reveals more of the dark undercurrents that exist as well as musical and production details that you didn't know were there. Great for re-assuring yourself that those new interconnects were not a waste of money. **CB**

CLASSICAL

CHOPIN: NOCTURNES
Vlado Perlemuter
NIMBUS NIM 5012 (CD)

Cassette recorder tests demand the use of classical piano, because if there is a problem with speed stability, long sustained piano notes will suffer most obviously. The outcome can be painful for a listener, especially since those I have come across have been highly critical, getting upset by even the smallest hiccup in speed stability.

To be totally free from recorded speed instability, a piano recording should ideally be digital right through. One I use that fulfils this requirement is a Nimbus live recording at their own studios of Vlado Perlemuter playing Chopin Nocturnes. It is a peculiar recording in many ways, having a very phasy quality and incidental sounds from Perlemuter as he plays. The phasiness is almost certainly due to Ambisonics surround sound encoding, although use of a Calrec mic in a reverberant room doubtless reinforces the effect.

This apart, the performance is an enjoyable one, if not quite as well timed or spectacular as one might hope for. Track seven is the real acid test. The popular Opus 48, No. 1 has plenty in the way of simple sustained notes that hold a magnifying glass up to cassette deck transport performance. If you have any doubts about your cassette deck, tape this track and it will identify a problem just as well as any spectrum analyser. The only difference is the price! **NK**

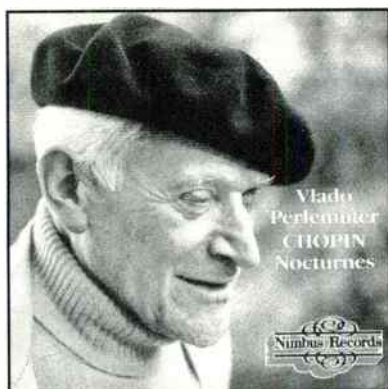

DVORAK: CELLO CONCERTO
Janos Starker. Antal Dorati. LSO

MERCURY LP SR90303; CD 432001-2 (LP & CD)

A superb performance of power and sensitivity in a classic Mercury Living Presence recording. Massive scale and wide dynamics coupled to a potent bass serve the music well (which isn't always the case!). The LP is a collector's classic and hence both rare and (very) expensive. Happily, Philips have recently started transferring the Mercury back catalogue to CD, so you can all enjoy this fantastic recording. Not only have they done a good job sonically, but the CDs are only £8 each! **RG**

FINZI: ORCHESTRAL WORKS
English String Orchestra.
William Boughton
NIMBUS CD NI5101 (CD)

Gerald Finzi is perhaps one of the most under-rated of the 20th century British composers, although when listening to the music on this CD, I fail to see why. Recorded in the Great Hall of the University of Birmingham, the rich, ambient production and playing perfectly match the romantic feel of the music. Rather like Vaughan Williams, this is the aural equivalent of the British countryside on a warm summer's evening. Close your eyes and be there. **CB**

RACHMANINOV: SYMPHONIC DANCES. VOCALISE
Donald Johanos. Dallas Symphony Orchestra
ATHENA ALSW-10001 (LP)

In the top right-hand corner of this LP is a sign which says proudly "100% analogue". This means that it is an expensive audiophile pressing (not available on CD!), but one of such quality that it forces the listener and his money, into submission. The composition, the last Rachmaninov was

ever to write, has some of the most dramatic crescendo yet performed, equal in drama and scale to Wagner or Tchaikovsky.

It is a superb recording of such a difficult piece, made on valve recording and cutting equipment, without any form of sound processing. This gives the record a superb acoustic, which is excellent for assessing imagery and ambience. When the crescendo arrives, it stretches hi-fi components to their limits, so testing the system's dynamic capabilities. **AS**

TCHAIKOVSKY: VIOLIN CONCERTO
Itzak Perlman. Charles Munch. RPO

CHESKY CD 7 (CD)

An excellent example of the Chesky brothers work, this CD retains the huge soundstage, locational precision and warmth of the Readers Digest original. Perlman can't match Heifetz for tension or intensity, but his lyrical reading has its own appeal. **RG**

VARIOUS: MUSIC FOR DRUMLANRIG
Scottish Baroque Ensemble.
Leonard Friedman
CRD 1043 (LP)

Two of the tracks on this album, Albinoni's Adagio and Pachelbel's Canon in D, are well-loved within the advertising and film world. Pachelbel's Canon is probably better known as 'Pure New Wool' music, while Albinoni's Adagio has been used in countless films as incidental music to suggest melancholia, the passage of time or space travel.

Beautifully recorded, the CRD version gives a wonderful insight into instrument voices and their tonal colours. It is therefore very useful in determining the performance of equipment with regard to tonal separation and detail, especially when considering the unique requirements of the string enthusiast. Stringed instruments are notoriously difficult to reproduce well - and lovers of stringed instruments have their own, unique criteria. This recording is a little lacking in spatial information, as the soundstage appears a trifle compressed, especially with regard to image depth. **AS**

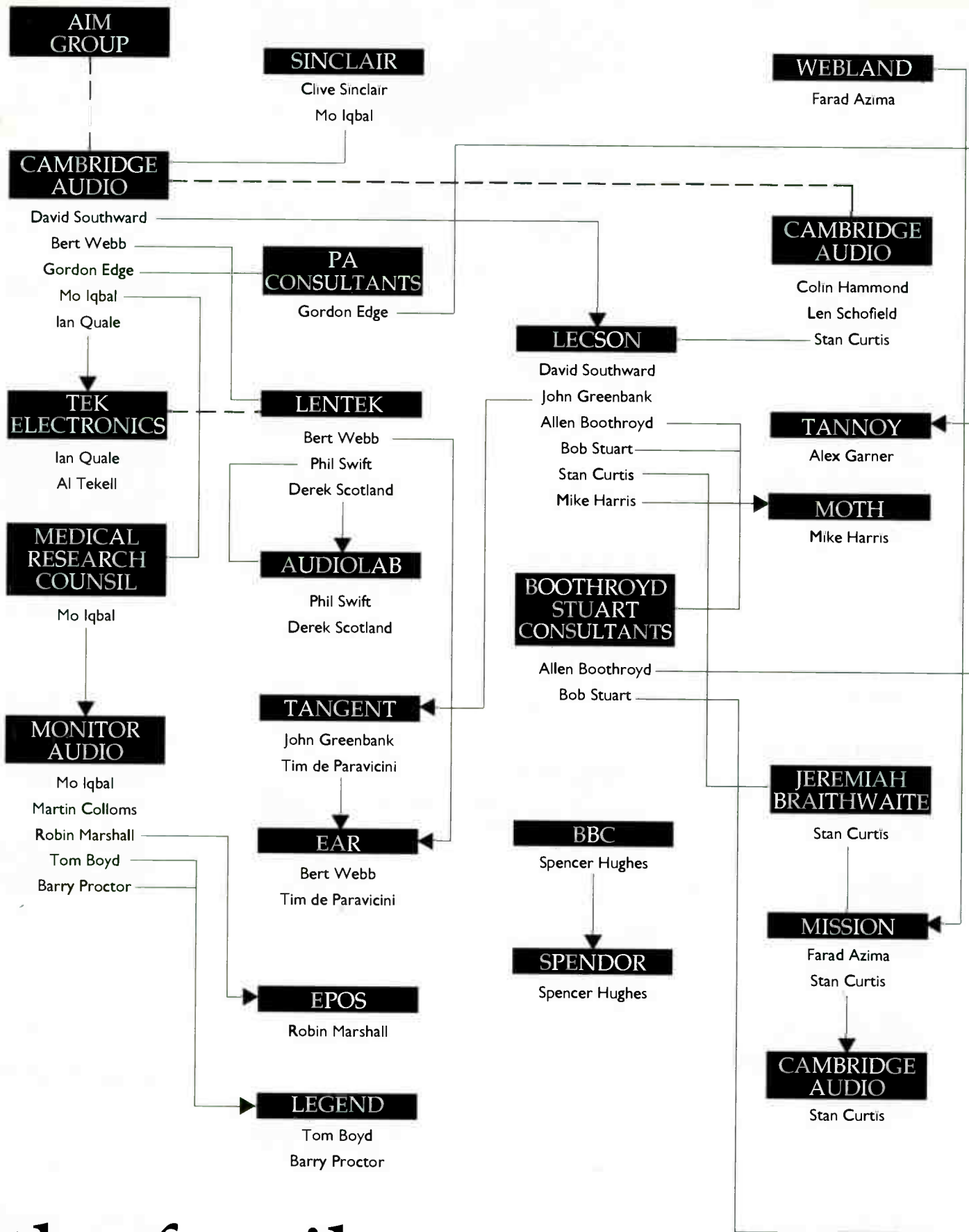

the family tree

This tree illustrates movement and changes over the years in the U.K. hi-fi industry. New companies start; new designers emerge, make a reputation and move on. As a guide, the solid lines denote personnel movements, the dotted lines show company relationships and the black arrows suggest the end of the line... for now.

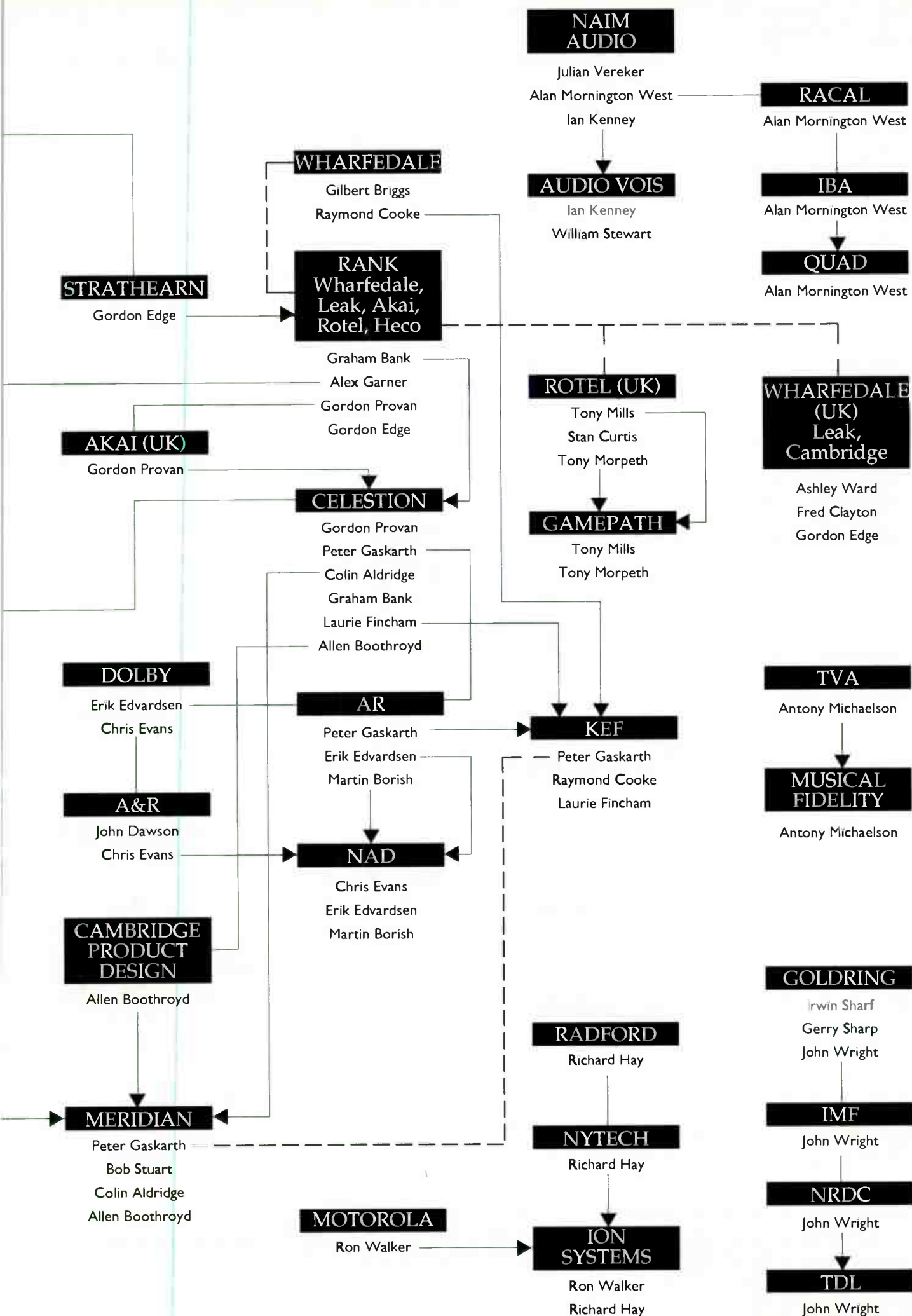

A HAT-TRICK FROM THE AUDIO FILE

Great performers have the knack of making even the most difficult tricks look easy so you never realize just how much hard work and determination they need to perfect them; to say nothing of a highly developed sense of balance.

A bit like winning the Sony/Hi-Fi News dealer award for three years running - it might not look difficult but it requires the same sort of hard work, determination and balance.

Determination for instance to make sure every customer receives the high standard of service and

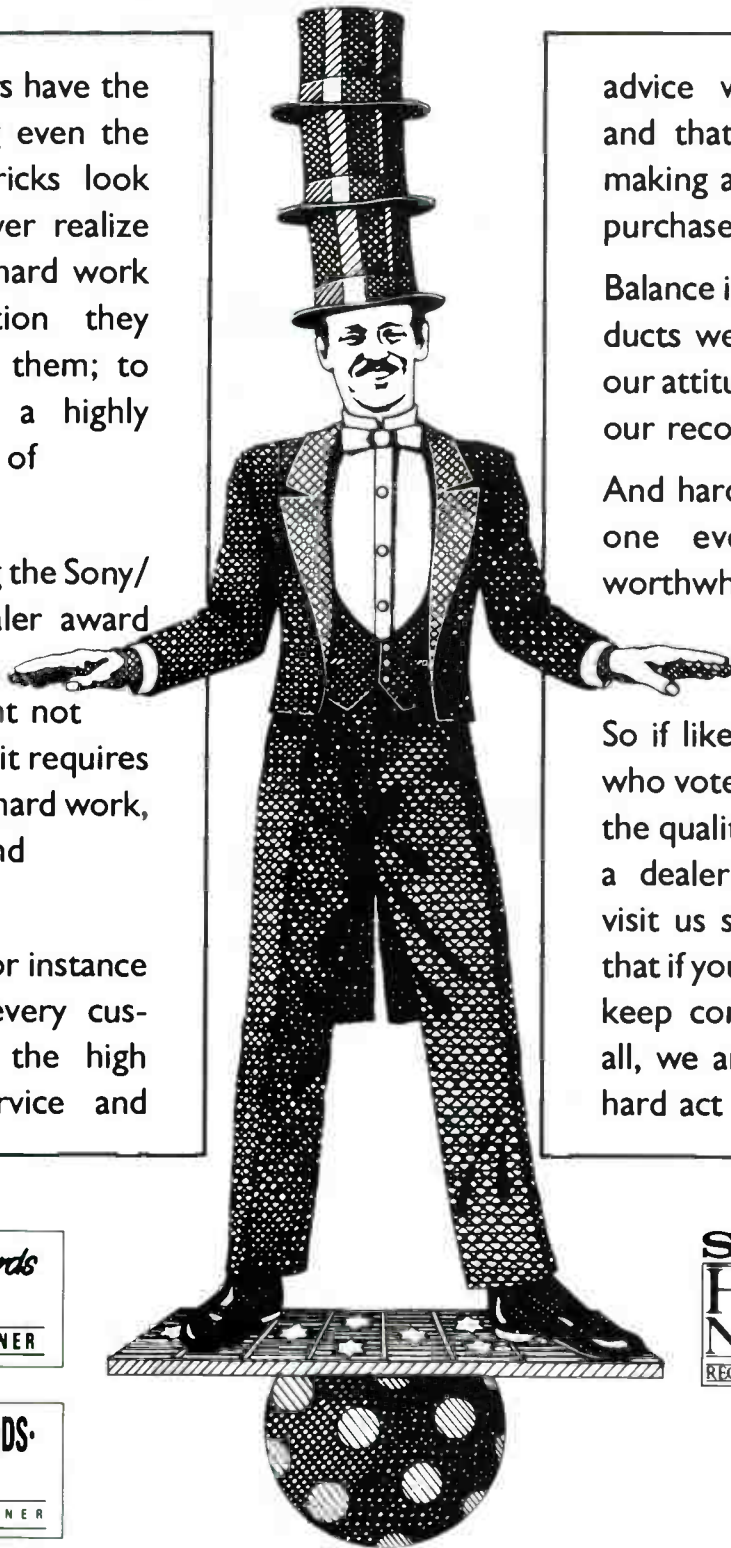

advice we're famous for and that no-one ends up making an unsuitable purchase.

Balance in the range of products we stock, balance in our attitudes and balance in our recommendations.

And hard work - well, no-one ever did anything worthwhile without a little bit of hard work did they?

So if like the many people who voted for us, these are the qualities you look for in a dealer, make sure you visit us soon. We're sure that if you do, you'll want to keep coming back. After all, we are something of a hard act to follow!



The Audio File

27 HOCKERILL ST, BISHOP'S STORTFORD, HERTS. TEL: 0279 506576. 2 FOUNDRY WK, MARKET HILL, ST. IVES, CAMBS. TEL: 0480 66123.
 Audio Lab • Acoustic Energy • Arcam • Audio Innovations • B & W • Beyer • Bose • Boston • Castle • Creek • Cyrus • Deltec • Denon • Dual • Epos • Exposure • Foundation • Goldring • Heybrook • JPW • Kef • Linn • Marantz • Maxell • Meridian • Mission • Monitor Audio • Mordaunt Short • Musical Fidelity • Naim • Nakamichi • Proac • QED • Quad • Rega • Rogers • Roksan • Rotel • Royd • Ruark • Sennheiser • Snell • Sony ES • Sound Organisation • Tannoy • Wharfedale • Yamaha.

I decided to write to you with some hints, tips and comments gleaned from my experiences renovating not one but, so far, four Thorens TD150's and a few TD160's to boot. I have to say that despite incredible success tweaking the TD150 design, I actually use a Linn Sondek which, interestingly, bears more than a passing resemblance to the turntable in question.

How's this for starters, the top plate on both decks is exactly the same size, as is the geometry of the three suspension points. Note the length of the armband compared to almost every other turntable and also the split platters (which incidentally, are very nearly interchangeable). Of course, a good design is a good design. Linn just 'perfected' the turntable with improved engineering. I feel that it is a shame that Thorens seem to have lost their way in between time; it could so easily have been their success. Anyway to the nitty gritty, here are my observations on renovating a Thorens TD150.

Cleaning

To clean the metal work, which will probably be dull grey/brown after twenty years of neglect, use Autosol Chrome cleaner with fine grade wire wool and plenty of elbow grease. Those platters can and will shine like new.

Mat

Get rid of the cruddy rubber mat and buy yourself a felt one. Don't bother with a Linn mat, it's far too expensive. Rega make one for around a fiver.

Springs

The old Thorens springs are usually shot - no wonder they won't support a heavier arm! Again, interestingly, the Linn Nirvana kit - which consists of new springs, bolts, grommets, washers and Nylock nuts will all fit in nicely. It's surprising how little your friendly Linn dealer can supply this for when the labour charge usually incurred for fitting is removed!

If you find all this too much aggravation or the local dealer is insistent on Linn pricings then do remember to seal the old Thorens' nuts with same nail varnish or similar as they work loose quite easily.

Arm Boards

I was amazed to see that Portfolio are still supplying armboards (in Medite?) as every time I've asked for one, it's always been the last one that they were going to do! The prices have gone up. I paid a tenner for the last one (undrilled); the same goes for the motor. Even a Linn motor (around £45) looks positively good value against that price!

Motor

While on the subject of motors the TD150 usually comes with a captive mains lead which has no polarity markings. If you don't replace it anyway (because it's so old) try reversing the wires inside the mains plug and listen to

the resulting sound.

Strange as it may seem, the motor phase does have an effect on the sound. One way round you should notice a focussed and natural sound, the reverse being blurred and hollow in comparison.

Components

The components inside the deck are also likely to be pretty old and the phase capacitor - the little barrel shaped object - is usually dicky, so replace it. It's also probably a good idea to do the same with the dropper resistor too.

If you decide to invest in a new belt, beware of the Bاندridge accessories 'version' of a TD150 belt: it's too small and pulls the whole sub-chassis over, making it a high impossible job to set up the suspension without it jarring.

Speed Change

The non-ability to achieve 45 rpm is a problem endemic with TD150's and TD160's. I've tried everything to solve it with little success (e.g. realigning the motor bearing, the belt guide etc.). In my opinion to make the best of a bad job, remove the whole ugly on/off switch/speed selector and the assembly underneath altogether. Change speed by hand, a la LPI2. The deck benefits sonically too.

This of course, leaves a gaping hole in the top plate which you can fill with a new on/off switch. It improves the appearance of the deck no end. Unfortunately, those nice Linn switches with the little red light won't go in the hole!

I've also played with motor control boards. My spare Valhalla board after the LPI2 was Lingo'd didn't seem to want to work. But I also had problems with the HFN & RR 'Flutterbuster'. A lack of start up torque meant that I went through three different units before finally giving in. There was a noticeable improvement in sound quality with it in place though: perhaps some of the other commercially available supplies may work?

I felt that I had to relate my experiences with the TD150, as I have obtained very encouraging results with it. Using a Rega RB300 arm and Audio Technica ATF5 cartridge actually produced a cleaner and more neutral midrange than the Sondek. I didn't quite get it right though as I've stuck with the Sondek - albeit upgraded to Lingo, Naim Aro and Art II!. But in my estimation the TD150 is an overlooked turntable with great potential at a reasonably low outlay. It is most certainly better than the TD160 and I can tell you from experience that no



renovating the Thorens TD-150

Reader Chris Bagust passes on his experiences with the venerable Thorens TD-150. Here's how to prolong the life - or renovate - a fine old turntable.

amount of bituminous lining, glass platters, acrylic armbands and heavy rubber mats can make that turntable sound as good as the '150. I've still got one TD150 left waiting.... and I only paid a tenner for it - with arm!

Parts for Thorens TD-150

Portfolio Marketing,
67 New Road,
Little Kingshill,
Great Missenden,
Bucks. HP16 0EU.
Tel: 0494 890277

Parts and Prices, inc. P&P and VAT.

| | |
|------------------------|--------|
| Arm boards blank | £31.14 |
| Belts | £8.52 |
| Lids | £49.94 |
| Motors (inc. resistor) | £78.14 |

life begins at 40!

Ion Systems SAM 40 amplifier system has life and detail, but has never been reviewed. Alan Sircom samples its delights.

Ion Systems SAM 40 amplifier system is like a forgotten painting in the audio attic. Well built, innovative, good sounding and thoroughly Welsh, the SAM 40 rarely gets a mention in the press. This is surprising, for in many ways it is the kind of product hi-fi enthusiasts love, being good, honest, minimalist stuff!

The amplifier range itself initially looks complex, which could account for this reluctance to review the system. It does have a distinct upgrade path. The system begins with the £431 NEXUS preamplifier, £259 X-PAK 2 power supply and SAM 40 power amplifier, also priced at £259. From here, the next step is to add a second X-PAK 2 power supply, to divorce the preamplifier from the power amplifier totally. After this, it is possible to bi-amp actively certain loudspeakers, by using a second SAM 40 power amplifier and £175 active crossover boards that fit within the power amplifiers themselves. Finally, one can then add a third X-PAK 2 to drive this new power amplifier.

This means that the upgrade path to a full active system is both inex-

pensive and does not render any previous purchases obsolete. Excluding the interconnect and loudspeaker cable, the total cost of a fully active system, for a two way loudspeaker, is £1901, which compares very favourably with competitors' systems. Loudspeakers that can be driven actively are the earlier active-ready Linn Kans and Saras, along with the current Linn Isobariks, Naim IBLs, SBLs, Royd Edens, Apex and finally Roksan Darius loudspeakers.

Excellent Build

As with all Ion products, build quality is excellent. The system has been designed with long term use and flexibility as high priorities. The preamplifier has a variety of interchangeable input cards so that it can be tailored to suit specific requirements. Electronic component quality is every bit as well specified as Ion System's direct competitors and it would be difficult to use more expensive components without drastically increasing the cost of the individual units.

The casework of the units shares Ion System's design ethic. In other words, while not being obtrusive, the only product that matches Ion System amplifiers is other Ion System equipment. This styling does not detract from the standard of finish, which is very good indeed. All the controls have a positive feel about them, especially the ALPS volume control. It has a solid resistance to it, suggesting reliability.

For this review, the more standard pre/power amplifier combination was supplied, along with a second power supply to show what improvement the extra £259 can bring. In addition, two sets of interconnect, a standard red cable of unknown origin and a white Isoda cable were used to connect preamplifier and power amplifier.

Put to the Sword

I put the amplifiers to the sword by using Hi-Fi World's own Linn/Lingo/Ittok/Asaka (while my own Linn is having new tyres fitted), along with a Voyd Valdi/RB-250/Goldring 1012 and a Marantz CD-60SE Compact Disc player driving a Musical Fidelity Digilog digital to analogue convertor. All the sources were sited on a Mana Reference table, while the two turntable power supplies and the Digilog were placed on an Audiotech table.

My old trusty Naim 42/110 amplifier was set to take on the challenger, along with an Audio Innovations Series 500 integrated amplifier, although comparing these two was a little like comparing a fish to a banana.

To determine how the different

amplifiers fared, both Linn Kans and Snell type K loudspeakers were used on their relevant stands, using Linn K20 and Audio Note ANB loudspeaker cables.

After a suitable warm-up period, the Ion Systems units were allowed into my system to play. My first reaction was of surprise at how a small amplifier could wrest such a powerful sound from my loudspeakers. The SAM 40 is rated at 40 Watts but obviously has such reserves of power that it is quite capable of seeing off amplifiers that are quoted as more powerful. My Linn Kans were not being driven to their extremes, but my ears were. After one protracted listening session, I could feel the damage that I was inflicting upon my ears.

Subjectively, the amplifier combination is slightly brighter than my tastes dictate. This is not meant as a

‘ My first reaction was of surprise at how a small amplifier could wrest such a powerful sound from my loudspeakers.

criticism, because I do not feel that this is a problem with the SAM 40 combination. It is purely that my preferences veer towards a sound that is less bright than that which the Ion amplifier produces. This suggests that some caution should be taken when partnering these amplifiers with sources. Using this amplifier with the Voyd Valdi turntable, I felt that the combination was too bright to listen to for long. The Linn, while considerably more expensive, combined with the amplifier perfectly, despite a few reservations about the Linn in question. In addition, this brightness did not feel like a major problem to me. Aside from this minor reservation, I enjoyed the way that the Ion amplifier presents music.

Remarkable Capacity

The SAM 40 combination has a remarkable capacity to show even the most subtle changes to a system. Changing over from the standard interconnect to the Isoda cable, or from the normal mains to Sonic Link mains in the Compact Disc player brought about dramatic differences,



usually expected with more expensive upgrades. Yet even when using the lesser interconnects, the Ion amplifier always sounded precise and detailed. This sense of change was even more apparent when the second X-PAK 2 was incorporated. It improved upon the sound of the existing system in all areas and should be first on the shopping list for upgrades to the amplifier.

Instruments were portrayed with a great sense of solidity and articulation. Guitar playing on 'Oh I Swear' by Richard Thompson from our free CD (March issue) sounded powerful, accurate and well delineated from the rest of the accompaniment. Vocals were easy to follow and detailed, having a sense of solid power and authority.

On 'Losing My Religion' from REM's excellent 'Out Of Time' LP, Michael Stipe's vocals were strong and I felt that the Ion amplifier portrayed the passion and emotion with which he sings without any strain. This album, one of the best produced REM albums to date, is also good for evaluating dynamic changes within an amplifier. Here again, the Ion fared well, making sense of the transients presented to it, without any apparent lack of control.

Melody

The SAM 40's reproduction of pitch was almost as good as its tuneful competitors. I still feel that Linn and Naim amplifiers will carry a melody better than the Ion Systems models, but the ability to predict a tune, the foot-tapping factor, was still there in great proportion. Its sense of rhythm and timing was excellent, never once sounding slow or lacking, even when

playing difficult pieces from Little Feat or dance music numbers. One record that showed this up well was a 12 inch single of Malcolm McLaren's 'Buffalo Girls', previously hidden within the bowels of my collection. On the remix version, the bass and drum interplay did not dissolve into a low frequency thump, as is common.

Besides its timing, the SAM 40 resolved a great deal of informational detail. On 'Furry Sings The Blues' from Joni Mitchell's 'Hejira' LP, John Guerlin's delicate drumming lost little of its subtlety, while the breathy quality of Neil Young's harmonica playing showed just how damaged my old copy of this record really is.

The Path of Musicality

Previously, I have found detailed amplifiers to suffer from a lack of coherence. Not so with the SAM 40, which never swerved from the path of musicality, despite source or type of music. Listening to Lloyd Webber/Menuhin's recording of Elgar's Enigma Variations, the amplifier was capable of producing a clear picture of the music, which never undermined the music itself.

Not everything is rosy, however. I felt that the imagery of the amplifier, while good, is not the SAM 40's strongest point. Nor is its tonal separation; the SAM 40 had a little difficulty in differentiating between the tonal colours of cello and viola. These are criticisms that the Ion Systems amplifier share with most solid state devices, especially when compared to valve amplification.

While comparisons here should be kept to a minimum, I feel that it is a good time to compare the performance of the Ion Systems amplifiers to

This sense of change was even more apparent when the second X-PAK 2 was incorporated. It improved upon the sound of the existing system in all areas and should be first on the shopping list for upgrades to the amplifier.

what is seen by most people as their direct competitors, Naim. The two amplifiers have a very similar performance, but do have distinct traits about them.

The Ion Systems amplifiers have a light open sound that is at once delicate and powerful. The Naim amplifiers, on the other hand, opt for a more dramatic sound, giving a greater sense of dynamism, but still maintaining detail and subtlety. Both angles are valid; no-one should criticise the Ion Systems amplifiers by suggesting that they are the poor man's Naim amplifier.

As a long standing Naim owner, I would find it difficult to move over to the Ion Systems amplifier combination. While initially very similar, their sound is quite different in some fundamental ways. Had I not purchased a Naim amplifier some years ago, I feel that the SAM 40's sound quality could win me over ●

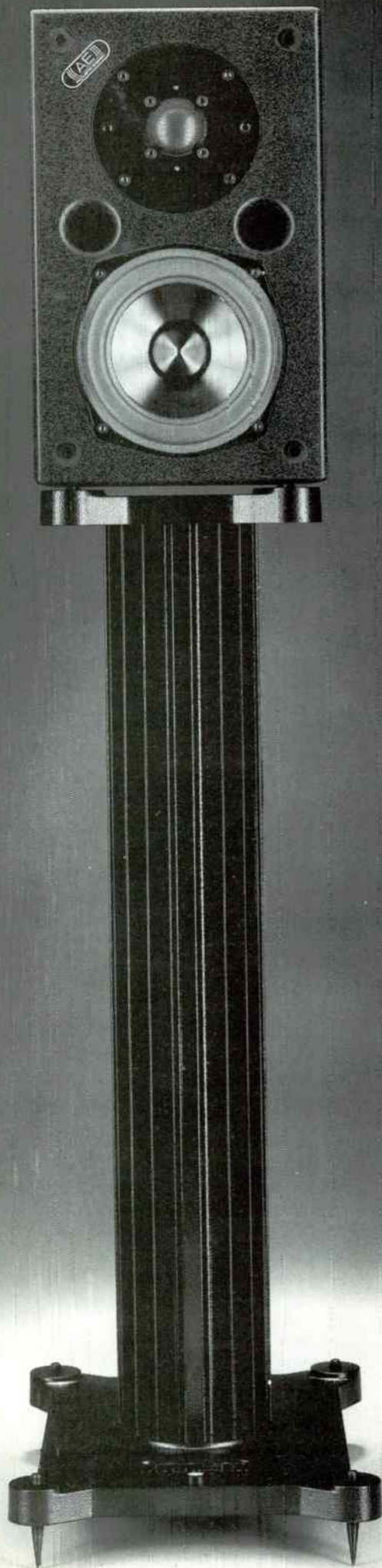

ACOUSTIC ENERGY SPEAKS FOR ITSELF.

"As far as I'm concerned, the AE1 re-defines the art of miniature speaker design"

John Atkinson, Stereophile, September 1988

"To the author's knowledge, the most awesomely dynamic and articulate miniature ever made"

Alvin Gold, Hi-Fi Choice, June 1988

"...the best looking, most immaculately turned out stands I've ever clapped eyes on"

Jonathan Kettle, New Hi-Fi Sound, July 1989

"The AE1 leapfrogs existing references and sets new standards of technical and musical excellence..."

David G Prakel, Hi-Fi Answers, March 1988

HEARING IS BELIEVING

To audition Acoustic Energy loudspeakers — contact any of the dealers listed below.

- | | | | |
|--|---|--|---|
| Doug Brady Hi-Fi London WC2 Tel 071-379 4010 (also at Warrington & Liverpool) | Cleartone Bolton, Lancs Tel (0204) 31423 (also at Manchester & Wolverhampton) | In Hi-Fi Edinburgh, Scotland Tel 031-225 8854 | Basically Sound of Norfolk Nr Norwich, Norfolk Tel (0508) 70829 |
| Grahams Hi-Fi London N1 Tel 071-226 5500 | Brentwood Music Centre Brentwood, Essex Tel (0277) 221210 | Farnborough Hi-Fi Farnborough, Hants Tel (0252) 520146 | Sound Approach Norwich, Norfolk Tel (0603) 622833 |
| KJ Leisure Sound London W1 Tel 071-486 8262/3 | The Powerplant Brighton, E Sussex Tel (0273) 775978 | Lintone Audio Gateshead, Tyne & Wear Tel 091-477 4167 (also at Whitley Bay & Durham) | Audio Counsel Oldham, Lancs Tel 061-633 2602 |
| Thomas Heinitz Ltd London W2 Tel 071-229 2077 | Steve Boxshall Audio Cambridge, Cambs Tel (0223) 68305 | Stereo Stereo Glasgow, Scotland Tel 041-248 4079 | Oxford Audio Consultants Oxford, Oxon Tel (0865) 790879 |
| The Cornflake Shop London W1 Tel 071-631 0472 | Audio Excellence Cardiff, Wales Tel (0222) 228565 (also at Gloucester, Swansea & Newport) | Manders Hi-Fi Grimsby, S Humberside Tel (0472) 351391/2 | The Audio Gallery Nr Petersfield, Hants Tel (0730) 66556 |
| Peter Jones London SW1 Tel 071-730 3434 | Peter Tyson Ltd Carlisle, Cumbria Tel (0228) 46756 | PJ Audio Guildford, Surrey Tel (0483) 504801 | Rayleigh Hi-Fi Rayleigh, Essex Tel (0268) 779762 (also at Chelmsford & Southend-on-Sea) |
| The Listening Rooms London SW5 Tel 071-244 7759 | Gilson Audio Middlesborough, Cleveland Tel (0642) 248793 | Harrow Audio Harrow, Middx Tel 081-863 0938 | Audio Centre Sheffield, S Yorks Tel (0742) 737893 |
| Studio 99 London NW6 Tel 071-624 8855 | Soundstage Crewe, Cheshire Tel (0270) 255488 | Compact Music Havant, Hants Tel (0705) 473952 | Alternative Audio Solihull, W Midlands Tel 021-742 3884 |
| Robert Taussig Co London W9 Tel 071-286 1728 | Sound With Style Doncaster, S Yorks Tel (0302) 321421 | The Sound Gallery High Wycombe, Bucks Tel (0494) 31682 | Chelston Hi-Fi Torquay, Devon Tel (0803) 606863 |
| Overture Hi-Fi Banbury, Oxon Tel (0295) 272158 | Data Sound Dorking Surrey Tel (0306) 882897 | Audio Projects Leeds, Yorks Tel (0532) 304565 | Tonbridge Hi-Fi Tonbridge Wells, Kent Tel (0892) 24677 |
| The Hi-Fi Centre Barrow-in-Furness, Cumbria Tel (0229) 838757 | Wentworth Audio Dunstable, Beds Tel (0582) 663383 | Image Hi-Fi Ltd Leeds, Yorks Tel (0532) 789374 | Uxbridge Audio Uxbridge, Middx Tel (0895) 30404 |
| Paul Green Hi-Fi Bath, Avon Tel (0225) 316197 | Audio Inc East Molesey, Surrey Tel 081-941 4234 | The Leicester Hi-Fi Co Leicester, Leics Tel (0533) 539753 | Acoustic Arts Watford, Herts Tel 0923 245250 |
| Pure Sound Birkenhead, Merseyside Tel 051-645 6690 | Hi-Fi Corner Edinburgh, Scotland Tel 031-220 1535 (also at Falkirk & Glasgow) | Better Hi-Fi Liverpool, Merseyside Tel 051-227 5007 | West Midlands Audio Worcester, Worcs Tel (0905) 58046 |
| The Audio File Bishops Stortford, Herts Tel (0279) 506576 (also at St Ives, Cambs) | | Audio Insight Milton Keynes, Bucks Tel (0908) 561551 | Mike Manning Audio Yeovil, Somerset Tel (0935) 79361 |

Acoustic Energy has distributors in the following countries:

| | | | | | |
|-----------|-----------|-------------|-----------|-------------|--------|
| Australia | Germany | Italy | Norway | Sweden | Taiwan |
| Belgium | Hong Kong | Japan | Portugal | Switzerland | U.S.A |
| Eire | Indonesia | Netherlands | Singapore | Thailand | |
| France | Israel | New Zealand | Spain | | |

((AE))
LOUDSPEAKERS

Acoustic Energy Limited
3A Alexandria Road, London W13 0NP
Tel 081-840 6305 Fax 081-579 1761

domestic considerations have never featured highly in British hi-fi. Unless you live in a minimalist, matt black home, most components give no quarter towards the living room. The assumption seems to be that if you are 'into' hi-fi, you will be prepared to put up with intrusive black boxes that do not even match each other, let alone their surroundings.

One company that is attempting to change this situation is Alphason. Best known for their turntables and tonearms, Alphason have recently expanded their range to include loudspeakers, equipment tables and amplifiers. All their products, including the £299.95 Apollo amplifier tested here, are designed to blend into domestic settings.

Following a line that runs throughout the Alphason range, the Apollo integrated amplifier features a solid wood front panel, that can be stained with a number of different finishes. This is offset by a large circular on-off switch in the left corner (a feature also common in all of Alphason's electronics), followed by a red LED, tape monitor button, source selector and a large volume control.

Stylish Dials

These last two dials are finished with a stylish black plastic bevelled knob. One observation here is that the volume control does not have a solid feel to it, suggesting the use of an inexpensive potentiometer. This was borne out by a very slight rushing sound when twiddling with the volume control. I wonder whether this could worsen with age.

Another slightly strange point worth mentioning here concerns the number of line level sources the Apollo has. In addition to the listed Phono, Compact Disc and Tuner, there are three extra line sources. As the Alphason only features one tape circuit, surely it would have been a better idea to feature one less line source, including in its place facilities for a second tape recorder? As it stands, the Apollo has plenty of room for a hi-fi video machine, the playback of a cassette or DAT player and still have a spare input to play with.

Apart from the metal chassis, a large proportion of the amplifier's casework is made from MDF (Medium Density Fibre-board). This is said to improve sound quality, as extensive use of some metals in casing effects sonic capabilities, we are told. This is backed up by companies like DNM, who avoid all unnecessary metal in their amplifiers, and by Naim Audio, who switched from steel casework to aluminium some time ago, because steel cases affect sound quality*.

Captive Lead

At the rear of the Apollo, we see a row of good, solid gold plated phono sockets, Moving Coil/Moving Magnet cartridge selector button, an earth plug, facilities for one set of loudspeakers and a captive (i.e., permanently connected to the amplifier) mains lead. This last point troubles me, as I know that in the near future European standards will forbid the use of captive mains leads in domestic appliances, replacing them with IEC-type sockets. I expect that when the time comes, Alphason, along with many other companies will adopt the new ruling, but I still think that it is a little short sighted of them to launch a new product only to

change production when the new edict is enforced shortly.

This is not a great criticism, particularly when the mains cable that is used is of as good quality as used with the Alphason. Many people consider hard-wired captive mains leads to sound better than IEC leads, as there are then fewer connections to the amplifier itself. Such details aside, the Apollo feels well built and should give years of trouble-free use.

To assess how the amplifier sounded, I used a variety of different sources, amplifiers and loudspeakers. My own turntable was in for service at the time (toenails clipped, checking for Hard Pad, Foot-and-Mouth and so on) so I called on Hi-Fi World's own Linn Sondek (c/w Lingo power supply, Linn Ittok arm and Linn Asaka cartridge) along with a Voyd Valdi (plus RB-250 tonearm and Goldring 1012 cartridge), Marantz CD 605E Compact Disc player (with and without a Musical Fidelity Digilog digital-to-analogue converter, but always with highly pricey Isoda cable).

Amplifiers were harder to come by, but a Audio Innovations Series 500 amplifier and

Unfortunately the Apollo's reproduction of pitch, timing and its apparent lack of dynamic range let the side down. On listening to the first track, 'Blood And Gold/Mohacs' from 'No More To The Dance' by Maddy Prior and June Tabor I was disappointed by the lack of change in volume of the two unaccompanied singers voices. This made the track appear lifeless and uninteresting. When the band take over, the sense of a rhythm usually apparent was lost, leaving the track without bounce.

Warmth

The amplifier is very definitely on the warm side of neutral and this is its saving grace. The Apollo has a 'niceness' about its portrayal of music that is very endearing. With all the reservations I have mentioned above, the Alphason Apollo always sounded polite and refined and I am sure will prove very popular with those who enjoy easy listening. This is not a back-handed insult, meant to summon up images of James Last or Mantovani, but instead this is a great amplifier for those who do not feel the need to struggle with the vagaries of hi-fi listening.

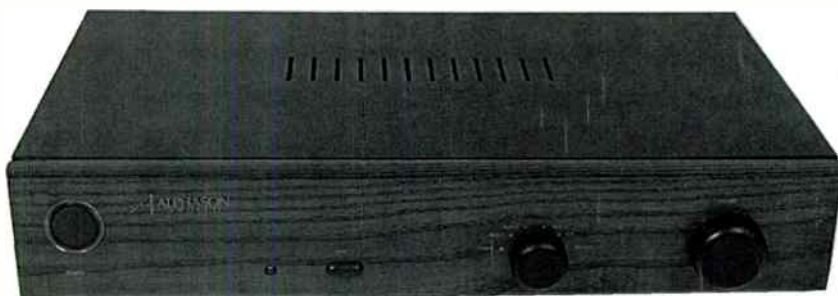

an aging Naim 42/110 pre/power combination amplifier were pressed into use. Finally, both Linn Kan II (on Linn Kan II stands) and Snell Type K loudspeakers (on Pirate stands) were used, with both Linn and Audio Note cables.

When played through the Snells, that are capable of producing fine images, the Alphason acquitted itself well. It produced good imagery for an amplifier of its price, but I did feel that these images were a little unstable. By this, I noticed Miles Davis had a habit of walking around the soundstage on 'So What' from the famous 'Kind of Blue' set, which was not apparent before. This was not a major problem, but after prolonged listening with my critical ears on, I did notice this slight difficulty the Apollo had.

While articulate, I felt that the Alphason was a little lacking in solidity, particularly with rock guitar. When playing The Stone Roses 'Waterfall', the guitar appeared gutless, compared to how I expected to hear it. The guitar was well delineated from its double tracked entity, however and vocals were easy to follow.

Tonal Separation

One area that the Alphason excelled in was tonal separation. Once again on the Miles Davis track, the Alphason was clearly able to separate the bright sound of Miles Davis' trumpet against the more seductive tenor sax of John Coltrane. This, combined with the sense of an acoustic that the Alphason portrayed created quite a natural sound, on both CD and vinyl.

house trained

Alphason's £299.95 Apollo integrated amplifier fits in well with the living room.

Alan Sircom checks to see if it sounds as good as it looks.

Overall, I found myself enjoying the Alphason Apollo's impression of music. I enjoyed it not for what it did or did not do, but because of this warm, embracing factor that is very hard to qualify. I would find it unlikely that the committed hi-fi enthusiast would put this amplifier high on his or her list, as they may find it a little bland. Many other people will probably find it highly musical, however. I know that this word should be reserved for sweet, frail old aunts and biscuits, but the Apollo is simply nice ●

In the May issue of Hi-Fi World, we featured a review of the Musical Fidelity P180 power amplifier. After the review, the company's MD, Antony Michaelson approached us with its dedicated Choke Regulated Power Supply (CRPS) suggesting that we assess its improvements on the power amplifier.

Fitted into a case identical to the P180, the £499 CRPS works to smooth the power supply feeding the power amplifier. It removes alternating current ripples from the mains, while allowing direct current to pass unhindered. This is not new technology; choke regulation dates from the days of valves.

How does this regulation affect the sound quality of the P180? Well, its smoothing quality is not only confined to mains power, it also affects the power amplifier, making it sound more controlled and refined.

This sense of control and refinement was especially true at the lower ends of the frequency scale. Bass guitars, cellos and organ music became tighter and better controlled. This also improved the imagery and added a spaciousness to the sound, while improving upon the sense of tightness in a performance.

The track that showed everything up for me was 'Don't Give Up' by Peter Gabriel on his famous 'So' Compact Disc. Here, the deep, pseudo-dub bass line toward the end of the track became less woolly, and the band appeared to be playing more tightly together than with the P180 alone. The thickness that I mentioned earlier disap-



peared almost completely, only to be replaced by better separation of the instruments. Kate Bush's voice developed an echo that was not apparent on the non-CRPS version.

A question still arises when it comes to the upgrade path: which is better, two P180s in mono mode, or one stereo P180 with a CRPS? I feel that this depends upon the individual. For the out-and-out headbangers of this world, two P180s running in mono mode will provide more than enough grunt to send their ears ringing. The addition of the CRPS adds a level of subtlety and refinement that the classical music enthusiast will prefer.

For myself, I would prefer to use the P180 with a CRPS first, especially as the CRPS has the facility to run two P180s from it. With the CRPS, the latest crop of Musical Fidelity amplifiers can be summarised using the title of an album by John McLaughlin, Al DiMeola and Paco DeLucia: Passion, Grace and Fire ●

smoothing the way

Musical Fidelity's new P180 power amplifier, has two distinct upgrade paths. The Choke Regulated Power Supply is the smoother of the two, suggests Alan Sircom.

PM Components Limited

Selectron House, Springhead Enterprise Park, Springhead Road, Gravesend, Kent DA11 8HD

Fax No: 0474 333762 Telex No. 966371 Tel: 0474 560521



Gold Dragon

Gold Dragon preamplifier tubes represent the peak of tonal purity, with a unique construction that offers low noise, low microphonics, and reduced coupling between each section of the tube.

British audiophiles and engineers have worked diligently with Shuguang over the past two years to recreate the quality, reliability, and sonic purity that we once took for granted. The result is a difference that you will hear.

12AT7A/E81CC £4.95 Excl VAT, 12AU7A/E82CC £4.95 Excl VAT
12AX7A/E83CC £4.95 Excl VAT, 6DJ8/E88CC £7.95 Excl VAT

Gold Dragon power tubes are precision made and selected for optimal performance and sound quality. All Gold Dragon power tubes are provided in matched pairs only to ensure that your equipment provides the best performance possible.

6BQ5/EL84 £6.95 Per matched pair excl VAT, 6CA7/EL34 £15.00 Per matched pair excl VAT

6L6GC £15.00 Per matched pair excl VAT, 6550A £32.00 Per matched pair excl VAT
KT66 £20.00 Per matched pair excl VAT, KT88 £39.50 Per matched pair excl VAT

2A3 £39.50 Per matched pair excl VAT, 6B4G £39.50 Per matched pair excl VAT
211/VT4C £35.00 Per matched pair excl VAT, 811A £18.00 Per matched pair excl VAT
845 £49.50 Per matched pair excl VAT

PM COMPONENTS CLASSIC HI-FI VALVES

As many of these types are no longer in production we can only offer these 'brands' whilst our stocks last.

General Electric USA Range

| | |
|-------------------|-------|
| 6CA7/EL34 | 11.50 |
| 6DJ8/ECC88 | 3.95 |
| 6L6GC | 10.50 |
| 6LF6 | 14.50 |
| 12AT7/ECC81 | 5.50 |
| 12AT7WA/6201 | 6.50 |
| 12AU7A/ECC82 | 3.95 |
| 12AX7A/ECC83 | 6.50 |
| 12BH6E7A | 6.50 |
| 211/VT4C | 25.00 |
| 6SN7WGTA Silvania | 6.95 |
| 6146B/6288A | 15.00 |
| 6550A | 15.95 |
| 7027A | 13.95 |
| 730B/E88CC | 8.95 |
| 756LA/KT66 | 11.95 |
| 786B | 11.95 |
| 8417 | 11.95 |
| 12AX7WA/5751 | 6.50 |

Mullard Special Quality

| | |
|----------------------|-------|
| E80CC | 25.00 |
| E81CC/6201 | 6.45 |
| E188CC (E88CC) | 8.50 |
| E182CC | 7.50 |
| E288CC | 17.50 |
| ECC81 | 4.95 |
| EL86 | 2.75 |
| M8136/ECC82 | 7.00 |
| M8137/ECC83 | 7.95 |
| M8162/ECC81 | 5.50 |
| ECL86 | 2.95 |
| German Valves | |
| ECC81 Siemens | 3.50 |
| ECC81 Telefunken | 3.95 |
| E81CC Siemens | 5.50 |

| | |
|------------------|-------|
| AC701 Telefunken | 85.00 |
| EF86 Siemens | 5.50 |
| PCC88 Siemens | 2.50 |
| 6201 Siemens | 6.45 |

British 'CV' Series Military Spec. Double Triodes

| | |
|--|------|
| Of all CV Specs the RAF Series are commonly regarded as of the Highest Specification | |
| CV2492/E88CC | 6.50 |
| CV2493/E88CC-01 | 7.50 |
| CV2975/EL84 | 4.50 |
| CV4085/EF86 | 7.50 |
| CV4003/E82CC | 6.50 |
| CV4004/E83CC | 6.50 |
| CV4024/E81CC | 4.50 |
| CV378/GZ37 | 4.50 |

Teonex Range

Our own brand of good, standard quality, reliable new valves tested and approved by our Quality Control and Test Department.

| | |
|-------------|------|
| 6DJ8/ECC88 | 2.50 |
| 6L6GC | 3.50 |
| 6SN7GT | 3.15 |
| 12AT7/ECC81 | 1.95 |
| 12AU7/ECC82 | 1.50 |
| 12AX7/ECC83 | 1.95 |
| ECC83/Super | 3.50 |
| EF86 | 3.50 |
| KT66 | 5.00 |
| EL34 | 4.50 |
| 6146B | 8.50 |
| PL519 | 4.85 |
| GZ34 | 5.95 |

MAIL ORDER/CALLERS WELCOME
Please add £2.50 Carriage + 17.5% VAT
TRADE ENQUIRIES WELCOME

Until recently, it has been casually assumed that the individual components that go to make up a piece of hi-fi equipment are, in themselves, passive. That is, they do not affect sound quality. This is a simplistic assumption however. When examined closely, electronic components can be seen to differ greatly in construction. Such differences account for their respective impact upon sound quality.

RESISTORS

A resistor is, apparently, a very simple component. It is usually assumed that its resistance value is fixed. In reality this value (the relationship between current through it and voltage across it) will vary according to operating conditions. It is failure to understand this fact and account for it that can have a bad affect upon sound quality in an otherwise good circuit design.

To see how this happens, we shall look in great detail at the way in which real resistors are constructed. The main parts are shown in the diagram, Fig 1, and are as follows -

Wire Leads

Generally these are made from solder coated copper of around 0.6mm diameter, often described as 'tinned'. If the leads are too long they will exhibit inductance which limits high frequency current through the resistor.

End Connectors

The way in which the wire leads of a resistor are connected to the resistive element is very important. The apparently simple job of connecting the lead wire to the resistive element is an area which can easily affect audio sound quality. A low cost resistor is much less likely to have a decent connection than a more expensive branded 'precision' type, crimped end caps being common. This is a mechanical connection, which is not especially appropriate for hi-fi work. Such contacts degrade with time and can take on a diodic effect, which produces distortion.

Resistive Elements and Coatings

Resistive element or coating. The resistive element is the actual part that determines the resistance value. Resistive elements are commonly made of Carbon, Metal wire, Metal film or Metal foil. Their properties are considered below.

Carbon

Carbon resistors are very inexpensive to manufacture, but their resistance value alters with temperature, giving them a poor 'temperature coefficient'.

Because a resistor will heat up and

cool down according to the current passing through it, its resistance value will alter in sympathy, so modulating the signal. The effect is to blur the sound, rather like a photograph is blurred when it is taken with a camera out of focus.

Metal Wire

Wirewound resistors, made from metal wire wound round a former, are less prone to temperature change, but have very high inductance. This affects high frequencies. When used as voltage dropper resistors for power supplies their inductance is an asset.

Low inductance wirewound resistors can minimise inductive effects, but are more expensive and comparatively difficult to obtain.

Metal Film

Metal Film resistors are most common in audio. These have an acceptably low temperature coefficient and are inexpensive to manufacture, typically costing a manufacturer less than 1p each when bought in bulk. Most audio manufacturers use this kind of resistor, though some may stick to particular brands. Roderstein 'Resista' types tend to find particular favour amongst audio cognoscenti. Because the film is wound, inductive effects are present, but they are not serious enough to cause problems.

Precision Metal Film

Precision metal film resistors differ

tweaky corner

Following on from last month's Tweaky Corner, Graham Nalty of Audiokits and Sonic Link explains the theory behind component sound quality.

from standard metal film resistors in the quality of manufacture. Generally, greater attention to detail in all areas of construction results in better audio quality. The popularity of the British made Holco range of precision resistors amongst more advanced audio manufacturers is proof of this. Replacing standard quality metal film resistors in an amplifier with Holcos is a popular and cost effective way to upgrade an amplifier after the

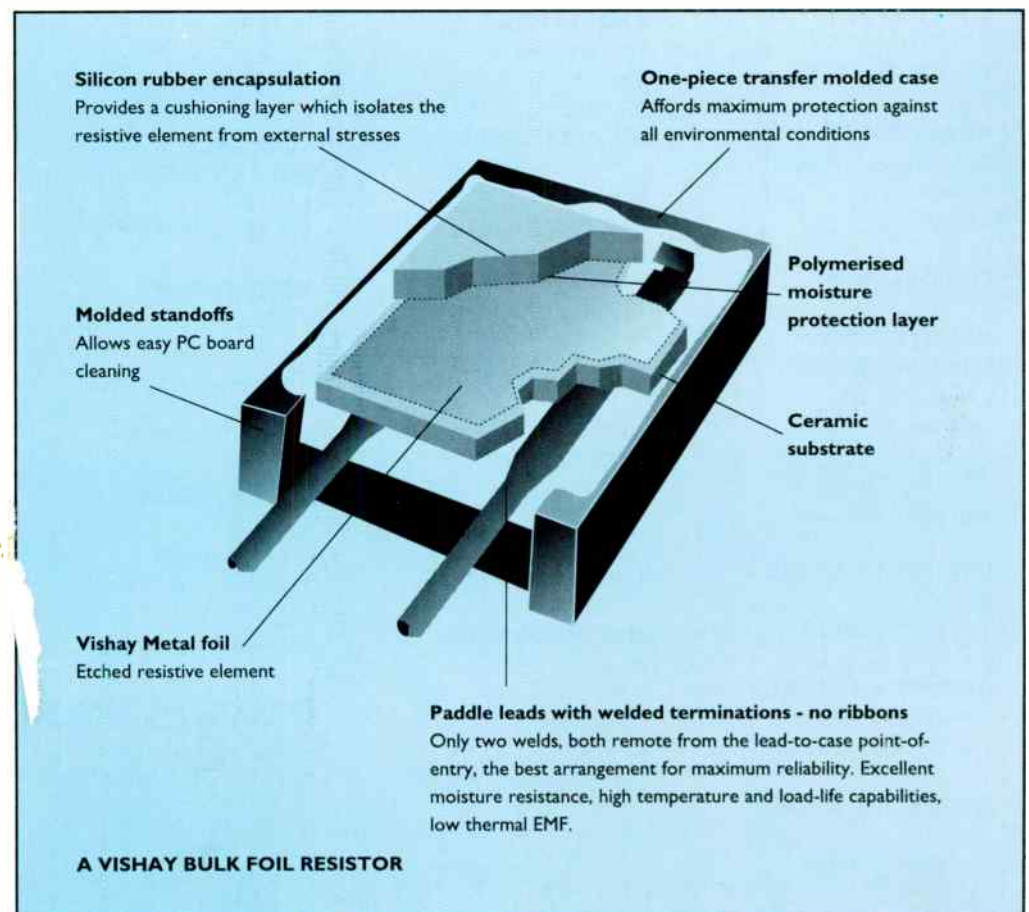

For further
details and
a full
demonstration
contact your
local dealer

Audio Innovations



**ACTION
ACOUSTICS**

155-157 High Street
Redcar
Cleveland
TS10 3AN
Tel: 0642 480723

**AUDIO
ACOUSTICS**

49 Coleridge Square
West Ealing
London W13 0JX
Tel: 081-998 9041

**AMADEUS
SOUND & VISION**

10 Boldmere Road
Sutton Coldfield
D73 5TD
Tel: 021-354 2311

AUDIO SCENE

132 Chatsworth Road
Brampton
Chesterfield
Derby
Tel: 0246 204005

**BRENTWOOD
MUSIC CENTRE**

2 Ingrave Road
Brentwood
Essex
CM15 8AT
Tel: 0277 221210

DEFINITIVE AUDIO

Brighton
Tel: 0273 208649

DEFINITIVE AUDIO

Nottingham
Tel: 0602 813562

DEFINITIVE AUDIO

Cornwall
Tel: 0726 844039

**ENGLISH
AUDIO**

95 Whitecross Road
Hereford
Tel: 0432 355081

**HI-FI
EXCELLENCE**

3-5 Skene Square
Aberdeen
AB2 4UU
Tel: 0224 624408

**HI-FI
CONFIDENTIAL**

43 Buckingham
Palace Road
London
SW1W 0RE
Tel: 071-233 0774

**KAMLA
ELECTRONICS**

251 Tottenham
Court Road
London W1P 9AD
Tel: 071-323 2747

**MIDSHROPSHIRE
HI-FI**

4 Holland Court
High Street Drawley
Nr Telford Shropshire
Tel: 0952 630172

**MOORGATE
ACOUSTICS**

6 Westgate Chambers
Rotherham
W. Yorks
S60 1AN
Tel: 0709 370666

**MUSICAL
PREFERENCE**

Norfolk
Tel: 0953 89562

**NORTHWOOD
AUDIO**

126 Pinner Road
Northwood
Middlesex
Tel: 09274 20877

**PROGRESSIVE
AUDIO**

2 Lovelace Close
Rainham Gillingham
Kent ME8 9OP
Tel: 0634 389004

SOUND SENSE

350 Edgware Road
London W2
Tel: 071-402 2100

STANDENS

92a High Street
Tonbridge
Kent
Tel: 0732 353540

ZEUS AUDIO

6 Hope Street
Donaldson & Littles Precinct
N. Ireland
Tel: 0232 332522

AUDIO COMPONENTS LTD.

Albany Court, Albany Road, Granby Industrial
Estate, Weymouth, Dorset DT4 9TH
Tel: 0305 761 017

guarantee has run out (providing you know what you are doing, or it might be a short route to the grave - Ed.).

Bulk Metal Foil

Bulk metal foil resistors are the highest quality types currently manufactured. Every possible technique is used to ensure that the resistors behave as closely as possible to the ideal. In the Bulk Foil resistor, temperature changes are kept extremely low by balancing opposing physical phenomena. Inductive effects are self cancelling because no two resistance paths carry current in the same direction. In addition, capacitance effects are minimised and the resistor substrate has a high thermal conductivity which keeps temperature uniform between the leads so that thermal EMFs are extremely low.

Bulk metal foil resistors are very expensive, costing anything from £1 to £5 each when ordered in commercial quantities. Vishay make bulk foil resistors in Britain, although their main plant is in the U.S. The only

types. A more detailed list of capacitor types is given below, together with a range of typical values and their loss factor.

| TYPE | RANGE OF VALUES | POWER FACTOR |
|------------------------|----------------------------|--------------|
| Aluminium Electrolytic | 1 μ F - 33,000 μ F | 0.08 - 0.16 |
| Tantalum Electrolytic | 1 μ F - 220 μ F | 0.04 - 0.1 |
| Polyester film | 10nF - 10 μ F | 0.01 |
| Polycarbonate Film | 10nF - 4.7 μ F | 0.003 |
| Silver Mica | 2.2pF - 10nF | 0.002 |
| Polypropylene Film | 1nF - 100 μ F | 0.0005 |
| PTFE film | very difficult to obtain | |
| Polystyrene | 10pF - 250nF | 0.0003 |

In general, capacitors which have a low loss factor sound better than those with a higher loss factor. This is probably because low loss capacitors also exhibit low dielectric absorption, meaning the insulating layers have minimal interaction with the signal. When this is the case, a capacitor approaches an ideal model.

The operation of a capacitor can be described in fairly simple terms. In construction it comprises two

frequency. Capacitors can therefore be used to discriminate on the basis of frequency in various circuits where this is required, notably in tone

controls, loud-speaker crossovers, disc equalisation circuits and what have you. They are also used to filter out frequencies above the audio range that would otherwise impair the performance of an amplifier.

In addition, capacitors are very important in blocking DC (direct current) between circuits. Where amplifiers are powered from an AC supply, capacitors are used to smooth the rectified DC supply. In this application they are commonly called reservoir capacitors.

With the exception of a very few extremely expensive amplifiers, reservoir capacitors are almost exclusively made from electrolytic types.

Fig 1. The construction of a conventional resistor

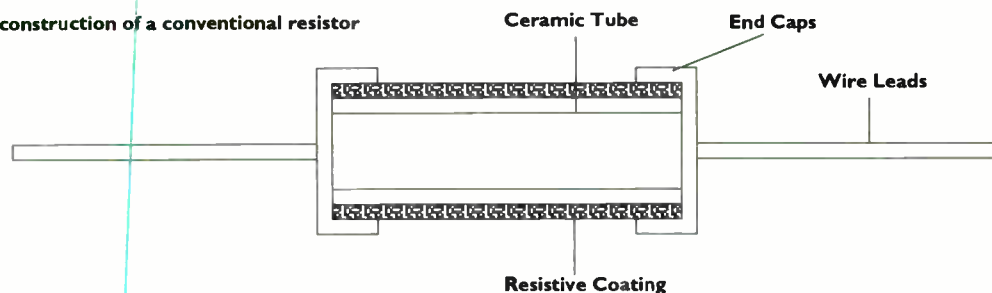

other major manufacturer is Alpha, a Japanese company. This shows just how specialised they are.

CAPACITORS

Capacitors are made in so many different types, it is confusing to anyone who has not encountered them before. There are two basic types of capacitor -

Electrolytic capacitors

These have large values of capacitance, but exhibit high power loss. Electrolytic capacitors are mostly polarised and must be connected the right way around, otherwise they may explode.

Plastic film capacitors

These are only available in smaller values but more accurately reproduce the characteristics of a perfect capacitor.

There are also ceramic and silver mica capacitors. Ceramics are used extensively in radio circuits, but are not recommended for use in audio circuits as they have an undesirable effect on the sound. Silver mica capacitors exhibit characteristics comparable to the better plastic film

In general, capacitors which have a low loss factor sound better than those with a higher loss factor.

conductive plates separated by a very small gap (Fig 2). Whilst this can be air, it is usually an insulating material, in order to reduce size (Fig 3).

Up to the rated voltage, no current will flow across the plates, providing the voltage remains steady. If it changes, the charge on each plate will change. When electric charges change, current flows and this current depends on the size of the capacitor and the rate at which the voltage changes. The higher the rate of voltage change, the larger the current.

When used in audio circuits, a capacitor will have a decreasing impedance value for increasing

These are the largest capacitors used in audio and values of up to 33,000 μ F may be seen in larger power amplifiers. Values of around 3300 μ F - 6800 μ F are more common, whilst a typical hi-fi preamp may use 1000 μ F - 2200 μ F.

Large electrolytic capacitors exhibit inductance and cannot react quickly to very high frequencies. For this reason, many large electrolytic capacitors in audio circuits may be bypassed by a smaller value capacitor which performs better at high frequencies. Usually, this will audibly improve the high frequency quality of reproduced music. A general rule is to select a bypass capacitor with a value one hundredth that of the main capacitor.

In more serious hi-fi applications, capacitors may be bypassed down as far as 1nF, but the best results will always be found by trial and error. Obviously, the best types available should be used for bypass capacitors. However where space is limited, a higher value polyester may bring better results than a smaller value polypropylene of the same physical size.

Blocking capacitors prevent DC

Mana Acoustics

'SEEK AND YE SHALL FIND'

Either way the Mana Spirit level is one of the most useful turntable tweaker tools we've come across.

Jason Kennedy, HiFi Choice, Feb '90

1990 has got to be the year of the Mana Sound Table. It's as big an upgrade as the ARO was, and at half the price.

Paul Messenger, HiFi Choice, May '90

One could imagine that turntable, arm and cartridge had all been instantly upgraded.

Martin Colloms, HiFi News, July '90

I haven't experienced such a startling improvement through changing a single component for a very long time.

Paul Messenger, HiFi Choice, June '90

The Mana Turntable table seems to have made my deck combine the better aspects of CD with the greater involvement of analogue.

Peter Turner, Audiophile, July '90

Dynamics expanded, low level information was scavenged from inaudibility, and timing, speed and precision nothing less than a substantial leap forward.

Malcolm Steward, Audiophile with Hi-Fi Answers, Dec '90

The Mana Reference Sound table deserves each and every superlative that's been heaped upon it.

Malcolm Steward, High Fidelity, Dec '90

Several hours and many albums later I was even more convinced as to the worth of the Sound Frame

Paul Hartley, Hi-Fi World, May 1991

Mana Reference Table

(comes with spirit level)£300

Mana Sound Table£200

Mana Sound Shelf (wall mounting)£150

Mana Mini Table (approx 5" high)£125

Mana Sound Frame£99

Mana Spirit Level£25

Prices apply U.K. mainland only

14 Day Money Back Guarantee

Designed & Made in England

Please send cheque or Postal Order to:

Mana Acoustics

59 Jubilee Close, Pinner,
Middx HA5 3TB

Tel: 081-429 0118

Allow 28 days for delivery

Available from selected dealers

AUDIO VENUE

24 Church Road, London SE19 2ET Tel: 081-771 7787

AUDIO ACOUSTICS

49 Coleridge Square, London W13 Tel: 081-998 9041

AUDIO GALLERY

28 Andlers Ash Road, Liss, Hants. Tel: 0730 66556

DOUG BRADY HI-FI

18 Monmouth Street, London WC2H 9HB Tel: 071-379 4010

Kingsway Studios, Warrington, Cheshire Tel: 0925 828009

PRO-MUSICA

6 Vineyard, Colchester, Essex CO2 7DG Tel: 0206 577519

RADFORD HI-FI

28 Cowick Street, Exeter, Devon EX4 1AL Tel: 0392 218895

RPM Ltd.

2 Burland Road, London SW11 6SA Tel: 071-585 0274

SOUND GALLERY

65 Castle Street, High Wycombe, Bucks. HP13 6RN
Tel: 0494 31682

THE RIGHT NOTE

The New House, Lambidge Street, Bath BA2 6RX
Tel: 0225 424334

voltages at the output of one amplifier stage affecting the performance of the next. Typical values used in audio range from 100nF to 10uF. Many pieces of hi-fi, including cheaper CD players, use low value electrolytic capacitors to save money and space. Those seriously concerned with sound quality will use plastic film types for DC blocking and more and more are turning towards polypropylene rather than polyester for even better sound quality, despite their larger physical size and higher cost.

Tone controls, RIAA disc equalisation and RF filters all use capacitors as well. Further capacitors may also be used in amplifiers to shape the frequency response of individual stages of amplifiers. Typical values range from 10pF to around 100nF. For values up to 10nF, capacitors in RIAA stages and tone controls may be polyester types in low priced amplifiers, whilst serious hi-fi manufacturers are more likely to use polypropylene or polystyrene types.

Loudspeaker crossover capacitors are usually quite high in value, ranging from about 1uF to 60uF. Most commercial loudspeakers in the past have used non-polarised electrolytic types. Unlike polarised types, these capacitors can be used in either direction and will give the same response on both positive and negative parts of the voltage to the loudspeaker. However, plastic film capacitors, in particular polypropylene types, have enabled considerable strides forward in sound quality to be gained. A polypropylene capacitor will make the bass notes far clearer, by removing resonances. Treble becomes less blurred and indistinct. This effect may alter the tonal balance, giving more treble and less bass, which in turn might require a change in crossover values to get a frequency response that sounds flat.

There are a number of ways in which capacitors can alter the sound quality of a signal. They are as follows

Dielectric Absorption

This occurs when energy stored in a capacitor is absorbed in the electrolyte. This energy can and will release itself over a period of time. It does not take much to realise that passing an audio signal through a capacitor exhibiting dielectric absorption will cause audible distortion of the music.

Dielectric loss

This is often called power factor and is the power converted into heat when an electrical signal passes through the capacitor. The heat causes expansion that alters the size of the capacitor plates and the distance between them. This changes the capacitance value. As with resistors, this will cause audible distortion.

Mechanical resonance

This occurs when an electrical signal applied across the capacitor causes mechanical resonance within the capacitor. All capacitors are subject to this effect, to a lesser or greater degree.

Connecting of leads

As with resistors, good electrical connection between the leads and capacitor plates is important.

While specifications can help in selecting capacitors for high quality audio use, they can only be a rough guide. Careful listening under relaxed conditions can produce reliable results on which types of capacitor distort the music least.

‘Careful listening under relaxed conditions can produce reliable results on which types of capacitor distort the music least.’

SEMICONDUCTORS

Finally, semiconductors also have an effect on sound quality, but in a passive way. By that I mean that the substitution of different types of semiconductor one for another without making any significant change to the circuit can alter the sound quality. The most obvious is the substitution of one transistor for another with lower thermal resistance. This will lower the Temperature Generated Distortion and give a cleaner, clearer sound, noticeable in particular at frequency extremes.

Other changes can improve sound quality without changing the circuit, for example replacing ordinary zener diodes with higher power zeners and using voltage regulators with power dissipation abilities well in excess of that apparently needed.

A good example of semiconductor substitution is to replace a T092 transistor with a T0220 power transistor in the circuit of a real amplifier, preferably in the driver transistors of a high power amplifier. Even changing a power transistor insulating pad with one of lower thermal resistance on only one transistor can be heard by careful listening.

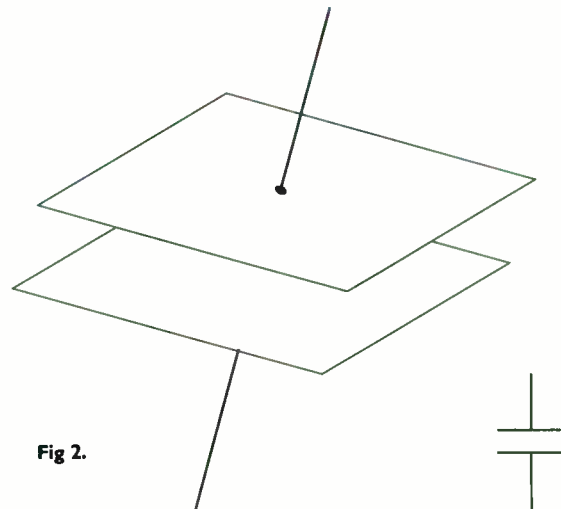

Fig 2.

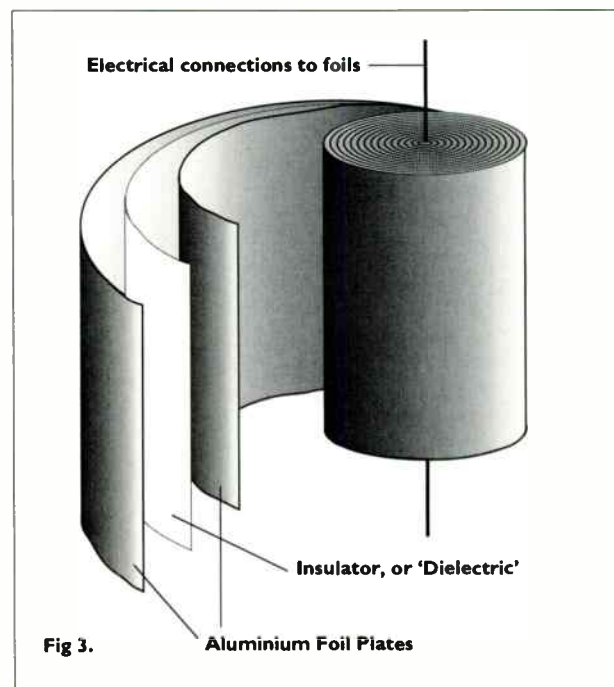

Fig 3.

CONCLUSION

Most audio products rely on actual circuit arrangement to account for sound quality. There is much talk, for example, about amplifier output stage configurations. Yet very little is said about component quality. A few manufacturers are beginning to experiment in a limited and somewhat timid manner, but the remainder are quite happy to use, without question, components that cost just pennies.

There is great potential for improvement within most audio products. This is best implemented in the original design and at the factory assembly stage. However, 'after-market' conversions are now beginning to appear where amplifiers are fitted with better components on a simple one-to-one substitution basis, preferably when any guarantees have run out. It is possible, with care and judicial selection of critical components, to virtually transform performance by this technique ●

Graham Nalty, Audiokits Precision Components, 6 Mill Close, Borrowwash, Derby DE7 3GU

Fig 2. A capacitor comprises two metal plates spaced apart, either by air or a solid dielectric. The symbol at the right is used to represent a capacitor in circuit diagrams.

Fig 3. Capacitors are commonly made by winding two strips of foil with a thin insulating dielectric between them.

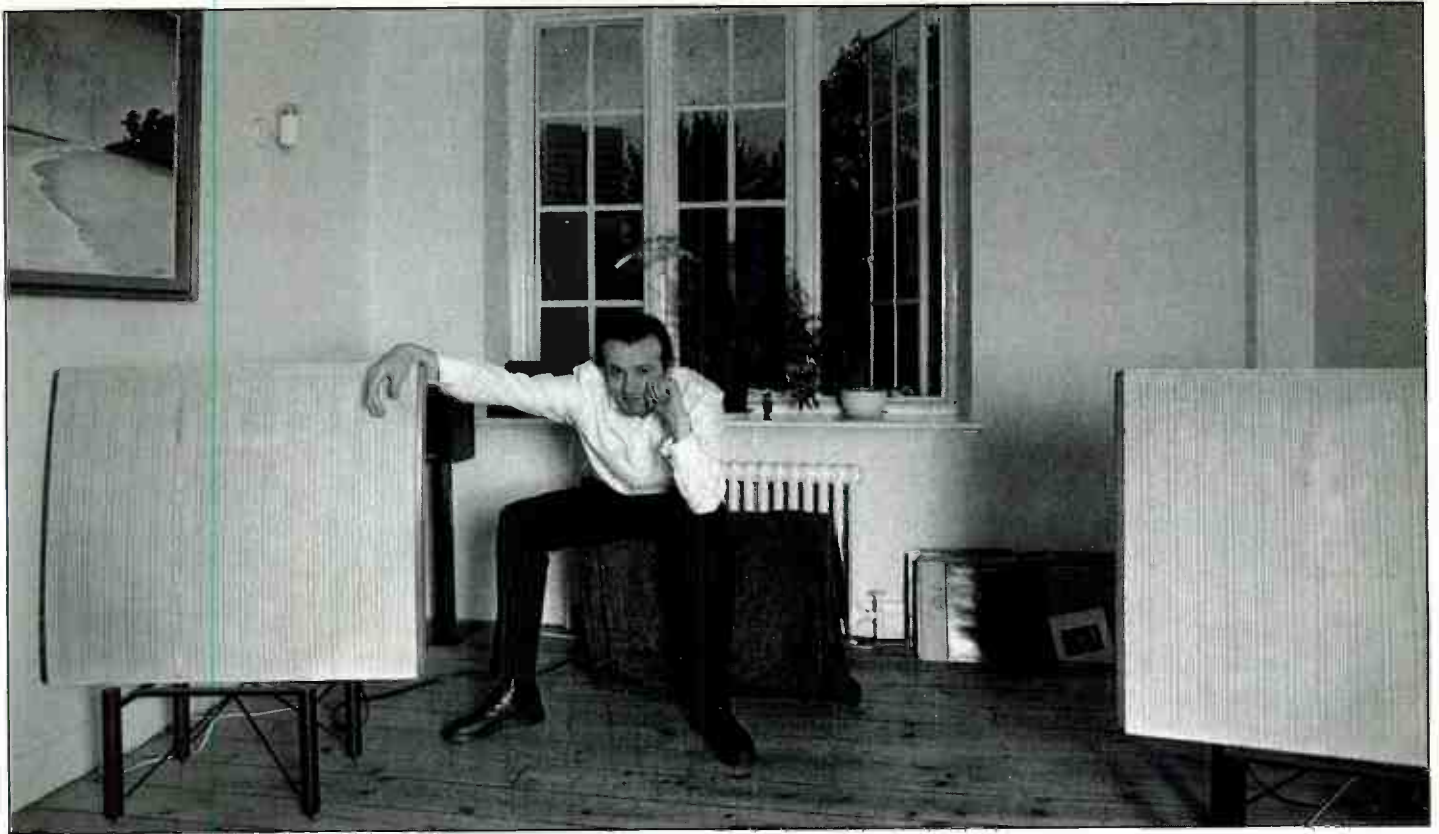

This month I underwent a conversion. I was passing by my local used furniture shop, when I spied a pair of original Quad Electrostatic Loudspeakers. They looked OK, although their feet were missing and they were painted a funny shade of white I'd never seen before. I casually asked the owner how much he wanted for the "funny looking speakers". "Cor, you're the first person whose known what they are, guv. £50 and they're yours."

I wonder what he thought of me as I went sort of wobbly. It was so bad I couldn't even get the coordination together to count out five ten pound notes without dropping them over the floor, together with my shopping.

I had just broken my first rule of buying secondhand - I hadn't checked that the goods were working. I reckoned, however, that even with shot treble panels and dicky rectifier blocks they would still prove financially sensible for anything less than £250. As it happens, the gods were definitely smiling on me.

When I got home, I immediately plugged the Quads into the mains to give them life. It was here that I found the only fault with my new toys: the little neon light that tells you that they are being energised had expired on both of them. This is of no consequence and can be rectified with little effort and cost.

As they were legless, I sobered them up on spiked stands that lifted them eleven inches off the floor. At first, I placed them two feet away

they don't make 'em like they used to...

This month Richard Kelly chances upon some 'funny-looking speakers' in his local junk shop, and gets the bargain of the decade.

from the back wall and 18 inches away from the side walls. They sounded wonderfully smooth, detailed and they also imaged well. In short, they displayed all their traditional strengths. Unfortunately, they also displayed their much talked about weakness. Put simply, they are a bit lacking in bass output and have no real slam.

I was contemplating whether or not to sell them and get something with a bit more balls, when I was overcome by the desire to play. Buried deep in my brain was the notion that Quad recommend pulling the speakers as far up the room as you can and away from the back wall. Ideally they should be placed about a quarter to a third of the way along the full length of the room, with no space between the panel and the side wall. In my room, just touching the side walls and slightly toed in seems about right. Boy, oh boy, was I glad that I'd remembered this! I can only describe the transformation as a revelation.



Richard Kelly's monthly look at budget hi-fi - old, new, borrowed or blue.

SONIC LINK

6 Mill Close, Borrowash, Derby DE7 3GU



SONIC LINK DM20 AMPLIFIER - £299

Better sound quality than any other amplifier under £300.

Visit our dealers (listed below) for a demonstration.

NEW SONIC LINK DM20 MASTERPIECE GOLD £598 NEW

A high quality version of the DM20, incorporating some 50 changes of internal components each to a more expensive high grade part selected after careful listening to offer audible improvement. The sum total of all these changes is a big, big increase in clarity, detail, ambience and musical accuracy to a level never before achieved at the price. Price includes interchangeable MC and MM input boards.

SONIC LINK AMPLIFIER STOCKISTS

| | | | |
|--|--------------|--|--------------|
| ACTON GATE AUDIO, Wrexham | 0978-364500 | LISTEN HEAR, Ilkeston, Derbyshire | 0602-304602 |
| ACOUSTIC ARTS, Watford | 0923-245250 | MJS HI-FI, Barwell, Leicestershire | 0455-846977 |
| ALBION AUDIO, Sunderland | 091-510-9969 | OMNI AUDIO, Leeds | 0532-758326 |
| AUDIOCRAFT, Uxbridge | 0895-53340 | PORTSMOUTH HI-FI, Portsmouth | 0705-664411 |
| AUDIO INC. East Molesey, Surrey | 081-941 4234 | RADLETT AUDIO, Radlett, Hertfordshire* | 0923-856497 |
| AUDIO SUITE, Aberdeen | 0224 625635 | SOUNDS EXCLUSIVE, Cranleigh, Surrey | 0483-268185 |
| AUTHENTIC AUDIO, Stratford upon Avon | 0789-414533 | SOUNDS GOOD, Ealing | 081-579 3963 |
| AVONDALE AUDIO, Chesterfield | 0246-200096 | SPEAKERS CORNER, Norwich | 0603 743457 |
| AYLESBURY HI-FIDELITY, Aylesbury | 0296 28790 | STANDENS HI-FI, Tonbridge | 0732-353540 |
| DOUG BRADY, Covent Garden, London * | 071-379 4010 | STEREO SHOP, Ipswich | 0473-233832 |
| DOUG BRADY, Warrington* | 0925 828009 | STEVE BOXSHALL AUDIO, Cambridge* | 0223-68305 |
| FRANK HARVEY, Coventry | 0203 525200 | WARSTONES HI-FI, Wolverhampton | 0902 345114 |
| IN CONCERT HI-FI, Wallasey | 051-630-5055 | ZEUS AUDIO, Belfast | 0232 332522 |

* DM20 Masterpiece Gold on demonstration at these dealers

SONIC LINK INTERCONNECTS

Extensive research over several years into conductors and insulating materials have enabled SONIC LINK to offer cables of superior sound quality at extremely competitive prices.

In many systems, SONIC LINK Interconnects will sound better than highly rated 'audiophile' cables costing much more.

The only way to find out is to try them out yourself!

Interconnect Cables fitted with

Gold plated phono plugs - 1m pairs.

SONIC LINK PINK £25.00

SONIC LINK RED £35.00

SONIC LINK WHITE £55.00

SONIC LINK VIOLET HPMC £80.00

CARE MUSIC Interconnect £100.00

CARE MUSIC Mk 2 HPMC £150.00

CARE MUSIC SOLID SILVER £300.00

Screened Interconnect Cable Off The Reel

SONIC LINK PIN £5.00/m

SONIC LINK RED £7.50/m

SONIC LINK WHITE £15.00/m

SONIC LINK VIOLET HPMC £20.00/m

SONIC LINK MAINS CABLES

Use SONIC LINK Mains cable and you will see just how much ordinary mains cables can degrade your sound quality.

SONIC LINK Mains Cable and SONIC LINK Supermains can recover the lost sonic information that other upgrading cannot retrieve.

Off The Reel

SONIC LINK MAINS 3 core ... 19x0.25mm £12/m

SONIC LINK SUPERMAINS 3 core ... 19x0.45mm £30/m

Terminated Cable sets

Gold plug - IEC Mains Cable ... 1.25m - £39.95 2.5m - £55

Supermains Cable 1.25m - £65.00 2.5m - £105

Gold plated 13A plug - 4 gold plated 13A sockets

Mains Cable 1.00m - £105 4m - £140

Supermains Cable 1.00m - £125 4m - £215

HFW 7191

ORDER FORM

TO: AUDIOKITS PRECISION COMPONENTS, 6 Mill Close, Borrowash, Derby DE7 3GU.

Please send me the following cables:

| Description | Quantity | Price | Name |
|-----------------------|----------|-------|----------------|
| _____ | _____ | _____ | Address _____ |
| _____ | _____ | _____ | _____ |
| _____ | _____ | _____ | _____ |
| _____ | _____ | _____ | _____ |
| I enclose cheque/P.O. | TOTAL | _____ | Postcode _____ |

FREE 7 DAY TRIAL, FULL REFUND IF NOT SATISFIED

Please debit credit card no.

Exp



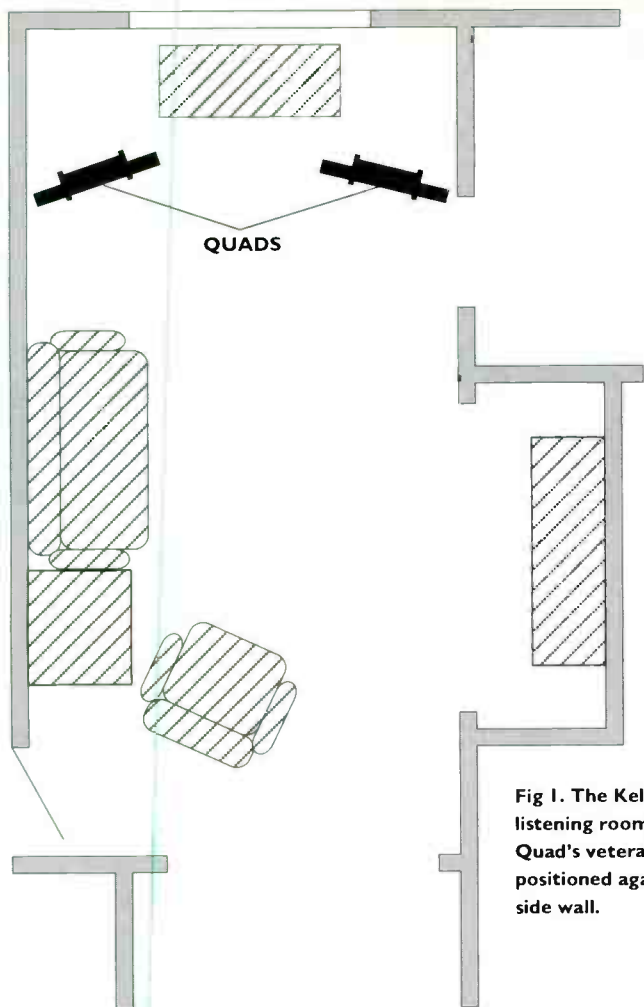

Fig 1. The Kelly listening room, with Quad's veterans positioned against the side wall.

Where was all the bass coming from? I was staggered to hear a clear definition twixt drummer and bass player, with no merging of notes. Both players were standing clearly apart yet totally unified in tying the music together. I started to worry, because I really wanted to believe what I was hearing. However, I thought I was losing my marbles, as the only way to get bass out of a Quad is to splice in a sub-woofer or two.

I quickly phoned the editor and deputy editor to come round with a strait-jacket. Fortunately, I was not imagining things. The looks of total disbelief and bewilderment on their faces were most reassuring. I quickly started spinning heavy dub reggae tracks and this reduced the deputy ed. to just grinning stupidly and muttering "they're not supposed to do that, you know, they're not supposed to do that." This is Sir-comspeak for "they're really rather good old chap."

I have listened to the Quads in various places and systems. They have always had the potential to be excellent, but really did need the sub-woofer treatment that sometimes befalls them. I have changed my mind on this matter and now consider the only way you can improve the Quad is to get more volume out of it. The most sensible and obvious way of doing this is to get two or even three

pairs and stack them.

With this arrangement, I'm led to believe that even a demented headbanger like myself should find them more than ample. I intend to implement this course of action and shall let you know how it gels together. So if any of you out there have the odd Quad or two knocking around, let me know. Even knackered items will be considered, but remember, I'm still impecunious and a tad mean!

I have shown how the speakers are orientated in my room (see Fig. 1). As you will see, the right hand channel is firing from the end of a wall with a 30" doorway immediately off to the right. I'm not totally sure of this and I suspect it might reduce an acoustician to fits of laughter. If this door was not there, I could pull the Quads even further up the room to possibly gain further improvements in the bass. But with the speaker firing directly back towards the door, I would lose all the bass reinforcement that I have at present.

If you have a pair of old Quad Electrostatics, I would advise you to try removing the original feet and sort out some form of spiked stand, using speed frame or angle iron. After this, start moving all the furniture around, having arranged for the lady of the house to be elsewhere for the day. If she goes ape when she gets home, blame Kelly! ●

Quad Facts

This ingenious, innovative speaker first went on general sale in 1957 and was in production right up until 1985 with final serial numbers around the 54,000 mark. Quite a few of the early models were sold as single units, because mono was still in general usage then. So there are probably about 27,000 pairs in existence in various states, ranging from early, untouched models to those upgraded to include the latest protection circuits, that evolved approximately 2 years ago! I suggest that if you are offered a pair and there is not sufficient documentation to verify exactly what state they are in, seek out the help of your local Quad dealer. I'm sure he could look at them for you, although possibly at a nominal charge.

Onto the spares situation and upgrading costs. At this point, I would like to recommend that unless you are absolutely confident of your audio and electronic engineering skills, do not attempt to replace anything that isn't made of wood. There are fatally high voltages floating about inside this speaker. Repairs undertaken by Quad themselves only cost about 10% more (including carriage) than buying the parts retail and doing it yourself. I hope you have the packing, otherwise a pair of cartons will set you back £60.

It is the treble panel that is most often damaged and repair by Quad costs £60. The bass panel, fortunately, is quite robust and rarely perishes. However, should it need replacing, farewell £85; what's more there are two to each speaker! Rectifier blocks cost £26, while the EHT transformer is £20 and the Audio Transformer is £75. The woodwork is still available, although at £80 for a complete set of legs I would suggest trying a set of home-made spiked stands, for reasons of economy, let alone sound quality. The side strips are available in beech or black and are £27 and £30 respectively. Should you need further information, contact Quad directly. Their service is legendary and is an ideal that others would do well to follow.

Quad Electroacoustics Ltd.,
Huntingdon, Cambs. PE18 7DB.
Tel: 0480 52561.

The Chesterfield Design Show April '91

A hot, sunny Sunday in a hotel in Derbyshire, The Chesterfield Design Show proved yet again that it has a unique character and charm all its own. Alan Sircom sweated it out.

Top: Avondale Audio - showing their new Genesis turntable, loudspeakers and modified amplifiers, all on Mana tables.

Below: Doug Dunlop, of Concordant explaining the virtues of his valve equipment to an enraptured public. Note the dancing mechanical cat below the record deck.

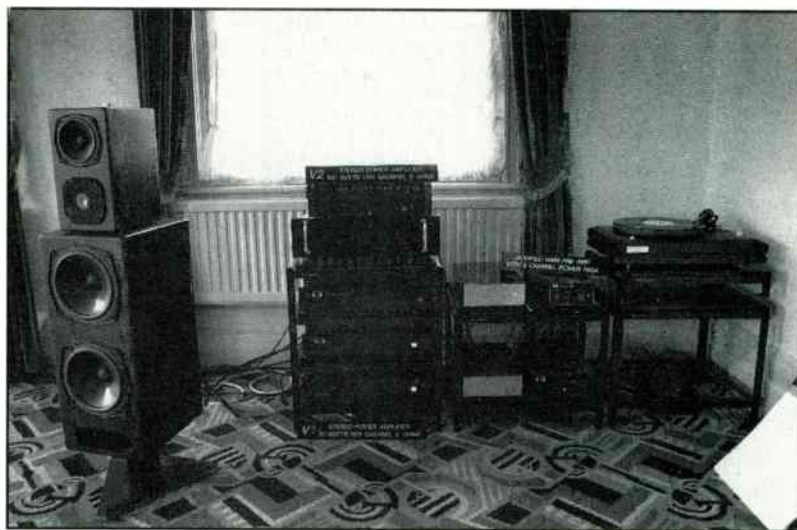

The Design Show itself was a smaller, but friendlier, affair than the likes of the Penta and Bristol shows. Bigger names stayed away, leaving the show to be dominated by the small enthusiast-led manufacturers. It came as a welcome relief from the world of big business and volume sales, to come to an event populated by people there primarily out of enthusiasm and love of music, hi-fi and tweaking.

On the subject of tweaking, Graham Nalty, contributor to this month's Tweaky Corner had the stall next to us in the hotel's main ballroom. Displaying his range of cables, amplifiers and electronic bits, he seemed to be having a great time. Many of the public visiting this show were staunch tweekers and found his ideas informative and useful. We had visions of soldering irons being switched on all over the North that Sunday night.

The most enjoyable part of the Chesterfield show was the people. While the show was not packed out, there was a steady stream of people throughout the day. Most of these

were well informed, quite often putting the average reviewer to shame. Roy Gregory, one of Hi-Fi World's reviewers, was put to shame when, while trying to look cool, he walked into a pillar. Twice.

On the same floor as Graham and ourselves, was one of Wilmslow Audio's two stands. This was the one without music. Their music demo room was doing a fine job, presenting a pair of mini-monitors to the public. Interest in these BBC-type monitors ensured that their music free counter was also kept busy.

Interesting Products

The ballroom had some interesting products, many of which I would have liked to have seen in action. On Audio Conversions stand, for example, there was information on a modular amplifier, that uses plug-in cards in a similar manner to a computer. Doreen Jordan was showing some of her new Bandoor drive units, as installed in the new Pentacolumn loudspeaker, described later. As she spent a fair amount of time nursing a drive unit in her hand, she is obviously very proud of it.

New to the hi-fi industry was Ian Hartnall, of Action Hardware Ltd. His company produces a range of gold plated connectors that look impressive and are very competitively priced. He admitted that the packaging was designed more for the trade than for retail. I'm convinced that we shall be hearing more from Action Hardware in the future.

Finally on this floor we had John Petrie-Baker, who was displaying a range of classic second-hand equipment, including two well cared for Leak Stereo 20 power amplifiers. Surprisingly enough, no-one expressed any interest in these amplifiers, considered by many to be one of the finest amplifiers made in Britain at that time. Considering that these were priced at £120 each, I think many missed a bargain. Most of the bargain hunters descended upon John's supply of Decca cartridges,

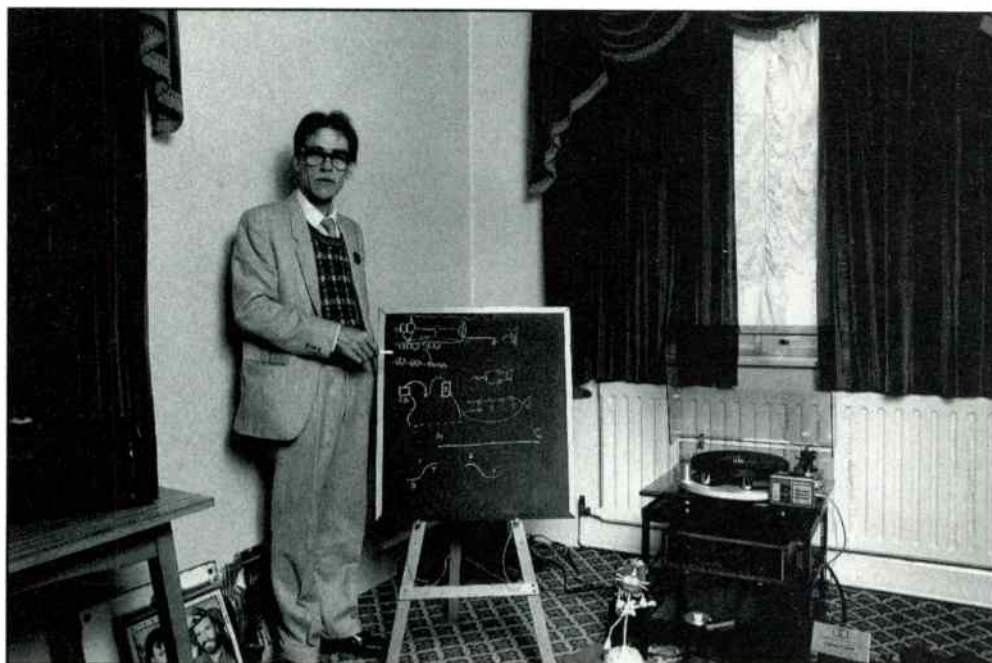

while I quickly noticed an interesting Fidelity Research FR-1 box. This proved to be empty, drawing quips about its transparent sound.

Close enough to the swimming pool for jealous looks, Lynwood and Origin Live had a room displaying many items, including Lynwood's mains conditioners, while just around the corner, Reference Music Systems, Avondale Audio's manufacturing arm, were displaying their flagship loudspeakers, with other products in their range, described later. These sounded very interesting, if a little quiet at the time. John Watson, of Mana Acoustics suggested that he should take the controls of the amplifier for the last hour, to show the people "what these speakers are made of." Whether he was allowed to be DJ or not remains to be seen, but I decided to make my excuses and leave. I was a bit too sensitive to withstand high sound pressure levels that day. John's excellent Mana tables featured strongly at the show; both the turntable tables and his newer range of equipment supports were on display.

Stay Cool

One problem at the show was trying to stay cool. Swimming pool aside, the combination of a hot sunny afternoon and a very high proportion of valves cooking away in most rooms meant that it got a little warm by the end of the day. Everybody displayed a cool head, however, including the hotel staff who took it all in their stride.

Valves were everywhere. Aside from the valve amplifier manufacturers' displays, several rooms were using valve amplification by such luminaries as Croft and Art Audio. One such room was Nottingham Analogue, who were displaying their Space Deck and Mentor Reference turntables, together with huge full-range horns. The Reference deck proved to be of interest to many people. Fitted with their Omega Point unipivot arm and a Decca cartridge, this vast white turntable was said to have a platter weighing 2cwt, according to its designer Tom Fletcher.

Opposite from Nottingham's room, Doug Dunlop of Concordant was giving lectures on his ideas in amplifier design. In these lectures, he was aided by a blackboard, a Tandy personal cassette and a dancing mechanical cat. His outlook, especially the idea of 'electric petrol' and serenading people by singing 'What's New, Pussycat?', is certainly unconventional, but nonetheless interesting.

Along from here, Oliver Brooke of Pentachord tentatively unveiled his latest loudspeaker. Still unpriced, the Pentacolumn is a 1.08m high floor-standing model, using two 50mm and



Nottingham Analogue's 2 cwt Mentor Reference turntable and full range horns.

two newly designed 100mm Bandor units. They appear to share many of the characteristics of the smaller Pentachords, only taking the concept a stage further for larger rooms. He also had the existing model, with subwoofer on display. Both loudspeakers were sounding on song, due in part to the Art Audio amplifiers used to drive them.

Stephen Harper, of Vinyl Tube Audio could be seen wandering around these rooms, rubbing his hands in glee. Many products that impressed him are already on sale at his London shop. I can see a few more appearing soon.

REL Acoustics were displaying a new subwoofer system. Its paint was still wet in places, as it had just been finished the night before. Interest was expressed in a magazine review, so maybe we will get our hands on a dry model later.

Mortgage Facilities

The largest variety of goods came from Moorgate Acoustics. Along with Croft, they were displaying products from Audio Research, SD Acoustics, Voyd, Magneplanar and the Michaelson Chronos amplifiers. This room was packed with people saying things like "I'd need a second mortgage for that." Moorgate missed a trick by not having mortgage facilities on hand.

As it was his show, Les Wolstenholme had more rooms than anyone else. His Reference Music Systems' equipment proved to be of interest to many people, certainly to those with ageing Naim amplifiers. The RMS modifications to elderly amplifiers, while a little controversial, are becoming increasingly popular. In addition, Avondale/Reference Music Systems are now modifying the humble Rega RB250 tonearm, strengthening it with a bolt running down the centre of the arm. This is said to push the quality of this arm far beyond its original specification.

Les has been keeping himself very busy recently. Besides producing amplifier and tonearm modifications,

Reference Music Systems have been developing their range of loudspeakers, power amplifiers and even a turntable. This last item, known as the Genesis, costs about £1200 complete with a modified arm. The waiting list is running into months, so it does seem to have a solid following.

There was also a room that was displaying small transmission line loudspeakers. Unfortunately, the layout of the show meant that few people, myself included, found this mysterious room, manned by David and Simon Briggs.

This aside, The Design Show proved to be an enjoyable way to spend a Sunday. The people on both sides of the stalls were friendly, relaxed and enthusiastic about their music. While it was a bit warm, no-one complained too heavily. Southerners who made the trip to Chesterfield were not disappointed ●

Pentachord's latest loudspeaker, the floorstanding Pentacolumn.





NOTTINGHAM ANALOGUE STUDIO

If, like us, you believe in the superiority of Analogue reproduction and, in particular, the ability of vinyl to convey the maximum in listening pleasure – you need to visit our studio.

Here we can offer you what we consider the ultimate in domestic musical reproduction. No shelves of flashy boxes or flavours-of-the-month, just a wealth of the finest hi-fi we can find.

Croft ★ Albany ★ EAR ★ Sound Design ★ Tube Technology ★ Space Deck ★ Space Arm Mentor ★ Mentor Reference ★ Klipsch Horn ★ British Horns ★ London Supergold ★ Decca fitted with extended contact area stylus ★ Analogue Tracer

For a musical experience you will remember, please contact us on —
0773 762947.

THE PENTACHORD LOUDSPEAKER SYSTEM

◆ ◆ ◆
UNRIVALLED IMAGING



Pentachord miniature speakers
plus matching low bass unit and active crossover:
an English handmade product of the highest quality.

Pentachord Loudspeakers, 49 Rusholme Road,
Putney London SW15 3LF
Telephone 081 788 2228

Concordant Premier Tube

(0455) 843752

**EXULTANT EXEMPLAR EXCELSIOR EXHILARANT
EXQUISITE**

DEVON
(0626) 64060

SCOTLAND
(0475) 31066

SCOTLAND
(0506) 884045

LEEDS
(0532) 528850

MILTON KEYNES
(0908) 562377

SUFFOLK
(0502) 731002

NORFOLK
(0379) 740227

NORTHANTS
(0933) 460745

BATH
(0225) 424334

NUNEATON
(0203) 373309

LANCS
(0457) 835802

CHESTERFIELD
(0246) 200096

MANCHESTER
(061) 835 1366

RUGBY
(0788) 572983

BANBURY
(0295) 267383

LEICESTER
(0455) 846977

LONDON
(081) 997 6189

LONDON
(071) 485 4854

LONDON
(0883) 730210



What's new Pussy Cat?

CONCORDANT MUSIC CLUB

HIGH PERFORMANCE LOUSPEAKERS £28.50
Fourth Edition
Martin Colloms
 PENTECH PRESS LTD. ISBN 0-7273-0807-6

Tracts on loudspeakers can take many forms, from the light-hearted and amusing insights offered by Gilbert Briggs (*Loudspeakers*) to the heavyweight, maths loaded research papers published in virtually every edition of the *AES Journal*. Martin Colloms book comes about two thirds of the way up a notional scale that joins them. It is adequately technical for serious designers, containing a wealth of fundamental design equations, but it also explains a very wide variety of loudspeaker phenomena in understandable terms.

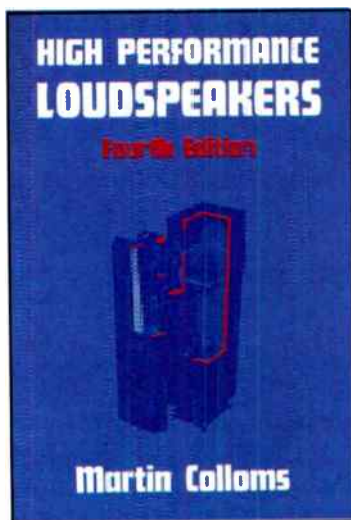

I would rate High Performance Loudspeakers a must for those who want to reach a sound basic understanding of how loudspeakers work and what their problems are. It is based on practical working experience and benefits from the widest possible range of research input any author is likely to enjoy. Martin has been diligent and thorough in his own information gathering - and it shows. For those wanting to know even more, all necessary references are provided.

I would say straight away that the book is not really aimed at hobbyist DIY'ers. If you walk around muttering about Thiele/Small parameters, however, like someone I met at the Chesterfield hi-fi show (full of nutters!), then look no further. In other words, if you have a serious interest in loudspeakers - in designing them or knowing about them, then I would suggest this book is the place to start.

The reasons for saying this are actually multiple. Unlike most authors, Martin makes his sources known in copious References and Bibliographies at the end of each chapter. He quotes and discusses the works of researchers and research from loudspeaker companies within the texts, too. And this, I suspect, is where his background as a reviewer starts to show and becomes a benefit. Reviewers are fairly buffeted by outside views; it's not a cloistered profession. Martin has drawn from his wide contacts in the UK loudspeaker industry, plus AES Research material and historical papers of significance, to give a very wide overview. High Performance Loudspeakers is very strong in this respect and valuable as a reference because of it.

The content of the book is very wide ranging, but the accent is on current popular practice. There is little on horns, mouth size and such like, for example. The book starts with general theory and moves on to moving coil transducers. Many will be interested in Chapter 4, which covers box design (IB and reflex) in detail, using the theories of Thiele and Small. A difference between this coverage and simpler treatments is that the latter are often inaccurate. The design theory discussed in this book is current, representing the best we know, derived from recent research. Unusual principles, such as those used by Naim and Linn are discussed, something no other book will contain. Martin even provides an alternative explanation to Linn's of the Isobarik principle and credits its invention to a Frenchman, in the early 1960's. Harry Olson discussed this principle in *Elements of Acoustics*, published way back in 1937 or thereabouts.

Finally, High Performance Loudspeakers covers loudspeaker measurements in a most comprehensive fashion, as you might expect from a reviewer who both measures and designs loudspeakers.

THE SETMAKERS. £14.95
A HISTORY OF THE RADIO AND TELEVISION INDUSTRY
First Edition
Keith Geddes and Gordon Bussey
 PUBLISHED BY BREMA. ISBN 0 9517042 0 6

The *Setmakers* is, in its own words, a history of the Radio and Television Industry. And an impressively comprehensive one I found it too. From the dry but precise style of its prose, to the detailed nature of its coverage, I sensed this was the work of an academic mind. In truth, it is the work of two experienced researchers, Keith Geddes and Gordon Bussey, working on behalf of the British Radio Equipment Manufacturers Association (BREMA). They have put together what virtually amounts to a reference book, which is required reading for anyone in the industry. However, style and content stop short of being indigestible, making *The Setmakers* an easy and entertaining read for anyone.

The story starts at the turn of the century with the invention of the valve. Even at this early time, *The Setmakers* is well illustrated with pictures, such as the machine shop of the Marconi Wireless Telegraph Company in 1905. Almost every page carries a picture or illustration of factories, posters, products and people. The coverage is very comprehensive and includes candid outlines of company founders, who often seem tough but colourful characters.

The book is full of fascinating historical facts. I was surprised, for instance, to learn that Mullard were taken over by Philips in January 1925, their shareholding costing

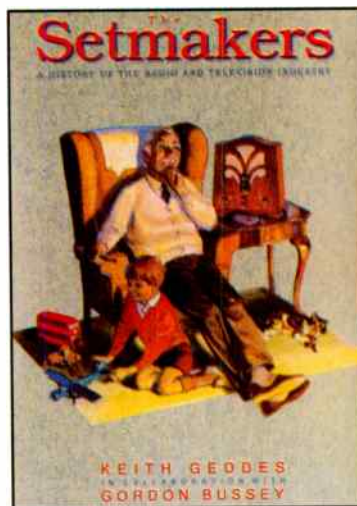

£65,000. This was Philips' entry into Britain and, at the time, access for them to the British Empire. Even though Philips seem a very distant and typically Dutch company, this book makes it clear that they have had numerous factories and operations in Britain from that time.

The story moves on through radio to cover television as well. The role of John Logie Baird is an interesting one. He seemed to be a maverick, but at the same time he was single handedly promoting the idea of television to the public through demonstrations and press stories in the late 1920's - well before broadcasting began anywhere in the world. High definition television then takes over, with EMI major players in its development.

The role of the industry during the Second World War is covered briefly. No details on the development of radar are given, for example. I suspect the authors decided to restrict coverage to civilian products, which limits scope a little. The early radar experiments, described beautifully in *Wireless World* I seem to remember, were fascinating but are omitted here.

The story behind the introduction of the early transistor radios and some superb sixties posters were loved by all of us on the magazine. The best picture is of a mink covered Roberts Radio, circa 1959. We are told it was available in pony skin, too!

Sadly, the tone changes as the late 1960's are reached. Increasing competition, especially from Japan, starts to eat away at

sales. British factories are shown to be inefficient and incapable of improving themselves. "An industry under invasion" is how the situation in 1973 is described. Yet by 1974, Sony had decided to open a plant in Bridgend, Wales and from that moment the Japanese slowly take over. Both working practices and efficiency change rapidly and for the better, with detailed explanations of the problems the Japanese faced and how they solved them. The

detailed and forthright analyses, free from prejudice, are a tribute to the authors. I found the latter part of the book, covering the seventies, both sobering and enlightening.

New products of the eighties and especially the stories behind commercial disasters like Video 2000, Elcassette, Betamax and such like, are not covered comprehensively. However, by this time, the UK had become a passive market. This is a pity, because through no fault of the authors, the story rather tails away.

I was left intrigued by Frank Chapple's closing comments in his Foreword: "I do hope that this book, *The Setmakers*, will inspire a sequel for the British Hi-Fi makers".

Both these books are obtainable from: *The Modern Book Co., 19-21 Praed Street, London W2 1NP. Please add £2 post and packaging per book. Tel: 071-402 9176.*

CD players and discs demand regular maintenance for crystal clear sound. Run your system through A-T's service bay soon and hear the difference!

 **CD**
TUNE-UP
CENTRE



AT 6078
CD LENS CLEANER

Unique 8 brush action removes dust/smoke contamination from internal CD lens for reduced tracking error and greater fidelity. Disc contains digital control codes for fully automatic cleaning - in 10 seconds flat. Solve this industry acknowledged problem today!

AT 6079
DAMPING RINGS
(Five Pack)

Green damping rings fit CD's outer edge to absorb stray laser light and increase moment of inertia for smoother sound. Protects face and edge from handling and surface scratching.



AT 6059
BATTERY CD
CLEANER

Automatic disc cleaning in 40 seconds! Spray on special fluid and 'spin' the dirt away to leave your collection sparkling. Includes fluid and additional micro-porous cleaning pad.



AT 674
CD STABILISER

Carbon fibre disc to place on CD and stabilise it during play. Especially effective in 'economy' players, it helps reduce servo movement and error correction in all transports.



AT 6030
MANUAL CD
CLEANER

Simple yet effective radial cleaning for optimum disc performance. Each lever slide cleans and advances platter 30° for quick and safe operation. Special cleaner fluid included.



CD ACCESSORY PRODUCTS
AVAILABLE FROM £ 5.95



audio-technica®

□ INNOVATION □ PRECISION □ INTEGRITY

Technica House, Lockwood Close, Leeds LS11 5JU. SALES: 0532 771441. FAX: 0532 704836

SEE THEM AT GOOD HI-FI STORES

Unrepeatable Offer

TANNOY
DC3000

at **£570** (INC. CARR.)

(WHILE STOCKS LAST)

Highly acclaimed loudspeaker
High efficiency also makes it very
suitable for low power amps (eg. valves)

Telephone immediately to secure
at this bargain price

Tel: 0462 452248

Hypertec

6-8 Bancroft, Hitchin,
Herts. SG5 1JQ



Retailers of Fine

Audio Equipment

Congleton



- Arcam ⇨ Audio Innovations ⇨
- Audiotech ⇨ Audio Technica ⇨
- Dual ⇨ Epos ⇨ Linn ⇨
- Marantz ⇨ Micromega ⇨ Naim
- Audio ⇨ Proton ⇨ Rational
- Audio ⇨ Revolver ⇨ Royd ⇨
- Sennheiser ⇨ Sound
- Organisation ⇨ Voyd ⇨

1/1a DUKE STREET CONGLETON
CHESHIRE CW12 1AP

- ⇨ **Superbly appointed**
single speaker demonstration
facilities
- ⇨ **Home demonstrations**
- ⇨ **Full installation service**
- ⇨ **Two year guarantee on all**
equipment

Open 9.30 - 5.30 Monday to Saturday
and at any other time by appointment

0260 297544

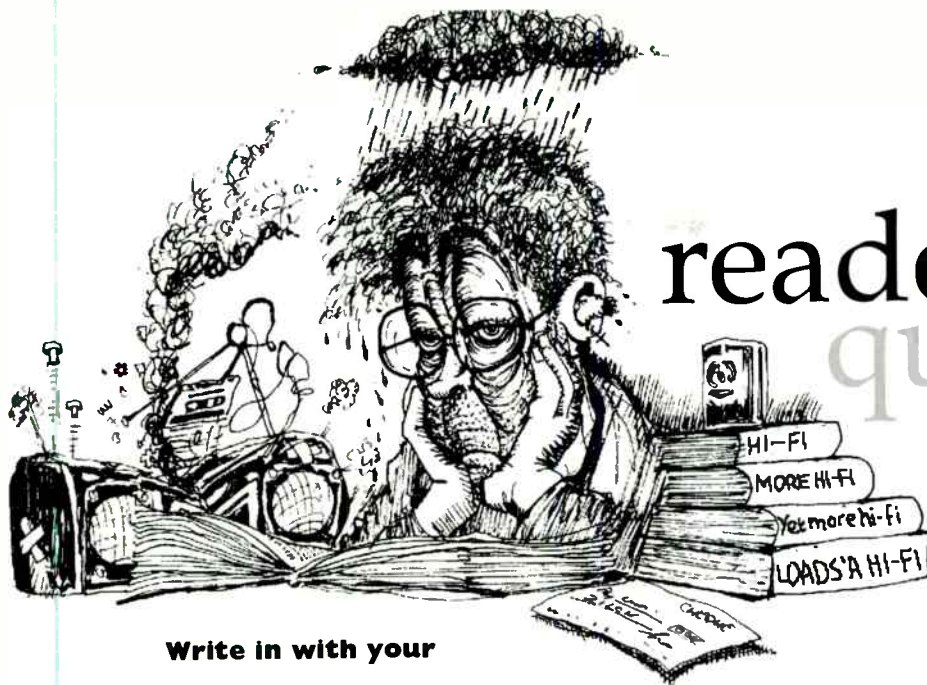

readers' queries

**Write in with your
problems to Hi-Fi**

**World, 64 Castellain
Road, Maida Vale,
London W9 1EX.**

**Our panel of experts
will endeavour to
solve them or at
least offer some
practical advice.**

● Having decided to upgrade my Musical Fidelity B1 amplifier, I auditioned the new series Audiolab 8000A and MF's own B200 with my own Rogers LS4a loudspeakers.

Although I found the 8000A very good, I personally preferred the B200 with the LS4as. It provided a better 'overall' sound although not as detailed as the 8000A. The dealer seemed to agree.

For the audition, a Linn LP12 and a Marantz CD were used.

I have not seen any reviews on the B200, despite having seen very good reviews of the A1, A100 and B1.

Is the B200 a good choice or should I try something else? The rest of my system consists of the Pioneer CT656 deck, 656 tuner and a Linn Axis.

P.S. I am thinking of adding the Arcam Alpha CD later.

**K. T. Kumar
New Malden, Surrey**

The Musical Fidelity B200 is indeed a good amplifier, very much in the valve-like MF vein. If you found you enjoyed its warm sound over the more analytical Audiolab's, then I would suggest that there is little that would better the B200, within the price range.

At the price, amplifiers like Onix's OA21, Ion's Obelisk 3, and the Naim's

NAIT 2 all offer valid alternatives. Another suggestion, albeit a more expensive one, is the little Kelvin Labs Class A Integrated. The amplifier is a little under-powered, in comparison to amplifiers like the Audiolab, but has a sweet, open sound that you may find enjoyable. **AS**

● At the moment I do a 'guest worker' job here in England. When I came over about two months ago it was not possible to bring my hi-fi equipment over from the continent. So I have been looking for a small system just for my time here.

Fortunately, I've found an old tube set consisting of a pair of Quad II mono power amps, the stereo 22 preamp and the matching FM tuner at a junk dealer, who is holding

them for me. Visually, they look OK, but I wonder if Quad still provide replacement parts for this equipment, being more than 30 years old.

How can I check that there is no irreparable internal damage before I buy? Do you think it's worth reactivating this old legendary equipment and can its sound compete with a modern integrated amp? I was just about to purchase a Rotel RA820 BX3 or a Cyrus amplifier with a pair of Celestion 3 or 5 loudspeakers (or Mordaunt Short MS3.10s) to use with a portable CD player and cassette deck during the time here. Do you think it would be reasonable to use the Quad combination for this purpose instead of an integrated amp?

**Fred Schnetz
Sunderland District
General Hospital**

The Quad 22/II pre and power combination is one of the all-time classics of hi-fi. Long standing and successful, Quad's valve duo survived until the early Seventies, only to be replaced by transistorised models such as the 33/303. Its sound is light, sweet and open, but a little lacking in guts, when compared to more modern amplification. This can mean that some loudspeakers will prove to be too inefficient

to be driven well by the Quads. If you do decide to take the old equipment, try to audition the loudspeakers before buying. JPW, Tannoy and Goodmans all make inexpensive loudspeakers that are also efficient, so it may be worth seeking these companies out.

With regard to the equipment's serviceability, Quad's repair department has a reputation virtually second to none. They will overhaul, maintain, service and repair Quad equipment, regardless of age. Whether the equipment works immediately, however, is a different matter. If you have a copy of last month's issue, Mike Solomons described a procedure for reviving old equipment, which involves waking the equipment slowly and methodically. This, combined with a fair amount of caution and commonsense, is the best way to approach older equipment. **AS**

● My system comprises the following: Linn Sondek LP12, Linn Basik Plus tonearm with a Roksan Corus Blue cartridge. This goes through an Exposure combination, VII and VIII to Linn Index II loudspeakers on Linn's own Q-stone stands. Also, I have an Aiwa ADF-800 cassette deck and a rather tired looking Technics PJ-280 CD player.



The SAM 40 combinat **by ION SYSTEMS**

Other ION SYSTEMS products:

- OBELISK Integrated Amplifiers
- NEXUS Separate Pre/Power Amplifiers
- FM Stereo Tuners
- ACTIVE/PASSIVE Loudspeaker Systems

ION SYSTEMS Ltd., 42 Mochdre Industrial Estate, Newtown, Powys SY16 4LE. Tel: 0686 625266 Fax: 0686 625241

Cam *Audio*

“If we can't help you we'll tell you where to go.”

0% Finance

WRITTEN DETAILS AVAILABE ON REQUEST

SPECIALIST AUDIO RETAILERS
110 MILL ROAD, CAMBRIDGE
TEL: 0223 60442



STATION SOUNDS

W O R T H I N G
DOWN PLATFORM WORTHING STATION SUSSEX

FOR A SELECTION OF VALVE AMPLIFIERS AND OTHER OLDER QUALITY EQUIPMENT

VALVE AMPLIFIERS (COMBOS AND HI-FI) OVERHAULED AT SENSIBLE RATES

Valve and other equipment always wanted
FISHER • RADFORD • RICHARDSON • QUAD • EMI
KERR-McINTOSH • BEAM-ECHO • DYNACO • B&W
TANNOY • DYNATRON • and anything interesting

I also stock manufacturers line ends and ex-demo models - please ring for details

MIKE POINTER

0903 39980

Evenings

0903 213192

Having read much about this 'valve revival', as it were, I am wondering if, with a budget of £800 - £900, it would be feasible to acquire a pair of valve amplifiers. My system seems to sound very clinical, even harsh at times. Would valves solve my problem, or is there another reason? I would be grateful for any advice.

Gary Ellmes
Reading, Berks.

You could be right about a valve revival. There are a number of amplifier combinations at the price you mention. These will change the sound radically. For the budget you suggest, the Croft Micro/Series 5, Audio Innovations Series 200 models would add some warmth to the system, but this change may well spell the beginning of more radical changes.

However, I am not convinced that the clinical nature of your sound lies with the amplification. Exposure amps are detailed and dramatic, although rarely bright. I would suggest that a change of arm (a Linn Ittok or a Naim Aro would be within limits) may be a better prospect, as this should reduce any 'tizziness' that the Basik would inject, without fundamentally changing the sound.

The sound can also be modified by adding one of the power supplies for the Linn, either Linn's own Lingo, Pink Triangle's Pink Linnk, or even Reference Music Systems new little box. All of these radically alter the Linn's character, but in differing ways. Finally, you make no mention of equipment tables. These can affect the sound quality drastically. Look at the versions by The Sound Organisation or Audiotech, for example, or even the Mana Reference table. This last can make profound improvements in a system, far greater than one would expect. **AS**

● My present system consists of a Rega Planar 2 Turntable (RB250 arm/K5), a Kenwood DP5020 CD player, Kenwood KA3020 amplifier and Wharfedale Diamond IV speakers.

The speakers sit on 24" spiked stands and the amp/CD player both sit in a wooden hi-fi cabinet on top of which is a spiked turntable shelf for the Planar 2. My listening room is approx. 10ft x 10ft.

In general I am fairly happy with my system but I am wondering if I would benefit from mounting my amp and CD on a spiked shelving unit, bearing in mind that both components fall into what I would imagine is the budget category, or would I be better advised spending the money elsewhere on the system.

I would also be grateful for advice on any other suitable arm/cartridge combinations for the Rega Planar 2 for a possible upgrade at a later date.

I look forward to hearing your views and advice for improving my system.

D. Jackson
Glasgow

A specialised spiked shelving system for CD and amplifier does improve the sound quality, but in a less dramatic manner than with a turntable. Obviously, the Compact Disc player benefits from a stable platform, sounding a little more solid and open. Apollo, Target and many others make stands that would suit.

With regard to your second question, there are other cartridges that you could try when upgrading, such as Goldring's 1012, or Rega's own Bias models. Stick to cartridges under the £50 mark with this deck. If your Rega was an older model, with the S-shaped R200 Rega arm, it would be worthwhile upgrading to the newer RB250 arm, as fitted to current decks. As it stands, the only significant

upgrade that can be done to a Rega Planar 2 involves changing the cartridge, or changing the deck altogether! **AS**

● My system consists of a Yamaha CDX 930 Compact Disc player, connected to a Mission Cyrus 2 amplifier via the thrown-in interconnect. The speakers are Epos ES11, bi-wired using Linn K20 cable.

I would like to upgrade this system, but I am not sure whether I should add the Mission PSX power supply to the Cyrus 2 or to invest in a pre/power amplifier combination. I am also considering whether it is a good idea to upgrade the CD player. I have in mind the Meridian 203 or Deltec's 'The Little Bit'. Or would it be more sensible to go for a high quality CD player?

Please, also advise me as to whether I should stick with my current speaker cable and recommend on interconnect cable. My budget is about £1200 and my tastes are mainly classical and light rock/pop.

Henry Tan,
West Hampstead

Yamaha's CDX 930 player is a good device, but it is a little out of place, given the quality of the rest of your system. I think that it would still be within the confines of your budget to check out Arcam's Delta 170 or Teac's P500 transports, together with one of Arcam's own Black Box convertors, Audio Alchemy's Decoding Engine or Deltec's 'The Little Bit', the Mission PSX and good interconnect cables (Sonic Link, Audioquest, Kimber or Audio Note would fit well here, I believe). This would be a better move, I believe, than going for a more expensive DAC with your existing player.

I do not think that it is wise at this point to upgrade the Cyrus 2 to a pre/power combination. This would sap a large proportion of your

budget and would possibly highlight idiosyncrasies within the Yamaha's transport. **AS**

● My current system consists of the following: Linn LP12/Akito/AT-F5 turntable combination on a Sound Organisation table, Exposure X amplifier and JPW AP2 loudspeakers on Sound Organisation stands. I like the overall sound of this set up, but I feel that there is something missing in the bass.

I have around £350 to spend and I do not want to sacrifice the mid-band quality of the system as it stands today. My room size is 13ft by 14ft, with a suspended floor. I listen to mostly jazz and folk music.

W. J. Barrett,
Co. Tipperary, Eire.

The problem here lies with the loudspeakers. JPW AP2s do have a wonderful mid-band for the price, but they are notoriously bass-light. It is possible to improve upon their strengths, however. Your budget would happily cover loudspeakers such as Rogers LS4as, Heybrook HBIS3 or Castle Durhams on good quality loudspeaker stands. Alternatively, Epos ES11 loudspeakers on their own dedicated stands, would fit well. While slightly outside your budget, the ES11s improve upon many of the AP2s strong points, while adding a greater depth to the bottom end.

If you do decide on speakers such as the Heybrooks or Epos, be sure to use their bi-wire facility, preferably using good quality cable like Linn's or Exposure's own. **AS**

Northwood A U D I O

- AIWA
- AUDIO INNOVATIONS
- CAMBRIDGE AUDIO
- CASTLE
- EXPOSURE
- HECO
- INFINITY
- LUXMAN
- MARANTZ
- MISSION
- MONITOR AUDIO
- MORDAUNT SHORT
- MOTH
- MUSICAL FIDELITY
- NAD
- PINK TRIANGLE
- PROTON
- QED
- REVOLVER
- RODGERS
- ROTEL
- RUARK
- SD ACOUSTICS
- TANNOY
- TARGET
- TDL
- TEAC
- THE SOUND ORGANISATION
- THORENS
- VOYD
- WHARFEDALE

where
music
matters

Northwood A U D I O

126 PINNER ROAD (Nr. IRONBRIDGE)
NORTHWOOD MIDDLESEX HA6 1BP
TEL: (09274) 20877

***WE'VE BEEN GIVING SOUND ADVICE
FOR OVER 50 YEARS***

**TDL STUDIO 4
& GOLDRING
TURNTABLE**
now on
demonstration

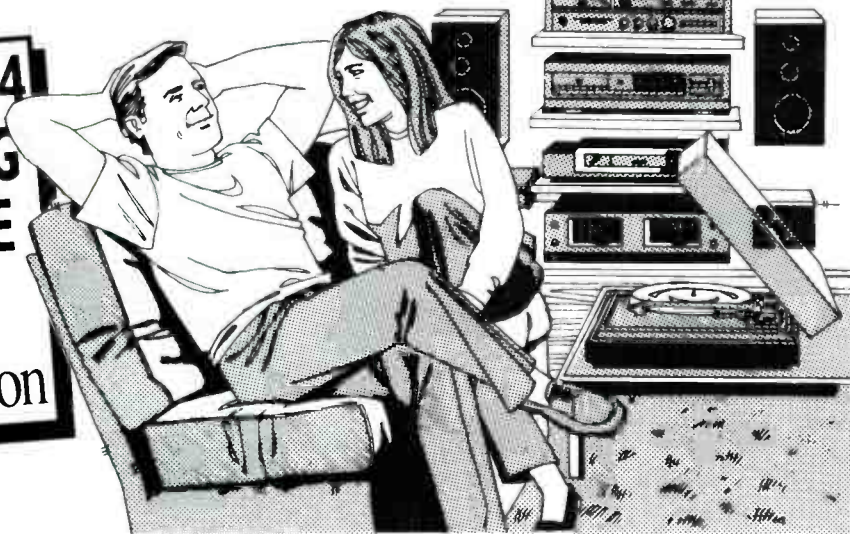

- AIWA
- ALPHASON
- ARAGON
- ARCAM
- AUDIO INNOVATIONS
- AURA
- B&W
- CAMBRIDGE
- DELTEC
- DENON
- DUAL
- DMC
- INCATECH
- JPW
- KEF
- KELVIN LABS
- KENWOOD
- LINX
- MARANTZ
- MICROMEGA
- MORDAUNT-SHORT
- MUSICAL FIDELITY
- NAKAMICHI
- PHILIPS (CD)
- PINK TRIANGLE
- PROAC
- QUAD
- RADFORD (CD)
- REVOLVER
- RUARK
- SD ACOUSTICS
- SME
- SNELL
- SONIC LINK
- TDL
- TOWNSHEND

S Standens
92A HIGH STREET
TONBRIDGE 0732-353540

*Listen to some of the
UK's finest hi-fi
equipment in our two
demonstration rooms*



Here's a selection
of articles appearing
in the August issue



★ **LINN KAIRN
PREAMPLIFIER**

Top of the range preamplifier from the turntable giant. What does it do for Compact Disc?

★ **MERIDIAN D-6000
ACTIVE SYSTEM**

Is it a loudspeaker, an amplifier, or a convertor? In fact, it's all of these and more.

★ **PRO-AC STUDIO 1
MK 2.**

Pro-Ac's new revisions to their popular Studio 1 loudspeaker give us a chance to listen to this classic model.

★ **SOUND DESIGN
STUDIOS' AMPLIFIER**

Radical high-end British valve amplification that is designed without compromise and built like a tank - and it has no output transformers!

THERE'S ALSO A LOT MORE...

GET THE AUGUST ISSUE
OF HI-FI WORLD ON SALE 18th JULY

RUN BY HI-FI ENTHUSIASTS
FOR HI-FI ENTHUSIASTS

HI-FI WORLD SUBSCRIPTION FORM

Please send me the next 12 issues of Hi-Fi World, starting with

the _____ issue.

I enclose my cheque/postal order for £18 made payable to
Audio Publishing Ltd.

Name _____

Address _____

Send to : **Audio Publishing Ltd, 64 Castellain Road, Maida
Vale, London W9 1EX**

HFV7



In Search Of Excellence

While on a whistle-stop tour of some manufacturers in Wales, we were invited to visit Audio Excellence's record shop, above their Cardiff Sony Centre hi-fi store. Expecting to see a few rows of grubby second-hand records, we were quite taken aback by the quality and scale of their collection.

There was a small row of Compact Discs, but apart from that this is an old fashioned record shop, with row upon row of records, most of which are in superb condition. Besides the range of second-hand discs, Audio Excellence are actively obtaining new and difficult to find records.

Vinyl nutters like myself find places like this fascinating. Unfortunately, due to an oversight, I took my cheque book with me. This is not a clever thing to do, as the angry letter from my bank manager a few days later proved. Approach this record shop with great caution and cash only, as discs cry out to be bought, like doe-eyed puppies in a dogs' nome.

The salesman at the Sony Centre, knowing my love for the black disc said that I would "go mad" there. I tried to look cool and professional, swaggering up the stairs. Then I went mad. Even Noel 'Mr. Digital' Keywood couldn't resist the temptation and succumbed to the obvious charms of The Shirelles, Fleetwood Mac and Sam & Dave, all on LP.

**Good record shops
are hard to come by.
And second hand
ones, even harder.
Audio Excellence
Records, of Cardiff,
is one to seek out, as
it impressed Hi-Fi
World's staff (but
not their bank
managers).**

My cheque book raised the white flag after boxed sets of Beethoven symphonies, Peter Ustinov reading 'The Little Prince' and discs of Orchestral Manoeuvres In The Dark, The Nelson Mass, The Blues Brothers and several other 'must buy' records found their way into my hands.

Our own purchases aside, it's refreshing to see that enterprising dealers like Audio Excellence are buying up old record collections, as their customers switch over to Compact Disc.

I hope that Audio Excellence Records is the first of a new line of hi-fi shops. Shops that move away from just selling equipment and get involved with music ●

Don't bother to waste time searching for specialist audio accessories. We are looking carefully for you and, where necessary, are even having them made to fulfill our quality requirements.

KONTAK Contact Cleaning Fluid

Left alone, mechanical contacts tarnish. Oxidation occurs and other airborne agents - especially in smoke filled rooms - also combine to form surface deposits. The effect often becomes serious enough over a period of time even to make self wiping contacts go intermittent. Mechanical contacts can deteriorate unless cleaned.

Hi-fi signals are, by their nature, very prone to degradation from this phenomenon - and there are myriads of contacts that slowly tarnish in any system.

Kontak is a unique and

NAGAOKA Anti-Static Record Sleeves

Nagaoka specialise in pickup cartridges and record accessories. They are recognised experts in this field, producing very high quality products in the way Japanese companies do. Their translucent, plastic record sleeves are treated to be immune to static build up. You can clearly see the entire disc surface through them, so labels or even picture discs can be recognised instantly. Lack of dust attraction makes for a clean sleeve and helps keep records pristine. Nagaoka's sleeves come in packs of fifty. We suggest you get a pack, have a good record cleaning

Use carefully to keep your pickup cartridge stylus and cantilever clean.

NAGAOKA STYLUS CLEANING KIT Price: £2.50

NAGAOKA CD Cleaning Kit

I have tested a variety of CD cleaning devices (the editor writes), including the cogs and wheel types, using a Cambridge Audio CD-1 dropout counter to measure errors and detect improvement. Of all the kits, this one from Nagaoka gave the best results. It better removes sticky deposits (like jam!), whereas the machines do not. So again, it might not look so complex as some, but it is very effective. We recommend it from testing and personal trial.

NAGAOKA CD CLEANING KIT Price: £10.50

HI-FI WORLD SPECIAL AUDIO ACCESSORIES

RECORD STORAGE CUBE

Here's the record storage cube so many people have asked for. It has been designed to hold roughly one hundred LPs, having an internal width of 37cms. Internal height is 32.5cms and depth 32cms. The cubes can be stacked or placed alongside each other, in a line. They offer useful storage for a variety of household goods.

Strongly made from 20mm MDF, the panels are machined to have strong side joints. We have specified an expensive two-part paint finish, with a textured acrylic top coat in black. High tensile machine screws with cross heads are supplied, plus instructions. All holes are pre-drilled; simply bolt the panels together.

The cube is delivered in a flat pack.

RECORD STORAGE CUBE Price: £42

effective two part cleaning solution that removes contaminants from electrical connectors of all sorts. It is applied with the pipe cleaners supplied. Clear instructions list the most sensitive contacts that need treatment in a hi-fi system, but others not in the signal path, such as fuses, should not be ignored. Make sure equipment is turned off and unplugged from the mains of course, before cleaning any contacts - mains related or otherwise.

The dirt that Kontak removes is clearly visible on the pipe cleaners, demonstrating just what degree of contamination contacts have reached and what Kontak is achieving. Those who use it, including the staff of Hi-Fi World, find this two part cleaning solution very effective. After application, the sound of a system regains its original life, sparkle and vigour. You will be surprised at the difference Kontak makes.

KONTAK Price: £21.20

session and replace all the old inner sleeves with these new, spotless ones.

NAGAOKA LP SLEEVES Price: £7.50

NAGAOKA Rolling Record Cleaner

The big drawback with most record cleaners is that they fail to lift dirt effectively off the record. Brushes pick up fluff, but they also redistribute fine dust around the grooves, causing noise to build up. Nagaoka's rolling record cleaner actually lifts dirt from the bottom of the groove - even fine dust! This is the only way we know to properly dry clean a record.

NAGAOKA ROLLING RECORD CLEANER Price: £10.20

NAGAOKA Stylus Cleaner

Here's another simple but effective cleaning kit from Nagaoka. It consists of a stylus brush and cleaning solution.

STILTON Gold Plated 4mm Plugs

Gold is, chemically, one of the least active metals. It resists corrosion well as a result. Gold is also highly conductive. These are both excellent properties for electrical contacts, which is why all the best switches have gold plated contacts. Look at the nickel plated surface of most 4mm loudspeaker plugs and you'll see it is dirty. Try cleaning it and you'll prove it is dirty.

We suggest you consider using our gold plated 4mm loudspeaker plugs instead. They stay free of contamination longer and ensure an excellent electrical connection is made. To maximise their potential, they solder to the speaker cables, eliminating the additional metal contact made by clamp screws. Heat shrink sleeving is provided, plus conventional plug caps. You will need a soldering iron to connect these; a dealer should be able to do the job in minutes.

STILTON PLUGS Price: £8.00

THE GREEN PEN

Straight from Japan, where they can get seriously nutty about hi-fi, comes THE LASAWAY GREEN PEN. Manufactured by an offshoot of one of Japan's largest engineering companies, this pen is designed to improve the light distribution from the laser

of a Compact Disc player. By reducing optical interference, it produces a purer reflected signal from the disc surface. This in turn improves faithfulness of the optical signal and results in better sound quality.

When red laser light hits the silvered reflective surface of a disc, some of it scatters and is reflected back off the disc edges, causing optical interference. Because green is at the opposite end of the light spectrum to red, an opaque green coating best absorbs this light.

The LASAWAY GREEN PEN provides such a green coat and has been formulated to be harmless to the plastic of the disc. It is carefully applied to the outside and inside edges, but not to the reflective face of course. I have tested this (the editor writes) and personally feel that Lasaway's claims are justified. We were careful not to adjust volume, but individual images - like singers became denser sounding and louder too. It was as if the images were focussed and strengthened. There was an enriching process to be heard as well. More information was coming from the performers and instruments. I was pleasantly surprised by the LASAWAY GREEN PEN, because I am slightly sceptical about such products. This one worked.

LASAWAY GREEN PEN
£7.00

AUDIO TECHNICA CD Lens Cleaner

Here's a product for smokers in particular. However, seeing the peculiar haze that coats the inside of my windows after a few weeks - and I don't smoke - suggests to me that non-smokers are included. It is a laser lens cleaner for your CD player, beautifully made by Audio Technica. Contained in the pack is a disc with fine brushes on it, plus cleaning fluid. Each brush takes one drop of fluid, then the disc is inserted and played. These brushes gently clean the laser lens, removing oil, grime, dust and other airborne deposits like nicotine (ugh!). Audio Technica recommend use every month or so (just watch your windows!).

CD LENS CLEANER
Price: £15.30

AUDIO TECHNICA Cassette Deck Head Cleaner

We've seen the automatic cassette head/capstan cleaners - those natty little cassettes with all the wheels and cogs inside. Trouble is, Nakamichi tell us they do not recommend such gadgets are used with their cassette decks. I own a Nakamichi ZX-9 (the editor writes), which is used for tape testing, as a reference and such like. This poses a dilemma, over which there has been much discussion on the magazine. If I am not prepared to use one, then should we sell one?

The truth is that they are fine for simple two head decks, but are best not used with more complex and delicate precision mechanisms found on a Nakamichi. The dilemma is resolved by Audio Technica's cassette head cleaner system. Using good, old fashioned manual techniques with cleaning buds and a carefully formulated cleaning solution that will not harm the rubber of pinch rollers, this little kit works wonders. Heads are cleaned with light pressure and plenty of care. Use of disposable pads means dirt isn't retained, to possibly cause damage by scratching. This kit might not look so natty, but that isn't our concern. We feel obliged to make an informed decision about products on your behalf: our choice is this cleaning kit.

**AUDIO TECHNICA
CASSETTE DECK HEAD
CLEANER** Price: £7.25

AUDIO TECHNICA Electronic Stylus Cleaner

Scared of damaging your stylus when cleaning it? Try this amazing little device - an electronic stylus cleaner that vibrates gunge right off the tip! Powered by a small AA battery, it's a doddle to use and safe too. Just rest the stylus on its high speed vibrating brush.

**AUDIO TECHNICA
VIBRATING STYLUS
CLEANER** Price: £19.95

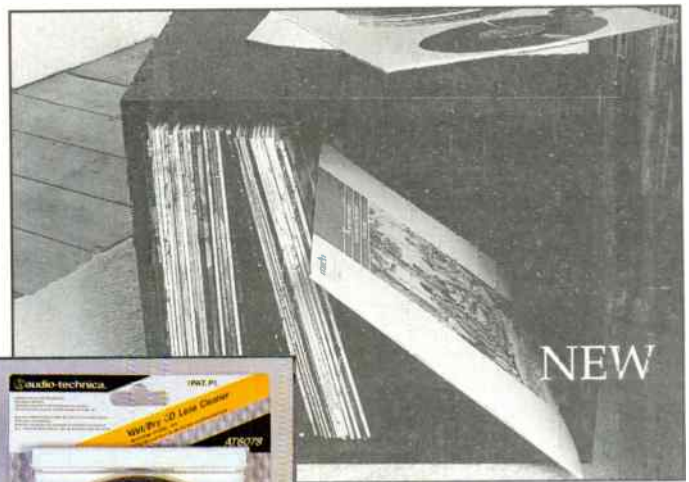

HI-FI WORLD SPECIAL AUDIO ACCESSORIES ORDER FORM

Please send me:

- RECORD STORAGE CUBE £42.00 each
- KONTAK Cleaning Fluid £21.20 each
- NAGAOKA Anti-Static Record Sleeves £7.50 per pack
- NAGAOKA Rolling Record Cleaner £10.20 each
- NAGAOKA Stylus Cleaner £2.50 each
- NAGAOKA CD Cleaning Kit £10.50 each
- STILTON Gold Plated 4mm Plugs £8.00 per set
- LASAWAY Green Pen £7.00 each
- AUDIO TECHNICA CD Lens Cleaner £15.30 each
- AUDIO TECHNICA Cassette Deck Head Cleaner £7.25 each
- AUDIO TECHNICA Electronic Stylus Cleaner £19.95 each

All prices include postage & packing in the UK only.

I enclose cheque/PO for £..... made payable to **Audio Publishing Ltd.**

NAME

ADDRESS

Please send completed order form together with your cheque/PO to:

HI-FI WORLD,
64 Castellan Road,
Maida Vale,
London W9 1EX.



SEVENOAKS HI-FI & VIDEO

This advertisement is valid until at least 31st July 1991.

SAVE £80

SYSTEM OF THE MONTH £269.95

Including cartridge and all leads.

- NAD 5120 or (Dual CS505/4 add £60)
- Rotel RA820AX
- JPW Sonata (v) (real wood veneer add £10)

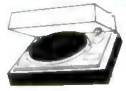

SUGGESTED SYSTEMS

The suggested systems priced below all include the popular Dual CS503/1 turntable but an alternative turntable or CD player is available at extra cost. Please see "OPTIONS" list below for further details.

| SPEAKERS | Guomans Maxim II W/Dale Delta 30.2 JPW Minim Gale GS210 JPW Sonata (vinyl) | Celestion 3 JPW Sonata M/Short MS 3.10 W/Dale Diamond 4 Mission 760 Royal A7 | Celestion DL4 II Tannoy E11 JPW Sonata - M/Short MS3.20 Widale 410 | Nad 6225e Celestion 5 | Monitor Audio R7 Hibrook P15 Celestion DL6 II Tannoy M15 Wharfedale 505.2 | Castle Warwick KEF C45 Celestion DL8 II Arcam Alpha Monitor Audio P9 M/Short MS 3.30 | Castle Durham Heybrook HE113 Tannoy M20 (Blk) Tannoy DC 2000 (Add £70) Rogers LS4A |
|---------------------|---|---|--|--------------------------|---|---|---|
| Rotel RA820AX | 289.95 | 299.95 | 319.95 | 339.95 | 369.95 | 379.95 | 419.95 |
| Rotel RA820E44 | 319.95 | 339.95 | 349.95 | 369.95 | 399.95 | 409.95 | 449.95 |
| Dual CV5600 | 289.95 | 299.95 | 319.95 | 339.95 | 369.95 | 379.95 | 419.95 |
| Pioneer A300 | 349.95 | 379.95 | 409.95 | 419.95 | 439.95 | 469.95 | 519.95 |
| Rotel RA840BX4 | 369.95 | 379.95 | 399.95 | 419.95 | 449.95 | 449.95 | 499.95 |
| Harmar HK6100 | 309.95 | 319.95 | 339.95 | 359.95 | 379.95 | 399.95 | 444.95 |
| Rotel RA810A | 259.95 | 279.95 | 299.95 | 309.95 | 329.95 | 349.95 | 399.95 |
| QED A240CD II | 339.95 | 359.95 | 379.95 | 399.95 | 419.95 | 439.95 | 479.95 |
| Yamaha AK330 | 249.95 | 269.95 | 279.95 | 299.95 | 309.95 | 339.95 | 379.95 |
| NAD 3240 | 329.95 | 349.95 | 359.95 | 389.95 | 399.95 | 419.95 | 459.95 |
| Marantz PM40SE | 349.95 | 369.95 | 389.95 | 399.95 | 429.95 | 429.95 | 479.95 |
| Kenwood KA5020 | 339.95 | 349.95 | 369.95 | 389.95 | 419.95 | 429.95 | 469.95 |
| Nad 3225PE | 249.95 | 269.95 | 279.95 | 299.95 | 309.95 | 329.95 | 379.95 |
| Nad 3020 i | 329.95 | 349.95 | 369.95 | 389.95 | 419.95 | 429.95 | 469.95 |
| Marantz PM 30SE | 349.95 | 369.95 | 389.95 | 399.95 | 429.95 | 429.95 | 479.95 |
| Technics SU 810K | 339.95 | 349.95 | 369.95 | 389.95 | 419.95 | 429.95 | 469.95 |
| Musical Fidelity B1 | 289.95 | 299.95 | 319.95 | 339.95 | 369.95 | 379.95 | 419.95 |
| | 279.95 | 289.95 | 309.95 | 319.95 | 329.95 | 349.95 | 399.95 |
| | 309.95 | 329.95 | 349.95 | 369.95 | 389.95 | 409.95 | 459.95 |
| | 279.95 | 289.95 | 309.95 | 319.95 | 329.95 | 349.95 | 399.95 |
| | 329.95 | 349.95 | 369.95 | 389.95 | 419.95 | 429.95 | 469.95 |

FREE

Cartridge supplied with these systems

Leads provided with these systems (QED 79 strand add £1/metre)

Carriage for mail order customers on all systems in excess of £300 (UK mainland only) NB speaker stands are NOT included but highly recommended - wide range available from £20 per pair



SANSUI CDX211E CD Player a best buy at £119.95

We have a limited quantity of these award winning players, absolutely brand new, but with slightly soiled outer boxes. All are absolutely new (not manufacturers' returns) and each player has been individually inspected by Sansui and guaranteed for 12 months.

OPTIONS

The following Compact Disc Player or Turntable may be ordered instead of the Dual CS503/1 in the above systems.

CDs

- Awa XCT700
- Denon DCD560
- Denon DCD660
- Denon DCD860
- Denon DCD960
- Marantz CD40
- Marantz CD41
- Marantz CD50SE
- Marantz CD60SE
- Nad 5420
- Nad 5425
- Nad 5440
- Philips CD624

- add £50 Philips CD634
- add £50 Philips CD634
- add £70 Philips CD850
- add £125 Philips CD610II
- add £160 Pioneer PD650II
- add £30 Rotel RCD855
- add £70 Rotel RCD865
- add £130 Samsu CDX211
- add £150 Technics SLPG200AK
- add £60 Technics SLPG400AK
- add £75 Technics SLPG500AK
- add £160
- add £65

TURNTABLES

- add £100 Dual CS503-2
- add £100 Dual CS505-4
- add £245 AR EB 101
- add £35 AR EB 120
- add £90 Arston Q Deck
- add £115 Rotel RP855
- add £165 Systemdek IIX900 + MOTH + AT110E
- add £70
- add £30
- add £60
- add £80

MINI/MIDI SYSTEMS. Sony, Technics, Kenwood, Yamaha. Special offers on selected models typically from £300-£1000

This month, something a little different. I have introduced recordings which may have some durable musical value and productions that might actually enhance the record catalogues rather than merely fattening them. I'll leave this month's selection, with its strongly British emphasis, to make their own points.

peter herring

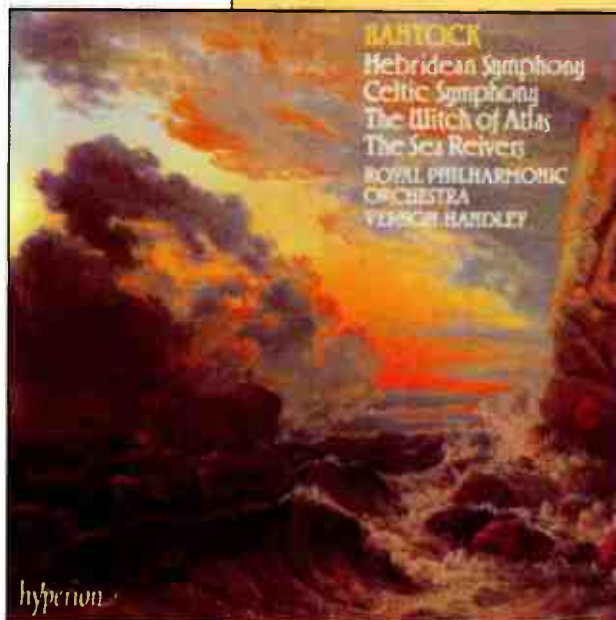

RECORD OF THE MONTH

I have to report that one of Britain's leading recording engineers, Tony Faulkner, has hit the bottle in a bad way. A great many bottles - KT66s, KT88s, EL34s and the rest. In an extraordinary marriage of technologies ancient and modern, he now works with antique Neumann valve microphones and has had a valve mixing desk custom-built for him by Tim de Paravicini of Esoteric Audio Research.

As far as is technically possible, Faulkner is now using valves in the recording chain, all feeding into the latest Sony PCM and U-Matic digital hardware. Is it merely fetishism, or is he benefitting from what those of us with valve amplifiers have known for years? This new Hyperion issue provides a pretty unequivocal answer.

SIR GRANVILLE BANTOCK
Celtic Symphony; The Witch of Atlas; The Sea Reivers; A Hebridean Symphony Royal Philharmonic Orchestra; conductor, Vernon Handley
HYPERION CDA66450 (DDD/73.30)

★ After showing no interest whatsoever in the Civil Service career his parents had planned for him, Granville Ransome Bantock entered the Royal College of Music in 1889, aged twenty-one. Although he composed prolifically and on a grand scale, it was as a conductor and teacher that he first made an impact on British musical life. On the podium, he was audacious in his choice of repertoire, introducing Richard Strauss, Debussy and Liszt to his audiences. He even did the unthinkable by putting on concerts of music by living British composers. In

1908 he succeeded Elgar as Peyton Professor of Music at Birmingham University.

Bantock was also an eager scholar and a devotee of things Eastern or Celtic (he was Scottish by ancestry). He was much influenced by Liszt and Wagner and was motivated by the potential of descriptive 'programme music'. All these facets come together in the three 'Celtic' works here; the fourth, The Witch of Atlas, takes its inspiration from Shelley's poem of the same name and the forty-four lines of verse 'illustrated' are reproduced in the booklet.

He completed the Celtic Symphony for string orchestra and six harps (no less!) in 1940, six years before his death. Its twenty-minute span is divided into five sections, beginning with a hauntingly atmospheric and compelling quiet introduction which is supremely well caught by the recording. But, then, so is everything else here, including the orchestral riot of The Sea Reivers (three-and-a-half minutes of musical lightning) and the mighty climaxes of the Hebridean Symphony. It is a staggering sound, combining scale and impact with warmth and translucency. How much those valves have to do with it, I cannot judge, but I didn't contradict the engineer when he told me 'a lot'.

The greatest of Bantock's Celtic inspirations and, at thirty-five minutes, the longest work here is 'A Hebridean Symphony'. Bantock himself conducted the first performance in Glasgow in 1916. Like the Celtic Symphony it is played in one continuous movement, but sub-divided into several distinctive sections each of which is briefly described in the accompanying notes. It is music on an epic, heroic scale, sumptuously scored yet also very lucid: Bantock displays a mastery of orchestration and he certainly knows how to make the most of his material.

A Wagnerian grandeur is evident, as is brass writing reminiscent of Bruckner, all supplying a vividly contrasting backdrop to the Hebridean folksongs which are magically woven into the score. On first hearing, the impact is overwhelming, especially in the spacious acoustic of this recording and subsequent hearings have revealed substance beyond the spectacle, though I'm left with the feeling that the effects are just a little too deliberate at times.

Nevertheless, this has to be judged one of the important orchestral recordings of the year, and it is difficult to imagine Bantock's opulent scores being more persuasively played than by the RPO and Vernon Handley, as here. Handley's enthusiasm and commitment takes him to the heart of so much neglected British music, almost always forcing if not a revision of its status, at least a reappraisal. Bantock merits the attention which this new recording will hopefully bring.

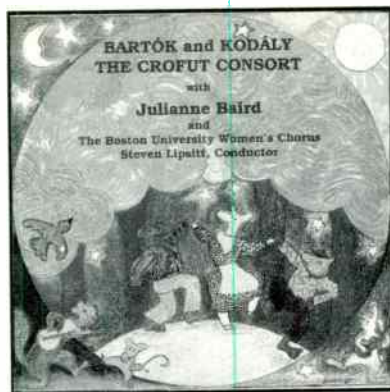

BELA BARTOK

Rumanian Folk Dances Sz56; selections from: Duos for Two Violins Sz98; For Children Sz42; Mikrosomos Sz107; Two- and Three-Part Choruses

ZOLTAN KODALY

Ave Maria; The Gypsy; Evening Song The Crofut Consort; Julianne Baird; Boston University Women's Chorus; conductor, Steven Lipsitt
ALBANY TROY046 (DDD/52.53)

Two threads link this diverse selection from what might be described as the lighter side of Bartok's output. They are his dedication to writing useful and enjoyable 'educational' music for children, inspired by the needs of his own son, and his lifelong researches into the folk music of his native Hungary and neighbouring countries - witness the Rumanian Folk Dances which open this programme, in a delicious arrangement for folk band: whistles, recorders, guitars, banjo, bass and cimbalom, the dulcimer-like instrument which supplies such characteristic colouring to Kodaly's 'Hary Janos' music.

Here, Bartok's friend and fellow ethnomusicologist, Kodaly, is represented by just three songs. Each, though, is a jewel, and delicately sung by Julianne Baird.

Mikrosomos, For Children, and the violin Duos, are all part of the legacy of music Bartok provided for young musicians and it is noteworthy that, although the Mikrosomos are graded from 'very easy' to 'difficult', the composer felt it was quite unnecessary to 'protect' music students from such radical notions as bitonality, atonality and the more unusual rhythmic structures. It is music of extraordinary vitality and colour and the flavour of folk music is readily discernible even when, as in the half-dozen choral pieces recorded here, the music is entirely original. I'm sure Bartok would have approved of the sparkling arrangements made here by banjost, Bill Crofut, and his colleagues in a much-augmented Crofut Consort; certainly, the essential rhythmic bite and zest is always there. In the choruses, spicing the shining voices with piquant instrumental touches makes for a lovely sound. An entertaining introduction to Bartok, the rhythms of the Balkans, and a bunch of American musicians that is remarkably at home in both!

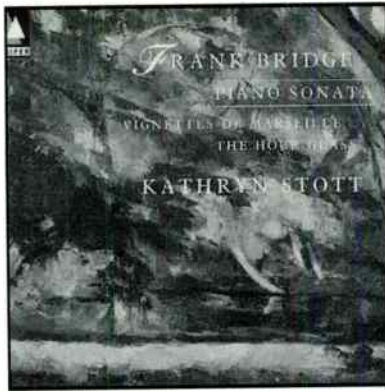

FRANK BRIDGE

Piano Sonata; Capriccios Nos 1 and 2; A Sea Idyll; Ecstasy; Vignettes de Marseille; The Hour Glass
Kathryn Stott, piano
CONIFER CDCFI86 (DDD/72.13)

Lancashire-born Kathryn Stott is one of the very finest of the younger generation of British pianists, with all the flair and technique required in the standard repertoire of Chopin, Liszt and Rachmaninov. Yet her career to date has also been distinguished by a commendable involvement with British music: recordings of Walton and George Lloyd spring immediately to mind. Here, the pianism and the personal involvement come together in what, for me, is her most important recording to date. The solo piano music of Frank Bridge has been overdue playing and recording of this quality.

As a programme, it is both representative and revealing, spanning the carefree Capriccio of 1905, written when Bridge was twenty-six, to the emotional storms and heartfelt eloquence of the Piano Sonata from 1922-25. Separating those works, of course, is the First World War. To have any hope of expressing the impact this had upon him, Bridge had to radically revise his musical language. The post-Romantic echoes of Mendelssohn and Liszt heard in the Capriccios was replaced by something altogether tougher, searching and more potent. The Sonata is wholly uncompromising in its responses: there is sadness, reflection, anger, nobility and, in the hollow martial music of the finale, a certain bitter irony. No wonder Frank Bridge made such an important contribution, morally as well as musically, to the development of his most famous pupil, Benjamin Britten.

However, Bridge could still reveal a lighter side, as the charming and colourful Vignettes de Marseille reveal, while The Hour Glass, from 1920, belies its lightweight title with music both evocative and haunting.

It is difficult to imagine more sensitive, more finely shaded playing of Bridge's music than Kathryn Stott offers here. Alongside the chamber music and the orchestral masterpieces such as Oration and Phantasm, it clearly demonstrates how he shook off the prevailing, imitative traditions to become an individual voice not just in British, but world music - and a voice with plenty to say.



FRANZ JOSEF HAYDN

Fortepiano Sonatas in D Major Hob.XVI/33; in A flat Major Hob.XVI/43; in C Major Hob.XVI/21; in E Major Hob.XVI/22; in F Major Hob.XVI/23
Lola Odiaga, fortepiano
ALBANY TROY045 (DDD/67.20)

Inevitably, Haydn's keyboard sonatas have been overshadowed by his output of symphonies and string quartets, yet it was a genre to which he contributed almost to the very end of his life. The five recorded here by the Peruvian-born soloist, Lola Odiaga, all date from the 1770s and generally display a genial optimistic temperament. Noticeably absent is the minor-key angst that permeated so much of Haydn's music in the 1760s. Perhaps it is because these sonatas were almost certainly practice pieces, if highly-inventive and sophisticated ones. Three (Nos 21, 22 and 23) constituted the first of his music to be published for domestic consumption, all of his compositions until that date being for the sole pleasure of his employers, the Esterhazys.

However mundane the purpose of the music, it failed to dull Haydn's endless capacity for invention and surprise, or the odd touch of wit. The pedagogic intentions are more than taken care of in the many complex passages, such as that in the A flat No43 where the left-hand is asked to play a mixture of scale passages, arpeggios, and off-beat accompaniments.

The fortepiano used would have been familiar to Haydn - or at least its original would: Lola Odiaga plays a 1985 copy of a Viennese instrument produced by Anton Walter around 1790, and it is known that Walter's company supplied and maintained the fortepianos at the Esterhaza court. It has a compass of just over five octaves and two knee-operated levers in place of pedals. One of these lifts the dampers above each string while the other inserts a cloth between hammers and strings, producing a quite distinctive sound.

The performances of this essentially late Baroque music are fully of spirit and imagination and are beautifully articulated. To sample the pleasures of this well-produced American recording, I'd suggest the F Major sonata, so full of characteristic touches and wholly representative of the entire programme.

Audio Inter connects..

MIDAS AUDIO

GOLD PLATED PHONO PLUGS : METAL LOCKING DIN PLUGS
QUALITY 16/02 BLACK CABLE : ALL LEADS 1.2 MTR LONG

| | | |
|---|--------|--------|
| 5 DIN - 4 PHONOS..... | £25:95 | £..... |
| 5 DIN - 2 PHONOS..... | £17:95 | £..... |
| 5 DIN - 5 DIN..... | £17:95 | £..... |
| 5 DIN - 2 MINI JACKS..... | £18:95 | £..... |
| 5 DIN - 1 MINI JACK..... | £15:95 | £..... |
| 4 PHONOS - 4 PHONOS..... | £32:95 | £..... |
| 4 PHONOS - SCART..... | £25:95 | £..... |
| 4 PHONOS - 2 MINI JACKS..... | £25:95 | £..... |
| 2 PHONOS - 2 PHONOS..... | £19:95 | £..... |
| 2 PHONOS - 1 MINI JACK..... | £17:95 | £..... |
| 1 PHONOS - 1 PHONO STEREO PAIR..... | £22:95 | £..... |
| GOLD PHONO PLUGS PAIR..... | £6:50 | £..... |
| METAL DIN PLUGS (ALSO NEW NAIM TYPE)..... | £4:50 | £..... |
| EXTRA CABLE PER METRE..... | £2:20 | £..... |

| | | |
|--|--------|--------|
| NAGOAKA/TONAR ANTI-STATIC SLEEVES PK 50..... | £7:50 | £..... |
| HUNT EDA CARBON FIBRE BRUSH..... | £7:95 | £..... |
| AUDIO TECHNICA STYLUS CLEANER..... | £21:00 | £..... |
| ZEROSTAT PISTOL..... | £19:00 | £..... |

AGENTS FOR : NAIM LINN EXPOSURE CREEK ARCAM EPOS RUARK ROYD ONIX DENON NAKAMICHI
TRIPOD AUDIO TECHNICA REVOLVER AURA MORDAUNT SHORT AND MANY MORE ALSO RECORDS

SOUNDWAVES

1 HOLBURY DROVE PRECINCT HOLBURY HANTS SO4 1PW 0703 899131
20 TEVILLE GATE PRECINCT WORTHING SUSSEX BN11 1UA 0903 212133

naim LINN exposure SPEAKER CABLE

MADE WITH SOLDERED BANANA PLUGS

| | LINN | EXPOSURE | NAIM | |
|---------|-------------|-------------|-------------|--------|
| 3.5m pr | £22.95..... | £22.95..... | £32.95..... | £..... |
| 5m pr | £32.95..... | £30.95..... | £45.00..... | £..... |
| 7m pr | £45.95..... | £42.95..... | £65.00..... | £..... |
| 10m pr | £62.95..... | £58.95..... | £90.00..... | £..... |

PLEASE SEND ALL ORDERS TO HOLBURY

I enclose cheque/PO for £..... made payable to
'soundwaves' credit card hotline 0703 899131
CREDIT CARD No.....exp.....

Name.....

Adress.....

.....Post code.....

THE NVA CHALLENGE

We believe NVA hi-fi equipment out-performs ANY other equipment on the market price for price. But, due to the political nature of a majority of UK hi-fi dealers, people have a lot of difficulty getting to hear our equipment in a good environment free from bias and bull ****.

In order to counteract this state of affairs, we are willing to spend an evening letting you listen and compare our equipment with yours, in the comfort of your own home.

No pressure or selling, just sit back and listen!

If you do not agree with us it's just too bad, but we are very confident!
Phone 0767 50532 to arrange

NENE VALLEY AUDIO

1 CHURCH FARM, HATLEY ST. GEORGE, NEAR SANDY, BEDS.



GIOVANNI PIERLUIGI DA PALESTRINA

Missa Assumpta est Maria; Missa Sicut liliium; Plainchant and motet Assumpta est Maria in caelum; Motet Sicut liliium inter spinas

The Tallis Scholars; director, Peter Phillips

GIMELL CDGIM020 (DDD/71.28)

● Those who feel they detect little variety between compositions in the corpus of sacred polyphony from the Renaissance would do well to compare the 'emotional temperatures' of this recording and the last by The Tallis Scholars to be reviewed here, that of Victoria's Responsories for Tenebrae. At the outset, the ritual of Christ's Passion is bound to provoke a different response to the text proclaiming the Assumption of the Virgin into Heaven. But there is more to it than the difference between grief and exultation; there is colour and atmosphere, too - Victoria pleads, implores, touching the nerve endings with his mystical intensity. It is music of flickering candlelight and deepening shadows. By contrast, in his Mass setting *Assumpta est Maria*, Palestrina floods every corner with pure, shining light. And both works number among the many musical glories of their time.

How Palestrina achieves this radiant effect is immediately apparent from the score, with its two tenor and two soprano parts. The wonder is in how he uses these forces so inventively and so seductively and rarely can the sheer beauty of this work have been revealed as it is here. It is hardly surprising that it has become, along with the *Missa Papae Marcelli*, the most celebrated of Palestrina's six-part Mass settings though I take Peter Phillips's point that its popularity is also due to a measure of luck (early recognition and publication) which works of comparable quality have not been blessed with.

I would venture to suggest this is one of the very finest recordings the choir has made - which is really quite a claim, given what has preceded it. It deserves to be heard well beyond the confines of the aficionadas of Renaissance polyphony and could well make many conversions to the cause of 16th Century choral music, I hasten to add, not Catholicism! This music has long since transcended the needs of one liturgy to become a universal balm.



ORGAN SPECTACULAR - VOLUME 2

David Hill, organ
PICKWICK IMP CLASSICS PCD945
(DDD/74.43)

● Normally, I find 'organ spectaculars' (any 'spectacular' for that matter) usually induce little more than aural indigestion. But this second recital for IMP Classics by the Master of Music at Winchester Cathedral is nothing if not diverse and imaginative. There is, for example, generous representation of the French school, an organ sonata by Mendelssohn, who was chiefly responsible for reviving interest in the instrument in the 19th century, two pieces by that fine English organist, Percy Whitlock, and the obligatory Bach Prelude and Fugue. However, this one is something of a rarity, the C Major BWV547. The Prelude meanders gently, becoming increasingly more decorative as it goes along, while the Fugue is remarkable for its treatment of what is just a single-bar subject.

The Trois Chorals of Cesar Franck, among the last compositions he wrote before his untimely death, fully exploit the sonorities of the organ in their intensity and possess the low notes to test the mettle of a few bass drivers. The Second Fantaisie of Saint-Saens, an unashamedly romantic work, is similarly wide-ranging. David Hill further gets a chance to show his dexterity in the brilliant Toccata Placare Christe Servulis from Marcel Dupre's tribute to the founder of the French school of organ composition, Le Tombeau de Titelouze.

Perhaps the most unexpected inclusion here is a surprisingly successful transcription by Guilmant of the lyrical, rather mysterious andante from Debussy's String Quartet. It is remarkable how well the score retains the delicacy of the original. Its appearance here is also evidence of the care taken to balance the programme on this disc. It is far from being seventy-odd minutes of 90 decibels and flashing fingerwork.

Of the two 'blockbusters' which open and close the recital, Walton's Coronation march 'Orb and Sceptre' and Sibelius's 'Finlandia', the latter is the more effective transcription; a real show-stopper, in fact, and David Hill plays it for all he's worth. Credit, too, to the recording team for not only capturing the full range and weight of the Winchester instrument, but giving it plenty of air as well.



SUMMER MUSIC - BRITISH WORKS FOR FLUTE

Kenneth Smith, flute; Paul Rhodes, piano
ASV CD DCA739 (DDD/73.35)

● An appropriately seasonal release. This collection, assembled by Kenneth Smith, principal flute with the Philharmonia, is clearly designed to showcase the full expressive range of the instrument and includes music from the 18th century to the present day.

The surprise is that it is all British. The flute is invariably associated with, first, the French then the German schools and I'm sure there are many who will find it difficult to believe that a programme of seventy-plus minutes of extremely fine music could be put together entirely from the outputs of native composers. Eric Fenby's transcription of *La Calinda* from Delius's *Koanga* is an ideal starting point and the Malcolm Arnold Flute Sonata, one of the most significant works written for the instrument in recent times, is an excellent conclusion - especially when played as memorably as here.

The recording takes its overall title from the attractive three-movement suite, *Summer Music*, by Richard Rodney Bennett, music which also gives a strong supporting role to the piano. Accompanist, Paul Rhodes, comes to the fore here. With its sumptuous melodies, and skilful treatment, this ten-minute work deserves to be better-known. Peter Lamb's equally short sonata of 1988 doesn't possess quite the same consummate fluency, but its formal structure gives the soloist every opportunity to shine.

Similarly formal, but not without its imaginative flourishes is the Sonata by the 18th Century Cambridge-based flautist, John Ranish, and the noble elegance of Thomas Dunhill's Suite for Flute and Piano allows Kenneth Smith to reveal other aspects of his art. These longer works are punctuated by two short, lyrical pieces: Elgar's *The Serious Doll* from the *Nursery Suite*, and Cyril Scott's *The Extatic Shepherd*, which is about as close as we get here to the enchanted Arcadia evoked by Debussy in *L'Après-Midi d'un Faune* and *Syrinx*. Altogether an engaging and relaxing recital, yet far from lightweight, and a most natural recording of 'drawing room' intimacy.

B.A.D.A. Dealers - the ultimate in Sound Advice

NORTHERN ENGLAND

Alderley Edge (Cheshire)
Aston Audio Ltd. 4 West Street.
Tel: 0625 582704/583472.

Altrincham
Clearstone Hi-Fi. 15 Ashley Road. Tel: 061-928 1610.

Bolton
Clearstone Hi-Fi. 235 Blackburn Road.
Tel: 0204 31423.

Bradford
Hi-Fi Experience at Erricks. Fotosonic House.
Rawson Square. Tel: 0274 309266.

Gateshead
Lintone Audio. 7/11 Park Lane.
Tel: 091-477 4167.
Lintone Audio. 8 The Arcade, Metrocentre.
Tel: 091-460 0999.

Leeds
Audio Projects. 45 Headingley Lane.
Tel: 0532 304565.
Image Hi-Fi. 8 St Anne's Road. Tel: 0532 789374.

Liverpool
W A Brady & Son. 401 Smithdown Road.
Tel: 051-733 6859.

Manchester
Clearstone Hi-Fi. 54 Bridge Street.
Tel: 061-835 1156.

Preston
Norman Audio. 131 Friargate. Tel: 0772 53057.

Rochdale
Clearstone Hi-Fi. 52 Drake Street. Tel: 0706 524 652.

Rotherham
Moorgate Acoustics. 8 Westgate. Tel: 0709 370666.

Sheffield
Moorgate Acoustics. 184 Fitzwilliam Street.
Tel: 0742 756048.

Stockport
Chris Brooks Audio. 10/12 Oak Street.
Hazel Grove. Tel: 061-419 9050.

Warrington
Chris Brooks Audio. 29 Gaskell Street.
Stockton Heath. Tel: 0925 61212.
Doug Brady Hi-Fi. Kingsway Studios.
Kingsway North. Tel: 0925 828009.

Whitley Bay
Lintone Audio. 242 Park View. Tel: 091-252 4665.

Wilmslow
Swift Of Wilmslow. 4/8 St Anne's Parade.
Parsonage Green. Tel: 0625 526213.

York
Sound Organisation. 2b Gillygate. Tel: 0904 627108.

SCOTLAND

Aberdeen
Holburn Hi-Fi. 441/445 Holburn Street.
Tel: 0224 585713.

Edinburgh
Russ Andrews Hi-Fi. 34 Northumberland Street.
Tel: 031-557 1672.

Glasgow
Hi-Fi Experience. 145 Bath Street.
Tel: 041-226 4268.
Stereo Stereo. 278 St. Vincent Street.
Tel: 041-248 4079.

WALES

Cardiff
Audio Excellence. 134 Crwys Road.
Tel: 0222 228565.

Newport
Audio Excellence. 37 High Street.
Tel: 0633 220012.

Swansea
Audio Excellence. 9 High Street.
Tel: 0792 474608.

NORTHERN IRELAND

Belfast
Hi-Fi Experience. 47/49 Fountain Street.
Tel: 0232 249117.
Lyric Hi-Fi. 163 Stranmills Road.
Tel: 0232 381296.

Portadown
Lyric Hi-Fi. 84 Bridge Street. Tel: 0762 358059.

CENTRAL ENGLAND

Birmingham
Griffin Audio. 94 Bristol Street.
Tel: 021-692 1359.
Hi-Fi Experience-Superfi. 67 Smallbrook.
Tel: 021-631 2675.

Cambridge
Steve Boxshall Audio. 41 Victoria Road.
Tel: 0223 68305.

Coventry
Frank Harvey. 163 Spon Street. Tel: 0203 525200.

Derby
Active Audio. 12/16 Osmaston Road. The Spot.
Tel: 0332 380385.

Kings Lynn
Martins Hi-Fi. 5 High Street. Tel: 0553 761683.

Leicester
Leicester Hi-Fi. 6 Silver Walk. St. Martins Square.
Tel: 0533 539753.

Milton Keynes
Technosound Ltd. 7 Granville Square.
Willen Local Centre. Tel: 0908 604949.

Norwich
Martins Hi-Fi. 85/91 Ber Street. Tel: 0603 627010.

Nottingham
Nottingham Hi-Fi Centre. 120/122 Alfreton Road.
Tel: 0602 786919.

Royal Leamington Spa
Hi-Fi Experience. 44 Park Street.
Tel: 0926 881500.

St. Ives
The Audio File. 2 Foundry Walk. Tel: 0480 66123.

Stoke-on-Trent
Active Audio. 95 Stafford Street. Hanley.
Tel: 0782 214994.

Tamworth
Active Audio. 29 Market Street.
Tel: 0827 53355.

Wolverhampton
Clearstone Hi-Fi. 39 Victoria Street.
Tel: 0902 772901.

SOUTHERN ENGLAND

Ashford (Kent)
Photocraft Hi-Fi. 40 High Street. Tel: 0233 624441.

Bishops Cleeve
The Audio File. 27A Hockerill Street.
Tel: 0279 506576.

Brighton
Jeffries Hi-Fi. 69 London Road. Tel: 0273 609431.

Chichester
Chichester Hi-Fi. 7 St. Pancras. Tel: 0243 776402.

Croydon
Spaldings. 352/4 Lower Addiscombe Road.
Tel: 081-654 1231.

Eastbourne
Jeffries Hi-Fi. 4 Albert Parade. Green Street.
Tel: 0323 31336.

Enfield
Audio T. 159 Chase Side. Tel: 081-366 8820.

Guildford
P J Hi-Fi. 3 Bridge Street. Tel: 0483 504801.

Harpenden
Studio 99. 82 High Street. Tel: 058-276 4246.

Harrow
Harrow Audio. 27 Springfield Road.
Tel: 081-863 0938.

Ipswich
Eastern Audio. 41 Bramford Road. Tel: 0473 217217.

London NI
Grahams Hi-Fi. Canonbury Yard. 190A New North Rd.
Tel: 071-226 5500.

London NW1
Hi-Fi Experience. 2/4 Camden High Street.
Tel: 071-388 1300.

London NW6
Studio 99. 79/81 Fairfax Road. Tel: 071-624 8855.

London SE13
Billy Vee. 248 Lee High Road. Tel: 081-318 5755.

London W1
Hi-Fi Experience. Lion House. 227 Tott. Ct. Road.
Tel: 071-580 3535.

London WC2
Doug Brady Hi-Fi. 18 Monmouth Street.
Tel: 071-379 4010.

Portsmouth
Jeffries Hi-Fi. 29 London Road. Tel: 0705 663604.

Reading
Reading Hi-Fi. 4 Queens Walk. Tel: 0734 585463.

Uxbridge
Uxbridge Audio. 278 High Street. Tel: 0895 30404.

Watford
Acoustic Arts. 101 St. Albans Road. Tel: 0923 245250.

Windsor
Radford Hi-Fi. 43 King Edward Court.
Tel: 0753 856931.

Woking
Aerco. 11 The Broadway. Tel: 0483 714667.

SOUTHWEST ENGLAND

Bath
Radford Hi-Fi. 12 James Street West.
Tel: 0225 446245.

Bournemouth
Suttons Hi-Fi. 18A Westover Road.
Tel: 0202 25512.
Movement Audio. 926 Wimbourne Road, Moordown.
Tel: 0202 529988.

Bristol
Radford Hi-Fi. 52/54 Gloucester Road.
Tel: 0272 428247.
Radford Hi-Fi. 4 Merchant Street.
Tel: 0272 294183.

Exeter
Radford Hi-Fi. 28 Cowick Street. St. Thomas.
Tel: 0392 218895.

Gloucester
Audio Excellence. 58 Bristol Road. Tel: 0452 300046.

Plymouth
Radford Hi-Fi. 107 Cornwall Street. Tel: 0752 226011.

Poole
Movement Audio. 588 Ashley Road, Parkstone.
Tel: 0202 730865.

Salisbury
Suttons Hi-Fi. 3 Endless Street. Tel: 0722 27171.
Salisbury Hi-Fi. 15 Catherine Street. Tel: 0722 322169.

Southampton
Hampshire Audio. 8 & 12 Hursley Road.
Chandler's Ford. Tel: 0703 252827.

Weymouth
Weymouth Hi-Fi. 28 Walpole Street.
Tel: 0305 785729.



BRITISH AUDIO DEALERS ASSOCIATION. P.O. BOX 299, LONDON NI 7UU.

IF YOU KNOW WHAT THESE INSTRUMENTS REALLY SOUND LIKE . . .

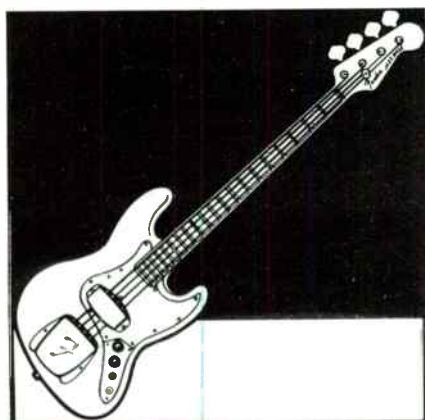

FENDER JAZZ BASS GUITAR



SELMER TENOR SAXOPHONE

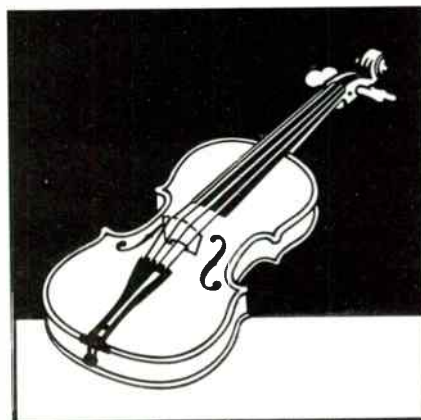

STRADIVARIUS VIOLIN

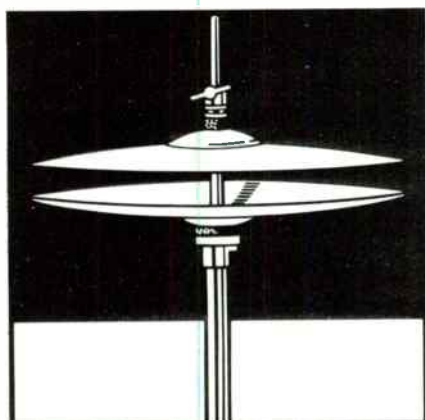

PAISTE HI HAT CYMBALS



GIBSON SUPER 400 ELECTRIC GUITAR

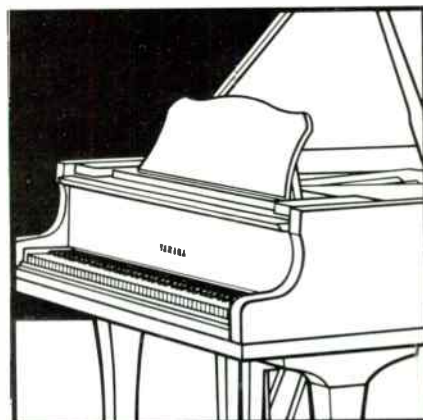

YAMAHA GRAND PIANO

**. . . YOU EITHER LISTEN
TO LIVE MUSIC OR YOU BUY
YOUR HI-FI FROM A
BADA DEALER**

BRITISH AUDIO DEALERS ASSOCIATION

BADA

**THE ULTIMATE IN
SOUND ADVICE**

• THE COUNTRY'S LEADING GROUP OF SPECIALIST HI-FI DEALERS •

For a list of BADA Members, see opposite page.

This month's theme is variety. Thank the ReBirth Brass Band for expanding the horizons. However, if you prefer not to deviate from your straight Rock groove, there's plenty to keep a smile on your face.

malcolm steward



PETER HOLSAPPLE & CHRIS STAMEY
Mavericks
RNA R2 70795

● The names Holsapple and Stamey might be unfamiliar to many, but guitar-band aficionados will recognise them instantly: Holsapple is the unofficial fifth member of R.E.M., and was co-founder, with Stamey, of The dB's, whose albums 'Stands For Decibels' and 'Repercussion' are regarded as classics. 'Mavericks' is the duo's first full album together since The dB's broke up in 1983 after five years together.

If, like me, you consider there's no place for pomp and pretension in Rock music, you'll enjoy this album. Without lacking sophistication, it



manages to capture the straightforward and direct feel of the music of bands like The Byrds and pre-acid Beatles. All the elements important to rock are well represented, particularly those of a melodic nature. As a bonus to the fine tunes on offer, Holsapple and Stamey provide some enjoyable vocal harmonising, for which I'll confess to being a sucker. They might not be the Everly Brothers but they're pretty damn good, nonetheless.

The album's arrangements and production are sympathetically open and uncluttered. It gives the decidedly uncommercial impression that it's merely a bunch of friends having fun making music. Because of that vital and all too rare constituent, it deserves to be astoundingly successful.

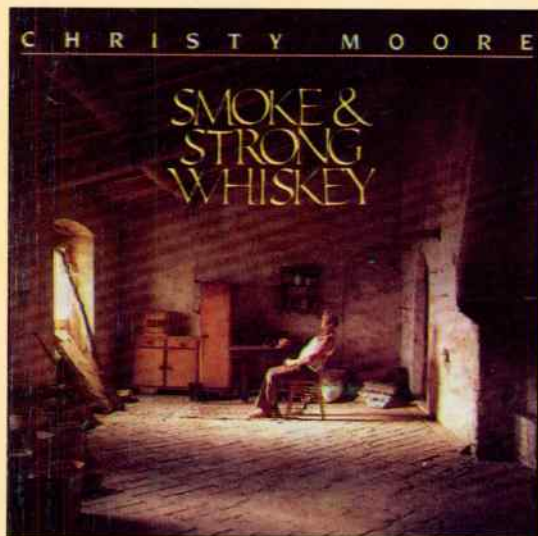

RECORD OF THE MONTH

CHRISTY MOORE

Smoke and Strong Whiskey

NEWBERRY CM0002-2

● There's an unmistakable aura surrounding certain albums; when you listen to them you sense that the performer made the disc for more spiritual and virtuous reasons than merely fulfilling contractual obligations or appeasing the bank manager. This is one of those records. 'Smoke and Strong Whiskey' is crammed to overflowing with genuine sentiment and heart-felt emotion. In terms of both content and performance it makes for compelling listening.

Christy Moore, in case you're not familiar with him, is an Irish balladeer and protest singer. His songs regularly reflect the injustices and inequalities he perceives in the world. However, the way in which he voices his opinions doesn't fit the stereotype attached to the genre. Polemic and dogma are traded for lyricism and, quite often, humour. Moore's songs don't batter you round the head, they seduce you. Their aesthetic wins your attention while the 'message' slips subliminally into your subconscious.

Naturally, the situation in his homeland is a major influence upon his writing. Songs like the album's title track and 'Whacker Humphries' put life in Northern Ireland into a far more human perspective than any amount of television documentaries

could ever hope to do. Listeners might find that their perspectives become altered after seeing the situation through Moore's eyes. In a lighter vein, other songs like 'Welcome To The Cabaret' and 'Encore' reflect his passion for music and offer an autobiographical insight into his personality.

The songwriting on this album is marvellous: his ability to articulate ideas is outstanding and wonderfully lyrical. If you enjoy well-crafted phraseology and vivid pictorial use of language, you'll doubtless appreciate Moore's talent in this respect. The musical performances, too, are excellent, and typify the magical harmony that occurs when the best of Irish musicians play together.

If the thought of 'folk' music normally deters you from buying an album, I'd encourage you to set aside your prejudices on this occasion and give this recording a try. It has a very contemporary feel, mixing acoustic and electric instruments, which lends it a superficially mainstream feel. Once you're into it, however, you'll discover that it's distanced by miles from mainstream 'product'. It's a class album by a modern-day troubadour cast in the Woody Guthrie mould.



SEAL
Seal
ZTT 9031-745571-1

● It's my opinion that when the likes of Otis Redding and Marvin Gaye departed this earth, Soul music suffered out of all proportion. Gone are the heydays of the sixties when Soul was true to the colloquialism after which it was named ('soul' was black American slang for sincerity and authenticity); in the past few years it has metamorphosed into a sugary slush. Back when the likes of Sam and Dave were injecting healthy shots of R'n'B into songs like 'Soul Man' and Aretha Franklin was bringing her stirring gospel into the popular mainstream, Soul wasn't soul-less.

I lost interest in the genre when it became ballad-ridden, but things look as though they might change. Passion and sincerity - is creeping back, and singers like Seal will be responsible for the renaissance of Soul. His eponymous debut album has really impressed me. It's not in any way retrospective or a rehash of cliches; it simply has the same sort of energy, vitality and spunk that characterised the soul music of old.

The record is highly contemporary in both its subject matter and production (courtesy of Trevor Horn). It frequently hits the button - like the single 'Crazy', or the killer bass line on 'Wild'. The track 'Deep Water' is sublime: funk with chiaroscuro and delicacy. With a few more albums like this, Soul will be able to venture out from the cloistered confines of the disco and take its place in the real world again.

RICHARD THOMPSON
Rumor and Sigh
CAPITOL 064-7 95713 1

● I'll admit at the outset that I'm biased: if someone released an LP of Richard Thompson doing the dishes or hoovering the carpet I'd probably buy it. But I can't help liking everything the man does. It comes from being a frustrated guitarist: if I was granted one wish, I'd ask the genie to appropriate Richard Thompson's talents for my own. If I couldn't have all his skills

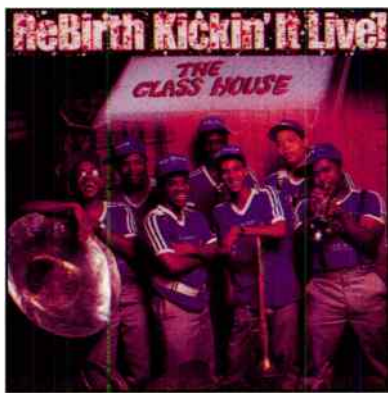

I'd be satisfied with just the ability to bend notes as perfectly and with the same telling expressiveness that he manages.

Don't, however, think that this is an album of axe-heroism: if you're looking for stunt playing buy Steve Vai's 'Passion And Warfare' or something similar. Thompson's recordings aren't excuses for pyromaniacal whammy-bar cranking. In fact, for an album from such an accomplished guitarist, you might find the scarcity of conventional instrumental breaks surprising. But Thompson isn't just a guitarist, he's also a brilliant songwriter and a powerful singer.

The mixture of material on 'Rumor and Sigh' is so eclectic yet well balanced that it's hard to pick out songs as favourites. If forced, I would incline towards the final track 'Psycho Street'. I found this track reminiscent of his contributions to the mind-blowing album he did with Henry Kaiser, John French and Fred Frith 'Live, Love, Larf and Loaf', another sure-fire recommendation for those with broad tastes.

THE REBIRTH BRASS BAND
Kickin' It Live!
SPECIAL DELIVERY SPDCD 1040

● This month's out-of-the-rock-genre inclusion comes from a band who featured on the first issue of Hi-Fi World's cover CD, The ReBirth Brass Band. Their live album hadn't reached the shops then but it's out now. If you want to take a break from your normal rock diet and try something different, this music might appeal. ReBirth are essentially a New Orleans marching band but their music draws on diverse influences and crosses boundaries with disarming ease.

Their exuberant playing draws on assorted idioms which include jazz, pop and rock, funk, rap and reggae. One of their most requested numbers 'Talk That Shit Now' came as a result of a football match: the local team, the Saints, beat the visiting side from Atlanta and the New Orleans fans began chanting the aforementioned phrase. The ReBirths had been playing



in the stands and immediately struck up an instrumental accompaniment: an instant new song.

Keeping it company are seven other numbers captured during a performance at New Orleans' Glass House during 1990's Mardi Gras. After hearing the incredible energy and drive this band invests in its performances, you'll feel like booking your flight immediately.

ELVIS COSTELLO
Mighty Like A Rose
WARNER BROTHERS 7599-26575-1

● There are few artists who regularly release albums of consistent quality. Elvis Costello does. Even fewer are able to cram quite as much contrast and intelligence into their collections of compositions. Elvis Costello can. Very few indeed put out albums without filler tracks. Elvis Costello doesn't.

'Mighty Like A Rose' is a particularly consistent album. It leaves you wondering how a writer as prolific as Costello manages to maintain the quality and inventiveness his writing exhibits (he reputedly composes new songs on a daily basis). It can only be a result of the passion that's painfully evident in every song - even on ersatz pop songs like 'The Other Side Of Summer' the customary vituperative Costello emerges, virtually spitting out the lyrics. Even when he's happy it seems that venom still courses through his veins.

This Mitchell Froom-produced album shows that the varied repertoire of styles which vie for inclusion in Costello's compositions remains ever-expanding, as does the number of musicians with whom he works since the Attractions-years. Former Attractions drummer Pete Thomas still gets a look-in but the rest of the credits are familiar session names like Jim Keltner, Marc Ribot, and Benmont Tench. There are writing collaborations too: two tracks are credited to MacManus (Costello) and (Paul) McCartney, the latter having co-written two songs on 'Spike' album.

As I said at the beginning, Costello remains consistent in every respect. Long may he continue so to do.

RESERVE YOUR COPY TODAY!

Complete this form and hand to your local newsagent



Please reserve/deliver* Hi-Fi World on a regular basis, commencing with the next issue, until further notice.

Name _____

Address _____

Signed _____ Date _____

*Delete as appropriate

Distributed to the
newstrade by **COMAG**
MAGAZINE MARKETING

Neil Ramsden 0535 • 606086

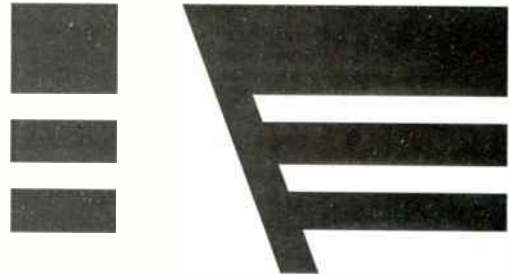

HI-FI PRODUCTS & SERVICES

- The Can Opener headphone adaptor unit
- The Stock Cube LP storage system

the



DEN

• The Main Course separate mains spur and equipment installation service

- Almost any commercially available title from anywhere in the world on any format
- The finest in-store listening facility in the UK
- Full International mail order service

Open Mon - Sat • 9am - 5.30pm • Closed Tues

COMPLETE RECORD SERVICE

Basement • 38 Cavendish St • Keighley • BD21 3RG

advertiser's index

| | |
|-----------------------------------|-------|
| ACOUSTIC ENERGY | 52 |
| ANTIFERENCE | 42 |
| AUDIO ENGINEERING SOCIETY | 42 |
| AUDIO EXCELLENCE | 40 |
| AUDIOFILE | 56 |
| AUDIO INNOVATIONS | 66 |
| AUDIO TECHNICA | 78 |
| CAM AUDIO | 80 |
| CLEAR CRYSTAL SYSTEMS | 96 |
| CONCORDANT | 76 |
| CONGLETON HI-FI | 78 |
| DENON | 4 |
| GRAHAMS HI-FI | 64 |
| HYPERTEC | 78 |
| ION SYSTEMS | 80 |
| MANA ACOUSTICS | 68 |
| MONITOR AUDIO | IFC |
| MOTOROLA | IBC |
| MUSICAL FIDELITY | 32/33 |
| NAIM AUDIO | 6 |
| NEWBURY AUDIO | 64 |
| NORTHWOOD | 82 |
| NOTTINGHAM ANALOGUE STUDIOS | 76 |
| PENTACHORD | 76 |
| PROAC | 24 |
| RON SMITH AERIALS | 42 |
| RUSS ANDREWS | 42 |
| SANSUI MISSION | BC |
| SEVENOAKS | 86/87 |
| SONIC LINK | 72 |
| STANDENS | 82 |
| STATION SOUNDS | 80 |
| VINYL TUBE AUDIO | 26 |
| VOLUME ONE | 70 |

CLEAR • CRYSTAL • SYSTEMS

WANTED: EARLY HI-FI

Loudspeakers and Units:

Tannoy 15" Monitors, ILLZ, Lancaster, York, GRF etc.
Western Electric/Westrex drivers and speakers.
Lowther, Voigt, Axiom 80, Airdale, Seimans, Vitavox,
Lockwood, Altec, Quad, JBL, Dual concentric units etc.

Turntables:

Garrard 301, BBC, EMT,
Thorens TD124 and TD224 etc.

Pickup Arms and Heads:

SME 12" Arms, Ortofon Arms and Heads,
Decca FFSS, EMT.

Valve Amplifiers:

Quad, Radford, McIntosh, Leak,
Western Electric, RCA etc.

Valves:

Audio Output...DA30, DA60, KT66, KT88,
PX4, PX25, 300 etc.

All interesting early Hi-Fi and Valves considered.

John Petrie-Baker,

CLEAR CRYSTAL SYSTEMS

Flat 2, 18 Canfield Gardens, London NW6 3JY

Tel: 071-328 9275 • Fax: 071-833 3008

MOBILE FIDELITY

24 CARAT GOLD PLATED COMPACT DISCS

A unique opportunity to obtain the ultimate in CDs. For high resolution and immortality Mobile Fidelity plate these discs with 24 carat gold. Almost unobtainable elsewhere, they are not cheap - but what price excellence?

THE WHO

TOMMY (double)

SUPERTRAMP

BREAKFAST IN AMERICA

CRIME OF THE CENTURY

FRANK SINATRA

SONGS FOR SWINGING LOVERS

ELTON JOHN

HONKEY CHATEAU

MADMAN ACROSS THE WATER

GOODBYE YELLOW BRICK ROAD

BOZ SCAGGS

SILK DEGREES

ROD STEWART

EVERY PICTURE TELLS A STORY

JEFF BECK

WIRED

JOE JACKSON

WILL POWER

NIGHT & DAY

BLIND FAITH

BLIND FAITH

HUEY LEWIS & THE NEWS

SPORTS

JETHRO TULL

THICK AS A BRICK

STAND UP

THE POLICE

SYNCHRONICITY

MOODY BLUES

DAYS OF FUTURE PASSED

ALLMAN BROTHERS

EAT A PEACH (dbl)

STEELY DAN

AJA

CAT STEVENS

TEA FOR THE TILLERMAN

DEF LEPPARD

PYROMANIA

BEACH BOYS

SURFER GIRL/SURFIN USA (dbl)

JOHN KLEMMER

TOUCH

JEFFERSON AIRPLANE

CROWN OF CREATION

VOLUNTEERS

CARPENTERS

SONG FOR YOU

THE BAND

MUSIC FROM THE BIG PINK

STING

THE DREAM OF THE BLUE TURTLE

HALL & OATES

VOICES

HARRY NILSSON

NILSSON SCHMILLSON

AFTER THE HURRICANE

SONGS FOR MONSERRAT

All Gold CDs: £22.95 (single);
£32.95 (dbl)

SHEFFIELD LABS

DIRECT TO DISC

PRIME CUTS

ROCK/JAZZ CD SAMPLER £4.99

THELMA HOUSTON

& PRESSURE COOKER

I'VE GOT THE MUSIC IN ME

HARRY JAMES & HIS BIG BAND

THE KING JAMES VERSION

DAVE GRUSIN

DISCOVERED AGAIN

HARRY JAMES & HIS BIG BAND

COMIN' FROM A GOOD PLACE

HARRY JAMES & HIS BIG BAND

STILL HARRY AFTER ALL THESE

YEARS

HI-FI WORLD JULY 1991

THE SHEFFIELD TRACK RECORD & THE SHEFFIELD DRUM RECORD

JAMES NEWTON HOWARD AND FRIENDS

ROCK INSTRUMENTALS

All CDs £14.49

CHESKY RECORDS

JAZZ SERIES COMPACT DISCS

Oversampled x 128 Audiophile Quality, considered by some to be the finest quality jazz recordings.

JAZZ SAMPLER

& AUDIOPHILE TEST CD

DAVID CHESKY

THE NEW YORK CHORINHOS

JOHN PIZARELLI

MY BLUE HEAVEN

HERBIE MANN

CAMINHO DE CASA

JOHNNY FRIGO

& JOHN PIZZARELLI

LIVE FROM STUDIO A

PHIL WOODS

HERE'S TO MY LADY

LUIS BONFA

NON-STOP TO BRAZIL

PAQUITO D'RIVERA

TICO! TICO!

CLARK TERRY

PORTRAITS

ANA CARAM

RIO AFTER DARK

DAVID CHESKY

CLUB DE SOL

All CDs £13.49

CHESKY CLASSICAL

RCA CLASSICAL CATALOGUE ON VINYL REISSUED

BERLIOZ

SYMPHONIE FANTASTIQUE

RESPIGHI

PINES OF ROME/FOUNTAINS

OF ROME

ALBENIZ, DE FALLA & GRANADOS

SPAIN

RAVEL/RACHMANINOFF

THE REINER SOUND

RAVEL

DAPHNIS ET CHLOE

RIMSKY KORSAKOV

SCHEHERAZADE

GERSHWIN

RHAPSODY IN BLUE/AN

AMERICAN IN PARIS

PROKOFIEV/ STRAVINSKY

LT. KIJE/SONG OF THE NIGHTIN-

GALE

LIZT/DOHNANYI

PIANO CONCERTO NO.1/ VARI-

ATIONS ON A NURSERY SONG

MOUSSORGSKY

POWER OF THE ORCHESTRA

A NIGHT ON BALD MOUNTAIN/

PICTURES AT AN EXHIBITION

All LPs £13.49

FANTASY

A truly amazing catalogue of top flight artistes. These American LPs capture all the life and zest of the jazz scene in the post war years.

DAVE BRUBECK

BEST FROM THE FANTASY YEARS

MILT JACKSON QUARTET

MILT JACKSON QUARTET

THE MODERN JAZZ QUARTET

CONCORDE

MILES DAVIS

THE MUSINGS OF MILES

FEATURING SONNY ROLLINS

NEW MILES DAVIS QUINTET

SONNY ROLLINS

WORKTIM

STAN GETZ/ZOOT SIMS

THE BROTHERS

THE THELONIOUS MONK

TRIO

THE THELONIOUS MONK TRIO

S.ROLLINS/MODERN JAZZ

QUARTET

S ROLLINS/MOD JAZZ QUARTET

MILES DAVIS/MILT JACKSON

QUINTET/SEXTET

GENE AMMONS ALL STARS

THE HAPPY BLUES

THELONIOUS MONK

MONK

THELONIOUS MONK

PLAYS DUKE ELLINGTON

BRILLIANT CORNERS

KENNY BURRELL

KENNY BURRELL

JOHN COLTRANE

COLTRANE

SOULTRANE

COLEMAN HAWKINS

THE HAWK FLIES HIGH

SONNY ROLLINS

SOUND OF SONNY

MOVING OUT

FREEDOM SUITE

WES MONTGOMERY

WES MONTGOMERY TRIO

INCREDIBLE JAZZ GUITAR

MOVIN ALONG

BILL EVANS TRIO

EXPLORATIONS

THELONIOUS MONK/ JOHN

COLTRANE

THELONIOUS MONK/JOHN

COLTRANE

CHARLIE PARKER

BIRD AT ST NICKS

MILES DAVIS

BLUE MOODS

AND HORNS

PHILWOODS QUARTET

WOODLORE

MODERN JAZZ QUARTET

DJANGO

THELONIOUS MONK/SONNY

ROLLINS

THELONIOUS MONK/SONNY

ROLLINS

JOHN COLTRANE

SETTIN THE PACE

BILL EVANS TRIO

PORTRAIT IN JAZZ

All LPs £7.99

ECM

JAN GARBAREK

EVENTYR

THOSE BORN WITH WINGS

PATHS AND PRINTS

DAVID TOR

CLOUD ABOUT MERCURY

JOHN ABERCROMBIE

GETTING THERE

CURRENT EVENTS

CHICK COREA

TRIO MUSIC LIVE IN EUROPE

RALPH TOWNER/GARY

BURTON

SLIDE SHOW

MARK JOHNSON

BASS DESIRE

OREGON CROSSING

KEITH JARRETT

STANDARDS VOL 2

PAT METHENY

TRAVELS

OFF RAMP

AS WICHITA FALLS

LIVE 80/81

AMERICASN GARAGE

CHAUTAUQUA

WATERCOLOURS

BRIGHT SIZE LIFE

FIRST CIRCLE

REJOICING

Hi-Fi World record mail order service

Hi-Fi World offers you a rich and varied selection of interesting artists, rare performances and very special audio recordings. We even have Digital Audio Tapes and gold Compact Discs both of which offer the best in digital audio quality. All these recordings are offered at very competitive prices!

ABERCROMBIE/ JOHNSON/ ERSKINE

LIVE

KEITH JARRETT

NUDE ANTS

KOLN CONCERT

STANDARDS VOL I

PERSONAL MOUNTAINS

DARK INTERVALS

KEITH JARRETT TRIO

STILL LIVE

CHANGELESS

DAVE HOLLAND TRIO

TRIPPLICATE

OREGON

ECOTOPIA

MARC JOHNSON

SECOND SIGHT

Z.HUSSAIN/J.MC,LIN

MAKING MUSIC

JAN GARBAREK

WAYFARER

RALPH TOWNER

SOLSTICE SOUND & SHADOWS

OLD FRIENDS NEW FRIENDS

BLUE SUN

CHICK COREA

TRIO MUSIC

(dbl)

LIVE 80/81

GARY BURTON/CHICK

COREA

DUET

LP (single): £8.99

LP (double): £12.99

CD (single): £12.99

CD (dbl): £16.99

GRP

DAVE GRUSIN

DG & THE NY-LA DREAM BAND

NIGHTLINES

ONE OF A KIND

MOUNTAIN DANCE

GLENN MILLER ORCHESTRA

IN THE DIGITAL MOOD

GERRY MULLIGAN

LITTLE BIG HORN

SPECIAL EFX

SPECIAL EFX

MODERN MANNERS

SLICE OF LIFE

CONFIDENTIAL

MYSTIQUE

DOUBLE FEATURE

DAVE VALENTIN

KALAHARI

JUNGLE GARDEN

LIVE AT THE BLUE NOTE

MIND TIME

LIGHT STRUCK

DIANE SCHUUR

DEEDLES

SCHUUR THING

TALKIN' ABOUT YOU

DIANE SCHUUR & THE BASIE OR-

CHESTRA

TIMELESS

THE COLLECTION

KEVIN EUBANKS

OPENING NIGHT

KEVIN EUBANKS
SHADOW PROPHETS
THE SEARCHER
MARK EGAN
A TOUCH OF LIGHT
DON/DAVE GRUSIN
STICKS AND STONES
EDDIE DANIELS
MEMOS FROM PARADISE
BLACKWOOD
DAVE GRUSIN
THE COLLECTION
GARY BURTON
TIMES LIKE THESE
OMAR HAKIM
RHYTHM DEEP
JOHN PATITUCCI
ON THE CORNER
DAVID BENOIT
URBAN DAY DREAMS
THE RIPPINGTONS
TOURIST IN PARADISE
DAVE GRUSIN
MIGRATION
LEE RITENOUR
COLOR RIT
NELSON RANGELL
PLAYING FOR KEEPS
DAVID BENOIT
WAITING FOR SPRING
DAVE GRUSIN
THE FABULOUS BAKER BOYS
C. COREA ELEKTRIC BAND
INSIDE OUT
STEVE KHAN
PUBLIC ACCESS
PAT METHENY/GARY BURTON
REUNION
DEBORAH CONANT
CAUGHT IN THE ACT
EDDIE DANIELS
NEPENTHE
PATTI AUSTIN
LOVE IS GONNA GETCHA
GEORGE HOWARD
PERSONAL
DON GRUSIN
RAVEN

LP: £9.49 CD: £12.99

TOPIC

SPECIAL DELIVERY

RORY BLOCK
TURNING POINT
GREGSON/COLLISTER
MISCHIEF
A CHANGE IN THE WEA.
LOVE IS A STRANGE HOTEL
HOME AND AWAY
CLIVE GREGSON
WELCOME TO THE WORKHOUSE
JONATHAN RICHMAN
JONATHAN GOES CTRY.
JONATHAN RICHMAN
REBIRTH BRASS BAND
REBIRTH KICKIN' IT LIVE
VARIOUS ARTISTS
HARD CASH
MARTIN CATHY AND DAVE SWARBRICK
LIFE AND LIMB
BLOWZABELLA
VANILLA
WEB WILDER & BEATNECKS
IT CAME FROM NASHVILLE
BOBBY KING & TERRY EVANS
LIVE & LET LIVE
RHYTHM, BLUES, SOUL
OTIS GRAND & DANCE KINGS
ALWAYS HOT
MIGHTY FLYERS
UNDERCOVER
SUGAR RAY & THE BLUE-TONES
KNOCKOUT
ROBERT EARL KEEN JNR
WEST TEXTURES
WOODIE GUTHRIE
STRUGGLE
THE METERS
GOOD OLD FUNKY MUSIC

DELMARK

(Available on LP only)
EARL HINES
AT HOME
CALLOWAY/HAMILTON/FIELDS/BIG BAND JAZZ
TULSA TO HARLEM
SLEEPY JOHN ESTES
LEGEND OF
BROKE AND HUNGRY
IN EUROPE
JUNIOR WELLS
HOODOO MAN BLUES
SOUTH-SIDE BLUES JAM
ON TAP

RAVEN

THE ANIMALS
THE MOST OF (ALL ERAS COMP)
ROADRUNNERS
THE BYRDS
FULL FLUTE
THE YARDBIRDS
OVER UNDER SIDEWAYS DOWN

ROUNDER

CLARENCE 'GATEMOUTH' BROWN
ALRIGHT AGAIN (LP only)

SHANACHIE

LADYSMITH BLACK MAMBAZO
ULWANDLE OLUNEGWELE
INALA
CLASSIC TRACKS (comp)
CLANNAD
IN CONCERT
STEELEYE SPAN
TEN MAN MOP (CD only)
THE VILLAGE WAIT (LP only)

YAZOO (Available on LP only)

BIG BILL BROONZY
THE YOUNG BIG BILL
DO THAT GUITAR RAG

CRIPPLE CLARENCE LOFTON & WALTER DAVIS
BO CARTER (1931-40)
TWIST IT BABE
TAMPA RED
BOTTLENECK GUITAR
FRANK STOKES
CREATOR OF THE MEMPHIS BLUES
BLIND BOY FULLER
TRUCKIN' MY BLUES AWAY
MISSISSIPPI JOHN HURT
THE 1928 SESSIONS
MA RAINEY'S
BLACK BOTTOM
ROBERT JOHNSON
THE ROOTS OF

LP: £7.49 CD: £10.99

LINN RECORDS

BLUE NILE
A WALK ACROSS THE ROOFTOPS
HATS
CAROL KIDD
CAROL KIDD
ALL MY TOMORROWS
NICE WORK (LP only)
THE NIGHT WE CALLED IT A DAY
DAVID NEWTON
VICTIM OF CIRCUMSTANCE
AKH013
MARTIN TAYLOR
DON'T FRET

Linn Records: LPs £7.99
CDs £11.99

RECUT RECORDS

RAVEL & BARTOK
PIANO CONCERTO £8.99
BEETHOVEN
5th SYMPHONY £8.99
PIANO CONCERTO (dbl £11.99)
STOCKHOLM ART TRIO
BRAHMS PIANO TRIO £8.99

LINN SELEKT RECORDS

SOLOMON BURKE
A CHANGE IS GONNA COME
ELVIS COSTELLO & THE ATTRACTIONS
ARMED FORCES
THE PENTANGLE
BASKET OF LIGHT
NANCI GRIFFITH
LAST OF THE TRUE BELIEVERS
ALPHA BLONDY & THE WAILERS
JERUSALEM
STEVE PHILIPS
STEEL RAIL BLUES
MILCHO LEVIEV QUARTET
BLUES FOR THE FISHERMAN
CRUSELL CLARINET QUARTETS
THEA KING/ALLEGRI ST QUARTET
HILDEGARD OF BINGEN
FEATHER ON THE BREATH OF GOD
DEBUSSY/RAVEL STRING QUARTETS
FAIRFIELD QUARTET
T-BONE BURNETT
PROOF THROUGH THE NIGHT
J. B. LENOIR
ALABAMA BLUES!
JOHNNY ADAMS
ROOM WITH A VIEW OF THE BLUES
BOBBY KING, TERRY EVANS
LIVE AND LET LIVE!
JOHN COLTRANE
BALLADS
MUSICIANS OF SWANNE ALLEY
IN THE STREETS & THEATRES OF LONDON
All Linn Selekt LPs £7.99

DAT
ELVIS COSTELLO
GIRLS VOL.1 (dbl £29.80)
DUKE STRING QUARTET
DUKE STRING QUARTET

DURUTTI COLUMN
GUITAR & OTHER MACH.
VINI REILLY
HAPPY MONDAYS
BUMMED
ROLF HIND
ROLF HIND
JOY DIVISION
SUBSTANCE
NEW ORDER
SUBSTANCE (dbl £36.80)
TECHNIQUE
KREISLER STRING ORCH.
VARIOUS WORKS
STEVE MARTLAND
STEVE MARTLAND
WILLIAMS/KELLY
ROBIN WILLIAMS & JUL

All DAT: £19.80 (or as priced)

★ For a limited period we are able to supply the following GRP recordings on DAT at the special price of £10.99. ONLY WHILE STOCKS LAST!!



GRP LIVE IN SESSION
GLENN MILLER ORCHESTRA
IN THE DIGITAL MOOD
CHICK COREA ELEKTRIC BAND
LIGHT YEARS
DAVE GRUSIN/LEE RITENOUR
HARLEQUIN
DIANE SCHUUR
& THE COUNT BASIE ORCHESTRA
NEW MAGIC
DIGITAL SAMPLER
DUKE ELLINGTON ORCHESTRA
DIGITAL DUKE
DAVE GRUSIN
CINEMAGIC

RECORD MAIL ORDER SERVICE ORDER FORM

PLEASE FILL IN THE DETAILS BELOW IN BLOCK CAPS

| ARTIST | TITLE | LABEL | PRICE | LP | CD | DAT |
|--------|-------|-------|-------|--------------------------|--------------------------|--------------------------|
| _____ | _____ | _____ | _____ | <input type="checkbox"/> | <input type="checkbox"/> | <input type="checkbox"/> |
| _____ | _____ | _____ | _____ | <input type="checkbox"/> | <input type="checkbox"/> | <input type="checkbox"/> |
| _____ | _____ | _____ | _____ | <input type="checkbox"/> | <input type="checkbox"/> | <input type="checkbox"/> |
| _____ | _____ | _____ | _____ | <input type="checkbox"/> | <input type="checkbox"/> | <input type="checkbox"/> |
| _____ | _____ | _____ | _____ | <input type="checkbox"/> | <input type="checkbox"/> | <input type="checkbox"/> |
| _____ | _____ | _____ | _____ | <input type="checkbox"/> | <input type="checkbox"/> | <input type="checkbox"/> |
| _____ | _____ | _____ | _____ | <input type="checkbox"/> | <input type="checkbox"/> | <input type="checkbox"/> |

In the United Kingdom add £1.00 per Record for postage and packing. Five or more records postage free. Overseas: add £2.00 per record P&P. Five or more records add £1.00 each.

Total number of albums ordered: _____ Total for P&P: £ _____ Total Price: £ _____

Please make your cheque/postal order payable to **Audio Publishing Ltd.**
Send to: **Hi-Fi World, 64 Castellain Road, Maida Vale, London W9 1EX.**

Name: _____

Address: _____

Daytime tel. no: _____

Delivery within 28 days subject to availability. Prices are subject to alteration without prior notice. E&OE

THE IDEA BEHIND THE NEW MOTOROLA PERSONAL PHONE.



Take a look at the telephone in your home or on your desk. Chances are it's perfectly ordinary with no particularly special features or functions. Why then should a portable phone be any different? The Motorola Personal is a simple straightforward portable telephone. Its design is unique. The mouthpiece folds neatly away when not in use making it small enough to fit into a pocket. And like all Motorola portable and car phones, it is built to exceptionally high standards and stringently tested well beyond the rigours of normal daily use. So it's one of the most durable phones around. The new Personal. Another bright idea from the world's largest and most experienced cellular portable phone manufacturer. For more information about the Motorola Personal and the rest of the Motorola range, dial 100 and ask for Freephone Motorola.



SANSUI



D-X211HX-R

r.r.p. £169.95

"The SANSUI works well
and deserves every success.
A clear Best Buy."

HI-FI CHOICE April 1991



For your nearest dealer phone 061 866 8101