

**BOARDMAKER 1 – Special Offer Inside**

# **ELECTRONICS** **in ACTION**

February 1994 £2.25

## **VR** Virtual Reality

From Childrens  
Television to  
Space Shuttle  
Aerodynamics

**Future View**  
Virtual Shopping

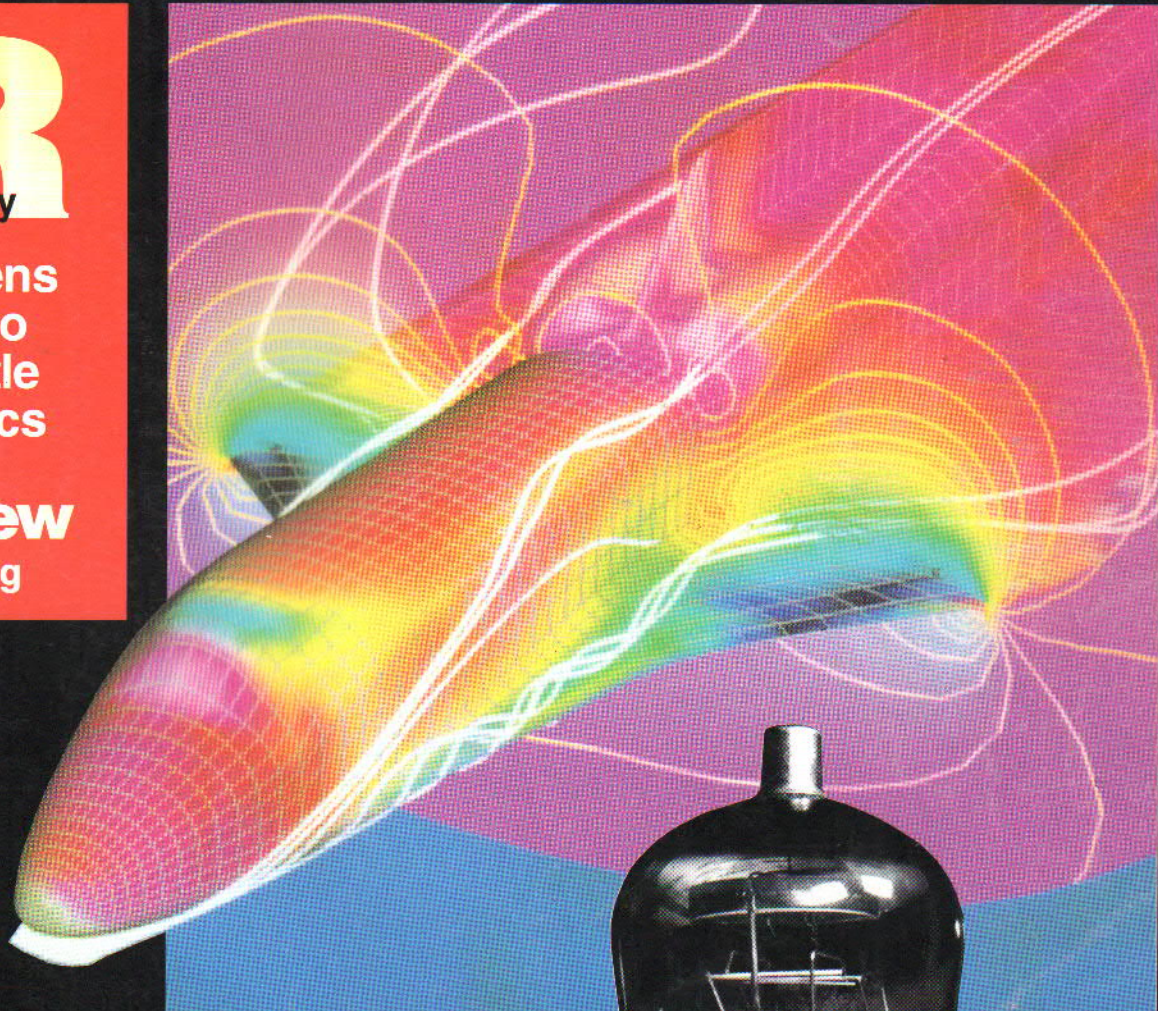

## **Class A Amplifier**

Part 2  
PSU Construction

## **The Switcher**

Adding a  
remote  
control



**John  
Linsley  
Hood**

The  
Evolution  
of Audio  
Amplifier  
Design



## **In Control**

Constant speed for  
your PCB drill

## **Chick, Chick, Chicken**

Building your own hatchery controller





# Design and Verify Circuits. Fast.

DOS, Windows versions available

## Electronics Workbench®

**NEW** Version 3

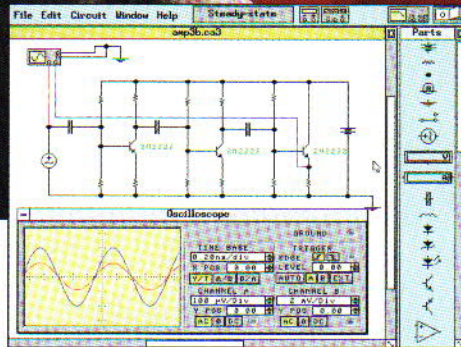
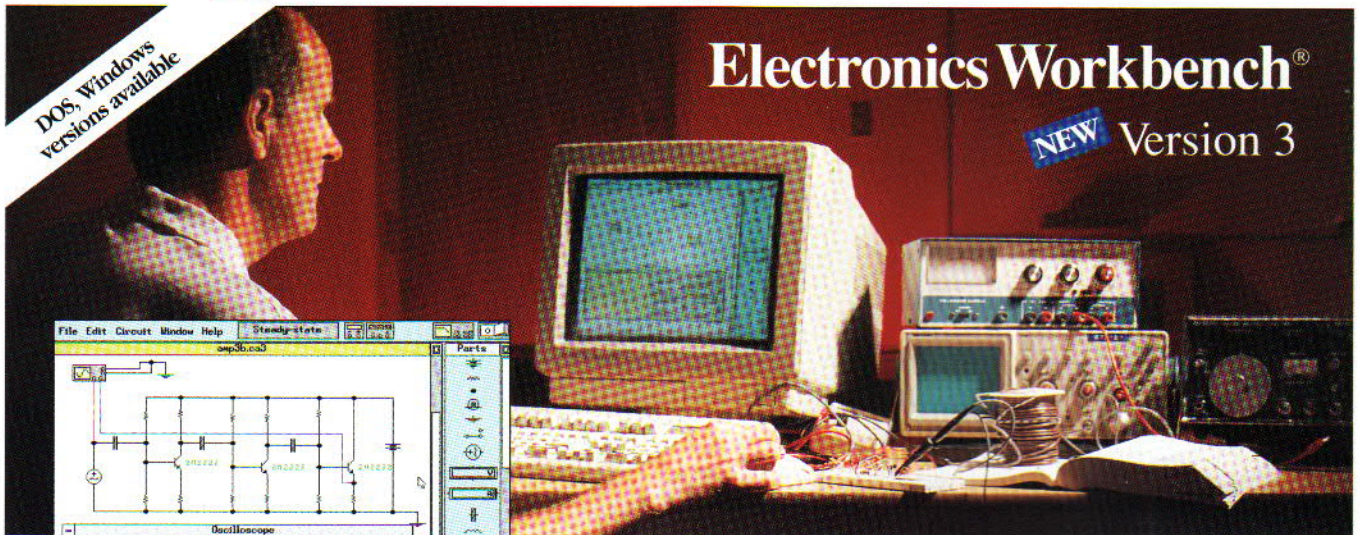

### Analog Module includes:

- complete control over all component values
- ideal *and* real-world models for active components
- resistors, capacitors, inductors, transformers, relays, diodes, Zener diodes, LEDs, BJTs, opamps, bulbs, fuses, JFETs, and MOSFETs
- manual, time-delay, voltage-controlled and current-controlled switches
- independent, voltage-controlled and current-controlled sources
- multimeter
- function generator (1 Hz to 1 GHz)
- dual-trace oscilloscope (1 Hz to 1 GHz)
- Bode plotter (1 mHz to 10 GHz)
- SPICE simulation of transient and steady-state response

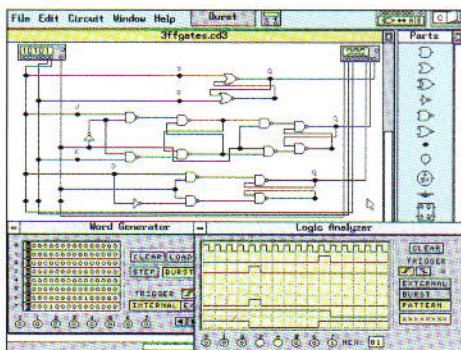

### Digital Module includes:

- fast simulation of ideal components
- AND, OR, XOR, NOT, NAND and NOR gates
- RS, JK and D flip-flops
- LED probes, half-adders, switches and seven-segment displays
- word generator (16 eight-bit words)
- logic analyzer (eight-channel)
- logic converter (converts among gates, truth table and Boolean representations)

## Complement Your Test Bench

Here's why Electronics Workbench belongs on *your* test bench: Wires route themselves. Connections are always perfect. And the simulated components and test instruments work just like the real thing. The instruments are indestructible and the parts bin holds an unlimited supply of each component. The result: thousands of electronics professionals and hobbyists save precious time and money. **Over 90% would recommend it to their friends and colleagues.** Electronics Workbench: the ideal, affordable tool to design and verify your analog and digital circuits before you breadboard.

And now the best is even better - Electronics Workbench Version 3.0 is here. It simulates more and bigger circuits, and sets the standard for ease of use. Guaranteed!

### **NEW** Features in Version 3

- new components include JFETs, MOSFETs, voltage-controlled and current-controlled sources and manual, time-delay, voltage-controlled and current-controlled switches
- real-world models for opamps, BJTs, JFETs, MOSFETs and diodes - over 100 models available
- MS-DOS version now supports up to 16 MB of RAM for simulation of bigger circuits
- new Microsoft® Windows™ version available
- technical support now also available on CompuServe®

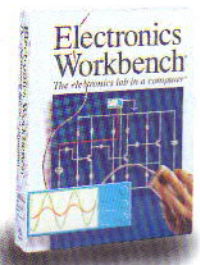

**Just £199!**

## Electronics Workbench®

*The electronics lab in a computer™*

# Call: (0827) 66212



ROBINSON MARSHALL (EUROPE) LTD.  
17 Middle Entry, Tamworth, Staffordshire, England B79 7NJ  
Fax: (0827) 58533

\*30-day money-back guarantee.

Shipping charges - UK £4.99. All prices are plus V.A.T.  
All trademarks are the property of their respective owners.





### EDITOR

Paul Freeman-Sear

### SUB EDITOR

Helen Armstrong

### DESIGN and TECHNICAL ILLUSTRATION

Iain Houston

### CONTRIBUTORS

Andrew Armstrong

Helen Armstrong

Andrew Chadwick

John Linsley-Hood

Mike Meechan

Brian Padgett

David Silvester

Paul Stenning

Professor Bob Stone

### ADVERTISING SALES

Gilly Martin

☎ 0442 842069

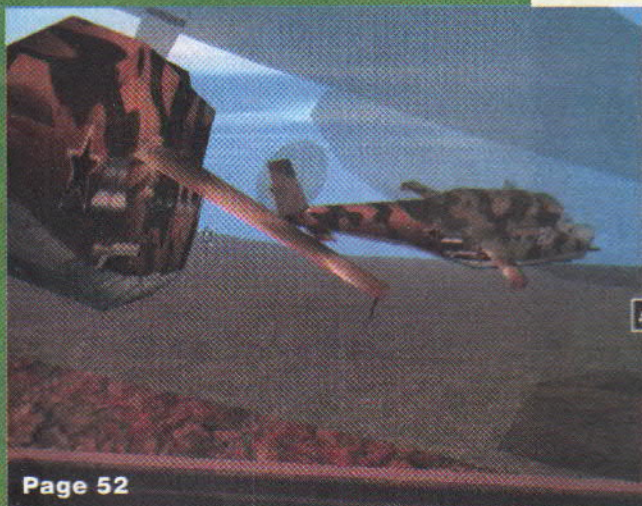

Page 52



PO BOX 600, BERKHAMSTED  
HERTS HP4 1NL  
TELEPHONE 0442 842069  
FAX 0442 842279

## 4 Here is the news...

What's going on in the technology world  
A news view from all points of the compass

## 8 Research World

Technical advances from around the globe.

## 10 Egg Patrol

David Silvester plays mother hen and provides  
the egg-nition for the hatch.

## 18 In Control

Say goodbye to erratic 12V drill speed.  
Paul Stenning keeps things constant.

## 22 The Evolution of Audio Amplifier Design

Starting with the ever popular valve, John Linsley-Hood  
charts the rise and rise of an important part of many peoples  
everyday life.

## 28 Signal to Noise

Another batch of correspondence from the post bag.

## 32 Technoshop

More offers and exchanges in our monthly team-up with The  
Technology Exchange.

## 33 The Switcher Part 4

Mike Meechan looks at another optional extra - remote control.

## 42 Class A Power Amplifier Part 2

This month Andrew Armstrong provides us with a power  
supply and a few running modifications.

## 46 REMAP Part 2

Technical help for the disabled. A report by Andrew Chadwick.

## 48 Hijaak Review

Paul Stenning puts Hijaak Pro under the microscope.

## 50 From Paper to PCB

Want to make your own PCBs? David Silvester takes you  
through the steps required.

## 52 Virtually Real

Andrew and Helen Armstrong  
report on the latest Virtual Reality  
developments from the VR User Show.

## 62 Ideas Forum

Where innovative ideas turn into inventions.

## 63 At Your Service

The one stop shop for PCBs past and present.

## 64 Future View

Professor Bob Stone from Advanced Robotics Research Ltd.  
grabs his trolley and races around a virtual supermarket.

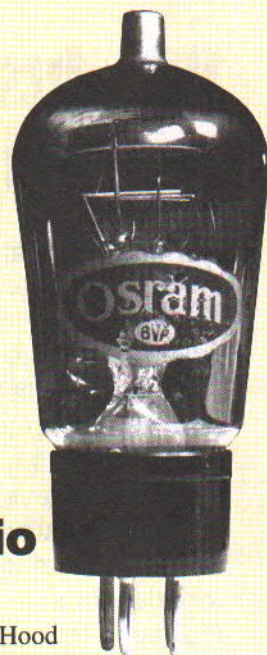

Page 52



# VR Just like the real thing

In this Virtual Reality edition of EIA we look at what is on offer for this emerging technology and where it will take us in the future.

I am in no doubt that VR will succeed as a form of amusement. Almost total immersion into a computer generated world will always be an attractive idea to escape reality and to effectively achieve the impossible in the quest for adventure.

However, fears have been expressed over the dangers of VR, where long periods of immersion could lead to the extension of those fantasies into the real world, harming oneself and others in the process. But then, that's what they said TV would do.

The positive benefits of VR will make it easier to visualise mechanisms using 3D in molecular chemical processes, prepare oneself for specific activities like future football or cricket matches or even racing circuits and carry out remote operations in space from the comfort of earth.

## Virtual Shopping

Some say that teleshopping (buying from the TV screen) will not catch on. If not, then maybe Virtual shopping will. For many, an essential part of shopping is to experience the act of being there. If that is the case, the social interactive nature of shopping could be fulfilled using Virtual reality, meeting virtual people but buying real goods. Only time will tell.

**Paul Freeman-Sear**

Every care is taken when compiling the magazine. However, the publishers cannot be held legally responsible for errors in the magazine or from loss arising from those errors. Any errors discovered will be published in the next available edition of the magazine.

Electronics in Action is published on the third Thursday of the month preceding the cover date. The magazine contents remain the copyright of Quantum House Publications Ltd. Any reproduction requires written consent of Quantum House Publications Ltd. All prices contained in the magazine are correct at time of going to press. The publishers or the advertisers cannot be held responsible for any variations in price or availability after the magazine has gone to press.

Published by **Quantum House Publications Ltd.**, PO Box 600, Berkhamsted, Herts HP4 1NL. Newstrade distribution by Seymour, Windsor House, 1270 London Rd., Norbury, London SW16 4DH Tel: 081 679 1899. Reproduction by Island Graphics, Chesham, Bucks. Tel: 0494 773082. Printed by Wiltshire (Bristol) Ltd., Philip St., Bedminster, Bristol BS3 4DS. Tel: 0272 760076

# NEWS



## Fast PostScript Colour Printers

Mitsubishi has announced an exclusive agreement with BIT (UK) Limited to provide exceptionally fast and accurate colour PostScript printing with the new Zenographics Zscript 1.0 and SuperPrint 3.0 software. Included are Mitsubishi's advanced full A3 bleed and A4 thermal transfer and dye sublimation colour printers. The printer and software packages are available from Bit, the UK's Zenographics software distributor. The complete printer and Zenographics

software packages cost £4495 for the G6710 full A3 bleed thermal transfer and the S3410 A4 dye sublimation printers. The S3600 A4 and S6600 full A3 bleed dye sublimation printer packages cost £5995 and £8995 respectively.

The combination of ZScript 1.0 and Superprint 3.0 will work for even difficult products that normally require PostScript printers. ZScript 1.0 software runs an application and interprets

## Europe Discovers Columbus

The Columbus handheld routefinding computer will be one of the traffic auto-navigation methods taking part in the EC Drive Programme in 1994. Partly funded by the European Commission and partly by its participants all over Europe, Drive 2 - the programme is now in its second phase - aims to establish a Europe-wide format for communicating road and traffic information to organisations and drivers. The BBC, Department of Transport, British Telecom and the AA are among the organisations taking part in the trials, which include in-car navigation,

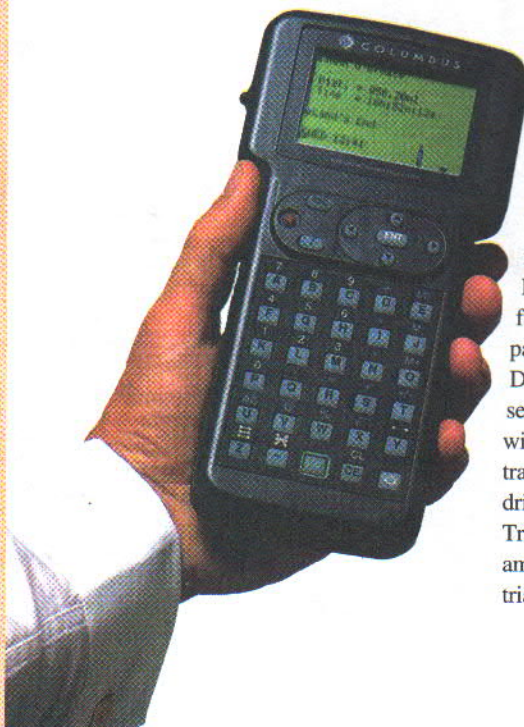



# Nuclear Safety On Paper

## The Health and Safety Executive

(HSE) has issued the second edition of its Nuclear Safety Newsletter, published by the Nuclear Safety Division of the HSE.

The four-page newsletter concentrates

mainly on reporting the activities of the Nuclear Installations Inspectorate, investigating possible weak points in safety measures. It aims mainly at reassuring people working in the industry that everything is being done to keep watch on safety issues, in line with the HSE's brief. The newsletter reports, for instance, that Trawsfynydd power station in Snowdonia will be decommissioned because metal welds are turning brittle faster than expected,

PostScript files from almost any source including Windows, DOS, Macintosh and Unix environments. The output files from ZScript can be viewed, imported into Windows applications and output on a non PostScript printer. SuperPrint 3.0 is a 32bit print engine for Windows which provides high speed output to the printer.

The software is device independent, 32bit and multitasking to optimise printing operations.

SuperPrint 3.0 incorporates 32bit Windows Super Drivers which accelerate Windows applications via SuperRip imaging technology. High quality graphics, pictures and text are output at high speed using Windows 3.1's 32bit architecture. Where users have sufficient memory in their PCs then complete images can be rasterised without having to rasterise to disk, providing even faster performance.

SuperText provides SuperPrint 3.0 with effective font scaling facilities. On the fly scaling to screen and printer is readily provided simultaneously for TrueType, Adobe, Bitstream, Intellifont and Nimbus Q fonts.

These dye sublimation and thermal

transfer printers can also be supplied for dedicated workstation solutions, and are capable of printing full bleed on A3 and A4 paper respectively as well as on A3/A4 transparency. BIT (UK) Limited can also supply a range of software for use with Mitsubishi printers in workstation applications, such as Easycopy.

The near photographic quality, continuous tone dye sublimation printers provide noticeably fine curves and smooth colour gradations from a palette of 16.7 million colours.

Full page buffer memories are provided and built-in colour adjustment capabilities enable realistic photo images to be easily achieved. Close control is provided for Gamma correction, contrast, density and sharpness and as well as multiple copies, the printers are able to work with three or four colour ink rolls according to user requirements, on paper and transparency.

For further information, please contact either: **Phillip John or Brian Evans at Mitsubishi Electric UK Ltd, Electronic Products Group, Telephone:0707 278614 Fax:0707 278659** ●

and that Bradwell's turbine cooling intake had been blocked by seaweed and mussels. The reactors were shut down while pump strainers were cleared. "Although the incident was rated as having little nuclear safety significance, it generated considerable public concern", says the newsletter.

The October newsletter carries reports from May to September, and everything appears to be under control. Would they tell us if it wasn't? Nuclear Safety Newsletter appears three times a year free of charge from the Health and Safety Executive - phone 0742 892345 or fax 0742 892333. ●

**The famous Avometer** multimeter, almost a legend in its own lifetime, celebrated its 70th birthday in December. Launched in 1923 as the world's first test meter with multi-range facilities, the Avometer multimeter earned its name (bestowed by inventor Donald Macadie) from its Amps, Volts and Ohms ranges - an imaginative move which paid off in terms of memorability.

Not that the Avometer is anything other than memorable. In continuous production since 1923, with new, extended models following - the Universal Avometer in 1933, introducing AC ranges; the Avometer Model 7 in 1936, notably adding an automatic cut-out in place of the fuse; the robust Avometer Model 40 in 1940 to measure 3-phase voltages for the power industry; the Avometer Model 8, perhaps the most classic model, in 1948.

The heavy-duty black Avo housing with its integral leather carrying-stap became a mandatory symbol of the trade for everyone involved in live electrical

relaying traffic data through the phone network and RDS radio, Point of Information touch-screen terminals in motorway services and other aspects of route-planning using electronics, telecommunications and computing.

Columbus manufacturer Panstar plans to use around 20 new Ford Mondeos, supplied by Hertz Hire, for system trials in the projected London/Paris corridor, codenamed "Pleiades". Trials are due to start in February in the Kent area. Columbus will be specially adapted to receive live traffic data from RDS radio, and further modifications will allow the computer to display and speak the traffic messages received so that the driver only receives traffic warnings relating to his or her journey. The driver will be offered an alternative route to avoid hold-ups. ●





(later electrical and electronic) engineering professionally or as a serious interest. The company went public as Avo Ltd. in 1957, one year before the 1,000,000th Avo Model 8 was manufactured.

New models have continue to appear as needs and modern components change, but the Avo Meter has kept its classic build, fondly known as one of the few portable test instruments that can double as a tool-stand and doorstep on those awkward in-the-field jobs. We wish Avo an equally successful 21st century.

Information on the latest Avometers can be obtained from:

**Avo International, Archcliffe Road, Dover, Kent CT17 9EN. Tel. 0304 202620. Fax 0304 241491.**

## Leeds University to hold an Information Technology Day

**BIT '94** is a one-day conference bringing together over 500 students from further and higher education institutions throughout the UK with people from research, industry and commercial companies. Several other IT conferences will run simultaneously in other parts of Europe, and the sites will be linked in a videoconference so that the debate can be carried on in the proper style - live.

Following BIT, 200 delegates from each country will fly to Toulouse in France for a pan-European two-day conference. This is the fifth IT conference organised by the European Conference on Advance Information Technology (JETAI).

The 1994 theme is the buzzword of the era, Virtual Reality, biased towards its importance to business and industry. The conference, which is already backed by British Telecom, the National Westminster Bank and KPMG Peat Marwick, is looking for involvement from other companies and organisations. Contact with researchers at University level and committed technology students will be one benefit of closer involvement, especially for companies looking to recruit IT staff in the future.

## The Gadget Shop

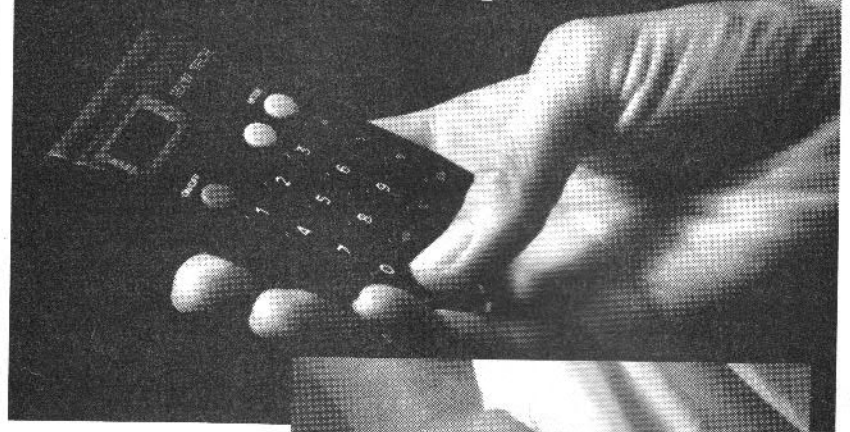

Some of us just love tinkering around with electronic gadgets. There is a new chain of shops to fulfil that demand. Called appropriately The Gadget Shop here are one or two items of interest.

### Universal Remote Control

A must for those constantly hunting around for separate remote controls for the TV, Hi-Fi, CD etc., this ingenious device can store all the functions of the others in one unit. Just place one of the existing controls opposite it and copy each function across. (Price 29.95)

### Weather Station

This precision instrument measures barometric pressure, comparing it to that over the previous 24 hours and predicts the weather using symbols to denote cloudy, sunny, overcast and rainy. In addition it can function as an alarm, calendar and clock, making the perfect desk accessory. Requires 4 AA batteries. (£89.95)

### Talking Calculator

Each time a key is pressed, the function chosen is spoken out which helps to double check calculations as they are typed in. When the calculation is complete the answer is also spoken. Requires 2 AA batteries. (£14.95)

### Battery Manager

Until recently it has been assumed that it was unsafe to recharge ordinary general



**Above: The talking calculator and digital pedometer**

purpose batteries which has resulted in economic and environmental waste. This battery charger is a safe and effective alternative. (£29.95)

### Circuit Board Stationery

All the items in this range are made from genuine circuit boards which would otherwise have been binned due to technical imperfections. Each item is therefore unique in its own right and the range includes filofax and notebook covers and clip boards. A good idea for anyone into computers or electronics. (Notepad £5.95; filofax £19.95)

### Digital Pedometer

The world's smallest digital pedometer, this is bought mainly by joggers or serious walkers which counts your steps and converts it into the distance travelled (switchable between walking and jogging.) Simply clipped to a belt, it also features a clock, top display for easy readout and is weather proof. Battery included. (£9.95)

**For further information, please contact Jonathan Elvidge (0482-871001)**

Information about BIT '94, including a list of sponsorship opportunities and exhibition facilities, contact: **BIT '94 Committee,**

**School of Computer Studies, University of Leeds, Leeds LS2 9JT or call Steve Rowette (0532 335461) or Nik Silver (0532 336798).**



## Information services available with a modem

The booklet, *The Sportster Guide to On-Line Services*, has 40 pages stuffed with brief descriptions of software, bulletin boards, how to set up a modem system, CompuServe and general information which can be retrieved from



various sources. The publication is a tribute to US Robotics' Sportster "personal modem", endorsed by TV personality Sarah Greene, which is introduced as appealing to users from children looking for the latest on-line games to businessmen carrying out last-minute credit checks.

It's a handy guide, written in laymen's language, with a glossary explaining terms like JANET, Pseudo Full Duplex and V.32 turbo which baffle the nontechnical and sometimes catch the initiated unawares too.

The Sportster Guide is free of charge on request, and includes a hotline number for more information. For a free copy, contact **Lucy Brown, US Robotics Ltd., 224 Berwick Ave., Slough, Berkshire SL1 4QT. Tel. 0753 811180.**

normal mains outlet. A battery charge led on the lantern shows when the charger is in use.

This is a handy, ergonomic-looking lantern with many uses.

The offer price until 28 February for the ratchet set (O/N CJ33L) is £7.95, and for the rechargeable lantern (O/N GW44X) is £8.95, both vat-inclusive, from Maplin Electronics, telephone sales 0702 554161, or Maplin stores around the country.

## Light and Handy

Tinkering in the dark is not something to look forward to if you have a breakdown or a power cut to deal with.

Maplin are now offering two low-cost items for difficult jobs. A 24-piece ratchet screwdriver set comes in chrome vanadium with broad-grip rubber-padded handles housing a reversible ratchet mechanism. The latched pivoting mechanism allows the handle to be bent at any angle up to a right angle to help with leverage. The screwdriver is designed to accept .25in hex bits, and an adapter is supplied to hold .25in square sockets. The set comes in 6 metric .25in drive sockets, 6 imperial .25in drive sockets, 4 flat-bladed hex-drive screwdrivers and 6 crosshead bits - 3 Posidrive and 3 Philips.

For breakdowns is a rechargeable torch-lantern which combines an amber emergency flashing lamp, a powerful halogen spotlight torch and a fluorescent lantern with a selector switch for one or both of the two 210 mm 6 watt tubes. The sealed 6 volt, 3 amp-hour lead acid battery is recharged by plugging into the supplied charger and connecting to a

## Multimedia Comes To Maplin

Maplin Electronics reckons that Soundblaster, now in the Maplin catalogue, is the most popular PC sound card in the world. With over a million already installed, Maplin has now produced a Sound Blaster Multimedia Internal Upgrade kit, comprising the upgraded Sound Blaster Pro card, a CD-ROM drive and a collection of CD-ROM software. The upgraded card is compatible with existing Sound Blaster and Ad Lib software, but now has 8-bit stereo and mono sampling and playback with a variable sampling rate from 4kHz to 44.1kHz. The internal 22-voice, 4-operator OPL-3 FM synthesiser gives an increased range of instrumental voices and sound effects. The card has inputs for microphone, stereo line in and CD playback via the CD-ROM audio interface.

The SoundBlaster Upgrade kit from Maplin Electronics, telephone sales 0702 554161, or Maplin stores.

## EV Catalogue

If you haven't already got it Electrovalue's '93-'94 catalogue is available for only £1.50 if you phone 0784 442253 and quote your credit card number and expiry date or fill in the coupon in their ad.

## Let's Rip it Up

ULTiroute GXR, from ULTimate Technology is a Ripup & Retry Autorouter. This Windows based PCB design package offers customised control. ULTiroute GXR is fully supportive of Surface mount devices.

The new versions 4.50 of ULTiboard and 1.50 ULTicap are now 32 bit using a Windows compliant DOS extender. The user can decide whether or not to run in Windows, without loss of performance. Also included are features such as Global Shape editing and expanded libraries.

ULTicap offers several automatic features which reduce editing time

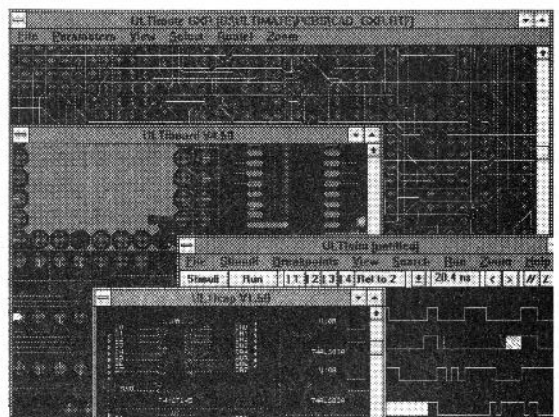

these include Autowire, Auto Snap to Pin, Auto Junction and Real Time Electrical Rule Checking.

A utility called ULThole speeds up the making of prototypes and it now supports HP laser printers as well as Postscript and HPGL plotters.

ULTimate Technology operates on systems from DOS to UNIX and Sun workstations.



# Research World

## Technical Advances from around the Globe

### Building high temperature superconductor circuits

**A** new technique for building high-temperature superconductor circuits is promised as a result of joint research between AT&T Bell Laboratories and the State University of New York. The technique uses electron-beam apparatus to bore submicron holes along YBCO microbridges, creating the weak resistive links required by Josephson junctions.

In the past, creating such weak links in a controlled manner to build HTS devices and circuits has been difficult. Previous research focused on using grain boundaries of metal-superconductor interfaces to create the resistive link, to mixed results.

The YBCO microbridges are created by standard deposition and photolithography techniques. Using the fine controls of a scanning transmission electron beam to drill a series of holes precisely defines the electronic properties of the junction. The drawback of the technique is that it took the researchers from 5 to 10 minutes per micron to create the junctions but dramatic speed-up could be achieved with higher-powered beams. Other advantages, such as the ability to pattern and tailor complex

### Improved micromachines technology

**T**he prospects for micromachine technology have improved now that researchers at Sandia Laboratories have built a power source - a micromotor no bigger than a couple of DRAM cells. The actuator consists of a hollow tube filled with liquid (water in this case, although other liquids can be used) and a piston with a cross section of 6 x 2 microns. A bubble formed at one end of the tube by a polysilicon micro-bridge heater can be made to propagate down the tube. The meniscus captures the end of the piston and carries it along the tube as the bubble expands. In essence, the motor is a tiny steam engine.

Two contact pads are connected to the heater element. When voltage is applied, the liquid is heated to a vapour; the displacement and speed of the piston can be controlled by varying the voltage applied. Sandia said that piston displacement measured on a vernier scale was greater than 20 microns.

The piston, a folded spring assembly, and the bridge are formed from a polysilicon layer. An oxide is deposited, followed by a second layer of poly that partially encapsulates the piston and the channel in which the piston and heater reside.

### Improving electro-luminescent displays

**T**he Advanced Research Projects Agency has established a Phosphor Technology Centre of Excellence at the Georgia Institute of Technology, as part of its high-definition display initiative.

Arpa is providing an initial \$10 million. The research is aimed at improving low-voltage thin-film electro-luminescent displays, field-emission display films and thin-films for cathode-ray tubes. Other goals include the development of novel phosphor materials as well as new device and array processing techniques.

### Virtual Reality

**E**quipment incompatibility is becoming an issue, with some members of the Virtual Reality community warning that the lack of standards is a recipe for disaster.

'For the industry to grow, it needs to adopt standards for virtual reality developments,' warned recently retired IBM Corp. researcher Barry Shepherd. 'Without even de facto standards, the technology will not stabilize.'

The usual types of standards are needed, according to Shepherd, to define hardware and software interfaces to which multiple vendors can conform for plug-and-play compatibility. Such standards must address the needs of three-dimensional input devices, such as electronic gloves, head and body position trackers, and exoskeleton joint-angle sensors. Likewise, the standards must also address VR's specialized, three-dimensional output devices, such as tactile pads, force-feedback mechanisms, heaters, coolers, wind machines, vibrators, odour synthesizers and even more exotic devices as they develop.

'The first need is to standardize voice-recognition commands, so that navigation knowledge from one virtual reality can be transferred to others,' Shepherd said.

Likewise, software standardization for aural feedback needs to be made so that participants used to finding their position with three-dimensional sonic cues can transfer that knowledge when using VR systems from different manufacturers.

Finally, the VR needs standard "world components," according to Shepherd, so that any virtual world built with one design tool kit can be transferred to systems based on different world-design tool kits.

The impetus to making the force display was derived from an idea of startling simplicity akin to Newton's being hit on the head by an apple - that participants in VR want to force objects to move, to feel objects forcing them to move.

The surface display uses a moving planar surface to allow participants to explore a virtual world using their fingertips. As participants push with their fingers, the surface display pushes back with an equal but opposite force, as if their fingers were pushing on a solid object. When participants are "pushing" empty air, the surface display recedes out of reach. A robotic arm tracks the participants' movements and quickly moves a small contact area to model the virtual objects. Texture is modelled with vibrations increasing with increasing roughness.

Centre of Excellence members include the American Display Consortium, whose members are donating a total of \$750,000; the David Sarnoff Research Centre, and five universities. Beneficiaries of the research could include the budding US HDTV industry, as well as manufacturers of vehicular dashboard controls, medical instrument monitors, computer displays, virtual environment displays and industrial process-control panels.



# Roline Systems Ltd

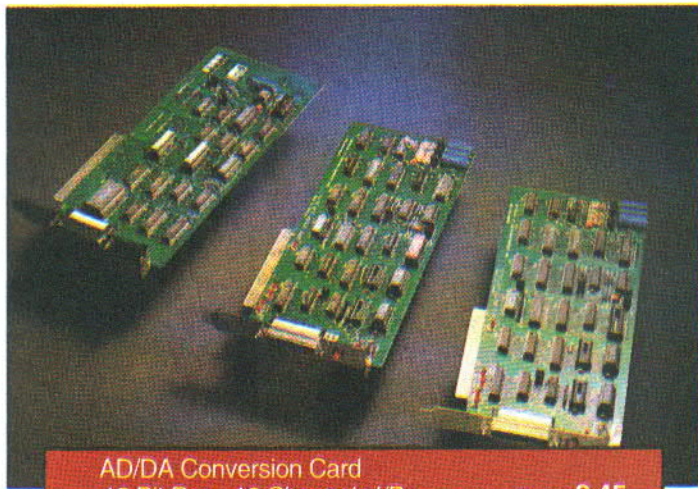

AD/DA Conversion Card  
12 Bit Res, 16 Channels I/P  
From £ 45

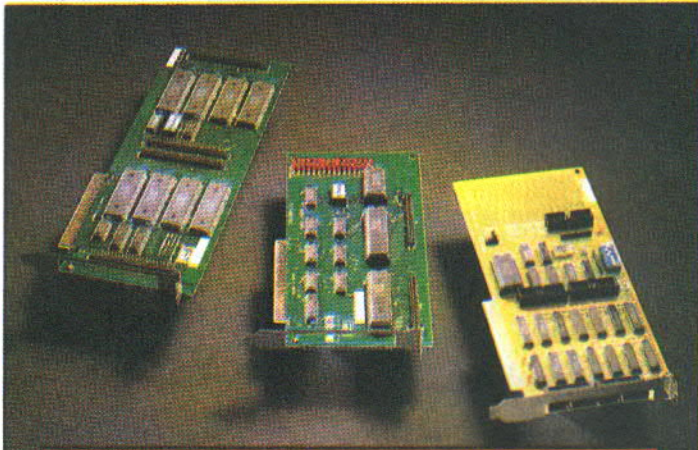

Digital I/O Cards 48 Programmable I/O Lines  
(3 Independent 16 Bit Counters)  
From £ 23

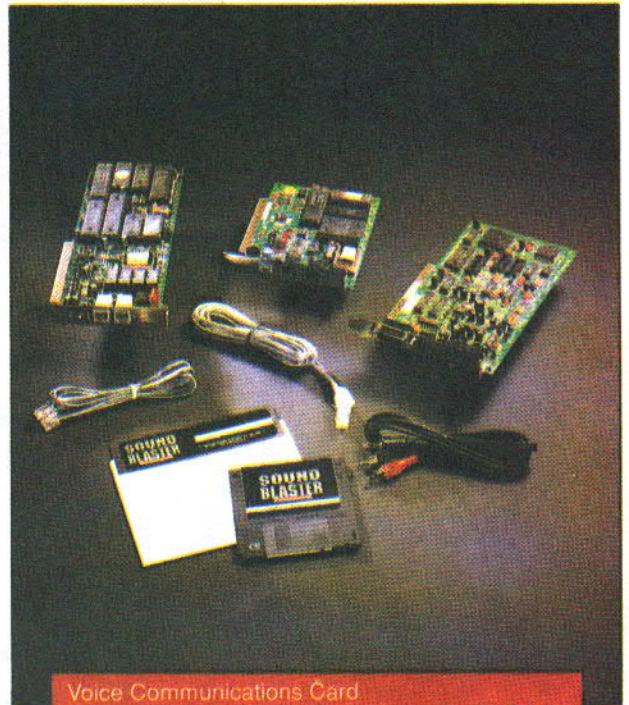

Voice Communications Card  
Intelligent Telephone Card  
From £ 175

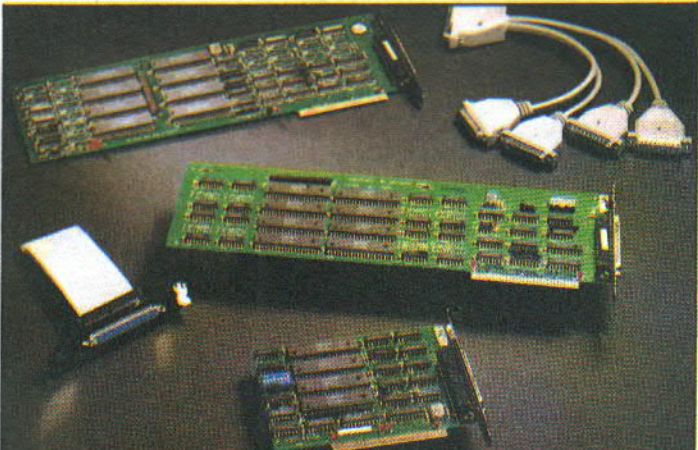

8 Port RS-232 Card with Software  
From £ 115

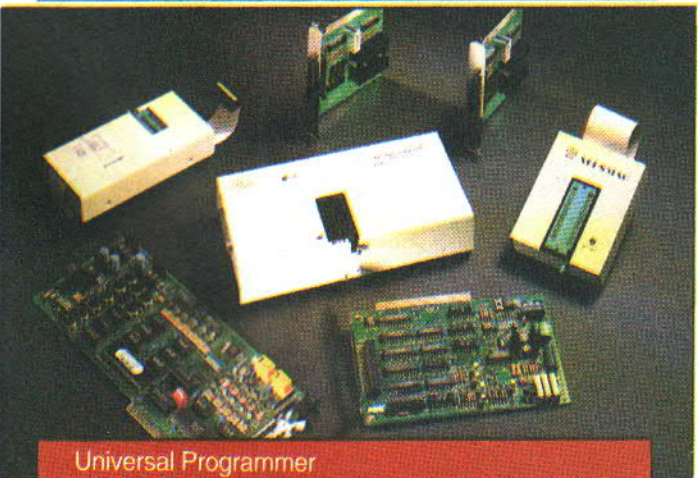



Universal Programmer  
(A11-3A)  
From £ 395

## PC Based Industrial and Lab, Data Acquisition, Control and Measurement, Instrument Cards

- |                             |                          |
|-----------------------------|--------------------------|
| AD/DA Cards                 | Interface Converters     |
| Plus Accessories & Software | Relay Output Cards       |
| C.P.U. Boards               | RS 232 Cards             |
| Device Programmers          | Single, 2, 4, 8, 16 Port |
| Digital I/O Cards           | RS 422 Cards             |
| I EEE 488 Cards             | Single, 2, 4, 8, Port    |
| Industrial Chassis          | PC ROM Disk Cards        |
| Industrial Control Cards    | Slot Extender Cards      |

## Specialist PC & Multimedia Add-on Cards

PC - Telecommunication Cards

- |   |                                |   |
|---|--------------------------------|---|
|  | Fax Modem Cards                |  |
|   | Voice Recognition Cards        |   |
|   | Voicé Digitiser Cards          |   |
|   | Video/TV - PC - Video/TV Cards |   |

## Components

- |                    |                        |
|--------------------|------------------------|
| Cases              | Monitors               |
| Floppy Disk Drives | Mother Boards          |
| Hard Disk Drives   | Cache Controller Cards |
| From 40MB to 2.1GB | Network Cards          |
| Keyboards          | Tape Back Up Units     |

For further information, Product/Price List

Call Us On:

Tel: 0902 20267 Fax: 0902 28439

Roline Systems Ltd, Imex House,  
Imex Business Park, Upper Villiers Street,  
Wolverhampton, West Midlands. WV2 4NU



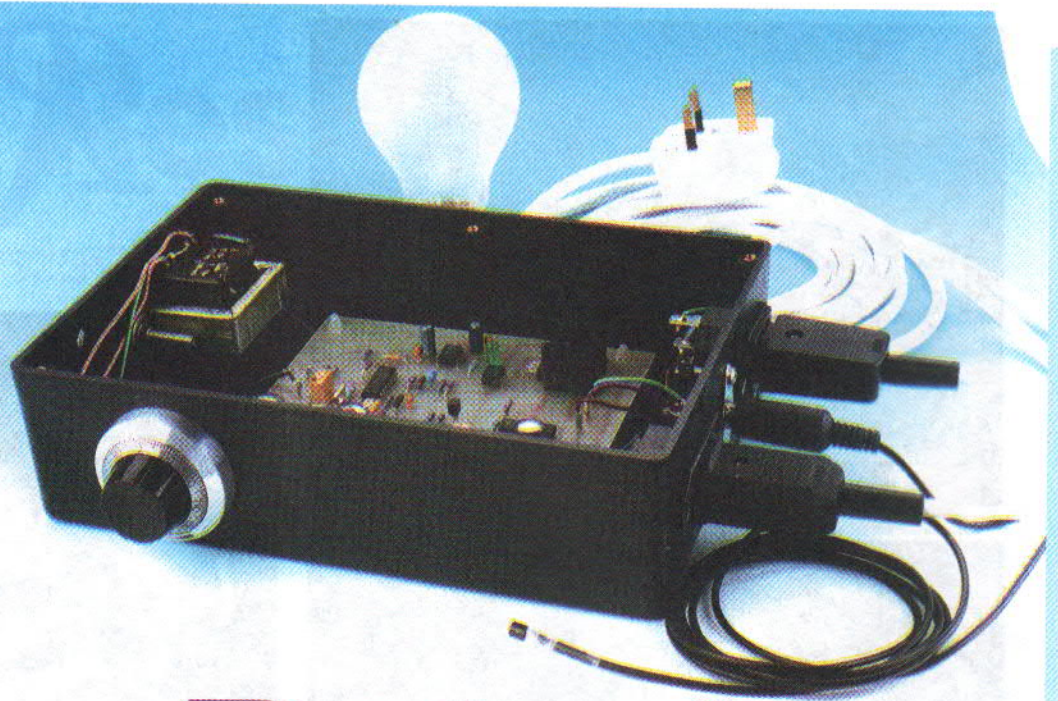

# Egg Patrol

David Silvester plays mother hen and provides the egg-nition for the hatch

**T**his project started as a chance remark by a friend who has an interest in the raising of game bird eggs in a home built hatchery. He had been using a lightbulb to warm the hatching box but had found that temperature control was erratic to say the least. He had however raised a good percentage of the eggs and was looking for a better result next year if he could control the temperature more efficiently.

At this point I suggested that I could construct a suitable control unit if he was interested. Thus the project began, but gradually I came to see that the same circuit could have a wider use given small changes to the heating elements and in some cases the temperature sensing circuitry.

## The Works

The circuit uses one of the latest semiconductor temperature sensing devices. These devices allow a fixed current to pass through them depending on the absolute temperature of the device. Since zero Celsius (0C) is 273 degrees absolute (273K) and the devices pass one microamp per degree absolute then at room temperature the device passes just under 300 $\mu$ A. This current is independent of the voltage across the device providing it has between 4 and 30V across, sufficient to put in it's linear operating range. The current is unaffected by resistances in the leads to the sensing element which is housed in a standard TO92 or TO18 transistor case. One of the leads in the transistor case is not required and I assume is connected to the device substrate thus the spare lead may be left unconnected or connected to the low potential, in this case the voltage from P13. The sensing

limits are -25° to 105°C mainly due to the package for the device. As the temperature varies then the current changes and this can be converted into a voltage output with a simple op-amp circuit.

Figure 3 shows the full circuit for the controller. The temperature sensor fits between P11 and P13 taking a constant current of 273 $\mu$ A at 0°C at which temperature it was decided that the op-amp IC5b would have an output

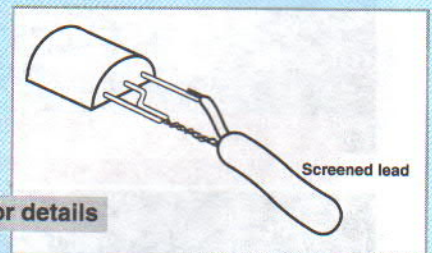

Fig.1 Sensor details

of zero volts. At zero volts output and with the inverting amplifier configuration resistor R13 will not be passing any current.

Thus to set the op-amp to zero at 0°C a current of 273 $\mu$ A is supplied by the stabilised supply of R6, R10, VR2, D1 and C5. As the sensor's temperature increases then the current through it increases and the voltage at pin 6 of IC5b tries to fall below zero volts. However the action of the inverting





amplifier is for the voltage at the output to rise so that it compensates for the error. With R13 at 100K ohms the output of IC5b rises at a rate of 100mV/C so that 0°C is 0V output and 100°C is 10V output, the full range of the circuit as shown here. With a simple output voltage from IC5b representing 0 to 100°C a ten turn resistor with a 0 to 10 scale on it was used as the input device for the set temperature. This potentiometer needs to be driven from a 10V stabilised reference and this is supplied by IC5c and it's associated circuitry.

Having the set voltage and the actual voltage we can get on to the control circuit itself. From the centre tap of the pot at P2 arrives a voltage that is the representation of the required temperature in the hatch box. From IC5 pin 7 comes the voltage representing the actual temperature. Op-amp IC5a is a differential amplifier that takes these voltages and outputs on pin 1 a voltage that is a representation of the difference between the set and required values. Without any gain, the difference would still be at 100mV/C rate, ie an error of 10°C would give either a + or - 1V output depending on whether the sensor was hotter or colder than required. In this circuit the amplifier is arranged so that too high a sensor temperature causes

positive output from IC5a. Keep in mind that the amplifier circuit around IC5a does give gain, I shall come to the reason for this soon.

The last amplifier in IC5 is a simple triangle wave oscillator based around C8. In this circuit C8 is charged and discharged alternately by the output of the op-amp via the resistor R17. The op-amp has only two output condition, full

on close to either + or - 15V rail. When the output of IC5d is at +15V then C8 charges through R17 up to the point where the input at pin 13 exceeds that at pin 12. Since the voltage at pin 12 is 1/3 of that at the output the op-amp flips at a voltage of 5V on C8. At this point the output of the IC flips to -15V. Now C8 discharges through R17 down to a voltage of -5V on C8 at which point it flips back to the original condition. Thus the voltage across C8 rises and falls in an approximately triangular manner, and at a rate set by the values of R17 and C8. In this case the frequency is set at 5Hz approximately. The fact that the output 'triangular' waveform is curved due to the exponential charge/discharge cycle in no way affects the operation of the device. This 'triangular wave passes to the comparator IC7. IC7 is set up so that it receives the DC error signal from op-amp IC5a and the triangular waveform. Ignore the connection to IC7 on pin 6 for the moment. The comparator is a pulse width modulator producing a low output and therefore lighting the LED and the LED in the opto-triac IC6 when the voltage coming from the triangle waveform is greater than that from the DC error signal. If we assume a steady

Fig.2 Component positioning

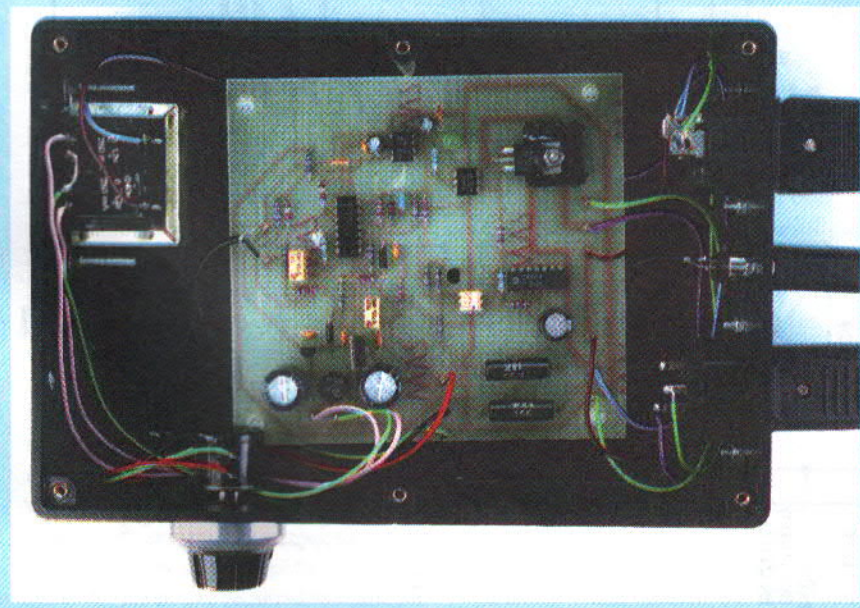
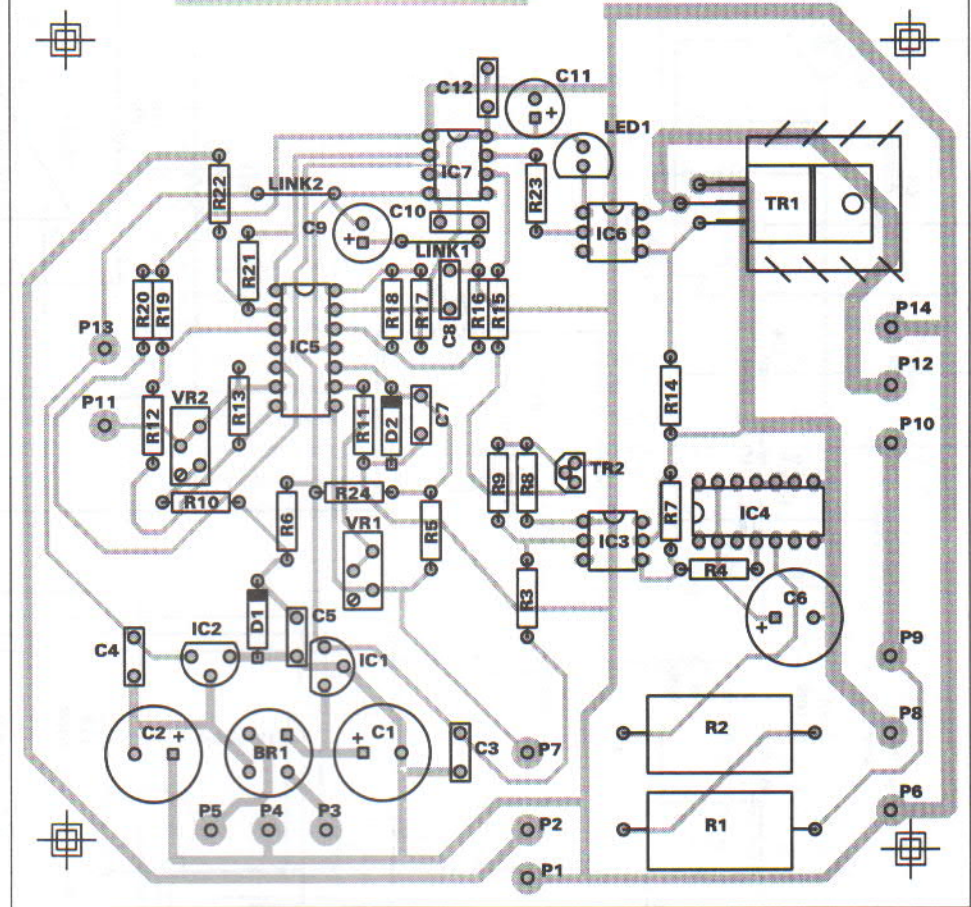
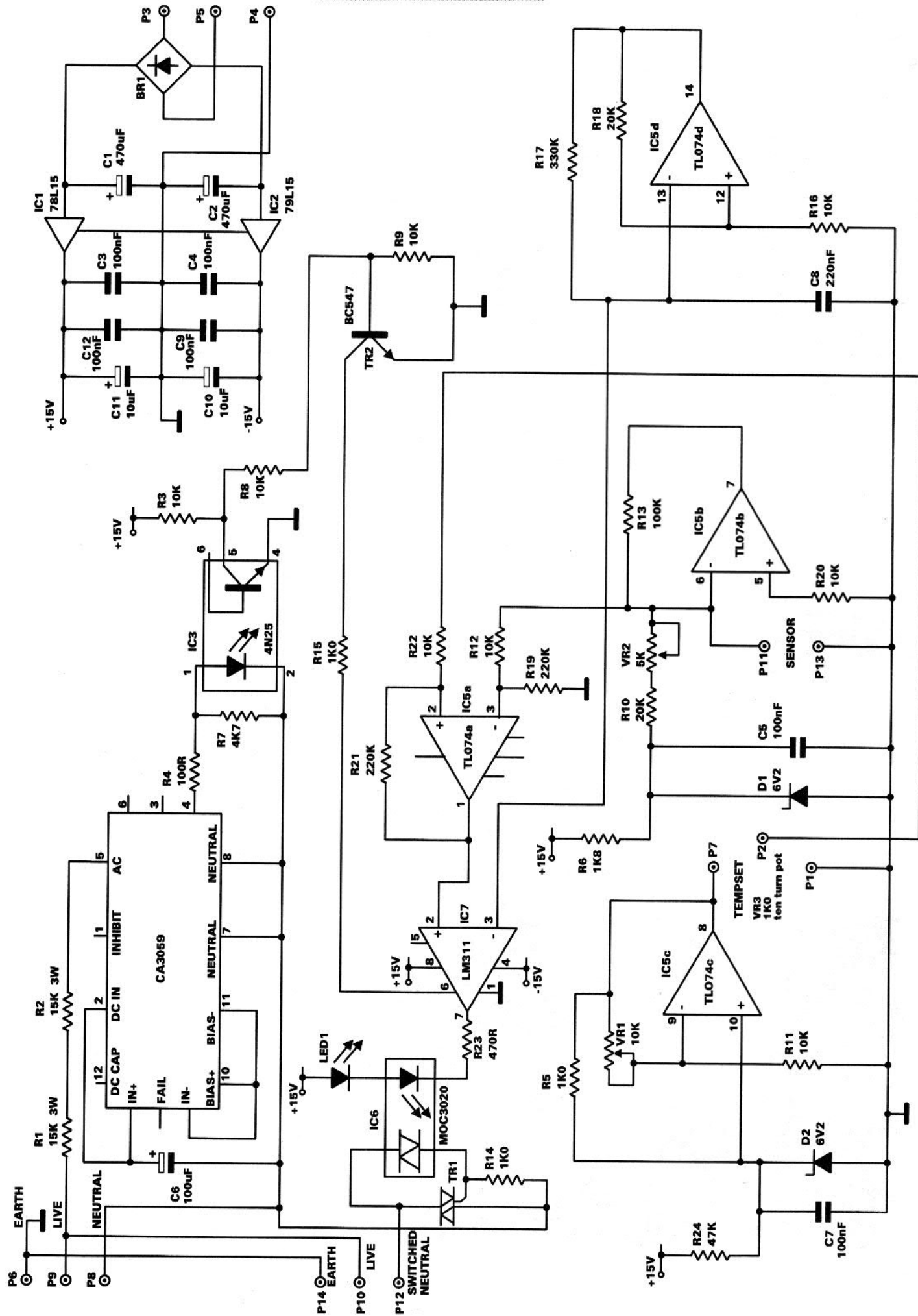



Fig.3 Full circuit of controller





state where the DC error is zero then the output from the comparator will be on for half of the time and off for the other half. If the sensor sees a lower temperature then the output of the error amplifier will go to a lower voltage, and the LEDs will be illuminated for a longer part of the pulse width cycle.

The LED in IC6 fires the triac controlling the heat input to the hatchbox and as the sensor cools the circuit will fire the triac more often to correct the error.

We now come to the gain of the error amplifier. With an input triangle wave of  $\pm 5V$  and an error signal rated at  $100mV/^{\circ}C$ , then the triac will be fully on only if the sensor is  $50^{\circ}C$  below the setpoint. With this situation the

the box temperature varies vastly and the temperature in the box could vary by  $\pm 2.3^{\circ}C$ . With higher error amplifier gain this range could be cut but it could produce temperature oscillation during a recovery from say opening the box. The error amplifier gain can be set to any value depending on the ratio of R19 and R21 to R12 and R22. The error amplifier has a FET input device and R19 and R21 can be increased in value, up to any resistor value available. If the value of R12 and R22 is lowered then the lower value of R22 will affect the setpoint potentiometers linearity.

There remains one problem, caused by the high switching speed of the triac itself. If we allow the triac to fire at any point in the mains cycle then by chance

extent. To allow direct connection to the mains live there are two dropper resistors R1 and R2. Anyone familiar with the CA3059 will know that the chip contains all of the components to build a controller. The problem is that the sensor will be directly connected to the mains neutral. Now whilst this may be satisfactory for some circuits and it is shown used in that way in the data sheet for the CA3059 it was not felt to be good engineering practice and certainly not safe enough for use by amateurs. In this design everything is referenced to the earth terminal. Isolation is provided by the two opto-couplers. The CA3059 is wired so that at every zero cross, that is at  $100Hz$ , a pulse will light the lamp in the opto-coupler IC3. This pulse will

be for a very short period where the mains voltage is below  $\pm 1.2V$  (referred to neutral). This pulse turns the transistor in IC3 on and transistor TR2 off. IC7 (LM311) is an interesting device in that it can be disabled, ie the transistor output of the device can be forced into an open circuit condition, and this occurs when pin 6 is grounded via a  $1K$  resistor. The switching of TR2 forces this open circuit condition to occur at all times except when the mains voltage is very close to zero. When IC7's output is open circuit, the output triac cannot fire.

The input to IC7 will determine when the triac should fire. The switching of TR2 will prevent this until zero crossing time. The triac will fire on every half cycle that its voltage is above the error amplifier voltage.

The main triac TR1 is fired by the secondary triac in the opto-coupler IC6. When IC6 LED turns on, its triac turns on and fires TR1. Resistor R14 only receives a very short voltage spike and does not dissipate much power. Tests have shown that R14 remains cold even with the power full on and the triac firing on every half cycle.

The heat producing load, the light bulb in the case of the hatchery connects from the live to the MT2 terminal of TR1. Although the bulb is live all of the time the circuit is safer since a failure of the bulb will leave the TR1 circuit unpowered. The whole circuit is driven by a standard power supply unit of a

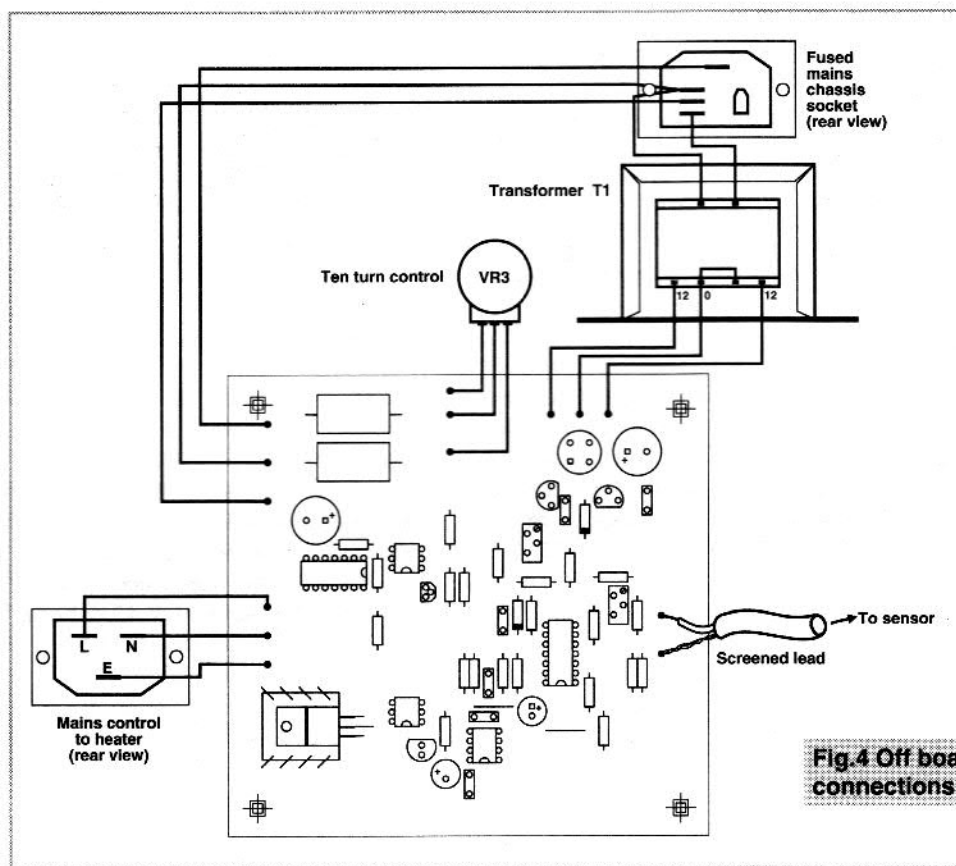

**Fig.4 Off board connections**

hatchbox would only heat up very slowly and recover from opening the lid in a similar slow way. To achieve much more rapid heating the error amplifier has gain so that the error is rated at  $2.2V/^{\circ}C$  thus the full on for the triac condition occurs when there is an error of around  $2.3^{\circ}C$  at the sensor. The gain of the error amplifier is therefore 22 times and this seems to result in a stable temperature in the hatchery box. By increasing the gain of the error amplifier the full on to full off situation can be made to cover a smaller temperature range. With the error amplifier range at  $2.2V/^{\circ}C$ , the power required to maintain

the triggering will occur when the voltage across it is about  $320V$ , the highest voltage in the  $240V$  AC cycle. The triac rapidly turns on and results in a very sudden increase in load current which causes RF emissions into the mains that interferes with other electrical equipment. In this circuit the triggering is synchronised to the point at which the mains voltage crosses zero volts. This results in a much lower RF emission from the circuit.

Internal to the CA3059 device, IC4, is a power supply that runs from the mains, using only the electrolytic capacitor C6 to stabilise the DC to some



centre tapped transformer and bridge rectifier to give about  $\pm 20V$ . This occurs from the 12V AC transformer due to a problem called regulation. This leads to a higher output voltage than expected when the transformer is run at a low load current. The 15V supply only operates the op-amp and the sensor and so uses a very small current. The 79L15 regulator would be suitable for use here but the +15V supply powers a number of additional circuits and although a 78L15 has been used for IC1 it becomes very hot. To increase reliability use a 7815 regulator in the TO220 package instead.

### Construction

Whilst this project has been designed for safe operation, the constructor should remember that the project uses mains voltages. Neither the author or the magazine can accept responsibility for any accidents that may occur due to mistakes. If in any doubt as to your capabilities do not attempt this project.

I started construction with the building of the sensor assembly. The AD592 is a typical TO92 package with three leads on it. Take the device and looking with the wires pointing towards you and the flat of the D downwards, the pin on the left is the sensor negative terminal, see Figure 1. Bend the central wire so that it lies along side the left hand wire and cut to about 1/4 inch long. Take a length of audio coax cable and cut back the outer sheath so that you have about 1 inch of bared wire. Tin the screen and cut back giving two wires about 1/2" long. Bare the central conductor for the last 1/4", tin, push over a 1/4" length of shrink wrap tubing and solder to the right hand pin of the AD592. Pull the shrink wrap over the solder joint and shrink the tubing with a heat gun. Repeat for the screen and the other two terminals of the AD592. Finally cover with a larger piece of shrink wrap tubing. This part is very fiddly so take your time. Fit a plug to the far end of the coax and the sensor is complete.

The main circuit board is easy to build following Figure 2. If you prefer to build the circuit in sections testing as

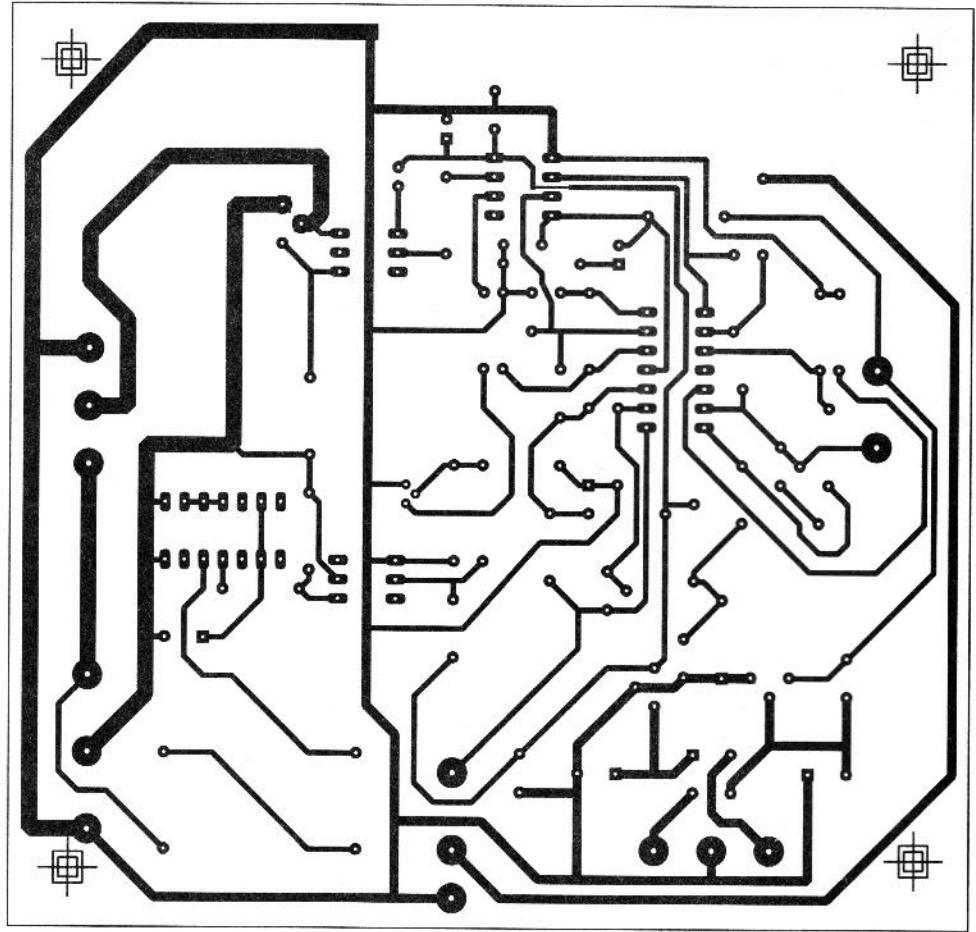

Fig.5 Foil pattern

you go then you may like to build the low voltage power supply around BR1 first. For the off board connections I recommend the use of terminal pins as these make the final wiring easier. Having built the circuit around BR1 make a temporary connection to the transformer and look for -15V across C4 and +15V across C3 with the central terminal P4 as the ground. See Figure 5 for off board connections.

Moving on to the circuit around IC4, you should find around 6V across C6 and R1 and R2 get hot when running. BE VERY CAREFUL this circuit is at mains voltages. Check carefully for solder bridges around the IC or it will go up with a puff of smoke. Take precautions when testing. If you add IC3 and R3 then using a logic probe or oscilloscope you should find a pulse at 100Hz. With an oscilloscope do not connect the probe screen to neutral, it is dangerous and the repair bill to the 'scope may be expensive, use the Earth pins only. You will see a very wobbly trace due to the difference in voltage between the neutral and earth lines and on top of this a sharp pulse at 100Hz. It is then reasonably simple to complete the rest of the circuit. Those components to the left of the ground track through IC3 and IC6 can have

mains on them so special care needs to be taken in this section. The triac TR1 has a small twist vane heatsink mounted below it and then screwed to the PCB. If you use the recommended BTA triac then this contains internal isolation and the heat sink can be grounded. You can use almost any other 400V 4A or higher triac in a TO220 case but then the heatsink will be live.

Rather than use the sensor for testing I calculated that a 47K resistor across 15V would give a current that is a temperature representation of about 45°C. The sensor costs a few pounds whilst the resistor costs pence, the resistor forms a safe option for initial testing.

Take the case and cut the holes for the ten turn pot, the input and output mains connectors and the sensor connector. I suggest the Euro type sockets for the mains connectors and have used an input socket that contains a fuse in it. There is an LED on the board and some constructors may want to have this fitted into an additional hole in the case. This may be helpful if the heating element does not give off light as is the case for our 'bulb' heater.

I should add a few notes about the hatching box itself. This contains the lamp as the heater a small electronics



bay cooling fan to blow air across the bulb to keep the temperature even in the box, similar to a fan assisted cooking oven. The sides of the box need to have two holes, one close to the fan inlet to allow fresh air in and the other as an exhaust. The inlet hole size is about 1/4 of the diameter of the fan.

## Setting Up and Testing

There are only two potentiometers to be set up for the circuit after the constructor is certain that the board operates correctly. Firstly, connect a voltmeter across the off board connector P1 (ground) and P7 (higher voltage). Adjust VR1 so that the reading is 10V. This sets the voltage across the 'set temp pot' and gives the range 0 to 100°C. With the 47K test resistor in place move the dial of the ten turn pot and check to see that the LED goes from always on with the set temperature low, through a phase where the LED flashes at a fixed rate but with a decreasing on time, to a point where the LED is always off. Remove the 47K resistor across the sensor connectors and fit the wires to the sensor itself. Put the sensor alongside a thermometer and put the voltmeter across P13 and the junction of R19 at the end connected to IC5b. After the temperatures has stabilised set the voltage across P13 and IC5b output to a voltage that works on the 100mV/C scale, (20°C is equivalent to 2.0V). This sets the calibration of the sensor circuit. The sensor has guaranteed error limits for the type used. This is less than 2°C over the 0° to 100°C range, although there are other more expensive versions with better specifications.

## User Modifications

This design may not suit the exact requirements of the user, the prototype being built to power a 100W lightbulb. The triac is rated at 8A at 240V AC and the ballast resistors are also for a mains voltage of 240V. The unit can be used without modification in Europe on 220V mains whilst in the USA on 117V AC, one of the two ballast resistors R1 and R2 must be shorted out to allow the CA3059 to operate correctly. The unit is triggered by mains zero crossing but needs no modification for the 50 or 60Hz frequency difference.

As given here the unit is limited to 0 to 100°C by the sensor itself. If required the constructor can modify the sensor circuit to other types and temperature ranges. The 3A fuse in the mains input socket limits the output current.

# Parts

## Resistors

(All 0.25w 1% unless stated)

- R1,2 15K 3W Wire wound
- R3,8,9
- R11,12,16 10K
- R20,22
- R4 100R
- R5,14,15 1K0
- R6 1K8
- R7 4K7
- R10,18 20k or 2 by 10K in series
- R13 100K
- R17 330K
- R19,21 220K
- R23 470R
- R24 47K
- VR1 10K 64y style pot
- VR2 5K 64y style pot
- VR3 1K0 ten turn pot

## Capacitors

- C1,2 470µF/25V electrolytic (0.2)
  - C3,4,5,7 100nF ceramic (0.2)
  - C6 100µ/63V electrolytic (0.2)
  - C8,9,12 220nF ceramic (0.2)
  - C10,11 10µF electrolytic (0.1)
- (figure in brackets is lead spacing in inches. Obtain the correct size or the component will not fit in the PCB)

## Semiconductors

- IC1 7815
- IC2 79L15
- IC3 4N25 opto isolator
- IC4 CA3059
- IC5 TL074C
- IC6 MOC3020 opto triac
- IC7 LM311C
- D1,2 6V2 400mW zener
- LED1 Small LED any colour
- BR1 W005 or equivalent
- TR1 BTA08-400 internally isolated triac, see text for alternative
- TR2 BC547 or any equivalent
- Sensor AD592 A, B, or C (see Text)

## Additional Items

- PCB (available through Electronics in Action)
- PCB standoffs by 4
- Twist vane heatsink
- Shrink sleeving to make sensor
- Plug and socket for sensor
- Fused Euro inlet socket and mating connector
- Euro outlet connector and mating connector
- ABS box (Maplin YN39), mains cable
- Mains plug
- Transformer 12-0-12V output 3 or 6 watt
- Ten turn dial unit
- 2 metres of audio type coax
- Various connection wires as needed but sections of brown, blue and green/yellow recommended to continue the mains colour scheme.

Almost all of the items for this project were purchased from Verospeed in Eastleigh 0703-644555 although they deal only in packs of components rather than single items. Catalogues are available from them direct.

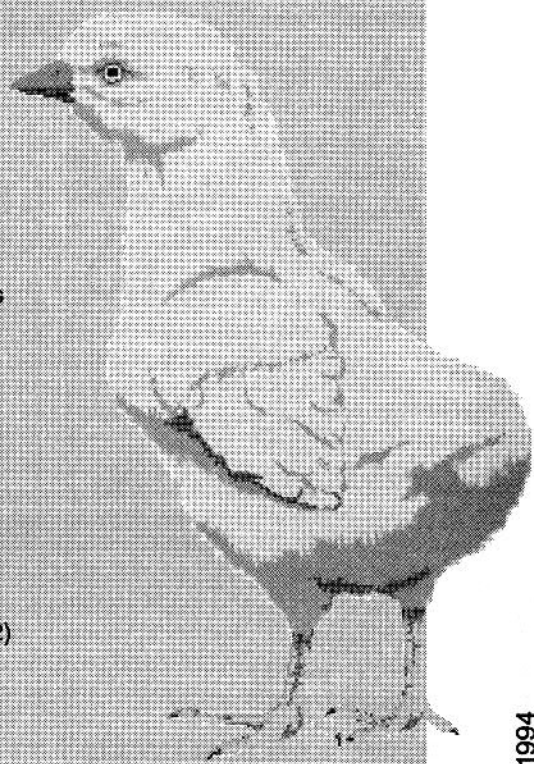





# TECHNICAL BOOKS



A selection from our range of books for the repair trade

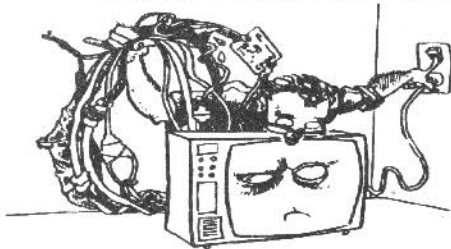

**TELEVISION CHASSIS GUIDE.**  
Full cross reference for all models  
*Order MP-18. £5.95.*

**TELEVISION EQUIVALENTS**  
Lists models which are the same  
*Order MP-150. £5.95.*

**FAULT LISTS FOR TELEVISIONS.**  
Hundreds of specific faults for  
dozens of different makes and  
models.  
*Order MP-205. £6.95.*

**TELETEXT REPAIR MANUAL.**  
Covers SAA range of boards.  
*Order MP-38. £6.95.*

**TELEVISION REMOTE CONTROL  
CIRCUITS.**  
Dozens of Diagrams on many  
remotes.  
*Order MP-167. £10.00.*

**TV POWER SUPPLY CIRCUITS.**  
Dozens of P.S. circuit stages.  
*Order MP-219. £10.00.*

**SCART EUROCONNECTOR  
SYSTEM.**  
Comprehensive details of the system.  
*Order MP-21. £3.00.*

**P.C. HARD DISC DRIVE  
REFERENCE MANUAL.**  
Comprehensive Drive Details.  
*Order MP-84. £5.00.*

**P.C. DIAGNOSTICS SOFTWARE.**  
Dozens of programs to aid you in  
diagnostics of PC's and Drives etc.  
2 sets of 7 x 3.5" Discs per set.  
*Set 1. Order MP-250. £12.50.*  
*Set 2. Order MP-251. £12.50.*



**VIDEO  
RECORDER  
AND  
CAMCORDER EQUIVALENTS.**  
Full Cross-reference guides.  
*Makes A-J. Order MP-217. £5.95.*  
*Makes K-Z. Order MP-218. £5.95.*

**FAULT LISTINGS FOR VIDEO.**  
Lists Hundreds of Faults for  
dozens of makes and models.  
*Volume 1. MP-206. £6.95.*  
*Volume 2. MP-228. £6.95.*

**VHS VIDEO RECORDER  
PRINCIPLES.**  
Detailed guide on how it works.  
*Order MP-58. £3.95.*

**VIDEO TEST JIG.**  
Special cassette lets you operate  
the machine in test mode.  
*Order VTJ. £15.00.*

**VIDEO HEAD CLEANING KIT.**  
Special kit with comprehensive  
instructions on how to service heads.  
*Order VHCK. £4.00.*

**VIDEO RECORDER FAULTS.**  
Unique repair guide for beginners.  
*Order MP-5. £3.95.*

**WIRE ANTENNAS FOR  
H.F. OPERATORS.**  
THE aerial book for Amateurs.  
*Order MP-243. £5.95.*

**REEL TO REEL TAPE  
RECORDER SERVICING.**  
Theory and circuits for repairs.  
*Order MP-201. £5.00.*

**TRANSISTOR RADIO REPAIR  
GUIDE.**  
Comprehensive servicing charts.  
*Order MP-7. £2.50.*

**RECORD PLAYER SPEED DISC.**  
Get your phonograph up to speed.  
*Order MP-8. £1.00.*

**SWITCH MODE POWER SUPPLY  
I.C. TYPE TDA-4600.**  
Circuitry and operation explained.  
*Order MP-37. £6.00.*

**VOLTAGE REGULATORS,  
STABILISERS  
& POWER SUPPLIES.**  
Identification and specifications.  
*Order MP-9. £3.00.*

**CMOS DATABOOK.**  
Pinouts and circuits for 4000 series.  
*Order MP-10. £5.00.*

**TTL DATABOOK.**  
Pinouts and circuits for 7400 series.  
*Order MP-34. £5.00.*

**TRANSISTOR EQUIVALENTS.**  
Includes details on testing them.  
*Order MP-24. £3.00.*

**OFFICE EQUIPMENT  
EQUIVALENTS.**  
Photocopiers & Fax machines  
covered.  
*Order MP-200. £6.00.*

**TELEPHONE CODE LOCATION  
GUIDE.**  
Find the Town from the Phone Code.  
*Order MP-19. £4.00.*

**MANUFACTURERS  
EQUIVALENTS.**  
What makes are the same.  
*Order MP-220. £3.00.*

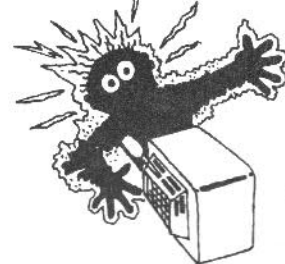

SHOCKINGLY  
GOOD BOOKS

**SERVICE MANUALS**  
available for most equipment.

**Order TODAY using Access/Visa for immediate despatch.**

**All orders plus £2.35 Post and Packing. (Overseas £5.00)**

The above selection are just a few of the Hundreds of Unique Repair and Data Guides shown in our FREE catalogue - Yours for the asking.  
Sent FREE with all orders or send 2 x 1st class stamps for your copy TODAY!

**MAURITRON TECHNICAL SERVICES (EA)**

47A High Street, Chinnor, Oxfordshire, OX9 4DJ.

Tel:- 0844-351694. Fax:- 0844-352554.

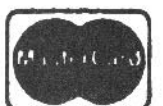



# DATA ACQUISITION WITH THE PC

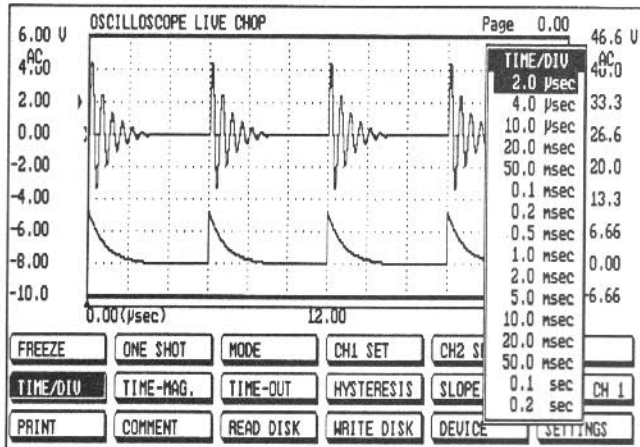

**TiePie engineering** manufactures a complete range of computer-controlled measuring instruments. Connecting these units to a PC (MS DOS 3.0 or higher) results in a number of comprehensive test instruments:

- oscilloscope;
- voltmeter;
- spectrum analyzer;
- frequency meter;
- transient recorder.

All measured data can be stored on disk or run off for documentation. Because of the many trigger possibilities, a variety of signals can be measured, while the powerful software enables a multitude of measurements to be carried out in a straightforward manner. Application areas include: service; medical research; automatic test systems; research and development; and education.

## LOW COST: HANDYPROBE

Connect the HANDYPROBE to the parallel printer port of the PC and start the software. Measuring can be carried out at once. The HANDYPROBE does not need an external power supply. Some technical parameters:

0.5-400 V software select input range;  
one input channel;  
8 bits resolution (overall accuracy 2%);  
A complete software program consisting of a digital storage oscilloscope, spectrum analyzer, voltmeter and a transient recorder is provided.

The HANDYPROBE is eminently suitable for servicing and educational purposes.



£ 99

## BEST PERFORMANCE: HANDYSCOPE

The HANDYSCOPE is connected to the parallel printer port. This makes it possible to carry out measurements with a laptop or notebook PC. Because of its high resolution (12 bits), the HANDYSCOPE is a very accurate instrument. The measuring rate is 100,000 samples/sec. Either of the two channels can be set independently over a range of 0.5-20 V (with a 1:10 probe up to 200 V). The advanced software enables many measurements to be carried out. Two probes (switchable 1:1-1:10) are provided. The HANDYSCOPE is constructed as a small table model with two BNC connectors.

The length of the cable linking the PC and the HANDYSCOPE is 1.8 m, which can be extended to 3.8 m.

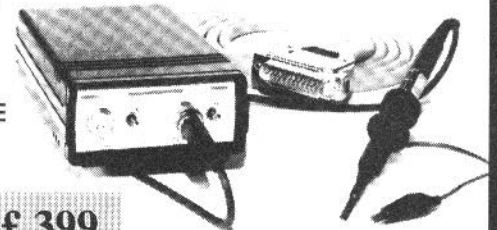

£ 399

## MULTIFUNCTIONAL: TP5008

The TP5008 is an interface card that provides an analogue output in addition to two input channels. This output in combination with the two inputs may be used for the setting up of a complete control loop. The output may also be used as a function generator.

The TP5008 has a resolution of 8 bits and a sampling rate of 200,000 samples/sec (200 kHz). The input range may be set to 0.5-20 V full-scale deflection. The output range covers 1.25-2.5 V. The TP5008 is fitted with BNC connectors and is delivered complete with a user manual and software. Separately available are 1:1-1:10 probes and 1:100 oscilloscope probes.

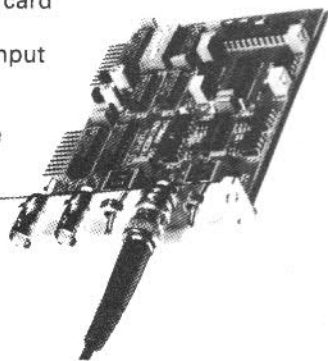

£ 197

## VERY HIGH SPEED: TP208

The TP208 is an interface card with a measuring speed of 2x20 Megasamples/sec (8 bits). Phenomena shorter than one millionth of a second can still be measured well.

The completely digitized triggering ensures very stable triggering with many trigger possibilities. The TP208 has an input range of 5 mV/div to 20 V/div in 12 steps and an auto calibration function. Since both channels may be sampled simultaneously, phase differences can be measured very accurately. Even single phenomena can be measured since each channel has a 32 KByte memory. Comprehensive software is provided.

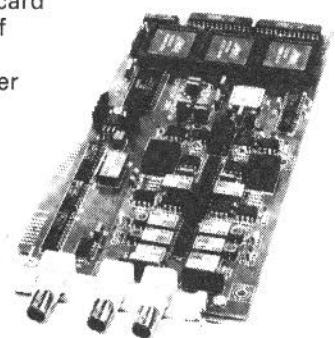

£ 595

(All prices are exclusive of VAT and P&P)

Interested? Then write or fax for a FREE demo diskette to

**INSTRUTEK (UK)**

28 Stephenson Road  
Industrial Estate  
St Ives, Cambs PE17 4WJ  
England

Telephone (0480) 460028  
Fax (0480) 460340



Fig.1 Circuit diagram

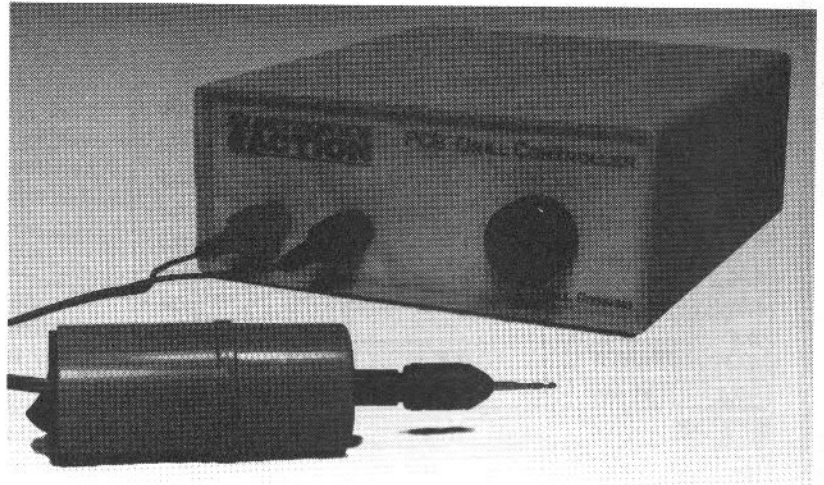
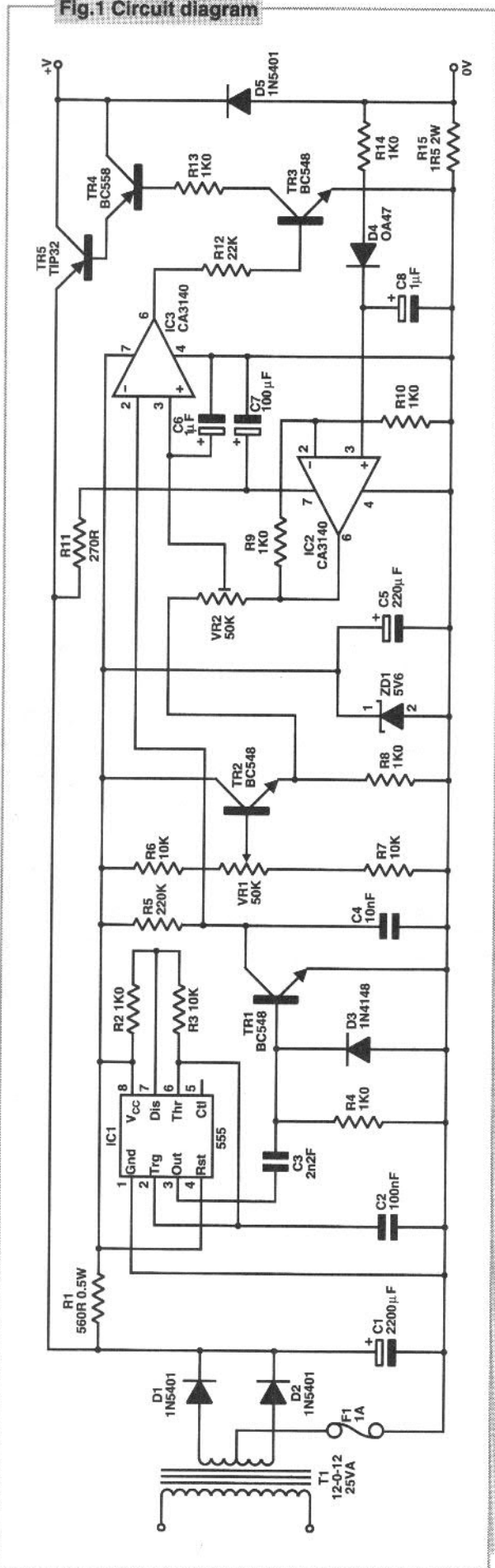

# In Control

Ever been frustrated by your 12V drill speeding up and slowing down? Paul Stenning's latest project will help you keep your sanity.

One problem with the smaller PCB drill machines is that the speed drops rapidly as the load increases. This can be overcome to some extent by increasing the supply voltage, however the off-load speed is then too high.

The speed controller in this article overcomes this problem by

raising the voltage to the drill as the load is increased. The unit uses a basic Pulse Width Modulation (PWM) regulator to reduce the power dissipation.

This unit was designed for the Expo Reliant drill. This popular low cost tool is ideally suited to light duty use.

## The Works

The circuit diagram is shown in Figure 1. IC1 acts as an oscillator, running at several kilohertz. The pulses from this briefly turn on TR1, which discharges C4. Between these pulses C4 charges via R5, producing a rough sawtooth waveform.

This sawtooth is connected to one input of a comparator circuit IC3, while the other input is fed from a reference voltage. The output of the comparator controls the switching transistor TR5, via TR3 and TR4.

Thus as the reference voltage is increased, the switching transistor is turned on for a longer period, and the drive to the drill is increased.

VR1 is the front panel speed control, the voltage from which is

buffered by TR2, and fed to the reference input of the comparator circuit by VR2.

R15 senses the current flowing in the drill. The peak voltage across this is amplified by IC2, the output from which is also fed to the reference input of the comparator via VR2.

Thus as the load on the drill increases, its current consumption raises, which in turn causes this unit to increase the drive to the drill. VR2 sets the ratio of control to feedback.

The fuse F1 will blow if the drill is stalled for long period, or if the output is short-circuited. Since the circuit can withstand the short circuit current until the fuse blows, a more elaborate over-current circuit is not necessary.



Fig.2 Component positioning and foil

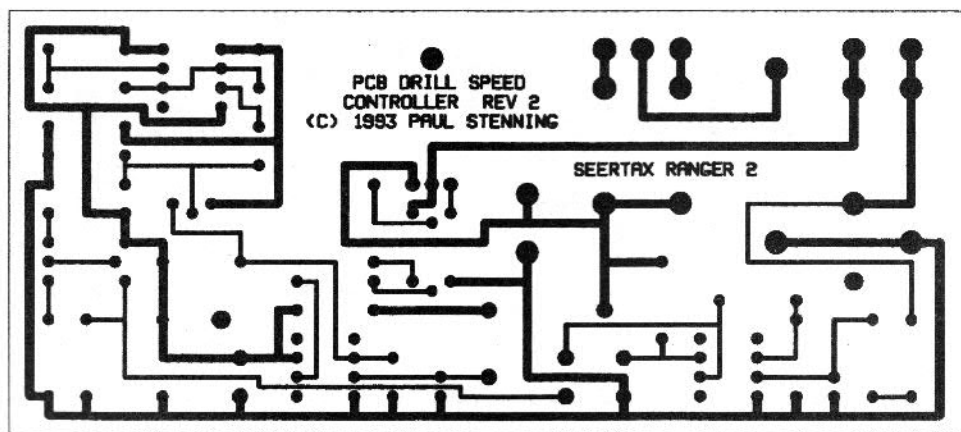
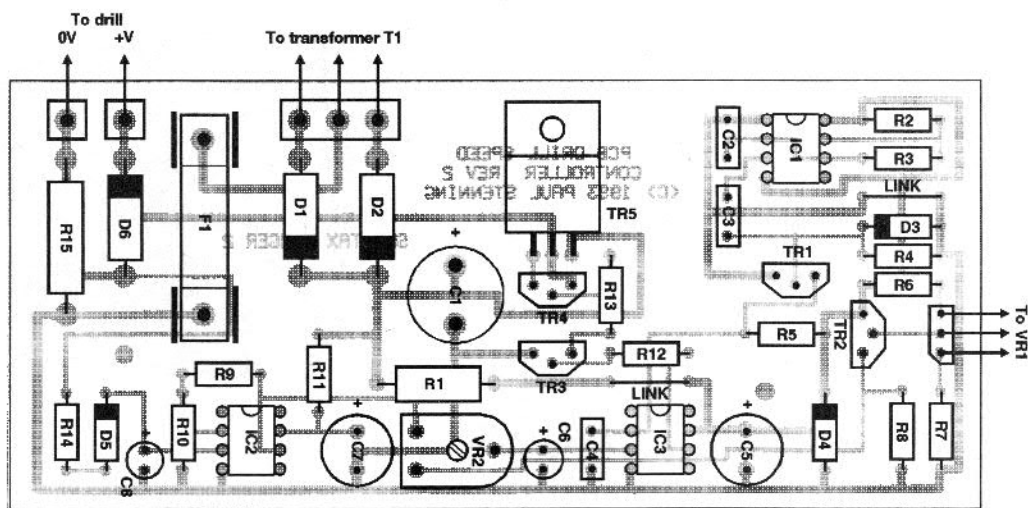

The controller can power other small PCB drills, as well as other devices containing small 12 Volt DC motors, although some changes to component values may be necessary.

### Construction

The circuit is assembled on a single sided PCB, 126mm x 56mm. The component overlay is shown in Figure 2. There is nothing out of the ordinary about the PCB construction, the components are fitted in the usual size order.

A small heatsink may be fitted to TR5 if desired. This runs cool in normal operation, but will heat up if the output is short-circuited until the fuse blows.

R15 will run warm in normal operation and should be mounted a few millimetres above the surface of the PCB. The 2 Watt power rating suggested in the parts list should be regarded as a minimum.

The prototype was built in a plastic case, 190mm x 165mm x 68mm, see parts list for details. Check the dimensions of the transformer before buying the case. A suitable template for the front panel is shown in Figure 4, this may be

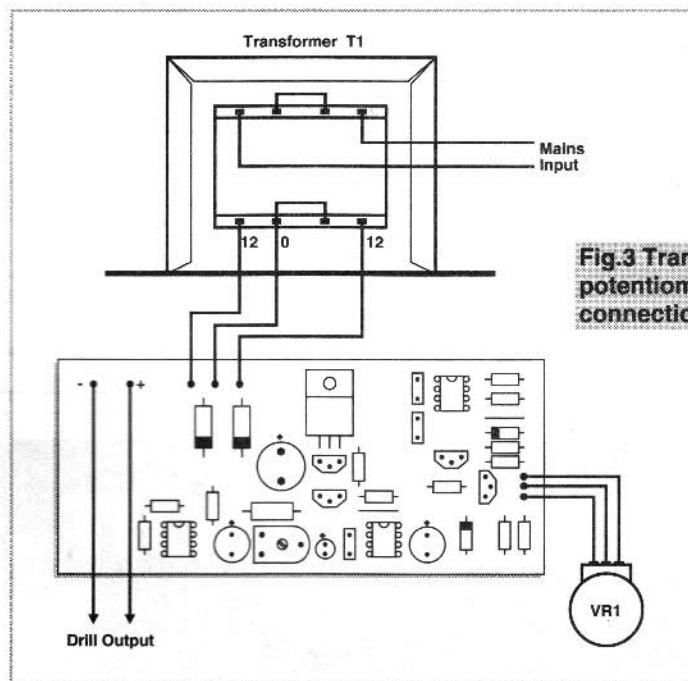

Fig.3 Transformer and potentiometer connections to board

photocopied and fixed to the front panel with clear self-adhesive vinyl.

The internal layout can be seen in the photographs and the interwiring is shown in Figure 3. No mains fuse or switch were fitted on the prototype for

simplicity, however a 3A fuse was fitted in the main's plug.

### Testing

Ensure that main's connections within the unit are well insulated for safety. Set



VR1 fully anti-clockwise and VR2 fully clockwise. Connect the unit to the mains and switch on. Connect the PCB drill to the output terminals.

As VR1 is turned clockwise, the speed of the drill should increase. Set this control to about one quarter, then load the drill lightly by placing a finger against the chuck. Note how much the drill slows.

Now gradually turn VR2 anti-clockwise. The speed of the drill will increase a little. If the drill is lightly loaded again, the speed should remain more constant.

If VR2 is set too far anti-clockwise the speed control will have little effect and the drill speed may pulsate. The suggested position for VR2 is a little more clockwise than halfway.

The unit is now fully tested and can be put into use.



### Resistors

(All 0.25W 5% unless stated)

R1	560R 0.5W
R2,4,8	} 1K0
R9,10	
R13,14	
R3,6,7	
R5	220K
R11	270R
R12	22K
R15	1R5 2W
VR1	50K Horizontal Preset
VR2	50K Lin Rotary Pot

### Capacitors

C1	2200 $\mu$ /25V Radial
C2	100n 0.2" Pitch
C3	2n2 0.2" Pitch
C4	10n 0.2" Pitch
C5	220 $\mu$ /10V Radial
C6,8	1 $\mu$ 0/25V Radial
C7	100 $\mu$ /16V Radial

### Semiconductors

IC1	555
IC2,3	CA3140
TR1-3	BC548
TR4	BC558
TR5	TIP32 or TIP42
D1,2,6	1N5401
D3	1N4148
D4	5V6 Zener
D5	OA47

## Parts

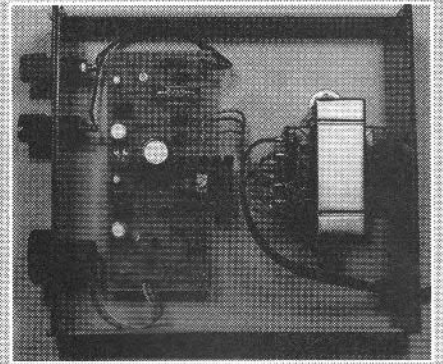

### Additional Items

- X1 12-0-12V 25VA Transformer
  - F1 20mm 2A Anti-Surge with PCB Fuse Holder
  - PCB (available from Electronics in Action)
  - Case
  - Knob for VR1
  - Red and Black 4mm Terminals
  - Mains Flex
  - Expo Reliant PCB Drill.
- The plastic case used for the prototype is made by Bafbox, and is available from RS/Electromail, stock no 506-788.

Fig.4 Front panel template

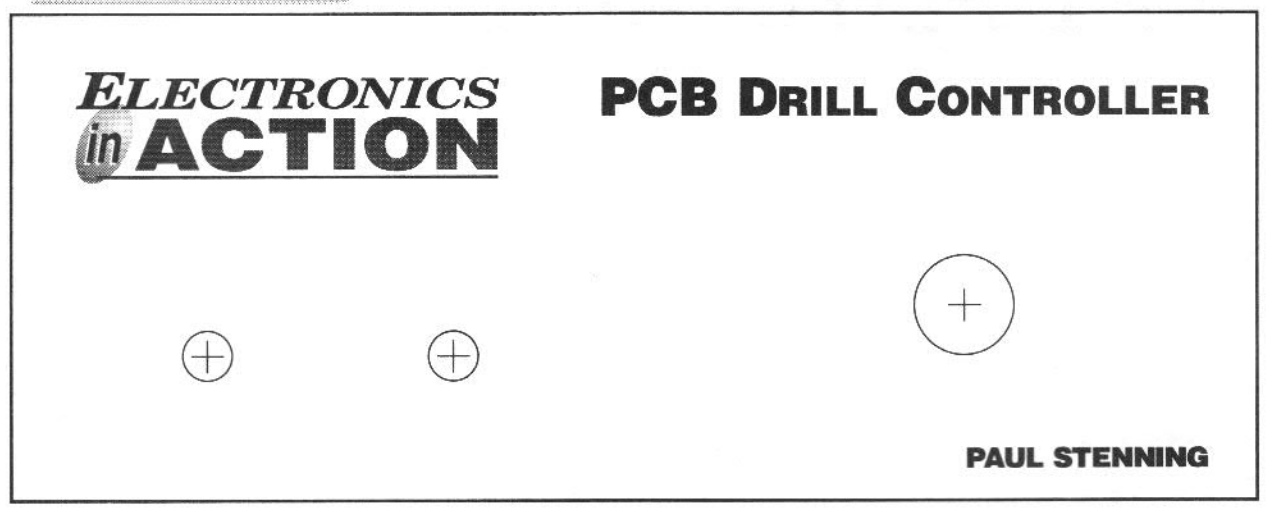

# Coming soon...

Paul Stenning will be showing us an easy to construct test card and pattern generator, requiring no EPROMs.

**Make sure you don't miss it**



**POWER AMPLIFIER MODULES-TURNTABLES-DIMMERS-LOUDSPEAKERS-19 INCH STEREO RACK AMPLIFIERS**

\* PRICES INCLUDE V.A.T. \* PROMPT DELIVERIES \* FRIENDLY SERVICE \* LARGE (A4) S.A.E., 60p STAMPED FOR CATALOGUE \*

**OMP MOS-FET POWER AMPLIFIERS**  
HIGH POWER. TWO CHANNEL 19 INCH RACK

**THOUSANDS PURCHASED BY PROFESSIONAL USERS**

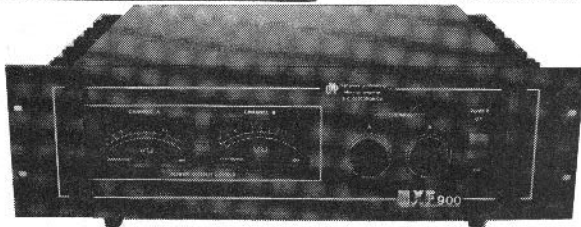

**THE RENOWNED MXF SERIES OF POWER AMPLIFIERS**  
FOUR MODELS:- MXF200 (100W + 100W) MXF400 (200W + 200W)

**MXF600 (300W + 300W) MXF900 (450W + 450W)**  
ALL POWER RATINGS R.M.S. INTO 4 OHMS, BOTH CHANNELS DRIVEN

**FEATURES:** \* Independent power supplies with two toroidal transformers \* Twin L.E.D. Vu meters \* Level controls \* Illuminated on/off switch \* XLR connectors \* Standard 775mV inputs \* Open and short circuit proof \* Latest Mos-Fets for stress free power delivery into virtually any load \* High slew rate \* Very low distortion \* Aluminium cases \* MXF600 & MXF900 fan cooled with D.C. loudspeaker and thermal protection.

**USED THE WORLD OVER IN CLUBS, PUBS, CINEMAS, DISCOS ETC.**

**SIZES:-** MXF200 19" x H3 1/2" (2U) x D11"  
MXF400 19" x H5 1/4" (3U) x D12"  
MXF600 19" x H5 1/4" (3U) x D13"  
MXF900 19" x H5 1/4" (3U) x D14 1/2"

**PRICES:-** MXF200 £175.00 MXF400 £233.85  
MXF600 £329.00 MXF900 £449.15  
SPECIALIST CARRIER DEL. £12.50 EACH



**OMP X03 STEREO 3-WAY ACTIVE CROSS-OVER**



Advanced 3-Way Stereo Active Cross-Over, housed in a 19" x 1U case. Each channel has three level controls: bass, mid & top. The removable front fascia allows access to the programmable DIL switches to adjust the cross-over frequency: Base-Mid 250/500/800Hz, Mid-Top 1.8/3/5KHz, all at 24db per octave. Bass invert switches on each bass channel. Nominal 775mV input/output. Fully compatible with OMP rack amplifier and modules.

**Price £117.44 + £5.00 P&P**

**STEREO DISCO MIXER SDJ3400SE**

**\* ECHO & SOUND EFFECTS \***

**STEREO DISCO MIXER** with 2 x 7 band L & R graphic equalisers with bar graph LED Vu meters. **MANY OUTSTANDING FEATURES**- including Echo with repeat & speed control, DJ Mic with talk-over switch, 6 Channels with individual faders plus cross fade, Cue Headphone Monitor, 8 Sound Effects. Useful combination of the following inputs:- 3 turntables (mag), 3 mics, 5 Line for CD, Tape, Video etc.

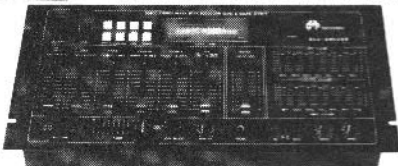

**Price £144.99 + £5.00 P&P**

**SIZE: 482 x 240 x 120mm**

**PIEZO ELECTRIC TWEETERS - MOTOROLA**

Join the Piezo revolution! The low dynamic mass (no voice coil) of a Piezo tweeter produces an improved transient response with a lower distortion level than ordinary dynamic tweeters. As a crossover is not required these units can be added to existing speaker systems of up to 100 watts (more if two are put in series). **FREE EXPLANATORY LEAFLETS ARE SUPPLIED WITH EACH TWEETER.**

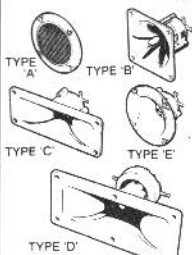

**TYPE 'A' (KSN1036A)** 3" round with protective wire mesh. Ideal for bookshelf and medium sized Hi-Fi speakers. Price £4.90 + 50p P&P.  
**TYPE 'B' (KSN1005A)** 3 1/2" super horn for general purpose speakers, disco and P.A. systems etc. Price £5.99 + 50p P&P.  
**TYPE 'C' (KSN1016A)** 2' x 5" wide dispersion horn for quality Hi-Fi systems and quality discos etc. Price £6.99 + 50p P&P.  
**TYPE 'D' (KSN1025A)** 2' x 6" wide dispersion horn. Upper frequency response retained extending down to mid-range (2KHz). Suitable for high quality Hi-Fi systems and quality discos. Price £9.99 + 50p P&P.  
**TYPE 'E' (KSN1038A)** 3 1/2" horn tweeter with attractive silver finish trim. Suitable for Hi-Fi monitor systems etc. Price £5.99 + 50p P&P.  
**LEVEL CONTROL** Combines, on a recessed mounting plate, level control and cabinet input jack socket. 85x85mm. Price £4.10 + 50p P&P.

**IBI FLIGHT CASED LOUDSPEAKERS**

A new range of quality loudspeakers, designed to take advantage of the latest speaker technology and enclosure designs. Both models utilize studio quality 12" cast aluminium loudspeakers with factory fitted grilles, wide dispersion constant directivity horns, extruded aluminium corner protection and steel ball corners, complimented with heavy duty black covering. The enclosures are fitted as standard with top hats for optional loudspeaker stands.

**POWER RATINGS QUOTED IN WATTS RMS FOR EACH CABINET**  
**FREQUENCY RESPONSE FULL RANGE 45Hz - 20KHz**

**IBI FC 12-100WATTS (100dB) PRICE £159.00 PER PAIR**  
**IBI FC 12-200WATTS (100dB) PRICE £175.00 PER PAIR**  
SPECIALIST CARRIER DEL. £12.50 PER PAIR

**OPTIONAL STANDS PRICE PER PAIR £49.00**  
Delivery £6.00 per pair

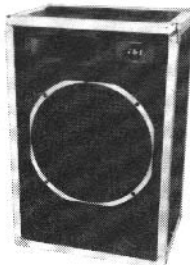

**IN-CAR STEREO BOOSTER AMPS**

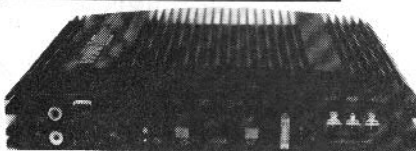

**PRICES:** 150W £49.99 250W £99.99  
400W £109.95 P&P £2.00 EACH

**THREE SUPERS HIGH POWER CAR STEREO BOOSTER AMPLIFIERS**  
150 WATTS (75 + 75) Stereo, 150W Bridged Mono  
250 WATTS (125 + 125) Stereo, 250W Bridged Mono  
400 WATTS (200 + 200) Stereo, 400W Bridged Mono  
**ALL POWERS INTO 4 OHMS**

**Features:**  
\* Stereo, bridgable mono \* Choice of high & low level inputs \* L & R level controls \* Remote on-off \* Speaker & thermal protection.

**OMP MOS-FET POWER AMPLIFIER MODULES**

SUPPLIED READY BUILT AND TESTED.

These modules now enjoy a world-wide reputation for quality, reliability and performance at a realistic price. Four models are available to suit the needs of the professional and hobby market i.e. Industry, Leisure, Instrumental and Hi-Fi etc. When comparing prices, NOTE that all models include toroidal power supply, integral heat sink, glass fibre P.C.B. and drive circuits to power a compatible Vu meter. All models are open and short circuit proof.

**THOUSANDS OF MODULES PURCHASED BY PROFESSIONAL USERS**



**OMP/MF 100 Mos-Fet** Output power 110 watts R.M.S. into 4 ohms, frequency response 1Hz - 100KHz -3dB, Damping Factor >300, Slew Rate 45V/uS, T.H.D. typical 0.002%, Input Sensitivity 500mV, S.N.R. -110 dB. Size 300 x 123 x 60mm.  
**PRICE £40.85 + £3.50 P&P**



**OMP/MF 200 Mos-Fet** Output power 200 watts R.M.S. into 4 ohms, frequency response 1Hz - 100KHz -3dB, Damping Factor >300, Slew Rate 50V/uS, T.H.D. typical 0.001%, Input Sensitivity 500mV, S.N.R. -110 dB. Size 300 x 155 x 100mm.  
**PRICE £64.35 + £4.00 P&P**



**OMP/MF 300 Mos-Fet** Output power 300 watts R.M.S. into 4 ohms, frequency response 1Hz - 100KHz -3dB, Damping Factor >300, Slew Rate 75V/uS, T.H.D. typical 0.001%, Input Sensitivity 500mV, S.N.R. -110 dB. Size 330 x 175 x 100mm.  
**PRICE £81.75 + £5.00 P&P**

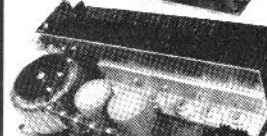

**OMP/MF 450 Mos-Fet** Output power 450 watts R.M.S. into 4 ohms, frequency response 1Hz - 100KHz -3dB, Damping Factor >300, Slew Rate 75V/uS, T.H.D. typical 0.001%, Input Sensitivity 500mV, S.N.R. -110 dB, Fan Cooled, D.C. Loudspeaker Protection, 2 Second Anti-Thump Delay. Size 385 x 210 x 105mm.  
**PRICE £132.85 + £5.00 P&P**

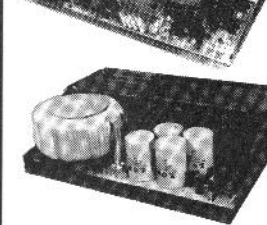

**OMP/MF 1000 Mos-Fet** Output power 1000 watts R.M.S. into 2 ohms, 725 watts R.M.S. into 4 ohms, frequency response 1Hz - 100KHz -3dB, Damping Factor >300, Slew Rate 75V/uS, T.H.D. typical 0.002%, Input Sensitivity 500mV, S.N.R. -110 dB, Fan Cooled, D.C. Loudspeaker Protection, 2 Second Anti-Thump Delay. Size 422 x 300 x 125mm.  
**PRICE £259.00 + £12.00 P&P**

**NOTE: MOS-FET MODULES ARE AVAILABLE IN TWO VERSIONS: STANDARD - INPUT SENS 500mV, BAND WIDTH 100KHz. PEC (PROFESSIONAL EQUIPMENT COMPATIBLE) - INPUT SENS 775mV, BAND WIDTH 50KHz. ORDER STANDARD OR PEC.**

**LOUDSPEAKERS**

**LARGE SELECTION OF SPECIALIST LOUDSPEAKERS AVAILABLE, INCLUDING CABINET FITTINGS, SPEAKER GRILLES, CROSS-OVERS AND HIGH POWER, HIGH FREQUENCY BULLETS AND HORNS, LARGE (A4) S.A.E. (60p STAMPED) FOR COMPLETE LIST.**



McKenzie and Fane Loudspeakers are also available.

**EMINENCE- INSTRUMENTS, P.A., DISCO, ETC**

**ALL EMINENCE UNITS 8 OHMS IMPEDANCE**

- 8" 100 WATT R.M.S. ME8-100 GEN. PURPOSE, LEAD GUITAR, EXCELLENT MID, DISCO. RES. FREQ. 72Hz, FREQ. RESP. TO 4KHz, SENS 97dB. PRICE £32.71 + £2.00 P&P
- 10" 100 WATT R.M.S. ME10-100 GUITAR, VOCAL, KEYBOARD, DISCO, EXCELLENT MID. RES. FREQ. 71Hz, FREQ. RESP. TO 7KHz, SENS 97dB. PRICE £33.74 + £2.50 P&P
- 10" 200 WATT R.M.S. ME10-200 GUITAR, KEYB'D, DISCO, VOCAL, EXCELLENT HIGH POWER MID. RES. FREQ. 65Hz, FREQ. RESP. TO 3.5KHz, SENS 99dB. PRICE £43.47 + £2.50 P&P
- 12" 100 WATT R.M.S. ME12-100LE GEN. PURPOSE, LEAD GUITAR, DISCO, STAGE MONITOR. RES. FREQ. 49Hz, FREQ. RESP. TO 6KHz, SENS 100dB. PRICE £35.64 + £3.60 P&P
- 12" 100 WATT R.M.S. ME12-100LT (TWIN CONE) WIDE RESPONSE, P.A., VOCAL, STAGE MONITOR. RES. FREQ. 42Hz, FREQ. RESP. TO 10KHz, SENS 98dB. PRICE £36.67 + £3.60 P&P
- 12" 200 WATT R.M.S. ME12-200 GEN. PURPOSE, GUITAR, DISCO, VOCAL, EXCELLENT MID. RES. FREQ. 58Hz, FREQ. RESP. TO 6KHz, SENS 98dB. PRICE £46.71 + £3.50 P&P
- 12" 300 WATT R.M.S. ME12-300GP HIGH POWER BASS, LEAD GUITAR, KEYBOARD, DISCO ETC. RES. FREQ. 47Hz, FREQ. RESP. TO 5KHz, SENS 103dB. PRICE £70.19 + £3.50 P&P
- 15" 200 WATT R.M.S. ME15-200 GEN. PURPOSE BASS, INCLUDING BASS GUITAR. RES. FREQ. 46Hz, FREQ. RESP. TO 5KHz, SENS 99dB. PRICE £50.72 + £4.00 P&P
- 15" 300 WATT R.M.S. ME15-300 HIGH POWER BASS, INCLUDING BASS GUITAR. RES. FREQ. 39Hz, FREQ. RESP. TO 3KHz, SENS 103dB. PRICE £73.34 + £4.00 P&P

**EARBENDERS- HI-FI, STUDIO, IN-CAR, ETC**

- ALL EARBENDER UNITS 8 OHMS (Except EB8-50 & EB10-50 which are dual impedance tapped @ 4 & 8 ohm)
- BASS, SINGLE CONE, HIGH COMPLIANCE, ROLLED SURROUND
- 8" 50WATT EB8-50 DUAL IMPEDANCE, TAPPED 4/8 OHM BASS, HI-FI, IN-CAR. RES. FREQ. 40Hz, FREQ. RESP. TO 7KHz SENS 97dB. PRICE £8.90 + £2.00 P&P
- 10" 50WATT EB10-50 DUAL IMPEDANCE, TAPPED 4/8 OHM BASS, HI-FI, IN-CAR. RES. FREQ. 40Hz, FREQ. RESP. TO 5KHz, SENS. 99dB. PRICE £13.65 + £2.50 P&P
- 10" 100WATT EB10-100 BASS, HI-FI, STUDIO. RES. FREQ. 35Hz, FREQ. RESP. TO 3KHz, SENS 96dB. PRICE £30.39 + £3.50 P&P
- 12" 100WATT EB12-100 BASS, STUDIO, HI-FI, EXCELLENT DISCO. RES. FREQ. 26Hz, FREQ. RESP. TO 3 KHz, SENS 93dB. PRICE £42.12 + £3.50 P&P
- FULL RANGE TWIN CONE, HIGH COMPLIANCE, ROLLED SURROUND
- 5 1/4" 60WATT EB5-60TC (TWIN CONE) HI-FI, MULTI-ARRAY DISCO ETC. RES. FREQ. 63Hz, FREQ. RESP. TO 20KHz, SENS 92dB. PRICE £9.99 + £1.50 P&P
- 6 1/2" 60WATT EB6-60TC (TWIN CONE) HI-FI, MULTI-ARRAY DISCO ETC. RES. FREQ. 38Hz, FREQ. RESP. TO 20KHz, SENS 94dB. PRICE £10.99 + 1.50 P&P
- 8" 60WATT EB8-60TC (TWIN CONE) HI-FI, MULTI-ARRAY DISCO ETC. RES. FREQ. 40Hz, FREQ. RESP. TO 18KHz, SENS 89dB. PRICE £12.99 + £1.50 P&P
- 10" 60WATT EB10-60TC (TWIN CONE) HI-FI, MULTI ARRAY DISCO ETC. RES. FREQ. 35Hz, FREQ. RESP. TO 12KHz, SENS 98dB. PRICE £16.49 + £2.00 P&P

**TRANSMITTER HOBBY KITS**

**PROVEN TRANSMITTER DESIGNS INCLUDING GLASS FIBRE PRINTED CIRCUIT BOARD AND HIGH QUALITY COMPONENTS COMPLETE WITH CIRCUIT AND INSTRUCTIONS**

**3W TRANSMITTER** 80-108MHz, VARICAP CONTROLLED PROFESSIONAL PERFORMANCE, RANGE UP TO 3 MILES, SIZE 38 x 123mm, SUPPLY 12V @ 0.5AMP. PRICE £14.85 + £1.00 P&P

**FM MICRO TRANSMITTER** 100-108MHz, VARICAP TUNED, COMPLETE WITH VERY SENS FET MIC, RANGE 100-300m, SIZE 56 x 46mm, SUPPLY 9V BATTERY. PRICE £6.60 + £1.00 P&P

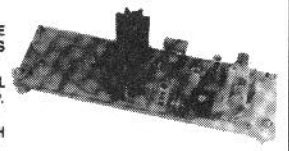

PHOTO: 3W FM TRANSMITTER

**B.K. ELECTRONICS**  
UNITS 1 & 5 COMET WAY, SOUTHDEN-ON-SEA,  
ESSEX. SS2 6TR.  
Tel.: 0702-527572 Fax.: 0702-420243

POSTAL CHARGES PER ORDER £1.00 MINIMUM. OFFICIAL ORDERS FROM SCHOOLS, COLLEGES, GOVT. BODIES, PLCs ETC. PRICES INCLUSIVE OF V.A.T. SALES COUNTER, VISA AND ACCESS ACCEPTED BY POST, PHONE OR FAX.



# The Evolution of Audio Amplifier Design



**T**here is, unfortunately, a continuing divergence between the approach and attitudes of most audio system design engineers and the views of Hi-Fi journalists and a good proportion of up-market Hi-Fi users. By and large the designers, like most practical engineers, tend to rely on calculations based on theory, and explore the performance of their designs by performance tests and other measurements. On the other hand, the journalists and their more with-it readers mostly suspect the validity of measurements, which they feel, like opinion polls, can be made to give any answer which is required. They tend, therefore, to rely on judgments of technical excellence and assessments of sound quality made by a select band of knowledgeable critics.

I read Hi-Fi magazines, though not as many, or as thoroughly as I should because of my rather sceptical viewpoint. I have noted the current views of their correspondents and contributors, and the ideas in (temporary) vogue, some of which I think are just plain daft, while others give me cause to stop and think, and wonder whether there really might be something in what they say.

My problem is I suppose, that long experience of audio systems and circuit design has made me cynical about innovations. I have seen, or heard, a lot

## Part 1

## The early valve years

by John Linsley-Hood

of it before, and I often suspect ulterior motives. For example, if Joe Bloggs advertises some super new connecting wire, or freshly re-labelled component, at ten times the price you first thought of, he will obviously extol its virtues as persuasively as his command of adjectives or his understanding of user psychology will allow.

Similarly, if a Hi-Fi journalist hears of some new idea in equipment design or use, especially if it is likely to prove a bit controversial, he will want to publish details in his journal, since it will help to sell more copies. It is obvious, also, that his write-up will have to be favourable; if it isn't, end of story; though if he feels it may prove to be a lemon, within the effective memory span of his readers, he will build in some small let-out phrase among his praise.

In reality, the progress of consumer audio - from the crystal and cat's-whisker, to the modern stereo FM

receiver, or from the simple battery operated amplifier, driven by a Rochelle salt crystal pick-up, ploughing its way along the spiral groove of an emery powder loaded 78rpm shellac disk, to the modern transistor amplifier driven by a digital compact disk - has been one of continuous and dramatic improvements.

I sometimes contemplate the effect a 1993 technology demo. would have on a 1933 listener recently woken from a sixty year sleep. I suspect he would not agree with some of the more reactionary Hi-Fi pundits that modern Hi-Fi gear lacks the warmth and musicality of the old.

### Battery operated valve amplifiers

For myself, I cut my electronic teeth, as a schoolboy on simple, battery operated amplifiers of the kind I have shown in Figure 1, operated from a 2 volt 'accumulator', and a 120V HT dry battery, available most cheaply from



**Fig.1 Simple valve PU amplifier**

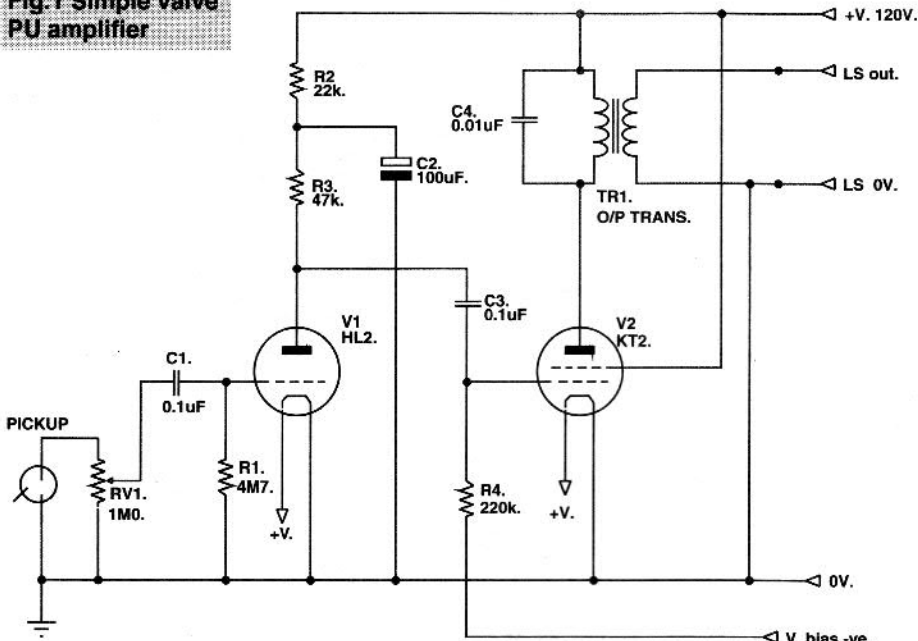

was 0.5 watts, at about 10% distortion - though amplifier distortion tended to be thought of as just a fact of life in those days and was largely ignored. The distortion would mostly be second harmonic, which was not too unpleasant to listen to, but there would also be about 2% of third. The distortion due to V1 was probably less than 0.5%, again mostly second harmonic.

The most obvious effect of these harmonic components was to make the amplifier sound a bit shrill, so a capacitor C4 was connected across the primary of the LS transformer to mellow it down a bit. At the 17k load impedance of the

output transformer, the HF roll-off due to C4 would start at around 1-2KHz.

Inevitably with battery operated equipment, there was always a choice between sound quality and HT battery life - since the 2 volt filament supply came from a rechargeable lead-acid battery, one didn't worry about this too much. HT batteries were expensive and at a 10mA total current, the HT battery life would be about 50-100 hours. If one increased the output valve bias from the recommended 4.5V level, one could increase battery life at the expense of reducing the output power and worsening the distortion. So if one was entertaining friends, one would set the bias at a bit lower voltage.

**Marks and Spencers!**

The gramophone pick-up I used, like most of my friends, was a 'Cosmocord' crystal type, in which a postage stamp sized sandwich of crystalline Rochelle salt was caused to twist along its length - and thereby generate an output voltage by piezoelectric action - by the wiggling of the gramophone needle as it followed the undulations of the groove.

The output voltage one could get, on the louder passages of the record, was of the order of 1 volt RMS and the

frequency response, due mainly to the record characteristics, began to fall off beyond 1KHz, though crystal and stylus resonances helped improve the flatness of the frequency response up to about 3-4KHz. Generally, some kind of electrical roll-off was used anyway above about 5KHz to try to reduce the loud hiss caused by the record surface.

The maximum rated power output from the KT2 output beam-tetrode, a high quality output valve which had not long been introduced at the time of my 1939 Marconi-Osram valve catalogue,

**Fig.2 Simple 30watt power amp**

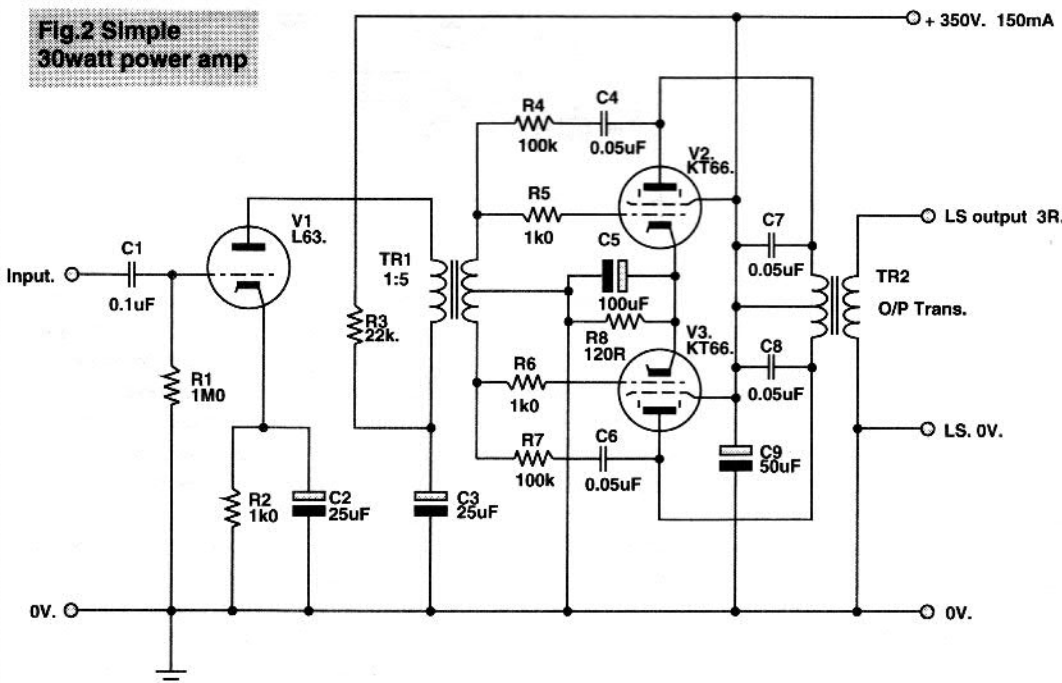

**Mains powered amplifiers.**

The availability of mains operated valves, and for me as a schoolboy, the courage to use them, allowed the design of much more powerful amplifiers. This could be up to 10 watts or more from a pair of KT61s, used in push-pull. In addition to giving a larger power output, push-pull



operation of the kind used in the circuit shown in Figure 2, cancelled most of the second harmonic distortion. What was left was mainly third at a much lower level - say 1% at full output power. This last point is important, since the distortion in most valve amplifier designs will decrease with output power, so that at typical listening levels the distortion would probably be below 1%.

A small practical problem with push-pull systems was the need to drive the control grids of the output valves with a pair of anti-phase inputs. A pair of signals of this kind was most easily obtained from a coupling transformer with a centre-tapped secondary winding, such as TR1 in Figure 2. The use of yet another transformer in the signal line, the output transformer was unavoidable. It tended to limit the performance of the design, and prevented the use of overall negative feedback to reduce distortion and increase bandwidth of the circuit.

The bandwidth available, and the distortion produced by a circuit of this kind depended entirely on the quality of the coupling and output transformers. By popular repute, Ferranti - an electrical engineering firm, in those days, made the best, and these commanded a good price in the second-hand radio component shops. With good quality transformers, a bandwidth of 100Hz-10KHz was practicable, and the THD at 1KHz would probably be less than 1%. However, this would worsen to perhaps 3-4% towards the ends of the audio passband. The lower the step-up or step-down ratio of the transformer, the better it would usually be, so 15 ohm speakers became more popular.

Some local negative feedback was often used, for example via R4/C4 and R7/C6, to reduce the third harmonic contribution of the output valves, but some HF roll-off components, such as C7 and C8, would also be added to camouflage this defect.

A problem with all multi-stage amplifiers was caused by signal voltage feedback along the supply lines. It was not, then, as widely appreciated as it is today, just how much such unwanted feedback of signal components could worsen the circuit distortion level: mainly it was only noticed at all when it was large enough to cause LF oscillation - known as 'motor-boating' because of its sound. HT line decoupling elements such as R2/C2 in Figure 1, and R3/C3 in

**Fig.3a Simple phase inverter**

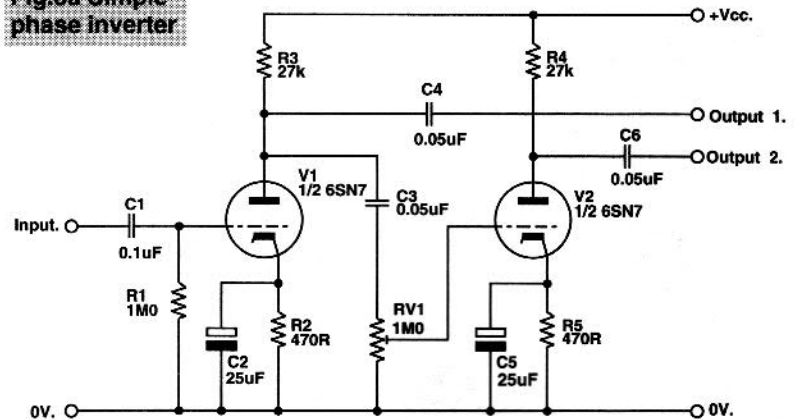

**Fig.3b 'Floating paraphase' layout**

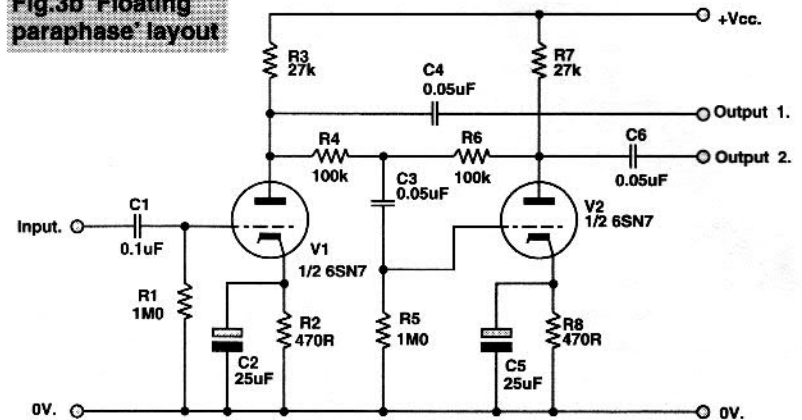

**Fig.3c Long tailed pair phase splitter**

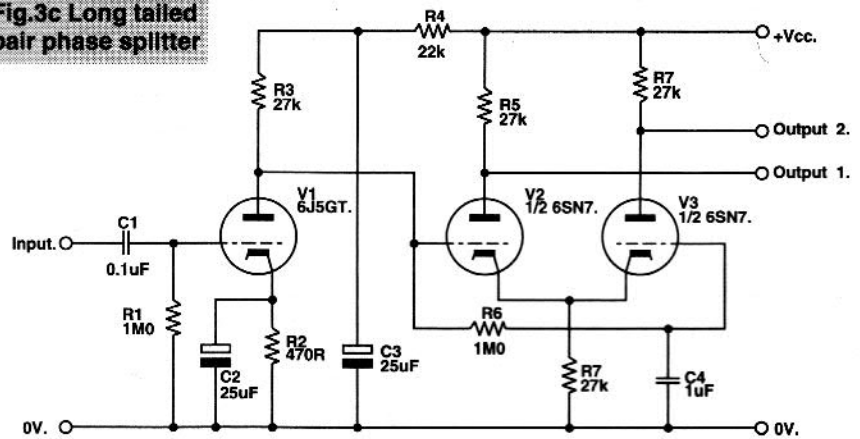

Figure 2, were added to lessen the likelihood of this problem.

At the cost of an extra valve, and some increase in circuit complexity, it was possible to make a 'phase-splitter' stage which would provide the necessary pair of anti-phase signals to drive the output valves without the use of a push-pull input driver transformer. This immediately gave a substantial improvement in circuit performance. Various types of phase-splitter could be used, of which the simplest and crudest was just to incorporate an additional

amplifier stage, shown in Figure 3a. The gain could be adjusted by a preset input pot. so that the two outputs were the same in size. Although popular, this wasn't really a good circuit, since attenuating any signal, and then amplifying it again added needless distortion.

Alternatively, this gain adjustment to make the two drive signals the same in size could be achieved automatically by the use of negative feedback, in the 'floating paraphase' layout I have shown in Figure 3b. This had the advantage



**Fig.3d Split load phase splitter**

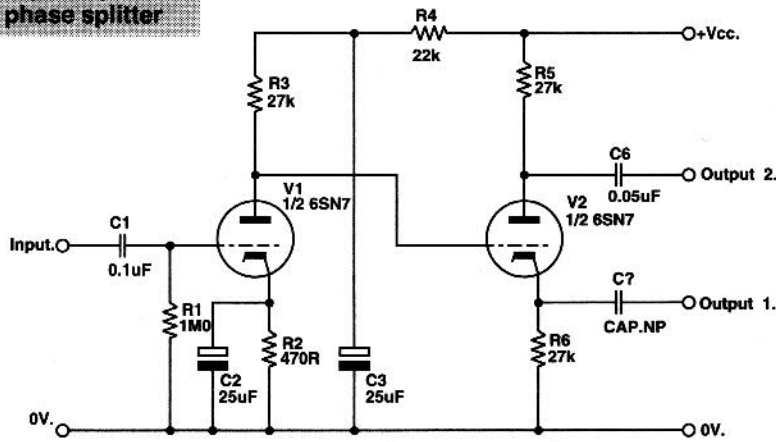

that, since V2 operated with nearly 100% negative feedback, this stage generated a negligible amount of distortion. Other popular layouts were the 'long-tailed pair' circuits of Figure 3c and the split load driver stage of Figure 3d. This last design also added very little distortion, and was the circuit adopted by D T N Williamson in his classic 15 watt Hi-Fi valve amplifier of 1947-8. However, since this stage operated at unity gain, it would generally require a pair of further gain stages between the phase-splitter outputs and the output valve inputs.

I have shown, in Figure 4, an amplifier circuit of my own, dating from 1950-51, using a pair of high gain pentode small signal gain stages, of which the second, V2, was a 'floating

paraphase' phase splitter circuit. Local negative feedback was applied via R16/R19 and some 15dB of overall NFB was also used, from TR1, via R23 and R2. I had no way of measuring THD at the time, but I would guess that it had about 0.4%, at its 25-30 watt maximum output. I was very chuffed by its performance, and my friends also must have liked the sound since several of them pleaded with me to make them one too.

The performance of any amplifier of this kind depends on the primary inductance, and leakage inductance of the output transformer, and though quite a lot of firms made 'Williamson' or equivalent output transformers, they were dear, and I had therefore tailored the circuit design of my amplifier so that I could use the good, but much less

expensive, 'Wharfedale' equivalent.

Inevitably, I built a proper Williamson amplifier a year or two later, winding the output transformer myself, to the constructional details given by 'DTN' in his articles, which had been, by that time, reprinted by 'Wireless World', (the journal in which DTN's articles had originally been printed), as a small booklet. I probably wouldn't have done this but for the fact that I met an elderly (and relatively wealthy) gentleman who had bought a 'Williamson output transformer kit', complete with wire, laminations, and all the other bits and pieces, but had then lost the courage to complete the job, and so was willing to sell me the bits at a bargain price.

For the record, and because there is a high degree of contemporary interest in amplifiers like the 'Williamson', (which, privately, I still think to be the best of the bunch), I have shown the original Williamson circuit in Figure 5. The brief specs. for the o/p transformer were: Primary load impedance = 10k, Primary inductance = 100H (min.), Leakage inductance = 30mH, (max.), Primary winding resistance = 250 ohms, (max).

The 'Williamson' amplifier established the 0.1% figure for THD at maximum output which has remained the criterion for 'Hi-Fi' amplifier performance. In addition it offered a

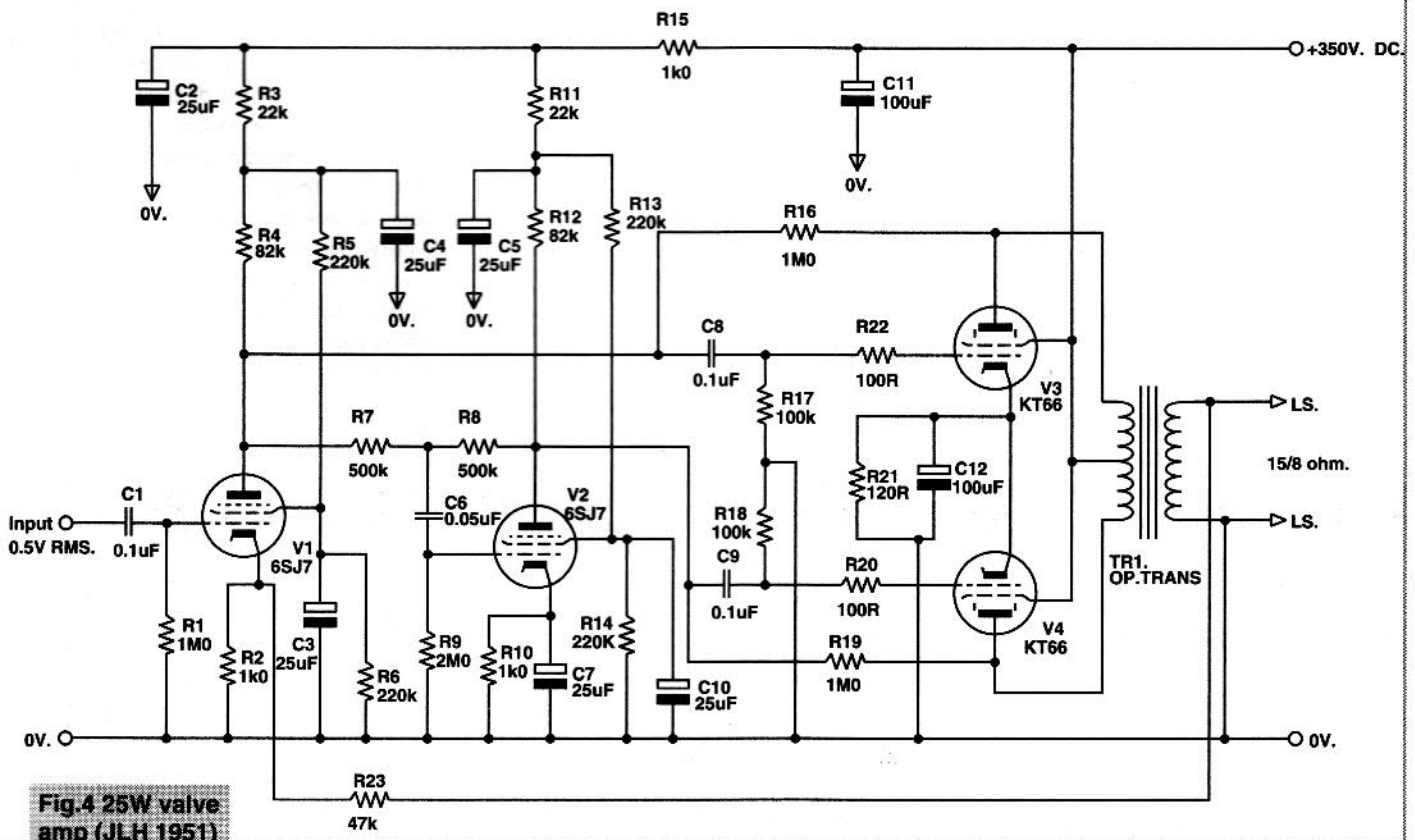

**Fig.4 25W valve amp (JLH 1951)**



**Fig.5 The Williamson Amplifier**

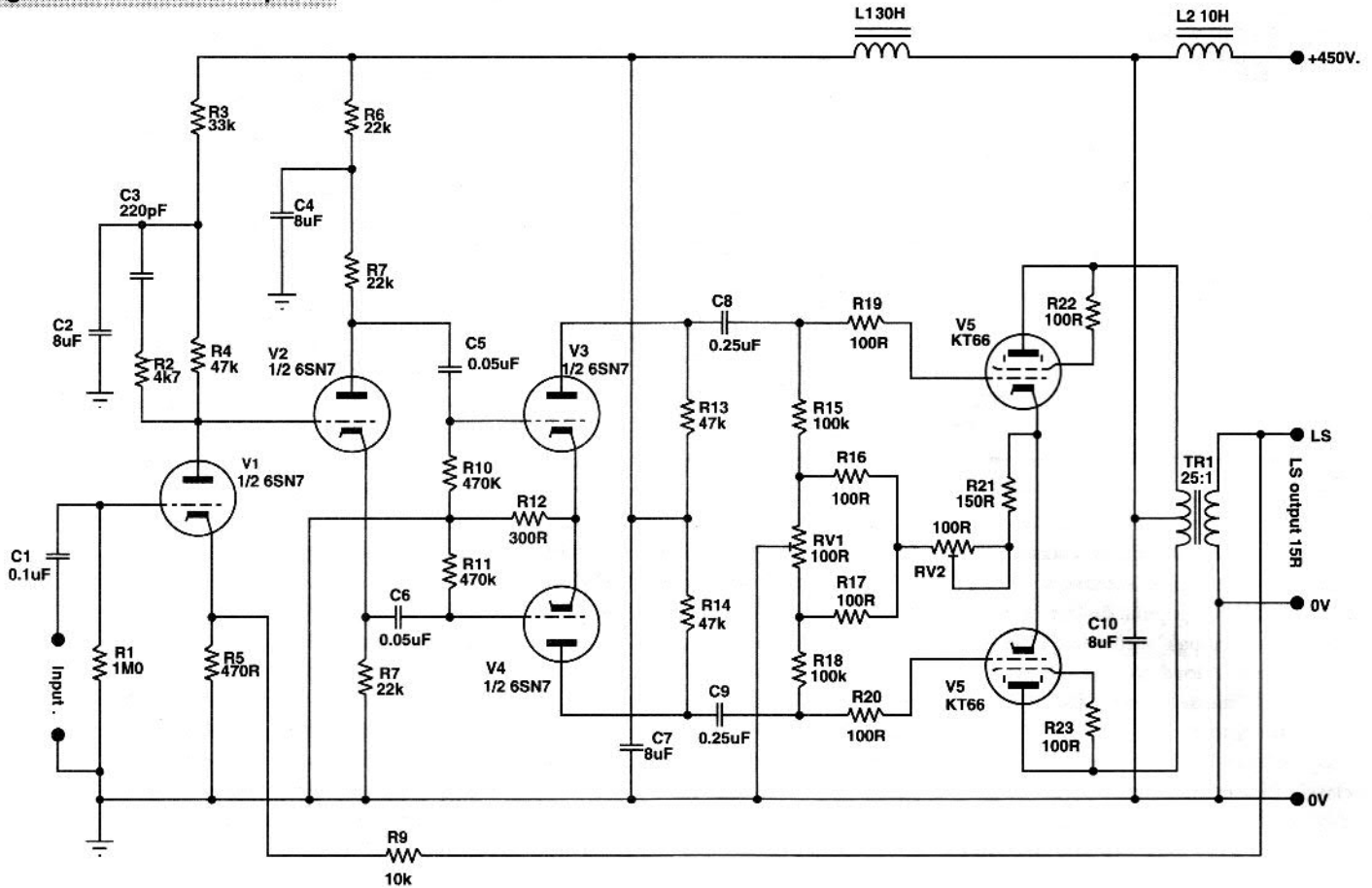

bandwidth of 2Hz - 100kHz, an excellent figure for a valve amplifier, even by today's standards.

The 'Williamson' circuit had several features which are beginning to attract the interest of modern circuit designers, such as the unbypassed cathode bias resistors, to provide local negative feedback, and the exclusive use of non-polar capacitors, but its successful use of about 26dB of overall NFB was undoubtedly the major reason for its superb performance.

There were other comparable designs around at the time, mainly using variations

of the 'ultra-linear' output transformer layout, in which the screen grids (or sometimes the cathodes) of the output valves were taken to additional tapping points on the primary winding. This generally allowed about twice the output power for the same HT voltage compared to the 15 watts given by the triode connected KT66s used by Williamson.

**Progress in other audio fields.**

So far, the designs shown, from Figures 1 and 2, to those in 4 and 5, all show an

increase in quality and performance, partly in response to the designers sharpening their skills, but also to significant improvements in related fields, such as better LS units, using two or more drivers, and 'LP' records.

In particular, the LP record offered most people a signal source with a wider bandwidth, and a better signal to noise ratio than anything previously available, while the growing use of good quality 'magnetic' pick-up cartridges, and agreed recording characteristics meant that circuit designers began to take the requirements of record replay equalisation seriously, with the aim of achieving a flat replay frequency response from 30Hz - 20kHz. I have shown a contemporary gramophone pick-up input equalisation stage in Figure 6.

So far, all of the design and product improvements had brought about a clearly audible gain in sound quality, and there was little feeling amongst the music loving fraternity that anything might be amiss. However, into this cosy environment crept the junction transistor, and all of a sudden, doubts arose about the whole basis of 'Hi-Fi' and I will look at this event in the next part of this series.

**Fig.6 Input RIAA equalisation circuit**

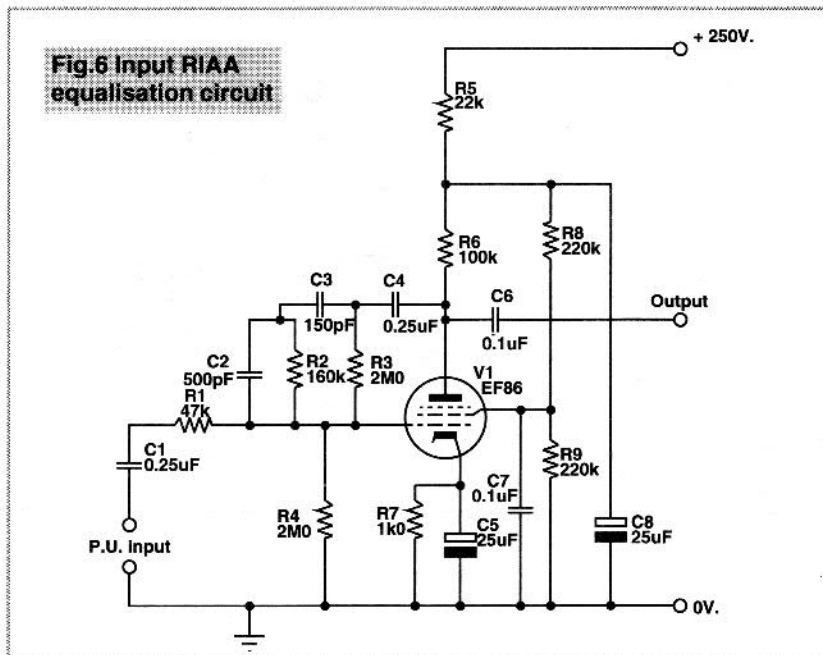

The diagrams in this article were generated using ISIS Illustrator from Labcenter Electronics



# HART

## HART AUDIO KITS – YOUR VALUE FOR MONEY ROUTE TO ULTIMATE HI-FI

HART KITS give you the opportunity to build the very best engineered hifi equipment there is, designed by the leaders in their field, using the best components that are available.

Every HART KIT is not just a new equipment acquisition but a valuable investment in knowledge, giving you guided hands-on experience of modern electronic techniques.

In short HART is your 'friend in the trade' giving you, as a knowledgeable constructor, access to better equipment at lower prices than the man in the street.

You can buy the reprints and construction manual for any kit to see how easy it is to build your own equipment the HART way. The FULL cost can be credited against your subsequent kit purchase.

Our list will give you fuller details of all our Audio Kits, components and special offers.

### AUDIO DESIGN 80 WATT POWER AMPLIFIER.



This fantastic John Linsley Hood designed amplifier is the flagship of our range, and the ideal powerhouse for your ultimate hifi system. This kit is your way to get EK performance for a few tenths of the cost! Featured on the front cover of 'Electronics Today International' this complete stereo power amplifier offers World Class performance allied to the famous HART quality and ease of construction. John Linsley Hood's comments on seeing a complete unit were enthusiastic: "The external view is that of a thoroughly professional piece of audio gear, neat elegant and functional. This impression is greatly reinforced by the internal appearance, which is redolent of quality, both in components and in layout." Options include a stereo LED power meter and a versatile passive front end giving switched inputs using ALPS precision, low-noise volume and balance controls. A new relay switched front end option also gives a tape input and output facility so that for use with tuners, tape and CD players, or indeed any other 'flat' inputs the power amplifier may be used on its own, without the need for any external signal handling stages. 'Slave' and 'monobloc' versions without the passive input stage and power meter are also available. All versions fit within our standard 420 x 260 x 75mm case to match our 400 Series Tuner range. ALL six power supply rails are fully stabilised, and the complete power supply, using a toroidal transformer, is contained within a heavy gauge aluminium chassis/heatsink fitted with IEC mains input and output sockets. All the circuitry is on professional grade printed circuit boards with roller tinned finish and green solder resist on the component ident side, the power amplifiers feature an advanced double sided layout for maximum performance. All wiring in this kit is pre-terminated, ready for instant use!

RLH11 Reprints of latest articles.....£1.80  
K1100CM HART Construction Manual.....£5.50

### LINSLEY HOOD 1400 SERIES ULTRA HIGH-QUALITY PREAMP

Joining our magnificent 80 Watt power amplifier now is the most advanced preamplifier ever offered on the kit, or indeed made-up marketplace. Facilities include separate tape signal selection to enable you to listen to one programme while recording another, up to 7 inputs, cross recording facilities, class A headphone amplifier, cancellable 3-level tone controls and many other useful functions, all selected by high quality relays. For full details see our list.

### LINSLEY HOOD 'SHUNT FEEDBACK' R.I.A.A. MOVING COIL & MOVING MAGNET PICKUP PREAMPLIFIERS

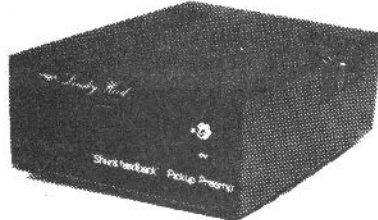

Modern, ultimate sound systems are evolving towards built-in preamplifiers within or near the turntable unit. This keeps noise pickup and treble loss to a minimum. We now offer two units, both having the sonically preferred shunt feedback configuration to give an accurate and musical sound, and both having the ability to use both moving magnet and moving coil cartridges.

Kit K1500 uses modern integrated circuits to achieve outstanding sound quality at minimal cost. The very low power requirements enable this unit to be operated from dry batteries and the kit comes with very detailed instructions making it ideal for the beginner. K1500 Complete kit with all components, printed circuit board, full instructions and fully finished case.....£67.99  
Instructions only.....£2.80  
Kit K1450 is a fully discrete component implementation of the shunt feedback concept and used with the right cartridge offers the discerning user the ultimate in sound quality from vinyl disks. Can be fitted inside our 1400 Preamp, used externally or as a standalone unit. It has a higher power requirement and needs to be powered from our 1400 Series preamplifier or its own dedicated power supply. K1450 Complete Discrete Component RIAA Phono Preamp.....£109.58  
Factory Assembled and Tested.....£159.58  
K1565 Matching Audio Grade Power Supply with potted toroidal transformer and limited shift earthing system.....£79.42  
Factory Assembled and Tested.....£118.42  
U1115 Power Interconnect Cable.....£7.29

### SPECIAL OFFER PRECISION Triple Purpose TEST CASSETTE TC1DD.

Are you sure your tape recorder is set up to give its best? Our latest triple purpose test cassette checks the three most important tape parameters without test equipment. Ideal when fitting new heads. A professional quality, digitally mastered test tape at a price anyone can afford.

Test Cassette TC1DD.....Our price only £10.99.

### DISK-COUNT Classical CDs.

Top Quality, Full Digital (DDD) Compact Disks of the great classical favourites. Like everyone else we didn't like the idea of paying silly prices for CDs. After a long search we have now located a source of top quality classical recordings at prices that make you suspect the quality - until you try them! Send for our list of titles.

### CD ROMs

Like music CDs these have overpriced for some time but with low prices of CD ROM drives the multimedia revolution is with us now. Send for our list of titles. Most popular up to now have been "Too Many Typefonts" with 514 TrueType fonts along with 393 ATM and lots of others. "Shareware Overload" with over 6100 programs extending to 550MB and "Kodak Photo CD Access". The first two are only £12.95, the Kodak only £24.

### TECHNICAL BOOKSHELF

Modern Books. Selected to represent the state of the art today.

#### "THE ART OF LINEAR ELECTRONICS."

J.L. Linsley Hood.

Just Out! Hot off the Press, the definitive electronics and audio book by the renowned John Linsley Hood.

This 300+ page book will give you an unparalleled insight into the workings of all the types of audio circuits. Learn how to read circuit diagrams and understand amplifiers and how they are designed to give the best sound. The virtues and vices of passive and active components are examined and there are separate sections covering power supplies and the sources of noise and hum. As one would expect from this writer the history and derivation of audio amplifier circuitry have an entire chapter, as does test and measurement equipment.

Copiously illustrated this book is incredible value for the amount of information it contains on the much neglected field of linear, as opposed to digital, electronics. Indeed it must be destined to become the standard reference for all who work, or are interested in this field.

#### SPECIAL OFFER.

With each book purchased you may request a FREE extended index, written by the author, exclusively from HART. 0-7806-0868-4.....£16.95  
Don't forget most of our kits have reprints of articles by John Linsley Hood that you can purchase separately.

#### "THE ART OF SOLDERING"

R Brewster.

Absolutely essential reading for anyone who ever picks up a soldering iron. Written from knowledge gained in a lifetime in the field, this is the first book ever solely devoted to this essential and neglected skill for all electronic enthusiasts. Covers everything from the correct choice of soldering iron and solder to the correct procedures to follow with many illustrations and practical exercises.

0-85935-324-3.....£3.95

#### "AUDIO" F.A. Wilson.

320 pages. 178 x 111. Publ. 1985

BP111 "AUDIO" by F.A. Wilson.....£3.95

#### "AN INTRODUCTION TO LOUSPEAKERS & ENCLOSURE DESIGN" V Capel.

160 pages. 178 x 111. Publ. 1988

BP256.....£2.95

#### "LOUDSPEAKERS FOR MUSICIANS" V Capel.

176 pages. 178 x 111. Publ. 1991.

BP297.....£3.95

#### "HOW TO USE OSCILLOSCOPES & OTHER TEST EQUIPMENT" R. A. Penfold.

112 pages. 178 x 111. Publ. 1989

BP267.....£3.50

#### Classics from the "Golden Age"

#### "THE WILLIAMSON AMPLIFIER."

D.T.N. Williamson.

In April 1947, Williamson's power amplifier, using excellent quality push-pull output valves, a special output transformer, and a highly filtered power supply, became an overnight success. The author takes the reader deep into his design considerations, offering practical advice on how to build the units plus concise instructions on setting up the new amp. A cult classic. 1947, Reprinted 1990. 40 pages.

0-9624-1918-4.....£4.95

#### LOUDSPEAKERS; THE WHY AND HOW OF GOOD REPRODUCTION.

G.A. Briggs

This easy-to-read classic, last revised in 1949, introduces the reader to concepts such as impedance, phons and decibels, frequency response, response curves, volume and watts, resonance and vibration, cabinets and baffles, horns, room acoustics, transients, crossovers, negative feedback, Doppler and phase effects, and much more. A provocative survey of the right questions about sound reproduction. 1949 reprinted 1990. 88 Pages. 215 x 140

0-9624-1913-3.....£6.95

#### COMPUTER TITLES.

#### "A CONCISE ADVANCED USERS GUIDE TO MS DOS"

N. Kantaris.

144 pages. 198 x 130. Publ. 1992

BP264.....£3.95

#### "A CONCISE USERS GUIDE TO MS DOS 5"

N. Kantaris.

144 pages. 198 x 130. Publ. 1992.

BP318.....£4.95

#### "MAKING MS DOS WORK FOR YOU"

N. Kantaris & P.R.M. Oliver

160 pages. 198 x 130. Publ. 1993.

BP325.....£4.95

#### "A CONCISE USERS GUIDE TO WINDOWS 3.1"

N. Kantaris.

160 pages. 198 x 130. Publ. 1992.

BP325.....£4.95

Send or 'phone for your copy of our List (50p) of these and many other Kits & Components. Enquiries from Overseas customers are equally welcome, but PLEASE send 2 IRCs if you want a list sent surface post, or 5 for Airmail. Ordering is easy. Just write or telephone your requirements to sample the friendly and efficient HART service. Payment by cheque, cash or credit card. A telephoned order with your credit card number will get your order on its way to you THAT DAY.

Please add part cost of carriage and insurance as follows:--INLAND Orders up to £20 - £1.50,

Orders over £20 - £3.50. Express Courier, next working day £10.

OVERSEAS - Please see the ordering information with our lists.



QUALITY AUDIO KITS

24 hr. SALES LINE (0691) 652894

ALL PRICES INCLUDE UK/EC VAT

# HART

HART ELECTRONIC KITS LTD  
3 PENYLAN MILL  
OSWESTRY, SHROPSHIRE  
SY10 9AF



# Signal to NOISE

A selection of your views and thoughts

## Switch to Audio

Firstly, congratulations on the new publication. It really is very good indeed and seems to cover my particular interest (professional quality audio) very well.

Just a note about the correction to "The Switcher" project published in the December edition. Now firstly let me say that I consider "The Switcher" to be one of the finest audio projects I've seen in any magazine for an awfully long time, however, I'm sure I won't be the only one to notice the deliberate mistake in

question I have is this. Why choose a 1K input impedance? The SSM2412 data sheet specifies the distortion with a 5K load and the graphs bear out the fact 1K that a 1K load will increase the distortion at 1KHz from 0.001% to around about 0.02%. Admittedly this is quoted with a  $V_a$  of 10V RMS, but I'm sure there will be a comparable increase in distortion at lower levels. I realise we're talking about a very low THD to start with here, but I would be interested in the reasoning behind Mike Meechan's choice, rather than (say) 4K7.

While I'm in nit-picking mode here, the Distortion graph for the SSM2412 printed as Figure 8 in the November part of "The Switcher" (Page 23) has a misprint... the second curve up from the bottom labelled  $R_L = 2k$ ,  $V_m = 10V$  RMS should read  $R_L = 5k$ ,  $V_m = 10V$  RMS.

Apart from that I wish you every success with this new venture, I for one will certainly be buying every issue from now on and as soon as I can afford it "The Switcher" is one project I will definitely be building. My ancient Quad 44 ran out of line level inputs several

years ago, and before you mention the intrinsic distortion present in the Quad inputs is due to their use of 4066 CMOS switches, let me assure you that I am four years into building Ben Duncans excellent AMP-02. Just one more module to go (and the chassis) and I'm finished... maybe another year or two if I'm lucky!

**J R Evans**  
Director

**Robin Evans & Associates Ltd.**  
Stansted, Essex

### Mike Meechan replies:

I shall answer the points you have raised (or otherwise) in the order that you have posed them. Yes, the correction should have been as you have shown it, with the 1K resistor providing a DC path to ground for both the Left and Right busses and the op-amp NON-INVERTING inputs. Your diagram shows the INVERTING input connected to ground via the resistor, with feedback returned to the NON-INVERTING input. Your diagram, too, seems to have suffered from the gremlins which plagued mine and the magazine's - less a deliberate mistake and more of technology getting its underwear somewhat in a twist.

As far as the value was concerned - mea culpa. I chose 1K as an arbitrary value but I should

have perhaps looked more closely at my own graphs and chosen something around the 5 or 10K mark, although noise does increase slightly with larger values of resistance. In my defence, even with 1K, distortion was below the measurable limits of

the audio test apparatus which I used.

However, I'll eat a generous portion of humble pie and say that I shouldn't have worsened distortion

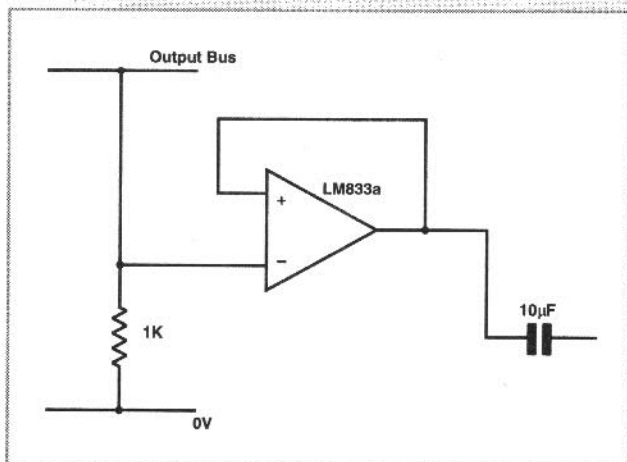

the correction, i.e. the missing connection symbols. I assume the idea was to provide a 1K input impedance to the LM833 op amps being used as output buffers, however your "correction" shows no connections to the busses, whereas I guess one resistor should be connected to the Left Output Bus and the other to the Right, something like the drawing above. The

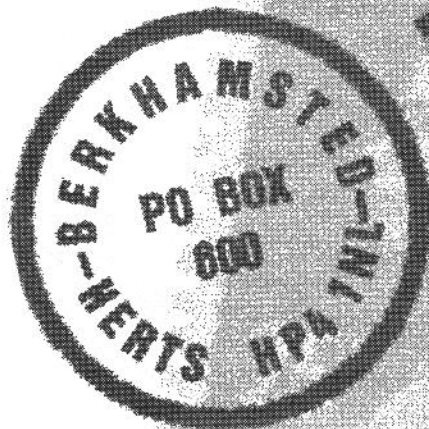



performance unduly with this carelessness. Well spotted, sir.

Finally, thank you very much for the very generous praise - all of it ill-deserved - which you heaped upon me in the opening paragraphs. You might be interested to know that forthcoming hi-fi/pro-audio projects include *The Alchemist* (a Moving Coil preamp) and the *Equaliser*, a 1U high 2 channel mic/line preamp with High Pass Filter, 4 band parametric equaliser and Pan and Fade facilities.

### Wireless Guitar

I am currently studying for a Communication Engineering degree at the University of Plymouth. I am now in the final year of the course and I am required to design and build an electronics project of my choice. I have chosen to build a VHF receive/transmit system for use with an electric guitar or microphone in order to eliminate the need for a connecting lead between the device and its associated amplifier. I am writing to see if you can supply me with any relevant information.

Neil Allies  
Plymouth

Such is the popularity of a project like this that your wish is our command. Look out in next month's issue. Many thanks - **Ed**.

### Chemistry in Action

Congratulations on your new electronics magazine, its three plus months old now and I'm looking forward to every issue but I have a feeling that your title could be wrong as we seem to have a large number of electronic magazines on hand and having read Ideas Forum in the December issue, the write up gives me the impression of electrochemistry so why not rename your title Electronics and Chemistry in Action. Try and obtain the American science magazine titled 'Science Probe' a very interesting magazine. However, the young student or experimenter would like more projects to build, fault finding in electronic circuits especially digital, such as clocks, timers, burglar alarms, PIR sensors and of course not forgetting Ideas Forum.

N R Dobson  
South Shields  
Tyne and Wear

### Shocking Stuff

After all other enquiries have ended in disappointment, I am advised to write to you direct seeking your valid assistance. As a youngster, 60 years ago, I was given an Electric shocking machine powered by a low voltage torch battery. The overall measurement would not have exceeded 6" with a coil diameter of a little over 1". A knurled thumb screw adjusted to make and break action and a hollow tube could be extended from the centre to increase the power of the harmless shock.

I also recall about forty years ago, kits to make this type of machine were freely available from electrical shop.

I would very much like to make one of these for my young grandsons, and have the use of several engineering machines to make a worthwhile model, but I am unable to find either a plan or kit. (I would prefer a plan) which would allow me to proceed. Is there any way you could assist please.

G Hall  
Sunderland  
Tyne & Wear

My how times have changed and indeed only in such a short space of twenty years. I speak of ethical and cultural changes. Looking further back, Victorian society used electrical treatment - there was no shortage of magazine adverts claiming to cure all sorts of ills.

I can even remember in my youth in the 60s making a shocking machine from the 'Meccano

*Elektrikit'* instruction book (The kit must be worth a few bob now!) and taking it to school to excite my colleagues. But now everything has changed, the curiosity and fascination has gone in what electricity can do to the person. Remember Tesla was fascinated in what effect electricity had on the person. He also went to great lengths to show that AC electricity was 'safer' than DC.

But rather like Mercury being a bad substance and banned from use in schools, society has placed a very different emphasis on electricity as a 'potential killer'.

Getting back to your point Mr Hall, these devices are easy to construct and still to this day, the principle of transformer induction is being taught in schools. You will find such diagrams as electric bells, ignition coils and induction coils in any school Physics text book as they still form part of the curriculum.

Whilst I would applaud anyone for wanting to understand how electromagnet induction works and to put it to good use, I would certainly not want it to be abused. That is the black side. On the positive side, we all learn by experience and receiving a 'safe' electric shock would tell us what a shock is and how bad it could be. The difficulty here is how safe is safe, for we are all slightly different in our makeup and so tolerance levels can be very different? -**Ed**

## CD Winners

We received a heap of entries to our Kodak Photo CD player competition and not many of you got the answers wrong, so sorting out who went in the hat was easy. Thank you to all those who entered.

The lucky winners were:

**Mr F.R. Stephens from Worthing in Sussex and Mr J.M.G. Davies from Ferndown in Dorset.**

Well done to both of you and we hope you enjoy your players.

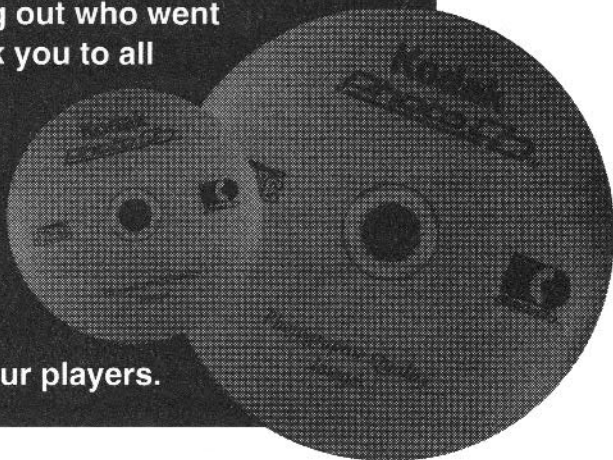



Special Offer • Special Offer • Special Offer • Special Offer

Electronics in Action in association with Tsien (UK) Ltd. is pleased to be able to offer you the chance to buy BoardMaker 1 at a specially reduced price. Professional PCB design for less of your hard earned cash.

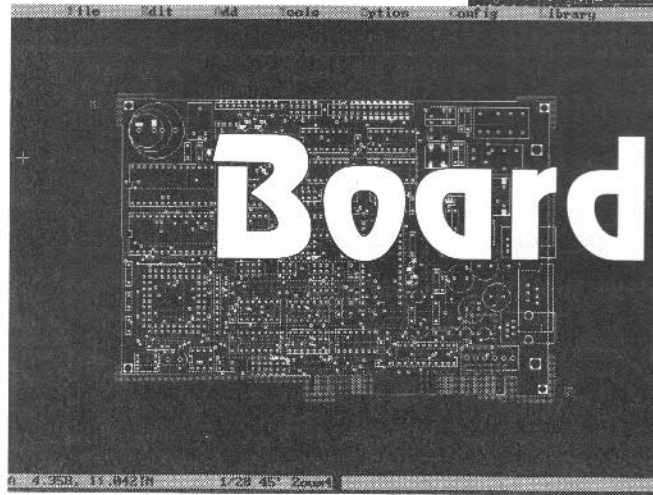
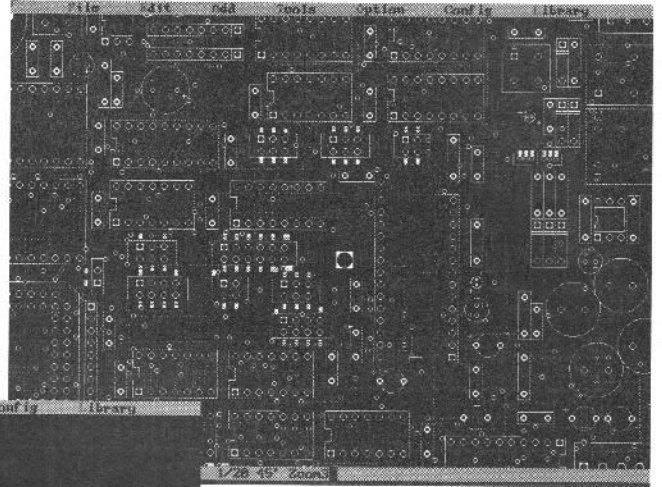

# BoardMaker

ELECTRONICS in ACTION

30

FEBRUARY 1994

**W**e at Electronics in Action know the importance of a well designed, logical PCB. We also know how hard it can be to achieve this goal. That's why we have teamed up with Tsien (UK) Ltd. to offer you the chance of purchasing BoardMaker 1 at the exclusively reduced price of £60.00\* - a **saving of £35\***. To take advantage of this not-to-be missed offer all you have to do is collect the two special tokens (token no.1 is below and token no.2 will appear next month) and post them to Tsien with a cheque or postal order for the correct amount next month. So be sure to keep this token safe until then.

\*Prices exclude VAT



## BoardMaker 1 Specifications

### Cursor

Cross hair or target cursor with imperial or metric display and absolute or relative read-out

### Auto via

Vias are automatically placed when you switch layers. Layer pairs can be assigned by the user

### Block support

Groups of tracks, pads text and symbols can be block manipulated using repeat, move, rotate, kill and mirroring commands

### SMD support

Top and bottom layer component placement. Any SMD symbol can be rotated and mirrored to suit particular layout orientations

### Arcs / Circles

Arcs and circles up to the maximum board size can be drawn

### Ground plane

Areas of copper can be filled to provide a ground / power plane or localised copper fill. Design clearances around existing tracks and pads are automatically respected

### Manual

A concise, illustrated User Guide and Command Reference with full cross referencing and index

### Layers

8 signal layers, 2 silk screen layers

### Maximum PCB

17 x 17 inches

### Resolution

2 thou nominal

### Tracks

User definable from 2-531 thou. Automatic 45 degree track chamfering as well as 90 degree and any angle corners

### Pads

User definable diameter and hole size. Multiple pad shapes including circular, square, oval and rectangular. Pad matrix facilities allow rapid placement for SMD's and PGA's

### Symbols

1000 symbols per layout. Symbols can be moved, rotated, repeated and mirrored, whilst maintaining connectivity. Standard libraries are provided for through hole and surface mount devices.

### Libraries

New symbols are created graphically and library independent PCB design files ensures symbols can be updated and exported without cumbersome library maintenance

### DRC display

When routing tracks you can see a continuous graphical display of the design rules

### Grid sizes

Separate visible and snap grids. 7 placement grids from 2 thou to 0.1 inch



**At last, a fully functional upgradeable PCB CAD system to suit any budget. Substantial trade-in discounts are available against other "professional" PCB design packages ...**

**... call now for details.**

## Board Capture

### *Schematic Capture Design Tool*

- Direct netlist link to BoardMaker2
- Forward annotation with part values
- Full undo/redo facility (50 operations)
- Single-sheet, multi-paged and hierarchical designs
- Smooth scrolling
- Intelligent wires (automatic junctions)
- Dynamic connectivity information
- Automatic on-line annotation
- Integrated on-the-fly library editor
- Context sensitive editing
- Extensive component-based power control
- Back annotation from BoardMaker2

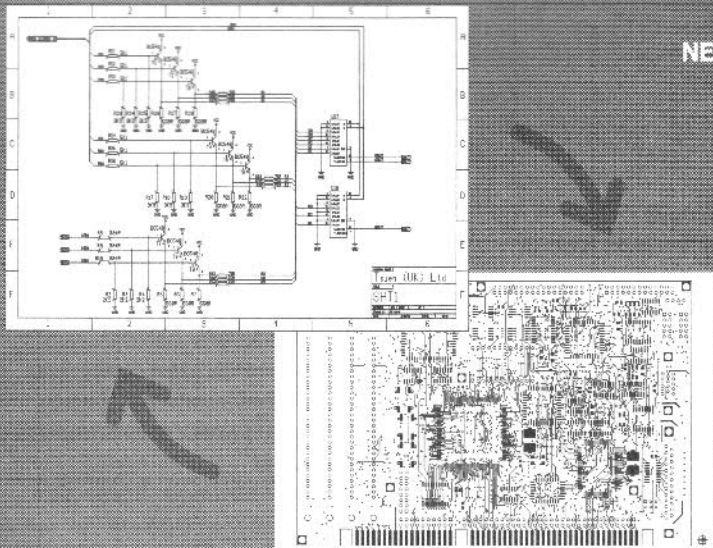

## BoardMaker

### *BoardMaker1 - Entry level*

- PCB and schematic drafting
- Easy and intuitive to use
- Surface mount and metric support
- 90, 45 and curved track corners
- Ground plane fill
- Copper highlight and clearance checking

### *BoardMaker2 - Advanced level*

- All the features of BoardMaker1 +
- Full netlist support - BoardCapture, OrCad, Schema, Tango, CadStar and others
- Full Design Rule Checking both mechanical and electrical
- Top down modification from the schematic
- Component renumber with back annotation
- Report generator - Database ASCII, BOM
- Thermal power plane support with full DRC

NEW

## Board Router

### *Gridless re-entrant autorouter*

- Simultaneous multi-layer routing
- SMD and analogue support
- Full interrupt, resume, pan and zoom-while routing

### *Output drivers - Included as standard*

- Printers - 9 & 24 pin Dot matrix, HPLaserjet and PostScript
- Penplotters - HP, Graphtec & Houston
- Photoplotters - All Gerber 3X00 and 4X00
- Excellon NC Drill and Annotated drill drawings (BM2)

Call, write or fax for more information or a full evaluation kit

Tsien (UK) Limited  
Aylesby House  
Wenny Road, Chatteris  
Cambridge  
PE16 6UT

Tel (0354) 695959  
Fax (0354) 695957

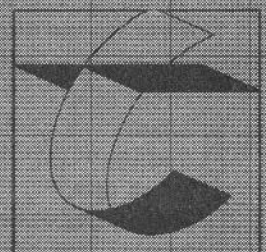

**tsien**



# Technoshop

Bringing the world closer together

**E**lectronics in Action in co-operation with The Technology Exchange Ltd, the international technology matchmaking service based in the UK, brings you each month a selection of technology partnership opportunities to which you are invited to respond.

The Technology Exchange, which was formed in 1985 as a not-for-profit technology sourcing service to industry, holds a biannual 'Technoshop' Technology Transfer Fair at Heathrow Airport and several 'Techmart' Fairs overseas for the United Nations (UNIDO).

For this issue of Electronics in Action, we are presenting a series of offers of licence, joint venture and patents rights for sale from organisations in 34 countries.

If you would like to have an introduction to any of the sources of the offers describes in these profiles, please write to the The Technology Exchange quoting the reference number at the head of the entry and giving full contact details for the contact person in your own organisation and your requirements for a new product or process development.

The only cost associated with this process is a simple £10 plus VAT introduction fee for each entry to which you respond. For this we will send you full contact details for the source of the offer and invite them to send you more detailed information about their offer.

The code letters at the head of each offer indicate the stage of development, type of offer and the type of organisation making the offer as indicated in the table

Each entry is preceded by a reference number and letters indicating STATUS, OFFER and SOURCE.

Please respond directly to:

**The Technology Exchange Ltd**  
**Wrest Park**  
**Silsoe**  
**Bedford**  
**MK45 4HS**  
**or Fax: 0525 860664**  
**Phone: 0525 860333**

The payment of £10 plus VAT (£11.75) per item should be sent with your requests.

KEY	Example: S O S U		
	Status	Offer	Source
Status: Indicates the stage of development:			
P	Patent or design only	M	Laboratory model
W	Working prototype		
U	Pro-production units available	F	In current production
C	Commercialised		
Offer: Indicates the type of agreement sought:			
L	Manufacture under licence	S	Design and/or patent for sale
J	Joint venture offer		
Source: Indicates the type of organisation making the offer:			
C	Limited Company	E	Educational Institution
R	Independent Research Organisation		
G	Government Research	P	Private Individual

## 505055 G Electromagnetic radiation transducer

Transducers transform invisible electromagnetic radiation into the visible one. They can be used in opto and micro-electronics for the laser system and electron microscope tuning, for visual evaluation of light spot uniformity and as gamma - radiation dose meters. Luminescent composition, operating in clearance and reflection mode is the base of visualisers.

## 605120 W L G Magnetic valve-type reactor

is a high power inductive reactance, smoothly regulated in its value by magnetic biasing of magnetic circuit with direct current. The reactor magnetic circuit is of a special transformer type design which cores operate in high saturation conditions. The cores incorporate mains, control and the converter transformer windings in one.

## 105254 F L G Automatic system of heat moisture treatment control for concrete products

A multichannel temperature controller RTM-3 is a digital regulator on microschemes of H 561 series with programmes generation. RTM-3 is aimed for the control of reinforced concrete products heat treatment in various technological units; steam curing chambers, thermoforms, printed circuit boards etc.

## 105236 G Transient electromagnetic system

The 'Cykl' TEM system is a high power ground of borehole electromagnetic system designed to determine the complete geoelectrical sections from the surface to depths of 4000-5000m. The system comprises the 4-channel receiver with time range of 50s -50s and the transmitter in two modifications (45.4kw) compatible on the electrical and logical levels and synchronised by cable or crystal controlled clock.

## 705266 F J G Universal positive-negative photoresist. Production forms PhSN-3 and PhSN-3PV

A new photosensitive composition which includes polymer components (phenol formaldehyde and/or epoxy resins), a light sensitive component and a mixture of organic solvents. Production forms make it possible to prepare photoresist layers of 0,3-3,0mm thickness. This adds new possible applications of the photoresist, in particular, in the lift off lithography.

## 105429 C L/S C Starodyne: synchronous electric motor

includes an oscillating core, which does not rotate but causes a high speed spindle to rotate. Advantages: very low response time, compactness, robustness, easy to service, adaptable, no power limit. Applications: mechanisms, automation, handling, electrical systems.



# The Switcher

## Part 4

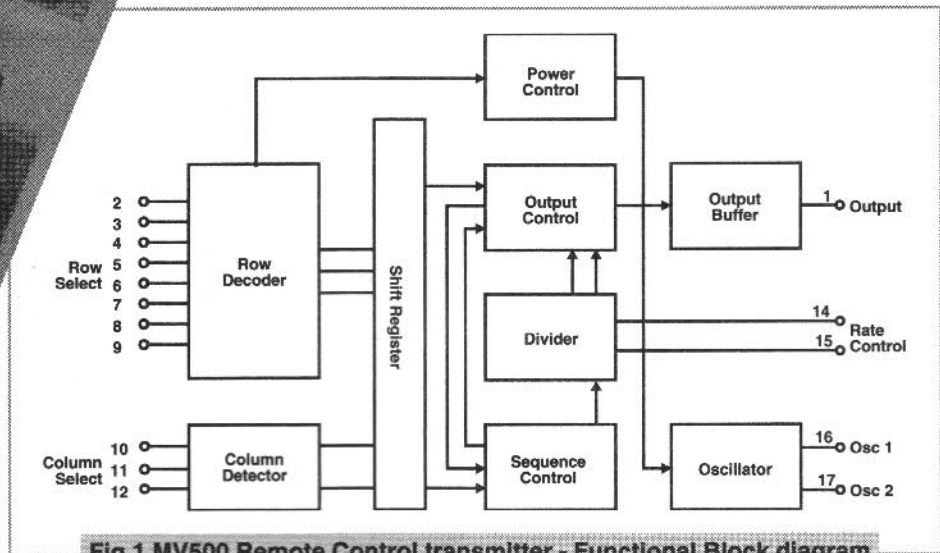
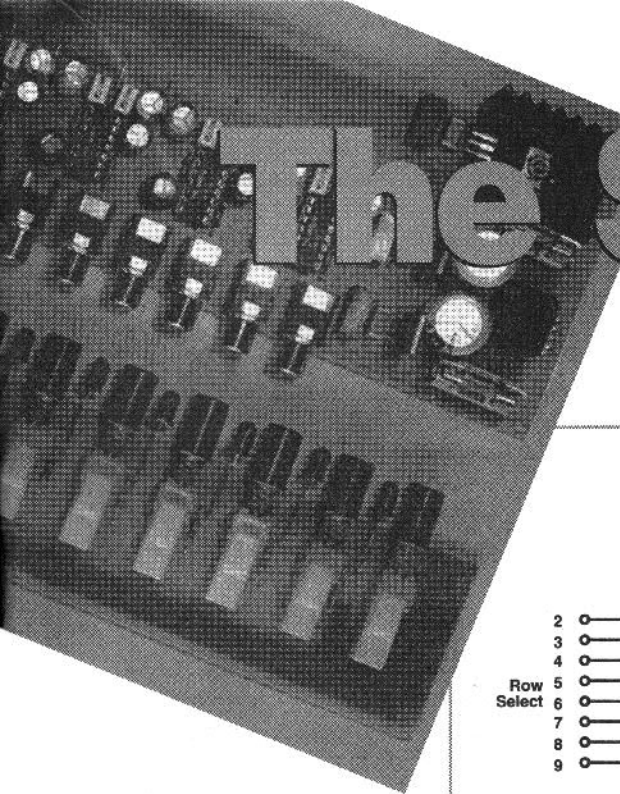

Fig.1 MV500 Remote Control transmitter - Functional Block diagram

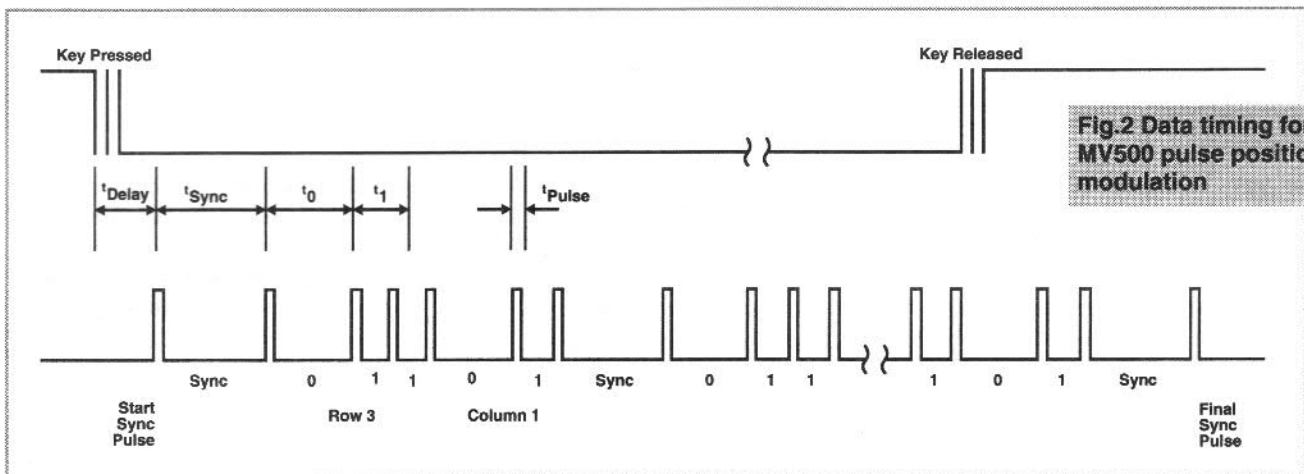

Fig.2 Data timing for MV500 pulse position modulation

Last month, we looked at the optional VCA section of The Switcher. Before we present constructional details and line-up procedures for this board, let us look at the final optional facility. I should mention at this point some major league gremlins crept in to last month's episode. The PCB layout and circuit were of an earlier design. The correct layouts and amendments will be shown next month. My apologies for any confusion this has caused.

### Why Remote Control?

In recent years, much of our consumer society seems to have become increasingly concerned or obsessed even with convenience. Most consumer goods these days come preprogrammed with a

multitude of different operating configurations and setups. Whether most people actually make use of more than 10% of these facilities is open to conjecture. For many adults, the new science and technology invading their otherwise orderly lives is an unwelcome intrusion. Being able to cook food in two minutes is all very well, but we'll have to READ the manual and learn something new!

The ability to gain new knowledge and to process new information quickly and efficiently seems much less pronounced when one is working within an infrastructure where it is "the norm" to do so. High level disciplines such as science, technology and other similar ones such as medicine and law are filled by fraternities of people who have a

learning curve with a much shallower gradient. This means that when it comes to gathering new (or updating old) information, it is expected that individuals in these areas and disciplines take a much shorter time to assimilate and remember information of a complex nature. Now, just what has all of this got to do with remote control?

Pause to consider the typical video cassette recorder - and accompanying remote control handset - which reside in just about every suburban home in Western society.

How many healthy, intelligent, and otherwise completely normal adults seem to physically pale at the thought of programming such a beastie to record, for argument's sake, two programmes which are on at different times on



**Fig.3 Infra red remote transmitter circuit diagram**

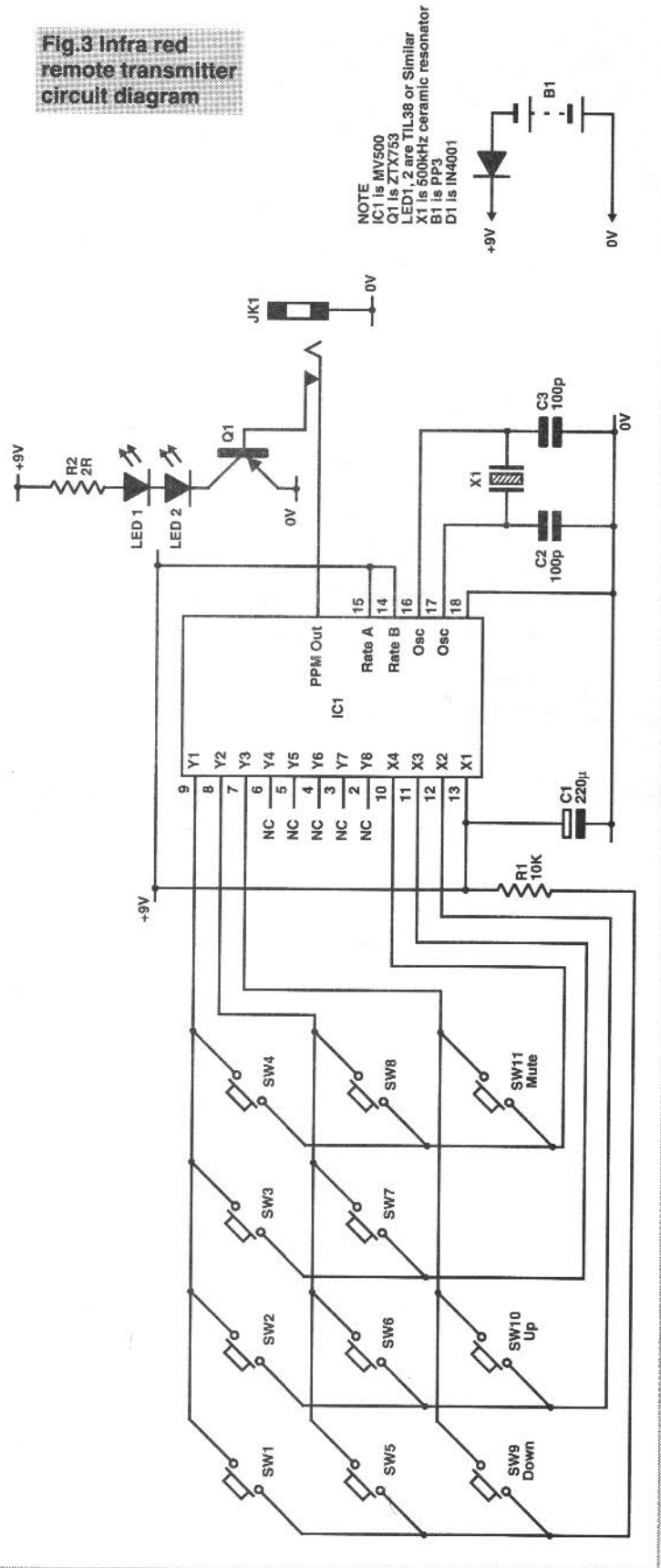

## The Works

### Remote Control Transmitter

The IR Transmitter has just one IC, some IR diodes, a handful of passive components, a matrixed switch array and a battery. All of the clever stuff is done in the MV500 IR Transmitter IC. The MV500 should more correctly be called a 'remote control transmitter IC', since it can be used with hard-wired, twisted pair data links, or indeed, ultrasonic remote control applications. We will concentrate on Infra-Red data exchanges.

It is an 18 pin device with very low power requirements, the capability for operation from a wide voltage range, and uses a minimum of external components for basic operation. Selectable data rates mean that a kind of device multiplexing can be achieved - ie when fitted with the appropriate receivers, two completely different devices can be controlled, independently, from one handset. Code synchronising pulses before the main code word provide reliable decoding and immunity to spurious response.

A block diagram of the IC is

are at fault, and not the people trying to operate it at home AND stay sane. The manufacturers - engineers, product designers, boffins - seem to assume just a mite too much on the part of the average individual user of said equipment. Design teams can manage to make a simple operation complicated and an involved one impossible - it's a malaise which is far too prevalent for the long-term good reputation of the industry.

The Switcher remote control DOESN'T have sixty buttons on it, It's uncomplicated, easy-to-use, and above all, effective. In any case, what isn't there can't cost money.

There are just eleven buttons on a fully equipped handset. These control the input select switching, the optional remote attenuator - VCA - and a mute function (which is also part of the VCA circuitry). The infrared part of the data-exchange link between the remote handset and the switching unit itself could be replaced - or supplemented - by a hard-wired, twisted pair data link. This might be useful if you have a second set of speakers sited remotely and in a different room, say, from the primary pair, but wish to control the volume/

different channels, the first one of which commences a week on Thursday? It is the kind of scenario which is guaranteed to strike fear and dreading into the hearts of a large proportion of the adult population. What about children? Actually, they're fine. Youngsters don't yet have this inbred techno-fear or intellectual arrogance. They'll read the

instructions, carefully and logically, undertake each of the specified operations by rote, and by the third or fourth time, they'll have it off pat and will then try and tell Mum or Dad, patiently of course, how to do it for themselves.

In many instances, it is the manufacturers of consumer goods who



shown in Figure 1. Keys are arranged as an X-Y matrix, with a switch closure creating a crosspoint which is then decoded by a row decoder and a column decoder in the front end of the IC. When a key is pressed, and either or both of the 'rate' pins are asserted high (more on this later), the device comes out of power conserving stand-by mode and the oscillator starts. A delay is imposed before the keypress data is inputted to a shift register and a change in the output can occur. A sync pulse is outputted before any data is transmitted. This is then followed by a unique codeword which is repeated for the duration of any keypress. Once a key is released, the codeword is allowed to finish before another sync word is transmitted. The device then enters stand-by mode again. The system uses pulse position modulation which is transmitted without carrier, with timing and synchronisation information derived from a low-cost 1-2% ceramic resonator. A resonator working at 500kHz has been used for this application and a pulse timing diagram after a typical keypress is shown in Figure 2.

The rate pins, Pins 14 and 15, determine the data exchange rate and whether or not the device is in power down (stand-by) mode or normal mode. One of three data rates is available, as well as an 'output inhibit' mode. (Data rate on the associated receiver side of things must match the transmitter data rate setting). The inhibit mode is used where current consumption is minimal and isolates the oscillator and the logic from the supply when no keys are pressed. SPST switches have been used for the keyboard. There is also no 'TRANSMIT' button to be pressed at the same time as one of the function keys. Realising this function from the available hardware was an impossible task. Current consumption is still around 0.5mA when stand-by operation is not invoked, so a PP3 should last for some time.

Two infra red LED's are connected in series and driven by a transistor with a high current gain and a fast switching speed, since it must operate in saturated mode and with very low collector voltage. With a low 3V min supply with the CMOS devices present in the IC, the

transistor gain expected will be very low, and the transistor current drive will be below that required for correct operation at normal distances. The range is directly proportional to the diode current and sourced by the transistor. It is for this reason that I have used a 9V supply rail instead of the more usual 3V one, since a higher supply voltage allows a series connection for the diodes, which in turn reduces power consumption for a given operating current through each diode. R1 simply limits the diode peak current to around 150mA.

The 3.5mm jack socket has switched contacts. When no jack plug is inserted, the PPM output drives the output transistor TR1. Inserting a jack breaks the signal from this stage and the pulsed output is transmitted instead via the socket/plug over a fixed wire data link. Maximum distance over which the PPM waveform can be transmitted and subsequently decoded is determined, ultimately, by the noisiness, electrically-speaking, of the immediate environment.

source selection of the amplifier/second set of speakers from this remote location. It avoids having to use long runs of screened lead, which would be prone to hum and other noise pick-up and contamination, and which would require a second amplifier/selector in any case. How many commercial designs can offer this kind of facility as an option? Certainly not many, if at all, in any price range in the domestic equipment market. The fitting of this particular option necessitates only two extra 3.5mm jack sockets, and a lead of the desired length which is terminated at each end with 3.5mm jack plugs.

## Construction

### IR Transmitter

There are no complicated constructional procedures to follow with this board. Components are soldered in order of ascending size, starting off with wire links (some of which reside underneath the IC sockets and which must be soldered before the IC sockets), IC sockets next - paying careful heed to the aforementioned advice - resistors, small capacitors IR LED's etc., then the two Veropins, and ending with the larger electrolytics, 3.5mm jack socket, front

panel push-button switches and the battery connector. The LED's are mounted with their bodies parallel to the surface of the board, i.e. with a right angle bend in the legs and facing towards the front of the PCB. The switches MUST be aligned as shown in the component overlay, that is, with the flat on the switch body lying inline with the PCB. Mounting them at 90° to this will mean that both halves of the switch will be permanently shorted together since each pin shares a parallel connection with its neighbour. Some care is necessary when soldering the ceramic resonator to the board as the pins are fine and fragile and easily damaged. This advice holds true for all of the soldering operations. Because of the diminutive size of the PCB, and the packing density of it, some of the tracks are VERY fine and as such, easily damaged. Great care is necessary throughout the construction stage if these aren't to be damaged. Construction of the IR Receiver is very straightforward, with the technique detailed above being followed closely. The IR phototransistor must be mounted at right angles to the PCB. If the board is to be used solely for remote control of

sources - no VCA board fitted - PL2 can be omitted and the board can be mounted either horizontally (alongside) or vertically with respect to the main analogue board orientation. Minicon connectors (straight or right-angled) must be fitted as appropriate. When the VCA and the IR Remote board are constructed, the IR Receiver board MUST be mounted vertically. It is better, where this is the case, to fit the Minicon socket to the Receiver board and a straight Minicon plug to the Main Analogue board, since it raises the Receiver board fractionally above the VCA and makes the whole assembly more secure.

## Setting Up - Remote Control section

### Transmitter

There are no setting up procedures necessary for the transmitter. Functionality of each of the keys must be checked, of course, but this requires use of the receiver section.

### Receiver

Firstly, fit a 9V PP3 battery to the transmitter. Now, carefully plug the Receiver/VCA board into the main analogue board so that the two sockets



**Fig.4 MV601 remote control receiver IC Block diagram**

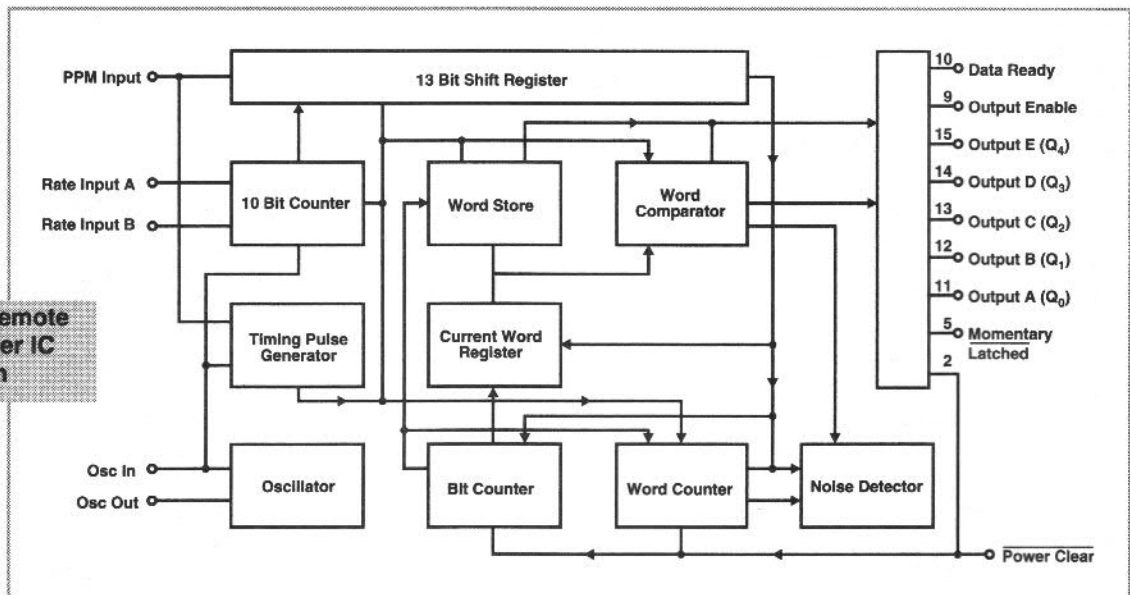

mate fully with the corresponding plugs. Apply power to the main board and with the transmitter pointing towards the receiver and within a 3 metre 30° arc, systematically check that each of the source selection keys causes the correct LED on the front panel switch board to light. Check also that the selection can be made manually via the front panel switches. Make a short length of lead

terminated at each end with a 3.5mm jack plug - this is used to check the wire-link data interface. Once both plugs are connected to the sockets on the Transmitter and Receiver boards, check the functionality of all keys. Fault finding is confined to checking that all polarity-conscious components are correctly fitted, the presence or otherwise of the 500KHz square wave

on the both the transmitter and receiver boards, and the generation and correct decoding of the Data Ready signal.

### Construction - VCA

The VCA board can be constructed in one of two ways. If used with the IR Receiver board, the 4-way plug, PL2, shown in the circuit diagram of last month should be soldered in place

### The Works

#### Remote Control Receiver

The MV601 IC is designed for use with the MV500 transmitter. When data rate and operating frequency corresponds to the transmitter - using a matched ceramic resonator (within 4%) - the device generates a five bit tri-state binary output. This corresponds to the PPM transmitted code and to the switch address generated by the MV500. Two identical words must be received before the output responds. The IC produces a Data Ready signal after the output has settled.

Prior to the MV601 decoder is IC1, a TBA2800 infrared preamplifier. It has three amplifiers, the first is gain controlled for wide dynamic signal range. This gives interference free operation even in bright sunlight. Furthermore, it allows the IR transmitter to be very close to the receiver, without causing any malfunction from overdrive. The second stage is a normal amplifier, whilst the final stage separates the pulse shaped signal from noise. Both positive and negative going outputs are available.

MV601 is shown in Figure 4. Serial PPM data is applied to the input pin. The input is insensitive to

pulse width, but the incoming pulses must remain high or low for at least one clock cycle. A capacitor to ground (C6) is normally connected to the Power Clear pin, and with an internal 150K resistor, generates a logic low upon power up. This resets the internal logic.

The Rate pins are set for a rate of 1024 as in the transmitter. The Momentary/Latch controls the output. Whilst latching mode would be more attractive for operation with only the input select switching board - no separate data storage necessary - it is not applicable to the VCA control, where counters ramp up or down when the keys are pressed. Our application requires momentary mode of operation, with the data on the output pins remaining only whilst a code is at the PPM input.

Data Ready and Output Enable, show when valid data is present at the output pins A to E, and determine whether these outputs are enabled or tri-stated.

#### Receiver Multiplexer Interface

As the MV601 generates a 5-bit code, and the source selection requires a 3-bit word for correct operation, the first three lowest significant bits are connected directly to the main analogue board

and OR-ed with the 3-bit word generated by the front panel switch interface. The low-active Data Ready signal generates a positive pulse (via C10, R5, IC3d trailing-edge detector) and is implemented as a latch enable signal for the 3-bit address from the MV601.

One of the remaining two most significant bits - bit D - detects keypresses from keys 9-16 (9-12 in our application). Rather than use a 4 to 16 line demultiplexer like the 4067, the address is decoded by a 1-of-8 decoder/demultiplexer (IC4) with the low-active Output Enable pin used as the fourth, most significant address line input. The low-active Data Ready signal and Q3 of the MV601 address lines generate the fourth line. The Data Ready line is inverted using IC3c and NANDed in IC3b with Q3. As the multiplexer Enable pin is only activated (forced low) when the fourth address line AND Data Ready are asserted, the multiplexer does not respond to the lower 8 of the 16 possible ghost addresses generated by the MV601. Doing it this way uses otherwise redundant NAND gates and saves about £2.00 over the cost of using a 4067. The three multiplexer outputs control the VCA



according to the component overlay. As well as the 'Down', 'Up' and 'Mute' signals from the IR Receiver board, the +5V supply is also derived from this plug. So if the IR Receiver board isn't fitted, the +5V supply must be come from another source. Where this is the case, a 4-way socket is fitted to the edge of the board, next to PL1 on the VCA PCB. This mates with the corresponding plug on the Main Analogue board and transfers power between the two. The capacitor, C33, is beside this socket when fitted.

Construction is straightforward - place links, DIL sockets, resistors and diodes first, then small capacitors, transistors, presets next, before finishing off with larger caps, the LED's, plugs, Veropins and switches. Note here, the link labelled 'A' which joins Veropins 'W' and 'X' should be left unsoldered. The PCB is densely populated with tracks, and many of these pass between the roundels underneath DIL sockets. Extra care should be taken when soldering in the vicinity of such areas as these tracks are easily bridged. There are 38 links on the board and should be counted off when soldering in.

**Volume Up, Down and Mute.** The Y input, pin 3, is held low, since the three Z outputs required for VCA control are low-active. When a valid address is applied to the three address pins and the chip enable pin is asserted (for addresses more than 0111), the corresponding Z output goes low. Address 1000 corresponds to Volume Down (Q0 low), 1001 to Volume Up, and 1011 to Mute.

The Volume Down and Up signals are Nanded with manual signals from the front panel via IC1a and IC1d, where they control the Up/Down circuitry.

The mute signal flips the Q output of IC4b. The Q output toggles to load a value into the up/down counters to provide 20dB of attenuation. This signal is ORed with one generated by a power on parallel load.

The lower address lines also respond to ghost codes. Nothing inhibits the response to the upper 8 of the 16 possible four-bit numbers from the MV601. Arranging that no clock (latching pulse) is sent to the analogue board, when A3 is asserted high, is the most likely and most economical solution. A3 is inverted and ANDed in the D1, 2. R6 diode AND gate. Pulses only pass through the gate when A3 is low.

**Fig.5 Infra Red Receiver**

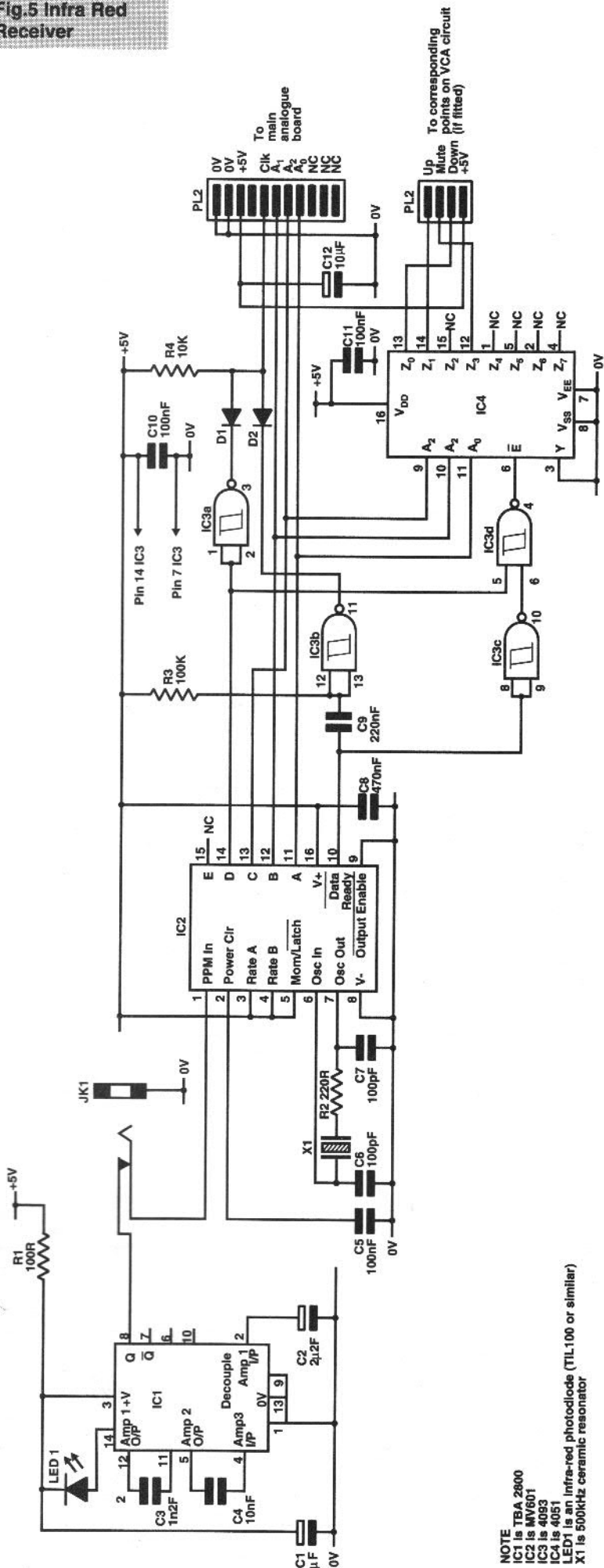



**Fig.6 Timing diagram for MV601 in momentary output mode**

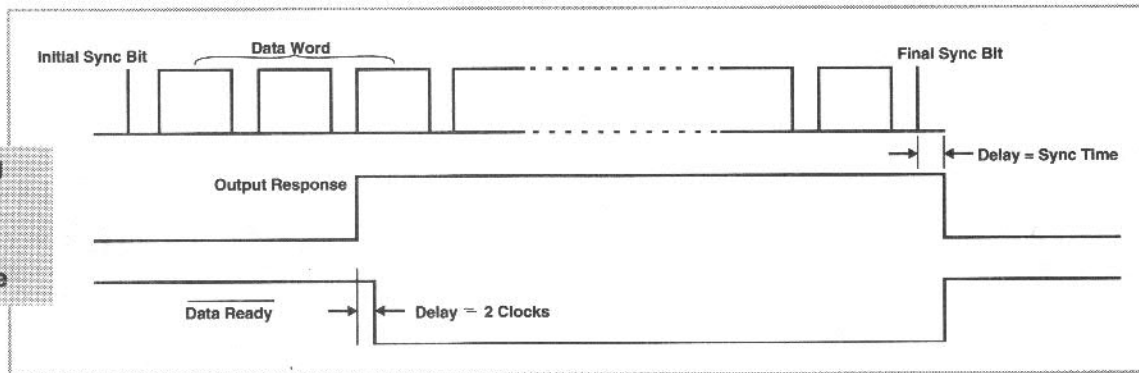

## Setting Up - VCA Board

Setting Up procedures for this board are slightly more complicated. With no IC's plugged into their sockets, mate the VCA board with the Main Analogue one and apply power. Check for the presence or otherwise of +18V, +5V and -18V on the relevant pins of the DIL IC sockets and if all is well, disconnect power and plug all of the IC's into their sockets, being aware that IC's 1 - 6 are CMOS and should be handled with the appropriate care. Once this has been done, reapply power and watch for the premature expiry (heralded by cracking noises, flames and horrible smells) of any of the aforementioned devices.

If nothing appears to be amiss, correct operation of the UP/DOWN keys must first be verified, using both the front panel keys and the IR handset to test for this. Check firstly that the Clock Active LED flashes when the Up or Down keys are pressed. Check also that the LED stops flashing about 13s after the Up or the Down key is pressed.

## D/A Converter

Once you're satisfied that the digital counter section is working correctly, it can be used as an aid to the line-up of the DAC, since a full count - 11111111 - and an empty count - 00000000 - are needed to adjust full scale reading and to null any offset respectively.

- 1 Using the front panel up key, press until the LED clock active indication stops flashing. The counter is now in an all 0's state.
- 2 With a DVM connected to the output pin of IC8 op-amp, pin 6, adjust PR1 for a reading of exactly 0.000V on the meter.
- 3 Using the front panel down key, press until the LED clock active indication stops flashing. The counter is now in an all 1's state.
- 4 Adjust PR2 for a reading of 2.8V  
 $1 \text{ LSB} = 2.8 - 2.8/256$   
 $= 2.789\text{V}$
- 5 Repeat 1 to 4 above.

The DAC can now be considered to be fully lined-up.

## VCA

We've mentioned already that untrimmed audio performance of the SSM 2018 - albeit, in certain operating modes - is pretty darn good and probably of a high enough quality that MOST discerning listeners will be more than satisfied. However, for those dedicated few among us who strive for the impossible (what are you doing building a system with a VOLTAGE-CONTROLLED AMPLIFIER in it!), I'll include some rudimentary line-up procedures just to appease you.

## Symmetry Trim

Both trims affect offset and control feedthrough performance. The symmetry trim also affect distortion performance and so while mandatory where the Class AB mode of operation is used, it is desirable but not absolutely necessary when the VCA is operated in pure Class A.

Where both trimming operations are to be undertaken, the symmetry adjustment should precede the offset one. It should be mentioned that an audio signal generator (tone source) is necessary for both adjustments while a scope/distortion meter is needed for the

distortion trim. It is also desirable when adjusting the offset, but an amplifier and a good pair of ears can make a quite satisfactory substitute.

A 1KHz sine wave of around +12dBu should be connected to one of The Switcher input sockets (left channel initially) and that particular source selected as an output. PR4 should then be trimmed to minimise the distortion seen, measured or heard at the left channel output sockets.

Transfer the signal source to the right hand channel of the same input, the 'scope, distortion meter to the Right channel output, and repeat the above trim operation, this time using PR6.

## Offset Trim

Considering the control null trim is of most relevance where the device is employed as part of the fader automation system of a large mixing desk. VCA's used in this way are likely to have their attenuation settings changed rapidly and frequently, and this is where 'zipper noise' (the generic term for control breakthrough) is likely to be most objectionable. Still not convinced that you don't really WANT to go through with the offset trim operation? Then read on, suckers, and be ACTIVELY dissuaded...

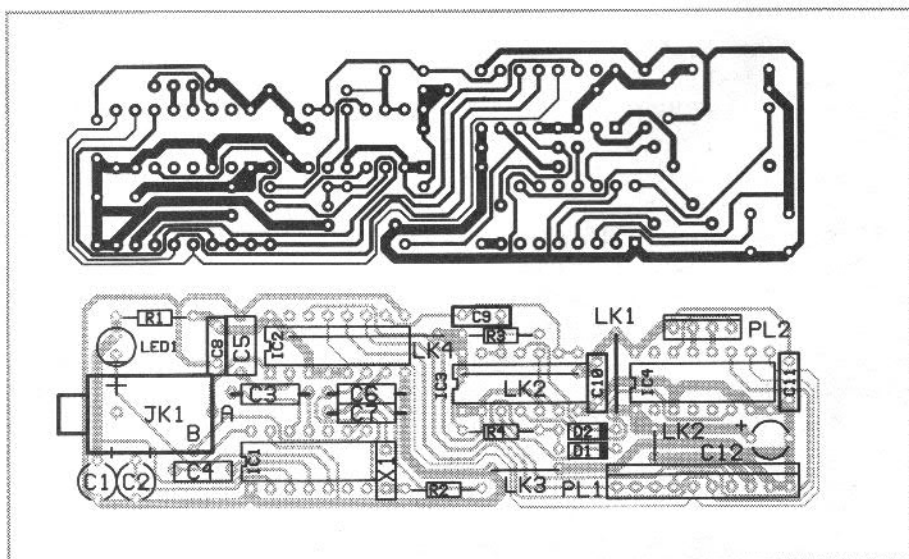

**Fig.7 Component placing for Infra red receiver**



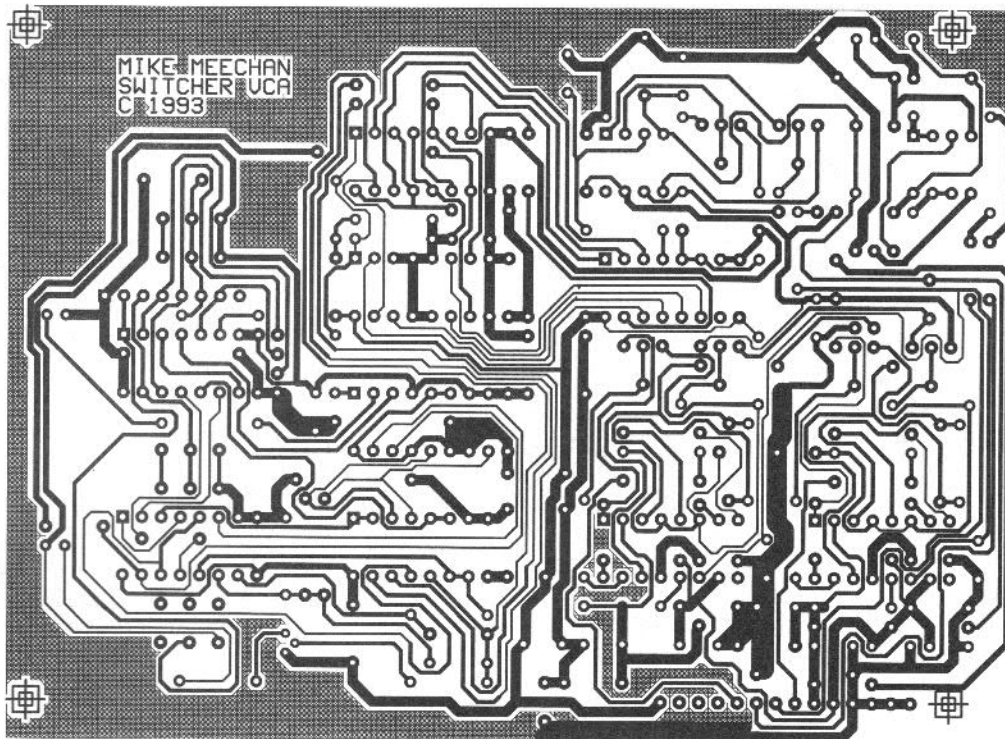
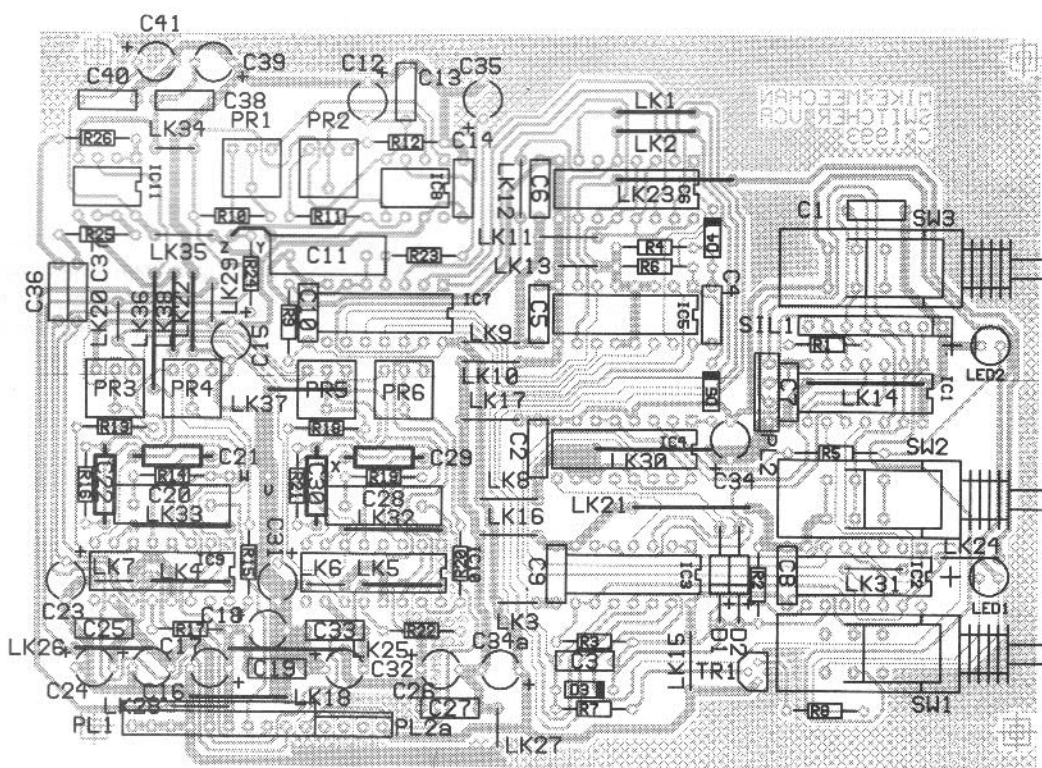

Fig.8 Foil and Component placing for VCA Board



Firstly, disconnect the signal source and ground the left channel VCA input by temporarily connecting Veropin 'W' to Veropin 'V'. Now connect a 60Hz sinewave to Veropin 'Z'. The sinewave must swing between a voltage necessary to give 30dB of attenuation (+840mV) and one with a maximum gain, which in our case is 0dB (and 0V). PR3 should then be

adjusted for minimum feedthrough of the 60Hz signal. A 'scope could be used, or the left channel output could be connected to an amplifier/loudspeaker and PR3 trimmed for minimum audible breakthrough of the 60Hz signal.

The right channel VCA can now be trimmed, this time temporarily connecting Veropin 'X' to Veropin 'W'. The 60Hz signal is injected at the same

point but adjustment for minimum is made using PR5. Once that you're happy that control breakthrough has been minimised, remove the temporary grounding jumpers and solder wire links across 'Y' and 'Z'. The system is now fully lined up and operational. If you don't wish to trim the VCAs, simply omit the aforementioned procedure and solder the links at the onset.

**Fig.9 Foil and Component placing of Remote Controlled transmitter**

## Housing Benefits

The only component which is critical as regards housing in an enclosure of some sort is the IR Transmitter. The PCB has been designed to fit snugly and securely into the hand-held box specified in the Parts List. With other boxes, care with the internal dimensions must be taken. The front panel and the IR aperture must be cut according to the pattern shown in Figure 9. A craft knife fitted with the associated fine-toothed sawblade attachment, or a small Abrafile, are the best tools for the job. Open the holes out to the

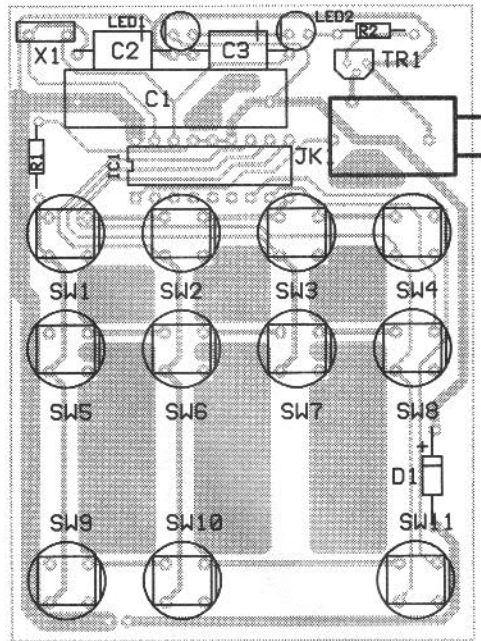
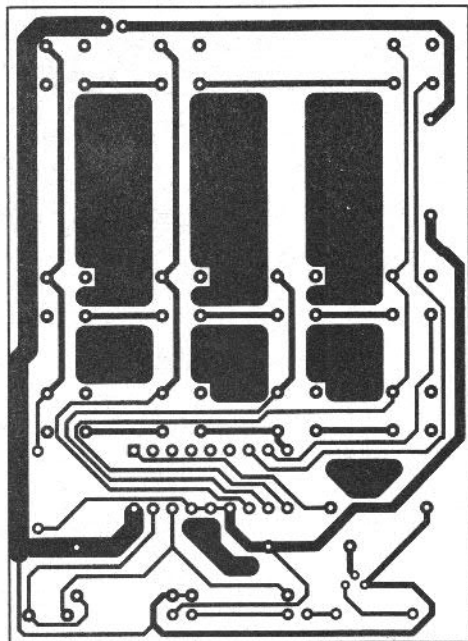

nominal size shown in the drawing and then use a fine warding file to fine tune the apertures so that the bodies of the switch caps don't foul the casing edges. The PCB is secured using PCB standoffs - M3 tapped spacers - which support it at the distance required below the panel facia.

Unfortunately, the box specified doesn't have a parabolic reflector for the infrared emitting diodes, so some improvisation is necessary. Red celluloid or similar is ideal, but any optically-transparent material would suffice. It is left to the constructor's discretion.

## Overall System Housing

The boards have been designed with a 19' rack-mounted enclosure in mind. All of the PCB's will fit - albeit tightly, height-wise - into a 1U case if all of the specified components are used. The RS Components toroidal transformer is the only one I could source which was of a height sufficiently small enough to fit into the required 44mm of space. Even so, great care is needed when securing this component to the chassis since the central securing bolt must not be allowed to contact the top and bottom parts of the enclosure simultaneously. This would constitute a shorted turn and cause irreparable damage to the transformer.

The only other caveat, dimension-wise, is the depth of the enclosure, and then, only if PCB-mounted phono connectors are used, since these must protrude through the rear panel of the

enclosure while the switches and LED's must protrude through the front. This leaves a front-to-back dimension of around. Unless you're very lucky in your choice of ready-made enclosure, or trim it accordingly, or manufacture your own, it is unlikely that the dimension for the depth of the case and that specified as necessary for the PCB's will coincide. Basically, it's a case of shopping around.

The black anodised panels of the rack-mounting cases are particularly aesthetically-pleasing and so don't stand out from other similarly-coloured components in a typical hi-fi stack. The only aspect of their appearance which makes them slightly incongruous is the width. At 19', they're around two inches wider than the almost-industry-standard-for-hi-fi-components 17'. To paraphrase a more widely circulated text than this, 'If your ears offend, cut them off'. In the biblical sense, I am, of course, referring to the 1' rack mounting 'ears' of the 1U enclosure. Careful removal of an inch of metal from either side of the panel makes it the same width as just about every other full-sized domestic hi-fi component.

The front panels should be drilled, then legending can be done using Letraset dry lettering or similar. This should then be lacquered for protection. Should you wish to use a turntable with The Switcher, might I suggest The Audiophile RIAA preamp from the first issue of EIA. This can be interspersed between one of the inputs and the

cartridge signal source. Happily, the RIAA preamp uses supply rails similar to those of The Switcher.

There is a minimum of internal wiring, due, in the main, to the plug-together nature of all of the boards. A total of two plug assemblies are required if the full system complement is constructed. One carries AC power onto the main analogue board from the toroidal transformer. The other transfers remote volume level/mute information and +5V from the IR Receiver PCB to the VCA board. This 4-way plug-together assembly should be as short as possible.

Mains power for the transformer should be derived from a rear panel mounted IEC mains inlet or similar. All 240V connections should be properly shrouded, and an 500mA inline fuse wired in the 'Live' side of the supply. As all of the boards have been tested individually for functionality and correct operation, all that remains is for the completed and enclosed assembly to be tested once more to see that nothing has come a cropper during the assembly process.

And finally next month, any loose ends will be tied up of bits that couldn't be fitted in here plus any updates.

Once it all has been done to your satisfaction, connect up some live signal sources and an amplifier and speakers, find your favourite armchair, get out the cocoa and furry slippers, choose between CD, DAT cassette or NICAM video, and proudly resume couch potato status...



# BACK NUMBERS

## IR Transmitter

### Resistors

R1 10k

R2 2R

### Capacitors

C1 220u 16V axial electrolytic

C2,3 100p polystyrene

### Semiconductors

IC1 MV500

Q1 ZTX753

LED1,2 TIL 38 IR LED or similar

### Additional Items

SW1-11 PCB momentary PCB-mounting pushbutton

X1 500kHz ceramic resonator

JK1 PCB-mounting 3.5mm jack socket

PP3 battery clip

DIL sockets to suit

PCB (available from Electronics in Action)

Pushbutton caps, case

## IR Receiver

### Resistors

R1 100R

R2 220R

R3 100K

### Capacitors

C1 22u/16V radial electrolytic

C2 2u2/63V radial electrolytic

C3 1n2 polystyrene

C4 10n polyester

C5,10,11 100n polyester

C6,7 100p polycarbonate/polyester (10%)

C8 470n polyester

C9 220n polyester

C12 10u/16V radial electrolytic

### Semiconductors

IC1 TBA 2800

IC2 MV601

IC3 4093

IC4 4051

D1,2 1N4148

LED1 TIL100 infra red photodiode or similar

### Additional Items

JK1 3.5mm PCB-mounting jack socket

PL1 10-way right-angled Minicon socket (see text)

PL2 4-way Minicon plug

X1 500KHz ceramic resonator

DIL IC sockets to suit

PCB (available from Electronics in Action)

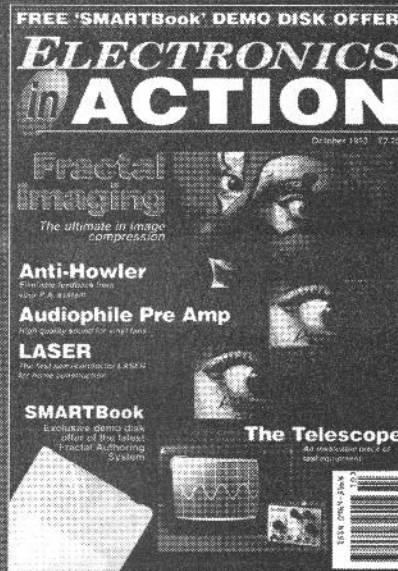

**October 93** •Fractal Imaging  
•The Telescope Pt1 •Anti-Howler  
Audiophile Pre-amp •Sine wave  
generator

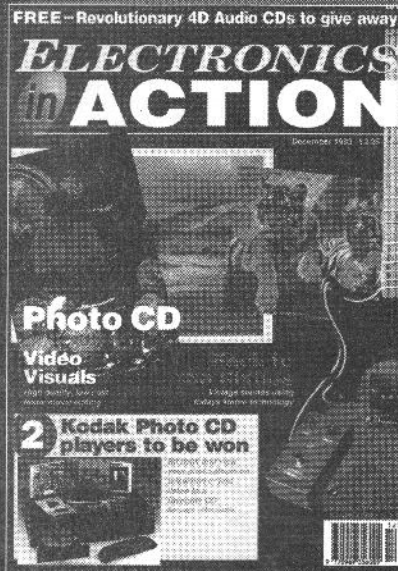

**December 93** •Photo CD  
•4D recording •Video editing  
unit •Stereo tremolo unit •The  
Switcher Pt2

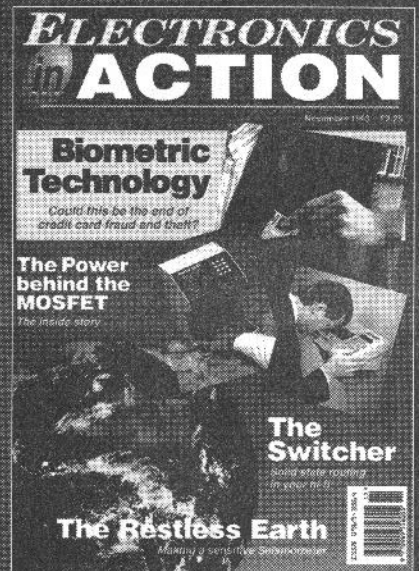

**November 93** •Biometric  
Technology •The Switcher Pt1  
•Seismometer Project •The  
Telescope Pt2

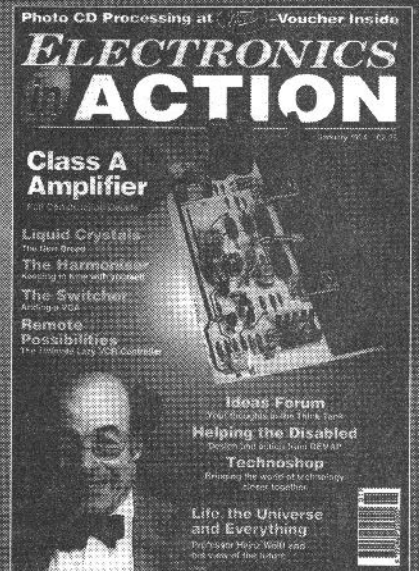

**January 94** •Liquid crystals  
•Class A power amp •The  
Harmoniser •Remote control  
extender •The Switcher Pt3

## BACKNUMBERS

Please print your name in **BLOCK CAPITALS**

Name .....

Address .....

Postcode .....

Please send me.....issue(s) of the October '93 edition  
Please send me .....issue(s) of the November '93 edition  
Please send me.....issue(s) of the December '93 edition  
Please send me .....issue(s) of the January '94 edition  
Each copy including postage & packing, costs £2.50  
I enclose a cheque/postal order for .....

Please send to: **Electronics in Action, PO Box 600  
Berkhamsted, Herts. HP4 1NL**

# Class A MOSFET Power Amplifier

## Part 2

Testing and Adjustment  
by Andrew Armstrong

ELECTRONICS in ACTION

42

FEBRUARY 1994

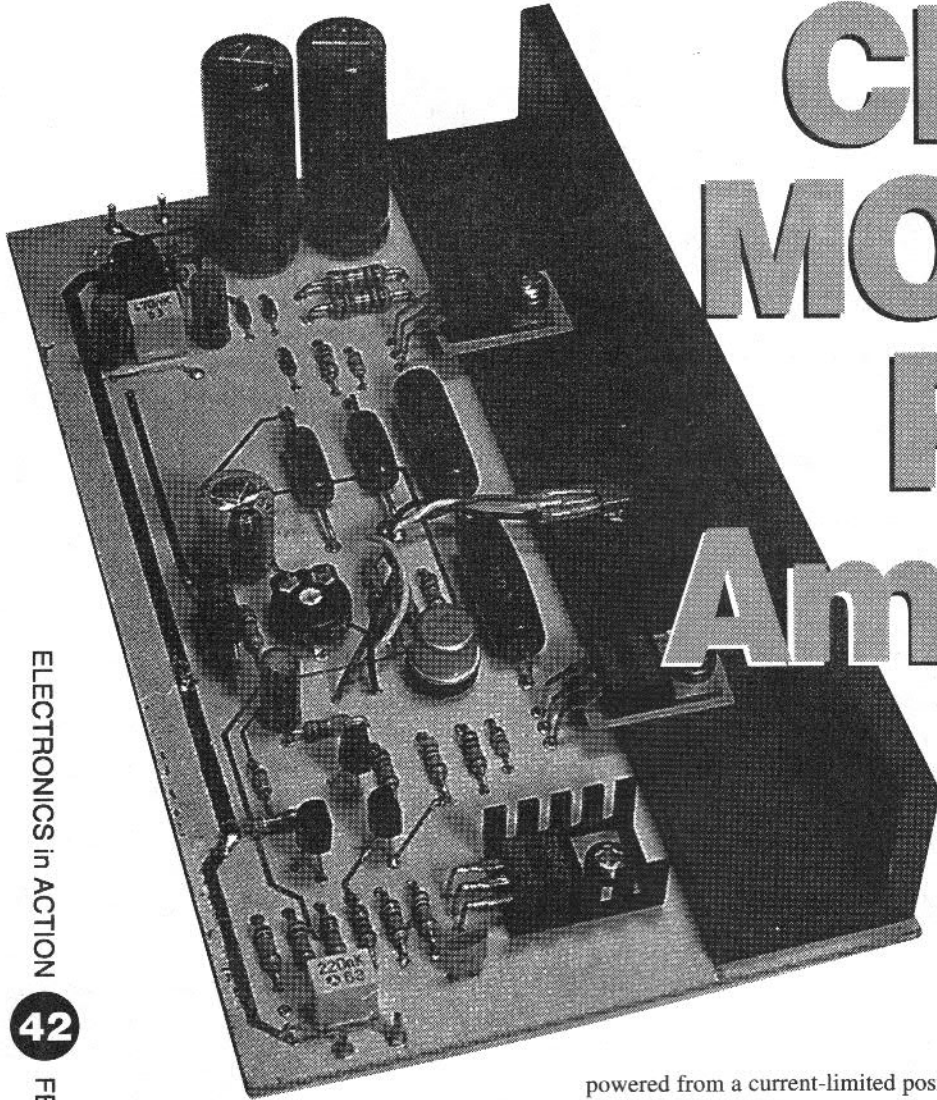

**T**he power amplifier featured here and last month adopts Class A operation at lower power levels and Class AB on the louder parts.

Before testing the amplifier, set the quiescent current adjustment potentiometer fully anticlockwise. As an initial test the amplifier should be

powered from a current-limited positive and negative supply set to between 18 and 20 volts. The output voltage should be measured, and should be within 10mV of zero. VR1 should then be adjusted for a suitable quiescent current. To determine the quiescent current, measure the voltage across R19 or R20 with no signal and no load. The voltage drop is 2.2mV for every 10mA flowing.

What constitutes a suitable quiescent current depends on the use of the amplifier. It will work quite successfully if biased conventionally into class AB. On test, the crossover distortion had conclusively disappeared on the oscilloscope at 150mA quiescent current, so this level is recommended for class AB operation. As the quiescent power dissipation is not too high in this mode, I suggest a power supply voltage of around 30V. This will permit a power output of approximately 40W into 8R

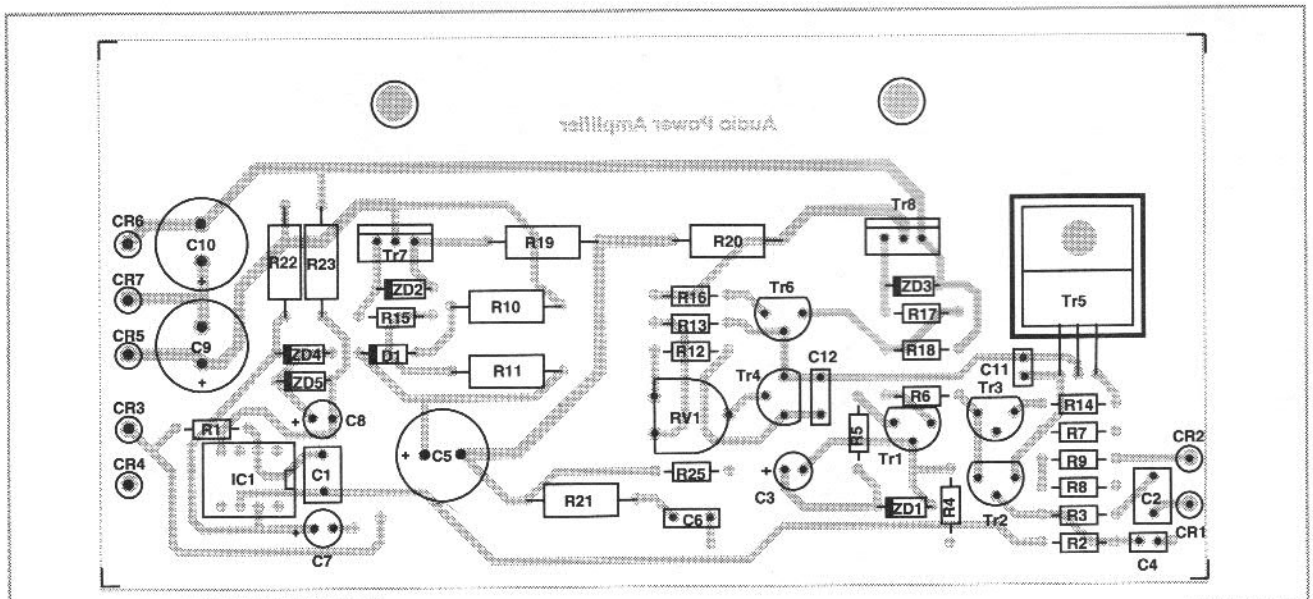

Fig.1 Component positioning



and 80W into 4R.

It is intended that this design should be run in class A for a greater part of its operating cycle, and if adequate heatsinking is available, the quiescent current should be set between 500mA and 1A. This will ensure that playing music at medium volume is always in class A. It is, after all, under these conditions when distortion is most obtrusive. No distortion could be heard with loud music even though it may be bad enough to stand out in quiet passages.

At above a certain signal level, depending upon the quiescent current, one or another of the output devices will cease to conduct. This will happen softly, and as it does, the loop gain will halve. Because the signal path is fast and uncomplicated, the negative feedback can deal with this in a way that it cannot be expected to deal with conventional crossover distortion. There must be some distortion at this point on the waveform. However, every audio component contributes some noise or distortion, no matter how slight and this

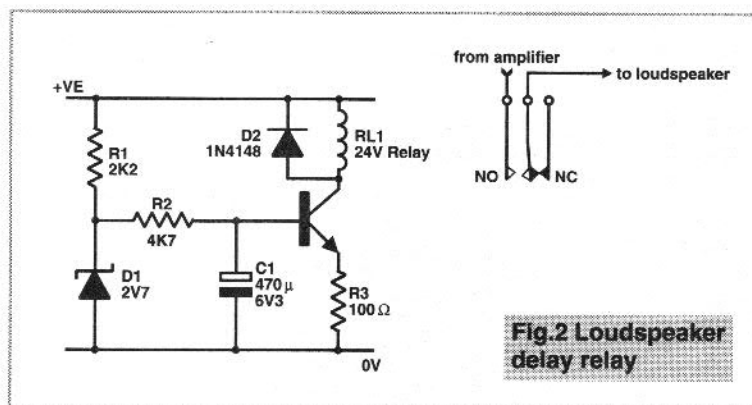

**Fig.2 Loudspeaker delay relay**

500mA corresponds with 110mV across R19 or R20.

### In Use

The amplifier has been tested with a resistive load and various input waveforms. With a squarewave test, the output rise and fall times were similar to those from the signal generator, at 4µs. With sinewave drive, just below clipping amplitude, the central part of the waveform, expanded on the oscilloscope screen, showed no trace of crossover distortion, as one would

reduced to 47R, and two relays should be used, with their coils in parallel.

I recommend that a fuse should be placed in series with the output. There is no output protection on this amplifier, which removes one possible source of distortion, but it leaves the loudspeakers somewhat vulnerable. A 2A fuse will provide worthwhile security.

It has been pointed out to me that I did not explain in part 1 why such a fast op-amp is used to provide DC servo action for the amplifier. The reason is that it must work as an integrator over

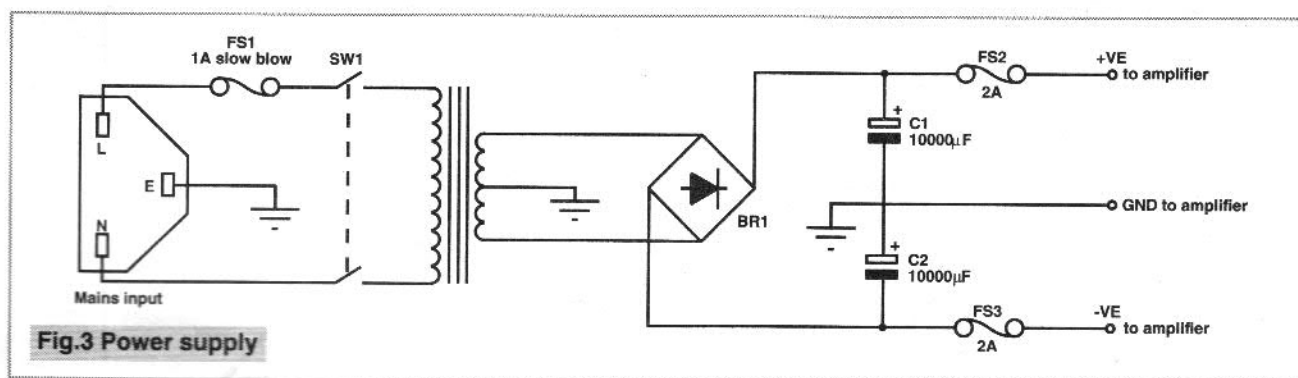

**Fig.3 Power supply**

distortion is likely to be masked by the volume of the sound. I certainly could not detect any waveform distortion on the oscilloscope.

It is unfortunate that class A operation is very inefficient, otherwise the amplifier could be run in class A all the time. People with extremely sensitive ears may find it worthwhile fitting truly massive amounts of heatsinking and increasing the quiescent current. At 2 amps, with +/- 25 volt supplies, 100 watts must be dissipated continuously. This may be regarded as a practical maximum, as the thermal conductivity between transistor and heatsink will not permit much more to be dissipated safely.

In class A, with 22V supplies, the amplifier can provide 18W into 8R.

If class A biasing is to be used, set the quiescent current, then wait half an hour for thermal stability, then reset it.

expect. When tested with a hi-fi speaker (a small JPW model), with the input fed via a potentiometer from a CD player, the sound was completely satisfactory.

On the lab bench, running with an unregulated 22V power supply and playing an Iron Maiden CD in mono, the heatsink was warm, but not too hot. One minor snag I have noticed on testing is that, at switch on, there is a thump in the loudspeaker, as the amplifier servos its DC level close to 0V. If this bothers you, I would suggest the use of a relay to connect the loudspeakers, with a time delay to switch it on after the amplifier has had time to reach 0V. A suggested circuit (as yet untested) is shown in Figure 2.

This circuit provides approximate current limiting so that the relay will not overdissipate on higher voltage supplies. If a stereo pair of amplifiers are to be protected, then R3 should be

the audio frequency range. If it runs out of gain x bandwidth and ceases to integrate, positive feedback (admittedly heavily attenuated) will be applied to the input, with resulting distortion.

### Power Supply

Tests have shown the amplifier is relatively insensitive to power supply variations, so use an unregulated supply. The circuit is shown in Figure 3.

If the amplifier is to be biased in to class A, an 18V transformer is recommended, to keep the quiescent dissipation within reasonable limits. If you use class AB biasing, with 150mA quiescent current, a 25V transformer is more suitable. This power supply design is for one amplifier. If a stereo pair is adopted, either use two separate supplies to eliminate interaction, or the components can be uprated as shown in the second parts list.

**Note:** There have been some parts list revisions to the main amplifier as a result of testing:

**R11** changed from 470R to 1k **R12** changed from 1k to 220R  
**R13** changed from 470R to 100R **RV1** changed from 2K2 to 470R

### Resistors

(0.25W metal film unless otherwise stated)

- R1** 1M
- R2** 100K
- R3,8,25** 10K
- R4** 3K9
- R5,7** 1K2
- R6** 2K2
- R9** 1K
- R10,13** 100R 2.5W
- R11** 1K 2.5W
- R18,RV1** 470R
- R14,16** 10R
- R12,15,17** 220R
- R19,20** 0R22 2.5W
- R21** 10R 2.5W
- R22,23** 1K5 0.75W

### Capacitors

- C1** 470n polyester
- C2** 220n polyester
- C3,7,8** 10 $\mu$  16V electrolytic
- C4,11** 220p ceramic
- C5** 100 $\mu$  63V electrolytic
- C6,12** 100n polyester
- C9,10** 470 $\mu$  63V ELNA RSH series electrolytic

### Semiconductors

- D1** 1N4148
- ZD1** BZX796V2
- ZD2,3** BZX79C15V
- ZD4,5** BZX79C12V
- TR1,2,3** BC212B
- TR4** BC182B
- TR5,7,8** IRF630
- TR6** BC461
- IC1** TL061

### Power Supply

- C1,C2** 4700 $\mu$ F radial 50V or 63V
- BR1** Bridge Rectifier 50V 4A or greater
- T1** Transformer 18V + 18V, 50VA or greater  
OR, for class AB, 24+24V, 60VA or greater
- F1** 1A slow blow
- F2,3** 2A
- SW1** double pole mains switch  
Fused IEC mains input socket

### Power Supply for stereo pair

- C1,C2** 10,000 $\mu$ F radial 50V or 63V
- BR1** Bridge Rectifier 50V 8A or greater
- T1** Transformer 18V + 18V, 100VA or greater.  
OR, for class AB, 24V + 24V, 120VA or greater
- F1** 1A slow blow
- F2,3** 2A
- F3,4** 2A (fuses for second amplifier)
- SW1** double pole mains switch  
Fused IEC mains input socket

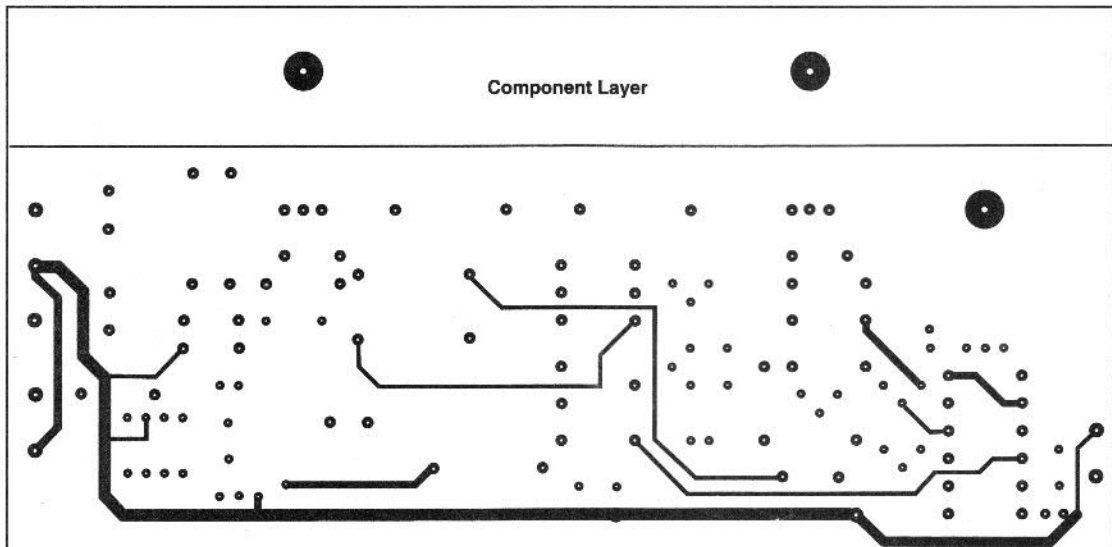
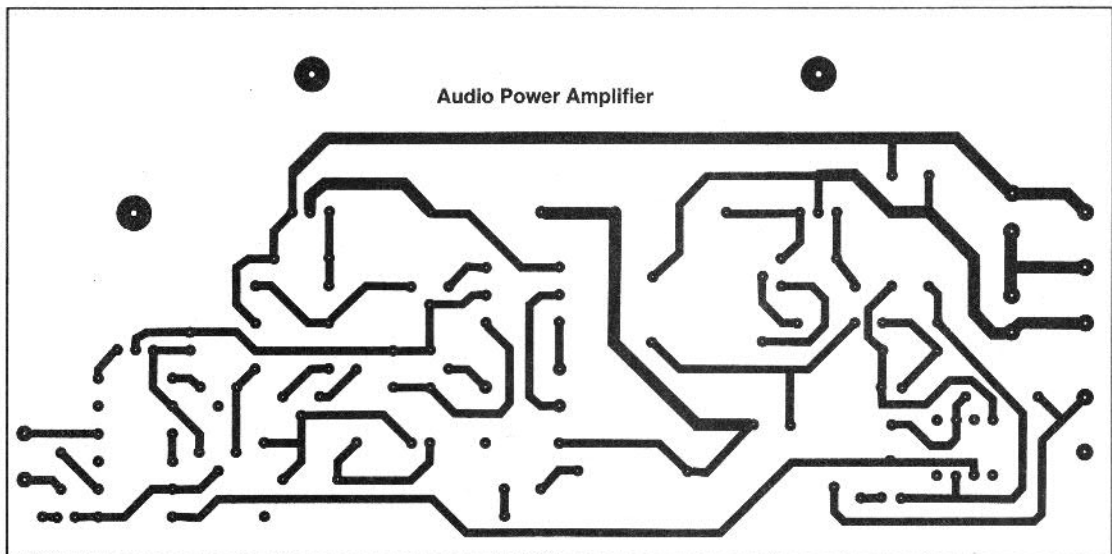



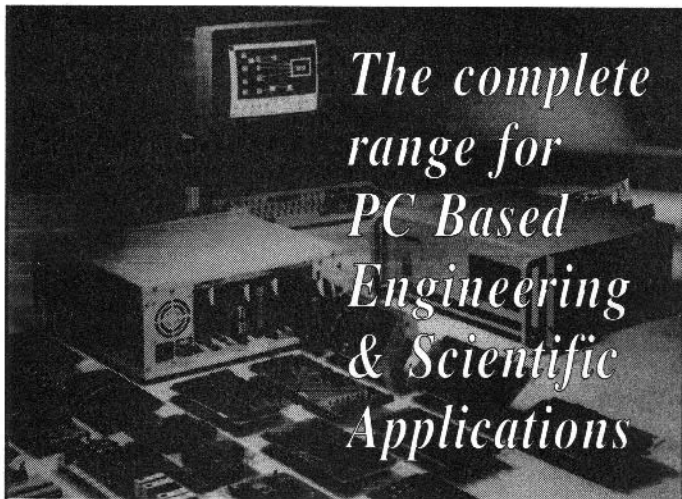

The complete  
range for  
PC Based  
Engineering  
& Scientific  
Applications

**MEASUREMENT DATA ACQUISITION & CONTROL BOARDS**

AR-B3001	16 Channel, 12Bit A/D Card .....	£66
AR-B3201	8 Channel, 12Bit A/D + 3 Channel D/A Card .....	£96
AR-B3204	16 Channel, 12Bit, Data Acquisition & Control Card, Programmable Gain .....	£235
PCL-711B	8 Channel, 12Bit, Data Acquisition & Control Card, Programmable Gain .....	£185
PCL-812-PG	16 Channel, 12Bit, Data Acquisition & Control Card, Programmable Gain .....	£306
PCL-813	32 Channel, 12Bit, Data Acquisition Card .....	£347
PCL-818H	High Performance 16 Channel, 12Bit Data Acquisition & Control Card .....	£472
PCL-814	Modular Multifunction 16 Channel, 14Bit, Data Acquisition & Control Card ...	£680
PCL-816	Modular Multifunction 16 Channel, 16Bit, Data Acquisition & Control Card ...	£964
PCL-860	4 1/2 Digit Voltmeter (DCV/ACV/DCR) Card .....	£369
AR-B2001	16 Channel Opto-Isolated Digital I/P Card .....	£52
AR-B2102	16 Channel SPST Relay Switch Card .....	£74
AR-B2201	64 Channel Digital I/O Card .....	£41
AR-B9221	3 Port (24 Bit) Digital I/O, 3 Chan Counter/Timer, Prototype Card .....	£41
AR-B9101	16 Channel SSR Switching Card (For AR-B9221) .....	£242
PCL-720	32 Channel Digital I/P + 32 Channel O/P, 3 Channel Timer/Counter .....	£128
PCL-722	144 Bits (24*6) of Buffered Digital I/O .....	£250
PCL-724	24 Bit Digital I/O Card .....	£77
PCL-725	8 Channel Relay + 8 Channel Isolated Digital I/P .....	£167
PCL-726	6 Channel 12 Bit D/A Output Card (16 Channel Digital I/P + 16 Channel O/P)	£389
PCL-838	Stepper Motor Control (3 Motors), 16 Channel D/I/P + 16 Channel D/O/P .....	£319
PCL-750	Prototype Development Card .....	£66
PCL-755A	Slot Extension Card (XT/AT) .....	£41
PCL-756	PC-Bus 8 Bit Switch/Extension Card .....	£125
PCX-794	PC/XT BUS Expansion System (Master + Slave Cards + 1m Cable) .....	£211
PCL-830	10 Channels of 16Bit Counter Timer (AMD9513 * 2) .....	£204

**SIGNAL CONDITIONING/CONTROL DAUGHTER BOARDS (For use with PCL cards)**

PCLD-782	Opto Isolated Digital I/P (16 Channel) .....	£132
PCLD-785	16 Channel Relay O/P Board .....	£153
PCLD-787	8 Channel Sample & Hold Card .....	£361
PCLD-788	Relay Scanner/Multiplexer Board .....	£195
PCLD-779	8 Channel Isolated Relay Mux and Amplifier Board .....	£264
PCLD-789	Amplifier & Multiplexer Board .....	£243

**COMMUNICATIONS & INTERFACE BOARDS (RS232/RS422/RS423/RS485/IEEE-488)**

I-104	4 Port Serial RS232 PC Card .....	£59
PCL-743	Dual Port RS422/485 PC Interface Card .....	£98
PCL-744	Intelligent 8 Port RS232 PC Interface Card with on-board CPU .....	£410
AR-B9011	Dual Port RS422/485 PC Interface Card .....	£86
PC-232-485	RS232-RS485 or (232-422) Converter Adaptor, Self Powered .....	£85
PCL-848A	IEEE-488 Interface Board .....	£222

**ADAM REMOTE/DISTRIBUTED MODULAR DATA ACQUISITION MODULES**

ADAM-4011	Analogue Input Module (mV, V, mA, Thermocouple) .....	£154
ADAM-4021	Analogue Output Module (V or mA) .....	£154
ADAM-4050	Digital Input/Output Module .....	£112
ADAM-4060	Relay Output Module .....	£112
ADAM-4520	Isolated RS-232/RS-485 Converter Module .....	£84

**19" RACK MOUNTING MULTI-SLOT INDUSTRIAL PC CHASSIS**

AR-IPC12A	Industrial 19" Rack Mounting Chassis, 12 Slot, 200W PSU .....	£454
AR-IPC12M	Industrial 19" Rack Mounting Chassis, Motherboard fitting, 200W PSU .....	£396
IPC-610A	Industrial 19" Rack Mounting Chassis, 14 Slots, 250W PSU .....	£718
IPC-610MB	Industrial 19" Rack Mounting Chassis, Motherboard fitting, 250W PSU .....	£644
IPC-6520	19" Rack Mount Monitor Kit for 14" Monitor .....	£352
IPC-6305	19" Rack Mount Keyboard & Drawer, Telescopic Slides .....	£279

**PC-BUS CARD CHASSIS FOR CUSTOM ENCLOSURES/EMBEDDED APPLICATION**

IPC-6706	PC-Bus Card Cage Enclosure Chassis (With 6 Slot Passive Backplane) .....	£176
IPC-6806	6 Slot Node IPC Chassis, 150W PSU, Floppy + Hard Disk Mountings .....	£410
AR-IPC6MP	6 Slot Node IPC Chassis, 200W PSU, Floppy + Hard Disk Mountings .....	£290
MBPC-640	Micro Box Industrial PC Chassis (With 3 Slot Backplane) .....	£135
PCXU-205	PC BUS Expansion Unit (With 5 Slot Backplane & Power Supply) .....	£176
IPC-6010	8 Slot Passive Backplane Card Cage (6*16 + 2*8 Bit), card clamp, speaker .....	£132
IPC-6010B	6 Slot (16 Bit) Passive Backplane Card Cage, Full Length, 150W PSU .....	£227
AR-CC6LP	11 Slot (16 Bit) Passive Backplane Card Cage, Full Length, 150W PSU .....	£246

**SOLID STATE FLASH/SRAM/ROM DISK CARDS**

AR-B7008	512K ROM or 256K SRAM Disk Card .....	£80
AR-B7010	512K ROM Disk Card .....	£59
AR-B7040	4MB Flash/SRAM/ROM Disk Card .....	£118
PCD-890	12MB Flash/SRAM/ROM Disk Card. Dual Floppy Emulator .....	£200
PCD-892B	6MB Flash/ROM Disk Card .....	£118

Plus MUCH more ...

Please CALL for your FREE copy of our latest Catalogue

OEM, Dealer & Educational Enquiries Welcome

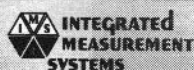

**INTEGRATED MEASUREMENT SYSTEMS**  
Integrated Measurement Systems Ltd.  
305-308 Solent Business Centre, Millbrook Rd West  
Southampton SO1 0HW, HAMPSHIRE  
Tel: (0703) 771143 Fax: (0703) 704301  
Designers & Suppliers of Measurement, Test & Control Systems & Software

# READY NOW

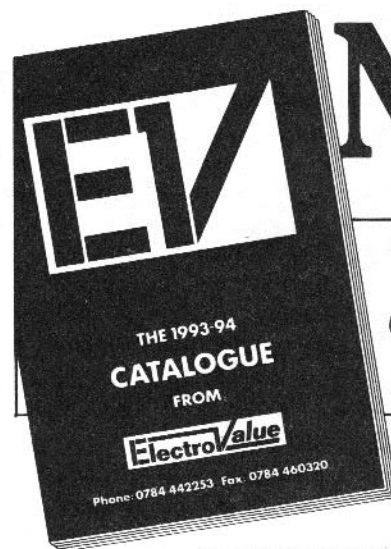

Every keen  
constructor  
needs it

THE 1993-94

## ElectroValue CATALOGUE

Profusely illustrated, this 140+ page A4 size catalogue packs a wealth of information on items from the highly sophisticated to modest but essential screws, washers and wire, etc. With 28 years in personal mail order service we know how much you rely on quality of goods above everything plus back-up service from the supplier *i.e.* Electrovalue. We've got the catalogue you want *and we deliver the goods!*

**To get your Catalogue**  
Send cheque or postal order for £1.50 to address on coupon or phone your Credit Card No. & its expiry date. Catalogue comes with two £1 vouchers, each for spending with orders value £10 or more.

**\*Shops at**  
Egham, Surrey  
28 St. Jude's Road, Englefield Green.  
Tel: 0784 434757.

Burnage, Manchester  
680 Burnage Lane  
Tel. 061 4324945.

\*PERSONAL SHOPPERS, NOT MAIL ORDER

DISTRIBUTORS FOR

**SIEMENS**

PROFESSIONAL  
ELECTRONIC  
PRODUCTS

SEMICONDUCTORS  
OPTO-ELECTRONICS

FERRITES  
CONNECTORS  
SWITCHES  
CAPACITORS  
INDUCTORS

etc.

ELECTROVALUE LTD., UNIT 3, CENTRAL TRADING ESTATE,  
STAINES, MIDDXX TW18 4UX  
Tel: 0784 442253 Fax: 0784 460320

Your 1993/94 Catalogue please, to

Name .....

Address .....

Block letters please, and POST CODE  
I enclose cheque/postal order for £



If not using coupon please quote this journal when writing.

# REMAP

## Technical Help for Disabled People

By Andrew Chadwick

### Part 2

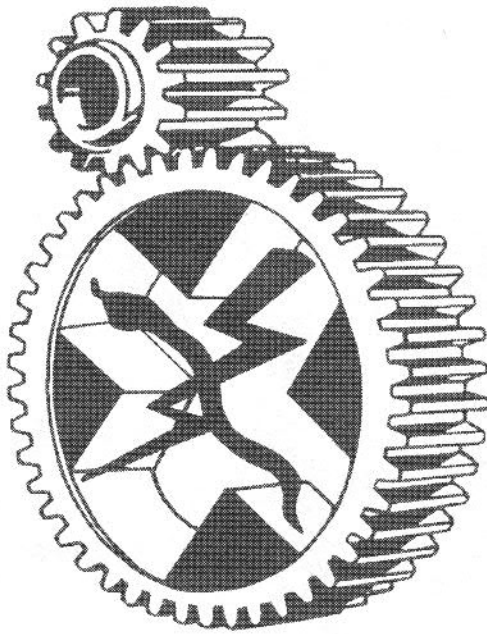

**W**e continue our look at the many ideas suggested for the disabled with a second example. This is a unit designed to allow a man paralysed from the neck down to change TV channels without having to call someone else. Various possibilities were considered and rejected on grounds of cost or complexity. The design finally adopted consists of the outer case of a felt tipped pen fitted with a number of contacts to form a mouth operated switch and linked to the standard remote control handset. The client uses the tip of his tongue to bridge the contacts for the appropriate channel.

One particularly ambitious project that appeared in the 1990 yearbook was entitled "sonic headlights". This was an ultrasonic radar to enable a blind person in a wheelchair to guide himself around his home. A later development was the addition of an ultrasonic beacon to enable the user to guide himself across large open spaces. This equipment has since been refined and a similar system built for another user.

One of the advantages of devoting your ingenuity to REMAP projects is that there is always a market for the product. True, that market may be limited to one customer but their appreciation will make up for the lack of financial reward. Having said that there is no restriction on ideas generated

as a result of a REMAP job being developed into commercial products and there has in fact been some interest in the epilepsy alarm described previously.

One of these was a request for a toilet training device for a mentally handicapped boy. The boy had already been successfully trained to use a potty by means of a commercially available reward device. These usually operate by sensing the presence of urine in the potty by means of conductivity probes triggering an audible reward. However, he was now growing too big for the potty and the staff wanted him to use a full-size toilet.

Obviously, sensing the presence of liquid was no use in this case as there would always be some present in a toilet

Fig.3 Toilet trainer Block diagram

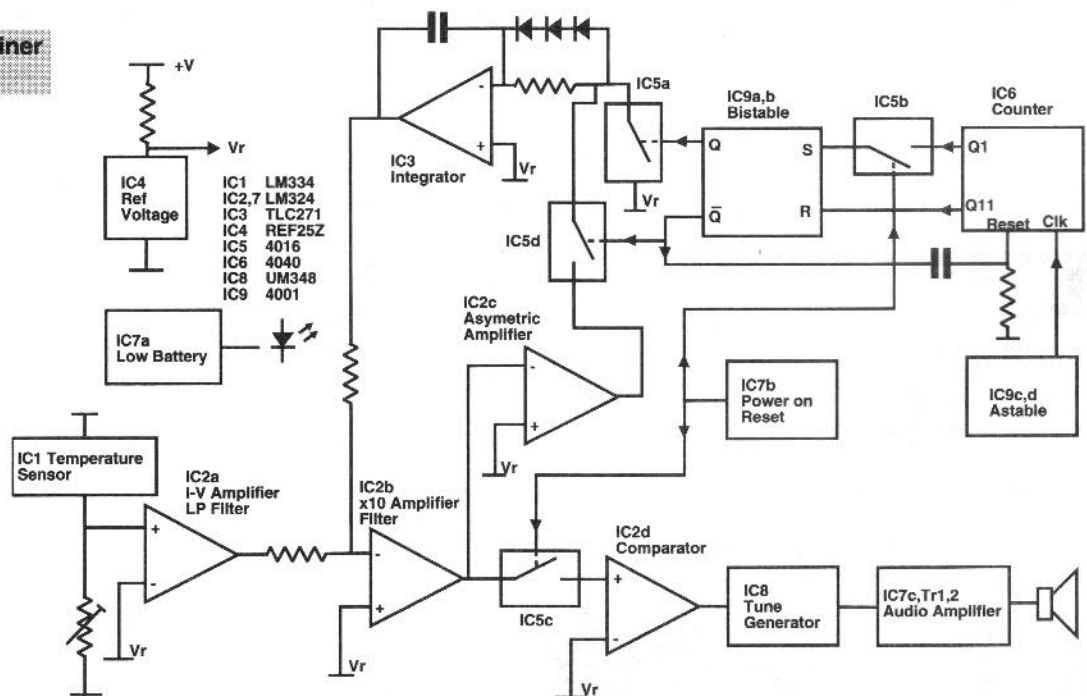





Changing TV channels using the tongue

bowl. I toyed with a number of possibilities but finally decided on temperature or more precisely change of temperature as the simplest solution. A rough calculation showed that the minimum change in temperature of the water in the toilet bowl when the boy performed would be about 0.2° Celcius. The normal temperature of the water however might vary from about 2 to 25° Celcius. The block diagram of the circuit I designed is shown in Figure 3. The circuit is insensitive to slow variation due to changes of ambient temperature. However any rapid rise in temperature triggers a musical reward.

An LM334 adjustable current source IC is immersed in the toilet bowl. This IC produces a current proportional to absolute temperature which is converted by IC2(a) into a voltage corresponding to a range of about -5 to 30 degrees Celcius. The output of IC2(b) is the difference between this voltage and a feedback voltage from IC3. IC2(c) tries to maintain the output of IC2(b) at VR (a reference voltage) by adjusting the feedback via IC3.

However IC3 acts as an integrator with a very long time constant so that although rises in temperature are eventually nulled out by feedback there is a temporary increase in the output of IC2(b). The magnitude of this rise is related to the rate of change of temperature and if sufficient will trigger the comparator IC2(d) which in turn enables the tune generator.

The time constant required for the integrator IC3 is about 1800 seconds which is totally impractical using a simple RC circuit. IC6 and IC9 generate a 5KHz clock with a mark-space ratio of 1024 to 1. This clock controls analogue switches IC5(a) and IC5(d) in anti-phase hence only allowing the integrator to operate for 1/1024 of the time. This increases its basic time constant by roughly 1000.

On first turning power on, the integrator capacitor is uncharged. In order to reduce the time taken for the circuit to stabilise, analog switches IC5(b) and IC5(c), which are normally closed, are held open for a short period. This disables the alarm and also the

clock signal so that the integrator operates at 1000 times the usual rate. Both IC2(c) and IC3 also deliberately respond non-linearly to provide rapid stabilisation after a drop in temperature which occurs when the toilet is flushed.

Whilst developing the circuit I discovered two interesting phenomena. One was the effect of light on the leakage current of clear glass-bodied diodes and the other was the reduction in insulation resistance of a PCB due to traces of surface moisture. Both caused considerable frustration at the time but the design eventually worked very successfully.

If you would like to know the location of the nearest REMAP panel then please contact:

**Eur Ing J J Wright**  
**REMAP GB**  
**Hazeldene**  
**Ightham**  
**Sevenoaks**  
**Kent**  
**TN15 9AD**  
**Tel: 0732 883818**

**Call us now! We have the widest range of components available - At competitive prices!**

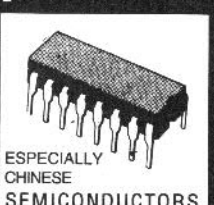
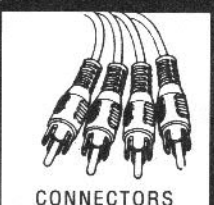
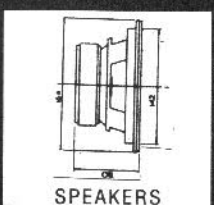
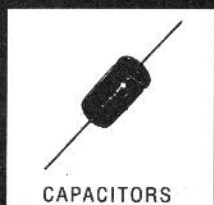
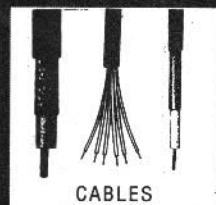

**CRICKLEWOOD**  
 ELECTRONICS

Cricklewood Electronics Ltd. 40 Cricklewood Broadway London NW2 3ET  
 Telephone: 081 452 0161  
 Facsimile: 081 208 1441

All Major Credit Cards Accepted



# HiJaak Pro 2.0 for Windows

by Paul Stenning

**M**ost software packages can be summed up in one or two words - Word Processor, Spreadsheet and the like. HiJaak is not so easy - it offers graphics conversion, image manipulation, screen capture (DOS and Windows), image management and graphics viewing. I suppose you could call it a Graphics Toolkit.

My original interest in the package was for the graphics conversion. I needed to convert the DXF or IFF output formats from my electronic CAD software, to a form that was suitable for the DTP system used for this magazine.

### Installation and Manuals

The software is supplied on three high density disks, while a fourth contains 300 clipart files. There are also two manuals, totalling 10mm in thickness. The product was contained in a large display box, along with some folded cardboard and lots of fresh air!

The manuals give adequate information, without getting bogged down with the technicalities. However the writing style is rather dry, which makes manual reading tiresome. On-line help is comprehensive, and possibly more useful than the manuals, since the information needed is immediately available.

Installation is straightforward. The installation routine advises the use of a disk cache such as SmartDrive to speed the process. They mean it - installation took an hour without SmartDrive, and five minutes with! This is mainly due to the large number of small files on the clipart disk.

### After a Bad Start . . .

The initial behaviour of the software was rather worrying. The dreaded "General Protection Error" and "Fatal Application Error" messages from Windows appeared regularly, and the system locked up on a couple of occasions. The technical support department in the USA

diagnosed the problem was due to incompatibility with my video card, and suggested adding the line INTREG=OFF to the HJPRO.SET file. I don't know what it does but it worked!

---

*If you don't know what format you need to convert to, you can enter the target software package and HiJaak will choose the best format for you.*

---

### Graphics Conversion and Screen Capture

The graphic conversion facilities are comprehensive, and I had no problems loading the files created into other applications. The software can handle over seventy different raster and vector formats. I was interested to see Kodak PhotoCD listed, but slightly disappointed to find the First Publisher \*.ART format was not included. If you don't know what format you need to convert to, you can enter the target software package and HiJaak will choose the best format for you.

There are numerous facilities for image manipulation and enhancement. Cropping, resizing and rotating; altering colours, contrast and brightness - the list of features goes on, and I spent several enjoyable hours playing with them. With practice some impressive results can be achieved.

The Windows screen capture worked OK, although there were slight colour variations. I could not get the DOS screen capture to work in graphics mode, but I have only spent a few minutes

testing this. The manual gives little information on the Windows capture, and almost nothing on DOS capture.

### Image Browser

The HiJaak Browser is started from a separate icon, and detailed in a separate manual. "Thumbnails" of the images on the hard disk are created - these are small views that allow you to search rapidly through the files. The thumbnails are stored in a file that is created in the same directory as the images. Once the thumbnails are produced, searching for a particular image is easy.

However the thumbnails take a ridiculously long time to create, although this can be done automatically in idle time. The thumbnail files are not as small as they might be (about 150K for ten images), which may be a problem if hard disk space is at a premium.

### And the Rest

A wide variety of images are included on the clipart disk, and thumbnails are included. It's worth taking a good look through these - I've used a few already! The clipart disk is a free extra and may not be included with all copies of HiJaak Pro.

The package has many more features, which I have not had time to try or write about. With this sort of software you discover things as you use it!

Technical support is available from the USA, which could prove expensive if a long telephone call is needed. Unfortunately we cannot benefit from the American freephone number. However the time difference allows us to call in the evenings when the telephone charges are lower. If you purchase the product from Software Compatibility Centre Ltd, they will offer UK technical support themselves.

### Conclusion

HiJaak Pro offers a good range of features for a reasonable price. I am



most impressed with the image conversion, manipulation and enhancement options. If you have a requirement for this type of software, and you have the hardware to run it, HiJaak Pro deserves a serious look. However the package may be too expensive for the casual user.

The software ran a little slowly on my 25MHz 386SX, particularly the screen redrawing. A more suitable system would be a 486 with 4MB of RAM and a decent SVGA graphics board. Dream on!

### Availability

HiJaak Pro for Windows is published by Inset Systems, 71 Commerce Drive, Brookfield, CT 06804-3405, USA. Tel. 0101 203 740 2400, or Fax 0101 203 775 5634 (from the UK).

The UK list price is £165. At the time of writing (December 1993), the best price I could find was £82 from Shareware Marketing, 3A Queen Street, Seaton, Devon, EX12 2NY. Tel. 0297 24088 or Fax 0297 24091. Their catalogue number for the product is ISI-106 (HiJaak Pro is not a shareware product).

The product is also available from Software Compatibility Centre, 68 Ross Way, Eltham, London, SE9 6RL. Tel 081 319 1478 or Fax 081 856 9993. Their price of £117.50 includes UK technical support.

### Software Reviews

Calling software publishers and distributors - if you have a product that may be of interest to our readers, we will seriously consider reviewing it. We would prefer products of a more specialised nature. Please send details to Paul Stenning, 1 Chisel Close, Hereford, HR4 9XF.

# PROMOTE YOURSELF

**If your company has not placed an advertisement within Electronics in Action then you are missing the golden opportunity of getting through to scores of electronics engineers, technicians, scientists and electronic hobbyists.**

**Telephone Gilly Martin on 0442 842069 for an immediate booking**

**GET YOURSELF KNOWN**



## Cooke International SUPPLIER OF QUALITY USED TEST INSTRUMENTS

ANALYSERS, BRIDGES, CALIBRATORS,  
VOLTMETERS, GENERATORS, OSCILLOSCOPES,  
POWER METERS, ETC.  
ALWAYS AVAILABLE

ORIGINAL SERVICE MANUALS FOR SALE  
COPY SERVICE ALSO AVAILABLE

EXPORT, TRADE AND UK ENQUIRIES WELCOME  
SEND SAE FOR LISTS OF EQUIPMENT AND  
MANUALS

REPAIRS & CALIBRATION UNDERTAKEN  
ENQUIRE FOR DETAILS

ALL PRICES EXCLUDE VAT AND CARRIAGE  
DISCOUNT FOR BULK ORDERS. SHIPPING ARRANGED

OPEN MONDAY TO FRIDAY 9AM-5PM

### COOKE INTERNATIONAL ELECTRONIC TEST & MEASURING INSTRUMENTS

Unit Four, Fordingbridge Site, Main Rd, Barnham,  
Bognor Regis, West Sussex PO22 0EB  
Tel: (+44) 0243 545111/2 Fax: (+44) 0243 542457

● HIGH END TEST & COMMUNICATIONS EQUIPMENT PURCHASED ●



## Chelmer Valve Company for High Grade Audio Valves

Major Brands e.g Mullard, Brimar, Philips, GE (UK), GE(USA), etc.

A2900 GEC.....	£12.00	GZ34 Mullard.....	£10.00
E80F Philips.....	£10.00	GZ37 Mullard.....	£7.00
ECC81/CV4024 Mullard.....	£6.00	6CA7/EL34 GE.....	£9.50
ECC82/CV4003 Mullard.....	£6.00	6L6GA Sylvania.....	£7.00
ECC88 Mullard.....	£6.00	6SN7GT Brimar.....	£4.50
E88CC Mullard.....	£8.50	6V6GT Brimar.....	£4.00
EF86/CV4085 Mullard.....	£8.50	12AT7WC Sylvania.....	£6.00
EL84 Mullard.....	£6.00	6146B GE.....	£15.00
EL84 GE (USA).....	£5.00	6550A GE.....	£15.00
GZ32 Mullard.....	£8.00	7581 GE.....	£12.00
GZ33 Mullard.....	£8.00		

**CVC PREMIUM:** Our own BRAND from selected worldwide sources, processed in our special facility to provide low noise/hum/microphony Pre-Amp valves and Power Valves burnt-in for improved stability and reliability.

#### PRE-AMP VALVES

ECC81/12AT7.....	£5.00
ECC82/12AU7.....	£4.00
ECC83/12AX7.....	£5.00
ECC85.....	£4.00
ECC88.....	£5.00
EF86.....	£4.00
E81CC (GOLD PIN).....	£6.00
E82CC (GOLD PIN).....	£6.00
E83CC (GOLD PIN).....	£6.00
E88CC (GOLD PIN).....	£7.00
E80F.....	£9.00
E83F.....	£5.50
6SL7GT.....	£4.00
6SN7GT.....	£4.20

#### POWER VALVES

2A3 (OCTAL) or (4pin).....	£14.00
211.....	£22.00
300B.....	£9.50
811A.....	£9.50
845.....	£29.90
EL34/6CA7.....	£7.50
EL84/6BQ5.....	£4.00

#### POWER VALVES - contd.

E84L/7189A.....	£15.00
KT66.....	£9.20
KT88.....	£12.50
KT88 (GOLD Q).....	£18.50
6L6GC.....	£6.50
6L6WGC/5881.....	£8.00
6V6GT.....	£5.00
6146B.....	£10.20
6336A.....	£30.00
6550A.....	£11.00

#### RECTIFIERS

GZ33.....	£4.50
GZ34/SAR4.....	£5.00
5U4G.....	£5.00
5Y3GT.....	£3.20
5Z4GT.....	£3.50

#### SOCKETS

B9A (PCB).....	£1.60
B9A (CHASSIS).....	£1.60
OCTAL (CHASSIS).....	£1.75
4PIN (UX4).....	£3.00
4PIN (for 211).....	£11.00

Add £1.00 per valve for matching if required.

Plus Post & Packing £3.00 + VAT at 17.5% for UK/Europe.

Send Fax order with cheque or credit card details to:

Chelmer Valve Co., 130 New London Rd, Chelmsford, Essex CM2 0RG  
Tel: (0245) 265865 Fax: (0245) 490064

## David Silvester reports on an inexpensive way to produce your own Printed Circuit Boards

# From Paper to PCB

**W**hilst most of the constructors in the UK who are now reading *Electronics in Action* will have no trouble in obtaining a printed circuit board for a project that interests them, what happens to readers who may be outside the UK. The simple answer is to make their own board from the published layouts in *Electronics in Action*, and the very white paper that the magazine is printed on used actually helps in this job.

The process is extremely simple and if the constructor is willing to make the UV exposure box it can be cheap as well. What you require is a simple photocopier which must by now be the most common piece of office equipment and there are also a large number of businesses that will make photocopies for a small charge.

The revolution in the production process has come about by the use of laser printers for PCs as these use an identical method of reproduction to the photocopier. In both a toner is deposited on a sheet of paper where the dark areas are needed and a heating bar melts the toner to fuse with the paper. However it was found the laser printers and photocopiers were ideal for making overhead projector slides, the only problem being the heat. Recently transparency film has been available for laser printers and photocopiers that do not warp or shrink when making a copy. This type must be used to make the positive.

### Making the positive

**STEP 1** Have the circuit layout printed in EIA photocopied onto one of these transparencies. It is advisable to check that the copy is actually 1:1 scale with the original. Within a few seconds you will have a negative that can be used for the generation of the PCB using the photo etching process.

### Expose the PCB material

**STEP 2** Experiments I have carried out have shown me that it is cheaper in the long run to buy pre-coated PCB material, having had a total lack of success with boards that I have coated myself. The UV exposure unit consists of two 8 watt UV bulbs in a wooden box and a sheet of glass about 6cm above them onto which the photocopied negative and the PCB material are compressed by a heavy weight. This sort of unit although of a much better design and construction than the author could manage can be bought easily and although costly will last a lifetime.

Exposure time for the pre coated boards in my unit has always been 8 minutes for many different types and ages of the board material.

### Develop the exposed board

**STEP 3** The exposed photoresist is developed in a 0.7% solution of Sodium Hydroxide (Caustic Soda) or one of the proprietary developers which as far as I can see are the same thing. The 0.7% solution does not have to be accurately measured, I use one heaped teaspoonful of the pellets to one litre of water, tap water will do. The development takes place in a photographic developing tray that is rocked continuously to keep fresh solution on the board surface.

### Etching

**STEP 4** The etching of the now exposed copper can be carried out with a number of mixtures. The most obvious and possibly the easiest to obtain is a solution of Ferric Chloride. This is a very messy material being a dark red solution that stains anything it come into contact with

and will even attack stainless steel leaving marks that are impossible to remove. A cleaner option and the authors favourite is a 30% solution of Hydrochloric Acid (Spirits of Salts from a local ironmongers, sold as toilet de-scaler, diluted 1:3) to which is added Hydrogen Peroxide solution (from the chemist/druggist in the next door shop). Although 20 vol. Hydrogen Peroxide will work it is much better if you can get 100 vol. as it prevents the dilution of the acid. This acid mix is also much faster at etching, taking only a few minutes whilst the Ferric Chloride etchant seems to take ages to work. As with all chemicals extreme care is needed but do not be afraid of them as fear leads to accidents. Always wear safety glasses when the chemicals are around and rubber gloves if you are worried although a drop on the hand if washed off quickly will cause no damage. Protect the surfaces on which you are working as the chemicals can stain.

### Wash & Drill

**STEP 5** The final stages are to wash the board in water to remove all of the chemicals that were used in the production, remove the remaining etch resist with Acetone (from the chemist, it's used as nail polish remover), spray coat with a lacquer to prevent atmospheric action on the copper tracks and drill the holes.

Take care and enjoy making those PCBs.

EIA

**If you don't feel like making circuit boards for yourself, then why not buy them from the EIA PCB service. Turn to page 63 for more details.**



## SYSTEM 200 DEVICE PROGRAMMER



**SYSTEM:** Programs 24,28,32 pin EPROMs, EEPROMs, FLASH Memories and EPROM Emulators as standard, quickly, reliably and at low cost. Expandable to cover virtually any programmable part including serial EEPROMs, PALs, GALs, EPLDs and microcontrollers, in many different packages.

**DESIGN:** Not a plug-in card but connecting to the PC serial or parallel port; it comes complete with powerful yet easy to use software, cable and manual.

**SUPPORT:** UK design, manufacture and support. Same day dispatch, 12 month warranty. 10 day money back guarantee.

**mqp**



**ASK FOR FREE INFORMATION PACK**

MQP ELECTRONICS Ltd  
Park Road Centre  
Malmesbury, Wiltshire SN16 0BX. UK  
Tel: 0666 825146 Fax: 0666 825141

GERMANY 089/4602071  
NORWAY 0702-17890  
SWEDEN 8 590 754 04  
ITALY 02 92 10 35 54  
FRANCE 1 69 30 13 79  
Also from VEROSPEED UK

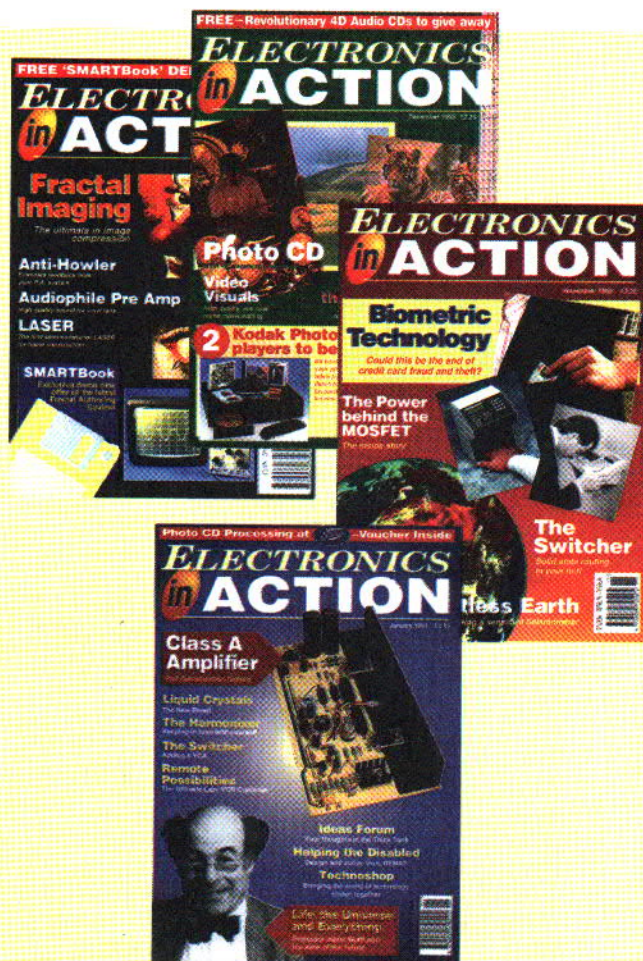

**Don't miss out on a single issue**  
**Don't get caught in a massive queue**  
**Don't be the last to build that project**  
**and certainly don't pay any postage\***

# Subscribe

A 12 month subscription to Electronics in Action costs just **£27** if you live in the UK and **£42** if you live overseas. Subscribe now and we will send you a free Frax SMARTBook demo disk as featured in our first issue.

\*In the UK only

## SUBSCRIPTIONS

Please start my 12 month subscription to  
**Electronics in Action** from the ..... issue  
Please print your name and address in **BLOCK CAPITALS**  
Name .....  
Address .....  
..... Postcode .....

I enclose a cheque/postal order  
(payable to Electronics in Action) for £.....  
Please send this form to:

**Subscriptions Dept.**  
**Electronics in Action, PO Box 600,**  
**Berkhamsted, Herts. HP4 1NL**

## Baylin Publications

**ALL ITEMS EX-STOCK.**

**Ku Band Satellite TV, Theory, Installation & Repair**

4th Edition. Footprints, dish theory, cables, site survey, polar mount adjustment.

**£25.**

**European Scrambling**

**Systems, Circuits, Tactics & Techniques.** By John McCormac, digital sound, smart cards, pirate decoders, for hackers. **£32.**

**World Satellite TV & Scrambling Methods.** 2nd Edition, by Baylin, Madox & McCormac for the service engineer. **£29.**

**Home Satellite TV Installation Videotape.** Forty minutes VHS Pal. See how 3 metre dishes are installed. **£27.**

**Satellite Installation Guide.** 3rd Edition. By John Breeds. **£13.**

**The Satellite Book.** 2nd Edition. A complete guide to satellite TV. Theory and practice by John Breeds. **£31.**

**World Satellite Almanac.** 3rd Edition by Mark Long. 300 Footprints, Frequencies, Transponder Loading, Orbital Assignments. **£69.**

**World Satellite Annual.** Update by Mark Long. **£39.**

**TVRO System Analysis and Aiming Software.** 5.25 or 3.5 disk, (DOS 3.2). Calculates dish size and lists coordinates of all satellites in view. **£39.**

**Satellite Toolbox Software,** for IBM Comp. Hard Disk-5.25 or 3.5. **£59.**

**Wireless, Cable & SMATV,** Microwave broadcasting & cable TV. **£35.**

**World Satellite Yearly** by Dr. Baylin, Loading and 200 Footprints. **£38.**

**PRICES INCLUDE P. & P. UK. Airmail Europe add 10%. Outside Europe +20%.**

24 River Gardens,  
Purley, Reading.  
RG8 8BX. England.

Tel/Fax 0734-414468

Mobile 0836-582785

Pay by: UK£ cheque,  
Access, Mastercard,

Visa,  
C.O.D.



**World Satellite TV and Scrambling Methods**  
The Technicians' Handbook



**WORLD SATELLITE YEARLY**

by Dr. FRANK BAYLIN





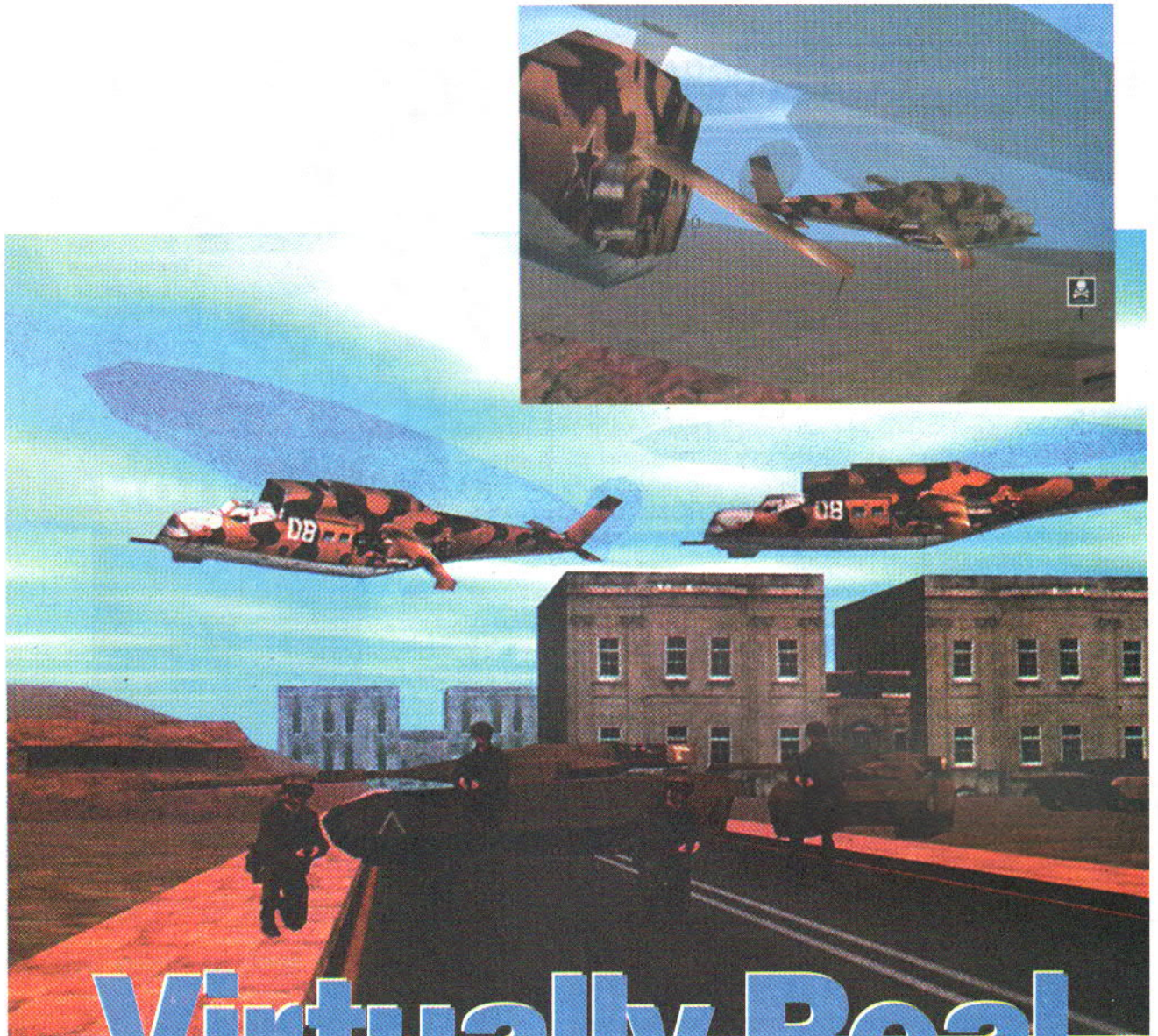

# Virtually Real

Helen and Andrew Armstrong report on the latest Virtual Reality developments from the VR User Show

**N**ever mind amusement arcades; virtual reality is getting on in the real world. In a few years, if computer graphics systems continue to get faster, memories expand, and costs shrink, virtual reality applications will be as commonplace as word processing is now.

Virtual reality is a computer simulation that mimics the look and feel of a real environment. Ideally the user could move around the simulated space in real time, apparently interacting with it as if it were a real place containing real people and things. Inevitably, even simple applications need a great deal of computing power, but though the ideals of genuine real-time response and complete sensory interaction are still some way off, the groundwork has been laid.

Some sorts of virtual reality have been around for years. Flight simulators, for instance, are full-scale mock-ups of airliner cockpits, usually a real, fully-fitted cockpit section moved bodily by hydraulic rams. Simulators mimic an aircraft's controls and behaviour with such accuracy that trainees frequently have to rest up after an "emergency", although they know intellectually that the risks are zero. Modern simulators have computerised headup displays of the view from the cockpit window. To the pilot, though, it is the hardware which is the link with the real world.

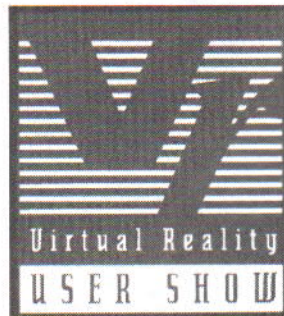

The same principle is exploited in games which use moving cockpits and computer graphics to create a feeling of absolute reality. The ultimate aim in entertainment VR is to create an "environment" which combines reality with fantasy, or which moves right away from everyday environments into worlds of the imagination. It's theoretically possible to do this, by manipulating sound effects, movement and touch response so that they affect our senses exactly as they would if they were real.

But for real-world applications accurate reproduction of an existing



## Finding the Target

The most popular display at the show, judging by the queues to have a go, was a shoot-em-up game used by Division Group to demonstrate their VR technology.

Division Group supplies immersive VR systems and image-generation technology for entertainment, collision testing, and living environment simulation. A walk-through immersive display of projected designs for a housing development in the Netherlands speeded up the rate of sales dramatically before the houses were built.

But "virtual worlds" are not the match of the real world yet. Goggle-screens are limited in their effectiveness by their reduced size.

In the words of our designer, Iain, his shoot-out was like watching the world through tracing

paper. I had to agree with him. The helmet was an older model, as demand for display helmets is high.

VR helmets cost from \$7,000 to \$70,000 now, but that may change when game companies like SEGA move into VR games, perhaps in 1994. Resolution is from 320x240 to 400x300, but designers are working towards VGA resolution.

Division makes VR workstations and graphics accelerators, and markets the VR software environment DVS. The

Unix-based stations use 486 processors for management. An array of transputers carries out fast message handling, and a series of I860 processors do the VR processing. This is true parallel processing: one I860 could be given the task of detecting all object collisions in the simulated space.

The multi-user, multi-machine system can link users by over a telephone line. Each end of the line must start from the same point with the same world data, after which communication via modem keeps both models updated.

Simulation and training applications include hazardous environments like space. Within two years, training for missions like the Hubble Space Telescope repair will take place largely on VR, rather than underwater as at present.

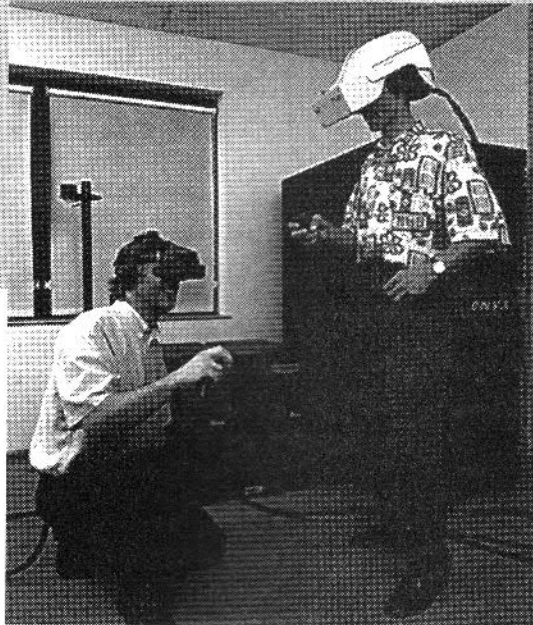

situation is essential. They need the same hardware and software techniques, but there is no room for a spatial error or a mistimed response when, for example, carrying out surgery from a distance by telepresence. Much of the ingenuity of virtual reality is in the software, but most of these ground-applications will depend on special hardware as well. Most important are movement sensors and other transducers, without which virtual reality would just one more display medium.

## On Show

The VR User Show exhibition and conference at the Hammersmith Novotel, London was dedicated to virtual reality as a business tool. The conference on the second day explored some future possibilities, but the first day and the exhibition provided a sampler of what the art is doing now.

What virtual reality is doing for industry and science now is both more diverse and less mind-bending than you might imagine. I went expecting to see a VR helmet on almost every stand, and hoping to find VR feedback gloves in use as well. This wasn't the case, although there were several visual projection helmets and one motor-sensor helmet on display. We found a lot of mouse-driven applications. And yes, the most popular exhibit of the day, with obvious students, boffin types and business-suited executives queuing patiently for a turn, was the Division Group's VR shoot-'em-up.

British companies are at the heart of VR development, and it is said that the British are better informed about VR than Americans. It seems a lot of VR development is carried out in Britain, but the most important market is America, closely followed by Japan. One pundit quoted *Dimension*, *Division*, and *Virtual Reality* as the three major British companies in the field.

## VR Technology

Virtual reality visualisation demands specialised hardware and software. The most essential element is the 3D display system. This can be a VR helmet, or a conventional monitor with shutter-spectacles (described later).

The field of vision should be as large as possible in systems requiring psychological acceptance of realism, because, say psychologists, if the field of vision exceeds about 60°, it is more readily accepted as real by the subconscious.

In all but the simplest systems, a head position sensor is necessary. If you turn your head, you must naturally see what you would see in a real scene. The software and hardware should ideally

provide a full sphere of vision.

A widely used method of position sensing is the three-coil method, in which three orthogonal sensing coils are attached. Three larger fixed coils are pulsed in sequence, and the relative phase and amplitude information from the sense coils is processed to determine three dimensional position and three orthogonal angle measurements. The American company Polyhemus supplies such a system.

Much of what is required from the software is available on conventional 3D CAD systems which use normal 2D computer displays. A wireframe model of each object is generated, then texture (colouring effects) and lighting are added to surfaces. One time-consuming process is to determine which surfaces are visible from a given direction, and which are hidden. Parts of an object which are "hidden" behind another object must also be computed.

This computation provides one view of an object. For VR visualisation, a second view from a point displaced by the visual width of one eye must also be generated, to give a stereoscopic image. The left and right views are shown to the left and right eyes. The only fundamental difference is that the focus of the eye does not need to adjust to cope with objects apparently closer or farther away. In practice, this fact does not seem to disturb the 3D illusion.

To update the moving images in real time needs very fast computation.

Continued on page 56

**WE HAVE THE WIDEST CHOICE OF USED OSCILLOSCOPES IN THE COUNTRY**

**TEKTRONIX 7000 SERIES OSCILLOSCOPES**  
Dual Trace plug-in with TB from £200  
Many plug-in options available. 4Traces;  
Differential etc. **PLUG-INS SOLD SEPARATELY**

TEKTRONIX 2235 Dual Trace 100MHz Delay Sweep.....	£900
PHILIPS 3065 2 1 channel 100MHz Dual TB Delay Sweep.....	£700
TEKTRONIX 475 Dual Trace 200MHz Delay Sweep.....	£550
HP 1715A Dual Trace 200MHz Delay Sweep.....	£500
HP 1740A Dual Trace 100MHz Delay Sweep.....	£400
TEKTRONIX 2215A Dual Trace 60MHz Delay Sweep.....	£500
PHILIPS PM3217 Dual Trace 50MHz Delay Sweep.....	£400
HITACHI V422 Dual Trace 40MHz.....	£325
TELEQUIPMENT D83 Dual Trace 50MHz Delay Sweep.....	£200
GOULD O3300A Dual Trace 40MHz Delay Sweep.....	£200
KIKUSUI 5530 Dual Trace 35MHz.....	£180
GOULD OS1100 Dual Trace 30MHz.....	£160
HITACHI V229 Dual Trace 20MHz CRT Delay Sweep.....	£300
GOULD OS300 Dual Trace 20MHz.....	£200
GOULD OS250B Dual Trace 15MHz.....	£125
TEKTRONIX 466 Dual Trace 100MHz Storage.....	£450

THIS IS JUST A SAMPLE, MANY OTHERS AVAILABLE

PHILIPS PM 5139 Programmable synthesizer/Function Generator 0.1MHz-50MHz IEEE-488 as new.....	£1500
MARCONI 2019 Synthesized AM/FM Sig/Gen 60KHz-1040MHz.....	£2000
MARCONI 2018 Synthesized AM/FM Sig/Gen 90KHz-520MHz.....	£950
EIP/DANA 3510 Microwave Frequency counter 20Hz-18GHz.....	£350
RACAL 9921 Frequency Counter 3GHz.....	£300
RACAL/DANA 1991 Nanosecond Universal counter.....	£800
RACAL 9302 Millivoltmeter True RMS 10KHz-1.5GHz.....	£450
RACAL 9301A RF Millivoltmeter True RMS 10KHz-1.5GHz.....	£300
RACAL 9009 Auto Mod. Meter 10MHz-1.5GHz Wide deviation.....	£250
LYONS PG73N Pulse Gen. PRF 1Hz-20MHz.....	£150
GOULD Bionation K5000D Logic Analyser.....	£500
FARNELL PSG520H Synthesized Sig Gen AM/FM 100KHz-520MHz.....	£600
LEADER LSG216 AM/FM Sig/Gen 0.1-30MHz & 75-115MHz.....	£400

**BRUEL & KJOER Vibration Exciter System**  
Consisting of Exciter Control 1047; Power amp 2708 in exciter  
body 4902 (up to 1780W - 400lb)  
Other B & K equipment available

**SPECTRUM ANALYSERS**

HP 141T with 855A & IF Plug-in 10MHz-18GHz.....	£2000
HP 141T with 854B & 8552B 500KHz-1250MHz.....	£1300
HP 140T with 8554L & 8552A 500KHz-1250MHz.....	£1000
HP 141T with 8556A & 8552B 20Hz-300KHz.....	£1000
HP 140T with 8553L & 8552A 1KHz-110MHz.....	£1000
MARCONI TF2370 30Hz-110MHz.....	£1500
HP 1820 with 8558B 100KHz-1500MHz.....	£1500
HP 3582A 0.02Hz-25.5KHz.....	£2000

**Used Equipment - GUARANTEED. Manuals supplied if possible**

This is a VERY SMALL SAMPLE OF STOCK. SAE or telephone for lists. Please check availability before ordering.  
CARRIAGE all units £16. VAT to be added to total of Goods and Carriage

**STEWART of READING**

110 WYKEHAM ROAD, READING, BERKS RG6 1PL  
TELEPHONE (0734)268041 Fax: (0734)351696  
Callers Welcome 9am-5.30pm Monday to Friday (until 8pm Thursday)

DATRON 1061A - 6 1/2 digit true RMS AC/Current.....	£1250
DATRON 1065 Multimeter 5 1/2 digit AC/DC/Ohms IEEE.....	£600
HEWLETT PACKARD 3490A Bench Multimeter 5 1/2 digit AC/DC/Ohms.....	£200
PHILIPS PM2534 Multifunction DMM 6 1/2 digit GPIB IEEE.....	£450
MARCONI Digital Frequency Meter 2430A 10Hz-80MHz.....	£125
MARCONI Digital Frequency Meter 2431A 10Hz-200MHz.....	£150
MARCONI Universal Counter Timer 2437 DC - 200MHz.....	£175
MARCONI Universal Counter Timer 2438 DC - 520MHz.....	£225
HP 3311A Function Generator 0.1Hz - 1MHz Sine/Square/Triangle.....	£125
BLACK STAR Jupiter 500 Sine/Sq/Tri 0.1Hz - 500KHz.....	£70
FEEDBACK FG600 Sine/Sq/Tri 0.1Hz - 100KHz.....	£80
MULTIMETERS Hand-Held M2555-32 ranges AC/DC 10A Diode/ Transistor Tester, Prog counter.....	£32.50
FARNELL ELECTRONIC LOAD RB1030-35 1KW 30A 35V.....	£800

HP 8890 Sweep Osc with 88974 Plug-in 26.5-40GHz.....	£300
RACAL/DANA RF Power Meter 9104.....	£400
RACAL/DANA 9341 Dalabridge, Automatic LCR & C.....	£350
WAYNE KERR BR95 Automatic Precision bridge 0.05%.....	£900
WAYNE KERR BR95 Automatic Component bridge 0.1%.....	£350
WAYNE KERR B424 Digital Component Meter LCR.....	£125
FARNELL FSU TVSTWIKZ 770 5A/30V/10A.....	£400
FARNELL PSU HB025 0-50V 0.5A Metered.....	£90
FARNELL PSU L30E 0-30V 0-5A Metered.....	£250
FARNELL B3020 0-30V 20A.....	£200
FARNELL B5010 0-30V 10A.....	£125
HP 6299B 0-320V DC 1A Metered.....	£150
MARCONI TF2700 Universal LCR Bridge, Battery from.....	£300
AVO Characteristic Meter VCM163.....	£175
FARNELL LAS20 RF Power Amp. 1.5-520MHz 300mW.....	£100
RACAL 9100 Absorption Wattmeter 1MHz-1GHz 3W.....	£100

**FARNELL Isolating Transformers**

GU500, 240V 500VA, unused..... £50

**NEW EQUIPMENT**

HAMEG OSCILLOSCOPE HM1005 Triple Trace 100MHz Delay Imbese.....	£947
HAMEG OSCILLOSCOPE HMB04 Dual Trace 80MHz Delay sweep.....	£653
HAMEG OSCILLOSCOPE HM203.7 Dual Trace 20MHz Component Tester.....	£653
HAMEG OSCILLOSCOPE HM205.3 Dual Trace 20MHz Digital Storage.....	£953

All other models available - all oscilloscopes supplied with two probes

**BLACK STAR EQUIPMENT (P&P all units £5)**

APOLLO 10 - 100MHz Counter timer Ratio/Period/Time interval etc.....	£222
APOLLO 100 - 100MHz (As above with more functions).....	£325
METEOR 100 FREQUENCY COUNTER 100MHz.....	£119
METEOR 900 FREQUENCY COUNTER 600MHz.....	£145
METEOR 1000 FREQUENCY COUNTER 1GHz.....	£189
JUPITOR 500 FUNCTION GEN 0.1Hz - 500KHz Sine/Square/Tri.....	£119
ORION COLOUR BAR GENERATOR PAL/TV/Video.....	£229

All other Black Star Equipment Available

OSCILLOSCOPE PROBES Switchable x1 x10 (P&P £3).....	£12
---	-----



## A LIBRARY OF IBM-PC SOFTWARE at your fingertips

**SHAREWARE** is the **TRY-BEFORE-YOU-BUY APPROACH TO SOFTWARE:**  
You pay a nominal charge for program distribution to cover disks, copying, carriage, etc.

ONLY IF YOU FIND A PACKAGE USEFUL ARE YOU THEN REQUIRED TO PAY A REGISTRATION FEE (to the software author), which allows you to continue using it.

THIS CAN WORK OUT CONSIDERABLY LESS EXPENSIVE THAN BUYING SIMILAR SOFTWARE IN THE CONVENTIONAL WAY.

### Electronics design on your PC

**- Now simple & AFFORDABLE !**

**ENGINEERING - GRAPHICS - BUSINESS - PC-TUTORIALS - CALCULATIONS - SCIENCE - EDUCATION**

Re-inventing the wheel? Don't do it!! Quickly select software tailored to your needs from the many 1000's of packages available in the Public Domain, and as Shareware. We distribute IBM-PC compatible programs exclusively on carefully grouped sets of high quality disks - **which saves you time, and money.**

**Ask for our latest catalogue!**

**CAD/CAM - PCB DESIGN - CIRCUIT EMULATION & TEST - PC-ENGINEERING - RADIO - COMM'S**

**Profile Electronics (EIA)**  
"Getting the job done"

100-102 Woodhouse Road, Leytonstone, London, E11 3NA.  
Tel: 081-470 2038 (24 hours) Mail order only

# ULTRA LOW COST 8051 DEVELOPMENT SYSTEM



**MG51EV EVALUATION BOARD BUILT & TESTED**

## £49

+VAT + (£5 P&P)

- MONITOR / DEBUGGER EPROM
- all debug commands: Dump, Enter, Fill, Go, Move, Register...
- ASSEMBLE & UNASSEMBLE functions...
- full access to ROM, internal and external RAM areas
- 8kbytes RAM for prog./data (Extendable upto 32kbytes)
- 16 I/O LINES (including the serial port, timers, interrupts)
- DOWNLOAD INTEL HEX FILES
- HW/SW RESET
- AUTOMATIC BAUD-RATE ADJUSTING (600, ... 4800 baud)
- TERMINAL PROGRAM & USER'S MANUAL

supplied on 5.25" or 3.5" disks for IBM PC compatibles

- SERIAL COMMUNICATION CABLE for IBM PC compatibles
- FULL TECHNICAL SUPPORT
- 8052 FAMILY SYSTEMS ALSO AVAILABLE

**CALL US NOW ON 081-656 96 43**



**microGem systems**  
COMPUTER BASED SYSTEMS  
DESIGN & CONSULTANCY

112 LONGHEATH GRDNS  
ADDISCOMBE  
CROYDON  
SURREY  
CR0 7TP

# Wilmslow Audio

Britain's leading loudspeaker kit and drive unit suppliers. Four demonstration rooms.



**Wilmslow Audio** **ATC**

If you require the legendary and renowned performance of ATC based loudspeaker systems in kit form, Wilmslow Audio have the answer. A close collaboration with ATC has resulted in the:

**ATCK50 & ATCK100**

Contact Dr Stephen Leigh for details to arrange a demonstration.

**Now available**

Loudspeaker Design Cookbook  
The bible for the home constructor.

**Write or call for details**

Dept EIA, Wilmslow Audio  
Wellington Close  
Parkgate Trading Estate  
Knutsford, Cheshire WA16 8DX

**Tel: 0565 650605**  
**Fax: 0565 650080**



# COMPONENTS

74LS SERIES		TRANSISTOR	
74LS500	0.10	AM27S20	1.99
74LS501	0.10	AM27S29	8.99
74LS502	0.10	AM27S37	4.99
74LS503	0.10	AM27S45	4.99
74LS504	0.10	AM27S49	18.99
74LS505	0.10	AM2841	8.75
74LS507	0.38	AM2901	28.99
74LS508	0.10	AM2918	4.50
74LS509	0.12	AM2952	8.99
74LS510	0.10	AM2955	8.99
74LS511	0.10	AM2981B	4.99
74LS512	0.10	AM2982	8.99
74LS513	0.17	AM500	9.60
74LS515	0.25	AM7910	14.50
74LS514	0.21	AM7911	8.99
74LS515	0.11	AM8035	8.99
74LS520	0.11	AM9122-25	2.78
74LS221	0.11	AM9122-35	9.99
74LS222	0.11	AM9150-35	14.99
74LS224	0.32	AM91L12	4.99
74LS226	0.11	AM91L22-45	9.99
74LS227	0.11	AM92L44	8.99
74LS228	0.11	AM9551	8.99
74LS30	0.12	AMPAL16H	15.00
74LS32	0.11	AMZ8120	12.99
74LS33	0.12	CA3046	0.35
74LS37	0.13	CA3080E	0.49
74LS38	0.13	CA3081	4.99
74LS40	0.13	CA3130E	0.73
74LS42	0.22	CA3140E	0.38
74LS44	1.60	CA3240E	0.99
74LS47	0.50	CA3290	1.35
74LS48	0.45	CNY51	2.99
74LS49	0.61	CNY71	1.40
74LS51	0.11	D2125H-2	2.50
74LS55	0.13	D2147	9.30
74LS73	0.20	D2148	7.75
74LS74	0.15	D4016C-5	7.50
74LS75	0.21	D416C	1.80
74LS26	0.21	D8041	12.99
74LS77	0.42	D8048C-127	5.50
74LS83	0.34	D8155	18.99
74LS85	0.34	UA1489	2.90
74LS86	0.22	UA723DC	0.52
74LS90	0.24	UA747	0.55
74LS91	0.50	UA749	1.60
74LS92	0.29	UA78S40	1.10
74LS93	0.24	UA9636	3.70
74LS95	0.38	UA9667	0.48
74LS96	0.46	UDN2982	2.38
74LS107	0.25	UHP400	4.99
74LS109	0.25	UHP402	5.90
74LS112	0.25	ULN2002A	0.60
74LS113	0.25	ULN2003A	0.24
74LS114	0.25	ULN2004A	0.39
74LS115	0.25	ULN2803A	0.44
74LS123	0.32	ULN2804	1.55
74LS125	0.27	ULN3008	6.99
74LS126	0.21	UM62C11	6.99
74LS132	0.28	UPB8212	6.99
74LS133	0.24	UPB8286	2.80
74LS136	0.21	UPB8287	3.99
74LS137	0.62	UPB8288	7.40
74LS138	0.23	UPD2114	1.75
74LS139	0.25	XR2206	3.95
74LS145	0.57	XR2206	3.95
74LS147	0.88	XR2206	3.95
74LS148	0.60	XR2206	3.95
74LS153	0.31	XR2206	3.95
74LS154	0.70	XR2206	3.95
74LS155	0.24	XR2206	3.95
74LS156	0.24	XR2206	3.95
74LS157	0.20	XR2206	3.95
74LS158	0.24	XR2206	3.95
74LS160	0.31	XR2206	3.95
74LS161	0.31	XR2206	3.95
74LS162	0.31	XR2206	3.95
74LS163	0.31	XR2206	3.95
74LS164	0.29	XR2206	3.95
74LS165	0.47	XR2206	3.95
74LS166	0.52	XR2206	3.95
74LS168	0.58	XR2206	3.95
74LS169	0.52	XR2206	3.95
74LS170	0.65	XR2206	3.95
74LS173	0.55	XR2206	3.95
74LS174	0.23	XR2206	3.95
74LS175	0.23	XR2206	3.95
74LS181	1.46	XR2206	3.95
74LS182	1.56	XR2206	3.95
74LS183	1.56	XR2206	3.95
74LS190	0.24	XR2206	3.95
74LS191	0.23	XR2206	3.95
74LS192	0.28	XR2206	3.95
74LS193	0.38	XR2206	3.95
74LS194	0.38	XR2206	3.95
74LS195	0.23	XR2206	3.95
74LS196	0.23	XR2206	3.95
74LS197	0.23	XR2206	3.95
74LS221	0.35	XR2206	3.95
74LS240	0.31	XR2206	3.95
74LS241	0.31	XR2206	3.95
74LS242	0.31	XR2206	3.95
74LS243	0.31	XR2206	3.95
74LS244	0.31	XR2206	3.95
74LS245	0.32	XR2206	3.95
74LS247	0.31	XR2206	3.95
74LS249	0.65	XR2206	3.95
74LS251	0.23	XR2206	3.95
74LS253	0.34	XR2206	3.95
74LS256	0.50	XR2206	3.95
74LS257	0.23	XR2206	3.95

## EXCLUSIVE!

WE NOW SUPPLY KITS OF PARTS FOR ALL THE PROJECTS FEATURED IN

### ELECTRONICS in ACTION

CALL NOW FOR PRICE OR SEND A LARGE S.A.E. FOR LIST AND OUR FREE CATALOGUE.



POSTAGE AND PACKING AT 0.99 p PER ORDER  
ALL PRICES ARE PLUS VAT AT 17.5 %  
NO MINIMUM ORDER. NO COUNTER FACILITIES.

VOLTAGE REGS	DIODES	AXIAL ELECTROLYTIC
78L05	0.21	IN4001 10 PACK 0.22
78L12	0.21	IN4002 .. 0.23
78L15	0.21	IN4003 .. 0.24
79L05	0.23	IN4004 .. 0.25
79L15	0.23	IN4005 .. 0.26
7805	0.23	IN4007 .. 0.27
7812	0.23	IN4148 .. 0.22
7815	0.23	IN914 5 PACK 0.20
7905	0.25	1N4149 .. 0.40
7912	0.25	OA47 .. 0.95
7915	0.25	OA90 .. 0.40
78S05	0.37	OA91 .. 0.45
78S12	0.37	ZENERS AVAILABLE AT 400 MW 0.03
LM323K	1.95	1.3W 0.07
LM317T	0.43	CERAMIC CAPS.
LM200	0.78	THESE VALUES COST 0.95 EACH ALL VALUES IN PP
LM723	0.34	1.8, 2.2, 3.3, 4.7
IC SOCKET		6.8, 10, 12, 15, 22
8 PIN	0.08	27, 33, 47, 56, 68
14 PIN	0.10	82, 100
16 PIN	0.14	THE FOLLOWING COST 0.07 EACH VALUES PP
18 PIN	0.14	120, 150, 180, 220
20 PIN	0.15	270, 330, 390, 470
24 PIN	0.18	560, 680, 820
28 PIN	0.20	1N, 1N5, 1N8, 2N2
40 PIN	0.24	3N3, 3N9, 4N7
TURNED PIN AVAILABLE AT EXTRA CHARGE		6N8, 10N, 20N
MINI PUSH TO MAKE SWITCH		100N
0.10P EACH COLOURS: RED, BLACK, GREEN, BLUE, YELLOW, WHITE		POLYESTR.
		ALL AT 0.05 P EACH ALL VALUES UP TO 0.90N

### ALSO IN STOCK.

4000 SERIES  
74HC SERIES  
TANTALUM S  
L.E.D.S  
DISPLAYS.  
PLUGS  
SOCKETS  
LEADS  
RADIAL ELECT.  
CAPS.  
FUSES.  
DISCS  
RECTIFIERS  
POTS.

TANTALUM CAPS.  
RADIAL ELECTROLYTICS  
LEDS WIRE NEONS.  
SOLAR  
CELLS CRYSTALS  
RECTIFIERS PLUGS,  
SOCKETS ADAPTERS.  
COMPUTER DISCS,  
MOTORS.

SPECIAL OFFERS:  
AIRCRAFT CIRCUIT  
BREAKERS.  
3A, 7A, 5A, 10A,  
PUSH BUTTON TYPES.  
**1.00 !!!**

COMPUTER PRINTER  
LEADS.  
HIGH QUALITY 35 PIN  
MALE D CONNECTOR  
TO 36 PIN CENTRONICS  
1.5 M  
**4.99 !!!**

## EXPRESS COMPONENTS

P.O. BOX 517.  
HOVE.

EAST SUSSEX. BN3 5QZ

SALES: 0273-771156  
FAX: 0273-206875



Ordinary desktops like Macs and PCs/compatibles are normally considered inadequate, and both Silicon Graphics and Sun hardware was in evidence at the show. Even with a fast machine, software must compile efficiently, so it was no surprise that C and its variations are widely used.

## The Nuclear Dump

**Virtual Presence** had the only other stand with a VR headset, and this was a viewer rather than a complete helmet. The game is a practical one: you must pick up a spent radioactive fuel rod in a mechanical claw, and deliver it to a ceiling-mounted hopper - good training for teleoperated robot control.

The picture was clear and bright, though the subtlety of the graphic images was less than the shoot-out game. By the time we tried it, the 1.5kg helmet had suffered from constant manhandling and adjustment, so that the left eyepiece would not focus perfectly. Although the helmet had to be altered quickly to only a rough fit (and pinched) we found it quickly became intuitive to use. Not everyone took to it so quickly.

The system uses a pair of CRTs, with rotating coloured disks in front of them. Alternate rasters are in red, green, and blue, with two sets of coloured filters per disk rotation to avoid the need for an absurdly fast spin.

It is likely that in the long run LCD technology will take over completely from CRTs. In the near future, Virtual Presence plans to use LCD shutter technology to switch the colours in front of its CRTs.

## Crystal Eyes

**Ambitron's** Crystal Eyes spectacles caught my imagination, partly because I see myself using it with a CAD system in the next few years. Looking at a computer monitor through the spectacles, with suitable software, makes the monitor image appear in 3D.

The image is shown from two different perspectives, on alternate fields (complete scans of the monitor). The spectacles have liquid crystal shutter lenses,

which show the even fields to one eye and odd fields to the other. The spectacles are synchronised to the monitor display via an infra-red link. The infra-red transmitter sits on top of the monitor, and a tiny sensor built in to the glasses receives the digital synchronisation signal. The specs are powered by a lithium cell, and are quite light. At the

moment, the system, at £2500 plus VAT, is a little too expensive for the individual engineer, but companies are making encouraging claims for increased productivity using 3D viewing instead of conventional 2D screens.

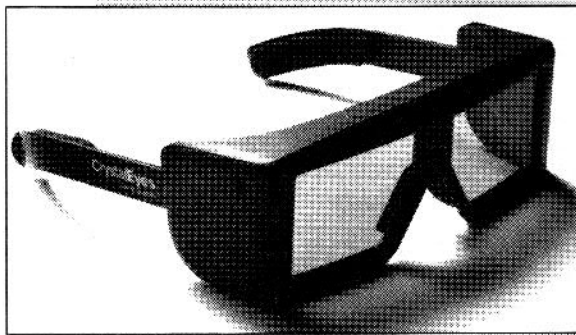

## The private eye

The **Infodisp** Portable Information Package (PIP) makes its appearance as a medium-sized belt-pack holding a digital storage box which can display up to 100 screens of text and graphics. Each page may display text, graphics, line drawing or a combination. In future will be possible to send data to the portable unit by means of licence-exempt short-range radio, or via one of the national mobile data radio networks.

The picture shows the portable information pack in use as a car repair

manual, though at a cost of 840 it might be cheaper to take the car to the garage! But the PIP is user-reprogrammable, and images can be compiled into a document on a PC using PIP Publisher for Windows software, downloading images to the PIP's memory via an RS232 interface.

The Private Eye display screen (made by Reflection Technology) has a resolution of 720 x 280 pixels, and gives a bright red image on a black background, resulting in startling clarity. The principle of the 2.25oz, headband-

## Unrolling the texture

**Evans and Sutherland** was displaying its Freedom Series graphics accelerators for Sun SPARCstations. A graphics accelerator builds images from image data, using object-oriented techniques and as many short-cuts as it can to build the type of graphic scene the user requires as quickly as possible and with minimum processing overhead on the central processor.

One of the main techniques used is texturing, a fast-result alternative for picture building. The standard means of building objects for VR visualisation is to generate a series of polygons, each with its own shape and colour. An image may use millions of polygons, not all visible. To achieve less computing-intensive real-time animation, bitmaps are used for objects which do not have to move and change

shape. In one demonstration, of driving a train into a station, the people on the platform are collectively a texture. Equally, a map of the terrain in, say, a flight simulation may be a wireframe to give the contours, with a texture dropped

Scene realism is greatly enhanced by the use of transparency

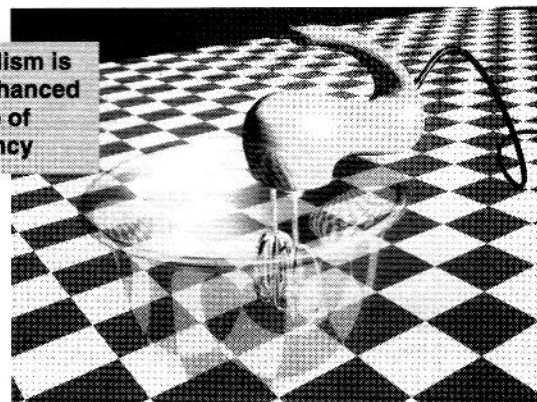

on to it. Close up, such a texture is not realistic, because it does not contain all the right details, but viewed from a distance a texture with blurs of colour and shading looks realistic.

**Evans and Sutherland** provide software for many industries. They claim 80% of the world market for flight simulators, as we as providing simulation software and optical systems.

Military combat pilots often fly in a helmet mounted display, rather than relying on watching their real surroundings, partly to protect them from optical flash weapons which would blind them. These helmets are in effect advanced virtual reality helmets. Target acquisition by looking at the target, then giving a verbal fire command is possible. Possible inputs for VR display in this situation are from cameras and other optical sensors, RADAR, and control panel simulation.

A system used by automobile designers generates mathematically accurate shapes as the artists draw, so that it is possible to mill the shape straight from the design drawing. Cost, of course, is another question.



mounted screen is that it sits in the "glance down" eyeline of the user's dominant eye. When the user glances at the small display, the brain "sees" an image approximating to a 12in display screen floating a few feet in front, carrying a clear image of the text and graphics. The hands-free system does not cut the user off from the real world in the way that immersive virtual reality does, so that practical work can be carried out at the same time.

The screen sounds tiny,

Another VR application is 3D molecular modelling. This helps pharmaceutical companies to simulate drugs to weed out potential designs which will not work properly. Before computer aided design of drugs, maybe 10,000 prototype combinations would have to be tested to get one effective drug. Using molecular modelling, this number is reduced to about 500.

3D visualisation for molecular design is carried out using Crystalise LCD shutter spectacles. Before LCD shutter spectacles were discovered, industry used a mechanical shutter technique of slotted drums - nicknamed "spinning beercans" - rotating in front of each eye, synchronised so that each eye received the image alternately, giving the illusion of stereoscopic vision.

but we found it very clear to read. The "dominant eye" principle was voted a bit of a red herring, as some people preferred to have it set for the other eye, and treat it simply as a small, clear information display close to their eyeline.



### Design and engineering get together

Two days of conferences brought engineers and marketing executives from all over the world to swap notes on practical applications. Jim Humphries, Chief Engineer at the Systems Scientific Division, Federal Systems Group of Sterling Software in the USA, gave an overview of development with NASA,



the motor industry and ground-breaking early work in immersive VR and helmet technology.

A psychologist by training, Humphries has worked on "classic" VR with 3D display headsets since 1984. Sterling has been developing VR as an adjunct to CAD systems, to aid visualisation of airflow patterns. Jim Humphries reasoned that if the engineers could follow an airflow track in 3D, this would help them to gain the necessary insights for



Jim Humphries

innovative design. Virtual reality visualisation software and hardware was added to flow analysis software toolsets, as an alternative to normal conventional screen displays.

In 1984 the project started with the aim of producing a system for under \$2M. It required a 3D display with at least 45x horizontal and vertical range - and a light head-mounted display. An initial \$10,000 was allocated for feasibility study.

Liquid crystal displays were chosen for lightness and safety. They need no high voltages, and there is no danger of implosion. At the time, the rate of improvement of liquid crystal display technology was expected to be more rapid than has happened.

The first unit was monochrome, with a resolution of 100x100 pixels for each eye, 100 degrees (h) by 70 degrees

The 3D airflow patterns around this shuttle make the true movements of the air easier to grasp visually.

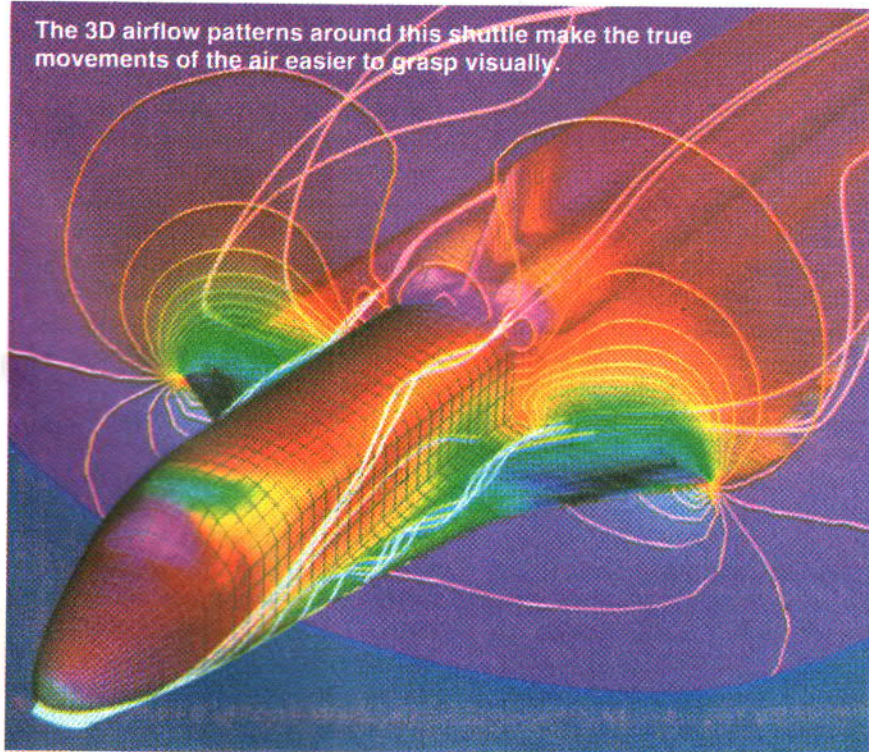



A Jack figure moving across a room lit with radiosity lights

DRoW

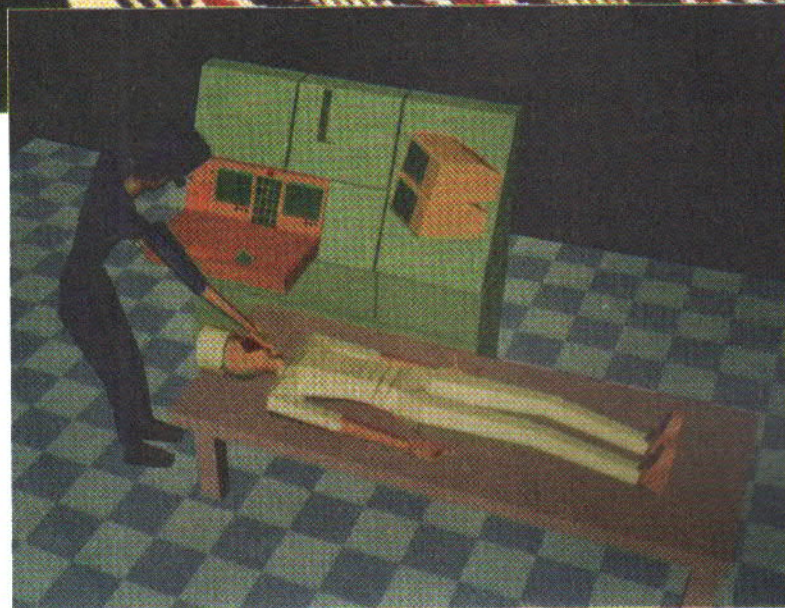

### Hit the Brakes, Jack

Goodwin Marcus Systems' Jack is a human modelling system with applications in Computer Aided Design (CAD) and ergonomics development software. The diagrammatic figures imitate the characteristics of the human body which must be taken into account when designing hardware and software for direct interactive use.

the engine to overheat, crossing what Jim Humphries calls "The Wall" between design and engineering.

Virtual reality will be a part of future space projects, not only in training simulations, but as part of telepresence, where Earth-based operators will control remote robots using datagloves as a major control device. In situations where screen-based data and programming is more appropriate, the operator can be surrounded by virtual screens and see the situation at a glance.

### The cat in a hat

Ratz the cat is a TV-presenter cartoon character put together by UK broadcast technology company TeleVirtual. The character is literally a "talking head", floating in free space and interacting with human presenters and viewers who phone in. The face is animated by a collection of operator-driven electronic inputs. Ratz, which was sculpted and set

(v) viewing angle, and a 10lb headset. The next model had the same performance, but the headset was a mere 2lb. The aim is a visual area of 120 x 120 degrees for true immersive VR, a "sense of being there" at a price affordable for industry.

Using VR for simulation, **Sterling** can provide training systems for pilots to supplement work in a full simulator, as well as simulating engineering tests which would be expensive to carry out with real hardware. Simulating events in a car crash enables engineers to carry out more tests to improve crumple zones, etc.

The potential drawback of electronic simulation is that analogue and mechanical structures rarely behave in exactly the way predicted by

electronic logic, so that real prototyping still has to be undertaken to make sure that the simulation is accurate. A VR system can, after all, be programmed to break the laws of physics. If the program were to deviate from reality in a subtle way, it could be hard to detect the error. On the other hand, VR demands massive computing power, so that the overhead of using smaller steps in finite element analysis is less significant than for most CAD.

Nevertheless, VR allows early and physically difficult designs to be developed faster and at lower cost. Engineers and visual designers can work on the same virtual model at the same time, the designer introducing new shapes and the engineer checking whether a new grille shape might cause



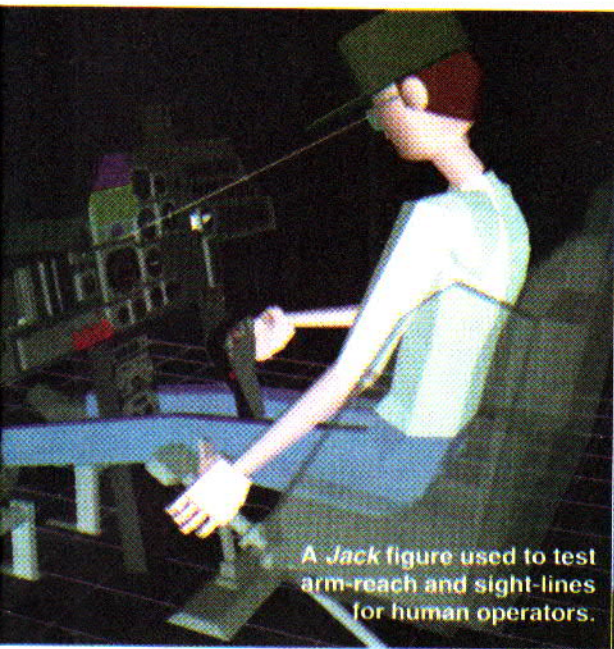

A Jack figure used to test arm-reach and sight-lines for human operators.

Below: A female Jack pilot with realistic facial features. The sky and camouflage uniform are achieved through texture mapping

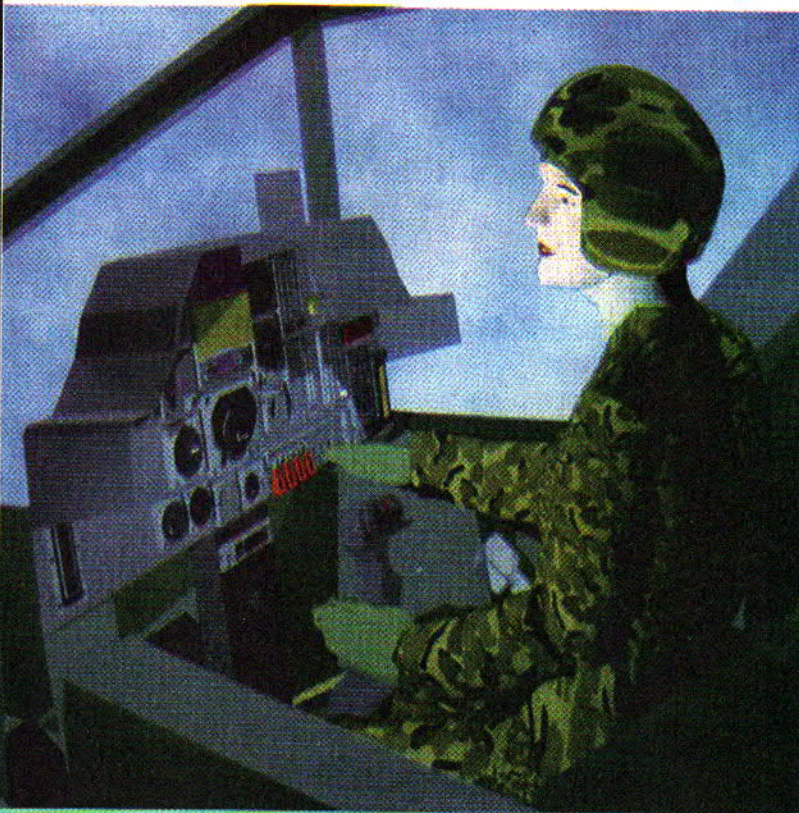

Reach, freedom, rotation and torque load in joints, balance, eyelines and visual fields, stretch, strength and comfort are some of the factors which can be tested in software using Jack figures. Fully contoured body models with textures and realistic facial features can also be generated.

Modelling software of this type is used to test and display physical human factors before building expensive hardware prototypes. They are also handy for demonstrating systems to potential customers well before the hardware is built, reducing development

costs and increasing the understanding and involvement of end-users at an earlier stage.

Misunderstanding between makers and clients have been a major source of contention since computing first appeared, as users of home micros to the biggest industrial networks will testify.

Unsurprisingly, cheaper, more predictable and more accurate test and demonstration applications are now the most widespread and fastest-growing market for virtual reality in business and industry.

up in eight weeks, uses sliders, a foot pedal, a helmet with two on-face motion sensors for the operator's mouth, and the "Flying Mouse", a magnetic pulse-detector which spins the head around in space.

RATZ is operated by comedian Paul Brody, strapped into a modified ice-hockey helmet which traces his head positions, and the "Facial Waldo", a rig made up of two button-sized motion detectors stuck to his skin, one just below his mouth and one just to the right of it. The pads are connected to potentiometers by thin pieces of piano wire and a rack and pinion drive, and pass information about the relative position of his lips so that, when he speaks, the virtual character's lips move in synchronisation.

The "Flying Mouse" is a tiny hand-held sensor on the end of several feet of cable. The mouse is connected to a Polhemus tracking device and detects magnetic pulses sent out on three axes

from a coil box, defining its position in space. Position information is passed back via the cable to a decoder box. Held and moved around by the operator, it can shift the character's head around freely, including 360-degree turns. Although it will be possible to "read" free movements from a live actor quite soon, it is not possible in a cable-linked helmet. Many VR helmets are designed to limit head-movement. The helmet worn by Paul Brody - which is an animation helmet rather than a virtual reality one - is based on a ice hockey helmet, and developed for use with motorised characters like Jim Henson's Muppets.

Ratz's eyes are blinked by a foot-pedal. A slider moves through a series of hand-closing commands and brings up a cordless telephone image at the far end of its travel. Two other sliders can rotate his hand and elbow. A joystick produces a range of extra cartoon-expressions - exaggerating yawning, nose twitching,

and so on. It's possible to have most of these expressions, and eye movements, driven by further facial pads on the operator's eyebrows and mouth. Ratz's controls were worked out with Paul Brody for ease of movement and control of the cartoon's features.

The software behind the star is SimGraphics Engineering's VActor (Virtual Actor) system, developed in the United States. TeleVirtual is now working on other VActor characters and environment for television in Britain and Germany. There is room for many more character movements to be driven directly from motion sensors on the operator. Eventually, no doubt, these could be added to a VR headset to animate your own icons in cyberspace, when virtual communications comes of age.



**Electronics in Action** is pleased to offer its readers Roy Kalawsky's fascinating book - *The Science of Virtual Reality and Virtual Environments*. This book provides a wealth of material for those who require a thorough scientific and engineering background in Virtual Reality whether they be scientist, engineer, student or layperson.

# Virtual Reading

Professor Roy Kalawsky is head of the British Aerospace Virtual Environment Laboratory

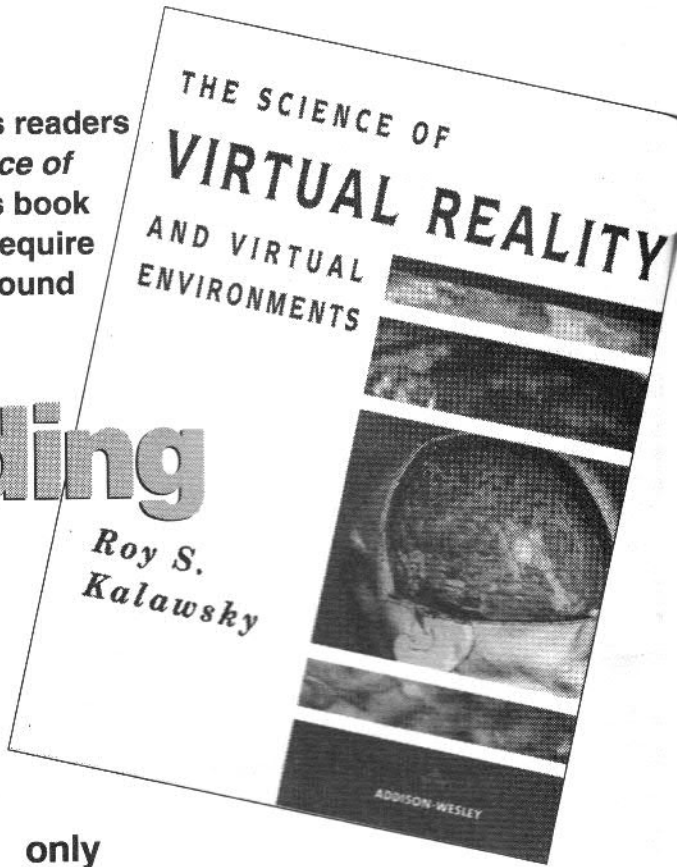

only  
**£24.95**  
(+ £3.00 Postage & Packing)

Print your name in **BLOCK CAPITALS**

Name .....

Address .....

Postcode .....

Please send me.....copy of *The Science of Virtual Reality and Virtual Environments* by Roy Kawalsky (Each copy costs £24.95 plus £3.00 postage and packing)

I enclose a cheque/postal order for .....

Please send this form to:

**VR Book Offer, Electronics in Action**  
**PO Box 600, Berkhamsted, Herts. HP4 1NL**

ELECTRONICS in ACTION

60

FEBRUARY 1994

## NEW THE DEFINITIVE 'OFF-AIR' FREQUENCY STANDARD



Only  
**£195.+VAT**  
carriage extra

- \* Provides 10MHz, 5MHz & 1MHz
- \* Use it for calibrating equipment that relies on quartz crystals, TCXOs VXCOS, oven crystals
- \* Phase locks to Drotwich (rubidium controlled and traceable to NPL)
- \* For ADDED VALUE also phase locks to ALLouis (caesium controlled and traceable to DP - French equivalent to NPL)
- \* British designed and British manufactured
- \* Now with Sine wave option, output 1V into 50 ohm

Output frequencies:  
10MHz, 5MHz, 1MHz  
Short term stability: better than  $1 \times 10^{-11}$  (1sec)  
Typical:  $\approx 4 \times 10^{-12}$  (1sec)  
Long term: Tends to  $2 \times 10^{-12}$  (1000sec)

IDEAL BEGINNERS SCOPE, SCOPEX 456 6MHz SINGLE TRACE, INTXTR TRIG, TRACE LOCATE, BRIGHT LINE AUTO, 10mV SENSITIVITY, 1µs-100ms/cm, etc.	£95	756G 12" x 9" DISPLAYS DIGITEX/SIGNAL EX	£15 & £10
DAWE 1405D SOUND LEVEL METER 0-120dB(A)	£75	RADIOMETER BKFS DIST. METER 20Hz-20KHz	POA
IWATSU SS5116 DUAL TRACE 100MHz	£175	RADIOMETER AFM2 MOD. METER 7MHz-1GHz	POA
TELEQUIPMENT D1011 10MHz DUAL TRACE	£165	LPS MICROPAC SX250 250W	£135
IWATSU SS-5802 DIGITAL STORAGE	POA	CITOH CX6000 6PEN A4 PLOTTER, CENT RS232	£135
TEKTRONIX 2215 60MHz DUAL TRACE DEL T/B	£475	GENERAL RADIO 1531A XENON STROBOTAC	£79
TELEQUIPMENT D67A 25MHz, 2T, DEL T/B	£249	THANDAR TG501 FUNC GEN 0.005Hz-5MHz	£165
H.P. 1700A 35MHz DUAL TRACE	£95	BACHARACH MW2 MERCURY SWIFFERS	£85
HITACHI VC 6015 10MHz DIGITAL STORAGE	£58	FISONS F1 MONITORS LIQ LEVEL SENSORS	£59
HP1340 X-Y DISPLAYS	£58	JAQUET TIMER 1110secs RES'N 0.01s	£29 ea
DERTLING V20 SINGLE PAN BAL 0.1mp/200g	£95	COMMODORE PETS, D/DRIVES, PRINTERS	£49
ANALYTICAL BALANCES WITH WEIGHTS 250g	FROM £99	COMARC 2303 MV SOURCES, DUAL RANGE	£125
VACUUM PUMPS 1.5 & 2.5m <sup>3</sup> /hr	£215	INTRON IFG42Z FUNC GEN 0.1Hz-7MHz	£75
KINGSHILL NS1540 15V 40A PSUs CASED, AS NEW	£125 & £149	ERG MONITOR SEM430 WITH SEM420/2	£195
ACRON 402P SYNC PULSE GENERATOR & 60SP ENCODER	£37/SEA £695/gr	GOULD 2400 4PEN CHART RECORDER	£195
MARCONI TP2304 AM/FM MOD METER PORTABLE	£249	X-Y PLOTTERS A3 & A4	FROM £35 TO £139
MARCONI TP2330 WAVE ANALYSER 20Hz-50KHz	£149	PHILIPS PM6456 FM STEREO GENERATORS	£195
H.P.5315A 16Hz FCTR, DPTS 1.2 & 3	£750	VALVE TESTERS AVO MK1.2 & 3	FROM £49 TO £89
		MARCONI TP2300 FM/AM MODULATION METER	£195
		McKENZIE 7DAY TEMP/HUMIDITY RECORDER	£95
		FEEDBACK SSO603 1MHz SINE/SQUARE OSC	£125
		FARNELL E350 0-350V 100mA 2 x 6.3V	£59 TO £69
		COMMUNICATIONS RECEIVERS, HF, LF, VHF	POA
		LOR MARCONI TP1313 0.25%	£95
		LEVELL TMB8 MICRO V-METER 450MHz	£95
		LEVELL TMB8 MICRO V-METER 3MHz	£85

LIST AVAILABLE BUT 1000'S OF UNLISTED BARGAINS FOR CALLERS. ALL PRICES EXC. OF P & P AND VAT QUALITY ELECTRONIC EQUIPMENT ALWAYS WANTED



**HALCYON ELECTRONICS**



423, KINGSTON ROAD WIMBLDON CHASE, LONDON SW20 8JR.  
SHOP HOURS 9-5.30 MON-SAT. TEL 081-542 6383. FAX 081-542 0340

Inverter toroidal transformers 225A 10.5-0-10.5	£29.95	light with output wave form chart	£ 9.95
primary 0-260-285 secondary	£29.95	DC-DC converter Reliability model V12P5 12V	in 5V 200mA out 300V input to output isolation with data £4.95 each or pack of ten £39.50
LEDs 3mm or 5mm red or green	5p each	Airpax A82903-C large stepping motor 14V	Hour counter used 7 digit 240V AC 50Hz £1.45
yellow	11p each	QWERTY keyboard 58 key Quality switches new	£5.00
High intensity red, green or yellow 5mm 30p each		7.5' step 27ohm 68mm dia body 6.3mm shaft	£8.95 or £200.00 for a box of 30
cable ties 1p each or £5.95 per 1000 £49.50 per 10,000		Polyester capacitors box type 22.5mm lead pitch	0.9uf 250VDC 18p each 14p 100+ 9p 1000+
Small stepping motor 4 phase 12V 7.5' step	£8.95	1uf 250VDC 20p each, 15p 100+ 10p 1000+	2.2uf 250VDC 30p each, 20p 100+ 15p 1000+
50ohms	£8.95	3.3uf 100VDC 30p each, 20p 100+ 15p 1000+	1uf 50V bipolar electrolytic axial leads 15p each
SAA1027 stepping motor drier chip	£4.95	7.5p 1000+ 0.22uf 250V polyester axial leads 15p each	7.5p 100+
Hi-quality photo resist copper clad epoxy glass boards		Philips 123 series solid aluminium axial leads	33uf 10V & 2.2uf 40V 40p each, 25p 100+
Dimensions single sided double sided		Philips 108 series 22uf 63V axial 30p each 15p 1000+	Multilayer AVX ceramic capacitors all 5mm pitch 100V
3x4 inches	£0.95	100pF, 150pF, 220pF, 10,000pF(10n) 10p each	5p 100+ 3.5p 1000+ 500pF compression trimmer 60p
4x8 inches	£2.40	40uF 370VAC motor start capacitor(dialectrol type containing no PCBs)	£5.95 or £49.50 for 10
6x12 inches	£5.37	Weilyn W23 9W 120ohm 35p each 20p 100+	680 ohm 2W metal film resistor 4p 100+ 2p 1000+
12x12 inches	£10.66	Solid carbon resistors. Very low inductance ideal for	RF circuits 27ohm 2W, 68ohm 2W 25p each 15p 100+
Rechargeable Batteries		We have a range of 0.25w 0.5w 1w and 2w solid carbon resistors please send SAE for list.	Intelligent 4 digit alphanumeric (5x7 dot 0.145") red LED display 12 pin 0.6 inch wide package Siemens type
AA(HP7)500mAH	£0.99	DLR1414 £2.50 each £2.00 30+ data sheets £1.00	AMD 27256-3 EPROMs £2.00 each £1.25 100+
AA 500mAH with solder tags	£1.55	60p each 40p 100+	DP/ Switch 3PCO 12 pin (ERG SDC-3-023)
AA 700mAH	£1.95	Disk drive boxes for 5.25 disk drive with room for a power supply light grey plastic 67x268x247mm	£7.95 or £49.50 for 10
C(HP11) 1.8AH	£2.20	Hand held ultrasonic remote control	£3.95
C 2AH with solder tags	£3.60	CV2486 gas relay 30 x 10mm dia with 3 wire terminals	will also work as a neon light 20p each or £7.50 per 100
D(HP2) 1.2AH	£2.60	A23 12V battery for car alarms or lighters 75p each	£50.00 per 100
D 4AH with solder tags	£4.95	All products advertised are new and unused unless otherwise stated. Wide range of	CMOS TTL 74HC 74F Linear Transistors kits.
PP3 8.4V 110mAH	£4.95	Rechargeable batteries capacitors	tools etc always in stock.
1/2AA with solder tags	£1.55	Please add £1.95 towards P&P	
Sub C with solder tags	£2.50		
AAA (HP16) 180mAH	£1.75		
1/3 AA with tags (Philips CTV)	£1.95		
Standard charger charges 4 AA cells in 5 hours			
or 4Cs or Ds in 12-14 hours-1xPP3 (1,2,3 or 4 cells may be charged at a time)	£5.95		
High power charger as above but charges the Cs and Ds in 5 hours AAs Cs and Ds must be charged in 2s or 4s	£10.95		
Special offers please check for availability			
F cells 32dia x 87mm	£3.95		
F cell with solder tags 1.2V	£4.30		
42x 16mm dia 1.2V	£1.45		
stick of 4 171mmx16mm dia with red & black leads 4.8V	£5.95		
4 cell battery 94x25mm dia (1/2C cells) £3.50			
Computer grade capacitors with screw terminals			
38000uF 20V £2.50 87000uF 10V £1.95			
68000uF 15V £2.95 10000uF 16V £1.50			
58000uF 60V £4.95			
7segment common anode LED display 12mm	£0.45		
LM2931AT5.0 low drop out 5V regulator	£0.85		
TO220 package	£0.85		
7812 and 7912 12V 1A regulators	£20.00 per 100		
LM337K TO3 case Variable regulator	£1.60		
	£1.10 100+		
GaAs FET low leakage current	S8873 £12.95 each		
£9.95 10+ 7.95 100+			
BS250 P channel MOSFET	£0.45		
BC559 transistor	£3.95 per 100		
74LS05 hex inverter	£10.00 per 100		
used 8748 Microcontroller	£3.50		
SL952 UHF Limiting amplifier LC 16 surface mounting package with data sheet	£1.95		
AM27502	£1.25 each		
CD4007UB 10p 100+	90p 100+		
Sinclair light gun terminated with a jack plug and PP3 clip gives a signal when pointed at 50Hz flickering	6p 1000+		

VAT included in all prices

**JPG ELECTRONICS**

276-278 Chatsworth Road  
Chesterfield S40 2BH  
Access/Visa Orders  
(0246) 211 202

Callers welcome



# PROTEUS

## The Complete Electronics Design System

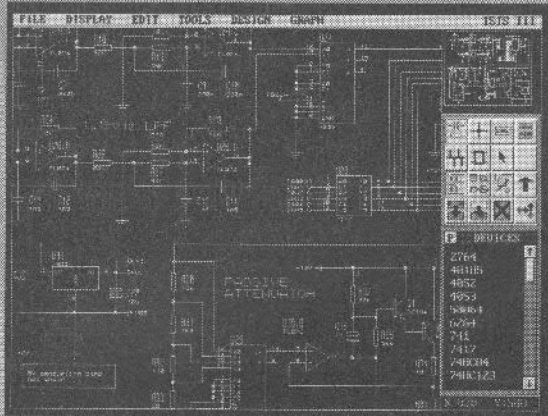

### Schematic Capture

- Easy to Use Graphical Interface.
- Netlist, Parts List & ERC reports.
- Hierarchical Design.
- Extensive component/model libraries.
- Advanced Property Management.
- Seamless integration with simulation and PCB design.

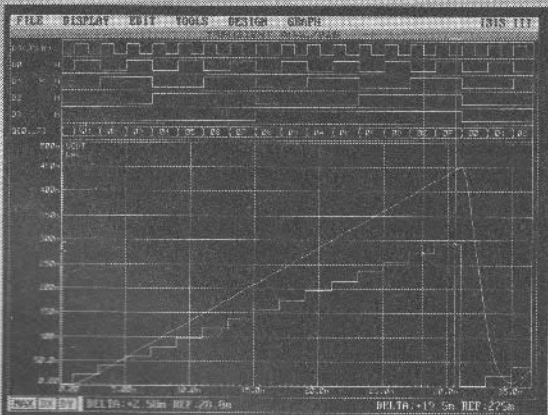

### Simulation

- Non-Linear & Linear Analogue Simulation.
- Event driven Digital Simulation with modelling language.
- Partitioned simulation of large designs with multiple analogue & digital sections.
- Graphs displayed directly on the schematic.

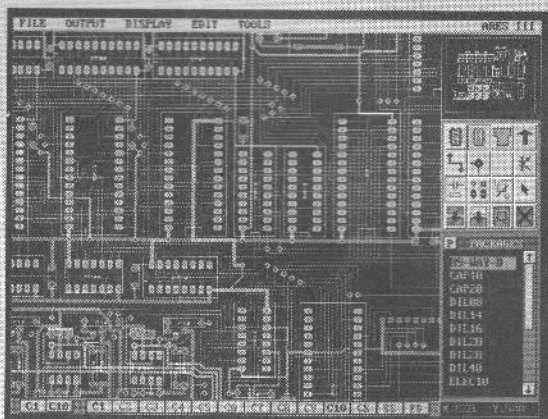

### PCB Design

- Multi-Layer and SMT support.
- Unlimited Design Capacity.
- Full DRC and Connectivity Checking.
- Advanced Multi-Strategy Autorouting.
- Output to printers, plotters, Postscript, Gerber, DXF and DTP bitmaps.
- Gerber View and Import capability.

**labcenter**  
**E l e c t r o n i c s**

*Write, phone or fax for your free demo disk, or ask about our full evaluation kit.*  
**Tel: 0274 542868. Fax: 0274 481078.**  
**14 Marriner's Drive, Bradford BD9 4JT.**



## February

### Security

High Voltage electric fence. Although suggested to us, this is in fact against the law, but it seems that people are still prepared to go to these measures. Electronic tagging ought to be encouraged so that not only does the article have a unique identity but also it could be tracked if the tag is a transmitter. This is currently being experimented with in the car industry.

### Telephone projects

Interactive games by phone link to computer.

Credit card reader to initiate transactions over the phone from home

### Signature Analyser

Need to develop a two dimensional flat plate positional detector.

### Music Effects

A simplified Vocoder. This is a bank of filters to treat and mix incoming signals for special effects. Vocoder were used on ELO records in the 70s.

An octave pedal for guitars that gives you the choice of one or two octaves below the guitar signal plus the original signal, thus fattening the sound.

Audio Compressor to keep sound levels constant.

### Video

Video mixer for editing home movies.

### Around the Home

Warning devices with time out facility. e.g. Deep fat friers can easily be left on. An audible warning is required after a preset time. Many devices in the home do not seem to have this, even computer hardware. Butter warmer as mentioned in the text opposite (some people still like real butter).

Making light bulbs last much longer by usage of circuitry to reduce input voltage.

Cordless stereo headphones to wander around the house listening to your favourite music.



# Ideas Forum

**Scribble pads at the ready, brains in gear and component catalogues to hand. Its thinking time again**

**H**as anyone out there thought of an idea for an electric butter warmer that softens the butter but doesn't turn it to a liquid? A microwave would do the job but that is a little too much like overkill. You may think we are joking but this could be just the sort of useful thing an elderly or disabled person would require.

Coming up with the initial ideas is half the battle really and this is where Ideas Forum comes in. The intention is, each month, is to list a whole host of notions and thoughts that could be expanded into fully fledged projects. So far none of you have taken the plunge and contacted us with the project of the century, but then maybe you're all hard at work putting on the finishing touches.

If you have any suggestions or have developed any of the ideas that have been appearing in this column please send them in to us at:  
**Electronics in Action, PO Box 600, Berkhamsted Herts HP4 1NL**



# At Your Service

**S**o you don't fancy messing up your best measuring jug with Ferric Chloride, but you still want to make some of our projects properly - with a PCB? This is where we step in. At Electronics in Action we can offer, at very reasonable prices, PCBs for all of our featured projects.

Just select which PCBs you require, fill in the coupon and post it to us with a cheque or postal order (for the full amount) made payable to **Electronics in Action**.

The coupon lists all the projects featured in the last four issues and anything older than that is listed below. We have left some blank spaces on the coupon should you wish to order an older PCB.

## October issue

QH1093-1	Telescope Main Board .....	£12.00
QH1093-2	Hi-fi Preamp .....	£4.50
QH1093-3	Laser Zone .....	£5.00
QH1093-4	Anti-howler (double sided) .....	£5.50
QH1093-5	Sig Gen board .....	£4.50
QH1093-6	Crossover unit .....	£3.00

Please print your name and address in **BLOCK CAPITALS**

Name .....

Address .....

..... Postcode .....

Send the completed coupon (include 80p for postage and packing) to:  
**At Your Service, Electronics in Action**  
**PO Box 600, Berkhamsted, Herts. HP4 1NL**

Please enter amount required in appropriate box

<input type="checkbox"/>	QH0294-1	Hatchery Controller .....	£8.00
<input type="checkbox"/>	QH0294-2	12V drill speed controller .....	£5.00
<input type="checkbox"/>	QH0294-3	The Switcher IR transmitter .....	£5.50
<input type="checkbox"/>	QH0294-4	The Switcher IR receiver .....	£3.50
<input type="checkbox"/>	QH0294-5	The Switcher VCA board .....	£7.50

## January issue

<input type="checkbox"/>	QH0194-1	The Harmoniser (2 boards) .....	£10.00
<input type="checkbox"/>	QH0194-2	Power Amplifier (double sided) .....	£7.00
<input type="checkbox"/>	QH0194-3	Remote Control Extender .....	£5.00

## December issue

<input type="checkbox"/>	QH1293-1	Guitar Tremolo .....	£5.00
<input type="checkbox"/>	QH1293-2	Switcher Main board .....	£10.00
<input type="checkbox"/>	QH1293-3	Switcher Front panel .....	£6.00
<input type="checkbox"/>	QH1293-4	Video Editing Unit .....	£8.00

## November issue

<input type="checkbox"/>	QH1193-1	Power Supply (double sided) .....	£6.00
<input type="checkbox"/>	QH1193-2	Telescope Input board .....	£5.50
<input type="checkbox"/>	QH1193-3	Drainpipe Seismometer .....	£5.50

<input type="checkbox"/>	<input type="text"/>	<input type="text"/>	<input type="text"/>
<input type="checkbox"/>	<input type="text"/>	<input type="text"/>	<input type="text"/>

Total remittance including P&P £

Allow 28 days for delivery

## ADVERTISERS' INDEX

BK Electronics .....	21	Intergrated Measurement Systems ....	45
Baylin Publications .....	51	J.D. Photo-Tools .....	54
J & N Bull .....	IBC	JPG Electronics .....	60
Chelmer Valve Company .....	49	Labcenter Electronics .....	61
Cirkit Distribution Ltd. ....	OBC	Mauritron Publications .....	16
Cooke International .....	49	MicroGem Systems .....	54
Cricklewood Electronics Ltd. ....	47	MQP Electronics Ltd. ....	51
Electrovalue .....	45	Robinson Marshall (Europe) Ltd. ....	IFC
Express Components .....	55	Roline Systems Ltd. ....	9
Halcyon Electronics .....	60	Stewart of Reading .....	54
Hart Electronics .....	27	Tsien (UK) Ltd .....	31
Instrutek (UK) .....	17	Wilmslow Audio .....	54



**Bob Stone, Technical Manager of Advanced Robotics Research Limited and Visiting Professor of Virtual Reality at the University of Salford, considers the future of VR as it could affect industry by explaining the background to the Company's Virtual Reality & Simulation Initiative - Europe's first industrial VR project, supported by 13 British companies.**



If a newcomer to the field of Virtual Reality (VR) happens to acquire a copy of *The Virtual Reality Primer* (Larijani, 1993), he might be forgiven for assuming that the UK had very little effort under way in VR and that the Country was not considered worthy of an entry under a section entitled "Other Major Players: Germany, France & Japan", in Chapter 15. If the author and editor had performed their research with just a little diligence, then they might have discovered that, not only does the UK lead Europe in its VR endeavours, but the so-called other major players openly admit this fact as well!

### Telepresence

The UK's Advanced Robotics Research Centre (ARRC), based on the campus of Salford University in the North of England, was the first establishment in Europe to exploit VR technologies as a means of achieving telepresence for hazardous environments (e.g. nuclear, space, subsea). Essentially, telepresence - one of the first serious VR development areas pioneered by researchers at NASA Ames in California in the 1980s - means that the human operator of a remotely controlled robot receives sufficient information about the hazardous environment, displayed in a natural or intuitive way, that he feels as if he is physically present at the remote site. In effect, VR is a form of telepresence in that typically, a VR system "immerses" its users into a "remote", three-dimensional environment, albeit computer-generated, monitoring body movement and updating the view of the environment accordingly. From 1989, research at the ARRC concentrated on the use of VR hardware and software as tools for achieving telepresence, not only to

provide the means of displaying and interacting with three-dimensional computer models of hazardous environments, but also to demonstrate the power of being able to convert remote sensory data (relayed from those environments using a scanning laser rangefinder) and to control real robot manipulators and vehicles. In addition, related research addressed new forms of sensory display for virtual environments, such as large-screen 3D projection and glove-based tactile feedback, new hand controllers and input devices, head-controlled stereoscopic TV, and VR for advanced microscopic inspection (Stone, 1992; 1993).

---

***Contrary to early expectations, it is not computing technology which is letting VR down.***

---

As the end of the ARRC's initial 5-year period of Government part-sponsorship drew nearer, decisions had to be made as to which key research areas should be selected for taking forward as the Centre took on its full commercial status in the form of Advanced Robotics Research Limited. As far as VR was concerned, and despite numerous presentations to Government bodies, emphasising the general importance of the technology, not just to Salford, but to the UK's VR community, very little interest could be generated. VR and its associated technology base is, without doubt, a very exciting and stimulating field in which to work or carry out research. But one question had

to be answered. Had VR "matured" to such a level that it was reasonable to expect that there might be real industrial applications which warranted - technically and commercially - the introduction of this radically new form of human-system interface? Certainly there were, and still are, a wide range of potential applications being researched across the globe, from medical visualisation and molecular modelling to architectural "walk-throughs", from advanced fighter cockpit and future infantryman research to virtual Olympic stadium design and skiing trainers. Yet, in the main, these applications are still confined to research laboratories. Even at Siggraph '93 in Anaheim, one of the world's most prestigious advanced graphics exhibitions, questions similar to those being asked over 3 years ago were still evident - superb graphics, excellent real-time performance, but what are the applications?

After 18 months of intensive lobbying of industry, these questions were answered and a range of novel applications had been found. In May of 1993, what was to become Europe's first and largest collaborative VR venture was launched under the general title of Virtual Reality and Simulation (VRS). Space does not permit a review of the short history leading up to the launch of the VRS Initiative; further details can be found in Stone (1993). In brief, and following a short feature on the BBC's 9 O'Clock News in January of 1993, enough interest and financial support was secured from a range of British companies to put together a programme of research and development into the application of VR technologies to solve real commercial and technical problems.

The aim of VRS, initially planned as a 2-year programme of work, is not



# Future View

## Virtual Reality? It's Just A Clever Arcade Game... Isn't It?

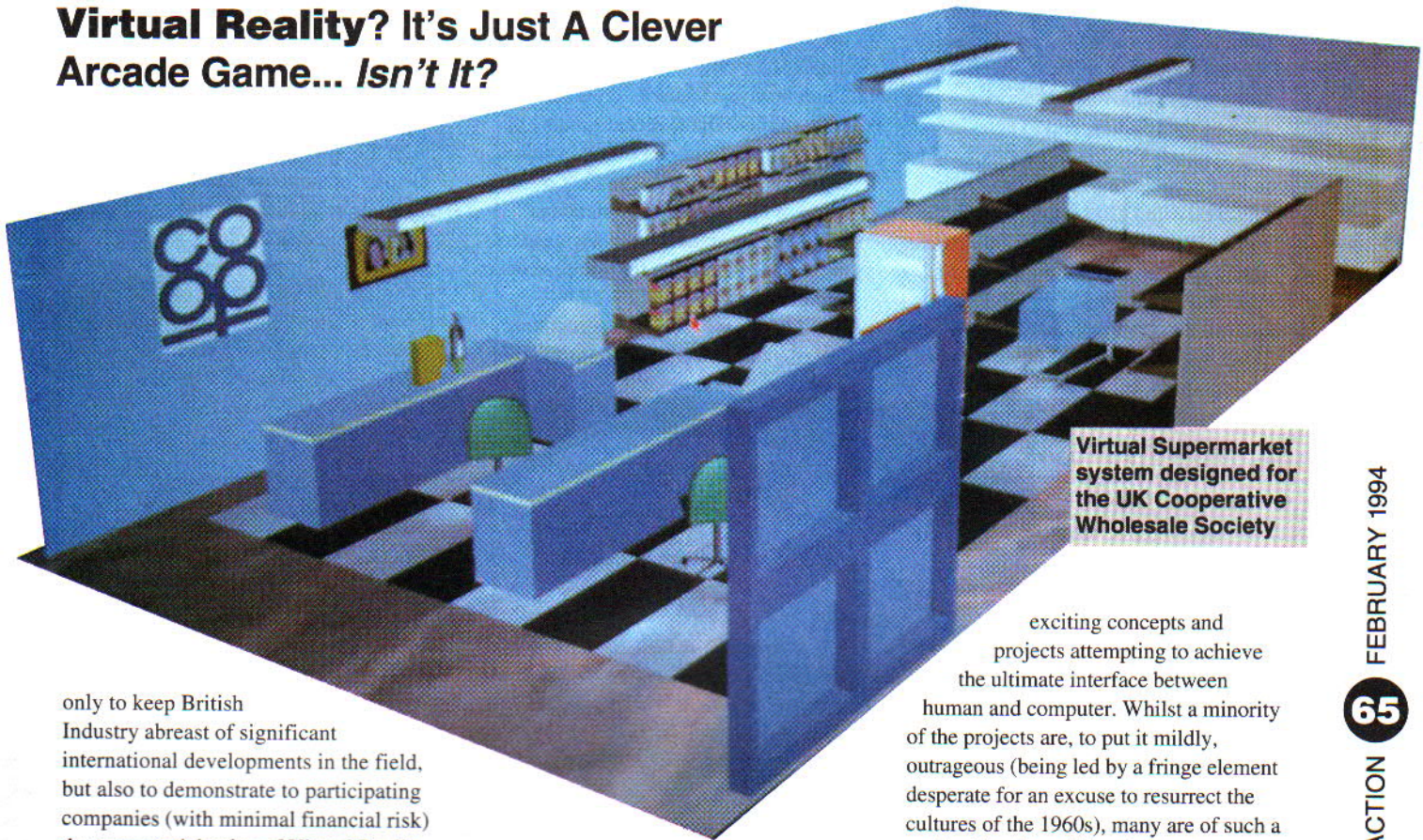

Virtual Supermarket system designed for the UK Cooperative Wholesale Society

only to keep British Industry abreast of significant international developments in the field, but also to demonstrate to participating companies (with minimal financial risk) the commercial value of Virtual Reality and Simulation. At the end of the 2-year Programme, VRS will provide the participating companies with sufficient know-how to introduce the technologies into their own businesses with minimal technical and financial risk. Members of the 13-strong VRS Collaborative Group include: the Cooperative Wholesale Society (supermarket space planning, exploiting related developments in electronic point-of-sale systems, electronic shelf-edge pricing, customer tracking systems and intelligent packaging), Rolls-Royce plc (Trent 800 aero engine design and maintenance evaluation), United Kingdom Nirex Limited (nuclear repository design and operational training), Vickers Shipbuilding and Engineering Limited (submarine design, compartment visualisation and refit planning), and ICI Chemicals & Polymers Limited (computational fluid dynamics).

### The Future?

One gratifying aspect of leading a team closely involved with the application of

*...being able to handle complex graphical images, approaching the quality of those used in Jurassic Park and Terminator 2 in the laboratories of VR researchers, is not the end of the story.*

VR technologies to real industrial problems is that one regularly gets invited to speak at conferences and meetings across the globe. Not only does one come away from such events truly convinced that the UK currently leads Europe and, in some cases, the world in terms of VR computing developments and applications, but one also gains an otherwise expensive insight into new and

exciting concepts and projects attempting to achieve the ultimate interface between human and computer. Whilst a minority of the projects are, to put it mildly, outrageous (being led by a fringe element desperate for an excuse to resurrect the cultures of the 1960s), many are of such a quality that they will undoubtedly shape the future face of VR.

However, any attempt now to predict the near-to-mid-term future of VR with a high degree of certainty must surely be classed as foolhardy. Incredible developments in the real-time computer graphics field over the past 18 months or so were as unpredictable in 1992 as were the two multi-million pound flotations by British VR companies in 1993, selling products based essentially around a couple of electromagnets, a pair of pocket televisions and a cannibalised PC joystick!

Seriously, being able to handle complex geometries and graphical images, effectively bringing images approaching the quality of those used in Jurassic Park and Terminator 2 into the laboratories of VR researchers, is not the end of the story. Contrary to early expectations, it is not computing technology which is letting VR down. Nor is it virtual environment modelling and run-time software which, despite worldwide sales of, frankly, beta-release



quality products, is evolving slowly but surely. It's the peripheral devices - the headsets, the gloves or hand controllers, the body tracking systems - the very means by which immersion is achieved.

For immersive VR to become the norm rather than the exception, a lot has to happen in a short space of time, especially if the technology is to offer a commercially viable and professional tool for industrial applications, not to mention a means for training physicians, helping the handicapped to enjoy new experiences or in finding widespread use in civil engineering and architecture. Head-mounted displays, be they in the form of "ski-goggle" visors, miniature glasses, or laser retinal projectors will have their day - we are just waiting for the "killer" combination of high resolution colour imaging panels with optics which approximate the human's natural field of view. Providing "cable-less" VR - thereby removing one of the technology's frustrating characteristics - has to be addressed seriously. The possibility of direct neural interfacing - linking silicon with human nervous tissue - is a question I am often asked in the lectures I give throughout the UK and Continental Europe. Many scientists and medical practitioners are sceptical about the ability to feed computerised images directly into the optical nerve. Yet I believe the time will come when current developments in neural prostheses will enable direct VR-sensory linkages, albeit initially to enhance the lives of individuals with pathological disorders.

Linked to the improvement of VR peripherals will be a parallel improvement in the sense of presence in a virtual environment and a reduction in the incidence of known psychological and physiological problems associated with immersion. The large number of legal representatives, psychologists and ophthalmologists at the New York VR Expo' in December of 1993 is testament to the current existence of a variety of health and safety problems. Despite the

somewhat scare-mongering reports featured in the tabloid press during 1993, claiming that "VR damages your health", there is, sadly, only a handful of respectable studies which have tackled this emotive subject. Human factors issues related to the acceptability and usability of VR peripherals, most notably the resolution and field of view offered by immersive head-mounted displays are only now being addressed in a practical yet academically credible way. In the UK, the recent funding of psychological and ergonomics studies, together with the establishment of professional bodies of "watchdogs" should help establish relevant standards and codes of practice for VR developers and distributors.

If we are to believe international "intelligence", VR is set to invade the

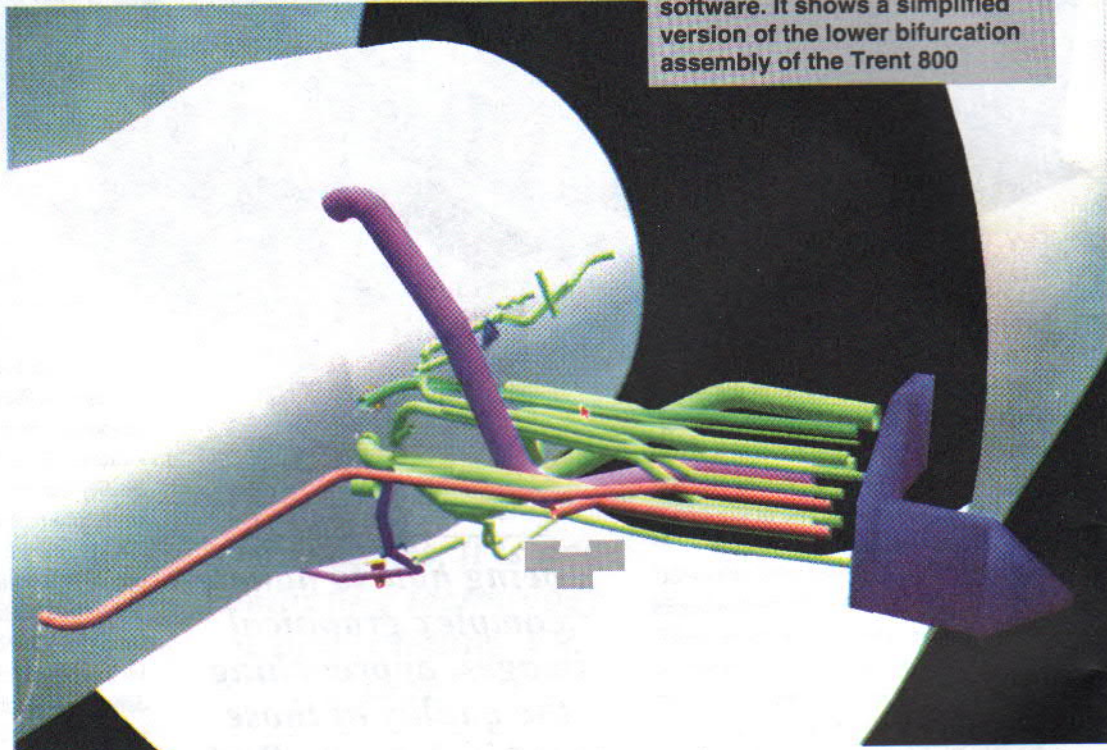

**Virtual model of part of Rolls Royce Trent 800 aero engine, hosted on Silicon Graphics Onyx system running Division dVS software. It shows a simplified version of the lower bifurcation assembly of the Trent 800**

homes of ordinary people some time in 1994. What form it will take and, more importantly, what quality of experience it will offer is open to debate. Most likely, going by the mentality of the well-known video console developers, low-resolution, unstable images of violence will secure the greatest expenditure from the gullible general public and their families.

Despite the achievements and false promises of those involved in the VR community, it is fair to say that VR is here to stay. Europe in general is already ramping up to launch a major effort in VR. The Commission of European Communities (CEC) has placed small consultative contracts with a group of

key personalities within the Continent to advise the Brussels Coordinators as to developments and trends across the globe, including reviews of hardware, software and applications. This effort will pick up sometime early in 1994 with the likely establishment of a European Advisory Committee in VR, involving representatives from many countries. Within 18 months to 2 years, and if all goes according to plan, the scene will be set for an exciting era in the evolution of VR on this side of the Atlantic. It is therefore encouraging that British Industry has taken, arguably, the first and most difficult step in adopting a radically new technology, helping to

establish a national "try-before-you-buy" and risk-sharing project in order to judge the technical and commercial viability of VR before investing further.

## References

- Larijani, L.C.** *'The Virtual Reality Primer'* - McGraw-Hill Series on Visual Technology, 1993.
- Stone, R.J.** *'Virtual Reality and Telepresence'* - Robotica, 10, 1992.
- Stone R.J.** *'A Year in the Life of British Virtual Reality: Will the UK's Answer to Al Gore Please Stand Up?!'* - New York Virtual Reality Expo '93; November 30 - December 2, 1993; New York Hilton. Also published in *Virtual Reality World*; 2(1); January/February, 1994 (Meckler).



**AMSTRAD DMP4000** Entire printer assemblies including printhead, platen, cables, stepper motors etc. Everything bar the electronics and case. Good stripper!! Clearance price just £5 REF: MAG5 or 2 for £8 REF: MAG8

**VIEWDATA SYSTEMS** Brandnew units made by TANDATA complete with 1200/75 built in modem, infra red remote controlled keyboard, BT approved, Prestel compatible, Centronice printer port, RGB colour and composite output (works with any TV) complete with power supply and fully cased. Price is just £20 REF: MAG20 Also some customer returned units available at £10 each REF: MAG10

**PPC MODEM CARDS**. These are high spec plug in cards made for the Amstrad laptop computers. 2400 baud dial up unit complete with leads. Clearance price is £5 REF: MAG5P1

**INFRA RED REMOTE CONTROLLERS** Originally made for hi spec satellite equipment but perfect for all sorts of remote control projects. Our clearance price is just £2 REF: MAG2

**TOWERS INTERNATIONAL TRANSISTOR GUIDE**. A very useful book for finding equivalent transistors, leadouts, specs etc. £20 REF: MAG20P1

**SINCLAIR C6 MOTORS** We have a few left without gearboxes. These are 12v DC 3,300rpm 8"x4", 14" OP shaft. £25 REF: MAG25

**UNIVERSAL SPEED CONTROLLER KIT** Designed by us for the above motor but suitable for any 12v motor up to 30A. Complete with PCB etc. A heat sink may be required. £17.00 REF: MAG17

**VIDEO SENDER UNIT**. Transmits both audio and video signals from either a video camera, video recorder, TV or Computer etc to any standard TV set in a 100' range! (tune TV to a spare channel) 12v DC op. Price is £15 REF: MAG15 12v psu is £5 extra REF: MAG5P2

**\*FM CORDLESS MICROPHONE** Small hand held unit with a 500' range! 2 transmit power levels, Reqs PP3 9v battery. Tuneable to any FM receiver. Price is £15 REF: MAG15P1

**LOW COST WALKIE TALKIES** Pair of battery operated units with a range of about 200'. Ideal for garden use or as an educational toy. Price is £8 a pair REF: MAG8P1 2 x PP3 req'd.

**\*MINIATURE RADIO TRANSCIVERS** A pair of walkie talkies with a range of up to 2 kilometres in open country. Units measure 22x52x155mm. Complete with cases and earpieces. 2xPP3 req'd. £30.00 pair REF: MAG30.

**COMPOSITE VIDEO KIT**. Converts composite video into separate H sync, V sync, and video. 12v DC operation. £8.00 REF: MAG8P2.

**LQ3600 PRINTER ASSEMBLIES** Made by Amstrad they are entire mechanical printer assemblies including printhead, stepper motors etc etc in fact everything bar the case and electronics, a good stripper! £5 REF: MAG5P3 or 2 for £8 REF: MAG8P3

**PHILIPS LASER 2MW** helium neon tube. Brand new full spec £40 REF: MAG40. Mains power supply kit £20 REF: MAG20P2. Fully built and tested unit £75 REF: MAG75.

**SPEAKER WIRE** Brown two core, 100 foot hank £2 REF: MAG2P1

**LED PACK** of 100 standard red 5mm leds £5 REF: MAG5P4

**JUG KETTLE ELEMENTS** good general purpose heating element (about 2kw) ideal for all sorts of heating projects etc. 2 for £3 REF: MAG3

**UNIVERSAL PC POWER SUPPLY** complete with flyleads, switch, fan etc. Two types available 150w at £15 REF: MAG15P2 (23x23x23mm) and 200w at £20 REF: MAG20P3 (23x23x23mm)

**OZONE FRIENDLY LATEX** 250ml bottle of liquid rubber, sets in 2 hours. Ideal for mounting PCB's, fixing wires etc £2 each REF: MAG2P2

**\*FM TRANSMITTER** housed in a standard working 13A adapter!! the bug runs directly off the mains so lasts forever! why pay £700? or price is £26 REF: MAG26 Transmits to any FM radio.

**\*FM BUG KIT** New design with PCB embedded coil for extra stability. Transmits to any FM radio. 9v battery req'd. £5 REF: MAG5P5

**\*FM BUG BUILT AND TESTED** superior design to kit, as supplied to detective agencies etc. 9v battery req'd. £14 REF: MAG14

**TALKING COINBOX STRIPPER** originally made to retail at £79 each, these units are designed to convert and ordinary phone into a payphone. The units we have generally have the locks missing and sometimes broken hinges. However they can be adapted for their original purpose or used for something else?? Price is just £3 REF: MAG3P1

**100 WATT MOSFET PAIR** Same spec as 2SK343 and 2SK413 (8A, 140v, 100w) 1 N channel and 1 P channel, £3 a pair REF: MAG3P2

**VELCRO** 1 metre length of each side 20mm wide (quick way of fixing for temporary jobs etc) £2 REF: MAG2P3

**MAGNETIC AGITATORS** Consisting of a cased mains motor with lead. The motor has two magnets fixed to a rotor that spin round inside. There are also 2 plastic covered magnets supplied. Made for remotely stirring liquids! you may have a use? £3 each REF: MAG3P3 2 for £5 REF: MAG5P8

**TOP QUALITY SPEAKERS** Made for Hi Fi televisions these are 10 watt 4R Jap made 4" round with large shielded magnets. Good quality general purpose speaker. £2 each REF: MAG2P4 or 4 for £6 REF: MAG6P2

**TWEETERS** 2" diameter good quality tweeter 140R (would be good with the above speaker) 2 for £2 REF: MAG2P5 or 4 for £3 REF: MAG3P4

**AT KEYBOARDS** Made by Apricot these quality keyboards need just a small modification to run on any AT, they work perfectly but you will have to put up with 1 or 2 foreign keycaps! Price £6 REF: MAG8P3

**XT KEYBOARDS** Mixed types, some returns, some good, some foreign etc but all good for spares! Price is £2 each REF: MAG2P6 or 4 for £6 REF: MAG6P4

**PC CASES** Again mixed types so you take a chance next one off the pile! £12 REF: MAG12 or twical ones for £20 REF: MAG20P4 component pack bargain 1,000 resistors +1,000 capacitors (all same value) £2.50 a pack. REF: MAG2P7

**1994 CATALOGUE  
OUT NOW**

## BULL'S BULLETIN BOARD

**MASSIVE  
WAREHOUSE CLEARANCE  
FANTASTIC £20.00 REDUCTION**

**REFURBISHED PC BASE UNITS  
COMPLETE WITH KEYBOARD**

FROM ONLY **£29.00**

**AMSTRAD 1512 BASE UNITS  
GUARANTEED  
PERFECT WORKING ORDER.**

A LOW COST INTRODUCTION TO THE HOME COMPUTER MARKET.

**AMSTRAD 1512SD**

1512 BASE UNIT, 5.25" FLOPPY DRIVE AND  
KEYBOARD. ALL YOU NEED IS A MONITOR AND  
POWER SUPPLY. WAS £49.00

NOW ONLY **£29.00**  
REF: MAG29

**AMSTRAD 1512DD**

1512 BASE UNIT AND KEYBOARD AND TWO  
5.25" 360K DRIVES. ALL YOU NEED IS A MONITOR  
AND POWER SUPPLY. WAS £59.00

NOW ONLY **£39.00**  
REF: MAG39

## SOLAR POWER PANELS

**3FT X 1FT 10WATT GLASS PANELS**

14.5v/700mA

**NOW AVAILABLE BY MAIL ORDER**

**£33.95**

(PLUS £2.00 SPECIAL PACKAGING CHARGE)

TOP QUALITY AMORPHOUS SILICON CELLS HAVE ALMOST A  
TIMELESS LIFESPAN WITH AN INFINITE NUMBER OF POSSIBLE  
APPLICATIONS, SOME OF WHICH MAY BE CAR BATTERY  
CHARGING, FOR USE ON BOATS OR CARAVANS, OR ANY  
WHERE A PORTABLE 12V SUPPLY IS REQUIRED. REF: MAG34

ALSO 1FT X 1FT GLASS SOLAR PANELS 12v 200mA  
ONLY £15.00 REF: MAG15P3

## FREE SOFTWARE!

Brand new, UNUSED top quality Famous brand  
licensed software discs. Available in 5.25" DSD or 5.25"  
HD only. You buy the disk and it comes with free BRAND  
NEW UNUSED SOFTWARE. We are actually selling you the  
floppy disc for your own "MEGA CHEAP" storage facilities,  
if you happen to get software that you want/need/like as  
well..... you get a "MEGA BARGAIN" too!  
DSD PKT10 £2.99 REF: MAG3P7 PKT100 £16.00 REF: MAG16  
HD PKT10 £3.99 REF: MAG4P3 PKT100 £26.00 REF: MAG26P1

LARGER QUANTITY PRICES AVAILABLE ON APPLICATION

\*\*\*\*\*WE BUY SURPLUS STOCK\*\*\*\*\*

TURN YOUR SURPLUS STOCK INTO CASH.  
IMMEDIATE SETTLEMENT. WE WILL ALSO QUOTE FOR  
COMPLETE FACTORY CLEARANCE.  
COMING SOON

**1994 CATALOGUE.**

PLEASE SEND 42P, A4 SIZED SAE FOR YOUR FREE COPY.  
MINIMUM GOODS ORDER £5.00 TRADE ORDERS FROM GOVERNMENT, SCHOOLS,  
UNIVERSITIES, & LOCAL AUTHORITIES WELCOME ALL GOODS SUPPLIED SUBJECT TO  
OUR CONDITIONS OF SALE AND UNLESS OTHERWISE STATED GUARANTEED FOR 30  
DAYS RIGHTS RESERVED TO CHANGE PRICES & SPECIFICATIONS WITHOUT PRIOR  
NOTICE. ORDERS SUBJECT TO STOCK. QUOTATIONS WILL NOT BE GIVEN FOR QUANTITIES  
HIGHER THAN THOSE STATED.

\*SOME OF OUR PRODUCTS MAY BE UNLICENSEABLE IN THE UK

**BULL ELECTRICAL**  
250 PORTLAND ROAD HOVE SUSSEX  
BN3 5QT

**MAIL ORDER TERMS: CASH PO OR CHEQUE  
WITH ORDER PLUS £3.00 POST PLUS VAT.**

PLEASE ALLOW 7 - 10 DAYS FOR DELIVERY

TELEPHONE ORDERS WELCOME

TEL: 0273 200506

FAX: 0273 532077



**COMMODORE MICRODRIVE SYSTEM** mini storage  
device for C64's 4 times faster than disc drives, 10 times faster  
than tapes. Complete unit just £12 REF: MAG12P1



**SCHOOL STRIPPERS** We have quite a few of the above  
units which are 'returns' as they are quite comprehensive units  
they could be used for other projects etc. Let us know how many you  
need at just 50p a unit (minimum 10).

**HEADPHONES 16P** These are ex Virgin Atlantic. You can have  
8 pairs for £2 REF: MAG2P8

**PROXIMITY SENSORS** These are small PCB's with what look  
like a source and sensor LED on one end and lots of components on  
the rest of the PCB. Complete with fly leads. Pack of 5 £3 REF: MAG:  
3P5 or 20 for £8 REF: MAG8P4

**FIBRE OPTIC CABLE** Made for Hewlett Packard so pretty good  
stuff! you can have any length you want (min 5m) first 5m £7 REF:  
MAG7 thereafter £1 a metre (ie 20m is £22). REF: MAG1 Max length  
250m.

**SNOOPERS EAR?** Original made to clip over the earpiece of  
telephone to amplify the sound-it also works quite well on the cable  
running along the wall! Price is £5 REF: MAG5P7

**DOS PACKS** Microsoft version 3.3 or higher complete with all  
manuals or price just £5 REF: MAG5P8 Worth it just for the very  
comprehensive manual! 5.25" only.

**DOS PACK** Microsoft version 5 Original software but no manuals.  
hence only £3 REF: MAG3P6 5.25" only.

**FOREIGN DOS** 3.3-German, French, Italian etc £2 a pack with  
manual. 5.25" only. REF: MAG2P8

**MONO VGA MONITOR** Made by Amstrad, refurbished £49  
REF: MAG49

**CTM644 COLOUR MONITOR** Made to work with the CPC464  
home computer. Standard RGB input so will work with other machines.  
Refurbished £69.00 REF: MAG59

**JUST A SMALL SELECTION** of what we have to see more get  
our 1994 catalogue (42p stamp) or call in Mon-Sat 9-5.30

**HAND HELD TONE DIALLERS** Ideal for the control of the  
Response 200 and 400 machines. £5 REF: MAG5P9

**PIR DETECTOR** Made by famous UK alarm manufacturer these  
are hi spec, long range internal units. 12v operation. Slight marks on  
case and unboxed (although brand new) £8 REF: MAG8P5

**WINDUP SOLAR POWERED RADIO** AM/FM radio com-  
plete with hand charger and solar panel! £14 REF: MAG14P1

**COMMODORE 64** Customer returns but ok for spares etc £12  
REF: MAG12P2 Tested and working units are £69.00 REF: MAG69

**COMMODORE 64 TAPE DRIVES** Customer returns at £4  
REF: MAG4P9 Fully tested and working units are £12 REF: MAG12P5

**COMPUTER TERMINALS** complete with screen, keyboard  
and RS232 input/output. Ex equipment. Price is £27 REF: MAG27

**MAINS CABLES** These are 2 core standard black 2 metre mains  
cables fitted with a 13A plug on one end, cable the other. Ideal for  
projects, low cost manufacturing etc. Pack of 10 for £3 REF: MAG3P8  
Pack of 100 £20 REF: MAG20P5

**SURFACE MOUNT STRIPPER** Originally made as some  
form of high frequency amplifier (main chip is a TSA5511T 1.3GHz  
synthesiser) but good stripper value, an excellent way to play with  
surface mount components £1.00 REF: MAG1P1.

**MICROWAVE TIMER** Electronic timer with relay output suitable  
to make enlarger timer etc £4 REF: MAG4P4

**PLUG 420?** showing your age? pack of 10 with leads for £2 REF:  
MAG2P11

**MOBILE CAR PHONE** £5.99 Well almost! complete in car  
phone excluding the box of electronics normally hidden under seat.  
Can be made to illuminate with 12v also has built in light sensor so  
display only illuminates when dark. Totally convincing! REF: MAG6P6

**ALARM BEACONS** Zenon strobe made to mount on an external  
bell box but could be used for caravans etc. 12v operation. Just  
connect up and it flashes regularly! £5 REF: MAG5P11

**FIRE ALARM CONTROL PANEL** High quality metal cased  
alarm panel 350x165x80mm. Comes with electronics but no informa-  
tion. £15 REF: MAG15P4

**SUPER SIZE HEATSINK** Superb quality aluminium heatsink.  
365 x 183 x 61mm, 15 fins enable high heat dissipation. No holes!  
£9.99 REF: MAG10P1P

**REMOTE CONTROL PCB** These are receiver boards for  
garage door opening systems. You may have another use? £4 ea  
REF: MAG4P5

**LOPTX** Line output transformers believed to be for hi tes colour  
monitors but useful for getting high voltages from low ones! £2 each  
REF: MAG2P12 bumper pack of 10 for £12 REF: MAG12P3.

## PORTABLE RADIATION DETECTOR

**£49.99**

A Hand held personal Gamma and X  
Ray detector. This unit contains two  
Geiger Tubes, has a 4 digit LCD dis-  
play with a Piezo speaker, giving an  
audio visual indication. The unit de-  
tects high energy electromagnetic  
quanta with an energy from 30KeV to  
over 1.2MeV and a measuring range  
of 5-9999 UR/h or 10-99990 Nr/h. Sup-  
plied complete with handbook.

REF: MAG50



# CIRKIT ELECTRONIC CONSTRUCTORS CATALOGUE

- ◆ 240 Pages
- ◆ 26 Sections
- ◆ Over 4000 lines
- ◆ Send for your copy today!

**£1.90**  
+30p p+p



**Cirkit**

**Cirkit Distribution Ltd**

Park Lane • Broxbourne • Hertfordshire • EN10 7NQ • Tel: Sales (0992) 448899 • Fax (0992) 471314

