

Mr. MOUNTGATE

BBC ENGINEERING

Number 96 November 1973



BBC Engineering

including Engineering Division Monographs

A record of BBC technical experience and developments
in radio and television broadcasting

Published approximately four times per year by
BBC Publications,
35 Marylebone High Street,
London W1M 4AA
ISBN 0 563 12645 0

Edited by
BBC Engineering Information Department,
Broadcasting House,
London W1A 1AA

Printed by
The Broadwater Press Ltd,
Welwyn Garden City,
Herts.

Price
40p or \$1.00 per issue post free
Annual Subscription
£1.50 or \$4.00 for 4 issues post free

Articles are copyright © 1973 by the
British Broadcasting Corporation
and may not be reproduced in whole
or part without written permission.

The cover photograph shows a Fernseh KCR40 lightweight colour television camera and a Sennheiser directional microphone in use for shooting a sequence from the play 'The Needle Match' on location. A comparison of the advantages of film and electronic methods for location shooting is given in George Cook's article on page 4.

Contents

Editorial: Towards Digital Sound and Television Broadcasting	2
Principal Articles	
Lightweight Colour Mobile Control Rooms G. D. Cook	4
Reducing non-linear effects in klystrons for television broadcasting A. G. Lyner	9
Digital sound signals: further investigation of instantaneous and other rapid companding systems D. W. Osborne	18
Pulse-code modulation for high-quality sound signal distribution: subjective effect of digit errors G. R. Mitchell and M. E. B. Moffat	27
Short Items	
Stereophonic Coder	17
COSINE: Coded Source Identification Equipment	33
Video Tape Time Code Equipment	34
Biographical Notes	35
Publications available from Engineering Information Department	36

The major contributions are preceded by individual lists of contents.

Editorial

Towards Digital Sound and Television Broadcasting

The application of digital technology to the transmission of telephone signals has been proceeding apace for some years, stimulated largely by methods that have been used in connection with the development of digital computers, and the engineering divisions of many broadcasting authorities are now taking an active interest. Opportunities for converting analogue audio and video signals into digital form are coming thick and fast. However there is no thought of an early radiation of digital signals to the listening and viewing public, because the capital investment in existing receivers designed to convert analogue signals into audible and visual forms is immense. It is seen nevertheless that there will eventually be many advantages in converting the analogue signals emerging from the acoustic and optical transducers in the studio complex into digital signals and maintaining them in this form until a final conversion back to analogue form at each transmitter. Although there are also disadvantages it is expected that these will be outweighed by the advantages.

Studies are already in progress within many broadcasting organisations and in the international field directed towards, on the one hand, the reduction of bit-rate and therefore of necessary bandwidth, and, on the other hand, on the problems connected with replacing the present extensive and complicated methods of signal processing by digital techniques.

International bodies in which these studies are being discussed are the European Broadcasting Union (EBU) which is concerned with both bit-rate reduction and signal processing by digital means, and the International Telecommunication Union (ITU) which is concerned with bit-rate reduction as this has a direct influence on the bandwidth required of the international and intercontinental transmission circuits for radio and television.

Three committees of the ITU are dealing with various aspects, the present structure is shown in Fig. 1.

The duties of the International Telegraph and Telephone Consultative Committee (CCITT) are to study technical, operating and tariff questions relating to telegraphy and telephony and to issue recommendations on them. It can in principle deal with both cable and radio circuits for telegraphy and telephony use. However, it is also concerned with some aspects of television operations and maintenance and its Special Study Group D has been concerned with various

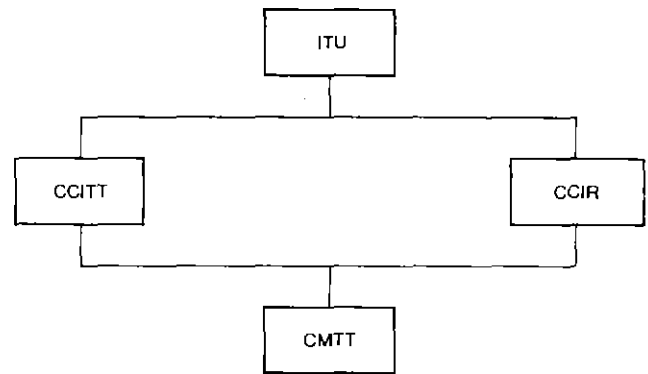

Fig. 1 Structure of the ITU at present

applications of digital techniques in both sound and television transmission.

The duties of the International Radio Consultative Committee (CCIR) are to study technical and operating questions relating specifically to radio communication and to issue recommendations on them. Thus the terms of reference of the two bodies CCITT and CCIR are not mutually exclusive.

The Mixed Committee on Television Transmissions (CMTT) studies in co-operation with the Study Groups of the CCIR and CCITT, the specifications to be satisfied by telecommunication systems to permit the transmission of sound and television broadcasting programmes over long distances.

The CMTT seeks to fulfil the requirements of broadcasting and now that satellite telecommunication is an established activity, various joint groups have been set up in order to cover the special requirements of that method of transmission. Inevitably with various committees dealing with similar aspects difficulties arise. Some examples of such difficulties are:

- (i) Scales of objective criteria to be used in testing various systems and methods of sound and picture reproduction have been independently established not only by the EBU but also by the three main committees of the ITU, namely CCITT, CMTT and CCIR. Not only is the establishment of such scales for picture assessment rather more advanced than similar scales for sound assessment but the various scales proposed for picture assessment differ one from another. Efforts are now proceeding to ensure that only one scale is recommended by the ITU and that this scale shall apply to both pictures and sound.
- (ii) The study of digital systems for the transmission of sound

and television is still in the development stage, yet, notwithstanding this fact, these matters are being discussed from a quite basic and fundamental point of view by the CCITT, the CMTT, and the CCIR. Documents have been written attempting to allocate various aspects of studies of digital systems amongst the three ITU bodies but the lines of demarcation have not been clear. Recently attempts have been made to improve this situation by arbitrarily curtailing the activities of CMTT and pressing for an increased effort over a wider front in the CCIR. A joint meeting of all working parties and study groups is planned to clarify the situation but to some it seems unlikely this will produce a general solution.

- (iii) The lack of a clear boundary is evident not only between the CMTT and its parent bodies but also between the people served by these organisations. Thus the broadcaster has a variety of internal problems and the solutions adopted will affect the interface with the common carriers. The point at which the coding of the signal becomes of concern to those who have to handle the digital traffic is unclear. Matters of prime importance to the broadcaster are being discussed in several of the ITU Committees and it is difficult to maintain a presence at a number of meetings discussing similar subjects; moreover problems of internal communication and briefing for a common policy are not insignificant

A possible way out of the difficulties might be to change the organisation to that shown in Fig. 2.

The International Consultative Committee on Radio and Television (CCIT & R) would:

- (i) Study, in so far as there is relevance to international affairs, technical aspects of systems of broadcasting and the signals appropriate to them.

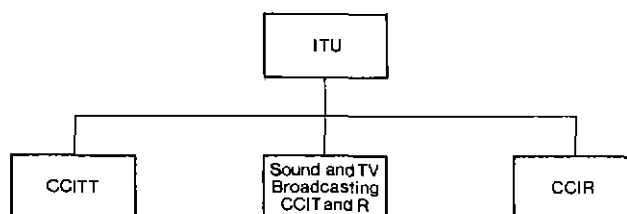

Fig. 2 Proposed new structure of the ITU

- (ii) Co-operate with the CCITT with regard to the international and intercontinental transmission of sound and television signals by conducted or guided waves and with the CCITT and/or with joint bodies of the ITU for the transmission of radiated waves.
- (iii) Co-operate with the CCIR with regard to the international and intercontinental broadcasting, whether intentional or unintentional, or radiated waves.

In the suggested new arrangement the CCIT & R would be on the same administrative level as the CCITT and the CCIR and not subservient to them. One of the CCIT & R's prime duties would be to give consideration to the question of the avoidance of overlapping and duplicating activities.

The block encompassing CCIT & R could consist of a Co-ordinating Committee, supported by a Research, Development and Planning Committee, supported in turn by an Operations Committee. The latter two committees might well be sub-divided according to subject matter (not necessarily according to hardware) in the same way as the working parties of the Technical Committee of the European Broadcasting Union.

To reorganise the ITU is no light matter and the foregoing suggestions should be regarded as a stimulus to discussion rather than firm proposals.

Lightweight Colour Mobile Control Rooms

G. D. Cook, F.I.E.E.

Assistant Chief Engineer, Television Operations

- 1 Introduction
- 2 Single-camera units
- 3 Two-channel units
- 4 Film and Electronic Production: a Comparison
- 5 Conclusion

1 Introduction

The BBC's main Television Outside Broadcast fleet consists of a number of four-camera colour units, some of which can be augmented to use six cameras. Requirements for single-camera units have, so far, been met by two single-channel units installed in 'gown' vans and by the Safari unit, while four two-channel OB units are also available. A new lightweight unit is now in construction for drama and other OB use. This article surveys small colour mobile control rooms and discusses the possible advantages that lightweight units may have in the future, particularly in the drama field.

2 Single-Camera Units

Two simple single-camera units are available to provide remote cameras feeding in to main CMCR's; typical applications would be race-course starts and remote cameras on golf courses.

Fig. 1 shows a single-camera unit.

Fig. 2 shows the Citroen Safari unit. A single camera is mounted on the roof of the vehicle which can have v.h.f. vision and sound links to a base receiving vehicle. The unit is self-contained, it tows its own power generator and was designed originally as a fast single-camera roving eye for covering the Grand National at Aintree. It is, of course, used for many programmes both static and roving, its radio facility enables it to work up to a mile from the receiving vehicle. The vehicle is 24ft long when towing its generator and weighs two tons.

3 Two-Channel Units

Figs. 3 and 4 show general views of the two-channel news OB unit. Such a unit has to be small and present no parking problems but still be large enough to remain reasonably comfortable for programme and engineering staff who may be operating on site for long periods. The vehicle can in fact, utilise a parking-meter bay. A four-camera colour mobile control room is 35ft long and weighs fourteen tons. The news

OB unit is only 19ft long and weighs five and a half tons. Its normal power requirements are 30 amps at 240 volts but it can operate from a 13 amp domestic power outlet with one camera and basic sound and vision facilities. This unit uses Marconi Mk. VIII cameras fitted with Angenieux 15:1 zoom lenses.

The vehicle layout is shown in Fig. 5. It is provided with an s.h.f. link on which is multiplexed sound, vision and communications channels. The s.h.f. link can operate into the BBC's receiving points at Swains Lane, North London or Crystal Palace in South London. The unit can be supported by a mid-point radio link and by a trailer generator if these are required.

The BBC has recently produced a number of location dramas using electronic rather than film cameras and is now building a lightweight CMCR to gain further experience in this field. The layout of this vehicle is shown in Fig. 6.

4 Film and Electronic Production: a Comparison

If it is accepted that the present division between film and electronic production output has in the past been dictated mainly by economic, technical and historic considerations, it is of interest to study whether some of the latest technical advances in television equipment may cause a change in this ratio.

The use of small mobile electronic recording units has previously been impracticable due to the size, weight and cost of the electronic colour cameras and video tape recorders. During the past few years, smaller colour cameras have been used for broadcast purposes, and more recently broadcast colour helical scan video tape recorders are becoming available. The cost and size of helical scan VTR's make them suitable for mobile use.

Although the cost of a one- or two-camera mobile unit will be higher when compared with a film unit, in a total costing activity the possible increase in productivity can offset the additional capital costs. Improved picture quality can also be achieved and this is especially important for studio insert material shot on location.

I do not propose to claim that tape is better than film or that film will be superseded by electronic methods of production; each, I think, have their place. Clearly the supreme mobility of the film camera is essential for many productions, particularly news, documentary and drama productions, with a highly mobile script style.

A 16mm sound film unit costs approximately £10,000 and a two-camera electronic unit complete with a helical scan recorder might cost £120,000, but greater productivity can be achieved using electronic equipment. I will show later that comparisons on a total costing basis taking into account script style can favour electronic equipment.

The difference in productivity between television and film is partly historical and when the movie industry first started it became customary to break down the script into small manageable portions seldom exceeding two-minute takes. Individual takes were often repeated a number of times until the director was satisfied and the director expected to indulge in considerable editing after filming. It seems unlikely that film units will be able to make any major increase in productivity.

When television first started there were no means of recording either on film or on tape. Productions were mounted in real time using multiple cameras and a Vision Mixer to cut or mix between the cameras. In present-day BBC studios directors are required to produce 25-30 minutes of programme material a day. Studio shooting ratios* seldom exceed 1.5:1 and are usually nearer 1.2:1. On location drama a film unit may achieve only 2-3 minutes of completed programme material a day. The target for a location electronic unit would be about 20min/day of completed material.

The economic comparison of film and electronic production in terms of comparison between studio, film stage, electronic location and film location is shown in the table. This

30-minute Theatre Cost Comparison

	<i>Electronic</i>		<i>Film</i>	
	<i>Studio</i>	<i>OB</i>	<i>Stage</i>	<i>Location</i>
	£	£	£	£
Artists/Copyright	1,200	1,380	1,500	2,100
Facility Fees		150		300
Transport/ Expenses		250		450
Film or VTR Costs	121	116	780	950
Studio Costs	1,727			
OB Unit Costs		2,236		
Film Unit Costs			2,389	2,919
Production Team	1,842	1,842	2,969	3,277
Design/Make-up				
Scenery/Costume	3,673	1,841	4,243	2,851
Total	8,563	7,815	11,879	12,847
Production Times	20 days	20 days	40 days	45 days
Shooting days	1	2	5	10
Shooting ratio	1.2:1	1.2:1	6:1	8:1

particular 30 Minute Theatre had a script style which did not require extreme camera mobility and which could be handled in a studio or on location. The table is based on the BBC's total costing system in which programmes are charged for

* The ratio of the amount of material recorded to the amount of material used on transmission.



Fig. 1 Single-camera OB unit



Fig. 2 Citroen Safari unit with camera mounted and towing its generator

Fig. 3 Two-channel news colour OB unit with Marconi Mk VIII camera



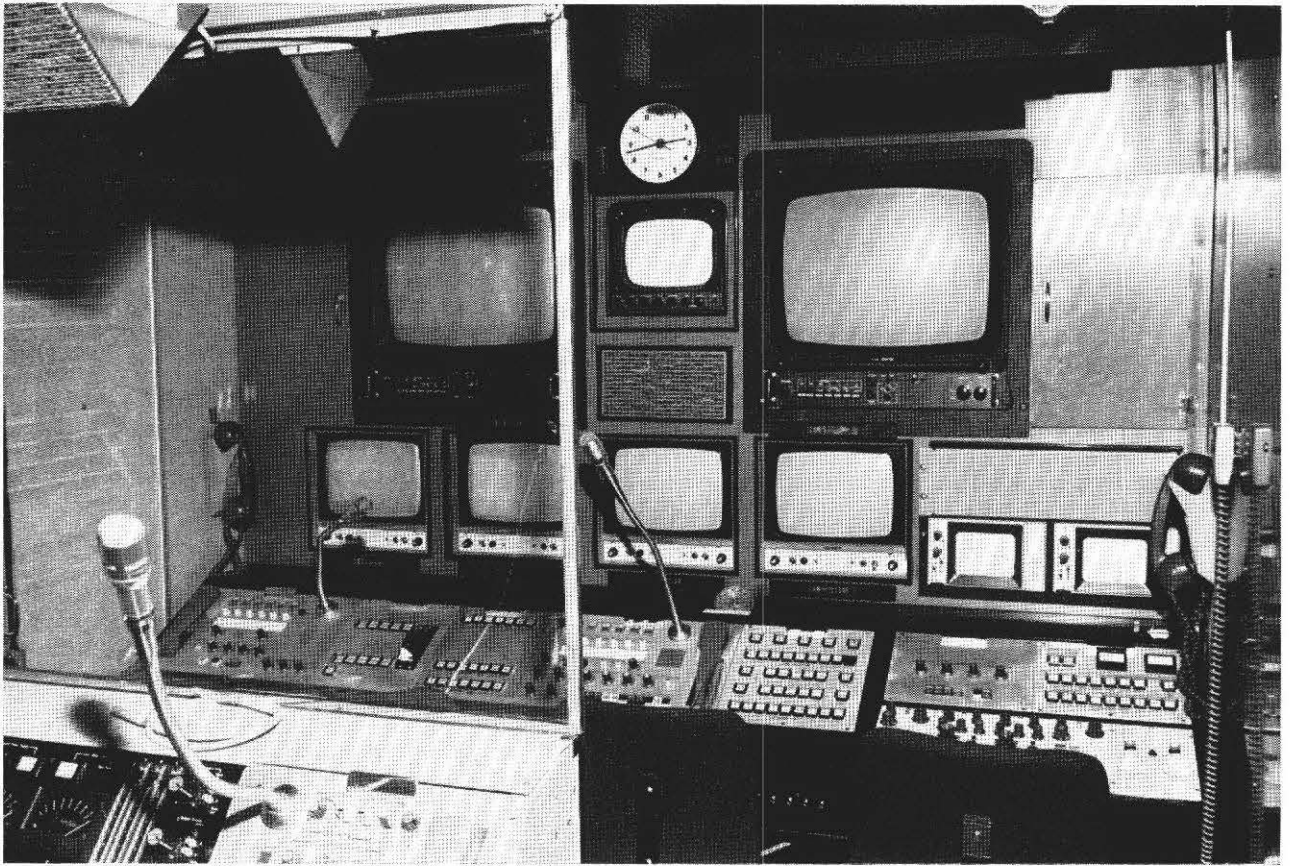
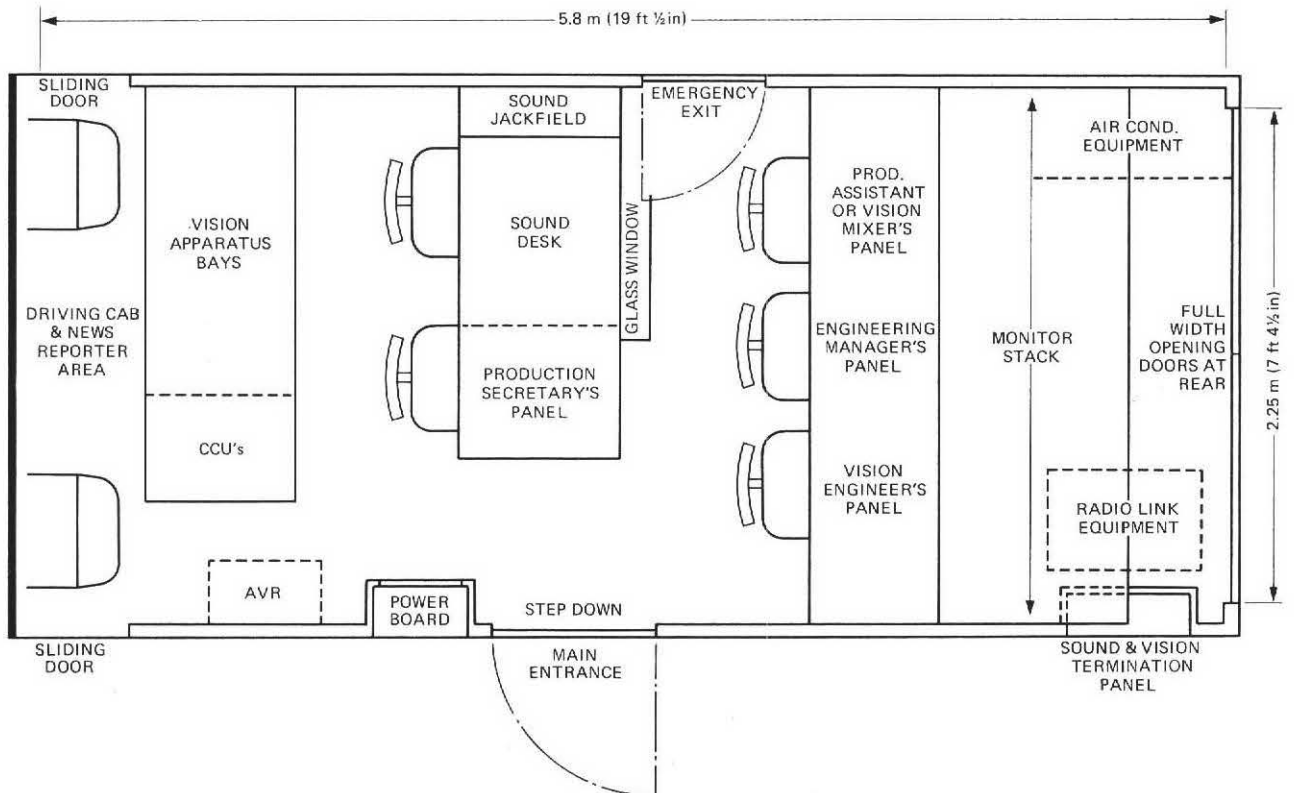

Fig. 4 Monitors and control disk of the two-channel news colour OB unit

Fig. 5 Layout of the two-channel news colour OB unit



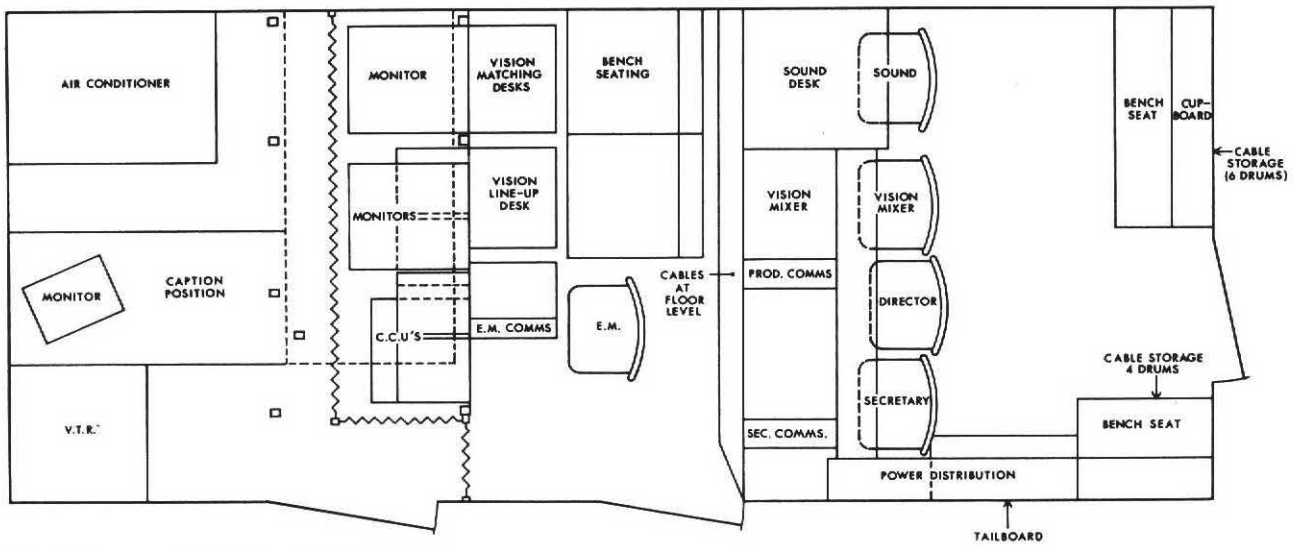

Fig. 6 Layout of the lightweight CMCR

the actual cost of staff and facilities allocated to them. Equipment charges include depreciation, maintenance and all operating costs, and staff costs include the actual cost of the effort plus overheads such as accommodation and management.

The comparison between electronic and film location costs are clearly very dependent on script style and treatment. One hour of video tape costs £75 and if the video tape has been electronically edited it is reusable. A 45-minute complete film programme *Dixon of Dock Green* resulted in a total film stock and processing cost of £1,617.

If electronic equipment is to compete in economic terms with film, television productivity must be maintained by using multi-camera set-ups and a mixer. I suspect that the Producer using a single electronic camera would use it much like a film camera and shooting ratios of 8:1 or more for drama productions would occur.

The main advantages of electronics are:

- (1) Greater camera sensitivity of up to two stops on conventional film stock. This can reduce location lighting costs.
- (2) There are no problems in matching studio sequences. Electronic cameras make no noise and they can accommodate a greater range of light levels and colour temperatures than do film cameras.
- (3) The Director on a television monitor, can direct both his artists and cameramen from either a monitor in the vehicle or from a monitor at the scene of the action.
- (4) Instant replay: this can save time and money. If the first shot is wrong the director knows straight away and can reshoot before leaving the location. The camera can be colour balanced to previous takes.
- (5) Two or more cameras with a Vision Mixer allow television production methods – immediate assembly – greater productivity. Recent advances in editing technology can make video tape easier and even more sophisticated than film editing techniques. Indeed, in Hollywood, some programmes are shot on film and edited by CMX (a sophisticated automated VTR editing system) on video tape. This edited video tape then determines the assembly of the original film material.

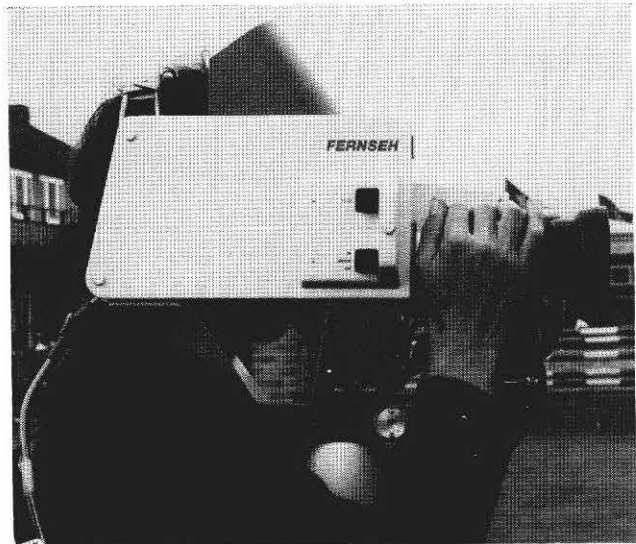

Fig. 7 Fernseh KCR 40 camera

- (6) Miniature cameras are available which can operate on batteries on lightweight cable or via radio links.
- (7) Properly used, costs can be very competitive with film, dependent on script style.
- (8) Tape-to-colour-film recording systems are available. These are the CBS laser beam recorder, the Image Transform system, and the Vidronics system.

The first generation lightweight colour camera was the CBS minicam. Fernseh have recently introduced a new lightweight camera, the KCR40, with a shoulder weight of some 7kg—comparable with a 16mm film camera—and a back-



Fig. 8 Cameraman wearing Fernseh KC R40 camera

pack weight of about 4kg. The back-pack can operate on 12mm cable for distances of up to 792m from the camera control unit, and the camera is capable of operating with an 18m run of cable to the back-pack. This camera is shown in Figs. 7 and 8. Two such cameras will be used by the BBC in the new lightweight colour OB unit.

Film cameras are, I think, largely incapable of much further development. It is just possible that more sensitive film stocks will appear, although they have, I suspect, reached certain physical and chemical boundaries which inhibit further major stock development. Electronic equipment on the other hand will inevitably be developed further.

5 Conclusion

Recent developments in broadcast-standard electronic equipment have resulted in a reduction in size, weight, and, in some cases, equipment costs. The capital cost of a small location unit has been considerably reduced and virtually all operational problems overcome. I foresee electronic and film methods of production continuing in partnership. Film will continue to have the advantage of supreme mobility but electronics will, over the next few years, make steady progress.

Reducing Non-linear Effects in Klystrons for Television Broadcasting

A. G. Lyner

Research Department

Summary: After a brief discussion of klystron operation, a transfer characteristic is derived for a klystron. The effects of the non-linearity on a combined television sound and vision signal are discussed. A simplified klystron transfer characteristic is derived and a design of circuit is suggested for narrow band pre-correction of the input signal to the klystron for elimination of the effects of its non-linear behaviour on a television signal.

- 1 Introduction
 - 2 Transfer Characteristic of a Two-cavity Klystron
 - 3 Ballistic Analysis of the Electron Beam
 - 4 The effect of Cavities. Multicavity Klystrons
 - 5 The Effects of Non-linearity upon the TV Signal
 - 6 Possibilities of Reducing Non-linear Effects at High Power
 - 7 Possibilities of Pre-correction
 - 8 Forms of Pre-correction Circuit
 - 9 Possible Use of an Adaptive System
 - 10 Conclusions
 - 11 References
- Appendix A
Appendix B
Appendix C

1 Introduction

Klystron amplifiers currently used for u.h.f. television broadcasting from main transmitting stations and from translator stations are, at present, severely underrun when used to transmit sound and vision signals simultaneously, in order to reduce the effects of non-linear distortion to acceptable levels. This is extremely inefficient and a method of using present devices at higher output powers would be highly desirable.

The mechanism of amplification in a klystron depends on the dynamic behaviour of a beam of electrons, and is fundamentally non-linear, so that a change of klystron design would not bring about any improvement.

The long group delay through a klystron prohibits the use of negative feedback to reduce non-linear distortion. Two further methods remain which can be used to improve the linearity of the device; pre-distortion of the input signal by a non-linear law which is the inverse of the klystron non-linear law, and post-correction where a low level correcting signal is added to the transmitter output to cancel the distortions generated by the klystron.

In this article a transfer characteristic for a simple two-cavity klystron is derived using a ballistic theory already

justified by other authors.^{1,2,3,4} Ideally the effects of non-linearity could be overcome by pre-correcting the input signal with a suitable circuit having the inverse of this transfer characteristic. Complete pre-correction would only be possible in a system with a very large bandwidth and, is therefore not applicable to a klystron because of the band limiting effect of the tuned cavities which form part of the amplifier and couple with the electron beam. Methods are discussed, which can reduce the levels of those few in-band products which prove most objectionable, to the level of the next most noticeable effects, thus permitting an increase in the usable power of existing transmitters.

2 Transfer Characteristic of a Two-cavity Klystron

Briefly a two-cavity klystron operates as follows.^{2,3,4,6} An electron gun generates a uniform beam of electrons (typically 2 A at 20 kV) which passes through the gap in the input cavity (Fig. 1). A coupling loop introduces signal energy into the cavity which produces a magnified electric field across the gap in the direction of the beam. The velocity of the electron beam is modulated by the r.f. field across the gap and, as the electrons drift along a field free region the faster ones begin to

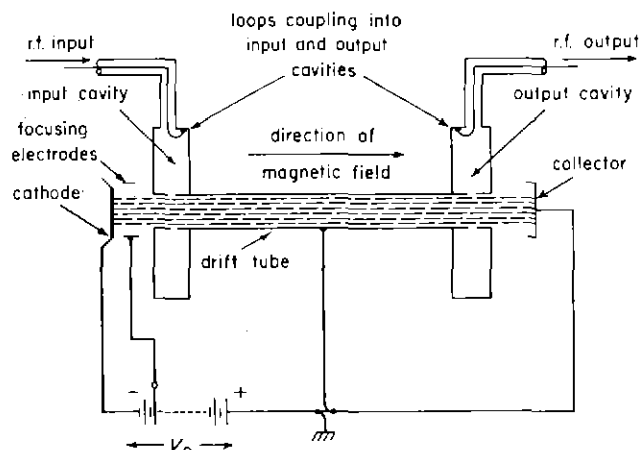

Fig. 1 A two-cavity klystron

overtake the slower ones and bunching occurs.* When the bunched beam passes the output cavity the r.f. energy associated with the current variations is coupled into the cavity and a loop couples this energy into an output feeder.

3 Ballistic Analysis of the Electron Beam

In Appendix A a transfer function for a velocity modulated electron beam is derived from simple ballistic theory. Equations (A(11)) and (A(12)) show the output current $I(\tau)$, at time τ , in terms of the input signal $V_1 x(t)$ at time t . For a sinusoidal input where $x(t) = \sin \omega t$ Equations (A(11)) and (A(12)) may be written:

$$I(\tau) = I_0 / (1 - K \cos \omega \tau) \tag{1}$$

and
$$\tau = t - \frac{K}{\omega} \sin \omega t \tag{2}$$

where K is the so-called bunching parameter which is proportional to the amplitude of the input signal, and I_0 is the mean beam current.

Fig. 2 shows how, for a sinusoidal input, the output current $I(t)$ of the klystron beam may be derived by applying the solution of (2), graphically to (1) to eliminate the variable τ .

For a sinusoidal input where $K > 1$ (2) will become multi-valued and this corresponds to some overtaking of electrons, causing 'over bunching' of the beam. Equations (1) and (2) must then be modified to account for this as $I(\tau)$ will comprise contributions from more than one portion of the input signal.

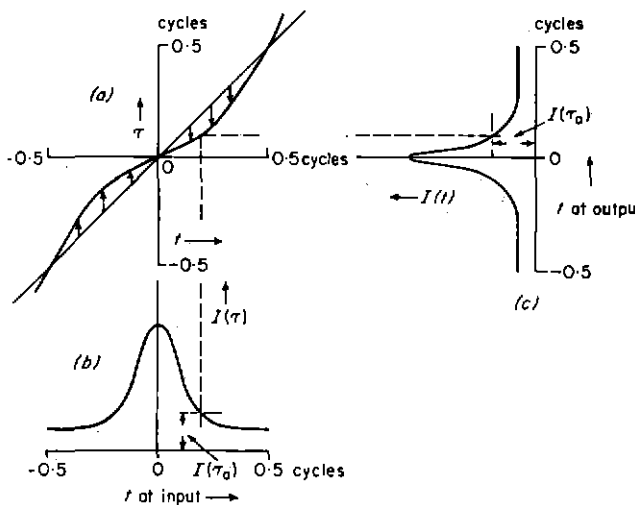

Fig. 2 The current waveform of the klystron output cavity for sinusoidal input (no overbunching of electrons)
 (a) Shows the relationship between τ and t for a sinusoidal drive

$$\tau = t - \frac{K}{\omega} \sin \omega t$$

 (b) Shows how $I(\tau)$ varies with time at the input (Eq.1)
 (c) Shows the actual output current $I(t)$ measured at the output cavity found by combining graph (a) with graph (b)

* The longitudinal magnetic field used to focus the beam does not affect the forward velocity of the beam.

Equations (1) and (2) may be combined to give a fuller description of the behaviour of the electron beam for any value of K .

$$I(\tau) = \sum_n \left| \frac{I_0}{1 - K \cos \omega t_n} \right| \tag{3}$$

where t_n are roots of

$$\tau = t - \frac{K}{\omega} \sin \omega t$$

The modulus sign in (3) is needed as electrons arriving at the output in reverse order from that in which they left the input will still register as a positive current through the gap. The solution to Equation (2) will have either single values, or odd numbers of values, the number of solutions increasing as K increases. In practice K never exceeds a value where there are more than three solutions. Figure 3 shows the output current from a sinusoidal input when I is a little less than 1.5.

By an extension of this argument, for a general input function, as discussed in Appendix A, the transfer equation of the electron beam becomes, by modifying A(12):

$$I(\tau) = \sum_n \left| \frac{I_0}{1 - \frac{z \Delta}{u_0} x(t)^n} \right| \tag{4}$$

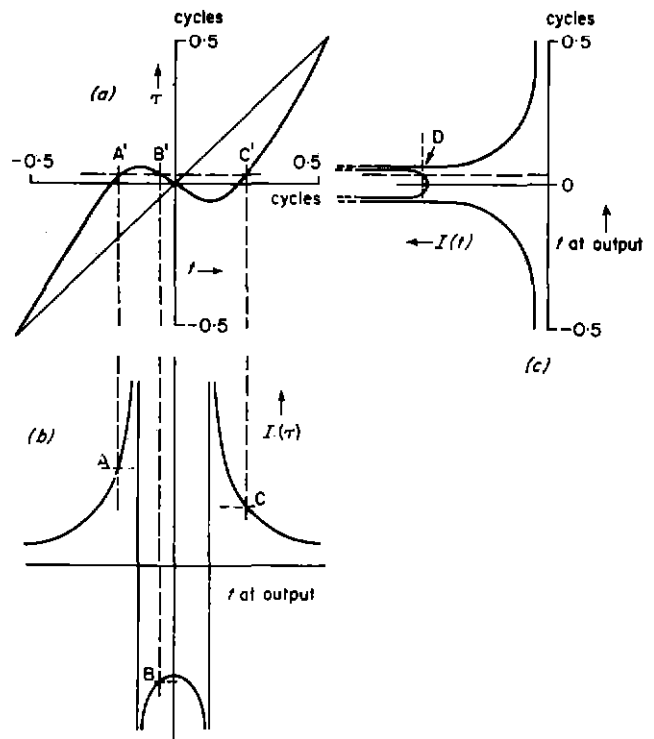

Fig. 3 Overbunching at the output for a large amplitude sinusoidal input
 (a) Shows the multiple values of τ as a function of t
 (b) Shows how $I(\tau)$ varies with t
 (c) Shows the net result of the contributions from (b) to the total output current
 Currents at times A, B, and C in 3(b) contribute to the current at time D in 3(c). A', B', and C' in 3(a) show the multiple solution of t for one value of τ (at D)

where t^* are roots of

$$\tau = t - \frac{z \Delta}{u_0} x(t)$$

In principle Equation (4) describes the ballistic behaviour of the beam however much 'over bunching' occurs although the output waveform may not be readily deduced because of the intrinsic time relationship

Because the transfer equation of the klystron is implicit in time it does not give a readily understandable description of the distortion caused by a klystron. The output waveform may be more conveniently expressed as a series of Fourier components once the form of input waveform has been specified. This has in fact been done by several authors for a single tone* input and for the sum of two and three tones.^{3,6,9}

For a single tone input, the output $I(\tau)$ may be written

$$I(\tau) = I_0 a_0 + I_0 \sum_{r=1}^{\infty} \left[a_r \cos(r\omega\tau) + b_r \sin(r\omega\tau) \right] \quad (5)$$

Where $a_r = \frac{1}{\pi} \int_{-\pi}^{\pi} \frac{I(\tau)}{I_0} \cos(r\omega\tau) d(\omega\tau)$ (6)

and $b_r = \frac{1}{\pi} \int_{-\pi}^{\pi} \frac{I(\tau)}{I_0} \sin(r\omega\tau) d(\omega\tau)$ (7)

By changing the integral variable in (6) and referring to (3)

$$a_r = \frac{1}{\pi} \int_{-\pi}^{\pi} \sum_n \left| \frac{1}{1 - K \cos \omega t_n} \right| \cos \left(r(\omega t_n - K \sin \omega t_n) \right) (1 - K \cos \omega t_n) d(\omega t_n) \quad (8)$$

If bunching is limited so that electrons contributing to one cycle of signal on the beam are conserved with the cycle throughout the bunching process, then all solutions for

$$\tau = t_n - \frac{K}{\omega} \sin \omega t_n \quad (9)$$

lie within $-\pi \leq \omega t_n \leq \pi$ and so (8) may be written as

$$a_r = \frac{1}{\pi} \int_{-\pi}^{\pi} \cos \left(r(\omega t_n - K \sin \omega t_n) \right) d(\omega t_n) \quad (10)$$

which gives

$$a_r = 2J_r(rK) \quad (11)$$

Similarly $b_r = 0$ and $a_0 = 1$

So (3) may be expressed as

$$\frac{I(\tau)}{I_0} = 1 + 2 \sum_{r=1}^{\infty} J_r(rK) \cos(r\omega\tau) \quad (12)$$

Equation (12) has been plotted by several authors^{3,9} for a number of values of K (see Fig. 4).

* 'tone' is used as a convenient term for a single-frequency r.f. signal.

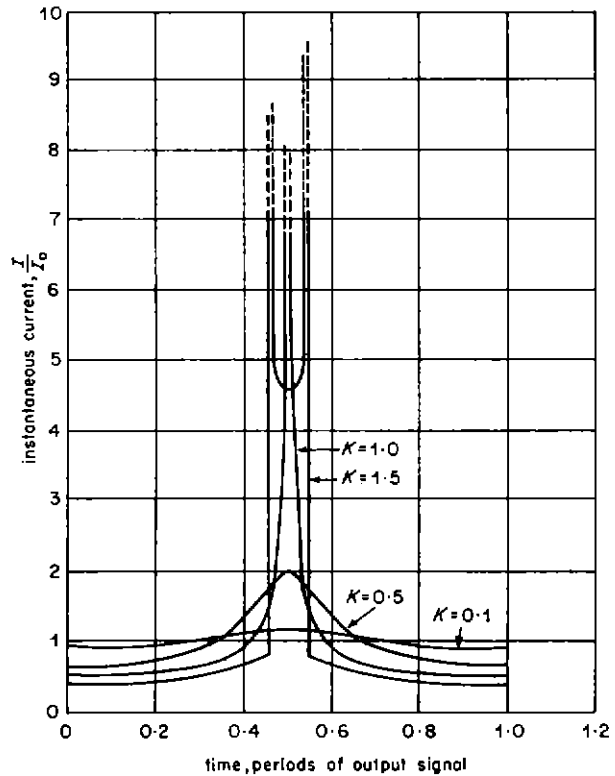

Fig. 4 Waveform of current entering output cavity of two-cavity klystron

By a similar approach, it has been shown that,⁸ for a three tone input, the beam at the output contains frequency components with amplitudes proportional to

$$a_{mnp} = J_m(\alpha) J_n(\beta) J_p(\gamma) \quad (13)$$

where

$$\left. \begin{aligned} \alpha &= K_1(mf_1 + nf_2 + pf_3)/f_1 \\ \beta &= K_2(mf_1 + nf_2 + pf_3)/f_2 \\ \gamma &= K_3(mf_1 + nf_2 + pf_3)/f_3 \end{aligned} \right\} \quad (14)$$

m, n, p , are integers, positive or negative and f_1, f_2, f_3 are frequencies of the input tones. K_1, K_2, K_3 are the 'bunching parameters' of the three signals, defined as for Equation (12) with a value which would apply if each tone were applied in the absence of the other two.

The mutual repulsion of electrons in the beam, which has been neglected in this analysis, has been found to leave the form of the output very little different from that described by Equation (13) except that the values of the bunching factors K_1, K_2, K_3 need slight modification.³ The debunching of the beam due to space charge shortens the effective lengths of the drift spaces.

N.B. In the case of a single tone where $K_2 = K_3 = n = p = 0$, Equation (13) reduces to

$$a_{m00} = J_m(mK)$$

which compares with the coefficients of Equation (12).

The saturated output power occurs where the output at the fundamental frequency is at a maximum. This is when $J_1(K)$ is a maximum, i.e. when $K=1.84$ and $J_1(K)=0.582$. It is convenient to express the levels of inputs and outputs relative to this value. The output powers at various frequencies generated by a three-tone input can be written as:

$$\left(\frac{P_{mnp}}{P_o}\right)^{\frac{1}{2}} = \frac{F_{mnp}}{0.582} J_m(\alpha)J_n(\beta)J_p(\gamma) \quad (15)$$

with α , β , and γ redefined as

$$\left. \begin{aligned} \alpha &= 1.84K_1(mf_1 + nf_2 + pf_3)/f_1 \\ \beta &= 1.84K_2(mf_1 + nf_2 + pf_3)/f_2 \\ \gamma &= 1.84K_3(mf_1 + nf_2 + pf_3)/f_3 \end{aligned} \right\} \quad (16)$$

where K_1 , K_2 , K_3 are the normalised bunching parameters, P_o and P_{mnp} are saturated output power and power at $mf_1 + nf_2 + pf_3$ respectively, and F_{mnp} is a factor depending upon the amplitude/frequency characteristics of the klystron cavities.

4 The Effect of Cavities. Multicavity Klystrons

Whereas Equation (4) describes the non-linear behaviour of the electron beam, the complete transfer characteristic of the klystron is affected by the frequency response of the tuned cavities. Non-linear products generated by the electron beam will be coupled, to varying degrees, by the output cavity to the output of the device, depending on their frequency. Harmonics and products outside the passbands* of the cavities will not be coupled to the beam. In order to increase the bandwidth and gain of a klystron amplifier it is normal practice to cascade two or three amplifying sections along the same electron beam by means of intermediate cavities resistively loaded and stagger-tuned. The r.f. power level in the final drift space is higher than in the preceding spaces and it is there that the main effects of non-linearity occur. It is sufficient in fact to consider the final drift space as being the only non-linear part of the amplifier. However, the frequency response of the linear section prior to the penultimate cavity must be taken into consideration when calculating intermodulation products in the final drift space as the signal spectrum there will differ from that at the klystron input.

5 The Effects of Non Linearity upon the TV Signal^{3, 4, 5, 7, 8}

For television transmissions, klystron amplifiers are used in either of two ways. At main stations separate klystron amplifiers are used to amplify the vision signal and sound signal to the required output power levels before they are combined in a passive network into a common aerial system. The primary effect in the vision amplifier in this case is the crushing of the chrominance signal by the stronger luminance signal. In a colour picture this causes the colour saturation of an object to vary as its brightness varies and transmitters are run at about 2dB lower than saturated power level to reduce the effect to an acceptable level.

* The harmonics of the beam may well not coincide with higher order modes in the cavities.

In relay stations and, under standby conditions at some high power stations when a sound or vision klystron has failed, a single klystron is used to amplify both sound and vision signals together. Under these conditions, the non-linearity introduces distortions into the signal at lower operating powers. The most objectionable effects are caused by intermodulation products, and occur at

- (1) The sound carrier frequency,
- (2) $f_v + f_s - f_c$ at 1.57 MHz above vision carrier and
- (3) $2f_c - f_s$ at 2.85 MHz above vision carrier;

where f_v , f_s and f_c are the frequencies of vision carrier, sound carrier and colour subcarrier respectively.

(1) corresponds to a crushing of the sound carrier by the vision carrier and manifests itself as amplitude modulation of the sound carrier by the line and field synchronising pulses. In some domestic receivers, the f.m. sound section cannot reject high levels of amplitude modulation and a buzz on the output can be heard. (This buzz, due to sound crushing in the klystron, is not to be confused with similar effects due to receiver non-linearity.)

(2) and (3) are interference patterns on the picture which constantly change in phase and amplitude as the sound and picture change. Of these, (2) is at the higher level and is most noticeable.

Assessment of television transmitter amplifiers used to broadcast a combined sound and vision signal is frequently made using a three tone test.⁸ Three frequencies, corresponding to vision carrier, sound carrier and colour subcarrier are injected into the klystron at input levels of -8 dB, -7 dB, and -17 dB relative to peak sync power. If the intermodulation product at $f_v + f_s - f_c$ is less than -52 dB relative to peak sync power then, experience has shown, the impairment will be subjectively imperceptible under most picture conditions. To reduce the level of the $(f_v + f_s - f_c)$ product to the acceptable level of -52 dB the common sound and vision amplifier must be derated by some 7 dB more than for vision amplification alone. This reduces the efficiency of the amplifier to about 6 per cent and it would be a great advantage if a method were developed to increase the available power from transmitters without raising the level of the non-linear products.

6 Possibilities of Reducing Non-linear Effects at High Power

The length of delay introduced by a klystron amplifier is too great for the use of negative feedback to linearise its behaviour. Two possibilities remain; post-correction and pre-correction of the signal.

Post-correction of the klystron by adding a correcting signal to the output would be one solution to the problem of non-linear distortion, but the realisation in practice of such a system would be difficult. The correcting signal would have to be added to the klystron output in the correct phase over the bandwidth used and in a way which involved no appreciable loss of transmitted power. Whilst this method cannot be rejected totally, it is thought that pre-correction would be easier and less costly to achieve and it is with pre-correction that the latter part of this report deals.

7 Possibilities of Pre-correction

Ideally, the range of output power of a klystron could be extended by pre-distorting the input waveform by means of a circuit possessing the inverse of the non-linear transfer function of the klystron (see Appendix B). The input waveform necessary to produce a sinusoidal output from the klystron is derived in Appendix C and Fig. 5 shows that the required

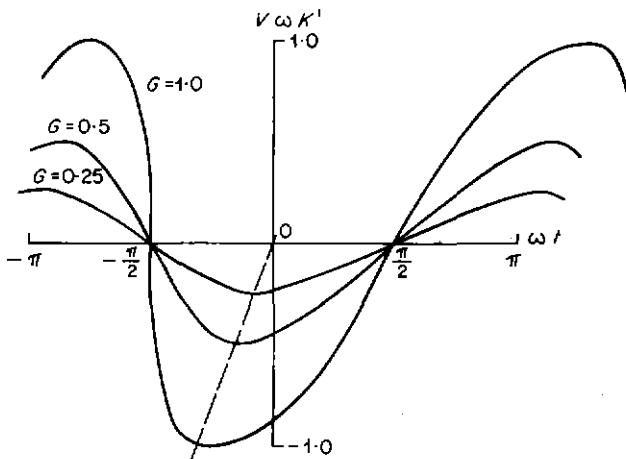

Fig. 5 The input waveform necessary to produce a sinusoidal output of various amplitudes

input waveform would contain a number of high-frequency components to achieve high output amplitudes. The input and intermediate cavities would severely alter the relative amplitudes and phases of their components. Consequently, the possibility of overall pre-correction of the signal with a wideband pre-corrector must be dismissed.

As complete overall pre-correction would seem to be impracticable the possibility of partial pre-correction is now discussed. Basically, the only troublesome effects of non-linearity are in-band intermodulation products, as any out-of-band products can be controlled by the use of output filters. All products of a measurable level which fall within band must be odd-order and the three most offending products are those described in Section 4.

For pre-correction it is necessary that the input signal should have, added to it, components of equal magnitude and opposite phase to those generated by the klystron. Pre-correction for total cancellation of all in-band products would not be possible but, if the three most objectionable intermodulation products could be significantly reduced, the output power of the klystron could be raised until a new set of products produced noticeable impairment.

These three products could either be generated separately and added to the signal or the whole signal could be passed through a network which would produce the necessary pre-distortion. The latter, would be preferable provided that it is possible to control independently the phases of the products so generated.

Reference to the transfer function (Equation 4) of the klystron shows that the non-linearity is not generally in power series form, viz.

$$V_{out}(t) = a + b V_{in}(t) + c V_{in}^2(t) + d V_{in}^3(t) + \dots \text{ etc.} \quad (17)$$

The offending in-band products, however, which are third

order* can be generated by a static non-linearity which involves no higher than a fifth-degree polynomial with suitable coefficients. The function $J_1(1.84K_1)/0.582$ gives the input-output law of the fundamental frequency for a single-tone input (see Equation (15)) and, for $0 < K_1 < 1$, this can be approximated to within ± 1 per cent by

$$\left(\frac{P}{P_0}\right)^{\frac{1}{2}} = 1.58K_1 - 0.6613K_1^3 + 0.0797K_1^5 \quad (18)$$

It can be easily shown that, to produce a power transfer characteristic of polynomial form:

$$\left(\frac{P}{P_0}\right)^{\frac{1}{2}}_{out} = aK_1 + a_2K_1^3 + a_3K_1^5 \quad (19)$$

the required instantaneous voltage transfer characteristic is

$$V_{out} = G \left\{ 1. a_1 V_{in} + \frac{4}{3} a_2 V^3 + \frac{8}{5} a_3 V^5 + \dots \right\} \quad (20)$$

where $1, \frac{4}{3}, \frac{8}{5}$ etc. are the so-called 'degeneracy' coefficients and G is the overall gain. A transfer characteristic producing the fundamental input/output characteristic of Equation (18) would consequently be

$$V_{out} = G \{ 1.58K_1 - 0.885K_1^3 + 0.1278K_1^5 \} \quad (21)$$

As well as producing a single tone power in/power out law approximating to that of a klystron, a non-linearity of the form of Equation (21) would produce in band distortions closely similar to those produced by a klystron on a television signal or three-tone test signal. A pre-corrector with the inverse of this law would produce distortions which would cancel those generated by the klystron. Equation (22) gives a pre-corrector law which would effectively linearise the system.

$$V_{out} = G' (1.58K_1 + 0.885K_1^3 - 0.276K_1^5) \quad (22)$$

(G' being the gain or loss of the pre-corrector)

It is possible that the phases of the intermodulation products generated by the pre-corrector may need some adjustment to achieve a high degree of cancellation. The exact nature of the phase adjustment required is not known. It is possible that a simple variable delay may be sufficient for good cancellation but a variation of phase across the video band may be found necessary.

In assessing the performance of a pre-corrector at u.h.f. it is more convenient to observe the intermodulation products it generates from a three-tone signal than to measure its input output law. This is possible as the levels of the intermodulation products relate to the coefficients of the polynomial transfer characteristic.

Having arrived at a form of circuit that can be expected to have the correct sign of curvature to its transfer characteristic, study of its action upon a three-tone signal will then give a convenient assessment of its performance prior to its being used in conjunction with a klystron.

8 Forms of Pre-correction Circuit

A circuit in the form shown in Fig. 6 would produce a distortion of the general form required (i.e. a stretching of the signal at large amplitudes).

*See Section 4.

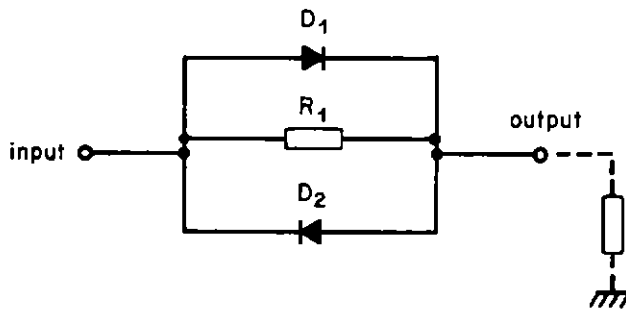

Fig. 6 Simple form of pre-corrector to 'stretch' the input signal at high levels

This simple circuit has a number of limitations however. The knee voltage of available diodes is limited to the region of a few hundred millivolts and the forward resistance is, at best, a few tens of ohms. If the correcting device is to be placed between the driver amplifier and the klystron, powers of up to 1 watt will need to pass through it. The degree of 'bending' achievable with the circuit is not sufficient, whatever impedance the circuit is designed to have.

Using transistors as in Fig. 7, to perform the same function

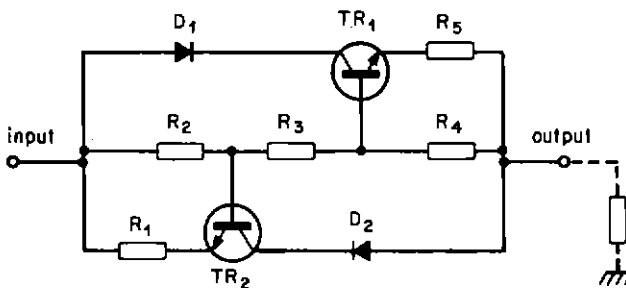

Fig. 7 Circuit with similar characteristics as in Fig. 6 but with 'higher' knee voltage achieved by using transistors

as the diodes in Fig. 6 a power in/power out law can be achieved with a knee at about 100mW. An experimental circuit of this type has been built and has been found to produce an in-band intermodulation product corresponding to $(f_v + f_s, -f_s)$ at a level of -40dB (relative to a notional peak sync power of 100mW) in a three-tone test. Ideally, this product would be of opposite phase to that which the klystron would generate and the resulting output of the amplifier should contain the intermodulation product at a greatly reduced level due to partial, if not total, cancellation. By introducing reactive elements into the circuit of Fig. 7 it should be possible to achieve a variation in both phase and amplitude of non-linear products. Some flexibility could be achieved in the law of the device by preceding and following it with variable attenuators with complementary characteristics so that the corrector worked at a variable level whilst the input level to the klystron remained unchanged. A more complex system which would provide more flexible pre-correction is shown in Fig. 8. This would enable the phases of the products, generated by a non-linear circuit, to be varied with respect to the main signal.

Because of the nature of the klystron non-linearity, it is quite likely that all three non-linear effects described in Section 4 will not be eliminated simultaneously with one

setting of the corrector. Further correction could be applied as envelope modulation. A suitable modulator could be driven by a detected video signal which had been modified by a gamma-corrector type of circuit. Such a modulation could eliminate crushing of sound and chrominance carriers by the vision carrier whilst the non-linear network in the alternative signal path would provide intermodulation products, variable in amplitude and phase to cancel with those produced by the klystron.

The advantage of this approach lies in the large number of parameters that may be varied and, thus, the wide range of non-linear conditions for which it could compensate.

9 Possible Use of an Adaptive System

Long-term drift of klystron and pre-corrector characteristics may limit the amount of correction achievable by cancellation of intermodulation products. For a high degree of correction necessary to run the klystron at high powers, this instability might be overcome by an automatic system whereby pre-corrector parameters were changed to optimise the performance.

Several problems would arise with such a system. The performance must be judged by comparing input and output signals and a suitable criterion signal produced. By a series of changes of pre-corrector parameters, the optimum setting of the system must be found for any condition of the klystron likely to occur. Whether or not the adjustments to parameters would be best made randomly or according to a pre-determined law would depend upon the nature of the criterion signal and how it was produced.

Any such system would be necessarily complex and expensive and it has yet to be decided whether the cost and effort would be justified in order to increase the usable powers of the klystron above those made possible by a pre-set system. Work by others would suggest that significant improvements in performance may be achieved without resorting to an adaptive system.

10 Conclusions

Exact pre-correction of the intrinsic non-linearity of the klystron is not possible. Nevertheless, a system permitting substantial power increases and improved efficiency is feasible using partial pre-correction.

The technique to be adopted is to distort signals before they are amplified in the klystron by means of a polynomial-type non-linearity which contains mainly third-order and fifth-order terms, suitably scaled. It is valid to replace actual television signals by the standard three-tone signal for purposes of calculation and measurement and on the basis of this test signal the levels of in-band intermodulation products produced in klystron amplifier can be calculated. These calculated levels also agree well with measured levels.³ Good approximations to the principal in-band intermodulation terms can be generated with a third and fifth order polynomial and to apply pre-correction a suitable radio frequency network must be devised exhibiting the required 'inverse' properties.

It may be necessary to include some degree of phase adjustment of products from the pre-corrector to ensure good

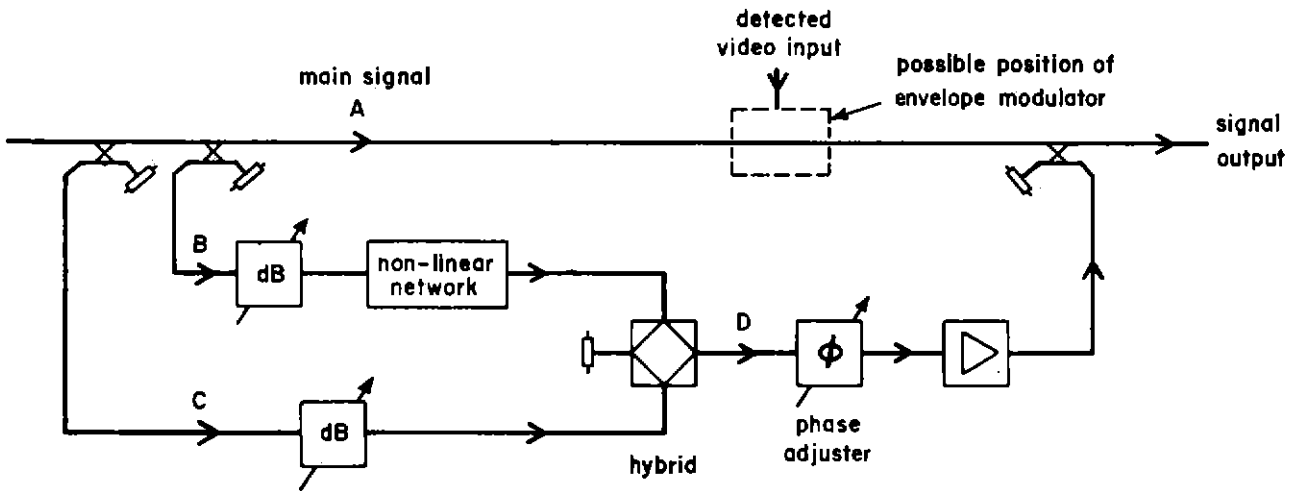

Fig. 8 Possible pre-correction circuit with phase adjustment. Portions B and C are taken from the main signal A. B passes through a non-linearity and is subtracted from C using a hybrid ring and suitable attenuators to leave only the non-linear products. The phases of these products may then be adjusted and, after amplification, the distorted signal is coupled on to the main signal A. An envelope (video) modulator placed in the main path could give still more flexibility

cancellation of the principal intermodulation products. In addition some video envelope modulation may be considered to improve overall linearity.

It is understood that such pre-correction will be limited to use at powers still well below the saturation power of the klystron but possible increases in power of about 4dB for combined sound and vision amplifiers are believed to be realistic. A system to produce this degree of improvement in performance would be highly desirable.

11 References

1. Webster, D. L. 1939. Cathode ray bunching. *J. appl. Phys.*, 1939, 10, July, pp. 501-8.
2. Webber, S. E. 1958. Ballistic analysis of a two cavity finite beam klystron. *I.R.E. Trans. electronic Devices*, 1958, April, pp. 98-108.
3. Eaton, J. L. and Whyte, D. J. 1967. The non-linear characteristics of klystron amplifiers. BBC Engng. Monogr., 1968, No. 74.
4. Chalk, C. O. and O'Loughlin, C. N. 1968. Klystron amplifiers for television. *Electronic Equipment News*, 1968, Feb.
5. Edgcombe, C. J. and Heppinstall, R. 1968. Non-linear behaviour in klystrons for u.h.f. television. *Nachrichtentech. Fachber.* 1968, 35, pp. 151-6.
6. Murata, S. 1964. Intermodulation produced by double cavity klystron. *Tech. J. Japan Broadcasting Corporation*, 1964, 16, 5, pp. 1-8 (in Japanese).
7. O'Loughlin, C. N. 1965. Intermodulation characteristics of high-power klystrons used in frequency transposers for colour television. International Conference on u.h.f. Television, London, Nov. 1965. I.E.R.E. Conference Proceedings, 1965, No. 6, Paper No. 10.
8. Savage, D. C. and Carter, D. A. 1964. Subjective impairment resulting from common amplification of modulated sound and colour television signals to UK 625-line standards. BBC Designs Department Technical Memorandum, 6.49 (64).
9. Sims, G. D. and Stephenson, I. M. 1963. Microwave tubes and semi-conductor devices. London, Blackie, 1963.
10. Mullard Ltd. 1964. High-power klystrons for Band IV/V television transmitters. Technical Information 1, 6 April, 1964.

Appendix A

Transfer Function of a Modulated Electron Beam

The velocity of an electron leaving the electron gun will be

$$u_0 = (2\eta V_0)^{\frac{1}{2}} \tag{A(1)}$$

Where η is the electronic charge/mass ratio (1.76×10^{11} coulomb/kg).* A signal $V_1 x(t)$ applied across the input cavity gap ($-1 < x(t) < 1$) gives an electron passing the gap at time t a velocity $u(t)$ where

$$u(t) = u_0(1 + \Delta x(t)) \tag{A(2)}$$

where

$$\Delta = \xi V_1 / V_0$$

and ξ is the gap coupling factor, dependent upon the gap and beam geometry. Δ has a value considerably less than unity.

This assumes that the drift time of the electron across the gap is short enough for the changes in velocity to be considered to be impulsive. Such an assumption is reasonable as the transit time is less than 1 per cent of a cycle for a signal at 500MHz.

If the length of the drift tube is z the time taken τ_1 for an electron starting at time t to arrive at the output gap will be

$$\tau_1 = z/u(t) \tag{A(3)}$$

or

$$\tau_1 = z/u_0 \{ 1 + \Delta x(t) \} \tag{A(4)}$$

As $-1 < x(t) < 1$ term in Δ^2 and higher orders may be dropped

$$\therefore \tau_1 \approx \frac{z}{u_0} \left(1 - \Delta x(t) \right) \tag{A(5)}$$

For an electron leaving the input gap at time δt later, the transit time will be

$$\tau_2 \approx \frac{z}{u_0} \left(1 - \Delta x(t + \delta t) \right) \tag{A(6)}$$

Assuming to begin with, that by the end of the drift space, no fast electrons have overtaken slower ones and that the mutual

* For a 10keV beam, relativistic effects cause an error of about 1.5 per cent in Equation A(1).

repulsion between electrons may be neglected the incremental change on the electron beam δQ which passed the first cavity in time δt will pass the second cavity between times $(t + \tau_1)$ and $(t + \tau_2 + \delta t)$. (See Fig. 9.)

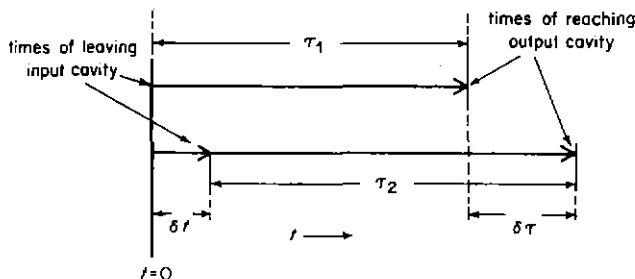

Fig. 9 Electron transit times

Let $\tau_2 + \delta t - \tau_1 = \delta \tau$ A(7)

Then from A(5) and A(6)

$$\frac{\delta Q}{\delta \tau} = \delta Q \left/ \left(\delta t + \frac{z \Delta}{u_0} \left[x(t) - x(t + \delta t) \right] \right) \right. \quad \text{A(8)}$$

Now $\lim_{\delta t \rightarrow 0} \frac{\delta Q}{\delta \tau} = \frac{dQ}{d\tau} = \frac{dQ/dt}{1 - \frac{z \Delta}{u_0} x(t)}$ A(9)

Let $\tau + \frac{z \Delta}{u_0} = t + \tau_1$ A(10)

So from A(5)

$$\tau = t - \frac{z \Delta}{u_0} x(t) \quad \text{A(11)}$$

Now $dQ/d\tau$ in A(9) represents the current passing the output cavity at time τ and dQ/dt represents the current (d.c. in this case) passing the input cavity at time t . Neglecting the term z/u_0 in A(10) which merely represents a constant average delay down the drift tube we can write

$$I(\tau) = I_0 \left[1 - \frac{z \Delta}{u_0} x(t) \right] \quad \text{A(12)}$$

Equation A(12) represents the transfer function of the electron beam in implicit form. A(11) shows the relationship between τ and t so the behaviour of the beam is completely described by A(11) and A(12) together. The frequency response of the input and output cavities will cause the overall behaviour of a klystron to vary considerably from this.

Appendix B

Pre-correction Using an Inverse Characteristic

The non-linear effects of the klystron could be eliminated in principle by pre-distorting the input by means of a circuit having the inverse characteristic. Such a pre-correction could be achieved in two stages, corresponding to the two bunching effects shown in Fig. 2 for a sinusoid. Firstly a circuit with the inverse characteristic of the amplitude function in Fig. 2(b) could be employed, and secondly a phase distortion to counteract the effect shown in Fig. 2(a). The first would involve a transfer function of the form

$$V_{out} = P \int \left[1 - \frac{1}{Q(t)} \right] dt \quad \text{B(1)}$$

which can be seen to be the inverse of the expression contained in the modulus sign of Equation (4).

The required phase distortion would involve a delay line through which the propagation time depended upon the amplitude of the signal – thus

$$V_{out}(t) = V_{in}(t + R V_{in}(t)) \quad \text{B(2)}$$

This approach would be fundamentally limited to amplitudes for which the time Equation A(11) has single valued solutions, corresponding to running the amplifier at levels below that at which over bunching occurs.

Appendix C

Synthesis of a Sinusoidal Wave at the Output of a Klystron

In order to produce a given output waveform at a high level from a klystron it is necessary to input a signal with a waveform such that the non-linearity of the klystron will distort the input signal into that which is required at the output.

Assuming, for simplicity, that a sinusoidal output is required then the current in the beam at the output will be

$$I(\tau) = I_0 (1 + G \sin \omega \tau) \quad \text{C(1)}$$

From Equation (4) we have

$$1 + G \sin(\omega \tau) = \sum_n \left| \frac{1}{1 - K' V_1(t_n)} \right| \quad \text{C(2)}$$

where $V_1(t)$ is the input waveform

and $t_n - K' V_1(t_n) = \tau$ determines the values of t_n over which the RHS of C(2) is to be evaluated.

Provided $V_1(t)$ is restricted in amplitude so that there is only one value of t_n for each τ

$$1 + G \sin \left[\omega t - K' \omega V_1 t \right] = \frac{1}{1 - K' V_1(t)} \quad \text{C(3)}$$

$$\therefore G \left[1 - K' V_1(t) \right] \sin \left[\omega(t - K' V_1(t)) \right] = K' V_1(t) \quad \text{C(4)}$$

The LHS of Equation C(4) may be expressed as

$$-\frac{G}{\omega} \frac{d}{dt} \left\{ \cos \left[\omega(t - K' V_1(t)) \right] \right\} \quad \text{C(5)}$$

so that

$$\cos \left[\omega(t - K' V_1(t)) \right] = -\frac{K' \omega}{G} V_1(t) \quad \text{C(6)}$$

The most convenient form of solution of Equation C(6) is the pair of parametric equations

$$V_1 = -\frac{G}{K' \omega} \cos \phi \quad \text{C(7)}$$

and

$$\omega t = -G \cos \phi \quad \text{C(7A)}$$

Figure 6 shows $V_1(\omega t)$ plotted for various values of G . For the equations $t - K' V_1(t) = t$ to have single-valued solutions G must not be greater than unity. This condition is also neces-

sary to satisfy the requirement for non-reversal of beam current.

Of course, the high rates of change of input voltage shown

by Fig. 5 to be necessary to produce a large output signal will be unattainable due to the frequency selective behaviour of the early cavities in the klystron.

Stereophonic Coder

The CD2L/4 Stereophonic coder is intended for use at either national or local-radio v.h.f. transmitting stations. It accepts a stereophonic pair of audio signals and delivers a multiplexed output signal conforming to the specification for the pilot-tone system. The normal input signal is programmed at zero volume, but by the movement of internal links the sensitivity can be increased by 6 dB, enabling lower-volume signals to be accepted. The input impedance is high. The coder delivers an output signal having a maximum amplitude of 1 V p-p into a load; the output impedance is also 75 Ω , unbalanced.

The left and right signals can be pre-emphasised by a time constant of 50 μ s; this is optional, depending on the positions of internal links. If the pre-emphasis is used, a suitable audio limiter must precede the coder in the chain. During stereophonic transmissions, the normal 19 kHz pilot tone is added to the output. When the monophonic mode is selected, the coder continues to process the A and B signals but does not add the pilot tone. A facility is provided for replacing the 19 kHz by a 23 kHz tone from an external source to satisfy transmitter-monitoring requirements. The selection of stereo or mono mode can be made by remote control or by means of a switch on the front panel of one of the sub-units of the coder.

The switch has contacts wired to the unit connector to enable the station 'systems normal' signalling circuit to be broken when the coder is not switched for remote control. Indicator lamps are provided for the stereophonic and monophonic modes of operation.

A monophonic signal is derived from the multiplexed output signal and is available as a balanced feed which can be used for quality-monitoring or to provide a signal for a

monophonic extension to a stereophonic distribution chain. Because this signal contains low-level components in the frequency range 19 kHz–53 kHz, an external low-pass filter may be required in some applications of the coder.

The coder comprises a monophonic signal amplifier, a stereophonic waveform generator and a 100 kHz low-pass filter, linked by a termination panel suitable for accommodation in a bay-mounting panel measuring 483 mm \times 133 mm, in which it occupies 216 mm of panel width.

General Data

Power-requirement	a.c. mains, 24 V
Input signal-level	Zero programme-volume (+6 dB by adjustment)
Input-impedance	>10 k Ω
Output signal-level	1 V p-p
Output-impedance	75 Ω
Design output-load	75 Ω
Pre-emphasis	50 μ s, optional
Pilot-tone	19 kHz \pm 2 Hz
Carrier-leakage at 38 kHz	Less than -40 dB w.r.t. 1 V p-p
Crosstalk	Less than -40 dB, 100 Hz - 10 kHz Less than -36 dB, 10 kHz - 15 kHz
Signal/Noise ratio (peak signal to peak noise, measured by PPM weighted with network specified in CCIF 1959)	Better than 70 dB
Harmonic content	Less than -50 dB for a 1 kHz input-signal at +10 dBm

Digital Sound Signals: Further investigation of Instantaneous and other Rapid Comping Systems

D. W. Osborne, C.Eng., M.I.E.E.

Research Department

Summary: Previous investigations, using simulation techniques, into the possibility of using instantaneous companding for broadcast-quality sound pulse code modulation systems have been limited in scope. This article describes subjective tests carried out with a different and more flexible method of simulating both instantaneous and 'near-instantaneous' companding. The results indicate that considerable benefits might be derived from a novel form of 'near-instantaneous' companding.

- 1 Introduction
- 2 Comping
 - 2.1 Syllabic analogue companders
 - 2.2 Instantaneous companders
- 3 Method of simulation
- 4 Comping laws
 - 4.1 General discussion
 - 4.2 Comping laws tested
- 5 The subjective tests
- 6 Results and discussion
- 7 Conclusions and recommendations
- 8 References

1 Introduction

In general the essential parameters required for a high-quality sound pulse code modulation (p.c.m.) transmission system have been determined¹ and the development of equipment by the BBC to establish a multiplex distribution system is proceeding. This equipment will be able to transmit over a video-type link up to thirteen audio channels each of which will use 14 bits per sample (including one parity check bit) at a sampling rate of 32kHz. The coding will be linear and with the use of 14-bit words the signal-to-quantising noise (q.noise) ratio would be acceptable* with up to four codecs operated in tandem.

It is likely, however, that more channels will be required in the future and means for increasing the information-carrying capacity of p.c.m. communication systems are desirable in the interests of economy. To this end various techniques² which would enable the number of bits per sample in p.c.m. systems to be reduced ('bit-saving') have been investigated. These techniques consist mainly of methods of maintaining an adequate signal-to-q.noise ratio, since the principal effect of reducing the number of bits per sample is to increase the quantising noise. This article describes an extension to a previous investigation into the possibility of using instan-

* A minimum overall signal-to-noise ratio of 63dB (peak signal/peak weighted noise) is required.

taneous companding as a bit-saving technique in a broadcast-quality sound p.c.m. system.³

2 Comping

Comping is a well-known technique for improving the signal-to-noise ratio in sound-signal processing and transmission systems. In general there are two types of companding action—'syllabic', a form often employed in analogue systems, and 'instantaneous', usually found in p.c.m. telephony systems. The main features of these two types of companding will be discussed in considerable detail to provide the reader with an understanding of the essential differences between them and of the way in which developments have led to the work described in this report.

2.1 Syllabic analogue companders

In a syllabic analogue compander a compressor, which reduces signal gain with increasing signal amplitude, is used at the sending end of a system to allow the smaller signals to be transmitted at a higher relative level, while an expander, having an output/input characteristic which is complementary to that of the compressor, is introduced at the receiving end to restore the overall gain to a constant value for all signal levels.

The maximum rate at which the gain changes in the compressor may be effected has to be restricted in order to avoid a significant increase in the bandwidth of the transmitted signal required by the additional products which are generated in the gain-modulation process, and because of the difficulty of avoiding phase distortion on the intervening signal path. If, to take an extreme case, the companding action were controlled by the instantaneous value of the signal waveform, complete restoration of the original signal would not be possible unless the waveform of the signal arriving at the expander input were identical with that at the compressor output. To avoid this difficulty, the control voltages applied to the variable-gain elements in both the compressor and expander are commonly derived from the signal envelope by rectifying circuits having smoothing time-constants of the

order of tens of milliseconds. With this arrangement, usually described as 'syllabic' companding, the control voltage is not critically dependent on the phase characteristics of the signal path; moreover, insofar as the overall gain of the system does not change significantly during one cycle of the signal, such gain errors as there are do not result in waveform distortion.

The full noise reduction is achieved only at low signal levels, for which the compressor gain is at maximum and the expander gain is at minimum. With increasing signal level, the noise level also rises, and the effectiveness of the compandor then depends on the extent to which this programme-modulated noise is subjectively masked by the programme. When the programme material is predominantly low-pitched, whereas the noise is high-pitched, there is little masking, and the result can be very objectionable, the effect being somewhat similar to multipath distortion in f.m. reception. This difficulty can be largely overcome, at the cost of some instrumental complication, by using separate compandors for different parts of the audio-frequency range. When the noise is predominantly high-pitched, a similar effect may be obtained more simply by applying considerable pre-emphasis of the higher frequencies before compression, with a corresponding de-emphasis after expansion; the operating level can then be so adjusted that reductions of compressor gain (and increases of expander gain) take place only when the signal contains high-frequency components of such a level as to mask the increase in noise.

In a multi-channel distribution network for broadcast programmes, it may be necessary to use the channels in pairs for stereophonic transmissions. Stringent requirements have then to be imposed on the compandor system to avoid unwanted differences between the gains of the left- and right-hand channels, which under both transient and steady state conditions, can give rise to image-displacement effects. These requirements can be met, but only with considerable instrumental refinement. Syllabic compandors could therefore be used to achieve bit-saving in a p.c.m. system but because of the complex analogue circuitry required they are unattractive from the points of view of both economy and reliability.

2.2 Instantaneous compandors

As stated in Section 2.1 it is not normally practicable to use instantaneous companding in an analogue system because of the difficulty of avoiding waveform distortion of the compressed signal over the transmission path. In a p.c.m. system, however, this fundamental difficulty does not arise provided all the additional products generated by an instantaneous compressor operating on the analogue signal are fed unimpaird to the analogue-to-digital converter (a.d.c.) and, at the receiving terminal, from the digital-to-analogue converter (d.a.c.) to an instantaneous expander. These requirements can be met as there is no great difficulty in providing adequate bandwidth in the circuits concerned although there are instrumental difficulties with this technique in maintaining a sufficiently precise complementary relationship between the non-linear compressor and expander characteristics. This disadvantage can, however, be overcome with an alternative technique in which compression and expansion to each signal sample is obtained by introducing a non-linear transformation between the digitally coded signal produced by the a.d.c.

and the digital signal actually transmitted, an inverse transformation being introduced at the receiving end of the system; this technique is known as instantaneous *digital* companding. Further discussion of the various methods of achieving instantaneous companding is given in Section 4.1 of this article.

The object of employing companding in a p.c.m. system, as distinct from an analogue system, is to make efficient use of the available number of quantising levels, rather than to minimise the effects of noise introduced in the transmission path. The companding laws are such that the quantum steps are effectively smaller in the regions occupied by signals of low magnitude and larger in the regions reached by signals of high magnitude. For a given number of quantising levels, the amount of quantising noise imposed on small signals can thus be reduced at the price of imposing more noise on large signals.

With instantaneous companding in a p.c.m. system the overall gain of the system is maintained precisely constant, there being no limitations of the speed and accuracy of operation as in syllabic companding. Moreover, since the expander action follows the instantaneous values of the analogue signal, as represented by successive samples, the noise power averaged over each cycle of the analogue waveform is relatively less than that produced by a syllabic expander, which follows the envelope value. From these aspects therefore, instantaneous companding appears to be potentially advantageous compared with syllabic companding, especially for stereophonic transmissions.

The subjective effects of instantaneous companding (i.e. programme-modulated quantising noise) and the techniques (e.g. pre- and de-emphasis) which can be used for reducing these effects to acceptable proportions are in general similar to those described above in relation to syllabic compandors.

Instantaneous companding is an established feature of p.c.m. systems used for telephony but a limited preliminary investigation⁹ by the BBC indicated that little worthwhile improvement to a high-quality sound-signal p.c.m. system could be obtained by using this type of companding. This preliminary investigation was limited however to a range of companding laws extending only from three to five segments.* In view of the potential advantages compared with syllabic companding it was felt that examination of the possibilities of using instantaneous digital companding in a broadcast-quality sound p.c.m. system should be extended. Accordingly, it was decided, as a first step, to resume the investigation with a different simulation technique which would be more flexible than that used in the previous investigation. This article describes this simulation technique and the results of subjective tests carried out with it.

3 Method of simulation

A simulation technique was employed which makes use of the fact that, provided the number of bits per sample is not too small and the signal level not too low, the subjective impression of quantising noise in a p.c.m. system is similar to that of white random noise. If, therefore, the level of white noise added to an audio signal is controlled by the instantaneous magnitude of the signal itself, it is possible to simulate the

* Companding laws are discussed in detail in Section 4 of this article.

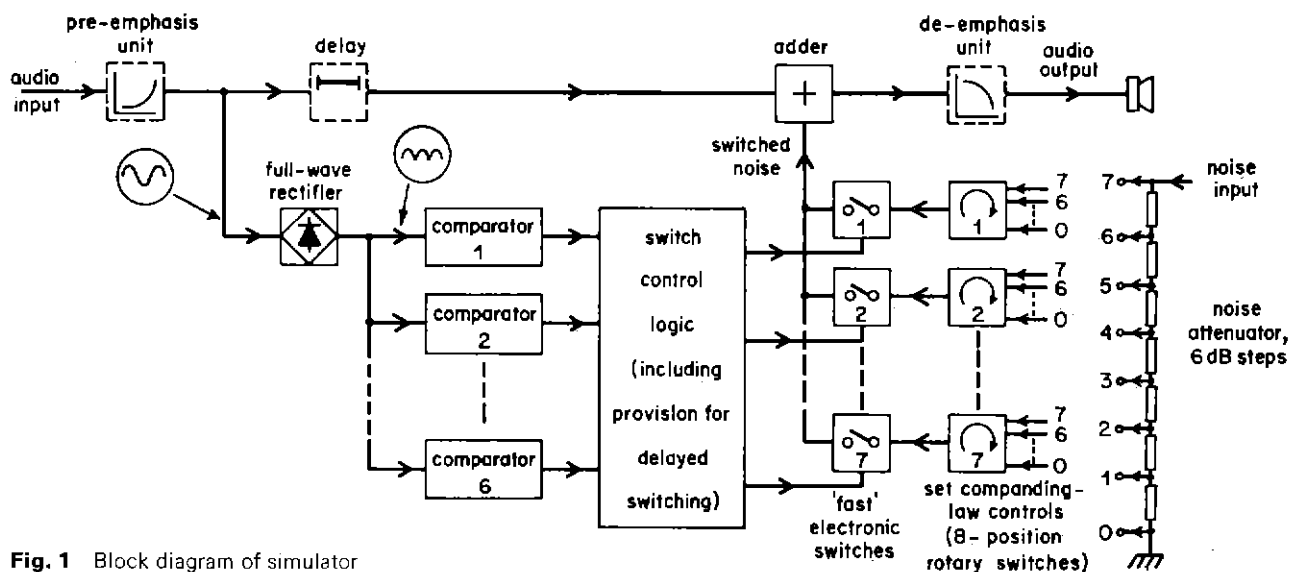

Fig. 1 Block diagram of simulator

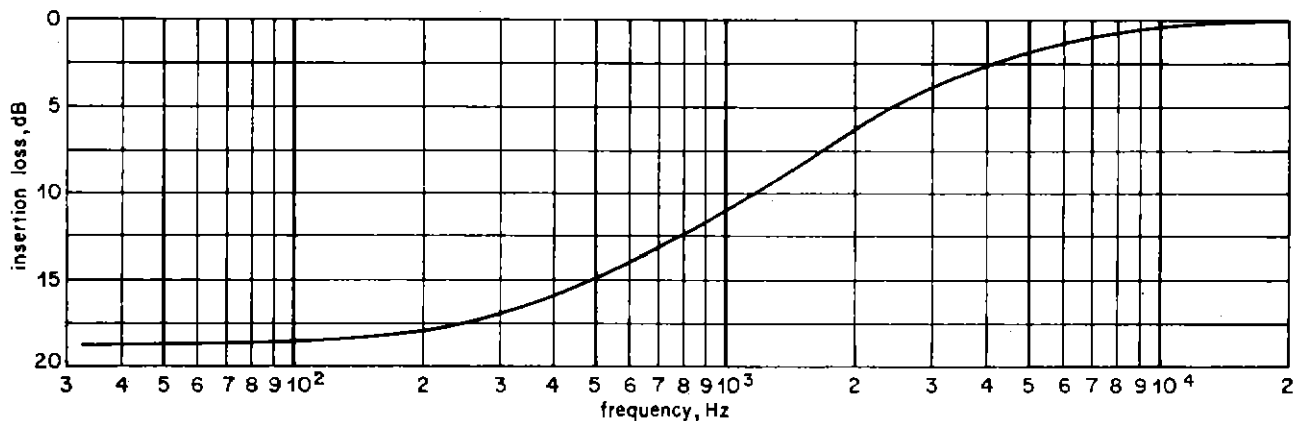

Fig. 2 CCITT pre-emphasis characteristic as used in the simulator

performance of an actual p.c.m. system employing instantaneous companding.

Fig. 1 is a block diagram showing the arrangement used to simulate the effect of companding in which the compression law consists of a number of straight-line segments. The instantaneous signal magnitudes at which changes corresponding to variations in the heights of quantum steps could be made were determined by six comparators whose reference voltages were adjusted to correspond to signal magnitudes of -6, -12, -18, -24, -30, and -36 dB relative to the peak. Other reference voltages could be set up if necessary but 6 dB intervals, each representing one step of significance in a binary system, are of particular interest in digital companding and were thought to offer a reasonable selection of laws. Each comparator was fed with a full-wave rectified version of the input signal, and each comparator output indicated when the signal magnitude, regardless of polarity, exceeded the reference level. By means of logic circuits the comparator outputs were processed to control seven electronic switches such that only one of the switches was 'ON' at any one time, each switch 'ON' condition corresponding to a particular input signal amplitude. Each electronic switch was fed with white noise, the level of which could be varied (by a manually operated switch fed from the noise attenuator chain) in 6 dB

increments. These noise level increments correspond to changing heights of the corresponding quantum steps by a factor of 2, as would occur in a purely digital compandor, where the companding action is carried out entirely by digital processing of a binary-coded signal. The outputs of the seven electronic switches were combined and fed to a mixing network in which the switched noise was added to the audio signal. Thus by adjusting the noise level fed into the noise attenuator, and by appropriately setting the noise-level selection switches, it was possible to set up the equipment to simulate various instantaneous companding laws.

Pre- and de-emphasis was used for some of the subjective tests; Fig. 1 shows the positions where the units were inserted. The pre-emphasis characteristic was that recommended by the CCITT⁴ for carrier systems. As shown in Fig. 2, however, the gain was reduced under these conditions, as would be desirable in an actual p.c.m. system so as to avoid overloading by programme material having higher-frequency components of above-average level. The effect of this gain reduction together with the use of pre-emphasis in a p.c.m. system without instantaneous companding would be to degrade the signal-to-q.noise ratio by about 3 dB. In a system with companding, however, a reduction in programme-modulated q.noise is likely to result because signal excursions to the

regions where quantising noise is high occur only for above-average levels of the higher-frequency components. Such excursions are likely to be infrequent and, in any case, mask the increased noise; the result of subjective tests supported this hypothesis. In practice the gain might be adjusted to obtain a compromise between minimising the probability of overloading and maximising the low-level signal-to-q.noise ratio. It is also possible that a different pre-emphasis curve could be evolved to enable a better compromise to be reached on these conflicting requirements.

Also shown in Fig. 1 are provisions for delays in both the audio signal path and in the logic controlling the electronic switches; the reasons for these provisions will be discussed in Section 4.1.

It is realised that the simulation technique employed is such that certain effects which might occur in an actual p.c.m. system would not appear. For example, a low-level signal superimposed on a high-level signal could suffer severe distortion at the extremes of the coding range where the quantum steps are widely spaced. However, it was thought that the most important impairment produced by instantaneous companding would be that of programme-modulated noise and the purpose of the simulator was to obtain more information on this aspect alone. If tests with the simulator proved that instantaneous companding gave rise to intolerable programme-modulated noise, then the considerable effort which would be required to develop an actual p.c.m. system with instantaneous companding would have been saved. On the other hand, if the simulator tests proved encouraging then the results could possibly provide useful information for some aspects of the design of a digital compandor, which would be the next stage in the investigation.

4 Companding laws

In this Section a general discussion of companding laws precedes a description of the particular laws tested.

4.1 General discussion

As has been stated previously, instantaneous companding involves a non-linear relationship between the analogue signal magnitude and the corresponding digital quantity. In describing a companding law it is sufficient to specify the compression law since it follows that the associated expansion law must be precisely complementary in order that the overall transfer characteristic be linear. In general the non-linear functions may be generated in the following ways:

- (a) by an analogue compressor and a linear a.d.c.
- (b) by a non-linear a.d.c.
- (c) by a linear a.d.c. followed by a digital compressor.

Method (a) has been found impracticable for high-quality sound p.c.m. systems⁵ since it is necessary in an instantaneous compandor to match the compression and expansion non-linear characteristics to a very high order of precision in order to reduce distortion to an acceptable level. Method (b) also has certain instrumental difficulties in maintaining the correct non-linear characteristic. Method (c) may be achieved by digital means if a smooth companding law is approximated by straight-line segments having slopes related by integer powers of 2. The digital manipulation may be further simplified if the

changes in slope ('break' points) occur at input signal levels corresponding to digital numbers (in the linear a.d.c.) which are also exact integer powers of 2. These considerations entered into the proposal for a thirteen-segment law, known as the 'A-law', to be used for p.c.m. telephony systems to obtain a near-constant signal-to-q.noise ratio over a wide range of input signal levels⁶. Fig. 3 shows the positive quadrant of this law; since companding laws are skew-symmetrical through the origin, it is sufficient to show only one quadrant in each case. As may be seen there are seven segments, each with a slope related by a factor of 2 to the adjacent segment, with the break points occurring at 6dB increments of the amplitude of the input signal. The height of a particular quantum step is related to the slope of the corresponding segment. If, at the initial slope through the origin, the slope corresponds to linear coding over the whole of the input signal range with n bits per sample, the final slope will correspond to $n-6$ bits per sample, whilst the number of bits actually transmitted is $n-4$, as given by the slope of the dashed line from the origin to the point $(Q, 1)$. Thus, use of such a law could be said to 'save' 4 bits.

Other laws having fewer segments may be constructed on the basis described, but it was thought unlikely that any significant benefit would be obtained from a law having a greater number of segments. The digital companding simulator, described in Section 3, was therefore designed to be able to simulate laws up to the complexity of the thirteen-segment 'A-law' shown in Fig. 3.

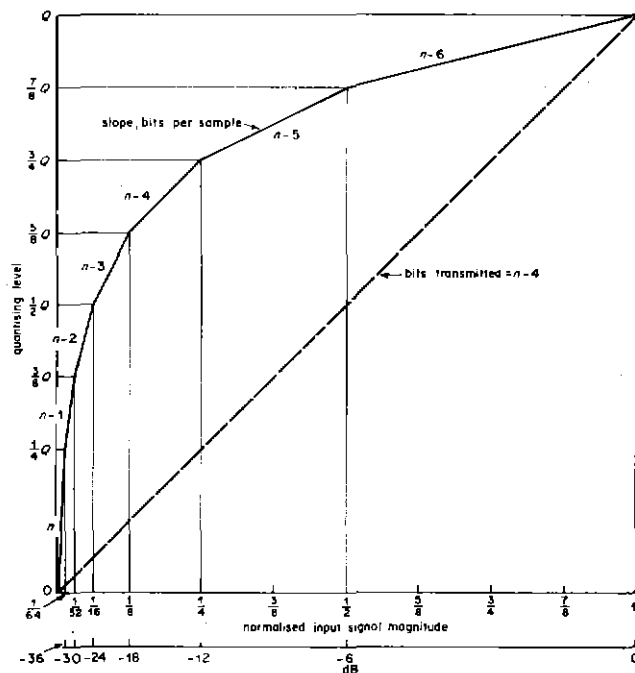

Fig. 3 13-segment 'A' companding law, positive quadrant only shown
 Q represents maximum number of digital codes available in positive quadrant

An alternative means of achieving an instantaneous companding action by a special method of digital companding has been proposed by Bartlett and Greszczuk⁷, in which, for example, a switched attenuator is inserted in the analogue

signal to a linear a.d.c. With this method of companding the compression law takes the form of a discontinuous, multi-valued function as shown by the four-range example given in Fig. 4. It is therefore necessary to include 'scale factor'

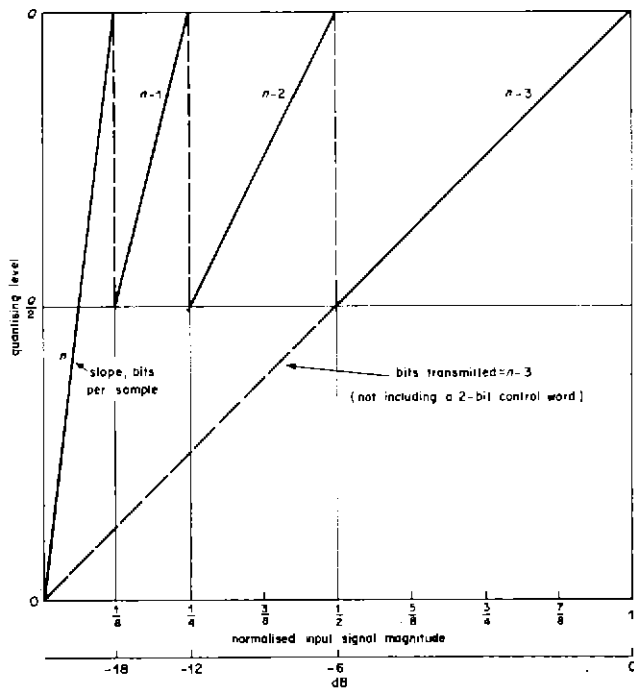

Fig. 4 Example of four-range 'a.r.c.' companding law, positive quadrant only shown
Q represents maximum number of digital codes available for positive quadrant

information with each signal-sample word transmitted so that the correct expansion gain can be inserted in the analogue output from the decoder; expansion would in practice be provided by a fixed gain amplifier and a switched attenuator. This technique is analogous to the operation of a digital voltmeter provided with automatic ranging; it will therefore be referred to for brevity as 'automatic ranging coding' (a.r.c.).

The main purpose of the original a.r.c. proposal was to avoid the use of non-linear devices and the consequent difficulty in matching compression and expansion characteristics. This difficulty can, however, be overcome with conventional multi-segment companding laws by using entirely digital techniques as discussed earlier. Nevertheless these digital techniques can be applied with advantage to the a.r.c. principle by using a form of near-instantaneous companding.

For instantaneous companding the digital a.r.c. techniques can be disadvantageous as demonstrated in Fig. 5 for the four-range a.r.c. example. Since a 2-bit word is required to identify the scale factor only one-quarter of the available number of quantising levels remains for completing the coding of the sample. Thus the full-line characteristic (a), peaking to $\frac{1}{4}Q$ is the actual law transmitted and the dotted curve (b), rising to $\frac{3}{4}Q$ is the equivalent multi-segment law. In this case, therefore, the method has 'wasted' three-eighths of the total number of quantising levels and it is not immediately attractive when we are in fact primarily concerned in saving bits. However, the action of this method of companding can be

modified so that the change from one slope of the characteristic to another need not follow every variation in the analogue signal magnitude. When the latter is increasing, the necessary changes in slope must be effected without delay to avoid non-linear distortion caused by exceeding the range of the a.d.c. When the analogue signal is decreasing, however, slope changes may be deferred for a period which is limited only by considerations of signal-to-noise ratio. Since the companding action then does not follow the instantaneous value of analogue signal, the scale-factor information or 'control word' need only be transmitted at intervals of time which are long compared with the sampling period. This form of near-instantaneous a.r.c. companding then offers the prospect of considerable bit-saving,* since, as shown in Fig. 5, the companding law then consists of the set of lines (c) with four times the slope of the instantaneous companding mode. Compared to the latter, therefore, near-instantaneous a.r.c. companding offers a further bit-saving approaching two bits for the four-range law. The actual law followed depends on the peak magnitude of the analogue signal and its frequency in relation to the rate at which control words are transmitted. For a low-frequency signal, the companding law followed would be similar to that of the conventional a.r.c. characteristic shown in Fig. 4. For high-frequency signals however the law followed

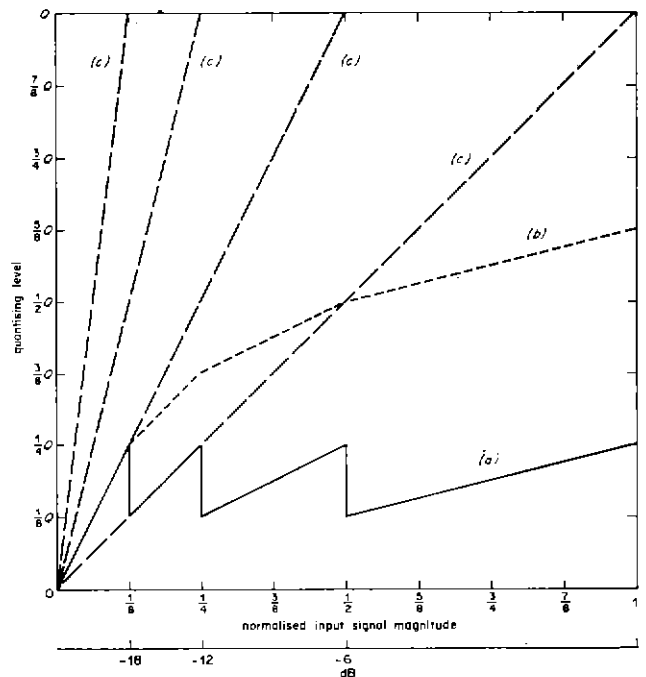

Fig. 5 Comparison of instantaneous and near-instantaneous companding laws with four-range a.r.c. law, positive quadrant only shown
Q represents maximum number of digital codes available for positive quadrant
(a) instantaneous companding a.r.c. law actually transmitted (including 2-bit scale-factor word)
(b) instantaneous companding multi-segment law equivalent to a.r.c. law
(c) laws followed with near-instantaneous companding mode of operation of same a.r.c. law (ignoring occasional 2-bit scale factor word)

* This development of the 'a.r.c.' method of companding was proposed by D. E. L. Shorter and is the subject of a patent application.⁸

would be one of the dashed lines (c) radiating from the origin in Fig. 5, the actual law is used depending on which of the four ranges ($0-\frac{1}{8}$, $0-\frac{1}{4}$, $0-\frac{1}{2}$, or $0-1$) the input signal occupied.

In practice, the control word for the near-instantaneous a.r.c. compandor could possibly be associated with the framing sequence in a multiplex p.c.m. system; it could occur once per frame and be associated with each channel on a sequential basis. If, for example, the number of active channels were sixteen and the sampling frequency 32kHz the control word would be allocated to a given channel at every sixteenth sample, i.e. at intervals of 0.5 ms. Thus the fraction of the total information-carrying capacity required for the control word would be reduced from say, 15 per cent (i.e. 2 bits in 13) for the instantaneous mode of a.r.c. companding to about 1 per cent (i.e. 2 bits in 176) for the near-instantaneous mode.

It is not proposed in this article to describe in detail how the near-instantaneous form of a.r.c. companding would be engineered. It is clear, however, that since there could be a time delay of up to about 0.5 ms before the control word for a given channel could be transmitted, it would be necessary to incorporate suitable delays in the system to avoid momentary overloading. In order to be able to test this proposed near-instantaneous form of companding, therefore, appropriate delays were made available in the simulation equipment, as shown in Fig. 1 and described in Section 3.

4.2 Companding laws tested

Initially a considerable number of companding laws were briefly tested but many were discarded either because they were clearly disadvantageous or because they were sufficiently similar to those chosen for detailed testing that it was considered unlikely that any significantly different results would

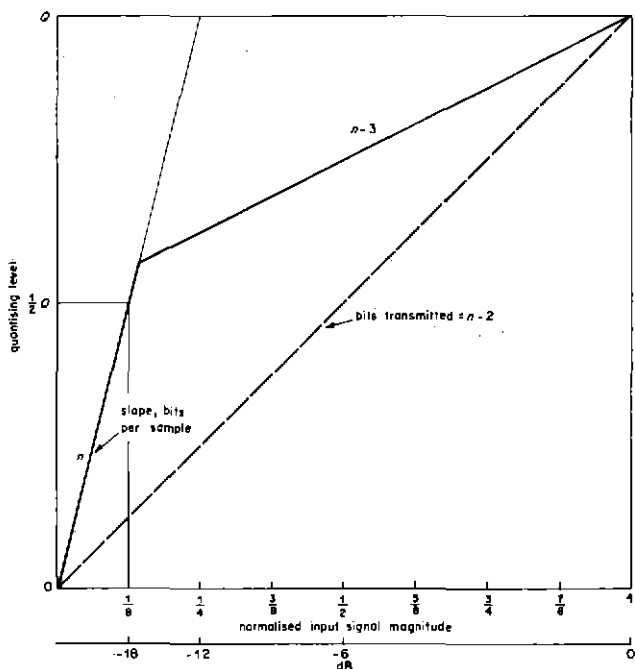

Fig. 6 Three-segment companding law, positive quadrant only shown
Q represents maximum number of digital codes available for positive quadrant

be obtained. Tests were accordingly concentrated on four laws. These consisted of the thirteen-segment 'A-law' shown in Fig. 3, the four-range a.r.c. law shown in Figs. 4 and 5, and the three-segment and seven-segment laws shown in Figs. 6 and 7. In the case of the 'A-law' (Fig. 3) and four-range a.r.c.

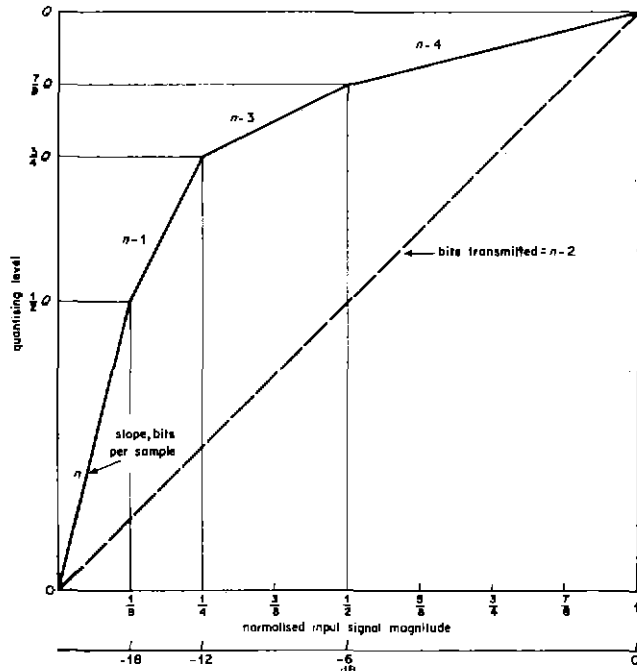

Fig. 7 Seven-segment companding law, positive quadrant only shown
Q represents maximum number of digital codes available for positive quadrant

law (Fig. 4), tests were made on an instantaneous basis and also on the near-instantaneous basis described in Section 4.1, the near-instantaneous implementation of the four-range a.r.c. law is depicted in Fig. 5. In all cases tests were made both with and without pre- and de-emphasis.

In all four laws the slope ratios are always in integer power of 2 as would conveniently apply in a digital compandor. In the case of the three-segment law (Fig. 6) a slight approximation was involved in the simulation in that the break point actually occurred at the -18 dB input signal level rather than at the level corresponding to intersection of the 'n' and 'n-3' slope lines as shown in Fig. 6. It is not considered that this minor discrepancy caused any serious errors in the subjective tests.

5 The subjective tests

Preliminary listening tests showed that the programme-modulated noise which resulted from instantaneous companding was particularly apparent with piano music. A tape-recorded excerpt of piano music was therefore used for the subjective tests. The short excerpt was rerecorded repetitively on a second tape so that listeners could more easily assess the distortion for a given condition by hearing the same excerpt many times.

Eight listeners were used, most of whom were technical staff experienced in the assessment of reproduced sound

quality and only one listener was present in the listening room at any one time. The tests were conducted using a high-quality monitoring loudspeaker type LS5/5 in a room having acoustics designed to simulate good domestic listening conditions; the sound level was adjusted to the satisfaction of each listener and left constant for the duration of each series of tests. A switch was provided which enabled the listener to switch between the impaired and unimpaired signals and, for each companding condition set up on the simulator, the listener was asked to adjust a control until he considered that the programme-modulated noise was on the threshold of perceptibility, i.e. approximately equivalent to a mean grade 1.5 on the EBU standard six-point impairment scale.

The listeners' control consisted of an attenuator inserted in the noise input path to the simulator. To be rigorous an input noise reference level should be set, for a particular companding law, so that an integer number of bits transmitted is simulated. Strictly speaking, therefore, the noise level should be varied in 6dB steps about this reference level. However, for the tests described, the noise level was adjustable in 1dB steps, thus introducing the notion of fractions of a bit, an impractical concept but one providing a finer degree of discrimination.

6 Results and discussion

The tests indicated that in all cases the use of CCITT pre- and de-emphasis, with the gain set as described in Section 3, reduced the audibility of programme-modulated noise to an extent that, on average, one less bit would be required than in the case of no pre- and de-emphasis. As discussed in Section 3 some reduction in the audibility of programme-modulated noise might reasonably be expected since the signal energy redistribution following pre-emphasis is such that signal excursions into the regions of increased quantum steps occur only for above-average level high-frequency components and are thus comparatively rare. Moreover the increased noise is effectively masked by the programme content. Only those results for tests in which pre- and de-emphasis was used are therefore given in Table 1 below.

The results, which are the mean for eight listeners, and are expressed as the number of bits required to be transmitted for each law, are presented in rank order, although in view of the rather high standard error of the mean, it is doubtful whether the smaller differences are significant.

Table 1 shows that the near-instantaneous a.r.c. implementation of the 'A' law (result 1) required the least number of bits. The next most favourable law, also on a near-instantaneous a.r.c. basis (result 2) required one additional bit. The near-instantaneous a.r.c. technique thus appears to be advantageous, presumably because the number of bits transmitted (neglecting the occasional scale-factor word) is more nearly that associated with the law of least slope, i.e. the least number of bits per sample, whereas with instantaneous companding, using a conventional multi-segment law, the number of bits transmitted is always greater than that corresponding to the segment of least slope. For example, Fig. 3 shows that the number of bits transmitted for the conventional 'A'-law would be $n-4$; for the near-instantaneous a.r.c. implementation of the same law however, the number of bits transmitted would be $n-6$. In each case n is the initial slope through the

origin and is the number of bits per sample that would be required for linear coding over the whole of the input signal range.

As described in Section 4.1, the near-instantaneous a.r.c. technique has a considerable advantage compared with the instantaneous a.r.c. technique in that transmission of the scale-factor control-word requires only a small fraction of the information rate of the main signal. However, in the near-instantaneous version, in which the companding action (except at the lower audio frequencies) is controlled by the envelope of the analogue signal, the mean noise output from the decoder must of necessity be greater than that for the instantaneous version in which the companding action follows every detail of the analogue signal waveform. This effect is apparent from a comparison of results 2 and 6 in Table 1 which shows that the 0.5ms time constant introduced into the range-changing system has caused a degradation equivalent to about 0.5 bit.

The information obtained from the simulation tests relates only to the programme-modulated noise effect of companding, and so far the discussion has been concerned with this aspect alone. However, in assessing the significance of the results, the low-level signal-to-q.noise ratio is also of prime concern. The results in Table 1 are therefore embodied in Table 2 below, in which the figures have been rounded off to the nearest number of whole bits, which also shows the slopes (bits per sample) of the initial and final segments for each law. The number of bits per sample indicating a slope is the number that would be required in a linear system with this slope maintained over the whole of the range of the input signal amplitude. The 'transmitted' value is the actual number of bits per sample required. A second set of figures is given which apply when four coding and decoding processes (codecs) in series are involved, since planning of the proposed linear p.c.m. system is effected on this basis, as outlined in Section 1.

Again, this table shows that the best law is the near-instantaneous a.r.c. 'A' law in that this requires the least number of bits to be transmitted. However, this law would require an initial slope corresponding to 14 bits per sample for a single codec or 15 bits per sample for four codecs. Now it is known from previous work¹ that 13 bits per sample is sufficient* for low-level signal requirements for a system with up to four codecs in tandem, provided that suitable artifices are employed to eliminate 'granular' distortion of low-level signals. The 'A' law does not therefore appear to be the optimum since the initial slope corresponds to 15 bits per sample. Moreover, there might well be instrumental difficulties in achieving 15 bits per sample. The next most favourable law has the desired initial slope of 13 bits per sample but requires 10 bits to be transmitted instead of 9 as for the 'A' law. It appears therefore that an optimum law may exist between

*To be exact, 13 bits per word is sufficient when no pre- and de-emphasis are in use. With pre- and de-emphasis, as described in this report, the low-level signal-to-q.noise ratio would be degraded by about 3dB as stated in Section 3. This loss could be offset by a 3dB increase in gain at the input to the a.d.c. with a corresponding reduction in gain at the output of the d.a.c. It is felt that this gain increase would be acceptable since an overload protection limiter inserted after pre-emphasis would be caused to operate only rarely due to above average level, high-frequency programme content.

TABLE 1

<i>Result</i>	<i>Law</i>	<i>Bits required to be transmitted</i>	<i>Standard deviation</i>	<i>Standard error of the mean</i>
1	Near-instant. a.r.c. 'A' law, 0.5ms delay	8.2 ÷ *	0.6	0.21
2	Near-instant. a.r.c. four-range law, 0.5ms delay (Fig. 5)	9.15 + *	1.06	0.38
3	Instant. 'A' law (Fig. 3)	9.8	1.25	0.44
4	Instant. seven-segment (Fig. 7)	9.9	1.22	0.43
5	Instant. three-segment (Fig. 6)	10.4	1.19	0.42
6	Instant. a.r.c. four-range (Fig. 4)	8.7 + 2 †	1.04	0.37

* A small increase (about 2 per cent) in this bit-rate would be required to accommodate the control word (see Section 4).

† The additional 2 bits would be required for a control word transmitted with every signal sample.

TABLE 2

<i>Result</i>	<i>Law</i>	<i>SINGLE CODEC</i>			<i>FOUR CODECS IN SERIES</i>		
		<i>Segment slopes in bits per sample</i>		<i>Transmitted bits per sample</i>	<i>Segment slopes in bits per sample</i>		<i>Transmitted bits per sample</i>
		<i>Initial</i>	<i>Final</i>		<i>Initial</i>	<i>Final</i>	
1	near-instant. a.r.c. 'A'-law, 0.5ms delay	14	8	8 + *	15	9	9 + *
2	Near-instant. a.r.c. four-range law 0.5ms delay (Fig. 5)	12	9	9 + *	13	10	10 + *
3	Instant. 'A'-law (Fig. 3)	14	8	10	15	9	11
4	Instant. seven-segment (Fig. 7)	12	8	10	13	9	11
5	Instant. three-segment (Fig. 6)	12	9	10	13	10	11
6	Instant. a.r.c. four-range (Fig. 4)	12	9	9(+2) †	13	10	10(+2) †

* A small increase (about 2 per cent) in this bit-rate would be required to accommodate the control word (see Section 4).

† The additional 2 bits would be required for a control word transmitted with every signal sample.

these two, such as for example, the five-range a.r.c. law shown in Fig. 8. With this law, implemented on a near-instantaneous basis, a satisfactory performance might be achieved with 9 bits transmitted, since the initial slope would then be 13 bits per sample.

7 Conclusions and recommendations

A simple simulation technique, in which white random noise represented the effect of quantising noise in a p.c.m. system has been used to investigate programme-modulated noise associated with the use of a number of instantaneous companding laws. In general, the results indicate that it should be

possible to obtain a satisfactory performance for a high-quality sound signal with less than the 13 bits transmitted known to be necessary for a system using linear coding with up to four codecs in tandem. The actual number of bits required depends on the companding law. The results of test indicate that possibly 10, or even 9, bits transmitted might be sufficient, using a novel form of near-instantaneous companding which would be satisfactory for stereo signals and which would thus be suitable for general use in broadcasting. A suitable compandor could probably be instrumented mainly with digital components of relatively high stability, reliability, and economy compared with their analogue counterparts.

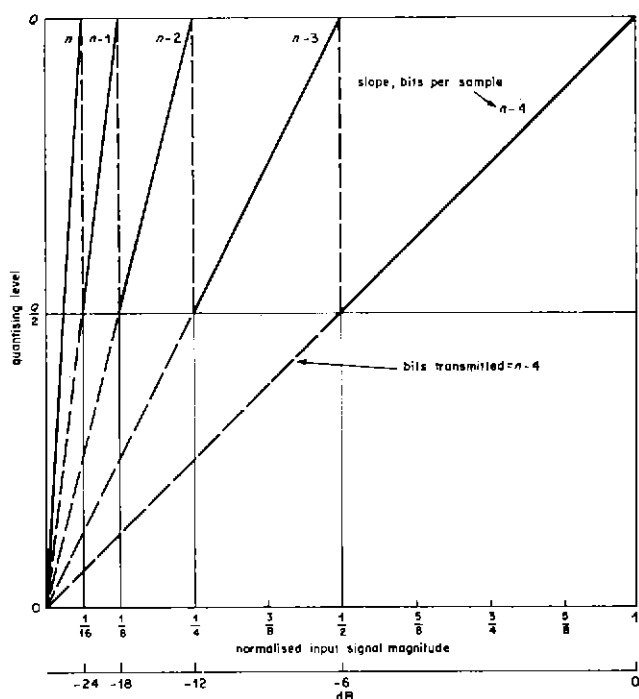

Fig. 8 Possible optimum near-instantaneous companding law, positive quadrant only shown
 Q represents maximum number of digital codes available in positive quadrant

The investigation, still using the simulator, could be continued to search for an optimum companding law, an opti-

imum pre- and de-emphasis characteristic, and to explore the effects of various delay times involved in the near-instantaneous technique. It is felt however that sufficiently encouraging results have been obtained from the work already done to justify the design and construction of an experimental p.c.m. system embodying a real digital compandor. With this, important additional aspects, such as the effects of digit errors (which would in general be expected to be different from those found in a linearly coded system), the use of 'dither' signals¹ and interaction between high-level and low-level signals, could be investigated.

8 References

1. Pulse code modulation for high-quality sound signal distribution: quantising distortion at very low signal levels. BBC Research Department Report No. 1970/18.
2. Pulse code modulation for high-quality sound signal distribution: appraisal of system requirements. BBC Research Department Report No. EL-10, Serial No. 1967/50.
3. Pulse code modulation for high-quality sound signal distribution: a simulation of instantaneous companding. BBC Research Department Report No. 1969/26.
4. CCITT Red Book, Vol. III, p. 273.
5. Pulse code modulation for high quality sound signal distribution: instantaneous compandors using diodes as non-linear elements. BBC Research Department Report No. EL-15, Serial No. 1968/7.
6. CCITT Temporary Document No. 20-E, Com.Sp.D.
7. Bartlett, C. J. C. and Greszczuk, J. 1964. Companding in a p.c.m. system. Symposium on Transmission Aspects of Communication Networks. London, I.E.E. 1964, pp. 183-6.
8. British Patent Application No. 10382/72. 6 March 1972.

Pulse-code Modulation for High-quality Sound-signal Distribution: Subjective Effect of Digit Errors

G. R. Mitchell, T.Eng.(CEI), M.I.T.E.

M. E. B. Moffat, M.A., D.Phil., C.Eng., M.I.E.E., M.Inst.P.

Research Department

Summary: In a BBC report (Report No. 1972/18) a digit-error-protection technique was recommended for use in a multiplex pulse-code modulation (p.c.m.) system for high-quality sound-signal distribution. The technique is briefly summarised in the present report. Tests have been carried out with and without the application of the protection technique to assess the impairment caused to critical programme material when random errors were introduced into the p.c.m. signal. It was found that the technique, as used in the recently commissioned BBC sound distribution links, afforded acceptable transmission performance at bit-error probabilities up to about 10^{-5} . This represents a useful improvement over the performance with an unprotected channel.

- 1 Introduction
- 2 Error-protection Technique
- 3 Assessment of programme-quality impairment due to Digit Errors
 - 3.1 Scope of subjective tests
 - 3.2 Choice of test-programme material
 - 3.3 Conduct of subjective tests
 - 3.4 Results of the tests
 - 3.4.1 Programme-pause test (A1)
 - 3.4.2 Female-reader test (A2)
 - 3.4.3 Horse-race commentary intelligibility test (A3)
 - 3.4.4 Glockenspiel test (B1)
 - 3.4.5 String-quartet test (B2)
 - 3.4.6 Average results
- 4 Conclusions
- 5 References
- 6 Appendix
 - 6.1 Details of test tapes
 - 6.1.1 Tests A1, A2, B1, B2: Tape recorded sequence
 - 6.1.2 Test A3: Tape recorded sequence
 - 6.2 Details of test forms
 - 6.2.1 Series A form: test instructions
 - 6.2.2 Series B form: test instructions

1 Introduction

For a recently completed study of multiplex distribution of high-quality sound signals by pulse-code modulation (p.c.m.),^{1,2,3} a set of experimental equipment was constructed which incorporated a digit-error protection system as described in Section 2. The work described in this article was carried out to evaluate the effectiveness of the error-concealment technique employed.

Essentially, there were three parameters whose variations with bit-error probability were investigated. They were, first and second, subjective impairments of critical programme material with and without error concealment, respectively, and third, the intelligibility of speech. The investigation was

confined to the subjective effects of random bit-errors, to which all transmission channels are prone. Other types of errors such as error bursts may sometimes be present as well, depending upon the characteristics of the particular bearer channel chosen for the p.c.m. signals. At the time that the work described here was carried out, it was known that the results of the study of multiplex p.c.m. mentioned above would probably be applied first to transmission over s.h.f. radio channels, but there was insufficient available knowledge of those channels to support burst-error tests. However, the results are valid for one kind of burst error, namely, that which is equivalent to periods of several seconds duration when a very high random-error rate prevails.

After describing the error-protection technique used, the article goes on to discuss the choice of programme material and the way in which tests were conducted to establish the subjective effect of bit errors upon that material.

2 Error-protection technique

A full description of earlier work on error-protection, and the application of the particular error-protection technique assessed in these tests, is discussed in a BBC report.³ The more important aspects of this technique may be summarised as follows.

In each sound channel the signal sample is converted into a binary number of thirteen digits, or a thirteen-bit word, to which a check bit is added for error detection in the following manner. Among the group of six consecutive bits comprising the five most significant bits in the word and the check bit, an odd number of 'ones' is preserved, i.e. the check ('parity') bit is made one or zero to ensure that the number of ones among the six bits is odd. The parity bit is added before transmission, and is computed again at the receiving terminal. If the received and recomputed values of the parity bit are different, then a transmission error is indicated and an error-concealment technique is invoked in which the erroneous word is replaced by the preceding word. The latter technique is termed zero-order extrapolation. Although the technique described is an

economic solution to the problem of random errors at low to moderate error probabilities (10^{-7} to 10^{-4}), it is desirable to mute the sound completely when the error probability is so high that the programme is unintelligible. This form of protection was not provided in the experimental equipment used here because speech intelligibility was one of the subjective factors being investigated.

The instrumental arrangement used for the tests described in this article was an experimental time-division multiplex p.c.m. system with one active channel, twelve channels bearing dummy data, and a digital synchronising signal ('framing pattern') whereby synchronisation between the sending and receiving terminals was maintained over the required range of bit-error probabilities (10^{-1} and below). The terminals were linked back-to-back via a co-axial cable, the errors being generated by the addition of white Gaussian noise at a tee-junction on the link. The average error rate in the active channel was measured by counting the detected errors at the output of the parity check unit, due account being taken of undetected errors in accordance with the curve of multiple bit-error probabilities given in Ref. 3, Fig. 4. For optimum error concealment⁹ the sound-signal chain included high-frequency pre- and de-emphasis with a $50\mu\text{s}$ characteristic, and a delay-line limiter to protect the analogue-to-digital converter from overload. The input programme level was reduced by 4dB to avoid unacceptably frequent gain-reduction by the limiter. Pre- and de-emphasis was not included for the tests where the programme was unprotected from errors.

3 Assessment of programme-quality impairment due to digit errors

3.1 Scope of subjective tests

Only random bit-errors were introduced in the subjective tests. The bit-error probability was varied from 10^{-7} to 10^{-2} when evaluating subjective impairment with and without error protection in use, and from 3×10^{-8} to 10^{-1} for the tests in which speech intelligibility was assessed, again with and without error protection.

It was intended that the subjective tests at the lower error probabilities would show by how much the bit-error probability could be increased with error protection in use without introducing significant impairment to programmes. A reasonable threshold of acceptability of high-quality sound-signal distribution systems when expressed as an average subjective impairment on the EBU six-point scale, is grade 1-5. The impairment scale is shown in Table I.

It was recognised that the speech intelligibility tests were not rigorous when judged by the standards of experts in the communication of marginally intelligible speech. The intention was simply to establish a reasonably accurate value of bit-error probability at which listeners who were prepared to make an effort to understand a programme because they were keenly interested in its information content, as for example, with crucial stages of a horse-race commentary, reached a threshold of intelligibility. There would be little point in continuing with a programme if the bit-error probability exceeded this threshold value, and channel muting should then be applied.

TABLE I

The EBU Six-point Subjective Impairment Scale

Grade	Impairment
1	Imperceptible
2	Just perceptible
3	Definitely perceptible but not disturbing
4	Somewhat objectionable
5	Definitely objectionable
6	Unusable (Intolerable)

3.2 Choice of test-programme material

The choice of programme material for these tests was governed by three main factors:

- 1 It was necessary for practical reasons to pre-record all of the test sequences on magnetic audio-tape. Programme signals which had been passed through the record-replay process only once or twice were essential to obtain the best signal-to-noise ratio and distortion level on the final presentation tapes. Masking of the effects of errors would thereby be minimised.
- 2 Several examples of critical material were desirable in order to cover the different subjective effects predominant at particular error rates. Errors in bits of lesser significance, which were always unconcealed, produced a programme-modulated noise at bit-error probabilities above about 10^{-4} , while occasional undetected word errors (two bit-errors in a word), significant only at probabilities above about 10^{-4} , caused loud clicks.
- 3 A previous preliminary investigation had indicated that a solo glockenspiel excerpt provided a very critical programme, and it was therefore used for this series of tests. A solo glockenspiel would however represent a rather rare or unusual programme and therefore the remaining excerpts were chosen, bearing in mind the other two factors, to be more representative of typical broadcast programmes.

The choice was further restricted by the need to minimise the duration of each subjective test to avoid listener fatigue, and five programme excerpts were finally chosen. Of these, one, the male-voice horse-race commentary, was used only at high error rates as an intelligibility test. The remaining four excerpts chosen were: programme pause, female reader, glockenspiel, and string quartet. The three latter excerpts were each of approximately 30s duration. The programme pause consisted of 7s of a female voice relating the end of a short story followed by a 10s pause, followed in turn by 5s of glockenspiel, (representing a programme identification 'jingle'), the total duration being 22s.

The male-voice horse-race commentary excerpt used for the intelligibility test was 16s in duration. All of the items were halved in duration in the case of the higher error rates where a rapid assessment of grading was expected, in order to reduce listener fatigue.

3.3 Conduct of subjective tests

It was thought desirable that each test condition should be presented twice, to facilitate a rough check on the consistency of each listener's judgement. This, together with the need to cover adequately the relevant range of error rates, with and

without error protection, resulted in a need for twenty-four presentations of each programme excerpt for each of the four impairment tests and eighteen for the intelligibility test. Subjective test tapes were therefore prepared on this basis with the items presented in random order, as detailed in the Appendix.

The five tests were divided between two listening sessions as shown in Table 2.

TABLE 2

The Subjective Tests

First listening session (Subjective tests, series A)

Programme pause	A1
Female reader	A2
Male-voice horse-race commentary	A3
Total duration 29 minutes	

Second listening session (Subjective tests, series B)

Glockenspiel	B1
String quartet	B2
Total duration 28 minutes	

With the exception of the commentary test A3 for intelligibility, all tests were preceded by an example of unconcealed bit-errors alone, at a bit-error probability of 3×10^{-4} . In addition, the glockenspiel test B1 was preceded by a presentation of the excerpt unimpaired by bit-errors to assist the listeners in ignoring sounds which they might attribute to bit-errors or the error-concealment technique.

In the four impairment tests, A1, A2, B1, and B2, the listeners were asked to grade the impairment of each of the twenty-four presentations using the EBU six-point impairment scale (Table 1). For the programme-pause test, A1, the listeners were asked to assess the impairment during the pause. For the intelligibility test, A3, only two alternative grades were offered to the listeners for each of the eighteen presentations, a 'U' if the commentary was considered unintelligible and an 'I' if intelligible. In all the tests each item was separated by a 5s period of silence, during which the listener was expected to write down his assessment. Details of the forms used in the tests are given in the Appendix, Section 6.2.

All of the tests were carried out in a listening room having acoustics similar to those of an average domestic living room. Not more than five listeners attended each session. The test recordings were reproduced at a sound-pressure level of approximately 85dBA on a BBC monitoring loudspeaker type LS5/5. Nine observers participated in all of the tests, and two more took part in about half of them. All of the listeners were engineers experienced to some degree in this type of subjective test, and of these about half were concerned with the critical assessment of sound quality in their normal work.

3.4 Results of the tests

As stated in Section 3.3, each test condition was judged twice by the listeners. The average of the two assessments was used in the subsequent analysis of results.

Fig. 1 shows the mean subjective impairment grade plotted against bit-error probability for tests A1, A2, B1, and B2. Comparison of the graphs with and without error protection indicates the improvement due to the error-protection tech-

nique. The mean grade for nominally unimpaired items is quoted to indicate the degree to which the sound signals were impaired by the instrumentation in the absence of bit-errors.

3.4.1 Programme-pause test (A1)

Test A1 differed from all the others in that the listeners were asked to assess the impairment during a pause between two short programme excerpts. During the pause there were no programme-modulation effects due to the errors, no masking of errors by the programme, and, apart from normal equipment noise at a low level, instrumental imperfections were imperceptible. These facts probably explain why only in this test were the listeners unanimous in finding the impairment for the nominally unimpaired condition to be imperceptible.

As shown by Fig. 1(a), with error protection the bit-error probability corresponding to a grade of 1.5 was approximately 8×10^{-6} while that for grade 2 was approximately 2×10^{-5} . For a given bit-error probability up to 10^{-3} , error protection gave an improvement of at least 1.3 impairment grades.

3.4.2 Female-reader test (A2)

Test A2, inasmuch as the programme excerpt consisted of quiet speech with some short natural pauses, produced test conditions somewhat similar to those of the previous test. The results are given in Fig. 1(b). Comparing Figs. 1(a) and 1(b) it can be seen that the curves for error protection are similar, except that in Fig. 1(b) the linear portion is displaced slightly towards the region of higher error probability. This indicates some degree of error-masking by the programme. The listeners found the nominally unimpaired excerpt to be impaired with a mean grade of 1.2, due in part to the distortion introduced in the recording and replaying of the excerpt. With error protection the results corresponding to grades 1.5 and 2 were 10^{-5} and 3×10^{-3} respectively, and the average improvement was about 1.5 grades up to a bit-error probability of 10^{-3} .

3.4.3 Horse-race commentary intelligibility test (A3)

The results of test A3 are plotted in Fig. 2 and show that the intelligibility threshold for 80 per cent of the listeners was at a bit-error probability of about 5×10^{-2} with or without error protection.

It should be emphasised here that for virtually all values of bit-error probability used in this test the programme would have been graded in the normal way as unusable (grade 6). Only when the information in the programme is vital to a listener, e.g. the announcement of a national emergency, should he be expected to tolerate such a high error rate.

3.4.4 Glockenspiel test (B1)

The results for test B1 are plotted in Fig. 1(c). They confirm the glockenspiel excerpt as the most critical of those used, with error protection giving grade 1.5 at an error probability of 10^{-6} and grade 2 at approximately 10^{-5} . However, the relatively large impairment at 10^{-4} was almost certainly due to the fact that the listeners were influenced to a large degree

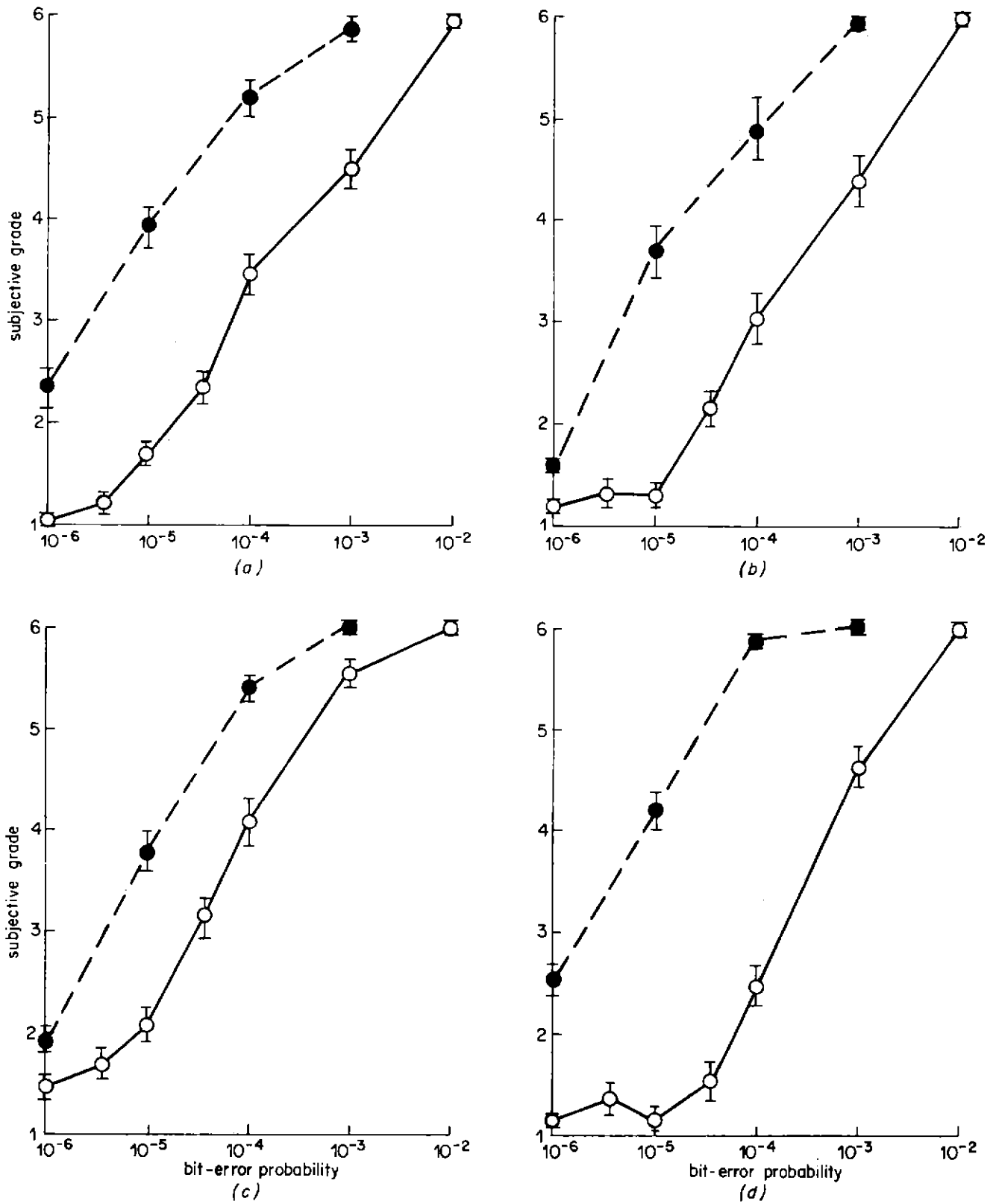

Fig. 1 Mean subjective impairment grade versus bit-error probability

	Mean grade for nominally unimpaired items	
(a) Programme-pause test, A1		1.0
(b) Female-reader test, A2		1.2
(c) Glockenspiel test, B1		1.5
(d) String-quartet test, B2		1.3
I	Twice the standard error of the mean	
	—○— Channel protected	—●— Channel unprotected

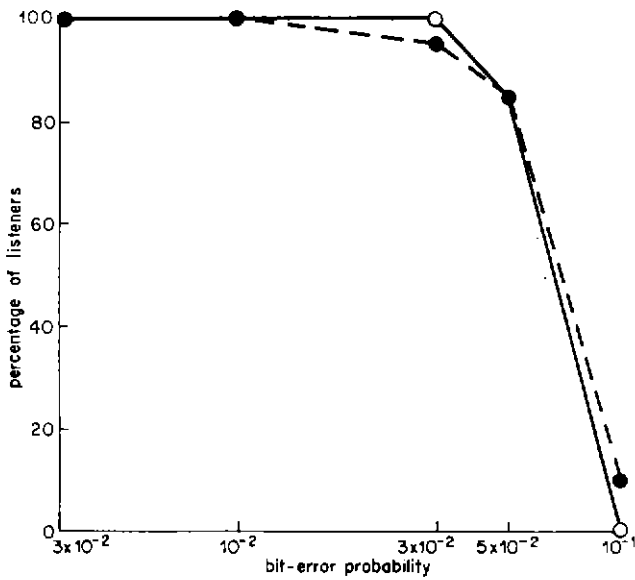

Fig. 2 Horse-race commentary intelligibility test, A3 Percentage of listeners who found the excerpt intelligible, versus bit-error probability
 —○— Channel protected -●- Channel unprotected

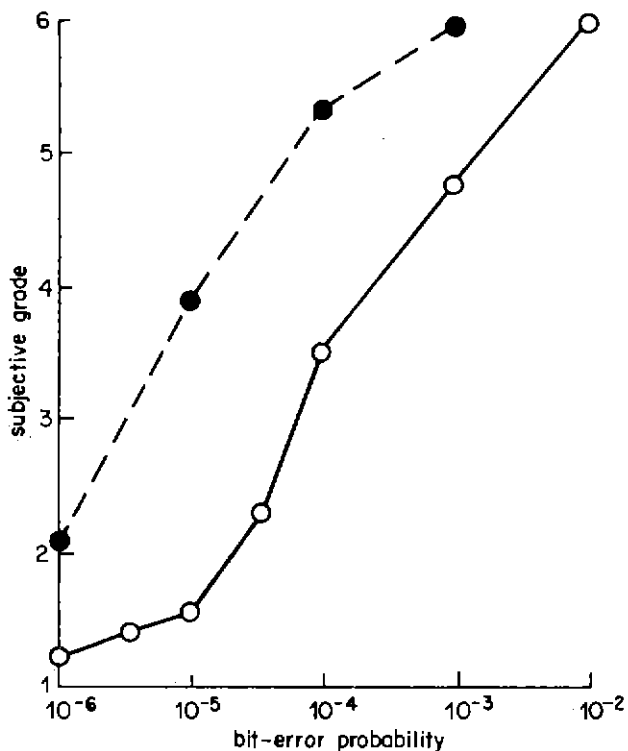

Fig. 3 Average of the mean subjective impairments in tests A1, A2, B1, and B2, versus bit-error probability
 Average of the mean grades for nominally unimpaired items = 1.25
 —○— Channel protected -●- Channel unprotected

by the nature of the programme and unavoidable imperfections in its recording and reproduction. The listeners gave a mean grade of 1.5 to the nominally unimpaired items in this test. Allowing for this it can be seen in Fig. 1(c) that error protection gave an improvement of at least one impairment grade up to a bit-error probability of about 2×10^{-4} .

3.4.5 String-quartet test (B2)

The results for test B2 are shown in Fig. 1(d) and indicate that, without error protection, we have a relatively large impairment. The error-protection technique used is, however, shown to be particularly effective for this kind of programme which is musically rich in harmonic and intermodulation content because of the non-linearities natural in string instruments. In this test grade 1.5 with error protection came at a bit-error probability of about 3×10^{-5} , and grade 2 at about 6×10^{-5} . Error protection gave an improvement of at least 1.5 impairment grades up to 10^{-3} ; there was an improvement of three grades at around 10^{-3} . The mean grade for nominally unimpaired items was 1.3.

3.4.6 Average results

The averages of the mean results shown in Fig. 1 are shown in Fig. 3. The curves indicate that with error protection grade 1.5 is reached at a bit-error probability of about 10^{-5} , and grade 2 at about 2×10^{-5} . The improvement due to error protection is seen to be at least one impairment grade over most of the range tested; the maximum improvement was about 2.3 grades.

In view of the fact that the average of the mean grades for nominally unimpaired items is 1.25, it is likely that, but for distortion in the nominally unimpaired excerpts, the curve for error protection in Fig. 3 would pass through grade 1 rather than grade 1.2 at a bit-error probability of 10^{-6} .

4 Conclusions

The subjective effect of random bit-errors upon a selection of critical programme material has been investigated with and without the use of the error-protection technique recommended for use in the distribution of high-quality sound signals by p.c.m. Also, the threshold at which an attentive listener becomes unable to understand a speech programme has been evaluated in terms of random-bit-error probability.

Using the recommended error-protection technique, it was found that for the most critical programme item included in the tests, namely a solo glockenspiel, the bit-error probability could be as high as 10^{-6} without giving a subjective impairment worse than grade 1.5 on the EBU six-point scale; grade 2 was reached at a bit-error probability of about 10^{-5} . The corresponding bit-error probabilities averaged for all the programme excerpts used in the tests were 10^{-3} and 2×10^{-5} , respectively. The use of the recommended error-protection technique was found to allow an increase by a factor of about thirty in the bit-error probability, for a given subjective grade, up to a bit-error probability of about 10^{-4} . Up to 10^{-3} the error-protection technique gave an improvement of at least

one impairment grade; the maximum improvement was about 2.3 grades at about 3×10^{-5} .

The threshold of male-speech intelligibility for 80 per cent of the listeners was found to be at a bit-error probability of about 5×10^{-2} with or without error protection.

5 References

1. Pulse-code modulation for high-quality sound-signal distribution: feasibility of multiplex system. BBC Research Department Report No. 1970/34.
2. Pulse-code modulation for high-quality sound-signal distribution: instrumentation of experimental multiplex system. BBC Research Department Report No. 1970/36.
3. Pulse-code modulation for high-quality sound-signal distribution: protection against digit errors. BBC Research Department Report No. 1972/18.

6 Appendix

6.1 Details of test tapes

6.1.1 Tests A1, A2, B1, B2: Tape-recorded sequence

Items in order on tape:

400 Hz line up tone, 8 dB below peak-programme level.

(Test B1 only: example of programme excerpt unimpaired.)

Example of p.c.m. bit-errors alone without protection at bit-error probability of 3×10^{-4} .

Item 1	P at 10^{-4}
2	U at 10^{-5}
3	U at 10^{-4}
4	P at 10^{-6}
5	U at 10^{-3}
6	P at 10^{-2}
7	P at 3×10^{-6}
8	U at 10^{-6}
9	P at 3×10^{-6}
10	P at 0
11	P at 10^{-3}
12	U at 10^{-4}
13	P at 10^{-5}
14	U at 10^{-3}
15	P at 10^{-3}
16	U at 10^{-4}
17	P at 3×10^{-5}
18	P at 0
19	P at 3×10^{-6}
20	P at 10^{-2}
21	P at 10^{-6}
22	U at 10^{-5}
23	P at 10^{-4}
24	P at 10^{-5}

U = Programme unprotected

P = Programme protected by single bit parity operating on the five most significant bits. With $50 \mu\text{s}$ pre- and de-emphasis and limiter, the input programme level being reduced by 4 dB.

6.1.2 Test A3: Tape-recorded sequence

Items in order on tape:

400 Hz line-up tone, 8 dB below peak-programme level.

Item 1	U at 10^{-2}
2	P at 5×10^{-2}
3	U at 10^{-1}
4	P at 10^{-2}
5	U at 5×10^{-2}
6	P at 3×10^{-2}
7	U at 3×10^{-3}
8	P at 10^{-1}
9	U at 3×10^{-2}
10	P at 5×10^{-2}
11	P at 10^{-2}
12	P at 3×10^{-2}
13	U at 10^{-2}
14	U at 10^{-1}
15	U at 3×10^{-3}
16	P at 10^{-1}
17	U at 5×10^{-2}
18	U at 3×10^{-2}

6.2 Details of test forms

For the subjective tests, forms were used on which boxes were provided for the entry of the listener's assessment of each item. The instructions given on the form for each test are reproduced below.

6.2.1 Series A form: test instructions

Test A1 (24 items: total duration 10 minutes):

An example of the audible effect of p.c.m. bit-errors alone precedes the test. The test material simulates a short pause between two programmes, impaired by p.c.m. bit-errors. Grade the impairment of the pause caused by the p.c.m. bit-errors, bearing in mind the nature of the two adjacent programme excerpts. The EBU subjective impairment scale should be used. (Scale of Table 1 was given on the form.)

Test A2 (24 items: total duration 12.5 minutes):

The example of p.c.m. bit-errors alone precedes the test. The test piece is an excerpt from the reading of a novel. Grade the impairment caused by the p.c.m. bit-errors, again using the EBU scale.

Test A3 (18 items: total duration 6.25 minutes):

An excerpt from a horse-race commentary is seriously impaired by p.c.m. bit-errors. State whether or not you would expect that an attentive and keenly interested listener could understand the commentary sufficiently well to prevent him declaring the programme to be intolerable *because it is unintelligible*. In other words, our special listener should be reasonably confident that he has correctly understood the commentary.

Mark the box I for intelligible, U for unintelligible.

6.2.2 Series B form: test instructions

Test B1 (24 items: total duration 14.25 minutes):

An example of the test material, namely the playing of a

glockenspiel, *unimpaired* by p.c.m. bit-errors, and an example of the audible effect of p.c.m. bit-errors alone, precede the test. Grade, according to the EBU scale shown below, the impairment of the test items caused by the p.c.m. bit-errors. (Scale of Table 1 was given on the form.)



COSINE: Coded Source-identification Equipment

The coded source-identification equipment (acronym COSINE) provides a means of inserting into the field interval of a video signal information identifying a programme, its source and its destination, and for retrieving this information and displaying it, if required, in the form of alphanumeric characters within the picture area. It has been designed for use in a 625-line television system, but could be adapted for use in systems employing other line standards. The equipment comprises the Source-identification Coder CD2/511 and the Source-identification Decoder CD3/524.

The coder is located at a studio or at an OB point. It inserts up to thirty-one alphanumeric characters, in ISO six-bit coded form, into the video signal; the characters are preceded by a coded letter A which acts as a synchronising pulse and is suppressed in the final display. The complete pulse train occupies lines fourteen and 327 of six successive fields of the video signal waveform. The pulses correspond to binary 1, and each is 0.35 V in amplitude, with a duration of 1.2 μ s.

The coder is constructed on a printed-circuit board positioned horizontally on a specially constructed chassis with a 45 mm-high (1 U) panel for mounting on a 483 mm (19 in.) bay. Behind a slot in the front panel is a row of edge-contact connectors of the type used to mate with double-sided printed-circuit boards, and into these connectors are plugged, operationally, up to thirty-one small boards, each of which defines a character of the inserted information. These character-boards are four edge-contacts wide and of convenient size to be grasped between finger and thumb. Being double sided, they are reversible and therefore their circuitry can be con-

Test B2 (24 items: total duration 13.5 minutes):

The example of p.c.m. bit errors alone precedes the test. The test piece is an excerpt from the playing of a string quartet. Grade the impairment caused by the p.c.m. bit-errors, again using the EBU scale.

nected into that of the coder in two alternative ways, enabling each board to define either of two characters, depending on the orientation with which it is inserted. The projecting character-boards are protected by a perspex cover.

The coder incorporates a power-supplier circuit, and requires a supply of a.c. mains. A switch is provided to control the output of the unit, so that it can be left powered and connected to a video circuit even when no inserted signal is required.

The decoder is located at a switching-centre, central apparatus room or other point where a display of the inserted information is required. It accepts a feed of the video signal, gates out the coded information, and applies this to a read-

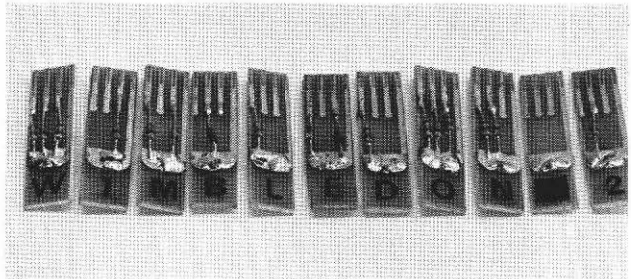
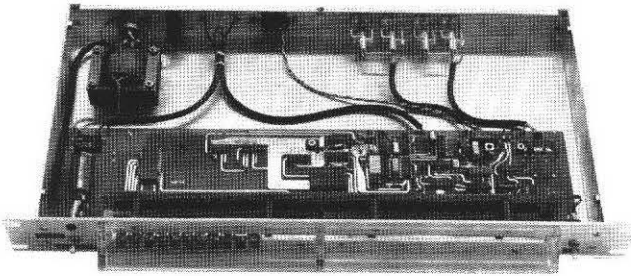

only memory character-generator. The character-generator produces signals which, when added to the video signal during the picture period, build up a display of the original alphanumeric characters, each in 5 \times 7 dot matrix form. The display is located near the top of the picture and is of dark characters in a white rectangular box, the width of which is automatically adjusted to suit the number of characters being displayed. The presence or absence of the display can be controlled by means of a circuit extended to a switch outside the unit; if this connection is not used, the display is constant.

The decoder is constructed on three printed-circuit boards on a chassis forming a plug-in module 121 mm high and occupying 108 mm of panel-width in a standard 483 mm (19 in.) bay. A separate power supplier is needed to power the decoder, and for this a supply of a.c. mains is required.



Video Tape Time-code Equipment

When a unique identification of each part of a magnetic recording is required, it can be provided by recording a time code, in the form of a serial bi-phase mark coded signal to standards adopted by the EBU (see EBU Document Tech. 3097), on the cue-track of a quadruplex video tape or on a spare track on other forms of magnetic record. (See: From Manual Splicing to Time Code Editing, *BBC Engineering*, No. 95.

The time-code signal represents data for hours (up to 24), minutes, seconds, and picture-periods ($\frac{1}{25}$ seconds), and is recorded at a rate of 80 bits per picture-period. It can be derived from television synchronising information, in which case the phasing of the picture count in the code is synchronised so that the start of a PAL four-field sequence can be identified.

A range of equipment is being developed to generate, read, and utilise the EBU time-code signals, and brief details of some of these units are given below.

Time-code-Generator

This unit generates the time-code signal from 625-line PAL television signals; either video or 7.8 kHz squarewave switching signal can be used. The generator can also be operated as 'slave' to another, similar, unit or to a time-code decoder, in which case it accepts the time-code signal as eight-digits in parallel BCD form (26 bits + earth) and converts it into serial form.

An output of eight-digit BCD logic is provided for parallel local distribution of time-information.

The logic system is not fully loaded by the information representing the time code, and the generator provides a facility for utilising the spare capacity for additional information to suit the needs of the user; the input for this purpose is in 32-bit parallel form.

A numeric display of the output time-code is provided on the front panel of the unit. The particular time from which counting is required to commence can be selected by means of thumb-wheel switches and, on operation of a further switch, the counter of the generator is set to this time and counting proceeds from it. Another switch enables the count to be either halted or advanced at the rate of one second for each operation of the switch. A fine control is provided, which enables two picture-counts to be added to or subtracted from the count by each operation of a switch.

The generator is constructed on an Imhof chassis, measuring 89 mm × 483 mm, for bay-mounting. A supply of a.c. mains is required.

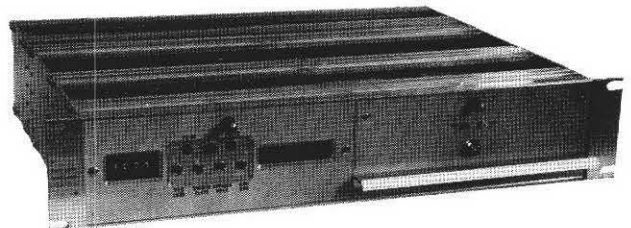

Time-code Generator GE1M/577

Time-code Decoder

This unit receives the 80 bit picture serial time-code signal reproduced from the magnetic record, after amplification, and decodes it to parallel BCD signals for driving a dot-matrix video display. The unit accepts a video signal and adds the time code to it as dot-matrix figures. The decoder comprises five plug-in units in an Imhof CDX chassis measuring 89 mm × 483 mm, for bay-mounting. A supply of a.c. mains is required.

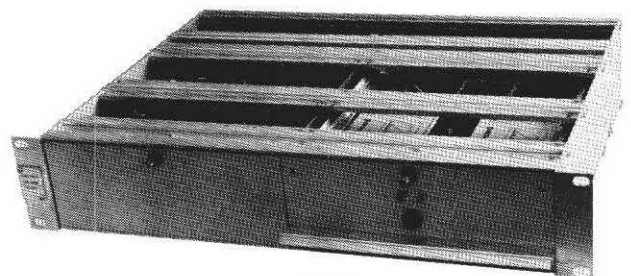

Time-code Decoder CD3M/518

Time-code Comparator-equipment EP1M/529

This equipment decodes and displays two feeds of the serial time-code signal, the difference between them and the sign (+ or -) of the difference. These displays are in the form of rows of numeric indicators behind windows in the front panel of one of the seven plug-in units which make up the equipment. The units are housed in an Imhof chassis, measuring 222 mm × 483 mm, for bay-mounting. A supply of a.c. mains is required.

Contributors to this issue

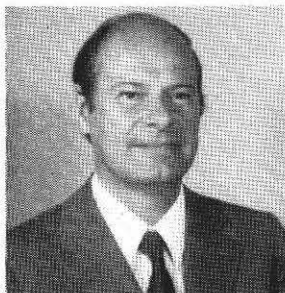

George Cook joined the BBC in 1947 as a maintenance engineer at the Brookmans Park transmitting station. In 1949 he transferred to the Transmitter Section of the Planning and Installation Department and in 1955 to the Television Service, when he became Assistant to the Superintendent Engineer, Television (Regions and Outside Broadcasts). In 1959 he was appointed Engineer-in-Charge (Television) Manchester, and in 1962 he became Head of Engineering, Wales. Since 1967 he has been Assistant Chief Engineer, Television Operations.



Andrew Lyner joined Research Department in 1967 after graduating in physics at Reading University. For most of his time in Research Department he has worked in the Transmitters and Propagation Section of Radio Frequency Group where his work has included aerial design, h.f. reflectometer design and u.h.f. power amplifier investigations.

His work at present is concerned with solid-state u.h.f. power amplifiers and an aerial array for the BBC Monitoring Service.



Dennis Osborne joined the BBC in 1943 and Research Department in 1944.

For many years he was engaged in the design of aerials for v.h.f. transmitters. More recently he was a member of the team in Special Projects Section which developed the Advanced Field-store Standards Convertors and Synchroniser for television.

In 1971 he joined Baseband Systems Section where he has been particularly associated with work on Ruggedised Sound-in-Synchs and on digital techniques for sound transmission.



George Mitchell joined the BBC in 1963, initially as a member of Radio Frequency Group at Research Department where he was concerned with the development of transmitter aerials for u.h.f. relay stations. He also assisted in tests and development of the v.h.f./f.m. stereo transmission system. Since 1966, when he transferred to Electronics Group, as a member of Baseband Systems Section, he has been involved with audio techniques, in particular assisting with the problems of level control of sound signals and with tests and instrumentation of digital sound systems.



Bruce Moffat graduated in engineering science at Oxford University in 1959. He remained at Oxford to carry out research in microwave electronics, for which he received a D.Phil. degree.

He joined the BBC in 1962 and worked in the Acoustics Section of Research Department where he was chiefly concerned with the application of computer techniques to studio acoustics.

In 1966, Dr Moffat transferred to Television Section in Research Department and investigated the problem of head-clogging in video tape recorders.

After a two-year spell working in Industry, Dr Moffat returned to the BBC in 1970 to Electronics Group of Research Department and was engaged in the development of the PCM system now used for the distribution of high-quality sound signals. In 1971 he was appointed to his present position as Head of the Baseband Systems Section of Transmission Group.

Publications available from Engineering Information Department

Information Sheets on the following subjects can be obtained from Head of Engineering Information Department, Broadcasting House, London W1A 1AA, and are available free of charge, except where otherwise indicated.

General

9002 Wavebands and Frequencies Allocated to Broadcasting in the United Kingdom

Television

- 4006 UHF Television Reception
- 9003 Television Channels and Nominal Carrier Frequencies
- 2701 Television Interference from Distant Transmitting Stations
- 4101 Television Receiving Aerials
- 4306 Test Card F
- 2001 Transmitting Stations, 405-line Services (BBC-1 and BBC Wales): Channels, Polarisation, and Powers
- 2901 Transmitting Stations, 405-line Services (BBC-1 and BBC Wales): Map of Locations
- 4003 Transmitting Stations, 625-line Services: Channels, Polarisation, and Powers
- 4919 Main Transmitting Stations, 625-line Services: Map of Locations
- 2020 405-line Television: Nominal Specification of Transmitted Waveform
- 4202 625-line Television (Colour and Monochrome): Brief Specification of Transmitted Waveform
How to receive BBC TV – 625 lines and colour

Radio

- 1042 BBC Local Radio Transmitting Stations (MF2 VHF): Frequencies and Powers
- 1701 Medium-wave Radio Services: Interference
- 1603 Stereophonic Broadcasting: Brief Description
- 1604 Stereophonic Broadcasting: Technical Details of Pilot-tone System
- 1605 Stereophonic Broadcasting: Test Tone Transmissions
- 1034 VHF Radio Transmitting Stations: Frequencies and Powers
- 1919 VHF Radio Transmitting Stations: Map of Locations

Service Area Maps

Individual maps showing the service areas for many radio and television transmitters are also available.

Specification of Television Standards for 625-Line System I Transmissions

A detailed specification of the 625-line PAL colour-television signal transmitted in the United Kingdom is published jointly by the British Broadcasting Corporation and the Independent Broadcasting Authority, and can be obtained for 50p post free from Head of Engineering Information Department, Broadcasting House, London W1A 1AA.