

BBC ENGINEERING TRAINING MANUAL

**BROADCASTING ASPECTS OF RADIO WAVE PROPAGATION
AND TRANSMITTER NETWORK PLANNING
AT FREQUENCIES ABOVE 30 MHz**

by

H.E. Farrow, C.Eng., M.I.E.R.E.

and

C.P. Bell, B.Sc.

BBC ENGINEERING TRAINING MANUAL

**BROADCASTING ASPECTS OF RADIO WAVE PROPAGATION
AND TRANSMITTER NETWORK PLANNING
AT FREQUENCIES ABOVE 30 MHz**

by

H.E. Farrow, C.Eng., M.I.E.R.E.

and

C.P. Bell, B.Sc.

Editor, Graham Higgs, C.Eng., M.I.E.E.

(C) Copyright British Broadcasting Corporation 1974

**Printed and published by
The British Broadcasting Corporation
London**

CONTENTS

Chapter		Page
	ACKNOWLEDGEMENTS	v
1.	INTRODUCTION	1
2.	TRANSMISSION AND RECEPTION: BASIC CONSIDERATIONS	3
	2.1 The Dipole Aerial	3
	2.1.1 The Short Dipole	3
	2.1.2 The Half-wave Dipole	3
	2.1.3 Gain of Dipole Relative to Isotropic Source	4
	2.2 Effective Radiated Power	5
	2.3 Field Strength in Free Space	6
3.	PROPAGATION OF V.H.F. AND U.H.F. SIGNALS IN THE PRESENCE OF THE GROUND	11
	3.1 Characteristics of Signal Propagation under Normal Conditions	11
	3.1.1 General	11
	3.1.2 The Free-space Wave	11
	3.1.3 The Ground-reflected Wave	12
	3.1.4 Effect of Earth's Curvature	21
	3.1.5 Refraction and Diffraction	21
	3.1.6 Other Effects of Terrain upon the Level of Received Field Strength	35
	3.2 Characteristics of Signal Propagation under Abnormal Conditions	37
	3.2.1 General	37
	3.2.2 Abnormalities in the Troposphere	37
	3.2.3 Abnormalities in the Ionosphere	43
4.	ESTIMATION OF FIELD STRENGTH	47
	4.1 General	47
	4.2 Service Area Field Strength Predictions	47
	4.2.1 General	47
	4.2.2 Use of Field Strength Curves	49
	4.2.3 Predictions for a Specific Path	55
	4.3 Field Strength Predictions for Abnormal Propagation Conditions	57

Chapter	Page
5. REQUIREMENTS FOR SATISFACTORY TELEVISION	
RECEPTION	67
5.1 General	67
5.2 Minimum Signal-to-Noise Requirements	67
5.3 Interference from Other Television Transmitters	71
5.3.1 General	71
5.3.2 Interference from Stations Operating on Different Line-standards	72
5.3.3 Interference from Co-channel Stations with the Same Line-standard	72
5.3.4 Local-oscillator, Harmonic and Image-channel Interference	74
5.3.5 Receiving Aerial Directivity and Polarisation Protection	76
5.4 Multipath Effects	76
5.4.1 General	76
5.4.2 Reflections from Hills or Large Buildings	76
5.4.3 Reflections from Aircraft	79
5.4.4 Reflections from the Surface of the Sea	81
5.5 Corona and Precipitation Interference	88
6. V.H.F. TELEVISION BROADCASTING	91
6.1 Transmission and Modulation Characteristics	91
6.2 Television Broadcasting in Band I	94
6.2.1 Historical	94
6.2.2 Network Planning Considerations	94
6.2.3 Propagation Characteristics in Band I	96
6.3 Television Broadcasting in Band III	99
6.3.1 Historical	99
6.3.2 Network Planning Considerations	100
6.3.3 Propagation Characteristics and Minimum Field- strength Requirements in Band III	102

Chapter	Page
7. U.H.F. TELEVISION BROADCASTING	105
7.1 Transmission and Modulation Characteristics	105
7.2 Historical	105
7.3 Transmission and Network Planning Considerations ...	108
7.3.1 Transmitting Aerials	108
7.3.2 Frequency Allocations	114
7.3.3 The Transmitter Network	117
7.3.4 Active Deflectors	118
7.4 Propagation Characteristics at U.H.F.	120
7.4.1 Diffraction	120
7.4.2 Ground Reflections and Standing-wave Effects ...	122
7.4.3 Delayed Image Interference	123
8. FREQUENCY MODULATED SOUND BROADCASTING ...	125
8.1 Historical	125
8.2 Pre-emphasis and De-emphasis	127
8.3 Requirements for Satisfactory V.H.F. Radio Reception ...	128
8.3.1 General	128
8.3.2 Minimum Signal-to-Noise Requirements	128
8.3.3 Channel Spacing and Protection Radio	132
8.4 Choice of Plane of Polarisation	135
8.5 Stereophonic Broadcasting	138
8.6 Service Impairments due to Reflections	142
9. S.H.F. PROPAGATION	147
9.1 Introduction	147
9.2 Diffraction	147
9.3 Reflections	148
9.4 Variations in Refractive Index, and Use of Diversity Reception	153
9.5 Atmospheric Attenuation	154
9.6 Examination of Proposed Transmission Paths	155
9.6.1 General	155
9.6.2 Path Profiles	155
9.6.3 Allowance for Earth Curvature	158
9.6.4 Effect of Refraction	159
9.6.5 Fresnel Clearance	162

Chapter	Page
9. S.H.F. PROPAGATION <i>(continued)</i>	
9.7 Requirements for Satisfactory Reception Quality	167
9.7.1 General	167
9.7.2 Transmission Loss or Path Attenuation	171
9.7.3 Signal-to-Noise Ratio Requirements	175
REFERENCES AND BIBLIOGRAPHY	183
APPENDIX A. BAND-I TELEVISION STATIONS IN THE U.K. ...	189
APPENDIX B. BAND-II F.M. SOUND RADIO TRANSMITTERS IN THE UNITED KINGDOM	193
INDEX	199

ACKNOWLEDGEMENTS

Thanks are due to the Institution of Electrical Engineers for permission to reproduce Figs. 18, 33, 34 and 36 and to the CCIR for permission to reproduce Figs. 21 to 31, 46 and 48.

CHAPTER 1

INTRODUCTION

This Manual provides a survey of the broadcasting aspects of radio propagation at frequencies above 30 MHz. The relevant frequency bands are

- (a) *Very High Frequency* (v.h.f.) 30 to 300 MHz, in which the bands used for broadcasting in the U.K. are
- | | | |
|----------|----------------|--------------------------------------------------------------------------------------|
| Band I | 41 to 68 MHz | 5 television channels (1-5) used by the BBC. |
| Band II | 88 to 100 MHz | A number of f.m. sound channels used by the BBC* between 88 MHz and 97.6 MHz. |
| Band III | 174 to 216 MHz | 8 television channels (6-13) used primarily by the IBA with some sharing by the BBC. |
- (b) *Ultra High Frequency* (u.h.f.) 300 to 3000 MHz, in which the bands allocated to television broadcasting by the BBC and IBA in the U.K. are
- | | | |
|---------|----------------|---------------------------------|
| Band IV | 470 to 582 MHz | 14 television channels (21-34). |
| Band V | 614 to 854 MHz | 30 television channels (39-68). |
- (c) *Super High Frequency* (s.h.f.) 3000 to 30,000 MHz, in which two fairly narrow bands of frequencies around 11,000 MHz (11 GHz) and 7000 MHz (7 GHz) are used for permanent programme feeds and television outside broadcast links (often called *microwave links*).

Within these limits the Manual aims to explain the general principles of radio propagation and to discuss simply the factors influencing the transmission and reception of signals and so determining whether or not the output of a receiver is satisfactory. A number of references are given for those wishing to study any particular topic further.

Detailed discussion of aerials is outside the scope of this Manual and may be found, for example, in BBC Technical Instruction T.11⁽¹⁾, and other publications.

The modes of propagation of signals in different bands above 30 MHz show basic similarities and to discuss each fully would involve repetition. Consequently characteristics of signal propagation are discussed first in general terms and the

*and, as from 1973, also by the IBA for local radio.

differences appropriate to the various broadcasting bands are considered in the later Chapters.

The mathematical treatment of radio wave propagation, based upon the Maxwell wave equations, does not come within the scope of this Manual, but is of course fully discussed in appropriate reference textbooks^{(2), (3)}. It suffices here to state that the wave equations describing the electromagnetic field around an aerial in free space yield a solution containing several terms, all but one of which show field intensity to decrease rapidly with distance so that it is negligible beyond a few wavelengths from the aerial. The remaining term describes a field having electric and magnetic components in phase and with field strength inversely proportional to distance. This wave may itself be divided into component parts comprising a space wave and a surface wave. As its name implies, the surface wave mode depends on the presence of the earth's surface and is the principal mode of propagation in daytime at m.f. It is of negligible importance above about 40 MHz and will not be further discussed.

The only mode of radio wave propagation of importance at v.h.f., u.h.f. and s.h.f. is the space wave, which in principle is not affected by the presence of the earth. As will become clear in later Chapters the received signal is however greatly modified by reflections and diffractions due to the presence of the terrain intervening between transmitting and receiving terminals.

CHAPTER 2

TRANSMISSION AND RECEPTION: BASIC CONSIDERATIONS

2.1 The Dipole Aerial

The basic functions of a transmitting aerial are, firstly, to act as an impedance-matching device matching the transmission line impedance to that of free space and, secondly, to direct the transmitted radiation into desired directions. A completely omnidirectional or *isotropic* aerial radiates energy equally in all directions. Such an aerial is neither practicable nor generally desirable, but is a convenient theoretical concept, particularly for gain comparison purposes.

2.1.1 The Short Dipole

In practice, any radiating element must have some finite length, and thus forms an elementary dipole. The magnitude of the field strength E in free-space at distance d from such a dipole is given by

$$E = \frac{60\pi}{\lambda d} M \sin \theta$$

where M = the moment of the dipole
 = product of mean current I and dipole length l
 = Il

and θ = the angle between the dipole axis and the point of reception
 (see Fig. 1)

Due to the axial symmetry of the dipole, the horizontal radiation pattern is uniform, i.e., a circle, when the dipole is vertical. In any vertical plane through the axis the field varies as $\sin \theta$.

2.1.2 The Half-wave Dipole

If the dipole is centre-fed and of overall length equal to half the radiated wavelength, the current distribution is not uniform, but approximates to a cosine law, i.e., the current at angular distance γ radians from the centre feed point has a value proportional to $\cos \gamma$.

The mean current is therefore given by

$$I_{\text{mean}} = \frac{2}{\pi} \int_0^{\pi/2} \cos \gamma \cdot d\gamma = \frac{2}{\pi} I_{\text{max}}$$

where I_{max} is the r.m.s. value of current at the feed point ($\gamma = 0$).

Hence the moment of a half-wave dipole

$$\begin{aligned} &= (\text{mean current}) \times (\text{dipole length}) \\ &= \frac{2}{\pi} I_{\text{max}} \times \frac{\lambda}{2} = I_{\text{max}} \frac{\lambda}{\pi}. \end{aligned}$$

It is usual to specify the current I in a half-wave dipole by the r.m.s. value of the maximum current, that is, by I_{max} as just defined. Consequently the dipole moment is the product of this current and a factor given by λ/π . This factor is generally termed the *effective length* of the half-wave dipole.

The free-space field strength at distance d in the plane through the centre of a half-wave dipole and perpendicular to its axis is given by

$$E = \frac{60\pi}{\lambda d} \times I \frac{\lambda}{\pi} = \frac{60I}{d}.$$

For any other angle θ relative to the dipole axis, the magnitude of the field strength is less than that for $\theta = 90^\circ$ and is given by

$$E = \frac{60I}{d} \times \frac{\cos\left(\frac{\pi}{2} \cos \theta\right)}{\sin \theta}$$

2.1.3 Gain of Dipole Relative to Isotropic Source

No power is radiated along the axis of a dipole and the relative fields at other angles θ are as given in the equation above. Maximum fields are radiated perpendicular to the dipole axis. It follows therefore that if equal power is radiated from an isotropic source and from a dipole aerial, a greater proportion of this power is radiated by the dipole in the plane through its centre perpendicular to its axis. The dipole is thus said to possess gain relative to an isotropic source in this plane. For a short dipole this power gain is 1.5 (1.76 dB),

and for a half-wave dipole is it 1.64 (2.16 dB). This characteristic of aerial gain due to the directional properties of a dipole is shown in Fig. 1.

For engineering purposes the half-wave dipole is the usual reference transmitting or receiving aerial, since it forms the basic element of most aerial arrays used at v.h.f. and u.h.f.

2.2 Effective Radiated Power

At v.h.f. and u.h.f., the wavelength is sufficiently small for it to be convenient to build transmitting aerial arrays consisting of a number of radiating elements (usually half-wave dipoles or derivatives of these), thereby giving a certain directivity in the vertical plane. Most of the coverage of a given transmission is produced by the power radiated at or near the horizontal; power radiated at angles considerably above or below this plane does not contribute usefully to the coverage and is therefore wasted. Useful increases in range can be achieved by concentrating the radiated power into a narrow horizontal beam. This is achieved by stacking radiating elements above each other, generally with vertical separations of the order of a wavelength. An aerial of this type possesses gain relative to a single half-wave ($\lambda/2$) dipole, the gain depending upon the extent to which the elements are stacked, usually expressed as the vertical radiating aperture in wavelengths.

The *horizontal radiation pattern* (h.r.p.) required depends upon the siting of the transmitter in the area to be covered. High power transmitters are generally sited near the centre of the service area, and omnidirectional radiation patterns are therefore required, i.e., equal radiation is wanted all round the transmitter. There are, of course, exceptions to this, as for example when it is required to 'fill in' an awkwardly shaped area, or to cover an area without causing interference to other transmissions on the same or adjacent channels. For these installations, the transmitting aeriels might have h.r.p.s that are far from omnidirectional, often with deep minima. Specifications of such aeriels usually quote the maximum and minimum radiated power figures, with directions of maxima.

The field strength obtained at a given receiving location depends both on the power supplied to the transmitting aerial and on the gain of this aerial in the direction of the receiving location. A transmission is usually specified in terms of its effective radiated power (e.r.p.) in any direction. This is the equivalent power which must be applied to a single $\lambda/2$ dipole to produce the same field strength as the original transmission at any receiving location in the particular direction. As already discussed in Section 2.1.3, a $\lambda/2$ dipole itself possesses gain relative to an isotropic source. In some contexts, it is usual to specify the

gain of a transmitting (or receiving) aerial relative to such an isotropic source rather than to a $\lambda/2$ dipole, the corresponding power relationship being given as the *effective isotropic radiated power* or *e.i.r.p.* The e.i.r.p. of a particular aerial will exceed the e.r.p. by a constant factor of 1.64 (2.16 dB) corresponding to the gain of a $\lambda/2$ dipole relative to the isotropic source.

2.3 Field Strength in Free Space

The first step in the determination of the coverage of a transmission is to consider the field strength of the signal radiated by the transmitting aerial.

Let us first consider some simple power relationships for a plane electromagnetic wave*.

Ignoring end effects, the capacitance between two square metal plates forming opposite sides of a one-metre cube is given by

$$C = 10^{-9}/36\pi \text{ farads} = 8.8 \text{ pF.}$$

The energy stored between the plates with voltage E between them is given by

$$\text{Energy} = \frac{1}{2}CE^2 \text{ joules.}$$

Since the spacing between plates is 1 metre, the field strength in the dielectric is E volts/metre and the stored energy density is $\frac{1}{2}CE^2$ joules/metre. This represents the energy density in air of any steady electric field, and also of an alternating field providing E corresponds to the r.m.s. value. The total energy is the sum of the equal magnetic and electric field energies and is therefore given by

$$\text{Total Energy} = CE = E^2 \times 10^{-9}/36\pi \text{ joules/metre}^3.$$

The velocity c of an electromagnetic wave in vacuo is 3×10^8 metres/second, and therefore an area of wavefront 1 metre square will sweep through a volume of 3×10^8 cubic metres in one second. The total energy in this volume is

$$3 \times 10^8 \times E^2 \times 10^{-9}/36\pi = E^2/120\pi \text{ joules.}$$

This total amount of energy crosses a square metre of area perpendicular to the direction of propagation each second and hence the power through this square

*Method of analysis suggested by H.V. Sims of BBC Engineering Training Department.

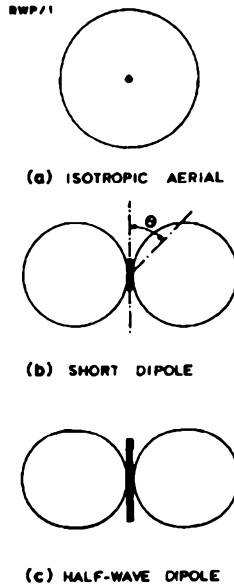

Fig. 1. Relative field patterns of isotropic, short dipole and half-wave dipole aerials

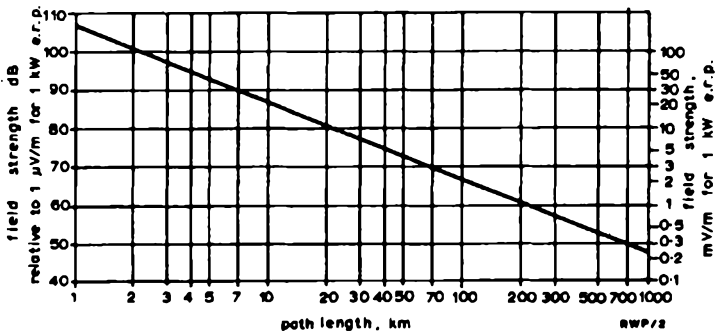

Fig. 2. Free-space field strength as a function of path length

metre is $E^2/120\pi$ or, alternatively, the power in a plane wavefront

$$P = E^2/120\pi \text{ watts/metre}^2.$$

This expression conforms to the basic relationship

$$\text{Power} = \text{Voltage}^2/\text{Resistance}$$

in which the constant 120π can be considered as a resistive impedance, generally referred to as the *characteristic impedance of free space*.

Let us now consider the radiation from an aerial, which for convenience can be assumed to be an isotropic source. Suppose this isotropic source is situated at the centre of a sphere of radius r metres, and surface area A equal to $4\pi r^2$ square metres. Since the source radiates power P uniformly over the surface, the power per unit area at radius r is

$$P/4\pi r^2 \text{ watts/metre}^2.$$

Equating this to the power value previously derived, we have

$$E^2/120\pi = P/4\pi r^2$$

or
$$E = \sqrt{30P}/r \text{ volts/metre.}$$

Providing the radius r is sufficiently large, the wave may be considered to be plane, in which case it is more usual to express the field in terms of a distance d .

As discussed in the previous section, it is more convenient to relate field strength to a standard represented by a $\lambda/2$ dipole rather than to an isotropic source. Since a $\lambda/2$ dipole has a gain of 1.64 relative to an isotropic source, the field strength at distance d from a $\lambda/2$ dipole is given by

$$E = \frac{\sqrt{30 \times 1.64 \times P}}{d} = \frac{7\sqrt{P}}{d} \text{ volts/metre.}$$

A convenient field strength reference is that occurring at 1 km for a power of 1 kW. For a $\lambda/2$ dipole source, this is given by

$$E_1 = \frac{7\sqrt{10^3}}{10^3} = 220 \text{ mV/m} = 107 \text{ dB above } 1 \mu\text{V/m.}$$

This means that a transmission with an e.r.p. of 1 kW in any direction produces a field strength of 220 mV/m at a distance of 1 km in that direction if situated in free space. Similarly, as voltage is proportional to $\sqrt{\text{power}}$, an e.r.p. of 100 kW produces a field strength of 2200 mV/m at 1 km. The relationship between free space field strength and distance is of fundamental importance in field strength prediction and is represented in Fig. 2. In this diagram the field strength has for convenience been expressed in logarithmic form as dB relative to 1 $\mu\text{V/m}$. Since field strength is inversely proportional to distance, the use of a logarithmic ordinate scale also requires a logarithmic abscissa to retain a straight-line relationship.

CHAPTER 3

PROPAGATION OF V.H.F. AND U.H.F. SIGNALS
IN THE PRESENCE OF THE GROUND

3.1 Characteristics of Signal Propagation under Normal Conditions

3.1.1 General

We have established the relationship between transmitter power and field strength in free space and can now examine the behaviour of the radiated signal as it travels toward the receiver when both terminals are situated just above the surface of the earth. Various transmission modes are possible. These are

1. The direct or free space wave, which follows the shortest path between two intervisible terminals.
2. The ground or surface wave such as is the principal mode at medium and low frequencies⁽⁴⁾.
3. A wave reflected from ionised layers as at high frequencies.
4. A wave reflected from the ground or other large surface.
5. A wave that is refracted or 'bent' in the lower atmosphere, particularly during abnormal atmospheric conditions.

Of these modes, the surface wave may be ignored because at frequencies above 40 MHz the attenuation is so high that the mode contributes almost nothing toward the coverage. Ionospheric modes may be relevant to Band-I coverage as will be discussed in 3.2.3, but are of little practical significance at Band-II frequencies and above.

3.1.2 The Free-space Wave

The magnitude of the free-space wave component of the received signal may be derived from Fig. 2 with suitable correction for e.r.p.s greater or less than 1 kW. For example, the free-space field strength at a distance of 55 km from a transmission having an e.r.p. of 25 kW is given by

$$E = \frac{220\sqrt{25}}{55} = 20 \text{ mV/m or } 86 \text{ dB above } 1 \mu\text{V/m.}$$

For this signal component to be received without attenuation, there must be no obstacle intervening between transmitting and receiving terminals.

3.1.3 The Ground-reflected Wave

Suppose that power is radiated from a transmitter aerial T (Fig. 3) at height h_t above ground level (a.g.l.) and is received by an aerial at R at height h_r a.g.l., the intervening ground being flat and smooth. The resultant signal may, if the effects of the upper and lower atmosphere are neglected, be considered as the vector sum of the two components traversing paths TR and TOR.

For normal path geometries, the angle β in Fig. 3 is usually small, and hence path length TR is nearly equal to TOR, insofar as the effect upon signal amplitude is concerned. However, the small path difference may be an appreciable fraction of a wavelength, and may therefore significantly affect the vector sum of the two components.

Furthermore, the process of ground reflection introduces a change of both amplitude and phase. The evaluation of ground reflection coefficients is complicated, since many factors are involved including frequency, polarisation*, angle of incidence, the conductivity and permittivity of the ground at the point of reflection and the roughness of the ground at this point.

Tables⁽⁵⁾ and series of curves^{(6), (7)} are available relating modulus and phase angle of reflection coefficient to these parameters, assuming the ground to be smooth. Examples of these curves are shown in Figs. 4a to 4d, which give the modulus and phase angle for ground of typical conductivity and permittivity. These diagrams show one of the interesting differences between horizontal and vertical polarisation. This is, that if the angle of incidence is reduced gradually from 90°^\dagger , the modulus and phase angle of the reflection coefficient remain sensibly constant for horizontal polarisation, but vary considerably for vertical polarisation. For this latter, the modulus goes through a minimum, with a rapid variation of phase angle. The angle of incidence at which this occurs is known as the *pseudo-Brewster angle*.

This difference between signals of horizontal and vertical polarisation is of considerable importance in calibrating aerials for field strength measurement. For this purpose horizontal polarisation is preferred, being less dependent upon ground constants so that measurements are more easily checked by calculation. For broadcasting however the differences, with two exceptions

* By convention, the plane of polarisation, e.g., vertical or horizontal, is always given for the electric vector. The magnetic vector is at right-angles to this.

† The angle of incidence is measured from the normal to the surface and thus corresponds to $(90 - \beta)^\circ$. See Fig. 3.

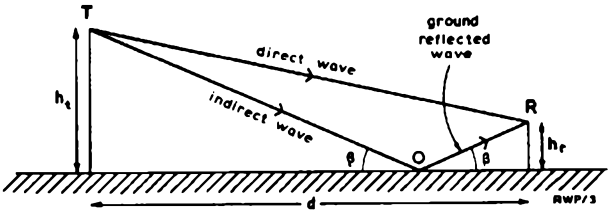

Fig. 3. Idealised path profile between transmitter T and receiver R

discussed in Chapters 7 and 8, are not usually significant since the heights and distances involved restrict our interest to angles within one or two degrees of 90. The incident wave thus makes a very small angle with the ground and hence the expressions *grazing incidence* and *grazing angle* are often used. It is clear from Fig. 4 that for grazing incidence and either plane of polarisation it is roughly true to say that the reflection coefficient is -1 , i.e., has a modulus of unity and a phase angle of 180° .

In Fig. 3, for very small angles β , the total signal at R is the resultant of two components of equal amplitude which are almost in antiphase. The reason for their not being exactly in antiphase is that path TR is slightly shorter than path TOR. This situation must be examined in more detail.

$$\text{Path length TR} = \sqrt{d^2 + (h_t - h_r)^2}$$

$$\text{Path length TOR} = \sqrt{d^2 + (h_t + h_r)^2}$$

$$\text{Whence TOR} - \text{TR} = \sqrt{d^2 \left[1 + \frac{(h_t + h_r)^2}{d^2} \right]} - \sqrt{d^2 \left[1 + \frac{(h_t - h_r)^2}{d^2} \right]}$$

$$\text{Since } d \gg (h_t + h_r), \quad \frac{(h_t \pm h_r)^2}{d^2} \ll 1$$

and the binomial expansion $\sqrt{1+a} \simeq (1+a/2)$ is valid.

$$\begin{aligned} \text{Hence TOR} - \text{TR} &\simeq d \left[1 + \frac{(h_t + h_r)^2}{2d^2} \right] - d \left[1 - \frac{(h_t - h_r)^2}{2d^2} \right] \\ &= \frac{(h_t + h_r)^2 - (h_t - h_r)^2}{2d} \\ &= \frac{4h_t h_r}{2d} = \frac{2h_t h_r}{d} \end{aligned}$$

This difference is expressed in linear units, but to obtain the vector sum it is necessary to convert to angular units. The angular phase difference, α ,

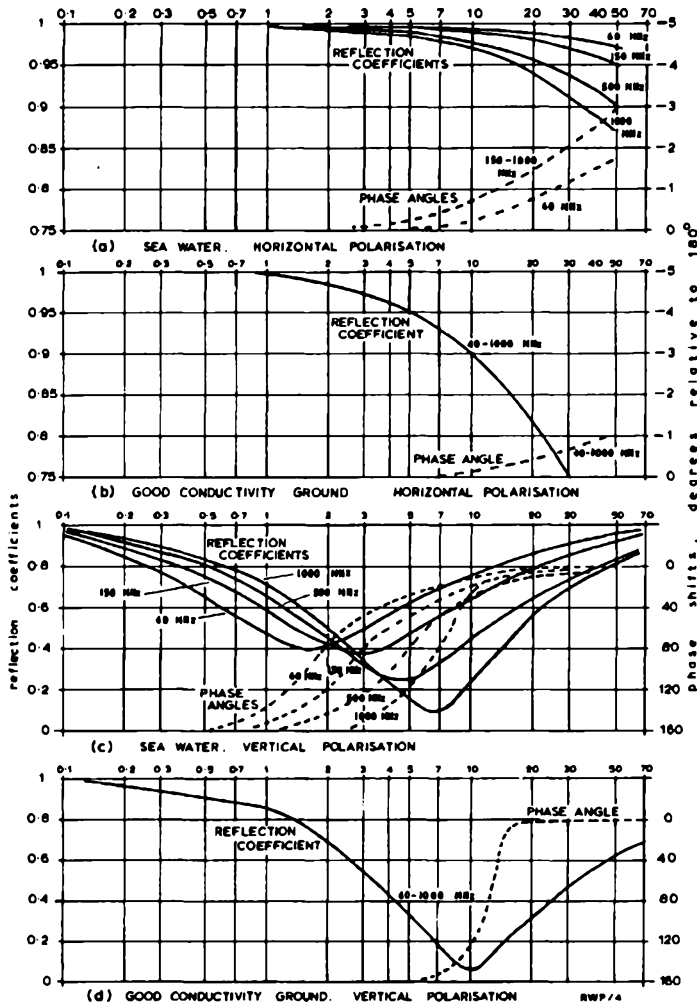

Fig. 4. Modulus and phase angle of ground reflection coefficients

equals $2\pi/\lambda$ multiplied by the path length difference, and thus

$$\alpha = \frac{4\pi h_1 h_2}{\lambda d}$$

We can now consider the total field strength at R resulting from vector addition of the direct and ground-reflected components.

Let E be the total field strength at R,

E_1 the field strength in free space at 1 km from T,

E_d the field strength in free space at d km from T, and

ρ the modulus of the coefficient of reflection.

For small angles of reflection, ρ is nearly unity.

$$\text{Now } |E_{TR}| \simeq |E_{TOR}| = E_d = E_1/d.$$

$$\text{and so } E = E_d(1 + \rho e^{j\alpha})$$

$$\text{or } E = (E_1/d)(1 + \rho e^{j\alpha})$$

The vector addition is shown in Fig. 5, and

$$E = (E_1/d) \times 2 \sin(\alpha/2).$$

For small angles, $\sin \alpha = \alpha$

$$\begin{aligned} \text{and } E &= E_1 \alpha/d \\ &= E_1 \cdot 4\pi h_1 h_2 / \lambda d^2. \end{aligned}$$

This formula gives the factor by which the direct-wave (or free-space) field strength must be multiplied to allow for a ground reflection, and is the basis of many calculations concerning aerial calculations at v.h.f. and u.h.f. The relationship may be conveniently obtained from the nomogram of Fig. 6, in which the modulus of the reflection coefficient is assumed to be unity with 180° phase shift.

$$\alpha = \text{phase change due to path length difference} = \frac{4 \pi h_1 h_r}{\lambda d} \text{ radians}$$

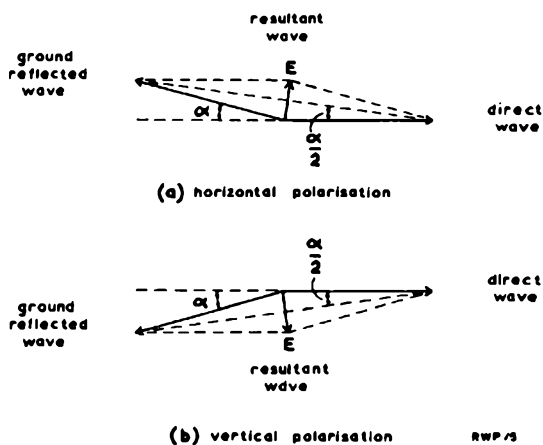
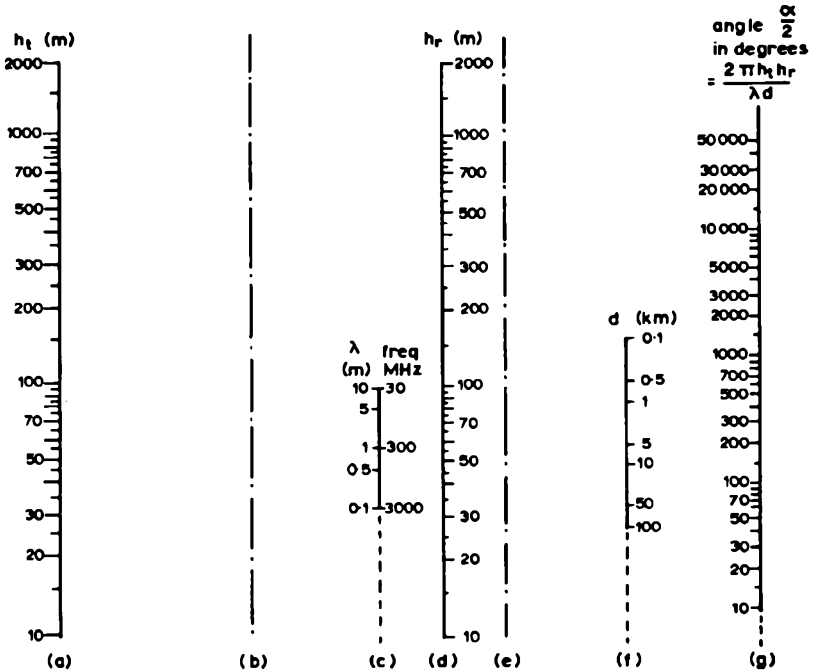

Fig. 5. The resultant signal of direct wave and ground-reflected wave



Sequence :- (a) → (d) = (b) , (b) → (c) = (e) , (e) → (f) = (g)

$$E = \frac{2E_1}{d} \cdot \sin\left(\frac{\alpha}{2}\right) \approx \frac{2E_1}{d} \cdot \frac{\alpha}{2}$$

assuming :-

- (a) angle α is small
- (b) unity ground reflection coefficient with 180° phase shift

RWP/c

Fig. 6. Nomogram for phase angle due to path difference between direct and ground-reflected signal components

Some of the changes of received signal occurring with this value of reflection coefficient are indicated below.

- Path difference 0** The two signals arriving at R are in antiphase with resultant field strength zero. This condition can occur only when both terminals are at ground level for a flat earth, as when the ray path is tangential to the earth in the practical case.
- Path difference $n\lambda/2$,** The two signal components arriving at R are in phase and the resultant field strength is $2E_1/d$.
where n is an odd integer.
- Path difference $n\lambda$,** The two signal components are in antiphase and the resultant field strength is zero.
where n is any integer.

A curve of received field strength against distance for constant terminal height therefore has the form shown in Fig. 7. This represents the theoretical condition for propagation over a smooth earth. Path differences up to $\lambda/2$ are said to be in the *first Fresnel zone*, and differences between $\lambda/2$ and λ in the *second Fresnel zone* and so on.

At frequencies in the lower section of the v.h.f. band it is rare for paths to lie other than in the first Fresnel zone as is demonstrated by the following example.

Example Find the height required for a receiving aerial to produce a path difference of $\lambda/2$ at a receiving site 20 km from a Band-I transmitting aerial ($\lambda = 5$ m) which is 200 m above ground level, assuming a flat earth.

$$\text{Path difference} = \frac{2h_t h_r}{d} = 2.5 \text{ m}$$

$$\text{Hence } h_r = \frac{1.25 \times d}{h_t} = \frac{1.25 \times 2 \times 10^4}{200} = 125 \text{ m.}$$

This is unlikely under normal topographical conditions, and it should also be remembered that the effect of the earth's curvature is to reduce the effective terminal heights. Since the transmission path generally lies within the first Fresnel zone it may, therefore, be expected that the field strength will increase

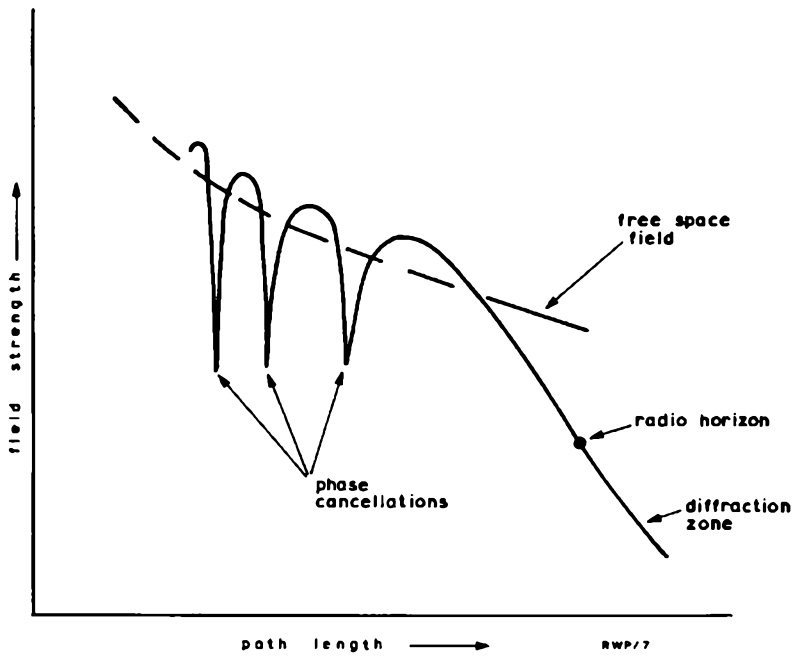

Fig. 7. Theoretical relationship between field strength and path length for constant terminal heights

with receiving aerial height and there will be *receiving aerial 'height gain'*. For small grazing angles, the field strength is directly proportional to receiving aerial height, i.e., there is a condition of linear height gain. For this reason it is desirable to mount receiving aerials as high as possible. For the purpose of estimating service coverage it is generally assumed that receiving aerial heights will be of the order of 10 metres a.g.l. At frequencies in the upper v.h.f. and u.h.f. broadcast bands it is generally equally important to mount receiving aerials as high as possible. In this case the importance arises not only from consideration of receiving aerial height gain resulting from two-ray theory, but also from the need for the aerial to be clear of surrounding building 'clutter' which also attenuates the signal.

3.1.4 Effect of Earth's Curvature

The two-ray analysis discussed in the previous section was based on the geometry for a flat earth. In practice the earth's curvature has two important effects. Firstly, radio waves reflected from a convex surface are divergent and a more accurate analysis would show a reduction in the amplitude of the ground reflected wave due to this divergence factor⁽⁸⁾. This reduction is equivalent to a reduction in ground reflection coefficient and in general increases the received signal.

Secondly, over a spherical earth the heights of the transmitting and receiving aerials above the plane tangential to the earth at the point of reflection are less than their actual heights above earth. In other words earth curvature reduces the path length difference between direct and ground reflected components by shortening the path length of the reflected component. This normally leads to a reduction of the resultant signal and here also modifying factors arise⁽⁸⁾.

These two effects of the earth curvature tend to oppose each other, although the second is the more significant, and it is not proposed to discuss them further at this stage.

Two other assumptions have been made in the previous analysis, both complex in nature and requiring further consideration. These are that the earth is smooth, i.e., that there are no hills and valleys, and that the wave fronts travel in straight lines, i.e., that there is no bending in the atmosphere.

3.1.5 Refraction and Diffraction

There are two principal effects preventing radio waves from travelling in straight lines. These are refraction and diffraction. The first occurs in the lower atmosphere and generally bends signals back towards the ground; the second

permits signals to bend round obstacles. Both effects are beneficial in extending the service areas of broadcast transmitters beyond the optical horizon, diffraction being particularly helpful in preventing excessive shadows behind hills and in valleys. In view of their importance both will be discussed in some detail.

(a) Refraction

The atmosphere surrounding the earth may be regarded as comprising two parts:-

1. An upper layer, called the *stratosphere*, in which there is no material change of temperature with height.
2. A lower layer, called the *troposphere*, in which the temperature falls with increase of height.

The boundary between these layers is called the *tropopause* and has an average height above the earth of about 10 km. The troposphere is of the greater interest for broadcasting at v.h.f. and higher frequencies, since the signals travelling between transmitter and receiver pass through and are affected by only this part of the atmosphere. To consider in detail the effect of the troposphere upon radio propagation ⁽⁹⁾, ⁽¹⁰⁾, it is necessary first to define what is meant by normal tropospheric conditions. The effects of abnormalities will be discussed in Section 3.2.

Apart from local variations the usual rate of fall of temperature with increasing height above ground level has been shown by measurement to be of the order of 6° K per kilometre. Pressure also falls with increase of height, a characteristic made use of in the operation of aneroid altimeters. Humidity variations with height may be more complex depending upon the nature and extent of cloud formation at any particular time, but this also falls fairly rapidly with increase of height above cloud level. The importance of these three factors, pressure, temperature, and humidity, lies in the combined effect upon the refractive index which falls from a value of about 1.00035 at sea level by about 4×10^{-6} per hundred metres provided the atmosphere is 'well mixed'. Atmospheric conditions which produce these typical values are said to be standard or normal.

Since the refractive index, n , of the atmosphere exceeds unity by less than one part in a thousand, even at sea level, it is more convenient to express the refractive index by a factor N , such that:-

$$N = (n - 1) 10^6$$

Using this nomenclature the relationship between refractive index, pressure, temperature and relative humidity is of the form

$$N = \frac{77.6}{T} \left[P + \frac{4810w}{T} \right]$$

where T is the absolute temperature, P the atmospheric pressure in millibars* and w the partial pressure of water vapour in millibars.

In the above equation the first term containing only the variables of pressure and temperature is proportional to air density and is known as the 'dry' term. This normally constitutes at least 60% of N and falls exponentially with increasing height. The second or 'wet' term is independent of pressure and contains the variables of temperature and relative humidity.

The velocity of propagation, or phase velocity, v , of a radio wave travelling through a medium of refractive index n is related to the velocity in vacuo, c , by

$$v = c/n$$

Thus, the greater the value of n , the lower the phase velocity of the wave. Consequently, the gradual decrease of refractive index with increasing height in the troposphere causes a gradual increase in the phase velocity, and a wave travelling at an angle to the surface of equal refractive index is bent back towards the earth. This type of bending is small under normal tropospheric conditions, but is nevertheless significant, since it means that the wave travels beyond the geometric horizon. However, when ground profiles and the paths taken by radio signals are being plotted, it is a great simplification to draw these radio wave paths as straight lines. This can be done if the earth's radius is suitably modified.

Fig. 8 represents a special condition in which a wave-front AA' travels a distance d to BB' in time dt at wave velocity v , being bent by tropospheric

*One bar, or 1,000 millibars, equals the atmospheric pressure of 29.53 inches of mercury at 32°F in latitude 45°.

refraction in a curve of radius r at constant height above the earth of radius a .

For the path AB,

$$r.\theta = v.dt,$$

and for BB',

$$(r + dh).\theta = (v + dv).dt,$$

or
$$\frac{\theta}{dt} = \frac{dv}{dh}$$

But
$$v = \frac{c}{n}$$

and hence
$$\frac{dv}{dh} = \frac{-c}{n^2} \cdot \frac{dn}{dh} = \frac{-v}{n} \cdot \frac{dn}{dh}$$

$$\cong -v \frac{dn}{dh} \text{ since } n \cong 1.$$

Thus
$$r = \frac{v}{d\theta/dt} = \frac{v}{dv/dh}$$

$$= \frac{-1}{dn/dh}.$$

More typically, tropospheric refraction will not be enough to make the wave-front bend sufficiently to maintain a constant distance from the earth's surface, and in Fig. 8 the wave-front may move outwards so that the original point A goes to B' rather than to B. Bearing in mind that the heights of ray paths above the earth's surface are always small with respect to the earth's radius a , it is convenient to replace the general situation depicted in Fig. 8 by the configuration of Fig. 9. In this diagram the ray traverses a path from A to B' which approximates to the arc of a circle of radius r , where r is greater than the earth's radius a . The line AC represents a tangent to the ray path and to the earth at A.

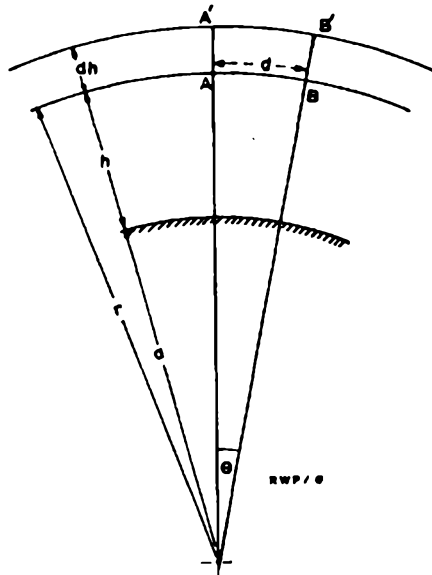

Fig. 8. Geometry for tropospheric refraction: ray bending to maintain constant height above earth's surface

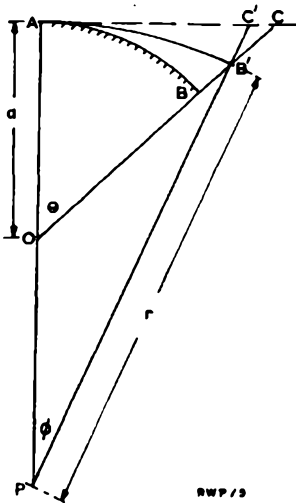

Fig. 9. Geometry for tropospheric refraction: representation of ray path as a straight line above earth of increased effective radius

Since the distance BB' is small with respect to AB and AB' , these lengths may be considered as approximately equal and represented by d .

$$\text{Thus} \quad a\theta \cong r\phi, \quad \theta = \frac{d}{a} \quad \text{and} \quad \phi = \frac{d}{r}.$$

$$\text{Now} \quad BC = OC - OB = a(\sec \theta - 1),$$

$$\text{and since } \theta \text{ is a small angle,} \quad \sec \theta \cong 1 + \frac{\theta^2}{2}$$

$$\text{and thus} \quad BC = \frac{a\theta^2}{2} = \frac{d^2}{2a}$$

Similarly since $B'C$ is approximately equal to $B'C'$

$$B'C = PC' - PB' = r(\sec \phi - 1),$$

and since ϕ is also a small angle,

$$B'C = \frac{r\phi^2}{2} = \frac{d^2}{2r},$$

$$\begin{aligned} \text{and thus} \quad dh &= BB' = BC - B'C \\ &= \frac{d^2}{2a} - \frac{d^2}{2r} \\ &= \frac{d^2}{2} \left[\frac{1}{a} - \frac{1}{r} \right] \end{aligned}$$

It is convenient to represent the actual ray path AB' by the straight line AC and this may be done for any desired value of refractive index gradient dn/dh by increasing the earth's radius a to give an effective radius a' such that

$$\frac{1}{a'} = \frac{1}{a} - \frac{1}{r}.$$

The necessary increase in effective radius is generally expressed as a multiplying factor k such that

$$a' = ka$$

that is
$$\frac{1}{ka} = \frac{1}{a} - \frac{1}{r}$$

whence
$$k = \frac{1}{1 - \frac{a}{r}}$$

As previously shown
$$\frac{1}{r} = -\frac{dn}{dh}$$

and thus
$$k = \frac{1}{1 + a \frac{dn}{dh}}$$

Since, for typical tropospheric conditions, dn/dh is about -4×10^8 and a is 6370 km, the factor k has a value of about four-thirds.

Consequently, to plot paths of radio signals over land profiles it is convenient to plot the latter on a scale curved to represent an effective earth radius of four-thirds the true radius in order that the ray paths can be drawn as straight lines.

Abnormal atmospheric conditions can occur during which the rate of decrease of refractive index with height varies, sometimes dramatically. This can lead to *super-refraction*, *sub-refraction* or an effect similar to reflection, each having a considerable influence upon the radio propagation path. These effects are more fully described in a later section. Even under normal conditions variations in refractive index gradient occur, giving rise to fading at the edges of the service areas of high power stations.

(b) Diffraction

When a solid body is put in the path of a beam of light a shadow is formed. The boundary between shadow and beam is not precisely defined, since there is a spread of energy from the beam. The angle of spread increases as the frequency is decreased until, at radio frequencies, the beam appears to bend over

the edge of solid obstacles. At m.f. the process is almost complete since shadows are seldom formed behind natural obstacles. At v.h.f. and above shadows are formed; a receiving aerial located behind a hill receives little signal, but the signal is restored fairly rapidly as the receiving site is moved away from the hill.

The effect is called *diffraction*, and is of major importance in v.h.f. and u.h.f. broadcasting, since it limits the extent of shadows behind natural topographical features. The reduction in field strength may be calculated if the path geometry is accurately known. Theoretical discussion of the knife-edge optical diffraction formulae originally due to Fresnel is beyond our scope, but a simplified explanation will be given, and the attenuation produced by diffraction over an idealised knife-edged obstacle will be formulated without proof.

Assume a sharp ridge to be placed in the path of the transmitted signal. The field strength above the ridge can be estimated in the usual way, the energy being considered to be contained in a vertical wavefront composed of an infinite number of sources of electromagnetic energy, each capable of inducing a voltage in a receiving aerial. Assume for simplicity that as shown in Fig. 10 the wavefront contains eight such sources. A receiving aerial in the plane perpendicular to the centre of the wavefront thus has induced in it eight e.m.f.s, and their resultant is the vector sum of these eight components. If the receiving point is sufficiently distant, the path lengths from all sources to the receiving aerial are virtually equal. Consequently, the components arrive in phase and the e.m.f.s are added together linearly.

Suppose now that the aerial is taken below the central plane so that a line from the centre of the wavefront to the receiving aerial makes an angle to the horizontal. The path lengths are now no longer equal, and hence the eight components are no longer in phase at the receiving aerial. There is a progressive phase shift, and the resultant voltage is found by completing the vector polygon as shown in Fig. 10. Thus, the effect of this phase shift (expressed in terms of wavelength λ) is to reduce the resultant voltage. Similarly, an increase in frequency would also increase the relative phase shift, and hence decrease the voltage. In other words, the diffractive effect decreases as frequency increases, and so relatively longer and deeper shadow areas can be expected at u.h.f. than at v.h.f. For the path geometry shown in Fig. 11a it can be shown that the reduction in field strength due to the knife-edge obstacle, assumed to be of infinite extent in the plane perpendicular to the diagram, may be expressed in terms of a parameter ν such that

$$\nu = H \sqrt{\frac{2(d_1 + d_2)}{\lambda d_1 d_2}}$$

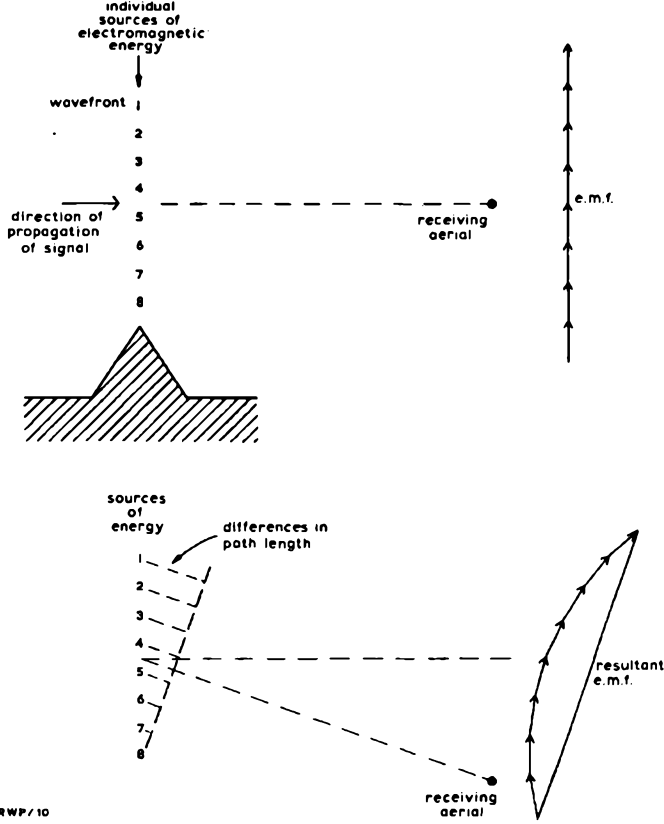

Fig. 10. A simplified approach to the diffraction of a v.h.f. signal over a sharp ridge

The relationship between ν and the field strength in the absence of the knife-edge is shown in Fig. 11b, from which it may be seen that:-

1. When $H = 0$, i.e., when the knife-edge is at the exact height of the line between transmitting and receiving terminals, the field strength is exactly half the free space value.
2. As the knife-edge height is progressively reduced below the line of sight, the field strength oscillates about the free space value, the amplitude of oscillation diminishing as the edge becomes remote from the line of sight.

To appreciate the cause of this oscillation it is necessary again to consider the contribution to the received signal provided by all parts of the wavefront in the plane of the knife-edge obstruction. Fig. 12 indicates concentric circles in this plane such that the total path length from T to R via points on each circle is successively greater than the direct path TOR by half a wavelength,

$$\text{i.e., } TP_1R - TOR = \lambda/2,$$

$$TP_2R - TOR = \lambda,$$

$$TP_3R - TOR = 3\lambda/2, \text{ and so on.}$$

These zones, comprising the inner circle and concentric annuli, are called *Fresnel zones*. The contributions to the field at R from successive zones are of opposite phase, due to the $\lambda/2$ path difference. If an obstructing screen of infinite extent having a circular aperture of radius OP_1 equal to that of the first Fresnel zone were to be placed in the plane shown in Fig. 12, the field strength received at R would be double that in the absence of the screen. If, however, the aperture were increased to have radius OP_2 , thus permitting the energy in both the first and second Fresnel zones to be received at R, the field would be almost zero since contributions from successive zones almost cancel. Further increases in aperture give rise to oscillations in amplitude of the received signal as contributions from successive zones of opposite phase are provided. Since, however, the contributions from successive zones are not exactly equal in amplitude, but decrease as the angle through which the wavefront is diffracted increases, the oscillation has a decreasing amplitude, tending to the free space field value as the aperture tends to infinity.

A similar concept applies if the obstructing screen with a circular aperture is replaced by a knife-edge obstruction, except that in this instance there is no longer any axial symmetry and all field contributions due to sources above the

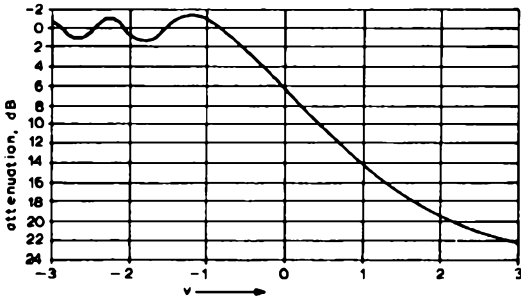
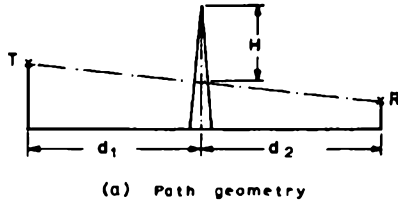

(b) Relationship between parameter v and diffraction loss

$$\text{where } v = H \sqrt{\frac{2(d_1 + d_2)}{\lambda d_1 d_2}} \quad \text{RWP/11}$$

Fig. 11. Fresnel knife-edge diffraction theory

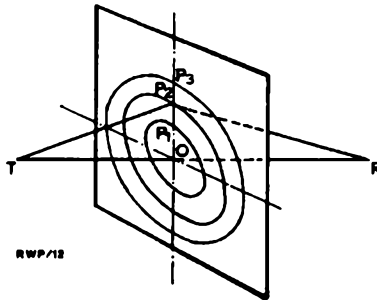

Fig. 12. Fresnel zones, as developed across a plane perpendicular to a transmission path TR

level of the knife-edge will be received. Consequently, the oscillation no longer reaches a maximum of twice the free space value, but merely rises to about 1.2 times the free space value. Similarly there is no virtually complete cancellation, as there is for a circular aperture passing the first two Fresnel zones. The result is thus as represented in the curve of Fig. 11b.

Estimates of diffraction losses form an essential part of field strength prediction techniques in the v.h.f. and u.h.f. bands, and it is therefore convenient to express the attenuation in the form of the nomogram shown in Fig. 13. To use this nomogram it is first necessary to establish the equivalent distance d' corresponding to $d_1 d_2 / (d_1 + d_2)$, and it may be noted that

$$d' \simeq d_2 \text{ if } d_1 \gg d_2, \text{ and } d' \simeq d_1 \text{ if } d_1 \ll d_2.$$

Methods are also available^{(11), (12), (13)} for estimating diffraction losses over obstacles of finite radius of curvature. Losses due to such obstacles are always greater than for a single knife-edge of corresponding value 'H', and this excess loss increases as the radius of curvature of the obstacle increases. The effect of surface roughness is however to reduce this excess loss, the irregularities on the surface acting as individual knife-edge obstructions.

A rigorous mathematical treatment is also available⁽¹⁴⁾ for the estimation of diffraction losses due to two or more knife-edge obstacles in series. A simple empirical method due to Epstein and Peterson⁽¹⁵⁾ is often used for the path geometry shown in Fig. 14. Using the method of Epstein and Peterson to determine the diffraction loss on the profile shown in Fig. 13, this loss is assumed to be the sum of the individual losses due to the diffracting ridge at P and Q. Thus the Fresnel knife-edge loss is calculated firstly for transmitter at T and receiving point at Q, the obstacle height being h_1 at P. Point P is then considered as the virtual source and the Fresnel knife-edge loss estimated for the path PQR with obstacle height h_2 at Q. These two losses (in dB) are then added. This method can be extended to deal with multiple diffractions.

Modifications of this method are also used^{(7), (16)}. For example, it has been suggested⁽¹⁷⁾ that the second diffraction loss should be estimated for the path T'QR where T' is obtained by projecting the line PQ back to cross the vertical plane containing the original transmitting source T. The difference between the loss calculated in this manner and that due to the original Epstein Peterson method corresponds to the correction factor resulting from the more rigorous mathematical approach.

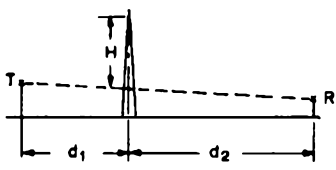
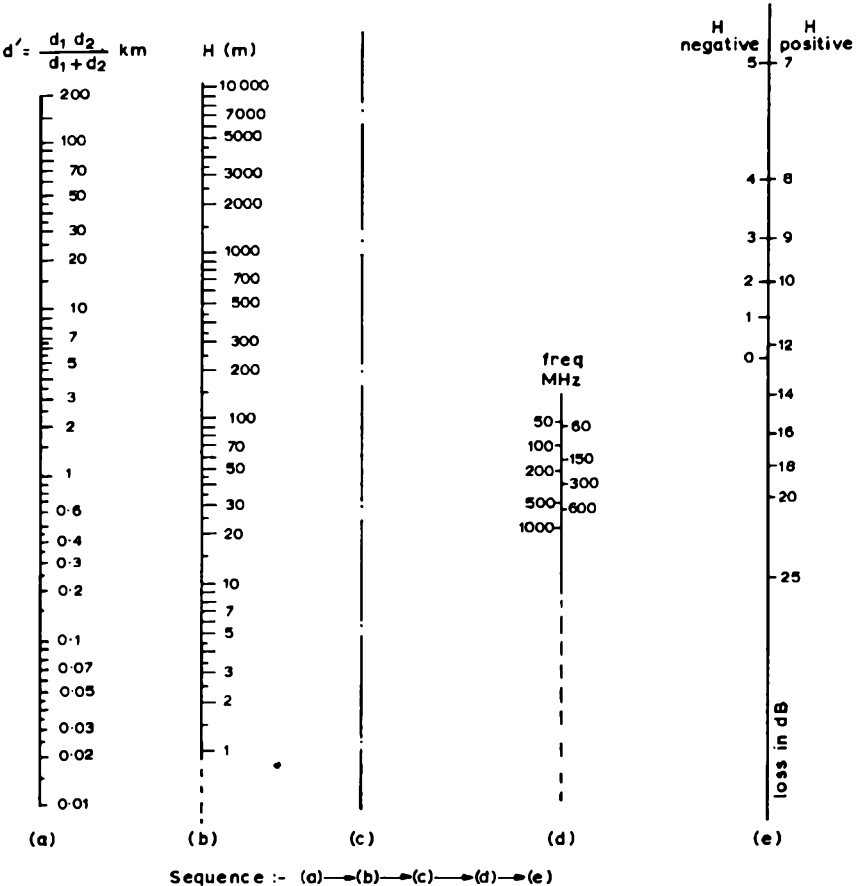

RWP / 13

Fig. 13. Nomogram for the estimation of diffraction loss

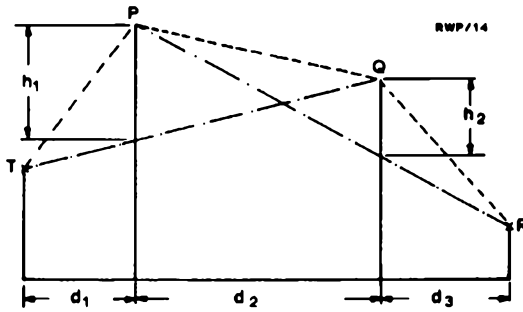

Fig. 14. Diagram illustrating geometry for double diffraction calculation method of Epstein and Peterson

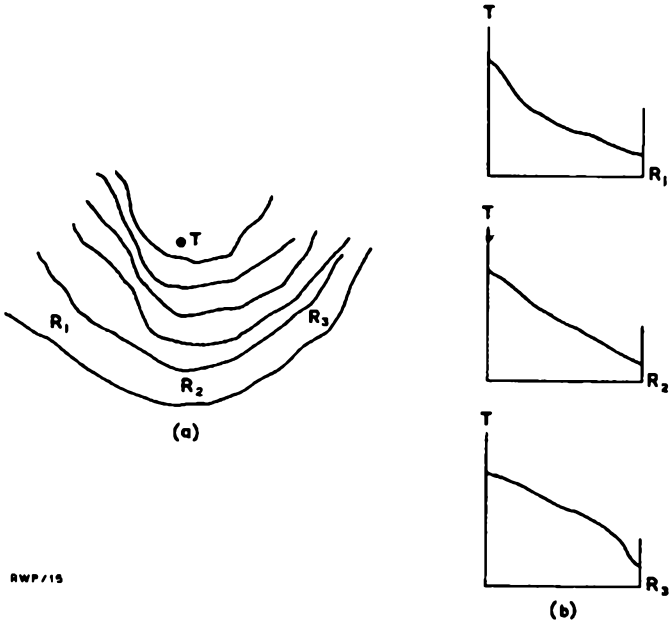

Fig. 15. Examples of different types of simple path profile between transmitter and receiver

3.1.6 Other Effects of Terrain upon the Level of Received Field Strength

From what has been said so far it is obvious that the topography of the ground between transmitter and receiver has a considerable influence upon the received field strength. Apart from the effects of refraction and diffraction discussed in the previous section, other important features are:

- (a) The general shape of the ground profile, whether flat, convex, or concave.
- (b) The shape in the more immediate vicinity of the receiving aerial.
- (c) The roughness of the ground at critical parts of the path profile.
- (d) Clutter losses due to the presence of building and trees, particularly near the receiving terminal.

The first consideration can be illustrated quite simply as shown in Fig. 15. Fig. 15a shows the plan view of a transmitter and three receiving sites all equidistant for the transmitter and at equal heights. The topography of the ground is shown by the height contours. In the absence of ground reflection, and assuming the transmitter to radiate equal power in all directions, the field strengths received at the three sites would be identical. In practice it would probably be found that the concave profile (TR1) would provide the highest field strength and the convex profile (TR3) the lowest field strength, this difference being due to the greater path difference between direct and ground reflected components for the concave profile. The effect of concave curvature is to increase the effective terminal heights h_t and h_r , these heights being measured above the plane containing the point of ground reflection.

The roughness of the terrain has another important influence upon the received field strength, namely that the magnitude of the ground reflection coefficient is dependant upon the extent of terrain irregularities. The importance of this reflection coefficient has been discussed in Section 3.1.3, and the variation of coefficient with frequency and polarisation on ground of good conductivity shown in Fig. 4. These results, however, assume the ground to be perfectly smooth, thereby producing a specular reflection analogous to optical reflection from a mirror. If the ground surface is rough, the signal is scattered after reflection in a way more like optical reflection from a matt white surface. In this case the received signal comprises a large number of reflected components arriving in random phase relative to the direct signal component.

A convenient criterion for establishing the greatest degree of roughness still supporting specular reflection was first developed by Lord Rayleigh. Referring to Fig. 16 assume the surface to contain a number of corrugations of height h above the general level of the reflecting plane. A ray striking the surface at point A has a path length from transmitter to receiver which is

shorter than that from point O by a distance BOC. This represents a path difference of $2h \sin \psi$, or in radians, for small angles, ψ ,

$$\text{BOC} = 4\pi h \psi / \lambda$$

A surface is usually considered to be rough if this phase difference exceeds $\pi/4$ radians, that is, if

$$4\pi h \psi / \lambda > \pi/4,$$

$$\text{or } h > \lambda/16\psi.$$

If ψ is in degrees the corresponding roughness criterion is given by

$$h > 3.6\lambda/\psi.$$

From the above formulae, it will be noted that the criterion for the ground to be considered as rough occurs at decreasing values of h as either ψ increases or λ decreases.

For a typical grazing angle of 1° , the criterion is satisfied for $h > 18$ m at 60 MHz ($\lambda = 5$ m), or for $h > 1.8$ m at 600 MHz ($\lambda = 0.5$ m).

These figures show that, at Band-I frequencies and small grazing angles, even quite substantial irregularities, such as might occur when the reflection point is in a residential area, are not sufficient to prevent specular reflection. Conversely, at u.h.f., with the single important exception of reflection from the surface of an expanse of water, ground surfaces may generally be considered as rough. Thus estimation of field strength based on the two-ray theory is generally appropriate at v.h.f. Band I⁽¹⁸⁾, but inapplicable at u.h.f. As discussed later, v.h.f. Bands II and III present severe problems in field strength prediction due to the difficulty in determining whether the ground surface should be considered as rough or smooth at the point of reflection.

The presence of obstructions such as buildings and trees on the transmission path can greatly reduce the received field strength, particularly at u.h.f. and when close to the receiving terminal. Generally, if built-up areas and woods are sufficiently dense and are remote from the receiving terminal their effect is merely to increase the effective terrain height. When they are near the receiving terminal and intersecting the line of sight transmission path, their effect is to attenuate the signal and to provide multiple reflections of short delay. The degree of attenuation depends on the frequency, the proportion

of area occupied by buildings or trees (i.e., the density of occupation) and the length of transmission path traversing this region. Obviously, this last feature is determined largely by the receiving aerial height, since if this can be made sufficient the effects of surrounding 'clutter' may often be greatly reduced.

Methods⁽¹⁹⁾ of predicting the attenuation due to clutter near the receiving terminal can only be empirical, since information on the density and heights of building and trees cannot be accurately determined from ordnance survey maps. Error in estimating such losses tends to be the limiting factor in the accuracy of field strength prediction methods, particularly at u.h.f. The effect of the clutter is not only to attenuate the received signal but also to create a complicated standing wave pattern due to multiple reflections.

3.2 Characteristics of Signal Propagation under Abnormal Conditions

3.2.1 General

So far, the influence of the troposphere and the ground have been considered only with respect to normal propagation conditions. There are, however, a number of natural phenomena which influence the propagation of signals at v.h.f. and above and which result in significant field strengths at considerable distances, although only for a small proportion of the time. The means by which this abnormal propagation may occur are reflection, super-refraction and scattering in the troposphere, and also, at the lower end of the v.h.f. band, ionospheric reflection.

3.2.2 Abnormalities in the Troposphere

(a) Effect of Conditions in Lower Atmosphere

Normal tropospheric conditions have been discussed in Section 3.1.5, and these occur when the lower atmosphere is well stirred by unsettled or cyclonic weather. Pressure, temperature and water-vapour density decrease with increasing height, producing a roughly exponential fall in refractive index which is allowed for by assuming the earth to have an effective radius equal to $4/3$ times its actual value. This rate of decrease in refractive index with increasing height is generally referred to as the (*refractive index*) *lapse rate*, and has a normal value near ground of $40N$ per km, N being the number of parts in a million by which the refractive index exceeds unity. Changes in meteorological conditions can greatly alter this lapse rate, and hence influence the mode of propagation of signals through the troposphere. Statistics of the variation of lapse rate over a three-year period at a site in the United Kingdom (Cardington, Bedfordshire) are fully discussed in reference (20). These show that lapse rates exceeding $157 N/\text{km}$, which is the value causing ray bending

with the same curvative as that of the earth, occurred on 16% of occasions. These large values are caused mainly by humidity variations, the highest lapse rate values being most likely to occur at heights greater than 300 m above ground level.

(b) Elevated Temperature and Humidity Inversions

General weather conditions are largely controlled by relative atmospheric pressures, and the leading edge of a pressure variation giving rise to a change in weather is called a *front*. Fronts do not necessarily extend to great heights, or to ground level, and the troposphere near the ground may sometimes have the normal refractive index gradient, while at greater heights a frontal system produces a less than normal decrease of temperature with height (or even an increase of temperature known as a *temperature inversion*). This, together with associated changes in the humidity lapse rate, can provide sudden and considerable increases in refractive index lapse rate as shown in Fig. 17a.

The effect of these inversion layers is to provide what is effectively a partially reflecting layer to incident radio waves. A diagram of possible alternative ray paths between a transmitter and receiver could then be as shown in Fig. 18. In addition to the usual direct and ground reflected rays, usually significant only within the horizon or in the near diffraction zone, other paths are:

1. Transmitter - elevated layer reflection - receiver.
2. Transmitter - ground - elevated layer reflection - receiver.
3. Transmitter - elevated layer reflection - ground - receiver.
4. Transmitter - ground - elevated layer reflection - ground - receiver.

Computations based on this four-ray path model⁽²¹⁾ have been carried out⁽²²⁾ to investigate the relative sensitivity of received field strength to parameters such as terminal heights, path length, layer height, signal wavelength and effective earth radius. These show the most critical parameter to be terminal height, and the least critical to be path length and effective earth radius. Since the height of an elevated layer is generally continuously varying throughout its duration, the relative phases of signal components received by the various possible paths also vary continuously. This causes deep but slow fading of the received signal.

Inversion layers may occur over a wide range of heights in the troposphere. There is some evidence to suggest a most probable height of about 1.2 to 1.4 km in the U.K.⁽²³⁾. The maximum range of a signal reflected from a layer at this height is of the order of 300 km.

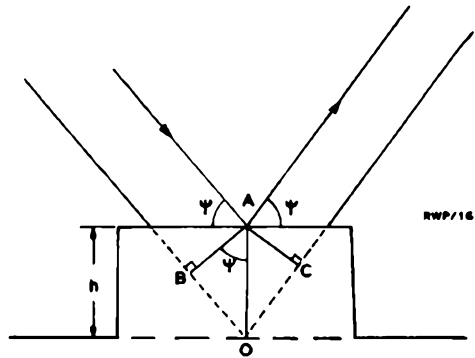

Fig. 16. Diagram illustrating Rayleigh roughness criterion

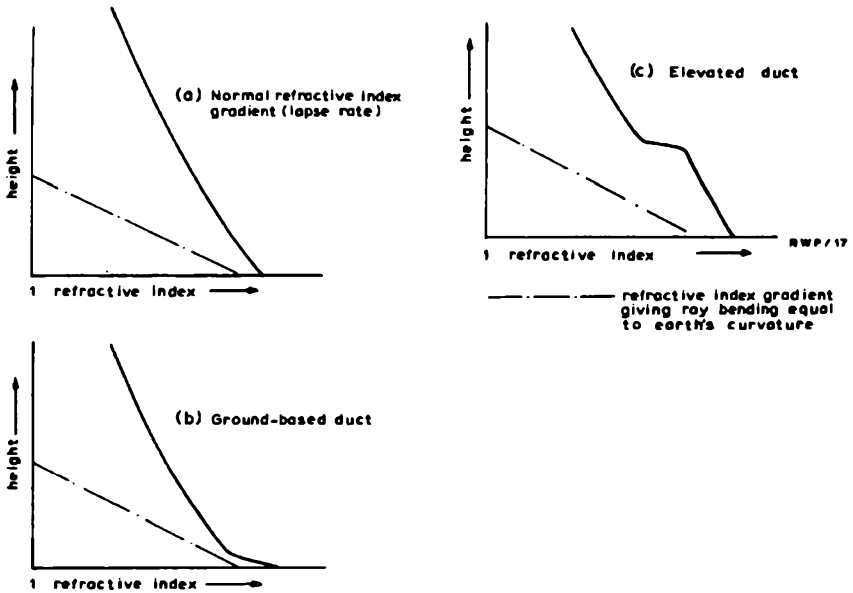

Fig. 17. Diagram showing normal refractive index lapse rate, and ground-based and elevated ducts

In addition to the possibility of propagation by a single reflection from an elevated layer, there is also evidence^{(24), (25)} supporting the probability of propagation modes by successive reflections as indicated in Fig. 19. Since an inversion layer provides only partial reflection, it may be considered surprising that paths involving more than one-layer reflection are of importance. However, the effective reflection coefficient is an inverse function of the grazing angle between the incident ray and the layer, and the grazing angle for double reflection is always less than for single reflection. Consequently, for certain path geometries, double-hop propagation from a layer at a low height may lead to greater field strength than single-hop propagation from a higher (but otherwise identical) layer.

(c) *Ground-based Ducts*

During anticyclonic conditions of high pressure and fine clear weather, the earth's surface may cool quickly after sunset by radiation, giving rise to an increase of air temperature with height in the lower troposphere. The consequent increase in refractive-index lapse rate as shown in Fig. 17b produces the condition termed *super-refraction*, with an effect on propagation which increases with frequency.

If the transmitting aerial is relatively low, the signal radiated from it is refracted down in the lower troposphere, and travels in a series of bounces from the earth. With increasing transmitting aerial height, the distance between bounces increases, until a certain height is reached where the signal travels parallel to the curve of the earth's surface. The troposphere below this height acts as a waveguide or duct of width* corresponding to the maximum height from which signals can be bent back to earth.

Minimum duct widths for efficient propagation modes are proportional to the signal wavelengths and this mode of propagation is therefore of greater significance at u.h.f. than at v.h.f., particularly over land paths. Long distance propagation over uneven terrain at frequencies in the lower v.h.f. bands is therefore more likely to be due to elevated inversion than to super-refraction near the ground.

Over sea paths large duct widths are more common, and this mode of propagation is important both at v.h.f. and u.h.f., although u.h.f. field strengths are greater due to the better duct efficiency at the higher frequencies. The probability of high field strengths occurring with increasing frequency under

* or 'thickness'.

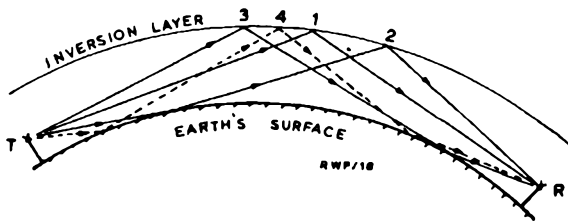

Fig. 18. Possible paths between transmitter and receiver with reflections from the ground and from an inversion layer⁽²²⁾

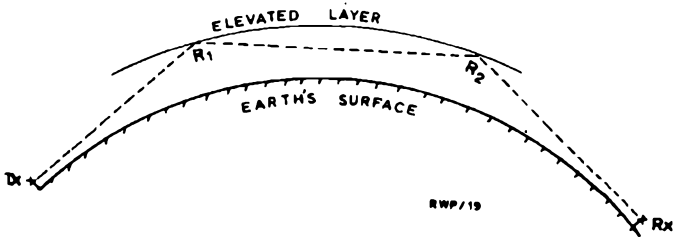

Fig. 19. Propagation by double reflection from an elevated inversion layer

abnormal propagation conditions is shown in Fig. 20. This diagram shows, in the form of cumulative distributions, the results of long-term propagation tests carried out over the North Sea at various frequencies in the v.h.f. and u.h.f. bands. The transmitter site was at Scheveningen (Holland) and the receiving sites at Happisburgh (Norfolk) and Flamborough Head (Yorkshire), the path lengths being 198 km and 365 km respectively. The duration of measurement at each frequency was 18-24 months, enabling a representative sample of propagation conditions to be experienced. It may be seen that for 1% of the time at Happisburgh the field strength exceeded at the Band-V frequency (774 MHz) was 38 dB greater than in Band II (94 MHz), whereas at both receiving sites under normal conditions the u.h.f. field strengths were lower than at v.h.f. due to the lesser diffraction losses at the lower frequencies.

(d) Diurnal and Seasonal Variations

Both inversion layers and ducts tend to occur during anticyclonic weather, since this permits the necessary 'stillness' for stratification to form. Interference with television services by distant transmitters during fine weather is a well-known phenomenon. There are however considerable differences in the times of occurrence of abnormal propagation over sea and land paths. Over sea paths, experimental evidence indicates a much greater incidence of abnormal propagation in the summer than in the winter, and an absence of marked diurnal trends, at least during the normal hours for television.

Over land paths, conversely, the seasonal trend is less pronounced, but there is a marked tendency for abnormal propagation to be confined to early morning and late evening in the summer. This tendency results from the effect of convection current turbulence in the lower troposphere, induced by the heating of the earth surface under summertime anticyclonic conditions. The turbulence breaks down the stratification which gives rise to ducts and elevated inversion layers. These generally re-form only towards sunset. This diurnal trend is less pronounced, or absent, in the winter months, presumably because the lower ground temperatures do not induce the same degree of turbulence.

One result of this differing diurnal and seasonal pattern over land and sea paths is that of reducing the probability of coincident abnormal conditions over a propagation path which is partially oversea and partially overland.

(e) Tropospheric Scattering

In addition to propagation modes resulting from stratification in the troposphere, it has long been known that there is a further method of long-distance tropospheric propagation, not closely related to climatic conditions.

The exact means by which this propagation is induced has been the subject of much discussion, but it is generally agreed that the process is one of scattering of the incident radio wave from small-scale refractive-index irregularities always present in the troposphere. These refractive index variations are due to sudden changes in temperature and humidity resulting from random turbulent-air movements. The levels of scattered signal are small, but for communication purposes a satisfactory link can be engineered by aiming a high-gain receiving aerial at the volume of troposphere 'illuminated' by a high-gain transmitting aerial radiating considerable power. This well-known technique is discussed fully in the relevant literature, for example, in the Scatter Propagation Issue of the *Proc. I.R.E.* (Vol. 43, No. 10, October 1955). The only relevance to broadcasting is that if a scatter communication system operates within the broadcasting bands, some of the scattered energy may return to earth to cause interference to the broadcast transmission. Side lobes from the transmitting aerial can also cause local but severe interference.

3.2.3 Abnormalities in the Ionosphere

Although the troposphere provides the only cause of long distance propagation and interference at u.h.f. and in the upper v.h.f. channels, there are other causes originating in the ionosphere. The use of the ionosphere to reflect high-frequency signals back to earth is well known. The highest frequency reflected from an ionised layer depends on the angle of incidence of the signal and on the ionisation density. Reception of Channel-I signals (sound 41.5 MHz and vision 45 MHz) from Crystal Palace in South Africa during the sunspot maximum period of 1957-58 has been well publicised. The received signals (with the lower-frequency sound signal more consistent than the vision signal) showed seasonal variations approximating to the expected m.u.f. variations. This reception represents the upper limit of normal h.f.-type propagation through the F2 layer at sunspot maxima and at extreme ranges (i.e., those involving the maximum angle of incidence).

Under certain conditions, scattering or reflection can occur from the E layer. This may be due to turbulences (as in the troposphere) or to ionised meteor trails that are prevalent in the E region and which result in weak rapidly fluctuating signals.

Occasionally, the ionisation density of the E layer becomes abnormally high and the *sporadic E ionisation*, as it is called, can cause reflection of v.h.f. signals. The reflection coefficient falls rapidly with increasing frequency, and consequently Channels 1 and 2 are more susceptible to interference than Channels 4 and 5.

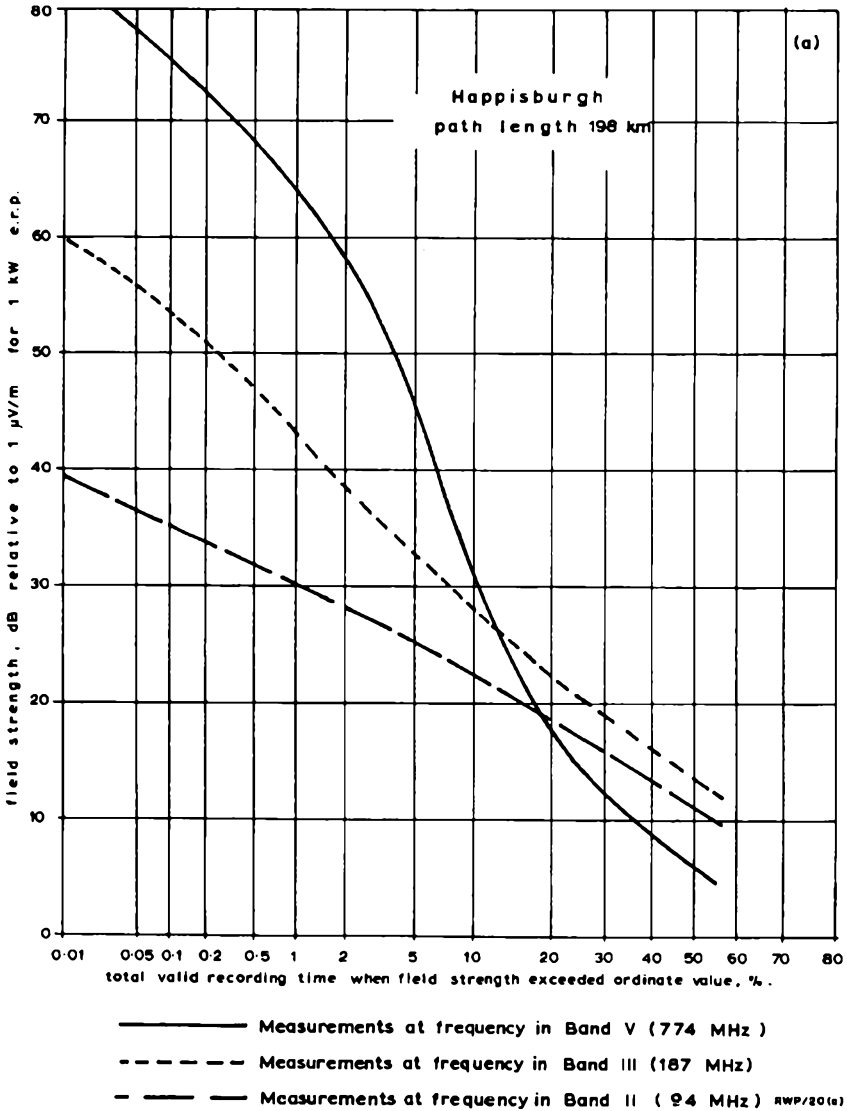

Fig. 20a. Field-strength/Time-percentage distributions for propagation over the North Sea at various frequencies in the v.h.f. and u.h.f. broadcast bands

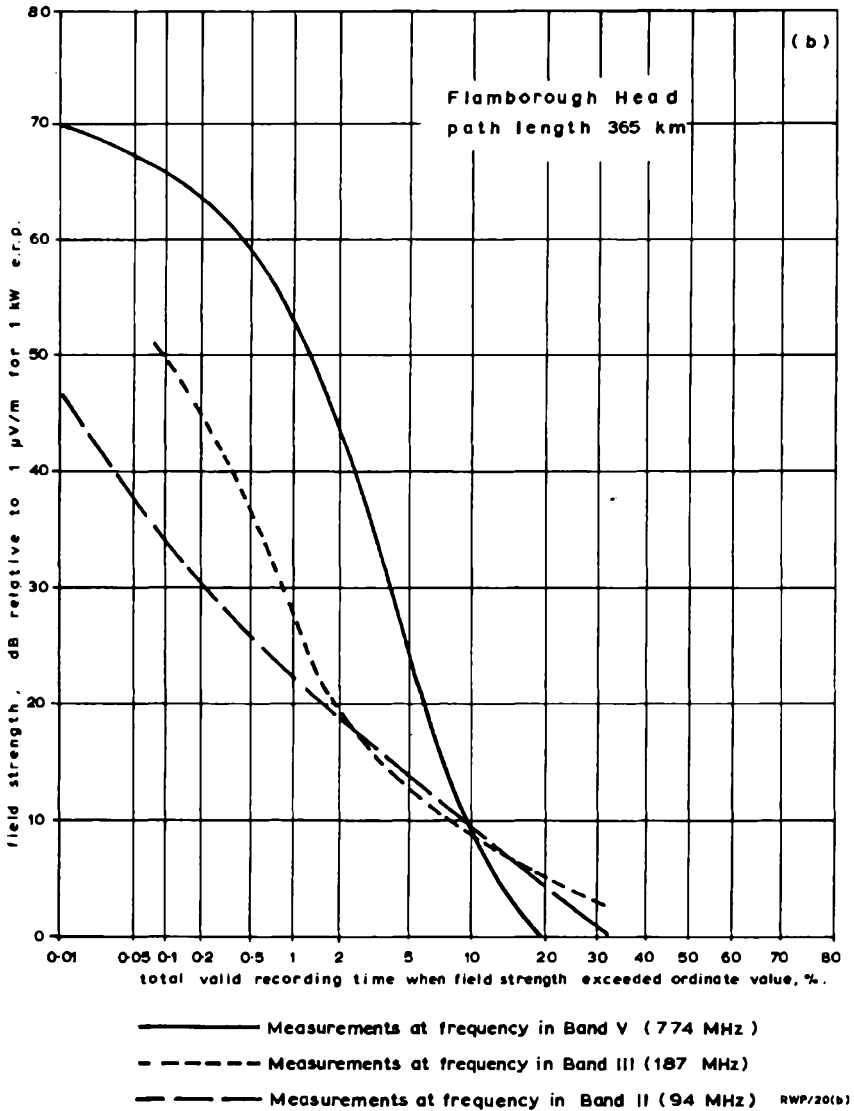

Fig. 20b. Field-strength/Time-percentage distributions for propagation over the North Sea at various frequencies in the v.h.f. and u.h.f. broadcast bands

The nature and occurrence of sporadic E have been widely discussed in the literature^{(25), (26)}. The most widely accepted theory explaining the formation of sporadic E clouds in temperate latitudes is that they result from steep vertical gradients of wind velocity at the height of the E layer. The resultant movement of the ionised medium across the earth's magnetic field lines induces height changes in the layer. Because wind velocity can vary rapidly with height, any vertical movements of the ionised gas can greatly increase the ionisation density along the lines of wind shear. Since the resultant highly ionised clouds are fairly local, only single reflections are likely, giving maximum ranges of about 2400 km.

In the northern temperate zone, the occurrence of sporadic E shows a pronounced seasonal variation, with maximum probability of occurrence in June and July. There appears to be little, if any correlation with the sunspot cycle. For a given frequency, levels of field strength received via sporadic E layers have a different relationship with distance from those for tropospheric propagation, in that fields propagated via sporadic E show broad maxima over distance ranges from about 1200 to 1800 km. At short distances the angle of incidence to the layer is too small for efficient reflection, whereas at greater distances the extra attenuation due to distance becomes more significant than the increase of reflection coefficient resulting from increasing the angle of incidence. Measurement campaigns organized by the EBU⁽²⁷⁾ have been carried out each year since 1961 in order to obtain sufficient data to provide sets of propagation curves for oblique incidence reflections analogous to those for tropospheric propagation.

At high latitudes, the high ionisation density in the sporadic E layer can be maintained by auroral streamers, and reflections may occur from the streamers themselves. A characteristic of this mode of propagation is extremely rapid fading, often sufficiently fast to modulate the carrier at an audio frequency. This is detected in the normal way by receivers and gives an audible output superimposed on the programme.

The importance of sporadic E propagation from an interference aspect may be judged from the fact that received field strengths can approach the free space value at frequencies in the lower channels of Band I and at distances from about 1200 km to 1800 km. This means that any transmitters of, say, 100 kW e.r.p. within this distance range from a wanted station can give interfering field strengths of the order of 1 mV/m. Such levels of signal can cause objectionable interference even in areas where the received field strength of the wanted signal may be as much as 10 mV/m.

CHAPTER 4

ESTIMATION OF FIELD STRENGTH

4.1 General

The ability to estimate the field strength of a transmission at a particular location is of importance not only within the normal service area of the transmitter, but also at greater distances at which the transmission may form a source of interference to other services using the same or adjacent frequency channels. Within the service area the variation of field strength with time can generally be neglected, but when the transmission forms an interfering source at a considerable distance the field strength will vary according to conditions in the troposphere. Since it is impracticable to plan broadcast networks to ensure complete protection against interference, it is usual to plan for protection against such unwanted transmissions for specified percentages of the time, e.g., 90% or 99%. These two aspects of field strength prediction will be considered separately.

4.2 Service Area Field Strength Predictions

4.2.1 General

It is often required to test proposed transmitting sites to determine their suitability⁽²⁸⁾. Sometimes it may be impracticable to carry out such tests, as for example when the site is in a wood and it is therefore impossible either to fly a captive balloon or to erect a temporary mast. Alternatively time and effort may not permit the testing of all possible sites as, for example, in the development of the u.h.f. broadcast network in the U.K.

In such instances it is necessary to predict⁽²⁹⁾ the service provided by a specific transmission condition, or alternatively, to determine the required transmission characteristics, e.g., aerial height and radiated power to satisfy a known requirement. Prediction techniques are basically of two types, which may conveniently be classified as 'statistical' and 'specific'. In the former case use is made of the large amount of data available from previous field strength surveys, usually presented in the form of field strength/distance curves. This method of prediction takes no account of the particular terrain features of any individual path, and can therefore obviously only provide a very rough indication of the extent of coverage of a transmitter. For more detailed predictions, specific to a particular path, it is necessary to plot the path profile, and to calculate the individual effects of diffraction, ground reflections and clutter losses.

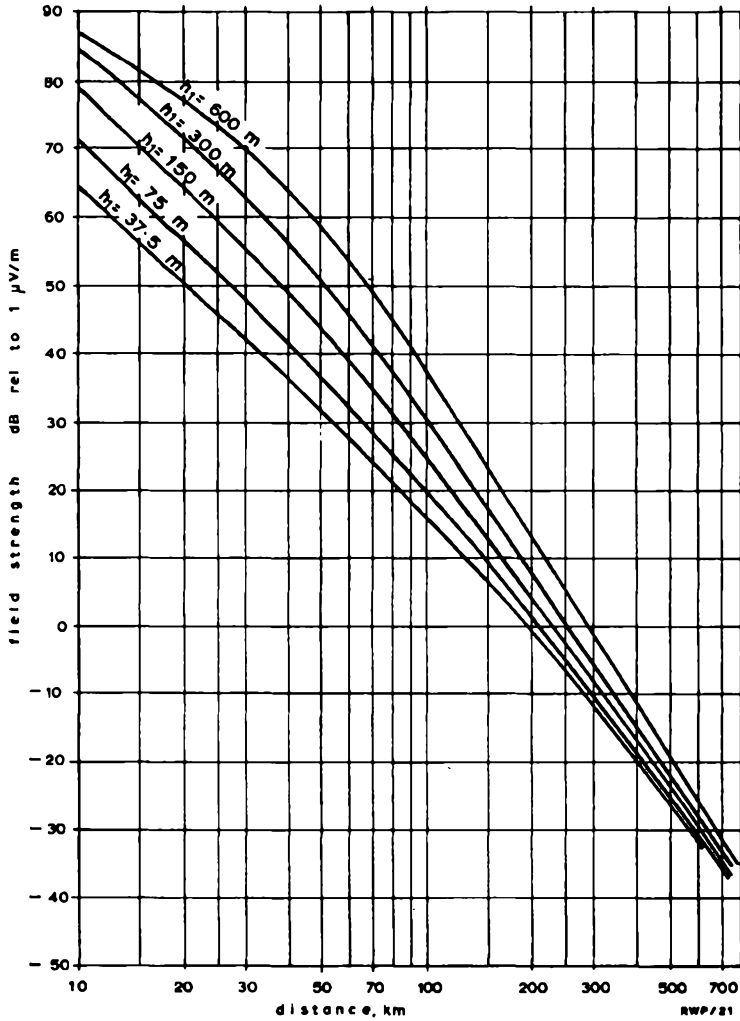

Fig. 21. V.H.F. 50% time curves: land and sea paths
(CCIR Recommendation 370-1)

4.2.2 Use of Field Strength Curves

The simple theory of propagation over a smooth earth is generally of little assistance in determining the field strength received over typical terrain. However, much information is available from previous measurements, and this has been collated by various authorities into the form of curves relating field strength to distance, using parameters such as frequency and transmitting and receiving aerial heights. Such curves have been published by the CCIR (Comité Consultatif International des Radiocommunications) and the FCC (Federal Communications Commission of the U.S.).

The difficulty in producing and using such curves lies in the fact that in any given small area and at any given time the field strength varies considerably from place to place across the area, and at any given place may vary with time. The former variation is due to the effect of local terrain, and the latter to continuous changes in the refractive index of the troposphere. The curves must therefore be regarded merely as representative of the value of field strength existing in a given percentage of locations for a given percentage of the time. The value of greatest utility for service area predictions is the median time/location value corresponding to the expected field strength exceeded at 50% of the locations in a given area for 50% of the time. This median curve is often called the F 50-50 curve. Within the service area of a transmitter it is usually reasonable to assume that the variability of wanted signal with time can be neglected. However, as already discussed, this time variability is of great importance at long distances when the transmission is to be considered as a potential source of interference to the service of another station using the same frequency channel.

The results of the many measurements upon which the various series of field strength curves are based show the effect of frequency to be less pronounced than would be expected from theoretical consideration of propagation over a smooth earth. This is because the frequency gain factor (field strength inversely proportional to λ) is largely compensated by the increased diffraction and clutter losses at higher frequencies. The CCIR therefore considered it necessary to produce only two series of curves, covering respectively the v.h.f. (30 MHz to 250 MHz) and u.h.f. (450 MHz to 1000 MHz) broadcasting bands. It was however considered necessary at u.h.f. to differentiate between propagation over land and sea paths. This differentiation is considered to be necessary at v.h.f. only for the curves pertaining to very abnormal propagation conditions, i.e., the 1% time (F 1 - 50) curves.

Various sets of curves, taken from a CCIR document⁽³⁰⁾ are reproduced in Figs. 21 to 23 and the appropriate correction factors to be applied to receiving locations estimated to be other than typical (50% values) are reproduced in Figs. 24 and 25.

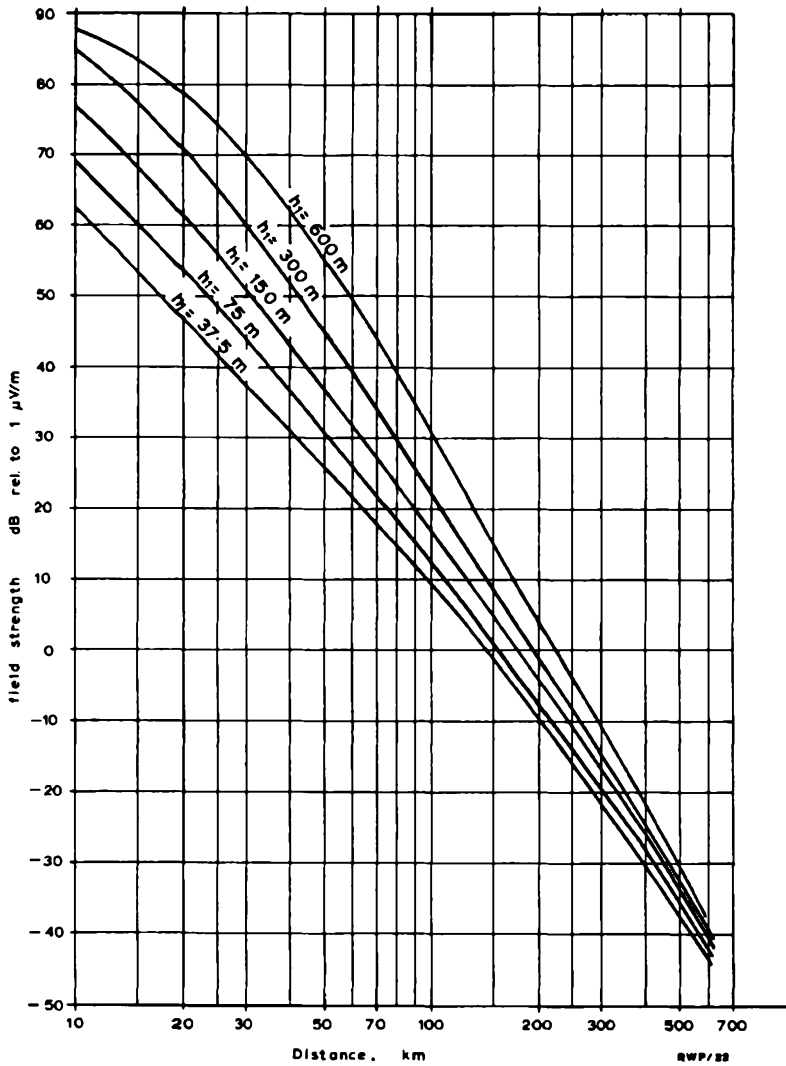

Fig. 22. U.H.F. 50% time curves: land path
(CCIR Recommendation 370-1)

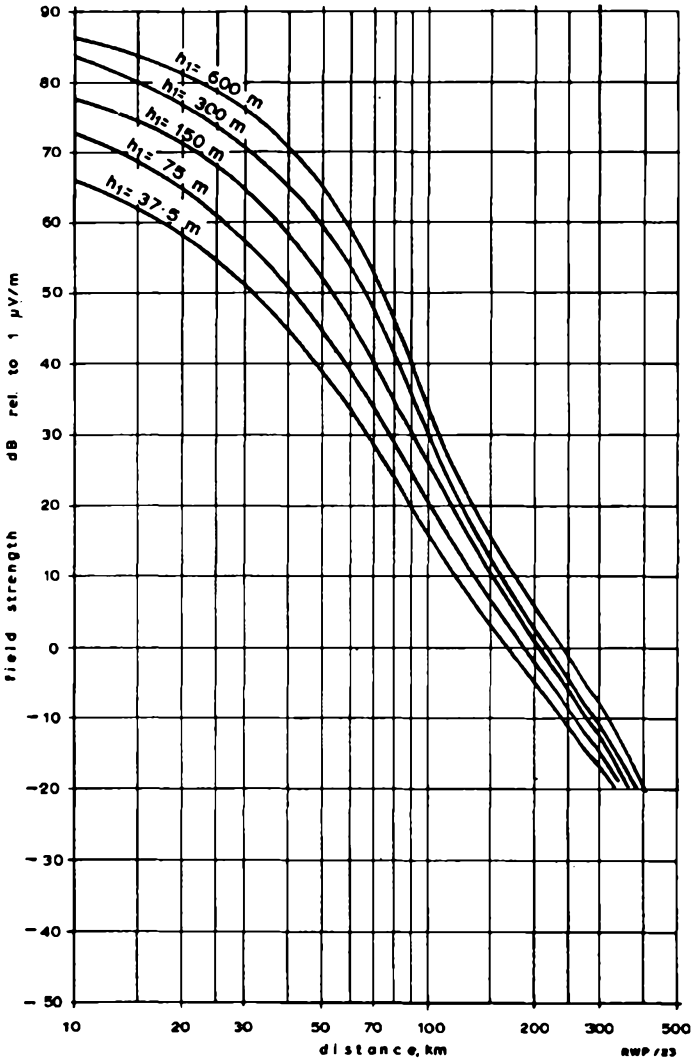

Fig. 23. U.H.F. 50% time curves: sea path (CCIR Recommendation 370-1)

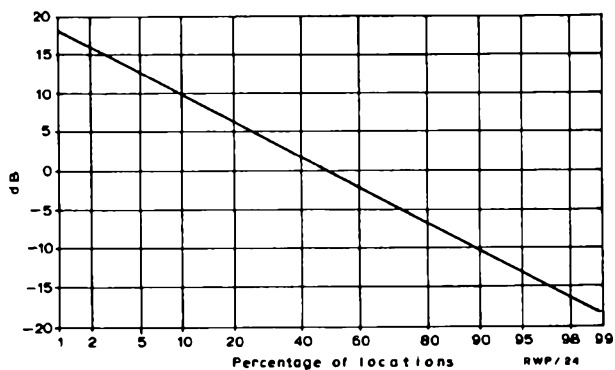

Fig. 24. Location correction factor at v.h.f.
(CCIR Recommendation 370-1)

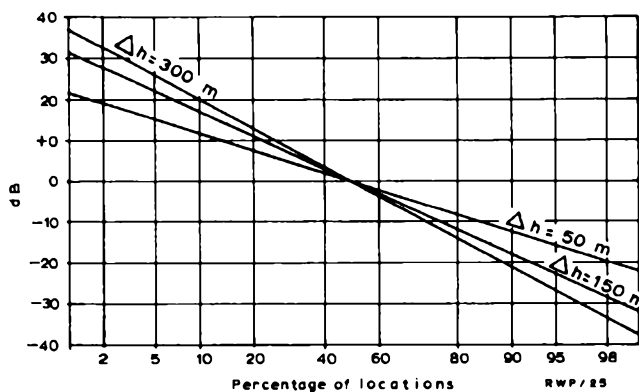

Fig. 25. Location correction factor at u.h.f.
(CCIR Recommendation 370-1)

It may be noted that the location correction of Fig. 25, used at u.h.f., involves a parameter Δh . This parameter defines the degree of terrain irregularities; it is the difference in the heights exceeded by 10% and by 90% of the terrain in the range between 10 and 50 km from the transmitter. A further correction factor based on Δh is shown in Fig. 26.

The curves of Figs. 21 to 23 all assume the receiving aerial height to be 10 metres a.g.l., this being considered to be a typical height at which viewers may be expected to mount outdoor receiving aerials. This assumption of a height of 10 metres for receiving aerials is common to the presentation of most field strength maps showing the service area of a transmitter. Obviously, use of a reduced aerial height may be expected to result in a reduction in field strength. Typical median values of receiving aerial height gain between 3 and 10 metres a.g.l. are of the order of 5 to 10 dB, but at any specific location the actual height gain, particularly at u.h.f., may differ by many dB from the median in the area.

The effective height of a receiving aerial may of course be much greater than 10 metres, either because the aerial is itself mounted high, or because the ground slopes downward toward the transmitter. Any adjustment to allow for this takes the form of a subjective assessment in terms of percentage of locations. (See the following worked example.) At distances beyond the probable horizon, a less subjective correction may be made, as an equivalent path length reduction equal to the increased distance to the horizon as seen from the receiving terminal. This reduction in path length approximates to $4.1 \sqrt{(h_2 - 10)}$ km, where the necessary receiving aerial height h_2 is in metres.

In other respects the curves of Figs. 21 to 23 are self-explanatory, each being normalised for an effective radiated power of 1 kW. The only problem relates to the height, h_1 , of the transmitting aerial above mean terrain. The height of mean terrain is arbitrarily defined as the mean height of the terrain between 3 and 15 km from the transmitter on the bearing toward the receiving location. This height can usually be assessed with sufficient accuracy from the one-inch Ordnance Survey; h_1 is then the difference between the actual height of the transmitting aerial above mean sea level and the mean terrain height.

Example. It is required to find the probable field strength exceeded for 50% of the time at 10% of locations in an area 45 km from a 200-MHz transmitter of 100 kW e.r.p. The transmitting aerial height is 270 m above sea level, the mean terrain height (between 3 and 15 km from the transmitter) is 45 m, Δh is 25 m and the receiving aerial height h_2 is 10 m.

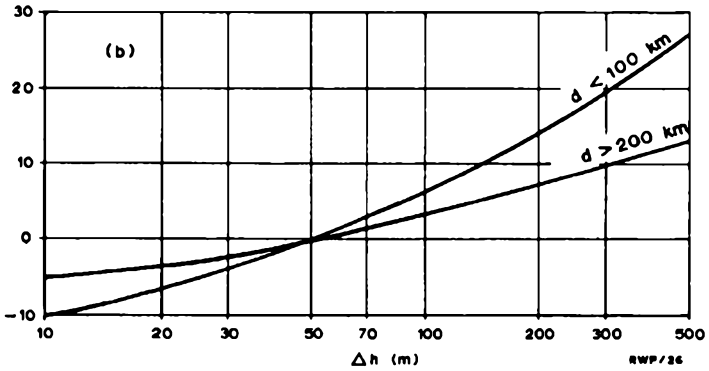
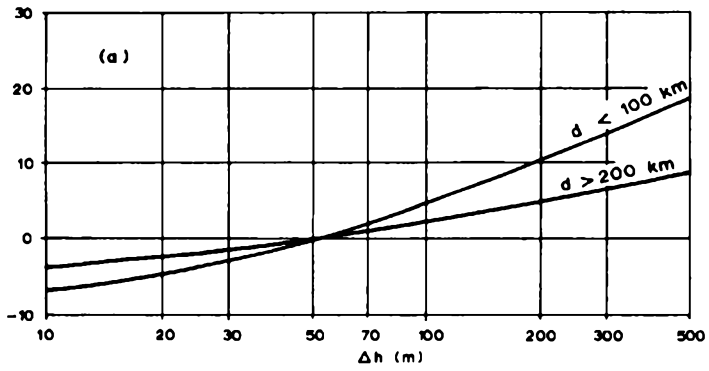

Fig. 26. Correction factors for terrain roughness (CCIR Recommendation 370-1)

The working may be set out as follows:-

1. Height h_1 above mean terrain = $270 - 45 = 225$ m.
2. Interpolating on Fig. 21 between h_1 values of 150 and 300 m, we find that the field strength for 1 kW e.r.p. is 49 dB above $1 \mu\text{V/m}$ at 50% of locations.
3. Power radiated = 100 kW = +20 dB relative to 1 kW.
4. From the location correction curve (Fig. 25) we see that the 10% location value is 10 dB higher than the 50% location value.
5. For $\Delta h = 25$ m, Fig. 26a shows an attenuation correction factor of -2 dB to be required. (The minus sign appears because Δh is less than the reference value of 50 m, the path attenuation being therefore reduced and the field strength increased.)
6. Corrected value of field strength

$$= 49 + 20 + 10 - (-2)$$

$$= 81 \text{ dB above } 1 \mu\text{V/m.}$$

Two features of the use of field strength curves for service area prediction should be emphasised. Firstly, since the curves are statistical in nature and derived from measurement data over varying types of path, relatively large discrepancies may be expected in individual paths in spite of the various correction factors to be applied. The magnitude of the discrepancy increases with frequency.

Secondly, although it is usual to use the median time, median location (F 50 – 50) curves it should not be supposed that a broadcasting authority is content to serve only half the population for half the time. As mentioned previously, the variation of field strength with time within the service area can generally be neglected. The level of field strength taken to represent the limit of service normally contains a factor making allowance for the local variation factor. For example, suppose theoretical considerations to indicate the minimum acceptable field strength to provide a satisfactory signal-to-noise ratio in a particular v.h.f. band to be x dB relative to $1 \mu\text{V/m}$. A suitable value of town median field strength representing the limit of service may then be taken as, say, $x + 6$ dB. From Fig. 24, this implies that the minimum acceptable signal level should be exceeded at about 75% of locations in an area of typical terrain.

4.2.3 Predictions for a Specific Path

Only very rough results can be expected from field strength predictions using field strength curves alone. Errors in excess of 6 dB at v.h.f. and 10 dB

at u.h.f. are common, even in determining the median field strength in an area. To obtain greater accuracy, it is necessary to draw the profile of the particular path to be investigated. Special 'profile paper' is generally used. This is graphically constructed so that a ray path can be drawn as a straight line over an earth of radius equal to $4/3$ times the true radius. This modification takes account of the radio wave bending due to the normal refractive index gradient as discussed in Section 3.1.5.

When this profile has been drawn, it is then necessary to calculate the individual losses due to diffraction, to phase cancellation of direct and ground reflected signal components, and clutter losses due to buildings and trees, particularly those near the receiving aerial. Most of these aspects have been discussed in previous sections.

It is beyond the scope of this manual to discuss prediction methods involving diffraction, reflection and clutter parameters in detail. The methods in use are generally empirical, manual methods in particular requiring considerable experience to make subjective assessments of clutter losses and effective ground reflection coefficients. The effects of ground reflection are of paramount importance at the lower end of the v.h.f. band; the effects of diffraction and clutter are of greatest importance at u.h.f.

Computer methods for service area prediction have been developed by the BBC and others. These methods are of two types:

- (a) Fully computerised prediction⁽³¹⁾,
- (b) Partially computerised prediction.

(a) Fully Computerised Prediction

Here the essential terrain data for the whole area to be examined are stored in the computer in the form of ground heights at regular intervals in a uniform lattice. The accuracy of the prediction is limited by the spacing of the lattice, since this determines the accuracy with which the particular path profile can be interpolated. To provide such detailed information over a large area presents formidable data storage problems. For example, the smallest quadrilateral shape enclosing the mainland of Great Britain is about 3.5×10^5 square km in area. If this forms the basic lattice, and terrain heights are to be specified at 0.5-km intervals, the data bank must contain about 1.5 million height entries, each identified by appropriate spatial coordinates. Even this amount of detail is less than the minimum desirable for useful service area predictions.

(b) Partially Computerised Prediction

The serious data storage problems of the fully computerised prediction method can be avoided if predictions are confined to particular radials for which the terrain data are specifically provided. Such data are of the form of a series of entries relating terrain height to distance from the transmitter along the radial, together with additional information regarding the positions of buildings and trees. Suitable radials can be selected from examination of the relevant Ordnance Survey map, those of interest usually passing through the principal centres of population.

The main problem inherent in this form of prediction is that of transferring the required input data from the Ordnance Survey map to the computer. A manually operated coder unit, developed by the BBC, enables the information to be transferred directly from the map to punched paper tape. Once the basic terrain data are provided, computation techniques may be identical for both fully and partially computerised methods. Mathematical techniques of varying complexity are available for calculating diffraction losses, while clutter losses due to the presence of buildings and trees near the receiving terminal are usually estimated semi-empirically.

However complex the computer prediction calculation may be, its accuracy is limited by the detail available regarding the transmission path. The partially computerised method, in which the computer is provided with data for selected radials, permits greater prediction accuracy along these specific radials than is practicable in a fully computerised system in view of the formidable terrain data storage problems of the latter method. The fully computerised method does however permit the direct computation of field strength contour, or service area, maps. Furthermore, by storing population data as well as terrain data, it is possible to obtain a direct estimate of the population within the predicted service area.

4.3 Field Strength Predictions for Abnormal Propagation Conditions

Every broadcast transmission not only provides a service to the area immediately around the transmitting station, but also forms a potential source of interference to other stations using the same or adjacent frequency channels. For satisfactory reception of the wanted station, the ratio of wanted to interfering signal levels must exceed a minimum value which depends on the type of transmission and the relative frequencies of the two signals.

As discussed in Section 3.2.2, abnormalities occurring for a small proportion of the time in the troposphere can cause considerable enhancements in signal levels received over long distances, particularly over sea paths at u.h.f. It is not

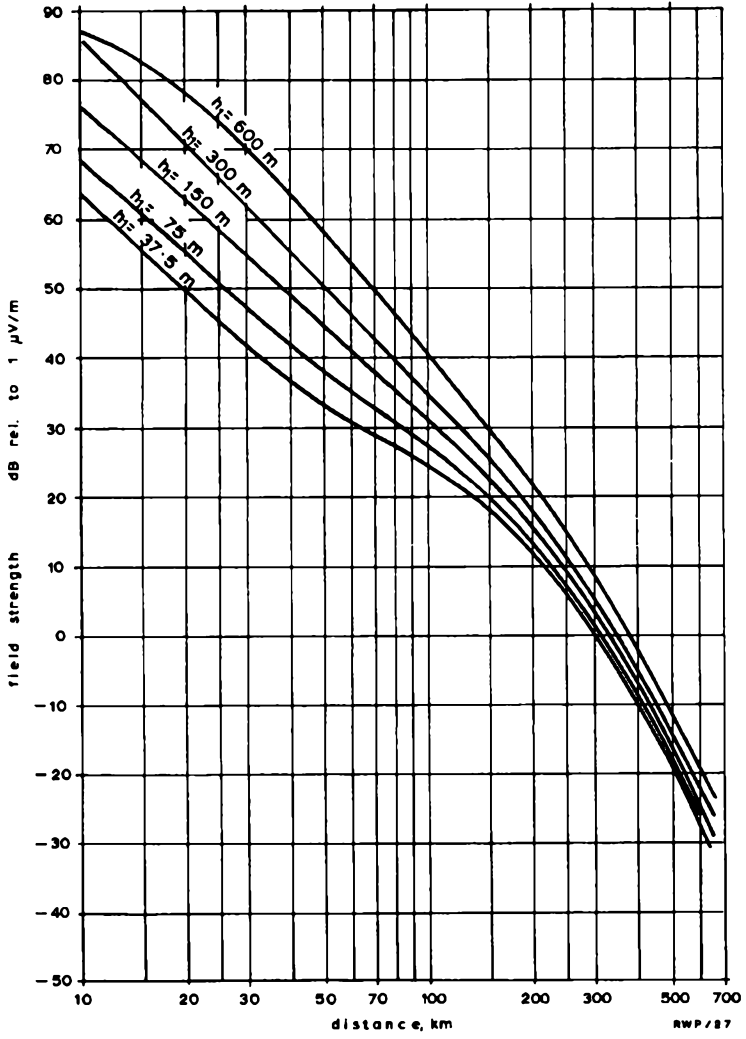

Fig. 27. V.H.F. 10% time curves: land and sea paths (CCIR Recommendation 370-1)

RWP/87

practicable to plan a broadcast network to ensure freedom from interference from other stations under all propagation conditions, the usual practice being to plan for adequate protection for interference for a specified percentage of the time. Such planning standards at present used in the U.K. are:

<i>Service</i>	<i>Protection</i>
V.H.F. Television	At least 90% of the time
U.H.F. Television	95%
V.H.F. Radio (national services)	99%

For frequency planning purposes, it is therefore important not only to be able to predict field strengths within the service area of a wanted station, but also to have statistical information regarding field strength probabilities at greater distances under abnormal propagation conditions, i.e., for small percentages of the time.

Curves produced by the CCIR for the prediction of field strength under normal propagation conditions (50% of the time), for both v.h.f. and u.h.f. have already been shown in Figs. 21 to 23. Similar curves are available for the prediction of field strengths under 'somewhat abnormal' (10% of the time) and 'very abnormal' (1% of the time) conditions*. These curves (Figs. 27 to 30), together with the associated curves of Figs. 24 to 26, are used in the same manner as previously described for the 50% time curves, except that in this instance it is the strength of the interfering signal rather than that of the wanted service which is being predicted.

The useful limit of service of many television stations is determined by interference from other co-channel transmitters rather than by receiver noise. It follows therefore that prediction of these levels of interference forms a vital factor in frequency planning, each transmitting station forming a potential source of interference to viewers in other service areas. Because of the very large number of transmitters required to provide satisfactory coverage of the U.K. at u.h.f., the use of a computer was considered essential for carrying out these interference predictions, bearing in mind that interference levels from many potential sources must be predicted at a substantial number of these locations in the service area of each station.

*Curves are also produced for 5% of the time, for u.h.f. propagation over sea paths only.

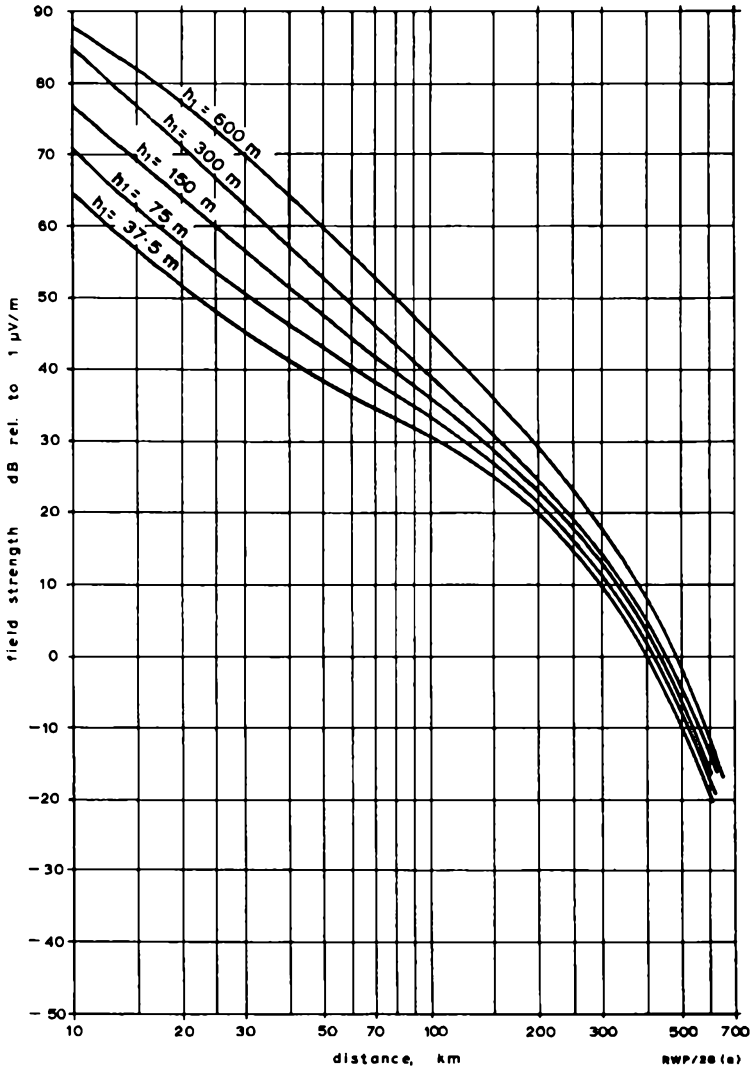

Fig. 28a. V.H.F. 1% time curves: land path
(CCIR Recommendation 370-1)

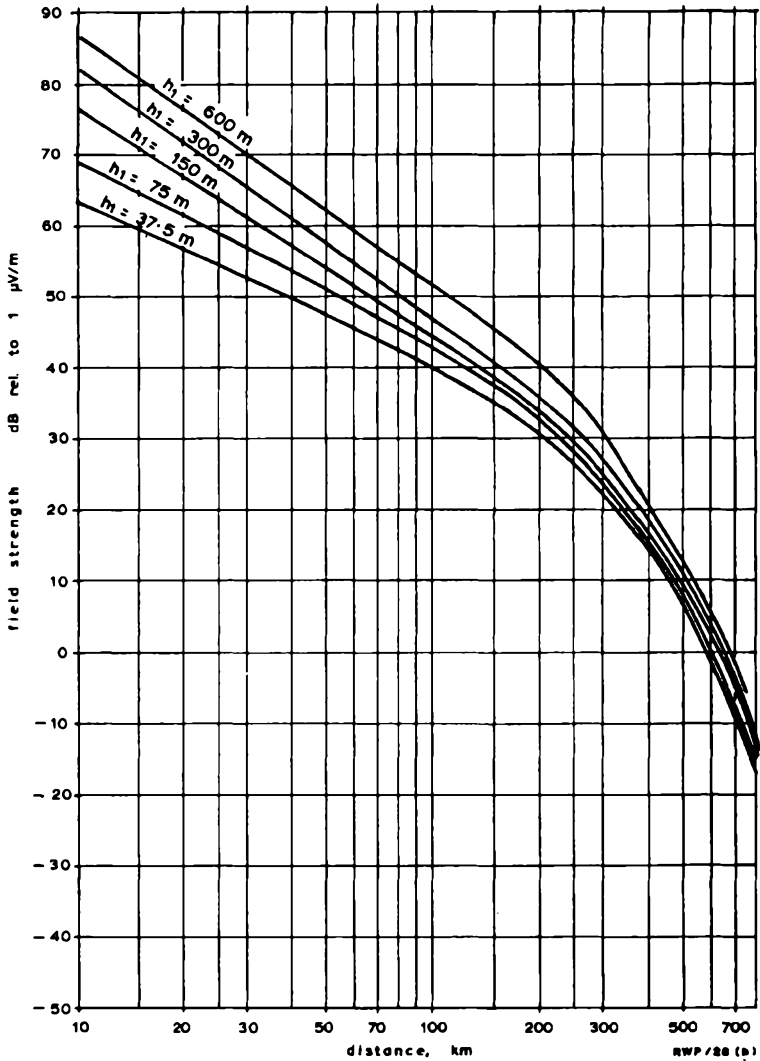

Fig. 28b. V.H.F. 1% time curves: sea path
(CCIR Recommendation 370-1)

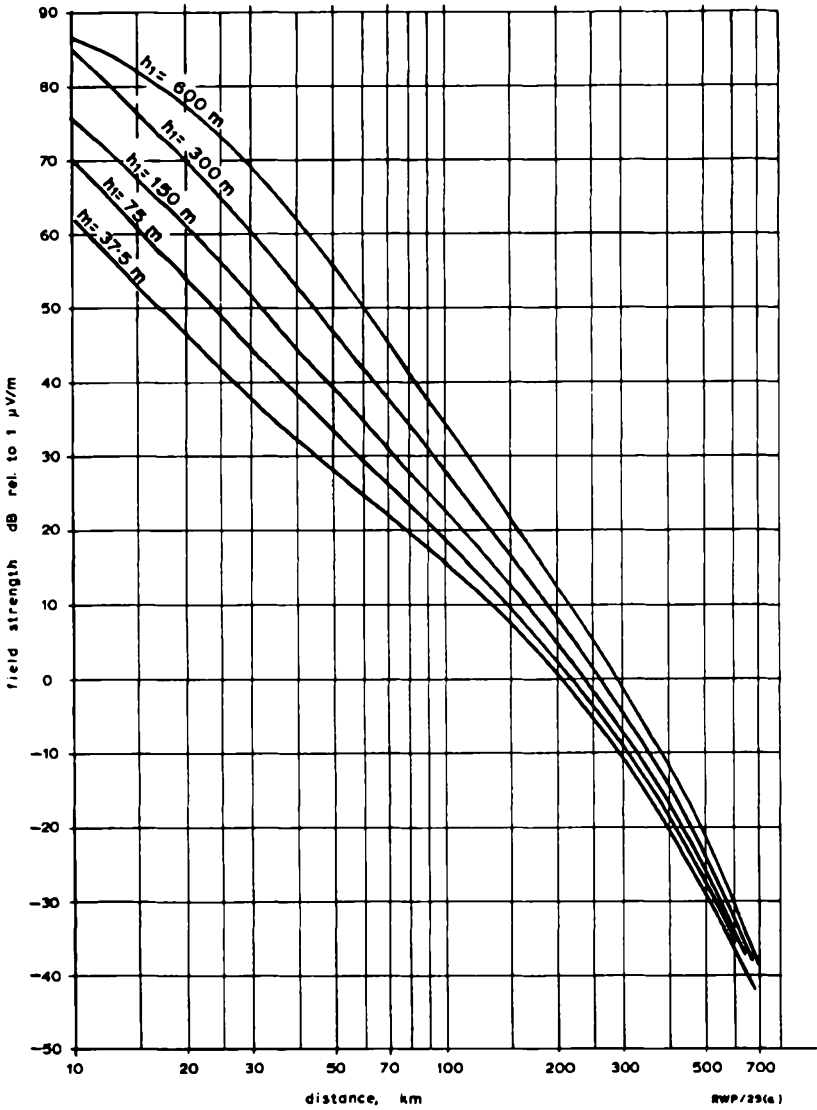

Fig. 29a. U.H.F. 10% time curves: land path
(CCIR Recommendation 370-1)

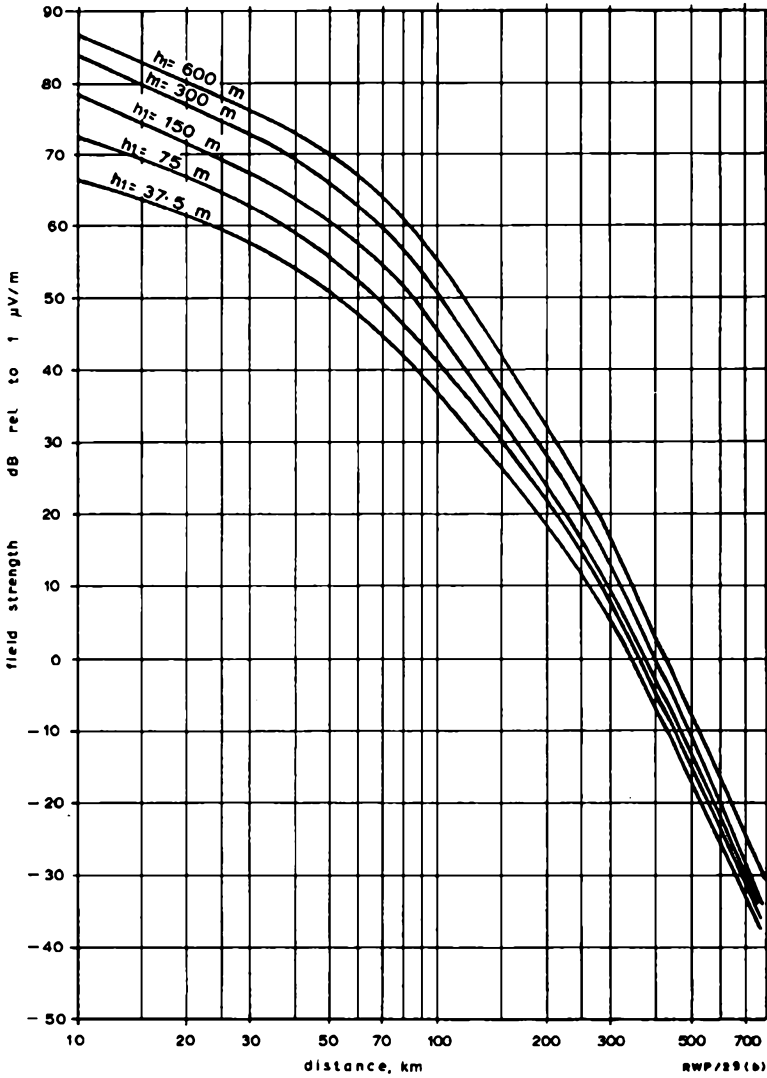

Fig. 29b. U.H.F. 10% time curves: sea path (CCIR Recommendation 370-1)

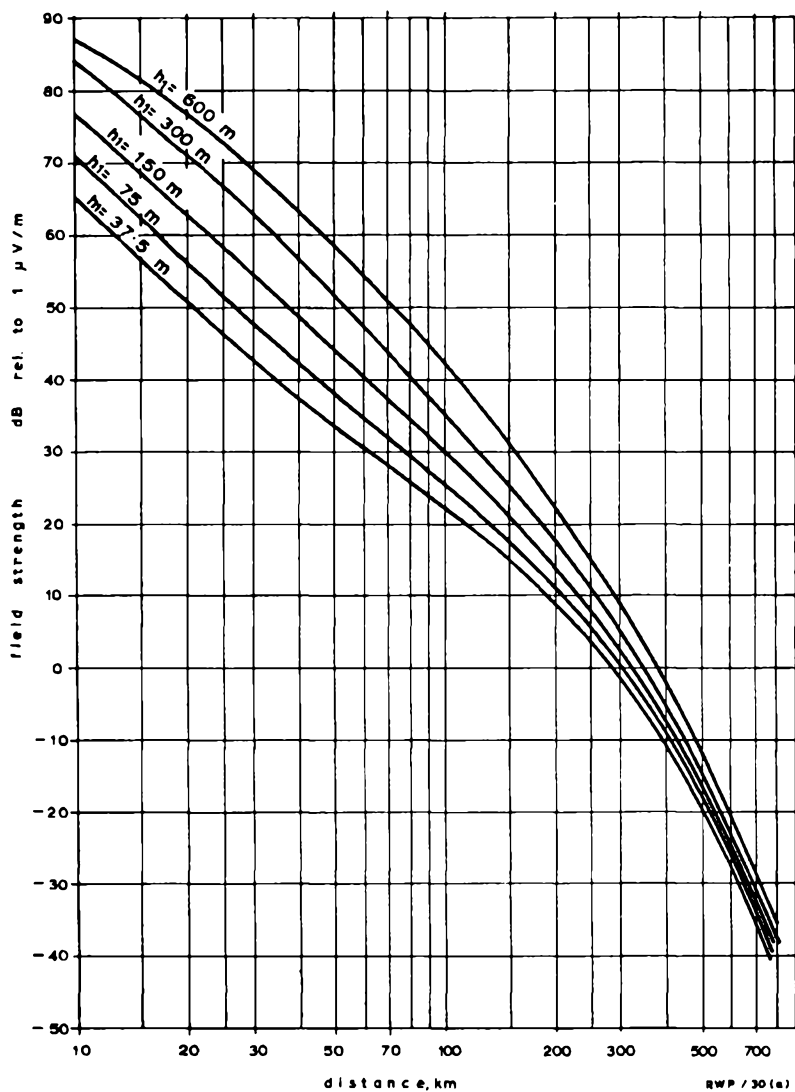

Fig. 30a. U.H.F. 1% time curves: land path
(CCIR Recommendation 370-1)

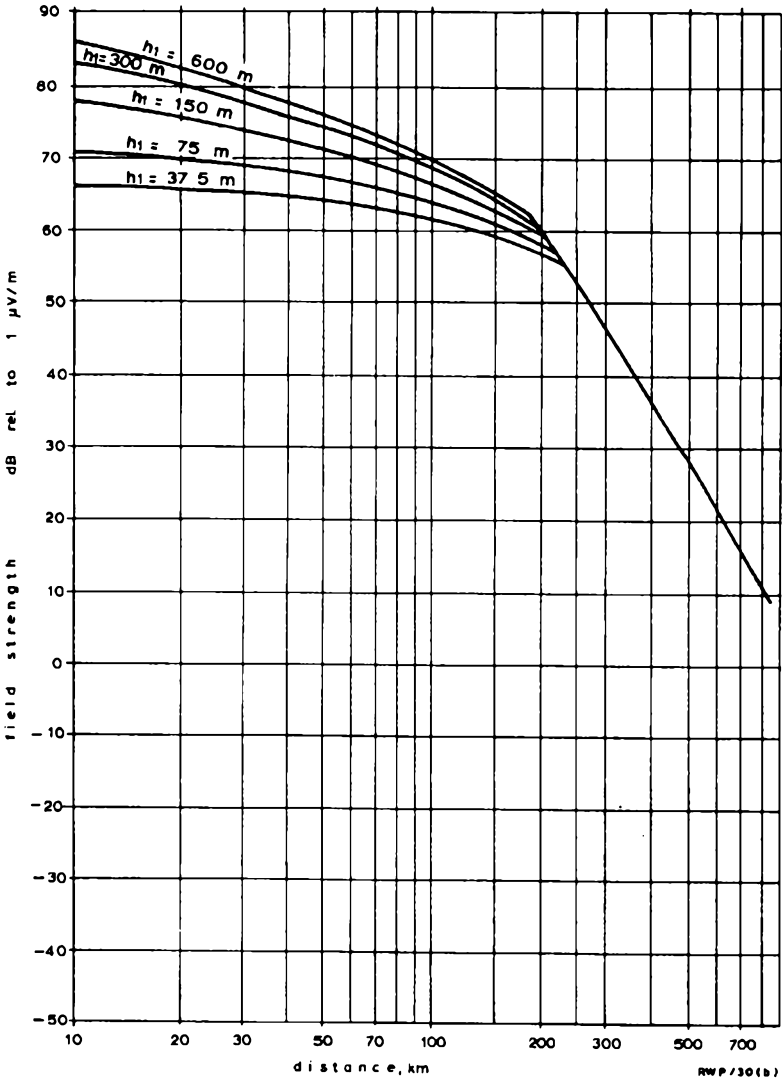

Fig. 30b. U.H.F. 1% time curves: sea path
(CCIR Recommendation 370-1)

The curves of CCIR Recommendation 370-1 (Figs. 21 to 30) were not considered suitable for computer use for several reasons, principally because a subjective assessment is required of the nature of each receiving location (Fig. 25). The BBC therefore developed an alternative u.h.f. prediction method suitable for computer use. This method, which will not be described in detail in this manual, is given in CCIR Report 425⁽³¹⁾. The principal differences from the method of Recommendation 370-1 are as follows:

1. The principal parameter is no longer the effective transmitting aerial height h_t , but the sum of the distances to the nominal (smooth earth) horizons from transmitting and receiving aerials.
2. The receiving location correction factor (analogous to Fig. 25) is a function of the elevation angle of the actual horizon on the bearing towards the transmitter. Under certain conditions a corresponding correction factor is also applied at the transmitting terminal.

Both prediction methods require special interpolation techniques for predictions involving paths which are partly overland and partly oversea. These are described in the appropriate CCIR Reports^{(31), (32)}.

CHAPTER 5

REQUIREMENTS FOR SATISFACTORY TELEVISION RECEPTION

5.1 General

In previous Chapters, we have discussed various factors affecting received field strengths. It is of considerable importance to determine the minimum field strength value required to provide satisfactory reception, since this determines the useful service range of a transmitter. The limits of service range may be determined by:

- (a) Insufficient signal to overcome thermal noise (a noise-limited service).
- (b) Interference from other transmitters (an interference-limited service).
- (c) Other forms of interference. These include multiple reflections (ghosting), impulsive interference, aircraft flutter, sea scatter and so on. Many of these impairments are either local or transient.

5.2 Minimum Signal-to-Noise Requirements

In the absence of other forms of interference, the service is limited by degradation of picture quality due to the visibility of receiver noise, and thus the limit can be expressed in terms of a minimum video signal-to-noise ratio. Obviously, degree of degradation is a matter of opinion, and a considerable amount of experimental work has been carried out to assess suitable practical subjective limits^{(33), (34), (35), (36)}. This has resulted in the adoption⁽³⁷⁾ of a figure of 30 dB for the 405-line system as a minimum acceptable ratio of peak-to-peak video signal amplitude (excluding sync pulses) to r.m.s. random noise. In more recent CCIR Recommendations⁽³⁸⁾ it is usual to express the required minimum ratio in terms of signal to weighted noise.

Following the analysis method of Swann⁽³⁹⁾, it is possible to work backwards from the required minimum peak-to-peak video signal-to-r.m.s.-noise ratio, to determine minimum field strength limits, assuming typical values for receiver noise factor and receiving aerial characteristics. To demonstrate the principles involved this calculation will be carried out for a frequency in Band III of 200 MHz.

STAGE 1

The output peak-to-peak video-signal-to-r.m.s.-noise ratio must first be related to the input ratio of r.m.s. r.f. signal (at peak white for positive modulation) to r.m.s. noise.

The picture content of a video signal comprises only 70% of the range from peak white to sync pulse level. Thus, for double-sideband reception with envelope detection, the peak-to-peak video signal is equivalent to the r.m.s. value of r.f. signal output at peak white, whereas the r.m.s. output at video frequency is equivalent to the r.m.s. noise input at r.f. Since, however, single-sideband transmission and reception are universal for television broadcasting, the i.f. response at carrier frequency and all sideband frequencies is reduced to half that for a double-sideband system having the same effective noise bandwidth.

Thus, for a 30-dB peak-to-peak video-output-to-r.m.s.-noise-output ratio, the corresponding ratio of radio frequency r.m.s. signal (peak white) to r.m.s. noise must be 30 plus 6 dB, i.e., 36 dB.

STAGE 2

The next stage is to determine the thermal noise contribution due to aerial input impedance and receiver.

The thermal noise power P_n developed in the input impedance of the receiving aerial is given by

$$P_n = kTB$$

where k is Boltzmann's constant, equal to 1.38×10^{-23} joules per degree absolute (room temperature is typically 290° absolute),

T is absolute temperature in degrees,

B is the energy bandwidth of the receiver (typically 3 MHz for a 405-line receiver).

For a correctly terminated aerial input, the open-circuit e.m.f. E across the receiver terminals is double the input voltage V to the receiver. Hence, for a typical input impedance of 75 ohms,

$$P_n = kTB = \frac{V^2}{75} = \frac{(E/2)^2}{75}$$

$$\begin{aligned} \text{or} \quad E^2 &= 300 \times kTB \\ &= 300 \times 1.38 \times 10^{-23} \times 290 \times 3 \times 10^6. \end{aligned}$$

$$\text{Hence} \quad E = 1.9 \mu\text{V} \approx +6 \text{ dB relative to } 1 \mu\text{V}.$$

It therefore follows that in a noise-free receiver the required r.f. input signal to give an output signal-to-noise ratio of 30 dB must be

$$36 + 6 = 42 \text{ dB relative to } 1 \mu\text{V.}$$

However, the receiver itself contributes thermal noise. This contribution is usually defined in terms of a noise factor which is the ratio of the actual noise power at the receiver output to the noise power which would appear at the receiver output if the resistance component of source impedance were the only source of noise in the system. Typical receiver noise factors in Band III are of the order of 8 dB. Hence, the required signal for such a receiver to provide an output signal-to-noise ratio of 30 dB must be

$$42 + 8 = 50 \text{ dB relative to } 1 \mu\text{V.}$$

STAGE 3

We now consider the effect of the receiving aerial.

It was shown in Section 2.1.2 that the effective length of a half-wave dipole is λ/π . At 200 MHz, λ/π is 0.5 metre. Thus, for a field strength of $x \mu\text{V/m}$ received by a loss-free $\lambda/2$ dipole, the e.m.f. developed across the receiver input terminals is $x \times \lambda/\pi$, i.e., $0.5x \mu\text{V}$, or expressing this in logarithmic form, a field strength of x dB relative to $1 \mu\text{V/m}$ gives an e.m.f. of $(x - 6)$ dB relative to $1 \mu\text{V}$.

Hence, for a required e.m.f. of 50 dB relative to $1 \mu\text{V}$, the corresponding field strength must be $50 + 6$, or 56 dB, relative to $1 \mu\text{V/m}$.

Lastly, the effect of practical receiving aerials must be taken into account. Typically, in fringe areas, viewers may be expected to use simple Yagi receiving aerials in Band III with gains of about 6 dB relative to a half-wave dipole. Typical feeder losses are of the order of 2 dB.

Hence the required field strength for a 30 dB signal-to-noise output ratio at Band III assuming typical receivers and receiving aerials is

$$56 + 2 - 6 = 52 \text{ dB relative to } 1 \mu\text{V/m}$$

The corresponding limiting field strengths for reception of Band I may be determined in a similar manner. Stages 1 and 2 are identical to those worked out for Band III, but with corresponding values for λ/π and effective aerial gain of about +6 dB and +2 dB respectively. These give a minimum field strength of $50 - 6 - 2 = 42$ dB relative to $1 \mu\text{V/m}$.

For television transmission at u.h.f. further differences result from the use of a 625-line system with a consequent requirement of greater receiver bandwidth. In the first few years of the u.h.f. television service there was a wide variation in receiver noise factor, but the trend toward universal use of transistorised tuners has proved beneficial. The effective lengths of dipoles are small at u.h.f. but to some extent this is compensated for by the greater aerial gains that are obtainable.

Finally it will be realised that the minimum field strength values derived by this analysis refer to individual receiving locations. In general even though the field strength in an area may be specified in terms of a median (50%) location value it is not considered adequate for only half the receiving locations to receive the minimum field strength required for satisfactory reception. It is usual therefore to add a factor proportional to the local variation factor when specifying minimum field strength requirements. Such minimum values appropriate for planning have been specified by the CCIR⁽⁴⁰⁾ for rural areas and are given in Table 5.1.

TABLE 5.1

<i>Band</i>	<i>Minimum Field Strength (dB w.r.t. 1 μV/m)</i>	
	<i>(a) For satisfactory grade of picture at a specific receiving location</i>	<i>(b) Minimum median value for planning purposes (CCIR Rec. 417-1)</i>
I	47	48
III	53	55
IV	62	65
V	67	70

In urban areas higher minimum values are required, both on account of the greater location factor, and because of the higher background level of impulsive electrical interference. It is difficult to generalise upon required minimum median field strength in large towns and cities since this depend greatly upon the local variation factor, i.e., upon the nature of the topography of the area. Typical values are:-

Band I	60 dB(μ V/m)
Band III	66 dB (μ V/m)

Even higher values of field strength may be required, particularly at Band-I frequencies, to ensure satisfactory discrimination against impulsive interference in city centres. At u.h.f. the effect of topography and building clutter is so important that it is generally impracticable to assess the completeness of service coverage solely in terms of the median field strength. Thus in hilly terrain a town may be inadequately served even though the median field strength may be substantially greater than that for a comparable but flatter town which is considered to be adequately served.

5.3 Interference from Other Television Transmitters

5.3.1 General

In Sections 3.2.2. and 3.3 the effects of abnormal propagation conditions in the troposphere and ionosphere have been discussed. Such conditions substantially increase the field strengths of distant transmissions which can thus interfere with the wanted service. For satisfactory reception it is necessary to ensure that the ratio of wanted to interfering signal exceeds some specified value for a given proportion of the time (generally 90%, 95% or 99%). This ratio is termed the *protection ratio* and is dependent upon the relative transmission systems of wanted and interfering services and upon the frequency separation of the respective carriers. The subjective effects of this form of interference have been extensively studied and appropriate values of protection ratio are given in a CCIR Recommendation⁽⁴¹⁾ for all relevant combinations of wanted and interference modulations and relative frequencies. Generally, however, these may be grouped into:-

- (i) Interference from a transmitter operating with a different transmission system and with a carrier frequency significantly different to that of the wanted service.
- (ii) Interference from co-channel stations using this same transmission system.

5.3.2 Interference from Stations Operating on Different Line-standards

The first of these conditions occurs when tropospheric and ionospheric conditions cause interference between continental and U.K. stations in Band I, since the U.K. 405-line system is not used elsewhere on the continent. The interference takes the form of bars or striations in the television picture having a pattern dependent upon the frequency difference between wanted and interfering carrier frequencies; if this is an exact multiple of the line frequency of the wanted transmission, this pattern takes the form of vertical bars, but in the more general case the bars are diagonal and drift across the screen.

5.3.3 Interference from Co-channel Stations with the Same Line-standard

At u.h.f., and also at v.h.f. when the interference is from other U.K. transmitters, interference is normally due to stations operating within the same frequency channel. Here also the interference to the picture results from the heterodyne beat between wanted and unwanted carriers, but in this instance the frequency difference is small. The pattern takes the form of horizontal striations across the screen and consequently is often referred to as the *Venetian-blind effect*. The subjective annoyance of this form of patterning can be much reduced by a suitable choice of offset (i.e. carrier frequency difference). If the offset contains an exact number of half-cycles in each field period, the pattern is stationary and these patterns can be arranged so that successive fields tend to cancel each other.

The subjective interference between two signals is a minimum if the carrier frequencies have an offset of half the line frequency and rises if this is reduced to nearly zero or increased to line frequency. Thus in a 405-line system the best condition that can be achieved with two transmitters is to use carrier frequencies of f_c and $(f_c \pm 5.06)$ kHz. If, however, mutual interference is possible between more than two transmitters, this condition is not the best available, since two of these stations must have either zero offset or an offset of line frequency. Thus, it is better to use offsets which are multiples of one-third line frequency, since this permits up to three potentially mutually interfering transmitters to be offset from each other.

To ensure that interference between the amplitude-modulated sound carriers of co-channel stations is minimised, it is usual to offset these carriers sufficiently to make the heterodyne inaudible (a frequency difference of 20 kHz being commonly used in the v.h.f. band). However, some stations receive their programme by direct reception from a parent transmitter, and reradiate on a different channel after *frequency translation*, a process which changes both sound and vision carrier frequencies by an equal amount. In this

circumstance, to ensure a sufficient offset of the sound carrier frequency and still retain a vision carrier offset which is a multiple of one-third line frequency, it is often convenient to use offsets of $5/3$ or higher multiples of the line frequency.

Table 5.2 gives protection ratios recommended by the CCIR, the figures quoted being considered acceptable for interference occurring for a small proportion of the time. Ratios for just perceptible interference would be some 10 to 20 dB higher, and in practice therefore these ratios should be adjusted in the knowledge of the expected fading range of the interfering signal.

TABLE 5.2

<i>Frequency Separation</i>	<i>Protection Ratio (for just tolerable interference)</i>
Less than 1 kHz but not synchronised (405 or 625 lines)	45 dB
Less than 50 kHz but not synchronised (405 or 625 lines)	35 to 40 dB
$\frac{1}{3}, \frac{2}{3}, \frac{4}{3}, \frac{5}{3}$ line frequency	30 dB: 625-line system* 35 dB: 405-line system*
$\frac{1}{2}$ or $\frac{3}{2}$ line frequency	27 dB: 625-line system 31 dB: 405-line system

*These values may be reduced to 20 dB for a 625-line system and 28 dB for a 405-line system if a carrier difference equal to an appropriate multiple of the frame frequency can be maintained; the line frequency should be kept constant to within 5×10^{-6} , the frequency tolerance of each transmitter not exceeding ± 2.5 Hz.

5.3.4 *Local-oscillator, Harmonic and Image-channel Interference*

In addition to interference from co-channel and adjacent-channel stations, one further factor which must be taken into account in planning a television network is that of interference caused by radiation, at the local-oscillator frequency or its harmonics, from nearby receivers. Two receivers in adjacent flats or in semi-detached or terraced houses may be only a few feet apart. Their feeders may lie close together over part of their length and terminate in aerials mounted on the same chimney-stack. Interference can thus be caused by radiation, either directly from the chassis or by the aerial, and picked up by a neighbouring receiver, again either directly or by the aerial. In acknowledgement of this problem the radio industry has recommended maximum limits to the permissible fundamental oscillator frequency radiation of a u.h.f. tuner, and at harmonics of the oscillator frequency of a v.h.f. tuner operating in Band III.

The channel spacing in the u.h.f. broadcast bands is 8 MHz, with a vision channel intermediate frequency for virtually all 625-line receivers standardised at 39.5 MHz. Consequently, the local-oscillator frequency of a receiver tuned to channel n is only 0.5 MHz below the vision carrier of channel $(n + 5)$. Care is therefore taken in planning to ensure that this channel combination is never used for co-sited transmissions nor, wherever possible, for adjacent stations with overlapping service areas.

The local oscillator of a receiver tuned to Channel n is 7.5 MHz above the vision frequency of a receiver tuned to Channel $(n + 4)$. This normally presents no interference risk, and frequency allocations in the u.h.f. band are such that the great majority of co-sited transmitter groupings have one pair of channels with this frequency relationship. However, interference to reception on Channel $(n + 4)$ can occur if the receiver on Channel n is seriously mistuned. This interference is most severe for colour reception, since the interfering oscillator frequency may be very close to the colour subcarrier frequency on Channel $(n + 4)$. It is unlikely that a colour receiver operating on a colour transmission on Channel n could be mistuned sufficiently to cause interference, since such severe mistuning would produce unacceptable picture degradation, but while the proportion of colour receivers remains small the risk of this form of interference at 4-channel spacings will remain.

The extent of the Band-I spectrum is insufficient for local oscillator interference to occur within the band, but it can arise in Band III. In this instance the vision channel intermediate frequency is commonly 34.65 MHz, and the oscillator of a receiver tuned to Channel 6 operates at 214.4 MHz, thereby presenting a potential source of interference to a nearby receiver

tuned to Channel 13 (vision frequency 214.75 MHz). In addition to interference problems arising from radiation from local oscillators at their fundamental frequency, further problems can arise from radiation of harmonics. In this instance the interference is caused by a nearby receiver tuned to a transmission in a lower broadcast band. For example, second harmonics of oscillators tuned to transmissions on Channels 3 to 5 fall in Band III. Similarly, second and third harmonics of Band-III oscillator frequencies fall in the u.h.f. bands. In the current U.K. u.h.f. plan there are a number of areas having one channel vulnerable to this form of interference. The following are two examples.

(a) Sutton Coldfield: One u.h.f. channel allocation is channel 46 (vision frequency 671.25 MHz). Lichfield ITA transmitter serves the same area and operates on Channel 8 (vision frequency 189.75 MHz). The oscillator frequency is thus 224.4 MHz and the third harmonic is 673.2 MHz, i.e., 1.95 MHz above the Channel-46 vision frequency.

(b) Black Hill (Scotland): One u.h.f. channel allocation is Channel 50 (vision frequency 703.25 MHz). The vision frequency of the co-sited ITA transmission on Channel 10 is 199.73 MHz, and hence the third harmonic of the local oscillator frequency is 703.04 MHz, i.e., 0.21 MHz below Channel-50 vision frequency.

Image channel interference is also possible at u.h.f. For a receiver tuned to Channel n , the intermediate frequency of the sound carrier received from a nearby station operating on Channel $(n + 9)$ would be 38.5 MHz, which is separated by only 1 MHz from the wanted vision carrier intermediate frequency. Similarly, the intermediate frequency of the vision carrier received from a station on Channel $(n + 10)$ would be 40.5 MHz, also 1 MHz from the wanted vision carrier. However, in this latter instance, the interfering image channel signal occurs on the vestigial sideband of the wanted transmission and may be adequately rejected by the passband response of the intermediate frequency circuits. Field trials⁽⁴²⁾ carried out in 1962/3 using test transmissions radiated from Crystal Palace on Channels 34 and 44 confirmed the feasibility of using a 10-channel spacing for co-sited transmissions.

One further interference possibility requires mention, namely that of harmonics radiated by nearby or co-sited television or v.h.f. sound broadcasting stations. Third harmonics of transmissions on Channels 4 and 5 fall within Band III, as do second harmonics of Band-II transmissions. Third and fourth harmonics of Band-III transmissions fall within Bands IV/V. Such problems of

harmonic interference are normally confined to areas in the immediate proximity of the interfering transmitter.

5.3.5 Receiving Aerial Directivity and Polarisation Protection

The protection ratios specified in the previous sections make no allowance for any directional properties of the receiving aerial, which under favourable conditions may be used judiciously to discriminate against the interfering station. Domestic receiving aerial directivity characteristics appropriate for planning purpose are specified in CCIR Recommendation 419 and are reproduced in Fig. 31. Receiving aerial directivity protection increases with frequency since it becomes practicable to have aerials of higher gain and directivity.

Additional protection is also available if wanted and interfering transmissions are cross-polarised.⁽⁴³⁾ The degree of protection available varies greatly, according to the nature of the receiving location and the care with which the receiving aerial is mounted. Protection is greatest at open rural sites, and least in 'cluttered' urban areas, and in zones of deep diffraction. Typically, protections of 10 dB are available at a considerable proportion of receiving locations. In the Band-I and Band-III networks, the original high power stations have used vertical polarisation. As later stations have been added to the network, the choice of polarisation has been determined by that of the existing station considered to be the most probable interfering source. In the u.h.f. television network all main stations, i.e., stations with e.r.p.s of 20 kW to 1 MW, are horizontally polarised and all relay stations (with e.r.p.s up to 10 kW) are vertically polarised.

5.4 Multipath Effects

5.4.1 General

So far, two principal limitations of service have been discussed, namely the requirement for adequate signal-to-noise ratio, and adequate protection from other transmissions. Attention has been given only to the direct propagation path. Unfortunately other paths can exist, either permanently or temporarily, which may mar the picture, sometimes to the extent of rendering useless a normally acceptable signal. These paths may be of different types which will be discussed individually.

5.4.2 Reflections from Hills or Large Buildings

The reflection of a signal from the ground in the vertical plane has already been discussed. Reflection can also occur in the horizontal plane

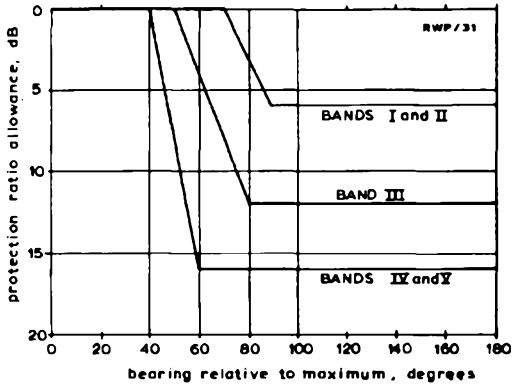

Fig. 31. Protection ratio allowance for receiving aerial directivity (CCIR Recommendation 419)

from surfaces such as hills and large buildings. Any signal arriving at the receiving aerial by a path other than the direct path from the transmitter must traverse a longer distance than the direct path and thus arrives delayed in time, thereby producing a signal component displaced in time on a television screen. The consequent degradation of picture quality is a function of the amplitude, phase and time delay of this component relative to the direct signal.

Before discussing this further, it is useful first to consider the effective duration of a picture element on a television screen. This may be considered to be half the period of the highest picture modulation frequency, since this the shortest time in which the modulation can change from white to black. Thus, for a 405-line system, the picture element duration is about $0.2 \mu\text{s}$, and for a 625-line system about $0.13 \mu\text{s}$. Any reflected signal components having delay times shorter than this are not, therefore, seen as a separate ghost image, but merely change the r.f. signal amplitude by a process of vector addition.

As the delay time increases, the first effect is of a loss of horizontal resolution or apparent defocusing. Separate ghost images become apparent at delay times in excess of about $0.4 \mu\text{s}$ for 405 lines and $0.3 \mu\text{s}$ for 625 lines, the effect of such short delay times being often confused with the ringing distortion resulting from a poorly aligned receiver response.

Generally, the degree of subjective impairment increases with delay time for delays up to about $3 \mu\text{s}$, but thereafter an increase in time of delay has little effect upon the subjective impairment. The delayed image may be in the form of either a positive or negative ghost, depending upon whether the direct and delayed components are in phase or in antiphase. Obviously, all other phase relationships are possible, but these two limits provide the most critical impairment. This subjective impairment is also critically dependent upon picture content, being most objectionable in pictures having large areas of contrast, such as captions. Colour reception presents additional problems, in that severe impairment can occur with short delays due to interaction between the colour burst and the sync pulses of the delayed signal. Colour ghosts may also differ in hue from the main picture content.

Although it is generally agreed that a relative delayed image level of 38 dB renders the delayed image imperceptible even under the most stringent conditions, no firm agreement seems to have been reached upon acceptable limits of relative levels for domestic reception. This is no doubt due to the large number of factors involved. However, typical minimum values of required wanted-to-delayed signal component ratios for domestic reception are of the order of 15 to 20 dB for delays of less than $1 \mu\text{s}$, and 25 to 30 dB for delays greater than $3 \mu\text{s}$.

By determining the delay time as a function of picture width it is often possible to establish the extra distance travelled by the delayed signal and thus, from a knowledge of local topography, to identify the source of a reflection. Steps can usually be taken to align the receiving aerial to minimise the impairment. With long delays, however, it must be remembered that errors of one or more line timebase periods can occur.

Example

Suppose that a well-adjusted 21-inch 405-line receiver situated 20 miles from the transmitter has a ghost picture visible 3 inches to the right of the primary picture.

The 21-inch dimension is the diagonal for a picture of aspect ratio 5:4. The active period of the line timebase is $80.7 \mu\text{s}$, and hence 3 inches correspond to $(80.7 \times 3) \div (21 \times 4/5)$, or $14.4 \mu\text{s}$.

The excess delay time is thus $14.4 + nt \mu\text{s}$, where t is the line timebase period of $99 \mu\text{s}$ for a 405-line system and n is an integer.

The velocity of propagation is $0.186 \text{ mile}/\mu\text{s}$, and hence the excess distance is either 2.7 miles or 21 miles (values of n greater than 1 being improbable).

The possible sources of the delayed image must therefore lie on one of two ellipses, having transmitter and receiving location as loci as shown in Fig. 32. If required, the source of a delayed image may be identified by constructing the appropriate ellipse on an ordnance survey map, but in practice the source is frequently self-evident from the local topography and can often be confirmed by rotating the receiving aerial.

The majority of sources of delayed images tend to occur nearer to the receiving terminal than to the transmitter. If the relative bearings of the direct and delayed signals are widely separated, receiving aerial directivity can often be used to improve the ratio of direct to delayed components. Particular problems arise either if the delayed image is generated at the transmitting end of the path or if multiple delayed images occur. In such cases it is often difficult to optimise the receiving aerial position.

5.4.3 Reflections from Aircraft

Signals of considerable amplitude may be received by reflection from aircraft flying near the transmission path. Since an aircraft is moving, the relative path length of the direct signal and of that reflected from the aircraft are varying continuously and pass from the in-phase to the antiphase condition at a rate dependent upon the transmission frequency and upon the aircraft's speed, height and direction relative to the transmission path. This results in a

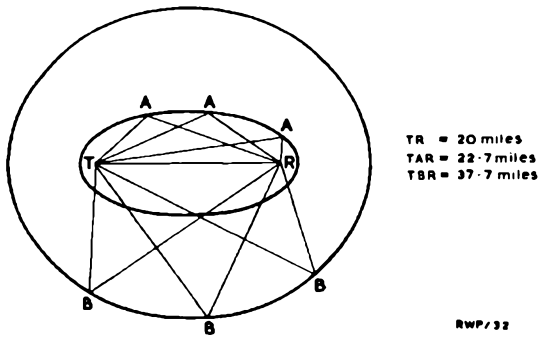

Fig. 32. The locations of sources of reflection having two time-differences

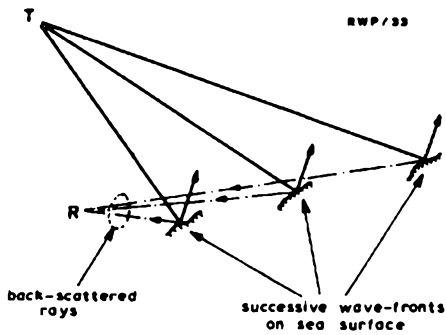

Fig. 33. Path geometry for phase-coherent back-scatter from the sea's surface⁽²²⁾

series of field strength maxima and minima, giving rise to an amplitude flutter which may be highly objectionable or in extreme cases may render a picture unusable with complete loss of line and frame synchronisation. The fading may be accompanied by a ghost picture.

The effect of aircraft flutter at u.h.f. is generally more serious on colour than on monochrome transmissions, the effect of over and under saturation of colour being more disturbing than the flutter of the luminance component. This effect may however be a function of the particular characteristics of luminance and chrominance automatic gain control circuits. The most serious effects of aircraft flutter occur when the receiving site is in a diffraction zone, since this tends to increase the ratio of reflected to direct signal components; also when the aircraft is travelling almost along the line of the transmission path, since receiving aerial directivity is then of little use in discriminating against the reflected signal.

5.4.4 Reflections from the Surface of the Sea

(a) Back Scatter (Sea-scatter)

Soon after the Band-I television station at North Hessary Tor (Devon) was brought into operation at full power in May 1956, reports were received from coastal areas of Devon and Cornwall of signal amplitudes varying over a wide range and of numerous echoes on the screen.^{(44) (45)} The places from which the complaints originated were shadowed from the direct transmission by local cliffs, but had a clear view of the sea. The variations in signal took the form of a rhythmic surge with a periodicity around 40 cycles/minute. This occurred for a large proportion of the time and could render the service unusable. The same surging was apparent on the Band-II f.m. radio service giving rise to multipath distortion.

This form of surging interference results from back-scattering of the transmitted signal from the surfaces of sea waves facing the transmitter as indicated in Fig. 33. If the spacing between the back-scattering surfaces is such that the phase angle between the back scattered rays when reaching the receiving aerial is 2π , then amplitudes will add. Thus, if a large number of such equally spaced surfaces simultaneously reflect the incident transmission, a signal of greatly increased amplitude is returned to the receiving aerial. Obviously, therefore, the condition providing the greatest reflection is a function of the sea wave length relative to that of the transmitted signal.

For sea-waves of small amplitude in deep water, the wavelength λ_s is

related to the forward velocity v as follows:

$$v^2 = \frac{3}{2} \lambda_s.$$

If the direction of back-scattering for this wave formation is in the plane of propagation of a radio signal of wavelength λ_r then, for the back-scattered rays to arrive in phase at the receiving aerial, the reflecting surfaces must be spaced by $\lambda_r/2$, i.e., λ_s equals $\lambda_r/2$.

Hence, for the particular case of the vision carrier of the North Hessary Tor Channel-2 transmission,

$$\begin{aligned} \lambda_r &= 5.8 \text{ metres} \\ &= 2\lambda_s \\ v &= \sqrt{3/2 \times 5.8/2} = 2.1 \text{ m/s} \end{aligned}$$

One cycle of change occurs when the wavecrests have travelled a distance of

$$\lambda_s = \lambda_r/2 = 2.9 \text{ metres}$$

and hence the periodicity of the change is $2.1/2.9$ or 0.73 c/s, i.e., 44 cycles/minute. This periodicity corresponds closely to the observed rate.

In practice, however, the surface of the sea can be considered as random and movement of waves in one general direction is that of unrelated sine waves each with its own characteristic velocity. The faster waves travel ahead and the slower ones fall back and thus if the sea surface profile in the direction of wave propagation is examined it will be seen to be changing continuously.

Consequently if a single frequency radio wave falls on such a surface a phase coherent reflection is provided by areas in which λ_s equals $\lambda_r/2$. A short time later λ_s has changed and so also has the value of radio frequency giving phase coherent reflections. Thus reflection of two different frequencies may occur at the same place but not simultaneously. An example of this is shown in the direct recording of received sound and vision signals comparing Fig. 34.

The extent to which sea-scatter affects a television broadcast depends upon the relative amplitudes of direct and back-scattered signal components reaching the receiver. Obviously therefore, as with aircraft reflections, the worst interference occurs in coastal areas severely shielded from the direct transmission. The effect can be mitigated by use of directional receiving aerials. Unfortunately at many places suffering this form of interference

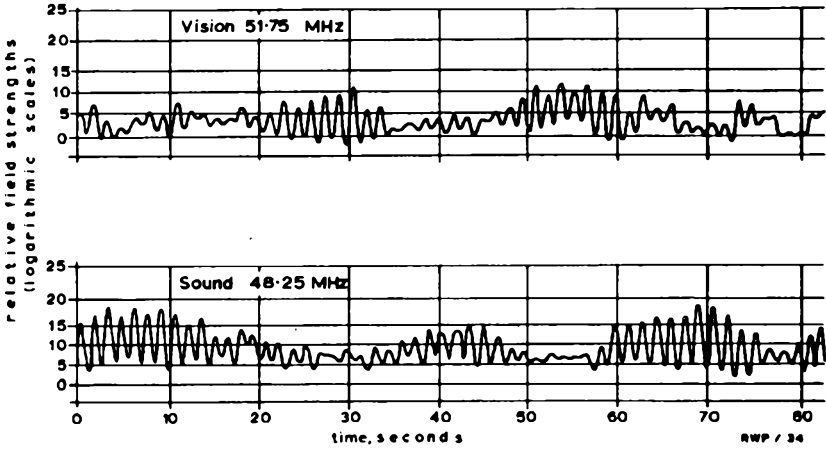

Fig. 34. Simultaneous records of sea-scatter at sound and vision frequencies of Channel 2⁽⁴⁵⁾

the sea is visible over a wide arc and it is therefore impracticable to design domestic receiving aerials (at least for Band I) to provide the required directivity.

There seems to be little evidence of sea-scatter being a severe problem in Band III or at u.h.f. This is partially due to the improved aerial directivity possible at these frequencies, and partially because the frequencies are too high for the relationship λ_s equals $\lambda_r/2$, giving phase-coherent reflections, to apply.

(b) Tidal Fading

The path geometry required for cancellation of direct and ground reflected components of a received signal is discussed in Section 3.1.3. This cancellation occurs when, for wavelength λ ,

$$\theta + \phi = n + \frac{1}{2}$$

n being an integer, and θ the path difference in wavelengths between direct and reflected components.

$$\theta = \eta \left[\frac{2h_t h_r}{\lambda d} \right]$$

where η is a modifying factor to take account of the earth's curvature.

ϕ is the phase delay on reflection (in wavelengths). This is roughly equal to $\frac{1}{2}$ for horizontally polarised signals, and for vertically polarised signals at small angles of incidence.

At v.h.f. the path differences are seldom sufficient for cancellations to occur. At u.h.f. over land paths terrain roughness is generally sufficient to reduce the ground-reflected signal component to insignificant proportions, and even if cancellations occur they may generally be overcome by suitable positioning of the receiving aerial. If, however, the reflection point is the surface of the sea, then, since in this instance the surface is both relatively smooth and of variable height, it may be impossible to position the receiving aerial to avoid cancellation at some phase of the tide.

This effect has been investigated^{(46) (47)}, and (smoothed) experimental recordings of the sound and vision channels of a u.h.f. television transmission are reproduced in Fig. 35. These recordings are representative of reception at unobstructed locations over line-of-sight paths for which changes in field strength exceeding 40 dB may occur. In urban areas near the coast some

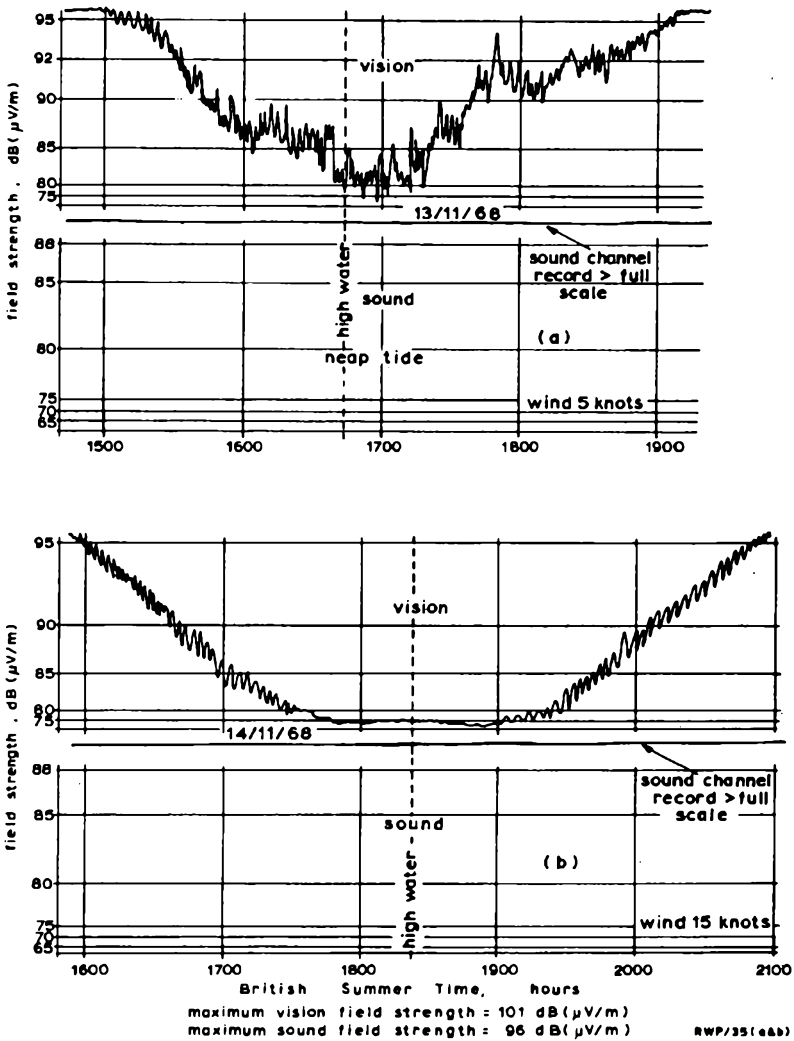

Fig. 35 (a) and (b). Tidal fading at u.h.f.: example showing differential fading on sound and vision frequencies (path Llanddona to Great Orme's Head)

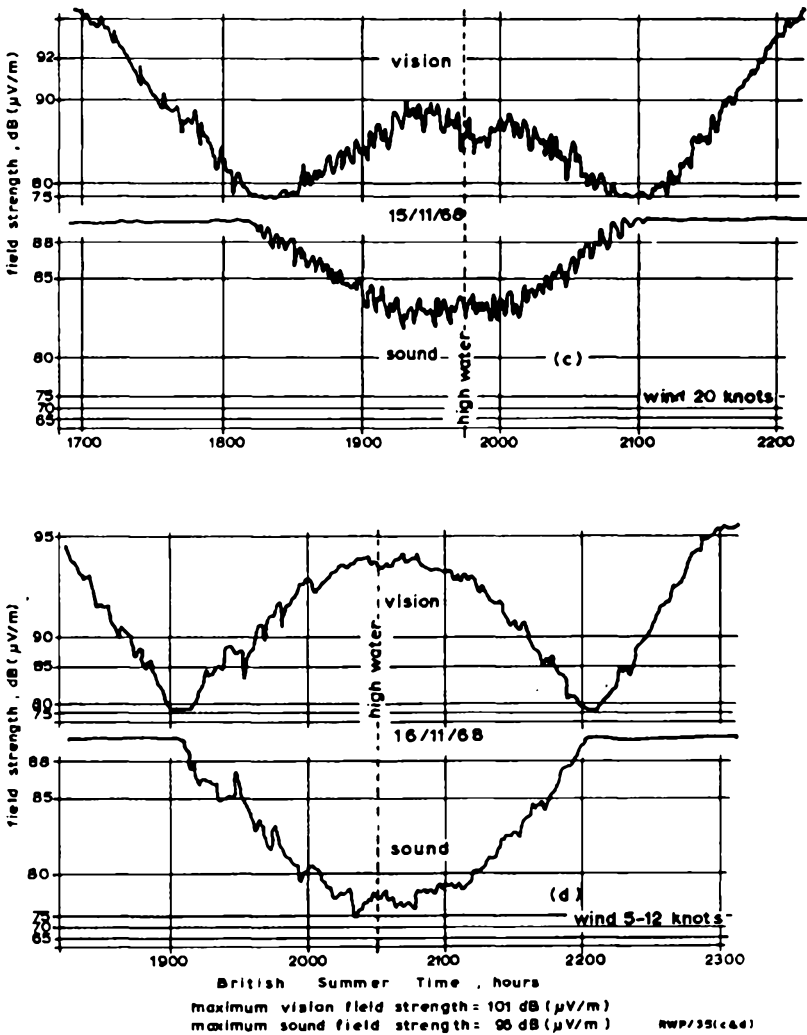

Fig. 35 (c) and (d). Tidal fading at u.h.f.: example showing differential fading on sound and vision frequencies (path Llandona to Great Orme's Head)

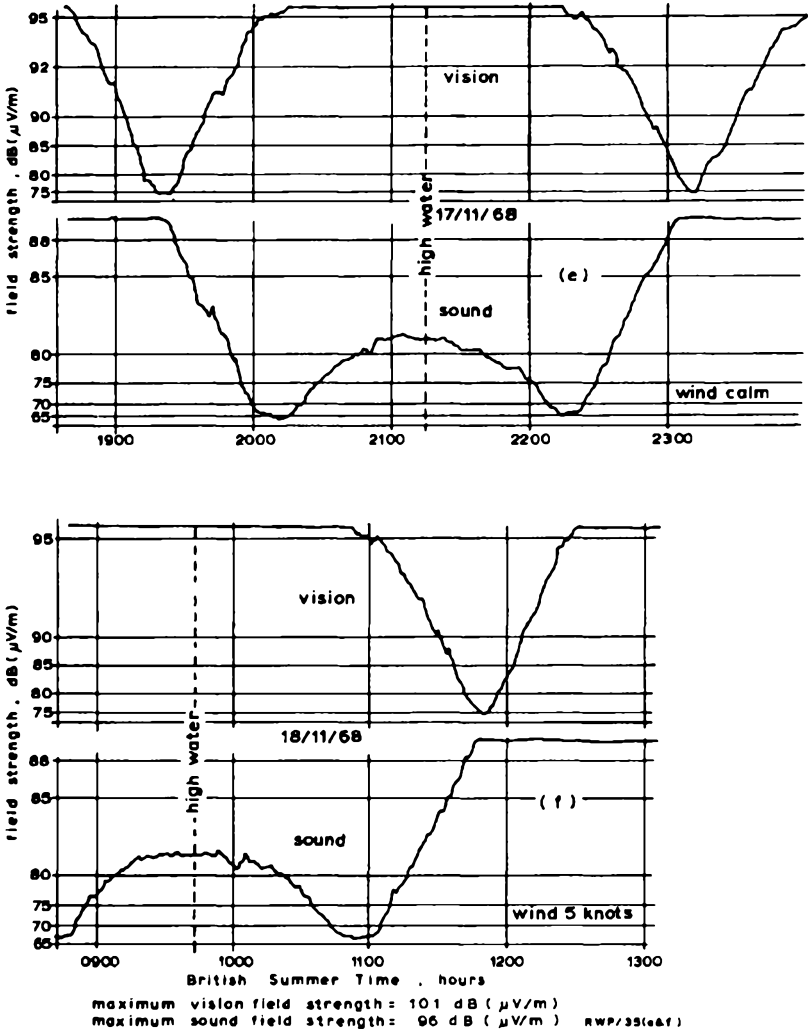

Fig. 35 (e) and (f). Tidal fading at u.h.f.: example showing differential fading on sound and vision frequencies (path Llandona to Great Orme's Head)

additional attenuation of the sea-reflected signal component will generally occur and fading ranges may be between 10 and 30 dB. Use of vertical polarisation helps to reduce the fading range except at small grazing angles of incidence on the sea's surface. Tests have, however, shown that the advantage of vertical polarisation in this respect may be less than predicted by theory.

The principal subjective effects of this signal fading are frequency selective distortion and the occurrence of multipath effects giving delayed images on the picture and distortion of the sound. The former trouble arises because the times of phase cancellation at luminance, chrominance and sound carrier frequencies are not coincident. Multipath effects arise because of the low amplitudes of the principal signal component (i.e., direct plus sea-reflected components) relative to delayed components near the time of phase cancellation. The problem is rendered more serious by the eventual intention to radiate four programmes at u.h.f. At many locations positioning of the receiving aerial to avoid fading on all four channels at all stages of the tides will be impracticable. Some improvement may, however, be expected if the receiving aerial can be screened from the sea reflection.

5.5 Corona and Precipitation Interference

From the earliest days of radio communication it has been known that reception is subject to interference in thundery weather due to wide-band impulsive noise generated by lightning discharges. In addition to this very severe but short-lived interference, background noise may persist for prolonged periods even in the absence of lightning. In television reception this interference takes the form of dots (white with positive modulation) on the screen, associated with an increase in background noise level on the sound channel. Severe interference of this form can result in loss of synchronisation and consequent line tearing.

These phenomena are most noticeable at exposed receiving sites and are thus a serious problem at low-power transmitting stations which obtain their programme by direct reception of a parent station. Such sites naturally tend to be in exposed positions and any interference on the received signal is re-transmitted to all viewers receiving the relay station service.

The problem has been examined in detail⁽⁴⁸⁾ both by laboratory tests and by field trials, and it is considered that the interference is caused by two mechanisms:

- (i) Charged clouds setting up a potential gradient sufficient to cause a corona discharge from the receiving aerial or nearby structures.

- (ii) Charged drops of rain, snow or sleet falling on the receiving aerial and causing interference as this precipitation discharges to the aerial element.

The first of these mechanisms is known as *corona interference*, and the second as *precipitation interference*. Both are impulsive in character and so can affect reception over a wide band of frequencies, but the intensity of interference due to precipitation is generally much greater than that due to corona discharge.

Field trials to investigate means of reducing these forms of interference were carried out at two re-broadcast link sites on the exposed flat plateau of northeast Caithness. These sites, at Brabstermire and Thrumster, suffered particularly severely from this form of interference.

It was found that corona interference can be greatly reduced if the receiving tower is terminated by a discharge spike together with several tiers of quarter-wave tuned radial reflectors arranged as shown in Fig. 36. The purpose of the reflector elements is to reflect the surface wave generated down the tower by the discharge. Later tests showed that comparable protection can be provided without need of reflectors if the tower is terminated in a conducting sphere of about 15 cm diameter.

Precipitation interference is caused by spark discharges occurring as charged water particles⁽⁴⁹⁾ touch the conducting surface of the receiving aerial. For such a discharge to occur the charge on the drop must exceed a certain threshold value below which no interference occurs. Laboratory tests indicated that whilst this threshold is a function of the size of the drop and of the roughness of the dipole surface it is typically about 300 picocoulombs.

For a conventional rod dipole element the interference level caused by the discharge of a single drop varies inversely with the rod diameter. However, the number of drops falling on the rod is directly proportioned to its surface area and thus to its diameter. Doubling the diameter will double the number of drops, each being of half the intensity. With severe interference, the reduction in intensity may not be apparent, and the overall effect of increasing the diameter is thus to increase the degree of interference. Thus, it may be better to simulate a large diameter rod by use of several thin rods in parallel, or better still by shrouding the aerial in an insulated cover. In principle, this form of interference can be entirely eliminated by shrouding the elements in a perfectly insulating tube, but in practice the insulation of the protective tube is reduced when wetted by the rain. It is thus advantageous to use a water-repellant material such as p.v.c. for the shrouding material. For a

Yagi type of receiving aerial, it is generally sufficient to shroud the driven elements.

Since the amount of precipitation interference is proportional to the number of drops discharging on the aerial, the smaller size of Band-III aerials produces less interference than in Band I. Likewise u.h.f. receiving aerials are still less prone to this form of interference, but here the normal design of receiving aerial at transmitting stations is such as to eliminate the possibility of rain falling on the aerial elements.

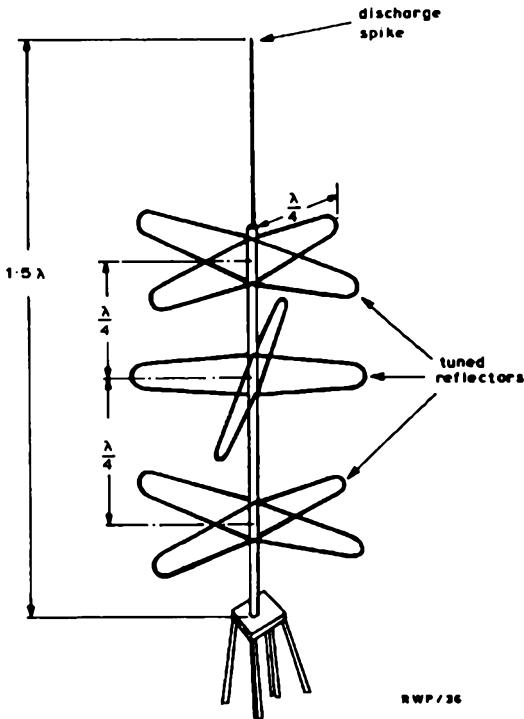

Fig. 36. Layout of discharge spike and tuned reflectors to prevent corona interference⁽⁴⁸⁾

CHAPTER 6

V.H.F. TELEVISION BROADCASTING

6.1 Transmission and Modulation Characteristics

Two bands are available for television broadcasting at v.h.f. in the United Kingdom. These are:-

Band I 41 - 68 MHz, containing television Channels 1 - 5

Band III 174 - 216 MHz, containing television Channels 6 - 13

Of these, Band I is used exclusively by the BBC. Band III, which contains more channels, is used primarily by the IBA with some sharing by the BBC. The same line standard and modulation system is used in both bands. This system, defined by the CCIR⁽⁵⁰⁾ as system A is basically the same as that used from the start of the television service in 1936 and is not used by any countries other than the United Kingdom and Eire. It is not proposed to discuss modulation characteristics in detail, but the most important features are summarised below:-

Number of Lines:- 405

Line Frequency:- 10125 per second

Field Frequency:- 50 per second)

Picture Frequency:- 25 per second) i.e. 2:1 interlace

Video Modulation:- Positive amplitude modulation with vestigial sideband,
i.e., peak white corresponds to 100% modulation.

Nominal Video Bandwidth:- 3 MHz

Sound Modulation:- Amplitude Modulation

Sound Carrier Frequency relative to Vision Carrier:- -3.5 MHz

Channel Spacing:- 5 MHz - except for spacing between Channels 1 and 2.

TABLE 6.1

BAND I: NOMINAL CHANNEL FREQUENCIES

<i>Channel</i>	<i>Frequency (MHz)</i>	
	<i>Vision</i>	<i>Sound</i>
1	45.0	41.5
2	51.75	48.25
3	56.75	53.25
4	61.75	58.25
5	66.75	63.25

The non-standard spacing between Channels 1 and 2 is a legacy from the use of double-sideband vision carrier modulation on Channel 1 at the original Alexandra Palace transmitter.

TABLE 6.2

BAND III: NOMINAL CHANNEL FREQUENCIES

<i>Channel</i>	<i>Frequency (MHz)</i>	
	<i>Vision</i>	<i>Sound</i>
6	179.75	176.25
7	184.75	181.25
8	189.75	186.25
9	194.75	191.25
10	199.75	196.25
11	204.75	201.25
12	209.75	206.25
13	214.75	211.25

6.2 Television Broadcasting in Band I

6.2.1 Historical

In 1935 a Television Committee⁽⁵¹⁾ appointed by the Postmaster-General recommended that the BBC should be responsible for establishing a public high definition television service at v.h.f. Experimental transmissions commenced from Alexandra Palace in North London in August 1936 and the service was formally opened by the Postmaster-General in November 1936. Initially, transmissions were made by the Marconi-E.M.I. electronic scanning system and the Baird mechanical system alternately. The former was adopted in February 1937 on the advice of the Television Advisory Committee.

This transmission, which operated on Channel 1, continued until the commencement of World War II, and re-opened in 1946. No further stations were constructed for 3 years after the re-opening of the television service but by 1952 a high power station (100 kW e.r.p.) had been brought into commission on each of the other channels in Band I. These stations were:-

<i>Station</i>	<i>Opened</i>	<i>Channel</i>	<i>Serving</i>
Sutton Coldfield	1949	4	Midlands
Holme Moss	1951	2	Lancashire and Yorkshire
Kirk o' Shotts	1952	3	Central Scotland
Wenvoe	1952	5	South Wales

The approximate service areas of these five original stations are shown in Fig. 37, the estimated population coverage of the U.K. being 65%.

After 1952 a series of medium power stations were brought into service until by 1960 over 50 million people were within the service area of at least one of a network of 23 stations. A further 77 stations, some of very low power, (e.g. 2 watts e.r.p. at Kinlochleven) were added in the following decade, thereby extending the service to 99.5% of the population of the U.K. The original Alexandra Palace station was closed in 1956 when the London station was transferred to a new site at Crystal Palace. Details of all transmitters in the existing U.K. Band-I television networks are summarised in Appendix A and full details of the development of Band-I television in the U.K. up till 1961 are available elsewhere^{(52),(53)}.

6.2.2 Network Planning Considerations

The original high-power stations all radiate vertically polarised transmissions from omnidirectional aerials. Thereafter, as already discussed in Section 5.3.6,



Fig. 37. Nominal coverage of the first five U.K. television stations

successive additional medium and low-power stations were allocated either vertical or horizontal polarisation as appropriate to minimise the possibility of mutual interference. In many instances, as for example at the Rowridge (Isle of Wight) station, directional transmitting aerials were specified, either to minimise interference to existing services or because there is little requirement for power to be radiated in certain directions. In addition to the use of directional aerials and opposite planes of polarisation, further protection against mutual interference is obtained, as discussed in Section 5.3.3 by use of frequency offsets on sound and vision carriers.

Because in Band I the wavelength is of the order of 5 to 7 metres, the possibility of increasing the effective radiated power of a transmitter by vertical stacking of radiating elements is somewhat limited. The four 100-kW stations have transmitting aerials consisting of only 2 tiers of dipole elements fed from transmitters having peak vision carrier powers of 50 kW. Typically, medium-power stations have transmitter powers of the order of 0.5 kW to 5 kW, and aerials comprising 2 to 4 tiers of elements. Exceptionally, as for example at Crystal Palace,⁽⁵⁴⁾ arrays of 8 tiers of elements are used.

Programme feed to the majority of high and medium power stations is by s.h.f. link, although some stations when first installed received programmes by direct reception of existing stations. In such instances these direct reception facilities, usually referred to as re-broadcast links (R.B.L.) are retained in reserve in case of s.h.f. link failure. In a number of cases, as for example at Orkney, Shetland and the Channel Islands, consideration of distance and topography entail use of an s.h.f. link from a remote reception point.

The majority of low-power stations are fed by R.B.L. from the parent station, this arrangement being preferred to use of s.h.f. on account of the reduced cost. In such instances the required transition from the received to re-transmitted channels is achieved by means of a single frequency change without need for demodulation and remodulation of sound and video signals, thereby simplifying the installation and increasing its reliability. Such stations are known as *translators* and it may be noted that, although the vision frequency offsets can be changed as required by appropriate choice of local oscillator frequency, it is not possible to change the relative separation of vision and sound carriers.

6.2.3 Propagation Characteristics in Band I

Signal propagation is discussed in detail in Chapter 3 and therefore only the distinctive characteristics of propagation at the lower end of the v.h.f. spectrum will be summarised here. These features are:

- (i) For normal terrain and typical angles of incidence the ground surface

appears smooth in the context of the Rayleigh roughness criterion, and consequently the ground reflected signal component is important. Typically, therefore, field strength increases linearly with the height of the receiving aerial above ground level, although for reasons discussed more fully in Section 8.4 this linear relationship may not hold for vertical polarisation at low receiving aerial heights.

- (ii) Compared with higher frequencies diffraction losses are relatively small. This means that transmitters provide a more uniform coverage within their nominal service area with less requirement for low-power relay stations to make good service deficiencies, although a number of these are still required, e.g. at Sheffield.
- (iii) Because of the great importance of the ground reflected signal component and the relatively low diffraction losses, transmitting aerial heights may be critical. To minimise diffraction losses it is obviously desirable to choose a prominent transmitter site with a reasonable aerial height. However, transmitting aerial height gains may often reveal that over considerable areas increase of transmitting aerial height may result in a decrease in received field strength as the direct and ground reflection components tend to cancel each other. Minimum field strengths thus correspond to conditions in which the path difference between these signal components is an integral number of wavelengths (remembering that there is 180° phase shift on reflection). Typical examples of transmitting aerial height gains showing this cancellation effect are reproduced in Fig. 38. Although consistent height gains may be obtained over a substantial area, they may differ greatly on different bearings or even at different points on the same bearing. Consequently the preferred transmitting aerial height is often a compromise between conflicting requirements in different parts of the service area.
- (iv) Impairment of reception in Band I by co-channel interference, ghosting, back-scatter from the sea, and so on is fully discussed in Chapters 3 and 5. It is therefore relevant here only to mention that in addition to interference from other stations due to abnormal tropospheric propagation, which is common to all television Bands, Band I is also subject to interference by means of sporadic-E propagation. This is very frequency dependent, affecting principally the lower channels in the band. Since the ionospheric reflection coefficient increases as the incident wave becomes more tangential to the sporadic-E layer, it follows that up to a certain path length the level of interfering signal increases with distance, and there is consequently a broad zone of high interference

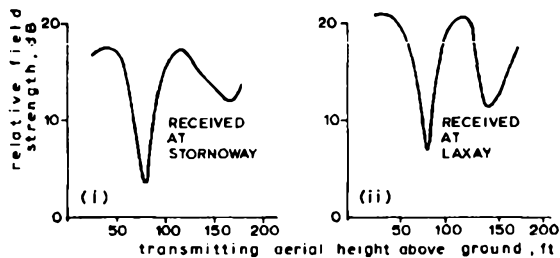

(a) Transmissions from Melvaig

(b) Transmissions from Forfar RWP/38

Fig. 38. Examples of transmitting-aerial height-gains at v.h.f., showing
 (a) anomalous height-gain due to two-ray cancellations, and
 (b) normal height-gains without minima

probability extending from about 1000 km to 2000 km. The size of the U.K. is sufficiently small for sporadic-E interference between U.K. stations to be of significance only in a few areas, e.g., Northern Scotland; elsewhere, this form of interference is solely due to continental stations. These operate on different line standards and carrier frequencies, and the nature of the interference as seen on the television screen is thus different from tropospheric interference due to other U.K. transmitters. A further characteristic difference is the very rapid change in level of sporadic-E interference as compared with the more gradual build-up and decay of tropospheric interference during abnormal propagation conditions.

One disadvantage of Band I not so far mentioned is that due to the relatively long wavelength highly directional domestic receiving aerial arrays are not practicable. It is thus more difficult than at higher frequencies to use receiving aerial directivity to reduce co-channel and delayed image interference.

6.3 Television Broadcasting in Band III

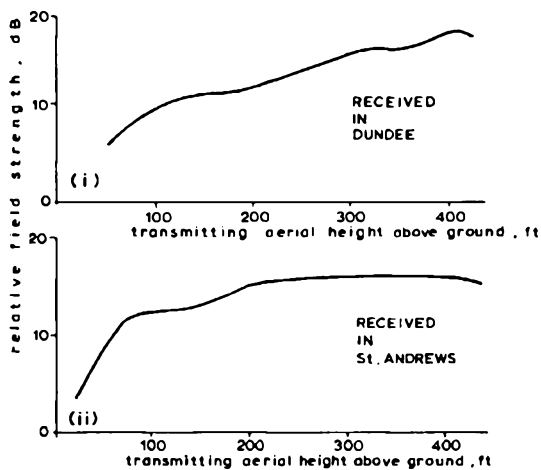
6.3.1 *Historical*

The use of Band III for television broadcasting in the U.K. dates from the formation of the Independent Television Authority under the Television Act of 1954. Since no channels remained available for a second network in Band I, use of a new portion of the frequency spectrum was inevitable, but to avoid the need for dual-standard receivers it was decided to retain the same 405-line system used in Band I. In the initial stages only two, and later five, channels (8 - 12) were made available for the development of the ITA transmitter network.

The first ITA transmitter to be commissioned was that at Croydon serving the London area. This was opened in 1955 and was followed in 1956 by a station at Lichfield to serve the Midlands, and stations at Winter Hill and Emley Moor to serve the West and East sides of the Pennine chain respectively. Further stations were quickly brought into operation over the next decade until by 1968 a network of 32 stations provided a service to about 98% of the population⁽⁵⁵⁾. Full details of the transmission characteristics of all IBA* stations are given in the current edition of the IBA Handbook.

*The Independent Television Authority became the Independent Broadcasting Authority in 1972.

In 1960 the Government set up the Pilkington Committee⁽⁵⁶⁾ to consider and advise upon the future of television and sound broadcasting. One recommendation of the Committee was that the first call upon allocated frequencies in Band III should be to enable the BBC to separate its service to Wales from that to the English Regions; the second priority was improvement of reception of the existing two programmes and completion of their coverage. Accordingly the Postmaster General authorised the BBC to open a second transmitter at Wenvoe radiating a Welsh programme on Channel 13, thereby permitting the original Band-I transmitter to be used exclusively for the appropriate English regional programme. Similarly at Sandale (Cumberland) an additional transmitter operating on Channel 6 was installed to provide a Scottish programme to South-West Scotland. BBC transmitters operating in Band III were also co-sited at the existing IBA stations at Winter Hill and Belmont, and frequencies in this band used to provide another seven BBC relay stations for which no suitable Band-I frequencies could be found. It was of course necessary to ensure that the additional transmitters at Wenvoe, Sandale, Winter Hill and Belmont radiated on the same plane of polarisation as existing ITA services in these areas in order that existing receiving aerials might be used.

The additional channels (6, 7 and 13) made available for television were also used by the IBA in the later stages of their network development, for example to provide an additional transmitter at St Hilary to provide the ITV service for Wales.

6.3.2 Network Planning Considerations

A half-wave dipole operating in Band III is only about a quarter of the length of one operating in Band I. It is thus mechanically easier to construct a Band-III transmitting aerial that has a high gain in the vertical plane and any required directional pattern in the horizontal plane.

High gain in the vertical plane is economically desirable since it enables large effective radiated powers to be obtained with modest transmitter powers. Care must however be taken if the transmitter is sited in or near a densely built-up area, (e.g. Croydon), to ensure that areas of distorted signal do not arise due to minima in the vertical radiation pattern. This problem is more fully discussed in the chapter on u.h.f. television.

Most high and medium power Band-III transmitting aerials have considerable gain in the vertical plane and directional properties in the horizontal plane. Thus, whereas in the U.K. Band-I network only six stations have an e.r.p. equal to or greater than 100 kW, and of these only one (Rowridge) has a directional

aerial, some twenty Band-III stations have a maximum e.r.p. of at least 100 kW and only two of these (Winter Hill and St Hilary Channel 10) are omnidirectional. Furthermore, although a vision transmitter power of 50 kW is used at four of the Band-I stations, the maximum transmitter power used in Band III is 20 kW and only three stations use more than 10 kW. Typical transmitting aerial gains of high power Band III stations, measured in the direction of maximum radiation, are 13 to 14 dB. The highest value, 17 dB, is that of the Durriss station. The use of aerials that are not horizontally omnidirectional avoids unnecessary overlaps, can reduce the likelihood of interference to other co-channel stations, and reduces the wastage of power over areas with few or no viewers; this applies particularly to stations near the coast.

Although it is not proposed to discuss the IBA network in detail it is of interest to consider some of the main similarities and differences between the Band-I and III transmitter networks. When the requirement to find prospective sites for Band-III transmitters arose the general principle was applied that, where possible, ITA stations should be sited near existing BBC stations. With one exception all the major conurbations in the U.K. are served by adjacently sited Band-I and Band-III stations as indicated in Table 6.3.

Adjacently sited stations serving comparable areas also occur in a number of other regions, e.g., the Channel Islands, South East Scotland, Cumberland/Solway and the Moray Firth area. In most instances of adjacently sited stations comparable coverages are achieved, the use of higher transmitting aerial heights and e.r.p.s in Band III doing much to compensate for the greater diffraction losses.

The most important difference between Band-I and Band-III networks is that instead of having a single station (Holme Moss) serving both sides of the Pennines it was decided to have separate Band-III stations at Winter Hill and Emley Moor in view of the greater diffraction losses in this hilly terrain. Although this decision was originally based on propagation and coverage considerations it also has the great advantage of permitting different programmes to be radiated to the East and West of the Pennines. The BBC later co-sited a Band-III transmitter at Winter Hill to improve the standard of reception in some parts of this area since the Holme Moss service fringe was particularly susceptible to severe sporadic-E interference.

Other areas in which substantially different locations have been chosen for Band I and Band III transmitters are East Anglia, South-West England and North Wales. Some low-power relay stations making good deficiencies in the Band-III coverage are sited where there is no Band-I requirement and vice-versa, but a substantial proportion have equal coverage requirements in both bands, and a number of these stations are co-sited.

TABLE 6.3

<i>Area</i>	<i>Band-I Station</i>	<i>Band-III Station</i>	<i>Distance Apart (km)</i>
London and Home Counties	Crystal Palace	Croydon	2
West Midlands	Sutton Coldfield	Lichfield	6
Central Scotland	Kirk o' Shotts	Black Hill	3
South Wales and Bristol Channel	Wenvoe	St Hilary	8
Solent and Bournemouth	Rowridge	Chillerton Down	4
Belfast	Divis	Black Mountain	2
Tyneside/Teesside	Pontop Pike	Burnhope	6

6.3.3 Propagation Characteristics and Minimum Field-strength Requirements in Band III

Signal propagation is discussed in detail in Chapter 3 and little need be added at this stage. Relative to the characteristics of Band-I propagation summarised in Section 6.2.3 Band III differs as follows:-

- (i) The ground surface is no longer generally smooth as defined by the Rayleigh roughness criterion, particularly in hilly terrain and built-up areas. Consequently the effect of the ground-reflected signal component is less predictable. Although an increase in receiving aerial height usually gives an increase in received field strength, this is often due as much to reduction of local diffraction and clutter losses as to the effect of increasing the path difference between direct and ground reflected signal components.
- (ii) The increase in diffraction losses, associated with the general use of high radiated powers, means that the range of field strengths in a particular

area is greater for a Band-III service than for a Band-I service. Thus Band-III field strengths are generally greater than for Band I on high ground, but lower in valleys and other locations having high diffraction and clutter losses. Consequently, the standard of reception quality tends to be somewhat less uniform within the nominal service boundary of the transmitter; in other words the local variation factor is greater than in Band I.

- (iii) In view of the lesser importance of the ground reflection and the greater importance of diffraction losses, transmitting aerial height gains are more predictable than at Band I, and it is normal to use transmitter masts which are as high as economically practicable or permitted by planning considerations.
- (iv) The smaller wavelength permits the use of more directional receiving aerials, which in turn make it easier to provide discrimination against co-channel interference and ghosting. Reflections from aircraft tend to be somewhat less troublesome both on account of the narrow beam-width of the receiving aerial which means that the aircraft is in the beam for a shorter time, and because the frequency of the flutter is higher.
- (v) Conversely, since the voltage developed at the terminals of a receiving dipole is proportional to its length and thus to the wavelength of the signal, the e.m.f. at the terminals of a Band-III dipole is about 10 to 12 dB less than for a Band-I dipole in an equal field. Although a roughly 3 to 4 dB advantage is achieved from the greater aerial gain obtainable at Band III, some of this benefit is lost in increased feeder losses. Thus in the absence of interference, the required minimum field strength for satisfactory Band-III reception is about 8 to 10 dB more than for Band I at an individual receiving location. This differential is increased when the greater location variation factor at the higher frequency is taken into account.

The field strengths limits of various grades of service in Band III are defined by the IBA⁽⁵⁷⁾ as follows:-

- (a) Primary Service Area:- Within 2 mV/m median contour - most viewers except those in particularly unfavourable positions should receive a consistently satisfactory service.
- (b) Secondary Service Area:- Within 0.5 mV/m median contour - a substantial proportion of viewers should receive a satisfactory service but in a few unfavourably sited places reception may be poor.

- (c) Fringe Area:- Within 0.25 mV/m contour - acceptable reception may be obtained in many locations although this may be subject to some interference from time to time.

CHAPTER 7

U.H.F. TELEVISION BROADCASTING

7.1 Transmission and Modulation Characteristics

Two bands are available in the U.K. for u.h.f. television broadcasting. These are:-

Band IV 470 - 582 MHz, containing television Channels 21 - 34

Band V 614 - 854 MHz, containing television Channels 39 - 68

The portion of spectrum between channels 34 and 39 is used for air navigation and radio astronomy. Both bands are shared by BBC and ITA and the same modulation system and line standards are used throughout. This system, defined by the CCIR as system I⁽⁵⁰⁾ has the features detailed below:-

Number of Lines:- 625

Line Frequency:- 15625 per second

Field Frequency:- 50 per second)

Picture Frequency:- 25 per second) i.e. 2:1 interlace

Video Modulation:- Negative amplitude modulation with vestigial sideband, i.e., sync pulse level corresponds to highest modulation depth.

Nominal Video Bandwidth:- 5.5 MHz

Sound Modulation:- Frequency Modulation

Sound Carrier Frequency relative to Vision Carrier:- +6 MHz

Channel Spacing:- 8 MHz

7.2 Historical

The considerations and decisions leading to the commencement of u.h.f. television broadcasting in the U.K. are summarised in the Report of the Television Advisory Committee⁽⁵⁸⁾ and elsewhere⁽⁵⁹⁾. To quote from this report:-

‘At the time of the commencement of our improved television service in 1936 the 405-line standard was called ‘high’ -definition. By 1960, however, it was the lowest definition used for any public television broadcasting service in the world’.

Chronologically, the principal events leading to the establishment of the u.h.f. 625-line PAL colour television service may be summarised as follows:-

1943. The Hankey Committee was appointed to prepare plans for the re-instatement of the television service after the end of the war. The Committee recommended⁽⁶⁰⁾ that the service should re-start on the standards previously used. The choice of standards was reviewed in the following two years but the Government decided no change should be made.

1956. The Television Advisory Committee (T.A.C.) were asked to specify whether the existing 405-line standard would remain adequate for the next 25 years; also whether there was any reason why the U.K. should not adopt 625-lines at u.h.f. in Bands IV/V if this was recommended as the European standard by the CCIR.

1957-8. Extensive field trials were carried out in the U.K.⁽⁶¹⁾ using transmitters at Crystal Palace to compare the characteristics of v.h.f. and u.h.f., and of 405 and 625 line systems including colour transmissions. The main conclusion was that over terrain such as that of South-East England, the first-class service area of a Band-V transmitter with an e.r.p. of 1 MW would, irrespective of the line standard, be comparable in size but more irregular in shape than that of the existing Band-I station. The second-class service would also be of about the same size as for Band I, but the shape would be materially altered by topography. Owing to the greater irregularity of service contours arising from this greater dependence on topography, the number of transmitters required to give national coverage at u.h.f. would be substantially greater than at v.h.f.

1959. The TAC recommended that the U.K. delegation to the IXth Plenary Assembly of the CCIR at Los Angeles should be briefed that the U.K. would adopt 8 MHz-channel spacing in Bands IV/V if this was generally adopted in Europe. All European countries accepted 8-MHz channel spacing at Los Angeles and this decision was confirmed at the European VHF/UHF Broadcasting Conference in Stockholm in 1961⁽⁶²⁾.

1960. The TAC reported that:-

- (i) Existing 405-line standards would not be adequate for the next 25 years, and their retention would show the U.K. at a disadvantage in Eurovision since picture quality is degraded on conversion to a higher line standard.
- (ii) The 625-line standard, making full use of the 8-MHz channel width, would give a definite improvement, particularly with large pictures, and would ease the problems of channel sharing with neighbouring countries.

- (iii) The commencement of u.h.f. television would offer the last opportunity for the U.K. to change line standards, and if 405 lines were introduced into the u.h.f. band the U.K. would be committed to this standard indefinitely. Conversely, if 625 lines were used at u.h.f., they should also eventually be introduced at v.h.f. to provide a single standard throughout. Consideration was given to the use of even greater numbers of lines, but it was considered that 625-lines with 8-MHz spacings offered the best compromise and the only one likely to be acceptable as a common European standard for u.h.f.

1960. The Pilkington Committee was set up to advise on the future of broadcasting in the U.K.

1961. At the Stockholm European Broadcasting Conference, the U.K. tabled assignments of frequencies in Bands IV and V against the possibility of their being required for television services and on the basis that four programmes would be required at u.h.f. A document⁽⁶³⁾ formulating technical data such as field strength/distance curves, protection ratios, and so on was produced at the Meeting of Experts at Cannes prior to the Stockholm conference.

1962. The Pilkington Committee in their report⁽⁵⁶⁾ endorsed the technical recommendations made by the TAC in 1960 and recommended:-

- (i) That a change from 405 to 625 lines should be authorised forthwith.
- (ii) That the BBC should provide the next additional television programme and should be authorised to do so as soon as possible.
- (iii) That while not recommending a particular colour system this should be on 625 lines and should be compatible, i.e., it should be capable of being received on a monochrome receiver.
- (iv) That the Postmaster-General be empowered to direct the broadcasting authorities to co-site their u.h.f. transmitting stations. This was agreed to be desirable on technical grounds as well as on those of amenity and cost.

The Government accepted these recommendations, and specified⁽⁶⁴⁾ that new programmes on u.h.f. should be on 625 lines from the start, although the existing services would have to continue on 405 lines for some considerable time before being changed to 625 lines. This implied that there could be no colour service on v.h.f. in the foreseeable future and thus the existing services could be broadcast in colour only by duplication in the u.h.f. band. This decision therefore resolved the discussion as to whether the re-engineering

of the v.h.f. bands on 625 lines should be by a sudden switchover or by the more gradual process of duplication.

1962-3. A further series of u.h.f. field trials was carried out, again using Crystal Palace as the transmitting site. These tests⁽⁶⁵⁾ involved simultaneous transmissions on Channels 34 and 44, and included comparative assessments of the NTSC, SECAM, and PAL colour systems.

1964. Opening of BBC-2 transmitter at Crystal Palace on Channel 33.

1965. The TAC recommended to the Postmaster-General that the U.K. should adopt the PAL colour television system, with the proviso that if unanimous international agreement to any alternative standardised system should be obtained at the CCIR Oslo Conference in 1966 the U.K. should be prepared to accept it. In the event no common system was agreed at Oslo, and the PAL system was adopted by the U.K. The reasons for this particular choice are fully discussed in a previous reference⁽⁵⁹⁾.

1967. Colour television service commenced on BBC-2.

1969. Commencement of duplication of BBC-I and ITA v.h.f. services at u.h.f.

7.3 Transmission and Network Planning Considerations

7.3.1 *Transmitting Aerials*

In Section 6.2.2 it was pointed out that the relatively short wavelength of Band III (as compared with Band I) permitted the use of greater transmitting aerial directivity in both vertical and horizontal planes. Aerials consisting of up to 16 vertical tiers of radiating elements, giving a power gain of 10 to 12 dB are commonly used in Band III.

At u.h.f. even greater apertures in terms of wavelength are practicable; for example, the aerial installed at Crystal Palace for the commencement of the u.h.f. television service had a vertical aperture of 40 wavelengths, corresponding to a physical height of about 20 metres. The use of such high gain transmitting aerials⁽⁶⁶⁾ presents a number of interrelated problems:-

(a) *Beam Tilt and Gap Filling*

As the vertical aperture of a transmitting aerial is increased, the width of the main beam in the vertical plane is correspondingly reduced, and a number

of subsidiary lobes are formed as shown in Fig. 39. In this diagram, the main lobe is directed in the horizontal plane, and it can be seen that a large proportion of the radiated power is wasted because it is radiated at too high an angle to be received within the service area. It is therefore necessary to tilt the beam downwards either towards or within the horizon. The precise angle of optimum beam tilt for a particular station depends upon factors such as the transmitting aerial height and the required service range, which in turn depend on the nature of the terrain and the proximity of adjacent transmitters. Typically, beam tilts are of the order of 0.5° to 1.5° below the horizontal and are obtained by suitable electrical phasing between the tiers of the aerial.

Measured vertical radiation patterns for a transmitting aerial of 32 wavelength aperture are shown in Fig. 40. Unless special precautions are taken in the design of the aerial, poor reception may be expected in annuli around the transmitter corresponding to the angles at which the vertical radiation pattern minima occur. These distances are a function of the transmitting aerial aperture, effective height, and beam tilt as demonstrated in the following example.

Example. Determine the distance from a transmitter of aperture 32λ at which the furthest vertical radiation pattern minimum occurs, assuming an effective transmitting aerial height of 500 metres and a beam tilt of 0.5° and neglecting the effect of the earth's curvature.

The condition for the most distant minimum is shown in Fig. 41. This minimum occurs at an angle α relative to the main beam such that contributions from the upper and lower halves of the transmitting aerial are in antiphase.

This angle is defined by the equation $\sin \alpha = AC/AB$, and

$$\frac{AC}{AB} = \frac{\lambda/2}{16\lambda} = \frac{1}{32}$$

$$\text{whence } \alpha = 1.8^\circ.$$

Since there is a beam tilt angle θ of 0.5° , the angle of the minimum relative to the horizontal plane is $(\alpha + \theta)$, or 2.3° . Whence, for an effective aerial height of 500 metres,

$$d = \frac{500}{\tan(\alpha + \theta)} = 12.5 \text{ km.}$$

(tan(2.3°))

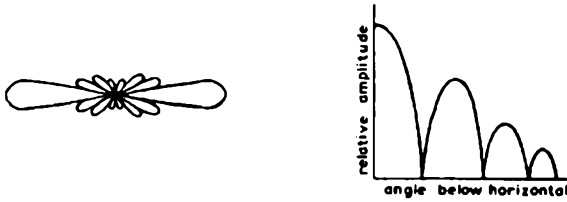

(a) Vertical radiation pattern without beam tilt.

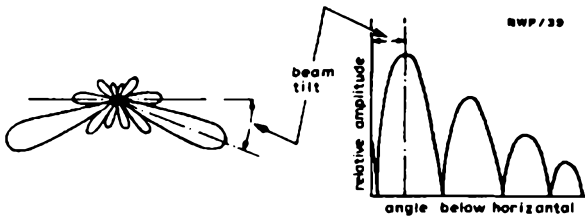

(b) Vertical radiation pattern incorporating beam tilt.

Fig. 39. Idealised vertical radiation patterns

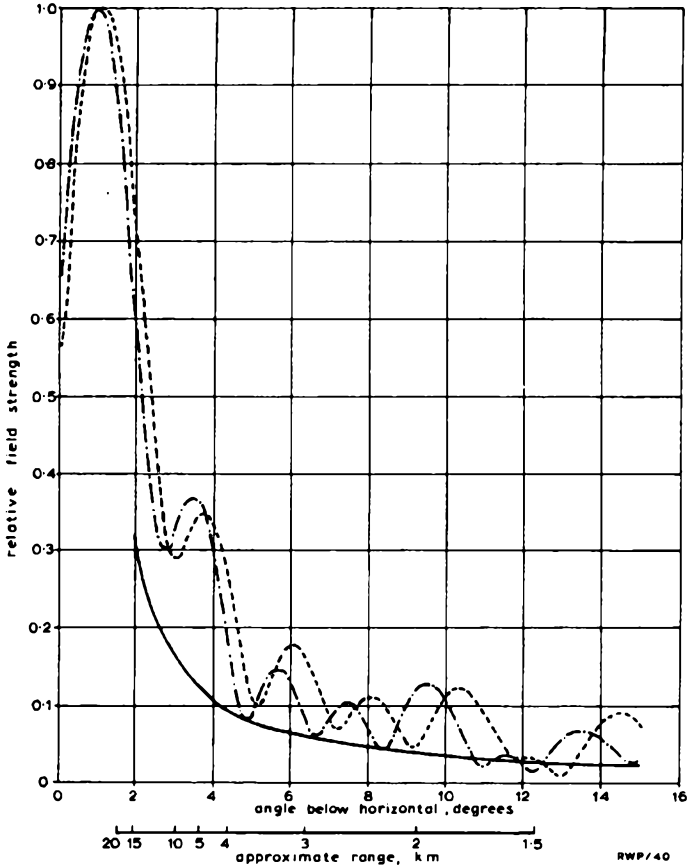

Fig. 40. Typical u.h.f. transmitting aerial radiation pattern, showing differences between two transmission channels

It may be noted in the above example that $\sin \alpha$ is the inverse of the aerial aperture in wavelengths. Thus the position of the most distant minimum (and all other minima) is also a function of the aperture in wavelengths and of the beam tilt. Since the aperture is fixed by the physical dimensions of the aerial, it follows that this aperture expressed in wavelengths is not identical at sound and vision frequencies, or at chrominance and luminance frequencies of a colour transmission. Consequently, in the low field areas caused by vertical radiation pattern minima, severe frequency selective distortion is also probable unless precautions are taken to fill these minima. Such 'gap-filling' is normal practice in the design of aerials, and is achieved by appropriate de-phasing of some of the tiers of the array at some small expense in terms of maximum e.r.p. The extent of gap-filling required is dependent upon the siting of individual transmitters. Some stations are remote from centres of population and gap-filling is unimportant, whereas others, such as Crystal Palace, have minima falling in densely populated areas and extreme care is required to ensure satisfactory aerial performance. The necessary degree of gap-filling required forms an important factor in the performance specification of transmitting aerial design.

(b) Multiple Channel Operation

The eventual intention to radiate four programmes from each u.h.f. transmitting site further complicates the problem of aerial gap-filling, since satisfactory performance must be provided over a frequency range of at least 80 MHz if all programmes are to be radiated from the same aerial. Similarly comparable horizontal radiation patterns must be provided on all channels.

In view of the difficulty in achieving parity of performance on all four channels from a single aerial, it is often preferable to use two separate co-linear aerials each radiating two channels only. This arrangement simplifies the electrical design of the aerial, but can be used only at new stations or at those existing stations at which the present mast is capable of carrying the additional structural load of two separate aerials.

At lower power main stations and all relay stations⁽⁶⁷⁾ a 4-channel transmitting aerial of a standardised and relatively simple design is used. The lower transmitter power makes it easier to design an aerial with a good performance over four channels. Furthermore, vertical apertures used at relay stations do not exceed 16λ , with a consequent reduction in gap-filling requirements.

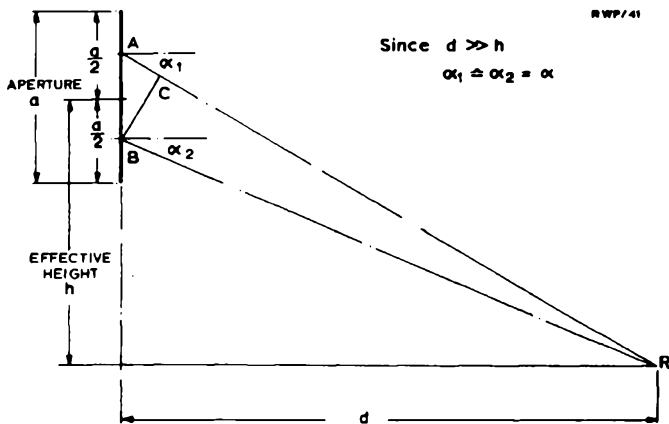

Fig. 41. Condition for most distant minimum in vertical radiation pattern

7.3.2 Frequency Allocations

In determining the frequency allocations to be used for u.h.f. television in Bands IV and V, the following factors must be considered:-

- (i) It is proposed that four programmes shall eventually be radiated from each site, in most cases using the same transmitting aerial.
- (ii) Planning is obviously simplified if the allocations of 4 channels are arranged into standard groups, which should wherever possible be similar to those used in neighbouring countries. To some extent the planning for four programmes in the U.K. is incompatible with planning in neighbouring countries since none of these are planning for more than 3-programme network coverage. Nevertheless it should be ensured that at least 3 channels in a standard group coincide with groupings used elsewhere.
- (iii) To simplify design of transmitting and receiving aerials, the total frequency spread of a channel group should be as small as possible. Conversely, the separation between channels at each station must not be too small in order to avoid severe problems associated with transmitter combining units and receiver selectivity. Thus it is not practicable to use adjacent channels in a standard group.
- (iv) Channels in a group must be chosen to eliminate the possibility of local oscillator or image channel interference and of channels spaced by the receiver intermediate frequency. These restrictions exclude the use of 5 and 9 channel spacings in a group. See Section 5.3.5.
- (v) Since Band IV contains only 14 channels, only 3 standard groups can be formed in this Band, however they may be arranged.

Taking the above restrictions into consideration, it was decided that standard channel groups should have one or other of the following relationships:-

- (a) Channels $n, n+3, n+6, n+10$.
- or (b) Channels $n, n+4, n+7, n+10$.

Nine standard groups are thus available in the u.h.f. bands, three in Band IV and six in Band V. These are:-

These are:-

<i>Channel Group</i>	<i>Channels</i>				<i>Band</i>	<i>Grouping</i>
A	21	24	27	31	IV	$n, n+3, n+6, n+10$
B	22	25	28	32		
C	23	26	29	33		
D	39	42	45	49	V	$n, n+3, n+6, n+10$
E	40	43	46	50		
F	41	44	47	51		
G	53	57	60	63		$n, n+4, n+7, n+10$
H	54	58	61	64		
I	55	59	62	65		

The difference between the channel groupings of the lower and upper halves of Band V is determined by the need to match the U.K. allocations to those used by neighbouring countries in which Band V is used to provide 9 groups of 3 channels rather than 6 groups of four channels. Thus, the lowest three channels in Groups D, E and F coincide with channel groups used on the Continent, as do the highest three channels in Groups G, H and I. Other countries, however, use Channels 48 and 56 to provide three more groups each of three channels.

It may be noted that this grouping leaves channels 34, 48, 52, 56, 66, 67 and 68 unallocated in the U.K.

The need to maintain suitable frequency relationships is not confined merely to the various channels within the frequency group radiated from an individual station. Many stations receive their programme feed by direct reception of a parent transmitter. Here also the dangers of local oscillator radiation interference and image channel interference must be avoided by ensuring no 5-channel or 9-channel spacings occur between parent and relay stations. Adjacent channel spacings must also be avoided on account of receiver selectivity problems both at the relay station and within the overlap service area between relay and parent stations.

These considerations severely restrict the choice of frequency groups available for stations (either main or relay) adjacent to or fed from existing stations. Thus, if an existing station operates in Band IV, neither of the other standard groups in this band is suitable on account of adjacent channel spacings; also, one of the groups in the lower part of Band V will have an image channel relationship $n : (n+9)$ as one channel pair. Fig. 42 shows the standard

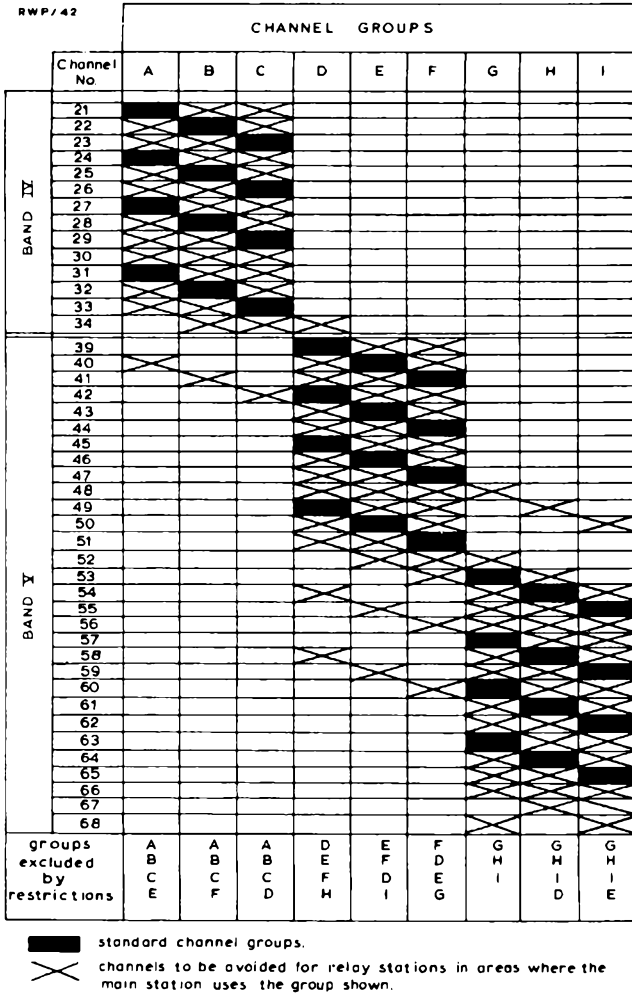

Fig. 42. U.H.F. channel groupings and exclusions

channel groupings used in the U.K. and those channels which are unsuitable for use by overlapping services.

7.3.3 *The Transmitter Network*

It was appreciated from the start in planning the u.h.f. transmitter network that many more stations are required to give nationwide coverage than for the Band I and Band III networks. Cost and amenity considerations dictated that existing v.h.f. stations should whenever practicable be used for u.h.f., and provision for a u.h.f. aerial had in fact been made at a number of stations constructed in the later stages of the v.h.f. development. The BBC and ITA agreed that each would be responsible for providing about half the stations, either at new or existing sites.

In the Stockholm Plan⁽⁶⁷⁾ provision was made for 64 main stations in the U.K. with effective radiated powers of 100 kW to 1000 kW. Thirty-four of these are or will be co-sited with existing v.h.f. stations on 14 BBC sites and 20 ITA sites. As planning has proceeded, it has appeared that about 6 of the originally planned main stations may not be required. In conformity with u.h.f. planning practice elsewhere in Europe it was proposed that all main stations should radiate horizontally polarised signals.

In view of the large number of irregularly shaped pockets of unserved population remaining even after all main stations are brought into service, it is inevitable that a number of relay stations will be required to produce an overall coverage comparable with that of the existing v.h.f. services. The total number of relays to be provided will depend upon the economic limit in trying to approach 100% coverage. Assuming an intention of ensuring that no individual pockets of 1000 or more people are to remain unserved, it is estimated that at least 400 relay stations will be required. These will be of widely varying powers, ranging from 10 kW e.r.p. to 5 W e.r.p. or less. The lower power transmitters will be solid-state devices to give improved reliability and reduced cost. All relay stations will radiate vertically polarised signals.

Wherever possible, relay stations will be of the translator type with direct reception and frequency transposition of the signal from the parent station. They must therefore be positioned not only to ensure that the desired coverage is achieved but also that satisfactory reception of the parent station is possible. The number of relay stations fed from a particular parent station varies greatly according to the nature of the terrain and the extent of overlap with other main stations. For example, whilst no relays are currently envisaged in the flat terrain of Lincolnshire served by Belmont, at least 75 relays are already planned for the highly populated and rugged terrain of Lancashire

and South Wales, incompletely served by the main stations of Winter Hill and Wenvoe respectively.

In planning frequencies for relay stations, four of the nine standard frequency groups are usually unsuitable for use, since they result in undesirable frequency relationships to the parent station transmission (see Fig. 42). Further frequency groups may be excluded by the proximity of adjacent main stations. It follows, therefore, that when a large number of relays are to be fed from the same parent station, several of these must share the same channel. This introduces a further restriction on siting, in that not only must the site be suitable for reception of the parent station and for serving the required area, but it should be chosen with the aim of minimising interference to other stations on the same channel. This protection is obtained from local terrain or transmitting aerial directivity, on both. A corollary to the requirement to use the same frequency groups at several closely spaced relay stations is that prominent hilltops, although superficially suitable, may often not be the most satisfactory relay station sites, since such siting may preclude the further use of this channel group over a considerable area. Consequently there is often little choice of suitable location for a relay station site, and if the one selected is not available, a chain reaction may occur involving change of frequency and/or site at a number of other proposed relay stations.

7.3.4 Active Deflectors

The problems associated with the provision of frequencies for the many relay stations required in areas of rugged terrain have led to the investigation of the possibility of operating relay stations on the same frequency as the parent station. These relay stations are usually referred to as *active deflectors*^{(68) (69)}. The inherent limitation on this form of relay station is that of preventing mutual interference between parent and relay station transmissions which take the form of a ghost image, either delayed (in the case of interference from the active deflector in the service area of the parent station) or advanced (in the case of interference by the parent station).

As previously discussed in Section 5.4, the visibility of a ghost image depends upon its relative phase and delay time, but for delay times exceeding about $2.5 \mu\text{s}$ the wanted-to-interfering signal ratio should be at least 25 to 30 dB. If therefore the active deflector service overlaps that of the parent station, the most critical protection requirement is at locations where equal field strengths are provided from both sources. In this circumstance the full protection against the unwanted transmission must be derived entirely from receiving aerial directivity and the use of opposite planes of polarisation

for parent station and active deflector. This is a difficult requirement to satisfy even with only one programme coverage. In the practical case of three (and eventually four) programmes radiated at u.h.f., standing wave effects in the vicinity of the receiving aerial will result in different wanted-to-interfering signal ratios on each channel and satisfactory reception of all programmes will require even more careful positioning of the receiving aerial. Consequently active deflectors appear to be suitable primarily for extending the service to isolated communities in deep shadow areas from the parent station, the re-transmitting aerial characteristics being tailored to ensure the minimum possible power is radiated into the parent station service area.

A further restriction on the power that can be radiated from active deflectors is that of ensuring adequate isolation between receiving and re-transmitting aerials. Insufficient isolation results in generation of a delayed image, or in extreme cases self-oscillation. This is best demonstrated by means of an example.

Example. Determine the maximum effective radiated power of an active deflector, assuming the received field strength of the parent station is 30 mV/m (or 90 dB relative to 1 μ V/m) at a frequency of 600 MHz. The isolation between receiving and re-transmitting aerials is 100 dB, and the net gains of both aerials are 13 dB. The relative level of the delayed image is not to exceed -20 dB. (A somewhat greater relative level of delayed image is acceptable in the case of direct coupling between aerials in view of the short delay time, generally less than 1 μ s.)

The effective length λ/π of a dipole at 600 MHz is $0.5/\pi$ metres. Or, expressed in decibels, the effective length relative to 1 metre is

$$20 \log_{10} (\lambda/\pi) = -17 \text{ dB.}$$

The receiving aerial gain is 13 dB, and thus, for a field strength of 90 dB relative to 1 μ V/m at the receiving aerial, the e.m.f. at the receiver input terminals is

$$90 - 17 + 13 = 86 \text{ dB}(\mu\text{V/m}) = 20 \text{ mV/m.}$$

Assuming the aerial to be correctly matched to the receiver input of impedance 50 ohms, the output power to the receiver is

$$\frac{\left(\frac{20 \times 10^{-3}}{2}\right)^2}{50} = \frac{10^{-4}}{50} \text{ watts}$$

$$= 2 \mu\text{W or } -57 \text{ dB relative to 1 watt.}$$

If the isolation between aerials is 100 dB and the relative level of the delayed image is not to exceed -20 dB, the total system gain must not exceed 80 dB, of which 26 dB is provided by receiving and re-transmitting aerials. Hence the amplifier gain must not exceed 54 dB.

Whence, with a receiver input power of -57 dB relative to 1 watt, the output power must be -3 dB relative to 1 watt and the e.r.p. for transmitting aerial gain of 13 dB is

$$-3 + 13 = 10 \text{ watts.}$$

Not only must direct coupling between receiving and re-transmitting aerials be minimised, but care must be taken to ensure that coupling does not occur due to reflections from nearby buildings or hills.

7.4 Propagation Characteristics at U.H.F.

The principal differences distinguishing u.h.f. propagation from that at v.h.f. are the greater attenuation due to diffraction, the lesser importance of the ground reflected signal component, and the greater variation of field strength over small areas resulting from the more complex standing wave patterns.

7.4.1 Diffraction

As discussed in Section 3.1.5 diffraction losses are related in a complex way to the geometry of the propagation path. The relative importance of diffraction in the various television Bands may be demonstrated by the example in Fig. 43.

Example. In Fig. 43 a receiving site at A is 25 km from the transmitter and 10 km beyond a hill in whose shadow it lies. The height of the hill is 150 m and that of the transmitting aerial is 300 m. Assuming Fresnel knife-edge diffraction theory to apply, the diffraction loss between the transmitting aerial and point A is 8 dB at 50 MHz (Band I), 10 dB at 200 MHz (Band III) and 13 dB at 750 MHz (Band V). If, however, the receiving site is moved to B, which is only 5 km from the hill, the corresponding losses are 13 dB at 50 MHz, 18.5 dB at 200 MHz and 24 dB at 750 MHz.

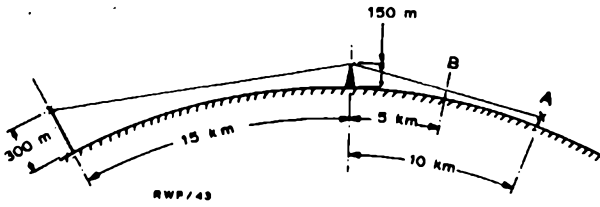

Fig. 43. Example for diffraction calculation

These differences in diffraction loss are even greater if more than one diffraction is involved. Looked at in another way, this example indicates that undulating terrain which may produce only small variations in field strength in Band I can produce deep shadows at u.h.f.⁽⁷⁰⁾. To provide a service in these shadow areas requires supplementary relay stations.

The large scale effect of terrain is not the only factor which modifies the broadcast signal. The effects produced by the presence of trees and houses in the neighbourhood of the receiving aerial are also important. Shadowing by large buildings can severely affect reception at houses situated in the shadow. In the case of isolated large buildings a rough estimate of the loss may be made using Fresnel knife-edge theory, although it must be remembered that with multi-storey blocks the field provided by diffraction round the sides of the building may often be greater than that due to diffraction over the top. More typically, in heavily built-up areas several buildings will contribute to the shadow loss and standing wave patterns will be generated by short-delay reflections from other buildings.

Diffraction effects at rooftop level are of great practical interest. A series of measurements⁽⁷⁰⁾ made in typical suburban areas over the height range from 6 to 10 metres indicated a median gain of signal strength with height of the order of 2.3 dB/metre within this height range, thus showing the importance of positioning the receiving aerial at the greatest possible height in difficult reception areas. Investigations of the relative attenuation due to trees at v.h.f. and u.h.f. indicate that woods which have negligible effect upon Band-I reception can provide very high attenuation at u.h.f.

7.4.2 Ground Reflections and Standing-wave Effects

In Section 3.1.6 it was pointed out that specular reflection from the ground, which provides one component in the simple 2-ray theory for calculating field strengths within the horizon, occurs only if the ground can be considered as smooth. The criterion for this is that the phase difference between components received from various elevation levels of the reflecting surface are small relative to the wavelength. This condition is seldom satisfied at u.h.f. with certain important exceptions, such as that occurring when the reflection point is the surface of the sea as discussed in Section 5.4.4. Since the ground reflection is generally diffuse rather than specular, the variation of field strength with increase of receiving aerial height seldom has the linear relationship predicted by 2-ray theory. In practice the height gain between, say, 3 and 10 metres above ground level is generally less than linear in open country, but

greater than linear in built-up areas. In the latter case the variation with height is usually determined primarily by the reduction in local diffraction (clutter) losses as the aerial is raised above rooftop level as discussed in the previous section.

A consequence of the increase in radio roughness of the propagation path with frequency is that an increasing number of objects become scatterers of the transmitted energy. Complex standing wave patterns result, and because of the small wavelength large variations of field strength occur over short distances. This may be advantageous for receiving a single transmission, because the location giving the best signal may be found with only small changes in aerial position. However, when several programmes radiated on different channels are to be received on the same aerial, this small-scale standing wave pattern is a disadvantage since the patterns on different channels are not coincident. Consequently if locations have steep changes in field strength over small distances it may prove difficult to find a position for the aerial which affords a satisfactory compromise on all channels.

Measurements⁽⁷⁰⁾ made at some 335 locations in built-up areas of the ratio between the received field strengths of two u.h.f. transmissions spaced by 80 MHz radiated from co-sited transmitters indicated that at 20% of the locations the fields differed by more than 6 dB. It is obvious that in fringe areas where the field strength is near the acceptable limit a compromise position for an aerial intended to receive four programmes may be difficult to find. The situation is further complicated by the fact that not all programmes radiated from a particular station commence on the same date, or even in the same year. This may mean that if at difficult locations care is taken to optimise the receiving aerial position for the first programme, it may be to the detriment of reception of the later services.

In the type of wooded residential areas typical of much of Surrey the attenuation of u.h.f. signals by trees is probably much greater than that due to building clutter. Furthermore, trees near the receiving aerial may produce variable standing wave patterns which change the received signal level appreciably in windy conditions.

7.4.3 Delayed Image Interference

Delayed image interference due to signals reflected from hills or large structures such as high buildings, gasholders, dockyard cranes, electricity pylons, and so on, is common to all television bands and has been discussed in Section 5.4.2. This form of interference normally occurs when the receiving site is in shadow for reception of the direct signal, whereas the reflecting

surface is well illuminated. although the relatively deeper shadow zone occurring at u.h.f. may give a higher delayed-to-direct signal ratio, this is largely offset by the greater receiving aerial directivity obtainable.

In principle, it might be expected that the greater displacement of the delayed image caused by the shorter line timebase period used in the 625-line system would make such images more conspicuous than with the 405-line system. In practice the visibility of delayed images is not critically dependent upon delay time unless they are short, i.e., less than about $2 \mu\text{s}$. In general, the visibility on a colour picture is not significantly greater than for monochrome, except in special circumstance or if the levels are sufficient for severe degradation of even a monochrome picture.

CHAPTER 8

FREQUENCY MODULATED SOUND BROADCASTING

8.1 Historical

Prior to 1954, all domestic sound broadcasting in the U.K. was by means of amplitude-modulated transmitters in the medium-frequency (m.f.) and low-frequency (l.f.) bands. The European Broadcasting Convention at Copenhagen in 1948 allocated one l.f. and 13 m.f. channels to the U.K. Even at that time, this allocation was scarcely adequate for envisaged requirements, and since the Copenhagen Plan came into force there has been a continual increase in the number and power of m.f. and l.f. transmitters in Europe. This has not only caused severe restriction of service on some BBC channels during the hours of darkness as a result of co-channel interference from the continent, but has also resulted in the manufacture of receivers having restricted bandwidths to minimise adjacent-channel interference. Thus, the majority of m.f./l.f. receivers now have audio-frequency bandwidths of only about 3 or 4 kHz.

This congestion of the l.f./m.f. bands was already serious in the United States prior to World War II, and gave rise to pioneering development work on frequency modulation in the 40 to 50 MHz band. At the Atlantic City International Telecommunication and Radio Conference of 1947, the band from 87.5 to 100 MHz was reserved for broadcasting in the region containing the European Broadcasting Area. In the U.K., part of this band was later allocated on a temporary basis to mobile services, the spectrum available for broadcasting being limited to 88 to 94.6 MHz.

In anticipation of the requirement to transfer radio broadcasting services to the new v.h.f. band, the BBC carried out a series of laboratory tests and low-power field trials⁽⁷¹⁾ in 1945-6. A later prolonged high-power field trial was carried out from 1950 to 1953 using two transmitters having effective radiated powers of 120 kW and sited at Wrotham, Kent. These tests were designed to compare the following three modulation systems:

- (a) Conventional amplitude modulation (a.m.).
- (b) Amplitude modulation with an impulsive noise limiter in a wideband receiver (a.m.l.). The bandwidth used for the majority of tests was ± 75 kHz.
- (c) Frequency modulation (f.m.) with peak deviation of ± 75 kHz.

The results of these tests are detailed elsewhere^{(72), (73)} and may be summarised as follows:

- (i) The improvement of the f.m. system over a.m. and a.m.l. with respect to receiver noise was 24 dB.
- (ii) This same advantage relative to a.m. was shown with respect to impulsive interference, provided the ratio of peak carrier to peak interference exceeded unity. For lower ratios, the improvement was less, and very dependent upon receiver design. A typical value of improvement using f.m. was 12 dB. The performance of a.m.l. in respect of impulsive interference approached but did not equal that of f.m.
- (iii) This improvement shown by f.m. relative to conventional a.m. was achieved at the expense of a considerably greater bandwidth. An a.m. network providing equal coverage to that of an f.m. network might require about three times as many transmitters. Despite this threefold increase in the number of transmitters (and hence frequency allocations) an a.m. network would be much more economical in spectrum requirements in view of the very much smaller bandwidth required. In practice, however, this advantage in spectrum usage resulting from the use of a.m. might not be achievable due to the difficulty in providing adequate local oscillator stability. The spectrum requirements for an a.m.l. network would be even greater than for an f.m. network, since more transmitters would be needed, each requiring the same bandwidth as an f.m. system.
- (iv) The considerably smaller number of transmitters required for an f.m. system was attractive, not only because it reduced the number of stations, but also because the coverage of a Band-II f.m. station was comparable to that of a Band-I television station of equal power, and so the major part of the Band-II network could be provided by extensions to existing or proposed television transmitting stations.
- (v) A further advantage of f.m. was that the transmitter carrier output power remained constant, whereas an a.m. transmitter at 100% modulation had to handle four times the mean carrier power. This gave a smaller and more efficient transmitter for a given power if f.m. were used.

The results of the comparative tests of modulation systems detailed above led the BBC to recommend the development of a national three-programme network employing wide-deviation frequency modulation. This recommendation

was supported by the Television Advisory Committee in their Second Report⁽⁷⁴⁾ issued in January 1954. The following month this Committee's recommendations were accepted by the Postmaster-Général and in July 1954 the BBC was authorised to commence the first stage of its plan for national coverage.

The v.h.f. broadcasting service in the U.K. opened on 2nd May 1955 with three programme transmissions from Wrotham, the station previously used for the trial transmissions. The subsequent development of the transmitter network was based virtually entirely upon the principle of co-siting with Band-I television stations. Apart from Wrotham itself, only one other station (Llangollen) has been built purely for v.h.f. radio transmission.

Stage I of the national network comprised 10 stations each radiating three programmes and was completed by 1957, giving coverage to about 85% of the population of the U.K., priority being given to areas where the m.f. service was least satisfactory. Thereafter, the network was developed to provide v.h.f. transmitters at virtually all existing BBC television stations, except for those areas in S.E. England having different Band-I and Band-II coverage requirements resulting from the use of Wrotham rather than Crystal Palace for the main London Band-II station. Details of all v.h.f. broadcast transmitters in the U.K. are given in Appendix B.

8.2 Pre-emphasis and De-emphasis

Pre-emphasis is the term used to describe an increase in the relative amplitude of the higher frequencies programme content. If this is applied at the transmitter, it is compensated by a corresponding de-emphasis or treble cut in the receiver. It can be shown⁽⁷⁵⁾ that the noise spectrum in an f.m. receiver is such that this de-emphasis can produce a useful increase in signal-to-noise ratio which is not obtainable with amplitude modulation. Early tests indicated that an improvement of about 4 dB in signal-to-noise ratio could be achieved by use of pre-emphasis, followed by de-emphasis in a high-quality receiver using a loudspeaker of wide frequency range. The improvement obtainable using loudspeakers such as those in relatively cheap receivers is marginal, but pre-emphasis in the transmitter is generally considered worthwhile as it involves little additional complication.

It is usual to define pre-emphasis in terms of the time-constant of the circuit giving the desired frequency characteristics. A pre-emphasis time-constant of 50 μ s is standardised in Europe. Although greater pre-emphasis and de-emphasis theoretically increases the signal-to-noise ratio, this advantage is lost in practice by the need to reduce the transmitter modulation level to avoid exceeding the nominal peak deviation. Such

overmodulation would cause distortion unless the receiver bandwidth were sufficient to cater for it. However, the receiver bandwidth ought not in fact to exceed the nominal deviation, because of susceptibility to interference from adjacent channels.

8.3 Requirements for Satisfactory V.H.F. Radio Reception

8.3.1 General

The limit of service of an f.m. Band-II transmitter is determined by the same criteria as previously discussed in Chapter 5 for a television service, namely:-

- (a) Insufficient signal to overcome thermal noise, or
- (b) Interference from other transmitters, or
- (c) Other forms of interference such as impulsive interference or multipath reflections.

These limitations will now be considered in detail.

8.3.2 Minimum Signal-to-Noise Requirements

In the absence of other forms of interference, the service is limited by degradation of sound quality due to thermal noise in the receiver, apparent in the form of a background hiss. The effect on noise in an f.m. receiver has been fully discussed elsewhere⁽⁷⁵⁾ and will be considered here only briefly.

As shown in Fig. 44a, a noise voltage may be considered as a vector varying randomly in amplitude and phase with respect to the carrier as reference. The resultant vector contains both amplitude and phase modulation components as represented in Figs. 44b and 44c.

Provided the receiver contains a fully effective amplitude limiting circuit, the amplitude modulation component of noise can be virtually eliminated, leaving only the phase modulation. It can be shown that the effective noise power distribution in an f.m. receiver due to this phase modulated component has a triangular energy spectrum (Fig. 45a) as compared to the rectangular form of an a.m. noise spectrum (Fig. 45b).

This triangular spectrum has an energy content of only one-third of the equivalent rectangular distribution, thus giving a signal-to-noise improvement of 4.75 dB. The effective bass cut of the thermal noise results in the background noise of an f.m. receiver having a much higher pitch than that of an a.m. receiver. This advantage of the f.m. system is only maintained provided the peak carrier amplitude is sufficiently great to provide effective limiter operation. If there is no carrier, an f.m. receiver may be much noisier than a conventional narrow band a.m. receiver. For this reason, the transition from satisfactory to poor

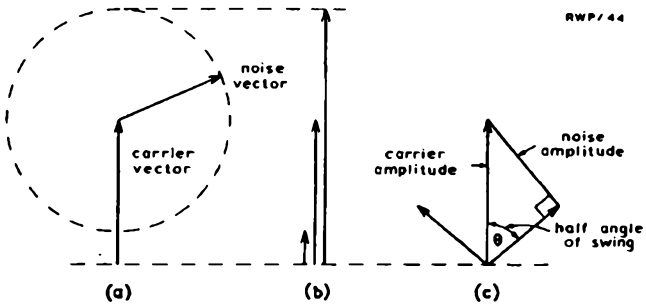

Fig. 44. Effect of noise on a carrier

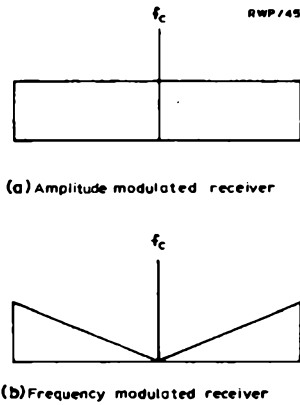

Fig. 45. Energy spectrum of noise in amplitude and frequency modulated receivers

reception quality at the limit of an f.m. service area may be more clearly defined than for an a.m. service, assuming the limit to be determined purely by receiver noise.

A further major advantage in signal-to-noise ratio in an f.m. system results from the fact that it is no longer necessary to confine the carrier frequency deviation within the audio frequency range (about ± 15 kHz). The modulation process transfers the original modulating amplitude E_m occurring at modulation frequency f_m into a frequency deviation f_d also at frequency f_m . By increasing the deviation, the audio output from the receiver is also increased, since this is directly proportional to the frequency deviation.

Thus, increasing f_d from ± 15 kHz to ± 75 kHz is equivalent to increasing the signal voltage by a factor of 5, i.e., by 14 dB, compared with an a.m. signal of ± 15 kHz sidebands. The ratio f_d/f_m is usually referred to as the *modulation index*.

The minimum field strength required to provide satisfactory f.m. reception can be determined in a manner analogous to that used for television reception in Chapter 6, i.e., by first specifying the minimum required output signal-to-noise ratio, and thence working back to determine the corresponding signal input at the aerial terminals and thus the minimum field strength. Tests under good listening conditions have indicated that receiver noise is just perceptible for a signal-to-noise ratio of 60 dB.

This somewhat exacting condition therefore represents the limit of a service restricted solely by receiver noise. A typical Band-II receiver noise factor is about 10 dB, and hence the required signal-to-noise input ratio to give 60 dB output ratio would be 70 dB for an a.m. system. However, as just discussed, the f.m. system gives an improvement of 4.75 dB due to the triangular noise-energy spectrum, and 14 dB due to the five-fold increase in effective modulation depth resulting from the transformation of a maximum audio modulation frequency $f_{m(\max)}$ of ± 15 kHz to a deviation $f_{d(\max)}$ of ± 75 kHz.

There may also be a small advantage, as discussed in the previous sections, due to the use of pre-emphasis and de-emphasis, but in practice this advantage may be partly lost because of the need to reduce modulation to avoid distortion if pre-emphasis is applied, and will not therefore be considered here.

Consequently, for an f.m. system with ± 75 kHz deviation, the equivalent required input signal-to-noise ratio of 70 dB for an a.m. system can be reduced to

$$70 - (14 + 4.75) \text{ or } 51.25 \text{ dB.}$$

The receiver input power P_n (Section 5.2) is given by

$$P_n = kTB$$

where B , the effective noise bandwidth, is in this instance about 15 kHz.

Thus, the signal power P_s required to produce an output signal-to-noise ratio of 60 dB is given in decibel form by

$$10 \log_{10} P_s - 10 \log_{10} P_n = 51.25$$

$$\begin{aligned} \text{or } 10 \log P_s &= 51.25 + 10 \log_{10} (1.38 \times 10^{-23} \times 290 \times 15 \times 10^3) \\ &= 51.25 + 10 \log_{10} (6.8 \times 10^{-17}) \\ &\simeq -110 \end{aligned}$$

Whence $P_s = \text{antilog } -11$, or 10^{-11} watts.

Now, for a correctly matched input impedance R ,

$$P_s = \frac{(E/2)^2}{R}$$

where E is the e.m.f. at the receiver input terminals.

If R is 75 ohms,

$$E = 2 \sqrt{(10^{-11} \times 75)} = 55 \mu\text{V}.$$

If it is assumed that a listener at the fringe of the service area is prepared to use a simple directional receiving aerial comprising a dipole and reflector for f.m. reception, then the aerial gain (relative to a dipole) roughly cancels the effect of feeder attenuation. Since, therefore, at Band II the effective length λ/π of a dipole is about 1 metre, an e.m.f. of $55 \mu\text{V}$ at the receiver input terminals corresponds roughly to a field strength of $55 \mu\text{V/m}$ at the receiving aerial. This value of field strength is therefore the minimum required for satisfactory reception in an area in which receiver noise is the sole service limitation.

Sources of noise interference other than thermal noise have a considerable bearing on the minimum field strength required for satisfactory reception; electrical machinery and car ignition systems produce impulsive noise in the form of rhythmic series of clicks which can be very disturbing. The minimum field strengths required to overcome impulsive interference are generally very much greater than those required to overcome receiver thermal noise and vary greatly according to the siting of the receiving aerial. In general the required minimum field is greater in urban areas than in rural areas and greater still in city centres, but there are obvious exceptions in that interference levels in a small village on a trunk road may be much higher than in a housing estate in a city suburb.

The CCIR have recommended⁽⁷⁶⁾ the following minimum field strengths for f.m. reception using a deviation of ± 75 kHz or ± 50 kHz and a pre-emphasis characteristic of $50 \mu\text{s}$.

- (a) In the absence of interference from industrial and domestic equipment a minimum field strength (at 10 metres above ground level) of $50 \mu\text{V/m}$ can be considered to give an acceptable service.
- (b) In the presence of such interference a satisfactory service requires a minimum field strength of
 - 0.25 mV/m in rural areas,
 - 1.00 mV/m in urban areas,
 - 3.00 mV/m in large cities.

In planning the BBC national v.h.f. radio network it was considered impracticable to neglect the effect of impulsive interference, and thus the service limit in the absence of interference from other transmissions has been taken as represented by a field strength contour of 0.25 mV/m . With the network fully implemented, all but a few of the major towns have median field strengths in excess of 1 mV/m .

8.3.3 Channel Spacing and Protection Ratio

When an interfering carrier is within the receiver passband both amplitude and phase modulation of the wanted carrier can occur. An efficient limiter removes the a.m. component, but the p.m. component may still cause a beat note which is particularly audible during the quiet parts of the wanted programme. Imperfect a.m. limiting makes this more obvious and annoying. Whether wanted and interfering programmes are the same or different, the annoyance caused by the interference depends very much on the type of programme on both carriers.

The annoyance caused by adjacent channel interference depends very much on the performance of the receiver in respect of a.m. limiting and bandwidth. Obviously the annoyance value and hence the required protection ratio of wanted and unwanted signal levels can be expected to fall as the carrier separation increases.

The relationship between required protection ratio and frequency separation has been examined in detail by broadcasting authorities on the basis of subjective tests using a large number of representative makes of domestic receiver. This work has resulted in the monophonic protection ratio curves of CCIR Recommendation 412, which are reproduced in Fig. 46. It should be emphasised that these curves represent selectivity characteristics which it is considered reasonable to expect receivers to achieve, but it does not unfortunately follow that the majority of currently available receivers meet this requirement. It will be seen that at small frequency spacings Fig. 46 differentiates between a steady interfering signal and one which, due to abnormal tropospheric propagation conditions, is only present for a small proportion of the time. Obviously continuous interference requires the higher value of protection ratio.

The U.K. v.h.f. radio broadcasting network was developed to accommodate 3-programme broadcasting from co-sited transmitters within a frequency spectrum from 88.0 to 94.6 MHz. For planning purposes it was therefore convenient to divide the 6.6 MHz of spectrum into three equal sub-bands of 2.2 MHz, each carrying one programme. Thus at each transmitting station the standard frequency grouping of the transmissions is x MHz, $(x + 2.2)$ MHz and $(x + 4.4)$ MHz respectively.

The appropriate frequency separation between adjacent channel transmissions (which carry the same programme in each sub-band) is inevitably a compromise between reducing co-channel interference by increasing the number of channels and of increasing adjacent channel interference by having too small a frequency separation between channels. A spacing of 200 kHz was selected as apparently providing the best compromise, permitting 11 channels in each sub-band. Thus the lowest standard frequency group is 88.1, 90.3 and 92.5 MHz, and the highest is 90.1, 92.3 and 94.5 MHz, i.e., standard groupings use the odd 100-kHz intervals.

As development of the network proceeded, it was found necessary to intersperse frequencies for some of the later stations between existing ... allocations using the even 100-kHz intervals. Some stations required completely non-standard groupings, sometimes extending beyond the

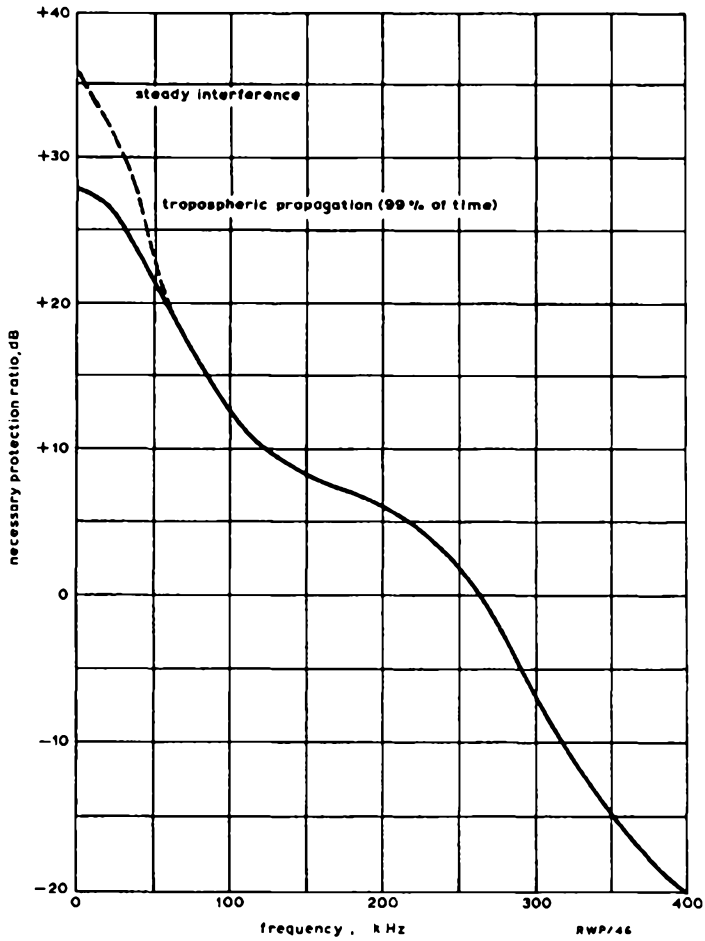

Fig. 46. Selectivity characteristics for mono reception in Band II (CCIR Recommendation 412)

nominal limit of available spectrum, e.g. Les Platons (Channel Islands) using 91.1, 94.75 and 97.1 MHz.

Reference to Fig. 46 shows that, whereas with the original standard grouping only interference from co-channel stations and those on immediately adjacent channels (i.e., ± 200 kHz) is significant, the use of smaller spacings means that stations on various other frequencies, e.g., (± 50 , ± 100 , ± 150 and ± 250 kHz) are also potentially significant sources of interference.

A complete list of U.K. v.h.f. radio stations and frequency allocations is given in Appendix B.

8.4 Choice of Plane of Polarisation

As discussed in an earlier section, the most serious limitation upon the level of minimum field strength required for satisfactory v.h.f. f.m. reception is impulsive noise. During the early low power field trials in the U.K., comparisons were made of the relative susceptibility of vertically and horizontally polarised transmissions to motor vehicle ignition interference, the most common form of impulsive noise. The results of these tests, which were carried out at both 45 and 90 MHz using aerials at 9 metres above ground, indicated that:-

- (i) For either plane of polarisation the interference was much more severe at the lower frequency.
- (ii) For either frequency horizontal polarisation was less affected by this form of interference. For the same subjective impairment the vertically polarised field needed to be 6 to 10 dB greater.

In the report on these tests⁽⁷⁷⁾ it was pointed out that certain circumstances might tend to reduce this advantage of horizontal polarisation, one such circumstance being that of reception using indoor aerials near the ground.

Comparative measurements of the propagation characteristics of both planes of polarisation were made at the time of the Wrotham field trials in 1950-53⁽⁷²⁾. Provision was made at Wrotham for transmission of either vertically or horizontally polarised signals, and comparative field strength measurements were made in various types of terrain within the service area.

It was found that there was little difference between propagation characteristics of the two planes of polarisation, but that there was some evidence that vertically polarised signals suffered slightly less severe attenuation in deep diffraction zones; it was also found that the field strength variation with location in areas screened by trees is much greater with vertical polarisation.

In view of the relatively minor nature of the propagation differences, the decision was made to adopt horizontal polarisation for all f.m. v.h.f. radio broadcasting in the U.K. on account of the better signal-to-impulsive-noise ratio obtainable with this polarisation. This decision also afforded the following advantages:-

- (i) The possibility of using the directional properties of a horizontal dipole to provide receiving aerial discrimination against interference transmissions provided these arrive from a substantially different direction to the wanted signal.
- (ii) Use of horizontal polarisation simplified transmitting aerial design, by permitting the use of omnidirectional aerials consisting of tiers of vertical slots in a cylinder. This form of slot aerial entailed less mast loading than a vertically polarised array of the same gain. This was an important factor in that v.h.f. radio transmitting aerials were to share the masts at existing or proposed television stations.

The decision to adopt horizontal polarisation on Band II was also taken by all other European countries except Eire, and was based on the premise that typical domestic receiving installations would comprise a mains-driven receiver with a roof-top or loft-mounted receiving aerial.

With the advent of v.h.f. car radios and transistor portable receivers using telescopic aerials, and with some overall reduction in impulsive noise levels resulting from legislation relating to vehicle ignition suppression, some of the factors leading to the original choice of polarisation are no longer valid. For example, the most convenient form of car or transistor portable aerial is the vertical whip aerial such as used for m.f. car radios. Such an aerial of suitable length is appropriate for vertically polarised v.h.f. reception, but only receives the de-polarised component of a horizontally polarised transmission.

The use of horizontal dipoles for car radios presents problems both of mounting and of directivity. Both car aerials and transistor portables with built-in telescopic aerials are normally required to operate relatively close to ground level. Under such conditions the received field strength is no longer virtually independent of plane of polarisation, being more critically dependent upon the ground reflection coefficient. The two polarisations behave rather differently because the reflection coefficients change from -1 by differing amounts.

The path geometry is shown in Fig. 3. It may be shown⁽⁷⁸⁾ that for a grazing angle β less than about 10° the ground reflection coefficients ρ_h and ρ_v may be expressed in the forms:

$$\rho_h = \frac{\beta - \alpha}{\beta + \alpha} \quad \text{and} \quad \rho_v = \frac{\kappa_r \beta - \alpha}{\kappa_r \beta + \alpha}$$

where β is in radians, and α is $\sqrt{\kappa_r - 1}$.

κ_r is the complex relative permittivity of the ground, which at Band-II frequencies approximates to ϵ_r , the relative permittivity or dielectric constant of the ground.

The v.p./h.p. field strength ratio at ground level is given by

$$\begin{aligned} \frac{E_v}{E_h} &= \frac{1 + \rho_v}{1 - \rho_h} = \frac{1 + \frac{\epsilon_r \beta - \alpha}{\epsilon_r \beta + \alpha}}{1 + \frac{\beta - \alpha}{\beta + \alpha}} \\ &= \frac{2\epsilon_r \beta (\beta + \alpha)}{2\beta (\epsilon_r \beta + \alpha)} = \frac{\epsilon_r (\beta + \alpha)}{\epsilon_r \beta + \alpha} \end{aligned}$$

At grazing incidence, when $\beta \rightarrow 0$, this expression reduces to $\epsilon_r \alpha / \alpha$, i.e., to ϵ_r and thus the field strength ratio E_v/E_h corresponds numerically to the value of relative permittivity of the ground. This may vary from 30 for 'good' ground to 5 for poor ground. Table 8.1 shows how for idealised conditions the v.p./h.p. field strength ratio at ground level varies with grazing angle β for two different values of relative permittivity ϵ_r .

This ratio decreases rapidly as the receiving aerial height is increased, becoming negligible for heights greater than one wavelength above ground. The ratio is also decreased if the ground reflection coefficient is reduced by the roughness of the ground surface.

A series of comparative tests of vertically and horizontally polarised Band-II transmissions carried out by the BBC in 1968-9 confirmed that although the full theoretical advantage of vertical polarisation at low receiving aerial heights was not obtainable, this plane of polarisation did nevertheless produce a significant improvement in reception particularly for car radios. Since it is impracticable to change the plane of polarisation of existing stations, consideration was given to the possibility of introducing an additional vertically polarised field component. This can be done either in the form of elliptical polarisation (circular if components are of equal amplitude) or 45° slant polarisation. In the former case the two field

TABLE 8.1

VP/HP FIELD STRENGTH RATIO IN dB FOR SPECIFIED GRAZING ANGLE

<i>Relative Permittivity</i>	<i>Grazing Angle (Degrees)</i>				
	<i>0</i>	<i>2</i>	<i>4</i>	<i>6</i>	<i>8</i>
20	26	24.5	23.5	22.5	22
5	14	13.5	13	12.5	12

components are phase displaced by 90° , and in the latter case they are in phase. Of these modes, slant polarisation offers the following advantages:-

- Simpler transmitting aerial design in instances where a directional aerial such as a Yagi array is used. Slant polarisation is achieved merely by tilting the transmitting aerial into the desired plane.
- Improved reception with normal elevated receiving aerials. Since the field components of an elliptically polarised transmission are displaced in phase, they cannot both be received on a simple receiving aerial, whereas both components of slant polarisation can be picked up by orienting the aerial into the correct plane. This may be unimportant at low receiving aerial heights, since the received signal is predominantly vertically polarised but slant polarisation affords a possible advantage of 3 dB if a correctly oriented elevated receiving aerial is used. This permits some extension of the service area for the same total radiated power.

Taking the above factors into consideration it was decided that several of the BBC v.h.f. local radio stations opened in 1968-70 should operate with 45° slant polarisation.

8.5 Stereophonic Broadcasting

8.5.1 General

All aspects of v.h.f. f.m. transmission discussed so far have referred to monophonic broadcasting in which the outputs of all the studio microphones

are combined to produce a single modulating signal which is then transmitted and results in a single output from the receiver. Several systems have been evolved for the broadcasting of stereophonic outputs from a studio. It is not proposed to discuss the various systems here but merely to detail these aspects of the system used by the BBC which are relevant to service coverage.

The system adopted for stereo broadcasting in the U.K. is the Zenith-G.E. system in which the output from the left-hand channel (A) and the right-hand channel (B) are combined in an encoder, and the resulting multiplex signal applied to the transmitter modulator comprises:-

1. An addition signal (A + B) which modulates the transmitter in a normal manner with peak deviation of 90% of ± 75 kHz if the outputs from the two channels are identical in amplitude and phase (i.e., if the difference signal is zero). This additional signal is reproduced by a monophonic receiver in the normal manner, this being one of the requirements for compatibility.
2. The stereophonic information, which is contained on a subcarrier. This sub-carrier, at 38 kHz, is amplitude modulated by the difference signal (A - B) in such a manner that the carrier is suppressed. This part of the modulating signal can also provide peaks up to 90% of ± 75 kHz if the outputs of both channels are of equal amplitude but in antiphase.
3. A carrier of 19 kHz peaking to about 10% of ± 75 kHz which is transmitted to enable the decoders in the stereo receivers to demodulate the (A - B) difference component. This is generally referred to as the *pilot tone*. The frequency spectrum of the stereo transmission is shown in Fig. 47 and the effect on coverage will be discussed for reception by both monophonic and stereophonic receivers.
 - (a) **Stereophonic Transmission - Monophonic Receiver.** The difference signal and pilot tone are heavily attenuated in a monophonic receiver, particularly in the de-emphasis circuits. As previously mentioned, full deviation of the addition signal (A + B) occurs only if there is no difference signal (A - B), a condition which is of little interest in a stereo broadcast. Thus, in general, the deviation level of the (A + B) signal is less than for a corresponding monophonic transmission, this reduction depending upon the relative levels of addition and difference components, i.e., upon the programme content. For a typical stereo programme the average reduction in deviation of the (A + B) signal is about 4 dB, and thus the effective signal-to-noise ratio is reduced by this amount.

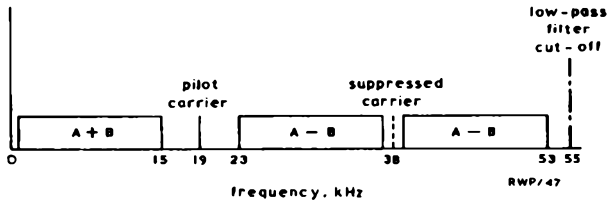

Fig. 47. Frequency spectrum of stereo transmissions

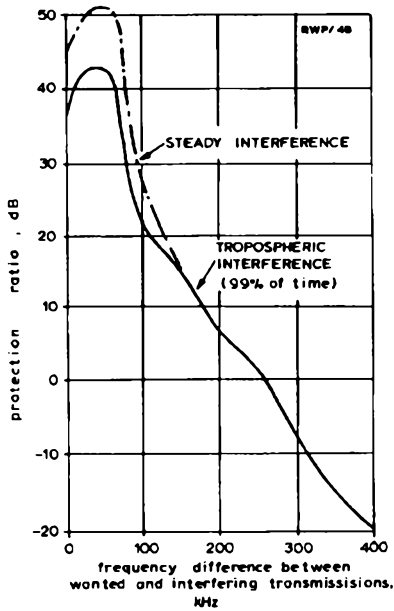

Fig. 48. Selectivity characteristics for stereo reception in Band II (CCIR Report 462)

- (b) **Stereophonic Transmission - Stereophonic Receiver.** The noise produced in a stereophonic receiver is much higher than in a monophonic receiver. This is largely because noise voltages at frequencies up to 53 kHz (38 kHz + 15 kHz) pass the discriminator to be detected in the (A – B) demodulator as compared with frequencies up to only 15 kHz in a monophonic receiver. This increase in effective noise bandwidth is emphasised by the triangular noise spectrum characteristic of frequency modulation and gives a reduction in signal-to-noise ratio of about 20 dB. This in turn implies that (excluding external interference) the minimum field strength required for a satisfactory service is about 500 $\mu\text{V/m}$. Thus the coverage for stereo reception is appreciably less than for monophonic reception, and requires more expensive aerial installations at the fringe of the service area if stereophonic reception is not to be seriously degraded by receiver noise.

8.5.2 Protection Against Interference from Other Transmissions

Requirements for the protection of a monophonic transmission against interference from co-channel and adjacent channel transmissions have been discussed in Section 8.3.3. A curve relating required protection ratio to frequency separation between wanted and interfering transmissions (reproduced from CCIR Recommendation 412) was shown in Fig. 46. Protection requirements for reception of a stereo transmission are more stringent on account of the necessarily greater bandwidth required for stereo reception. Fig. 48 shows the corresponding CCIR⁽⁷⁹⁾ protection ratio curves for stereo reception. Comparison of these figures shows that the required protection ratio for stereo operation is greater than for mono reception at frequency separations less than ± 200 kHz. It may also be noted that the protection ratio required at small separations (± 50 kHz) is greater even than that required for co-channel operation.

The increased protection ratio requirements for stereo reception mean that if a network is to be planned for stereo operation the distances between co-channel and adjacent channel stations should be greater than for mono operation. Per contra, if a network originally planned on the basis of mono operation is converted to stereo transmission (as in the U.K.) it will be found that it is not possible to protect the service from interference from other stations for such a high percentage of the time. Thus, for example, whereas a mono transmission network may be planned on the basis of providing interference-free reception for 99% of the time, it may only be possible to guarantee protection for 95% of the time to a stereo transmission covering

the same area. Fortunately, the greater directivity of the more efficient receiving aerial required to improve signal-to-noise ratio at the fringe of a stereo service area also often helps to reduce the probability of interference from other transmitters, always provided these are on substantially different bearings to the wanted station.

8.6 Service Impairments due to Reflections

The effect on a television picture of delayed signal components resulting from reflections from hills, large buildings and aircraft has been discussed in some detail in Section 5.4.2. In the case of television the delayed signal is visible as a ghost image. With f.m. the result is also distinctive and worth consideration since it may be of considerable annoyance.

The effect is called *multipath distortion* and, as with video signals, takes a form which depends upon the location of the point of reflection. If reflection occurs from a distant surface the additional path length may be of several hundreds or thousands of wavelengths. A fairly small change in frequency makes this path length difference vary by a substantial part of a wavelength or even by several wavelengths, and consequently the relative phase of this component change appreciably. This may be demonstrated by taking an example.

Example

Consider the multipath distortion caused when the delayed signal component traverses an additional path length of 12 km, the modulating signal being a 1-kHz sinusoidal tone giving a deviation of ± 30 kHz. The amplitude of the reflected signal component is 20% of the direct component.

Let the transmission have a centre frequency of f_{mid} with a corresponding wavelength λ_{mid} of $300/f_{\text{mid}}$ metres. It follows that the path length difference, d metres, equals d/λ_{mid} wavelengths.

Since the transmitted signal is frequency modulated, the frequency and hence the path length difference (expressed in wavelengths) are continually varying. This in turn causes modulation of the resultant signal.

If the path length difference in wavelengths varies from d/λ_{min} to d/λ_{max} then, as the frequency varies from f_{max} to f_{min} , the two individual signals received go into and out of phase the same number of times as the path length difference varies in number of wavelengths.

$$\begin{aligned} \text{Number of variations} &= \frac{d}{\lambda_{\min}} - \frac{d}{\lambda_{\max}} \\ &= \frac{d}{300} \left[f_{\max} - f_{\min} \right] = \frac{2df_{\text{dev}}}{300} \end{aligned}$$

where f_{dev} is the deviation in MHz from the centre frequency. Note that this result so far is independent of carrier frequency and modulating frequency, and depends only on path length difference and on deviation.

If d is 12 km, and the transmitter is modulated to ± 30 kHz, the number of wavelengths is $2 \times 12,000 \times 0.03 \div 300$, or 2.4. Thus, when deviating ± 30 kHz, the two signals will go into and out of phase 2.4 times.

The corresponding value for programmes peaking to ± 75 kHz would be six times.

The signal received is the resultant of direct and reflected components and the effect of the latter is demonstrated in Fig. 49. In Fig. 49a, vector AC represents the direct component, and vector CB the reflected component which rotates a number of times first in one direction and then in the other as the signal frequency deviates above or below the centre frequency. As indicated in the figure, the amplitude of the reflected component is generally much smaller than that of the direct component, due to the larger path length and the coefficient of reflection being less than unity.

The resultant signal AB varies in both amplitude and phase; it is of importance to realise that the amount of amplitude modulation generally far exceeds the amount of phase modulation. It is clear from Fig. 49 that the amplitude modulation reaches a depth given directly by the ratio of the amplitude of the reflected component to that of the direct component. This may be very variable depending upon the exact path geometry, but in this example is taken as 20%.

Assessment of the amount of phase modulation is not so straightforward, since it depends upon the nature of the modulating signal. The vector representation of an f.m. carrier⁽⁷⁵⁾ is usually given with respect to the centre frequency, the vector rotating alternately clockwise and anticlockwise about this reference position. The angle of rotation in each direction is given by the modulation index, i.e., by the ratio of deviation frequency f_{dev} to modulation frequency f_{mod} expressed in radians. In this example we have specified that f_{dev} is ± 30 kHz and f_{mod} is 1 kHz, whence $f_{\text{dev}}/f_{\text{mod}}$ equals 30 radians.

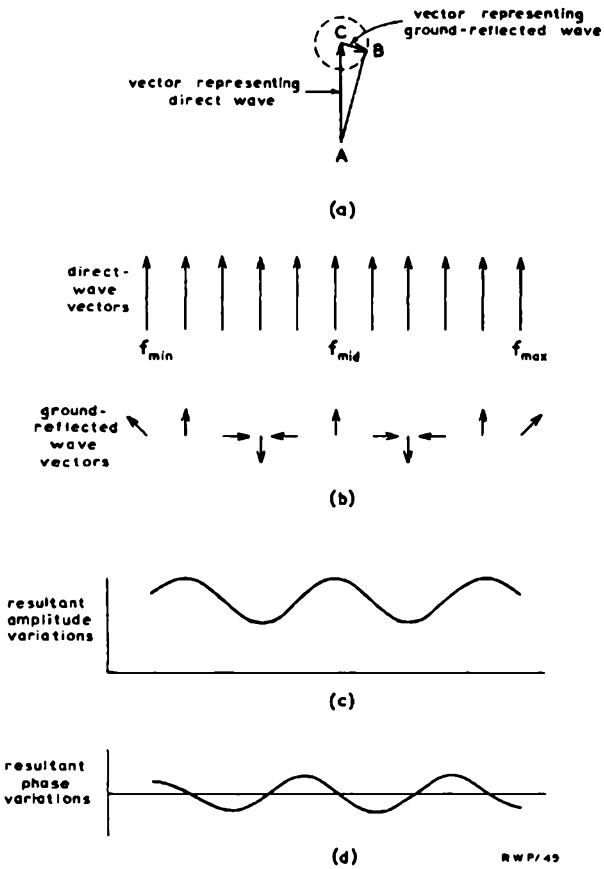

Fig. 49. *The effect on a frequency modulated carrier of an additional reflected signal*

Superimposed on this swing is the phase-modulation component of the variation due to the reflected signal component. Referring again to Fig. 45 this will have a maximum value corresponding to $\sin^{-1} (BC/AC)$, equal to 0.25 radian, since in this example BC/AC equals 0.2. Thus, the amount of phase-modulation distortion due to the reflected signal component is given by the ratio of (swing due to multipath) to (swing due to modulation), which equals 0.25:30 or 0.83%. This is very much less than the 20% of amplitude-modulation distortion, but it should be noted that whereas the a.m. distortion is constant for a given reflection, the p.m. distortion depends on the modulation index.

The above example emphasises a characteristic feature of multipath distortion, namely that amplitude and phase modulated components are produced. The amplitude modulated component is much the greater, whatever the programme modulation may be. To ensure protection against the a.m. component of multipath distortion, it is therefore necessary to incorporate an a.m. limiter in an f.m. receiver and to make certain that the received signal has sufficient amplitude to operate this limiter.

In the example, the effect of the multipath distortion is to introduce a vector which varies through 2.4 cycles while the programme modulation varies through one cycle. Thus, the 1-kHz modulation has superimposed on it a component at 2.4 kHz.

The subjective sound effect with normal modulation is a mechanical buzz and its annoyance value depends on the type of programme. A directional receiving aerial can often be helpful, provided the reflected signal arrives from a substantially different direction to the direct signal.

The above comments relate to multipath distortion due to reflections from hills, large buildings or aircraft. One further form of distortion due to reflection from aircraft should also be mentioned. Under appropriate conditions of aircraft height, direction, speed and distance from the receiver, an aircraft can produce a very low frequency fluctuation component, similar to that causing slow deep fading of a television picture. This fluctuation is due to a change in path length difference, brought about by the true physical change in path length, rather than by the change in frequency occurring in frequency modulation. The subjective effect of this slow fading depends largely on the type of detector used in the f.m. receiver, a ratio detector being more susceptible than a phase discriminator.

CHAPTER 9

S.H.F. PROPAGATION

9.1 Introduction

The s.h.f. Band extends from 3000 MHz to 30,000 MHz (3 GHz to 30 GHz). Although it is envisaged that frequencies in this band will eventually be directly used for broadcasting either from terrestrial stations or from satellites, present usage by broadcasting authorities is confined to point-to-point programme links. Such links used for television may be classified as either:

- (i) Permanent fixed links, used to distribute programmes to transmitting stations. The majority of such links in the U.K. are rented from the Post Office.
- (ii) Temporary links, used for the relaying of an outside broadcast originating at a place remote from the normal transmission network. One or more such s.h.f. radio-links may be used to send the programme to a receiving terminal from which video signals may be fed into the P.O. fixed link network.

This chapter is confined primarily to a consideration of the factors required to ensure satisfactory operation of such outside broadcast links which are allocated frequencies in the bands from 7.1 to 7.4 GHz and 11.7 to 12.1 GHz. A comprehensive treatment of other aspects of planning and construction of s.h.f. links is given in the EBU Technical Monograph on radio-relays for television⁽⁸⁰⁾.

9.2 Diffraction

Diffraction is discussed in general terms in Section 3.1.5. Diffraction losses occurring over an obstructed path increase substantially with increase of transmission frequency as indicated by the example shown in Fig. 50. In this example a knife-edged hill is situated midway between transmitting and receiving terminals, and the effective height H above the line of sight path TR is assumed to vary. When H equals 0, the attenuation due to the presence of the hill is 6 dB and is independent of frequency, but as H increases the loss at s.h.f. rapidly becomes very large. Furthermore, if the obstruction is not knife-edged, as in the case of the obstruction caused by the bulge of the earth in transhorizon propagation, the attenuation is even greater than for knife-edge diffraction. With normal s.h.f. link equipment the overall transmission losses are generally such that any additional attenuation due to diffraction would give rise to unacceptable impairment of the received signal-to-noise ratio.

It is thus important to ensure that such link paths have adequate clearance over obstructions.

The usual criterion for defining the minimum required clearance is that the path length difference between the direct wave and that reflected from the ground at any point between transmitter and receiver should be at least half a wavelength. Reference to Section 3.1.5 indicates that this clearance corresponds to that of the first Fresnel zone and hence to a field strength slightly in excess of the free space value. (See Fig. 11.) Since, however, this first Fresnel zone clearance is merely considered as the minimum required clearance, it is not usual to plan on the basis of obtaining this small advantage over the free space field, but merely to assume that the field should be within 1 dB of the free space value if this minimum clearance is provided.

9.3 Reflections

The concept of a received signal being the vector sum of direct and ground-reflected components is discussed in Section 3.1.3. As in the case of diffraction, a path difference of half a wavelength between direct and ground-reflected components corresponds to first Fresnel zone clearance. It should, however, be noted that whereas for diffraction a first Fresnel zone clearance over an infinite knife-edge obstruction gives a field strength about 1½ dB above the free space value, a similar clearance over a reflecting plane having a reflection coefficient of -1 provides a field strength of double the free space value, since direct and reflected components arrive at the receiver in phase and with equal amplitude. Corresponding values for second Fresnel zone clearance are about 1½ dB below free space for diffraction, but zero for reflection.

In practice, as discussed in Section 3.1.6, the ground reflection coefficient has a modulus of unity only if the ground is sufficiently smooth to support specular reflection. If the ground is rough, the reflection is diffuse and incoherent and has little influence upon the level of the received signal. The degree of roughness for which the reflected component can be considered to become unimportant is defined by the *Rayleigh criterion* in terms of an effective height h_0 of ground undulation. For small grazing angles, this height is given by

$$h_0 = \lambda/16\psi$$

where ψ is the angle in radians between the incident ray and the ground, and λ is the wavelength of the transmission.

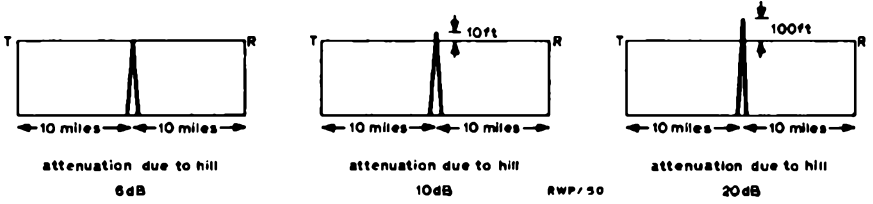

Fig. 50. Attenuation of u.h.f. signals with an obstacle on and obstructing the line of sight

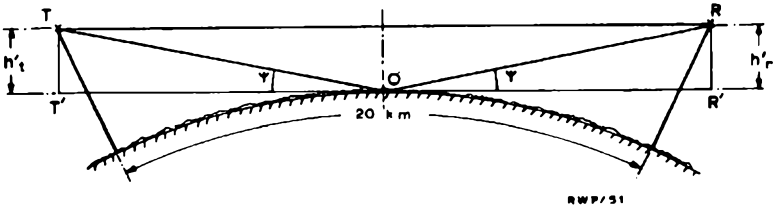

Fig. 51. Geometry of simple transmission path

Although in theory very small angles ψ can give rise to large values of h_o , implying that even fairly rough ground can appear smooth at sufficiently small grazing angles, it must be remembered that at s.h.f. diffraction loss considerations require provision of at least first Fresnel zone clearance. Thus these extremely small grazing angles do not generally occur in practice. This may be shown by considering a typical example.

Example

Assuming transmitting and receiving terminals on a 20 km s.h.f. link path operated at 7.15 GHz to be of equal height, what average height of undulation satisfies the Rayleigh roughness criterion for reflections at mid-path, assuming first Fresnel zone clearance to occur?

The path geometry is represented in Fig. 51. Although the effect of earth curvature may be significant, for our purpose it is only necessary to consider the effective terminal heights h'_t and h'_r above the tangent plane of reflection at mid-path.

For first Fresnel zone clearance the path difference TOR-TR is by definition equal to one half wavelength.

Since the path is symmetrical

$$h'_t = h'_r$$

and it follows that

$$TO - T'O = \lambda/4 = 1.05 \times 10^{-2} \text{ metres.}$$

$$\text{Now } (TO)^2 = (T'O)^2 + (h')^2$$

$$\text{and } h'_t/T'O = \tan \psi.$$

$$\text{So } h'_t = T'O \tan \psi$$

$$\text{and } (TO)^2 = (T'O)^2(1 + \tan^2 \psi)$$

$$\begin{aligned} \text{or } TO &= T'O \sqrt{1 + \tan^2 \psi} \\ &= T'O \left[1 + \frac{\tan^2 \psi}{2} \right] \end{aligned}$$

since ψ is small.

$$\begin{aligned}
 \text{Hence} \quad \text{TO} - \text{T}'\text{O} &= \text{T}'\text{O} \left[1 + \frac{\tan^2 \psi}{2} \right] \\
 &= \lambda/4 = 1.05 \times 10^{-2} \\
 \text{or} \quad \tan^2 \psi &= \frac{2.1 \times 10^{-2}}{\text{T}'\text{O}} \\
 &= 2.1 \times 10^{-6} \\
 &\quad \text{since T}'\text{O is } 10^4 \text{ metres.}
 \end{aligned}$$

$$\text{Thus} \quad \tan \psi \simeq \psi = 1.4 \times 10^{-3} \text{ radians.}$$

The Rayleigh criterion is satisfied if the ground conditions are such that

$$h_o \ll \lambda/16\psi \text{ or } \frac{4.2 \times 10^{-2}}{16 \times 1.4 \times 10^{-3}}$$

$$\text{or} \quad h_o \ll \text{about 2 metres.}$$

There are few regions where over a moderately large area variations in level do not exceed 2 metres, and hence for s.h.f. propagation the surface of the ground can usually be considered as rough. It should also be remembered that this example was worked for the limiting case represented by a grazing angle only just sufficient to provide first Fresnel zone clearance. In a more usual case, with greater clearance, the angle ψ is greater and hence the Rayleigh roughness criterion is satisfied for smaller values of h_o .

Typically, at s.h.f., ground reflection coefficients are of the order of 0.1 to 0.2, implying that the effect of ground reflections should not cause field strength variations of more than about ± 2 dB from the free space value. An important exception occurs if the reflection point is on the surface of water rather than land, since reflection coefficients may then exceed 0.9. Under such conditions large fluctuations in received field strength can occur with small changes in path length or terminal height. Attention has already been drawn to this problem as it concerns u.h.f. propagation in Chapter 7. Wherever possible, s.h.f. transmission over water should be avoided unless, as indicated in Fig. 52, it can be ensured that no reflection from the water surface contributes significantly to the received signal. Alternative methods of

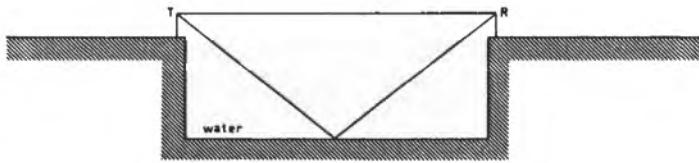

(a) path that is likely to prove troublesome

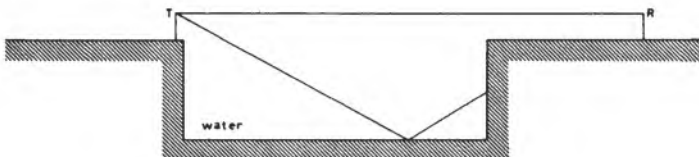

(b) the screening method whereby a cliff screens the receiver from the sea-reflected path

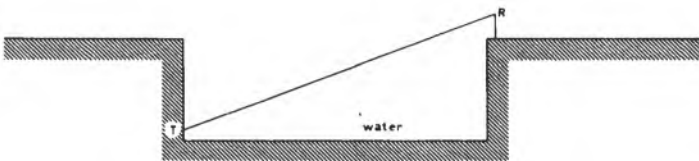

(c) the low-high method in which the direct and reflected paths are equal in length

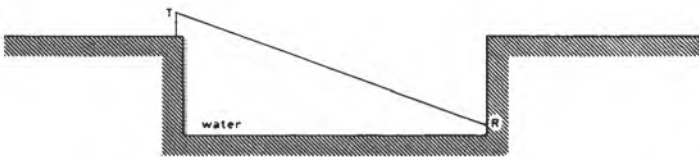

(d) the high-low method, again with no difference in path length

RWP/52

Fig. 52. S.H.F. transmissions over water

reducing the effect of the sea-reflected signal are (1) to move one terminal inland so that there is no sea reflection point visible from both terminals as shown in Fig. 52b, or (2) to have one terminal as low as possible to minimise the path length difference between direct and reflected components as shown in Figs. 52c and d.

9.4 Variations in Refractive Index, and Use of Diversity Reception

The refractive effect of the troposphere under normal propagation conditions may be taken into account by assuming that the earth has an effective radius greater than the true radius by a factor of $\frac{4}{3}$. However, as discussed in Section 3.2.2, anomalous propagation can occur, usually during anticyclonic weather conditions, due to stratification of the troposphere. This produces steep refractive-index gradients and hence partial reflections or 'ducting'.

Anomalous propagation tends to be more widespread and continuous on oversea paths than overland. The sea has no marked diurnal temperature variation, and hence the air immediately above it remains cool and moist. Air from higher levels in a high-pressure system tends to settle as a warm dry layer above this cool moist boundary layer, thereby producing a temperature inversion with a sharp negative refractive-index gradient. Although similar conditions occur overland, the air near the earth's surface tends to be heated by the sun. Turbulent air currents are formed and these, helped by the effect of terrain undulations, tend to stop the formation of stratified layers.

The result of these anomalous propagation conditions is to produce fading of the received signal; the probability and depth of this fading increases with the length of the transmission path, being greatest, for the reasons just explained, if the path is over sea or along the coast. It is useful to distinguish between fading due to changing attenuation such as caused by variations in effective earth radius and by duct effects, and that due to reflections either from ground or water surfaces or from tropospheric stratification. Both may give rise to impaired signal-to-noise ratio. In addition, fading due to reflections may be frequency-selective, causing differential-phase and differential-gain distortion, although the signal-to-noise ratio does not always get much worse.

Where fading occurs, or is expected, it may be necessary to use space or frequency diversity reception. Space diversity involves the use of two receiving aerials, which are generally spaced vertically. To minimise the chance of fading at the two aerials at the same time, they should be separated by at least 100 wavelengths.

Each aerial is connected to a separate receiver, and the outputs fed to a combining unit with an electronic switch selecting the better signal at any instant.

Frequency diversity requires the use of two transmitters as well as two receivers, but in this instance it may be possible to use a common receiving aerial if both frequencies are in the same band. Here also video switching at the receiver output is required. Either diversity system may also be used to minimise the effect of fading due either to changes in the troposphere or to reflections from the sea surface in instances where it is not possible to produce a satisfactory reduction in fading range by suitable positioning of the terminals as shown in Fig. 48.

9.5 Atmospheric Attenuation

S.H.F. signals are attenuated by scattering and absorption in the atmosphere. Absorption of the wave energy by oxygen and water vapour molecules occurs at certain resonant frequencies. Attenuation due to oxygen has a peak value at about 60 GHz but is negligible below 20 GHz; that due to water vapour becomes significant above 10 GHz, with a peak at about 23 GHz when for typical humidities the attenuation may be about 0.2 dB/km. Losses due to the water content of the atmosphere may increase substantially during periods of rain, snow or fog, the actual attenuation depending upon path length, frequency, and the amount of water present. At frequencies up to about 15 GHz, the additional attenuation due to fog is unlikely to exceed 0.05 to 0.07 dB/km. The effect of rain is more serious, attenuations up to 0.5 dB/km occurring at 11 GHz in heavy rain. Fortunately in the U.K. such rainfall rates are restricted to fairly local areas and to short duration storms such as thunderstorms. Even so this additional attenuation could be significant over a path of already marginal signal-to-noise ratio and it may be necessary to make allowance for bad weather conditions in planning the link.

Wet snow can be a more serious problem than rain, since, for a given amount of water, snow occupies a greater volume than rain and snowflakes are large enough to be comparable with the radio wavelength. Dry snow, i.e., precipitation through air at a temperature well below freezing point, produces negligible attenuation. Typical attenuation rates due to rain or snow are given in Table 9.1.

Local problems due to precipitation can occur if rain or snow gets in the aerial system and by causing a mismatch detunes the oscillator.

TABLE 9.1

<i>Type of Precipitation</i>	<i>Attenuation (dB/km)</i>			
	<i>5 GHz</i>	<i>10 GHz</i>	<i>15 GHz</i>	<i>20 GHz</i>
Light rainfall	-	0.01	0.04	0.075
Heavy rainfall or moderate moist snowfall	0.03	0.3	0.8	1.5
Equatorial rainstorm or thick moist snowfall	0.05	0.7	1.5	3

9.6 Examination of Proposed Transmission Paths

9.6.1 General

A good s.h.f. propagation path is one in which all reflecting surfaces and diffracting obstacles are outside the first Fresnel zone. When this is so, virtually the only attenuation is that occurring in free-space transmission. The survey of a proposed path should thus be in two parts:

- (i) examination of the profile, to establish that the path is obstacle-free and has first Fresnel zone clearance.
- (ii) estimation of the received signal level to ensure that this is sufficient to maintain an adequate signal-to-noise ratio.

9.6.2 Path Profiles

It will be assumed that a new path is to be investigated. The site of the programme source is on flat and fairly low ground, and nearby is a range of hills on which can be found an area which

- (a) is visible from the programme source,
- (b) forms a likely start for a path to the injection point into the main programme distribution network.

- (c) has a sufficiently extensive flat area for the installation of the link equipment (with the permission of the owner)
- (d) has reasonable access, and preferably an electricity supply nearby.

A starter link at s.h.f. or u.h.f. would relay the programme from the source to the hilltop; then an s.h.f. link at about 7000 MHz would transmit the programme to the injection point. It is proposed to explain in detail the method of conducting a theoretical survey of the proposed link path. In practice such a survey would be made first, and if satisfactory, would be followed by transmission tests. A theoretical survey can look for obvious conditions, but the final choice is made by a site test.

The survey is started by drawing a profile containing both transmitter and receiver. The one-inch Ordnance Survey is convenient for this except for a frequent shortage of height data in built-up areas. Graph paper with a suitable base to allow for earth curvature is desirable, but since this is not always available, it will be assumed that normal squared paper is to be used, and the earth curvature allowance included in the calculations. Suitable horizontal and vertical scales must be chosen. These will of course be very different since the path length may be several tens of miles and the vertical height only hundreds of feet.

Locate the positions of the terminals on the map, and draw the profile on the graph paper by plotting the distances at which successive height contours are crossed by the line joining these terminals. Allowance should be made for the heights of obstacles, particularly when these occur near the tops of hills or in other areas where they may approach the first Fresnel zone. Suitable allowances are 60 ft for trees and 30 ft for houses (or more if it is reasonable to suppose that tall buildings are present). At both terminals allow for the height of transmitting (T) and receiving (R) aerials above ground, and draw a straight line on the profile from T to R. An example of a 36-mile path is illustrated in Fig. 53. This path is in the Midlands, T being a van-roof aerial at Hidcote Bartrim, 850 ft above sea level (a.m.s.l.), and R the receiving aerial 600 ft up the Sutton Coldfield transmitter mast on ground 560 ft a.m.s.l. This path is often used for programmes originating in Stratford or Warwick.

As drawn, this profile is of limited use, because

1. no allowance has been made for the earth's curvature,
2. straight-line propagation has been assumed, whereas in practice refraction tends to bend the radio waves towards the earth, and
3. it is difficult to see whether all reflecting surfaces are outside the first Fresnel zone.

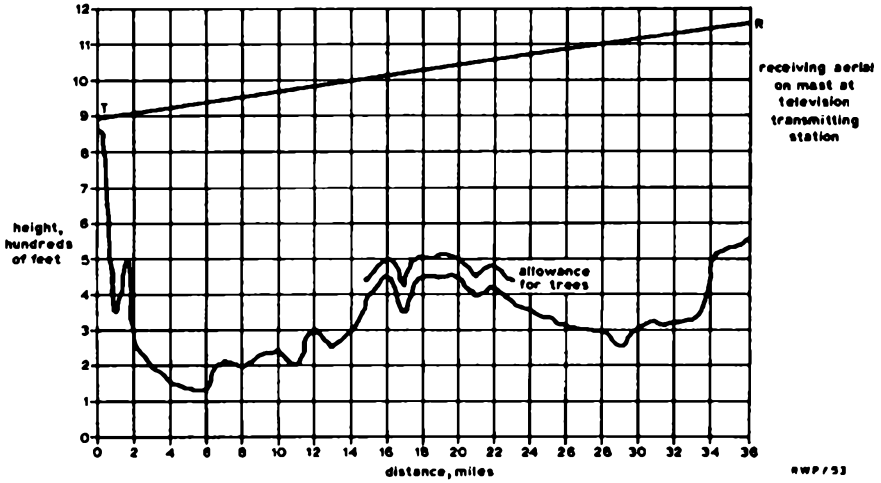

Fig. 53. An example of a path profile – assuming a flat earth

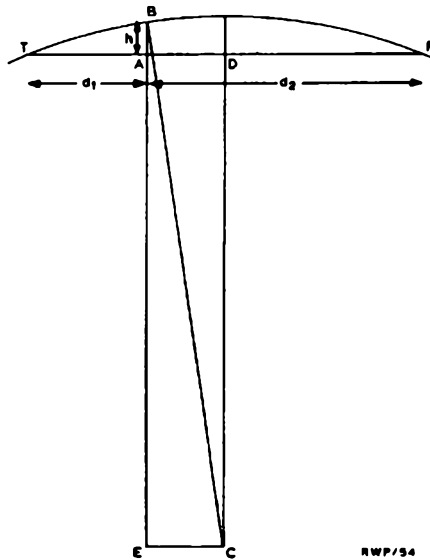

Fig. 54. Illustrating allowance for earth's curvature

However, as will be shown, this profile can easily be modified to take these factors into account and thus become of considerable practical significance.

9.6.3 Allowance for Earth's Curvature

The height measurements taken from the Ordnance Survey map are relative to sea level, and the earth's curvature was ignored in plotting the profile on paper with rectangular coordinates. This curvature may be taken into account by modifying the base of the graph by a factor that will now be evaluated by means of Fig. 54.

It is required to find the height h of the earth's segment above the flat base (i.e., straight line) between T and R at a distance d_1 from T and d_2 from R. This point is shown as A. C is the centre of the earth. Hence

$$TC = BC = RC = r, \text{ the radius of the earth.}$$

CE is drawn parallel to TR, CD is the perpendicular to TR and BE is parallel to CD. Thus

$$\begin{aligned} h &= BE - AE \\ &= BE - CD \\ &= \sqrt{BC^2 - CE^2} - \sqrt{CR^2 - DR^2} \end{aligned}$$

where CE = AD. Therefore

$$h = \sqrt{r^2 - AD^2} - \sqrt{r^2 - DR^2}.$$

AD and DR are now required in terms of d_1 and d_2 .

$$\begin{aligned} TR &= d_1 + d_2 \\ DR &= \frac{TR}{2} = \frac{d_1 + d_2}{2} \\ AD &= TD - AT \\ &= \frac{d_1 + d_2}{2} - d_1 = \frac{d_2 - d_1}{2} \end{aligned}$$

$$\text{Therefore } h = \sqrt{r^2 - \left[\frac{d_2 - d_1}{2} \right]^2} - \sqrt{r^2 - \left[\frac{d_1 + d_2}{2} \right]^2}$$

To simplify evaluation, we put both expressions into the form $\sqrt{1 - a}$. Where a is much smaller than 1,

$$\sqrt{1 - a} = (1 - a/2).$$

This simplification is justified because r is very much greater than d_1 or d_2 . Thus

$$\begin{aligned} h &= r \left[\sqrt{1 - \left[\frac{d_2 - d_1}{2r} \right]^2} - \sqrt{1 - \left[\frac{d_1 + d_2}{2r} \right]^2} \right] \\ &= r \left[1 - \frac{1}{2} \left[\frac{d_2 - d_1}{2r} \right]^2 \right] - r \left[1 - \frac{1}{2} \left[\frac{d_1 + d_2}{2r} \right]^2 \right] \\ &= r - \frac{r}{2} \left[\frac{d_2^2 - 2d_1d_2 + d_1^2}{4r^2} \right] - r + \frac{r}{2} \left[\frac{d_1^2 + 2d_1d_2 + d_2^2}{4r^2} \right] \\ &= \frac{-d_2^2 + 2d_1d_2 - d_1^2 + d_1^2 + 2d_1d_2 + d_2^2}{8r} \\ &= \frac{4d_1d_2}{8r} = \frac{d_1d_2}{2r} \end{aligned}$$

9.6.4 Effect of Refraction

The effect of the troposphere in refracting radio waves back towards the earth's surface has been discussed in detail in Section 3.1.5. For the purpose of plotting profiles it is, however, convenient to draw the radio wave path as a straight line, and to do so it is appropriate to consider an effective earth radius somewhat greater than the true value. Under normal propagation conditions the factor used is $\frac{4}{3}$.

If the evaluation of h derived above is modified to take account of tropospheric refraction, we have

$$h = 3d_1d_2/8r.$$

In this expression, all dimensions are in the same units. It is however, more convenient to express h in feet and distance in miles, the earth's radius being

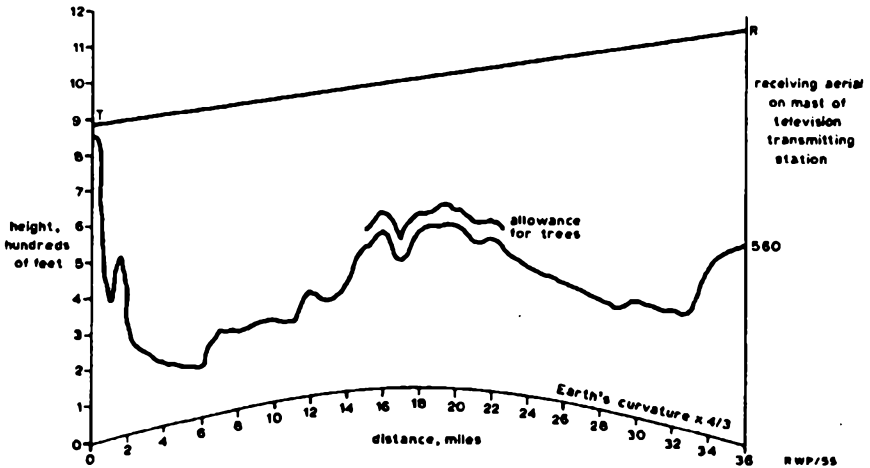

Fig. 55. Sample profile drawn on base that allows for earth's curvature

3960 miles. Thus

$$h = \frac{3 \times 5280 \times d_1 d_2}{8 \times 3960}$$

$$= d_1 d_2 / 2 \text{ feet, } d_1 \text{ and } d_2 \text{ being miles}$$

It is now possible to modify the sample profile of Fig. 53 by compiling a table for h giving d_1 and d_2 all appropriate values between T and R. Table 9.2 gives the figures for the sample 36-mile path examined. Note that, since the value of h for a given value of d_1 is identical to that for the same value of d_2 , Table 9.2 and subsequent tables give only those values for which d_1 is less than or equal to d_2 . For points in the other half of the path, T and R may be considered to be transposed.

TABLE 9.2

ALLOWANCE FOR EARTH'S CURVATURE AND REFRACTION
OVER 36-MILE PATH

	d_1 in miles									h in feet								
d_1	1	2	3	4	5	6	7	8	9	18	34	50	64	78	90	102	112	122
h	10	11	12	13	14	15	16	17	18	130	138	144	150	154	158	160	161	162

The corrections obtained from Table 9.2 are incorporated in Fig. 55 by modifying the base line as shown. The straight line drawn from T to R now does represent the true signal path and the profile shows that a line of sight clearance exists.

9.6.5 Fresnel Clearance

We require to establish not only that a line of sight condition exists, but also that all reflecting surfaces are outside the first Fresnel zone, i.e., that the shortest ground-reflected path is at least half a wavelength longer than the direct path TR.

This is illustrated in Fig. 56, in which a reflection may occur from point P. It is required to find the minimum value of x for which

$$(\text{TPR} - \text{TR}) \text{ is at least } \lambda/2.$$

This condition occurs when

$$\begin{aligned} \lambda/2 &= \text{TPR} - \text{TR} \\ &= (\text{TP} + \text{PR}) - \text{TR} \\ &= \sqrt{(\text{OP}^2 + \text{OT}^2)} + \sqrt{(\text{OP}^2 + \text{OR}^2)} - \text{TR} \end{aligned}$$

where $\text{OP} = x$, $\text{OT} = d_1$, $\text{OR} = d_2$, and $\text{TR} = d_1 + d_2$.

$$\begin{aligned} \text{Thus } \lambda/2 &= \sqrt{(x^2 + d_1^2)} + \sqrt{(x^2 + d_2^2)} - (d_1 + d_2) \\ &= d_1 \left[\sqrt{1 + \frac{x^2}{d_1^2}} \right] + d_2 \left[\sqrt{1 + \frac{x^2}{d_2^2}} \right] - (d_1 + d_2) \end{aligned}$$

We can now use the simplification $\sqrt{1 + a} = (1 + a/2)$, since x will be much less than d_1 or d_2 .

$$\begin{aligned} \lambda/2 &= d_1 \left[1 + \frac{x^2}{2d_1^2} \right] + d_2 \left[1 + \frac{x^2}{2d_2^2} \right] - (d_1 + d_2) \\ &= d_1 + \frac{x^2}{2d_1} + d_2 + \frac{x^2}{2d_2} - (d_1 + d_2) \\ &= \frac{x^2}{2d_1} + \frac{x^2}{2d_2} \end{aligned}$$

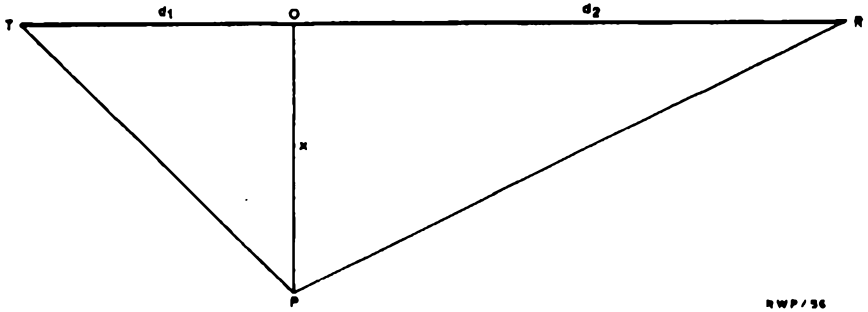

RWP/56

Fig. 56. Fresnel clearance for a single reflection

$$\begin{aligned} \text{and } \lambda &= \frac{x^2}{d_1} + \frac{x^2}{d_2} \\ &= x^2 \left[\frac{d_1 + d_2}{d_1 d_2} \right] \end{aligned}$$

$$\text{or } x = \sqrt{\lambda \frac{d_1 d_2}{d_1 + d_2}}$$

Here again, there is a conflict of units; d_1 and d_2 are usually expressed in miles and λ in cm, but x is normally required in feet. Applying the required conversions:

$$\begin{aligned} x &= 5280 \left[\sqrt{\frac{1}{12 \times 2.54 \times 5280} \times \frac{\lambda d_1 d_2}{d_1 + d_2}} \right] \\ &= 13.2 \left[\sqrt{\frac{\lambda d_1 d_2}{d_1 + d_2}} \right] \text{ feet,} \end{aligned}$$

with λ in cm, and d_1 and d_2 in miles.

This can be taken a shade further by removing λ . When the frequency is about 7,150 MHz, λ is 4.2 cm, and hence

$$x = 27 \left[\sqrt{\frac{d_1 d_2}{d_1 + d_2}} \right]$$

A table can now be compiled to make due allowance for Fresnel clearance. For the sample profile previously considered, the clearances are as shown in Table 9.3.

TABLE 9.3

FRESNEL CLEARANCE REQUIRED FOR 36-MILE PATH AT 7,150 MHz

	d_1 in miles				x in feet					
d_1	1	2	3	4	5	6	7	8	9	
x	28	37	45	51	56	60	64	68	70	
d_1	10	11	12	13	14	15	16	17	18	
x	73	75	76	78	79	80	80	81	81	

Fig. 57 shows how these clearances are applied to the path profile. At regular intervals of distance from T, drop from the direct path TR vertical distances representing the appropriate value of x given in Table 9.3. Join the points so plotted with a smooth curve. There should be no reflecting surface projecting above this curve. The diagram shows that, in this particular instance, the whole path profile lies well outside this Fresnel clearance curve and the path is therefore likely to be a satisfactory one.

The process just described of using two separate tables of corrections is somewhat tedious, and it is more convenient to transform from the simple rectilinear profile of Fig. 53 by means of a single correction. This can be done by merely adding the h correction given in Table 9.2 to the x correction of Table 9.3 for each distance d_1 . Application of this method to the sample profile is demonstrated in Fig. 58.

This method is much simpler, particularly if tables are available to give the required clearances. Suitable values have been compiled in Table 9.4 for path-lengths increasing from 15 to 50 miles in 5-mile steps. These are for a transmission frequency of 7,150 MHz. To make similar tables for any other frequency, f , it is merely necessary to multiply the Fresnel clearance height by a factor of $\sqrt{7,150/f}$.

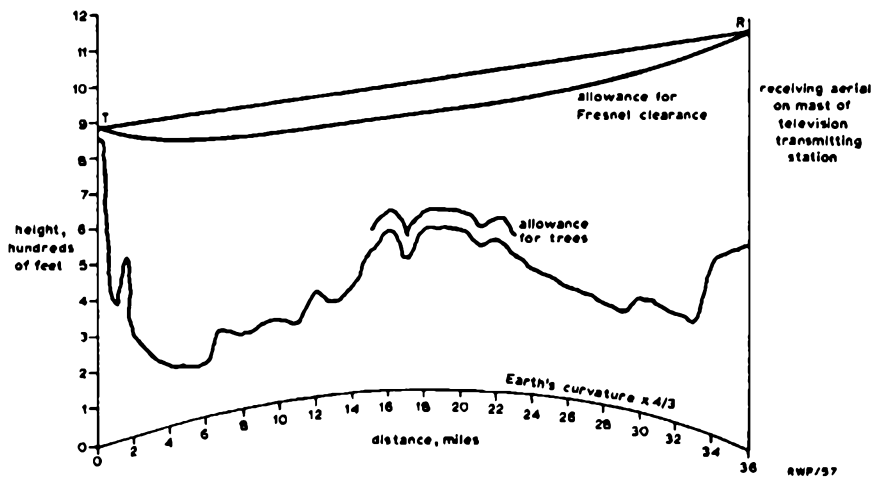

Fig. 57. Sample profile with allowances for earth's curvature and Fresnel clearances shown separately

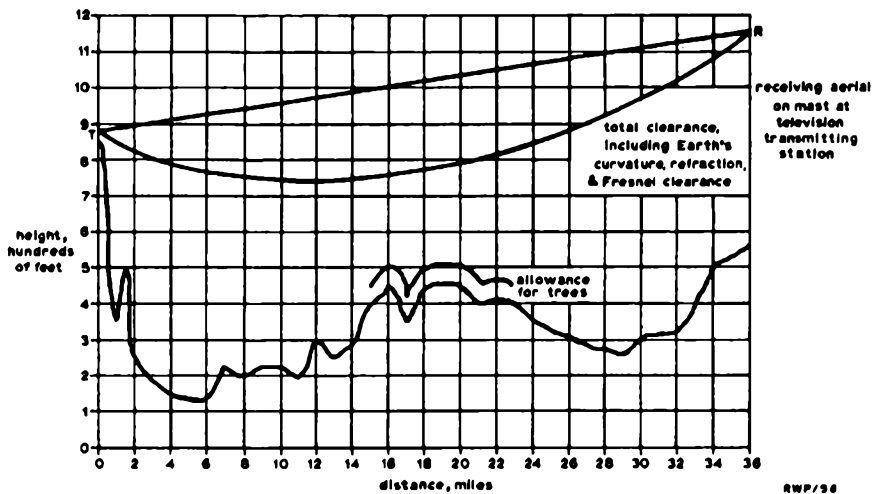

Fig. 58. Sample profile with total clearances made as one allowance

The procedure required to assess the suitability of a transmission path is thus quite straightforward, and is as follows:

1. Locate the proposed terminal positions on the map, and draw a line joining them,
2. On suitably scaled axes such as provided by normal linear graph paper draw a profile, making allowance for trees and buildings as appropriate, and paying particular attention to the extrapolations required to determine the maximum heights of any hills and ridges traversed.
3. Draw a straight line TR on the profile, making allowance for the heights of the aerials above ground.
4. Select the most appropriate section of Table 9.4, i.e., the one for the nearest total path length, and plot the clearances below the line TR.
5. Check that no point on the path profile rises above this clearance curve.

If the path looks reasonable, thought can be given to signal-to-noise ratio. The term 'reasonable' needs some interpretation. If the path length is about 40 miles or so in length, then complete Fresnel clearance as specified in (5) is necessary, and to provide a margin of safety against poor propagation conditions it may even be prudent to plot profiles assuming an earth curvature factor of unity rather than $\frac{4}{3}$. For a 20-mile path, some loss of signal may be tolerated and the profile may just cross the clearance curve into the first Fresnel zone. Even for shorter paths, however, the straight line path TR should not be obstructed. The use of binoculars on a clear day may therefore give a good indication of whether it is worth proceeding to the stage of test transmissions.

9.7 Requirements for Satisfactory Reception Quality

9.7.1 General

We have so far discussed only the preliminary part of a survey, which is to examine the profile to ascertain that the path is free from obstacles. The next step is to ensure that the transmission produces from the receiver an adequate signal-to-noise ratio.

At the levels of power required for satisfactory operation, the transmission path itself may be considered as free from noise, but noise is generated in the receiver. Thermal noise is present in the resistance terminating the input of the receiver and in the input stages.

Noise voltages so produced will modulate the signal, producing both amplitude and phase modulation. The limiter stage in the i.f. amplifier removes most of the amplitude modulation, but the phase modulation will be detected to give an output that is visible on a picture monitor. The degradation of the

TABLE 9.4

**TOTAL CORRECTIONS REQUIRED TO GIVE FIRST
FRESNEL ZONE CLEARANCE AT 7,150 MHz**

Earth Curvature Factor $\frac{4}{3}$

d_1 is miles from nearer terminal

clearance corrections are feet

Path Length 15 Miles

d_1	1	2	3	4	5	6	7
Earth's Curvature	7	13	18	22	25	27	28
Fresnel Clearance	26	36	42	46	49	51	52
Total Clearance	33	49	60	68	74	78	80

Path Length 20 Miles

d_1	1	2	3	4	5	6	7	8	9	10
Earth's Curvature	10	18	26	32	38	42	45	48	50	50
Fresnel Clearance	26	36	43	48	52	55	58	59	60	60
Total Clearance	36	54	69	80	90	97	103	107	110	110

Path Length 25 Miles

d_1	1	2	3	4	5	6	7	8	9	10
Earth's Curvature	12	23	33	42	50	57	63	68	72	75
Fresnel Clearance	26	37	44	50	54	58	61	63	65	66
Total Clearance	38	60	77	92	104	115	124	131	137	141

d_1	11	12
Earth's Curvature	77	78
Fresnel Clearance	67	68
Total Clearance	144	146

Path Length 30 Miles

d_1	1	2	3	4	5	6	7	8	9	10
Earth's Curvature	15	28	41	52	63	72	81	88	95	110
Fresnel Clearance	26	37	44	56	61	65	69	73	75	77
Total Clearance	41	65	85	108	124	137	150	161	170	177

d_1	11	12	13	14	15
Earth's Curvature	105	108	111	112	113
Fresnel Clearance	79	81	81	81	82
Total Clearance	184	189	192	193	195

Path Length 35 Miles

d_1	1	2	3	4	5	6	7	8	9	10
Earth's Curvature	17	33	48	62	75	87	98	108	117	125
Fresnel Clearance	27	37	45	51	56	60	64	67	70	72
Total Clearance	44	70	93	113	131	147	162	175	187	197

d_1	11	12	13	14	15	16	17
Earth's Curvature	132	138	143	147	150	157	158
Fresnel Clearance	74	76	77	78	79	80	81
Total Clearance	206	214	220	225	229	237	239

Path Length 40 Miles

d_1	1	2	3	4	5	6	7	8	9	10
Earth's Curvature	19	38	56	72	88	102	116	128	140	150
Fresnel Clearance	27	37	45	51	56	61	65	68	71	74
Total Clearance	46	75	101	123	144	163	181	196	211	224

d_1	11	12	13	14	15	16	17	18	19	20
Earth's Curvature	160	168	175	182	187	192	196	198	200	200
Fresnel Clearance	76	78	80	81	83	84	84	85	85	85
Total Clearance	236	246	255	263	270	276	280	283	285	285

Path Length 45 Miles

d_1	1	2	3	4	5	6	7	8	9	10
Earth's Curvature	22	43	63	82	100	117	133	148	162	175
Fresnel Clearance	27	37	45	52	57	66	68	70	72	75
Total Clearance	49	80	108	134	157	183	201	218	234	250

d_1	11	12	13	14	15	16	17	18	19	20
Earth's Curvature	187	198	208	217	225	232	238	243	247	250
Fresnel Clearance	78	80	82	84	85	87	88	89	89	90
Total Clearance	265	278	290	301	310	319	326	332	336	340

d_1	21	22	23
Earth's Curvature	252	253	253
Fresnel Clearance	90	91	91
Total Clearance	342	344	344

Path Length 50 Miles

d_1	1	2	3	4	5	6	7	8	9	10
Earth's Curvature	24	48	70	92	113	132	151	168	185	200
Fresnel Clearance	27	38	46	52	57	62	66	70	73	76
Total Clearance	51	86	116	144	170	194	217	238	258	276

d_1	11	12	13	14	15	16	17	18	19	20
Earth's Curvature	215	228	240	252	263	272	281	288	294	300
Fresnel Clearance	79	82	84	86	87	89	90	92	93	94
Total Clearance	294	310	324	338	350	361	371	380	387	394

d_1	21	22	23	24	25
Earth's Curvature	305	308	311	312	312
Fresnel Clearance	94	95	95	95	96
Total Clearance	399	403	406	407	408

signal is denoted by the signal-to-noise ratio, and to establish this it is necessary to determine the signal power at the receiver and to relate this to the noise power generated in the receiver and its terminating resistor.

In practice the measurement of signal-to-noise ratio is a simple routine operation, but to give an understanding of what is involved it is proposed to establish theoretically the standards used in testing s.h.f. links.

9.7.2 Transmission Loss or Path Attenuation

(a) General

The first step in determining the signal-to-noise ratio is to establish the signal power at the receiver. Since the transmitter power is known (even if only nominally) this really means determining the attenuation of the signal over the propagation path.

If a power P_t is radiated by an isotropic aerial, the field-strength E at d metres from this aerial is given by

$$E = \frac{\sqrt{30P_t}}{d} \text{ volts/metre.}$$

The power P_r received by an isotropic aerial is the product of the plane wave power intensity and the effective area of the aerial. (See Section 2.3.)

$$\text{Hence } P_r = \frac{E^2}{120\pi} \times \frac{\lambda^2}{4\pi} .$$

Replacing E^2 by $\frac{30P_t}{d^2}$

$$P_r = \frac{30P_t}{120\pi d^2} \times \frac{\lambda^2}{4\pi},$$

and
$$\frac{P_t}{P_r} = \frac{16\pi^2 d^2}{\lambda^2}.$$

Thus the path attenuation A between isotropic aerials is given in dB by

$$A = 20 \log \frac{4\pi d}{\lambda}$$

this and all subsequent logarithms being taken to the base 10.

This expression is represented in the nomogram of Fig. 59. The value of A is given by the intercept on the attenuation scale of the projected straight line joining points on the frequency and distance scales.

Isotropic aerials are often assumed in calculations for simplicity. In practice such aerials do not exist and in fact at s.h.f. highly directional aerials are used to reduce transmitter power requirements.

If the transmitting and receiving aerials used have gains of G_t and G_r relative to an isotropic aerial, the transmission loss is given by

$$P_t/P_r = 16\pi^2 d^2/\lambda^2 G_t G_r.$$

Expressed in dB form, this becomes

$$10 \log (P_t/P_r) = 20 \log 4\pi + 20 \log d - 20 \log \lambda - g_t - g_r$$

where g_t and g_r are the respective aerial gains in dB relative to an isotropic aerial.

Aerials used at s.h.f. usually consist of slots, dipoles or open-ended waveguides radiating into parabolic reflectors. The gain of these types of aerial is usually determined by the area of the reflector.

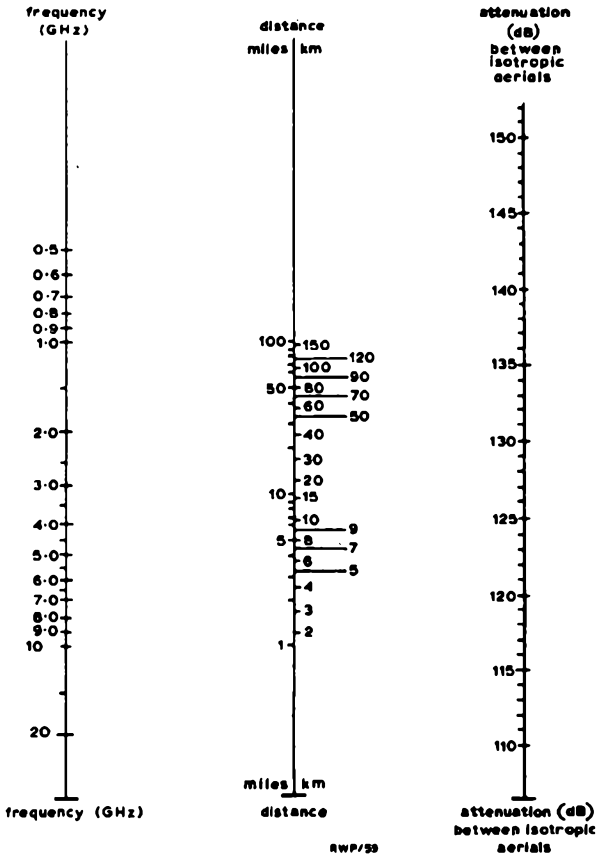

Fig. 59. Nomogram relating attenuation, path length and frequency

The theoretical gain G of a parabolic reflector of area a relative to an isotropic source is given by

$$G = 4\pi a/\lambda^2.$$

If D is the reflector diameter,

$$a = \pi D^2/4$$

and

$$G = (\pi D/\lambda)^2$$

$$= 9.87(D/\lambda)^2.$$

It is more convenient to refer the aerial gain to a half-wave dipole. The gain of a half-wave dipole relative to an isotropic source is 1.64, as discussed in Section 2.2. Hence the theoretical gain of a parabolic reflector with respect to a $\lambda/2$ dipole is given by

$$G' = 6(D/\lambda)^2.$$

In practice, the problems of providing a feed to the parabolic reflector are such that uniform illumination over the whole area is not usually achievable. Account is usually taken of this by assuming a gain relative to a $\lambda/2$ dipole of

$$G'' = 4(D/\lambda)^2.$$

As transmission and reception are reciprocal functions of the aerial, the formulae for G' and G'' relate to both applications.

(b) *Testing of Link Equipment*

If equipment is to be used for a link over a transmission path having first Fresnel zone clearance, the path transmission loss is a function only of path length and frequency and may be derived from the nomogram of Fig. 59. Thus for a 40-mile path at 7,150 MHz the attenuation between isotropic aeriels is 146 dB. If 4-ft paraboloid aeriels are to be used at the terminals,

the gain of each will be given by

$$\begin{aligned} G'' &\simeq 4(D/\lambda)^2 = 4(4 \times 12 \times 2.54)^2/4.2^2 \\ &= 3,360 \text{ relative to a } \lambda/2 \text{ dipole} \end{aligned}$$

or, alternatively, $3,360 \times 1.64 = 5,500$, or +37 dB, relative to an isotropic source.

Hence the net attenuation over this 40-mile path would be

$$146 - (2 \times 37) = 72 \text{ dB.}$$

Consequently, to test the equipment on the bench prior to transporting it to site it is only necessary to insert 72 dB of attenuation between transmitter and receiver to simulate the expected path losses. This is illustrated in Fig. 60.

9.7.3 Signal-to-Noise Ratio Requirements

(a) General

The signal-to-noise power ratio in an a.m. receiver is given by

$$S/N = P_{\text{sig}}/nkTB$$

where P_{sig} is the r.m.s. signal power in the input stage of the receiver, which if the receiver is correctly matched to the receiving aerial is equal to half the power generated in this aerial,

n is the receiver noise factor,

T is the absolute temperature,

k is Boltzmann's constant of 1.38×10^{-23} joules per degree absolute,

B is the effective noise bandwidth of the receiver.

For a frequency modulated system, the effective noise bandwidth is given by $2f_{\text{mod}}$, where f_{mod} is the maximum modulation frequency.

Also, as discussed in Section 8.3.2, with frequency modulation the signal-to-noise ratio is multiplied by a factor of $3(f_{\text{dev}}/f_{\text{mod}})^2$, where f_{dev} is the peak frequency deviation of the carrier from the mean.

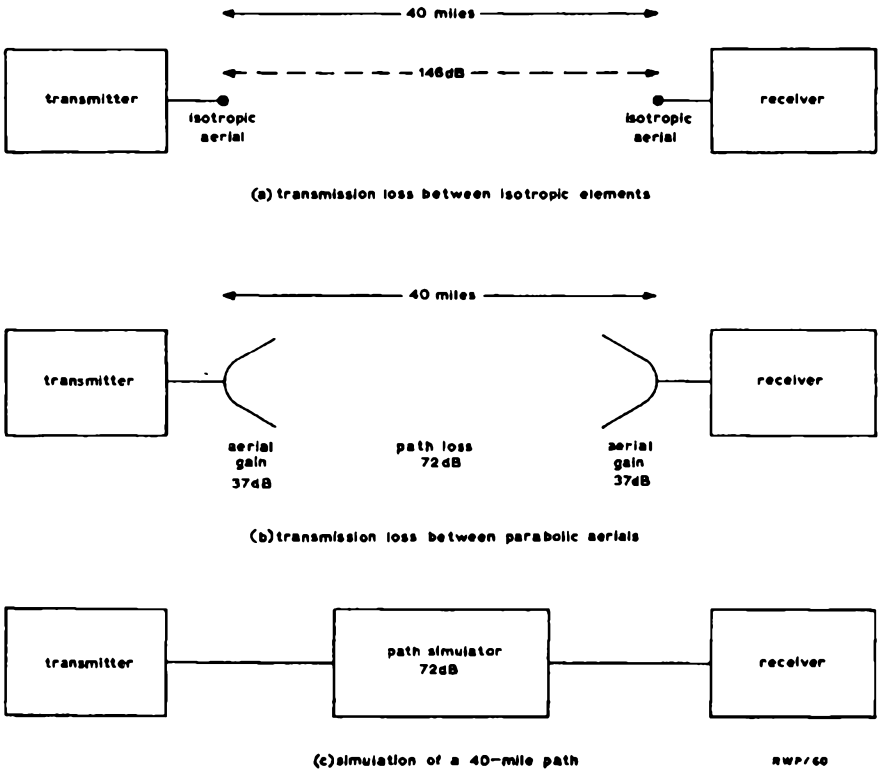

Fig. 60. Path attenuations and simulation of a 7,150-MHz transmission

Thus, the signal-to-noise ratio is given by

$$S/N = \frac{P_{\text{sig}}}{2nkTf_{\text{mod}}} \times 3 \left[\frac{f_{\text{dev}}}{f_{\text{mod}}} \right]^2$$

or, in dB form,

$$S_{\text{rms}} - N_{\text{rms}} = P_s - F - 10 \log \frac{3}{2} kTf_{\text{mod}} + 20 \log (f_{\text{dev}}/f_{\text{mod}}) \text{ dB}$$

where S_{rms} and N_{rms} correspond to the r.m.s. levels of signal power and noise power in dB relative to 1 watt,

P_s is the input signal power in dB relative to 1 watt,

F is $10 \log n$, i.e., the receiver noise factor in dB.

In television work, it is usual to express signal-to-noise ratio as the ratio at video frequency of the peak-to-peak signal amplitude (excluding sync pulses) to the r.m.s. noise amplitude. The peak-to-peak amplitude of the total video signal is $2\sqrt{2}$ times its r.m.s. value, but since the luminance component of signals from peak white to black represents only 0.7 of the total signal, the ratio of peak-to-peak luminance to r.m.s. signal is $2\sqrt{2}/\sqrt{2}$, i.e., 2, which corresponds to 6 dB.

Hence the expression for signal-to-noise ratio may be rewritten as

$$S_{\text{p-p}} - N_{\text{rms}} = P_s - F - 10 \log \frac{3}{2} kTf_{\text{mod}} + 20 \log (f_{\text{dev}}/f_{\text{mod}}) + 6 \text{ dB.}$$

For transmission of 625-line pictures using f.m. the normal standard are maximum deviation frequency, f_{dev} : ± 4 MHz,

maximum modulation frequency, f_{mod} : 5 MHz.

The absolute temperature T is generally taken as 290 degrees.

Whence

$$(S/N)_{625} = P_s - F + 143 \text{ dB.}$$

Similarly, for 405 lines, for which f_{dev} is ± 3 MHz and f_{mod} is 3 MHz,

$$(S/N)_{405} = P_s - F + 147 \text{ dB.}$$

P_s is often expressed in *dB relative to 1 mW* (dBm), rather than in dB relative to 1 watt, in which case the constants in the above expressions are reduced to 113 and 117 respectively.

(b) Noise Weighting Networks

The subjective effect of random noise on an f.m. television link is dependent upon the spectral distribution of the noise power. It follows that two sources of random noise may have equal r.m.s. powers, but not give equal impairments to picture quality. Thus, to fully evaluate the subjective effect of random noise it is desirable to use a noise weighting network designed to ensure that noise sources of equal powers give equal impairments irrespective of their power spectra.

One such network is specified by the CCIR⁽³⁸⁾ and gives a weighting factor of 8.5 dB for noise with a flat spectrum and 16 dB if the spectrum is triangular. The unweighted signal-to-noise formulae previously derived must therefore be correspondingly adjusted if such a weighting network is used.

(c) Minimum Acceptable Signal-to-Noise Ratio for a Single Link

For satisfactory s.h.f. link performance, the signal-to-noise ratio should not be permitted to fall below a certain specified level. The standard recommended by the CCIR⁽³⁸⁾, primarily for fixed links transmitting 625-line pictures, is that the signal-to-weighted-noise ratio should not fall below 52 dB for more than 1% of the time in any month. For white noise, i.e., noise with a flat frequency spectrum, this corresponds to a signal-to-unweighted-noise ratio of about 60 dB. The CCIR figure represents a fairly stringent quality standard, and obviously for temporary links a lower standard may sometimes be accepted, as for example in the case of news and sports items, in which the essence of programme value is topicality.

The minimum receiver input power required to provide a specified signal-to-noise ratio depends on the receiver noise factor. For currently available solid-state equipment⁽⁸⁰⁾ typical receiver noise factors are about 10 dB. Lower values are obtainable by means of devices such as parametric amplifiers and tunnel diodes.

Thus, for a 625-line system, with a receiver noise factor F of 10 dB, and a minimum signal-to-unweighted-noise ratio of 60 dB,

$$(S/N)_{625} = P_s - F + 143$$

$$\begin{aligned}
 \text{or } P_s &= (S/N)_{625} + F - 143 \\
 &= 60 + 10 - 143 \\
 &= -73 \text{ dB relative to 1 watt.}
 \end{aligned}$$

Since P_s is the signal power in the input stage of the receiver, this must, for a correctly matched input, have been produced by a power of $2P_s$ generated in the receiving aerial.

When P_s is -73 dB relative to 1 watt, the power generated in the aerial is thus -70 dB relative to 1 watt, i.e., $0.1 \mu\text{W}$.

After determining the minimum value of received power to be tolerated, it is obviously possible to estimate the required transmitter power and aerial gains, provided the path transmission loss can be estimated. Alternatively, for a given set of s.h.f. link equipment, the maximum path loss and thus the maximum hop length can be specified.

In Section 9.7.2 it was shown that, for a 40-mile path and paraboloid aerials with gains of 37 dB relative to an isotropic source, the net path attenuation at 7.15 GHz was 72 dB. Consequently, to generate a power of -70 dB relative to 1 watt in the receiving aerial, a transmitter power of 2 dB relative to 1 watt is required.

The simulation of a 40-mile path shown in Fig. 60 is therefore a suitable means of testing link equipment having nominal transmitter powers of the order of a watt and operating in the 7-GHz band. The value of attenuation required to simulate the path transmission loss can, of course, easily be adjusted for other values of transmitter power or aerial gain.

(d) *S.H.F. Links in Series*

Often more than one s.h.f. link may be required to transmit programmes from the point of origin to the point of injection into the main distribution network. Similarly, the programme feed distribution from studio centres to the transmitters via the Post Office s.h.f. link network also involves many such links in series. The noise contribution from each link is cumulative, and it therefore follows that the signal-to-noise ratio for the overall path will be poorer than that on any individual link section.

Suppose the transmission system to consist of two links in series having signal-to-noise ratios of N_1 and N_2 dB. The overall signal-to-noise ratio can be found by first calculating the equivalent power ratios P_1 and P_2 .

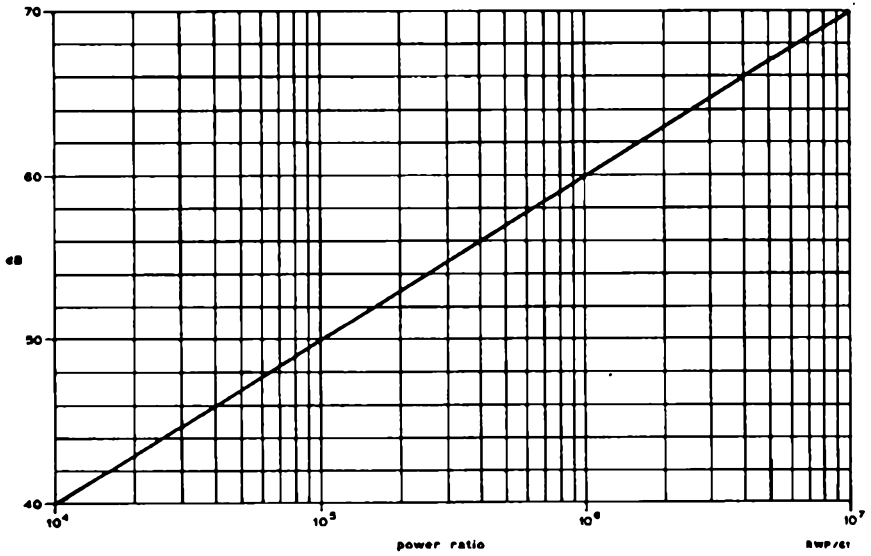

Fig. 61. Relationship between dB and power ratio

The overall signal-to-noise ratio P_3 is then given by

$$1/P_3 = 1/P_1 + 1/P_2.$$

P_3 may be converted back into dB to obtain N_3 .

A curve for conversion from dB to power ratio is given in Fig. 61, the use of which may be explained by the following example.

Example. Three s.h.f. links connected in series have individual signal-to-noise ratios of 54, 56 and 58 dB. Find the overall signal-to-noise ratio.

From Fig. 61, 54 dB corresponds to a power ratio of 2.5×10^5 ,

56 dB corresponds to a power ratio of 4×10^5 ,

58 dB corresponds to a power ratio of 6.3×10^5 .

$$\begin{aligned} \frac{1}{P_4} &= \frac{1}{P_1} + \frac{1}{P_2} + \frac{1}{P_3} \\ &= \frac{1}{2.5 \times 10^5} + \frac{1}{4 \times 10^5} + \frac{1}{6.3 \times 10^5} + \frac{1}{1.23 \times 10^5} \end{aligned}$$

or $P_4 = 1.23 \times 10^5.$

This corresponds to a value of 51 dB for N_4 , the overall signal-to-noise ratio.

(e) *Direct Addition of Noise-to-Signal Ratios*

The need to convert from dB to power ratios and back may be avoided by using Table 9.5 for direct addition of power ratios expressed in dB. The table is based on the fact that it is the noise powers that are additive, and therefore it is the noise-to-signal ratio that is increased with links in series.

For example, if P_{n1} and P_{n2} are the noise-to-signal ratios of two links in series, and

$$P_{n1} - P_{n2} = 1 \text{ dB, where } P_{n1} > P_{n2}$$

and both are expressed in dB relative to the same datum, then, from the table, the noise-to-signal ratio of the series system is given by

$$P_{n(1+2)} - P_{n1} = 2.6 \text{ dB. So } P_{n(1+2)} = P_{n1} + 2.6 \text{ dB.}$$

TABLE 9.5

$P_{n1} - P_{n2}$	0	1	2	3	4	5	6	7	8	9	10	12
$P_{n(1+2)} - P_{n1}$	3.0	2.6	2.1	1.8	1.5	1.2	1.0	0.8	0.6	0.5	0.4	0.3

Example. Three links in series have signal-to-noise ratios of 60 dB, 60 dB and 56 dB. What is the overall signal-to-noise ratio?

Consider the first two links:

$$P_{n1} - P_{n2} = (-60) - (-60) = 0$$

Whence, from the table, the overall noise-to-signal ratio is $-60 + 3$. The overall signal-to-noise ratio of these two links is thus $60 - 3$ or 57 dB.

These two links with an overall signal-to-noise ratio of 57 dB are in series with the third link, which has a signal-to-noise ratio of 56 dB.

$$\text{Hence} \quad (-56) - (-57) = 1$$

and thus the overall noise-to-signal ratio for all three links is

$$-56 + 2.6$$

and the signal-to-noise ratio is

$$56 - 2.6 = 53.4 \text{ dB.}$$

Two points may be noted from the above example:

1. The signal-to-noise ratio of the overall system *must* be lower than that of the worst link.
2. The effective signal-to-noise ratio of two equal stages in series is 3 dB less than that of either stage, since the noise power is doubled.

REFERENCES AND BIBLIOGRAPHY

1. BBC Technical Instruction. T.11. 'Aerial and Feeder Systems for V.H.F. Transmission.'
2. Jordan, E.C. 'Electromagnetic Waves and Radiating System.' Constable.
3. Bleaney, B.J. and Bleaney, B. 'Electricity and Magnetism.' Clarendon Press, Oxford.
4. BBC Engineering Training Supplement No. 10. 'Long Wave and Medium Wave Propagation.'
5. McPetrie, J.S. and Stickland, Miss A.C. 'Reflection Curves and Propagation Characteristics of Radio Waves along the Earth's Surface.' Proc. IEE Vol. 15, No. 45, September 1940.
6. Reed, H.R. and Russell, C.M. 'Ultra High Frequency Propagation.' Chapman and Hall, London.
7. 'Atlas of Radio-wave Propagation Curves for Frequencies between 30 and 1000 Mc/s.' Ministry of Postal Services Report, Radio Research Laboratories, Tokyo.
8. Millington, G. 'Curved Earth Geometric Optics.' Marconi Review No. 80, 1946.
9. Bean, B.R. and Dutton, E.J. 'Radio Meteorology.' N.B.S. Monograph 92, 1966.
10. du Castel, F. 'Tropospheric Radio-wave Propagation beyond the Horizon.' Pergamon Press, 1966.
11. Hacking, K. 'U.H.F. Propagation over Rounded Hills.' Proc. IEE Vol. 117, No. 3, March 1970.
12. Domb, C. and Pryce, M.H.L. 'The Calculation of Field Strengths over a Spherical Earth.' J. IEE 1947, 94, Pt. III.
13. Furutsu, K. 'On the Multiple Diffraction of Electromagnetic Waves by Spherical Mountains.' J. Radio Research Labs. 1956, 3.
14. Millington, G., Hewitt, R. and Immirzi, F.S. 'Double knife-edge Diffraction in Field Strength Predictions.' Proc. IEE 1962, 109C. Also, 'The Fresnel Surface Integral.' Proc. IEE 1962, 109C.
15. Epstein, J. and Peterson, D.W. 'An Experimental Study of Wave Propagation at 850 Mc/s.' Proc. Inst. Radio Engineers 1953, 41.
16. Keller, J.B. 'Geometrical Theory of Diffraction.' J. Optical Soc. America, 1962, 52.
17. Hacking, K. 'Approximate Methods for calculating Multiple-diffraction Losses.' Electronics Letters, 1966, 2.

18. Saxton, J.A. 'Basic Ground Wave Propagation Characteristics in the Frequency Band 50 - 800 Mc/s.' Proc. IEE 101, Part III, 1954.
19. Kinase, A. 'Influences of Terrain Irregularities and Environmental Clutter Surroundings on the Propagation of Broadcasting Waves in the U.H.F. and V.H.F. Bands.' N.H.K. Technical Monograph No.14, March 1969.
20. Hall, M.P.M. and Comer, C.M. 'Statistics of Tropospheric Radio-refractive Index Soundings taken over a 3-year Period in the United Kingdom.' Proc. IEE Vol. 116, No. 5, May 1969.
21. Saxton, J.A. 'The Propagation of Metre Radio Waves beyond the normal Horizon. Pt. 1:—Some Theoretical Considerations with Particular Reference to Propagation over Land.' Proc. IEE 105B, Suppl. 8, 1958.
22. Paltridge, G.W. 'Reflection from Elevated Layers in the Troposphere.' Proc. IEE Vol. 117, No. 1, January 1970.
23. Lane, J.A. 'Small-scale Variations of radio refractive index in the Troposphere. Pt. 1:—Relationship to Meteorological Conditions.' Proc. IEE Vol. 115, No. 9, 1968.
24. Hall, M.P.M. 'V.H.F. Radio Propagation by Double-hop Reflection from a Tropospheric Layer.' Proc. IEE Vol. 115, No. 4, 1968.
25. Hall, M.P.M. 'Further Evidence of V.H.F. Propagation by Successive Reflections from an Elevated Layer in the Troposphere.' Proc. IEE Vol. 115, No. 11, 1968.
26. Smith, E.K. and Matsushita, S. 'Ionospheric Sporadic E.' Pergamon Press, 1962.
27. Lari, G., Tagholm, L.F. and Bell, C.P. 'Research on V.H.F. Ionospheric Propagation (Band I).' E.B.U. Technical Monograph No. 3085-E, August 1967.
28. Tagholm, L.F. and Ross, G.I. 'The Selection and Testing of Sites for Television Transmitters in the U.K.' Proc. IEE Vol. 99, Part IIIA, No. 18, 1952.

29. Kaltbeitzler, K.H. et al. 'Site Selection for V.H.F. and U.H.F. Transmitting Stations.' EBU Technical Monograph No. 3104, 1965.
30. C.C.I.R. Documents of the XIIth Plenary Assembly, New Delhi, 1970. Recommendation 370-1 and Report 239-2. Vol. II, Part 1.
31. Edwards, R. and Durkin, J. 'Computer Prediction of Service Areas for V.H.F. Mobile Radio Networks.' Proc IEE Vol. 116, 1969.
32. C.C.I.R. Documents of the XIIth Plenary Assembly, New Delhi, 1970. Report 425, Vol. II, Part 1.
33. Maurice, R.D.A., Gilbert, M., Newell, G.F. and Spencer, J.G. 'The Visibility of Noise in Television.' BBC Engineering Monograph No. 3, October 1955.
34. Weaver, L.E. 'Subjective Impairment of Television Pictures.' Radio and Electronic Engineer No. 36, 1959.
35. Prosser, R.D. and Allnatt, J.W. 'Subjective Quality of Television Pictures impaired by Random Noise.' Proc. IEE Vol. 112, No. 6, 1965.
36. Allnatt, J.W. and Prosser R.D. 'Subjective Quality of Colour Television Pictures impaired by Random Noise' Proc. IEE Vol. 113 No. 4, 1966.
37. C.C.I.R. Documents of the VIIIth Plenary Assembly, Warsaw, 1956. Recommendation 154.
38. C.C.I.R. Documents of the XIIth Plenary Assembly, New Delhi, 1970. Recommendations 421-2 and 451-1. Vol. 5, Part 2.
39. Swann, G.F. 'The Field Strength Required for the Reception of Television in Bands I, III, IV and V.' Proc. IEE Vol. 106, 1959.
40. C.C.I.R. Documents of the XIIth Plenary Assembly, New Delhi, 1970. Recommendation 417-2. Vol. 5, Part 2.
41. C.C.I.R. Documents of the XIIth Plenary Assembly, New Delhi, 1970. Recommendation 418-2. Vo. 5, Part 2.

42. 'Television U.H.F. Field Trials 1962-3.' BBC, 1965.
43. C.C.I.R. Documents of the XIIth Plenary Assembly, New Delhi, 1970. Recommendation 419. Vol. 5, Part 2.
44. Jowett, J.K.S. 'Television Interference from Sea Reflections.' *Wireless World* Vol. 63, No. 6, June 1957.
45. Sofaer, E. 'Phase-coherent Back-scatter of Radio Waves at the Surface of the Sea.' *Proc. IEE* Vol. 105 B, July 1958.
46. Rider, G.C. 'Fading due to Sea Surface Reflection in Tropospheric Propagation.' IEE Conference publication No. 48, 1968.
47. Laven, P.A. and Bell, C.P. 'The Effect of Tidal Variations upon U.H.F. Television Reception over Short Sea Paths.' International Broadcasting Convention 1970 : IEE Conference Publication.
48. Page, H. and Whythe, D.J. 'Corona and Precipitation Interference in V.H.F. Television.' *Proc. IEE* Vol. 114, No. 5, May 1967.
49. Manson, B.J. 'Clouds, Rain and Rainmaking.' Cambridge University Press, 1962.
50. C.C.I.R. Documents of the XIIth Plenary Assembly, New Delhi, 1970. Report 308-2. Vol. 5, Part 2.
51. Report of the Television Committee. H.M.S.O., 1935.
52. Pawley, E.L.E. 'BBC Television 1939-60 - A Review of Progress.' *Proc. IEE* Vol. 108, Part B, No. 40, July 1961.'
53. Bishop, Sir Harold. 'Twenty-five Years of BBC Television.' BBC Engineering Division Monograph No. 39, October 1961.
54. Wharton, W. and Platts, C.G. 'The Crystal Palace Band-I Transmitting Aerial.' BBC Engineering Division Monograph No. 23, February 1959.
55. Bevan, P.A.T. 'Some Highlights in the Engineering of the Independent Television Service.' *Proc. IEE* Vol. 114, No. 1, January 1967.

56. Report of the Committee on Broadcasting, 1960. H.M.S.O., 1962.
57. IBA Handbook. (Published annually.)
58. Report of the Television Advisory Committee, 1967. H.M.S.O., 1968.
59. Redmond, J. 'Television Broadcasting 1960–70: BBC 625-line Services and the Introduction of Colour.' Proc. IEE Vol. 117, No. 7, August 1970.
60. Report of the Television Committee, 1943. H.M.S.O.
61. 'Television Field Trials of 405-line and 625-line Systems in the U.H.F. and V.H.F. Bands.' BBC, May 1960.
62. Annex 2 of the Final Acts of the European V.H.F./U.H.F. Broadcasting Conference, Stockholm, 1961.
63. Technical Data used by the European V.H.F./U.H.F. Conference, Stockholm 1961. Published by the ITU, Geneva, 1961.
64. Broadcasting. Memorandum on the Report of the Committee on Broadcasting 1960. H.M.S.O. July 1962.
65. 'Television U.H.F. Field Trials 1962–3. Results of Field Trials with 625-line Monochrome and Colour Television Systems: a Contribution to the Planning of a four-programme Transmitter Network.' BBC, 1963.
66. Nolan, S.U. and Wills, R.G. 'A High-power multi-channel U.H.F. Transmitting Aerial.' International Broadcasting Conference: IEE Conference Publication No. 46, Pt. 1, 1968.
67. 'A vertically-polarized transmitting aerial for U.H.F. relay stations.' BBC Research Department Report No. E–122, 1966/74.
68. Beadle, D.G. and Susans, D.E. 'An Active Deflector suitable for U.H.F. Television Transmissions.' International Broadcasting Conference: IEE Conference Publication No. 46, Pt. 1, 1968.

69. Bell, C.P. and Black, R.I. 'The Use of Active Deflectors for U.H.F. Relay Stations.' IEE Conference Publication No. 46, Pt. 1, 1968.
70. Sofaer, E. and Bell, C.P. 'Factors affecting the Propagation and Reception of Broadcasting Signals in the U.H.F. Band.' Proc. IEE Vol. 113, No. 7, 1966.
71. Kirke, H.L. 'Frequency Modulation: BBC Field Trials.' BBC Quarterly, July 1946, Vol. 1, No. 2.
72. Kirke, H.L., Rowden, R.A. and Ross, G.I. 'A V.H.F. Survey on 90 Mc/s.' Proc. IEE Part III, No. 55, Sept. 1951.
73. Hayes, E.W. and Page, H. 'The BBC Sound Broadcasting Service on Very High Frequencies.' Proc. IEE Part B, No. 15, May 1957.
74. Second Report of the Television Advisory Committee, 1952. H.M.S.O., 1954.
75. Sturley, K.R. 'Frequency Modulation.' BBC Engineering Training Supplement No. 9, 1955. (Appendix 3.)
76. C.C.I.R. Documents of the XIIth Plenary Assembly, New Delhi, 1970. Recommendation 412. Vol. V, Part 1.
77. Page, H. and Gouriet, G.G. 'An Experimental Investigation of Motor-vehicle Ignition Interference.' BBC Quarterly Vol. 3, No. 3, October 1948.
78. Stratton, J.A. 'Electromagnetic Theory.' McGraw Hill, 1941.
79. C.C.I.R. Documents of the XIIth Plenary Assembly, New Delhi, 1970. Report 462. Vol. V, Part 1.
80. Anderson, W.N., Brun, G. and Gallagher, J.C. 'Radio-relays for Television.' EBU Technical Monograph No. 3110, 1969.

APPENDIX A

BAND-I TELEVISION STATIONS IN THE UNITED KINGDOM

<i>Chan.</i>	<i>Station</i>	<i>Region</i>	<i>Maximum Power (kW)</i>	<i>Pol</i>
1	Ashkirk	Scotland	18	V
	Ballater	Scotland	0.01	V
	Carmarthen	Wales	0.02	V
	Churchdown Hill	Midland	0.25	H
	Crystal Palace	London and S.E.	200	V
	Divis	Northern Ireland	35	H
	Grantown	Scotland	0.4	H
	Kendal	North West	0.025	H
	Kinlochleven	Scotland	0.005	V
	Llanddona	Wales	6	V
	Llandrindod Wells	Wales	1.5	H
	Llangollen	Wales	0.035	H
	Lochgilphead	Scotland	0.02	V
	Millburn Muir	Scotland	0.01	V
	Penifiler	Scotland	0.025	H
	Pitlochry	Scotland	0.2	H
	Redruth	South West	10	H
	Scarborough	North	0.5	H
	Sheffield	North	0.05	H
	Skegness	North	0.06	H
	Thrumster	Scotland	7	V
	Weardale	North East	0.15	H
	Wensleydale	North	0.02	V
	Weymouth	South	0.05	H

<i>Chan.</i>	<i>Station</i>	<i>Region</i>	<i>Maximum Power (kW)</i>	<i>Pol</i>
2	Ayr	Scotland	0.05	H
	Ballachulish	Scotland	0.1	V
	Brighton	South	0.4	V
	Cambridge	East Anglia	0.1	H
	Cardigan	Wales	0.045	H
	Dundee Law	Scotland	0.01	V
	Hereford	Midlands	0.05	H
	Holme Moss	North	100	V
	Kilvey Hill	Wales	0.5	H
	Londonderry	Northern Ireland	1.5	H
	Oxford	London and S.E.	0.65	H
	North Hessary Tor	South West	15	V
	Port Ellen	Scotland	0.05	V
	Rosemarkie	Scotland	20	H
	Rosneath	Scotland	0.02	V
	Swingate	London and S.E.	1.5	V
	3	Abergavenny	Wales	0.03
Barnstaple		West	0.2	H
Bexhill		London and S.E.	0.15	H
Blaen Plwyf		Wales	3	H
Bressay		Scotland	6	V
Girvan		Scotland	0.02	V
Isles of Scilly		South West	0.02	H
Kilkeel		Northern Ireland	0.025	H
Kirk o' Shotts		Scotland	100	V
Larne		Northern Ireland	0.05	H

<i>Chan.</i>	<i>Station</i>	<i>Region</i>	<i>Maximum Power (kW)</i>	<i>Pol.</i>	
3	Llanelli	Wales	0.015	V	
	Morecambe Bay	North West	5	H	
	Northampton	Midland	0.09	V	
	Richmond	North East	0.045	V	
	Rowridge	South	100	V	
	Rye	London and S.E.	0.05	H	
	Skriaig	Scotland	12	H	
	Swindon	West	0.2	H	
	Tacolneston	East Anglia	45	H	
	4	Ballycastle	Northern Ireland	0.05	H
		Bettws-y-Coed	Wales	0.035	V
Bude		South West	0.1	V	
Folkestone		London and S.E.	0.04	H	
Girvan		Scotland	0.02	V	
Hastings		London and S.E.	0.015	H	
Haverfordwest		Wales	10	H	
Holyhead		Wales	0.01	H	
Hungerford		London and S.E.	0.025	H	
Les Platons		South West	1	H	
Manningtree		East Anglia	5	H	
Meldrum		Scotland	17	H	
Melvaig		Scotland	25	V	
Newry		Northern Ireland	0.03	V	
Oban		Scotland	3	V	

<i>Chan.</i>	<i>Station</i>	<i>Region</i>	<i>Maximum Power (kW)</i>	<i>Pol.</i>
4	Okehampton	South West	0.04	V
	Perth	Scotland	0.025	V
	Sandale	North East	30	H
	Sidmouth	South West	0.03	V
	Sutton Coldfield	Midlands	100	V
	Whitby	North East	0.04	V
5	Aldeburgh	East Anglia	0.025	V
	Bodmin	South West	0.01	H
	Brougher Mountain	Northern Ireland	7	V
	Campbeltown	Scotland	0.5	V
	Canterbury	London and S.E.	0.03	V
	Dolgellau	Wales	0.025	V
	Douglas	North West	3	V
	Eastbourne	London and S.E.	0.05	V
	Ffestiniog	Wales	0.05	H
	Forfar	Scotland	5	V
	Fort William	Scotland	1.5	H
	Kingussie	Scotland	0.035	H
	Machynlleth	Wales	0.05	H
	Maddybenny More	Northern Ireland	0.02	H
	Orkney	Scotland	15	V
	Peterborough	East Anglia	1	H
	Pontop Pike	North East	17	H
	Toward	Scotland	0.25	V
	Ventnor	South	0.01	H
	Wenvoe	West (Wales)	100	V

APPENDIX B

BAND—II F.M. SOUND RADIO TRANSMITTERS IN THE U.K.

(a) National Services (all transmissions horizontally polarised)

Station	Region	Maximum Power (kW)	Frequency (MHz)		
			Radio 2	Radio 3	Radio 4
Ballachulish	Scotland	0.015	88.1	90.3	92.5
Ffestiniog	Wales	0.015			
Llanidloes	Wales	0.005			
North Hessary Tor	South West	60			
Sandale	North East	120	88.1	90.3	94.7
Sandale	Scotland	120			-
Bettws-y-Coed	Wales	0.01	88.2	90.4	92.6
Campbeltown	Scotland	0.35			
Bressay	Scotland	10	88.3	90.5	92.7
Forfar	Scotland	10			
Lochgilphead	Scotland	0.01			
Londonderry	N. Ireland	13	88.3	90.55	92.7
Sutton Coldfield	Midlands	120		90.5	92.7
Wensleydale	North	0.025		90.5	92.7
Douglas	North West	6	88.4	90.6	92.8

<i>Station</i>	<i>Region</i>	<i>Maximum Power (kW)</i>	<i>Frequency (MHz)</i>		
			<i>Radio 2</i>	<i>Radio 3</i>	<i>Radio 4</i>
Barnstaple Carmarthen Pontop Pile Rowridge Skriaig Toward	West Wales North East South Scotland Scotland	0.15 0.01 60 60 10 0.25	88.5	90.7	92.9
Newry Windermere	N. Ireland North	0.03 0.02	88.6	90.8	93.0
Blaen Plwyf Kendal Maddybenny More Meldrum Okehampton	Wales North West N. Ireland Scotland South West	60 0.025 0.03 60 0.015	88.7	90.9	93.1
Bath Belmont Isles of Scilly Kilkeel	West North South West N. Ireland	0.035 8 0.02 0.035	88.8	91.0	93.2
Llangollen	Wales	10	88.85	91.05	93.25
Brecon Brougner Mountain Cambridge Northampton Oban	Wales N. Ireland East Anglia Midlands Scotland	0.01 2.5 0.02 0.06 1.5	88.9	91.1	93.3

<i>Station</i>	<i>Region</i>	<i>Maximum Power (kW)</i>	<i>Frequency (MHz)</i>		
			<i>Radio 2</i>	<i>Radio 3</i>	<i>Radio 4</i>
Ballycastle Churchdown Hill	N.Ireland Midlands	0.04 0.025	89.0	91.2	93.4
Ashkirk	Scotland	18	89.1	91.3	93.5
Kingussie	Scotland	0.035			
Larne	N. Ireland	0.015			
Llandrindod Wells	Wales	1.5			
Melvaig	Scotland	22			
Wrotham	London & S.E.	120			
Pitlochry	Scotland	0.2	89.2	91.4	93.6
Fort William	Scotland	1.5	89.3	91.5	93.7
Haverfordwest	Wales	10			
Holme Moss	North West	120			
Orkney	Scotland	20			
Perth	Scotland	0.015			
Machynlleth	Wales	0.06	89.4	91.6	93.8
Ventnor	South	0.02			
Oxford	London & S.E.	22	89.5	91.7	93.9
Penifiler	Scotland	0.006			

<i>Station</i>	<i>Region</i>	<i>Maximum Power (kW)</i>	<i>Frequency (MHz)</i>		
			<i>Radio 2</i>	<i>Radio 3</i>	<i>Radio 4</i>
Llandona Swaledale Rosemarkie Whitby	Wales North East Scotland North East	12 0.035 12 0.04	89.6	91.8	94.0
Hereford Kinlochleven Tacolneston Redruth Weardale	Midlands Scotland East Anglia South West North East	0.025 0.002 120 9 0.1	89.7	91.9	94.1
Grantown	Scotland	0.35	89.8	92.0	94.2
Kirk o'Shotts Scarborough Sheffield	Scotland North North	120 0.025 0.06	89.9	92.1	94.3
Wenvoe Wenvoe	Wales West	120 120	89.95 -	96.8 -	94.3 92.125
Morecombe Bay Swingate	North West London & S.E.	4 7	90.0 90.0	92.2 92.4	94.4 94.4

<i>Station</i>	<i>Region</i>	<i>Maximum Power (kW)</i>	<i>Frequency (MHz)</i>		
			<i>Radio 2</i>	<i>Radio 3</i>	<i>Radio 4</i>
Brighton	South	0.15	90.1	92.5	94.7
Divis	N. Ireland	60			
Dolgellau	Wales	0.015			
Peterborough	East Anglia	20			
Thrumster	Scotland	10			
Les Platons	South West	1.5	91.1	94.75	97.1

(b) BBC Local Radio Stations

<i>Station</i>	<i>Freq. (MHz)</i>	<i>Max. Power (kW)</i>	<i>Station</i>	<i>Freq. (MHz)</i>	<i>Max. Power (kW)</i>
Sheffield (relay)	88.6	0.03	Birmingham	95.6	5.5
Leeds (Holme Moss)	92.4	5.5**	Carlisle†	95.6	5
Durham†	94.5	2.5	Merseyside	95.8	5
London	94.9	16	Solent	96.1	5
Leicester	95.1	0.3*	Stoke-on-Trent	96.1	2.5
Manchester	95.1	4*	Blackburn	96.4	1.5*
Oxford	95.2	4.5	Derby	96.5	5.5*
Brighton	95.3	0.5	Medway	96.7	5.5
Newcastle	95.4	3.5	Humberside	96.9	4.5
Nottingham	95.4	0.3*	Sheffield		
Bristol	95.5	5	(Holme Moss)	97.4	5.5**

† The Durham station was closed in 1972 and is to be replaced by the Carlisle station.

* Stations operating with slant polarisation. Other stations radiate horizontally polarised transmissions.

** Stations eventually to radiate slant polarised transmissions. Both stations were brought into operation in 1973, the Leeds transmitter replacing an original station at Meanwood Park operating on 94.6 MHz and the Sheffield transmitter permitting an original relay station in Rotherham to be closed.

INDEX

- Abnormalities in the ionosphere 43
- Abnormalities in the troposphere 37
- Abnormal propagation conditions 57
- Acknowledgements v
- Active deflectors 118
- Aircraft, Reflections from 79
- Aerial:
 - Dipole 3
 - Isotropic 3
 - Receiving, directivity and polarisation protection 76
 - Receiving, height gain 21
 - Transmitting 108
- Angle, Grazing 14
- Angle, Pseudo-Brewster 12
- Atmosphere, lower, Effects of conditions in 37
- Atmospheric attenuation 154
- Attenuation, Atmospheric 154
- Attenuation, Path 171
- Band I:
 - network planning considerations 94
 - propagation characteristics 96
 - television broadcasting 94
 - television stations 189
- Band II sound radio transmitters 193
- Band III:
 - network planning considerations 100
 - propagation characteristics and minimum field-strength requirements 102
 - television broadcasting 99
- BBC local radio stations 198
- Beam tilt and gap filling 108
- Belmont 117
- Bibliography 183
- Black Hill 75
- Boltzmann's constant 68
- Brewster angle, Pseudo- 11
- Broadcasting:
 - F.M. sound, 125
 - Stereophonic 138
 - Television, in Band I 94
 - Television, in Band III 99
- Broadcasting:
 - U.H.F. television 105
 - V.H.F. television 91
- Buildings, Reflections from large 76
- Channel operation, Multiple 112
- Channel spacing and protection ratio 132
- Characteristic impedance of free space 8
- Computerised prediction 56, 57
- Corona interference 88, 89
- Curvature, Effect of Earth's 21
- De-emphasis 127
- Deflectors, Active 118
- Delayed image interference 123
- Diffraction 21, 27, 120, 147
 - Effect of 159
- Dipole:
 - aerial 3
 - Gain of, relative to isotropic source 4
 - Half-wave 3
 - Short 3
- Directivity and polarisation, Receiving aerial 76
- Distortion, Multipath 142
- Diurnal and seasonal variations 42
- Diversity reception, Use of 153
- Ducts, Ground-based 40
- Earth's curvature:
 - Allowance for 158
 - Effect of 21
- Effective isotropic radiated power 6
- Effective length of half-wave dipole 4
- Effective radiated power 5
- Elevated temperature and humidity inversions 38
- Examples 53, 79, 109, 119, 120, 142, 150, 181, 182
- Fading, Tidal 84
- Field strength:
 - estimation 47
 - in free space 6
 - curves, Use of 49

- Field strength:**
 predictions for abnormal propagation conditions 57
 received, Effects of terrain on 35
 requirements, Minimum, in Band III 102
- First Fresnel zone** 19
- Free space:**
 Characteristic impedance of 8
 Field strength in 6
 wave 11
- Frequency:**
 Super high 1
 Ultra high 1
 Very high 1
- Frequency allocations** 114
- F.M. sound broadcasting** 125
- F.M. sound radio transmitters, Band-II** 193
- Frequency translation** 72
- Fresnel clearance** 162
- Fresnel zones** 19, 30
- Gain of dipole relative to isotropic source** 4
- Gain, Receiving aerial height** 21
- Gap filling, Beam tilt and** 108
- Grazing angle** 14
- Grazing incidence** 14
- Ground-based ducts** 40
- Ground-reflected wave** 12
- Ground reflections and standing-wave effects** 122
- Half-wave dipole** 3
 Effective length of 4
- Harmonic interference** 74
- Height gain of receiving aerial** 21
- Hills, Reflections from** 76
- Historical** 94, 99, 105, 125
- Horizontal radiation pattern** 5
- Humidity inversions, Elevated** 38
- Image-channel interference** 74
- Image interference, Delayed** 123
- Impedance of free space, Characteristic** 8
- Interference:**
 Corona 88, 89
- Interference:**
 Delayed image 123
 from co-channel stations with the same line-standard 72
 from other television transmitters 71
 from stations operating on different line-standards 72
 Local-oscillator, harmonic and image-channel 74
 Precipitation 88, 89
 Protection against, from other transmissions 141
- Introduction** 1
- Inversions, Elevated temperature and humidity** 38
- Ionisation, Sporadic E** 43
- Ionosphere, Abnormalities in the** 43
- Isotropic aerial** 3
- Isotropic radiated power, Effective** 6
- Isotropic source, Gain of dipole relative to** 4
- Lancashire** 117
- Lapse rate of refractive index** 37
- Lincolnshire** 117
- Link equipment, Testing of** 174
- Lower atmosphere, Effect of** 37
- Local-oscillator interference** 74
- Local radio stations, BBC** 198
- Loss, Transmission** 171
- Microwave links** 1
- Minimum signal-to-noise requirements** 67
- Modulation characteristics** 105
- Modulation index** 130
- Multipath distortion** 142
- Multipath effects** 76
- Multiple channel operation** 112
- National services** 193
- Network planning considerations:**
 Band I 94
 Band III 10
 U.H.F. television 108
- Network, Transmitter** 117
- Noise weighting networks** 178

- Operation, Multiple channel 112
- Path attenuation 171
- Path profiles 155
- Paths, Proposed transmission 155
- Polarisation, Choice of plane of 135
- Polarisation protection, Receiving aerial directivity and 76
- Power, Effective radiated 5
isotropic 6
- Precipitation interference 88, 89
- Prediction:
for a specific path 55
Fully computerised 56
- Pre-emphasis 127
- Profiles, Path 155
- Propagation characteristics:
at u.h.f. 120
in Band I 96
in Band III (and minimum field-strength requirements) 102
of v.h.f. and u.h.f. signals in the presence of the ground 11
S.H.F. 147
under abnormal conditions 37
under normal conditions 11
- Proposed transmission paths 155
- Protection against interference from other transmissions 141
- Protection ratio 71
Channel spacing and 132
- Pseudo-Brewster angle 12
- Radiated power, Effective 5
isotropic 6
- Radiation pattern, Horizontal 5
- Radio reception, Requirements for satisfactory v.h.f. 128
- Radio stations, BBC local 198
- Radio transmitters, Band-II f.m. sound 193
- Ratio, Protection 71, 132
- Rayleigh criterion 148
- Received field strength, Other effects of terrain on 35
- Receiving aerial directivity and polarisation protection 76
- Receiving aerial height gain 21
- Reception:
Diversity 153
Requirements for satisfactory quality 167
Requirements for satisfactory television 67
Requirements for satisfactory v.h.f. radio 128
- References 183
- Reflections 148
from aircraft 79
from hills or large buildings 76
from the surface of the sea 81
Ground 122
Service impairments due to 142
- Refraction 21, 22
- Refractive index:
lapse rate 37
Variations in 153
- Scattering, Troposcopic 42
- Scotland 75
- Sea, Reflections from the surface of 81
- Seasonal variations 42
- Second Fresnel zone 19
- Service area field-strength predictions 47
- Service impairments due to reflections 142
- Short dipole 3
- Signal propagation:
under abnormal conditions 37
under normal conditions 11
- Signal-to-noise ratio:
for a single link 178
requirements 67, 128, 175
- Signal-to-noise ratios, Direct addition of 181
- Sound broadcasting, Frequency modulated 125
- Sound radio transmitters, Band-II f.m. 193
- South Wales 118
- Specific path, Prediction for a 55
- Sporadic E ionisation 43

- Standing-wave effects 122
- Stereophonic broadcasting 138
- Stockholm plan 117
- Stratosphere 22
- Sub-refraction 27
- Super high frequency 1
 - links in series 179
 - propagation 147
- Super-refraction 27, 40
- Sutton Coldfield 75

- Television broadcasting:
 - in Band I 94
 - in Band III 99
 - U.H.F. 105
 - V.H.F. 91
- Television:
 - Requirements for satisfactory reception of 67
 - Band-I stations 189
 - transmitters, Interference from other 71
- Temperature inversion 38
- Terrain, Effects of, on received field strength 35
- Tidal fading 84
- Translation, Frequency 72
- Transmission:
 - and modulation characteristics 105
 - and reception 3
 - and network planning considerations for u.h.f. television 108
 - loss or path attenuation 171
 - paths, Proposed 155
- Transmitter network 117
- Transmitters:
 - Band-II f.m. sound radio 193
 - Interference from other television 71
- Transmitting aerials 108
- Tropopause 22
- Troposcopic scattering 42
- Troposphere 22
 - Abnormalities in the 37

- Ultra high frequency 1
 - propagation 120
 - propagation in the presence of the ground 11
 - television broadcasting 105

- Venetian blind effect 72
- Very high frequency 1
 - propagation in the presence of the ground 11
 - radio reception 128
 - television broadcasting 91

- Wales, South 118
- Wave, Free-space 11
- Wave, Ground-reflected 12
- Weighting networks, Noise 178
- Wenvoe 118
- Winter Hill 118

- Zones, Fresnel 19, 30

