

Radio & Electronics

The communications and electronics magazine

World

**HAMS:
ANCIENT AND MODERN**

**DATA FILE:
ACOUSTIC ALARM
GENERATOR CIRCUITS**

**NETWORK 934
MEDIUM WAVE DXING
AMATEUR RADIO WORLD**



World Radio History

SCANNER CORNER

CHALLENGER BJ200 Mk 2 HF/VHF scanning receiver. Our most popular scanner! 26-520 MHz (with some gaps) - 16 memory channels, search scan, priority and delay - covers civil and most military bands complete with free Raycom air band antenna.
£189.00 plus £10.00 post/packing

SONY AIR-7 AIR/PMR/VHF/AM scanner. 150 KHz - 2.2 MHz, 88-108 MHz, 108-136 MHz and 144-174 MHz. A quality sensitive hand scanner with good sound, 10 memories per band, priority and delay functions.
£249.00 plus £10.00 post/packing

SONY PRO-80 AIR/PMR/VHF/AM scanner. The executive version of the AIR-7. More features, functions and more coverage.
£349.00 plus £10.00 post/packing

BEARCAT BC55 XLT starter scanner. 29-54 MHz, 136-174 MHz and 406-512 MHz. 10 memories. An ideal first unit.
£99.99 plus £10.00 post/packing

BEARCAT BC100 XLT pro scanner, as the BC200 XLT (see above) but without 950 MHz. This is real value at **£179.99 plus £10.00 post/packing**

MOBILE

ICOM 3210E DUAL BAND MOBILE, 144/430 MHz, simple to use but sounds good on the air and packed with too many features to list. We both use one so it has to be good.
£499.00 plus £10.00 post/packing

ICOM 3200E 144/430 MHz DUAL BAND MOBILE package. 25W on both bands, 10 memories and built in duplexer, this rig was selling at over £500 not long ago! A real bargain, and with a free dual band antenna.
£399.00 plus £10.00 post/packing
RAYCOM modded version for boom mics with tone on front panel at £419.00 plus £10.00 post/packing

RAYCOM COMMUNICATIONS SYSTEMS LIMITED
INTERNATIONAL HOUSE, 963 WOLVERHAMPTON RD,
OLDBURY, WEST MIDLANDS B69 4RJ.
TEL 021-544-6767, Fax 021-544-7124, Telex 336483.

RAYCOM gives you MORE PURCHASING POWER

ALL MAJOR CREDIT CARDS ACCEPTED. BC, ACCESS, DINERS. INSTANT CREDIT UP TO £1000 (SUBJECT TO STATUS) WITH RAYCOM CREDIT CARD. FREE CREDIT ON CERTAIN ITEMS AT M.R.P. CALL NOW FOR APPLICATION FORMS AND MORE DETAILS.

TEL: 021-544-6767

FULL RANGE OF ICOM, YAESU, BEARCAT, MFJ, BUTTERNUT, CUSHCRAFT, AEA, NAVICO, TONNA, TEN-TEC, WELZ IN STOCK. MOST PRODUCTS YOU SEE IN THIS MAG ARE AVAILABLE AT RAYCOM. PLUS OUR SPECIAL PACKAGE DEALS. CALL US NOW FOR DETAILS OR SEND LARGE SAE!

NAVICO AMR1000/S 144 MHz mobile transceiver. A highly intelligent and well thought out rig, it mounts just about anywhere and features auto tone burst, proper repeater channelling. Excellent results on our Marconi tester. Well worth a look at. Prices from **£247.25 plus £10.00 post/packing**

HF/VHF/UHF RX/TRX

ICOM ICR7000 V/UHF The ultimate in receivers, all mode 25-1300 MHz (2 GHz) with free Royal 1300 discone
£925.00 plus £10.00 post/packing

ICOM ICR71 SW Receiver covers all short wave bands. For the serious listener, with free short wave antenna
£825.00 plus £10.00 post/packing

YAESU FT747GX All band/mode transceiver with RAYCOM Mk. 2 mod for better RX performance. 120W TX, general coverage RX and free 20 amp regulated PSU. A great TRX package
£725.00 plus £10.00 post/packing

YAESU FRG9600 with the famous Raycom modifications. Supplied with free Royal 1300 discone and free mains psu. We really make them perform. Why not let us mod your 9600? **Mark 2, 60-950 MHz + tweaked RX! £545.00 plus £10.00 post/packing**
Mark 5, 100 KHz-950MHz plus 'N' connector plus active front end £699.00 plus £10.00 post/packing
Your '9600 modded to Mark 2 £40.00 plus £10.00 post/packing
Your '9600 modded to Mark 5 £129.00 plus £10.00 post/packing
(2-3 week turnaround subject to parts)

TEN-TEC PARAGON. A fine transceiver from one of the worlds best. A world-class rig you must come in and try out. 100w all mode, general coverage receiver. Computer i/f and voice module optional.
£1898.00 plus £10.00 post/packing

We stock much more than we can possibly list here. Please call us if you don't see what you want or if you would like a detailed price list of our products.

EASTER MADNESS!

FOR ONE MONTH ONLY!

Bearcat BC200xLT

THE BEST HANDHELD VHF/UHF SCANNER.

£199.99

Save £50 on current MRP!
Bearcat 100xLT as above less 950 MHz only £179.99
PLUS £10.00 post/packing
This offer cannot be repeated!

COVERS 29 TO 956MHz (with some gaps). Covers all popular VHF/UHF PMR, Amateur, Air Band, Marine, Cellular and many other interesting frequencies. *200 Memory Channels. Complete with helical, detachable Ni-Cad pack and charger. Green keyboard/display nightlight. Super fast scan and search mode.* Free where-to-listen guide and backed by Raycom scanner expertise and service.

RAYCOM NEWS BOX

Lots happening at Raycom! We are now stockists of the HRS range of Cushcraft and Butternut antennas, MFJ accessories and Packet terminals. See the TEN-TEC Paragon HF TRX and have a go. It's a beauty! - We are now stocking AEA PK-232 Packet terminals and software - **RAYCOM goes digital!** - We are now carrying NAVICO VHF mobiles. A nicely designed rig from the marine radio specialists, worth a look. - New Yaesu handhelds in stock, little beauties and best designed HT we have seen for a while. Look for a RAYCOM special mod for this one. - ICOM 725's now in stock, this will be a winner with the same type of DDS synth system as the IC781. *Don't buy an HF rig without looking at it.* - We always look around for good scanners. Watch this space! 50-950 MHz plus Pan Display! - New ICOM mobiles and HT's on the horizon. - Re-organisation in our service and shipping departments to improve service turnaround. - If you need anything to do with radio please call us, if we haven't got it we can probably get it! - We have thousands of items too numerous to list here. - We are always looking for used kit and will give you a good part exchange on new equipment. - We are SONY dealers and carry a wide range of their quality receivers and scanners. - **Don't forget we are now open again Thursdays,** and late Friday until 7 pm. - ICOM 3200 with tone button mod now available for headset use at £419 plus carriage. Raynet modded 3210 available - call.

ANTENNA FARM

10-3CD	3-ele 10m	£115.04
R4 vert.	10/15/20	£219.00
AV4	4-band	£104.58
Ranger	VHF	£42.95
Ranger	UHF	£42.73
HF6V	5-band	£159.00
SC3000	Scanner	£63.99
70N2DX	Mobile dual	£37.00
G5RV	Full size	£16.95
G5RV	Half size	£14.95
R1300	Discone	£59.50

STOP PRESS! TCL Professional dipole kits. Complete with all fittings and guys. 1-30 MHz coverage.

TCLDSB	Single band	£69.95
TCLDDB	Dual band	£99.95

This is only part of our stock of HF, VHF, UHF and mobile antennas. We also carry a wide range of accessories for antennas. Call for info or drop in for free advice! And of course, there's always our famous ROYAL 1300 discone (improved spec. over ICOM AH7000/Diamond D109) still at **£59.50 plus £5.00 post/packing.**

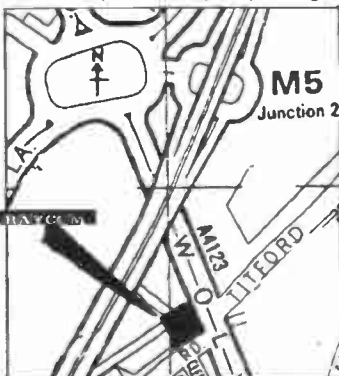

ORDERING INFORMATION

ALL PRODUCTS SHOWN ARE NORMAL STOCK ITEMS. PHONE BEFORE 4 P.M. FOR NEXT DAY DELIVERY. MAIL ORDER PLEASE INCLUDE CARRIAGE AND PHONE NUMBER. ITEMS OVER £750 CARRIAGE FREE. PLEASE ALLOW TIME FOR PERSONAL CHEQUES TO CLEAR. MANY OTHER ITEMS IN STOCK. PLEASE CALL FOR MORE INFORMATION AND FOR EXTRA SPECIAL DEALS.

INFOLINE 0836-282228
5-9 pm (weekdays only)

STOP PRESS! DUE TO POPULAR DEMAND WE ARE OPEN THURSDAYS AGAIN. OPENING HOURS ARE NOW 9-5 MONDAY TO SATURDAY, LATE NIGHTS 'TIL 7 PM ON FRIDAY. 73 DE RAY G4KZH AND JIM G8ZMP.

RAYCOM

COMMUNICATIONS SYSTEMS LIMITED

FOR THE BEST IN AMATEUR RADIO

RAYCOM are authorised dealer/distributors for all of the products we sell.

CONTENTS

- 4 The Age of the Valve
- 6 Data File
- 14 DX-TV Reception Reports
- 20 ATV on the Air
- 21 Network 934
- 23 Hams : Ancient and Modern
- 24 Short Wave News
- 26 Amateur Radio World
- 27 Advertisers Index
- 28 Medium Wave DXing
- 30 Spectrum Watch
- 31 Free Classified Ads
- 34 Advertising Rates and Information

ON THE COVER

This month's cover shows **top**: the OX725 20MHz oscilloscope from ITT Instruments; combining a variable-delayed sweep function, X/Y mode, Z-input, beamfinder and variable hold-off. For full details tel: (0753) 824131. **Bottom**: the Lloyd Graphic 450 single pen chart recorder; features include full-scale deflection in four ranges, eleven electronically controlled chart speeds between 10mm/per second and 0.1mm/per minute, and a common-mode rejection ratio of 100dB minimum at dc and 90dB at 50 to 60MHz. Available from Reltech Instruments. Tel: (0480) 63570

Editorial

Iain Mackenzie
Penny Phillips

Advertisement Manager
Marian Vidler

Advertisement Executive
Maria Smith

Publisher
Peter Williams

Published by
Radio & Electronics World
Magazines
Sovereign House
Brentwood, Essex.
CM14 4SE, England
Tel: (0277) 219876

ISSN
0262-2572

Printed
In Great Britain

Newstrade sales

S M Distribution
6 Leigham Court Road
Streatham, London SW16
2PG. Tel: 01-677 8111

Subscriptions

Tel: 01-684 9542

© Copyright 1989
Radio & Electronics World Magazines

Safety in the shack

Some of the constructional projects featured refer to additions or modifications to equipment; please note that such alterations may prevent the item from being used in its intended role, and also that its guarantee may be invalidated.

When building any constructional project, bear in mind that sometimes high voltages are involved. Avoid even the slightest risk - safety in the shack please, at all times.

Whilst every care is taken when accepting advertisements we cannot accept responsibility for unsatisfactory transactions. We will, however, thoroughly investigate any complaints.

The views expressed by contributors are not necessarily those of the publishers.
Every care is taken by **RADIO AND ELECTRONICS WORLD** to ensure that the information given to our readers is reliable. We cannot however guarantee it and we cannot assume legal responsibility for it nor for any effects howsoever caused.

NEVADA

THE UK'S SCANNER SPECIALISTS



BLACK JAGUAR MkIII

The new Mark III is probably our most popular handheld scanner with 16 channels of memory and a sensitive receiver. Selectable AM or FM reception and the facility to power the set from the mains or car using one of the many accessories now available.

Frequencies: 28-30 MHz, 50-88 MHz, 115-178 MHz, 200-280 MHz, 360-520 MHz.

£199 NEW LOW PRICE

Black Jaguar Accessories

(suitable for all models, BJ200, Challenger etc.)
Mobile Mount £6.95
Base Mount £5.95
BJ1 Car Supply (Mk III version only) £14.95
BCA6 Mains Slow/Fast Charger £14.95
Airband Rubber Duck Antenna £6.00
SA7 UHF Stub Antenna £4.95

We are the UK Distributors for Bearcat Scanners Handheld Scanners

Bearcat 55 XLT	£99.00
Bearcat 70 XLT	£149.99
Bearcat 100 XL	£189.99
Bearcat 100 XLT	£199.99
Bearcat 200 XLT (including 900 MHz)	£249.00
Base/Mobile Scanners	
Bearcat 175 XLT	£169.99
Bearcat 210 XLW	£179.99
Bearcat 580 XLT	£199.00
Bearcat 800 XLT (including 900 MHz)	£229.00
Bearcat 950 XLT (including 900 MHz)	£269.00

NEW MODELS

COBRA SR925 Base Receiver - Ideal for aircraft enthusiasts. Covers 29-54 MHz, 118-174 MHz, 406-512 MHz	£149.00
AOR 800 Handheld with 900 MHz	£199.00
AOR 900 Handheld with 900 MHz	£235.00
AOR 2002 Base with full coverage	£487.00
AOR 3000 New Broadband Base Model	P. O. A.
SAB9 MW and Airband Handheld	£19.95
Sony Air 7 Handheld - Airband	£249.95
Sony Pro 80 Handheld - Wide band	£349.95

NEW LOW LOSS JAPANESE COAX

Essential for best performance with wideband UHF scanners. We have directly imported this cable which has exceptional low loss.

Frequency	5D	8D	10D
Loss/mtr @ 100 MHz (dB)	0.055	0.039	0.031
Loss/mtr @ 400 MHz (dB)	0.121	0.085	0.068
Loss/mtr @ 1 GHz (dB)	0.187	0.130	0.105
Price per meter	£0.56	£1.40	£1.99

DISCONE ANTENNAS - New British Made Antennas

Nevada WB1300 (25-1300 MHz)
Wideband Top of the range
stainless steel £59.95

Nevada Discone
(50-700 MHz)
High Quality
8 Element
£24.00



USE YOUR CREDIT CARD FOR IMMEDIATE DESPATCH

HOTLINE (0705) 662145

NEVADA COMMUNICATIONS

189 London Road, North End,
Portsmouth PO2 9AE. Telex: 869107

THE AGE OF THE VALVE

Ian Poole takes a nostalgic look at the advantages and performance of valves and circuits

Like the passing of the Steam Age, valves are missed by many people. Although the performance of the small multi-legged devices which adorn our equipment today is better, valves will never be properly replaced. The 'atmosphere' generated by listening to a large, warm receiver is unique. The dull red glow of the valves and the gentle odour from the dust on hot glass contribute to the fond memories of many amateurs. Unfortunately, many of today's amateurs have had little or no experience of valves, so their advantages, even today, may not be recognised. In fact, many people will look up in amazement if the idea of using valves is ever put to them.

Some may look back at the old valve days and breathe a sigh of relief. The thought of all that metalwork was sometimes enough to deter amateurs from constructional projects. A large hole had to be cut in the chassis for each valve, and then all the other holes had to be cut for tag strips, etc.

The voltages which were used were another disadvantage. The HT (high tension) line had about 250V in a receiver and higher voltages were used in transmitters. With voltages like these

around, it was necessary to be very careful. Most old-timers will have a few good stories of receiving nasty shocks or seeing sparks fly after dropping a screwdriver into the works.

Advantages

Not everything was that bad. Many people look back on those days and remember the advantages of valves. Basically, they worked well. It is a sobering thought that in spite of all the advancements made with semiconductors and ICs, many valve receivers compare favourably with today's equipment.

One of the first advantages was the robustness of valves. This is particularly true when they were used in PA stages. Unlike today's transistors which are prone to sudden death from exceeding their ratings, valves were capable of enduring quite a lot of punishment. There are many stories of people excessively loading valves, hearing them groan and, after removing the load, finding that no damage was done. There is a story of someone putting 1500V on a pair of 807s in a linear amplifier (their maximum is only 600V). After using it for a

while and watching the valves glow blue, it still worked perfectly well with the correct voltage afterwards.

Valves were also very resilient to being overloaded when used in receivers. In receiver front ends their intermodulation performance was much better than in transistors; it was a long time before semiconductor design could compete with valves in this area.

Another advantage was the ease with which a faulty valve could be replaced. As it was so easy to swap valves around, it was common practice to do some 'bottle swapping' and change some valves to see if it made any difference.

Whenever there was a problem with valve circuits, it was usually a wiring error which could be easily resolved. There seemed to be fewer problems with circuits oscillating, but if they did there were a few standard 'fixes' which invariably worked.

Building circuits

The circuits which had to be used were often more complicated than some of today's simpler transistor circuits. Valves with screen and suppressor grids were popular because they offered

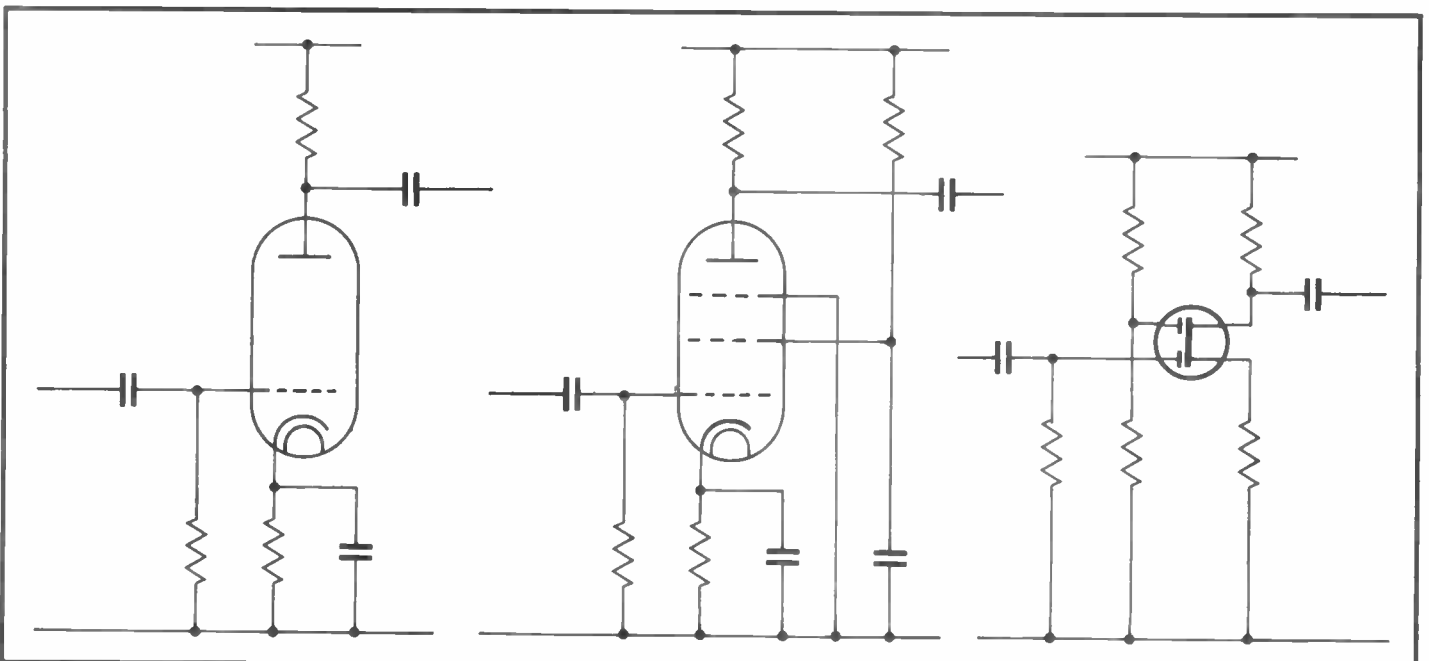

Fig 1 a, b and c

higher gain, better stability and generally an improved performance. Using extra grids meant that more resistors and capacitors were needed over the basic triode circuit as shown in Fig 1. The use of dual gate FETs over the more usual single gate devices is probably today's equivalent.

Apart from the extra grids, the heater circuit also had to be taken into consideration. The wires had to be routed so that they did not induce hum into sensitive areas. This often required twisting the two wires and occasionally running the heaters off a 6.3V supply earthed via a centre tap in the transformer. This meant that the heater supply was effectively balanced.

The main hurdle was always the metalwork. Fortunately, for some major projects such as the G2DAF transmitters and receivers, it was possible to buy a ready-drilled chassis. This made tackling a difficult project far more tolerable, especially for anyone without workshop facilities. After completing the metalwork, all that was left to do was bolt everything on and methodically finish wiring the circuit.

The wiring may seem to be a mammoth task by today's standards, but when tackled stage-by-stage it was surprising

how quickly it went. Some projects even looked like works of art with the resistors and capacitors all neatly bent into position and the wires properly loomed. A very different technology to that used today and far more labour intensive, but even so it worked well.

Favourite valves

Many people will be able to look back and remember some of their favourite valves. Probably most people will think of their transmitter PA bottles. The trusty 807 must be the most famous. This was a development of the even more well-known 6L6 which was first made in the late 1930s. In fact, the 807 was manufactured before the Second World War. However, it was during the war that a vast number of 807s was produced. Many of them went into the legendary 19 sets. After the end of the war these valves flooded on to the surplus market. This means that almost every radio amateur must have built a transmitter using one of these valves. They were cheap, reliable and produced a useful amount of RF.

Other valves eventually usurped the position of the 807. The 6146 was introduced and used in many designs. First it was used in its basic form and later the improved 6146B was introduced,

which had slightly higher ratings.

Of course many other valves will also be remembered. For example, the ECC81, 82 and 83 series. They must be the equivalent of the BC107 as general-purpose devices. They were very often used as low level audio devices, although they found their way into many other circuits as well. Other familiar valves included the EF80 and EF91. These general-purpose pentodes were reliable work-horses and could be found in all types of circuits.

The age of valves may have passed and the semiconductor era may be with us for a long time to come. In spite of this, valves earned their keep for over sixty years, enabling radio technology to be where it is today.

The May issue of
**Radio and
Electronics World**
will be on sale:
Thursday
13 April 1989

Component Source

USA Mil Spec
Transformers, Power Supplies, Fans, Connectors, Capacitors, Semiconductors.

UK Mil Spec
RF Power, JANTX, Diodes, Resistors, Lamps, Crystals, Electron Tubes, Relays, Circuit Brakers, Fuses.

COMPONENT SOURCE - THE ONE STOP SOURCE FOR ALL MIL SPEC ELECTRONICS

5 Brougham Road, Worthing, West Sussex BN11 2NP.

Telephone:
National - Worthing (0903) 208560
International - 44 903 208560

Telex: 878500 Source G. Fax: (0903) 211705

HIGH QUALITY Electronic Components LOW PRICES

Order code	Quantity of parts	Pack description - all K packs are just £1 each - all parts brand new		
K1	400	Mixed resistors, mostly 1/2-1 watt	K34	1
K2	50	Mixed power/wirewound resistors	K35	5
K3	50	Mixed electrolytic capacitors	K36	5
K4	100	Mixed polyester capacitors	K37	50
K5	200	Mixed capacitors, all types/values	K39	7
K6	200	Mixed mica & ceramic capacitors	K42	20
K7	100	Mixed diodes, silicon & germanium	K51	10
K8	40	Mixed transistors, fantastic value	K54	10
K9	25	Mixed pots & presets, very popular	K55	10
K10	100+	Workwires, eg knobs, grommets, clips	K57	1
K14	12	Wirewound potentiometers, good mix	K65	1
K16	5	Fuseholders, of least 3 different	K66	6
K17	25	EHT capacitors, mostly 8kV wkg	K67	6
K18	1	Mullard RPY20 light dependent resistor	K69	100
K24	25	Mixed zener diodes, type numbers marked	K70	5
K25	3	Red LED displays, 7 seg, data	K76	20
K29	50	OC71 transistors, nice long leads	K80	20
K30	3	Microswitches with long lever arm		

More packs available - ask for our free list

TRANSISTORS	DIODES	74LS280 .49p	OPERATIONAL AMP. FIBRES	Components - twin section electrolytics
2N2223 .£7.50	1N270 .10p	CMOS 4000	709 (TO99) .29p	5.000+5.000µF/25V 9.6A ripple .45p ea
BC393 .50p	1N541 .9p	HCC4002 .14p	741 (14 DIL) .12p	7.500+7.500µF/14V 10.5A ripple .80p ea
BD375 .39p	1N3062 .12p	HCF4051 .44p	747 (14 DIL) .49p	11.000+11.000µF/16V 13.6A ripple .60p ea
BD376 .29p	1N3605 .9p	MICRO CPU		16.500+16.500µF/10V 13.4A ripple .75p ea
BD710 .79p	AA116 .12p	EF6800P .£2.50		Mixed dielectric caps 1.0µF/600V .30p
BDX33B .64p	BAK13 .4p	EF6800P .£4.90	COMPARATORS	Metalised film capacitors 1.0µF/250V .6 for £1
BDY53P .£1.30	OA91 .4p	EF6803P .£4.50	311 (TO99) .45p	Potentiometers
BF393 .50p	OA95 .9p	16 BIT CPU		Panel mounting, integral knob, 100 ohm or 100k or 10 Meg (oil linear) .10 for £2.25
BR39 .14p	SFD49 .9p	Z8002AD2 .£45	POWER DIODES	25k Log. carbon .10 for £2.00
BU911 .90p	IC EPROMS		1K In, 2 watt, wirewound .10 for £2.00	Copperclad circuit boards, stripboards like
BU912 .90p	2716 .£1.99	CRT CONTROL	BYX62-600 £2.25	Yero but unpunctured, 3 sizes
OC71 .24p	2764 .£1.99	EF9365C .£24	BYX67-600 .£2.30	A: 100x125mm, 0.1 or 0.15in pitch .25p
TP31C .24p	27128 .£2.49	INTERFACE		B: 70x125mm, 0.1 or 0.15in pitch .20p
TP110 .10p	74LS LOGIC	AM26LS32 .£1.15	TRIYSTORS	C: 65x95mm, 0.15in pitch .7 for £1
TP111 .44p	74LS10 .20p	REGULATORS	BYR54-400T .28p	Sound effects module - incredible value
TP112 .39p	74LS30 .20p	2815 (1A) .29p	BTW27-200R .55p	A ready assembled PCB complete with on-board microprocessor which is programmed with a wide variety of sound effects: eg steam train, limphone, police siren, music notes etc. etc. Built-in audio amplifier. Just add loudspeaker, TV battery and a few switches or keypad. Only £4.99 with Data Sheet!
TP115 .44p	74LS40 .20p	SPECIAL IC		
TP116 .44p	74LS42 .20p	TDA1151 .29p	ZENER DIODES	
TP117 .44p	74LS54 .20p	TDA1670 .£1.99	400mW most .5p	
TP131 .44p	74LS175 .44p	GRAMS 450NS	1 watt most .10p	
TP132 .45p	74LS195 .80p	SFF82114J .£4.30	10W, 36V .95p	
TP133 .45p	74LS259 .69p			
RF120 .£1.39				

Valves. Brand new, boxed quality valves - just a selection from our vast stocks. Many rarities and 'antiques' available.

6AT6 .85p	CV4006 .£3.60	EB91 .48p	ECC91 .£1.50	EF80 .60p	EF183 .40p	EZ81 .70p	T41 .£1.25
6AU6 .80p	DAF91 .£1	EBF80 .80p	ECC180 .£1.90	EF83 .£3.50	EF184 .50p	GZ32 .£2.75	UBC81 .£1.25
6BE6W .£2	DF91 .45p	ECC81 .£1	ECF80 .95p	EF85 .50p	EL32 .70p	GZ34 .£4.50	UF42 .£1
6F33 .£9	DF92 .70p	ECC82 .80p	ECF82 .£1.80	EF86 .£1.40	EL34 .£2.75	K166 .£14	UF80 .£1.60
6XS5G .£1	DF96 .60p	ECC83 .£1	EF36 .£2.95	EF89 .£1.50	EL85 .£4	K188 .£20	UK41 .£7
6X30L2 .38p	DK91 .£1	ECC84 .55p	EF37A .£1.75	EF91 .£1.25	EL91 .£5	N37 .£5.30	UY41 .£3.25
12BH7 .£1.20	DL92 .£1	ECC85 .70p	EF39 .£1.48	EF92 .£1.75	EF86/7 .50p	OA2 .£1.25	X78 .£8
6059 .£3.60	DY802 .£1	ECC88 .£1.80	EF41 .£3.50	EF94 .70p	EZ41 .£2.50	SP61 .£1.70	X79 .£7.50

All prices include VAT when applicable. Please add £1 post/packing. Cheques payable to: Kenzen, Unit 9, 16-20 George Street, Balsall Heath, Birmingham B12 9RG. Tel: 021-472 3688

DATA FILE

Ray Marston looks at acoustic alarm generator circuits in the latest part of his power control mini-series

In last month's edition of 'Data File' we looked at a variety of practical dc lamp/LED flasher, switcher, and brightness-control circuits. This month we continue the dc control theme by looking at a selection of dc-powered acoustic alarm generator circuits.

Bell/buzzer alarm circuits

One of the easiest ways of activating a self-interrupting audible alarm device such as a bell or buzzer is via an SCR; **Figs 1 to 9** show a selection of circuits of this type. All of these are designed around the inexpensive and readily available type C106 SCR, which can handle mean load currents up to 2.5A, needs a gate current of less than 200 μ A and has a 'minimum holding current' value of less than 3mA. Note in all cases that the circuit's supply voltage should be about 1.5V greater than the nominal operating voltage of the alarm device used, to compensate for voltage losses across the SCR, and that diode D1 is used to damp the alarm's back emfs.

Fig 1 shows the circuit of a simple non-latching, multi-input alarm which activates when any of the S1 to S3 push-button input switches is closed, but stops operating as soon as the switch is released.

Fig 2 shows how the above circuit can be converted into a self-latching, multi-input 'panic' alarm (which can be activated by the owner if he feels immediately threatened while at home). This is done by simply wiring R3 plus normally-closed reset switch S4 in parallel with the alarm device, so that the SCR's main-terminal current does not fall below the 3mA 'minimum holding current' value when the alarm self-interrupts. Once this circuit has latched, it can be unlatched again (reset) by briefly opening S4.

Note that both of the above circuits pass typical stand-by currents of only 0.1 μ A when the alarm is in the off condition, and can thus be powered from battery supplies. Also note that the S1 to S3 switches pass activating currents of only a few mA, so can be safely connected to the alarm circuit via considerable lengths of cable.

Fig 3 shows how the self-latching circuit can be converted into a simple burglar alarm system, complete with the 'panic' facility. Here, the alarm can be activated by briefly opening any of the series-connected, normally closed S1 to S3 'burglar alarm' switches (which can take the form of microswitches activated by the action of opening doors or windows, etc), or by briefly closing any of the parallel-connected, normally open 'panic' switches. Note that this circuit passes a typical stand-by current of

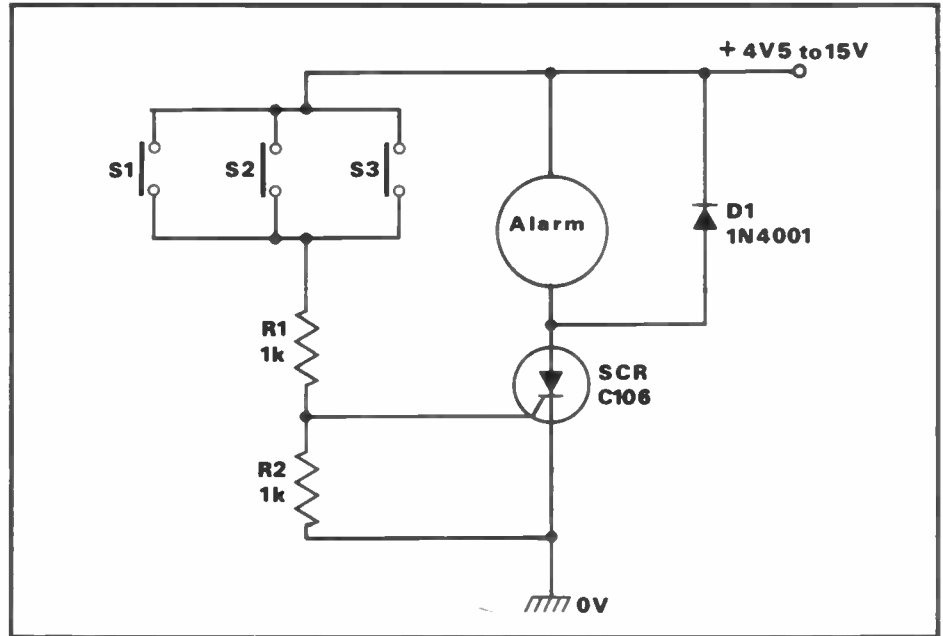

Fig 1: Multi-input, non-latching alarm circuit

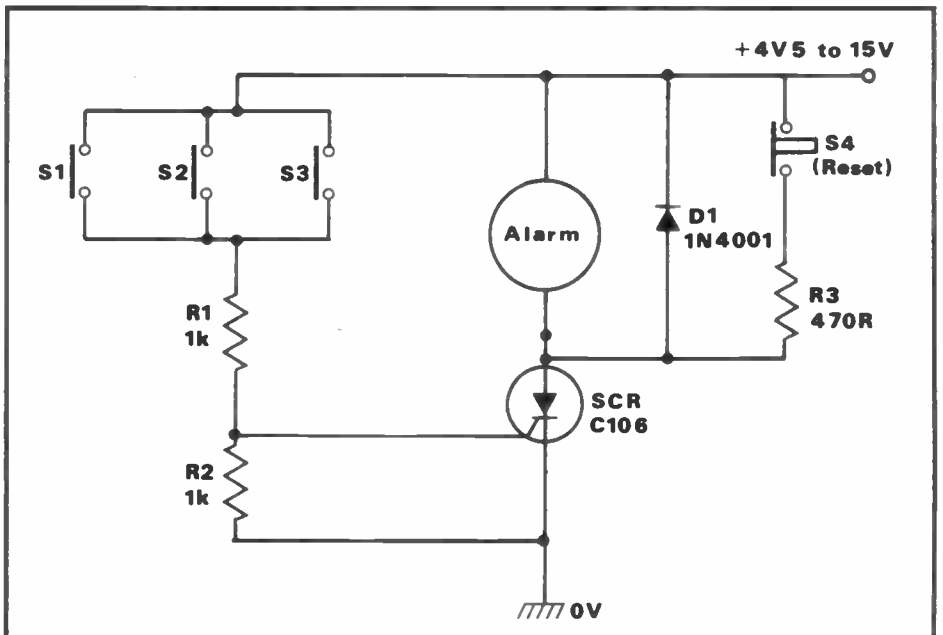

Fig 2: Multi-input, self-latching 'panic' alarm

0.5mA (via R1) when powered from a 6V supply, and that C1 acts as a noise-suppressing capacitor that ensures that the alarm will only operate if the S1 to S3 switches are held open for more than a millisecond or so, thus enhancing the circuit's reliability.

The stand-by current of the burglar alarm circuit can be reduced to a mere 1.4 μ A (at 6V) by modifying it as shown in **Fig 4**. Here Q1 and Q2 are connected in the Darlington mode and wired as a common emitter amplifier which inverts and boosts the R1-derived 'burglar'

signal and then passes it on to the gate of the SCR.

Water, light and heat alarms

The basic SCR-driven alarm circuit can be used to indicate the presence of excess water, light or temperature levels by driving the SCR gate via suitable 'detection' circuitry; **Figs 5 to 9** show alarm circuits of this type.

The **Fig 5** water-activated alarm uses Q1 to effectively increase the SCR's gate sensitivity, and activates when a resistance of less than about 220k appears

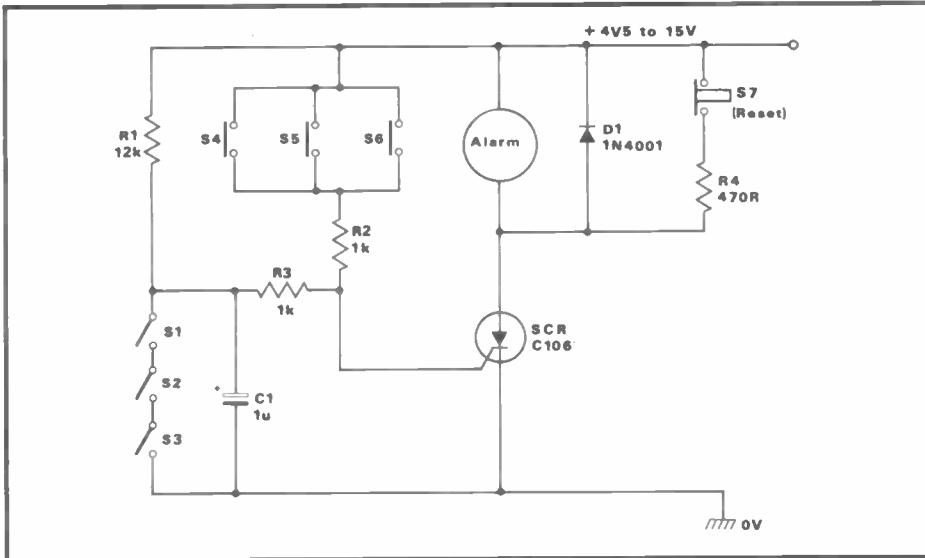

Fig 3: Simple burglar alarm system, with panic facility

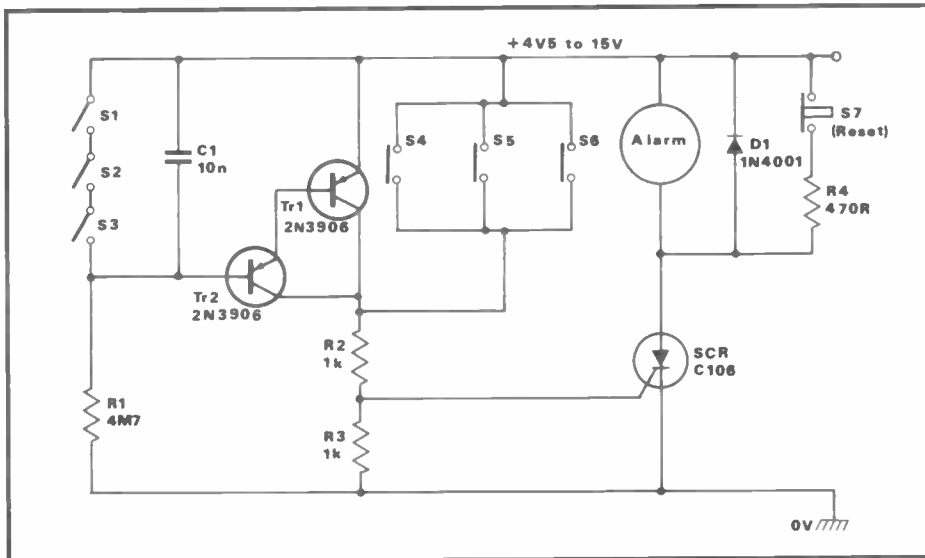

Fig 4: Improved burglar alarm circuit

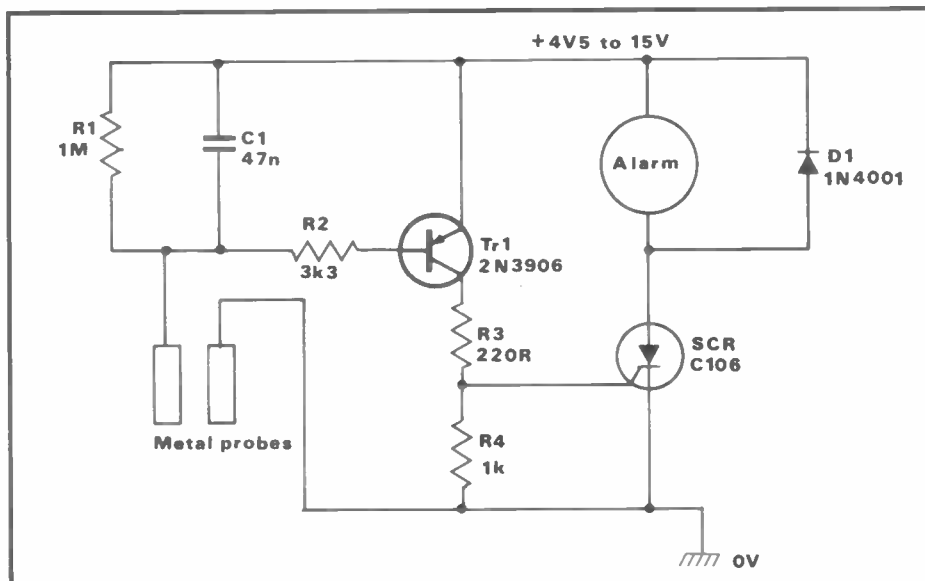

Fig 5: Water-activated alarm

across the two metal probes. Its operation as a water-activated alarm relies on the fact that the impurities in normal water (and many other liquids and vapours) make it act as a conductive medium with a moderately low electrical resistance. Hence, this causes the alarm to activate when water comes into contact with both probes simultaneously. C1 is used to suppress unwanted ac signal pick-up, and R2 limits Q1's base current to a safe value. By suitably adjusting the placing of the two metal probes, this circuit can be used to sound an alarm when water rises above a pre-set level in a bath, tank or cistern, etc.

The operation of the Fig 6 light-activated alarm is very simple. The LDR and RV1 are wired as a light-sensitive, voltage-generating potential divider that has its output buffered via Q1 and fed to the SCR gate via R1. This output is low under dark conditions (when the LDR resistance is high) but goes high under bright conditions (when the LDR resistance is low) and thus drives the SCR and alarm on. The precise light-triggering point of the circuit can be pre-set via RV1, and almost any small cadmium sulphide photocell can be used in the LDR position. This circuit can be used to sound an alarm when light enters a normally dark area such as a drawer or wall safe, etc.

Temperature-activated alarms can be used to indicate either fire or overheat conditions, or frost or underheat conditions. Figs 7 to 9 show three such circuits; in each of these designs TH1 can be any ntc thermistor with a resistance in the range 1k Ω to 20k Ω at the required trigger temperature, and pre-set pot RV1 needs a maximum resistance value roughly double that of TH1 under this trigger condition.

The Fig 7 over-temperature alarm operates as follows. R1-R2 and TH1-RV1 form a Wheatstone bridge in which R1-R2 generate a fixed half-supply 'reference' voltage and TH1-RV1 generate a temperature-sensitive 'variable' voltage, and Q1 is used as a bridge balance detector and SCR gate driver. RV1 is adjusted so that the bridge is normally balanced (giving equal reference and variable voltages) at a temperature just below the required trigger value. Under this condition, Q1 base and emitter have equal voltages and Q1 and the SCR are thus cut off. When the TH1 temperature is below this balance value the TH1-RV1 voltage is above the reference value, so Q1 is reverse biased and the SCR remains off, but when the TH1 temperature is significantly above the balance value the TH1-RV1 voltage is below the reference value, so Q1 is forward biased and drives the SCR on, thus sounding the alarm. The precise trigger point of the circuit can be pre-set via RV1.

The action of the above circuit can be

DATA FILE

reversed, so that the alarm turns on when the temperature falls below a pre-set level, by simply transposing the TH1 and RV1 positions, as shown in the frost or under-temperature alarm circuit of **Fig 8**.

These two circuits perform very well, but their precise trigger points are subject to slight variation with changes in Q1 temperature, due to the temperature dependence of the Q1 base-emitter junction characteristics. Therefore, these circuits are not suitable for use in precision applications, unless Q1 and TH1 operate at equal temperatures. This snag can be overcome by using a two-transistor differential detector in place of Q1, as shown in **Fig 9**.

The **Fig 9** circuit is wired as a precision over-temperature alarm. It can be made to function as a precision under-temperature alarm by simply transposing the RV1 and TH1 positions. Note that the circuit is shown without a latching resistor, since sensitive circuits of this type are usually required to sound the alarm only if the TH1 temperature is beyond the pre-set limit.

Piezo electric alarms

Piezo electric transducers are widely used as sound generators in toys, clocks, watches, calculators, electronic games, and in many other applications where space and operating efficiency are at a premium. They consist of a thin slice of electro-constrictive (piezo) ceramic material plus two electrical contacts, and act as super-efficient electric-to-acoustic power converters when operated in the 1kHz to 5kHz frequency range. They give typical power conversion efficiencies of 50%, compared to about 0.5% for conventional loudspeakers. Hence, they are excellent 'sound makers'.

Piezo electric transducers are available from several manufacturers. The Toko PB2720 is fairly typical of the type. It houses the actual transducer in a small, easy-to-use plastic-moulded housing, and its two input terminals appear to the outside world as a simple capacitor with a static value of about 20nF and a dc resistance of near infinity. The most effective and cheapest way to drive the device is to feed it with square waves, but in this case the driver must be able to source and sink currents with equal ease and must have a current-limited (short-circuit proof) output. CMOS drivers fit this bill perfectly.

Figs 10 and **11** show two inexpensive ways of driving the PB2720 (or any similar device) from a 4011B CMOS astable oscillator. Each of these circuits generates a 2kHz monotone signal when in the on mode, is gated on by a high (logic-1) input and can use any dc supply in the range 3 to 15V.

In the **Fig 10** design, IC1a-IC1b are wired as a 2kHz astable that can be gated on electronically or via push-button switch S1, and IC1c is used as an

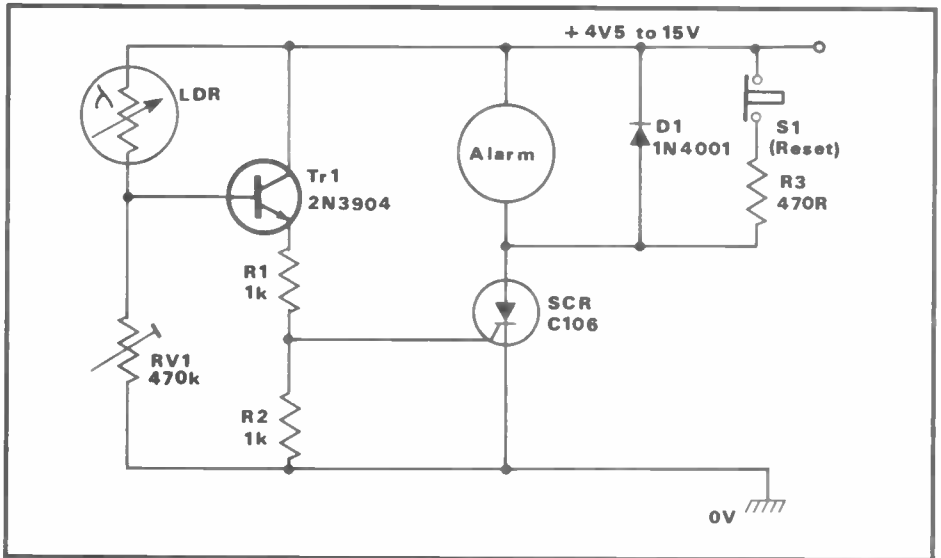

Fig 6: Light-activated alarm

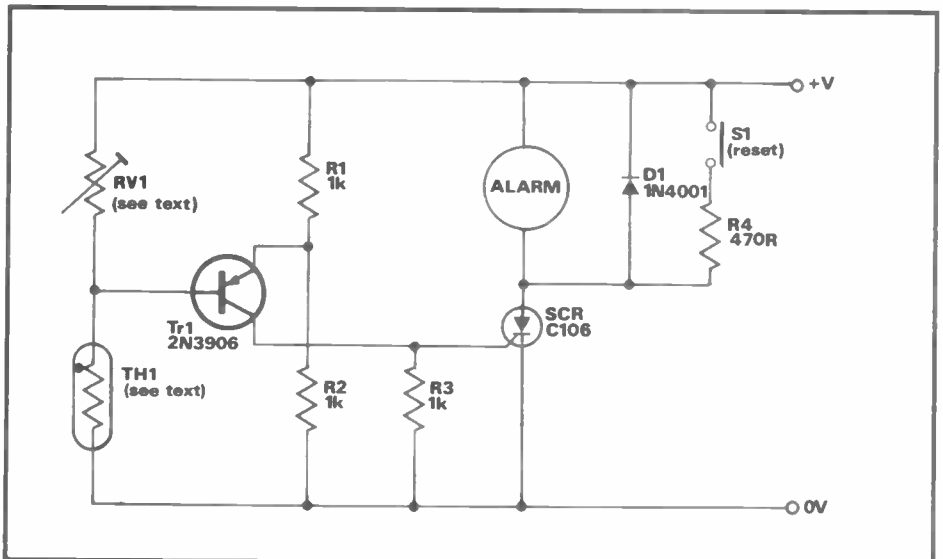

Fig 7: Simple over-temperature alarm

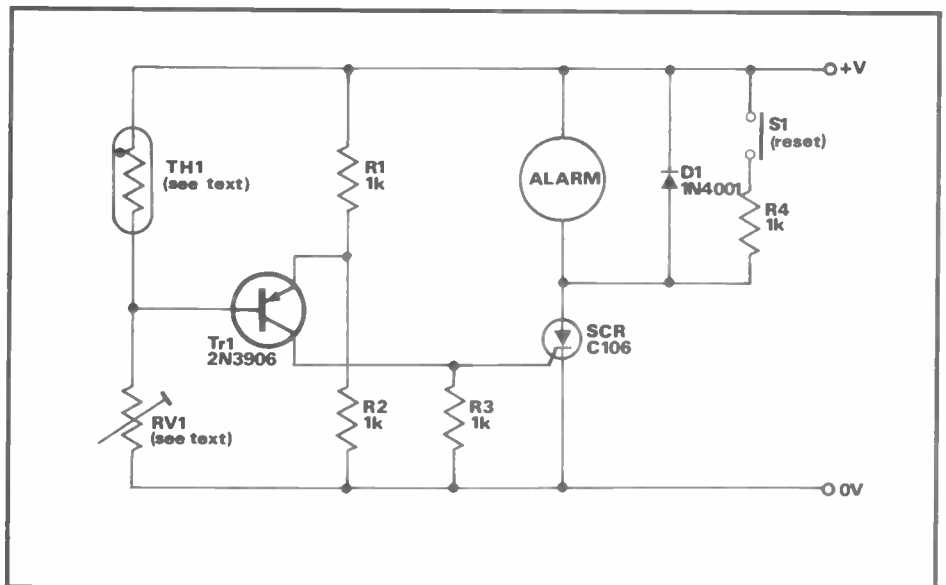

Fig 8: Simple frost or under-temperature alarm

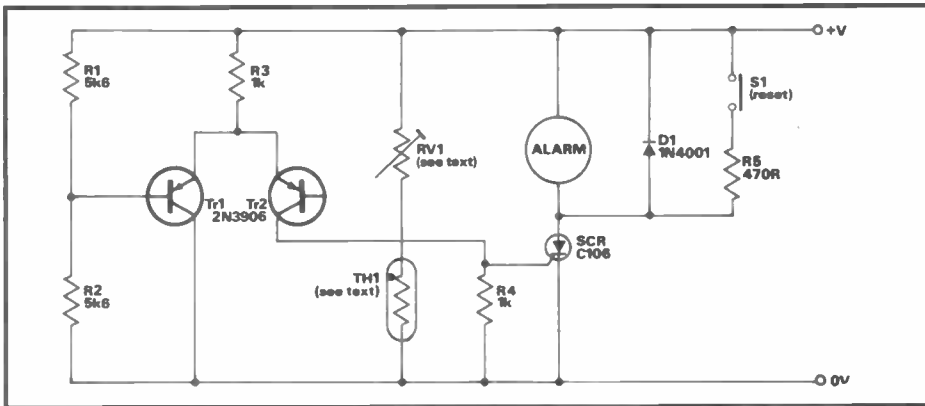

Fig 9: Precision over-temperature alarm

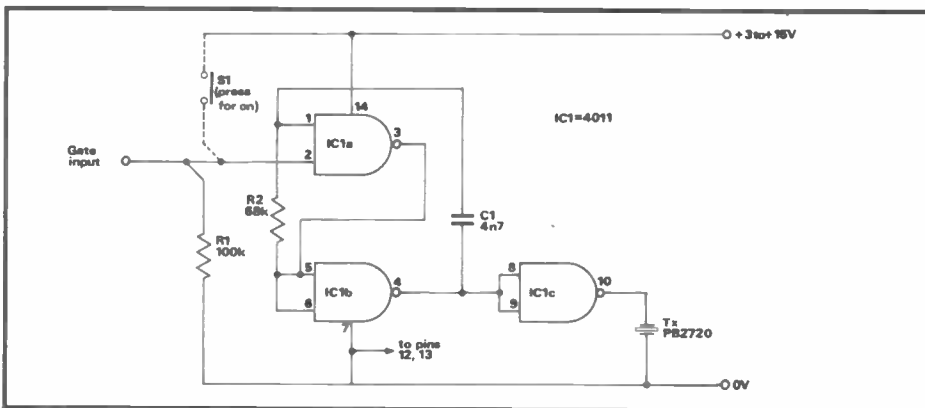

Fig 10: Gated piezo-electric monotone alarm with single-ended output

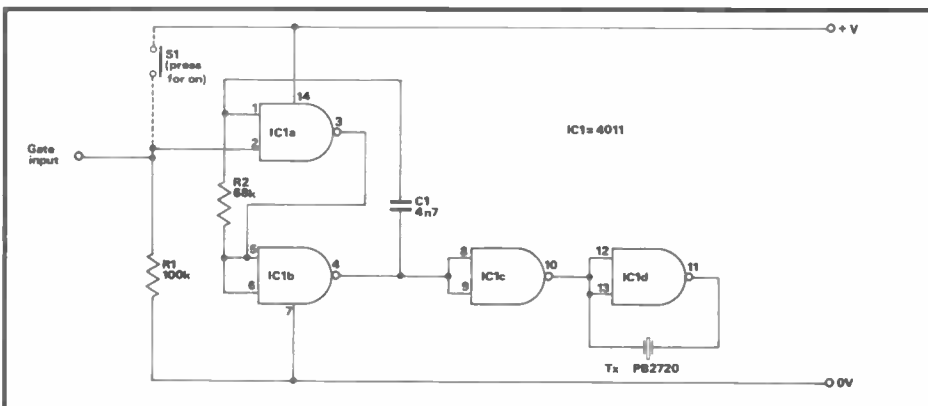

Fig 11: Gated piezo-electric monotone alarm with bridge-drive output

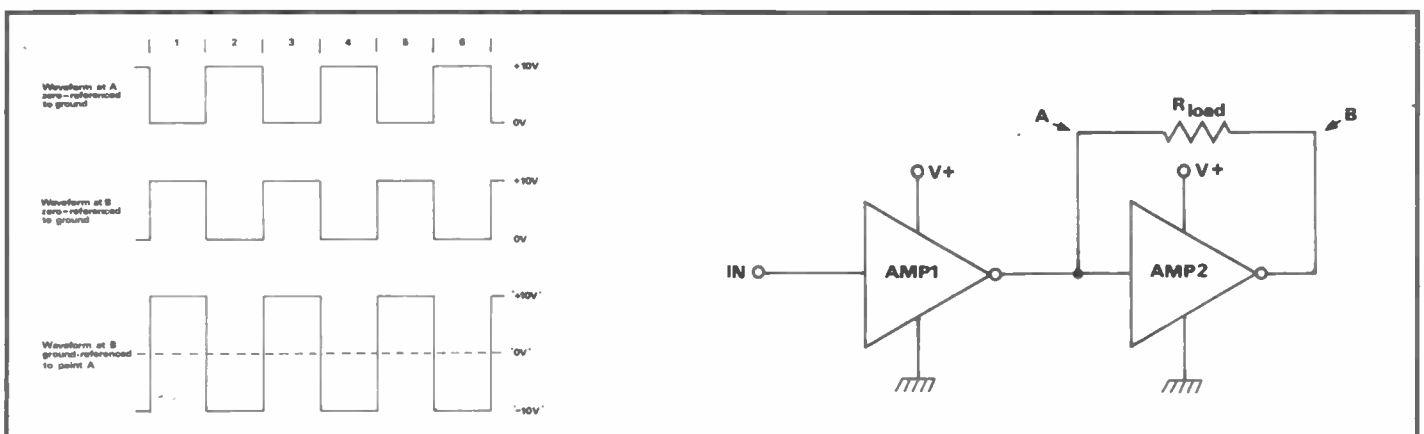

Fig 12: A pair of amplifiers connected in the bridge-driving mode gives a power output of $2V^2/RW$, ie, four times the power of a single-ended circuit

inverting buffer/amplifier that gives single-ended drive to the PB2720. The signal reaching the PB2720 is thus a square wave with a peak-to-peak amplitude roughly equal to the supply voltage, and the rms signal voltage across the load equals roughly 50% of the supply line value.

The Fig 11 design is similar to the above, except that inverting amplifiers IC1c and IC1d are series-connected and used to give a bridge drive to the transducer, with anti-phase signals being fed to the two sides of the PB2720. The consequence of this drive technique is that the load (the PB2720) actually sees a square wave drive voltage with a peak-to-peak value equal to twice the supply voltage value, and an rms voltage equal to the supply value, and thus gives four times more acoustic output power than the Fig 10 design. This action can be understood with the aid of Fig 12, which shows the waveforms applied to the load from the bridge circuit when it is fed with a 10V pk-to-pk square wave input signal.

Note in Fig 12 that although waveforms A and B each have peak values of 10V relative to ground, the two signals are in anti-phase (shifted by 180°). Thus, during period 1 of the drive signal, point B is 10V positive to A and is thus seen as being at +10V. In period 2, however, point B is 10V negative to point A, and is seen as being at -10V. Consequently, if point A is regarded as a zero voltage reference point, it can be seen that the point B voltage varies from +10V to -10V between periods 1 and 2, giving a total voltage change of 20V across the load. Similar changes occur in all subsequent waveform periods.

Thus, the load in a 10V bridge-driven circuit sees a total voltage of 20V peak-to-peak, or twice the single-ended input voltage value, as indicated in the diagram. Since doubling the drive voltage results in a doubling of drive current, and power equals the V-I product, the bridge-driven circuit thus produces four times more power output than a single-ended circuit.

DATA FILE

Alarm circuit variations

Gated CMOS oscillator/driver circuits can be used in a variety of ways to produce useful sounds from the PB2720. A few variations are shown in **Figs 13 to 15**. **Fig 13**, for example, shows how the basic bridge-driving circuit can be modified so that it can be gated on by a low (logic 0) input (rather than by a high one) by simply substituting a 4001B CMOS IC for the 4011B type.

Fig 14 shows how to use a single 4011B to make a pulsed-tone (bleep-bleep) alarm circuit with direct drive to the PB2720. Here, IC1a-IC1b are wired as a gated 6Hz astable and this is used to gate the IC1c-IC1d 2kHz astable on and off. This circuit is gated on by a high input; if low-input gating is wanted, simply swap the 4011B for a 4001B and transpose the positions of S1 and R1.

Finally, **Fig 15** shows a warble-tone (dee-dah-dee-dah) version of the gated alarm which generates a sound similar to a British police car siren and has a bridge-driven output. Here, 1Hz astable IC1a-IC1b is used to modulate the frequency of the IC1c-IC1d astable; the depth of frequency modulation depends on the value of R3, which can have any value from 120k to 1 megohm.

Loudspeaker alarms

The basic CMOS alarm-sound generator astable circuits of **Figs 10 to 15** can easily be modified to generate acoustic outputs via loudspeakers, thus giving greater sound levels. **Fig 16**, for example, shows how the **Fig 13** 4001B gated astable can be operated at 800Hz and used to generate such an output. Here, the astable's pin 4 output is fed to the base of pnp common emitter 'driver' amplifier Q1 via R3, and Q1 uses the speaker and current-limiting resistor Rx as its collector load. The output of the 4001B astable goes high when gated off, and under this condition the pnp transistor is cut off and consumes zero current; when the astable is active, Q1's output switches on and off at an 800Hz rate and generates an acoustic output via the speaker.

Note that the 4011B version of the gated CMOS astable (see **Figs 10 and 11**, etc) gives a pin 4 output that is grounded when gated off, and this output must thus be fed to the input of an npn driver stage (with a grounded emitter) if a speaker output equal to the above is required.

The basic **Fig 16** circuit is meant for low-power applications and can be used with any speaker in the range 3Ω to 100Ω and with any supply in the range 5 to 15V; note that Rx and the speaker form a series combination with a total resistance of about 100Ω, thus keeping Q1's power dissipation within acceptable limits. The actual output power level depends on the individual values of speaker impedance and supply voltage

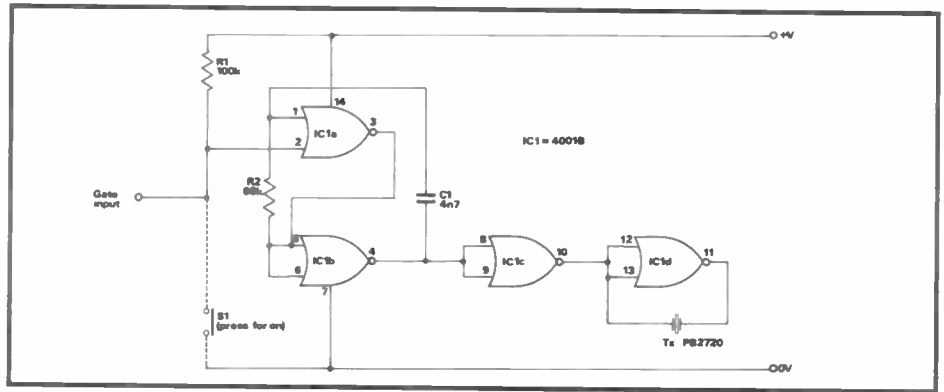

Fig 13: Alternative version of the gated bridge-driving circuit

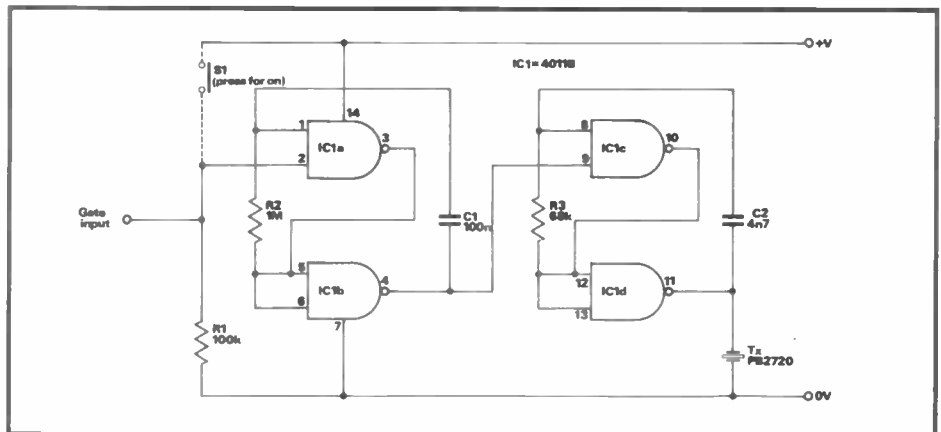

Fig 14: Gated pulsed-tone (6Hz and 2kHz) alarm with piezo output

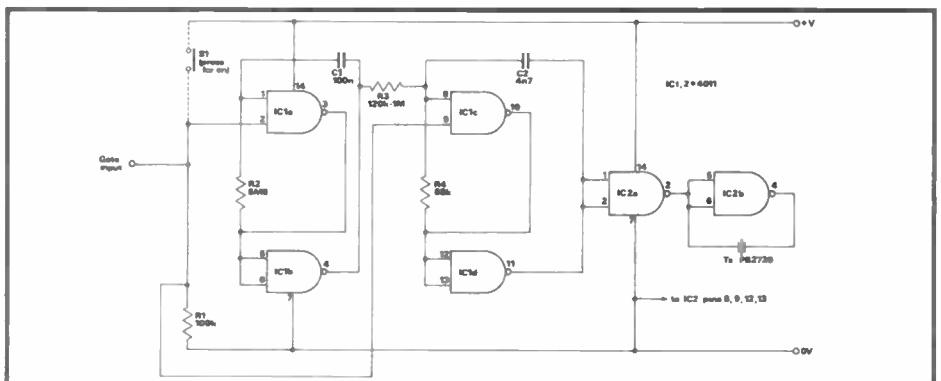

Fig 15: Gated warble-tone alarm with bridge-driven piezo output

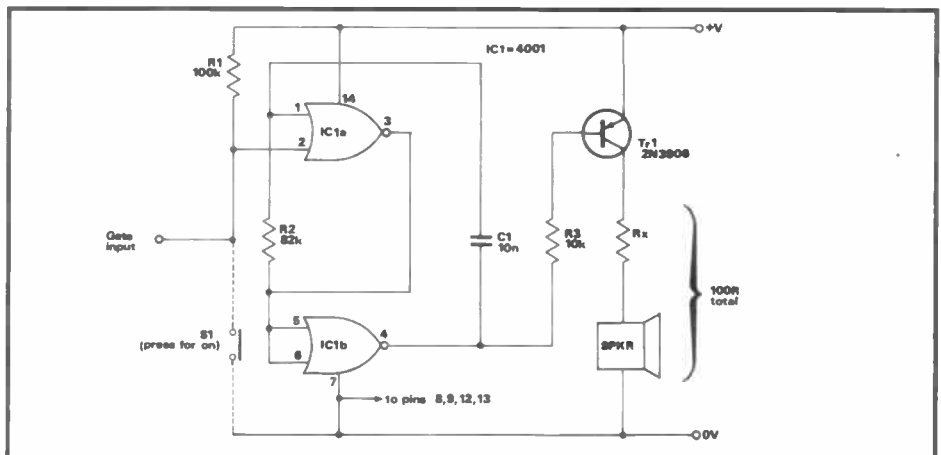

Fig 16: Low-power 800Hz monotone alarm with speaker output

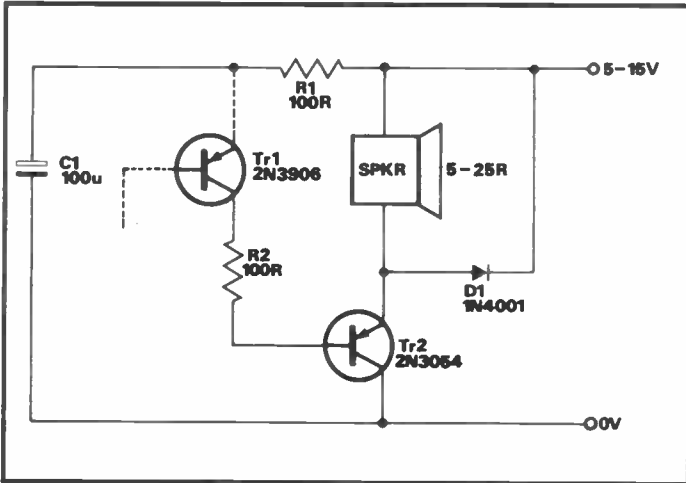

Fig 17: Medium-power (0.25W to 11.25W) booster stage

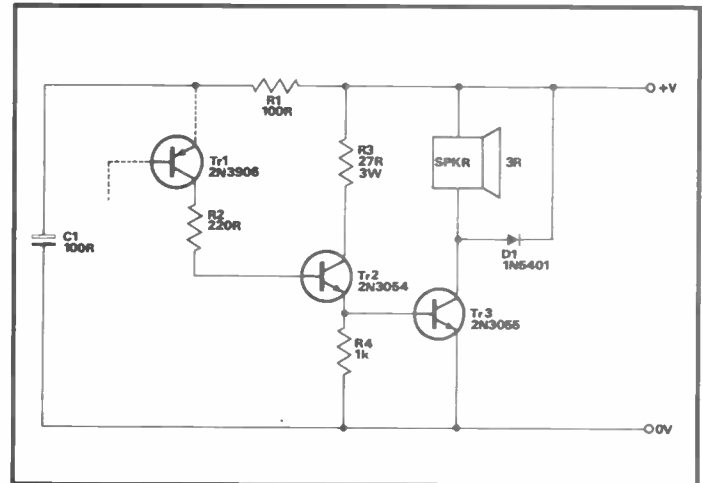

Fig 18: High-power (18W) booster stage

used, but is usually of the order of only a few tens of milliwatts. Using a 9V supply, for example, the output power to a 15Ω speaker is about 25mW, and to a 100Ω speaker is about 160mW.

If desired, the output power of the above circuit can be greatly increased by modifying its output to accept the power booster circuits of **Figs 17** or **18**. In these circuits, R2 is wired in series with the collector of the existing Q1 alarm output

transistor and provides base drive to a one or two-transistor booster stage, and the alarm's power supply is decoupled from that of the booster via R1-C1. Note that protection diodes are wired across the speakers of these circuits to prevent the speaker back emfs from exceeding the supply rail voltage.

The **Fig 17** booster circuit can be used with any speaker in the range 5Ω to 25Ω and with any supply from 5V to 15V. The

available output power varies from 250mW when a 25Ω speaker is used with a 5V supply, to 11.25W when a 5Ω speaker is used with a 15V supply. The **Fig 18** circuit is designed to operate from a fixed 15V supply and uses a 3Ω speaker. It gives a mean output power of about 18W. Note that, because of transistor leakage currents, these circuits pass typical quiescent current of about 20μA when in the stand-by mode. REW

PROFESSIONAL SURVEILLANCE	
EQUIPMENT KITS	
<p>A RANGE OF HIGH QUALITY KITS AS SUPPLIED TO LEADING UK SECURITY COMPANIES. ALL KITS COME FULLY DOCUMENTED WITH CONCISE ASSEMBLY AND SETTING-UP DETAILS, FIBRE GLASS PCB AND ALL COMPONENTS. PLEASE ADD £1.50 TO COVER P&P. ALL UNITS AVAILABLE READY BUILT, DETAILS IN CATALOGUE.</p>	<p>MTX Micro-miniature VHF transmitter. The smallest kit on the market measuring an incredible 17mm x 17mm including on-board mic. Super sensitive. Fully tuneable over FM band. 9V operation with range up to 1000m. £10.95</p>
<p>VT800 High power version of the MTX with on-board PA stage providing 250mW of RF. Measures just 20mm x 40mm, power requirements 9-15V. Excellent sensitivity and stability. Fully tuneable over FM band. Ranges over 3000m can be expected. £12.95</p>	<p>VOX75 Voice-activated transmitter. Variable sensitivity trigger level switches transmitter on when sounds are detected. Stays on for time delay variable between 1-20 sec. Fully tuneable output covers all FM band. Very sensitive and low standby current through CMOS circuitry. 9V operation. Range up to 1000m. Measures 30mm x 40mm. £18.95</p>
<p>CTX900 Sub-carrier scrambled transmitter. Audio is double modulated providing very secure transmissions. Any unauthorised listener will not be able to demodulate signal without DSX900 Decoder unit. Fully tuneable output covering FM band. 9V operation. Range up to 1000m. Measures 30mm x 40mm. £18.95</p>	<p>DSX900 Decoder unit for CTX900. Connects to earphone output of receiver to descramble signal from CTX900 output to headphones. 9-12V operation. Measures 35mm x 50mm. £17.95</p>
<p>TLX700 Micro size telephone transmitter. Connects onto line at any point and requires no batteries. Clearly transmits both sides of conversations on both incoming and outgoing calls. Undetectable by phone users. Fully tuneable output covering FM band. Range up to 1000m. Measures just 20mm x 20mm. £10.95</p>	<p>ATR2 Micro size telephone recording unit. Connects onto line at any point and connects into ANY normal cassette recorder having MIC and REM sockets. Requires no batteries. Switches recorder on silently when phone is used for incoming or outgoing calls, switches off when phone replaced. Clearly records both sides of conversations. Undetectable by phone user. Measures 10mm x 35mm. £10.95</p>
<p>XML900 RF Bug Detector/Locator. Wide band input circuitry detects presence of RF field and triggers flashing LED and piezo bleeper. Variable sensitivity enables source of transmission to be pinpointed to within 6 inches. Max sensitivity will detect MTX or similar transmitter at around 15-20 feet. 9V operation. Measures 55mm x 55mm. £21.95</p>	<p>SUMA DESIGNS (Dept REW), THE WORKSHOPS, 95 MAIN ROAD, BAXTERLEY, Nr ATHERSTONE, WARKS CV9 2LE. TEL 0827 714476</p>
<p>Send 28p stamp for new 1989 Catalogue including crystal transmitters, mains transmitters, surveillance receivers etc. PHONE ORDERS ON ACCESS OR AMEX ACCEPTED. Tel 0827 714476</p>	

ASTRID +

Access UoSAT OSCAR 9 & 11 Scientific Satellites with your BBC B upwards or Spectrum 48K upwards computers. (Others via RS232 serial port).
A **complete** Satellite Receiving System including all cables, aerial, display software etc.
All for only £156+VAT, direct from the **designers**.

Send for full details to:

SRW Communications Ltd
ASTRID House, The Green
Swinton, MALTON, N Yorks YO17 0SN
or Telephone Malton (0653) 697513

GROSVENOR SOFTWARE (G4BMK)

PACKET RADIO – Dragon 32/64

Software on disk or tape (now with CW Ident) plus modem for HF/VHF with watchdog timer and HF Tuning indicator, £104 including P&P. Additional modes (RTTY CW SSTV AMTOR) £10 each
CW Ident upgrade for existing users £7

2 Beacon Close,
Seaford, E Sussex BN25 2JZ
☎ (0323) 893378

DX-TV RECEPTION REPORTS

Compiled by Keith Hamer and Garry Smith

December turned out to be quite a pleasing month with many different propagational modes present. There was a hint of F2 activity on several mornings, mainly confined to channel E2.

On the whole, Band I was alive and well with Sporadic E providing excellent openings, some of long duration, on several days, notably later in the month.

Tropospheric activity was reasonable with reception from mainly the Low Countries and West Germany.

DX-TV log for December 1988

This month we are featuring the reception log of Bob Brooks in Wirral.

13/12/88: ORF (Austria) on channel E2a displaying the 'ORF FS1' (PM5544 at 1453; TSS (USSR) on R1 with news programme at 1500; unidentified news programme on R1 at 1533; MTV-1 (Hungary) on R1 radiating the multiburst test pattern at 1605; CST (Czechoslovakia) on R1 identified by the 'PRAHA' logo followed by a feature film at 1640.

21/12/88: CST R1 radiating the 'RS-KH' EZO test pattern at 1243.

22/12/88: TSS R1 UIET test card at 1225 followed by the news; TVR (Rumania) on R2 received with logo and clock at 1653; TVE-1 E2, E3 and E4 children's programmes at 1759; TVE-1 E3 cookery programme at 1836.

28/12/88: NRK E4 'NORGE TELEVERKET' PM5544 at 1040.

29/12/88: DR E3 programme at 0850; CST R1 test pattern and PRAHA caption in colour, at 0920; unidentified close-down flag on channel R2 at 2220.

30/12/88: TVE-1 on channel E2 with programmes in colour at 1132; SVT-1 E2 and E4 with the PM5534 test card in colour at 1205; RTP (Portugal) on channel E3 identified by the 'RTP' logo at 1218.

31/12/88: West Germany on channel E8; France (Canal Plus) on L9 and RTE-1 (Eire) on channel H via enhanced tropospherics.

Reception reports

Simon Hamer also noted Sporadic E during the month. Strong Spanish signals emerged on 19 December on channel E2, identified by the 'Telediario'

news programme, while on the 22nd, *Upstairs Downstairs* was noted on the TVE-1 network. Increased meteor-shower activity around the 14th provided many signals in Band I for Simon. Among those countries identified were Czechoslovakia, Poland and Sweden.

Bertrand Prince of France took advantage of the many tropospheric openings during December. On many days UK and distant French stations were observed but on the 19th and 30th, DX from further afield was present. Around noon on the 19th Bertrand logged the Swiss FuBK test card on channel E7 with the inscription '+PTT SRG1'. Later, an unknown West German station was resolved on E8. On the 30th the 'SW3 BADN' FuBK emerged on channel E41 and E56 during the early part of the afternoon. Other reception around at the time included RTL Télévision on L21, the 'hr3 FFTM' FuBK from Hessischer Rundfunk on E54, the 'SW3 BADN' FuBK on E55 and the 'TELE 21' PM5544 from Belgium (2nd network) on channel E60.

Many interesting DX signals were

PHOTO FILE ● PHOTO FILE ● PHOTO

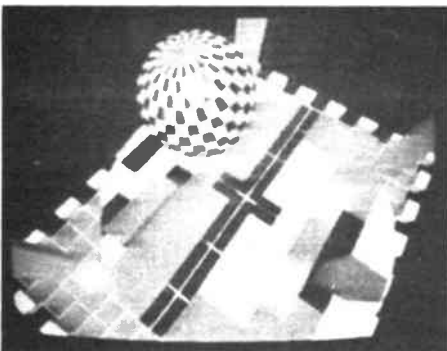

Fig 1: Part of the Spanish animated opening sequence

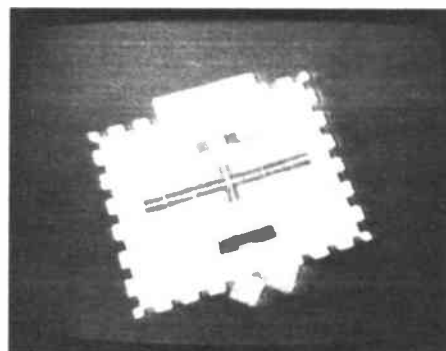

Fig 2: Final part of the opening sequence - the face is formed!

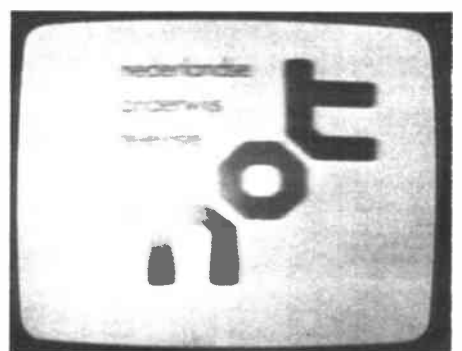

Fig 3: Caption seen via the Nederland-1 TV network



Fig 4: Weather map radiated by Doordarshan TV (India)



Fig 5: Doordarshan TV feature film preview caption

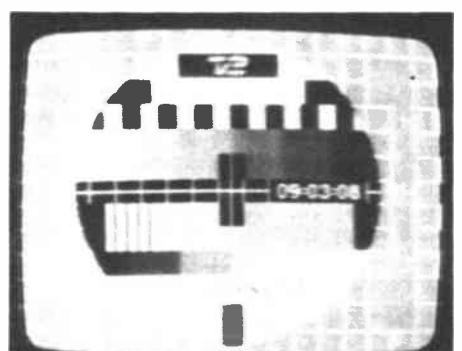

Fig 6: The new Danish TV-2 network as received on channel E30 from Hedensted

observed by Chris Howles of Lichfield during the course of the month. The 11th was fairly dramatic when the Swiss '+PTT SRG1' FuBK was resolved on E7 during a tropospheric lift. Evening viewing paid off too when a cartoon was received via Sporadic E on channel 1A. Chris comments that this sounds very much like an Italian private station because there was no on-screen identification. The state service, RAI, normally displays 'RAI UNO' in the corner of the picture throughout its broadcasts.

F2 reception was noted at least twice by Chris. On the 23rd it was observed between 1010 and 1015GMT on channel R1, but on the 29th strong signals were present on both channels E2 and R1 from 0930 until 0950. The E2 reception consisted of a play or drama programme while on R1 an Asian-looking female presenter or newsreader was visible for much of the time.

Bob Brooks of South Wirral had an active month with plenty of Sporadic E openings to swell his logbook. 13 December was a particularly good day with an opening around the middle of the afternoon. Countries identified included Austria, USSR, Hungary and Czechoslovakia. The 22nd provided excitement too when Rumania was identified from the log and clock caption on channel R2.

Grid arrays

Many enthusiasts are using grid arrays for UHF DX reception. They are relatively inexpensive, compact and cover all UHF channels with very little gain variation throughout channel groups A to C/D. Their response seems to extend somewhat beyond the normal TV channel allocations and thus provides a useful level of gain at the 70cm ATV band just below channel 21. Triax, Kathrein and WISI are some of the manufacturers producing grids of this type. In fact the 'Colour King', originally manufactured by Wolsey, is still available from some suppliers.

David Glenday of Arbroath is so impressed with the results obtained at UHF using a single wideband grid aerial, that he is contemplating making a scaled-up version, or variation, for Band III reception. Unfortunately, the dimensions for a scaled-up grid are rather large (the reflector grid measures 5ft x 8ft) and so it is doubtful whether the chimney stack will be the ideal place for installing such a creature. David has sketched an alternative design that is seriously being considered. It comprises the following features: two 'X' dipoles; a large, efficient reflector screen (similar to the Triax grid or 'Short-Backfire' design); smaller reflectors in front of the dipoles forming a cavity resonator (similar to the Short-Backfire); some 'X' directors (similar in style to the Triax Unix arrays).

Whatever the outcome, we wish David luck with the project and hope that an

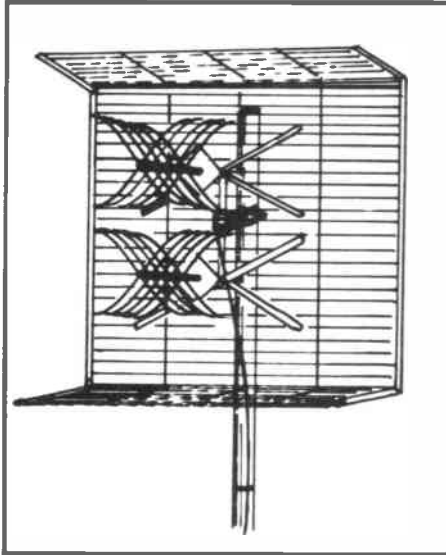

Fig 1: Sketch of David Glenday's proposed Band III aerial

efficient aerial system for Band III will soon emerge.

F2 story continued

There were well over 150 days of F2 activity between October 1978 and March 1982 when TV signals were detected in the United Kingdom. At times channel R1 was jammed solid with transmissions from mid and eastern areas of the USSR and China. Unfortunately, positive identification was extremely difficult at times, not only because of the problems imposed by several signals being simultaneously received but also because of the multiple images and general distortion of the image. In many instances signals were as strong as one would expect to encounter via Sporadic E propagation.

Reception is more favourable when noon falls roughly at the mid-point between the transmitter and the reception site. Consequently, many of the transmissions present around 0800GMT were from areas with a time difference of +8 hours GMT or more. The location of channel 0 just below E2 meant that Australian signals were easy to identify provided they weren't blasted off the screen by the numerous USSR forward scatter communications networks operating in this part of the band! Receiver systems with reduced IF bandwidths and high selectivity were the order of the day for such challenging reception. On occasions there were as many as three different Australian transmissions staging an ionospheric battle! Signals from the Middle East and the closer time zones of the USSR were mostly received during the late morning period, although transmissions on channel R1 were sometimes noted well into the afternoon.

It was mainly the TV channels below 50MHz, such as E2 and R1, that were

affected by F2 propagation but there were instances of channel E3 reception when the muf rose high enough. Transatlantic reception was possible under these circumstances and the best observations took place during December 1979 and 1981 when signals were available over several consecutive days. It became a daily ritual watching the 'Canada AM' breakfast news programme while eating lunch!

African signals were numerous considering the small number of Band I transmitters in operation. Signals were not as strong as their east-west counterparts but to compensate they seemed more mysterious and exotic. Openings from the south occurred at unexpected times of the day and even as late as 1800 to 1900, which suggested that trans-equatorial rather than F2 layer propagation may have been the cause.

Many European TV transmissions found their way into other continents during the height of F2 activity. Not surprisingly, due to the low transmission frequencies involved, signals from the BBC-1 Crystal Palace transmitter on channel 1 (41.50MHz sound and 45.00MHz vision) were regularly received all over the world.

1988 spectacular

Looking back through the logs of 1988 shows that it was a spectacular year – not in terms of quantity but certainly in terms of variety and exotics. Even we notched up a few firsts after two decades of DXing! Sporadic E excelled itself especially in early June on the 5th, 6th and 7th. In fact the opening was more or less a continuous serving of exotics. The dates are worthy of mentioning in some detail since these are events which are unlikely to be repeated.

Diary date 1

On 5 June 1988, shortly after noon, Simon Hamer resolved a picture just above the channel E4 vision frequency but with an unlocked frame. Adjusting the vertical hold produced a steady picture with reduced height confirming the presence of a 525-line signal from across the Atlantic. Signals from RUV Iceland were also present at the time, not only on the usual E3 and E4 channels but also on E2. The latter, low-power relay of RUV is no longer listed but obviously it is still in operation.

However, the best was yet to come. While tuning through Band III Simon became aware of a PM5544 around E6 and E7. At first RTE-Eire was suspected but as the signal improved the initials 'RUV' could be clearly seen. According to the **WRTVH**, the E6 transmitter at Vadlaheidi has an erp of 490kW while the E7 outlet at Hafell is 1100kW!

Diary date 2

Towards midnight on 6 June 1988, US

DX-TV RECEPTION REPORTS

and Canadian signals were received over much of the UK on A2, A3 and A4. For a time 525 line pictures on channel A5 (R3) were noted here in Derby. The A4 signals were stronger and clearer than those on A2 and A3. The latter two were very indistinct and distorted because several stations were present on each channel thus making visual identification virtually impossible. Fortunately, sound was present.

On A4 there were two stations at times – an English-speaking channel and another with French accents. The former was predominant and an 'ntv' globe and caption were regularly shown. A flick through the **World Radio TV Handbook** suggested this might be CJCN-TV Grand Falls in Newfoundland, a relay of CJON-TV St John on channel A6.

Monitoring the sound via a D-100 converter eventually confirmed it was CJCN-TV, when an address in St John was announced during the adverts for a record promotion. A recording made of the A3 sound contained references to New Burlington, Vermont. In all probability, the programme originated from the WCAX-TV outlet which is part of the CBS network.

French-speaking stations were also received in the Netherlands on A2 and A4. These could have originated from the Quebec area – there are at least four A2 French channels, although the A4 signals probably originated in New Brunswick.

Diary date 3

Around lunchtime on 7 June, several French-speaking FM stations were heard via Sporadic E which were subsequently identified as being from Tunisia by Chris Howles at his Lichfield location. Scrutinising the lower end of Band III revealed an Arabic programme on channel E5 which was later identified as Algeria. Upon checking the band here at Derby, the same Arabic programme was also resolved, at reasonable strength, on E7. The subsequent monitoring of channel E6 showed that an FuBK test pattern was emerging and although it didn't remain for long, the Tunisian 'RTT' identification across the centre was clearly visible. Further monitoring on this channel produced the Libyan FuBK test pattern from the 20kW transmitter at Tripoli.

F2 conditions returned towards the end of the year giving many enthusiasts a taste of what's to come over the next year or so. Moving on to tropospheric reception, the new Danish TV-2 network at UHF is putting in extremely good signals in many parts of the UK. So is the Nederland-3 service, much to the annoyance of many enthusiasts who are finding that it blocks the channels for the more distant DX! So there we have it, some of the more memorable DX events of 1988. We wonder if 1989 can beat it!

Service Information

Spain: Before the TVE opening logo appears, the GTE test card changes to an animated PM5544 which assumes various positions and performs strange acts with a rolling ball before finally emerging as a face complete with hat!

China: A Chinese-built telecommunications satellite is now in orbit and will be used to expand telephone links and television broadcasting in remote areas.

Tunisia: RTT-1 radiates standard colour bars prior to the FuBK test pattern.

West Germany: The mystery blockboard test pattern received in the United Kingdom last September/October on channel E36 is used by many of the cable TV networks operating throughout West Germany. Technically it is known as the 'Heucke Test Card No 979' and on the occasion mentioned it originated from the 20kW Düsseldorf/Burscheid transmitter which relays RTL+ material via the satellite downlink. It is sometimes generated locally and fed into the network when the normal test patterns are not available. Normally the PM5534 or PM5537 test patterns are shown. The latter is also of a blockboard appearance with the identification 'RTL+ KÖLN' just below the centre. Sometimes the satellite test pattern can be seen which consists of colour bars with the lower half blank featuring the 'ECS/F4 TRANSPONDER 1' inscription.

The Heucke test pattern is also aired over other transmitters, such as SAT-1,

while they are undergoing tests before being brought into service. Sometimes details about the channel and transmitter location are shown.

Poland: The vertically polarised channel R1 TVP-1 transmitter at Siedlce has finally been abandoned in favour of a move to UHF. For many years now the TVP-1 broadcasts have also been aired at UHF on channel R52 from the same location.

Czechoslovakia: A five-minute summary of the CST teletext is now aired on weekdays over the CST-1 network at the end of the morning programme (1200-1300 CET) and at the start of the afternoon programme (1500-1600 CET).

A new electronic test pattern is now being aired over the CST-1 network and carries the identification '1 SR-P' which stands for 'Správa Radiokomunikaci Praha' (Radiocommunications Administration Prague). This will eventually be used on both the 1st and 2nd networks.

The FuBK test pattern is screened for fifteen minutes before programmes commence with identification alternating between '1 PROGRAM' and 'DDK 3' every eight seconds! The identification '2 PROGRAM' is displayed on the CST-2 network.

Denmark: The TV-2 transmitters at Hadsten (channel E26) and Thisted (channel E28 with vertical polarisation) are now on test. The PM5534 displays the identification 'TESTUDSENDELSE'.

TV Transmitters in Estonia

Transmitter	Channel	Network	Transmitter	Channel	Network
Tallinn	R2	Eesti-TV	Haapsalu	R3	CT-1
	R3	Leningrad-TV	Järvakandi	R10	CT-1
	R12	CT-1	Kunda	R1	CT-1
	R28	CT-2	Jõgeva	R5	CT-1
Tartu/Valgjärve	R6	Eesti-TV	Võru	R3	Eesti-TV
	R4	CT-2		R27	CT-1
	R30	CT-1	Põlva	R5	CT-1
Kohtla-Järve	R11	Eesti-TV	Ruhnu	R5	Eesti-TV
	R29	CT-1	Kuressaare	R31	CT-1
	R5	Leningrad-TV	Kärdla	R34	CT-1
	R1	CT-2	Viljandi	R22	CT-1
Pärnu	R4	Eesti-TV	Põltsamaa	R1	CT-1
	R9	CT-1	Võhma	R11	CT-1
			Särve	R8	Eesti-TV
Orissaare	R11	Eesti-TV		R41	CT-1
	R22	CT-1	Kallaste	R3	CT-1
Paide	R8	Eesti-TV	Valga	R10	Eesti-TV
	R39	CT-1		R7	CT-1
Rakvere	R3	Eesti-TV	Narva	R4	CT-1
	R27	CT-1	Sillamäe	R2	Leningrad-TV
			R3	CT-1	

Planned station: Kihelkonna R24 for CT-1

CT-1 = USSR 1st Network CT-2 = USSR 2nd Network

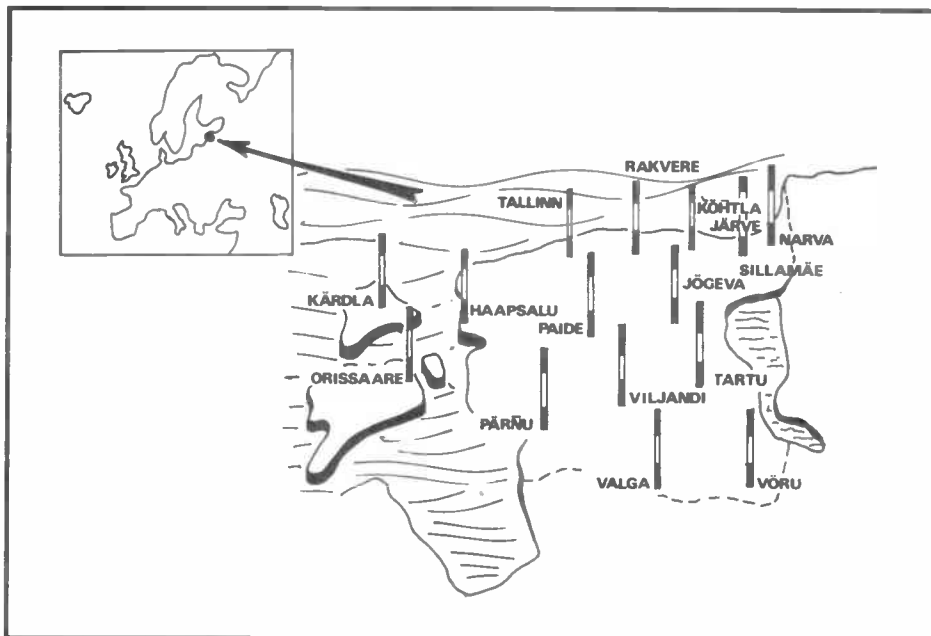

Fig 2: The major transmitter locations in Estonia

Estonia: The new Tartu transmitting mast at Valgjärve was opened on 8 December 1988. The TV transmitters in this part of the USSR are shown in the table.

Details of the main transmitter locations are shown in **Fig 2**.

Hungary: Cable TV in Pécs uses the old Marconi Resolution Chart No 1 with 'KTV' identification.

On Monday evenings between 1830 and 1900GMT, MTV-2 transmits regional test cards from the various studios:

Pécs: EBU bar with 'MTV PECS' identification and PM5544 with 'MTV' at the top and 'PECS' below. Main transmitters are on channels R22, R32 and R35.

Budapest: PM5544 with 'MTV-2' at top and 'BUDAPEST' below. Main transmitters use R24, R26 and R36.

Szeged: Colour bar test pattern with 'MTV SZEGED' identification on R7, R23 and R32.

Iceland: The private network Stöd 2 is using the same type of encryption as TV-2 in Sweden occasionally uses. There is now a discussion about introducing a third TV station in Reykjavik, ie a second private one. This might be called 'Stöd 3' and use the E12 allocation currently assigned to Stöd 2. The latter station would then move to UHF.

This month's service information was kindly supplied by Gösta van der Linden (Rotterdam, Netherlands), the Benelux DX Club (Netherlands), Dalibor Frkovic (Yugoslavia), Bertrand Prince (France), Duncan Fraser (New Zealand) and Thomas Graf (West Germany). The photographs were supplied by Lt Col Rana Roy (India) and HS Publications (Derby, UK).

REW

LOOK WHAT YOU GET EVERY MONTH IN

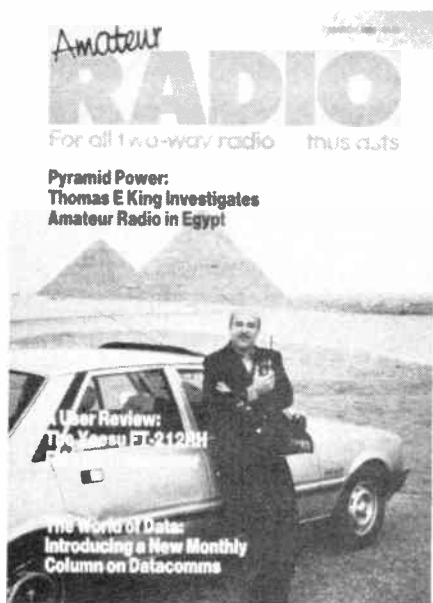

Amateur RADIO

- ★ **DX DIARY** Don Field G3XTT with all the news of rare DX, contests and DXpeditions
- ★ **ON THE BEAM** Glen Ross G8MWR with all the news and comment from bands above 50MHz
- ★ **STRAIGHT & LEVEL** The latest news, comment and developments on the amateur radio scene

Make sure of your copy by placing a regular order at your newsagent

ICOM

IC-228E 2 Meter FM Transceiver



Actual
size

Features:

- Multicolour Liquid Crystal Display.
- 25 Watt output.
- 20 Memory channels.
- Scanning.
- Call and priority function.
- Compact size.
- HM15 microphone supplied.

Take a close look at this easy to use and compact VHF Mobile Transceiver. It's unique orange, red and green LCD highlights the numbers and letters for easy viewing. With a 25 watt output from a custom designed power module and a extra large heatsink, this transceiver does not get too hot under your dashboard

Each of the 20 memory channels can store frequency, offset and direction, in fact all the information to work simplex or a repeater. The memory scan function will scan the memory channels and with the skip function

miss those you choose. The program scan will scan all frequencies between two programmable limits. The call channel ensures that your favourite frequency is within easy reach, and with the priority watch the call channel or memory channels can be monitored every five seconds.

This transceiver provides you with so many features, its small compact size and simple front panel design make it a superb mobile transceiver. See the IC-228E or the IC-228H 45 watt high power version at your local ICOM dealer.

Icom (UK) Ltd.

Dept REW, Sea Street, Herne Bay, Kent CT6 8LD. Tel: 0227 363859. 24 Hour.

Count on us!

IC-3210E Dual Band FM Mobile



If you are newly licensed or just undecided about which band to operate first, then the new ICOM IC-3210 is just the answer. This dual band FM transceiver is ideally suited for the mobile operator. Transmit on one frequency and receive on the other and you're operating full duplex. It's just like talking on the telephone.

The simple and well laid-out front panel ensures quick and easy operation of all its many functions. A great convenience when driving. Optional accessories available are the UT40 tone squelch board. HS15 + SB mobile microphone and switch box SP8 external speaker and PS45 AC power supply.

Features:

- Full crossband duplex.
- 20 double-spaced memory channels.
- Built-in duplexer.
- 2 call channels.
- 4 priority watch functions.
- Programmed, memory and selected band memory scan.
- Variable LCD backlight intensity.
- Tone squelch and pocket beep functions (optional).
- 25 watts output.

Helpline: Telephone us free-of-charge on 0800 521 145, Mon-Fri 09.00-13.00 and 14.00-17.30. This service is strictly for obtaining information about or ordering Icom equipment. We regret this cannot be used by dealers or for repair enquiries and parts orders, thank you.

Datapost: Despatch on same day whenever possible.

Access & Barclaycard: Telephone orders taken by our mail order dept, instant credit & interest-free H.P.



ATV ON THE AIR

Andy Emmerson G8PTH puts you in the picture

In the hobby side of amateur radio and video, firms tend to come and go. Some stand the test of time but others disappear after a while, when their owners (presumably) follow other, more profitable pursuits. One name that has been around for some time is Crofton Electronics; they have been involved in the video field now for twenty years.

Live on TV

The firm's entry into the market place began after their small CCTV camera design was demonstrated on the BBC-TV programme *Tomorrow's World* back in 1969. This little camera was actually hooked up to the transmitter and produced live pictures over the air, and although there was some trepidation at the time, everything went smoothly. It was, Crofton believes, the first time ever that the BBC had allowed a non-standard video source to do this.

Back to the future

Crofton Electronics are probably best known now for the very competitive CCTV security packages they sell (cameras, monitor and switcher) and they also have a range of computer peripherals at discount prices. The firm still develops products in-house, though, and supplements these with miniaturised CCD cameras and AM and FM video transmitters, with or without sound for normal and covert surveillance applications. The latter equipment is so small and light that it may be mounted in a briefcase for portable use, or indeed carried on one's person.

The upshot is that the firm has not forgotten its early roots and still supplies both the serious amateur as well as the professional markets. Lately two rather tasty new products have been released from the Crofton stable, which the firm hopes will create interest in the professional security and surveillance market, as well as the industrial process control market. One is a CCD camera the size of a matchbox, priced very definitely in the professional bracket, but the second of these might also be in the price range of amateurs (TV repeater groups, perhaps) with a specific application.

Tiny camera

The miniature CCD solid-state television camera is known as the model CCD2. It is described as the smallest video camera available on the market today. The resolution capabilities are far better than the average vidicon camera, and its sensitivity goes down to -3 Lux. When I had a play with it, it was clear that rapid changes of light level had barely

any effect on the picture, nor was it fazed by bright lights shone straight at the CCD-sensor. The picture was the crispest I have ever seen from a black and white camera.

The size of the camera is little larger than some C-mount lenses (which it takes) and the only other projection is the BNC socket on the rear. Power (12V dc) is fed on a separate pair of wires, though it should be possible to modify the camera so that the power can be fed along the coaxial video line. As the unit requires no tube change and has no user replacement parts it can literally be installed and forgotten, thus making it an obvious choice for many applications.

The price competes favourably with all of the more conventional CCD cameras currently available on the market. The specifications are in the table below.

Versatile video ident

The second product is a time/date and message generator with stop-watch facility. Known as the TDMS1, this generator is an all British designed and manufactured video overlay unit, which also incorporates a stop-watch function that may be locally or remotely controlled. It is available in two basic forms:

1. Basic PCB (OEM version) which allows other firms to build it into their own equipment.
2. Boxed free-standing unit complete with mains transformer, input and output BNC sockets and setting push buttons.

This product has been designed and produced to seriously compete with similar Far Eastern designs and yet, unlike them, it incorporates up-to-the-minute technology and has a far wider and more flexible specification.

The TDMS1 has been designed round a single chip micro, and all the functions offered within the specifications are under software control, thus making tailor-made versions a reality.

According to Crofton, considerable time and effort was put into design parameters and overall specifications at the drawing board stage, so the product could be accepted world-wide regardless of line standard or mains frequency, and thus interface with almost all video signals without the need for hardware changes. This has been achieved and it allows production lead times to be based purely on sales demand, rather than on the differing video standards of customers. This is a truly big advantage as it allows sales to be pitched at the world rather than just Europe. Availability, at present, is only a matter of days for small numbers and only three weeks for large orders (hundreds).

Diverse uses

The applications for this product are extremely diverse and range from a simple time/date insert generator for video signal chains, to an event timer, a message generator for airport/hotel or other public places, and a video editing ident signal, to name but a few. (What about TV repeaters too? Time and date, input signal strength, confidence quotient of a decent tropo inversion within seven days, etc). The price (starting at around £120.00) has been kept to an absolute minimum to allow its incorporation into equipment produced by the original manufacturer (OEM), and good quantity discounts are available.

The PCB alone measures just 148mm x 86mm, whilst the boxed version measures a modest 173mm x 150mm. In its boxed version the user controls have been kept very simple and comprise just two push-buttons. These buttons allow the user to set up all stored and displayed data from an automatically accessed on-screen menu, as well as to position the inserted data anywhere on the screen.

Once set the data, as well as time and

Pick-up element:	0.5in CCD image sensor
Pixels:	500x582 CCIR
Line standard:	625/50 or 525/60
Image size:	0.5in image pick-up chip (6.5mm (h) x 4.85mm (w))
Output:	1.0V p-p into 75 ohms
Synchronisation:	Internal
Resolution:	Horizontal 450 lines Vertical 350 lines
Signal to noise ratio:	More than 46dB (AGC off)
Sensitivity:	Standard - 400 Lux at F4
Lens mount:	Standard 'C' mount
Power supply:	11-16V dc
Operating temperature:	14° to 118°F (-10 to 45°C)
Dimensions (whd):	5.7 x 5.7 x 4.8mm
Weight (less lens):	140 grams.

date, will remain in memory and be accurate for many months, even when power is removed, by virtue of the incorporated battery back-up facility provided. The message facility field has a character set comprising 128 characters including European characters and symbols, whilst the standard configuration allows a message field of eight characters. Provision has been allowed for the OEM to have a forty-character field if required. The stop-watch function allows for times of up to 99 hours 59 minutes 59 seconds. Time is twenty-four hour format.

Remote controls

Provision has been allowed for two on-board relays, which may be individually user programmed to switch on and off once in any twenty-four hours. Only two user controls are provided on the PCB – one for pre-setting insert brightness and the other for adjusting the line timing. The brightness control could be brought out on to the front panel if desired. The TDMS1 has been designed to be used with either monochrome or colour composite signals.

Power supply requirements for the OEM user are flexible, and the board may be powered from 15V ac at 6VA, 15V dc

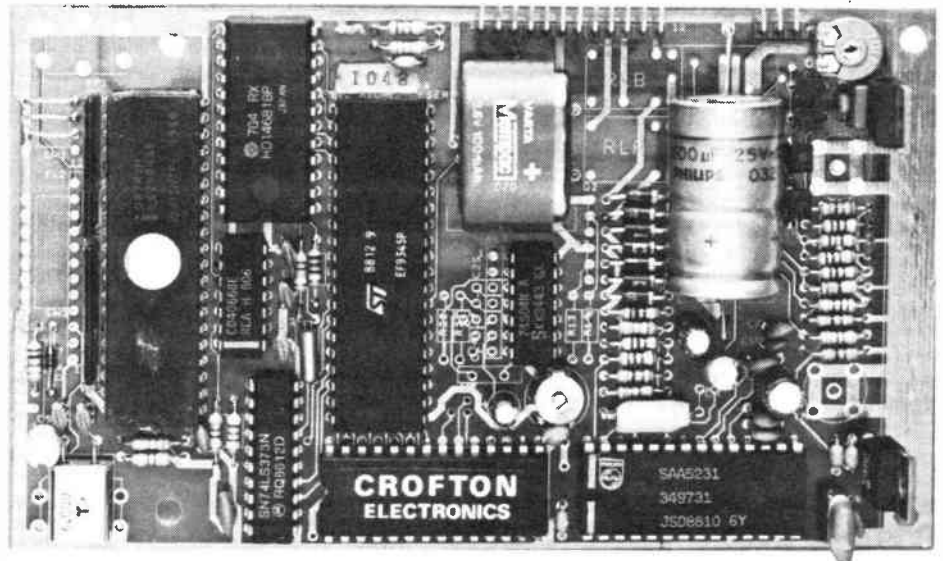

Crofton's new time, date and message generator is a neat PCB which can be incorporated in many kinds of video equipment

unregulated, 12V dc regulated or even the separate regulated dc supplies of +5V and +12V. All interface signals and power requirements are provided for by a Molex-type PCB connector, including video input/output. Provision for on-

board BNC sockets has also been allowed for.

For further details of this and other products from Crofton Electronics telephone: (05448) 557 (fax 05448-558).

As promised, this month starts a series of reviews of second-hand goodies which may turn up in the small ads and at rallies. First in line is a preamp, something most stations could do with.

The problem defined

On our 32cm band every watt of signal counts, especially when you are trying desperately to make a marginal contact during a rapidly fading opening. We are allowed an effective radiated power (erp) of 25W but only 8W may be applied to the aerial. Most of the rigs on the market produce only half of this output level, and by the time this reaches the antenna a further half of this signal may have been spirited away in feeder losses. Thus as little as 2W may actually be applied to the aerial! This is rather a sorry state of affairs and the cable losses apply equally to received signals.

Solutions

Despite all this there is a healthy activity on 934MHz, with many contacts made daily – and nightly. However, most operators would improve matters if they could, if only to get out further and to do better when the tropics open. Some try to compensate with aerial gain, using up to four long yagis stacked and bayed, but this route has its problems. Apart from (sometimes) being against the terms of the licence (and all that metalwork in the sky does rather advertise itself!) you now need a rotator and to be beaming in the right direction to hear that elusive CQ-

NETWORK

934

Andy Emmerson G9BUP

DX call. The beamwidth of such a high-gain array is very narrow and it will present a considerable windload during the January gales.

A better solution would be a masthead amplifier system; this would boost the transmitted signal and apply a fully legal 8W to the antenna. It would also amplify received signals to compensate for any attenuation or losses between the aerial and transceiver. Surprisingly it has taken a while for such a device to materialise; the technology has been around for a while but higher power transistors for the 900MHz band were expensive. We have the mass market of cellular radio to thank for bringing the price of these transistors down and Crestbyte of Mildenhall for producing the first masthead power amplifier. This is out of production now but turns up now and again.

What it does

The APT-605 is in fact more than a

masthead PA and preamplifier as it also incorporates a remote-controlled relay switch, allowing you to change from an omnidirectional collinear antenna to a beam. This saves the expense of two feeder cables or a separate remote switch. The PA is designed to give 8W out for 3W input: the sort of power you are likely to have left after feeder losses.

The equipment supplied comprises the masthead apparatus and a control switch for use in the shack. The masthead gear is in a compact, sealed, diecast box 5in x 3in x 2in; it is provided with a clamp and U-bolt for easy fitting to masts up to 2in diameter. The control box, which goes next to the rig, is a plastic grey and white Verobox with a red pilot lamp and a small switch for selecting between beam antenna and collinear or what have you. The rig should not be used when the switch is in the centre-off position but I did so. This, of course, will not do your rig any good even though it is so easy to do; I would prefer a non-centre-off switch to remove the possibility. The masthead unit is fitted with three 'N' type sockets and ample dc power cable is supplied.

The instruction leaflet points out that the masthead unit is to be mounted with the 'N' sockets facing downwards with an adequate coating of silicone grease over the joints to protect against rain and condensation. My own choice would be 'Coax-Seal', a pliable type of 'goop on a reel' available from Tandy shops. This stuff has excellent sealing and lasting

qualities and is not nearly as messy as silicone grease. It is best to do the fitting on a dry day to avoid getting moisture trapped in the system. Use the best quality 'N' connectors on your cable and take care not to strain any cables or joints.

Do you need it?

It is worth going into a little detail to see what use this PA will have. It is, as I said, designed to bring 3W up to 8W, so under what circumstances will you have 3W at the antenna? The length of most people's feeder is around ten metres; if this is RG-58 ('bootlace') coax you will lose three-quarters of your signal in it. So if you have a transceiver giving, say, 5W, a mere 1.25W will reach the antenna! With the standard half-inch coax (UR-67 or RG-213) the loss is a more acceptable 40%, leaving 3W to hit that antenna. If you invested in H-100 you should be left with 3.62W. Thus in all these cases the Crestbyte PA could do things for you.

If on the other hand you have a massaged Reftec poking out 6W, or a Uniace giving the full 8W, the picture is different and you should keep your wallet in your pocket. Again, if your coaxial cable run is shorter you will have less loss to overcome and a masthead PA will not be required.

Construction...

The masthead unit is made in a high-quality diecast box with rubber O-ring hermetic seal, as used on a lot of German amateur gear. Unlike those devices, however, there is no pressure equalisation hole for getting rid of water vapour, but Jeffrey Smith, the designer, says he has no trouble with prototypes which have been in service twelve months. Paper guarantee seals warn of dire consequences if you break them – your reviewer put curiosity first and a voided guarantee second!

Inside I found a glass-fibre printed circuit board liberally sprinkled with chip capacitors, high-quality sub-miniature trimmers and other exotica. A Philips BLV93 is the power transistor and the PA

design appears to be original and does not rely on the one in the Mullard data sheet. A slab of steel and the box lid serve as heatsink. Three Omron G4Y relays are used for switching between antennas and bypassing the preamp on transmit; these relays are very good at 900MHz and are used in most cellular radio sets as well. The RF-switched preamplifier is a two-stage device with a quoted gain of 20dB minimum, which seems excessive but would be necessary with Reftecs, which have very deaf front ends. I just hope you don't intend to use it near a Vodafone site! The active devices are bipolar, which the designer finds more robust than GaAsFETs for masthead use. Helical bandpass filters help ensure that the preamp does not also amplify out-of-band signals or noise.

Construction quality is adequate but not exemplary – there is a lot of flux residue left and rather more solder used than I would like to see. Equally the constructor has not yet discovered end cutters for trimming miniature coax, as the braid on the ends is rather 'frizzy'. Judge for yourself whether these are valid criticisms – the main point is that the thing works!

...and performance

The Crestbyte instruction sheet gives one graph showing power output while the Mullard data sheet gives another! Ignoring both I made my own tests and got 9W out for 3W in, 11.5 for an input of 4, and just under 13 out from 5W in. From this you can deduce that (i) my sample lay halfway between the two predictions and (ii) that the law of diminishing returns applies to drive levels above 4W.

In fact, hitting a PA such as this with more than 4W will not do it any good; it will produce undesirable harmonics and could even fry the power transistor to destruction. A more desirable level is 3W, and the instructions make it clear that a minimum of five metres of RG-58, ten metres of RG-213 or fifteen metres of H-100 must separate the transceiver and PA to avoid overloading. In case you're wondering how expensive a replace-

ment BLV93 is, the answer is £19.75 retail from LMW Electronics. However, with care you should not need to know this.

The verdict

The unit is robustly made and does all that it claims and does it well. My only gripes are the scruffy instructional and the distinctly tatty plastic stickers on the two units – completely inappropriate on expensive equipment and belying the quality of the electronics inside the boxes. When new, the price was £179.95 which is expensive, right? Well, not really if you consider that without a masthead PA you may be throwing away half the performance of your rig which cost a lot more. What's more, for your money you get a masthead switch which another supplier charges £60.00 for, a preamplifier (£140.00 from the same supplier) and the PA to boot. Our sample came from Selectronic (four years ago!). Many thanks to Mike Machin for his assistance. 

MANUFACTURER'S SPECIFICATION

Operation:

12-14V dc

Consumption:

0.1A receive, 1.5A transmit

Transmit gain:

approx 5dB

Receive gain:

at least 20dB, typically 24dB

Noise figure:

better than 1.5dB

RUGGED

LCD MULTIMETER PROJECT

- * Full application notes
- * Resolution 100 micro volts
- * Minimum add on components

ONLY £16.04 inc VAT + p/p £1.25

Why not call us now



RUGGED DISPLAYS LIMITED

1 Mars House, Calleva Park,
Aldermaston, Berks. RG7 4QW

LCD CLOCK PROJECT

- * Full application notes and novel circuit ideas
- * 12/24 Hour
- * Snooze and alarm functions
- * Tape counter/control timer

ONLY £10.34 inc VAT + p/p £1.25



Mail-Order Tel: (07356) 79521

Hams : Ancient and Modern

by David Lazell

Genuine radio enthusiasts are interested in new advances in the hobby, keen on testing the latest equipment, but at the same time fascinated by the old radio gear, much of which has found its way into museums across the world.

Australia

Australia, a radio pioneering nation if ever there was one, opened its amazing Telecommunications Museum in Adelaide over twenty-five years ago, thanks to the efforts of Mr V F Reeves, the Assistant Director of Engineering for Telecommunications.

South Australia was the first Territory to use telephony over long distance wire in 1878, as well as publicly demonstrate wireless telegraphy within a building in 1897 and to establish a station-to-station link in 1899. It was also the first to calculate the longitude of a portable station at Port Augusta, from Adelaide to Melbourne.

Australia had its first telegraph line from Melbourne to Williamstown in 1854, only nine years after Samuel Morse's first US line. This achievement owed much to Samuel McGowan, Deputy Postmaster General of Australia, who was a good friend of Morse.

By 1906, while the British Government was still hoping that the rumours about wireless were false, the Australians were pressing ahead.

The Australian Prime Minister, Alfred Deakin, observed, 'Wireless telegraphy seems likely to transform the future economic, political and war-like proceedings all over the world'. Despite this warning, the British were slow to see the advantages of military radio communication, although the Royal Navy had done some good work by the outbreak of the first world war.

The first Australian radio communication, station-to-station, was made in 1906 over a distance of 175 miles. Hams were eager to push for radio broadcasting services in Australia, just as they were in the USA from the early 1900s. However, a radio broadcasting service did not begin until 1923, when a commercial station (2SB, later 2BL) was set up in Sydney.

When Sir Charles Kingsford-Smith made his transatlantic flight in June 1930, he carried a short wave transmitter and asked hams world-wide to listen for his callsign, VMZAB. Incidentally, the RSGB arranged for 200 hams to listen in.

In 1976, the Telecommunications Museum moved to Electra House, King William Street in Adelaide, the former home of the Eastern Extension Telegraph Company. Among the many exhibits in the museum is an experimental transmitter used by an

operator in Adelaide to turn on the lights of a house in New York!

America

In the USA, anything worn-out is considered a possible antique. The diverse museums and showplaces devoted to radio and early video/TV are now a national resource. One of the best is the Museum of Broadcast Communications in Chicago.

Many museums rely on initial funding from benevolent people with a special interest in the museums' exhibits. A benefactor in New York donated a generous sum of money to the Chicago Museum, and New York's Museum of Broadcasting began with a donation of \$1.5 million from William S Paley.

The Museum of Broadcast Communications was the brain-child of Bruce Du Mont, a well-known Chicago broadcaster. He realised that valuable material was gathering dust on studio shelves and that it would eventually be discarded. Although the original conception was as a resource centre, the museum is now far more than that. Starting a museum is, as they say, a test of character financial influence.

In 1982, Bruce Du Mont suggested establishing a radio/TV museum to celebrate the broadcasting traditions of the mid-west while attending a meeting of the National Academy of Television Arts and Sciences, Chicago chapter. Sympathetic to the idea but hardly knowing how to proceed, the Academy's committee voted a small sum for expenses and suggested that he see what could be done. It was a tough assignment, but in 1983 WLS-TV, Chicago, donated \$5,000 to the museum's fund in honour of a city broadcaster, Flaherty Flynn and an ABC News anchorman, Frank Reynolds. When this news reached Rance Crain, publisher of **Advertising Age** magazine, he donated another \$5,000 to the fund.

The original site for the museum was abandoned because of committee problems at city authority level. Fortunately, after various fund raising events an option on a large site in South Wells Street, River City in Chicago, became available.

The A C Neilsen Research Centre at the Museum of Broadcast Communications in Chicago, includes an audio-visual broadcasting library; a \$400,000, ninety-nine seat theatre, and a news and documentary archive. It is impossible to list all its attractions but full details are available from: The Museum of Broadcast Communications, River City, 800 South Wells Street, Chicago, Illinois 60607.

United Kingdom

Private radio/TV museums have been around for some years, of course, and Britain has not been slow to follow suit. There has always been an exchange of news and views between the British Vintage Wireless Society and the American Antique Wireless Association, which began its own museum facility many years ago. The Antique Wireless Association has many former industry professionals and radio hams among its membership, so the displays are likely to evoke deep sighs from those who visit the museum at East Bloomfield, New York.

This museum exhibits five amateur radio stations including several from before the first world war. Marconi exhibits include examples of his military and communication equipment going back to the Civil War. Personally, the mid-1920s style radio store is the most endearing exhibit; similar to premises from the same period in Britain. As someone who worked in radio retailing for some years, I can only say that it exudes an air of tranquility which rarely exists in Britain today. Well, not unless you are selling satellite television!

Strangely, Britain has yet to open its own national radio or broadcast communication's museum, though the Museum of the Moving Image (MOMI) in London, which opened in 1988, is an excellent step in that direction.

The next eye-catching project must be the Kodak Museum, which is due to open at the National Museum of Photography, Film and Television, at Bradford, in spring 1989. Over 1,000 square metres of displays will reflect the story of popular photography over the past 150 years. The first gallery devoted to the hand camera includes a handsome Edwardian room setting, and was among the first galleries to be completed in 1988. The exhibition involved some four years' work by the curator, Roger Taylor. Does this exhibition bring us any nearer to our own national museum?

Bradford may decide that a celebration of radio, hams included, could be the next logical step, though some people say that the Government's recent white paper on the future of broadcasting could turn the BBC itself into a sort of museum! 

Radio and
Electronics World
May issue
on sale 13 April

Short Wave News for DX Listeners

by Frank A Baldwin

All titles in UTC, bold figures indicate the frequency in kHz

Shortly entering into the period which provides good chances of hearing the signals radiated from Latin America on the tropical bands, the attention of DXers is drawn to those stations located in Bolivia.

Some Bolivian stations are apt to be less than reliable with respect to frequency stability, often wandering during a transmission and displaying day-by-day variation. In addition to these variations, Bolivian transmitters are noted for changing to a channel far removed from that on which they were immediately and regularly reported by DXers who are nearer to the signal source than those residing in Europe.

Programme languages are Spanish, Quechua and Aymara, the folk music is typical in that the cumbia style is often heard. The sounds of the marimba and wooden xylophone are a feature of such presentations.

With one exception, Radio Tezulutlan, Coban on **4835**, Bolivian stations are not that easy to receive, being mainly low-powered and subject to near or co-channel interference. Nevertheless, reports of reception do appear from time-to-time in the European short wave listener-oriented press, representing a real DX achievement for the operator concerned.

In this review, only those stations believed to be currently active are featured, being presented in their frequency order for ease of reference.

90m band

Radio 9 de Abril, Planta Industrial de Pulacayo (power unknown) has reportedly been heard from 2310 to sign-off at 0300 on **3200.3**, this represents a frequency change from **3198.1**.

Radio San Miguel, Riberalta, operates from around 0900 to 1700 and signs on at any time between 2000 and 0200 to a final close at 0300. I should warn you, however, that there is an alternative channel – that of **3320.3**. The power is 1kW.

Radio Cumbre, Tazna on **3380.3** identifies as La Voz del

Trabajador del Bismuto, but is on the air irregularly from 1030 (Sunday from 1200) to 1300 (Saturday until 0330), from 1500 to 1700 and from 2100 to around 0330 (Sunday until 0120). The power is 1kW and this station is rarely heard by European listeners.

Another Bolivian station transmitting irregularly is Radio Camargo, Camargo, on **3390.2**. At 1kW, it is scheduled from 2230 to around 0200, and is seldom heard far from its signal source.

Out of band

Radio Melodia in Bermejo is on the air from around 1100 to 1800 and from 2100 to 0100, power unknown. The frequency is **3420.4**.

Sometimes appearing in European listener reports, the Spanish programming Radio Padilla, Padilla, mostly on **3474.5** transmits from 2300 to around 0200, but has lately varied its frequency from **3474.2** to **3475.3**. The power is 0.5kW.

Radio Movima, Santa Ana de Yacuma, is on **4472** at 1kW, the schedule is from 1030 to around 1900 and from 2200 to sign-off at around 0230. This Bolivian station is regularly reported by European DXers.

A new station recently reported is Radio Nuevo Horizonte in Riberalta, working on **4530**, it closes at 0400. The power is unknown.

On **4540** Radio Galaxia, Guayamerin, has been heard by DXers located near the station at various times between 0145 to close at 0300. The power is unknown.

A Bolivian station heard regularly throughout our spring and summer periods is Radio Santa Ana, Santa Ana de Yacuma, on **4649**. With a power of 1kW it operates from 1100 to 1800 and from 2100 to 0200 or 0300 and sometimes to 0400. The frequency can vary to **4648.5** on occasions.

Radio Paititi, Guarayamerin, on **4681** with a power of 5kW, is on the air from 1000 to 1900 and from 2130 to 0300, all times are variable.

Radio Abaroa, Riberalta, is on, or around, **4719.8** from 1000 or 1100 to 0400 with a power of 0.5kW, and is often heard by DXers living in Europe.

Radio Riberalta, Riberalta, has changed channel from **4723** to **4731.3** and transmits from 1130 through to 0200. The power is 0.5kW.

Radio Mamore, Guayamerin is, at the time of writing, varying from **4735.5** to **4735.7** having changed from **4739.6**. Its 1kW transmitter reportedly operates from 0930 to 1000 and from around 2145 to 0200.

60m band

The rarely heard Radio Guanay, Guanay, is on the air from 1030 to 2300, although it is sometimes heard around 0130. At 0.5kW on **4765.3**, it identifies itself as La Voz del Minero Aurifero, the frequency varying to **4764.5**.

Radio Los Andes, Tarija, operates irregularly on **4774.8** from 1000 to 0300, sometimes 0400 (Sunday until 2300). The power is 3kW.

On **4795.9**, the often reported Radio Nueva America operates from studios in the *de facto* capital city of La Paz, Sucre being the *de jure* capital. At 10kW, it transmits on weekdays from 1000 to 1310 (varying to 1810) and from 2200 (varying from 2000) to sometime around 0400, Sunday from 1000 to 2245. The power is 1kW.

The 1kW Radio Libertad, Centro Minero de Santa Fe, on **4810.4**, has recently been active, reportedly heard when signing off around 0240 and on another occasion at 0445.

Radio Grigota, Santa Cruz de la Sierra, varies in frequency from **4829.9** to **4834.8**, the schedule being from 1000 or 1030 to around 1830 and from 2200 to 0030, times are variable. It has been reported programming in German on Saturday from 2230 to 2300. The power is 5kW.

The Bolivian station I hear regularly is Radio Tezulutlan, Coban, on **4835**. The schedule is from 1100 to 1500 and from 2100 to 0230. The prime period for logging this one is after 2400 when the co-channel African station at Bamako, Mali, closes, leaving a clear channel for the signals from Radio Tezulutlan.

Radio Fides, La Paz, on **4845.2**, identifying as La Voz Catolica de Bolivia, operates from 0900 to 1730 and from

2200 to 0200 (Saturday and Sunday until 0600) with a power of 5kW.

Our review of Bolivian stations which are currently active on the LF bands will be continued in the next issue.

ON THE AIR

Listed below are some of the stations logged during the month prior to publication. Tuning some of the frequencies specified at the time stated, should result in a successful outcome providing the prevailing conditions are good.

AFRICA

Cameroon

Radio Garoua on **5010** at 0534, English language lesson with French translations. The Home Service in French and vernaculars is scheduled from 0425 to 0800 and from 1610 to 2315, with Radio Yaounde newscasts in English being relayed at 0530, 1800 and at 2100. The power is 100kW.

Djibouti

Radiodiffusion TV de Djibouti on **4780** at 1847, OM with chants in Somali, some monotonous music, announcements and then the National Anthem predominated by orchestral drums. Also heard at 0302 with recitations from the Holy Quran, but the signal suffered interference from co-channel La Voz de Carabobo, Venezuela. Djibouti is on the air with the National Service in Somali, Afar and Arabic from 0300 to 0800 (Friday from 0500 to 0900) and from 0900 to 1900 with a power of 20kW.

Mali

Bamako on **4835.7** at 2400, OM with the station identification in French followed by a martial music-style National Anthem. The schedule is from 0600 (Sunday from 0700) to 0800 and from 1800 to 2400 with an English programme timed from 1830 to 1900.

Morocco

Rabat on **17595** at 1610, an English programme entitled Spectrum, on this occasion all about local marriage customs, then OM with the sta-

tion identification and address for reports.

Mozambique

Maputo on **3210** at 1708, OM with a talk in Portuguese, choir with some songs. Emisao Nacional, Maputo, operates in Portuguese from 0250 to 0600 and from 1730 to 2210 with a power of 100kW, but it is not easily received owing to near and co-channel utility interference.

South Africa

RSA Johannesburg on **17755** at 1956, the interval signal, a time check of six pips, OM with the station identification in English followed by a news bulletin in Portuguese.

RSA has also been heard on **17795** at 1914, OM with some announcements and then news comment on both local and world affairs. This English transmission is directed to East Africa and the Middle East from 1900 to 2100.

Zaire

Radio Candip, Bunia, on **5066.3** at 0435, OM with a talk in French. The Home Service is in French, local vernaculars and Swahili and is radiated from 0330 to 0600 and from 1300 (Saturday from 1000) to 1945 with power of 10kW.

CENTRAL AMERICA

Costa Rica

Faro del Caribe (Lighthouse of the Caribbean), San Jose, on **5055.2** at 0305, an interview in English followed by a religious talk. The English language schedule is from 0300 to 0400, making the station identification a relatively easy matter. At 5kW, Faro del Caribe operates in Spanish (except from 0300 to 0400) from 1030 to 2000 and finally from 2300 to close at 0600.

Cuba

Radio Rebelde (Rebel), Havana, on **5025** at 0309, OM with a talk in Spanish having several mentions of Angola. Radio Rebelde is on the air in Spanish from 1000 (sometimes from 1100) to around 0400. The power is 50kW.

Guatemala

Radio Tezulutlan, Coban, on **4835** at 0002, OM with a talk in Spanish followed by the station identification. This station has recently been putting a good signal into the UK.

NORTH AMERICA

Canada

RCI Sackville on **17820** at 1919, OM with some announcements followed by a music programme transmitted in English, intended for Africa and timed from 1800 to 1930.

USA

VOA (Voice of America), Washington, on **17710** at 1725, OM with news comments in Spanish to South America and scheduled from 1700 to 1730, the station identification is in English, then sign off.

WHRI, Noblesville, on **17830** at 1921, OM with a religious talk in the English programme for South and Central Africa, timed from 1800 to 2400.

SOUTH AMERICA

Guatemala

Radio K'ekchi, Las Casas, on **4844.4** at 0132, OM with a talk in K'ekchi, some accordion music, folk songs and more music, then OM with the station identification. At 5kW, Radio K'ekchi is on the air in K'ekchi and some Spanish from 1000 to 1500 and from 2200 to 0300 weekdays, Sunday from 1200 to 1500 and from 2100 to 0200 but reportedly sometimes closing as late as 0530.

Venezuela

Radio Tachira, San Cristobal, on **4830** at 0355, OM with the station identification in Spanish followed by an orchestral/choral rendition of the National Anthem and the State Anthem at sign-off. The power is 10kW and the schedule is from 1000 to 0400 but irregularly around the clock.

ASIA

Bahrain

Relayed via the facilities of Radio Kuwait, Bahrain was logged on **15505** at 1137 when featuring a talk and some local-style music in an Arabic programme timed from 1130 to 1230.

China

CPBS Beijing on **3815** at 1858, YL with a talk in Chinese and some orchestral music with announcements. This was a transmission in the Taiwan Service 1 in Chinese, Amoy and Hakka, the schedule being from 0955 to 2400.

Xinjiang PBS, Urumqi, on **4330** at 0103, OM and YL with a discussion in Kazakh. The Home Service in Kazakh is on

this channel from midnight to 0230, from 0530 to 0730 and from 1200 to 1700 with relays of the Radio Beijing Minorities Language Service in Kazakh timed from 0100 to 0125 and from 1400 to 1425.

Guangxi PBS on **5049.7** at 1526, YL with a talk in Vietnamese. This Chinese station radiates in Vietnamese from 1000 to 1600, the schedule includes a relay of the Radio Beijing Foreign Service in Vietnamese timed from 1300 to 1400. The power is 50kW.

Radio Beijing on **17700** at 0736, play theatre during the Chinese schedule for north-west China timed from 0218 to 0800.

Lebanon

King of Hope on **6280** at 1515, OM with a religious talk in English followed by some hymns. This station broadcasts in a variety of languages to the Middle East and south-east Europe from 1430 to 2300.

Mongolia

Choibalsan, Eastern Aimak Province, on **4995** at 2348, OM with a talk in Mongolian. The Home Service 1 in Mongolian is scheduled from 2200 to 1600, this includes relays of the Moscow Foreign Service in Mongolian timed from 0600 to 0630, 0930 to 1000 and from 1200 to 1245, the exception being a Russian programme which is broadcast on Tuesday and Friday from 1130 to 1200.

Pakistan

Islamabad on **17640** at 0740, OM with a talk in the Burmese transmission for south-east Asia, timed from 0715 to 0815.

Islamabad on **17660** at 1101, OM with an English news bulletin mainly dealing with internal events.

Taiwan

Voice of Free China on **9955** at 2229, OM with a talk followed by the station identification. The English programme is directed at Europe from 2200 to 2300.

SOUTH EAST ASIA

Indonesia

RRI Bukittinggi, Sumatra, on **4910.9** at 1540, OM with announcements in Indonesian, then some low-toned stringed instrument music. Now at 5kW (previously 1kW), the schedule of Bukittinggi varies but is heard here in the UK from around 1530 to close at 1715 when the prevailing

conditions for reception of the area are favourable.

Kampuchea

Phnom-Penh on **4910.1** at 1520, high-pitched YL voice with a song in Kampuchean followed by some announcements, four low-pitched tones at 1530, OM with a newscast complete with place names.

CLANDESTINE

Radio Caiman (Alligator) on **9966** at 0225, YL with a political talk in Spanish followed by some music and a song. This clandestine is thought to be located in Guatemala.

Voice of Unity on **12230** at 0212, OM with a talk in Pushto, but jammed by a programme overlay with the two-letter Morse identification 'UR'. This clandestine was also heard at 1521 on **11490** (without jamming), OM with a talk mentioning Pakistan, Islam and Pushto, and also at 1518 on **15685**, this transmission being jammed by a programme overlay with the two-letter Morse identification 'RP'.

NOW HEAR THESE

Xizang PBS, Lhasa, Tibet, on **4750** at 0001, YL with a talk in Chinese. At 50kW, the schedule of the Home Service in Chinese from Lhasa is from 2230 to 0200, from 0350 to 0650 and from 1000 to 1445; this schedule includes English language lessons from midnight to 0030 and from 1400 to 1430, Tibetan language lessons from 0100 to 0120 and from 1200 to 1250.

San'a, North Yemen, on **4853** at 0300, OM with the station identification in Arabic, an orchestral rendition of the National Anthem, some announcements and then recitations from the Holy Quran.

NOW LOG THESE

Radio Santa Ana, Santa Ana de Yacuma, Bolivia, on **4649** at 2304, OM with prayers in Spanish having many mentions of Santa Maria, congregation with responses. Radio Santa Ana is on the air from 1100 to 1800 and from 2100 to close at 0200, on occasions at 0300 or 0400. The power is 1kW.

Radio Satellite, Santa Cruz, Cajamarca, Peru, on **6726.5** at 0154, announcements, OM with folk songs in Spanish. Radio Satellite is on the air from 2200 to 0300. The power is unknown. 

AMATEUR RADIO WORLD

Compiled by Arthur C Gee G2UK

Amateur radio has always been intimately involved with the sun; propagation of radio waves being determined by solar activity, not only the longer radio waves such as those used for long distance radio transmission, but also the shorter ones used for TV and FM broadcasts.

As the central body of the solar system and the nearest star to the earth, the sun has fascinated mankind from the beginning of time and has been worshipped by many civilisations as historical records show. It has a very important effect on many aspects of life on our planet. As more and more information about even the smallest changes in the amount of heat radiated from the sun becomes known, it seems that even major climatic changes on earth may have their origin in changes in solar radiation.

Solar plasma physics

Although the processes which take place on the sun have been studied extensively from the earth, much more can be learnt from spacecraft sent to study it at close quarters. Such a project is being planned by an international team of unprecedented scope. The European Space Agency and NASA are setting up two related missions: SOHO, the Solar and Heliospheric Observatory and CLUSTER, made up of four spacecraft to study solar plasma physics. ISAS, Japan's Space Agency and the Institute of Space Research of the Soviet Academy of Sciences will also take part.

The sun produces energy in its core by the conversion of hydrogen into helium. The sun is made up of approximately ten parts of hydrogen to one part of helium with a trace of heavier elements. The transformation of four hydrogen atoms into helium is known as nuclear fusion. In this process about four million tons of its mass are converted into radiated energy every second! Despite this tremendous loss of mass, there is no fear of it 'burning out' just yet! The sun's estimated lifespan so far is about 10,000 million years and during that time it will have used up less than a thousandth of its total mass.

This energy produces the heat and light which is so vital to the earth. But, in addition, it also emits 'particles' - mainly protons and electrons.

The visible surface of the sun is called the photosphere. Immediately above this

is the chromosphere which is a few thousand kms thick and in which the temperature rises to about 10,000K. Above the chromosphere is the corona, where the gas is ionised and reaches temperatures of a million degrees K.

The corona extends for millions of kilometres and becomes the solar wind, which is a flow of charged protons and electrons which is ejected outwards throughout the solar system. Near the earth, these particles are moving at great speed though they are only present in very small numbers, something like eight particles per cubic centimetre of space.

The SOHO mission

The SOHO mission is designed to answer a number of questions. For instance, what is the sun's inner structure made of? Why does the solar corona exist and why is it highly irregular in shape? Where and how are the solar wind streams accelerated?

SOHO will be a three-axis stabilised spacecraft; an important feature as it will make it possible for the instruments to be pointed continuously at the sun. It will be a very bulky spacecraft 3.7 metres in diameter and 3.6 metres high, weighing 1350kg. Its solar panels provide about 750W of power. The payload consists of telescopes and spectrometers, some of which are the size of telephone boxes! In order to make continuous observations of the sun, SOHO will be placed in an orbit around the sun where it will move in a parallel track inside the earth's orbit where the gravitational attractions of the sun and the earth are equal and opposite. In this way SOHO will remain fixed on the earth-sun line about one and a half million kilometres from the earth.

UoSAT-1's beacons

UoSAT-1, or Oscar 9 as it is also designated, has four beacons in the HF bands. These transmit on 7002, 14002, 21002 and 29510kHz, and were intended to be used for propagation studies. They transmit telemetry in 12wpm Morse code. Due to the non-deployment of the gravity gradient boom, their performance was not as good as had been anticipated and only the 21MHz beacon has been in intermittent operation in the past. As a test, the 14MHz beacon was switched on a few months ago and recently the 29MHz beacon has also been switched on. All

four HF beacons are now switched on and all have been reported in action by listeners. They are not very strong and the 7002kHz one is likely to be obliterated by the inevitable bandedge DXer hogging the edge of the band. Reports are coming in of interesting propagation effects such as sub-horizon signals appearing up to twenty minutes before VHF signals.

Reports on these beacons would be welcome, especially on any transequatorial signals which may show up. Send reports direct to the University of Surrey Space Centre, Guildford.

Re-entry of Oscar 9 is predicted to occur sometime towards the end of this year. It has been losing orbital height quite noticeably recently and the latest prediction for its demise from the Greenwich Observatory is early October this year.

The UoSAT-Data Booklet is available from the University of Surrey or from AMSAT-UK. It contains everything you want to know about the two UoSAT spacecraft: history; spacecraft sub-systems; modulation; data formats; decoding algorithms; telemetry equations, etc. Details from the University of Surrey or AMSAT-UK.

Microsats

These miniature satellites were announced and demonstrated at the AMSAT-UK Colloquium last year and the first of them is due to be launched in June of this year on the SPOT 2 mission, a replacement for the SPOT 1 Imaging Satellite, from an Ariane launcher. At the same time, six amateur radio satellites are going into a sun-synchronous orbit of roughly 98° inclination and 815km altitude. There will be two UoSATs and four satellites from other countries.

Amateur Satellite Report

The newsheet 'Amateur Satellite Report' produced by the American AMSAT organisation is to be replaced by a new publication edited by Joe Kasser G3ZCZ/W3. 'ASR' ran to 188 issues, when it became a casualty of the rapid advance of satellite and data technology in recent years; packet radio and bulletin boards are taking the place of the printed word! AMSAT news items became so readily available from these sources that many satellite users questioned the value of

ASR as a means of disseminating satellite news. Joe Kasser will be remembered as the editor of the original 'AMSAT newsletter'.

Radio amateurs fined

Radio Communication for February reports in detail the case of four licensed radio amateurs who were prosecuted by the Radio Interference Service for offences against the 1949 Wireless Telegraphy Act. The offences included: communicating with unlicensed persons; failing to maintain a logbook correctly; transmitting from a captive helium balloon; interfering with US Navy communications; inciting others to commit illegalities, and listening to various frequencies, inciting others to listen to them, publishing lists of them and disclosing information heard on them. One of the culprits was running a broadcast station on 6MHz!

It is good to see that the four chief offenders were realistically dealt with – equipment worth over £10,000 being forfeited and fines of £400.00 plus £140.00 costs being imposed on some of the others. An unlicensed person involved was eventually fined £1,150.

It is also a good thing to see that a real effort has been made to clear out some of the rogue operators who have come into

amateur radio recently, who deliberately break the amateur radio code of conduct which over the years has been one of the outstandingly pleasant features of our hobby. Perhaps those who continue to jam repeaters, use excessive power and work in sections of the bands which have been agreed by common consent to be used for special amateur radio activities, etc, will take heed from the knowledge that their activities are being observed by the authorities and that retribution will eventually come their way.

SYLEDIS

The same issue of **Radio Communication** also reports that SYLEDIS – one of the 'location determining' systems used by the oil and surveying industries, which has been causing so much interference on 430MHz – has been banned from operating within 100km of the UK coastline from 1 January 1989, by an edict from the Ministry of Defence.

This did not please the surveying operators at all who fought it tooth and nail! A compromise has now been reached. As of 1 February, the main SYLEDIS frequency has been moved to 438MHz. However, there is a sector on the south-east coast where 432MHz will still have to be used for a while longer. The DTI says it is trying to find

alternatives to SYLEDIS but so far without success.

The CEPT licence

Those who wish to operate amateur radio in other European countries will be pleased to hear that at last the CEPT licence is now a reality. Since 1 January this year, the CEPT licence permits operation of a mobile or portable station in the following countries: Austria, Belgium, France, Germany (Fed Rep), Holland, Liechtenstein, Luxembourg, Monaco, Norway, Sweden, Switzerland and Turkey.

You must operate within the terms and conditions of the countries you propose visiting as well as within the terms of your own licence. It is therefore wise to write to the licensing authorities of the countries concerned to get a copy of their regulations. Identification when operating abroad is simply to use your home call with the added prefix of the country you're in, ie, if in France I'd use F/G2UK. You must only use bands authorised in the country you're visiting.

The DTI is producing an information sheet which will contain all the information you should need to know about using this facility. It is entitled: 'Amateur Radio Information Sheet No 9 – CEPT Amateurs (UK Licensees)'. 

ADVERTISERS INDEX

Birmingham Sony	36
S R W Communications	11
P M Components	12, 13
Component Source	5
Grosvenor Software	11
Icom	18, 19
Kenzen	5
Keytronics	35
Nevada Communications	3
Rugged Displays Limited	22
Suma Designs	11
Technical Software	27
R Withers	2

NEW

RX-8 MULTIMODE RECEIVER For the BBC Computer

FAX: screen and printer

PACKET: HF and VHF

SSTV: in colour

RTTY: copies any signal

AMITOR/SITOR: ARQ and FEC

MORSE: best copy available

UoSAT: 1 and 2

ASCII: all speeds

Full specification in every mode. Printer and tape/disc support. Text store etc, etc.

This is the ultimate receive system for the serious listener with a BBC computer.

We can't begin to list all the features here so send for full information about it and all our other products

RX-8 System (EPROM, interface, leads and instructions) **£259.00** inc VAT and p&p

FREE Klingenfuss 1989 Utility Guide to first 50 purchasers of RX-8. **DISCOUNT** to existing RX-4 users.

technical software (REW)



Fron, Upper Llandwrog,
Caernarfon LL54 7RF
Tel 0286 881886



MEDIUM WAVE

DXING



by Steve Whitt

The Middle East

The Middle East is a distinct region of the world that encompasses a number of neighbouring countries and societies closely linked by historical tradition and modern allegiances. The common denominators linking many of the Middle Eastern countries are a belief in Islam and a common language, Arabic, of which several dialects exist. Another factor that is common to many of the countries is their oil-generated wealth, which has enabled radio stations to be set up to carry the voice of Islam to the rest of the world.

Over the years, as more and more stations have appeared on the MW band competing for a limited number of frequencies, the average power of transmitters has been steadily increased in an attempt to override interference. Today, looking at a list of stations on the MW band reveals that the vast majority of super-power stations are located in the Middle East; indeed, there are eighteen stations in this area alone using power of 1000kW or more. Just compare this with the maximum power of 500kW in use in the UK (by the BBC World Service on 648 and 1296kHz) or even the 50kW upper limit in North America.

Some of the more readily heard stations are: 621kHz, Egypt – 2000kW; 702kHz, Oman (BBC) – 1500kW; 900kHz, Saudi Arabia – 1000kW; 1134kHz, Kuwait – 1500kW; 1413kHz, Oman (BBC relay) – 1500kW; 1449kHz, JRT Jordan – 1000kW; 1481kHz, Dubai UAE – 1500kW; 1512kHz, Saudi Arabia – 1000kW; 1521kHz, Saudi Arabia – 2000kW.

At first sight much of Middle Eastern broadcasting seems to be influenced by the local dominance of Islam. However, the Koran is not the basis for all programming and you may well be surprised to find out the extent to which English programmes are aired. The following should make good hunting for the DXer and be of interest to the traveller heading to this part of the world. **Bahrain:** Bahrain Broadcasting Station; 1300-2100hrs on 1584kHz.

Egypt: ERTVU; 0500-0700 and 1000-2200hrs on 558kHz (foreign language channel includes English).

Iran: IRIB; 1400-1500hrs on 702kHz and 1930-2030hrs on 1404kHz.

Israel: IBA; 0500-0515, 1100-1130, 1500-1505 and 1800-1815hrs on 576 and 1458kHz.

Jordan: R Jordan; 0500-2200hrs daily on 855kHz and local FM stereo.

Kuwait: R Kuwait; 0500-0800 and 1800-2100hrs on 1341kHz.

Lebanon: Voice of Free Lebanon; 0830, 1230, 1530 and 1700hrs on 963kHz. Radio Voice of Lebanon; 0900, 1315, 1815hrs on 872kHz.

Qatar: QBS Doha; 0300-1100 and 1400-1830hrs on 1233kHz.

Saudi Arabia: BSKSA Jeddah; 1000-1300 and 1600-2100hrs on 1485kHz.

UAE: Voice of United Arab Emirates; 0800-1100hrs on 810kHz.

All times are UTC.

DIY Beverage aerials

In this column in the past I have mentioned DXpeditions to remote locations in Anglesey and north-west Scotland, and referred to the Beverage aerials used to winkle out the DX signals. However, you certainly don't have to plan a full-scale DXpedition to try out a Beverage type aerial and if you are fortunate to live in or near open countryside, experimenting with this sort of aerial should be relatively easy.

The Beverage, developed by Harold Beverage in the 1920s, is one of the oldest aerial designs around. In fact, an aerial of this type, 12km long, was used by Beverage in 1922 for the reception in the USA of some of the first low frequency (approx 1.2MHz) transmissions from Europe.

For a Beverage to be reasonably effective it needs to be between one and ten wavelengths long, which on the MW band implies lengths between 200 and 5000 metres. The longer it is relative to the wavelength of interest, the more directional the aerial becomes. Remember that the Beverage has its maximum signal pick-up along its length and that the aerial should point along the great circle path towards the desired reception area. Over the last half-century considerable research into the Beverage has been conducted and detailed design rules exist, but for the radio

enthusiast this is one aerial design that is very tolerant of design imperfections. Here's what you need to do to put your own Beverage aerial together and to put it to the test.

Location:

Unfortunately, the Beverage is a big aerial, but it doesn't really need much space and it can often be a 'secret' aerial erected unobtrusively. Ideally, you need to have a large field or woodland at the back of your house but a long straight fence can be used to support the wire. If you have lots of space you have the freedom to choose the beam direction but if you are just taking advantage of local geography, then you may have to accept the limitations imposed on you. A bearing (from true north) of 280 to 320° is good for North America, 250 to 280° for Central America, and 220 to 260° is best for South America. If you lack any significant space at home a good alternative is to find some open land nearby.

Wire:

Hard-drawn copper wire is best for a permanent aerial since it won't break, but it is not cheap and is quite heavy. I tend to use 7/0.2mm multi-stranded insulated wire for temporary DXpedition type aerials. A continuous barbed wire fence (galvanised steel) is all right also, so long as it's not too rusty to make good electrical connections. If you want to put up a cheap and disguised aerial, use thin transformer wire (eg, 40 gauge) which you can lay along a hedgerow. Whatever wire you choose, you'll need to be prepared for breaks and repairs; 'chocolate block' connectors are very useful accessories when working with Beverages.

Supports:

Garden-style bamboo canes (4-6ft tall) are cheap and good for the job. Just cut a slit at one end with a penknife or junior hacksaw to hold the wire. Lightweight wire (eg 7/0.2mm) needs a support every fifteen metres. If a straight hedgerow or fence runs in the desired direction you can dispense with the bamboo canes; likewise it is possible to support wire in trees or bushes as long as a reasonably constant height (between 4 and 10ft) above ground can be maintained.

Earth stake and terminating resistor:

If a Beverage is operated just as a long wire it will be directional but will pick up signals from both ends of the wire. However, if the end of the wire furthest from the receiver and nearest the target reception area is terminated in a non-inductive (eg carbon) resistor equal in value to the aerial's characteristic impedance (usually about 500 to 600 ohms), the aerial becomes unidirectional (**Fig 1**). For best results it's a good idea to experiment with the resistor value but even a fixed resistor of, say, 560 ohms, connected between the aerial and the ground stake will do the job. One good way to produce the terminating resistor

is to solder in series a dozen ½W 47 ohm resistors which are then encased in either heat-shrink plastic tubing or self-amalgamating tape. The use of many low-value resistors makes the whole combination less prone to moisture affecting the total resistance value. Do not forget that for best results a good earth stake is needed at both ends of the aerial, one for the terminating resistor and the other for the receiver.

Receiver:

If you aren't operating from a permanent home installation, or planning a full scale DXpedition from, for example, a farmhouse, you'll need portable equipment. One good portable receiver that performs very well with Beverage aerials on the MW band is the Sony ICF2001D. This radio can run off its internal batteries but, alternatively, an SW/MW communications receiver that runs off 12V could be used. To make the most of the 2001D (and many other receivers) it is advisable to place an aerial tuning unit between the Beverage and the radio; this should avoid overload problems caused by strong local signals. Just imagine the simplicity of driving up to your aerial, parking in a lay-by off the road, and then all you need to do is pass the aerial wire through the car window, connect it to the receiver and you are ready to go! With a bit of ingenuity and a few simple bits and pieces you could be DXing with your own Beverage aerial; you certainly don't need to own several acres of land.

My experiences

Recently I erected a Beverage on a piece of wasteland not far from my home. To find the location I did a little browsing through local OS maps and then surveyed the sites by driving around the neighbourhood. I guess I was lucky but I only needed to visit four locations before I found an almost ideal site allowing an aerial of 330 metres on a 290° bearing. Furthermore, the site was derelict and deserted so I put up a simple piece of wire slung through the bushes. The receiver end terminates on a fence post with some large nails to which I simply connect the receiver with crocodile clips, whilst at the other end I installed the terminating resistor between the aerial wire and a copper earth stake driven deep into soft earth in a ditch. In my case a good ATU is essential since I have an MW transmitter on 1170kHz not far from the aerial, making DX on frequencies 1150 to 1190kHz impossible. Despite this problem, limited tests already show the aerial performs well.

For instance, one night in January at 2300hrs, I was able to sit in the car hooked up to the Beverage and tune in the Caribbean Beacon from Anguilla on 1610kHz with 100% word-perfect reception, whereas back home using the usual loop aerials all I could make out was a weak carrier without any recovered audio!

DX file

As you may have heard elsewhere, the

last few months have witnessed a phenomenal increase in solar activity as the sun progresses towards the peak of solar cycle 22. Indeed, the rate of increase has been so great that some scientists are predicting the most active sun since records began. This has clearly had a marked effect on radio propagation in general, and in particular, high solar flux and an almost consistently unsettled, active geomagnetic field seem to have wiped out all high latitude MW DX signals. Conditions since Christmas have been particularly disappointing at my listening post in Suffolk. If conditions are directly attributable to solar activity, the prospects for the next few years don't seem very promising. However, there may be a glimmer of hope for the coming months around the equinox. In the past, the best DX conditions have tended to appear around the spring and autumn equinoxes and often an extended period of poor MW conditions known as the Mid-Winter Anomaly has arisen. So, there is no need yet to get discouraged by propagation conditions and there is still time for springtime DX to make amends for the poor show this winter.

Reports and news

Keep those dials tuned to the medium waves and why not tell everyone what you've been hearing? You can send your logs, reports or news tips to me care of **Radio & Electronics World**. Till next time, good DX.

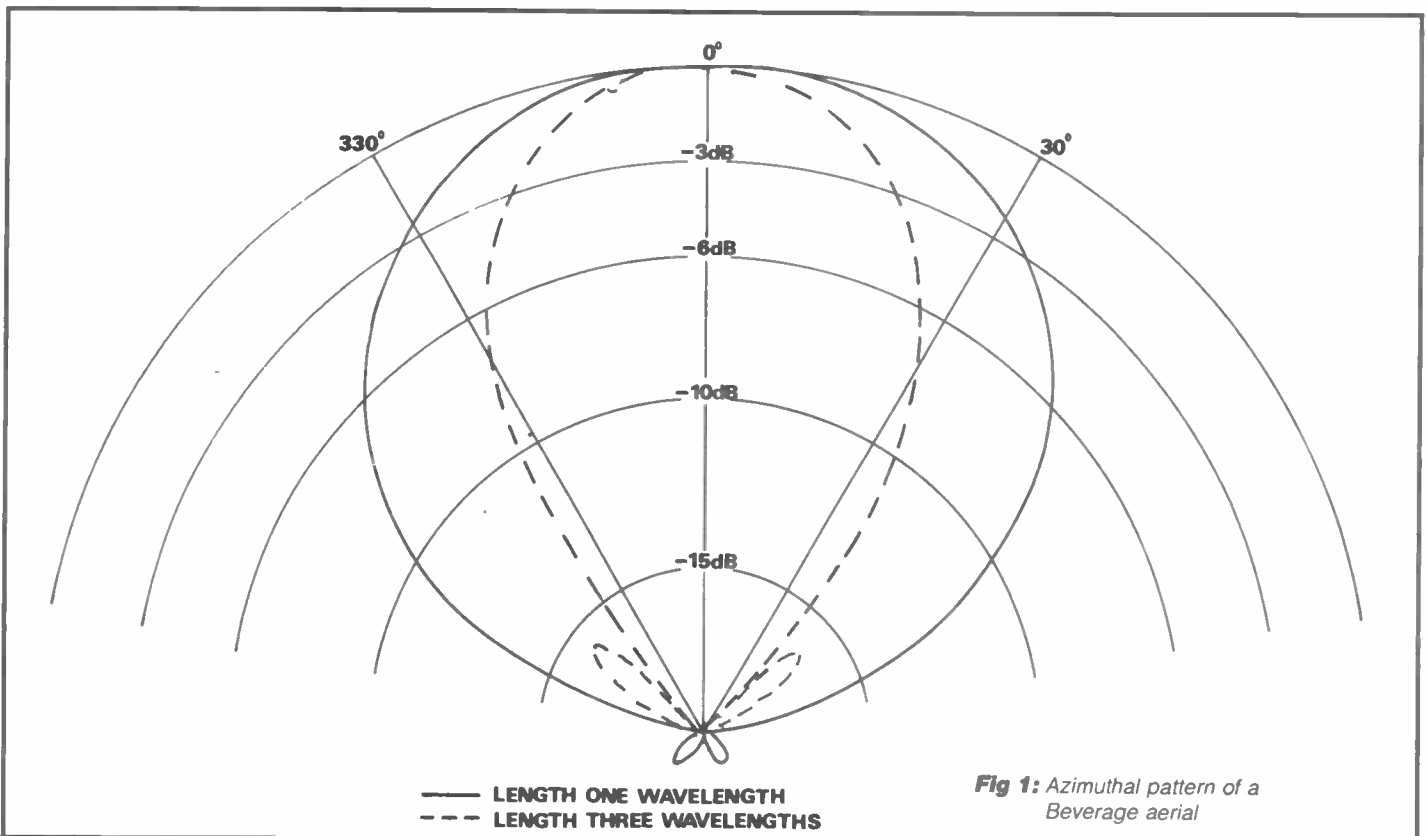

Fig 1: Azimuthal pattern of a Beverage aerial

SPECTRUM WATCH

by John Andrews

Super transistor created

Researchers at the American Telephone and Telegraph's Bell Laboratories in New Jersey have demonstrated a new transistor which can switch on and off *140 billion times a second*, or twelve times faster than transistors used in current supercomputers. Even if this is an American billion, that's some going. Present-day transistors of this type, known as bipolar, are typically made of silicon and can operate at 12 billion operations a second.

AT&T says the device may be useful in integrated circuits and ultra-high-speed electronics for optical fibre communications systems, among other things. The new transistor is made of indium phosphide and gallium indium arsenide, rather than silicon. High-speed electrons are used to relay signals in the transistor, travelling across the device at half of a trillionth of a second in a new fashion. Unlike the multiple collisions of electrons in silicon transistors, in the new device the electrons move quasi-ballistically, colliding with only one or two atoms in the semiconductor crystal.

The new transistor's test-speed is only the tip of the iceberg, according to Richard Nottenburg, a member of the technical staff at Bell Labs. At 140GHz these new transistors are operating at less than 50% capacity. He says, 'We are cracking a new frontier in which we will be able to operate at frequencies never before envisioned'.

And a vacuum transistor . . .

Vacuum tube devices are bouncing back! The US Naval Research Laboratory (NRL) is developing a radically new vacuum microelectronic device, which is reminiscent of a miniaturised vacuum tube (valve), yet is thousands of times smaller.

Dr Henry F Gray, a research physicist at NRL, states that the vacuum device is superior to the solid type with respect to saturation velocity and associated transit time, yet it has the size and cost advantages of solid-state technology. It is also ultra-fast, ultra-radiation-hard, temperature insensitive and very efficient. It can be used for analogue (eg medium and high-power millimetric wave amplifiers) and digital (eg ultra-fast signal processor and computer) applications in both normal and hostile environments, says Gray.

Whether this will stimulate a revival of interest in nuvistors is not clear, but it proves there is nothing new under the sun (and this report is not dated 1 April)!

Dish wars?

Being overtaken by events is one of the hazards of writing a column that takes a couple of months to appear in print. That said, it looks as if a price war may be starting in the provision of satellite receivers for the Astra bird. Dixons are quoting £199.00 but are only taking orders; the actual equipment was not available off-the-shelf at the time of writing, nor was the precise specification. Now Sir Clive Sinclair's Cambridge Computer company has entered the fray with a flat square antenna, reminiscent of BSB's 'squarial' but intended for the Astra satellite. Prices quoted are £149.95 for the basic 60cm aerial and indoor tuner/receiver, £179.95 for a version with an armchair remote control unit and £229.95 for the deluxe version with stereo sound, graphic equaliser and other bells and whistles. Up to now I have considered products at these low prices to be no more than vapourware, so let's see if they can be sustained!

Microwave frequencies run out

The growing use of private radio links and the increase in the amount of voice and data traffic over them is causing problems for Britain's gas, electricity and water utility industries. First located around 460MHz, many of these links then moved up to 1500MHz to allow better use of the 460MHz frequencies for mobile radio. Microwave radio is more appropriate for the telemetry data and internal telephone calls sent over these links, but the 1500MHz band is now virtually full in many parts of the country.

New and replacement radio systems are now being installed on 7.5GHz, previously used only for trunk links. The beams at this frequency are narrower, reducing the risk of mutual interference, and more bandwidth is available for the growing level of traffic.

A report from the Utilities Telecommunications Council in the USA says that because of the shortage of radio frequency spectrum in some regions there, various large utilities are replacing all or part of their private microwave networks with fibre-optic systems. Seventy-five municipal and state utilities

now use fibre in their networks, in systems ranging from a few miles up to 500 miles. Electrical concerns have switched from microwave to microwave/fibre-optic hybrids or all fibre-optic networks faster than gas and water utilities, mainly because they own rights of way along pylon routes and it is easy to string fibre between the pylons. The same is happening in Britain.

Radio telescopes enhanced

A new radio telescope is to be built at Cambridge and, when linked with others elsewhere in Britain, will form the world's most powerful telescope for observing radio waves from the sun and other stars. It will become part of the MERLIN network, MERLIN standing for Multi-Element Radio-Linked Interferometer Network. By taking simultaneous readings from a number of dishes across the country and combining the measurements, scientists can build a composite result equivalent to one received from a dish the size of the sum of the individual ones. The larger the array of dishes, the finer the details of radio sources MERLIN can resolve.

The contract is worth £3 million, half of which will go to British firms. It will enable MERLIN to resolve radio details as small as 0.01 arcseconds in width, equivalent to a few millionths of the width of the full moon and ten times better than the world's current best.

In the USA, scientists and engineers from the Jet Propulsion Laboratory (JPL) and the National Radio Astronomy Observatory (NRAO) are to link their radio telescope systems in similar fashion. This will couple the twenty-seven radio telescopes of the NRAO's Very Large Array to JPL's Deep Space Network to enhance communications abilities for the flypast of Neptune by Voyager 2 which is scheduled for August of this year. A new X-Band receiver system is being built, using liquid helium cooling to minimise internal electronic noise in the circuitry.

The size of these antennas is stunning. The dishes at the Deep Space Network site in California are 112 and 230ft in diameter, while the twenty-seven at the NRAO's Very Large Array (Socorro, New Mexico) are each 82ft across. The sites will be interlinked by satellite, whereas those in the British MERLIN system use normal terrestrial microwave. 

FREE CLASSIFIED ADS

FREE CLASSIFIED ADS CAN WORK FOR YOU

We are pleased to be able to offer readers the opportunity to sell your unwanted equipment or advertise your 'wants'.

Simply complete the order form at the end of these ads, feel free to use an extra sheet of paper if there is not enough space on the order form. We will accept ads not on our order form.

Send to: *Radio & Electronics World*, Sovereign House, Brentwood, Essex CM14 4SE.

DEADLINE AND CONDITIONS

Advertisements will be inserted in the first available issue on a first come first served basis. We reserve the right to edit and exclude any ad. Trade advertisements are not accepted.

FOR SALE

- 1973, 75, 77, 83, 84 and 85 WRTH: £5.00 each including p&p. Sinclair 48K PSU, leads, GWO. Will exchange for Satellit 1100 Rx, with or without BFO, or Sony CRF-5090, Earth Orbiter improved model Rx. F Amoroso, 60 Highfield Rd, Lancs M6 5LA
- Canon 7x50 quality binoculars, mint condition, leather case, £45.00. Coinshooter 3 metal detector, induction balance, triplet coil, bandspread tuning, temp compensation, water immersible. VGC, £30.00. Steve GM4GTU, QTHR. Tel: (0224) 743039 anytime
- Sony STR VX ICL tuner amplifier, 25W per channel. Good condition. Exchange for amateur radio equipment. Tel: (0277) 823434
- CB radio, can be converted to MHz, power pack 507A, £15.00. Speech processor, £25.00. 934 and aerial, £65.00. TV B/W, suitable for Sporadic E, dual control, £25.00. Also D100 converter for Sporadic E. Tel: (0283) 221870
- Sommerkamp FT-250, 8-10m HF transceiver, with manual, and FP-250 240W pep matching PSUs. GWO. Exchange for Sony ICF2001D or Satellit 2500 onwards, digital multibander. Tel: 061-743 1570
- Technics SX-K500 digital electronic keyboard 4½ octaves. Full rhythm section, percussion, special FX, fully polyphonic, built-in sequencer, storage memories, key transposer, composer functions all fully editable, memory card facility. Midi in/out. A truly amazing keyboard, beautiful sounds. Too many facilities to mention. An unwanted Xmas present. New, costs £700.00, sell for £550.00. Complete with stand and foot switch

(extras). Steve GM4GTU, QTHR. Tel: (0224) 743039 anytime (Aberdeen)

- 934MHz Delta 1, H100 cable, two beam antennas, connections, £250.00 or swap for Ham International Jumbo. Mr G Strange. Tel: Godalming 29419
- Yamaha DG5 Electone organ, mint condition, cost £3,680, asking £900.00. Complete with bench seat and instruction manuals. Or exchange for Kenwood TS811E 70cm transceiver. G1UUE. Tel: (091-263 9460 (Tyneside))
- Rolon non-magnetic tweezers, ideal for etching circuit boards, etc: 3 pairs £1.00. Multimeter shunt £2.50. Disco party light circuit with built-in mic, £9.00. Stereo circuit £11.00. All by post only. Mr Martin, 7 Griffin Crescent, Littlehampton, Sussex BN17 7LH
- Yaesu FT101B, modified by G3LLL to cover all WARC bands and 160-10m, CW filter, speech clipper, £290.00. Yaesu FT101ZD, mkIII, FM, CW filter, £425.00. Microwave Modules MML 432/100W linear, £295.00. Tel: (0543) 481202
- Icom IC2E, £120.00 and Yaesu FT2700RH, £320.00. Both in excellent condition and with accessories. Tel: (0782) 630843 for full details
- Old receiver service manuals (copies): Pye Bantam HP1AM; Cambridge AM10D; Westminster W15AM, W15FM, W30AM; Vanguard U-30; Racal RA17, RA17L; Eddystone 770R, 770U; EC10/II, 640, 504. All at £8.00 each inc post and packing. Mr Small, 10 Sibleys Rise, South Heath, Great Missenden, Bucks HP16 9QQ
- Sony Walkman WM-R202, cost £190.00 will exchange for used Rolex or full Hunter pocket

watch. Also for exchange: Einstein 80 computer joystick, two discs, all books new plus five new compact discs. Exchange for old Rolex, Omega, Hunter, or any old wrist or pocket watch might be suitable depending on make and condition. Gent's gold diamond ring also wanted. Mr Pilditch, D2, Broadmoor Hospital, Crowthorn, Berks RG11 7EG

WANTED

- Sony CRF-330K Rx for a good cash price. Tel: 061-743 1570
- Radio Constructor: Vol 1 No 7 February 1948, Vol 1 No 8 March 1948, Vol 1 No 12, July 1948, Vol 3 No 3 October 1949. High price offered. Volery, Poste Restante, CH-8953, Dietikon, Switzerland. Tel: 01041 1740 3762
- Datong ASP automatic RF speech processor. Steve GM4GTU (QTHR). Tel: (0224) 743039 anytime
- Does anyone have any CV 2979 miniature valves in working condition? I urgently need preferably three. Write to 38 Quantock Road, Watchet, Somerset TA23 0DY
- TV4 Magic Eye radio valve for Bush receiver circa 1938. Would also appreciate service manual. R B Bain, 60 Beechwood Road, Newport, Gwent NP9 8AH. Tel: (0633) 273951
- Cobra 148 GTL DX, Super Star 360, President Adams or Jackson urgently required for conversion to 29MHz, or any SSB inc USB receivers. Must cover 500kHz to 29.00-30.00MHz. Good money ready to be paid for the above. Mr Nigel John Wilson, 195a Hamlet Court Road, Westcliff-on-Sea, Essex SS0 7EL. Tel: 339772

FREE CLASSIFIED AD ORDER FORM

Send to: Radio & Electronics World Classified Ads-Sovereign House · Brentwood · Essex · CM14 4SE

Classification: (tick appropriate box) If you want to insert ads under more than one classification use separate sheets for second and subsequent ads

For Sale Wanted.....

USE BLOCK CAPITALS (One word per box)

To avoid mistakes please write clearly and punctuate your ad

Name/Address Postcode/Telephone							

USE SEPARATE SHEET FOR MORE WORDS

Ensure that you have included your name and address, and/or telephone number

CONDITIONS: Your ad will be published in the first available issue. We will not accept trade advertisements. We reserve the right to exclude any advertisement.

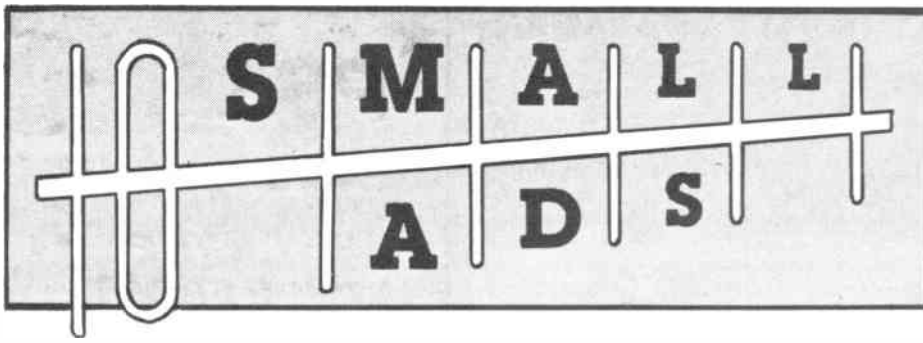

**MRZ MICROWAVE
MOBILE ANTENNA**
ICOM-BUSINESS/AMATEUR/ MARINE/AIR
UK AND EXPORT
MRZ COMMUNICATIONS LTD
NEWCASTLE UNDER LYME

ICOM

TEL: (0782) 619658
7 DAY SERVICE

JAYCEE ELECTRONICS LTD
JOHN GM30PW
20 Woodside Way,
Glenrothes,
Fife KY7 5DP
Tel: 0592 756962
Open: Tues-Sat 9-5

Quality secondhand equipment in stock. Full range of TRIO goodies. Jaybeam - Microwave Modules - LAR.

Selectronic
Radio communications and scanning receiver specialist

203 High Street
Canvey Island, Essex,
Tel: 0268 691481
(Open Mon-Sat 9-5.30)
Amateur radio equipment also in stock

**IAN FISHER COMMUNICATIONS
OF STANHOPE**
CB Works, The Market Shop, Market
Place, Stanhope, County Durham
☎ (0388) 528464

Main Distributors of 27MHz CB radios and the NEW CEPT models including UNIDEN and DNT.
Including U.K. and CEPT walkie talkies.
Large stocks of coaxial cable, plugs, sockets and adaptors.
Stockists of the new UNIDEN 28/30 Multimode Transmitter receiver

AIRBAND RADIO
Superb new SKIPTECH 9000 airband and PMR band receivers £18.50
Very latest sonic 4-8342 multiband radio receiver airband +PMR from 54MHz to 176MHz two aerials £21.00
Very latest SONIC 8342 Multi Band Radio receiver AIRBAND & PMR from 54MHz to 176MHz with two aerials £21.00
All available via mail order. Retail/Wholesale

OPEN: MON-SAT 10.30am-6.00pm SUN 2.30 - 4.30
RING FOR DETAILS (0388) 528464

MILITARY SURPLUS EQUIPMENT MANUAL
Giant collection Military Equipment Circuits/Data.
Only £10.00 including Post/Packing.
Just one of many unique Repair and Data Guides.
LSAE for your FREE catalogue.

FULL WORKSHOP SERVICE MANUALS
Video Recorders £12.50. All others £6.00 inclusive.
State Make/Model/Type with order.

MAURITRON ELECTRONICS LIMITED (REW)
8 Cherry Tree Road, Chinnor
Oxfordshire OX9 4QY
Tel: (0844) 51694

TURN YOUR SURPLUS
IC's TRANSISTORS etc, into cash, immediate settlement. We also welcome the opportunity to quote for complete factory clearance.

CONTACT:
COLES-HARDING & CO
103 South Brink, Wisbech, Cambs
TEL: 0945 584188/Fax. No. 0945-588844
Est Over 10 years

AGRIMOTORS
MERTON CB AND RADIO CENTRE
MERTON GARAGE AND POST OFFICE, MERTON.
Nr OAKHAMPTON, DEVON EX20 3DZ
OPEN 6 DAYS 9-6 LUNCH 1-2pm
EARLY CLOSING THURSDAY 1.00pm
(SUNDAYS BY APPOINTMENT)
SPECIALIST IN 934 MHz
SUPPLIERS OF ALL 27MHz AND 934 MHz EQUIPMENT
AMATEUR ACCESSORIES CATERED FOR
08053 200

Radio & Electronics World
The communications and electronics magazine

This method of advertising is available in multiples of a single column centimetres — (minimum 2cms). Copy can be changed every month.

RATES
per single column centimetre:
1 insertion £9.65, 3 — £9.15, 6 — £8.65, 12 — £7.75.



ETESON ELECTRONICS
15B Lower Green,
Poulton-le-Fyde, Blackpool
Tel: (0253) 885107

Open: 9.30am - 12.30, 1.30 - 5.30. Closed Wed & Sun.
Electronic Component Specialists.

A wide range of electronic components, IC's, capacitors, transistors, resistors, plugs and sockets etc.

Trade Mark No 1189926 consisting of the word "SECURITRON" and registered in respect of "Radio telephones incorporating digital coding apparatus for preventing unauthorised use" was assigned to 21st June 1988 by Fidelity plc of Victoria Rd, London NW10 6ND to Browns Trading Company Limited of Pearl Assurance House, 319 Ballards Lane, London N12 8LY, WITHOUT THE GOODWILL OF THE BUSINESS IN THE GOODS FOR WHICH THE MARK WAS THEN IN USE

JAPANESE IC's (PART OF OUR RANGE)
AN7178 £2.95, BA5406 £2.20, HA1377 £2.20, HA1392 £2.50, HA1394 £2.95,
HA1397 £2.75, HA1398 £2.75, HA13001 £2.95, LA4460 £1.80, LA4461 £1.80,
LA4507 £4.25, LC7137 £4.50, M51517 £2.80, MB3705 £1.80, MB3712 £1.50,
MB3722 £3.50, MB3730 £2.50, MB3731 £3.50, STK461 £7.50, STK463 £8.40,
TA7205AP £1.00, TA7222AP £1.30, TA7240 £2.95, TA7241 £2.95, TA7270
£2.75, TA7271 £2.75, TA7274 £2.95, TA7280 £3.50, TA7281 £2.95, TA7282
£2.95, TA7283 £2.95, TA7288 £2.95, TA7611 £3.20, UPC575 £1.00, UPC1156
£2.95, UPC1181 £1.10, UPC1182 £1.10, UPC1185 £2.50, UPC1188 £2.75,
UPC1230 £2.50, UPC1263 £2.50, UP1277 £2.75, UPC1278 £2.75, UPC1365
£3.80, UPC1394 £1.95,
ADD 60p POST AND PACKING AND THEN ADD 15% VAT TO TOTAL
T POWELL 16 PADDINGTON GREEN LONDON W2 1LG
OPEN MON-FRI 10AM-5PM, SAT 9AM-12 NOON.
TELEPHONE: 01 723 9246
ACCESS/VISA. TELEPHONE ORDERS ACCEPTED OVER £5.00

RADIO & ELECTRONICS WORLD SMALL AD ORDER FORM

TO: Radio & Electronics World · Sovereign House
Brentwood · Essex CM14 4SE · England · (0277) 219876

PLEASE RESERVEcentimetres bycolumns
FOR A PERIOD OF 1 issue..... 3 issues..... 6 issues..... 12 issues.....

COPY enclosed..... to follow.....

PAYMENT ENCLOSED:..... £ —

CHARGE TO MY ACCOUNT.....

COMPANY
ADDRESS
SIGNATURE TELEPHONE.....

C P I

HYBRID POWER CONTROLS

☆ **BF HYBRID** £7.95
12 Amp 240 Volt complete Zero Voltage Proportional Heater Control (no radio interface).

☆ **PC1R** £3.45
1 Amp 240 Volt Phase Angle Controller - Light Dimmer (requires 220k pot)

☆ **PC12R** £6.95
12 Amp 240 Volt Phase Angle Controller - Light Dimmer, Drill Speed, Heater Control. (Requires 220k pot)

Prices include VAT + p&p 62 PARK ROAD, SWANAGE, DORSET BH19 2AE
SAE for details on above products TELEPHONE: 0929 426400
Full range of Thyristors, Triacs, Fuses, Heatsinks & Firing Circuits etc.
Trade enquiries welcome



THE VALVE DATAMAN

1914-1959 for circuits, service sheets, manuals, handbooks on all valve and early transistor equipment including audio, military (British & Foreign), radio and TV. Quotation by return via letter (SAE) or phone. Brochure supplied with SAE. Credit card orders taken over the phone.

THE DATAMAN
Tudor House, Cosham Steet,
Magotsfield, Bristol BS17 3EN
Phone: 0272 565472

★ **PSSS....** ★
ALL THE SUPER BARGAINS ARE ON THE INSIDE FRONT COVER



★ ★

AMDAT

THE PACKET RADIO EXPERTS
Authorised dealer for ICOM
CROFTERS, HARRY STOKES ROAD
STOKE GIFFORD,
BRISTOL BS12 6QH
Tel: 0272 699352/559398



SOUTH WALES ELECTROMART

Equipment, Components, Howes Kits, Eldy Kits, A.R. Gear & much more.
Taillwyd Road (off Main Road)
Neath Abbey, Neath
Tel: (0639) 644111

QUARTZ CRYSTALS and FILTERS

Large numbers of standard frequencies in stock for amateur, CB, professional and industrial applications. Stock crystals £5.00 each (inc VAT and UK post). Any frequency or type made-to-order from £6.50. Phone or SAE for lists.

GOLLEDGE ELECTRONICS
Merriott, Somerset TA16 5NS
Tel: (0460) 73718

COMPONENT KITS RESISTORS, CAPACITORS, FUSES, DIODES ETC

Save time, trouble and expense on that project by having the components you require to hand. Our kits are ideal for the Development Lab, service engineer, Repair Shop, Tech college and hobbyist alike. The components supplied in our kits are new and to full specification. They come individually packed in handy re-usable plastic tubes, all contained within a storage unit.

RESISTORS 1/4w CF. 5%
KIT 25E12-20 12R-1MEG (80 values, 20 of ea.) 1200 = £12.00
KIT 25E24-20 12R-1MEG (120 values, 20 of ea.) 2400 = £21.00
Replacement tubes complete with Resistors 25p ea.

RESISTORS 1/2w CF. 5%
KIT 50E12-10 12R-1MEG (60 values, 10 of ea.) 600 = £13.75
Replacement tubes complete with Res. 25p ea.

RESISTOR TWIN KIT 1/4w and 1/2w CF.
KIT 25E12-20 12R-1MEG (80 values, 20 of ea.) = 1200
KIT 50E12-10 12R-1MEG (60 values, 10 of ea.) = 600 £25.00
FUSE KIT 20x5mm. 25-10amp 5B & QB 10 of ea. (300) = £26.25

ZENOR DIODE KIT
400mW KIT Z12-10 2.7-V 10 of ea. (150) = £12.20
1.3w KIT Z12-10 2.7-27V 10 of ea. (150) = £18.00

ZENOR TWIN KIT
KIT Z12-TWIN-10 2.7-27V 10 of ea. (300) = £30.00

DIODE KIT
400mA IN4148 (200) 1Amp 4007 (50 ea.)
3 amp 5401, 5408 (25 ea.) Total 350 = £12.00
Any kit can be put together, if you or your company have a requirement for special or mixed kits we will be happy to quote. Please send sae for full component and product list. Please add 50p P&P and 15% VAT to all orders. MAIL ORDER ONLY

A.D.A.M. Electronics
P.O.Box 24, Church Crookham, Aldershot.
GU13 0DH. Tel: 0252 617193

PROFESSIONAL SURVEILLANCE EQUIPMENT

Crystal Controlled Micro Transmitters, Telephone Transmitters and Covert Body Transmitters

High Grade. Superb Stability

Countersurveillance

Portable and Pocket Bug Detectors and the Unique CS420 Top Defeat System which will Nullify the Effect of ANY Telephone Interceptions

(Includes audio recording transmitters etc)

Cyberscan International

3 Eastcote View, Pinner, Middlesex HA5 1AT.
01-866 3300. FAX: 01 429 0950

USED AMATEUR EQUIPMENT?

I buy, sell and exchange

For the deal you've been looking for, phone Dave, G4TNY, anytime on Homchurch (0708) 862841 or (0836) 201530

9am-7pm Mon-Sat or send SAE
Personal callers by appointment please

G4TNY Amateur Radio, Unit 14
Thurrock Commercial Centre, Juliet Way, South Ockendon, Essex, RM15 4YG

COUNTY GUIDE

RATES
BOXES ad sizes
20mm x 59mm single
40mm x 59mm double

Total prepayment rates	Ad space	3 issues	6 issues	12 issues
	single	£47.00	£88.00	£158.00
	double	£94.00	£176.00	£316.00

RADIO & ELECTRONICS WORLD COUNTY GUIDE ORDER FORM

TO: Radio & Electronics World · Sovereign House · Brentwood · Essex
CM14 4SE · England · (0277) 219876

print your copy here

NUMBER OF INSERTIONS REQUIRED

Single County Guide 3 £47.00..... 6 £88.00..... 12 £158.00.....
Double County Guide 3 £94.00..... 6 £176.00..... 12 £316.00.....

PAYMENT ENCLOSED

£ —

Cheques should be made payable to Radio & Electronics World. Overseas payments by International Money Order

Conditions — Payment must be sent with order form. No copy changes allowed. Ads accepted subject to our standard conditions, available on request.

Registered No 2307667 (England)

C P I

J P G ELECTRONICS

Resistors 1/4w 5% carbon E12 1P1% metal fm E243P Resistor Pack 85 different E12 values plus ohm link, total content of resistor 1,000 £8.95
LED's Red/Green 3/5mm 6p each, Yellow 11p each Cable Ties 75mm 1p each. £5.91/1,000: £49.50/10,000
Power Transistors T/T 35C, TIP 36C, 100V, 25A TOP3, £1.56 each
Plastic case £1.50
100db Piezo Buzzer 80p
Solar Cells 0.45v 100mA £1.48;
70mA £3.50
Stepping motor 4 phase 12v 7.5 step 50ohms £8.95
SAA 1027 Stepping motor drive chip £3.95
Miniature FM Transistor kits 100-108MHz high quality, sound ideal for cordless microphones or guitars etc. £7.48
Metal Latching XLR line plug £1.35
Line Socket £1.48
Ferric Chloride pack for mixing with 1/2 litre water £1.40
Flux cord solder 500g reel £4.95
Automatic Squeeze action wire stripper £3.45

SPECIAL OFFERS
Computer grade capacitors with screw terminals 50,000 uk 60v £4: 4 700 of 63v £1.50; 38,000 of 20v £1.95; 87,000 of 10v £1.50
Stereo LW/MW/FM tuner, pre-amp, complete with volume/tone control and tuning scale Brand new in makers box £5.95; faulty £1.95
Circuit diagram, description and setting up to procedure for tuner assemble, described above 50p
LCD display 16 digit 7 x 5 dots matrix £2.50
Qwerty keyboard 58 key uncased good quality switches £5
CMOS TTL 74 HC 74F linear transistor kits, capacitors, resistors, tools etc, always in stock

Please add 75p + p per order VAT inc
J P G ELECTRONICS, 275 Chatsworth Road
Chesterfield S40 2BH. Callers welcome
Access orders (0246) 211202

DISPLAY AD RATES		series rates for consecutive insertions			
depth mm x width mm	ad space	1 issue	3 issues	6 issues	12 issues
61 x 90	1/8 page	£91.00	£86.00	£82.00	£73.00
128 x 90 or 61 x 186	1/4 page	£160.00	£150.00	£145.00	£125.00
128 x 186 or 263 x 90	1/2 page	£305.00	£290.00	£275.00	£245.00
263 x 186	1 page	£590.00	£560.00	£530.00	£475.00
263 x 394	double page	£1140.00	£1070.00	£1020.00	£910.00

COLOUR AD RATES		colour rates exclude cost of separations	series rates for consecutive insertions			
depth mm x width mm	ad space	1 issue	3 issues	6 issues	12 issues	
128 x 186 or 263 x 90	1/2 page	£420.00	£395.00	£375.00	£335.00	
297 x 210	1 page	£810.00	£760.00	£730.00	£650.00	

SPECIAL POSITIONS	Covers:	Outside back cover 20% extra, inside covers 10% extra
	Bleed:	10% extra [Bleed area = 307 x 220]
	Facing Matter:	15% extra

DEADLINES		*Dates affected by public holidays				
issue	colour ad	mono proof ad	mono no proof & small ad	mono artwork	on sale thurs	
Apr 89	8 Feb 89	9 Feb 89	15 Feb 89	17 Feb 89	9 Mar 89	
May 89	14 Mar 89	15 Mar 89	21 Mar 89	23 Mar 89	13 Apr 89	
Jun 89	12 Apr 89	13 Apr 89	19 Apr 89	21 Apr 89	11 May 89	
Jul 89	10 May 89	11 May 89	17 May 89	19 May 89	8 Jun 89	

CONDITIONS & INFORMATION			
<p>SERIES RATES Series rates also apply when larger or additional space to that initially booked is taken. An ad of at least the minimum space must appear in consecutive issues to qualify for series rates. Previous copy will automatically be repeated if no further copy is received. A 'hold ad' is acceptable for maintaining your series rate contract. This will automatically be inserted if no further copy is received. Display Ad and Small Ad series rate contracts are not interchangeable.</p>	<p>If series rate contract is cancelled, the advertiser will be liable to pay the unearned series discount already taken.</p> <p>COPY Except for County Guides copy may be changed monthly. No additional charges for typesetting or illustrations (except for colour separations). For illustrations just send photograph or artwork. Colour Ad rates do not include the cost of separations.</p>	<p>Printed — web-offset. PAYMENT Above rates exclude VAT. All single insertion ads are accepted on a pre-payment basis only, unless an account is held. Accounts will be opened for series rate advertisers subject to satisfactory credit references. Accounts are strictly not and must be settled by publication date.</p> <p>FOR FURTHER INFORMATION CONTACT Radio & Electronics World, Sovereign House, Brentwood, Essex CM14 4SE. (0277) 219676</p>	<p>Overseas payments by International Money Order. Commission to approved advertising agencies is 10%.</p> <p>CONDITIONS 10% discount if advertising in both Radio & Electronics World and Amateur Radio. A voucher copy will be sent to Display and Colour advertisers only. Ads accepted subject to our standard conditions, available on request.</p>



THE COMMUNICATIONS AND ELECTRONICS MAGAZINE

- Regular well-informed columns on various aspects of amateur communication
- Simple and useful constructional projects, plus clear explanations of the theory behind them
- Delivery to your door by publication date each month

On sale NOW at your newsagent and at equipment dealers

RADIO & ELECTRONICS WORLD SUBSCRIPTION ORDER FORM

To: Subscription Department • Radio & Electronics World • 45 Union Road • Croydon • Surrey • CR0 2XU
Tel: 01-684 9542

NAME

ADDRESS

Postcode

PLEASE SUPPLY: (tick box) for 12 issues, all rates include P & P

Inland World-Surface Europe-Air World-Air
 £26.00..... £27.50..... £30.10..... £34.10.....

PAYMENT ENCLOSED: £ —

Cheques should be made payable to Radio & Electronics World. Overseas payment by International Money Order, or credit card.

CREDIT CARD PAYMENT EXPIRY

.....

Signature

SONY[®]

Tune in to faraway places.

**NOTHING CAN CLOUD
YOUR RECEPTION WITH A
SHORT WAVE OR AIR
BAND RADIO**



B·A·T·S

BIRMINGHAM
160-162 CORPORATION ST
Telephone: 021-236 2139
(NR LAW COURTS)

SONY
CENTRE