

# TV



# Troubleshooter Reference Handbook

by **STUART HOBERMAN**

**A Six-Step Troubleshooting Technique  
for faster, more efficient service.**

## TROUBLESHOOTING CHART

TROUBLE	ASSOCIATED SYMPTOMS	CHECK AREA
No video	Raster normal; no sound	<ul style="list-style-type: none"> <li>a. Video I-F amplifier</li> <li>b. Tuner</li> <li>c. AGC stage</li> <li>d. Video output stage (on some sets, sound takeoff after this stage)</li> </ul>
No raster	Sound normal on all channels	<ul style="list-style-type: none"> <li>a. Horizontal sweep circuits</li> <li>b. High voltage rectifier</li> <li>c. Video output stage</li> <li>d. Shorted CRT</li> </ul>
No sound	No video; raster normal	<ul style="list-style-type: none"> <li>a. Tuner stage</li> <li>b. Video I-F</li> <li>c. AGC stage</li> <li>d. Audio output stage (on some sets)</li> </ul>

**\$2.95**

Cat. No. TVH-1

# **TV Troubleshooter's Reference Handbook**

by

**Stuart Hoberman**



**HOWARD W. SAMS & CO., INC.**

**THE BOBBS-MERRILL COMPANY, INC.**

*Indianapolis • New York*

FIRST EDITION

FIRST PRINTING—JUNE, 1963  
SECOND PRINTING—NOVEMBER, 1965

TV TROUBLESHOOTER'S REFERENCE  
HANDBOOK

Copyright © 1963 by Howard W Sams Co., Inc., Indianapolis,  
Indiana. Printed in the United States of America.

All rights reserved. Reproduction or use, without express permission, of editorial or pictorial content, in any manner, is prohibited. No patent liability is assumed with respect to the use of the information contained herein.

Library of Congress Catalog Card Number: 63-19104

# Preface

*TV Troubleshooter's Reference Handbook* has been prepared as an aid to the television technician in analyzing and repairing television troubles. Not only does this handbook cover the more common problems likely to be encountered, but it also includes some of the more unusual troubles.

This handbook has eight chapters, seven of which cover troubleshooting in a particular area of a television receiver. Repair techniques are described for low-voltage supply circuits, tuner, video, audio, and synchronization circuits, as well as horizontal and vertical sweep, chroma sync, bandpass, and amplifier circuits. Each of these chapters approaches troubleshooting from the same viewpoint. The technician is asked to observe the TV defect, interpret the symptoms, and then isolate the trouble to possible defective components or stages. To help in doing this, sample waveforms and measurements are provided for the typical circuits shown. By considering all the symptoms associated with a particular trouble, the service technician will be better able to tell which stage is defective. Using this diagnostic approach will help to improve repair techniques in easy sets, as well as "dogs."

Chapter 1 describes how to use these systematic troubleshooting techniques to increase troubleshooting ability and improve efficiency. No hard and fast rules are given because there is no sure-fire method of pinpointing defec-

tive components by observation alone. Instead, the approach followed can be used most effectively when coupled with the technician's individual service background. Throughout the book will be found charts and tables designed as a guide to the most common TV troubles, both black and white and color. These helpful aids are included in the index as well as the contents page.

In the television repair business there is no real substitute for good practical experience. Accordingly, all the examples given in this book are factual, not theoretical; the original troubles caused servicemen much time and effort before they were finally located and repaired.

The usefulness of *TV Troubleshooter's Reference Handbook* as an effective tool to aid the service technician is not impaired by the lack of experience of the user. The technician whose background is filled with gaps and omissions will find an amazing improvement in his troubleshooting skill as he learns and uses this technique.

STU HOBBERMAN

May, 1963

# Contents

## CHAPTER 1

TROUBLESHOOTING TECHNIQUES . . . . .	7
Six-Step Troubleshooting Technique	

## CHAPTER 2

TROUBLESHOOTING LOW VOLTAGE POWER SUPPLIES . . . .	17
Doubler Power Supply — Vacuum-Tube Power Supply— Power Supply Trouble Analysis	

## CHAPTER 3

TROUBLESHOOTING TUNER CIRCUITS . . . . .	29
Types of Tuners—Tuner RF-Amplifier Classification—Tuner Theory—Interpreting Tuner Troubles	

## CHAPTER 4

TROUBLESHOOTING VIDEO CIRCUITS . . . . .	50
Block Diagram Description — Video Circuit Theory and Trouble Symptoms — Troubleshooting Individual Stages— Preanalysis	

## CHAPTER 5

TROUBLESHOOTING SOUND CIRCUITS . . . . .	63
Theory of operation—Troubleshooting Individual Stages	

## CHAPTER 6

TROUBLESHOOTING SYNC CIRCUITS . . . . .	72
Theory of Operation—Troubleshooting Sync Circuits—Sync Circuit Summary	

## CHAPTER 7

TRUBLESHOOTING SWEEP CIRCUITS .....	83
Theory of Operation—Troubleshooting Sweep and AFC Circuits—Component Breakdown Due to Voltage Transients—Thermal Connections and Temperature-Sensitive Components.	

## CHAPTER 8

TRUBLESHOOTING COLOR FAILURES .....	102
Waveforms Appearance—Troubleshooting Procedures	

## APPENDIX

QUICK REFERENCE TROUBLESHOOTING CHARTS .....	117
Width—Height—Picture—Sound—Picture Stability—Hum—No Height	
INDEX .....	126

## TRUBLESHOOTING TABLES AND CHARTS

Table 1-1. Troubles and Check Areas .....	15
Chart 2-1. No B+ Trouble Flow Chart .....	26
Chart 2-2. Intermittent or Low B+ Troubleshooting Chart ..	27
Chart 3-1. Tuner Troubleshooting Flow Chart .....	48
Chart 4-1. Video Trouble Flow Chart .....	60
Chart 4-2. Intermittent or Weak Video Troubleshooting Chart .....	61
Chart 5-1. Audio Circuit Troubleshooting Chart .....	69
Chart 5-2. Distorted or Intermittent Sound Trouble Chart ..	70
Chart 6-1. Sync Troubleshooting Chart .....	81
Chart 7-1. Horizontal Sweep Troubleshooting Chart .....	98
Chart 7-2. Vertical Sweep Troubleshooting Chart .....	100
Chart 8-1. Loss of-Color Troubleshooting Chart .....	107
Chart 8-2. Incorrect Hue Trouble Analysis .....	110
Chart 8-3. How to Analyze One-Color Troubles .....	111
Chart 8-4. Guide for Troubleshooting Washed-out Color .....	113
Chart 8-5. Poor Color Sync Troubleshooting Chart .....	115

## CHAPTER 1

# Troubleshooting Techniques

Each technician uses his own troubleshooting techniques for repairing television receivers. One of these techniques might well be called a “hit or miss” method. For example: A television set has horizontal and vertical sync trouble; this usually means that the trouble is located somewhere in one of the sync stages. Rather than check waveforms or voltage and resistance values in these circuits, some technicians immediately replace all the components—resistors and capacitors—that could possibly cause the trouble. While the chances are good that the trouble will be eliminated by this total replacement procedure, there also looms the possibility that it will not, and the not inconsiderable time spent in replacing the components will be completely wasted. However, even if this replacement procedure does clear up the trouble, the amount of time spent in removing and replacing all of these parts could have been better spent in making a few quick circuit measurements and locating the defective component (s). Not only will the technician save time by avoiding wasteful parts replace-



ment, but he *should* profit from the added know-how gained from performing a troubleshooting procedure and locating the malfunction.

On the other hand, there is the technician who has carefully acquired a complete set of test equipment, and insists on using all this gear each time he has to repair a set. By the time he has set up his test equipment, and is ready to begin troubleshooting the set, a technician using an efficient troubleshooting approach could have diagnosed the trouble, repaired the set, and returned it to the customer.

Perhaps you can begin to see the troubleshooting approach that this book intends to develop, illustrate, and recommend. Basically, this approach is made up of a logical cause-effect-cure procedure, which uses, for the most part, a good quality VTVM and a great deal of common sense. With these two basic ingredients, not only can you learn more about improving your troubleshooting technique, but you will eventually show a material gain in profit by reducing repair time—thereby servicing more sets within a given time interval.

Really productive TV technicians, which admittedly are scarce, use this type of approach with a great deal of success because they need to process a large number of sets within a given time; they *must* be able to analyze trouble in the shortest possible time. In fact, repair shops that process a large volume of repair work often require that any serviceman they hire be able to finish—(locate and repair the trouble) several sets in a specific time interval, e.g., an hour, and with a minimum of call-backs. Not every technician operates this rapidly, and the majority of servicemen could well improve their speed and performance by merely adopting a systematic troubleshooting procedure. Such a logical procedure will be developed in the following pages.

### SIX-STEP TROUBLESHOOTING TECHNIQUE

The approach to a cause-effect-cure troubleshooting technique is simple. It consists of following these six basic steps:

- Step 1. Observation
- Step 2. Analysis
- Step 3. Fault Isolation
- Step 4. Defective Component Location
- Step 5. Repair
- Step 6. Checkout

#### **Observation**

This means looking and listening. Watch the raster for trouble symptoms and listen to the sound for distortion. Get an idea what stage is causing the trouble and whether it is happening on one, two, or all channels. Is it a trouble that occurs regardless of different control settings? Decide if the trouble is intermittent; and so on. Gather all these factors and mentally list them. They are important to proper diagnosis of the trouble.

#### **Analysis**

After observation comes analysis. This consists of evaluating all the information gathered during observation, and deciding in which functional area of the television set the trouble is originating. As a practical example, consider that a vertical sync (rolling) problem is present. In observation, you have seen that adjustment of the vertical hold control did not stabilize the rolling picture, and so you assume that the trouble is in the vertical oscillator circuit. However, one additional check should be performed before making this assumption; namely, testing the horizontal sync action. If the horizontal range is also insufficient

Fig. 1-1. Block diagram of TV receiver.

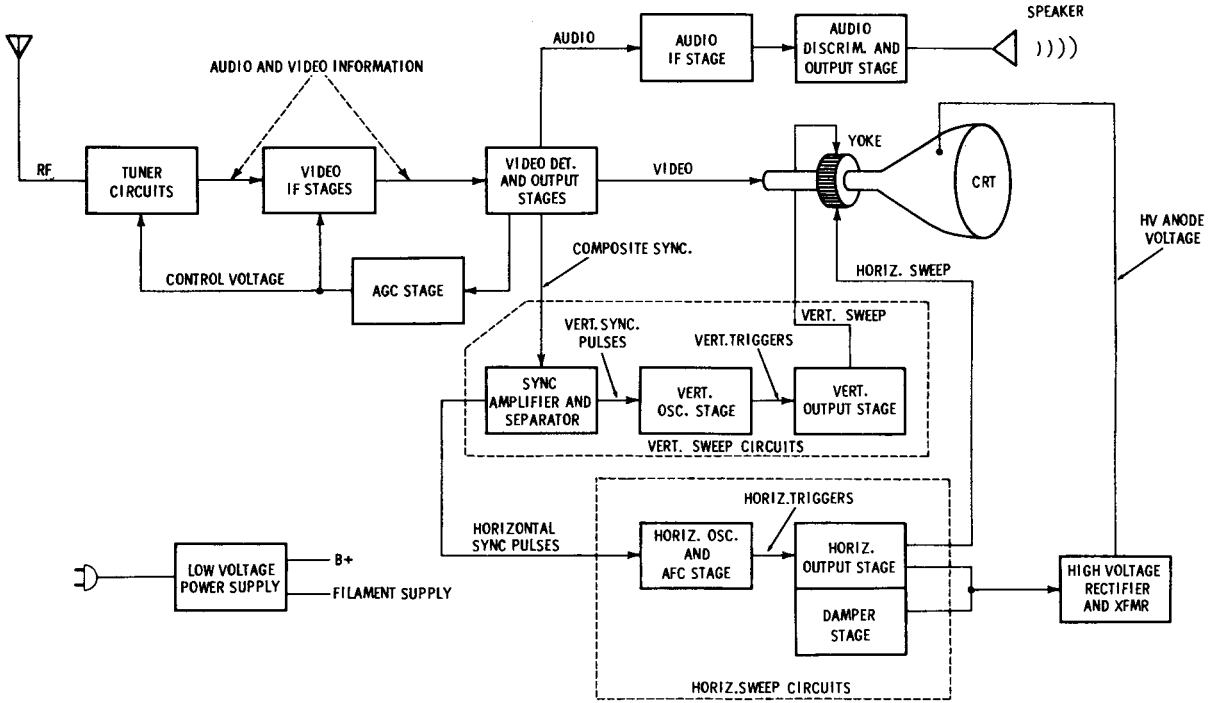

(weak holding action), this indicates that a *sync* problem exists in both the horizontal and vertical circuits. Many technicians tend to overlook simple tests of this type and find themselves wasting a great deal of time trying to locate the trouble in the vertical circuits, when it is probably in the sync or video stages.

A block diagram of a typical television receiver is shown in Fig. 1-1. Note that the diagram breaks down the television receiver into functional areas, rather than individual stages. The reason for this is that the purpose of *analysis* is to locate the trouble to a defective functional area, rather than to an individual stage. Unless, of course, the defective stage is obvious.

Table 1-1, which will be found at the end of this chapter, and which can be used in conjunction with the block diagram, is a listing of the more common TV troubles, together with associated symptoms. Used together, the block diagram and the table can aid in isolating the trouble to a specific functional area.

Use the table as shown in the following example:

---

<b>TROUBLE</b>	<b>ASSOCIATED SYMPTOMS</b>	<b>CHECK AREA</b>
3. No sound	a. Video and raster normal	a. Sound IF stages b. Audio output stages c. Speaker
	b. No video; raster normal	a. Tuner b. Video IF stages c. AGC stage

---

The observed trouble is *No sound* and *No video*. Referring to the TROUBLE column under No sound, and reading across to the ASSOCIATED SYMPTOMS column under No video, the CHECK AREA listing indicates which functional circuits should be tested, and in which order they should be checked. Frequent use of this table will develop a well rounded troubleshooting technique.

Table 1-1 is not intended to be a comprehensive overall trouble chart, but is provided as an example in using the analysis procedure.

### **Fault Isolation**

This step is intended to take the technician to the point where he has located several suspected components, any one of which could be the cause of the trouble. Generally, the technician arrives at this point by performing a few common-sense voltage and resistance measurements, and by referring to the voltage and resistance chart for the set, which lists these measurements for each of the tube-element terminals. Regardless of the approach used, the end result is the location of a difference between the normal operating measurements and the actual measurements which is sufficient to indicate the origin of the trouble.

### **Defective Component Location**

This step can usually be omitted if a good fault isolation procedure has been followed. However, the results of circuit measurements throughout several related stages can differ radically from normal, and it becomes difficult to pinpoint where the trouble actually is. When this occurs, a step-by-step check of the suspected components should be made. This will usually require resistance, continuity, and leakage checks (particularly of capacitors), for which a high-range ohmmeter is very useful. Check for point-to-point continuity, especially if printed circuit boards are present.

### **Repair**

Be careful, when choosing replacement components, that proper tolerances are maintained. Choose resistors with

wattage ratings that are sufficient to withstand local heat dissipation requirements; select capacitors with DC working voltage (WVDC) ratings higher than the voltage transients that might be present in the particular circuit. Also, be careful to avoid relocating the replacement component in areas which might upset tuned circuits, or create intermittent sync problems and the like; try to duplicate their original physical position.

### Checkout

This after-repair step requires only a bench check of the television receiver to see that the trouble has been corrected—and that no other trouble exists. It will help to avoid call-backs. The test usually consists of allowing the set to “cook” for a period of time, and also performing certain additional checks, such as:

1. Use a Variac, or other variable-voltage transformer, to lower the source voltage to the set, while checking for loss of width, height, brightness, sync, and other symptoms that are caused by potential low-voltage rectifier circuit problems.
2. Rotate the channel selector through each position to insure for the reception of all stations in the area (this checks tuner contact-action, too).
3. Rotate the front-panel operating controls through their range and check for noisy operation.
4. In general, watch for changes in the operation of the set as it cooks.

### Application Of The Six-Step Procedure

An example of how these steps can be applied to correcting a particular trouble is given below.

*Problem*—No raster; sound normal on all stations.

*Observation*—Examining the set shows that no brightness appears on the television screen regardless of brightness and contrast control settings. The sound appears normal and undistorted on all stations.

*Analysis*—The observation indicates that either of two troubles are present; lack of high voltage for the CRT anode; or a video output problem. Or, of course, the CRT filament *could* be open. The first step is to determine which of these is causing the trouble.

To determine if the high-voltage circuits are at fault, check for the presence of high voltage at the anode lead by disconnecting it from the CRT and “arcing” it to ground. If a small arc, or no arc, appears, then the trouble is probably in the horizontal-output or high-voltage circuits. If sufficient high voltage is present, then check to see if the ion trap is misadjusted (if an ion trap is used). If no adjustment is required, then the high-voltage circuits can be eliminated as a source of trouble.

The next step is to check the operation of the video-output stage, because this section can also cause this trouble. Also check for proper operation of the brightness control and the contrast control by monitoring the output of the respective slider arms as the controls are rotated. Check the voltage and resistance values in the video-output stage against those provided in the service information for the set until the trouble is located in a particular stage or circuit.

*Fault Isolation and Defective Component Location*—Once the trouble is isolated to a particular stage, as, for example in the video amplifier output stage, the fault isolation procedure takes over. At this point, either a dynamic check or a static check can be made. The dynamic check requires that the circuits be tested while the set is operating; the static check is made with power off, and consists primarily of resistance tests. The static check is pre-

## Troubleshooting Techniques

ferred because it gives more of an opportunity to perform preventive maintenance checks as well, thus locating components which might prove troublesome in the future. Once defective components are located and replaced, thoroughly bench check the set again, to prevent a possible call-back.

**Table 1-1. Troubles and Check Areas.**

TROUBLE	ASSOCIATED SYMPTOMS	CHECK AREA
1. No raster	a. Sound normal on all channels	a. Horizontal sweep circuits b. High voltage rectifier c. Video output stage d. Shorted CRT
	b. No sound	a. Low voltage power supply b. Audio output (B+ divider)
2. No video	a. Raster normal; sound normal on all channels	a. Video output stage b. AGC stage
	b. Raster normal; no sound	a. Video I-F amplifier b. Tuner c. AGC stage d. Video output stage (on some sets, sound takeoff is after this stage) e. Audio output stage (on some sets, B+ for the video strip is taken from the cathode load of this tube)
3. No sound	a. Video and raster normal	a. Sound IF stages b. Audio output stage c. Speaker
	b. No video; raster normal	a. Tuner stage b. Video I-F stages c. AGC stage d. Audio output stage (on some sets, B+ for the video strip is taken from the cathode load of this tube)



## TV Troubleshooter's Reference Handbook

**Table 1-1. Troubles and Check Areas (cont.)**

TROUBLE	ASSOCIATED SYMPTOMS	CHECK AREA
No sound	No video; raster normal	e. Video output stage (on some sets, sound takeoff is after this stage)
4. Vertical roll	a. Sound and picture normal	Vertical oscillator stage
	b. Sound normal (picture distorts or tears horizontally)	Sync amplifier-separator stage
	c. Sound and picture distorted; picture tears horizontally	Low-voltage power supply filtering
5. Picture tears horizontally	a. Sound and picture normal	a. Horizontal oscillator stage b. Horizontal AFC stage
	b. Picture rolls vertically	Sync amplifier-separator stage
6. Weak picture	a. Picture weak on all stations; sound is lower than normal	a. Video IF stage b. AGC stage c. Video output stage
	b. Picture and sound weak only on some stations	a. Tuner circuits b. Antenna
7. Reduced width	Sound and height normal	a. Horizontal output stage b. Damper stage
8. Reduced height	Sound and picture normal	a. Vertical oscillator stage b. Vertical output stage
9. Reduced height and width	Sound and picture normal	a. Low voltage power supply b. High voltage power supply

## CHAPTER 2

# Troubleshooting Low Voltage Power Supplies

One section in the television set that has changed little since the introduction of the first commercial home television receiver is the power supply section. Its basic function was then, as it is now, the generation of B+ operating voltages for the rest of the set. Its basic theory, the use of half- or full-wave rectification, coupled with capacitor and inductor or resistor filtering networks, is still the same. Of course, with the introduction of silicon rectifiers, which replace the selenium types, servicing and design techniques have changed, but only slightly. For obvious reasons—space considerations and heat dissipation—the use of silicon or selenium rectifiers in portable, transformerless receivers has become more or less standard. The still popular vacuum-tube rectifier has remained mostly in receivers using a power transformer. However, many of the transformer-type receivers also use silicon-diode rectifiers.

Most receivers use either a silicon (or selenium) rectifier voltage-doubler supply, or the vacuum-tube transform-

er-powered supply. An example of each type is given in the following paragraphs.

### DOUBLER POWER SUPPLY

A typical voltage-doubler supply is shown in Fig. 2-1A. This is the circuit that is used in most portable and console-type sets not equipped with power transformers. The voltage-doubling action in this circuit is a result of electrolytic capacitor C1, connected in series with the fusible resistor R83, and rectifier M2. Initially, when power is applied by closing the On-Off switch (on the volume control), C1 is charged through M1 to ground for the negative half-cycle. On the positive half-cycle of the AC input, the polarity of the charge across electrolytic capacitor C1 is such that it is placed in series with the positive half-cycle, "doubling" the peak amplitude of the input. On this positive swing, conduction occurs in forward-biased rectifier M2, providing approximately 280 volts DC across filter capacitor C2A.

You will note that the effectiveness of the doubler action is determined by the series capacitor C1. If this capacitor becomes *leaky*, two problems can occur:

1. Since the capacitor is connected between the input AC line and ground (through rectifier M1) for each negative half-cycle, it may act as a low-resistance path and damage the fusible resistor and/or the rectifier. Often a loud "pop" will accompany the capacitor break-down.
2. A high resistance path may develop, which, while not greatly impairing the storage capacity of the capacitor, will cause a reduction in the DC output voltage by reducing the doubler action.

Electrolytic capacitors C2A and C3A, and inductor L15 provide an LC filtering network, with the 270-volt DC

## Troubleshooting Low Voltage Power Supplies

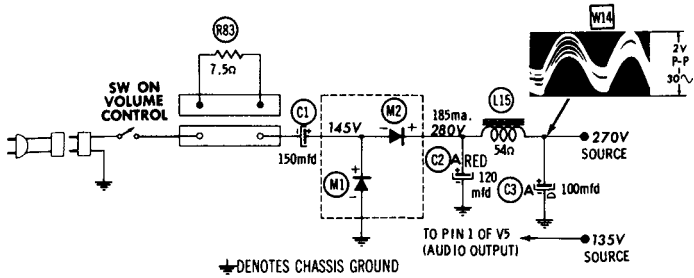

(A) Silicon/selenium circuit.

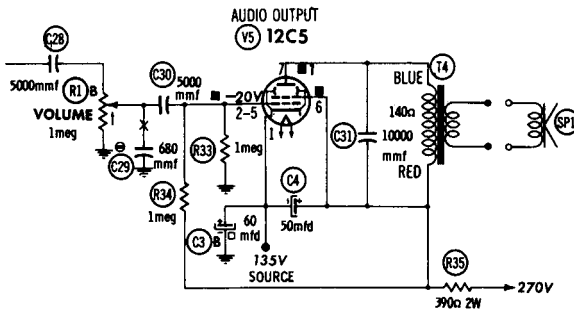

(B) Voltage division.

**Fig. 2-1. Voltage doubler circuit.**

output being supplied across C3A. A waveform taken at this point shows (riding on the DC component) the 30-cycle, 2-volt peak-to-peak ripple voltage normally present in this type of power supply.

In this receiver, the audio and video IF amplifier stages require a 135-volt DC power source. To use a limiter resistor for this application would require a high-wattage component, which in turn would dissipate much heat and provide excessive power supply loading. Instead, the audio output stage is used as a voltage divider to develop the 135-volt source, which is taken from the cathode of the stage, V5, across capacitors C3B, C4, and resistor R35 (Fig. 2-1B).

Note that this 135-volt source is dependent on proper operation of the audio output stage, and the related circuit components which provide operating bias. The DC output from this stage will not be sufficient unless the bias voltages are within the required tolerances, electrolytic capacitors C3B and C4 are not leaky, and the output tube is not faulty. In all too many instances, low B+ in the IF stages is assumed to be a fault of the rectifier power supply, when the audio output stage is really at fault. In this type of circuit, always be sure to check the audio output stage if the secondary 135-volt source is low.

**VACUUM-TUBE POWER SUPPLY**

A schematic diagram for a typical vacuum-tube power supply, using a power transformer, is shown in Fig. 2-2. The AC input voltage is applied directly to the primary winding of power transformer T1. The heater-cathode of the rectifier is supplied from the transformer secondary filament taps, and the plate voltage is supplied from step-

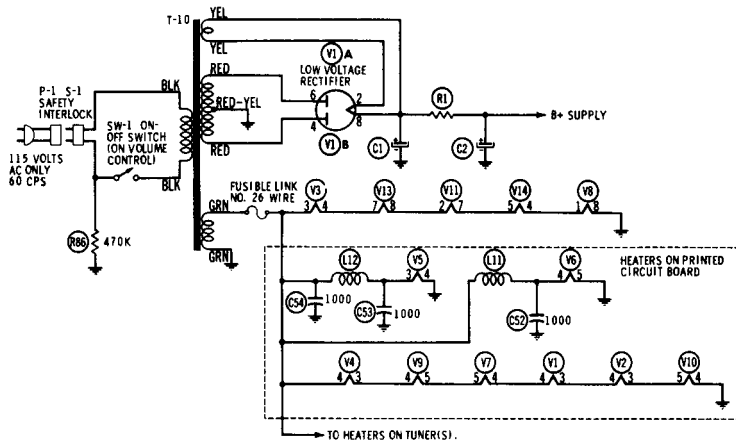

**Fig. 2-2. Vacuum-tube power supply.**

## **Troubleshooting Low Voltage Power Supplies**

---

up windings on the secondary. As in all rectifiers, tube conduction occurs only during the half-cycle that the tube section is favorably biased—with the plate positive with respect to the cathode. When V1A conducts, V1B is nonconducting; when V1B conducts, V1A is nonconducting. The current flow through each section results in a full-wave output being supplied from the cathode, applied across filter capacitor C1, through limiter-filter resistor R1, and across filter C2. Resistor R1, usually a wire-wound type, provides additional filtering action due to the inductance of the turns of resistive wire.

### **POWER SUPPLY TROUBLE ANALYSIS**

According to the schematic diagrams shown in Figs. 2-1 and 2-2, there are only a limited number of components which can become defective in a power supply section. In fact, most troubles attributed to a defective power supply are actually caused by circuits external to the supply—shorts, leakage paths, and intermittent overloads. These external causes are those which cause the technician the most trouble to locate and repair; therefore, the problem is first to determine whether the power supply or the external circuits are at fault. The following trouble analysis techniques and procedures are supplied to aid in determining the problem area.

Consider the power supply as a “black box”: AC voltage comes in, DC comes out. This DC power is distributed throughout the set via printed or other wiring, voltage divider and plate load networks, and filter circuits.

#### **Power Distribution**

If you were to draw a simple power distribution diagram for a television receiver, it might appear similar to that shown in Fig. 2-3.

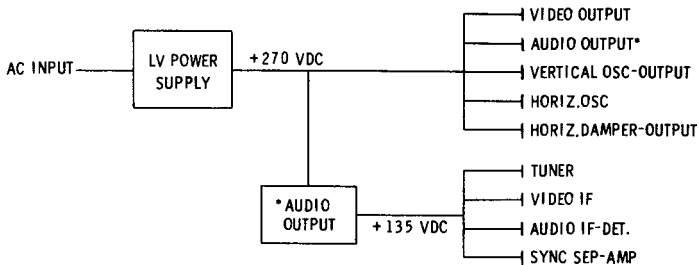

**Fig. 2-3. Typical power distribution diagram.**

A short, or low leakage resistance path to ground at any point in the distribution path, will upset the B+ distribution, or cause a complete loss of B+ to the set. For these reasons, it may be necessary for the technician to locate exactly which branch of the B+ is causing an overload. To do this will often require the actual disconnecting of the different B+ branches to pinpoint which stage is drawing excessive current.

First, however, look for signs of overheating of any component—especially B+ dropping resistors. Usually, they are one- or two-watt units; be sure to look these over carefully. If the short is severe—a shorted capacitor to ground, for instance—the supply resistor feeding that particular stage is sure to show some signs of overheating. This is one of the best procedures for getting into the troubled area rapidly.

On the other hand, as mentioned, it may become necessary to disconnect each supply line feeding a number of stages. When this is necessary, try to isolate the largest number of stages with one disconnect. As an example, take a look at Fig. 2-4.

This might be a simple distribution network for the B+ found in a typical receiver (sometimes you'll find even more branches and dropping resistors). Suppose this low-voltage supply is overloaded, caused by a short circuit

## Troubleshooting Low Voltage Power Supplies

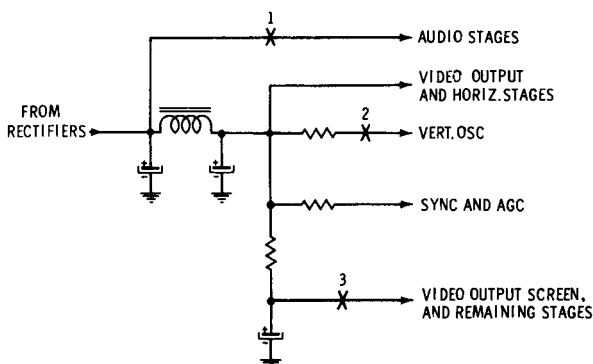

**Fig. 2-4. Simplified schematic of B+ branches in TV receiver.**

in one of the stages shown. First, look over the schematic diagram of the receiver, trying to visualize what B+ source can be disconnected to eliminate the largest number of stages at one time. In Fig. 2-4 assume that the leg feeding the audio stages is one of the easiest and quickest to unsolder—a single lead carries the supply voltage for the sound IF amplifier, the audio detector, and the audio output circuits. Disconnecting this wire, and then applying power to the receiver, you may observe that the low voltage rectifier runs cool, and that the circuit overload is gone. This simple test clearly indicates that one of the three stages fed by this branch contains a defective component (s). The rest is simple; merely use your ohmmeter to locate the low resistance path to ground in one of those circuits.

A similar isolation procedure will work in case the short wasn't in the first B+ source disconnected. Depicted by the X breaks 1, 2, and 3, in Fig. 2-4, merely unsolder the branches, one at a time, until the low voltage returns (or returns to its normal value). Keep a mental note of the points you disconnected, and be sure to reconnect them after repair. A better way is to resolder them as soon as they are cleared.



### TROUBLESHOOTING METHODS

Most repairmen are in the habit of minimizing power supply faults and wind up making only partial repairs, rather than doing a complete job. Of course, some sets have characteristic troubles, so that troubleshooting is simply a matter of replacing a part which has a history of becoming defective. One such set, many technicians will recall, used metal-encased bleeder resistors mounted on one side of the chassis. Two such tapped bleeders were used to develop various bias voltages required by the set. After a period of time, these components, which were undoubtedly underrated originally, would overheat and short to the chassis. This required replacement of this particular part and usually some related components. Actually the reason for using a metal-encased bleeder connected to the chassis was to provide a heat sink for excessive power dissipation, which obviously proved to be too much for the resistor to handle. Rather than replace this, or a similar component with an equivalent metal-encased unit, try using ten-watt wire-wound resistors, connected to terminal lug standoffs.

Getting back to component replacement, never assume that because a resistor is charred or open that the trouble will be remedied when this component is replaced. Remember, for every trouble there is a reason, so look for the reason why the part became defective, because the trouble will probably repeat itself after the set is returned to the customer's house. True, some components will just "give up" due to physical fatigue; however, this usually occurs only in older "vintage" receivers.

#### **Low B+ or No B+**

As previously mentioned, most power supply troubles can be traced either to low B+ or no B+, as covered in the following paragraphs. Low B+ can be caused by leaky

or open filter capacitors, weak rectifiers, or excessive circuit loading. Open filter capacitors are easily checked by bridging with a known good electrolytic while monitoring the B+ output with a voltmeter. If the output voltage increases, then the filter is defective. On the other hand, if a filter is suspected of being leaky, then bridging it will not show up the trouble. Referring to Fig. 2-1 again, if filter C2A were to develop leakage, causing a drop in the output voltage, the only way to check it would be by direct substitution. This may mean removing and replacing several filter sections until the defective section is located. A quicker way to identify the defective part is to look for signs of overheating (warm casing) or electrolytic oozing from the filter terminals (in electrolytic can sections). These are usually reliable indications of a leaky filter. As further callback insurance, make a visual check on the condition of the remaining filters in the set.

Another important fact to consider when replacing a filter is if the trouble was a result of filter failure, or if it was brought about by an external problem? Either way, thoroughly check out the associated circuits before the component is replaced. (At least, watch it closely when power is once more applied.) Remember that defective rectifiers are a sure cause of filter failure, considering that the capacitor is a DC device, and that an impressed AC voltage is sufficient to break down the capacitor, or cause a leaky condition.

Capacitor C1, which is the doubler capacitor, is a common failure item. If either of rectifiers M1 or M2 are shorted, the full AC voltage across the filter will damage it. Usually the fusible resistor is too slow-acting to prevent a failure of this type.

Excessive circuit loading can cause an appreciable drop in the DC output voltage, with possible overload damage

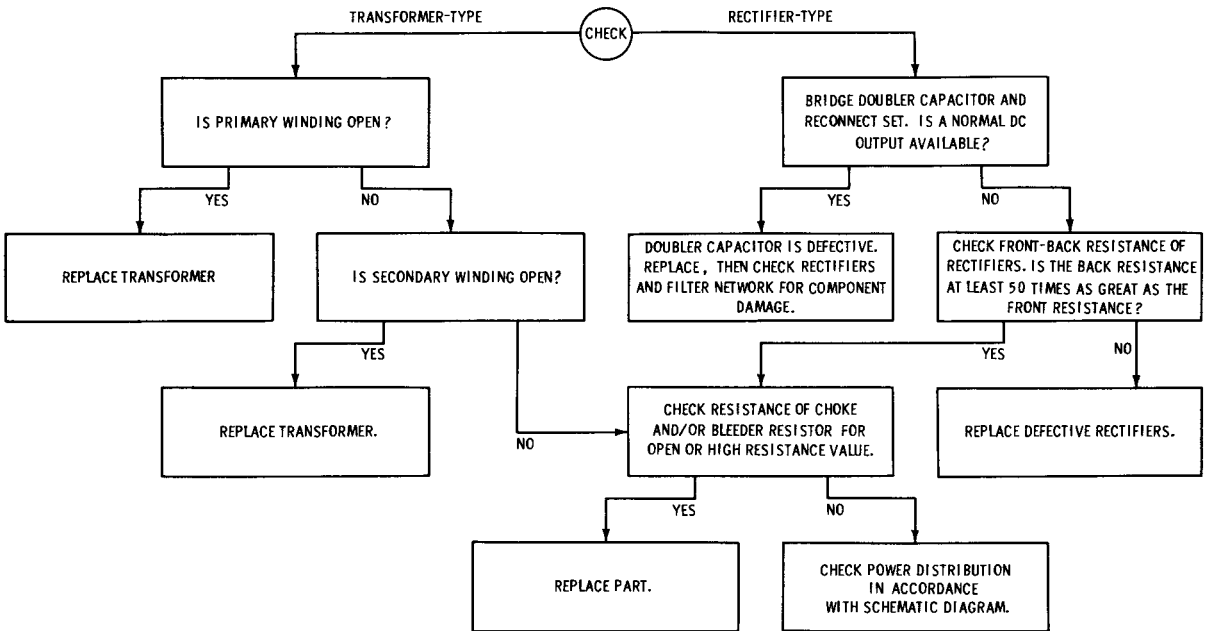

Chart 2-1. No B+ Trouble Flow Chart.

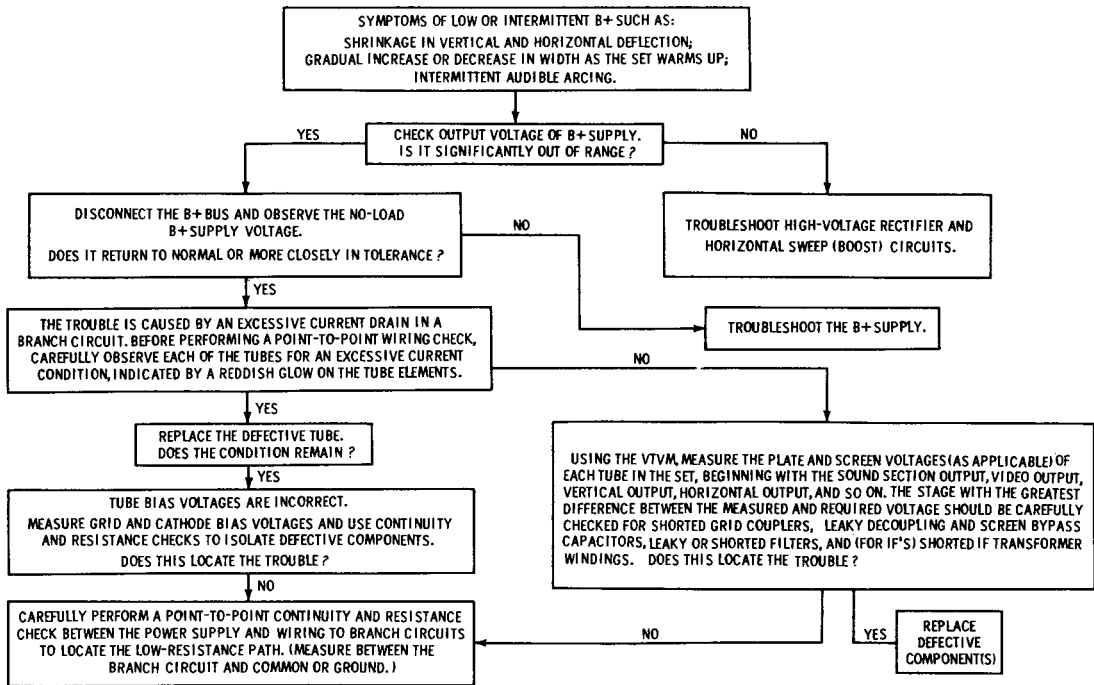

Chart 2-2. Intermittent or Low B+ Troubleshooting Chart.

to the rectifiers. Usually, visible symptoms can lead directly to the cause of the overload. Look for charred or over-heating resistors as mentioned, warm or waxy capacitors, tube elements glowing red, and the like. The best method of troubleshooting this problem is through a point-to-point resistance check, with one side of the ohmmeter connected to ground (or common). Use the schematic diagram, beginning with the output line from the power supply, and connect the meter lead sequentially along the various points on the power distribution chain. **BE CAREFUL** that the power is off, and that the filter capacitors are discharged to avoid damaging the ohmmeter or causing erroneous indications.

Lack of B+ is a condition which can usually be traced to a particular component, or a combination of related components, whereas low B+ can be caused by almost any circuit component in the receiver.

Shown in Chart 2-1 is a troubleshooting flow chart that can be a valuable aid to help locate the defect causing a loss of B+ voltage. Chart 2-2 is a flow chart for locating intermittent or low B+. These charts and the others included in the remaining chapters are self-explanatory and simple to use.

## CHAPTER 3

# Troubleshooting Tuner Circuits

The operation of the tuner circuits can set the pattern for the response of the entire television receiver. Poor signal amplification, improper grounding, insufficient shielding, or weak tubes can cause trouble symptoms ranging from ghosts to poor synchronization and hum in the video or audio stages.

Since the tuner is the input stage to the television receiver, it should receive special attention during troubleshooting, especially when checking for video and/or audio trouble symptoms.

A typical tuner, as shown in the block diagram in Fig. 3-1, performs three basic functions:

1. Selection of input information—This is accomplished by the channel selector switch and the fine tuning control. Operation of the channel selector controls varies the inductance (or capacitance) of tuned circuits located in the amplifier, mixer, and oscillator stages; the fine tuning control provides additional precise

oscillator adjustment of each channel over a limited range.

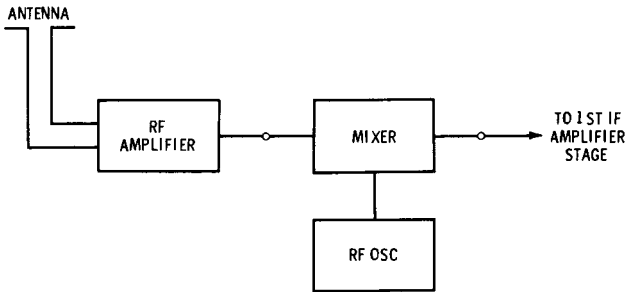

**Fig. 3-1. Tuner block diagram.**

2. Conversion of RF signals to video and audio information—This is accomplished by the RF oscillator and mixer stages, which operate in conjunction to produce the respective IF signals. The oscillator stage is tuned by the channel selector circuits to supply a frequency usually higher than the incoming frequency of the desired channel. This oscillator signal is then applied to the mixer stage simultaneously with the tuned RF signals from the desired channel. The amplified RF signals are mixed with the oscillator output, producing the IF signal that is fed to the first IF amplifier stage.
3. Amplification of selected RF signals—The RF amplifier stage provides amplification of the incoming signals and establishes the signal-to-noise ratio for the tuner. Cascode RF amplification, one type commonly used, provides signal amplification equivalent to that of conventional pentode amplifier stages, with the low noise characteristics of a triode. For fringe-area reception, cascode RF amplifiers provide a picture which is less snowy than many other RF amplifiers.

### TYPES OF TUNERS

Five basic tuner types have been used in most television receivers. These are: (1) Drum Tuner (turret-type); (2) Switch Tuner; (3) Continuous Tuner (Inductance); (4) Permeability Tuner; and (5) Variable Capacity Tuner.

#### Drum Tuner

The drum tuner is a standard which most technicians have worked on at one time or another. As shown in Fig. 3-2, it consists of a drum and detent, with 12 sets of two

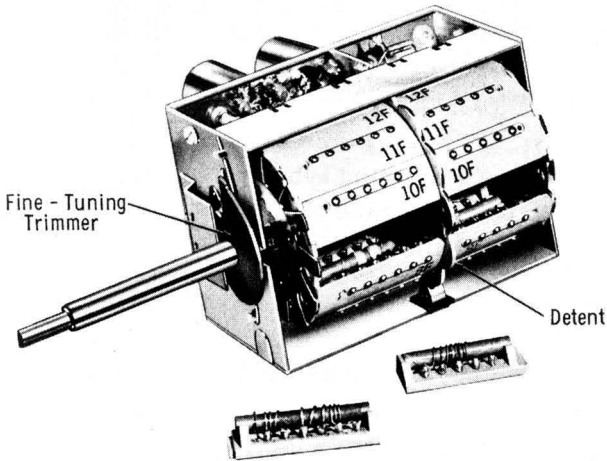

*Courtesy Standard Coil Products Co.*

**Fig. 3-2. Drum-type tuner.**

tuned coil strips attached to the drum by spring clips. Each set of two strips is tuned to a different channel, and tunes the oscillator, amplifier and mixer stages simultaneously. Each strip contains coils wound on a circular form, into which a slug tuning core, as shown in Fig. 3-3, is inserted. The core is usually accessible from the front of the tuner, and can be adjusted by a fiber or other non-magnetic screw



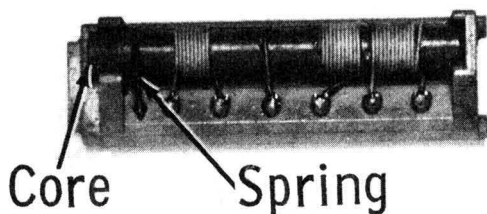

**Fig. 3-3. Drum tuner channel wafer.**

driver. The inductance of the coil is increased as the core is tuned in a clockwise direction; and is decreased as the core is turned in a counterclockwise direction.

In this respect, several manufacturers have devised "slug" retrievers, so that the technician who loses the core slug in the coil through excessive clockwise rotations, can easily retrieve the slug without removing the tuner (and usually the chassis) from the cabinet. Note that the core is held in place by a spring, and that the slug is lost if it is turned past this spring retainer.

### **Switch Tuner**

The increment-coil, or switch-type tuner, was used on many older sets, and is still popularly used on portables where space is an important consideration.

As shown in Fig. 3-4, this tuner consists of several wafers (usually three or four in all), each containing a set of coils for channels two through thirteen. Depending on the position of the channel selector (detent) switch, the wafer contacts short a portion of the series-connected coils as required to match the frequency of the desired channel.

Some of these tuners can be adjusted from the front section by a padder arrangement that adds to or reduces the value of a shunt capacitance, thereby raising or lowering the tuned frequency. Other tuners, using ferrite cores, per-

## Troubleshooting Tuner Circuits

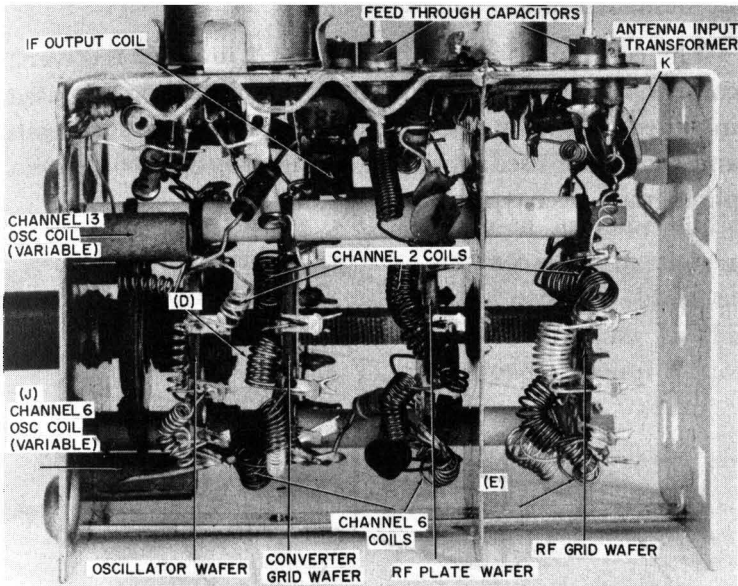

*Courtesy Sarks Tarsion, Inc.*

**Fig. 3-4. Typical switch tuner.**

mit adjustment of a core through an air-coil arrangement, raising or lowering the coil tuning frequency, as in the turret tuner previously described. Still a third version of this tuner required that the coil forms be adjusted by compressing or expanding the coils, so as to decrease or increase the tuned frequency as required. This type of adjustment is facilitated by the use of a tuning wand, which is a plastic fiber (or aluminum) rod, having a brass tip on one end, and a ferrite tip on the other. To determine if a coil requires compression to lower the tuned frequency, bring the ferrite end of the rod near or into the coil and observe if the desired station begins coming in. If this occurs, then compress the coil as needed. However, if the coil is tuned too low for the station, decrease the coil inductance by using the brass tip, raising the frequency and indicating that the coil requires expansion.

### Continuous Tuner

The continuous tuner (mainly used in older receivers) consists of a plated wire helix that is shortened or increased in tuned length by a slider arm. Usually three such coils and sliders are used, as shown in Fig. 3-5. Fig. 3-6 shows a photograph of a typical coil section.

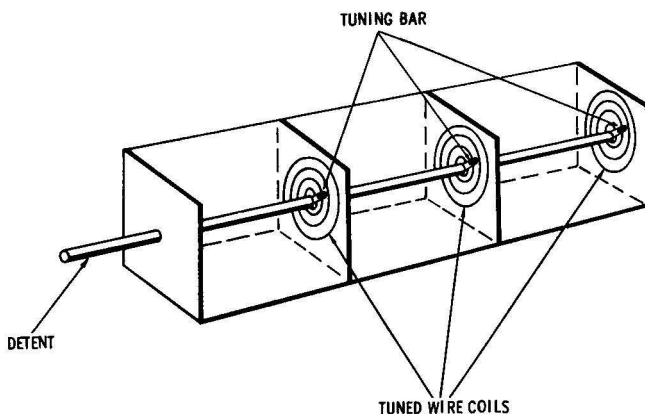

**Fig. 3-5. Simplified continuous tuner.**

If the length of the coil spiral represents tuning for channels two through thirteen, then positioning the slider at the extreme outer end of the coil is tuning for the lower channels; and positioning the slider at the inner section

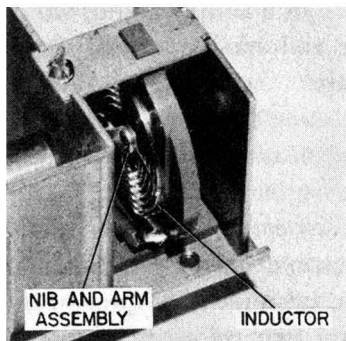

**Fig. 3-6. Typical coil section from continuous tuner.**

(as shown) is tuning for the higher channels. Because of the continuous tuning action used in this tuner, no separate fine tuning control is needed.

### Permeability Tuning

Permeability tuning, which was used in some earlier models of television receivers, was achieved by moving a ferrite core through a coil, or set of coils, to obtain the desired frequency. This arrangement is similar to that used on some FM tuners. Fig. 3-7 shows a typical section from a tuner of this type.

**Fig. 3-7. Typical permeability tuning section.**

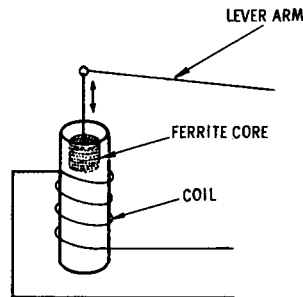

The lever arm positions the core in or out of the coil through a mechanical linkage controlled from the channel selector. The further into the coil that the core is moved, the lower the tuned frequency of the channel; and vice versa.

### Variable Capacity Tuning

This type of tuner operates on the same principles as the ganged tuning capacitor in most radios. Its construction at the high-frequency ranges required for television reception, however, creates drift and instability problems

as a result of excess humidity, dust, and the like. This type deserves only mention; it was not used in many receivers.

### TUNER RF-AMPLIFIER CLASSIFICATION

Electrically, TV tuners are often known by the type of RF amplifier circuit used. Oscillator circuits are almost always constructed around double-triode tubes; and mixers, which formerly used triodes, are currently designed for tetrodes or pentodes.

The most common type of RF amplifiers are the:

1. Pentode RF amplifier.
2. Tetrode RF amplifier.
3. Cascode RF amplifier.
4. Neutralized-triode RF amplifier, including the nuvistor RF amplifier.
5. Shadow-grid RF amplifier.

Prior to 1954, almost every type of tuner RF amplifier, except the shadow-grid amplifier, was used. From about 1954 to 1957 (these dates are approximate) the cascode and pentode RF amplifiers were in great use, as were some tetrode circuits. After this time, however, these circuits yielded in popularity to the neutralized-triode amplifier. It remains dominant in the field in several forms, i.e., circuits using the nuvistor (approximately 1959), and

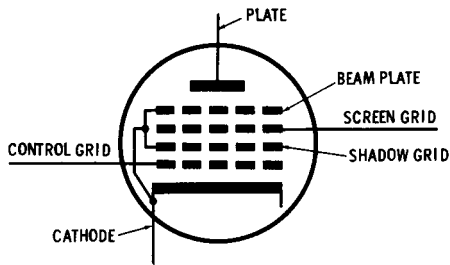

Fig. 3-8. Shadow-grid tube diagram.

*Guided-grid*, or frame-grid, tubes (1960-1961). Details on the neutralized-triode circuit will be given; information on either the nuvistor or frame-grid tubes can be secured from their various manufacturers.

Perhaps the newest development in RF amplifiers is the *shadow-grid* tube. In this tube, an extra grid is wound between the control and screen grids, with turns that line up with the screen grid wires. The idea is to reduce screen current while still enjoying the electron-accelerating effect of a screen grid. The shadow-grid is connected internally to the cathode and the beam plate as shown in Fig. 3-8. The  $G_m$  of the nuvistor, the shadow-grid tube, and the frame-grid tube are all very high; and depending on the unit, can be expected to be about the same value—10,000-plus micromhos.

### Pentode RF Amplifier

About the pentode RF amplifier, very little need be said. Fig. 3-9 shows the basic diagram. The pentode am-

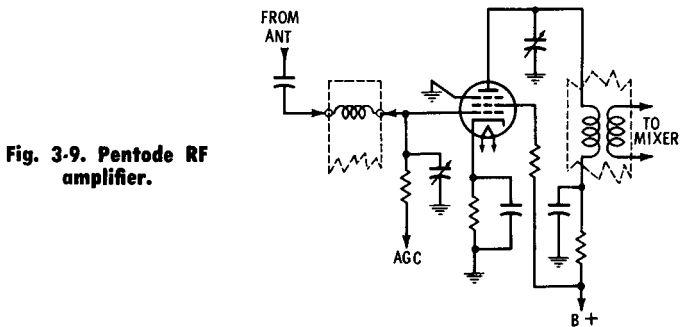

**Fig. 3-9. Pentode RF amplifier.**

plifier has several advantages; the tube is easy to build, and the circuit is not critical. The tube has fairly high gain, with very good stability. However, the pentode RF amplifier has one serious drawback—its inherent noise is much higher than most other RF-amplifier circuits.

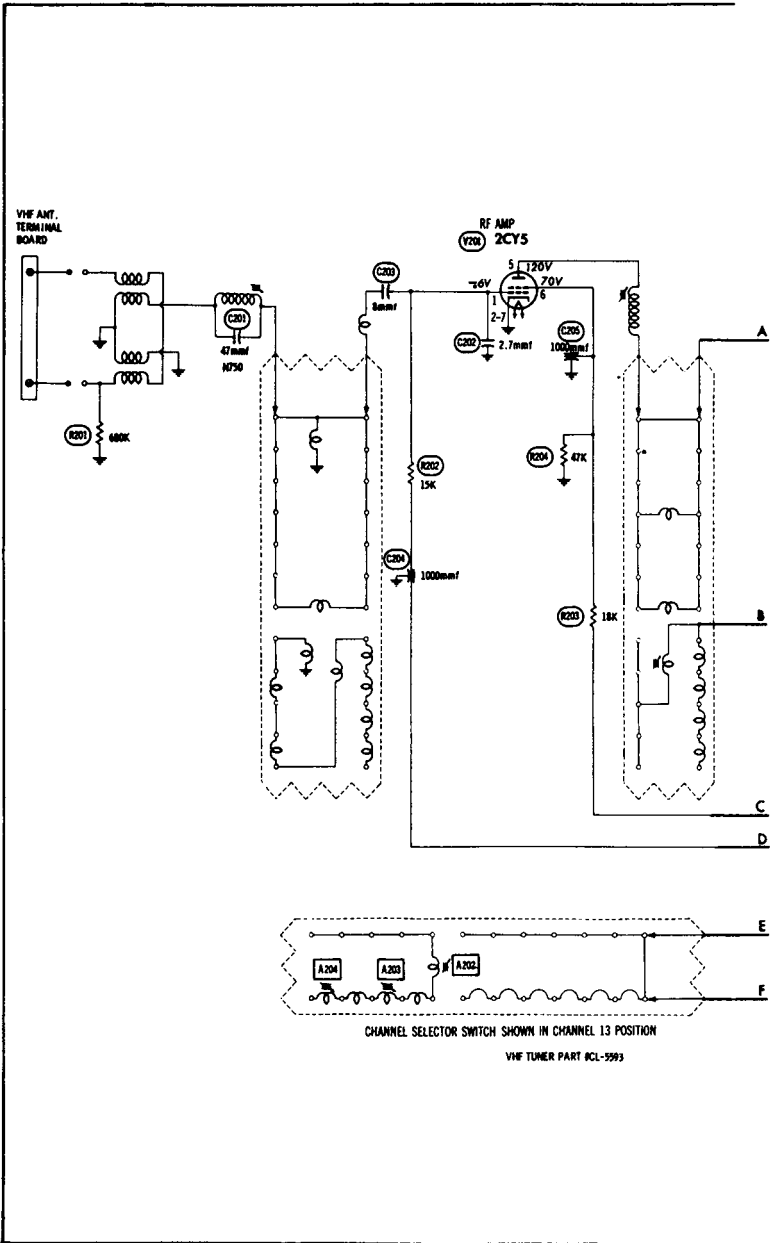

Fig. 3-10. Coil tuner





### Tetrode RF Amplifier

In order to offset the noise-generating properties of the pentode grids, the tetrode RF amplifier was introduced. The tetrode can approach the gain of a pentode, but the tube is more difficult to build, and the adjustment of the tetrode circuit is much more critical. Special tubes have been developed for use as tetrode RF amplifiers. The screen voltage of these tubes is considerably lower than that of pentodes, the lowered screen voltage serving to reduce the signal-to-noise ratio of the tetrode circuit. Fig. 3-10 shows one type of tetrode RF amplifier, Fig. 3-11 shows a slightly different circuit. Coil L3 is included in the latter stage to provide some degeneration, preventing self-oscillation, further aiding in noise reduction.

### Cascode RF Amplifier

The cascode RF amplifier circuit is a later development, intended to replace the noisier pentode and tetrode circuits with a high-gain low-noise triode circuit. This circuit was for many years the high-performance standard of the TV industry. A typical circuit, using the 6BQ7A, is shown in Fig. 3-12. Tube V1A acts as an impedance matching device between the antenna and grounded-grid amplifier V1B. L3 and the interelectrode capacitance of the tubes combine to neutralize the stage at VHF operation.

Note that V1A and V1B are in series across the DC power supply. This is one of the most important facts to remember when troubleshooting the cascode circuit, because it means that in order to divide the voltage equally between the two triodes, the grid bias of V1B must be very carefully adjusted. This fixed bias voltage is furnished by divider network R2 and R3; hence, if the plate-to-cathode voltages of the two halves of V1 are not equal, one

## Troubleshooting Tuner Circuits

of these resistors may have changed value. Or C2 may be shorted or leaky, or V1 could be defective.

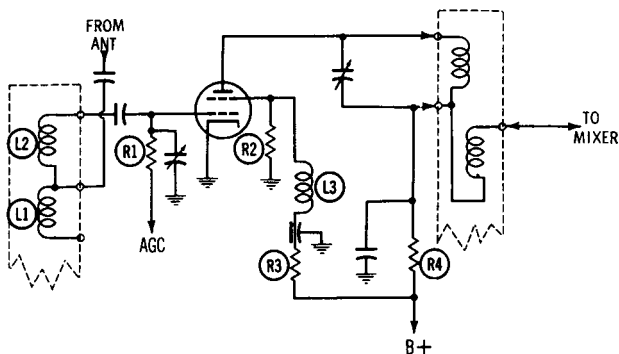

**Fig. 3-11. Tetrode amplifier circuit.**

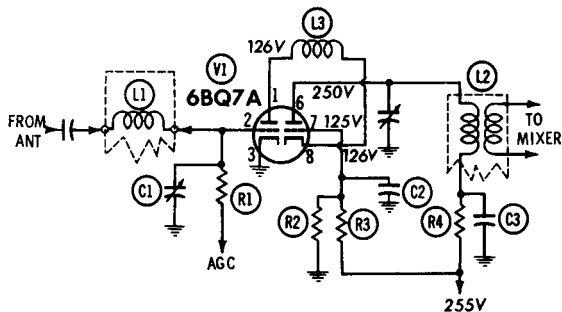

**Fig. 3-12. Cascode RF circuit.**

### Neutralized-Triode Amplifier

Perhaps the most commonly used circuit in current manufacture is that of the neutralized triode, or *neutrode* (Fig. 3-13). This circuit is simple, mechanically as well as electrically, yet it is equal to or superior to those in previous use.

Due to the neutralization network, the circuit is stable over a wide range of frequencies. However, the circuit can

oscillate if C1 is not correctly adjusted or is defective. An open C4 can also cause oscillation, for then the circuit

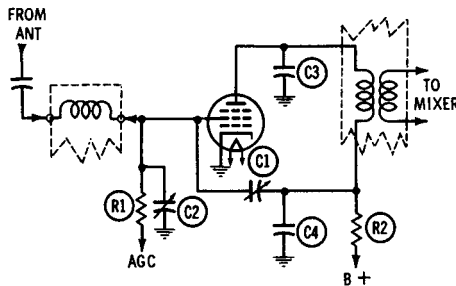

**Fig. 3-13. Neutralized-triode RF amplifier.**

would behave as an ultra-audio oscillator. Oscillations in the neutralized triode RF amplifier should be treated as follows: First replace the tube; if oscillations remain, adjust C1 with an insulated screwdriver— $\frac{1}{4}$  turn in either direction—to stop the oscillation, and then, if trouble remains, check C4 for an open condition.

### TUNER THEORY

The following discussion is concerned with a coil type tuner, whose operation and theory is very similar to the drum (turret) type; with the exception that the drum tuner uses separate wafers for each channel, and the coil tuner uses series connected coils, as shown in Fig. 3-10.

Automatic gain control (AGC) voltage from the external AGC circuits is applied to the RF amplifier grid to provide uniform gain for all channels. RF input signals are applied through the antenna to the RF amplifier stage, V201, through a set of tuned coils. Note that the channel selector is shown in channel 13 position which is the shortest coil length. The amplified RF is further tuned at the output (plate) through additional tuned circuits, then ap-

plied to the grid of the mixer stage, V202A. Here it mixes with the output of the oscillator stage, V202B. The frequency of the "beat signal" from V202B is determined by the tuned-plate circuit connected between the grid and plate of this stage. Note that this tuned circuit is also adjusted for the respective frequencies as the channel selector is operated, permitting each stage to select the correct frequency, depending on the position of the channel selector.

The amplified RF signal, and the output from the oscillator, are mixed at the grid of V202A, amplified, and applied through the tuned mixer-plate coil (tuned to the IF frequency), then supplied to the IF amplifier stages.

### INTERPRETING TUNER TROUBLES

In most tuners, a dual-section tube is used as the mixer and oscillator. Failure of the oscillator stage will cause a complete loss of picture and sound, or a loss of picture and sound in one or more of the channels. A breakdown or value change of components in the mixer stage may also cause a complete or partial signal loss.

Weak picture and/or sound on only one channel is usually caused by misalignment of the tuning slug for that particular channel, and can be corrected by simple adjustment. In the type tuner used in this discussion, tuning the slug or coil for one particular channel can upset the alignment for the remaining channels. For this reason, tuner channel alignment should begin with the highest channel (13) and work down to the lowest—regardless of the type tuner used.

Oscillator drift can be caused by temperature-sensitive components or by defective decoupling resistors or capacitors in the oscillator plate circuit. Sometimes, the tube itself will cause frequency drift.

Low gain is caused chiefly by a defective RF amplifier stage. A cathode-filament short can cause 60-cycle hum bars to appear in the video channel, or 60-cycle hum to be heard in the audio. Due to close capacitive or inductive linkages, a defect in the RF amplifier stage might result only in weak video and audio. Be careful when troubleshooting for this symptom, because one or more defective IF amplifiers will produce the same symptom.

In this type tuner (Fig. 3-10), as well as in others which are similar, the feedthrough capacitors are especially subject to leakage and breakdown. This applies to feedthrough capacitors C206 and C207. If the latter component becomes defective, resistor R208 will burn out. Replacement of these feedthroughs can be facilitated, without any side effects to the video or audio, by drilling it out from the tuner chassis, then replacing the wiring (using insulated spaghetti). If, however, bypass action is necessary, just solder in a 1000-mmf capacitor to the affected terminals. Use a capacitor with at least a 600-WVDC rating; tolerance is not important here, but space considerations due to signal interaction are. Using a mica or ceramic capacitor will usually solve the space problem.

Another problem component in the mixer stage is plate load resistor R207. Some mixer tubes tend to develop microphonic or transient shorts between plate and suppressor grid, causing R207 to burn out, or increase in value. If this occurs, the usual symptoms are partial response on the low channels; and almost no response on the high channels. If this resistor ever requires replacement, make sure that the mixer-oscillator tube is also replaced.

### **Reducing Ignition Noise**

In some older receivers, especially those operating near heavy traffic areas, ignition noise caused by automobiles

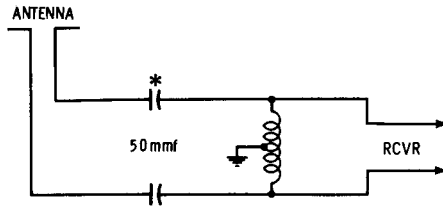

\* VARIABLE CAPACITORS MAY BE USED

**Fig. 3-14. Ignition-noise suppressor network.**

can adversely affect picture and sound. A simple ignition-noise suppressor can be devised, as shown in Fig. 3-14, which consists of a 50-mmf (mica or ceramic) capacitor connected in series with each leg of the antenna transmission line. Connected across the line, after the capacitors, is a coil consisting of 10 turns of #20 enameled wire, wound on a  $\frac{1}{2}$ " diameter non-conductive form. Scrape away the insulation near the center of the coil and solder a ground lead to the center tap of the coil. If this ignition-noise eliminator does not significantly reduce the interference, re-run the antenna leads as far from the street exposure as possible, trying to avoid long horizontal runs. If the situation still exists, it may be necessary to relocate the antenna.

### Eliminating Ghosts

Ghosts are often caused by a faulty impedance match between the transmission line and the receiver, and can usually be minimized by installing a corrective impedance-matching network. Fig. 3-15 shows such a network, which essentially consists of two trimmer capacitors connected in series with each leg of the transmission line. Note that the trimmers can be adjusted separately to improve the antenna-to-receiver matching.

Tune the channel selector to the station producing the strongest ghost, adjust the fine-tuning control for the best picture, then rotate each trimmer, in turn, until the ghost is minimized or eliminated. Check the other channels to ensure that they have not been affected.

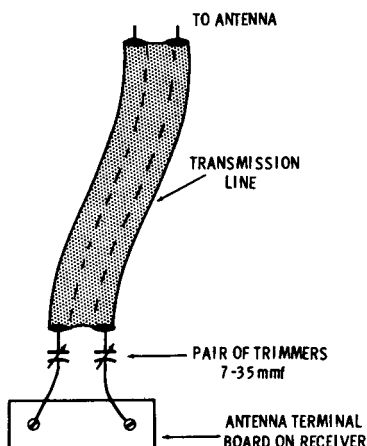

**Fig. 3-15. Impedance-matching network.**

If tuning capacitors are unavailable, connect about 3 feet of lead-in wire from the antenna terminals of the set, and allow this lead-in to hang freely behind the set. Beginning at the antenna terminals, successively short portions of the lead-in wire until the best picture is received. You can use a razor blade to accomplish the shorting job.

Another technique is to cut a 3-inch piece of aluminum foil, and wrap it around the lead-in wire; slide the foil back and forth (starting at the antenna terminals), looking for an improvement in the picture. When this point is reached, tape the foil in place. Many home-made remedies of this type have been employed to reduce or eliminate ghosts. However, these remedies are dependent on the type of ghost and the condition causing it.

Ghosts generally result from reflected signals; that is, one signal reaches the antenna directly from the TV station, and the other signal (reflection) is bounced from a

building, water tank, or other large object in the path of the signal. Because the reflection is actually delayed in time, and arrives at the antenna later than the original signal, the resulting ghost will appear displaced to the right of the original image. In this instance, the only remedy is to reorient the antenna as needed to correct the condition. Alternatively it may be corrected in the set by improving the tuner shielding or shunting the antenna terminals on the set. One method used to correct this imbalance, or phase mismatch, is by connecting a 500-ohm balancing potentiometer between the antenna terminals on the receiver, and grounding the center arm of the control. Make sure that the wiring to the potentiometer is short-run and evenly matched.

### Other Types of Interference

Besides ignition noise and ghosts, most TV sets are also subject to buzz, jitter, smear, Barkhausen oscillations, and the like. These are internal conditions that can often be remedied easily. Many sets have a buzz control to eliminate the buzz condition, if not, a *slight* (note: slight!) touch-up of the IF amplifiers will do. Jitter may be caused by microphonic tubes, which can be detected by tapping the tubes and observing the picture for an indication of microphonics. Smear is usually remedied by adjusting or peaking the mixer coil on the tuner to improve picture response. Be careful to note the original position of the adjustment screw; in case this does not cure the trouble it can be returned to its original setting. Barkhausen oscillation usually appears as vertical black bars at the left side of the screen, and are usually caused by the horizontal oscillator section. Either insufficient shielding or adjustment of the horizontal drive is usually the cause of this trouble.



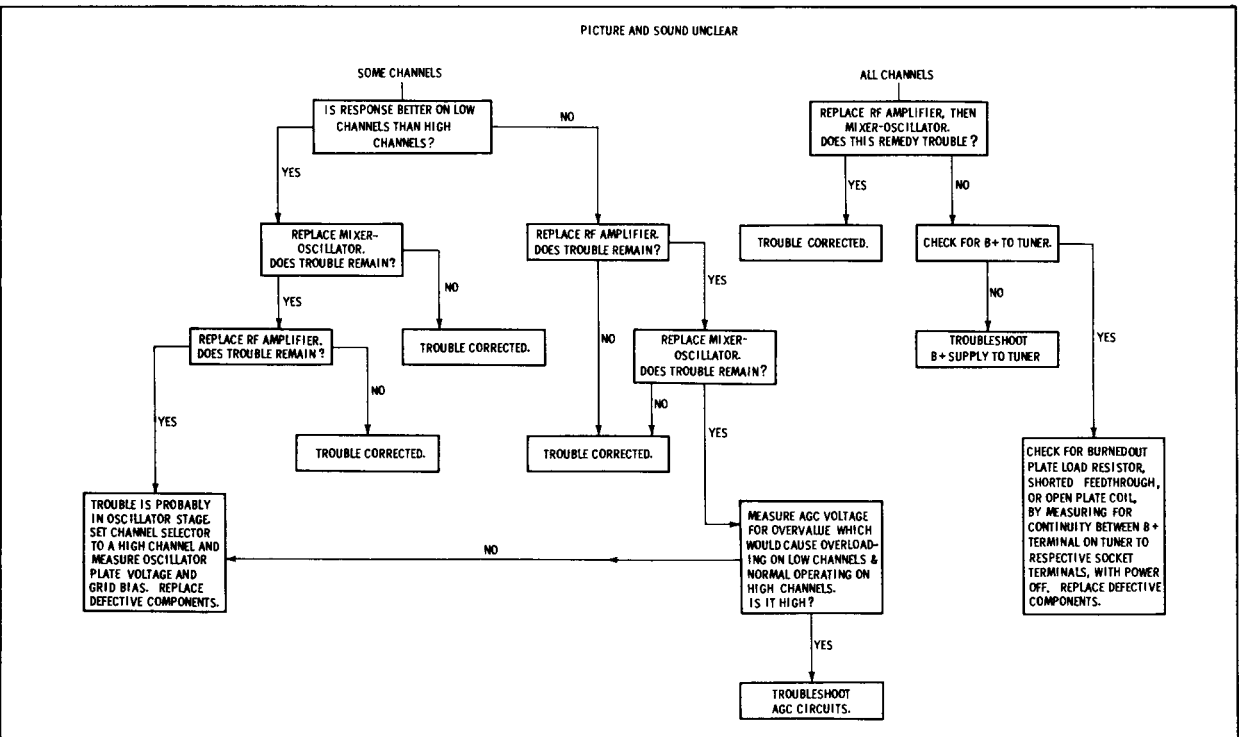

Chart 3-1. Tuner Troubleshooting Flow Chart.

## **Troubleshooting Tuner Circuits**

---

Chart 3-1 is a flow chart for typical tuners and can be used as an aid to isolate tuner defects. The chart indicates troubleshooting steps for unclear picture and sound; some channels or all channels.

## CHAPTER 4

# Troubleshooting Video Circuits

Split sound and intercarrier are the terms used to describe the two basic types of video IF circuits. Modern receivers use the intercarrier technique, which is common amplification of both sound and video in the IF amplifier sections. A separate sound take-off point, usually where the sound and video information are separated, feeds the sound stages.

Split sound was more commonly used on older sets, where the sound and video were split at the output of the tuner stage and supplied to their respective IF amplifier stages. In many respects, split sound was cleaner than intercarrier because there was no interaction between the video and sound information, such as intercarrier buzz, sound modulation of the displayed video, and so on. However, split-sound circuitry had a large drawback in tracking; sometimes it was impossible to tune the video and sound information for best reception of both signals. Usually, sound had to be sacrificed to obtain a worthwhile picture. Although the coverage in this chapter is mainly

concerned with intercarrier sets, basic circuit operation can be adopted to receivers having split sound.

### BLOCK DIAGRAM DESCRIPTION

A block diagram of typical IF and video sections is shown in Fig. 4-1. Three identical stages of IF amplification are used, and each stage is stagger-tuned to obtain optimum bandpass characteristics.

Input signals are supplied from the output of the mixer stage in the tuner, and applied to the first IF amplifier stage. In an intercarrier set, both sound and video are applied for common amplification to all three IF stages. The sound take-off point is shown to be either at the output of the video detector or the video amplifier.

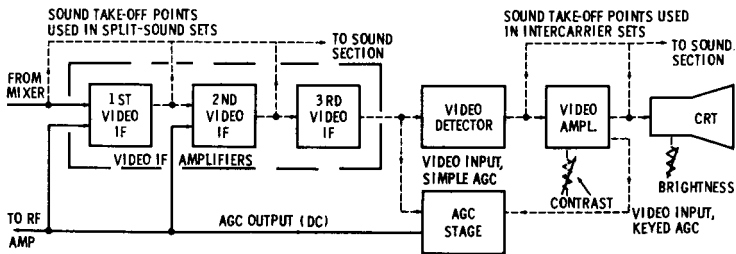

Fig. 4-1. Video section block diagram.

In receivers having a split-sound system, the sound take off is either directly before the first IF, or at the output of one or more of the succeeding IF stages.

The amplified IF signals are applied to a video-detector stage, which is normally either a germanium diode or a vacuum-tube diode. The detected video information is supplied to the video-amplifier stage for signal amplification. As shown, the AGC stage develops AGC voltage in either of two ways: (1) By sensing the output of the video amplifier; or (2) By monitoring the output of the IF am-

plifier preceding the detector. The first method is designated "keyed AGC" the second is "simple AGC". In some cases, the AGC voltage is developed directly by the video detector; a DC voltage is developed across a load resistor that varies in amplitude corresponding to the strength of the incoming signal.

The gain of the video amplifier, and the level of the video information applied to the CRT is set by the Contrast control, normally connected in the cathode circuit of the video amplifier stage.

Note that the sound IF for most intercarrier-type receivers is usually at 4.5-mc and results from heterodyning the sound and video IF carriers. This type of arrangement is subject to intercarrier buzz, a trouble which results from poor alignment of the video IF stages. Often a simple touch-up of the IF alignment will clear up troubles of this type.

### **VIDEO CIRCUIT THEORY AND TROUBLE SYMPTOMS**

A schematic diagram of the video circuits used in a typical intercarrier receiver is shown in Fig. 4-2. Note that this particular set uses two stages of IF amplification in addition to a video detector-AGC stage and a video amplifier.

Tuned plate and grid circuits are used throughout the IF-amplifier section to provide a bandpass sufficiently wide enough for the video-IF carrier and related modulation frequencies. This bandpass is largely the result of using stagger-tuned IF stages. Note that coil L2 is tuned to 44.5 mc, L3 is tuned to 43.5 mc, and L4 is tuned to 45.5 mc.

Both sound and video are amplified in the first two IF stages and applied through IF transformer L4 to the germanium diode detector, M4. Diode M4 is connected so that only the negative-going portion of the video envelope is

passed. This signal is applied through peaking coils L5 and L6, and coupling capacitor C16, to the grid of video amplifier stage V3A.

Diode detectors of this type are a not uncommon source of video troubles, such as AGC problems, video smear, and the like. The surest method of checking these diodes is to measure their forward-to-backward resistance (with the diode disconnected from the circuit), and see if the back resistance is at least 50 to 100 times greater than the forward resistance. This should mean at least 100K back resistance, and 200 ohms forward.

Peaking coils L5 and L6 pass the high-frequency components with low-frequency components bypassed to ground through capacitor C15. If the high-frequency response is poor, picture quality will decrease. If the response is highly peaked, video ringing may result. If these problems develop, check the peaking coils for open or shorted windings, or to see if they are in close proximity to high-temperature components.

The amplification factor of the video output stage (or the gain) is determined by the setting of the Contrast potentiometer, R1A. As this control is rotated clockwise (increased contrast), the cathode becomes more positive with respect to ground, and the plate voltage increases. Poor contrast may result from a gassy video-output tube, shorted bypass capacitor C18, or off-value grid resistors R17 and R18.

Waveforms W1 and W2 illustrate the video information before and after passage through the video amplifier stage. When checking for these waveforms, be sure to observe if the sync pulses are clearly defined and that hash-free operation exists, indicating that the video stage is operating correctly. It is a common mistake to interpret sync troubles as resulting from a defective sync amplifier or in-

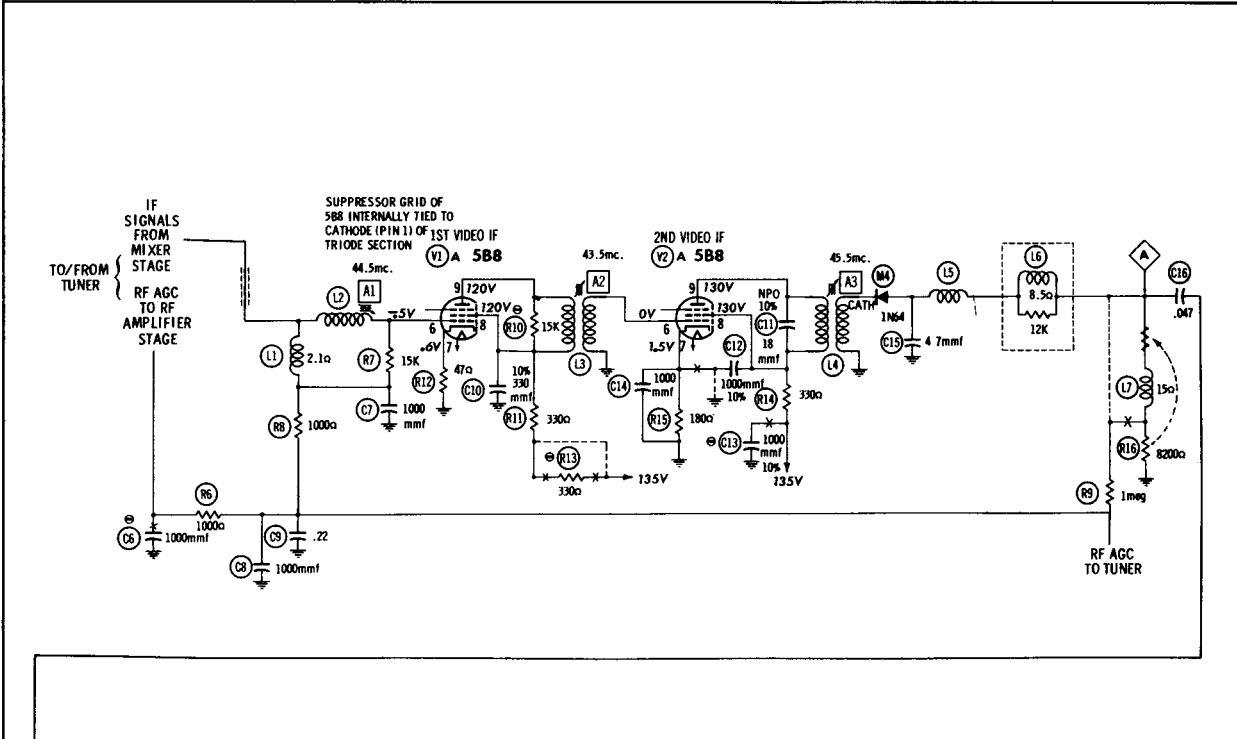
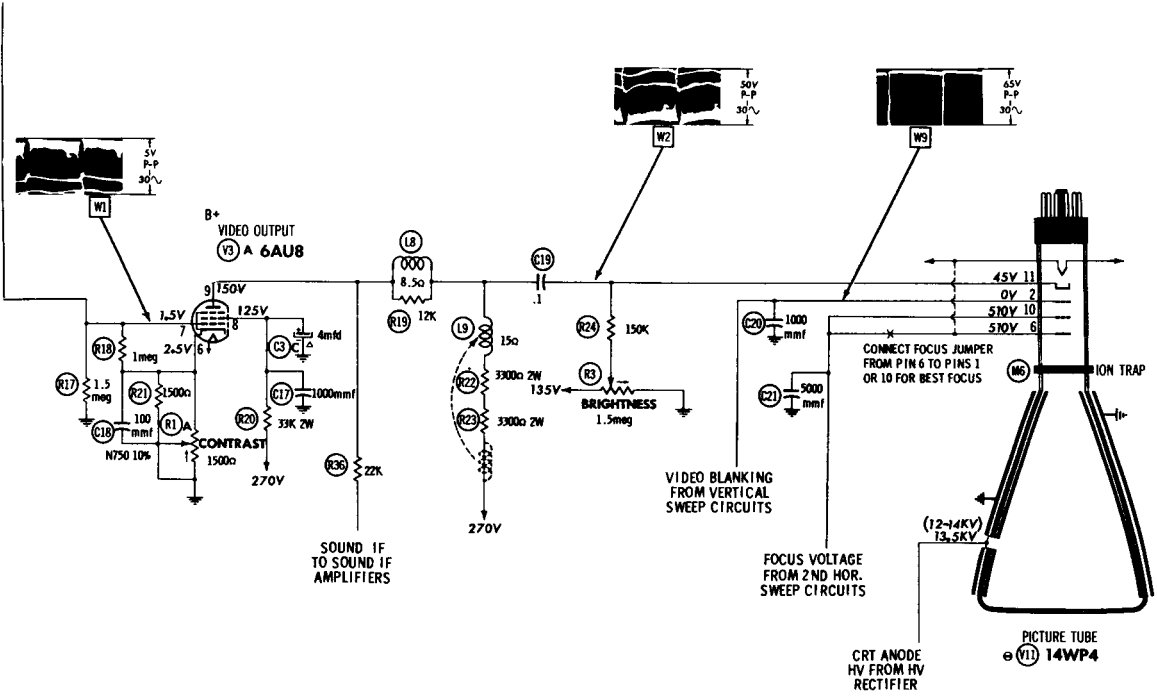

Fig. 4-2. Video



circuit diagram.



verter stage. Don't overlook the possibility that the video or IF stages are at fault.

Two fairly reliable indications that the video circuits are operating properly, are the AGC bias and the voltage drop across the Contrast control. If there is any question that the video circuits are at fault, refer to the schematic diagram and determine that the proper voltages appear at these points.

Although brightness control circuits are not generally a source of trouble, a common trouble in older sets was "no control of brightness," with a darkened screen. This was generally caused by coupling capacitor C19 which shorted or became leaky, applying a high positive voltage to the CRT cathode, effectively cutting off CRT conduction. In sets having the picture information fed to the grid, the reverse action—high brightness, no control—would occur if C19 developed leakage.

Never underestimate the AGC circuits as a source of trouble. Although a simple AGC circuit is used in the receiver, Fig. 4-2, the detector can break down, or the load resistor can increase in value; either of these troubles will upset the operation of the video circuits. The basic function of the AGC circuit is to keep the level of the video signals, at the output of the video amplifier, at a more-or-less constant level, regardless of the signal strength of the input RF signals. This is accomplished by applying the AGC voltage from the detector (or AGC stage) to the grids of the RF-amplifier and the IF-amplifier stage(s). A strong RF signal develops a high negative AGC voltage, while a weak RF signal develops a low negative AGC voltage. If AGC is developed by a very weak RF signal such as that found in fringe areas, the result is an even weaker video signal. Since this is undesirable, most television receivers have a control which establishes the signal threshold at which the AGC will operate.

The appearance of sound bars in the picture can be caused by poor RF oscillator alignment, misaligned sound traps, poor fine-tuning adjustment, poor video-IF alignment, defective video detector (crystal), or leaky (or open) filter capacitors in the sound-output stage. This last item is especially true if the set is intercarrier and a secondary B+ supply is developed from the cathode load of the audio output stage.

Try to eliminate the hum condition by changing tubes in the video-IF amplifier, RF amplifier, and the audio-output stage. If this condition remains, use a filter capacitor (about 40-mfd at 450 WVDC) to shunt all the filters in the B+ distribution chain until the defective filter is found.

### TROUBLESHOOTING INDIVIDUAL STAGES

Consider that the video circuits are made up of several blocks, as shown in Fig. 4-1. Each of these blocks—the IF amplifiers, video detector, AGC stage, and the video amplifier—has its own peculiar trouble symptoms.

#### IF Amplifier

The IF amplifier stages are usually trouble-free except for IF transformer alignment and defective or aging tubes. Many times, however, a shorted tube burns the plate-load resistor. A trouble which is more or less common to the IF amplifier is oscillation, or ringing. This shows up on the screen as diagonal bars, herringbone, or even a complete loss of video information. This trouble is usually caused by poor grounding, insufficient tube shielding, IF misalignment, closely-coupled stage components, poor solder connections, loose tube-socket pins, and the like. One really common cause of this type trouble is open decoup-

ling capacitors in the plate or screen circuits. It's simple to check these by bridging with good components.

### **Video Detector**

A defective video detector-AGC stage will cause overloading, picture smear, or complete loss of video and sound. Two ways to determine if the trouble is in this stage are: (1) Check forward-to-reverse resistance of the diode detector (if a crystal is used); and (2) Check across the diode load resistor for the small negative voltage which should be present if the video information is being demodulated.

### **Video Amplifier**

Proper operation of the video-amplifier stage is dependent on the preceding stages: tuner, IF amplifiers, and detector. A defective video detector, with high leakage resistance, could so affect the video amplifier that the displayed picture would appear dull, low in contrast, or smeared. A leaky decoupling capacitor, or off-value screen resistor can also cause this trouble. If the set is an inter-carrier type with the sound take-off at the output of the video amplifier, a defective video amplifier can also cause a loss of sound as well as picture. If, in sets where the sound is removed prior to the video-amplifier stage, the sound appears normal but the picture is lost or fuzzy, then this is also an indication of a defective video amplifier.

An emergency method of repairing a defective contrast control (if the circuit permits) is to reconnect the wires to the high side of the potentiometer to the other side. This will mean that the control must be turned counter-clockwise instead of clockwise for more contrast, but it will work in a pinch.

### Picture Tube

Although the picture tube may appear to be an unlikely cause of trouble, remember that microphonic CRT elements can cause symptoms ranging from video ringing to poor or intermittent contrast or brightness, or even sound or synchronization problems.

### B+ Supply

Consider the B+ supply circuits when video trouble is present. A drop in B+ can cause poor frequency response or a complete loss of sound and video. Some television receivers rely on the operation of the audio-amplifier stage (as a voltage divider) to provide the supply voltages for the IF strip. Check this secondary B+ source at the cathode element of the audio output tube, to be sure the correct amount is available. Also be suspicious of sweep and sync circuits when fighting troubles which appear to be unique to the video circuits.

## PREANALYSIS

Don't go off in all directions! Inevitably, every technician will remind himself, after the trouble has been found, "There must have been an easier way to do this!" There is an easier way! Use common sense in analyzing the problem, because a proper diagnosis of the trouble is half of the battle. Use the process of elimination and work on the trouble stage by stage. Shortcuts are fine, providing that you know what you are looking for (and what you are doing).

Most video troubles can be located by using a VTVM, and, as mentioned earlier, common sense. If you make the assumption that the television receiver was properly de-

Chart 4-1. Video Trouble Flow Chart.

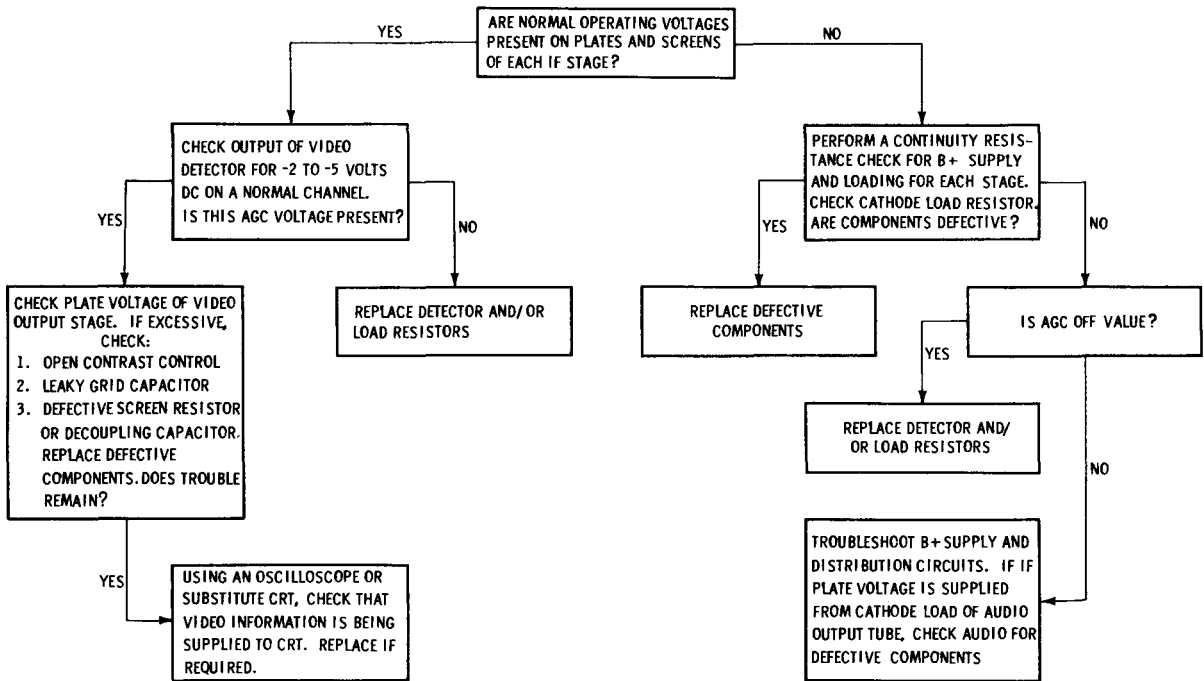

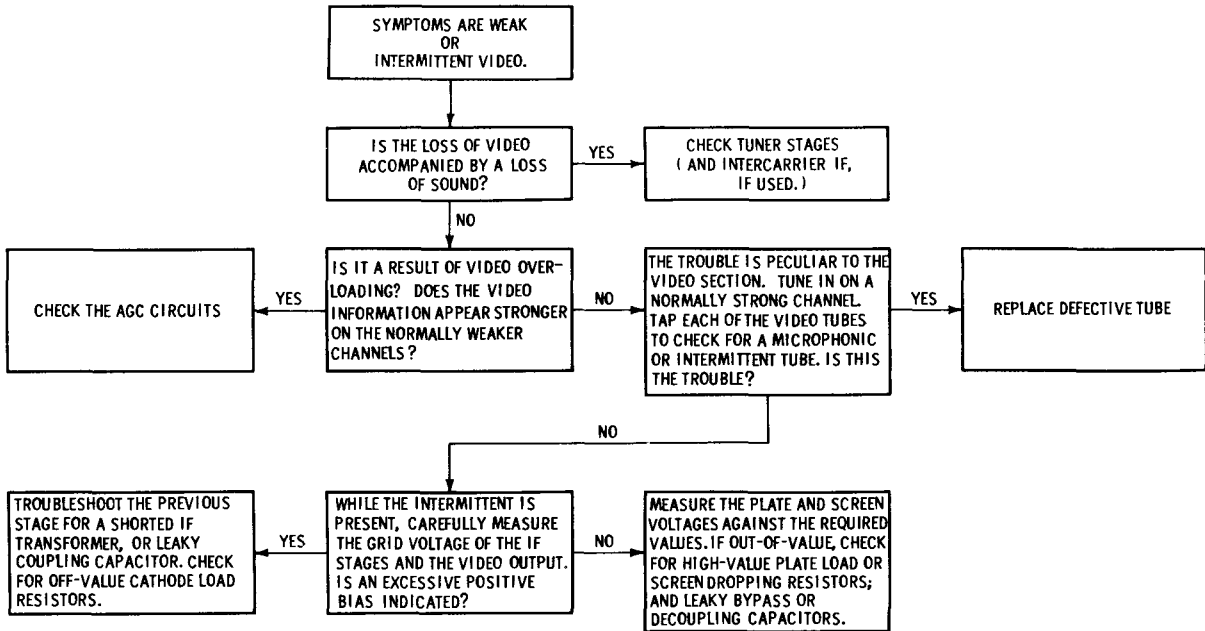

Chart 4-2. Intermittent or Weak Video Troubleshooting Chart.

## **TV Troubleshooter's Reference Handbook**

---

signed, and that the voltage and resistance charts are accurate, there is no reason why a point-to-point voltage or resistance check can't show up most troubles.

Use the troubleshooting flow chart in Chart 4-1 to help isolate video troubles to a component or group of components. Chart 4-2 is a flow chart for locating intermittent or weak video defects.

## CHAPTER 5

# Troubleshooting Sound Circuits

Usually, sound troubles that develop in most television receivers are the result of leaky or shorted capacitors, or off-value resistors, rather than defective tubes. Because of this, it is often harder to troubleshoot the sound sections than, for example, the video section. This chapter provides theory of operation for a typical sound section, from IF to output stage, as well as some general troubleshooting procedures for locating defective components.

### THEORY OF OPERATION

A schematic diagram for a typical sound section is shown in Fig. 5-1. The sound IF signal, supplied from the video section (if in an intercarrier set), or tuner stage (for split sound), is applied through a bandpass network consisting of a 5-mmf capacitor and an IF transformer (L10), then through coupling capacitor C22 to the grid of sound IF amplifier V3B. The amplified signal from the plate cir-



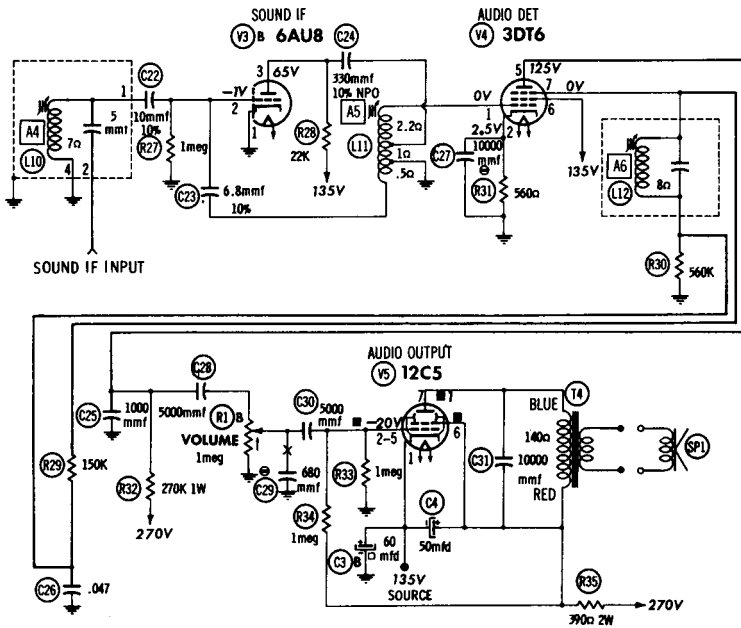

Fig. 5-1. Audio section of TV.

circuit of V3B is applied through coupling capacitor C24 and IF transformer L11 to the grid of audio detector V4. Negative feedback is applied to the sound IF stage V3B through C23.

In some receivers, a dual section tube such as a 6T8 is used as a ratio detector and first audio-amplifier stage. Other receivers use a single gated-beam detector tube, such as the 3DT6 shown in the schematic diagram in Fig. 5-1. This tube functions as a sound detector *and* audio amplifier stage. In this instance, audio detector V4 demodulates the audio signal and limits the noise transients through the use of externally-tuned networks and bypass circuits. Inductor L12 must be correctly aligned to reduce external noise and keep sound buzz to a minimum. Improper bias voltages in the detector stage can cause distortion, buzz, and other sound troubles.

## Troubleshooting Sound Circuits

---

The audio signal from the detector is applied through coupling capacitor C28 across volume control R1, which in turn taps off a portion of the audio signal for amplification in the sound output stage, V5. The sound-output stage performs a dual function: (1) It provides power amplification for the audio signal; (2) It develops the 135-volt B+ source for the video IF strip, tuner, and some sync circuits, as previously described in Chapter 2. The amplified signals at the plate of the audio output stage are applied to the primary of output transformer T4, which then drives the speaker.

Note the circuit location of electrolytic capacitors C3B and C4. Each of these components provide filtering for the 135-volt source at the cathode of V5. If C4 becomes shorted or develops leakage, several symptoms will become apparent. An increase in the 135-volt source would result, and cause overloading of the video strip. This *could* cause a complete loss of video and sync information, in addition to possible damage to some of the components in the IF circuits. At the same time, since the cathode-grid bias of V5 would also be upset by an increase in the cathode voltage, audio distortion or loss of sound would occur. If the elements of the IF tubes, or the audio output tube, appear to glow red, (a result of excessive current flow), then capacitor C4 should be suspected. If C3B becomes leaky or shorted, symptoms appearing would be a reduction, or complete absence, of B+ in the IF strip, sync stages, etc., and excessive audio distortion. Or, possibly, no audio at all.

If any of the above symptoms appear, first check that the bias voltages on the audio-output tube (for this type of set) are correct; even a 10-percent change can often cause troubles of this type. Also check the audio output tube, and the filament voltage on that tube, since improper filament voltage can cause improper tube action.

### **TROUBLESHOOTING INDIVIDUAL STAGES**

Troubleshooting sound circuits can be done with a good VTVM and a signal simulator; this can be an oscillator or hand-held screwdriver. General practice is to begin troubleshooting from the output stage, working backwards to the sound IF stages.

#### **Speaker**

Check the speaker by substituting a known good one. In many instances, distortion and intermittent volume are the result of a sticking or rubbing voice coil.

#### **Output Stage**

Check the output transformer by substitution; grounded windings are generally indicated by transformer overheating, intermittent windings by "popping". Many output transformers "talk" at high volume settings; if the primary winding is good and the secondary winding (voice-coil winding) is open, the transformer may talk, but no sound will be heard from the speaker. (The talking sound referred to above is similar to that heard by placing the ear close to a needle running in the grooves of a phonograph record, the sound of which is not being amplified.)

Check the output tube and circuits by tube substitution and voltage and resistance measurements. Sometimes tube replacement will clear up distortion problems that otherwise appear to come from defective circuit components. Try more than one replacement tube, and make sure that an exact replacement is used. Using a so-called "replacement type" is not the answer; many output circuits are designed for a particular tube characteristic, and another tube type might eventually cause trouble.

## **Troubleshooting Sound Circuit**

---

Check the output tube for negative grid bias (with respect to the cathode); check that the plate and screen voltages are within operating tolerance. If the sound output tube is also part of the B+ supply network, make sure that the filter capacitors in the cathode are not leaky or open. Be careful to check for leaky grid coupling capacitors; these will usually cause a gradually worsening distortion, intermittent sound or no sound, and possibly tube saturation. This latter, in turn, may cause the tube elements to glow red, or damage the output transformer or other parts.

### **Sound Discriminator-Audio Amplifier**

Discriminator transformers often change adjustment as a result of set overheating, excessive humidity, or microphonics. Be sure that the discriminator is set properly, then use a corona dope or Glyptal, or even nail polish, to secure the slug settings. Check the base terminals for loose solder connections and chassis shorts. Remember that the function of the discriminator is to demodulate the audio information, so resistors and capacitors must be within tolerance. Use a capacitor checker or substitution box to check circuit components; carefully check load resistors while disconnected from the circuit.

An audio oscillator, or a hand-held screwdriver, when applied to the center-tap of the volume control should produce a hum from the speaker. If it doesn't, check for trouble between the discriminator stage and the speaker.

### **Sound-IF Stages**

The sound-IF stages are usually fairly stable in their operation. Possible trouble sources are interstage transformers that are often subject to heat and humidity conditions, as well as B+ to ground shorts. Check transformers by measuring the resistance between both sets of wind-

ings on the highest resistance scale of the ohmmeter. When disconnecting the transformer leads, be sure to use a heat sink to avoid damaging the IF coils with heat from the solder gun. Check the transformer alignment either with a sweep generator and marker generator, or connect a good VTVM across the discriminator load and tune the IF transformers for proper output indication. (Check the alignment procedure outlined in the service information for the particular receiver you are servicing.)

Filter hum is another trouble area to consider. This can be easily checked by setting the volume control to the minimum (counterclockwise) setting and listening to determine if excessive hum is present. If it is, then an open filter is the most probable trouble. Shunt each filter in the power supply, audio section, and vertical section until the defective capacitor is found. If, however, the hum disappears at a low volume setting, then it is probably the result of AC leakage into the sound section at some point before the volume-control potentiometer. Check for this trouble by sequentially removing the tubes in the sound section; beginning with the sound IF amplifiers, and working toward the sound output tube. This procedure is suitable for a set with parallel-wired tube filaments, but can also be used in series-string sets if the tubes are removed only momentarily, before the low-voltage electrolytics are discharged.

If the above methods fail to locate the source of hum, use an oscilloscope, or a set of headphones in series with a DC blocking capacitor, and trace the signal through each stage, beginning with the input circuits. You can generally tell if a defective filter in the vertical circuit is interfering with the sound output; simply rotate the vertical hold control while listening for a change in the sound. If the frequency of the buzz shifts during this test, you will know it is caused by improper vertical circuit filtering.

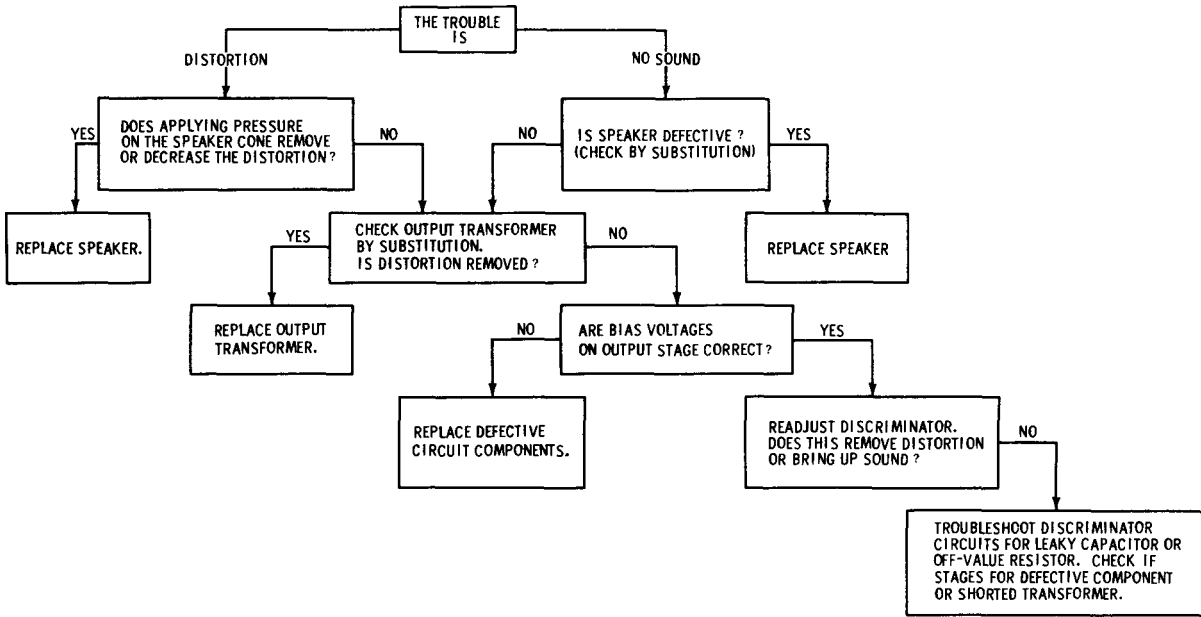

Chart 5-1. Audio Circuit Troubleshooting Chart.

TRUBLESHOOTING FOR INTERMITTENT OR DISTORTED SOUND

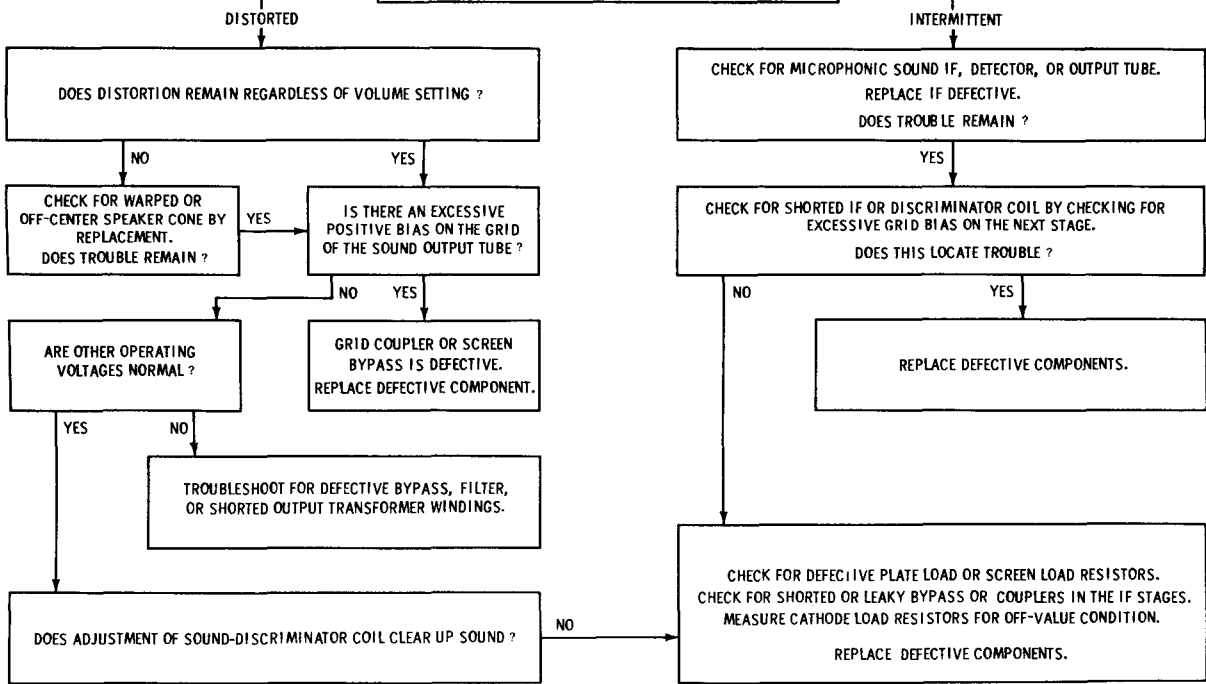

Chart 5.2. Distorted or Intermittent Sound Trouble Chart.

Motorboating, which is a common trouble in radio receivers, can also affect the sound section of the television receiver. As in the motorboating radio, the cause of this trouble is normally an open bypass, usually in the audio amplifier or output stage. In some instances, the same trouble has been caused by an AC leakage in a 6J6 tuner stage, but this usually appeared as an intermittent symptom.

Intercarrier buzz, which is also a common complaint in receivers using this system, can be caused by either of the following:

1. A defective discriminator transformer, or misadjustment of the buzz control or discriminator.
2. Insufficient B+ filtering, or pickup from AC lines too close to audio leads.
3. Pickup in the volume control leads from vertical sweep circuits, and poor shielding of audio circuit components, including tubes.

A troubleshooting flow chart for sound circuits is shown in Chart 5-1. Two different routes can be followed—one for distortion, the other for no sound. The flow chart in Chart 5-2 shows the system for locating a defect causing distorted or intermittent sound.



## CHAPTER 6

# Troubleshooting Sync Circuits

Many technicians overlook the fact that picture synchronization is one of the more important (and troublesome) sections in the television receiver. If a trouble occurs in any of the other sections, the resulting symptoms are usually clear enough so that the trouble can readily be isolated to that section. However, the operation of the sync section is so interrelated with the operation of the rest of the set, that apparent sync troubles might actually be the result of a defective tuner, video stage, AGC or power supply rather than a defect in the sync circuits.

Consider that the television raster consists of 525 lines, being displayed at a rate of 30 times each second, and that precise synchronization must be maintained between the scanning camera at the television station and the home television receiver. Composite video information transmitted from the television station contains synchronization pulses that are required to synchronize the transmitted video information at the receiver. To recover these sync

pulses, a portion of the composite video signal is removed and fed to the sync stages before being applied to the CRT. The vertical sync pulses are derived from the wide pulses that appear at the end of each video field; the horizontal sync pulses are derived from the narrow vertical pulses that appear at the end of each line.

### THEORY OF OPERATION

A schematic diagram of a typical sync section is shown in Fig. 6-1. The positive-going video information (composite video), waveform W3, is applied to the grid of the sync separator stage, V2B, through capacitor C32. Capacitor C33 and resistors R37 and R38 provide noise limiting and grid leak bias in proportion to the amplitude of the input video information.

Because the sync separator stage normally operates with a low plate voltage (in this example, 45 volts), the  $-1.5$ -volt grid bias is sufficient to cut off this stage—except for the time that the amplitude of the positive-going video (the sync level) exceeds the cutoff level. This portion of the video information contains the vertical and horizontal sync pulses, which are passed by V2B. The inverted signal appearing as the output waveform at the plate of V2B then consists only of the sync information—no video. This separated signal is applied to the grid of sync amplifier V1B, and also to the horizontal sweep circuits, via coupling capacitor C41. The portion of the sync pulses applied to V1B is amplified and inverted, then supplied to the vertical integrator network as the vertical sync pulses.

### TROUBLESHOOTING SYNC CIRCUITS

Although the majority of television troubles can be checked out with a VTVM, the sync section is one area

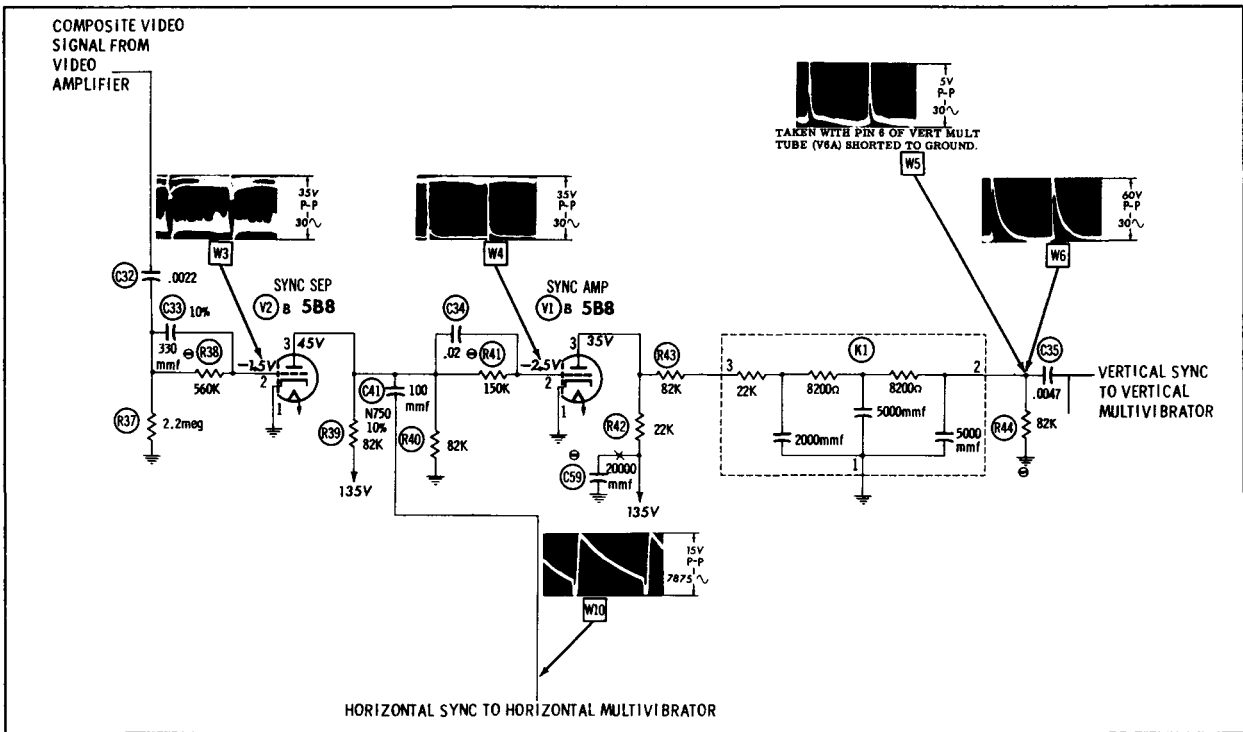

Fig. 6-1. Sync section schematic.

where a good oscilloscope will save a great deal of time and effort.

One of the considerations when diagnosing a sync problem from the display on the face of the TV picture tube is the area of the set in which the trouble exists. Too often a sync trouble will be misinterpreted as being common only to the sync section, when the trouble is actually originating in the tuner, power supply, or video section. Before going into the various types of sync problems, first determine where the trouble begins.

### External Sync Troubles

Externally-caused sync troubles result from one or the other of the following causes:

1. Poor video signal amplification.
2. Power supply filtering.
3. Interference.

*Poor video-signal amplification*—From the previous discussion of the operation of the video section and the tuner, it can be seen how important a strong video signal is in ensuring normal set operation—especially sync stability. Weak video, producing a washed-out raster, can easily upset the operation of the sync circuits. As explained previously in this chapter, the operation of the sync-separator stage depends on the fact that the amplitude of the positive-going video signal applied to the sync separator is greater than the cutoff level for that stage. If the video amplifier or one of the IF stages is weak, the composite video information is insufficient to overcome the cutoff bias, and the sync pulses will be very low in amplitude, or nonexistent. Poor sync naturally ensues.

From this discussion, it can be seen that an *apparent* sync problem may not be the result of a defective sync circuit—especially if the loss of sync is accompanied by weak

or washed-out video, insufficient contrast, poor tuner response, or overloading.

*Power supply filtering*—Insufficient power supply filtering is also a common cause of sync problems, although this usually has a more noticeable effect on vertical, rather than horizontal, sync. The reason for this is that the vertical sync is keyed to a 30-cycle repetition frequency (30 frames per second—actually 60 cycles per second), and if power supply filtering is poor the vertical section will tend to sync with the unfiltered 30-cps AC component rather than the vertical sync pulses. One symptom of this trouble is an intermittent loss of vertical sync, like a gradual vertical roll, yet the set has good horizontal stability. Make sure that the trouble is not in the power supply by shunting the filter capacitors with a good unit; or use an oscilloscope to check for excessive ripple voltage in the power supply circuits.

Occasionally, both horizontal and vertical sync will be affected by excessive ripple voltage (poor filtering). The symptoms of this type trouble are shown in Fig. 6-2 A and B. Note that one of the pictures is distorted by a heavy wavy bar running down the left-hand side of the picture. At the same time, the vertical hold range is decreased and the horizontal hold control has little effect on picture stability. This trouble can also be caused by a cathode-filament short in one of the tuner or video tubes; sometimes this symptom is accompanied by a slight hum or sound distortion.

*Interference*—Last but not least, interference is another cause of sync trouble. However, this is usually an intermittent trouble, and may be the result of excessive noise pulses getting through the sync section, or poor noise rejection by noise cancellation circuitry. Some television receivers provide a noise cancellation or rejection adjustment, and

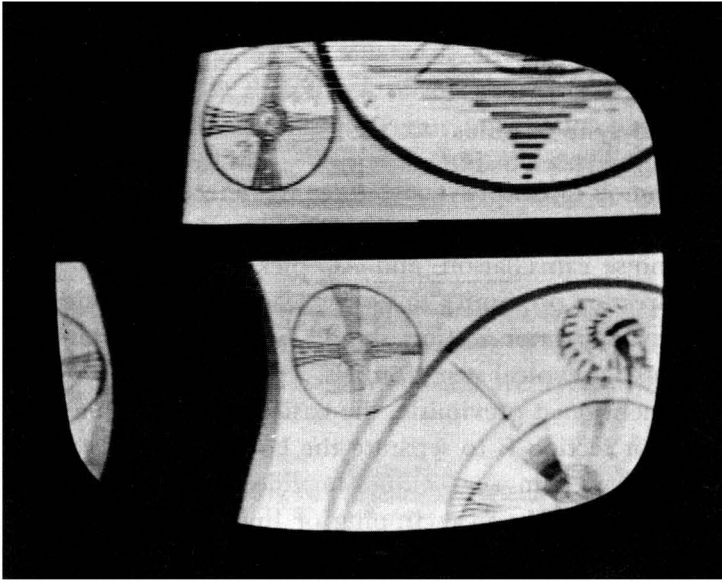

(A) Loss of horizontal and vertical sync.

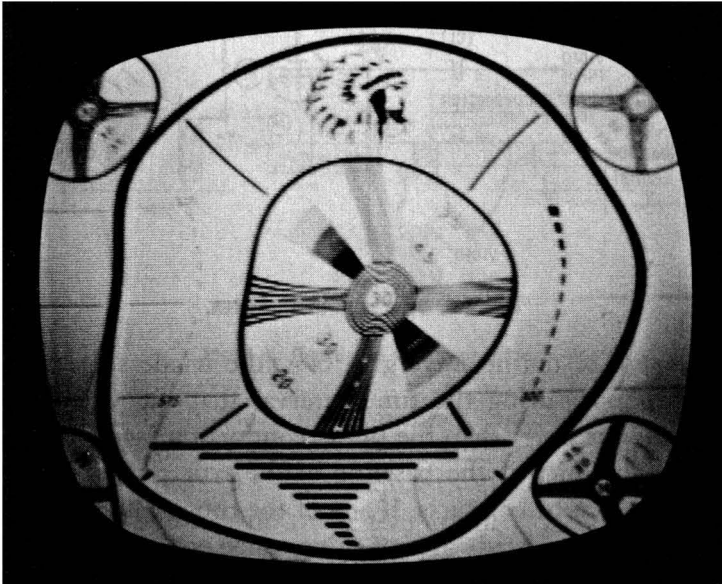

(B) Horizontal distortion.

Fig. 6-2. Effects of ripple voltage on sync.

too high a setting may cancel out the sync pulses as well as the noise.

**Internal Sync Troubles**

Common causes of sync troubles are defective sync tubes, open or leaky coupling capacitors, changed resistor values, poor noise cancellation, and AC pickup because of poor lead dress or proximity to power leads. A brief review of the sync separator section should help in understanding and locating typical sync troubles.

As mentioned previously, the basic function of the sync-separator section is to separate the horizontal and vertical sync pulses from the composite video information, this being accomplished by clipping or limiting action of the separator (or sync clipper) stage; as shown in Fig. 6-3.

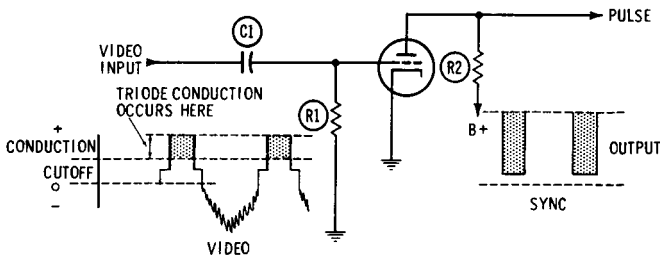

**Fig. 6-3. Sync separation action.**

Because of the negative grid bias, the triode stage will not conduct during the time interval that the video information is lower than the preset conduction level. When this level, which is the baseline of the sync pulses, is exceeded, the tube conducts. If any of the components in the sync separator circuit are off-value, open, or shorted, the bias level will be upset, preventing conduction and eliminating the sync pulses. Alternatively, conduction may occur

## Troubleshooting Sync Circuits

too soon, or too late, providing the wrong type of sync pulse at the output of the separator. Since the amplitude of the sync pulse at the output of this stage is also critical, an off-value plate load resistor can be another cause of trouble. Each of these points should be carefully considered, so check each of the stage components in conjunction with the schematic and normal operating voltages.

Some television receivers use a pentagrid tube, rather than a triode, in the sync separator stage. This type of circuit is shown in Fig. 6-4. Two signals are applied to this

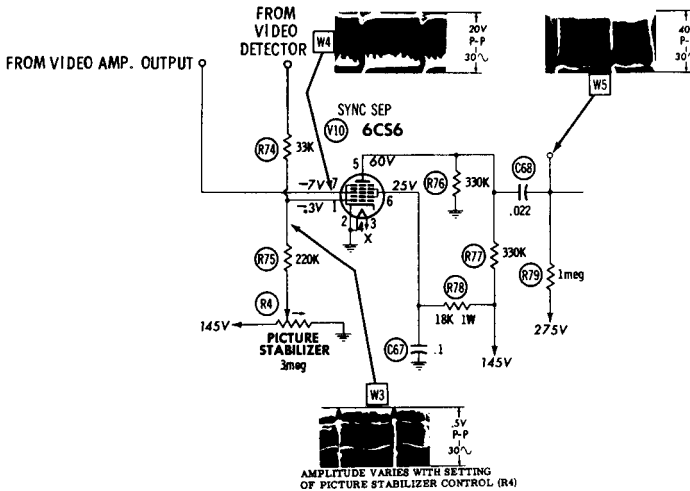

Fig. 6-4. Pentagrid sync separator.

stage—one from the video amplifier, and one from the video detector. These signals are unequal in amplitude and  $180^\circ$  out of phase, consequently the net signal is an algebraic addition of these two inputs. The major advantage in this type of circuit is the elimination of noise pulses that results from this additive action. Because the two signals are of opposite phase, the noise pulses cancel



out, so that the stage functions as both a sync separator *and* noise clipper. In addition to this dual function, the use of a pentode stage provides more amplification than a triode.

Troubleshooting a circuit of this type is similar to the procedure followed for the triode equivalent. Make sure components are within value tolerance.

### SYNC CIRCUIT SUMMARY

Horizontal sync problems can result when the video component is passed through the sync separator on top of the sync pulses. This action could be caused by overloading the IF amplifiers or video stages, and usually causes a general horizontal instability. To see if overloading is responsible, short the antenna terminals or disconnect the antenna at the set. If the horizontal becomes stable, then the trouble is video overloading. This trouble can be caused by poor AGC action.

In some cases, the horizontal sync appears stable, while the vertical rolls. As explained previously, this is because of the lesser stability of the vertical sync circuits as compared with the stability of the horizontal, which has integral AFC for stabilization. This, however, does not rule out trouble in circuitry common to both channels, such as sync amplification stages.

Vertical sync troubles can be caused by any of the defects covered previously. In addition, vertical jitter can also be caused by pickup from the CRT anode lead, or arc-over between the yoke windings. Also consider that sync troubles in most older sets may be caused by a general component deterioration. Replacement of **one part** may not clear up the trouble; it's just as easy in aged receivers, to avoid future sync troubles and callbacks, to replace all the components in the sync section.

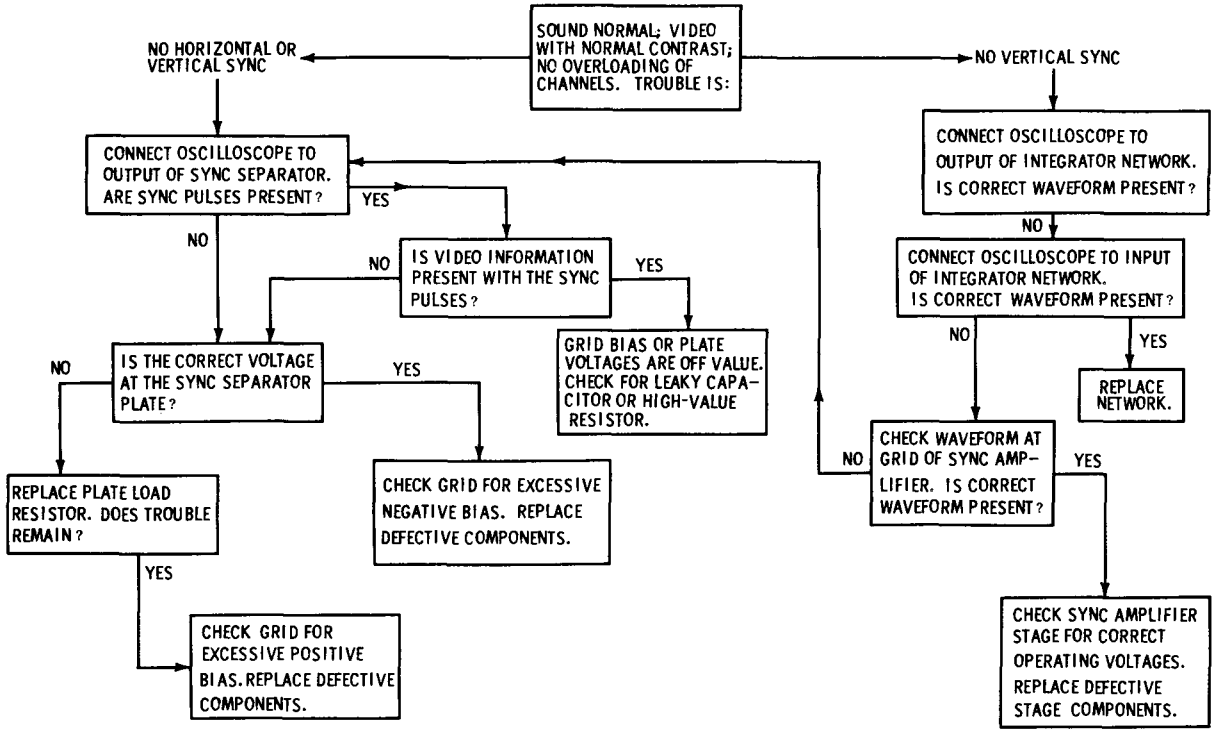

Chart 6-1. Sync Troubleshooting Chart.

## **TV Troubleshooter's Reference Handbook**

---

Chart 6-1 is a troubleshooting flow chart to aid in the stage isolation of sync troubles. Use it as a reference for a loss of vertical sync, or the loss of both vertical and horizontal sync.

## CHAPTER 7

# Troubleshooting Sweep Circuits

Fig. 7-1 is a block diagram of horizontal and vertical sweep circuits. As shown, the vertical sweep section consists of a free-running multivibrator stage and a vertical output stage. The multivibrator normally oscillates near the vertical repetition frequency, but is slaved to the repetition rate of the vertical sync pulses from the sync-amplifier section, through the vertical integrator. The output of the vertical multivibrator is shaped to a sawtooth and drives the vertical-output stage. This stage provides the deflection currents for the vertical deflection coils of the yoke.

Similarly, the horizontal oscillator is synchronized with the horizontal sync pulses from the sync-separator stage. An automatic frequency control (AFC) loop is used to further stabilize the oscillator frequency at the nominal 15,750 cycles per second. The output of the horizontal oscillator drives the horizontal output stage, which in turn, develops the horizontal deflection currents through the high-voltage flyback transformer for the yoke windings. The damper stage prevents secondary oscillations (horizontal ringing) and develops the boost voltage (B + +).

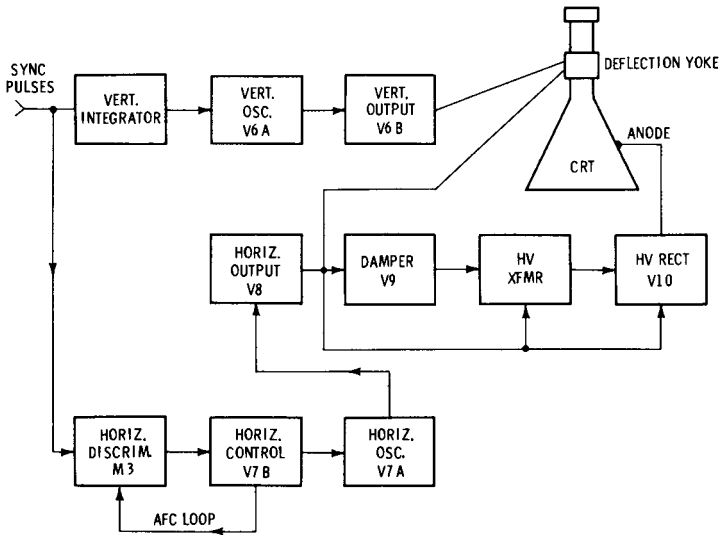

**Fig. 7-1. Horizontal and vertical sweep circuit block diagram.**

**THEORY OF OPERATION**

Due to the nature of the operating voltages, transients and general power dissipation in the sweep circuits, most of the troubles that occur are a result of component breakdowns, such as leaky capacitors, open or high-value resistors, and the like. Because of this, a greater percentage of intermittent troubles occur in the sweep and high voltage sections than elsewhere in the television receiver. The theory and troubleshooting information which follows covers both intermittent and constant sweep and high-voltage troubles.

**Horizontal Sweep Circuits**

A schematic diagram of typical vertical and horizontal sweep circuits is shown in Fig. 7-2. The horizontal sweep

section consists of multivibrator V7, horizontal output stage V8, damper tube V9, and high-voltage rectifier tube V10.

Multivibrator V7 develops the 15,750-cps drive signal which is applied to the grid of horizontal output tube V8. The grid bias on V8 is normally negative to prevent tube conduction between drive pulses, and to set the baseline, or starting point, for the beginning of each sawtooth-initiated sweep. Insufficient negative bias can cause overdriving of the output stage to the point where the characteristic red glow on the tube elements appears, and the current through the flyback windings of the high voltage transformer increases excessively.

Coupling capacitor C51, connected from the plate of the oscillator to the grid of the output stage, is a potential troublemaker. Many sweep troubles start with this capacitor, and a bit of preventive maintenance replacement is advised.

Flyback transformer T3 develops the high pulse voltage for the high-voltage rectifier. Damper V9 develops the 520-volt *boost* voltage, and prevents horizontal ringing by damping out secondary oscillations in the flyback windings. Capacitor C54, connected between the 270-volt B+ supply and the 520-volt B+ + boost, provides a filtering action for the boost voltage. Because of the peak voltages across this filter, breakdowns can occur, causing intermittent width reduction, poor horizontal linearity, or a complete loss of horizontal sweep. Intermittent troubles are quite common in this area.

High-voltage arcing or spray, caused by high humidity conditions or worn insulation on the flyback windings, can cause symptoms ranging from Barkhausen oscillations to picture blooming. Shorted flyback windings will cause intermittent or reduced deflection, poor linearity, and blooming.

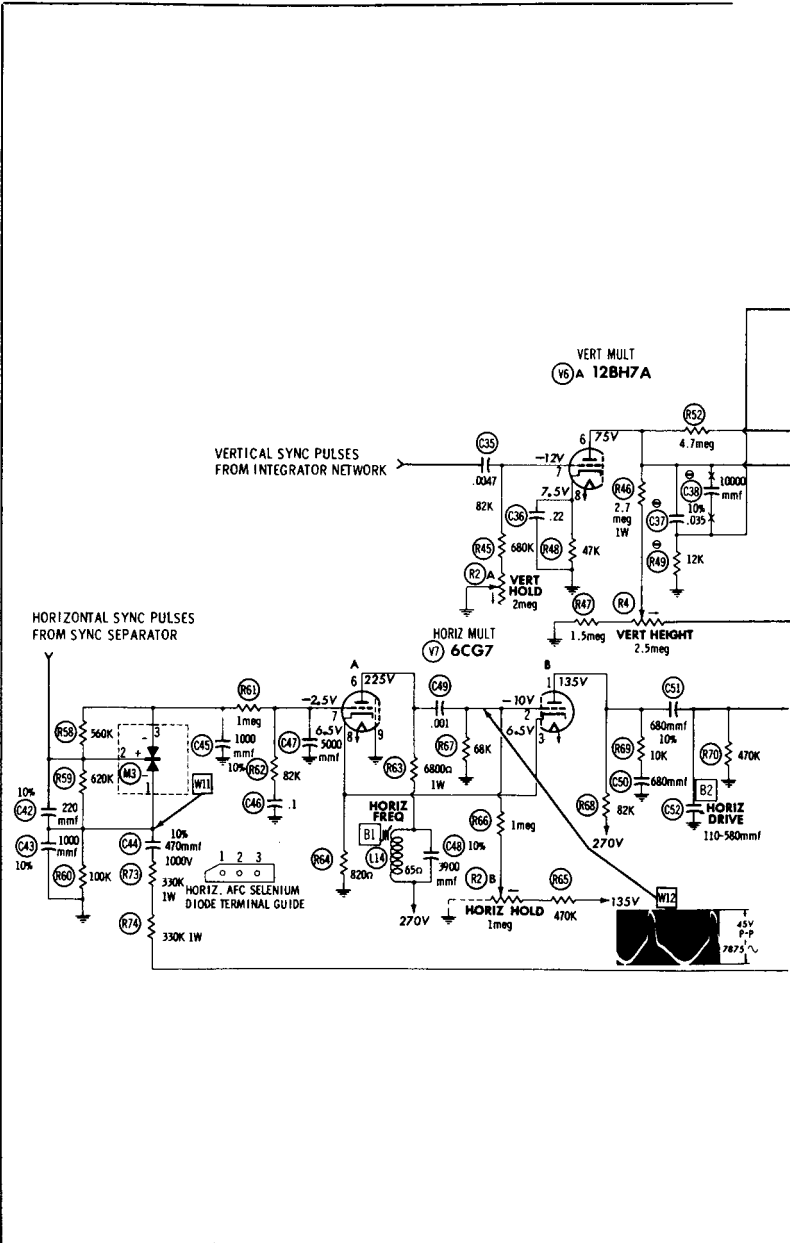
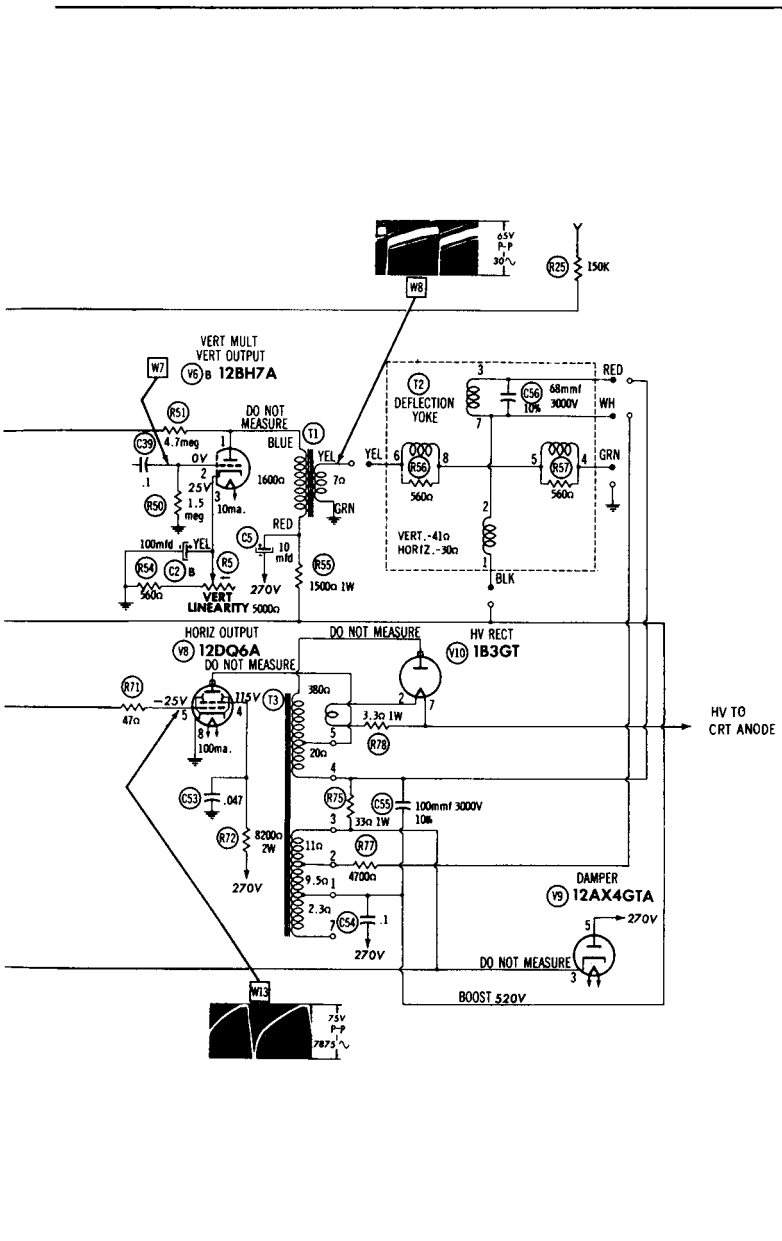

Fig. 7-2. Horizontal and vertical

# Troubleshooting Sweep Circuits



sweep circuit schematic.



### AFC Circuits

The automatic frequency control circuits provide further regulation of the horizontal oscillator frequency by generating DC correction voltage. This voltage is used to keep the oscillator on frequency.

The AFC detector, or discriminator (or comparator), responds to changes in phase between incoming sync signals and the horizontal sweep signal (sample), supplied to the AFC network through a feedback circuit. The horizontal sync pulses received from the sync separator stage are considered a standard (or reference), and are compared with the sweep feedback voltage. The correction voltage produced through this comparison is used to regulate the oscillator frequency. This section then forms a "closed loop," similar to that used to develop AGC or AVC voltages. A functional block diagram of a typical AFC network is shown in Fig. 7-3.

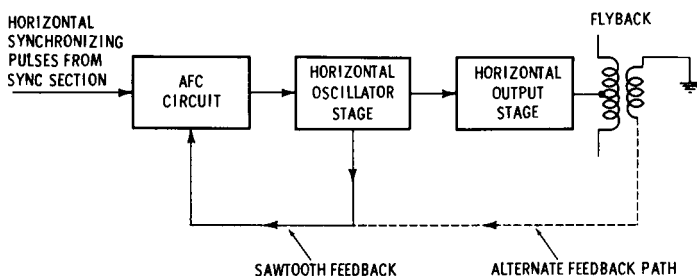

**Fig. 7-3. AFC network.**

The output of the AFC circuit is either positive- or negative-going, depending on the phase and amplitude relationship between the two input signals. The schematic diagram in Fig. 7-2 shows that the two input pulses (sweep feedback and sync) are applied to AFC diode M3 so that an amplitude and phase comparison takes place, causing a current flow through the AFC diode proportional to the

## Troubleshooting Sweep Circuits

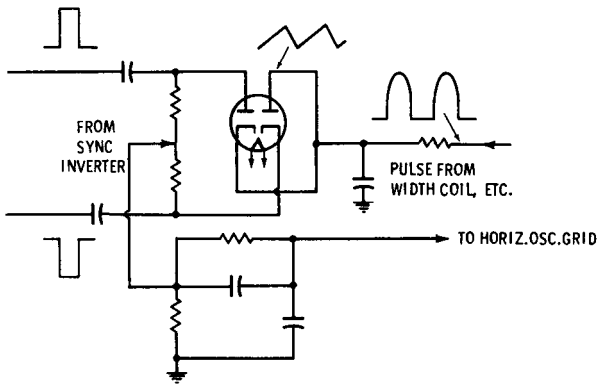

(A) Vacuum-tube circuit.

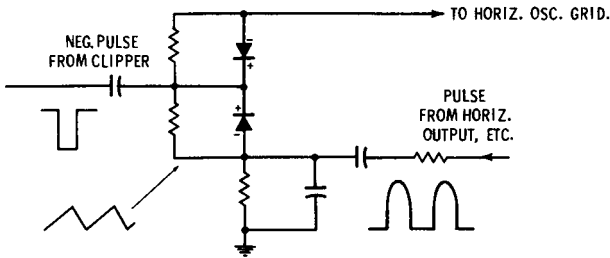

(B) Diode circuit.

**Fig. 7-4. Simplified AFC circuit.**

difference between the two applied signals. A resulting DC *error voltage* is developed across the diode, which controls the bias of the control section, V7B, of the horizontal oscillator stage. The bias control voltage is automatically adjusted by this continuous comparison to ensure that the oscillator holds at the sweep frequency. A simplified schematic diagram for the AFC circuit, with input waveforms, is shown in Fig. 7-4. Illustration A shows the vacuum-tube circuit; illustration B shows the diode type.

Another version of the AFC circuit is shown in Fig. 7-5. This is a pulse-width AFC control circuit, using one half of the dual triode to control the horizontal oscillator stage (blocking oscillator). A positive-going sync pulse

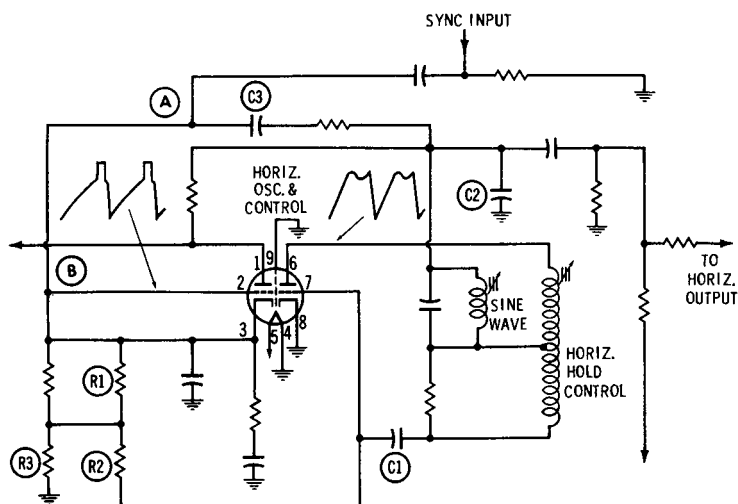

**Fig. 7-5. Pulse-width AFC control circuit.**

and a sawtooth (or modified sinewave) are applied to the AFC control grid. Some prior versions of this circuit combined three different waveforms from various control points in the sweep circuit.

**Vertical Sweep Circuits**

In the circuit shown in Fig. 7-2, half of dual triode V6 is used as the oscillator stage and the other half is used as the output stage. Oscillator V6A is a free-running oscillator which is synchronized by the sync pulses applied to the grid from the vertical integrator stage. The negative grid bias on V6A, normally a good indication that the oscillator is operating, is developed through the action of C35, R45, and R2; it is usually in the  $-10$ -volt range. The vertical multivibrator output, which resembles a sine wave, is shaped by a network consisting of C37, C38, and R49, to produce a sawtooth drive for the vertical-output stage.

Height control R4 is connected in series with the plate load resistor R46 and adjusts the plate voltage of V6A, controlling the amplitude of the output signals. Linearity control R5 is connected as a variable cathode load resistor for V6B and adjusts the bias of the output stage, thereby controlling the vertical linearity. The amplified sawtooth at the plate of V6B is transformer-coupled through T1 to the vertical windings of the yoke. Transformer T1 is basically an impedance-matching device between the yoke windings and the vertical output stage.

### TROUBLESHOOTING SWEEP AND AFC CIRCUITS

A wide variety of symptoms indicate faults in the AFC circuits of the horizontal sweep section. Some of these are:

1. Bending or horizontal displacement.
2. Tearing, or Christmas-tree effect.
3. Complete loss of sync, or weak horizontal sync.

Another, less common, fault is an intermittent loss of horizontal sweep, caused by a defect in the AFC circuit. Any problem causing cutoff negative bias on the horizontal oscillator grid can result in a loss of high voltage. The horizontal oscillator generally resumes operation and the high voltage reappears when the sync pulse is removed from the phase detector circuit. In this case, a defective phase-detector diode or tube is at fault. A VTVM reading at the horizontal oscillator control grid will usually show this trouble by a positive bias, and the plate of the output tube will probably run red hot, until the screen or cathode load resistor burns out. (If the output tube is glowing, it's advisable to remove that tube from the socket while checking out the other horizontal circuits.)

Although all these troubles appear common to the sweep circuits, don't make the assumption that other sections of

the set cannot affect the operation of the horizontal circuits. The first step in trouble analysis then, is to determine the particular section where the trouble has its origin.

### **Horizontal Bending**

Gassy tubes or slight cathode-heater leakages are a common source of bending and pulling symptoms. Any tube from the sync separator back through the video output, IF amplifiers, and tuner, can cause this symptom. When substituting tubes, leave each new tube in the set until the defective tube is located, or until all have been replaced.

A fast method to detect heater leakage or shorts in parallel-heater strings (where chassis ground is at zero potential) is to short the cathode of each tube to chassis, and observe if the hum is removed from the raster. If this occurs, that tube or stage is defective.

Many horizontal sync troubles have been traced to nothing more than improper adjustment of the ringing coil, sync phasing, or hold controls. AGC, fringe, or noise controls should be checked to ensure they are properly set. Likewise, many instances of bending can be traced to an improperly adjusted phasing coil in blocking-oscillator circuits. In this type circuit a scope is essential for accurate alignment.

If no satisfactory results are obtained after tube substitutions or adjustments, determine if the bending or pulling is originating in the AFC circuits. Depending on the particular trouble, the horizontal sync input to the AFC circuit should be checked with a scope, paying close attention to the peak-to-peak values of the sync pulses. Also check that the feedback waveform from the sweep circuit is not distorted or off value. In observing scope waveforms, it must be remembered that these traces

seldom appear exactly like those shown in a service manual or on the manufacturer's schematic diagram. Idealized waveforms are generally shown; real ones will vary somewhat, depending on the particular scope. Attention should be on major considerations such as the presence or absence of a pulse or waveform; its peak-to-peak value; its phase characteristic; and general shape.

A rapid approach to further isolation is to disconnect the sync input at point A, Fig. 7-5. The picture must then be steadied by carefully adjusting the horizontal hold control while observing if the pulling or bending symptom is still present. If not, the trouble is probably before the AFC circuit, or in the B+ supply. If the symptom remains, the AFC circuit is probably at fault, or there is excessive ripple in the B+ supply to these circuits.

A scope check of the B+ should be performed to determine if more than the normal amount of ripple is passing the power supply filtering circuits. Note that a defective capacitor in the damper boost circuit can also cause horizontal bending. To check this, the scope should be set at 7,875 cps and the scope probe connected to the B+ + boost line.

If the trouble is isolated to the AFC circuit, carefully check each of the components in this stage. The best method for checking the AFC diode is by replacement. Carefully check the balanced resistor divider at the input to the AFC circuit; small deviations in resistor value can greatly upset the AFC control voltage developed by the circuit.

### Horizontal Tearing

In some oscillator circuits either *Christmas tree* or heavy tearing can be caused by improper phase setting. In later circuits, however, this effect is normal at some extreme

positions of the hold control setting. A defective horizontal oscillator tube can also cause tearing symptoms, as can excessive power-supply ripple, or feedback (or pickup) from the vertical oscillator section. Resistors or capacitors which are off value in the AFC grid circuit are common causes of horizontal tearing, as are defective diodes.

### **Loss of Sync**

If the tubes check out good, the horizontal controls are properly adjusted, and the horizontal hold has little or no effect on the hold range; or when there is a complete loss of sync, then check the sync pulse between the output of the sync section and the input to the AFC circuit. If this sync pulse checks normal, check the sawtooth feedback waveform and the coupling circuits which develop this feedback. Check the AFC diodes by substitution. If some components are in doubt, and resistance checks are inconclusive, change these components.

Referring to Fig. 7-5, resistor R1, R2, and R3 are critical, and replacement with 5% tolerance types is recommended. Capacitors C1, C2, and C3 are equally critical. Usually, these are silver mica types; as should be their replacements.

Some sets use temperature-compensated capacitors and resistors in the sweep circuits. Replacement of these type components must be made with exact equivalents.

### **COMPONENT BREAKDOWN DUE TO VOLTAGE TRANSIENTS**

Voltage transients are most likely to damage components that are underrated, such as filter and some coupling capacitors. Rarely will resistors or inductors break down under transient voltages.

An example of a potential intermittent breakdown is shown by capacitor C54, Fig. 7-2. This capacitor is used as a filter between the B+ supply and the 520-volt boost B++ . Initially, before the oscillator and output sections are warmed up and conducting normally, the applied voltage across this filter can exceed 300 volts, and depending on whether the set is cold, or the output section is defective, the applied voltage can be even greater. Even though this capacitor appears to be adequately rated, aging of the dielectric, or deterioration or aging of other circuit components, coupled with a large transient voltage, could eventually result in a shorted, leaky, or intermittently-shorted capacitor.

Troubleshooting for intermittents which result from component breakdowns, such as that just described, is not difficult. In some instances, a “crack” will occur, sometimes loudly, as the intermittent occurs. Sometimes a carefully-performed voltage check is required to isolate the defective component. The safest method to locate intermittent components is by direct substitution—watch to see if the intermittent trouble is cured.

### **THERMAL CONNECTIONS AND TEMPERATURE-SENSITIVE COMPONENTS**

Thermal conditions can affect both resistors and capacitors. As an example, capacitor C39, in Fig. 7-2, connected between the plate of the vertical oscillator and the grid of the vertical output stage, may develop a slight leakage as the set warms up. Initially, the symptom will be a gradual decrease in vertical deflection, with the vertical at first decreasing from the bottom, then at the top. Connecting a voltmeter between the grid and ground will show a positive bias and indicate that the coupling capacitor needs replacement.



Another method of checking for temperature-sensitive components is to use a heat lamp or hot soldering iron near the suspected component, and then watch the raster for the trouble symptom, thereby pinpointing the defective component if the symptom appears.

In most instances, however, it is a resistor that becomes temperature-sensitive and causes intermittent troubles. In some older sets, and even some of the newer models, the resistor connected in series with the vertical hold control (R45 in Fig. 7-2) increases in value as the set warms up. The symptom of this trouble is a gradual loss of vertical sync which can be compensated by the vertical hold control until the limit of the adjustment is reached. This occurs because the resistance of R45 increases as the set temperature increases, requiring less resistance from the vertical hold control. Replacement of this resistor with a temperature-compensated equivalent is recommended.

The same trouble can occur with resistor R46, connected in series with the vertical height control in Fig. 7-2. The symptom is a gradual decrease of height, requiring constant adjustment of the vertical height control. Again, a replacement with a higher wattage rating, or a temperature-compensated type of resistor, will clear up the problem.

Another trouble source, although peculiar to the horizontal sweep circuit, is the screen dropping resistor, R72, Fig. 7-2. This is the first component to suspect in sets where intermittent width, or a gradual decrease in width is a problem. Check the resistance of this component when it is cold and when it is hot; also check the voltage drop across this screen resistor during both extremes. If space permits, replace this component with one of a higher wattage rating, and avoid any future callbacks for this type of trouble.

Width problems may also develop from leakage of the coupling capacitor connected between the horizontal oscillator plate and the grid of the output stage, C51, Fig. 7-2. The easiest method of checking for this trouble is to measure the bias at the output tube grid for a positive bias, or check for the red glow in the tube elements. If the bias voltage is correct, check for an off-value screen dropping resistor, or leaky cathode filter.

Drift in horizontal oscillator frequency is usually caused by a temperature-sensitive capacitor shunting the horizontal oscillator coil. When replacing this component, use a temperature-compensated type.

Troubleshooting for temperature-sensitive intermittents is probably one of the more difficult aspects of a technician's job. The most effective method for analyzing intermittent troubles is a careful before-and-after check of all operating voltages in the suspected circuit, if possible. If not, then match each of the measured circuit voltages against the values in the schematic diagram while the trouble takes place, and especially check for the following points:

1. Are any components overheating or showing signs of previous damage?
2. Is the negative bias on the oscillator and output stages sufficient?
3. Does applying heat near suspected components change circuit measurements?
4. If a printed circuit is used, does flexing the board with an insulated tool change the circuit measurements?
5. Is the intermittent trouble more likely to occur with the chassis positioned in one way in particular, and if so, have all solder connections been thoroughly checked for rigidity?

# TV Troubleshooter's Reference Handbook

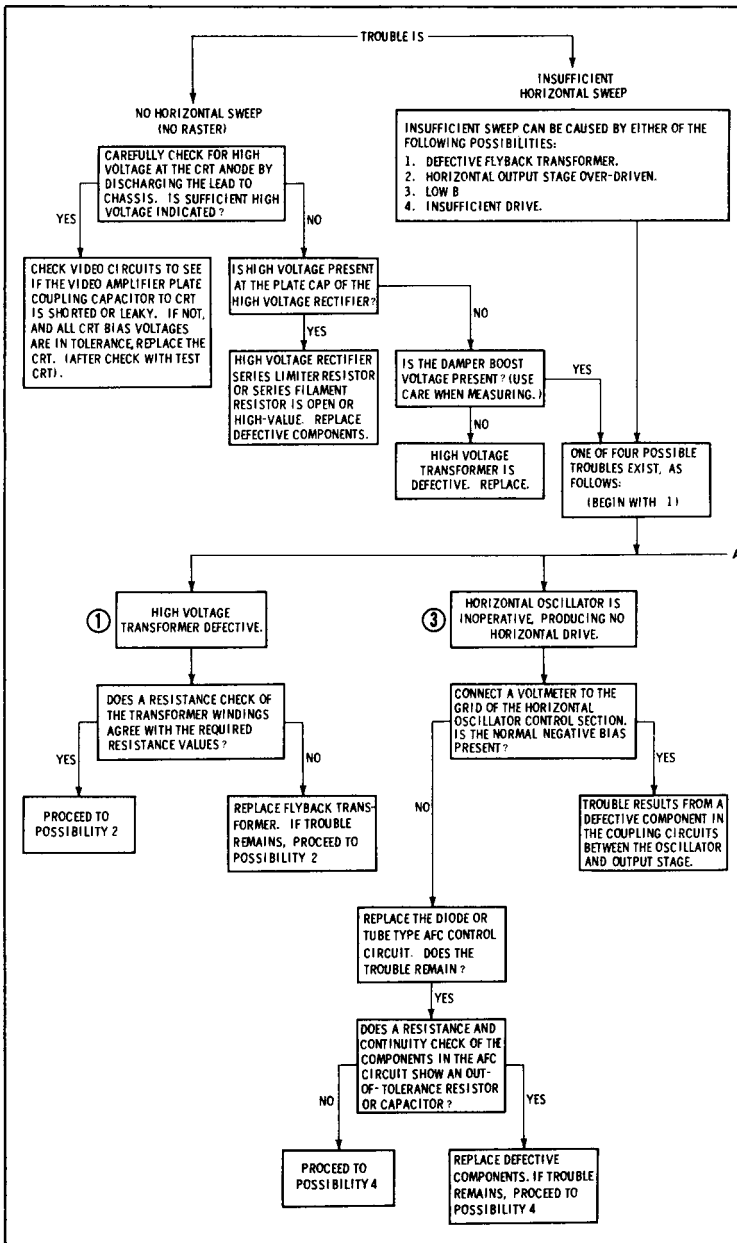

**Chart 7-1. Horizontal Sweep**

## Troubleshooting Sweep Circuits

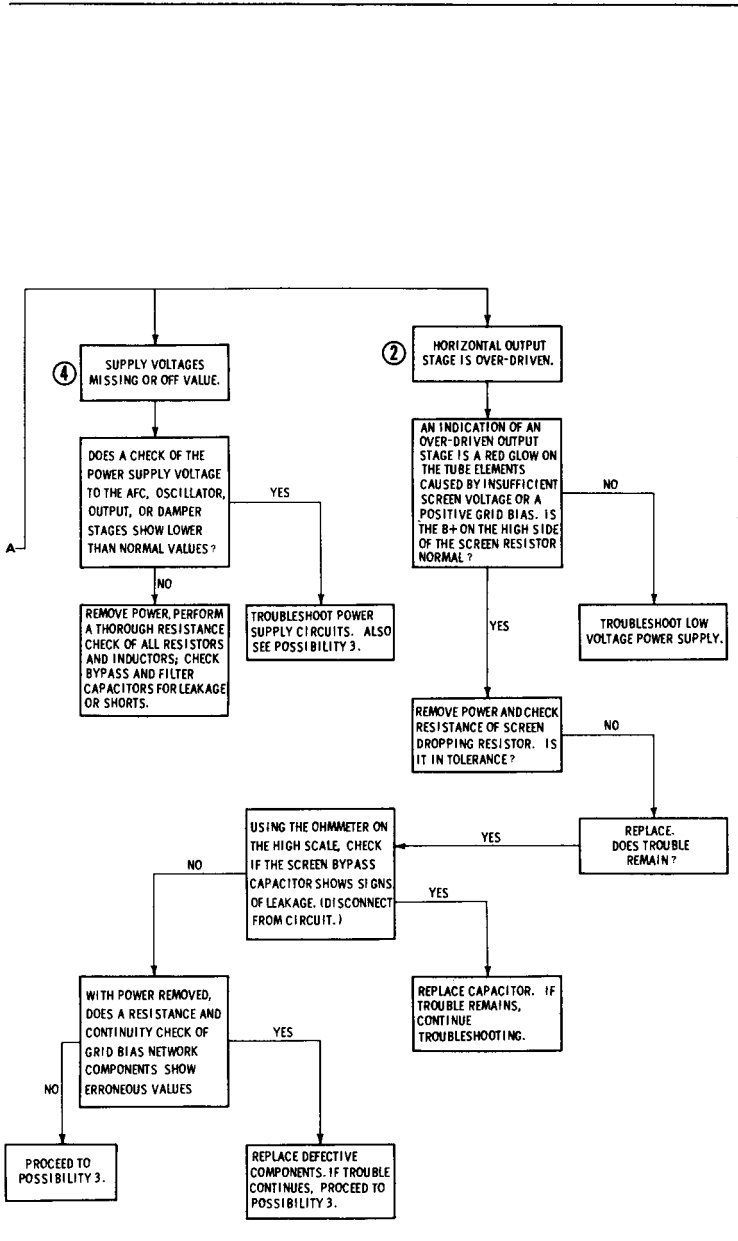

**Troubleshooting Chart.**

Chart 7-2. Vertical Sweep Troubleshooting Chart.

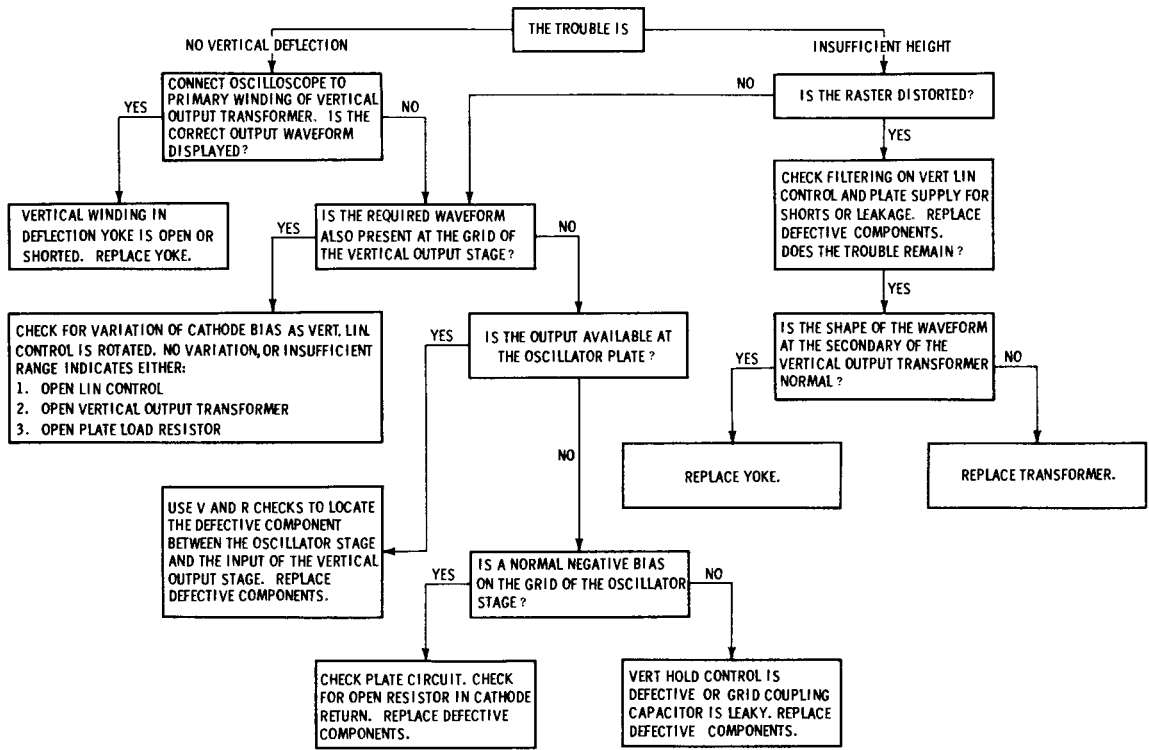

## **Troubleshooting Sweep Circuits**

---

### **Troubleshooting Charts**

Two sets of troubleshooting flow charts are provided for this chapter. Chart 7-1 covers the horizontal sweep circuits; Chart 7-2 covers the vertical sweep circuits.

## CHAPTER 8

# Troubleshooting Color Failures

Pale, washed-out color, loss of color sync, wrong hues, complete absence of color—all these symptoms fall into the category of chroma trouble. In order to localize the causes of these symptoms in the shortest possible time, it is imperative to develop a logical troubleshooting procedure.

The first thing to do is find the general trouble area. Since misadjusted controls, trouble in the AGC, RF, IF, or video circuits, and even antenna-system defects, can produce color-trouble symptoms, such possibilities should be checked prior to bench testing. Also, in this discussion, it is assumed that all tubes have been tested.

On the bench, trouble can be conclusively isolated to the chroma circuits (Fig. 8-1) by injecting a video signal from a color-bar generator to the video-amplifier circuit. If the set fails to produce a normal color display, it is a sure indication of trouble in the chroma section.

Once it has been determined that something is wrong in the chroma circuits, the next step is to isolate the trouble to a certain stage or group of stages. After this is ac-

## Troubleshooting Color Failures

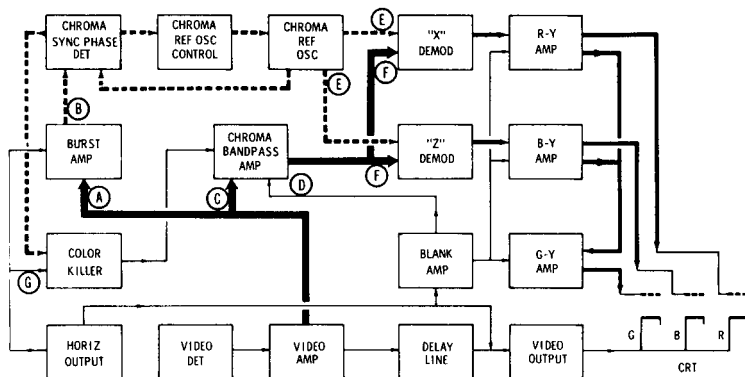

**Fig. 8-1. Test points for troubleshooting color circuits.**

completed, simple voltage and resistance measurements will help to pinpoint the defect. Chroma troubles are most easily isolated by thinking in terms of circuit blocks as shown in Fig. 8-1.

Notice that the various signal paths are shown by means of different types of lines. The thin, solid lines show the luminance and blanking signal paths that are also common to black-and-white reception; the medium, solid lines show the paths of the detected chroma (color) signals; the dashed lines point out the reference-oscillator and synchronizing-circuit paths; and the heavy, solid lines show the circuits that receive the composite chroma signal.

### WAVEFORMS APPEARANCE

Knowing normal signal paths will prove to be of little value unless the kind of signals present are known. This is why an oscilloscope is so vitally important for troubleshooting. Naturally, unless several color sets are serviced each day, it will be impossible to remember all of the complex waveforms found in the color stages following demodulation. But when these waveforms are checked any-



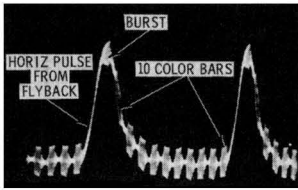

(A) Grid of burst amplifier.

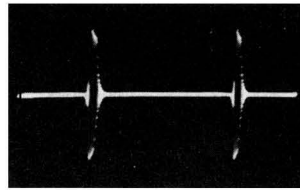

(B) Output of burst amplifier.

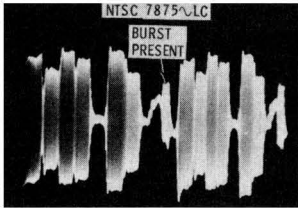

(C) Grid of chroma bandpass amplifier.

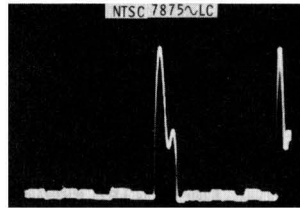

(D) Keying pulse at cathode of chroma bandpass amplifier.

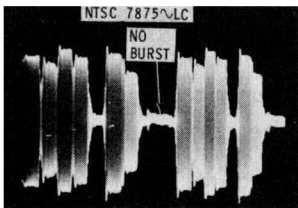
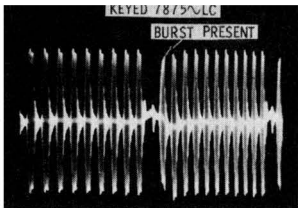

(F) Chroma input signal to de-modulator grids.

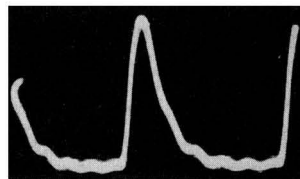
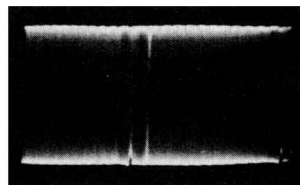
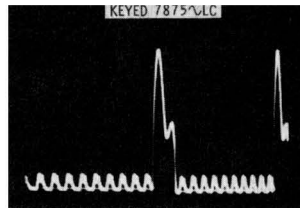

(G) Keying pulse to plate of color killer.

**Fig. 8-2. Chroma waveforms keyed to Fig. 8-1.**

where up to and including the demodulator inputs, it should be possible to tell whether or not the proper signal is being received.

Some of the standard troubleshooting waveforms are shown in Fig. 8-2. The letters below these waveforms are keyed to the illustrations throughout this chapter; i.e., **(A)** will signify waveform 8-2A. The pattern of Fig. 8-2A is typical of what should be found at the grid of the burst amplifier. Referring to Fig. 8-1, note that there are two signals fed to this stage. The high-amplitude keying pulse from the horizontal section is easily recognized in Fig. 8-2A; the rectangular-shaped pulses along the base of the waveform are the chroma signals.

The pattern in Fig. 8-2B is the burst signal which is passed to the phase detector from the burst amplifier.

Fig. 8-2C shows the waveform which should be present at the grids of the chroma bandpass-amplifier and demodulator stages. The signal on top is seen when a standard NTSC color-bar signal is fed to the receiver. The bottom type of chroma signal in Fig. 8-2C is produced by a keyed rainbow generator.

Fig. 8-2D is a horizontal blanking pulse often found at the bandpass amplifier. Many circuits employ a positive pulse of this sort at the cathode to cut off the tube during burst-signal time. Therefore, the burst signal (center pulse) present in Fig. 8-2C is normally lacking beyond the bandpass amplifier.

Fig. 8-2E is the signal produced by the reference oscillator. This waveform should be found not only at the oscillator, but also at both demodulators and the sync phase detector. While there is a phase difference in the three signals, this characteristic cannot be discerned from an analysis of scope waveforms.

If trouble is experienced in identifying the waveforms in Fig. 8-2, practice on them until you know what to ex-

pect at various points in the chroma circuits. Learning these basic troubleshooting patterns will eliminate the need for constant reference to pictures in service data, and will thus speed servicing.

## TROUBLESHOOTING PROCEDURES

Once you know the paths of various signals in the chroma section, and are familiar with the appearance of the chroma signals, isolating a specific chroma trouble becomes a matter of simple deduction. Remember it was said that chroma trouble falls into four categories? Here is how a troubleshooting procedure is developed for each symptom.

### Loss of Color

Complete loss of color can be caused by many things. However, when preliminary tests have shown the trouble is in the chroma section, it can be localized in any of the stages shown as *unshaded* blocks in Fig. 8-3. This illustration also indicates the normal waveforms to be expected at the key check points.

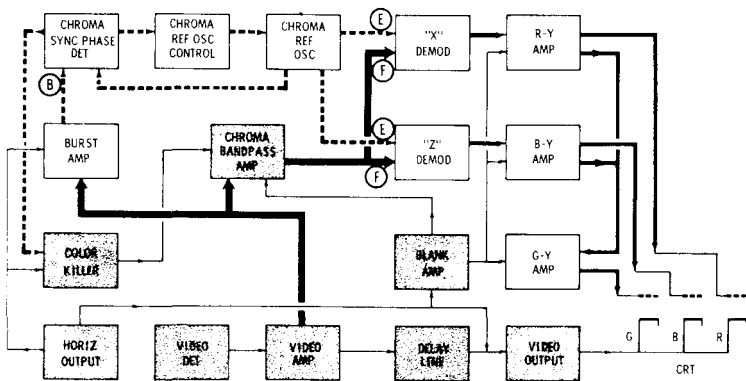
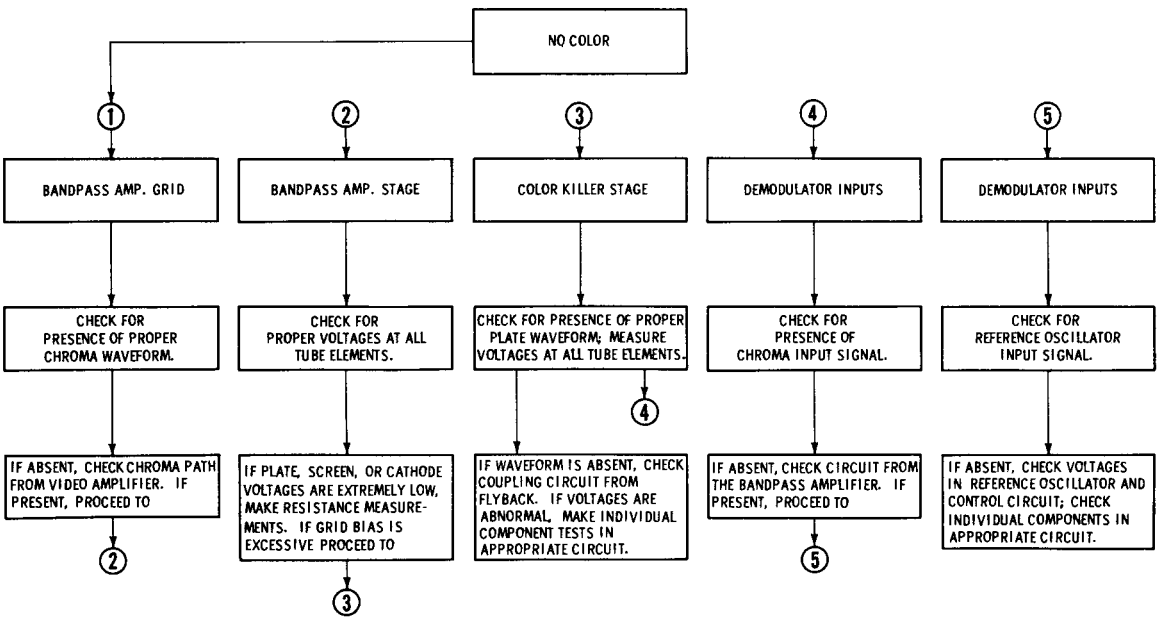

Fig. 8-3. Test points for troubleshooting the loss of color.



TEST CONDITION: INJECT VIDEO SIGNAL FROM COLOR-BAR GENERATOR TO OUTPUT OF VIDEO DETECTOR; USE OSCILLOSCOPE AND VTVM AS INDICATED.

Chart 8-1. Loss of Color Troubleshooting Chart.

The best place to start checking is at either demodulator stage. Since there is a complete loss of color, it is obvious that either the chroma input signal (**F**) or the reference-oscillator signal (**E**) is missing. If both signals were present at either demodulator, some sort of color would appear.

Suppose a check shows that the reference-oscillator signals are present, but the chroma signal is absent. Under such circumstances, go back along the chroma path (heavy line) to see where the signal is being interrupted. The logical place to check will be the bandpass amplifier. Waveform(**F**) should appear at both the grid and the plate. If the signal is absent at the plate, but does appear on the grid, check the plate, screen, and grid voltages. Undoubtedly, either a severe drop in plate and screen voltages, or excessive bias at the control grid will be found. In the latter case, the trouble is probably due to a malfunction in the color killer.

When a color signal is being received, the color-killer tube is normally cut off by a negative voltage on its grid. This voltage is developed in the chroma sync phase detector whenever a burst signal (**B**) is present. Therefore, if the color killer is not cut off, trace through the phase-detector and burst-amplifier stages to find out why.

If preliminary scope checks show that loss of color is caused by an inoperative reference oscillator, troubleshoot this section in the same manner as a conventional horizontal-oscillator and AFC stage. Chart 8-1 shows a procedure to be used in troubleshooting a loss of color.

### Wrong Colors

In its broadest sense, the term wrong colors could apply to many visual symptoms. However, in this discussion, only two basic types of faults will be considered. A good example of the first type is a picture which has all colors

## Troubleshooting Color Failures

present, but everything appears in wrong hue. The second type of symptom involves a complete absence of one primary color in the picture.

Hues are what most people have in mind when they speak of "different colors," such as red, blue, green, yellow, etc. In a color set, hue is determined by comparing the phase of the incoming chroma signal with two signals generated by the reference oscillator. This comparison is made in the demodulator stages.

The sections of the receiver associated with wrong-color troubles are shown as unshaded blocks in Fig. 8-4. Notice that the key waveforms for troubleshooting this sort of problem are the same ones used in checking for complete loss of color. When certain colors are missing from the picture, the quick waveform checks shown in Fig. 8-4 should

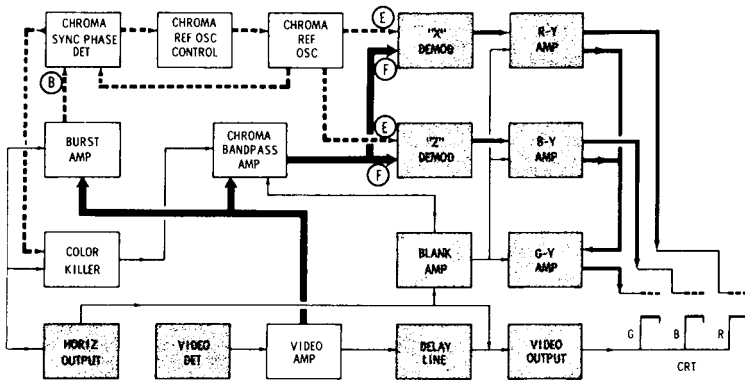

**Fig. 8-4. Test points for localizing the cause of wrong colors.**

be made. If the input signals appear to be correct, move the scope to the output of the demodulators to see if they are functioning. Incorrect outputs mean the chroma alignment procedures outlined in the service manual for the receiver should be followed; correct outputs point to trou-

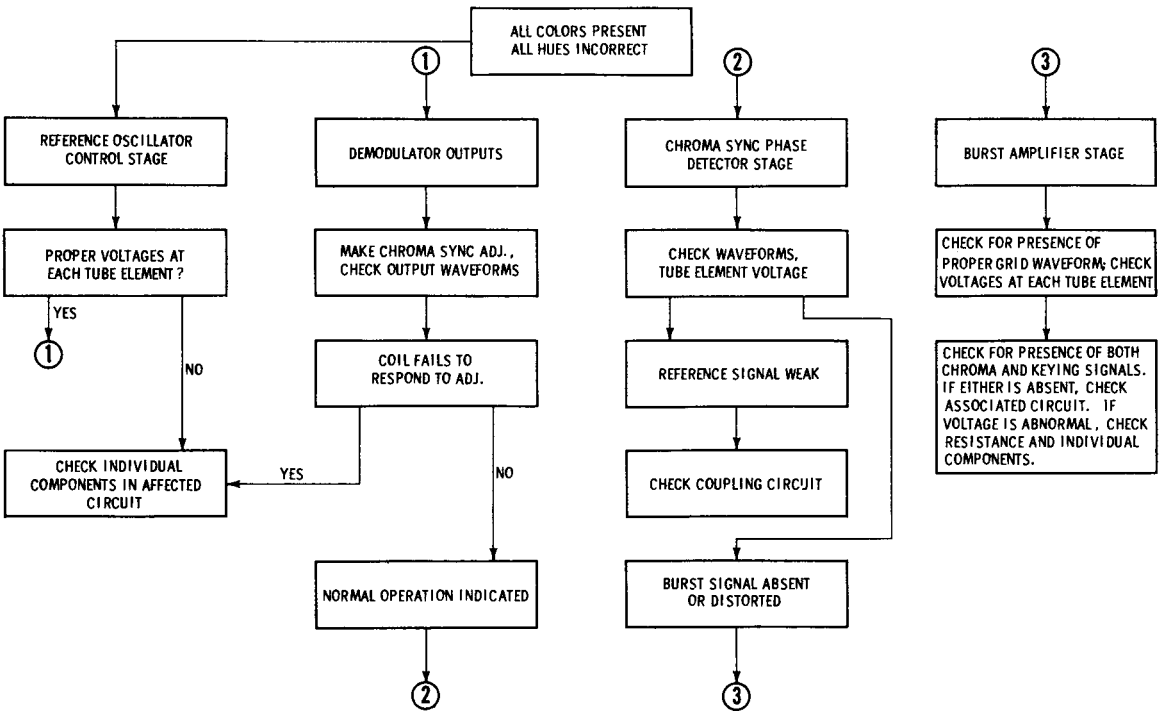

Chart 8-2. Incorrect-Hue Trouble Analysis.

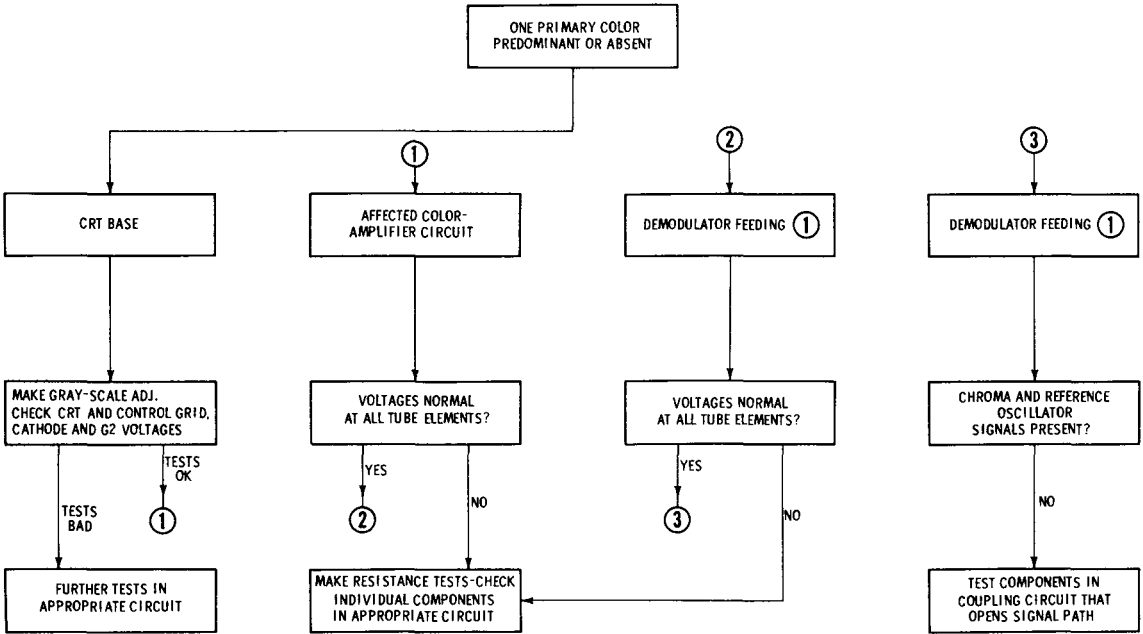

Chart 8-3. How to Analyze One-Color Troubles.



ble in the color-amplifier or picture-tube circuits. Charts 8-2 and 8-3 may be helpful in analyzing wrong color failures due to defective components or improper adjustments.

### Washed-Out Colors

When color bars appear as pastels instead of fully-saturated colors, the reason is improper signal amplitude. To explain this point more fully, saturation depends on the amplitude ratio of the luminance and chroma signals. Since it has previously been determined that the luminance signal is correct (black-and-white operation is normal), it becomes obvious that the outputs of all the color amplifiers must be low in amplitude. Therefore, the washed-out colors must be the result of insufficient output of either the chroma bandpass amplifier or the reference oscillator.

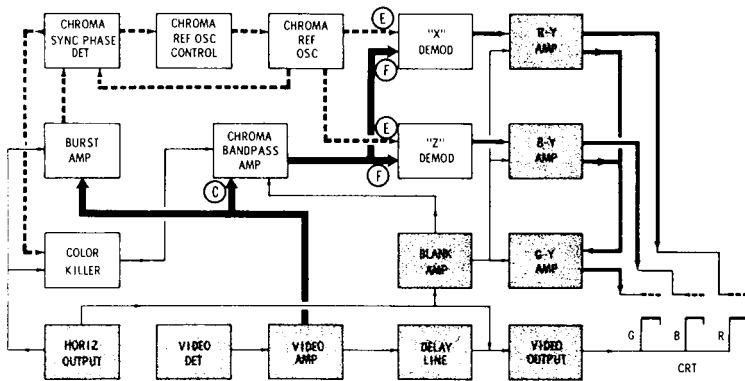

Fig. 8-5. Weak-color test points.

As shown in Fig. 8-5, the input signals to the demodulators provide key troubleshooting information. However, the main emphasis must be placed on signal amplitudes rather than waveshapes or mere presence of the signals. Of course, the amplitude of the chroma signal can be regulated by a control often referred to as the *color saturation*

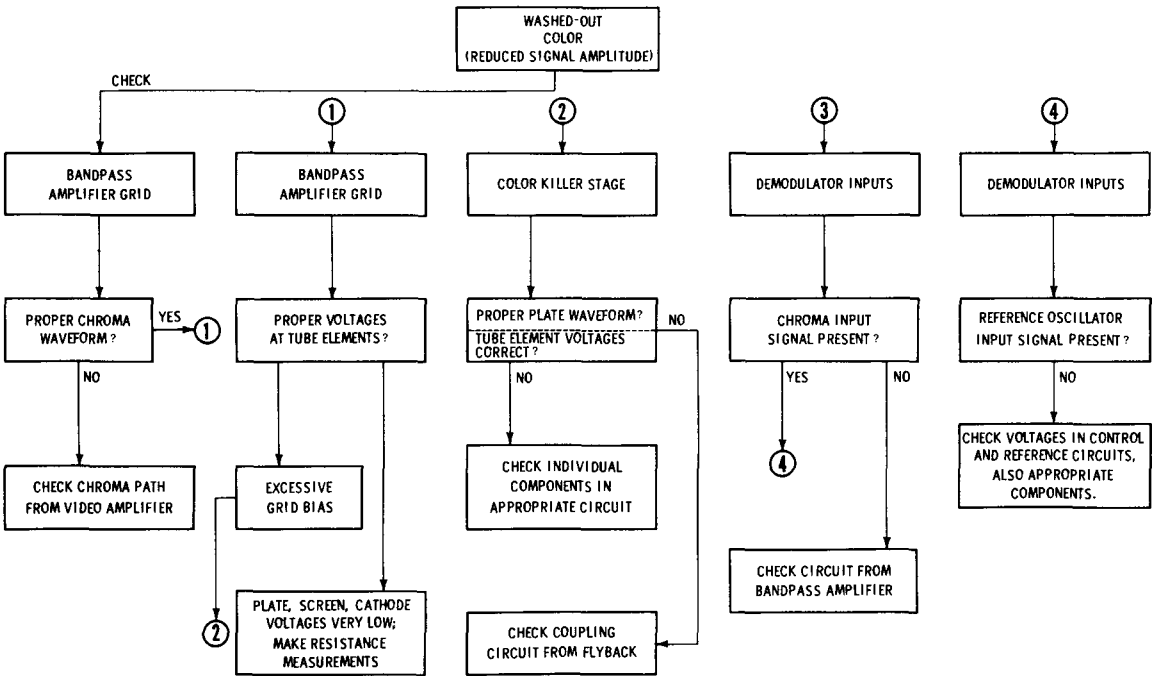
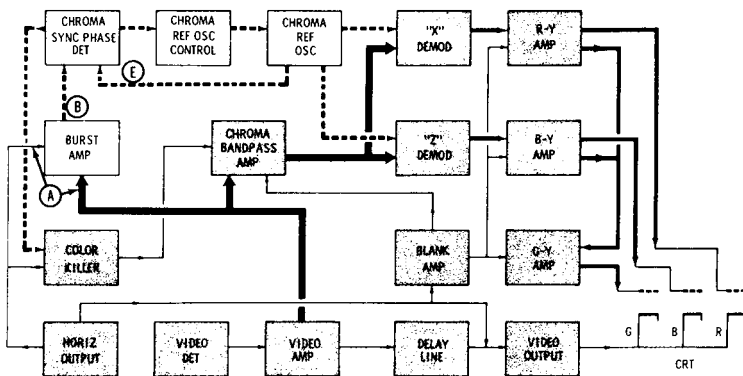

Chart 8-4. Guide for Troubleshooting Washed-out Color.

*control.* In normally-operating receivers, this control should provide a signal of the required amplitude when set at its midpoint. If the control must be advanced beyond its normal setting, the signal feeding the chroma band-pass amplifier, and the voltages of this circuit, should be checked in order to localize the trouble. Don't forget, the bias on the bandpass amplifier can be altered by a malfunction in the color-killer circuit. Therefore, it may be necessary to troubleshoot the stages associated with this circuit. Chart 8-4 may be helpful in working on weak-color symptoms.

### Color-Sync Troubles

As shown in Fig. 8-6, color-sync problems are associated with only a few of the chroma circuits. Troubleshooting these sections becomes a familiar process if related to the experience gained from servicing horizontal-oscillator and



**Fig. 8-6.** Test points for analyzing the loss of color sync.

AFC circuits. Making rapid checks of the waveforms shown in Fig. 8-6 will normally direct attention to the defective stage. For example, if a check for the burst signal at the phase detector (waveform **B**) shows the presence of chroma

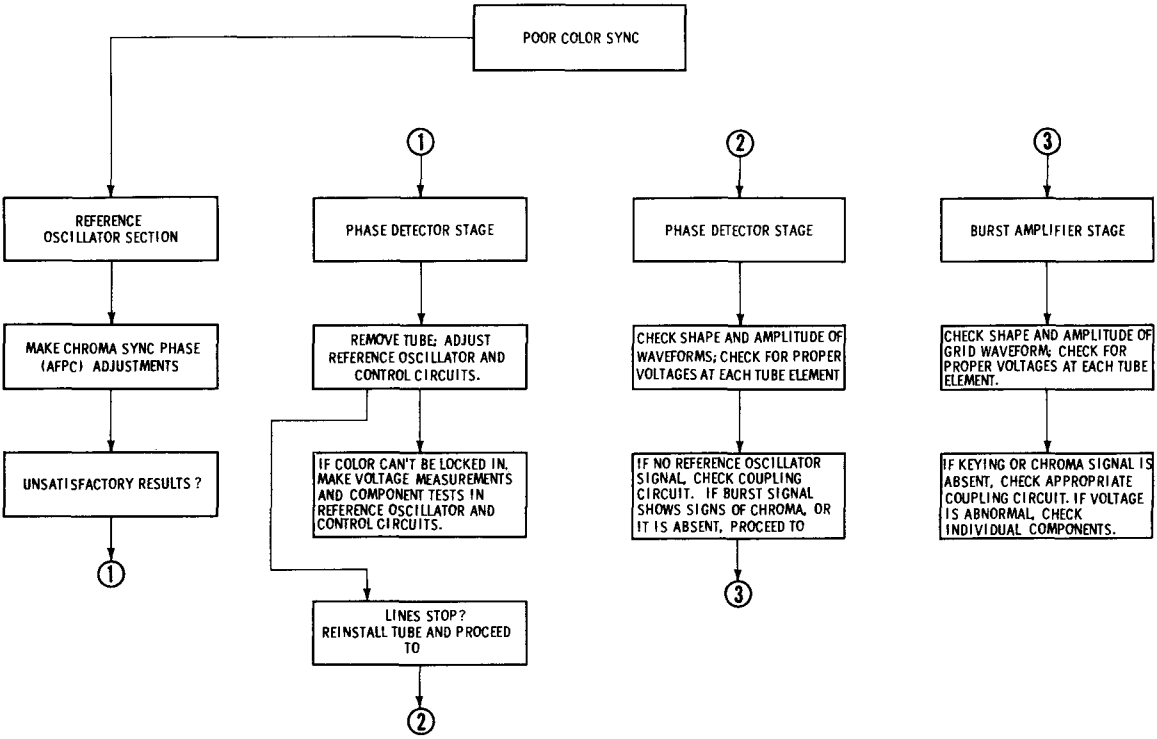

Chart 8-5. Poor Color Sync Troubleshooting Chart.

information, it can be reasonably assumed the trouble is being caused by improper bias on the burst amplifier, and attention can be directed to that stage. If, on the other hand, the amplitude of the reference-oscillator signal happens to be considerably different from the value shown in the service data, concentrate on the oscillator and control circuits.

Chart 8-5 is a valuable guide to troubleshooting color sync troubles.

# Appendix

## QUICK REFERENCE TROUBLESHOOTING CHARTS

The contents of this appendix comprise quick-reference picture symptom charts which can be used by the technician on house calls. Use the charts in the following manner:

1. Define the general trouble area, e.g., **Width, Height, Picture**, etc.
2. Refer to the portion of this Appendix which covers that area and use the tables and symptom pictures to locate **PROBABLE CAUSES**.
3. Refer to the **REMEDY** column and check or replace the tubes listed.

This list can also be used as a guide for stocking the tube caddy.

### WIDTH

Fig. A-1. Insufficient width–height, sound and picture normal.

PROBABLE CAUSE	REMEDY
Insufficient horizontal deflection.	Check or replace horizontal output tube: 6AV5, 6BQ6, 6CD6, 6EX6, 12AV5, 12BQ6, 12DQ6, 17DQ6, 18A5, 21EX6, 25CD6, 25EC6. Check or replace damper tube: 6AF3, 6AL3, 6AU4, 6AX4, 6DA4, 6DE4, 12AF3, 12AX4, 12D4, 17AX4, 17DE4, 19AU4, 22DE4.
Insufficient low voltage–power supply defect.	Check or replace low voltage rectifier tube: 3DG4, 5AS4, 5AU4, 5U4, 5V3, 5Y3.

### WIDTH (CONT.)

**Fig. A-2. Poor horizontal linearity–height, sound and picture normal.**

---

<b>PROBABLE CAUSE</b>	<b>REMEDY</b>
Nonlinear horizontal deflection.	Check or replace damper tube: 6AF3, 6AL3, 6AU4, 6AX4, 6DA4, 6DE4, 12AF3, 12AX4, 12D4, 17AX4, 17DE4, 19AU4, 22DE4.

---

### HEIGHT

**Fig. A-3. Insufficient height–width, sound and picture normal.**

---

Insufficient vertical deflection.	Check or replace vertical multi- ibrator tube(s): 5AQ5, 5B8, 5EA8, 5DH8, 5U8, 6AG7, 6AQ5, 6AU8, 6AV6, 6BL7, 6BX7, 6C4, 6CG7, 6CH7, 6CM7, 6CU4, 6CY7, 6CZ5, 6DR7, 6EA7, 6EM5, 6EM7, 6EY6, 6EZ5, 6S4, 8CM7, 8GN8, 8EB8, 10C8, 10DE7, 11CY7, 12AX7, 12B4, 12BH7, 12CU5, 12L6, 12R5, 12W6, 13DE7, 13EM7.  Check or replace vertical output tube: 5AQ5, 5DH8, 6AQ5, 6BL7, 6BX7, 6CK4, 6CM7, 6CY7, 6CZ5, 6DR7, 6DT5, 6EA7, 6EM5, 6EM7, 6EY6, 6EZ5, 6S4, 7EY6, 8CM7, 10C8, 11CY7, 12B4, 12BH7, 12CU5, 12DT5, 12L6, 12Q7, 12W6, 13DE7, 13EM7.
Vertical height control needs ad- justment.	Adjust vertical height control as needed.

---

**Fig. A-4. Poor vertical linearity–width sound and picture normal.**

---

Nonlinear vertical deflection.	Check or replace vertical output tube: 5AQ5, 5DH8, 6AQ5, 6BL7, 6BX7, 6CK4, 6CM7, 6CY7, 6CZ5, 6DR7, 6DT5, 6EA7, 6EM5, 6EM7, 6EY6, 6EZ5, 6S4, 7EY6, 8CM7, 10C8, 11CY7, 12B4, 12BH7, 12CU5, 12DT5, 12L6, 12Q7, 12W6, 13DE7, 13EM7.
Vertical linearity control needs ad- justment.	Adjust vertical linearity control.

---

**PICTURE**

**Fig. A-5. Picture very dark—adjustment of brightness control does not improve picture—sound normal.**

<b>PROBABLE CAUSE</b>	<b>REMEDY</b>
Insufficient high voltage—power supply defect.	Check or replace high voltage rectifier tube: 1B3, 1G3, 1J3, 1K3, 1X2, 1AX2, 1S2, 3A2, 3A3.
Defective video output stage.	Check or replace video output tube: 6AQ5, 6AU8, 6AW8, 6BA8, 6BH8, 6CX8, 6EB8, 6GK6, 6GN8, 8AU8, 8AW8, 8BA8, 8CX8, 8EB8, 8ET7, 8GN8, 12BV7, 12BY7, 12CT8.

**Fig. A-6. Screen is lighted but no sound or picture is present.**

Defective video circuits.	<p>Check or replace video output tube: 6AQ5, 6AU8, 6AW8, 6BA8, 6BH8, 6CX8, 6EB8, 6GK6, 6GN8, 8AU8, 8AW8, 8BA8, 8CX8, 8EB8, 8ET7, 8GN8, 12BV7, 12BY7, 12CT8.</p> <p>Check or replace video IF amplifiers: 3AU6, 3BZ6, 3CB6, 3CF6, 4BZ6, 4CB6, 4EW6, 5AM8, 5AS8, 5B8, 5DH8, 6AM8, 6AU8, 6BZ6, 6CB6, 6CH8, 6CU8, 6DE6, 6DK6, 6EW6.</p>
Defective tuner tubes.	<p>Check or replace mixer—oscillator tube: 3AF4, 5AT8, 5BE8, 5CG8, 5CL8, 5CQ8, 5EU8, 5FK8, 5U8, 5X8, 6AF4, 6AT8, 6BL8, 6BR8, 6CG8, 6EA8, 6EH8, 6EU8, 6J6, 6U8, 6X8, 9CL8, 9U8.</p> <p>Check or replace RF amplifier tube: 2BN4, 2CY5, 2FH5, 3BC5, 3CE5, 3CB6, 4BC8, 4BQ7, 4CY5, 4ES8, 5BK7, 6BC5, 6BC8, 6BK7, 6BN4, 6BQ7, 6BS8, 6BZ7, 6CB6, 6CE5, 6CY5, 6ER5, 6ES5, 6ES8, 6FH5, 6FQ5, 6FV6, 6FY5.</p>
Poor automatic gain control. (AGC)	Check or replace automatic gain control tube and video detector: 3AU6, 3BU8, 4BU8, 5AM8, 5AS8, 5BR8, 6AU6, 6AU8, 6AV6, 6BU8, 6BY8, 6DT6, 6EA8, 6EB8, 6T8.

**Fig. A-6. Screen is lighted but no picture appears—sound normal.**

Defective video circuits.	Check or replace video output tube: 6AQ5, 6AU8, 6AW8, 6BA8, 6BH8, 6CX8, 6EB8, 6GK6, 6GN8, 8AU8, 8AW8, 8BA8, 8CX8, 8EB8, 8ET7, 8GN8, 12BV7, 12BY7, 12CT8.
---------------------------	--



## PICTURE (Cont.)

PROBABLE CAUSE	REMEDY
	Check or replace automatic gain control tube and video detector: 3AU6, 3BU8, 4BU8, 5AM8, 5AS8, 5BR8, 6AU6, 6AU8, 6AV6, 6BU8, 6BY8, 6DT6, 6EA8, 6EB8, 6T8, 6U8, 12AX7.

**Fig. A-7. Screen dark—sound normal.**

High voltage circuits defective.	Check or replace high voltage rectifier tube: 1B3, 1G3, 1J3, 1K3, 1X2, 1AX2, 1S2, 3A2, 3A3.
Horizontal sweep circuits defective.	Check or replace horizontal output tube: 6AV5, 6BQ6, 6CD6, 6EX6, 12AV5, 12BQ6, 12DQ6, 17DQ6, 18A5, 21EX6, 25CD6, 25EC6.

**Fig. A-7. Set completely inoperative—no sound, picture or brightness.**

	Check or replace horizontal oscillator tube(s): 5EA8, 5GH8, 5U8, 6CG7, 6CM7, 6EA8, 6GH8, 6SN7, 7AU7, 8CG7, 8CM7, 8CN7.
Low voltage circuits defective.	Check or replace low voltage rectifier tube: 3DG4, 5AS4, 5AU4, 5U4, 5V3, 5Y3.
Defective line fuse.	Check or replace line fuse.
Defective AC line cord.	Check or replace AC line cord.
Defective on-off switch.	Check or replace Switch.

**Fig. A-8. Picture snowy on all or on some stations—sound normal.**

Defective tuner tubes.	Check or replace RF amplifier tube: 2BN4, 2CY5, 2FH5, 3BC5, 3CE5, 3CB6, 4BC8, 4BQ7, 4CY5, 4ES8, 5BK7, 6BC5, 6BC8, 6BK7, 6BN4, 6BQ7, 6BS8, 6BZ7, 6CB6, 6CE5, 6CY5, 6ER5, 6ES5, 6ES8, 6FH5, 6FQ5, 6FV6, 6FY5.  Check or replace mixer-oscillator tube: 3AF4, 5AT8, 5BE8, 5CG8, 5CL8, 6CQ8, 5EU8, 5FK8, 5U8, 5X8, 6AF4, 6AT8, 6BL8, 6BR8, 6CG8, 6EA8, 6EH8, 6EU8, 6J6, 6U8, 6X8, 9CL8, 9U8.
------------------------	---

**PICTURE (Cont.)**

---

<b>PROBABLE CAUSE</b>	<b>REMEDY</b>
Defective video circuits.	Check or replace video IF amplifier tubes: 3AU6, 3BZ6, 3CB6, 3CF6, 4BZ6, 4CB6, 4EW6, 5AM8, 5AS8, 5B8, 5DH8, 6AM8, 6AU8, 6BZ6, 6CB6, 6CH8, 6CU8, 6DK6, 6EW6, 6GM6.

---

**SOUND****Fig. A-9. No sound or sound distorted—picture normal.**

---

Defective sound circuits.	Check or replace sound output tube: 5AQ5, 5V6, 6AQ5, 6AS5, 6BQ5, 6CU5, 6DS5, 6K6, 6V6, 6W6, 8BQ5, 9EJ5, 10C8, 12C5, 12CA5, 12L6.  Check or replace audio frequency amplifier: 5U8, 6FM8, 6T8, 6U8, 7AU7, 8BN8, 10C8, 12AX7.  Check or replace audio detector: 3AL5, 3BN6, 3DT6, 4BN6, 6AL5, 6BN6, 6DT6, 6T8.  Check or replace sound IF ampli- fiers: 3AU6, 5BR8, 5EA8, 5U8, 6AU6, 6AU8, 6AW8, 6BY8, 6CX8, 6GN8, 6U8, 8AU8, 8AW8.
---------------------------	--

---

**Fig. A-9. Hum in sound—picture normal.**

---

AC leakage in sound circuits.	Check or replace sound IF amplifier tubes: 3AU6, 5BR8, 5EA8, 5U8, 6AU6, 6AU8, 6AW8, 6BY8, 6CX8, 6GN8, 6U8, 8AU8, 8AW8.  Check or replace audio frequency amplifier tube: 5U8, 6FM8, 6T8, 6U8, 7AU7, 8BN8, 10C8, 12AX7.  Check or replace audio output tube: 5AQ5, 5V6, 6AQ5, 6AS5, 6BQ5, 6CU5, 6DS5, 6K6, 6V6, 6W6, 8BQ5, 9EJ5, 10C8, 12C5, 12CA5, 12L6.
-------------------------------	--

---

**PICTURE STABILITY**

**Fig. A-10. Picture rolls vertically—horizontal stability and sound normal.**

<b>PROBABLE CAUSE</b>	<b>REMEDY</b>
Defective vertical synchronization circuits.	<p>Check or replace vertical multi-vibrator tube(s): 5AQ5, 5B8, 5EA8, 5DH8, 5U8, 6AG7, 6AQ5, 6AU8, 6AV6, 6BL7, 6BX7, 6C4, 6CG7, 6CH8, 6CM7, 6CU8, 6CY7, 6CZ5, 6DR7, 6EA7, 6EM5, 6EM7, 6EY6, 6EZ5, 6S4, 8CM7, 8GN8, 8EB8, 10C8, 10DE7, 11CY7, 12AX7, 12B4, 12BH7, 12CU5, 12L6, 12R5, 12W6, 13DE7, 13EM7.</p> <p>Check or replace vertical sync tubes: 3BU8, 5B8, 5DH8, 6AG7, 6AQ5, 6BE6, 6BL7, 6BX7, 6C4, 6CM7, 6CY7, 6CZ5, 6DR7, 6EA7, 6EM5, 6EM7, 6EY6, 6EZ5, 6S4, 7EY6, 8CM7, 8EB8, 8GN8, 10C8, 10DE7, 11CY7, 12AX7, 12BH7, 12CU5, 12L6, 12R5, 12W6, 13DE7, 13EM7.</p>

**Fig. A-11. Picture tears horizontally.**

Defective horizontal synchronization circuit.	<p>Check or replace horizontal oscillator tube(s): 5EA8, 5GH8, 5U8, 6CG7, 6CM7, 6EA8, 6GH8, 6SN7, 7AU7, 8CG7, 8CM7, 8CN7.</p> <p>Check or replace horizontal sync and automatic frequency control tubes: 3AL5, 5EA8, 5GH8, 5U8, 6AL5, 6CN7, 6CG7, 6EA8, 6GH8, 6U8, 7AU7, 8CG7, 8CM7, 8CN7, 8ET7.</p>
---	--

**Fig. A-12. Picture tears horizontally and rolls vertically.**

Defective horizontal and vertical sync circuits.	<p>Check or replace horizontal and vertical sync tubes: 3BU8, 3CS6, 4BU8, 5B8, 6AG7, 6AV6, 6AW8, 6BA8, 6BE6, 6BH8, 6BU8, 6BY6, 6CG7, 6CH8, 6CX8, 6EA8, 6EB8, 6SN7, 6U8, 7AU7, 8AW8, 8BA8, 8CX8, 12BY7, 12CT8.</p>
--	---

**HUM**

**Fig. 13. Hum in picture—sound normal.**

<b>PROBABLE CAUSE</b>	<b>REMEDY</b>
AC leakage in video circuits.	<p>Check or replace video IF amplifier tubes: 3AU6, 3BZ6, 3CB6, 3CF6, 4BZ6, 4CB6, 4EW6, 5AM8, 5AS8, 5B8, 5DH8, 6AM8, 6AU8, 6BZ6, 6CB6, 6CH8, 6CU8, 6DE6, 6DK6, 6EW6, 6GM6.</p> <p>Check or replace tuner RF amplifier tube: 2BN4, 2CY5, 2FH5, 3BC5, 3CE5, 3CB6, 4BC8, 4BQ7, 4CY5, 4ES8, 5BK7, 6BC5, 6BC8, 6BK7, 6BN4, 6BQ7, 6BS8, 6BZ7, 6CB6, 6CE5, 6CY5, 6ER5, 6ES5, 6ES8, 6FH5, 6FQ5, 6FV6, 6FY5.</p>

**NO HEIGHT**

**Fig. A-14. Horizontal white line across screen—sound normal.**

No vertical deflection.	<p>Check or replace vertical multivibrator tube(s): 5AQ5, 5B8, 5EA8, 5DH8, 5U8, 6AG7, 6AQ5, 6AU8, 6AV6, 6BL7, 6BX7, 6C4, 6CG7, 6CH8, 6CM7, 6CU8, 6CY7, 6CZ5, 6DR7, 6EA7, 6EM5, 6EM7, 6EY6, 6EZ5, 6S4, 8CM7, 8GN8, 8EB8, 10C8, 10DE7, 11CY7, 12AX7, 12B4, 12BH7, 12CU5, 12R5, 12W6, 13DE7, 13EM7.</p> <p>Check or replace vertical output tube: 5AQ5, 5DH8, 6AQ5, 6BL7, 6BX7, 6CK4, 6CM7, 6CY7, 6CZ5, 6DR7, 6DT5, 6EA7, 6EM5, 6EM7, 6EY6, 6EZ5, 6S4, 7EY6, 8CM7, 10C8, 11CY7, 12B4, 12BH7, 12CU5, 12DT5, 12L6, 12Q7, 12W6, 12E7.</p>
-------------------------	---

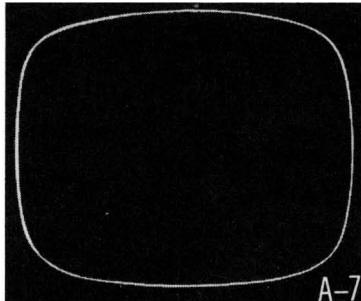
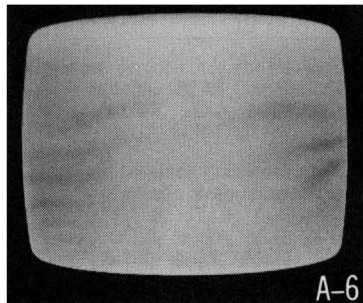
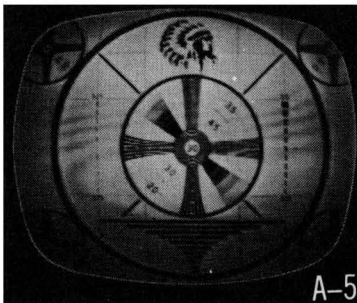
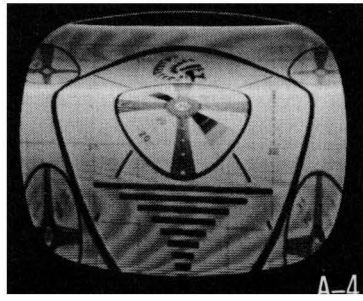
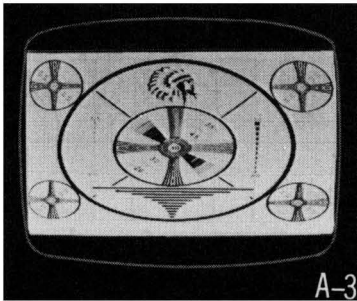
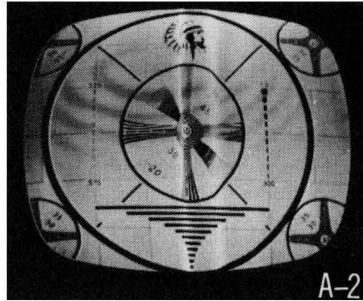
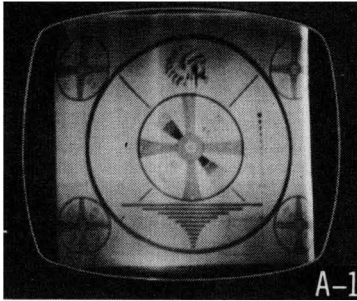

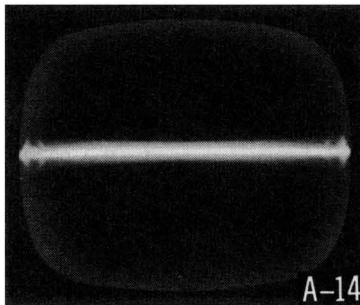
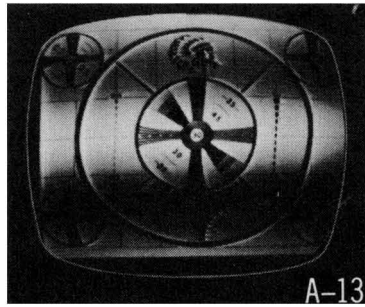
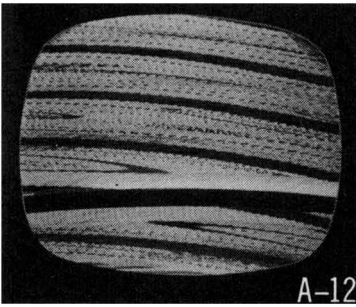
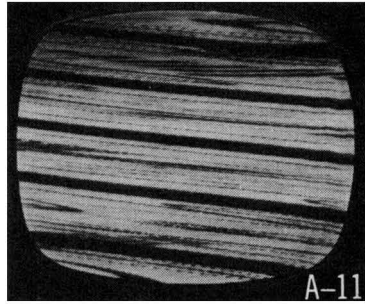
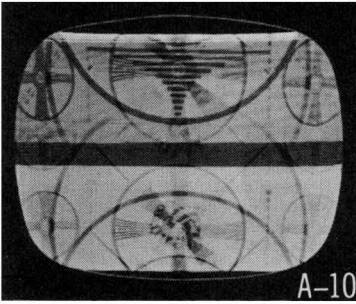
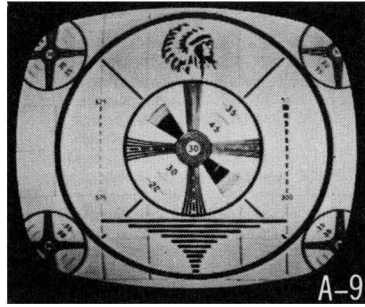
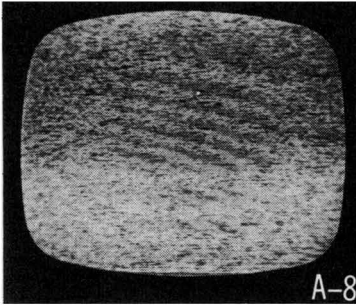

## INDEX

- AFC and sweep circuits, troubleshooting, 91-94
  - bending, horizontal, 92-93
  - sync, loss of, 94
  - tearing, horizontal, 93-94
- AFC circuits, 88-90
- Amplifier
  - RF, 36-42
    - cascode, 40-41
    - neutralized-triode, 41-42
    - pentode, 37
    - tetrode, 40
  - sound discriminator-audio, 67
- Analysis, troubleshooting technique, 9-16
- Audio circuit troubleshooting chart, 69
  
- B+ supply troubleshooting, 59
- Bending, horizontal, 92-93
- Block diagram
  - tuner, 30
  - TV receiver, 10
  - video section, 51-52
  
- Capacity tuner, 35-36
- Cascode RF amplifier, 40-41
- Chart
  - how to analyze one-color troubles, 111
  - incorrect-hue trouble analysis, 110
  - trouble, distorted or intermittent sound, 70
  - trouble flow
    - no B+, 26
    - video, 60
  - troubleshooting
    - audio circuit, 69
    - horizontal sweep, 98-99
    - intermittent or low B+, 27
    - intermittent or weak video, 61
    - loss of color, 107
    - poor color sync, 115
    - sync, 81
- Checkout, troubleshooting technique, 13
- Chroma waveforms, 104
- Circuits
  - AFC, 88-90
  - horizontal sweep, 84-87
  - sound, theory of operation, 63-65
  - vertical sweep, 90-91
- Color
  - circuits, test points for troubleshooting, 103
  - loss of, 106-108
  - troubleshooting chart, 107
  - signal waveforms, 103-106
  - sync
    - poor, troubleshooting chart, 115
    - troubles, 114-116
  - troubles, troubleshooting procedures for, 105-106
    - color-sync troubles, 114-116
    - loss of color, 106-108
    - washed-out colors, 112-114
    - wrong colors, 108-112
  - washed-out, guide for troubleshooting, 113
  - weak, test points, 112
- Colors
  - washed-out, 112-114
  - wrong, 108-112
- Components, temperature-sensitive, 95-97
  
- Dark picture, 119
- Defective component location, troubleshooting technique, 12
- Discriminator-audio amplifier, 67
- Distorted or intermittent sound trouble chart, 70
- Doubler power supply, 18-20
  
- Fault isolation, troubleshooting technique, 12
- Flow chart, troubleshooting, tuner, 48
  
- Ghosts, eliminating, 45-47
- Guide for troubleshooting washed-out color, 113
  
- Height, no, 123
- Height problems, troubleshooting chart, 118
- Horizontal
  - and vertical sync, poor, 122
  - bending, 92-93
  - sweep circuits, 84-87
  - troubleshooting chart, 98-99
  - tearing, 93-94, 122
- Hue, incorrect, trouble analysis chart, 110
- Hum in picture, 123

- IF amplifier troubleshooting, 57-58
- Ignition noise, reducing, 44-45
- Interference, 47-49
- Intermittent or distorted sound
  - trouble chart, 70
- Intermittent or low B+
  - troubleshooting chart, 27
- Intermittent or weak video
  - troubleshooting chart, 61
- Internal sync troubles, 78-80
  
- Loss of color, 106-108
  - troubleshooting chart, 107
- Low B+ or intermittent
  - B+ troubleshooting chart, 27
- Low B+ or no B+, 24-28
  
- Neutralized-triode amplifier, 41-42
- No B+ or low B+, 24-28
- No B+ trouble-flow chart, 26
- No height, 123
- No raster, 120
- No video, 119
- Noise, ignition, reducing, 44-45
  
- Output stage troubleshooting, 66-67
  
- Pentode RF amplifier, 37
- Picture
  - dark, 119
  - hum in, 123
  - problems, troubleshooting chart, 119-120
    - no raster, 120
    - no video, 119
    - snowy picture, 120
    - very dark picture, 119
  - rolls, 122
  - snowy, 120
  - stability, troubleshooting chart, 122
    - picture tears horizontally, 122
    - poor horizontal and vertical sync, 122
    - tube troubleshooting, 59
- Poor color-sync troubleshooting chart, 115
- Poor horizontal and vertical sync, 122
- Power
  - distribution, 21-23
  - supply
    - doubler, 18-20
    - trouble analysis, 21-23
    - troubleshooting methods, 24-28
    - vacuum-tube, 20-21
- Preanalysis of video troubles, 59-62
  
- Raster, no, 120
- Reducing ignition noise, 44-45
- RF amplifier
  - cascode, 40-41
  - neutralized-triode, 41-42
  - pentode, 37
  - tetrode, 40
  
- Six-step troubleshooting technique, 9-16
  - analysis, 9-12
  - application, 13-15
  - checkout, 13
  - defective component location, 12
  - fault isolation, 12
  - observation, 9
  - repair, 12-13
- Snowy picture, 120
- Sound
  - circuits, theory of operation, 63-65
  - stages, troubleshooting, 66-71
    - discriminator-audio amplifier, 67
    - output, 66-67
    - sound-IF stages, 67-71
    - speaker, 66
- Speaker troubleshooting, 66
- Stages, video, troubleshooting, 57-59
  - B+ supply, 59
  - IF amplifier, 57-58
  - picture tube, 59
  - video
    - amplifier, 58
    - detector, 58
- Sweep
  - and AFC circuits,
    - troubleshooting, 91-94
  - bending, horizontal, 92-93
    - sync, loss of, 94
    - tearing, horizontal, 93-94
  - circuit theory of operation, 84-91
    - AFC circuits, 88-90
    - horizontal sweep circuits, 84-87
    - vertical sweep circuits, 90-91
    - vertical, troubleshooting chart, 100
- Sync
  - circuit theory of operation, 72
  - circuits, troubleshooting, 73-80
    - external sync troubles, 75-78
      - interference, 76-78
      - poor video-signal amplification, 75-76
      - power supply filtering, 76
    - internal sync troubles, 78-80
  - loss of, 94
  - troubleshooting chart, 81
- Tearing, horizontal, 93-94
- Test points
  - for troubleshooting color circuits, 103
  - weak color, 112
- Tetrode RF amplifier, 40
- Theory, tuner, 42-43
- Theory of operation
  - sound circuits, 63-65
  - sweep circuit, 84-91
    - AFC circuits, 88-90
    - horizontal sweep circuits, 84-87
    - vertical sweep circuits, 90-91
  - sync circuits, 72
- Transients, voltage, 94-95
- Trouble
  - analysis
    - chart, incorrect-hue, 110
    - power trouble, 21-23
  - chart, distorted or intermittent sound, 70
  - flow chart
    - no B+, 26
    - video, 60
  - symptoms and theory, video circuit, 52-57



- Troubles
  - and check areas table, 15-16
  - color-sync, 114-116
- Troubleshooting
  - chart
    - audio circuit, 69
    - height problems, 118
    - horizontal sweep, 98-99
    - intermittent or low B+, 27
    - intermittent or weak video, 61
    - loss-of-color, 107
    - picture problems, 119-120
    - poor color sync, 115
    - sync, 81
    - vertical sweep, 100
    - width problems, 117-118
  - flow chart, tuner, 48
  - individual sound stages, 66-71
    - discriminator-audio amplifier, 67
    - sound-IF stages, 67-71
    - speaker, 66
    - output, 66-67
  - individual video stages, 57-59
    - B+ supply, 59
    - IF amplifier, 57-58
    - picture tube, 59
    - video
      - amplifier, 58
      - detector, 58
  - methods, power supply, 24-28
  - procedures for color troubles, 105-116
    - color-sync troubles, 114-116
    - loss of color, 106-108
    - washed-out colors, 112-114
    - wrong colors, 108-112
  - sync circuits, 73-80
    - interference, 76-78
    - internal, 78-80
    - poor video-signal
      - amplification, 75-76
    - power supply filtering, 76
  - sweep and AFC circuits, 91-94
    - bending, horizontal, 92-93
    - sync, loss of, 94
    - tearing, horizontal, 93-94
  - technique, six-step, 9-16
    - analysis, 9-12
    - application, 13-15
    - checkout, 13
    - defective component location, 12
    - fault isolation, 12
    - observation, 9
    - repair, 12-13
- Tuner
  - block diagram, 30
  - RF-amplifier classification, 36-42
    - cascode, 40-41
    - neutralized-triode, 41-42
    - pentode, 37
    - tetrode, 40
  - theory, 42-43
  - troubles, interpreting, 43-49
    - eliminating ghosts, 45-47
    - other types of interference, 47-49
    - reducing ignition noise, 44-45
  - troubleshooting flow chart, 48
  - types of, 31-36
    - continuous, 34-35
    - drum, 31-32
    - permeability, 35
    - switch, 32-33
    - variable capacity, 35-36
- Vacuum-tube power supply, 20-21
- Vertical sweep
  - circuits, 90-91
  - troubleshooting chart, 100
- Video
  - amplifier troubleshooting, 58
  - circuit theory and trouble
    - symptoms, 52-57
  - detector troubleshooting, 58
  - no, 119
  - section block diagram, 51-52
  - stages, troubleshooting, 57-59
    - B+ supply, 59
    - detector, 58
    - IF amplifier, 57-58
    - picture tube, 59
  - trouble flow chart, 60
  - troubles, preanalysis of, 59-62
- Washed-out colors, 112-114
- Waveforms
  - chroma, 104
  - color signal, 103-106
- Weak-color test points, 112
- Wrong colors, 108-112