

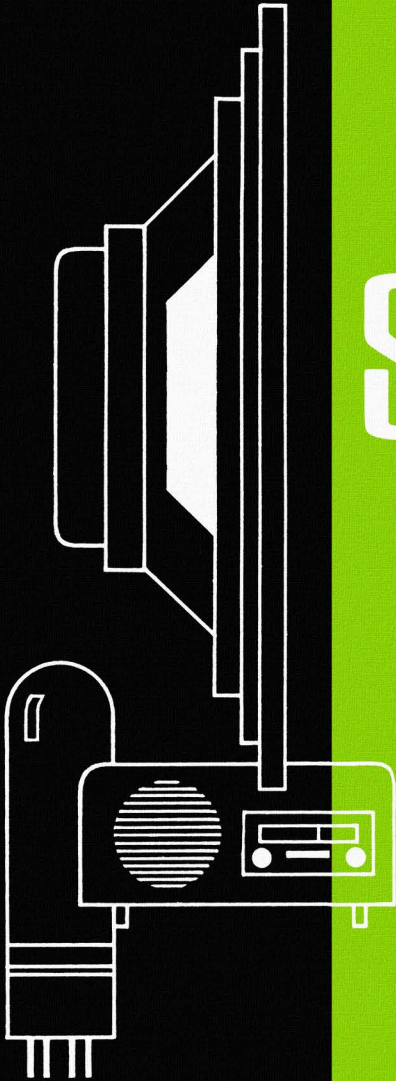

Howard W. Sams
®

PUBLICATION

20343



RADIO SERVICE

TRAINING MANUAL

By Edward F. Rice

RADIO SERVICE TRAINING MANUAL

By Edward F. Rice



HOWARD W. SAMS & CO., INC.
THE BOBBS-MERRILL CO., INC.
INDIANAPOLIS • KANSAS CITY • NEW YORK

FIRST EDITION
SIXTH PRINTING—1972

Copyright © 1964 and 1966 by Howard W. Sams & Co.,
Inc., Indianapolis, Indiana 46268. Printed in the United
States of America.

All rights reserved. Reproduction or use, without express
permission, of editorial or pictorial content, in any manner,
is prohibited. No patent liability is assumed with respect
to the use of the information contained herein.

International Standard Book Number: 0-672-20343-X
Library of Congress Catalog Card Number: 64-7886

Preface

This book was written to help both the beginner and experienced technician in the isolation and repair of troubles found in modern radio receivers. I have formulated and presented a simple and easy approach for analyzing trouble symptoms and isolating the faulty components through the use of programmed Servicing Charts and key Test Points.

Both students and practicing technicians will find that the Servicing Charts will speed the work on the servicing bench. In addition, the charts also serve as invaluable summaries of the isolation procedures for each of the symptoms described in the chapters.

The use of the programmed Servicing Charts is explained in Chapter 1. It is pointed out how they are keyed to sections of the text and how the result of each Test Point leads to the next step. The theme of the book is the development and use of *systematic servicing procedure* where each test in the process of elimination is planned to cover the largest possible amount of circuitry.

This book includes the theory and trouble symptoms of AM receivers using tubes, as well as a study of transistor-radio circuitry. The development of isolation procedures for various symptoms prevalent in transistor receivers is also included. Auto radios, both tube and transistor models, are fully covered, along with the automatic tuning systems used in each type. The essentials of FM receivers are explained in detail. This is followed by a thorough discussion of multiplex circuitry used in FM stereo receivers, along with an explanation of servicing techniques to use in the repair of this comparatively new form of entertainment equipment.

EDWARD F. RICE

Contents

CHAPTER 1

INTRODUCTION	9
Organization of This Book — Suggestions for Working on the Chassis	

CHAPTER 2

AM RECEIVERS WITH TUBES	14
The Power Supply — Dead Receiver — The Audio Stages — The Oscillator and Mixer or Converter — The Intermediate-Frequency Amplifier — The Diode Detector Circuit — Review Questions	

CHAPTER 3

NO SIGNALS, AUDIO FAILURE	43
Review Questions — Servicing Chart I	

CHAPTER 4

NO SIGNALS, RF OR IF FAILURE	55
Review Questions — Servicing Chart II	

CHAPTER 5

DISTORTION	68
Uncontrollable 60-Cycle Hum — Tunable Hum — Squeals and Motorboating — Review Questions — Servicing Chart III	

CHAPTER 6

WEAK, NOISY SIGNALS	81
Review Questions — Servicing Chart IV	

CHAPTER 7

REPAIRING 3-WAY PORTABLE RECEIVERS	91
Circuit Analysis of Power Supply — Other Circuit Differences — Troubleshooting Procedures — Dead Receiver with Tubes OK — Frequent Tube Burnout — Distortion and Tunable Hum — Review Questions — Servicing Chart V	

CHAPTER 8

FUNDAMENTALS OF TRANSISTOR RECEIVERS	105
How Transistors Amplify — Biasing and Stability — Automatic Gain Control of Transistor Stages — Power Supply and Decoupling — Audio Output Stages — The Mixer/Oscillator Stage — Review Questions	

CHAPTER 9

NO-SIGNAL SYMPTOM IN TRANSISTOR RECEIVERS	131
Symptom — No Signals — Review Questions — Servicing Chart VI — Servicing Chart VII — Servicing Chart VIII	

CHAPTER 10

ADDITIONAL SYMPTOMS IN TRANSISTOR RECEIVERS	164
Distortion — Oscillation or Motorboating — Review Questions — Servicing Chart IX — Servicing Chart X — Servicing Chart XI	

CHAPTER 11

AUTO RADIOS	177
Vibrator-Type Power Supplies — Automatic-Tuning Signal-Seeking Circuits — 12-Volt Hybrid Receivers — Transistor Output Stages — Direct-Coupled Transistor Stages — Review Questions — Servicing Chart XII — Servicing Chart XIII — Servicing Chart XIV	

CHAPTER 12

FM RECEIVERS	211
FM Receiver Circuitry — The FM Detector — FM Receiver Alignment — AM-FM Combinations — Troubleshooting — Review Questions	

CHAPTER 13

STEREO MULTIPLEX SYSTEMS	244
The Transmitted Signal — Receiver Circuits — Frequency-Division Type Multiplex Detectors — Multiplex Alignment — Troubleshooting Multiplex Units — Warbling or Gargling — Squeals and Birdies — Hissing Background Noise — Review Questions — Servicing Chart XV	

APPENDIX	273
--------------------	-----

INDEX	286
-----------------	-----

1

Introduction

Most books about radio deal primarily with details of electronic theory. It is often assumed that a thorough knowledge of circuit design and theory is all that is needed for troubleshooting. But expertness in troubleshooting does not come automatically from a study of theory—it requires the use of special techniques which, though based on theory, are more extensive than theory alone.

Troubleshooting consists of selection and orderly examination of key test points leading to a logical deduction of the cause of a symptom. This requires a study of the symptom itself, taking into consideration the frequency of the various types of failures, the reliability of test results, and the practicality of using certain kinds of test instruments. The effect that a defective component has on the operation of other parts of the receiver must be understood from previous experience and study. The physical construction of receivers and components leads to variations in the test procedures, and this requires the mental sifting and sorting of circuits into groups suspected of containing the fault. Then a test procedure must be decided on, which will eliminate entire sections of the suspected circuitry with a minimum of tests.

Theory will not be neglected in this book where it contributes to the study of the test procedures, but the emphasis will be on the art of troubleshooting radio receivers. The skillful technician, like all highly proficient journeymen, combines his knowledge of electronic fundamentals with his experience and intuition to achieve a blend of techniques which is as unique as his own personality. Symptoms of failure in receivers can be successfully approached in many ways, and the procedures set forth in this book are basic examples to be expanded by the technician as he grows through experience.

ORGANIZATION OF THIS BOOK

The chapters in this book are grouped into three parts: AM Receivers with Tubes; Transistor Receivers; FM and Stereo Multiplex Receivers. Each part contains chapters devoted entirely to troubleshooting as well as chapters explaining the necessary theory. A **SERVICING CHART** which summarizes the isolation procedures described is included at the end of each troubleshooting chapter.

The following letters and abbreviations used on the charts indicate the types of tests to be used :

E	Voltage Measurement
R	Resistance Measurement
Scp	Oscilloscope Waveform
S	Substitution of New Parts
I	Signal Injection
Opn	Opening the Designated Connection

Numbers on the charts, such as **3-4**, indicate the paragraphs in the chapter where the discussion of the particular test can be found.

The testing procedure starts at the top of the chart and works progressively downward, with each test eliminating those on one side of the horizontal line below that particular test.

To become familiar with the system, turn to **SERVICING CHART I** at the end of Chapter 3 and try this example: The symptom is **NO SIGNALS, AUDIO FAILURE**.

The first test is at **TEST POINT 1**. It is indicated that a signal is injected at the volume control; the numbers **3-1** indicate that an explanation can be found in paragraphs marked **3-1**.

The labels on the horizontal line beneath **TEST POINT 1** correspond to the only two possible results that can occur and lead to the next step.

If a sound is heard at **TEST POINT 1**, the symptom is not audio failure, and reference is made to Chapter 4. If no sound results from **TEST POINT 1**, then testing proceeds with **TEST POINT 2**, which again leads to two possibilities.

SUGGESTIONS FOR WORKING ON THE CHASSIS

1. Be equipped with both a good selection of quality tools of convenient size and shape and a set of various lengths of clip leads made of good materials.

2. Keep your soldering iron, or gun, in good condition. A piece of steel wool should be kept in the tool box for this purpose.
3. Have a small flashlight handy.
4. Use a sharp-pointed object as a soldering aid and, whenever possible, unsolder connections instead of cutting leads. However, do not hesitate to cut leads when it seems that unsoldering will damage the terminals due to excessive mechanical pressure or damage the components due to excessive heat.
5. After a connection has been opened for purposes of testing, resolder it at once if the part is not going to be replaced; it is easy to forget to do this later or to forget where the part came from. Do not hesitate to make a sketch when several leads are unsoldered at once in removing a part for replacement. The toughest repair jobs are those which are the result of an error made in previous testing, since this usually introduces a second fault that was not there when the receiver failed.
6. Unless you have a schematic, do not try to work on a chassis with which you are unfamiliar. Even though the operation of the circuits is understood perfectly, the time wasted looking for things that are supposed to be there is never recovered.
7. When testing at oscillator grids, isolate the scope or VTVM with a resistor or capacitor in series to avoid loading down the oscillator grid circuit. Often, the use of a voltmeter having low internal resistance will stop oscillator operation entirely.
8. Resist the impulse to adjust controls, unless you have a means of observing the results of the adjustment while it is being made. It is seldom that a receiver can be repaired by making adjustments, so wait to take this step until you know the circuits are working. A receiver does not fail because some control has misadjusted itself.
9. Subscribe to at least one of the monthly publications which have information on circuitry of new models, and form the habit of reading this material as soon as it is published. Keep a card file of important articles, or tear out the pages and file them.
10. In many places throughout the text, the directions, "Trace toward B+," are given. This refers to a simple technique used by all technicians after measuring for a positive voltage at some point and not finding it there. The probe is then moved across each component in series with the

point, moving toward B+ (Fig. 1-1). If one of the components in this series line is faulty, the voltage appears on the B+ side of the part, and the technician knows that he has just crossed the faulty part. When a capacitor from the line to ground, such as C1 (Fig. 1-1), is shorted, the voltage will appear at the B+ end of R2. When a capacitor is associated with the suspected part of the B+ line, it is faster to check the capacitor by removing one end of it and measuring the voltage again. The possibility of damage to R3 when the capacitor is shorted must not be overlooked.

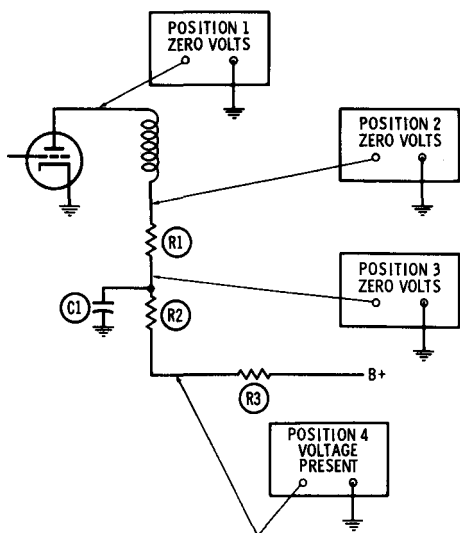

Fig. 1-1. Tracing toward B+.

11. Sometimes, when testing at the plate of a tube for positive voltage, an interesting phenomenon occurs. Instead of the positive voltage expected, a small negative voltage is found. This is a sure sign that a connection from the plate to B+ is open. The reason for the negative reading on the voltmeter is that the meter completes a circuit from the plate of the tube to ground, or to the cathode. With the cathode heated, electrons are emitted and form a space charge in the tube. Because electrons have left the cathode, it takes on a positive charge with respect to the neutral plate. When the voltmeter completes the path from plate to cathode, electrons flow from the neutral plate to the positive cathode through the meter. This causes the meter to be deflected in a negative direction when the positive probe of the meter is on the plate of the tube.

12. The cathode circuit should always be checked with an ohmmeter instead of a voltmeter. This is because an open cathode will cause the voltmeter to operate as a microammeter and produce a deflection which can be easily mistaken for normal cathode voltage. This erroneous reading is produced by the drawing of electrons from B⁻, through the meter, and into the cathode.
13. When full B⁺ is found at the plate of a tube which has a resistive load in series with the plate, then it is certain that the tube is not conducting. With a large resistance in series between the plate and B⁺, any electron flow from the plate through this resistance causes a voltage drop at the plate, and the reading there should be less-than-normal B⁺ voltage. The technician then knows he must check the cathode circuit for opens and that he must measure the grid-to-cathode voltage, looking for possible cutoff bias.

It is often helpful to remove the tube while measuring the plate voltage with a voltmeter in order to determine if abnormally low plate voltage is due to conduction through the tube, or to a shorted capacitor connected from ground to someplace along the B⁺ line.

14. In checking capacitors connected from B⁺ to ground, such as filter capacitors in the power supply or plate bypass capacitors, a shorted unit is identified by the missing voltage or by the burned components associated with the capacitor. Further testing of the capacitor can be done with an ohmmeter, or one end of the capacitor can be disconnected and another voltage measurement taken.

An ohmmeter does not give a good check for leakage or opens on small-value capacitors. This is especially true in the case where the capacitor is used across a high voltage or handles large peaks of AC. The small voltage supplied by the ohmmeter may not be enough to cause the capacitor to break down in the same manner as it does in the circuit. When in doubt, disconnect one end of the capacitor, and put a new one in the circuit.

2

AM Receivers With Tubes

Fig. 2-1 shows a block diagram of a typical AM broadcast receiver. The order of the blocks in the signal path must be kept clearly in mind when studying the isolation procedures for symptoms in the following chapters. In this chapter the operation of the circuits will be described briefly, with emphasis on those points of circuit theory which are important to the servicing technician.

THE POWER SUPPLY

The power supply converts the 120-volt AC line voltage to the required DC voltage for B+ in the radio. The following are the types of power supplies used in radio receivers.

1. The half-wave rectifier. Used in a transformerless circuit, it utilizes either a diode tube, such as the 35W4, or a selenium or silicon rectifier.
2. The full-wave, transformer-powered type. It uses a dual diode, such as the 5U4, 5Y3, 5V3, 6X4, or 6X5.
3. The half-wave voltage doubler.
4. The full-wave voltage doubler.
5. The full-wave bridge.

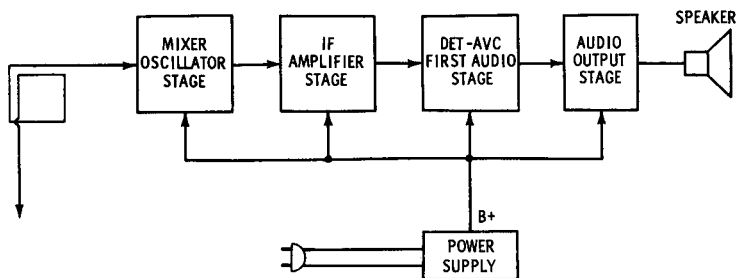

Fig. 2-1. Block diagram of a 5-tube AC/DC receiver.

Half-Wave Transformerless Rectifier

The first type listed above is shown in Fig. 2-2. Rectification occurs only on that half of the input cycle when the polarity on the anode (arrowhead) of the diode is positive, and the cathode is negative. The currents shown in solid lines flow during this half of the cycle, charging filter capacitors C1 and C2. On the other half of the cycle, the currents shown by dotted lines will flow. It can be seen that the electrons stored on the negative plates of the capacitors are released to flow through the load

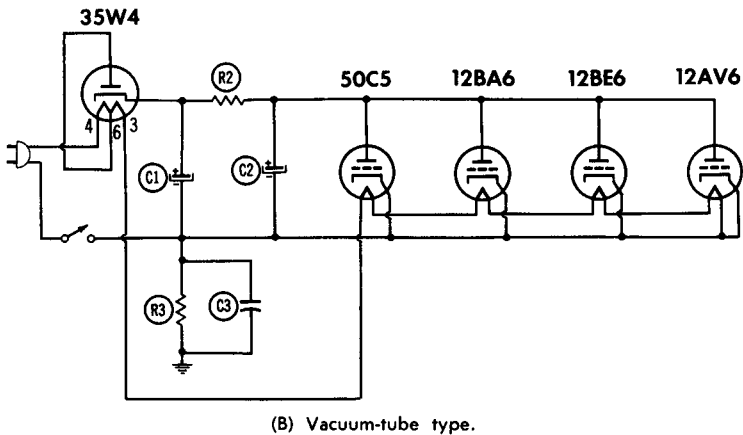
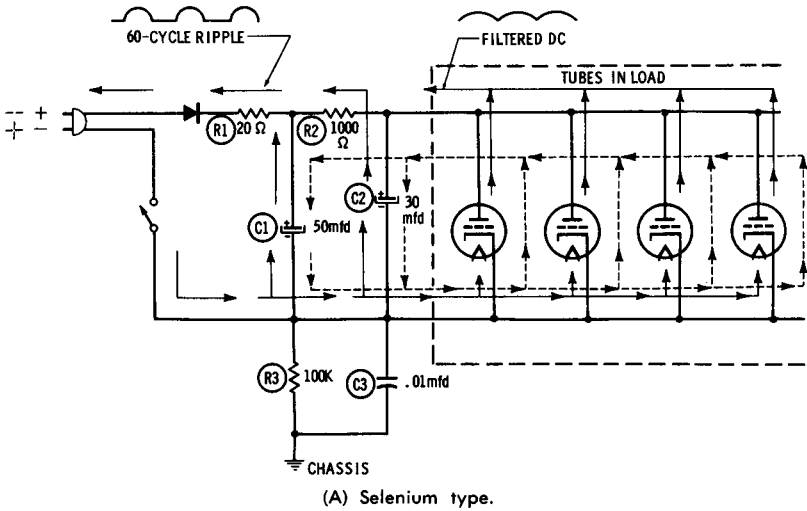

Fig. 2-2. Half-wave transformerless rectifiers.

during the time when the input voltage puts a negative polarity on the plate of the diode. In this manner, a continuous current is available for the tubes in the load, provided the capacities of the electrolytics are large enough to support the total load current for one-half cycle.

If no load current is drawn, the electrolytic capacitors will be charged by the solid-line current to approximately 1.41 times the 120-volt input voltage. But, in practice, the output voltage of the supply will be less than this value because of the voltage drops across R1, R2, and the rectifier when current is drawn through the load. With a moderate load, the normal output voltage will be from 110 to 130 volts DC with a 120-volt rms input.

R1 is called a *surge resistor*. Its purpose is to reduce the first surge of current into the completely discharged electrolytic capacitors when the switch is turned on. This current might be high enough to exceed the rating of the rectifier because the uncharged capacitors represent a short circuit.

R2 serves to slow down the discharge of C1 during the off-duty half-cycle of the input. The result is a filling of the deep valley between the peaks of voltage across C1. This reduces the 60-cycle ripple on the DC output voltage and maintains it at a higher value. R2 is sometimes replaced by a choke.

R3 and C3 isolate the B- from the chassis. Since B- is connected directly to one side of the 120-volt lines, a dangerous condition would result if this 120 volts were also connected to the chassis. In one position of the plug in the 120-volt socket, the chassis would be connected to the side of the 120-volt line *which is not grounded to water pipes, conduits, etc., in the house or the repair shop. With this connection there would be 120 volts between the chassis and any grounded object.* Some power supplies of this type are not isolated from the chassis, as many technicians have found out to their surprise.

This type of power supply often uses a 35W4 rectifier tube instead of a selenium or silicon diode. The circuit action is the same in either case. The plate of the 35W4 tube is connected to the tap on the filament of the tube. Thus, part of the filament resistance is in series with the plate of the rectifier and with the flow of B+ current. In this way, the resistance between filament pins 4 and 6 serves as the surge resistor. This means that a short across the output of the power supply will cause the filament of the 35W4 to burn out and remove all B+. This is a common failure in radios using this type of power supply. A pilot lamp is frequently connected across pins 4 and 6 to shunt some current around the filament.

The tube filaments must be connected *in series* across the 120-volt line. This means that the total of all the filament voltages must be approximately 120 volts, and that the tubes must all draw the same filament current. The tubes shown all draw 150 ma of filament current, and the voltage for each tube is given by the first numbers of the tube designation.

The Full-Wave Transformer-Operated Power Supply

The circuit is shown in Fig. 2-3. On one half of the input cycle, the lower plate of the rectifier is positive, and the solid-line currents flow. On the other half cycle, the upper plate is positive, and the dotted-line currents flow. Both currents flow out of the transformer secondary through the center-tap,

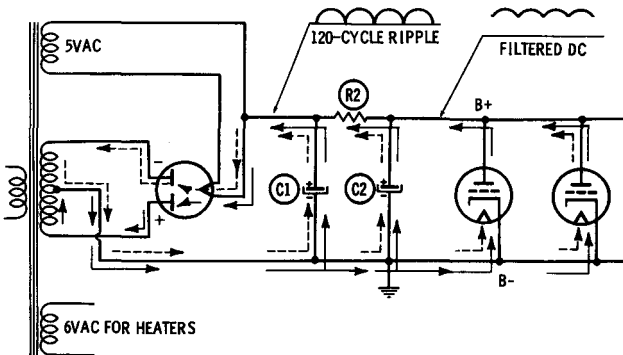

Fig. 2-3. Transformer-powered full-wave power supply.

charging the filters, supplying the load, and returning to the cathode. Thus, there will be charging current for the filters and current supplied to the load on both halves of the input cycle. This is one advantage of the full-wave system.

Since the filters are charged twice during each input cycle, the valleys in the voltage waveform are narrower and occur at a rate of 120 cycles per second instead of 60 cycles as with the half-wave systems. The filters are not required to support the load during an entire off-duty input cycle, and the DC voltage output can be made quite free from ripple even under heavy loads.

The use of the transformer in this power supply gives another advantage—the line voltage can be stepped up to any desired value. Usually, the voltage at the ends of the secondary winding (which are connected to the plate of the rectifier) is about 600 volts rms. But since only half of the transformer is used at a time, about 300 volts DC is produced across the filters.

If the secondary voltage were 1200 volts rms, then with no load, the filters would be charged to about 846 volts on the peaks.

$$\frac{1}{2} (1200) (1.41) = 846 \text{ volts}$$

Since any amount of voltage output is possible with the proper turns ratio in the transformer and sufficiently high breakdown ratings of the capacitors, this type of power supply is used in high-power equipment. When the transformer is used in low-power equipment, it is because of the better filtering which is possible with heavy-current loads.

It is customary for the transformer to have a separate winding to provide voltage for the filaments of the tubes. The tubes are connected in parallel across this filament winding. This requires that all tubes have the same filament voltage, although the currents drawn by each may differ.

The Half-Wave Voltage Doubler

The circuit of a half-wave voltage doubler is shown in Fig. 2-4A. The 120-volt AC input is represented by the generator. In Fig. 2-4B, the charging half-cycle is shown with only one diode present because, with this polarity, D2 does not conduct, rendering the right half of the circuit inactive. Electrons flow, charging C1 to the generator voltage. In Fig. 2-4C the other half of the input cycle is shown with D2 and C2 in the circuit, but with D1 omitted because the polarity is such that it does not conduct. Electrons flow from the generator, charging C2 and passing through the load, returning to C1 through D2.

It is because C1 was already charged to approximately 120 volts that voltage doubling now takes place. The voltage previously on C1 during the first half cycle is now *in series* with the generator voltage. The voltage applied to C2 and to the load is therefore the *sum of the generator voltage and the voltage stored on C1*, or approximately 240 volts.

Theoretically, the output voltage would rise to twice the peak generator voltage if there were no load, but, in practice, there are losses in the diodes and capacitors. Thus, the output voltage supplied from C2 and C3 tends to drop during the off-duty input cycle because the load must be supported entirely from the charges on C2 and C3. With moderate loads, the output is seldom more than 285 volts DC; its value will be greater if the capacitances are made larger and the load current smaller.

Since the system is essentially a half-wave rectifier, the output capacitors are charged only during one half of the cycle,

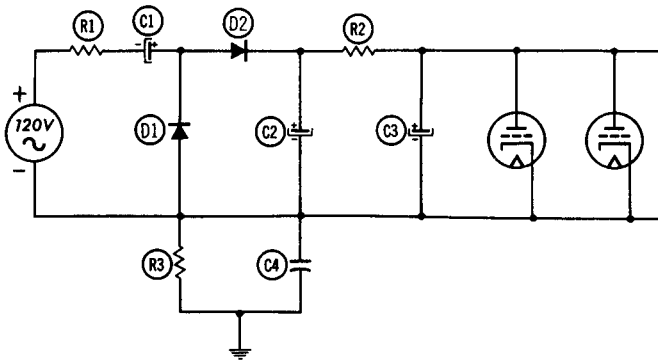

(A) Basic circuit.

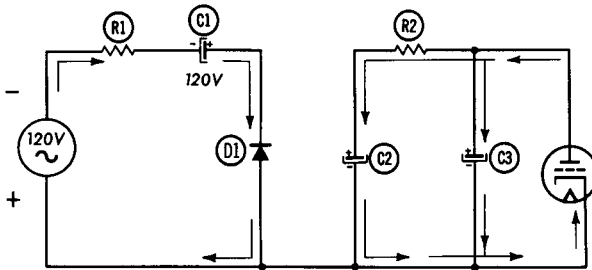

(B) Charging half-cycle. Filters supplying load current.

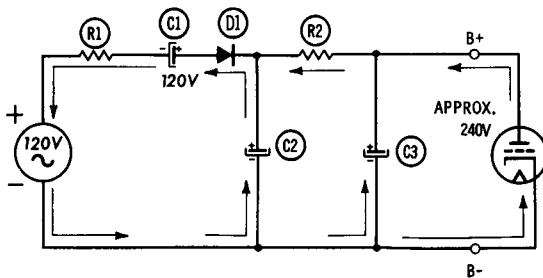

(C) Charge on C1 is in series with source.

Fig. 2-4. Transformerless half-wave doubler power supply.

so the ripple frequency is 60 cps. The voltage rating of C1 is usually 150V, and the rating of C2 and C3 is 350V to 450V. C3 does not play a part in the doubling, but is merely a ripple filter.

The advantage of the doubler is its ability to produce larger output voltages without a transformer. Thus, in order to avoid the filament winding necessary in the transformer-type models,

the filaments are usually connected in series as they are in a regular half-wave transformerless system.

Full-Wave Doubler

The operation of a full-wave doubler, shown in Fig. 2-5, is similar to that of the half-wave doubler except that C1 and C2 are each charged separately on alternate halves of the input cycle. The ripple frequency is 120 cps and is thus easier to filter. In addition, the system is capable of somewhat more output current before a serious decrease in the amount of output voltage occurs.

The full-wave doubler is not used often, however, because it is impractical to connect the tube filaments in series across the 120-volt line as they are in the half-wave system. This necessitates the use of a transformer to supply the filaments, and the main advantage of the doubler is lost.

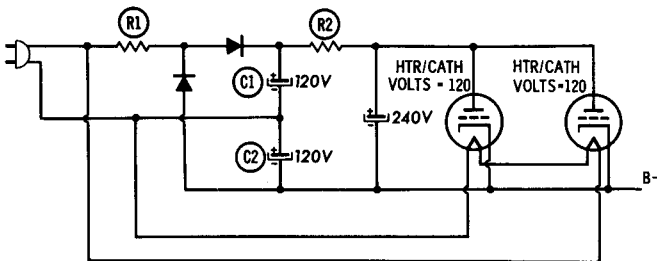

Fig. 2-5. Full-wave doubler power supply.

The reason why it is not practical to connect the filaments in series across the line can be seen by a study of Fig. 2-5. The cathodes of the tubes in the load are returned to B-, and their heaters must be returned to the 120-volt lines if no transformer is used. B- is connected to the bottom end of C2, and the heaters are actually connected to the top end of C2. Thus, the voltage across C2 (about 120 volts) appears between the cathode and heater of the first tube in the series string. The second tube in the string would have a heater-to-cathode voltage lower than the first by the amount of heater voltage dropped in the first tube, etc. Not many tubes are manufactured to withstand such high heater-cathode voltages, so the full-wave doubler is not widely used in the transformerless circuit. The full-wave circuit has been used, however, to double the voltage from a transformer secondary when very high DC voltages are required, such as those in radio transmitters, test equipment, and X-ray equipment.

The Full-Wave Bridge

Besides the extra expense and bulk of the transformer used in the conventional full-wave circuit described previously, the circuit also has the disadvantage of producing a DC voltage from only one half of the full secondary voltage because the winding must be center-tapped. The bridge circuit in Fig. 2-6 rectifies the full secondary voltage and is capable of twice the DC output that the conventional circuit using the same transformer has. The arrows show that the system is a full-wave

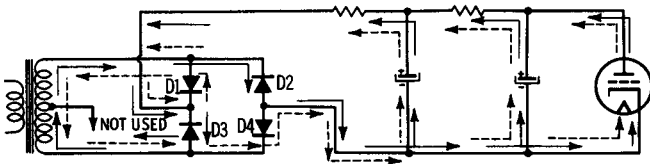

Fig. 2-6. Full-wave bridge rectifier.

rectifier using two of the diodes on each half of the input cycle. This method of rectification is capable of greater output current at high voltages than the others, but it is expensive, requiring four rectifiers and a transformer.

The important points about power supplies are summarized here for convenience.

Type	DC Output Voltage Under Load	Ripple Frequency	Voltage Regulation Under Load
Half-Wave Transformerless	Approx. equal to input rms	60 cps	fair
Full-Wave Transformer	Approx. equal to $\frac{1}{2}$ the rms secondary	120 cps	good
Half-Wave Doubler	Approx. 2 \times input rms	60 cps	poor
Full-Wave Doubler	Approx. 2 \times input rms	120 cps	fair
Bridge	Approx. equal to secondary rms	120 cps	good

In addition, the following facts should be remembered:

1. Rms is the effective value of AC as read on an ordinary meter.
2. With no load, filters will be charged to 1.41 times the input rms. This voltage can exceed the rating of the filters if the power supply is operated with no load.
3. In voltage doublers, the filters must have breakdown voltage ratings greater than $2.82 \times$ the rms input.
4. The output voltage under load is dependent on the capacity of the filters. With heavier loads, larger capacitors are needed.
5. Hum is the result of the deep valleys in the output waveform. The frequency of the peaks is called the *ripple frequency*.
6. The filter capacitor connected closest to the rectifier is the input capacitor and serves mainly to support the output voltage. Capacitors connected later in the circuit are ripple filters.
7. Transformerless circuits can have a dangerous voltage between B- and grounded objects, such as water pipes or conduits. Therefore, the B- should be isolated from the chassis.
8. A surge resistor is always placed between the input filter and the rectifier to reduce the current when the supply is first turned on. This resistor is part of the filament in a 35W4-type tube and is frequently shunted by a pilot lamp.

DEAD RECEIVER

The preceding discussion of power supplies provides the background for understanding the troubleshooting method for a common and very simple symptom. A *dead receiver* is one in which there is no sound of any kind present when the volume control is turned to maximum. This trouble nearly always leads to repairs in the power supply. One of the exceptions is the case where the speaker itself has failed. Discussion of speaker failure will be reserved for later chapters in which a more extensive analysis of the complicated symptoms will be presented.

In receivers having transformerless power supplies where all the tube filaments are connected in series, a burned-out filament will break the series string, and none of the tubes will light. This results in a completely dead receiver when the

rectifier is one of the tubes in the series-filament string, because there will be no B+. The 35W4 rectifier tube is commonly used in these circuits, and part of its filament also carries B+ current, as was explained earlier. Any short in the load will cause excessive current in the 35W4 filament and burn it out. This is the most frequent cause of a dead receiver and should always be checked first.

Often the filament of a new rectifier will also burn out immediately when inserted in the socket, due to the same cause that burned out the first one. So, it is advisable to measure the resistance between the rectifier cathode at the socket and B- before inserting a new tube. With the filter capacitors connected, the ohmmeter will swing to a very low resistance and gradually climb to 10K or more if there is no short. With a resistance greater than 10K it is safe to install the new rectifier. If the receiver operates normally for a few hours, the technician should conclude that the rectifier filament burned out through continued normal operation.

If the rectifier filament is good, or the receiver uses a selenium or silicon rectifier, the other tubes should be checked next. This can usually be done without removing the chassis by simply measuring across the filament pins (pins 3 and 4 on most seven-pin miniature types) with an ohmmeter. A deflection will indicate that the filaments are not burned out.

If all of the filaments are found to be good, the chassis should be removed to check the switch and line cord. This can also be done by using the ohmmeter. A good way is to short the prongs of the AC plug and, with the switch on, place the ohmmeter across the two ends of the cord where they are soldered in the receiver.

Instead of using the ohmmeter, some technicians short across the switch terminals with the receiver plugged into the outlet and watch for the filaments to light. If the filaments do not light, the line cord is to be suspected. If they do light, the switch is to be suspected.

In a few cases of *dead-receiver* symptoms, all the tube filaments as well as the line cord will be found good, and still the filaments fail to light. This can only be due to a break in the filament wiring between the tube sockets. An easy way to find such a defect is to use the AC voltmeter in the manner shown in Fig. 2-7. Starting at either end of the filament string, the meter probes are placed across successive points in the line where continuity is expected. If the points are actually connected, there will be no reading on the meter; but when the probes are placed across an open place in the line the meter

will read the full line voltage if the line cord and the switch are both good.

When a receiver using a transformer-powered rectifier with parallel filaments is found completely dead, the analysis is much simpler. This is because it is very unlikely that all the filaments are burned out at the same time. The technician looks for one of three conditions:

1. All filaments, including that of the rectifier, are out, indicating that the trouble lies in the primary side of the transformer.
2. Only the rectifier filament is out, indicating that the transformer primary circuit is energized and that the trouble lies either in the rectifier tube itself or in its filament winding on the transformer, which is separate from the rest of the filaments.
3. The rectifier is lit, and one or more of the other filaments in the amplifier tubes are out, indicating again that the primary circuit of the transformer is energized. This means the rectifier circuit is working and that the trouble lies in the filament winding for the amplifier tubes, or in the filament wiring of one or more of the tubes, or perhaps only in the tubes themselves.

Further testing will be governed by which one of these conditions exists. In the first case, the primary of the transformer, the line cord, the switch and the fuse (if one is present) should be examined for continuity with the ohmmeter.

In the second case, after the rectifier tube is replaced, the rectifier filament-winding of the transformer should be checked for continuity.

In the third case, if none of the amplifier tubes are lit, the voltmeter can be used to check the AC output of the filament

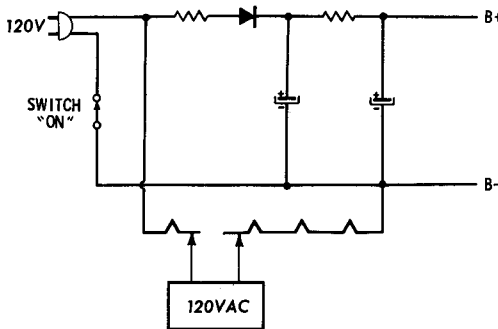

Fig. 2-7. Checking for continuity with a voltmeter.

winding. If only a few tubes are out, they should be replaced. The ohmmeter will aid in finding breaks in the wiring between the tube sockets, but the technician must remember that the tube filaments are connected in parallel.

THE AUDIO STAGES

A typical output stage using a 50C5 beam-power pentode is shown in Fig. 2-8. The cathode is biased by allowing the cathode current to be drawn through R3 to produce the cathode voltage of +5. With the grid returned to ground (zero volts), there will be a potential difference of 5 volts between grid and

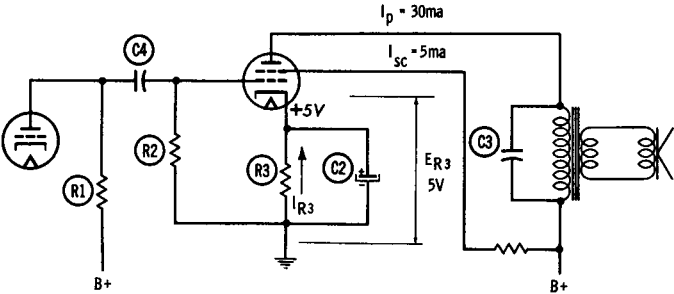

Fig. 2-8. A beam-power pentode output stage.

cathode, with the grid being negative. The fact that no voltage is dropped across R2 permits the control grid to be at ground potential (zero volts). This may be confusing when first encountered, but it can be understood when one remembers that no current flows in R2.

The value of R3 is calculated as follows :

$$\begin{aligned}
 I_{R3} &= I_p + I_{sc} \\
 I_{R3} &= 35 \text{ ma} \\
 E_{R3} &= \text{bias desired} = 5V \\
 R3 &= \frac{E_3}{I_{R3}} = \frac{5V}{35 \text{ ma}} \\
 &= 143 \text{ ohms.}
 \end{aligned}$$

C2 prevents what is called *cathode degeneration* by keeping the cathode voltage constant as the cathode current changes with the signal. From the previous calculation it can be seen that when the incoming signal swings positive (increasing the current through the tube), the cathode voltage will also go

more positive. This makes the grid more negative with respect to the cathode and tends to decrease the plate current. This action of decreasing the plate current while the incoming signal is trying to increase it is called *degeneration* and would take place if it were not for C2. Degeneration reduces the output.

C2 is a *cathode bypass capacitor* which permits AC current at audio frequencies to pass around the cathode resistor and thus cause no change in cathode voltage. The DC portion of the cathode current must pass through the resistor, and it is this current that produces the desired constant cathode voltage. Failure of the cathode bypass capacitor is a common cause of distortion or low volume, and it will be discussed later in detail.

Capacitor C3 serves the purpose of bypassing high-frequency audio currents around the primary of the output transformer. This action broadens and flattens the frequency response of the stage by keeping very-high-frequency audio out of the transformer. The inductive reactance of the transformer increases with the frequency of the current through it, and so it presents a higher impedance to the high-frequency audio. This higher impedance gives rise to higher voltages across the primary and greater output from the speaker at higher audio frequencies. If it were not for C3, the radio would have a rather "tinny" sound due to the emphasis that would be given to the higher audio tones.

Three methods of connecting the capacitor are shown in Fig. 2-9. The results are about the same for either of the connections, but the symptoms caused by the capacitor if it shorts are different in each case.

In part A, a shorted capacitor merely removes all audio without seriously affecting any voltages. In part B, a shorted capacitor will remove the plate voltage and put the full B+ across the transformer winding. In part C, a shorted capacitor makes the plate and cathode voltages equal and effectively places the cathode resistor and the transformer in series across the power supply. The cathode bypass may sometimes be damaged in this last instance because it may be subjected to a greater DC potential than it was designed to withstand.

Capacitor C4 in Fig. 2-8 blocks the DC voltage that is present on the plate of the preceding stage and passes on to the grid only the AC variations of the signal. This capacitor is a very common cause of distortion because a slight leakage of DC current through it changes the biasing of the stage. As shown in Fig. 2-10, electrons are drawn upward through R2,

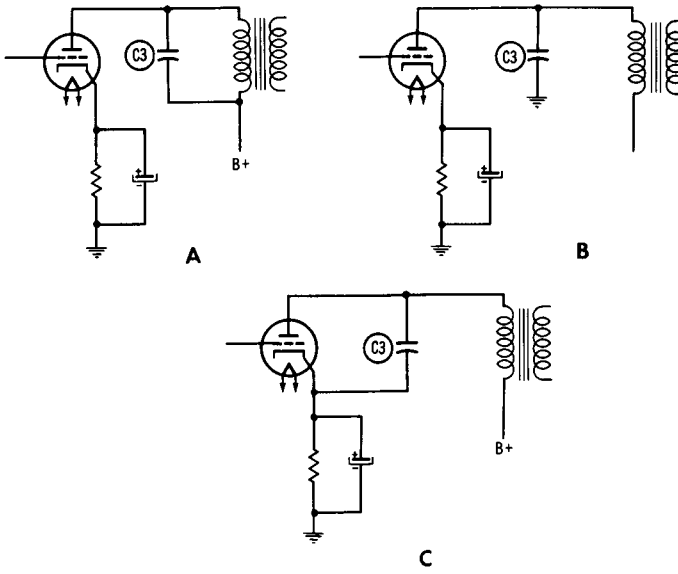

Fig. 2-9. Three ways of connecting the plate bypass capacitor.

producing an unwanted voltage drop between the grid and ground. The tube may be damaged because the polarity of the voltage makes the grid positive, which increases the plate current.

Push-Pull Output Stages

Power output of a stage can be doubled by using the circuit shown in Fig. 2-11. The name *push-pull* is derived from the fact that while one tube is increasing the current in its half of the output transformer, the other tube is decreasing the

Fig. 2-10. The effect of a leaky coupling capacitor.

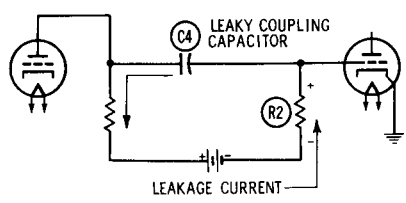

current in its half. This is indicated by the polarities of the waveforms shown.

The tubes are driven by equal signals which are 180° out of phase. That is, when the signal is going positive on one grid, it is going negative on the other grid. A positive-going signal on the grid of an amplifier *increases* plate current and *de-*

creases plate voltage. The waveforms represent voltage changes at the respective points.

The increase in output power occurs in an interesting manner. When current is *increasing* through the upper tube, a magnetic field is built up around the upper windings of the transformer. The poles of this magnetic field are dependent on the direction of the winding on the core. Let us assume that the north pole is at the top and the south pole at the middle.

At the same time the current through the upper tube is increasing, the current through the lower tube is *decreasing*.

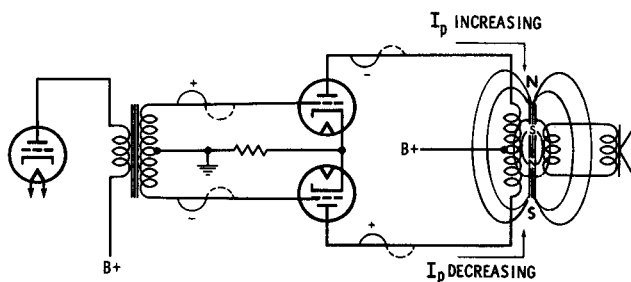

Fig. 2-11. Push-pull stage doubles power output.

This current is flowing in the opposite direction through the bottom half of the transformer. The two halves of the primary are wound in the same direction, and this would seem to produce magnetic poles in the lower half of a polarity opposite to those in the upper half. But this is not the case, because the current is *decreasing* in the lower half and a decreasing current through a coil produces the *opposite* magnetic field from that caused by an *increasing* current. The result is that the field produced in the lower winding actually *aids* the field produced in the upper winding. With the field aiding, the transfer of power to the secondary is twice what it would be if the transformer were driven by only a single tube.

The push-pull arrangement is not the only way to double the power output by using two tubes, but it is the one most commonly used because of additional advantages over the other methods. Since B+ is fed to both tubes directly, any variations in the power-supply voltage, such as unfiltered AC ripple, appear at both plates simultaneously. This causes *in-phase* changes across the transformer with resulting magnetic fields which oppose each other. For a similar reason, all second harmonics of the signal which are generated in the stage are cancelled in the output. Also, cathode degeneration, which was

described in the single-tube output stage, does not occur, and no cathode bypass capacitor is necessary when the two cathodes are fed from a common resistor.

Low-power stages for home-type radios and phonographs are sometimes connected in push-pull to utilize these advantages. In these devices, one of the tubes is capable of furnishing more than enough power, and the tubes are operating well below their full capacity. Many technicians are surprised to find practically no change in the volume level when one tube is removed. However, there may be a slight increase in hum and distortion.

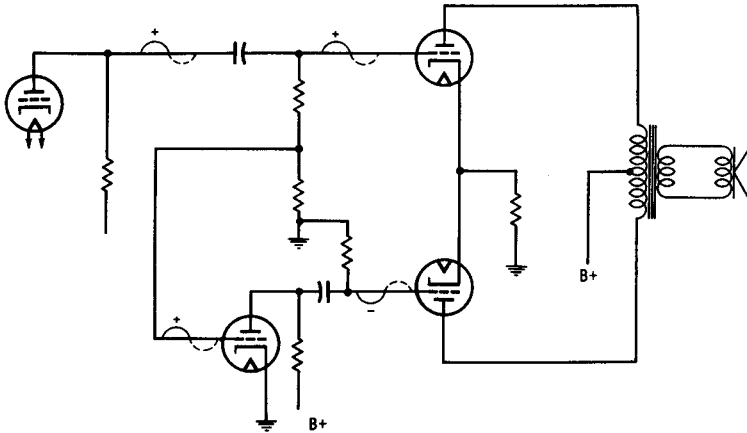

Fig. 2-12. A resistance-coupled push-pull stage.

What was previously said about low-power stages does not apply to high-power output stages of the type used in modulators for transmitters, or in large public-address systems. When high power is involved, considerable damage can be done to the output transformer and the remaining tube when one tube is inactive.

A push-pull stage using resistance coupling in the input is shown in Fig. 2-12. The extra triode is necessary to give the phase reversal needed to drive the second tube in the push-pull combination. Note that the input to the phase-inverter triode is reduced so that one output tube will not be overdriven.

The First Audio Stage or Voltage Amplifier

The power-output stage is driven by a circuit which produces a large swing in its output voltage with only a small voltage swing at its input. Because only output voltage (not

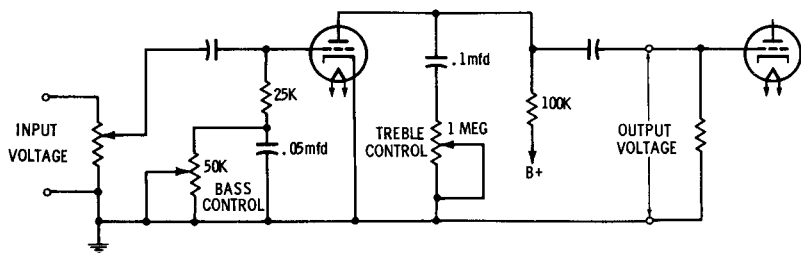
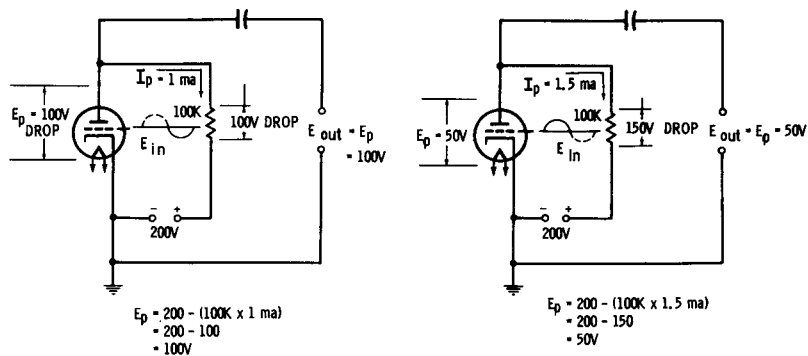

Fig. 2-13. A voltage amplifier with volume and tone controls.

current or power) is coupled to the next stage, the first audio stage is called a *voltage* amplifier. The example shown in Fig. 2-13 includes some interesting extra features.

The grid of the stage is coupled through C1 to the volume control. Any signal voltage appearing across the volume control will be transferred to the grid and an amplified version will appear in the plate circuit. The sliding contact arm on the volume control allows any fraction of input signal to be selected. The very large resistor in series with the plate results in large changes in the plate voltage with only very small current changes. An example is shown in Fig. 2-14.

In general, the larger the plate-load resistance can be made, the greater will be the peak-to-peak swing of the plate voltage and, therefore, the greater will be the output signal. But the size of the plate-load resistor is limited by the amount of B+ voltage available. This is because the slight amount of no-signal plate current causes a voltage drop across the resistor which is in series with the plate voltage. For example, if a 100K plate resistor were used with a B+ supply of 100 volts, a current of 1 ma through the tube would cause the entire



E_{out} CHANGES 50V WITH A CHANGE OF 0.5 ma IN I_p

Fig. 2-14. A small plate-current change causes a large plate-voltage change

B+ to be dropped across the plate resistor and leave no voltage applied between plate and cathode.

Tone Controls

Except for a few high-fidelity amplifiers, tone controls are merely filters which remove either the high frequencies or low frequencies. Even when the controls are labeled "boost controls," the circuit itself does not actually add highs or lows that were not present in the previous stages. When treble sounds are filtered out, the effect to the ear is like an increase in bass, and vice versa. In some circuits, an extra amplifier is added, which raises the signal level after filtering to give a more pronounced increase in those frequencies that were not filtered.

The principle of a change in capacitive reactance with a change in frequency is used in the tone-control circuit. Any capacitor which shunts the output or input of a stage will cause the stage to have very low gain at frequencies to which the capacitor presents low impedance.

In Fig. 2-13, assume that the 1-meg potentiometer is turned so the arrow is at the top, and that the signal through the tube contains some notes at 5000 cps.

$$X_c = \frac{159 \times 10^{-3}}{fC} = \frac{159 \times 10^{-3}}{5 \times 10^3 \times 1 \times 10^{-7}} = 318 \text{ ohms}$$

So the 5000-cycle note finds the output of the amplifier shorted to ground through 318 ohms. Only the AC signal is shorted, not the DC plate current, because no DC current can pass through a capacitor.

A signal at 50 cps sees 31,800 ohms from plate to ground, and thus is not shorted by this large resistance. The output to the next stage will then be about 100 times larger at 50 cps than at 5000.

If the entire resistance of the 1-meg variable resistor were put in the circuit by turning the control so that the arrow is at the bottom, the shunting effect of the 0.1-mfd capacitor would be nullified by the 1 meg which would be in series. So the circuit is an adjustable treble filter.

A simple bass filter can be made by placing a capacitor between the grid resistor and ground. In this way, highs are not affected by the low impedance of the capacitor, since the grid resistor is normally grounded when no tone control is used. Bass notes, however, find the grid resistor increased by the amount of X_c which is in series. The control places an adjustable resistance in parallel with X_c , thereby reducing it to the desired value.

In Fig. 2-15 is shown a very effective tone-control circuit which has become popular in high-fidelity equipment. C3, R3, and C4 form a voltage divider for highs only, having no effect on the bass. R4 selects the proportion of the high-frequency signal voltage to be applied to V2. R1, R2, and R3 form another voltage divider which is adjustable for low-frequency signals. The highs are shunted around R2 by C1 and C2, so

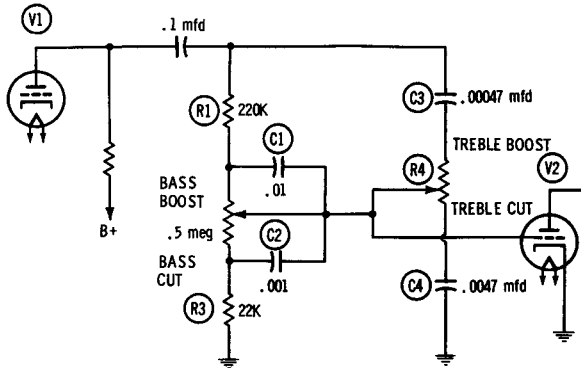

Fig. 2-15. A tone-control circuit for use in high-fidelity equipment.

that changing this control does not affect the total impedance to high-frequency signals. C1 and C2 also give some compensation to the mid-range frequencies as R2 is moved from bass cut to bass boost.

THE OSCILLATOR AND MIXER STAGE OR CONVERTER

Nearly every AM radio uses the combined osc/mixer stage shown in part A of Fig. 2-16. The signal from the station (720 kc, for example) is picked up by the loop antenna, which is tuned to the desired frequency by C1. This signal is then fed to the signal grid through pin 7 of the 12BE6. An amplified version of this signal appears in the plate circuit.

At the same time, the cathode current is carrying an oscillator signal generated by coil L1. The cathode tap on the coil causes a small amount of cathode voltage to be fed back to the control grid, causing oscillation to occur at the frequency for which L1 and C2 are resonant. In this example, the oscillator frequency is 1175 kc.

Both signals, 720 kc from the station and 1175 kc from the oscillator, appear in the plate circuit, and it is here that the

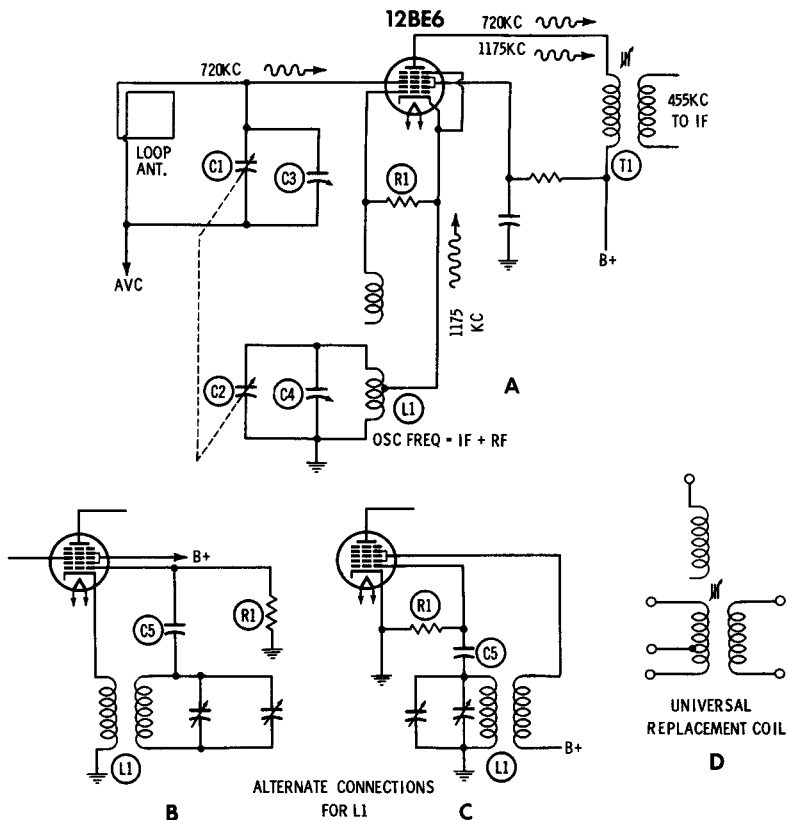

Fig. 2-16. A combined mixer/oscillator circuit.

mixing takes place. Whenever two signals are mixed in a non-linear device, such as a vacuum tube, two additional signals equal to the sum and the difference of the originals will be produced. When the radio is tuned to receive 720 kc, there are four signals present in the plate circuit:

- 720 kc, from the station
- 1175 kc, from the oscillator
- 1895 kc, the sum
- 455 kc, the difference

Of particular interest is the fact that the same difference-signal, 455 kc, is produced in the plate circuit for *any* incoming frequency. This is accomplished by tuning the oscillator coil and the loop antenna simultaneously with capacitors C1 and C2, both of which are varied by the same shaft. The circuits

are arranged so that the combination of L1 and C2, the oscillator tank, is always tuned to a frequency 455 kc above the incoming signal.

If the radio were tuned to a new station, say 900 kc, C1 and the loop would resonate at 900 kc, and the oscillator tank would resonate 455 kc higher, at 1355 kc. The four frequencies in the plate circuit would then be:

900 kc, from the station
1355 kc, from the oscillator
2255 kc, the sum
455 kc, the difference

For *any* incoming station, the first three signals vary, but the difference signal will always be 455 kc. Furthermore, this difference signal will have all the characteristics of the signal from the station; that is, it will carry the audio modulation from the studio.

This is the *superheterodyne principle*. Its advantage is that the output of the mixer stage can be fixed-tuned and the following stages designed for maximum efficiency at one frequency only. It does not matter where the receiver is tuned in the broadcast band: the station frequency will always be converted to 455 kc. This frequency is called the *intermediate frequency* and is fairly well standardized at 455 kc for broadcast-band receivers, although other frequencies are used in other types of receivers.

C1 and C2 in Fig. 2-16 are the main tuning capacitors, and the dotted line shows that the rotors are connected on one shaft. Capacitors C3 and C4 are small screwdriver-adjusted units connected in parallel with the large capacitors to enable the two tank circuits to be initially adjusted 455 kc apart and to remain so as C1 and C2 are tuned with the main dial. Keeping the two circuits aligned over the entire dial presents a problem, and adjustments dealing with this are a part of the alignment procedure called *tracking*. Alignment is discussed in Chapter 6.

The circuit in part A of Fig. 2-16 shows a popular type of grid connection to the oscillator coil L1. The little coil above the tapped tank coil is called a *capacitor link*. It is actually not used as a coil, but serves the function of a capacitor between the grid of the tube and the main tank coil. The little coil has only one end exposed as a terminal with the other end being hidden inside. One can see the problems confronting the unsuspecting technician who uses his ohmmeter to test for continuity from the grid terminal of the coil to ground.

To complicate matters, the alternate connections shown in parts B and C are used frequently, and in this case there should be continuity from the grid terminal to ground. With this type, a grid blocking capacitor C5 will be soldered in the circuit. Both types of coils have four external solder terminals, and a careful examination with the ohmmeter and reference to the schematic drawing is necessary to determine a failure in the oscillator coil.

Universal replacement-type coils (part D) are a combination of both types and have six solder terminals so that they can be used in either circuit. This type of replacement is also equipped with an adjustable core to aid in the tracking alignment.

This circuit will be referred to again in Chapter 4, where measurement of grid-leak bias voltage is used as a key test point to indicate the presence or absence of the oscillator signal in those cases where a receiver will not tune in any stations, but does pick up noise.

THE INTERMEDIATE-FREQUENCY AMPLIFIER

The output from the mixer/osc stage is developed as a voltage in the first IF transformer at 455 kc. The secondary of

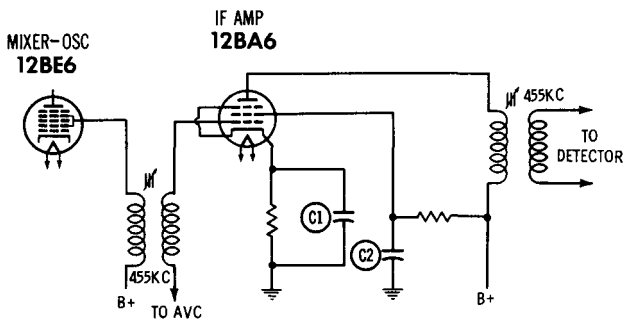

Fig. 2-17. A typical IF-amplifier circuit.

this transformer is the grid circuit of the IF amplifier, as shown in Fig. 2-17, and is practically standard in every radio. From the standpoint of servicing, it is the simplest and most trouble-free of the five stages in the receiver.

As mentioned in the section on the mixer/osc stage, the advantage of the superheterodyne is that the major amplification can take place in a stage designed for maximum efficiency and operating at only one frequency.

Because its input and output are tuned to the same frequency and the stage has fairly high gain, there is occasionally a tendency for oscillation to occur through mutual coupling between the plate and grid. A well-shielded tube is used, and the input and output wiring are kept separated under the chassis. Some receivers use a small metal shield under the chassis to isolate the input circuit from the output circuit. Technicians often slightly detune one of the transformers in order to reduce the tendency of the stage to oscillate. This does not seem to impair the overall gain of the receiver seriously, and often will improve the fidelity by broadening the total bandwidth of the stage.

The screen-grid bypass capacitor, C2, is quite important in keeping the gain high and preventing oscillation. It may seem to be missing from some circuits but, in these cases, it will be found that the screen grid is returned directly to the power supply and that the output filter capacitor there serves the purpose.

THE DIODE DETECTOR CIRCUIT

A few facts about the transmission of AM radio signals are needed in order to understand the operation of the detector. When an RF amplifier in a transmitter is amplitude modulated with an audio frequency, two additional signals are produced. They are called the *upper* and *lower sidebands*. The upper sideband will have a frequency which is the sum of the main transmitter carrier and the audio frequency, and the frequency of the lower sideband will be the difference between the two.

As an example, suppose WGN in Chicago, which operates on 720 kc, is modulated with a 2000-cycle audio note. Fig. 2-18 shows that the total bandwidth of the signal will be 4000 cycles (or 4 kc). Also, from the diagram it can be seen that the orig-

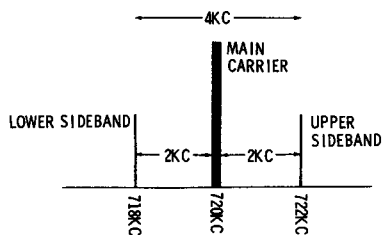

Fig. 2-18. Sidebands produced by modulating a 720-kc carrier with a 2000-cps note.

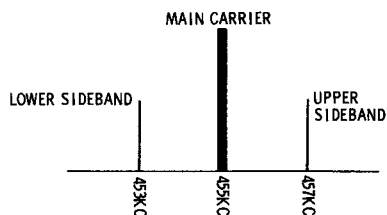

Fig. 2-19. The sidebands are reversed in the conversion process.

inal audio tone, 2000 cycles, is represented by the distance between the carrier and either sideband.

All these signals will pass through the tuner and each will be converted to an IF frequency, as explained earlier in this chapter. If the main carrier is converted to 455 kc, the sidebands will be converted to 457 kc and 453 kc, respectively. The upper and lower sidebands are now reversed by the conversion process, as shown in Fig. 2-19. Note that the original audio (2 kc) is still represented by the distance between the carrier and either sideband.

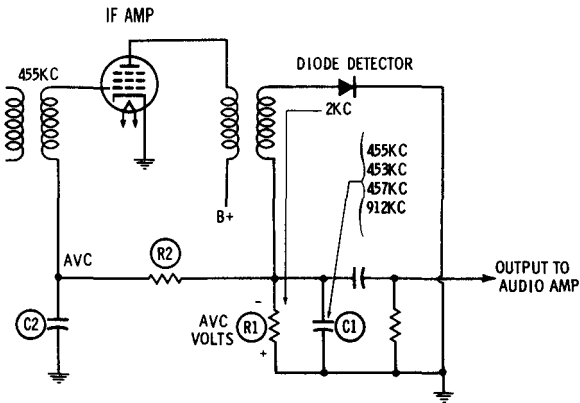

Fig. 2-20. A diode detector circuit.

The three signals enter the diode detector, Fig. 2-20, which is simply a half-wave rectifier and filter. The reactance of capacitor C1 across load resistor R1 is very low for frequencies in the range of 400 kc to 500 kc. Thus, the load resistor is shorted out for currents at these frequencies. There is practically no output voltage produced for input currents above 400 kc.

In the detector circuit, the sidebands will combine with the main carrier to produce two beat frequencies which are the sum and difference. Using the upper sideband and the carrier, this gives:

$$\text{Sum: } 455 + 457 = 912 \text{ kc}$$

$$\text{Difference: } 457 - 455 = 2 \text{ kc}$$

The sum (912 kc) is shorted around the load resistor through C1, but the reactance of C1 at 2000 cps is quite high, and the beat frequency develops an output voltage across R1. In this manner, the difference frequency between the upper sideband

and the carrier, which is the original audio signal, is produced at the output of the detector. The same action occurs between the lower sideband and the carrier and produces the same beat frequency equal to 2000 cps.

AVC Voltage

The current flowing through R1, the detector load resistor, produces a voltage at the top which is negative with respect to ground. Furthermore, this voltage will vary as the strength of the incoming signal changes, becoming more negative for stronger signals. This negative voltage is fed back to the grids of the IF and mixer stages and gives an automatic increase in negative grid bias when the incoming signal is strong. The increase in bias reduces the output signal from these stages, preventing a sudden burst of sound from the speaker when a strong station is tuned in. This *automatic volume control* (AVC) has the additional advantage of removing all bias from the controlled stages when no signal is present, thus making the receiver most sensitive when it is tuned between stations. In this way, weaker stations are not overlooked when tuning across the dial.

Resistor R2 and capacitor C2 comprise a filter to remove the audio variations from the AVC voltage. The time required for C2 to charge and discharge through R2 is very long compared to the time between cycles of the audio frequency. Thus, the voltage across C2, which is the AVC voltage, remains reasonably constant until the strength of the incoming signal changes.

The tuning capacitor across the loop antenna may be returned to ground as in Fig. 2-22 or to the AVC line as in Fig. 2-21. In Fig. 2-21, the capacitor is insulated from the chassis, usually by rubber grommets, and a breakdown of this insulation results in a shorted AVC line. It is interesting to note the very great difference in the normal ohmmeter readings to be expected across the capacitor plates.

The AVC circuit used in most home-type receivers is not too effective. More elaborate circuits are used in short-wave, FM, and auto radios. In the automatic-tuning auto radios, the AVC voltage is used to control the tuning mechanism.

The Combination Detector, AVC, and First Audio Stage

The circuit of V3 in Fig. 2-21 combines several functions into one tube, and is the circuit used in nearly every broadcast-band receiver. The 12AV6 tube contains a triode and a pair of diodes. The triode is used for the voltage amplifier, and one

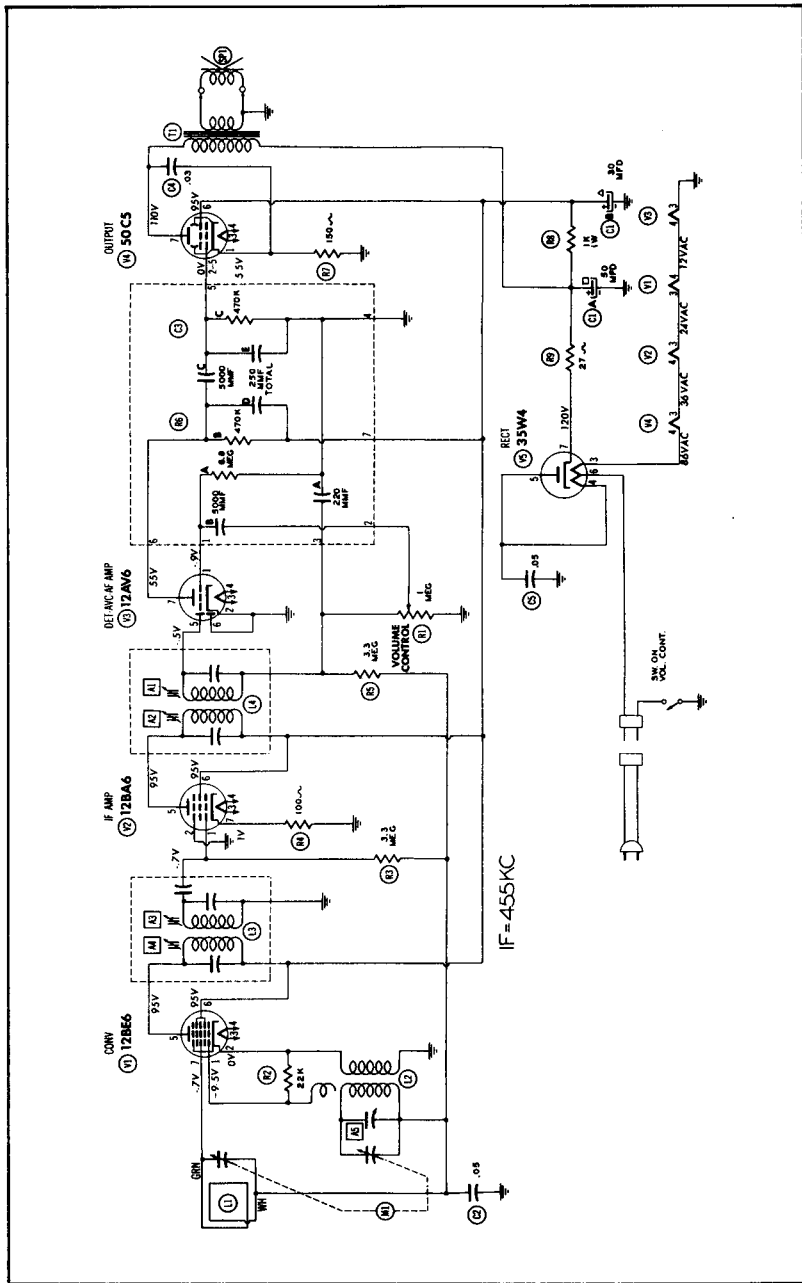

Fig. 2-21. A typical 5-tube AC/DC receiver.

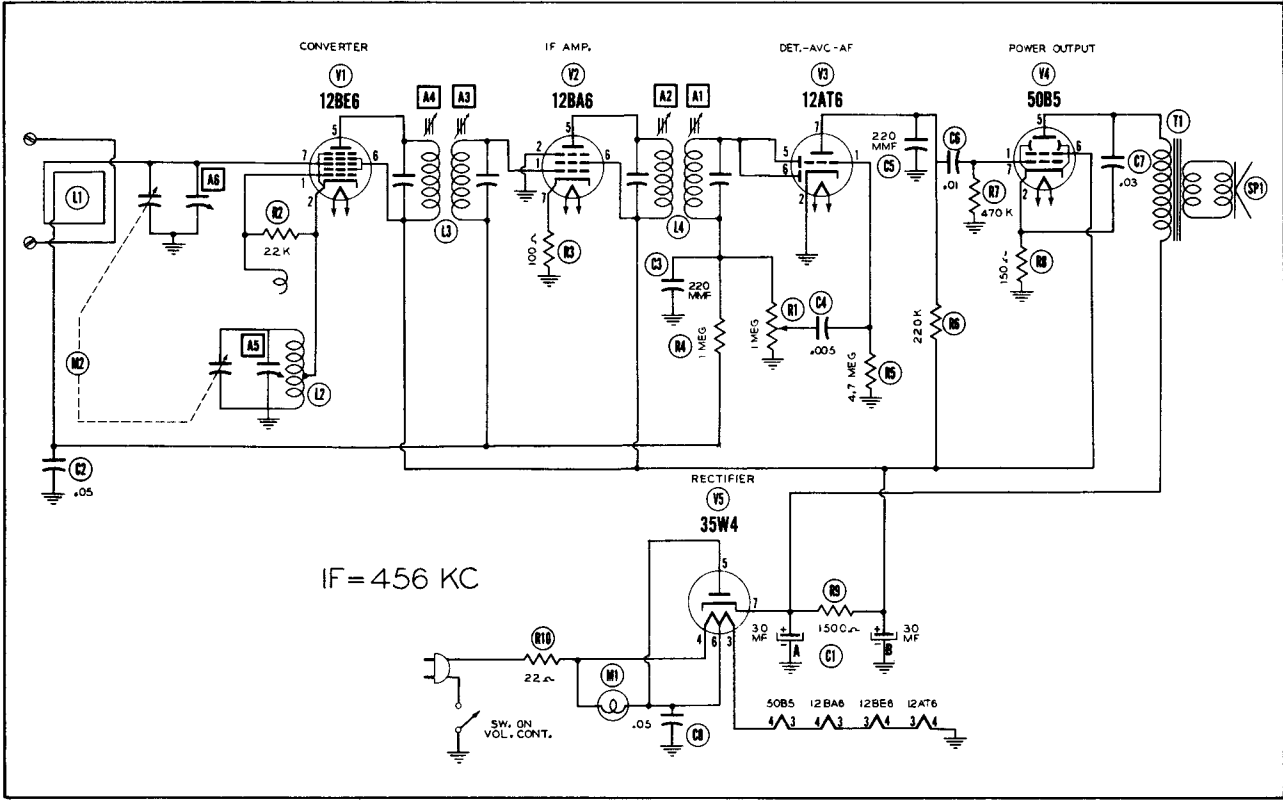
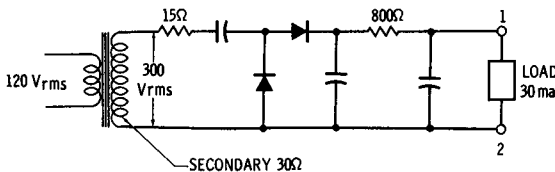

Fig. 2-22. AC/DC receiver with tuning capacitors grounded and including pilot light.

diode plate is used with the common cathode for the detector and AVC. The other diode is grounded. In Fig. 2-22, the diode plates are tied together. In other circuits, one plate is used for the detector, and one is used for AVC.

REVIEW QUESTIONS

1. List five types of power supplies, and give one advantage and one disadvantage of each.
2. In the power supply shown below, what is the approximate voltage at terminals 1 and 2 under the load conditions shown, neglecting losses in capacitors and diodes? What is the resistance of the load?



3. Draw the schematic of a full-wave bridge-type power supply using 6V3 rectifiers, and show the filament connections.
4. What dangerous condition could develop if a technician were working on two radios next to each other on the bench and both used a transformerless power supply?
5. In the circuit shown below, what is the value of the cathode resistor?

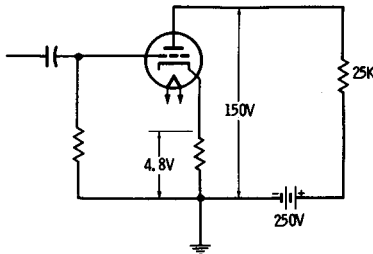

6. What would be the effect on the sound of the radio if C3 in Fig. 2-8A were open?
7. When the cathodes in a push-pull stage are returned through a common resistor, the bypass capacitor can be omitted. Why?

8. Describe the effect of the control shown in the circuit below.

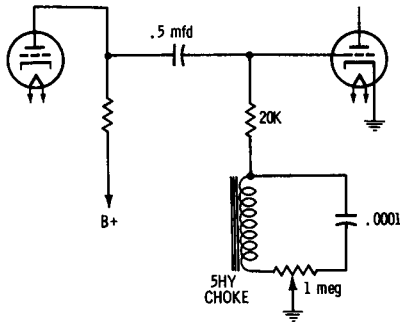

9. Draw a schematic of a universal-type replacement oscillator coil. If you were going to install such a coil, and the solder terminals had no identification, describe how you would determine which part of the coil is connected to each terminal.
10. List all the frequencies present in the detector circuit of an ordinary receiver when it is receiving a 1500-cycle audio note from the station.
11. Draw the detector circuit for Question 10, using a 1-meg load resistor and a .0001-mfd capacitor. Compute the reactance of the capacitor at each of the frequencies listed.
12. Describe two methods for preventing oscillation in an IF stage.
13. A radio using 455-kc IF stages is tuned to a station at 920 kc. What is the oscillator frequency?
14. In Fig. 2-17, what is the purpose of C2? What do you think would be the result if it were shorted?
15. What is meant by "tracking"?

3

No Signals, Audio Failure

A *no-signal* condition does not necessarily mean that there is no sound of any kind present; it means that no signals can be received from stations. There may be a quiet hum from the speaker. Noise radiated from nearby electrical devices, such as fluorescent lights, may be picked up and amplified by the receiver. The identifying conditions for this symptom are that the filaments are lit and no stations can be tuned in.

TEST POINT 1, CHART I

3-1 The block diagram in Fig. 3-1 illustrates the two main sections of a receiver—the section ahead of the volume control, operating at RF and IF frequencies, and the section after the volume control, operating at audio frequencies. The volume control is the entrance to the audio section of the receiver, and injection of a signal here will divide the receiver into its two main sections. If the injected signal is heard from the speaker, the audio section is working and the trouble must be in the RF and IF sections, which are discussed in the next chapter. If no sound results from the signal injection, then it is certain that the defect affects the audio section.

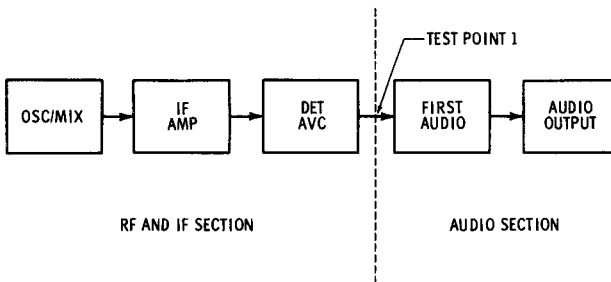

Fig. 3-1. Block diagram of a typical radio receiver.

Any audio signal of $\frac{1}{2}$ volt or more can be used for the injection at TEST POINT 1. This signal is fed to the center terminal of the volume control, which is turned for maximum volume. Many technicians use the tip of a soldering gun for a convenient source of 60-cycle buzz. A few volts of 60-cycle signal exists on the tip when the gun is on, and this is simply touched to the test point. Even touching the finger tip to the volume control will usually inject sufficient signal to make the test.

TEST POINT 2, CHART I

INJECTION OF SIGNAL AT GRID OF OUTPUT STAGE

3-2 If TEST POINT 1 produces no sound from the speaker, or very weak sound, the audio tubes should be checked, and then the testing follows the left side of the chart. The two audio stages can be divided by making a signal injection at the grid of the audio output stage. As seen on the chart at the end of this chapter, this isolates the trouble into either the audio output or the first audio amplifier. In cases where there is more than one amplifier between the detector and the output stage, the test must be repeated for each stage.

TEST POINT 3, CHART I

CAPACITOR FROM PLATE OF OUTPUT STAGE TO B-

3-3 If no sound is heard from TEST POINT 2, it is certain that the defect lies in the power supply or in the output stage. Next, a test is applied which isolates the grid and cathode circuits of the output stage from the other suspects. Fig. 3-2 illustrates the method used.

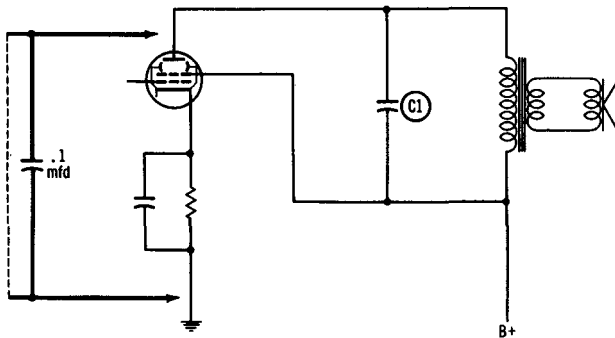

Fig. 3-2. Method used for TEST POINT 3.

The plate can be shorted directly (using a clip lead) if it is done carefully, because the resistance of the transformer limits the current. When the plate is momentarily shorted, either through a capacitor or directly, a "pop" will be heard in the speaker if all the following components are functioning properly.

1. The power supply.
2. The output transformer.
3. The bypass capacitor C1.
4. The speaker.

The explanation of the popping sound heard from the speaker lies in the fact that the uncharged capacitor represents a short circuit for an instant when it is connected. When a wire jumper is used, the "pop" sound is louder. B- is then briefly connected to the top end of the primary winding of the transformer. With B+ on the other end, a large surge of current flows through the primary, creating a magnetic field and inducing current in the secondary speaker. If the output transformer or the speaker has failed, no sound will be heard. Likewise, no sound will be produced if the power supply has failed. If C1 is shorted, the surge current will pass through it and not through the primary, and no sound will be produced.

The test capacitor should be discharged by shorting the leads together when it is removed, in order to avoid the possibility of accidentally discharging it through the technician's fingers, and also because it must be discharged if the test is to be repeated.

TEST POINT 4, CHART I

WHEN A "POP" IS HEARD

3-4 With the knowledge gained from TEST POINT 3, and knowing the tube to be good, the grid and cathode circuits are the only remaining possibilities. Failure in the cathode is more frequent, so this is checked first. TEST POINT 4 uses a clip lead to short the cathode to ground. The cathode resistor can also be checked with an ohmmeter, but this takes more time. Technicians frequently short the cathode pin to the chassis with a screwdriver when the chassis is at B-. Failure of the cathode resistor is common, but many times it is not necessary to make any test at this point because the burned-out condition of the resistor is obvious to the eye. However, the importance of making the test is emphasized whenever there is any doubt about the condition of this resistor. If the

resistor is open, signals will be restored when the cathode is grounded.

3-5 Another important point in connection with measurements at cathodes was mentioned in Chapter 1. This is that voltage measurements here can be misleading because the tube may draw current through the voltmeter, giving a reading which can appear like correct cathode voltage.

The cathode capacitor does not need to be checked in the symptom of *NO SIGNALS*, since a shorted unit still completes the cathode connection to B- and will not disable the stage, and an open unit causes only a slight loss of gain in the stage.

Under TEST POINT 4, the cathode resistor is listed as the cause if sound results from shorting the cathode pin of the tube to B-.

Procedure When No Sound Results From TEST POINT 4, CHART I

3-6 No sound when the cathode of the output stage is grounded isolates the defect to the grid circuit. The resistance

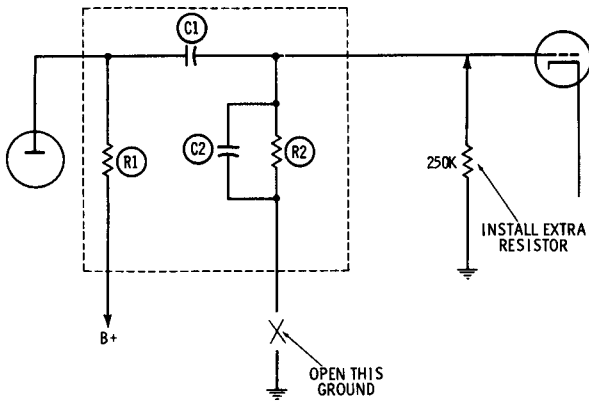

Fig. 3-3. Temporary repair of an encapsulated unit.

from the grid pin of the tube to B- should be checked. It is normally between 250K and 1 meg. Since the grid resistor may be part of an encapsulated electronic circuit, its exact value may not be obvious, and reference must be made to the schematic if replacement is necessary.

Temporary repairs on encapsulated units can sometimes be made in the manner shown in Fig. 3-3 if only R2 or C2 has failed. If the internal connections between the components or to the external terminals are open, then the entire unit must be replaced. If there is enough space on the chassis, some tech-

nicians will install individual parts in place of the unit, rather than waiting until the replacement can be obtained.

Procedure When No Sound Is Heard at TEST POINT 3, CHART I

3-7 Going back to the test with the capacitor from the plate to B-, and assuming this does not produce a "pop" from the speaker, the analysis then continues on the left side of the line under TEST POINT 3.

TEST POINT 5, CHART I

SCREEN VOLTAGE MEASUREMENT

3-8 In most receivers, the screen grid of the audio output is connected directly to B+, and measuring the screen-grid voltage provides a convenient check on the power supply. If the screen voltage is missing or very low, it is clear that the trouble is in the power supply.

In Chapter 2 the symptom DEAD RECEIVER was discussed, and several of the tests used in the power supply were described. In the case of NO SIGNALS where the filaments are all glowing, the testing is simpler. TEST POINT 6 is used to isolate the failure to the AC input circuit or the DC filter.

TEST POINT 6, CHART I

RECTIFIER CATHODE VOLTAGE MEASUREMENT

3-9 In this test, the voltmeter is connected to the cathode of the rectifier where the source of B+ can be measured. If a normal reading is found here, the defect lies between this cathode and the screen grid of the audio output. The circuit can be checked for continuity by simply moving the voltmeter probe across each component in series until the voltage disappears. See Fig. 3-4.

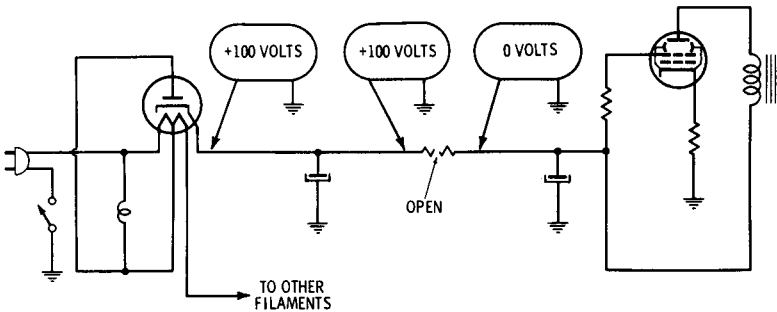

Fig. 3-4. Using a voltmeter to check for continuity in the B+ line.

Procedure When the Voltage at the Rectifier Cathode Is Missing

3-10 Voltage missing at the rectifier cathode indicates a failure in the AC input circuit or in the rectifier itself. In transformer-powered receivers in which the filaments are lit, the high-voltage secondary is the only part of the AC input circuit which could have failed. It is also most probable that the failure is in the form of an open winding, so it is simple to check from the plate pins of the rectifier socket to B- for continuity with an ohmmeter. Normal windings will show resistance less than 200 ohms.

Checking the AC-input portion of the power supply in transformerless models in which the filaments are lit is also a simple matter. The ohmmeter is used to check for continuity from the rectifier plate to the AC line plug.

Necessary Tests Before Replacing a Defective Rectifier

With no DC voltage at the rectifier cathode, and the AC-input section of the power supply checked out, the defect is isolated to the rectifier itself. But the experienced technician does not jump to the conclusion that only the rectifier has failed. It is possible that some other component associated with the B+ in the receiver is shorted and has caused the rectifier to fail.

Rectifier tubes can be checked on a tube tester if necessary. Silicon and selenium units can be checked with an ohmmeter by reversing the probes after the first reading and comparing the two resistances, but with larger units this test may be unreliable. The actual value of the resistance readings depends on the amount of voltage supplied by the ohmmeter and is not of much importance in determining the true condition of semiconductors. Direct substitution with a good unit is recommended for silicons and seleniums whose peak inverse voltage is 100V or more.

A check should be made of the resistance from the positive side of the filter capacitors to B- before a new rectifier is installed. The familiar "capacitive action" should be seen on the ohmmeter. This is where the meter initially swings to a low value of resistance and then slowly rises to a value of 25K or more if the components are normal. If normal resistance is found, it is safe to install the new rectifier and the surge resistor if necessary.

A low resistance at this point usually indicates a shorted filter capacitor which must be replaced before the new recti-

fier is installed. The defective capacitor can be isolated by disconnecting them one at a time and rechecking the resistance after each is removed from the circuit. When one of the capacitors in a multiple unit is defective, it is always best to replace the entire unit.

If no shorted filter capacitor is found, the low resistance may be due to a short located somewhere in the receiver circuitry beyond the power supply, and this calls for a more extensive analysis with the ohmmeter.

When a choke is used in the filter network, an ohmmeter check should be made of it to determine if the windings have shorted to the frame. To find a component shorted from B+ to ground in the receiver circuitry, several methods are used. One way is to check the schematic for the presence of capacitors connected between the B+ line and B-, with no large resistance in series. There will be only a few such components, and each can be checked by unsoldering one end and measuring the resistance again from the positive side of the filters to B-.

Another method is to unsolder all the connections at the positive terminal of the output filter capacitor and measure the resistance of each lead to ground. One of the leads will show low resistance, and the technician knows that the faulty part is connected to this line. If tracing this line through the chassis leads to another terminal having multiple connections, this junction must be completely unsoldered and each lead checked with the ohmmeter as before.

Tests Made When Screen Voltage Is Present at TEST POINT 5

3-11 When screen voltage is present and no sound results from placing a capacitor from the plate to B-, the steps to take are shown on the right side of CHART I under TEST POINT 5. The power supply is working, and the cathode circuit is probably intact, because if an open cathode had been the cause of NO SIGNALS, then a "pop" would have been heard when the capacitor was used. With B+ present, the capacitor will produce a noise whenever the speaker and transformer are operative, regardless of the condition of the rest of the circuit.

TEST POINT 7, CHART I

PLATE-VOLTAGE MEASUREMENT

3-12 The screen-voltage measurement confirms the presence of B+ and leaves only the output transformer, speaker, and plate bypass capacitor as suspects. The presence of plate volt-

age shows that the primary of the transformer has continuity, and attention is immediately turned to the plate bypass capacitor and speaker, as shown on the right side of CHART I under TEST POINT 7.

The easiest way to check for a shorted bypass capacitor is to unsolder one end and operate the receiver. If the capacitor is shorted, sound will reappear—if it is not shorted, there will still be no sound.

The speaker can be checked with an ohmmeter in the manner illustrated in Fig. 3-5. Open the connection between one

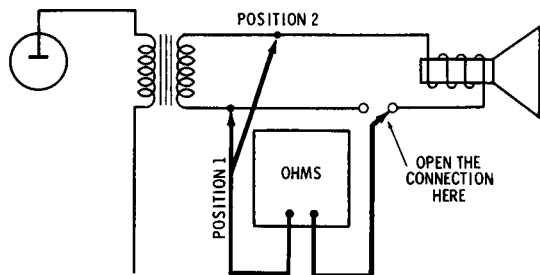

Fig. 3-5. Checking the speaker.

side of the speaker voice coil and the transformer, and connect a probe of the ohmmeter to the voice coil. Connect the other meter probe to the point from which the speaker lead was removed. With the ohmmeter set on the lowest scale, a click will be heard in the speaker if there is continuity throughout the circuit. If a click is not heard, the probe on the speaker lead should be moved to Position 2, as shown in the drawing, and a new test made. If there is still no continuity, the speaker voice coil is open. If there is continuity, then an open secondary winding in the transformer caused no continuity from the first position of the probe.

3-13 If plate voltage is missing and screen voltage present, then the reason for the negative results at TEST POINT 3 is obviously an open primary of the transformer. This should be checked with an ohmmeter. If open, it must be replaced.

TEST POINT 8, CHART I

SOUND RESULTING FROM SIGNAL INJECTION INTO GRID OF AUDIO OUTPUT STAGE

3-14 When sound results from injection of a signal at the grid of the audio output stage, it is clear that the fault is in the earlier stages. The analysis for this situation is diagramed

on the right side of CHART I. TEST POINT 8, injection of the test signal on the plate side of the grid coupling capacitor, will reveal the condition of this capacitor. If no sound is heard, the capacitor is probably open, and a new one should be tried.

3-15 In certain circuits, a shorted plate bypass capacitor in the first audio stages will cause the same results. This is also shown on the chart. Instead of checking the capacitor, the plate voltage of the stage can be measured to ascertain the shorted condition.

TEST POINT 9, CHART I

SOUND RESULTING FROM TEST POINT 8

3-16 This condition clearly points to a failure in the first audio stage, and measurement of the plate voltage here will locate faults in the plate circuit. The components which can affect the plate voltage are shown at the left under the heading MISSING PLATE VOLTAGE. The technician expects this voltage to be considerably lower than the other plate voltages in the receiver because of the large plate-load resistor. This was explained in Chapter 2. Also, the technician will be suspicious if an unusually high voltage or a negative voltage is found here, because this will indicate that no plate current is flowing through the tube. In this case, the analysis moves on to TEST POINT 10, in the lower right corner of CHART I.

TEST POINT 10, CHART I

SHORT CATHODE TO GROUND

3-17 This is the same test as applied in the audio output stage but, in this case, there may not be a cathode resistor. Nevertheless, the test should be made, since it is still possible that the connection from the cathode to ground is broken, especially with so-called printed wiring. A clip lead should be used and the cathode pin connected to B-.

If sound results from this test, the repairs are simple. If no sound results, the defect is isolated to the grid circuit of the first audio stage. The resistance from grid to ground should be measured, remembering that it should be several megohms. The coupling capacitor between the grid and the center tap of the volume control should be substituted. In the case of printed wiring, the continuity of the connections should be checked with the ohmmeter. An ohmmeter check of printed wiring is recommended in all cases where a large component, particularly a control mounted on the printed board, is involved.

Service Chart 1: No Signals, Audio Failure.

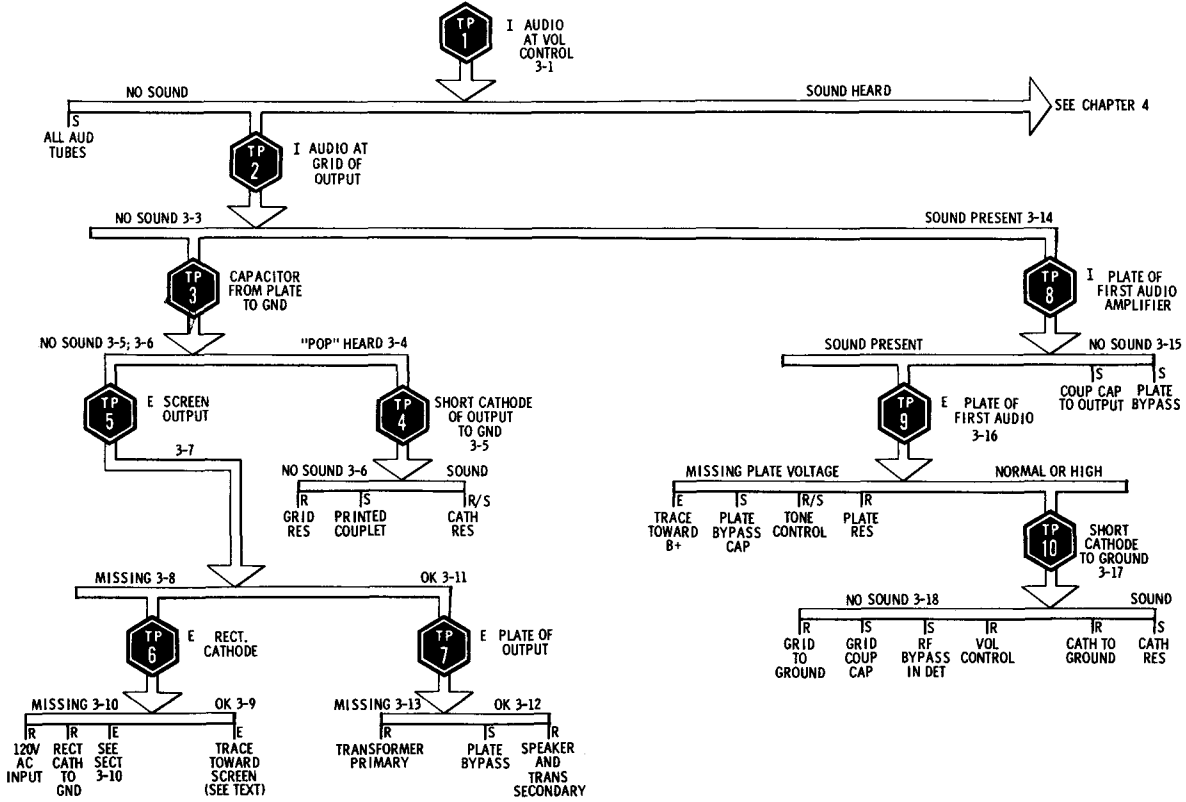

The RF bypass capacitor is the one in the detector circuit which shunts the detector load resistor, or the volume control. A shorted unit here results in a condition in which the volume is very low at both ends of the volume control, but when the control is at the center, stations may be heard weakly. This is a distinctive symptom, and recognizing it at the beginning may save much time.

REVIEW QUESTIONS

1. Obtain a receiver which is working normally and short across the volume control. Explain the reason why stations are heard only when the control is set in the middle. What defect is simulated by the short?
2. Why is it not good practice to immediately install a new rectifier when one is found defective?
3. What would be the symptom if C2 in Fig. 3-6 were shorted? What would be the symptom if it were open?
4. Under what conditions could C3 in Fig. 3-6 prevent a signal from being injected at TEST POINT 8?
5. What additions should be made to the right side of SERV-ICING CHART I to cover push-pull stages?

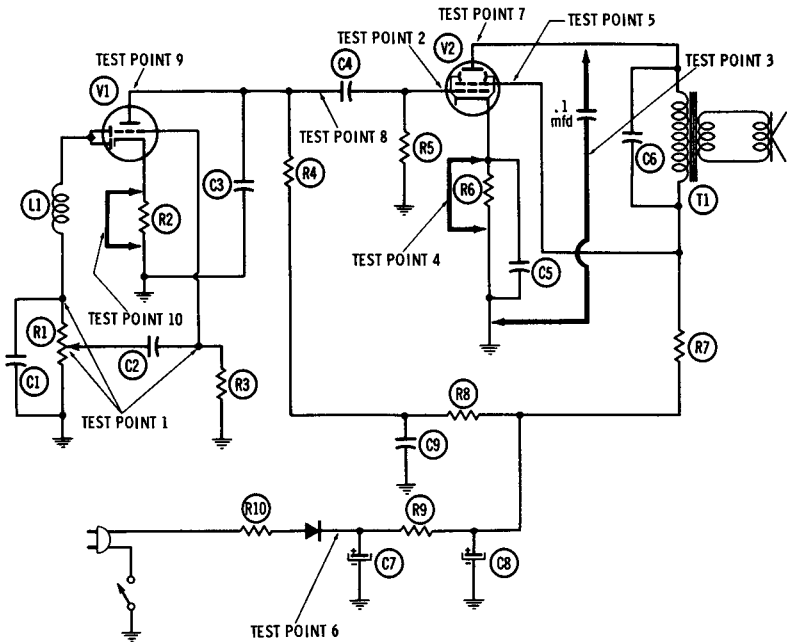

Fig. 3-6. Test points in audio section and power supply.

6. The following tests were performed on a receiver with the NO SIGNALS symptoms:

1. Audio injected at TEST POINT 1 produced no sound.
2. Audio injected at TEST POINT 2 produced no sound.
3. TEST POINT 5 showed zero volts.
4. TEST POINT 6 showed 100 volts.

State one component in Fig. 3-6 which could be defective, and describe the tests you would make to find it.

7. A receiver has the NO SIGNALS symptom, and when the technician placed a capacitor from the plate of the output tube to ground, there was no noise in the speaker. List all the parts which could have failed.
8. Look up the schematic of an amplifier which uses resistance coupling into a push-pull output stage. Describe the symptom and the test necessary to identify a faulty component which does not appear in SERVICING CHART I or in Fig. 3-5.
9. Name four components in Fig. 3-6 which, if they were open, would not affect any DC voltages.
10. Several components in Fig. 3-6 are not mentioned on SERVICING CHART I. List as many as you can find.
11. Select one of the components in your list in Question 10, and describe the symptom and all the tests necessary to find it.
12. If C6 in Fig. 3-6 were shorted, list in the proper order all the tests and the results of each necessary to locate it.
13. A receiver has the NO SIGNALS symptom and the technician performed the following tests in this order:
 1. Audio injected into the center of the volume control produced no sound.
 2. Audio injected into the grid of the output stage produced no sound.
 3. Plate voltage on the output stage measured 0 volts.
 4. Cathode voltage on the rectifier measured 100 volts.
 5. C7 and C8 were checked with an ohmmeter and found to be 50K.
 6. R9 measured 1500 ohms, which was correct.

The technician was stumped because he had not followed a logical procedure. What mistakes did he make?

14. What is the next test you would make after finding 15 volts on the plate of V1 in Fig. 3-6?
15. Draw a circuit of an audio voltage amplifier with a tone control, and explain how a component in the tone-control circuit could cause a NO SIGNAL condition.

4

No Signals, RF or IF Failure

4-1 In this chapter we will be dealing with those sections of the receiver which handle the signal before it reaches the detector. It will be assumed that the audio stages are working. This is verified by the results of TEST POINT 1— injection of audio at the volume control—which will produce normal sound from the speaker. When no sound results from this test, SERVICING CHART II at the end of this chapter refers to Chapter 3.

TEST POINT 2, CHART II

MEASUREMENT OF OSCILLATOR GRID VOLTAGE

4-2 After it has been established at TEST POINT 1 that the audio section is working, the analysis shown on Chart II moves at once to a measurement of the oscillator grid voltage. This test isolates the trouble to either the RF or IF sections of the receiver. If a negative voltage is found at the oscillator grid, it is probable the the oscillator section is operating, and further tests are confined to the mixer and IF stages. If no grid voltage is present, all further testing will be in the oscillator circuit.

The reason for the negative voltage on the grid of oscillators can be understood from a study of Fig. 4-1. Two common forms are shown in parts A and B. Part C is a drawing of an equivalent circuit which shows the action of the oscillator. When a positive voltage is first applied to the plate, there is no voltage on the grid, and current starts to flow from the cathode to the plate. L1 and L2 are close to each other and are so wound that electrons passing through L1 induce a voltage across L2 with a plus polarity at the top. This is the same as a positive signal voltage applied to the grid of the tube and, therefore, the current increases. Increasing current through L1 increases the positive voltage applied to the grid, and the process continues.

This action of taking a small amount of the plate or cathode signal and feeding it back to the grid in such a way as to increase the current through the tube is called *regeneration*. Every oscillator depends on regeneration to drive its grid. If the process were to continue indefinitely, the tube would be ruined because the cathode current would increase beyond the power capability of the tube.

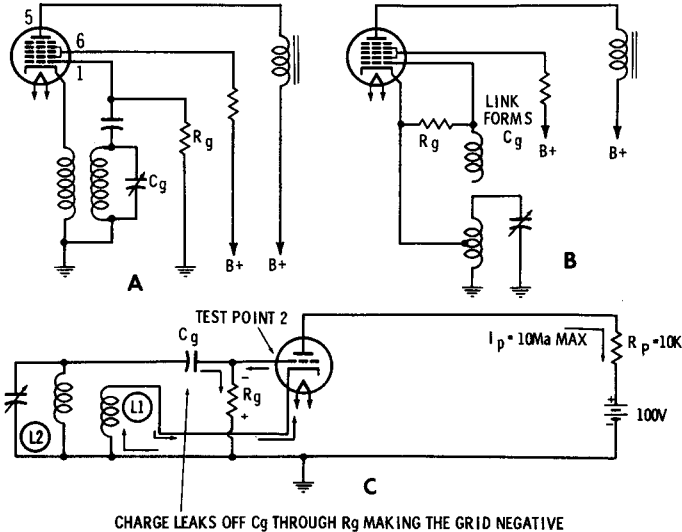

Fig. 4-1. Typical oscillator circuits.

But the action does not reach this limit because of the drop across the plate resistor, R_p . In Fig. 4-1, if the plate current reaches 10 ma, the voltage drop across R_p is 100 volts, and no voltage is left to appear between the plate and cathode. Thus, 10 ma is the limit of plate current before the action stops. In practice, the current levels off at some point below 10 ma where the remaining plate voltage is just large enough to keep it going.

During the time when plate current is rising, another action is taking place. The grid has been carrying a positive charge and has been attracting a small number of the electrons released from the cathode. These come out of the tube through the grid connection and are stored on C_g . By the time the plate current levels off, a charge of several volts will be present on C_g .

With no further change in current through L1, the induced voltage across L2 disappears, and this releases the electrons

stored on C_g . These electrons leak down through R_g , creating a negative voltage on the grid of the tube. This voltage cuts off all current through the tube until the charge on C_g is reduced, and the cycle begins again.

As successive cycles repeat, a residual DC voltage is left across R_g , and it is this voltage which is measured to give proof of oscillator operation. Any failure in the oscillator will result in no DC grid-leak voltage across R_g . Two precautions are necessary in taking this voltage measurement. (1) The internal resistance of the voltmeter connected between the grid and cathode of an oscillator can change the circuit sufficiently to stop oscillator action. (2) Some circuits use a small fixed DC voltage between the grid and cathode which could be mistaken for oscillator grid-leak voltage.

The first difficulty is overcome by isolating the meter with a 1-meg resistor fastened to the end of the probe. Some technicians insert a $\frac{1}{4}$ -watt resistor into the probe and solder the test lead to it so that the resistor is in series between the end of the probe and the test-lead wire.

Experienced technicians use a simple trick to avoid the second difficulty. When a negative voltage is found on an oscillator grid, the finger tip is touched to the metal end of the probe. If the voltage is true oscillator grid-leak voltage, it will drop to almost zero when the probe is touched, because the circuit action is destroyed by the application of the finger. If the voltage does not drop considerably, it was not really grid-leak voltage, and it is safe to assume that the oscillator is not running.

An exception occurs in rare cases. The oscillator may be operating, but it may still be the cause of the no-signal condition because it is running at the wrong frequency. When this happens, the technician should return to an examination of the oscillator coil and tuning capacitors after TEST POINT 4.

TEST POINT 3, CHART II

OSCILLATOR GRID VOLTAGE IS MISSING

4-3 After it has been established that the oscillator has failed, a new tube should be substituted. A substitution is recommended instead of testing the tube, because the tube tester does not check the tube in its true operating condition. Oscillator tubes can fail in ways which are not shown on the tube checker.

4-4 When the new tube does not restore operation, the voltage at the oscillator anode is checked. This is actually the

screen grid of the tube and is composed of the two grids which are tied together within the tube. It is pin 6 on the popular 12BE6. This is a more important measurement than the plate voltage in the case of oscillator failure. This is because many circuits will continue to oscillate if the plate voltage is missing, but the screen voltage must be present in all circuits for the oscillator to operate. 60 to 100 volts is expected at this point.

Under TEST POINT 3 on SERVICING CHART II is the notation "Trace toward B+." The voltmeter is moved across each component, following the line toward B+, until a voltage is found. The defective component will be the preceding one in the line. Fig. 4-2 shows some possibilities and the readings which will be found with the voltmeter.

Further Tests If Oscillator Anode Voltage Is Present

4-5 The series of tests to make is shown on the right side of the line under TEST POINT 3. They are listed from left to right, starting with the most frequent cause. The chart indicates that first a check should be made for plate voltage on the tube. Absence of this potential will stop the oscillator and, in this case, the other tests will not be necessary.

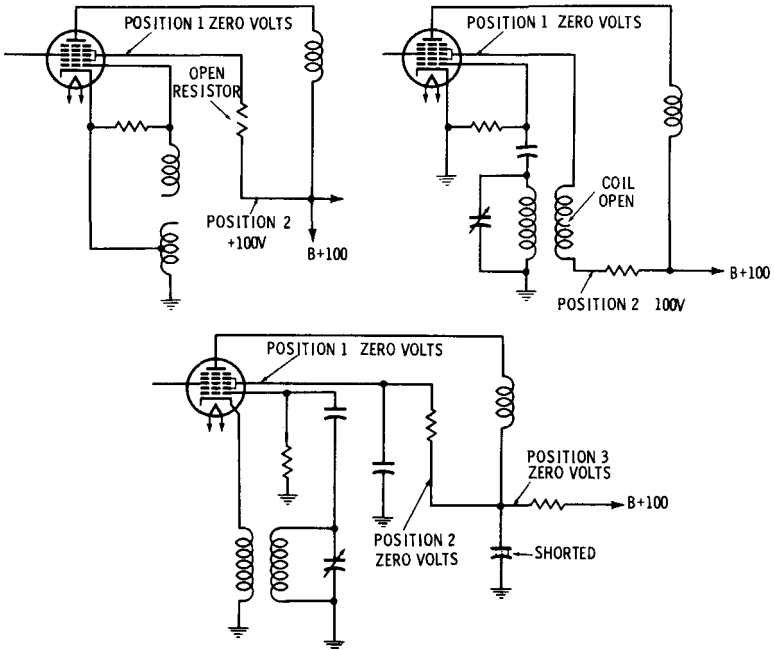

Fig. 4-2. Possible causes of loss of oscillator plate voltage.

When the plate voltage is present, the technician should make ohmmeter checks of the oscillator coil, and from the cathode pin to ground. The grid capacitor and resistor seldom fail, but they should not be overlooked when all other parts seem good.

Although it is not shown on the chart, a receiver occasionally has oscillator failure because of shorted plates in the oscillator section of the main tuning capacitor. This is usually apparent upon examination of the unit, but it can be checked with an ohmmeter if the lead to the oscillator coil is first unsoldered from the stator plates.

The little screwdriver-adjusted trimmers on the side of the tuning capacitor have also been known to short. The movable plate on these capacitors is insulated from the body of the main unit by a thin piece of mica. Sometimes this insulation is missing and the two parts of the trimmer are touching, which shorts out the entire tuning capacitor. The location of this particular fault is difficult because it requires the use of all the logical and systematic tests we have been discussing, in addition to the practical know-how required in remembering to disconnect the leads to the coils before using the ohmmeter.

TEST POINT 4, CHART II

OSCILLATOR GRID VOLTAGE IS PRESENT

4-6 The presence of the grid-leak voltage in the oscillator leads to the conclusion that the *NO-SIGNAL* symptom was due to a failure in either the mixer, IF, or detector circuit. A measurement of AVC voltage at the top of the volume control or at the AVC capacitor will confirm this. The tuning capacitor should be rotated through its range while observing the AVC voltage on the meter. There will often be a slight negative voltage on the AVC line even though no station carrier is present in the detector. If this voltage does not vary as the receiver is tuned through its range with the oscillator operating, trouble in either the mixer, IF, or detector circuit is a strong possibility.

Some technicians use a signal generator to supply a signal to the receiver while checking the AVC. The generator can be tuned to a local-station frequency and loosely coupled to the antenna. When the receiver is tuned to the generator frequency, there should be a sharp increase in negative AVC voltage if all the circuits are working.

4-7 In a few cases, the AVC voltage will respond normally even though no signal is heard from the speaker. The causes

for this are associated with some unusual circuitry in the detector circuit, such as where the volume control is not the detector load resistor, or the AVC originates from a source other than the detector load resistor. Fig. 4-3 shows some examples.

The phono switch used in some models will disconnect the detector load resistor from the input of the audio stage but will not disable the detector or AVC. When the switch is in the phono position, the AVC will be found to respond properly with no signal present in the audio stages.

Procedure When AVC Does Not Respond Normally

4-8 A few possibilities to be checked before concluding that the defect is in either the mixer, IF, or detector are:

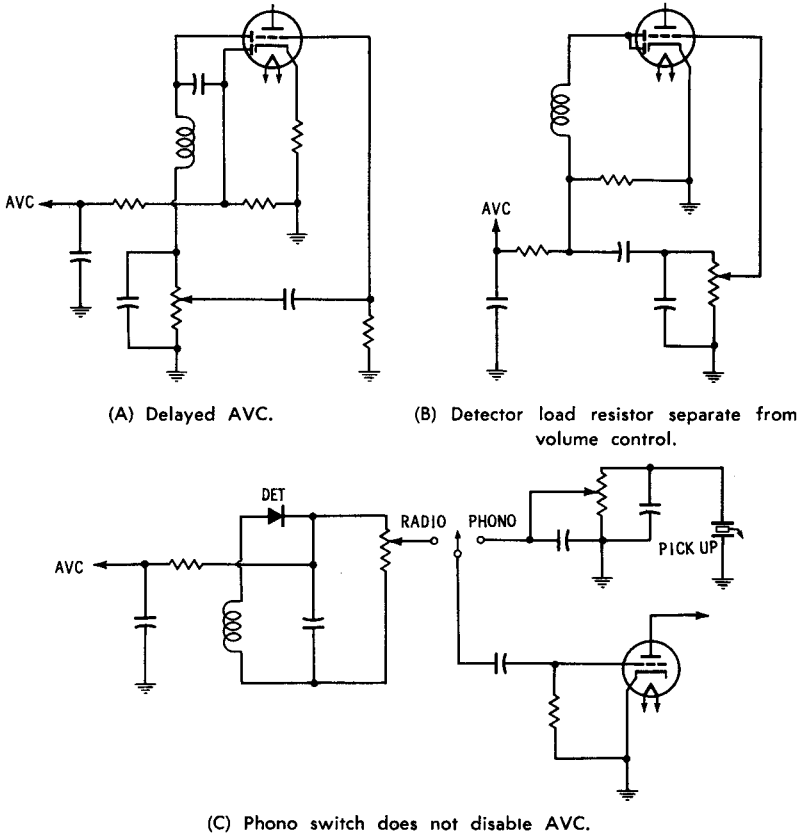

Fig. 4-3. Circuits in which AVC voltage may be normal with no signal present in the audio.

1. The mixer, IF, and detector tubes.
2. The AVC filter resistor and capacitor.
3. The loop antenna.
4. The mixer section of the main tuning capacitor.

The same unusual possibility of a shorted trimmer capacitor exists here, as with the oscillator tuning capacitor explained before. When these four possibilities have been checked, testing of the mixer, IF, and detector begins with TEST POINT 5.

TEST POINT 5, CHART II

VOLTAGE AT PLATES AND SCREENS OF MIXER AND IF

4-9 At this point several different approaches can be taken. Some technicians use a signal generator tuned to 455 kc to inject a signal into each of the suspected stages, beginning with the detector. When the modulation fails to appear in the speaker, the defective stage has been found. But this method has a disadvantage for inexperienced technicians because it is often possible to inject a strong signal into a defective stage and have the signal pass through to appear in the audio in spite of the defect. This is because of the tendency for IF and mixer stages to couple a strong signal from the input to the output through internal capacity in the stage. Also, the signal generator may lead to confusion because of the different impedances at the input and output of the stages, which cause a mismatch between the generator output and the point of signal injection. In some cases, the mismatch may produce less audio at the speaker when the signal is injected into the grid of the IF than when it is injected into the plate, and this can lead to the erroneous conclusion that the IF stage has failed.

The voltmeter gives a more positive indication of failure since most failures cause a change in one of the plate or screen voltages. So, use of the voltmeter to measure all plate and screen voltages in the IF and mixer stages is recommended at TEST POINT 5.

4-10 A missing voltage at one of these points leads to the familiar direction, "Trace toward B+," as shown on the chart. The IF-transformer primaries in the plate circuits are good suspects when plate voltage is missing. An open winding is identified with an ohmmeter check or by the presence of full B+ at one end with no voltage on the plate. The connections from the plate coil to the terminals on the bottom of the transformer are easily broken when the tuning slug sticks slightly

during alignment. Even a slight torque exerted on the slug when it is binding inside the coil form turns the entire form and breaks the connections. When the tuning slug binds, it is always best to replace the entire unit because it is likely to stick again if freed.

TEST POINT 6, CHART II

ALL PLATE AND SCREEN VOLTAGES ARE PRESENT

4-11 With plate and screen voltages present, the technician moves on to measure resistance of the cathode circuits in the IF and mixer stages. An open cathode causes very high plate and screen voltages and, frequently, the faulty stage can be located in this manner. But, when there is no large resistance in series with these tube elements, the loss of plate or screen current does not always cause an appreciable increase in the voltages. The cathode of the IF stage can be tested with a clip lead in the manner suggested in Chapter 3. This procedure is not recommended in the mixer stage, however, since the oscillator might be part of the cathode circuit and would be shorted out.

With the oscillator running and plate and screen voltages present, an open cathode in the IF amplifier is very likely. The tube should be checked before replacing the resistor because it is the only component which could cause excessive current through the resistor to burn it out. Where printed circuitry is used, breaks in the circuit board are a common cause of open cathodes.

TEST POINT 7, CHART II

CHECK OF IF TRANSFORMER SECONDARIES

The technician reaches this point after finding the following series of results from his tests:

1. Oscillator running.
2. AVC voltage missing.
3. No failure in the AVC, loop antenna, or tuning circuits.
4. All plate and screen voltages present.
5. All cathodes connected to B-.

By process of elimination, this leaves only the secondaries of the IF transformers. The testing of these units is done last.

4-12 The partial schematic of Fig. 4-4 shows one way this can be done with an ohmmeter. One lead is clipped to the detector diode (pins 5 and 6 on a 12AV6), and the other lead is

moved through the three positions shown. The resistance to be expected at each point is shown in the figure. An open or infinite reading at Position 1 means that one of the secondaries is open or that the AVC filter resistor R is open. Position 2 eliminates the input IF transformer as a possibility if the circuit is still open. Position 3 eliminates the filter resistor if the circuit is still open.

In making the foregoing analysis on a printed board it is well to consider the possibility of breaks in the wiring as a cause of the open reading before the IF transformer is replaced.

Replacing an IF transformer can be a problem even for experienced technicians because the replacement units are

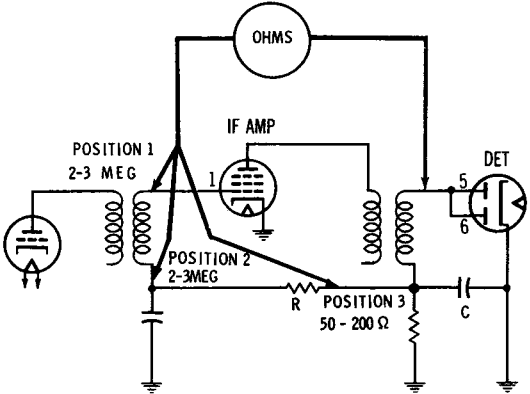

Fig. 4-4. Checking IF-transformer secondaries with an ohmmeter.

not consistent in their terminal markings. Reference should be made to the data supplied with the transformer before installation—make no assumptions. Also be sure to sketch the positions of leads as they are removed, because an error in wiring here can lead to much tiresome and wasteful rechecking of the entire analysis, or it may lead to destruction of the new transformer.

Some output IF transformers have a built-in filter network intended for circuits in which the detector RF filter capacitor is included in the transformer shield can. These units are a bit confusing because they have six terminals instead of four (see Fig. 4-5). If the original unit has only four terminals, then only terminals 1, 2, 3, and 4 and are used. If the original unit contains the filter, then either 5 or 6, or both terminals, will be used in addition to the four regular terminals.

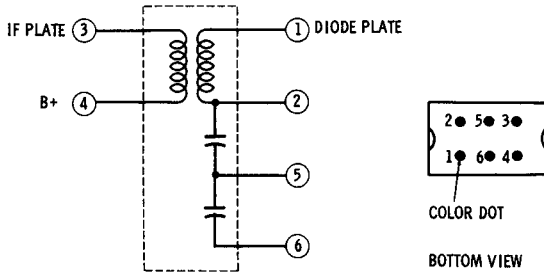

Fig. 4-5. Replacement-type output IF transformer with built-in filter network.

The RF filter capacitor in the detector, labeled C in Fig. 4-6, was described in Chapter 3 because, when it is shorted, the symptom presents a very obvious clue making it possible to skip the entire analysis and go directly to checking the capacitor. When C is shorted, the receiver will produce weak signals when the volume control is set in the middle of its range, but no signals can be heard when the control is rotated to either end.

Most replacement transformers are already factory aligned, but a slight touch-up of the tuning slugs will usually improve performance. If the circuit tends to break into oscillation, try detuning the transformer slightly. Oscillation also responds to rearrangement of the leads in the IF stage. Keep the grid lead well away from the plate lead, and at right angles to it, if possible.

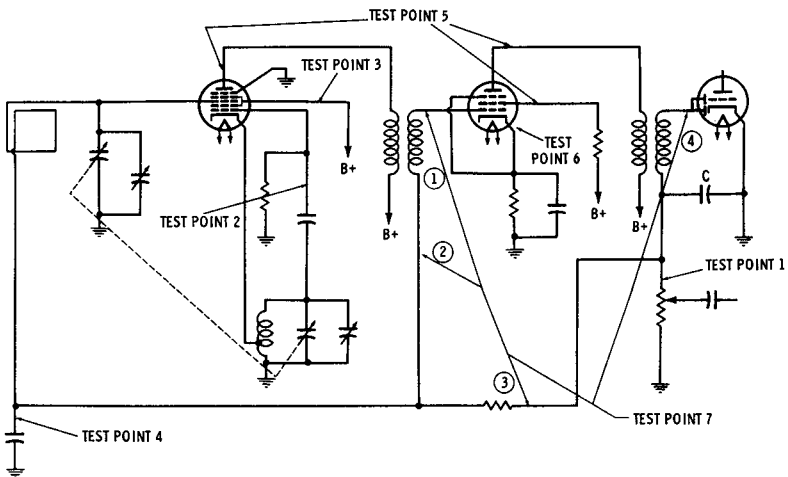
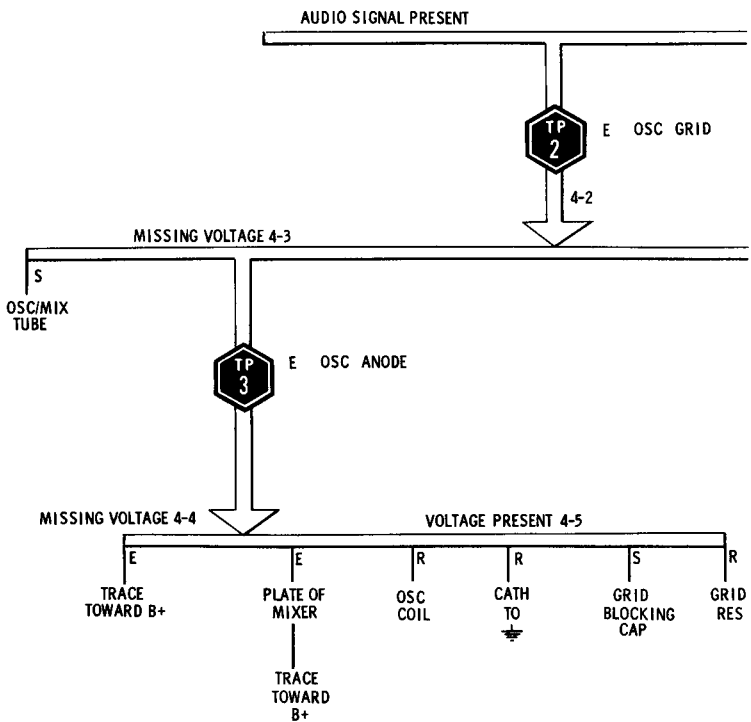

Fig. 4-6. Test points in the mixer, IF, and detector stages.

REVIEW QUESTIONS

1. What precautions are necessary when making tests at TEST POINT 2?
2. What are the components which should be checked immediately after finding no AVC voltage and before proceeding to the next test point?
3. A receiver with NO SIGNALS was found to have no grid-leak bias on the oscillator grid, but the screen-grid voltage was normal. What components would you suspect?
4. List all the steps and the results of each that would be found before concluding that the secondary of the output IF transformer was open.
5. If you are replacing an output IF transformer and find that the only replacement available has 4 terminals while the original had 6, what would you do to complete the repairs? Draw a schematic and label it with values.
6. Redraw the left side of SERVICING CHART II, beginning after TEST POINT 2, but using only a signal generator and an ohmmeter as test instruments.
7. The following series of tests and results were found in a case of no signals:
 1. Audio injected at the volume control produced signals.
 2. The oscillator grid voltage was normal.
 3. AVC voltage was -0.5 volt and did not vary.
 4. All tubes were good.
 5. There was no failure in the AVC circuit, loop antenna, or tuning capacitor.
 6. All plate and screen voltages were present.What parts would you suspect next, and how would you proceed with the testing?
8. List the results of each test point which would occur if the ground connection to the volume control were open in Fig. 4-6.
9. Look up the schematic of a receiver which uses an AVC circuit separate from the detector load resistor. How would the procedure described in this chapter be modified to take this into account?
10. What kind of defect could produce a positive AVC voltage?



Servicing Chart II: No Signals--

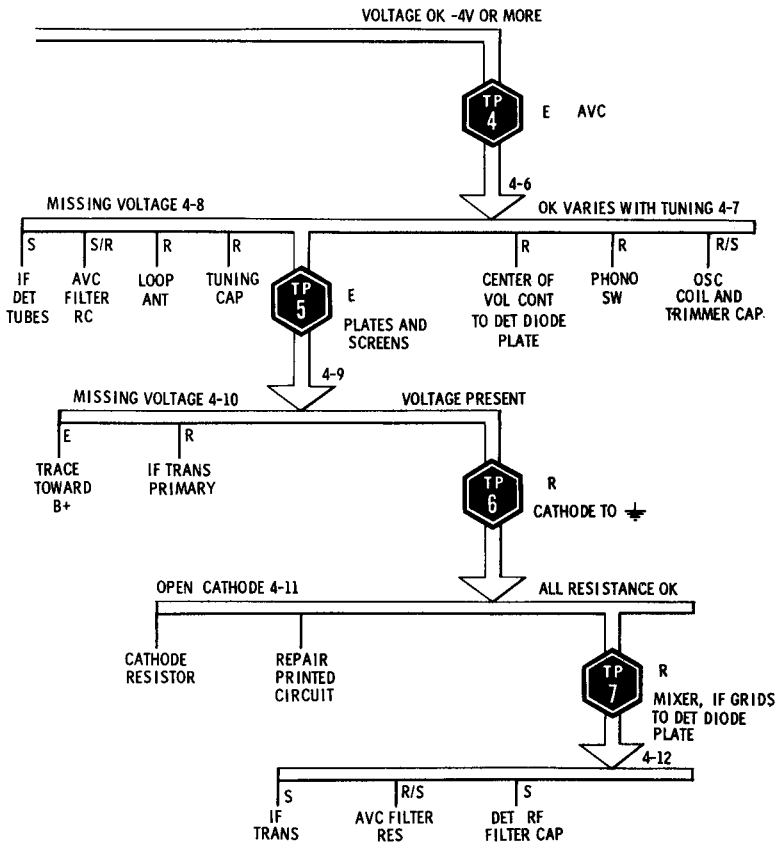

Mixer, IF, or Detector Failure.

5

Distortion

Because the term "distortion" is widely used and could mean any symptom except a completely dead receiver, the conditions referred to in this chapter will be defined as:

1. Uncontrollable 60-cycle hum.
2. Tunable hum.
3. Squeals and motorboating.
4. Rattle or mushy sound from defective speaker.
5. Audio clipping.

Each of these has a distinctive sound which the technician learns to recognize quickly, and test routines are modified accordingly.

UNCONTROLLABLE 60-CYCLE HUM

5-1 This is the most easily recognized form of distortion because it cannot be changed by any adjustment of tuning or volume control. It is nearly always due to an open filter capacitor in the power supply. In such a case, the filters can be checked very simply by shunting a good unit across them of sufficient capacitance and voltage rating. In all other cases of defective filters, it is necessary to disconnect the original unit before substitution of a new one. But in the case of uncontrollable 60-cycle hum it is clear that the capacitor is open.

SERVICING CHART III shows two other causes of uncontrollable hum which may need to be checked. Heater-to-cathode leakage in the audio output tube produces 60-cycle hum which cannot be controlled by the volume control, and this tube should be checked before the chassis is removed. The 50C5 output tube is a frequent offender in this way.

An open connection from the volume control to ground causes this symptom in rare cases. This is easily checked with the ohmmeter. The resistance from grid to ground in the out-

put stage should also be checked. The failure may be in printed wiring associated with the control, and this should not be overlooked.

TUNABLE HUM

5-2 This form of distortion differs from the preceding one in that the hum is not as loud and is present only when a station is being received. When the receiver is tuned to a quiet place on the dial, the hum disappears. In some cases, it will be present on only one or two of the stations and this sometimes leads the inexperienced technician to suspect trouble at the station as the cause.

Three common failures which cause tunable hum are shown on SERVICING CHART III. Of these three, the mixer-oscillator tube is the most frequent cause. A new tube should be substituted, rather than testing the suspected tube, because the checker may not show the defect. Heater-to-cathode leakage in the tube puts 60-cycle modulation on the oscillator signal that is generated in the cathode circuit. The 60-cycle signal is amplitude modulation of the oscillator signal and, as such, will not appear in the grid of the IF stage unless the radio is tuned to an incoming carrier so that conversion to 455 kc can take place. When a carrier is present, the 455-kc beat will contain the 60-cycle modulation from the oscillator as well as the modulation from the station.

Another, less well known, cause of tunable hum is an open line-bypass capacitor. This is the capacitor connected directly across the 120-volt AC input line in transformerless receivers. Its purpose is to bypass radio signals which are present on the electric lines, and thus prevent them from entering the receiver through the common B- line.

In some receivers, the AVC filter capacitor can cause a type of tunable hum which sounds the same as the others, but is due to audio variations in the grid-bias voltages of the mixer and IF stages.

SQUEALS AND MOTORBOATING

5-3 The sound of this symptom is unmistakable. The receiver may emit a high-pitched squeal when it is tuned through an incoming carrier, or it may produce a slow "put-put" sound between stations. There is sometimes a low-pitched growl resembling the noise of a large truck laboring under a heavy load. These sounds are the result of oscillations caused when a

signal from one part of the receiver is fed back to another and reamplified.

The oscillation may be confined to a single stage, or it may involve several stages. Technicians frequently use a simple trick to help locate the stage giving trouble. As explained in Chapter 4, oscillation always develops a negative charge in some part of the grid circuit, and this charge is affected by placing the finger on the grid pin of the tube socket. So the technician touches each grid with his finger while listening for a change in the oscillation. If no change occurs, the stage being checked is not likely to be part of the feed-back loop. Testing is therefore confined to components in stages where touching the grid affects the symptom.

Oscillation often results when the input and output transformers in an IF stage are tuned to exactly the same frequency. This is due to feedback from the plate to the grid through the internal capacity of the tube or through magnetic coupling between wires connected to the input and output circuits. When a single stage oscillates, the technician can frequently trace the trouble to displacement of the wiring during an earlier repair job.

In receivers using more than one IF stage, magnetic coupling may take place between the tubes themselves when tube shields have been removed. Although it is not as common because of the different frequencies involved, this kind of coupling can occur between the mixer stage and the IF stage.

Often a slight "touch-up" of the alignment of the IF transformers is all that is needed to subdue an oscillating IF stage. It may seem detrimental to detune the transformers away from the 455-kc IF frequency, but it should be remembered from the description of the diode detector in Chapter 2 that the stage must also pass the audio sidebands and, therefore, it was not designed to peak sharply at 455 kc. For good fidelity, the IF bandpass should range from at least 450 kc to 460 kc. So, it is not unreasonable to tune the input near 450 kc and the output close to 460 kc. The tendency for oscillation is greatly reduced when the input and output transformers are tuned to slightly different frequencies.

The above procedure applies only to ordinary broadcast-band receivers and should not be attempted on communications receivers designed with very sharp IF response. In these receivers, the shielding is much better, and oscillation is probably the direct result of a component failure. Alignment of communications receivers should be attempted only by technicians who have experience with this type of equipment and

only when manufacturer's data and the proper test instruments are available.

Components To Be Tested

5-4 Directly under the suggestion to touch-up alignment in **SERVICING CHART III** are listed components which often cause the symptom of *squeals and motorboating*.

The output filter capacitor in most 5-tube receivers is also the screen bypass capacitor for all the stages. When this capacitance decreases, it permits coupling between the stages through the common screen supply, resulting in oscillation. Many technicians overlook this capacitor as a cause, assuming that an open filter will always cause 60-cycle hum. But in this case, the capacitor is not open—it has only decreased in value. Shunting with a good capacitor will identify the defective unit. It is good practice to replace all the filters at this time, especially if they are combined in a common container.

In the better receivers, multistage phono amplifiers, and in tape recorders, special networks are used to improve the isolation between stages. These are called *decoupling networks*; some examples are shown in Fig. 5-1. Resistor R and capacitor C hold the voltage on the top plate of the capacitor constant when the plate current goes through large changes at an audio rate. The reactance of the capacitor to audio signals is about 1/10 the value of the resistor, and audio current is thus shunted to B— without passing through the power supply. In this way, the B+ voltage of the power supply does not vary due to large changes in current which would otherwise pass through it. An open decoupling capacitor usually causes distortion on low audio notes only, producing a kind of low-pitched growl when the signal contains a large proportion of low frequencies.

Plate and screen bypass capacitors in the RF, IF, and first audio stages in a receiver are supposed to remove RF and IF signals from the following stages. If they fail to do so because of an open condition, oscillation frequently results. The capacitors can be checked by shunting across them, because, with normal volume present, it is certain they are not leaking or shorted. Capacitors in the AVC filters can cause oscillation in a similar manner and should be checked by shunting them also.

When an IF or audio transformer has been replaced, oscillation may result from an error in wiring which does not affect the receiver in other ways. When this happens, oscillation can be cured by reversing the leads to the windings of the trans-

former. This may mean exchanging the primary for the secondary or simply switching the ends of a single winding. In stubborn cases where oscillation results after replacing an IF transformer, and no amount of detuning will help, the efficiency of the tuned circuits can be lowered by shunting the windings with resistors of 50K to 100K. While this method cannot be correctly called a "repair," it may be the last resort in cases where the original IF transformer is not available for replacement, and a more efficient substitution has been used.

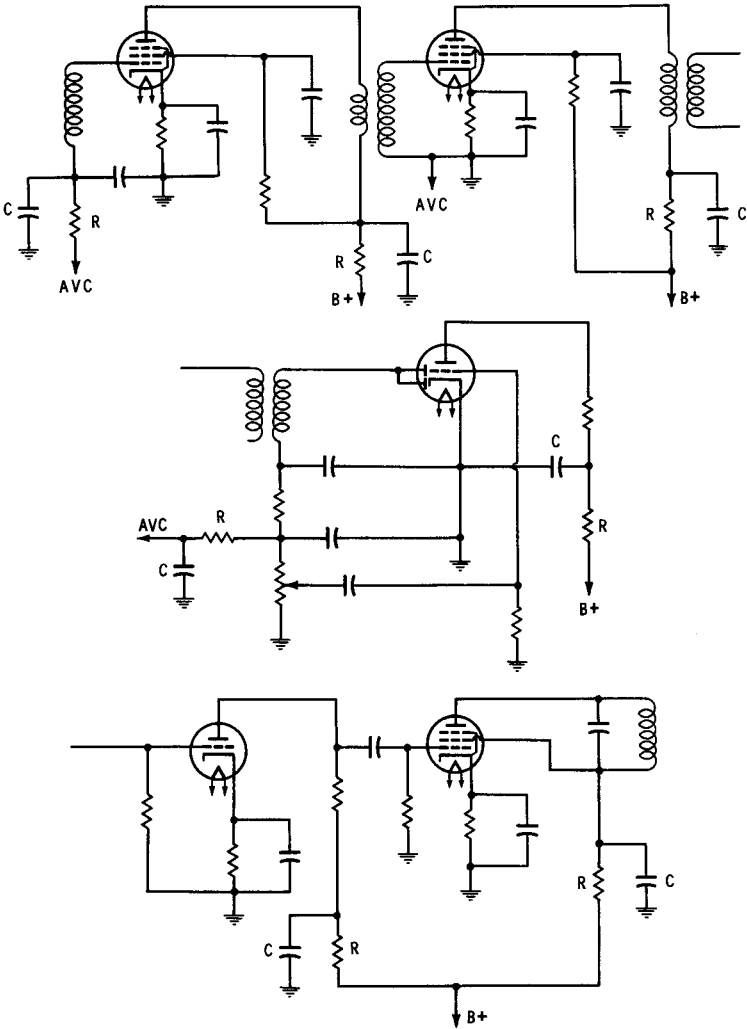

Fig. 5-1. Examples of decoupling networks.

Fig. 5-2 shows a type of feedback used in high-fidelity audio systems. The polarity of the feedback signal taken from the output transformer is intended to be such that the feedback *subtracts* from the signal input. By inadvertently reversing the connections to the secondary, the technician could obtain a feedback signal which adds to the incoming signal and thus produces oscillation.

TEST POINT 1, CHART III

CLIPPING AND MUSHY AUDIO

The types of distortion discussed earlier in this chapter are easily recognized and isolated because each one has a distinctive sound. Mushy audio, however, is a broad category cover-

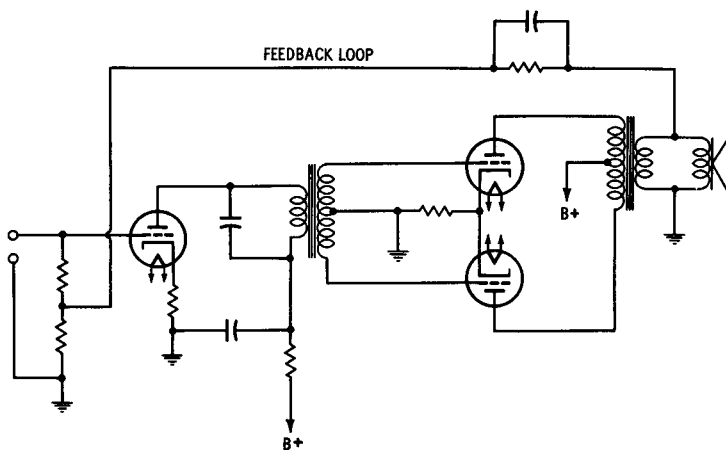

Fig. 5-2. Inverse feedback.

ing all the kinds of distortion not previously mentioned, and the causes may be in a number of different parts of the receiver.

Technicians learn to recognize the "tinny," flat response or rattle of a defective speaker. One type of speaker failure which has been difficult for many technicians to find causes the sound to be distorted at low volume only. The sound of audio clipping when an audio stage is driven to saturation can also be recognized with experience. When the sound of the distortion is familiar and can be classified at once, further testing is restricted to the suspected area, but there are cases where it is difficult to guess which section of the receiver is at fault; it is in these cases that TEST POINT 1 is used.

5-5 Many repair shops keep handy a small record player that is equipped with a shielded cable leading from the crystal pickup and having clips on the free end. This is used to inject music of known quality into the volume control, the purpose being to determine whether the cause of the distortion is in the audio section or in the RF and IF sections. If the sound from the phonograph record is distorted when it is played through the receiver's audio system, tests will continue in the audio section only.

TEST POINT 2, CHART III INJECTED AUDIO IS DISTORTED

5-6 On the right side of SERVICING CHART III, below TEST POINT 1, are listed some things to check before moving on to TEST POINT 2. These are the audio tubes (which should be substituted rather than checked in a tube tester), and an ohmmeter check of the volume control, which may not be grounded as it should be.

After these tests, the music from the phonograph is injected into the grid of the audio output stage or into the next audio stage. The sound from the speaker will be weaker now, but it should be possible to tell whether or not it is distorted.

Further Tests When Sound Is Clear

5-7 This proves that the first audio stage is responsible for the distortion. The coupling capacitor between the plate of the voltage amplifier and the grid of the following stage is the most common cause, and a new one should be tried. It is possible to test the capacitor using the method shown in Fig. 5-3. Here, the VTVM is used as a sensitive microammeter. It is not sufficient to check this capacitor for leakage by measuring it with an ohmmeter, because the leakage may be several meg-

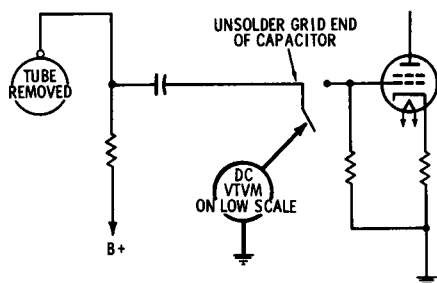

Fig. 5-3. Checking a coupling capacitor for leakage.

ohms, or it may not begin to leak until it is subjected to the B+ voltage of the receiver.

Tone-control circuits can cause distortion when they are filtering out frequencies above or below the intended range. A resistance measurement of the components is recommended in this case. When in doubt, substitute new parts.

Plate bypass capacitors cause distortion when they leak intermittently and should be checked by substituting new ones. Also, the value of the plate-load resistor affects the audio quality, and this should also be measured. In like manner, the decoupling circuit shown in Fig. 5-4 should also be checked.

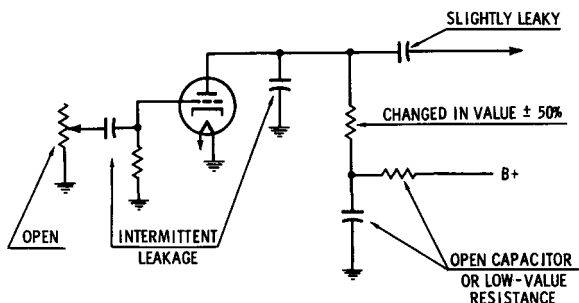

Fig. 5-4. Sources of distortion in an audio voltage amplifier.

Further Tests When the Injected Audio Is Still Distorted

5-8 The coupling capacitor to the grid of the next stage is mentioned again on the right side of **SERVICING CHART III** under **Distorted Sound** because certain defects in this unit will cause distortion even when audio is injected at the grid of the following stage.

This is also a good time to check the speaker. There are no good tests of speaker quality which are simple enough to be employed on a radio service bench, so substitution with a speaker of known quality is recommended.

TEST POINT 3, CHART III

VOLTAGE AND RESISTANCE MEASUREMENTS AT THE PLATE AND SCREEN OF THE OUTPUT STAGE

5-9 Even when voltage measurements are normal, distortion can be caused in the plate circuit of the audio output stage if the bypass capacitor is intermittently leaky. When loud passages are reproduced, the voltage across this capacitor rises and may cause it to break down only on these peaks. The same thing is true of the windings in the transformer primary

which may short between adjacent turns or to the core when the voltage is high. The best test is to substitute new parts, although the defects might be revealed by a sharp change in DC plate voltage when certain audio notes are present. This cause of distortion is more prevalent in auto radios and transistor portables, which are more often subjected to moisture and are operated at volume levels near the maximum.

In push-pull output stages, the resistance of the windings in the input-transformer secondary and the output primary should be checked to make sure that there is equal resistance from either end to the center tap. An off-balance condition here can result in distortion.

The cathode circuit of the audio output stage should be examined with the ohmmeter, and the technician should not hesitate to substitute a new cathode capacitor in cases where distortion has been isolated to the circuitry of this stage. The value of the grid resistor should not be overlooked.

TEST POINT 4, CHART III

AUDIO INJECTED AT THE VOLUME CONTROL PRODUCES UNDISTORTED SOUND

5-10 The procedure is shown on the left side of SERVICING CHART III under TEST POINT 1, and all the tests are concerned with the IF or RF sections of the receiver. The mixer/osc and IF tubes should be substituted first, followed by an ohmmeter check of the resistance in the volume control, and from the AVC line to ground. An open here indicates a defective volume control or poor connections to it. This is a common failure in radios using printed-circuit boards. A very low resistance indicates that the AVC line is grounded, perhaps through a shorted AVC filter capacitor, or that the RF bypass capacitor in the detector is defective.

TEST POINT 4, CHART III

OHMMETER CHECK OF MIXER AND IF CATHODES

5-11 It is unlikely that a cathode will be found open, since the receiver is still able to receive stations, but a shorted cathode capacitor in the IF stage can produce a muffled type of distortion in many receivers. In circuits where the mixer cathode is part of the oscillator circuit, it will not be necessary to make the resistance check at this point, since any failure would stop the oscillator and thus remove all signals from the audio output.

Further Tests When the Cathode Resistances Are Normal

The only remaining possibility is a defective IF transformer. A detailed discussion of some of the tests applied to IF transformers was given in Sections 4-10, 4-11, and 4-12; another test should be made in connection with the symptom of distortion.

Fig. 5-5 illustrates a way in which IF transformers can be checked for leakage between the primary and the secondary. This defect will often be discovered by noticing that a slight positive voltage is present on the AVC line. But the test should be applied even when no change in AVC voltage can be noticed.

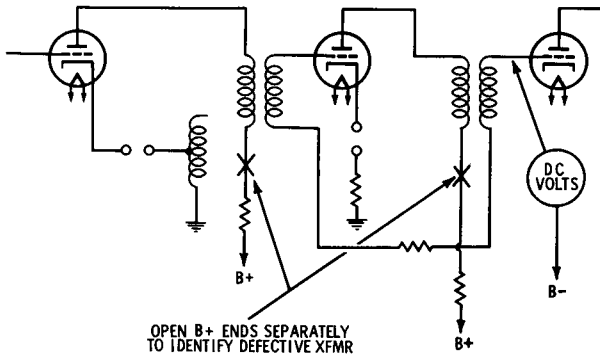
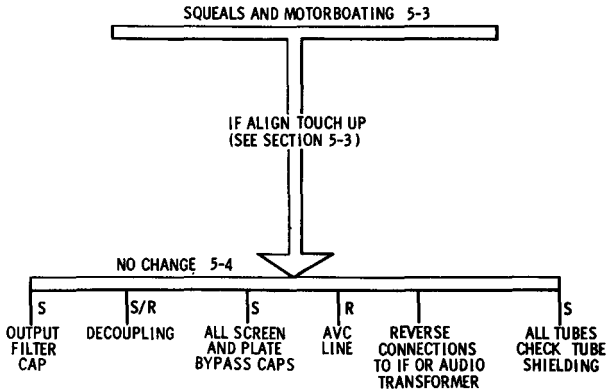
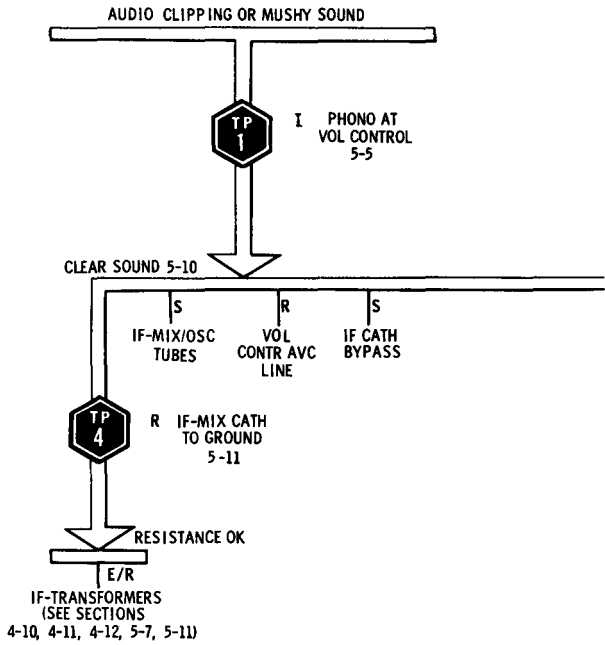

Fig. 5-5. Checking for a leaky IF transformer.

When the heaters are in parallel, the mixer and IF tubes are removed to stop all incoming signals and to increase the voltage between the transformer windings by eliminating any voltage drops caused by plate current flowing through resistors in series with the primary. When the heaters are in series, the tubes can be removed and B+ restored by soldering a silicon rectifier from the 120-volt AC line to the cathode pin of the rectifier-tube socket, making sure that the correct side of the AC line is used and that the cathode end of the silicon is on the cathode pin of the tube socket. Alternatively, the cathodes of the mixer and IF tubes can be opened.

A DC voltmeter set on a low scale is connected from the grid terminal of the secondary to B-. With the receiver turned on, a slight positive voltage indicates leakage. The reading may become more noticeable if the transformer is tapped with a small tool during the voltage measurement. A slight flicker of the voltmeter needle is enough indication to warrant changing an IF transformer. But it must be remembered that the



Servicing Chart

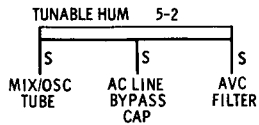
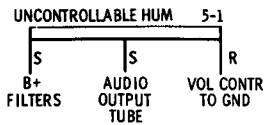
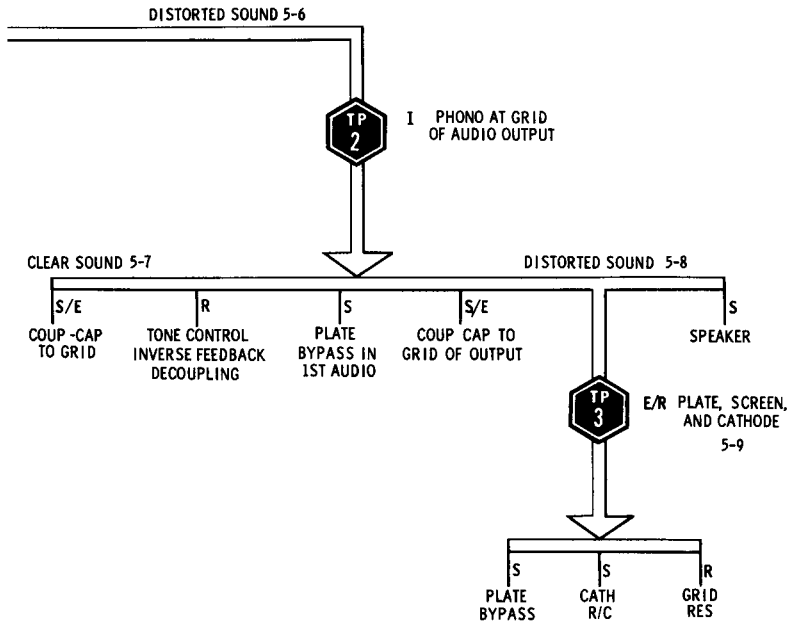

III: Distortion.

secondaries of the IF transformers are tied together through the AVC line and that the leakage measured at one transformer could be caused by B+ current leaking through the other one. For this reason, once leakage has been found, the primary of each transformer is disconnected from the B+. The leakage will disappear when the defective transformer is disconnected.

When impedance coupling is used, there will be only a tuned plate coil coupled to the grid of the next stage by a capacitor. The same method described in Section 5-7 can be used to check for leakage of the capacitor.

REVIEW QUESTIONS

1. In the case of audio clipping or mushy sound, what other test could be used in place of the test recommended at TEST POINT 1?
2. Describe the difference between tunable hum and uncontrollable hum.
3. Suppose there were an intermittent short between adjacent turns in the audio output-transformer primary. Describe the series of tests that would be followed to find this failure.
4. A receiver has distorted sound when music from a phono crystal is injected either at the volume control or at the grid of the output stage. What parts should be checked before moving on to TEST POINT 3?
5. After the audio output transformer in a HI-FI audio amplifier is replaced with an exact replacement, the amplifier howls and squeals. What is probably wrong?
6. For what specific kinds of distortion would you suspect tubes?
7. Describe the series of tests necessary to discover that a defective IF transformer is the cause of distortion.
8. What component will cause the receiver to have distortion on very low volume but to play normally with normal setting of the volume control?
9. A five-tube AC/DC receiver has a loud hum which can be controlled by the volume control but is not tunable. What parts would you suspect, and what tests would you use?
10. Draw a partial schematic of a tone-control circuit, showing a component which could cause distortion if it failed.

6

Weak, Noisy Signals

“Weak, Noisy Signals” is the last of the general categories of symptoms to be discussed, and it is the least complicated. The condition occurs when signals can be received weakly, but electrical interference and atmospheric noises seem to be almost as strong as the stations. This symptom should not be mistaken for the No-Signals condition of Chapters 3 and 4. In the case of Weak, Noisy Signals we shall be concerned with problems of misalignment or weak amplification, and the tests used will be of no use in finding the cause of the No-Signals symptom.

TEST POINT 1, CHART IV

INJECT SIGNAL AND MEASURE AVC

6-1 SERVICING CHART IV shows that the symptom divides itself into two distinct conditions. Thus, the testing is confined to the right or left side of the chart, depending on whether the signals are found to be weak at only one position of the dial, or over the entire broadcast band.

When using radio stations as a source of signals, it may be impossible to tell if reception is weak over the entire band, because of the different strengths of the incoming carriers at various points on the dial. The local stations, of course, will normally have the strongest signals, regardless of the condition of the receiver. So the method recommended at TEST POINT 1 is to use a signal generator and to measure the sensitivity of the receiver in terms of the AVC voltage present when the tuning is adjusted to various points on the dial. The chart suggests taking samples of the AVC using 600-kc, 1000-kc, and 1500-kc signals from the signal generator.

If the alignment instructions are available, the signal should be fed to the receiver in the manner recommended. If there are no instructions, a good way to inject the signal is to form

several turns of wire into a loop of approximately the same dimensions as the loop antenna used on the receiver being tested. This homemade loop is then connected to both of the leads from the signal generator, and when it is brought close to the receiver, sufficient signal will be injected to make the test at TEST POINT 1. A method used by some technicians is to remove the loop antenna from a discarded receiver and store it with the signal generator for use when it is necessary to inject signals simulating the incoming stations on the broadcast band.

When the receiver being checked does not use a loop antenna, then an actual antenna must be installed before any testing of the AVC response is done. Signals can be injected into this type of receiver just as easily as before and using the same method.

Set the signal generator at a low output, and maintain the same output strength while attempting to compare AVC readings at the various points on the dial. If all the readings are the same, then further testing will proceed on the right side of the chart. If the AVC is different on one portion of the dial than on other portions, then this indicates that the sensitivity of the receiver is not consistent throughout the broadcast band, and the remedy will be found on the left side of the chart.

Further Tests When the AVC Is the Same All Over the Dial

6-2 This indicates that a defect exists which is not affected by changing the tuning circuits. The trouble could be a single tube, or it may be a general run-down condition of the entire receiver which will require several new tubes and even some other parts. All the tubes should be checked first.

When tubes have been eliminated as a cause for the weak signals, the antenna is inspected for damage or incorrect connections. The ohmmeter is a handy instrument for this job, and it can be used further to check the connections to the mixer-grid tuning capacitor. In receivers using printed-circuit boards, continuity between parts should never be assumed—it should always be checked with the ohmmeter.

6-3 With a weak signal at all points across the dial it is likely that the trouble is in the IF or detector stages, but there is a possibility of a deficiency in the audio amplification. One can usually decide which is the case by noting the sensitivity of the receiver to outside electrical noise and atmospheric static; the audio should be suspected when there seems to be good sensitivity.

TEST POINT 2, CHART IV

INJECT PHONOGRAPH SIGNAL AT VOLUME CONTROL

In cases where it is difficult to place the symptom in the audio or in the IF detector section of the receiver, a signal from a phonograph player can be injected as described in Section 5-5. Normal volume resulting from this test proves that the fault is in the IF or detector circuits, and the tests to be made are shown on the left of the chart under TEST POINT 2. Weak reproduction indicates that the audio sections are at fault, and reference is made on the chart to the analysis in Chapter 3.

Further Tests When Audio Is Normal

If a Sams PHOTOFACT® is available for the receiver under test, the alignment instructions will be found on the front page of the folder. This should be consulted to determine the IF frequency used in the receiver. Older models vary greatly in the frequency of the IF, and there is no simple way to determine the original frequency experimentally. The most common IF frequency currently in use is 455 kc.

It is important while injecting the IF frequency to keep in mind that the signal strength should be held to the lowest value consistent with good voltmeter readings. With the generator tuned to the IF frequency, the hot lead is connected to the signal grid of the mixer stage through an isolation capacitor. The value of the capacitor is not critical, and is usually given in the alignment instructions as .001 mfd. On many receivers an easy way to inject the signal is to connect the generator lead to the solder terminal on the mixer tuning capacitor. The DC voltmeter is connected to the AVC line as shown in Fig. 6-1. Alternate connections for the voltmeter are shown in the figure, but in these positions the readings will be affected by the setting of the volume control.

After the generator and the voltmeter are adjusted for minimum signal input consistent with good readings on the lowest scale of the meter, adjustment of the IF transformers begins. It is not necessary to follow any order in the adjustment, but all the transformers should be adjusted a little at a time, working back and forth between them so that all the tuned circuits are brought to peak at the same time.

As the stages are tuned, the AVC voltage will increase, and the signal input should be decreased, rather than changing the voltmeter to a higher scale. If necessary, the generator can be disconnected and the signal fed into the receiver through

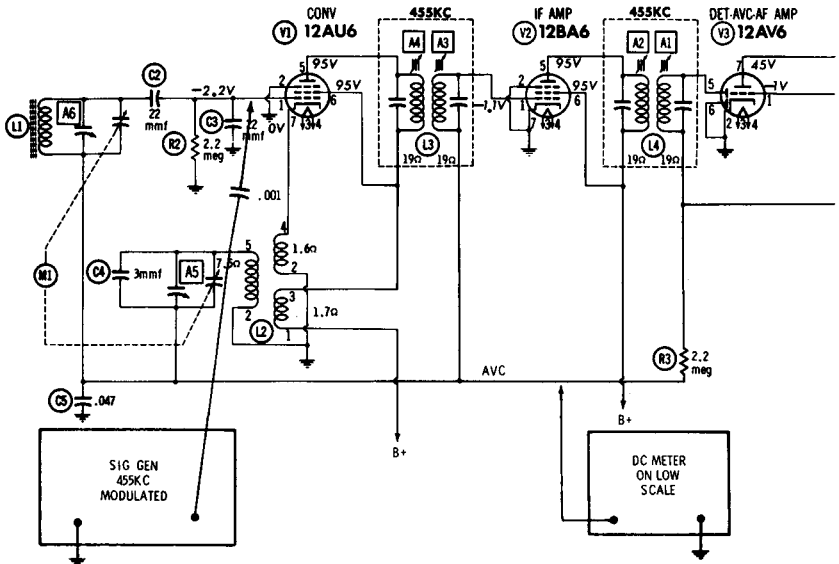

Fig. 6-1. Test-point connections

the loose coupling obtained when the lead from the generator is merely brought near the mixer tube.

Besides giving assurance that the stages are aligned properly, the preceding alignment serves as a test procedure, checking out several different components and circuits at once. If any of the IF transformers fails to show a peak adjustment, it is likely that the trouble which produced the symptom of weak signals will be found to be associated with that transformer. If there is no AVC voltage, or it does not vary with the adjustments, the defect may be in the AVC circuit itself. **SERVICING CHART IV** suggests using the methods described in Sections 4-12 and 5-11 for checking IF transformers and the AVC circuit.

Two more places which should not be overlooked when alignment does not seem to cure the symptom are the cathode circuit of the IF stage and the RF filter capacitor in the detector circuit. A routine check of all plate and screen voltages in the mixer and IF stages may reveal the stage which has failed.

Procedure When TEST POINT 1 Produces Weak Signals at One Part of the Dial Only

6-5 The mixer/osc tube should be substituted at once, but since certain signals are amplified normally, there is probably no component failure of any kind; instead, the tracking of the

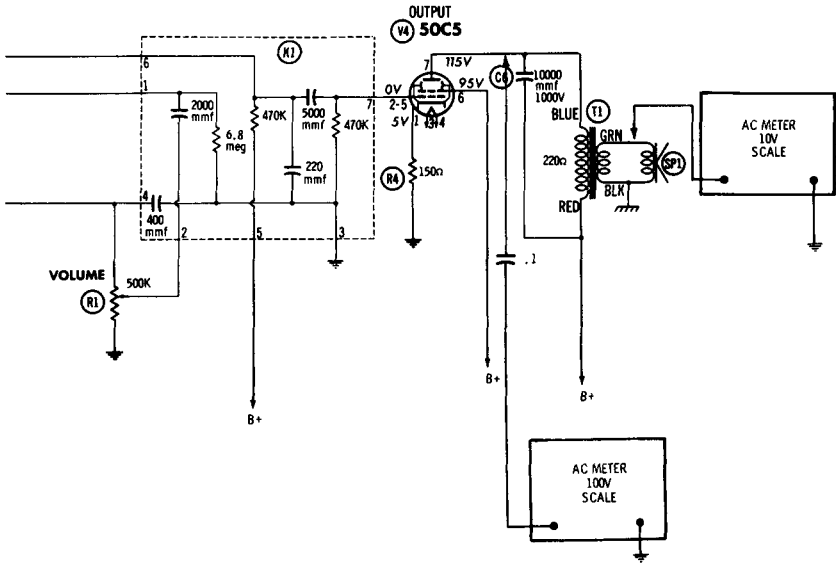

for receiver alignment.

oscillator and mixer tuning should be suspected. As explained in Chapter 2, the circuits are tuned so that the difference between their frequencies will always be the same, regardless of the setting on the tuning dial. In this manner, the IF frequency will be produced constantly as the oscillator and incoming carrier signal circuits are tuned simultaneously through their respective ranges.

For this explanation we shall assume that the IF frequency used is 455 kc, but the same principles will apply for receivers using any other IF frequency. Fig. 6-2 shows a typical tuning capacitor with the screwdriver-adjusted trimmer capacitors visible on the side of the stator frame. The purpose of these capacitors is to maintain the same difference frequency between the oscillator and mixer frequencies. It is these capacitors which must be adjusted to correct the "tracking."

Suppose the mixer is tuned to 600 kc :

$$\begin{aligned} \text{Osc freq.} &= RF + IF \\ &= 600 + 455 = 1055 \text{ kc} \end{aligned}$$

If the receiver is now tuned to a new station at 900 kc, the new oscillator frequency will be :

$$900 + 455 = 1355 \text{ kc}$$

When the receiver is tuned through a range of 300 kc, both circuits must change their resonant frequencies by 300 kc. The graph in Fig. 6-3 shows that a change of 300 kc in the mixer tuning is a 50% change, while a change of 300 kc in the oscillator is only about 28%. With the tuning capacitors cou-

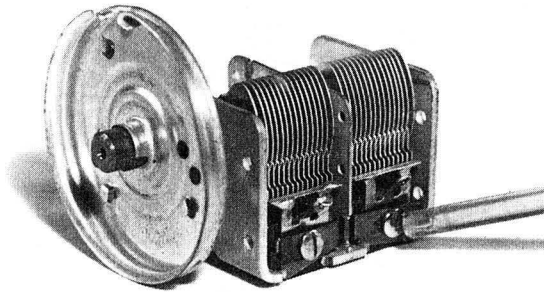

Fig. 6-2. Tuning capacitor showing trimmers.

pled together on the same shaft, it is necessary to make one circuit change its resonant frequency by 50%, while the other changes only 28% with exactly the same amount of shaft rotation. This is accomplished by using capacitors with each having a different total capacity and differently shaped rotor plates.

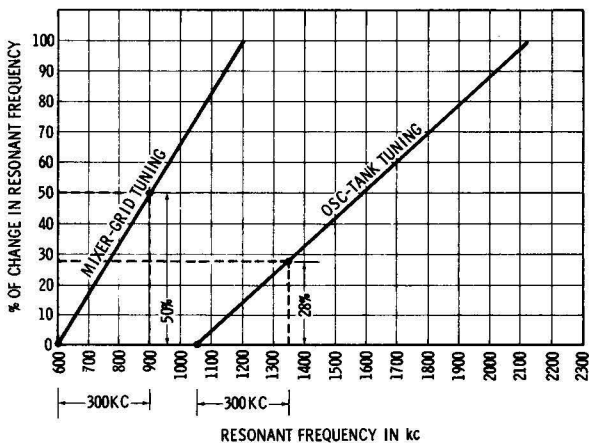

Fig. 6-3. Comparison of change in mixer and oscillator tuning.

The trimmer capacitors aid in the adjustment of the tracking to keep the two circuits tuned exactly 455 kc apart at all points throughout the tuning range. The trimmers are adjusted as follows:

1. Tune in a station at the high end of the broadcast band.
2. Adjust the trimmer on the mixer tuning capacitor for maximum.
3. Tune to a station on the low end of the band.
4. Adjust the trimmer on the oscillator capacitor for maximum.
5. Readjust the main tuning and the oscillator trimmer until the best combination can be found.
6. Recheck the mixer trimmer at the high end of the dial for a maximum signal.

Step 5 is called the "rocking" process because it is accomplished by rocking the tuning dial across the station frequency and readjusting the trimmer until the point of best tracking is found.

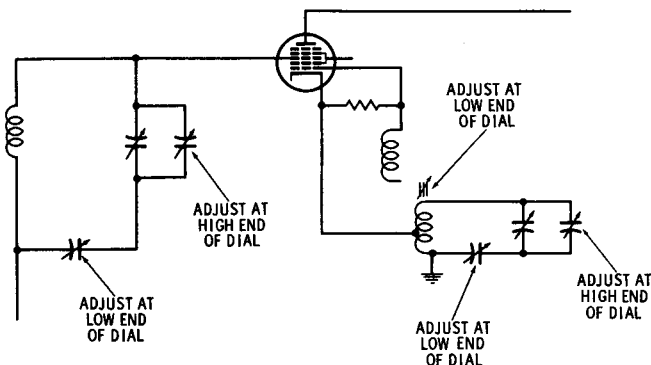
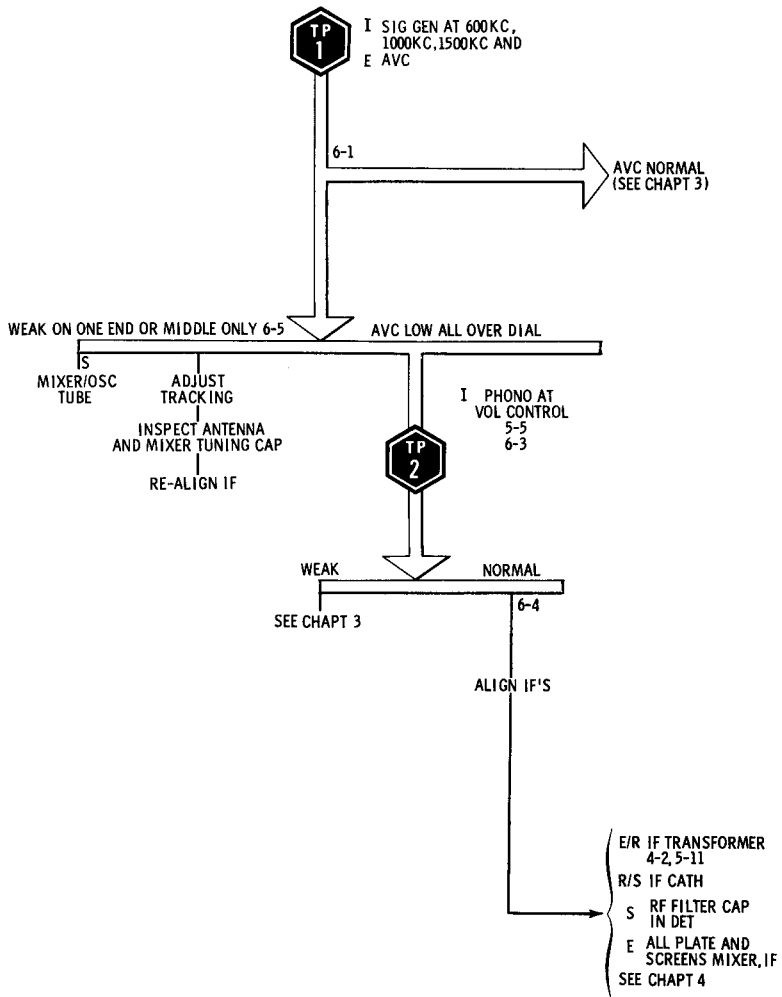

Fig. 6-4. Padder and slug adjustments found in some receivers.

Some circuits include an adjustment of the oscillator-coil tuning slug, or another small capacitor connected in series rather than in parallel with the main tuning capacitor (see Fig. 6-4). These are intended to adjust the tracking at the low end of the dial. When they are used, the oscillator trimmer on the main tuning capacitor is adjusted at the high end of the dial along with the mixer trimmer.

A signal generator can be used to create the alignment signal in the above procedure but it is not necessary since the tracking should be adjusted at the frequency of some local station which is desirable to receive.



Servicing Chart IV: Weak, Noisy Signals.

Further Tests When Tracking Does Not Bring in Stations at the Proper Place on the Dial

If the antenna loop or the tuning capacitor has been replaced, it is likely that the new part does not exactly match the circuit. This will spoil the original tracking. When this has happened, the performance of the receiver may be improved by changing the frequency of the IF channel.

By using a signal generator, the IF transformers can be peaked about 10 or 20 kc higher than normal, and the tracking adjustment repeated. If there is no improvement, the IF's can be peaked lower than normal, and the tracking adjustment repeated. It is often possible to make a great improvement in the tracking by altering the IF frequency in small receivers which do not perform well at one end of the dial. This method is not recommended, however, until all other possibilities have been investigated.

REVIEW QUESTIONS

1. If the value of the cathode resistor in the IF stage increases, would this cause weak signals all over the dial, or at one end only?
2. Explain two failures which could produce Weak, Noisy Signals in the circuit of Fig. 6-1 and which are not mentioned in the chapter.
3. In what ways is the convertor circuit of Fig. 6-1 different from most?
4. What components associated with the different circuitry described in Question 3 could cause poor tracking that would not be improved by adjustment of A5 and A6?
5. List in order and describe the results of all the tests necessary to isolate L4 in Fig. 6-1 as the cause of Weak, Noisy Signals.
6. Name two parts in the encapsulated circuit, K1, in Fig. 6-1, which could cause Weak, Noisy Signals.
7. Look up the alignment instructions for a recent-model broadcast receiver, and explain any differences compared to the instructions given in the chapter.
8. The following tests were made on a receiver having Weak, Noisy Signals:
 1. All tubes OK.
 2. All B+ voltages normal.
 3. Audio injected at volume control produces normal sound.

4. AVC voltage does not vary with changing input signal.
5. IF cathode resistor correct.
What tests would you make next?
9. Under what conditions would you change the IF frequency of a receiver?
10. In Fig. 6-1, AVC voltage is found at the top end of R3, but it is not present at the bottom end where the meter is shown attached. What would you do next?

7

Repairing 3-Way Portable Receivers

The name, 3-way portable, refers to a type of receiver which operates on AC, DC, or batteries. These portables were very popular until transistor receivers came onto the market. But the 3-way portable has several advantages over the transistor receiver and will perform better in certain applications. Among its advantages is the fact that it has better sensitivity and greater output power than comparably priced transistor receivers. It can also be operated continuously from the 120-volt AC lines, thus saving the battery, a feature available in only the highest priced transistor units.

Although transistor receivers have taken over completely for portable use out-of-doors, the 3-way portable is still an extremely popular receiver to be carried about the house. Batteries for the 3-way portable are expensive compared with those used in transistor radios, so most owners of 3-way portables do not use them on batteries. The technician, however, will continue to see many of this type in his shop, primarily for repairs on the AC/DC power-supply section. For this reason, a detailed discussion of this section follows.

CIRCUIT ANALYSIS OF POWER SUPPLY

All models use a special series of tubes designed to operate with very low filament current and voltage, and having directly heated cathodes. The filaments are intended to operate on DC, and there are no separate cathodes—electrons are emitted directly from the filaments. The filament-current rating is 50 ma, and the filament voltage is 1.4 V DC. The audio

output tube, a 3V4, has a 2.8-volt center-tapped filament so that it can be operated at 2.8 volts and 50 ma by using the series connection, or it can be used with 1.4 volts at 110 ma if pins 1 and 7 are tied together, placing the two sections of the filament in parallel. The series connection is the one most often used.

A basic power-supply circuit is shown in Fig. 7-1. The transformerless half-wave rectifier and R/C-type filter are familiar from Chapter 2. C4 is a line bypass capacitor to keep out RF signals present on the 120-volt AC lines. R1 is a surge resistor and usually serves as a fuse, preventing damage to the rectifier when a short causes excessive B+ current to be drawn. A selenium or silicon rectifier is always used instead of a tube, and the B+ voltage output is from 90 to 100 volts at the point indicated in the illustration.

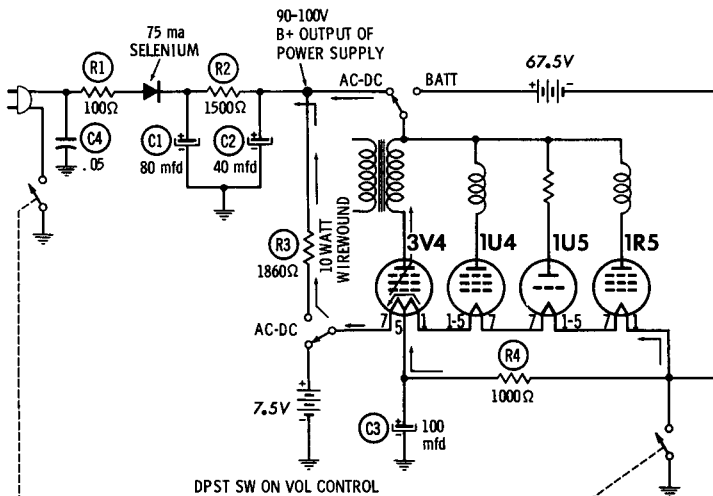

Fig. 7-1. Power-supply circuit of a 3-way portable receiver.

Because the tube filaments must operate on DC, a portion of the B+ output is used to supply current for them. R3 is a dropping resistor for this purpose. It is always a wirewound unit of at least 10 watts. Its value will vary slightly in different models, even though the same tubes are used. This is because there are different values of B+ present at the output filter capacitor in different receivers. In Fig. 7-1, the value of R3 is calculated as follows:

Total filament voltage required between pin 7 of 3V4 and ground is the sum of all the filament voltages in series:

3V4	2.8 volts (series connection)
1U4	1.4 volts
1U5	1.4 volts
1R5	1.4 volts
	<hr/>
	7.0 volts total

If the B+ at the output filter is 100 volts, then R3 must drop 93 volts:

$$100 - 7 = 93 \text{ volts}$$

The current drawn by the tube filaments in series will be 50 ma, so:

$$\frac{93 \text{ volts}}{50 \text{ ma}} = 1860 \text{ ohms}$$

In most commercial circuits, the value of the resistor is based on a voltage of from 7.5 to 8.5 volts at pin 7 of the 3V4. This voltage range is to allow for changes in B+ due to line-voltage variations. For battery operation, a 7.5- or a 9-volt filament battery is used.

Figure 7-1 shows the power changeover switch which changes the operation from AC/DC to battery. This switch is usually operated by a lever which can be moved only when the AC line plug is inserted in a special receptacle on the chassis. This arrangement prevents the batteries from being connected when the AC line is being used. A great many different switch circuits will be found. In some models, the switch also changes connections in the filament line to place some of the tubes in parallel. A double-pole, on-off switch is frequently used.

C3 is a filter capacitor across the filaments to remove excessive ripple from the filament voltage. This capacitor is usually from 100 to 200 mfd with a DC working voltage of 25 volts. It may be connected between ground and pin 1, 5, or 7 of the 3V4. If it is connected as shown in Fig. 7-1 and should develop a short, the 3V4 filament will burn out because the entire filament-line voltage of 7 to 8 volts will now be present across the tube. However, this connection may have an advantage over connecting the filter to pin 7, where a shorted unit would result in damage to the power supply.

The two paths of current through the filament supply are shown in Fig. 7-1, with R4 shunting the filament line for the purpose of providing a separate path for cathode current. If, through some malfunction, the plate current of the 3V4 were to increase greatly, R4 would prevent a large increase in the current drawn through the filaments of the other tubes. R4 in

series with R3 also forms a voltage divider from B+ to ground, preventing the voltage across C3 from becoming excessive when the receiver is operated on AC with the filament line open due to a burned-out tube. Without R4 in the circuit, there would be no current through R3 and no drop across it, putting the full B+ across the capacitor.

OTHER CIRCUIT DIFFERENCES

Certain circuit complications arise because the filaments of the tubes are also the cathodes, and the voltage from the filament to ground is also the cathode bias for the stage. In the 3V4 circuit, this filament-to-ground voltage can be 7 or 8 volts positive and, if the control grid were returned to B-, the tube would be cut off. Fig. 7-2 shows a typical model with the power changeover switch eliminated for simplicity. The 3V4 grid can be seen to return to the junction of the 1U4 and the 3V4 filaments, a point which is just 4.5 volts positive. If there is 8 volts at the 3V4 filament, this gives a net negative bias on the control grid of 3.5 volts, which is correct for normal operation.

Fig. 7-3 shows another arrangement to overcome the problem of cathode bias due to filament voltage. In this model, the control grid of the 3V4 is returned, via R4 and R5, to pins 1 and 5 of the 1R5 which are connected inside the tube. The power-supply wiring shows that pins 1-5 of the 1R5 are at 4.8 volts positive. R13 and R14 are added to the circuit to produce the proper drop across the 1U4 and 1U5 filaments.

In the circuits of Fig. 7-2 and 7-3, special connections are also used for the ground return of the volume control. The volume control is returned to pins 1-5 on the 1U5 tube. If the volume control were grounded, the diode plate at pin 4 of the 1U5 would have a negative bias of about 1.4 volts. No AVC voltage is used on the IF stage of Fig. 7-2, and the model shown in Fig. 7-3 does not use AVC on the converter stage.

Fig. 7-4 shows a deluxe model which includes a special 1.5-volt battery to operate a pilot light controlled by a separate switch. This receiver also has an RF-amplifier stage. The volume control is grounded in this model, and the control grid of the 3V4 returns to a point in the filament line which is just 1.4 volts above ground.

The use of B+ to obtain DC for the filaments gives rise to an unusual symptom peculiar to 3-way portables. The receiver plays normally for 10 or 20 minutes, then suddenly all signals disappear, and only electrical and atmospheric noise can be

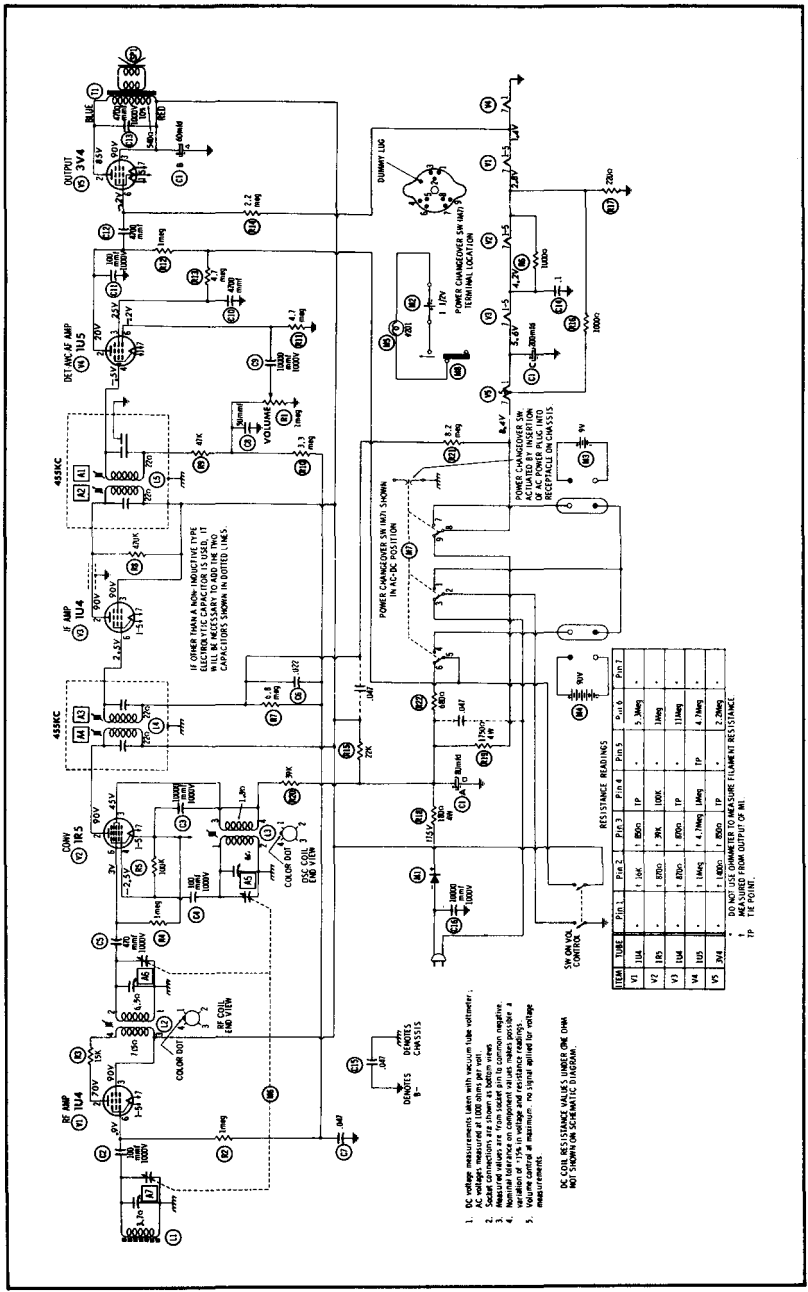

Fig. 7-4. Schematic of a 3-way portable with pilot light.

heard. If the receiver is turned off for an hour, it will again play temporarily. Upon analysis, the technician will find that, when no stations can be received, the oscillator has stopped. All other circuits are working normally. Replacing the 1R5 gives a temporary cure, but the symptom returns in a few weeks.

The cause of this trouble is related to the fact that the oscillator stage depends on good emission of the 1R5 filament (cathode). If the input filament voltage to the series string drops a volt or two, the oscillator will stop.

The reason for the drop in voltage is usually that the selenium rectifier in the power supply has developed a high forward resistance. There is still enough B+ to support the other stages and all the filaments, except the 1R5 which is most critical. The selenium will perform normally until it begins to heat, and then the B+ drops. A permanent cure for this trouble is to replace the selenium rectifier with a silicon unit having the proper rating.

TROUBLESHOOTING PROCEDURES

Besides the general symptoms discussed in Chapters 3, 4, 5, and 6, 3-way portables are subject to other symptoms peculiar to themselves. The rest of this chapter is devoted to a study of these special symptoms, but the technician must bear in mind that all the symptoms described in other chapters in connection with conventional receivers can also occur in the 3-way portables.

DEAD RECEIVER WITH TUBES OK

The condition of the tubes must be determined first. This is most easily done by making an ohmmeter check of the filaments. Schematics will often contain a warning note that these filaments should not be tested with an ohmmeter, but there is actually no danger in doing so. It is conceivable that some particular ohmmeter might be able to supply more than 1.5 volts at 50 ma on the lowest scale, but it is very unlikely. Besides, there is no need to use the lowest scale. In any case, it is impossible to tell whether the filaments are all lit by looking at them, because they glow very dimly and cannot be seen in a lighted room. Thus, it is obvious that some test of filament continuity must be made.

7-1 Once it has been determined that all the tubes are good, analysis of the circuit begins with **TEST POINT 1** in **SERV-**

ICING CHART V. This is a measurement of the total filament voltage at pin 7 of the 3V4. This voltage may be incorrect in one of two ways—it may be too high or it may be too low, and the corresponding routines are shown separately on the left side of the chart.

If the filament voltage is too high, this can only mean that not enough current is being drawn through the filament dropping-resistor. This resistor is usually not suspected since it is a wirewound unit and cannot change in value without burning out completely. The technician should suspect a break in the filament wiring between tubes or an open resistor, such as R6, R8, or R9 in Fig. 7-5. A search of the filament circuit with the ohmmeter should reveal the fault.

TEST POINT 2, CHART V

FILAMENT VOLTAGE MISSING OR LOW

7-3 If the voltage is too low or completely missing, a different approach is taken. If the filament dropping-resistor is normal, a defect in the power supply should be suspected. Therefore, the voltmeter is applied across the input filter capacitor, C1 in Fig. 7-5, to measure the power-supply output voltage.

7-4 If this voltage is missing or very low, the surge resistor, switch, line cord, and rectifier should all be checked. The rectifier can be most easily checked by substituting a new one but, when none is available, the ohmmeter can be used by measuring the resistance and then reversing the ohmmeter probes and measuring again. The ratio of forward resistance to the back resistance should be at least 100:1. If the rectifier is found to be defective, the resistance from the output filter to ground should be checked before the new unit is installed, as explained in Chapter 2 under the heading of Dead Receiver. In 3-way portables, the normal resistance from B+ to ground is likely to be lower (2K to 3K), because of the low resistance of the filament circuit.

Further Tests When the Voltage at TEST POINT 2 Is Normal

7-5 This excludes the power supply as the cause for the low voltage at pin 7 of the 3V4 and isolates the faulty part to either the filter resistor R13 (Fig. 7-5) or to the filter capacitor C1C. These can be checked with the ohmmeter or by substitution with new units. Bypass capacitors in the filament line, such as C8 and C9 in Fig. 7-2, should not be overlooked as sources of possible trouble.

Fig. 7-5. Schematic of a typical 3-way portable receiver.

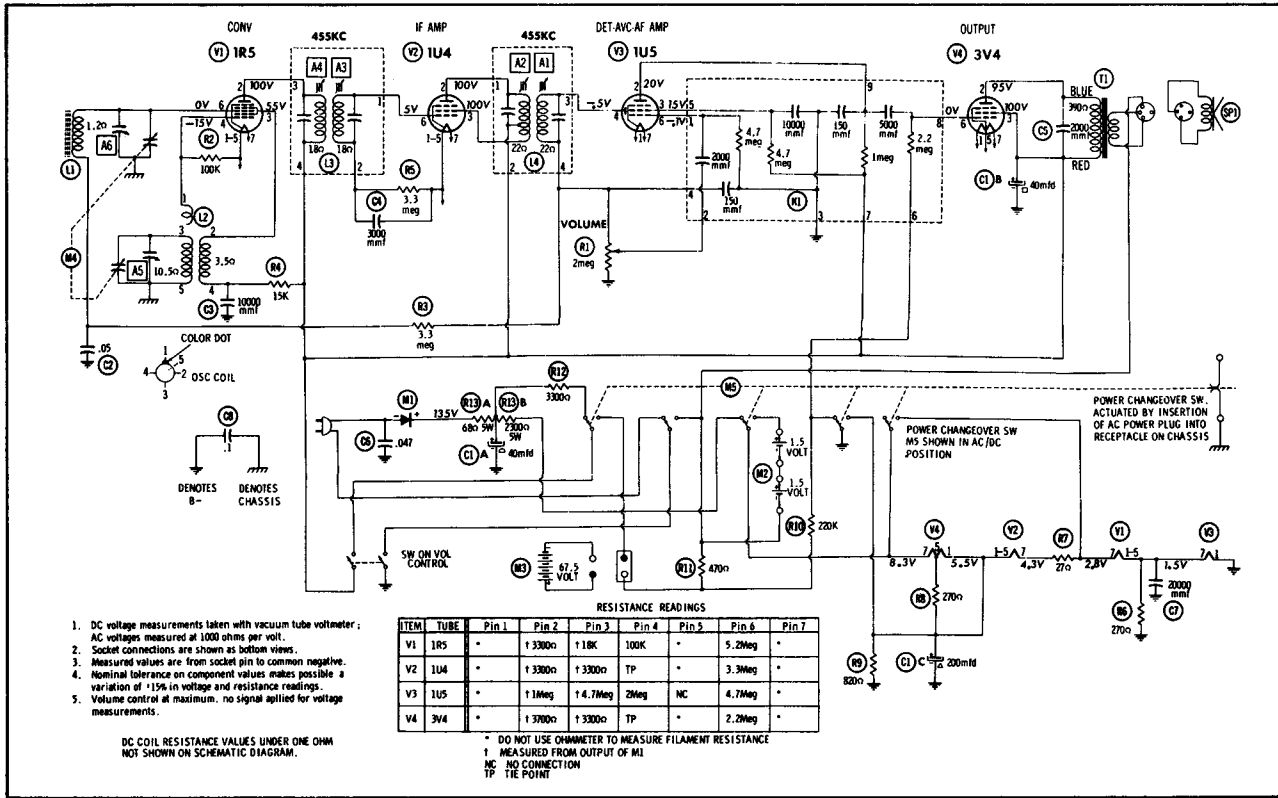

TEST POINT 3, CHART V

FILAMENT VOLTAGE NORMAL AT PIN 7 OF THE 3V4

7-6 When the receiver is dead, and normal filament voltage is found at the beginning of the filament string at TEST POINT 1, this indicates that the symptom is actually a No-Signals condition as discussed in Chapter 3 and 4, with normal filaments and power supply. For this reason, the same procedure of injecting an audio signal at the volume control is recommended to determine whether the RF/IF or audio section has failed. There is one exception in the case of 3-way portables, and this is shown on the right side of the chart under TEST POINT 3. The rectifier should be checked if the injection at the volume control results in sound from the speaker. The rectifier could be weak enough to prevent the oscillator from functioning but still strong enough to provide sufficient B+ to allow the audio sections to work, as explained earlier.

FREQUENT TUBE BURNOUT

7-7 This trouble occurs in several ways and is often very difficult to handle because the receiver cannot be left on long enough to make tests. However, a study of any of the filament supplies shown in this chapter will produce several good suspects. The chart suggests the filament filter capacitor would be suspected, especially when the 3V4 burns out immediately.

The coupling capacitor to the grid of the 3V4 is not such a well-known cause and requires some explanation. In Fig. 7-6, if C_g were shorted, a positive voltage would be applied to the

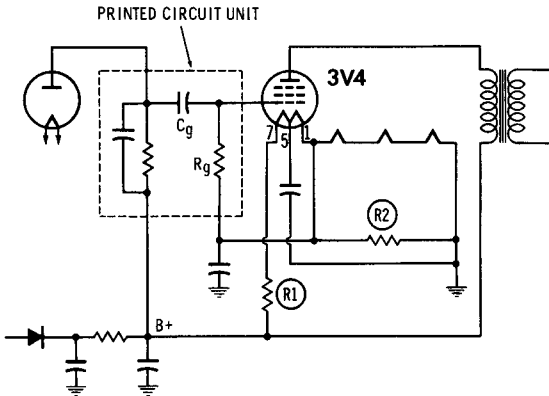

Fig. 7-6. Printed-circuit unit used in some 3-way portables.

control grid of the 3V4 with a consequent increase in plate current. The filament circuit is shown redrawn slightly to make clear that plate current in the 3V4 flows through the voltage divider formed by R1 and R2. This current will destroy the 3V4 filament if the coupling capacitor is shorted.

In most models, this coupling capacitor is part of a small printed-circuit unit, and the identical replacement may no longer be available. Repairs can be easily made by putting in new components as shown in Fig. 7-7. The terminals leading to the grid of the 3V4, and to grid resistor R_g in the printed-circuit unit, are disconnected and new parts installed as

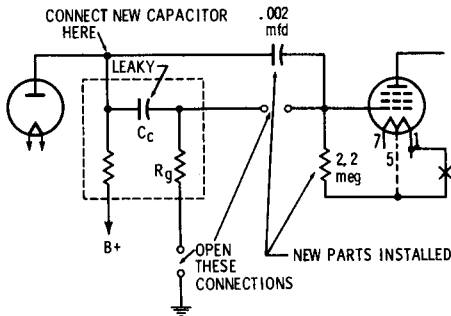

Fig. 7-7. Repairing a defective printed-circuit unit.

shown. The new grid resistor can be safely soldered to pin 1 or 5 of the 3V4 in most circuits, but when this produces distortion because of incorrect cathode bias on the tube, the new grid resistor should be tried on other tube filaments.

Tube filaments can burn out due to a similar defect in an IF transformer which allows B+ to appear on a grid. The method for checking transformers was described in Section 5-11.

DISTORTION AND TUNABLE HUM

7-8 After tubes, the speaker is the most frequent offender in 3-way portables. The 3V4 is often damaged by leakage of its grid coupling capacitor as explained in Section 7-7 and, whenever this tube is the cause of distortion, the capacitor should be changed also.

The mixer-oscillator tube (1R5) and the line bypass capacitor are common causes of tunable hum, as in any receiver. The 1U5 tube has a peculiar characteristic of becoming microphonic and producing a strange metallic ringing from the speaker. This tube should be replaced whenever there is such a symptom.

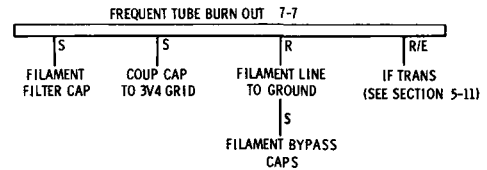
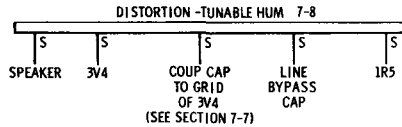
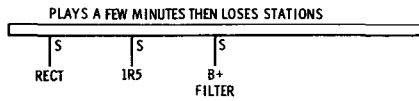
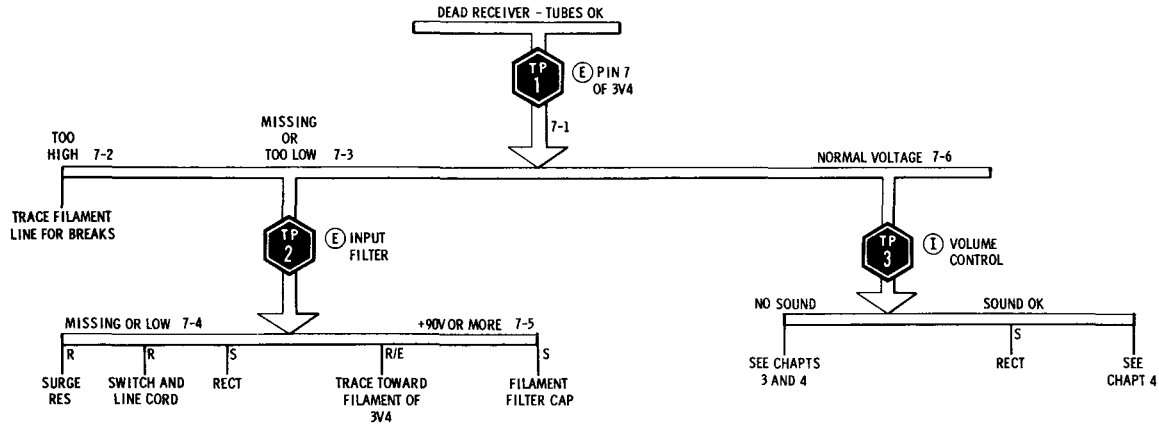

Oscillation and motorboating are common faults in these portables and usually respond to the procedures described in Chapter 5. Alignment and tracking are more critical and more important to good performance in these receivers, and the individual instructions for each model should be followed carefully.

REVIEW QUESTIONS

1. For what reasons might a customer prefer to have an old 3-way portable repaired, rather than buying a new transistor receiver?
2. In Fig. 7-3, what is the purpose of R12 and C10 in the audio section?
3. In Fig. 7-2, what would be the effect on the sound if R10 were open?
4. In Fig. 7-2, explain the purpose of R9 and what the effect would be if it were open.
5. Show calculations to determine exactly what the grid-to-filament voltage is supposed to be on the 3V4 in Fig. 7-2.
6. In Fig. 7-4, assume a total current through R18 of 65 ma, and calculate the value of voltage which would be required at R19. The value will be different from that specified, because of the assumed current in this problem.
7. What are the two most common causes for burnout of the 3V4 filament?
8. A 3-way portable plays about 20 minutes, and then the station disappears, leaving only atmospheric noise. What should you do to repair this receiver?
9. The receiver of Fig. 7-5 is brought in because of distortion, which is corrected by merely replacing the 3V4. Two weeks later the distortion is again present. Explain what should be done to effect permanent repairs.
10. AVC is not applied to all the stages before the detector in the examples shown in this chapter. Explain the reason why either the IF or the converter stage is not connected to the AVC line.
11. What is the purpose of R7 and R21 in Fig. 7-4?

8

Fundamentals of Transistor Receivers

Since certain aspects of transistor receiver theory are of much greater importance to troubleshooting than others, this chapter will consider only those points of theory which are important to the understanding of the techniques to be explained in Chapter 9. If the reader is not already familiar with the basic principles of transistor circuitry, or wishes to gain deeper understanding of the theory, he should make use of one of the many good texts available on the subject.

HOW TRANSISTORS AMPLIFY

A transistor is a solid-state semiconductor. This means that it is formed out of minerals joined together in a solid piece, and that its electrical resistance is greater than ordinary metals such as copper, silver, iron, aluminum, etc. As we shall see later, the conductivity of the semiconductor materials used in transistors can be varied by application of currents in special ways. The internal resistance of a transistor can be changed from several megohms to less than ten ohms by adjustment of the current applied to one of its parts.

Fig. 8-1 is a very simple illustration showing the construction of a transistor. Note that two kinds of materials are used: *P-type* and *N-type*. It is important to note, also, that these materials are represented as a sort of sandwich with one type of material placed between two pieces of the other. Part A of the illustration shows a PNP transistor and part B an NPN. The designations PNP and NPN indicate the positions of the materials in the sandwich. Both kinds of transistors are used, but the PNP is more often found in ordinary broadcast-band receivers. Thus, all examples presented in this chapter will employ the PNP.

PNP transistors are commonly made by purifying germanium and then adding about 5 parts-per-million of some impurity such as arsenic, phosphorus, or antimony to make N-type material. P-type material is made by adding boron, indium, gallium, or aluminum to the pure germanium. The P-type germanium and the N-type germanium are formed in the sandwich with the N-type material between two pieces of P-type material.

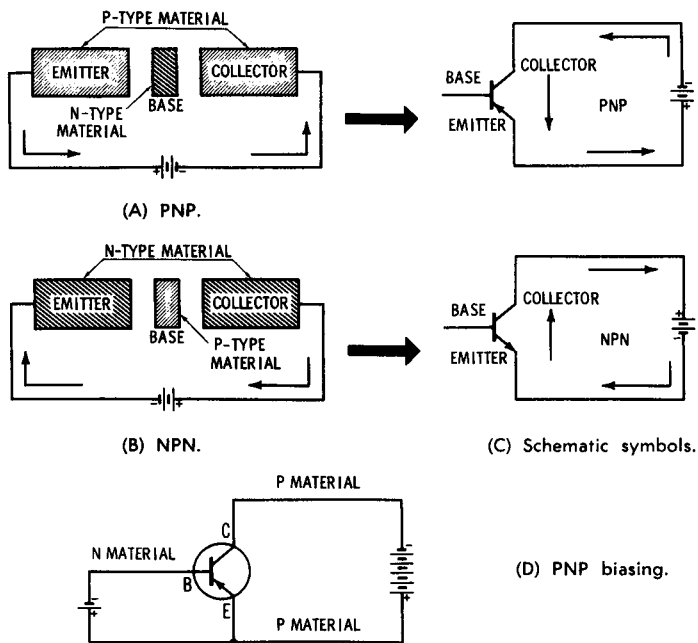

Fig. 8-1. Transistors.

Part C of Fig. 8-1 shows the schematic symbols for the two types. The only difference between the symbols is the direction of the arrow. As in all semiconductor schematic symbols, the arrow points in the direction opposite to the flow of electrons. It is important to note that in the external part of a circuit which uses a PNP transistor, electrons flow toward the collector. This means that a PNP transistor will have its collector connected to the negative side of the battery.

In a PNP transistor, both the emitter and collector are P-type material, but each has a different biasing arrangement. The emitter-base junction is said to be *forward-biased*, while the collector is *reverse-biased* with respect to the emitter.

As shown in part D of Fig. 8-1, the *positive* side of the emitter-base battery is connected to the P-type material, which is the emitter. The *negative* terminal of the collector battery is connected to the collector, which is P-type material. Thus, it can be seen why the emitter is said to be forward biased and the collector reverse biased.

In Fig. 8-2, a greatly simplified schematic diagram shows the effect of the base section of a PNP transistor. The base is shown containing an adjustable resistor. The resistance of this base region varies with the amount of current flowing

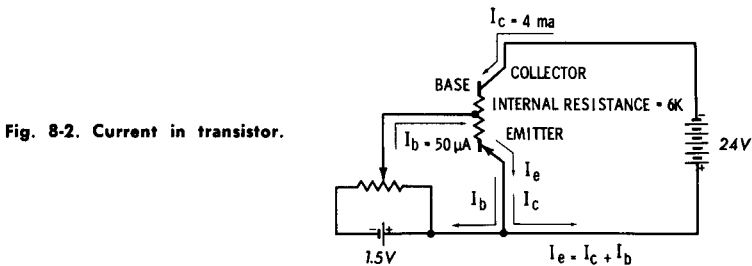

through the base, and this small current has a large effect on the current flow between the emitter and collector.

The base current, I_b , is normally from 10 microamps to about 300 microamps and must be supplied from some regulated DC source. This current is the “fuel” which keeps the current in the transistor flowing from the collector, through the base, and out the emitter. If the base current stops, then the main current, I_c , will also stop. A slight change in I_b results in a relatively large change in I_c . This action makes it possible for the transistor to amplify.

Fig. 8-2 shows the following current directions in the circuit:

- Base current, I_b : From the 1.5V battery, through the base, out the emitter, and back to the battery.
- Collector current, I_c : From the 24V battery, through the collector, through the resistance of the base, out the emitter, and back to the 24V battery.
- Emitter current, I_e : The sum of I_c and I_b flowing out of the emitter, dividing into separate currents, and returning to their respective batteries.

A basic relationship of currents in transistor circuits is, therefore:

$$I_e = I_c + I_b$$

In small transistors the base current is small, so the emitter current is often taken to be equal to the collector current, with the base current being ignored completely.

To see how a transistor amplifies, assume that 50 microamps of I_b is flowing in the circuit in Fig. 8-2, and that this brings the adjustable base resistance to 6000 ohms. When $I_b = 50$ microamps:

$$I_c = \frac{E}{R} = \frac{24V}{6K} = 4 \text{ ma}$$

If the base current increases to 75 microamps, and if this causes the internal resistance of the transistor to *decrease* to 4K, then the new collector current is:

$$I_c = \frac{24V}{4K} = 6 \text{ ma}$$

If the base current decreases to 25 microamps, and if this causes the internal resistance to *increase* to 12K, then the new collector current is:

$$I_c = \frac{24V}{12K} = 2 \text{ ma}$$

Note that a change of ± 25 microamps in base current results in a change of ± 2 milliamps in collector current.

In the preceding circuit, no output signal can be taken between the collector and emitter because this voltage is always equal to the battery voltage. To see how output voltage is taken, consider the circuit in Fig. 8-3. This circuit has a collector resistor, R_c , and uses a 2N414, which is a typical small-signal PNP transistor. The characteristics are shown on the graph in Fig. 8-4.

At Point 1 on the Graph:

$$I_b = 50 \text{ microamps}$$

The collector current depends on the internal resistance of the transistor, and is obtained from the graph:

$$I_c = 2.5 \text{ ma}$$

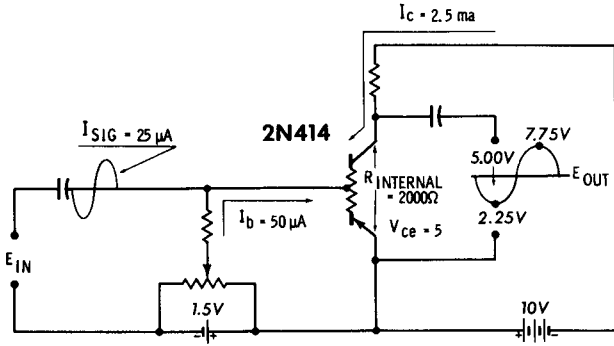

Fig. 8-3. Voltage across transistor elements.

The voltage from collector to emitter, as indicated by the graph, is:

$$V_{ce} = 5V$$

$$R_{\text{internal}} = \frac{V_{ce}}{I_c} = \frac{5V}{2.5 \text{ ma}} = 2000 \text{ ohms}$$

If a signal is now applied which increases I_b to 75 microamps, then:

At Point 2 on the Graph:

$$I_b = 75 \text{ microamps}$$

$$I_c = 3.75 \text{ ma}$$

$$V_{ce} = 2.25 \text{ volts}$$

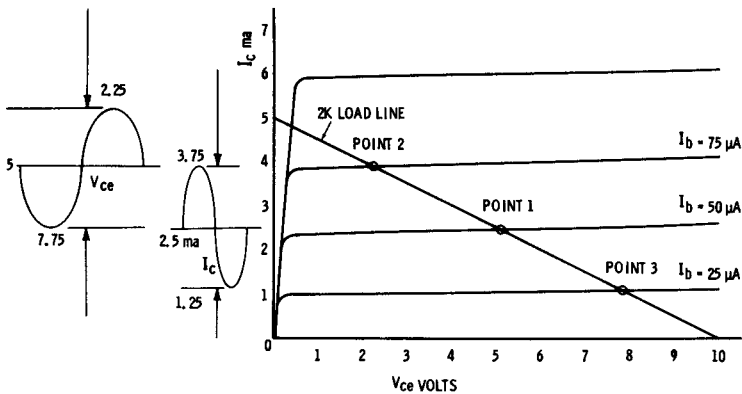

Fig. 8-4. Characteristic curve of a typical PNP transistor.

R_{internal} is now :

$$\frac{2.25\text{V}}{3.75 \text{ ma}} = 600 \text{ ohms}$$

When the input signal reduces I_b to 25 microamps, then :

At Point 3 on the Graph:

$$I_b = 25 \text{ microamps}$$

$$V_{ce} = 7.75 \text{ volts}$$

$$I_c = 1.25 \text{ ma}$$

$$R_{\text{internal}} = 6.2\text{K}$$

Thus, it can be seen that when an incoming signal causes the base current to vary, the internal resistance of the transistor will change, causing large corresponding changes in the collector current. Also, voltage V_{ce} , from collector to emitter, will vary according to the input signal, and this is an amplified version of the input voltage.

If the output is taken from across the collector and emitter terminals through a capacitor, the stage becomes a voltage amplifier. If variations in I_c are passed through an inductance, the stage can be a power amplifier.

In the above example, we found that a change of ± 25 microamps in I_b would cause a change in the internal resistance of the 2N414 transistor, resulting in a change in I_c of ± 1.25 ma. The relationship between the change in base current and the resulting change in collector current is a very important characteristic of each individual transistor. It is given in the manufacturer's specifications as β (*beta*) and is called the *gain* of the transistor. Some manufacturers designate this as H_{fe} . It is the ratio of :

$$\beta = \frac{\text{change in } I_c}{\text{change in } I_b}$$

The value of β will range from 10 to 200, with 50 being about average. In our example, the transistor we used had a β of :

$$\frac{I_c}{I_b} = \frac{1.25 \text{ ma}}{25 \text{ microamps}}$$

or

$$\frac{1.25 \times 10^{-3}}{25 \times 10^{-6}} = .05 \times 10^3$$

$$\beta = 50$$

It should be noted that the presence of $R_c = 2K$ in the circuit of Fig. 8-3B makes it possible for the output voltage, V_{ce} , to vary. The peak-to-peak swing of V_{ce} is dependent on the value of R_c as indicated by the slanted line on the graph. This line is called the *load line*. In our example, the peak-to-peak swing of V_{ce} is from 7.75 to 2.25, or 5.5 volts. To become more familiar with the effect of R_c , the reader should repeat the preceding calculations, finding all the new values when $R_c = 2.5K$. The new load line will cross the horizontal axis at $V_{ce} = 10$, and the vertical axis at $I_c = 4$ ma. The peak-to-peak swing of V_{ce} will then be approximately 6.5 volts.

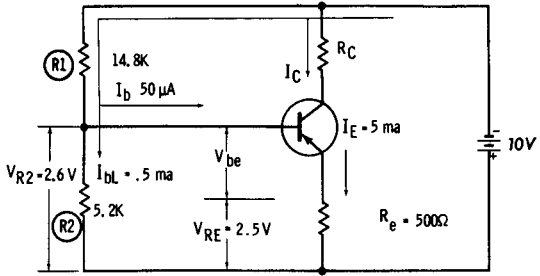

Fig. 8-5. Method of obtaining base bias.

BIASING AND STABILITY

The circuits we have been discussing are not practical for two reasons :

1. A separate battery source was used for base current.
2. There was not sufficient control over unwanted variations in the base and collector currents due to leakage and heat.

A popular method for using a single battery is illustrated in Fig. 8-5. R1 and R2 form a voltage divider across the collector battery so that the 10 volts will be divided across the two resistors. The base-to-emitter voltage, which is the forward-bias voltage, is the difference between V_{r2} and V_{re} :

$$V_{re} - V_{r2} = V_{be}$$

$$2.5 - 2.6 = 0.1 \text{ volt}$$

The bleeder current flowing in R2 and neglecting $I_b = 50 \mu A$ is approximately :

$$I_{bl} = \frac{10V}{R1 + R2}$$

$$= \frac{10V}{20K} = 0.5 \text{ ma}$$

In addition to the bleeder current, the base current of 50 microamps flows in R1. It can be seen that the base current is a very small part of the total current in R1, and therefore has negligible effect on voltages V_{r1} , V_{r2} , and V_{re} .

The stability of the bias bleeder system is very important since any slight change in the base current will result in a large change in collector current, especially when the beta figure is high:

$$I_c = \beta I_b$$

In order to keep the collector current within the maximum limits of the transistor, and also to insure that the output signal will not be distorted, it is essential that the base bias voltage does not drift.

The two main causes for changes in the base bias voltage or current are: (1) heat generated in the transistor causing

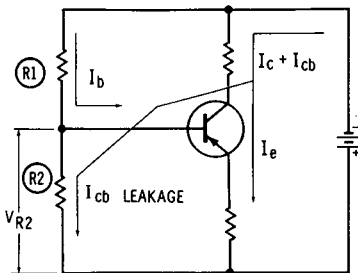

Fig. 8-6. Direction of I_{cb} leakage.

leakage, and decreasing the resistance from base to emitter, and (2) changes in the battery supply voltage. The former is by far the most important.

The leakage current, I_{cb} , shown in Fig. 8-6, is present in all transistors and is the cause of the principal disadvantage of all semiconductors as compared to vacuum tubes. This leakage current is sometimes specified by manufacturers under only one set of conditions. However, it increases in proportion to the temperature of the junctions in the transistor. I_{cb} exhibits the following characteristics:

1. It doubles for each 10°C of junction temperature in germanium transistors.
2. Its direction is always in *opposition* to the desired base current.
3. It causes an increase in collector current which is uncontrolled by the base current.

Thus, the base voltage, V_{r2} in Fig. 8-6, must always be well regulated. The regulation is usually achieved by use of a voltage divider such as R1 and R2.

Voltage measurements in the biasing system are so important to successful troubleshooting in transistor circuits that we will take one more example:

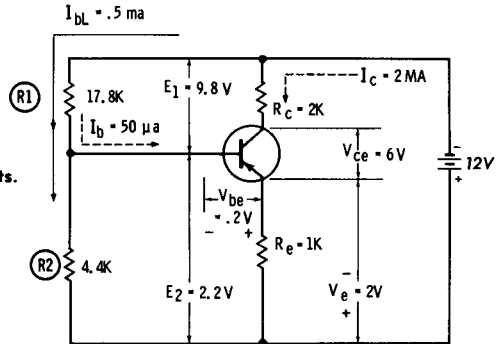

Fig. 8-7. Bias-voltage measurements.

In Fig. 8-7, a transistor is shown in which there is 2 ma of I_c when $V_{be} = 0.2V$, $I_b = 50$ microamps and $V_{ce} = 6V$.

$$V_e = (R_e) (I_e)$$

Neglecting I_b as part of I_e , then:*

$$R_e = \frac{10 V_{be}}{I_e} = \frac{2V}{2 \text{ ma}} = 1000 \text{ ohms}$$

$$V_e = 1000 \times 2 \text{ ma} = 2V$$

To find the value of E2:

E2 must be larger than V_e by the amount of the required V_{be} :

$$\begin{aligned} E2 &= V_e + V_{be} \\ &= (2) + (.2) \\ &= 2.2V \end{aligned}$$

To find the value of E1:

$$\begin{aligned} E1 &= 12 - E2 \\ &= 12 - 2.2 \\ &= 9.8V \end{aligned}$$

* R_e is usually chosen to make $V_{re} = 10 V_{be}$. This ensures good stability.

To find the value of R2:

First choose any small bleeder current, I_{bl} . It is standard design practice to choose I_{bl} ten times the required base current it is supposed to stabilize.

$$\begin{aligned} I_{bl} &= 10 I_b \\ &= 10 \times 50 \text{ microamps} \\ &= 500 \text{ microamps (or 0.5 ma)} \end{aligned}$$

Then :

$$R2 = \frac{E2}{I_{bl}} = \frac{2.2V}{0.5 \text{ ma}} = 4.4K$$

To find the value of R1:

The current through R1 is the sum of :

$$\begin{aligned} I_{r1} &= I_{bl} + I_b \\ &= 0.5 \text{ ma} + 50 \text{ microamps} \\ &= 0.5 \text{ ma} + .05 \text{ ma} \\ &= 0.55 \text{ ma} \end{aligned}$$

and :

$$\begin{aligned} R1 &= \frac{E1}{I_{r1}} \\ &= \frac{9.8V}{0.55 \text{ ma}} \\ &= 17.8K \end{aligned}$$

Almost every failure in transistor circuits will cause a change in one of these values. The necessity for understanding these calculations arises from two facts: (1) all the values are interdependent, and a change in one causes changes in others; and (2) all this information about the circuit is not given in the schematics, so the technician may have to calculate to find whether some measured value is correct in relation to other measurements.

AUTOMATIC GAIN CONTROL OF TRANSISTOR STAGES

The partial schematic in Fig. 8-8 illustrates the AVC connections in transistor receivers. The bleeder system which sets the base voltage is modified somewhat. Resistor R1 is still

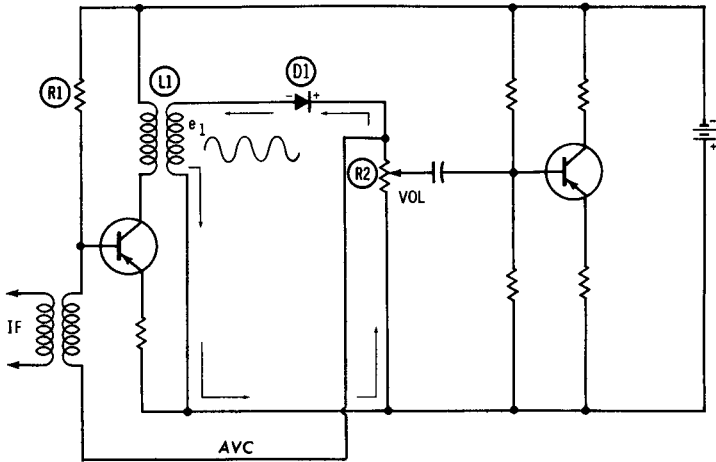

Fig. 8-8. Simplified AVC circuit.

present and still returns to the negative battery line, but the second resistor, R2 in the bleeder system, is missing. It is replaced by the volume control, which also serves as the detector load resistor.

Notice the loop consisting of L1, D1, and the volume control. The bottom end of L1 is returned to the positive battery line. The cathode of the diode returns, via the volume control, to the same point.

With no bias on the diode, a signal voltage, e_1 , appears in L1 and causes current to flow in the direction shown on the half-cycle when the diode plate is positive. In this way, the carrier is rectified, and audio variations appear across the volume control. This is like the familiar tube-type detector circuit.

The difference to be noted in PNP transistor circuits is that the polarity at the top of the volume control is positive. It is at this point that the AVC line is connected. So, the AVC voltage applied to PNP stages is a *positive* voltage with respect to the emitter which is returned to the bottom of the volume control.

The resistance of the volume control takes the place of R2 in the base voltage-divider system. This resistance provides fixed bias when there is no signal and makes the base of the IF stage more positive (less negative) when a carrier appears at the detector diode.

The troubleshooting technician must realize that when PNP's are used in the IF stages, the base must *always* be nega-

tive with respect to the emitter. While the AVC voltage is positive, it is very small and causes only a slight change in I_b . If the base voltage on a PNP in an IF stage is ever found equal to the emitter, or positive with respect to it, the stage is not operating correctly.

Fig. 8-9 shows two circuits in which the AVC line is connected to the "cold" end of the 1st IF-transformer secondary. AVC is not always applied to all stages because of the different base currents required by various transistors. Also, a separate resistor is sometimes used for the detector load, rather than using the volume control. The examples shown in Fig. 8-9 are typical.

C15 in Fig. 8-9A is the IF bypass capacitor across the detector load. Its purpose is to present a low impedance to the IF carrier and sidebands so that they will not develop voltage across the detector load resistor. The beat frequency between the sidebands and the carrier is the desired audio signal which produces voltages across the load resistor, since audio frequencies are not shorted out by the bypass capacitor. This capacitor plays no part in the AVC, but leakage here will reduce the AVC voltage. If C15 in Fig. 8-9(B) is shorted or leaky, it will reduce the audio signal and destroy the fixed bias on the IF stage, because R15 is part of the base-bias voltage divider. This condition may be confusing to the troubleshooter because the receiver appears to have two different troubles—the audio system is not working, and one IF stage may be cut off.

R14 and C14 in Fig. 8-9(B) form the AVC filter. They serve the same purpose as similar components in a tube-type receiver. However, the value of the resistor is much smaller and the value of the capacitor much larger in transistor receivers. A shorted capacitor affects the bias of the IF stage as described before. An open capacitor allows the base voltage to vary with the audio modulation, producing distortion. The distortion is much greater in transistor circuits than in tube-type receivers when the AVC filter capacitor is open, however.

C11 and C12 in Fig. 8-9A are neutralizing capacitors to provide negative feedback, preventing the stage from oscillating. The internal capacity of a transistor is greater than that of a vacuum tube, and positive feedback from the collector to the base occurs. The capacitors are chosen to be equal to the internal capacity, and will provide sufficient negative voltage feedback to cancel the effect of the internal capacity.

Diode D1 is called an auxiliary AVC, and is for overload protection in the event of a large signal input. The operation

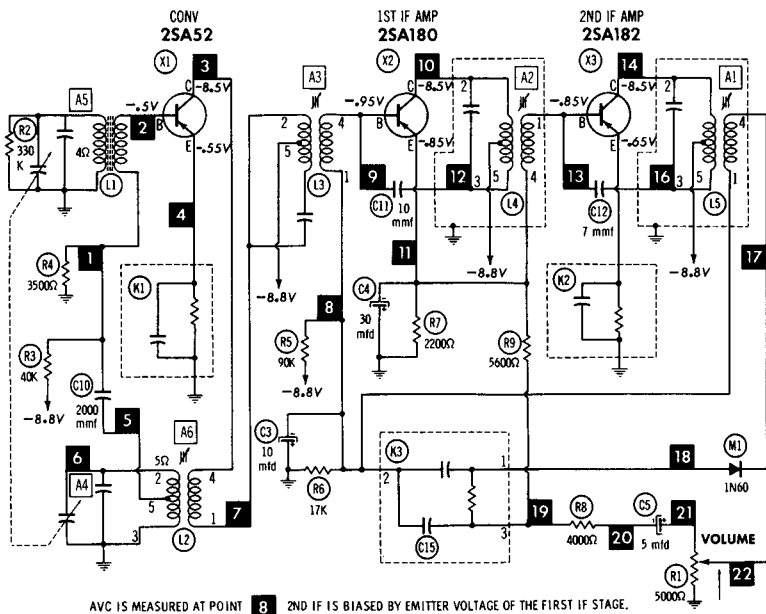

(A) Ungrounded detector load resistor.

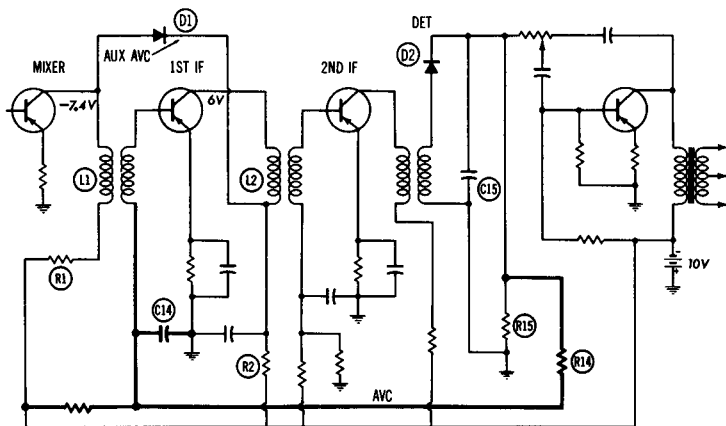

NOTE POLARITY OF DETECTOR DIODES IN TWO CIRCUITS.
AUXILIARY AVC DIODE IS NORMALLY CUT OFF.

(B) Grounded detector load resistor.

Fig. 8-9. Typical AVC circuits.

is explained in Fig. 8-10. Part A shows the circuit of Fig. 8-9B, but redrawn without resistors R1 and R2.

The resistance of the diode essentially shunts the primary of L1 so that when the internal resistance of the diode is low, the output of the first stage is reduced. Part B of Fig. 8-10 shows the connections redrawn without the coils to show the DC circuitry involved.

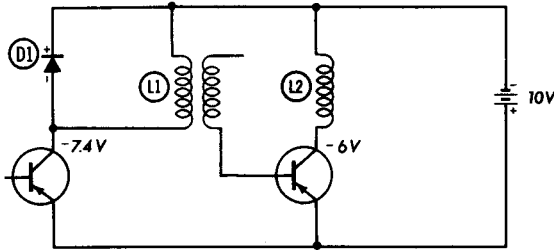

(A) Fig. 8-7B redrawn without resistor.

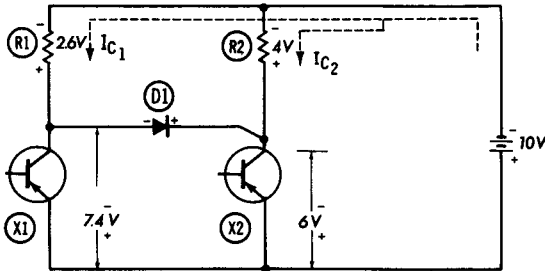

(B) DC circuitry of D1.

Fig. 8-10. Auxiliary AVC simplified.

The voltages on the diode cathode and anode are determined by R1, R2, and the collector-emitter resistances of the transistors. The cathode voltage measured to ground is -6V , and the voltage on the anode is -7.4V . The diode is reverse-biased, and its resistance is extremely high, making negligible its effect in the circuit of part A.

However, if a strong signal were applied, the collector of X1 might drop to -5 volts due to increased collector current through R1. The diode would then conduct because its anode would be positive with respect to the -6 volts on its cathode. In this condition, the internal resistance of the diode is lowered, and its shunting effect is greater.

In addition, the overload protection is enhanced by the normal action of the receiver's AVC. An increase in signal strength is reflected as a decrease in the negative bias on X2,

and its collector current is reduced. This makes the cathode of the diode more negative because of less drop through R2, with resulting lower resistance shunting the primary of T1.

The reverse bias on the diode under normal signal conditions is set by the circuit designer so that the diode does not begin to conduct until after a predetermined signal strength has been reached. With judicious choice of diode characteristics and bias voltage, this circuit is a very effective auxiliary AVC.

Symptoms of failure important to the troubleshooter will immediately suggest themselves. High leakage or low internal resistance in the diode produces excessive shunting action across the output coil. A change in R1 or R2, or in the characteristics of the transistors, upsets the intended reverse bias on the diode.

POWER SUPPLY AND DECOUPLING

Transistor circuits are much more sensitive to change in the power-supply voltage than vacuum-tube circuits. Also, since the supply voltage is small for the amount of power delivered, the current drawn is much greater than in a comparable vacuum-tube circuit using voltages in the vicinity of 100 volts. This means that the transistor power supply must have low internal resistance, and somewhat better voltage regulation than is found in power supplies for home-type vacuum-tube radios.

A battery is therefore the natural choice of power source for transistorized equipment, and several types have been especially developed for this application. The construction and specific characteristics of the batteries are not of much concern to the technician, except to note that the internal resistance must be low to give the required voltage regulation with the varying current load. The internal resistance of batteries tends to increase as they become exhausted with use, or even as they age on the shelf, and this leads to many symptoms of failure in transistorized equipment. A check of the battery terminal voltage *under load* is therefore one of the early tests that should always be applied to transistor radios which do not perform properly.

Many technicians have devised home-made AC power supplies to use on transistor receivers undergoing tests and repair. The ordinary battery eliminator used for auto radios usually works well if its voltage output is adjustable. These eliminators have the necessary low internal resistance. In some

cases, it is helpful to add a 500- to 1000-mfd electrolytic capacitor across the output terminals to improve the filtering.

Many technicians are surprised to find a complete pi-type RC filter included in battery-powered transistor radios. Fig. 8-11 shows a few examples taken from actual circuits. The capacitances used are likely to be somewhat higher than those in vacuum-tube radios because the current variations will be greater. The value of the series resistor is smaller for the same reason. The voltage ratings of the capacitors will be less than 25V. Failure of these units is just as common as it is in tube-type receivers, but the symptoms are different.

When batteries are used, there is no 60- or 120-cycle hum to be filtered. The purpose of these capacitors is to maintain the supply voltage constant with the large current variations resulting from the demands of the transistor audio output stage which must furnish the necessary audio power. The filter

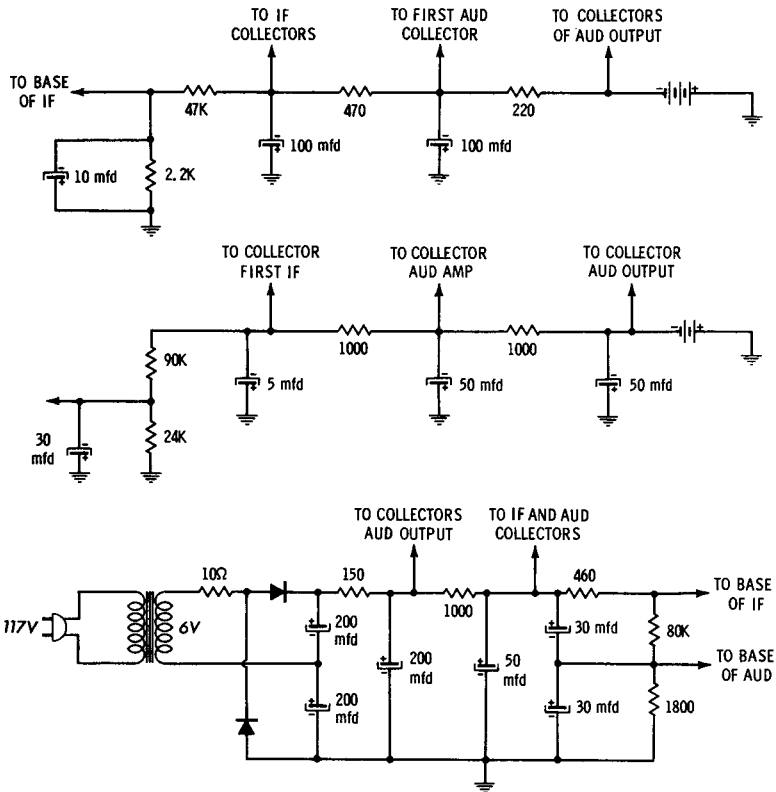

Fig. 8-11. Examples of decoupling.

is actually an audio bypass across the battery. This kind of filtering is called *decoupling*.

In addition to the decoupling at the battery, transistor radios usually have several other decoupling filters inserted in the supply lines to the various stages. (See Fig. 8-11.) The general rule for the value of the resistor and capacitor in decoupling networks is that the resistor should be 1/10 of the impedance in the collector or emitter circuits of the stage, and the reactance of the capacitor should be 1/10 of the resistor value at the lowest frequency to be filtered.

AUDIO OUTPUT STAGES

The power output stage in pocket-type transistor radios delivers from 0.1 to 0.5 watt of power. The larger receivers can produce from 1 to 3 watts. While these seem to be very small amounts of power, it is important to remember that the voltage supplied to the output stage is seldom more than 9 volts. If 2 watts were to be developed, this would require approximately 220 ma of current from the battery. The problem of maintaining a stable output voltage from the battery supply becomes more difficult as the power-output requirement increases, and symptoms resulting from defective decoupling circuits are more prevalent.

In order to obtain better efficiency in the output stage, and to allow the use of smaller transistors, the stage is almost always a push-pull circuit operating close to class B. This means that the transistors will have very little forward bias, which means that they are nearly cut off when no signal is applied.

It is interesting to note that if one transistor in a push-pull output stage is disconnected, the change in the output from the speaker is barely noticeable. But the technician must realize that the one remaining transistor is now subjected to much different operating conditions. Some typical push-pull stages are shown in Fig. 8-12.

Notice that transformer coupling is most commonly used throughout. This method is somewhat more expensive, and the fidelity is limited by the transformer. When one considers these disadvantages in addition to the fact that transformers are large and relatively heavy components to be included in miniature radios, the transformer-coupled circuit seems a poor choice.

However, the loss of fidelity is not an important factor in the smaller radios, since the speaker and cabinet enclosure

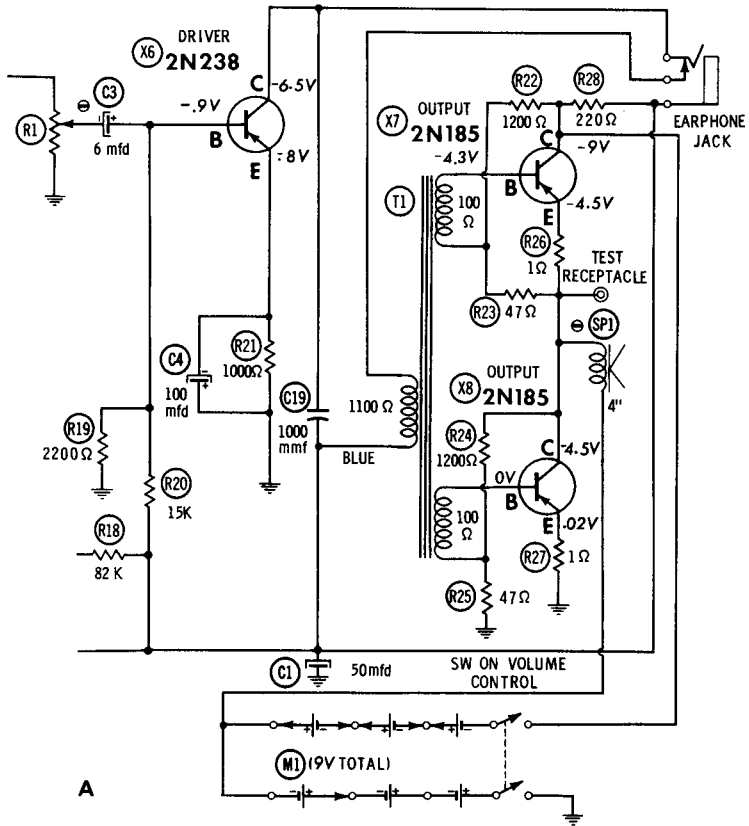
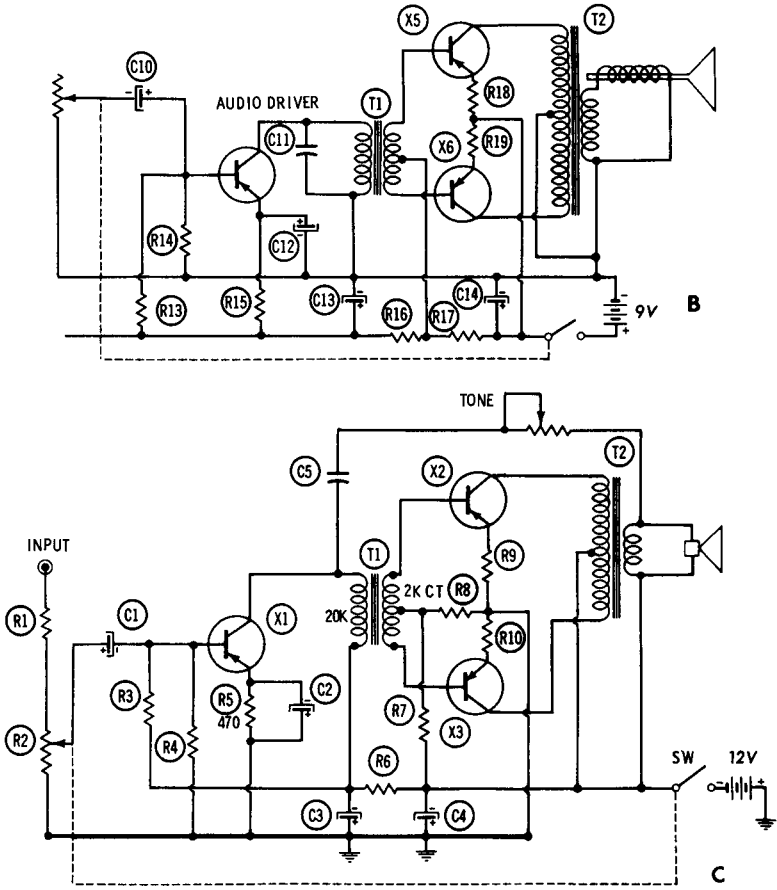

Fig. 8-12. Transistor

must be so small that the fidelity is limited anyway. The cost of the transformer is offset by the increased efficiency obtained, and by the possibility of matching any inexpensive speaker.

The output transformer is eliminated in the circuit shown in part A of Fig. 8-12 by placing a special speaker in series with the emitter-collector line. The transistors are driven 180° out of phase and are in series for the output current. When the upper transistor is conducting, the lower one is going out of conduction, and thus current from the emitter of the upper transistor returns through the speaker. When the lower transistor conducts and the upper one is out of conduction, current is drawn up through the speaker.



push-pull output stages.

Audio Distortion

An example of one way in which distortion can occur due to a component failure is shown in part A of Fig. 8-13, in which two audio voltage amplifiers are resistance coupled. If the coupling capacitor between the two stages is leaky, an unwanted current, I_L , will flow through the capacitor, increasing the forward bias on the base of X2.

Suppose that X2 were originally biased at 50 microamps of base current, and that the incoming signal consists of ± 25 microamps. Without the leakage, the base current of X2 was supposed to vary from 50 to 75 microamps on one half of the input cycle, and from 50 to 25 microamps on the other half.

As shown on the graph in part B of the illustration, this would cause a change in the output signal voltage, V_{ce} , corresponding exactly to the shape of the input waveform. This shows a correctly operating class-A stage with no distortion.

The results of the leakage, I_L , through the coupling capacitor can be seen in part C. Assume that the capacitor leaks

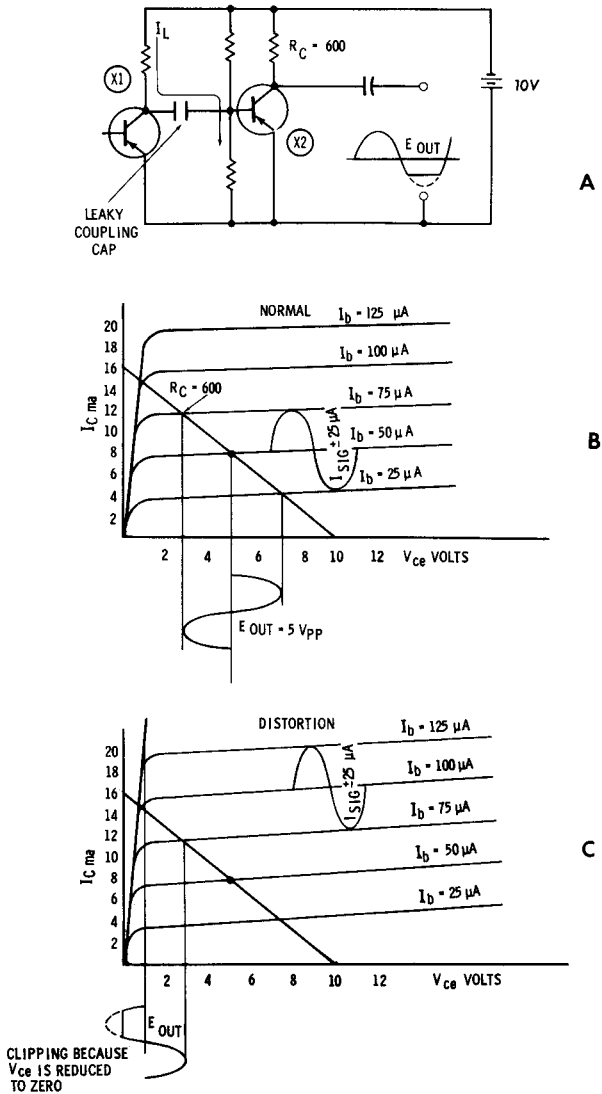

Fig. 8-13. Audio distortion.

enough to increase the forward bias to 100 microamps. The same signal input now starts its swing from the line, $I_b = 100$. The upward swing of the base current to 125 microamps should cause about 19.5 ma of collector current to flow, except that the load line shows this to be impossible.

19.5 ma of current through the 600 ohms of R_c would result in $600 \times 19.5 \text{ ma} = 11.7$ volts dropped across R_c . But the battery voltage is only 10 volts, so only 10 volts can appear across R_c . This will reduce V_{ce} to zero. The output signal, V_{ce} , drops to zero before the input signal has reached its peak, and the result is clipping on half of the output waveform.

Similar results can occur from a change in the value of R_c which changes the slope of the load line, or from excessive input signal. The same kind of distortion is caused by overheating in high-power transistors.

An emitter resistor greatly improves the biasing stability. If one had been used in our example here, much more leakage could be tolerated before clipping would occur, because the increased collector current would make the emitter more negative, reducing the forward bias.

Transistorized Hi-Fi

Transformerless high-fidelity transistorized output stages are used in larger, more expensive equipment. One circuit is shown in Fig. 8-14.* This amplifier illustrates some features of interest to the troubleshooter.

Fuses are used in the emitter leads of X4 and X5. Besides providing protection against transistor burnout due to excessive current, the fuses also give additional stabilization because they insert about 1 ohm of emitter resistance. X2 and X3 are biased by the 1N91 diodes. (The voltage drop across a diode, after it begins to conduct, is practically constant over a large range of current.) This method of stabilization is frequently used in more expensive equipment. A large amount of negative feedback is used, as is common practice in transistorized high-fidelity equipment. The amplifier is described as capable of delivering, with a 1-volt input, 8 watts output directly into an 8- or 16-ohm speaker. Practically flat response from 30 cycles to 50 kc with a 1-watt output is possible.

Troubleshooting this type of equipment is not difficult because the critical components can be seen immediately in the schematic. Failure of the 1N91 diodes, for example, upsets the biasing of X2 and X3 with consequent distortion or changes

* This circuit is described fully in the *General Electric Transistor Manual*, 1962, p. 130.

in gain. Leakage or a change in value of the electrolytic capacitors or resistors in the feedback circuits, such as R5 and C3, results in loss of gain or distortion. Replacing one of the fuses with a type having a different resistance will change the bias on one of the transistors. X4 and X5, as well as X2 and X3, are operating in class-B, and so the technician should look for

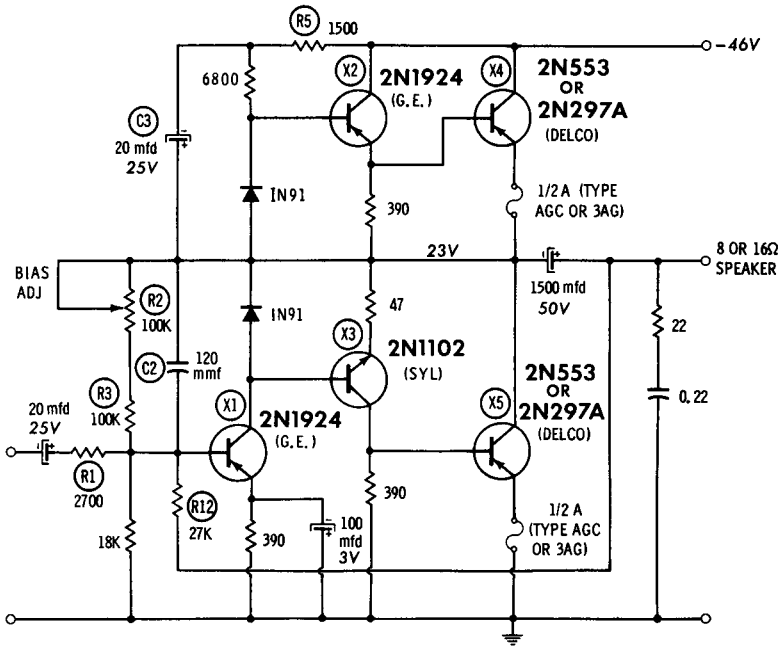

Fig. 8-14. A high-fidelity transistor amplifier.

changes in the forward bias when there is loss of gain. The forward bias on a class-B stage should be almost zero to keep the transistors practically cut off when no signal is applied. When one transistor fails in a push-pull combination, such as the ones used in this circuit, the change in output from the speaker is definitely noticeable.

THE MIXER/OSCILLATOR STAGE

The circuitry of the converter stage is not as well standardized in transistor receivers as it is in vacuum-tube receivers, and nearly every model will have some variations. In addition, many of the better transistor receivers include an RF amplifier stage between the loop antenna and the converter.

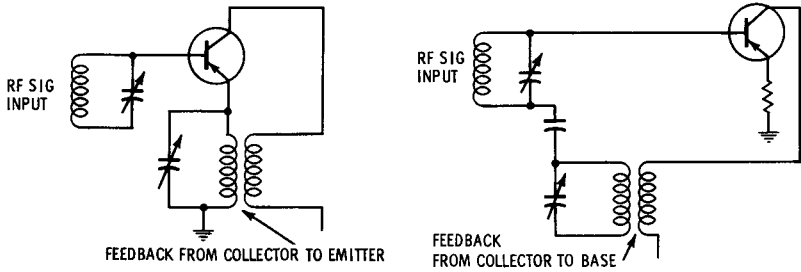

Fig. 8-15. A simplified mixer/oscillator stage.

Two elements of the converter circuitry which most stages have in common are shown in Fig. 8-15. The RF input signal is fed to the base, and there is always a provision for feedback either from the collector to the emitter, as shown in Part A, or from the collector to the base, as shown in Part B.

The operation is essentially the same in both circuits. The current from the collector excites the tuned circuit in the feedback transformer, thus setting up oscillation. The feedback transformer is tuned 455 kc higher than the incoming RF signal to provide the proper beat-frequency.

Whether the oscillator signal is fed into the emitter or coupled to the base through a capacitor makes very little difference. In both cases, it will mix with the incoming RF, and the beat at 455 kc can be taken from a tuned transformer inserted in series with the collector. For simplicity, this output transformer is omitted in Fig. 8-15, as is the biasing network. Fig. 8-16 shows a complete stage, including :

1. C1 and C2, the main tuning capacitors coupled to the same shaft.
2. C3 and C4, the screwdriver-adjusted alignment capacitors for adjusting the tracking.
3. T1, the oscillator tuned circuit operating at 1175 kc when the radio is tuned to a station at 720 kc.
4. R1 and R2, the biasing network which fixes the base voltage.
5. T2, the output transformer tuned to 455 kc, the difference beat between the incoming RF and the oscillator signals.
6. C5, which couples the oscillator signals.
7. C6, which prevents the bias voltage from being shorted to ground through the loop antenna.
8. R3 and C8, a decoupling network which prevents the collector signal from appearing in the base bias network and thereby being fed back to the base.

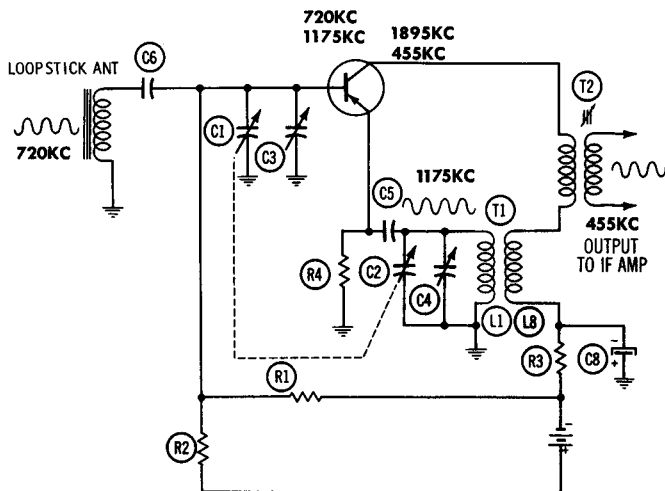

Fig. 8-16. A complete mixer/oscillator stage.

Fig. 8-17 uses feedback from collector to base, and employs tapped coils. The variations are endless, and each must be studied for differences which determine the approach the troubleshooter will take. Besides knowing the key test points to be described in Chapter 9, the technician must realize that the circuit performs two functions—the amplification of in-

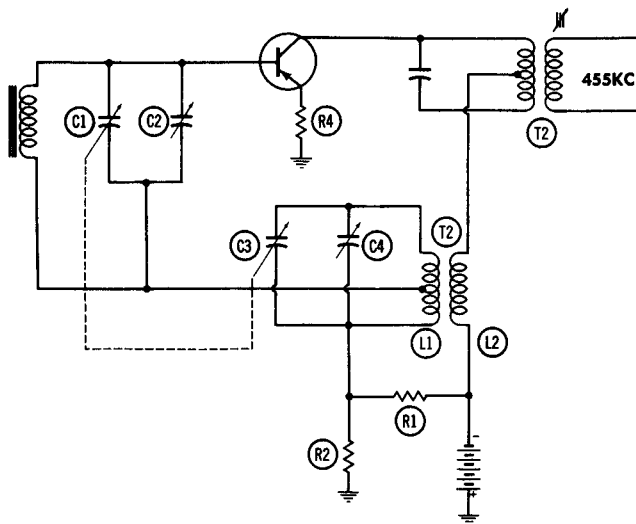

Fig. 8-17. A mixer/oscillator stage with tapped coils.

coming signals, and the generation of the oscillator signal. When certain of the components are defective, both functions will be disabled; in other cases only one of the functions fails.

Symptoms and testing techniques are classified accordingly. In Fig. 8-16, if either L1 in the oscillator transformer, or C5 fails, only the oscillator will be disabled, and the radio will still respond normally to a 455-kc signal fed to the base from a signal generator. But if the lower part of L1 in Fig. 8-17 were open, the entire stage would be dead because of loss of forward bias on the base.

Similarly, the technician would take a different approach to the two circuits if the antenna coil were open. In Fig. 8-16, the oscillator would still be operating but no stations could be tuned in. Fig. 8-17, the oscillator would not be running. In Fig. 8-16, a shorted RF tuning capacitor, C1, will stop the oscillator by removing the base bias; in Fig. 8-17, it would not.

REVIEW QUESTIONS

1. Look up the characteristics of three PNP transistors.
 - a. One suitable for the converter stage in a broadcast receiver.
 - b. One suitable to drive a high-powered audio-output stage.
 - c. One suitable for use in a 10-watt, push-pull, audio output stage.

State:

1. Maximum collector-to-emitter voltage for each.
2. Maximum collector current for each.
3. Operating temperature for each.
4. Leakage current for each at a specific temperature.

Make a sketch of each, labeling the three terminals.

2. Look up the schematic of a radio which uses separate transistors for the oscillator and converter, and draw the circuits.
3. Construct a graph showing the load line and operating point of the transistor stage shown on page 130.
4. In the circuit on page 130, the input signal swings ± 50 microamps. What is the peak-to-peak output voltage?
5. Using a transistor which has 4 ma of collector current when V_{ce} is 6 volts, an I_b of 20 microamps, a V_{be} of 0.2 volt, and using a 9V battery, draw the schematic of a voltage amplifier suitable to follow the detector in a receiver. Include a volume control, a tone control, emitter resistor, and biasing network. Label the values of all parts.

6. In what way is the AVC in a transistor radio different from that in a vacuum-tube circuit? Illustrate with partial schematics.
7. In the circuit below, a technician measured the two voltages indicated. By making some calculations and referring to the collector-characteristic graph, he was able to determine whether the stage was operating correctly. Perform the necessary calculations and state whether the stage is operating normally.

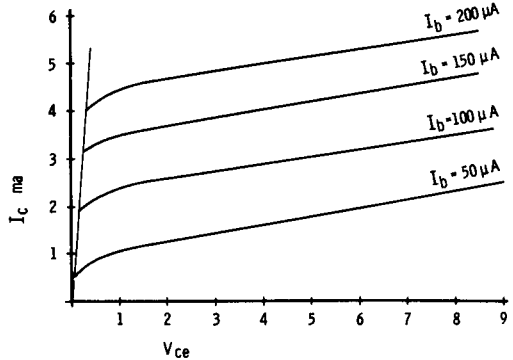
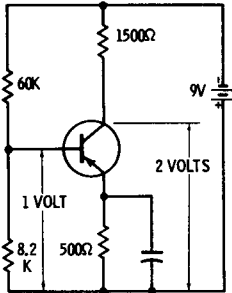

8. Look up the schematic of a converter circuit, and make a drawing of a stage.
 - a. Indicate one component whose failure would prevent reception of station but leave the oscillator running.
 - b. Indicate one component whose failure would stop oscillation without preventing passage through the stage of a 455-kc signal injected at the antenna.

9

No-Signal Symptom in Transistor Receivers

The charts at the end of this chapter are more complex than those used previously, because, in transistorized receivers, the symptoms may overlap and some of the tests appear in more than one of the charts. In addition, the stages are complicated by the bias network, which is always necessary and requires extra testing. It is often important to consider current measurements which are not usually necessary in servicing vacuum-tube equipment.

Besides the electronic differences, servicing transistor receivers is complicated by the compactness of the printed-circuit board and the difficulty in identifying transistor leads and other components. The schematic and technical data are sometimes unavailable, and replacement parts cannot be obtained because the original part cannot be identified. It is extremely difficult to locate test points in the circuits and make measurements on a printed-circuit board without schematic data.

Despite the difficulties involved, transistor radio servicing can be profitable to the technician who has the knowledge, skill, and tools to do the work efficiently. Expert workmen in all trades exhibit one characteristic in common—they possess specialized tools for their work, and they have a well-arranged place in which to work. Therefore, good advice to the beginning technician who considers transistor radio servicing is to obtain the special tools and equipment needed and arrange a place where the job can be “set up” and worked on properly. This will include:

1. DC milliammeter with ranges from 0.1 ma up to 50 ma.
2. Needle-point probes and miniature clips.
3. A suitable power supply.

4. Tools for working on printed-circuit boards, including a razor blade mounted in a holder similar to the ones used in model building.
5. An audio signal source capable of injecting signals into low-impedance circuits.
6. An RF signal source.
7. A work space lighted from beneath through frosted glass to facilitate looking through semitransparent circuit boards which have printed wiring and components on both sides.

In connection with the preceding list, the importance of having a schematic and a pictorial view of the circuit board is emphasized. The beginning technician soon learns that without the technical data it is impossible to make profitable repairs on transistor radios. Many of these receivers are low-priced units, and the work must be done quickly in order to keep the repair costs commensurate with the value of the equipment. It is embarrassing to present a bill which includes a charge for 4 or 5 hours of labor to replace a part whose value is only a few cents, and it is doubtful that the owner of the receiver would recommend the technician even if his radio was satisfactorily repaired. In most cases, repairs cannot be completed without the technical data; and even when they can be, there will be either little satisfaction to the customer or no profit to the technician. Follow the rule of refusing to take repair work which cannot be completed profitably.

SYMPTOM—NO SIGNALS

9-1 This condition often means a completely dead receiver. But there are no tube filaments to observe, and one cannot tell by listening whether to suspect the power supply or some circuit such as the audio output stage. For this reason, the first step is to check the battery. The battery voltage should be measured while under load (with the receiver turned on), and if it is more than one volt below its rating, it should be replaced after repairs are completed. But during repairs, it is better to use an AC-powered supply which is metered.

TEST POINT 1, CHART VI MEASURE INPUT CURRENT

9-2 The symptom of *No Signals* occurs in one of three ways—with very low (or zero) input current, with normal input

current, or with very high input current. Since the testing procedures will be different for each of these conditions, the first test is to determine the input current by inserting a 0- to 50-ma meter in series with one battery lead. The ammeter on the ordinary battery eliminator will not respond to the small currents drawn by transistor equipment, so an extra meter will be needed. The correct currents at minimum and normal volume are always stated on the front of the Sams PHOTOFACT® for that particular receiver. The rating at normal volume will be much higher than at minimum because of the increase in conduction of the class-B output stage which is practically cut off when there is no audio signal to drive it.

Fig. 9-1 illustrates the procedure thus far. The decision as to which chart to use as a guide is based on the amount of input current drawn by the receiver. Each of the charts will be discussed separately.

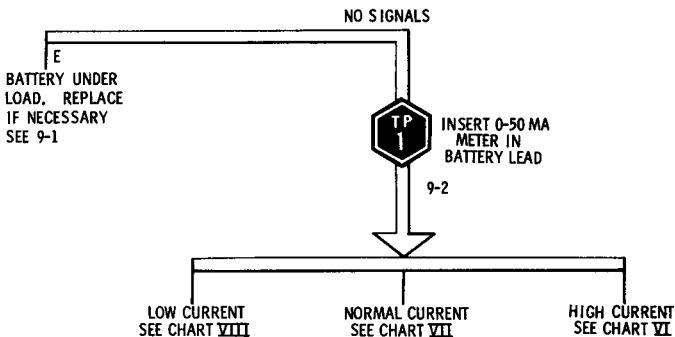

Fig. 9-1. Initial testing procedure.

TEST POINT 2, CHART VI

SHORT BASE TO EMITTER IN EACH STAGE

9-3 Chart VI is for the condition of *No Signals* with higher than normal input current. Since this condition is most likely to result from shorted or leaking electrolytics in the battery decoupling networks, it is best to check these first. The leaky capacitor can be identified by the decrease in input current when it is disconnected. If all decoupling circuits seem to be functioning properly, and no parts are overheated by the excessive current, the testing proceeds with TEST POINT 2.

9-4 When the emitter is shorted to the base, zero bias is applied to the transistor base and, in this state, it is supposed to be cut off. If a large change in the input current results from shorting the base to the emitter of a particular stage, it

is probably that stage which is responsible for the excessive current. Further, since a normal transistor cuts off when the bias is removed, it is clear that the defect is in the bias circuitry and not in the transistor itself.

Tests When Input Current Decreases

9-5 In CHART VI under TEST POINT 2 are several suggested tests. Figs. 9-2, 9-3, and 9-4 show examples of the components mentioned. In Fig. 9-2, R13 and R14 are the bias resistors.

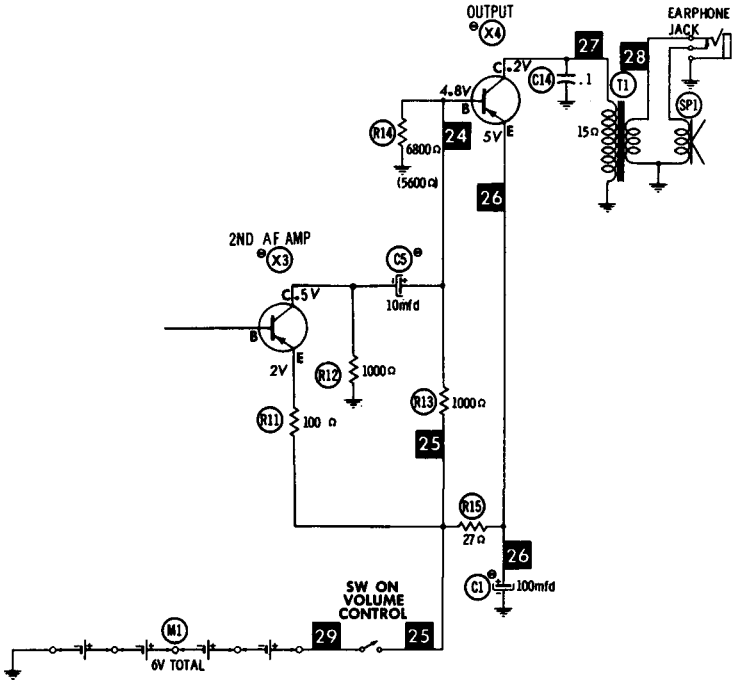

Fig. 9-2. Test points in the output stage of a transistor receiver.

tors, and they should both be checked, especially R13, for if this resistance is open, the forward bias on the output transistor will be greater.

It is advisable to measure between points which are indicated on the schematic and on the pictorial drawing of the circuit board, such as between points **24** and **25** to check the resistance of R13. Besides making it easier to locate the test points accurately, this practice also provides an additional check on the condition of the printed connections to the component being checked.

One precaution should be mentioned when using the ohmmeter to check components which are connected to elements of a transistor. The transistor, unlike its vacuum-tube counterpart, is activated by the voltage from the ohmmeter and thus becomes an active part of the circuits, even though the power supply to the receiver is disconnected. Fig. 9-5 shows how an erroneous reading could be obtained because of conduction through the emitter-base junction when the ohmmeter polarity puts forward bias on the transistor. An unsuspecting technician might conclude from the reading in part A of Fig. 9-5 that the bias resistor had changed value. Whenever the possibility of such an error exists, it is best to reverse the ohmmeter leads and repeat the measurement.

If C5 in Fig. 9-2 is partially shorted there will also be excessive negative voltage on the base of the output transistor, resulting in very heavy input current which will decrease when the base and emitter are shorted together. The voltage readings at the elements of the transistors in Fig. 9-2 may be confusing because they are stated as positive voltages relative to ground. Some schematics are drawn this way with the negative terminal of the battery grounded and the collectors of the PNP transistors returned to ground. Since all voltages are measured from chassis ground, the collector voltage on X3, for example, is 0.5 volt positive with respect to chassis ground. It is still a negative voltage with respect to the emitter line numbered [25] and [26] on the schematic, however.

Fig. 9-3 is drawn in the usual fashion, with the emitters grounded and the positive terminal of the battery grounded. Note that the primary of transformer T1 is connected to -5.7 volts, and that the secondary is connected to the bases of the output transistors. Leakage through the transformer could put nearly 5.7 volts negative on the bases of the output transistors and cause excessive current to be drawn by the stage. There probably would be no output signal because the saturated output transistors would be conducting simultaneously, and the input signal would be too small to have any effect on collector currents. SERVICING CHART VI suggests checking the transformer by opening the battery end of the primary and rechecking the input current at TEST POINT 1. The abbreviation, OPN, meaning to open the connection, is used in the chart for this test; this is the first time this symbol has been used in any of the Servicing Charts.

Other possible causes of excessive current in the AF and driver stages (X5 and X6 in Fig. 9-3) are the emitter bypass capacitors, C7 and C9. X6 is supposed to have -1.4 volts on

Fig. 9-3. Audio section of a transistor receiver.

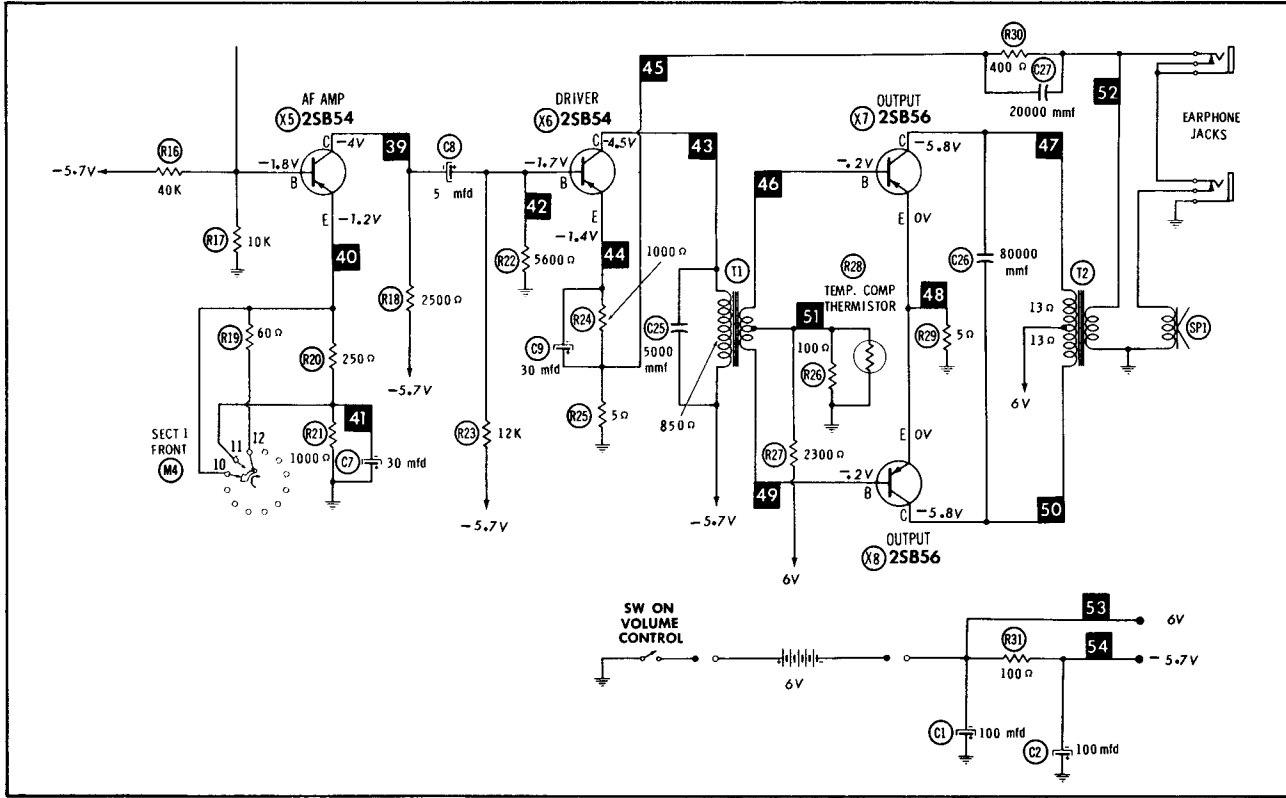

its emitter and -1.7 volts on its base, thus placing -0.3 volt of forward bias on the base. If C9 is shorted, the emitter voltage will be zero, and the base voltage will remain nearly the same. This will result in about -1.7 volts of forward bias on the base and greatly increase the input current. If the base and emitter are shorted together, as in TEST POINT 2, the bias will disappear, and the input current will return to a reasonable value.

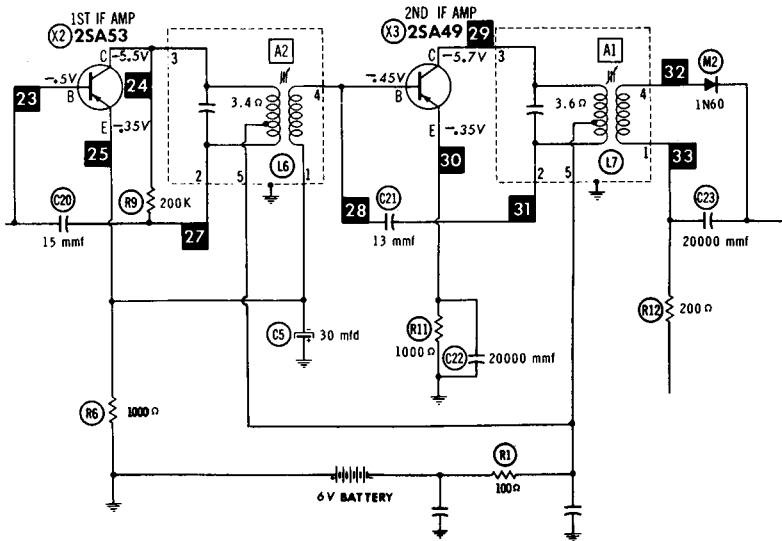

Fig. 9-4. Transistor receiver IF-amplifier section.

Fig. 9-4 shows two IF stages that could cause excessive input current due to increased forward bias. If the IF transformer L6 has a short from primary to secondary, the same condition will prevail, as noted in the case of T1 in Fig. 9-3. Another cause is a shorted neutralizing capacitor, such as C21 in Fig. 9-4. This capacitor can easily be eliminated as a suspected faulty part by disconnecting one end of it and checking the input current.

When the transistor itself is the cause of excessive input current, it is unlikely that the current will be reduced by shorting the base to the emitter. The remote possibility does exist, however, that the gain of the transistor has greatly increased, or that a transistor having characteristics greatly different from the original has been used as a replacement. In such a case, the transistor can be roughly tested with an ohmmeter in the following manner.

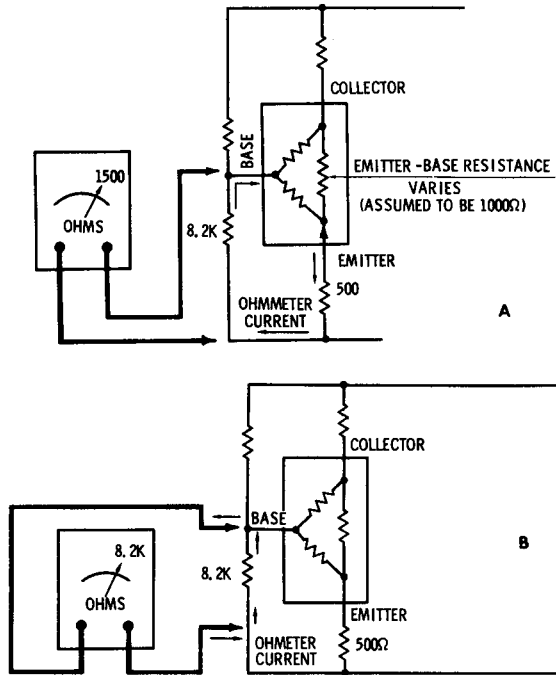

Fig. 9-5. An Ohmmeter can cause erroneous readings in a transistor circuit.

Remove the transistor from the circuit by disconnecting at least two leads, and examine the bottom to determine which lead is from each of the elements. Fig. 9-6 shows that the base lead is always in the middle, and that when two of the leads

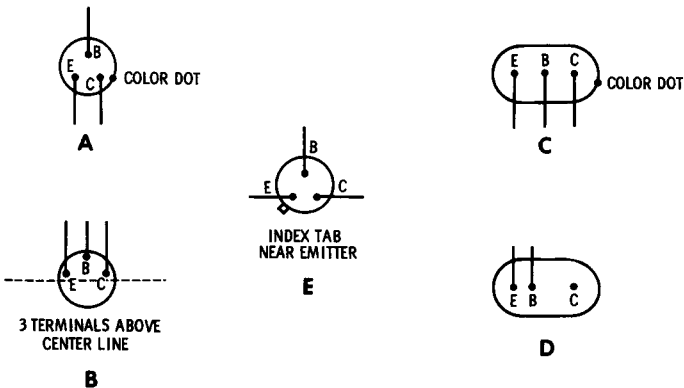

Fig. 9-6. Identification of transistor leads.

are closer together, they are the base and emitter. When the leads are evenly spaced, the collector is identified by a colored dot.

9-6 An ordinary ohmmeter on the $R \times 100$ range will supply enough voltage and current for checking any low-power transistor. Table 9-1 lists the average resistances to be expected with the probes used in either polarity.

**TABLE 9-1. Resistance Reading for Low-Power Transistors
(use $R \times 100$ range)**

Meter Connection	Forward Reading	Reverse Reading
base to emitter	0 to 1000 ohms	over 20K
base to collector	0 to 500 ohms	over 20K
emitter to collector (base open)		
RF type	5K to 50K	5K to 50K
AF type	500 to 25K	500 to 25K

**TABLE 9-2. Resistance Reading for High-Power Transistors
(use $R \times 1$ range)***

Meter Connection	Forward Reading	Reverse Reading
base to emitter	2 to 10 ohms	over 10K
emitter to collector base open	100 to 1K	100 to 1K
base shorted to collector	10 to 100 ohms	over 10K

* In power transistors which have only two leads, the collector is connected to the outer shell.

The resistances given in the tables are only general guides; the actual value depends on the voltage applied across the junction and will be different with various makes of ohmmeters. Also, some transistors fail only after they have been in use long enough to raise the temperature of the junctions. This is particularly true of the small power transistors commonly used in the push-pull output stages of receivers. The best way to check a transistor which has such a failure is to substitute one known to be good.

A different approach to using the ohmmeter is preferred by many technicians, although it is really not any more reliable than other methods. Begin by placing the probes across the emitter and collector leads. Reverse them until the polarity which gives the minimum resistance is found. Next, adjust the ohmmeter to the lowest scale which gives a nearly full-scale deflection (minimum resistance). Now, when the probes

are reversed, the meter should show about mid-scale deflection. The larger the power capability of the transistor, the lower this second reading will be.

Further Tests When There Is No Change in the Input Current at TEST POINT 2

This indicates that the defect is either a component which does not affect the bias of a stage like those already described, or it is a transistor with a direct short from emitter to collector, which is not affected by removing the base bias in TEST POINT 2. The next test will decide which condition exists.

TEST POINT 3, CHART VI

OPEN THE EMITTER OF EACH STAGE

9-7, 9-8 If a stage can be found which causes the input current measured at TEST POINT 1 to decrease a considerable amount when the emitter is opened, it is obvious that the transistor in this stage is defective, since its current did not change when the base was shorted to the emitter in TEST POINT 2. The transistor can be checked with the ohmmeter after it is removed. The voltage between the base terminal in the circuit and ground should be checked against the value given in the schematic to make sure that the new transistor will not be ruined. The voltage will be fairly accurate even when it is measured with the transistor removed. The resistance from the emitter terminal to the + battery line should also be checked.

Further Tests When There Is No Change in the Input Current With Emitters Opened

9-9 This indicates that the defect is not a transistor. A voltage reading at each collector is recommended in the chart because a low voltage at one of these may lead to the discovery of a shorted capacitor such as C8, C11, C6, C15, or tuning capacitor A5, in Fig. 9-7. When the voltage is absent at a collector, the meter is moved across the next component in series toward the battery, and a new measurement is taken. For example, in Fig. 9-7, suppose C8 is shorted. There will be no voltage at the collector of X1. The next reading should be taken from terminal 2 of L2 to ground, where there should still be no voltage. A reading at terminal 1 will also show no voltage. The meter should now be moved to the battery side of R5 where 3 or 4 volts will be present, indicating that the meter has just been moved past the defective component.

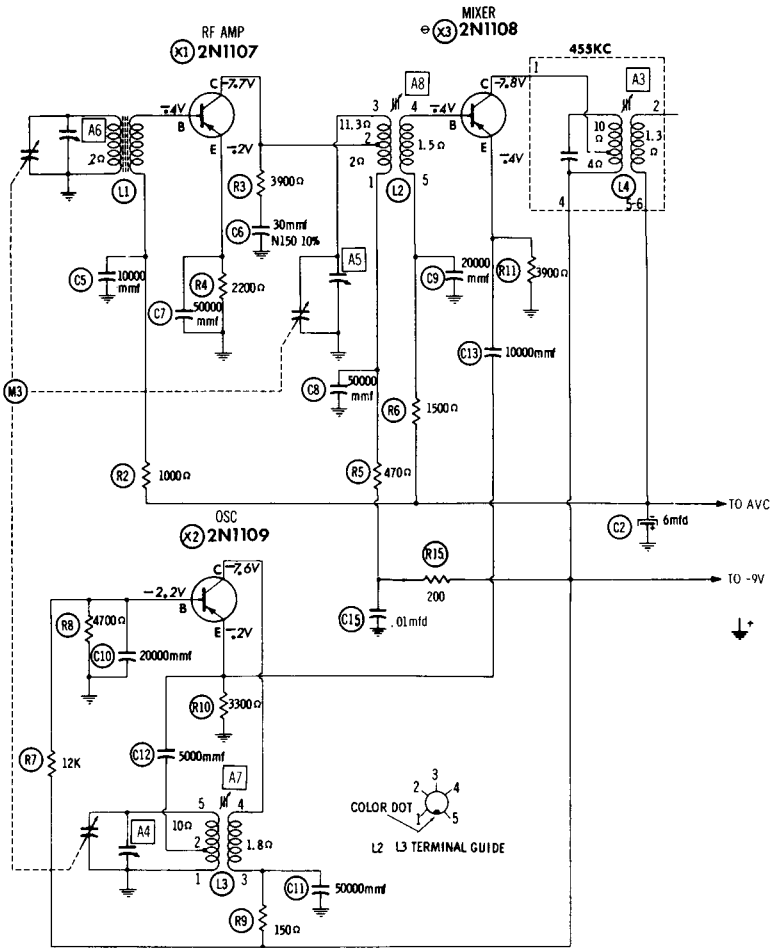

Fig. 9-7. RF amplifier, mixer, and oscillator section of a typical transistor receiver.

In a circuit like the one shown in Fig. 9-8, a high reading indicates trouble. Other components which could cause the input current to be high are listed on the right under TEST POINT 3 in SERVICING CHART VI.

CHART VII

NO SIGNALS, NORMAL INPUT CURRENT

9-10 When the input current checks normal, the procedure for the symptom of *No Signals* follows the pattern of SERVICING CHART VII. It is probable that the current reading

will be the minimum value because, with no signals, the output stage will not be driven into high conduction. There is an exception, however. If the speaker has failed and the output stages are functioning normally, then the input current may be up to the value given in the schematic for normal volume. If the speaker is suspected, it can be checked at once by using the ohmmeter test described in Section 3-12.

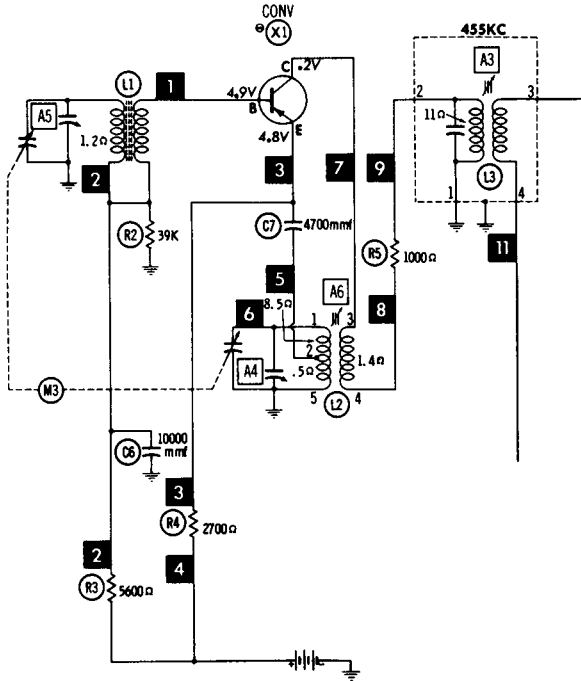

Fig. 9-8. Collector returned to common ground.

TEST POINT 4, CHART VII

INJECT AUDIO AT VOLUME CONTROL

9-11 When the input current is at the minimum specified in the schematic, there is no way of knowing whether the audio stages have actually failed and are not drawing their share of current from the battery, or whether there is no signal to drive the audio stages and cause them to conduct. TEST POINT 4, injection of audio at the volume control, is a familiar operation from the study of vacuum-tube radios, and it is done here for the same reason. The technician must keep in mind that the input impedance may be quite low, and the finger or

the tip of the soldering gun might not provide enough signal to produce much output. The signal injection should be done with care because the rest of the analysis will be based on the results of whether or not the audio stages will amplify.

Further Tests When No Sound Results From TEST POINT 4

9-12 Once the conclusion has been reached that the audio section has failed, a number of preliminary tests should be made immediately. These are shown in SERVICING CHART VII under TEST POINT 4, and all are associated with the audio output stage. Injection of a signal directly into the output transistors is not a reliable test, nor are the other tests that were used with tube-type receivers.

Only one of the tests requires explanation—the measurement of AC voltage across the primary of the audio input transformer (see Fig. 9-9). This should be done with the volume control turned to maximum and while the station selector is turned through its range. An alternative method is to inject audio from a signal generator at the volume control. If any signal appears in the transformer, the AC voltmeter will respond—about 3 to 5 volts AC can be expected. If there is no voltage indicated with collector voltage on the audio-driver transistor, there is still the possibility that bypass capacitor C19 is shorted. The suggestion in the chart is to open one end of this capacitor and look for the AC signal, but if the transformer resistance is given, the ohmmeter can be used without disconnecting C19.

TEST POINT 5, CHART VII

NO SIGNAL OUTPUT FROM THE DRIVER

9-13 With no output from the driver stage, this test is used to decide whether the defect is in the transistor or in the circuitry of the input or output of the stage. With the DC voltmeter between the collector and emitter, points 44 and 45 in Fig. 9-10, for example, the base is shorted to the emitter, thus removing all bias. One of three results must occur:

1. The normal voltage (3.1 volts in Fig. 9-10) will rise to the full battery voltage. It is important to note that the V_{ce} will not be 4.5 volts, as given at the collector in the schematic, because V_{ce} is the difference between the emitter and collector voltages.
2. V_{ce} will be missing.
3. V_{ce} will be incorrect, or it will not change correctly.

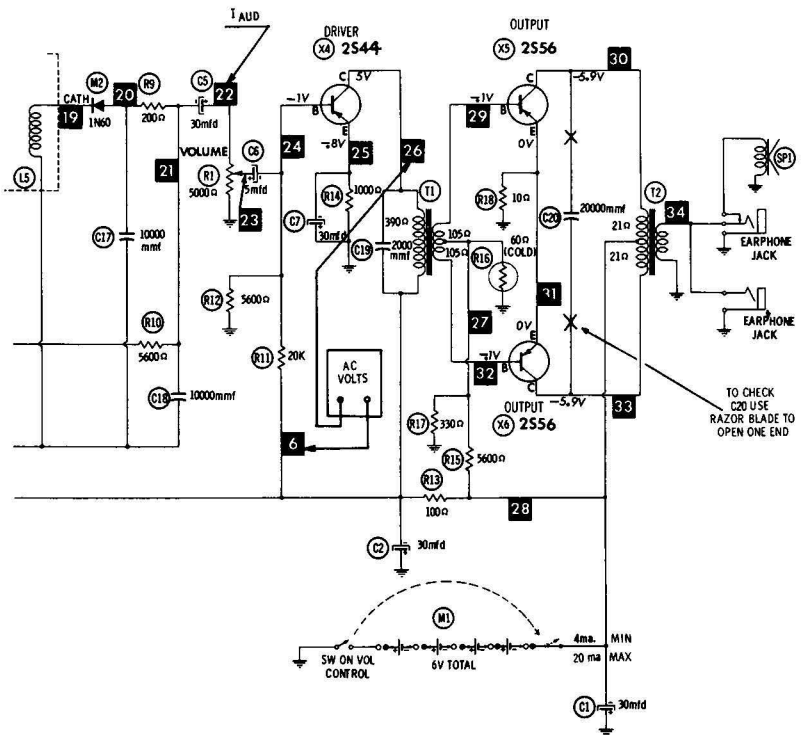

(A) Partial schematic.

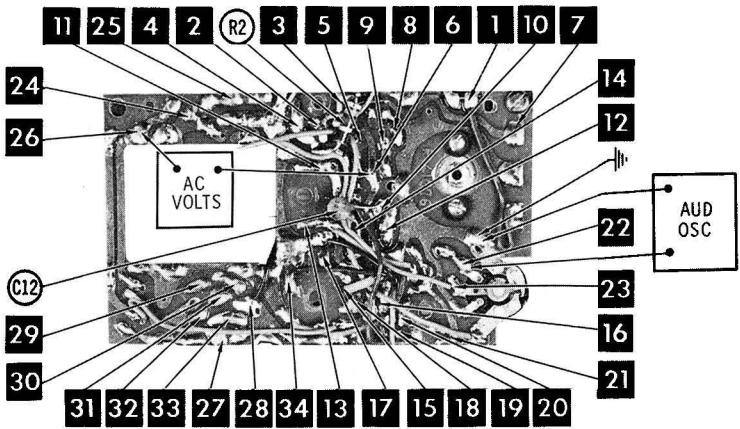

(B) Printed board showing test points.

Fig. 9-9. Typical transistor receiver.

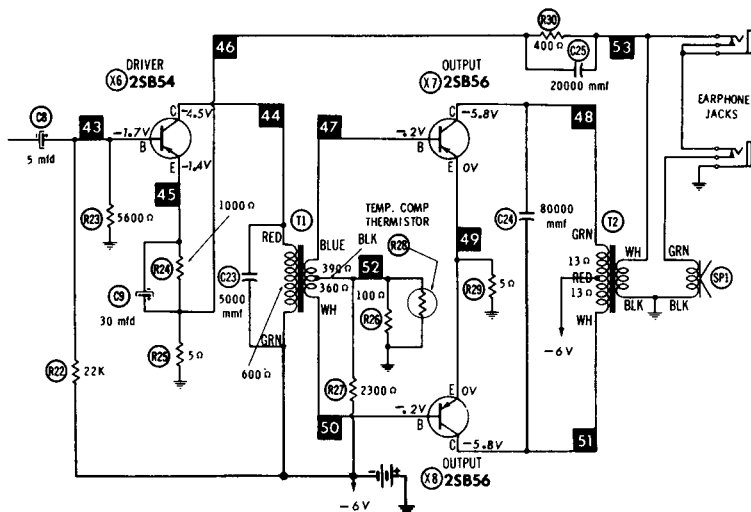

Fig. 9-10. Circuit showing application of TEST POINT 5, CHART VII.

9-14 In the first case, the response is entirely normal, and the driver transistor as well as its bias network, R22 and R23, and output circuit C23 and T1 must all be operating properly. Obviously, the defect must be present in the coupling through C8 to the preceding stage. An ohmmeter can be used to examine the components here. The chart also mentions the collector bypass capacitor, C23, as a possibility, but this is unlikely when V_{ce} is normal before shorting the base and emitter. It is mentioned only because its leakage could reduce the load resistance in the collector but slightly, resulting in inconclusive readings at TEST POINT 5.

9-15 When the second result listed occurs, it is clear that either the collector or the emitter lead to the battery is open because of an open in the printed wiring, a defective part in series, or a shorted transistor. It is difficult to establish a rule for the amount of change in input current to expect at TEST POINT 1 when a low-power transistor is shorted. The current drawn by a shorted audio-driver transistor may not register on the milliammeter because, simultaneously, the current in the class-B output transistors drops to a low value due to no incoming signal to drive them. The output transistors may account for a large part of the normal current stated in the technical data for the receiver.

In circuits like the one in Fig. 9-9, where there is still a total resistance in the emitter-collector circuit of 1490 ohms,

even with a shorted transistor, the maximum current that could be drawn by the stage is only:

$$\frac{6 \text{ volts}}{1490 \text{ ohms}} = 4.02 \text{ ma}$$

From the 0.8 volt on the emitter, it can be determined that normal no-signal emitter-collector current is 0.8 ma (taking I_b as negligible with no signal), and it would not be unreasonable to expect peaks of 1 or 2 ma with a signal applied. So it can be seen that a shorted driver might not increase the input current at TEST POINT 1 by more than a milliamp or so.

The best way to proceed when V_{ce} is missing is to remove the transistor from the circuit by slashing the emitter and collector leads with a razor blade and measure the voltage again. If full battery voltage appears, the transistor was bad. If the voltage does not appear, some component in series with the battery, or the leads themselves, may be open.

A confusing situation can arise in circuits which use a large emitter resistance, like the driver stage shown in Fig. 9-9. The purpose of the emitter resistor is to increase the stability by establishing -0.8 volt of emitter voltage. This voltage, when applied in conjunction with -1 volt of base voltage formed by the divider R12 and R13, produces the net forward bias of -0.2 volt. Keeping in mind that the emitter voltage is produced as a result of current which flows in the collector circuit, one can see that if the collector were open-circuited (by an open transformer primary, for instance), there would be practically no emitter voltage.

The base voltage, however, would not change much under these conditions because it is the drop across R12 and is determined by the proportions in the voltage divider. Now, if the emitter voltage is reduced to almost zero and the base voltage remains nearly -1 volt, the base-emitter voltage will become almost -1 volt. The resulting increase in base current may ruin the transistor, and may also ruin subsequent replacements which are installed without first checking to see if the collector circuit is open.

9-16 The third possible result of TEST POINT 5 is that V_{ce} does not change properly, or that it is not correct to start with. The parts to be checked are shown on the chart.

One of the tests suggests an ohmmeter check of the bias network. A new abbreviation is used on the chart at this point, where the negative terminal of the battery is referred to as $-B$ and the positive terminal as $+B$. Since so many other things about transistors are backwards as compared to con-

ventional vacuum-tube circuits, it seems justifiable to reverse the usual symbols of B- and B+ because there are no B+ or B- power-supply terminals in the sense that they are used with vacuum tubes.

TEST POINT 6, CHART VII

AUDIO SECTION WORKING PROPERLY

9-17 Referring to SERVICING CHART VII under TEST POINT 4, the procedure shown is to be followed when it is found that the defect is in the RF or IF sections. TEST POINT 6 calls for a check on the operation of the oscillator section, and there are several ways that this can be done. The choice will depend on the accessibility of terminals for testing on the individual chassis. A method which works on most receivers is to measure the AC voltage across the oscillator tuning capacitor, or across the oscillator tank. If a good VTVM is used, oscillator operation will be determined by a small AC voltage generated. Another way is to use an oscilloscope across either of the above points.

A method recommended by some experts is to bring the suspected chassis near another operating receiver which is tuned to a weak station, and rotate the tuning dial on the receiver being tested. If a beat can be obtained at some point on the tuning, this is due to radiation from the oscillator in the receiver undergoing repairs and is evidence of oscillation.

A favorite method of many technicians is to measure the DC bias between the base and emitter of the oscillator transistor while the tuning dial is rotated through its range. There should be a DC voltage present, of course, even if the oscillator is not functioning, *but when it is operating, the DC bias will fluctuate as the tuning capacitor is rotated.* Sometimes when oscillations are strong, a positive voltage will be found on the base which disappears with a touch of the finger, like grid-leak bias.

The determination of oscillator operation in transistor receivers is a tricky test procedure, and the results of any of the tests described should be considered as indications only, not as conclusive proof. It will soon become apparent if an error has been made, and the technician should then retrace his steps.

Further Tests When It Appears That the Oscillator Has Failed

9-18 The components to be suspected will depend on whether the oscillator stage still has a fixed forward bias, or whether

the defect has removed all forward bias. Two typical oscillator-mixer stages are shown in Figs. 9-8 and 9-11, in which loss of bias might be caused by different components. The test results will be different in each circuit because of +B ground in Fig. 9-11 compared to -B ground in Fig. 9-8.

9-19 In Fig. 9-8, the fixed DC bias is 0.1 volt and, if this is missing, the first test suggested on the chart is to use an ohmmeter from the base to ground and from the base to +B. The condition of R2 and R3 can thus be determined if the precautions mentioned in Section 9-5 regarding polarity of the ohmmeter are observed. The missing bias could be the result of a shorted tuning capacitor, A5, or a shorted capacitor, C6. The chart also suggests measuring the resistance from the emitter to +B, which will indicate the condition of R4. The resistance from the emitter to ground should also be measured in this circuit. The condition of the transistor itself should not be overlooked, and it too can be checked with the ohmmeter or by substitution.

If the bias in the circuit of Fig. 9-11 is missing, a somewhat different procedure should be followed. The tuning capacitor will not be suspected, but a shorted C9 will probably remove the forward bias. It is not necessary to check the resistance from the emitter to -B.

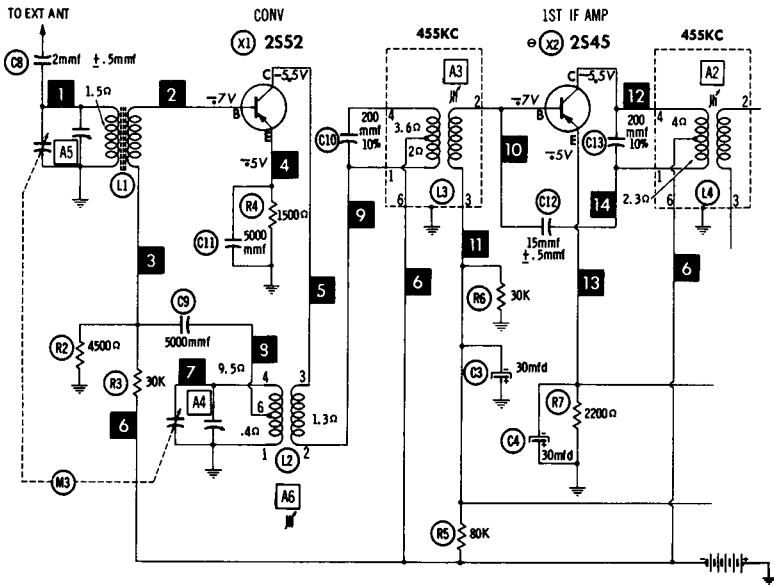

Fig. 9-11. Circuit showing application of TEST POINT 6, CHART VII.

9-20 When the DC forward bias voltage is present, a different approach is taken to the problem. Referring again to Fig. 9-8, nothing in the emitter or base circuits is suspected, because all these parts must be good to produce the forward bias. Tests should begin with the collector voltage and tracing through test terminals [7], [8], and [9] if it is missing. The oscillator tuning capacitor, A4, and blocking capacitor C7 should not be overlooked as a trouble source if the collector voltage seems normal.

In the circuit in Fig. 9-11, a normal bias of 0.2 volt does not exclude the tuning capacitors A5 and A4 from suspicion. But it seems unnecessary to check C9 or C11 for shorts, although an open C9, or the printed leads thereto, would stop oscillation without removing the DC bias.

The oscillator coil in both circuits is a good suspect and the soldering at the terminals should be checked. It is a good idea

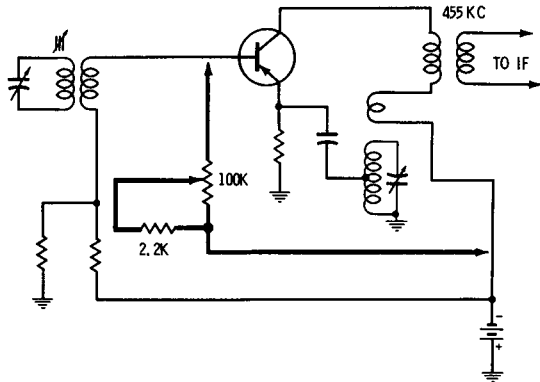

Fig. 9-12. Increasing forward bias.

to resolder all of the connections around the oscillator components if DC bias is present but the oscillator is not running.

9-21 The transistor itself is a common cause of oscillator failure and an interesting test is suggested in the chart. The forward bias is purposely increased while measuring the voltage between the emitter and +B. Fig. 9-12 shows the method to use. A 100K potentiometer is connected from the negative terminal to the base, and a small resistor is used in series with the center tap to prevent shorting the base directly to -B. Begin with maximum resistance, and carefully reduce the resistance to increase the bias. The transistor should begin to conduct more, and the voltage drop across the emitter resistor should increase. For low-power transistors with an emitter

resistance of 1000 ohms or less, $\frac{1}{2}$ to 1 volt should be considered a significant increase.

If the voltage increases, the transistor is probably behaving normally, and the reason for oscillator failure is a defect in the feedback circuit. If the emitter voltage does not increase when the forward bias is increased, and proper collector voltage is present, it is very likely that the transistor will need replacement.

TEST POINT 7, CHART VII

IF OSCILLATOR IS RUNNING, MEASURE V_{ce} IN RF AND IF STAGES

9-22 TEST POINT 7 is used to determine which IF or RF stage has failed when there are no signals and the oscillator is running. The antenna coils and tuning capacitors should be checked with the ohmmeter first.

A signal generator could be used to inject signals starting at the detector and moving progressively toward the antenna, but using a signal generator in transistorized IF stages requires considerable experience to avoid the confusion resulting from the signals feeding through a dead stage. It is easier and much more reliable to measure V_{ce} in each RF and IF stage. A defective stage will always exhibit incorrect V_{ce} . When V_{ce} is normal throughout, it is easy to check the few components whose failure could cause the *No-Signal* condition without affecting any V_{ce} .

Further Tests When V_{ce} Is Found To Be Incorrect

9-23 Four suggestions are given in the chart, but the choice of which one to use will depend on the convenience of test terminals on the chassis, and whether V_{ce} is too high or too low. To illustrate, we shall take a hypothetical case history and compare the test results in the two circuits of Fig. 9-13 and 9-14.

Suppose the receiver in Fig. 9-13 has a *No-Signal* condition, and the input current is not excessive, although it cannot be reduced to the minimum given on the schematic when the volume control is turned down. Therefore, the current is *tentatively* assumed to be normal. An injection of audio at the volume control produces normal sound, and it is noted that the input current rises when a signal is present, indicating that the output stages are operating normally.

Correct DC bias in the oscillator is found between points **3** and **5**, and it varies slightly when the tuning capacitor

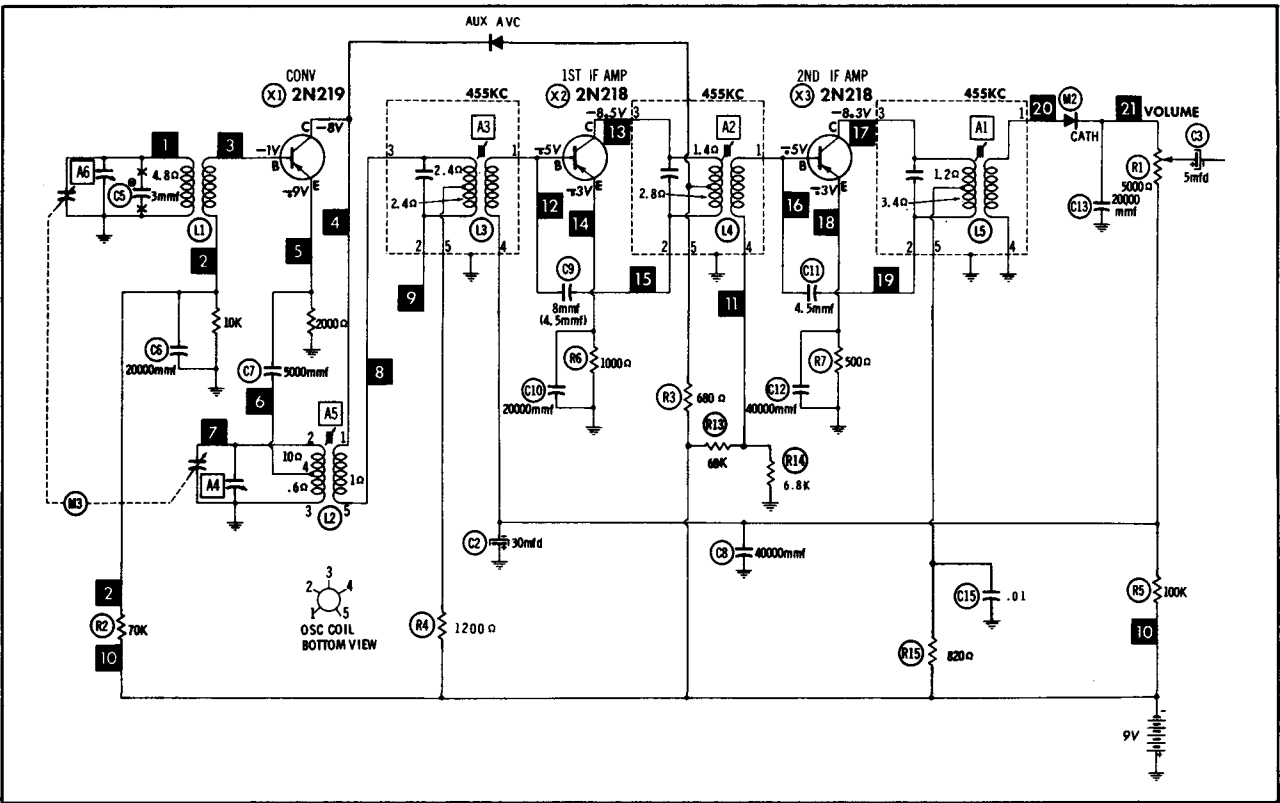

Fig. 9-13. Circuit showing application of TEST POINT 7, CHART VII.

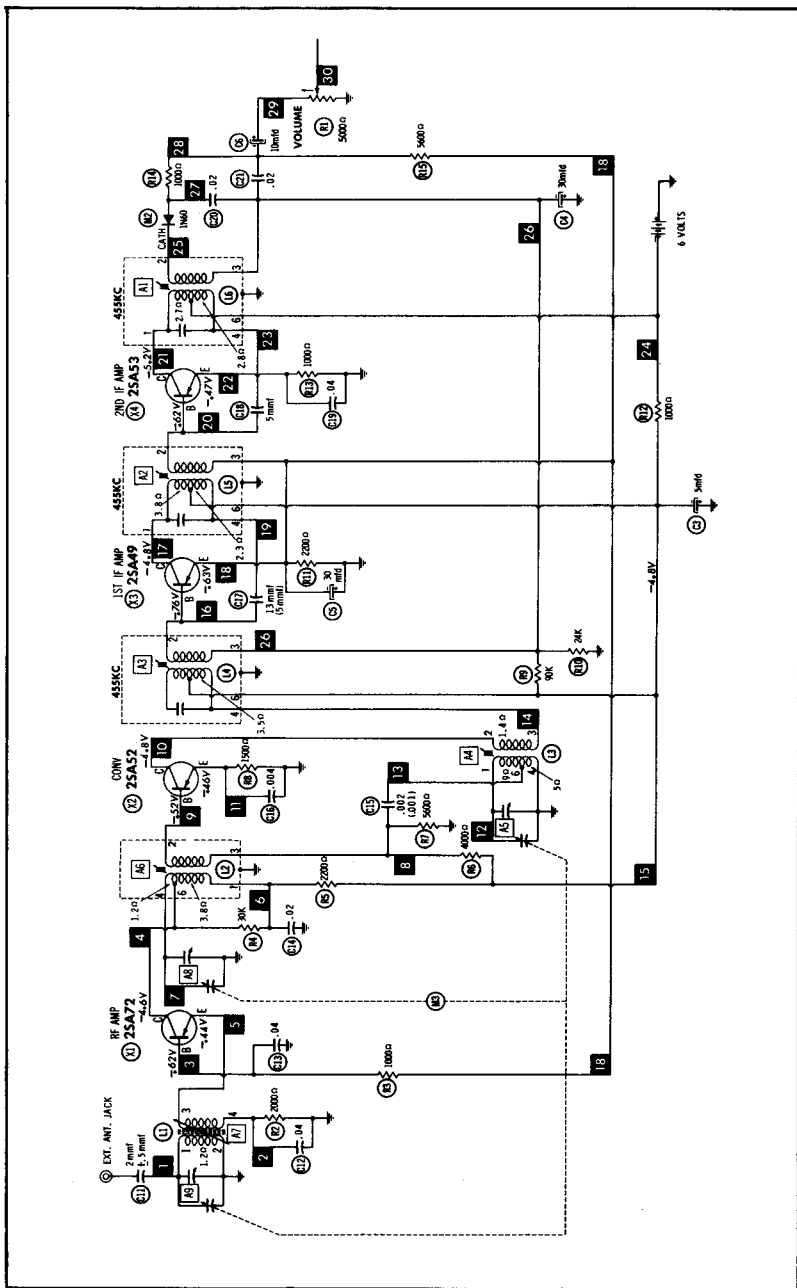

Fig. 9-14. Circuit showing application of TEST POINT 7, CHART VII.

is rotated through its range. Also, 0.8 volt AC can be measured across the oscillator tuning capacitor; so it is assumed that the oscillator is operating and that the failure must be in the RF, IF, or detector circuit, or in the coupling between the detector and the audio.

Next the voltmeter is used to measure all V_{ce} 's in the RF and IF stages. This reveals a very low voltage in the second IF stage, indicating that the stage is conducting very heavy collector current or that a component in series with the collector supply line has failed, reducing the voltage available for the stage. All other V_{ce} 's are normal.

If it were shorted, the emitter bypass capacitor could increase the bias by removing the emitter voltage; but when C12 is opened there is no change. R7 checks correctly also. C2 and C8 are not suspected, since these units could not increase the forward bias.

The ohmmeter is applied between the base and $-B$, and the base and $+B$, test points [16] to [10], and [16] to ground. The precautions mentioned in Section 9-5 regarding the possibility of incorrect readings obtained in circuits where a transistor junction is connected, should be observed.

The reading from [16] to $-B$ with the positive probe on [16] should be about 68K. In this instance, however, it reads 1000 ohms with the probes in either direction. The low reading in one direction is expected, but a low reading in both directions indicates either a defective transistor or trouble in the bias circuit. The next test is to cut the printed wiring leading to one end of R13, removing the resistor completely from the circuit. When this is done, the resistor reads 68K on the ohmmeter.

Two tests of the transistor itself are mentioned in the chart. The ohmmeter check seems most appropriate, since it is already known that the transistor is conducting heavy collector current. The application of additional forward bias is used when unusually high V_{ce} indicates that the transistor may be cut off. After two of the leads are cut to remove the transistor from the circuit, it is checked with an ohmmeter according to the method described in Section 9-6, and it responds normally in every way. With the transistor still out of the circuit, the resistance from the base lead to $-B$ is checked again, and it is still about 1000 ohms. It is clear now that there is a shorted component between the base of the transistor and $-B$.

Only two possibilities remain—leakage from primary to secondary in L4, or leakage through the neutralizing capacitor, C11. By making a slice with a razor blade to open the printed

wiring at some convenient place, such as between terminal **19** and C11, the fault will be located. When this is done, V_{ce} rises and a replacement of C11 restores normal operation. If V_{ce} did not rise to normal, extensive tests of the transformer and the AGC line would have to be made.

A defective transformer is identified by the procedure described in Section 5-11, taking note of the opposite polarity used with PNP transistors. IF transformers often fail in transistor radios, and many such receivers are not repaired because the technician does not carry his analysis far enough to find the defective unit (see Fig. 9-15).

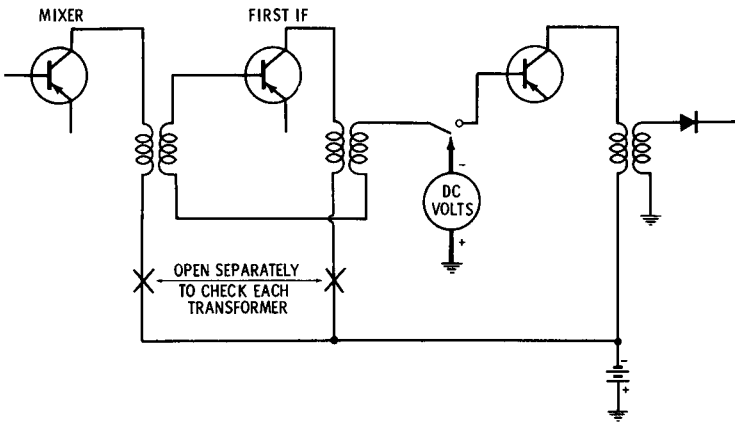

Fig. 9-15. Checking IF transformer for leakage.

A different series of tests will result from the same failure in the circuit of Fig. 9-14. This receiver includes an RF amplifier stage, and V_{ce} on this stage as well as the others must be checked. Assuming the same fault (about 1000-ohms leakage through neutralizing capacitors C18 in the second IF stage), the same series of preliminary tests should be followed until the missing V_{ce} is located in the second IF stage.

It should be noted in this circuit that part of the bias network is R11, the emitter resistor of the first IF stage. The bias voltage is taken from the emitter resistor of the first IF stage, and thus it depends on the proper conduction of current in this transistor. If the neutralizing capacitor C18 were shorted, additional current would flow through R11, making the emitter of the first IF stage more negative. This would certainly cut off the transistor, but V_{ce} would not rise to the full battery voltage, as it usually does when the transistor is cut off, be-

cause of the voltage-divider action shown in Fig. 9-15. The technician must be aware of the differences in circuitry which cause exceptions to the usual rules. With incorrect V_{ce} on two stages, one should immediately look for some component which is common to both stages, rather than tracing individual sections of each stage.

In other cases when the V_{ce} is found to be very high when making the test at TEST POINT 7, this may be due to shorted decoupling capacitors, such as C2 or C8 in Fig. 9-13. It could also be the result of an open connection from a base to $-B$ through a defective resistor such as R9 in Fig. 9-14. High V_{ce} can also be the result of an open collector or emitter element in the transistor. This possibility should not be overlooked, especially if there has been much soldering done at the transistor lead connections. The leads are easily disconnected from the transistor elements at the junction inside by excessive heat applied to the leads.

Further Tests When All V_{ce} 's Are Normal

9-24 Normal V_{ce} on all stages means that no stage is cut off or saturated with excessive collector current, and the defect is not in any transistor or base-bias circuit. Five possibilities are listed in CHART VII below TEST POINT 7. A study of Figs. 9-13 and 9-14 will reveal how these parts could produce the symptom of *No Signals* with the oscillator running and normal V_{ce} throughout.

The emitter bypass capacitor is mentioned in the list, although it is rather an exception. It actually will increase collector current if it is shorted but, when the voltmeter is placed between collector and emitter, the voltage may still be high enough to be mistaken for normal. This is because in IF and mixer stages there may be very little resistance in series with the collector to drop the voltage on the negative side of the transistor, and the emitter will be connected directly to $+B$ through the shorted capacitor. This results in most of the battery voltage still appearing across the emitter-collector junction.

TEST POINT 8, CHART VIII NO SIGNALS, LOW INPUT CURRENT

The foregoing discussions have dealt with the symptom of *No Signals* when the input current is high and also when it is normal. CHART VIII is concerned with the condition of *No Signals* when the input current is less than the minimum

specified in the schematic. This can be due to one of three causes:

1. A weak battery.
2. A increase in the value of a resistor in the battery decoupling network.
3. A defect in one of the stages which prevents the collector from drawing normal current.

9-25 A check of the battery is mentioned first in all the charts, and no further testing should ever be done until it is certain that the battery is in good condition, or unless the receiver has been connected to a battery eliminator. Then, if the input current is found to be more than 10% below the minimum, TEST POINT 8 calls for a measurement of the collector-to-emitter voltage on each stage. If V_{ce} is low on all the stages, it is probable that the defect will be found in the battery decoupling network. Most likely it will be the resistor that has failed because the capacitors will cause increased input current if they are leaking.

Further Tests When One V_{ce} Is Low

CHART VIII mentions a resistance check of the decoupling networks immediately under the heading *Low or Missing*, and this test should be made whenever all the V_{ce} 's are affected. If only one stage shows low or missing V_{ce} , then the defect is obviously confined to the emitter or collector circuit of that stage. The base-bias circuit would not be suspected with low input current, because bias failures which reduce V_{ce} always do so by increasing the collector current.

Transistor failures usually involve shorted junctions which cause excessive current, or open junctions which cause a high V_{ce} . Since both V_{ce} and the input current are low, it is not likely that a transistor is defective.

Further Tests When One V_{ce} Is High

9-26 With low input current, and no failure in a decoupling network, it is common to find V_{ce} very high in one stage. This means that the stage is not conducting and is therefore the cause of the *No Signal, Low Input Current* symptom. Of the three checks shown on the chart, the resistance measurement from the base to +B and to -B is the easiest to make, and will identify a failure in the bias network. Some technicians prefer to measure the base-to-emitter voltage as a check on the bias network, but it seems easier to measure relatively large resist-

ances than to measure voltages that are in the order of tenths of a volt.

The application of forward bias, as described in Section 9-21, is another way to decide whether the transistor or some other component in the stage has failed. If the V_{ce} drops when forward bias is applied to the transistor, the defect is probably in a bias network component, not the transistor itself.

A rough check on the transistor can be made according to the procedure described in Section 9-6, but the final proof that a transistor is bad is often the substitution of a new unit.

TEST POINT 9, CHART VIII

WHEN V_{ce} IS NORMAL ON ALL STAGES

9-27 When no information can be gained from a check of V_{ce} 's, it is necessary to use another approach to isolate the trouble to a particular section of the receiver. If the injection of audio at the volume control produces sound in the speaker and causes the input current to increase to normal, then it can safely be assumed that the problem is in the front end of the receiver and probably related to a tuned circuit. Defects such as those discussed in Section 9-17 should be suspected.

TEST POINT 10, CHART VIII

APPLICATION OF FORWARD BIAS TO THE OUTPUT STAGE

9-28 If the injection of audio does not result in sound from the speaker along with an increase in input current, then it is clear that the trouble is in an audio stage. The method described for TEST POINT 5 in Section 9-12 can be used from this point on, or alternatively, TEST POINT 10 can be used to isolate the defective part into either the output stage or the audio driver. The method for applying forward bias was described in Section 9-21.

Further Tests When Forward Bias Does Not Change Input Current

This definitely indicates a failure in the output stage. With normal V_{ce} there are only three possibilities.

1. High resistance in the collector circuit due to a defective output transformer (or speaker when no output transformer is used).
2. High resistance in the emitter circuit.
3. Defective transistor.

The ohmmeter is the instrument recommended in the chart to complete the isolation of the failure to one of the three places mentioned.

TEST POINT 11, CHART VIII

FORWARD BIAS CAUSES AN INCREASE IN INPUT CURRENT

9-29 The output stage is probably working normally, but there is no input signal to drive the class-B transistors into conduction. TEST POINT 11 calls for the use of an AC voltmeter to determine the presence of an audio signal at the primary of the driver transformer. In using this method, it is a good idea to supply an audio signal at the volume control.

In Fig. 9-16 the AC voltmeter is applied between points **19** and **9**. If there is an AC signal present, the parts listed under TEST POINT 11 should be checked. It is necessary to check only a few parts in the driver circuit because the determination of normal V_{ce} at TEST POINT 8 eliminates most of the components.

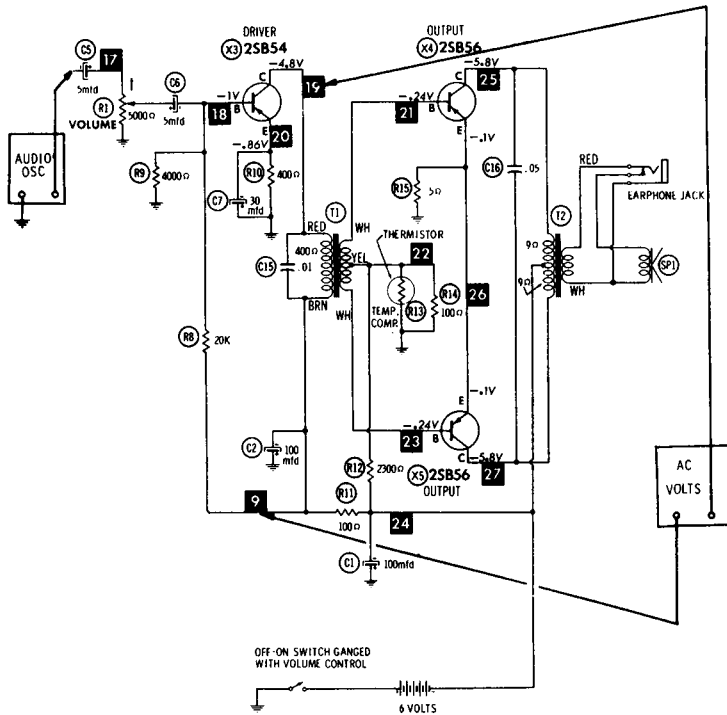

Fig. 9-16. Circuit showing application of TEST POINT 11, CHART VIII.

Capacitor C15 is not mentioned on SERVICING CHART VIII because it does not appear in every circuit, but this part must also be checked when it is present. One end of the capacitor must be disconnected and the AC voltage measurement repeated. The capacitor cannot be checked with an ohmmeter while connected in the circuit because of the coil across it.

Further Tests When an AC Signal Is Found on the Driver Primary

9-30 This condition, combined with a normal V_{ce} and a normal response to applied forward bias at TEST POINT 10, limits the fault to a few parts in the output stage. These are also shown in Fig. 9-16. The resistance from the emitters to +B should be checked. A greatly increased resistance at R15 still leaves a normal V_{ce} , even when there is no driving signal, but will prevent the transistors from conducting when audio appears at the secondary of the input transformer. R12, R13, and R14 are suspects, as well as the transformer secondary itself. C16 should be disconnected and the resistance between the collectors measured.

REVIEW QUESTIONS

1. State several reasons given for the statement that one must specialize in transistor receivers in order to repair them successfully.
2. There is one exception to the statement made in Section 9-2 regarding the change in input current with changes of the volume level from minimum to normal. Explain how a receiver in perfect working order might have practically the same input current at minimum volume as it has at normal volume.
3. In Fig. 9-4, list all the voltages that would change if C21 were leaky.
4. (a) What is the reasoning behind TEST POINT 2 which calls for shorting the base to the emitter to identify a stage that is drawing excessive current?
(b) Under what conditions does shorting the base to the emitter fail to identify the stage which has excessive current?
5. Explain why signal injection techniques are seldom recommended in this chapter.
6. What are three ways to determine if the oscillator is running in a transistor receiver?
7. With a symptom of *No Signals*, a low input current, a good

Serviceing Chart VI: No Signal, High Input Current.

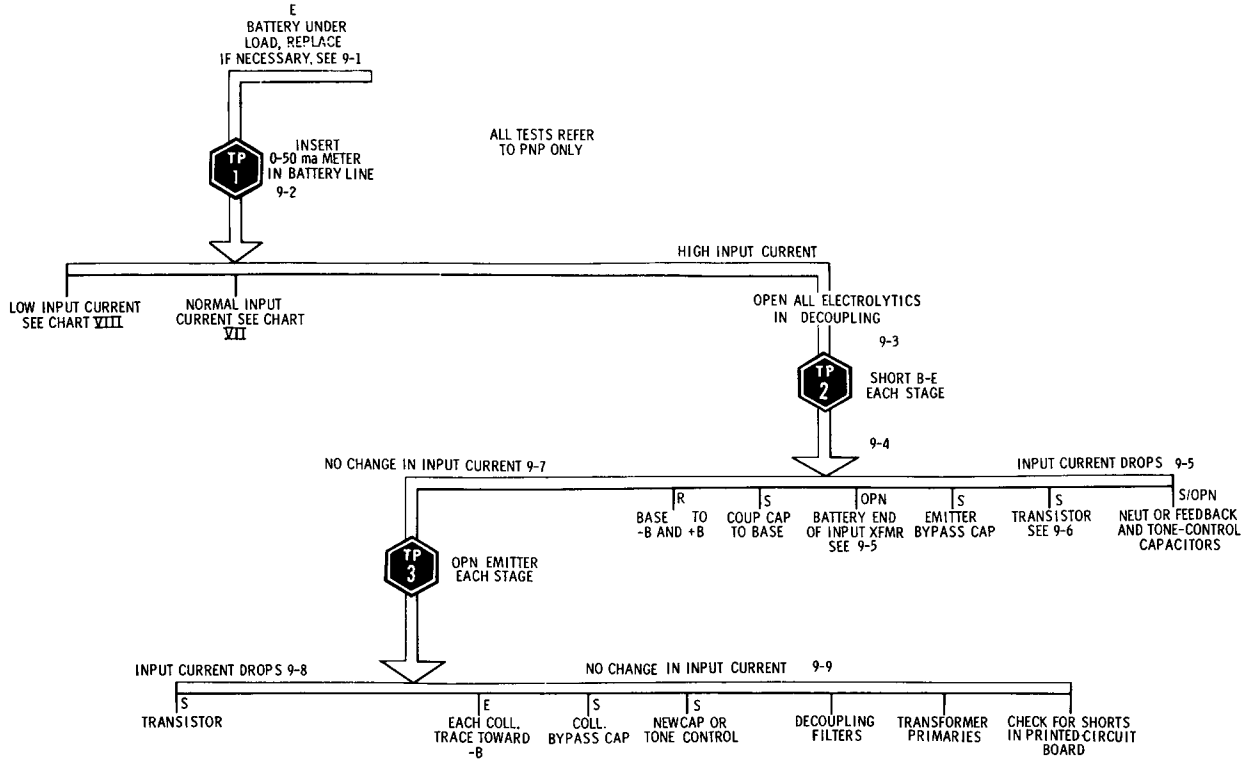

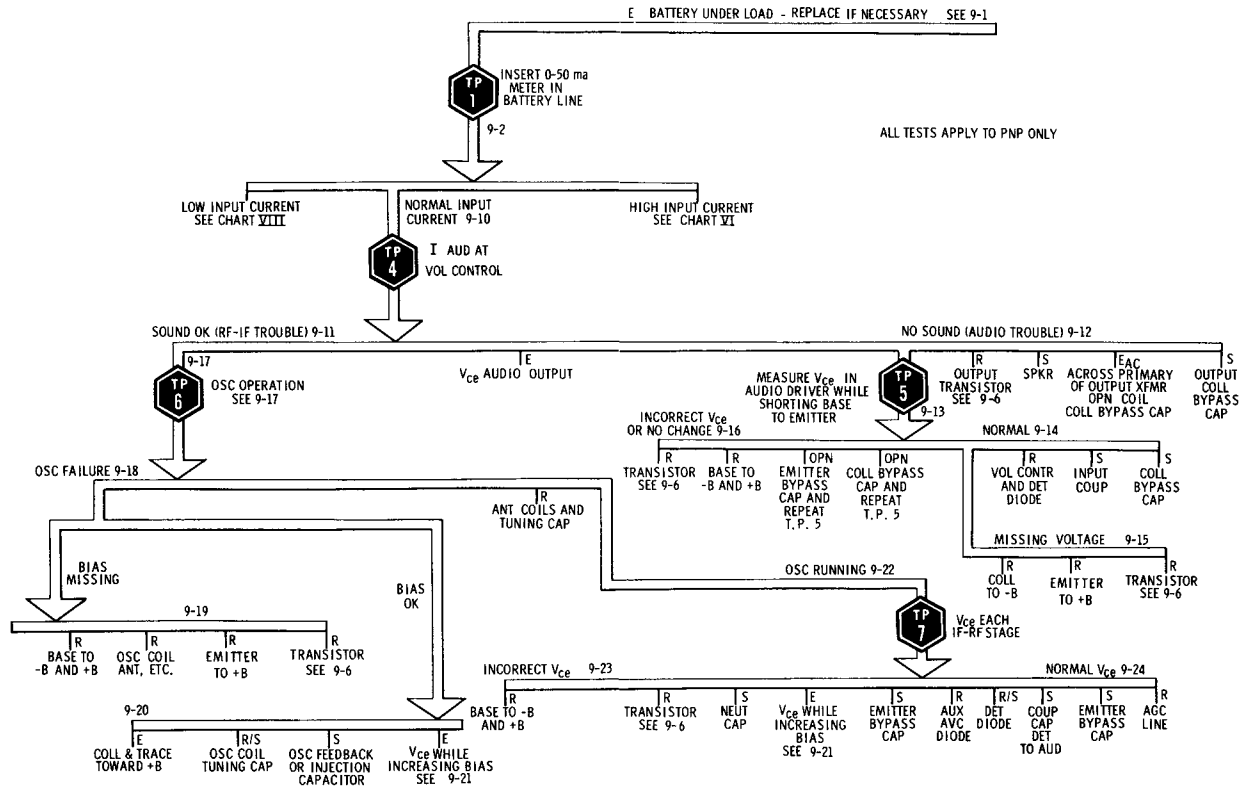

Service Chart VIII: No Signal, Low Input Current.

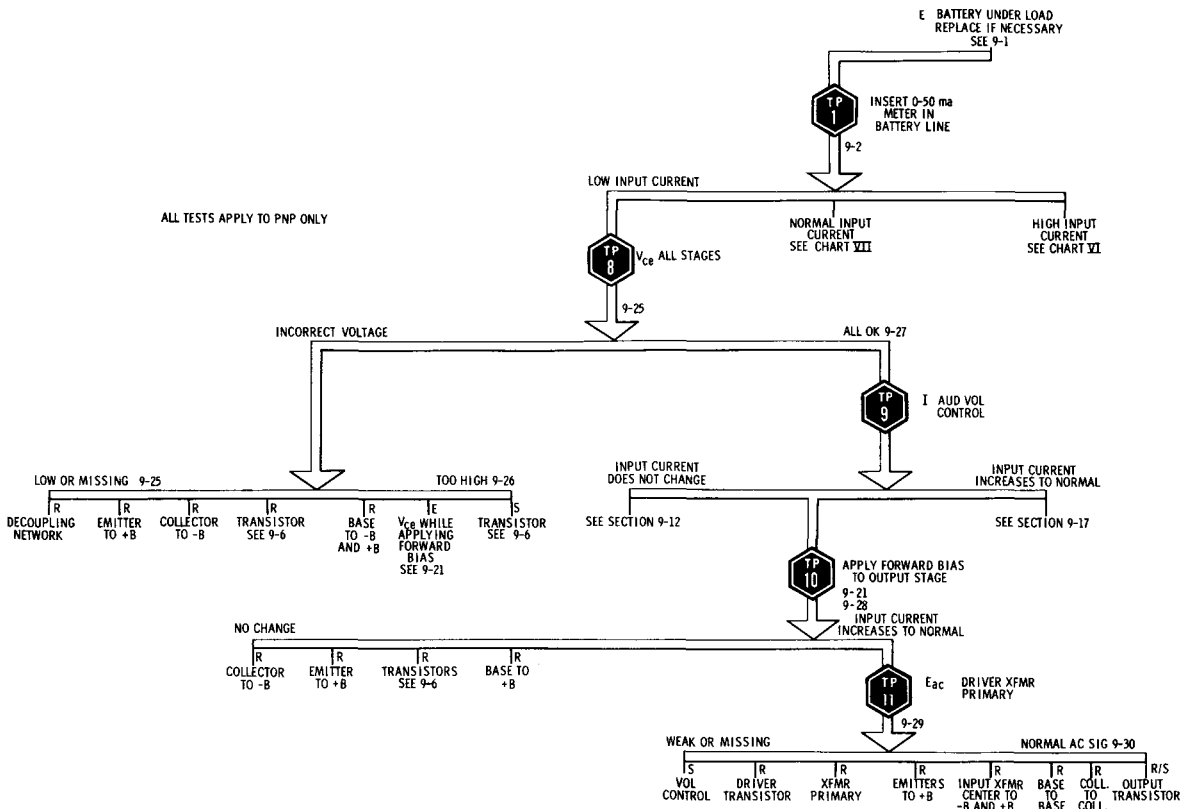

battery, and a low V_{ce} on one of the stages :

(a) Explain if you would suspect a transistor.

(b) Explain if you would suspect the bias network.

8. In Question 7, if one V_{ce} were found to be high, what would be your answers to (a) and (b) ?
9. In a receiver using the circuit in Fig. 9-9, the following test results were obtained with the symptom of no sound :
 1. Battery voltage = 6V.
 2. Milliammeter in the battery lead shows 5 ma with normal volume.
 3. Audio injected at the volume control produces no sound.
 4. With Test Points 24 and 25 shorted together, V_{ce} of X4 = 5.9V.

State three parts which could have failed.

10. In the circuit of Fig. 9-14, which voltages would be affected by leakage from primary to secondary of L4?

10

Additional Symptoms in Transistor Receivers

In addition to the *No-Signal* condition, three more symptoms are commonly found in transistor receivers:

1. Distortion.
2. Oscillation or motorboating.
3. Low gain or poor sensitivity.

The procedures to follow for these three symptoms are summarized briefly in **SERVICING CHARTS IX, X, and XI**. Most of the tests have been used before, so very little comment is required.

DISTORTION

10-1 The first step in servicing any battery-powered equipment is to check the battery voltage under load. This test should especially be made in a transistor receiver which has distortion.

The speaker should be the next unit checked as soon as proper battery voltage is established. The best check is to substitute a good one, but when the original speaker has an odd value of voice-coil resistance this may not be possible. Using a speaker which does not match may produce as much distortion as the defective speaker. A careful visual check of the speaker may reveal a fault.

The next step is the same **TEST POINT 1** which was used to begin each analysis in Chapter 9. If it can be determined that the minimum input current (with the volume control at minimum) is normal as specified in the schematic, then the testing is confined to only a few possibilities.

10-2 Electrolytic capacitors in decoupling networks are the most likely suspects, and from the normal input current read-

ing it can be safely assumed that a defective one will be open and not shorted. Bridging across the capacitors with a unit known to be good is an easy method of checking them. Many technicians clip a pair of leads having needle-pointed probes to the test capacitor which can then be used conveniently on the printed-circuit board. Fig. 10-1 shows C1, C4, and C16 as the electrolytics in decoupling networks.

In addition to the electrolytics, the circuit in Fig. 10-1 employs a number of 10,000-mmf (that is, 0.01-mfd) capacitors in decoupling and bypass circuits. These are C7, C8A and B, C10, C11, C14, and C15. These can all be checked by bridging them with a capacitor known to be good.

It is not necessary to check electrolytics C2 or C3 when the input current is normal, because if either of these units is shorted, the collector current of transistor X4 will increase. If the capacitors are open, there will be no sound in the case of C2 and low volume in the case of C3.

The input and output transformers in the push-pull output stage are a common cause of distortion because they usually fail in a way which causes them to have unequal resistances between the center and the end. The chart therefore recommends that the ohmmeter be applied from the center to each end so that the resistances can be compared.

TEST POINT 12, CHART IX

HIGH INPUT CURRENT

10-3 The high input current is caused by excessive collector current through a transistor, or by some leaky component (such as C14 in Fig. 10-1) connected from +B to -B with low resistance in series. Parts which are connected like C14 cause high input current when they are leaky, but they do not cause distortion. This is because the current drawn by their failure does not carry any signal and does not pass through any amplifier. A leakage through C14, for example, would be wasted bleeder current drawn from the battery. As long as this current does not become large enough to reduce the battery voltage, it will have no effect on the operation of the receiver, except to shorten the life of the battery.

Therefore, when distortion is the symptom and the input current is high, all components whose leakage current would not pass through a transistor can be eliminated as suspects. When the offending stage is identified, tests can be performed to decide whether the transistor is defective or the bias circuit has failed in a way which puts high forward bias on the base.

Fig. 10-1. Typical components in a transistor receiver that can cause distortion.

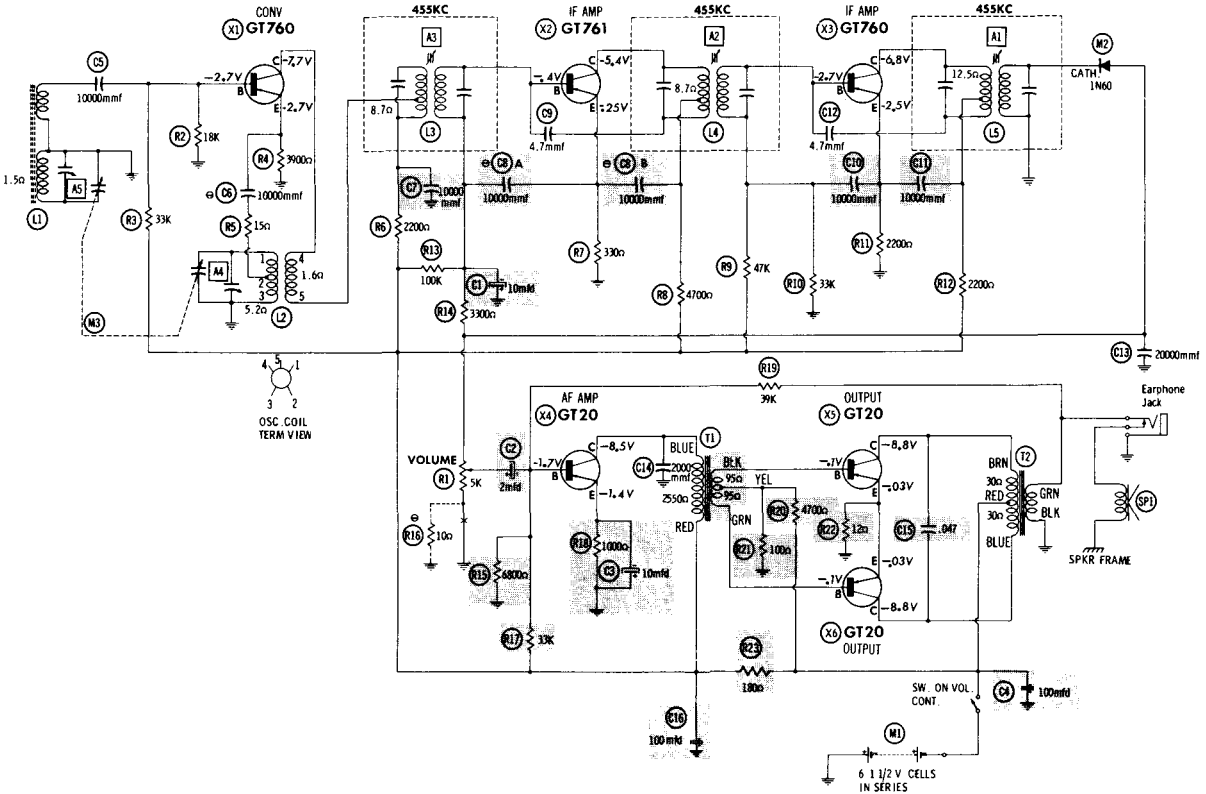

After finding high input current, the testing can move directly to TEST POINT 2 in SERVICING CHART VII, described in Section 9-4, or to TEST POINT 7 (in the same chart) which is described in Section 9-22, because these tests lead to components whose leakage affects the current through transistors. However, since it is most often the output transistors which cause distortion, TEST POINT 12 can be used to analyze the output stages first.

TEST POINT 12, CHART IX

USING A ZERO-CENTERED VTVM TO FIND A FAULTY OUTPUT TRANSISTOR

Fig. 10-2 illustrates the use of a zero-centered VTVM to identify the output transistor that is causing distortion. The

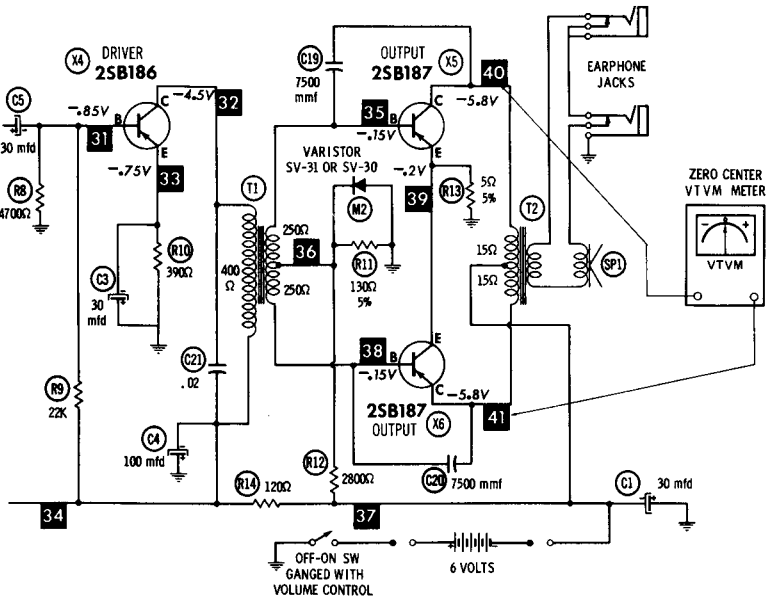

Fig. 10-2. Using a zero-centered VTVM to detect a faulty output transistor.

schematic shows that there should be equal voltages from each collector to ground when there is no incoming signal. Thus, the VTVM will not be deflected in either direction. But if one of the transistors has excessive collector current its collector voltage will be lower (more positive) than the collector voltage of the other transistor, and this will cause the meter to be deflected. The deflection will be toward the positive end of the

scale when the positive probe is on the defective transistor, and toward the negative end when the negative probe is on the defective transistor.

With a considerable amount of unbalance in the output circuit, the voltage between the collectors will still be less than 1 volt. Excessive deflection which pins the needle on the 1-volt scale indicates that one transistor is open. In this case, its collector voltage will be greater (more negative), and the indications described in the preceding paragraph will be reversed.

The technician should expect some slight unbalance, even with well-matched transistors which are working properly, because of the unbalance in the transformer resistance, but this will be in the order of 0.1 or 0.2 volt. Obviously, this test is useful only when the output transistors are connected in push-pull and use a center-tapped output transformer.

Further Tests When the Voltage Is Balanced

10-4 A balanced voltage seems to eliminate the output transistors as the cause of distortion. Only three simple tests need to be made to establish this with certainty:

1. Resistance measurement from the base to +B and -B in both output transistors, as well as the audio driver.
2. Open one end of the collector bypass capacitor, and check for distorted sound.
3. Resistance measurement of the thermistor or varistor.

The collector bypass capacitor (C15 in Fig. 10-1) does not need to be checked for distortion unless there is also motor-boating. The *varistor*, shown in Fig. 10-2 as M2, is a temperature-sensitive device that changes its resistance as the temperature of the transistors increases. It must be checked when it is cold and also when it is hot. This can be done easily by bringing the soldering gun near the unit while measuring the resistance. The two values of resistance will be given in the parts list, but this referral is not necessary, since, if the resistance changes at all, it is very likely that the unit is functioning properly.

When the preceding checks are completed, the technician should move to Sections **9-4** and **9-22**, as shown in the chart.

Further Tests When the Collector Voltages Are Not Balanced

10-5 If the collector voltages are not equal it is certain that the output stage is responsible for the distortion, and it only remains to locate the exact component causing the fault. Four possibilities are indicated on the chart, but individual circuits

differ in the “extras” which may be included, and the technician must leave no part unchecked. A comparison between the output stages of Figs. 10-1 and 10-2 will indicate a number of differences which would not be apparent from looking at the two chassis without the schematics. Note, in particular, capacitors C19 and C20 in Fig. 10-2. These permit feedback to stabilize the amplifier at high frequencies. It is easy to see how leakage in either one would cause unbalanced collector voltages.

OSCILLATION OR MOTORBOATING

Again it is important to make sure of the condition of the battery—never assume it to be good, even if it is new. Next, in order to get a clue as to which section of the receiver is at fault, the tuning capacitor is rotated through its range. If this affects oscillation, it is likely that one or more of the stages between the antenna and the detector are involved.

10-7 The first step is to perform a complete IF alignment according to the instructions given in the schematic. In some models, the IF transformers are sealed with wax, making it difficult to reach the tuning slugs. These transformers can be aligned easily if a small metal screwdriver is heated and then pushed down through the wax. After the slug is adjusted, the wax can be resealed with the soldering gun.

There is a double reason for going through the alignment procedure first: (1) it gives assurance that the stages are aligned properly; (2) it may reveal the defective stage because the signal cannot be peaked properly with the IF-transformer adjustment.

The circuit in Fig. 10-3 has neutralizing capacitors, C8 and C11, in the IF stages. These are a common cause of oscillation, but not always because the capacitors themselves have failed. Instead, it is because the internal capacity of one of the transistors has changed, and a different amount of capacity is needed to neutralize the stage.

Each of the electrolytic capacitors, C1, C2, C3, C15, and C16, should be bridged with a good unit of sufficient capacity. As in the case of distortion, it is very unlikely that one of these capacitors is shorted, so it is not necessary to remove them from the circuit before testing. The bypass capacitors in the IF and detector stages should also be bridged using a .05-mfd unit.

One precaution should be given in connection with these electrolytics. These capacitors often fail because one of the

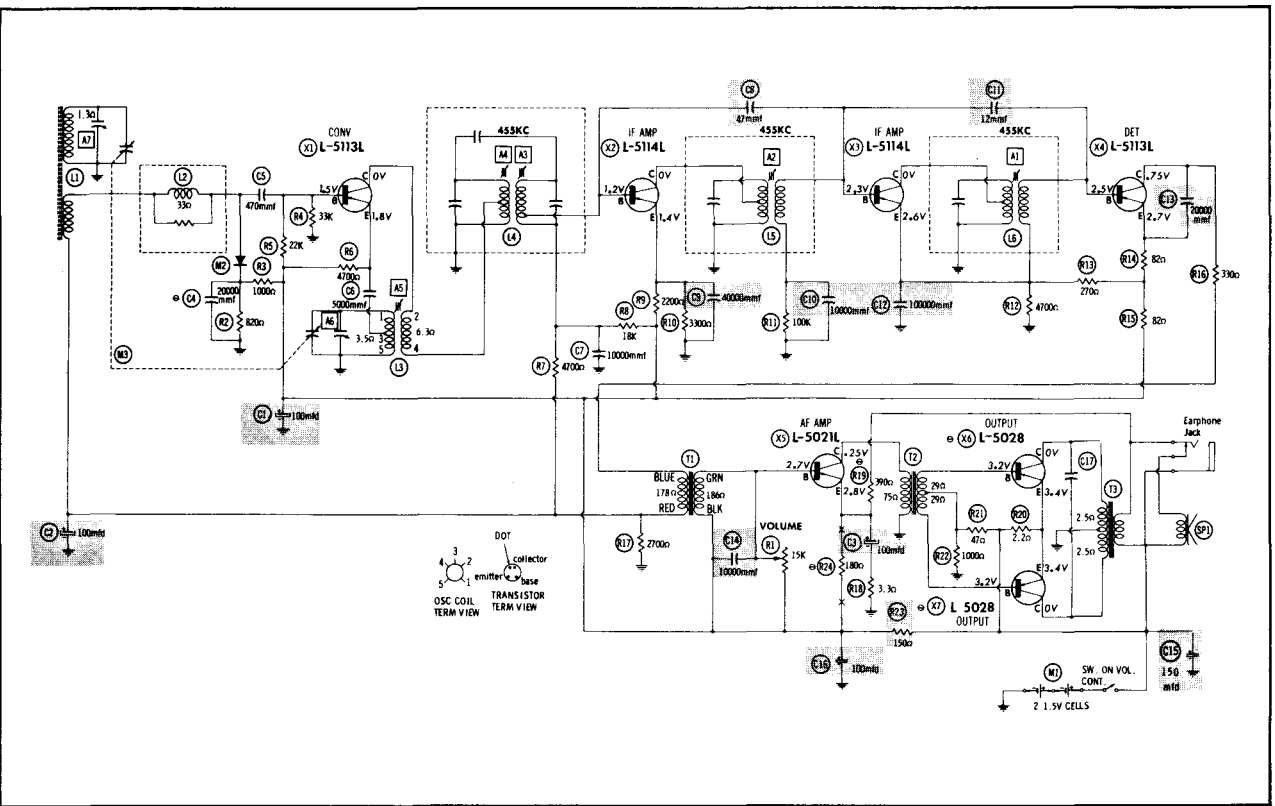

Fig. 10-3. Components to check in a transistor receiver when oscillation or motorboating is present.

leads comes unsoldered inside the unit, giving the impression of an intermittent in the printed-circuit board. The fault may respond to resoldering the lead at the board because the lead is sometimes heated enough to resolder it temporarily, but it will undoubtedly break loose again. It is better to replace the electrolytic involved, even when the trouble seems to be in the printed board.

Further Tests When the Oscillation Is Not Affected by Tuning

10-8 This points to a failure in the audio section, and TEST POINT 13 is used to separate the audio output from the driver stage.

TEST POINT 13, CHART X

TURN THE VOLUME CONTROL TO MINIMUM

10-9 If changing the setting of the volume control to a minimum changes the oscillation, this suggests that the volume control and base of the driver stage are both part of the oscillatory path. Besides the detector diode and the AVC filter, which should be suspected at once, the chart suggests testing decoupling filters such as C14, C15, C16, and C3 in Fig. 10-3. The feedback network in this circuit does not return to the base of the driver stage, so it does not need to be checked in this case.

Further Tests When the Oscillation Remains the Same

10-10 This definitely limits the testing to the audio stages following the one which contains the volume control. The collector bypass capacitor C17 should be bridged first, followed by a check of the resistances from the center to either end of the input transformer. If none of these is the cause of oscillation, it may be assumed that one of the output transistors is at fault. This fault can be found by shorting the base to the emitter in each of the push-pull transistors. The one which causes the oscillation to stop when the base is shorted to the emitter is probably the defective unit.

CHART XI

LOW GAIN

10-11 As in every symptom, the testing starts with a check of the battery. Then the milliammeter is inserted in the battery line to measure the input current, which is checked against the value given in the schematic.

10-12 Only the minimum value of the input current is useful now, because there is probably not enough signal to draw the rated current at normal volume. When the minimum input current is correct, a complete alignment is called for in the case of low gain. The manufacturer's instructions should be followed as closely as possible. The antenna should be inspected carefully at this time. Leads are often broken while changing batteries.

If all the adjustments seem to go well, but the receiver does not track properly in the middle of the broadcast band, the tuning capacitor itself may be at fault. It is unusual to suspect the tuning capacitor when signals can be tuned in, but in transistor receivers, failure of the tuning capacitor is a common fault. A cause of low gain that does not have much effect on input current is leakage through the auxiliary AVC diode. This should be checked early in the analysis. (See Section **9-24** and diode M2 in Fig. 10-3.) Disconnecting the diode will restore normal gain if it is defective.

Further Tests When Input Current Is Not Correct

10-13 It is common for a transistor to be the cause of low gain, and this usually is accompanied by a change in the input current. There is one exception, however, and this concerns the emitter bypass capacitors. If one of these is open, the result is increased input resistance to the stage and, consequently, a decrease in output. To test for this, simply bridge a good unit across each of the emitter bypass capacitors.

A shorted capacitor in the emitter of a stage can also reduce the gain by increasing the forward bias to the point where the collector is saturated, and incoming signals cannot produce a change in collector current. So, in the case of low gain, it is important to check all the emitter bypass capacitors very carefully.

A common cause of low gain is the AVC filter. Leakage here reduces the negative voltage on the base of the controlled stage, which reduces the output voltage of the stage.

The chart finally refers to Section **9-3** if the input current is high, and to Section **9-25** if it is low. Analysis in these sections will serve to locate the cause of low gain.

REVIEW QUESTIONS

1. What precaution should always be taken when checking a battery?
2. When it appears that the printed circuit is intermittent in

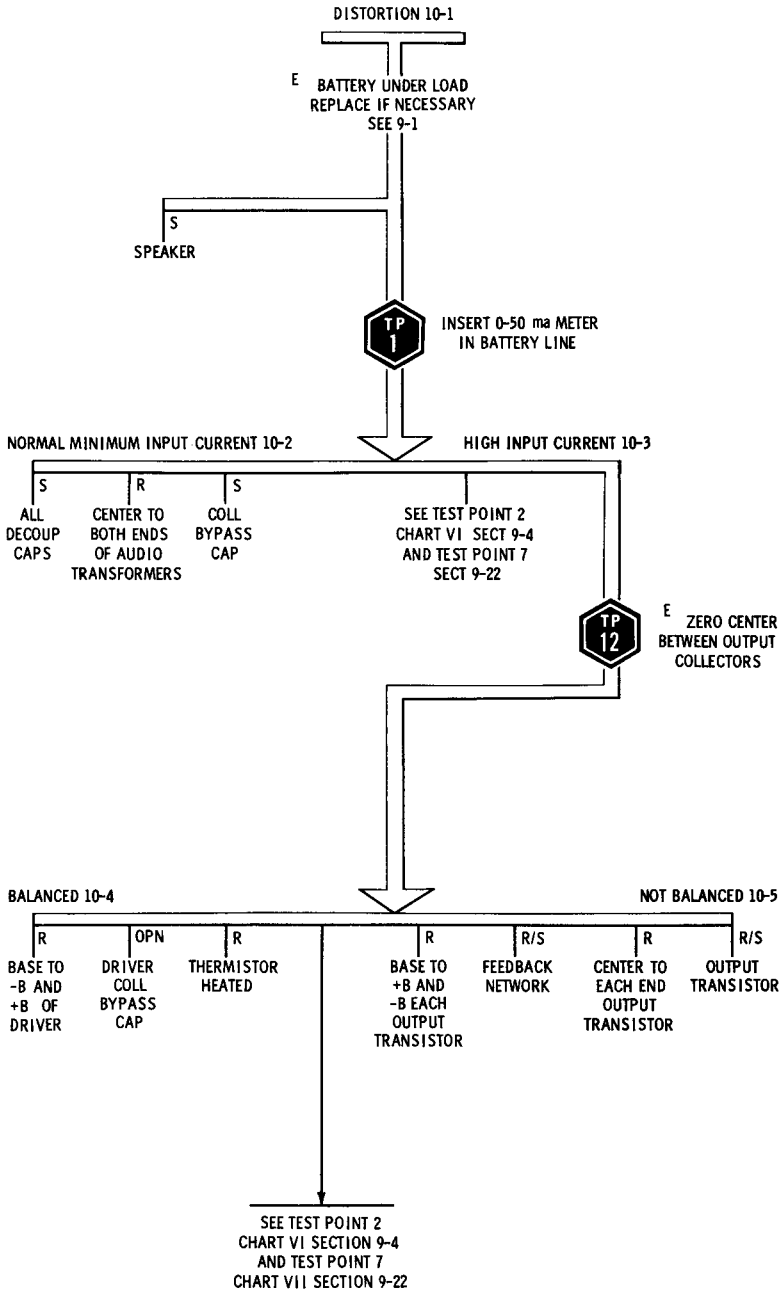

Servicing Chart IX: Distortion.

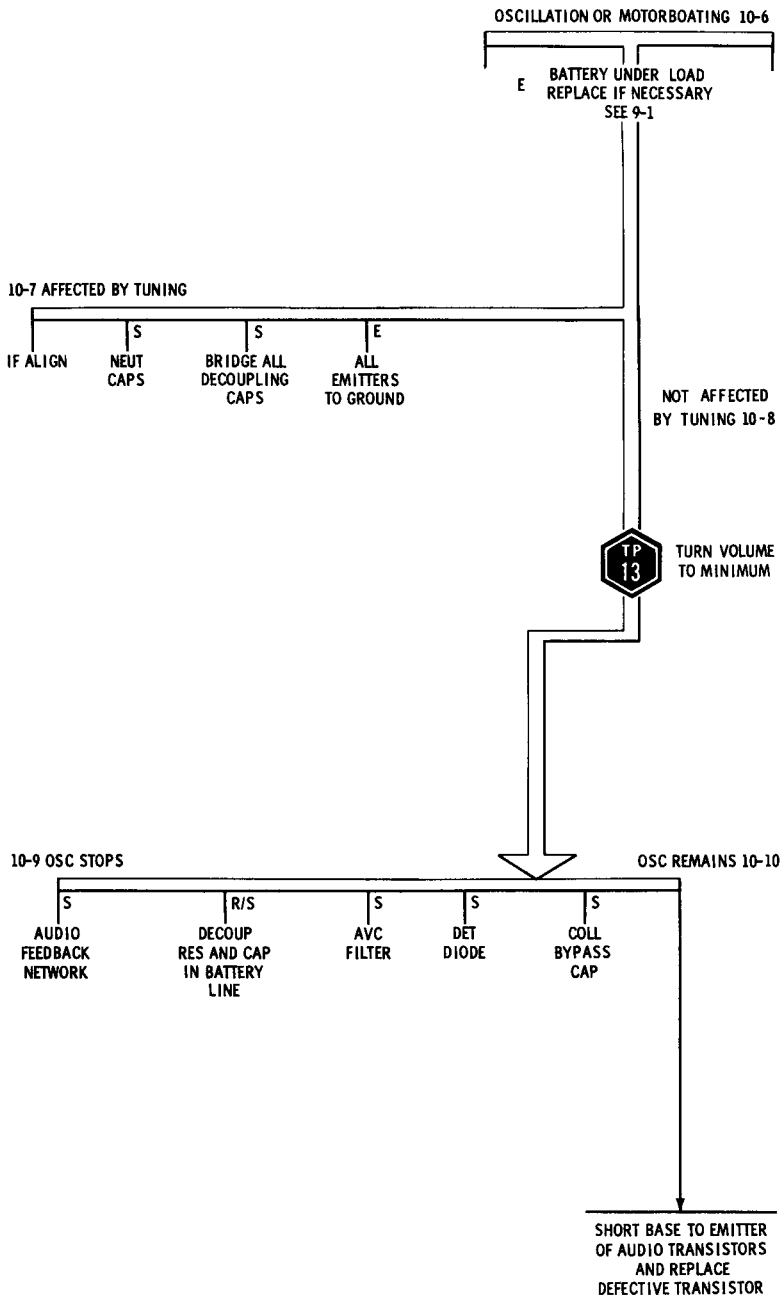

Servicing Chart X: Oscillation or Motorboating.

ALL TESTS APPLY TO PNP ONLY

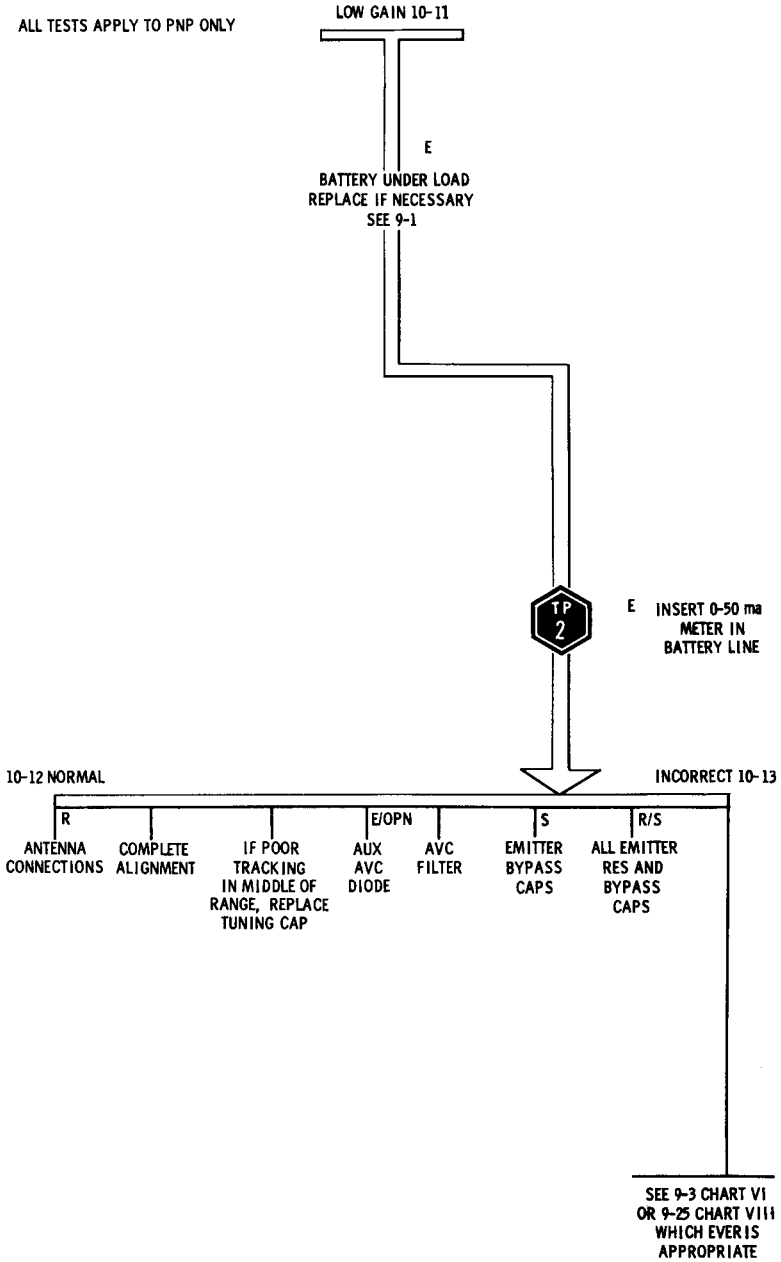

Servicing Chart XI: Low Gain.

connection with an electrolytic capacitor, what is likely to be wrong, and what action is recommended?

3. Describe the symptom and the preliminary tests which should be used before the zero-centered voltmeter is applied to the collectors of the output transistors.
4. Suppose the complaint is that the sound is distorted, and the batteries seem to wear out faster than they did when the radio was new.
 - a. Refer to Fig. 10-1 and list the first five steps that you would take.
 - b. If the receiver has an output stage like that of Fig. 10-2, what part not mentioned above might you also suspect?
5. Describe the three tests used to isolate the cause of oscillation to a definite section of the receiver.
6. In Fig. 10-3, suppose R13 is open.
 - a. Describe all the changes in voltages and currents that would occur.
 - b. What would be the symptom in the sound, and what would be the result of each of the steps taken according to the chart at the end of this chapter?
7. The receiver in Fig. 10-3 has severe distortion. The following tests have been made:
 - a. Battery current is normal at minimum volume.
 - b. All decoupling and bypass capacitors have been checked.
 - c. Both audio transformers are OK.
 - d. Voltage analysis reveals that the emitter voltage of X5 is 3 volts positive, the base voltage is normal, and the collector voltage is 1.25.

What part would you suspect, and what would be your next test?
8. With what symptom in the sound and after what tests would you recommend complete alignment?
9. List all the ways that the battery can be responsible for symptoms mentioned in this chapter and in Chapter 9. State the symptom and the tests which identify the battery in each case.
10. Look up the schematic of a receiver which has some feature not mentioned in this chapter which could cause distortion. Draw a partial schematic of the circuits involved, and explain how distortion might be caused.

11

Auto Radios

The circuitry of auto radios differs from that of other types of radios in several ways. The most important differences, from the standpoint of troubleshooting, are in the power supply and in the audio output stages when transistors are used.

VIBRATOR-TYPE POWER SUPPLIES

The source of power in automobiles is usually 6 or 12 volts DC. Thus, it is necessary to convert this low DC voltage into AC in order to step it up to the relatively high voltage required for the receiver. After it has been stepped up to about 600 volts, the AC is rectified, producing about 250 to 300 volts DC.

A typical vibrator circuit for converting the low DC voltage to AC is shown in Fig. 11-1. The vibrator consists of a spring-loaded reed which oscillates between two DC contacts like a buzzer. The action of this reed reverses the DC current through the primary of the transformer with each cycle of the vibration, as illustrated in Figs. 11-2A and 11-2B. A study of these figures will reveal how AC can be generated in the secondary by the switching action of the vibrator.

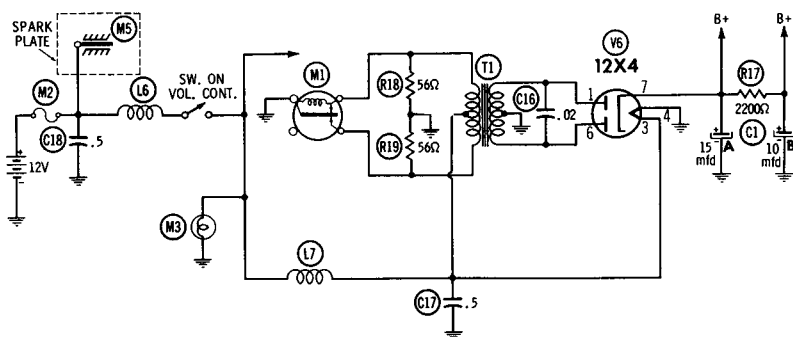

Fig. 11-1. A typical auto-radio vibrator circuit.

In Fig. 11-2A, the full 12 volts of battery voltage is placed across the top half of the transformer secondary, with current flowing in the direction indicated. In Fig. 11-2B, the battery voltage is placed across the bottom half of the secondary.

The rectifier and filter circuit is the same full-wave circuit we have already studied. It is interesting to note, however, that the ripple frequency is about 300 cycles instead of the 60 cycles used in earlier discussions of power supplies.

Buffer Capacitor

C16 is a very important part of the circuit which frequently causes breakdowns leading to burned-out vibrators and even burned-out power transformers in auto radios. It is called the buffer capacitor, and its purpose is to reduce the sparking at the vibrator contacts. The capacitor is connected in the secondary circuit because its reactance is reflected into the primary in proportion to the square of the turns ratio of the transformer. Thus, with a 1:100 step-up from primary to secondary, the reflected reactance of C16 will appear as only 1/10,000 of its original value. In this manner, a much smaller capacitor can be used across the secondary than would be required to produce the same low reactance if it were connected directly across the vibrator contacts.

The value of the buffer capacitor is critical and depends on the characteristics of the transformer. It is good practice to replace this capacitor on every repair job because it fails frequently, and such failure may result in considerable damage. But the technician must be aware of the extra high breakdown voltage required for this unit. Replacements should have at least a 1600V rating.

As with any inductive circuit, the inductance of the transformer tends to keep current flowing in the same direction after the switch contacts in the vibrator have opened, and this gives rise to a large spark across the vibrator contacts. The voltage that appears across the points is made even larger by the effect of the square wave which appears in the inductance when the points are opened suddenly. For example, in Fig. 11-2A, when the vibrator points open suddenly, the magnetic field around the top part of the primary will collapse. In so doing, there will be a large current generated in the top part of the circuit. R18 provides a path for this current, completing the circuit around the top loop when the vibrator points are open. R19 serves the same purpose on the other half of the vibrator cycle. These two resistors are often overheated in normal use and should be replaced as a precaution whenever

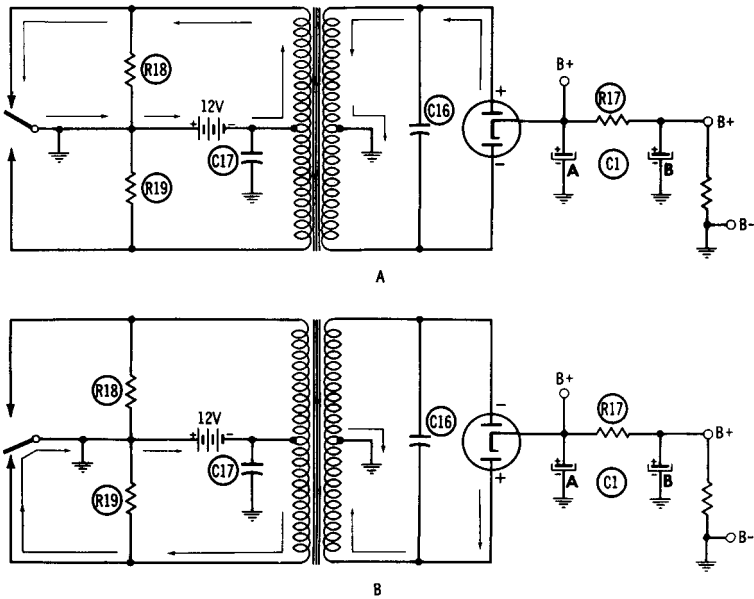

Fig. 11-2. Simplified versions of Fig. 11-1.

an auto radio is disassembled, even though the symptom may have nothing to do with the vibrator circuit.

The two coils, L6 and L7, and capacitors C17 and C18 (Fig. 11-1) are parts of a filter network to prevent pulses from the automobile ignition system from entering the receiver.

The unit marked M5 is an unusual type of capacitor which is found only in auto radios. It consists of a metal plate, usually copper, mounted flat against the radio chassis, but insulated from it by a thin piece of mica. By using this construction, it is possible to form a small but very efficient capacitor, which is essential in the reduction of noise pulses from the engine. This capacitor seldom fails, but it is mentioned here because it may appear that the input lead from the battery is soldered directly to the chassis, since the mica insulation is practically invisible.

Cold-Cathode Rectifiers

Fig. 11-3 shows another vibrator power supply which uses a capacitor, C16, across the primary, in addition to the regular buffer in the secondary. Another difference will be noted in the type of rectifier tube used. At one time, nearly all auto radios used this cold-cathode type of rectifier that does not require filament voltage. The tube is filled with argon gas,

which ionizes when sufficient voltage is placed across the elements. Hence the name, *cold cathode*.

Failure of the OZ4 is perhaps the most common breakdown in this type of auto radio. The tube fails in mysterious ways that confuse the technician who is not familiar with its peculiarities. Often, when the voltage across the secondary of the transformer is slightly low, or the tube is aged, it will fail to

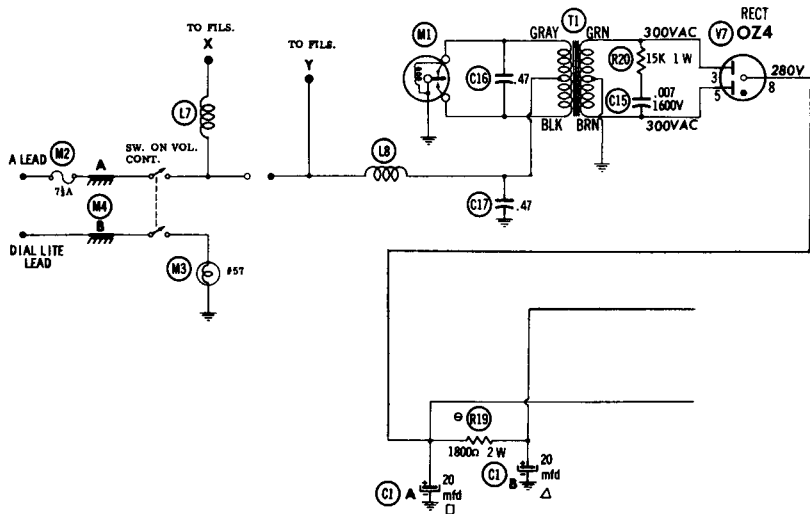

Fig. 11-3. A cold-cathode rectifier circuit.

ionize immediately. The operator will find that by switching the receiver on and off a few times it will suddenly come to life and operate normally until the next time the receiver is allowed to cool. This failure of the OZ4 is more troublesome in the winter or in cases where the receiver is not used often.

At other times, ionization of the OZ4 may be intermittent, so that the receiver operates in short bursts. The effect is very confusing if one is not familiar with this type of trouble, because speech, for example, is broken into successive short segments hardly more than a word or two in length.

Checking the OZ4 in a tube checker does not seem to be reliable. Good tubes occasionally test bad, and tubes which will not ionize properly in the receiver may check good when operated with the light loads in the tube checker.

Fig. 11-3 has some other interesting features. The use of the double-pole on-off switch makes it possible for the radio dial light to be connected to the dash-light switch in the auto. Thus, the radio dial light does not come on when the radio is operated

during the day, when the dash lights are off. At night, however, when the dash lights are on, the dial light will glow if the radio is turned on.

This switch frequently fails in auto receivers which use a vibrator-type supply, because of the large current drawn and the inductive spark present when the switch is opened. When it is difficult to obtain an exact replacement for a double-pole switch, a single-pole unit can be used by connecting the dial light lead to the "A" battery lead. This makes the dial light come on whenever the radio is turned on, even though the dash lights may be off, but this does not seem to be a severe disadvantage. A high-quality switch should always be used because of the heavy current to which it will be subjected and to avoid repeating this time-consuming job in the near future.

Special Features of Auto-Radio Circuits

There are several differences in the circuitry of auto radios which should be mentioned. Fig. 11-4 is a typical example of the older models which used vacuum tubes in the audio output and had vibrator power supplies.

Tuning is accomplished by moving the metal cores of the RF, mixer, and oscillator coils. This method is often used in mobile receivers because the movable cores can be made less susceptible to vibration. Each coil has trimmers and padders for tracking adjustments.

Auto receivers always include an RF amplifier, which is necessary to improve the signal-to-noise ratio. The circuit shown uses a 12BA6 RF stage which is coupled to the mixer through the combination of C4, L3, and C5. Leakage of B+ through C4 presents a symptom that is peculiar to auto radios of this type and does not occur in home radios.

The circuit of V4, the 12BF6 detector, AVC, and AF amplifier, has several features which are different from the familiar circuit used in home-type receivers. Besides the tone control, the circuit includes delayed AVC. The AVC diode plate (pin 5 of the 12BF6) is capacitively coupled to the plate of the IF amplifier, so that the IF carrier voltage developed in the primary of the transformer appears at this plate. The schematic shows that the cathode of the diode is held at 8.5 volts positive by the voltage drops across resistors R13 and R12. Therefore, the diode does not conduct and no AVC is produced until the carrier voltage exceeds the 8.5-volt cathode bias.

When the carrier strength is great enough to overcome this bias, the plate of the diode is driven positive with respect to the cathode. Electrons flow to the plate and through R10 to

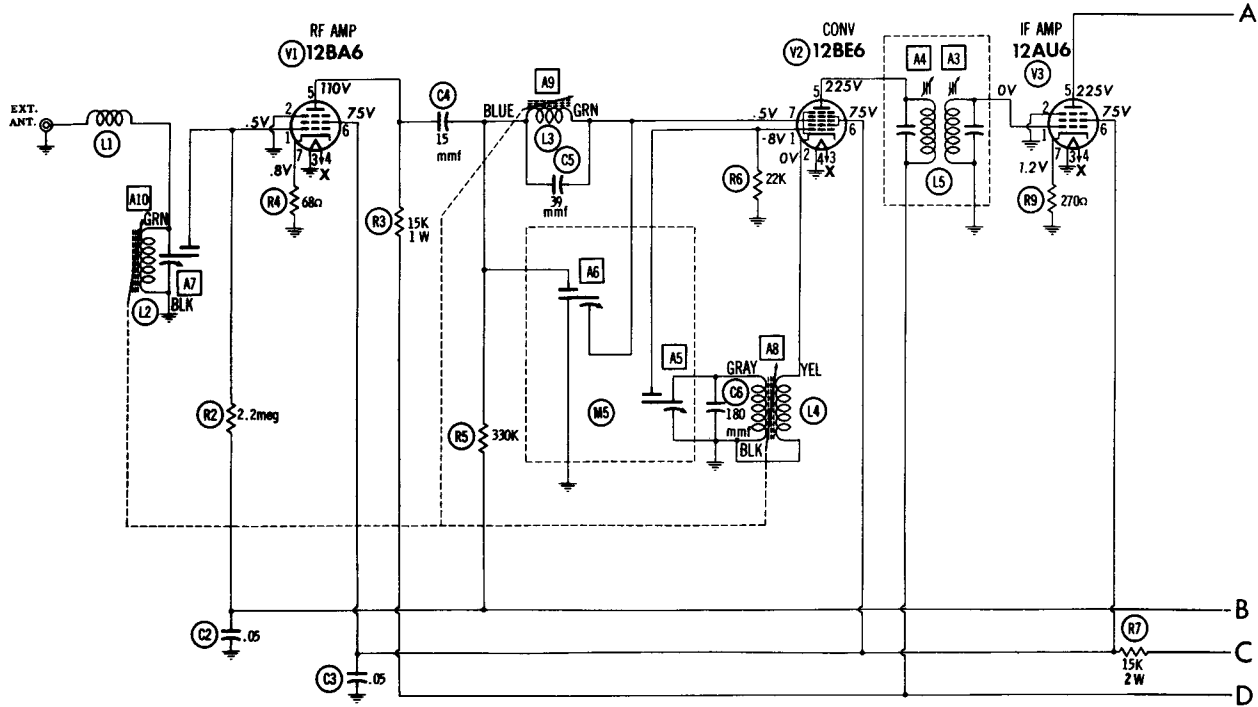
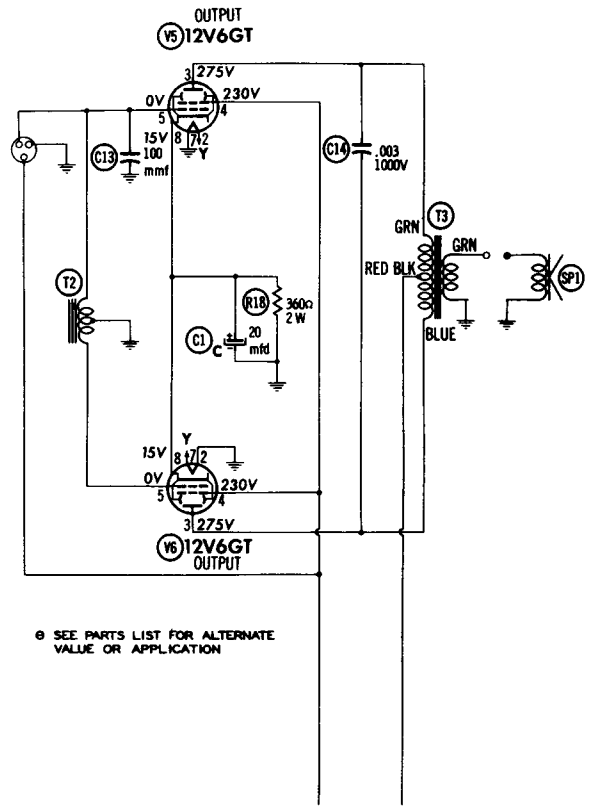
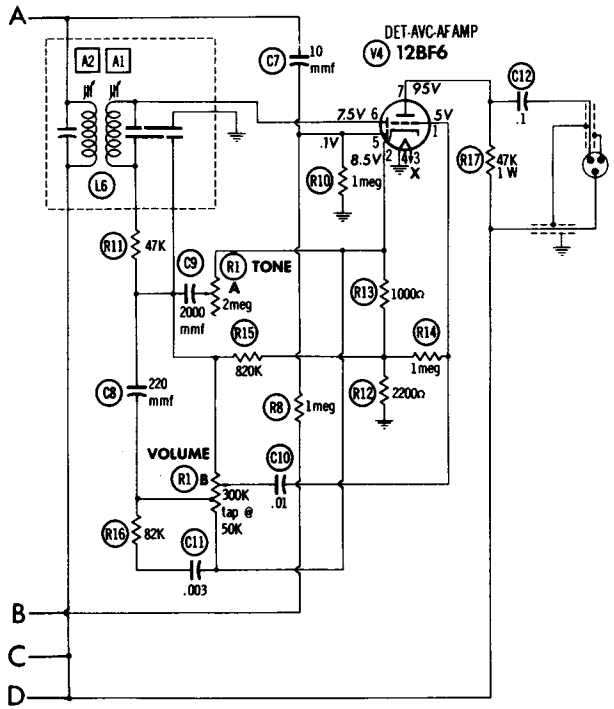

Fig. 11-4. A typical

IF=262KC

tube-type radio.



SEE PARTS LIST FOR ALTERNATE VALUE OR APPLICATION

ground, producing a negative voltage at the top of R10 that is in proportion to the signal strength.

It is important to note that the IF frequency used in many auto radios is 262 kc and not 455 kc, as in home receivers.

AUTOMATIC TUNING SIGNAL-SEEKING CIRCUITS

An older-type circuit for automatic tuning is shown in Fig. 11-5. Each section of the circuit will be discussed separately.

The Trigger Circuit

Notice that the two triodes are directly coupled—that is, no coupling capacitor is used between the grid of the second tube, V7B, and the plate of the first, V7A. This means that the grid voltage on the second tube must always be the same value as the plate voltage on the first tube. To maintain proper grid-to-cathode voltage on V7B, its cathode is connected to B+ through R30. With R24 connected to ground, a voltage divider is formed which holds the cathode of V7B at 145 volts positive. The grid is at 135 volts positive, giving a net negative bias from grid to cathode of -10 volts.

Not only does the relay coil, M8, operate the switch contacts, but the lever also controls the locking mechanism on the spring-loaded dial-drive apparatus. When the relay is not energized, the lever remains in the up position, as shown on the drawing, and keeps the dial locked in place. When V7B conducts through the relay, the lever pulls down, releasing the dial lock and also changing some important electrical connections.

With the lever in the up position, as it is when a station is locked in, the cathode of V7A is held at +145 volts because it is returned through R29 to the voltage divider as previously described. With the grid practically at zero volts this tube does not conduct; only a slight leakage current of 0.08 ma flows in R22 and R25. (See Fig. 11-6.)

The Operating Cycle

When the start switch, shown in Fig. 11-6, is closed momentarily, a large current flows through R23 and through the solenoid, pulling the lever down. This causes several changes in the circuitry:

1. The lock on the tuning gear train is released, and the dial begins to move due to the spring loading.
2. The cathode voltages of V7A and V7B are changed be-

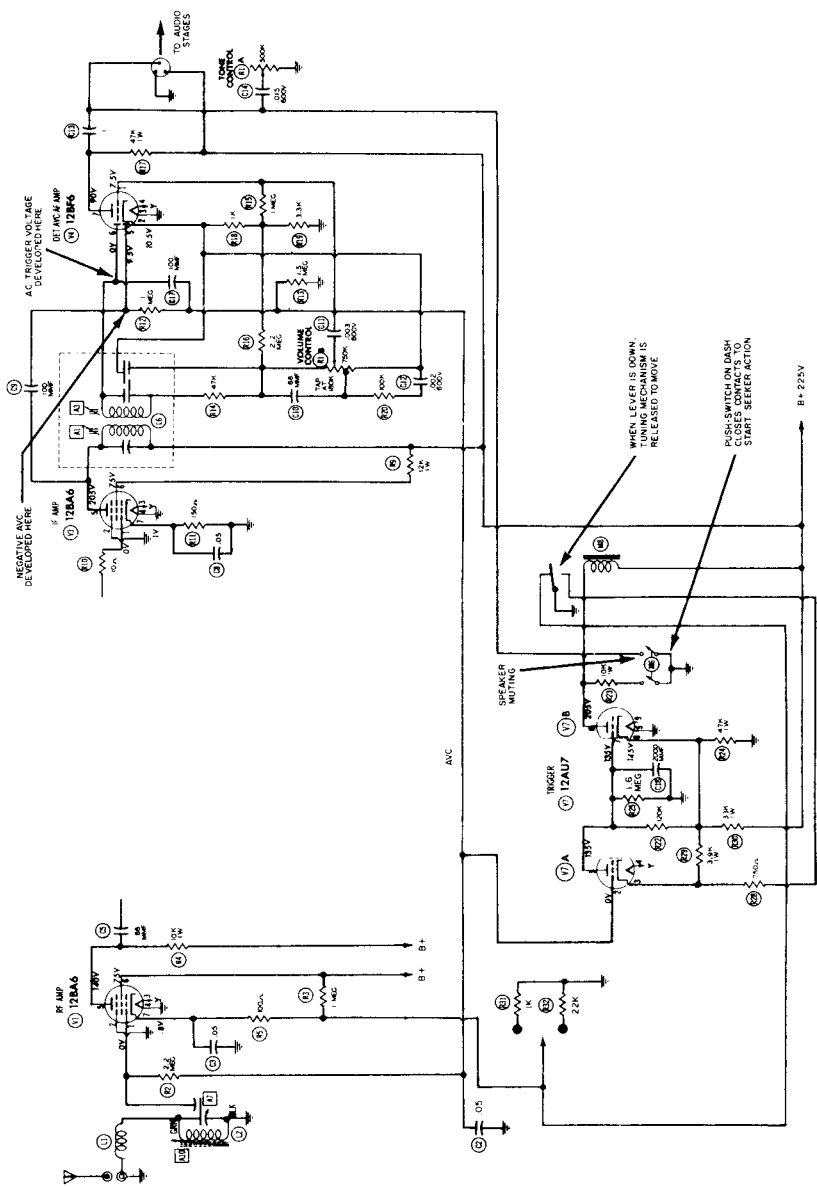

Fig. 11-5. An automatic-tuning circuit.

cause R28 is now in parallel with R29 and R24, making a relatively low-resistance path to ground. Both cathode voltages drop to about +10 volts, but only V7B conducts, because its grid is the one with the high positive voltage. There is still enough bias on V7A to keep its plate current very small.

3. The other section of the start switch shorts out the audio signal, temporarily muting the receiver so that noises are reduced. By the time the switch is released, the receiver is supposed to be between stations and not much noise should be present. Later models have the muting switch a part of the relay contacts so that the receiver remains silent during the entire search.
4. When the switch is released, V7B will continue to conduct, holding the relay lever down until there is a change in the grid voltage of V7B. This grid voltage will not change until V7A conducts heavily and its plate current lowers the plate voltage. This will not occur until a positive-going pulse appears at pin 2. This voltage will be the result of changes in the AVC voltage when the next station is reached. These changes are somewhat complex and are illustrated in Fig. 11-7.

Addition of AVC and Trigger Voltage

It is important to note that two signals are used to trigger the grid of V7A. When the tuner reaches a station, the IF car-

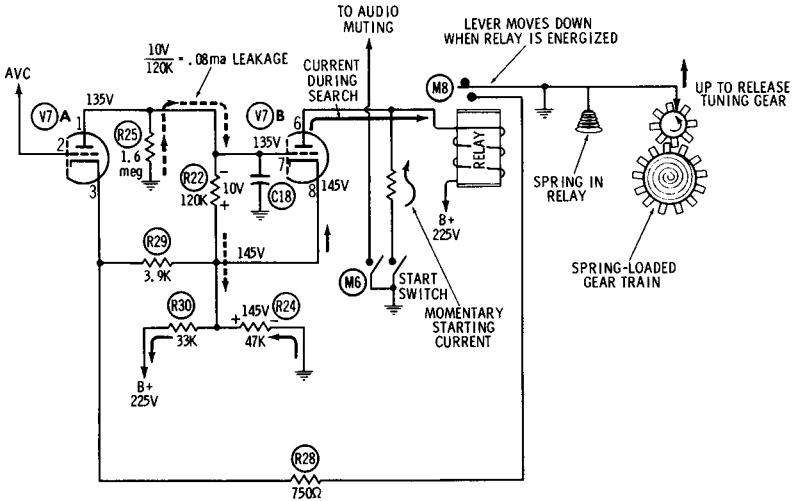

Fig. 11-6. Simplified version of Fig. 11-5.

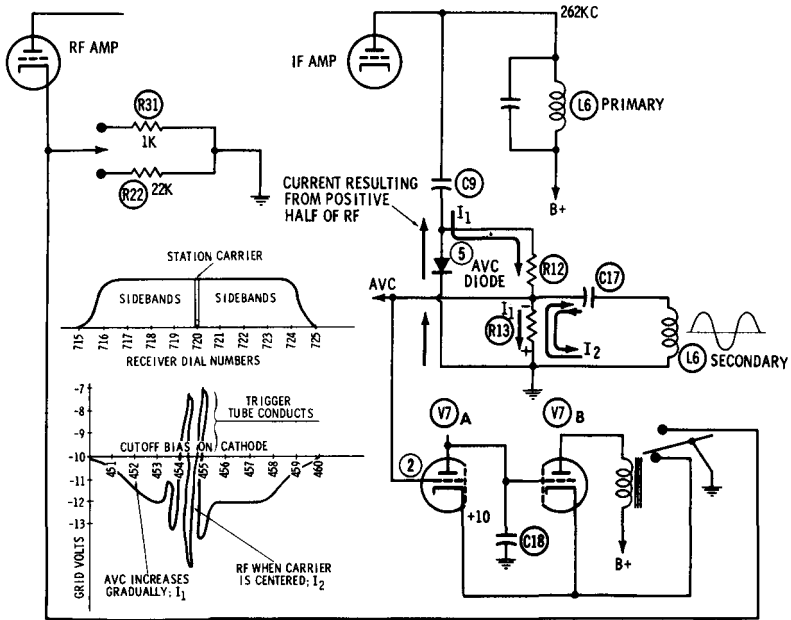

Fig. 11-7. Simplified version of Fig. 11-5.

rier appearing at C9 is rectified, and I_1 , the negative half of the RF cycle, flows through R12 and R13. But on the positive half of the RF carrier voltage, electrons flow through the AVC diode as noted on the schematic, and no voltage is developed across R12 and R13 by this current. Negative voltage for the AVC is taken from the tap between these resistors so that only half of the total rectified carrier is actually used for AVC.

At the same time, another signal is taken from the secondary of L6 and applied to the AVC line through C17. This is RF voltage, not rectified, and is larger in amplitude since none of it is lost across R12. The tuning of the detector input transformer, L6, is peaked more sharply on the secondary side so that this voltage rises to its maximum only when the carrier is exactly in the middle of the bandpass. In contrast, the AVC voltage taken from the primary increases gradually. It begins as soon as the carrier appears at the edge of the IF bandpass and reaches a broad, flat maximum when it is tuned in the center. It then gradually decreases as the carrier passes out of the bandpass on the other edge.

It is because of the broad response of the AVC that it cannot be used alone to operate the signal seeker. Negative bias appears before the incoming carrier is centered in the IF band-

pass, and this would cause the seeker to stop the tuning action before the station was correctly tuned in. This effect would be worse on the stronger local stations because a greater bias would be developed at the bandpass edges.

To prevent this difficulty, the seeker is designed so that it requires a *positive pulse* to stop the searching action. In this manner, negative AVC voltage is used as a bucking voltage to prevent triggering on strong stations before they are properly tuned in. At the bandpass edge, the negative AVC voltage keeps the trigger stage cut off, and the trigger does not operate until the AC signal from the secondary is applied. The AC will not appear until the carrier is centered in the IF channel of the receiver. Thus, the AVC automatically adjusts the DC level from which the triggering AC signal will start. The stronger the incoming carrier, the more negative will be the starting point.

The combination of the AC from the secondary of L6 and the negative AVC at the grid of V7A is shown in Fig. 11-7. The upward excursions of the resultant waveform cause the grid to become less negative and eventually bring the tube out of cutoff. The AC signal is thus detected in the plate of the tube, and the average plate current increases. With no AC applied to the grid, there is no plate current, and plate voltage is maximum (135 volts). Any plate current reduces the plate voltage and permits C18 (shown in Figs. 11-5 and 11-6) to discharge, lowering the grid voltage of V7B. When the plate current of V7B is reduced, the relay lever is released, stopping the searching action and increasing the cathode voltages again so that both tubes are cut off. Once this state is reached, no signal on either grid can start the searching action; it must be started manually by closing switch M6.

In the cathode of the RF amplifier, shown in Figs. 11-5 and 11-7, is a pair of switch connections used to control the sensitivity of the signal seeker during the search so that it can be adjusted to stop only on strong local stations or on all stations. Depending on how the operator sets the switch, either R31 or R32 is inserted between the cathode and ground when the relay is energized. When the tuner reaches the next station and the relay falls out, the cathode is grounded directly, increasing the sensitivity to maximum.

12-VOLT HYBRID RECEIVERS

The term "hybrid" means that both transistors and tubes are used in the same receiver. The last of the vibrator-powered

receivers were made about 1956; after that, most automobiles were supplied with 12-volt batteries. Special tubes, like the ones in Fig. 11-8, which use plate voltages in the vicinity of 12 volts, were designed for use in these cars. Because of the large plate current which is necessary to develop the required audio power at 12 volts, a transistor is used in the audio output stage. In a few models, a transistor driver stage is used to drive a pair of output transistors in push-pull.

The circuitry of a hybrid model using a single DS501 transistor in the output is shown in Fig. 11-8, where the relatively simple power supply can be seen. Some filtering is still needed to remove ignition noise and to provide decoupling.

Newer Versions of the Trigger Circuit

The trigger circuit shown in Fig. 11-8 uses two stages that are AC-coupled through C20. The circuit discussed earlier in Fig. 11-5 used DC coupling. When the start switch is closed momentarily, current through the relay coil closes switch M5, connecting the trigger stages to B+. Unlike the early version, the cathodes of the 12AL8 are permanently grounded, and so a heavy current flows in the tetrode section of the tube and through the relay coil. This current holds the plate switch closed during the searching and provides a cathode voltage of 2.5 volts for both cathodes, because of the drop across R27. With only -0.11 volt on its grid, the triode section of the 12AL8 is practically cut off by the cathode voltage. Accordingly, its plate voltage is high. The tetrode section will continue to conduct and hold the relay in until the plate voltage of the triode section drops, which will occur as soon as a positive pulse appears at the grid of the triode.

AVC taken from the primary of the IF transformer and rectified at pin 1 of the 12DV8 tube is combined with the secondary voltage to produce the stopping pulse in a manner similar to the earlier models. AVC delay is accomplished by returning the cathode of the 12DV8 to ground through R27.

When a station carrier is in the center of the IF bandpass, AC appears at pin 8 of the trigger amplifier. This tube conducts and its plate voltage drops to a low value because of the large resistance, R26. The negative-going pulse thus developed appears at pin 2 and reduces the plate current through the relay coil, causing M5 to open. This opens the plate and screen connections in the trigger section, and all conduction stops in both tubes. Once this state is reached, a signal on the grid cannot start the search again—it must be started manually by closing M6 momentarily.

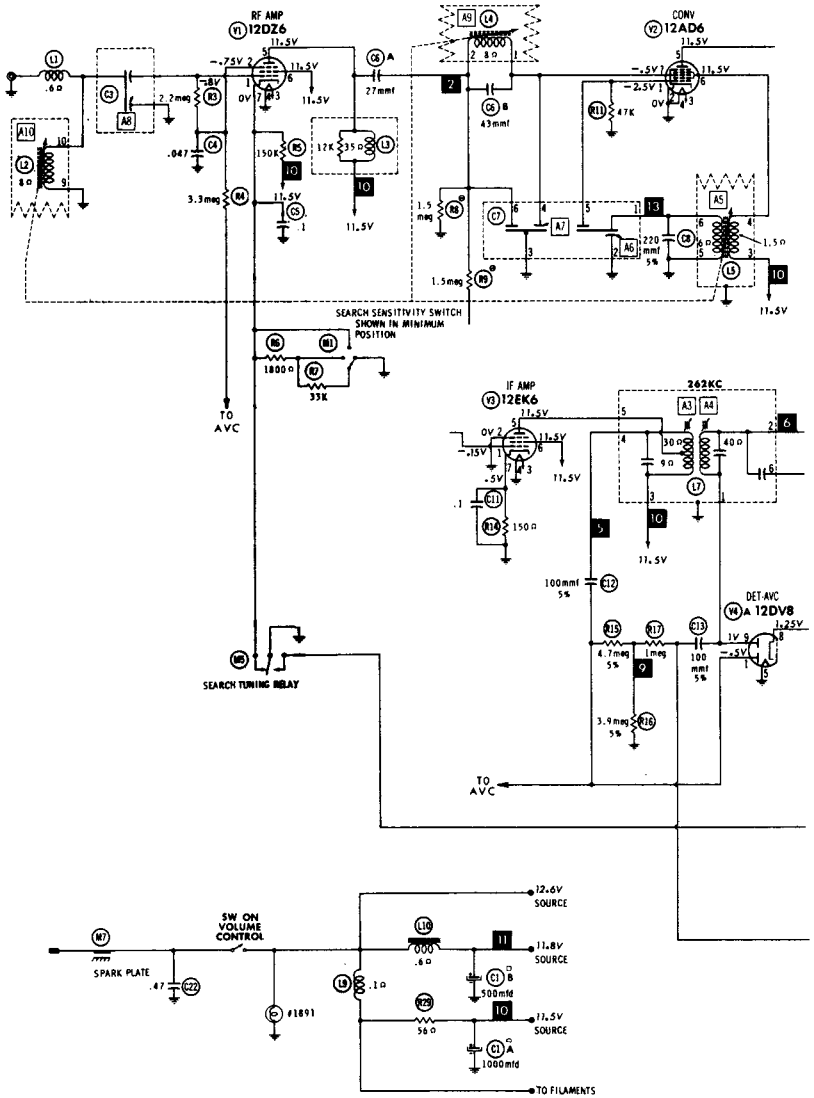

Fig. 11-8. A hybrid

The sensitivity switch is shown in the cathode of the RF amplifier, where a pair of relay contacts open the cathode connection to ground during search. This leaves the only return for the cathode through the route selected at M1, and sensitivity is reduced during search by the resistors which can be put in series with the cathode lead. The receiver then responds only to strong stations. This is exactly the same method as used in the earlier models.

Improved Muting

It will be noted that when the relay is in the search position, the sensitivity contacts of M5 are used to ground the top of the volume control, thus muting the receiver during search. This is an improvement over the old method because it provides continuous muting until a station is tuned in.

Transistorized Trigger Circuits

Fig. 11-9 shows a transistorized version of a trigger circuit used in an all-transistor receiver. NPN transistors are used

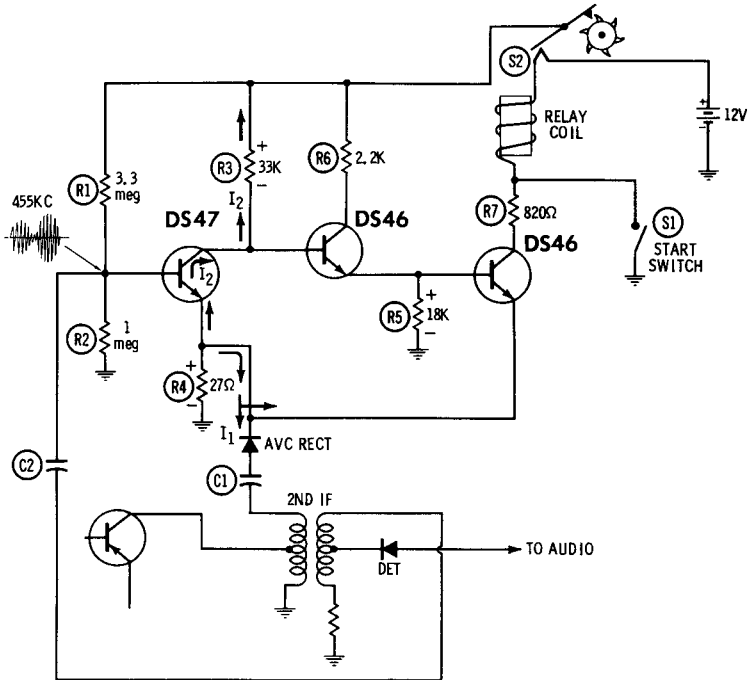

Fig. 11-9. A transistorized trigger circuit.

throughout. This means that a *negative* base with respect to emitter will cause cutoff and a positive base will cause conduction, with the electrons moving through the emitter and out the collector.

Two voltages are applied through C1 and C2 to the base and emitter of the DS47 trigger amplifier. One of these voltages is taken from the primary of the last IF transformer and rectified to produce current I_1 when a signal is present. The other voltage is taken from the secondary and is not rectified. This is similar to the method used in the vacuum-tube models to obtain a bucking voltage, except that the AVC voltage is applied to the emitter and the RF signal is applied to the base.

The search is started by momentarily closing the start switch, which causes a heavy current to flow through the relay, pulling the relay arm down and releasing the gear train. The DS47 is biased near cutoff by bleeder current through R1 and R2, and the additional current drawn by the DS46 output transistor drives it farther into cutoff by increasing the positive voltage on the emitter.

With the first stage cut off, there is no drop across R3, and the second stage has maximum positive voltage on its base (current I_2 is not present). In this condition, it conducts heavily, producing a positive voltage at the top of R5. This voltage appears at the base of the output stage to keep it conducting after the start switch is opened.

When the tuner reaches a station, the signal from the transformer primary is rectified and current I_1 flows. This increases the positive potential at the top of R4 slightly and prevents the DS47 from coming into conduction immediately when the signal through C2 reaches the base.

This RF voltage across C2 from the secondary comes to a sharp peak when the station is properly centered in the IF bandpass. This results in sufficient signal on the base of the DS47 to cause it to conduct. The resulting conduction on the positive halves of the signal causes current I_2 to flow in R3, lowering the positive base voltage on the second stage. With the conduction of the second stage so reduced, there is less positive voltage on its emitter resistor, and the base of the output stage becomes less positive.

A slight drop in the current through the output stage permits the relay spring to return the lever to the lock position, stopping the gear train at the precise instant when the station is centered in the bandpass. This decrease in current also opens S2, which kills the first two stages and leaves zero base voltage on the output stage.

The circuit is serviced by following the same general rules established for the tube versions but considering the delicate balance of small voltages on which operation depends. Leakage, bias-network failures, and effects of heat must be taken into consideration here, whereas these considerations are not important with the vacuum-tube counterpart of this circuit.

TRANSISTOR OUTPUT STAGES

In auto radios which use only the 12 volts DC supplied by the car battery as a power supply, the audio output stage must be transistorized. Since the radio must deliver about 10 watts of power, about 1 amp of current is required at 12 volts—a vacuum tube capable of such current would be very large and difficult to mount in an auto radio. Transistors capable of 1 amp on peaks at 12 volts are very convenient in size and can be easily mounted on the chassis.

A heat sink is used for mounting the transistor, and some extra circuitry is necessary for biasing and overload protection. Power transistors must be protected from thermal runaway, a condition which results from an increase in collector current with heat. As the transistor gradually heats, the leakage current increases, producing more heat. This, in turn, produces more leakage. Finally, the collector current becomes excessive, and the transistor is ruined.

Overload protection is usually provided in the form of a 0.47-ohm fusible resistor (R25 in Fig. 11-8 and R32 in 11-10). This combination resistor-fuse is often used in auto-radio power stages, and its value is critical. In most repair jobs which require servicing for the *No Signal* symptom, this resistor will be open, indicating that the transistor has been operating at excessive current loads. The resistor must be replaced with one of the exact value, and the transistor must be checked for leakage as described in Section 9-6.

Even when a power transistor seems to check OK, it should still be regarded with suspicion because there is no way to predict its behavior when it is heated. But some other components in the circuit could also cause the fusible resistor to burn out. In Fig. 11-10 these are:

1. Collector bypass capacitor C1.
2. Emitter bypass capacitor C23.
3. Base bypass capacitor C22.
4. Input transformer T1.
5. Base resistor R31.

Fig. 11-8). The instructions given on the schematic for this adjustment assume that the input voltage is exactly as called for and that the correct speaker is connected. Always allow the transistor to warm up for about 10 minutes before making this adjustment.

One more precaution should be mentioned in connection with high-power transistor output stages. That is the importance of keeping the proper load on the collector at all time. This means that the receiver should not be operated without a speaker connected, and that a speaker having a resistance very close to the original should always be used. These stages are operated near their maximum capabilities, and the values of components are critical.

Current and Voltage Analysis of Transistor Output Stage

When the output circuit of Fig. 11-10 is analyzed by Ohm's law, the critical values of currents and voltages present can be seen. In Fig. 11-11 the circuit is redrawn in the standard form which is always used for calculations. The battery voltage is shown as 11.8 volts because this is the value to which the base is actually returned in the original circuit.

In the original schematic, the voltages given at the base and emitter terminals are the voltages measured from these points to ground. In Fig. 11-11 the ground symbol is shown at the top and is connected to the negative terminal of the battery, and these two voltages are shown from the base and emitter terminals to ground. The true emitter voltage is the

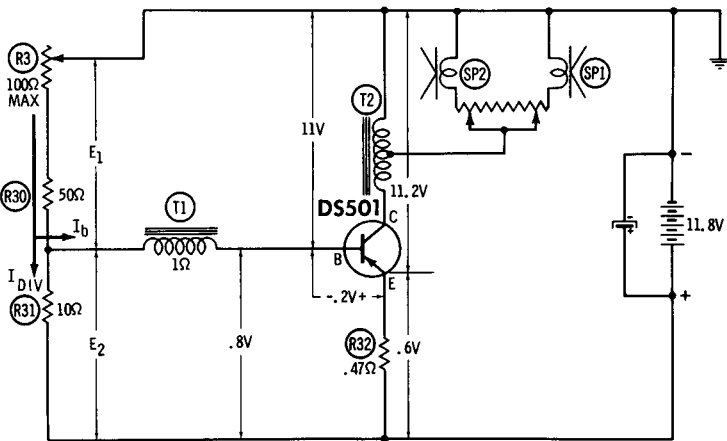

Fig. 11-11. Fig. 11-10 redrawn in the proper form for calculations.

voltage from the emitter to the positive side of the battery; it turns out to be 0.6 volt, after subtracting 11.2 from 11.8. The true base voltage is found in the same way, and it can be seen on Fig. 11-11 as 0.8 volt. The forward base bias is the difference between the emitter and base voltages: $V_{be} = 0.2V$.

The base current, I_b , flows through the secondary of the input transformer, T1, and since its value is not given, the resistance of this winding is assumed to be 1 ohm.

If a reasonable value of β is assumed, we can calculate the emitter, base and collector currents as follows:

$$I_e = \frac{.6}{.47} = 1.28 \text{ amp or } 1280 \text{ ma}$$

$$I_e = I_c + I_b$$

Since

$$\beta = \frac{I_c}{I_b}, \text{ then } I_c = I_b \beta$$

Substituting,

$$I_e = I_b \beta + I_b$$

$$I_e = I_b (\beta + 1)$$

Assuming

$$\beta = 29,$$

$$(\beta + 1) = 30$$

$$I_b = \frac{I_e}{(\beta + 1)}$$

$$I_b = \frac{1280}{30} = 42.6 \text{ ma}$$

$$I_c = I_e - I_b = 1237.4 \text{ ma}$$

The values in the biasing network can be found easily. Assume

$$R_{T1} = 1 \text{ ohm}$$

$$\begin{aligned} E_{T1} &= (I_b) (R_{T1}) \\ &= 0.04V \end{aligned}$$

To find R3,

$$E_1 = 11 - 0.04 = 10.96V$$

$$\begin{aligned} E_2 &= 11.8 - E_1 \\ &= 11.8 - 10.96 \\ &= 0.84V \end{aligned}$$

$$I_b + I_{DIV} = I_{R3 \text{ and } R30} = 42.6 \text{ ma} + 84 \text{ ma} = 126.6 \text{ ma}$$

$$\text{The sum of } (R3 + R30) = \frac{E_1}{I_b + I_{DIV}} = \frac{10.96}{126.6 \text{ ma}} = 86 \text{ ohms}$$

$$\begin{aligned} R3 &= 86 - R30 \\ &= 86 - 50 \\ &= 36 \text{ ohms} \end{aligned}$$

The *stability factor*, S_1 , of a circuit is the ratio of the change in collector current to the change in leakage, I_{cb} (see Chapter 8, Fig. 8-4) :

$$S_1 = \frac{\Delta I_c}{\Delta I_{cb}}$$

Since $\Delta I_c = (S_1) (\Delta I_{cb})$, it is clear that S_1 represents the factor by which ΔI_{cb} will be amplified in the collector current. Thus, the lowest value of S_1 is most desirable.

A very close approximation to the stability factor in a common-emitter circuit which has good β is,

$$S_1 = \frac{R1 R2}{(R1 + R2) R_e}$$

where $R1$ and $R2$ are the resistors in the base bias voltage divider.

Using the values $R1 = 86$ (that is, $R3 + R30$); $R2 = 10$ ohms (that is, $R31$); and $R_e = 0.47$ ohm (that is, $R32$),

$$\begin{aligned} S_1 &= \frac{(86) (10)}{(86 + 10) (.47)} \\ &= 19 \end{aligned}$$

So it can be seen that a change in leakage current will appear 19 times greater in the collector current. With germanium transistors, the leakage doubles for each 10°C of temperature increase.

If the temperature rises 50°C during operation, the leakage current will double itself five times, and the resulting change in collector current can be calculated as follows: Assuming a minimum leakage of $I_{cb} = 0.5$ ma,

Leakage after 50° rise in temp =

$$0.5 \times 2^5 = 0.5 \times 64 = 32 \text{ ma with } S_1 = 19,$$

$$\begin{aligned} \Delta I_c &= (S_1) (\Delta I_{cb}) \\ &= (19) (32 \text{ ma}) \\ &= 608 \text{ ma} \end{aligned}$$

This means that after the temperature of the transistor has increased 50°C the collector current will be 608 ma higher than normal for the same set of operating voltages. At 10 volts V_{ce} , this is an increase of 6 watts dissipation and could easily exceed the limits for which the transistor was designed.

The importance of adjusting R3, the bias pot, for the proper operating point can be easily seen. Too much bias will increase the temperature, with resulting changes in the collector current.

The importance of R32, the emitter resistor, can also be seen now. The stability is directly dependent on this resistance. If the resistor were made .75 ohm instead of .47 ohm, the stability factor would be 12 instead of 19, and this would make ΔI_c in the above example $32 \times 12 = 384$ ma instead of a 608-ma increase in collector current with a 50°C rise in temperature.

Increasing the size of R32 would, of course, call for corresponding changes in the other resistors in the bias network in order to maintain the 0.2 volt V_{be} which is required. We have neglected these changes, but when they are made, the improvement in stability is even more pronounced.*

Negative Feedback Through C2

In Fig. 11-8, a 1000-mfd capacitor, labeled C2, is connected between the emitter and the bottom end of the T1 secondary. The purpose of this component is to provide an AC voltage bucking against the input voltage. The negative feedback so produced reduces the current in the transformer secondary and, in this manner, increases the input resistance to the stage. Higher input resistance means more stable operation, less loading of the driver stage, and better gain.

Since C2 is connected to the emitter, the AC voltage through it is in phase with the incoming signal and opposes the base voltage. Since the emitter voltage is always .2 volt less than the base, C2 reduces the AC current in the secondary by keeping the potential nearly equal at both ends. If C2 is shorted, the base and emitter will be effectively shorted, and the forward bias will disappear, rendering the stage with little or no collector current. If C2 is open, the input resistance of the stage will be lowered, and heavy loading of the preceding stage will occur, producing a loss of volume and possibly some distortion.

* The stability formula we have been using is actually a shortcut approximation. It would seem that if R32 were made still larger (10 ohms, for example), S_1 would be less than 1; actually this can never happen, because the minimum value possible when the full formula is used is $S_1 = 1$.

DIRECT-COUPLED TRANSISTOR STAGES

A trend toward elimination of the driver transformer seems to be developing in auto radios. The typical direct-drive circuit shown in Fig. 11-12 is representative of this design. One of the advantages of direct coupling is that it improves frequency response, particularly at low frequencies.

The collector of NPN transistor X4 is connected to 12 volts through R26. Resistor R25 develops 1.4 volts of base voltage from the slight current flowing from ground (negative) across the base junction to the collector (positive). Voltage at the emitter depends on the value of R2. Thus, the emitter-base bias of X4 and, consequently, its collector current, is set by R2.

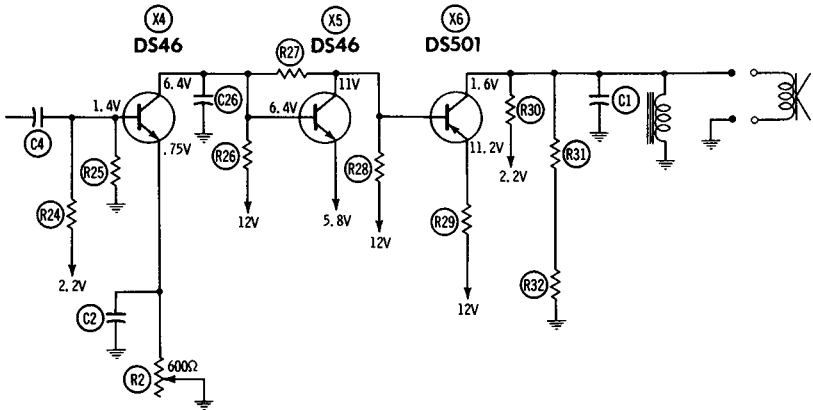

Fig. 11-12. Direct-coupled output stages.

Collector current for X4 flows through R26, dropping the collector voltage to 6.4 volts. The base of X5, connected directly to the X4 collector, acquires the same potential. A divider network in the power supply sets the bias at the emitter of X5. The voltage difference between base and emitter constitutes bias for X5. Current through R28 causes the collector voltage to stabilize at 11 volts.

The direct-coupled base of X6 attains the same 11 volts. Since X6 is a PNP transistor, the collector is connected to ground (negative) through a low-impedance choke, L8. Forward bias causes X6 to draw collector current. Fusible resistor R29 develops a slight drop (about 0.8 volt) to prevent thermal runaway in the output transistor. Since R2 controls the bias of the entire system, it is usually set for the correct collector voltage on X6—approximately 1.6 volts.

TEST POINT 1, CHART XII

TROUBLESHOOTING THE TRANSISTOR OUTPUT STAGE

11-1 Failure in the output stage is the most common trouble in hybrid receivers. CHART XIII at the end of this chapter gives details of the servicing procedure. The only test which has not been described in earlier chapters is the use of a speaker at TEST POINT 1.

At least one lead from the input transformer secondary should be disconnected to remove the winding from the circuit, and then an ordinary 4- to 6-ohm speaker can be connected across the winding while the receiver is operated. If signals are heard from the speaker, this proves that all previous stages are working, and testing is confined to the output stage only. If no signals are heard, the testing proceeds in the manner described in Chapters 3 and 4.

TEST POINT 2, CHART XII

BASE-TO-EMITTER VOLTAGE

11-2 Measurement of the forward bias is selected as the first step in isolating the trouble. Although several other tests could be used, this voltage is a critical one, and the base and emitter terminals can be located easily. Measurement of the collector voltage does not help much for the following reasons:

1. Even with the emitter open, there is likely to be considerable leakage current present, and a voltmeter from collector to ground might give a reading which could mistakenly be assumed to indicate that some normal collector current is flowing.
2. If the collector were open due to a burned-out output transformer, there might be some current through the meter, which would give a confusing indication.
3. If the meter shows no voltage between collector and ground, not much information has been gained, since there are numerous ways in which this could occur—shorted bypass capacitor C1 in Fig. 11-10, open junction in transistor, open bias pot causing cutoff bias on the transistor, etc.

TEST POINT 3, CHART XII

RESISTANCE FROM COLLECTOR TO -B

11-3 This test has been used before in Chapter 9. If the resistance is normal (about 10 ohms), the speaker and the

wiring associated with speaker plugs and cables should be suspected.

TEST POINT 4, CHART XII

INCORRECT BASE-EMITTER VOLTAGE

11-4 The fusible resistor R32 in Fig. 11-10 is the most probable cause for incorrect base-emitter voltage and must be replaced with exactly the correct part. Under no circumstances should a receiver be operated with a jumper across this resistor or with an incorrect value of resistance connected.

It is advisable to also replace the transistor at this time, and this will call for readjustment of the bias pot. The adjustment can be made by strictly following the directions given on the schematic. However, with certain universal replacement-type transistors, it may be found that the adjustment is best done by measuring the base-to-emitter voltage and setting the pot for about 0.2 volt. Allow the transistor to warm up a bit before adjustments are made.

It is not good practice to make this adjustment of the bias pot "by ear," that is, by listening for the "best" sound from the speaker. With many circuits, an adjustment of the bias which gives the most volume exceeds the ratings of the transistor or alters the stability factor, S_1 , so that thermal runaway is more likely to occur.

Auto radios have special symptoms because of the transistor output circuit which is not used in other kinds of receivers, and because of failures in the signal-seeking circuits, which are also unique. Also, in older models, the vibrator power supply requires special test methods. In addition, these receivers also have all the other symptoms common to other kinds of radios, and the test procedures described in earlier chapters apply to the RF, mixer, IF, detector, AVC, and audio stages of auto radios as well.

TROUBLESHOOTING THE TRIGGER CIRCUIT

TEST POINT 1, CHART XIII

CONTINUOUS SEEKING

11-5 This is the condition where, once started by depressing the manual starting switch, the tuner continues to recycle, tuning from one end of the broadcast band to the other, without stopping at any stations. A rare form of this symptom occurs when the tuner begins to seek after it has been locked on

a station for some time and without having the manual starting switch depressed. These troubles are usually due to dirty or defective switch or relay contacts, or a filament-to-cathode short in the trigger tube (in an older model) which could reduce the cathode voltage.

The first test, after checking the switch and tube, is accomplished by disconnecting the lead from the relay or starting switch which leads to the speaker-muting circuit, so that the speaker will not be muted during the search. Connect a VTVM to the grid of the input tube in the trigger circuit, and start the searching action by depressing the starting switch. One of the three results shown in CHART XIII should occur.

If no stations are heard in the speaker, it is probable that the receiver has a typical No-Signal condition, and reference should be made to Chapters 3 and 4. One common cause of no signals in auto radios which does not occur in other kinds of receivers is an open cathode in the RF stage. Because of this common trouble, an ohmmeter check from cathode to ground is recommended before beginning the procedures for a No-Signals condition.

Further Tests When Stations Are Heard but There Is No Change in the Grid Voltage

11-6 The receiver circuits are working, but the trigger voltage is not being developed. This limits the testing to a narrow area. First, the detector/AVC tube should be checked, preferably by substitution. If this tube is not at fault, then each of the parts listed on the chart should be methodically removed and new ones tried.

A common cause of this condition is a failure in the output IF transformer. There may be enough signal to operate the detector, but not enough to develop a trigger voltage. Alignment of this transformer may be necessary, although it is not likely that it could become misaligned by itself. Nevertheless, it is good practice to check the alignment at this point. If the transformer does not seem to respond properly, it is probably defective and should be replaced. (The IF frequency should be noted from the schematic. It will usually be 262 kc, but there are exceptions.)

One very important notation regarding the alignment of the secondary of the output IF transformer is that it must be tuned for *minimum* AVC voltage, and not maximum as is usually done. This fact is always noted in the alignment instructions furnished with the schematic. Proper operation of the seeker depends on accurate alignment.

Further Tests When Stations Are Heard in the Speaker and the Trigger Voltage Changes

11-7 In this case, there is good evidence that the entire receiving circuitry is working, and the failure is confined to the trigger stage itself. TEST POINT 2 calls for a voltage measurement on the plates in the trigger section. If a voltage is incorrect, the plate resistor and other components between the plate and B+ must be checked.

TEST POINT 3, CHART XIII

NORMAL PLATE VOLTAGES IN THE TRIGGER

11-8 TEST POINT 3 is an ohmmeter check of the cathodes in the trigger stage. The tube which controls the relay may be conducting too heavily, due to a low-value resistor in the cathode, making it impossible to reduce the plate current enough to drop the relay contacts out. If the cathode resistor is larger than normal, it may be difficult to get a pulse on the grid of the input tube strong enough to cause conduction.

If the cathodes are found to be normal, the possibility of sticking relay contacts remains. The contacts should be cleaned and burnished.

CHART XIV

SEEKER EITHER WILL NOT START OR WILL STOP WHEN THE SWITCH IS RELEASED

11-9 CHART XIV indicates that the test procedure is based on the clue obtained by noting whether the speaker is muted when the starting switch is depressed. If the speaker is not muted, it is likely that the failure is in the switch itself.

When the speaker-muting takes place with operation of the starting switch, the relay solenoid should be checked first, after which the resistance of the cathodes to ground in the trigger stage should be measured.

TEST POINT 4, CHART XIV

MEASURE CATHODE VOLTAGE WHILE SHORTING RELAY CONTACTS

11-10 The object of this test is to determine if the trigger output tube will conduct. In circuits like that of Fig. 11-5, shorting the relay contacts removes the positive voltage from the cathodes, and this should be observable on the voltmeter

placed at the common cathode resistor. In other models, the relay contacts control the B+ to the trigger stages, as shown in Fig. 11-9. In this case, the output tube will begin to conduct when the contacts are closed, because the screen voltage is connected, resulting in a change in the cathode voltage.

Further Tests When the Cathode Voltage Changes

In the circuit of Fig. 11-8, it is likely that the entire trigger stage is functioning properly electronically, but some mechanical defect, such as jammed gears, is preventing the tuner from searching. In the older models that used a 12AU7 in a circuit like those of Figs. 11-5 and 11-6, a change in cathode voltage does not prove that the output tube is conducting properly, so the tube should be checked and its plate voltage measured. Also, the resistance from grid to ground in the output tube should be checked to determine the condition of C18.

Further Tests When the Cathode Voltage Does Not Change

In the newer-model receivers, the cathode resistor should be suspected along with the relay contacts and the main source of B+, which may be absent. In older types, the relay contacts could cause the trouble. Another common cause is R28 in Fig. 11-6.

Seeker Stops on Strongest Station Only

11-11 This condition is commonly caused by a weak tube in the RF or IF sections of the receiver, by misalignment, or even by a defective antenna on the auto.

An ohmmeter check from the cathode of the RF stage to ground will indicate the condition of the resistors in the sensitivity selecting circuit. A resistor at R31 or R32 (Fig. 11-5) which has increased in value can reduce the sensitivity to a point where only a very strong carrier could stop the searching action. The other tests mentioned in CHART XIV are very simple and need no explanation.

Seeker Stops Between Stations

11-12 This kind of trouble does not occur very often, but when it does the technician may not know where to begin testing. First, it should be ascertained that there is no mechanical jamming which stops the tuner. The entire gear train and recycle mechanism should be cleaned and oiled.

Any defect which reduces the AVC voltage but does not weaken the incoming signal will tend to increase the stopping sensitivity of the trigger because the AC applied from the

transformer secondary will have no bucking voltage. The slightest incoming signal could bring the first tube into conduction.

Of all the causes listed in CHART XIV, the most difficult to isolate is a defective IF transformer. As was described in other chapters, a slight leakage sometimes develops through the transformer, which puts a tiny positive voltage on the secondary. When the secondary feeds the trigger stage, this leakage can stop the searching by causing conduction of the first tube in the trigger section. In a similar manner, a leakage of the capacitor feeding the AVC voltage from the primary to the AVC rectifier will put a small positive voltage on the grid of the trigger tube and stop the tuner when no station is present.

Dirty relay contacts are another common cause of stopping between stations. If the contacts open momentarily during the search, current ceases to flow through the relay coil, and the contacts will not be pulled closed again by the magnet. They will remain held open by the relay spring until the next time the relay is energized by the starting switch.

REVIEW QUESTIONS

1. Look up the schematic of a vibrator-type auto radio. Draw a schematic of the complete power supply, and describe two common failures, giving the symptoms and the procedure you would use to isolate the defect.
2. Describe two special features of auto-radio circuitry which lead to symptoms that do not occur in home radios.
3. In Fig. 11-5:
 - a. What is the purpose of R31 and R32?
 - b. What would probably happen if R29 were open?
 - c. Explain the purpose of C18.
4. Describe at least three ways in which the circuit of V5 in Fig. 11-8 differs from the earlier versions.
5. A hybrid receiver, like the one in Fig. 11-8, has a No-Signals symptom.
 - a. What test could you use to determine if the transistor stage had failed, or if the trouble were elsewhere?
 - b. Suppose your test proves that the output stage has failed and you make the following tests:
 1. Base-to-emitter voltage is $-0.2V$.
 2. V_{ce} is $11.8V$.
 3. Resistance from collector to ground is 0.5 ohm. What parts would you suspect, how can they be tested?

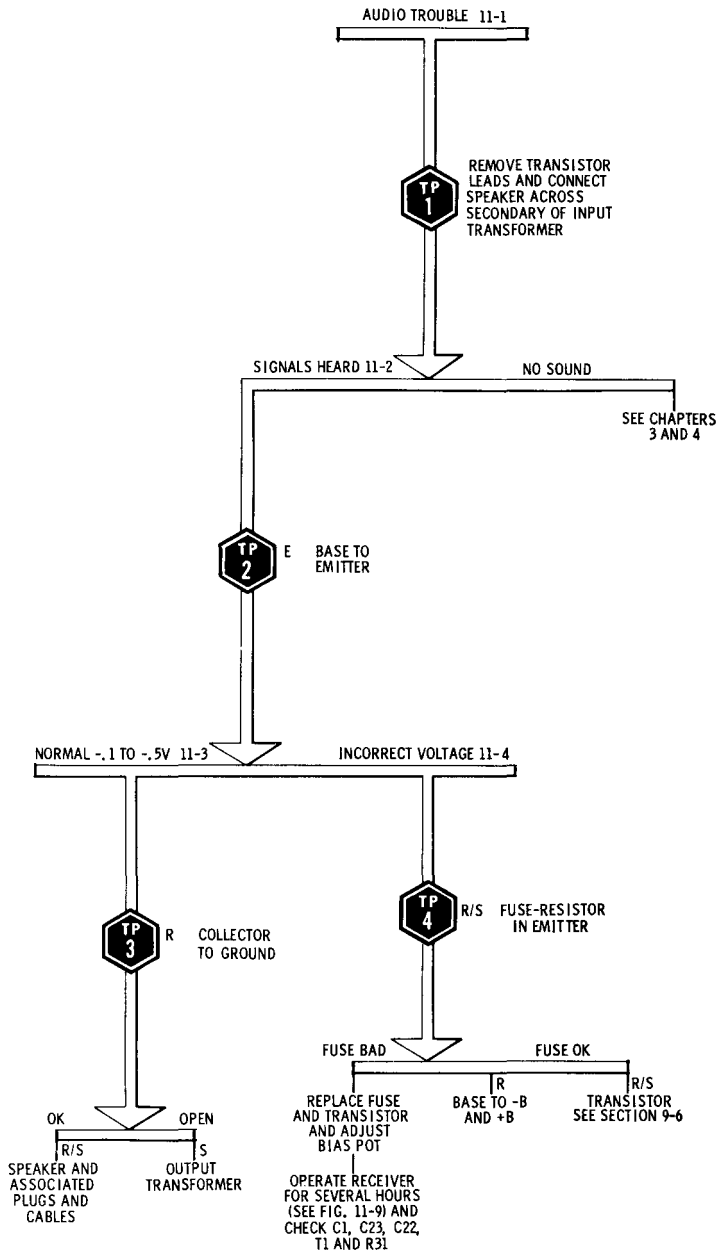

Servicing Chart XII: Hybrid Auto Radio, No Signals.

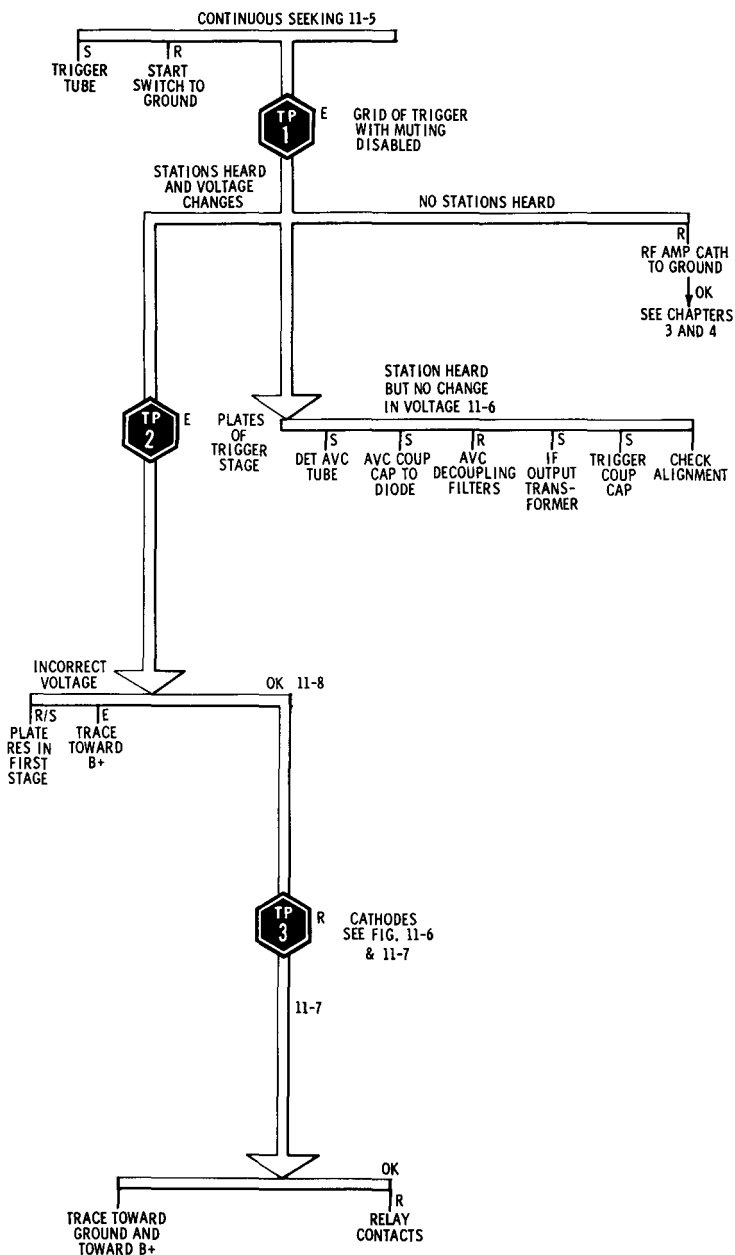

Servicing Chart XIII: Auto Radio, Automatic Tuning—Continuous Seeking.

6. In the signal seeker shown in Fig. 11-8, describe the symptoms which could result if R19 were open.
7. The circuit of Fig. 11-5 has the symptom of continuous seeking. The following facts have been established:
 - a. The tube, switch, relay contacts, etc., have been found to be OK.
 - b. The ground connection of M6 was opened, and when the bottom end of R23 was shorted to ground the seeker action began, but stations could only be heard briefly as the tuner passed by them.
 - c. The voltage from pin 2 of V7A to ground was -4V , and it jumped to -0.5V when stations were heard.
What would you do next?
8. Describe the symptoms that would result if R3 in Fig. 11-9 were open.
9. Set up in chart form a series of tests and probable results which would lead to isolation of the fault in Question 8.
10. The transistorized seeker in Fig. 11-9 seeks continuously after the start switch is closed momentarily. The following tests have been made:
 - a. With muting disabled, stations are heard as the tuner passes them by.
 - b. The voltage from the base of the input stage to ground jumps strongly positive when a station is heard.
 - c. The collector voltage of the first stage drops from $+10.5$ volts to $+5$ volts when a station is heard.
 - d. The collector voltage of the second stage is $+11.9\text{V}$ and changes only slightly when a station is heard.
 - e. When the base and emitter of the output stage are shorted, the seeker stops immediately and will not start again until the start switch is closed.

Assuming all transistors, switches, and relay contacts to be good, what parts would you suspect, and what tests would isolate the defects you are thinking of?

12

FM Receivers

A brief summary of the differences between the two systems of broadcast—AM and FM—will aid in the understanding of FM receiver circuits. As we have done in other chapters, only those points of theory necessary to the understanding of the troubleshooting techniques will be discussed.

In an AM transmitter, the audio modulation is mixed with the RF carrier in the modulated amplifier stage. As shown in Fig. 12-1, this produces three signals which are radiated from the antenna:

1. The original carrier.
2. The sum of the carrier and the audio, called the *upper sideband*.
3. The difference between the carrier and the audio, called the *lower sideband*.

The spacing between the main carrier and either sideband represents the frequency of the audio modulation. The amplitude (volume level) of the sound is represented by the relative amplitude of the sideband compared to the carrier.

The term *100% modulation* is used when the total amplitude of both sidebands added together is equal to one-half of the transmitter power. These relationships are shown in Fig. 12-2, which represents the transmitted signal from a station operating at 620 kc and modulated with a 2000-cps frequency. Note

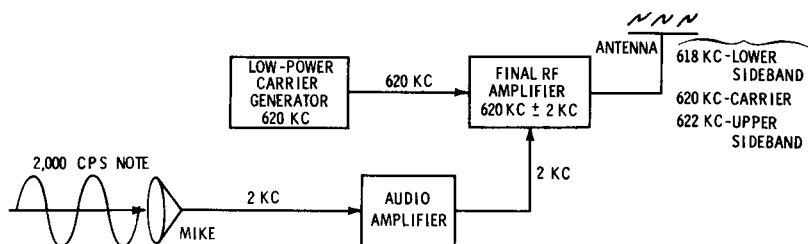

Fig. 12-1. AM modulation.

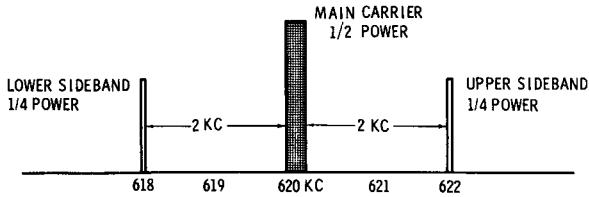

Fig. 12-2. Carrier and sidebands at 100% modulation.

that the total bandwidth is 4000 cycles. The FCC has limited the bandwidth of AM broadcasting stations to a maximum of 10,000 cycles. This means that the maximum audio signal allowed is 5000 cycles.

Thus, it can be seen that AM stations are limited in two ways:

1. The maximum audio power in the sidebands must not exceed one-half of the total transmitter power.
2. The maximum audio frequency must not exceed 5000 cycles per second.

Only one of these limitations applies to an FM station, however; the maximum audio power is limited, but the maximum frequency of the audio is practically unlimited. In fact, an FM station can be modulated by extremely high frequencies, even in the range of supersonic frequencies.

In an FM transmitter (Fig. 12-3), the audio is applied directly to the carrier-generating oscillator, where it is used to change the frequency of the carrier. (Technically, there is mixing of the audio and RF to produce sidebands, but these are not the intentional result of the modulation, and they are not used to carry the audio signal.)

It is especially important to understand that an increase in the *amplitude* (volume level) of the modulation at the transmitter results in a greater *deviation of the carrier* from its

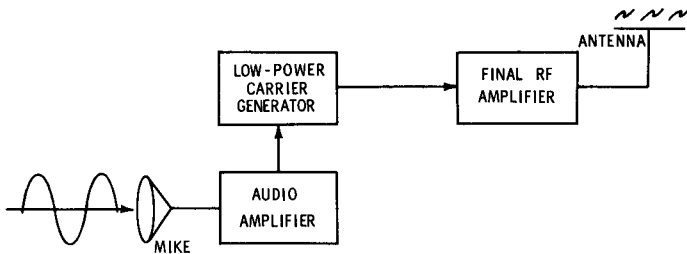

Fig. 12-3. FM modulation.

center frequency, *but the carrier amplitude does not change.* A change in the *frequency* of the modulating audio does not affect the amount of deviation but only changes the speed at which the deviation takes place.

Fig. 12-4 illustrates the changes in the frequency of the FM carrier for various kinds of audio. The movement from side to side represents changes in frequency of a transmitter carrier corresponding to changes in amplitude of the audio modulation. The carrier amplitude is always 100%, which means

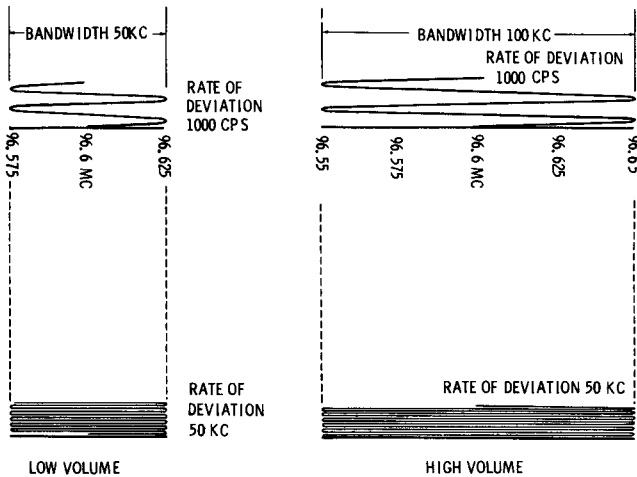

Fig. 12-4. Modulation of an FM carrier.

there are no appreciable changes in the FM carrier amplitude with changes in the modulation. The carrier does change in two other ways, representing changes in frequency and amplitude of the audio, but in neither case does the carrier amplitude change.

By comparing the two methods, we find that FM has several advantages:

1. The bandwidth is not directly affected by the frequency of the audio.
2. The transmitter is modulated in a low-power stage and thus requires very little modulating power to control a high-power RF carrier.
3. The amplitude of the carrier does not change.
4. The limitation on the FM station by the FCC is in terms of the maximum bandwidth allowed, and this primarily

affects the volume level and not the frequency of the modulation. Thus, the FM station can transmit any audio or supersonic modulation as long as the volume-level deviation is kept within the limits specified by the FCC.

5. The receiver can be made immune to noise because most noise is caused by changes in amplitude, and the receiver does not need to respond to amplitude changes.

The FCC places a limitation of 150 kc as the maximum deviation allowed. This is a deviation of 75 kc on either side of the center frequency. This allows more than enough dynamic range in volume level. By comparison, television sound (which is FM) is allowed to deviate only ± 25 kc.

In recent years the FCC has allowed some FM stations to increase their deviation to higher bandwidths. This is reasonable, since at the high RF frequencies where the FM stations are located, 200 kc is only about 0.2% of the entire FM band. In AM, 200 kc is about 20% of the entire broadcast band.

FM RECEIVER CIRCUITRY

The block diagram in Fig. 12-5 indicates some new stages that are not used in AM receivers—the limiter, the FM detector, the AFC, and the RF amplifier.

A typical limiter is shown in Fig. 12-6. This stage is the last IF amplifier, V7, which is a type 6AU6. The purpose of this stage is to remove all amplitude variations in the incoming signal. In this way, most of the noise and interference will be eliminated without affecting the frequency changes. The input

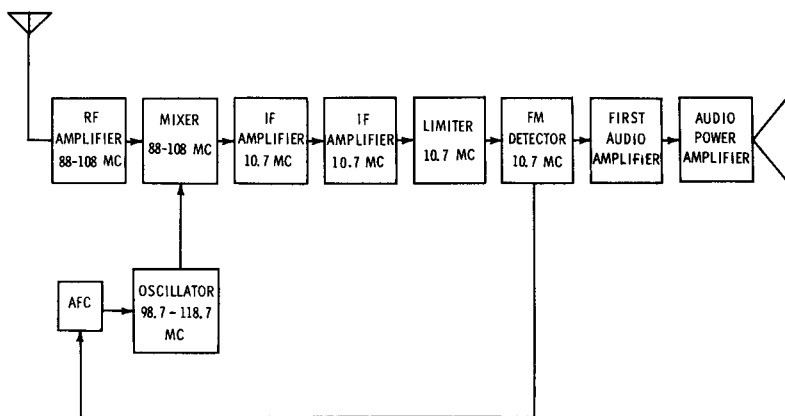
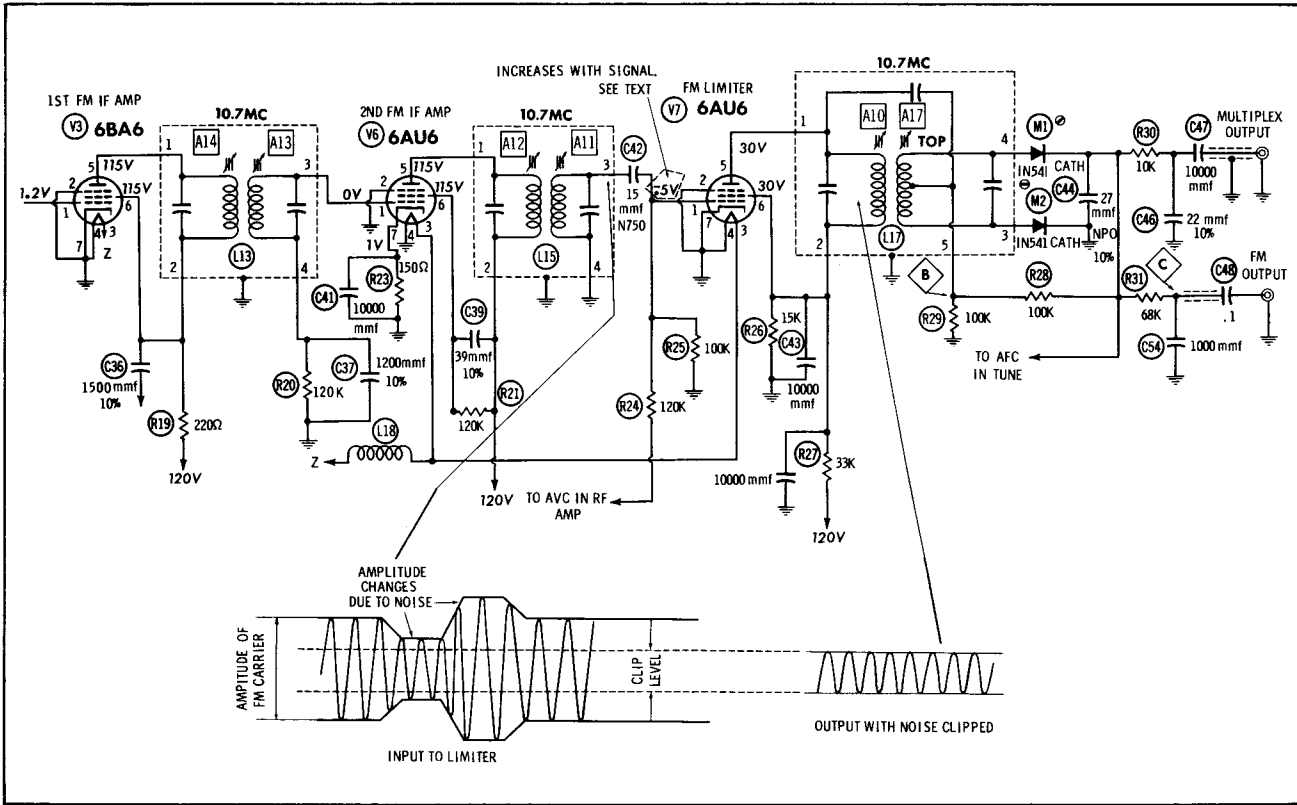

Fig. 12-5. Block diagram of an FM receiver.

Fig. 12-6. IF channel in an FM receiver.



and output waveforms indicate that amplitude variations are removed by the clipping action of the stage, which does not affect the frequency changes. Since the audio sound from the station is represented by the amount of frequency change and the rate at which the frequency changes take place, limiting the amplitude of the signal does not affect the FM sound. All forms of noise are amplitude changes, and these are removed by the limiter.

The limiting action is accomplished by operating the stage with very low plate and screen voltages. These low voltages result in a rather low amplitude of input voltage, causing the output signal to reach the maximum possible amplitude. This condition is called *saturating the limiter*, and once this state is reached, no further changes in the amplitude of the output are possible. The input signal must, of course, be great enough to drive the limiter stage to saturation before limiting will take place. This means that there is no limiting action on very weak carriers. It is for this reason that noise is sometimes heard on supposedly "noise-free" FM receivers.

Because of the large grid resistor R25 and grid capacitor C42, a small amount of grid-leak bias is developed in the limiter stage. Besides aiding the limiting action by reducing the sensitivity of the stage, this voltage varies in proportion to the strength of the incoming signal and serves as an AVC. In FM receivers, AVC is usually applied only to the RF amplifier in the tuner. We shall see later in this chapter that there are other sources of AVC voltage in the FM receiver which may be used.

The Tuner

The tuner is usually a separate unit housed on a subchassis which can be removed or replaced by removing a few screws and unsoldering a few connections. The dotted lines appearing in the schematic indicate the subchassis assembly.

The circuits shown in Fig. 12-7 are very simple since no AVC or AFC is used. Only a single twin triode is employed, and a minimum of tuned circuits are included. In part A of Fig. 12-7, the input of the RF amplifier is fixed-tuned. The plate circuit is tuned, along with the oscillator tank, by the station selector.

The signal from the RF amplifier is coupled to the grid of the mixer through C8. C7 and C9 aid in keeping the tracking aligned as the receiver is tuned through the FM band (88 mc to 108 mc). The reactance of all three capacitors changes with frequency, but since the capacitors are connected in the circuit

differently, the changes work together to keep the tracking nearly perfect.

The oscillator uses feedback from the plate, through C10 and the primary winding of the oscillator transformer. The secondary of the transformer is in the grid circuit of the oscillator, and this produces the proper feedback to sustain oscillation. The oscillator signal is mixed with the incoming RF station carrier at the grid of the mixer/osc stage.

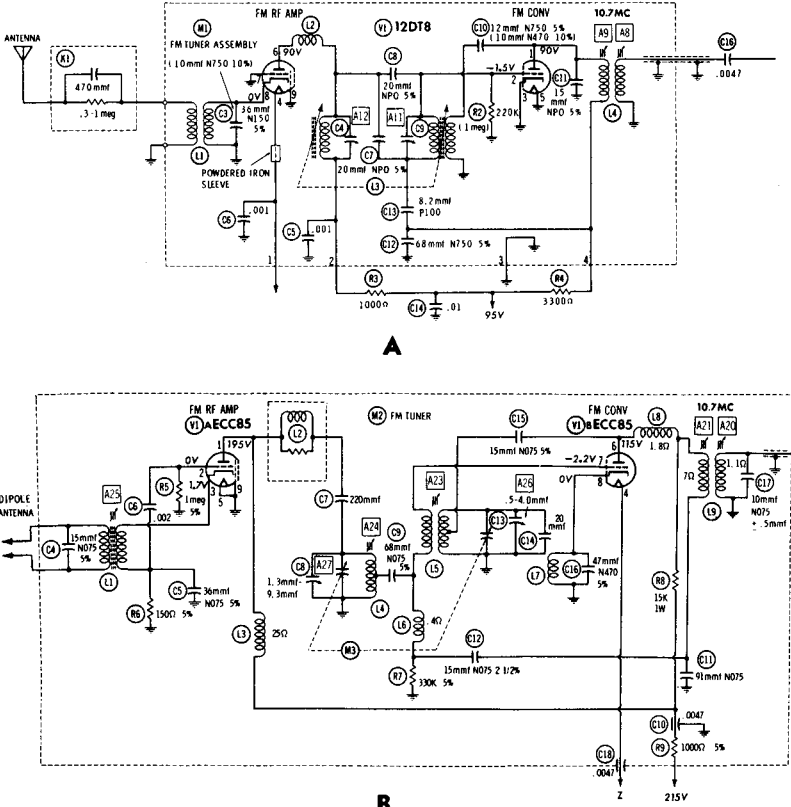

Fig. 12-7. Typical FM tuners.

Since the oscillator is always tuned 10.7 mc higher than the incoming station, a beat is developed in the mixer at this IF frequency. The plate transformer of the mixer is tuned to 10.7 mc.

R3, R4, and C14 form the B+ decoupling network. These resistors are of particular importance to the troubleshooting

technician because they usually burn out when the tube shorts. A defective tuner is easily isolated when it is found that an IF (10.7-mc) signal can be injected at the first IF stage but not at the grid of the mixer. Replacing one or both resistors is a simple repair job.

FM circuits usually include decoupling of the filament lines going to the tuner and occasionally to the IF stages. The powdered-iron sleeve in conjunction with C6, in the circuit in part A of Fig. 12-7, is for this purpose. Although the components in the decoupling networks seldom fail, the technician should be aware of the possibility of damage to the power supply due to a shorted unit such as C6.

The circuit in part B of Fig. 12-7 uses a different tube, the ECC85, which is equivalent to the more common 6AQ8. The plates of the tubes in this circuit are shunt fed. Notice, for example, that coil L3 feeds B+ to pin 1 of V1, but that the resonant tank circuit is the one containing L4, and is isolated from B+ by C7. Therefore, no plate current flows through the tuned circuit, allowing one side of the coil and capacitor to be grounded.

The output of the RF amplifier is tuned to one particular FM station, and is coupled to the grid of the mixer from the center tap of the RF plate tank. This signal is fed through C9 to the secondary of the oscillator tank where it is mixed with the oscillator signal, the combination appearing at pin 7 of the mixer. The plate circuit of the mixer is tuned to the IF frequency and is also shunt fed so that plate current does not flow through L9.

The circuit includes C18 to bypass the filament line, and R9 and C10 which form the B+ decoupling network. The schematic symbol for C10 is often found in VHF circuits and indicates that the capacitor is in the form of a feed-through insulator through which the wire passes from the underside of the chassis to the top side.

Some of the other capacitors in the circuit are specially constructed to give them a specific temperature coefficient, which means that the change in capacity with a change in temperature is controlled and can be predicted. These capacitors must always be replaced with similar units so that the balance of changes throughout the circuit as it heats will be maintained. Failure to compensate for changes in temperature causes drifting of the tuning with resulting distortion. Grid blocking capacitors, such as C8 and C9 in the circuit in part A of Fig. 12-7, are the most likely components in the receiver to cause drifting.

Automatic Frequency Control (AFC)

AFC has been advertised as a special circuit which makes receiver tuning easier because it eliminates the possibility of setting the tuning dial slightly to either side of the carrier center frequency. AFC does this superbly, and it also compensates for drifting by automatically adjusting the oscillator frequency to keep the carrier centered in the detector at all times.

Until recent years, the method of achieving automatic control of the oscillator frequency was to employ a reactance tube across the oscillator tank. V2A in Fig. 12-8 is connected in this manner, while V2B is the oscillator tube itself. The conduction of the AFC triode creates an effective reactance across the tank that is dependent on the amount of bias applied to the grid through the control line. The control tube acts as a variable reactance (in this case capacitive) across the oscillator tank.

When the oscillator drifts slightly, the incoming carrier will no longer be centered perfectly in the IF bandpass of the receiver, and this reduces the receiver's response to deviation in one direction, causing distortion. The discriminator develops a voltage at pin 5 of V10 which is proportional to the amount by which the carrier has shifted from the center of the bandpass.

The way the reactance tube responds to this voltage to correct the oscillator frequency is illustrated by the simplified drawing in Fig. 12-9. The B+ circuit to the plate of the reactance tube has been eliminated because it plays no part in the reactance function of the tube. Also, C11 is omitted because at these frequencies its effect is negligible. R9 and R10, the fixed cathode-bias divider, is also omitted for simplification. The resistance between grid and cathode is taken to be 220 ohms, the value of R7. This is approximately correct when only the AC path is considered.

The oscillator voltage appearing across the oscillator tank, L5, is designated E_1 . C12 and R7 are connected across this voltage and the reactance of C12 is much greater than R7, making the series path mostly capacitive. When AC current is passed through a network which contains more capacitive reactance than inductive reactance, the current will lead the source voltage, and when the network is mainly capacitive, the phase angle approaches 90° .

Therefore, I_1 (which flows through the series network, C12 and R7) leads E_1 by nearly 90° . Voltage E_x , produced in R7

Fig. 12-8. AFC circuit.

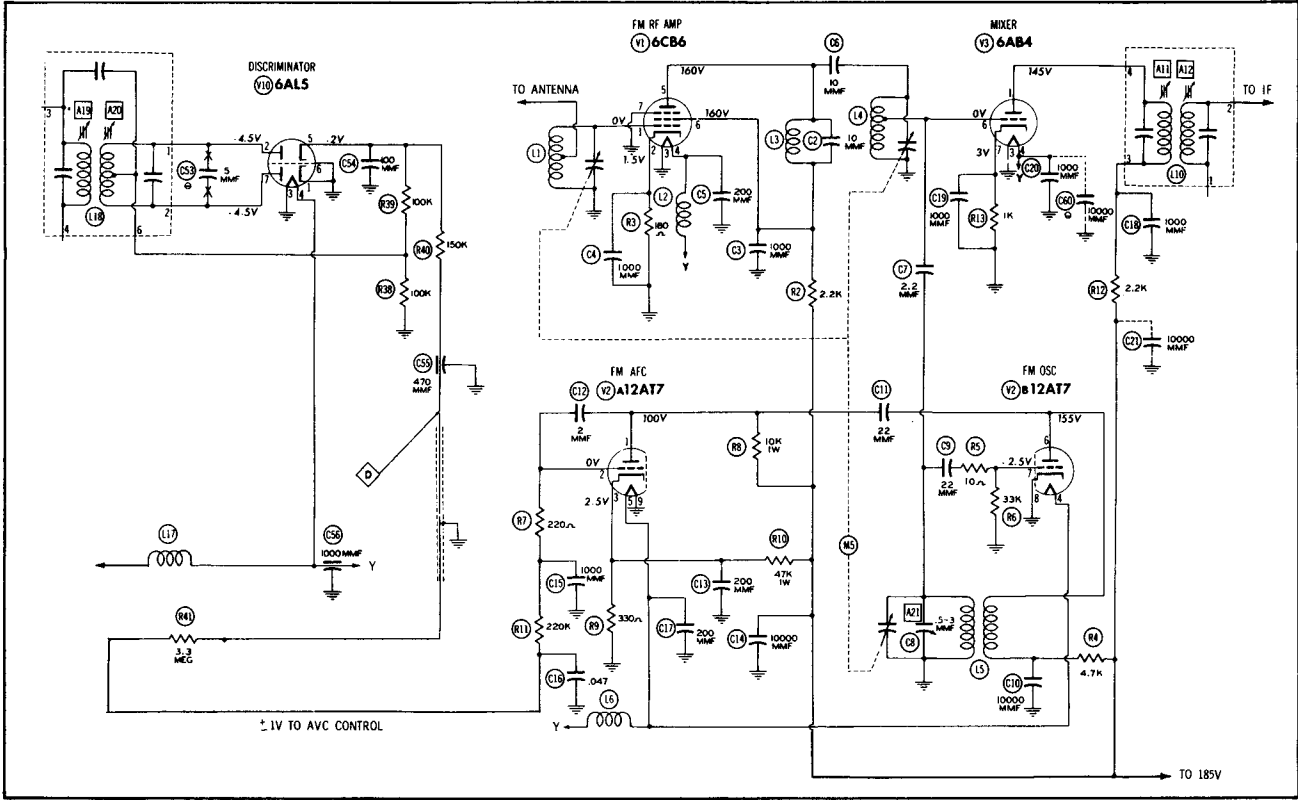

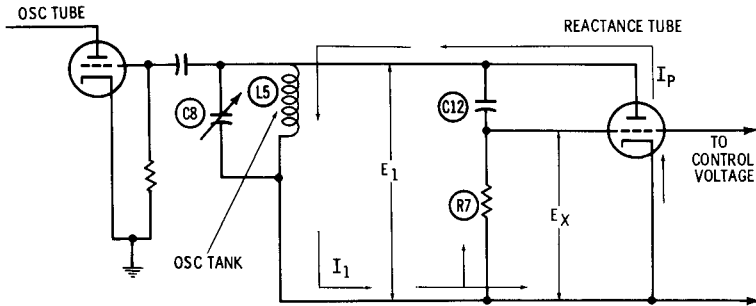

I_1 LEADS E_1 BY 90°
 E_x IN PHASE WITH I_1
 E_x LEADS E_1 BY 90°
 I_p LEADS E_1 BY 90°

Fig. 12-9. Simplified AFC circuit.

by this current, is in phase with the current. This means that E_x is also leading E_1 by 90° .

Since E_x appears between the grid and cathode of the reactance tube, it controls I_p , the AC plate current of the tube. Now, if I_p follows faithfully the variations of E_x , then I_p will also lead E_1 by 90° .* When I_p passes through the oscillator tank, it is exactly the kind of current which would appear in the tank if a capacitor were added in parallel with C8.

The amount of I_p depends on the DC grid bias supplied by the control voltage which, in turn, is proportional to the amount of detuning due to oscillator drift. In this manner, the oscillator can be kept precisely on frequency, regardless of changes in voltages or components.

Ordinary crystal diodes can be used for AFC, as shown in Fig. 12-10. The operation is quite simple, since no reactance tube is employed. The grid-leak resistor is divided into R1 and R2 so that a part of the grid-leak voltage can be placed on the diode plate. This negative voltage keeps the resistance of the diode very high, and the effect of C1 across the tank is minimum. When the control voltage applied at the cathode is more negative than the fixed bias, the resistance of the diode is reduced, and C1 is more effectively across the tank. Thus, the AFC system consists essentially of the shunt capacitor, C1, in series with a variable resistance.

* The 180° phase shift through a common cathode circuit applies to phase relations between grid voltage and plate voltage. Here, we are comparing grid voltage and plate current.

1. The Foster-Seely discriminator.
2. The ratio detector.
3. The gated-beam, or locked-oscillator, detector.

The first two are found most often in FM receivers, and the third is used primarily in TV sound sections. A brief discussion of the operation of each will aid in understanding the alignment procedures to be described.

The Discriminator

In Fig. 12-12, the discriminator is shown in its most basic form, with the incoming carrier voltage designated as E_c .

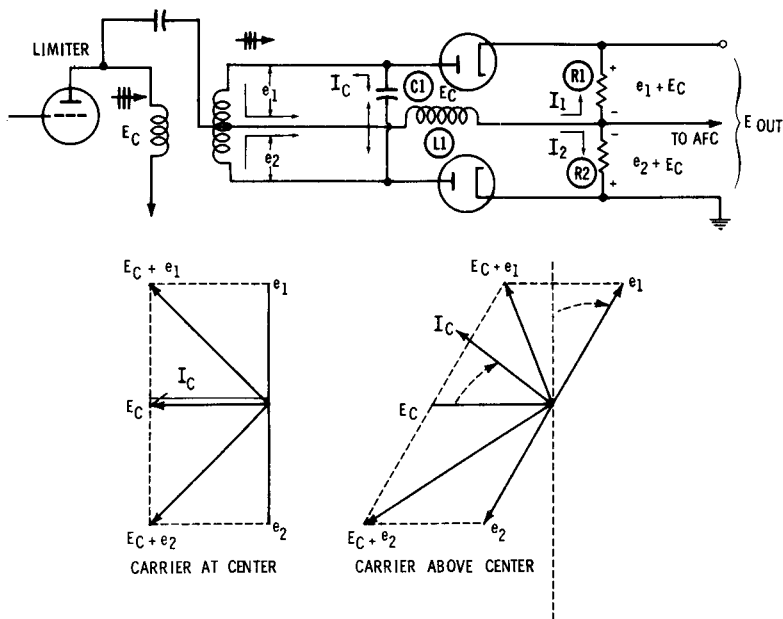

Fig. 12-12. A discriminator.

across the primary of the input transformer. The coil, L_1 , connected between the center tap of the secondary and the junction of R_1 and R_2 , is not found in practical circuits, but is useful here to give an indication that the full carrier voltage, E_c , appears in series with each diode. This is true because of the capacitive coupling between the top of the primary and the center of the secondary. While it is somewhat of an oversimplification to say that the E_c which is across the secondary and the primary are all exactly the same, they differ only in

phase. The differences seem to balance out, so they do not affect this explanation.

When the carrier is in the center of the IF bandpass (when there is no modulation), a current, I_c , is induced in the resonant tank circuit formed by the secondary and C1. Taking E_c across the secondary as a reference, the phase relations are as shown. The two voltages, e_1 and e_2 , formed by the center-tap must be 180° out of phase since they are at opposite ends of a coil, and they must also be 90° out of phase with I_c . This 90° phase difference arises from the fact that the current and voltage in any coil are always 90° out of phase unless there is a condition of resonance. Since e_1 and e_2 are not taken across the entire coil, the condition of resonance which exists between the full secondary and C1 does not apply to these voltages; they are merely the voltage resulting from the current, I_c , flowing through a random inductance.

Now, giving attention to the cathode end of the circuit, we see that in the upper diode the voltages E_c and e_1 appear in series across R1, and in the lower half of the circuit, E_c is in series with e_2 across R2. Because of the diodes, current must flow from left to right in the center leg of the circuit, and from right to left in the outside legs. This gives opposite polarities to the voltages across R1 and R2, as shown. The output is the sum of these voltages and will be zero when I_1 and I_2 are equal.

The vector diagram shows that the voltages must be added to E_c vectorially because they are not in phase. The fact that the two resultants are equal is also evident, and of course the output voltage taken across R1 and R2 is zero when the carrier is at the resonant frequency of the secondary tank circuit.

The circuit action when the carrier is above resonance is shown in the other vector diagram. I_c can be seen to have moved away from E_c . This is because when the secondary tank is out of resonance, the current and voltage (I_c and E_c) in the tank are not in phase. When the frequency is higher than resonance, the circuit is inductive and the current lags the voltage.

When I_c moves, voltages e_1 and e_2 which it generates must also move so that they can stay 90° out of phase with I_c . With these new phase relations, the vector sums across R1 and R2 are no longer equal. This means that the opposite polarities of these voltages no longer cancel, and an output voltage now appears.

From the vector diagram it can be seen that E_c and e_2 are closer together in phase and thus produce a resultant of greater magnitude, indicating that the voltage across R2 is

increased. However, e_1 is now farther away from E_c , and the sum of these two is reduced, indicating that the voltage across R1 is less than before.

The output voltage reverses in polarity when the carrier swings below resonance and, in this manner, an AC output is developed which has a frequency corresponding to the *rate* of carrier deviation, which is the *frequency* of the modulating audio. Further, the amplitude of the output voltage corresponds to how far the carrier moves off center, and this is the *amount of deviation* corresponding to the *amplitude* of the audio modulation.

The discriminator circuit has the disadvantage that noise pulses which affect the magnitude of the input voltage, E_c , will also affect the output, since it is partly composed of E_c . The circuit must therefore be used with a limiter stage to remove all amplitude variations. This is inefficient because of the necessity of amplifying all signals up to the level where they saturate the limiter.

The Ratio Detector

A circuit which is more popular than the discriminator is shown in Fig. 12-13. This is a ratio detector and can be distinguished from the discriminator by the fact that the diodes are connected in series; that is, one plate and one cathode are connected to the secondary. Analysis of this circuit will indicate that changes in amplitude of E_c do not appear in the output.

With the diodes in series, the input voltages cause the current, I_1 , to flow around the outside loop—through the entire secondary, the diodes, and C1 and C2, all in series. I_1 charges C1 and C2 so that the peak carrier voltage appears across the pair of capacitors.

When the carrier is centered exactly on the resonant frequency of the transformer secondary, the voltage applied to D1 is the vector sum of E_c and e_1 . This same voltage is applied to C1. The vector diagram on the left shows that the voltage applied to D2 and to C2 is equal in magnitude, being the vector sum of E_c and e_2 .

The carrier voltage appears across the combination of C1 and C2, and also across the combination of R1 and R2. Because of this, C3 is charged to the peak carrier voltage. It is very important to note that *the voltage across C3 is not the output voltage corresponding to audio modulation*.

The output signal is developed between the junction of the two capacitors and the junction of the two resistors. When

the carrier is centered, the charge on C1 represents one-half of the carrier voltage, and the voltage across R1 is also one-half of the carrier voltage. Under these conditions, there is no difference in potential across the output terminals and, consequently, no output. This is to be expected when the carrier is in the center of the bandpass.

Now it can be seen why the ratio detector does not respond to changes in the amplitude of the carrier. Suppose the value of E_c is suddenly increased in amplitude because of a noise pulse but it does not change in frequency. The voltage across C3 cannot change very fast because of the long time required to charge or discharge this large capacitor. Also, the voltage relationships still exist between C1, C2, R1, and R2, whereby there is no output due to equal voltage values at the output terminals. There will be no output voltage, regardless of the value of E_c , unless there is a change in frequency producing unequal voltages on C1 and C2.

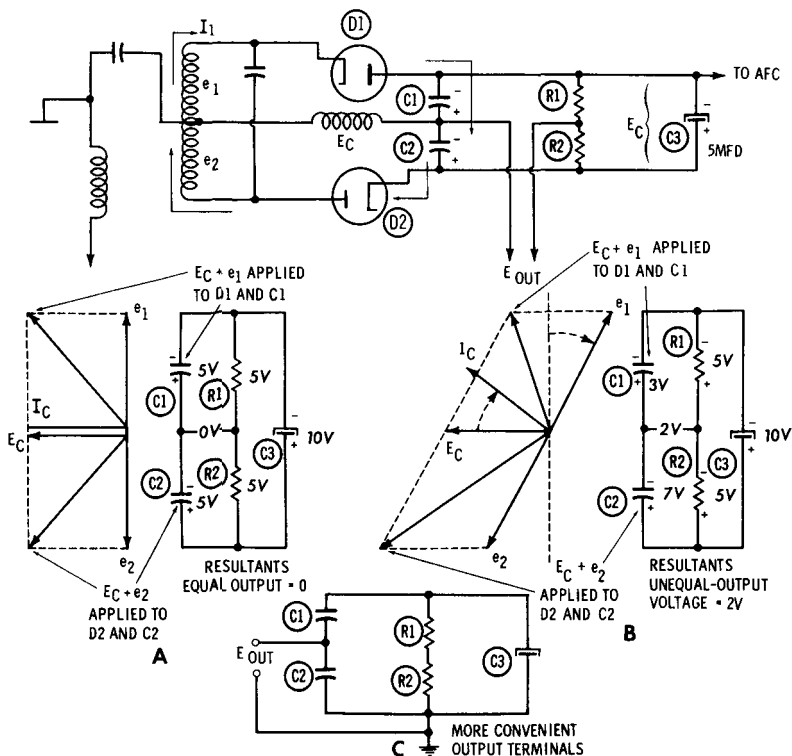

Fig. 12-13. A ratio detector.

When the carrier shifts frequency under modulation, the vector sum of E_c and e_1 (which charges C1) will no longer equal the vector sum of E_c and e_2 (which charges C2). This can be seen in the vector diagram on the right, and the explanation is exactly the same as for the discriminator. The voltages across R1 and R2 remain the same, however, since the charge on C3 is unchanged.

Referring now to the partial schematics in Fig. 12-13, suppose that the original voltages at resonance were as shown in part A. When the carrier shifts above resonance, the sum of e_2 and E_c is larger, and the total of 10 volts might distribute itself across C1 and C2 as shown in part B, with 7 volts across C2 and 3 volts across C1. There is now a difference in potential across the output terminals because the voltages across the resistors have not changed.

For convenience in the design of the next stage, it is common to take the output relative to one end of C3, as shown in part C. It does not matter which side of C3 is grounded. All that is necessary is to connect one output terminal to a fixed voltage and the other terminal to the voltage at the junction of C1 and C2.

The Gated-Beam Detector

A special tube, the 6BN6, is used in a gated-beam detector. A variation of this circuit, called the *locked-oscillator, quadrature-grid* detector, uses a 6DT6. The circuits are nearly the same in principle.

The grids connected to pin 2 and pin 6 are arranged in a special way so that either one is capable of completely cutting off the tube. Also, no current can flow in the tube unless both of these grids are above the cutoff voltage. The tube, therefore, has two gates, either one of which can reduce the plate current to zero.

The plate-current characteristics of the tube are such that a small signal applied to the grid at pin 2 drives the plate current to saturation. This feature enables the stage to perform the function of limiting and thus remove amplitude variations in the signal. After the plate current is driven to saturation, further increases in signal voltage do not change the amplitude of the output signal. As long as the incoming carrier is considerably larger than the voltage required to reach saturation, then a decrease in signal voltage is not likely to be great enough to bring the plate current out of saturation. This means that an amplitude change will not be reproduced in the plate circuit.

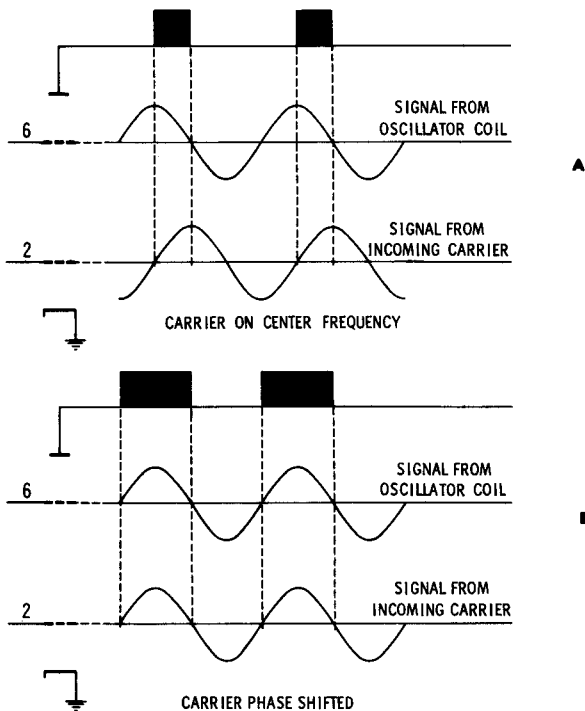

Fig. 12-14. A gated-beam detector.

The operation of the circuit as an FM detector is simple and can be seen from a study of Fig. 12-14. The oscillator signal supplied to the quadrature grid (pin 6) is induced in the resonant circuit connected to the grid by capacitive coupling through the tube from the signal on pin 2. Thus, the oscillator sine wave is 90° out of phase with the incoming signal.

The shape of the plate-current pulses is the result of the two special characteristics of the tube, which have been explained. Plate current can flow only when both grids are positive, and these small segments of time correspond to the positions of the sine waves indicated in the diagram. Also, the plate current is driven to saturation very rapidly, and this accounts for the rectangular shape of the pulses.

The action when the incoming carrier shifts frequency under modulation can be seen in part B of Fig. 12-14. The incoming signal on pin 2 is seen to be shifted in phase so that the relationship between the two sine waves is not the same. This results in plate pulses of different length. It is in this

manner that the output signal changes with changes in the frequency of the input signal.

It is natural to ask at this time why the quadrature signal on pin 6 does not also change, since it is generated by the incoming signals. It actually does change, but not to the same extent, so that the two signals do not remain exactly 90° out of phase.

A resistor and capacitor, R36 and C23, in the plate circuit are used to *integrate* the rectangular pulses and provide an audio signal dependent on the *average* current contained in the pulses as they vary in width.

The gated beam is not very popular in FM receivers, although it is used extensively in TV. The reason is that its output is likely to contain a large square-wave component which causes a buzz. Varying the cathode resistor to obtain the best possible limiting is the only way this can be eliminated.

AFC Control Voltage

A DC voltage which varies with the carrier amplitude is present in the circuits of Figs. 12-12 and 12-13. If the oscillator in the tuner drifts so that the incoming station is not centered in the IF bandpass of the receiver, there will be a change in carrier amplitude at the FM detector, and this DC voltage will change accordingly. We will see more clearly later why this causes distortion.

In Fig. 12-12, this voltage is between the junction of R1, R2, and ground. In this discriminator circuit, the output signal changes polarity and amplitude according to the difference in the voltages across R1 and R2. However, the voltage between R2 and ground is always present and always has the same polarity, but its amplitude varies with the strength of the incoming signal.

A similar voltage in the ratio detector of Fig. 12-13 is found across C3. Although this voltage does not respond to sudden changes in carrier amplitude, it does change gradually if the carrier amplitude changes. These two voltages can be taken in either polarity with respect to ground and, when filtered, they serve to control the oscillator through a reactance tube or diode, as explained earlier.

FM RECEIVER ALIGNMENT

Alignment of FM receivers is critical because it is necessary to achieve a relatively flat response throughout a range of 200 kc or more in the IF channel. It is also essential that the

response falls off evenly on both sides of center to avoid attenuating the carrier when it deviates in either direction.

Receiver circuits vary so greatly that only a few very general principles can be given. Alignment instructions must be followed exactly as to frequencies, methods of applying the signal generator, and measuring the output. The purpose of the discussion that follows is to help understand these instructions.

Symptoms of Misalignment

Loss of gain and sensitivity indicates a need for IF and tuner alignment when tubes, voltages, and antenna conditions have been checked. Another definite indication of the need for alignment is distortion which seems to change with tuning. If it is difficult to tune a station so that it falls in the center of the bandpass with room to deviate in both directions, this may mean that the IF channel is too narrow. More likely, however, it means that the secondary of the detector transformer is not tuned to resonance at the IF frequency.

Special Instructions for Alignment of FM Discriminators

Set the generator for a 10.7-mc unmodulated output, and connect it to the grid of the last IF stage through an isolation capacitor. Connect the VTVM to the center of the two resistors between the cathodes of the diodes. The meter should be set to read negative volts on the 10-volt scale. Turn the equipment on and adjust the attenuator of the signal generator so as to produce a minimum signal which will give an adequate reading on the meter.

Adjust the primary tuning of the transformer, shown in Fig. 12-15 as ①, for a maximum peak reading on the meter. The primary is usually the top slug, but reference should be made to the manufacturer's data for such information, whenever possible. Move the meter probe to position 2, which is the discriminator output. Zero-center the meter, and again set the generator for minimum signal input consistent with good meter deflection. Adjust the secondary of the transformer, shown in the figure as ②, for a zero reading on the meter. This adjustment is critical and must be made as carefully as possible. A lower-scale reading on the meter can be used for the final touching up. Whenever the secondary is out of resonance, deflection on the meter will be to the positive or negative side of zero-center. Perfect resonance is indicated by zero output from the discriminator with the input carrier signal at exactly 10.7 mc.

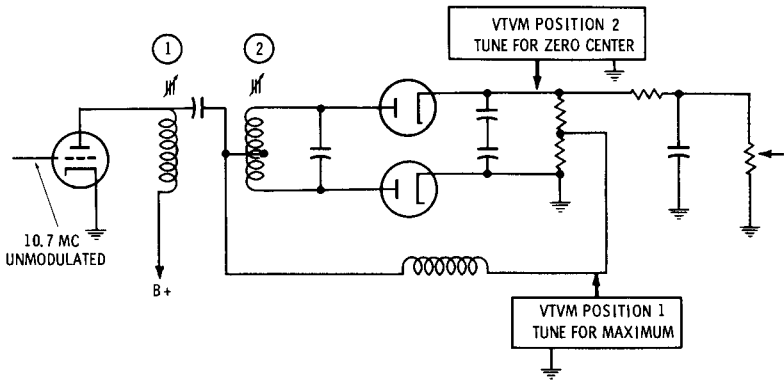

Fig. 12-15. Discriminator alignment.

An interesting check on the accuracy of alignment of the transformer secondary and overall efficiency of the detector is to turn on the AM modulation from the signal generator. If the secondary is perfectly tuned, the audio tone will almost completely disappear, indicating that the detector is least sensitive to AM modulation at this time.

Special Instructions for Alignment of the Ratio Detector

The generator is connected in the circuit in the same way that it was for the discriminator, but the VTVM has a different hookup. Fig. 12-16 shows, in dotted lines, two 100K resistors connected across the capacitor. Since the electrolytic capacitor is grounded, it is necessary to add these resistors if they are

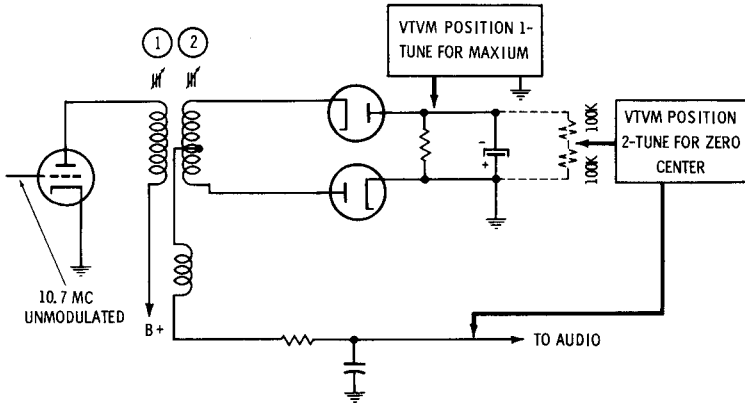

Fig. 12-16. Ratio-detector alignment.

not already in the circuit, in order to make the zero-center adjustment. The circuit shown in Fig. 12-16 is the most common type of ratio detector, and it will usually be necessary to add the resistors while the zero-centering is being done. Note that when the resistors are used the negative meter lead is on the audio output.

With the VTVM connected to position 1, tune the primary of the transformer for a maximum peak reading on the meter. Then move the meter probe to position 2, adding the resistors to the circuit if necessary. The meter should be zero-centered as before, and the secondary tuned in the same manner as it was for the discriminator.

Special Instructions for Alignment of the Gated-Beam and Locked-Oscillator, Quadrature-Grid Detectors

These two circuits, shown in Figs. 12-17 and 12-18 respectively, are very similar in operation. One exception, however, is that a conventional sharp-cutoff pentode is used in the locked-oscillator circuit to reject amplitude variations, and so does not require a buzz or quieting control. Successful alignment of either circuit depends on knowing that the input transformer must be tuned for maximum output on AM modulation. This can only be done if the input signal is weak enough so that limiting action does not take place.

Short out the quadrature coil, and connect a signal generator, set to 10.7 mc and with a low percentage of AM modulation, to the IF grid. Decrease the output from the generator

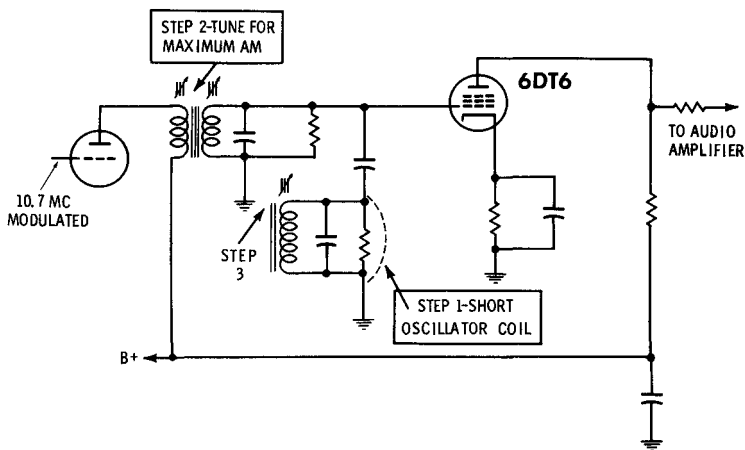

Fig. 12-17. Alignment of a locked-oscillator, quadrature-grid detector.

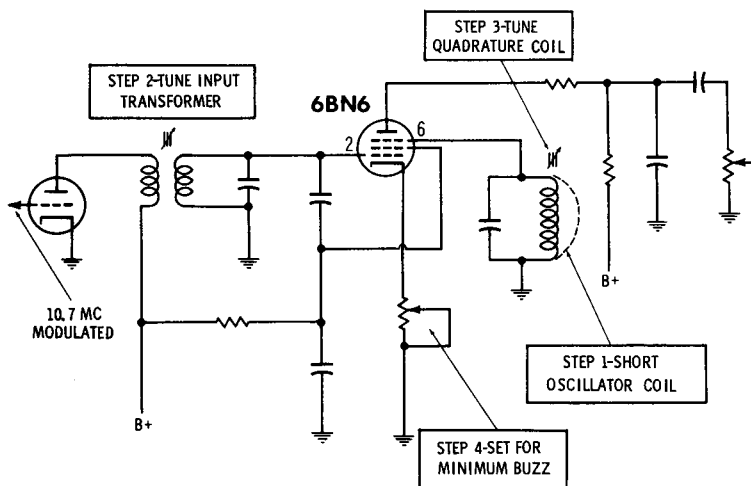

Fig. 12-18. Alignment of a gated-beam detector.

until there is a noticeable drop in the audio output from the speaker, or until the needle drops on the VTVM connected at the output of the audio power amplifier. This drop in audio indicates limiting is no longer taking place. Adjust the primary and secondary of the input transformer for maximum output, and continue to lower the input signal so that limiting does not take place.

After the input transformer is peaked, remove the short from the quadrature coil and tune in a strong station on the receiver. Then tune the coil for best audio output and minimum buzz. If there is a buzz or quieting control in the cathode to reduce the 60-cycle buzz, it should be adjusted at this time. A slight readjustment of the quadrature coil may be necessary after this operation. Complete alignment of all IF stages and the tuner may be further required in order to obtain undistorted sound of good volume.

Special Instructions for Alignment of IF Stages

As mentioned before, it is not likely that IF amplifiers will require alignment on a regular service job, and the task should never be attempted unless the technician is experienced and has the equipment and manufacturer's data available.

An interesting check of the width of the IF channel can be made with a regular signal generator and a VTVM. First, complete the alignment of the detector stage, and then prepare to take a number of meter readings which will be plotted on a

graph. Couple the generator loosely to the mixer stage or to the grid of the first IF stage. The zero-centered VTVM is connected to the output terminals (position 2, in the previous alignment instructions) and the signal generator set at 10.7 mc. Now, adjust the generator in 10-kc steps downward for 200 kc, recording the voltage at each step. Return the generator to 10.7 mc and repeat the 10-kc steps, this time upward for 200 kc, recording the voltage at each step.

When the voltages are plotted, the resulting curve indicates the total bandwidth of the IF and detector circuits. Fig. 12-19 shows an ideal curve. It is not likely that many receivers can actually produce a curve so wide and linear as this one. But what is important in reducing distortion is that the voltages be equal at points equidistant from the center. For example, if the voltage at 20 kc below the center (at 10.68 mc) does not agree with the voltage at 20 kc above the center (at 10.72 mc),

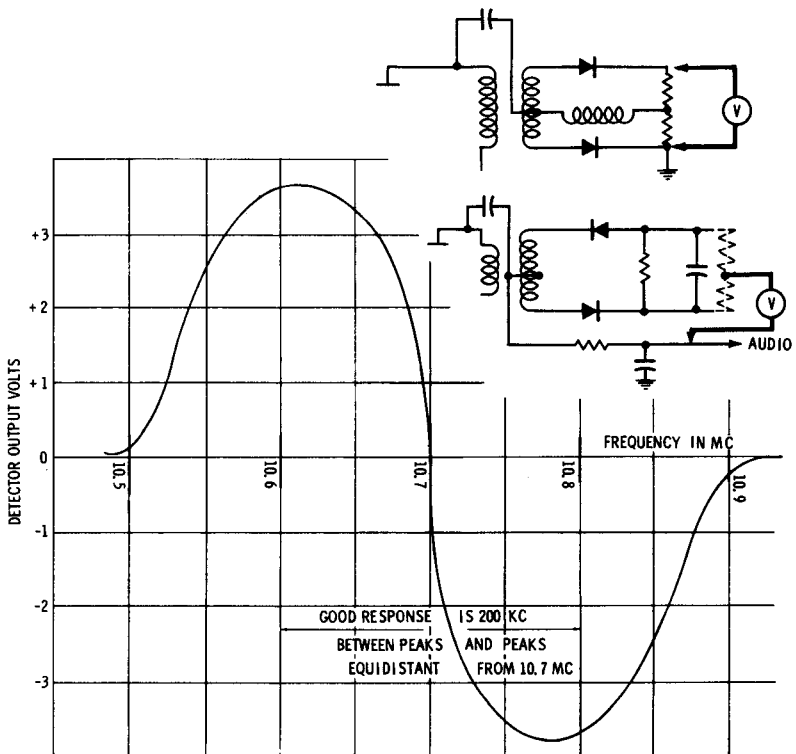

Fig. 12-19. IF stage frequency response.

this means that there is more audio produced on one side of the deviation than on the other, and this is not faithful reproduction of the transmitted audio.

Another observation can be made from the curve. When the curve turns toward zero (indicating decreasing output) at frequencies too close to the center, this indicates that the IF channel is too narrow, and both fidelity and dynamic range will be affected. 100 kc on either side of center is taken as a standard, but good results can be had from receivers which do not have this much bandwidth. If any portion of the curve needs improving, this can be done by tuning the signal generator to this frequency and adjusting alignment controls until the desired voltage output is reached.

One precaution should be emphasized in all alignment operations—do not overload the stages with too much input signal, as this distorts the response and results in over-correction with the alignment controls. When this has happened, the finished product will probably sound somewhat worse than it did before alignment was begun.

AM-FM COMBINATIONS

Fig. 12-20 shows a typical AM-FM combination that includes all the features we have been discussing. The AM tuner consists of a 12BE6 in the mixer/oscillator circuit with its output tuned to 455 kc. B+ to this stage is switched on by the AM-FM selector switch.

The windings of the AM and FM IF transformers are connected in series, with the AM transformers being left in the circuit while receiving FM, and vice versa. This is a very popular arrangement. It is possible to do this because the FM winding presents very low impedance at 455 kc, and the AM winding is connected on the "cold" side of the FM windings where the added impedance does not affect the FM signal.

The AM detector uses the grid and cathode of V5, the FM limiter stage. For AM reception, plate and screen voltages to the stage are disconnected by the AM-FM selector switch, and rectification of the AM signal takes place using the grid and cathode as a diode. The FM detector, V6A, is a typical balanced ratio detector with the output between Test Point 12 and ground. The AM-FM selector switch chooses the output from either of the detector circuits and sends it to the audio section.

When compared to Fig. 12-20, the receiver shown in Fig. 12-21 illustrates how much these AM-FM combination receivers can differ. The FM detector, V6, is a modified discrim-

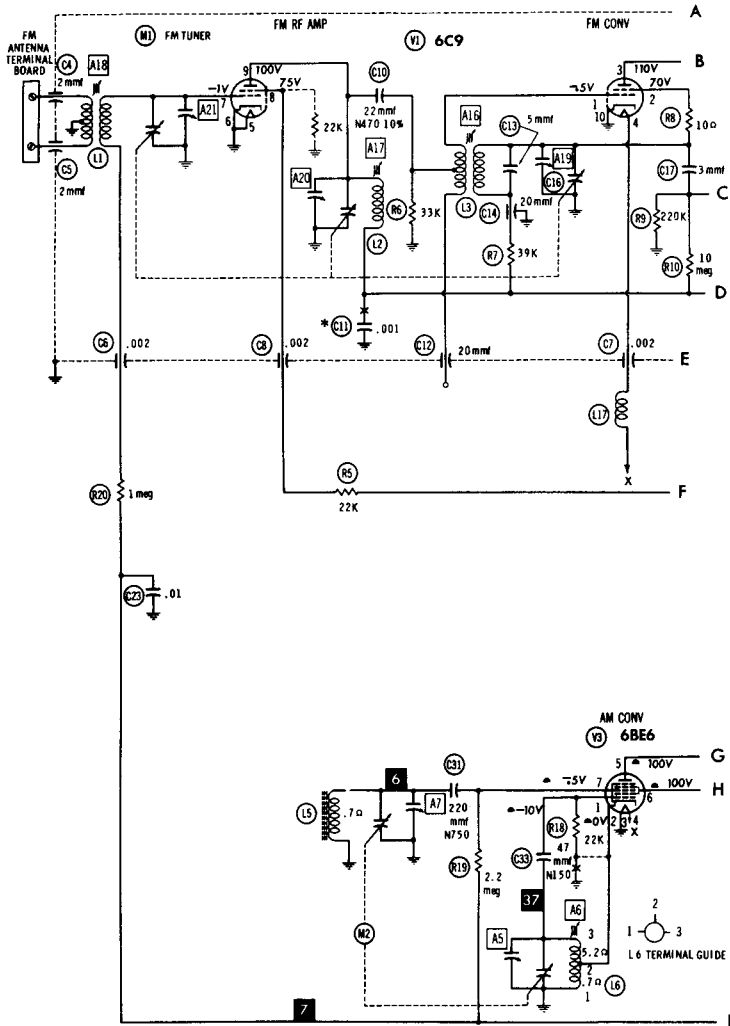
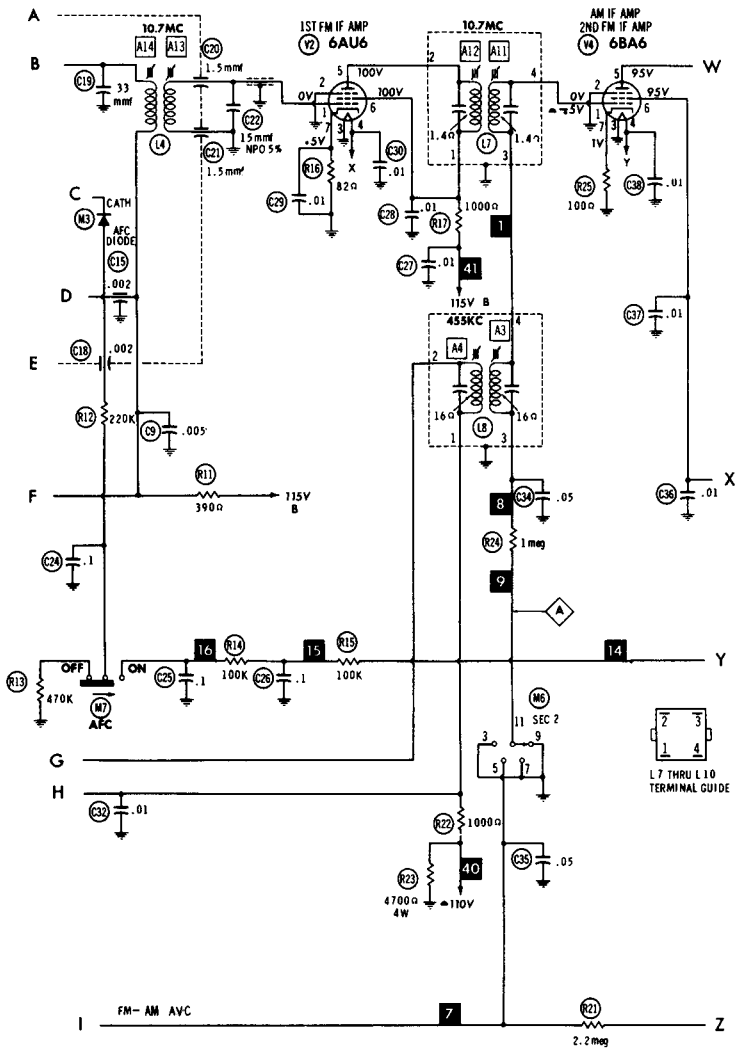

Fig. 12-20. A typical AM-FM



receiver with ratio detector.

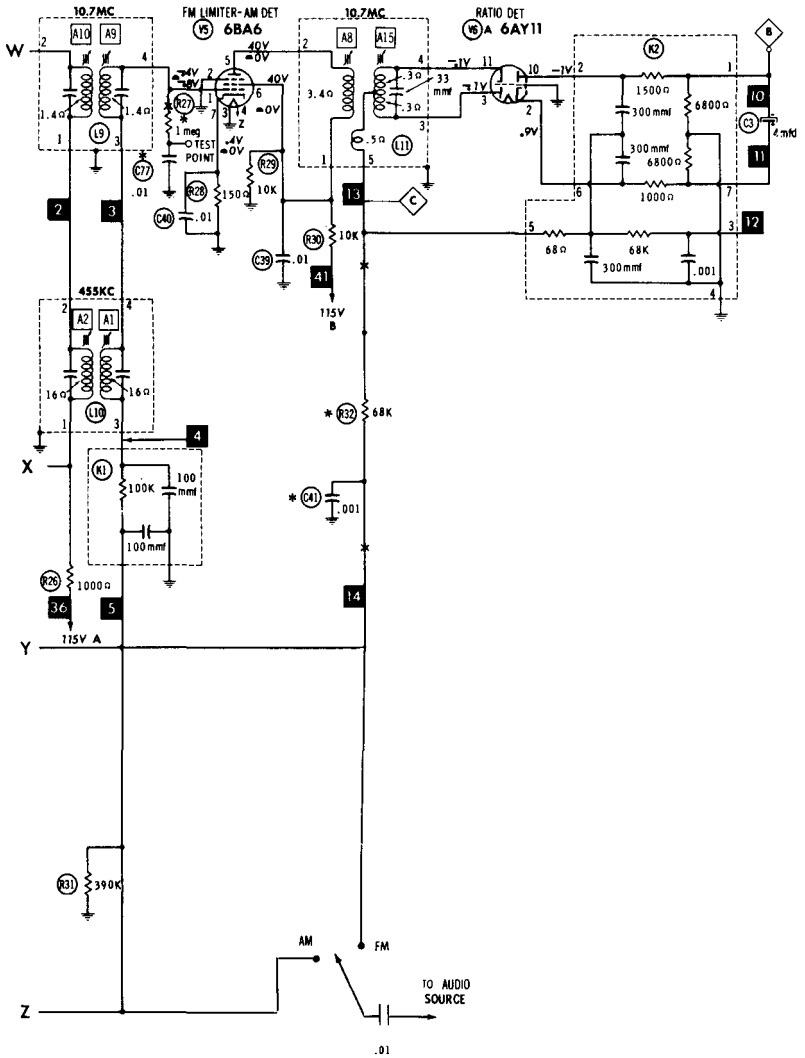

Fig. 12-20. A typical AM-FM receiver with ratio detector. (Cont'd)

inator with the balanced output resistors, R22 and R23, connected differently. The output signal voltage is taken between pin 5 of the tube and ground. The packaged circuit, K4, is called the *de-emphasis* network. Its purpose is to reduce the response on the very high audio frequencies which are always emphasized at the transmitter in order to improve the signal-to-noise ratio. Since noise is always greater on the high-frequency end of the audio spectrum, the high notes are transmitted with greater-than-normal volume so that when they are reduced to normal in the receiver, the noise, which has not been emphasized, will be reduced to below normal.

The tuner incorporates an unusual feature by using one triode, V2A, of the ECC85/6AQ8 tube as a combination FM mixer, FM AFC, and AM oscillator. A study of the schematic will show that the AFC function is a typical reactance tube connected across the FM oscillator tank, L3.

The AFC control voltage is taken from Test Point $\diamond C$ in the discriminator, filtered by R25 and C25, and finally connected to the grid of the AFC reactance tube. The same tube serves as a mixer on FM by combining the oscillator signal with the incoming RF in the plate circuit.

On AM, the tube serves as the oscillator by switching its cathode through L9 which is, in turn, coupled back to the plate through C14. The RF amplifier for AM is V3, the FM IF stage. By switching the AM antenna directly into its grid through C16, and leaving the plate untuned for AM signals, the stage becomes an untuned RF amplifier coupled to the AM mixer, V4, through C18. The mixer grid is tuned by the tank circuit of L8, and the mixer is coupled to the oscillator by the common cathode connections in L9.

The AM IF amplification is accomplished by using 455-kc transformers in series with the FM transformers. The 6EQ7 is the last FM IF amplifier (the limiter), and it also contains a diode plate (pin 8) which is used for AM detection. On FM, the stage is a limiter with the limiter grid-leak voltage (which can be measured at point $\diamond D$) being used for AVC on the FM stages. While on AM, the stage is the second AM IF amplifier and detector combined, with AVC for the AM stages being taken at point $\diamond A$.

TROUBLESHOOTING

Servicing straight FM receivers involves no more complications than those caused by more critical alignment. It will be recalled that distortion results from the slightest misadjust-

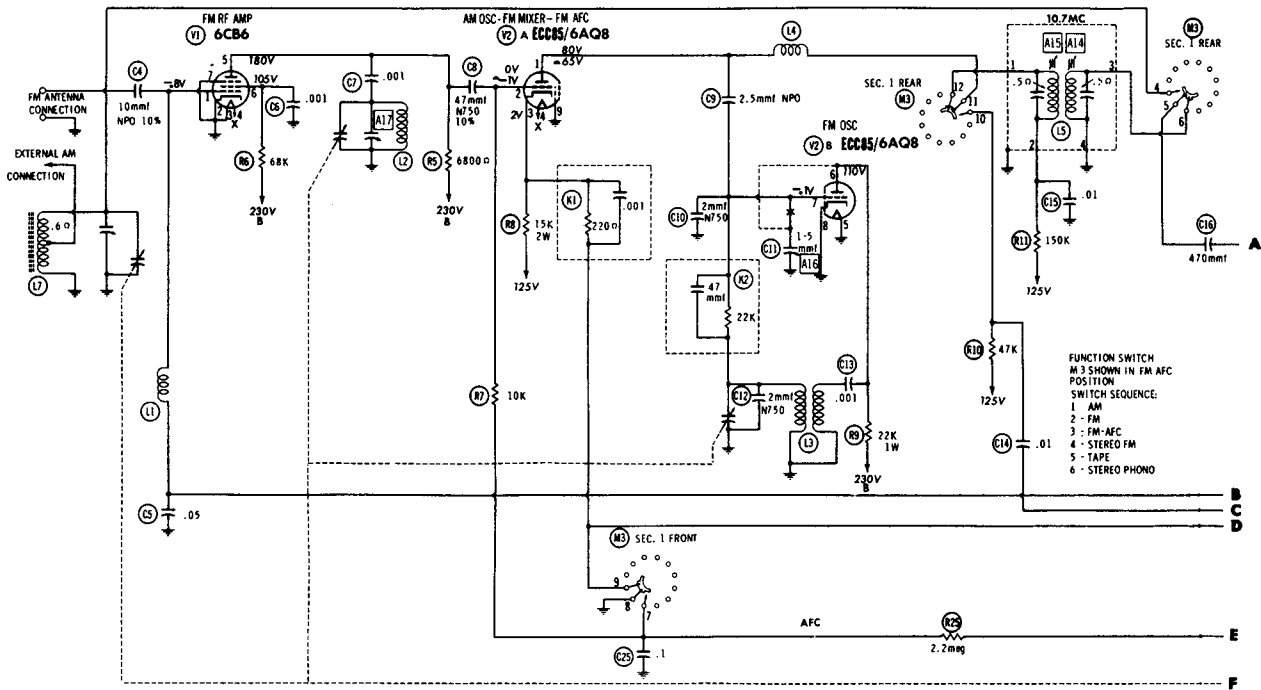
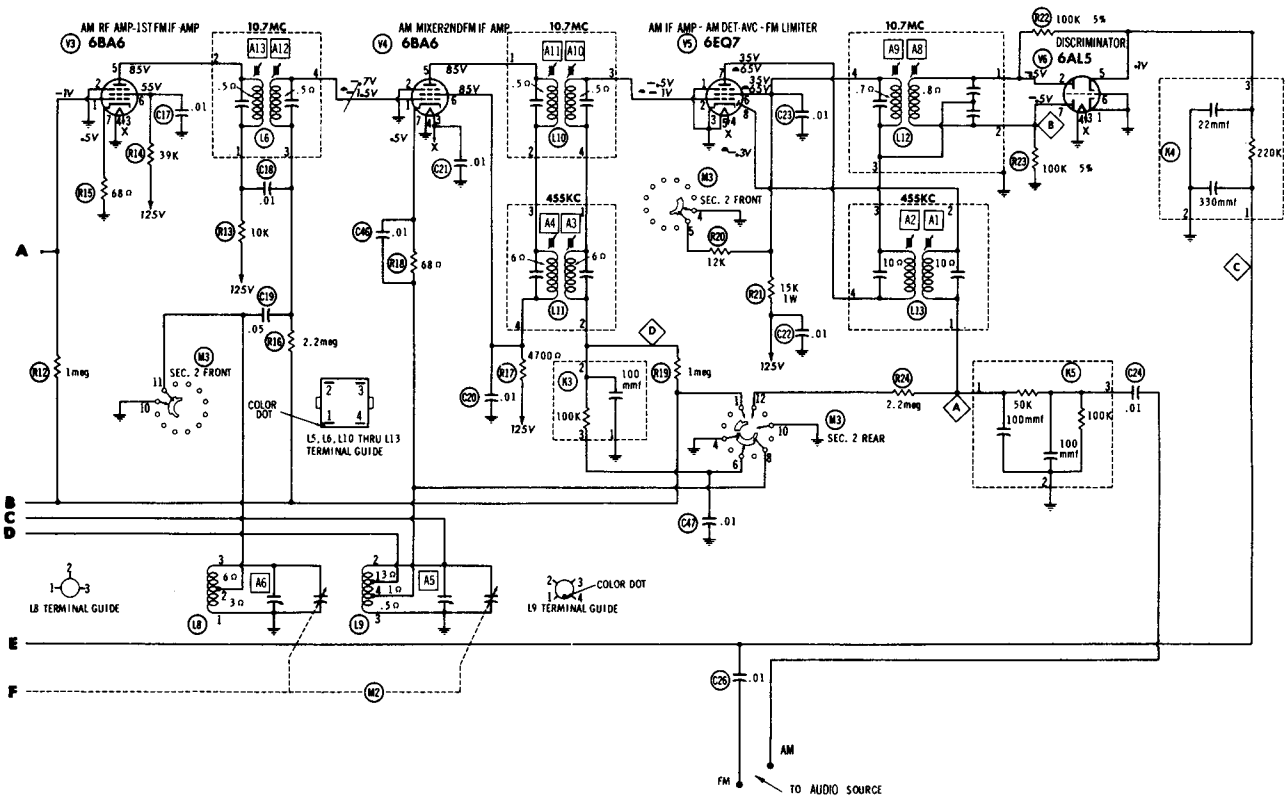

Fig. 12-21. A typical AM-FM

receiver with discriminator.



ment of the secondary of the FM-detector transformer. While this adjustment is critical, the setup for it is not difficult.

All other failures fall under headings discussed in earlier chapters, and the techniques explained there will suffice, with one exception—the problem of oscillator drift in FM receivers that do not use AFC is very difficult to handle. The usual measures are to replace the oscillator tube, followed by a systematic replacement of all resistors and capacitors in the oscillator circuit. When special temperature-compensated capacitors have been used in the original circuitry, they must be replaced with parts at least of equal quality and the same temperature characteristics. If no such capacitors have been used, perhaps the drifting can be reduced by putting some in.

When the AM-FM receiver must be serviced, the problems are greatly multiplied by the unorthodox circuitry and complicated switching networks which are used. A careful study of the schematic and the pictorial diagrams is necessary.

REVIEW QUESTIONS

1. Compare AM and FM with respect to the following aspects; make a chart, and give comparisons in a few words.

	FM	AM
Change of power output with modulation		
Simplicity of receiver		
Simplicity of transmitter		
Effects of atmospheric noise		
Bandwidth required		
Limitations on audio frequency		
Broadcast-band frequencies assigned		

2. Changes in the amplitude of the audio modulation applied to the FM transmitter cause what kind of changes in the transmitted signal?
3. Draw a circuit of a limiter stage giving correct values to all the parts. Include sketches of the waveforms at the input and output.
4. What determines the rate of change of the frequency of an FM signal?
5. Look up the schematic of an FM tuner using AFC and draw a partial schematic showing the AFC circuit. Ex-

- plain the operation of the AFC, and state the make and model represented.
6. In a small AM/FM combination, the audio is working but no signals can be received on either FM or AM. Make up a servicing chart showing a series of tests for locating faults that produce this symptom.
 7. In what important ways do the alignment procedures for discriminators and ratio detectors differ? Explain with the use of schematics of the two circuits.
 8. Explain why a slight mistuning of the detector input-transformer secondary in an FM receiver causes distortion.
 9. What is the effect of mistuning the primary of the detector input transformer?
 10. Is an FM receiver always free of noise? Explain why or why not.

13

Stereo Multiplex Systems

With recent approval by the FCC of a multiplexing system to permit broadcasting separate right and left channels, sales of FM stereo receiving equipment have increased rapidly. The troubleshooting technician must keep up with technological advances of this kind, and this involves the development of isolation techniques for symptoms, as well as the study of the theory of operation of these new circuits.

In order to afford space for development of isolation procedures for symptoms, the theory will be briefly covered in this chapter. If a more extensive coverage of theory is desired, reference should be made to texts devoted entirely to this topic.

THE TRANSMITTED SIGNAL

An understanding of the receiving systems is facilitated by acquiring a working knowledge of the characteristics of the signal that is to be detected. The fact that FM transmitters are capable of modulation at supersonic frequencies has been explained before. It is this property which enables a second signal to be transmitted.

Definition of Multiplex

When a second signal is imposed on the FM carrier, the process is called *multiplex*. A second carrier at a frequency of 38 kc is *amplitude* modulated with the additional information. The sidebands, which are in the supersonic range, are then used to frequency modulate the transmitter along with the regular program material.

Definition of Monaural or Monophonic

The regular program material containing both left and right channels is called the *monaural* (or *monophonic*) signal

and is designated as (L+R). As we shall see shortly, the (L+R), or monophonic signal, is an important part of the stereo signal.

Definition of Compatibility

The FCC requires that stereo broadcasts must be receivable on regular FM receivers, which means that a monophonic signal must be present at all times. This also means that the regular modulation must contain both left- and right-channel sounds so that there will be no loss of program material to listeners not equipped to receive stereo. It would be impossible to satisfy this requirement if, for example, the right channel were transmitted in the usual fashion, and the left channel were multiplexed at supersonic frequencies.

The problem at the transmitter then becomes one of continuing to transmit (L+R) in the usual manner while adding a special modulation, receivable only on stereo adapters, which enables the left and right channels to be separated. It is important to recognize that at no point in the system does the left or the right channel exist separately; they are combined until they reach the dual audio channels leading to the separate speakers. When the receiver is not equipped to separate the signals, they remain combined and appear as monophonic, (L+R), sound in the single speaker.

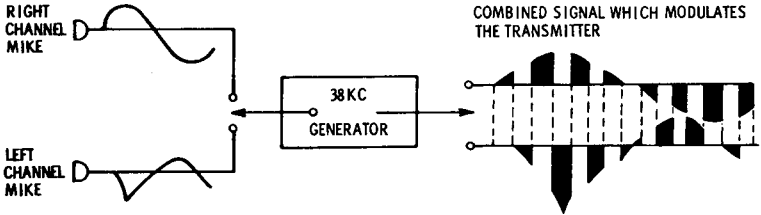

Fig. 13-1. Formation of modulation at the transmitter.

Figs. 13-1 and 13-2 illustrate a method by which this can be done. If the left and right channels are fed to a switch at the transmitter so that when the switch is on the right-channel input it is also on the right-channel output, the waveform shown can be produced. In this waveform, the voltage at the top output terminal carries the right-channel information, and the voltage at the bottom terminal carries the left-channel information. The dotted lines represent the switching rate and indicate that the entire modulation envelope is "chopped up" at the switching frequency of 38 kc.

This chopping does not distort the sound, because the switch in the receiver is synchronized with the one at the transmitter. It will switch to the upper terminals when the incoming waveform is positive and to the lower terminals when the waveform is negative. The output waveforms are shown in Fig. 13-2 without the 38-kc segments, because this component is removed by filters in the audio channels. If the receiver is not equipped with a multiplex detector, then the composite waveform containing (L+R) will be fed to the audio section, and both channels will appear as usual in the same speaker.

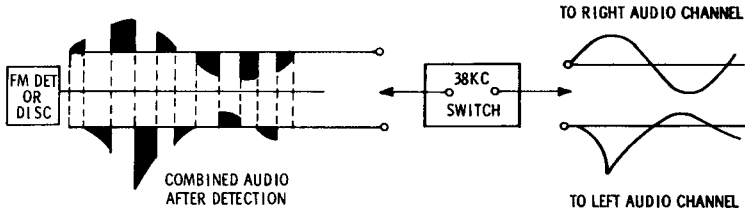

Fig. 13-2. Demodulation at the receiver.

The addition of the 38-kc synchronous detector following the FM detector is all that is necessary to convert any FM receiver into a stereo unit. Several adapters are available which can be connected between the output of the detector and the de-emphasis network. Two separate audio amplifiers are needed, of course.

This composite waveform is a bit more complicated than it appears in the drawing because it contains sidebands of the 38-kc switching frequency in addition to the (L+R) information. These sidebands will be from 23 kc to 53 kc, because they are the result of amplitude modulating a 38-kc carrier with audio ranging as high as 15 kc.

It will be recalled from the explanation of detectors in Chapter 2 that amplitude modulation results in sidebands which are the sum and difference of the audio and the RF frequencies. If 38 kc, for example, is modulated with 15,000 cycles, the resulting sidebands will be:

$$38 \text{ kc} + 15 \text{ kc} = 53 \text{ kc (upper sideband)}$$

$$38 \text{ kc} - 15 \text{ kc} = 23 \text{ kc (lower sideband)}$$

Since the audio will range from about 50 cycles to 15 kc, the sidebands will cover the range of frequencies 15 kc above and below 38 kc. Fig. 13-3 illustrates the distribution of the signals as they appear in the modulator of the FM transmitter.

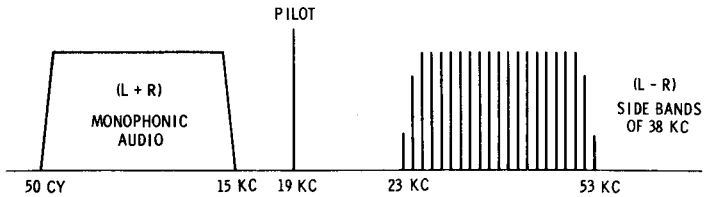

Fig. 13-3. Signal distribution in the modulator of an FM transmitter.

Notice that the regular monophonic (L+R) signals extend from 50 cycles to 15,000 cycles, and that there is another group of signals from 23 kc to 53 kc. The space between 15 kc and 23 kc is not used for program material, but the diagram shows that a 19-kc pilot signal is transmitted in this space. This pilot signal is transmitted continuously for the purpose of synchronizing the switching rate at the receiver. It is necessary to use 19 kc for the sync instead of 38 kc because 38 kc falls within the multiplexed sidebands. The frequencies between 23 kc and 53 kc are labeled (L-R).

Matrixing

Since the (L+R) signal must be present at all times, and the left and right channels cannot be separated during transmission, it is necessary to recover the separate channels by adding signals of opposite phase.

(L-R) is created at the transmitter, as illustrated in Fig. 13-4. This signal, which is actually a monophonic signal with

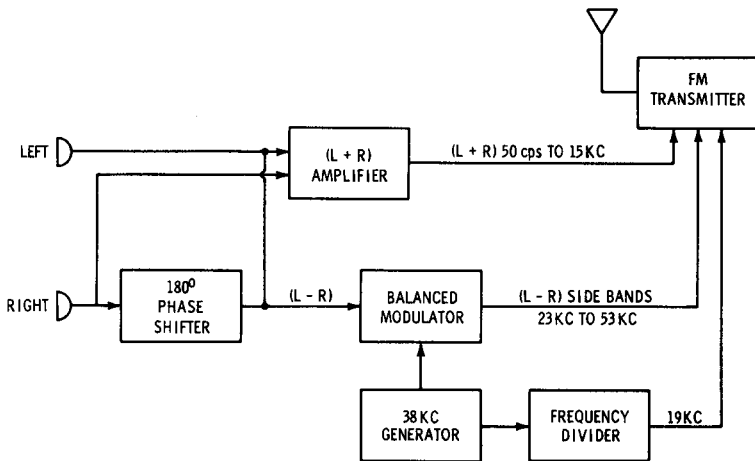

Fig. 13-4. Creation of the (L-R) signal.

the "R" voltage inverted, is used to modulate the 38-kc subcarrier, and the resulting sidebands carry the (L-R) information. Now it can be seen that the stereo system consists of sending (L+R) on the regular channel while sending (L-R) in the form of 38-kc sidebands which are inaudible with ordinary monophonic receiving equipment. The 38-kc subcarrier in the transmitter is suppressed by a balanced modulator, and only the 19-kc pilot signal is transmitted.

In the receiver, the original (L-R) signals are recovered by reinsertion of a 38-kc carrier generated locally in the receiver and controlled by the pilot. The *matrix* is a resistive network arranged to combine (L+R) and (L-R) as follows:

$$(L+R) + (L-R) = 2L$$

and

$$(L+R) - (L-R) = 2R$$

RECEIVER CIRCUITS

There are two popular types of stereo detectors. A third method that combines the circuitry of the other two is sometimes used by a few manufacturers. Because the alignment and servicing of the circuits varies with the type of demodulation employed, we shall discuss them separately and point out ways to recognize each.

The Sampling Demodulators

This method is also called *wave-envelope demodulation*, *time-division demodulation*, and *synchronous switching*. The block diagram in Fig. 13-5 shows the layout.

The operation of sampling demodulators depends on the principle of the synchronized switch depicted in Figs. 13-1 and 13-2. Since the signal is actually divided into segments, with the left and right channels being carried in alternate segments, it is possible to detect the channels separately.

The block diagram shows a wide-band input amplifier which takes the signal from the FM ratio detector or discriminator and amplifies all components; (L+R), (L-R), and 19 kc. A filter feeds the 19-kc sync signal to the 38-kc generator, and the reconstituted carrier is supplied to the synchronous switch, which is merely a pair of diodes. (L+R) and (L-R) are also fed to the switch.

When the switch is perfectly synchronized with the original chopping frequency at the transmitter, the right channel will be fed to the right audio amplifier and the left channel to the

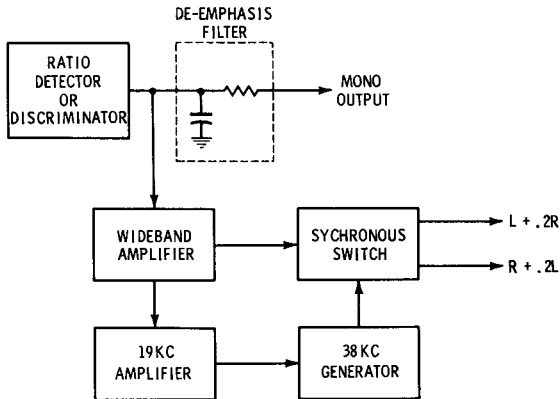

Fig. 13-5. Time-division multiplex unit.

left audio amplifier. The separation, however, is not perfect, and the right channel carries approximately 20% of the left channel. This imperfection is due to slight unbalance in the switching diodes, coupled with the fact that the switching voltage is not a square wave.

This results in less separation between the channels and destroys the illusion of stereo. This incomplete separation can be overcome by the use of negative feedback of a signal equivalent to:

$$-.20(L+R) \text{ or } -.20L - .20R$$

Adding this negative-feedback voltage to the output from the left and right diodes in Fig. 13-5 gives:

$$\text{Output from left diode: } L + .20R - .20L - .20R = .80L$$

$$\text{Output from right diode: } R + .20L - .20L - .20R = .80R$$

Note that the output from the right and left channels is now pure, but it has been reduced by 20%. The reduction in voltage output is not particularly noticeable, however, and is well worth the sacrifice since it removes the presence of the unwanted channel and improves the separation. But this necessitates additional circuitry and adjustments.

Manufacturers have used many methods to obtain the needed 38-kc signal in the receiver. In some cases, an oscillator running at 38 kc is synchronized on every other cycle by the 19-kc pilot signal. In other models, the grid tank of the oscillator operates at 19 kc while the plate tank is tuned to 38 kc. There are also several versions in which the 19-kc pilot is fed to an amplifier-doubler, and the resulting 38 kc is used instead

of generating the signal in a local oscillator. Fig. 13-6 shows an example of this type.

The entire circuit uses only one tube, two diodes, and a transistor. The input signal divides at point [17], and part of it is sent to the grid of the 19-kc input amplifier via the tuned circuit, L12. The plate of this stage is also tuned to 19 kc by the resonant tank, L13. The other path from [17] leads to the 38-kc switch via two 67-kc traps. 67 kc is the frequency of another subcarrier used for private broadcasts to special subscribers only. If this subcarrier is not removed, it may cause interference.

Amplified 19 kc appears at pin 7 of V7 and is doubled to 38 kc in the plate circuit of this second triode. Transformer L14 is the synchronous switch, having 38 kc fed into one end and (L+R) and (L-R) fed into the other end. As the diodes are switched on and off, they perform the job of separating the left and right channels. The diodes are followed by an extensive RC filter to remove the 38-kc component from the output. This filtering is important if the output is fed to a tape recorder, because the beat between the bias oscillator in the recorder and signals near 38 kc causes chirps and squeals in the recording.

The transistor (X1) is used to operate a lamp that glows when the 19-kc pilot signal is present, indicating that a stereo station is tuned in. The transistor has no forward bias on the base and is therefore cut off when 19 kc is absent. Thus, the bulb has no current flowing through it. When the pilot signal appears (in the form of 38 kc in the output of the doubler), the negative half of this sine wave causes conduction of the transistor, and enough collector current flows to operate the #49 bulb.

Figure 13-7 shows an entirely different approach. V1A is a wide-band amplifier handling all incoming signals. V2 amplifies the 19-kc pilot signal and feeds it to transformer L2. At the same time, (L+R) and (L-R) are taken off at the cathode of V2 and passed on to the detector, via R6 and C7.

The input circuit to V2B is very interesting. It consists of a full-wave rectifier with its output supplied to the grid of the tube. It will be recalled from Chapter 2 that a full-wave rectifier uses both halves of the input signal, and that its output contains a ripple frequency equal to twice the input frequency. In this manner, V2B is driven by negative pulses at 38 kc. The pulses are negative-going because of the manner in which the diodes are connected. The plate of V2B feeds the resonant circuit of L3, which operates as a switch in the usual manner.

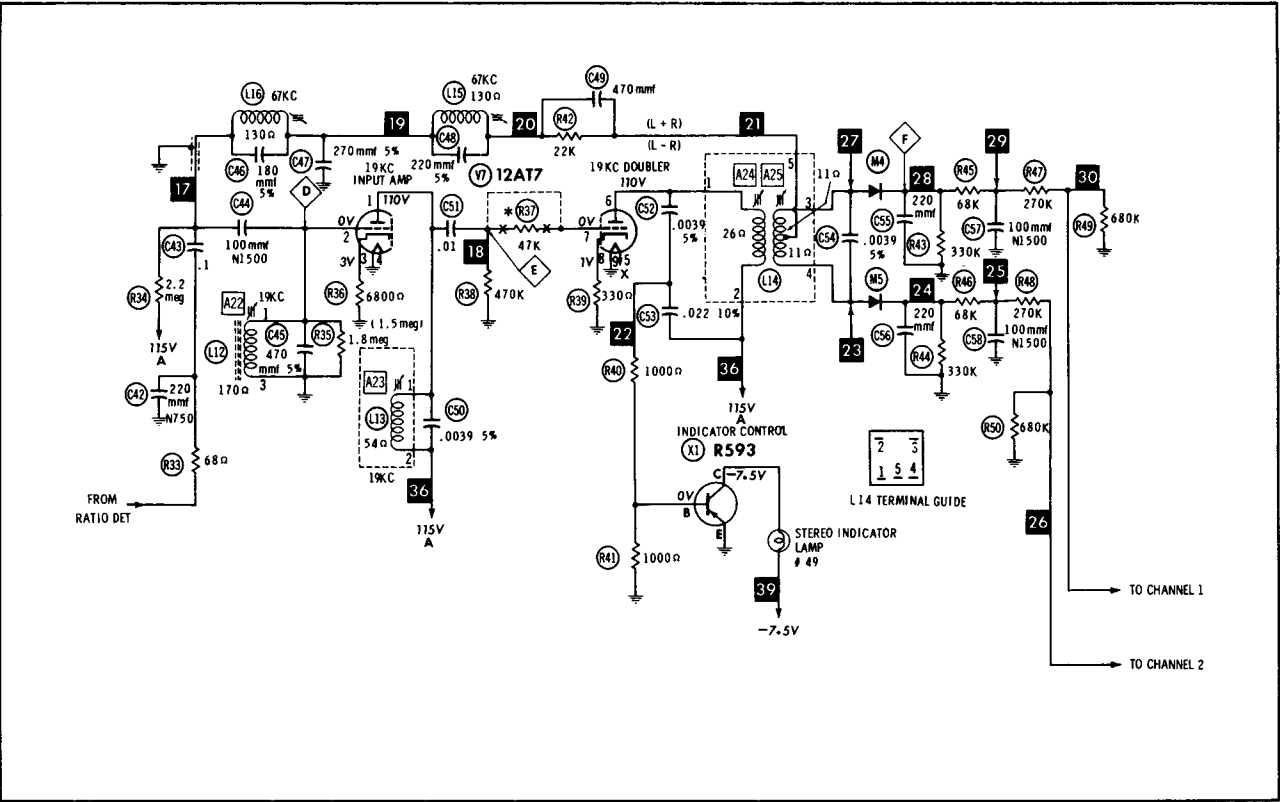

Fig. 13-6. A stereo-detector using a doubler to obtain 38 kc from the 19-kc pilot signal.

The two diodes of V1B are supplied with the 38-kc switching pulses plus $(L-R)$ and $(L+R)$ to produce the left and right channels separately. The detector is followed by filters.

Fig. 13-8 shows a transistorized version of the time-division, or switching-type, multiplex detector. The input signal is divided at the input terminal, and X2 handles the composite signal feeding the diodes. X1 has a 19-kc tank in its collector circuit, the output of which is used to synchronize the 19-kc oscillator formed by the collector-to-emitter feedback through the coils of L2. L3 is the switch that is tuned to 38 kc and

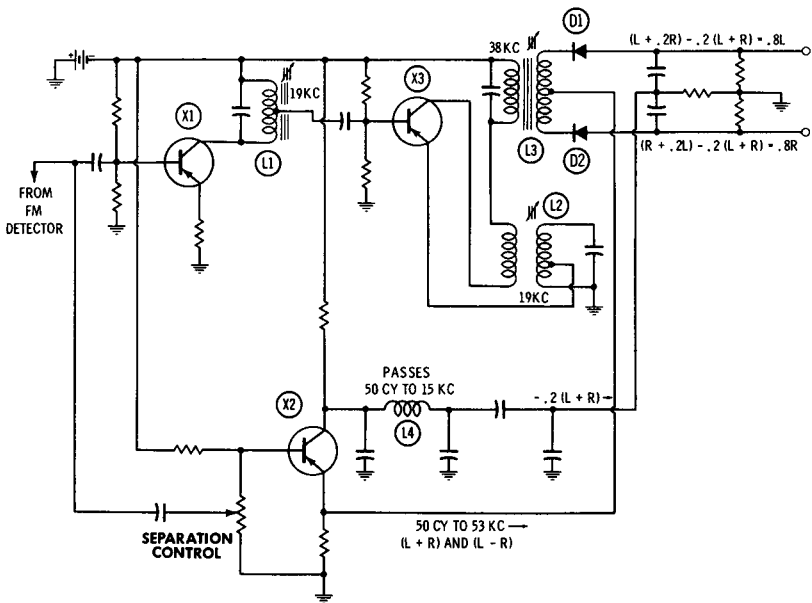

Fig. 13-8. A transistorized switching type stereo detector.

drives the diodes to produce the left and right channels separately. The separation control adjusts the level of the composite signal to correspond with the level of the 38 kc for optimum separation.

The circuit includes an inverse feedback to improve the separation, as discussed earlier. L4 and its associated capacitors form a low-pass filter that passes only $(L+R)$. Also, it will be noted that the signal taken from the collector of X2 is in the opposite phase from the one taken at the emitter. With the voltage divider formed by the capacitors, the resulting signal is $-.2(L+R)$, which is correct for cancelling the

error inherent in the separation with time-division circuits. The main signal is taken from the emitter because of the better frequency response obtainable with the emitter-follower circuitry.

The final time-division circuit to be discussed is shown in Fig. 13-9. It is essentially the same as the others, except for the bridge-type detector using four diodes. This is commonly done to eliminate the 38-kc carrier from the output. Part A of Fig. 13-10 shows the bridge circuit redrawn to clarify the

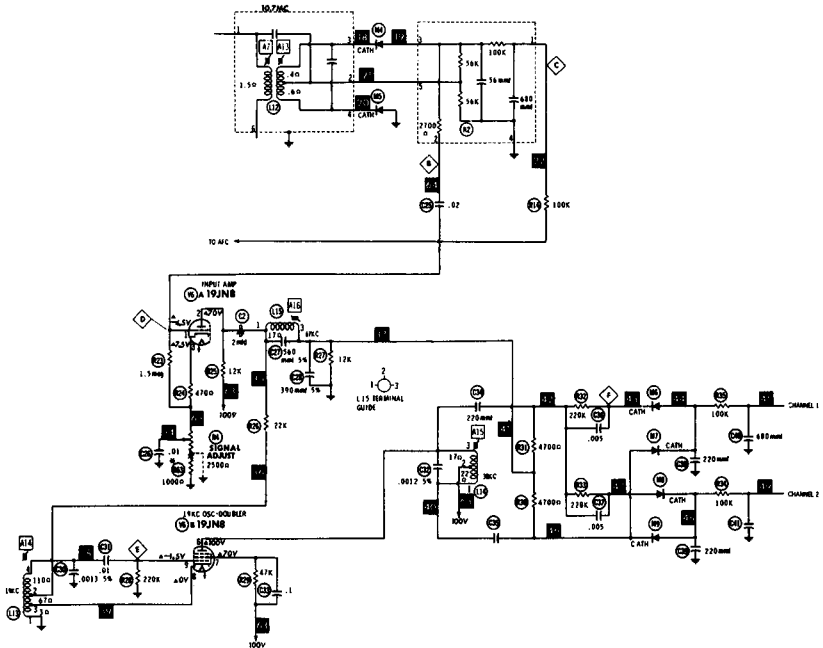

Fig. 13-9. A bridge-type stereo detector.

input and output connections. Part B shows the left side only for the time when there is no composite stereo signal applied. In this drawing, the 38-kc generator is represented as a center-tapped battery because we are considering only instantaneous voltages. M6 and M7 are shown as 100K resistors. The channel-1 output is shown as R_L , and it can be seen that there will be no voltage across it at this time, since it is connected between two points of equal potential. This is the balanced condition showing how the 38-kc carrier is kept out of the output.

This balanced condition will be changed when a voltage is applied to the composite-signal input. At the instant depicted

in part A, a negative voltage is applied to the cathode of M6 and to the anode of M7. The resistance of M7 is therefore increased, and the resistance of M6 is reduced. The drawing in part C shows the new relationships where the resistance of M6 is reduced to 50K, and the resistance of M7 is increased to 150K. The resultant change in voltages across the diodes leaves a net voltage of 2.5 volts across R_L . Similar changes

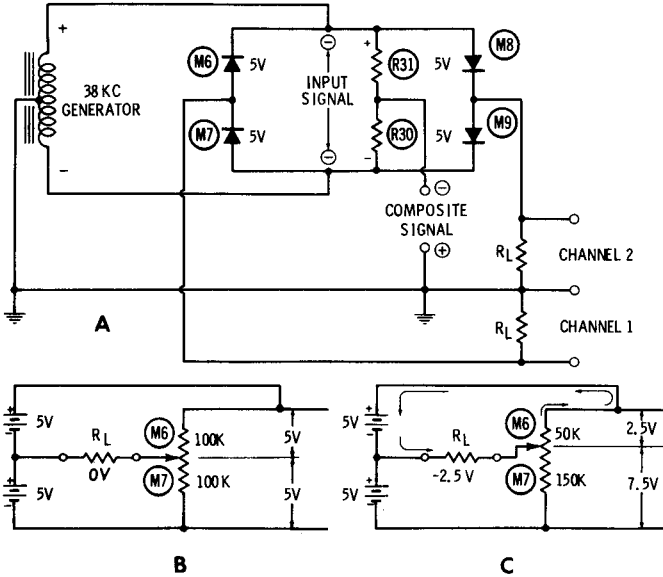

Fig. 13-10. The circuit of Fig. 13-9 redrawn for clarity.

occur on the other side of the bridge, resulting in an output signal in either channel which consists of the original stereo information without any of the 38 kc.

Frequency-Division Type Multiplex Detectors

In contrast to the switching- or sampling-type detectors which we have been discussing, are the frequency-division detectors which handle the sum and difference signals separately. In Fig. 13-11 is shown the circuit of a frequency-division multiplex unit in which the input is applied to a wide-band amplifier having three outputs. Output 1 feeds (L+R) directly to the output of the diodes. Output 2 extracts (L-R) by means of the filter and feeds this to the input of the diodes where it will be combined with the oscillator signal. Output 3 places the composite signal on the grid of a tube, the output of which

is tuned to 19 kc. This 19-kc signal is used to control the 19-kc oscillator whose plate tank is tuned to 38 kc.

The (L-R) signal fed to the diodes consists of sidebands of the suppressed 38-kc carrier. These sidebands extend from 23 kc to 53 kc, and are the sum and difference of the 38-kc and the audio frequencies, as explained before. When the sidebands are recombined with 38 kc, the beat will be the original audio frequencies. It is this beat (the difference between the sideband frequency and 38 kc) which appears at the upper cathode and lower plate of the diodes in Fig. 13-11. The origi-

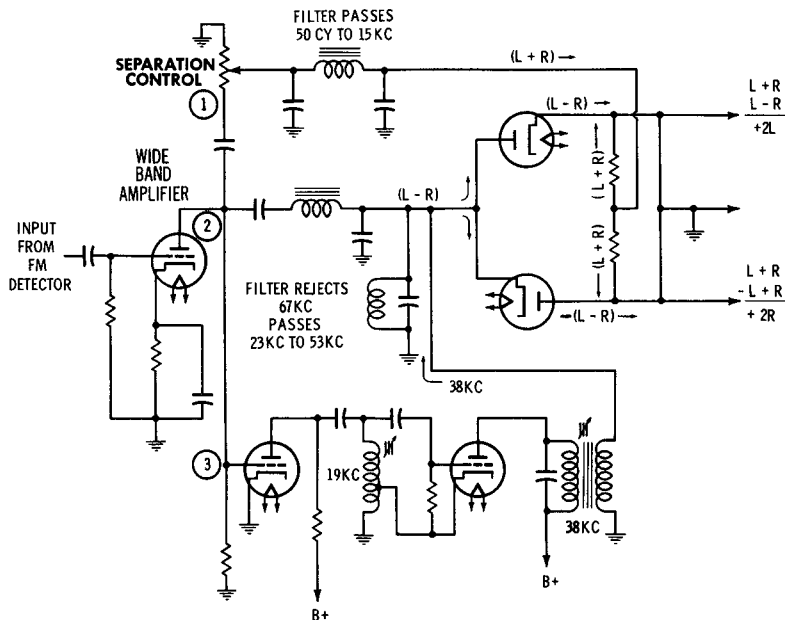

Fig. 13-11. Frequency-division multiplex.

nal (L-R) is at the cathode, and an inverted version, $-(L-R)$, is at the plate. $-(L-R)$ is the same as $(-L+R)$.

When these two diode outputs are combined with $(L+R)$, the left and right channels will be separated, as shown in the figure. It is emphasized again that at no point before the diodes does the left or right signal exist separately; they are always combined into the monaural signals, $(L+R)$ or $(L-R)$.

A transistorized version of a frequency-division type adapter is shown in Fig. 13-12. X1 has three outputs—one to the 19-kc tank, one to the $(L+R)$ line leading to the output of the diodes, and one which passes $(L-R)$ to the input of the

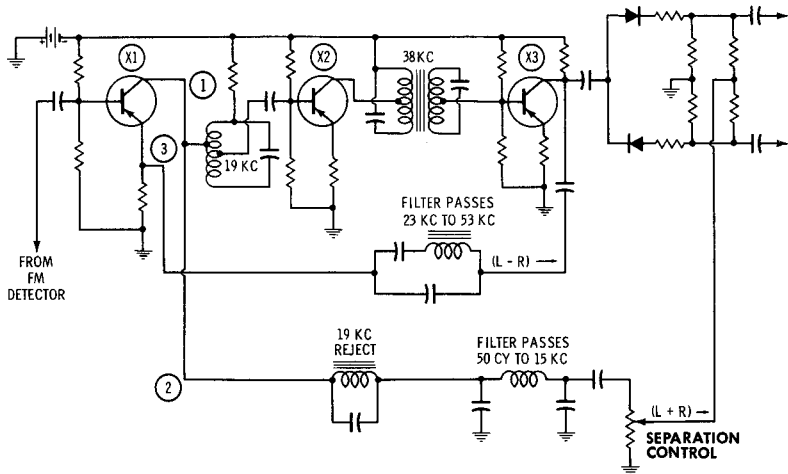

Fig. 13-12. Transistorized frequency-division multiplex.

diodes. An emitter follower is used for the (L-R) because of the better frequency response.

MULTIPLEX ALIGNMENT

Despite the elaborate instructions furnished by manufacturers, the alignment of multiplex equipment is very simple. In general, the following must be accomplished, preferably in this order:

1. The 67-kc trap must be tuned to reject any 67-kc interference.
2. The (L-R) bandpass filter leading to the diodes must be tuned so that it has a flat response from 23 kc to 53 kc.
3. The (L+R) low-pass filter must be tuned to pass all signals from 50 cps to 15 kc, and to reject 19 kc and above.
4. The oscillator output tank must be tuned to 38 kc and synchronized with the pilot signal.
5. Adjustment of the separation control must be made.

Tuning the 67-kc Trap

If this trap is included in the circuit, it may be identified from a study of the manufacturer's data and pictorial diagrams. Once the proper tuning slug is found, it is adjusted in the following manner:

Connect an audio oscillator, accurately tuned to 67 kc, to the input terminal of the wide-band amplifier. Set the oscillator signal for about 1 volt rms. Connect an oscilloscope or a high-quality AC VTVM to the output of the filter, and adjust the slug for minimum output.

Tuning the (L-R) Bandpass Filter

Tune an audio oscillator to 38 kc, and connect it to the input of the wide-band amplifier. Connect an oscilloscope or AC VTVM to the output of the filter, which is usually the input to the diodes. To avoid overloading the circuits, set the output attenuation of the audio oscillator for the minimum signal that gives a usable output indication.

First, adjust the tuning slug for maximum output at 38 kc. Then, check the output at 23 kc and at 53 kc—it should be not less than one-half the amplitude at 38 kc. Finally, check the output at 15 kc—it should be minimum at this frequency.

Tuning the (L+R) Low-Pass Filter

Tune an audio oscillator to 19 kc, and connect it to the input of the wide-band amplifier. Connect an oscilloscope or AC VTVM to the output of the filter (this will be at the junction of the two resistors across the outputs of the diodes). To avoid overloading, set the attenuator of the audio oscillator for the minimum signal that gives a good output indication.

First, adjust the tuning slug for minimum at 19 kc. Then, check for an output at 15 kc, which should be much greater. The output at frequencies from 15 kc down to about 50 cycles should be fairly constant.

The tuning of the filters just explained is required for *frequency-division* type units only. The more popular switching units do not separate (L-R) and (L+R), and are therefore simpler to set up. The following adjustments must be made on *all* types of multiplex units.

Synchronizing the 38-kc Oscillator to the Pilot Signal

Tune in a station that is broadcasting stereo. Stereo signals can be identified by viewing the waveform at the output of the wideband amplifier, using a scope with the sweep set to lock in a 19-kc sine wave. The audio program material will be seen as constantly changing variations superimposed on the 19-kc sine wave, as shown in Fig. 13-13. During quiet moments in the program, only the sine wave will appear on the scope, as in Fig. 13-14.

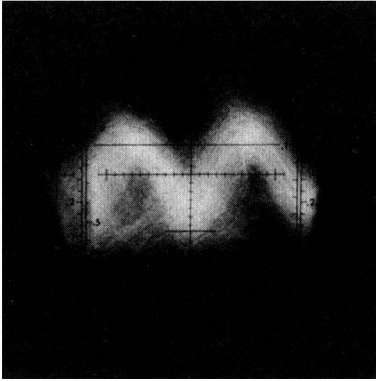

Fig. 13-13. Audio program material superimposed on the 19-kc pilot signal.

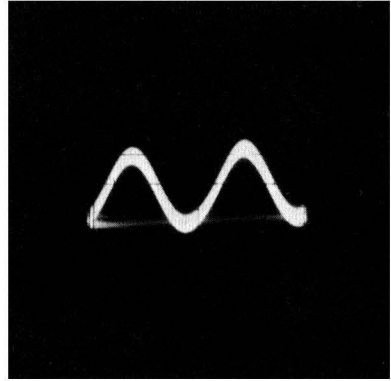

Fig. 13-14. Pilot sine wave viewed during a quiet moment in the program.

When it has been determined that the station is broadcasting stereo, the scope can be used to set the phase of the 19-kc circuits. Switch the scope to *external horizontal input* so that separate signals can be fed into the vertical and horizontal amplifiers of the scope. Feed the signal from the grid of the wide-band amplifier, or the 19-kc amplifier if one is used in the unit, into the vertical amplifier, and feed the signal from the grid of the 19-kc amplifier or oscillator into the horizontal amplifier. When signals of identical phase are fed to these two inputs, the resulting pattern on the scope will be a straight line sloping upward to the right. This type of pattern is shown in Fig. 13-15. Differences in the phase of the two signals affect the line as shown in Figs. 13-16 and 13-17. To make sure that the 19-kc circuit is in phase with the pilot signal, it is only

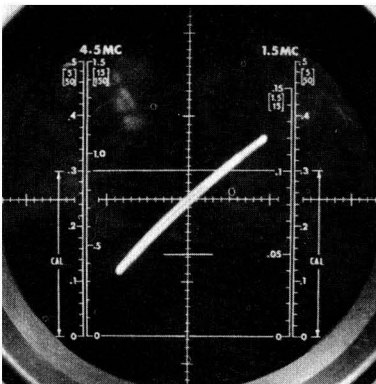

Fig. 13-15. Signals in phase.

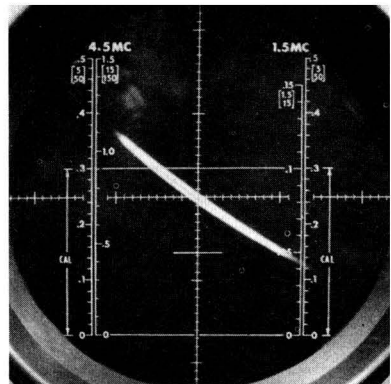

Fig. 13-16. Signals 180° out of phase.

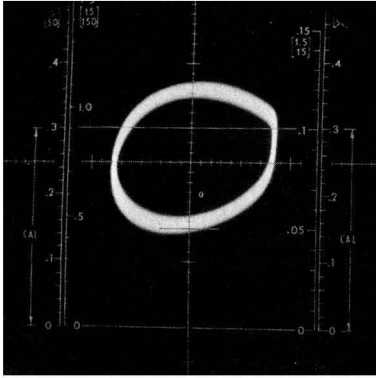

Fig. 13-17. Signals approximately 90° out of phase.

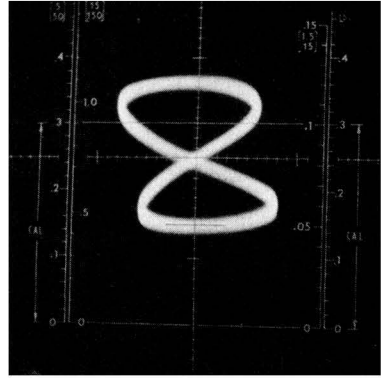

Fig. 13-18. Horizontal input frequency is twice that of the vertical input.

necessary to adjust the 19-kc until a straight line appears on the scope.

The 38-kc tank can now be adjusted by connecting the horizontal-input scope lead to the 38-kc input to the diodes. When the signal on the horizontal deflection plates of the scope is exactly twice the frequency of that on the vertical deflection plates, a figure "8" will be displayed, as shown in Fig. 13-18. When the 38-kc tank is slightly out of phase with the 19-kc pilot signal, the pattern shown in Fig. 13-19 will appear on the scope. The scope pattern with program material present is shown in Fig. 13-20.

If the 38-kc adjustment seems to tune broadly, it should be adjusted for maximum horizontal width of the figure "8."

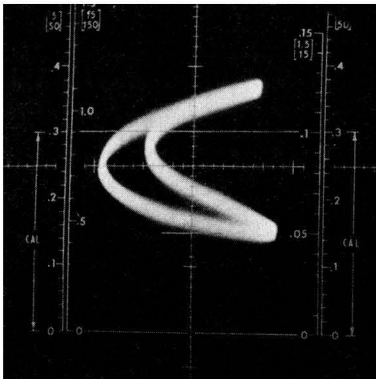

Fig. 13-19. The 19-kc and 38-kc signals slightly out of phase.

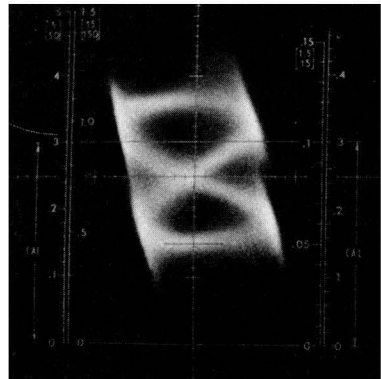

Fig. 13-20. Figure "8" pattern with program material present.

Most manufacturers recommend that the oscillator signal should be at least 3 times the amplitude of the (L-R). This can be checked by switching the scope back to normal internal sweep and checking the peak-to-peak voltages of the two signals separately. (L-R) can be measured at the input to the diodes if the oscillator is disabled by shorting its grid to its cathode. The oscillator signal can be measured at the same point during a quiet moment in the program.

One precaution which must be taken in the above procedure is to listen to the program material to be sure that the right channel is appearing in the right speaker, and the left channel in the left speaker. Proper left and right channels can be identified by listening to the announcements made between musical selections, because these are nearly always made on the left channel only. If the speakers are reversed, this is an unavoidable error resulting from the fact that the 38 kc can be synchronized by the 19 kc in two different phases; the only difference on the scope display is that the figure "8" is upside down. The difficulty can be easily corrected if the inputs to the audio amplifiers can be reversed. Or, if necessary, the phase can be corrected by adjusting the 19-kc tuning until the 38 kc is locked in the opposite phase.

It may be necessary to work back and forth between these adjustments several times to achieve perfect results. It is very important to note that the final adjustments must be made with the vertical input of the scope connected to the grid of the wide-band amplifier, and the horizontal input connected to the 38-kc input to the diodes. With these connections, undesired phase shifts in the wide-band amplifier and 19-kc circuits will be compensated for, since the final oscillator output is being compared with the original 19-kc pilot signal. If the vertical input to the scope is connected after the grid of the wide-band amplifier, certain undesirable phase shifts may have already occurred, and the oscillator signal will not be compared to the true pilot signal.

The adjustment of the separation control, which will be described next, often causes a change in the phase of the 19-kc signal because the control changes the load resistance of the wide-band amplifier. It is sometimes necessary to retouch the 19-kc adjustments after the separation control is adjusted.

Adjusting the Separation Control

Before making this adjustment, it is important to understand the meanings of the terms *balance* and *separation*. "Balance" refers to the volume level of the two audio channels and,

for good stereo, the gain controls should be adjusted so that equal volume appears in both channels while feeding the same signal (a monaural program) into both audio inputs. Likewise, the tone controls should be adjusted for identical tone quality in both channels.

The term "separation" refers to an adjustment of the amplitude of $(L+R)$ applied to the demodulators so that it exactly equals the amount of $(L-R)$ in the case of frequency-division units, or is equal to about one-third of the oscillator voltage in the switching type. The control to be adjusted usually consists of nothing more than a variable resistance in series with the $(L+R)$.

One way to adjust this control on the frequency-division units is to tune in a stereo station and arrange the speakers so they are equidistant from each ear of the operator at the time when he is in a position to operate the control. Turn the control fully clockwise (maximum resistance in the $(L+R)$ line), which will render only $(L-R)$ at the speakers. This is a good time to check for perfect synchronization of the 38 kc. A slight error in the adjustment of the 19-kc tank results in distortion of the $(L-R)$, which can be heard when the $(L+R)$ is removed.

The sound will be monaural—with the same signal in both speakers—and it will appear to come from a point directly overhead. As the control is turned to increase the $(L+R)$, the sound will appear to separate into left and right channels, and as the control is advanced still farther, it will again become monaural and appear overhead. The control is set at the point that gives the best separation.

Another way to set the separation control, which is more accurate because it does not depend on the amount of separation in the program material, is to listen for an announcement which is made entirely on the left channel. At this time, turn the volume to minimum on the left-channel audio system (or disconnect the wire from the input or from the speaker) and listen on the right channel only. If the separation is perfect, no sound will be heard from the right channel when the announcement is entirely on the left channel. Adjust the separation control to "null out" the sound as much as possible. Multiplex detectors do not have 100% separation, so some small part of the left channel will still be heard in the right channel, even with the best possible adjustment of the separation control.

Another way to adjust the separation control, preferred by some experts, employs the scope. The patterns shown in Fig.

13-21 were obtained with the vertical input connected to the left-channel output of the demodulators and the horizontal input connected to the right-channel output. The vertical and horizontal-gain controls were preset to give equal gain in both amplifiers of the scope.

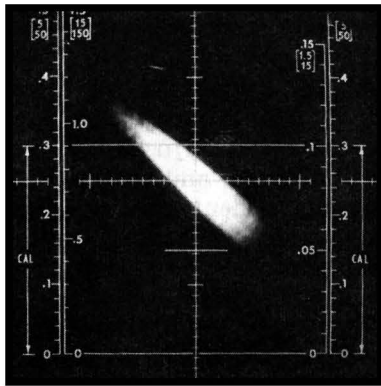

(A) (L-R) only.

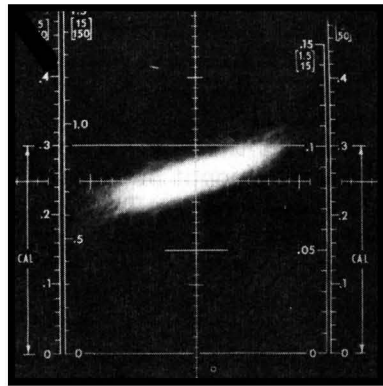

(B) (L+R) only.

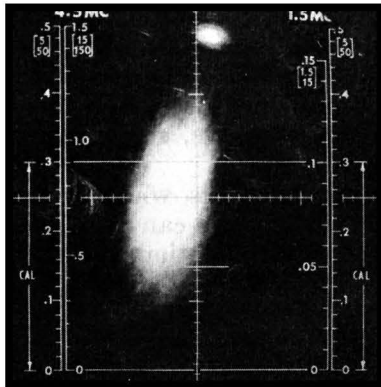

(C) Separation control advanced to mix (L+R) with (L-R).

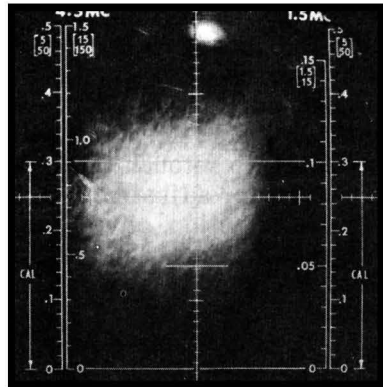

(D) Maximum separation.

Fig. 13-21. Scope patterns showing the adjustments of the separation control.

The trace at Fig. 13-21A was obtained with the separation control fully clockwise—that is, with no (L+R) present. In this condition the signals appearing at the output terminals are (L-R) and $-(L-R)$. Since these are 180° out of phase, the resultant on the scope is a straight line sloping upward to the left.

Fig. 13-21B shows the resultant when only (L+R) is present. In this condition, the output terminals will both have the same signal because (L+R) does not pass through the diodes but is applied directly to both output terminals. When the two inputs to the scope are equal and in phase, the resultant is a straight line which slopes upward to the right. It is important to realize that when either (L-R) or (L+R) is missing, the output is no longer stereo, but will consist of either the sum or difference signal rather than pure *R* or *L*.

Fig. 13-21C shows better separation as the control is advanced, allowing equal amounts of (L-R) and (L+R) to appear at the diode outputs. The control is adjusted to give the least amount of "straight-line" deflection and the greatest "fuzz-ball" effect. This method of adjustment, like the first one described, depends on the amount of separation in the program material at the time the tests are being made. The pattern changes constantly with the program material. Fig. 13-21D shows an instant when there was great separation in the program with almost equal volume level in both channels.

Obtaining this trace on the scope is an important part of the troubleshooting procedures to be described. The display is used to indicate the presence or absence of either channel at the output terminals. The scope can often be used as an output indicator when repairing a multiplex unit that does not have the twin audio channels available. As mentioned earlier, adjustment of the separation control causes a phase shift in the 19-kc pilot signal in some circuits, so it may be necessary to retouch the 19-kc adjustments.

Except for adjustment of the traps and filters, which seldom require attention, alignment of multiplex units can usually be done successfully "by ear," with a stereo station tuned in. Four simple steps are listed here:

1. Tune in a stereo broadcast, and turn the separation control fully clockwise to remove all (L+R).
2. Adjust the 19-kc tuning controls (usually the oscillator-grid tank) until the sound is undistorted. If no such point can be found, move the 38-kc adjustment in either direction about one-half turn, and try again.
3. When undistorted demodulation of (L-R) is accomplished in Step 2, turn the separation control to the middle of its range. If a low-frequency, growling oscillation is heard, it will be necessary to readjust the 19-kc circuit again, because the change in the separation control has affected it.

4. While an announcement is being made on one channel only, turn the volume to zero on the channel being used (usually the left one), and adjust the separation control for a null in the other channel. Retouch the 19-kc tuning if necessary.

TROUBLESHOOTING MULTIPLEX UNITS

Despite the complicated theory of multiplexing, the circuitry is relatively simple, and troubleshooting is straightforward. SERVICING CHART XV at the end of this chapter covers four symptoms:

1. Monaural sound only.
2. Warbling or gargling.
3. Squeals and birdies.
4. Hissing background noise.

Monaural Sound Only

13-1 This condition is the result of lack of separation, and the tests described are equally as effective when there is no separation as when there is partial separation. Remember that this symptom does not mean that only one speaker is operating—it means that the same sound appears in both speakers. Failure of one audio channel is handled by the methods described in Chapter 3.

13-2 The chart is divided according to the type of circuitry used. In the switching-type circuits, this symptom must be the result of a missing, or very weak, 38-kc oscillator signal. Since (L-R) and (L+R) are not separated in these units, neither one can be absent while the other is still present. The technician is therefore directed to the tests in the oscillator as shown on the chart.

In some units, no oscillator is used at all—the 19-kc pilot signal is amplified and doubled, and applied to the switching diodes. When the 38-kc signal is missing, distortion is usually not apparent because the (L+R) signal is still unimpaired, and the (L-R) remains in the inaudible range from 23 kc to 53 kc.

13-3 The situation in the frequency-division units is quite different, however, and a more extensive series of tests is used. Loss of the 38-kc subcarrier, with (L-R) present, results in severe distortion which can be heard if (L+R) is removed by grounding the center tap of the separation control. This is the purpose of TEST POINT 1.

Three possible results can occur by removing (L+R), and the following tests are chosen accordingly.

Further Tests When Removing (L+R) Results in Undistorted Monaural Sound

13-4 This indicates that (L-R) is being demodulated properly, so the lack of separation must be due to a loss of (L+R). The coupling capacitor leading to the separation control should be checked by substitution, and the resistance of the control itself should be verified. After this, the two load resistors in the output of the diodes should be measured. If these steps do not locate the failure, the (L+R) line should be opened at the junction of the two resistors mentioned above and the scope used to trace toward the separation control until the signal is found.

Further Tests When Removing (L+R) Results in No Sound

13-5 In this case, it is obvious that (L-R) is missing, so the tests mentioned on the chart are chosen to locate a failure which could remove (L-R) without affecting (L+R).

TEST POINT 2, CHART XV

REMOVING (L+R) RESULTS IN DISTORTED SOUND

13-6 This distortion can result from an insufficient 38-kc subcarrier injection to the diodes, or a defect in the diodes themselves. After checking the diodes (if they are of the vacuum-type), the voltage at the grid of the 38-kc oscillator is measured. A few tests are listed on the chart under TEST POINT 2; these are to be made when the oscillator appears to be inoperative. But the technician must keep in mind that the 38-kc circuit may not be a self-sustaining oscillator. It may depend on amplification of the 19-kc pilot, in which case tests of the 19-kc circuits are in order.

TEST POINT 3, CHART XV

NORMAL OSCILLATOR GRID VOLTAGE

13-7 A resistance check from the diode-input point to ground will determine the condition of the oscillator output secondary and any series resistors. If these are not defective, a check on the alignment of the 19-kc and 38-kc tuning should be made.

When the preceding preliminary checks do not locate the defect, it can be assumed that the lack of separation is caused by incorrect amplitude of either (L-R) or the 38 kc where

the two are combined at the input to the diodes. TEST POINT 3, therefore, calls for a comparison of the peak-to-peak voltages of these two signals. The (L-R) is most easily checked by shorting the oscillator cathode to the grid to remove the oscillator signal so that (L-R) can be viewed alone. The oscillator voltage should be at least three times greater than the amplitude of (L-R). If it is not, the most likely cause is maladjustment of the 38-kc output tank, or a failure of the tube itself. If the oscillator tank requires considerable retuning to increase the signal level, it is probable that some other defect has occurred in the oscillator, so it would be advisable to check voltages.

A weak (L-R) signal leads the technician to tests in the bandpass amplifier and bandpass filter circuits, and finally to alignment of the FM tuner.

WARBLING OR GARGLING

13-8 This effect is caused by upper audio frequencies between the two channels beating together, and is the result of loss of synchronization of the carrier regenerating oscillator. When the oscillator is only slightly off frequency, the effect is more like "warbling." When the error in oscillator frequency is greater, the sound is garbled or mushy, and may contain an audio howl. When this condition is suspected in the frequency-division circuits, it is possible to listen to (L-R) only by turning the separation control down in the manner described for TEST POINT 1.

A scope connected to the input and output of the 19-kc amplifier is the best method of analysis. Once the point where the pilot or 38-kc signal disappears has been located, the VTVM can be used to examine the circuit components.

The possibility of misalignment always exists, of course, but the technician hesitates to perform alignment adjustments until he is certain that the trouble is not caused by some component whose defect will be temporarily compensated for.

SQUEALS AND BIRDIES

13-9 These are always caused by unwanted signals being demodulated in the multiplex circuits and beating with the desired audio frequencies. The trouble can often be traced to the presence of the 67-kc private-broadcast carrier which has not been filtered sufficiently. In some locations, the FM stations broadcasting stereo are also supplying this additional program

material to private subscribers, and the 67-kc carrier is necessarily a part of the composite signal received by the stereo multiplex unit.

Squeals may also be the result of misalignment of the band-pass filter, which permits 19 kc, or even lower frequencies, to enter the (L-R) channel. Squeals are a familiar complaint when attempting to record stereo broadcasts on a tape recorder. They result from the appearance of either 19 kc or 38 kc in the output of the multiplex detector which beats with the bias oscillator contained in the recorder. If this problem is not the result of unbalance in the diodes or misalignment of the filters in the unit, it can be cured by installing a 15-kc low-pass filter at each output of the multiplex detector. Shielding and physical separation of the multiplex unit and the recorder may also prove helpful.

HISSING BACKGROUND NOISE

13-10 This is a common complaint with new stereo installations where only monophonic FM has been received previously. The difficulty arises from the fact that a much stronger signal is required to produce noise-free stereo than for monophonic FM, and the user may find that his antenna system is inadequate or that the nearest station broadcasting stereo is simply not close enough. Sometimes nothing can be done, and at other times, improvement of the antenna solves the problem completely.

In cases where the user has already enjoyed good stereo from his equipment and suddenly finds a high noise level, the problem will nearly always be caused by tubes. The RF amplifier in the FM tuner is the most likely suspect, after which the IF tubes should be checked. The wide-band amplifier in the multiplexer is another possibility.

If the problem persists after tubes have been replaced, a check on the condition of the antenna should be made before extensive work begins on the chassis. If possible, a different tuner should be connected in place of the original to compare the noise level. This will allow you to gain evidence of the condition of the antenna without making a trip to the roof or the top of a tower.

REVIEW QUESTIONS

1. Write a short paragraph to define each of the following:
 - a. Monaural, or monophonic sound.

- b. Stereo sound.
 - c. (L+R). Explain whether it is monophonic or stereo sound.
 - d. (L-R).
 - e. Switching (time-division) type synchronous detector.
 - f. Frequency-division type multiplex detector.
 - g. Balanced modulator.
 - h. Subcarrier.
 - i. Pilot signal.
 - j. Separation, as differentiated from balance.
2. Draw block diagrams to illustrate the difference between the two multiplex systems discussed in this chapter.
 3. A stereo multiplex station is broadcasting a 5000-cycle audio note in the (L-R) channel:
 - a. Will this sound appear in the left or right speaker, or both?
 - b. What are the frequencies of the sidebands present at the output of the bandpass filter in the receiver?
 4. Sketch the scope waveform which will be seen with the vertical input of the scope connected to Test Point 22 and the horizontal input connected to D in Fig. 13-6, while receiving a stereo program.
 5. If the tuner which feeds the circuit of Fig. 13-6 were changed to a monaural FM station, would the waveform in Question #4 change? If so, redraw the waveform.
 6. Make up a servicing chart to cover the symptom of "No Separation" in the circuit of Fig. 13-11. Try to cover every possibility, and be specific about tests.
 7. Look up the schematics for two multiplex units, one of each kind, and draw the circuits. Label all tuned circuits with the proper frequencies.
 8. Why should the multiplex circuit be connected ahead of the de-emphasis network in the FM detector?
 9. Describe one good way to determine if a station is transmitting stereo.
 10. Explain how you would use a scope to determine the condition of the (L-R) signals.
 11. In the case of the same channel reproduced in both speakers from a frequency-division type adapter, the following tests have been made:
 - a. All tubes found to be OK.
 - b. All B+ voltages normal.
 - c. Oscillator running in sync.
 - d. (L-R) present at demodulators in sufficient amount. What would you check next?

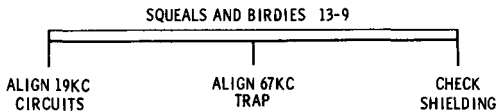
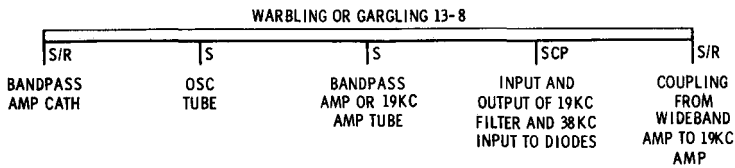
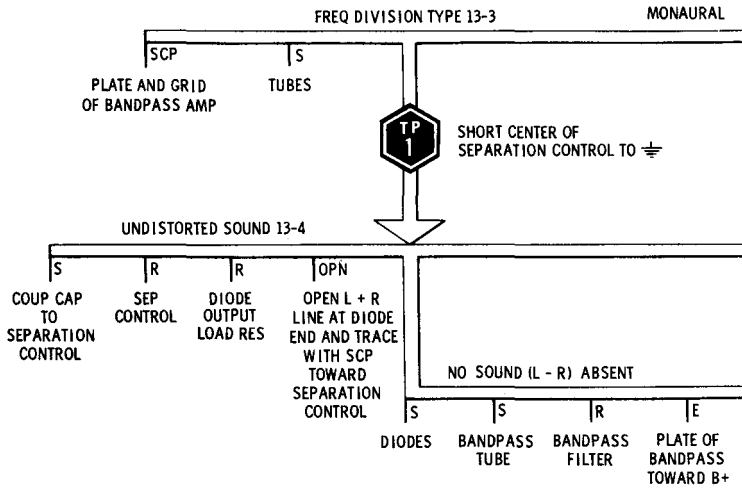

12. What steps would you take to remove the squeals that occur when you attempt to make a tape recording from a stereo adapter?
13. Suppose you are faced with the following difficulty in stereo reception: The program sounds very good from one station, but the program is distorted and full of squeals when another stereo station is tuned in. What would you suspect is wrong, and what would you do to correct the trouble?

Appendix

INDUCTIVE AND CAPACITIVE REACTANCE

A coil of wire, like the ones used in radio circuits, has an electrical property known as *inductance*. Basically, this is the ability of the coil to produce a magnetic field when current passes through it. The field so generated produces a voltage which opposes the flow of the current which produces it. Inductance depends on the diameter, the length, and number of turns in the coil.

The amount of opposition to AC current which a coil offers is called *inductive reactance*. This opposition has an effect similar to resistance in a DC circuit; it is measured in ohms and it causes an AC voltage drop across the coil. But in some other ways, inductive reactance is different from resistance.

One of the important differences is that the amount of reactance increases as the frequency of the AC current increases. The exact relationship is expressed in the formula:

$$X_L = 2\pi fL \text{ (see example 3 in appendix)}$$

where

X_L is the inductive reactance in ohms,
 f is the frequency of the current in cycles per second,
 L is the inductance in henrys.

It can be seen that as F is made larger in the formula, X_L also becomes larger. Therefore, less current will flow in the circuit at higher frequencies, and more current at lower frequencies.

A capacitor also exhibits a similar effect known as *capacitive reactance*. This also acts like resistance in an AC circuit, but again there are some important differences.

Capacitive reactance depends on the size of the plates in the capacitor, the spacing, and the insulating material between them. The expression for reactance produced by a capacitor is:

$$X_c = \frac{1}{2\pi fC} \text{ (see example 6 in appendix)}$$

where

X_c is the capacitive reactance in ohms,
 f is the frequency in cycles per second,
 C is the capacitance in farads.

This formula shows that X_c *decreases* as the frequency increases. This is the *opposite* effect from X_L , and it means that the AC current flowing in a circuit will be greater at higher frequencies, and less at lower frequencies.

The fact that the effects of X_L and X_c are exactly opposite with changes in frequency means that when a capacitor and an inductance are both present in a circuit their reactances tend to cancel each other. For any circuit containing both X_L and X_c , there will be one frequency where they are equal and will completely cancel, leaving no reactance. This frequency is called the *resonant frequency* of the circuit and represents the one condition when maximum current will flow.

Because their reactance is dependent upon frequency, coils and capacitors are used to filter out certain frequencies and pass others. A capacitor passes high frequencies easily, but resists the flow of current at low frequencies. A coil blocks the highs and passes the lows.

POWERS OF TEN

Technicians use a convenient way of writing very large and very small numbers used in electronics calculations. To multiply a number by 10 it is only necessary to affix a zero as:

$$2 \times 10 = 20$$

And to multiply by 100, add two zeros; by 1000 add three zeros, etc:

$$2 \times 100 = 200$$

$$2 \times 1000 = 2000$$

$$2 \times 1,000,000 = 2,000,000$$

This idea can easily be extended to numbers containing a decimal point when one recalls that the number "2" used above is also "2.0":

$$2.5 \times 10 = 25$$

$$2.5 \times 1000 = 2500$$

$$.25 \times 10 = 2.5$$

$$.025 \times 1000 = 25$$

In each case above, the product is obtained by *moving the decimal point to the right as many places as there are zeros in the power of ten used*, adding zeros as place holders when necessary.

Technicians indicate the power of ten used for multiplication as an exponent written above and to the right of the number. Thus, 100 can be written as 10^2

1000 can be written as 10^3 , and

1,000,000 can be written as 10^6 , etc.

By using the powers of ten it is no longer necessary to write all the zeros ordinarily needed to express a large number:

$$20 = 2 \times 10^1$$

$$200 = 2 \times 10^2$$

$$2000 = 2 \times 10^3$$

$$2,000,000 = 2 \times 10^6$$

It is sometimes more convenient to write numbers containing decimals by stating them as a number between 1 and 10, times the appropriate power of ten:

$$2500 = 2.5 \times 10^3$$

$$250,000 = 2.5 \times 10^5$$

$$2,500,000 = 2.5 \times 10^6$$

Dividing by powers of ten uses the same rule for moving the point except that it is moved to the left:

$$20 \div 100 = \overset{\curvearrowright}{.20}$$

$$200 \div 100 = \overset{\curvearrowright}{2.00}$$

$$250 \div 10,000 = \overset{\curvearrowright}{.0250}$$

$$3.59 \div 100,000 = \overset{\curvearrowright}{.0000359}$$

To express a number which is divided by a power of ten, the technician uses the exponent with a minus sign:

$$2 \text{ can be written as } 200 \times 10^{-2}$$

$$2.5 \text{ can be written as } 25 \times 10^{-1}$$

$$.0000359 \text{ can be written as } 3.59 \times 10^{-5}$$

The negative exponent indicates the number of places the decimal should be moved to the left if the number is to be written without the power of ten.

The answers to the following exercises are given at the end of the appendix.

Group 1

Write each of the following as a number between 1 and 10 times the appropriate power of ten. Example:

$$250 = 2.5 \times 10^2$$
$$.0093 = 9.3 \times 10^{-3}$$

- | | | |
|------------|------------|---------------------------|
| 1. 2000 | 5. .16 | 9. $2\frac{1}{4}$ million |
| 2. 17.9 | 6. .0257 | 10. 17 ten thousandths |
| 3. 208 | 7. .001 | |
| 4. 189.763 | 8. 675,000 | |

Write each of the following as a number without using the power of ten. Example: $2.7 \times 10^2 = 270$

- | | | |
|------------------------------|---------------------------|--------------------------|
| 11. 16.7×10^{-3} | 15. 2.6×10^6 | 19. 100×10^{-3} |
| 12. 129×10^{-1} | 16. $.007 \times 10^{-2}$ | 20. 10×10^1 |
| 13. $.067 \times 10^2$ | 17. 124.6×10^3 | |
| 14. $100,000 \times 10^{-5}$ | 18. $.1009 \times 10^2$ | |

Multiplication

When two numbers are multiplied, the powers of ten are added:

$$100 \times 1000 = 10^2 \times 10^3 = 10^{2+3} = 10^5 = 100,000$$
$$650 \times 800 = (65 \times 10^1) \times (8 \times 10^2) = 520 \times 10^{1+2}$$
$$= 520 \times 10^3 = 520,000$$

When necessary, negative powers can be used:

$$.039 \times .08 = (39 \times 10^{-3}) \times (8 \times 10^{-2}) = 312 \times 10^{-5} = .00312$$

When positive and negative powers of ten are mixed, the powers are combined algebraically, considering the signs:

$$490 \times .006 = (4.9 \times 10^2) \times (6 \times 10^{-3}) = 29.4 \times 10^{-1} = 2.94$$
$$.7 \times 8000 = (7 \times 10^{-1}) \times (8 \times 10^3) = 56 \times 10^2 = 5600$$

Division

When dividing, the powers of ten are subtracted:

$$1000 \div 10 = \frac{1000}{10} = \frac{10^3}{10^1} = 10^{3-1} = 10^2 = 100$$
$$\frac{100}{10,000} = \frac{10^2}{10^4} = 10^{2-4} = 10^{-2} = .01$$
$$.120 \div 30 = \frac{.120}{30} = \frac{12 \times 10^{-2}}{3 \times 10^1} = 4 \times 10^{-2-1} = 4 \times 10^{-3} = .004$$
$$\frac{1600}{.04} = \frac{16 \times 10^2}{4 \times 10^{-2}} = 4 \times 10^{2+2} = 4 \times 10^4 = 40,000$$

The answers to the following exercises are given at the end of the appendix.

Group 2

Write the product of the following as a number between 10 and 100 times the appropriate power of ten. Example:

$$1.69 \times 10^2 \times 3 \times 10^{-4} = 5.07 \times 10^{-2} = 50.7 \times 10^{-3}$$

- | | |
|----------------------------------------------------|---------------------------------------------------|
| 1. $17.3 \times 10^2 \times 70 \times 10^3$ | 6. $2 \times 10^{-3} \times 5 \times 10^2$ |
| 2. $.069 \times 1.7 \times 10^6$ | 7. $49,000 \times .0008$ |
| 3. $8.49 \times 10^{-6} \times 116 \times 10^{-2}$ | 8. $9.4 \times 10^{-6} \times .08 \times 10^{-6}$ |
| 4. $2 \times 10^3 \times 1.7 \times 10^{-4}$ | 9. $22.2 \times 2.22 \times 10^{-2}$ |
| 5. $12 \times 10^3 \times 8.73 \times 10^{-3}$ | 10. $1.2 \times 10^{-1} \times .008 \times 10^2$ |
- $\times .0006$

Write the quotients of the following as a number between 10 and 100 times the appropriate power of ten. Example:

$$\frac{1.8 \times 10^3}{9 \times 10^{-2}} = \frac{18 \times 10^2}{9 \times 10^{-2}} = 2 \times 10^4, \text{ or } 20 \times 10^3$$

- | | | |
|---------------------------------------------------|----------------------------------------------------|----------------------------------------------|
| 11. $\frac{16.9 \times 10^{-3}}{1.3 \times 10^2}$ | 15. $\frac{2 \times 10^3}{150 \times 10^{-6}}$ | 19. $\frac{5 \times 10^2}{5 \times 10^{-2}}$ |
| 12. $\frac{.209 \times 10^6}{1.8 \times 10^4}$ | 16. $\frac{27.3 \times 10^{-6}}{3.9 \times 10^3}$ | 20. $\frac{1.5 \text{ mv}}{2.2 \text{ meg}}$ |
| 13. $\frac{.0168}{8 \times 10^3}$ | 17. $\frac{148 \times 10^{-3}}{2,500}$ | |
| 14. $\frac{12,700}{3.6 \times 10^2}$ | 18. $\frac{390 \times 10^{-6}}{27 \times 10^{-6}}$ | |

Powers of ten gives a great advantage when dealing with the kind of numbers used in electronics because the units used for various quantities are usually extremely large or very small.

Current is often measured in milliamperes (ma). A milli-ampere is $\frac{1}{1000}$ of an ampere.

Capacitance is often measured in microfarads (mfd). A microfarad is $\frac{1}{1,000,000}$ of a farad.

Frequency is sometimes stated in kilocycles (kc), which is 1000 cycles.

The table on the next page gives common units and their abbreviations.

	<i>Units Used</i>	<i>Abbreviation</i>
voltage	volts millivolts microvolts	V mv μ v
current	amperes milliamperes microamperes	A ma μ a
frequency	cycles per second kilocycles megacycles	cy or cps kc mc
resistance	ohms kilohms megohms	Ω K meg
capacitance	farads microfarads micromicro- farads or picofarads	none mfd mmf or pico
inductance	henry millihenry microhenry	hy mh μ h

In making calculations it is convenient to shift from one kind of unit to another, as:

.032 amp might be written 32 ma, or 32×10^{-3} amps.

1250 ohms is often expressed as 1.25K.

120,000 cycles could be written 120 kc or .12 mc or 1.2×10^5 cy.

The technician must be able to change from one kind of unit to another quickly and accurately. To this end the conversion table on the next page should be memorized.

Nearly all electronic formulas require that the values be used in the original units. That is, resistance must be used in ohms; current in amperes; capacity in farads, etc. When the values are given in other units, they must be converted and this is easily done with the powers of ten. The examples of typical circuit problems, starting on the next page, illustrate the convenience of the system.

CONVERSION TABLE

<i>To Obtain</i>	<i>From</i>	<i>Move Decimal Point</i>	<i>Example</i>
ma	amp	3 places →	4A = 4000 ma .025A = 25 ma
amp	ma	3 places ←	2500 ma = 2.5A 150 ma = .15A
mv	volts	3 places →	.4V = 400 mv .0063V = 6.3 mv
V	mv	3 places ←	3200 mv = 3.2V 12 mv = .012V
ohms (Ω)	kilohms (K)	3 places →	3.9K = 3900 ohms .05K = 50 ohms
megohms	kilohms (K)	3 places ←	18.6K = .0186 meg 480K = .48 meg
kilohms	ohms	3 places ←	3200 ohms = 3.2K 125 ohms = .125K
kilohms	megohms	3 places →	2.2 meg = 2200K .5 meg = 500K
mmf	mfd	6 places →	.005 mfd = 5000 mmf .00025 mfd = 250 mmf
mfd	mmf	6 places ←	100 mmf = .0001 mfd 2200 mmf = .0022 mfd

Example 1

To find the voltage drop across R1:

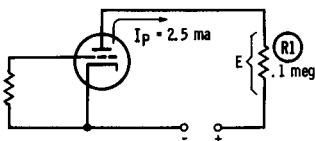

$$E = I_p R$$

$$E = 2.5 \text{ ma} \times .1 \text{ meg}$$

$$E = (2.5 \times 10^{-3}) \times (1 \times 10^5)$$

$$E = 2.5 \times 10^2, \text{ or } 250\text{V}$$

Note that .1 meg was changed to 1×10^5 instead of $.1 \times 10^6$. This is often done to eliminate decimal points.

Example 2

What is the input current through R_1 ?

$$I_{in} = \frac{E_{in}}{R_1}$$

$$I_{in} = \frac{20 \text{ mv}}{.5 \text{ meg}} = \frac{20 \times 10^{-3}}{5 \times 10^5}$$

$$= 4 \times 10^{-8}$$

$$I_{in} = .04 \times 10^{-6}, \text{ or } .04 \mu\text{a}$$

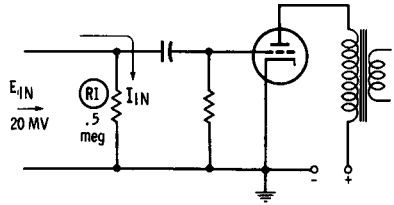

Final answers are usually stated in the most convenient units rather than with the powers of ten.

Example 3

What is the value of X_L when $f = 455 \text{ kc}$ and $L = 2.3 \text{ mh}$?

$$X_L = 2\pi fL$$

$$2\pi = 2 \times 3.14 = 6.28$$

$$X_L = 6.28 \times 455 \times 10^3$$

$$\times 23 \times 10^{-4}$$

$$= 65,720 \times 10^{-1} = 6572\Omega$$

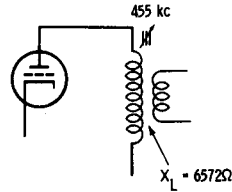

Another convenient way to use the powers of ten is to change all numbers to equivalents between 1 and 10:

$$X_L = 6.28 \times 4.55 \times 10^5 \times 2.3 \times 10^{-3}$$

[Estimating: $6 \times 5 \times 2 = 60 \times 10^2$ helps to locate decimal]

$$65.72 \times 10^2 = 6572\Omega$$

One important precaution should be emphasized. Numbers having different powers of ten can be multiplied or divided directly as we have seen, but they *cannot be added or subtracted*.

We can multiply:

$$6\text{K} \times 3\Omega = 18\text{K}$$

But we cannot add:

$$6\text{K} + 3\Omega \neq 9\text{K}, \text{ or } 6\text{K} + 3\Omega \neq 63\Omega$$

In order to add numbers with powers of ten, the powers must be the same:

$$6\text{K} + 3\Omega = 6000 + 3 = 6003\Omega, \text{ or}$$

$$6\text{K} + 3\Omega = 6 \times 10^3 + .003 \times 10^3 = 6.003 \times 10^3$$

Example 4 on the next page illustrates the idea.

Example 4

The total resistance resulting from the parallel combination of R1 and R2 below is given by the formula :

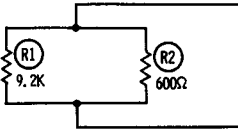

$$R_T = \frac{R_1 \times R_2}{R_1 + R_2}$$

$$R_T = \frac{(9.2K)(600)}{9.2K + 600}$$

Changing 600Ω to .6K facilitates adding in the denominator :

$$R_T = \frac{(9.2K)(600)}{9.2K + .6K} = \frac{9.2 \times 10^3 \times 6 \times 10^2}{9.8 \times 10^3}$$

6 × 9.2 can be done mentally :

$$R_T = \frac{55.2 \times 10^5}{9.8 \times 10^3} = 5.63 \times 10^2 = 563\Omega$$

Example 5

When two resistors are in series across a known voltage, the drop across one of them is found by the formula :

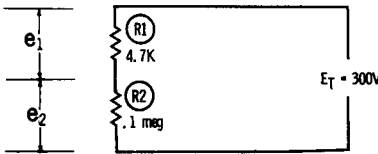

$$e_1 = \frac{E_T R_1}{R_1 + R_2}$$

or

$$e_2 = \frac{E_T R_2}{R_1 + R_2}$$

To find the voltage across R1 :

$$e_1 = \frac{300 \times 4.7K}{.1 \text{ meg} + 4.7K}$$

$$= \frac{3 \times 10^2 \times 4.7 \times 10^3}{100 \times 10^3 + 4.7 \times 10^3}$$

$$= \frac{14.1 \times 10^5}{104.7 \times 10^3}$$

$$= .134 \times 10^2$$

$$= 13.4 \text{ volts}$$

Note denominators with same power of ten to permit adding

.....
 Estimating mentally: $\frac{14}{100} =$
 .14 helps to locate decimal
 point

To find the voltage across R2 :

$$e_2 = \frac{E_T R_2}{R_1 + R_2} = \frac{3 \times 10^2 \times 1 \times 10^5}{104.7 \times 10^3} = \frac{3 \times 10^7}{104.7 \times 10^3}$$

$$= .02866 \times 10^4 = 286.6 \text{ volts}$$

Example 6

The capacitive reactance (X_c) of the coupling capacitor below varies with frequency. Find X_c at 100 cps and at 20 kc.

$$X_c = \frac{1}{2\pi fC}$$

$$2\pi = 6.28 \text{ and } \frac{1}{2\pi} = 159 \times 10^{-3}$$

so a convenient way to write the formula is:

$$X_c = \frac{159 \times 10^{-3}}{fC}$$

At 100 cps:

$$\begin{aligned} X_c &= \frac{159 \times 10^{-3}}{100 \times .02 \times 10^{-6}} = \frac{159 \times 10^{-3}}{2 \times 10^{-6}} \\ &= 79.5 \times 10^3 \text{ or } 79.5K \end{aligned}$$

At 20 kc:

$$\begin{aligned} X_c &= \frac{159 \times 10^{-3}}{20 \times 10^3 \times .02 \times 10^{-6}} = \frac{159 \times 10^{-3}}{4 \times 10^{-4}} = 39.75 \times 10^1 \\ &= 397.5 \text{ ohms} \end{aligned}$$

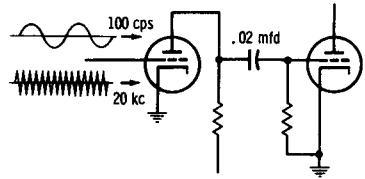

GRAPHIC ANALYSIS OF AMPLIFICATION BASED ON THE LOAD LINE

Plate voltage is determined by the amount of drop across the plate load resistor. As the plate current increases, more of the battery voltage is dropped across the resistor, and the plate-to-cathode voltage becomes less. The control grid of a vacuum tube behaves like a valve, controlling the plate current. The amount of plate current is controlled by the grid-to-cathode voltage. Grid voltage therefore controls plate voltage by controlling the amount of current through the load resistor.

For example, the 200 volts from the "B" battery in the figure below must be divided between the drop across the plate resistor and the drop across the tube. If there were 5 ma of plate current, the drop across the resistor would be:

$$20K \times 5 \text{ ma} = 100 \text{ volts}$$

This would leave 100 volts across the tube.

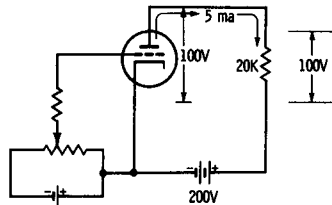

If the plate current were 2 ma, the drop across the resistor would be:

$$20K \times 2 \text{ ma} = 40 \text{ volts}$$

This leaves: $200 - 40 = 160$ volts across the tube.

With a plate current of 9 ma, the drop across the resistor is 180 volts, leaving only 20 volts across the tube.

Thus, it can be seen that the voltage across the tube is always the remainder after the resistor voltage is subtracted from the battery voltage. Also, as the plate current increases, the voltage across the tube *decreases, and vice versa*.

If the voltages and currents found above are graphed, the results of the 20K load resistor can be seen to be a straight line. The horizontal axis on the graph shows plate voltages, and the vertical axis gives the corresponding plate current. The slanted line is called the *20K load line*.

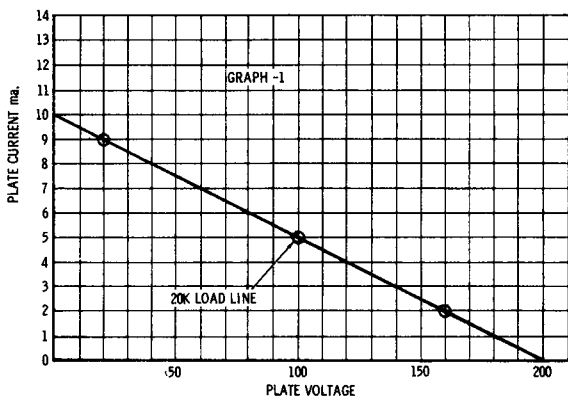

The load line crosses the horizontal axis at 200 volts because this is the maximum possible plate voltage in our example and will occur when the current is zero. The load line crosses the vertical axis at 10 ma because this is the maximum possible plate current that can flow, and at this time the plate voltage is zero because all the battery voltage is dropped across the resistor.

$$20K \times 10 \text{ ma} = 200 \text{ volts}$$

To graph a load line for any size resistor it is only necessary to determine these two points. The maximum voltage is at one end of the line (on the horizontal axis) and the maximum cur-

rent is at the other end (on the vertical axis). The maximum current is the maximum voltage divided by the resistance.

$$\frac{200 \text{ volts}}{10K} = 10 \text{ ma}$$

The curved lines in graph number 2 show the effect grid voltage has on the current through the tube. It can be seen that if the grid voltage were -3 for the triode in our example, the resulting plate current of 5 ma flowing in the $20K$ load resistor would produce 100 volts of plate voltage.

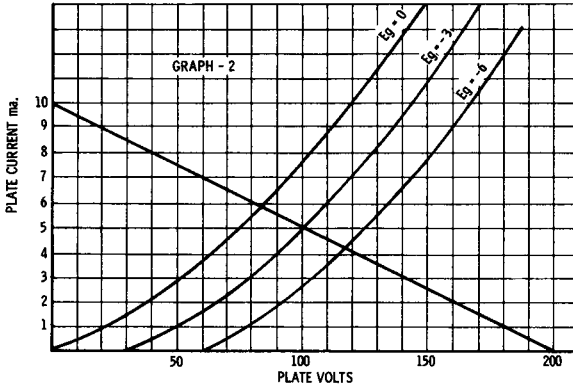

Similarly, if the grid voltage were 0 , the resulting plate current would be about 5.75 ma , and this would give a plate voltage of about 85 volts .

If the grid voltage were -6 , the plate current would be about 4.25 ma , and this would give a plate voltage of about 118 volts . These three points are indicated on graph number 2.

Graph number 3 shows what happens to the plate voltage when the grid voltage is made to vary according to an input signal. Suppose the no-signal grid voltage is -3 and that the input signal causes the grid voltage to vary up to 0 volts and down to -6 volts , as indicated on the graph. The peak-to-peak value of the input signal is then 6 volts .

The meaning of the expression "voltage amplification" becomes clear when we notice that the plate voltage changes correspond to the changing currents through the load resistor. The waveform drawn below the horizontal axis shows that the plate signal is 33 volts peak-to-peak.

Comparing the input and output voltages, we see that the output is 5.5 times greater than the input, and this represents a voltage gain of 5.5 .

The importance of the load resistor in producing voltage gain should not be overlooked. A larger load resistor causes

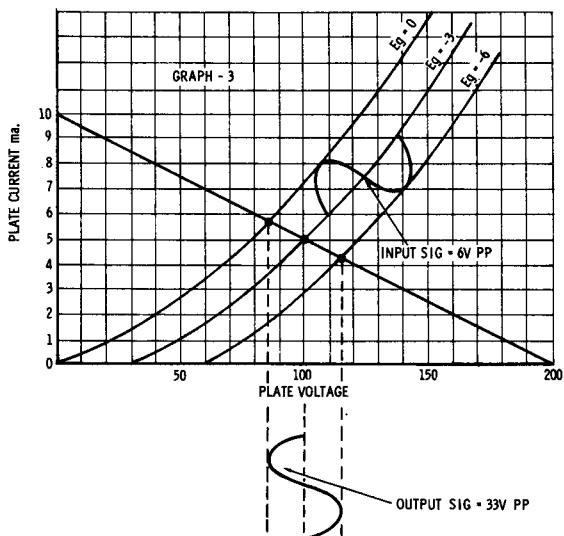

the load line to cross the vertical axis at a lower value, and this increases the peak-to-peak swing of the plate voltage.

Answers to Group 1

- | | |
|--------------------------|--------------------------|
| 1. 2×10^3 | 6. 2.57×10^{-2} |
| 2. 1.79×10^1 | 7. 1×10^{-3} |
| 3. 2.08×10^2 | 8. 6.75×10^5 |
| 4. 1.89763×10^2 | 9. 2.25×10^6 |
| 5. 1.6×10^{-1} | 10. 1.7×10^{-3} |
| 11. .0167 | 16. .00007 |
| 12. 12.9 | 17. 124,600 |
| 13. 6.7 | 18. 10.09 |
| 14. 1 | 19. .1 |
| 15. 2,600,000 | 20. 100 |

Answers to Group 2

- | | |
|----------------------------|-----------------------------|
| 1. 12.11×10^7 | 6. 10×10^{-1} |
| 2. 12.43×10^{-1} | 7. 39.2 |
| 3. 98.484×10^{-7} | 8. 75.2×10^{-14} |
| 4. 34×10^{-2} | 9. 49.284×10^{-2} |
| 5. 62.856×10^{-3} | 10. 96×10^{-3} |
| 11. 13×10^{-5} | 16. 70×10^{-10} |
| 12. 11.6 | 17. 59.2×10^{-6} |
| 13. 21×10^{-7} | 18. 14.44 |
| 14. 35.3 | 19. 10×10^3 |
| 15. 13.3×10^6 | 20. 68.18×10^{-11} |

Index

- A**
AFC, 219, 229, 239
Alignment
 AM receiver, 83, 87
 discriminator, 230
 FM receiver, 229
 gated-beam detector, 232
 IF, 233
 multiplex, 257
 ratio detector, 231
AM-FM combination receivers, 235
AM receiver
 audio stages, 25
 block diagram, 14
 power supply, 14
 full-wave, 17, 20, 21
 half-wave, 15, 18
Audio stages
 AM receiver, 25
 output, 121
Automatic
 frequency control, 219
 gain control, 114
 tuning, 184, 189, 202
 volume control, 38, 60, 81, 114,
 181, 216
Auto radios, 177
Auxiliary AVC, 116
AVC, 38, 60, 81, 114, 181, 216
 auxiliary, 116
- B**
Beta, 110
Biasing, transistor, 112
Birdies, 267
Block diagram
 AM receiver, 14
 FM receiver, 214
Bridge, full-wave, power supply, 21
Buffer capacitor, 178
- C**
Capacitive reactance, 272
- Capacitor
 leakage, 74
 link, 34
Cathode degeneration, 25
Cold-cathode rectifiers, 179
Compatibility, definition of, 245
Continuous seeking, 202
Converter, AM receiver, 32
Crystal diode, 221
- D**
Dead receiver, 22, 98
Decoupling, 71, 119
De-emphasis network, 239
Demodulators, sampling, 248
Detector
 diode, 36
 discriminator, 223
 FM, 222
 gated-beam, 227, 230
 multiplex
 frequency-division, 255
 time-division, 253
 ratio, 225
Deviation, 212
Diode detector, 36
Direct-coupled stages, 200
Discriminator, 223
 alignment, 230
Distortion, 68, 102, 123, 164
- E**
Encapsulated units, 46, 102
- F**
Feedback, inverse, 73
First audio stage, 29
FM
 detectors, 222
 receivers, 211
 alignment, 229
 stereo, 244
 tuner, 216
Forward bias, 106

Frequency
 control, automatic, 219
 -division multiplex detector, 255
Full-wave
 power supply, 17
 voltage doubler, 20
Fusible resistor, 194

G

Gain control, automatic, 114
Gargling, 267
Gated-beam detector, 227
 alignment, 232

H

Half-wave transformerless rectifier, 15
Heat sink, 194
Hi-fi
 tone-control circuit, 32
 transistorized, 125
Hissing background noise, 268
Hum, 68, 102
Hybrid receivers, 188

I

IF
 alignment, FM, 233
 amplifiers, AM, 35
 transformers, 62
 leakage, 77
 universal replacement, 35
Inductive reactance, 272
Inverse feedback, 73

L

Leakage
 capacitor, 74
 IF transformer, 77
Limiting, 216
Load line, 111, 282
Locked-oscillator, quadrature-grid detector, 227
Low gain, 171

M

Matrixing, 247
Microphonics, 102

Mixer stage
 AM receiver, 32
 transistor, 126
Monaural, 244
Monophonic, 244
Motorboating, 69, 169
Multiplex
 alignment, 257
 definition of, 244
 detector
 frequency-division, 255
 time-division, 253
Mushy audio, 73
Muting, 192, 204

N

Noise, background, 268
Noisy signals, 81
No signal, 43, 55, 131

O

Oscillation, 169
Oscillator
 AM receiver, 32
 grid voltage, 55
 transistor, 126

P

Padder adjustment, 87
Plate voltage, 49
Portable receivers, 91
Powers of ten, 273
Power supply
 AM receiver, 14
 full-wave, 17
 bridge, 21
 voltage doubler, 20
 half-wave
 transformerless, 15
 voltage doubler, 18
 3-way portable, 91
 transistor radio, 119
 vibrator, 177
Push-pull output stages, 27

R

Ratio detector, 225
 alignment, 231
Reactance, 272
 tube, 219

Rectifier
 cathode voltage, 47
 cold-cathode, 179
 full-wave, 17
 bridge, 21
 voltage doubler, 20
 half-wave
 transformerless, 15
 voltage doubler, 18
Regeneration, 56
Resistance coupling, 29
Reverse bias, 106
Ripple frequency, 22, 177
Rms voltage, 22

S

Sampling demodulator, 248
Screen voltage, 47
Separation control, 261
Sidebands, 36, 211
Signal-seeking circuits, 184
60-cycle hum, 68
Squeals, 69, 267
Stereo, FM, 244
Surge resistor, 16
Synchronous switching, 248

T

Temperature compensation, 218
Thermal runaway, 194
Thermistor, 168

Time-division
 demodulation, 248
 multiplex detector, 253
Tone controls, 31
Tracking, 34, 84
Transistors, 105
Trimmer adjustments, 87
Tube burnout, 101
Tunable hum, 69, 102
Tuner, FM, 216
Tuning, automatic, 184, 189, 202

U

Universal replacement IF trans-
formers, 35

V

Varicap, 222
Varistor, 168
Vibrator power supplies, 177
Voltage
 amplifier, 29
 doubler
 full-wave, 20
 half-wave, 18
Volume control, automatic, 38, 60,
 81, 114, 181, 216

W

Warbling, 267
Wave-envelope demodulation, 248
Weak signals, 81