

# Instructions to Radio Constructors

R. H. WARRING

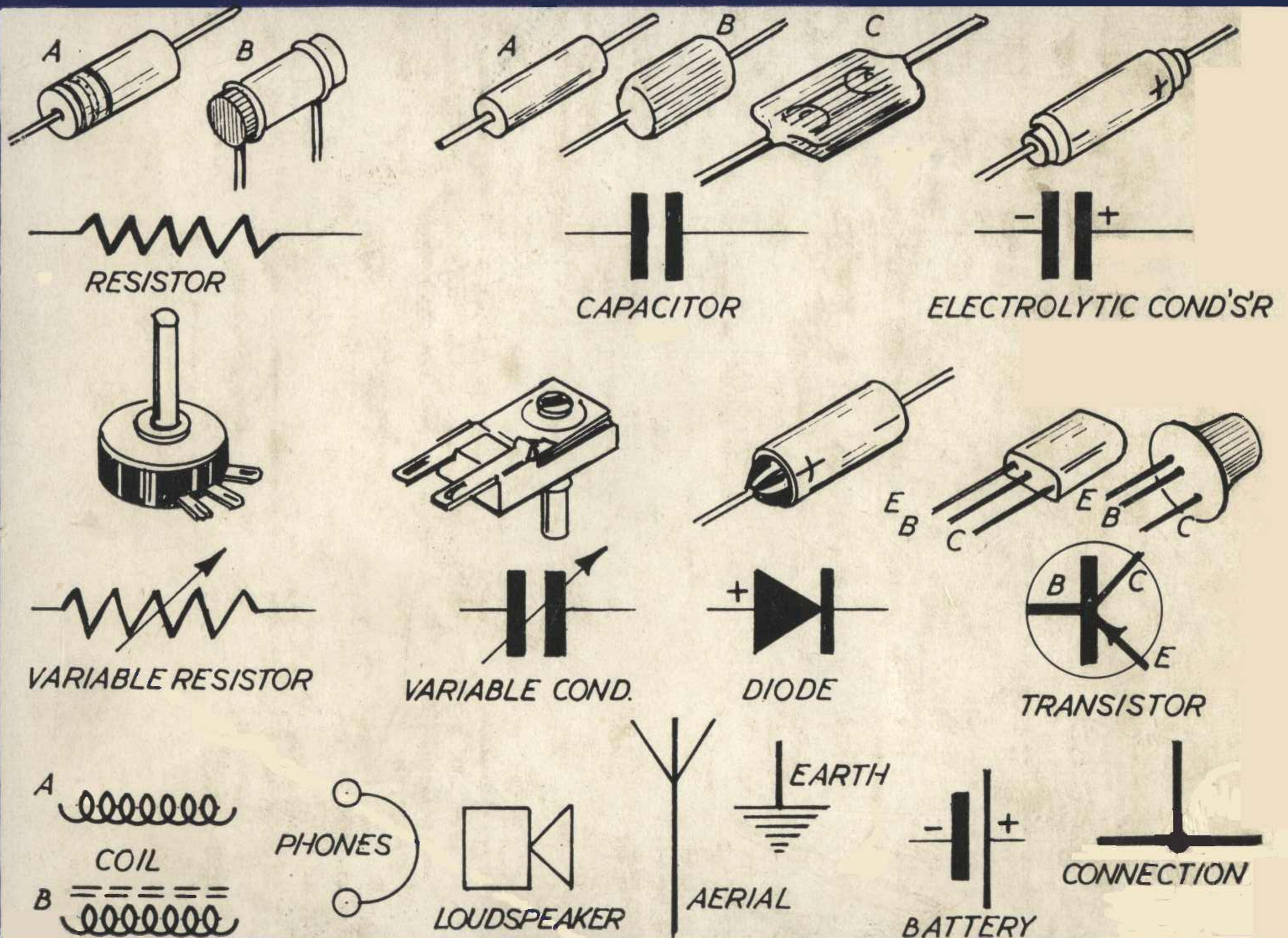

A practical step-by-step guide to the building of  
Transistor sets

The introduction of transistors in place of valves has made it very much simpler for the amateur to construct radio receivers and has rendered complete miniaturization possible.

In this very practical book the author begins with the simplest type of set, such as can be built for a few shillings, with the minimum of knowledge of technical principles. He then gives other progressively more elaborate basic designs which can be developed as time and money permit. In each case numerous clear illustrations make the step-by-step instructions extremely easy to follow.

The practical work involved is well within the capabilities of the average beginner and the book is so planned that a knowledge of radio principles will develop as he proceeds.

In the Second Edition the coverage of receiver construction has been extended and printed circuits have been included. A chapter on sub-miniature receivers has also been added.

# INSTRUCTIONS TO RADIO CONSTRUCTORS

BY

R. H. WARRING

*SECOND EDITION*



LONDON  
MUSEUM PRESS LIMITED

First published in Great Britain by Museum Press Limited  
26 Old Brompton Road, London, S.W.7

1960  
Reprinted, 1962  
Second Edition 1966

© R. H. Waring, 1960, 1966

Printed in Great Britain by  
The Camelot Press Ltd., London and Southampton  
R. 3434

## PREFACE

With the preparation of this new edition the opportunity has been taken to extend the coverage of simple receiver construction. The original series of circuit designs have been left unaltered since these are well proven in performance. In line with modern techniques, however, it has been thought desirable to extend descriptions to cover printed circuit as well as conventional "wired up" assembly. Thus additional material has been included covering both the design and making of printed circuit panels, and also presenting component layout diagrams and printed circuit details for a range of the original series of sets.

Since transistor circuitry also lends itself to miniaturization—and a particular modern trend has been the development of very small all-transistor receivers—a new chapter has also been added on sub-miniature receivers. Virtually any of the standard circuit designs given can be produced in sub-miniature size by crowding of the components on a minimum-size printed circuit panel, this offering an interesting exercise in ingenuity to the individual builder. However, an additional receiver design has been added which was specially evolved as a sub-miniature type and is unique in its conception. This is a commercial design, produced in kit form, and I am grateful to the originators, Sinclair Radionics Ltd., for permission to include complete details of this outstanding receiver.

Logical further additions would have been an extension of coverage of transistor receiver design and construction to superbets. However, a companion volume is available dealing specifically with this subject—*The Design and Construction of Transistor Superhets* (Museum Press) which is recommended as a "follow-on" book. The only other addition to this present volume, therefore, is a further Appendix on receiver faults—their causes and cures, tackled in an elementary manner. Most faults on simple receiver circuits are of an elementary nature and do not need elaborate test equipment to locate and rectify.

Largely it is a matter of knowing what to look for in fault finding—and this is the sort of information included in the new Appendix X.

I feel that with these various additions the treatment of transistor receiver design and construction up to superhet types has been brought right up to date and considerably extends the scope of the practical work described.

1965

R. H. W.

## CONTENTS

Chap.		Page
	PREFACE . . . . .	3
	LIST OF DESIGNS . . . . .	7
I	INTRODUCTORY . . . . .	9
II	ABOUT RADIO AND RADIO RECEIVERS . . . . .	13
III	THE SIMPLEST TYPE OF RECEIVER . . . . .	28
IV	IMPROVING ON THE BASIC RECEIVER . . . . .	37
V	DEVELOPING A TRANSISTOR RECEIVER . . . . .	51
VI	FURTHER EXPERIMENTS AND CIRCUIT MODIFICATIONS . . . . .	65
VII	IMPROVED TRANSISTOR RECEIVER DESIGNS . . . . .	71
VIII	MORE ADVANCED CIRCUITS . . . . .	80
IX	SUB-MINIATURE RECEIVERS . . . . .	90
X	PRINTED CIRCUITS . . . . .	97
	APPENDIX I Broadcast Frequencies . . . . .	110
	APPENDIX II Use of Low Impedance Phones . . . . .	112
	APPENDIX III The Tuned Circuit . . . . .	115
	APPENDIX IV Grid Bias and Grid Leak . . . . .	119
	APPENDIX V Valve Data . . . . .	123
	APPENDIX VI Transistor Data . . . . .	126
	APPENDIX VII Mains Power Pack . . . . .	128
	APPENDIX VIII Volume Controls . . . . .	132
	APPENDIX IX Tone Control . . . . .	135
	APPENDIX X Receiver Faults . . . . .	137
	GLOSSARY-INDEX . . . . .	141

## LIST OF DESIGNS

The following designs are fully described as constructional projects with schematic and theoretical diagrams, etc.:

- Design no. 1. A basic receiver: Fig. 12—p. 29
- Design no. 2. Triode amplifier circuit: Fig. 18: p. 41
- Design no. 3. Basic receiver with transistor amplifier: Fig. 28—p. 55
- Design no. 4. Improved transistor circuit: Fig. 30—p. 58
- Design no. 5. Improved transistor circuit for weak signals: Fig. 31—p. 60
- Design no. 6a. Design no. 4 with additional amplification: Fig. 32—p. 61
- Design no. 6b. Design no. 5 with additional amplification: Figs. 33 and 34—p. 62
- Design no. 7. Transistor receiver with loudspeaker output: Fig. 35—p. 63
- Design no. 8. Transistor three-stage reflex receiver: Fig. 46—p. 74
- Design no. 9. Transistor four-stage reflex receiver: Fig. 47—p. 75
- Design no. 10. Sinclair Micro-6 sub-miniature reflex receiver

Printed circuit panel designs for:

- Design no. 3. Figs. 65 and 67—pp. 99 and 101
- Design no. 4. Figs. 70 and 71—p. 106
- Design no. 5. Figs. 72 and 73—p. 107
- Design no. 6. Figs. 74 and 75—p. 108
- Design no. 8. Figs. 76 and 77—p. 109

The following additional designs are described together with circuit diagrams, component values, etc.:

- Triode amplifier with no bias battery: Fig. 20—p. 42
- Power amplifier with triode valve: Fig. 21—p. 43

- Triode detector/amplifier: Fig. 23—p. 46  
 Anode bend detector: Fig. 24—p. 47  
 Mains receiver: Fig. 25—p. 49  
 Three transistor T.R.F. receiver: Fig. 53—p. 82  
 Simple regenerative receiver: Fig. 55—p. 85  
 Mains power pack: Fig. 66—p. 110

## CHAPTER I

## INTRODUCTORY

RADIO is far from being the highly complicated, technical subject most people imagine it to be—unless you make it so. The basic principles of radio are quite simple and straightforward and the construction and setting up of elementary receivers is well within the capabilities of anyone interested in the subject. It is no more difficult than model-making and, in fact, follows a similar process of working from a plan (either a schematic drawing or a circuit drawing, or both), although the materials and techniques are a little different.

Of course, like any other technical subject, there are rules to learn and principles to master. While it is quite possible, for instance, to build a simple radio receiver and get it to work successfully simply by following printed instructions and with no knowledge of radio principles at all, knowing something about radio principles themselves will enable you to get the best out of every set. Also a knowledge of "how it works" will be invaluable in looking for, and finding, faults which may have developed.

It is beyond the scope of this book to cover a complete course in radio principle and design. However, we can tackle the subject of simple circuits in a comprehensive manner, showing how they can be developed and improved from the simplest possible receiver circuit, providing both a course of practical instruction in basic radio engineering and an understanding of the working principles and design factors involved. Experience gained in this manner will be the best possible background for further study, should the reader wish to pursue the subject further.

The theoretical side is only touched upon briefly and simply, where necessary, in order to explain basic principles involved. At the same time descriptions of the working of the more complicated types of receivers are given in Chapter VIII to

complete our "background study". It is not intended that the circuits given in this chapter be used as a basis for practical work (although the complete circuits given are, in fact, true working circuits) unless the reader has acquired a fair measure of experience in amateur radio construction. An excellent way of pursuing this more advanced type of work, incidentally, is by building from kits of parts and instruction manuals put out by various firms, some of whom also offer alignment facilities with regard to the completed receiver.

As we have stressed, we are concerned with *simple* radio receivers and we are drawing on the latest in modern techniques in employing *transistors* in place of valves. There are a number of reasons in favour of this—apart from being right up to date. Transistors make for simpler circuits, and a much more compact arrangement of components. A complete receiver with a performance comparable with a three- or four-valve set can be built into a space not much larger than a cigarette packet and operate for long periods on a single, small and inexpensive battery. Transistors cut both complication and cost in receiver construction and operation—and their very small size is another attractive property—to a degree quite impossible with valve receivers.

However, to gain a proper understanding of basic principles it is also necessary to study simple valve circuits, particularly showing how the valve is used as an amplifier. For this reason Chapter IV deals entirely with valve circuits, building up stages of amplification around a basic diode detector and also explaining the working principles of the triode valve. Whether this chapter is used merely for study, or as a basis for additional practical work is up to the reader. If he is more concerned with getting "results" with a minimum of wiring troubles and avoiding the difficulties of drilling a metal chassis (a standard feature of nearly all valve receivers) to take the various components in a valve set, he can skip this chapter as far as practical work is concerned and go on to Chapter V.

In fact, from all the circuits described, a number have been picked out both as typical of what can be done and how a basic circuit can be developed with the minimum of expense and trouble in construction, etc. These are designated *design no. 1*, *design no. 2*, etc., and if followed through form a complete

practical course in basic radio, up to the production of a miniature battery receiver which should be readily capable of loudspeaker output in areas of reasonable signal strength.

These recommended circuits described in the following chapters (a total of nine in all are fully detailed), follow two distinct lines of approach. Starting with the elementary diode receiver, or "crystal set" as it is popularly known, this is developed by modification of circuitry and the addition of transistor stages, to the ultimate performance which can be expected from a receiver of this type. The basic simplicity of the "crystal set" is retained throughout, however, and so following through the various development stages described is an ideal introduction to the subject of radio receivers, all of which can be covered at a very moderate cost.

For further improvement in performance we must turn to a different type of basic circuit, which in the domestic receiver range usually means a tuned radio frequency (T.R.F.) circuit or a "superhet" (superheterodyne receiver). Both are considerably more complicated circuits, the superhet very much so.

With transistors, however, a performance very much the same as that of a T.R.F. receiver can be obtained by using what is known as a "reflex" circuit and this principle we have adopted as the basis of the second series of receivers described in this book. Once again we start with the simplest type of reflex circuit to give reasonable results and go on to develop the performance stage by stage.

With either series of sets, therefore, the constructor can start with the simplest possible layout—which also implies a minimum outlay for materials and components—and add further stages progressively as he wants, or can afford. Further details regarding specific design or operating details are given in the Appendix for convenience of reference, since these apply to nearly all the circuits. Data included here may be used as a basis for possible improvements of a given circuit, or open up fields for further experimentation. Either will add more to the store of knowledge already gleaned of radio principles and the more one tries and proves (or disproves) the merits of an additional feature not included on an original plan, the more the "mystery" of radio drops away and the more familiar and realistic the subject becomes. As far as possible components are



standardised throughout the designs and represent a minimum number of different types and values readily obtainable from any local radio supplies shop.

Apart from basic materials and components, no special equipment or special facilities are required to construct even the most elaborate of the receivers described, and all the work can be done on the kitchen table. A few tools are *essential*—such as an electric soldering iron, pliers and a drill—but again represent only a minimum outlay, if not already available.

This, in fact is inexpensive radio engineering, right up-to-date in that we are dealing with transistor receivers and are confined to the development of *simple* circuits, capable of giving satisfactory loudspeaker reception at a fraction of the cost of a commercial domestic receiver. If, as a result, you find that you have become an enthusiast, then there is plenty of information on more advanced types of receivers as a basis for further practical work.

If the reader is in doubt about the meaning of any technical term used in the text, there is a glossary at the end of the book starting on page 141.

## CHAPTER II

## ABOUT RADIO AND RADIO RECEIVERS

RADIO waves travel with the speed of light—186,000 miles per second—and may have *frequencies* ranging from about 15,000 cycles per second up to 1,000,000,000 cycles per second or more. The *frequency* is simply the number of complete waves generated by the source in one second. Fig. 1, for example,

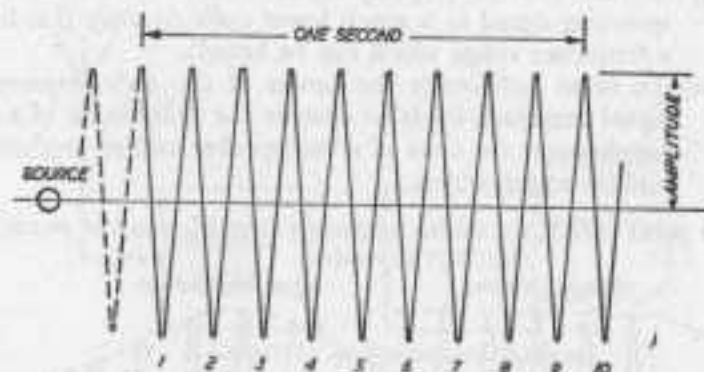

FIG. 1. DIAGRAM OF A SIMPLE WAVE FORMATION.

shows a wave of 10 cycles per second generated in a single direction. In the case of a radio wave the frequency is very much higher; also the waves are sent out in all directions from the source, a characteristic of all electro-magnetic radiation (unless "beamed" or constrained in a positive direction by suitable reflecting devices).

Sound waves are *pressure* waves, travelling through air or any other medium. The velocity of sound waves in air is about 1,100 feet per second (approximately 12.5 miles per minute). The frequency of a sound wave is determined by the pitch of the original note (or "sound") and varies from about 30 cycles per second (a very low, deep note), to around 16,000 cycles

per second, which is about the upper limit for audible notes put out by a radio loudspeaker.

There is thus a considerable difference in the frequency of radio waves compared with audible sound waves and also in the *characteristics* of the two types of waves, which means that we cannot receive and hear a radio wave directly. For example, a radio wave transmitted at a frequency within the audible frequency range would still not be heard by the human ear, which responds only to *pressure waves*.

Hence the job of a radio receiver is, basically:

- (i) To respond to a particular frequency of transmitted radio signal (i.e. to *tune in* specifically to this particular signal).
- (ii) To turn the *radio frequency* signal detected into a corresponding signal at a much lower *audio frequency* (i.e. in a frequency range which can be heard).
- (iii) To boost sufficiently the power of the *audio frequency* signal extracted for it to operate the diaphragm of an earphone or the cone of a loudspeaker and so produce audible sound waves.

In point of fact, the audio-frequency signal (speech or music)

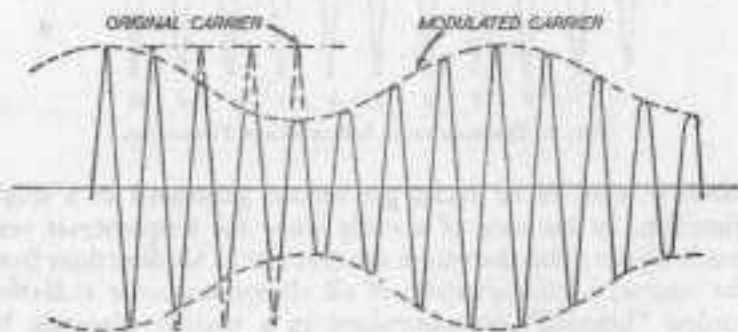

FIG. 2. THE EFFECT OF MODULATION.

originating at the microphone at the broadcast studio is made to vary the *amplitude*, or magnitude of the radio frequency power produced at the transmitter, giving what is called a *modulated radio frequency "carrier"*—Fig. 2. These modulated carriers are still at radio frequency and when they reach a

receiving aerial set up smaller voltages or currents of exactly the same pattern, but with a very much smaller amplitude, in the aerial. The power to set up this modulated radio frequency current in the aerial is extracted from the transmitted radio wave itself through the process of *induction* (the property whereby a current flowing in a wire introduces—or "induces"—a similar current flow in another coil next to it). It is possible to work the whole receiver from these induced currents—which is the principle of operation of any basic "crystal set"—but the power available is usually very, very weak, except in regions of strong signal strength (e.g. near a transmitting station).

Such a basic receiver consists of no more than an aerial, a tuned circuit, a detector and a pair of headphones—see Fig. 3.

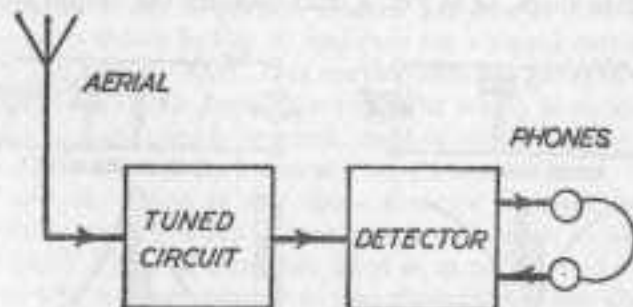

FIG. 3. LAYOUT OF AN ELEMENTARY RECEIVER.

The function of the aerial is obvious, from what we have just said. The purpose of the *tuned circuit* is to provide a means of adjusting the electrical characteristics of the aerial circuit so that it is in tune—or *in resonance*, as it is technically termed—with the frequency of the incoming signal we wish to pick up.

A tuned circuit consists, simply, of a coil and variable condenser connected together. By altering the effective electrical value of the condenser (i.e. by its adjustment) the resonant or "in tune" frequency of the tune circuit is altered. Hence by adjusting the condenser (i.e. operating the tuning control) we tune in by adjusting the resonant frequency of the tuned circuit to equal that of the broadcast signal we wish to receive.

There are two possible ways of connecting the coil and condensers, either in series (end-to-end) or in parallel (side-by-side), giving rise to two types of tuned circuits. With the coil and condenser connected in series, it is known as an *acceptor* or series resonant circuit; and with the coil and condenser connected in parallel (as in Fig. 3) a *rejector* or parallel resonant circuit. The latter type of tuned circuit is by far the most widely used.

At resonance, both circuits have exactly the same frequency for the same component values of coil inductance ( $L$ ) and capacity ( $C$ ) where

$$\text{resonant frequency} = \frac{1}{2\pi\sqrt{LC}}$$

We can best explain the difference between the two circuits by examining their behaviour when a radio frequency signal is fed into them, as in Fig. 4, and measure the output voltage

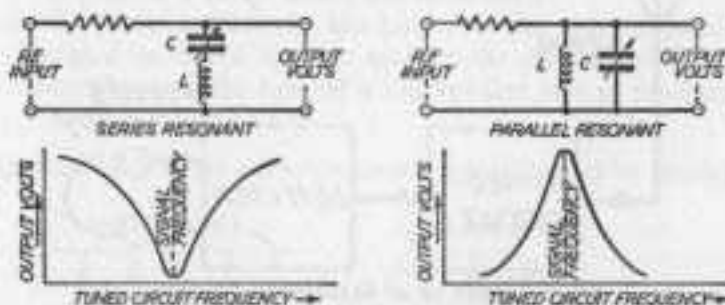

FIG. 4. TWO DIFFERENT TYPES OF TUNED CIRCUITS AND THEIR RESPONSE. The parallel resonant circuit is normally employed.

by some suitable device (e.g. a radio frequency valve voltmeter).

In the case of the series resonant or acceptor circuit the voltage across  $LC$  will fall to a minimum value as the tuned circuit is adjusted to the same frequency as the input signal (i.e. adjusted to resonant frequency). In the parallel resonant or rejector circuit, however, the voltage across  $LC$  will rise to a maximum when tuned to resonant frequency. In other words, the acceptor circuit selects by giving out *minimum* voltage at resonance and the rejector circuit selects by giving out *maximum* voltage at resonance.

Applied to a radio circuit this means a maximum voltage is

developed across the parallel resonant tuned circuit at the resonant frequency to be transmitted to the subsequent stages of the receiver. Other radio frequency signals, of a different frequency (i.e. not at the resonant frequency of the tuned circuit at that particular adjustment) are rejected in the sense that to all practical purposes they have no effect on the output voltage although, of course, they are actually present in the aerial. This also underlines the fact that it is *essential* to have an efficient tuned circuit coupled to the aerial, so that the receiver signal may be boosted (by tuning to resonance) to a level where use can be made of it in the next stage of the receiver.

The next stage is the detector, which is basically a rectifier (a rectifier is a device which only passes current in one direction; it cuts off one half of each cycle of alternating current, for example). The detector simply chops off one half of the modulated radio frequency current fed into it (i.e. like the wave form shown in Fig. 2) and puts out a signal current with a varying *average* value. This varying average value of current represents an *audio frequency* component which is an *exact copy* of the original speech or music used at the broadcast station to modulate the radio frequency wave.

The basic action of any diode detector (a diode is a germanium crystal which allows current to flow in only one direction) is that of a *rectifier*. That is, as we have just said, a device which allows current to pass through it in one direction, but will not allow current to flow in the other direction. In technical terms, the resistance to current flow in one direction is very low, whilst in the opposite direction it is very high; for all practical purposes so high that no reverse direction current will flow.

Used as a *detector* the purpose of the diode is to abstract the audio frequency *modulation* from the radio frequency *carrier* before passing on to the rest of the circuit, i.e. either direct to the headphones or to stages of amplification.

Suppose we consider first the case where an *unmodulated* radio frequency voltage (equivalent to a radio "carrier" wave) is applied to the diode (which can be either a diode valve or a germanium crystal diode—the action is the same). A resistor is included in the circuit—Fig. 5—to represent the *load*, i.e. the component to which the result of "detection" is to be applied,

which would be the headphones in the case of a simple circuit.

The current passing through the diode now consists of uni-directional flow, the bottom half of each cycle of applied R.F. (radio frequency) voltage being chopped off since the diode offers very high resistance to current flowing in this direction.

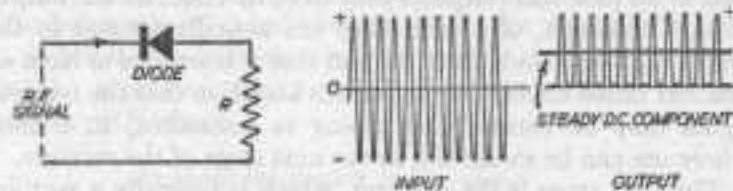

FIG. 5. DETECTION OF A STEADY R.F. SIGNAL.

This chopped-off flow can be considered as having two components—an alternating current about a new average centre line (although not a true A.C. sine wave since the bottom peaks are chopped off square); and a steady direct current component.

Now consider the effect of *modulating* the R.F. input, i.e. by varying its amplitude as in Fig. 6. Again one half of the signal

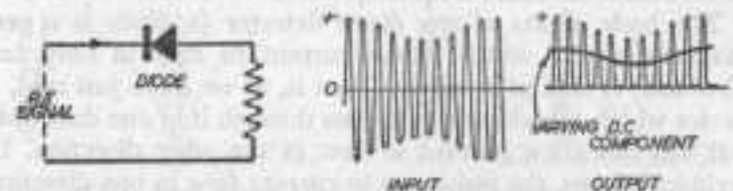

FIG. 6. DETECTION OF A MODULATED R.F. SIGNAL.

is chopped off by the diode but the instantaneous average or D.C. component value now varies with the height or amplitude of the modulated half waves. Hence the D.C. component is no longer steady but itself given a wave form which duplicates the pattern of the original modulation applied to the carrier. This forms the *audio* frequency component of the rectified (detected) signal, mixed with the chopped-off radio frequency signal. Strictly speaking, the final output through the diode, and thus flowing through the load resistance, now consists of three components:

- (i) a radio frequency component

- (ii) a direct current
- (iii) an audio frequency component, "modulating" this direct current in an identical pattern to that of the modulation applied to the radio frequency carrier signal at the transmitting station.

By feeding this audio frequency current directly into headphones we can use it to reproduce the original sounds, although the actual volume achieved must inevitably be quite low. If we want more volume we must *amplify* the audio frequency signal taken from the detector by one, or more, stages of amplification, as in Fig. 7. Depending on the degree of amplification achieved



FIG. 7. IMPROVING THE AUDIO FREQUENCY OUTPUT BY AMPLIFICATION.

(and any limitations of the preceding circuitry), the final audio frequency power is suitable for producing sound waves through phones, a balanced armature reproducer, or even a loudspeaker.

The performance of a simple receiver using a *crystal diode* for the detector is limited by the characteristics of the diode, which is worth explaining to understand why a crystal diode does not perform very satisfactorily on very small signals. If we draw a graph of the current passed by a crystal diode against voltage applied to the diode we get a curve like that shown in Fig. 8. On the positive (voltage) side the diode resistance decreases with increasing voltage so that the curve sweeps upwards. On the negative side the diode does actually still act as a conductor, but one with high resistance. Thus it will pass a little negative current, which means, in effect, that the alternating voltage is chopped off a little on the negative side below the zero line.

For a reasonably strong applied signal (i.e. reasonably large voltage applied to the diode) the diode is operated in the steeper part of its curve on the positive side, so that the mean value of

current flow, or D.C. average component assumes a reasonable positive value. If, on the other hand, the applied signal voltage is weak, the diode is operating on a relatively inefficient part of the positive side curve and the equivalent *negative* current value passed on the other half of the cycle may be almost as

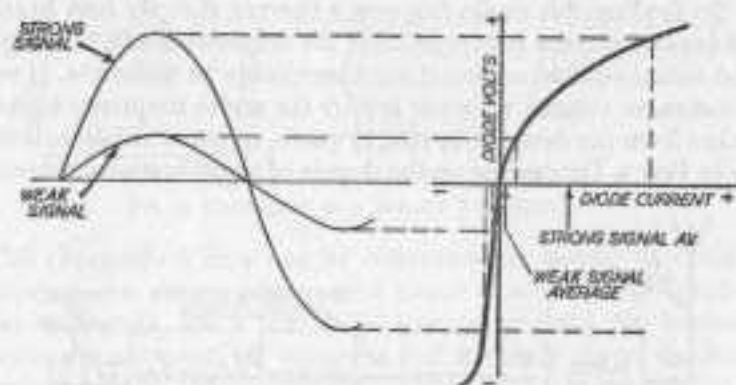

FIG. 8. LIMITATIONS OF THE CRYSTAL DIODE AT LOW SIGNAL STRENGTH.

large. Hence the value of the D.C. average component is very small. In other words, the rectified output of the crystal diode is low if the applied voltage is low, which is why a crystal diode does not work satisfactorily at very low signal levels. It means that every effort must be made to boost the signal level with a long aerial in areas remote from a transmitter in order to "work" the diode on a more favourable part of its characteristic curve.

In drawing and describing radio circuits, standard symbols are used to designate individual components—both for simplicity and convenience, and also because some components (e.g. resistors and capacitors) are often similar in outward appearance. Capital letters are used to specify individual components, for instance:

- R* for resistors (resistances)
- C* for capacitors (condensers)
- L* for coils (inductances)
- D* for diodes
- T* for transformers
- TR* for transistors
- V* for valves

Standard symbols used in drawing circuits are shown in Fig. 9, together with sketches showing the typical physical appearance of these components (although actual shape and size may vary).

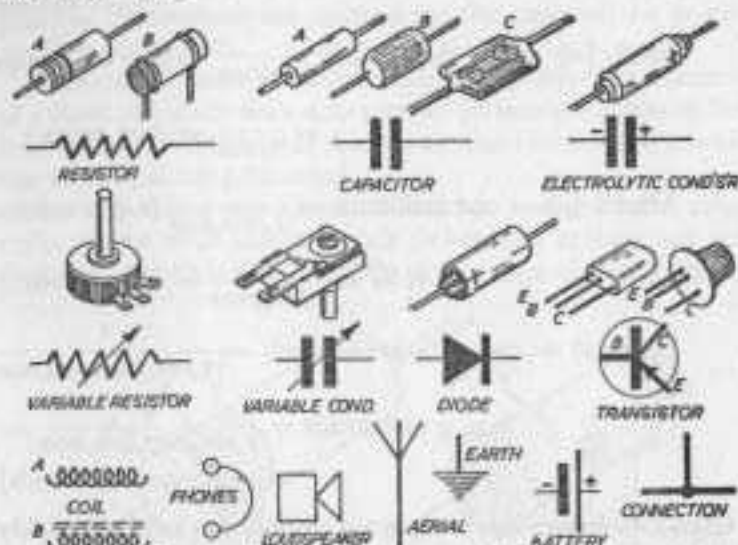

FIG. 9. TYPICAL RADIO COMPONENTS AND STANDARD SYMBOLS.

Resistors—type *A* is the more common, values marked by coloured rings.  
 Capacitors—Type *A* (paper covered) or *B* (wax coated) range in values from a few hundred picofarads up to a few microfarads. Type *C* (silver mica with wax coating) range from 1 picofarad up to 0.1 microfarad maximum. Electrolytic condensers (in metal cases) range in values from 1 microfarad up. All condenser values are marked on the body.  
 Transistors—all earlier forms have the configuration noted, the collector lead being separated from the other two. In the latest types the three leads emerge as from the corners of a triangle. The collector is then marked with a white or coloured spot near to it, with the base the nearest of the other two leads to the collector.  
 Coils—plain coils are designated as *A*, or with an iron core (or similar) as *B*.

Basic units employed are:

- Current*—measured in *Amps (I)*
- Potential difference (voltage)*—measured in *Volts (V or E)*
- Resistance*—measured in *Ohms (Ω)*
- Capacitance (capacity)*—measured in *Farads (F)*
- Inductance*—measured in *Henries (H)*

Quite often, in radio work, these basic units are inconveniently small, or large, and the prefixed Kilo-, Mega-, Milli-, Micro-, and Pico- are used in such cases, with the following meanings (appropriate symbols shown in brackets):

Mega (*M*) = one million = 1,000,000 (e.g. 1 megohm  
= 1,000,000 ohms)

Kilo- (*K*) = one thousand = 1,000 (e.g. 5.4 kilocycles  
= 5,400 cycles)

Milli- (*m*) = one thousandth =  $\frac{1}{1,000}$  (e.g. 2 milliamps  
=  $\frac{2}{1,000}$  = .002 amps.)

Micro- ( $\mu$ ) = one millionth =  $\frac{1}{1,000,000}$  (e.g. 2 micro-  
volts =  $\frac{2}{1,000,000}$  = .000002 volts)

Pico- (*p*) = one million-millionth =  $\frac{1}{1,000,000,000,000}$   
(e.g. 4 picofarads =  $\frac{4}{1,000,000,000,000}$  =  
.000000000004 farads)

Capacitor (condenser) values are usually marked on the body of the component (except variable capacitors, which are seldom marked with values). Fixed capacitors may be of the *mica type* (flat in shape, constructed of silver foil interleaved with thin mica sheets, the whole covered with a moulded and/or waxed casing); *paper type* (consisting of interleaved aluminium foil and waxed paper rolled into a tight cylinder, the whole then covered with paraffin wax to seal against moisture); or *ceramic type* (where a small ceramic tube is used as a dielectric and the inside and outside of the tube are coated to act as the plates of the condenser, the whole being lacquered to seal). Ceramic types are restricted to small values of capacitors.

For large values, *electrolytic capacitors* are used. This type uses an aluminium rod or foil plate in contact with borax in paste or liquid form, housed in a suitable container. The dielectric is formed by passing a direct current through the capacitor, after assembly, and takes the form of a very thin film of aluminium oxide deposited on the aluminium plate by electrochemical action. Because the dielectric formed in this fashion is so thin, very high values of capacitance are possible. The

type of construction does, however, limit the maximum working voltage and electrolytic capacitors can only be used where the current flowing through them can never change direction. They *must* be connected up the right way round (negative and positive connections are marked on the case, or the positive end is painted red).

Resistors are usually more simple in construction, consisting of a short rod made from a mixture of carbon and a binder fired in an oven. To the ends of this rod are fixed metal caps to which the two leads are connected.

Resistor values are almost invariably marked by a colour code, either with colour bands (when the colours are read from end towards the middle); or a coloured body, tip and

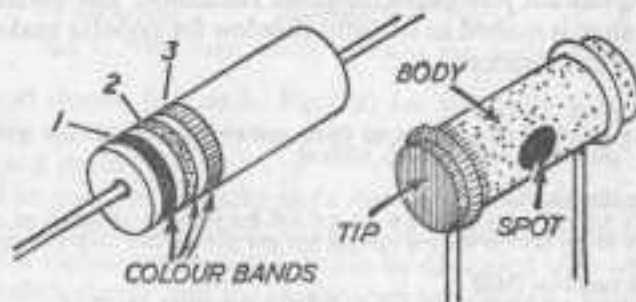

FIG. 10.

spot (read body, tip, spot)—see Fig. 10. The meaning of the colour code is the same in each case

Colour	1 gives first figure of resistance value	2 gives second figure of resistance value	3 gives number of noughts to put after first two figures
Black	0	0	none
Brown	1	1	0
Red	2	2	00
Orange	3	3	000
Yellow	4	4	0000
Green	5	5	00000
Blue	6	6	000000
Violet	7	7	0000000
Grey	8	8	00000000
White	9	9	000000000

Example: resistor colour code read as brown, blue, orange.  
brown blue orange  
value read as 1 6 000  
i.e. 16,000 ohms or 16 KΩ (kilohms)

Two other colours may also be found on resistors—silver or gold. These are not read as part of the colour code but merely show that the component is made to close tolerances. Normal manufacturing tolerance on resistors is plus or minus 20 per cent of its nominal value. A silver band specifies a closer tolerance of plus or minus 10 per cent; and a gold band a tolerance of plus or minus 5 per cent.

In practice, resistors are not made to what appear logical values, e.g. 50 ohms, 100 ohms, 200 ohms, 300 ohms, etc., etc., but to what are known as *preferred* values. These provide reasonably small intervals between adjacent values and are actually planned on a logarithmic scale. That is, the next value above or below a particular size represents an approximately constant *percentage* change in resistance. The preferred value range is quoted in its entirety below for popular makes of small carbon resistors.

Values in ohms

10 12 15 18 22 27 33 39 47 56 68 82 100 120 150 180 220 270 330 390  
470 560 680 820 1,000 (1 kilohm)

Values in kilohms (KΩ)

1 1.2 1.5 1.8 2.2 2.7 3.3 3.9 4.7 5.6 6.8 8.2 10 12 15 18 22 27 33 39 47  
56 68 82 100 120 150 180 220 270 330 390 470 560 680 820 1,000 (1 megohm)

Values in megohms (MΩ)

1 1.2 1.5 1.8 2.2 2.7 3.3 3.9 4.7 5.6 6.8 8.2 10 12 15 18 22

Armed with this information it is then a straightforward matter to translate circuit drawings and component specifications. As far as possible, too, all the working circuits described in the chapters which follow are laid out in the actual construction in a similar sense to the circuit drawings, although separate schematic drawings are given as a further guide. Whilst it is possible to work entirely from schematic drawings—and definitely easier for anyone with no previous experience of practical radio work—it is recommended that the habit be encouraged both of relating a schematic drawing to the appropriate circuit drawing, and eventually working mainly off a circuit drawing. Once familiar with the reading of a circuit drawing, for example, it is far easier to work from this to check a circuit than endeavouring to trace possible wrong connections from a schematic drawing.

As a typical example to illustrate the difference between

these two types of drawings, take the tuned circuit previously discussed. Fig. 11 depicts a tuned circuit both as a schematic drawing (right) and a circuit drawing (the latter using standard symbols). On a complete drawing, values (or specifications) for L, C<sub>1</sub> and C<sub>2</sub> would be given. Other stages added to the

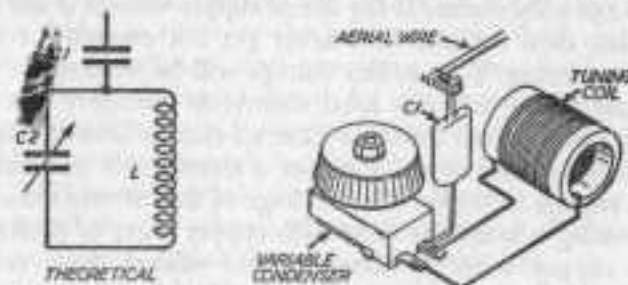

FIG. 11. THE TUNED CIRCUIT DRAWN IN TWO DIFFERENT WAYS.

tuned circuit (e.g. as in Fig. 12) are generally more easy to follow on the circuit drawing, particularly for checking the overall circuit.

The purpose of a schematic drawing, or a layout drawing, is to translate the circuit drawing in terms of physical layout of the various components. It can be dispensed with where the circuit is simple and the constructor has enough experience to appreciate how to lay out the various components in an orderly, efficient manner. On very much more complex circuits, the position of certain components may be quite critical and the layout may have to be planned for minimum wiring length, etc., which is rather another matter. With the sets we are concerned with here we can say that once the builder has learnt to work from a circuit drawing only he has established himself as having a good practical knowledge of basic radio engineering.

The other basic skill required is a certain dexterity in the use of a soldering iron and the ability to make strong, perfect soldered joints neatly and efficiently. Whilst an untidy receiver may work as well as one neatly constructed, untidy workmanship is often bad workmanship—and a poorly soldered connection may be a bad joint which will give trouble later on, or even prevent the set from working from the start.

Only an electric soldering iron is really suited to radio construction, preferably one of the smallest size with a pencil

bit. The two most important things about making a good soldered joint are a hot iron and a "tinned" and/or clean surfaces to be jointed.

First a word about the working temperature of the iron. Nearly all electric soldering irons are designed for operation on 230-250 volts mains. If the actual supply voltage is less than 220 volts, then the iron will never get hot enough for satisfactory soldering. Your mains voltage will be marked on your electricity meter, or your local electricity authority can give you this information. You *must* have an electric iron to suit this voltage—or in an extreme case use a transformer to boost the supply voltage to the specified voltage of the electric iron.

All wiring is normally done with copper wire, or preferably tinned copper wire. A tinned surface solders more readily than bare copper. In the case of insulated wire, the bare copper end exposed by stripping off the insulation can be tinned by laying on the point of a hot iron and then touching with solder. Clean, bare copper will always tin readily by this method. If the surface is greasy or dirty, the solder will not "run" properly, nor stick to the wire. Enamel insulation on wires must, of course, be scraped off before attempting to solder.

Even a tinned surface will not solder properly if it is dirty or greasy; you should particularly watch tags on condensers, leads on resistors or capacitors which have become dirty or greasy through handling. Cleaning of these surfaces can easily be done by scraping lightly, or rubbing with fine emery paper.

*Under no circumstances should an acid-type flux be used for electrical soldering.* In fact, no flux at all should be required other than that already contained in standard resin-cored solder supplied as a standard material for radio work. A clean iron, hot enough to melt the solder at a touch, clean surfaces to be jointed, and resin-cored solder should cope with all requirements.

It will usually pay anyone not experienced in soldering to practise joining spare pieces of wire and odds and ends until proficient at making a neat, strong joint efficiently and quickly. Components may be damaged by long application of heat near them when completing a joint. The correct technique is to apply the tip of the iron under the parts to be jointed, and the solder to the opposite side. In a matter of a second or so the joint area should have heated up enough for the solder to run,

when the iron can be removed to allow the solder to cool off immediately and complete a good joint.

In certain cases it may be necessary to use one hand to hold a component or wire in position whilst soldering when a blob of solder may have to be run on to the tip of the iron and carried to the joint—leaving the iron in place just long enough for the solder to run over the joint properly. Both techniques are worth practising—and practising again—until you are thoroughly proficient at them. An old terminal strip, which you can purchase for a few pence, makes a good practice piece—soldering wires to each tag, in turn, and then testing each joint. With a really good joint you should never be able to pull the wire off the tag—the wire itself should break off if you work it up and down, rather than the solder joint fail.

Your basic tool kit should also include a small pair of side-cutting pliers (used for cutting wire and also for stripping insulation); a small pair of pointed nose pliers; a small screw-driver; and a small hand drill with a selection of twist drills (used for drilling chassis plates, etc.). For cutting Paxolin sheet to size for chassis plates, a Junior-size hacksaw will also be most useful.

Components required for the construction of the individual sets are fully listed in the captions with each design. A certain amount of stock material will accumulate, such as tinned copper wire for wiring up, sleeving for insulation purposes, small screws, nuts and bolts, solder tags, etc.; or you can buy rather more of these than originally required as they will always come in useful for future work. Most of the other materials which may be required from time to time can usually be found about the house.



## THE SIMPLEST TYPE OF RECEIVER

The simplest type of receiver consists only of a tuned circuit and detector, feeding audio frequency power into a pair of headphones as explained in Chapter II. It operates entirely on the power of the transmitted radio signals picked up by the aerial, so requires no battery to operate it.

Since the aerial signal strength, even when the tuned circuit is in resonance, is probably only of the order of a few millivolts (one millivolt = one thousandth of a volt), there is obviously very little power to play with and so the performance of an elementary receiver of this type is seldom very good. Nevertheless, by employing an efficient tuned circuit and a proper selection of components it can give quite satisfactory headphone reception and pick up quite a number of different stations. Much will depend upon locality, i.e. how far the receiver is from a particular transmitter. The nearer the better, obviously, for maximum signal strength.

In some areas reception may be very poor indeed, to the point of being inaudible tuned to any broadcast station. In fact there are many areas in the British Isles where no basic set of this simple nature will pick up any station at good listening strength. There is nothing that can be done about this; it is just unfortunate. However the cost involved in the construction of a basic receiver is relatively small and so the loss involved in such cases is not very great in terms of cash. It should be emphasised, however, that the fact that a simple basic receiver does not appear to work does not necessarily mean that the area concerned is dead as far as signal strength is concerned. It may simply mean that more attention is necessary to getting a good aerial and earth rigged up. The limitations of the diode as a detector at low voltages has already been explained in Chapter I. Further, stations which would not otherwise be picked up even with a good aerial system may become audible

with a slight modification of the circuit (see design no. 5 described later).

The circuit diagram for the basic receiver (design no. 1) is shown in Fig. 12.  $L$  and  $C_1$  comprise the tuned circuit. The aerial is connected to a tapping point (2) on the coil through the

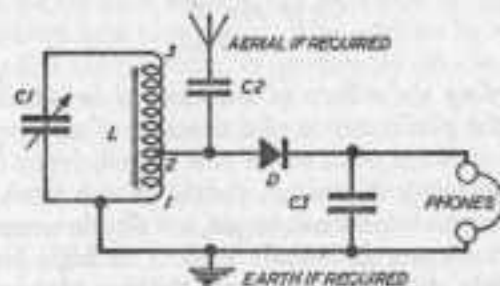

FIG. 12. DESIGN NO. 1—A BASIC RECEIVER.

- $C_1$ —500 pF mica compression trimmer, or equivalent  
 $C_2$ —220 pF  
 $C_3$ —001  $\mu$ F  
 $D$ —GEC GEX34 germanium crystal diode (or BTH CG IOE)  
 $L$ —50 turn wound coil on Ferroxcube B2 aerial rod (see Fig. 13 and text)  
 Note: high resistance phones must be used.

capacitor  $C_2$ . To the same point is connected a diode ( $D$ ) to act as a detector, passing audio frequency current on to the phones. The return circuit connects back to the tuned circuit, this being the earthed side of the receiver (physically connected to a suitable earthing point, if necessary, to improve the aerial efficiency).

Two other components are also included in the complete circuit—a capacitor ( $C_2$ ) in the aerial, and another capacitor ( $C_3$ ) across the phones. The function of the capacitor across the phones is to act as a filter or "by-pass" circuit for the high (radio) frequency current which passes through the diode. The capacitor thus integrates or averages the half cycle pulses of radio frequency energy. A small capacitor represents a conductive path for high frequencies, but blocks lower frequencies. Thus all the lower (audio) frequency current is directed through the phones.

The function of the capacitor in the aerial is less obvious—in fact it (or even the whole aerial) may not be necessary at all. It is often found, however, that capacitor-coupling of an external aerial in this manner improves reception on certain

stations by giving better selectivity or station separation, particularly in the medium wave band for which range the tuning circuit is usually designed (see Appendix I). The values of  $C_2$  and  $C_3$  are determined from experience and are, typically,

$$C_2 = 220 \text{ pF}$$

$$C_3 = .001 \text{ } \mu\text{F}$$

Disregarding the effects of the locality in which the set is operated, the performance of a receiver of this type depends on the effectiveness of its aerial and the efficiency of its tuned circuit. A majority of designs, purely on the score of keeping cost down to an absolute minimum, use simple wound coils and a tuning condenser inherently subject to high losses. For a matter of only another two or three shillings high-performance components can be used for both these vital components in the tuned circuit, with a consequent benefit to performance.

All this means, in fact, is avoiding the use of a variable condenser with a Paxolin or similar dielectric material and instead using a mica compression trimmer (or an air-spaced or ceramic type variable condenser of the required capacity); and the purchase of a ferrite rod on which the tuning coil is wound.

#### WINDING THE TUNING COIL (see also Appendix III)

The stages in making the tuning coils are detailed in Fig. 13.

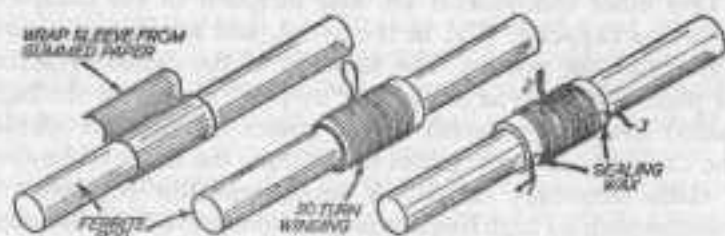

FIG. 13. WINDING THE TUNING COIL.

The first thing to do is make a paper sleeve from gumstrip to fit closely over the ferrite rod. Cut a one-inch length of gumstrip, moisten and wrap round the rod, as shown, with the gummed side *uppermost*. Now add about another half a dozen

wrappings of similar length of gumstrip over the first, this time with gummed side *down* to form a reasonably rigid tube. Make sure that the paper tube is a *sliding* fit on the ferrite rod and leave to dry thoroughly (preferably removed from the rod so that it cannot become stuck to it).

When the paper tube is quite dry it should be rigid, when the coil windings can be applied. The wire to be used is 38 s.w.g. enamelled copper wire, or preferably 38 s.w.g. double silk covered wire—the number 38 referring to the actual diameter size of the wire according to the standard wire gauge (s.w.g.).

Starting about  $\frac{1}{4}$  inch in from one end of the paper tube, wind the wire carefully round the tube with each turn tight against the one before it until 16 full turns have been completed. Then make a loop in the wire, as shown, and carry on winding, with succeeding turns touching, until 50 turns in all have been completed. The two loose ends of the coil (the start and finish) can be secured with a dab of sealing wax whilst the projecting loop can be twisted together (e.g. by putting a pencil through the loop and twisting up). Cut off the loop, leaving about  $\frac{1}{4}$  inch protruding from the main coil, bare the wire ends and solder together. This forms point 2 on the coil. The start is point 1, and the end point 3—the numbers referring to the circuit diagram. It will be easy to remember these without marking since the tapping point (2) comes much nearer one end (1) than the other (3).

This is the only component to be made. The remaining items are purchased to the specification given in the shopping list, leaving only the chassis unit to be assembled ready to take the components.

#### THE CHASSIS UNIT

Paxolin sheet is recommended for the chassis material, this being a rigid, tough material with good insulating properties. A number of other materials with insulating properties could be used, such as Perspex (more brittle and less easy to cut and drill than Paxolin), sheet plastic (usually subject to warping and not always with good insulating properties), or even ply, balsa or hardboard. But since our aim is to become competent radio engineers, let us stick to radio engineering materials.

The sheet Paxolin should be cut to the size given in Fig. 14. This is appreciably larger than that necessary to accommodate the components for the simple receiver, but is designed to take the further stages which may be added to improve performance (as described in later chapters).

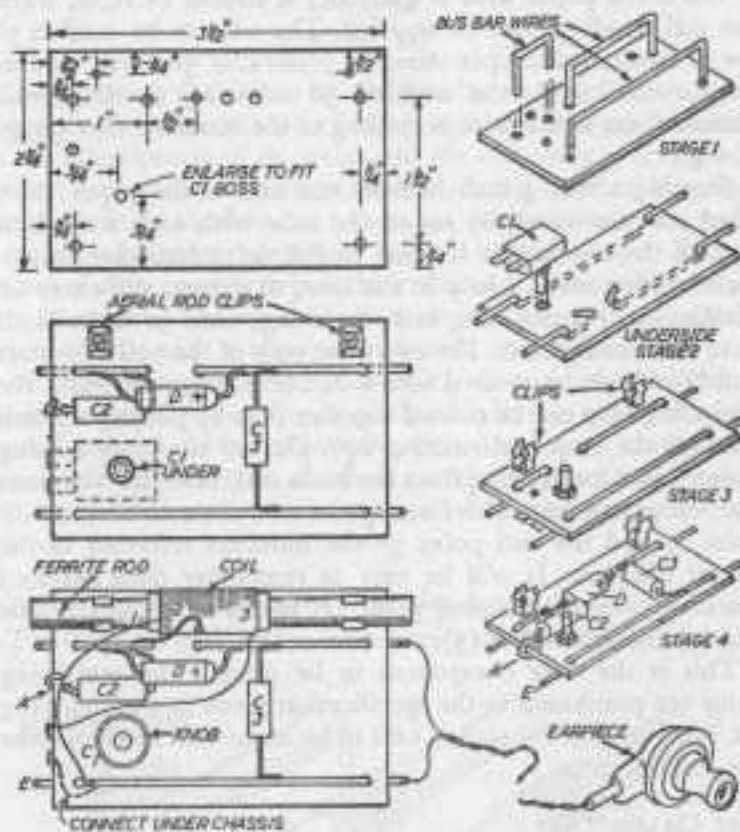
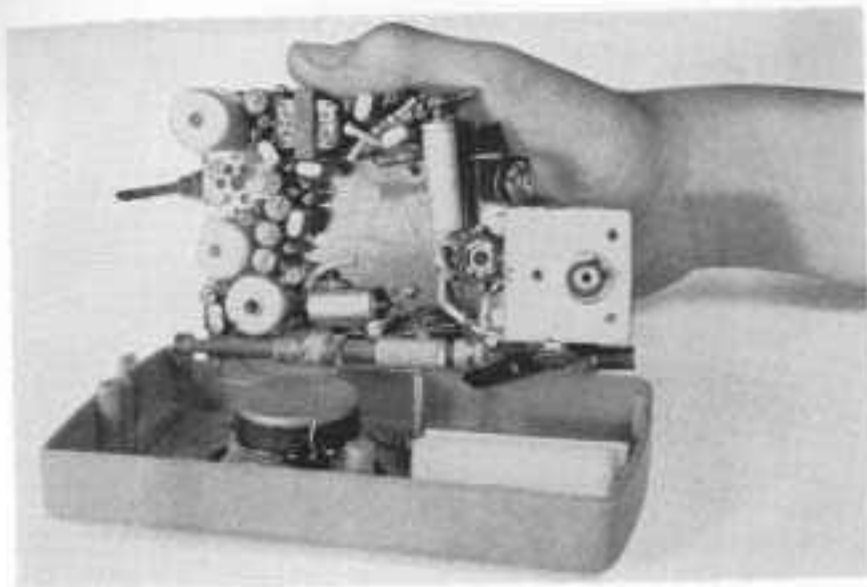

FIG. 14. ASSEMBLY STAGES IN CONSTRUCTING THE BASIC RECEIVER. The same chassis unit is retained for later designs.

Now mark the position of the holes detailed and drill these out using a 1/16 inch diameter drill. The basic chassis unit is then completed by bending and fitting the three 16 s.w.g. tinned copper wires which act as bus bars as shown in stages 1 and 2, and also the two spring clips to take the aerial rod (stage 3). The ends of the wires are simply bent at right angles



*Top:* This is a typical kit model superhet, suitable for amateur construction, although alignment of the finished receiver may be difficult. Note the size of the loudspeaker and plastic cabinet.

*Bottom:* Neat, tidy grouping of components is possible with miniature transistor receivers, but component spacing and wire lengths are not so important with simple designs. Typical components are identified by numbers: 1. Electrolytic capacitors; 2. Variable condenser; 3. Aerial coil; 4. Transistors; 5. Screened coils (used on superhet circuits); 6. Resistor; 7. Fixed capacitors; 8. Ferrite rod; 9. Paxolin chassis.

at each end, pushed through the holes in the base and then turned over to lock in place. The spring clips are anchored with self-tapping screws or small nuts and bolts.

#### MOUNTING THE COMPONENTS

Enlarge the hole for  $C_1$ , as necessary (e.g. by twisting a knife blade or the tang of a file around in the drilled hole) until the variable condenser ( $C_1$ ) will fit snugly, then secure by tightening up the nut on the top of the Paxolin panel.

The diode ( $D$ ) can then be soldered across the gap between the short and long lengths of bus bars on one side of the base, making sure that the end of the diode coloured red (or marked +) is joined to the long bus bar. It is important that the diode be connected the right way round in some later circuits.

Capacitor  $C_3$  is soldered across the two main bus bars, as shown in the diagram (stage 4). Cut the leads fairly short so that this component can be mounted neatly flat against the base plate, turning the ends at right angles to solder to the bus bars.

The wire lead on one end of capacitor  $C_2$  is bent down at right angles, pushed through the hole in the base near the end of the plate and turned over underneath to hold the component down firmly. The lead which comes out by the short bus bar is soldered to it. The other is cut off and bent around the edge of the chassis, as shown.

The aerial rod with its coil mounted on it can now be mounted by inserting in the spring clips. Coil lead 1 is taken across to solder to the long (negative) bus bar. Lead 3 is soldered to one side of the variable condenser ( $C_1$ ). Neither of these leads must be cut short. The other terminal of  $C_1$  is connected to the negative bus bar with a suitable length of tinned copper wire. Finally use a 2 inch length of the same wire as used for winding the aerial coil to connect point 2 on the coil to the short bus bar.

Other connecting points are then as indicated. The phones connect to the two bus bar ends on the right—marked  $P_1$  and  $P_2$ . An external aerial, if necessary, connects to point  $A$ . An external earth connection (again if necessary) connects to point  $E$ . Finally, fit the knob to the variable condenser spindle so that the condenser can be adjusted for tuning.

□

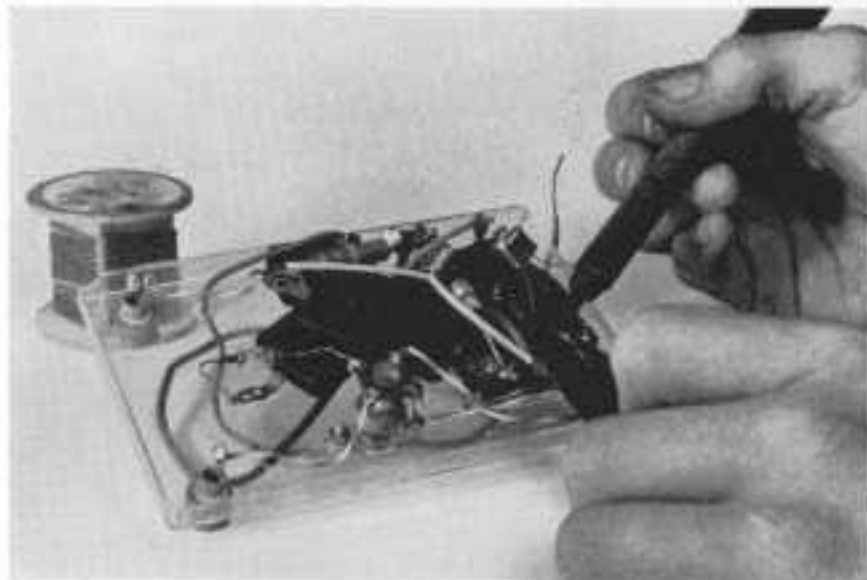
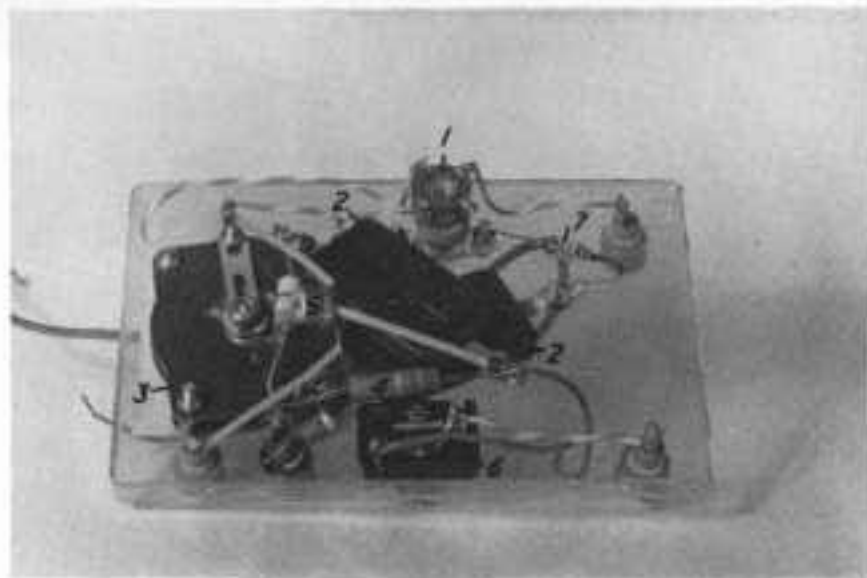

Top: Components for a simple two-transistor receiver are here mounted on a perspex chassis. 1. Aerial coil; 2. Fixed capacitor; 3. Tuning condenser; 4. Resistor; 5. Transistor (only one in position); 6. Switch; 7. Crystal diode.

Bottom: Soldering the second transistor in place to the receiver shown above. A pair of pliers is used to hold the transistor wire to act as a "heat sink" to prevent heat from the soldering iron damaging the transistor. It is advisable to unplug the soldering iron from the mains when actually soldering transistors.

In areas of strong signal strength, no external aerial or earth connections should be necessary. In other words, the set should work as it is, after adjusting. Performance will, however, be improved in any area by attaching an aerial wire, which can be any thin wire (e.g. using the same wire as for the coil winding again). An aerial length of up to 160 feet may prove advantageous—the longer the aerial (up to this figure) the better, provided it is led away from the receiver to as high a point as possible.

An earth connection may further improve aerial performance. By an earth connection we mean a connection to some conductor positively in contact with the ground (and preferably buried in the ground). A water pipe is an excellent earthed conductor. Thus if an earth connection is found to be necessary (or you want to try one to see how performance is affected), connect a wire from point *E* on the receiver to a convenient water pipe.

This question of getting a good aerial and earth is a most important one in areas of poor signal strength. As a general rule, increasing the aerial length improves its efficiency, but only if this length is used in the vertical direction—i.e. the aerial must be taken up to as high a point as possible. Linking up to a television aerial is often a good plan, since TV aerials are usually mounted as high as possible. If bare wire is used, it is also important that the upper (free) end of the aerial is not made fast to something which could produce an earth connection (e.g. a tree, which could be an earth connection, if damp); or at least is suitably insulated from such a support. String is not an efficient insulator. That, too, can conduct when wet.

Quite good results are often obtained by connecting to the springs of a bed as an aerial, in which case an earth connection is usually necessary. Sometimes, too, where other attempts have failed to yield a good signal strength in the aerial, connecting the aerial side of the tuning coil to a good earth (a water pipe) can produce better results, the normal earth connection being left off.

#### SETTING UP THE RECEIVER

Screw down the tuning condenser *C<sub>t</sub>* (or turn to fully close the vanes, as appropriate) and then back off about half a turn.

The tuning coil should now be slid up and down the ferrite rod (which is why the coil leads were left long to give the necessary freedom of movement) until the B.B.C. Third Programme is heard. (Check with the *Radio Times* or a daily paper that this programme is broadcasting at the time you are trying to tune into it, if you get no results!)

It may be necessary slightly to alter the adjustment of the variable condenser to tune in to this programme. Also, because of the ferrite rod aerial the set will be directional. That is, the signal strength received will depend to some extent on the direction in which the aerial rod is pointing, so turn the set to pick up maximum volume.

Having established the best position of the tuning coil on the rod to receive the Third Programme, fix the coil permanently to the rod with a dab of sealing wax. You should then find it possible to tune in to further stations by altering the setting of the variable condenser—e.g. typically the Home Service in about the middle of the condenser travel and the Light Programme towards the other end—see Appendix I.

If there is a complete lack of response, check for faulty wiring up. A more likely cause, however, is lack of an external aerial or earth connection in an area where these are strictly necessary for adequate reception; or an inefficient aerial (too short, or not high enough) or poor earth connection (bad electrical contact to a good earth point, or connection to a bad earth point).

Another possible cause of apparent failure may be too much outside noise entering the ear so that it is impossible to detect the very weak radio signal as it is being tuned in. Headphones are possibly better than a single deaf-aid type of earpiece in this respect, but in any case a really quiet room is virtually essential for initial setting up and tuning adjustments. Also if your adjustment of the tuning control is too coarse, you may miss the setting for the station you are looking for completely without realising it.

Reception will also tend to vary with weather conditions. Some days it may be good, at other times so poor that what was normally a strong station is hardly heard at all. The simple basic receiver has many limitations, but since it costs very little to construct and nothing at all to operate, these must be regarded as inevitable. You have succeeded, in fact, in mastering one of

the basic principles of radio in receiving any one station at all at a strength which is audible. You have learnt, in fact, to extract electro-magnetic (radio) energy out of the ether and turn it back into audible sound under a potential picked up in your aerial of the order of only a few thousandths of a volt. Having learnt how to capture that radio energy there are ways and means open to boost or amplify it to improve the performance of the receiver.

Meantime there are further experiments you can try even with this simple set, such as designing and winding different coils (see Appendix III); experimenting with different aerial lengths and positions (try attaching the aerial directly to point 2 on the tuning coil—i.e. to the short bus bar—instead of putting through the capacitor  $C_2$ ); disconnecting  $C_3$  to see if there is any detectable difference in reception; and so on.

## CHAPTER IV

## IMPROVING ON THE BASIC RECEIVER

IN the simple diode receiver described in Chapter III the voltages involved are very small indeed, so that it is possible only to receive the strongest local stations. To obtain a reasonable amount of audio frequency power it is necessary to increase the *amplitude* of the signals passing through the receiver, i.e. by adding an audio frequency amplifier stage. Actually there are two types of amplifier stages which may be involved—an audio frequency amplifier to increase the amplitude of the A.F. voltage; and an audio frequency *power amplifier* or *output* stage. These differ slightly in design, so we will discuss them both.

The basic amplifier used in radio circuits is the *triode* which consists, essentially, of three elements enclosed in an evacuated glass "bottle". The central electrode is a mesh-like structure called the *control grid*, or just the *grid*, interposed between the *cathode* and the *anode*. By applying voltages to the grid (actually a potential difference between the control grid and cathode), the flow of anode current (between anode and cathode, when the valve is acting as a conductor in the circuit) can be controlled or varied over a wide range. A comparatively small change in grid voltage can cause a big change in anode current.

Two types of triode are shown in Fig. 15. Both are the same

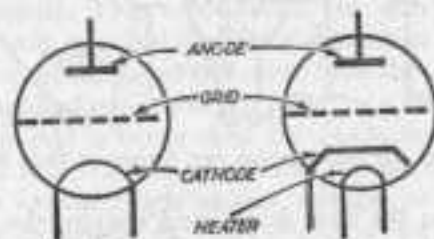

Fig. 15. TWO TYPES OF TRIODE VALVE (also see Appendix V for details of other valves operated as triodes).

in function but in one case the cathode is directly heated (connected to the low tension battery or voltage supply); and in the other it is indirectly heated by a separate element called the heater. Most mains-operated valves of modern type are indirectly heated, the chief advantage being that with the heater isolated from the rest of the circuit, alternating current can be applied for heating without causing hum which would otherwise be present if the cathode were directly heated by A.C. Directly heated valves are mostly used in battery receivers, where the voltage supply is D.C. and no question of mains hum arises. This also accounts for the fact that a battery receiver will operate almost immediately it is switched on whereas a mains receiver, with indirectly heated valve cathodes, requires a warming up period for the cathode to be raised to its operating temperature by the heat of the separate heater coil.

The action of a triode can be explained quite simply. In the case of a simple two-element valve (or diode) the valve becomes a one-way conducting element as far as electricity is concerned by the fact that the filament or cathode is heated up to give an emission of electrons. These freed electrons (being negatively charged) are attracted to the anode element, the flow of electrons in this direction being equivalent to a flow of electric current from anode to cathode (positive to negative) through the valve—(this is shown as dotted lines in Fig. 16). Thus,

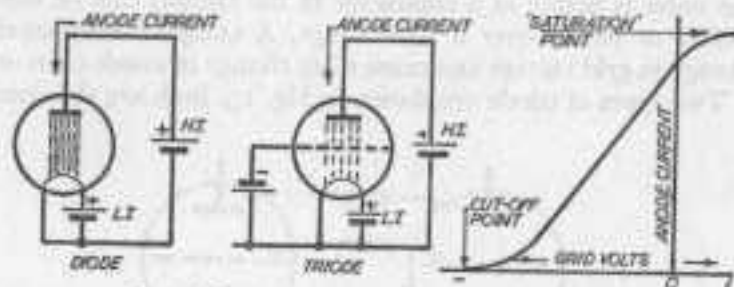

FIG. 16. ILLUSTRATING THE EFFECT OF GRID BIAS.

depending on the size, shape, and construction of the valve, for a given high tension voltage there will be a corresponding *anode current* flowing through this circuit.

The triode valve, connected in this manner, will have a

similar performance. The current flow will not be quite as high as for an otherwise identical valve construction, for the grid will offer a certain physical barrier to the flow of electrons and thus, effectively, give the valve a slightly higher internal resistance to current flow.

Now consider what happens when a *negative* potential is applied to the control grid. The grid being negative with respect to the cathode will *repel* electrons back towards the cathode, and the higher the grid (negative) potential, the greater this effect will be. If the grid (negative) voltage is small, most of the electrons will continue to pass through it to the cathode. But the more the grid (negative) potential is increased, the greater the number of electrons which will be held back.

Thus the *anode current* will vary directly with the amount of grid (negative) voltage—a small value of grid (negative) voltage giving a small reduction in anode current, and an increasing grid (negative) voltage a correspondingly decreasing anode current. If the grid (negative) voltage is increased up to a certain point *all* the electrons will be repelled and the anode current will drop to zero. The value of grid potential at which this occurs is known as the *cut-off point* for the valve.

This reduction in anode current with increasing grid (negative) voltage is shown in the graph, which is called a characteristic curve for the valve. It will, of course, vary for triodes of different design and construction, but is always a straight line (or very nearly so) over what is normally the working range of the valve. The effectiveness of the grid in controlling the anode current can be expressed by the *slope* of this straight line—e.g. in terms of milliamps anode current change per volt (grid negative potential). This value, with the standard unit of milliamps per volt, is called the *mutual conductance* of the valve.

A further important figure extracted from the characteristic curve is the *amplification factor* of the valve, or a measure of how many times the grid is better than the anode in changing the anode current. This is found by plotting a point or points at a different *anode voltage* (high tension voltage) and comparing the difference in anode current produced by this voltage change with the amount of grid voltage change required to give the *same* anode current change on the original curve. A figure of around 20 or 30 is quite common, i.e. the grid is

that number of times more effective than the anode in changing the anode current.

Yet another factor of significance is the *internal resistance or anode circuit resistance* of the valve—which is *not* the anode voltage divided by the anode current. It is computed as the *change in anode voltage divided by the change in anode current* which it produces. Internal resistance, amplification factor and mutual conductance are all related:

$$\text{Amplification factor} = \frac{\text{mutual conductance} \times \text{internal resistance}}{\text{resistance}}$$

Knowing any two of these factors, the other can easily be calculated.

Now to put the triode valve to work as an amplifier. First it is necessary to apply a negative *bias* voltage to the grid to ensure that whatever the variation in input voltage also fed to the grid the grid voltage always remains within the "straight line" operating part of the characteristic curve. Also it is essential to ensure that the grid voltage can never become *positive*, which might damage the valve through an excessively high anode current being developed. The grid bias voltage, in fact, just does what the term suggests—*biases* the valve to remain within its normal operating limits at all times.

A varying input signal superimposed on this bias voltage will now cause a corresponding variation in the actual grid voltage—see Fig. 17. This, in turn, will cause variations in the

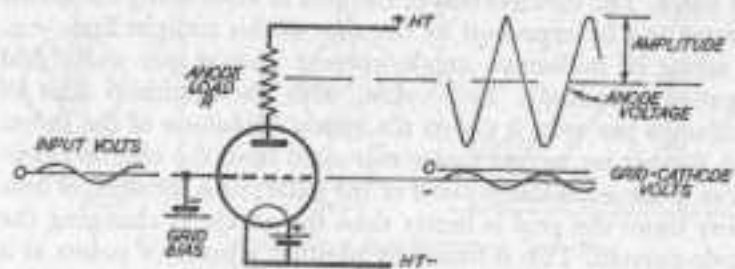

FIG. 17. THE TRIODE AS AN AMPLIFIER.

anode current flowing through the valve. This latter change also means that the anode *voltage* must vary accordingly and because of the amplification effect described above, the ultimate

change in anode voltage (or output voltage) will be a very much amplified version of the original alternating voltage applied to the grid. The actual degree of amplification achieved, i.e. the ratio of the output voltage amplitude to the input voltage amplitude is called the *gain* of the amplifier circuit. It will always be less than the amplification factor of the valve itself, but may approach this figure if the anode load resistance is high.

Fig. 18 shows a practical triode amplifier circuit (*design no. 2*)

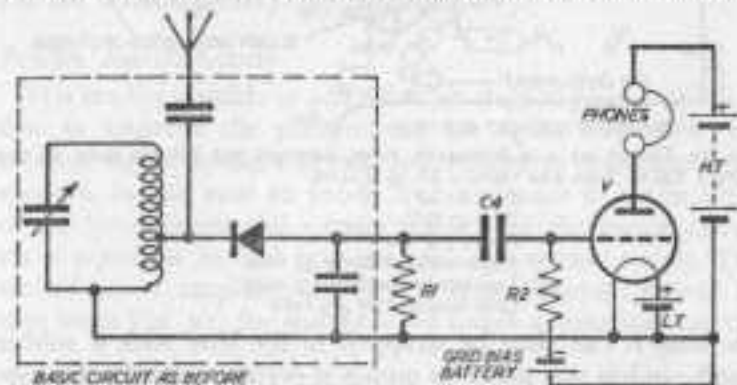

FIG. 18. DESIGN NO. 2. A PRACTICAL TRIODE AMPLIFIER CIRCUIT.

using a DLG1 (or equivalent) valve connected as a triode (see Appendix V), applied to the basic crystal diode receiver described in Chapter III. The resistor *R1* takes the place of the headphones on the original receiver to act as a suitable load for the detector stage, 2-2 megohms being a suitable value.

Negative bias is connected to the grid of the triode from a separate battery (the grid bias battery), connected up as shown. An interesting point here is that with the valve correctly biased the grid will never become positive with respect to the cathode and therefore no power is taken from the grid bias battery, hence it should have a very long life. The resistor *R2*, also connected to the grid of the valve, is termed the *grid leak*.

The capacitor *C4* provides the coupling between the detector output and the valve grid whilst the headphones are now used to form the anode load for the amplifier valve. That completes the circuit apart from the connections to the appropriate high tension grid bias and low tension batteries. (See Appendix V for appropriate battery voltages with types of valve used.)



All of these additional components can, in fact, be connected directly to the valve base, as shown in Fig. 19 (*design no. 2*), on the underside of the base plate. When the valve is mounted in

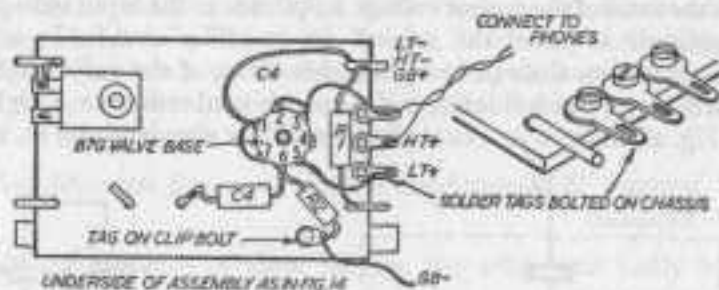

FIG. 19. DESIGN NO. 2 IN SCHEMATIC FORM, SHOWING THE WIRING MADE TO THE B7G VALVE BASE AND USING A DL60 VALVE.

$C_4$ —0.1  $\mu$ F.  
 $R_1$ —47 K $\Omega$   
 $R_2$ —1  $\mu$  $\Omega$   
 High-tension battery 45 volts  
 Low-tension battery 1.5 volts  
 Grid bias battery 4.5 volts

the base it can then be strapped to the base with a rubber band—unless you prefer to mount it permanently. In this case the base should be cut out to take the valve base and the base mounted on the plate.

A somewhat simpler circuit can be used with certain types of valves (e.g. W.17 or equivalent—see Appendix V). These valves have a very low anode current and may be operated satisfactorily *without* a separate grid bias voltage, thus dispensing with the need for an additional grid bias battery. The circuit then becomes as drawn in Fig. 20, the grid leak  $R_2$  being

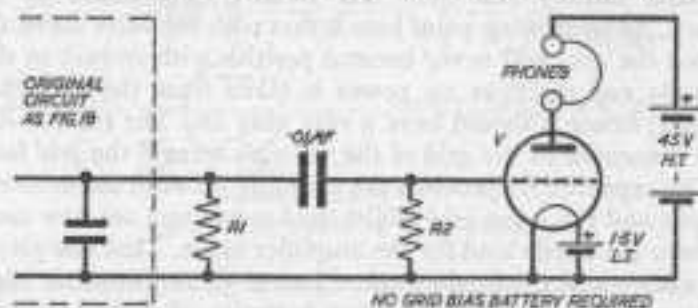

FIG. 20. TRIODE AMPLIFIER CIRCUIT USING NO GRID BIAS BATTERY, APPLICABLE TO CERTAIN TYPES OF VALVES.

retained, as before. It is instructive to try different values for  $R_2$  (say, ranging between 1,000 ohms and 1 megohm) to see which gives the greatest volume. The volume is, in fact, markedly affected by the value of  $R_2$  in a particular circuit and will generally tend to increase with an increasing value of  $R_2$ .

Yet another alternative method of applying negative bias to the grid of the valve in small battery receivers is to utilise the low tension battery (see Appendix IV).

#### POWER AMPLIFICATION

It is readily possible to add a further stage of *power* amplification to improve the performance yet again and boost the receiver signal strength to sufficient volume to operate a loudspeaker. In this case an anode load resistance is put in place of the headphones and output taken from the anode circuit via a capacitor to feed into the grid of a second triode. The second power amplifier circuit is a little different, as will be seen from Fig. 21, for this time we insert a *transformer* as the

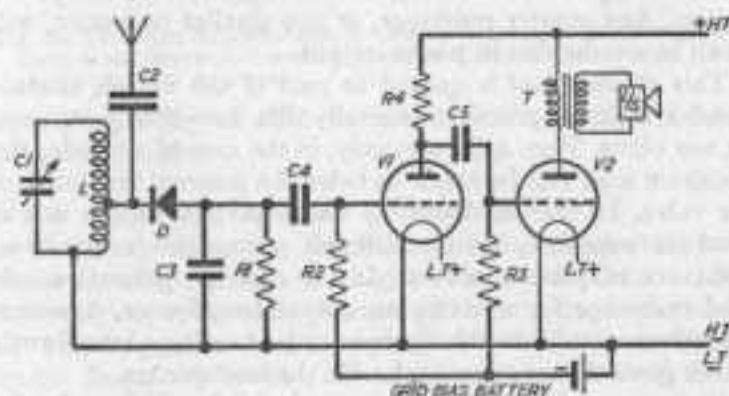

FIG. 21. EXTENSION OF THE CIRCUIT WITH POWER AMPLIFICATION.

anode load and operate the loudspeaker through this transformer. Thus the loudspeaker is not *directly* connected to the output circuit, but *inductively coupled* to it. Otherwise the amplifier circuit is the same as before, and the same possible variations apply (see Appendix IV).

The reason for using a transformer in the output stage of the

power amplifier is to provide the necessary high resistance load to achieve the maximum power gain. The headphones used in previous circuits have, necessarily, been of the high impedance (high resistance to alternating currents) type. Low impedance headphones, or a low impedance deaf-aid earpiece in these circuits, would have to be coupled in with a transformer to get any results at all (see Appendix II).

All modern loudspeakers of the moving coil type are low impedance, their actual effective resistance being of the order of only a few ohms (whereas the impedance of the headphones specified is usually about 10,000 ohms). Thus it is not possible to connect a loudspeaker directly in anode circuits since such a small impedance would give negligible output power—quite insufficient to drive the speaker to convert electrical energy into sound waves.

The use of a transformer sorts this out by matching the impedance of the speaker to the *required* anode load resistance for maximum performance. An important point arises here in that there is an *optimum* value for the anode load (depending upon the type of valve used), which will give *maximum* power output. Any greater resistance, or any smaller resistance, will result in a reduction in power output.

This *optimum load* is quoted as part of the valve's characteristics and in practice generally lies between 3,000 and 10,000 ohms. Very approximately, in the case of a triode, the optimum load can be taken as twice the internal resistance of the valve. In case of doubt, or where performance is not as good as expected, trying different values for anode load resistance may be a solution. In the case of optimum anode load resistance for selecting an output transformer, however, it is necessary to know this figure in order to select a transformer which gives the correct match with the loudspeaker.

If, for example, the optimum anode load resistance for the valve used was specified as 5,000 ohms and the impedance of the loudspeaker was 3 ohms, the required transformer ratio can be calculated as the *square root* of the ratio of the resistances, i.e.

$$\text{Turns ratio} = \sqrt{\frac{5000}{3}} = 40.8:1$$

In other words, in this case, the correct matching is provided by a transformer with a 41:1 step-down ratio.

#### USE OF DIODE VALVE IN PLACE OF DIODE CRYSTAL

All of the circuit designs above apply equally to the use of a diode *valve* as a detector in the basic circuit, instead of the germanium crystal diode specified in Chapter II. The diode valve is connected into the circuit in exactly the same manner,

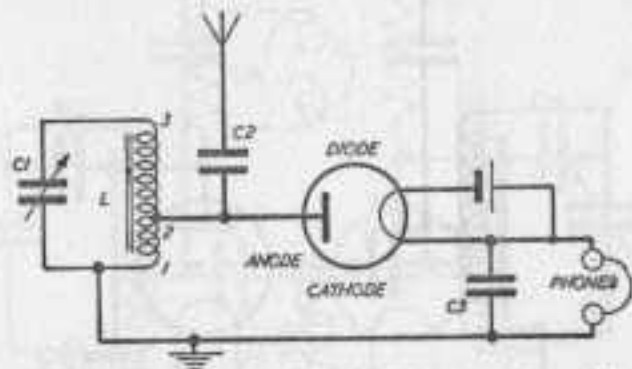

FIG. 22. THE BASIC RECEIVER DESIGN, USING A THERMIONIC DIODE VALVE—AN UNECONOMIC SOLUTION COMPARED WITH THE CRYSTAL DIODE, SINCE A LOW-TENSION BATTERY IS NEEDED.

as shown in Fig. 22. This cannot, however, be regarded as a practical circuit.

#### USING A TRIODE VALVE AS A DETECTOR

The triode valve can also be used in the *detector* stage of a receiver, with certain advantages over a *diode* detector. The triode detector, for example, as well as detecting or rectifying the aerial signal received through the tuned circuit, *amplifies* the audio frequency output. Thus it may be of considerable advantage where the audio output of a diode is very small, perhaps too marginal for headphones to work at all satisfactorily. The triode detector, however, does tend to introduce distortion and the *greater* the input signal the greater the distortion produced. Indeed the triode *cannot* handle a very large signal input whereas the diode detector can accept signals of almost unlimited amplitude without distortion of the audio frequency signal passed by it.

There are two basic ways in which the triode can be used as a detector. In the circuit shown in Fig. 23 the triode is effectively coupled to act both as a diode detector and a triode amplifier—i.e. the single valve performs both functions. No standing bias is provided so that in the absence of a signal grid

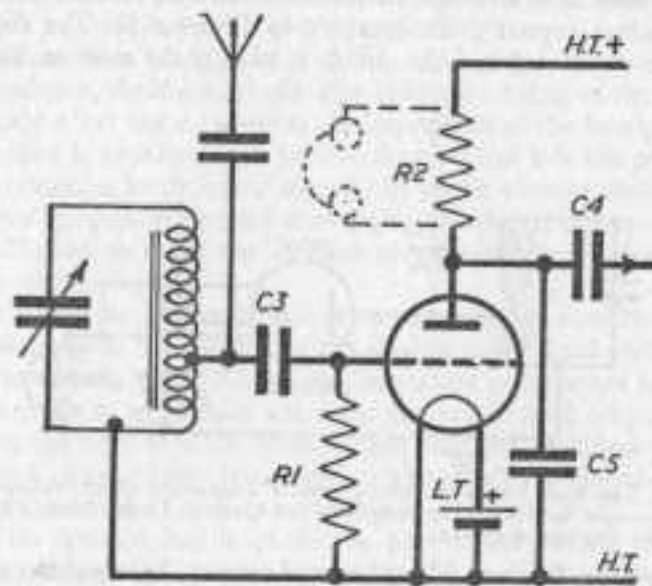

FIG. 23. THE TRIODE COUPLED TO ACT AS BOTH DETECTOR AND AMPLIFIER.

and cathode are at the same potential. The grid and cathode behave as a diode in the detector circuit, the grid acting like a diode anode.

When a signal current flows through this detector circuit the D.C. component flowing through the resistor  $R_1$  tends to bias the grid negatively, technically known as "self-bias" since the signal itself is responsible for the production of bias. The audio frequency (A.F.) and radio frequency (R.F.) components of the signal are applied between the grid and cathode, thus working the valve as a triode. Both the A.F. and R.F. components would be amplified and passed on to the output stage but for the presence of the capacitor  $C_5$ . This is chosen of a suitable value to provide a low reactance to R.F., but a high reactance to A.F. Hence it acts as a short-circuiting path across the output

of the triode as far as unwanted R.F. signals are concerned, but a high resistance path to wanted A.F. signal, which is thus passed on to the next stage.  $C_4$  is a coupling condenser for connection to a further stage. Alternatively phones may be inserted in place of  $R_2$ .

The other type of triode detector circuit—Fig. 24—employs

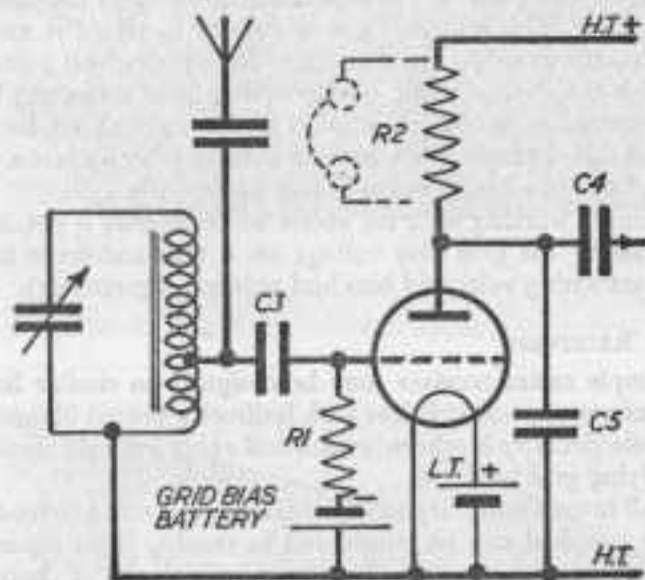

FIG. 24. THE TRIODE ANODE BIAS DETECTOR CIRCUIT.

a fixed bias which is selected to be of just the right value to cut off the anode current when no input signal is present. When the input signal is applied, positive half cycles cause an anode current to flow but negative half cycles are cut off, since the application of further negative to the grid drives the triode even further below the cut-off point. Thus the output A.F. is essentially similar to that passed by a diode, but with greater amplitude due to the amplification characteristic of the triode. As with the first circuit, however, it is again necessary to use a by-pass condenser  $C_5$  to short-circuit the unwanted audio frequency signal so that it cannot pass into the next stage. Performance is slightly better than the first circuit, although distortion may be quite pronounced with very weak signals.

This second circuit is technically known as an *anode bend detector*.

The discerning reader will have spotted that this circuit is identical with the circuit for a triode valve used as an *audio amplifier*. The only difference, in fact, is in the value of the bias used which pulls the triode down to operate about its cut-off point (above and below) when used as a detector, instead of around the mid-point of the characteristic curve in the case of an amplifier. This will also give a clue as to why the anode bend detector is subject to distortion. Near the cut-off point of the valve the characteristic curve departs from a straight line and becomes quite curved so that anode current no longer varies in direct proportion with grid voltage (check against the typical form of a triode curve shown in Fig. 16).

Optimum working with the anode bend detector is obtained by adjusting the grid bias voltage on a trial-and-error basis (e.g. start with 9 volts grid bias and reduce progressively).

#### MAINS RECEIVERS

A simple mains receiver may be designed on similar lines, using, of course, mains valves with indirectly heated filaments. The basic circuitry is otherwise identical apart from the method of applying grid bias.

To all intents and purposes the high tension and low tension voltage supplied can be considered as coming from separate points (equivalent to the battery terminals on a battery receiver). The power supply circuit, in other words, is quite independent of the remainder of the circuit, apart from connection to these output points, although it in itself is usually a valve circuit, using a diode as a rectifier (actually two diodes, or in practice a "double-diode" in a single envelope, to achieve full wave rectification of A.C.) Details of typical power circuit design are given in Appendix VII.

The most common method of applying bias to the valves is by what is termed the *cathode bias* method, which can be followed from the circuit shown in Fig. 25. Each of the triodes has a resistor ( $R_7$  and  $R_6$ ) inserted between the cathode lead and earth (high tension negative side). This resistor carries the D.C. anode current flowing through the valve and thus will have a direct potential difference developed across it. The *polarity* of this D.C. potential will be such as to make the

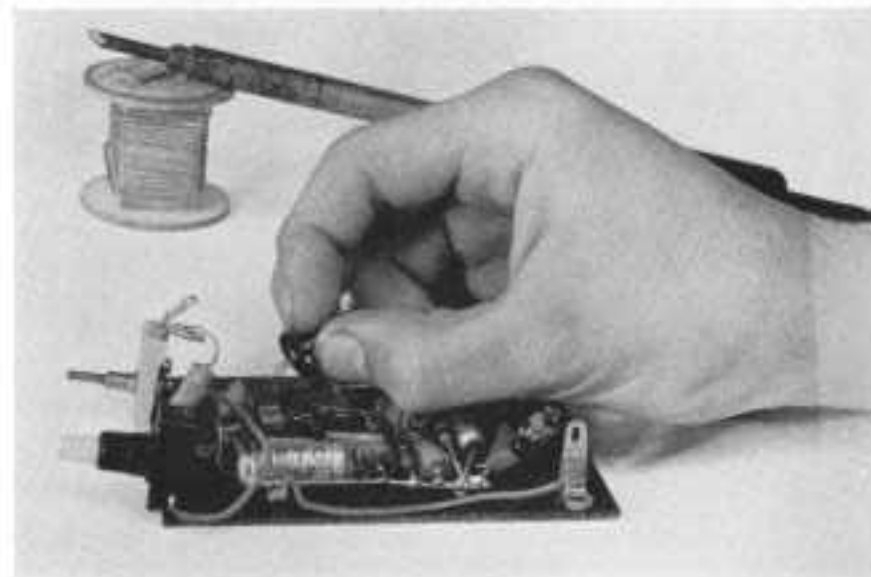
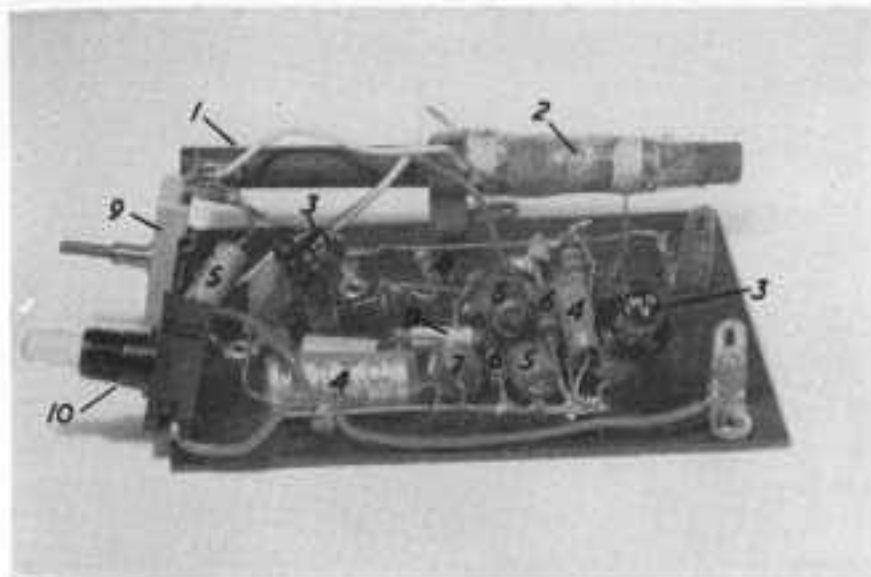

*Top:* Component assembly of a typical reflex circuit transistor receiver, mounted on a Paxolin chassis. 1, Ferrite rod; 2, Aerial rod; 3, Transistor; 4, Electrolytic capacitor; 5, Fixed capacitor; 6, Fixed resistor; 7, Choke coil; 8, Diode; 9, Tuning condenser; 10, Switch.

*Bottom:* It is recommended that transistors be plugged into a suitable base. The base only is then soldered to the circuit, eliminating any possibility of damage to the transistor when fitting. Be sure to plug the transistor in the right way round, however.

cathode a few volts *positive* with respect to earth. The grid of each valve, on the other hand, is returned directly to earth via the grid leak ( $R_3$ ,  $R_6$ ), thus making the grid *negative* with respect to the cathode (by the amount the cathode is *positive* with respect to earth).

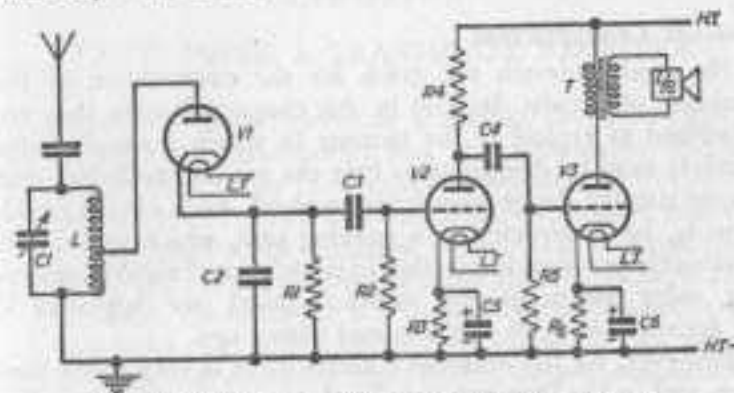

FIG. 25. APPLYING BIAS BY THE CATHODE BIAS METHOD.

The required value of this resistor ( $R_5$ ,  $R_5$ ) is very simply calculated by Ohm's law, which states that resistance = volts/amps. Knowing the D.C. anode current and the bias voltage required we can simply say:

$$\text{Resistance required} = \frac{\text{bias voltage required}}{\text{D.C. anode current}}$$

Thus, if the D.C. anode current is 1 milliamp and the bias voltage required 5 volts:

$$\text{Resistance required} = \frac{5}{.001} = 5,000 \text{ ohms}$$

To be sure that only the D.C. component of the anode current is used to produce the potential difference across the resistor, a by-pass circuit must be provided to provide an alternative path for any A.C. component. This takes the form of a condenser ( $C_5$ ,  $C_6$ ), connected as shown. This by-pass condenser is invariably of the electrolytic type, the value chosen so that the reactance (or resistance to A.C.) is very much lower than the resistance  $R_3$ ,  $R_6$  at the lowest frequency to be

D

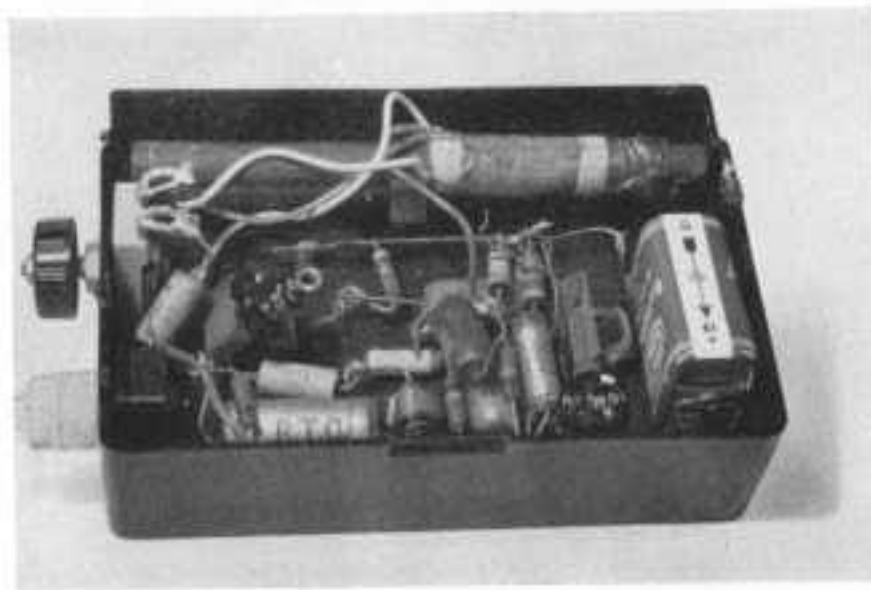
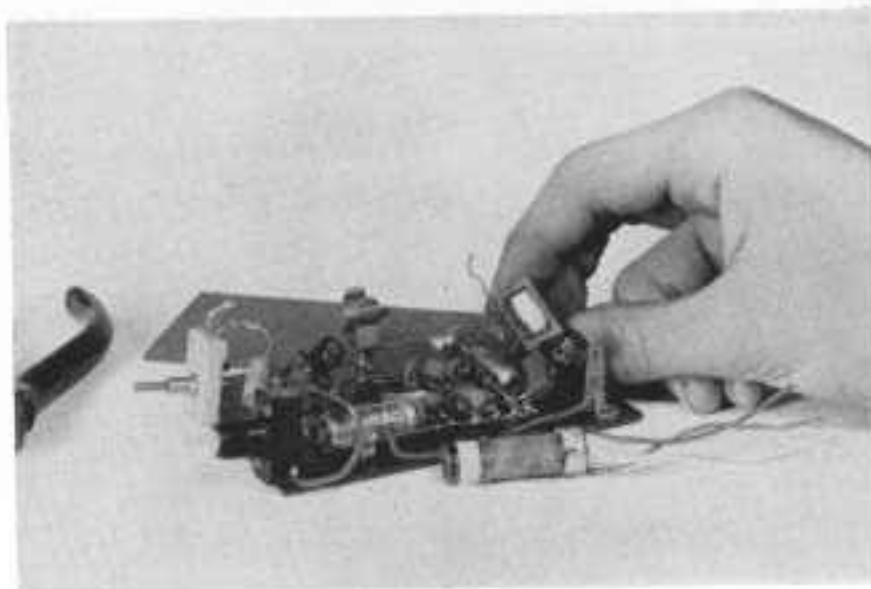

Top: Deal-aid earpiece is a better proposition than headphones for miniature receivers. Low impedance earpieces (or phones) must be coupled in with a suitable transformer (held in fingers in this photo).

Bottom: Compact assembly in this miniature transistor receiver, fitted in a moulded plastic case. Note the tiny size of the battery.

amplified. Since reactance decreases with increasing frequency, it will then provide increasing *smaller* resistance to the path of higher frequencies. A suitable value for  $C_5$  and  $C_6$  would be 25 microfarads which is, in fact, a common value for electrolytic condensers used as a by-pass in cathode bias circuits.

#### CIRCUIT CONSTRUCTION

No specific details are given for the construction of the majority of circuits detailed in this chapter. Rather they are described as typical of the manner in which a simple valve receiver may be developed so that the reader can follow and appreciate the design principles involved. Each circuit could, equally, be constructed as a working unit, which would give invaluable practical instruction in the science of radio engineering, using the component values specified (see Appendix V for appropriate valve selection and wiring up).

However, for the amateur constructor it is very much simpler, and in the long run usually cheaper, to pursue a similar line of development using *transistors* in place of valves. This method allows a complete receiver to be built down to quite diminutive proportions with a minimum of prefabrication of chassis components, etc. If not worked through as practical examples, however, the circuits in this chapter should be studied and their operation appreciated as a basis of understanding how a simple valve receiver works and the design considerations involved.

## CHAPTER V

### DEVELOPING A TRANSISTOR RECEIVER

THE transistor is an American invention, developed by the Bell Telephone Laboratories and first announced in 1948. Since that date it has been further developed and improved and has continued to find ever-increasing application both as a direct replacement for ordinary valves, and to supplement valve circuits, etc., in all types of radio and electronic work.

In essence, the transistor is a device capable of working like a triode valve, but with numerous advantages over a conventional valve. It is extremely small in size, ruggedly constructed, requires little power and no warming-up time and, if not abused, should have an indefinitely long life. With this, of course, come some disadvantages, such as limitations on performance in certain circuits, a tendency to vary its operating characteristics with temperature, and the fact that manufacture to a consistent performance is not always easy. Thus "any" transistor used in a particular circuit designed for transistor operation may not necessarily give the required results and it is important to bear in mind that there are different *types* of transistors as well as different *grades* (see Appendix VI).

It is not practical to discuss the theory of transistors here to any great length, since to understand their operation fully a knowledge of semi-conductor physics is necessary. As a generalisation, however, it can be stated that transistors are made from P-type or N-type germanium, or a combination of both and different methods of construction produce *point-contact* transistors, *junction* transistors and *diffused base* transistors, to name three typical forms. For the purpose of application to simple radio receiver circuits *junction* will meet our requirements.

The P- and N-type of germanium differ in the manner in which they conduct electricity. With P-type germanium conduction is effected by *positive* charges, and with N-type germanium by *negative* charges—hence the P and N designations.

*N*-type germanium is also known as a *donor* because it is in a state of readily giving out free electrons. *P*-type germanium is an *acceptor* because its atomic structure virtually contains a "hole" which is ready and willing to accept free electrons.

These different characteristics of the same (crystal) material—germanium—are the result of deliberately introduced impurities. Pure germanium, for example, is almost a non-conductor. The addition of impurity atoms in very minute quantities turns germanium into a semi-conductor. The addition of one impure atom for every 100 million germanium atoms increases the conductivity by 16 times. Germanium ceases to have semi-conductor properties and becomes more like an ordinary conductor if the impurity ratio is increased to one impurity atom per 10 million germanium atoms. Hence the degree of impurity must be carefully controlled for transistor application.

Since different impurities introduce different semi-conductor characteristics (e.g. *N*- and *P*-types) it is obviously also important that the original purity of the germanium should be high—actually of the order of less than one part of any impurity in 100 million. Were this not so the deliberate introduction of impurity to give certain desired properties might be cancelled by impurity of an opposite nature already present; or magnified out of the useful range by a similar impurity already present. Hence the production of the basic material for transistor construction is a most exacting process. Add to that the fact that the *construction* of the complete transistor is equally exacting and the reasons behind the relatively high price of such a tiny component, and the possibility of varying characteristics, are readily appreciated.

In the *point contact* transistor (Fig. 26) the pellet of germanium used is normally of the *N*-type, only about 1/20 inch thick and 1/50 inch long. The pellet is soldered to a suitable base, and in contact with the pellet are two tiny electrodes or "cat's whiskers" about 5/1,000 inch in diameter, pressing on the germanium with their points spaced about 1/500 inch apart. These electrodes comprise the *emitter* and *collector*, the third connection being made to the *base*. The whole is then enclosed in a suitable rugged case with three wires emerging from the bottom, always in the same characteristic positions. The wire

remote from the other two (i.e. with the biggest gap between it and the nearest wire) is always connected to the base. The wire at the opposite end connects to the collector and the inside wire nearer to the collector than the base connects to the emitter. This configuration of wires is retained on all point contact transistors.

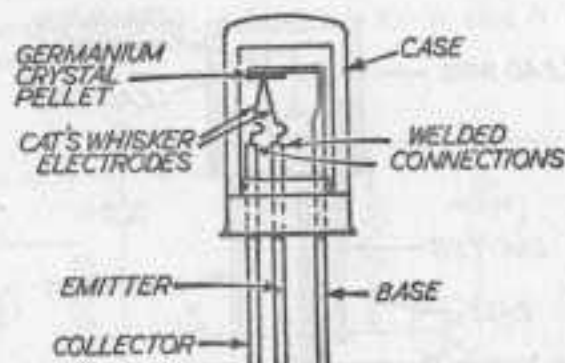

FIG. 26. A POINT-CONTACT TRANSISTOR (obsolete and now not used).

In the case of *junction* transistors the two basic types of germanium are combined in a sandwich construction. The combination of *N*-type and *P*-type germanium to form a *P-N* junction produces a germanium diode (the basis, in fact, of the construction of the germanium crystal diode used as a detector in the basic circuits of Chapter III). The combination of *two* such crystal diodes in a single unit, where obviously one half of each pair can be common to both, produces either a *N-P-N* or *P-N-P* junction transistor. The middle layer of the sandwich in each case is very thin, this being necessary for proper transistor operation.

The three leads are now led out in a different fashion—see Fig. 27. The isolated wire on one side now becomes the *collector* with the wire farthest away at the other end the *emitter*. The remaining wire (nearest the emitter) is connected to the base. This configuration applies to all junction type transistors.

It is also important to appreciate that although conduction is similar in the *P-N-P* and *N-P-N* junction transistors, the *polarity* of these two different types is *reversed*. They must be connected up the right way round, otherwise the transistor will

be ruined. Hence a *P-N-P* transistor cannot be plugged into a circuit wired to take a *N-P-N* transistor, or vice versa. In the circuits described later in this chapter a *P-N-P* junction transistor is specified throughout. The chief advantage of the junction transistor over the point-contact transistor is a very much

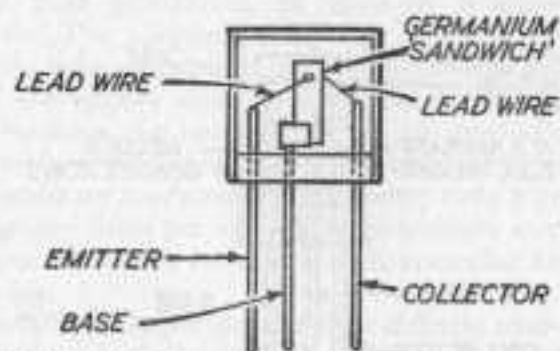

FIG. 27. THE JUNCTION TRANSISTOR. Note particularly the arrangement of the leads. A transistor must be connected up the right way round, otherwise it will be ruined.

greater voltage and power gain, which is the principal reason for the selection of this type. In fact, point contact transistors are not used at all in any modern circuits.

#### AMPLIFYING THE BASIC DIODE-DETECTOR

Using the basic receiver (*design no. 1*, described in Chapter II) with a crystal diode detector, the addition of a single stage of amplification with a *P-N-P* type junction transistor is very simple and straightforward. The circuit is shown in Fig. 28 (*design no. 3*), the amplification stage is simply added to basic receiver stage.

The *P-N-P* transistor acts as a *current amplifier* and this degree of amplification or current gain is referred to as the  $\beta$  of the transistor, which for an OC71 transistor has an average value of about 50. The *bias resistance*  $R_1$  is chosen accordingly to suit the desired *collector current* and battery voltage used. Almost any value between 1.5 and 20 volts could be used for the latter, a convenient battery size for optimum overall performance being 9 volts. A desired collector current of about .5 milliamps

to operate the headphones is about right, so by simple calculation:

$$R_1 = \beta \times \frac{\text{battery voltage}}{\text{collector current}} = 50 \times \frac{9}{.0005} \\ = 900,000 \text{ ohms}$$

The nearest preferred value\* for  $R_1$  is thus 1 megohm ( $1,000,000 \Omega$ ).

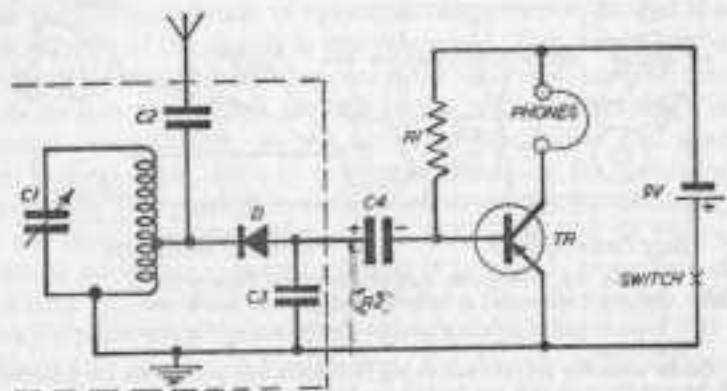

FIG. 28. DESIGN NO. 3—TRANSISTOR AMPLIFIER STAGE ADDED TO THE BASIC RECEIVER.

$C_1$ —5 $\mu$ F/15 volt electrolytic capacitor (T.C.C., Dubilier or Plissey recommended)

$R_1$ —1 megohm

$R_2$ —37 K $\Omega$  (should be connected in parallel with  $C_3$  for better results, like  $R_4$  in Fig. 30)

TR—Mullard OC71

Phones—high-impedance type (also see Appendix II)

Battery—9-volt dry battery

Whilst theoretically any *P-N-P* junction transistor will work in this circuit (adjusting the value of  $R_1$ , if necessary), it is strongly recommended that only the specified types be employed in order to be sure of getting the best results possible. Surplus transistors, although cheaper, are a relatively unknown item as regards performance. They may be perfectly satisfactory; satisfactory to a degree only; or unsatisfactory; and there is no way of telling into which category they fall without having first bought and tried them. Generally they have been rejected

\* See explanation of preferred values in Chapter II, p. 24.



by the manufacturers due to lack of performance in one respect or another.

The schematic diagram of the circuit just described is given in Fig. 29, with step-by-step assembly instructions appended. It is strongly recommended that the transistor connections be made to a transistor socket, into which the transistor can be plugged when all the wiring has been completed. Transistors

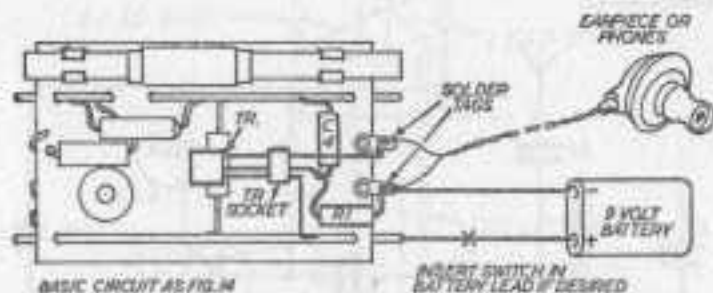

FIG. 29. SCHEMATIC ARRANGEMENT OF DESIGN NO. 3.  
Basic circuit is constructed as before. Then proceed as follows:

- (i) Drill holes in end of chassis plate and mount two solder tags with small nuts and bolts.
- (ii) Solder transistor socket leads to tag (collector) and bottom bus bar (emitter).
- (iii) Mount  $C_4$ , soldering one lead to top bus bar.
- (iv) Mount  $R_2$ , soldering one lead to second solder tag.
- (v) Join free leads of  $C_4$  and  $R_2$  and connect to transistor socket base lead. ( $R_2$ , if used, is mounted between the common connection of  $R_2$  and  $C_4$  and the top bus bar.)
- (vi) Connect phones to solder tags.
- (vii) Check circuit carefully.
- (viii) Fit transistor in socket holder.
- (ix) Attach battery and align set, as necessary.

can easily be ruined by excess heat applied to them, as may well be done in soldering leads directly to the transistor leads.

It is considered good practice if soldering is done directly to transistor leads to hold the lead between the joint and transistor body with a pair of round nose pliers so that the pliers help to draw off excess heat which would otherwise be conducted up the leads into the transistor itself (although this is not always done by the experienced constructor). Also it is recommended that with direct soldering the iron should be unplugged from the mains when actually completing the joint to avoid possible damage to the transistor through mains "hum" (A.C. current) present in the bit when the iron is connected.

If, on the other hand, a transistor socket is used to complete the wiring up, all these possible troubles are avoided, so the extra cost is usually well worthwhile. The use of a transistor socket in the circuit also enables other types of transistors to be tried as an experiment.

#### CIRCUIT WITH IMPROVED TEMPERATURE STABILITY (design no. 4)

One basic limitation with transistors is that they tend to be temperature sensitive. That is, their characteristics and thus their performance tends to vary with temperature, so that the performance of the circuit is not consistent. This is because as the external temperature increases the collector current also tends to increase, which in turn causes a further increase in junction temperature, so the effect is cumulative and goes from bad to worse, even to the point of ruining the transistor completely. It is possible to overcome this trouble by arranging for the circuit to be self-biasing or D.C. stabilised so that a constant operating collector current is provided, regardless of transistor type or temperature variations. In other words, the working point of the collector circuit is stabilised.

To do this we apply a bias resistor ( $R_3$ ) directly to the emitter connecting to earth, with an electrolytic condenser ( $C_5$ ) to act as a by-pass for alternating currents (i.e. the audio-frequency currents). The original bias resistor is also split into two separate resistors  $R_1$  and  $R_2$  of different values (see Fig. 30). The values given should be suitable for working with any P-N-P junction transistor tried. If a more theoretical approach is preferred, the individual values may be calculated as follows.

Taking 4,000 ohms as a typical resistance value for the headphones and 0.5 milliamps as a satisfactory operating current for the transistor:

$$\text{Voltage across phones} = \frac{4,000 \times 0.5}{1,000} = 2 \text{ volts}$$

Since the supply voltage is 9 volts, this leaves  $9 - 2 = 7$  volts to be shared by  $R_1$  and the transistor.

The impedance of the phones will be approximately 10,000 ohms. Therefore for optimum matching to the transistor the voltage across the latter should be:

$$\text{Volts (optimum)} = \frac{10,000 \times 0.5}{1,000} = 5 \text{ volts}$$

In practice the transistor "knee" voltage should be added to this. This is about 0.5 volts and represents, roughly, the minimum voltage below which no useful amplification exists.

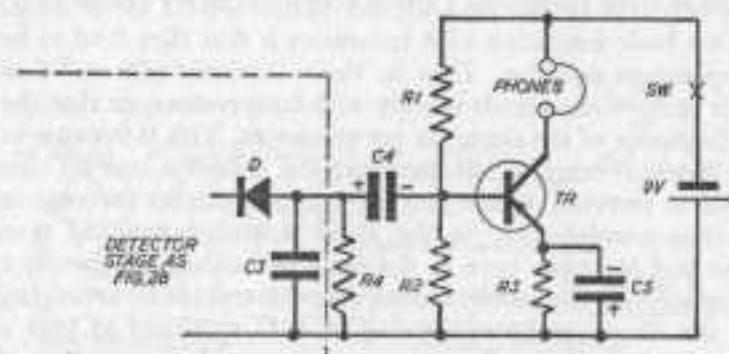

FIG. 30. DESIGN NO. 4. AN IMPROVED CIRCUIT WHERE THE WORKING POINT OF THE TRANSISTOR COLLECTOR IS STABILISED. CONSTRUCTION IS ESSENTIALLY SIMILAR TO DESIGN NO. 3, BUT WITH TWO ADDITIONAL RESISTORS AND ONE ADDITIONAL CAPACITOR TO BE CONNECTED.

$C_3$  and  $C_5$ —8  $\mu$ F/15 volt electrolytic condensers  
 $R_1$ —22 K $\Omega$   
 $R_2$ —4.7 K $\Omega$   
 $R_3$ —2.7 K $\Omega$  or 3.3 K $\Omega$  (1/10 watt, or greater)  
 $R_4$ —57 K $\Omega$   
 TR—OC71

For our purpose we can just adopt this value of 0.5 volts as necessary to ensure working the transistor under the best conditions.

We have now:

$$\text{Voltage across } R_1 = 7 - (5 + 0.5) = 1.5 \text{ volts}$$

Since the collector current, and thus also (approximately) the emitter current, is 0.5 milliamps:

$$R_1 = \frac{1.5 \times 1,000}{0.5} = 3,000 \text{ ohms}$$

In practice, nearest preferred values are 2.7 K $\Omega$  and 3.3 K $\Omega$ , either of which should be quite suitable.

To calculate the values of the two additional resistances  $R_2$  and  $R_3$ , the combined parallel resistance of these two should,

theoretically, be less than  $R_1$ . However, this would result in a considerable loss of input signal. Hence, in practice, it is usual to make this value about four times the impedance of the transistor, i.e.

$$4 \times 1,000 \text{ ohms (typically)} = 4,000 \text{ ohms}$$

A suitable practical value for  $R_2$  is therefore 4,700 ohms. We have then:

$$\begin{aligned} \text{Voltage across } R_2 &= \text{emitter voltage plus voltage between} \\ &\quad \text{emitter and base} \\ &= 1.5 + 0.05 \text{ (for an emitter current of 0.5 mA)} \\ &= 1.55 \text{ volts} \end{aligned}$$

Thus:

$$\text{Current through } R_2 = \frac{1.55}{4.7 \times 1,000} = 0.33 \text{ milliamps}$$

Finally:

$$\begin{aligned} R_3 &= \frac{\text{supply volts} - \text{voltage across } R_2}{\text{current through } R_2 + \text{base current}} \\ &= \frac{9 - 1.55}{0.33 + 0.01} \times 1,000 = 21,900 \text{ ohms} \end{aligned}$$

Thus a suitable practical value for  $R_3$  would be 22,000 ohms.

Both of these circuits described (Fig. 28 and Fig. 30) provide amplification at audio frequency of signals which can be heard on the basic circuit of Chapter II. In other words, if the basic crystal diode receiver previously described gives a "listening strength" in the earphones (with or without an added aerial, as necessary, according to distance from the transmitting station), either of these circuits will give an appreciable improvement in volume. However, because of the poor efficiency of a diode detector at low signal levels, the following circuit should show an overall improvement. It will, for example, enable signals to be heard which are not detectable on the original basic circuit (and consequently incapable of being amplified).

#### IMPROVED BASIC RECEIVER WITH SINGLE STAGE AMPLIFICATION (design no. 5)

The main difference lies simply in rearranging the connections to the tuning coil (see Fig. 31). The tuned circuit otherwise remains exactly the same. Rearrangement of wiring on

the tuned circuit (Fig. 28 or Fig. 29) consists of unsoldering one side of the diode (the lead connected to the short bus bar) and reconnecting to lead 3 on the tuning coil.

The amplifier circuit is identical with that described in Fig. 28, with the same component values, except that the headphones are now connected in the emitter circuit of the transistor.

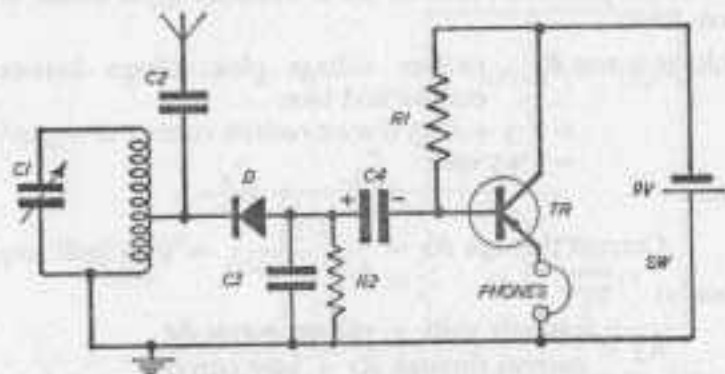

FIG. 31. DESIGN NO. 5. AN IMPROVED CIRCUIT WHICH WILL ENABLE VERY WEAK SIGNALS TO BE HEARD.

$R_1$ —470 K $\Omega$   
 $R_2$ —47 K $\Omega$  } all other values as before

Because of the simplicity of these circuits, and the ease with which they can be constructed and modified, it is strongly recommended that each circuit should be tried, in turn, and results compared—rather than selecting one of the improved circuits as a single project. In this way it is possible to get practical experience of just how effective these improvements are.

#### SIMPLE RECEIVERS ELIMINATING THE DIODE

Some radio construction manuals, particularly those dealing with transistor circuit designs, suggest elementary circuits eliminating the diode completely and using the transistor both as a detector and amplifier (rather in the manner of triode valve application). This, however, can only be done satisfactorily by using a far more expensive type of transistor designed for radio frequency work (i.e. specifically designed for handling high frequencies). The results obtained are hardly likely to be worth the extra cost and so this type of circuit is

not normally recommended. Circuits using an audio frequency transistor both as a detector and amplifier are not workable.

#### ADDITIONAL AMPLIFICATION (design no. 6)

Additional amplification can be applied to circuit designs 2, 3 and 4 to provide further gain. These virtually repeat the same amplifier stage, replacing the headphones in the first stage with a suitable load (e.g. a 4,700-ohm resistor). The superior consistency of the temperature-stabilised circuit (and the fact that it makes the circuit less dependent on individual transistor performance) makes it a logical choice, and so its application to circuits 3 and 4 only will be considered. The components are identical in each case, only the position of the load resistor being different.

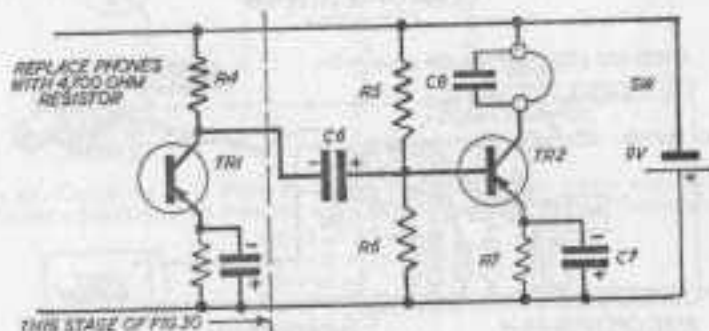

FIG. 32. DESIGN NO. 6A. AN ADDITIONAL AMPLIFIER STAGE ADDED, REPLACING THE PHONES IN THE PREVIOUS CIRCUITS (FIGS. 30 OR 31) WITH A 4,700-OHM RESISTOR.

$R_4$ —22 K $\Omega$   
 $R_5$ —10 K $\Omega$   
 $R_6$ —47 K $\Omega$   
 $R_7$ —47 K $\Omega$   
 $C_4$ —8  $\mu$ F/15 volt  
 $C_6$ —8  $\mu$ F/15 volt  
 $C_7$ —0.05  $\mu$ F  
 $TR_1$ —OC71

Fig. 32 shows the application of a further stage of amplification to circuit 4 (design no. 6a), and Fig. 33 the application of a similar stage to circuit 5 (design no. 6b). A schematic arrangement of components to act as a wiring up guide for design 6a is detailed in Fig. 34. Component values have been particularly selected to keep down the number of different values of components to a minimum.

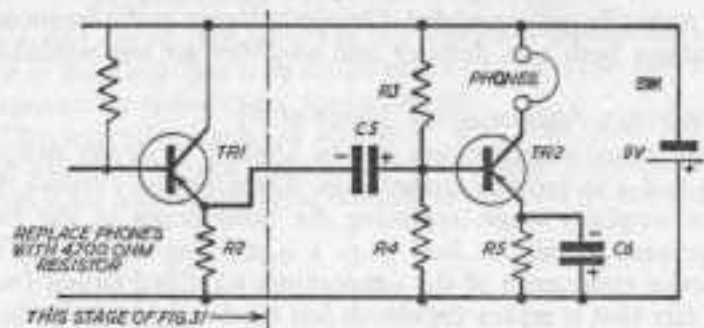

FIG. 33. DESIGN NO. 6b. ADDITIONAL AMPLIFICATION ADDED TO THE CIRCUIT OF FIG. 31.

$R_2$ —4.7 K $\Omega$   
 $R_3$ —22 K $\Omega$   
 $R_4$ —10 K $\Omega$   
 $R_5$ —4.7 K $\Omega$   
 $C_5$  and  $C_8$ —8  $\mu$ F/15 volt  
 $TR_1$ —OC71

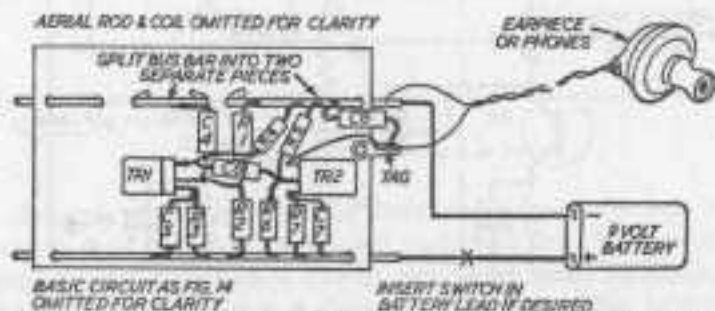

FIG. 34. SCHEMATIC DRAWING OF WIRING OF DESIGN NO. 6a. Note that the longer of the two top bus bars must be removed and replaced by two shorter lengths, as shown. These must be isolated from each other, the inner ends of the wires being turned over on the underside of the chassis. A single solder tag is also required to be mounted on the end of the chassis plate. Proceed by wiring all the resistors and capacitors to their correct bus bars, then fit the transistor sockets and finally  $C_8$ .

Note  $C_8$  connected across the headphones in Fig. 32 may improve performance by acting as a by-pass for any stray R.F. remaining. A suitable value for  $C_8$  is .005 microfarads. A similar condenser may be connected across the headphones in the other circuits described.

#### AMPLIFICATION FOR LOUSPEAKER OUTPUT (design no. 7)

Even with a second stage of amplification added, audio

power output is only sufficient for operating phones. One further stage of audio amplification can provide sufficient output to drive an 80 ohm balanced armature sound powered insert—a simple form of loudspeaker unit.

This further stage follows, again, the same amplifier circuit, replacing the phones in either design 6a or 6b with a 4,700 ohm resistor and feeding into a final output stage as shown in Fig. 35. Wiring up of this stage should be quite straightforward,

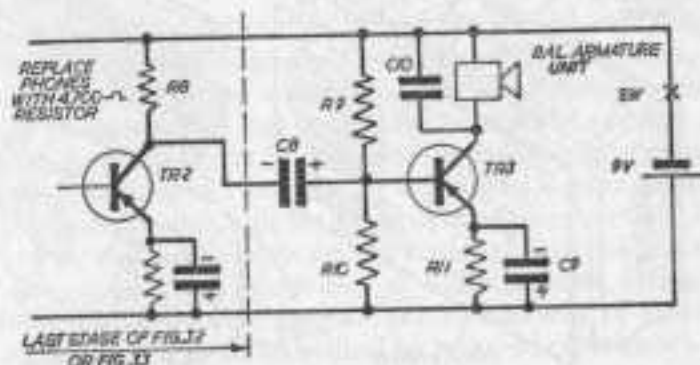

FIG. 35. DESIGN NO. 7. A FURTHER STAGE OF AMPLIFICATION ADDED WILL BOOST OUTPUT SUFFICIENT TO OPERATE A BALANCED ARMATURE INSERT (SPEAKER).

$C_8$ —8  $\mu$ F/15 volt  
 $C_9$ —100  $\mu$ F/6 volt  
 $C_{10}$ —01  $\mu$ F  
 $R_8$ —4.7 K $\Omega$   
 $R_{10}$ —3.3 K $\Omega$   
 $R_{11}$ —470 ohms  
 $TR_3$ —OC72 or OC71

Balanced armature unit 80 ohm DC resistance.

with the experience of the previous circuits as a guide. The basic chassis unit originally described is large enough to carry all the components up to circuit 7, with the exception of the balanced armature speaker. If the complete chassis unit is mounted in a simple cabinet, as in Fig. 36, the speaker unit itself can be mounted on the cabinet, connected to the respective circuit points by flexible leads. The same cabinet will, of course, house all the other circuits described, although it is larger than the *minimum* possible size into which the simpler circuits could be fitted.

This stage 7 circuit is about the logical limit to which the

simple diode receiver with audio amplification can be developed. Theoretically, at least, audio amplification stages can be added *ad infinitum*, but there are inherent limitations in the original circuit used to detect the signal in the first place i.e. lack of sensitivity and selectivity. The tuning, for example, is

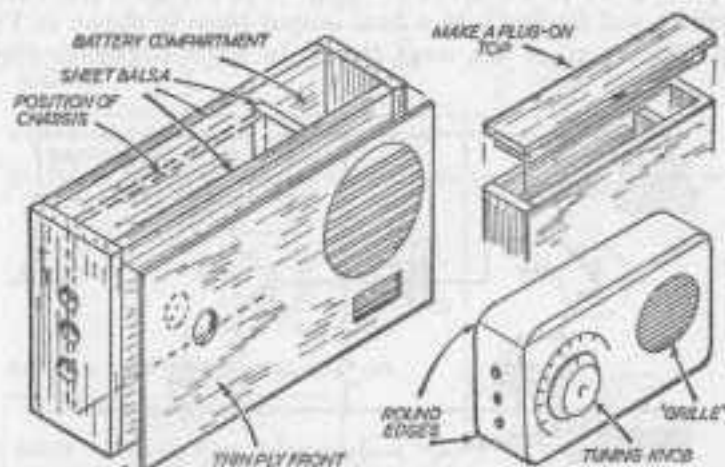

FIG. 795. A SUITABLE CABINET TO TAKE ANY OF THE RECEIVERS CAN EASILY BE MADE FROM BALSAM SHERRY, AS SHOWN. FACE WITH THIN PLY ON THE FRONT AND ROUND THE EDGES OF THE CABINET OFF BY SANDPAPERING. DETACH THE TUNING CONDENSER (C) FROM THE RECEIVER CHASSIS AND MOUNT ON THE FRONT FACE OF THE CABINET. ACCESS TO EXTERNAL AERIAL AND EARTH CONNECTION IS THROUGH HOLES IN ONE END OF THE CASE. THE BATTERY SHOULD BE FITTED INSIDE THE CABINET.

very broad, which means that in areas of strong signal strength two or more stations may be picked up simultaneously. In areas of only moderate signal strength a good aerial is still an essential feature for good reception, whilst amplification of the audio signal will also amplify unwanted background noises as well. The basic fact remains that no number of audio amplification stages can improve the efficiency of the detector circuit.

## FURTHER EXPERIMENTS AND CIRCUIT MODIFICATIONS

THE circuits discussed in the previous chapter although simple have been specifically designed to give as high a performance as possible. There are a number of different features which could be introduced, and in fact are commonly specified for similar types of circuits. It does not follow, however, that such different features will produce an *improvement* in performance. Quite probably they will have exactly the opposite effect. But it will be well worth-while for the reader to try modifications of this nature as an illustration of different basic *methods* of doing a similar job. The fact that one method may be superior to another can only be underlined by practical experience with all the alternatives. One can read that such-and-such a system is better than another, but it is much more realistic to try the different effects and form one's own conclusions as to their respective merits. Electronics is not a subject which can be fully appreciated visually, or by study—but practical results *can*.

### WORKING ON THE TUNED CIRCUIT

Although the design and construction of the tuning coil described in Chapter III and used for all the subsequent circuits appears very simple and elementary, it is, in fact, an extremely efficient coil. Wound on a ferrite rod, as specified, its performance for medium wave reception should be equivalent to the best of commercial coils, in the particular circuits to which it is applied. By taking out a tapping point on the coil for connection to the remainder of the circuit the coil is, in fact, being used as an *auto-transformer*. Capacity coupling of the external aerial, where called for, to the particular point specified also represents an optimum design feature.

As an experiment the aerial may be connected directly to

the end of the tuned circuit, as in Fig. 37, with or without the coupling capacitor (compare both results). This may well prove an effective way of working in areas of reasonably strong signal strength.

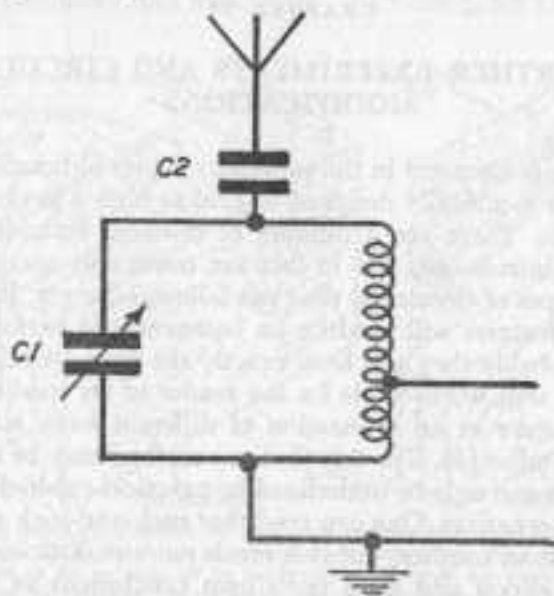

FIG. 37. EXPERIMENTAL COUPLING OF AERIAL DIRECTLY TO THE TUNED CIRCUIT.

The construction of another type of tuning coil with an "air core" (i.e. the coil is wound on an open former, with no ferrite rod or similar core) is detailed in Appendix III. The theoretical higher efficiency of a larger diameter coil is more than offset by the absence of a high-permeability core, so that the results should be by no means as good as with the original coil design. For one thing, it will have to be used with a good external aerial, even in areas of high signal strength (where the ferrite rod aerial may give results *without* an external aerial).

About the only advantage with a large diameter air core coil of this type is that it should be possible to extend the tuning range into the long wave band by increasing the number of turns (as detailed in Appendix III). The only practical limitation is that for good reception a very long aerial is essential.

On the other hand, with simple coil winding technique it is not possible to wind a long-wave coil on the original design of ferrite rod aerial. The only really satisfactory solution in such cases is to purchase a ready-wound commercial coil designed for long wave reception (sometimes such a coil may include leads for both medium wave and long wave connections). Typically these leads are wired to a *wavechange switch*, as in Fig. 38, so that the position of the switch determines whether

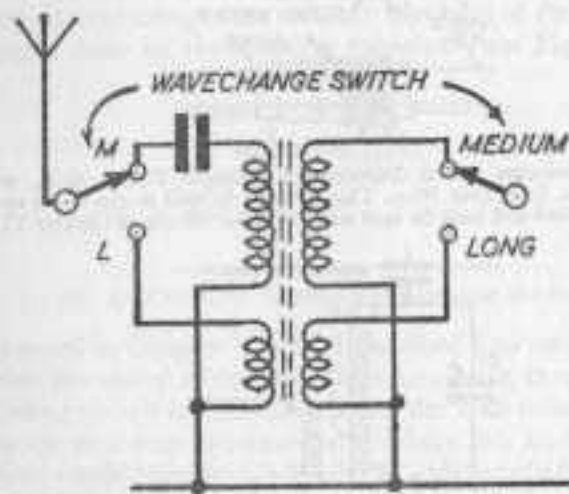

FIG. 38. TYPICAL ARRANGEMENT OF A WAVECHANGE SWITCH IN A DOMESTIC RECEIVER.

the tuned circuit is tunable either over the medium wave band or the long wave band.

An alternative form of tuning coil for medium wave reception which uses *inductive or transformer coupling* can be made as shown in Fig. 39. A fifty turn coil in 38 s.w.g. wire is wound on a paper sleeve over the ferrite rod, as in the original design, but with no tapping point. A wrapping of paper is then wound round the *bottom* (earth) end of this coil and on this is wound about thirty turns of the same wire.

Connection of this coil into any of the receiver circuits is then as shown in Fig. 40. Actually the number of turns specified for the second winding have been deliberately specified in excess of those required. Performance will be improved by

unwinding this coil, a turn or so at a time, until optimum performance is reached. This will probably be when there are about sixteen to twenty turns remaining on the second coil. Having arrived at the optimum turns figure, the end of the coil can be fixed with sealing-wax, excess wire cut off and a permanent connection made to the rest of the circuit.

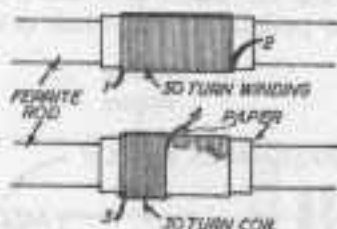

FIG. 39. CONSTRUCTION OF AN INDUCTIVELY COUPLED TUNING COIL, WOUND FROM 38 S.W.G. INSULATED WIRE. THIS COIL MAY BE USED IN ANY OF THE RECEIVER DESIGNS DESCRIBED AND MUST BE USED WITH THE REFLEX CIRCUITS OF CHAPTER VI.

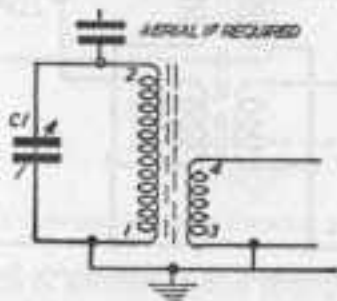

FIG. 40. CONNECTION OF THE EXPERIMENTAL COIL TO THE DETECTOR INPUT.

#### EXPERIMENTS WITH COUPLING

The basic circuit of Fig. 12 with the original design of tuning coil represents *direct coupling* of the tuned circuit to the detector stage, i.e. a lead is taken directly from the coil (and hence the tuned circuit) to the diode. With the type of coil just described above, the tuned circuit employs *transformer coupling* between the tuned circuit and the detector stage.

Both direct and transformer coupling could be employed between other stages. However, direct coupling of the diode to the amplifier stage by eliminating the capacitor would mean that the bias on the amplifier stage would be upset, with undesirable results. This is caused by the diode resistance being

effectively connected between grid and earth. With the diode detector one way round the grid bias would prevent the diode working by imposing a reverse bias to the diode.

The standard form of *resistance-capacity* (or R.C.) coupling comprises a resistor which is the "load" of the previous stage across which the output voltage of that stage is developed. Usually, in addition to the desired voltage (radio frequency or audio frequency) there is also a D.C. component which must not be passed to the next stage. The transmission of the alternating current component and the blocking of the D.C. component is done by the coupling capacitor—see Fig. 41.

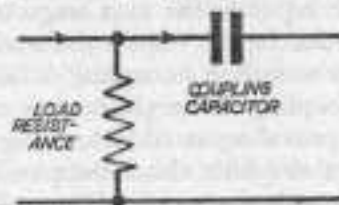

FIG. 41. ORTHODOX RESISTANCE-CAPACITANCE COUPLING.

As noted in Chapter V, which described how stages of amplification are added to the basic detector circuit, in each case the preceding circuit is "broken" across the load resistor, or effectively the next stage is connected to where this load resistor (or phones) would have been without the addition of a further stage.

On this basis we can use transformer coupling as an alternative method of connecting the different stages; one winding of the transformer replaces the load resistance in the first stage and the other connects to the second stage, as in Fig. 42. This

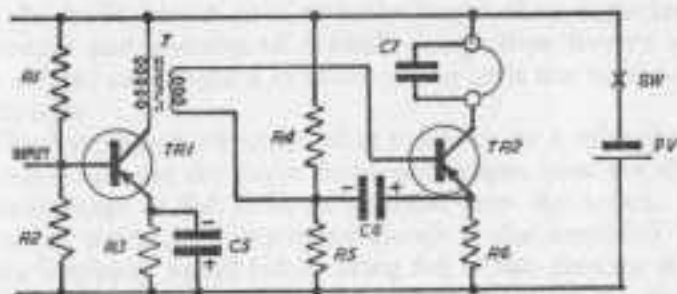

FIG. 42. TRANSFORMER COUPLING AND AN AMPLIFICATION STAGE APPLIED TO DESIGN NO. 4 (OTHERWISE AS DESCRIBED IN FIG. 30).

particular diagram is drawn for applying transformer coupling to design no. 4 (Fig. 30). Reference to the original circuit diagram will show exactly the difference involved. Suitable types of transformers for coupling between stages of the circuits detailed in Chapter IV include the Fortiphone N22, Ardent D217, or similar transformers—these being sub-miniature transformers of very compact size and designed specifically for operation in transistor circuits.

It will be appreciated that transformer coupling can also be used to add a measure of amplification in a thermionic valve circuit if the turns ratio of the transformer windings apply a step-up so that the input to the next stage is increased by a proportionate amount. In this respect the transformer is being used as an amplifier as well as a coupling device. Hence on this basis transformer coupling does represent a practical advantage in such a circuit in providing an additional degree of amplification. In a transistor amplifier this is not possible. However, a transformer does provide the means of "impedance matching" which is the way of obtaining maximum transfer of power from one stage to another.

#### OTHER CIRCUIT MODIFICATIONS

For convenience of reference other circuit modifications, such as the addition of volume and tone controls, are dealt with separately in the Appendices. Similarly, more advanced types of circuits designed to produce better results are detailed in the remaining two chapters.

## CHAPTER VII

### IMPROVED TRANSISTOR RECEIVER DESIGNS

No commercial receivers—other than elementary crystal sets—are produced on the lines of the simple circuits so far discussed, simply because of their inherent limitations in performance. By comparison the ordinary domestic receiver is quite complex; it is at least of the T.R.F. type and usually a superhet (see Chapter VIII). Neither of these is suitable for amateur construction except at a fairly advanced level of knowledge and practical experience, unless of course a complete kit of parts is purchased and a set made to a well-tryed design.

With transistor receivers, however, there is a special type of circuit which is capable of giving excellent results without becoming too complex, nor does it introduce any particular problems as regards alignment or setting up. Quite adequate headphone or earpiece reception can usually be obtained with three stages whilst additional amplification can be added, if required, to boost audio power output to a sufficient level for loudspeaker operation. A complete circuit of this type can be made extremely compact and will work in areas of reasonable signal strength with just a ferrite rod aerial. In less favourable areas an external aerial may be required. In general, however, this type of receiver makes an ideal pocket set for it can be built into a case scarcely larger than a packet of cigarettes and operates off a small, inexpensive battery with low current consumption so that running costs are an absolute minimum.

These designs incorporate what is known as a *reflex* circuit, so called because the audio frequency output from the diode detector stage is fed back or reflexed into the input. The incoming signal from the tuned circuit is also amplified as a radio frequency signal before being fed to the detector stage, thus overcoming one of the basic limitations of the simple tuned-circuit-detector designs previously described.



The reflex circuit is shown in block diagram form in Fig. 43. The tuned circuit feeds into a *radio frequency amplifier* stage and thence to the detector stage. All of the A.F. component in the detector is fed back into the R.F. amplifier stage input for amplification at A.F. The output from the reflex stage may

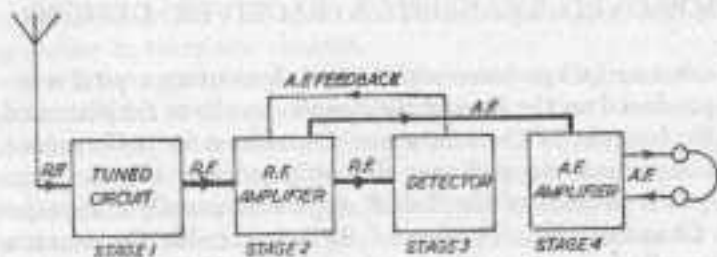

FIG. 43. BLOCK DIAGRAM OF THE REFLEX RECEIVER.

be fed directly into headphones (three-stage circuit); or may be followed by a stage of normal A.F. amplification (four-stage circuit); or further stages of amplification (five-stage circuit, etc., all the additional stages being A.F. amplifier stages).

As with the simpler circuits, however, there is a practical limit to the number of amplification stages which can usefully be added. The basic three-stage circuit (with no A.F. amplifier stage) should give audible headphone reception on a number of different stations. The four-stage circuit should give good headphone reception with local stations very loud. A five-stage circuit should be satisfactory for working a balanced armature speaker or even a miniature loudspeaker, via a suitable matching transformer. It may even prove possible to work a balanced armature speaker direct in a four-stage circuit.

The "front end" of the circuit comprises the tuned circuit feeding an R.F. amplifier stage (Fig. 44a), the latter employing an OC45 or similar transistor. In this type of circuit the tuning coil must be inductively coupled, i.e. a double wound coil to the specification described in Chapter V, Fig. 39. The output from the R.F. amplifier employs what is known as *choke capacitance* coupling,  $L_3$  being an R.F. choke coil used to ensure an adequate load impedance for radio frequency currents without having a D.C. voltage drop (i.e. offering high resistance to R.F. but low resistance to D.C.). The use of this choke coil

also means that the gain of the amplifier varies with the frequency of the input, because the reactance of the choke varies with frequency. This effect is not desirable, but it is tolerable in this type of circuit.

The output of amplified R.F. is fed from this stage into the

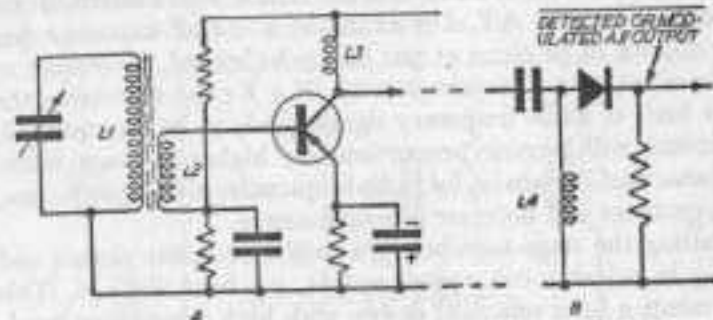

FIG. 44. FIRST AND THIRD STAGES OF THE REFLEX CIRCUIT.

detector stage (Fig. 44b), which comprises a more or less conventional circuit with another R.F. choke coil, the purpose of which again is to ensure an adequate R.F. load impedance with low D.C. resistance. If both  $L_3$  and  $L_4$  are made adjustable (i.e. by adjustment of an iron-dust core), optimum performance can be arrived at by using this measure of adjustment as a means of setting up the finished receiver.

The required "feedback" is arranged as shown in Fig. 45. The audio frequency signal passed by the detector, plus a little

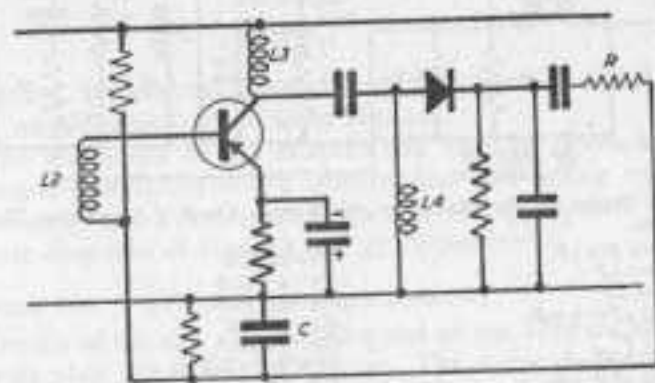

FIG. 45. THE FIRST AND THIRD STAGES LINKED TO PROVIDE FEEDBACK.

residual R.F. appearing at point 1, is passed back to the base of the transistor in the previous stage, the A.F. being little affected by the capacitor  $C$ . However, any R.F. is heavily attenuated or reduced. Thus the transistor is made to perform the additional function of an audio frequency amplifier. By choosing a suitable value for  $C$  a low reactance to R.F. is assured, but a high reactance to A.F. For example, a  $0.01 \mu\text{F}$  capacitor has a reactance of 30 ohms at 500 kilocycles/second, increasing to 3,000 ohms at 5 kilocycles/second. If 5 Kc/sec represents the upper limit of audio frequency signals likely to be encountered, reactance will become proportionately higher at lower audio frequencies. Conversely, for radio frequencies above 500 Kc/sec, the reactance will decrease proportionately.

Putting the stage together in a single, complete circuit and filling in suitable component values, we have Fig. 46. This represents a fully practical design with high impedance headphones or a high impedance deaf aid earpiece inserted where

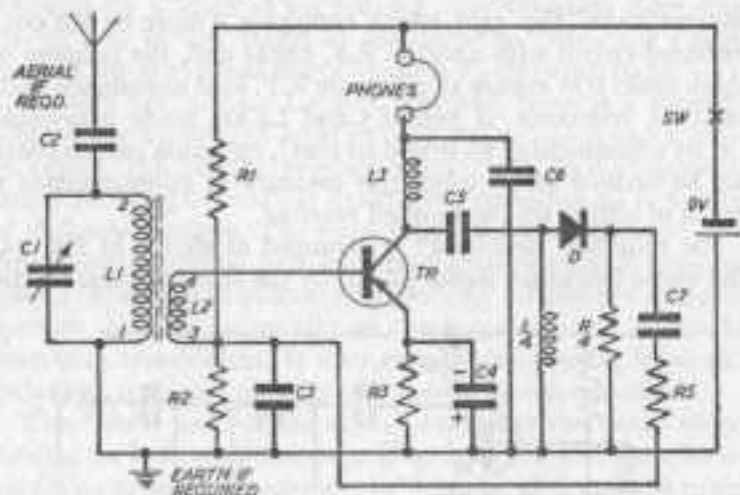

FIG. 46. DESIGN NO. 8. THE COMPLETE REFLEX CIRCUIT, COMPRISING THREE STAGES.

$C_1$ —100-500 pF	$R_1$ —22 K $\Omega$
$C_2$ —200 pF	$R_2$ —4.7 K $\Omega$
$C_3$ —0.01 $\mu\text{F}$	$R_3$ —3.3 K $\Omega$
$C_4$ —32 $\mu\text{F}/1.5$ volt	$R_4$ —22 K $\Omega$
$C_5$ —47 pF	$R_5$ —1 K $\Omega$
$C_6$ —0.05 $\mu\text{F}$	D—GEC GEX 34
$C_7$ —10 $\mu\text{F}/3$ volt	TR—OC44 (or OC45, XA102, XA101)
$L_3$ and $L_4$ —1 millihenry chokes.	

indicated—a complete three-stage reflex receiver, in fact.

If additional amplification is required—and this is recommended for good performance—this follows the standard method used with the previous receivers in Chapter V. The phones are replaced with a suitable load resistor and the amplification stage added at this point. The complete four-stage circuit then becomes as shown in Fig. 47. Alternatively,

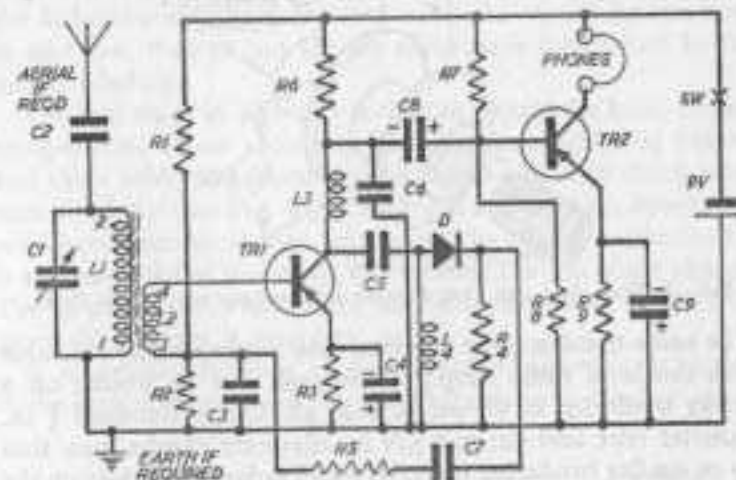

FIG. 47. DESIGN NO. 9. FOUR-STAGE REFLEX RECEIVER CIRCUIT DIAGRAM. Values as for Fig. 46, with the following additions:

$C_8$ —6 $\mu\text{F}/15$ volt
$C_9$ —8 $\mu\text{F}/15$ volt
$R_6$ —4.7 K $\Omega$
$R_7$ —22 K $\Omega$
$R_8$ —10 K $\Omega$
$R_9$ —4.7 K $\Omega$
TR2—OC71

of course, transformer coupling could be used for the fourth A.F. amplification stage, as in Fig. 42.

The remainder of the chapter will now be devoted to a practical description of the construction and setting up of a three-stage and a four-stage reflex receiver appropriate to the circuit diagrams of Figs. 46 and 47, respectively.

#### DESIGN NO. 8 (Three-stage reflex receiver)

Details of the size and marking out of the 1/16 in. Paxolin chassis plate are given in Fig. 49. The holes should all be drilled 1/16 in. diameter. The hole to fix condenser  $C_1$  can be

opened up, as required, with a larger drill, using the original hole as a guide. It is not advisable to drill the large hole directly, as this may split the chassis plate.

Standard components are used throughout, except that the two choke coils  $L_3$  and  $L_4$  will probably have to be wound.

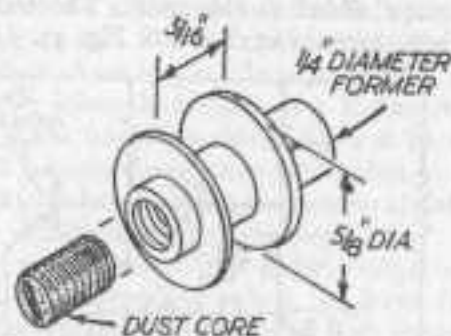

FIG. 48. PREPARING THE COIL FORMER FOR WINDING THE CHOKE COILS.

(The value of inductance specified may not be readily available from the local radio shop.) These coils can be wound on a former made up as shown in Fig. 48. Use a standard  $\frac{1}{4}$  in. diameter core and cut two  $\frac{5}{8}$  in. diameter checks from thin ply or similar insulating material (not card) to fit tightly on the core. Space  $\frac{3}{16}$  in. apart, as shown, and cement in place on the core. The space between the checks is then completely

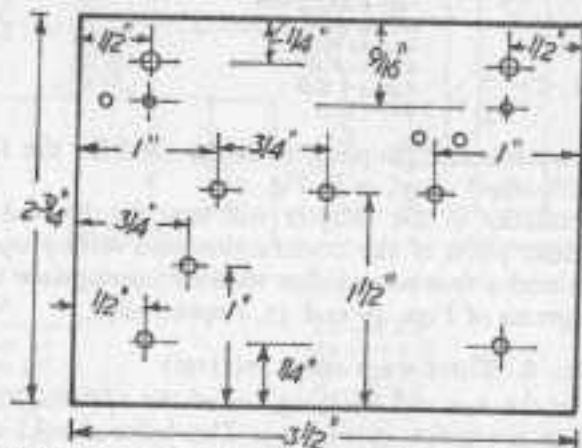

FIG. 49. CHASSIS SIZE AND DRILLING POSITION FOR DESIGN NO. 8 OR DESIGN NO. 9.

filled with a winding of 38 s.w.g. insulated wire, winding on one layer with turns adjacent, then a second layer over the top, and so on until the coil has built up to the same diameter as the checks. The coil windings can be held with a wrapping of cellulose tape and the ends should be secure to one of the checks with sealing wax or something of the sort. The provision of an iron dust core to fit the centre of the coil core enables the inductance of the completed coil to be varied by screwing in and out, thus taking up any differences introduced in the actual winding.

The first stage in assembly is then to mount the basic chassis components. These consist of two bus bars, fitted as before, and three solder tags mounted on the chassis with small brass nuts and bolts (see Fig. 50). The aerial rod clips are fitted with self-tapping screws or nuts and bolts. The tuning condenser  $C_1$  is also mounted at this stage, this time on the top of the chassis. The tuning knob is thus fitted on the underside of the chassis, when the receiver is complete.

A schematic drawing of the complete assembly is shown in the second diagram of Fig. 50. This can be used as an aid in

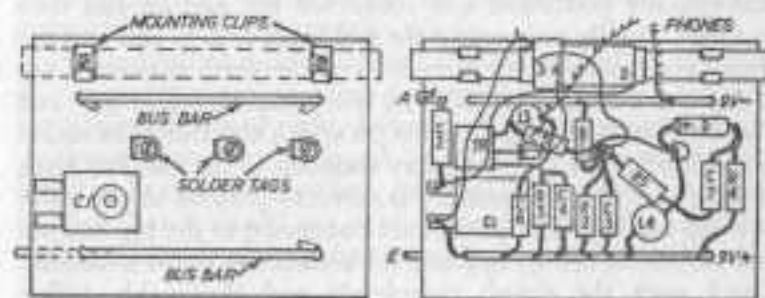

FIG. 50. DESIGN NO. 8 IN SCHEMATIC FORM.

wiring up, in conjunction with the circuit diagram of Fig. 46. It is better to use the schematic drawing only as a guide to the approximate positioning of the components and check all connections as they are made against the *circuit* or theoretical diagram. In this way, there is less likelihood of wrongly connecting up any individual component.

Start by fitting  $C_2$ , bending one lead down through the hole

in the chassis and turning over the edge. Solder the other lead to one of the tags of  $C_1$  after cutting to correct length with  $C_2$  resting snugly on the base. Next solder the transistor socket base connection to the first solder tag and fit  $R_3$  and  $C_4$ . Follow with  $R_1$ ,  $R_2$  and  $C_3$ , all mounted on the second solder tag.

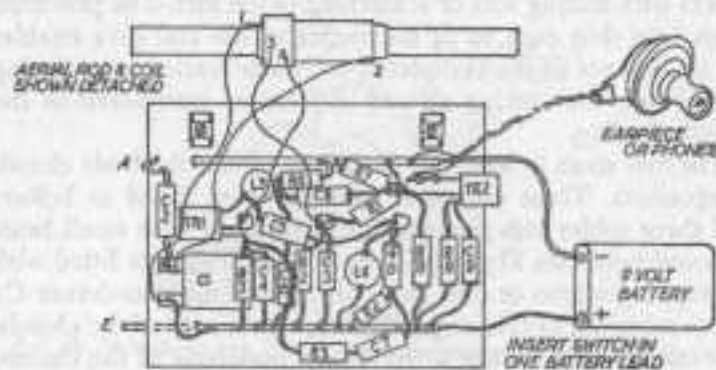

FIG. 51. DESIGN NO. 9 IN SCHEMATIC FORM.

Then mount the diode on the last solder tag and connect up  $R_4$ ,  $R_5$  and  $C_7$ . The two choke coils  $L_3$  and  $L_4$  can then be conveniently positioned and connected up, and  $C_6$  can then be fitted. Finally connect up the coil leads 1, 2, 3, and 4 to the appropriate parts of the circuit—1 to the earth connected tag of  $C_1$ ; 2 to the other tag of  $C_1$ ; 3 to the middle solder tag; and 4 to the first solder tag (the one on which the transistor socket is mounted). The 9-volt battery connects to the two bus bars, making sure that the polarity is correct—positive to the lower or earth bus bar. The phones are connected to the top bus bar and the side of coil  $L_3$  opposite the connection to the transistor. Check over the circuit completely and thoroughly before plugging in the transistor.

Adjust as for the basic receiver described in Chapter II, i.e. by screwing down the tuning condenser  $C_1$  and then backing off half a turn. Then slide the coil along the rod until the Third Programme is audible, when the tuning coil can be fixed to the rod. Further improvement in performance will then probably result from adjusting the dust cores of  $L_3$  and  $L_4$  for optimum results.

This receiver should work at reasonable listening volume in

areas of good signal strength but performance will undoubtedly be improved by the fitting of a good external aerial.

#### DESIGN NO. 9 (Figs. 47 and 51)

This utilises exactly the same circuit as before but with a stage of audio frequency amplification added, via a second transistor. The chassis is identical.

The receiver can be wired up exactly as before, An additional resistor  $R_6$  is connected between the top end of the choke coil  $L_3$  and the top bus bar, the remaining additions then being simply a complete transistor amplifier stage consisting of  $R_7$ ,  $R_8$ ,  $R_9$ ,  $C_9$  and  $TR_2$ . The final stage is coupled to the previous stage via an electrolytic condenser  $C_8$ , connecting to the top side of  $L_3$  (same side as  $R_6$ ) and joining to the base terminal of the second transistor.

The free collector lead of this second transistor can conveniently be taken through a hole drilled in the chassis and then up again through a second hole, as shown in Fig. 51. The phone leads then connect to this end, and to the top bus bar. Battery connections are as before. The schematic drawing of Fig. 51 shows a slight rearrangement of components which will be an advantage to accommodate the components for the final stage within the confines of the chassis.

This particular receiver should work quite well in any area of reasonable signal strength without any external aerial or earth connections. It will, however, be very directional and maximum signal can be found by rotating the set to align the aerial in its optimum position. Because of its compact size, and the fact that it should not need an external aerial, this design makes an ideal pocket receiver, fitted in a suitable case (Fig. 36).

## CHAPTER VIII

### MORE ADVANCED CIRCUITS

In all of the simple circuits the weak radio frequency signal in the aerial is fed directly to the detector, amplification then being applied to the audio frequency signal extracted from the detector to bring the A.F. signal up to the required level to operate headphones or a loudspeaker. As it has been pointed out, no amount of audio frequency amplification *after* detection is effective if the original radio frequency strength is too small in the first place.

An obvious method of improving this state of affairs would be to amplify the radio frequency signal picked up by the aerial and tuned circuit *before* passing to the detector. This is quite a practical arrangement, and was used in the reflex designs of Chapter VII, the immediate advantages being an improvement in both *sensitivity* and *selectivity*, and also *quality* of reproduction since the signal applied to the detector is greater. Improved sensitivity means that the weaker (more distant) stations can now be received at greater volume. Better selectivity means that sharper tuning can be obtained. (Sharper tuning is probably a necessity in any case, to eliminate interference from adjacent stations now more readily picked up.) Quality is improved because there is less demand for audio frequency amplification to get the required final volume, whilst the output power can readily be boosted to the level required to operate a loudspeaker without putting any particularly high demands on either the efficiency of the aerial system or the audio frequency amplifier stages.

This type of set, using valves, is a popular choice for more advanced amateur constructors since it is not particularly complicated to build, nor is it difficult to set up initial adjustments. It is generally known as a *tuned radio frequency (T.R.F.) set*, the basic stages being as shown in Fig. 52. The main difference from the simpler circuits described previously is in the provision

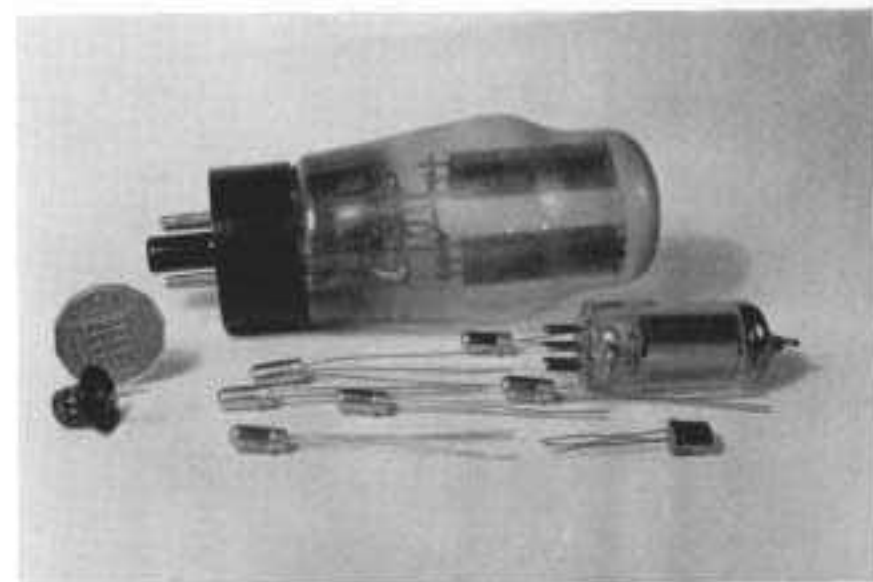
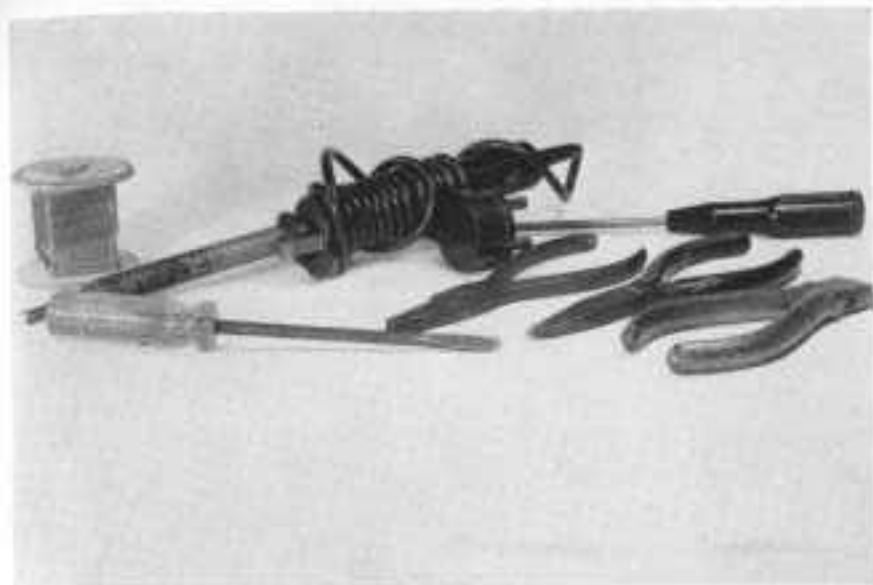

Top: Basic tool kit required comprises pliers, screwdrivers and electric soldering iron. The latter is a "must" for electrical work.

Bottom: Transistors can take the place of valves, but are very much smaller. This photo shows a standard radio valve, a miniature radio valve, and a collection of different types of transistors.

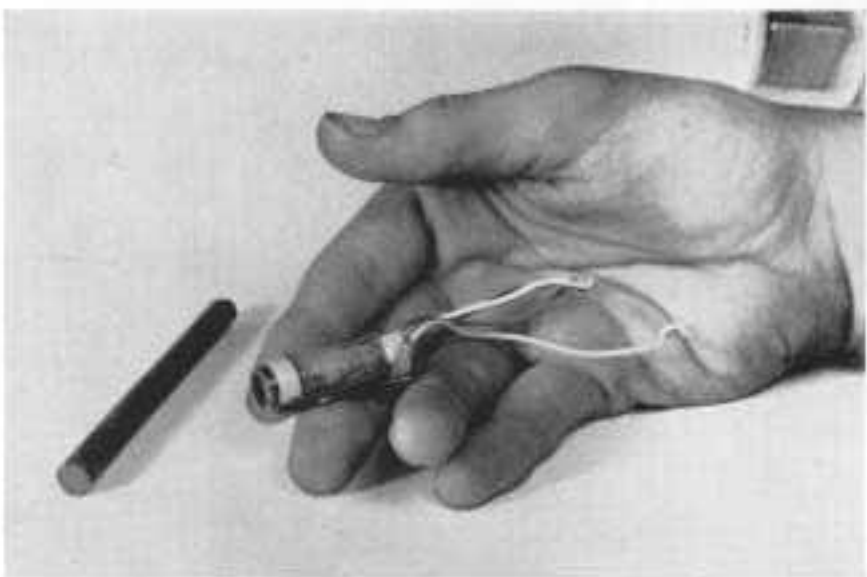
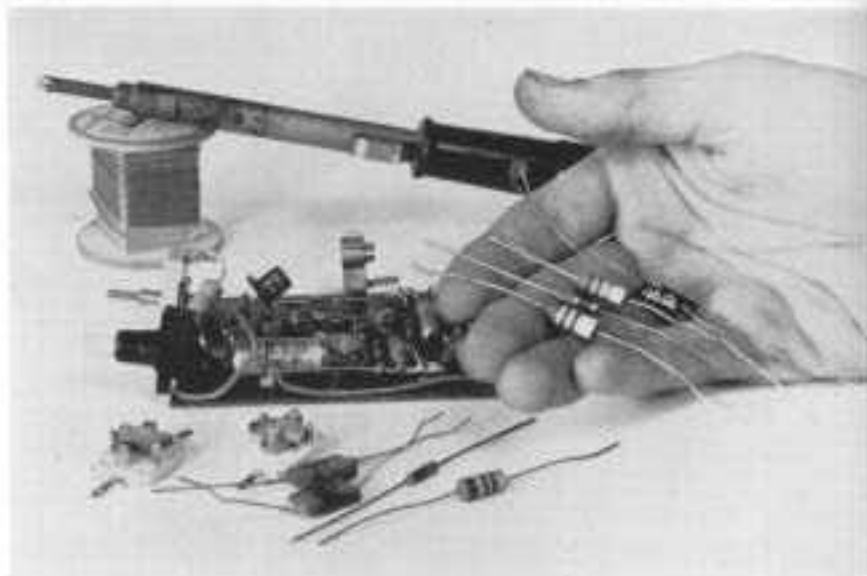

*Top:* Standard components used comprise variable condensers, capacitors, resistors, etc. Resistors and capacitors may be similar in shape, but resistors are colour coded.

*Bottom:* This is a typical wound aerial coil, the three leads in this case being taken to one end of the coil for neatness. The ferrite aerial rod on to which the coil fits can also be seen.

of a radio frequency amplifier stage before the detector stage. The two tuned circuits are literally identical and, in fact, are usually "ganged" together, using twin variable condensers (a twin gang condenser) mounted as a single unit and adjusted by a single control knob (although the respective circuits are wired to the separate electrical parts of the two-part condenser).

To provide *complete* matching of these two tuned circuits, individual adjustment of the two separate variable condensers is done with the aid of smaller "trimming" condensers mounted in parallel with them. Similarly, the inductances of the two tuning coils completing the respective tune circuits are

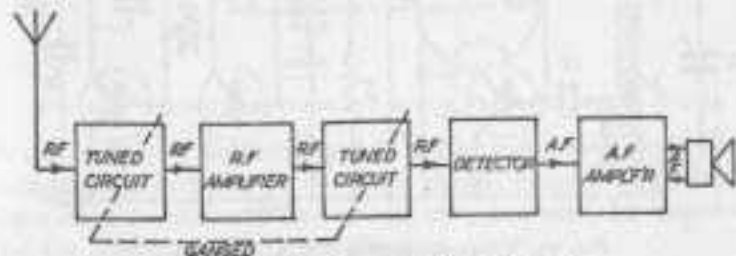

FIG. 52. T.R.F. RECEIVER BLOCK DIAGRAM.

matched for identical performance by means of adjustable iron-dust cores. Screwing the cores in increases the inductance of the coils; and screwing them out decreases the inductance. In this manner small differences in the actual wiring up of the two tuned circuits, and small differences in effective component values, can be balanced out for optimum performance. This, in fact, is a necessary process in setting up or *aligning* the complete receiver for best performance, and it can be done quite satisfactorily on a trial-and-error basis.

The T.R.F. receiver, using valves, is a good receiver for the advanced amateur constructor in almost all respects. It is usually made as a mains receiver, using a separate power pack for the supply (see Appendix VII). There are many excellent kits produced to T.R.F. sets suitable for the home builder which, simply by following instructions and the circuit diagram correctly, can be expected to give first class results. The price of such kits is generally comparable with the cost of individual components built separately for a particular circuit design.

It is not proposed to give constructional details for a typical

T.R.F. set in this present book since it does represent a rather more advanced stage of experience than the type of circuits with which we have been working.

Unfortunately, T.R.F. circuits do not lead themselves readily to the adoption of transistor stages (instead of valve stages).

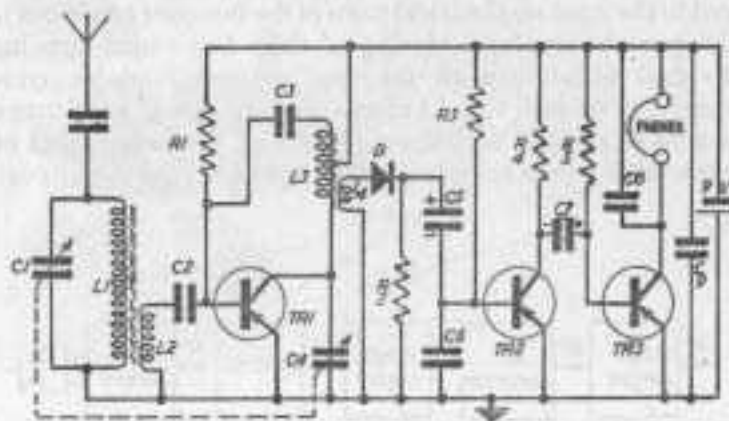

FIG. 53. THREE-TRANSISTOR T.R.F. RECEIVER.

$C_1, C_2$ ganged tuning condenser (Jackson preferred)	$R_1$ —1 M $\Omega$
$C_3$ —0.1 $\mu$ F	$R_2$ —10 K $\Omega$
$C_4$ —15 pF	$R_3$ —1 M $\Omega$
$C_5$ —8 $\mu$ F electrolytic	$R_4$ —4.7 K $\Omega$
$C_6$ —0.1 $\mu$ F	$R_5$ —1 M $\Omega$
$C_7$ —8 $\mu$ F electrolytic	TR1—OC45
$C_8$ —0.05 $\mu$ F	TR2—OC71
$C_9$ —100 $\mu$ F, 12 volt working	TR3—OC71
$L_1$ —50 turn coil on ferrite rod	D—GEN34 (crystal diode)
$L_2$ —10 turns (see text for construction)	
$L_3$ —50 turn coil on ferrite rod with centre tapping.	
$L_4$ —10 turns.	

$L_3, L_4$  can be wound exactly as  $L_1, L_2$ , except that the 50-turn winding has a centre tap. A short length of ferrite rod should be used for the core,  $L_3, L_4$  being wound on a paper sleeve so that the rod can be slid in and out for adjustment purposes.

Important. Coil  $L_3, L_4$  will need screening from  $L_1, L_2$  and associated components. This can be done with thin aluminium sheet, suitably fitted around  $L_3, L_4$ .

This is largely because transistor amplifier stages generally have less gain than comparable valve stages, so more transistor stages are required for the same degree of amplification, possibly requiring more variable tuned stages and complicating both construction and alignment. That is not to say that the transistorised T.R.F. set cannot be made successfully. It can, and again there are various kits put out for such receivers which

will operate successfully at loudspeaker volume. A typical theoretical circuit is shown in Fig. 53, again with suitable component values. This could be laid out in the manner of the simple transistor receivers described in Chapter V in very much the same space. It will not be a particularly cheap

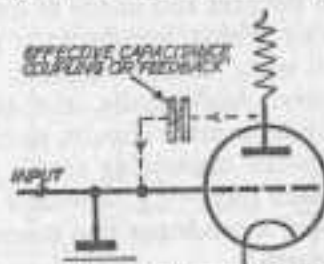

FIG. 54. "CAPACITANCE COUPLING" GIVING FEEDBACK WITH A TRIODE.

set to construct, however, and its performance is probably only comparable with the best of reflex circuit designs under similar operating conditions. The circuit can, however, be improved by the addition of D.C. stabilisation.

An inherent limitation with T.R.F. sets is a tendency for the radio frequency amplifier stage to become unstable and oscillate, producing a loud howl or whistle in the loudspeaker. If we look at the triode valve in a basic amplifier circuit again—repeated in Fig. 54 for convenience—there may well be an effective "capacitance coupling" between the anode and grid of the valve, either due to the construction of the valve itself (interelectrode capacitance), or the capacity of wiring connected to these two parts, or both. This capacitance will be very small, probably only of the order of a few picofarads, which in the case of audio frequencies represents a very high reactance (resistance) path—remembering that the lower the value of the capacitance the greater its reactance or resistance to the flow of low frequencies, and vice versa. At the much higher radio frequencies being applied to the valve grid, however, this external capacitance-coupling or feedback path, as it is called, may represent a relative low resistance path to the input signal. Hence part of the amplified output from the anode is fed back through the feedback path to the grid again, exciting instability or self-oscillation. This principle of applying feedback in this manner is, in fact, the basis of operating a valve

as an *oscillator*, which is used in some other types of circuits; or in *regenerative receivers* (see below).

This means that the R.F. amplifier stage in a T.R.F. receiver may be quite critical as regards layout of components (e.g. coils) connected to the grid and anode of the amplifying valve respectively, keeping wiring lengths to a minimum on this circuit, and even using electro-magnetic and electrostatic *screening*, if necessary. Additionally, the anode circuit may require *decoupling* from the other circuits, particularly the detector, calling for a special decoupling circuit to be added after the R.F. amplification stage—e.g. a resistor in series with the high tension lead and a condenser also connected between the anode circuit and earth.

#### REGENERATIVE RECEIVERS

Considering this question of feedback a little more carefully, it will be appreciated that a *certain amount* of feedback from the amplified (anode) signal into the grid again will result in *still greater* amplification, thus increasing the effective gain many times. The only limit is the point at which the feedback is too great for the valve to cope with properly and it goes unstable and oscillates. With controlled or restricted feedback, however, it should be possible to hold the valve within its stable operating limits and so take advantage of this additional gain produced.

Again it is possible to produce practical circuits using this principle, provision being made for adequate control of the amount of feedback so that the oscillation point is never reached.

It is also necessary to arrange that the feedback from anode to grid (or collector to base, in the case of a transistor) is in the right sense or "phase" to add to the input signal. The voltage appearing at the collector of the transistor, for example, would be 180 degrees out of phase with the input to the base. The collector voltage must therefore be reversed in sense or phase before it can be applied as positive feedback or regeneration to the input base of the transistor. This phase reversal is accomplished by the coil in the collector circuit which is inductively coupled to the base circuit. If the coil is connected the wrong way round the feedback will be negative instead of positive, resulting in a decrease in sensitivity.

A theoretical design of transistor regenerative circuit, simplified as far as possible, is shown in Fig. 55. A single transistor only is used, and this must be an OC44 or OC45 (or equivalent). The aerial tuning coil is the standard design evolved for the basic receivers but an additional feedback coil

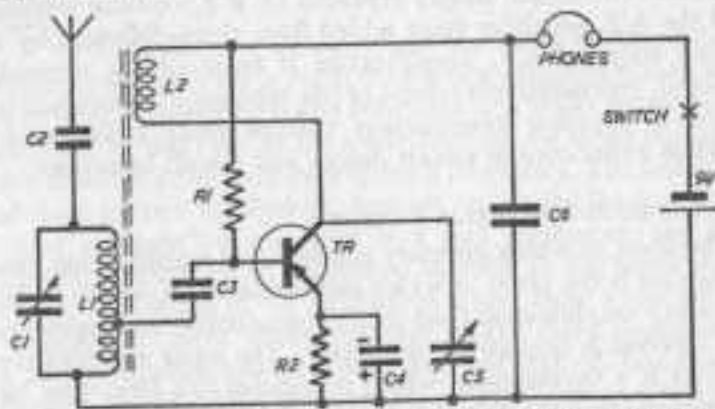

FIG. 55. THEORETICAL DESIGN FOR SIMPLE REGENERATIVE RECEIVER.

$R_1$ —4.7 megohms to 1 megohm (select for smoothest regeneration)

$R_2$ —5.1 K $\Omega$

$C_1$ —100-500 pF

$C_2$ —100-500 pF

$C_3$ —200 pF

$C_4$ —valve may be between 220 pF and .1  $\mu$ F

$C_5$ —2  $\mu$ F/35 volt

$C_6$ —100  $\mu$ F

TR—OC44 (or OC45)

Standard method of adding an amplifier stage is to replace phones with a 4,700-ohm resistor.

is mounted on the ferrite rod to produce the necessary coupling.

This feedback coil is made by winding 8 turns of 38 s.w.g. wire on a similar paper sleeve to the tuning coil, so that the finished coil can be slid up and down the ferrite rod. The degree of coupling can then be adjusted for optimum results by sliding this feedback coil up and down the rod to arrive at a position which gives optimum results. The amount of reaction or regenerative feedback is controlled by the setting of the 500 picofarad condenser connected to the transistor collector. If the set does not oscillate with this condenser adjusted to *minimum* capacity (i.e. vanes fully closed) then the feedback coil must be reversed on the ferrite rod, i.e. slid off and replaced the



other way round (alternatively reverse the coil connections to the rest of the circuit).

Provided the basic circuit can be got working satisfactorily, additional audio frequency amplification can, of course, be added as described in Chapter V. The headphones shown in the basic circuit are simply replaced by a 4,700-ohm resistor and the A.F. amplifier stage added from there, followed by a second stage of A.F. amplification if required. In general, however, regenerative receivers of this type are not particularly suited to amateur construction without some considerable previous experience of circuit design and circuit behaviour.

#### THE SUPER-REGENERATIVE RECEIVER

The limit to which ordinary regenerative amplification can be carried is the point at which oscillation starts, so the radio frequency amplification (and thus the sensitivity) of a regenerative receiver is limited by this factor. The super regenerative receiver is a development which overcomes this limitation by introducing into the detector circuit an alternating voltage of a frequency somewhat above the audible range (e.g. typically between 20 to 100 kilocycles per second) in such a manner as to vary the operating point of the detector. In effect this interruption or *quench* frequency switches the detector in and out of operation, with the detector originally adjusted to be near the point of oscillation. The time taken for the R.F. oscillations to build up to their peak will be proportional to the original modulated signal (i.e. the R.F. signal picked up by the aerial) and by arranging for these to be quenched before they can reach their peak, extremely high amplification is possible—equivalent to a gain of over one million in a single stage in certain cases.

On this basis, the circuit is ideal for increasing the sensitivity of a receiver in a relatively simple manner. However, both the design requirements and adjustment are somewhat critical, and it can only be considered as an advanced type of receiver beyond the scope of this present book for more detailed treatment. The super-regenerative receiver, too, is not particularly suited for the reception of normal broadcast frequencies. The circuit requires a ratio of signal frequency to quench frequency of the order of 1,000:1, or greater, which means that for a

broadcast signal of 500 kilocycles/second the quench frequency must be of the order of 500-1,500 cycles per second, or in the audio band. A further limitation is that they will cause interference on other receivers in the neighbourhood because they are oscillating all the time—although this effect can be cured.

A further variation, which is even less suited for lower radio frequencies but again is capable of giving excellent results with very high frequencies, is the self-quenching super regenerative receiver. In this case, as the name implies, the super regenerative detector supplies its own quench frequency. The frequency of these quench oscillations depends on the feedback and the "time constant" of the grid leak and condenser, the time between each burst of oscillation varying as the input signal varies. The action of the oscillations is said to be a blocking or "squegging" effect where the grid of the valve accumulates a strong negative charge which does not leak off fast enough through the grid leak to prevent a relatively slow variation of the operating point.

#### THE SUPERHETERODYNE RECEIVER (SUPERHET)

This type of circuit uses an entirely different principle of operation from those previously described. We have understood from the behaviour of a T.R.F. receiver and a regenerative receiver that amplification of a radio frequency signal has limitations as to what can be achieved without special circuitry to prevent the detector valve bursting into oscillation. From the simpler circuits we have also learnt that the amplification of lower frequency (A.F.) signals presents no such difficulties. The underlying principle of *superhet* operation is to take the radio frequency signal, convert it into a *lower frequency*, still within the radio frequency range but one which can readily be amplified without trouble, and then feed this amplified signal into the detector—and subsequently out of the detector into any further stages of audio amplification required.

This lower frequency is known as the *intermediate frequency* and may be any value within a range of about 110 Kc/s to 1600 Kc/s. In practice, common values are 255 Kc/s and 465 Kc/s, it being of practical importance to standardise on fixed values for the intermediate frequency so that suitable

components can be made readily available for superhet construction; also so that broadcast stations do not radiate on these chosen intermediate frequencies.

The majority of domestic receivers are designed on the superhet principle because of the many advantages—high

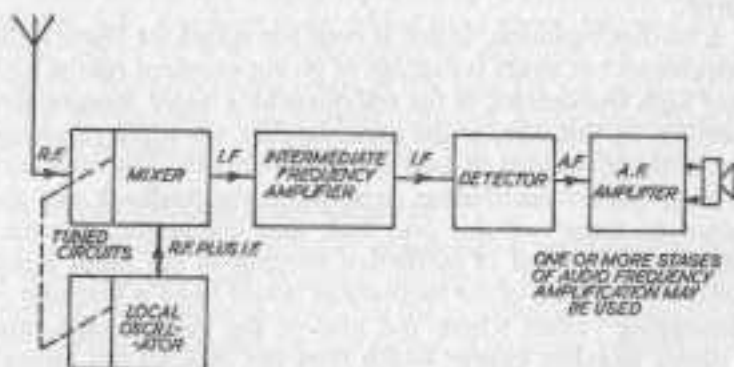

FIG. 56. BLOCK DIAGRAM OF THE SUPERHET RECEIVER.

selectivity, high sensitivity, high gain and good stability. Again, however, the superhet is a relatively complex design for amateur construction and a type which is almost impossible to align correctly for proper working efficiency without the aid of a *signal generator*. We will therefore restrict further description of this type of circuit to an explanation of the block diagram shown in Fig. 56.

The basic stages are a tuned circuit coupled to a *mixer* feeding into one or more *intermediate frequency amplifier* stages and thence to the *second detector* stage, followed by one or more audio frequency amplifier stages, as necessary. In addition, a *local oscillator* is coupled into the mixer stage to provide the necessary intermediate frequency for I.F. amplification. On some superhets, e.g. some car radios, a stage of *R.F. amplification* may precede the *mixer*, but no normal domestic receiver uses this additional stage.

The local oscillator is also provided with a tuned circuit which is mechanically interconnected or *ganged* to the tuned circuit at the front end of the *mixer*. Whatever the intermediate frequency selected for the design, this arrangement ensures that the frequency of the local oscillator fed into the mixer

*always* differs from the incoming R.F. signal by the intermediate frequency value.

To quote specific values. Suppose the incoming R.F. signal is 1,000 Kc/s and the intermediate frequency is 465 Kc/s. The tuned circuit in the front of the mixer is tuned to 1,000 Kc/s whilst the ganged tuned circuit on the local oscillator is likewise adjusted so that the local oscillator frequency fed to the mixer is 1,000 plus 465 = 1,465 Kc/s. This "difference" frequency is extracted from the mixer for amplification in the intermediate frequency amplifier stage(s); and whatever the original tuning (i.e. the original R.F. signal frequency to which the set is tuned), this "difference" frequency will remain the same and equal to the fixed intermediate frequency—465 Kc/s in this case.

The I.F. amplifier stages are therefore concerned solely with amplifying this intermediate frequency *modulated* by the original R.F. signal and the second detector stage (usually a diode) in rectifying this signal to give the required *audio frequency* output as with all the simpler circuits discussed.

## SUB-MINIATURE RECEIVERS

WHILST the circuits described in the previous chapters can be described as "miniature" in that the complete receiver, with its batteries, can be accommodated in quite a small case, transistor circuits also lend themselves to further compacting and space reduction resulting in the sub-miniature receiver, which is smaller in size than a box of matches. The use of a loudspeaker is precluded in such a small volume, so receivers of this type invariably utilize a deaf-aid type earpiece for listening, plugging into a matching jack on the side of the receiver case. Also, again to save space and reduce the number of components to a minimum, fairly simple circuits are usually employed and the smallest sizes of Mallory-mercury batteries.

The main limitation with such circuits is the rather low aerial efficiency which can be realized in a necessarily small size of aerial coil and ferrite rod or slab. Nevertheless, well-designed sub-miniature receivers are capable of providing satisfactory listening in areas of good reception and good sensitivity over a wide range of broadcast frequencies. In less favourable areas reception may be marginal and variable with conditions. In particular the final signal volume may be quite low with a suitable level for listening dependent on fairly precise alignment of the aerial relative to the source of signal. Such circuits, however, are readily adaptable to a further stage of a.f. amplification for working a speaker, although the combined volume of basic receiver, amplifier and speaker no longer conforms to the conception of a sub-miniature receiver.

In order to achieve minimum spacing of components together with a practical method of mounting and wiring up, sub-miniature receivers are invariably built on a printed circuit board. The original design of such a circuit is tricky and demands some experience to tackle successfully. For this reason the sub-miniature receivers are normally best built from kits

which include a printed circuit board ready prepared and drilled for the mounting of components. Building the receiver then becomes a matter of simple assembly, locating each component in its correct position on the printed board and

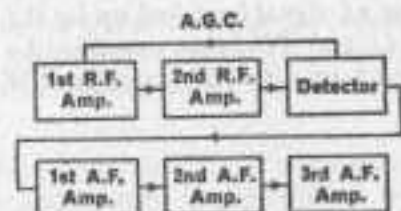

FIG. 57.

soldering the leads in place to the copper lands. Since the positioning of components can be quite critical—one component assembled in the wrong order may interfere with the mounting of a subsequent component—a definite sequence is usually specified for building. Certain precautions may also have to be observed, specific to the design. Thus, building from kits, the main point to remember is to follow the instructions for that kit specifically and not attempt what may appear to be "short cuts."

An outstanding example of a sub-miniature receiver of this

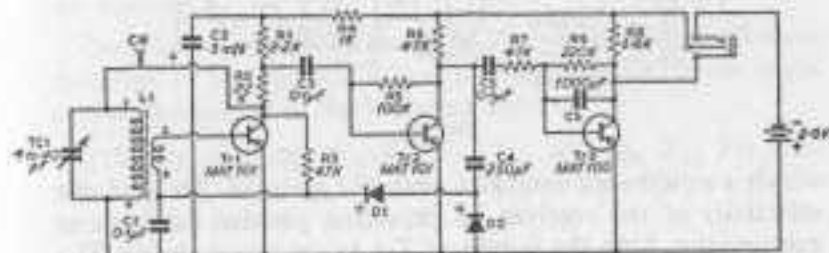

FIG. 58.

type is the Sinclair Micro-6. This is designed to fit into a case measuring only 1.8 x 1.3 x 0.5 inches and weighs less than one ounce, complete with batteries. The circuit is ingenious in that although only three transistors are employed the

performance is generally comparable to that of a six-transistor superhet. This is achieved by reflexing both the first and second transistors so that each amplifies successively at both a.f. and r.f. in the block diagram Fig. 57.

A circuit diagram of the Sinclair Micro-6 is shown in Fig. 58. The incoming r.f. signal is picked up by the aerial coil  $L_1$  and selected by  $L_1$  and  $TC_1$ , then amplified by  $Tr_1$  and  $Tr_2$  prior to detection. A semi-variable capacitor  $CW$  is introduced

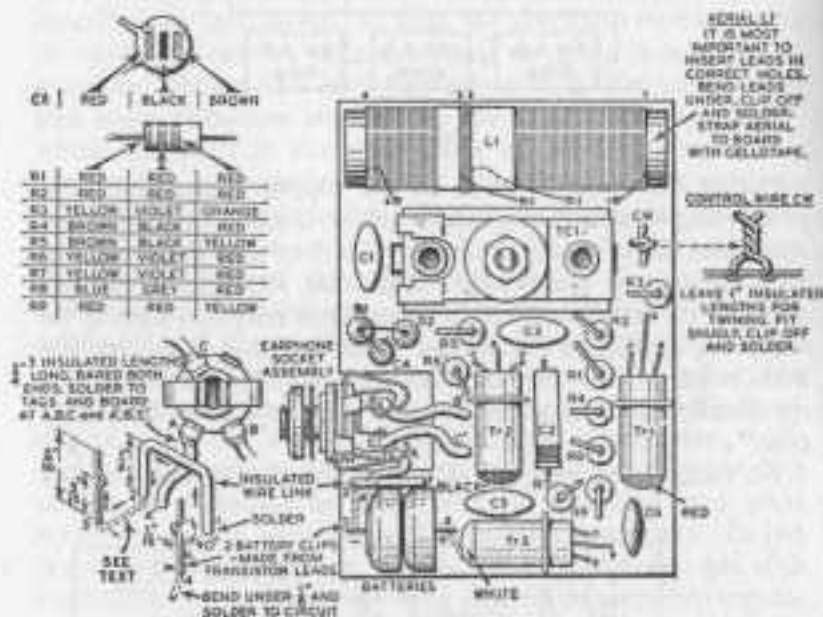

Fig. 59.

which considerably increases both the gain of  $Tr_1$  and the selectivity of the receiver by providing positive feedback or regeneration from the output of  $Tr_1$  to the tuned circuit. The level of regeneration is automatically controlled by the a.g.c. circuit. In practice,  $CW$  is simply two pieces of single stranded insulated wire twisted together, adjusted for best performance merely by twisting or untwisting the "coupling" until best performance is achieved.

The r.f. output from  $Tr_2$  is coupled directly to the double

diode detector  $D_1$  and  $D_2$  by capacitor  $C_4$ . The output from the detector stage consists of three parts:

(i) a D.C. voltage which is proportional to the signal strength and which controls the collector current and thus the gain of  $Tr_1$ .

(ii) an a.f. signal which is fed to the base of  $Tr_1$ . This a.f. signal is then amplified in turn by  $Tr_1$ ,  $Tr_2$  and  $Tr_3$ .

(iii) an unwanted residual r.f. signal which is removed by capacitor  $C_1$ .

The three transistors used are of micro-alloy type, enabling a satisfactory performance to be realized on a low battery voltage with very low current consumption. The batteries are

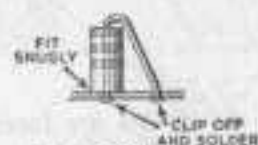

Fig. 60 SHOWING FITTING OF RESISTORS R1, R2, R3, R4, R5, R6, R7, R8 and R9.

Fig. 60.

Mallory ZM312 or RM312 mercury cells of 1.2 volts each. In areas of strong signals a single cell (1.3 volts) may be satisfactory but for most areas two batteries (2.6 volts) are required for working.

Component assembly is shown in Fig. 59. All components are mounted on the opposite side of the board to the copper lands and are assembled in the following order:

$TC_1$ ,  $C_1$ ,  $R_5$ ,  $C_3$ ,  $R_2$ ,  $R_3$ ,  $R_1$ ,  $R_4$ ,  $R_8$ ,  $R_9$ ,  $R_7$ ,  $Tr_1$ ,  $C_6$ ,  $Tr_2$ ,  $C_2$ ,  $C_5$ ,  $Tr_3$ ,  $R_6$ ,  $D_2$ ,  $D_1$ ,  $C_4$ , battery clips, earphone socket,  $CW$ ,  $L_1$ .

It is very important that all the components used to build this set are mounted as close to the board as possible. The leads must be clipped to within about  $\frac{1}{32}$  inch from the board and then soldered. The solder must not protrude from the board more than absolutely necessary. To ensure a good joint the solder should be held against the wire and the copper and the joint made quickly with the iron at full heat. The transistors can be

damaged by excess heat and it is wise to grip the transistor lead being soldered with tweezers or pliers to act as a heat sink. It is not essential to hold the solder to the joint in the case of the transistors as the leads are gold plated.

Remove any insulation from the leads of  $C_1$ ,  $C_3$  and  $C_5$  as shown in Fig. 61.

The assembly of  $D_1$ ,  $D_2$ , and  $C_4$  is shown in Fig. 62. Take

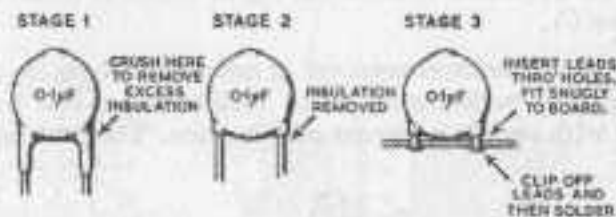

FIG. 61.

care to ensure that the diodes are inserted the correct way round. The positive end is that which looks like a tiny front arrow inside the glass body of the diode.  $C_4$  (250  $\mu F$ ) is mounted flush to bring the top to the level of  $D_1$  and  $D_2$ . The top lead of  $C_4$  is wound round the top leads of  $D_1$  and  $D_2$  as shown in Stage 3. Solder  $C_4$  to  $D_1$  and  $D_2$  as quickly as possible to avoid damaging the diodes and then clip off the rest of the diode leads

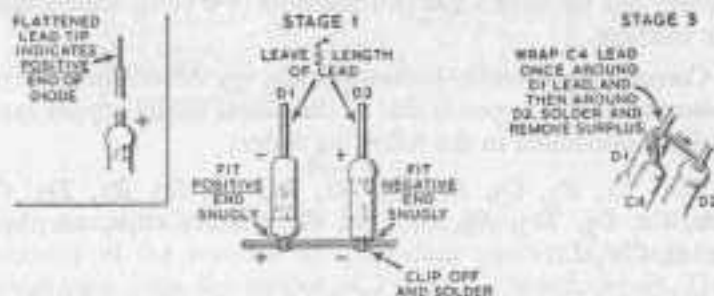

FIG. 62.

as close to the diodes as possible. Unless the leads are clipped close to the diodes the final assembly might not fit into the case.

Bend the transistor leads so that they can be assembled on to the board as shown in Fig. 63. Clip off the leads after mounting and keep them, as two are required to make the

battery clips. Remember to make the solder joints quickly and to use a heat sink if possible to avoid damaging the transistors.

$TC_1$ , the tuning capacitor, must lie flat on the board as shown in Fig. 59. The eyelet and the bush protrude slightly into holes provided on the board. It may be necessary to bend the leads slightly so that they coincide with the copper on the board to which they must be soldered. The leads, when clipped, must not extend more than  $\frac{1}{4}$  inch from the board and should be soldered as in Fig. 64.

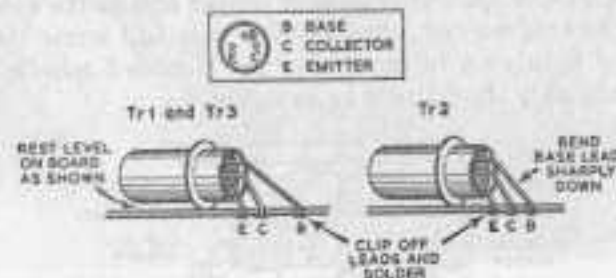

FIG. 63.

Mount  $L_1$  on to the board as shown in Fig. 59 and then fix it to the board carefully with clear cello tape so that it cannot move. If wished, the aerial may further be glued to the board for extra security.

For  $CW$  use two pieces of the single stranded, plastic insulated wire just over 1 inch in length. Bare one end of each and solder into position as shown in Fig. 59. It is not necessary to twist these wires together at this stage. The single stranded wire is only required for  $CW$ .

The assembly of the battery clips is shown in Fig. 59. These are bent from the transistor leads you will have saved. The positive clip (numbered 4 on the diagrams) requires about  $\frac{1}{2}$  inch of lead. The negative lead (numbered 3) extends under the board, up through the hole numbered 2, across and down again through hole 1. The section between 1 and 2 must be covered with  $\frac{1}{2}$  inch of plastic sleeving taken from the 4 inches length of single strand wire. This insulated wire link helps to keep the batteries in position. The clips must be soldered very firmly under the board to ensure sufficient rigidity. They must be clean at all times. Corrosion or dirt must be removed by gently filing or scraping.

Solder the earpiece socket to the board using three  $\frac{1}{4}$  inch

lengths of the multi-stranded, plastic insulated wire as shown in Fig. 59. Be careful to join the tags to the correct holes.

Remove the nut and washer from the earpiece socket and fit the entire assembly into the case passing the threaded neck through the hole on the side. Now replace the washer and nut of the socket on the outside of the case and tighten the screw firmly but carefully.

Remove the screw and two washers from TC1 and screw in the dial from the front of the case until the spindle projects through TC1. Replace the paxolin washer and fit the specially shaped locking washer provided over this and screw the nut provided tightly on to the end of the threaded spindle. The whole assembly should now be as in Fig. 64.

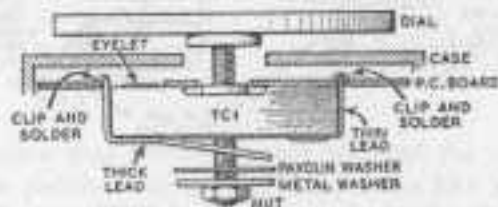
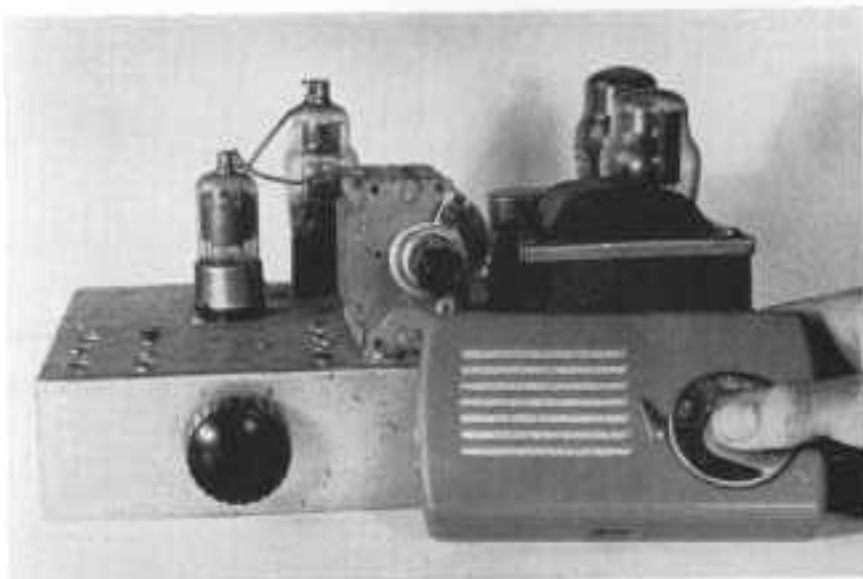
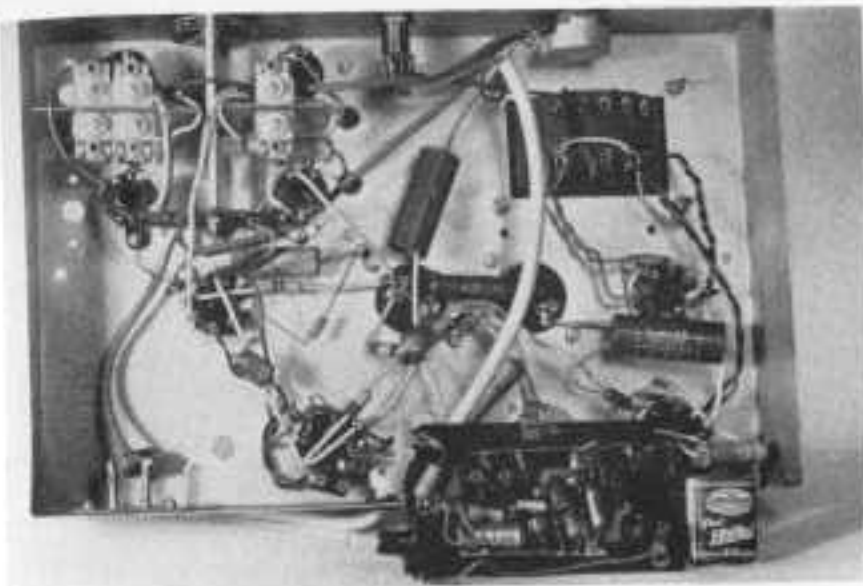

Fig. 64.

The Micro-6 uses two Mallory ZM312 (or RM312) mercury cells. These may be obtained from Boots the Chemists, or from most radio shops. Fit the cells between the battery clips, being very careful to insert them the correct way round as shown in Fig. 59. You will probably need to bend the battery clips inwards to ensure that they grip the cells tightly enough. Make sure the clips are always clean.

Plug the earpiece into the socket. This automatically switches the set on and you should now be able to tune in a station or two. Tune to the high frequency end of the band, that is with the dial turned clockwise as far as it will go, and twist the wires of CW tightly together until you hear a rushing or whistling noise. Now untwist them slightly so that the noise just stops. CW may be adjusted slightly for best performance and then bent over so that the lid can be fitted. Two lids are provided; one in white plastic and one in clear to give you a choice. The lid slides into place from the end of the box.

The kit for the construction of the Sinclair Micro-6 is produced by Sinclair Radionics Ltd, Comberton, Cambridge.



Top: Compare the size of a reflex type transistor receiver (foreground) with a three-valve T.R.F. receiver (underside of chassis view, showing components wired up).

Bottom: Here is a transistor receiver complete with speaker in cabinet compared in size with a T.R.F. valve receiver (same model as above, but top view of chassis). The large component on the right of the T.R.F. receiver is the mains transformer. Transistor receiver operates off a tiny dry battery.

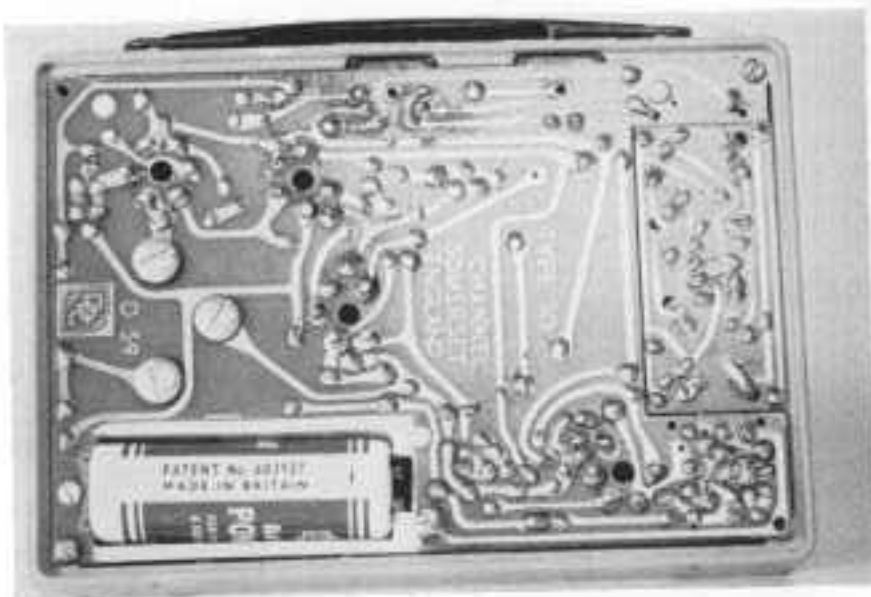
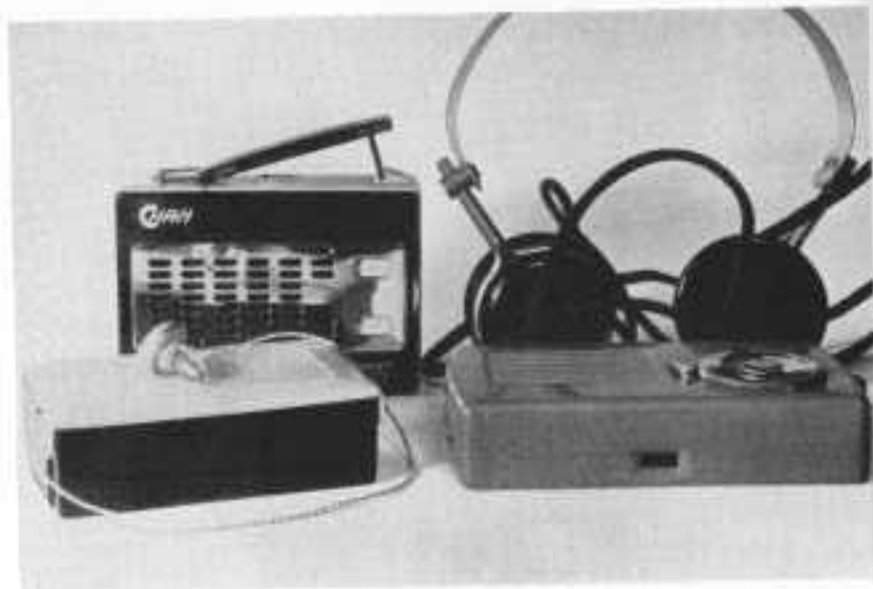

*Top:* Three different types of transistor receivers shown. Set on left (front) employs a deaf-aid earpiece. Compare in size with headphones in background. Other two receivers operate a receiver contained in cabinet.

*Bottom:* Wiring for a superhet transistor receiver can be very complicated. To make assembly more simple, printed circuits are normally used, where the circuit is actually "printed" on the Paxolin base and components are simply soldered in position.

## CHAPTER X PRINTED CIRCUITS

Most modern radio circuits, and virtually all transistor circuits, are assembled on printed circuit boards rather than wired up in the "old-fashioned" manner. In the series of designs described in Chapters III to VIII, "wired-up" circuits have been employed since the design and construction of printed circuit panels is a rather specialized job, needing skills which are only developed by practical experience. However, the construction of printed circuit panels is well within the scope of the amateur enthusiast and this chapter will be devoted to describing the techniques involved.

A printed circuit, as the name suggests, incorporates all—or as much as practicable—of the wiring "printed" in copper on a sheet of flat material with insulating properties. In fact, the circuit drawing, specially designed to accommodate all the components, is reproduced in copper foil bonded to a sheet of laminated plastic. "Printing," as such, is limited to reproducing a drawing of the circuit on the copper. The final production of the printed circuit panel involves a process of etching away unwanted copper areas, leaving just the copper wiring design, normally referred to as copper lands. After "printing"—or, rather, printing and etching—the panel is then drilled with holes to take the component leads. Components are mounted to the panel by inserting their leads through the appropriate holes and then soldered in place to the copper lands. The laminated plastic panel thus carries the circuit (in the form of copper lands) and also acts as a "chassis" or mounting panel for all the components.

Printed circuit base material consists of copper foil, 2, 3 or 5 thousandths of an inch thick, bonded to a sheet of laminated plastic, typically about  $\frac{1}{16}$  inch thick. The two main types of plastic sheet employed are phenolic laminate (e.g. Paxolin), distinguished by its brown colour; and glass fibre laminate. The

latter is whitish in colour and translucent, with the advantage that you can see through the panel from the "plain" side to identify the position of the copper lands underneath. This can be of considerable aid to assembly with complex circuits, and the material is also stronger than phenolic laminate. However, it is more costly and harder to drill. For normal amateur construction, phenolic laminate material is quite satisfactory.

Printed circuit "stock" is supplied in flat panels, with one face coated overall with copper foil. It is on this surface that the circuit design is drawn or "printed" and surplus copper subsequently etched away to provide the final printed circuit. The distinct processes involved are:

- (i) A suitable design of printed circuit.
- (ii) Transferring or "printing" this design on the copper side of the stock panel.
- (iii) Etching to remove surplus copper leaving the final printed circuit pattern.
- (iv) Drilling the holes for mounting the components in position.

The technique of soldering the components in place also differs from ordinary soldering up of wired circuits.

Starting with the printed circuit *design*, this has to provide both all the normal wiring connections and accommodate the physical shape and sizes of the various components. The starting point, therefore, is to find a suitable disposition of components which will fit in with the connections required. All the "wiring" as such, has to be accommodated on a flat panel, i.e. in two dimensions only, without crossing of conductors. The components themselves can, of course, form bridges between conductors, but you cannot "bridge" one copper land over another. If it proves impossible to design a suitable circuit without crossing conductors then the conductors will have to stop at such points and be joined by a length of insulated wire. This is poor printed circuit design and should be avoided if at all possible.

The various circuit components—resistors, capacitors, transistors—can be mounted flat against the panel (horizontally), or vertically. The former method requires a larger panel area, but is usually the easiest method as regards circuit design since

it avoids crowding of the various conductors. Vertical assembly is essential, however, if the size of the panel is to be reduced to a minimum. These remarks apply specifically to resistors and capacitors. Transistors are normally mounted vertically in any case, although sometimes the leads may be bent to allow the transistors to lie horizontally to reduce the height of the

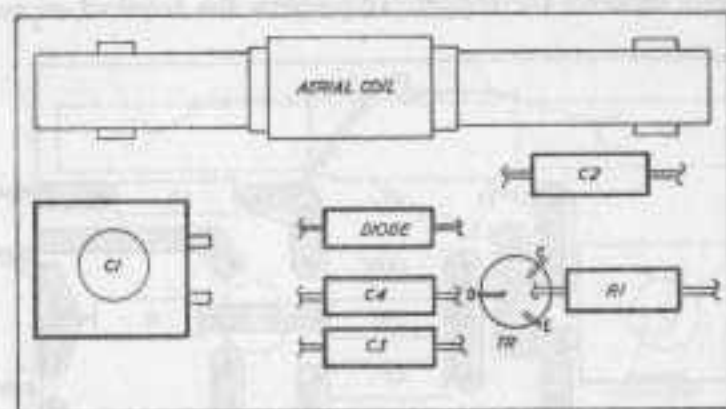

FIG. 65.

assembly—see Fig. 63 (Chapter IX). Other components, such as tuning capacitors and transformers, will have only one way in which they can be mounted.

As a simple example of printed circuit panel design, let us take Design no. 3 described in Chapter V. The component layout can follow very much on the same lines as the schematic of Fig. 29, as shown in Fig. 65. This should be drawn full size, with all the components involved actual size. Having checked that there will be no "crossing" connections—rearranging component positions to avoid this, if necessary—the required form of the copper lands to produce the required "wiring" connections can then be drawn in—Fig. 66.—marking also the hole positions for the various component leads. A tracing should then be made of this printed circuit design.

The drawing produced represents a view of the "plain" side of the printed circuit panel on which the components are mounted. The actual layout pattern for the copper lands on



the reverse side is laterally inverted or a "mirror image" of this. Thus turning the tracing paper over and transferring the pattern to the copper side of a clean panel will produce the required laterally inverted layout for the copper lands—Fig. 67.

This layout represents the actual areas of copper required. All the rest of the copper is unwanted and has to be etched away. This is done by immersing the panel in an acid bath which dissolves the copper. To preserve the required copper

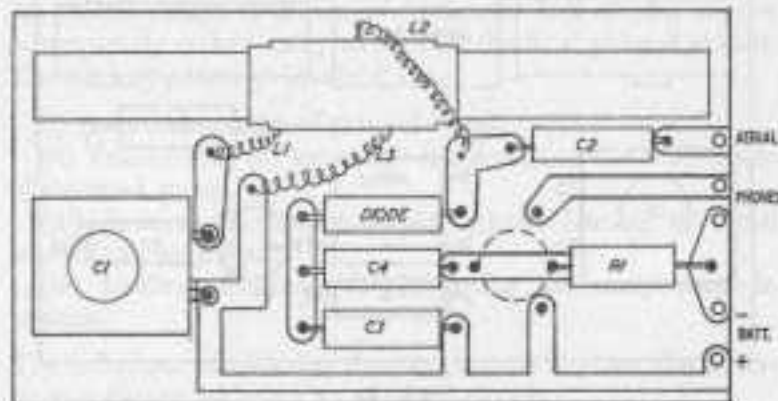

FIG. 66.

land areas, therefore, these have first to be protected with a coating which prevents them being attacked by the acid during the etching process. This is done simply by painting in these areas solid with a suitable "resist"—either a special resist ink made for the purpose, or, more simply, just quick-drying cellulose paint or model dope.

With simple circuits where the conductors are not crowded together, painting in can be done frechand. The outlines may be a little ragged as a consequence, but this will not affect the efficiency of the circuit. With a more complicated circuit it is best to tackle painting in as a proper draughting job, using a ruling pen for drawing straight lines and compasses for curves and circles. Professional printed circuits are printed in resist ink from larger scale drawings prepared on the drawing board and reduced photographically to the required size.

With all the copper land areas suitably coated and blocked in

with "resist," etching is then a quite straightforward process, once the resist ink or dope has dried. First, however, the panel should be cut to the required overall size, using a hacksaw or a fine razor saw. Cut edges can be smoothed with a fine file, as necessary.

There are a number of simple solutions which can be used for etching. A fairly strong solution of ferric chloride to which has been added a little dilute hydrochloric acid is excellent.

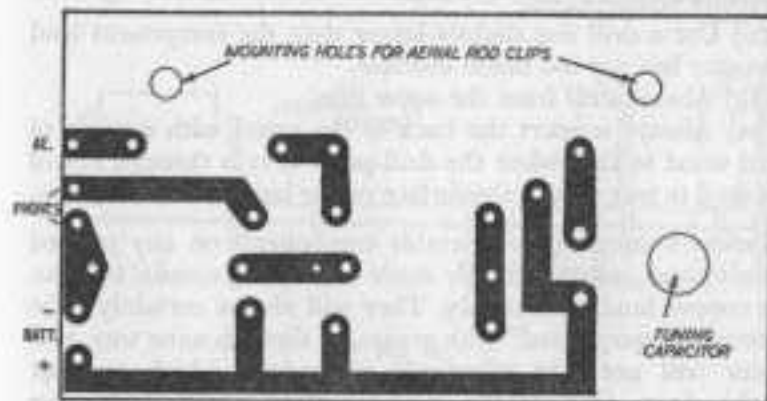

FIG. 67.

Ordinary dilute nitric acid can also be used, although this will "gas" more than the ferric chloride solution.

The etching solution is poured into a shallow tray or dish, such as the lid of a plastic sandwich box, and the panel to be etched immersed in it. At normal room temperature ferric chloride solution will etch away the unprotected copper areas at a rate of about 1 thou per 20 minutes—or take roughly an hour to etch completely a normal 3 thou foil stock panel. Rate of etching can be speeded up by using a warmer solution—with a bath temperature of 70 degrees F the etching time will be halved, compared with the solution at 50 degrees F—and by gently agitating the solution as etching proceeds.

The panel should be left in the bath until all the exposed copper areas have cleared, i.e. have been dissolved away. The panel is then removed and rinsed off in running water. The dope or resist ink covering the copper lands is then removed by

wiping over with a suitable solvent—i.e. resist-solvent in the case of a resist ink, or dope-thinners in the case of cellulose paint.

The final stage of preparation then consists of drilling the board to take the component leads. This is a fairly straightforward process but, for best results, the following precautions should be observed:

- (i) Always use a new drill—or at least a drill which has been correctly resharpened.
- (ii) Use a drill size slightly larger than the component lead diameter but not too much oversize.
- (iii) Always drill from the *copper* side.
- (iv) Always support the back of the panel with a piece of hard wood so that when the drill point breaks through it will not tend to tear or split the surface on the laminate on that side.

Before attempting to assemble components on any printed circuit panel, whether freshly made or not, it is *essential* to clean the copper lands thoroughly. They will almost certainly have become "fingerprinted" with grease, or dirty in some way, and solder will not take effectively to surfaces which are not bright clean. One of the most effective ways of cleaning a printed circuit panel is to scrub the copper side with a domestic abrasive cleaner, or fine steel wool, until all the copper surfaces are bright clean. A good test of cleanliness is to hold the panel under a tap, copper side up. If the water wets the whole area and runs evenly over it, the surface is clean. If isolated patches of copper remain dry, these are almost certainly covered with grease and require further cleaning. Time spent in cleaning a panel properly before starting assembly is not wasted. It ensures a quicker and more satisfactory job when it comes to soldering up.

A satisfactory soldering job also depends on using a suitable iron. Small-size electric soldering irons are invariably used for printed circuit assemblies. An iron with a  $\frac{3}{16}$  inch diameter bit is about right for most general work—not too large to handle within a fairly confined space, but large enough to retain enough heat for more or less continuous work. A smaller iron may be necessary with miniature and sub-miniature assemblies—e.g. a  $\frac{1}{8}$  inch or even a  $\frac{1}{16}$  inch bit—but will cool rapidly in

making a single joint and may need time to heat up again before tackling the next joint.

Apart from cleanliness of the parts to be soldered, the most important factor for successful soldering is that the iron should be *hot* enough. All joints should be completed in a matter of three or four seconds, no longer. If the joint does take longer, or has a pasty, dull appearance in this time, the iron is not hot enough. If the solder does not flow evenly over the joint although it melts readily enough, the iron is hot enough but

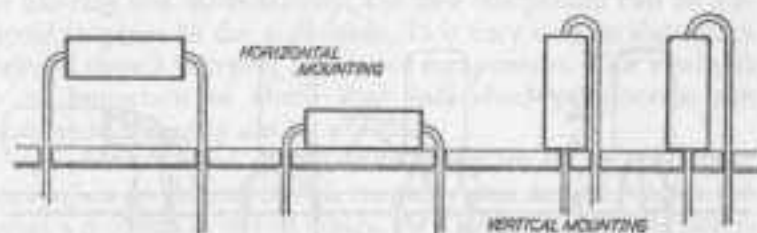

FIG. 68.

the joint surfaces are dirty. You cannot do a good job if these faults are present.

Components such as resistors and capacitors are mounted by bending the leads with fingers—not pliers—to match the hole spacings in the printed circuit panel. The component is then pushed into place to rest flat against the plain side of the board, either horizontally or upright (Fig. 68). Components are mounted one at a time and soldered in place before proceeding to the next one, being permanently fixed by soldering the protruding leads to the copper lands. There are three basic methods of doing this:

- (i) Cut off the leads to stand proud of the lands by about  $\frac{1}{8}$  inch (not more) after mounting the component, then solder.
- (ii) Solder in place first, then cut off surplus lead
- (iii) Cut the leads off short after mounting, then turn over against the land to hold the component in place and finally solder.

Method (i) usually produces the neatest job. Method (ii) is

probably easier. Method (iii) takes longer but holds the component located whilst the soldering is being completed. It is less suited to crowded circuits, however.

Transistors require special consideration since these are readily damaged by excessive heat. Unlike resistors and capacitors they are invariably mounted proud of the panel, allowing at least a  $\frac{1}{4}$  inch of lead above the panel (Fig. 69). Since the three leads from the transistor are bare wires it is also advisable to cover one (or all three) with a short length of sleeving. This will guard against the possibility of the leads shorting. Equally

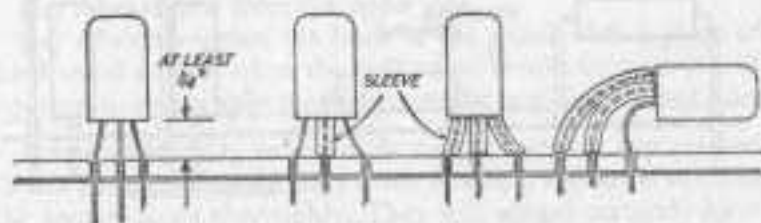

FIG. 69.

important is to ensure that the three transistor leads are correctly identified and inserted into their correct holes in the printed circuit panel.

Provided your iron is hot and your soldering technique satisfactory, you can solder transistors in place without using the recommended "heat sink." All modern transistors can take the heat of a soldering iron applied to their leads more than  $\frac{1}{4}$  inch away from the body of the transistor for ten seconds without suffering any harm. Thus if you can complete good joints in three seconds you do not have to bother about "heat sinks." If you prefer to "play safe" grip each lead of the transistor being soldered with a pair of pliers or a crocodile clip with the jaws filed flat to act as a "heat sink."

Excessive heat—i.e. the iron applied too long to one area—can result in damage to the printed circuit itself as well as components by causing the copper land to "lift." If this does occur, it can sometimes be stuck down again by pressing in place whilst still hot—but not with the iron. Usually, however, it is necessary to stick back on to the laminate with a suitable

adhesive. "Lifting" of the copper in this manner does not impair the efficiency of the circuit, unless the copper is broken away from the rest of the land. If this is so, it will have to be reconnected by soldering a short length of wire in place.

If a component has to be removed from a printed circuit panel for any reason—e.g. it may have been soldered in the wrong hole—extreme care is needed to avoid overheating both of the component and the copper. The safest way of removing a component is to cut off the leads. The stub ends of wire can then be removed one at a time by heating the solder and tapping or blowing out. Alternatively, the new component can be soldered in place to the stub leads. It is very easy to damage a printed circuit in trying to remove components. This is why it is so important to check that individual components are positioned correctly during assembly.

All of the designs described in Chapters III to VIII lend themselves to printed circuit assembly and do not present too great a problem in circuit design. As a general guide, the physical layout of components should follow the theoretical circuit diagram as closely as possible to obviate the problem of "crossing" conductors. This also provides logical placement of the more bulky components, such as the aerial coil assembly and tuning capacitor. Battery and phone connections (external wires) are made directly to terminal points on the printed circuit panel.

#### PRINTED CIRCUIT LAYOUTS

The following four pages give component layouts and printed circuit drawings, both actual size, for receiver designs Nos. 4, 5, 6 and 8 described earlier in the book; the size of printed circuit panel used is  $3\frac{1}{2} \times 2$  inches in each case. The printed circuit panel diagram should be transferred directly to the copper side of the panel and the black areas painted in with resist ink or model aircraft dope, after which the balance of the copper foil is etched away. The panel is then completed ready for assembly by drilling the holes for the component leads and for accommodating the tuning capacitor (C<sub>1</sub>) and ferrite rod aerial clips.

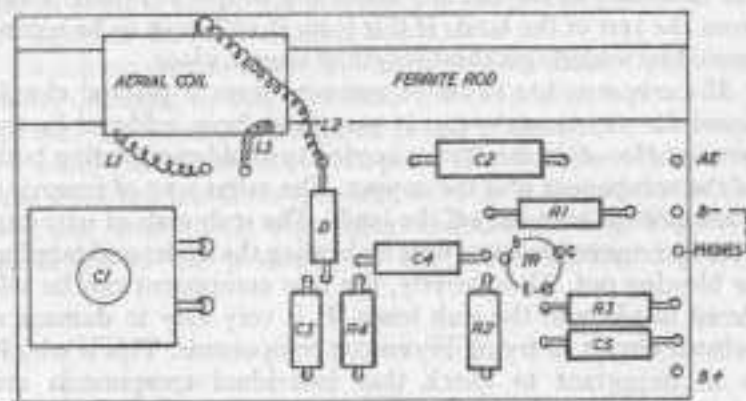

FIG. 70. COMPONENT LAYOUT FOR DESIGN NO. 4 (CIRCUIT DIAGRAM, FIG. 30) FOR PRINTED CIRCUIT ASSEMBLY.

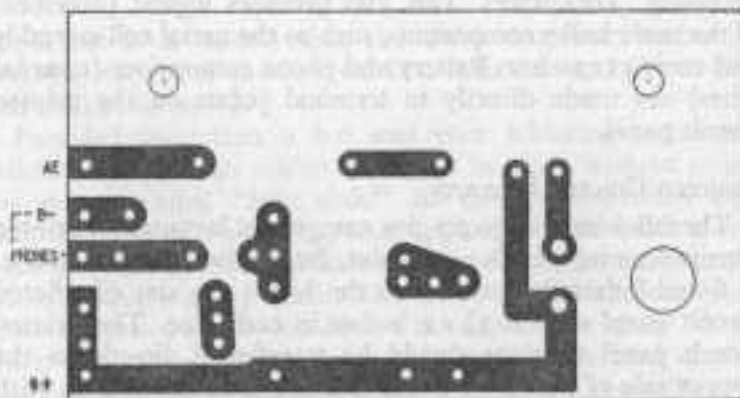

FIG. 71. PRINTED CIRCUIT PANEL FOR DESIGN NO. 4 CIRCUIT.

This printed circuit layout is based on a panel size of  $5\frac{1}{2} \times 2$  inches and the two diagrams above are reproduced actual size. The phones are connected by soldering the two leads to the appropriate points on the printed circuit panel. Battery connection is made by soldering two leads to the appropriate points marked on the panel, with the free ends of these leads to press studs to match the battery terminals. The correct battery polarity must be observed.

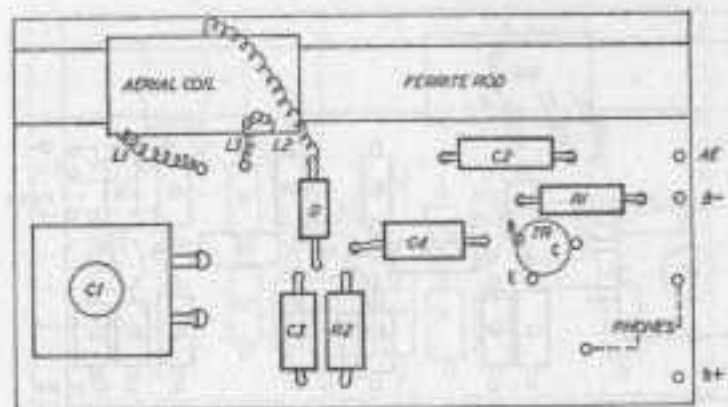

FIG. 72. COMPONENT LAYOUT FOR DESIGN NO. 5 (CIRCUIT DIAGRAM, FIG. 31) FOR PRINTED CIRCUIT ASSEMBLY.

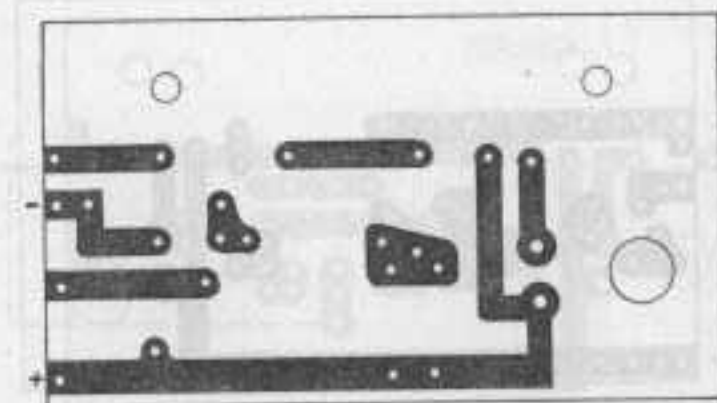

FIG. 73. PRINTED CIRCUIT PANEL FOR DESIGN NO. 5 CIRCUIT.

This printed circuit layout is based on a panel size of  $5\frac{1}{2} \times 2$  inches and the two diagrams above are reproduced actual size. The phones are connected by soldering the two leads to the appropriate points on the printed panel. Battery connection is made by soldering two leads to the appropriate points marked on the panel, with the free ends of these leads to press studs to match the battery terminals. The correct battery polarity must be observed.

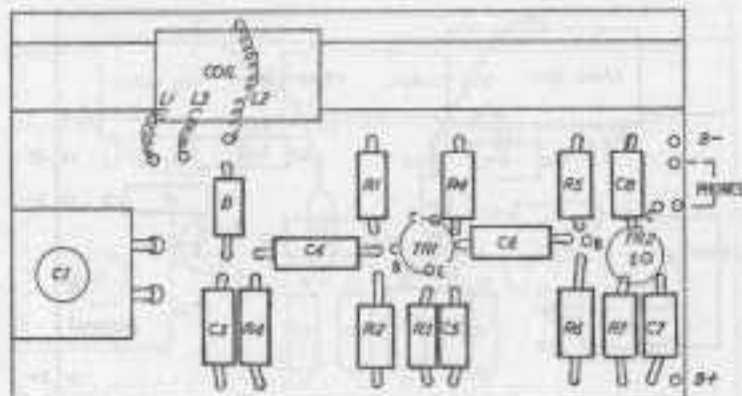

FIG. 74. COMPONENT LAYOUT FOR DESIGN NO. 6 (CIRCUIT DIAGRAM, FIG. 33) FOR PRINTED CIRCUIT ASSEMBLY.

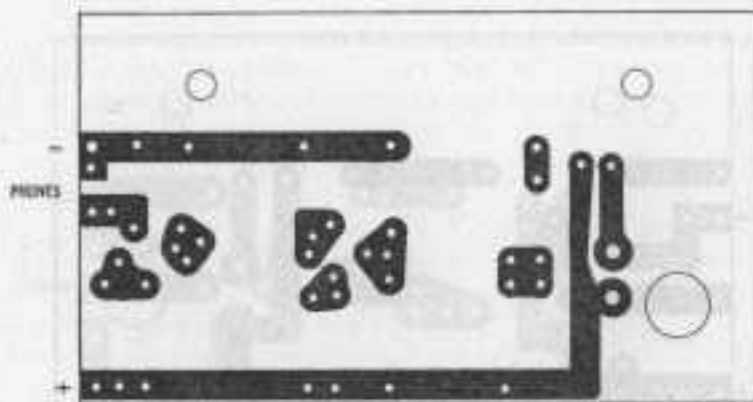

FIG. 75. PRINTED CIRCUIT PANEL FOR DESIGN NO. 6 CIRCUIT.

This printed circuit layout is based on a panel size of  $3\frac{1}{2} \times 2$  inches and the two diagrams above are reproduced actual size. The phones are connected by soldering the two leads to the appropriate points on the printed circuit panel. Battery connection is made by soldering two leads to the appropriate points marked on the panel, with the free ends of these leads to press studs to match the battery terminals. The correct battery polarity must be observed.

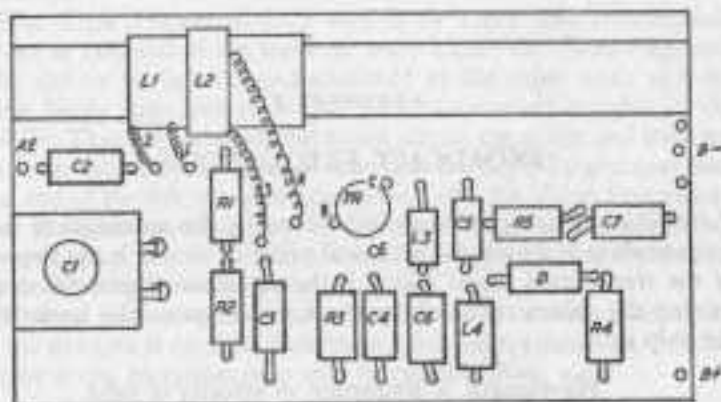

FIG. 76. COMPONENT LAYOUT FOR THE REFLEX CIRCUIT DESIGN NO. 8 (CIRCUIT DIAGRAM, FIG. 46) FOR PRINTED CIRCUIT ASSEMBLY.

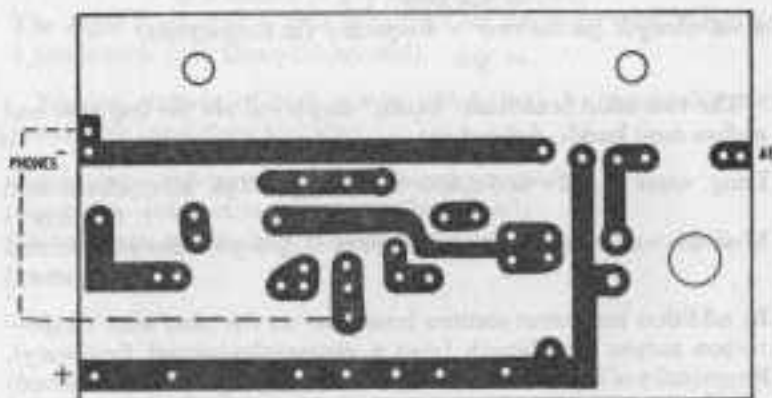

FIG. 77. PRINTED CIRCUIT PANEL FOR DESIGN NO. 8 CIRCUIT.

This printed circuit layout is based on a panel size of  $3\frac{1}{2} \times 2$  inches and the two diagrams above are reproduced actual size. The phones are connected by soldering the two leads to the appropriate points on the printed circuit panel. Battery connection is made by soldering two leads to the appropriate points marked on the panel, with the free ends of these leads to press studs to match the battery terminals. The correct battery polarity must be observed.

## BROADCAST FREQUENCIES

RADIO stations are commonly identified by the *wavelength* of their transmissions but from the technical point of view it is the *frequency* of the transmitted signal which is the significant factor for determining the values required for the tuned circuit. The basic relationship is:

$$\text{Wavelength} \times \text{frequency} = \text{velocity of light}$$

Wavelength is normally quoted in metres, the corresponding velocity of light being 300,000,000 metres per second. Hence:

$$\begin{aligned} \text{Wavelength (in metres)} \times \text{frequency (cycles per second)} \\ &= 300,000,000 \\ \text{or wavelength (in metres)} \times \text{frequency (in kilocycles)} \\ &= 300,000 \\ \text{or wavelength (in metres)} \times \text{frequency (in megacycles)} \\ &= 300 \end{aligned}$$

The two main broadcast "bands" employed are the *long wave* and *medium wave* bands, defined as:

- Long wave band—600-2,000 metres (500-150 kilocycles/second frequency)  
 Medium wave band—200-600 metres (1,500-500 kilocycles/second frequency)

In addition numerous stations broadcast on the *short wave* range—10-200 metres wavelength (30-1.5 megacycles/second frequency). Frequencies of higher values still (i.e. above 10 megacycles per second) are classified as ultra-short wave or V.H.F. (very high frequency) transmissions, used for special broadcast facilities, television, radar and radio communications, etc.

The wavelength and frequency of national broadcasting stations is given in the *Radio Times*. Simple receivers of the type described in this book are invariably designed to receive stations broadcasting on the medium wave band (also long wave stations, with a suitable modification of coil design—see Appendix III—although the

number of stations available on the long wave band are very limited).

The *Light Programme* (247 metres or 1,214 kilocycles/second) comes at one end of the medium wave band; the *Third Programme* (464 metres or 647 kilocycles/second) at the other end; and the *Home Service* (330 metres or 908 kilocycles/second) roughly in the middle. Thus the values of the tuned circuit capacitor and inductor (coil) are normally designed to tune into the *Light Programme* near one end of the full travel of adjustment, and the *Third Programme* near the other extreme, these two stations being used as check points for setting up any initial adjustment required and also, if required, for calibrating the tuning control.

This, of course, applies to receivers operated in areas where good signal strength is received from these National transmitters. In other region areas, reception may only be possible from, e.g.:

- Midland Home*—276 metres (1,088 kilocycles/second)  
*North Home*—434 metres (692 kilocycles/second)  
*Northern Ireland (Home)*—261 metres (1,151 kilocycles/second)  
*Scottish Home*—371 metres (809 kilocycles/second)  
*Welsh Home*—341 metres (881 kilocycles/second)  
*West Home*—285 metres (1,052 kilocycles/second)  
 206 metres (1,457 kilocycles/second)

The *Light Programme* is also broadcast on the long wave band at 1,500 metres (200 kilocycles/second).

Foreign stations of high power which may be received under favourable conditions include:

- Luxembourg*—208 metres (1,442 kilocycles/second)  
*Hilversum*—402 metres (746 kilocycles/second)  
*Athlone*—530 metres (566 kilocycles/second)

## APPENDIX II

## USE OF LOW IMPEDANCE PHONES

In the working circuits described the use of *high impedance* headphones or a *high impedance* deaf aid earpiece is essential for proper performance (except where stated otherwise in the description). Typical values of available commercial components are:

Headphones—D.C. resistance 2-4,000 ohms. Typical impedance 10,000 ohms at 1 Kc/s

Deaf-aid earpiece—D.C. resistance 2,000 ohms (typical impedance 7,500 ohms)

Balanced armature unit—D.C. resistance about 80 ohms (500-1,000 ohms impedance)

Any values within these limits specified should be satisfactory.

To employ low impedance headphones, a low impedance deaf-aid earpiece or a moving coil speaker in these circuits (the latter only suitable where output power is of a sufficiently high order), the phones or speaker must be coupled to the output with a matched

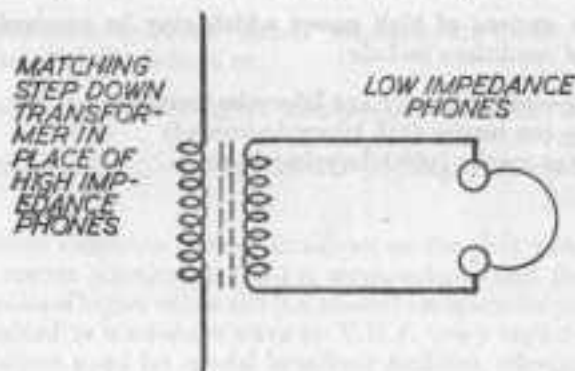

FIG. 78.

transformer. See Fig. 78. This transformer acts to supply the necessary load in the output circuit, the phone (or speaker) then being inductively coupled to this circuit under properly balanced conditions.

Transformer ratio required is:

$$\text{Turns ratio} = \sqrt{\frac{\text{output load resistance in ohms}}{\text{phone or speaker impedance in ohms}}}$$

The transformer required then provides a "step-down" of this ratio between output circuit and phones.

Suggested suitable types are:

Headphones—D.C. resistance 15 ohms.\* Transformer ratio 14:1  
D.C. resistance 80 ohms.\* Transformer ratio 5:1

Low impedance deaf-aid earpieces—  
Typical values are:

4 ohm D.C. resistance (15 ohm impedance at 1,000 c/s)  
14 ohm D.C. resistance (60 ohm impedance at 1,000 c/s)  
60 ohm D.C. resistance (250 ohm impedance at 1,000 c/s)

A matching transformer ratio can be calculated according to the value employed, taking 20,000 ohms as desired output load impedance for designs 8 and 9:

4 ohm resistance—transformer ratio 35:1  
14 ohm resistance—transformer ratio 18:1  
60 ohm resistance—transformer ratio 9:1

Loudspeakers—

All miniature speakers have a D.C. resistance of 3 ohms requiring the following transformer ratios:

For 10,000 ohm output load impedance—30:1  
For 20,000 ohm output load impedance—41:1

The above list of loudspeakers are suggested as suitable miniature types for use with the small transistor receivers, where sufficient A.F. power is available to operate. With valve circuits amplified to a sufficient degree for speaker operation, larger moving coil speakers may be employed, of which there are a wide variety of types and sizes available. The required transformer ratio can readily be calculated from the quoted impedance of the speaker and the optimum anode load figure for the output valve; or alternatively matching transformers may be specified with a particular speaker for use with particular valves.

As a guide to the suitability of a particular circuit for the operation of phones or speakers, the following are approximate values of

\* These are two typical values for low impedance headphones.

final audio frequency current required for satisfactory conversion of electro-magnetic energy into audible sound (pressure waves):

- High impedance headphones—"Threshold of audibility" approximately  $10 \mu\text{A}$  (This is dependent to some extent on the individual, some people being more adept than others in hearing weak sounds, etc.);
- $\cdot 1 \text{ mA}$ —Minimum level for comfortable listening, with concentration;
- $\cdot 5 \text{ mA}$ —Level for easy listening (sound can be heard with phones removed and laid aside);
- Over  $\cdot 5 \text{ mA}$ —"Swamp" level—phones overpowered, causing distortion, etc. . . .
- (Note: the fitting of a volume control—see Appendix VIII—is a solution here for reducing volume to a comfortable level and eliminating distortion through overloading).

For operation of a loudspeaker an audio power output of the order of  $5 \text{ mA}$  is required.

Transformer coupling of low impedance headphones or deaf aid earpiece; or low impedance loudspeaker, is as shown in Fig. 57. This coupling can be used in any of the circuits described for using low impedance headphones, replacing the high impedance headphones with the primary winding of the transformer. In the case of loudspeaker operation, transformer coupling *must* be used.

## APPENDIX III

## THE TUNED CIRCUIT

For practical purposes the tuned circuit comprises a coil of a certain *inductance* connected in parallel with a *capacitor* in a complete circuit. Being wound from wire the coil will also inevitably have a certain *resistance*, but this can be ignored for the purpose of calculating component values required.

The *resistance* of the coil is, however, significant in affecting the *selectivity* of the tuned circuit, i.e. its performance as a selector of the wanted signal. A low coil resistance gives a sharp "peaky" tuning, whilst with increasing coil resistance the peak of the response curve becomes flatter or broader and thus capable of being in resonance with signals over a *band* of frequencies rather than at a specific frequency only. At the same time the *magnification* of the original signal received when adjusted to resonance (i.e. when tuned to the original signal) decreases with increasing coil resistance.

The "magnification" produced in a resonant circuit is referred to as the "Q". A "high-Q" coil, as used for maximum selectivity and maximum performance, is therefore essentially a low resistance coil. For this reason larger diameter wound coils, using thicker wire, are more efficient than small coils wound from thinner wire (thick wire having less electrical resistance than thin wire). Small coils are, however, essential to fit into miniature sets and so a compromise on size usually has to be reached. In small aerial coils the efficiency can be improved by the form of winding employed, and by the use of iron-dust cores which have the effect of increasing the *inductances* of the coil. Such cores are adjustable in position in the coil, which type of adjustment also alters the *inductance* of the coil.

The standard tuning coils described in Chapters III and VI are wound on a *ferrite rod* which increases the efficiency or "Q" of the coils in a similar manner.

In practice the circuit may be *tuned*, i.e. its resonant frequency varied, by varying the inductance of the coil, by varying the value of the capacitance, or by varying *both* values. It is generally more convenient to use a coil of fixed inductance when tuning is accomplished simply by adjusting the capacitance (e.g. by movement of the vanes of a variable condenser, thus altering its capacitance).



Some additional adjustment of coil inductance may, however, be useful for setting up, particularly if the component values concerned do not quite give the range of tuning required.

Equally, the capacitance of the tuned circuit may be fixed (or variable, for initial setting-up adjustment) and tuning accomplished by varying the inductance of the coil by means of a dust core or, more conveniently, movement of the coil along a ferrite rod (which is also effective as an aerial). This latter form of tuning is, in fact, used on some types of miniature transistor receivers.

The basic requirement for tuning is that the resonant frequency of the circuit should correspond to the frequency of the signal. The resonant frequency can be calculated from the formula:

$$\text{Resonant frequency} = \frac{1}{2\pi\sqrt{LC}} = \frac{1593}{\sqrt{LC}}$$

(cycles per second)

where  $L$  is the inductance of the coil in henries  
 $C$  is the capacity of the condenser in farads

The range of the tuned circuit is matched to a particular broadcast band by selecting component values so that by simple adjustment the circuit is tunable over the whole of the band. That is to say, the extreme resonant frequency values obtainable must correspond to the two extreme limits of the broadcast band.

In practice the coil inductance is normally fixed (except for provision to make small adjustments to the inductance for setting up purposes, e.g. by adjustment of an iron-dust core, or altering the position of the coil on a ferrite rod). The fixed coil inductance chosen is matched to a selected size of variable condenser so that the combination meets the requirements of being tunable over the broadcast band required.

In the case of the medium wave band the range of frequencies to be covered is 500 to 1,500 kilocycles/second. Typical values of tuning condensers employed are nominally 50 to 500 picofarads, the actual capacity range of "swing" usually being as follows:

Typical air dielectric tuning condenser—Capacity swing from about 65 picofarads minimum up to about 450 picofarads maximum.

Typical mica "postage stamp" condenser—Capacity swing from about 120 picofarads minimum to 500 picofarads maximum.

The inductance of the required matching tuning coil can be calculated accordingly, e.g. checking at each end of the frequency band to see that the full range of possible resonant frequencies is

achieved. However, calculation for the physical design of the coil is too complex to consider in detail, the required proportions being best arrived at experimentally.

Regarding the operation of the variable condenser, it is useful to remember that the condenser will have its maximum value of capacitance when the vanes are fully closed; and its minimum capacitance in the fully open position (i.e. with the condenser fully open the circuit is tuned to the low frequency end of the band, and vice versa).

Suitable coil designs giving the required inductance value are shown in Fig. 79. All are wound from 38 s.w.g. enamelled copper

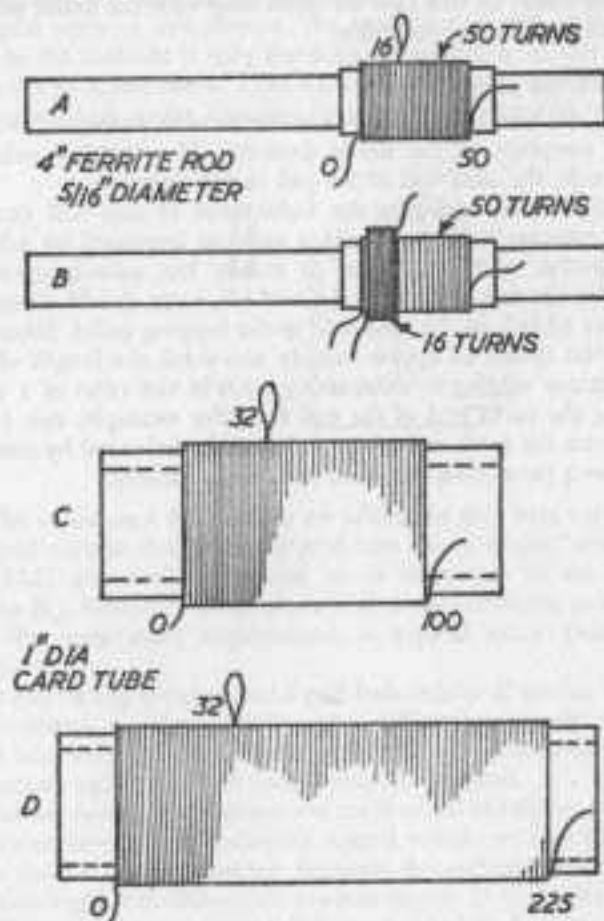

FIG. 79.

wire, or preferably 38 s.w.g. double silk covered copper wire. Coil (a) is the standard type specified for the majority of the receivers described in the book. Coil (b) employs transformer coupling and is used with the reflex circuits of Chapter VII. Both coils (a) and (b) are wound on a ferrite rod, which also acts as an aerial. Coil (c) is a large diameter air core coil suitable for medium wave reception with a good external aerial attached. It is not possible to produce a good high-Q coil in this manner and it is intended only for experimental use (see Chapter VI).

Coil (d) is the same air core coil enlarged to give an inductance value suitable for long wave reception in conjunction with a 500 pF tuning condenser. In this case an extra long external aerial will be essential for satisfactory reception.

#### ADJUSTING COIL INDUCTANCE

Coils (a), (c) and (d) are wound in the form of auto-transformers for direct coupling to the diode detector. The tapping point is always nearest the earth end of the coil in the circuit.

Using these basic designs, the inductance of any coil can be reduced by removing turns from either end; or increased by adding turns to either end. In order to retain the auto-transformer "balance" in the case of coils (a), (c) and (d), turns should always be removed, or added, in the same ratio to the tapping point. Since the tapping point comes at approximately one-third the length of the coil, this means adding or subtracting turns in the ratio of 1 to 2, considering the earth end of the coil first. For example, two turns removed from the earth end of the coil must be balanced by removing  $2 \times 2 = 4$  turns from the other end, and similarly.

## APPENDIX IV

### GRID BIAS AND GRID LEAK

The purpose of the grid leak resistor ( $R_g$ ) is to provide a D.C. path between the grid and the cathode without loading the previous circuit (see Fig. 80). If the bias battery were simply connected to the grid without this resistor, the resistance of the path from the grid to the cathode is only the internal resistance of this battery—a matter of a few ohms. Thus the load resistor  $R_g$  would be almost short-circuited, as far as audio frequency is concerned.

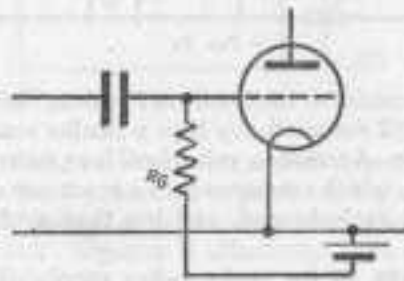

FIG. 80.

The value used for  $R_g$  does not affect the grid bias voltage, since no grid current flows (i.e. the grid bias circuit is not "complete" in the D.C. electrical sense) and hence there can be no P.D. drop across  $R_g$ . Hence its value is not critical and is chosen purely to suit the first mentioned requirement, a typical value being 1 to 2 megohms.

It will be appreciated that a grid leak resistor of similar value must be retained in other circuits using different methods of applying grid bias since all these forms involve a low grid-to-cathode D.C. resistance unless the grid leak resistor is included.

*Cathode bias* is the commonest method of obtaining grid bias in mains receivers using indirectly heated valves; see Fig. 81. Here the bias resistor  $R_b$  is connected between the cathode and earth (high tension negative). Since this resistor carries D.C. anode current it will have a direct potential difference developed across it and will

"drop" a certain voltage to make the cathode a few volts positive with respect to earth. The value of this resistor  $R_g$  to achieve the necessary bias voltage is readily calculated as:

$$R_g = \frac{\text{desired grid bias volts}}{\text{D.C. anode current}}$$

The capacitor  $C$  is employed simply as a by-pass for all audio frequency anode current components. Its value is chosen to have a

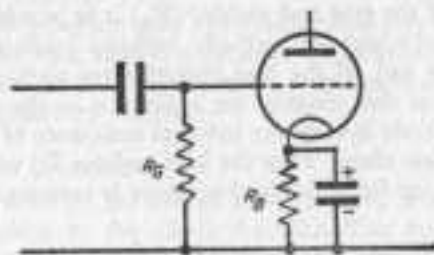

FIG. 81.

suitably low reactance at the lowest A.F. values likely to be encountered, when it will automatically have a smaller reactance at higher audio frequencies. A common value for  $C$  is 25 microfarads (electrolytic condenser), which corresponds to a reactance of 200 ohms at a frequency of 30 cycles/second, and less than 1 ohm above 6,000 cycles/second.

Bias voltage from the low tension battery supply (Fig. 82) can be

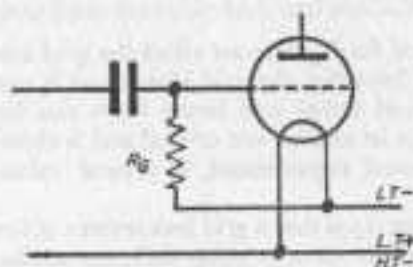

FIG. 82.

arranged in small battery receivers with directly heated valves, to save the use of an additional grid bias battery. Here the grid leak is returned to the negative side of the filament so that the grid is negative with respect to earth with a negative voltage corresponding to the low tension battery voltage. The average potential of the

filament (cathode) is negative *one half* of the low tension voltage. Hence the grid is a similar value *more negative* than the average filament potential, this being the amount of effective grid bias.

A third method of providing bias without the use of a separate bias battery is by means of bias resistors (see Fig. 83). This is normally never used for supplying a *single* stage.

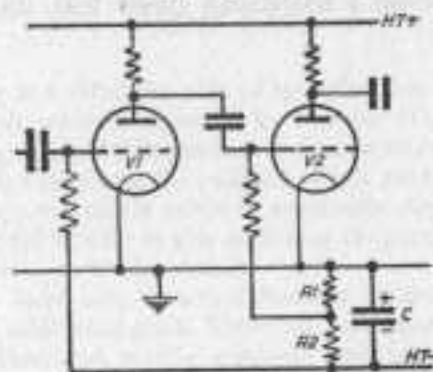

FIG. 83.

The cathodes of the valves are connected directly to earth but high tension negative is connected to earth via resistors  $R_1$  and  $R_2$  in series. A D.C. potential is therefore developed across these resistors so that H.T. negative is effectively a few volts negative with respect to earth.

The potential difference across each resistor can readily be calculated—

$$\text{P.D. across } R_1 = \text{resistance } R_1 \times \text{total H.T. current (amps.)}$$

$$\text{P.D. across } R_2 = \text{resistance } R_2 \times \text{total H.T. current (amps.)}$$

Knowing the total H.T. current and the voltage drop required, the respective values of  $R_1$  and  $R_2$  can be calculated. For equal bias voltages  $R_1$  and  $R_2$  will be equal, the connections to the valve grids being made as shown.

Example: for a negative bias of 1.5 volts, calculate the values of the bias resistors required with a total H.T. current consumption of 30 milliamps.

$$R_1 = R_2 = \frac{1.5 \times 1,000}{30} = 50 \text{ ohms}$$

It should be noted that with this method of providing bias the actual high tension voltage to the anode is *reduced* by the amount of P.D.

drop across  $R_1$  and  $R_2$ , i.e. in the case of the example just quoted by 3 volts.

Capacitor  $C$  must be included in the circuit to isolate the grids of the valves from any alternating components in the anode current by providing a by-pass to earth with negligible resistance (reactance), compared to that offered by the resistors. Typical values for  $C$  range from about 2 microfarads (never less), up to about 50 microfarads.



*[Faint, mostly illegible text, likely bleed-through from the reverse side of the page.]*

## APPENDIX V

## VALVE DATA

The following is a short list only of typical valves which may be employed in the circuits discussed in Chapter III, together with basic operating data. It is impossible, and unnecessary, to give a full list of available valves and the omission of any particular type does not necessarily mean that it would be unsuitable. Any local amateur radio shop should be able to give advice on the purchase of suitable components for a particular circuit.

The valves listed are, in actual fact, not triodes but pentodes, featuring two additional grids. These are particularly suited to the circuits described and readily available and are used as triodes, simply "strapping" or connecting the additional grid elements directly to the anode and cathode, respectively see Figs. 84-85.



67G VALVE BASE

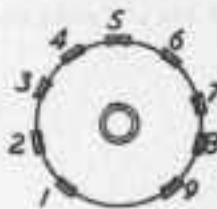

6DA VALVE BASE

FIG. 84. THE TWO-VALVE BASES USED, VIEWED FROM UNDERSIDE (I.E. FROM ASPECT OF WIRING UP).

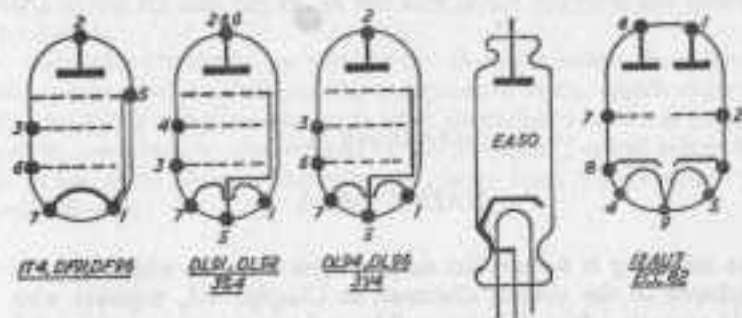

FIG. 25. DIAGRAM SHOWING THE INTERNAL GEOMETRY OF THE VARIOUS VALVES SPECIFIED, WITH PIN NUMBERS MARKED—i.e. when plugged into the respective bases the base pins of the same numbers connect to the various component parts of the valves as shown. In the case of the double filament valves fitting a B7G base, connecting pins 1 and 7 with a wire strap means that a 1.5-volt low-tension battery can be employed, the L.T. battery connection being made to this strap (i.e. to pin 1 or 7, as convenient) and to pin 5. In the case of the 12AU7 valve, pins 4 and 5 are strapped to utilize a 6.3 volt heater supply. For using the IT4, DF91 or DF96 in the circuit of Fig. 25, the valve is connected as a triode pin 3 to pin 2. Similarly to connect any other of the pentode (five-element) valves shown as a triode, strap the central grid to the anode.

#### USE OF W.17 VALVE IN FIG. 20

Filament (1.5 volts) connects to pins 1 (negative) and 7 (positive).  
High tension (45 volts) connects to pins 2 (positive) and 1 (negative).  
Grid connection to pin 6.  
Pin 3 should also connect to H.T. plus.

#### RECOMMENDED VALVES FOR FIG. 23

(Triode connected as Fig. 64)

Type	Make	L.T. volts	H.T. volts	Grid bias volts	"Slope" gm.	Base to fit
IT4	Brimar	1.5	90	0	75 mA/V	B7G
DF91	Mullard	1.5	90	0	75 mA/V	B7G
DF96	Mullard	1.5	90	0	85 mA/V	B7G

#### RECOMMENDED VALVES FOR FIGS. 19 & 24

(Triode connected as Fig. 64)

Type	Make	L.T. volts	H.T. volts	Grid bias volts	Optimum anode load	Base to fit
DL91	Mullard	1.5	90	7.0	8,000Ω	B7G
DL92	Mullard	1.5/3	90	7.0	8,000Ω	B7G
DL94	Mullard	1.5/3	90	4.5	10,000Ω	B7G
DL96	Mullard	1.5/3	90	4.5	10,000Ω	B7G

#### RECOMMENDED VALVES FOR FIG. 25

Circuit position	Type	Make	L.T. volts	H.T. volts	Grid bias volts	Anode load	Base to fit
V1	EA50	—	6.3	—	—	—	special diode base
V2 & V3*	12AU7	—	6.3	100	0	—	B9A

\* Valve 12AU7 is a "twin triode," V2 and V3 being connected to each half respectively, as in Fig. 25.

## APPENDIX VI

## TRANSISTOR DATA

The following transistors are specifically recommended for the various preferred circuits described in this book.

Design no. 3	Mullard OC71, Edison Swan XB102, XB103 or XB104
Design no. 4	
Design no. 5	
Design no. 6	
Design no. 7	
Design no. 8	
Design no. 9	

Data on these and other standard transistors are included in the following table. All voltage, current and power ratings are figures considered safe for the amateur to use. It is always advisable to keep well within these ratings.

*Special note:*

It is not permissible to apply both maximum voltage and current to the transistor together; if you do, the power rating of the transistor may be drastically exceeded.

For example, rated values for the OC72 transistor are:

$$V_{ce} = 16 \text{ volts } I_c = 125 \text{ milliamps}$$

If these maximum ratings are used together, then;

$$\begin{aligned} \text{Power} &= \text{volts} \times \text{amps} \\ &= 16 \times 0.125 \\ &= 2 \text{ watts} \end{aligned}$$

Compare with the recommended maximum power rating given in the table, which is only 100 milliwatts. The power being dissipated in the worked out example is 20 times as great as the rating of the transistor and would destroy it.

## ABBREVIATIONS USED IN TABLE

$V_{ce}$  max. Maximum permissible voltage to be applied between collector and emitter in the grounded earth configuration (i.e. in the manner of use in the transistor circuits described in this book).

- $I_c$  Maximum permissible collector current.
- $\beta$  Grounded emitter current gain, or the factor by which the base current is multiplied to give the collector current.
- $P_c$  Maximum permissible collector dissipation (or power loading) at an ambient temperature of 45 degrees C. *Note:* at any collector current and collector voltage  $P_c = V_c \times I_c$ .
- $f_{ca}$  Alpha or grounded base cut-off frequency. In general, a transistor is a useful amplifier up to about  $\frac{f_{ca}}{4}$ .

Type	Service	$V_{ce}$ max. volts	$I_c$ max. mA	$P_c$ max. mW	$\beta$	$f_{ca}$ Mc/s	Make	
OC71	A.F. Amplifier	20	10	75	47	0.5	Mullard	
OC72	A.F. Output	16	125	100 (with 14" sq. heat sink)	70	0.35		
OC44	R.F. amplifier M.W. oscillator M.W. mixer as frequency changer	10	5	50	—	15		
OC45	R.F. amplifier M.W. oscillator M.W. mixer I.F. amplifier	10	5	50	—	5		
XB103	A.F. amplifier	16	10	30	66	0.5		Mada (Siemens Edison Swan)
XC101	A.F. output	16	150	100	66	0.3		
XA102	R.F. amplifier M.W. oscillator M.W. mixer or frequency changer	15	10	30	60	8		
XA101	R.F. amplifier M.W. oscillator M.W. mixer I.F. amplifier	15	10	30	35	5		

## MAINS POWER PACK

In a mains receiver both the high tension voltage and the low tension supply from the mains voltage. A.C. mains voltage cannot be used directly, however, since the high tension must be a *direct* voltage; and whilst the low tension for the valve filament heaters can be A.C. or D.C., the actual voltage required is very much lower than the full mains voltage. These requirements are taken care of by feeding the mains into a suitable power supply circuit, from which the required output voltages can be extracted.

The construction of such a power pack, although straightforward, is relatively costly. Also in the case of simple receivers the additional cost and complication cannot be considered worthwhile as the necessary H.T. and L.T. supplies can readily be met with batteries. However, in order to complete a basic course in radio engineering, the principles involved in the design and construction of a mains power pack should be studied so that the reader is fully conversant with the workings of this part of a mains receiver.

The simplest way to convert A.C. mains voltage into a D.C. supply is by means of a transformer coupled to a rectifier, or a diode valve used as a rectifier. This is not a very efficient method of working, however, whilst there is also a high A.C. component remaining after rectification contributing a considerable amount of "hum" (which would be highly undesirable applied to the anode of the valves). This "hum" or "ripple" can be reduced, and the efficiency increased, by the simple method of introducing a *reservoir condenser* across the output, as in Fig. 86. Note also that this circuit

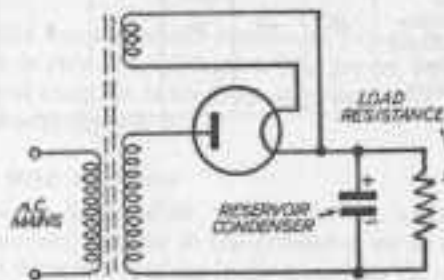

FIG. 86.

128

is using a diode as a rectifier and using an additional winding on the transformer to supply the heater current for the diode.

The action of the reservoir condenser is to store up energy during each half-cycle whilst the diode is conducting and then discharge to maintain the output when the diode cuts off on the other half of the cycle (i.e. by its rectifier action). The same principle would apply using a standard rectifier in place of the diode.

However, it is more satisfactory to work on *both* halves of the cycle of A.C. supply, which we can do by employing *two* diodes, one to work on each half-cycle. On the first half cycle, for example, one diode is conducting with the other cut off (not conducting). On the other half of the cycle the first diode has cut off and the second diode is conducting. Instead of using two separate diode valves, as such, the two can be combined in a single valve envelope with a common cathode, this type of valve being known as a *double diode*.

The power supply circuit is then arranged as in Fig. 87, together

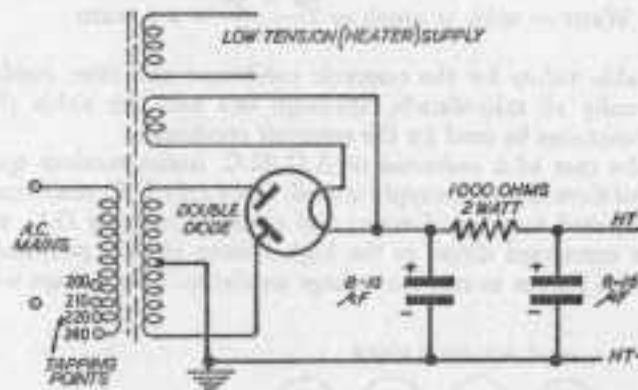

FIG. 87.

with typical component values. The primary of the mains transformer is usually supplied with a number of tapings to suit different mains voltages—e.g. 200, 220, 240. One separate *secondary* winding supplies *alternating current* directly, at the required stepped-down voltage for the valve heaters. Another separate secondary winding supplies the double diode filament direct. The main secondary winding is centre tapped, each end being connected to an anode of the double diode, the centre tap being connected to the common negative line (usually earthed on the chassis).

*Cr* is the reservoir condenser, but this is followed by a further *smoothing filter*, comprising either a choke coil or a resistor in series

with the positive line and a second condenser. The purpose of the filter is to reduce any remaining ripple to a negligible level so that A.C. hum is absent in the receiver. The choke coil filter is more effective than a plain resistor in this respect, but the latter is cheaper and smaller in size and often preferred on account of this.

The resistor also suffers from a further failing in that it has to be of relatively large value (e.g. up to 1,000 ohms) which results in a considerable voltage drop through the filter circuit and a high amount of electrical energy to be dissipated by the resistor. It thus tends to get very hot and must have a suitable rating to carry the power concerned, as well as being placed clear of other components so that it can receive as much cooling as possible.

A 1,000 ohm resistor, for example, will give a drop of  $1,000 \times 0.050 = 50$  volts for a 50 milliamp D.C. output current (the sum of the total current requirements of the high tension supply). The power rating for this resistor is then:

$$\text{Watts} = \text{volts} \times \text{amps} = \frac{50 \times 50}{1,000} = 2.5 \text{ watts}$$

Suitable values for the reservoir condenser and filter condenser are usually 16 microfarads, although one half this value ( $8 \mu\text{F}$ ) may sometimes be used for the reservoir condenser.

In the case of a universal or A.C./D.C. mains receiver quite a different form of power supply is used. Obviously D.C. mains cannot be connected to a transformer; and equally obviously D.C. mains can be connected direct to the high tension circuit, provided the valves are chosen to suit the voltage available. This voltage will be

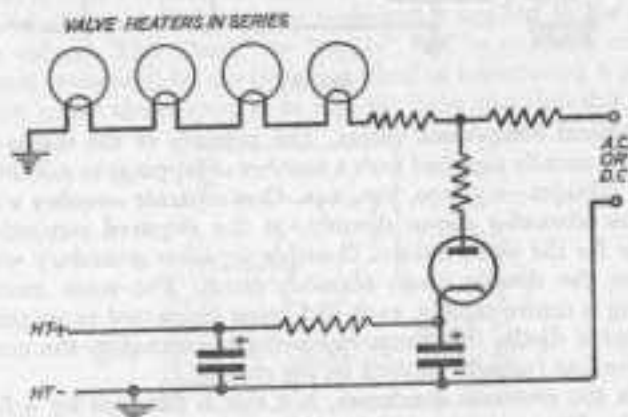

FIG. 88.

too high for supplying the low tension voltage direct, but if all the valve filaments are connected up *in series*, together with a suitable dropping resistance, this complete heater chain can be connected directly to the supply, with all the individual heater voltages correct. This series chain may also include dial lamps, etc. The same chain will operate equally well connected to A.C. mains direct.

To use A.C. mains for the direct voltage H.T. supply a single diode may be used for half-wave rectification, followed by a filter circuit, as with the A.C. mains power circuit, the complete circuit being shown in Fig. 88. Connected to D.C. supply, current will still flow through the high tension circuit since the diode will just as readily conduct D.C., provided the *polarity* of the supply is connected to *anode* of the diode rectifier. In other words, D.C. mains supply must be connected up the right way round for the set to have any high-tension supply.



## VOLUME CONTROLS

The volume control in any standard receiver is nothing more than a variable resistor (called a potentiometer), inserted in an appropriate part of the circuit—normally following the detector stage.

If, for example, the detector load resistor is replaced with a potentiometer (Fig. 89), the actual amount of audio frequency output

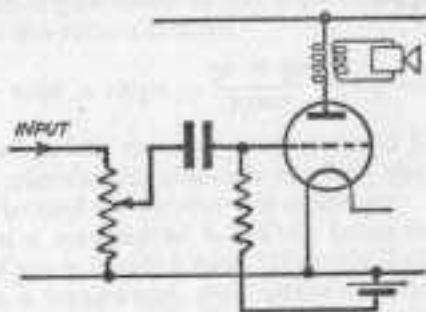

FIG. 89.

from the detector is variable from zero to maximum, according to the setting of the moving contact on the potentiometer. Thus the range of the potentiometer used would approximate to the normal value of the detector load resistance used. A limitation with this type of control is that it tends to produce distortion at low volume settings.

An alternative solution is to replace the grid leak of the first stage amplifier by a potentiometer, as in Fig. 89, thus providing control over the audio frequency applied to the grid of the triode. This will be equally effective in controlling volume, but again subject to distortion.

In some cases, where the volume control potentiometer is used in place of the grid leak resistor an additional resistance may be included in series with the potentiometer (i.e. connected between the bottom end of the potentiometer and the common earth as in Fig. 90), so that the range of volume control is restricted. Thus, if the

volume turned to the minimum position (volume "off"), effective grid leak resistance is still maintained by the additional fixed resistor and the volume is not reduced to zero. This also, to some extent, offsets the distortion effects previously mentioned.

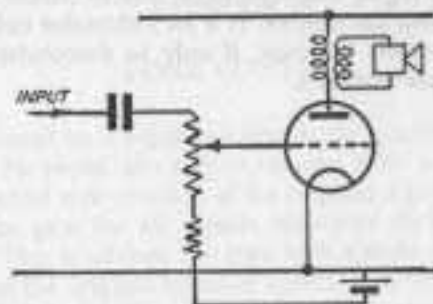

FIG. 90.

In the case of transistor receivers a rather better form of volume control is produced by putting the variable resistor in series with the flow of the circuit, immediately after the first audio frequency stage (see Fig. 91). This introduces minimum distortion over the range

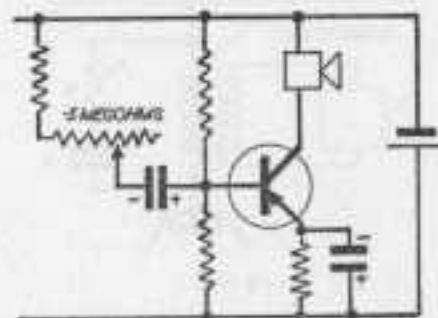

FIG. 91.

of adjustment. A suitable value for this potentiometer would be 5 megohms. It is simply inserted before the final amplification stage—see Fig. 35.

It should perhaps be mentioned that on domestic receivers the volume control often also provides an on-off switching action, i.e. rotating the volume control as far as it will go to one side (anticlockwise) switches the set off. This switching action is quite independent of the potentiometer side of the component and is, in fact, a separate

switch included in the component for convenience (and to minimize the number of control knobs used).

On simple receivers of the type described, a volume control is an unnecessary elaboration unless good, strong signals are obtained, when it may be highly desirable to be able to reduce the volume to prevent swamping the phones. It is an instructive extra to apply to any simple receiver, however, if only to demonstrate the simple working principle involved.



Another way of controlling volume is to connect a potentiometer in series with the primary winding of the output transformer. This is shown in Fig. 92. The potentiometer is connected in series with the primary winding of the output transformer. The potentiometer is connected in series with the primary winding of the output transformer. The potentiometer is connected in series with the primary winding of the output transformer.



This, in effect, forms another tuned circuit, the resonant frequency of which can be altered by adjusting the setting of the potentiometer to favour or bring up the treble or bass in the output signal by, effectively, additional amplification. The tone control on a domestic receiver is usually of this form—the knob controlling a potentiometer connected in series with a fixed capacitor across the output transformer. Typical values used are:

APPENDIX IX  
TONE CONTROL

## APPENDIX IX

### TONE CONTROL

THE tone control on a receiver controls the quality or tone of the final sound. However, the output voltage after amplification will only be a faithful reproduction of the original input if the amplifier gives the same gain for all signals, whatever their frequency and complexity. This is seldom the case with simple circuitry, so that the balance of the original sound or speech is upset and distortion is produced. If the gain is inadequate at low frequencies, the sound reproduced will tend to be tinny or harsh. Conversely, if the gain is inadequate at the higher frequencies the sound is subject to booming.

An adequate measure of tone control can be realized by connecting a variable resistance (potentiometer) and fixed capacitor in series across the primary terminals on the output transformer, as in Fig. 92.

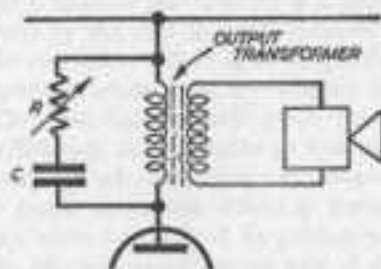

FIG. 92.

This, in effect, forms another tuned circuit, the resonant frequency of which can be altered by adjusting the setting of the potentiometer to favour or bring up the treble or bass in the output signal by, effectively, additional amplification. The tone control on a domestic receiver is usually of this form—the knob controlling a potentiometer connected in series with a fixed capacitor across the output transformer. Typical values used are:

Potentiometer, 0-10 kilohms  
Fixed capacitor, .1 microfarads

Tone control would, of course, normally be used only with a loudspeaker output.

Other methods of imparting tone control exist, another standard method with valve circuits being to apply negative feedback from the loudspeaker side of the output transformer.

### APPENDIX X

## RECEIVER FAULTS

FAILURE of a newly completed receiver to work is more likely to be a "circuit" fault than a component fault—caused either by a faulty connection or a poor soldered joint, or even by a misplaced component. It is surprisingly easy, for example, to misread resistor values from their colour code and in consequence accidentally insert a totally wrong value into a certain part of the circuit. It is equally easy to complete wiring up incorrectly so that the final job no longer follows the design circuit. It cannot be emphasized too strongly that a complete circuit should be checked through and, particularly with transistor circuits, battery polarity confirmed as correct before connecting up and switching on for the first time.

Simple circuits also have distinct performance limitations which are sometimes misinterpreted as "faults." Thus a very low listening level may not be a fault at all—merely a limitation of the circuit design emphasized by the fact that the receiver is being operated in a poor area for reception. There is, in fact, little that can be done in such circumstances other than try another circuit with better performance. Thus the basic crystal diode receiver, for example, has very poor efficiency as a detector at low signal levels and no amount of subsequent amplification can overcome this inherent limitation. On more advanced circuits, however, considerable improvement can often be realized by paying particular attention to developing an efficient aerial circuit and, if necessary, using an external aerial.

Provided a receiver performs satisfactorily initially, many subsequent "faults" which may develop are often the result of a weak battery. Typical symptoms in such cases are (i) fading of receiver volume after being switched on for a short period, and (ii) distortion. Both types of fault may also be caused by lack of stability in the receiver circuit (in which case it can be "cured" by re-tuning); and by the "drift" of certain broadcast signals under certain conditions—e.g. Radio Luxembourg being notorious in this respect.

The condition of receiver batteries can only be checked accurately *under load*. That is to say, a voltage measurement should be made with the set switched on and operating. The resulting reading will



Fig. 10

normally be lower than the "open circuit" voltage of the battery, measured with the battery disconnected and the voltmeter connected directly across the battery terminals. In the case of dry batteries, an "open circuit" voltage of 1.5 per cell is typical (higher on new batteries). Once the "on load" voltage has dropped to 1.2 volts per cell the battery is approaching a run-down stage; and by 1.1 volts per cell can be reckoned as useless for further work. However, the same battery may still show 1.5 volts per cell tested on "open circuit."

All standard dry batteries are made up from cells with an individual voltage of 1.5 volts each—thus a 4.5-volt battery comprises three 1.5 volt cells; a 6-volt dry battery four 1.5 volt cells, and so on. Thus the number of cells follows by dividing the nominal battery voltage by 1.5. The corresponding "end voltage" tested on load thus follows by multiplying the number of cells by 1.1. By the time this end voltage is reached, actual on load voltage will tend to fall off rapidly with further use "on load."

The life of a dry battery is dependent on the current drawn by the receiver and the battery capacity, the latter being more or less directly proportional to the physical size of the cells. Small receivers are generally used with small batteries, the pen cell size being particularly popular and inexpensive, although having a fairly low capacity.

A considerable improvement in battery performance is realized with the manganese-alkaline type of dry cell, often referred to as an "alkaline battery" or a "high energy" cell. Although costing roughly twice as much as an ordinary dry battery of the same size and voltage, life expectancy can be up to five times as long. Such batteries, too, tend to maintain a higher "on load" voltage for much longer periods. They are thoroughly to be recommended for general transistor radio use as they invariably prove more economical in the long run and also are less likely to give "battery troubles." They are, however, only available in a limited number of cell types (sizes), as yet. Thus a battery of suitable voltage may have to be made up as a "pack" of individual cells fitted into a suitable battery box, or with soldered connections for series connection.

An alternative battery type worth considering by the serious enthusiast is the DEAC nickel-cadmium battery. This is a secondary cell, that is to say, it is rechargeable, which is completely sealed and has excellent "constant voltage" output on load. Each cell gives only 1.2 volts, however, and thus a 6-volt battery would comprise five cells connected in series.

DEACs are produced both as single cells and made-up batteries

from 1.2 to 7.2 volts (and higher voltages, if required). The two main cell sizes are the 225 with a capacity of 0.25 ampere hours; and the 500 with a capacity of 0.5 ampere hours. Physical sizes of made-up batteries in these cells are summarized in the Table.

TABLE: DEAC BATTERY SIZES

NO. OF CELLS		1	2	3	4	5	6
VOLTAGE		1.2	2.4	3.6	4.8	6.0	7.2
225 type	Dia. (in.)	1	1	1	1	1	1
	Length (in.)	.36	.70	1.1	1.45	1.8	2.15
	Weight (oz.)	.5	1	1.5	2	2.5	3
500 type	Dia. (in.)	1.35	1.35	1.35	1.35	1.35	1.35
	Length (in.)	.39	.75	1.15	1.4	1.9	2.3
	Weight (oz.)	1	2	3	4	5	6

By comparison with dry batteries, DEACs are very expensive. They do, however, have an indefinite life as they can be recharged and used over and over again, like any accumulator, and are virtually indestructible. Each cell is also completely sealed so that there is no corrosive electrolyte to get spilt, nor any necessity to top up as with a normal accumulator. To the initial cost of the battery must also be added the cost of a suitable charger for recharging from normal mains supply at a D.C. current of approximately  $\frac{1}{20}$ th of the cell capacity—e.g. 125 milliamps in the case of the 225 size cell; and 250 milliamps in the case of the 500 size cell.

The Mallory-mercury is another type of sealed cell also used with miniature transistor receivers and similar devices. Although similar in appearance to a DEAC (but usually much smaller) the mercury cell is a primary battery and thus cannot be recharged. Its main attraction is that it gives a reliable and constant voltage in very small sizes, making it possible to produce a fully self-contained transistor receiver circuit in a total volume of the same order as that of the same voltage battery alone in standard dry cells—e.g. see Chapter IX.

In the case of both DEACs and Mallory-mercury cells the "on load" voltage remains substantially constant right up to the point where the cell is almost fully discharged and thus a voltmeter check is of little value (other than to confirm that the battery is still not completely discharged). The final drop in voltage will be quite sudden when the cell or battery approaches the final discharge point and the set will go "dead" rather than exhibit signs of a fading or distorted signal.

Component faults should not be common, provided the circuit is wired correctly and components have not been damaged in soldering up. This applies particularly in the case of printed circuit assemblies (see Chapter X). An elementary method of isolating a component fault is to measure and note the voltage reading on the original working circuit at each stage, taking a reading across the emitter resistor of each transistor in turn. If a fault subsequently develops, the respective emitter resistor voltages are again checked. Any variation on the original figures outside about 30 per cent will then indicate a fault at that particular stage. From there it is a relatively straightforward matter to check each of the components involved—e.g. by replacing them in turn.

Transistor faults are relatively uncommon, provided the original circuit design is sound. The most common faults likely to occur are:

(i) Heat damage to the transistor during assembly—which in extreme cases will mean that the transistor will not work at all and the circuit is dead. If the transistor has been damaged rather than destroyed, this fault will show up as a very noisy transistor or lack of gain, or both. The same faults will also show up if the original transistor characteristics are poor, e.g. the transistor has a high leakage current.

(ii) Junction open-circuited. This can be caused by a heavy overload in the circuit. In this case the transistor is permanently damaged and will not work at all.

(iii) Junction short-circuited. This can be caused by a sudden voltage surge in the circuit. Again the transistor is permanently damaged and useless. This type of damage can be caused by "working" on the circuit with the battery switched on—e.g. removing or replacing components with the circuit "live."

The time-honoured method of "fault finding" with valve-type receivers by "tapping" a spare capacitor across circuit capacitors as a check on their working can be harmful in the case of transistor circuits. Under such treatment, transistors can "blow" like fuses!

Excessive background noise, or lack of gain in amplifier stages, can often be improved by replacing the transistor(s) concerned. Transistors—particularly those offered at low prices as "surplus" stock—can be very variable in characteristics and whilst all may "work" in a particular circuit, some will give a much better overall performance than others.

In searching for faults or causes of poor performance, do not overlook the obvious. Poor soldering is a very common fault on amateur radio construction and any joint which looks "dry" is suspect. Satisfactory performance is as much dependent on the "mechanics" of assembly as on the electronic performance of components, in fact.

## GLOSSARY-INDEX

*Abbreviations:* see p. 20 for standard abbreviations.

*A.C.:* alternating current—a current which periodically varies in direction and magnitude.

*A-F or A.F.:* audio frequency—a wave frequency consistent with sound waves that can be heard by the human ear—pp. 13-14.

*Ammeter:* an instrument for measuring electrical current in amperes (amps) (note: a milliammeter measures current in milliamps—p. 22.)

*Anode:* positive electrode of a valve (p. 37) or the conductor through which an electric current enters a liquid or gas.

*Auto-transformer:* a transformer with a single winding tapped at one or more points—p. 65.

*Battery:* a single cell or assembly of cells of specified voltage.

*Bus bar:* a conductor which is used as a common connection for various electrical components or circuits—p. 32.

*Capacitor:* an electrical component designed to carry a charge of electricity (also originally called a "condenser," although the modern description is "capacitor")—p. 22.

*Cathode:* the negative electrode of a valve (p. 37) or the conductor through which an electric current leaves a liquid or gas.

*Cell:* a single battery unit. Thus a battery may be composed of a number of individual cells, usually connected in series. A single dry cell has a nominal voltage output of 1.5. Thus a 4.5 volt battery would be composed of 3 individual cells connected in series; a 9 volt battery 6 individual cells connected in series; and so on.

*Choke:* a coil having a "reactance" or resistance to alternating current flow. Note: reactance to A.C. would be higher than its resistance value—p. 73.

*Current:* the flow of electricity normally measured in amps, or milliamps—p. 22.

*D.C.*: abbreviation for direct current.

*Dielectric*: an insulating material (i.e. one that does not conduct electricity)—see p. 33.

*Dry cell*: standard type of "dry" battery cell, i.e. one which employs the electrolyte in the "dry" state, as opposed to an accumulator where the electrolyte is in liquid form.

*Earth*: the general mass of the earth which is considered as an electrical conductor.

*Earth return*: a circuit completed through connection to earth; or to some conductive mass which has the same effect as a common "earth."

*Earthing*: connection to earth or a suitable equivalent "earthed" conductor.

*Electrode*: a conductor through which electricity passes into a liquid or gas.

*Electrolytic condenser*: p. 22.

*E.M.F.*: electromotive force responsible for a flow of electricity.

*Farad*: practical unit of measurement of capacitance—p. 21.

*Frequency*: the number of complete cycles of change per second of an alternating quantity—see p. 13.

*Grid*: control element in a valve—p. 37.

*Ground*: another name for "earth".

*Henry*: practical unit of inductance—p. 22.

*Impedance*: effective resistance to A.C. flow, greater than pure resistance by virtue of additional reactances developed—p. 74.

*Inductance*: an e.m.f. produced in an electrical circuit by a change of magnetic flux—p. 15.

*Insulation*: materials or covering used to isolate electrical conductors from contact with other conductors, etc.

*Insulator*: a fitting or device made from insulating material.

*Kathode*: sometimes used in place of the more usual "cathode" spelling.

*Kilo*: 1,000, e.g. kilocycle = 1,000 cycles—p. 22.

*Low tension*: low supply voltage, usually taken as referring to the filament or heater supply of valve circuits.

*Main*: usually referring to the mains electricity supply.

*Megohm*: unit of resistance equal to 1,000,000 ohms—p. 22.

*Meter*: term used primarily to describe a measuring instrument, e.g. ammeter, voltmeter, etc.

*Micro*: one millionth—p. 22.

*Mil*: unit of length equal of one thousandth of an inch.

*Milli*: one thousandth—p. 22.

*Multicore cable*: a cable containing three or more insulated cores. (also applied to solder, multicore solder containing its own flux).

*Mutual induction*: the induction of an e.m.f. in one circuit (called the secondary) by a change of flux in another circuit (called the primary)—p. 67.

*Negative*: the terminal at which the current returns to the supply, or leaves the component or conductor.

*Ohm*: standard practical unit of electrical resistance—p. 21.

*Ohm's Law*: states that in an electrical circuit the D.C. current flow is equal to the applied voltage divided by the total resistance.

*Oscillation*: see p. 83 *et seq.*

*Parallel connection*: components connected so that the current divides between them; or batteries connected with terminals of like polarity joined together—p. 16.

*Phase*: applied to an alternating quantity is the fraction of the period which has elapsed since the preceding zero value when the quantity was increasing, usually measured in degrees—p. 84.

*Potential Difference*: P.D.—is the same as the voltage between two points in a circuit.

*Practical units of electricity*—p. 21.

"*Q*": the magnification produced in a resonant circuit—p. 115.

*Reactance*: the voltage drop produced in an A.C. circuit.

*Rectifier*: a device for changing alternating current into unidirectional or D.C. current—p. 17.

*Resistance*: a measure of the resistance to electric current flow offered by practical conductors, etc.

*Resonance*: a state in which the natural frequency of an oscillating system is equal to the frequency of impulses reaching or influencing it—p. 16.

*Ripple*: residual A.C. component remaining of rectified current supply, or similar—p. 128.

*Series connection*: components or circuits connected with the same current flowing through them all, or cells joined with alternate connections negative-positive, etc.

*Short circuit*: two points of an electrical circuit joined by a conductor of negligible resistance.

*Shunt*: a resistor joined in parallel with another component, or across an instrument.

*Tap*: intermediate connection point on a coil, etc.—p. 118.

*Transformer*: pp. 43, 128, 135.

*Turns ratio*: the ratio of the number of turns in the primary and secondary windings in a transformer—p. 113.

*Units*: p. 21.

*Volt*: practical unit of potential difference or e.m.f.—p. 21.

## Design and Construction of Transistor Superhets

by R. H. WARRING

The superhet receiver offers many advantages in the way of performance over other types and modern developments with transistor circuitry make amateur construction an attractive proposition. Good electronic design allied to printed circuit assembly can result in a compact, highly efficient superhet—pocket-size, if required—being built at a fraction of the cost of a comparable ready-made domestic receiver, and alignment problems can be eliminated, or at least minimized, by suitable selection of components.

After describing the principles of superhet operation in practical language this book deals with the construction of typical, proven designs. No previous knowledge of radio is assumed, and even such basic working requirements as soldering are fully described. Separate chapters are also devoted to the making of printed circuit boards, and the testing and alignment of superhets using elementary equipment.

Essentially this is a book intended for amateur radio enthusiasts who want to make their own superhets, rather than just read about them, although it also contains a wealth of information on superhet design, etc. The text is based on the latest available data, including the use of transfilters in place of the conventional transformers.

*Illustrated, 17/6 net*





## THE BROMPTON LIBRARY

- Instructions to Young . . .*
- Anglers** by Michael Shephard  
**Artists** by John F. Mills (15s.)  
**Astronomers** by H. P. Wilkins  
**Athletes** by Robert Bateman  
**Ballroom Dancers** by Alex Moore  
**Botanists** by C. L. Duddington (15s.)  
**Boxers** by Bobby Neill  
**Chess Players** by H. Golombek  
**Collectors** by Guy Williams  
**Cooks** by Elizabeth Craig (15s.)  
**Cricketers** by T. Graveney and B. Statham (15s.)
- Fencers** by Gillian Sheen  
**Footballers** by Tom Finney  
**Geologists** by D. H. Dalby (15s.)  
**Golfers** by David Thomas  
**Hockey Players** by Eric Green  
**Model-makers** by Guy Williams  
**Naturalists I** *Amphibians and Pond Dwellers*  
by Maxwell Knight  
**Naturalists III** *Mammals*  
by Brian Vesey-Fitzgerald  
**Naturalists IV** *Fossils*  
by W. E. Swinton  
**Ornithologists I** *Bird Biology*  
by J. D. Macdonald (15s.)  
**Ornithologists II** *Bird Behaviour*  
by Derek Goodwin  
**Ornithologists III** *Bird Migration*  
by Robert Spencer  
**Ornithologists IV** *Sea-Birds*  
by Mary E. Gillham (15s.)  
**Ornithologists V** *Birds' Nests and Eggs*  
by C. J. O Harrison (15s.)
- Ornithologists VI** *Domestic Birds*  
by Derek Goodwin (15s.)  
**Photographers** by Houston Rogers  
**Radio Constructors** by R. H. Warring (15s.)
- Ramblers** by Ronald Clark  
**Rugger Players** by Cedric Venables  
**Skaters** by Erik van der Weyden  
**Stamp Collectors** by Robert Bateman  
**Swimmers** by W. J. Juba  
**Tennis Players** by Susan Noel  
**Writers** by L. A. G. Strong  
**Zoologists** by C. L. Duddington
- Instructions in . . .*
- Archaeology** by A. V. B. Gibson (15s.)  
**Biology** by C. L. Duddington (15s.)  
**Chemistry** by R. H. Warring  
**Electricity and Magnetism**  
by R. H. Warring  
**Handicrafts** by Guy Williams (15s.)  
**Ponymastership** by Glenda Spooner (15s.)  
**Rock Climbing** by Anthony Greenbank (15s.)
- Rowing** by Desmond Hill  
**Sailing** by Hilary Tunstall-Behrens  
**Table Tennis** by Harry Venner  
and  
**Let's Have Some Music**  
by Dr. Donald Hughes (15s.)  
**Let's Have Some Poetry**  
by Elizabeth Jennings  
**What about Religion?**  
by Elfrida Vipont (15s.)  
**An Introduction to Space Travel**  
by P. E. Cleator (15s.)

*Each volume Demy 8vo., Illustrated, 12s 6d net*

*except where otherwise indicated.*

**MUSEUM PRESS LIMITED**

26 Old Brompton Road, London, S.W.7