

COLLINS NUTSHELL BOOKS

Electrical Hobbies

F. G. RAYER

With diagrams



COLLINS
LONDON AND GLASGOW

GENERAL EDITOR: J. B. FOREMAN, M.A.

First published 1964

Contents

	<i>page</i>
1. Circuit Principles	7
2. Illuminating Models	28
3. Magnetic Devices	38
4. Motors	51
5. Miscellaneous Equipment	63
6. Photographic Equipment	89
7. Audio Equipment	101
8. Controlling Models by Radio	117
LIST OF ABBREVIATIONS	155
INDEX	156

© William Collins Sons & Co. Ltd., 1964

PRINTED IN GREAT BRITAIN
BY COLLINS CLEAR-TYPE PRESS

1

CIRCUIT PRINCIPLES

A knowledge of circuit principles is useful when using electrical models and equipment. Calculation of current, voltage, or other factors is generally straightforward, and quicker than trial and error methods.

Current for a model or other unit can be from a dry battery, accumulator, mains pack, or dynamo. Dry batteries are often used when the current demanded is not too high, but accumulators and mains units can supply large currents.

Common dry batteries have zinc cased cells. The zinc case is negative. A central carbon rod, with cap, forms the positive terminal (Fig. 1). Its potential is about 1.5 volts. If a higher voltage is needed, two or more cells are placed in series. In Fig. 1, three 1.5V cells in series form a 4.5V battery. When cells are in series, positive on one cell is taken to negative on the next. A 3V battery would have two 1.5V cells, and a 6V battery four 1.5V cells.

If a larger current is required, the battery can be made from larger cells, or can have two or more cells connected in parallel. When cells are wired in parallel, positive is connected to positive, and negative to negative. The voltage is the same as for a single cell, but more current can be drawn. In Fig. 1, two small cells in parallel equal one cell twice as large. Some dry batteries consist of a number of cells wired in parallel.

The usual dry cell is a primary battery, producing current until exhausted. The central carbon rod is surrounded by a depolarising agent such as manganese

CIRCUIT PRINCIPLES

dioxide and carbon, and the electrolyte is paste sal ammoniac or ammonium chloride. The top is sealed with a waxed card disc or other means. The depolariser helps remove minute hydrogen bubbles which would act as an insulator between electrodes and electrolyte, reducing efficiency.

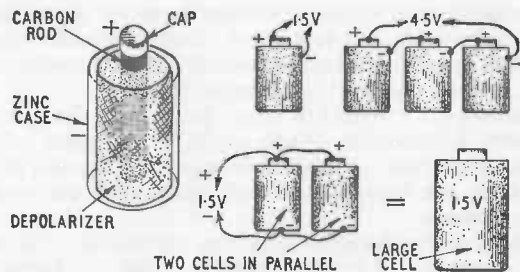

Fig. 1. Construction of dry cell, and cells in series and parallel.

Dry batteries are usually thrown away when discharged, but can sometimes be re-activated. This is explained in the section on accumulator charging.

For special purposes miniature batteries and accumulators are made. These may be fitted in electric watches, radio control devices, transistor equipment, etc. They are not generally used for ordinary models.

The usual type of secondary cell is the lead acid accumulator. The plates are lead grids or a spongy lead alloy, positive grids being covered with lead peroxide. A small cell may have a single positive plate and single negative plate immersed in the electrolyte (dilute sulphuric acid). For larger batteries, there are several negative plates and several positive plates. All the negative plates in a single

ACCUMULATORS

cell are connected together, as are all the positive plates. Insulating material, such as plastic grids, prevents contact between positive and negative plates.

Each cell provides about 2V. A 4V accumulator has two cells in series, while a 6V accumulator has three cells. The battery is charged from a dynamo or mains unit supplying direct current (Fig. 38). When run down, it is re-charged. An accumulator can deliver a much higher current than dry cells. "Dry" accumulators have the electrolyte absorbed in material which prevents spilling. Jelly accumulators have a jellified electrolyte to avoid danger of spilt acid.

Nickel iron accumulators use a potassium hydroxide electrolyte. They are very robust, and withstand high charge and discharge currents. Each cell provides about 1.4V. Miniature silver-zinc and sealed batteries are also made.

Capacity. The capacity of an accumulator is given in ampere hours, or A.H. A 20 A.H. accumulator could theoretically deliver a current of 1 ampere for 20 hours. The actual capacity will depend on the condition of the accumulator, and falls as the battery grows older. Capacity also depends on the rate at which current is drawn. At low currents, or with intermittent use, the battery is discharged more slowly. Trying to take very heavy currents will reduce the ampere hours obtained.

Accumulators of high A.H. capacity have large plates, or several plates in parallel, as explained. Two separate accumulators are sometimes used when an increased voltage is required. For example, two 6V accumulators, in series, give 12V.

A dry battery also has increased ability to deliver a moderately heavy current, if it has large cells. If the current drawn is too heavy, the voltage falls badly. So a

CIRCUIT PRINCIPLES

motor which runs well from a large 4.5V dry battery might not run satisfactorily from a small 4.5V battery, even though the latter were in good condition. The current drain of many models is within the capacity of dry batteries.

The following table lists some popular batteries. It is usually easy to obtain a battery to suit any purpose required.

TYPICAL BATTERIES

Dimensions in inches

EVER READY

Alldry 1	$2\frac{5}{8} \times 2\frac{5}{8} \times 5\frac{3}{8}$	$1\frac{1}{2}$ V
Alldry 4	$2\frac{5}{8} \times 2\frac{5}{8} \times 3\frac{7}{8}$	$1\frac{1}{2}$ V
Alldry 28	$4 \times 1\frac{3}{8} \times 4\frac{1}{4}$	$4\frac{1}{2}$ V
Alldry 31	$4 \times 2\frac{1}{2} \times 3\frac{3}{8}$	$7\frac{1}{2}$ V
U2	$2\frac{7}{16} \times 1\frac{5}{16}$ dia.	$1\frac{1}{2}$ V
1289	$2\frac{7}{16} \times \frac{7}{8} \times 2\frac{5}{8}$	$4\frac{1}{2}$ V
996	$2\frac{5}{8} \times 2\frac{5}{8} \times 3\frac{1}{8}$	6V

(Transistor radio, photoflash)

B155	$\frac{5}{8} \times \frac{5}{8} \times 2$	$22\frac{1}{2}$ V
B121	$1\frac{1}{8} \times \frac{1}{8} \times 1\frac{1}{16}$	15V
B105	$1\frac{1}{8} \times 1 \times 2\frac{3}{16}$	30V
B104	$3\frac{5}{8} \times 1\frac{5}{8} \times 4\frac{11}{16}$	45V
B101	$2\frac{1}{4} \times 1\frac{1}{8} \times 3\frac{1}{2}$	$67\frac{1}{2}$ V
B126	$2\frac{1}{4} \times 2 \times 3\frac{7}{8}$	90V

Circuit Resistance, etc.

Connecting leads and other conductors, which carry the current where needed, are generally copper, which is cheap, conducts well, and is easily soldered. Terminals, switch contacts and similar items also serve as conductors, as well as providing connecting points, etc. Silver is a better

RESISTANCE

conductor than copper, but is rarely used because of its cost.

When a metal conducts well it is said to have little resistance or resistivity. This is exactly what is generally required.

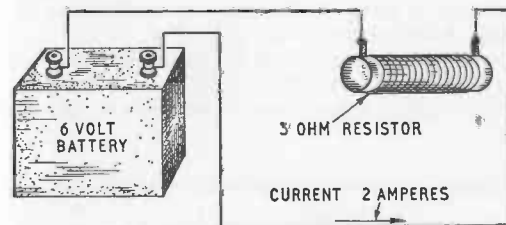

Fig. 2. Showing voltage, resistance and current.

Sometimes appreciable resistance is necessary, as when voltage is reduced by a speed controller or dimmer. Iron wire could be used, as it has much more resistance than copper wire. Various kinds of special resistance wire are produced, so it is easy to make a wire-wound resistor of any value.

The resistance of a conductor or circuit is given in Ohms. For example, 22 s.w.g. copper wire has a resistance of about 0.04 Ohm per yard, while typical 22 s.w.g. resistance wire is 1 Ohm per yard. (See p. 27.)

Ohm's Law. All circuits have some resistance, due to connecting wires, motor windings, lamps, and other items. Fig. 2 shows a battery (or other source of current) connected to a resistor, which may be taken as representing circuit resistance, or a lamp or motor.

Current flowing in a circuit is expressed in amperes

CIRCUIT PRINCIPLES

(abbreviated to A). E.g. 10 amperes=10A. In calculations, I is used to indicate current in amperes.

Voltage, or electrical potential, is shown by V (volts). 6V=6 volts. But in calculations, E is often seen. This indicates electromotive force, which can be regarded as the same as voltage.

Resistance is given in Ohms (Ω), as mentioned. In calculations, R indicates resistance.

Current (I), Voltage (V or E) and Resistance (R) are related in such a way that if two are known the third can be found. This is Ohm's Law. In Fig. 2, or any similar circuit:—

Voltage = current \times resistance ($V=I \times R$)

Current = $\frac{\text{voltage}}{\text{resistance}}$ ($I = \frac{V}{R}$)

Resistance = $\frac{\text{voltage}}{\text{current}}$ ($R = \frac{V}{I}$)

For example, assume the resistance is 3 Ohms, and a meter in one lead shows 2A flowing. What is the voltage applied? $I \times R = 2 \times 3 = 6V$.

Again, suppose a 6V battery is connected to a circuit having a resistance of 3 Ohms, and the current flowing is to be found. Current = $V/R = 6/3 = 2A$.

Or suppose a 6V battery is connected to a circuit, and a meter shows 2A to flow. What is the circuit resistance? Resistance = $V/I = 6/2 = 3$ Ohms.

Or we can say that the 3 Ohm resistor drops 6V when a current of 2A flows. This is another way of stating $V=I \times R$.

Ohm's Law is useful for practical problems. In Fig. 3 a 6V battery drives a 6V motor, and it is wished to light a 3.5V, 0.3A bulb from the same battery. Clearly the 6V needs to be reduced to 3.5V for the bulb. The resistor

OHM'S LAW

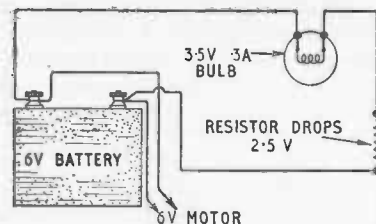

Fig. 3. Ohm's law applied to a voltage dropping resistor.

must drop $6 - 3.5 = 2.5V$. From Ohm's Law, Resistance = $\frac{\text{Voltage}}{\text{Current}}$ or $\frac{2.5}{0.3} = 8.3$ Ohms, approx.

A resistance wire table shows that 34 s.w.g. wire at 10 Ohms per yard could carry 0.3A for the bulb. As 36 in. of the wire equal 10 Ohms, 36/10 in. equal 1 Ohm, and 8.3 Ohms will be: $\frac{36 \times 8.3}{10} = 30$ approx.

So 30 in. of the wire wound on a strip or rod of insulating material is connected in series with the bulb.

The chart in Fig. 4 covers voltages from 1 to 12. When two factors are known, a straight rule placed across them indicates the third factor.

Assume a 10 Ohm resistor is wired across a 2V accumulator: the resistor passes 0.2A. Or suppose a 2.5V, 0.3A bulb is run from a 4.5V supply driving a motor. As the supply is 4.5V and the bulb needs 2.5V the voltage to be lost in a resistor is $4.5 - 2.5 = 2V$. A rule across 2V and 0.3A crosses the resistance scale (Fig. 4) at 7, so a 7 Ohm resistor is satisfactory (calculated value 6.6 Ohms). As 1,000 milliamperes = 1 ampere, 0.1A will be 100mA.

CIRCUIT PRINCIPLES

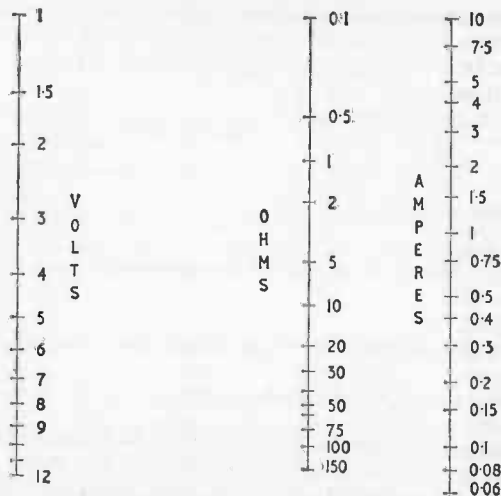

Fig. 4. Voltage, resistance and current chart.

Wattage. Power used, or dissipated, is expressed in Watts. Large appliances, such as electric fires, may consume 1,000 Watts or more, and 1,000 Watts=1 kilowatt, or 1kW. In models, it is sometimes useful to know the relationship between wattage and current. W is used to indicate Watts.

$W = V \times I$. That is, Voltage \times Current = Watts.

For example, 4V are applied to a circuit, and 2A flow. The wattage dissipated = $4 \times 2 = 8W$.

In the same way, $W/I = V$, and $W/V = I$. For example, suppose a 6W 12V bulb is run from an accumulator. What current is drawn? I (current) = $W/V = 6/12 = \frac{1}{2}$

WATTAGE

ampere. Again, suppose a 24W 6V enlarger lamp is to be run from a transformer. What current must the transformer be able to deliver? $W/V = 24/6 = 4$ amperes.

Wattage may also be found from:

$$\frac{V^2}{R} = \frac{\text{Voltage} \times \text{Voltage}}{\text{Resistance}}, \text{ or from: } I^2 \times R.$$

This is sometimes useful. For example, 3V will be dropped across a 10 Ohm resistor. What power is dissipated in the resistor?

$$\frac{V^2}{R} = \frac{3 \times 3}{10} = \frac{9}{10} \text{ Watt.}$$

It is often convenient to make resistors from wire, as described. Ready-made resistors may be wire wound, or consist of moulded carbon compounds. They are available in various wattages. Small $\frac{1}{4}W$, $\frac{1}{2}W$ and 1W resistors are used in radio circuits. When current is larger, 2W, 5W, 10W and other resistors are used. The wattage rating of the resistor should be at least equal to the wattage dissipated in it, as found by any of the methods described. For long life, and cool running, the wattage of the resistor is best rather larger than actually required.

Insulators. Many insulating materials are used in circuits, models and equipment. Enamel, cotton, silk and plastics are employed to insulate wires. Paxolin, fibre, bakelite and numerous other substances are used for terminal blocks, switches, etc.

Insulating materials, if perfect, would allow no current to pass. With many insulating materials there is some leakage, but this is so small it can be ignored.

Switches

Simple on/off switches break the circuit when "off" and complete it when "on." The train switch and low voltage toggle switch in Fig. 5 are for low voltages.

CIRCUIT PRINCIPLES

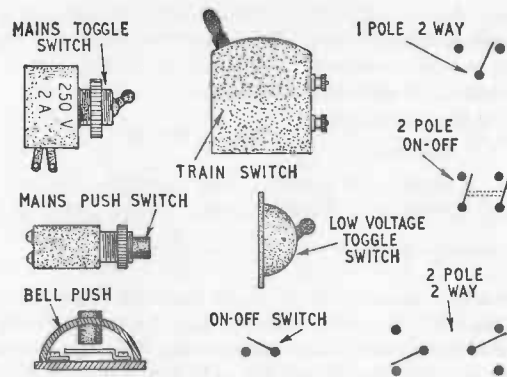

Fig.. 5. Various switches used in models.

For mains circuits, mains voltage switches are needed. Low voltage switches must not be used. Many mains switches are available. Fig. 5 shows a small 250V 2A toggle switch. If heavy currents are passing, the switch must be rated suitably. This should be remembered if large items such as photofloods (powerful lamps) are in use. (Fig. 48.)

Various special switches are useful. The bell push is for low voltage only. The 1-pole 2-way switch allows either of two circuits to be selected. Popular rotary switches have from 2 to 12 ways, allowing up to 12 circuits to be selected.

The 2-pole on/off switch in Fig. 5 has two sets of contacts, insulated from each other, and can thus interrupt two circuits. The 2-pole 2-way switch (also called "double-pole double-throw") is often used for motor reversing.

STANDARD WIRE GAUGE

Wire

The size of a wire is given in S.W.G. (Standard Wire Gauge). The larger the S.W.G. number, the finer the wire. The actual space taken up by a wire also depends on the kind of insulation, which may be important when winding a motor, magnet or transformer. The diameter, turns per inch and S.W.G. of various wires can be seen from the Wire Table which follows. (p. 18.)

The S.W.G. of unknown wire can be found by measuring its diameter with a micrometer, or by winding turns side by side on a pencil and counting the number of turns required to occupy 1 in. If burnt-out windings are to be restored, some wire should be saved so that new wire of the same S.W.G. and covering can be obtained.

Wire having a single conductor will fracture, if bent many times. It is used for windings and fixed, permanent wiring.

Flexible wires have several strands of thin wire. For example, 7/34 is 7 strands of 34 s.w.g. The wire may also be given by diameter. In this way, 14/·0076 is a flex consisting of 14 strands of ·0076 in. diameter wire, or 36 s.w.g. Current ratings for useful flexible cords are as follows:

2A	14/·0076
5A	23/·0076
10A	40/·0076

When polarity is important, flexible and other wires can have coloured insulation. Red is for positive and black for negative. With low voltages, the type of insulation is of no importance, except that it should be strong enough to withstand mechanical damage.

CIRCUIT PRINCIPLES

WIRE TABLE				
s.w.g.	Diam. of conductor in inches	Approx. current rating (1,000A per sq. in.)	Approx. turns per inch	
			Enamelled	Double Cotton Covered
20	.036	1.018	26	22
22	.028	.616	33	26
24	.022	.38	42	31
26	.018	.25	51	36
28	.0148	.17	61	40
30	.0124	.121	73	45
32	.0108	.09	83	50
34	.0092	.066	98	55
36	.0076	.045	116	64
38	.006	.028	143	71
40	.0048	.018	180	—

When voltages are high, as with mains circuits, all conductors and insulation *must* be chosen accordingly. Flex should be of good quality, as intended for mains equipment. Every care should be taken that no bare leads or connections could be touched. Full details for the safe running of models from the mains are given later.

Fuses. If a short circuit arises, due to a failure in insulation, or unwanted contact between conductors, a very heavy current may flow. This could damage equipment.

To prevent damage, a fuse may be included in circuit. This will carry the normal current, but "blows" or melts when the current is too heavy. Cartridge fuses have the fuse wire in an insulated tube with metal ends, while re-wireable fuses employ a holder for the fuse wire.

D.C. AND A.C.

Fuse wire sizes are as follows:

Current	Standard Alloy Wire s.w.g.	Tinned Copper Wire s.w.g.
1.8A	27	—
3A	23	38
5A	21	35
10A	—	29

An electro-magnetic trip may be used instead of a fuse. This is a spring-loaded device which opens circuit when excess current flows.

D.C. and A.C.

The current obtained from a dry battery or accumulator flows in one direction and is direct current, or d.c. If the battery were connected to the winding of an electro-magnet, one end of the magnet core would take on North magnetic polarity, and the other end South polarity. If connections to the battery were reversed, the magnetic polarity of the core would also be reversed.

Ordinary household mains supplies are alternating current, or a.c. Fig. 6 shows the difference between d.c. and a.c.

The direct current supply has a steady voltage, and makes a steady current flow in one direction.

The alternating current supply begins at zero and builds up to maximum in a positive direction, then falls again to zero. This is the positive half cycle. The voltage continues to change, reaching a maximum negative value, and then again falls away to zero, to complete the negative half cycle. Positive and negative half cycles form one complete cycle.

CIRCUIT PRINCIPLES

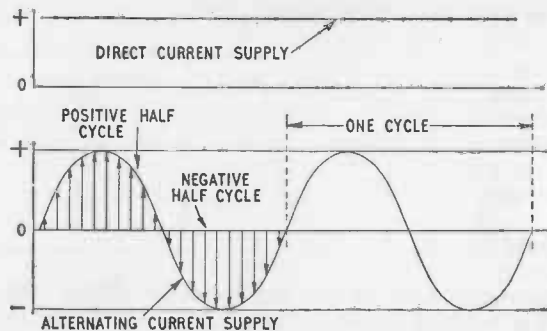

Fig. 6. Diagram showing the difference between d.c. and a.c.

In a resistive load, current will follow the voltage, building up to maximum one way, as shown by the arrows, then falling away to zero, and building up to a maximum in the other direction.

House supplies in Britain have a frequency of 50 cycles per second. The voltage depends on the locality, but is around 240V. This is the figure which would be shown by an a.c. voltmeter, and is actually the "Root Mean Square."

D.c. can be used for battery charging, electro-plating, lighting lamps, producing magnetism of fixed polarity, running permanent magnet motors and similar purposes. A.c. can be used for lamps, running motors with wound fields and armatures, supplying power to transformers, working synchronous clocks, etc. D.c. can be obtained from a.c. by means of a rectifier. (Fig. 36.)

Transformers work because of the build up and collapse of the magnetic field produced by a.c. There is no such effect with d.c. (except at the moment of switching

HOUSE SUPPLY

on or off) so transformers cannot be used with d.c. They are convenient for reducing a.c. mains supplies to the low voltage needed by a model. The transformer also isolates the model from the mains.

The voltage of a d.c. supply can be reduced by means of a series resistor, though energy lost in the resistor serves no useful purpose. This method is only employed with low, safe voltages.

House Supply

The way in which mains power is supplied to houses should be known. Two leads supply current. One is the "neutral" and is "earthed" or at low voltage relative to earth. The second conductor is "live" and at high voltage above earth. The voltage present is sufficient to cause severe or fatal shocks.

In many circuits, only these two conductors are present. All switches should be in the "live" conductor. Lamp-holders are in the neutral side of the circuit, for maximum safety. The appropriate switch should be off before removing or replacing a lamp.

Many circuits have a third conductor, for earthing. All metal items, such as fires, boilers, cookers, irons, etc. should be earthed by means of this conductor. If this earth is absent, the metal parts could become alive (and dangerous to touch) if a fault arose in the appliance.

Equipment intended to be earthed has a 3-core cord, taken to a 3-pin plug. Red is for "live" or L pin, black for "neutral" or N pin, and green for earth, or E pin, as in Fig. 7. (Equipment of foreign manufacture should be checked as different colour codes may be used.)

The flexible cord must be stout enough to carry the current—5 amperes for many purposes, but 10 or 15 amperes or more for fires and large appliances.

Modern ring mains use flat pin plugs, and these have an

CIRCUIT PRINCIPLES

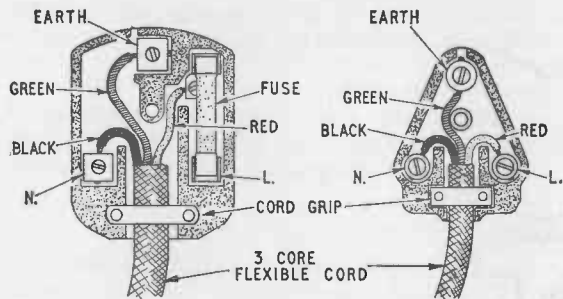

Fig. 7. Correct connections to 3-pin plugs.

internal fuse (Fig. 7). This fuse should not be of higher rating than required, and not of higher rating than the flex. For radio sets, chargers, motors, and similar equipment used at home, a 3A fuse can be fitted.

Older type round pin 5A and 15A outlets have fuses at the distribution board. A smaller fuse, in holder, can be built into chargers or power supply units.

A 3-pin plug ensures that L, N and E circuits are properly connected, with metal parts earthed, and all circuits should always be wired as in Fig. 7, to use the standard colour coding: red for L, black for N, and green for E.

When adaptors or reversible 2-pin plugs are used for switches or other items may chance to come in either the L or N circuits, according to the way the plug is inserted. Great care is thus needed to avoid danger of shocks. Adaptors or 2-pin plugs should never be used with appliances having 3-core cords.

METERS

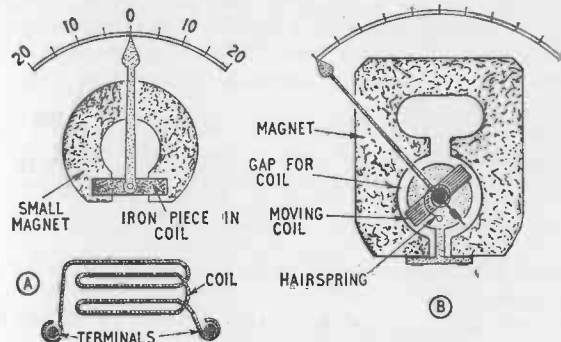

Fig. 8. Two meter movements.

Meters

An ammeter measures current and is often used in charging circuits. Some ammeters have a centre zero, and thus read "charge" in one direction and "discharge" currents in the other direction. Fig. 8A shows an ammeter reading 0-20A, charge or discharge. The meter coil has a few turns of stout wire, and the iron piece to which the pointer is attached pivots in this coil. The small fixed magnet induces magnetism in the iron piece, and also returns the iron piece and pointer to zero, when no current flows in the coil. When current flows, the coil field rotates the iron piece, moving the pointer.

A milliammeter is much more sensitive, and can read currents of $1/1,000$ th of an ampere (1 milliamper, or 1mA) and less. It has a moving coil pivoted in the magnetic field of a strong fixed magnet, as in Fig. 8B. Current is taken to the moving coil by hairsprings, which

CIRCUIT PRINCIPLES

return the coil and attached pointer to zero. When current flows, the coil rotates, moving the pointer. Micro-ampere meters measure exceedingly small currents. As mentioned, $1,000\text{mA}=1$ ampere, and $1,000$ micro-amperes (μA)= 1mA .

The range of a milliammeter can be increased by wiring a shunt in parallel with it. This shunt takes part of the current. The shunt resistance can be found from:

$$\text{Shunt} = \frac{\text{Meter resistance}}{N-1}$$

Here, N is the number of times the scale reading is to be increased. Assume a 20 Ohm meter reading $0\text{-}5\text{mA}$ is to hand, and is to be converted to read $0\text{-}25\text{mA}$. N is thus 5 . The shunt resistor is therefore:

$$\frac{20}{4} = 5 \text{ Ohms.}$$

Milliammeters with heavy gauge shunts are sometimes used to measure large currents and then act as ammeters. All moving coil instruments of this kind work with d.c. only.

Voltmeters of inexpensive kind resemble the ammeter, but the coil has very many turns of fine gauge wire. They read d.c. only. Inexpensive multi-range meters, reading d.c. voltages and currents, may be of this type.

Another instrument is the moving iron meter with a fixed iron piece, and small shaped moving iron piece, attached to a spindle carrying the pointer. The iron pieces are located in a coil. When current flows, repulsion between fixed and moving iron pieces causes the moving iron (and pointer) to be displaced. This instrument will work with either d.c. or a.c.

Cheap multi-range meters use the moving iron assembly, and are suitable for much general test work. Multi-range meters of better type have a moving coil milli-

METERS

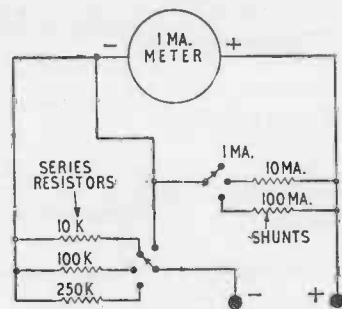

Fig. 9. Circuit for a 6-range test meter.

ammeter, with shunts for current ranges, and series resistors for voltage ranges. A circuit is shown in Fig. 9, and is easily adapted for almost any ranges wanted.

When the $10\text{k}\Omega$ ($10,000$ Ohm) resistor is in circuit, the meter reads $0\text{-}10\text{V}$ d.c. The $100\text{k}\Omega$ ($100,000$ Ohm) and $250\text{k}\Omega$ ($250,000$ Ohm, or $\frac{1}{4}$ megohm) resistors provide ranges of $0\text{-}100\text{V}$ and $0\text{-}250\text{V}$.

When the meter is not shunted, it reads $0\text{-}1\text{mA}$. The second switch contact selects 10mA and 100mA shunts, for $0\text{-}10\text{mA}$ and $0\text{-}100\text{mA}$ ranges. Usually, a 2-pole 6-way rotary switch would be used, to give 6 ranges at will. From Ohm's Law, and the shunt formula given, any ranges necessary can be obtained.

When both d.c. and a.c. measurements are wanted, the better type of multi-range meter consists of a milliammeter, with small rectifier. When a.c. tests are made, the rectifier changes the a.c. to d.c.

Galvanometers can show very small currents. A simple galvanometer can be made by placing a compass in a coil,

CIRCUIT PRINCIPLES

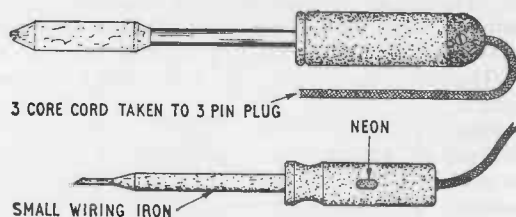

Fig. 10. Large and small irons for general work and soldering.

as mentioned later. A sensitive galvanometer may have a small magnet suspended between the poles of a large electro-magnet. A small mirror is attached to the suspended magnet. Light from a spot lamp falls on the mirror, and is reflected several feet to a fixed scale. This acts as a weightless pointer some feet long.

Soldering

Soldering may be needed for repair or construction. An ordinary iron may be heated over a gas ring, or with a spirit lamp. The iron must melt the solder rapidly, but must not be red hot.

Electric soldering irons are more convenient. For general work, a fairly large iron with a 45W or 60W element will do well. (Fig. 10.) For small work, and radio and similar wiring, a smaller iron is handy and may be a 25W model. Large metalwork cannot be soldered with a small iron.

If necessary, the iron is first tinned by heating it correctly, cleaning away scale with a small file, and applying solder and flux (or cored solder) to the bit.

For electric and radio wiring, a non-corrosive flux must be used. Cored solder, as sold for such purposes, is pre-

SOLDERING

ferable. Tags, leads and other parts to be soldered should be clean and bright. The solder is applied to the joint, and the iron is then held on the solder, so that the flux can take effect. The joint is made when the solder has flowed over the parts to be joined, and these will have to reach about the melting temperature of the solder. Joints may be strengthened by twisting wires together, or round tags, before soldering. With radio parts and similar items overheating may cause damage, so the iron is removed immediately the joint is made.

For other types of soldering, a separate paste flux may be used. This is smeared on the parts to be joined, and solder is then melted on with the iron.

Solders of various grades are made, to suit the work. A soft, quite low temperature solder is used for wiring. Harder solders can be used when more strength is needed. For special purposes, very low temperature solders are obtainable. Ordinary cored solder is intended for brass, zinc, copper, tin, and similar metals and cannot be used with aluminium.

EUREKA RESISTANCE WIRE	
S.W.G.	Ohms per yard
18	0.37
20	0.66
22	1.10
24	1.77
26	2.64
28	3.91
30	5.57
32	7.35

ILLUMINATING MODELS

Many models are considerably improved when fitted with suitable lighting. In dolls' houses, garages, etc. small lights will be required. Intermittent operation (flashing) may be needed for a lighthouse or other model.

Low voltage bulbs, as fitted in torches and hand lamps, are used. Smaller "pea" lamps, with holders to suit, may also be used. Current can be drawn from a dry battery, accumulator or mains transformer. Dry batteries are suitable for occasional running of a few bulbs, but not when many bulbs are present, or when long periods of running are in view.

The 2.5V 0.3A and 3.5V 0.3A torch bulbs can be easily obtained. The 6.3V 0.3A type of pilot bulb, used in mains radio receivers, fits the same screw holder, and is handy for 6V. Similar 12.6V 0.15A lamps may be run from a 12V supply. These also fit Miniature Edison Screw holders.

When economical running is required, bulbs of low current rating are fitted. The 6V 0.06A type of bulb is very economical. Five 6V 0.06A bulbs would only consume 0.3A—about the current drawn by a single 6.3V 0.3A lamp. Other bulbs obtainable include 2.5V 0.2A, 3.5V 0.15A, 4.5V 0.3A, 5V 0.15A, 6.5V 0.15A, 6.5V 0.3A, 6.5V 0.45A, and some 8V types.

Low consumption bulbs give much less light than the larger bulbs. This is often of little importance, as the illumination of a model is generally to make the model more attractive, rather than to light it in the normal way. Popular 2.5V and 3.5V bulbs can often be arranged to suit

higher voltages, by series connections. But in some models the other bulbs mentioned will be more suitable.

Holders, Switches, Wiring. Pea bulbs require pea holders. The other bulbs mentioned need Miniature Edison Screw holders. These can be obtained with screw terminals, or with tags, or to include in wiring. MBC (Miniature Bayonet Cap) bulbs are occasionally used, and need the appropriate holders.

Miniature lamp fittings are obtainable. They include ceiling, wall, and table lamps, and add to the attractive appearance of a model.

Miniature low voltage switches can also be purchased, and are in keeping with the general scale of the usual model. Miniature socket outlets, and switches with outlets, can also be used, with miniature plugs to connect table or other lamps. All fittings of this kind are intended for low voltages, and must never be used with mains voltages.

Thin, single strand plastic covered wire, as sold for bell circuits, may be used. This is neat, available in several colours, and suitable for permanent wiring in a model, if current is not heavy. Thin flex, or flexible bell wire, is satisfactory for leads to a dry battery and other items.

In large models with many bulbs the current may be fairly heavy, and stouter conductors are needed. 2A and 5A flex can be used, or 20 s.w.g. and similar insulated wire. There is no reason why stout wire should not be used in any model, even for small currents, if it is concealed by a baseboard or other features.

Bulbs in Series and Parallel

Bulbs may be arranged in various ways, and this modifies the operating current or voltage. It is thus easy to devise a method to suit a battery or transformer.

ILLUMINATING MODELS

Some under-running of the bulbs is in order, but slightly reduces the light obtained. For example, 6.5V bulbs will operate from a 6V supply with scarcely any reduction in brilliance, while 3.5V bulbs suit a 3V supply, and so on.

When bulbs are connected in parallel, the current required is the total of all bulbs. In Fig. 11A a single 6.5V 0.3A bulb draws 0.3A at about 6.5V or 6V. In B, three bulbs in parallel require 0.9A at 6.5V (or 6V).

When bulbs are wired in parallel, they are for a similar voltage. It is not necessary that they all take the same current. 6.3V 0.3A, 6.3V 0.15A, and 6V 0.06A bulbs could all be in parallel for 6V running (current drawn would be about 0.51A for the three). If one lamp fails the others continue to burn.

Any number of bulbs can be wired in parallel, but the total current drain may need to be known if a transformer is used. For battery running it is necessary to keep consumption down, either by low-drain bulbs, or by using fewer bulbs. If not, batteries of normal size will soon be discharged.

In most models, bulbs are in parallel for 3V, 4.5V, 6V or 12V running, from dry battery, accumulator, or mains transformer. When bright lighting is wanted, 3.5V bulbs may be used with a 4.5V dry battery, since the battery voltage drops somewhat. But if current is taken from a transformer or accumulator, bulbs should not be of lower voltage than the supply.

When bulbs are wired in series, the voltage required will be the total of the bulbs. All bulbs must be of the same current rating, but they need not be of the same voltage rating.

In Fig. 11C a single 3.5V 0.3A bulb requires a 3.5V 0.3A supply. If two such bulbs are in series, as in D, they need 7V at 0.3A. This would suit a 6V accumulator or

BULBS IN SERIES AND PARALLEL

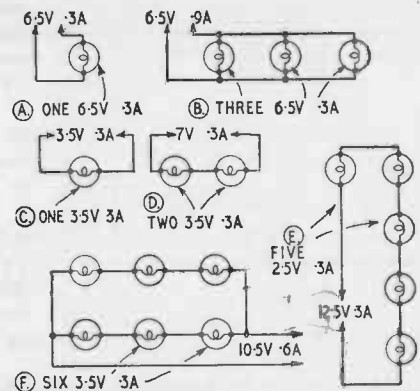

Fig. 11. Bulbs connected in parallel and series.

transformer. In E, five 2.5V 0.3A bulbs require 0.3A at 12.5V, so would do for a 12V supply.

By wiring a suitable number of low voltage bulbs in series, they can be run from a higher voltage. This happens with coloured decorative light strings—ten 25V lamps may be run from 200/250V a.c. or d.c. mains.

With series running, all bulbs will be extinguished if a single bulb fails or is removed. Nor can the bulbs be switched on or off individually. They may be switched in pairs, if wired as in D. There is the advantage that low cost torch bulbs may be used for 6V or higher supplies.

Two or more small chains of series connected bulbs can be wired in parallel, as in F. These six bulbs would draw 0.6A (two 0.3A chains) at 10.5V (three 3.5V bulbs in each chain).

For mains voltage strings, bulbs may be obtained which

ILLUMINATING MODELS

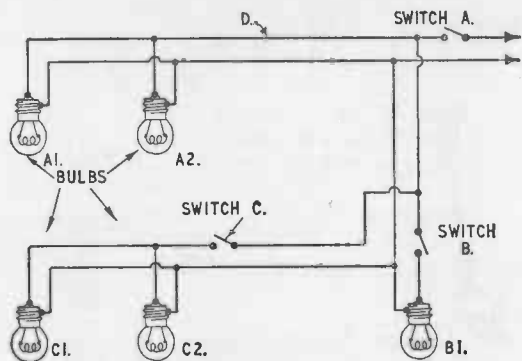

Fig. 12. Circuit for doll's house, toy garage, etc.

short when they fail, so that other bulbs are not extinguished.

Switching Circuits. The bulbs and control switches can be arranged as necessary, to give switching of individual lamps, or groups of lamps. In Fig. 12, the switch A interrupts the whole circuit, so that all bulbs are off. A switch of this kind is useful as it allows the whole model to be switched off at once.

When switch A is closed, lamps A1 and A2 light. Switch B allows lamp B1 to be lit, while switch C puts on lamps C1 and C2. If it is desired to switch off lamps A1 and A2, with B1, C1 and C2 burning, a switch is inserted at point D. If all five lamps are to burn together at all times, switches B and C may be omitted. All bulbs are in parallel, so that the bulb voltage is about that of the supply.

TRANSFORMERS

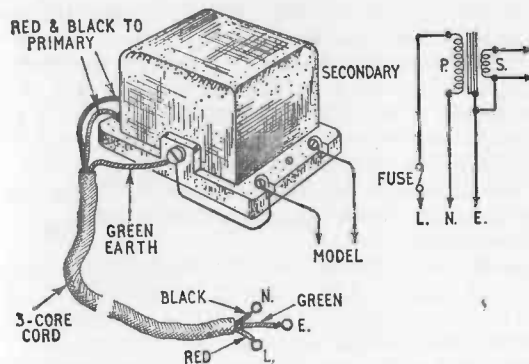

Fig. 13. Wiring to transformer for models, charging, etc.

Battery or Transformer

Occasional running of a few bulbs is feasible from a dry battery, and suits small children. It is only necessary to choose a battery of suitable voltage and capacity. The capacity (or ability to supply current) depends on the size of the cells. If current drain is moderate, a reasonably large 4.5V battery is sufficient.

For continuous running of several bulbs a mains transformer is more economical. The transformer draws power from the house a.c. mains and reduces the supply to a low voltage for the model. Transformers cannot be used with d.c. mains.

Fig. 13 shows correct connections for the transformer. If properly wired and protected, high voltages cannot arise in the low voltage circuit. This is very important in view of the risk of shocks, as the low voltage circuit may

include low voltage switches, bare terminals and bulb holders, train rails, etc.

Current for the transformer primary is drawn from L and N pins of a 3-pin plug, wired as shown in Fig. 7. A 3-core flexible cord is required. The large pin of the plug provides the earth connection, and the green conductor of the 3-core flex is used for this circuit. The transformer core, and one secondary lead, are earthed. If the transformer secondary has a centre tap, this is earthed instead of one outer lead.

A fuse is included in the L circuit. Current is best drawn from a 13A plug, and the fuse will then be present here. As the transformer primary current is small, a 3A or other low rating fuse can best be inserted.

If any fault in the transformer or wiring should bring the live mains circuit into contact with any part of the secondary circuit, a heavy current will flow to earth, and the fuse will blow. This protects the user, and is the reason for this method of wiring.

Suitably housed transformers for the mains running of models can be obtained. If a separate transformer is purchased, it should be totally enclosed in a box, so that mains circuits or primary connections cannot be touched. A primary mains voltage switch can be included and mounted on the box, and a fuse may be provided internally. This fuse should certainly be present if current is drawn from a 15A plug, since the mains outlet will only be protected by a high capacity fuse.

The box should be ventilated by several rows of small holes, or by apertures covered with metal gauze. It may be totally insulated (for example, with wood). If the box is metal, the transformer should be bolted to it, and the whole box should be earthed with the transformer core.

The output voltage of the transformer secondary should

suit the bulbs. Or bulbs can be chosen to suit the transformer. For many models, a 6V or 12V transformer will do.

Transformers are available with tapped secondaries giving various voltages. These are useful for experimenting.

The current rating of the transformer should be at least equal to the demand made on it. For example, eight 6.3V 0.3A bulbs would draw about 2.4A, so a 2½ ampere or 3 ampere secondary is required. The whole current which the transformer *could* supply need not be drawn—this merely shows the maximum rating. If this rating is exceeded, the transformer may overheat or be damaged.

The same transformer may drive a motor or other equipment. If so, the current needed for this purpose is added to that wanted by the bulbs.

A transformer can supply continuous currents impossible with dry batteries. A bell transformer giving 3V, 5V and 8V is suitable for some small models, care being taken to avoid over-running small transformers. Other models may need 4V, 6V, 12V, or some other particular voltage.

One or more low voltage bulbs may be dimmed by adding a stud contact or variable resistance in one lead, as shown for the speed control of motors. (Fig. 26.)

Fig. 14 shows a transformer with tapped primary and secondary. The primary tapping is taken to the appropriate terminal, to suit the actual mains voltage. The secondary delivers 14V, and has tappings at 2V, 2V and 4V from one end. It is thus possible to obtain 2V, 4V, 6V, 8V, 10V, 12V or 14V, by selecting suitable tappings or using the whole secondary.

Mains units providing a d.c. output are made to run trains and d.c. motors. They can also be used for bulbs, and may have additional terminals or sockets, giving un-

ILLUMINATING MODELS

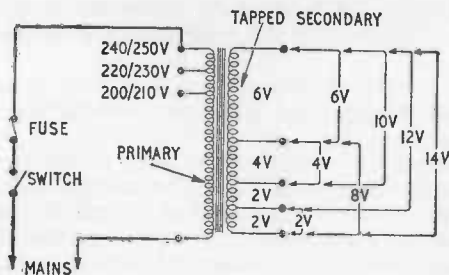

Fig. 14. Tapped transformer giving 2V to 14V output.

rectified a.c. Details appear in the section on trains, and accumulator charging.

Signal Lamps. Pilot, indicator, or signal lamps show if a circuit is switched on. A signal lamp may be wired to a transformer secondary, to show when the transformer is receiving current.

Occasionally, neon indicators are used. These work at

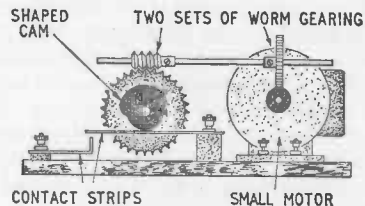

Fig. 15. Flasher for lighthouse, etc.

FLASHER UNITS

mains voltage, and are wired to a mains circuit. If a neon bulb is broken, it must be replaced by one of the same type.

Flasher. A flasher unit can be used with a model light-house, or with low voltage decorative lights. A mechanism of this kind is shown in Fig. 15.

The small motor drives a spindle carrying the shaped cam. For about one-half revolution of the cam, the contact strips are open, interrupting the circuit. For the other half revolution, the cam presses the strips together. The strips are in series with one lead to the bulbs.

If required, the speed can be reduced by lowering the battery or supply voltage, or using a speed controller. Little turning power is needed. Two 25 teeth gears, each meshing with a single thread worm, would provide two 25 : 1 ratios, or $25 \times 25 = 625 : 1$. So if the motor runs at 2,500 r.p.m. the cam will rotate 4 times per minute.

If the final axle is longer, it can carry more cams of different shapes. Three cams would operate model traffic control lights. One cam and set of contacts will control red, another cam and contacts amber, and the third set green. The axle speed should be 1 r.p.m. or slower.

The contacts may be used for other purposes. With a train with isolating rail, contacts can complete the rail circuit as well as lighting a green lamp. The train will then halt on red, and start automatically on green.

3

MAGNETIC DEVICES

Permanent and electro-magnets are used in many devices, and are of many shapes and sizes. Permanent magnets retain their magnetism for years. Electro-magnets, however, cease to be magnetised when the current is interrupted.

Alloys which retain magnetism well are used for permanent magnets. Fig. 16A shows a simple bar magnet, and it may be a round rod, or rectangular bar. One end is the magnetic North pole, and the other end the South pole.

B and C are horseshoe magnets. B is of ordinary shape, while magnet C is made to suit a motor armature. Or pole pieces are fitted to a short bar magnet, as shown elsewhere (Chapter 4. *Motors*).

The compass is a simple example of the use of a magnet. This is shaped like a needle, and pivoted so that it revolves freely, and seeks magnetic North.

Dissimilar magnetic poles attract each other. That is, any North and South poles try to draw together. Similar poles repel each other. Two North poles exert repulsion on each other, as do two South poles. This can be demonstrated with a compass needle and magnet, or by suspending a magnet on thread and bringing another magnet near.

The lines of force between magnetic poles can be demonstrated by scattering iron filings on card resting on the magnet. The card is tapped, and the filings take up positions along the lines of force.

ELECTRO-MAGNETISM

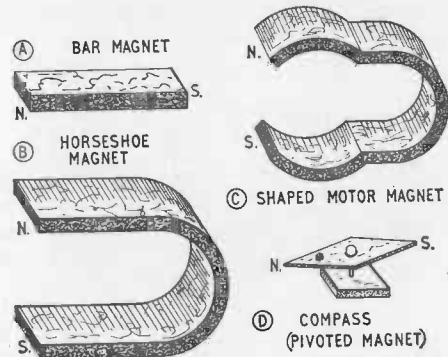

Fig. 16. Permanent magnets.

Permanent magnets are used in permanent magnet motors, small dynamos, moving coil speakers and moving coil microphones, magnetic headphones, various kinds of meters, etc. They are often of special shape, to suit the purpose in view.

Electro-magnets

If current is passed through a straight wire, A in Fig. 17, lines of magnetic force arise. This is shown by placing a compass under the wire, the wire being held in a North-South direction. If the wire is wound in a coil, the magnetic force is increased. B is a sensitive galvanometer able to detect small currents. The wire may also be wound in a coil, as in C.

When an iron core is placed in the coil, this concentrates the magnetic force. D is an electro-magnet of this kind. It lifts iron and similar objects when connected to a battery,

MAGNETIC DEVICES

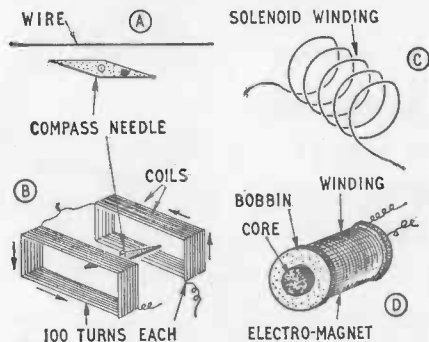

Fig. 17. Electro-magnetism.

but magnetism ceases when the supply is disconnected. To make an efficient magnet, many turns of insulated wire are contained in a bobbin, as at D. Twin magnet assemblies are also used.

If the polarity of the supply is reversed, the North and South poles of the magnet change position. If the direction of winding the bobbin were reversed, the magnetic polarity of the magnet would also be reversed. The direction of winding, and method of connecting the winding, can thus be important, when magnetic polarity must be correct. For proper results, a twin buzzer or bell magnet has dissimilar magnetic poles at the free ends of the cores facing the armature. This is so if the inner end of the first magnet is connected to the inner end of the second magnet, if both were wound in the same direction. Electro-magnets are often of special shape, to accommodate a motor armature, etc.

ELECTRICAL BELL

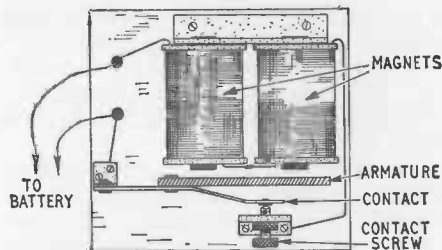

Fig. 18. Mechanism of buzzer or electric bell.

Buzzer and Bell. Fig. 18 shows a buzzer or bell using twin electro-magnets. Current flows to the armature contact, and from this to the fixed contact screw, and through the magnet windings. Magnetism attracts the iron piece of the armature. When this moves in, the armature contact is separated from the fixed contact, interrupting the current, so the armature springs back to its original position. This completes the circuit, so the cycle is repeated. A hammer can extend from the armature to strike a bell. Good ringing depends on the contact surfaces being clean, and meeting with sufficient pressure, and upon the armature, hammer, and spring tension being suitably adjusted.

Small buzzers or bells have only a single magnet. High note buzzers have a light armature, with adjustable contact screw and adjustable armature tension.

Relays. The relay has two terminals or tags for the magnet windings, and separate terminals or tags for armature and contact assembly. The relay is a type of electrically operated switch. A small current in the magnet

MAGNETIC DEVICES

windings can operate the armature, so that a second circuit is switched on to light lamps, start a motor, etc.

When models are controlled by radio, a sensitive relay is often used. This may operate with changes in current of under 1mA (0.001 ampere) to switch in steering motors or other items.

The relay shown in Fig. 19A has one fixed contact on each side of the armature. Current is applied to the winding through terminals X—X. When the armature rests as shown, A is switched to B. But when the armature is drawn towards the magnet, this changes the circuit from A to C. Relays may have several sets of contacts.

Some relays are sealed or fixed, and operate when a particular current flows in the windings. Other relays have adjustable armature tension and contacts, and can work over a wide range of currents. Light-weight, miniature relays are available for planes and small models. The chapter on radio control shows their uses.

The relay in Fig. 19B has spring leaf contacts A, B and C. Current normally flows from A to B. When the coil is energised by the circuit connected to tags X—X, the armature pushes A into contact with C.

Cut-Out. A dynamo charging circuit cut-out consists of a magnetically operated switch somewhat similar to a relay. When sufficient current is available from the dynamo, the cut-out contacts close, and the dynamo charges the accumulator. But when the dynamo is not running, or turns slowly, the cut-out contacts spring open, and the accumulator does not discharge through the dynamo windings.

A type of automatic cut-out or "fuse" device is also used with models. This has contacts held together by a catch. A low resistance electro-magnet is included in one circuit to the model. If a short circuit (such as derailed

SHOCKING COIL

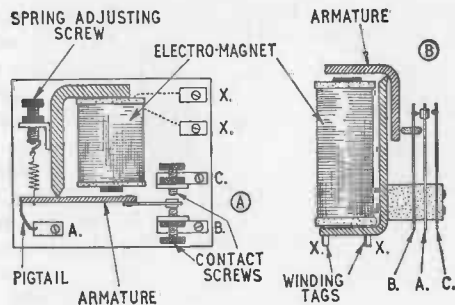

Fig. 19. Change-over relays.

train) causes a heavy current the catch is magnetically released, and the contacts open, breaking the circuit. When the fault has been corrected, the trip can be re-set by means of a spring-loaded button or lever.

Shocking Coil. A shocking coil, "medical" coil, or induction coil will produce a low current, high voltage output. To obtain this effect, the coil has primary and secondary windings. The primary is of relatively few turns, and is connected with an armature and battery, as shown for a buzzer or bell. The primary could be two layers of 22 s.w.g. cotton covered wire, on an iron core $2\frac{1}{2}$ in. long and $\frac{1}{4}$ in. in diameter.

The secondary has many turns of fine gauge wire. A typical secondary could have 2 oz. of 42 s.w.g. silk covered wire. The number of turns is not important, though the step-up ratio of the coil is increased by using more turns on the secondary. The secondary is wired to terminals, from which insulated flexible leads pass to metal handles, grasped when the coil is in use. Fig. 20 illustrates this.

MAGNETIC DEVICES

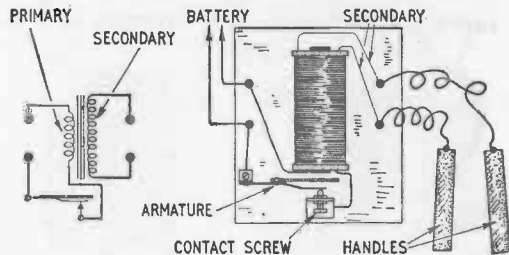

Fig. 20. Circuit and construction of shocking coil.

The output of the coil depends on the battery voltage, and adjustment of the armature, as well as the coil windings. A 1.5V or 3V dry battery will generally be sufficient for amusement purposes. Shocks should not be administered unexpectedly.

Dynamos and Generators

A permanent magnet motor, with armature windings and brush gear, acts as a direct current generator, if rotated at high speed. This may be useful for model purposes, or to demonstrate the working of a dynamo.

For a model dynamo, a straight 2-pole armature can be used. Each pole has several hundred turns of 28 s.w.g. or similar insulated wire (Fig. 21). The armature revolves with its ends near the poles of a strong permanent magnet.

For lighting, alternating current is suitable, so no commutator is required. Instead, the armature windings are connected to a slip ring and the axle. Current is taken from brushes bearing on the slip ring and axle. The output from the dynamo is a.c. Both sections of the armature winding must be in the same direction, a gap being left for the axle.

DYNAMO

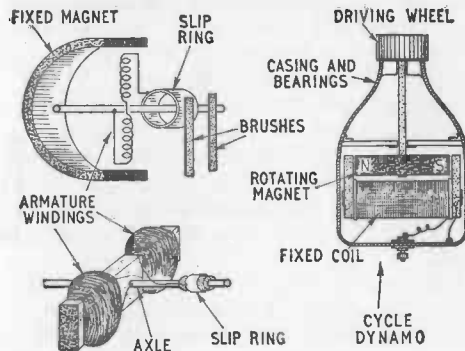

Fig. 21. Dynamo construction

If the magnet assembly carrying the windings were fixed, and the permanent magnet rotated, a.c. would be obtained in exactly the same way, but no brush gear would be needed. This method is used in the cycle dynamo and some other generators. In Fig. 21 the permanent magnet is shaped like a wheel, and the poles of the wound magnet fit closely round it. Current is taken from the fixed coil to the cycle lights.

Sometimes the wound magnet assembly is inside the permanent magnet. This is so with the flywheel magneto and flywheel generator, as used on some motor-cycles and similar engines.

Cycle Lighting Sets. Cycle lighting sets are designed to give a good light ahead at an average speed. At low speed, the light is reduced.

The bulbs specified by the maker must be used. These are chosen for best results from the voltage and current

MAGNETIC DEVICES

available. The back light may be a low consumption bulb (0.06 ampere) so that most current goes to the headlamp. When a bulb is provided for battery operation, this should also be of the recommended type.

Hub dynamos have virtually no working parts. Older lighting dynamos may be driven by pressure on a tyre. They should be correctly aligned, or there will be loss of power, slip, or unnecessary wear. Some tyres have a side tread for driving. A spring mechanism allows the small dynamo wheel to be lifted from the tyre when lights are not wanted.

If such equipment fails, output from the dynamo can be checked with a bulb. If light is obtained here, but not at the headlamp, wiring from dynamo to lamp is suspect. If the dynamo produces no current, connections to it should be checked and the windings may need testing for breaks. If the headlamp works, but not the tail lamp, a new bulb can be tried, or the existing bulb may be tested. If the bulb is in order, contact to it may be poor; if not, the lead to the lamp is suspect. There is usually one wire, and an electrical return through the machine frame, so good contact with the actual metal is necessary.

Scooter and Motor-cycle Lighting. Some small machines have a generator lighting system, with no accumulator. The generator is usually incorporated in the flywheel (see flywheel magneto) and produces current when the engine is running. Headlamp and tail lamp bulbs should be of the type, voltage and wattage recommended. Light varies considerably with engine speed, and no light is available when the engine is halted. A dry battery may be fitted for parking.

Some machines use an a.c./rectifier system, similar to that in Fig. 22. The generator is usually incorporated in the flywheel. Its output is a.c., but this is changed to d.c.

A.C. GENERATOR

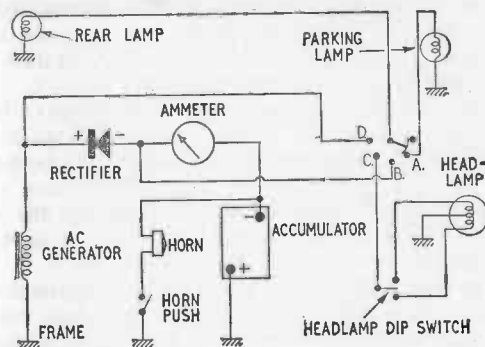

Fig. 22. A.c. generator lighting and charging circuit.

by the rectifier, and passes through the ammeter to the accumulator, which receives a charging current when the engine is running.

In Fig. 22, the switch is "off." When the moving contact bridges A and B, rear and parking lamps draw current from the accumulator. In the next switch position, B and C are bridged, so that the rear lamp and headlamp draw current from the accumulator. The 2-way dip switch allows the dip or main filaments of the 2-filament headlamp bulb to be selected. When the switch bridges C and D, current for rear lamp and headlamp is from the a.c. generator.

This system allows direct operation of the lamps from the generator, to economise on battery current. Running from the battery is possible when wanted for parking lights, and good light at low speed. A 24W/36W bulb may be specified for headlamp, with 3W for rear lamp and

MAGNETIC DEVICES

similar or smaller bulb for parking. The accumulator is often 6V, but 12V systems are used.

Generator, accumulator, and all lamp circuits are completed through the machine frame. The horn push switch may be between horn and accumulator, and the horn is then returned to the frame. Speedometer and other instrument lights are in parallel with the rear lamp.

The accumulator should be maintained as described elsewhere. If it slowly becomes discharged, smaller demands should be made on it. That is, direct lighting should be chosen and lengthy use of parking lights avoided. The accumulator may be charged separately, as described. If it is removed from the machine, it must be connected in the correct polarity, when replaced.

Flywheel Magneto. A flywheel magneto is often used on an auto-cycle, scooter, small motor-cycle, lawnmower, grass-cutter, garden cultivator, or similar engine. The flywheel is hollow, and bears a number of pole pieces and magnets. In Fig. 23 there are six pole pieces screwed to the inside of the flywheel, and shaped to hold six permanent magnets.

Two stationary magnet assemblies are fitted to the engine crank-case. The magneto assembly bobbin carries primary and secondary windings. The primary circuit is completed through contacts which are opened by a small cam on the engine crankshaft, and which close under spring pressure. The movement of the flywheel pole pieces past the fixed magnet assembly generates a voltage in the windings.

The contact breaker opens as the engine piston is reaching top dead centre. The interrupted current induces a large voltage in the secondary, which is conducted to the spark plug by the high tension lead, the plug being re-

FLYWHEEL MAGNETO

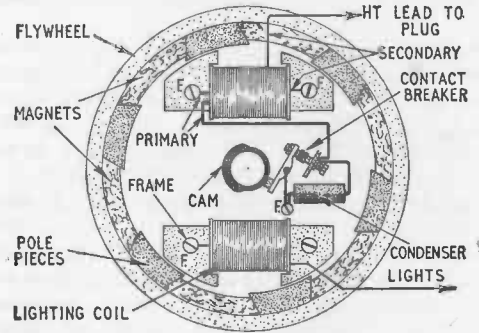

Fig. 23. Flywheel magneto and a.c. generator.

turned to the engine frame. The spark is thus produced at each revolution.

Correct timing of the spark depends on the contact breaker gap and on the cam being correctly positioned on the crank spindle. Some engines have cam and flywheel keyed to the crankshaft, so that timing here is correct. Other engines have the flywheel with cam on a taper shaft, and timing is set by hand. It is usual for the spark to arise just before the piston reaches top dead centre, and the figure given by the engine maker should be followed. The gap contacts should be perfectly clean, and set with a feeler. One contact may be on an adjustable rocker arm, or may be threaded, so that the gap can be adjusted. The gap is often around 0.015 in. to 0.02 in.

If no spark is visible with the plug resting on the engine, the plug may be defective or dirty. The plug gap should be as recommended for the engine—often around 0.02 in.

MAGNETIC DEVICES

Some 2-stroke engines run very hot and need particular plugs.

Lack of continuity from spark coil to plug may be caused by a broken h.t. lead, or by lack of contact between the h.t. lead and outlet. A lead with cracked insulation may cause trouble. Other defects include a broken coil winding, which can be checked with a meter and dry battery or test-meter. A defective condenser may cause erratic working. Coil primary and secondary are generally returned to the frame.

In Fig. 23 the second coil generates a.c. for headlamp and tail lamp, and may be used for direct lighting, or with a rectifier and accumulator, as in Fig 22. Small motor-cycles and scooters often have a generator of this type. The lighting coil is absent in a motor mower or similar engine.

4

MOTORS

One type of model motor uses a permanent magnet, and runs from direct current only (dry battery, accumulator, or mains unit with rectifier). The second type has no permanent magnet, and runs from either direct current or alternating current.

Various arrangements of bearings, brushes and magnets are used, to suit the motor. Many popular motors have a three-pole armature as in Fig. 24. These are self-starting and efficient. The armature has three shaped poles, each with its winding. The windings are in series, and connected to the three segments of the commutator. Current reaches the armature windings through brushes which bear on the commutator.

In Fig. 24, North and South poles of the permanent magnet are shown. Current is passing through the winding on armature pole 1 in such a direction that pole 1 is South. Repulsion arises between pole 1 and the permanent magnet South pole, and there is attraction between pole 1 and the P.M. North pole. The armature thus tries to turn clockwise. Current in the winding on pole 3 results in attraction between pole 3 and the P.M. South pole, and repulsion between pole 3 and the P.M. North pole, so the force exerted helps that obtained from pole 1.

When a pole is near the magnet, as for pole 2, current in that winding is reversed, because the commutator has rotated with the armature. The movement is thus always clockwise, and the motor runs in this direction.

If the polarity of the supply is reversed, the magnetic

MOTORS

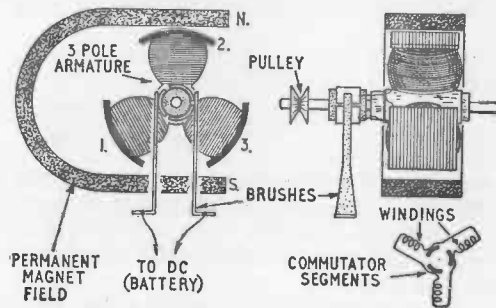

Fig. 24. Permanent magnet motor.

polarity of the armature poles is reversed. The motor then runs in the reverse direction.

If both armature polarity and field magnet polarity are reversed, the motor continues to run in the same direction. This is why motors with electro-magnet field assemblies will run from either a.c. or d.c., but cannot be reversed merely by reversing the battery supply.

No current is required for the permanent magnet field, so the motor is economical, and can run from dry batteries. The P.M. motor can be reversed from a distance, by reversing the polarity of the supply. This is an advantage with trains and some other models.

The axle may be in line with the permanent magnet in a compact motor. The magnet is often shaped so that its poles are closer to the poles of the armature, to increase efficiency. (Fig. 25 A.)

In some motors bar magnets are used, as shown in B. Other motors have horse-shoe magnets, as in Fig. 24, but shaped pole pieces fitting near the armature are attached.

BRUSH GEAR

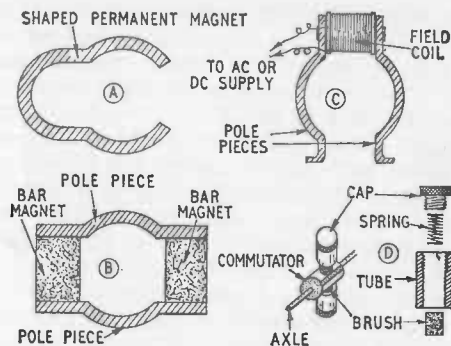

Fig. 25. Motor magnets and brushes.

Brush Gear. Small motors often employ metal strip brushes, bearing on the commutator, as in Fig. 24. Larger motors may have brushes in tubes, as in Fig. 25D. Springs keep these brushes in contact with the commutator. This type of brush is more suitable for continuous use.

The brushes should bear on the commutator with moderate pressure. Excessive pressure will slow the motor and increase wear. Light pressure will cause bad sparking and loss of power. The brushes, and commutator segments, should be clean, and lubricating oil should not be applied to them.

A somewhat different motor has a round armature enclosed by a ring magnet. The armature has a winding, and brushes bear lightly on the winding turns, which are bared to allow contact. This type of motor is usually made only in a small size.

Many model motors have only three poles, as in Fig. 24, although larger motors usually have more as shown later.

Field Windings. The field magnet may consist of shaped pole pieces, no permanent magnet being incorporated. A winding is then provided, and current magnetises the field assembly. This type is shown in Fig. 25C, the pole pieces being shaped to fit a baseplate.

This motor is less economical, as current is needed for both armature and field. It can be run from large dry cells, or from an accumulator. It also runs from a.c., so power can be drawn from a mains transformer. It cannot be reversed from a distance, as with the P.M. motor.

The field winding is frequently in series with the armature. But in some cases connections may be changed to suit the voltage. For example, if both field and armature were wound for 6V, they could be in parallel for 6V, or in series for 12V.

Running and Speed Control

An electric motor develops full power when running at high speed—some 2,000 to 10,000 revolutions per minute, according to the type and size of motor. Considerable reduction gearing will thus usually be needed between the motor and working parts of the model.

For efficient running the commutator segments must also be in correct relationship to the armature poles. If the commutator can be rotated slightly on the axle, and has been moved, it should be restored to the position giving best running.

Motor speed and power also depend on the voltage. Very small motors run from $1\frac{1}{2}$ V or 3V. Many popular motors require 3V or $4\frac{1}{2}$ V, while others are for $4\frac{1}{2}$ V, 6V, or more. Trains often use 12V motors.

The voltage must be available when the motor is drawing current. So a large motor intended for 6V would not run satisfactorily from a small 6V dry battery, because the voltage would drop too much. Many popular motors run

satisfactorily from dry cells, but large motors require an accumulator or mains unit.

If the battery voltage is checked with a meter, this is done with the motor running. A battery in poor condition may show its full voltage when disconnected, but this may fall badly when the motor is switched on.

Accumulator cells of the usual acid type are about 2V each. A 2-cell battery is thus 4V, while a 3-cell battery is 6V. Dry cells are about $1\frac{1}{2}$ V each, so a 2-cell battery is 3V, a 3-cell battery is $4\frac{1}{2}$ V, and a 4-cell battery is 6V. Excess voltage may cause overheating or bad sparking at the brushes. Low voltage results in insufficient speed or power.

A large cell will retain its voltage better, when current is drawn, than a small cell. So a large battery cannot always be replaced by a small battery of the same voltage.

Speed Control. Trains, boats and other models may be fitted with a speed controller. This is some type of variable resistance, connected anywhere in the circuit between motor and supply, as in Fig. 26.

The motor runs at full-speed when all the resistance is excluded. Fig. 26 also shows a stepped controller, with a rotating arm bearing on any one of seven studs. This provides full-speed running, and five slower speeds. The final stud is not connected, and switches the motor off.

The remaining controllers in Fig. 26 have a pivoted arm, which bears on the resistance winding. They may be used with trains or other models. Such controllers are readily made, resistance wire being wound on fibre or other insulating material.

In some models, two-speed running is convenient. This can be arranged by including a resistance in one lead, as in Fig. 27. With the resistance in circuit, the motor runs at reduced speed. When the switch is closed, the motor runs at full-speed.

MOTORS

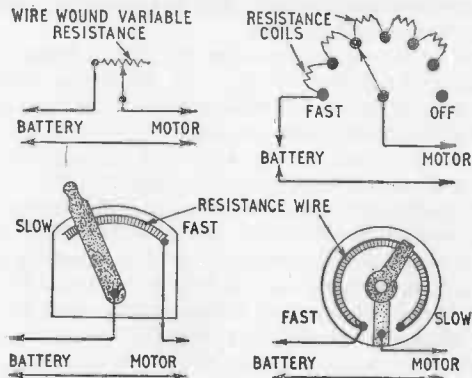

Fig. 26. Speed controllers and dimmers.

Two-speed running is suitable for some models, such as a radio controlled boat. The switch would be replaced by relay contacts, and the relay is controlled by radio. This gives full-speed (contacts closed) or half-speed (contacts open). The speed control relay might be operated by a circuit also reversing the motor, to give sailing full-speed ahead, and half-speed astern.

Two-speed running can be added to any model by providing a switch and small coil of resistance wire. The motor speed obtained with the switch open can be adjusted by altering the length of resistance wire.

Controllers can be used with dry batteries, accumulators, or mains units, with d.c. or a.c./d.c. low voltage motors. The resistance required depends on the motor. Low consumption motors will require more series resistance than will motors drawing a heavy current.

Controllers of the same type can be used to dim low

RUNNING AND SPEED CONTROL

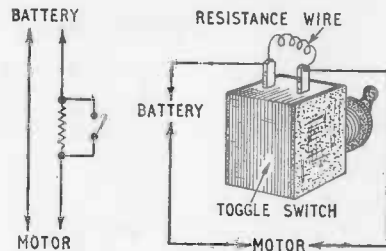

Fig. 27. 2-speed motor control.

voltage bulbs. *Such controllers must not be used at mains voltage.*

Reversing. Permanent magnet motors may be reversed by changing the battery polarity. A 2-way switch is used for this purpose.

Circuits are shown in Fig. 28. Circuit A needs two batteries, but only a single pole 2-way switch. It is simple and convenient. In a boat it may be handy to use a slightly discharged battery, or lower voltage, for reverse. Or a series resistor may be added in one lead from the reverse battery. The circuit is seen in radio control, where a 2-way relay replaces the switch.

Fig. 28 also shows a reversing circuit (B) for a single battery, though a 2-pole 2-way switch must be employed. Throwing the switch reverses the polarity of the supply to the motor. The switch should have a central "off" position. Current is drawn from any d.c. source—dry battery, accumulator, or mains unit with rectifier. A speed controller can be added in one lead.

The shape, size, and constructional details of reversing switches vary. Toggle switches and slide switches may be

MOTORS

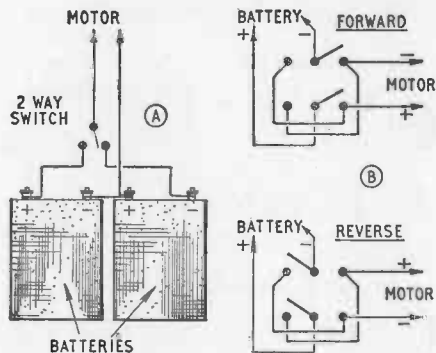

Fig. 28. Reversing permanent magnet motors.

used, or rotary switches. Special switches are made to suit particular motors or models. The switch in Fig. 28A is a 1-pole 2-way (single-pole double-throw) type. That for B must be 2-pole 2-way (double-pole double-throw).

Reversing a.c./d.c. Motors. When the motor has a wound field magnet, reversing the supply will not reverse the motor. It is necessary to reverse the polarity to the field, or the brushes (but *not* both). This needs several connections between motor and switch, so the switch is generally incorporated in the motor. One circuit is shown in Fig. 29, and reverses the supply to the field only. The switch has six studs in an insulated plate. Two semi-circular contacts are fitted to a rotating plate with lever, and complete the circuits between the studs. With the switch in the central position, no circuit is completed, and the motor is off.

Contact surfaces of any switch should be bright and

RUNNING AND SPEED CONTROL

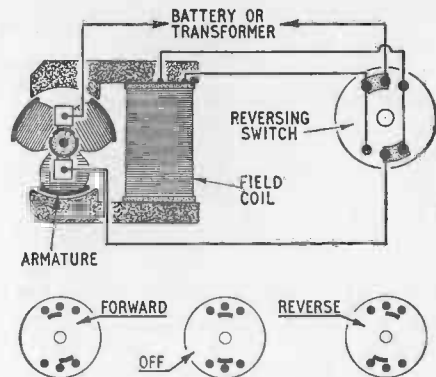

Fig. 29. Reversing an a.c./d.c. motor.

clear of dirt or oil, which may cause bad contact. Many switches have a long life, but may require cleaning. Bad contact results in irregular running, or reduced power, and sparking may be visible at the switch. Switches should not be tampered with unnecessarily.

In radio control, a 2-pole 2-way relay may be used to change over the circuit to either the field or brushes to reverse a motor.

Reduction Drives

As small electric motors run at high speed, a reduction drive is generally required. This slows the rotation of the road wheels or other working parts.

In trains and mobile models, worm gearing is often used and provides a large reduction ratio. The worm in Fig. 30 has a single thread, and meshes with a 16 teeth gear. The

MOTORS

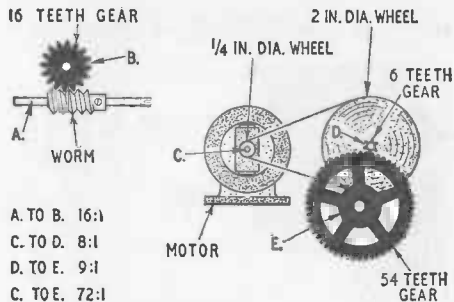

- A. TO B. 16:1
- C. TO D. 8:1
- D. TO E. 9:1
- C. TO E. 72:1

Fig. 30. Ratio obtained with gears, etc. shown.

ratio is then 16 : 1. That is, the worm rotates 16 times, for one rotation of the gear. If the worm were fitted to a motor running at 3,200 r.p.m., the gear would rotate at 200 r.p.m. With a single thread worm, the ratio equals the number of teeth on the gear.

A single thread worm also provides an automatic brake because pressure exerted on the gear will not cause the worm to rotate. This is handy for model cranes, hoists, etc.

Light belt drives are also used. The ratio depends on the diameters of the wheels. For example, 1 in. and 2 in. diameter wheels provide 2 : 1, or a 1/4 in. wheel driving a 2 in. wheel gives about 8 : 1 (Fig. 30). The ratio is not exact, as with gears. With small motors belt drives must run freely, or power is lost in friction. A thin rubber band belt is often used, and should not be very tight.

Gears are also often used and the ratio depends on the number of teeth. In Fig. 30, the small pinion has 6 teeth, and rotates 9 times for each turn of the 54 teeth gear.

When a drive has two or more sets of gearing, the total

GEAR RATIOS

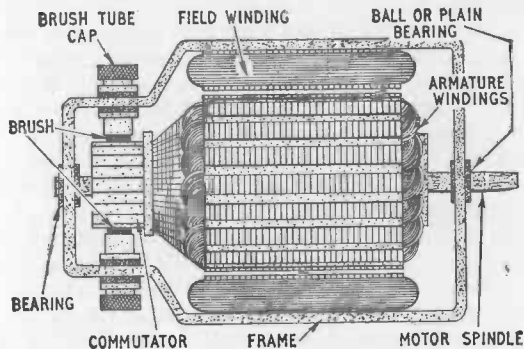

Fig. 31. Universal motor as used for tools, etc.

ratio is found by multiplying the ratios of each part of the drive. In Fig. 30, the belt provides 8 : 1, and the gears 9 : 1, resulting in 72 : 1 from the motor spindle C to gear E. Large ratios may be obtained by having several stages of gearing, or sets of worm gearing.

Variable speed gears have various gear wheels of different sizes, which can be brought into mesh to change the ratio. A reverse gear can be arranged by an intermediate pinion. If a gear were placed between the pinion D and gear E, the rotation of the latter would be reversed, the ratio remaining unchanged.

Some model motors have a gear drive fitted, with a secondary shaft rotating at lower speed. All axles should rotate easily, and the gears should mesh correctly, not binding together. A little thin lubricating oil may be used on worms, gears and bearings.

Tool Motors

Many popular fretsaw and hand tool motors run on a.c. or d.c., 200/250V. These "universal" motors have a wound field and armature. A typical universal motor is shown in Fig. 31. Armature coils fit between the armature poles, and are connected to segments of the commutator. The brushes are in tubes, and should be replaced when worn down to 1/3 of their original length. The field windings are usually in series.

Such motors are made in many sizes, and may have sintered plain bearings or ball or roller bearings, usually with seals to exclude dust. The motor is generally enclosed, and may have a blower fan fitted to the spindle, air being expelled through ventilation holes. Electric drills and similar hand tools have a reduction drive to obtain a suitable speed and to increase torque.

Motor units of this kind may be obtained for fretsawing, power usually being taken from the motor by a composite rubber belt. Typical fretsaw and hand tool motors draw quite a small current, and can be run from any household power point. Earthing is usually required for safety, so a 3-core cord is necessary, connected as described earlier.

5

MISCELLANEOUS EQUIPMENT

This chapter deals with miscellaneous items—trains, boats, mains units, battery charging, soil heating, aquaria, light control, clocks, static electricity, electro-plating, etc.

Trains

Many popular models use OO Gauge track, and are to a scale of 4 mm. to the foot. The space between the rails is 16.5 mm., or just over $\frac{3}{8}$ in. HO Gauge is the same, but models are to about 3.5 mm. scale.

OOO Gauge is also used, and the track is 9 mm. (approx. $\frac{3}{8}$ in.) with models to 2 mm. scale. Between this and OO Gauge are TT Gauge models, with 12 mm. track and 3 mm. scale rolling stock and locomotives.

OO Gauge models use 2 and 3 rail track. Fig. 32 shows ways in which current can be carried to the locomotive. With a 2-rail track, rails are insulated, and form positive and negative circuits. Some 3-rail track employs the outer rails as a common circuit, with a central rail insulated from them. Other 3-rail track has rails all insulated from each other, so that two circuits are provided. This permits individual control of two trains on the same section of 3-rail track.

Track is also used with projecting studs between two running rails, the studs acting in a similar manner to a central conductor rail. This method is employed by one HO Gauge manufacturer.

The correct track must be used, so that sections can be

MISCELLANEOUS EQUIPMENT

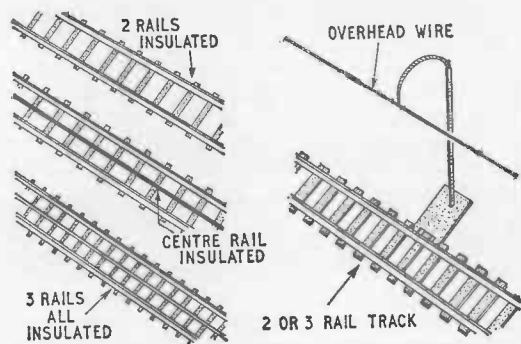

Fig. 32. Various types of model train track.

joined, and so that the conductor system and size suit the rolling stock.

Track may also be used with an overhead conductor, or catenary system. Pantograph contacts on an electric style loco pick up current from the overhead line.

An isolating rail has one current carrying rail interrupted, so current may be cut off from one part of the track, while remaining available on other parts. The rail can be used in a siding, so that a train can be taken in and switched off, while other trains operate on the main track. The isolated locomotive may be brought out by switching in the isolated portion of track, and reversing. Isolating points are made so that locomotives run on to sections of track past the points may be halted separately.

Control Methods. A 2-way relay may interrupt one circuit when a second circuit is completed. This allows one

MODEL TRAINS

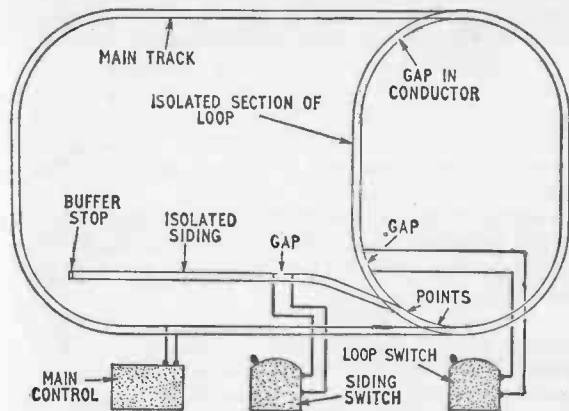

Fig. 33. Track layout with two isolated sections.

locomotive to exercise control over a second locomotive, to increase interest when two trains are run.

Clockwork or electrical switches may be used to interrupt a single circuit, to bring a locomotive to a halt for a time. The switch may be triggered electrically, so that rolling stock will come to rest at a station, then start after an interval.

Circuits may be used where the passage of trains will control signals, etc. Points may be controlled from a distance, by electro-magnets. This allows stock to be switched from one section of track to another.

Fig. 33 shows a track, with loop and siding. Isolator rails are included and have a gap in the conductor. The main control box furnishes power, and has a speed control and reversing switch. Many methods of working are

MISCELLANEOUS EQUIPMENT

possible with this and similar systems. For example, one train may be taken round into the siding. The siding switch may then be opened, leaving this train stationary, while another train is run on the main track or loop. The second train can be driven to the isolated section of the loop, and left out of circuit by opening the loop switch. The siding switch can then be closed, and the first train reversed out on to the main track.

A siding needs only one isolating rail or isolating points. But if a section of track connects with other track in more than one place, isolating points or rails are required at each junction.

Mains Units. Most locomotives require 12V d.c., so current is obtained from a transformer and rectifier, the latter changing a.c. to d.c. Many units provide up to 1 ampere for the train. If the model requires more, the unit will need to be able to supply the extra current. A small unit intended for a single train only is thus unsuitable for two trains running simultaneously.

Many units have one or more a.c. outputs for lamps and other accessories which may be operated from a.c. These outputs are not suitable for d.c. trains.

Some units have no speed controller, which can be added externally. Others have a controller incorporated. Larger units may provide two or more controlled d.c. outputs, for trains, with other a.c. outputs for accessories. The total consumption of all the trains and equipment which will run continuously should not exceed the maximum rated output of the mains unit.

Fig. 34 shows a control box which draws current from a 3-pin plug. The mains connections should be as described earlier, the large pin being used for earthing.

The unit delivers up to 12V at 1 ampere, through a speed controller. This may be used for permanent magnet

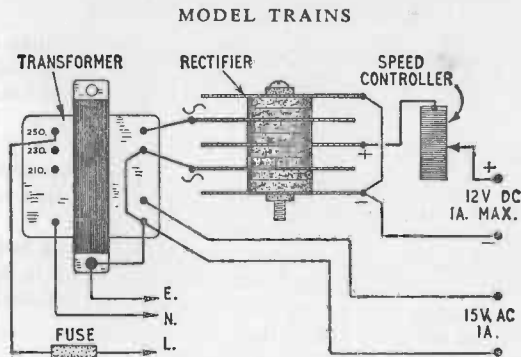

Fig. 34. Mains unit delivering 12V d.c. and 15V a.c.

motors, trains, and any other items requiring not more than 1A at 12V. Most trains could be run from this output, and a reversing switch can be added. The 15V a.c. output is not rectified, and does for lights and other accessories which do not require d.c. Up to 1A may be drawn.

Some control boxes deliver 16V a.c. If a larger transformer and rectifier are employed, the output may be increased. Extra a.c. supplies can readily be obtained from a mains transformer. But when d.c. is necessary, a rectifier is also required. So a.c. is used when d.c. is not specifically needed.

A control box is readily made from thin wood, and may accommodate a battery, on/off switch, reversing switch, speed controller, etc. This is better than assembling such items separately. With mains running, the box can house the mains transformer and rectifier, instead of a battery.

Larger control panels and boxes will be required for

MISCELLANEOUS EQUIPMENT

layouts with electrically operated points, lighting, and various trains. All switches, speed controllers and other items should be clearly marked.

Electric Boats

Small model boats usually run from dry batteries. The batteries should be as recommended for the model, and connected according to the instructions.

Speed control adds interest, and can be provided by a variable wire wound resistor, or a stud resistor with several speed settings. Or an on/off switch may be added, with resistance wire, for "Full" and "Half-Speed" sailing. It is also easy to fit a reversing switch, as in the section on motors.

Larger boats may use small accumulators, or large dry cells. If a model does not run satisfactorily, the battery voltage should be checked with a meter, with the motor switched on. If the motor does not run, and the battery is in good condition, tests for voltage can be made step by step, beginning at the battery. If one lead, switch, or other item is taken in at a time, the position where the break arises (no voltage) will be found. If the full voltage reaches the motor, the motor is faulty, and may need removing. Brushes and windings can then be checked.

Boat Motors. Small motors, which run from dry cells, are powerful enough for small, light boats. These run well from 3V or 4½V, from 2 or 3 dry cells. It is always in order to use a battery of lower voltage, if enough power is obtained. But an increase in voltage may be unwise, and may cause damage.

Small motors consume some ¼A or so, the current depending on the load. Somewhat larger motors consume ½A or so, while large motors consume 1A, or more. The latter are unsuitable for average dry cells. The current

MODEL BOATS

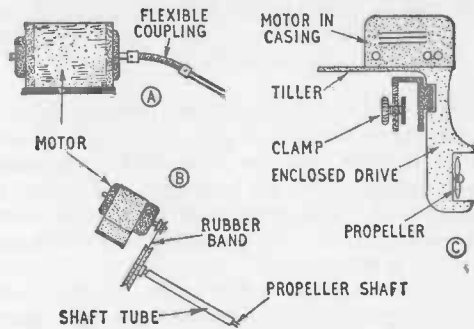

Fig. 35. Power units for boats.

drawn increases if the motor is loaded so that its speed falls badly.

Boat Drives. Some boats have a direct drive to a small propeller. The propeller rotates at the same speed as the motor. A spring or other flexible coupling is often included to avoid friction due to incorrect alignment. Fig. 35A shows a flexible coupling between motor and shaft.

With small, high speed motors, a rubber band is often used to drive the shaft, as in B. This avoids a flexible coupling, and provides a reduction ratio, so the propeller rotates at a more suitable speed.

In larger models, watertight packing glands are used, so that water cannot enter the hull through the propeller tube. With small models, the tube slopes and is brought up above water level inside the boat.

With home-built models, it is essential that the motor should be able to run at normal speed. The propeller will

MISCELLANEOUS EQUIPMENT

be small and of slight pitch, unless a reduction drive is used. A solid coupling should not be employed between motor and prop shaft, as slight misalignment will cause friction.

Outboard motor power units are obtainable, and are easily attached to suitable models. (Fig. 35C.) The whole unit pivots to steer. Motors fitted with a propeller tube, shaft and propeller can be obtained, and simplify constructional work. The prop. tube is sealed in a sloping hole in the boat hull. The projecting stern tube may be supported by a bracket.

Motor manufacturers indicate the maximum size of boat which can be powered successfully by a particular motor. If the motor is too small, the craft will be sluggish.

Watertight power units to fit in the bottom of the boat are also obtainable. They avoid any propeller tube, and may provide steerage in a similar manner to the outboard motor.

Rectifiers

A rectifier provides d.c. from a.c. Metal rectifiers are often used, and two are shown in Fig. 36. The half wave rectifier has two tags, and is included in one lead from the transformer secondary. It allows one half cycle to pass, but acts as a high resistance to the other half cycle, so pulsating d.c. is obtained.

The full wave rectifier in Fig. 36 has three tags, and requires a transformer with a centre tapped winding. Each half of the winding delivers the required voltage, so the complete secondary is for twice this voltage. Two separate half wave rectifiers can be used in the same way. Both half cycles are used, one half cycle being obtained from each half of the secondary.

Full wave bridge rectifiers are much used, and require

RECTIFIERS

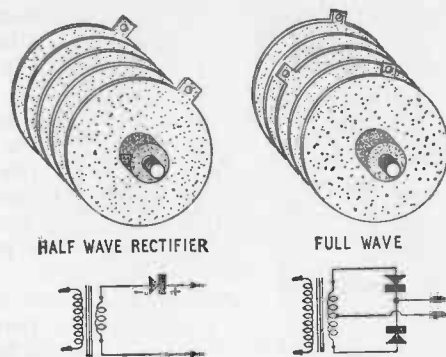

Fig. 36. Two metal rectifiers.

no centre tap. A circuit is shown for accumulator charging (Fig. 38). There are five tags on the rectifier, the two outer tags being joined.

Care is necessary with all types to connect the tags correctly. Red or a plus sign indicates positive. Black or a minus sign shows negative. Bridge rectifiers have an a.c. input, two tags being marked "a.c." or with a symbol resembling "S", or with green. Plates may be square or any other shape, and the rectifier should be mounted with plates vertical, so that best cooling is achieved. Rectifiers should not be dismantled.

Charging

The usual accumulator, as used for models, vehicles, motor-cycles and scooters, etc., has lead plates in dilute sulphuric acid electrolyte. As the cells discharge, chemical action reduces the specific gravity (S.G.) of the electrolyte.

MISCELLANEOUS EQUIPMENT

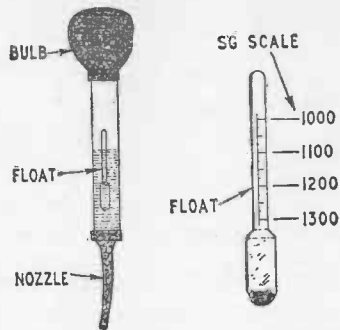

Fig. 37. Hydrometer used to check s.g. of electrolyte.

The S.G. rises when a cell is charged. So the state of charge of the cell can be found by measuring the S.G.

A hydrometer is used for S.G. tests, and has a glass tube with bulb (Fig. 37). A vertical float is free in the electrolyte, which is drawn up when a cell is tested. The depth to which the float sinks depends on the S.G., which is read on the float scale, level with the surface of the electrolyte.

Water has a S.G. of 1, or 1.000. The S.G. depends somewhat on temperature, but at average temperatures the following is a good guide to the state of the cells :

S.G.	Condition
1.100 or lower:	Battery discharged
1.190 to 1.200:	Battery half discharged
1.275 to 1.300:	Battery charged

In a multi-cell battery, each cell is tested. If all cells are in good condition all the S.G. readings will be similar.

ACCUMULATOR CHARGING

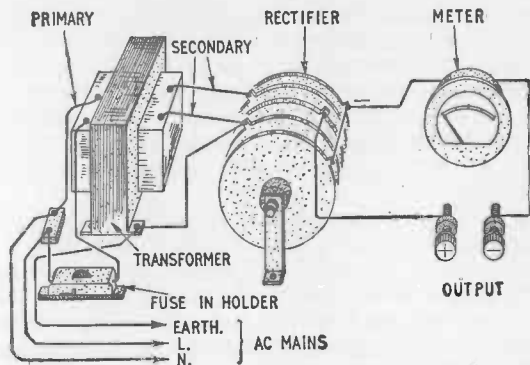

Fig. 38. Accumulator charger.

Any fall in the level of the electrolyte, due to evaporation, is made good by adding distilled water. Plates should not be exposed to the air, nor should an accumulator be left discharged.

In vehicles, d.c. for charging is obtained from a dynamo. This is also so with some motor-cycles and scooters. A.c. generators, with a rectifier, are also used.

Mains chargers use a transformer and rectifier. A meter (to show charging current) and variable resistor (to alter the charging rate) may be present. Or the transformer may have tappings delivering a range of voltages.

A typical charger, for a.c. mains, is shown in Fig. 38. It can be used for any current or voltage, transformer and rectifier being selected to suit. The variable resistor mentioned is added in one meter lead, if wanted.

A wide range of charging rates may be used with an accumulator. Each battery has a maximum rate, which

MISCELLANEOUS EQUIPMENT

should not be exceeded. This could be 1A for a small battery, but more for large accumulators. If an accumulator could be charged fully in 10 hours with a current of 2 amperes, it would be about fully charged in 20 hours with a current of 1A. When very low currents are used, this is termed "trickle charging." Charging may begin at any time. It is not necessary to wait for the cells to be fully discharged.

For 6V and 12V accumulators, a transformer delivering 9V and 18V is suitable. Each 2V cell rises to about 2.8V when charged. The rectifier voltage rating must be equal to the highest voltage used. The current rating of transformer and rectifier is chosen according to the maximum current wanted, and 2 amperes do for many purposes.

Observe the correct polarity, and avoid overcharging. Naked lights should not be taken near a cell on charge, and vent plugs may need removing. If an accumulator has sulphated plates, from misuse, a long period of charging at a very low rate may help.

If electrolyte is spilled it should be replaced with fresh electrolyte of the same S.G. This is done by measuring the S.G., and mixing dilute sulphuric acid and distilled water to obtain new electrolyte of the same S.G. Water should not be poured into concentrated sulphuric acid. Instead, the acid is poured into water in a vessel. Acid purchased from a garage at "accumulator strength" is already diluted.

Sediment may bridge plates, causing a cell to run down. Misuse, such as excess discharge rates, or leaving the cell uncharged, may cause deterioration of the plates. Cells are sometimes washed out with distilled water, after being fully charged. New electrolyte is then added, the cell is charged briefly, and the S.G. adjusted to the correct figure.

"Dry" or jelly cells have distilled water added at the

BATTERY CHARGING

vent, before charging. Surplus is poured away after charging. The top should be kept clean and dry, and vaseline can be smeared on terminals to reduce corrosion.

To charge vehicle batteries, a non-reversible 2-pin plug and socket may be used to connect charger output and vehicle accumulator. The charger can then be connected readily.

Dry Cell Reactivation. Dry cells can sometimes be renovated. Old, corroded dry cells are not satisfactory, but dry batteries in good condition, but run down, may be tried. The process is uncertain, and can only be carried out a few times.

For dry cells, the charging rate is low. For small cells, 10mA to 20mA (0.01A to 0.02A) may be tried, with 25-50mA for large cells. A very small rectifier and transformer will suffice for low voltage batteries. But if h.t. batteries are dealt with, the transformer and rectifier voltage will have to be high enough to suit.

Soil Warming

Electric soil warming produces early crops. Heating wires are buried about 6 in. in the beds. Bare galvanised iron wire may be used, with power from a transformer at 6V to 30V. The transformer is moisture proof, with secondary, core and case earthed. In view of the danger from incorrect installation, the transformer and primary mains circuit should be fitted up by a competent electrician. Requirements include protection of wiring in exposed positions, support for overhead wiring, use of outdoor grade materials, and sealing against moisture, in addition to earthing.

For normal purposes, heating at 5 watts per square foot is considered adequate. E.g. a wire consuming 8A at 20V would be 160W, and thus do for 32 sq. ft. For hotbeds, up

to 15W per sq. ft. may be used. The wire is spaced to cover the required area.

Soil has considerable thermal capacity, and the temperature can be varied by adjusting the number of hours during which current is flowing. A daily total of 45 to 60 watt-hours per sq. ft., per 24 hours, is usual. E.g. if the wires receive such a current that the heating is provided at 5W per sq. ft., then 50WH per sq. ft. would be obtained by switching on for 10 hours each day. (Watts \times hours = watt-hours.) Automatic time switching, or manual switching may be used. The temperature may be allowed to fall by reducing the number of hours per day, or it may be raised by increasing the number of hours.

Loss of heat should be reduced. A frame in a greenhouse will more easily retain its temperature than one exposed. Running costs can be estimated on the basis of 1,000WH equalling 1 Unit. If 1,000 is divided by the wattage, this gives the approximate number of hours the system may be run for a consumption of 1 Unit.

High-voltage, insulated cables are also made, and need no transformer. They are obtainable in various lengths and rating, such as 125W, 25 ft. Great care is necessary to avoid damage to these cables. Wires or cables may be laid in beds upon which seed-boxes can be placed.

Timer, Alarm

Automatic switches are used to close a circuit at a pre-set time for lights, radio, bell, buzzer, etc. Ready-made time switches are available for mains voltages. These are set in advance, and close at the pre-arranged time. An additional trip may open the circuit when desired. They are used for pre-set heat dosage in soil warming, and for the early morning lighting of laying birds, etc.

For low voltages a spring alarm clock can be fixed in a wooden box, with a brass strip soldered to the bell winder.

When the mechanism is wound, this strip is clear of a fixed bracket forming the second contact. When the bell mechanism is released, the winder brings the contacts together. *The switch must not be used at mains voltage.*

A clock can also be adapted so that a small arm on the bell spring winder operates a light action mains switch. This is safe for mains equipment if switch and wiring are properly insulated, with no bare joints or leads. A 2A switch should not control a load of more than about 400 watts.

Burglar Alarm

A simple burglar alarm can operate a bell. Windows and doors are fitted with contacts which close when entry is made. All contacts are wired in parallel, and included in the circuit to a bell, with battery or mains transformer. No current is drawn when the equipment is not working.

Alarms are often arranged to operate when a circuit is broken. For this system, all sets of contacts are closed when windows and doors are closed. Contacts are wired in series, and to a relay. If the circuit is interrupted, the relay is released, closing a circuit which rings a bell. If wiring is cut, this causes the circuit to operate.

Aquaria

Oxygen may be restored by pumping air through small nozzles near the bottom. Aeration of this kind is used when many fish are present, and in the absence of sufficient plants.

A single or double acting piston pump can be used, operated by a reduction belt from a motor. The pump may have a swinging cylinder which opens and closes ports, or valves may be included in inlet and outlet ports. A tube

MISCELLANEOUS EQUIPMENT

connects the pump to the aquarium aerator, which is a tube or hollow plate with holes.

Working parts should be lubricated sparingly, and excess oil may spoil rubber flap valves or tubing. Excess oil may also reach the aquarium. A glass U-tube between pump and aquarium will act as an oil trap. If possible, the pump should be higher than the aquarium, so that a back siphon action cannot arise. Or the air pipe can be taken to a high support, then descend to the aquarium. The motor should be of good manufacture, with durable bearings.

Vibrator pumps work from a.c. only. They have no moving parts except the vibrating diaphragm or bellows, driven by an armature. They are unlikely to break down, unless the rubber diaphragm or flap valves fail.

Illumination. Fairly soft lighting is usual, and filament lamps are easily installed. Tubular filament lamps may be preferred. Plants need sufficient light, but too much light is undesirable for some fish. Filament lamps generate heat, so fluorescent lighting may be needed for other than low wattage.

Heaters. Small aquarium heaters have a low wattage heating element, fully enclosed, and are used with a thermostat. The latter may have two leaves of dissimilar metal, forming a bi-metal strip. Due to the difference in expansion rates, the strip curves when the temperature changes. A contact attached to the strip completes the circuit when the temperature falls. When a suitable temperature has been regained, the strip returns to its original position, interrupting the circuit. A magnet, spring or other arrangement helps to give a quick make-and-break action.

Fig. 39 shows an aquarium heater circuit, with thermo-

AQUARIUM HEATERS

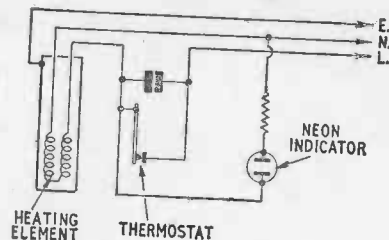

Fig. 39. Aquarium heater.

stat and element. The neon indicator usually has a series resistor of about 1-2 megohm, and glows when the element is in action. If the water temperature is not raised, and the pilot lamp does not glow, the mains connections or thermostat contacts are suspected. If the pilot bulb glows, but the heater does not work, the element itself, or connections to it, should be checked. The heater should be immersed before switching it on. The volume of water that can be heated by a small element is limited, and depends on the lowest room temperature.

Light Sensitive Switches

A light sensitive switch circuit operated by a selenium cell is shown in Fig. 40. The cell is of the type described for photo-electric exposure meters *see* p. 89, and may have a surface area of 1 sq. in. or so. Transistor connections will be found later.

Contacts on the relay may be chosen so that the external circuit is broken when light reaches the cell. Or the external circuit may be interrupted when light falls on the cell. (*See Relays.*) Adjustment of the relay tension and

MISCELLANEOUS EQUIPMENT

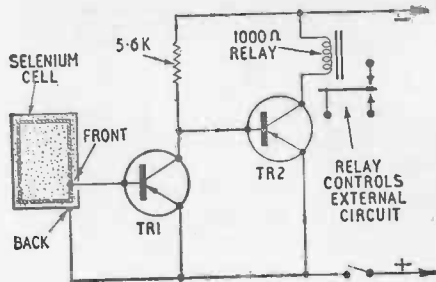

Fig. 40. Circuit for light operated switch.

battery voltage allows the relay to operate at a pre-determined level of illumination.

Such a device may be used to switch on vehicle parking lights when daylight fails. It can also be used for various models or games. For example, the cell may form the bull's-eye of a target, and the pistol or gun may incorporate a battery, bulb and lens, to throw a narrow beam. A "hit" can then ring an electric bell.

Clocks

A master clock has exceedingly good timekeeping ability. It is usually fitted with contacts operated by a spindle, so that they close briefly each minute.

Slave clocks are operated from the master clock. Each has a ratchet wheel with 60 teeth, and a magnetically operated pawl turns the wheel one tooth, each time the circuit is completed. The usual reduction drive is provided between hands. A number of slave clocks can be controlled by the master clock, and all will show the same time.

SYNCHRONOUS CLOCKS

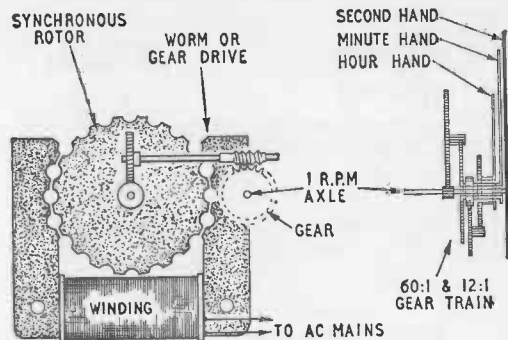

Fig. 41. Parts of a synchronous clock.

Synchronous Clocks. These run from 50 cycle a.c. mains (or other frequency when required). Power is obtained from a small synchronous electric motor. Fig. 41 shows a typical motor. The rotor has 20 teeth. The fixed magnet assembly coil receives power from the 50 cycle mains. Each cycle produces two magnetic impulses, so there are 100 each second. If the rotor is started at such a speed that its teeth pass the fixed teeth at 100 per second, it continues to run. The 20 teeth rotor runs at 300 r.p.m.

Some motors are self-starting. Others have a spring or similar mechanism, which starts the rotor at the correct speed.

Worm or other gearing reduces the speed for the clock hands. A drive of 300 : 1 would be needed between 300 r.p.m. rotor and a hand making 1 revolution per minute. A 60 : 1 ratio is provided between this hand and the hand

MISCELLANEOUS EQUIPMENT

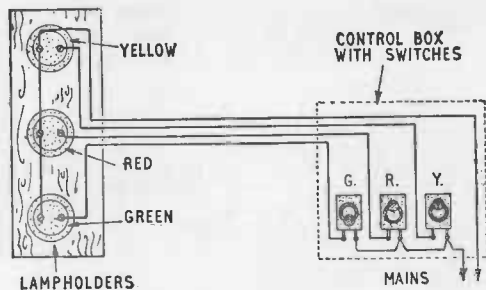

Fig. 42. Colour lamps with control box.

making 1 revolution per hour, with 12 : 1 to the remaining hand.

In Fig 41, worm drives of 25 : 1 and 12 : 1 provide 300 : 1. The gear assembly provides the required drive between hands. Some clocks have no centre second hand, and the gearing from second hand to minute hand is omitted.

Battery Clocks. Battery operated clocks usually have a pendulum fitted with a magnet which swings in a fixed solenoid. The solenoid has many turns of fine wire, and draws a small current. Current flows when the pendulum is moving in the correct direction, and a small pawl and wheel give rotating motion to the hands.

Some clocks have delicate mechanisms. The contacts may only close when the swing of the pendulum falls below a set arc, so that impulses increase in number per minute when the voltage falls. Contacts may be fragile, easily displaced or affected by dust.

If such a clock fails to run, a sensitive meter will show if

ROTARY CONVERTOR

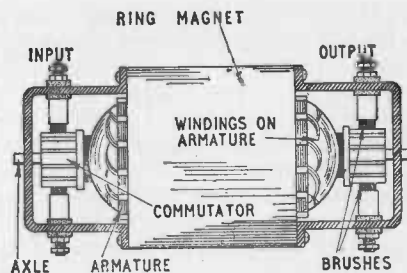

Fig. 43. Rotary convertor.

current is drawn when the contacts close. If not, connections can be examined and contacts and solenoid checked for electrical continuity. Moisture from the hands or breath should not reach working parts.

Coloured Stage Lamps

A method of using three coloured lamps is shown in Fig. 42. The lampholders are mounted on a board, and a sheet of clean tinfoil is curved to form a reflector.

Four flexible leads pass from the lampholders to the switches in the control box. One lead is common to all lamps, and is joined at the control box to mains neutral. Any lamp may be switched on, or any combination of lamps may be used, to produce various colours. The lamps may be at floor level, one side, or may be suspended. Green switch is shown "on" in diagram.

Rotary Convertor

This resembles an electric motor and dynamo, constructed on the same armature. (Fig. 43.) It operates on direct current, so can be used when a transformer (which

MISCELLANEOUS EQUIPMENT

works on a.c. only) cannot be employed. A convertor with 12V or other low voltage input may deliver 200/250V for a.c./d.c. mains equipment. Convertors may also be used to reduce the voltage, so that 200/250V d.c. can be reduced for charging or other purposes.

When a rotary convertor is used to step up a low voltage, the current taken from the low voltage supply may be heavy. Suppose 100 watts at 240V were required. If the convertor were of 100 per cent efficiency, drain from a 12V supply would be almost $8\frac{1}{2}$ amperes. This is heavy, unless the accumulator is large and frequently charged. It is thus often impossible to operate mains equipment successfully from a convertor, though intermittent running of low consumption items, such as shavers, radio sets, etc. is practicable. Losses in the convertor will increase the current drawn, as efficiency is well below 100 per cent.

Glowplug Motors

Some miniature internal combustion motors require a glowplug for fuel ignition. This has a platinum wire element, brought to red heat by current passing through it. A 1.5V supply of large capacity is required, and obtained from a large $1\frac{1}{2}$ V dry cell, or two or more cells in parallel.

The plug element should reach a good red heat, and this will not be so if the battery cannot supply enough current. Connection to the plug can be by a clip device, removed when the motor has started. Failure of such an engine to start may be due to unsuitable or stale fuel, wrong carburettor adjustment, or other mechanical troubles.

Thermocouples

The thermocouple consists of two dissimilar metals, joined at one end. When the junction is heated, a small current

STATIC ELECTRICITY

is produced. Thermocouples are used in radio frequency ammeters, remote temperature indicators, etc.

The current produced by heating may be demonstrated by twisting together two wires of dissimilar metal, and connecting them to a galvanometer (Fig. 17B) or other sensitive instrument. When the twist or junction is heated with a match, a reading will be obtained.

Electric Pokers

These are used to burn ornamental designs on wood. They have a shaped bit, made red hot by a large current at low voltage, obtained from a mains transformer.

Connections from the transformer to poker should be of low resistance, so stout flexible leads are needed. The secondary winding of the transformer may consist of a very few turns of extremely stout wire, or copper rod or strip. Ordinary transformers are not suitable, as the current obtainable is insufficient. Wiring should be as described for mains transformers.

Static Electricity

Static electrical charges are at high voltage, but provide very low current. Static electricity can be generated by friction. An ebonite comb, used to comb dry fur or hair, will gain a charge. Brown paper, drawn over dry rough cloth, or between the body and clothed arm, may also be used.

The presence of static charges can be shown by an electroscope. This has silver-paper leaves about $\frac{3}{8}$ in. wide and 1 in. long, on a hook, as in Fig. 44. The hook is fitted to a wire or rod placed in a glass vessel. A top disc or knob forms the terminal.

If a charged object is brought near the terminal, and discharged to it, the leaves repel each other, and remain separated until the charge leaks away. Further

MISCELLANEOUS EQUIPMENT

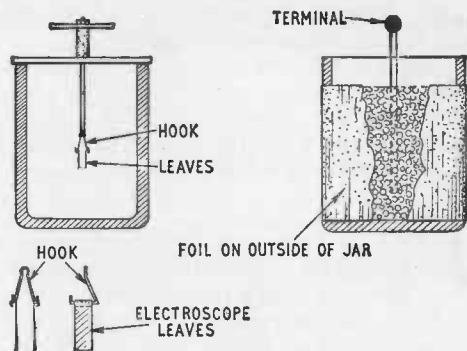

Fig. 44. Electroscope and Leyden jar.

charges of the same polarity will increase the separation.

Unlike charges attract, while like charges repel. This can be demonstrated by various experiments with paper fragments, or a light pith ball suspended on silk.

The Leyden jar has metal foil glued outside, and is filled with lead shot or other conductor, with a projecting rod and terminal (Fig. 44.) It is a type of condenser. It may be charged from a static machine, or by repeatedly discharging a charged object to it.

Any leakage in materials will remove static charges. Experiments should be with perfectly dry materials, in a dry atmosphere. This is assured by working with warm materials, before a radiant fire. Failure in experiments is usually due to unsuspected damp.

One machine to generate static electricity has a rotating glass cylinder, rubbed by a pad of silk. A metal bar takes off the charge. The well known Wimshurst machine operates by induced capacity, and has foil segments on

ELECTRO-PLATING

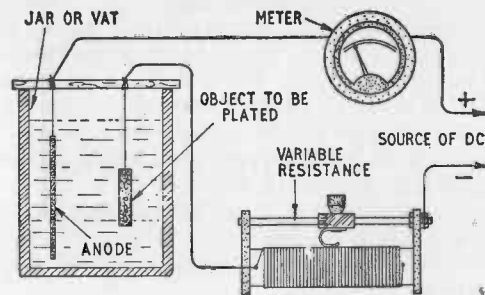

Fig. 45. Circuit for electro-plating.

rotating glass discs driven by a handle, and produces quite strong charges.

Electro-plating

Objects to be plated must be free from grease, dirt, etc., and may be washed in an alkaline solution. If necessary, surface oxide or scale is removed by pickling in acid.

The object is suspended in a bath (Fig. 45), an anode being immersed in the solution. The anode is inert lead for chromium plating, but otherwise generally the same metal as will be deposited on the object. The bath also contains compounds of the metal to be deposited.

For copper plating, a typical cyanide copper bath is cuprous cyanide, CuCN , 22.5g.; sodium cyanide, NaCN , 34g.; sodium carbonate, Na_2CO_3 , 15g.; and sodium thiosulphate, $\text{Na}_2\text{S}_2\text{O}_3 \cdot 5\text{H}_2\text{O}$, 2g., amounts being in grams per litre. The bath is used at 40°C . and the current is 0.1 ampere per sq. in. surface of the object plated.

A bath for chromium is chromic acid, CrO_3 , 250g.;

MISCELLANEOUS EQUIPMENT

sulphate ion, SO_4 (as sulphuric acid), 2.5g. Amounts are again in grams per litre. A bath for silver plating consists of 4 oz. of silver nitrate, 3 oz. of sodium cyanide and 6.4 oz. of sodium carbonate. Amounts are in ounces per gallon. Use at 15-25°C. with a current of 3-6 amperes per square foot surface of the object to be plated. Many plating baths are highly corrosive and should only be used with great care, and not by children.

D.c. is most readily obtained from a mains unit (transformer and rectifier). Negative is connected to the object, and positive to the anode. A resistor allows the current to be adjusted.

6

PHOTOGRAPHIC EQUIPMENT

Various photo gadgets are easily constructed, and some knowledge of how they work may allow existing equipment to be modified, or used more effectively.

Photo-electric Meters

These usually have a light sensitive selenium cell wired to a meter, as in Fig. 46. Light on the cell produces current, and this moves the meter pointer. The meter readings depend on the light intensity, and are taken off in terms of exposure (shutter speeds and lens apertures).

A hinged grille, partly obscuring the cell, may be present. When this is closed a bright light (exterior) range is obtained. With the grill opened, dim light may be measured. Other meters have a series resistor (Fig. 46B). Bright light is measured with the resistor in circuit. If the switch is pressed, the resistor is shorted, and dim light readings are obtained. Most meters also have a grid over the cell to limit the angle at which light will be able to reach it.

Readings are taken from parts of the subject to be rendered best, so the meter may need sloping away from bright sky. Most meters are pointed at the subject and measure the light reflected by it. Other meters have attachments allowing the light falling on the subject to be measured.

The meter should not be left in bright light, or set for dim light when in strong light outside. After a consider-

PHOTOGRAPHIC EQUIPMENT

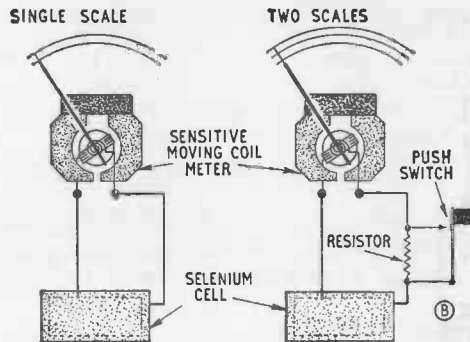

Fig. 46. Single and double range exposure meters.

able time the cell may lose its sensitivity. Negatives will then be over-exposed (too dark).

Some meters use a cadmium sulphide cell, which varies in resistance according to the light. Methods of translating readings into photographic exposures depend on the instrument.

Home-made photometers may be calibrated from a borrowed photometer, or by consulting the leaflet of lighting conditions and subjects issued by many film manufacturers.

Flash Guns

The older gun employs a 3V or similar dry battery, with bulb and synchro lead, as in Fig. 47A. When the shutter is released, the synchro contacts in the camera close, and current flows through the bulb, igniting it. This is satisfactory when the battery is fairly large and in good condition. If the battery is poor, the bulb may not

FLASH GUNS

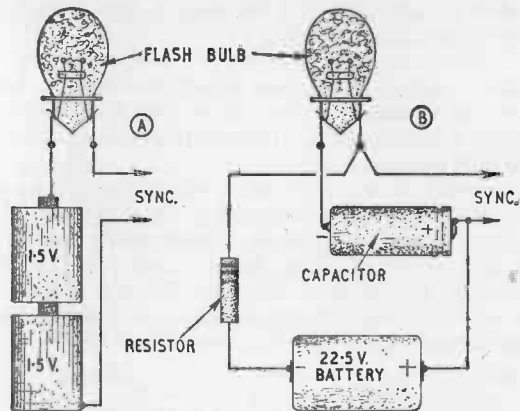

Fig. 47. Battery and capacitor firing circuits.

fire, or may only do so after a delay, so that the shot is lost.

The capacitor circuit is more popular, as in B. The resistor value is not important, but may be $3k\ \Omega$ to $5k\ \Omega$ (3,000-5,000 ohms). A $22\frac{1}{2}V$ miniature (deaf aid) battery is commonly used. A $25\ \mu F$ capacitor is suitable.

When the flashbulb is inserted, current flows through bulb and resistor, charging the capacitor. When the synchro contacts close, the capacitor discharges abruptly through the bulb, firing it. Only a small current is required from the battery, so firing is much more reliable.

Flash guns can be checked by inserting a test bulb, which lights when the shutter is fired. The bulb has a 3.8V 0.06A or similar filament. Camera synchronisation can be

PHOTOGRAPHIC EQUIPMENT

checked to some extent if the bulb is seen to light when viewed through the shutter.

To obtain correct exposure with flash photos, a guide number is used. This is given by the bulb maker. Capless bulbs are commonly employed, as they are cheap. They have no metal base, but wires as in Fig. 47. Each bulb is used only once.

For example, a typical small capless bulb has a guide number of 260, for fast pan film. In normal conditions exposure is correct if *camera aperture* \times *distance between gun and subject in ft.* = approximately 260. If 260 is divided by the distance, this gives the lens aperture. Or 260 may be divided by the aperture to find the distance from subject to gun. The following would do :

$f/32$ at 8 ft.	$f/22$ at 12 ft.
$f/16$ at 16 ft.	$f/11$ at 23 ft., etc.

Distances are from bulb to subject, not from subject to camera, though the camera is often at a similar distance. They assume that the bulb is fired in a gun with a normal reflector. The shutter is set at 1/25th or 1/30th second.

If general lighting is subdued, flash shots may be taken with a camera having no synchro contacts. To do this, open the shutter on the B or T setting, fire the bulb, then close the shutter at once.

Photofloods

These are bright lamps used for indoor photos. Inexpensive photofloods are over-run, and have a short life, so are not left switched on unnecessarily. Typical exposures, using a fast pan film and one photoflood in a proper reflector, are as follows:

PHOTOFLOODS

Distance	Exposure
3 ft.	1/10th at $f/8$, 1/60th at $f/3.5$
6 ft.	$\frac{1}{2}$ at $f/8$, 1/20th at $f/3.5$
10 ft.	$\frac{2}{3}$ at $f/8$, $\frac{1}{2}$ at $f/3.5$

If two photofloods are used, exposures are halved. The exposures are for frontal lighting. Many photo-electric meters will indicate the exposure, but the above may be followed if no meter is available.

For still subjects and models, brief time exposures are satisfactory, and domestic pearl bulbs can be used. Exposures, with fast pan film, and 100W lamps with no reflectors or shades, are as follows:

No. of Lamps	Distance	Exposure (Sec.)	
2	3 ft.	$f/8$: $\frac{1}{2}$	$f/22$: 6
2	6 ft.	$f/8$: 2	$f/22$: 16
3	4 ft.	$f/8$: $\frac{1}{2}$	$f/22$: 6
3	8 ft.	$f/8$: 3	$f/22$: 24
4	5 ft.	$f/8$: 1	$f/22$: 8
4	10 ft.	$f/8$: 4	$f/22$: 32

Lamps are within about 40 degrees of the front of the subject, and distances are from lamp to subject. The camera lens is shielded from the lamps, if necessary. To avoid harsh shadows some fill-in light is required, from general room lighting, or the reflection from walls or a large white card.

The camera should be on a tripod and is operated by a cable release. For close-up shots of still objects, a small aperture such as $f/22$ gives good depth of field, but larger apertures, such as $f/3.5$, may be required with sitters.

Fig. 48 shows how photofloods may be dimmed by a series resistor made from a small electric fire element.

PHOTOGRAPHIC EQUIPMENT

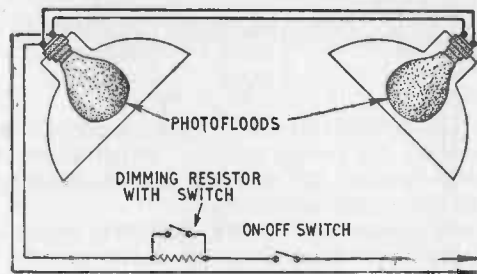

Fig. 48. Photofloods with dimming switch.

The lamps are run at reduced brilliance until the exposure is made.

Contact Printing Box

A contact printing box is shown in Fig. 49, and can be made from wood, dimensions not being important. Strips pinned and glued inside support the sheet of opal glass, and illumination is from a 15W lamp. The hinged lid with felt keeps the negative and printing paper in close contact.

A thin card mask gives a white border round prints. It has an aperture of about 3×2 in. for $3\frac{1}{4} \times 2\frac{1}{4}$ in. negatives, or 2×2 in. for $2\frac{1}{4}$ in. square. Work is done by an orange or similar safelight, or by subdued artificial light. Improvised safety lighting can be checked by seeing that it does not darken printing paper developed normally.

The negative is placed emulsion side up on the opal glass, and the printing paper is sensitive side down. The lid holds paper and negative together. Exposure is made by switching the lamp on and off, and must be timed. Tests can be made as described for enlarging. If negatives

CONTACT PRINTING BOX

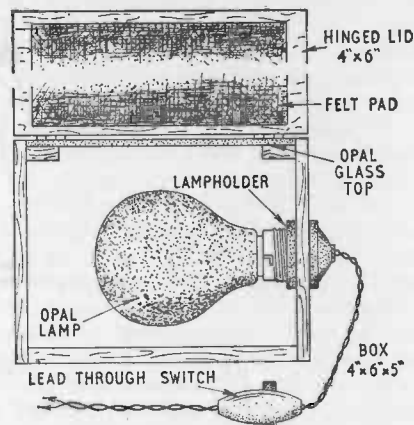

Fig. 49. Contact printing box.

are graded into very dense, dense, normal, thin and very thin, and the exposure times noted, future prints can readily be made, by grading new negatives accordingly.

Enlargers

The parts of a typical enlarger are shown in Fig. 50. An enlarger is intended primarily for a particular negative size, such as $2\frac{1}{4}$ in. square, or a 35 mm. format. Lens and illuminating system will be most suited to the chosen negative size, though negatives of smaller size, and portions of negatives, can be enlarged.

The lamp may be 60W flashed opal, or a high intensity lamp. Domestic lamps usually fail to give even lighting. Some enlargers use special lamps. The distance between

PHOTOGRAPHIC EQUIPMENT

lamp and condensers may be adjustable, to secure even illumination.

A condenser, or pair of condensers, may be fitted to focus light through the negative. Condensers need to have a diameter a little greater than a diagonal across the negative. Condensers are sometimes omitted, a sheet of flashed opal glass resting above the negative. This reduces cost, but lighting is less bright.

The carrier may hold the negative between glass, or in channels. The lens is commonly of about 2 in. focal length for 35 mm. negatives, or 3 in. to 3½ in. for 2¼ in. square and 4 in. to 4¼ in. for 2¼ × 3¼ in. negatives.

Cheap lenses have two glasses or elements. Better lenses have three or more elements, and give more critical definition, especially towards the corners. Most lenses have an adjustable iris, with stops to about $f/16$.

For negatives of ordinary contrast "normal" enlarging paper is used. Soft negatives of small contrast are best enlarged on "hard" or contrast paper, while "hard" or contrasty negatives will be done on "soft" paper. Useful paper sizes are postcard, 3½ × 5½ in., half-plate, 4¼ × 6½ in., and whole plate, 6½ × 8½ in.

The paper is placed in a frame on the baseboard. Exposure can be found by making a test strip, or enlargements of typical portions of the picture. Exposures of 5, 10, 15, 20, 25 and 30 seconds may be given on the same strip of paper, by moving an opaque card each 5 seconds. The strip is then developed, to find the best time. Test exposures such as 2, 4, 8, 16 and 32 seconds cover an increased range, but are less easily timed.

Exposure Indicators. Brightness meters are available, and allow small areas of the image to be measured. A grease-spot photometer allows an internal light source to be matched for brightness with portions of the pro-

ENLARGERS

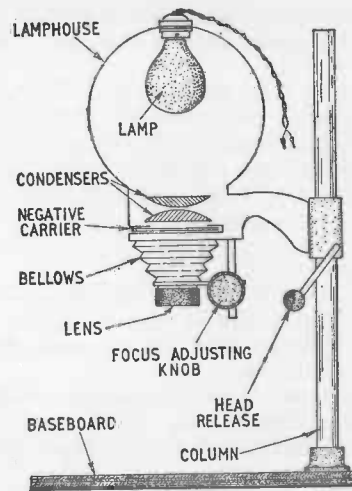

Fig. 50. Vertical enlarger with condenser illumination.

jected image. Readings are then transposed into exposure times.

The usual photo-electric exposure meter is not sufficiently sensitive, unless the enlarger illumination is exceptionally good.

Solution Heaters

Immersion heaters have a small element in a tube, and are placed in a dish or vessel, to raise the temperature of the solution.

Dish heaters resemble a shallow box, on which dishes are placed. Current is from a 3-pin plug, and thermo-

PHOTOGRAPHIC EQUIPMENT

static control is generally provided. If a heater is not working, the flexible cord, element and thermostat can be tested with a meter.

A shallow box, large enough to take two dishes, and fitted with a top cut from sheet aluminium can be made. Heat is obtained from two household lamps, and a thermometer used to check the solution temperature. The metal should be earthed, and the lamps need to be of quite low power.

Photo Dryers

Photo dryers usually have a shaped casing with curved sides, so that prints can be held by cloth blinds. The dryer has a low temperature element, and mopped prints dry flat in a short time.

Similar equipment is used for glazing, and some dryers have optional glazing plates. Prints to be glazed are pressed into contact with the plates, which must be clean and unscratched.

Some dryers and glazers are single sided. Others are double sided, so that twice the number of prints can be held. The flexible cord should be in good condition, and securely connected. Current is taken from a 3-pin plug, to allow earthing.

Slide and Transparency Projectors

These are used for 35 mm. colour transparencies and other sizes. Small models use 100W, 200W or similar lamps. More powerful projectors use 300W, 500W or other large lamps. When a powerful lamp is fitted, the projector usually has a blower (Fig. 51), to provide cooling. The blower must be running before the lamp is switched on, so the blower motor may be wired to the mains cord, a switch on the projector controlling the lamp only.

The brightness of the screen image depends on: (1) *Size*.

PROJECTORS

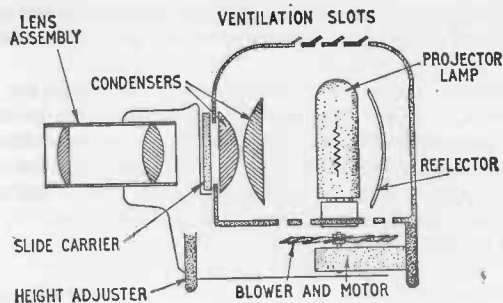

Fig. 51. Transparency projector.

A small projector cannot give a very large picture, as brilliance falls rapidly. If a picture 1 ft. 6 in. long is sufficiently bright, a picture 3 ft. long will be of only *one quarter* the brilliance (illumination falls off as the *square*). (2) *Type of Screen*. Linen and similar white materials do not reflect light well, and give a relatively dim picture. This may prove satisfactory with a moderate picture size and powerful projector. Silver screens reflect more light. Beaded screens are expensive, but reflect very well, though they are not very suitable for viewing from a sharp angle. Various screen materials are obtainable. (3) *Lens*. In general, lenses of large aperture ($f/2.8$) are needed for good illumination. Lenses of smaller size are cheaper, but may pass less light, though this depends on the efficiency of the illuminating system. (4) *Lamp Power*. This is sometimes optional. But otherwise a larger lamp may cause overheating, or the projector may be unsuitable for different lamps. (5) *Illumination System*. This should be satisfactory if reflector and condensers are correctly placed, and cleaned by careful wiping with a soft cloth.

PHOTOGRAPHIC EQUIPMENT

Uneven illumination may arise from displaced or wrongly assembled condensers or reflectors, or wrong spacing of them. (6) *Background Light*. When the eye is accustomed to darkness, the apparent brightness of the screen image is increased. The room should be as dark as possible. (7) *Transparency Density*. Dense transparencies give a dim image. Under-exposure results in such transparencies. Over-exposure gives thin transparencies, but colouring is poor. So careful use of an exposure guide is needed, if a meter is not available.

Episcope

An episcope or epidiascope projects images of non-transparent objects, such as photographs, written and printed matter, drawings, etc. The object is strongly illuminated by one or more lamps in the instrument, and a lens throws an enlarged image on the screen. The image is in natural colours, but would be reversed. To obtain a correct image, a mirror is incorporated, frequently between the lens and object, at 45 degrees.

Transparency Viewers

Illuminated viewers obtain power from a battery or mains transformer. Battery running is convenient for occasional use. The battery and bulb specified should be fitted.

For longer use, mains running is economical, and full brightness is always obtained. Viewers suitable for mains running may take a 6.5V or other bulb, and the recommended voltage should be used. Most inexpensive viewers using a 3.5V or similar bulb and battery can take a 6.3V 0.3A bulb, and a 6.3V transformer can easily be obtained. The transformer is placed in a small box, and wired as explained elsewhere. A twin flex lead passes from transformer to viewer.

7

AUDIO EQUIPMENT

In amplifiers, model control equipment, etc., various radio components are used. Most of these are shown in Fig. 52, which will be of assistance in following circuits in this and later sections.

Resistors are shown as indicated. The actual components are colour coded, and usually have three coloured bands, to give the value. These bands are read from one end, in the order in Fig. 52. The colour code is as follows:

Black	0	Green	5
Brown	1	Blue	6
Red	2	Purple	7
Orange	3	Grey	8
Yellow	4	White	9

Band 1 gives the first figure, band 2 the second figure, and band 3 the number of noughts. Orange/orange/orange=33,000 ohms. Red/green/orange=25,000 ohms. Brown/black/red=1,000 ohms. Red/red/green=2,200,000 ohms.

A 4th band may be present. If gold, the resistor is within 5 per cent of its marked value. If the 4th band is silver, the resistor is within 10 per cent of marked value. If no 4th band is present, the resistor is within 20 per cent of marked value.

Some resistors have body, tip and dot colours. If so, the colours are read in that order. E.g., red body, red tip, and orange dot=22,000 ohms.

AUDIO EQUIPMENT

High value resistors are generally marked "k Ω ." This indicates thousands of ohms. $22k \Omega = 22,000$ ohms. $1k \Omega = 1,000$ ohms, $5.7k \Omega = 5,700$ ohms, $100k \Omega = 100,000$ ohms. Very high value resistors are marked in megohms (M Ω). 1 megohm = 1,000,000 ohms, so 2.2 megohms = 2,200,000 ohms, and so on.

Potentiometers are a type of variable resistor with tags or terminals A and B (Fig. 52) connected to the element. The slider, with tag C, moves along the element.

Capacitors or condensers are indicated by the symbol shown. Small capacitors are of disc type or rectangular. Larger capacitors are moulded or tubular. Electrolytic capacitors have positive and negative ends. Values are usually given in pF or μF . $100pF = 0.0001\mu F$.

Trimmers are capacitors with variable plates, so the value can be adjusted. Fully variable tuning capacitors have plates attached to the control spindle.

Any coil, radio frequency choke, or similar winding is shown by the symbol indicated. If the coil or choke has a dust iron core, dotted lines are drawn (Fig. 52). A choke with a solid core has unbroken lines (as for transformer).

Transformers with iron cores are drawn as shown, with the various windings indicated. The on/off switch is easily remembered. (See also Fig. 5.)

Aerial and earth symbols are shown. The second earth symbol is also used for connections to a metal chassis.

One valve symbol is shown, with filament, grid 1, grid 2 and anode. Triode valves have no grid 2. Pentodes have a grid 3, between grid 2 and anode. Some valves have an indirectly heated cathode round the filament, but insulated from it. The filament is then termed the "heater."

Transistors have base, emitter and collector wires, shown in circuits as in Fig. 52. It is essential that connections are correct, or transistors may be damaged.

MICROPHONES

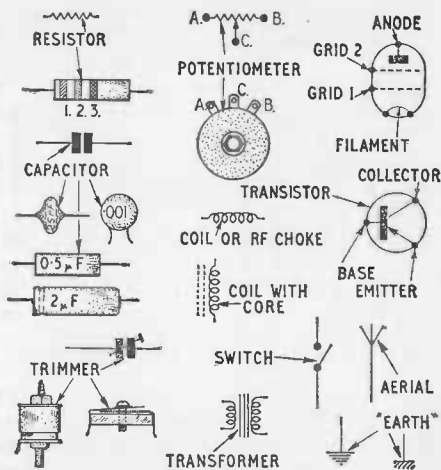

Fig. 52. Electrical and radio symbols.

Microphones

A carbon microphone will give a large output, when used with a suitable transformer and battery. Carbon granules between diaphragm and a fixed electrode vary in resistance under the pressure of sound waves reaching the diaphragm. The microphone is connected in series with a battery and the primary of a step-up transformer (Fig. 53A). Connections from the secondary are taken to the amplifier. The frequency response is not particularly good, but the output large. The battery is $1\frac{1}{2}V$ to 6V, a fairly low voltage resulting in less background noise. The transformer has a step-up ratio of 50 : 1 or 100 : 1.

AUDIO EQUIPMENT

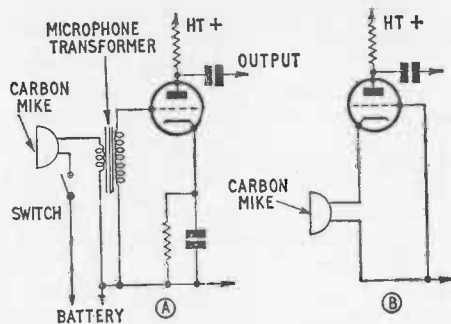

Fig. 53. Ways to connect a carbon microphone.

A carbon microphone may be included in the cathode circuit of the first valve in an amplifier (Fig. 53B). This avoids the need for a battery or transformer, but the output is less than with circuit A.

A crystal microphone has a piezo-electric crystal which produces an electrical output. It can be taken directly to a valve amplifier, A in Fig. 54. Output and quality are quite good, and crystal mikes are much used.

Moving coil microphones are more expensive, and give good reproduction. A small permanent magnet moving coil speaker can be pressed into service as a moving coil mike. The microphone is of low impedance, so a step-up transformer is incorporated between it and the grid circuit of the amplifier. This transformer is sometimes in the microphone casing.

Ribbon microphones give high quality reproduction, but a small output, and require a matching transformer and usually a small, extra pre-amplifier.

For general purposes, a crystal microphone is popular.

MICROPHONES

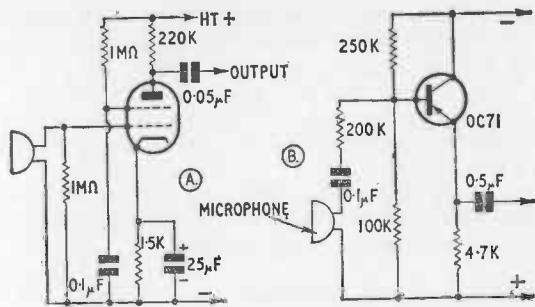

Fig. 54. Two crystal microphone amplifier circuits.

If a microphone is in the same room as the loudspeaker, sound from the latter should not reach the microphone strongly, or howling will be set up (acoustic feedback).

High impedance connections from a microphone or mike transformer to amplifier should be of screened cable. This has the outer brading earthed, as described for Fig. 55.

B in Fig. 54 shows a transistor pre-amplifier for a crystal microphone. This can be constructed as a separate unit, and run from a 3V dry battery. It is useful if volume is not sufficient when the microphone is connected to the main amplifier.

Guitar Pick-up

A small crystal unit can be mounted on a guitar or similar instrument. The output from the unit is taken to an amplifier, which operates loudspeakers. Wiring is as described for a microphone.

A volume control may be incorporated on the guitar, as shown for a gram pick-up (Fig. 55). A tone control may also be present. The simplest arrangement is to wire a

AUDIO EQUIPMENT

variable resistor (potentiometer) and capacitor in series, and to connect these across the microphone circuit. Values depend somewhat on the amplifier, but a 1 meg-ohm potentiometer, and 0.02 μ F capacitor should do.

Leads must be screened, to avoid mains hum. The output is greater than obtained by playing the instrument near a microphone.

Instruments with steel strings may have small electromagnets fixed with their poles near the strings. Old head-phone magnet assemblies can be used.

Pick-up and Volume Control

A pick-up and turntable unit is required to play records with a radio or amplifier. A mains driven motor is generally used when mains are available. For battery and transistor equipment, battery driven turntables are available. Most units have speed settings for 78, 45 and 33 r.p.m., or for 45 and 33 r.p.m. The pick-up needs to be for the correct speed. Single speed players with a pick-up to suit can only be used with records of one type.

When a volume control is fitted on the motorboard near the turntable, it can be wired as in Fig. 55. Screened leads are used. The outer connections are made by unweaving the brading and twisting all the wires together, forming a pigtail which can be soldered. The potentiometer is usually $\frac{1}{2}$ megohm (500k Ω) or 1 megohm.

Many amplifiers have co-axial sockets, and the co-axial plug is connected as shown, with inner lead to the pin, and outer brading to the sleeve. The inner lead passes down the pin, and is soldered at the tip.

Jack plug sockets are often used, and the inner lead goes to the jack plug tip, with the outer lead to the sleeve. The exact size of plugs varies slightly, so the correct one must be obtained to suit the amplifier.

Separate sockets, for small plugs, are provided on some

PICK-UP AND VOLUME CONTROL

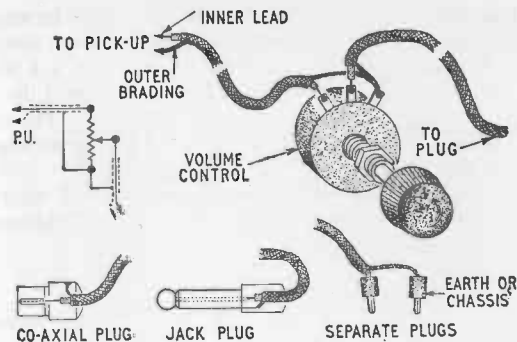

Fig. 55. Method of connecting volume control and plugs.

amplifiers. It is important that the brading is taken to the chassis or earthed socket, as in Fig. 55.

The same method of providing a volume control can be used for other purposes. With a carbon microphone, the leads from the volume control are taken from the transformer secondary. If the volume control potentiometer has a metal case, this and the fixing bush are connected to the earthed circuit (brading).

Home Telephones

A house phone can be used between rooms, or between tool-shed and house. The simplest circuit has two magnetic earpieces, connected with a twin lead. Earpieces for such purposes are easily obtained, and both should be of similar impedance. Balanced armature phones are satisfactory. Each unit is alternately employed as microphone and for listening.

Two units may be provided at each end of the line, one

AUDIO EQUIPMENT

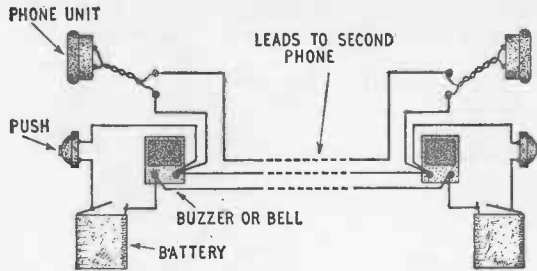

Fig. 56. Home telephone circuit.

employed for listening, and the other as microphone. This is more convenient, but reduces volume.

A signalling system to call a distant person is of advantage, and may use a bell or buzzer. If calling is to be in one direction, one bell push, battery and buzzer will do. If calling is from either end, two pushes and bells or buzzers can be provided, as in Fig. 56. This circuit is simple but needs three wires.

If preferred, manually operated or spring-loaded switches may be used to change the circuit from the buzzers to the phones. Only two wires are then needed. Spring-loaded hook switches to carry the phones are convenient. When both phones are in place, the circuit is switched to the buzzers. When the receivers are lifted, the hooks spring up, transferring the circuit to the phones.

To increase volume, carbon microphones can be used, with a battery and microphone transformer. Surplus phone sets of quite conventional type can be obtained.

Another way to increase volume is to use a valve or transistor amplifier. This gives as much increase in sound as wanted, so that loudspeakers can be operated.

HOME INTERCOM

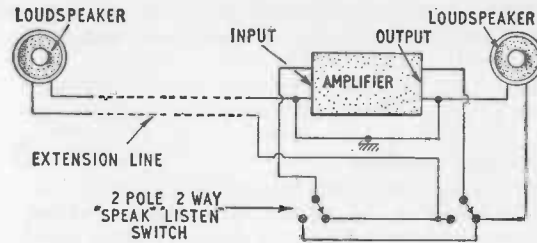

Fig. 57. Circuit for 2-way loudspeaking intercom.

Home Intercom

A home intercom which avoids complicated circuits is shown in Fig. 57. One unit is the master control station, and the amplifier and control switch are situated here. The other unit has a small loudspeaker, and calling button if wished.

Similar equipment is used in offices. It is best to use a spring-loaded 2-way switch, so that it normally rests in the "listen" position, and is held down while speaking. Small 2½ in. to 5 in. diameter permanent magnet moving coil speakers are satisfactory, each with an output transformer.

The amplifier may be transistor, battery valve or mains type. It provides a fairly high amount of amplification. The input circuit is of normal type. The output circuit, however, is changed so that one lead is "earthed." An audio choke or l.f. choke is connected from the output valve anode to h.t. positive. A 1μF or 2μF 500V good quality capacitor is then taken from the valve anode to the 2-way switch. A surplus output transformer can be used as an audio choke, the secondary being ignored.

AUDIO EQUIPMENT

With equipment wired as in Fig. 57, the switch is in the "listen" position. The distant loudspeaker acts as microphone, and a person calling there is heard in the loudspeaker at the amplifier. When the person at the amplifier wishes to reply or call, he moves his switch to "speak."

Extension Speakers

An extension speaker can be used in a second room, and may be handy in the kitchen, a bedroom or elsewhere. Many receivers have extension speaker sockets, and leads are taken from these to the extension speaker. For proper results, the new speaker should suit the receiver. Many speakers are of 2-3 ohms impedance, but 7 ohms, 15 ohms, and other impedances are found.

If no extension sockets are provided, they may be wired to the secondary of the output transformer as in Fig. 58. A 5-in. or similar unit is satisfactory for the extension point and requires no transformer. It is enclosed in a cabinet, or attached to a baffle. The latter is a flat board having an aperture of similar size to the speaker cone. A baffle wider at the top than at the bottom may be suspended in a corner, sloping forwards. The speaker can be placed in a muslin bag, before screwing it to the baffle, to exclude dust.

Twin flex can be used for the extension circuit. An on/off switch can be included in one lead, at the extension speaker. If the receiver speaker is to be silenced, with the extension speaker working, the optional switch in Fig. 58 may be added.

An extension speaker should not be added to a receiver in which the chassis is wired directly to the mains.

Tape Recording

Recordings of radio programmes, parts of programmes, and disc records can be made without permission, but only

TAPE RECORDING

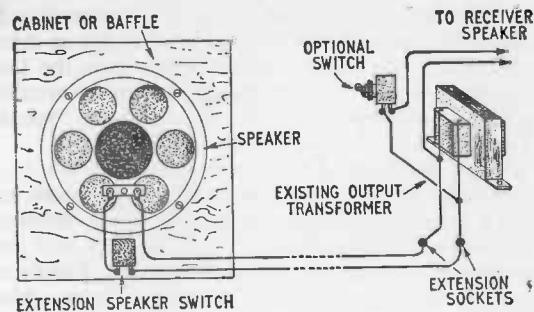

Fig. 58. Connections for an extension loudspeaker.

for private use. They may not be re-sold, hired, or reproduced in public¹.

The simplest way of recording from the radio is to place the recorder mike near the speaker, and adjust volume so that the recording is of suitable strength. Extraneous noises can be reduced by having the speaker volume fairly high. There is some loss of quality.

Recordings of improved fidelity are obtained by feeding the recorder electrically from the radio. Some recorders have radio input sockets. The audio signal is taken from a low level stage in the receiver, such as the detector diode or first audio amplifier.

Most recorders can be fed from a radio tuner—this is a unit consisting of the early stages of a radio set, with the audio amplifier and loudspeaker omitted. Input leads should be screened as described. Some recorders have a socket for gram pick-up, so that tape recordings can be made directly from a disc.

¹ See *The Law of Copyright* by J. P. Eddy, published by Butterworth & Co. (Publishers) Ltd.

AUDIO EQUIPMENT

Recorders frequently have a magic eye or meter recording level indicator, which is observed during recording. A weak recording may give insufficient volume on play-back, and increased noise. But recording at excess strength is likely to cause distortion.

When recording, two or more sources may be combined. One way is for a vocalist to sing while the music required is obtained from a disc or radio. The necessary balance is secured by placing the microphone in a suitable position and adjusting volume.

Two or more inputs may be mixed electrically, by using a volume control for each input (such as pick-up and microphone). This allows background music to be introduced for amateur sound theatricals. It also allows speakers or music to be faded in.

Tape recorders differ widely. In general, low tape speeds are most suitable for speech, higher tape speeds giving better musical results. Inexpensive equipment of limited frequency response cannot be expected to provide recordings of best fidelity.

For individual recording, a comfortable position 12 in. or more from the microphone is adopted. The recorder gain control is adjusted so that the recording level is correct with a normal voice. For strong singing, piano, etc. the microphone is some feet away, and removed from mechanical vibration (not resting on a piano being played).

Some recorders have indicators so that items can be found. An alternative is a strip of paper cemented from centre to perimeter of each spool, and marked where required¹.

¹For a fuller discussion of this subject see Nutshell Book, No. 32 *Tape Recording and Hi-Fi* by Frederick Oughton.

MORSE CODE

A	— — — —	N	— — — —
B	— — — — —	O	— — — — —
C	— — — — —	P	— — — — —
D	— — — —	Q	— — — — —
E	—	R	— — — —
F	— — — —	S	— — —
G	— — — —	T	—
H	— — — —	U	— — —
I	— —	V	— — — —
J	— — — — —	W	— — — —
K	— — — —	X	— — — — —
L	— — — —	Y	— — — — —
M	— — — —	Z	— — — —
1	— — — — —	6	— — — — —
2	— — — — —	7	— — — — —
3	— — — — —	8	— — — — —
4	— — — — —	9	— — — — —
5	— — — — —	0	— — — — —

Fig. 59. The Morse code:

Morse Code

Scouts and radio amateurs use Morse. The code has short and long sounds, often called dots and dashes. Morse may also be transmitted visually with a lamp.

When Morse is correctly sent, each "dash" is three times as long as a "dot." A space equal to three dots is left between letters. A space equal to about five dots is left between words. Fig. 59 shows the code.

If reception is by ear, the code is best memorised as long and short sounds. E.g. dit-diiiiir for A, diiiiir-dit-dit-dit for B. An ordinary key, which closes the circuit when depressed, is best for learning. The contacts are set about

AUDIO EQUIPMENT

1/32nd to 1/16th in. apart. The arm rests easily on the table.

A buzzer and battery can be used for practice, or a valve or transistor oscillator, with sets of headphones or a loudspeaker. It is important to send each letter correctly, and speed is obtained with practice.

Fig. 60 shows circuits for a valve or transistor oscillator. Almost any valve is suitable. For h.t., some 9V to 35V may be used, and a $1\frac{1}{2}$ V dry battery is satisfactory for the l.t. filament supply. The transformer is 1 : 2 or 1 : 5 or so, and the primary is connected from anode to h.t. positive. If no oscillation is obtained, the two connections to the primary are reversed. The tone can be altered by changing the h.t. voltage, or by wiring a capacitor across the transformer. The Morse key is in one h.t. lead. The phones can be in series with h.t. positive, or across the transformer primary.

With the transistor oscillator, components are not critical. The transformer can be of the kind employed for transistor receiver driver coupling. Connections to one winding are reversed, if no oscillation is heard. The phones can be in series with one battery lead, or across a transformer winding. The key is in one battery lead.

Either oscillator may be used with an amplifier. The audio tone is taken through a $0.01 \mu\text{F}$ capacitor from valve anode, or transistor collector, to amplifier input. A loudspeaker can then be used.

Speakers and Phones

Separate loudspeakers, as used with amplifiers or radio sets, should be permanent magnet moving coil units. For general purposes, the speaker is some 5 in. to 8 in. in diameter. When space is limited, smaller units are employed. The power handling capacity of the speaker is given in watts. Large amplifiers can have an output of

SPEAKERS AND PHONES

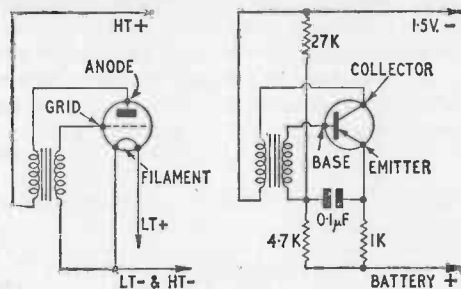

Fig. 60. Valve and transistor Morse oscillators.

several watts and any speaker used must have sufficient power handling capacity.

Many speakers have a 2-ohm speech coil. A transformer is needed between output valve and speaker. If the optimum load (best working load) for the valve is 5,000 ohms, the transformer ratio should be 50 : 1. The correct ratio for any optimum load is easily found as follows: Divide the valve optimum load by the loudspeaker speech coil impedance, and find the square root of the result. This is the ratio. (See p. 116.)

Amplifiers usually have an output transformer incorporated. For proper results, the speaker should have a speech coil impedance near to that specified.

Headphones for use with small transistor or battery driven valve sets usually have a resistance of some hundreds of ohms, and they are simply connected to the receiver. Expensive phones may be of several thousand ohms resistance. Cheap, low resistance surplus headphones may only give poor volume, especially from crystal sets.

Miniature "personal" earpieces may be of magnetic or

AUDIO EQUIPMENT

crystal type. Medium and high impedance magnetic earpieces can be used in the same way as magnetic headphones. Crystal earpieces have no windings, and do not allow d.c. to flow. They have to be coupled by means of a 1 : 1 or similar transformer, or a choke. The transformer or choke then provides the d.c. conductor to the valve or transistor.

OUTPUT TRANSFORMER RATIO FOR 2-OHM SPEAKER	
<i>Optimum Load</i>	<i>Ratio</i>
2,000 Ohms	32:1
3,000 "	39:1
4,000 "	45:1
5,000 "	50:1
6,000 "	55:1
7,000 "	60:1
8,000 "	63:1
10,000 "	70:1

8

CONTROLLING MODELS BY RADIO

Radio will control a model boat, plane or land vehicle, and the equipment required need not be very costly.

A boat is very suitable for radio control, as lack of skill or a fault in the equipment will usually cause no damage. Nor can the boat be lost, if sailed on a model boat pond.

For successful flying of a plane, skill is necessary, and a large space is required. Such models are sometimes lost or damaged, but stunt flying and other feats can be performed, in addition to competition flying.

Land vehicles can be used in a garden, or indoors. They include armoured cars, tanks and trucks. The same control devices can be used with many different models.

A G.P.O. licence is required to operate model control transmitting equipment. The form can be obtained from the G.P.O., Radio Services Dept., Headquarters Building, St. Martin's-le-Grand, London, E.C.1, and the fee is £1 for 5 years.

The licence conditions are chosen to avoid interference by model control transmitters with TV reception, etc. The transmitter must operate in one of the permitted model control bands. These are 26.96 megacycles to 27.28 megacycles, generally called the 27Mc band, and 458.5 megacycles to 459.5 megacycles. Equipment for the 27Mc band is most generally suitable, and is described here.

Only low power is permitted, and transmitters are usually run from batteries. The two transmitters described later are of popular type.

CONTROLLING MODELS BY RADIO

The licence does not permit radio transmission of messages but only of signals which will be used to control the boat, plane or other model.

The transmitter must work in the permitted band, because signals outside this band might cause interference. Some means of controlling and checking frequency will thus be needed. A transmitter is often tuned to the correct frequency by means of a wavemeter. Or the transmitter may be crystal controlled, and then has a crystal which controls the frequency.

The maximum range at which the model can be under direction depends on the transmitter and receiver, aerials, and other conditions. For a boat on a small pond, a few hundred feet is ample. For models indoors or in the garden, shorter range can suffice. With model planes, a range of $\frac{1}{2}$ mile or so is useful. Increased range requires that transmitter power be raised as far as permitted, and depends upon a sensitive receiver and good aerials.

The ways in which the model can be controlled depend on the servo-mechanism or actuators fitted. For example, a boat can merely be steered; or it could be steered, and the propulsion motor could be stopped and started, or reversed.

With simple equipment, a single control channel exists between the transmitter and receiver, and this system is much used. Fig. 61 shows the equipment.

The switch or controller is manipulated by the person working the model. A push-button switch can be employed, and the number of times this is pressed decides whether the model shall stop, sail ahead, or turn to right or left. Or the controller may be a tiller or steering wheel, whose movement is conveyed to the rudder or steering wheel of the model.

The switch or controller causes the transmitter to radiate a signal. Such transmitters often have 1 or 2 valves, run

C. W. TRANSMITTER

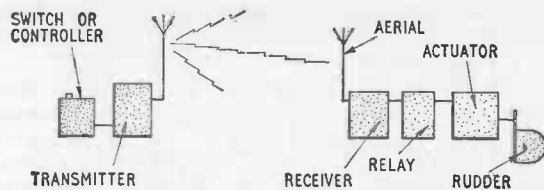

Fig. 61. Basic arrangement for radio control.

from batteries. The transmitter, with batteries, can occupy a single box, which supports a vertical aerial.

The radiated signal is picked up by the receiver aerial, and causes a change in current in the receiver, which opens or closes the relay contacts. Single valve receivers are popular. Complicated receivers are needed for long range. Simple transistor receivers can be used for very short range.

The relay contacts switch the actuator on and off. The actuator is a servo-mechanism which moves the rudder, or other part of the model. The whole system thus allows the rudder position, or other items, to be controlled from a distance.

C.W. Transmitter

A c.w. or continuous wave transmitter radiates an unmodulated radio frequency signal, switched on and off to control the model. A c.w. transmitter can control any home-built or commercially made c.w. receiver, but not tone receivers.

Fig. 62 shows a popular 2-valve c.w. transmitter circuit able to control a model at good range. The frequency is determined by the coil and parallel 30pF trimmer. A

CONTROLLING MODELS BY RADIO

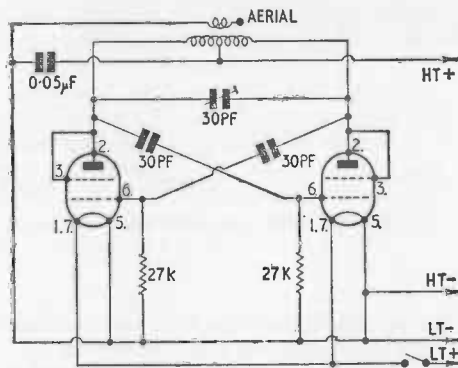

Fig. 62. 2-valve model control transmitter circuit.

small winding couples the aerial. The transmitter is tunable, and must be adjusted to a suitable frequency, as described later.

Many valves will operate in this circuit. Valves with 1.4V and 2.8V filaments are common, with low tension or filament current drawn from 1½V or 3V dry batteries. A twin valve, having two electrode assemblies in a single bulb, may also be used. The output and range depend on the h.t. voltage, which can be 90V for local working, and 120V for greater range.

Such a transmitter can be constructed quite easily. A practical wiring plan is shown in Fig. 63. The following parts are required:

- Two 3V4 valves. Two B7G holders.
- Two 30pF mica or ceramic fixed capacitors.
- Two 27k Ω (red-purple-orange) 1-watt resistors.
- 0.05µF 250V or 350V paper capacitor.
- 30pF air-spaced beehive trimmer.

C. W. TRANSMITTER

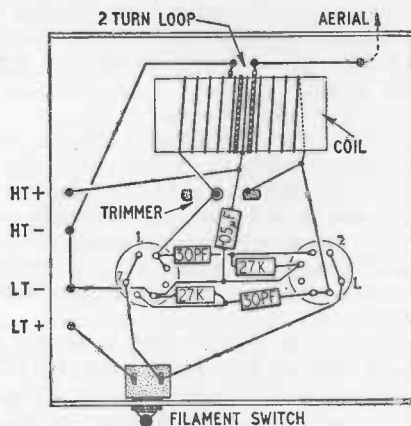

Fig. 63. Practical wiring plan of transmitter.

On/off switch.

1 in. dia. paxolin tube about 2¼ in. long.

Seven 6 BA ½ in. round-headed bolts, two 1 in. ditto, four ¼ in. ditto, two doz. 6 BA nuts. Few feet insulated flex and 20 s.w.g. tinned copper wire. 1 yd., 1 mm. insulated sleeving, paxolin panel 5in. x 5 in.

The coil is wound by straightening the 20 s.w.g. wire, and securing it through two small holes in the paxolin tube. Ten turns are wound on tightly, spaced so that the winding occupies 1⅜ in., and the wire is anchored by passing it through two small holes. A piece of wire to reach the h.t. positive terminal is soldered to the centre turn of the coil. The 0.05µF capacitor is also soldered on here.

The 2-turn loop is insulated flex, wound tightly with one turn on each side of the centre tap of the 10-turn coil. The ends of the flex are tied with thread. The coil is mounted clear of the paxolin panel by 1 in. bolts and extra nuts.

The components are assembled and wired as in Fig. 63. Holes $\frac{3}{8}$ in. in diameter take the valve-holders. Each holder has seven tags, with extra space between tags 1 and 7, and they must be placed as indicated. All leads should be short, the wire ends of resistors and capacitors being cut down. The 20 s.w.g. wire is used for connections, with insulated sleeving where required. Battery leads are of flex.

If new parts are used, and wiring is correct, with all joints properly soldered, the transmitter should work readily. It is tuned into the 27Mc band by one of the methods described later, and the aerial should not be added until this is done.

The 3V4 valves have tapped 2.8V filaments, and this is why pins 1 and 7 are joined, for 1.4V running. This supply can be had from any $1\frac{1}{2}$ V dry battery of reasonable size.

When the transmitter is in use, the valve filaments are left on. A signal is radiated briefly when the model is to change direction and the switch for this purpose is included in h.t. negative. A spring-loaded push switch is most convenient; it is normally open, and is closed by pressure.

The transmitter should be housed in a box which will also accommodate the batteries. Any $1\frac{1}{2}$ V supply is suitable for l.t.—a $1\frac{1}{2}$ V dry battery, or two or more cells in parallel. The l.t. or filament on/off switch is best attached to the side of the case, and is included in one l.t. lead.

For h.t., two 60V batteries may be wired in series, or a single 120V battery used. Combined h.t./l.t. batteries are not recommended. The control switch described may be

a pendant bell-push, attached to a few feet of twin flex, or a switch for this purpose may be attached to the transmitter box. H.t. current is only drawn when the control key or switch is pressed. Filament current is drawn all the time the l.t. switch is on, so this should be switched off when the model is not in use.

The aerial is usually self-supporting, and need not be of any particular length, though short aeriels reduce the range. Rod aeriels, standing vertically, and fixed to insulators on the transmitter box, are popular.

The transmitter can be tested with a lamp loop (Fig. 67). A 6V 0.04A bulb is soldered to a 2-turn loop of insulated wire. No aerial should be connected to the transmitter. The l.t. switch is on, and the loop is held near the transmitter coil. The bulb should then light when the h.t. switch is closed. If this test fails, all connections should be checked, and the batteries tested.

The 30pF trimmer is fixed by passing its tags through holes in the paxolin, and it has a top nut used for adjustments (Fig. 52). A length of ebonite rod or small-bore tubing should be filed to engage with the trimmer nut. This is used as an adjusting tool. Tuning cannot be accomplished with a metal tool, or tool with metal end and insulated handle.

A 2-valve transmitter is capable of radiating a strong signal, and is popular. The complete equipment is reasonably portable, and can be placed on the ground when in use.

Crystal Control

The frequency of a transmitter can be controlled by a piezo-electric crystal. The crystal acts as a tuned circuit of fixed frequency, to ensure that the transmitter frequency is within the permitted band, and does not change. Crystal circuits are popular.

CONTROLLING MODELS BY RADIO

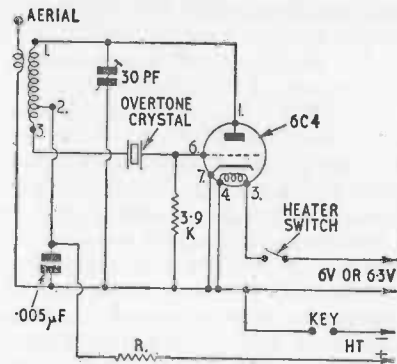

Fig. 64. Circuit of crystal controlled transmitter.

Crystals with a fundamental frequency in the 27Mc band are not readily made, so an overtone crystal is usual, where its multiple falls in the model control band. In this way, a 9.06Mc crystal will provide a 27.18Mc (9.06×3) signal. Other crystals, with multiples in the band, may be used.

Fig. 64 shows a crystal controlled transmitter circuit, using a 6C4 valve. This has a 6.3V 0.15A heater, and can be run from a 6.3V transformer, a 6V accumulator, or a 6V supply from 6V dry battery (4-cell). About 150V may be used for h.t.

The crystal is a series resonant 3rd overtone type, with a frequency near 9.06Mc. It is easily obtained from stockists of radio control equipment and components.

The transmitter can be built on a thin paxolin panel. The following parts are necessary:

124

CRYSTAL CONTROLLED TRANSMITTER

6C4 valve. B7G holder.

30pF air-spaced beehive trimmer.

0.005 μ F 350V or similar capacitor.

3.9k Ω (orange-white-red) $\frac{1}{2}$ -watt resistor.

Resistor R (see text).

On/off switch.

3rd overtone series resonant model control band crystal, with holder, for valve circuits.

4-in. \times 6 in. paxolin panel. 16 s.w.g. tinned copper wire for coil.

Fourteen $\frac{1}{2}$ -in. 6 BA round-headed bolts, with nuts. 1 doz. 6 BA tags. 20 s.w.g. connecting wire, 1 mm. sleeving, and flex.

The tuning coil is self-supporting, and wound from 16 s.w.g. wire. The wire is stretched to straighten it, and 13 turns are wound side by side on any object $1\frac{3}{8}$ in. in diameter. Ends are left projecting $\frac{1}{2}$ in. for connecting purposes. The coil is removed from the object and a pencil, or small tool handle, is run round and round between turns, to separate them, so that the completed coil is $1\frac{3}{4}$ in. long. It will be about $1\frac{3}{8}$ in. outside diameter. The tapping 2 is a short piece of wire soldered on 4 turns from end 3 (Fig. 65). The tapping and ends of the coil are soldered to tags bolted to the panel.

For aerial coupling, two turns are required, about $\frac{1}{4}$ in. from end 1 of the 13-turn coil. The spacing between the aerial coil and 13-turn coil can be adjusted by bending the aerial coil, to give suitable coupling for the aerial.

All leads should be short and direct, especially those to the coil, trimmer, valve and crystal holder. Resistor R can be 1,000 ohms for a 120-150V supply, but should be 10,000 ohms if the h.t. will be about 200-250V. A rotary generator (Fig. 43) is handy if a vehicle is near when working the model.

The trimmer is fixed as described for the 2-valve transmitter, and an adjusting tool should be made as explained.

125

Wavemeters

The user of a tunable transmitter must check that it is working in the permitted band. This can be done with a wavemeter. The 27Mc band is 26.96-27.28Mc/s. When several models are in use together, care may be necessary to select frequencies to avoid interference. But when a single model is used, it is best to tune the transmitter to the middle of the band, as out-of-band operation is then unlikely.

Fig. 66 shows a wavemeter with bulb indicator, built on a strip of paxolin about 1½ in. wide and 8 in. long. The bulb must be 6V 0.06A or similar, and is cemented in a hole at one end of the strip.

The coil is wound on a paxolin tube 1 in. in diameter and about 1¾ in. long. L1 is 10 turns of 26 s.w.g. enamelled wire side by side. A space of about ¼ in. is left, and the single turn of wire L2 is put on. The windings should be tight, as movement upsets calibration. Touches of cement will help hold the wire and the coil is cemented to the paxolin strip.

L1 is taken directly to fixed and moving plates tags of the 15pF variable capacitor. The ends of L2 are soldered to the side and end pip of the bulb. A knob with a pointer should be fitted to the capacitor so that calibration can be marked.

The wavemeter must be calibrated. This can be done from a crystal controlled transmitter, or by borrowing a transmitter set on frequency. The wavemeter coil is held near the transmitter coil and the tuning capacitor on the wavemeter is adjusted until the bulb lights. The correct tuning point is where the lamp lights best, but the wavemeter is kept at such a distance that the bulb only just glows, at the exact tuning point. The distance between the transmitter coil and wavemeter coil will be small (up to a few inches) and depends on the transmitter power. If

WAVEMETERS

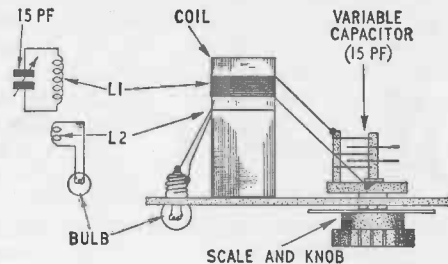

Fig. 66. Wavemeter with bulb indicator.

the wavemeter coil is near the transmitter coil, the correct tuning point is not easily found.

If a transmitter is in a metal cabinet, and access to its coil difficult, the wavemeter can be coupled to the aerial. Connect a lead between transmitter output and aerial, and make a 2-turn loop in this wire. The wavemeter is held near this loop.

When the tuning point has been marked on the wavemeter scale, it can be employed to tune other transmitters. To do so, set the wavemeter dial to its calibration mark. The wavemeter is held near the transmitter coil, and the transmitter tuning is adjusted until the bulb lights best. The distance between transmitter and wavemeter is kept fairly large.

The wavemeter can check a crystal controlled transmitter. If no signal is produced, the bulb will not light. It also allows a check to be made that the crystal is not being worked on wrong harmonics (or multiples).

For testing for radio frequency output only, the lamp loop in Fig. 67 is handy. Two turns of insulated wire are

CONTROLLING MODELS BY RADIO

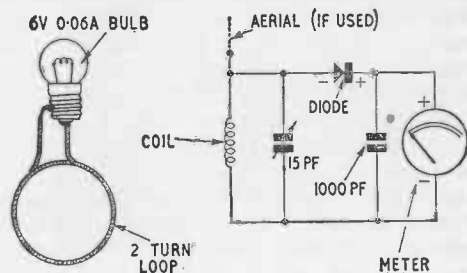

Fig. 67. Lamp loop to test for r.f., and field strength meter.

soldered to a 6V 0.06A or 0.04A bulb. The lamp lights when the loop is near a transmitter coil, if the transmitter is working. The lamp brilliance also gives some indication of the output.

Fig. 67 shows a second wavemeter circuit. A crystal diode rectifies the signal, and tuning is indicated by the $100\mu\text{A}$ (0.1mA) or similar meter. This instrument is sensitive and can be employed in the same way as the wavemeter in Fig. 66. It can, however, be situated much farther from the transmitter, and the meter pointer gives a good indication of the power radiated.

Tuning is for maximum indication on the microammeter. For best accuracy, the unit should be solidly constructed, and housed in a rigid box.

The wavemeter in Fig. 67 may be used as a field strength indicator, to show how powerful the radiation is from the transmitter. For this purpose, a small vertical aerial is added. This alters tuning, which should be re-adjusted for best sensitivity.

The instrument is carried some distance from the

AERIALS

transmitter, and will show the strength of the r.f. field. It is possible to make adjustments to the transmitter aerial, etc. while the field strength is observed on the meter, and any increase in radiated power will be shown. The field strength from different transmitters and performance of various aerials can be compared.

Aerials

A self-supporting telescopic aerial is generally used for the transmitter. Interlocking tubes which can be assembled to any reasonable length are also satisfactory.

When range is not important, the aerial can be 3 ft. to 5 ft. or so, the longer aerials giving better radiation. For good range, the aerial is about one-quarter wave long, that is, about $8\frac{1}{2}$ ft., including the lead from the coil to the aerial.

The aerial usually stands vertically, and then provides equal radiation to all points of the compass. The aerial is coupled to the transmitter coil by a 2- or 3-turn loop (Figs. 63 and 65). The batteries and other items form a counterpoise earth. It is convenient to have the aerial attached to the transmitter case so that it can easily be erected, or it may extend through a hole in the case top. If the aerial is longer than $8\frac{1}{2}$ ft. this is no disadvantage, provided aerial coupling in the transmitter is adjusted to suit.

When testing equipment at short range, it is better to leave the transmitter aerial disconnected, or not extended, or the signal at the receiver will be too strong. For working over short distances, lengthy aerials are not necessary. Nor need the aerial be of any specified dimension.

With a tunable transmitter (Fig. 63) changes to the aerial will modify the operating frequency, so that the transmitter must be re-tuned after fitting or extending the aerial, or at least checked for frequency to see that signals are in the permitted band. With a crystal controlled transmitter

CONTROLLING MODELS BY RADIO

changes to the aerial will not influence frequency. However, for best range final tuning should be with the aerial attached.

Fig. 68 shows a telescopic aerial which can be bolted to an insulated strip fixed to the outside of the transmitter case, or fitted inside and drawn up through a hole. Many aeriels of this kind are less than $8\frac{1}{2}$ ft. long. Maximum range is then reduced.

For a model indoors or in the garden, or worked over short range, a stout vertical wire will do. The wire gauge is not important and 12 s.w.g. or 14 s.w.g. tinned copper, copper, or enamelled wire may be used. Such an aerial cannot support itself for the full $8\frac{1}{2}$ ft.

Wire aeriels may be supported vertically by a thin bamboo. The wire may then be flexible, and is attached to an insulator at the top of the pole. This is sometimes handy for tests. Or a support such as an overhead branch may be available, string being used between insulator and tree.

Loaded Aeriels. These are shorter than $8\frac{1}{2}$ ft., but have a loading coil added in their length. This makes up the electrical "length" so that the aerial can work well. The loading coil needs to have relatively few turns when placed near the bottom of the aerial. When placed about centrally, more turns are needed, but radiation efficiency is greater, so this position is favoured.

Fig. 68 shows a loaded aerial. A loading coil can be 25 turns of 26 s.w.g. enamelled wire, spaced to occupy $1\frac{1}{2}$ in. on a $\frac{1}{2}$ in. diameter paxolin tube former. Wood blocks in the tube receive the aerial rods. The aerial is used vertically. The rod from the bottom of the aerial to the coil is 1 ft. long, and the aerial above the coil is adjustable in length—16 in. to 24 in. will be suitable, the exact length depending on the transmitter frequency, and

AERIALS

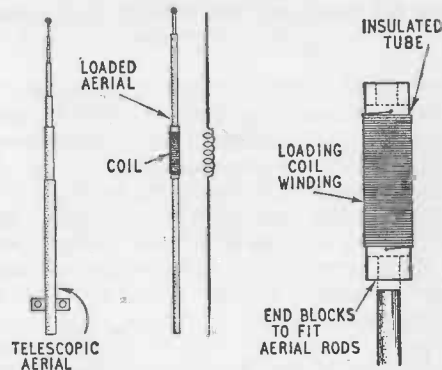

Fig. 68. Ordinary and loaded transmitting aeriels.

length of wire from the transmitter coupling coil to the aerial (some 6 in. to 12 in.). The top part of the aerial is easily made from a small telescopic aerial, a single 12 in. \times $\frac{1}{4}$ in. tube or rod forming the portion under the coil.

Radiation efficiency can be checked with the field strength meter. A short loaded aerial is more efficient than an unloaded aerial of the same length, but less effective than the full size aerial. A very short transmitter aerial will reduce range to a fraction of that obtainable with a long aerial.

The simplest procedure is to test the equipment with an aerial perhaps 4 ft. to 6 ft. or so long. If range is sufficient, no attempt to improve the aerial need be made.

Aeriels like those in Fig. 68 are normally vertical, or nearly so. The radiated signal is of about the same strength in all directions of the compass, and signal strength is good near ground level. This type of aerial is

CONTROLLING MODELS BY RADIO

thus useful for boats and land models, and general purposes.

Receiver Aerials. These are generally dictated by the size and style of model. A long, self-supporting vertical aerial, as used with the transmitter, would give excellent signal pick-up, but is awkward on many models.

Some models lend themselves to the use of a light, small vertical aerial. For small models and short range, a length of 12 in. to 18 in. or so will do. For greater range, a longer aerial, or a more sensitive receiver is necessary. Larger boats can carry a light vertical aerial several feet long. Some models have a horizontal aerial, suspended between masts.

The aerial must be insulated from earthed parts of the model at all fixing or suspension points. It is best vertical, but this may be difficult. The higher the aerial is above the model, water and ground, the better. When possible, vertical telescopic aerials are recommended, and are efficient and easily fitted. Slender aerials of this kind are not conspicuous.

Planes may use a thin wire strained between insulators from the rudder top to a support near the nose. Wire from wing tips to tail plane will be more clear of the fuselage.

For an armoured car, tank or similar model, a short vertical aerial may be adopted. If the receiver is fairly sensitive, operation over limited distances is possible with a very small aerial. But when good range is required, the aerial must be efficient, and therefore reasonably long and high.

Simple super-regenerative receivers such as those described later are considerably influenced by aerial length, because the aerial affects regeneration and tuning. These sets generally need an aerial some 16 in. to 24 in.

GAS VALVE RECEIVERS

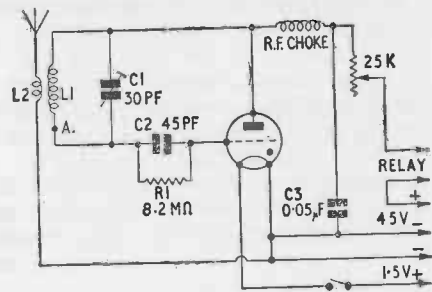

Fig. 69. Circuit of gas-filled valve receiver.

or so long, and to avoid unnecessary readjustment, the aerial should not be changed needlessly.

Gas Valve Receivers

Single valve receivers using a gas-filled triode have been common. The cost of this valve, and its reduced working life, have rendered it less popular, but it is still used. It requires few parts, has good range, and works from a dry cell for filament, and 45V for h.t.

It is easily built, and a circuit is shown in Fig. 69. C1 is a small trimmer, tuning L1 to the transmitter frequency, L2 being for aerial coupling. L1 is between anode and grid, and this produces regeneration. Grid rectification results in a negative charge at the grid side of C2, which stops oscillation until the charge leaks away through R1. The cycle is then repeated. This is termed super-regeneration, and arises several thousand times per second. The average anode current is 1mA-2mA, holding the relay armature down.

When the transmitter signal is received, the anode cur-

CONTROLLING MODELS BY RADIO

rent falls, so the relay armature is released, working an actuator as described later. When the transmitter ceases to radiate, the armature is drawn back. At fair range the change in anode current is some 0.25mA-0.5mA or so. This current change grows smaller as the distance between transmitter and receiver is increased, until the limit at which control can be maintained is reached.

Some commercially made receivers are of this type, and few parts are needed, the set being small and light. The receiver can be assembled on a thin paxolin panel, using the layout in Fig. 70. The following items are necessary:

- 30pF air-spaced beehive trimmer.
- 45pF mica or ceramic capacitor.
- 8.2M Ω (grey-red-green) $\frac{1}{4}$ -watt resistor.
- 0.05 μ F 150V or similar capacitor.
- Midget 25k Ω (25,000 ohm) potentiometer with knob.
- On/off switch.
- XFG1 valve.
- 16 s.w.g. tinned copper wire. 36 s.w.g. enamelled wire.
- Paxolin panel about $3\frac{1}{4}$ in. \times $4\frac{1}{4}$ in. Insulated tube or rod $1\frac{1}{4}$ in. \times $\frac{1}{8}$ in., one doz. each 6 BA nuts, tags and bolts.

The coil is wound by straightening the 16 s.w.g. wire, and winding 10 turns tightly side by side on any object $\frac{1}{2}$ in. in diameter. The coil is removed from the object, its ends bent to project, and cut $\frac{1}{2}$ in. long. A matchstick or similar item is run round and round between turns to separate them, so that the finished coil is 1 in. long. It is mounted by soldering its ends to tags bolted to the panel.

The r.f. choke is wound with 36 s.w.g. enamelled wire, using the $\frac{1}{8}$ in. diameter tube. A small hole is drilled near each end, and about 1 in. of stout wire is pushed through and bent over. The 36 s.w.g. wire is bared and soldered

GAS VALVE RECEIVERS

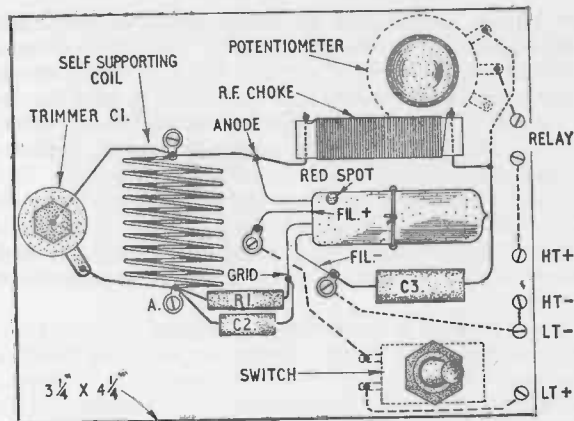

Fig. 70. Gas-filled valve receiver.

to one of these wires. About 75 turns are then wound on, side by side. The wire is soldered to the second stout wire tag.

The 30pF trimmer tags pass through holes in the paxolin. On/off switch and potentiometer are fitted in holes as shown. The valve has wire ends and is secured by passing elastic through two small holes. The red spot, denoting anode, is positioned as shown, and the wires are not bent near the glass.

The receiver requires a $1\frac{1}{2}$ V cell for filament, and two 22 $\frac{1}{2}$ V deaf aid type miniature batteries for h.t. in series to give 45V. More than 45V must not be used.

A first test can be made with no aerial. The potentiometer is rotated anti-clockwise, to bring all the resistance

CONTROLLING MODELS BY RADIO

into circuit, and a 2mA or similar meter is in the h.t. positive circuit, in series with the relay. When the receiver is switched on, a current of about 0.25mA is shown by the meter. The potentiometer knob is rotated to increase this to roughly 0.5mA. The transmitter is then switched on, and the receiver tuned with an insulated tool until the current drops each time the transmitter is keyed. This shows the receiver is tuned to the transmitter.

Without aerials, a current change of 0.25mA or so should be found at 5 yd. from the transmitter. Transmitter and receiver aerials may then be added, and the receiver tuned at range.

A useful range is obtained with a vertical aerial of 12 in. to 16 in. connected directly to tag A. If a long aerial is used make a 2-turn loop and fix it near the 10-turn coil, using bolts and tags. Connect the loop to aerial and l.t. negative (0.05 μ F capacitor).

H.t. current must never exceed 2mA. Lower currents will increase the valve life. For a pond of reasonable size a current of 1mA, falling to 0.25mA when the transmitter is keyed, will easily work a high resistance relay. It is preferable not to let anode current exceed 1.5mA.

If the current is too small it can be increased by reducing R1 to 6.8 megohms, 4.7 megohms or less. This is useful when the valve has aged somewhat. In some models it will be convenient to place the potentiometer and switch in the battery leads away from the receiver. If a light, high-speed relay tends to buzz, a 0.5 μ F capacitor should be in parallel with its windings. The circuit can be modified by wiring R1 from grid to l.t. negative. This reduces sensitivity, but increases valve life. A range of 500 yd. should be obtained with the 2-valve transmitter.

VACUUM VALVE RECEIVERS

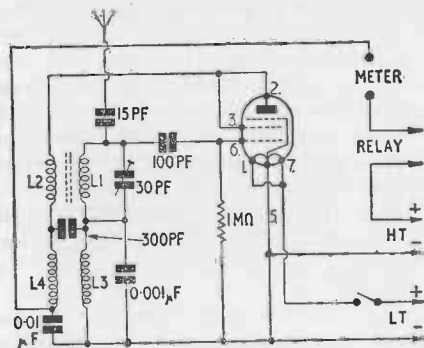

Fig. 71. Circuit for vacuum valve receiver.

Vacuum Valve Receivers

If an ordinary high vacuum valve is fitted into a circuit like that in Fig. 69, the change in anode current is very small, and reliable working is not possible. This is sometimes overcome by using a second valve, or transistor amplifier.

The vacuum valve may be used in a circuit having separate quench coils, to provide super-regeneration. The circuit is shown in Fig. 71. A 1.5V supply is needed for l.t., and 60V or 67.5V for h.t. The pin numbers given are for a 3V4 or DL94 valve, the valve being viewed from below, and its pins counted clockwise from the space.

Coil L1 is tuned to the transmitter signal, the winding L2 being a feedback coil to obtain oscillation. If a 7 mm. coil former is used, with dust iron cores, L1 may be 11 turns of 24 s.w.g. enamelled wire, turns side by side. L2 is about

CONTROLLING MODELS BY RADIO

16 turns, also 24 s.w.g. wire, turns side by side, and near L1.

L3 is the grid part of the quench coil, with its own feedback winding L4. The quench coil is made by fitting two strong card or paxolin discs on a short piece of wooden dowel $\frac{1}{2}$ in. in diameter. L3 is 600 turns of 36 s.w.g. enamelled wire, and L4 is 350 turns of 36 s.w.g. enamelled wire. The discs are $\frac{3}{8}$ in. apart, with the turns wound between them. The wire ends pass through small holes in one disc, and a strip of paper is wound on top of L3, before winding L4. Reverse leads to L2 or L4 if L1 or L3 fails to oscillate.

Adjustment is quite critical. The coupling between L1 and L2 is changed as necessary by screwing the cores in or out, so that anode current drops each time the transmitter is switched on (key closed). The aerial length is also adjusted, an inch or so at a time, to help achieve this, and the 30pF trimmer is tuned to the signal, as described for the gas-filled valve receiver. An aerial between about 15 in. and 25 in. should prove suitable.

Such receivers are quite popular, and can provide good working range. The receiver can be constructed on a panel, in the manner previously illustrated.

Transistor Receivers

Transistor receivers with a range equalling that of the 1-valve circuits are expensive. A simple transistor receiver for short range is shown in Fig. 72. It is suitable only for indoors, in a small garden, or for a model on a small garden pond. The current change is about 0.5mA at 15 ft. with a 3 ft. aerial.

The coil is 11 turns, 1 in. in diameter and $1\frac{1}{4}$ in. long, and is self-supporting. All parts may be mounted on a small panel $2\frac{1}{4}$ in. \times $3\frac{1}{2}$ in. and the following items are required:

TRANSISTOR RECEIVERS

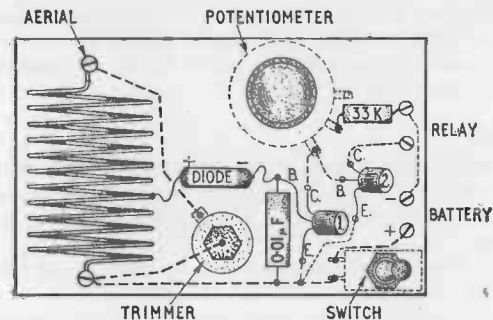

Fig. 72. Simple transistor control receiver.

Crystal diode.

500k Ω potentiometer and knob.

30pF air-spaced trimmer.

On/off switch.

33k Ω (orange-orange) $\frac{1}{4}$ -watt resistor.

0.01 μ F or similar capacitor.

Audio transistor such as OC71 (1 in Fig. 72).

Output transistor such as OC72 (2 in Fig. 72).

$\frac{1}{2}$ -doz. 6 BA nuts and bolts.

A sensitive relay as described for valve sets is used, and a 3V to 6V battery, of small cells. Adjustment is simple. The potentiometer knob is turned so that all the element is in circuit (fully clockwise in Fig. 72). The trimmer is rotated until a current dip is shown on a meter in one battery lead, when the transmitter is switched on. The potentiometer is set for best current dip, at a short distance, and the trimmer is finally adjusted with the receiver aerial connected.

CONTROLLING MODELS BY RADIO

and perhaps several contacts, for reversing or other purposes. (See Fig. 19.) Single-pole change-over contacts can reverse a motor (Fig. 28), or a 2-pole 2-way relay can be wired as in Figs. 28 and 29.

Steering Actuators

An actuator is a servo device which changes an electrical impulse into the mechanical movement required to work the ship's rudder, or other control. An actuator for steering is shown in Fig. 74.

The actuator has a hook engaging with the ends of the cross-shaped member. The latter is attached to a small clockwork motor, which would turn in the direction of the arrow. In Fig. 74, A is holding X, so rotation is prevented until current flows in the magnet. When this happens, A is drawn towards the magnet, the rotating part is released, and the end Y turns until it engages with the hook end B. When current ceases to flow, the spring draws B back, so end Y rotates and comes to rest against A. With the next operation, Z will rest against B, then against A.

The spindle and crank can thus be brought to rest in any of four positions, repeated as necessary. A link from the crank pin operates the rudder. The four positions could give:

- 1, sailing ahead
- 2, sailing to port
- 3, sailing ahead
- 4, sailing to starboard

As two ahead positions are not wanted, a small cam is fixed to the actuator spindle. In one straight ahead position this cam separates the contacts, to switch off the boat propulsion motor. It is possible to stop the motor, or sail the model straight, or turn it right or left.

If the actuator can be brought to rest in 8 positions,

STEERING ACTUATORS

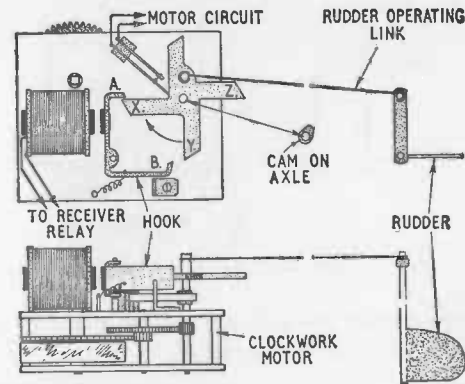

Fig. 74. Escapement actuator for controlling propulsion motor.

some will give half to port sailing, and some half to starboard. Unrequired duplicate positions may have a cam to close contacts, operating a reversing relay like that in Fig. 19. The eight positions could then be:

- 1, propulsion motor off
- 2, sailing half port astern
- 3, sailing full port ahead
- 4, sailing half port ahead
- 5, sailing full ahead
- 6, sailing half starboard ahead
- 7, sailing full starboard ahead
- 8, sailing half starboard astern

With this type of device, the operations always arise in the same sequence. When the model is under control, unrequired positions are passed through quickly, so the model does not respond to them.

CONTROLLING MODELS BY RADIO

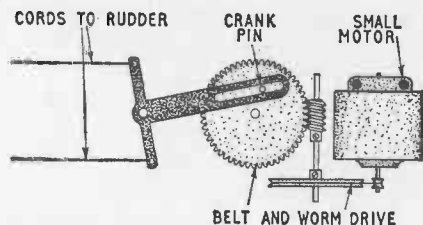

Fig. 75. Fully variable steering mechanism.

In small models the actuator can be driven by twisted elastic. This is popular with planes.

Variable Control. If fully variable steering is required, a system like that in Fig. 75 may be adopted. This is also satisfactory for the guiding wheels of a vehicle.

The small motor turns the crank through reduction gearing, and current may be drawn from the main battery. When the relay controlling the motor closes, the motor runs, moving the rudder, or vehicle guide wheels.

It should be possible to reverse the steering motor. This can be done by using an actuator with contacts, and a reversing circuit as previously described. The steering motor can then be switched on, made to run either way, and halted.

Two settings of the crank, at 180 degrees, give straight sailing or running, as with the escapement actuator. In one duplicate position, a cam can close contacts to energise a change-over reversing relay for the propulsion motor, or the cam may open contacts, bringing in a resistor for half-speed sailing (Fig. 27).

Mark/Space Control. This system uses a transmitter

MARK/SPACE CONTROL

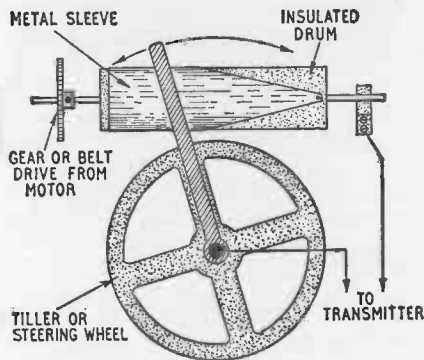

Fig. 76. Underside of mark/space automatic switch.

and receiver as described, but a mark/space switch replaces the simple on/off switch at the transmitter.

The underside of a mechanical mark/space switch is shown in Fig. 76. The insulated drum is wood, about 1 in. in diameter and 4 in. long. Thin metal is curved to fit the wood. It completely encircles the drum at the left, but tapers to a point at the right. The drum is rotated at moderate speed (say 100 r.p.m.) by gearing from a small motor.

A spring arm bears on the drum, and the metal sleeve is connected to the drum axle, so that leads may be taken as shown. The spring arm is turned by a tiller or steering wheel.

When the wheel is to the left in Fig. 76, contact between arm and drum is continuous. As the wheel is turned right, the time during which the transmitter signal is interrupted increases, until with the arm centrally placed, the circuit is completed for half the time, and interrupted for half the

CONTROLLING MODELS BY RADIO

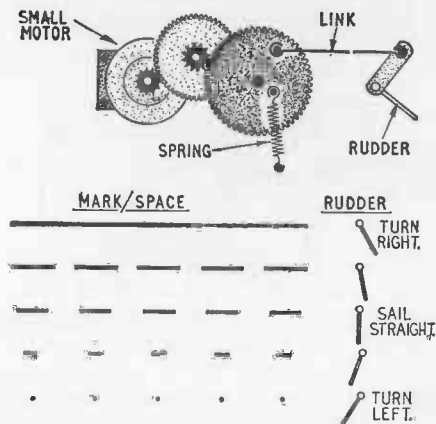

Fig. 77. Mark/space steering control.

time (equal mark and space). With the arm to the right, the transmitter is off almost continuously (short mark, long space). Any desired mark/space ratio is obtained by turning the tiller or wheel to the required extent.

The actuator in the model can be as in Fig. 77. A small, light motor is used, driving the rudder through a moderate reduction ratio. The ratio and spring tension are arranged so that if no current flows in the motor, the spring draws the rudder over to the position shown. If the motor is connected to a battery, it moves the rudder to the other extreme position.

The steerage motor is controlled by the receiver relay as already explained. When the transmitter is radiating signals with an equal mark/space ratio ("on" periods the

MODEL PLANES

same as "off" periods) the steerage motor runs briefly for each "on" interval, and is turned backwards slightly by the spring for each "off" interval, so that the rudder is straight. When the tiller or wheel is turned one way or the other, the intervals during which the steerage motor runs will be longer or shorter, so that the rudder is moved to the required extent.

The rudder fluctuates slightly about an average position, but this has no practical effect. A high speed relay with a light armature is needed in the receiver. The control is fully variable, the distant model responding to movements of the tiller or steering wheel.

A resistance speed controller can be wired to the motor driving the mark/space generator in Fig. 76, and also the steerage motor in Fig. 77, so that the speed can be adjusted for best results.

Planes

Fig. 78 shows a popular method of guiding a light plane. The escapement is operated as already described, and normally rests in the position indicated, with the rudder straight. For turning to right or left, the escapement is held down (transmitter on continuously).

As the rotating member has two ends, failure of the equipment will release the escapement, and place the rudder straight. This is a safety measure. Trim may be arranged so that the model loses height when turning, and climbs when flying straight with motor on, gliding safely to land when flying straight with motor off.

When variable elevators are provided, small cams on the crank spindle may be used to operate them. A light arm bearing on the cam profile is connected to the elevators by thread.

Throttle flaps and other devices are also used for engine control, or a radio controlled fuel cut-out may be fitted

CONTROLLING MODELS BY RADIO

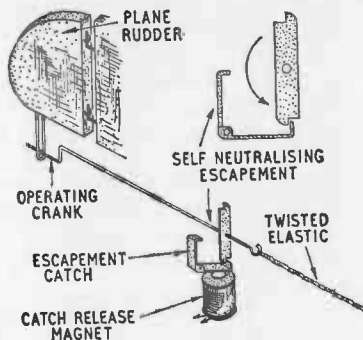

Fig. 78. Escapement for light plane.

Various very light items of equipment can be obtained for planes, and with the more comprehensive installations realistic flying is possible. Simplified systems use limited control, such as straight flying to gain altitude, turns to lose altitude and glides to land.

Tone Transmission

The transmitters and receivers shown are of c.w. type, and use a continuous radio wave. They will operate in conjunction with commercially made c.w. transmitters or receivers.

In more complex equipment, tone transmission is used. The radio wave is modulated with audio tones, and these tones are separated in the receiver, and operate individual relays. A 3-tone receiver provides three separate control channels, used for steering, motor and speed control, etc.

CARRYING THE EQUIPMENT

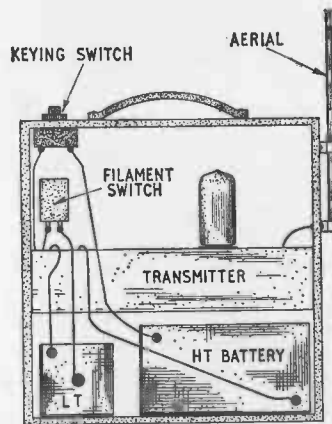

Fig. 79. Transmitter with aerial and batteries.

The tones are generated by a modulator at the transmitter. In the receiver, tones are separated by resonant circuits, or by a reed unit. The latter has tuned reeds, which respond only to the appropriate tone. For tone working, both transmitter and receiver must be designed to suit. The equipment is relatively complicated and expensive.

Complete Equipment

The transmitter and batteries can be fitted into a carrying case (Fig. 79). Details of the battery supplies, aerial, etc. have already been given. A push switch is attached to the case, to key the transmitter when guiding the model. The case is made of thin wood, and the back is attached with screws.

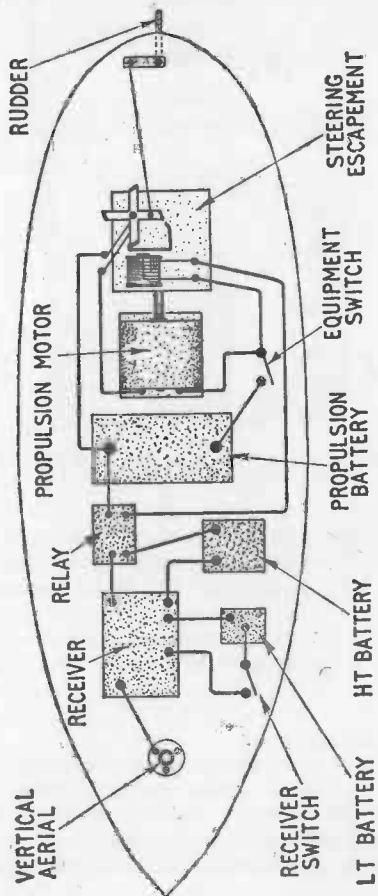

Fig. 80. Interconnection of equipment in boat.

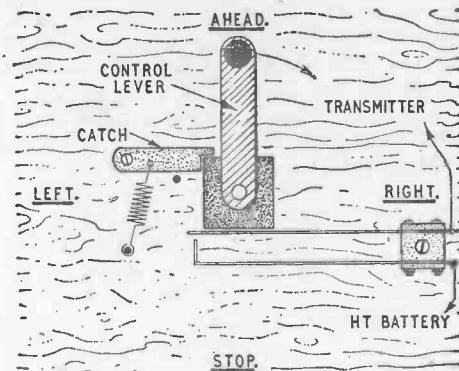

Fig. 81. Sequence control switch.

The receiving equipment has been described, and is shown in Fig. 80. Provision should be made for adding a meter in series with the relay, for tuning purposes. Boats of other than small size can carry the meter, but with small craft a twin socket strip should be fitted, and the meter is wired to plugs which are inserted in the sockets. After tuning, the meter is removed, and the sockets shorted by plugs wired together.

The equipment in Fig. 80 provides for sailing ahead, turning either way, or bringing the boat to rest. The clock-work actuator should be re-wound before each period of sailing.

If preferred, the simple keying switch in Fig. 79 may be replaced by the sequence switch in Fig. 81. The latter has a rotating control lever, with positions marked "Ahead," "Right," "Stop" and "Left," and this arm can only be

CONTROLLING MODELS BY RADIO

turned in a clockwise direction, due to the small catch. Each quarter rotation of the lever closes the control contacts once. The actuator in Fig. 80 thus follows the movement of the lever, so that the boat sails ahead, turns or stops, according to the control lever position. Control lever and actuator must both be set to "stop" (motor off) before sailing begins.

LIST OF ABBREVIATIONS

A	=	Amperes
a.c.	=	Alternating Current
A.H.	=	Ampere Hour
C.W.	=	Continuous Wave (of Transmitters)
d.c.	=	Direct Current
E	=	Electromotive Force, i.e. Volts (in Calculations)
E	=	Earth (green wire)
h.t.	=	High Tension
I	=	Current in Amperes (in Calculations)
kw	=	Kilowatt (1,000 Watts)
L	=	Live (red wire)
l.t.	=	Low Tension
mA	=	Milliampere (0.001 Amps.)
μ A	=	Microampere (0.000001 Amps.)
μ F	=	Microfarad (measurement of Capacitor capacity)
M Ω	=	Megohm (1,000,000 Ohms)
N	=	Neutral (black wire)
Ω	=	Ohm
pF	=	Picofarad (one millionth of a Microfarad)
PM	=	Permanent Magnet
R	=	Resistance
SG	=	Specific Gravity
S.W.G.	=	Standard Wire Gauge
V	=	Volt
W	=	Watt
WH	=	Watt-hour

Index

*Asterisked page numbers * refer to illustrations*

A.c., 19-20, 20*, 155
Accumulator, 8-9; capacity, 9, 55; charging, 9, 73-4; current, 19, 20, 20*; dry, 9; lead acid, 8-9; motor-cycle, 47, 48; nickel iron, 9; scooter, 47, 48
Acoustic feedback, 105
Actuator, 118, 119; steering, 144-9, 145*, 146*, 147*, 148*
Adaptor, 22
Aerial, 102, 103*, 131-5, 133*; loaded, 132-4, 133*; receiver, 119, 134-5, 138; telescopic, 131, 132, 133*; transmitter, 123, 125, 131-4, 133*
Aeroplane, model, 117, 118; aerial, 134; guiding, 149-50, 150*
Ammeter, 23
Ampere, 11-12
Amplifier, 106, 108, 109, 114-15
Aquarium, 77-9; heating, 78-9, 79*; illumination, 78; oxygen restoration, 77-8
Armature: three-pole, 51, 52*; two-pole, 44
Audio equipment, 101-16
Automatic cut-out, 42-3

Bar magnet motor, 52, 53*
Battery, dry cell, 7-8, 8*; capacity, 9-10, 55; charging, 20, 71-5; current, 19, 20, 20*; in parallel, 7; motor-cycle, 46
Bell, 41, 41*, 108
Belt drive, 60, 60*
Boat, model, 68-70, 117, 118; aerial, 134; checking, 68;

drive, 69-70, 69*; motor, 68-9, 70; receiver, 152*, 153; speed control, 55-6, 68; steering, 144-9
Brushes, 51, 53, 53*
Bulbs, 28-37; dimming, 35; 56-7; flashing, 36, 37; in parallel, 30, 31 31*; in series, 30-1, 31*; power source, 33-5; signal, 36-7, 79*; wiring, 29
Burglar alarm, 77
Buzzer, 41, 108, 114

Capacitor (condenser), 102, 103*, 106, 109, 114
Carbon microphone, 103-4, 107, 108
Cell, 7-8, 8*; connected in parallel, 7; connected in series, 9*; secondary, 8-9
Charger: mains, 73, 73*; accumulator, 73-4
Charging, 71-5; accumulator, 9, 73-4; dry cell, 20, 74-5; vehicles, 73, 75
Chromium plating, 87-8
Circuit: principles, 7-27; resistance, 10-15, 11*
Clock, 80-3; battery, 82-3; master, 80; slave, 80; synchronous, 81-2, 81*
Coil, 102, 103*
Commutator, 51, 52*, 53
Compass, 38, 39*, 40*
Condenser (capacitor), 102, 103*, 106, 109, 114
Contact printing box, 94-5, 95*
Continuous wave transmitter, 119-23; aerial, 123, 131-5, 133*; components, 120-1;

INDEX

construction, 119-22; control switch, 122-3; housing, 122; power source, 122; testing, 123; tuning, 128-31, 129*; wiring, 121, 121*
Control: aeroplane, 149-50, 150*; boat, 144-9; mark/space, 146-9, 148*; speed, 11, 55-6, 56*, 57*; variable, 146, 146*; vehicle, 146, 146*
Copper plating, 87
Crystal controlled transmitter, 123-7, 124*, 127*; aerial, 125, 131-5, 133*; components, 125; frequency, 123-4, 126-7; output, 127; power source, 124, 126
Crystal microphone, 104, 105*
Current, 7-10; a.c., 19-20, 20*; chart, 14; d.c., 19, 20, 20*; from dry battery, 7-8, 9-10; from lead acid accumulator, 8-9; from nickel iron accumulator, 9; mains, 19-20, 20*
Cut-out, 42; automatic, 42-3
Cycle lighting, 45-6

D.c., 19, 20, 20*; generator, 44
Dry cell battery, 7-8, 8*; capacity, 9-10, 55; charging, 20; current, 19, 20, 20*; in parallel, 7
Dynamo, 44-6, 45*; armature, 44; checking, 46; hub, 46; output, 44

Earth, 21, 22, 102, 103*; connection, 22*
Electric motor, 37, 51-62; bar magnet, 52; field magnet, 54; permanent magnet, 51-2, 52*; reversing, 57-9, 58*, 59*; running, 54-61; speed control, 55-6, 56*, 57*; turntable, 106
Electric poker, 85
Electro-magnet, 39-40, 40*, 42
Electroplating, 20, 87-8, 87*
Electroscope, 85, 86*
Enlarger, 95-6, 97*; condenser, 96; lamp, 95-6; lens, 96
Epidiastroscope, 100
Episcope, 100
Exposure indicator, 96-7
Extension speaker, 110, 111*

Field magnet motor, 54; reversing, 58, 59*
Flash gun 90-2, 91*; capacitor circuit, 91; testing, 91-2
Flywheel magneto, 48-50, 49*; checking, 50; contact breaker, 48, 49; primary circuit, 48, 50; secondary circuit, 48-9, 50; spark, 49-50
Full-wave bridge rectifier, 70-1
Full-wave rectifier, 70, 71*
Fuse, 18-19; mains plug, 21-2

Galvanometer, 25-6, 39, 40*
Gas valve receiver, 135-8, 135*; aerial, 138; circuit, 135; components, 136; construction, 136-7, 137*; power source, 137, 138; testing, 137-8
Gearing, 59-61; reverse, 61; variable speed, 61; worm, 59-60, 60*
Generator: d.c., 44; motor-cycle, 46, 47*, 50
Glazing (prints), 98
Glowplug motor, 84
G.P.O., 117
Guitar pick-up, 105-6

Half-wave rectifier, 70, 71*
Headphones, 115-16
Heating: aquarium, 78-9, 79*; developing solution, 97-8; soil, 75-6
Home: intercom, 109-10, 109*;

INDEX

telephone, 107-8, 108*
 Hydrometer, 72, 72*
 Indicator, exposure, 96-7
 Insulation, 15
 Intercom, home, 109-10, 109*
 Isolating: points, 64; rail, 37, 64, 65
 Jack plug, 106
 Lamp: parking, 80; projector, 98, 99; stage, 82*, 83
 Lamp loop, 123, 129-30, 130*
 Lead acid accumulator, 8-9
 Leyden jar, 86, 86*
 Loudspeaker, 114-15
 Magnet, 38-40; 39*; electro, 39-40, 40*, 42; permanent, 38-9, 39*
 Magnetic: polarity, 19, 40; pole, 38
 Mains, 19, 21-2; current, 19-20, 20*; plug, 21-2
 Mark/space control, 146-9, 148*; switch, 147, 147*
 Meter, 23-6, 23*, 25*, 118, 128-31, 129*; exposure, 96-7; microampere, 24; photo-electric, 89-90, 90*
 Microphone, 103-5; carbon, 103-4, 107, 108; connection, 105; crystal 104, 105*; moving coil, 39, 104; ribbon, 104
 Milliammeter, 23-5
 Morse, 113-14, 113*
 Motor, 37, 51-62; bar magnet, 52; field-magnet, 54; glow-plug, 84; permanent magnet, 51-2, 52*; reversing, 51-2, 57-9, 58*, 59*; running, 54-61; speed control, 55-6, 56*, 57*; tool, 61*, 62; turntable, 106; universal, 61*, 62

Moving coil microphone, 39, 104
 Motor-cycle lighting, 46-50; accumulator, 47, 48; a.c./rectifier system, 46-7; charging, 73; generator, 46, 47*, 50; switches, 47
 Negative, photographic, 94-5
 Nickel iron accumulator, 9
 Ohm, 11, 12, 13, 115
 Ohm's law, 11-13, 13*, 25
 Parking lamp, 80
 Pentode valve, 102
 Permanent magnet, 38-9, 39*; in dynamo, 45*; motor, 51-2, 52*
 Permanent magnet motor, 51-2, 52*; power source, 51, 52; reversing, 51-2, 57-8, 58*
 Photo dryer, 98
 Photo-electric meter, 89-90, 90*
 Photoflood, 92-4, 94*
 Photographic: equipment, 89-100; negative, 94-5
 Pick-up, 106-7; guitar, 105-6; volume control, 106-7, 107*
 Piston pump, 77-8
 Plug: jack, 106; mains, 21-2; three-pin, 21-2, 22*; two-pin, 22
 Potentiometer, 102, 103*, 106, 107
 Projector, 98-100, 99*; lamp, 98, 99; screen, 98-9
 Pump: piston, 77-8; vibrator, 78
 Radio control, 42, 117-54, 119*; licence, 117-18
 Receiver, 134-42, 152*, 153-4, aerial, 119, 134-5, 138; gas valve, 135-8, 135*; super-

INDEX

regenerative, 134-5 139-40; transistor, 140-2, 141*; vacuum valve, 139-40, 139*
 Rectifier, 70-1, 71*; full-wave bridge, 70-1; full-wave, 70, 71*; half-wave, 70
 Relay, 41-2, 43*, 142-4, 143*; testing, 142
 Resistance, 10-15, 11*; chart, 14
 Resistor, 13, 101-2, 103*; rating, 15
 Reversing motor, 51-2, 57-9, 58*, 59*; by radio control, 59
 Ribbon microphone, 104
 Rotary converter, 83-4, 83*
 Scooter lighting, 46-50; accumulator, 47, 48; a.c./rectifier system, 46-7; battery, 46; bulbs, 46-7; charging, 73; generator, 46, 47*, 50; switches, 47
 Screen, projection, 98-9
 Sequence switch, 153-4, 153*
 Servo-mechanism, 118, 119
 Shocking coil, 43-4, 44*
 Shunt, 24; formula, 24, 25
 Silver plating, 88
 Soil warming, 75-6; cost, 76
 Soldering, 26-7, 26*
 Solution heater, 97-8
 Specific gravity, 71-2, 74
 Speed controller, 11, 55-7, 56* 57*
 Stage lamp, 82*, 83
 Static electricity, 85-7
 Stepped controller, 55
 Super-regenerative receiver, 134-5, 139-40, 139*; adjustment, 140; aerial, 134-5, 140; power source, 139
 S.W.G., 17, 155
 Switch, 15-16, 16*, 21; automatic, 76-7; light sensitive, 79-80; maintenance 58-9; mark/space, 147, 147*; sequence, 153-4, 153*; time, 76-7
 Tape recording, 110-12; from diode, 111; from disc, 111; from microphone, 111, 112; from radio tuner, 111; mixing, 112
 Telephone, home, 107-8, 108*
 Telescopic aerial, 131, 132, 133*
 Thermocouple, 84-5
 Thermostat, 78-9, 79*
 Three-pin plug, 21-2, 22*
 Three-pole armature, 51, 52*
 Time switch, 76-7
 Tool motor, 61*, 62
 Tone transmitter, 150-1
 Track, train, 63-6, 64*, 65*
 Train, 37, 63-8; control, 64-8; control box, 67-8; power source, 66-7, 67*; track, 63-6, 64*, 65*; transformer, 66, 67
 Transformer, 20-1, 33-5; current rating, 35; iron core, 102, 103*; power source, 33; primary circuit, 34; secondary circuit, 34-5; wiring, 33*, 36*
 Transistor, 102, 103*
 Transistor oscillator, 114, 115*
 Transistor receiver, 140-2, 141*; adjustment, 141; components, 141
 Transmitter, 117-27, 150, 151*; aerial, 123, 125, 131-5, 133*; continuous wave, 119-23, 120*; control band, 117-18; crystal controlled, 123-7, 124*, 127*; licence, 117; power indication, 130-1, 130*; range, 118; tone, 150-1
 Transparency viewer, 100
 Trickle charging, 74
 Trimmer, 102, 103*
 Triode valve, 102
 Turntable, 106
 Two-pin plug, 22
 Two-pole armature, 44
 Two-speed running, 55-6, 57*
 Universal motor, 61*, 62

INDEX

- Vacuum valve receiver, 139-40,
139*; adjustment, 140; aerial
140; power source, 139
- Valve, 102, 103*; oscillator, 114,
115*
- Variable speed gearing, 61
- Vehicle, model, 117; aerial, 134;
steering, 146, 146*
- Vibrator pump, 78
- Voltage, 11*, 12; chart, 14
- Voltmeter, 20, 24
- Volume control, 106-7, 107*
- Watt, 14-15
- Wavemeter, 118, 128-31, 129*;
calibration, 128-9
- Wimshurst machine, 86-7
- Wire, 17-18; flexible, 17; insula-
tion, 17, 18; single conductor,
17; size, 17; table, 18
- Worm gearing, 59-60, 60*

