

# RADIO- CONTROLLED MODELS

F.J. CAMM

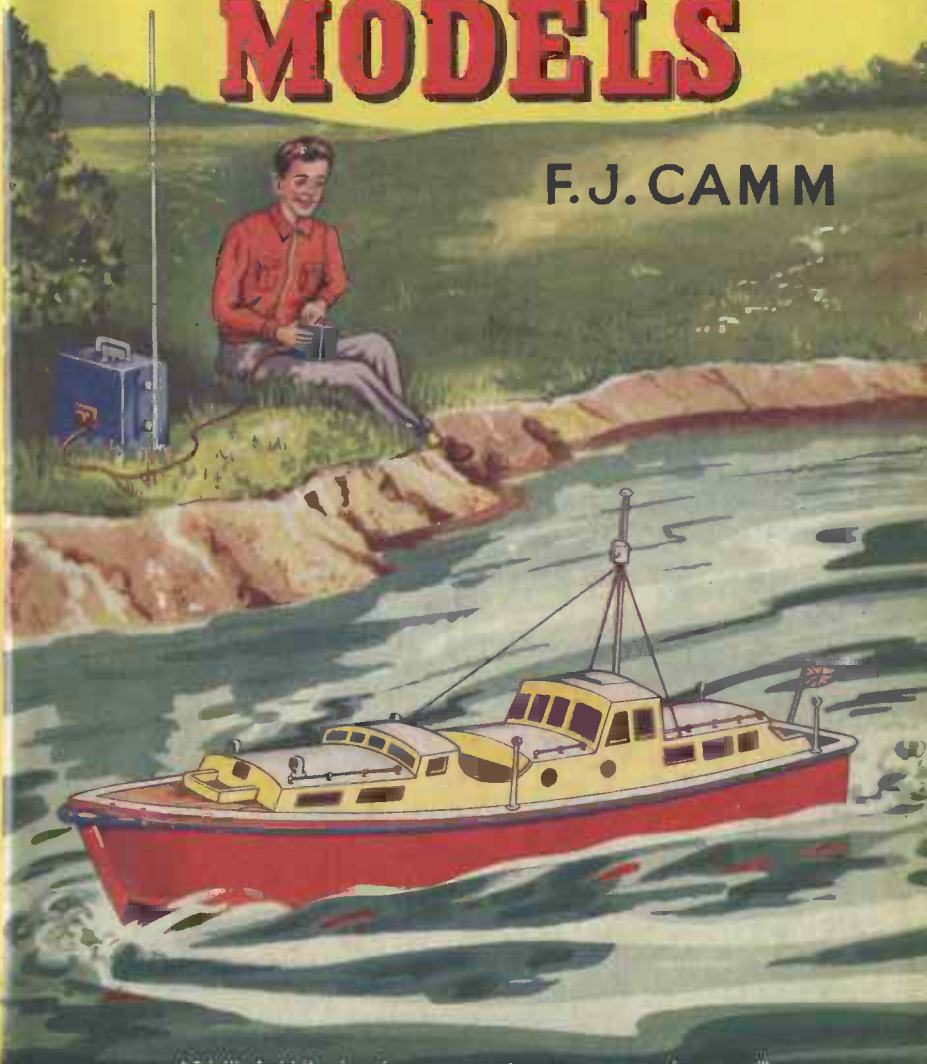

# RADIO-CONTROLLED MODELS

BY

F. J. CAMM

THE radio control, not only of models, but of a wide range of mechanisms, is a fascinating branch of electronics which has called for the preparation of this standard work on the subject.

It covers both the radio and mechanical side of the equipment necessary and describes in detail a number of practical examples of the application of radio control.

It is an ideal introduction to the subject of this important new hobby.

3600

12s. 6d.  
net

RADIO-CONTROLLED MODELS

*By the Same Author :*

MODEL BOAT-BUILDING  
MODEL AEROPLANE HANDBOOK  
MODEL ENGINEERING PRACTICE  
PRACTICAL MECHANICS HANDBOOK  
ELEMENTS OF MECHANICS AND MECHANISMS  
REFRESHER COURSE IN MATHEMATICS  
WIRELESS TRANSMISSION  
PRACTICAL WIRELESS ENCYCLOPÆDIA  
THE HOME ELECTRICIAN  
PRACTICAL MECHANICS HOW-TO-MAKE-IT BOOKS (2 Vols.)  
PRACTICAL WIRELESS CIRCUITS  
PRACTICAL TELEVISION CIRCUITS  
PRACTICAL MOTORISTS' ENCYCLOPÆDIA  
ETC., ETC.

# RADIO-CONTROLLED MODELS

BY

F. J. CAMM

*Editor of: "Practical Mechanics", "Practical Wireless",  
"Practical Television", "Practical Motorist and Motor  
Cyclist", and "Practical Householder".*

LONDON  
C. ARTHUR PEARSON LIMITED  
TOWER HOUSE, SOUTHAMPTON STREET  
STRAND, W.C.2

Mil  
A. 3. 58  
12/6

©  
1958  
F. J. CAMM

ISLINGTON PUBLIC LIBRARIES	
LIBRARY NO.	N 141469
CLASS. NO.	621.384196
CAT. NO.	DATE

B640.977

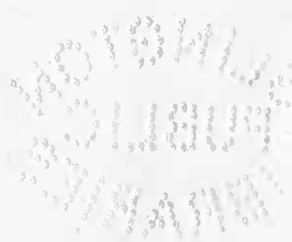

MADE AND PRINTED IN GREAT BRITAIN BY  
MORRISON AND GIBB LIMITED, LONDON AND EDINBURGH

## CONTENTS

CHAPTER	PAGE
INTRODUCTION . . . . .	9
1. SIMPLE STEERING CONTROL GEAR . . . . .	14
2. A SINGLE-VALVE SUPER-REGENERATIVE RECEIVER . . . . .	22
3. A TWO-VALVE TRANSMITTER FOR RADIO CONTROL . . . . .	33
4. CONTROL BOX : WAVEMETER : INTERFERENCE : LAYOUT . . . . .	43
5. OBTAINING A SECOND CHANNEL USING THE "MARK/SPACE" SYSTEM . . . . .	54
6. A PROPORTIONAL STEERING CIRCUIT AND REVERSIBLE SEQUENCE ENGINE CONTROL GEAR . . . . .	65
7. A DETAILED DESIGN FOR A RADIO-CONTROLLED BOAT USING A GLOW-PLUG ENGINE AND AN ELECTRIC MOTOR IN THE POWER UNIT . . . . .	77
8. A SIX-VALVE SUPERHETERODYNE RECEIVER FOR MODEL CONTROL . . . . .	91
9. A SINGLE-VALVE CRYSTAL-CONTROLLED TRANSMITTER . . . . .	103
10. RADIO CONTROL FOR MODEL AIRCRAFT (SEQUENCE SYSTEM) . . . . .	113
11. TUNED REEDS AND AUDIO CONTROL . . . . .	124
12. MORE ABOUT MODEL ACTUATORS . . . . .	133
13. TUNING MODEL-CONTROL TRANSMITTING AERIALS . . . . .	139
14. A BULB MODEL-CONTROL FREQUENCY METER . . . . .	146
15. AN AUTO-SWITCH FOR MODEL-CONTROL TRANSMITTERS . . . . .	150
16. A RADIO-CONTROLLED MODEL BATTLESHIP . . . . .	153
17. BUILDING A RADIO-CONTROLLED MODEL AIRCRAFT . . . . .	167

## PREFACE

THE remote control of models by means of radio is a post-war development which has reached national dimensions, and its devotees number tens of thousands. The International Radio-Controlled Model Society was formed some years ago to further the development of the radio control of models throughout the world.

This form of remote control has been chiefly applied to model aeroplanes, model boats and model locomotives, but it has been successfully applied to stationary models as well as to model tanks, steam-rollers and other mobile models. But the system can be adapted to the radio control of practically any mechanical movement.

The equipment and the operation are well within the purse and the ability of any amateur. The production of really tiny diesel engines coupled with the introduction of midget transmitters has enabled builders of model aeroplanes, boats and locomotives to add a mysterious fascination to the hobby of their choice. Annual competitions are held and valuable prizes are offered in these three fields.

I have conducted experiments over a long period of years in this subject, and articles giving the result of those experiments together with designs have regularly appeared in the pages of *Practical Mechanics*. More recently I have published articles based on information supplied by the International Radio-Controlled Society to whom I now tender my thanks.

This book includes most of the information published in my journal with a fair amount of additional matter, and I think it can fairly be claimed that the contents embrace most aspects of the subject and reflect the present state of our knowledge of it.

F. J. CAMM

## INTRODUCTION

**R**ADIO control has occupied the thoughts of modellers for many years now, but since the war, when many men had gained radio experience and good compact equipment became available on the surplus market, the range of interest has widened considerably. Although in the past radio control has been presented as a complex and specialised art, good and reliable control can be achieved with very simple equipment and without a lot of specialised knowledge. In addition, the surplus market enables the careful buyer to fit up his model at very reasonable cost.

To-day, systems which produce erratic control and just enable the model to turn right instead of left, are not sufficient, but the model must be made to behave as nearly as possible like its full-size counterpart. This calls for a system which will allow the operator to execute turns of just the right rate at the exact time and place required, and in the more complex schemes to have complete control of the model's speed.

It is proposed to deal mainly with the control of boats and aircraft models, but the same principles apply with little alteration to land vehicles, which offer a very interesting but so far poorly patronised field. The control of aircraft is, of course, well advanced and whilst it is true that some basic principles are common to all types of radio control the aircraft field has tended to become rather specialised due to weight limitations, together with the rather different type of control required.

**The Sequence Control System.**—In this system a rotary switch with, say, four positions is fitted in the model and arranged so that with the switch in each position a particular function is carried out. The radio gear is so arranged that a short burst of energy from the transmitter, having been

picked up by the receiver, moves the switch from position 1 to position 2, and two or three pulses in rapid succession (about four per second) will move the switch two or three positions. The switch may be arranged so that position 1 gives "Port Rudder", position 2 "Rudder Central". It will be seen that by giving the appropriate number of pulses of energy from the transmitter the rudder can be turned to port or starboard or can be returned to centre.

The snag with this system is that if the operator wishes to turn to starboard it may be that the rotary switch is in such a position that it will have to pass through the "Port Rudder" position. This will mean that whilst the rudder may be turned to port only for a very short time the boat will deviate slightly in the wrong direction. A much more serious snag, however, is the delay which takes place between the operator wishing to start a turn and the control mechanism putting this into effect due to the switch having to pass through one or two other positions. This makes it very difficult to steer an accurate course between buoys and almost impossible to hold a reasonably straight course with a cross wind.

The sequence method of steering control is, therefore, falling into disfavour and is being replaced by systems which enable the operator to simulate full-size practice more accurately. Sequence control is, however, still holding its own as a means of controlling the small types of aircraft, due to the fact that the weight of the mechanisms can be kept very low. Some very ingenious schemes have been evolved which overcome some of the snags of the system and it will probably be a long time before this method is ousted from the small plane field. Sequence is still used most effectively in boats as a means of controlling other functions after steering has been catered for by better methods.

**Requirements for Effective Control.**—Before embarking on the construction of any radio-controlled model it will be as well to summarise the requirements of any system which will give effective control of the model. Most of the points applying to boats also apply to land models.

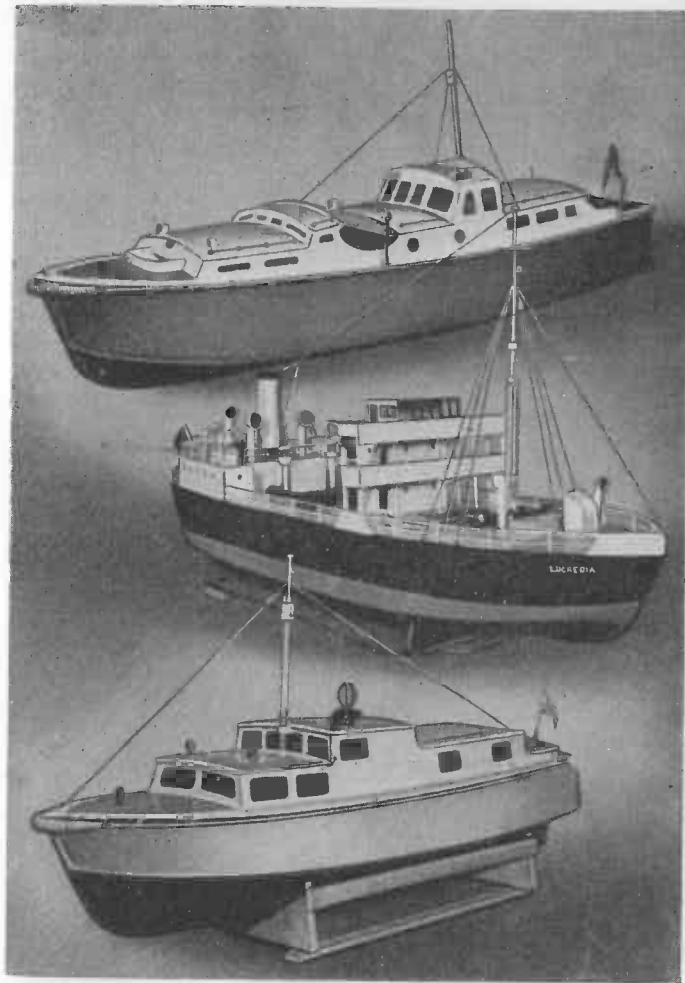

FIG. 1.—Three typical radio-controlled model boats.

Model of an Admiral's barge, 36 in. long, propelled by 3.5 c.c. diesel.  
 A model tanker, electrically propelled, fitted with a single-valve super-regenerative receiver and equipped with steering control only.  
 A 36-in. long electrically propelled model cabin cruiser. The radio receiver is a six-valve superhet. Steering is proportional. Engine speed is variable. All mark/space operation.



The basic needs are:

1. Instantaneous steering control in either direction must be available at all times.

In controlling a boat the operator's hands will continually be on the rudder control, and there is normally no question of being able to set a course, then leaving it for a while. This is due chiefly to the effect of cross winds and also to the fact that it is almost impossible to straighten up out of a turn at exactly the right moment. As a result continuous steering corrections have to be made and it is these which the sequence system cannot competently handle. The half-second or so delay with the sequence system can make all the difference between a boat which can execute a clean course and one which behaves erratically.

2. Maximum reliability is required from every component used.

This may seem fairly obvious, but it is intended here to point out the not so obvious places where reliability must be carefully watched. Sound design of all mechanisms, careful construction and patient testing to eliminate snags will be amply repaid by having a model which operates exactly as required.

3. Components should not be expected to do more work than that for which they were designed.

The government surplus market has been and still is a very fruitful source of components for the radio man. Small valves, compact relays and good small motors are available at very reasonable cost, along with various types of small accumulators, etc. Whilst it is important to keep expenditure down, it is folly to overdo this. For example, it is a good rule never to use resistors or condenser and the like stripped from ex-W.D. equipment. The new components are not very expensive and untold trouble can be caused and hours wasted due to faulty components in the radio gear. Surplus gear should be bought carefully and there are plenty of good clean components, sometimes unused, available.

4. Limited radius of control is quite adequate.

It is a common fallacy to think that long-range control

is required and that a large and powerful transmitter will, therefore, be needed. It is a fact that for the control of a normal size of model boat, say, up to 6 ft. in length, the maximum range at which the boat can be operated is set by the ability of the operator to see the model from the control point. On water which is perfectly calm, visibility can be quite good, but with the normal amount of surface ripple, together with the glare from the sun, the operator will have difficulty in seeing whether his boat is coming towards him or turning away at a range of 80 to 100 yds. The best distance will be found to be about 50 to 60 yds.

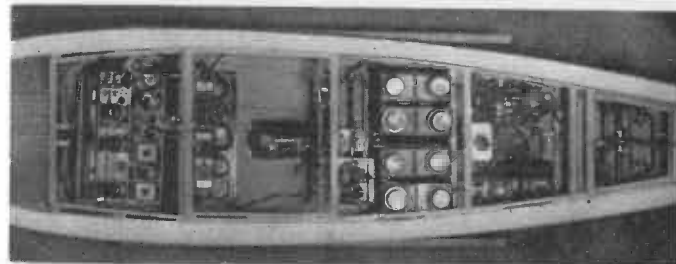

FIG. 2.—Interior of the model cabin cruiser shown in Fig. 1. Contents of compartments, reading from left to right: Six-valve superhet receiver; radio receiver batteries and main driving motor; engine speed controller and main driving batteries; pulse decoding unit ("Intergear"); steering mechanism.

Fig. 1 gives a good idea of the size and general layout of some typical boats and Fig. 2 an interior layout.

It is intended to describe the mechanism and operation of a well-tried rudder mechanism first of all. In later chapters the control of this will be shown, after which details of the receiver and how this does its job will be given. The place occupied by the transmitter will follow and at the same time various auxiliary equipments will be described. The final chapters will describe construction of a model boat and aircraft for model control. In this chapter rudder control only will be aimed at, but the control of speed, etc., will be dealt with later.

## SIMPLE STEERING CONTROL GEAR

FIGS. 3 and 4 illustrate a type of mechanism suitable for steering a model boat. It will be seen that it is simply a screwed rod driven by a small electric motor. A nut travels on the screwed rod and is arranged by a simple mechanical linkage to operate the tiller bar of the rudder. For land vehicles a similar system could be employed to operate the steering mechanism.

It will be appreciated that this is but one of a number of systems which can be employed, alternatives being worm and gear types or simple gear trains. An alternative steering mechanism is shown in Fig. 5. The essential is to operate the rudder from full port to full starboard in a time of approximately 4 seconds. This time has been found from

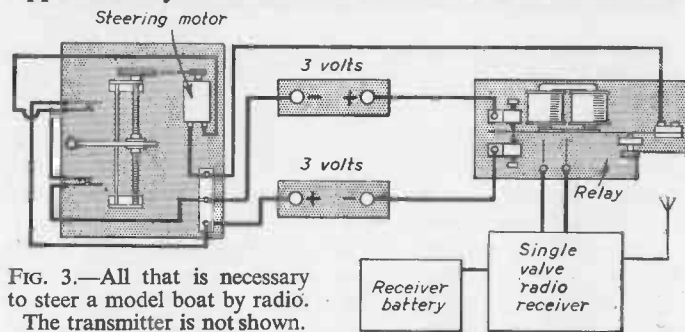

FIG. 3.—All that is necessary to steer a model boat by radio. The transmitter is not shown.

experience to give the most satisfactory handling of the model. The rudder should be made to operate only about 35–40 degrees either side of centre, otherwise too much braking action takes place. Another point is that, due to the fact that screwed rod drives sometimes tend to stick for no apparent reason, provision should be made where

possible for the electric driving motor to drive through a simple form of mechanism used for propeller shafts on models, i.e., a cranked pin engaging with an arm. This permits the drive motor considerable angular freedom and, therefore, the build up of kinetic energy before engaging the drive. The use of elastic bands as belt drives also gives a certain amount of freedom to the motor in this respect.

**The Steering Motor.**—There are on the market a number of small motors suitable for the job. Size is, of course,

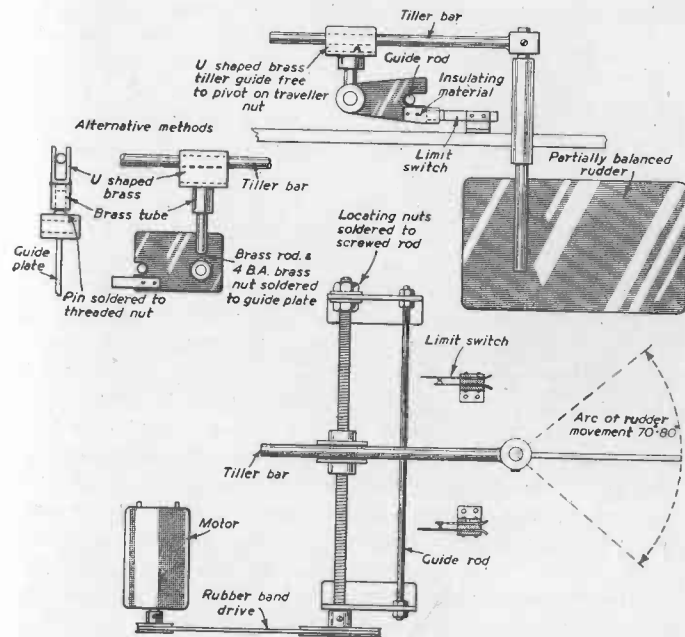

FIG. 4.—Two views of a typical screw and nut steering arrangement and an alternative system.

governed by the size of the model and, therefore, by the mechanical output needed to operate the rudder. For boats up to about 3 ft. 6 in. long, however, satisfactory results are obtainable from the "Mighty Midget" motor,

which is particularly attractive because of its geared drive and light weight. For larger models some of the small D.C. permanent-magnet motors currently available as ex-W.D. supplies could no doubt be employed. In essentials, however, what should be aimed at is a small light permanent-magnet type of motor (this is because of the need for reversing) which is reliable and which will always start upon application of the current. A government surplus P.M. motor and the "Mighty Midget" are shown in Fig. 6.

Whilst on the subject of electric motor mechanical output it should perhaps be pointed out that the work necessary to turn a rudder, particularly when using small diesel engines for the main drive, can be considerably reduced by the use of a partially balanced rudder. In this type a portion of the rudder blade area is arranged to be in front of the rudder post. The wash from the propeller therefore bears on it and assists in turning the portion astern of the post.

**Limit Switches.**—These are very simple mechanisms which perform the very necessary function of preventing the motor from trying to drive the rudder beyond the limit of its travel. In the case of the screwed-rod type of drive this would cause the model to go round in circles. The switches employed are simply pairs of thin strips of springy brass arranged so as normally to be in contact with each other. When the travelling nut reaches nearly the limit of its travel it should be arranged so as to push the end of one of the pieces of brass and so drive them apart, thereby breaking the circuit and stopping the movement. The circuit is wired so that the motion can be reversed, however, and the switch resets itself when the nut travels in the opposite direction.

Brass shim strip can be used for the switches, but better results are obtained using pairs of contacts stripped from old Post Office equipment. Do not make the switch contacts too stiff in the mechanical sense; otherwise the drive may jam. Make sure that the striker which opens the limit is of an insulating material otherwise short circuits may be experienced.

**Reversing Arrangements.**—To operate the rudder, it will be obvious that the electric motor must be capable of rotating in either direction to give port or starboard control. The simplest way of doing this is by the use of two batteries so connected in the circuit that each will drive the motor in alternative directions.

Fig. 7 illustrates how they can be connected using two batteries *A* and *B* connected in series (i.e., the negative of one connected to the positive of the other). If the moving arm of the switch is moved to position *A* the motor will be energised by battery *A* and terminal *X* will become positive, while terminal *Y* is negative. If the moving arm is positioned at *B*, however, battery *B* is used and terminal *X* then becomes negative and *Y* positive. Depending upon which side the switch arm rests, therefore, the motor runs clockwise or anti-clockwise. This is, of course, conditional upon a permanent-magnet type of motor being used, as motors with energised field coils require special treatment and are generally unsuitable for this type of work.

It will be seen that the circuit consists of two halves, so the limit switches can be wired one in each half as shown in Fig. 8. The mechanism should be arranged so that the

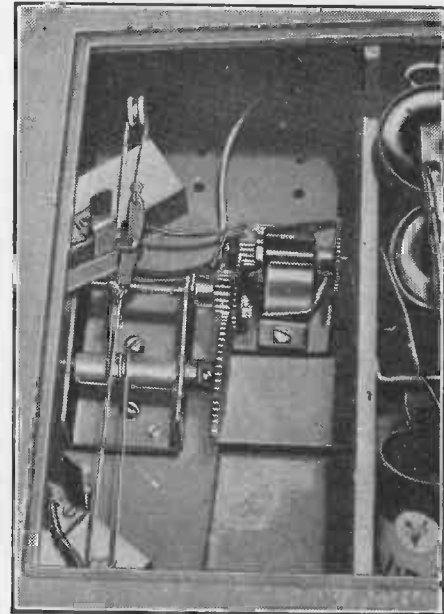

FIG. 5.—An alternative type of steering mechanism—winch-type control.

nut travels towards the limit switch which is in the half of the circuit in operation at the time. When the limit switch is opened it therefore cuts off current and stops the motor. As soon as the control switch is moved to the other side the current then flows in the opposite direction through the motor and it commences to run back again, therefore resetting the opened limit switch.

This simple circuit is the basis of a lot of radio-control circuits. A variation which simply juggles with the position

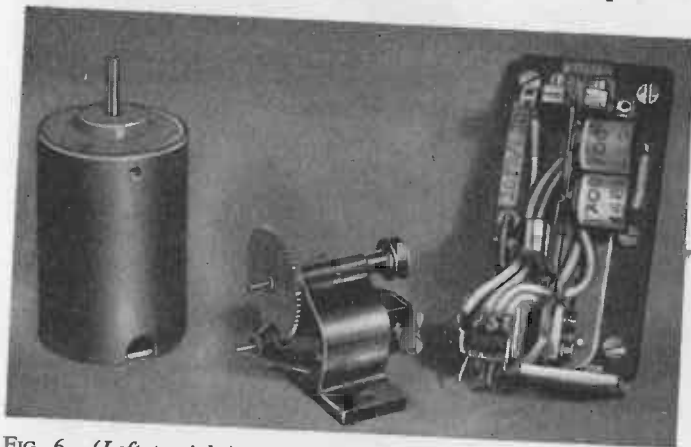

FIG. 6.—(Left to right.)—Government surplus P.M. type of motor; "Mighty Midget" and Siemens high-speed relay.

of the components in the circuit but simplifies the wiring in the model is shown in Fig. 9. This operates in exactly the same manner as before, but it will be seen that only three wires now feed to the motor and limit switches, which are grouped at the stern of the model, whereas using the original circuit, six wires are needed.

**Batteries.**—When using "Mighty Midget" motors we would recommend that only 3 volts are applied from each battery in the pair. This gives a much longer life to the small commutator and the leaf brushes. A pair of twin-cell cycle-lamp batteries will give reasonably good service,

but when they can be obtained, the use of a pair of Nife type of alkaline accumulators is recommended, type No. 5J1961, which give a terminal voltage of 2.5 each (rising to 3 volts when freshly charged). Four to six of these batteries give excellent results when used for powering the main driving motor of the boat; they can be obtained from suppliers of model accessories. It is most desirable that batteries for controlling rudder and

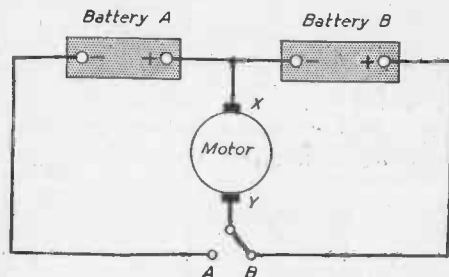

FIG. 7.—Circuit for reversing motor, using two batteries.

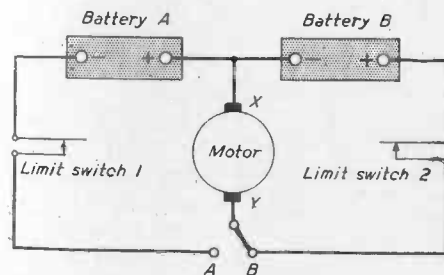

FIG. 8.—Reversing circuit with limit switches incorporated.

other mechanisms should be kept separate from the main driving batteries when using electric propulsion, as, due to the heavy current demands made by the driving motor, the battery voltage falls steadily. This

would affect the steering after a short time, causing a slower response to the control.

It would appear that according to the position of the switch in Fig. 8 the model would either circle to port or starboard (the switch must be either to one side or the other, and cannot stop in the middle). What is required is a neutral control which holds the rudder stationary. This is actually achieved by a very simple expedient. The switch is made to move from side to side at a regular steady rate of about four or five times per second with the result

that the steering motor rotates no more than a few turns before it is reversed and rotates the same number back again. In practice it is found that, due to inevitable backlash in the gearing, the rudder does not follow this movement, and it is held still at any intermediate position between its extremes of travel. Thus we are able to steer to port by holding the switch to one side, to starboard by holding it to the other, and to maintain any intermediate position, by switching steadily between the two.

**Using a Relay.**—When the apparatus is transferred to

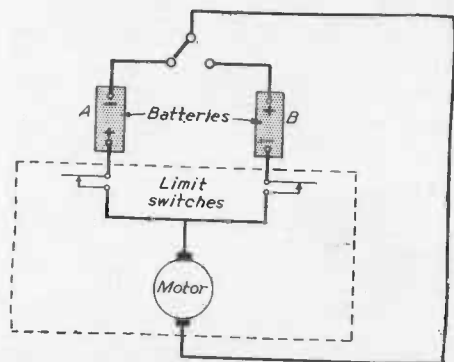

FIG. 9.—Alternative method of wiring (only three wires connect to steering gear).

the model it is, of course, no longer possible to use a switch as such to effect the control, and this is where it is changed for a magnetically operated switch—a relay.

Relays are made in many varied forms, but for this particular application a sensitive high-resistance type (about 3000 to 5000 ohms) should be chosen. The radio-controlled model trade make special relays, but very good results are obtainable from Siemens high-speed types (3400 ohms), which can be obtained on the surplus market. One of these is shown in Fig. 6.

As will be seen from Fig. 10, the relay is simply a switch having the moving arm fitted with a soft iron polepiece. This is attracted to the magnet assembly when current is passed through the coils and connection is then made between contact A and the moving arm. When the current through the coils is removed or reduced below a critical value spring pressure, which can be varied in a Siemens relay, causes the arm to fall back and rest on contact B.

It is the job of the receiver in the model to cause the current in the coil of the relay to change and therefore operate the steering gear. In simple receivers the relay energising coil is connected in the output circuit. When no signal is

being received the current in this coil may be 3 or 4 mA, and this will drop to about 1 mA on receipt of a signal from the transmitter. Therefore, when the relay shown in Fig. 10

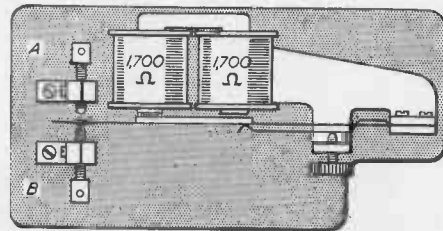

FIG. 10.—The Siemens high-speed relay.

is substituted for the switch in Fig. 8 it will be seen that, if the transmitter is radiating, the moving arm will contact B and battery B will drive the rudder motor in one direction. When the transmitter is cut off the moving arm will pull in and contact A, when battery A will reverse the direction of the rudder motor.

To hold the rudder stationary marks and spaces of equal length are required so that the rudder motor will oscillate an equal amount in each direction; in other words, 50 per cent. of the time will be on mark and 50 per cent. on space. This type of signal is known as a 50/50 Mark/Space transmission.

## 2

### A SINGLE-VALVE SUPER-REGENERATIVE RECEIVER

FOR reliable operation the receiver should be designed to give the biggest current change possible within the limits of the batteries carried. A drop from 3 mA down to, say, 1 mA is sufficient to ensure good clean operation of the contacts of most sensitive relays, and, of course, some of the special polarised versions which can be bought will work on much less.

A receiver for model control must be light in weight yet robust and capable of giving the required current change on receipt of a signal. A very popular receiver for some time was the soft-valve type making use of a gas-filled miniature thyratron. For aircraft use this type is still popular, mainly because of its lightness, but for model boat work the hard-valve receiver is to be preferred, as it gives a much longer valve life and is more stable in operation.

The receiver is of the super-regenerative type characterised by a high frequency oscillator, tuned to the transmitter, which is thrown in and out of operation at a much lower frequency called the quench frequency. When the transmitter is switched on the operation of the receiver is modified and the anode current falls from a standing value of 3 or 4 mA (according to H.T. voltage) down to approximately 1 mA or slightly less. For reasons already explained the bigger the drop the better. In fact, the super-regenerative receiver is a truly remarkable device, as with only one valve it can equal the signal amplification of a multi-valve superhet and at the same time produce the necessary current to work the relay. It is, however, notoriously unselective and it will pick up a transmitter tuned to any frequency

in the 27 Mc/s model-control band. For our purpose at present, however, this is a good point as it simplifies the transmitter design and eases the always present problem of going out of control. Figs. 11 and 12 show the completed one-valve receiver.

**Construction.**—The prototype of the receiver was built on a paxolin base  $3\frac{1}{2}$  in.  $\times$   $2\frac{1}{2}$  in.  $\times$   $\frac{1}{16}$  in. thick, but this can

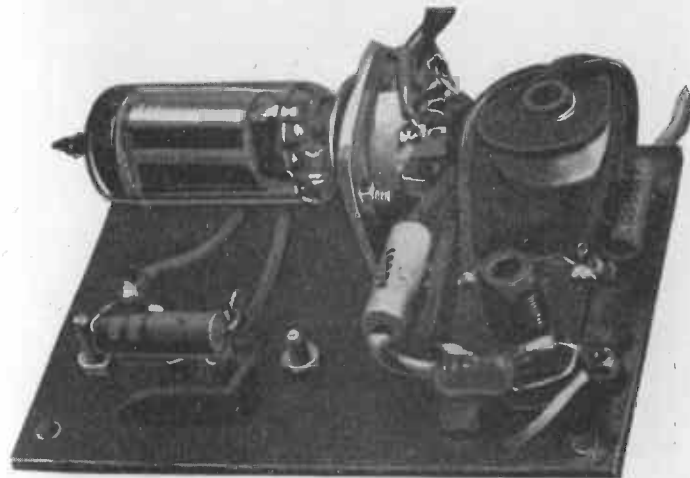

FIG. 11.—A view of the completed one-valve receiver.

be reduced if space is very restricted. However, it is not recommended that the design be altered if this is the reader's first attempt. Commence by drilling the base in accordance with the plan given in Fig. 13. The two  $\frac{3}{8}$ -in. diameter holes, at the bottom are to take the two  $\frac{1}{4}$ -in. diameter Aladdin formers and the rectangular hole above is for the tuning meter socket, which should be of the two-pin polarised type (i.e., one thick and one thin pin). The valveholder, which is of the B7G type, should be mounted on a small aluminium angle bracket so designed that the valve (1S4) will lie flat, spaced about  $\frac{1}{4}$  in. above the paxolin. The valveholder should be fastened to the bracket, but



not mounted on the paxolin until the wires have been attached. The next stage is to make the coils, of which there are three—the tuning coil, the quench coil and the sensitivity coil (see Figs. 14 and 15).

**The Tuning Coil.**—This consists of two 10-turn windings of 24 s.w.g. enamelled copper wire placed one above and

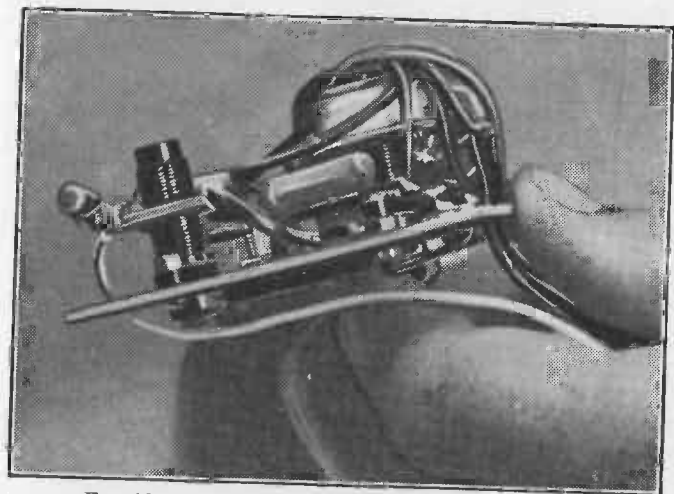

FIG. 12.—A further view of the completed receiver.

one below a paxolin terminal board. The board, which is  $\frac{3}{4}$ -in. square, should be cut first from  $\frac{1}{16}$ -in. paxolin. The centre hole should be drilled out to about  $\frac{3}{16}$ -in. diameter and then carefully filed so as to be a tight fit on the  $\frac{1}{4}$ -in. diameter Aladdin former on which the coils are to be wound. Four  $\frac{1}{16}$ -in. diameter corner holes should then be drilled to anchor the ends of the coil windings. Position the paxolin approximately half-way down the former with the sides of the square parallel to the base of the former. Now with the former base in 12 o'clock/6 o'clock position mark the bottom right-hand hole in the paxolin "2" and insert the end of a length of 24 s.w.g. enamelled copper wire previously stripped for about  $\frac{1}{2}$  in. of its insulation.

The end should be brought round and pushed through the hole again, then pulled tight, so as to make a firm anchorage and soldering point. Now wind on ten turns in a clockwise direction up the top half of the former (looking down on the coil) and cut off the wire, leaving about  $1\frac{1}{2}$  in. to spare.

This should be stripped, then pushed into the bottom

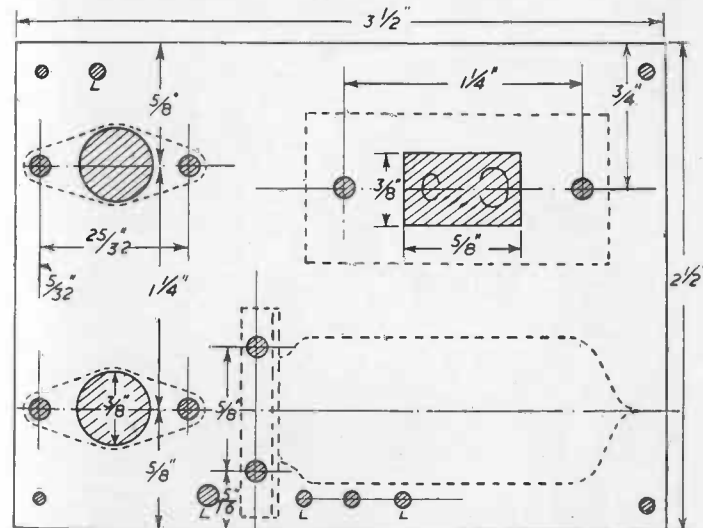

FIG. 13.—Drilling plan for single-valve model-control receiver. The drawing is full size. Holes marked "L" are for leads.

left-hand hole in the paxolin and a firm anchorage made as before. Mark this point "1". The process should be repeated for the second coil wound on below the paxolin starting at the top right-hand hole (mark "3") and terminating at the top left-hand hole (mark "4"). Note that the coil wound below the paxolin board should be wound on in the anti-clockwise direction (looking from the top of the former). The effect of this is that if Nos. 2 and 3 are joined together we should have one continuous coil from top to bottom (i.e., it would not change direction in the middle).

**Sensitivity Coil.**—This is also wound on a  $\frac{1}{4}$ -in. diameter Aladdin former. Commence by bolting two small solder tags to the base of the former through the two mounting holes. If the bolt shanks point downwards it will be possible to mount the coil later by using two more nuts.

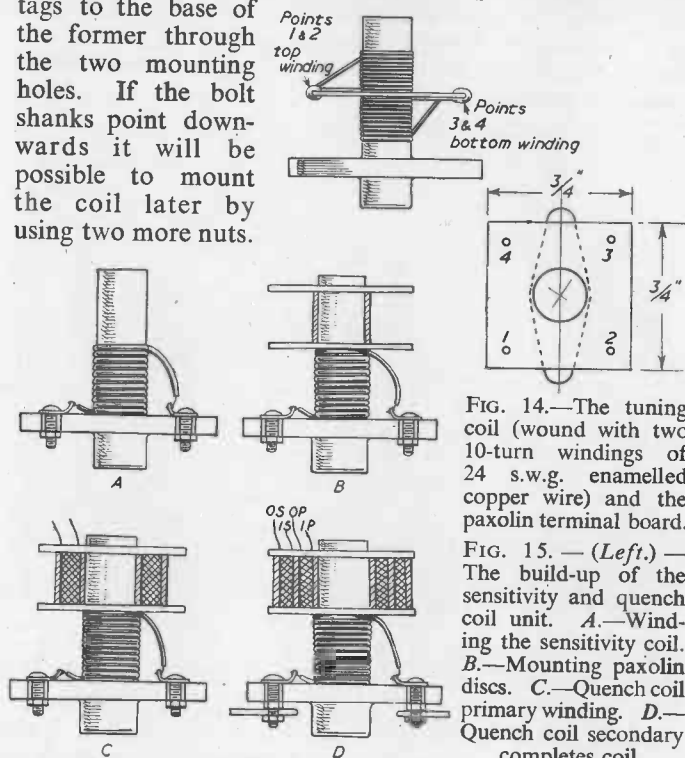

FIG. 14.—The tuning coil (wound with two 10-turn windings of 24 s.w.g. enamelled copper wire) and the paxolin terminal board.

FIG. 15.—(Left.)—The build-up of the sensitivity and quench coil unit. A.—Winding the sensitivity coil. B.—Mounting paxolin discs. C.—Quench coil primary winding. D.—Quench coil secondary completes coil.

Solder a length of 24 s.w.g. enamelled wire to one tag and commence winding a 12-turn coil up the former in a clockwise direction, keeping the turns together and as close to the bottom of the former as possible. Terminate by soldering to the other tag. It is important that this winding is kept down the former as the quench coils are to be wound on the top half (see A in Fig. 15).

**Quench Coils.**—Make two  $\frac{1}{16}$ -in. paxolin discs about  $\frac{3}{4}$ -in. diameter and carefully make a hole in the centres so

as to be a tight fit on the top of the sensitivity coil just wound. One disc should be sawn through from perimeter to centre at one point only, later to take coil leads. It will be found that this procedure also makes the disc easier to fit to the former as it permits a little flexibility. Push the uncut

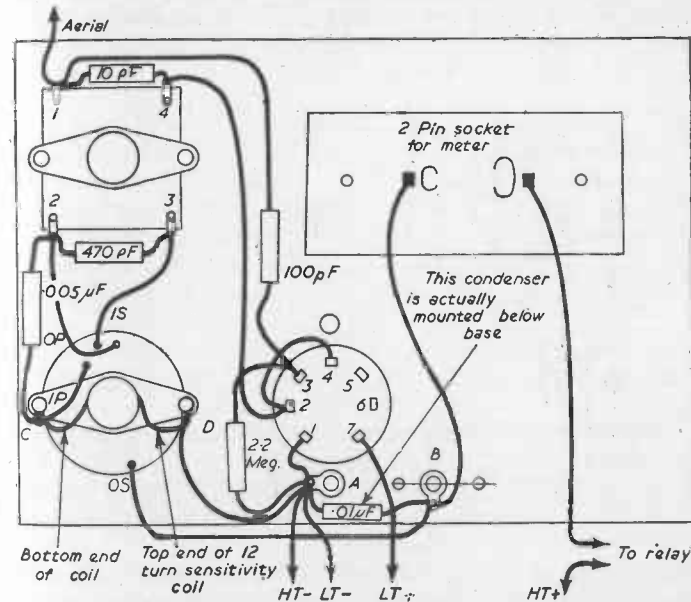

FIG. 16.—Wiring diagram of single-valve model-control receiver. For clarity, the valveholder is shown mounted flat. Note that this drawing shows the quench coil leads as being brought out through holes. The text describes an alternative, simple method using a radial slot.

disc down on top of the sensitivity coil, then wind on about 3 turns of paper strip  $\frac{1}{4}$  in. wide so as to make a spacing washer to separate the other disc, which should then be mounted and glued in place (B). Now remove the tuning slug and push a large bolt through the former. Fasten with a nut and hold the end of the bolt in the chuck of a drill. This arrangement permits the quench coils to be wound in a matter of a few minutes.



The primary should now be wound on and it consists of 350 turns of 36 s.w.g. wire. Leave about 3 in. of wire for connecting up later and label the start "IP" (Inside Primary). Depending upon the gear ratio of the drill for the number of revolutions required, then wind on the coil and label the end of the winding "OP" (Outside Primary).

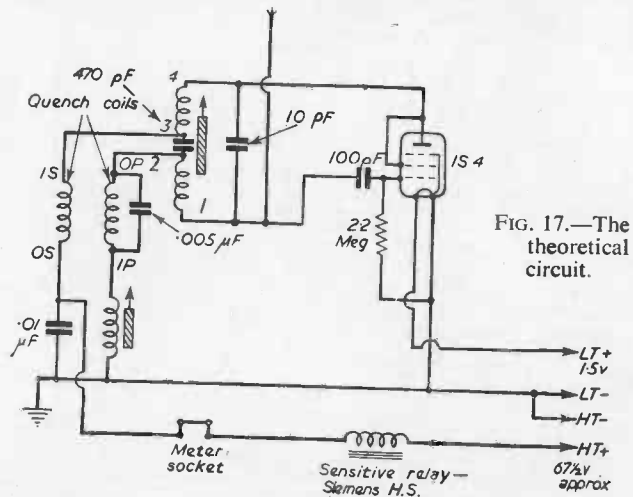

FIG. 17.—The theoretical circuit.

The wire ends should pass through the sawcut on the top disc (C). Insulate the winding with Sellotape or paper (about 3 layers) and wind on 150 turns of 36 s.w.g., in the same direction, to form the secondary. Label the start "IS" (Inside Secondary) and the finish "OS" (Outside Secondary). A layer of paper completes the coil, as shown in Fig. 15 (D).

The components should now be mounted on the base as shown in Fig. 16, with the exception of the valveholder on its bracket which should be wired up first, when the tags are more accessible. The wiring is shown theoretically in Fig. 17.

Using 22 s.w.g. tinned copper wire and pieces of 1 mm. Systoflex insulated sleeving, commence wiring the valveholder. Numbering the valve pins 1 to 7 counting from the

gap clockwise round the circle and looking at the connecting side.

1. Join pin 1 to a solder tag fixed under the bolt holding the valveholder to the bracket (A in Fig. 16).

2. Join pin 2 to pin 4 and join a 3-in. length of wire to pin 2 for later connection.

3. To pin 3 join one end of a 100 pF grid condenser and one end of the 2.2 MΩ  $\frac{1}{4}$ -watt grid leak.

4. The other end of the grid leak should be soldered to solder tag A.

5. To pin 7 solder a 12-in. length of flexible wire for the L.T. positive connection.

The valveholder and bracket can now be mounted on the base with 6-B.A. nuts and bolts and the remainder of the wiring carried out as follows:

6. From pin 2 of the valveholder, connect the wire mentioned in "2" to point No. 4 on the tuning coil.

7. To point No. 1 solder a short length of flexible wire to which the aerial is to be attached later and connect the other end of the 100 pF condenser.

8. Between points 1 and 4 connect a 10 pF ceramic condenser.

9. Between points 2 and 3 connect a 470 pF ceramic condenser.

10. To point 2 solder one end of a 0.005 μF condenser and join the other end of it to the solder tag fastened under the mounting bolt of the sensitivity coil (C in Fig. 16).

11. To the other tag of the sensitivity coil (D in Fig. 16) join a short piece of wire and connect to tag A.

12. Now wire the quench coils as follows: OS—to a solder tag bolted to the paxolin base (B in Fig. 16).

IS—to 3 on the coil. OP—to 2 on the coil.

IP—to tag C in Fig. 16.

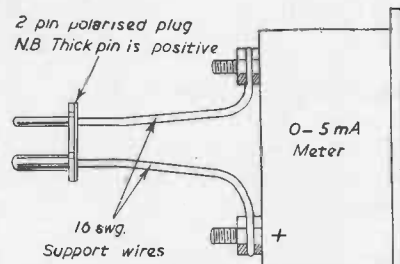

FIG. 18.—The two-pin polarised plug.

13. Between tags *A* and *B* solder a 0.01  $\mu$ F condenser. In the original this was mounted below the base for convenience.

14. Join *B* to the small pin of the meter socket.

15. To the large pin of the socket attach a flexible lead to be connected to the H.T. battery via the relay connection.

16. To tag *A* join two flexible leads for H.T. and L.T. negative.

The wiring is now complete. A 0-5 mA meter is essential for testing and it should be attached to a 2-pin polarised plug as shown in Fig. 18 for easy insertion in the meter socket. Note that when the meter is withdrawn the circuit is broken and it is therefore necessary to replace it with a similar 2-pin plug which has been shorted out by a loop of wire. Alternatively the socket can be bridged by a  $220\Omega$   $\frac{1}{2}$ -watt resistor, which obviates the need to use a shorting plug but which slightly reduces the meter readings. The latter course is the better.

To test the unit it is obviously necessary to have a transmitter such as is described in the next chapter, but if one can be borrowed in the meantime the receiver can be tested.

Attach approximately 30 in. of wire to the short aerial lead and connect up to the battery supplies. A single type D18 cell with a plug top connection makes a good L.T. source (1.5 volts) and two B105 30-volt deaf aid batteries connected in series to give 60 volts are suitable for H.T. Alternatively a combined H.T./L.T. type battery can be used. A selection of batteries is shown in Fig. 19.

The relay (Siemens 3400  $\Omega$ ) is placed in series with the H.T. positive connection and the receiver. Plug in the meter and the 1S4 valve, when a reading of approximately  $3\frac{1}{2}$  mA will be obtained. If it is lower screw out the slug of the sensitivity coil until this reading is obtained.

The transmitter (which should be accompanied by the licence holder) should then be switched on and the tuning coil slug adjusted until a drop is obtained on the meter. The sensitivity coil slug should then be screwed in until maximum drop is obtained, but this should not be overdone

as it will be found that the current will not then rise when the transmitter is switched off.

All receivers of this type are sensitive to aerial length adjustments and experiments should be carried out by cutting down the length given, in stages of 3 in. at a time



FIG. 19.—A selection of batteries suitable for use in radio control. Top row left to right.—(a) Cycle lamp battery—suitable for steering motor and general intergear work. Can also be used for driving small boats. (b)—Type D18 1.5 volt cell—an excellent L.T. source for single-valve receivers. (c)—U.2 unit cell—can be connected in parallel to provide L.T. for multi-valve receivers or transmitters.

Bottom row left to right.—(a)—Small type Nife battery (2.5 volts) makes a good small current battery for intergear work. It is rechargeable. (b) (c) (d) (e)—Deaf-aid type H.T. batteries suitable for receivers, 30 volts (with plug), 30 volts,  $22\frac{1}{2}$  volts and 15 volts respectively. (f)—Larger type of Nife battery (Type 5J1961). This is a first-class battery for all intergear and drive motor work (2.5v.).

until the best results are obtained. It may even be found that a longer length than 30 in. is necessary. The aim should be for a drop from about  $3\frac{1}{2}$  mA down to below 1 mA. Using 90 volts H.T. an even greater change can be obtained, but is not really necessary.

Range tests should be carried out at the full normal operating distance, which in the case of boats can be taken

to be about 100 yards maximum due to the difficulty in seeing the model's movements satisfactorily at much greater ranges.

**Increasing the Tuning Range.**—Many receivers of this type have been built and operated and the design has always proved very successful. However, if it is found that the receiver will not quite tune into the model-control band replace the 10 pF condenser with a Philips "Bee-hive" 3-30 pF trimmer and work this in conjunction with the tuning slug. The two variables will now enable a greater tuning range to be covered and the receiver should operate satisfactorily. Readers will quickly learn how to handle the tuning adjustments of the receiver, but a little patience may be necessary before the correct combination of control positions and aerial length is achieved.

For tuning up, use the end of a plastic knitting needle or crochet hook which has been filed to a screwdriver shape as these receivers are very sensitive to hand capacity effects.

#### PARTS LIST

- 1 small sheet of  $\frac{1}{16}$ -in. thick paxolin.
  - 1 type 1S4 valve.
  - 1 B7G valveholder.
  - 2  $\frac{1}{4}$ -in. Aladdin coil formers with tuning slugs.
  - 1 quench coil unit—see text.
  - 1 2·2 M $\Omega$   $\frac{1}{4}$ -watt grid leak resistor.
  - 1 100 pF ceramic condenser.
  - 1 10 pF ceramic condenser.
  - 1 470 pF ceramic condenser.
  - 1 0·005  $\mu$ F midget paper condenser (or ceramic).
  - 1 0·01  $\mu$ F midget paper condenser (or ceramic).
  - 1 2-pin polarised meter socket.
  - 2 plugs for the above (or else 1 plug and a shorting resistor of 220 ohms—see text).
  - 22 s.w.g. tinned copper wire for connecting up.
  - 1 mm. insulated sleeving.
  - 24 and 36 s.w.g. enamelled copper wire for coils.
  - Nuts, bolts, tags, solder, etc.
- Approximate cost of the above parts: not more than £1, plus cost of valve 7s. 6d. to 8s. 6d., if bought through advertisement columns of *Practical Wireless* and *Practical Television*. (The £1 stated is for all new parts.)

## 3

### A TWO-VALVE TRANSMITTER FOR RADIO CONTROL

**B**EFORE making a transmitter, the G.P.O. licence, which has been necessary since June 1st, 1954, must be obtained from the following address:

Radio & Accommodation Department,  
Headquarters Building,  
G.P.O., St. Martins-le-Grand,  
London, E.C.1.

The cost is £1 for a period of five years, and there are no tests to be passed or other complications. The licensee is permitted to work in the bands of 26·96-27·28 Mc/s and 464-465 Mc/s with powers of 1·5 and 0·5 watts (effective radiated power) respectively. It is the former band which interests most modellers, as it is usually considered easier to handle equipment working on the lower frequency.

**Transmitter Details.**—The design is an "Old Faithful" to radio-control fans—a push-pull Hartley circuit familiarly called a "cross coupled". It is, if correctly wired, almost impossible for it not to work satisfactorily. There is in addition only one tuning control, which can be easily adjusted to set the transmitter in the model-control waveband, and it is therefore ideal for the beginner and regular user alike.

Readers familiar with theoretical diagrams will see from Fig. 20 that the circuit is very simple and consists of a pair of battery pentode valves (connected up as triodes), anodes (cross connected) to grids with a centre-tapped anode coil which, along with its associated trimming condenser, determines the frequency. The valves used in the original circuit were 1C5's, but a pair of any similar type of battery

pentodes can be used providing that any necessary changes are made in wiring the valve base connection. Suitable alternatives are 3Q5, 3D6, DL33, etc., and Fig. 23 shows a transmitter employing 3D6's. A more compact arrangement could be made by using B7G-based valves or else a single type 3A5 miniature double triode, but the beginner is advised to use the 1C5's and wire up exactly as described.

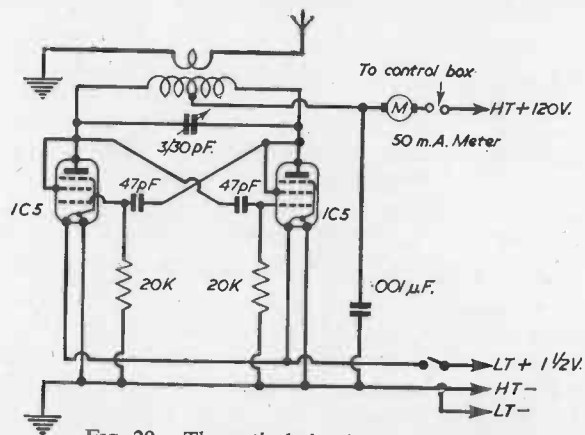

FIG. 20.—Theoretical circuit of transmitter.

**Construction.**—The transmitter is built on a piece of paxolin sheeting 5 in.  $\times$  4 in.  $\times$   $\frac{1}{16}$  in. thick, and this should be drilled as shown in Fig. 21. Using 6-B.A. nuts and bolts, two International Octal valveholders (Amphenol type) should then be mounted in the two large holes, with the keyways for the valve spigots in the position shown in Fig. 22. Three Eddystone midget stand-off insulators are then mounted as shown and a solder tag fastened under the centre nut of each. Four solder tags are then bolted to the paxolin in the holes marked X, Y1, Y2 and Y3 in Fig. 21. X should have its tongue upwards and those in Y downwards.

**Wiring.**—This should be carried out with 20 or 22 s.w.g. tinned copper wire and pieces of 1 mm. Systoflex

tubing slipped over the bare wire for insulation. Remember that for electrical work it is important to use a hot, well-tinned soldering iron and that corrosive fluxes like spirits of salt must be avoided. Use either stick solder or Fluxite or else a cored solder like Ersin Multicore. Now proceed as follows, referring to Fig. 22:

1. Join pin 3 to pin 4 on V1 valveholder and then connect pin 4 to the solder tag on the top of the left-hand insulator.

2. Repeat for V2 valveholder, but join pin 4 this time to the right-hand insulator.

3. Join pin 2 on V1 holder to pin 2 on V2 holder.

4. Join pin 7 on V1 holder to pin 7 on V2 holder.

5. Join pin 2 on V1 holder to the solder tag Y2.

6. Join pin 7 on V2 holder to the solder tag Y3.

7. Connect pin 5 to pin 7 on V1 holder with a 20,000  $\Omega$   $\frac{1}{2}$ -watt resistor.

8. Repeat on V2 holder.

9. Solder to pin 5 on V1 holder one end of a 47 pF ceramic condenser.

10. Solder the other end of condenser to R.-H. insulator.

11. Repeat 9 and 10, but this time join the 47 pF condenser from pin 5 on V2 holder to the L.-H. insulator.

12. Now solder a piece of 22 s.w.g. tinned copper wire to the solder tag at X (Fig. 21) and connect to pin 7 on V1 holder.

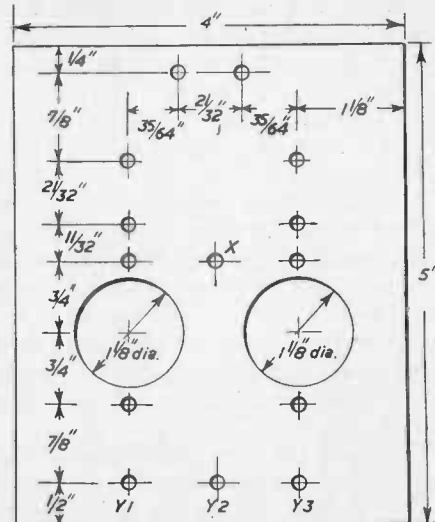

FIG. 21.—Drilling template for transmitter. All holes  $\frac{1}{8}$  in. diameter except valve holes.



surplus market has for some time now yielded several useful telescopic masts which can be used for this purpose and the very cheap 12-in. long copper-plated steel aerial sections which can be plugged together also make a good aerial. It will be found now that the radiation is much stronger and will increase as the aerial coupling coil is pushed into the turns of the transmitter coil. At the same time the H.T. current shown on the meter will rise and this should not be permitted to exceed the 30 mA mark, otherwise damage may occur to the valves.

Now move the wavemeter away from the transmitter until only a very weak reading is obtained and retune the transmitter into the centre of the model-control waveband.

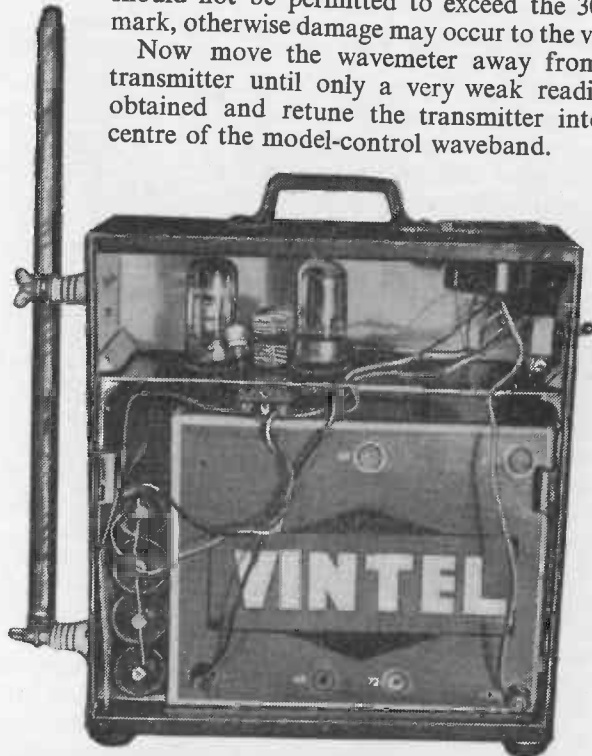

FIG. 23.—A two-valve transmitter similar to the one described in this chapter, but this version makes use of 3D6 type valves. The position of the meter and on/off switch is easily seen. Readers will also note the method of mounting the aerial on two large stand-off insulators.

**The Case.**—If all tests are carried out successfully the transmitter is ready to be boxed and the design of this is obviously a matter of personal taste. The photograph, Fig. 25, shows a typical method of installing a transmitter based on this circuit, the main considerations being those of removing valves and batteries and of positioning the trimming condenser so that it can be adjusted later. The question of transportation should be considered, however, and experience has dictated a small attaché case shape rather than a cubic design. It is very useful to have the H.T. current milliammeter permanently connected in the circuit and the meter mounted in the case where it can be watched while operating. Any strange readings will immediately indicate trouble. Provision should be made, by means of a simple plug and socket or preferably a closed circuit jack, for the transmitter to be keyed (i.e., switched off and on) by the control box. This entails a further series connection in the H.T. positive lead. The lead from Y1 will now go to the negative of the meter, the

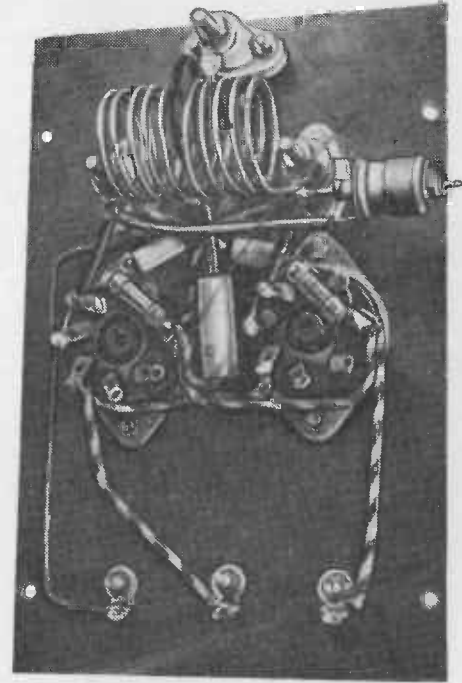

FIG. 24.—The two-valve transmitter described in this chapter. Note the position of the aerial coupling loop which is not shown on the general layout drawing, Fig. 22.



positive of the meter will go to one side of the control-box socket or jack and the other side of the socket will go to the H.T. battery.

It is often recommended that H.F. chokes are connected one in each lead to the control-box socket to reduce radiation from the leads to the control box, and if this trouble is experienced later they can easily be inserted. Chokes should be of 35 turns of 32 s.w.g. enamelled copper wire wound on pieces of  $\frac{1}{4}$ -in. diameter polystyrene rod. A switch should be inserted in the L.T. positive lead for switching off the unit. The aerial can be mounted on the side of the case by means of metal clips attached to a pair of the larger type of stand-off insulators. A connection should be made from the coupling loop (middle stand-off insulator) to the bottom clip holding the aerial by the shortest length of wire possible.

A connection should also be made from L.T. negative to a flat metal plate screwed to the base of the transmitter, which acts as an earth.

This unit should be retested in its case and the complete tuning up sequence gone through again to ensure that everything is in order and that the transmitter is still on frequency. Note that until the control box has been made it will be necessary to short a piece of wire across the control-box socket (unless a closed circuit jack is used) before the unit will work.

Now that the transmitter is working correctly, it can be tried on the receiver, and the full drop in anode current should easily be obtained at all ranges likely to be of use for controlling a model boat. As explained earlier, the range is actually limited to about 100 yards, due to the fact that the operator simply cannot see which way a model is going much farther away than this. Much greater range than this can be obtained when using the transmitter to control aircraft.

If there is any doubt about exceeding the licensed transmitter power the following test can be applied. As the licence now stipulates the maximum effective radiated power and not the input of the final valve as before it is not possible

to compute output from the current meter already installed. It is actually necessary to measure the aerial current flowing and this can be accomplished only with a thermocouple high-frequency type of meter. Fortunately these are available very cheaply on the surplus market and a 0-0.5 amp meter usually costs about 5s. A better meter would be rated at 0-0.35 (350 mA), but these are more difficult to find. The lead from the aerial coupling loop should be detached at the point where it connects to the base of the aerial and the H.F. ammeter connected. The other side of the ammeter then goes to the aerial using the shortest possible length of wire. (N.B.—There is no polarity to a meter of this kind.) With the aerial fully extended and the



FIG. 25.—A transmitter in its case together with its associated control box. Note the plug and jack connection on the transmitter.

transmitter case standing flat on damp concrete or soil (to ensure good earthing) a reading should be obtained of between 0.12 and 0.15 amp with this transmitter. For a quarter-wave vertical aerial the maximum aerial current permitted at 27 Mc/s is 0.2 amps (200 mA) and it will be seen that power is quite adequate yet comfortably within the limit.

## LIST OF PARTS

- 2 1C5 type valves (or alternatives—see text).
  - International Octal Amphenol type valve sockets.
  - 3 small type stand-off insulators ( $\frac{3}{8}$  in. high).
  - 2 large type stand-off insulators (approx.  $1\frac{1}{4}$  in. to  $1\frac{1}{2}$  in. high).
  - 2 20 k.  $\frac{1}{2}$ -watt resistors (or alternatively 22 k.).
  - 2 47 pF ceramic condensers.
  - 1 0.001  $\mu$ F ceramic or mica condenser.
  - 1 Philips "Beehive" type trimmer 3–30 pF.
  - 1 50-mA meter.
  - 1 on/off switch S.P.S.T.
  - 1 plug and socket (2 pin) for control box or preferably a closed circuit jack and plug.
  - 1 telescopic aerial or aerial sections.
  - Nuts, bolts, solder, Systoflex, 22 and 16 s.w.g. copper wire, flex, etc.
- Total cost should not exceed 45s. (allowing 12s. 6d. for meter ex advert. columns of *Practical Wireless* and *Practical Television*), but not including valves which should not cost more than about 8s. 6d. each.

## 4

CONTROL BOX: WAVEMETER:  
INTERFERENCE: LAYOUT

IN the Mark/Space system the rudder is arranged to move to, say, starboard when the transmitter is sending a continuous signal or "Mark", to move to port when the transmitter is switched off, or "Space", and to remain stationary when the transmitter is switched on and off rapidly (say, three to eight times per second). For 50 per cent. of the cycle the transmitter is on and for the remaining 50 per cent. it is off, and this is known as sending "50/50".

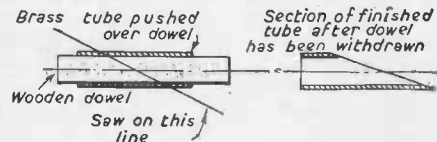

FIG. 26.— Three stages in making the contact drum. The completed drum is shown on the left.

**The Control Box.**— The transmitter has already been described and now a convenient way of switching it on and off must be found.



A well-tryed control box which can be easily built is one using a small motor-driven switch to give the 50/50 switching of the transmitter. However, if the control box switches the transmitter in such a way that instead of sending 50/50 the transmitter is on for 60 per cent. of the cycle and off for 40 per cent. (known as sending 60/40) the relay operated by the receiver will be on one contact for a greater percentage of the cycle than the other. Thus the rudder motor instead of oscillating an equal amount in each direction (and keeping the rudder substantially stationary) will tend to turn, say, two turns clockwise and one-and-a-half turns anti-clockwise each cycle. This will cause the



rudder to "creep" slowly to one side when it should be still, and could be very troublesome. Some scheme is therefore necessary to enable the 50/50 setting to be adjustable so

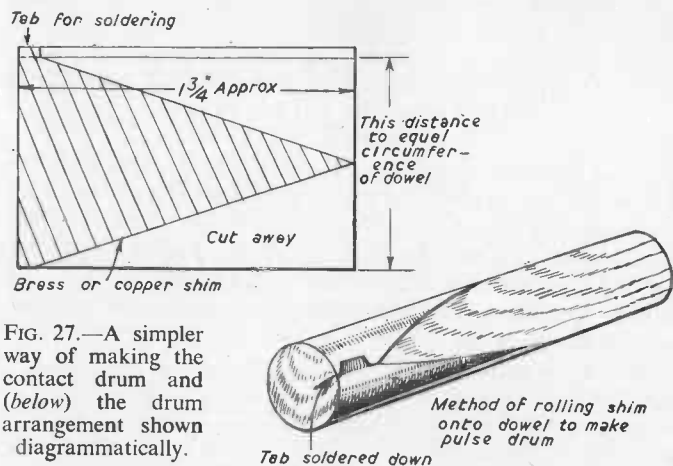
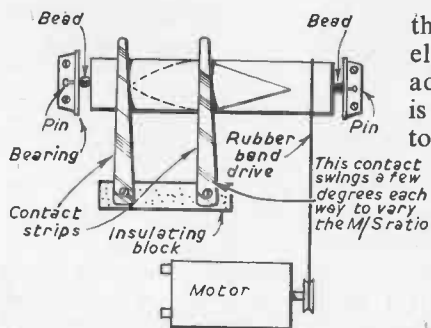

FIG. 27.—A simpler way of making the contact drum and (below) the drum arrangement shown diagrammatically.



**The Contact Drum.**—Obtain a piece of thin-walled brass tubing at out  $\frac{1}{2}$  in. outside diameter by 2 in. long and turn a piece of dowel so as to be a tight fit in the bore. The tube should be cut as shown in Fig. 26 and the edges filed smooth. The dowel should then be removed and replaced by a further length which has previously been drilled to take a

that this creep can be eliminated. Once the adjustment is made it is not usually necessary to touch it again and therefore the adjustment is usually catered for inside the control box and is set up before the lid of the box is screwed on.

length of  $\frac{1}{8}$ -in. diameter rod. A tight fit is required. When finished the drum should appear as in Fig. 26. A simpler job can be made by cutting a wedge-shaped piece of brass or copper shim and rolling this round the dowel. The joint should be overlapped slightly and soldered, but care should be taken to make the bump at the joint as small as possible (see Fig. 27).

Next, take a piece of 18 s.w.g. aluminium, measuring  $6\frac{3}{4}$  in. by  $4\frac{1}{2}$  in., and make a flanged lid as shown in Fig. 28. All the components will be mounted upside down on this lid. Other components needed are a single-pole three-way "Yaxley" type switch, a "Mighty Midget" motor, an on/off switch and a knob approximately  $2\frac{1}{2}$  in. diameter for the switch. Mount these components as shown in Fig. 29. Also shown is how the contact drum is mounted in its bearings and how the two wiping contacts made of springy brass about 0.015 in. thick are fitted. The contacts are mounted on a block of insulating material (wood if you have nothing better) and the one at the end of the drum, which is always in contact with the brass part of the drum, is rigidly fixed. The other contact should wipe over the drum about half-way along its length so that during each revolution it is on the brass part for  $180^\circ$  out of the  $360^\circ$ . This contact is not fixed rigidly, however, and must be able to swing a few degrees from side to side. This is the way in which the 50/50 signal is adjusted to eliminate rudder drift.

The end of the contact drum shaft is fitted with a small pulley and coupled to the motor by an elastic band. Power for the motor is provided by a 3-volt battery and a twin-cell cycle-lamp battery will give ample life. With this battery supplying power the pulley should be  $\frac{1}{2}$  in. diameter. This will mean that the contact drum will run at about

200-300 r.p.m. If for any reason this speed is not produced the pulley size should be altered or a resistance put in the motor circuit to reduce its speed. Alternatively the simpler method shown in Fig. 27 can be used, where the elastic band drives directly on the pulse drum.

**Transmitter/Control Box Connection.**—Fig. 29 shows how the lead from the transmitter is brought to the control box. Make a really good job of anchoring this, which should be a twin-core, tough, rubber-covered flexible lead, so that if it is inadvertently pulled no damage will be

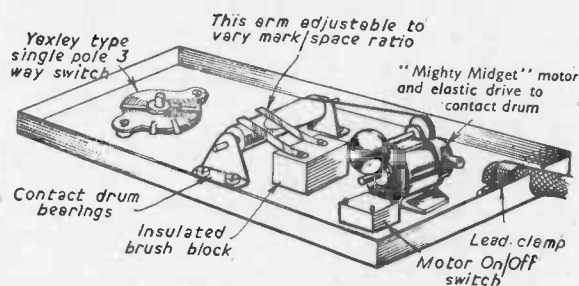

FIG. 29.—How the components are mounted.

caused. This lead forms part of the H.T. negative or positive supply to the transmitter (apparently it makes no difference which). The other end of this lead must be fitted with a suitable plug to fit into the transmitter so that the two units can be easily separated. A telephone type jack is quite useful for this, but if the H.T. positive is being switched be sure to obtain a jack on which both connections are insulated from earth, particularly if the transmitter is being fitted into a metal box.

Having mounted all the components, wire the base according to Fig. 30. It will be seen that the on/off switch controls the switching motor whilst the three-way Yaxley switch is arranged so that in position 1 the H.T. supply to the transmitter is broken, giving space or, say, "Port Rudder" position. Position 2 means that the contact drum switches the H.T. on and off, giving 50/50 or "Rudder

Stationary". Position 3 supplies continuous H.T. current and gives a mark or "Starboard Rudder".

Finally, make the bottom of the box deep enough to accommodate the cycle-lamp battery and fix the lid carrying all the parts to it with self-tapping screws going into the flanges. Fig. 31 shows the finished box.

Fit a large-size control knob. When sailing any boat, and particularly a fast one, steering may be easy when the craft is moving away from the operator. When approaching or moving at right angles the problem is much more difficult and it is easy to become confused with a small knob. With the box described the

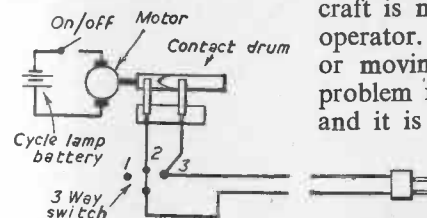

FIG. 30.—Wiring for control box.

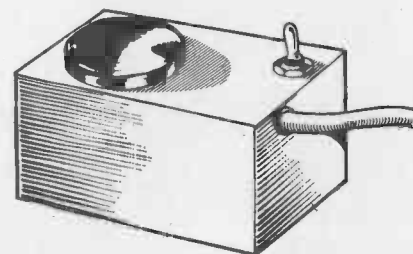

FIG. 31. (Right)—The completed control box.

operator should try to imagine that he is putting his hand down on to the top of the boat and by turning the knob twisting it in the direction in which he wants it to go. This works with the boat in most positions.

**Wavemeters.**—When the transmitter was described, it was pointed out that a wavemeter was necessary to enable the transmitter to be tuned so that it radiates at the correct frequency.

Due to the fact that some people seem to manage without a wavemeter, newcomers are tempted to think that it is superfluous. This is a mistake since the wavemeters used are very simple to make and provide a very convenient way of checking that the transmitter is working

correctly and that it is "in the band". A wavemeter can also be very useful for comparing the power output of transmitters.

**Winding the Coil.**—In addition a coil must be made up using a  $\frac{3}{4}$ -in. diameter former and 18 s.w.g. enamelled wire. The former can be a paper tube or wooden dowel, or anything of suitable diameter, since it is slipped out of the coil once this has been wound. Starting at one end of the former, leave about 2 in. of the 18 s.w.g. wire spare and then wind on 8 turns. Bare a small part of the wire here which will later be used for soldering a tapping, and then wind another 4 turns, forming a 12-turn coil tapped at 8 turns. The coil can now be slipped off the former and should be stretched out so that its overall length is approximately  $1\frac{1}{8}$  in.

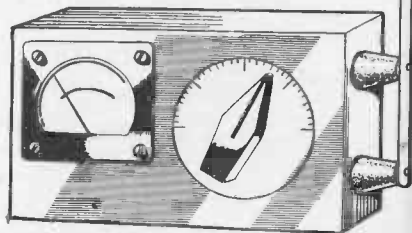

FIG. 32.—A view of the completed wavemeter.

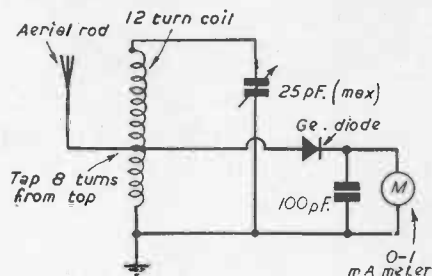

FIG. 33. (Left)—The wavemeter circuit.

#### COMPONENTS NEEDED FOR THE CONSTRUCTION OF A WAVEMETER

- 1 100 pF mica condenser.
- 1 25 pF (max.) variable condenser.
- 1 dial and pointer marked in suitable divisions with 180° movement.
- 1 germanium diode.
- 1 0-1 mA meter.
- 2 small stand-off insulators.

A metal box will be needed for the meter and some of the small boxes available on the surplus market can be employed here, otherwise any box approximately  $2\frac{1}{2}$  in.  $\times$  3 in.  $\times$  6 in. will do.

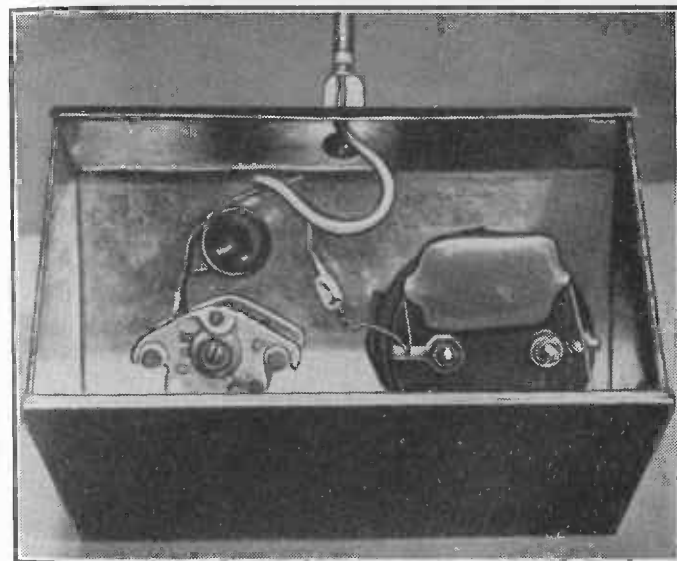

FIG. 34.—The interior of the wavemeter, showing simplicity of construction. In this version the aerial is attached to the top of the case.

The 25 pF condenser should be of the ceramic base type with silver-plated vanes and with a standard  $\frac{1}{4}$ -in. diameter spindle.

Mount the meter, variable condenser, dial and stand-off insulators as shown in Fig. 32. Now take the previously prepared coil and solder the end nearest to the tapping to the variable condenser tag connected to the moving vanes. These vanes are earthed to the box via the spindle. Connect the other end of the coil to the fixed vanes. From the tapping point two leads must be taken. The first goes to the bottom stand-off insulator and should be led through

a hole in the box to the terminal on this insulator. The top insulator is simply used as a support for the aerial, which is made from a piece of  $\frac{1}{4}$ -in. diameter brass tubing. The aerial should be about 12 in. long. The other lead from the coil tapping goes to one side of the germanium diode (it does not matter which). The other side of the diode is connected directly to the meter and the other meter terminal is earthed to the box. Finally, the 100 pF mica condenser is connected across the meter terminals. The circuit is given in Fig. 33. The interior of the wavemeter is shown in Fig. 34 and Fig. 35 shows a similar model.

**Testing and Calibration.**—The only testing required is to hold the wavemeter aerial about 12 in. from a transmitter aerial with the transmitter switched on. Turn the wavemeter tuning control slowly and a reading should appear on the meter. If no reading is obtained reverse the connections to the meter, since this may be reading the wrong way. It is worth going to some trouble to get the wavemeter calibrated accurately and the best way is to enlist the aid of a radio man with a suitable signal generator. To calibrate in this way, clip the signal generator earth connection to the wavemeter box and hold the signal lead of the generator close to the wavemeter aerial. Set the generator to 27 Mc/s and switch on. Swing the wavemeter control slowly until the maximum meter reading is obtained, then weaken the signal input by holding the signal lead farther away and again tune for maximum reading. Note the dial reading on the wavemeter. This process should be repeated with frequencies on each side of the 27 Mc/s setting until the full coverage of the wavemeter is known. (N.B.—Once calibration has started do not bend or move the coil in any way since this will alter the calibration.)

For checking transmitters for frequency hold the wavemeter 1 ft. or 2 ft. from the transmitter and adjust for maximum meter reading. Comparing the dial setting with that obtained during calibration will indicate the transmitter frequency.

**Interference Suppression.**—The suppression of interference from relay contacts and motor commutators is a most

important point in all types of radio-controlled models. When the model is completed and testing commences it may be found that all is well when things are first switched on. However, as soon as a signal is sent the intergear may start behaving very erratically. This will almost certainly be due to radio interference within the model. What happens is that on receipt of a signal the receiver operates the relay, which in turn operates the rudder motor. Now either the relay contacts or the rudder may produce a small spark, and this is a source of radio-frequency signal. The receiver, which may be located only a few inches away, can easily pick this up, therefore causing the relay to operate again. The whole process is consequently repeated over and over again.

Fortunately it is not too difficult to prevent this happening and condensers of approximately  $0.01 \mu\text{F}$  should be connected across the relay contacts. It may be found necessary to use larger condensers, but if this is the case a 22 ohm  $\frac{1}{4}$ -watt resistance should be connected in series with the condenser to reduce the risk of contact welding.

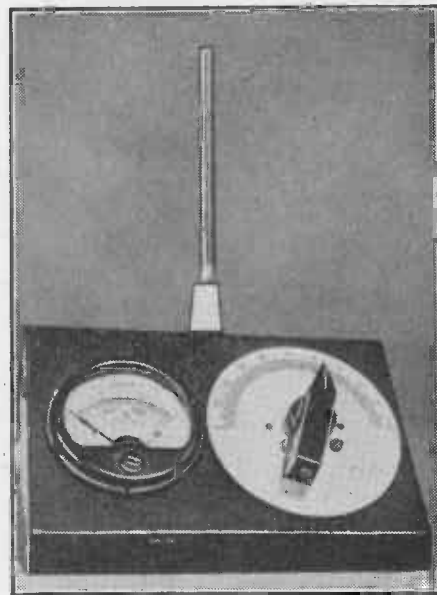

FIG. 35.—A wavemeter similar to the model described. This model was built into a case having a sloping front and a sliding back for easy access.

To suppress Servo motors 1000 pF mica condensers should be connected across the brushes and if this is not sufficient the small iron-cored chokes used for TV interference suppression should be connected in series with the motor leads as near as possible to the brushes.

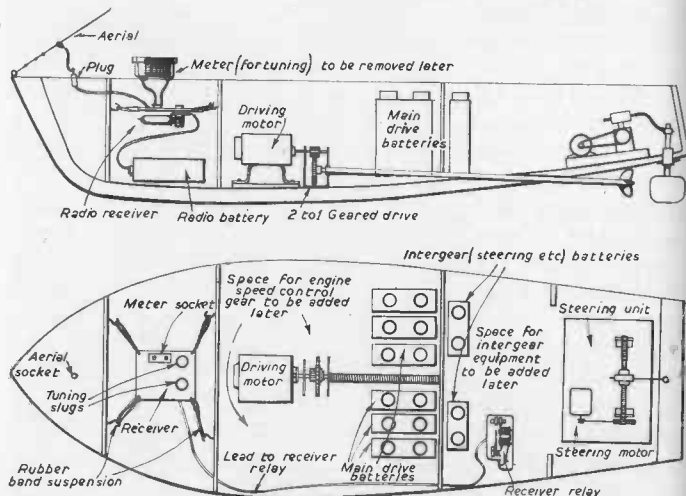

FIG. 36.—A typical radio-controlled model boat layout.

**Layout.**—Readers will have widely differing ideas on the type of model they wish to use, but with model boats there is a fairly clear-cut division on propulsion methods, i.e., electric or diesel. The electric type are normally slower, but are easier to handle; they also lend themselves more readily to speed control, etc., at a later date. Propulsion batteries can be quite a problem but the small Nife accumulators can be strongly recommended. Incidentally, do not use the propulsion batteries for the steering motor, since as these run down the steering will become sluggish. Separate dry batteries are well worth while. Diesel boats are much faster and usually lighter due to the absence of batteries, but they can, however, be awkward to start and rather dirty. Vibration is also a source of trouble.

For all radio-controlled boats, however, remember that quite a lot of weight is involved and the beginner is recommended to consider only a boat not less than 36 in. long and as broad as possible, otherwise difficulties will appear in the shape of lack of freeboard. Fig. 36 shows how the radio-controlled boat should be laid out.

## OBTAINING A SECOND CHANNEL USING THE "MARK/SPACE" SYSTEM

**I**n this chapter will be given some ideas on how to achieve engine speed and other controls using the mark/space system as the basis.

To sum up the present system, a continuous transmission (mark) is being used, to steer the boat one way, an absence of signal (space) to steer it the other and a pulsed signal (50/50 mark/space) at a frequency of about 5 per second

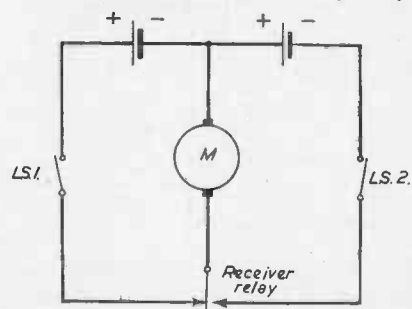

FIG. 37.—Basic two-battery mark/space steering circuit with limit switches (L.S.).

to hold the rudder in any intermediate position between extremes of steering. To control the engine speed it is necessary to transmit a type of signal which will not alter the rudder setting, but which can be easily separated by the equipment in the boat.

It will be assumed that the model is electrically propelled, but there is no reason why the principles involved should not be modified to control the speed of vessels powered by steam or diesel.

Fig. 37 shows the basic mark/space steering circuit, using alternately batteries A and B. When the 50/50 mark/space pulses are being received, an alternating (square wave) voltage is applied to the steering motor. From Fig. 38 it will be seen that a transformer has been connected across the motor terminals. A transformer is a

## SECOND CHANNEL USING THE "MARK/SPACE" SYSTEM 55

device which responds only to alternating currents and, so long as the pulsing on the motor continues, a current is induced in the secondary winding, which is rectified by the meter rectifier unit, stored in the 25  $\mu$ F electrolytic condenser, and then applied to the relay B. On slow speed, pulsing at the rate we have used so far, insufficient current is generated to operate the relay but (and here lies the key to the system) if the pulse rate is increased to about 20 per

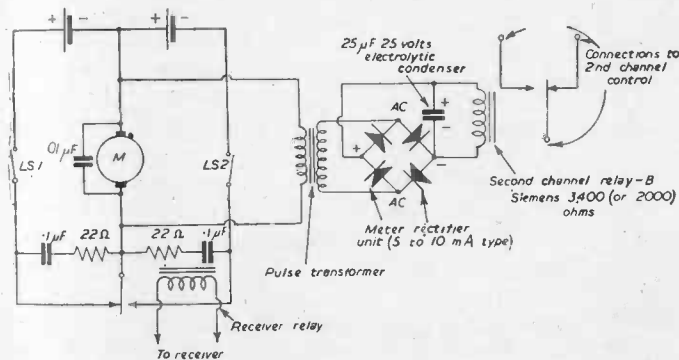

FIG. 38.—Additions to basic circuit to obtain second channel.

second the current produced also increases and the relay then closes. The closing of this relay can be used to operate a sequence switch which can in turn give stop, half speed, full speed and astern control (or any more positions desired). The second control relay could also be used to operate a "Mighty Midget" motor which by suitable gearing could open and close by a reciprocating motion a steam or throttle valve. It will be obvious that increasing the pulse rate will not affect the steering control (providing that the mark/space ratio is not disturbed) yet the vessel can now distinguish between normal steering signals and an engine-speed-change signal.

**The Modified Control Box.**—To provide the extra control, the control box must be altered so as to generate, when

necessary, high-speed pulsing to operate the engine-speed-change relay. It can be done very simply by increasing the battery voltage used for driving the pulse drum motor and normally keeping it slowed down by using a series resistance (a rheostat) in the circuit. When it is desired to change speed a button is pressed which shorts out the resistance and, therefore, speeds up the motor.

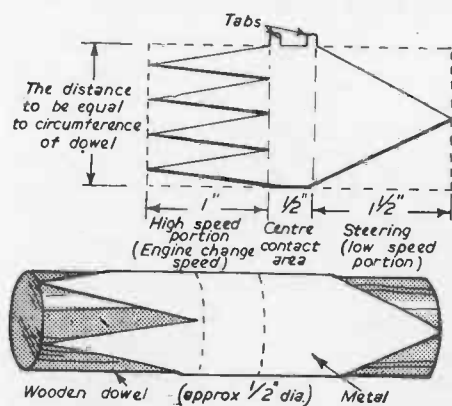

FIG. 39.—Method of rolling soft brass or copper shim round dowel rod to make up dual purpose pulse drum.

and therefore avoid "creep" in the steering motor in the boat. The left-hand part is the high-speed pulse section with a separate contact; it gives four pulses per revolution compared with one per rev. from the main drum and is equipped with its own sliding contact. The double drum can be made as before from thin brass or copper shim cut to shape and rolled round a wooden dowel rod, then the tabs are soldered to hold in position. A better job is made from a thin-gauge piece of brass tubing filed to shape and mounted on the wooden dowel as was described in Chapter 4. The three contact fingers should be of springy brass or copper shim which rest lightly but firmly on the drum. The control box should

This method suffers from the mechanical inertia of the pulse drum and motor which take time to speed up and slow down. A better method is to make a new pulse drum as illustrated in Fig. 39 which consists really of two drums in one. The right-hand portion is the normal steering drum with its two contacts, one of which can be slid along to alter the mark/space ratio

be rewired as shown in Fig. 40 and a S.P.D.T. type push button (a micro switch is suitable) incorporated to bring in the high-speed pulse unit when necessary, for changing engine speed. This system is very reliable and instantaneous in action.

**Extra Equipment in the Boat.**—To separate the high-speed pulsing from the normal steering pulsing in the model

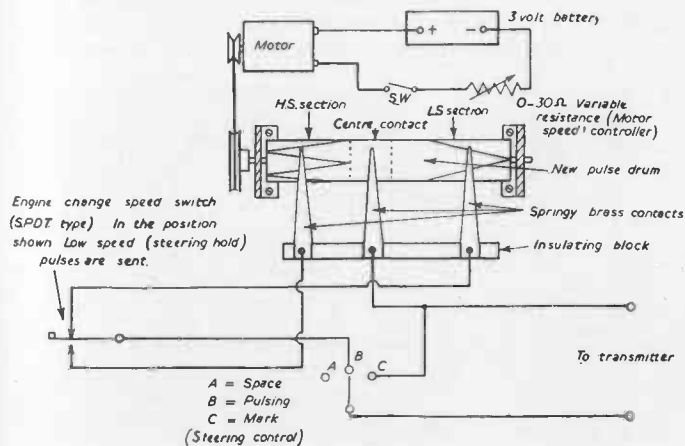

FIG. 40.—Method of wiring control box to include dual-speed pulse drum.

it is necessary to incorporate the pulse transformer, the meter rectifier, the  $25 \mu\text{F}$  25 volts D.C. working bias electrolytic condenser and the second relay which can be a Siemens 3400 ohm or a 2000 ohm high-speed type, together with a suitable sequence switch for operating the main driving motor.

It will be found very convenient to mount all of this "intergear" equipment, as it is called, on a suitable base, which can be a small piece of 3-ply wood, and then screw this into the model when tests have been satisfactorily concluded. This is much easier than trying to wire up the equipment and then adjust it *in situ*.



This extra equipment is shown in Fig. 41.

**Pulse Transformer.**—The pulse transformer is converted from a midget output transformer of the 1S4 type. The laminations should be removed and the original secondary (the outer layer of thick wire) removed. It should be replaced with as many turns of 32 s.w.g. enamelled copper wire as will go into the space and this winding now forms the primary of the pulse transformer (i.e., the winding

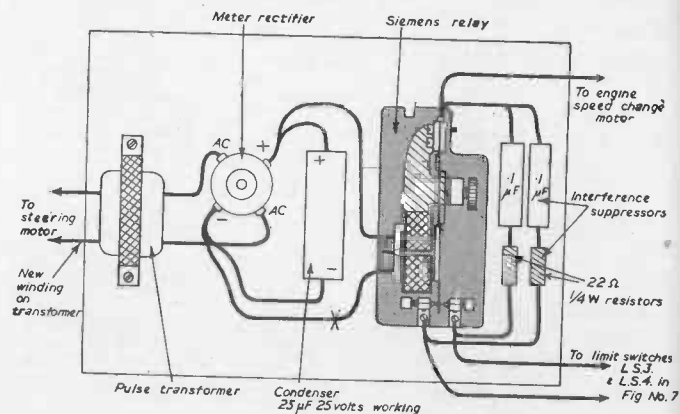

FIG. 41.—Extra components to operate engine control gear—practical wiring diagram. Insert meter at "X" for testing.

connected to the terminals of the "Mighty Midget" steering motor). It may be found necessary to experiment with this component to obtain the best results, as output transformers of different manufacturers vary. A winding of 30 s.w.g. or 34 s.w.g. may give better results, and obviously the thinnest wire that will work satisfactorily is the best, as current is saved from the energising batteries.

**Meter Rectifier.**—The output from the secondary of the pulse transformer is connected to a meter rectifier of 5 or 10 mA rating (the higher rating is to be preferred). The leads should be joined to the two A.C. connections sometimes marked ~ on the rectifier and the two other terminals

marked + and - should be connected to the second relay and to the electrolytic condenser.

**Electrolytic Condenser.**—The output from the rectifier consists of a series of pulses and the function of the 25  $\mu$ F condenser is to store the energy during a pulse and release it in the off period until the next pulse arrives. It therefore smoothes the output and prevents the relay from chattering. In common with all electrolytic condensers it is important that it should be correctly connected in the circuit and the positive from the meter rectifier should be connected to the

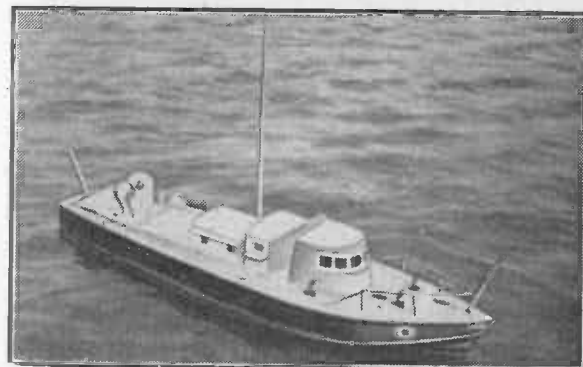

FIG. 42.—Radio-controlled model Vosper air-sea rescue launch.

positive terminal of the condenser. Likewise the negative of the rectifier should be connected to the negative of the condenser.

The relay which, as previously mentioned, should be of a high-resistance type, should now be connected across the electrolytic condenser to complete this part of the installation. For testing, a milliammeter should be connected in series with one of the leads to the relay so that the current generated in the circuit can be checked.

**Testing.**—This is best done via the radio link, i.e., using the transmitter and receiver as if working at a distance, although it is possible to connect the control box directly to the coils of the receiver relay (using a 30-volt battery in



series to energise the circuit). Note that, to prevent interference radiation and possible sticking of the relay contacts, suppression circuits have been included between the armatures of the relays and each contact point. They consist, in each case, of a 22 ohm  $\frac{1}{4}$ -watt resistor and a  $\cdot 1 \mu\text{F}$  condenser. This is standard practice and suppressors of this type should always be used across make-and-break

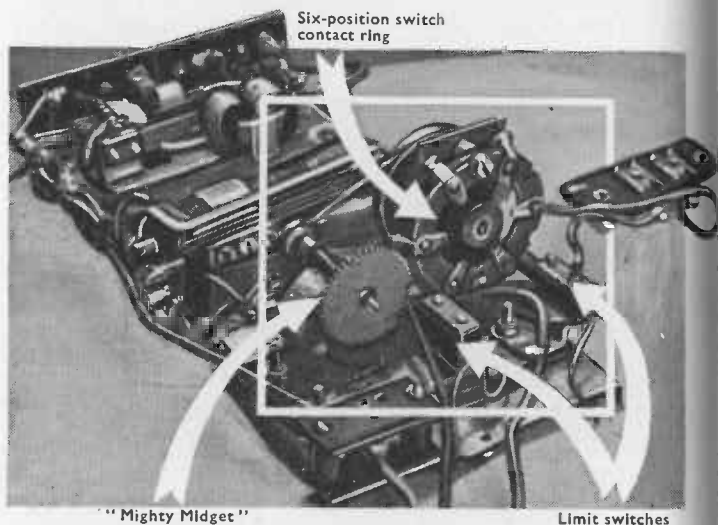

FIG. 43.—A six-position motor-driven sequence switch suitable for engine-speed control in electrically propelled boats.

contacts, otherwise trouble may be experienced due to the receiver operating from radiation in the boat.

The unit should be used first with the normal steering 50/50 pulse and the steering motor should work in the normal way. A reading should be obtained on the milliammeter connected in the relay circuit, but it should only be about 1 or 2 mA, and the second channel relay should be adjusted so as not to close on this current. The Siemens relay is very handy in this respect as the armature tension can be so easily adjusted. Mark and space will, of course,

provide the normal steering operation. Now press the engine change-speed button on the control box. The current shown on the milliammeter should at once rise to a value of 4 mA approx. (the actual amount depends upon the battery voltage used and the transformer windings). The second channel relay should at once close and should open again when the button is released. If difficulty is

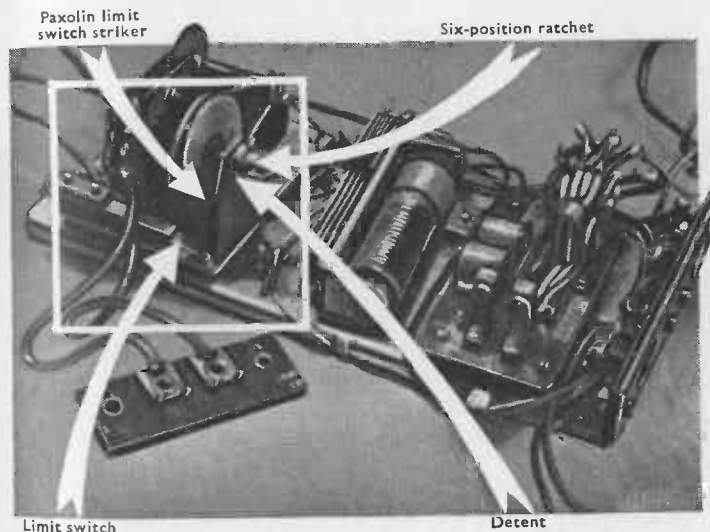

FIG. 44.—Another view of the six-position motor-driven sequence switch.

obtained in taking the current low enough on the normal steering 50/50 pulses it may be necessary to slow down the pulse rate by reducing the speed of the pulse drum. A variable resistance (0.30 ohm) to control its speed is therefore a useful auxiliary on the side of the control box.

Having proceeded this far it is now quite a simple matter to use the second channel relay to operate a further "Mighty Midget" type of motor which will, by suitable gearing, switch on or off or reverse the main motor or else open and close a throttle valve in sequence. Individual inventiveness

may be preferred for devising systems to control the model's movements, but here is one very good method of controlling electrically propelled models.

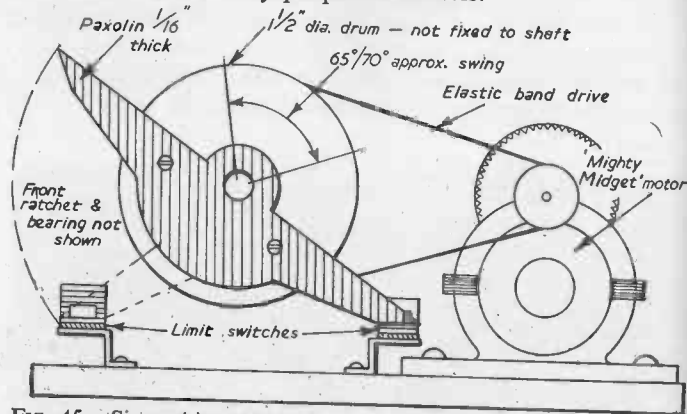

FIG. 45.—Six-position motor-driven sequence switch. *N.B.* Drum is driven approximately 65 to 70 degrees between limit switches, but the six-position ratchet (behind) only moves the shaft in 60-degree steps.

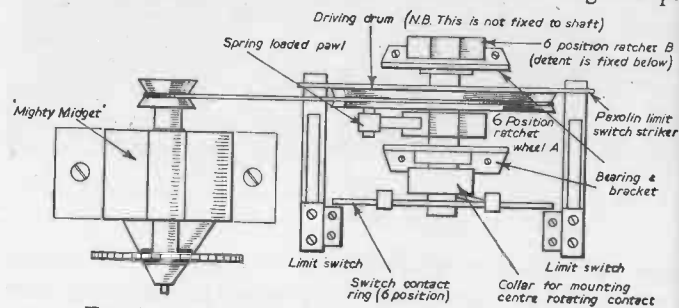

FIG. 46.—Six-position motor-driven sequence switch.

The system is based on a six-position sequence as follows: Off, half speed ahead, full speed ahead, half speed ahead, off, astern, and is incorporated in the air-sea rescue launch shown in Fig. 42. The unit is shown in Figs. 43 and 44.

A Yaxley type switch is the basis of the unit, and this has an outer ring carrying the six contacts corresponding

to the speeds mentioned above. The centre rotating contact is moved a step at a time by a six-tooth ratchet wheel. A second ratchet wheel and detent prevent return motion. The driving ratchet is engaged by a pawl carried on a drum which is in turn driven by a "Mighty Midget" motor. The drum is free to rotate on the common shaft and actually moves about 65–70° each time the sequence is moved to the next step (to make sure the pawl engages correctly). Originally this was done by a small length of cord being wound round the pulley of the motor when the

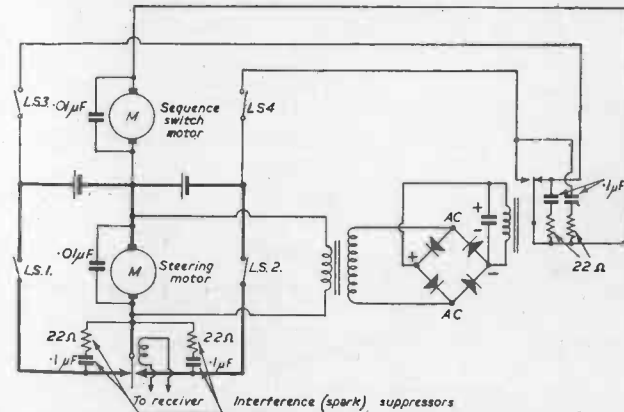

FIG. 47.—How to connect sequence switch into circuit shown in Fig. 38.

signal was given and a spring was used to unwind the coil and reset the unit. Now, however, two limit switches are used to determine the degree of rotation and a paxolin striker is rotated with the drum, opening the two limit switches in turn. By correctly positioning the switches and shaping the striker, the exact angular movement of the drum can easily be obtained. This method has the advantage that a spring return is unnecessary as the motor drives in both directions. Figs. 45 and 46 illustrate the method of constructing the unit, whilst Fig. 47 shows the method of wiring up the limit switches and motor into the circuit of Fig. 38.

The wiring up of the Yaxley switch to the main driving motor is shown in Fig. 48. It will be seen that a tap on the battery provides the current to give half speed on the motor, which in this case is a Hoover 11.5-volt motor-generator with the H.T. secondary removed and driving twin screws through reduction gearing. Full speed is obtained from the full battery voltage whilst astern is obtained by passing the current through a double-pole

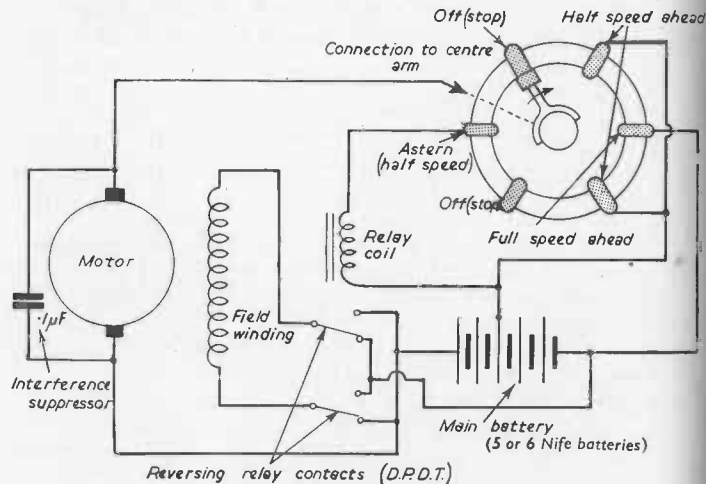

FIG. 48.—Method of wiring up six-position sequence switch to driving motor.

double-throw relay and then on to the motor brushes. When the relay is energised in the astern position it reverses the direction of current in the motor field winding and, therefore, reverses the drive. Suitable relays for this purpose are hard to find, and it is usually necessary to resort to rewinding the coil of a small D.P.D.T. type with 24 or 26 s.w.g. enamelled copper wire. This is quite easy if done in the chuck of a drill, and it is not necessary to be careful about laying the wire accurately. Pile winding is quite good enough, but it may be necessary to experiment with wire gauges before the best results can be obtained.

## 6

## A PROPORTIONAL STEERING CIRCUIT AND REVERSIBLE SEQUENCE ENGINE CONTROL GEAR

It will be appreciated that one of the defects of the mark/space system is the need for the exact setting of the 50/50 ratio to ensure that the steering of the model does not "creep" either to port or starboard, but holds still exactly where set. It is, however, possible to steer the model by deliberately sending unbalanced ratios, i.e., 20/80 and 80/20 and this is the basis of the proportional steering system.

By a simple addition to the steering mechanism in the model it is possible to make it "fully proportional", i.e., an alteration to the ratio of the pulse transmitted is followed by a proportional change in the position of the rudder. Therefore by sending a 50/50 ratio pulse the rudder will automatically centre whilst 20/80 and 80/20 (approx. ratios) correspond to full port and full starboard or vice versa.

The basic circuit to achieve this is given in Fig. 49, where it will be seen that the only

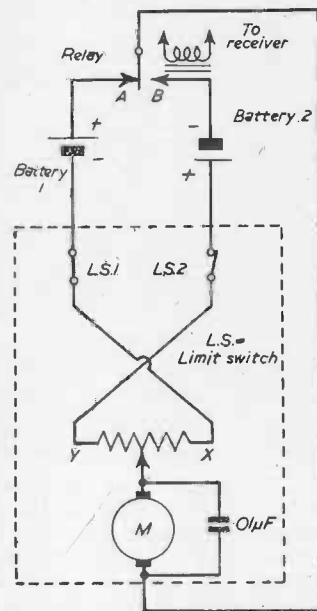

FIG. 49.—Basic circuit of proportional steering mechanism components inside dotted lines are those situated in stern steering gear.

addition is a resistance element. A slider, attached to the tiller mechanism, is arranged to track across the resistance and this must be wired so that the speed of the motor slows as the tiller travels to the opposite limit switch. Note the crossed wiring to the limit switches (see also Fig. 50). The action is as follows:

Assuming the relay is in position *A* (Fig. 49) and the slider at *X*, the steering motor *M* will receive the full

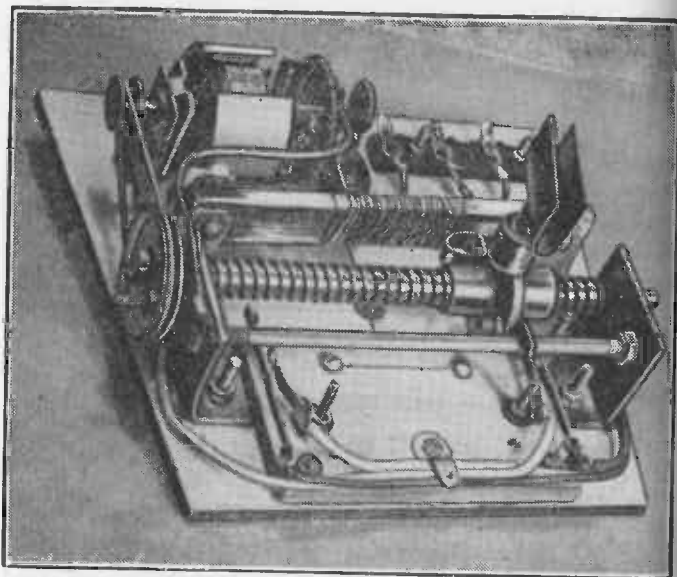

FIG. 50.—Proportional steering gear unit. Note the resistance unit situated behind the screwed driving shaft, and the slider which travels across it to produce the automatic positioning according to the Mark/Space ratio sent.

battery voltage from Battery 1 and the slider will start to track towards *Y*. When the relay is in position *B*, however, almost all of the resistance is in the circuit of Battery 2 and the motor therefore makes fewer revolutions in the opposite direction. If the relay is being pulsed in a 50/50

ratio (i.e., equal lengths of time on *A* and *B*) the motor will position the slider so that the current obtained through the two halves of the resistance (i.e., between slider and *X* and *Y* respectively) is equal. A 50/50 pulse therefore automatically gives midships rudder whilst unbalanced ratios give proportional positions. This is a very effective system and no trouble has been experienced in its use, with the exception of the fact that it is rather slow to find its

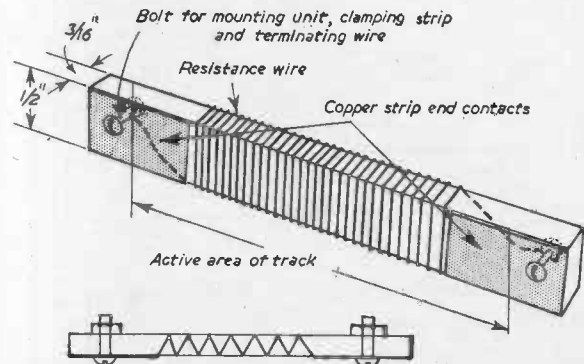

FIG. 51.—Method of making resistance track, length as required.

exact point of balance and a certain amount of over-steering is necessary. A little practice, however, soon gives the necessary skill.

Figs. 51 and 52 show a practical arrangement of the scheme. The resistance is wound on a  $\frac{1}{2}$ -in. wide strip of plywood or paxolin and the wire is obtained from a 750-watt type electric fire spiral. The exact length of wire necessary will depend on the motor used and experiments will have to be carried out first. The aim is to cause the motor to slow to a little over half speed with the full resistance in circuit. In the unit shown, the end sections are made from copper strip whilst the centre part only is made of resistance wire. This gives the proportional effect about the centre, but quicker steering on full-rudder positions.

From the foregoing description it will be realised that all steering of the model is now being carried out by using pulses of varying ratio (at a fairly low frequency) and that we are left with two very useful channels of control, i.e., "Mark" and "Space", to perform other duties in the model. These are non-pulsing channels and can easily be separated to control engine speed. Fig. 53 gives the basic circuit for this system and it will be recognised as having the

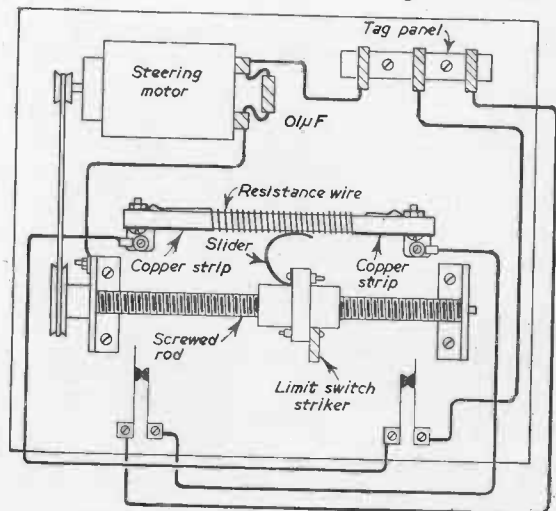

FIG. 52.—Wiring diagram of steering unit, unit "B" in Fig. 54.

elements of the two-battery circuit which is extensively used for model control. Here, however, one of two motors is controlled by Relay 1, according to whether the relay is pulsing or not pulsing. If a steady mark or space is sent (i.e., non-pulse conditions) Motor 1 will be driven either clockwise or anti-clockwise from Battery 1 or 2. If, however, the relay is pulsed a current will be generated in the secondary of the pulse transformer, rectified by the meter rectifier, stored in the electrolytic condenser and applied to the second relay (which is adjusted to close on a very small current). Motor No. 2 is therefore brought

into circuit and this functions on the mark/space pulses received. Both motors can therefore be worked in either direction or held still at will and this circuit is approximately equal to a four-channel control.

Both the circuit of Fig. 49 or Fig. 53 is usable as it stands and both are worth experimenting with in simple equipment, but some difficulty may be encountered when it is attempted to insert limit switches into Fig. 53. They can

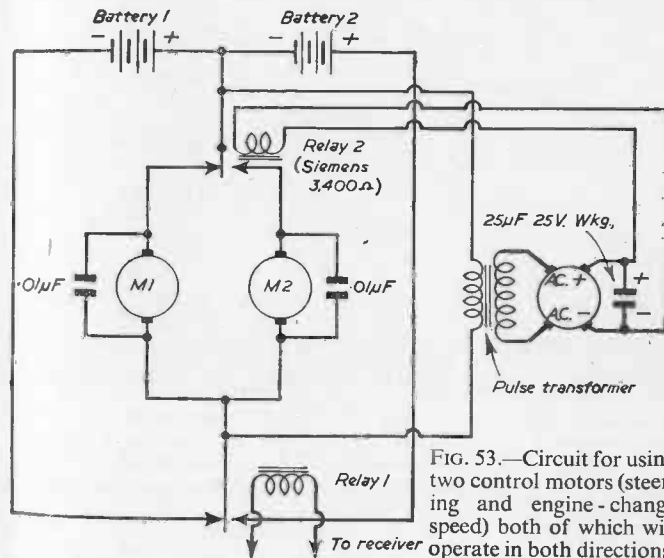

FIG. 53.—Circuit for using two control motors (steering and engine-change speed) both of which will operate in both directions.

be avoided, however, if slipping drives are used for the Servo motors.

**Combining the Circuits.**—It will be realised that the circuit in Fig. 53 provides the very conditions for Motor No. 2, which can be used in the proportional steering circuit in Fig. 49, although it will be necessary to alter the circuitry.

The complete circuit to do this is given in Fig. 54 and it operates as follows. All-pulsing brings in the steering Unit B, which then controls the rudder position according to the mark/space ratio sent. A non-pulse signal (either

mark or space), after a short time delay caused by the drop-out time of the pulse/no-pulse relay, which is slugged by the  $25\ \mu\text{F}$  25 volts working condenser, brings in Unit *A*. This is the engine-speed-control switch and is arranged to provide a reversible sequence. Space is used to increase speed and mark to reduce speed and to go astern. This is very useful as it is not necessary to go through all of the positions before returning to one just used, as it is with all normal sequences.

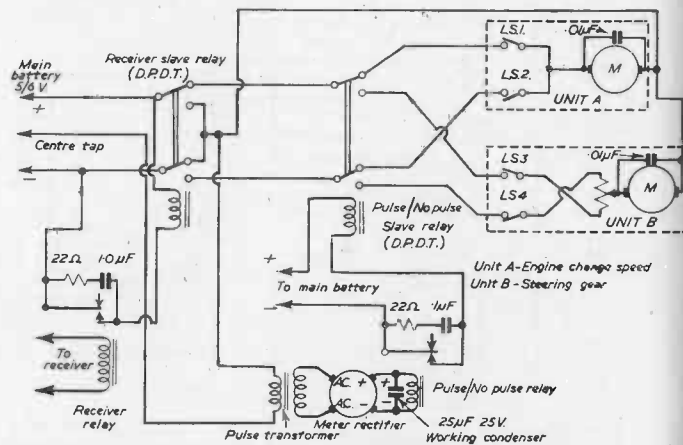

FIG. 54.—Complete wiring diagram of circuit to give proportional steering and reversible sequence engine-speed control.

Start at the receiver relay, which is a Siemens high-speed type in the equipment shown in Fig. 55. This is used to energise a double-throw slave relay, connected as a reversing switch. The pulse transformer is also connected between the receiver relay slave and the centre tap of the intergear battery. As described in the last chapter, this is a 1S4 output transformer rewound with 32 s.w.g. enamelled copper wire in place of the original thick secondary. (This new winding now forms the primary.) Pulsing from the receiver, therefore, causes current from alternate halves of the battery to flow through the pulse transformer

primary and a current is generated in the secondary. The meter rectifier (5 or 10 mA type) rectifies this and applies the D.C. output to the electrolytic condenser and finally to the second Siemens relay (the pulse/no-pulse relay).

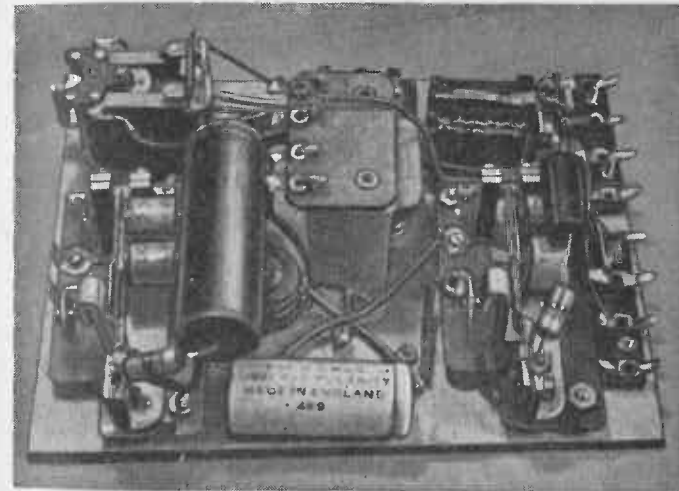

FIG. 55.—The complete "intergear" unit (pulse decoder). On the left is the Siemens H.S. receiver relay and above it, its slave relay (D.P.D.T.). Note the large ( $1\ \mu\text{F}$ ) condenser and  $22\ \Omega$  resistor to the right of the Siemens relay used as a spark suppressing unit. In the centre at the top is the pulse transformer, below to the left, the meter rectifier and at the bottom the  $25\ \mu\text{F}$  25 v. D.C. working electrolytic condenser. Bottom right is the Siemens H.S. pulse/no-pulse relay (with spark suppressors) and above it its slave relay (D.P.D.T.). All connections are brought out to the tag boards on the right and at the top, except the receiver connections which are joined to the relay tags on the left.

The closing of this relay causes its double-pole double-throw slave relay to close and the mark/space pulses are therefore channelled into Unit *B*, which is the steering unit. If pulsing ceases, the pulse/no-pulse relay and its slave will drop off and Unit *A* therefore becomes energised. The motor of this unit will therefore run either clockwise or



anti-clockwise according to whether the receiver is accepting a steady mark or space.

In practice the unit works quite well and it should be set up so that the pulse/no-pulse relay just holds in when an extreme radio pulse is being transmitted (i.e., 80/20 or even 90/10 if you can make the receiver slave relay follow this ratio). This will ensure that the changeover time between pulse and no-pulse conditions is as short as possible

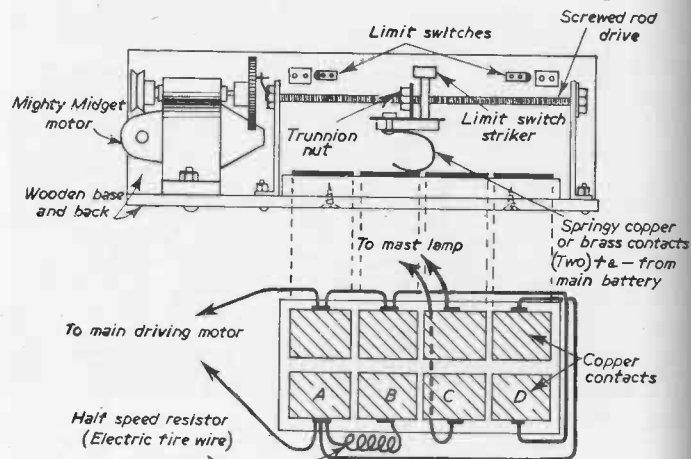

FIG. 56.—Reversible sequence engine change-speed switch. A.—Full speed ahead. B.—Half speed ahead. C.—Stop (mast lamp lights.) D.—Full speed astern. *N.B.*—The wiring shown is suitable for a P.M. driving motor.

and that the steering is therefore affected as little as possible when an engine-speed-change signal is sent. There is a tendency for the steering motor to run during the drop-out time of the second relay.

**The Engine Change-Speed Switch Unit.**—Figs. 56 and 57 show this unit, which is driven by the ubiquitous “Mighty Midget” motor. A pin driven into the large gear wheel engages with a crank soldered to a nut which is locked on to the end of a length of screwed rod. The drive is thereby transmitted to a nut secured to a flange on the top of

the travelling contact assembly. According to the direction of the motor, the contact assembly will be driven up or down the length of the screwed rod. A pair of limit switches governs the extent of its travel, so preventing the jamming of the moving parts against the end bearings.

The two moving contacts, which are made from springy copper or brass, bear down on to a copper track and these carry current from the main battery by means of flexible connections. The track on the original was made from

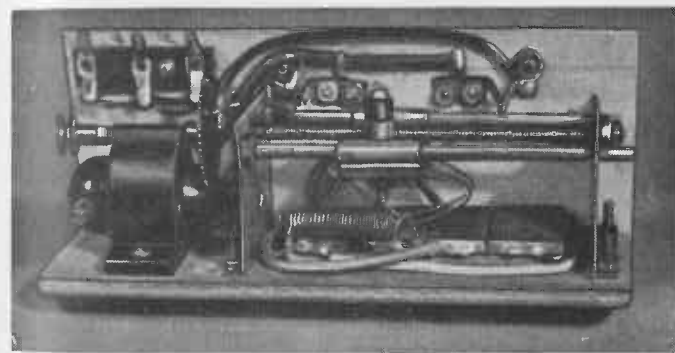

FIG. 57.—A reversible sequence engine-speed-control switch for electrically driven boats. For the photograph the two flexible leads connecting to the two moving contacts, have been removed. These leads bring in power from the main driving battery and distribute it according to the position of the travelling contact unit.

two strips of soft copper, 33 s.w.g. thick and cut the full length of the track; they were tacked down on to a plywood base, using brass brads. The individual sections were cut afterwards, by sawing across both halves with a fine-toothed saw. As many positions as desired can be cut but the four sections illustrated will give very good control. The off or stop position is wired so that the current passes to a mast-head lamp, thus indicating when the motor has stopped even though the model is still under way. Note the use of a piece of electric fire spiral to reduce current to the driving motor in the half-speed position. The length of wire required must again be determined

experimentally so as to give the correct low speed; the motor used will have a big effect upon the length required. If the driving motor used is of the energised-field type the field must be connected directly to the battery and not through the switch, otherwise it will not be possible to reverse. With this arrangement the field will be energised even when the motor is stopped and this can be overcome

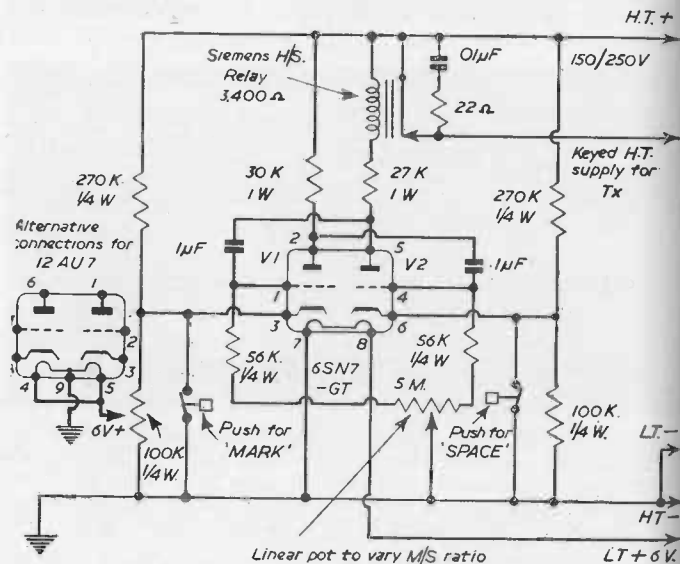

FIG. 58.—Multivibrator circuit to provide variable Mark/Space ratio.

by bringing in a relay energised from the mast lamp circuit which opens the field circuit in the motor "Stop" position.

**The Control Box.**—No mention has been made so far of a control box for this system, but obviously an adaptation of the pulse-drum type previously described will serve. Only one pulse frequency is required, but as the mark/space ratio has to be altered to steer, arrangements should be made to control the movable brass contact arm, which bears on the pulse drum, by means of a knob on the outside of the box. Full mark and space are no longer

steering controls as before and the switch (or switches) used to provide these signals should be labelled "Reduce Speed" and "Increase Speed" (respectively).

A point about this system is that if by any chance a fault develops and the model goes out of control the

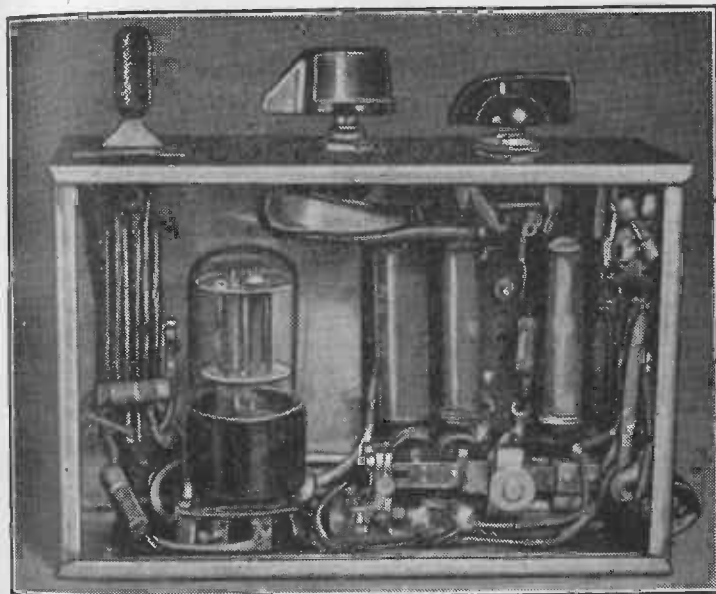

FIG. 59.—The multivibrator (Mark/Space) control box. The key switch at the front is used to increase speed when pushed forward and to reduce speed when pushed back. It is normally in the position shown when the box generates Mark/Space pulses in the ratio determined by the centre (steering) knob. The switch knob (right) is an experimental control and gives 80/20 and 20/80 in its three positions.

pulsing will stop and the equivalent of a space will be sent. This means that the model will steer on the last course given and the engine speed switch will move to the "Full-Speed Ahead" position. (It should be arranged so that "Full-Speed Ahead" is given on receipt of a space and



not a mark.) The model will therefore keep going until it reaches the side of the pond (unless it so happens that the last course was one of extreme rudder), which is a lot better than a series of tight circles which is the usual result of a mark/space boat going out of control.

**The Multivibrator Control Box.**—An alternative type of control box can be made up using the simple multivibrator circuit in Figs. 58 and 59. This circuit is recommended as being entirely trouble free and 100 per cent. effective. The prototype used a 6SN7-GT valve (a double triode), which requires a rather heavy heater current, and later versions used 12AU7 valves, which are more economical and also more compact. Even so the current for the heater in particular limits the circuit to the operation of transmitters fed from an accumulator supply. There is, however, no reason why a battery valve version (using a 3A5) should not function well, providing that the mark and space controls are incorporated after the relay, as there are, of course, no cathode connections in a battery valve.

It will be seen that the normal multivibrator circuit is used, in which each valve (half of the 6SN7) is cut off alternatively and the keying relay, in the anode of one valve, is therefore pulsed in unison. The pulse frequency is controlled mainly by the grid condenser/grid leak time constant of each half and the pulse frequency is therefore controllable by increasing or reducing the value of the grid condenser. The mark/space ratio is varied very smoothly by the linear potentiometer in the grid leak circuits. The two fixed grid resistors govern the extreme ratios which can be obtained and these are the only components which may need adjusting to obtain best results. A knob on the potentiometer controls the mark/space ratio and is thus the steering control for the model.

Mark and space are obtained by opening either of the two cathode circuits. This has the effect of elevating the cathode to a potential of about 50 volts and the valve is therefore cut off. With V1 cut off a mark is sent and with V2, a space.

## 7

## A DETAILED DESIGN FOR A RADIO-CONTROLLED BOAT USING A GLOW-PLUG ENGINE AND AN ELECTRIC MOTOR IN THE POWER UNIT

READERS will probably have different outlooks on the subject of the radio control of boats. Some will be chiefly interested in making the model and its fittings and may be quite satisfied with a minimum of control, i.e., merely steering their models by radio. Others will be



FIG. 60.—View of engine compartment (*centre*). *Left*—field rheostat, fuses and charging meter. *Right*—engine-speed-control gear.

mainly concerned with the techniques and circuitry involved and will see the boat merely as a floating test bed. The types of model favoured will, therefore, vary considerably and generalisations on boat design are difficult. However, a few main points stand out.

**Type of Propulsion.**—The good points about electric motors are that they are clean, have easy control of speed and direction and are not temperamental. The bad points

are poor power/weight ratio, need for heavy batteries, top speed usually not more than about 4 m.p.h.

Diesel, glow-plug or petrol engines have two principal good points—firstly high power-to-weight ratio, and secondly high speeds are possible depending merely on how big an engine is fitted. The disadvantages are that they make a lot of dirt and can be awkward to start. Speed control is difficult, especially with small sizes, simple reversing is not practicable and there is excessive noise.

The steam power unit appears to have most of the snags without many of the advantages.

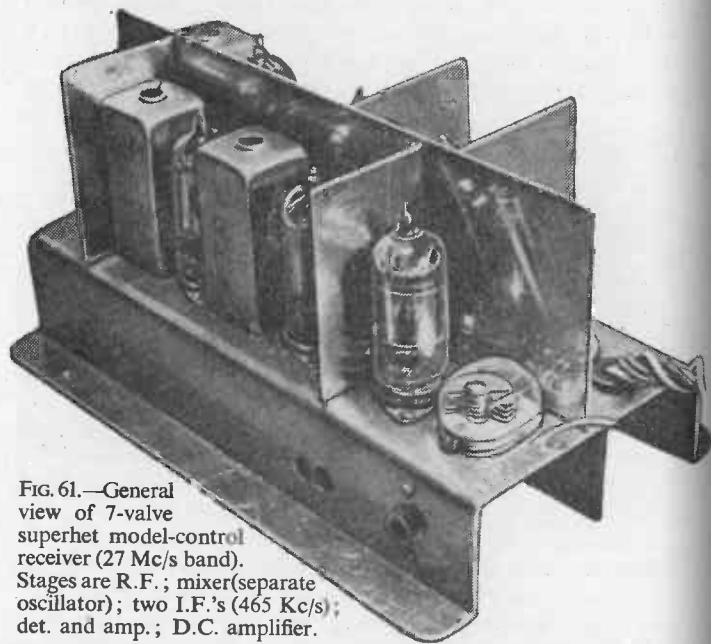

FIG. 61.—General view of 7-valve superhet model-control receiver (27 Mc/s band). Stages are R.F.; mixer (separate oscillator); two I.F.'s (465 Kc/s); det. and amp.; D.C. amplifier.

**The Control System.**—Systems have been dealt with from the simplest rudder control to a system with four channels giving rudder and speed control. The choice here rests largely with the builder concerned and his

particular inclinations. It should be borne in mind, however, that rudder control only is suitable for boats down to 24 in. to 30 in. long with 1.5 c.c. to 2.5 c.c. engines or suitable motors, whereas the comprehensive systems normally call for a boat 40 in. or more long, with more powerful propulsion machinery.

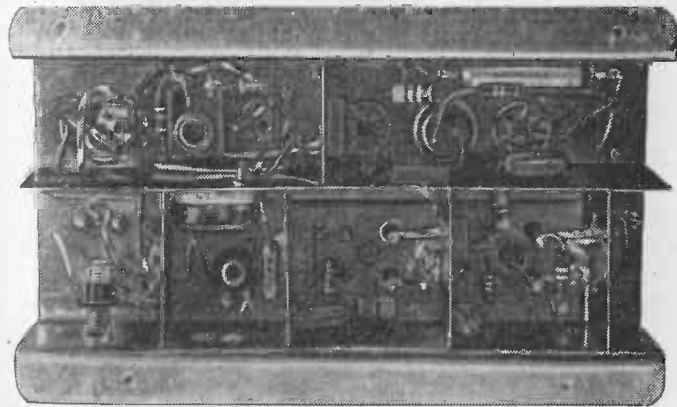

FIG. 62.—Under chassis view of 7-valve superhet receiver.

**The Boat Design.**—It is now intended to describe in some detail a boat which has been constructed with some of these points in mind. Many of the circuits used are similar to, and have developed from, those already described, whilst others have been designed to meet specific problems.

**The Power Unit.**—The design sets out to obtain some of the performance of the IC-engined boats together with the control and manoeuvrability of the electrically powered types. To do this the power unit in Fig. 60 was evolved. It consists of an ETA29 5 c.c. glow-plug engine coupled via a centrifugal clutch to one end of an electric motor which has a shaft at each end. The engine is fitted with forced air cooling by means of a ducted fan and has throttle controls fitted to the carburetter. These throttle controls allow the engine to tick over at about 4000 r.p.m. The centrifugal clutch is so adjusted that it begins to engage at

approximately 6000 r.p.m. Thus, with the engine on tick over, the clutch disengages but when the throttle opens, the engine revs. increase and the clutch takes up the drive.

On full throttle the engine settles down at about 16,000 r.p.m. Under full throttle conditions the drive is taken through the motor shaft and to the twin screws via 3-to-1 reduction gearing. The speed-control unit seen at the right of Fig. 60 is arranged so that normally the engine runs on tick over when two astern speeds, stop and two ahead speeds are provided by the electric motor in the usual way, drawing power from a battery. With the motor at maximum power the propeller spins at about 1300 r.p.m. When full speed is required, however, the engine throttles are opened by a solenoid and the propeller speed rises to about 5300 r.p.m. At full throttle the motor can be disconnected but in this case it is used as a dynamo to charge the main batteries and supply power for Servo motors, etc. The amount of power absorbed in this way can be adjusted by a rheostat in the field circuit. This can be seen just below the motor at the left of Fig. 60.

The curious stack-like attachment on the engine is the exhaust stack and oil collector to avoid fouling the lake with oil. The stack mates up with one or two stacks mounted side by side on deck similar to the latest gas-turbine boats.

Twin screws are adopted to cut out the tendency of a single-screw boat to slew when put into astern whilst travelling ahead.

**The Radio Apparatus.**—To enable several boats to be controlled simultaneously as may be necessary at a radio-control rally this boat is fitted with a 7-valve superhet receiver, which is seen in Figs. 61 and 62. The signals transmitted are mark, 80/20, 50/50, 20/80 and space, so quite a conventional set could be used if single boat operation only were being considered. Fig. 63 shows the receiver installed in the third compartment from the bow. The second compartment houses the main H.T. batteries for the receiver and pulse decoder, which is described later.

If the addition of a little weight is feasible, the use of B119 30-volt H.T. batteries and D18 1.5-volt L.T. batteries is strongly recommended for the receiver. Lighter batteries than these are obtainable but the fact that the types mentioned have plug connections makes battery changing very simple. On this boat the plugs are mounted as shown in Fig. 64. Here it can be seen that the 2- or 3-pin plugs used for these batteries are fixed on a paxolin baseboard

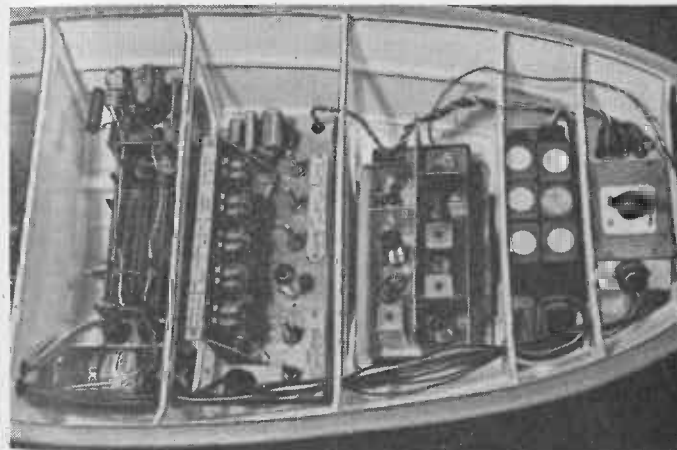

Fig. 63.—Contents of compartments, *left to right*—engine-speed-control gear; pulse decoder gear; superhet receiver; radio batteries; master on/off switch.

located in the boat. All wiring etc. is carried out underneath this base and the batteries are simply plugged into the baseboard at the appropriate point. This makes a very neat job, and a spare set of batteries can be installed in a few seconds.

The bow compartment houses a multi-way wafer-type switch which in the off position cuts out all circuits in the boat. With a complex system, it is very easy to leave some part of the gear switched on, if separate switches are used, and a main switch like this can save flat batteries.

**The Control Signals.**—The control signals for this boat are similar to those described in the previous chapter, although the means of decoding is different. The following signals are required:

Mark	.	.	· Increase speed
80/20	.	.	· Port rudder
50/50	.	.	· Neutral
20/80	.	.	· Starboard rudder
Space	.	.	· Decrease speed

The signals are produced by keying the transmitter by a multivibrator control box similar to that shown in the previous chapter. These are picked up by the receiver which

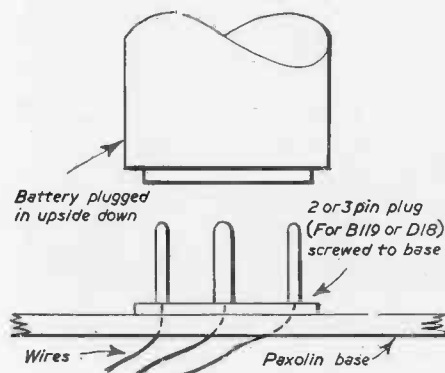

FIG. 64.—Method of mounting plugs.

The receiver relay Ry1 is on the right in Fig. 65 and this is fed in the usual manner in the anode circuit of the last valve in the receiver and therefore it follows exactly the action of the relay in the control box keying the transmitter. Ry1 is a Siemens high-speed relay as are all the others in Fig. 65. The front contact of Ry1 is used to drive Ry2 as a slave using power from the main battery, whilst the back contact feeds power from the same battery through one winding of a modified 1S4 output transformer. This was fully described in the previous chapter and it will be

passes the rectified and amplified signal to the pulse decoder. The function of this unit is to discriminate between the various types of signal which can arrive and to cause the correct function to take place on receipt of a particular signal. The circuit of this unit is given in Fig. 65, and Fig. 66 shows the general arrangement.

remembered that, with this arrangement, as long as a rapidly interrupted D.C. current flows through this winding, an induced voltage will appear in the other winding. This is rectified by a 10 mA bridge-type meter rectifier, smoothed by a 25  $\mu$ F 25-volt working electrolytic condenser and fed to Ry5. Thus when 80/20, 50/50 or 20/80 signal is being sent this action will take place and Ry5 will pull in, whilst on mark and space Ry5 will drop out. Ry5 is termed the pulse/no-pulse relay.

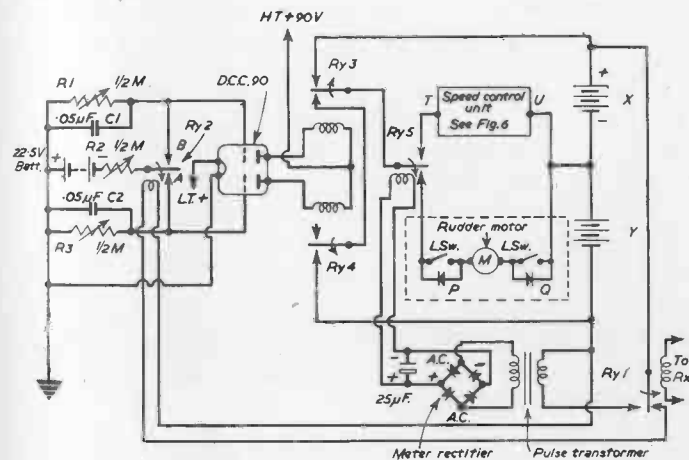

FIG. 65.—Circuit of pulse decoder.

Ry2, being driven by Ry1 as a slave, also follows exactly the transmitted signal. The contacts of this relay are connected in a balancing circuit using a twin triode valve (DCC90 or 3A5). Examination of the circuit will show that when the reed of this relay is on contact (a) condenser C2 will be charged from the 22½-volt battery, the charging rate being adjusted by R2. When the reed moves on to contact (b) C1 will be charged in the same way. While the reed is on contact (b) C2 is discharging through R3. This process is continuous and with 50/50 being sent out the reed will dwell for equal periods on contacts (a) and (b)

and if R1 and R3 are adjusted identically the mean voltage across C1 and C2 will be the same. The current is adjusted so that this voltage, which is applied to the grids of the triodes, will just cut them off in order that no anode current flows. If an 80/20 signal is now sent the reed of Ry2 will dwell on contact (a) for 80 per cent. of the cycle. Thus the voltage of C2 will more nearly approach the battery voltage and cut off one-half of the valve even more. C1, however, will have more chance to discharge and less chance to charge, and the negative voltage at the grid of the other half of the valve will be reduced and the circuit can easily be adjusted to allow anode current to flow through this half and so to close Ry3. Substantially the same effect will be caused by sending a mark, in that C2 will charge right up to battery voltage and C1 will discharge completely causing anode current to close Ry3.

The operation can be summarised as follows, with reference to Fig. 65:

(1) Mark received. Ry3 closes as described above and due to lack of transformer action Ry5 drops out. Thus power is fed to the speed control unit from battery X causing it to increase the speed of the propulsion unit.

(2) Space received. This time Ry4 closes due to C2 discharging completely. Ry5 will drop out due to lack of transformer action and power will again go to the speed control unit, but this time from main battery Y. The fact of the circuit now flowing in the opposite direction makes the speed control unit decrease the speed of the propulsion unit.

(3) 80/20 received. This will allow C1 to nearly discharge and Ry3 will again close. This time, however, Ry5 will be holding in due to the voltage induced in the transformer by the interrupted D.C. current flowing in its other winding. Power will now go to the rudder motor from battery X, giving port rudder.

(4) 20/80 received. This is just as item 3 except that Ry4 closes instead of Ry3. Power again goes to the rudder motor but this time in the opposite direction from battery Y, giving starboard rudder.

(5) 50/50 received. When Ry2 dwells for equal periods on both its contacts both halves of the valve are cut off. Thus both rudder motor and speed control unit are neutral (i.e., stay as they were last left).

It should be noted that the reed of Ry4 is connected via the back contact of Ry3. It could be connected directly to the reed of Ry3 but if for any reason such as the failure of the 22½-volt bias battery both Ry3 and Ry4 came in together, they would then impose a monumental short

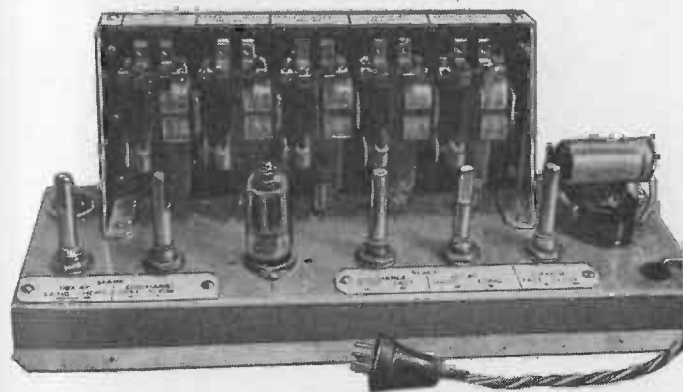

FIG. 65.—Pulse decoder unit.

across the main battery. The connection given makes this impossible.

Readers may also be curious about the rectifiers shown across the limit switches for the rudder motor.

It was mentioned previously that slipping drives can be used and that, in those cases, limit switches are not needed. Some people may not wish to use this method however, and, if positive drive is used, limit switches are essential. Location of the switches in the circuit shown is very difficult since each switch must only stop the rudder motor from going in one direction, leaving it free to travel the other way. This is usually done by putting one limit switch in each battery circuit, but with this circuit this cannot be

done as, when one of the steering limit switches opened, it would cut out the speed control unit and vice versa. The problem is overcome by putting both limit switches in series as shown and connecting rectifiers across them. Thus, if the rudder is going to port, it will eventually open, say, switch *P*, and the rectifier across this switch will not pass current in the direction to give more port rudder.

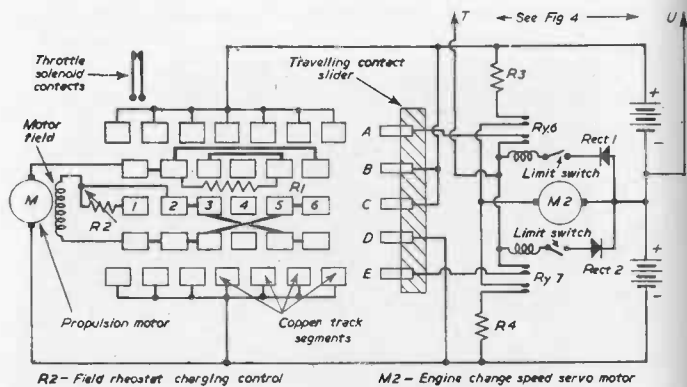

FIG. 67.—Speed control unit.

When starboard is called for, however, the current is reversed and can by-pass the open contacts of switch *P* via the rectifier allowing the rudder to go to starboard. The same action applies in reverse when the starboard limit *Q* opens. Quite small rectifiers can be used and they can be grossly overloaded since they are only in circuit for half a second or so until the switch they are shunting recloses, shorting them out.

Fig. 63 shows the pulse decoder installed in the fourth compartment from the bow. The adjustments mentioned above are easily seen. These, of course, once set up can be left. The 1S4 transformers can be just seen in Fig. 66 behind the black bridge rectifier with the smoothing condenser mounted on top of it.

**The Speed Control Unit.**—The first compartment houses the speed control unit. This is a reversible sequence unit and is arranged for the following speeds:

- |                           |                 |
|---------------------------|-----------------|
| (1) Half astern . . . . . | Electric drive  |
| (2) Slow astern . . . . . | ” ”             |
| (3) Stop . . . . .        | ” ”             |
| (4) Slow ahead . . . . .  | ” ”             |
| (5) Half ahead . . . . .  | ” ”             |
| (6) Full ahead . . . . .  | Glow-plug drive |

This type of equipment enables the operator to move either way through the sequence, e.g., if the boat is at slow ahead, a mark will move it to half ahead and if the mark is maintained to full ahead. A space would give

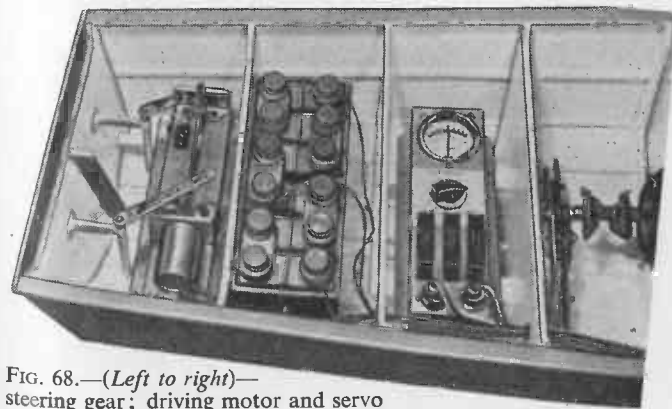

FIG. 68.—(Left to right)—steering gear; driving motor and servo batteries; field rheostat, fuses and charging meter.

stop and then slow and half astern. It will be seen that this is very similar to that described in the previous chapter. The unit consists of five segmented copper tracks on an insulated backing. A contact slider moves over this, propelled by a nut on a screwed rod driven by the Servo motor. Reference to Fig. 67 shows that the three centre tracks *B*, *C* and *D* control the electric propulsion motor. With the slider on position 6 the armature and field will



be straight across the main battery. This is half astern (there is no full astern). Position 5 inserts the resistance R1 in the armature lead and gives slow astern. Position 4 is stop. Position 3 is as position 5 except that the field connections are reversed giving slow ahead. The armature resistance comes out in position 2, giving half ahead. In position 1 the slider closes a pair of leaf contacts mounted at the side of the contact track. These contacts energise a solenoid which opens the throttle of the engine which is otherwise ticking over. When the engine speeds up the centrifugal clutch engages and the motor which normally spins at about 4000 r.p.m. is taken up to 16,000 r.p.m. Under these conditions it generates power which is fed into the main battery. In this position R2 is inserted in the field circuit to control the amount of power fed back in this way.

**A Servo Motor Refinement.**—The circuit associated with the Servo motor at the right of Fig. 67 is a refinement to ensure that the contact slide does not come to rest half-way between two positions. If the unit is at, say, slow ahead (position 3) and half ahead is required, a short mark (approximately 0.5 sec.) is sent out. This closes Ry3 (Fig. 65) and allows Ry5 to drop out. The back contact of Ry5 is connected to the control input lead of Fig. 67. This short mark will, therefore, start current flowing into the unit from battery X. If both limit switches on the unit are closed, this current will try to flow through both Ry6 and Ry7 but the rectifiers will only allow one to close, depending on the direction of the current flow. Once one of these relays (say, Ry6) has closed it starts the Servo motor in the correct direction for increasing the speed to half ahead, by means of one of its sets of contacts. Tracks A or E now come into the picture.

With the slider at rest on, say, position 3, the contacts on tracks A and E will be on the insulated portion between two segments. As soon as the Servo motor starts, however, the slider begins to move towards the half-ahead position and in doing so contact A will come on to one of the segments on track A. Once this has taken

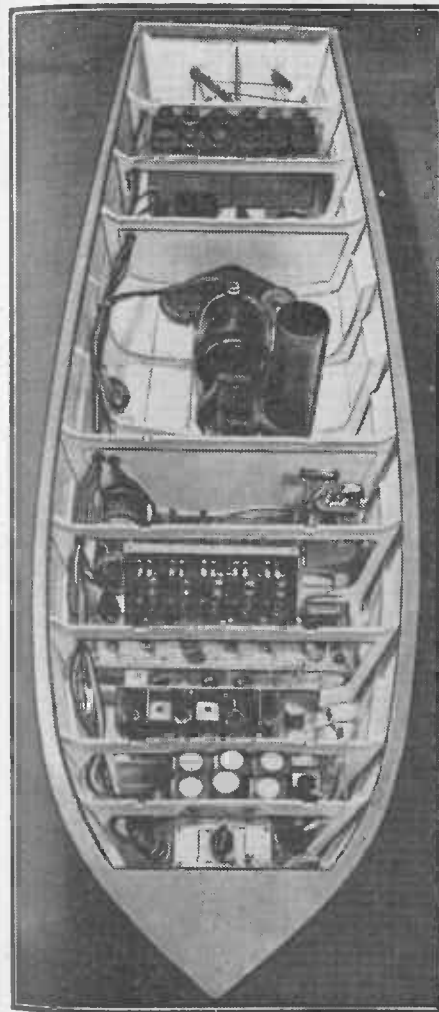

FIG. 69.—Overall view of radio-controlled M.T.B.

place the mark which initiated the process can be cut off and the flow of current to maintain Ry6 closed will come through track A. This will keep the Servo motor running until contact A comes on to the next insulated portion, Ry6 will drop out stopping the Servo motor when the main contacts (B, C and D) will be on the half-ahead position. In practice this takes place quite rapidly (approximately one second to change from one speed to the next) and short marks or spaces ensure that the control unit travels smartly to the right position and stops correctly. A maintained mark or space will cause the slider to move to full ahead or full astern when the limit switches will stop the Servo motor.



Resistances R3 and R4 in Fig. 67 are current-limiting resistances in case Ry6 and Ry7 come in together. This can happen if a mark is sent closing Ry6 and while the maintaining action is still in progress a space is received. In this event Ry7 comes in and Ry6 drops out immediately. For a split second, however, the battery is shorted through R3 and R4 but by adjusting these to limit the current to about one amp. welding of the relay contacts is avoided.

Astern of the control unit is the engine compartment seen in Fig. 60. Fig. 68 shows the remaining gear in the stern. The fuse unit and generator control can be seen and in the next compartment the main battery which is really in two sections. Finally, the stern compartment houses the rudder motor (permanent-magnet type) with its associated limit switches, rectifiers, etc.

The boat in which this gear is installed is 54 in. long and its general layout can be seen from Fig. 69.

## 8

### A SIX-VALVE SUPERHETERODYNE RECEIVER FOR MODEL CONTROL

READERS who have attended radio-controlled model meetings or watched demonstrations will realise that in most cases only one model can be operated at a time

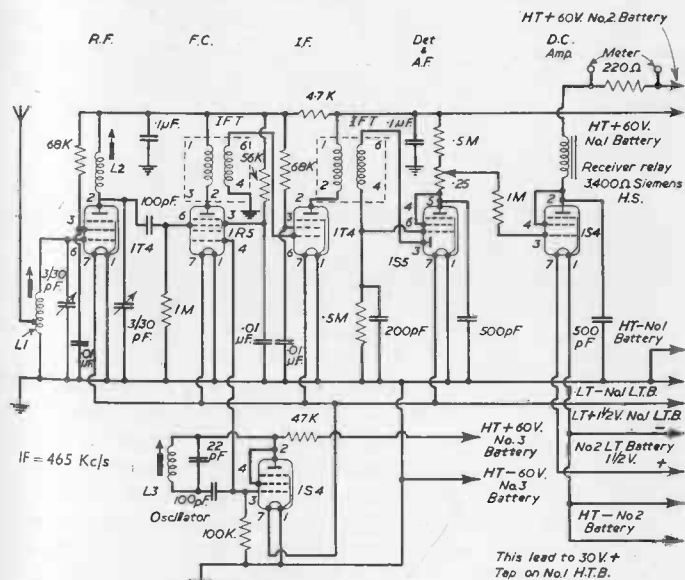

FIG. 70.—Circuit of the six-valve superhet model control receiver.

and that it is always necessary to take great care to avoid the accidental switching on of any transmitter not being used for the control of the model, so as to prevent putting the model out of control. This is due entirely to the fact

that super-regenerative receivers (such as that described in Chapter 2) are highly sensitive but very unselective. This type of receiver will usually respond to a transmitter tuned anywhere in the model-control waveband, although a small amount of success can be obtained with two models by tuning transmitters and receivers to opposite ends of the waveband and keeping the models well apart and away from the other transmitter.

The 27 Mc/s model-control waveband is, however, 320 kc/s in width, and by using selective receivers it can easily be split up into a series of channels which can be allocated to members in the case of a club. With the superhet receiver to be described the selectivity is of the same order as a broadcast receiver, i.e., 10 kc/s approximately between channels. Therefore, it is theoretically possible to use up to thirty-two models simultaneously.

**The Design.**—The receiver is designed to fulfil the following requirements:

- (a) To be highly sensitive and selective.
- (b) To be reasonably light (it is fitted to a 36-in. long boat).
- (c) To be reasonably economical on batteries.
- (d) To use the mark/space system of control (carrier wave transmission only).

It should perhaps be pointed out that, due to the very highly selective nature of this receiver, the simple transmitter described earlier cannot be used, and it is essential to make use of a crystal-controlled transmitter. This is, however, a simple one-valve affair using an overtone crystal (Q.C.C.).

Due to the confined space in the model, all tuning adjustments must be carried out from the top of the receiver, and consequently all trimmers and the potentiometer were made accessible for screwdriver adjustment looking down on to the top of the chassis. Fig. 71 shows this view.

As in all superhet receivers, it is the oscillator circuit which exercises control of the received frequency, and it cannot be emphasised too strongly that this stage must be wired up rigidly so as to avoid any possible movement of components or coil turns when in use. To avoid so far as possible the effects of falling voltage from the H.T.

source, a separate battery of 60 volts is provided. As the current consumption of this stage was only 0.7 mA in the original, the voltage drop was negligible on an average run.

A considerable number of experiments has been carried out on the stability of this receiver, and without doubt the major change of frequency is caused by temperature variation. A point must therefore be made of switching on the receiver and leaving the model in the water for at least ten minutes before tuning up to the transmitter.

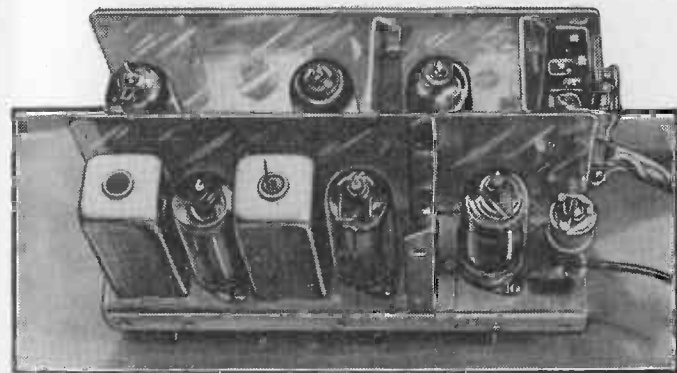

FIG. 71.—A top view of the completed receiver.

**The Circuit.**—Referring now to Fig. 70, the circuit follows orthodox practice, except in the last stage, which is a direct-coupled amplifier. A radio-frequency amplifier (1T4) is capacity coupled to the mixer grid of an 1R5, which in this case is used solely as a mixer. Local oscillations are generated separately in the 1S4 oscillator stage, which is triode connected, and these are injected into No. 1 grid of the 1R5. The intermediate frequency thus developed is fed into the I.F. transformer and then into the 1T4 I.F. stage. After the second I.F. transformer, detection is carried out normally using the diode of the 1S5, and the rectified output is then fed by direct coupling to the grid of the amplifier section of the 1S5, which is triode connected. No A.V.C. circuit is used or is necessary.

It must be mentioned that the receiver was designed for receiving non-modulated transmissions for mark/space control, and if at this point, conventional capacity couplings

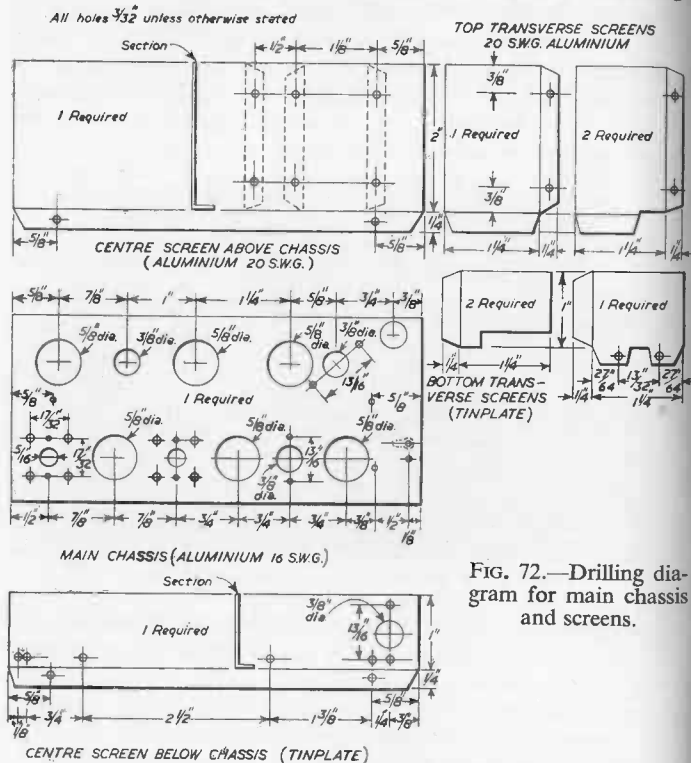

FIG. 72.—Drilling diagram for main chassis and screens.

had been used the signal would have been lost. If, however, it is required to use the receiver to operate tuned reeds, then normal radio couplings and bias circuits can be introduced.

The anode of the 1S5 is thus now rising and falling in voltage at mark/space frequency due to the current flowing through the potentiometer and fixed resistor of  $.5 \text{ M}\Omega$  forming the anode load.

The slider of the potentiometer is arranged to select, within a prescribed range, the exact voltage necessary just to feed by direct coupling (via the  $1 \text{ M}\Omega$  safety resistor)

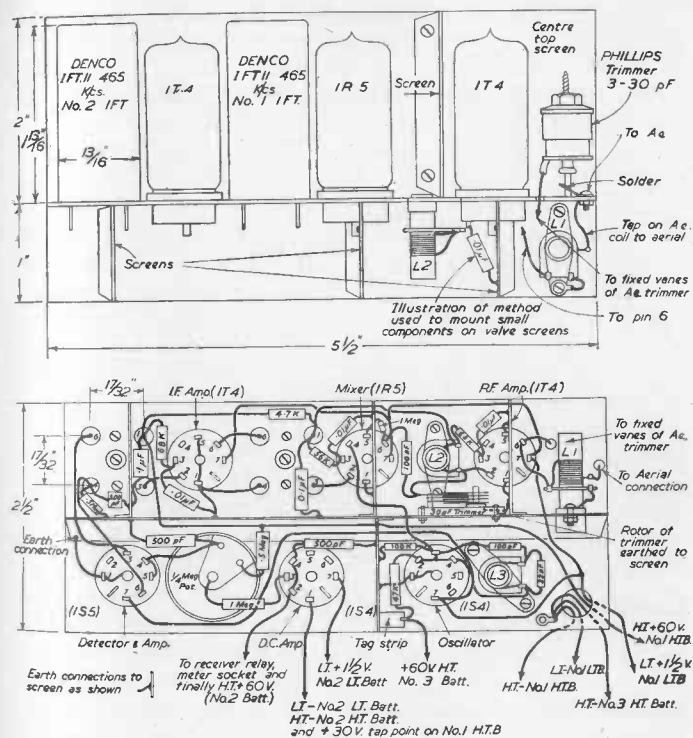

FIG. 73.—(Top) The R.F. and I.F. side of chassis. (Below) The underside of chassis.

the grid of the final triode-connected 1S4, so as to cause current cut off when a space (no signal) is transmitted. To attain this condition, which would normally be impossible, as the anode of the 1S5 would be positive with respect to the grid of the 1S4, it is necessary to raise the D.C. potential of the filament of 1S4 (not the applied voltage, of course)

by connecting the H.T. of this valve to the 30-volt positive connection of the normal H.T. supply. With battery valves this, unfortunately, means that the filament supply of the 1S4 must now be separated from the supply to the remainder of the receiver, as it is 30 volts positive with respect to chassis. A single U2 cell feeds this valve.

The operation of the last two valves is then as follows:

Normally the 1S5 amplifier section draws a fixed current through its anode load, which causes its voltage drop, and the anode is, therefore, at a potential of, say, 20 volts positive. This voltage appears at the grid of the 1S4, but since its filament is at a voltage of 30 volts positive (with respect to earth) the effect is as if the grid were 10 volts

negative. Hence no anode current can flow and the relay in its anode circuit is open.

If, however, a signal appears at the last I.F. transformer, it is rectified and a negative voltage is applied to the grid of the amplifier section of the 1S5. This causes the anode current to drop and the potential at the anode then rises in a positive direction. The grid of the 1S4,

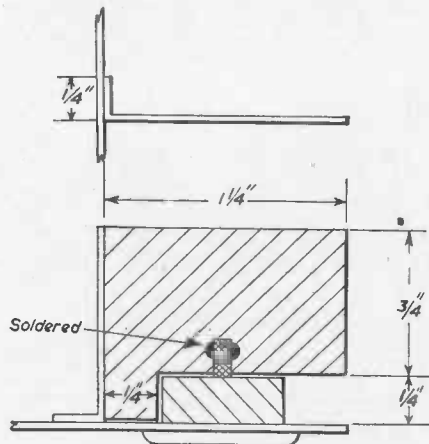

FIG. 74.—Method of cutting and mounting valve base screens (R.F. and mixer stages). The material used is thin tinplate.

therefore, is driven positive, and at a point of about 5 volts negative the valve starts to pass anode current. Usually the signal is sufficient to drive the grid of the last valve to a point where it is positive with respect to its filament, and the full anode current will pass with the consequent closing of the relay. Grid current is limited by the 1 M $\Omega$  grid resistor

and anode current by the relay resistance and the limited H.T. voltage applied. The potentiometer is used to set the anode current of the last valve so that it is just cut off when no signal is being transmitted.

Note that this receiver works on the current rise principle,

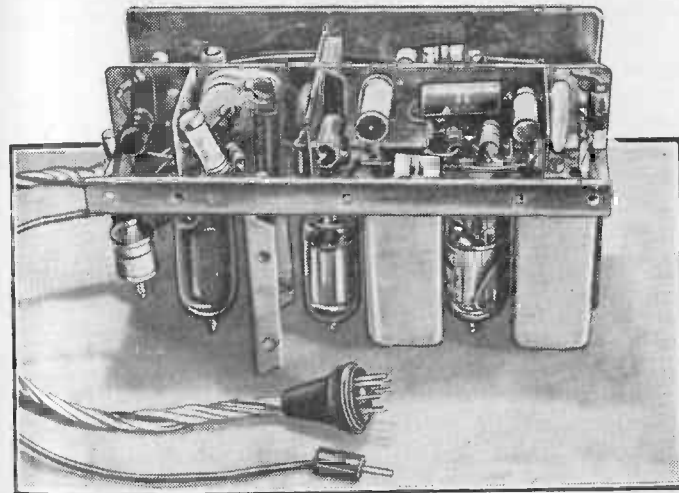

FIG. 75.—A view of the underside of the chassis.

not the current drop on receipt of a signal, as is the case with the single-valve super-regenerative receiver.

**Construction.**—The chassis is built up from a piece of 16 s.w.g. aluminium sheet 5½ in. by 2½ in., and in the original ⅜-in. flanges were added at each side for the mounting of side plates to protect the valves and assist screening. Later models dispensed with this, however. As can be seen from the photograph (Fig. 71) there is a central aluminium screen (20 s.w.g.) running the full length of the chassis on top, which separates the R.F. mixer and I.F. stages from the L.F. and oscillator stages. In addition there is a small vertical aluminium screen between the R.F. and mixer valves and between the D.C. amplifier

and oscillator valves. These screens assist stability in the receiver and also make the chassis strong and rigid, which is very necessary with the superhet design. A further aluminium screen is used just past the oscillator trimmer so increasing chassis strength and assisting screening. Below the chassis there is a similar full-length screen and in addition there is a number of small screens, two of which (R.F. and mixer) lie across the valve bases to screen the input and output pins, also to separate the aerial and H.F. coils. These under-chassis screens are all made from tinfoil, which means that soldering is easily accomplished. They are, in fact, soldered in place both to the valve base and to one another. The central screen must be bolted to the aluminium chassis.

Figs. 72, 73 and 74 illustrate the general layout of the receiver and the screens, and they also give the main dimensions for drilling the chassis and screens.

The precise positioning of some of the holes will depend to a certain extent upon the actual components to be used and it is, therefore, as well to collect all of the parts before drilling.

Details of the coils are given in Fig. 77, and here use is made of paxolin terminal boards to anchor the ends of the wires used in winding the coils. These are necessary as none of the commercially available paxolin tag boards is small enough for this receiver. The coils are all simple single windings with the exception of L1, which is tapped at five turns from the start (earth end) to make the aerial connection. Winding direction is not important. Coils should be wound very tightly and doped with polystyrene cement to fix the windings.

Full wiring details are given in Fig. 73, from which it will be seen that all wiring takes place under the chassis except for the aerial trimmer connection which is made through a hole in the chassis. The aerial lead also passes through a nearby hole.

A little difficulty may be experienced when attempting to fit the under-chassis valve-base screens, and care must be taken first to mount the valveholders the correct way

(see wiring plan) and, secondly, to ensure that the centre spigot is firmly soldered to the screen.

Tags 1 and 5, both of the R.F. stage and the mixer stage valveholders, must also be earthed by soldering to the screens, but no other tags must touch them.

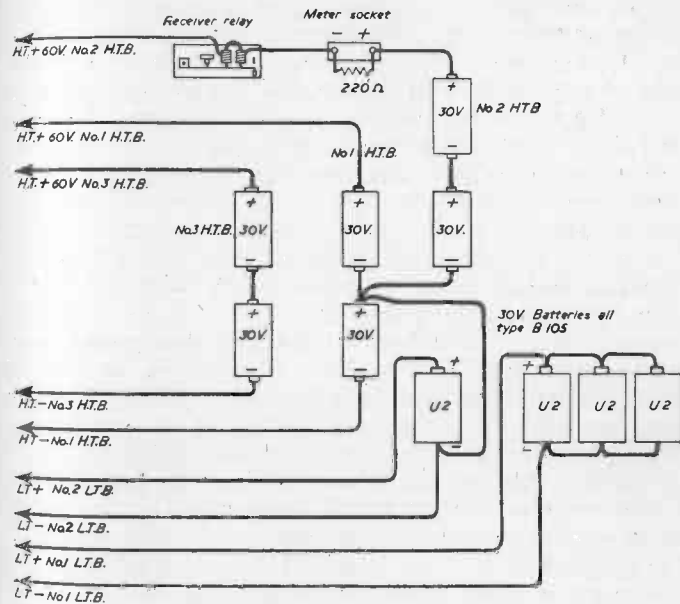

FIG. 76.—Method of connecting up H.T. and L.T. batteries, also relay and meter socket.

**Testing and Aligning.**—When wiring has been completed, tests should be carried out. Batteries, relay and meter should first of all be connected as shown in Fig. 76. This may seem complicated, but, as previously mentioned, it is partly caused by the requirements of the D.C. amplifier and partly by the need for frequency stability in the oscillator. In the original, six type B105 hearing-aid batteries were used for the H.T. and three U2 cells for the main L.T., while one U2 cell supplied the D.C. amplifier valve.

While testing, a 5 mA meter should also be connected in the H.T.+ lead to HTB No. 1. The 1S5 valve should now be plugged in and a small fraction of a milliamp will be drawn from HTB1. The D.C. amp. (final valve) 1S4 should be plugged in and the other meter watched (the tuning meter).

The potentiometer spindle should now be rotated, and in the full anti-clockwise position it should be found that the anode current of the 1S5 is cut off. Rotating the other way will cause full current to flow and the relay will close. A rise of about 7 mA is given in the original, which is more than adequate for good relay action. Now reset the potentiometer so as just to cut off the 1S4 current.

The 1T4 I.F. amplifier valve should now be plugged in and an increase should be noted in the meter to HTB1. The 1R5 mixer should then be plugged in and a further increase noted. At this point the I.F. transformer must be aligned to 465 kc/s, and this is a job calling for a signal generator, although it may be found possible to align on the transmitter if by chance the slugs of the I.F. transformer are sufficiently near to tune to enable a response to be obtained. This cannot, of course, be done until all the valves are in position and the oscillator set to a frequency of 465 kc/s under or over the normal crystal frequency of the transmitter.

Using the signal generator to align the I.F.s, a signal should first of all be applied to pin 6 of the I.F. valve (1T4) through a 50 pF condenser and IFT2 cores adjusted for maximum reading of the D.C. amplifier anode current (taking care to keep the signal strength low). Secondly, IFT1 should be adjusted by injecting the signal at the grid of the mixer valve (1R5) pin 6. It is most important that all cores peak to maximum without instability arising, which will show as a reading on the D.C. amplifier meter even with the signal generator off. The good screening and decoupling of this receiver helps a lot in this respect, but in difficult cases a resistor of about  $\frac{1}{4}$  M $\Omega$  can be shunted across pins 4 and 6 of IFT1. This will damp the grid

circuit of the L.F. stage, and the slight loss of selectivity does not matter.

Finally, all remaining valves should be inserted, when it will be found that the total HTB1 current is about 4 mA. HTB2 varies from zero to 7 mA on signal and HTB3 should be less than 1 mA, previously stated.

By adjusting the oscillator coil tuning slug it should now be possible to receive the transmitter signal, and this should be peaked by adjusting the aerial trimmer condenser in conjunction with the slug of L1 and the air spaced trimmer (below chassis) and the slug of L2.

The oscillator adjustment is the master control; it is

FIG. 77.—How the coils are wound. All formers are  $\frac{1}{4}$ -in. Aladdin type. L1, 15 turns 32 s.w.g. enamelled copper, tapped at five turns from bottom (earth) end. L2, 15 turns 32 s.w.g. enamelled. L3, 10 turns 24 s.w.g. enamelled. The direction of winding is unimportant.

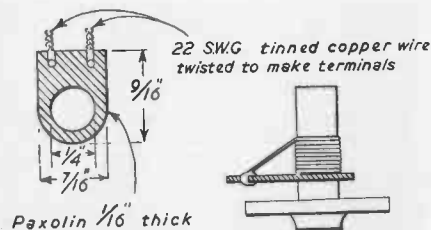

useless adjusting L1 and L2 until you get a signal by setting the core of L3. The setting of the oscillator slug is very critical and it must be turned slowly.

As would be expected, the transmitter will be received at two points when adjusting the oscillator tuning slug, and if there is any difference in strength, then obviously the stronger should be chosen.

Satisfactory results have been obtained at ranges up to 150 yards, at which point the model is practically invisible. This receiver is not so critical to aerial length alteration as are super-regenerative types, and in general the longer the aerial, the better; make sure, however, that L1 can be peaked for maximum signal strength.

Note from Figs. 71 and 75 that in the original, a midget B7G type plug is used to connect up the receiver to the battery socket in the model. This is very useful, as it



means that the receiver can be removed at any time without the trouble of disconnecting leads and heating the soldering iron. A single plug and socket also connects the aerial.

As previously mentioned, all adjustments for tuning the receiver are made from the top (except the two slugs of the I.F. transformers, which are under the chassis and which should not need touching after once aligning). Tuning should be carried out in the model by using a plastic knitting needle or similar non-metallic rod which has been sharpened to a screwdriver, and this will avoid difficulties due to metallic objects affecting the tuning. Slugs in the Aladdin formers should be made firm by rubbing something like zinc ointment into the threads. Fluxite has been used for this purpose quite successfully.

#### PARTS LIST

##### Six-valve Superhet Model-control Receiver

- 3  $\frac{1}{4}$ -in. Aladdin coil formers with slugs.
- 1 3-30 pF Philips trimmer.
- 1 3-30 pF midget air spaced trimmer.
- 6 Ceramic B7G valveholders.
- 2 "Denco" miniature I.F. transformers (Ref. No. 1FT11—465 kc/s.)
- 1  $\frac{1}{4}$ -M $\Omega$  miniature potentiometer (linear law if possible).

##### RESISTORS (all $\frac{1}{4}$ watt)

1 4.7 K $\Omega$ .	1 47 K $\Omega$ .	2 68 K $\Omega$ .	2 1 M $\Omega$ .
1 220 $\Omega$ .	1 56 K $\Omega$ .	1 100 K $\Omega$ .	2 .5 M $\Omega$ .

##### CONDENSERS

1 22 pF ceramic.	3 .01 $\mu$ F 150-volt wkg. (Hunts midget type).
2 100 pF ceramic.	
1 200 pF ceramic or silver mica.	2 .1 $\mu$ F 150-volt wkg. (Hunts midget type).
2 500 pF mica or ceramic.	

##### VALVES

2 IT4.	1 IR5.	1 IS5.	2 IS4.
--------	--------	--------	--------

##### MISCELLANEOUS

Tinplate and aluminium for chassis.  
 6-B.A. and 8-B.A. nuts and bolts.  
 Systoflex (1 mm.), enamelled copper wire for coils, tinned copper wire (22 s.w.g.) for connecting up, flexible wire for leads, paxolin, polystyrene dope, etc.

## 9

### A SINGLE-VALVE CRYSTAL-CONTROLLED TRANSMITTER

THIS transmitter is of very simple design and is given because of its suitability for operation with the superhet receiver described in the previous chapter which, due to its high selectivity could not be worked with the two-valve



FIG. 78.—Model of an Admiral's barge being prepared to compete in an I.R.C.M.S. annual contest. This model employs a superhet circuit to enable simultaneous operation to be carried out with other models using this circuit.

transmitter described in Chapter 3. Before proceeding further, however, it must be pointed out that this transmitter is not capable of such a high output as the two-valve unit, moreover, it is, in spite of its simple circuit, quite critical in



its initial adjustments, although once set up it will work without attention almost indefinitely. It is particularly suitable for controlling model boats and land vehicles but for model aircraft, which will, on account of weight limitations, almost certainly use super-regenerative receivers, the use of the two-valve type of transmitter already described is recommended. A transmitter of this type may be seen in use in Fig. 78.

**Transmitter Details.**—The circuit makes use of a 27 Mc/s over-tone crystal manufactured by the Quartz Crystal Co. Ltd., Kingston Road, New Malden, Surrey. This type of crystal is not suitable for use at parallel resonance and a series resonance type circuit must therefore be used.

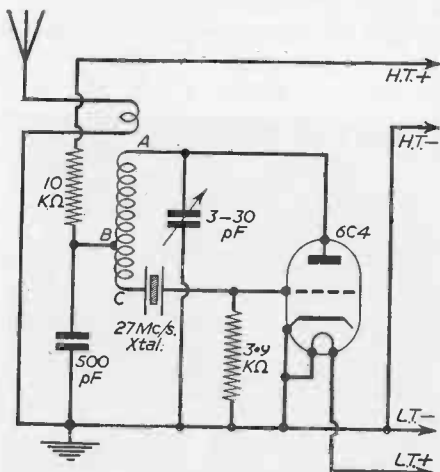

FIG. 79.—Single-valve transmitter circuit.

requires the use of a triode valve with a high gm. and the 6C4 type works very satisfactorily. This is an indirectly heated valve but the current requirement is only .15 amps. (at 6.3 volts), so this can easily be met. Two twin-cell cycle lamp batteries can be used to provide heater current for the transmitter. These batteries are used for the transmitter only—not the control box, and will last for many months with normal use.

It is the anode coil and the position of its tapping which makes the circuit rather difficult to set up initially. Although this is wound as a single coil with a tapping point it is best

thought of as two separate coils. The top half (A-B) is tuned by the 3-30 pF trimmer and the circuit is completed through the 500 pF T.C.C. "Micadisc". This part of the coil should resonate in the 27 Mc/s band and with the coil described this will take place with nearly minimum capacity in circuit. The lower half of the coil (B-C) is the feed-back portion necessary to maintain oscillation. If too many turns are used (i.e., too much feed-back) the circuit self-oscillates and the crystal loses control, whilst if too few turns are used no oscillation takes place. If the tapping point is adjusted to alter feed-back then the tuning of the top half is altered at the same time. For these reasons it is recommended that the coil winding instructions given are followed very carefully so as to ensure correct operation.

Fig. 79 shows the actual circuit used which is a modified Hartley type and is usually termed the Squirer's Circuit. It

The remainder of the circuit is conventional the 10 KΩ resistor being simply a current regulator and R.F. stopper. The makers of the crystal state that if the H.T. supply is 150 volts from a regulated source, the value of this resistor can be reduced to 1000 Ω. If the transmitter is fed from a dry battery H.T. source of 150 volts, this condition would apply.

**Construction.**—The transmitter unit is constructed on a base of  $\frac{1}{16}$ -in. thick paxolin sheet and this is drilled as shown in Fig. 80. The two-pin crystal has a pin spacing

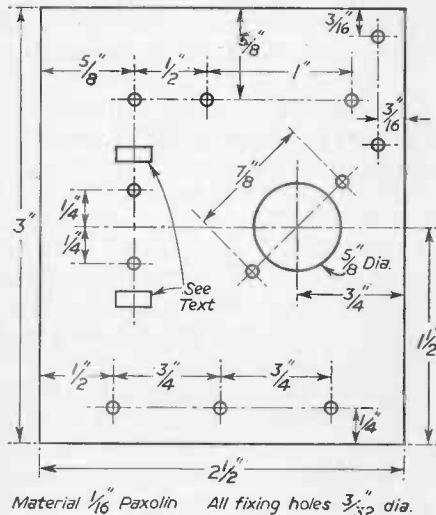

FIG. 80.—Drilling plan for one-valve transmitter.

of  $\frac{1}{2}$  in. and can be plugged into an International octal valveholder. Commercially made holders for the crystals are available but rather difficult to obtain. It is possible, however, to use two of the socket clips from an old I.O. valveholder of the paxolin type. The baseboard for the transmitter is drilled and cut to accept them as shown in Fig. 80. If a commercial crystal holder is available so much the better.

As previously stated, the coil in this transmitter is quite critical and this should be wound as follows:

Use 18 s.w.g. enamelled copper wire and wind on an  $\frac{11}{16}$ -in. diameter former. A tubular condenser was used as a former for winding the original, but if you do not have one of the right diameter, roll a strip of paper round a smaller diameter dowel or condenser until the correct size is obtained. A total of 24 turns is required, with the tapping at the 15th turn. Stubs of wire  $\frac{1}{4}$  in. long are left for connecting up and the tapping is formed by baring approximately  $\frac{1}{2}$  in. of wire and doubling back so as to form a  $\frac{1}{4}$ -in. stub for soldering to the mounting tag. The winding should be close wound but being of a fairly heavy gauge it will inevitably spring apart slightly when taken off the former.

All components should now be mounted and solder tags bolted to points X, Y and Z in Fig. 81 (battery connections), E (below chassis) and D (above chassis) and on both sides of the chassis at points A, B and C. The tags above chassis at A, B and C are intended for mounting the coil, which should be soldered in position. This three-point mounting will be found to make it reasonably firm and no difficulty has been found in this manner of construction. The remainder of the wiring is straightforward and is shown in Fig. 81.

Note that the tag of the crystal socket nearest to tag C (below chassis) should be soldered to tag C.

The only other point which needs to be mentioned is the aerial coupling loop. This is a two-turn winding one end of which is soldered to tag D. This tag also forms the point for attaching the aerial lead. The other end of the aerial loop is earthed to tag E through a hole in the paxolin.

The aerial coupling will have to be adjusted and this is done by bending the loop away from the anode coil.

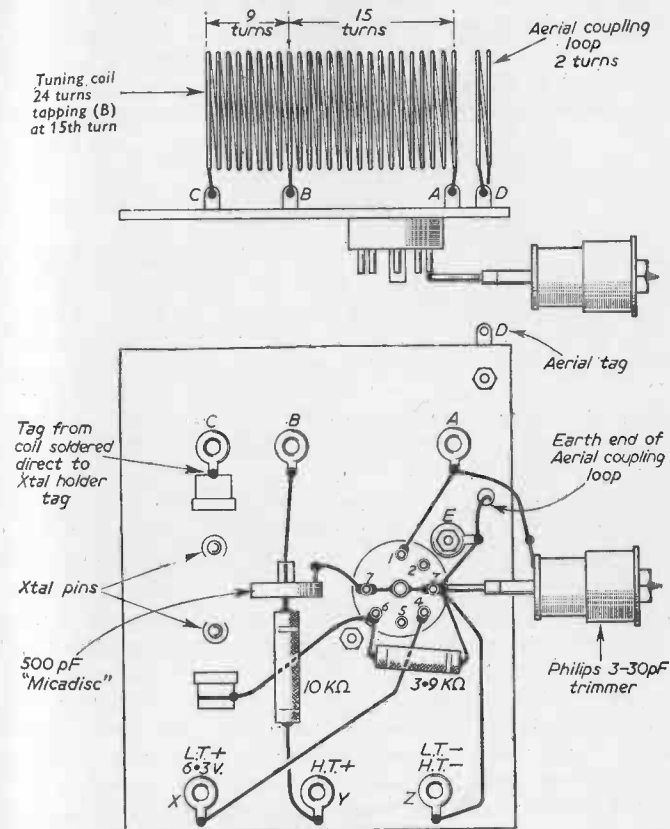

FIG. 81.—Wiring diagram and component layout for one-valve transmitter.

Initially, the loop should be separated from the anode coil by about  $\frac{1}{4}$  in. as too much coupling will prevent oscillation.

**Testing.**—For testing the unit, power supplies of 6 volts L.T. and 200–250 H.T. are necessary. As previously

mentioned dry battery sources can be used but it is better to use 2-volt L.T. accumulators and a small rotary transformer for H.T. These will be discussed later. The valve and crystal should be plugged in and a 0-30 mA meter connected in the H.T. lead. A wavemeter, such as that described in Chapter 4 is almost essential for tuning up as it enables the operator to confirm that the transmitter is operating in the band and radiating correctly. With power supplies turned on, a steady current of 10 mA will be drawn and the trimmer should now slowly be rotated, preferably with an insulated trimming tool.

At one point a definite dip in anode current will occur and a reading obtained on the wavemeter. If the crystal is in control the reading will be on the crystal frequency in the 27 Mc/s band. If excessive feedback is being applied, however, self oscillation will occur at other points in the rotation of the trimmer and this will result in off-frequency working. The effect should be counteracted by gently bending away turns from the feedback section of the coil (i.e., those connected to tag C). These should be bent away from the main portion until oscillation takes place only on the crystal frequency. The aerial coupling loop can only be set up with the full aerial extended and this is, therefore, best left until later.

**The Complete Transmitter.**—The transmitter carrying case and the method of mounting the transmitter are matters of personal taste and are dictated to some extent by the power supplies to be used. Fig. 82 shows the way the prototype equipment was mounted. The case is made from tinplate which solders very easily and access is gained by a sliding panel. This avoids the use of screws or bolts and is recommended as being highly convenient for making adjustments and for removing the batteries for recharging.

The case size is 10 in.  $\times$  8 in.  $\times$  4½ in. H.T. is obtained from a Hoover rotary transformer, supplies of which may be available on the surplus market. They usually cost about 15s., weigh 20 oz., and measure 2 in. diameter  $\times$  4½ in. long. It would be possible to operate this rotary transformer from 6 volts but this would tend to under-run the

transmitter and 8 volts are, therefore, used in the circuit given in Fig. 83. With fully charged batteries an H.T. voltage of 240 volts is available which is adequate for the transmitter and provides enough spare current to power the control box in addition.

Details of the multivibrator control box for use with this transmitter (Fig. 59) were given in Chapter 4, but it

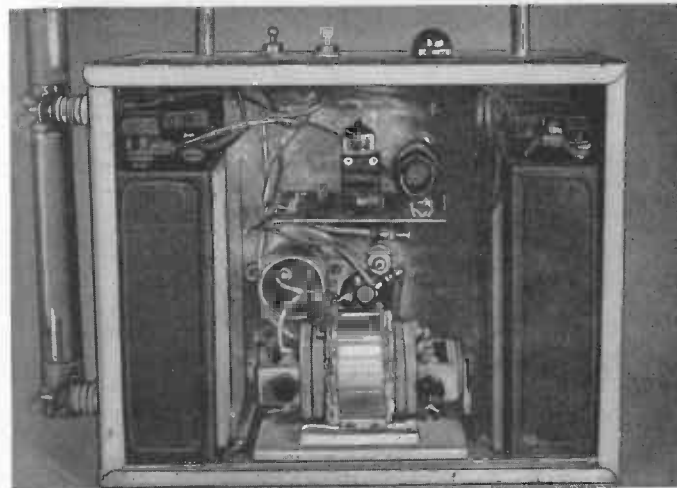

FIG. 82.—The single-valve transmitter shown in its case with rotary transformer H.T. power supply. The socket, visible at the back, is for plugging in the control box.

can, of course, be used with any type of control system. Four 2-volt 10-amp.-hour accumulators are used and these are of the type at present available on the surplus market from Lasky's Radio, 370 Harrow Road, London, W.9. Two accumulators are mounted at each end of the case and this balances the weight, which makes for ease of carrying. Smoothing of the H.T. is obtained by means of the 8  $\mu$ F electrolytic condenser shown and is adequate for pulse or mark/space operation. An additional choke-capacity filter may be necessary if modulation of the



the turns at the grid end of the coil (i.e., at C in Fig. 81). Too much aerial coupling will prevent oscillation. Fig. 84 shows the correct position of the trimmer for tuning a crystal oscillator (i.e., just before the peak).

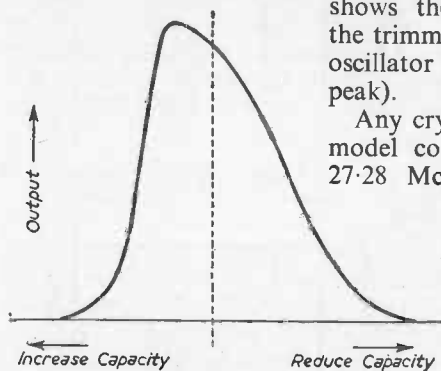

FIG. 84.—The correct position for tuning the transmitter which is just before the peak.

Any crystal frequency in the model control band (26.96 to 27.28 Mc/s) can be specified and used in this transmitter and, by arranging arbitrary frequency separation between transmitters, it is possible for several models to work simultaneously.

#### PARTS LIST FOR TRANSMITTER UNIT

- 1 27 Mc/s Overtone crystal (Type FO) and holder.
- 1 B7G valveholder.
- 1 6C4 valve.
- 1 3.9 K $\Omega$   $\frac{1}{2}$ -w. resistor.
- 1 10 K $\Omega$   $\frac{1}{2}$ -w. resistor.
- 1 500 pF T.C.C. "Micadisc".
- 1 3-30 pF Philips trimmer.
- 18 s.w.g. enamelled copper wire, paxolin, nuts, bolts, solder tags. Connecting-up wire, Systoflex, etc.

#### ADDITIONAL COMPONENTS TO MAKE COMPLETE TRANSMITTER

- 4 2-volt accumulators.
- 1 Hoover rotary transformer (11.5-volt input, 310-360-volt output).
- 2 Q.M.B. type single-pole switches.
- 1 8  $\mu$ F 350-volt working electrolytic condenser.
- 1 0-30 mA meter.
- 2 stand-off insulators for aerial mounting.
- 1 telescopic aerial.
- 1 indicator lamp (6/8 volt bulb).
- 2 .01  $\mu$ F mica condenser.
- 1 22  $\Omega$  resistor.
- 1 5-way plug and socket (for control box).
- 1 transmitter case.

## 10

### RADIO CONTROL FOR MODEL AIRCRAFT (SEQUENCE SYSTEM)

THE radio equipment for controlling model aircraft can very well be that described in Chapters 2 and 3. The meter socket as originally described will be inconvenient



FIG. 85.—A typical radio-controlled model aircraft.

for most aircraft, and a suitable metering point should be made on the fuselage. The meter should be fixed here for tuning up and then withdrawn for flight. The photograph (Fig. 85) shows the meter in position in a typical radio-controlled model. The receiver should be suspended within the fuselage from taut rubber bands which will permit considerable freedom of movement, absorb engine vibration and at the same time protect the receiver in the case of a hard landing.

The transmitter can make use of the quarter-wave vertical aerial (8 ft. 6 in.) as originally described, but for model aircraft use many enthusiasts prefer a "Vee" type of half-wave dipole. This consists of two 8 ft. 6 in. rods (either sectioned or telescopic for transport) mounted as shown in Fig. 86. An array of this type produces a stronger and better radiation pattern than the vertical aerial. The energy from the transmitter is directed in a lobe vertically upwards and extending almost to ground level on each side of the aerial at right angles to the axis of the aerial rods. A vertical aerial has a dead spot directly overhead, which is, for model aircraft work, the worst possible place.

**Suitable Type of Model.**—The type of model aircraft to be employed for radio control should have certain attributes. It must be robust, easily constructed, large enough to carry the radio, batteries and control gear and have inherent flying stability to enable it to recover from any peculiar attitude which the inexperienced pilot can so easily produce.

In order to meet these requirements, a fuselage of rectangular section often referred to as a "Slab Sider" is suggested. Models of this type can be made to look very realistic, are easily constructed, and readily repaired should damage be sustained.

The size depends on the complexity of the intergear intended, but it is strongly recommended that the beginner should stick to simple rudder control, which will enable him to execute most known aerobatics. It is suggested that the wing span should be between 4 ft. and 5 ft., with a wing loading of between 12 oz. to 14 oz. per square foot. The front end of the fuselage should be sheeted from the nose to the rear of the cabin as this is where all the radio weight is carried and most damage sustained in the event of a hard landing. The tailplane area should be approximately 30 per cent. of the main plane, whilst the fin should be in the region of 9 per cent. and the rudder 25 per cent. of the fin area. It is more effective to steer by moving a large rudder a small amount than vice versa.

There is a considerable freedom in the choice of engine to be employed as either glow-plug, deisel or petrol is

suitable, but for the size of plane suggested, the engine should not be less than 2.5 c.c. in capacity.

**Simple Control System.**—The easiest mechanical method of obtaining controlled rudder movement in a model aircraft is by means of a simple rubber-driven actuator, which converts the radio signal received into controlled mechanical movement.

There are several types manufactured and available through the model shops. They usually consist of a two-armed star or pawl driven by a skein of  $\frac{1}{8}$ -in. or  $\frac{3}{16}$ -in. rubber,

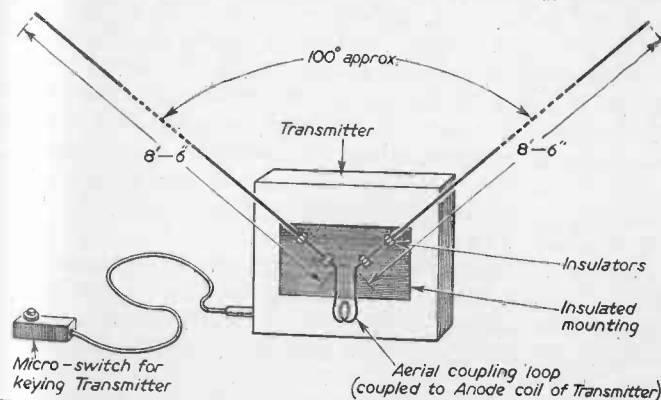

FIG. 86.—Vee-type aerial for use with model aircraft, giving increased radiation and a better field strength pattern.

often only one loop being employed. Fig. 87 illustrates the principle employed. The star is prevented from rotating by means of a claw-ended armature which is operated by an electromagnet. When the actuator is at rest, one end of the star wheel is held against one of the claw ends of the armature. On receipt of a signal from the transmitter the receiver anode current drops and the receiver relay opens, thus completing a circuit through the magnet bobbin of the actuator and creating a magnetic force which pulls the armature claw towards it and releases the star wheel. This now rotates until caught by the claw on the other end of the armature, which is so positioned

that it will hold the star wheel after a quarter of a turn and on cessation of the signal will allow the star to turn another quarter of a turn when the opposite end is caught by the first claw. This operation is repeated for each signal transmitted. To complete the mechanical application, it is necessary to attach a crank to the spindle of the star wheel which, when coupled to the rudder by means of a hairpin loop within which it rotates, moves the rudder to the desired position.

During the absence of a transmitted signal, the crank is arranged to be in a vertical position. On receipt of a signal the crank moves a quarter of a turn to a horizontal position, thus moving the rudder to the left, where it stays for the duration of the signal. When the signal ceases the crank rotates a further quarter of a turn and now rests in the opposite position when the rudder is once again at centre or neutral. The next signal will give right rudder returning to the original centre or neutral position when transmission ceases.

This is known as the self-centring type of actuator, and it will be seen that to go left and then left again means passing through the right position of the rudder. This, however, happens so quickly that it has no apparent effect upon the model. Should the aircraft fly out of control, this system ensures the rudder being in the neutral position, thus avoiding the possibility of a spiral dive to the ground. Its only defect is the need to remember whether the next signal to be transmitted will give left or right rudder.

**An Escapement-controlled Actuator.**—An improvement on the actuator just described, which will enable the operator to select the direction of turn at will, can easily be made, using a commercially manufactured actuator unit, with current-saving device embodied in its construction. These can be procured from most model shops, and the general arrangement of the unit, when modified, is shown in Fig. 88 (*A* to *E*).

The first alteration is concerned with slowing down the speed at which the driving shaft and star wheel rotate when released by the armature claw. This is necessary to

enable the operator to transmit a definite signal sequence during the period of a revolution (or part of a revolution).

The actuator is first mounted on a piece of thin paxolin or other insulating material which is  $\frac{1}{16}$  in. thick and shaped to fit into the required position in the fuselage of the plane. On the opposite side of the paxolin the driving shaft extends through a suitable hole and is shaped to form a

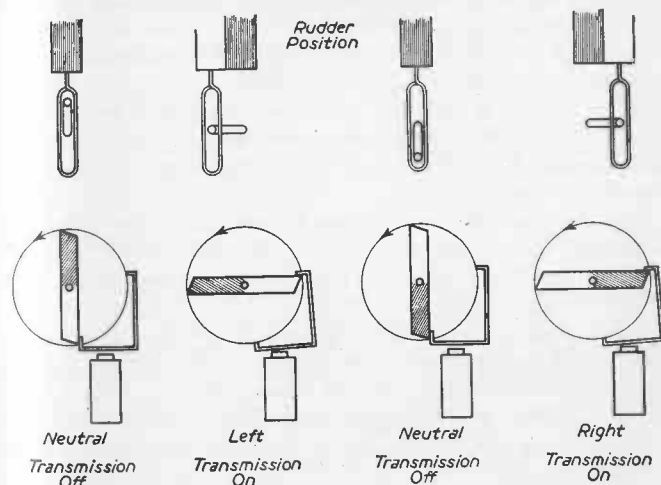

FIG. 87.—The principle of the rubber-driven actuator, showing the sequence.

hook upon which the elastic motor is attached (*B* in Fig. 88). On this shaft is soldered a toothed wheel, which is made roughly the size and shape of a penny, about  $1\frac{1}{4}$  in. diameter with a  $\frac{1}{16}$ -in. hole drilled in the centre, to be a nice fit on the actuator drive shaft would suit. The perimeter is filed into teeth  $\frac{1}{16}$  in. deep with  $90^\circ$  sides, using a small square file. The  $1\frac{1}{4}$ -in. diameter wheel has 32 teeth, but the number of teeth is not important. The discs should be made from steel, as a softer metal will wear too rapidly. *C* and *D* in Fig. 88 illustrate stages of the construction. The finished toothed wheel is soldered to the actuator drive



shaft so that it is approximately  $\frac{1}{2}$  in. from the baseboard and rotates truly. When finished, the drive shaft must be perfectly free to turn. An escapement is now made from a piece of thin steel sheet about 23 or 24 s.w.g. This is shaped as shown at *D* in Fig. 88 and drilled to take a brass tube which acts as a bearing on a 6-B.A. bolt; this tube is soldered at right angles and protrudes  $\frac{1}{8}$  in. on each side.

A hole to take the 6-B.A. countersunk-headed screw is drilled  $\frac{7}{8}$  in. from the centre of the drive shaft on the centre line of the paxolin and a 3-in. long 6-B.A. screw fitted and locked up tightly with two lock-nuts. The escapement is now mounted on this and held in place with a washer and "Simmonds" self-locking nut, which is taken up until all surplus play is restricted, yet the escapement is perfectly free to oscillate.

The vertical edges of the escapement are now filed and adjusted until when one side of the escapement enters a toothed groove the other side of the escapement rides over a tooth into the next groove. This causes the escapement to rock quickly and retards the speed of the driving shaft. This speed can be further reduced by adding weights to the wings of the escapement. The correct speed is about  $\frac{3}{4}$ -1 sec. per revolution. Weights can be added simply by adding blobs of solder to the wings of the escapement.

**Alterations to the Actuator.**—The type mentioned has one wire from the electromagnet earthed, i.e., taken to the metal frame of the actuator. This feature will be employed later to obtain another channel of control.

The clawed armature is first removed and a tongue of brass of similar thickness is soldered (silver soldered for preference) to the top edge of the claw, which is away from the magnet. The height of this attachment is  $\frac{1}{8}$  in. and the whole is filed and dressed up perfectly smooth with the original (see *E* in Fig. 88).

The rotating two-armed star wheel now receives attention. One arm is sawn off about  $\frac{1}{4}$  in. from the centre and a piece of brass wire (welding wire will serve) which has previously been cranked about  $\frac{1}{8}$  in. is soldered on in such a position

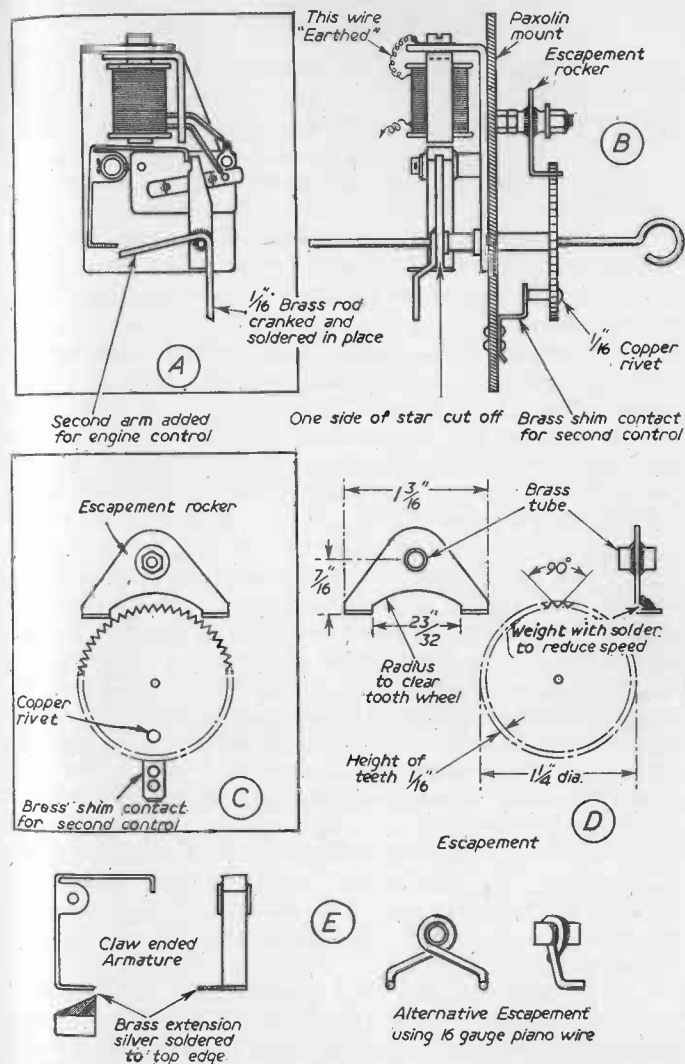

FIG. 88.—The improved compound actuator. A, B and C are three views of the actuator; D gives details of the escapement and E shows an alternative escapement and the claw-ended armature.

that it will stop the rotation in the same position as the part removed except that it will now be done by the raised tongue and will pass clear of the normal position of the armature (*B* in Fig. 88). In operation the original half of the star is lying against the armature claw beneath the magnet.

The magnet on being energised attracts the armature, releasing the star from the neutral position, allowing it to rotate and be caught by the claw at the other end in the normal manner, giving left rudder. On release, however, it completes the circle to its original starting place, so that there is now only one neutral position. Now to obtain right rudder all you have to do is transmit one short signal which produces the above result, then break transmission and send a second signal, with as short a space as possible between the signals. This releases the left rudder position and allows the cranked wire on the other end of the star to pass over the neutral position and be caught by the new tongue on the armature, thus giving right rudder. The sequence of signals is now as follows: one continuous signal—left rudder for as long as the transmission is held, then back to neutral; right rudder—one short signal followed by a very short space and then a second signal, which is held on as long as right rudder is wanted, i.e., one signal left rudder, two signals right rudder—no wondering which comes next in the sequence.

**A Compound Actuator.**—Once the thrills of flying a model plane equipped with this type of steering control have been experienced it will probably be desired to add another control. This could be either engine or elevator control, and it is arranged to work as a sequence from the actuator just described. A second actuator is employed for the second control.

The modified actuator just described will now require to be further altered so as to be able to control the second actuator when required. Means must be found of stopping the star wheel in a predetermined position, which will not affect the steering of the model, but in which a contact can be made to release the following actuator. This can

be done by making another cranked arm of  $\frac{1}{16}$ -in. wire and soldering it on to the star wheel in such a position that it holds the star wheel shortly before the neutral arm reaches the neutral position (*A* in Fig. 88). This will be about  $\frac{3}{16}$  in. before the neutral claw stops rotation. Naturally a slight amount of offset rudder is produced, but in practice the amount is so small that it has no noticeable effect upon the flying of the model. In addition, the offset position is held for only the very short time taken to

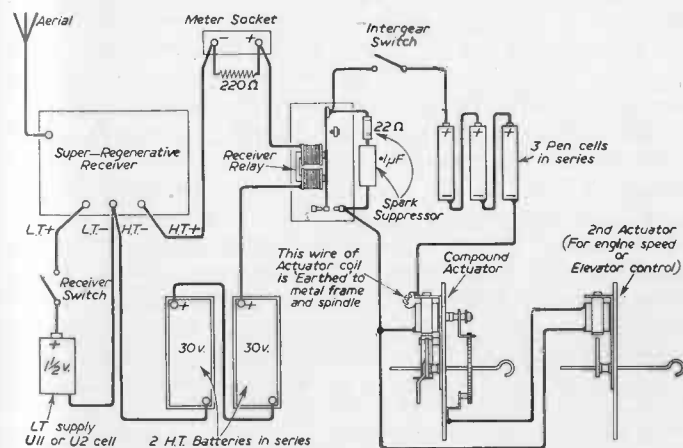

FIG. 89.—Complete wiring diagram of radio-controlled plane.

release the second actuator, and in practice this is nearly instantaneous.

To make the alterations, the star wheel is held in its new position, then the whole assembly is turned over and marked near the periphery of the escapement wheel. The point of marking should be selected so that a  $\frac{1}{16}$ -in. hole can be drilled and a copper rivet inserted and soldered in position in the hole in such a way that it will contact a  $\frac{1}{4}$ -in. wide piece of springy brass foil fastened underneath on the paxolin. The foil should be so shaped that as the rivet comes round it will pass over the leading edge of the foil

without making contact, but will make a light but firm contact when stopped by the new positioning arm. The rivet should protrude about  $\frac{1}{4}$  in. and the springy brass should be fastened to the paxolin with  $\frac{1}{16}$ -in. rivets or 12-B.A. bolts.

We now have a new contact which can be selected at will and which when wired up into the circuit of the second actuator will act as a switch controlling its operation.

It was previously mentioned that the actuator employed had one end of its coil earthed to the metal framework and this is employed in the following manner. When the receiver relay drops out, due to the transmitter being keyed, current from the actuator battery flows through the first actuator coil and according to the sequence transmitted holds on the desired control. Should this coincide with the copper rivet being in contact with the brass contact which is wired to the second actuator (see Fig. 89), this will also be energised causing it to make a quarter-turn. On cessation of the transmission both actuators will be released, the first returning to neutral and the second completing a half-turn. The second actuator can be connected to the engine and will give full throttle and slow speed in sequence. Should it be desired to operate the elevator, neutral position of the second actuator should be arranged for normal flying, whilst on signal "up" or "down" elevator should be arranged in sequence.

It should be pointed out that since the new contact on the first actuator acts as a switch for the second actuator it operates only when the receiver relay contacts are closed (i.e., when a transmission is being received). Thus when left or right rudder signals are sent and the actuator is returning to neutral it passes over the third contact position without energising it as the receiver relay contacts are then open. Therefore, no circuit is made and the second actuator does not operate. The second actuator will work only when three rapid signals are sent and the third signal held on.

**Control.**—For model aircraft control, using this system, a control box for keying the transmitter, such as that

employed for model boats, is not necessary and a "micro-switch" is usually employed to key the transmitter.

To recapitulate, the control sequence is as follows:

Left rudder: one signal held on for as long as the turn is required.

Right rudder: one short signal, a rapid space followed by a long signal for as long as the turn is required.

Engine speed or elevator: two short signals, with rapid

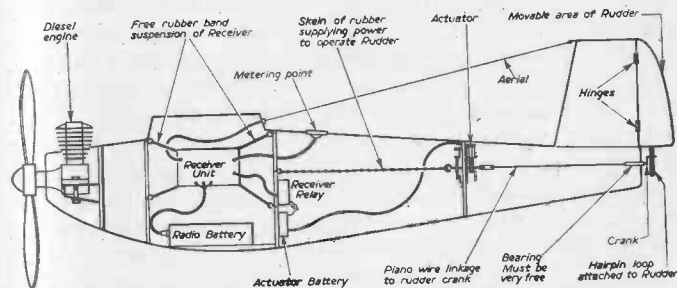

FIG. 90.—Layout of control gear in model plane. Flying trim is obtained by adjusting battery position.

spaces followed by a long signal for as long as required to effect the second control.

It should be noted that these signals must all be sent within the period during which the star wheel on the first actuator can complete one revolution, i.e., about one second. With a little practice, however, any desired operation can be selected at will.

Fig. 90 gives an overall view of the fuselage of a model plane and illustrates the usual positioning of the various components of a control system to give rudder control only. The rubber band powering the rudder escapement is wound up by winding the crank which extends from the tail of the plane. It is important that the piano wire linkage between the actuator and the rubber crank is in line and free to rotate, as any tendency to stick will cause uneven operation of the mechanism.

## TUNED REEDS AND AUDIO CONTROL

So far concentration has been on the mark/space system for model boat control and the sequence system for aircraft. These systems, with some of the embellishments detailed, can give several channels with easily made and very reliable gear giving consistently good results. The most serious challenger to these systems, however, namely reed control, has met with considerable success.

**Reed System Principle.**—The basic idea behind the reed system is that each channel or control function is represented by an audio or musical note; thus, on a boat, starboard rudder might be obtained when one note (say middle C) is transmitted, whilst port rudder and engine speed control, etc., use other notes. In the model, therefore, we must have a receiver, and this must feed some device which can recognise and separate the various notes received. This function of separation depends for its operation on the fact that a reed of say, steel of certain dimensions, will vibrate at one frequency only. If this steel reed is placed in a pulsating magnetic field it will not be affected by the magnetic forces until the frequency of the pulsation of the field is identical with the frequency at which the reed can vibrate. Then, and only then, will the reed start to vibrate.

**The Six-reed Unit.**—A typical six-reed unit (six reeds are the normal maximum in general use at the present time) is shown in Fig. 91. The unit consists essentially of a coil to produce the field, a laminated polepiece, and a permanent magnet. This magnet is used to obtain a greater change in force with a given change in coil current. The reeds are arranged so that the field passes through them and when the coil is fed with current at the natural frequency of one reed, this will start to vibrate. In vibrating, the reed

touches an adjustable contact and makes a circuit to close a relay. The reeds are silver-plated and the contact screws silver-tipped to obtain better electrical contact. The latest practice is to use gold instead of silver and it is reported that this gives even better results. The intermittent contact between the reed and the screw contact is not used to operate Servo mechanisms direct, but is simply used to close a relay, as in Fig. 92. The condenser across the relay holds its contact closed in spite of the interrupted current flowing through the coil. This relay then feeds the Servo mechanism. The condenser size used can vary considerably with the type of reed relay used and with the relay voltage available. The values given are typical but the precise value should be obtained by experiment. The correct value is the smallest condenser which will hold the relay firmly in when the appropriate reed is vibrating.

A typical reed installation using three reeds is shown in Fig. 93. Here it will be seen that two reeds are used for rudder control, whilst the third is used to operate a sequence switch to control the engine speed.

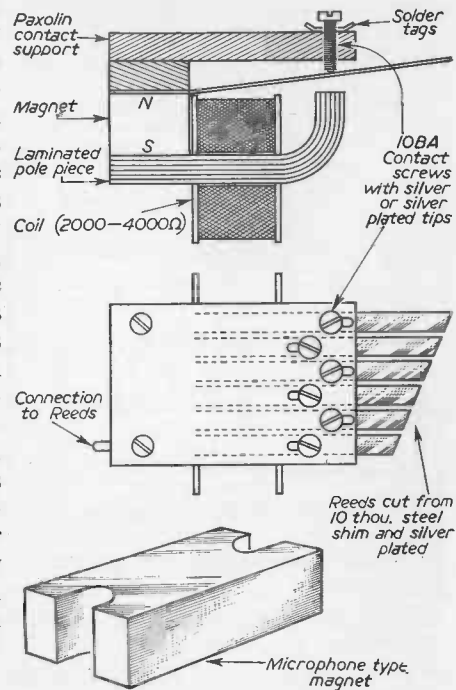

FIG. 91.—Construction of the reed unit.

A typical reed installation using three reeds is shown in Fig. 93. Here it will be seen that two reeds are used for rudder control, whilst the third is used to operate a sequence switch to control the engine speed.

It will be apparent that many schemes can be devised for different controls using reeds, but all systems have the above-mentioned reed relay arrangement.

**The Radio Part of the System.**—This is a conventional transmitter to produce radio-frequency power. It is connected to a modulator which is a means of producing the various audio tones required and impressing them on the R.F. signal.

A separate control box may be used with push buttons for each tone. In the model there must be a receiver to pick up the signal, amplify it and feed it to the coil on the reed unit.

The transmitter circuit detailed in Chapter 3 is quite suitable for reed work, except that

the H.T. connection must be made via the modulator. The circuit of this transmitter is given in Fig. 94.

There are many types of modulator suitable for reed operation. They usually consist of a small valve arranged as an audio oscillator with part of the circuit so arranged that by pressing one of the buttons on the control box a steady note of the desired frequency is produced, and fed to the transmitter. An amplifying stage between the oscillator and the transmitter is sometimes needed. Two typical circuits are shown in Figs. 95 and 96.

Fig. 95 is known as a blocking oscillator type and the three tones are selected by pressing S1, S2 or S3 in the grid circuit. R1, R2 and R3 are adjustable so that the note can be altered until it causes the maximum vibration on the reed. It must be stressed that with all these simple

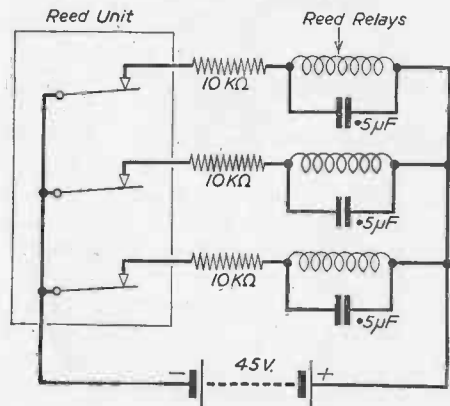
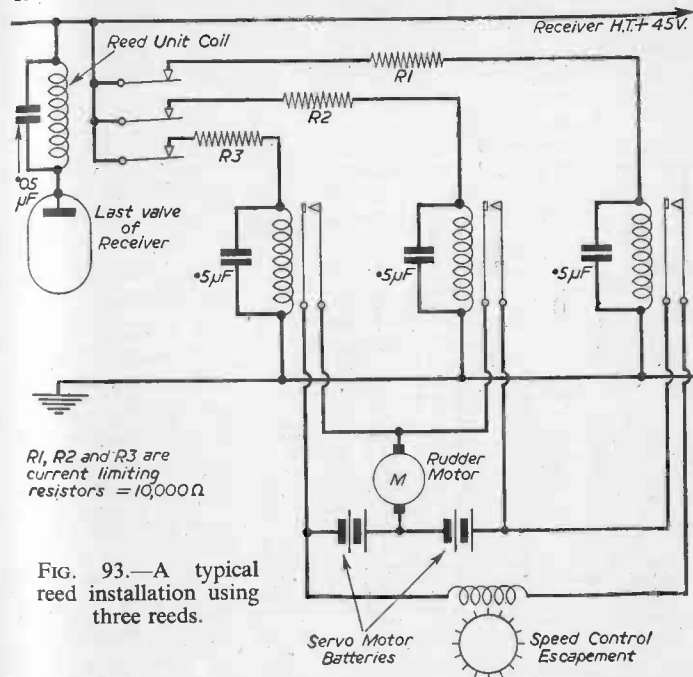

FIG. 92.—Wiring the reed unit.

modulators only one note at a time can be produced. The modulator in Fig. 96 is coupled to the transmitter via two output transformers back to back. With an audio modulator it is essential that adequate H.T. battery supply is available. If this is not watched carefully two faults



R1, R2 and R3 are current limiting resistors = 10,000Ω

FIG. 93.—A typical reed installation using three reeds.

can occur. The first is that if the H.T. voltage drops appreciably during a run the audio tone will change and the reeds will no longer be in tune. Secondly, when no signal is being sent, the H.T. voltage may stand at, say, 95 volts; when one button is pressed the H.T. current rises and this may pull the voltage down. The result is that the note starts on the correct tone but immediately falls a few cycles which can be sufficient to go out of tune with the reed.

The modulator shown in Fig. 96 uses what is known as a phase shift oscillator. Again, three tones can be produced and can be preset to tune each reed. A separate control box is also shown coupled to the modulator via a screened lead. The second valve in this case is an amplifier and the transmitter H.T. line is coupled straight to the anode of this valve.

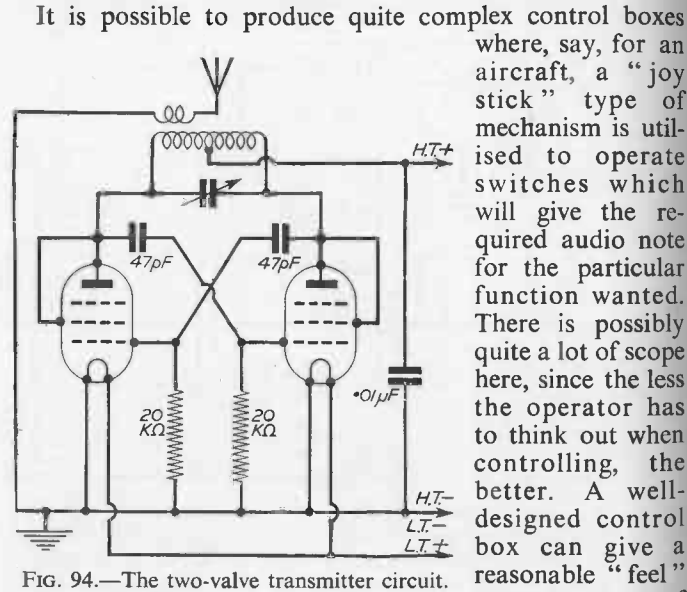

FIG. 94.—The two-valve transmitter circuit.

It is possible to produce quite complex control boxes where, say, for an aircraft, a "joy stick" type of mechanism is utilised to operate switches which will give the required audio note for the particular function wanted. There is possibly quite a lot of scope here, since the less the operator has to think out when controlling, the better. A well-designed control box can give a reasonable "feel" to the control of

the model and makes the best use of the operator's automatic reactions. The big snag, however, is reliability, since a complex control box if not very well made, so as to be very reliable, can be very much of a "white elephant".

**Radio Gear Required in the Model.**—In Fig. 97 is shown a typical reed receiver. In this circuit B7G valves are shown, but for ultra-lightweight sets there is no reason why deaf-aid valves should not be used, at any rate for V1 and V2. It will be seen that V1 is the R.F. stage which tunes the signal and rectifies it. This is then passed to V2, which

is an audio amplifier. The amplified signal is then fed to V3, which further amplifies and supplies sufficient signal to energise the reed unit which is in its anode circuit. The condenser C8 is shown as 0.05  $\mu$ F. This should be considered as a typical value, since the optimum value can vary considerably with different reed units. When the set is being tested, various values should be tried and the one which gives the best reed vibration utilised.

The set shown in Fig. 97 would also operate quite happily if the first stage, including V1, were replaced by the receiver detailed in Chapter 2. The H.T. line for that receiver would have to be fed by an audio choke and an R.F. choke, and the output to V2 taken from the junction of these chokes just as in Fig. 97.

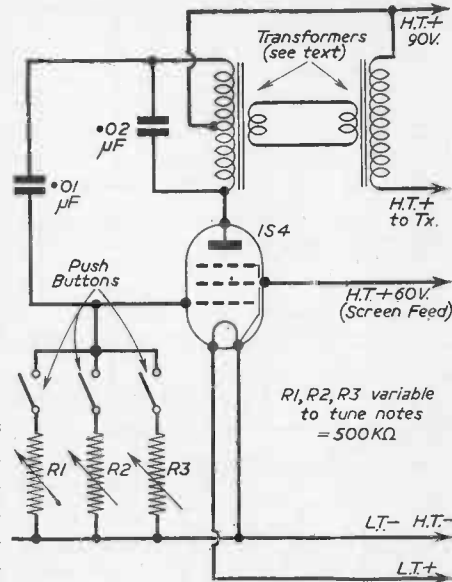

FIG. 95.—Blocking oscillator type of generator and modulator.

**The Audio System.**—As far as model control goes, the audio systems owe their success to reed units, since these units provide a lightweight and relatively inexpensive method of separating the various notes received, and sending the signal down the correct channel. It must be mentioned, however, that this separation can be done by other means which are as yet not nearly so popular. Most of these methods depend on the fact that a circuit can be made to resonate to an audio frequency just as the tuning

circuit of a radio receiver resonates to a radio-frequency signal. In both cases a circuit such as at *A* and *B* in Fig. 98 will resonate at a frequency found by the formula  $f = \frac{1}{2\pi\sqrt{LC}}$  (where  $f$  = frequency in cycles/sec.;  $L$  = Inductance of coil in henries;  $C$  = capacitance in Farads).

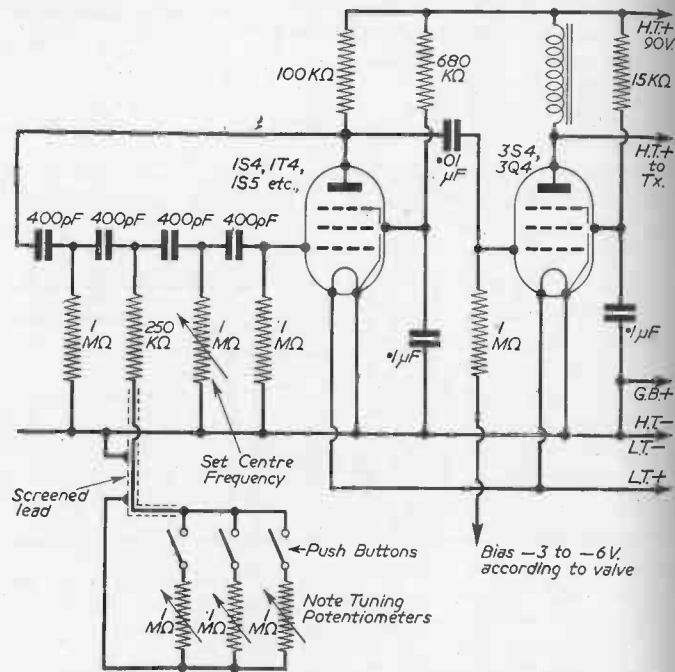

FIG. 96.—Phase-shift type oscillator and modulator.

At *A* in Fig. 98 the components are arranged for "series" resonance, and with such a circuit the maximum current will flow when the voltage applied across the circuit is at the frequency found by the above calculation. At *B* in Fig. 98 "parallel" resonance is shown, and in this case the resistance, or, in A.C. terms, the impedance of the circuit will reach a maximum at the resonant frequency.

At first glance this looks like a very promising means of separating audio frequencies, but a few calculations show up the snags. For R.F. work a condenser of a few micro-microfarads and an inductance of a few micro-henries will

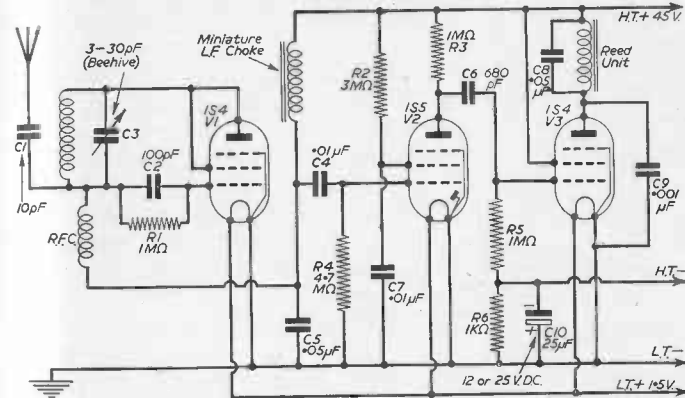

FIG. 97.—Three-valve receiver for reed control. Deaf-aid valves can be substituted for ultra-lightweight sets.

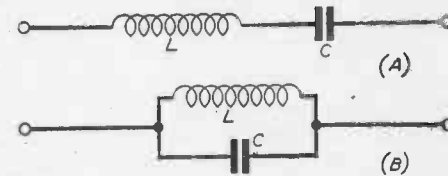

FIG. 98.—(Right) Circuits for "Series" and "Parallel" resonance.

produce resonance at, say, 27 Mc/sec. and these circuits use such components. For resonance at audio frequencies, however, large condensers and huge inductances with iron cores are necessary. This was the position until special inductances wound on Ferroxcube cores were produced which give high values of inductance with little weight. These inductances then, together with suitable condensers, can be used to form frequency selective circuits so that although the receiver feeds all the circuits in parallel, the only one



that passes any current is that in which the values of L and C are such that it will resonate at the frequency of the applied signal. This has led to some very elegant but necessarily complex systems, but it is certain that more will be heard of this method in the future.

## 12

## MORE ABOUT MODEL ACTUATORS

**M**ANY different types of actuator can be made up, and the actual construction of suitable units is not particularly difficult. In a sense, the actuator transforms the received impulse into the desired action, which may be starting, stopping, reversing, or speed-control of the propulsion motor, or so on.

The types of actuator described here are primarily intended for single-valve and other single-channel receivers. With such receivers, all desired operations in the model must be

controlled by the opening and closing of a single circuit. Accordingly, in all but the very simplest model, some type of actuator is essential. Without an actuator mechanism, radio control (with a single-channel receiver) would have to confine itself to one purpose only; for example, the starting and stopping of a model boat's propulsion motor. With an actuator there is almost no limit to the amount of control which may be exercised.

**Principles of Control.**—With a single-channel receiver, the transmitter is keyed so that a carrier-wave is radiated when desired. This causes the anode current in the receiver to fall, so that a relay is released. This should be a sensitive type so that it will operate with a current change of as little as .1 mA, and various relays are especially

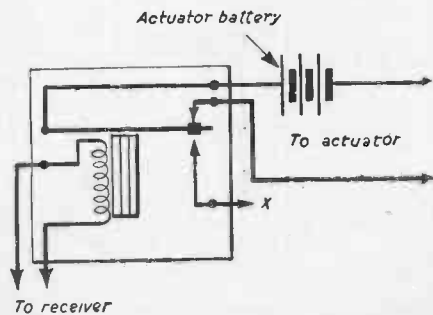

FIG. 99.—Connections for receiver relay.

produced for this purpose, and should be used in a receiver circuit as shown in Fig. 99.

When the transmitter is operated, the armature is released, thereby completing the battery circuit. If this circuit were wired directly to an electric motor, the motor would run when the key at the transmitter was depressed, and stop when the key was released. This would only be sufficient in the very simplest type of model.

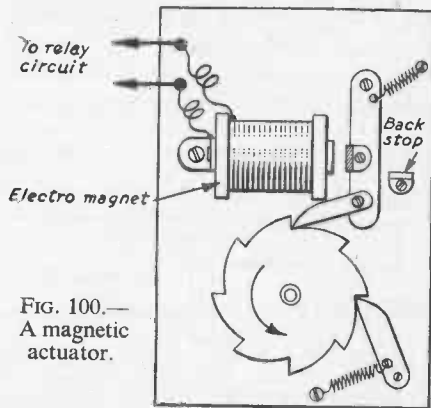

FIG. 100.—  
A magnetic actuator.

A further circuit might be connected to the lead X, but this would, in most cases, serve no useful purpose. One circuit would have to be switched on when the second was off, since the armature cannot be brought

to rest in a central position. As a result, the second circuit could not be used to operate a steering motor, or for any similar purpose.

Without an actuator the degree of control is, therefore, the same as that which would be afforded by a single on/off or change-over switch in the model.

**How Actuators Function.**—All actuators change the simple making and breaking of a circuit (as provided by the relay) into more complex functions. One method of doing this is shown in Fig. 100.

Here, an electromagnet and pawl assembly causes the rotation of a toothed wheel. Each time the magnet is energised, the wheel is caused to rotate one tooth. Such an arrangement is quite straightforward to make up. The magnet needs to be fairly powerful, and the pawl should move just sufficiently to take one tooth each time the circuit is energised.

By keying the transmitter, the wheel may be made to take up any one of eight positions. If necessary, undesired positions may be passed through almost instantly by keying the transmitter a number of times in succession.

A different type of actuator is shown in Fig. 101. Here, the wheel is constantly endeavouring to rotate in the direction shown. Each time the magnet is energised, the wheel is allowed to rotate one tooth. This arrangement has a number of advantages in some cases. The magnet only acts as a release, and the actual rotary force does not have to be provided by it. As a result, heavier mechanisms may be operated.

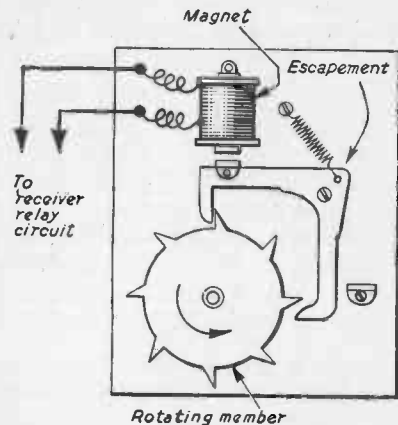

FIG. 101.—An escapement actuator.

In a model equipped with some form of continuous power, the toothed wheel may be driven through a friction clutch. It will then rotate each time the transmitter is momentarily keyed.

Rotation of the axle upon which the wheel is fixed is made to fulfil some useful purpose. One means of accomplishing this is made clear in Fig. 102. Here, a disc with projecting pin is fitted to the axle. This disc may be made to take up any one of eight positions. With the steering arrangement shown, this would enable the rudder to be set in any one of five positions, namely, straight ahead, half to port or starboard, and fully to port or starboard. Steerage of the model to this extent would thus be possible.

A rotary switch with eight contacts is also driven by the spindle. In the circuit shown, provision is made for forward and astern running, with off positions between each. It would also be possible to wire up so that only one contact

was unused, providing an off position. Other contacts could then bring a resistance into circuit for half speed running. Or, if desired, only one astern setting need be provided.

In all cases the switching of the circuit will take place simultaneously with movement of the rudder. Eight different combinations may be arranged for, and a good degree of control will, therefore, be secured. A sequence such as the following would be possible:

- Position 1—Rudder straight, full speed ahead.
- Position 2—Rudder half to port, full speed ahead.
- Position 3—Rudder fully to port, full speed ahead.
- Position 4—Rudder half to port, half speed ahead.
- Position 5—Rudder straight, half speed ahead.
- Position 6—Rudder half to starboard, half speed ahead.
- Position 7—Rudder fully to starboard, full speed ahead.
- Position 8—Rudder half to starboard, full speed ahead.

In each case undesired positions are passed through quickly by keying the transmitter a number of times

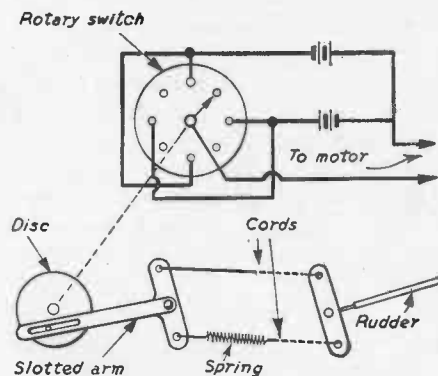

FIG. 102.—A reversing and steering arrangement.

If reversing were not desired, such an actuator could provide for full speed ahead, full speed to port, full speed to starboard, and

motor off with rudder ahead. The wheel of the actuator mechanism would require only four teeth. This would make the method shown in Fig. 100 impossible, but that shown in Fig. 101 would be equally suitable.

In Fig. 102, reversing of the motor is obtained by reversing the polarity of the supply. This can only be accomplished by using a permanent-magnet motor. If the motor has a wound field, the polarity of the

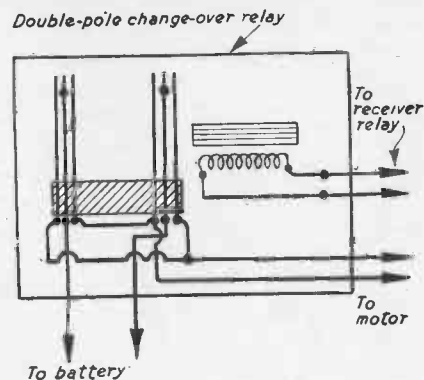

FIG. 103.—Motor reversing by means of a secondary relay.

supply to either field or armature should be reversed, to reverse the direction of rotation.

**Secondary Relays.**—The receiver relay may complete a circuit which energises a secondary relay with additional contacts. More complex circuits may then be used. A reversing circuit is shown in Fig. 103. A double-pole change-over relay is used, and wired so that the motor is reversed.

This type of circuit has a number of applications, usually in conjunction with an actuator such as has been described. The type of relay used here is of about 200 to 500  $\Omega$  resistance, is quite small, and normally energised by a 3 to 4.5 volt dry battery. The sensitive type of relay such as used in the receiver is not required. For example, the controlling circuit may be transferred from one motor or actuator to a second, by the change-over switching of the relay. This change can, in turn, cause yet other relays and mechanisms to come under control.

Secondary relays must also be used when the current flowing is heavy, or of fairly high voltage. The contacts

of the receiver relay operate a trifle slowly, and the contact pressure is small, especially when the model is at long range. Accordingly, the contacts will not satisfactorily make or break circuits passing a large current. They will, however, ably deal with small currents, at low voltage, and

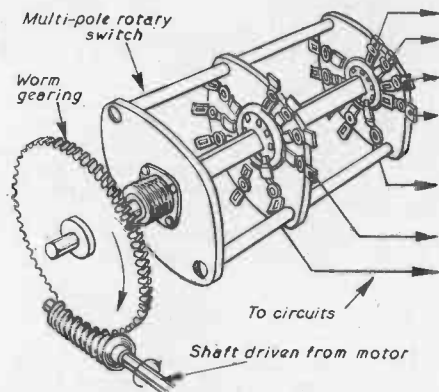

FIG. 104.—Multi-circuit switching.

**Motor-driven Switching.**—A small motor may be used to operate a rudder, or other units, including switches of suitable rotary type. Such switches become almost essential when very complex circuits are necessary.

A method of operation is shown in Fig. 104, where a small motor drives a rotary switch through worm gearing. Yaxley rotary switches, such as used in radio receivers, are suitable, provided the spring locator mechanism is removed.

When such a method of switching is adopted, there is almost no limit to the complexity of the circuits which may be used. The motor should, for preference, be reversible, as described. Such switches may bring into service further sections of equipment, such as small motors to rotate turrets, latching relays to switch on lights, and so on.

can, therefore, serve to control the energising of a second relay. Such a relay might be powered by a 3 or 4.5 volt battery, as mentioned, and its contacts could deal with higher voltages and currents. Such a secondary relay is essential in non-mobile mechanisms where mains-voltage circuits are interrupted.

## TUNING MODEL-CONTROL TRANSMITTING AERIALS

A POWERFUL radiated signal is very useful indeed when maximum reliability of control is wanted, great range is required, or a very small receiver aerial is desirable because of the type of model. With a given transmitter, the power radiated will depend almost entirely upon the efficiency of the transmitter aerial. Quite often a vertical rod or wire of no particular length is used, this generally being from 3 ft. or so up to 8 ft. or so in all. Such aerials may give good results. Nevertheless, the actual radiated signal may be increased in strength by using some form of tuned or resonant aerial, and this can often be worth while. The various advantages arising from maximum

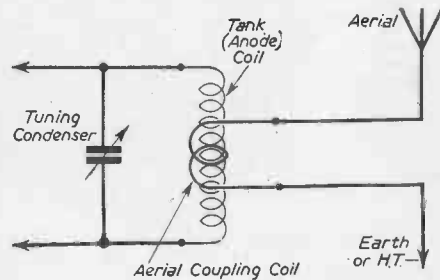

FIG. 105.—Usual method of aerial coupling.

efficiency will readily come to mind. For example, a single-valve transmitter will frequently be sufficient for a model on a boating pond, thus doubling the battery life which would have been available if a two-valve transmitter had been used. Control up to 50 yds. or more will be possible with no aerial at all on the receiver, or with a vertical wire aerial only a few inches long, and this is particularly convenient in very small models. If a valveless receiver is used, the extra signal strength will help to increase range and assure reliable control.

For these reasons, then, it is often useful to bring the aerial system more into line with that employed by commercial stations or in amateur transmitter single-wire systems. The actual increase in the power of the radiated signal will depend upon the efficiency of the old aerial and the method employed. A twofold increase is not unusual, but in any particular case only measurement will show exactly what improvement arises. Some method of measuring results is, indeed, essential when tuning the aerial, and

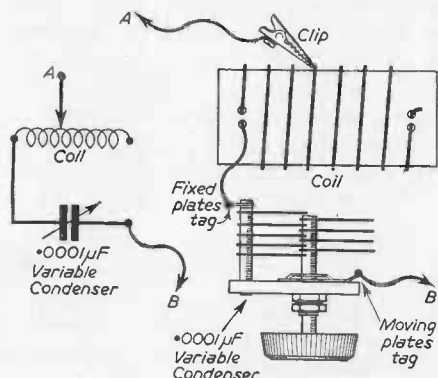

FIG. 106.—Aerial tuner.

any useful indication with small-power (one-valve) transmitters.

For any transmitter, the field-strength meter will be most satisfactory. This consists of a coil tuned to the 27 Mc/s band, crystal diode, and meter of 0-100 microamp or similar type. A few inches of wire will form an aerial, and the field-strength meter can be situated at some small distance from the transmitter—say 10 to 30 ft., according to transmitter power and length of aerial on the meter.

**The Tank Circuit.**—This is formed by the anode tuning coil and variable condenser already in the transmitter. Energy is usually drawn from the tank by means of an aerial coupling coil, as shown in Fig. 105. The coupling coil is about two turns, near the anode coil or overwound upon it.

a bulb, R.F. meter (see Chapter 14), or field-strength meter can be used.

The bulb is the simplest, and should be included in series with the aerial. A thermo-couple R.F. meter may also be included in this position, and will give a more exact indication than the bulb. Neither method will give

For maximum efficiency the coupling should be adjusted to an optimum value. If coupling is loose (coils too far apart) then little R.F. energy is transferred to the aerial. On the other hand, if coupling is very tight, the oscillations in the tank coil will be much damped. With the usual self-excited oscillator type of transmitter, this will reduce power. For the aerial systems to be described, the aerial loop may be left in its usual position. But if attempts are

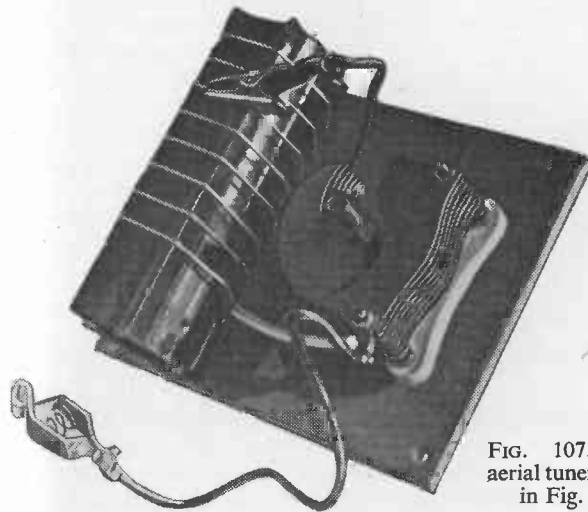

FIG. 107.—The aerial tuner shown in Fig. 106.

later made to obtain the maximum possible output from the transmitter, adjustment to the loop may be required, even with a commercially made set.

One end of the aerial coupling loop is usually returned to the chassis or earth line of the transmitter. With some forms of aerial tuning this can be left, but with others it will be necessary to remove this lead, so that two connections can be taken from the coupling loop.

**Resonant Lengths.**—It should not be overlooked that the aerial itself may be of such a length that it is resonant. As the full resonant length is impossible in any type of

portable equipment, a fraction of this is frequently used, around 8 ft. 6 in. being popular. The exact optimum length will depend upon the position in the band used, and has to be found by trial. To do this, a sliding rod can be fitted in the uppermost tube of the aerial, making good contact with it, and held by a collar or spring clip. The length can then be changed a little at a time until radiation is at maximum, as shown by maximum reading on the field-

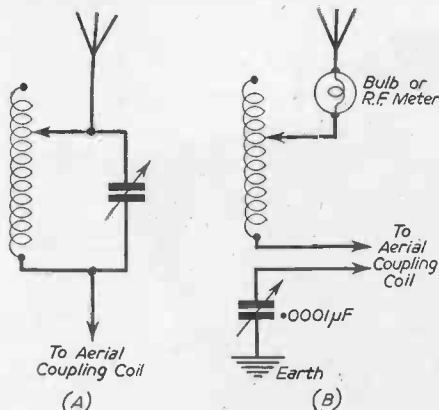

FIG. 108.—Methods of series tuning.

aerial externally, when it may be of virtually any length. There is then no need that the aerial length even be known.

**Aerial Tuner.**—This is shown in theoretical and practical form in Figs. 106 and 107 and can be used in various ways. The variable condenser is an ordinary short-wave type with a maximum capacity of around  $.0001 \mu\text{F}$  (sometimes written 100 pF), the actual value not being very important. It requires a knob, and can be mounted on a small paxolin panel, with the coil.

The latter is best of a type which can easily be tapped, as is so if turns are well spaced, and the former is ribbed. For such a coil, seven turns of 20 s.w.g. tinned-copper wire, occupying 2-in. winding length in all, on a  $1\frac{1}{2}$ -in. former will be satisfactory. If space is limited, or a smaller

former to hand, then 11 turns, occupying 1 in. on a  $\frac{7}{8}$ -in. diameter former, will be suitable. If the former is not ribbed, small loops should be twisted for tapping points. The lead *A* affords one tapping. An alternative is to find the correct position by trial, and then solder the lead to this point.

**Series Tuning.**—The simplest method of tuning the aerial is shown at *A* in Fig. 108. To do this, *A* and *B* in Fig. 106 are joined together, and taken to the aerial. The other condenser tag is taken to the transmitter aerial terminal. In practice, adjustment is a little difficult, since readings cannot be taken with the operator touching the aerial, or near it. It also sets a limit to aerial dimensions, which may itself be undesirable. These limitations are overcome by tuning the

former to hand, then 11 turns, occupying 1 in. on a  $\frac{7}{8}$ -in. diameter former, will be suitable. If the former is not ribbed, small loops should be twisted for tapping points. The lead *A* affords one tapping. An alternative is to find the correct position by trial, and then solder the lead to this point.

**Series Tuning.**—The simplest method of tuning the aerial is shown at *A* in Fig. 108. To do this, *A* and *B* in Fig. 106 are joined together, and taken to the aerial. The other condenser tag is taken to the transmitter aerial terminal.

If a bulb or R.F. meter is used to show the current flowing into the aerial, then it is always included in series with the lower end of the aerial itself, never between tuner and transmitter. If the transmitter is of low power, a bulb cannot be used. If of medium power, a  $.06$  amp-type bulb will be required, whereas a powerful transmitter will blow a bulb of this rating. In each case the bulb is shorted out after adjustment.

With transmitter on, the tuning condenser is rotated until R.F. or field-strength meters show maximum, or the bulb glows most brilliantly. If a definite tuning point cannot be found, then an unsuitable number of coil turns is in circuit. If resonance is being approached with the condenser at maximum, but cannot be reached, then an extra turn or two will be required. If, on the other hand, resonance is approached with the condenser open, then too many turns are in circuit, and the clip should be moved along the coil accordingly.

A method often used in larger equipment is shown at *B*

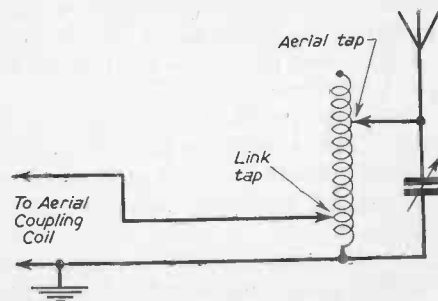

FIG. 109.—Link coupling.

in Fig. 108, and requires connections to both ends of the loop winding. The aerial tuning condenser and coil are disconnected, the coil being wired at the aerial end of the loop, and the condenser at its earthed end. The number of coil turns must now be adjusted by moving the clip, until resonance is possible with the variable condenser fairly well closed.

**Link Couplings.**—These are highly effective, but require more adjustment. One method is shown in Fig. 109. Here, two leads are brought from the transmitter aerial loop, it not being necessary to break the earth connection. The link tap is taken to a position only one to three turns from the earthed end of the aerial tuning coil, whereas the aerial tapping is taken to such a position that the aerial can be tuned to resonance (usually around 6 turns, with the  $1\frac{1}{2}$ -in. diameter coil mentioned).

The exact position of the link tap will greatly influence output, and is found by trial, retuning being necessary after each modification of its position. Both taps must be adjusted for maximum signal strength, or reading on the R.F. meter.

If both ends of the transmitter aerial loop are available, two leads may be taken from these, to a similar loop wound round the aerial tuning coil. In Fig. 109 the turns near the earthed end of the coil replace this second loop.

It will be found that the current which can be made to flow into a short aerial will not be so great as with a longer aerial. It will, however, be greater than an equivalent length of aerial which is untuned.

All such adjustments to the aerial system may make necessary slight retuning of the transmitter tank circuit, to restore the equipment to the exact original frequency. With normal degrees of aerial coupling in the transmitter this retuning will be very slight.

**Compact Aerial Unit.**—When equipment is to be carried about, it may be best to use a coil such as that shown in Fig. 110. For tuning, a 30 pF trimmer is used, held inside the coil by its tags passing through small slots, a hole

opposite making adjustment possible with a shaped bakelite rod or tube, notched to fit the trimmer top.

A tube about 1 in. in diameter and 2 in. long will be of ample size for this type of unit, and the ends may be closed with discs of wood or other insulating material. The number of turns will have to be found by trial, so that resonance is achieved by turning the trimmer, exactly as already described. Short flex leads terminating in crocodile clips will facilitate connecting up the unit and aerial when required.

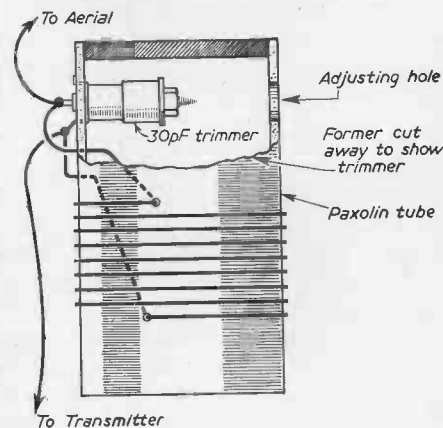

FIG. 110.—A small aerial resonator.

Such a unit is particularly easy to install in accordance with the series method in A, Fig. 108, though this will not quite approach results obtained with a link coupling correctly adjusted.



## A BULB MODEL-CONTROL FREQUENCY METER

**M**ANY frequency meters used for checking the operation of a model-control transmitter employ a moving-coil meter for measuring or indicating purposes. This is a good

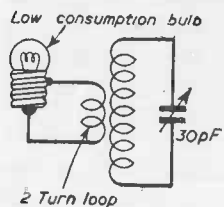

FIG. 111.—Circuit of bulb frequency meter.

method, but such meters are relatively expensive and require to be treated with care. It is, however, possible to replace the moving-coil meter by means of a small bulb, thereby reducing cost and producing a smaller and more robust instrument. Frequency and output of the transmitter may be tested with it, in the usual way.

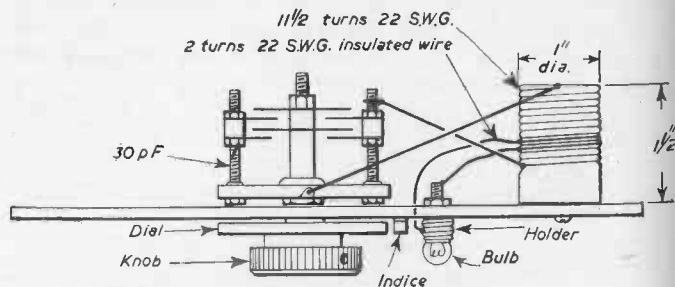

FIG. 112.—Wiring plan and coil.

The tuned circuit, shown in Fig. 111, is brought to resonance by the 30 pF variable condenser. R.F. energy is then developed across it and transferred to the bulb by means of the coupling loop. To ascertain whether a transmitter is within the permitted band, the frequency

meter is tuned for maximum brilliance, and the dial reading noted. To set a transmitter within the band, the meter dial is set to the correct reading, and the transmitter then tuned for maximum brilliance of the meter bulb.

A simple practical layout for the parts is shown in Fig. 112, the "panel" projection to the left serving as an extension by which the meter can be held. The exact

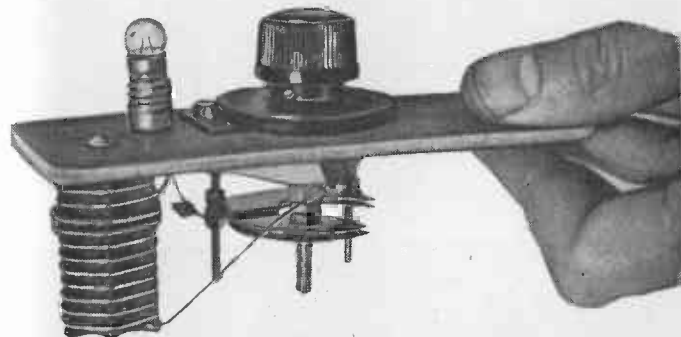

FIG. 113.—The completed bulb control frequency meter.

maximum capacity of the tuning condenser is not important, except that very small values will limit the wave-range covered, whereas large values will make tuning difficult. A maximum capacity of 15 pF to 50 pF is feasible, with around 25 pF maximum being most suitable. A degree dial or pointer is locked securely to the condenser.

As movement of the coil turns would upset calibration, a notched, ribbed former is used. A solid former may be substituted, but a few turns may then require removing from the winding, to compensate for stray capacity. The ends of the winding are tightly secured by passing through small holes, and the connections taken directly to the tuning condenser. A trace of varnish would hold secure the turns upon a smooth former.

The lamp loop is of insulated wire, wound on top of the tuned section, in the same notches. Its ends are similarly secured, and taken to the bulb holder. So that the meter

may be retained for continuous use, it is essential condenser and dial be firm, and turns on the coil absolutely immovable. The bulb requires to be a low-consumption type, that used being of 2 v. .04 amp. rating, intended as a dial

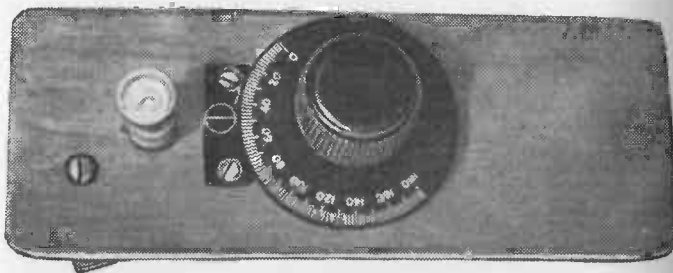

FIG. 114.—A top view of the completed meter.

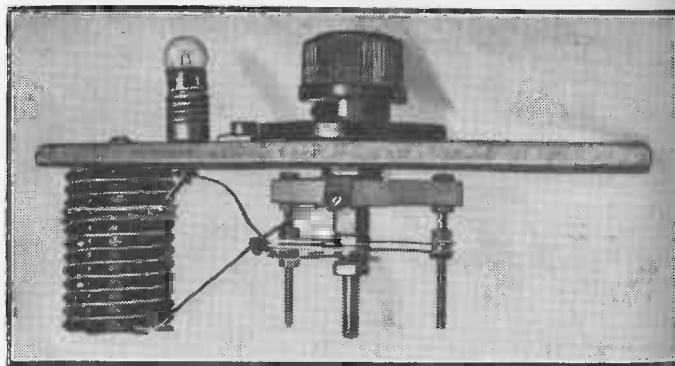

FIG. 115.—A side view showing the coil.

lamp in battery-operated radio sets. If this cannot easily be obtained, the 6 v. .04 or .06 amp. type used as a rear light with most cycle-dynamo sets will do.

When making checks, the tuning coil of the frequency meter is brought near the tank coil of the transmitter, and the meter or transmitter tuned for maximum brilliance, as mentioned. The meter should not be unnecessarily near

the tank coil, but withdrawn so that the bulb is extinguished when tuning is slightly off resonance. With a small one-valve transmitter, this will be at about 2 in. from the tank coil. With larger transmitters, care is necessary to avoid blowing the bulb. Initial calibration of the meter is obtained by tuning it to a transmitter known to be on frequency, and noting the dial or pointer reading. If the tank coil cannot be reached, the transmitter aerial may be connected by means of a lead with a one- or two-turn loop in it, and the meter brought near this loop. If the meter is to be carried out-of-doors, a box round coil and condenser is necessary. This should be fixed in position before calibrating the meter dial. The completed device is shown in Figs. 113, 114 and 115.

## AN AUTO-SWITCH FOR MODEL-CONTROL TRANSMITTERS

EXCEPT for a first test to see that the equipment is working, adjustment of a model-control receiver requires to be done at some distance from the transmitter. Only when this is so can both transmitter and receiver have



FIG. 116.—The completed apparatus.

their full aerials connected, thus allowing the equipment to be adjusted under actual working conditions, and enabling maximum reliable range to be discovered. When such adjustments are being made to the receiver it is very troublesome to have to return frequently to the transmitter,

to switch it on and off, if no second person is available to do this. To overcome this difficulty, a simple type of clock-work switch will be found very useful, and this is the arrangement which is described here and shown in the photograph (Fig. 116).

With the auto-switch in circuit the transmitter radiates for roughly 30 seconds and is off for the remaining 30 seconds of each minute. When the signal is present the receiver can be adjusted for maximum dip in current, and tuned correctly. When radiation ceases, quench adjustment for maximum anode current can be made and the relay also set appropriately. As

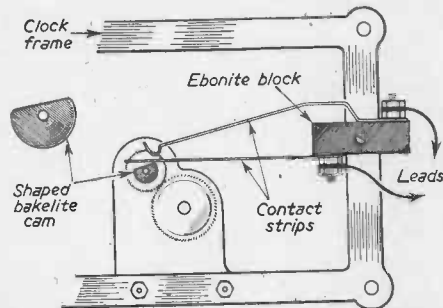

FIG. 117.—Fitting contact mechanism.

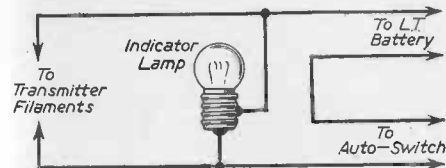

FIG. 118.—Electrical circuit.

the cycle is repeated the receiver can be carried to a greater distance and renewed adjustments made until no further improvement is possible. Finally,

the receiver relay will be opening and closing regularly at 30-second intervals in accordance with the transmitter at maximum range.

The mechanism shown in Fig. 117 consists of two thin strips of brass about 2 in. long and  $\frac{1}{4}$  in. wide, bolted to an insulating block. This block is fixed to a convenient point on the clock frame so that operation from a spindle rotating at 1 r.p.m. (e.g., that of the second hand) is possible.

The cam needs to be of small diameter or friction may stop the clock. A  $\frac{1}{4}$ -in. diameter piece of ebonite rod about  $\frac{1}{4}$  in. long, filed flat one side, and drilled for the spindle, is satisfactory. If the hole is of such a size that the cam is a tight push fit, no fixing is necessary. Unless the second hand is to be removed and the cam fitted in its place it will be necessary to loosen the one clock plate so that the spindle can be removed for the cam to be fitted. The parts are then replaced exactly as before.

The clock mechanism actually used was obtained from ex-Service stock, and many of these will be seen advertised. Though they only run for some hours they are very suitable for this purpose. One such mechanism widely advertised has no 1 r.p.m. spindle but one rotating once in 75 seconds, and this is equally suitable. A clock already to hand could also be used if not too small.

**Wiring and Indicator.**—When initially tuning-in it is helpful to know when the transmitter is radiating to avoid confusion, and a bulb is wired in parallel with the transmitter L.T. circuit for this purpose. This is desirable, for otherwise the reduction in anode current often encountered near minimum settings of the receiver tuning condenser due to increased quenching may be mistaken for the carrier.

Fig. 118 shows the circuit. Though the H.T. circuit is keyed the L.T. circuit is interrupted here to allow the bulb to be used without complication. With a 2-volt accumulator supply a 2-volt or 3.5-volt bulb is satisfactory, the latter also suiting a 3-volt dry battery L.T. supply. The bulb should be clearly visible, but it is no longer necessary to observe it once the receiver has been tuned, as the regular rise and fall of the anode current meter will then show when the transmitter is radiating.

In practice maximum range will be obtained with the relay set so that it is just held down when the transmitter is not radiating. This can be done during any appropriate half-minute. Tuning is then adjusted, together with aerial damping and quenching, to obtain maximum drop in anode current during those periods when the transmitter is radiating.

## 16

## A RADIO-CONTROLLED MODEL BATTLESHIP

THE model is based on photographs of the *King George V* type of battleship appearing in the press, and is



FIG. 119.—The completed model battleship.

shown completed in Fig. 119. The hull of the original model was carved from a solid piece of larch, but other types of wood would also be suitable. Overall dimensions are: Length 5 ft. 2 in., draught 3 in., and freeboard 2 in.; the hull was hollowed out to leave a wall thickness of approximately  $\frac{5}{8}$  in. The forward part of the deck, i.e. from the bow to the second breakwater, is a fixture and is made of larch; the bow is fitted with a  $\frac{3}{16}$ -in. brass cap. The after part of the deck, i.e. from behind the second breakwater to the stern, is removable and is made of  $\frac{1}{4}$ -in. plywood fitting flush into a recess so that the deck is actually split  $\frac{1}{4}$  in. from the edge all round. Four clips, disguised as bollards, hold the removable part of the deck in place. The greater part of the superstructure is built on this plywood deck and is made mainly from  $\frac{1}{16}$ -in. plywood glued and pinned to balsa-wood internal struts. The gun turrets are made from larch, with guns turned up from dowelling. The funnels and anchors are made up from sheet brass, the masts from brass rod, and the searchlights and small deck fittings turned up from aluminium rod. The anchor chains started life as cheap necklaces, while the various handrails consist of tinned copper wire soldered to ordinary domestic pins.

The after main gun turret fits into a wooden housing in the deck of a bayonet-type clip and is removable to allow access to the main battery switches without the necessity for removing the whole of the deck; similarly, the forward main two-gun turret is removable to allow access to the receiver tuning controls. The smaller guns, searchlights, and cranes may all be turned by hand if desired, while the anti-aircraft gun in the stern is mounted on an extension of the rudder shaft and serves as a useful indicator of the rudder position when the ship is sailing close to the shore.

Twin screws are fitted, these being three-bladed and 2 in. in diameter. They rotate, of course, in opposite directions. Propeller shafts are of  $\frac{3}{4}$ -in. diameter steel, and the tubes are of  $\frac{5}{16}$ -in. outside diameter copper, fitted with brass end-caps. These tubes pass through, and are

soldered to, oval brass plates fitted inside and outside the hull at the points where they pass through it. The rudder, built up from brass sheet, is fitted with a  $\frac{3}{16}$ -in. diameter shaft running in brass bearings at top and bottom, the latter bearing being provided with a felt water-seal.

The hull is divided into five watertight compartments by means of three-ply bulk-heads glued into position, as may be seen in Fig. 120, and the outside of the ship was finished with four coats of "battleship grey" paint.

**Propulsion.**—The propulsion motor is fitted athwartships and has a shaft extension at each end (see Fig. 121). Drive to the screws is via one-to-one bevel and spur gears, these latter being necessary in order to bring the drive in line with the propeller shafts. The gearing is carried in a frame attached to the motor body, brass bearings  $\frac{5}{16}$  in. long being provided for all spindles. These gears are extremely quiet, and are almost inaudible when the ship is in the water. The motor is an ex-W.D. 24-volt shunt-wound motor with a four-pole field. The four field windings were found to be connected in series so these were reconnected in parallel and the motor was then found to develop ample power

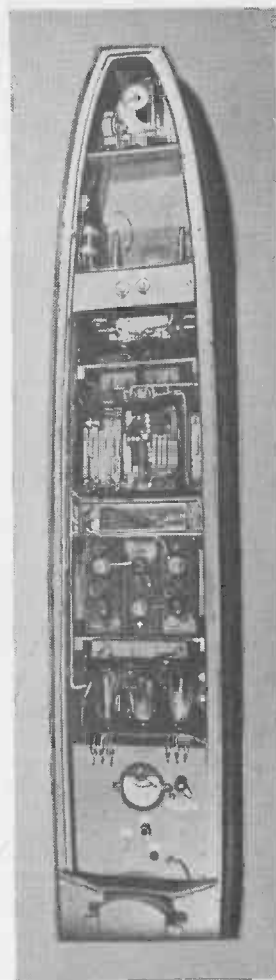

FIG. 120.—Interior of the ship, showing the receiver, accumulator, stud switch, propulsion motor and steering motor.

when run from a 6-volt accumulator. This gives a screw speed of 750 r.p.m. approximately, and drives the ship at about 3 knots. Half speed is obtained by inserting a small resistance in the armature circuit. Consumption is  $1\frac{1}{4}$  amps. at full speed, and a little under 1 amp. at half speed.

**Steering.**—A small permanent-magnet "Electrotor" motor is used to turn the rudder via a double worm-reduction gear, the final drive to the rudder shaft being via a single-plate friction clutch. This clutch is provided to prevent damage to the gears in the event of the rudder being accidentally turned by hand; it also serves to prevent the motor being stalled when the rudder reaches the limit-stops. These stops are built into the clutch housing and allow a travel of  $60^\circ$  on each side. Steering is effected by supplying current to the motor from the 6-volt accumulator in the appropriate direction until the rudder reaches the desired position. This simple arrangement has proved to be very effective, and after a little practice quite accurate navigation is possible. The time taken to move the rudder from one extreme to the other is approximately 15 seconds.

**Forward Main Four-Gun Turret.**—This turret is mounted on a  $\frac{1}{4}$ -in. diameter spindle and turns in brass bearings fitted in a wooden housing built into the fixed part of the deck. It is turned by an "Electrotor" motor via reduction gearing and a crank-and-link motion which slowly turns it back and forth through a total angle of  $160^\circ$ .

**Control System.**—Controls provided are: Position of rudder and four positions of the propulsion-motor control switch. The forward four-gun turret can also be turned when the ship is at rest or travelling at half speed forward. Operation of the rudder control is instantaneous, while the other operations involve a delay of two seconds at the maximum. The transmitter employs a carrier frequency in the 27 Mc/s model-control band, and control is effected by means of modulation tones. Three of these tones are at present in use, viz., 400 c.p.s., 1500 c.p.s., and 3500 c.p.s. Coded pulses of 1500 c.p.s. tone are used to control

the propulsion motor and turret motor. The other two tones are used to turn the rudder, 400 c.p.s. corresponding to "turn right" and 3500 c.p.s. to "turn left".

**Control Equipment on Ship.**—The aerial on the ship consists of a section of the handrail around the deck, and is approximately quarter-wave. No direct earth is used, the receiver being grounded to the L.T. wiring of the ship. The receiver circuit is shown in Fig. 122. No "miniature"

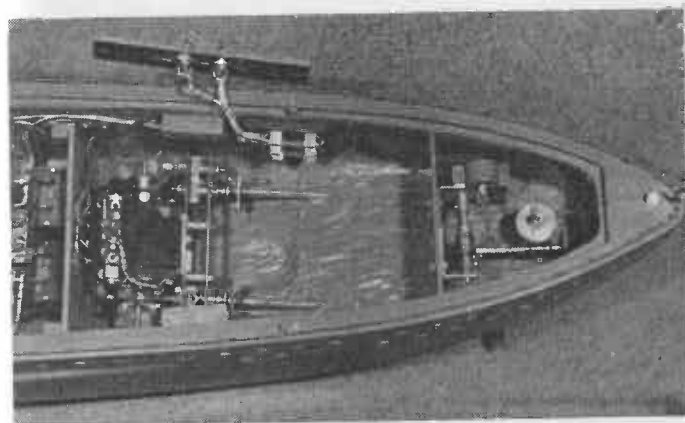

FIG. 121.—Driving and steering mechanism. The propulsion motor, with gearing to propeller shafts, is on the left, while the "Electrotor" steering motor with reduction gears may be seen at the right. (The battery switches have been removed for the photograph.)

components have been used, but it employs 2-volt valves throughout, and consists of a self-quenching super-regenerative detector (LP2) transformer-coupled to an output tetrode (OT220). The output from this tetrode is fed, via a 30-1 step-down transformer, to three acceptor circuits tuned to the three L.F. tones in use. The voltages developed across the inductances in these acceptor circuits are fed to the grids of three anode-bend rectifiers and the anode circuit of each rectifier contains the winding of a  $10,000 \Omega$  relay. Thus reception of a carrier, modulated by any of the three tones, will result in the operation of the

corresponding relay. In practice the carrier is radiated continuously and operation of the shore controls applies modulation at the appropriate frequency. The rectifiers are biased to slightly beyond cut-off and the receiver gain is such that the rectifiers reach the top bend (approximately 3 mA) at a range of about 200 yds. This is beyond the range at which the ship can be seen well enough to be controlled. The minimum current required for positive operation of the relays is 1 mA and this is obtained at a range of 800 yds.

A millimeter, with associated three-position switch, is fitted in the receiver so that the three rectified currents can be measured during the initial setting up of the transmitter modulation levels. LP2 type valves are used as rectifiers. The relay, operated by 400 c.p.s. tone is used to supply current to the steering motor and turn the rudder to the right; similarly the 3500 c.p.s. relay turns the rudder to the left. These two relays are electrically interlocked to prevent blowing of the battery fuses should they be operated simultaneously by accident.

The third relay—termed the impulse relay—is used to supply current to a rotary switch which controls the supply of current to the propulsion motor and turret motor. This rotary switch was made out of an ex-W.D. "Impulse-operated Yaxley Switch" rewound to work on 6 volts. It consists of a solenoid-operated armature, with make-and-break, turning a ratchet wheel, and constitutes in effect a slow-speed motor. This motor has been fitted with a six-position rotary stud switch (see Fig. 123) and modified so that if it is momentarily energised it will automatically turn through 60°, i.e., one position of the stud switch, and then stop. (The motor is, of course, unidirectional.) The complete switch unit has been mounted on a seven-pin valve base and plugs into a spring valveholder in the ship. This facilitates servicing and contact cleaning. The six positions of the stud switch give the following conditions: (1) Ship stopped; (2) ship stopped with turret turning; (3) half speed forward; (4) half speed forward with turret turning; (5) full speed forward; (6) half speed astern.

From the above it will be seen that to change the rotary switch from one position to another it must be momentarily energised by the impulse relay the requisite number of times to move it to the new position *in a forward direction*. A short pause must be left after each impulse to allow the stud switch to move to the next position before the next impulse.

To summarise, moving the stud switch involves the transmission of the requisite number of short pulses of 1500 c.p.s. tone with the necessary time intervals between.

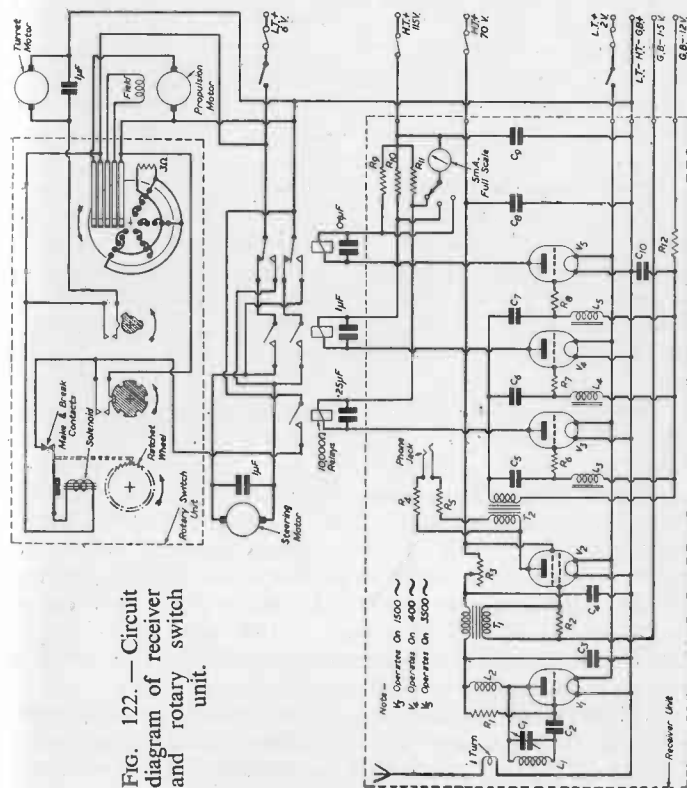

FIG. 122.—Circuit diagram of receiver and rotary switch unit.



A 6-volt 15-ampere/hour "Gel-Cel" accumulator supplies current for the three motors and the stud-switch solenoid, a 2-volt supply for valve filaments being tapped off the same battery. A separate switch is provided for the 2- and 6-volt supplies, and each is independently fused. Average running time on one battery charge is about six hours.

H.T. for the receiver is supplied by a miniature 69-volt battery, with an additional 45-volt battery in series for the supply to the anode-bend rectifiers. This latter battery, as it is only called upon to supply 3 mA for very short intermittent periods, is of the deaf-aid type. Bias for the output tetrode and rectifiers is obtained from a small 12-volt battery made up from pen torch cells. The receiver, including the acceptor circuits and rectifiers, is built on a wooden chassis and is easily removed for adjustments, if necessary. Supplies are picked up via an 8-pin plug and socket.

**Shore Equipment.**—This is divided into two parts contained in identical carrying cases 14 in.  $\times$  10 in.  $\times$  7 in. (Fig. 124). The first contains the transmitter and L.F. oscillator, while the second contains the batteries and controls, with compartments for tools, spares and an Avominor. An 8-core flexible cable connects the two units, Jones-type plugs and sockets being used on the cable ends.

**Transmitter Unit.**—The transmitter circuit is shown in Fig. 125. The R.F. section uses a conventional crystal oscillator (LP2), followed by two frequency doublers (LP2 and P2). The second doubler, which is modulated, feeds the aerial via a single-turn coupling coil. The aerial used may be either a vertical quarter-wave or horizontal dipole; both types have been used with equal success. Choke modulation is employed with a PT2 pentode as modulator; H.T. to all stages is 108 volts. The anode current of each stage can be measured by means of a switched milliammeter on the front panel.

**L.F. Oscillator.**—This uses two PM2DX type valves and consists of a two-stage R.C. amplifier with output coupled back to input. The oscillating frequency is determined

by a tuned circuit connected across the grid circuit of the second valve, one of these tuned circuits being provided for each of the three frequencies used. Output from the anode circuit of the second valve is fed through a transformer to three volume controls, one associated with each oscillator frequency. Three relays contained in the transmitter unit are used to connect the required tuned circuit

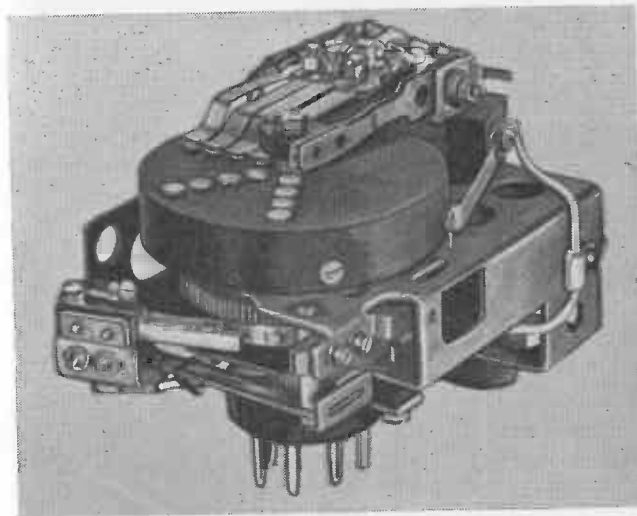

FIG. 123.—Impulse-operated stud switch on ship. The studs on the face of the disc control the supply to the propulsion motor field, while those around the periphery supply the armature.

to the oscillator, and additional contacts on these relays connect the oscillator output, via the appropriate volume control, to the modulator input. Thus, the modulation level on each tone is adjustable. A fourth relay, which operates when any of the other three is operated, serves to apply cut-off bias to the L.F. oscillator valves when no tone is being transmitted; this prevents random oscillation and economises in H.T. consumption. A monitoring jack is

provided so that the transmitter tone may be checked with headphones.

**Control Unit.**—This is shown in Fig. 126 and contains a 2-volt "Gel-Cel" accumulator for filament supply, a 108-volt H.T. battery, an 18-volt dry battery for relay operation

#### RECEIVER COMPONENTS

- C1: 50 $\mu$ pF variable.  
 C2: 50 pF.  
 C3: .005  $\mu$ F.  
 C4, C10: .1  $\mu$ F.  
 C5: .0075  $\mu$ F }  
 C6: .035  $\mu$ F } These must be exact values.  
 C7: .004  $\mu$ F }  
 C8, C9: 2  $\mu$ F.  
 R1: 10 M $\Omega$ .  
 R2, R12: 50,000  $\Omega$ .  
 R3: 50,000  $\Omega$ -variable.  
 R4, R5: 250,000  $\Omega$ .  
 R6, R7, R8: 50,000  $\Omega$ .  
 R9, R10, R11: 200  $\Omega$ .  
 L1: 8 turns 1 $\frac{1}{2}$  in. dia. (14 s.w.g.).  
 L2: S.W. H.F. choke.  
 L3: 1.5 henry }  
 L4: 4.5 henry } These must be exact values.  
 L5: 0.5 henry }  
 T1: 1 : 4 interval transformer.  
 T2: 30 : 1 output transformer.  
 V1, V3, V4, V5: LP2.  
 V2: OT220.  
 All resistances  $\frac{1}{4}$ -watt rating.

and bias, control mechanism, and tools, etc. A switch meter on the front panel measures L.T. and H.T. voltages and total H.T. consumption.

A small spring-loaded steering wheel controls the steering. This consists, in effect, of two separate make-and-break switches, so that turning the wheel 30° to the left (when it

reaches a limit-stop) operates the 3500 c.p.s. relay in the transmitter and turning to the right operates the 400 c.p.s. relay. Four push-buttons control the ship propulsion motor and the turret motor is switched on by means of a push-pull D.P.T.D. switch. The operation of both of these controls is as follows:

Associated with the push-button is an impulse motor similar to that used in the ship but energised by the 18-volt

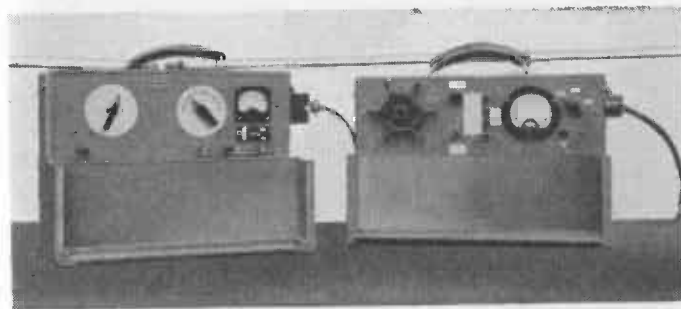

FIG. 124.—The transmitter (*left*) and the control box.

dry battery. This has been modified by the addition of a six-position Yaxley switch so that it will "home" to any one of six equally spaced positions, moving, of course, in one direction only. The buttons are connected so as to "home" the impulse motor on to the following positions:

Button 1 ("Stop"), Position 1; Button 2 ("Half speed forward"), Position 3; Button 3 ("Full speed forward"), Position 5; Button 4 ("Half speed astern"), Position 6.

Pushing the turret motor switch to the "on" position changes buttons 1 and 2 over to positions 2 and 4 respectively. (It will be noted that these positions correspond to those on the stud switch on the ship.)

A six-point cam carried on the impulse-motor shaft momentarily close a pair of contacts half-way between the "home" position: these contacts supply current to the 1500 c.p.s. relay in the transmitter unit. Thus if a push-button is pressed or the turret motor switch moved

## COMPONENT VALUES

## TRANSMITTER AND MODULATOR

- L1: 10 turns 1 in. dia. (22 s.w.g.).  
 L2: 10 turns 1 in. dia. (18 s.w.g.).  
 L3: 8 turns 1½ in. dia. (14 s.w.g.).  
 L4, L5, L6, L7, L9, L10, L11: S.W. H.F. choke.  
 L8: 60 henry L.F. choke.  
 C1: 75 pF variable.  
 C2, C3: 50 pF variable.  
 C4, C5, C7, C8, C9: .001  $\mu$ F.  
 C6: .0005  $\mu$ F.  
 R1, R2, R3: 20,000  $\Omega$ .  
 R4, R5, R6, R7: 200  $\Omega$ .  
 R8: ½ M $\Omega$ .  
 V1, V2: LP2.  
 V3: P2.  
 V4: PT2.

## L.F. OSCILLATOR

- L12: 4.5 henry } exact values.  
 L13: 1.5 henry }  
 L14: 0.5 henry }  
 C10: .035  $\mu$ F } exact values.  
 C11: .0075  $\mu$ F }  
 C12: .004  $\mu$ F }  
 C14: 0.5  $\mu$ F.  
 C15: 0.025  $\mu$ F.  
 C13: .005  $\mu$ F.  
 C16, C17: 2  $\mu$ F.  
 R9: 100,000  $\Omega$ .  
 R10: 10 M $\Omega$ .  
 R11: 5 M $\Omega$ .  
 R12: ½ M $\Omega$ .  
 R13: 50,000  $\Omega$ .  
 R14: ½ M $\Omega$ .  
 R15: 10,000  $\Omega$ .  
 R16, R17, R18: 250,000  $\Omega$  variable.  
 T1: 1: 3 interval transformer.  
 V5, V6: PM2DX.

from one position to the other, the control-box impulse motor will "home" to the corresponding position, and a pulse of 1500 c.p.s. tone will be transmitted for each position passed through. It follows that, if this motor and the stud switch aboard ship start off in the same position, then they will keep in step and the stud switch will move to the correct position to give the conditions selected by the controls. The stud switch moves slightly faster than the control-box impulse motor, so that in operation it pauses at each position until the arrival of the next impulse.

FIG. 125.—Circuit diagram of the transmitter and control box, with inset showing meter-switching arrangement.

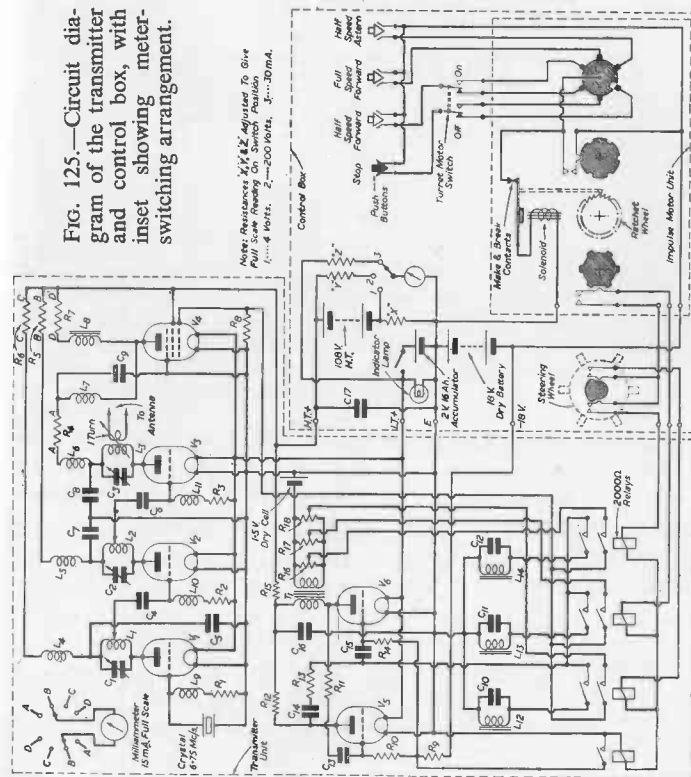

This may sound a rather slow process, but in actual fact the most lengthy operation, i.e., moving the switch through five positions, takes less than two seconds.

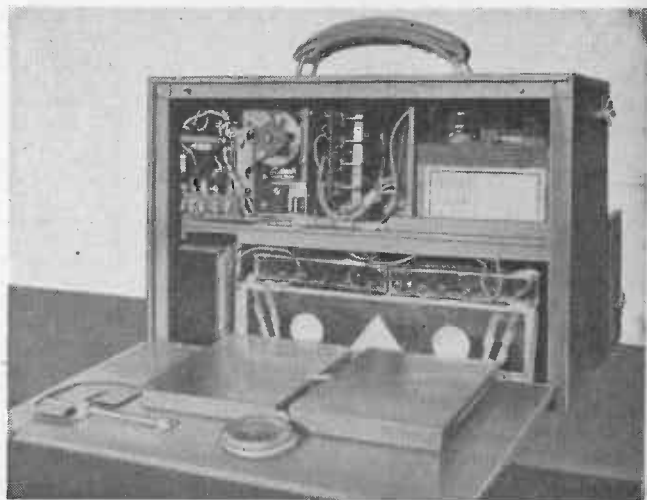

FIG. 126.—Rear view of the control box. The impulse motor is seen at the top left with the associated push-buttons (*top centre*). The flat boxes mounted on the inside of the opened back contain tools, and a selection of spare parts.

**General.**—The ship clips into a wooden crate also containing the aerial rods for the transmitter and a spare stud switch for the ship. It has been operated for many hours and has proved, after the usual “teething troubles”, to be perfectly reliable.

## BUILDING A RADIO-CONTROLLED MODEL AIRCRAFT

**T**HE use of a transistor in lieu of a normal valve is nowadays providing much lighter radio receivers, and one of this type is shown in Fig. 131, installed in the “Radio Rook”, which is the model to be described. The designer

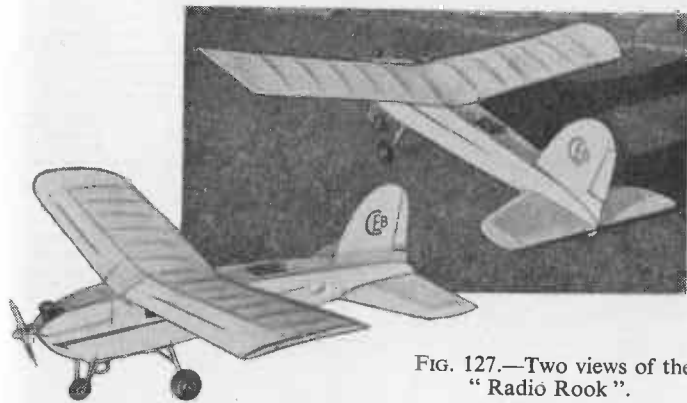

FIG. 127.—Two views of the “Radio Rook”.

of this first transistor single-channel model receiver commercially obtainable in this country is Mr. Honnest Redlich whose address is 148 Nelson Road, Whitton, near Twickenham, Middlesex.

**Size of Model.**—Very large models, around 9 to 10 ft. span and over, fly with great majesty and steadiness, ignoring minor disturbances and trim inaccuracies, but they are too large to build and keep in the average house. The middle sizes, around 8 ft. wing span, which are almost

but not quite so steady in the air, in common with 7 ft. and 6 ft. models, are still a little large to keep in most homes. The best all-round flying model for transport, housing, robustness and yet good flying ability is around 5 ft. span. It is not as rock-steady as the larger models, but it has many excellent attributes, and can take single-channel as well as three-channel "tuned reed" receivers, providing engine control as well as rudder. The little 45-in. span models have to be very light, with small radio batteries, demand considerable experience to build, and can be tricky to fly.

The 5 ft. class "Radio Rook" is therefore, chosen, as being most likely to form a good all-comers' model, that can take a variety of engines and receivers. The model is exceptionally stable for its size and very robust. It is the ideal model for flying for fun and if a generous rudder movement is given it will be found a good stunter on single-channel, rudder only. The model climbs fast on a 3.4 c.c. E.D. diesel motor or, with the lighter receivers, flies excellently, powered by a 2.4 c.c. E.D. diesel or a 2.5 c.c.

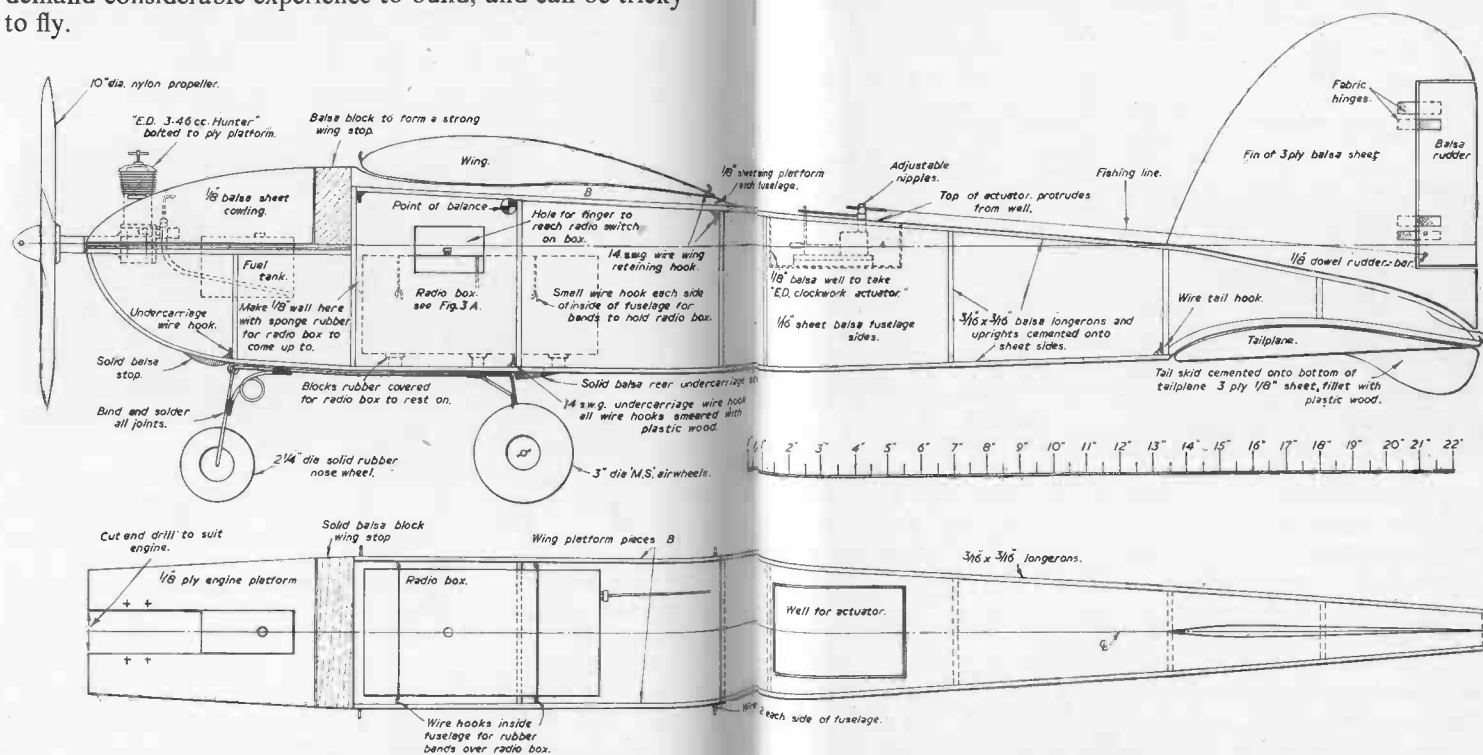

FIG. 128.—General arrangement drawing of the fuselage of the "Radio Rook".

Frog. A Frog 10-in. diameter, 5-in. pitch nylon propeller is used for the "Radio Rook". The model is shown on the ground in Fig. 127.

**Types of Commercial Radio Receiver.**—The model described is capable of using a wide range of receiver, including multi-channel three-reed. The latter type will give two-speed engine control as well as rudder as desired, whereas, of course, normal commercial single-channel can only provide sequence rudder right and left.

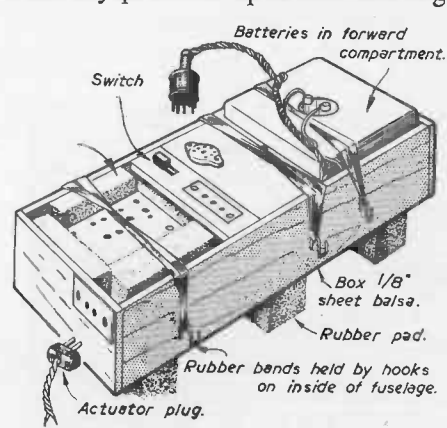

FIG. 129.—The transistor receiver and batteries mounted in detachable installation.

It is perhaps a little tricky to tune at times and does require a distance check by a helper as a rule between flights, if reliable results are to be obtained. However, if cheapness is important there is much in favour for the modern single-valve receiver.

**The Three-valve "Modulated" Receiver.**—At present the only firm making these excellent receivers is Messrs. E.D. Ltd. Among its advantages are very simple single-lever tuning, single-handed tuning and great range. Finally, they are not critical because there is a detector valve and two amplifiers. It is possible to tune single-handed by merely resting the transmitter on the control button to

**The Single-channel, Single-valve Receiver.**—This type of receiver is best for newcomers when fitted with a "hard" valve. The "soft" or gas-filled valve is inclined to change its characteristics too soon, and create difficulties for a beginner. The single-valve receiver is cheap to buy or it can be made up as described in Chapter 2.

keep a signal on, and then walking away for about 20 yards only, and plugging in a meter to the model. Now having switched on the model receiver, turn the single tuning lever either way until the highest rise in current drops. Place the tuning lever midway between these two drop-off points and you have enormous latitude of tune and range, as far as you can see to control any model, and

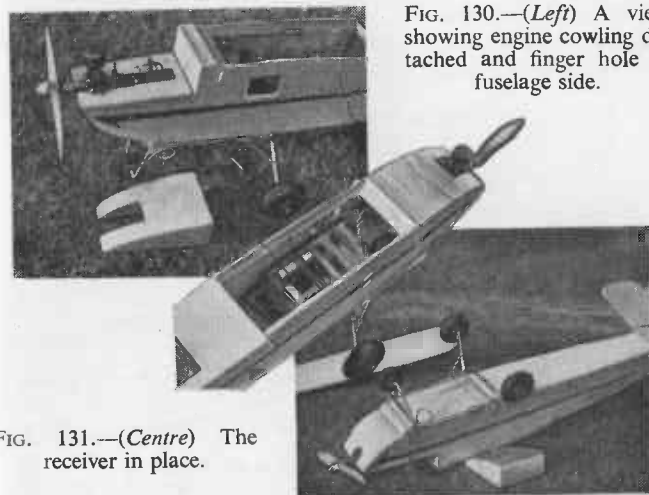

FIG. 130.—(Left) A view showing engine cowling detached and finger hole in fuselage side.

FIG. 131.—(Centre) The receiver in place.

FIG. 132.—(Bottom) The tricycle undercarriage.

farther. The tuning is then set for the day. It will be noted that there is a rise in current at the receiver, to switch on the actuator, and so operate the rudder through the relay; therefore, if the receiver should fail for any reason the model does not spiral, as may well happen on single-valve receivers which drop the current on receipt of signal. These three sub-miniature valves naturally cost a little more to produce, but single-handed tuning alone makes this receiver worth its extra cost.

**Multi-channel "Tuned Reed" Receivers.**—Multi-channel is perhaps the ultimate to date in the commercial world,

providing either three-channel or six-channel control. Designed by Mr. G. Honnest Redlich for his cross-Channel records and also for non-interference yacht racing, these sets can now be obtained from the designer, or Messrs. E.D. Ltd. For the "Radio Rook" the three-channel receiver is required, if multi-channel is decided upon, providing left and right rudder as desired, and the third channel to operate the twin butterfly carburetter on the 3.4 c.c. E.D. diesel motor. This carburetter gives a reasonably slow speed or "wide-open" and was designed by G. Honnest Redlich for competition work. It is now

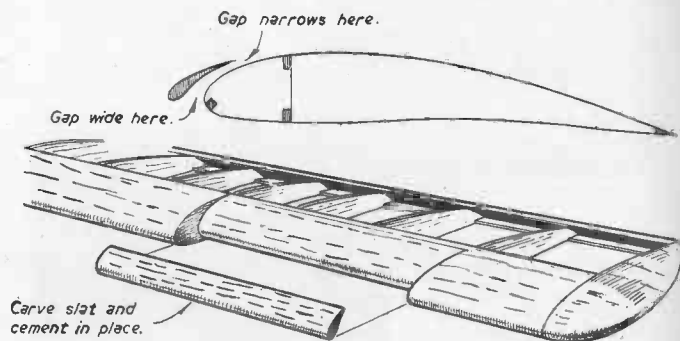

FIG. 133.—Wing slots and wing details.

commercially obtainable. Single clapper valves worked by the radio have been tried over the induction pipe of a diesel, but the control is not as effective as by twin butterfly carburetter on a diesel motor.

If it is decided to use multi-channel radio on the "Radio Rook", it is desirable to add 8 in. to the wing span, i.e., two extra panels or ribs are built into the wing, each rib being spaced 4 in. apart. The wing span then becomes 5 ft. 8 in. This provides a little more wing area for the slight extra weight of multi-channel radio sets, keeping the slow-flying characteristics of the model for reasonable winds. If fast penetrating flight is desired keep to the 5 ft. wing span. The "Radio Rook" has also been built in the 8 ft.

span size, a size of model that can carry six-channel radio and which is powered by an 8 c.c. Miles Diesel or a 9 c.c. petrol spark-ignition motor.

**The Transistor Radio Receiver.**—Fig. 131 shows the baby transistor receiver made by Mr. G. Honnest Redlich, mentioned in the opening paragraph, fitted into the "Radio Rook". It is surrounded by light-coloured rubber packing. A transistor itself is really minute, and, of course, battery drain is very low indeed. This Redlich transistor single-channel receiver seen in Fig. 131 has the valuable feature of a current rise on receipt of signal, with all its attendant safety for a model aeroplane, as already mentioned. Furthermore, the current rise is around  $3\frac{1}{2}$  mA, which provides a good safety factor. The receiver is made by Messrs. E.D. Ltd.

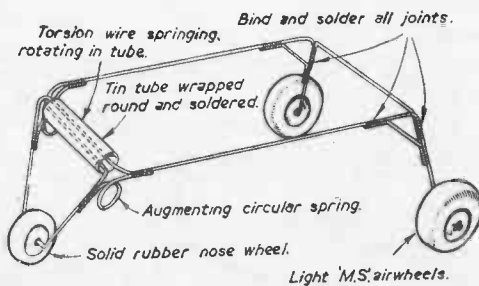

FIG. 134.—Perspective view of the tricycle undercarriage.

**The Power Unit.**—The use of E.D. 3.46 diesel with the Frog 10-in. diameter 5-in. pitch propeller made from nylon is recommended. This provides good power for high flights and stunting if desired.

Three-valve receivers and multi-channel "tuned reed" receivers are best flown with this motor, or any other motor of similar power output, with the correct propeller.

Good 2.5 diesels like the E.D. Racer and the Frog 2.49 B.B. will fly the model well with the lighter single-valve receivers, and of course, a transistor receiver, although the reserve of power in the 3.46 E.D. diesel is a definite advantage. For competitions, a large fuel tank should be fitted just behind the engine, providing several minutes' flight; otherwise a two-minute tank is ample. The fuel height when



taking off should be just below the needle valve, and the fuel line is always best taken down to the bottom of tanks well aft to collect fuel. If this is not done and the model is thrown hard when hand launched with a not-quite-full tank, the forward throw may cause starving when the fuel swills backwards. Radio flying becomes quite hopeless unless the correct engine and propeller, with correct fuel arrangements, are employed. It is quite essential to obtain

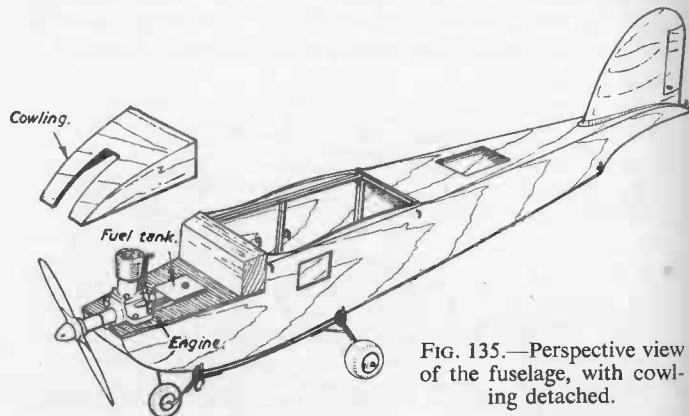

FIG. 135.—Perspective view of the fuselage, with cowling detached.

long duration under full power, without fading or engine failure.

**The Radio Gear Detachable Installation.**—The receiver and batteries are contained in a detachable balsa radio box, covered with fabric, because this method permits rapid interchange, removal for servicing and also sliding adjustment for final weight location to get the best trim during the tuning up period. It is an enormous advantage to be able to take out the complete radio for adjustment and repairs, battery changes, and to use the same radio for another model. The radio box has absorbent synthetic foam rubber surrounding the receiver. There are also further vibration and anti-damage rubber strips at the bottom of the fuselage and just ahead of the radio box. Very little damage is ever done with this set-up, and the

box is held to the fuselage floor by rubber bands to wire hooks inside the fuselage. These wire hooks are reinforced to the sheet balsa fuselage sides, with plastic wood and cement, see Figs. 128 and 129. This is a better method than slinging the naked receiver from four hooks in the fuselage by rubber bands. In a heavy landing, or if the model flies into an obstruction, the unfortunate receiver is slung violently back and forth and banged against the fuselage.

**The Actuator.**—This is an E.D. clockwork mechanism, which is more positive and more trouble free than the

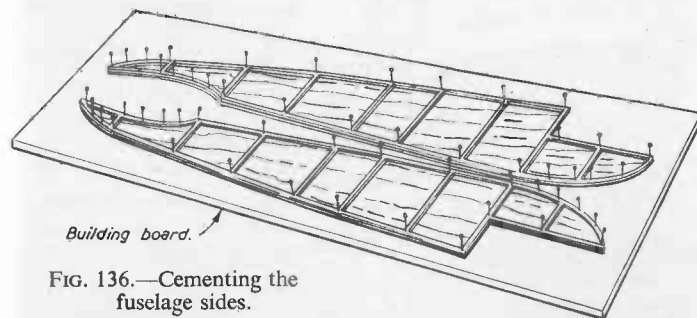

FIG. 136.—Cementing the fuselage sides.

type of actuator operated by rubber elastic, which requires constant renewal and correct tensioning. Tighten up the standard return spring a trifle and always employ a  $7\frac{1}{2}$ -volt battery, which gives the actuator a sturdy and reliable kick instead of the uncertain little digs of smaller voltages generally used. Reliable flying is the chief aim, and this sturdy model will carry the slight extra weight of clockwork actuator and this powerful actuator battery to operate the rudder. The actuator is partly sunk into the top of the fuselage in a small balsa well, as can be seen in Fig. 127. There are two fishing lines to the rudder crossbar from the actuator. If one of the E.D. adjustable swivel nipples is fitted to each arm of the actuator, small lengths of wire attached to the fishing line ends can then provide instant adjustment of rudder. The twin electrical leads from

actuator to radio box should be carefully intertwined and neatly fastened to the fuselage sides, ending at a two-pin plug to fit into the socket in the radio box, see Figs. 129 and 131.

Batteries are in a forward compartment of the  $\frac{1}{8}$ -in. balsa radio box to keep weight well forward, and furthermore, should the model crash, heavy batteries do not smash into the delicate receiver. A receiver on/off switch is fitted on a central "deck" in the box, which is reached by means of a rectangular finger hole in the fuselage side,

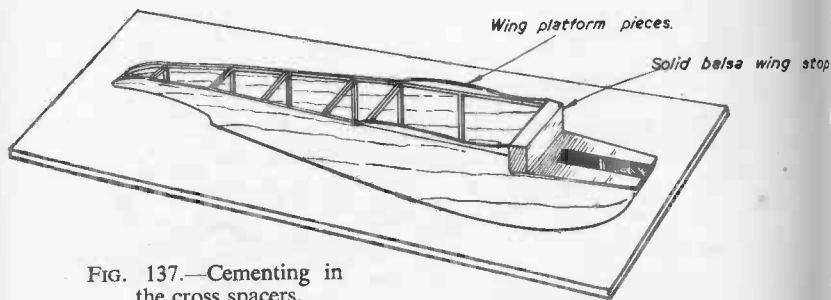

FIG. 137.—Cementing in the cross spacers.

see Figs. 128 and 130. After flying for the day, always disconnect batteries in the box, by means of a four-pin plug to prevent any slight current leakages.

Tuning the radio is done before the first flight for the day, with the wings off. If a three-valve receiver, or a transistor receiver is employed, tuning between flights is seldom necessary.

**Wing Slots and the Wing Details.**—Fig. 127 shows that the parallel chord is fitted with simple letterbox wing slots carved from balsa sheet. A rectangular-shaped wing stalls last at the wing tips, and when this feature is further reinforced by wing slots, great stability is obtained against dropping a wing tip, which is a dangerous possibility on model aircraft. Letterbox slots have many advantages, and any slight extra drag is of no moment on a model. The chief asset on model aircraft is stability, especially when

fitted with expensive radio gear! Even a normally stable model can be crashed by an inexperienced modeller through turning too sharply by radio. Models should only be turned in very slight bursts of rudder until the owner becomes experienced. Full rudder held on will always create a spiral dive if the rudder has sufficient action to allow stunting. Inbuilt wing slots, however, iron out a stall after a dive, provided there is adequate height available. They are very simple to construct from solid sheet balsa, see Fig. 133.

**The Tricycle Undercarriage.**—A tricycle undercarriage is a great crankshaft and propeller saver, provided the front wheel is anchored correctly to take adequately the blow of a poor landing. Most front model wheels are

too rigidly fixed to the fuselage, but a tricycle undercarriage built as a "detachable stay", and held to the fuselage by rubber bands, is the ideal solution. If the blow is serious, the torsion bar front legs give first, resisting further by two coil springs and *in extremis* the whole undercarriage goes back on its rubber bands. There are thus three lines of defence. Such a tricycle dolly undercarriage is easily removed for transport by unhooking the rubber retaining bands from the wire hooks located in the fuselage sides low down. These hooks are reinforced into the fuselage by plastic wood. Fig. 132 shows the undercarriage construction, whilst Fig. 143 is a sketch that will be found useful when making up the wire chassis.

When covering the bottom of the fuselage where the tricycle undercarriage sits, cover the balsa sheet with one layer of thin fibreglass cloth, also carrying this around the engine nosepiece. This is not strictly necessary, but is a

R.M.—12

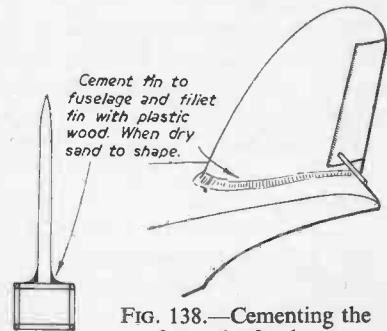

FIG. 138.—Cementing the fin to the fuselage.

fine strengthener. If fibreglass is not used, it is advisable to cement in two small reinforcing pieces of three-ply where the undercarriage rests against the fuselage bottom.

**The Engine Cowling.**—This is a very light balsa sheet construction made from  $\frac{1}{8}$ -in. and  $\frac{1}{16}$ -in. sheet, then covered with butter muslin or nylon and doped. It is held in position by a rubber band over the top to two little wire hooks on the engine platform. Figs. 130 and 135 show the cowl detached.

**The Fuselage Construction.**—The fuselage side elevation must be drawn out full size from the plans in Fig. 128. This is then laid on a table or flat surface, with carbon copying paper below it, over  $\frac{1}{16}$ -in. balsa sheets. The side elevation of the fuselage is then traced on to the balsa sheet. The sheet side of the fuselage is then cut out to shape by safety-razor blade. A second balsa sheet side is then made. As balsa sheet is usually 3 ft. by 3 in. or 4 in. wide, it will be necessary to butt-joint several sheets by smearing the edges with cement and leaving to dry under weights, which is a very simple operation. Light-weight  $\frac{1}{16}$ -in. thick sheet balsa is purchased.

Around the edges of the sheet fuselage sides are cemented  $\frac{3}{16}$  in.  $\times$   $\frac{3}{16}$  in. fairly hard balsa longerons, being kept in place by household pins till dry. Do not forget to cement the longerons, etc., on to the two sides so that in the next stage of erecting them side by side, the balsa longerons are inside. Now cement in the cross spacers of the same section balsa sticks as in Fig. 136 using pins to keep in position. Where the balsa longerons are severely bent to the shape of fuselage merely crack the balsa wood to the desired curve, the cement and sheet backing stiffen up. The two fuselage sides are cemented together with  $\frac{3}{16}$ -in.  $\times$   $\frac{3}{16}$ -in. balsa spacers, as shown in Fig. 137.

The fuselage is now fitted out with wire hooks for retaining wing, tailplane and undercarriage, etc., before the fuselage top balsa skin is put in position. These wire hooks are made from 14 s.w.g. piano wire, and where they pierce the fuselage they are well-smearred with plenty of plastic wood and cement to spread the highly stressed loads over

the balsa sheet covering. Do not spare the plastic wood. Small wire hooks are cemented and plastic wood reinforced into the inside of the fuselage to hold the radio box to the floor by rubber bands. Now fix the top and bottom sheet covering in place.

**The Fin and Radio Rudder.**—The fin and the rudder require great accuracy of construction and great care to prevent warping whilst cement is drying. The fin must then be cemented on to the fuselage top accurately along the centre line, or the model will turn violently.

After cementing the fin in position, run a plastic wood and cement filleting along each base to make it rigid with the fuselage (Fig. 138).

The fin is made, as shown in Fig. 139, of a central  $\frac{1}{8}$ -in. balsa

sheet slab lightened out in the centre. Again, butt-joint several pieces of sheet where necessary. Now cut out two sides of the fin from  $\frac{1}{16}$ -in. balsa sheet and cover the central sheet, smearing plentifully with cement. Place the whole "sandwich" between some flat irons whilst the cement sets. This form of fin will not warp once it is well dried out. Cut out the three-ply balsa rudder and sand everything smooth. Stages of construction are shown in Fig. 139.

The rudder hinges are strips of fabric cemented on after

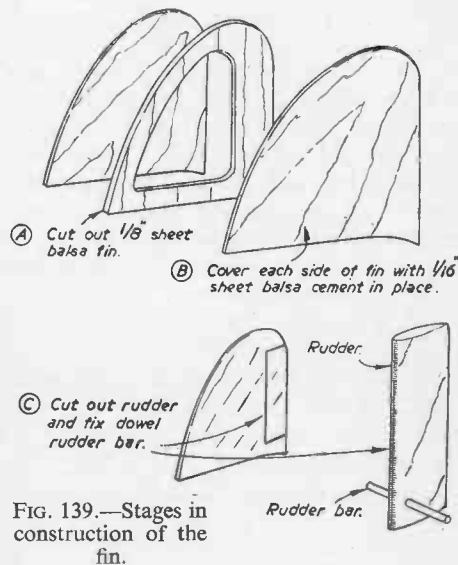

FIG. 139.—Stages in construction of the fin.

the fin has been covered with fabric. This is shown clearly in Fig. 128.

Now that the fin has been fitted to the fuselage, the whole can be covered with cheap "butter muslin" of light weight, obtainable at a fabrics shop. This material can be tautened over the fuselage, etc., after smearing the structure with photopaste. It is then doped with two thick-flowing coats of Cellon full-strength tautening dope. Real aeroplane dope is preferable to model dope, for it makes a very durable job, whereas model dope requires at least six coats, and is really too thin for radio models. One or two coloured coats of dope can then be put on, but remember too much "finish" weighs a lot, and always gets shabby through fuel, etc.

**The Wings and Tail.**—These must be drawn out full size from Figs. 140 and 141 on to kitchen paper, and the wings and tail built over the plan, with a sheet of greaseproof paper inserted between to prevent cement sticking to the plan.

Wing construction is very simple. First, lay down the trailing edge  $\frac{1}{16}$ -in. sheet balsa, and cement on the trailing edge spar of  $\frac{3}{8}$ -in. by  $\frac{1}{4}$ -in. balsa and the  $\frac{1}{8}$ -in. balsa tip. Now lay down the central lower main spar and cement the ribs into their correct positions over the plan, cementing the ends of the ribs to the trailing edge and its sheet. Pin until dry. The spars can be of hard balsa, but if you can obtain it, spruce or obechi wood are best for these two main spars. They are the only hard-wood spars in the model. Now cement in the leading-edge spars of balsa,  $\frac{3}{16}$  in. by  $\frac{3}{16}$  in.

The wing is best made in one piece on this size of model, but if transport forbids this, it can be "split" at the centre. A one-piece wing is far stronger and more true, giving more consistent flights. A five-foot structure is not too long to carry. Assuming you make the wing in one piece, the dihedral must now be put in as shown in Fig. 142. One end is jacked up on a table or building board, and 12 s.w.g. wire centrepieces are bound and cemented to the various spars, with the trailing edge wire well plastic-wooded

into the rear sheet balsa. When set hard the whole wing is sanded down, and the leading edge is covered with light  $\frac{1}{16}$ -in. sheet balsa, top and bottom, up to the central spars only, and at wing tips, using plenty of cement to adhere to ribs, etc., and temporary pins. Cement in wing hooks, well reinforced by plastic wood, and reinforce the wire dihedral pieces with plastic wood on the inside of the sheet covering. Finally, sand down.

Now cover with butter muslin or nylon. The first is cheaper, and is applied dry, using photopaste to stick down to the framework. If nylon is used it must be put on

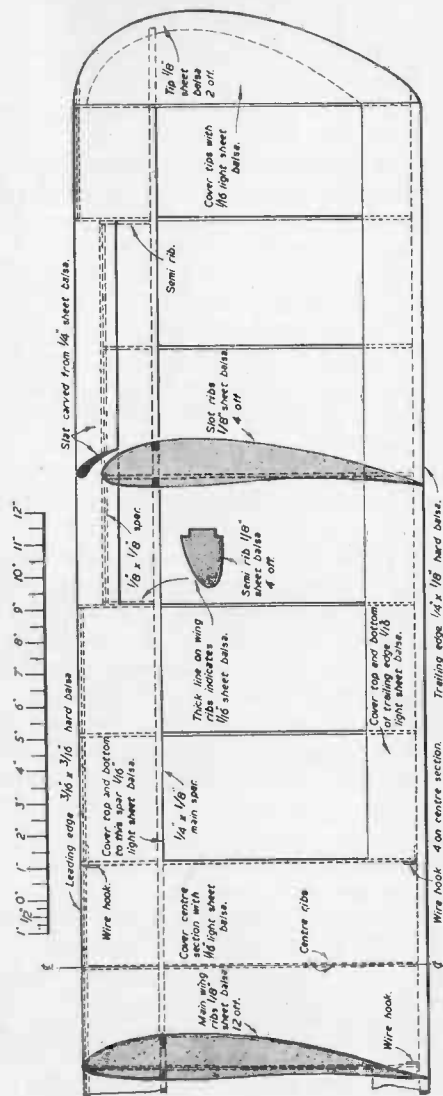

FIG. 140.—A scale drawing of the wing, showing details of construction.

damp and allowed to shrink dry before doping. Apply two coats of full-strength full-scale aeroplane tautening Cellon dope, and two of colour.

The tailplane is made in the same way as the wing, but there is no dihedral.

Be sure to weight down surfaces to flat boards or table whilst they are tautening after the dope loses tackiness, but before it dries hard. Should any warps develop in spite of this, they can be twisted out in front of an electric stove, being very careful not to set the wings on fire.

**Flying the Model.**—Make sure you have the angles of wing and tail correct, as shown on the side elevation of the fuselage drawing. Be sure there are no warps anywhere, and that wings and tail, etc., are set on square. If slightly out through poor building, pack up square with balsa.

Be certain that the model balances on the fingers at "C.G. Point of Balance", shown in Fig. 143. If not, due to poor building or balsa weight differences, move the balsa box slightly to obtain proper balance, and then fix position.

Now glide the model with radio in, over long grass, dead into a slight wind, throwing the model forward, and very slightly downward like a dart. It should glide nose slightly down, but flat. If it rears up in a stallish flight, put  $\frac{1}{8}$  in. packing under the tail end of the fuselage and tailplane. If it dives too steeply put in a nose packing above the front end of the tailplane between tail and fuselage. Get the glide perfect by these methods, and then never alter it, for the model must glide properly when the power ends.

Now try power flight. Too stallish a flight under power is adjusted by a little more down-thrust of the engine, or vice versa. This is automatically built into the engine platform, and no change is likely to be required, unless you have an unusually powerful motor. If the model turns too much to the left under power, point the engine slightly more to the right by altering engine bolts.

Try flying with radio, having the rudder to only half travel at first. Launch into wind, and allow the model to climb a little, then give very swift and small bursts of rudder, weaving the model up wind and climbing, steadily

until you can handle it competently. Never hold on a turn too long, until you have gained good height, and then only do spiral diving and long turn handling when you understand what you are doing. Turn more to the left than to the right when you start, for this is safer. To do a long turn give a short rudder left, a tiny one right, and follow up with another short left and so on. Later you can provide the rudder with full travel, and having gained height (good height), you can try some long periods with the rudder and start

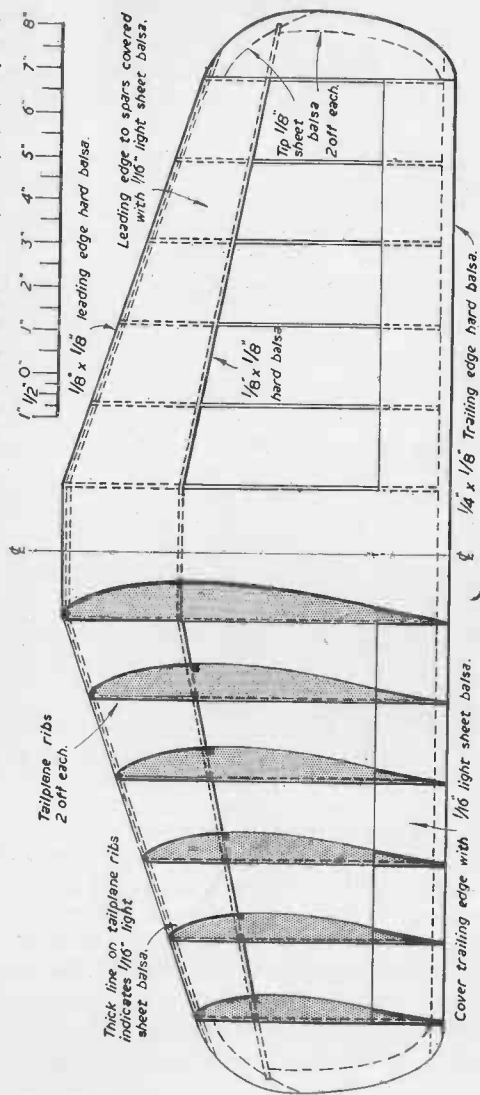

FIG. 141.—Scale drawing of the tailplane.

learning how to stunt. When the engine finally cuts you should steer the model by short turns into wind for the landing, with a final approach dead into wind.

With the E.D. clockwork actuator, there is provision to

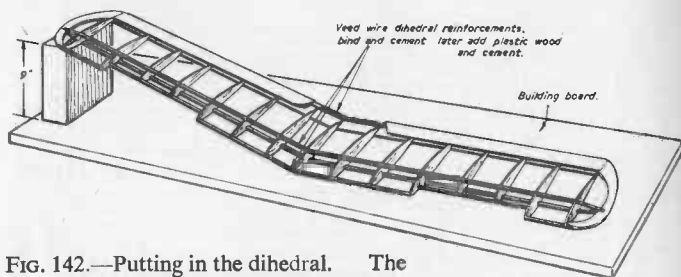

FIG. 142.—Putting in the dihedral. The wing is made in one piece and 12 s.w.g. wire centre pieces are bound and cemented to the spars as shown. Finally, plastic wood is added.

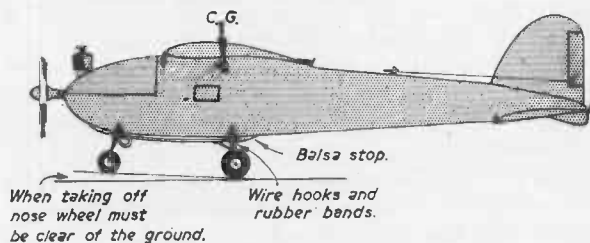

FIG. 143.—Aircraft in take-off position with centre of gravity marked

alter the amount of rudder travel. If the model always turns too much one particular way, adjust the rudder lines so that there is a trifle of offset to the rudder in the opposite direction, but first make sure that the model flies straight under power when the rudder is centralised, by engine offset adjustment, as already explained.

PUBLIC LIBRARIES  
\* ISLINGTON \*

# A MUST for MODEL MAKERS



Constructional details on every type of model, including radio controlled craft, are featured regularly in PRACTICAL MECHANICS. You will enjoy this fascinating magazine too for its invaluable "How-to-Make" features and articles on every branch of Science, Mechanics and Invention. Make sure of your regular copy . . . place an order with your newsagent today!

Edited  
by  
F. J. CAMM

## PRACTICAL MECHANICS

MONTHLY  
1/3

*Why YOU should Read*

# PRACTICAL WIRELESS

Improve your knowledge of radio principles and practice by getting PRACTICAL WIRELESS every month. Edited by F. J. Camm, this famous "practical" magazine covers every aspect of radio, with special features on radio transmission. Take no chances with your radio units . . . follow the experts . . . order PRACTICAL WIRELESS from your newsagent today!

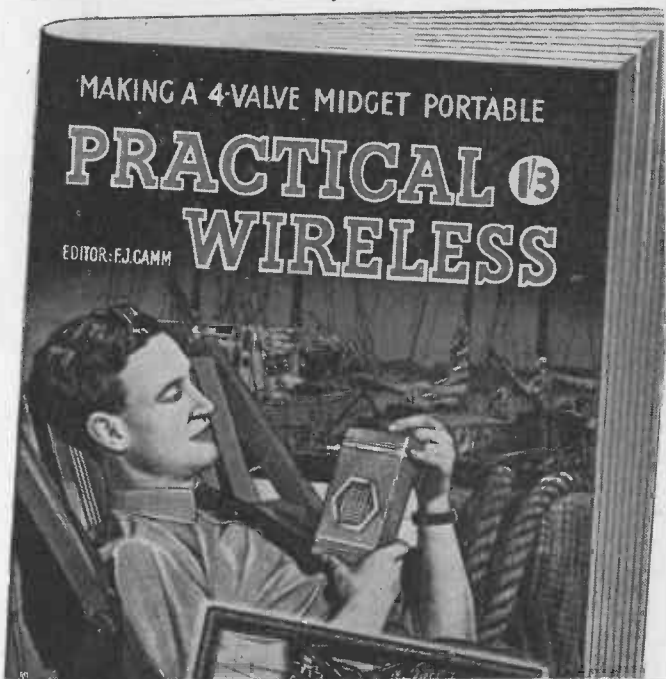

**Edited by F.J. CAMM • MONTHLY 1/3**

*. . . a truly "basic" course in  
radio transmission and reception—*

**F. J. CAMM'S**

# A BEGINNER'S GUIDE TO RADIO

**S**PECIALLY planned for teachers and students, this elementary first course in radio transmission and reception, written in simple language which the very beginner will understand, approaches the subject from a new angle. The student is taught how to build simple receivers and the theory and function of each part is explained as the student builds. The teacher is given the basis of instruction.

## CONTENTS

*Understanding the Circuit • One-Valver into Two-Valver • Adding of a Further L.F. Stage • Purpose of Grid Bias • Automatic Bias • Purpose of Decoupling • Adding Tone Control • Ohm's Law • Meters • Testing Without Instruments • Inductance and Capacity • Condensers • Superhet Transmission • Electric Currents • Detector Valve • Methods of Coupling Valves • Transformer and Output Stage • Reading a Circuit • Using Testing Instruments • Characteristic Curve • The Loudspeaker • Mains Valves • Rectifiers, Chokes and Smoothing • Accumulators • Abbreviations • Table • Index.*

**27 Lessons by F. J. Camm** (Editor of "Practical Wireless" and "Practical Television" etc.)

**Only 7s. 6d. net**

**104 illustrations**

**FROM ALL  
BOOKSELLERS**

or in case of difficulty 8s. 6d. by post from  
GEORGE NEWNES LTD., Tower House,  
Southampton Street, London. W.C.2



In addition to

## RADIO CONTROLLED MODELS

do not forget F. J. Camm's ideal book for model engineers, the new

## SECOND PRACTICAL MECHANICS "HOW-TO-MAKE-IT" BOOK

THE great success of the first "Practical Mechanics 'How-To-Make-It' Book", which has run through several editions, has encouraged the publishers to produce this second volume, describing the construction of a wide variety of articles which will appeal to the home mechanic and model maker. Like the first volume, this has been compiled from the most popular features appearing in "Practical Mechanics", the old-established monthly journal for practical amateurs. Here is a list of the contents:

A Reflecting Enlarger; One-stringed Fiddles; Folding Steps and an Extending Ladder; An Electric Guitarette; A Miniature Billiard-Table; A Synchronous Electric Clock; A Glove Puppet Theatre; An Automatic Garden Sprinkler; A Midget Camera; A Potter's Wheel; A Catamaran; A Rowing Machine; An Aqualung; Home-made Fishing Tackle; Installing a Tropical Aquarium; A Snow Scooter; Under Water Photography; A Pair of Skis; Projecting Time on the Ceiling; A Harpoon Gun; Small Wind-power Plants; An Electric Hedge Trimmer; Bathroom Scales; A Folding Outboard Motor-boat; Flash Photography; Gas Fired Pottery Kilns; A Back-projection Episcopes; Motorising your Lawn Mower; A Skeleton Synchro-electric Clock; A Viewer and Printer for 35 mm. Film; A Cycle Trailer; An Electric Imitation Coal Fire; A Mechanical Potato Peeler; A Home-made Duplicator; Making Rubber Stamps.

All of the items described have been built and tested in the "Practical Mechanics" Workshop.

Fully illustrated. 15s. net. (16s. by post)

FROM ALL BOOKSELLERS

... or in case of difficulty write to the publishers—

GEORGE NEWNES LTD.

Tower House, Southampton Street, London, W.C.2

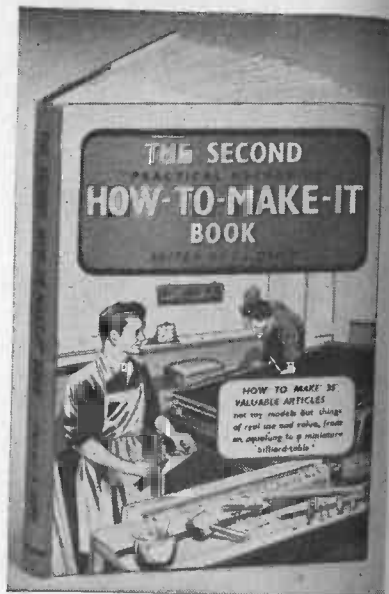

Shows you how to make 35 valuable articles—  
not toys but things of real use and value.

15s. net • 306 illustrations

Also still available—

### FIRST PRACTICAL MECHANICS "HOW-TO-MAKE-IT" BOOK

By F. J. Camm

Shows you how to construct a Tape Recorder; Master Battery Clock; Electronic Organ; Electric Washing Machine; Hand Vacuum Cleaner; Electrically operated Garage Doors; 15" Four-heddle Hand-loom; Potter's Wheel; Pottery Kiln; Westminster Tubular Door Chimes; Cycle Trailer; Pedal-cycle Sidecar; Portable Air Compressor; Water Softener; Spanish Hawaiian Guitar; Radio Deaf-aid Unit; Vertical Enlarger; Synchronised Flashgun; Combined Printing Box and Safe-light; Diascopes and Episcopes; Electric Wall Bracket; Inexpensive House Telephones; Electric Gas-lighter; etc., etc. 224 pages; 320 diagrams and illustrations.

12s. 6d. net. (13s. 6d. by post.)

. . . obviously here's a man who hasn't read that best of all books for the electrician round the home—

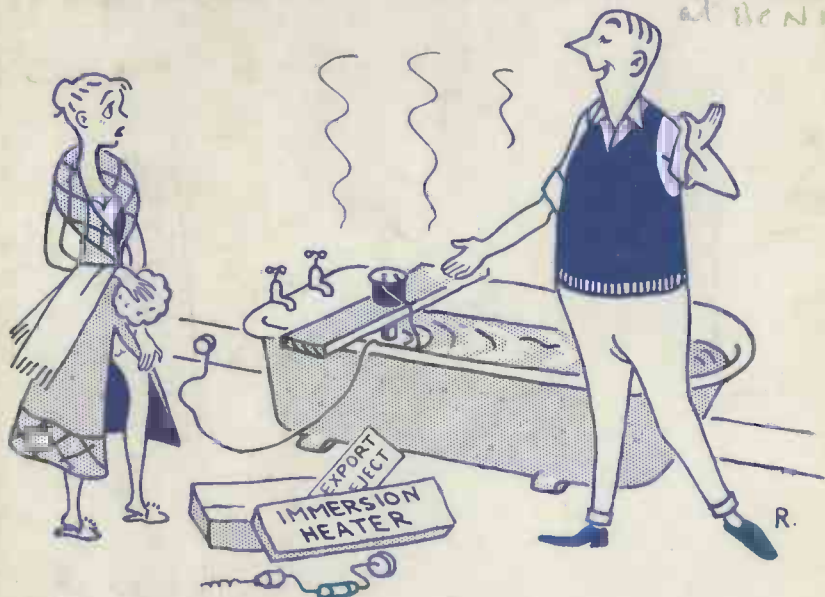

## F. J. CAMM'S The HOME ELECTRICIAN

THIS handbook deals with installation, upkeep, overhaul and repair of all electrical apparatus used in the home, with additional chapters on house-wiring. It is essentially a book for the handyman who prefers to do the job himself. Here is a complete guide for the non-technical householder, publication of which has been prompted by the increasing use of electricity and electrical labour-saving devices in the home.

**206 pages . 149 illustrations . Only 12s. 6d.**  
**FROM ALL BOOKSELLERS**

## CONTENTS INCLUDE

*About Electricity : Rules and Regulations : The Installation Explained : Power Wiring Explained : Electric Light and Power Installation : Layouts and Wiring Methods : House Circuits : Switches and Control Points : Installing Domestic Electrical Apparatus : Installing Electric Bells : Home-made Burglar Alarms : Electric Water Heating : Circulators for Electric Water Heating : Tank Capacities of Water Heaters : Electric Heater Plumbing : Piping and Electrical Installation of Water-heaters : Running Electric Models from the Mains : Motor-driven Apparatus : Accumulator Charging, etc.*

. . . or in case of difficulty 13s. 3d. by post from  
C. ARTHUR PEARSON LTD., Tower House,  
Southampton Street, London, W.C.2.