

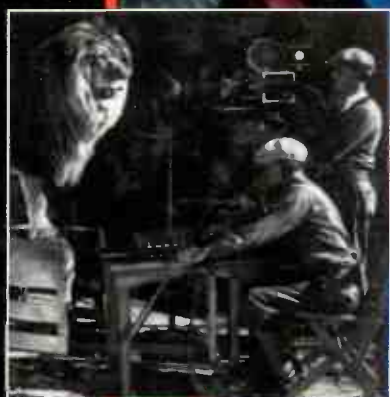

Milestones in
Discovery and Invention

Communications and Broadcasting



Harry Henderson



**Milestones in
Discovery and Invention**

Communications and Broadcast



The Milestones in Discovery and Invention series recognizes that science and technology are intricate webs of insight, experiment, and breakthroughs passed from one generation to the next. Created especially for young adults, this series traces the flow of scientific and technological ideas through the innovations that changed the face of society and made further exploration possible. Combining biography, scientific reasoning, and history, each volume in the series investigates a particular field. Enhanced by the use of primary sources, each chapter examines a milestone discovery or invention, the specific scientist or inventor, the underlying process and inspiration, and how the discovery forever changed the world.

This volume explores the inventors and inventions that have made modern communications and broadcasting possible and the scientific ideas used to visualize and build new communications devices. Each of the inventions discussed has had profound societal effects that go beyond entertaining people and helping them communicate. The telephone gave women more social freedom and brought many of them into the workplace; the phonograph turned music into a commodity one could buy; and movies and television brought powerful images a whole nation might share. This volume provides insight into how inventors worked, how a changing society reacted to their inventions, and how the meanings of *inventor* and *invention* have shifted in the course of the history of communications and broadcasting.

VOLUMES IN THE SERIES INCLUDE:

Genetics and Genetic Engineering
Medical Technology
Nuclear Physics

Harry Henderson is an educational and technical editor and writer in the fields of mathematics and computer science. His works include a young adult biography, *The Importance of Stephen Hawking*, and an adult computer manual, *Internet How-To*. Henderson is also the author of *Modern Mathematicians in Facts On File's Global Profiles* series.

On the front cover: circuit board © 1995 Telegraph Colour Library/FPG International;
inset MGM technicians record their trademark roar, courtesy
of the Library of Congress

ISBN 0 8160-3565 2



9 0000



9 780816 035656

Cover design by Smart Graphics

Printed in the United States of America

Milestones in Discovery and Invention

Communications and Broadcasting

HARRY HENDERSON

WANTONVILLE MIDDLE SCHOOL LIBRARY

Facts On File, Inc.

To the inventor in each of us

Communications and Broadcasting

Copyright © 1997 by Harry Henderson

All rights reserved. No part of this book may be reproduced or utilized in any form or by any means, electronic or mechanical, including photocopying, recording, or by any information storage or retrieval systems, without permission in writing from the publisher. For information contact:

Facts On File, Inc.
11 Penn Plaza
New York NY 10001

Library of Congress Cataloging-in-Publication Data

Henderson, Harry, 1951-

Communications and broadcasting / Harry Henderson.

p. cm — (Milestones in discovery and invention)

Includes bibliographical references and index.

Summary: Presents the history of modern communications and broadcasting through an overview of key inventions and their inventors, including, among others, the telegraph and Samuel Morse, sound recording and Thomas Edison, and television and Philo Farnsworth.

ISBN 0-8160-3565-2

I. Telecommunication—Juvenile literature.

[I. Telecommunication.] I. Title. II. Series.

TK5102.4.H46 1997

96-48633

384-dc21

Facts On File books are available at special discounts when purchased in bulk quantities for businesses, associations, institutions or sales promotions. Please call our Special Sales Department in New York at 212/967-8800 or 800/322-8755.

Text design by Cathy Rincon

Cover design by Smart Graphics

Illustrations on pages 7, 31, 52, 55, 56, 60, 69, 73, 92, 95, 113, and 122 by Jeremy Eagle

This book is printed on acid-free paper.

Printed in the United States of America

MP FOF 10987654321

Contents

Acknowledgments	iv
Introduction	v
– 1 Talking with Lightning SAMUEL MORSE AND THE TELEGRAPH	1
– 2 Voices in the Wires ALEXANDER GRAHAM BELL AND THE TELEPHONE	20
– 3 The Medium of Memory THOMAS EDISON, SOUND RECORDING, AND MOTION PICTURES	38
– 4 The Invisible Web GUGLIELMO MARCONI AND WIRELESS TELEGRAPHY	62
5 Triumph and Tragedy EDWIN ARMSTRONG AND RADIO BROADCASTING	79
6 The Ghost Light PHILO FARNSWORTH AND THE BIRTH OF TELEVISION	99
7 Digital Worlds HOW THE COMPUTER IS TRANSFORMING COMMUNICATIONS	117
Index	132

Acknowledgments

I would like to thank the archive staffs of the Smithsonian Institution, Library of Congress, and the Thomas A. Edison National Historic Site for help in obtaining illustrations for this book. I would also like to thank Ms. Elma Farnsworth for help in obtaining a photo and her book about her late husband, Philo Farnsworth.

Introduction

Imagine you are a Martian who has been observing the Earth with powerful instruments for the past 150 years or so. When you first began watching (the year 1840, Earth time), you saw wires on poles starting to spread across the North American and European continents, carrying signals that went “dit-dat-dit.” About 1860 Earth time, you might have noticed ships unreeling thick wire cables down to the ocean floor, crossing from one continent to another. About 1880, your sensitive instruments might have been able to tell that some wires now carried the sound of speech.

By 1900, you started to pick up electromagnetic signals that traveled through space without wires. Around 1920, the Earth’s atmosphere started to fill with broadcasts of speech and music. By 1930, crude pictures were also beaming out into space: television had been born.

As the 20th century progressed, you saw that what had been separate networks of wires had begun to merge into a thick, pulsing web of information. The information shuttled from place to place far too quickly to be controlled by a living hand. The Earthlings had invented computers.

This book is about the inventors and inventions that have made modern communications and broadcasting possible. The story has several interwoven threads. First, there is the flow of scientific ideas: electromagnetism leading to the telegraph and telephone; Maxwell’s wave theory leading to radio and television. Second, there are the inventors—the people who took scientific ideas and visualized and built new communications devices. Inventors had

to be part scientist, part engineer, and part business entrepreneur. It wasn't enough to have an idea: you had to be able to convince people that it was useful and worth investing in.

Finally, there is our changing society and how it has viewed inventions and inventors. Each of the inventions discussed in this book had profound social effects that went beyond helping people communicate or be entertained. The telephone, for example, gave women more social freedom and also brought many of them into the workplace. The phonograph turned music into an object you could buy. Movies and television brought powerful images that a whole nation might share.

The same society that was changed by inventions also changed the way it looked at the inventor. Nineteenth-century America created and celebrated the inventor-hero who single-handedly turned an idea into an industry. But by the mid-20th century, invention had become a product produced in giant corporate laboratories. While Thomas Edison and Guglielmo Marconi had created mighty companies and shaped the growth of industries, radio pioneer Edwin Armstrong and television wizard Philo Farnsworth found their ideas held hostage by the needs of a giant corporation. Yet in the 1970s, computer pioneers working in garage laboratories again reshaped the communication industry.

As you read through the coming chapters, think about how the inventors worked, how the world reacted to their inventions, and how the meaning of *inventor* and *invention* changed. You can also browse the many boxed features that present additional ideas, stories, and questions.

General Reading for Communications and Broadcasting

The following works deal with the general history of communications and broadcasting:

Lubar, Steven D. *InfoCulture: The Smithsonian Book of Information Age Inventions*. Boston: Houghton Mifflin, 1993. Illustrated









account of the development and historical context of inventions from the telegraph to today's computer networks.

Sharlin, Harold I. *The Making of the Electrical Age: From the Telegraph to Automation*. New York: Abelard-Schuman, 1963.

Good summary of major developments in electrical inventions.

[Smithsonian Exhibit] "Information Age: People, Information & Society." World Wide Web: <http://www.si.edu/organiza/museums/nmah/homepage/docs/infoag18.html>. Text and images from an exhibition.

Key to Icons in Boxed Features

	Key Concepts		Other Inventors
	Parallels		I Was There
	Solving Problems		Trends
	Social Impact		Issues
	Connections		



Talking with Lightning

SAMUEL MORSE AND THE TELEGRAPH



Samuel Morse used the principle of electromagnetism to create the first practical telegraph system. (Library of Congress)

S
 Samuel Finley Breese Morse (1791–1872) was born in Charleston, Massachusetts. The son of a Calvinist minister, he received a liberal education in both science and the arts at Yale College (later called Yale University). He became a skillful painter and the first president of the National Academy of Design.

Like many artists throughout history, however, Morse discovered that it was hard to make a living from his art. By 1837, Morse had decided to try to make his living as an inventor. Certainly people had been inventing things for thousands of years, but the idea of inventing as a profession was something new. In his book *InfoCulture*, Steven Lubar notes that “Americans celebrated the ‘ingenious Yankee,’ praised his cleverness at machines, and admired his ability to ‘get things done.’ That a project was technologically challenging was in itself a reason to do it . . .”

In the early 19th century, Americans were confident that they could solve any technical problem. They had a need for inventions that would help them manage a nation that was rapidly expanding in size and population. By the 1830s, the United States had grown to 24 states with a total population of about 13 million people. A generation earlier, in 1803, the Louisiana Purchase had extended the young nation all the way to the Rocky Mountains. Two inventions, the steamboat and the railroad, were beginning to form a transportation network that linked eastern cities such as New York and Philadelphia with new western communities such as St. Louis, Missouri, and Cincinnati, Ohio.

Even as transportation was improving, communications remained difficult. Mail could be carried by stagecoach or post rider on horseback between eastern cities such as New York and Philadelphia in only a day or so. Messages to interior cities such as Chicago or Cincinnati could take weeks, however. In 1837, the United States Senate asked for proposals for a nationwide telegraph system that could send important messages without delay.

The word *telegraph* comes from the Greek words *tele*, meaning far, and *graphein*, to write. At the time, *telegraph* meant a visual system for relaying signals from point to point. A series of towers

KEY CONCEPTS



circuit a path through which electricity flows from a source, through various devices, and then usually back to the source



conductor a material through which electricity can flow freely



electromagnetism the force of which electricity and magnetism are two aspects

insulator a material that keeps electricity from flowing



static electricity electricity that discharges suddenly rather than flowing in a current



called semaphores had movable arms that displayed combinations of flags. The crew of each tower had a spotter who used a telescope to read the message from the adjacent tower. A flag crew then relayed, or repeated, the message so that the next tower down the line could see it. In France, chains of semaphore stations linked the cities of Paris and Lille by the 1790s. Unfortunately, semaphore systems needed a tower and crew every 5 to 10 miles, (8 to 16 km.) and messages had to be kept short.

Back in 1832, as his ship was returning to New York City from an art study trip to Europe, Morse had thought of another way to send messages. He had read about Benjamin Franklin's electrical experiments and had long been fascinated with the mysterious power of electricity. Dr. Charles T. Jackson, a fellow passenger, remarked one day that electricity passes instantaneously through any length of wire. Morse excitedly replied that "If this be so, and the presence of electricity can be made visible in any desired part of the circuit, I see no reason why intelligence [information] might not be instantaneously transmitted by electricity to any distance."

This insight was not original with Morse. In 1816, English inventor Francis Ronalds had sent messages, using charges of

static electricity. But static electricity was of limited use in making practical electrical devices. Such electricity is generated by friction, usually from a turning wheel. The electricity is discharged in very brief bursts that are hard to detect or manipulate. In 1800, however, Italian scientist Alessandro Volta had invented a device that generated a continuous flow, or current, of electricity. It used a group, or “battery,” of disks of zinc and silver, separated by felt disks soaked in a salty solution of brine.

In order to use electricity for carrying signals, there had to be a receiver—some way to detect the electrical pulses at the other end of the circuit. In 1819, Danish professor Hans Christian Oersted discovered that when electricity was sent through a wire it made a nearby compass needle move. Oersted had discovered electromagnetism, the idea that electricity and magnetism were interchangeable forms of energy. Other experimenters discovered how to wind wire around a piece of metal to make a powerful magnet. Since the magnetism occurred only while electricity flowed, it could be used to move a needle or switch each time an electrical pulse was received.

Once they had a battery, a switch, and an electromagnet for detecting current, many experimenters realized that they could use an electrical circuit to carry messages. Most of them, however, were more interested in developing a theory to explain electromagnetism than in building practical devices that used it. Scientists of the 19th century did not often think about what we today call *technology*; they left that to “mechanics” or “tinkerers.”

Morse's First Telegraph

In 1837, when Morse had decided to be an inventor, he looked back in his 1832 notebooks. He had to translate his ideas into a practical device. Two things gave him considerable difficulty. First, while he had read about electricity, Morse wasn't a scientist. Knowing he had to learn more about electrical theory, he asked Dr. Leonard Gale, a geologist, for help. Gale became Morse's

partner in the telegraph project, and in turn put Morse in touch with Joseph Henry, a pioneer researcher in electromagnetism. Henry noted that Morse had “very little knowledge of the general principles of electricity, magnetism, or electro-magnetism.” While Henry thought that his own work gave him a better claim to a telegraph patent than Morse, he also felt that scientists shouldn’t get patents. Later, when Morse’s telegraph became successful, Henry came to regret his decision.

Morse was not a particularly good mechanic or engineer. He did, however, have the useful ability to improvise from materials at hand. Because his brother was a printer, Morse had some familiarity with the tools of that trade. For his telegraph transmitter, he cast lead type so that it had groups of raised ridges. Each group represented a number. He built a mechanism by which a stick passed over each ridge, briefly dipping wires into cups of

OTHER INVENTORS



THE WHEATSTONE TELEGRAPH

There are many possible ways that information can be signaled and received in an electrical circuit. While Morse was working on his telegraph in the United States, English inventors William Fothergill Cooke and Charles Wheatstone patented a different type of telegraph. The Wheatstone telegraph used five wires and five needles. Each needle could point two different ways, depending on the direction of a current sent to it. By triggering combinations of needles, the telegraph could point to one of 25 letters of the alphabet printed on a board underneath the needles. While these letters could be read without knowing any special codes, it was much more expensive to run a telegraph line with five wires instead of only one. The English inventors soon modified their telegraph to use a single wire and a code similar to that of Morse.

mercury (a conductor), closing the circuit to a battery and sending an electrical pulse. (For example, for the number three, there would be three ridges and three pulses would be sent.)

The receiver was built on a canvas-stretching frame from Morse's art studio. On it he mounted an electromagnet that pulled an arm with a pencil. Under the pencil, a clockwork mechanism pulled a strip of paper. Each time an electrical impulse was received, the electromagnet pulled the arm and pencil, making a V-shaped mark on the moving paper.

To read the message, the operator counted the marks to see what number each group represented. Each three digits were looked up in a code book. For example, the digits 215 stood for the word *successful*.

Improving the Telegraph

Morse's first telegraph worked, and after Gale showed him how to make a more powerful electromagnet by winding more turns of wire, Morse was able to send a message 10 miles.

But the device was complicated and subject to frequent breakdowns. One day Alfred Vail, who had been a student at New York University as well as a skilled mechanic, saw Morse's telegraph. Vail became enthusiastic about the project. In exchange for a quarter share of future profits, Vail agreed to build an improved telegraph.

Morse obtained a patent for his telegraph in 1840. He hoped that the federal government would buy his patent and set up a nationwide telegraph system. Morse felt that the telegraph, like the postal system, canals, and national roads, was a benefit to all Americans. The Senate, after all, had asked for a semaphore system, and Morse was ready to provide something much better. He believed that if the government didn't buy the telegraph, it would be controlled by "a company of speculators," and it would become a "means of enriching the corporation at the expense of the bankruptcy of thousands."

In March 1843, Congress finally agreed to appropriate \$30,000 for Morse and Vail to build a telegraph line from Washington,

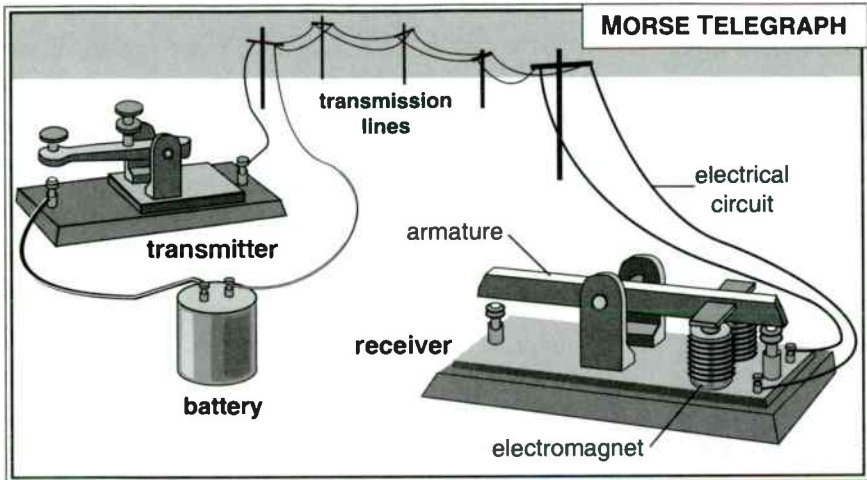

The telegraph sends an electrical signal by using a switch, or key, to momentarily complete a circuit with a battery. At the receiver, the surge of current from the signal enters an electromagnet, causing a magnetic pull that moves the arm of a “sounder” to make a click or draws a mark on a moving strip of paper. Some telegraph receivers used more elaborate printing mechanisms.

D.C. to Baltimore, Maryland, as a demonstration. Morse and Vail soon realized that the first model of the telegraph was too complicated and unreliable for regular service. They made two major improvements. They replaced the slug of type and mercury switch with a simple spring-loaded key to open and close the circuit. Instead of using numbers to stand for words, they represented each letter or numeral by a pattern of dots (short pulses) and dashes (longer pulses). For example, the letter *E* was a single dot, and the letter *X* was a dot, a dash, and two more dots. This system became known as the Morse Code.

The line was completed in 1844. The first official message Morse sent was “What hath God wrought [done]?” That year a presidential election took place, and the telegraph was used to relay news from the Democratic and Whig party conventions.

Congress showed little interest in setting up a government-run telegraph system, however. After the first flurry of messages, people seemed to have trouble finding a use for the invention. As Steven Lubar points out, “Businesses weren’t set up for dealing

PARALLELS



ENCODING INFORMATION

The Morse-Vail alphabetic code is a binary code—that is, it uses two elements (dot and dash) to make up each letter or numeral in the message. Modern computers also use a binary code to represent this information. The ones and zeroes in modern computer messages are very similar to the dots and dashes in Morse code messages.

In Morse code, the letter *A* is represented as “dot-dash.” In the ASCII code used in most modern computers, an uppercase letter *A* is represented by the binary pattern 1000001. Both the Morse and ASCII codes are based on the same fundamental idea that two electric signals can be combined to represent any kind of information.

with telegraph messages. For a new technology to be successful, customers have to be told that they need it, and shown how to use it, and how to reorganize their operations around it. They have to convince themselves of its value.”

Early telegraph lines also suffered from unreliability. The telegraph was the first major electrical technology to be developed. This meant that engineers and technicians had to learn all the basic rules for dealing with electricity safely and avoiding short circuits. One telegraph builder admitted that “insulation was a long word few of us understood.”

Networked Nation

Gradually, however, businesspeople began to see how getting news before their competitors could be profitable. The investor who first learned about changes in stock or commodity prices

could buy or sell favorably. During the Mexican War in 1846, newspapers and their readers realized that a telegraph could have brought them news in hours instead of days and weeks.

By 1847, telegraph lines stretched down the East Coast of the United States from New York City to New Orleans, Louisiana, and by 1854, there were 30,000 miles (48,000 km.) of telegraph wire around the country. Samuel Bowles, editor of the *Springfield Republican*, wrote in 1851 that “The increase of facilities for the transmission of news brought in a new era. The railroad car, the steamboat, and the magnetic telegraph, have made neighborhood among widely dissevered [separated] States. . . . These active and almost miraculous agencies have brought the whole civilized world in contact.”

Early telegraph operators had something like the status of today’s top computer programmers. They could work for a few months at high wages and move on to another good job when they became bored. Telegraphers found more efficient ways to work.

I WAS THERE

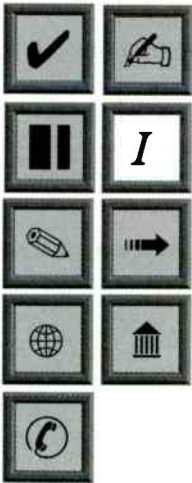

A CONTRARY OPINION

Henry David Thoreau’s book *Walden* (1854) expressed a skeptical reaction to new developments in telegraphy:

We are in great haste to construct a magnetic telegraph from Maine to Texas; but Maine and Texas, it may be, have nothing important to communicate. . . . We are eager to tunnel under the Atlantic and bring the Old World some weeks nearer to the New; but perchance the first news that will leak through into the broad, flapping American ear will be that Princess Adelaide has the whooping cough.

PARALLELS

ROUTING MESSAGES

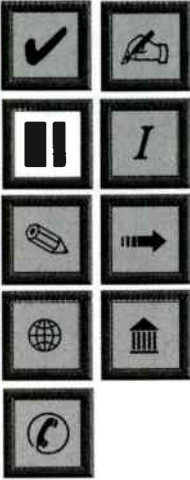

The telegraph system was actually made up of many separate lines linking major cities, plus smaller lines that connected cities to outlying towns. Suppose you wanted to send a message from Philadelphia, Pennsylvania, to Frederick, Maryland. The telegrapher at the Philadelphia office sends the message along the Philadelphia–Washington, D.C. line with a header that says something like “To Baltimore, relay to Frederick.” Most of the operators on the line would ignore the message as soon as they heard the “Baltimore” part. The Baltimore operator, however, would copy down the message and re-send it to Frederick.

Modern computer networks such as the Internet use the same principle for sending information around the world. When you send an electronic mail message, for example, the local computer breaks it up into a number of “packets” of data. Each packet has an address, or header, that gives its destination and says which part it is of the complete message. Instead of human telegraphers, the computer network uses computers called routers and gateways to find the most efficient route for forwarding the packet. At the destination, the packets are sorted back into order and assembled into a complete message.

They soon learned that they could write down messages by listening to the pattern of clicks on the line, rather than waiting for them to be printed out. A simple “sounder” replaced complicated printing mechanisms. Experienced operators could even sleep through the night shift and ignore the machine’s clattering, confident that they would awaken instantly for any message beginning with their station’s address.

The Telegraph at War

As with later technologies such as television and the Internet, telegraph enthusiasts tended to look toward a technological utopia. James Gordon Bennett, editor of the *New York Herald*, believed that the telegraph could “do more to guard against



During the Civil War, spies tapped enemy telegraph lines. (Smithsonian Institution Photo No. 89-21052)

disunion . . . than all the most experienced, the most sagacious [wise], and the most patriotic government could accomplish.”

But improvements in communication could not address such facts as Georgia and New York having very different opinions on slavery and other important issues. When the Civil War broke out in 1861, both sides began to realize that technology had become an important part of the war effort. Railroads could move troops and supplies into battle at unprecedented speeds. The telegraph made it possible to coordinate military operations hundreds of miles away. By the end of the war in 1865, the Union had built 15,000 miles (24,000 km.) of military telegraph line and handled more than 6 million messages. The Confederates, who trailed the North in technology and resources, had built only 1,000 miles (1600 km.) and relied mainly on existing commercial lines.

Fast-moving groups of cavalry raiders attacked the enemy's railroads and the telegraph lines that often ran alongside them. Scouts with portable telegraph sets soon began tapping into the enemy's wires and eavesdropping on their messages.

Spanning the Globe

By the 1860s, the United States had leapfrogged the continent all the way to the West Coast. The Gold Rush of 1849 and its aftermath had brought a need to link the growing population of California to the rest of the Union.

In 1860, Congress authorized contracts for completing a telegraph across the nation, and work began in May 1861. Since there was no transcontinental railroad yet, workers had to travel by wagon train. Wire and insulators for the western part of the line had to be shipped around Cape Horn at the tip of South America. On the plains, buffalo rubbed their itching backs against the poles and knocked them over. Some Indian peoples admired the “magic” in the wires, but others attacked what they saw as yet another intrusion of the white man into their country. Lightning

storms could easily knock out part of the line. Despite all these obstacles, the line was completed that October, well ahead of schedule.

As the United States became more industrialized, it needed to keep in close touch with overseas markets for manufactured goods. America's most important trading partner, Great Britain, had even more need for overseas communications because it administered a worldwide empire "on which the sun never set." By the 1850s, engineers had begun to lay underwater telegraph lines for short distances. In 1858, Cyrus Field succeeded getting investors in both the United States and Britain to finance a project to build a telegraph line from New York City to London. The cable ran to Newfoundland and then followed a route via Green-

I WAS THERE

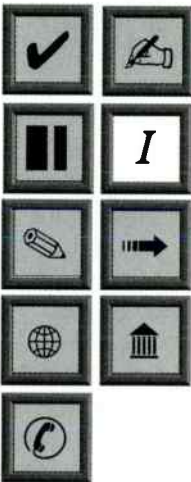

TELEGRAPHING FROM THE FRONT LINES

Telegraph operator Charles Jacques accompanied Union General Ambrose Burnside as he attacked Confederate General James Longstreet at Knoxville, Tennessee. Jacques was stationed on the city wall and told to keep the general informed of the progress of the battle. The messages he sent included the following:

They are attacking on the left . . . fighting hand to hand . . . troops so mixed we can't tell what is happening . . . Rebs fell back . . . they attack on the right . . . trying to outflank us, but make no progress . . . they attack the center . . . center holds firm.

Twice, the wire was shot in two. Each time Jacques crawled along the line under enemy fire, found the break, and repaired it. For his bravery, Burnside raised his rank to captain.

land, Iceland, and the Orkney Islands that had been charted by depth soundings from naval ships.

Laying the transatlantic cable pushed telegraph technology to its limits. The cable had to be carefully insulated against the salty ocean. It was easy for the cable to become snarled as it was fed from huge drums over the side of a steamship on the tossing sea. The first attempt failed when the cable broke after four days. On August 4, 1858, however, the crew succeeded in running out the full length of cable. Unfortunately, operators in New York and London could barely hear the test messages, and after a few weeks,

SOLVING PROBLEMS



LONG-DISTANCE TELEGRAPHY

Sending telegraph messages for long distances was difficult because electrical resistance in the wires weakened the signal as it traveled through the miles of wire. Having a telegraph station and operator every few miles was expensive. An invention called the relay solved this problem. The relay was simply an electromagnetic switch that responded to each signal by closing a circuit to a battery and sending a powerful new signal down the line to the next station.

The transatlantic cable brought a new problem. Electrical scientist Michael Faraday calculated that the very long line would act like a capacitor (a device that stores electricity). This made it take longer for a signal to build up to the level at which it could be detected at the other end. Relays could not be used to solve this problem, because the line was thousands of feet under the ocean. Instead, engineers came up with extremely sensitive detectors that could respond to very faint signals. One such detector was so sensitive that it easily picked up a signal sent from the other side of the ocean, using no more power than that of a modern watch battery.

I WAS THERE

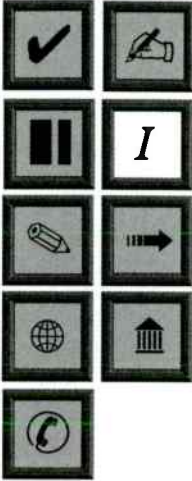
ABOARD THE CABLE SHIP *NIAGARA*

The Atlantic cable expedition evoked feelings not unlike those the exploration of space would a hundred years later. Henry Field reported the first day aboard the *Niagara* during the 1858 transatlantic cable attempt:

Slow passed the hours of that day. But all went well, and the ships were moving out into the broad Atlantic. At length the sun went down in the west and stars came out on the face of the deep. But no man slept. A thousand eyes were watching a great experiment as [though having] a personal interest in the issue . . . There was a strange, unnatural silence in the ship. Men paced the deck with a soft and muffled tread, speaking only in whispers, as if a loud voice or a heavy foot-fall might snap the vital cord. So much have they grown to feel for the enterprise, that the cable seemed to them like a human creature, on whose fate they hung, as if it were to decide their own destiny. . . .

the cable failed completely. Later, the engineers realized that a spool of cable had been left out in the hot sun after it had been manufactured. The insulation had probably melted off, so that the cable short-circuited (discharged into the ground) once it was in the ocean. In 1865, Field chartered the *Great Eastern*, the world's largest steamship, to lay a new cable. That cable was also lost, but a third try was successful.

The expanding telegraph business of the 1860s attracted investors who created new corporations. One of these, Western Union,

TRENDS

GROWTH OF THE TELEGRAPH NETWORK

Miles of telegraph lines in the United States in:

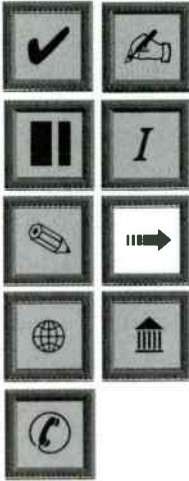

1846	1,200	(1,920 km.)
1852	15,000	(24,000 km.)
1854	30,000	(48,000 km.)
1880	290,000	(464,000 km.)

The 1880 U.S. Census reported that 32 million telegraph messages had traveled through America's 12,000 telegraph offices.

bought out its main competitors in 1866. This single company then controlled 37,380 miles (59,800 km.) of line with 2,250 offices. The monopoly did improve service by standardizing equipment and procedures. On the other hand, workers lost much of their bargaining position, and the telegrapher went from being a skilled technician to little more than a clerk. Many women were hired into the field because they could be paid lower wages.

By the 1870s, the telegraph had become an indispensable part of American life. In an 1873 article, *Harper's Magazine* featured the telegraph and its many uses. "The fluctuation in the markets; the price of stocks; the premium on gold; the starting of railroad trains; the sailing of ships; the arrival of passengers; orders for merchandise and manufacturers of every kind; bargains offered and bargains closed; sermons, lectures, and political speeches; fires; sickness and death; weather reports; the approach of the grasshopper and the weevil; the transmission of money; the congratulations of friends—everything, from the announcement of a new planet down to an inquiry for a lost carpetbag, has its turn passing the wires."

Morse, meanwhile, had profited by his dedication to the telegraph. He had enjoyed a comfortable estate and a happy family life. When he died in 1872, the news was quickly spread by the clattering keys.

Morse was a prototype for later American innovators in technology. Using his imagination and business skill, he had taken ideas from the frontiers of science, built a device that fulfilled emerging human needs, and convinced people to create a new industry.

Expansion and Decline

By the late 19th century, American cities were crisscrossed by a maze of telegraph wires. As the message traffic increased, engineers sought an alternative to stringing still more wire. There were two basic ways to increase the capacity of the telegraph system.

The first way was to speed up the sending of messages so that each line could carry more traffic. On some systems, messages were keyed onto a punched tape at a special typewriter and then sent at high speed through an automatic transmitter. At the other end, a printing receiver “typed” out the message faster than the most skilled of the old telegraphers could do.

The second approach was to make it possible to send more than one message at a time. In 1874, Thomas Edison built a “quadraplex” telegraph that could send two messages from each end of the line. In 1876, rival inventors Alexander Graham Bell and Elisha Gray invented a “harmonic telegraph.” This instrument sent several messages at once. Each message had pulses that vibrated at a different frequency. Only the receiver for the proper frequency responded to each message.

By the early 20th century, the telegraph was a mature technology. A rival, the telephone, began to replace it for many uses (see “Voices in the Wires”). The telephone allowed people to talk in their own voices without operators or codes. Another technology, the teletype, let operators type messages and send them along

telephone lines. As the century progressed, these technologies were joined by the facsimile (fax) machine and computer networks. The telegraph has been almost forgotten.

While the telegraph has vanished from today's world, it has left traces behind. If you send money by Western Union or send "flowers by wire" to a sweetheart, you are using services that originally operated by telegraph.

The most important legacy of the telegraph, though, is that it first taught people how to package information and send it at the speed of light by means of electricity. It changed the pace of business and daily life and gave news from distant places a new kind of immediacy. Linking cities and factories of the industrial world, the telegraph was our first "information superhighway."

Chronology of the Telegraph

- 1832 While returning from studying art in Europe, Samuel F. B. Morse conceives the idea for an electromagnetic telegraph
- 1838 Morse sends first message in Morse alphabetic code
- 1844 "What hath God wrought" sent on first regular telegraph line, Washington to Baltimore
- 1850 Telegraph operators begin to receive messages by ear rather than printing them
- 1858 Cyrus Field fails in first attempt to lay telegraph cable across the Atlantic Ocean
- 1860 Automatic repeaters extend range of telegraph for thousands of miles
- 1861 Transcontinental telegraph line completed
- 1866 Field's third attempt to lay transatlantic cable succeeds
- 1874 Thomas Edison invents a way to send four telegraph messages at once
- 1930 Associated Press closes its last telegraph line

Further Reading

- Coe, Lewis. *The Telegraph: A History of Morse's Invention and its Predecessors in the United States*. Jefferson, N.C.: McFarland & Company, 1993. Describes the development of the telegraph in the United States and its use in daily life.
- Latham, Jean L. *Samuel F. B. Morse*. Broomall, Penn.: Chelsea House Publishers, 1991. Biography of Morse for young readers.
- [Smithsonian Exhibit] "Information Age: People, Information & Society." World Wide Web: <http://www.si.edu/organiza/museums/nmah/homepage/docs.infoag18.html>. Text and images from an exhibition.
- Tiner, John H. *Samuel F. B. Morse: Artist with a Message*. Milford, Conn.: Mott Media, 1987. Biography of Morse as inventor and artist; for younger readers.

NOTES

- p. 2 "Americans celebrated the 'ingenious Yankee' . . ." Steven D. Lubar. *InfoCulture: The Smithsonian Book of Information Age Inventions* (Boston: Houghton Mifflin, 1993), p. 86.
- p. 3 "If this be so . . ." Quoted in Lewis Coe. *The Telegraph: A History of Morse's Invention and its Predecessors in the United States* (Jefferson, N.C.: McFarland & Company, 1993), p. 27.
- pp. 7–8 "Businesses weren't set up . . ." Lubar, p. 82.
- p. 9 "The increase of facilities . . ." Quoted in Lubar, p. 83.
- p. 9 "We are in great haste . . ." Quoted in Lubar, p. 89.
- pp. 11–12 "do more to guard . . ." Quoted in Lubar, p. 85.
- p. 13 "They are attacking . . ." Quoted in Coe, p. 54.
- p. 15 "Slow passed the hours of that day . . ." Quoted in Arthur C. Clarke. *How the World Was One: Beyond the Global Village* (New York: Bantam Books, 1992), p. 36–37.
- p. 16 "The fluctuation in the markets . . ." Quoted in Lubar, p. 90.

Voices in the Wires

ALEXANDER GRAHAM BELL AND THE TELEPHONE



Alexander Graham Bell was interested in helping the deaf, so he studied the transmission of sound. The result was the telephone.
(Library of Congress)

Until a bit more than a hundred years ago, talking with people meant meeting with them. With mail or even the telegraph, you could exchange messages but you couldn't carry on a conversation. The telephone changed all of that.

Today, in most places, you are never far from a phone. Indeed, many people have one in their car to make sure that they don't miss a call. Portable phones, beepers, and answering machines seem to make the phone inescapable. This invention has probably done more than any other to change the way people interact and the way society is organized. Oddly enough, it all began because Alexander Graham Bell wanted to help deaf people learn to speak.

Sound and Silence

Alexander Graham Bell (1847–1922) was born in Edinburgh, Scotland. His father, Alexander Melville Bell, was a speech teacher. In 1864, the elder Bell worked out a system called Visible Speech. It used symbols to represent all of the sounds that people make when speaking. He hoped to use his “sound alphabet” as a way to teach deaf people how to speak. Many deaf people have trouble speaking clearly because they can't hear what they are saying. With Visible Speech, they could practice making individual sounds and then put them together to form words.

Young Alexander (or “Aleck”) Bell was fascinated by his father's work. He helped his father demonstrate Visible Speech to visiting scientists. When he was 16, Bell's father challenged him and his older brother, Melville, to build a machine that could make speech sounds. The boys studied the larynx, or voice box, from a lamb. They built a model voice box that made different sounds when moved with levers while air blew through it.

While still a teenager, Bell became a schoolteacher. In his spare time, he studied how the mouth changes shape while making vowel sounds. Using tuning forks, he discovered that each sound

is made up of a combination of tones. He later learned that a German physicist named Herman von Helmholtz had already done this work—and furthermore, that he had used electrically operated tuning forks to reproduce the sounds! Bell recalls that

The interview had the effect of arousing my interest in the subjects of sound and electricity, and I did not rest until I had obtained possession of a copy of Helmholtz’s great work, and had attempted, in a crude and imperfect manner it is true, to reproduce his results.

From Telegraph to Telephone

In studying the transmission of signals with electricity, Bell learned that telegraph engineers were trying to find a way to send several messages along a wire at the same time (see “Talking with Lightning”). By 1872, Bell had the beginnings of an idea for solving this problem.

KEY CONCEPTS



amplifier a device that strengthens a sound or electrical signal



capacitance the tendency of electricity to accumulate or be stored



induction causing a current to flow, such as by a moving magnetic field



repeater a device that receives a signal and generates a new, stronger signal



Bell turned to his knowledge of how different sound pitches could be combined. He began to work on what he called a "harmonic telegraph." This device would allow several telegraph operators to send messages at the same time. Each message would have dots and dashes that sounded at a different pitch. Each receiver would respond only to the message to which it was tuned.

But Bell soon realized that he might be able to do even more than use sound to separate telegraph messages:

If I can get a mechanism which will make a current of electricity vary in its intensity, as the air varies in density when a sound is passing through it, I can telegraph any sound, even the sound of speech.

He had discovered the basic principle of the telephone. But Bell knew he would need money to turn his idea into a commercial success. He had become friends with Gardiner Greene Hubbard, whose daughter Mabel had become one of Bell's students in the school for the deaf. In 1875, Gardiner, Bell, and another friend, George Sanders, formed a partnership to develop and patent inventions.

Bell and a talented assistant named Thomas Watson began to experiment with the harmonic telegraph. Their device used steel reeds that could be vibrated by electromagnets. During June 1875, they worked to tune the reeds in the transmitter and receiver so that they could send messages.

One day Watson tightened an adjustment screw a little too much, stopping the reed from moving. He plucked the reed to try to set it in motion again. Bell came running into the room and shouted that he had heard the sound of Watson's reed clearly.

The vibration of the reed had set up a corresponding vibration in the magnetic coil. This in turn had induced an electric current in the wire without needing a battery at all. The current went to the electromagnet in the other instrument and vibrated it, which in turn vibrated the other reed, sounding a tone.

Importantly, this current was not the interrupted, on-and-off kind used in a telegraph but rather, a continuous current that

carried the pattern of the sound waves. Bell excitedly wrote to his parents:

At last a means has been found which will render possible the transmission . . . of the human voice . . . I am close to the land for which I am bound and when the fog lifts I shall see it right before me.

Gardiner Hubbard wanted Bell to finish the multiple telegraph so that they could make money licensing it. But Bell found that “in spite of my efforts to concentrate my thought upon multiple telegraphy, my mind was full of [the electrical transmission of speech.]”

Bell did have something else on his mind, though. He had gradually fallen in love with 18-year-old Mabel and wanted to marry her. Hubbard at first refused to give his permission for the marriage unless Bell finished the multiple telegraph. But Bell would not turn back. He and Mabel became engaged anyway, and work on the telephone continued furiously.

Bell replaced the reeds with a vibrating membrane, perhaps inspired by his knowledge of the human ear. By July, Bell was transmitting the sound of a human voice, though the actual words could not be made out. Bell had also learned about the work of rival inventor Elisha Gray, who also seemed to be close to making a working telephone. On February 14, 1876, Hubbard filed Bell’s preliminary patent for a “speaking telephone.” Only a few hours later, Gray arrived at the patent office to learn that Bell had beaten him to the punch.

Bell’s patent was entitled merely “Improvements in Telegraphy.” The real significance of the telephone was still unclear. Gray did not challenge Bell’s patent at first, believing that the telephone was of no real commercial value. He soon regretted this belief.

Bell did get some clues as to how Gray’s telephone worked, and he adopted Gray’s idea of using a diaphragm that dipped a needle into a dish of slightly acid water as it vibrated in response to the sound of a voice. As the needle dipped in and out, the resistance of an electrical current changed, varying the current according to

OTHER INVENTORS

ELISHA GRAY

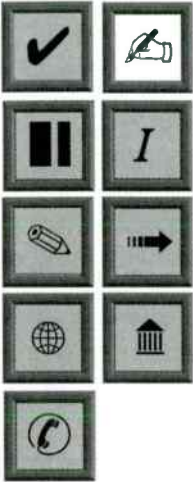

If things had worked out a little bit differently, Elisha Gray (1835–1901) might have been recognized as the inventor of the telephone. Gray made several inventions relating to the telegraph, including a device that could send and receive handwriting. Like Bell, Gray built a successful multiplex telegraph that used harmonic sound transmission, and he also discovered the basic principles of the telephone. Unfortunately for Gray, he filed a patent notice for the telephone a few hours after Bell. Gray decided not to challenge Bell's patent until after the telephone had become successful. He then waged and lost a lengthy legal battle with Bell.

the sound pattern. On March 10, 1876, Watson went into another room to listen to the telephone receiver.

Almost at once I was astonished to hear Bell's voice . . . distinctly saying, "Mr. Watson, come here, I want you!" . . . I rushed down the hall to his room and found he had upset the acid of a battery over his clothes. He forgot his accident in his joy over the success of the new transmitter.

The telephone was a reality.

The year 1876 was the centennial, or 100th birthday, of the United States. A great fair, the Centennial Exposition, was being held in Philadelphia. This fair included many technical marvels that celebrated American ingenuity. Bell used this national showcase to demonstrate his telephone to the public. According to legend, one astonished visitor, Brazilian Emperor Don Pedro, exclaimed, "My God, it talks!"

Battling for Business

In considering his invention, Bell wrote:

The telephone reminds me of a child only it grows much more rapidly. What is before it in the future, no man can tell—but I see new possibilities before it—and new uses.

Bell saw the essential difference between the telegraph, which was a kind of super-speedy mail, and the telephone, which let people talk in “real time,” with their own voice in a natural conversation. He believed that people would soon see the value of this kind of communication.

In 1877, Bell and his partners formed the Bell Telephone Association with a total investment of \$500,000. They decided to lease telephones to customers rather than simply selling them. By keeping ownership of the equipment, Bell Telephone could set the standards for its use and make sure phone users could connect to one another.

One drawback of this plan was that the company would make less money right away than they would have gotten for selling the phones. The company struggled to get enough money to expand production. People who were willing to invest the money demanded and received more control of the company.

Gradually, Bell himself became less involved in the business. He went on to work on less-known but interesting inventions such as a surgical probe, a “photophone” that sent messages on a light beam, and new kinds of kites and sea-skimming hydroplane boats. Most of all, Bell returned to his roots—his work on behalf of the deaf. Looking back on his life, he told his friend Helen Keller:

It is a pity so many people make money the criterion of success. I wish my experiences had resulted in enabling the deaf to speak with less difficulty. That would have made me truly happy.

The real builder of the telephone's business empire was Theodore Vail, a younger relative of the Alfred Vail who had been so important in helping Morse develop his telegraph. Starting as a telegrapher for Western Union, Vail developed his skills as a business executive until he took charge of the Post Office Railway Mail Service. When Vail joined the Bell Company, in June, 1878, it had 10,755 telephones in service.

The first problem Vail and the Bell Company faced was Western Union, the giant telegraph company. Western Union had ignored the telephone at first, agreeing with Gray that it was unlikely to be an important product. But when the telephone started to become popular, Western Union bought rights to patents held by Gray and Thomas Edison (who had invented a carbon microphone that improved telephone transmission) and

I WAS THERE

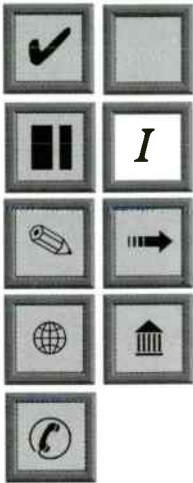

HELEN KELLER AND ALEXANDER GRAHAM BELL

Breaking the Silence

When she was only 19 months old, Helen Keller (1880–1968) was robbed of both sight and hearing by a brain infection. Teaching her to communicate seemed to be impossible. Still, Helen's doctor urged her father to take her to Alexander Graham Bell, who had a reputation as a superb teacher of the deaf.

Keller later recalled her first meeting with Bell. "He held me on his knee while I examined his watch, and he made it strike for me. He understood my signs, and I knew it and loved him at once." They would become lifelong friends and overcome many obstacles in her future education.

When Keller wrote her autobiography, she dedicated it "To Alexander Graham Bell who taught the deaf to speak and enabled the listening ear to hear speech from the Atlantic to the Rockies."

SOCIAL IMPACT

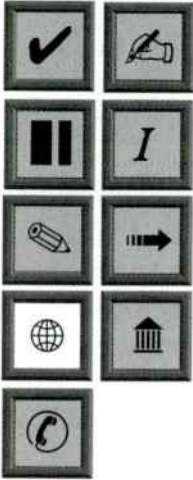
**“AHOY” OR “HELLO”?**

Not all of the problems involved with the telephone were technical. At first, most people thought that telephones would mostly be used in pairs (such as between office and warehouse) and left connected all day. This brought up the problem of how to tell the person at the other end of the line that you want to talk with him or her.

Alexander Graham Bell answered the telephone by shouting “Ahoy!” like a sailor calling to another ship. But when Thomas Edison was asked for a suggestion, he replied, “I don’t think we shall need a call bell as Hello! can be heard 10 or 20 feet away.”

started its own telephone company. The Bell Company went to court, claiming that Western Union had infringed on Bell’s patent. When courts began upholding Bell’s patent because it was well documented and had been filed before Gray’s, Western Union agreed to get out of the telephone business.

These great legal and financial battles signaled the beginning of a change in the role of the inventor in the later 19th century. Decisions made by the heads of giant corporations had become as important to the development of an invention as the solutions to technical problems.

Long Distance

There were two obstacles to widespread use of the telephone. One was the need to improve the equipment so that voices could be heard clearly regardless of the distance. The first public advertisement for phone service noted:

... on first listening on the telephone although the sound is perfectly audible, the articulation seems to be indistinct, but after a few trials the ear becomes accustomed to the peculiar sound and finds little difficulty in understanding the words.

Like most advertising, this overstated things. Early telephone users often had to shout or ask the other person to repeat something.

Bell's first commercial telephone turned the voice into a small electric current that quickly became weak with distance. Edison, however, came up with the idea of using a vibrating button of carbon to vary an existing current from a battery, thus making a stronger phone signal. Edison also invented a telephone receiver that could amplify the incoming signal.

As with the telegraph, long-distance telephone lines needed some way to keep the signal from fading out as the line "soaks up" the electricity through a process called capacitance. In 1894, Professor Michael Pupin of Columbia University invented the

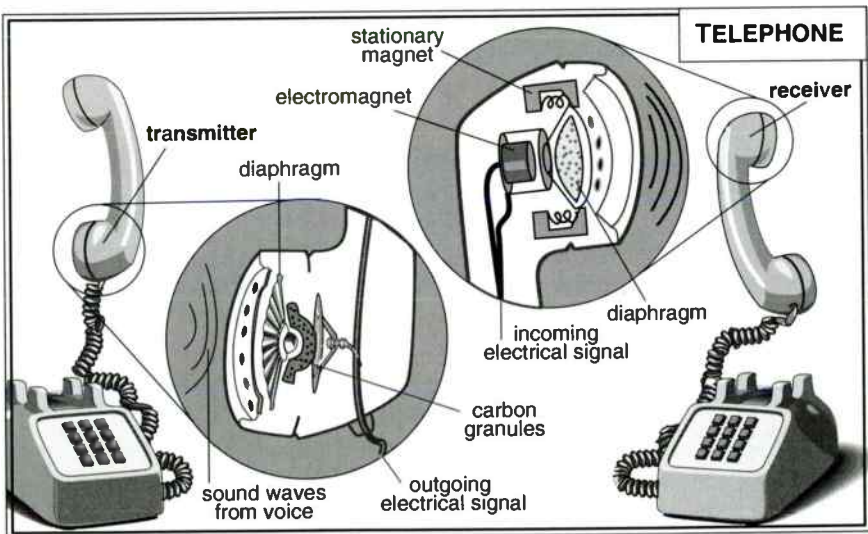

The telephone transmitter has a diaphragm that vibrates in response to the voice. This vibration compresses a carbon "button" so that louder sounds let more electrical current pass through. At the receiver, the varying electrical signal is turned into magnetism by an electromagnet. The magnetism vibrates a diaphragm that in turn reproduces the original sound waves.









“loading coil.” This device used induction (the creation of a current in a magnetic field) to counteract the loss of current through capacitance. Finally, as with the telegraph, a way was found to amplify a signal and “repeat” it from one part of the line to the next. The most effective amplifier or repeater used a new invention, Lee De Forest’s vacuum tube (see “Triumph and Tragedy”).

In 1915, Bell repeated his famous first telephone message: “Mr. Watson, come here, I want you!” But Bell was in New York and Watson was in San Francisco. Watson replied to Bell that this time it would take him a week to fulfill his request!

Automation

The other side of the problem of universal phone service was how to set up connections so that anyone could talk to anyone else.

I WAS THERE

BEDLAM AT THE BELL OFFICE

An observer reported that in an early telephone exchange:

“The racket was almost deafening. Boys are rushing madly hither and thither, while others are putting in or taking out pegs from a central framework as if they were lunatics engaged in a game of fox and geese.”









By 1881, the phone companies started replacing male switchboard operators with women. According to one supervisor, “[their] service is much superior to that of boys and men. They are steadier, do not drink beer, and are always on hand.”

What this official did not say was that women could also be paid about half the wage that men received.

TRENDS

THE TELEPHONE BECOMES COMMONPLACE

Approximate Number of Telephones in America

				
		1880	50,000	
		1886	167,000	
		1900	1,300,000	About 1 per 57 people
		1914	9,500,000	
		1935	17,000,000	
		1960	58,000,000	About 1 per 3 people
		1976	145,000,000	About 1 per 2 people
				

The first phone switchboards used improvised equipment to connect subscribers. At the very first exchange in New Haven, Connecticut,

... wire from discarded bustles [frames used under women's garments] was used, and in another switchboard placed in service in Meriden, a short time later, teapot cover handles and carriage bolts were successfully used to complete essential parts.

Telephone exchanges soon adopted the "crossbar" switchboard consisting of vertical and horizontal bars to which all the subscribers' lines were connected. To make a call, a phone user picked up the phone and told the operator the name (or later, number) of the person to whom he or she wished to speak. The switchboard operator plugged one end of a cord into the socket for the caller's line, and the other into the socket for the other telephone.

This worked fine when the phone exchange had no more than fifty or so subscribers. To handle more users, the "multiple switchboard" was invented in 1883. This allowed any operator at any switchboard to make a connection that would go through to

subscribers on other switchboards. Nevertheless, the need to make all connections by hand made service slower and less reliable as traffic increased.

In 1892, Almon B. Strowger, a Kansas City undertaker, invented the automatic switching system. Instead of using crossbars, the phone lines were connected to rotary switches that were linked by electromagnetic relays. The person making the call selected the number by turning a dial on the telephone. The dial sent pulses to the relays that automatically turned the switches to make the connection.

Changing Social Customs

In fifty years the telephone had gone from a curiosity to an essential part of daily life. One of the most fascinating parts of the story of this invention is how it changed so many aspects of our business and social lives.

In 19th-century American society (at least in the upper classes) people did not just meet: they had to be introduced. With the telephone, however, strangers could introduce themselves and carry on business without meeting at a particular place. At the same time, managers in a main office could directly supervise employees in a district office. This development contributed to the centralization of business in the national corporations that increasingly dominated the economy.

The telephone completed the speedup of the pace of business begun by the telegraph. Unlike the telegraph, however, the telephone also sped up social interaction. A picnic or dinner party could be organized without having to send and receive letters. Teenagers could make dates or just talk without having a chaperone.

Perhaps the most important effect of the telephone, however, is in the way it expanded the role of women. Three million women worked for the Bell System in its first hundred years. In the business world, male secretaries were largely replaced by women whose telephone skills made them the lifeline of business. As more

SOCIAL IMPACT



THE PHONE AS ATTENTION-GETTER

In his history *Telephone: The First Hundred Years* John Brooks shows that by the 1920s, American popular culture reflected the central place the telephone had gained in daily life.

Popular songs were built around [the telephone], by far the most celebrated of them Irving Berlin's "All Alone" written in 1924. The telephone onstage became the leading cliché of Broadway. The curtain would go up on an empty set—a well-furnished living room with a single telephone so placed as to claim the audience's attention immediately. The telephone would ring. The lady of the house would rush on and answer it; and the ensuing conversation, of which the audience would hear only one end, would announce the beginning of the plot. Thus, through the device of the telephone, the playwright had been able to create a sense of reality, start the action, accomplish some useful exposition, and arrange a dramatic entrance for a star actor—all at a single stroke.

women became able to earn a living, they were better able to assert their independence. The telephone also helped reduce the social isolation of women who remained at home.

The Telephone in the Electronic Age

The telephone industry was the first one to make systematic, ongoing research part of its business plans. In 1925, several different research laboratories were brought together into Bell Telephone Laboratories.

In the 1940s, the vast movement of people and resources during World War II strained the capacity of the phone system. By the 1950s, there were 50,000,000 phones in the United States.

But the war had also brought about an electronics revolution that would help the phone system meet the challenges. During the 1950s, the newly invented transistor began to replace vacuum tubes in amplifiers and switches. Transistors were faster, more reliable, more compact, and used less power. In the 1960s, radio technology (through microwave links and communications satellites) had reduced the system's dependence on copper wire.

The need to be able to connect all the parts of a rapidly growing system led to the harnessing of computer technology. Computer-controlled switches could route connections quickly, bypassing blockages.

But having this vast system controlled by a single corporate structure made people increasingly uneasy. It had brought the fulfillment of Theodore Vail's original goal of "One system with a common policy, common purpose, and common action." The

ISSUES

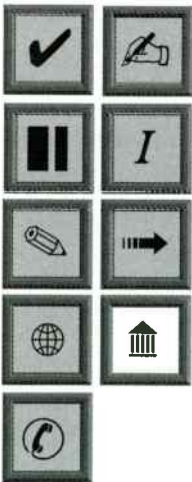

PRIVACY AND IMPERSONALIZATION

New technology has led to new social issues. Some involve privacy. A service called Caller ID lets the person you call automatically know your telephone number. This is convenient for business, but it might lead to your receiving unwanted sales calls. Automatic recorded sales calls can also be an unwelcome intrusion in your home.

Another issue involves the automatic menu-driven answering systems that often greet callers to business and government offices. This technology is efficient and convenient for business but can confuse or frustrate callers who could have been helped by a friendly human voice.

phone company had escaped the breakup of the big business trusts in steel, oil, and railroads in the early part of the century. In 1913, a compromise was reached in which the phone monopoly would be allowed to continue in exchange for having its prices set by local regulation.

But in the rapidly changing, increasingly flexible electronic world of the 1970s, the phone company seemed increasingly to be an obstacle to change. Bell, through its Western Electric subsidiary, controlled the production of phone equipment. Devices from other manufacturers could not be connected without “Ma Bell’s” approval. Many people began to feel that if the telephone giant was broken up into smaller companies and outsiders allowed to compete, consumers would have more choices of phone service at lower cost. A federal judge agreed, and in 1984 the breakup of the Bell System began.

Today there is a bewildering variety of phone equipment and services. The telephone and computer have become woven together even more tightly through the Internet (see “Digital Worlds”). If they were alive now, Bell would probably have Watson carry a beeper or a cellular telephone so he could be summoned anywhere.

Chronology of the Telephone

- 1847 Alexander Graham Bell born in Edinburgh, Scotland
- 1871–1873 Bell studies sound and teaches at schools for the deaf
- 1876 Bell patents and demonstrates the telephone
- 1877 Bell Telephone Company founded
- 1878 Edison improves telephone transmitter with carbon microphone
- 1892 Almon B. Strowger invents first automatic switchboard and dial phone
- 1915 Transcontinental phone service begins
- 1963 The Touch-Tone (pushbutton) phone is introduced

- 1976 First fully computerized phone switching system introduced
- 1982 Federal court orders Bell System to be broken up into separate operating companies

Further Reading

- “Alexander Graham Bell’s Path to the Telephone.” World Wide Web: <http://jefferson.village.virginia.edu/~meg3c/id/albell/homepage.html>. A detailed, interactive journey through Bell’s process of invention.
- Boettinger, H. M. *The Telephone Book: Bell, Watson, Vail and American Life, 1876–1976*. Croton-on-Hudson, N.Y.: Riverwood Publishers, 1977. Illustrated history puts the telephone in the context of the role technology has played in American society.
- Brooks, John. *Telephone: The First Hundred Years*. New York: Harper & Row, 1975. Deals mainly with the development of the telephone industry.
- Paschoff, Naomi. *Alexander Graham Bell: Making Connections*, New York: Oxford University Press, 1996. Biography of Bell for young readers.
- Pelta, Kathy. *Alexander Graham Bell*. Englewood Cliffs, N.J.: Silver Burdette, 1989. Biography of the inventor for young readers.
- St. George, Judith. *Dear Dr. Bell . . . Your Friend, Helen Keller*. New York: William Morrow, 1993. Inspiring story of how Alexander Graham Bell helped Helen Keller, leading to a lifelong friendship.
- Stern, Ellen and Gwathmey, Emily. *Once Upon a Telephone: An Illustrated Social History*. New York: Harcourt Brace & Company, 1994. A wonderfully illustrated and narrated account of how the telephone influenced American life.

NOTES

- p. 22 “The interview had the effect . . .” Quoted in Sharlin, Harold I. *The Making of the Electrical Age: From the Telegraph to Automation* (New York: Abelard-Schuman, 1963) p. 38.
- p. 23 “If I can get a mechanism . . .” Quoted in Lubar, p. 120.
- p. 24 “At last a means . . .” Quoted in Boettinger, H. M. *The Telephone Book: Bell, Watson, Vail and American Life, 1876–1976* (Croton-on-Hudson, N.Y.: Riverwood Publishers, 1977), p. 63.
- p. 25 “Almost at once . . .” Quoted in Brooks, John. *Telephone: The First Hundred Years* (New York: Harper & Row, 1975), p. 28.
- p. 26 “The telephone reminds me . . .” Quoted in Lubar, p. 119.
- p. 26 “It is a pity . . .” Quoted in Stern, Ellen and Gwathmey, Emily. *Once Upon a Telephone: An Illustrated Social History* (New York: Harcourt Brace & Company, 1994), p. 15.
- p. 27 “He held me on his knee . . .” Quoted in St. George, Judith. *Dear Dr. Bell . . . Your Friend, Helen Keller* (New York: G.P. Putnam’s Sons, 1992). pp. 8, 77.
- p. 28 “I don’t think we shall need . . .” William Grimes. “Ahoy! What is Wanted? How Thomas Edison came up with ‘hello’ to break the silence.” *San Francisco Chronicle*, March 1992, reprinted from *New York Times*.
- p. 29 “. . . on first listening . . .” Quoted in Sharlin, p. 44.
- p. 30 “The racket was almost deafening . . .” Quoted in Sharlin, p. 59.
- p. 31 “. . . wire from discarded bustles . . .” Quoted in Stern, p. 18.

The Medium of Memory

THOMAS EDISON, SOUND RECORDING,
AND MOTION PICTURES



Thomas Edison was the superstar of American inventors. Among other things, he is credited with the electric light, the phonograph, and motion pictures. (U.S. Dept. of the Interior, National Park Service, Edison National Historic Site)

The telegraph and the telephone make instant communication possible. Do you have a thought, a wish, or an idea? Pick up the phone and tell someone about it. Find out what they have to say.

But people don't communicate only in the here and now. They also set down thoughts, feelings, and images that become part of an ongoing conversation that can pass from generation to generation. The printed book has carried on this dialogue for more than 500 years. About 150 years ago photography added the ability to freeze an image in time for future eyes to see.

Sound and movement could not be recorded until about a hundred years ago. The work of Thomas Edison and later inventors brought about the development of the phonograph and motion pictures. These inventions made the past available in a new way. Today, we can play a cylinder and hear words spoken by a president or sung by an opera singer a century ago. We can look at a screen and watch a flickering scene of people rushing along crowded streets, living in a world that vanished before our parents were born.

KEY CONCEPTS



diaphragm a stretched membrane that can vibrate



laser a device producing a beam of light in which all waves have the same frequency and are synchronized



microphone a device that converts sound waves to an electrical signal

resistance the tendency to oppose the flow of electricity



The Creation of a Legend

Thomas Alva Edison (1847–1931) is the Babe Ruth or Michael Jordan of inventors—he is simply in a league of his own. In more than 50 years of work he filed more than a thousand patents, setting a record that no individual is likely to beat in today's team-oriented corporate world.

Edison was born in Milan, Ohio, though his family later moved to Port Huron, Michigan. Only a few months after beginning school at the age of 8, Tom found himself being constantly scolded by the teacher for not paying attention. He ran away from school and was taught at home by his mother. He also began to lose much of his hearing, possibly because of an infection. At the same time, he became an avid reader, soaking up knowledge on any subject that interested him. His hearing disability may have actually helped him develop his legendary concentration and work habits by shutting out distractions.

At the age of 12, Edison left home and became a “news butcher” on the railroad. News butchers sold food, candy, and newspapers to train passengers. With his earnings, he put together a small chemistry lab in which he performed experiments that sometimes got him in trouble with railroad conductors. Like today's technically minded teenagers, Edison was at home in a rapidly changing, always moving world.

When he was 16, Edison encountered the invention that together with the railroad defined “high tech” in 19th-century America. He learned to be a telegrapher and soon began to tinker with telegraph equipment. His first major invention, at age 21, was an automatic stock ticker that used telegraph signals to send prices from the floor of the New York Stock Exchange to brokers' offices. When he received \$40,000 for his invention, Edison established a laboratory at Newark, New Jersey (later moved to Menlo Park, New Jersey). From then on, he was a full-time inventor.

One reason why Edison was so successful as an inventor was that he had the kind of mind that let him develop several inven-

I WAS THERE

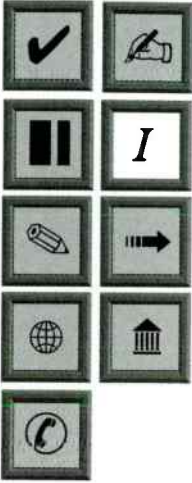

“UNREASONABLE THINGS”

One day Edison told M. A. Rosanoff, a young chemist, “Let’s you and I go to work on your damned problem [coming up with a coating for phonograph cylinders] to-night and make a resolution not to go to sleep until we have solved it!”

Rosanoff tried to beg off, saying, “Mr. Edison, you know I have been at my problem for months; I have tried every reasonable thing I could think of, and no result, not even a lead!”

“That’s just where your trouble has been,” Edison replied. “You have tried only reasonable things. Reasonable things never work. Thank God you can’t think up any more reasonable things, so you’ll have to begin thinking up *unreasonable* things to try, and now you’ll hit the solution in no time. After that, you can take a nap.”

tions at the same time, borrowing ideas from one to help with another. For example, during the early 1870s, he began studying how to improve the transatlantic telegraph. To aid in his work, he tried to build a tabletop model that would have the same electrical characteristics as the actual cable. When he tried to use carbon connectors to get the correct amount of electrical resistance, however, he found that the slightest vibration of the table or even a nearby sound would make the resistance change. He gave up the project.

Later in the decade, however, Edison began working on an improved microphone. He tried many different materials for the microphone without success. He then remembered how sensitive to vibrations the carbon contacts in his table model had been. He

built a microphone that used carbon buttons to convert the vibrations from the sound-catching diaphragm to changes in electrical current. The result was a big improvement in Bell's telephone. Edison's earlier failure had become the basis for later success.

Edison's ability to visualize and adapt new ideas was matched by his stamina. Like today's Silicon Valley software developers, Edison regularly worked for days on end with only occasional naps. He would later say that turning ideas into inventions was "1 percent inspiration and 99 percent perspiration."

Frozen Sound

Although Edison is most remembered for the electric light and power system, when asked which of his inventions was his favorite, he always answered "the phonograph." Its almost magical ability to record and re-create something as fleeting as sound seemed to fascinate both Edison and the popular imagination.

In the fall of 1877, Edison was, as usual, working on several different projects. He was trying to make a loudspeaker that would make it easier to hear telephone calls. Edison also had a contract with Western Union, which wanted devices that could automatically record or copy telegrams and perhaps voices from the telephone.

One day, according to his chief assistant, Charles Batchelor:

Mr. Edison had a telephone diaphragm mounted in a mouth-piece of rubber in his hand, and he was sounding notes in front of it and feeling the vibration of the center of the diaphragm with his finger. After amusing himself with this for some time, he turned round to me and he said: "Batch, if we had a point on this, we could make a record on some material which we could afterwards pull under the point and it would give us the speech back."

CONNECTIONS

**THE PHONAUTOGRAPH**

In 1857, an inventor named Leon Scott built a device he called the phonautograph. This “almost phonograph” used a diaphragm and a stylus and traced sound vibrations on a piece of smoked glass.

Bell and Edison noticed different things about the phonautograph. Bell noticed how the diaphragm could transmit distinctive sound vibrations, and this helped lead him to the telephone. Edison looked at the tracings and began to think of how they could be turned back into the original sound.

They immediately tried the experiment by attaching a stylus, or needle, to the diaphragm and passing a strip of waxed paper under it while shouting into the device. “Batchelor and I listened breathlessly,” Edison later recalled. “We heard a distinct sound, which a strong imagination might have translated as the original Halloo!” Although it was not yet in practical form, the phonograph had been born.

When Bell heard about Edison’s invention, he wrote, “It is a most astonishing thing to me that I could possibly have let this invention slip through my fingers when I consider how my thoughts have been directed to this subject for so many years past.” Indeed, the main difference between the telephone and the phonograph is in whether the sound vibrations are transmitted or recorded.

Having announced his invention, Edison then went to work making a practical instrument. For some time he had been working on an “embossing telegraph” that recorded telegraph messages on a revolving paper-covered cylinder, using the mechanism of one of his earlier inventions, the “electromotograph.” Something clicked in Edison’s mind. Why not record the sound of the human voice on the cylinder?

Edison attached a funnel to a diaphragm to help it pick up the sound. He found that substituting tinfoil for paper on the surface of the cylinder made the sound more distinct. To test his new machine, he shouted a nursery rhyme into the funnel: "Mary had a little lamb, its fleece was white as snow. And everywhere that Mary went, the lamb was sure to go," while turning the cylinder with a crank.

The tinfoil was now covered by a series of "bumps" corresponding to the sounds from his voice. To play back the message, he pulled back the funnel and stylus attachment and swung a second playback stylus so it just touched the cylinder. As he cranked the machine again, the stylus passed over the foil and reproduced the original sounds.

Edison noted that he "was never so taken aback in all my life. . . . I was always afraid of anything that worked the first time." He was now ready to patent the phonograph and fulfill his earlier boast.

The Battle for the Living Room

Edison's first public demonstration of the phonograph was held in the offices of *Scientific American* magazine. One columnist wrote with amazement that ". . . the machine inquired as to our health, asked us how we liked the phonograph, informed us that it was very well, and bid us a cordial good night."

Following his usual habit, Edison did some brainstorming and poured forth a torrent of ideas about possible uses for his invention even before he had perfected it:

I propose to apply the phonograph principle to make Dolls speak sing cry & make various sounds also apply it to all kinds of Toys . . . to reproduce from sheets music both orchestral instrument & vocal . . . A family may have one machine & 1000 sheets of the music thus giving endless amusement. I also propose to make toy music boxes & toy talking boxes playing several tunes also to clocks and watches for calling

out the time of day or waking a person for advertisements rotated continuously by clockwork . . .

Edison and his partners formed the Edison Speaking Phonograph Company to market the invention, but Edison's attention for the next four years would be taken up by the electric light and the establishment of power generating systems. Meanwhile, Alexander Graham Bell began to come up with different kinds of phonograph mechanisms that would not be covered by Edison's patent. One of these used a jet of air instead of a needle to make impressions in the record. Bell filed competing patents for what he called the "graphophone."

By 1888, the electric light system had been finished, and Edison responded to Bell's challenge by putting his "invention factory" into high gear. Edison's team of a hundred researchers looked for ways to improve every part of the machine. They found a coating for the cylinder that worked better than the fragile tinfoil, and they added a spring-powered motor so it wouldn't have to be cranked by hand.

ISSUES

MUSICAL QUANTITY OR QUALITY?

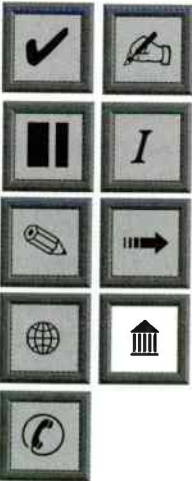

Not all musicians welcomed the phonograph. Band composer John Philip Sousa believed that sound recording would bring about "a marked deterioration in American music and musical taste." It is true that the 19th-century middle-class American pastime of singing around the piano began to be replaced by listening to the phonograph. On the other hand, Americans kept learning to play musical instruments, and the phonograph began to bring a rich variety of music to people who lived where there was no opera house or symphony orchestra.

At first, Edison marketed the phonograph as a business machine for recording phone messages or dictation. The first model was described by one listener as sounding “like a partially educated parrot with a sore throat and a cold in the head.” Though the machines gradually improved, it was many years before most businesses accepted them.

Finally, though, Edison turned to what is today the most obvious use of the phonograph—musical entertainment. He and his assistants put a phonograph in a box with a coin slot to attract passersby in hotel lobbies or special arcades. By 1891, about a thousand of these one-record jukeboxes were in operation. It was a modest moneymaker and a great way to introduce the phonograph to millions of people who had never heard it before.

The next step was to market phonographs for the home. By the turn of the century, there were about 800,000 phonographs in homes in the United States, and the production of records was soaring. The first “gold record” in the industry was a recording of the opera *I Pagliacci* by superstar singer Enrico Caruso that sold over a million copies.

OTHER INVENTORS



EMILE BERLINER

German-American immigrant Emile Berliner (1851–1929), like Elisha Gray, is a “near miss” inventor overshadowed by more famous rivals. Not only did he come up with a telephone receiver at about the same time as Alexander Graham Bell and Elisha Gray, he was also a pioneer of the phonograph. His 1887 disk phonograph (called the “gramophone”) overtook Edison’s cylinder and became the basis for the record players in use until the 1980s.

A new competitor named Emile Berliner then threatened Edison's business. Berliner invented a phonograph that used a disk record rather than Edison's cylinder. Edison had rejected disks earlier because the cylinder had better sound quality and the needle moved over the cylinder at a constant speed, avoiding distortion in the playback.

The disk, however, had one huge advantage. With cylinders, the record producer had to line up several phonographs in front of the singer or band. The performers had to keep repeating the piece of music in front of the assembled phonographs to produce a small batch of records.

The disk, however, could be copied by etching the original recording with acid, stamping its pattern on a master disk, and using the master to press out many records. Berliner's phonograph was also louder than Edison's which made it better for filling a whole room with music, even if the sound quality wasn't as good.

As shown in so many of his inventions, Edison had the ability to focus on one problem and keep working until it was solved. But the flip side of this strength of personality was a kind of rigidity that meant he stubbornly kept trying to improve a technology that had already become obsolete. In response to Berliner's disks, Edison came out with an improved cylinder that had better sound quality and that could play for four minutes instead of two. Unfortunately, the new cylinders wouldn't work in the old machines and didn't sell well.

Finally, Edison bowed to the inevitable and developed his own disk phonograph. His thoroughness again showed itself as he poured several million dollars into designing an all-new system.

The Phonograph Goes Electric

During the "jazz age" of the 1920s, the phonograph encountered a major competitor, however, the radio (see "Triumph and Tragedy"). Once you bought a radio, you could get all the entertain-

ment you wanted for the cost of a few pennies worth of electricity. During the depression decade of the 1930s, this was a real bargain.

The radio indirectly helped the phonograph, however. Radio stations began to play records on the air, encouraging record sales. Also, the electronic technology behind the radio could be adopted to the phonograph. Improved microphones and electronic tube amplifiers gave the new electric records players a much fuller and richer sound.

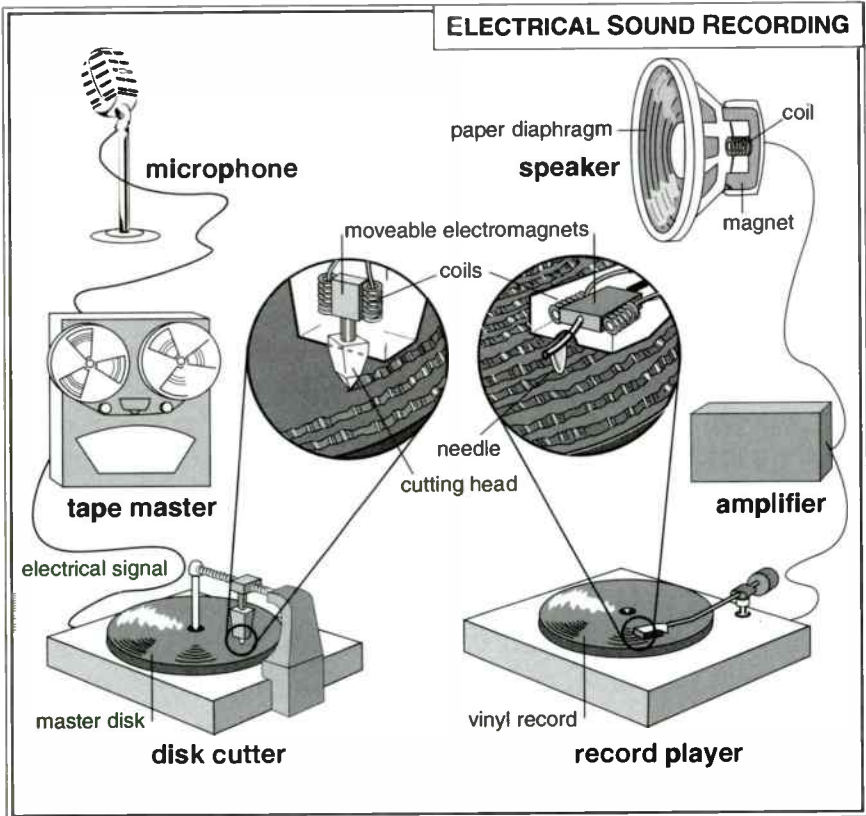

To record sound, an electrical signal from a microphone or a master recording tape causes varying magnetism in the electromagnets on the cutting head. The magnets move a sharp stylus to cut a wavy track in a master record, which is then reproduced. To play the record, the phonograph stylus moves from side to side as it follows the groove. As it moves, the electromagnets around the stylus generate a tiny current that is then amplified and turned into an electrical signal that drives a speaker.



During the 1920s, the phonograph helped African Americans preserve and enjoy their blues and jazz heritage. (Library of Congress)

TRENDS

RECORD SALES: DEPRESSED, THEN A WAR BOOM

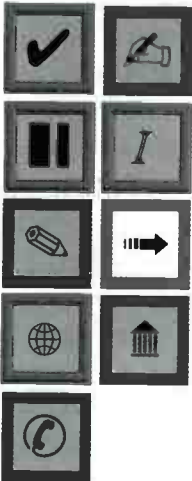

Year	Records Sold	Events
1927	100 million	Height of economic boom
1932	6 million	The Depression hits hard
1939	33 million	Beginnings of recovery
1941	127 million	America prepares for World War II
1947	400 million	The postwar boom begins

SOCIAL IMPACT

PRESERVING MUSICAL HERITAGE



The phonograph and sound recording, along with radio, created a mass entertainment industry. The big record companies (and nearly all radio stations) were not interested in playing ethnic music such as the blues of rural African Americans or the folk ballads of Appalachia. But as recording equipment became cheaper and more portable, small companies were able to produce the blues and jazz records that kept the traditional music alive and inspired a new generation of musicians to build on it. Aided by government grants during the 1930s, researchers went to rural areas to collect examples of blues, country music, and folk ballads.

Electrical recording had a more subtle effect on how people listened to music. As Steven Lubar points out:

Reactions to it were also based on changing standards of taste in music, and on changing ideas about what music reproduction should be. These changes had come about because of the radio, because of new kinds of music, because the phonograph had changed music, and, perhaps most important, because the increasing predominance of recording had changed the place of music in peoples' lives.

New Technologies for Sound Recording

The 1940s and 1950s brought a number of improvements in sound recording. The LP or "long-playing" record, introduced in 1948, could hold up to 23 minutes on each side of the record. Lovers of classical music could now listen to long symphonic

movements. The small 45 rpm record was also introduced about this time. It became popular in the 1950s because it held one popular song three minutes or so in length. This was a perfect fit for radio stations that played the exciting new rock and roll music at a frenetic pace set by a disk jockey.

There were also continuing improvements in sound quality. Inventors had been working on stereo recording for years. Early systems needed to record both the left and right sound tracks

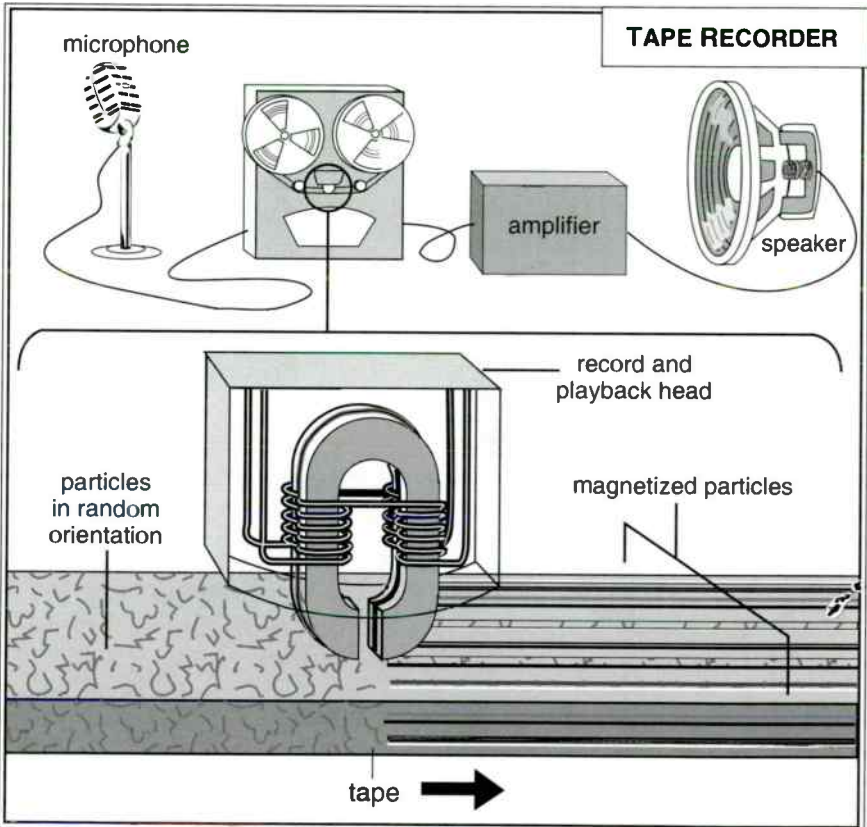

Tape recorders use tape that contains embedded magnetic particles. When the electrical signal from the sound source (such as a microphone) reaches the electromagnet in the recording head, the head magnetizes the particles on the moving tape in a pattern that corresponds to the signal. To play back the tape, it is passed under the head, where the pattern of magnetism is turned by the electromagnet into a varying current that is amplified and used to drive a speaker.

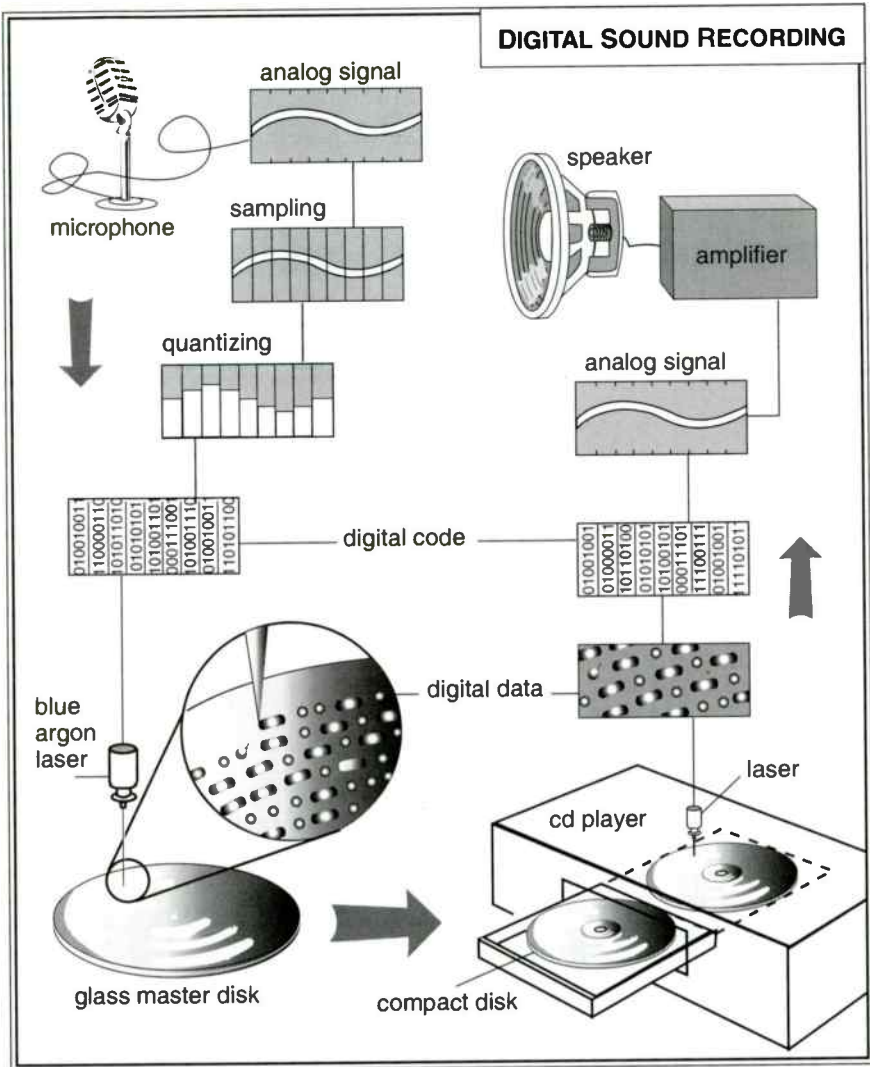

In digital sound recording, a pattern of dots and spaces is first recorded on a glass master disk. This pattern represents data that describes the amplitude of the incoming sound wave measured thousands of times a second. The information is then reproduced on compact disks in the form of pits and flat areas. To play the disk, a laser scans along the track. When the light hits a pit, it is scattered; when it hits a flat area, it is reflected. The returning light pattern is converted to a digital code representing the sound. The code in turn is fed to a device that creates a signal that goes to the speakers.

separately, which meant that the record could hold only half as much music. But inventors learned to combine an up-and-down track with a side-to-side one so that both left and right sound channels were recorded in the same record groove.

During World War II, the Germans perfected tape recording, where the signal from a microphone is fed to an electromagnetic recording head that magnetizes metal particles in a tape in a pattern that corresponds to the sound. Tape recording led in the 1960s to affordable portable recorders, tape players for cars, and in the 1980s to the Walkman and similar lightweight units that let people “wear” their music.

Tape recording had an important effect on the recording industry. It made it possible for recording engineers to record sound from 4, 8, 16 or more separate microphones, each on its own track on the tape. Using mixing technology, the recording engineer adjusted the sound characteristics of the performance and added special effects. The Beatles’ landmark 1967 recording, *Sergeant Pepper*, showed how a recording could be a complete package of sound in which it was no longer possible to separate the work of the musician from that of the engineer.

In the 1980s, recorded music entered the computer age as compact disks (CDs) replaced the vinyl phonograph record. Compact disk recording turns sound into thousands of numbers a second, each representing the exact size (amplitude) of the sound wave at an instant of time. The data is “burned” into the compact disk in coded patterns by a laser, which is also used to retrieve the information and feed it to the playback mechanism. Compact disks have none of the surface noise of records, and they don’t wear out with repeated playings. Some critics, however, believe that reducing sound to numbers may remove some of its more subtle qualities.

Moving Pictures

The same explosion of ideas and invention that make the late 19th century so exciting in the history of technology can be seen in the

birth of the movies. The idea behind motion pictures is something called “persistence of vision.” This means that the human brain continues to “see” an image for about a tenth of a second after it is no longer in front of the eye. By showing drawings or photographs in rapid succession one can create the illusion of movement. Because the time gap between pictures is shorter than the brain’s persistence time, the empty space between pictures is never seen. The viewer sees what appears to be a single, moving image.

Once you have a succession of images, you need a way to project them in rapid succession to create a moving picture. Eadweard Muybridge invented a device he called the Zoopraxiscope. It was a disk that had a series of drawings around the edge. When it turned, it produced an animated image, such as a horse running or a clown dancing. The French inventor Etienne-Jules Marey



At the turn of the century one could play a record or see a short film by dropping in a coin. (Smithsonian Institution Photo No. 87-1615)

OTHER INVENTORS



THE LUMIÈRE BROTHERS

Louis Jean Lumière (1864–1948), and Auguste Marie Lumière (1862–1954) invented the Cinématographe, a combination movie camera and film projector. The word *cinema* for motion pictures is from the Greek word *kinema*, meaning motion. Movie theaters in Great Britain are often called cinemas.

The Lumières began showing programs of two-minute films in theaters in 1895. Their films often recorded scenes from daily life, such as workers leaving a factory. They also created the idea of a newsreel—a film devoted to current events that was popular until television became widespread in the 1950s.

adapted the Zoopraxiscope idea by projecting through the turning disk to create a moving image from still photos.

In 1888, Edison and Muybridge met to discuss how they might combine the Zoopraxiscope with a phonograph to create moving pictures with sound. Edison assigned his assistant William Dickson to the project. The result of their work was a device called the Kinetoscope. The key insight was to replace the whirling disk, which could hold only a few dozen pictures, with a strip of film that had holes punched along the edges so it could be pulled through the projector to show the moving pictures. (For the time being, they dropped the idea of adding sound.)

As with the phonograph, Edison first marketed the Kinetoscope as a coin-operated device. The viewer inserted a nickel, looked through the viewing hole, and saw about fifteen seconds worth of movie.

The novelty of the Kinetoscope soon wore off. Edison, together with the Lumière brothers in France, began in 1895 to build projectors that could show short films to a theater

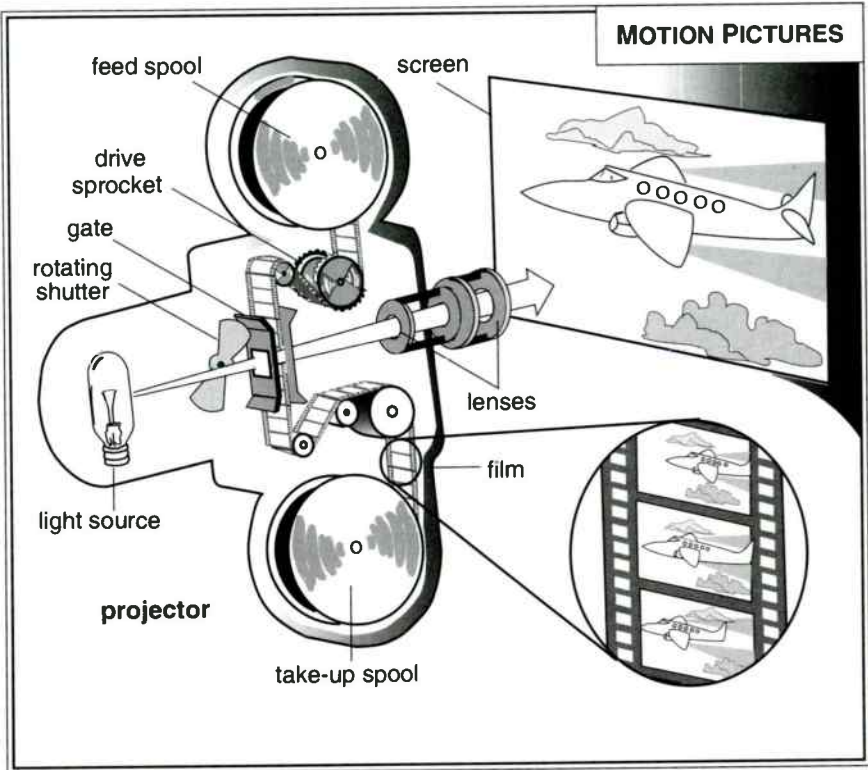

Both the movie camera and film projector use a motor that pulls film along from reel to reel using gears that engage holes along the edges of the film. In the camera, each frame is exposed as it passes through the lens and the shutter clicks—usually 24 times a second. In the projector, the developed frames of the film are passed between a bright light and a lens and appear on the screen too fast for the eye to distinguish the individual images.

audience instead of a single viewer. The theaters charged only a nickel for admission, so they were called nickelodeons. By 1909, the movie industry was thriving. In the United States more than a hundred companies were producing more than 2,000 films a year.

It is hard for us in the 1990s to realize what a powerful impact motion pictures had on society at the start of the century. Even the crude movies of the time looked so real that people in the audience sometimes ran in terror when they saw a train coming at them on the screen. Going to the movies became a popular

social activity for people of all ages. The rise of Hollywood and the creation of glamorous movie stars became important parts of popular culture.

Edison had played a pioneering role in working out the mechanics of movie production, including building the Black Maria, a shed that served as one of the first movie studios. But as with the phonograph and music, Edison became less relevant as artistry began to become more important than technology.

Movies Grow Up

In 1915, D. W. Griffith produced *The Birth of a Nation*, a three-hour feature movie that developed a complex narrative and pioneered modern techniques such as close-ups and a truck-mounted “tracking” camera that followed the action. Other movie directors such as Cecil B. DeMille and Sergei Eisenstein began to see

SOCIAL IMPACT



A THREAT TO MORALITY?



As movies began to tell stories of love and romance (and hint at sex), some observers feared that they would destroy morality and the family. Darrel O. Hibbard, a Y.M.C.A. official, wrote in 1921 a complaint that would be applied to television thirty years later:



From children's and divorce courts we hear of people going astray due to the movies. Therefore we need a law to step in and do for film what it did for meat and drug inspection, or the cinematographer [movie producer] will continue to inject into our social order an element of degrading principle.



themselves as creative artists working in a medium that was as important as literature or music.

The 1920s brought a practical way to add sound to the movies. Before then, movies were often accompanied by an organist, but of course all words spoken by characters had to be indicated by a panel of text on the screen. The first major “talking” movie, *The Jazz Singer* of 1927, used a special phonograph that had to be started by an operator when “cued” by a particular scene in the film. This awkward approach was soon replaced by a system that used a pattern of gray spots along the side of the film. This pattern was not projected on the screen, but rather passed through a photoelectric cell that converted it to a sound signal.

The effort to add color to the movies was longer and more difficult. At first, important frames in the film were often hand-tinted by artists. In 1935, a system called Technicolor began to be popular; perhaps the best known early color film was *The Wizard of Oz* in 1939. But difficulty in getting the color to look natural,



MGM celebrates the birth of sound movies by recording the roar of its trademark lion. (Library of Congress)

as well as expense, kept the majority of movies in black and white until the 1950s.

During the 1950s, sales in movie theaters were threatened by a new way to show moving pictures: television (see “The Ghost Light”). Moviemakers responded to this threat by making movies more like theater plays, by dealing with themes considered too complex or “adult” for TV, and by creating panoramic epics that could only be appreciated on the big screen. In 1977, director George Lucas’s movie *Star Wars* combined fantasy, high-tech imagery, and powerful visual and sound effects and suggested how the computer age might affect moviemaking. Today, visual images are often stored as data that can be manipulated by computer-based tools to create animation far more realistic than can be achieved by filming physical models set to a series of poses.

Chronology of Sound Recording and Motion Pictures

- 1877 Thomas Edison builds working tinfoil phonograph
- 1893 Edison introduces coin-operated Kinetoscope to show very short motion pictures
- 1895 Lumière brothers begin showing movies in theaters
- 1901 Edison studio’s *The Great Train Robbery* demonstrates the telling of a full-blown story through film
- 1915 D. W. Griffith’s *The Birth of a Nation* helps establish modern movie camera techniques
- 1928 Sound track added to movies
- 1932–1939 Great Depression kills phonograph sales; people turn to radio
- 1948 Long-playing (LP) record allows recording of longer works
- 1949 45 rpm record introduced; becomes a hit for popular music
- 1950s “Hi-Fi” is a popular hobby and stereo begins to emerge; television threatens the movie business; color used more often in movies

- 1967 Beatles' album *Sergeant Pepper* demonstrates new sound-mixing and production techniques
- 1977 The movie *Star Wars* creates technological fantasy of epic proportions
- 1982 Compact disks introduce digital music

Further Reading

- Adair, Gene. *Thomas Alva Edison: Inventing the Electric Age*. New York: Oxford University Press, 1996. Biography of Edison for young readers.
- Baldwin, Neil. *Edison: Inventing the Century*. New York: Hyperion, 1995. A lively and poignant biography of Thomas Edison, America's most prolific inventor.
- Briggs, John. "[Interview with] Reese Jenkins: Edison's Archives." *Omni* magazine, April 1989, p. 82–87, 102–110. A researcher reveals surprising discoveries about how Thomas Edison's mind worked.
- Chew, V. K. *Talking Machines*. 2nd ed. London: Her Majesty's Stationery Office, 1981. Early developments in the phonograph, particularly in the United Kingdom.
- Conot, Robert. *A Streak of Luck*. New York: Seaview Books, 1979. Biography that challenges the legends of Edison's life with newly uncovered material.
- Gleasner, Diana C. *The Movies*. New York: Walker, 1983. History of film for young people.
- Smart, James R. "*A Wonderful Invention*": *A Brief History of the Phonograph from Tinfoil to the LP*. Washington: Library of Congress, 1977. Illustrated account of early developments in the phonograph.

NOTES

- p. 41 "One day Edison told . . ." Quoted in Baldwin, Neil. *Edison: Inventing the Century* (New York: Hyperion, 1995), p. 323.
- p. 42 "Mr. Edison had a telephone diaphragm . . ." Quoted in Chew, V. K. *Talking Machines* 2nd ed. (London: Her Majesty's Stationery Office, 1981), p. 2.
- p. 43 "Batchelor and I listened breathlessly . . ." Quoted in Conot, Robert. *A Streak of Luck* (New York: Seaview Books, 1979), p. 99.
- p. 43 "It is a most astonishing thing . . ." Quoted in Lubar, p. 170.
- p. 44 "was never so taken aback . . ." Quoted in Baldwin, p. 83.
- p. 44 "... the machine inquired as to our health . . ." Quoted in Baldwin, p. 84.
- pp. 44-45 "I propose to apply . . ." Quoted in Conot, p. 106.
- p. 50 "Reactions to it were also . . ." Quoted in Lubar, pp. 175-76.
- p. 57 "From children's and divorce courts . . ." Quoted in Lubar, p. 203.

The Invisible Web

GUGLIELMO MARCONI AND
WIRELESS TELEGRAPHY



Guglielmo Marconi built a practical wireless telegraph system that provided life-saving communications for ships and competition for the Atlantic telegraph cable business. (Smithsonian Institution Photo No. 52202)

The 19th-century communications technology of the telegraph and telephone is based on one idea: the ability to change electricity and magnetism into each other. Starting with the simple on/off signaling of the telegraph, inventors gradually learned how to use a continuous electric current to carry the complex pattern of the human voice, creating the telephone. As the century drew toward an end, however, a new understanding of the nature of electricity offered the possibility of communication without wires.

Discovering Radio Waves

In 1864, physicist James Clerk Maxwell published a new theory of electromagnetism. Unlike Hans Christian Oersted, Michael Faraday, and earlier experimenters, Maxwell took a mathematical approach. He devised a set of equations that explained the shape of electromagnetic fields and how electricity and magnetism interacted with each other. His theory implied that any change in

KEY CONCEPTS



alternating current electrical current that reverses direction many times a second



electrode a connector that provides electric current to a device

electromagnetic wave a wave of electrical and magnetic energy (such as a radio wave) that can pass through space



frequency the number of electromagnetic waves that pass a point in one second



oscillation back and forth wavelike motion

wavelength the distance from one wave peak or trough to the next



an electrical or magnetic field starts a train of waves that radiate out into space. Further, he suggested that these “electromagnetic waves” traveled at exactly the same speed as light, about 186,000 miles (300,000 km.) a second. In fact, Maxwell, suggested, the only difference between light and electricity was in the length of the waves.

Scientists argued about whether Maxwell’s bold hypothesis was correct. In 1879, the Berlin Academy of Science offered a prize to anyone who could prove that electromagnetic waves existed. The challenge was taken up by German physicist Heinrich Hertz (1857–1894), who devised a simple experiment. He fed current from a battery into a wire coil that was placed near a second coil that was more tightly wound. Following the laws of electromagnetism, the current in the first coil induced a rapidly oscillating current in the second coil. The current was then led to a pair of capacitors—metal plates that stored the current until they could hold no more. At that point the plates discharged, sending a spark across the space between two small ball-shaped electrodes.

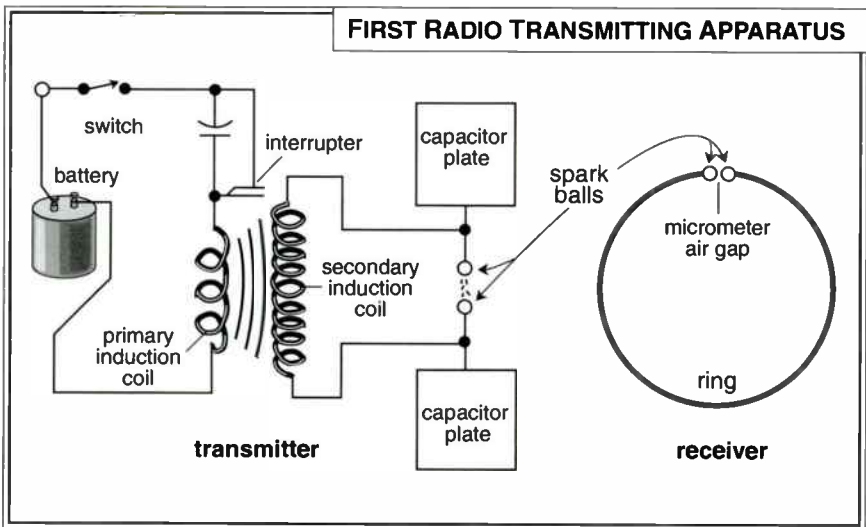

Heinrich Hertz built a simple circuit to test James Clerk Maxwell’s electromagnetic wave theory. The battery current is stepped up to a high voltage as it passes from the primary to the secondary coil. A spark then jumps between the ball-shaped electrodes and generates radio waves that can be detected as a small spark passing between the ends of the wire loop.

OTHER INVENTORS



EARLY ATTEMPTS AT WIRELESS COMMUNICATION

Strictly speaking, Guglielmo Marconi was not the first person to send wireless telegraph signals. "Induction telegraphs" in use on some railroads allowed moving trains to communicate over regular telegraph lines by using induced current to carry the message a few inches between train and wire. In 1885, Thomas Edison built a "grasshopper telegraph" that performed a similar function but, unknown to the inventor, may have actually worked by generating radio waves.

While Marconi was beginning his experiments, a Russian inventor named Alexander Stepanovitch Popov was also sending wireless messages for 820 feet (250 meters) at St. Petersburg University. Popov did not patent or commercially develop his invention, however.

Hertz then built a simple detector that used a wire with a ball on either end, bent into a circle so that the ends were not quite touching. He found that when a current was discharged in the main apparatus while the detector was held some distance away, a smaller spark leapt across the detector's gap. This showed that electromagnetic waves were being transmitted through the air by the oscillating current and received by the detector. Maxwell's theory had been proven correct.

In 1892, British scientist Sir William Crookes wrote an article titled "Some Possibilities of Electricity." Among them, according to Crookes, was

the bewildering possibility of telegraphy without wires. . . . Any two friends, having first decided on their special wavelength and attuned their respective instruments to mutual receptivity could thus communicate as long and as often as they pleased by timing the impulses to produce long and short intervals in the ordinary Morse code.

Another distinguished scientist, Oliver Lodge, agreed that wireless telegraphy was possible. But at the time, he didn't think there was much point to it. Why bother

thus with difficulty [to] telegraph . . . across space instead of with ease by the highly developed and simple telegraphic and telephonic methods rendered possible with the use of a connecting wire?

Within a decade, these questions would be answered.

Marconi and Wireless Telegraphy

The person who would first turn Hertz waves into a practical, commercial technology was a young Italian man named Guglielmo Marconi (1874–1937). At age twenty, Guglielmo was still living with his mother in their Italian villa, while looking for a way to make a successful career.

Marconi was similar to Samuel Morse in some ways. Both were imaginative, rather dreamy persons who decided to become inventors because they felt that their careers had stalled and that it was worth taking a chance on something new. Both were interested in making money, not in scientific discoveries. While Marconi described himself as “an ardent amateur student of electricity,” like Morse, he had little mechanical skill and would depend on finding good assistants who could make his ideas work. But Marconi, even more so than Morse, had the persistence and showmanship that helped 19th-century inventors turn their ideas into industries.

Marconi began by building an apparatus similar to that used by Hertz to prove the existence of radio waves. He added a telegraph key to the spark generator so he could send the dots and dashes of Morse code. It worked as expected, but was it a practical communications device? When he moved the apparatus outdoors to try for longer-range transmissions, Marconi made a lucky

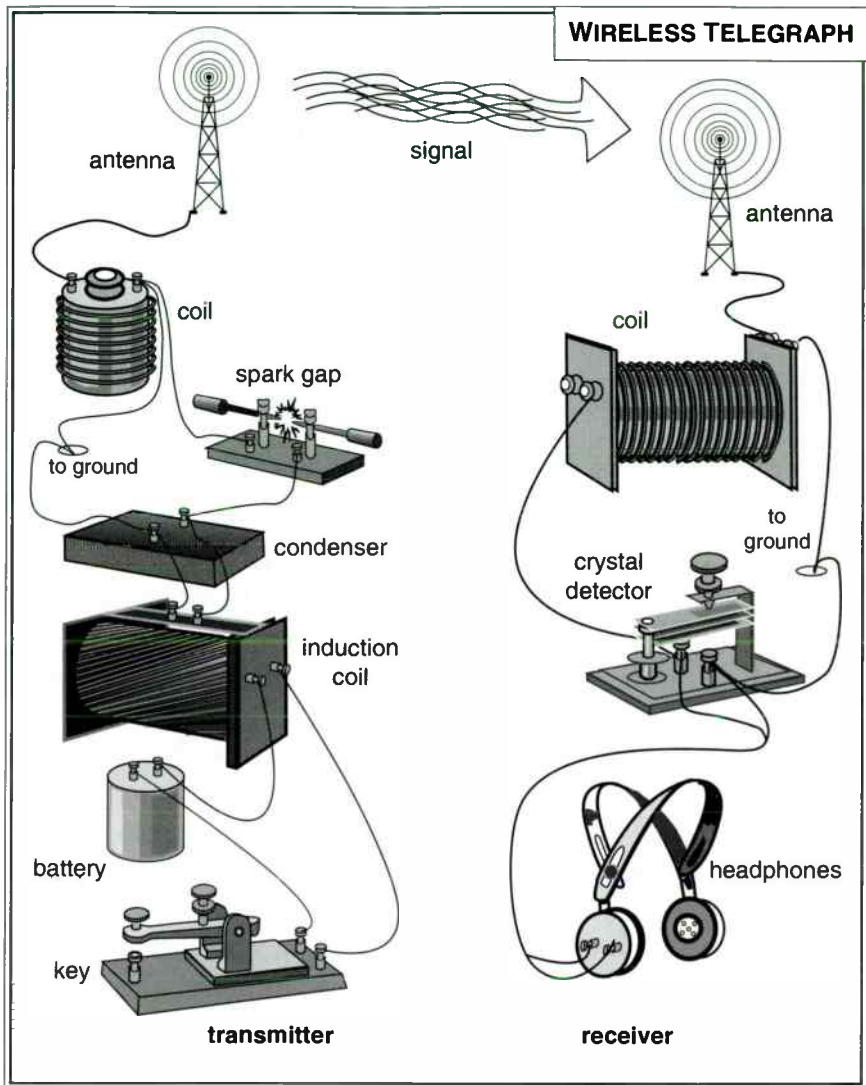

The wireless telegraph is a simple extension of Hertz's circuit. As with the regular telegraph, a key is used to briefly close the circuit and send a burst of current from the battery. The induction coil increases the voltage of the current, and the condenser lets the current build up until it sparks across the gap and creates a radio signal. Another coil can further step up the signal before feeding it out the antenna. The receiver reverses the process, bringing the radio signal from the antenna through a coil to a detector (such as a piece of crystal) that turns it into a signal that can be fed into headphones or speaker.

discovery: when one terminal of the generator was connected to a metal pole and the other to the ground, the invisible waves traveled much farther.

Hertz had detected radio waves at close range by the spark they created in the receiving antenna. This was fine for proving that the waves existed, but it worked only at short distances. Marconi needed a detector that responded to radio waves at a distance.

Back in 1866, an English engineer had noticed that when lightning struck a tube filled with iron filings, its normal high resistance to electricity fell abruptly. Telegraph builders began to add such tubes to their telegraph circuits to help protect them from lightning by discharging it to the ground. A number of scientists also observed this effect, but didn't find it remarkable until 1894, when Oliver Lodge suggested that the tube might be detecting electromagnetic waves from the lightning.

Marconi learned about this tube, now called a "coherer," and decided to use it as a detector for wireless telegraph signals. Like Edison, Marconi believed in systematically trying every variation of a device that he could think of, in the hope of improving it. Marconi eventually discovered that a mixture of nickel and silver filings worked better than iron did.

Gradually, Marconi extended the range of his transmitter to several miles. When the Italian government refused to buy rights to his invention, he decided to go to England and patent it there. Why England? For one thing, Marconi's mother's family lived there and was willing to help fund his experiments. But a more important reason was that there was an application where wireless didn't have to compete with the wire telegraph: communication between ships, or between ship and shore. At the time England was the world's foremost maritime nation and had the greatest need for this kind of communication.

William H. Preece, the head engineer of the British Post Office, had been unsuccessfully experimenting with wireless telegraphy with the same idea in mind. When Marconi demonstrated his apparatus to him, Preece was very impressed. He noted that:

The distance to which signals have been sent is remarkable. On Salisbury Plain Marconi covered a distance of four miles. In the British Channel this has been extended to over eight miles, and we have by no means reached the limit.

British investors were also favorably impressed. On June 20, 1897, the first wireless business, the Marconi Wireless Telegraph Company, was established. One of its first customers was the famous insurance company Lloyd's of London, which installed a wireless link so that an offshore lighthouse could report arriving ships.

Marconi's company, like Bell Telephone, decided to lease, not sell its equipment. This prevented the British government from taking over the equipment as it had with the telegraph and telephone. It also meant that Marconi would be able to control maritime communications for a decade or more, since he could specify that Marconi's operators would communicate only with other Marconi installations.

Marconi tirelessly publicized the wireless. In 1899, he went to the United States, which had defeated the Spanish in a short war and was beginning to think of itself as a world power. Americans were also ready to cheer on their entry in the International Yacht Races. The *New York Herald* announced in a front-page headline: "Marconi Will Report the Yacht Races by His Wireless System." Many Americans read about the wireless for the first time, and they were eager to learn more. Marconi later recalled that

what impressed the public most was the extraordinary rapidity of the system. Whenever the Marconi bulletins, as they were called, were posted all over the city, the public was less than seventy-five seconds behind the yachts and in many cases less than thirty seconds.

As more experimenters went on the air with their own wireless systems, interference became a problem. In the 1901 yacht races, Marconi's and Lee De Forest's competing installations often drowned each other out. They had to agree to take turns transmitting, and meanwhile a third transmitter, operated by a com-

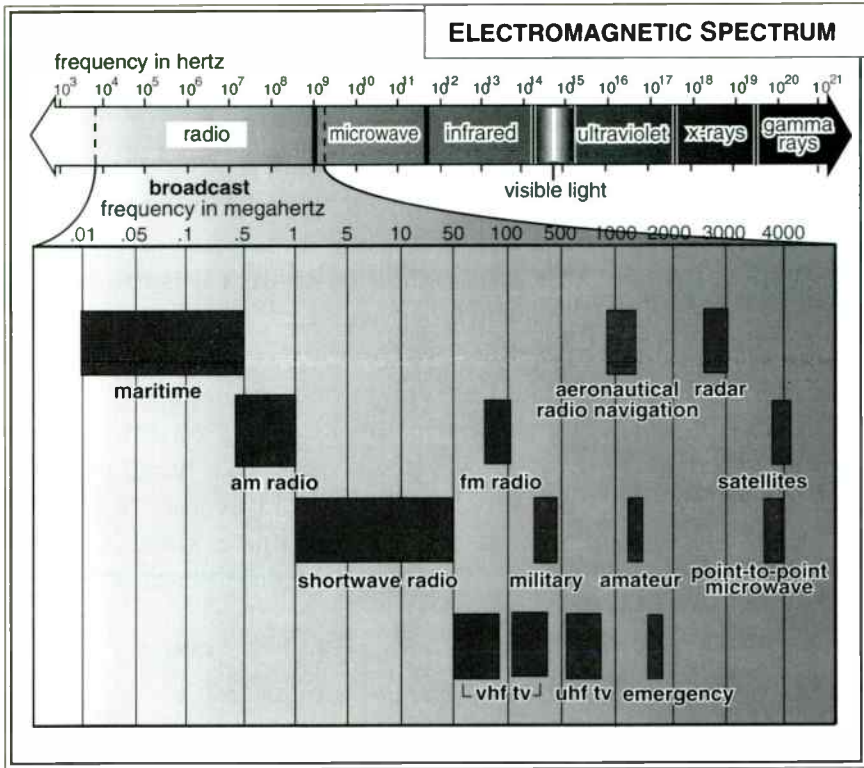

Different frequency ranges of the broadcast spectrum are allocated to different kinds of radio and television services. Note that as the frequency increases, microwave gradually gives way to infrared light and then visible light.

pany seeking to make money on the stock market, interfered with both. The magazine *Electrical World* noted that “the problem of securing immunity from interference remains to be solved.”

The problem was that there was no easy way to tune the early transmitters and receivers so they could connect on a particular frequency. In 1897, Oliver Lodge had discovered “syntony,” the fact that each electrical circuit has a particular frequency at which the whole circuit resonates, or vibrates together, using energy more efficiently. Marconi used this idea to develop tuning mechanisms that could change the resonance. If two wireless installations tuned to the same resonance, they would receive much less interference from other signals.

There was still a problem with the detector, though. The coherer had a mechanism that used a hammer to tap the metal filings loose after each signal was received, preparing it to respond to the next signal. This made for a slow rate of reception.

In 1895, another great British physicist, Ernest Rutherford (1871–1937), had reported that electromagnetic waves tended to demagnetize magnetic objects and suggested that magnetism might be used to detect “Hertzian” (radio) waves. In 1902, Marconi patented a new detector based on this principle. It used a band of wire that passed continuously between two horseshoe magnets. Normally, a given section of wire kept its magnetism for some time as it traveled away from the magnet. But when radio waves hit the wire, it lost its magnetism. This change of magnetism caused a current that could be turned into a signal that the wireless operator could hear. The new “maggie” detector was more sensitive and reliable than the coherer was. Yet again, Marconi showed that he could “borrow” a scientific idea and use it to build an improvement in his apparatus.

Leaping the Atlantic

Marconi now decided to try to send signals more than 2,000 miles (3,220 km.) across the Atlantic Ocean. Many scientists doubted that any wireless signal, no matter how powerful, could travel for thousands of miles. They believed that electromagnetic waves always travel in straight lines. The waves would therefore not follow the curvature of the earth, but rather beam out into space and be lost. The only way to send signals over the curvature would be to build an antenna a thousand or more feet high.

Marconi had little interest in the scientific debate. He began to build a transmitting station at Poldhu, a bay in Cornwall, England. His antenna was huge, consisting of “a ring of twenty wooden masts, each about 200 feet (60 m.) high, arranged in a semicircle 200 feet (60 m.) in diameter, covering about an acre (0.40 hec-

I WAS THERE

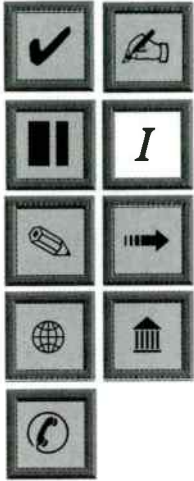

A SENSE OF WONDER

Marconi's successful transatlantic transmission excited the imagination of many writers. Ray Stannard Baker, writing for *McClure's Magazine*, asked his readers to:

Think for a moment of sitting here on the edge of North America and listening to communications sent *through space* across nearly 2,000 miles of ocean from the edge of Europe! A cable, marvelous as it is, maintains a tangible and material connection between speaker and hearer; one can grasp its meaning. But here is nothing but space, a pole with a pendant [dangling] wire on one side of a broad, curving ocean, an uncertain kite struggling in the air on the other—and thought passing between.

tares)." Altogether, about 4,000 wires were strung from the masts. He built a similar antenna at Cape Cod, Massachusetts.

Marconi tried to make his transmitter as powerful as possible. As *McClure's Magazine* observed: "When the operator pressed the telegraphic key, a spark a foot long and as thick as a man's wrist, the most powerful electric flash yet devised, sprang across the gap; the very ground nearby quivered and crackled with the energy."

Within a month, though, fierce storms had demolished both antennas. Marconi had hoped to start right away with a complete two-way transatlantic service. Now, his business devastated by the loss, Marconi struggled to find a way just to get a simple signal across the ocean to show that it could be done. He set up a simpler antenna at Poldhu and moved his receiving station to Newfoundland, which was considerably closer to England. He would gain height for his receiving antenna by attaching a kite to it.

On December 15, 1901, newspaper headlines announced that Marconi had heard in Newfoundland a message sent by his station in England. The message was the “dot dot dot” that stands for the letter S in Morse code.

The growing demand for international communications had begun to clog the cable telegraph system. But the cable companies were a monopoly that felt little need to change. As the *New York Times* complained:

There has been no reduction in the cost to the public of cable communication for the past score of years. This has not only been a distinct hindrance to the development of business, but it has been a hindrance to that improvement in the relations of nations to each other. The cable companies have been as incapable of improvement as the Martian canals, and were

SOLVING PROBLEMS



LONG-DISTANCE RADIO

It turned out that scientists were right that radio waves basically travel in straight lines. After Marconi's successful long-distance transmission, British physicist Oliver Heaviside (1850–1925) and American electrical engineer Arthur Edwin Kennelly (1861–1949) theorized that there was a layer of the upper atmosphere that was electrically charged and that acted like a mirror to bounce radio signals back down to Earth hundreds or thousands of miles from their origin. This layer came to be known as the ionosphere.

The ionosphere varies in height from 50 to 240 miles (80 to 385 km.). If you turn your AM radio dial slowly during the late hours of the night, you may pick up stations from hundreds of miles away. That's because at night the ionosphere layer is in a higher, thinner part of the atmosphere, and it lets radio signals bounce back to Earth instead of being absorbed in the air.

managed with about as much reference to the needs and wishes of the population on earth.

The *Times* hoped that Marconi's wireless would offer a cheaper alternative. A pair of wireless stations was much less expensive and much easier to install than an Atlantic cable. But it would take considerable technical effort to make wireless truly reliable over long distances. Marconi and his backers needed to make money soon, and that meant ship-to-ship and ship-to-shore communication. This was something they could handle with existing equipment and without competition from cables.

The most dramatic use of wireless was for rescuing ships in trouble at sea. During the night of January 23, 1909, the lookout on the steamship *Republic* heard the blasts of a horn and saw a huge shape looming out of the darkness. It was too late to avoid a collision, and the *Republic* crashed into another steamer, the *Florida*. Fortunately, the *Republic's* wireless operator and his equipment were not hurt. He began to send the letters *CQD*, the distress call that was eventually replaced by the now familiar *SOS*. He was able to give his ship's approximate position.

Several wireless-equipped ships responded to the distress call. As the *Republic* began to sink, passengers and crew calmly got into the lifeboats. The ship *Baltic* was the first rescuer on the scene. Its wireless operator sent a running account of the rescue operations:

The steamship *Florida* collided with the *Republic* 175 miles east of the Ambrose Lightship at 5:30 AM on Saturday. The *Republic's* passengers were transferred to the *Florida*. The *Republic* is rapidly sinking. It is doubtful if she will remain afloat much longer. The *Baltic* has taken all the passengers aboard . . .

Later, the operator reported, "I can send no more. I have been constantly at the key without sleep for fifty-two hours."

After wireless had so dramatically proved its value, the United States and most other seafaring nations passed laws requiring that ships carry wireless equipment.

A Voice in the Air

On Christmas Eve of 1906, wireless operators aboard ships off the New England coast put on their headsets and waited for a special message they had been told to expect from a station operated by Reginald Fessenden (1866–1932), a Canadian-born physicist and electrical engineer.

Most of them no doubt were expecting some sort of Christmas greeting encoded in the usual Morse dots and dashes. Instead they heard Fessenden's voice, music from phonograph records, and even a bit of violin music played "live" by the inventor!

About six years earlier, Fessenden had begun to create a radio system that could transmit the human voice—what would become

PARALLELS

FROM BURSTS TO CONTINUOUS WAVES

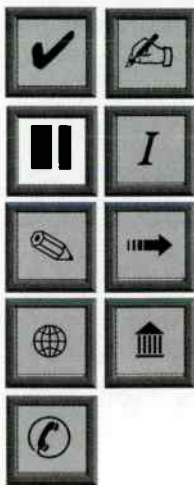

The relationship of the telegraph to the telephone is similar to that between the wireless telegraph and the radio telephone. Both the regular and wireless telegraph send "burst" signals—dots and dashes—through brief discharges of electric current. In inventing the telephone, Alexander Graham Bell realized that he would need to generate a continuous current that received its pattern from the sound waves of the human voice striking a diaphragm or microphone. Similarly, Reginald Fessenden knew he needed a continuous current to carry voice messages. His task was complicated by the need to create high-frequency electromagnetic waves from the current. The alternators that were built to meet this need pushed the limits of electro-mechanical technology. The breakthrough into electronic technology, discussed in the next chapter, would provide an easier way to generate continuous waves.

known as radio telephony. To do this he had to make several changes in the wireless technology of the time.

Regular radio telegraphy, like its wire-carried counterpart, uses small bursts of current. These bursts can carry the simple dots and dashes of Morse code, but Fessenden realized that to carry sound, a continuous signal would have to be generated. The signal would have the pattern of the waves of voice or music superimposed on it—what is called “modulation.”

In order to carry the detailed pattern of sound, the current would have to have a much higher frequency, or number of waves generated per second. To generate these waves, he needed varying, or “alternating,” current. Existing generators (alternators) normally produced current at the rate of 60 cycles per second (which is still the standard for electric power today). Fessenden needed an alternator that would produce tens of thousands of cycles per second. When he went to General Electric and insisted that they build him such a machine, they decided to meet the challenge, and newly employed Ernst Alexanderson was given the job.

Alexanderson came through and eventually delivered a machine that could run at 50,000 cycles. With this machine Fessenden was able to generate a continuous radio wave and create the voice-carrying radio telephone. Thanks to Fessenden, the United States entered World War I with the world’s most powerful radio transmitters.

Fessenden thought of his invention as simply doing for wireless what the telephone did for the telegraph—making “point-to-point” voice communication possible. It didn’t occur to him that there might be a reason to send speech and music over the airwaves to a whole audience of listeners. This idea, radio broadcasting, is the subject of the next chapter.

Chronology of Wireless Telegraphy

1864 James Clerk Maxwell develops theory of electromagnetic waves

- 1879 Heinrich Hertz first sends and receives radio waves
- 1896 Guglielmo Marconi arrives in England to work on wireless; files first patent
- 1899 Marconi reports yacht race results and other news by wireless
- 1901 Marconi broadcasts Morse code for S across the Atlantic
- 1906 Reginald Fessenden broadcasts music to astonished wireless operators
- 1909 First use of wireless to rescue a ship at sea
- 1912 U.S. Congress begins to regulate wireless to prevent interference problems
- 1921 Radio amateurs discover that shortwave signals are more reliable for long-range transmissions

Further Reading

[Bellingham Antique Radio Museum] "Time line of the history of radio technology." World Wide Web: <http://www.antique-radio.org/timeline/time.html>. Chronology with links to important people.

Douglas, Susan J. *Inventing American Broadcasting, 1899–1922*. Baltimore: Johns Hopkins University Press, 1987. Describes the technical and business developments in wireless telegraphy and early broadcast radio, as well as the social context.

Dunlap, Orrin E. *Marconi: The Man and His Wireless*. New York: Macmillan, 1937. An older biography of Marconi.

[History of the development of wireless communications and radio.] Texas Wesleyan University. Mass Communication Center. World Wide Web: http://www.txwesleyan.edu/masscomm/b_histroy.html. History of communications, includes sound clips from historic broadcasts.

Leinwoll, Stanley. *From Spark to Satellite: A History of Radio Communication*. New York: Charles Scribner's Sons, 1979.

Parker, Steve. *Guglielmo Marconi & Radio*. Broomall: Chelsea House Publishers, 1995. Biography of Marconi for young readers.

NOTES

- p. 65 “the bewildering possibility of telegraphy . . .” Quoted in Lubar, p. 101.
- p. 66 “thus with difficulty to telegraph . . .” Quoted in Lubar, p. 10.
- p. 69 “The distance to which signals . . .” Quoted in Sharlin, pp. 92–93.
- p. 69 “what impressed the public most . . .” Quoted in Douglas, Susan J. *Inventing American Broadcasting, 1899–1922* (Baltimore: Johns Hopkins University Press, 1987), p. 20.
- p. 72 “Think for a moment . . .” Quoted in Douglas, p. 58.
- p. 72 “When the operator pressed the telegraphic key . . .” Quoted in Douglas, p. 56.
- pp. 73–74 “There has been no reduction in the cost . . .” Quoted in Douglas, p. 147.
- p. 74 “The steamship *Florida* collided . . .” Quoted in Dunlap, Orrin E. *Marconi: The Man and His Wireless* (New York: Macmillan, 1937), p. 170.

Triumph and Tragedy

EDWIN ARMSTRONG
AND RADIO BROADCASTING



Edwin Armstrong developed key radio inventions including feedback amplification and the superheterodyne. He wanted to replace AM radio with his new FM system, but RCA had other plans. (Courtesy of Jeanne Hammond)

In 1915, David Sarnoff, chief inspector for the Marconi Wireless Telegraph Company of America, wrote a memo in which he proposed a new kind of radio service “which would make radio a ‘household utility’ in the same sense as the piano or phonograph.” He called the new device a “radio music box,” and explained that “the receiver could be arranged for several different wavelengths, which should be changeable with the throwing of a single switch or the pressing of a single button.” He went on to note that radio listeners could be provided with baseball games, news reports, and musical concerts. Sarnoff’s memo fell on deaf ears, however. To the Marconi Company, radio was simply wireless telegraphy.

The development of radio broadcasting would demand new ideas in both technology and business. An inventor named Edwin Armstrong (1890–1954) would make many of the key discoveries that make modern radio possible. In the end, however, he would become the victim of social change as corporate power overshadowed the individual inventor.

The Birth of Electronics

So far wireless technology had depended on relatively simple electro-mechanical devices. The signal was generated by a spark or by a spinning generator, or alternator. The signal was detected by a coherer, magnetic detector, or other device that responded to the effects of the waves.

The first clue to a new way to generate and detect radio waves had come in 1882, before radio even existed. Thomas Edison was trying to figure out why his light bulbs began to blacken and burn out after a while. He discovered that a small electric current was flowing inside the bulb, traveling through the vacuum and depositing particles from the carbon filament on the inside of the glass. He thought of a way to solve the problem. He put a small piece

KEY CONCEPTS



AM amplitude modulation; varying the strength of a radio signal



anode electrode that attracts electrons

cathode electrode that gives off electrons

electron tiny negative particle that makes up electrical current



electronics study and control of the flow of electrons

FM frequency modulation; varying the frequency of a radio signal



rectifier a device that changes an alternating current into a direct current



of tinfoil on the inside of the bulb and connected it to a positively charged plate and diverted the current.

In 1897, British physicist Joseph J. Thomson had been studying the flow of electricity in gases. He discovered that the “cathode rays” that a hot filament gave off could be bent by magnetic and electrical fields. He concluded that what had appeared to be some kind of radiation was in fact a stream of negatively charged particles many times smaller than an atom. He called these particles “electrons.”

In 1904, another researcher, John Fleming, was working for Marconi, who wanted him to come up with a new detector for wireless waves. Years earlier, Fleming had worked for Thomas Edison, and he remembered the mysterious current in the light bulbs. He wondered whether he could turn a light bulb into a radio detector. He inserted a piece of tinfoil in the bulb and connected it to a galvanometer (current detector), a coil, and then to the negative power terminal. When he turned on a wireless transmitter, the galvanometer showed that a current was flowing in the coil.

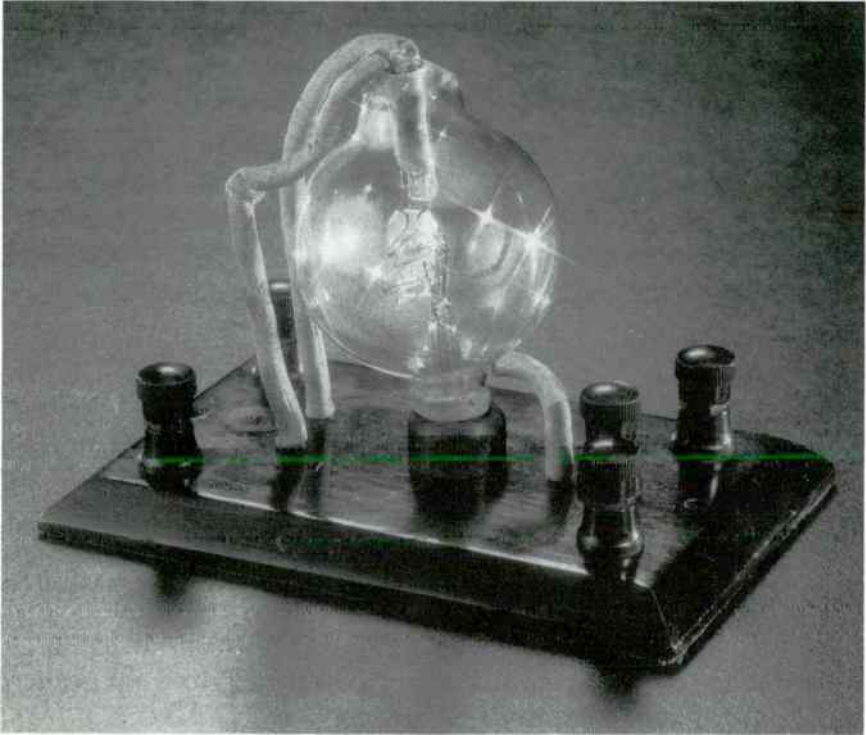

Lee De Forest's audion tube was the first electronic amplifier. It greatly improved radio reception. (Smithsonian Institution Photo No. 92-16889)

The current alternated (changed direction) at the same rate as the frequency of the transmitter. When the current was positive, it flowed toward the negatively charged filament. When the current's charge changed to negative, it was repelled by the negative filament and stopped flowing. This meant that the alternating current from the radio signal was being turned into a one-way, or direct current. This process is called rectification. It meant that Fleming had a radio wave detector that was more reliable than any that depended on a mechanical magnetic device. Because Fleming's "valve" worked by directly changing a flow of electrons, it was the first *electronic* device.

Lee De Forest, an engineer for Western Electric, had been trying to launch his own career as an inventor. De Forest started

by building a tube similar to Fleming's, but then had an insight. He realized

that [a] third, or control electrode could be located more efficiently *between* the wing [plate] and filament . . . I decided that the interposed third electrode would be better in the form of a grid, a simple piece of wire I had bent back and forth and located as close to the filament as possible.

A small negative charge on the grid could stop the flow of electrons from the filament, or cathode, to the positive plate, or anode. A positive charge let the current flow again. Since the radio signal consisted of alternating positive and negative charges, that meant that a tiny radio signal could control the flow of a much larger current in the grid. This imposed the wave pattern of the radio signal on the grid current, which is the equivalent of greatly strengthening, or amplifying, the signal.

OTHER INVENTORS



LEE DE FOREST

Iowa-born Lee De Forest (1873–1961) combined a deep interest in the mysteries of wireless with grandiose ideas about becoming an inventor of great stature and the founder of an industry. Although he filed more than 300 patents, the audion, or amplifying vacuum tube, was his main invention of lasting significance.

While De Forest's work brought him considerable financial success at first, his energy became increasingly tied up in long patent battles, particularly with Edwin Armstrong. Crooked business partners destroyed much of his business ventures, and his later attempts to develop a sound film system and a combination movie and television system met with little success.

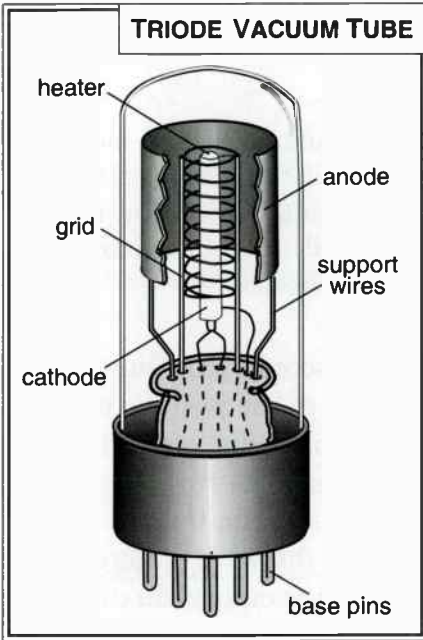

The diode and triode vacuum tubes have a cathode that releases electrons and is surrounded by an anode. The electron flow can be controlled by changing the charge on the anode. When the anode is positive, the negatively charged electrons flow toward it. If the current on the anode is negative, however, it will repel (and block) the electrons. This means that an alternating current of varying charge will be converted to a direct current that does not vary in charge. The triode adds a grid that can control a second current, amplifying the signal.

De Forest patented his “audion” tube in 1906. It soon found use in telegraph and telephone amplifiers, as well as radio.

Armstrong Gives Radio a Boost

About the time De Forest was inventing the amplifying tube, a teenage boy named Edwin Armstrong was reading about the excitement of invention. By the start of the 20th century, the ideal of the “inventor-hero” was as much part of a child’s education as were stories about George Washington or Abraham Lincoln. One of Armstrong’s books, *The Boy’s Book of Inventions: Stories of the Wonders of Modern Science*, was full of diagrams that explained such marvels as the submarine, phonograph, and X-ray machine. When young Edwin turned to the chapter on Marconi and wireless, he decided that was the area where he would seek inventions of his own.

Armstrong turned an attic room in the family's large Victorian house into a radio station, exchanging messages with other radio-minded boys in the neighborhood. After graduating from high school, Armstrong entered the engineering school at Columbia University, where he excelled in a rigorous series of courses in basic science and an electrical engineering. Armstrong enjoyed sports and extracurricular activities, though not when they interfered with his single-minded pursuit of radio.

By 1912, Armstrong was beginning his senior year at Columbia and had become interested in vacuum tubes. Armstrong, unlike De Forest, grasped the implications of the electron. He realized

OTHER INVENTORS



NORA STANTON BLATCH

In 1908, Lee De Forest married Nora Stanton Blatch. The "Stanton" came from her great-grandmother, Elizabeth Cady Stanton, the women's rights pioneer. Her mother had raised her in the tradition of independent women, and she became the first woman to receive a civil engineering degree from Cornell University.

Although the engagement had its problems, the De Forest marriage started out on a happy note. After meeting De Forest, Blatch had studied electrical engineering and became a capable radio engineer. She also used her business connections to help the De Forest company. She wanted to study and apply the latest radio theories to the design of new equipment. But De Forest built a mansion called "Riverlure" and wanted her to stay there and manage a cozy household "nest." When the De Forest Company collapsed amid charges of fraud, Blatch sued De Forest for divorce.

We can only wonder what technical achievements might have come if Nora Blatch had been able to pursue her ideas, either working as a full partner with her husband, or on her own.

that because the audion created a steadily swinging, or oscillating, flow of electrons that moved at the speed of light, this flow could be fed back to the grid as many as 20,000 times. Each time it went back, the current would become stronger. “Great amplification obtained at once,” Armstrong noted. Further, Armstrong tied the current flowing through the antenna into the circuit going through the grid, making the receiver even more sensitive.

The result of Armstrong’s “regeneration” circuit was a dramatic improvement in radio reception. Armstrong also discovered that

SOCIAL IMPACT



BIRTH OF A TECHNICAL CULTURE

In 1907, the *New York Times Magazine* featured an article on the young men—many still boys—who had become “wireless wizards,” the amateur wireless operators who had built their own stations and spent the nights picking up messages hundreds of miles away and comparing notes with their peers. Amateur operators, (“hams” for short), would make many technical contributions, particularly in pioneering the use of the shortwave frequencies. Ironically, once they had demonstrated the usefulness of a frequency band, the government would “kick them upstairs” to a higher frequency, turning their old haunts over to commercial broadcasters.

Amateur radio would help create another enduring culture. Hugo Gernsback, editor of *Modern Electrics*, pioneered magazine science fiction in the 1920s and helped create a legion of fans who would avidly discuss their favorite authors.

The amateur radio culture and the early science fiction culture were almost completely male pursuits. The computer “hacker” culture would be mainly male, too. But the new culture of the Internet seems to be slowly gaining in women participants who often bring a different perspective to the technical world.

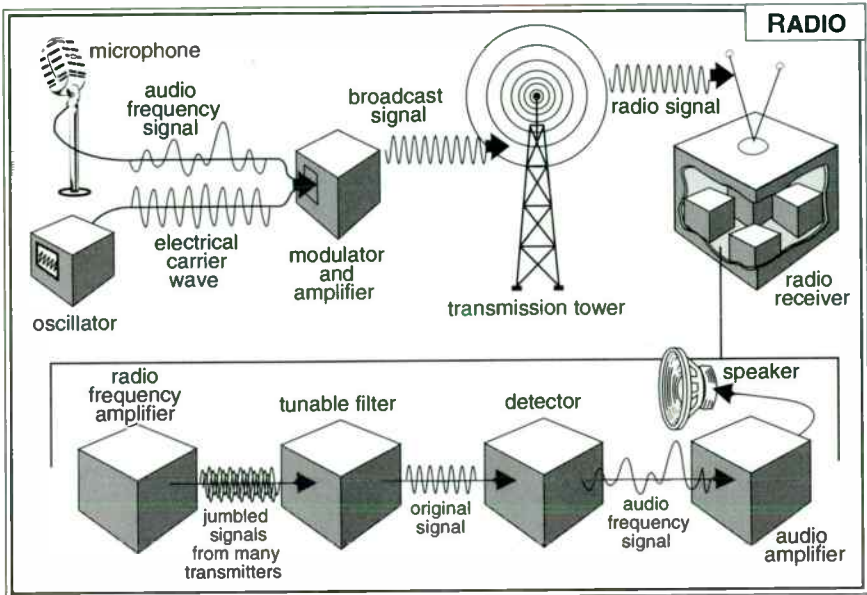

Modern radios have several circuits for processing a signal, including detectors, filters, and amplifiers.

if he fed the current back through the circuit enough times, the tube began to give off radio waves of its own. This meant that electronic radio transmitters were also possible.

When the United States entered World War I in 1917, Armstrong joined the army and went to France. During the war, Armstrong developed powerful transmitters and receivers for field headquarters and trenches, and pioneered in equipping airplanes with radio sets.

Broadcasting in Daily Life

After the war Armstrong and other pioneers finally brought radio into the electronic age. With vacuum tube amplifiers and transmitters, radio became reliable enough to become a consumer product. In 1920, Armstrong announced a new invention that came from his wartime work with high-frequency radio: the

superheterodyne circuit. The superheterodyne worked by generating a radio frequency that was close to (but not the same as) that of the incoming signal, and electronically combining the two somewhat in the way two piano keys can be pressed at the same time to produce a third sound. Because a combined signal has a frequency that is the difference between that of the original signal and the second signal, the resulting signal was at a much lower frequency and easier to work with. The new signal could then be passed through one or more stages of amplification. The receiver no longer had to “stretch” to fit the signal; the signal could in effect be adjusted to the range where the amplifiers worked most efficiently. As the 1920s began, many amateur radio operators bought the new equipment and set up their own broadcast stations, carrying music and news to their local community.

The Westinghouse Corporation then built what many consider to be the first commercial radio station, KDKA in Pittsburgh, Pennsylvania. On November 2, 1920, the station began broadcasting the returns of the presidential election in which Warren

I WAS THERE

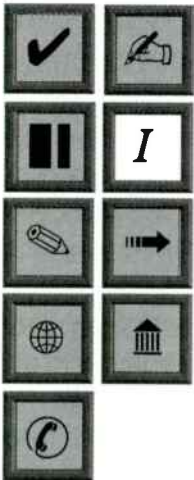

UNCLEAR ON THE CONCEPT

W. J. Baker in his *History of the Marconi Company* reports a bit of confusion when opera star Dame Nellie Melba was preparing to sing on the radio.

Melba was shown the transmitting equipment and then the towering antenna masts, the engineer in charge of the tour explaining that it was from the wires at the top that her voice would be carried far and wide. “Young man,” exclaimed Melba, “if you think I am going to climb up there you are greatly mistaken.”

TRENDS



A "SNAPSHOT" OF THE RADIO INDUSTRY IN THE UNITED STATES, 1923



In his book *Empire of the Air*, author Tom Lewis assembles some facts and figures to show how the radio broadcast industry, in only its third year, had mushroomed:



Number of stations: 1920 (1); 1922 (30); 1923 (556)



State with most stations in 1923: California (63)

Number of radio sets produced: 1922

(100,000); 1923 (500,000)



Cost of a "complete tube [radio] set" from Sears Roebuck in 1923: \$23.50.

Mix of programming from radio station WJZ

in 1923: "98 baritone solos, 6 baseball games, 5 boxing bouts, 67 church services, 7 football games, 10 harmonica solos, 74 organ concerts, 340 soprano recitals, 40 plays, 723 talks and lectures, and 205 bedtime stories."

G. Harding beat James W. Cox. Radio as we know it today had arrived. As J. Fred MacDonald notes:

Radio aerials now began to clutter the skyline, and people shopping for new homes began looking for locales with good reception. Since early 1922, a daily radio log listing programs for the day became a regular feature of most newspapers, and by the end of the year twenty-seven fan magazines were being published in the United States . . .

But who was going to pay for radio broadcasting, and who would control what went on the air? In Great Britain and many other European countries the government controlled the broadcast networks just as they had the telegraph and telephone. The radio listener usually paid the government an annual fee for each radio set.



As the 20th century went on, the radio became the “entertainment center” in many homes. (Library of Congress)

In the United States there was no tradition of government ownership of communications. Stations were private businesses that sold advertising time to sponsors, making radio free for the listener, though at the cost of having to listen to commercials. The government served more as a “traffic cop” that gave out licenses and tried to keep stations from interfering with each others’ transmissions.

Besides paying for radio, there was the question of what kinds of programs were to be broadcast. Playing recordings of popular and classical music was certainly a possibility, although musicians’ unions and record companies tried at first to stop radio from giving out their product for free. Spoken drama was another popular choice. At first, according to radio writer Arch Oboler:

Radio in those days was an imitation of motion pictures, and an echo of the stage. No one had really used it as a theater of the mind, had realized that a few words, a sound effect, a bit of music, could transport—in the mind of the listeners—one

to any corner of the world, evoke emotions that were deep in the consciousness of the listener.

But radio soon evolved unique forms of drama or changed existing ones to fit its format: the detective story, the western adventure story, the science fiction superhero, and the soap opera—the last so named because it was aimed mainly at women and featured commercials for laundry soap.

A severe economic depression brought social turmoil to the United States and much of the industrialized world during the 1930s. As people looked to leaders for assurance, radio became a powerful political force. Beginning on March 12, 1933, President Franklin D. Roosevelt began to speak directly to the American people on his radio “fireside chats.”

Leaders had always used their speaking skills to persuade people, of course. The difference was that radio made it possible to “personally” persuade millions of people at the same time. Whether the leader spoke from the fireside or took on the more sinister tones of Germany’s Adolf Hitler or the U.S.S.R.’s Joseph Stalin, the power of the new medium could not be denied. As the world lurched toward a devastating new war, radio newscasters such as Edward R. Murrow brought the latest developments from Europe directly to American homes.

When, in 1938, a “news broadcast” by Orson Welles claimed that Martians were invading the world and destroying whole armies with disintegrator beams, many listeners believed what they heard and panicked. They had learned to rely on the radio for information and assurance as well as for entertainment.

The End of the Inventor?

With his inventions being fundamental to the development of the radio industry, Armstrong might well have expected that his career would now follow the path set by Bell, Edison, and Mar-

coni—bringing not only financial success, but the ability to shape a new industry.

The American Marconi Company had agreed to pay Armstrong for the use of his regeneration circuit, but AT&T, the huge telephone company, said that it could use it without payment because someone else had invented it. Armstrong became embroiled in what would be the first of many legal battles when several inventors claimed that they had discovered regeneration first.

Of these rivals, the most persistent was Lee De Forest. When he discovered Armstrong's patent, he filed one of his own, together with a complicated and confusing explanation and a circuit diagram. The patent examiner rejected it because he saw that De Forest's circuit was fundamentally the same as Armstrong's already patented one.

De Forest didn't give up, however, and the battle moved from court to court. Armstrong had neglected to mention the transmitting feature of the circuit in his original patent, but De Forest did include it in his rival patent, somewhat strengthening his claim.

PARALLELS

COMPARING DE FOREST AND ARMSTRONG

According to author Tom Lewis

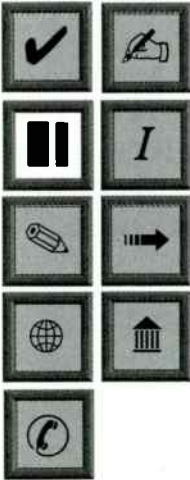

The differences between the character and inventive practice of De Forest and Armstrong are striking: De Forest was extroverted and gregarious; Armstrong was introverted and shy. De Forest read voraciously in the technical literature searching for new ideas; Armstrong read technical literature, but to learn rather than pillage. De Forest liberated ideas from others and adapted them to his own purposes; Armstrong generated ideas himself that often stunned the art.

Nevertheless, court after court rejected De Forest's claim and awarded patent rights to Armstrong.

But then Armstrong made a mistake. He had been deeply angered by De Forest's persistence in claiming an invention that nearly all electrical engineers had agreed was Armstrong's original idea. When De Forest continued to use the invention without payment, an outraged Armstrong went on the offensive and filed suit against De Forest.

At first, Armstrong seemed to prevail again in the courts, but eventually De Forest found a judge who was confused about the technical issues and decided in favor of De Forest. The case went to the Supreme Court of the United States, which simply affirmed the earlier decision in De Forest's favor.

Armstrong had also suffered a personal blow. As legal costs ate away most of his savings, he had turned for financial help to his longtime friend David Sarnoff. Sarnoff, who had worked with Armstrong in the early days when radio broadcasting was only a dream, was now head of the Radio Corporation of America (RCA), the biggest company in the radio industry. But while he expressed personal sympathy, Sarnoff refused to back Armstrong, because if De Forest won, RCA would continue to be able to use the patent rights.

Armstrong did not give up. He began to work on a third great invention, frequency modulation (FM). Standard radio transmissions used amplitude modulation (AM). This meant that the sound to be broadcast was used to vary the amplitude, or strength of the signal. The problem with AM is that any electrical discharge in the environment, such as a lightning storm or even the spark plug in a car, can affect an AM wave, causing a burst of static.

Armstrong wondered what would happen if he built a circuit that modulated the frequency rather than the amplitude. John Renshaw Carson, a researcher at Bell Laboratories, didn't think much of the idea, declaring that "I have proved, mathematically, that this type of modulation inherently distorts without any compensating advantages whatsoever. Static, like the poor, will always be with us."

Like Marconi, Armstrong didn't think much of such expert opinion: "I could never accept findings based almost exclusively on mathematics. It ain't ignorance that causes all the trouble in this world. It's the things people know that ain't so."

Armstrong was still working for RCA, but Sarnoff seemed reluctant to help him with FM. It turned out that Sarnoff was much more interested in developing television broadcasting (see "The Ghost Light"). He shut down Armstrong's FM lab and transmitter on the roof of the Empire State Building.

By November 5, 1935, however, Armstrong had made other arrangements. At a meeting of the Society of Radio Engineers he gave a lecture explaining the principles of FM. He then raised the curtain, revealing what appeared to be an ordinary radio set. First, he tuned it to the regular, static-filled AM broadcast band. Armstrong then tuned it to his FM test station and the static completely disappeared. Out of the silence came the announcer's voice, music, and sounds as delicate as the pouring of water into a glass. The audience had encountered true high-fidelity sound for the first time.

After World War II, he continued the commercial development of FM, which by then had attracted a small but enthusiastic group of stations and listeners.

Sarnoff needed to use FM for the sound portion of television. He refused to pay Armstrong to use the patent. Again, Armstrong went to court, but he was now up against the legal department of one of the world's largest corporations. A further blow came when RCA successfully urged the government to assign the original FM broadcasting frequencies to the new television service. This made all existing FM equipment obsolete and virtually bankrupted Armstrong.

Armstrong snapped under the relentless pressure. He hit his wife, Marion, shattering thirty years of happy marriage. They separated, and on January 31, 1954 he wrote the following note to her:

I am heartbroken because I cannot see you once again. I deeply regret what has happened between us. I cannot understand how I could hurt the dearest thing in the whole world

SOLVING PROBLEMS

**HEDY LAMARR VERSUS THE JAMMERS**

Whenever you make a cell phone call, you might want to remember Hedy Lamarr. What did the glamorous Austrian actress have to do with electronics? Quite a bit, actually. Before World War II, Lamarr was married to a German arms designer. She overheard many conversations about experiments with radio-controlled rockets, and evidently she did some quiet thinking about radio on her own.

In 1942, after she had fled from the Nazis, Lamarr and music composer George Antheil patented a method for protecting radios from being jammed by enemy signals. Lamarr and Antheil's device used something called frequency hopping. The idea was to have the transmitter rapidly and unpredictably change frequency so that the jammer can't lock onto the signal. The problem was how to synchronize the transmitter and receiver so they hopped to the same frequency at the same time. Their solution: encode the series of frequency settings on matching player piano rolls that moved at the same speed in both devices.

Today, an electronic version of frequency hopping is used in cordless and cell telephones as well as global positioning satellite (GPS) systems and wireless computer networks. The technique enables many users to in effect "slice up" and share a limited number of frequencies.

to me. I would give my life to turn back to the time when we were so happy and free. God keep you and may the Lord have mercy on my soul.

The next morning Edwin Armstrong jumped out of the window of his 13th-floor apartment.

Armstrong's life and death raise important questions about the history of invention in the modern world. Author Gary Stock suggests that Armstrong

. . . was among the last of the great individual American inventors, a breed presently reduced in rank or perhaps extinct, in a period during which vast corporations came to dominate virtually all scientific and technological development in this country . . .

Radio in the Modern World

Like the movies, radio responded to the challenge of television by becoming more specialized, serving in ways that were not easy for TV. By the 1960s, the big radio networks had become little more than news services. But radio had become the driver's companion and a source of portable music to take on a picnic. In the 1980s, "talk radio" stations gave ordinary people a new way to voice their opinions and complaints. Television had taken center stage as the great mass medium, but radio survived because it was versatile and relatively inexpensive.

Ironically, Armstrong's FM radio rose from the dead in the 1960s. Its superior sound quality made it the medium of choice for classical music, jazz, and the emerging, increasingly sophisticated sounds of rock and roll.

Chronology of Radio Broadcasting

- | | |
|------|--|
| 1882 | Thomas Edison discovers the "Edison effect" but doesn't understand its true nature |
| 1897 | Joseph J. Thomson discovers the electron |
| 1904 | John Fleming builds the first rectifying vacuum tube |

- 1906 Lee De Forest creates the audion, or triode, a vacuum tube that can amplify signals
- 1912 Edwin Armstrong invents the regeneration (feedback) amplification of radio waves
- 1915 David Sarnoff of RCA proposes a “radio music box” for the household
- 1920 Armstrong invents the superheterodyne circuit used in modern radio receivers
- 1928 Supreme Court upholds court decision in favor of De Forest in patent dispute with Armstrong
- 1935 Armstrong stuns engineers with a demonstration of FM broadcasting
- 1954 Armstrong commits suicide

Further Reading

- [FECHA “the Church of the Electron”] “Edwin Armstrong: Creator of FM radio.” World Wide Web: <http://pacmedia.com/fecha/saints/armstrong.html>. An odd source, but a well-told short biography.
- Lewis, Tom. *Empire of the Air: The Men Who Made Radio*. New York: HarperCollins, 1991. The tumultuous lives and times of radio pioneers Lee De Forest, Edwin Howard Armstrong, and David Sarnoff.
- MacDonald, J. Fred. *Don't Touch That Dial! Radio Programming in American Life from 1920 to 1960*. Chicago: Nelson-Hall, 1979. History of radio broadcasting; relates the themes of radio programs to issues in daily life.
- Stock, Edwin. “Edwin Armstrong: Genius Inventor.” *Audio*, November 1980, p. 53. Biographical article with good brief technical explanations.

NOTES

- p. 83 “. . . that [a] third, or control . . .” Quoted in Leinwoll, Stanley. *From Spark to Satellite: A History of Radio Communication* (New York: Charles Scribner’s Sons, 1979), p. 45.
- p. 88 “Melba was shown the transmitting . . .” Quoted in Leinwoll, p. 102.
- p. 89 “Radio aerials now began to clutter . . .” Quoted in MacDonald, J. Fred. *Don’t Touch That Dial! Radio Programming in American Life from 1920 to 1960* (Chicago: Nelson-Hall, 1979), p. 12.
- pp. 90–91 “Radio in those days . . .” Quoted in MacDonald, p. 56.
- p. 92 “The differences between the character . . .” Quoted in Lewis, Tom. *Empire of the Air: The Men Who Made Radio* (New York: HarperCollins, 1991), p. 74.
- p. 93 “I have proved, mathematically . . .” Quoted in [FECHA “the Church of the Electron”] “Edwin Armstrong: Creator of FM radio.” World Wide Web: <http://pacmedia.com/fecha/saints/armstrong.html>.
- p. 94 “I could never accept findings . . .” Quoted in [FECHA] Web page.
- pp. 94–95 “I am heartbroken . . .” Quoted in Lewis, p. 326.
- p. 96 “. . . was among the last . . .” Quoted in Stock, *Audio*, November 1980.

The Ghost Light

PHILO FARNSWORTH AND THE BIRTH OF TELEVISION



Philo Farnsworth “invented” television while he was still in high school. By 1927, he had a working all-electronic TV system.

(Courtesy of Ms. Elma G. Farnsworth)

Although television did not become a household reality until the 1950s, it has a surprisingly long history. After the telephone was invented, cartoonists drew fanciful pictures of people watching events such as badminton matches on a screen connected to a “picture telephone.”

In 1884, an engineer named Paul Nipkow suggested a way to convert a picture into electrical signals. His invention consisted of a disk that had a spiral-shaped pattern of holes. As it whirled, each hole scanned across a horizontal strip of the picture. For each part of the picture, a cell of light-sensitive selenium produced an electrical current in proportion to the amount of light falling on it. This information was sent along a telephone line to the receiver, which consisted of a similar wheel, electrically driven to synchronize with the transmitter. In theory, the light shining through it would reproduce the original picture.

Charles Jenkins, an American inventor, built a very crude version of this system and used it to broadcast a picture of a

KEY CONCEPTS



cathode ray tube a device that generates streams of electrons



global village an idea that communications are making the world act like a single community



phosphor a spot on a television tube that glows when struck by an electron beam



V chip a proposed device to block reception of TV programs with objectionable content



windmill in 1925. In 1927, President Herbert Hoover became the first politician to appear on television. Jenkins called his invention “radio vision” and predicted that

In due course folks in California and Maine, and all the way between, will be able to see the inauguration ceremonies of their President, in Washington; the Army and Navy football games at Franklin Field, Philadelphia; and the struggle for supremacy in our national sport, baseball. . . . The new machine will come to the fireside as a fascinating teacher and entertainer . . . with photoplays, the opera, and a direct vision of world activities.

In 1926, British inventor John Logie Baird built a system based on Nipkow’s idea. Some sets were sold, and the British Broadcasting Company (BBC) began to broadcast TV pictures.

But none of these mechanical televisions worked very well, because they were slow and the limited number of lines they could scan made the picture very coarse.

Dreams of a Boy Inventor

In order for a television system to provide good quality pictures, the mechanical approach would have to be abandoned in favor of an electronic one. It would take an inventor born in the 20th century and growing up in the golden age of electronic discovery to create the modern television system.

Philo Farnsworth (1906–1971) seemed an unlikely candidate for the job. When he was 13, young Philo arrived with his family at their new home in Idaho (they had come from Utah). As he got down from the wagon, he noticed the wires near the farmhouse. “This place has electricity!” he exclaimed.

A few weeks later, the generator that provided power to the farm broke down and Philo figured out how to fix it. Using an assortment of parts and scrap, he built electric motors to run his

mother's washing machine and some of the farm equipment. Most of all, Philo tried to get his hands on every book or article about electricity that he could find.

In 1922, Philo, now a high school student, read an article on "Pictures That Could Fly Through the Air." While the writer provided little useful information about how this could be done, the very idea spurred his imagination. But, as Paul Schatzkin, author of "The Farnsworth Chronicles," notes:

When Philo determined to learn everything he could about the subject, he stepped into a Jules-Vernian world where scientists were trying to convert light into electricity with the aid of whirling discs and mirrors. Farnsworth realized right away that those discs and mirrors would never whirl fast enough to transmit a coherent image, and searched for a device that could travel at the speed of light itself. He found the solution in his invisible new friend, the electron.

One day in January 1922, Philo's chemistry teacher, Justin Tolman, was startled to find the boy sketching electronic diagrams and equations all over the blackboard. "What has this to do with chemistry?" Tolman asked. "I've got this idea," Farnsworth told him. "I've got to tell you about it because you're the only person I know who can understand it. This is my idea for electronic television."

Tolman had never heard the word *television* before, of course, but the boy was persuasive. After weeks of discussions, they agreed the idea was practical. Farnsworth had visualized the basic idea of electronic television: a magnetically controlled beam of electrons creating an image line by line with no mechanical parts.

A Working Model

Farnsworth's college career was sidetracked when his father died and the family needed his help. When a temporary job as a charity fund-raiser in Salt Lake City ended, his employer, George Everson,

asked him whether he was going back to school. Their dialogue went like this:

Farnsworth: I can't afford school. Besides, I need to finance an invention of mine.

Everson: What's your idea?

Farnsworth: It's a television system.

Everson: A television system. What's that?

Farnsworth: Oh, it's a way of sending pictures through the air the same as we do sound. I thought of it when I was in high school. I went to Brigham Young University and told a couple professors about it. They encouraged me to try out some things in the lab, and now I think I've got something that works.

Everson grilled Farnsworth about whether anyone else was working on such a system. Farnsworth explained that the other systems were all mechanical. Finally, Everson asked Farnsworth how much money he thought he would need to produce a working model, and Farnsworth suggested \$5,000, though he really had no idea. Everson agreed to provide the money, saying:

Your guess is as good as any. I surely have no idea what is involved. But I have about \$6,000 in a special account in San Francisco. I've been saving it with the idea that I'd take a long shot on something and maybe make a killing. This is about as wild a gamble as I can imagine. I'll put the \$6,000 up to work this thing out. If we win, it will be fine, but if we lose, I won't squawk.

And so, at a time when Bell Labs, Marconi, RCA, and other technological powerhouses had seemingly ended the age of the individual inventor, television was being born in an improvised home laboratory.

Unfortunately, it soon became clear that much more money would be needed to design a whole new technology from the ground up. In 1928, Farnsworth got an appointment to see W. W. Crocker, a famous San Francisco banker. By then, the television

I WAS THERE

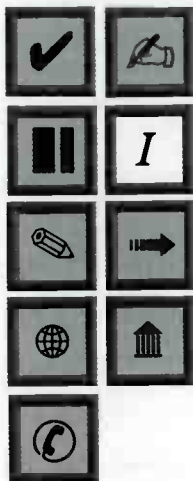

NOT WHAT IT APPEARED TO BE

In "The Farnsworth Chronicles" Paul Schatzkin recounts an incident that happened shortly after Farnsworth had started assembling magnetic coils for his experimental television set:

Given that this all occurred in the middle of prohibition, it must have seemed a bit suspicious, all this unusual activity. Now, here was this total stranger to the neighborhood, sitting out in the backyard, winding copper wire around a cardboard tube. Certainly someone noticed, for one day in August, [Philo's wife] opened the door to find her porch filled with a small squad of blue LAPD [Los Angeles Police] uniforms, demanding to search the house. They had received a report that a still was being operated on the premises. The squad proceeded to ransack the apartment despite protests from the Farnsworths. Nothing alcoholic was found, but the sergeant was amazed by the things that he did find, and began to wonder if he had stumbled onto something even more sinister than a still.

With carefully guarded words, he asked Phil what all the stuff was. Phil looked around at the strange gear he had collected, stared the sergeant straight in the eye and answered, "This is my idea for electronic television."

The sergeant shook his head, took another look around and said, "Tell a what?"

system was far enough along that it could transmit a simple fixed image. When one of Crocker's bankers asked, "When are we going to see some dollars in this thing?" Farnsworth responded by throwing a switch. The image of a dollar sign glowed on the screen. Crocker agreed to invest \$25,000 on condition that Farnsworth move his lab to San Francisco.

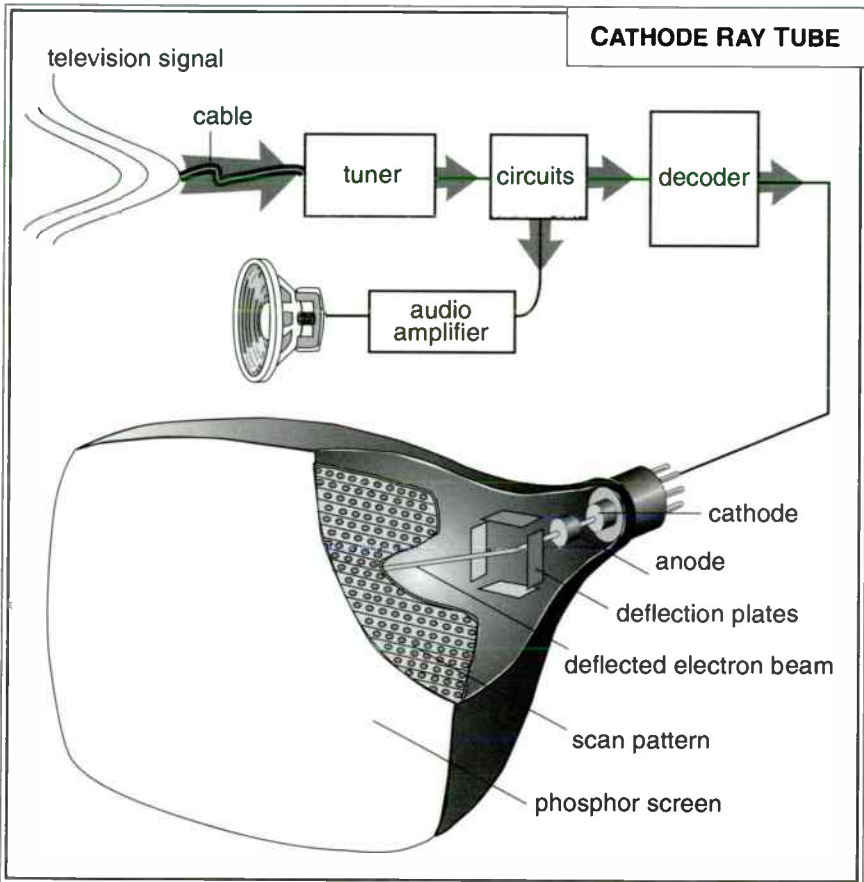

The cathode ray tube is the heart of television. Once the incoming television signal is isolated by the tuner, it is fed to a decoder that turns information in the signal into instructions for the electron "gun." Electrons from the gun are controlled by magnets so that they hit the appropriate phosphor dots on the inside face of the tube to represent the picture. A standard American TV sweeps the beam across 525 lines each second.

One day in 1928 Farnsworth was looking at the television screen and saw wisps of smoke in the picture. He was afraid the lab was on fire (an ever-present hazard with the delicate tubes), but then he saw a hand with a cigarette waving in the picture. His friend and assistant Cliff Gardner had been smoking while working on the TV camera. The clarity of the smoke swirls in the picture told Farnsworth that they were making considerable progress. Soon they continued their tests with moving pictures, gradually gaining the ability to project a movie on a screen, scan it through the television camera, and broadcast it to the receiver.

By the end of 1928, the system was essentially complete, but Farnsworth and his backers now needed the money and business connections to begin manufacturing and marketing it.

The Empire Strikes Back

David Sarnoff and the giant Radio Corporation of America (RCA) took a belated interest in Farnsworth. Sarnoff, a visionary who had predicted radio broadcasting back in 1915, had decided that television would be the technology that would keep RCA profitable and ahead of the competition. Sarnoff hired a Russian inventor named Vladimir Zworykin to develop an RCA television system. Sarnoff had heard about Farnsworth's work, and he asked Zworykin to visit Farnsworth but not tell him about RCA's interest in television. When the time came to negotiate, Sarnoff offered \$100,000 for Farnsworth's entire operation and wanted to hire Farnsworth to work for RCA. Farnsworth refused.

Sarnoff could probably have paid Farnsworth for the right to use his patents, but legend has it that Sarnoff always insisted that "The Radio Corporation does not pay patent royalties, we collect them." RCA and AT&T had made an arrangement that each could use the other's patents, as long as AT&T stayed out of broadcasting and RCA didn't try to compete in the telephone

field. This “patent monopoly” made it very difficult for upstarts like Farnsworth to enter the market.

Farnsworth found what seemed to be a suitable business partner in the Philco Corporation (no relation to Philo), a radio company that had managed to compete successfully with RCA. Paul Schatzkin recalls that

[Farnsworth] set up a prototype receiver in his home, and [his son] little Philo III became the first charter member of the “television generation.” His usual program diet consisted of a Mickey Mouse cartoon, “Steamboat Willy,” which ran over and over again through the film chain at the laboratory

OTHER INVENTORS



VLADIMIR ZWORYKIN (1889–1982)

Vladimir Zworykin became interested in electricity as he worked summers for a boat company.

When he went to study at the Imperial Institute of Technology, Zworykin met Boris Rosing, who in 1906 had begun to experiment with the use of a cathode ray tube to create pictures. Rosing and Zworykin developed a hybrid system that used a mechanical scanner as the “camera” and a cathode ray tube as the receiver. In 1919, Zworykin went to the United States, where he worked first at Westinghouse and then at RCA, where he was put in charge of television development.

There has been considerable dispute about whether Zworykin or Farnsworth is the true “father of television.” Zworykin applied for a patent for an all-electronic television system in 1923, but it was never granted and no working model was built. By 1927, it was Farnsworth who had a working system, and his patent was upheld by the courts. It is not clear how much Zworykin’s subsequent work owes to his having had the chance to examine Farnsworth’s equipment for three days.

several miles away. While little Philo watched, his father and the engineers at Philco made adjustments and tuned the circuits.

But Farnsworth left Philco when Philco executives demanded more control over the development and seemed to be working with his partners behind his back. He started a new company, Farnsworth Television. As research continued, he improved the television system in many ways. He added an “electron multiplier” to create a brighter image in the tube. An improved magnetic deflector allowed the system to produce 220 picture lines, creating a sharper picture.

In 1934, Farnsworth put on the first public demonstration of electronic television at the Franklin Institute in Philadelphia. He “broadcast” a variety of programs from an improvised studio on the roof of the building. Thousands of visitors took 15-minute turns to see vaudeville acts and short speeches by assorted politicians on the small round screen.

I WAS THERE

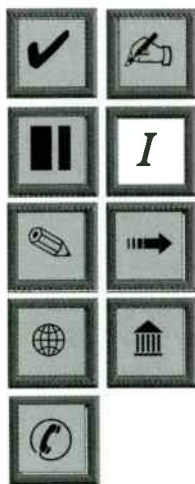

INVENTOR ON TELEVISION

In 1957, Philo Farnsworth himself appeared on television. It was a popular show called *I've Got a Secret*, where a group of panelists tried to guess the identity of the guest. Farnsworth was identified as “Dr. X” and outside the panelists’ view, the audience was told that Farnsworth’s secret was “I invented electronic television.”

The panelists thought that “Dr. X” was some kind of a medical doctor. One asked if he had invented some kind of machine that might be painful when used. Farnsworth slyly agreed: “Yes, sometimes, it’s most painful.”

None of them could guess who Farnsworth was, so he won the \$80 prize.

I WAS THERE



A BIT OF IRONY

One response to Paul Schatzkin's attempt to interest the TV networks in Philo Farnsworth's life perhaps illustrates how the medium he had invented has failed to reach its full potential.

"Although television itself is of paramount interest to all of us," wrote a functionary at CBS, "it is my feeling that this alone does not make the life of the man who invented television necessarily of dramatic interest. His trials and tribulations on the way to fame and fortune are familiar to the American success story and so too his ultimate rejection of the fruits of his own invention . . . It is rare when a true life story has the appropriate ingredients so it plays out less as biography and more like a movie."

Fading Away

Meanwhile, RCA had launched a full-scale legal attack on Farnsworth's 1930 television patent. They tried to claim that Zworykin's unpatented television ideas of 1923 should take precedence over Farnsworth's 1927 system. When Farnsworth claimed he had come up with the essential ideas of television while he was still in high school, the RCA attorneys laughed. But then Farnsworth's lawyer put chemistry teacher Justin Tolman on the stand. Tolman recalled his detailed conversations with young Farnsworth, and amazingly, sketched an electronic tube from memory—a tube that was identical to the disputed invention!

In April of 1934, the U.S. Patent Office found in favor of Farnsworth on all counts. RCA appealed the decision, hoping that Farnsworth would go broke because no one would invest

TRENDS

TELEVISION TAKES OFF LIKE A ROCKET

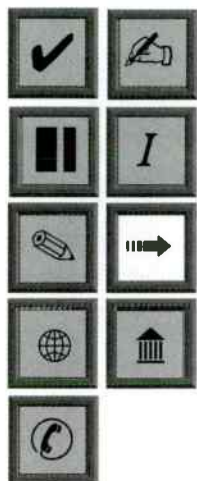

Year	Number of American homes with TV
1946	8,000
1949	1,000,000
1951	10,000,000
1960	45,000,000—about 90 percent

in a system that was tied up in litigation. Meanwhile, Farnsworth went to Great Britain and received \$50,000 from Baird Television, which had finally realized that its mechanical system was no longer adequate. However, when Farnsworth returned, he and his partners quarreled. The partners wanted to see an immediate return on their investment. But Farnsworth wanted to be an inventor, not a manufacturer.

RCA eventually paid Farnsworth to use his patent. Sarnoff's genius for publicity turned the New York World's Fair of 1939 into a showcase for television as an RCA product. RCA set up an impressive display and even built the first mobile TV news van to broadcast events live from the scene.

Unlike Armstrong, Farnsworth was not broken by his struggle with the corporate giants. He faded away from public sight, but he kept working on other inventions and ideas. After his death in 1971, his widow, Elma (Pem) Farnsworth, began a crusade to restore him to what she and a growing number of supporters believe is his true place in history.

The Changing World of TV

By 1939, television was on the brink of becoming a booming business. But World War II intervened. Television development was put on hold, and broadcasting was limited to a few large cities with a few thousand viewers.

After the war the television market exploded. Now attention had to be paid to the kinds of programs that would be shown. As with radio, existing forms of drama were adapted to the new technology. Many kinds of radio programs, such as variety shows, westerns, and soap operas carried over easily to TV.

Gradually, however, programmers learned how to use the new medium more creatively. The first TV news consisted mainly of “talking heads”—people reading printed wire stories. As the 1950s progressed and TV crews learned to work in the field, film and “live” images began to be narrated by reporters on the scene.

Television added a new dimension to political persuasion. It became a person’s appearance, not just his or her voice, that could

I WAS THERE

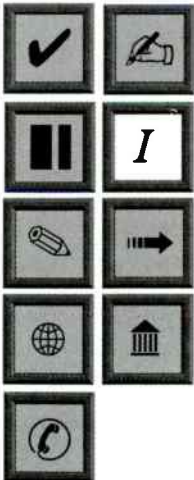

BEHIND THE LINES

Perhaps the ultimate TV news story came in 1991 when the Cable News Network (CNN) broadcast reports on the Gulf War from both the allied nations and Saddam Hussein’s Iraq. Military and government officials quipped that if they wanted to know what was going on they tuned in CNN rather than waiting for reports from their own spies and experts. Although both sides in the war censored TV reports, it has become harder for government leaders to control what their people see or what other people will know about them.



The first televised American presidential debate. John F. Kennedy may have beaten Richard Nixon because he looked better on TV. (Smithsonian Institution Photo No. 84-10773)

be decisive. In the 1960 election, John F. Kennedy met Richard Nixon in the first televised presidential election debate. On the screen Nixon looked awkward and uncomfortable compared to the young, attractive Kennedy. A new word, *telegenic*, entered the vocabulary. It meant “having an appearance that comes across well on TV.” By 1996, it became clear that the Democratic and Republican conventions, originally vigorous debates about issues, had become slick, professionally produced television commercials for the candidates. But this is at least partly a reaction to the tendency of TV news to show only ten-second “sound bites” rather than longer, more thoughtful statements. In turn, television executives argue that the public has a short attention span and won’t sit still for long periods.

90 Channels in Living Color

The two main technical improvements in television were color and new methods of transmission. Early color TV systems proposed before World War II by various inventors used wheels and

suffered from the same drawbacks as other mechanical systems. RCA eventually came up with an electronic system that used three separate electron beams that activated separate sets of dots on the screen, one for each of three colors (red, green, and blue). Color TV remained expensive, however, and it was not until 1972 that more than half of all television sets in American homes were color models.

What changed TV most deeply, however, was not the picture but how it was delivered. Until the 1980s, television in the United States was dominated by the three big networks, NBC, ABC, and CBS. The networks produced the most important programs and thus decided what would be shown. But two new technologies of

ISSUES



MEDIUM OR MESSAGE?

One of the most influential thinkers about the impact of TV on society was Canadian-born Marshall McLuhan (1911–1980). During the 1960s, he wrote a series of books that argued two main points. He claimed that electronic communications had created a “global village” where everyone could see everyone else and participate in each other’s lives. He also argued that television had such a powerful effect on the human mind and nervous system that *how* something was portrayed was more important than the actual ideas being conveyed. McLuhan said that “the medium is the message.”

While most people today acknowledge the great power of TV, there is less agreement about how to reduce its possible harmful effects. Should an electronic “V chip” be used to filter out programming that is too violent or sexual for children? Should broadcast networks be required to carry a certain amount of educational programming?

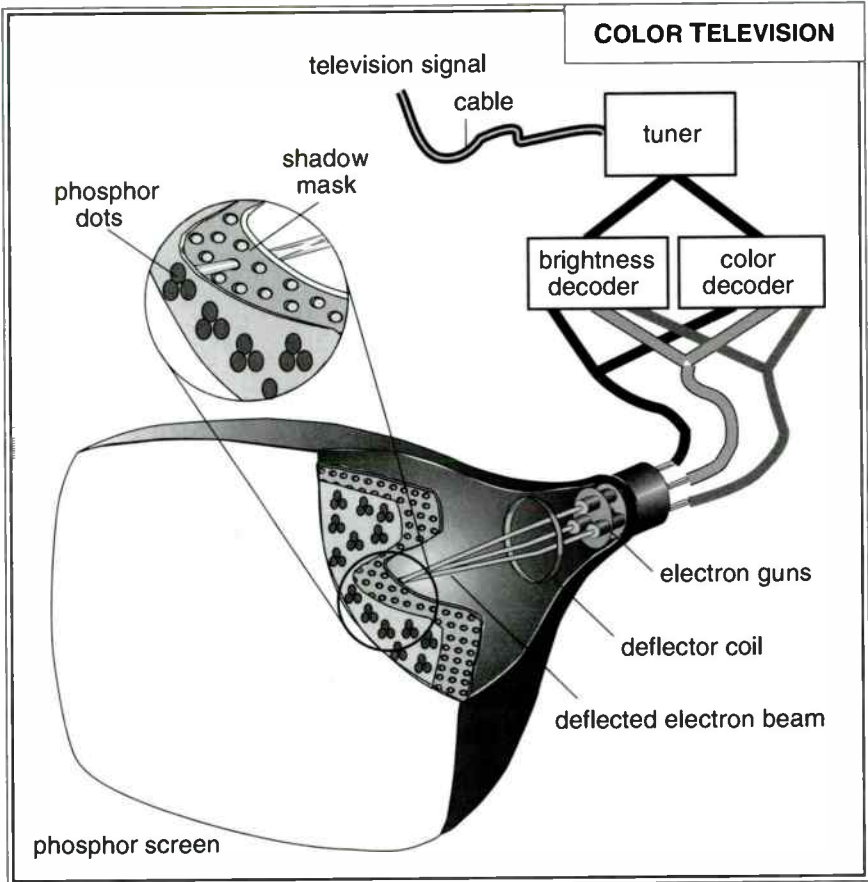

Color television is more complicated than black and white because it uses two separate signals: one for the brightness and one that contains information for each of three colors (red, green, and blue). A color decoder extracts information from the color signal to control a separate electron gun for each color. The picture is colored by combining the glowing dots activated by the beams.

the 1980s, cable and satellite, would greatly increase the choices available to the TV viewer.

Cable TV started back in the 1940s as a way to get programming to remote communities that couldn't receive broadcast signals. In the 1960s, cable companies offered the technology as a way to provide better reception, free of "snow" and "ghosts." In the later 1970s and 1980s, however, cable companies began to

offer not just better pictures but more choices. Together with direct satellite broadcasting to home “dish” receivers, cable brought to viewers who could afford it programs ranging from recent movies to scientific and historical documentaries to political debates live from the halls of Congress. Where the broadcast networks had to program for the widest possible audience, cable was able to produce such specialized channels as MTV (Music Television), A&E (Arts and Entertainment), and the Discovery Channel (which featured nature shows).

Chronology of Television

- 1884 Paul Nipkow devises a mechanical television system
- 1897 Cathode ray tube invented; first used for physics experiments
- 1907 Boris Rosing first uses a cathode ray tube to display a scanned picture
- 1926 Philo Farnsworth broadcasts a dollar sign to impress bankers; British begin TV broadcasting using John Logie Baird’s mechanical system
- 1927 President Herbert Hoover becomes first American leader to appear on (mechanical) television
- 1934 Farnsworth demonstrates electronic TV to the public
- 1939 First televised baseball game
- 1941–1945 World War II stops most television development
- 1972 Color TV replaces black and white in many homes
- 1975 Cable TV companies start offering programming from satellites
- 1991 Cable network CNN broadcasts the Gulf War live from Iraq

Further Reading

- Cramer, Robert R. "A Tinkerer Who Became the Father of Video." *San Francisco Chronicle Datebook*, Dec. 4, 1977. Brief biography and highlights of early TV broadcasting.
- Farnsworth, Pern. *Distant Vision: Romance and Discovery on the Invisible Frontier*. Salt Lake City: Pemberly Kent Press, 1994. Biography of Farnsworth by his widow.
- McPherson, Stephanie S. *TV's Forgotten Hero: The Story of Philo Farnsworth*. Minneapolis: Lerner Group, 1996. Biography of Farnsworth for young readers.
- Ritchie, Michael. *Please Stand By: A Prehistory of Television*. Woodstock, N.Y.: Overlook Press, 1994. A history of early television broadcasting, focusing more on the programs than the technical developments.
- Schatzkin, Paul. "The Farnsworth Chronicles." World Wide Web: <http://songs.com/noma/philo/index.html>. Farnsworth's story and related matters, told in an engaging style.

NOTES

- p. 101 "In due course . . ." Quoted in Ritchie, Michael. *Please Stand By: A Prehistory of Television* (Woodstock, NY: Overlook Press, 1994), p. 18.
- p. 102 "When Philo determined to learn everything . . ." Quoted in Schatzkin, p. 1.
- p. 102 "What has this got to do with chemistry . . ." (and following). Quoted in Schatzkin, p. 1.
- p. 103 "I can't afford school . . ." Quoted (with following dialogue) in Ritchie, p. 10.
- p. 103 "Your guess is as good as any . . ." Quoted in Schatzkin, p. 2.
- p. 104 "Given that this all occurred . . ." Quoted in Schatzkin, p. 2.
- pp. 107–108 "[Farnsworth] set up . . ." Quoted in Schatzkin, p. 3.
- p. 109 "Although television itself . . ." Quoted in "The Farnsworth Chronicles": "Restoring Philo's place in history" [with Schatzkin].

Digital Worlds

HOW THE COMPUTER IS TRANSFORMING
COMMUNICATIONS

In the previous chapters we have looked at a variety of communications technologies. Each of them, from the telegraph to television, can be summarized by answering three questions:

- What kind of message is sent?
- To whom is it sent?
- How is the information converted so it can be transmitted?

The technologies we have discussed in this book are summarized in the accompanying table.

INVENTIONS IN COMMUNICATIONS AND BROADCASTING

Invention	Kind of Message	Message Intended for	Converts
telegraph	words in dot/dash code	one person	on/off key to electrical impulse in wire
telephone	voice	one person	sound to patterns in current in wire
phonograph	sound	many people	sound to physical impressions in surface
motion picture	moving images	many people	photographs to projected images
wireless telegraph	words in dot/dash code	one person	on/off impulses to bursts of electromagnetic waves
radio telephone (cellular/cordless phone)	voice	one person	sound to electromagnetic wave patterns
radio broadcasting	voice and sounds	many people	sound to electromagnetic wave patterns
television	pictures and sounds	many people	scanned image to electromagnetic wave patterns

In general, each of these inventions fulfilled a particular need. For example, the telephone made it possible for two people to communicate using their voice. The wireless telegraph and radio telephone let two people exchange messages without wires.

Usually, one invention did only one thing: a telephone didn't send pictures, for example.

Of course it has always been rather arbitrary to think of inventions in this way. As you have seen, part of the creativity in being an inventor is the ability to see how a technology can be adapted to new purposes. The telephone, for example, was the result of Alexander Graham Bell's combining what he knew about sound with what telegraph engineers had learned about electrical transmission. Once the telephone system was in place, other inventors learned how to send pictures over it (fax) or how to use it to send network programs to radio stations for broadcast. Thus each invention built on previous ones. Still, people usually thought of the inventions as being separate.

In the last decades of the 20th century, however, a new technology, the computer, has transformed the way people think about communications. In the age of computer networks it no longer makes sense to think of separate kinds of messages being sent in different ways. Today, on the Internet, communications

KEY CONCEPTS



graphical user interface the use of pictures and a pointing device (mouse) to control a computer



integrated circuit a silicon "chip" containing thousands of individual electronic components



Internet the worldwide linked system of computer networks



modem a device that converts between digital computer signals and analog phone signals



packet a "chunk" of data that includes addressing information

semiconductor a material that is neither a good conductor nor a good insulator

transistor an electron control device made from semiconducting material; replaces vacuum tubes

can include text, the sound of voice or music, still photos, and moving video images. This communication can arrive at its destination by copper wire, fiber optic cable, microwave link, or satellite beam. The message can go specifically from one person to another or be “published” by one person for any interested person to see. All of these possibilities are part of essentially the same technology.

Computer-age communications were made possible by three interrelated developments:

- the semiconducting “chip,”
- techniques for storing and representing information in the computer, and
- the design of networks linking computers together.

From Transistor to Computer Chip

The first true general-purpose electronic computers were developed in the mid-1940s toward the end of World War II, for such applications as code breaking and the calculation of the path of artillery shells. These early computers, such as the famous ENIAC, used vacuum tubes to calculate and store numbers in binary (one and zero, or off-and-on) form. The use of tubes meant that the computers were very large, consumed a great deal of power, and weren’t very reliable—since tubes could burn out.

In 1948, however, three researchers, William Shockley, John Bardeen, and Walter Brattain, announced the invention of the transistor. The transistor was based on the idea of the semiconductor, a substance that was neither a good conductor of electricity (like copper) or a good insulator (like glass). By properly arranging the semiconducting and insulating materials, the designer of a transistor controlled how and when electrons will flow through the device. The various types of transistors could do the same things that vacuum tubes did. But transistors were a fraction of the size of a vacuum tube, drew only a small amount of current,

and were much more reliable. The transistor transformed the computer. Transistors made computers smaller, yet more powerful and reliable.

The next stage in computer processing was the development of integrated circuits in the 1960s, when the components (logical “gates,” resistors, capacitors, and so on) were no longer separate, but laid on as tiny “regions” on a chunk of silicon no larger than a fingernail. Each integrated circuit replaced thousands of transistors.

Finally, in the early 1970s, the microprocessor started to become available. The microprocessor is basically an integrated circuit “chip” that contains the complete circuitry needed to enable a computer to carry out its calculation and logical functions. The microprocessor made the desktop computer, or personal computer (PC), possible.

On the Computing Frontier

Of course improved hardware is only part of the computer story. People had to learn how to get the most out of the machines. In the 1950s, since computers were so large and expensive, they were controlled by government, big corporations, and a few lucky universities. A kind of “priesthood” of technicians controlled the machine, accepting programs on punched cards and handing the printed results back hours or days later.

As computers became smaller, an alternative way of using them arose. In places like the Massachusetts Institute of Technology (MIT), a “hands-on” computer culture developed. People typed in programs on typewriterlike teletype machines and saw the results right away. They rigged up cathode ray tubes to display numbers and words on a screen.

Like the culture of the amateur wireless operators, the new computer culture of campus “hackers” was very independent-minded. As author Steven Levy notes:

Hackers believe that essential lessons can be learned about the systems—about the world—from taking things apart, seeing how they work, and using this knowledge to create new and even more interesting things. They resent any person, physical barrier, or law that tries to keep them from doing this . . . All information should be free.

Making Computers Interactive

The computer pioneers had pushed the frontiers of computing beyond the mere calculation of numbers. There remained the question of how to make computers usable by people who were

PARALLELS

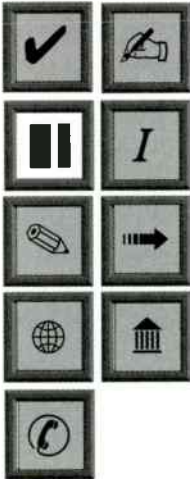

WHAT'S IN A WORD?

In the early part of the 20th century radio, amateur, or “ham,” operators worked on the leading edge of radio technology, pioneering voice transmission and the use of shortwaves. As big corporations moved into radio, however, they found the sometimes unruly and undisciplined hams to be a nuisance or even a threat to their operations. They prevailed on the government to strictly regulate their operations.

Something similar happened in the computer field. In the 1950s and 1960s the word *hacker* referred to someone who had tremendous technical skill and a driving desire to master the most subtle aspects of computer systems. As computers became essential for operating the telephone system, banking, and government, however, there were increased opportunities for the criminally minded to use technical skill for destructive purposes, vandalizing systems or stealing valuable information such as credit card numbers. The media began to refer to computer criminals as “hackers” who threatened the public’s security.



The Smithsonian Institution presents a “guided tour” of a selection of its treasures to browsers on the World Wide Web.

not programmers or engineers. One important step was to put information on a screen where it could be seen instantly, rather than having to work with printouts. In 1962, the MIT hackers went a step further: they figured out how to generate pictures and move them around the screen. The pictures were very crude—two “spaceships” and little dots to represent stars and missiles. But with “Spacewar” they had invented the first computer game and had made computers interact directly with their users.

Researchers applied their growing graphics knowledge and began to develop ways for computer users to control the computer by interacting with symbols and pictures. Much of this work was done by pioneers at a Xerox Corporation research lab starting in the 1970s. They developed the “graphical user interface” where, for example, a user moved a file from one part of the computer disk to another not by typing commands but by selecting the file’s symbol with a handheld “mouse” device and “dragging” it to a

I WAS THERE



CYBERSPACE VERSUS REALITY

Long before science fiction writer William Gibson coined the term *cyberspace* in his 1984 novel *Neuromancer*, users of the ARPANET in the early 1970s encountered the strange sense of being in two worlds.

"Two people had logged in to the University of Utah. One saw that somebody else he knew but had never met was logged in. They were in talk mode, so he typed, 'Where are you?' The other replied, 'Well, I'm in Washington.' 'Where in Washington?' 'At the Hilton.' 'Well, I'm at the Hilton, too.' The two turned out to be only a few feet from each other."

"window" that represented the desired location. The results of this Xerox research were turned into commercial products in the 1980s, first by Apple in its Macintosh computer, and then by Microsoft in its Windows operating system for IBM-compatible computers.

The growing graphics capability of desktop computers was also to lead to a new emphasis on multimedia—the ability to store any kind of image or sound as a file on disk, ready to play or show on demand. By the 1980s, computer games and educational programs for personal computers began to use animated pictures and music.

Today, the process of "digital convergence" continues. This means that nearly everything in the physical world—the sound of a voice, a sculpture, the movements of a football player, a painting in a museum, the pages of a book, or the photograph of a distant galaxy—can be turned into a pattern of ones and zeroes and stored in a computer file. They all become resources that can be manipulated by a program or communicated through a telephone line. Nicholas Negroponte, director of the MIT Media Lab says that "I can see no reason for anyone to work in the analog domain anymore—sound, film, video . . . *All* transmission will be digital."

The Information Highway

The third challenge was how to connect computers and their users together. Why did people want to do this? Businesses, of course, had to make information (such as bank balances) available to people who dealt with customers in their different branches or stores.

Researchers, particularly in the universities and high-tech companies, began to realize that they could use computers to have real conversations and to post information about the latest scientific findings. They might even be able to coordinate several computers to work together on a problem. In 1965, the U.S. Defense Department began a major effort to create such a network, called ARPANET (Advanced Research Projects Agency Network). The network came on line in 1969 and grew through the 1970s.

A key development in the ARPANET and its 1980s successor, the Internet, is the idea of packet switching. Each piece of data to be transmitted is broken up into packets, which consist of some

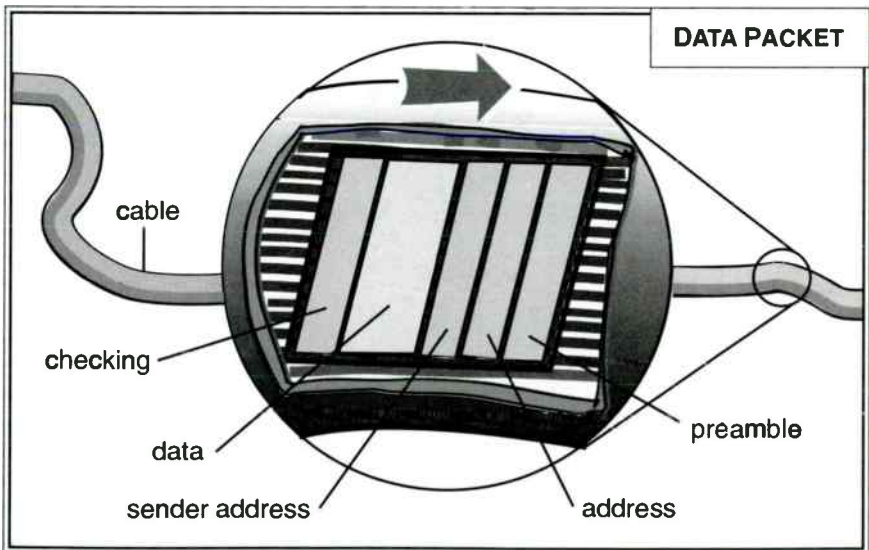

A data packet is like an electronic “envelope” that has forwarding and return addresses as well as a number that is used to check to make sure the data has not been garbled. The data in the packet can represent words, pictures, video, or sound.

data plus addressing information that basically says where it came from and where it should go, much like an envelope with a letter in it. Computer programs look at these addresses and figure out the best way to send the packet, often relaying it through several computers before it reaches its destination. A key invention, the modem, turns the digital information into pulses that can travel over an ordinary phone line to its destination, where another modem will convert the signal back to data. At the destination, other programs assemble the packets in the correct order and extract their data into an appropriate file.

There are several important things to notice about packet networks like the Internet. First, it doesn't matter what *kind* of message you send—whether it's text, pictures, video, or sound, it

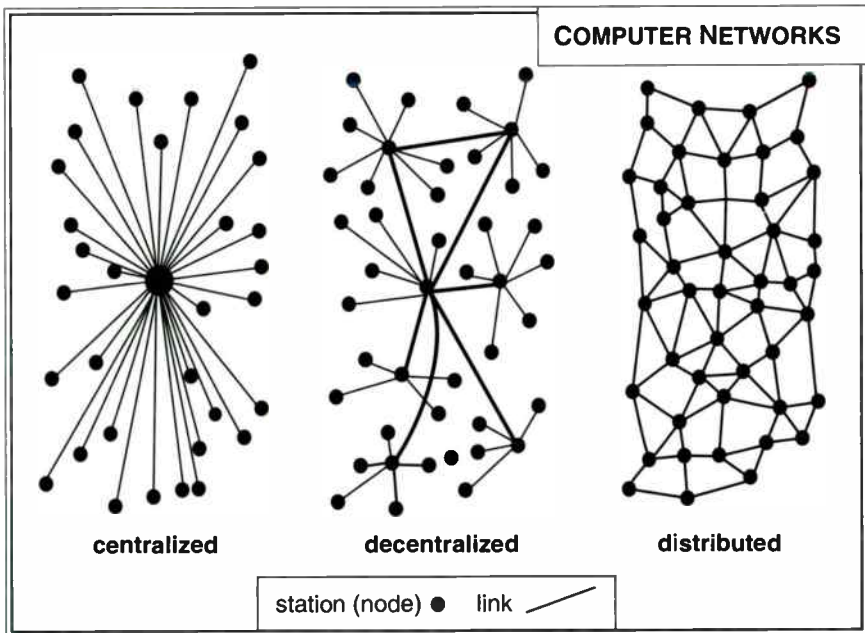

A distributed network provides the most protection against failure when a computer "goes down" because there are always alternate paths between any two nodes, or points. Unfortunately, high-speed data lines to connect all users would be very expensive. A decentralized network like the Internet is a good compromise. The major "backbone" sites are connected to each other, and each backbone deals with a cluster of smaller local sites.

can be turned into binary codes using rules established by graphics and multimedia programmers, and placed in packets. Second, there are usually many ways the message can get to its destination. The network does not depend on any one computer being available. If a given computer is down, there is usually another route it can take.

Finally, users are not forced to use only one kind of software. Provided that the agreed-upon rules are followed, designers are free to create a variety of programs to send and retrieve electronic mail, read news bulletin boards, or transfer data and programs from one computer to another.

A Web of Ideas

The Internet seemed to offer a model of how to tie together communications and information sources around the world. But while the Internet had tremendous potential, it was not very easy to use. Users usually had to learn how to use many different programs: one program to send a mail message, another to copy a file, still another to read news articles or consult a database. The programs themselves were often complicated, requiring users to memorize commands and select options.

In 1989 Tim Berners-Lee, a researcher at CERN, the huge European physics laboratory, decided to do something about it. "CERN had very complex structures," Berners-Lee said.

I needed the power of hypertext and the unrestrained ability to represent any relationship. This sort of information about what is going on and what is related to what is very important when you're running a project.

A hypertext system is a way to let the reader move quickly from one idea or image to another, related one. For example, a hypertext file about Samuel Morse and the telegraph might mention how the telegraph was important for managing the railroads. The

TRENDS

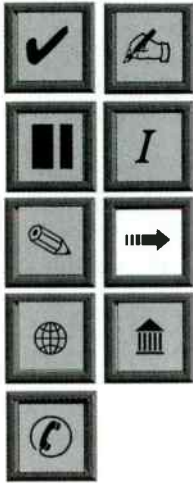

NUMBER OF COMPUTER SITES ON THE WORLD WIDE WEB

June 1993	130
December 1993	623
June 1994	2,378
December 1994	10,022
June 1995	23,500
January 1996	100,000
June 1996	230,000

word *railroads* might be highlighted in a different color. By selecting that word, you might see more material about railroads, such as a map showing railroad routes in the eastern United States in 1860 or a graph showing the growth in mileage of railroad track between 1840 and 1900. In turn, the map might have names of cities highlighted, and if you select the name of a city you would see more information about that city.

Berners-Lee wasn't the inventor of hypertext. The idea goes back to work by Vannevar Bush and Ted Nelson in the 1950s and 1960s. In the 1980s, encyclopedias began to appear on compact disk, with hypertext cross references and multimedia graphics and sound.

What Berners-Lee did was to use hypertext as a way to make information available to Internet users in a consistent, easy-to-use way. He and his colleagues wrote a software program that established an information system called the World Wide Web (or just "the Web" for short). On the web each piece of information had its own address, and users anywhere in the world could request the information. On the World Wide Web (WWW), documents and multimedia could be connected as with the CD-ROM encyclopedia, but hypertext links could do more than that. Some links

are “live” connections to computer services such as databases, news wires, weather forecasts, and of course, games. This made the World Wide Web immediately useful. As Berners-Lee puts it:

The way we found of bootstrapping it was by finding servers which provided entry to existing databases. That was a really powerful way of getting large amounts of data on-line very quickly.

The programs used to provide information on the web are called “servers,” and the programs used to request and display the information from the servers are called “client programs.” The important thing is that designers are free to create new and better programs for each task, and the programs will work together. A user with a Macintosh computer, for example, has no problem browsing a Web site that runs on an IBM computer. The original

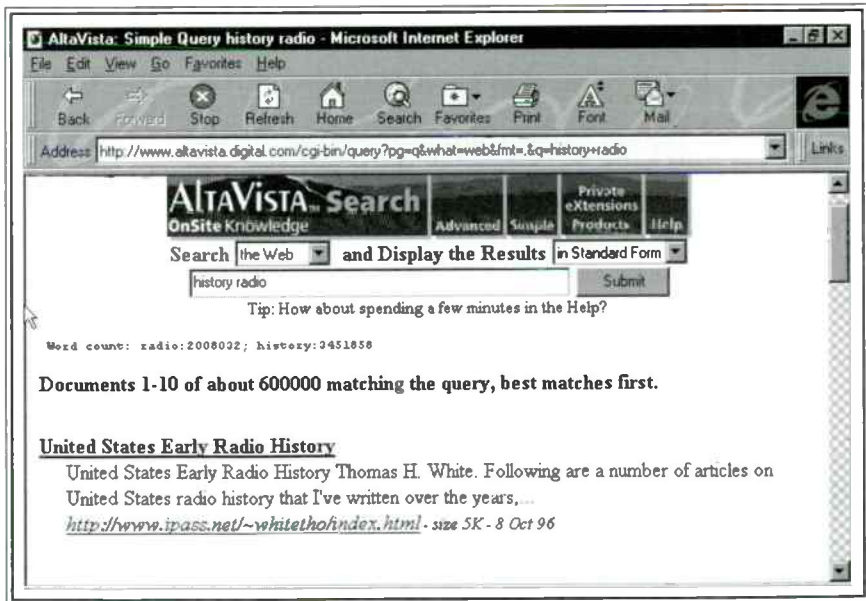

A Web browser lets you view text and images. As you jump from page to page, your computer can be connecting to other computers around the world.

World Wide Web showed only text information. In 1993, however, Mosaic, a graphical “web browser” came out. Today users have many choices for visual, “point and click” access to the Web.

While the corporate mainframe computers of the 1950s and 1960s seemed to leave little room for the individual inventor, the university “hackers,” the 1970s microcomputer pioneers such as Apple’s Steve Wozniak and Steve Jobs, and the modern developers of the Internet in the 1980s and 1990s have brought back the spirit of Armstrong and Farnsworth. As we enter the 21st century, the inventor appears to be very much alive.

Chronology of the Computer

- 1946 The ENIAC computer uses 18,000 vacuum tubes to perform calculations
- 1948 Bell Labs researchers invent the transistor
- 1965 U.S. Government begins to design the ARPANET computer network
- 1970s Xerox researchers invent the graphical user interface and the mouse
- 1971 Intel introduces the first microprocessor chip
- 1977 The Apple II personal computer is introduced
- 1979 USENET computer news bulletin boards established
- 1989 Tim Berners-Lee invents the World Wide Web
- 1993 The Mosaic program introduces graphics to Web users

Further Reading

Clarke, Arthur C. *How the World Was One: Beyond the Global Village*. New York: Bantam Books, 1992. Readable essays that show how telecommunications and transportation effectively united the world.

- Hewitt, Andrew. "The History of Computers." World Wide Web: http://www.txwesleyan.edu/masscomm/b_histroy.html. Many links to famous people and machines in the history of computing.
- Goldstone, Bruce. *The Kid's Guide to the Internet*. Mahwah: Troll Communications, 1996. An introduction and guide to the Internet for young people.
- Levy, Stephen. *Hackers: Heroes of the Computer Revolution*. Garden City, N.Y.: Anchor Press/Doubleday, 1984. Entertaining account of the remarkable culture of experimenters that brought breakthroughs in computer science.
- Time-Life Books (editors). *Communications*. Understanding Computers series. Alexandria, Va.: Time-Life Books, 1986. Illustrated overview of computer communications and networking technology of the pre-Internet era.
- [Virginia Tech.] "The History of Computing." World Wide Web: <http://ei.cs.vt.edu/~history/>. Links to documents about many topics in computer history, including interviews with computer pioneers.

NOTES

- p. 122 "Hackers believe that essential lessons . . ." Quoted in Levy, Stephen. *Hackers: Heroes of the Computer Revolution* (Garden City, N.Y.: Anchor Press/Doubleday, 1984), p. 27.
- p. 124 "Two people had logged in . . ." Quoted in Hafner and Lyon pp. 181–82.
- p. 124 "I can see no reason . . ." Quoted in Lubar, p. 158.
- p. 127 "I needed the power of hypertext . . ." Quoted in "Tim Berners-Lee: The One Who Started It All" (interview on the World Wide Web).
- p. 129 "The way we found of bootstrapping . . ." Quoted in "Tim Berners-Lee."

Index

Numbers in *italics> indicate illustrations. Numbers in bold-face indicate major treatment of a topic.*

A

- A&E (Arts and Entertainment Television) 115
- Advanced Research Projects Agency Network *See* ARPANET
- African Americans 49, 50
- Alexanderson, Ernst 76
- alternator 76
- AM (amplitude modulation) 93
- amateur radio 86
- Apple Computer Corporation 124
- Armstrong, Edwin vi, 79, **80–88**, **91–96**
 - childhood and education 84–85
 - chronology 96–97
 - FM radio 92–93
 - further reading 97
 - patent battle with De Forest 92–93
 - patent battle with RCA 94
 - regeneration 85–87
 - suicide 94–95
 - superheterodyne 86–88
- ARPANET (Advanced Research Projects Agency Network) 125
- Arts and Entertainment Television *See* A&E
- ASCII code 8
- AT&T (American Telephone and Telegraph) 106
- Atlantic telegraph cable 13–15
- audion tube *See* triode

B

- Baird, John Logie
- Bardeen, John 120
- Batchelor, Charles 42
- Beatles, The 53
- Bell, Alexander Graham 20, **21–26**, 30, 119
 - and phonograph 43, 45
 - childhood and education 21
 - chronology 35–36
 - early studies of sound 21–22
 - further reading 36
 - invention of telephone 23–25
 - work with the deaf 26–27
- Bell Telephone Company 26–28, 32, 34–35, 69
- Bell Telephone Laboratories 33–34
- Berlin, Irving 33
- Berliner, Emile 46–47
- Berners-Lee, Tim 127
- Blatch, Nora Stanton 85
- Brattain, Walter 120

C

- caller ID 34
- carbon microphone 27, 41–42
- Caruso, Enrico 46
- cathode ray tube 105
- cathode rays 81

CD (compact disk) 52, 53
 CD-ROM 128
 Centennial Exposition (Philadelphia, 1876) 25
 CERN (European Commission for Nuclear Research) 127
 cinema *See* motion pictures
 Civil War, American 12–13
 CNN (Cable News Network) 111
 coherer 68
 communications
 spread of v, 9
 summary of inventions 117–118
 computer 119–130
 chronology 130
 communications 119–120
 further reading 130–131
 networks 125–127, 126
 Cooke, William Fothergill 5
 Crocker, W. W. 103
 Crookes, Sir William 65
 cyberspace 124

D

De Forest, Lee 30, 69, 82–84, 92–93
 DeMille, Cecil B. 57
 Dickson, William 55
 digital convergence 124
 Discovery Channel 115

E

Edison, Thomas vi, 27–29, 38, 39–47, 55–57, 65, 80–81
 childhood and education 40
 chronology 59–60
 further reading 60
 as inventor 40–41, 47
 Kinetoscope 54, 55
 laboratory 40
 motion picture projector 56
 phonograph 42–44
 stock ticker 40
 Edison Speaking Phonograph Company 45

Eisenstein, Sergei 57
 electric light 45
 electromagnetic waves 63–64
 electromagnetism 3–5
 electronics 80–87
 electrons 81
 European Commission for Nuclear Research *See* CERN
 Everson, George

F

Faraday, Michael 14, 63
 Farnsworth, Philo vi, 99, 101–110
 childhood and education 101–102
 chronology 115
 development of television 103–106
 further reading 116
 idea for electronic television 102
 later career 110
 patent battle with RCA 109–110
 Philadelphia demonstration 108
 Farnsworth Television Company 108
 Fessenden, Reginald 75
 Field, Cyrus 13
 film *See* motion pictures
 Fleming, John 81–83
 FM (frequency modulation) 93–94
 Franklin Institute (Philadelphia) 108

G

Gale, Leonard 4–5
 global village 113
 Gold Rush (1849) 12
 graphical user interface 123–124
 Gray, Elisha 24–25, 27
 Great Depression 91
Great Eastern (steamship) 15
 Griffith, D. W. 57

H

hackers 121–123
 hams *See* amateur radio
 Heaviside, Oliver 73

COMMUNICATIONS AND BROADCASTING

Helmholtz, Herman von 22
Henry, Joseph 5
Hertz, Heinrich 64–68, 64
Hitler, Adolf 91
Hoover, Herbert 101
Hubbard, Gardiner 23–24
hypertext 127–129

I

I've Got a Secret (TV program) 108
Indians, American 12
integrated circuits 121
Internet 118, 125–127
inventors
 role in society vi, 2, 91–92, 96, 130
 way of working 119, 130

J

Jackson, Charles T. 3
jazz 50
Jazz Singer, The (film) 58
Jenkins, Charles 100–101
Jobs, Steve 130

K

KDKA (radio station) 88–89
Keller, Helen 27
Kennedy, John F. 112
Kinetoscope 54, 55

L

Lamarr, Hedy 95
Lodge, Oliver 66, 68, 70
Louisiana Purchase 2
Lucas, George 59
Lumière brothers 55

M

Macintosh computer 124
Marconi, Guglielmo 62, 66–74
 broadcasts yacht races 69–70

 chronology 76–77
 first radio experiments 66–68
 further reading 77–78
 as inventor 66
 signals across Atlantic 71–73
Marconi Wireless Telegraph Company 69
Marey, Etienne-Jules 54–55
Massachusetts Institute of Technology (MIT) 121
Maxwell, James Clerk 63–65
McLuhan, Marshall 113
Media Lab (Massachusetts Institute of Technology) 124
microprocessor 121
Microsoft Windows 124
Morse, Samuel 1, 2–7, 66
 childhood and education 2
 chronology 18
 further reading 18
 invention of telegraph 3–7
 as inventor 5, 17
Morse Code 7–8, 66
motion pictures 53–59, 54, 118
 color 58–59
 competition from television 59
 development as an art 57–58
 early developments 54
 growth of industry 56
 impact on society 56–57
 projector 55–56, 56
 sound 58
mouse (computer) 124
movies *See* motion pictures
MTV (Music Television) 115
multimedia 124
Murrow, Edwin R. 91
Muybridge, Eadweard 54–55

N

Negroponte, Nicholas 124
New York World's Fair (1939) 110
Niagara (cable ship) 15
nickelodeons 56
Nipkow, Paul 100
Nixon, Richard 112

O

Oersted, Hans Christian 4, 63

P

packet switching 10, 125–126, 125
 persistence of vision 54
 personal computer 121
 Philco Corporation 107–108
 phonautograph 43
 phonograph 42–53, 118
 applications 44–45
 business use 46
 competition from radio 47–48
 cylinder records 43–45
 disk records 46–47
 effect on music 45, 50
 electric 47–50, 48
 growth in sales 46, 49
 long-playing and stereo records
 50–53
 Preece, William H. 68–69
 Pupin, Michael 29

R

radio 62–76, 118
 circuits 64, 87
 competition with cable 73–74
 frequency spectrum 70
 Hertz apparatus 64–65, 64
 magnetic detector 71
 rescues at sea 68–70, 74
 voice transmission 75
 wireless telegraph 67–74
 radio broadcasting 87–91, 118
 growth of industry 89–91, 90
 programming 89–91, 96
 railroads 2
 RCA (Radio Corporation of America)
 93–94, 106–107, 109–110
 regeneration circuit 85–87
 rock and roll 96
 Ronalds, Francis 4
 Roosevelt, Franklin D. 91
 Rutherford, Ernest 71

S

Sanders, George 23
 Sarnoff, David 80, 93–94, 106–107
 satellite television 113–114
Scientific American (magazine) 44
 semaphore 2
Sergeant Pepper's Lonely Hearts Club Band
 (record album) 53
 Shockley, William 120
 Smithsonian Institution 123
 Sousa, John Philip 45
 Spacewar (computer game) 123
 Stalin, Joseph 61
 stock ticker 40
Star Wars (film) 59
 Strowger, Almon B. 32
 superheterodyne circuit 86–88

T

tape recording 51, 53
 telegraph 2–18, 118
 business applications 8–9
 decline in importance 17–18
 growth of network 12–16
 improvements in 6–7
 in Civil War 11–13, 11
 Morse instrument 5–7, 7
 multiple 17, 23
 relays 14
 routing messages 10
 Wheatstone-Fothergill system 5
 wireless *See* radio
 telegraphers 9–10
 telephone 23–35, 29, 118–119
 exchanges and switches 30–32
 growth of network 31
 impact on society 32–33
 long distance 28
 role of women in 30, 32–33
 use of electronics with 34
 television 100–115, 118
 broadcasting 101
 cable and satellite 113–115
 color 112–113, 114
 domination by networks 113

COMMUNICATIONS AND BROADCASTING

electronic systems 102–106
and FM 94
growth of industry 110–111
improvements 108
mechanical systems 100–101
and politics 111–112
programming 111–114, 113
Thomson, Joseph J. 81
Thoreau, Henry David 9
transatlantic cable *See* Atlantic telegraph
cable
transcontinental cable 12
transistor 120–121
triode 30, 82, 82–84, 84

U

vacuum tube *See* triode
Vail, Alfred 6
Vail, Theodore 27, 34
V-chip 113
Visible Speech 21
Volta, Alessandro 4

W

Watson, Thomas 23

Welles, Orson 91
Western Union Company 15–16, 27,
42
Wheatstone, Charles 5
wireless telegraph *See* radio
Wizard of Oz, The (film) 58
women
engineers 85
telegraphers 16
telephone and role of 30, 32–33
World Wide Web 123, 127–130
browsers 129
client and server programs 129
growth of network 128
Smithsonian site 123
Wozniak, Steve 130

X

Xerox Corporation 123

Z

Zoopraxiscope 54
Zworykin, Vladimir 106–107