

BASIC RADIO

The Essentials of

ELECTRON TUBES AND THEIR CIRCUITS

By

J. BARTON HOAG, PH.D.

PROFESSOR (T), WITH THE RANK OF LIEUTENANT COMMANDER, U.S.C.G.

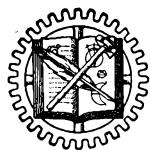
Head of the Department of Science, U. S. Coast Guard Academy

Fellow of the American Physical Society

Member of the Institute of Radio Engineers

FORMERLY, *Assistant Professor, Dept. of Physics, Univ. of Chicago*

FIFTH PRINTING



NEW YORK

D. VAN NOSTRAND COMPANY, INC.

250 FOURTH AVENUE

1942

COPYRIGHT, 1942
BY
D. VAN NOSTRAND COMPANY, INC.

ALL RIGHTS RESERVED

*This book or any parts thereof, may not
be reproduced in any form without
written permission from the publishers.*

First Published, May 1942
Reprinted, July 1942, August 1942
September 1942, January 1943

PRINTED IN THE UNITED STATES OF AMERICA
BY THE PLIMPTON PRESS, NORWOOD, MASS.

PREFACE

Electron tubes and circuits, with their wide ramifications in radio and line communications, in industrial production and in research work, are so numerous and complex as to bewilder the beginner. He needs a guide which will present the important items in orderly sequence from the simple to the complex.

Many special tubes and circuits have been tested and discarded during the past thirty years. Others have proven their merit and remain with us today, and will be used in the future. These are the ones to study. This book attempts to select the important and the tested, the *basic* tubes and circuits and to present both a simple explanation of how they work and where they are applied, together with sufficient numerical constants and other details to make them readily understandable.

The book is designed for the student with only a limited background in physics and mathematics. Only too often the design and principle of operation of radio gear is either oversimplified or is clouded in elaborate mathematical form. There is a happy medium, striven for in this book. The more involved material is presented graphically; the few simple, widely used equations are explained in detail.

This is a textbook. The subject is unfolded systematically from the simpler to the more complex ideas and equipment. The preliminary chapters cover the fundamental concepts of direct and alternating currents and of radiation and the propagation of radio waves. The elementary subjects, such as two-electrode tubes, gas-filled tubes, photoelectric cells, etc., are then examined in detail utilizing only the ideas and theories presented in the previous chapters. This procedure is continued throughout all of the elementary subjects. The student is then prepared for the more intricate conditions used in feedback amplifiers, transmitters and receivers, square-wave and pulse generators, television equipment, oscilloscope testing, superheterodyne circuits and alignment, frequency modulators, direction finders, and the like. To emphasize the comparative size of circuits and the length of radio waves, the succeeding chapters carry the subject matter from the long and

short transmission lines and antennas through ultra-high frequency transmitters and receivers into the realm of microwaves.

The book contains over four hundred problems of a practical nature designed to assist the student to apply and fix firmly in his mind the principles he has been studying. The problems for each chapter have been graded in order of difficulty. Some of them have been purposely designed so that the student will need to consult radio handbooks or more advanced texts in order to obtain all the data necessary for their solution. In a few cases, the problem can only be answered after practical experience with the equipment itself, or in consultation with someone who has had such training. It is hoped that the study of this book will be accompanied either by a laboratory course or at least with dimensions of the equipment, or with field tests.

Permission to reproduce numerous circuits and photographs has been generously granted by the Institute of Radio Engineers, Electronics, The Journal of Applied Physics, the Bell System Technical Journal, The "Radio" Handbook, The General Radio Experimenter, The RCA Review, The Western Electric Company and The National Bureau of Standards. This co-operation is greatly appreciated by the author. The abbreviation, "From E. and N. P.," on certain of the cuts refers to their source as coming from the author's book, "Electron and Nuclear Physics."

The author wishes particularly to thank Mr. E. B. Redington for his assistance in the preparation of the problems, and Lieutenants (j.g.) Norman Oleson (Ph.D.), Robert Reed-Hill, and Preston Taulbee of the Science Department of the United States Coast Guard Academy for their advice and co-operation during the preparation of the book. The author has drawn freely from many textbooks, scientific magazines, and trade journals of this and foreign countries from the time he first taught in the Army Radio School at Colorado College in 1918 up to the present. In particular, he appreciates the merit of the tried and tested circuits, their constants and constructional details as developed by the radio amateurs and presented in the "Radio Amateur's Handbook" and in The "Radio" Handbook.

J. BARTON HOAG

U. S. COAST GUARD ACADEMY,
NEW LONDON, CONNECTICUT,
April, 1942

Special Acknowledgment

A majority of the problems and questions
at the end of this book were prepared by

MR. E. B. REDINGTON

INSTRUCTOR IN CHARGE

Radio Engineering and Maintenance School, U. S. C. G.

CONTENTS

CHAPTER	PAGE
1. THE ELECTRON	1
Introduction. The Charge of the Electron. The Mass of the Electron. Velocity of Electrons in a Vacuum Tube.	
2. METALLIC CONDUCTION	6
The Structure of Matter. Theory of Metallic Conduction. Electrical Units and Ohm's Law. Resistance Laws. Heating Effects of Currents. The Decibel.	
3. CAPACITANCE AND INDUCTANCE	13
Introduction. Capacitance and Condensers. Magnetic Fields of Currents. Induction. Inductance. The Time Constant.	
4. ALTERNATING CURRENTS	22
A Simple A.C. Generator. Frequency. Effective, Peak, and Average Values. Complex Wave Forms. Phase.	
5. A.C. CIRCUITS	27
Reactance and Impedance. The Partial Separation of the Component Parts of a Complex Current. Power Factor. Actual Coils, Condensers, and Resistors in A.C. Circuits. A.C. Ammeters. Transformers. Reflected Impedance.	
6. RESONANT CIRCUITS	33
Series Resonance. Parallel Resonant Circuits. Selectivity. Q of a Circuit. The L to C Ratio. Resonant Voltages. Crystal Resonators.	
7. COUPLED CIRCUITS	36
Introduction. The Effect of "Neighboring Bodies." Shielding. Introduction to Filters. Low-Pass Filters. High-Pass Filters. Band-Pass and Band-Elimination Filters.	
8. RADIATION	45
Introduction. Radiation. Frequency and Wave-Length. Field Intensity. Standing Waves. Simple Antennas. Directed Radiation. Transmission Lines.	

CHAPTER	PAGE
9. PROPAGATION OF RADIO WAVES	52
The Ground Wave. The Ionosphere. Propagation of Sky Waves. U.H.F. Propagation.	
10. HIGH VACUUM DIODES	58
Introduction. The Evaporation Theory. The Change of Thermionic Current with Temperature of the Filament. Different Kinds of Fila- ments. Types of Cathodes. Saturation Currents. Space Charges. Plate Control of the Space Charge. Feld Emission. Secondary Emission.	
11. SOME DIODE RECTIFIERS	65
Rectification. Half-Wave Rectifiers. Full-Wave Center-Tap Recti- fiers. The Full-Wave Bridge Rectifier. Voltage for Rectifier Circuits. Component Parts of Rectifier Filters. Voltage Regulation. Vibrator Units.	
12. HIGH-VACUUM TRIODES	73
Grid Control of the Space Charge. The Grid or "C" Bias. Dynamic Curves. Voltage Amplification Constant ($\mu = \mu$). The Lumped Voltage. The Cutoff. The Plate Resistance. The Mutual Conduct- ance g_m .	
13. SOME SIMPLE AMPLIFIERS	80
Introduction. Class "A" Operation. Voltage Amplification per Stage. Effective Input Capacitance. Multistage or Cascade Amplifiers. Fil- tering for the Voltage Supplies. Phase Reversal. Power Amplifica- tion. Regenerative and Degenerative Feedback. Push-Pull Ampli- fiers.	
14. SOME SIMPLE OSCILLATORS	90
Introduction. A Tickler Circuit Oscillator. A Hartley Oscillator. A Colpitts Oscillator. The Tuned-Plate, Tuned-Grid Oscillator. The Ultradion Oscillator. A Simple Crystal Oscillator. The Multivi- brator Oscillator. Magnetostriction Oscillators. A Simple Audio Os- cillator. Push-Pull Oscillators.	
15. SOME HIGH-VACUUM MULTI-ELECTRODE TUBES	98
Tetrodes. Pentodes. Beam-Power Tubes. Combination Tubes. Some Electron-Multiplier Tubes.	
16. THE PRINCIPLE OF AMPLITUDE MODULATION	106
The Carrier Wave. Modulated Carrier Waves. A Crude Method of Amplitude Modulation. Plate Modulation. Grid-Bias Modulation. Suppressor-Grid Modulation. Cathode Modulation. Modulation Percentage. Side Bands.	

CONTENTS

x

CHAPTER	PAGE
17. THE PRINCIPLE OF DETECTION	114
Introduction. Diode Detector Circuits. Plate Detectors. Grid-Leak Detectors. Regenerative Detectors. A Super-Regenerative Detector. A Comparison.	
18. GAS-FILLED TUBES	120
Introduction. The Glow-Tube. The Strobotron. Ionizing Potentials. The Disintegration Voltage. Gas-Filled Triodes. Gas-Filled Tetrodes.	
19. OPERATION OF GAS-FILLED TUBES	127
A Counting Circuit. A Self-Stopping Circuit. A.C. Plate Voltage and D.C. Grid Voltage. Frequency Control of the Average Plate Current. Phase Control. Phase Shifters. Thyatron Rectifiers. Inverters.	
20. PHOTOELECTRIC CELLS	136
Introduction. The Intensity of Light. The Photoelectric Current. Photoelectric Currents and the Battery Voltage. The Time Factor. The Scientific Measure of the "Color" of Light. Photoelectric Current for Light of Different Wave-Lengths. Some Phototube Circuits. Photoconductivity. The Photo-Voltaic Effect. Photo-Multiplier Tubes.	
21. CATHODE-RAY TUBES	147
Introduction. Electron Lenses. Electron Guns. A Cathode-Ray Tube. Picture Tubes. The Iconoscope. The Image Dissector. An Electron Telescope. Magnetic Focusing.	
22. THE OPERATION OF OSCILLOSCOPES	162
Introduction. A Simple Sweep-Circuit. An Approximately Linear Sweep-Circuit. A Linear Sweep-Circuit. A Second Type of Linear Sweep-Circuit. The Use of Two Saw-Toothed Sweeps. Synchronization. Multiple and Sub-Multiple Linear Sweep Frequencies. Lissajou Patterns.	
23. CLASS A, B, AND C AMPLIFIERS	176
Introduction. Linear and Non-Linear Circuit Elements. Distortion in Class A Amplifiers. A.F. Class B Amplifiers. Class AB Amplifiers. R.F. Class B Amplifiers. Class C Amplifiers.	
24. DIRECT CURRENT AMPLIFIERS	183
Direct Current Amplifiers. Stabilized D.C. Amplifiers. Multistage D.C. Amplifiers.	

CHAPTER	PAGE
25. AUDIO-FREQUENCY AMPLIFIERS	187
Introduction to Resistance-Capacitance Coupled Amplifiers. A Typical <i>R-C</i> Coupled Circuit. <i>R</i> and <i>C</i> Values. A Pulse Amplifier. Shielding. A Wide-Band Amplifier. Impedance-Coupled Amplifiers. Transformer-Coupled Amplifiers. Microphones. Speech Amplifiers.	
26. FEEDBACK AMPLIFIERS	198
The Principle. A Single-Stage Degenerative Amplifier. A Two-Stage Degenerative Amplifier. Balanced Feedback Amplifiers. High- and Low-Pass Amplifiers. A Selective Circuit.	
27. R.F. AND I.F. AMPLIFIERS	205
Introduction. A Typical R.F. Class A Amplifier for a Receiver. I.F. Class A Amplifiers. Neutralization. R.F. Linear Amplifiers. Operation of R.F. Class C Power Amplifiers.	
28. THE MODULATION OF R.F. AMPLIFIERS	213
Introduction. Plate Modulation. Choke-Coupled Plate Modulation. Modulation of a Pentode Amplifier. Grid-Bias Modulation. Suppressor-Grid Modulation. Cathode Modulation.	
29. FURTHER DISCUSSION OF OSCILLATORS	218
Electron-Coupled Oscillators. Negative Resistance or Dynatron Oscillators. Crystals for Oscillators. Crystal Oscillators. The Tri-tet Oscillator. Beat-Frequency Oscillators. Phase and Voltage Considerations. Harmonic Distortion versus Feedback Voltage. Power Output and Plate Efficiency. Frequency Stability. Constant-Current Systems.	
30. SOME SPECIAL CIRCUITS	229
Square Waves Produced by Clipper Action. Square Waves Produced by Blocking Action. Square Waves Produced with a Multivibrator. Testing Amplifiers with Square Waves. Pulse Generators. Some Applications of Pulses. Counting Pulses. A Circuit to Convert Random Pulses into Uniform Pulses. A Frequency Meter. Coincidence Counters. Scaling Circuits. A Frequency Divider. Electronic Switches. An Interval Timer. Voltage Stabilizers.	
31. TRANSMITTERS	244
Introduction. Interstage Coupling Methods. Measurement of Power Output. Harmonics. Parasitic Oscillations. Frequency Multipliers. A Complete Phone Transmitter. Checking Phone Transmitters. Output-Coupling Devices.	

CHAPTER	PAGE
32. RECEIVERS	254
Introduction. Sensitivity and Circuit Noise. Selectivity. Fidelity. Stability. The Superheterodyne Receiver. Frequency-Converters. Alignment Methods. A Bird's-Eye View—Looking Backwards and Forwards. Automatic Volume Control (a.v.c.). Some Special Features of Receivers.	
33. FREQUENCY MODULATION	271
Introduction. A Reactance Modulator. Deviation. Checking the Transmitter. Differences Between F.M. and A.M. Receivers. The Limiter. The Discriminator. Aligning the Receiver.	
34. DIRECTION FINDERS	277
Loop Antennas. The Radio Compass or Goniometer. Sense Determination from a Fixed Position. Errors Due to Background Voltages. The Shore Effect. The Night Effect. Homing Devices. The Principle of the "A and N" Radio Beacon. Simultaneous Weather and Beacon Transmission. The Reduction of Static. Markers. Instrument Landing. A Cathode-Ray Direction Finder.	
35. LONG-LINES	291
Introduction. Types of Transmission Lines. Non-Resonant Transmission Lines. Resonant Transmission Lines. Long-Wire Antennas.	
36. SHORT-LINES	300
Introduction. Linear-Circuits. Short-Wire Antennas. Coaxial Line Filters.	
37. U.H.F. TRANSMITTERS AND RECEIVERS	311
Introduction. U.H.F. Receivers. An U.H.F. Transmitter. The Use of Linear-Circuits in U.H.F. Oscillators.	
38. MICROWAVES	322
Introduction. Positive-Grid Oscillators. The Magnetron. The Magnetron Oscillator. Cathode-Ray Oscillators—The Klystron. Wave-Guides. Properties of Microwaves.	
PROBLEMS AND QUESTIONS	337

CHAPTER 1

THE ELECTRON

1.1 Introduction. Because "electronics" deals with electrons, their sources and their movements through metals and through vacuum tubes, it is but common sense that we should have a clear knowledge of the nature of the electron itself. Let us proceed, therefore, to study:

1.2 The Charge of the Electron. Consider two metal plates placed parallel to each other but not in contact, with their inner faces ground very smooth. Imagine also that several small holes have been drilled in the center of the top plate and that an electrical battery has been connected, one side to the upper plate and the other side to the lower plate, as in Fig. 1 A. Let small drops of oil sprayed from an atomizer fall

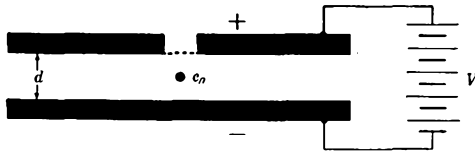


FIG. 1 A. Measurement of the charge of the electron. (From E. & N. P.*)

through the holes in the upper plate; then let us examine the droplets of oil between the plates by means of a long focus microscope. If it were not for the battery the droplets would fall under the force of gravity, but when the battery is connected, it is found that the droplets can be suspended and even moved upwards, according to the strength of the battery. This means but one thing — that the droplets are electrified. Their electric charge was produced at the time the oil was broken up into droplets at the nozzle of the atomizer.

By properly adjusting the battery, one of the oil drops can be precisely suspended in a fixed position midway between the upper and lower plates. Then, of course, the downward pull of gravity is exactly

* "Electron and Nuclear Physics." By J. Barton Hoag. Published by the D. Van Nostrand Company, Inc., New York.

equal to the upward electrical force. When the expressions for these two forces are written down and equated to each other, an equation is obtained in which all quantities can be measured except the electrical charge on the drop of oil. This quantity can then be calculated. Indeed, there are many ramifications to a precise calculation of this electrical charge, but when all of the details have been followed, a most interesting fact is found, namely, that the electrical charge on the drop of oil is always a certain definite amount, or two, or three times, or any integral multiple of this small unit charge. The oil drop never has a charge of $\frac{1}{2}$ or $1\frac{3}{4}$ or some other non-integral multiple of the unit charge. In other words, Nature has built her electrical world out of units or "building blocks," like the bricks in a building; not in a continuum like a concrete wall. It can be shown that the individual charges given off by a hot filament in a radio tube are always of a definite amount, equal to the least charge on the oil drop. This is true regardless of the material of which the filament is constructed, or its temperature. Also, certain electrical particles spontaneously emitted from radioactive substances have this same identical electrical charge.

This small "bit" or "grain" of electricity is *the electron*, first found in 1874 by C. J. Stoney and first convincingly established to the scientific world in the years between 1909 and 1913 by R. A. Millikan. The amount of this quantity of electricity, the smallest known to exist, is exceedingly small: 4.802×10^{-10} electrostatic unit. This is equal to 1.602×10^{-19} coulombs. This amount of electricity is so small that a prodigious number of electrons is needed to make up the total that flows through an ordinary light bulb each second. If three million people were to count for eight hours a day at the rate of 200 per minute, they would have had to count from the time of the Trojan War down to the present date in order to count all of the electrons passing through an ordinary Mazda lamp in one second.

There are two kinds of electricity — positive and negative. The electron is negatively charged. As such it is repelled by any other negative charge of electricity and is attracted to a positive charge.

Since the discovery of the granular nature of electricity and the naming of this small quantity of electricity (the "electron"), an additional property of the electron has been found. Thus:

1.3 The Mass of the Electron. Consider a glass tube, highly evacuated, cylindrical in shape, with a filament sealed in at one end. In front of the filament let there be a metal plate with a hole in the center and a

wire leading to the outside of the tube. On the other end of the tube, on the inside wall, let there be a thin layer of a white powder called phosphorescent zinc sulfide. Now let us heat the filament by sending an electric current through it, and let us fasten a battery between the filament and the metal plate in such a manner as to make the metal plate positive with respect to the filament. Then, the small bits of electricity, electrons, emitted by the filament will be attracted toward the positively charged plate. Some of these in fact will succeed in passing through the small hole in the plate to travel in a straight line down the tube and strike the coated surface at the other end where they pro-

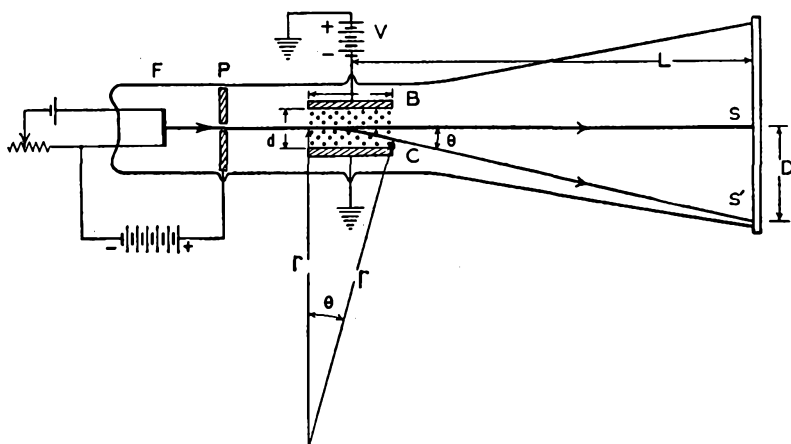


FIG. 1 B. Measurement of the mass and velocity of the electron.
(From E. & N. P.)

duce a bright green spot. Now, as in Fig. 1 B, let us deflect the stream of electrons (it is called a *cathode ray*) by means of an electrical field placed across its path. This can be accomplished by means of two metal plates *B* and *C*, and battery *V*, as in the figure. It will then be found that the spot of light moves sideways from the central spot *S* to *S'*.

Next we shall add a magnetic field at right angles to the electron beam, and also at right angles to the electrical field. If this magnetic field is properly adjusted, it will just compensate for the deflection of the beam caused by the electrical field. The green spot on the screen will return to its original position *S*. By measuring the strength of the electric and magnetic fields when this condition has been attained,

it is possible to compute the ratio of the charge to the mass of one of the electrons in the beam. Because we already know the charge, it is a simple matter to compute the mass of the electron. This was first done in a crude way by J. J. Thomson in 1897.

There are many other indirect methods of measuring the mass of an electron. The value is 9.11×10^{-28} gram.¹ This extremely small mass has never been measured by any direct method. It is so small that five hundred billion billion billion electrons would be needed to make up 1 pound. The mass of the electron is essentially constant unless the electron is traveling very fast. The faster the electron travels, the greater its mass, in agreement with experimental measurements and with theoretical equations obtained from the Relativity Theory.

1.4 Velocity of Electrons in a Vacuum Tube. It is also possible with the apparatus of Fig. 1 B to measure the speed at which the electrons travel down the vacuum tube. It is found that they travel very fast; with velocities of the order of one hundred million (10^8) cms.² per sec. or about ten million (10^7) miles per hour. This is approximately one one-hundredth the speed of light. The velocity of electrons depends upon how many cells make up the battery which is used to speed them up. When the total accelerating voltage is the same as that of the electric light circuits in our homes, namely 110 volts, the electron velocity will be 6.55×10^8 cms. per sec. When the voltage is doubled to 220 volts, the velocity will be increased to 10×10^8 cms. per sec. It is to be noted that the velocity does not double when the voltage is doubled. In fact, the voltage must be made four times as great in order to double the velocity of the electrons, and it must be made nine times as great in order to treble the velocity of the electrons. In other words, the velocity of the electron is proportional to the square root of the voltage (provided the voltage is not too high). The relationship will be readily seen in Fig. 1 C.

The equation connecting the voltage E and the velocity v is as follows: $Ee/300 = mv^2/2$, where e is the charge of the electron in electrostatic units and m is its mass in grams. This equation is accurate to within 1 per cent up to 7,000 volts. For higher voltages, a more complicated relativity equation must be used. The right-hand side of the equation is a well-known expression for the energy of moving bodies. This "kinetic" energy is expressed in units called "ergs." An energy

¹ 453.6 grams = 1 pound.

² 2.540 centimeters = 1 inch.

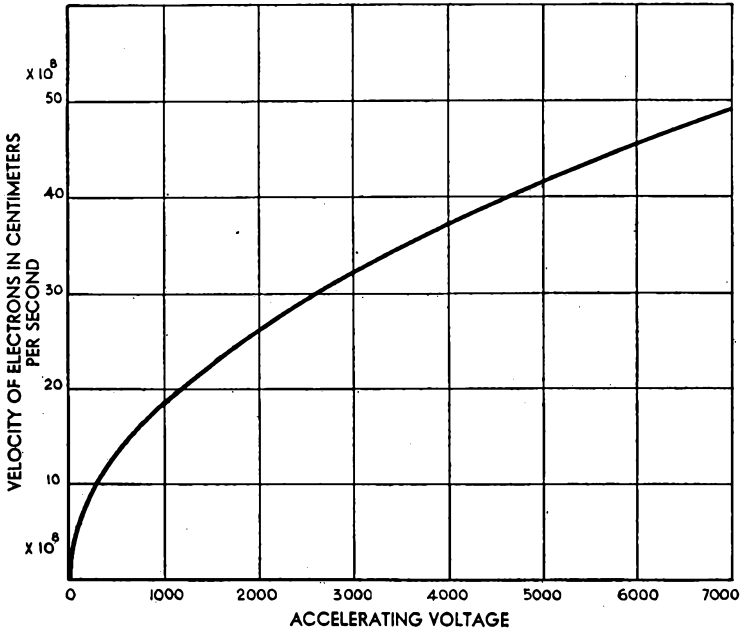


FIG. 1 C. Velocity of electrons accelerated by various voltages

of 1.60×10^{-10} ergs will be acquired by an electron speeded up by means of a 100-volt battery. Thus 1 *electron volt* is equivalent to 1.60×10^{-12} ergs. The electron volt is abbreviated "e.v." and is often used today in referring to the velocity of a charged particle. It should be clear, however, that the volt is a measure of the energy of the particle rather than its velocity.

CHAPTER 2

METALLIC CONDUCTION

2.1 The Structure of Matter. Let us examine a piece of metal very carefully. If we polish its surface and look at it under a microscope we shall see small crystals of various shapes. Their shape depends on the heat and mechanical treatment which the metal received. These microscopic crystals are arranged in haphazard fashion and are sometimes long and narrow, sometimes fatter, like distorted polygons. Frequently there are impurities such as slag in the region between the crystals. If, now, any one crystal could be still further magnified, it would be found to contain atoms which are arranged in beautiful geometrical patterns, called space-lattices. This has been revealed to us by means of X-ray studies. The atoms are essentially fixed in position, although they may vibrate a little about their "fixed" positions. In addition to the metals, there are hosts of other physical objects in the world around us. Be they metals or non-metals, they are all but complex forms and combinations of only ninety-two basic substances called *elements*. Aluminum and copper are elements, whereas brass is an alloy of the elements zinc and copper. Each element is composed of small parts, called *atoms*, each measuring approximately 0.000,000,01 cm. ($= 10^{-8}$ cm.), or four-billionths of an inch in diameter. In some substances, the atoms form close-knit groups, called *molecules*. For instance, two hydrogen atoms and one oxygen atom make up a molecule of water.

The atoms are not solid spheres. In fact a great deal is already known about the insides of an atom. There is a heavy central core or *nucleus*, which is positively charged, around which electrons revolve rapidly, like the planets revolving around the sun. In an ordinary, electrically-neutral atom, the positive charge of the nucleus is equal to the total negative charge of all the planetary electrons around it.

The outermost electrons of an atom determine to a large extent the chemical combinations which are possible, and are called the *valence* electrons. If these electrons are disturbed and then return to their

normal states, light rays are emitted. On the other hand, if electrons close to the nucleus are disturbed, and then return to their normal states, X-rays are emitted. When some of the planetary electrons are removed completely from the atom, it is left with an excess of positive charge and is said to be *ionized*. Then, it is an *ion*. Finally, when parts are added to or ejected from the nucleus itself, or when the nucleus is split asunder, a new element is produced. This is "atom smashing."

2.2 Theory of Metallic Conduction. Metals, such as copper, silver, brass, mercury, tin, zinc, and iron, will conduct an electric current whereas wood, rubber, bakelite, amber, sulfur, textiles, resins, and the like, do not. Solutions of salts and acids are fairly good conductors, and gases at reduced pressures also pass an electric current. Of course there are no perfect conductors, nor are there any perfect insulators, but in many cases, the relative conducting or insulating ability is very pronounced.

In the case of metals, the atoms are so arranged in their space-lattices as to properly influence each other, and contain outer electrons which are so loosely bound to the atom that, on the average, one or two such electrons of each atom escape into the intervening space between the bound atoms. These semi-free electrons move about between the atoms at comparatively high speeds, comparable indeed to that of a small caliber rifle bullet. The metal as a whole is electrically neutral because the negative charge of the free electrons is counterbalanced by the positive charge of the atoms from which they have temporarily escaped. The atoms from which insulators are made are of such an internal structure, and interact upon each other in such a manner, that practically no electrons can escape to move about between them.

A free electron in a metal will travel past approximately one hundred atoms (0.000,001 cm.) before "colliding" with other particles or entering an atom. Thus the *free electrons* are in a continuous state of movement or thermal agitation; they move about in tortuous paths, and on occasion enter or leave the fixed atoms. Because of these motions, the "cloud" of free electrons contains some which are going fast and some which are going slowly, with all gradations between.

When a battery is connected to the ends of a wire, say a copper wire, the free electrons *drift* slowly down the wire while they continue their rapid random motions. Suppose a drop of water were to fall into a brimful lake. Immediately, a little wave would travel across the water and shove out a drop of water at the spillway. Later, perhaps,

the original drop might wend its way across the lake and leave it. Similarly in the wire, immediately upon connecting the battery, an impulse of electricity travels to the other end of the wire, at just a little less than the velocity of light (which is 186,000 miles per second). Conceivably the drift motion of an individual free electron, which amounts to only a few centimeters per second, might carry it to the other end of the wire in due time.

Over a long interval of time, say one second, the thermal movement of the free electrons is quite uniform. But during a very short time interval, the clouds of free electrons in one part of the wire are denser than in other parts, having slightly larger numbers in a unit volume than the average. Although these variations from the mean value are very small, nevertheless they can be detected. They actually serve as a source of noise in high gain amplifiers. This so-called thermal noise depends on the temperature and electrical resistance of the wires in the input end of the amplifier and on the frequency band which is being amplified.

2.3 Electrical Units and Ohm's Law. Nature's unit of electricity, the electron, is too small for everyday use. In fact, long before the electron was discovered, man had chosen a unit of electricity: the *coulomb*, of practical size. There is another, more theoretical unit called the *electrostatic* unit or "e.s.u." One coulomb is equal to three billion electrostatic units. The relationship of these units to that of the electron was given in the preceding chapter.

When we speak of a current of electricity, we refer to the rate at which it flows in a wire. Thus, $I = Q/t$, where I = current in units called *amperes*, Q = quantity in coulombs and t = time in seconds. Amperes of electricity flowing in a wire are analogous to gallons of water per second flowing down a pipe.

A battery or a generator separates positive and negative charges from each other. These charges try to get back together again to set up the neutral state. The greater this tendency, the greater the *electromotive force* ("e.m.f."). The *volt* is a unit of e.m.f. A single dry cell produces approximately 1.5 volts; a storage battery, about 2 volts per cell; our lighting circuits use 110 to 117 volts. We think of voltage as a driving force, although technically it is a measure of work done upon a unit charge. After expending work in moving a pail of water to the top of a hill against the pull of gravity, it is in a position to give back the energy put into it. It is said to be at a higher *potential* than before.

The higher we lift the water, the more force it will exert when it falls. Similarly, the higher the voltage of an electrical circuit, the more readily will it drive an electric current through a wire. Doubling the voltage will double the current; trebling the voltage will treble the current.

The free electrons of a metal do not drift down the wire under an impressed e.m.f. without some opposition; they collide with atoms and other electrons; there are no perfect conductors. The measure of this lack of perfection is called resistance; and its unit is called the *ohm*. Thus we have *Ohm's law*, $E = IR$; or, volts equal amperes times ohms. The product IR is often referred to as the *potential drop* in the wire.

According to convention, electricity flows from the positive to the negative terminal of a battery, from plus to minus. Actually the free electrons move from negative to positive. In this book, unless we speak of the "electron flow" specifically, we shall mean the conventional positive to negative direction.

2.4 Resistance Laws. The same opposition to the flow of water through a series of pipes of large and small diameter can be attained by a single pipe of proper size. So also, a single resistance can be found in electrical circuits which is the equivalent of a combination of several resistances in series with each other. Instead of connecting the pipes or the resistances in series with each other, they might be joined in parallel, or in more complex series and parallel combinations. In all cases, however, they can be replaced by a single, equivalent unit. The laws for a number of typical circuits are given in Figs. 2 A through 2 E.

2.5 Heating Effects of Currents. Due to the collision of free electrons with atoms, the passage of a current down a metal wire heats it up. The amount of heat that is generated depends upon the square of the current and varies directly with the resistance of the wire and the time. Thus, in power units,

$$P = EI = I^2R = \frac{E^2}{R},$$

where P is the power lost in the wire in watts, E = volts, I = amperes, R = ohms.

The heat developed in a wire must not be confused with the temperature to which the wire will eventually rise. The latter depends on both the rate at which heat is produced in it by the current and the rate at which heat is lost to the surroundings. The loss of heat depends on

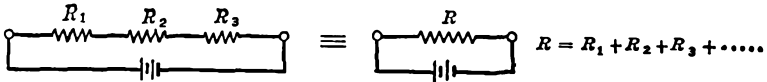


FIG. 2 A. For resistances in series

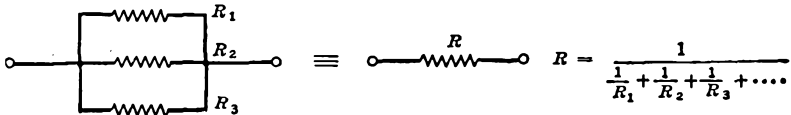


FIG. 2 B. For resistances in parallel

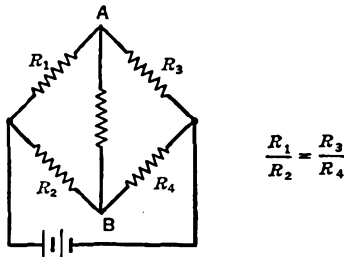
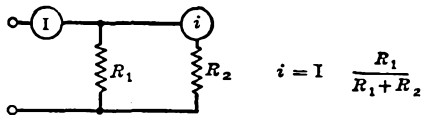
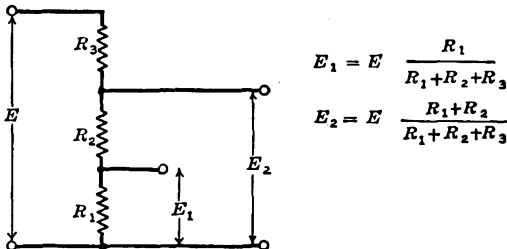
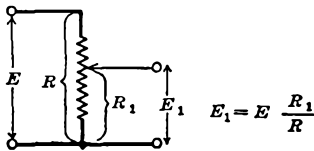
FIG. 2 C. For no current flow from
A to *B*FIG. 2 D. For shunts, the current *i* is given by the equation above

FIG. 2 E. For voltage dividers

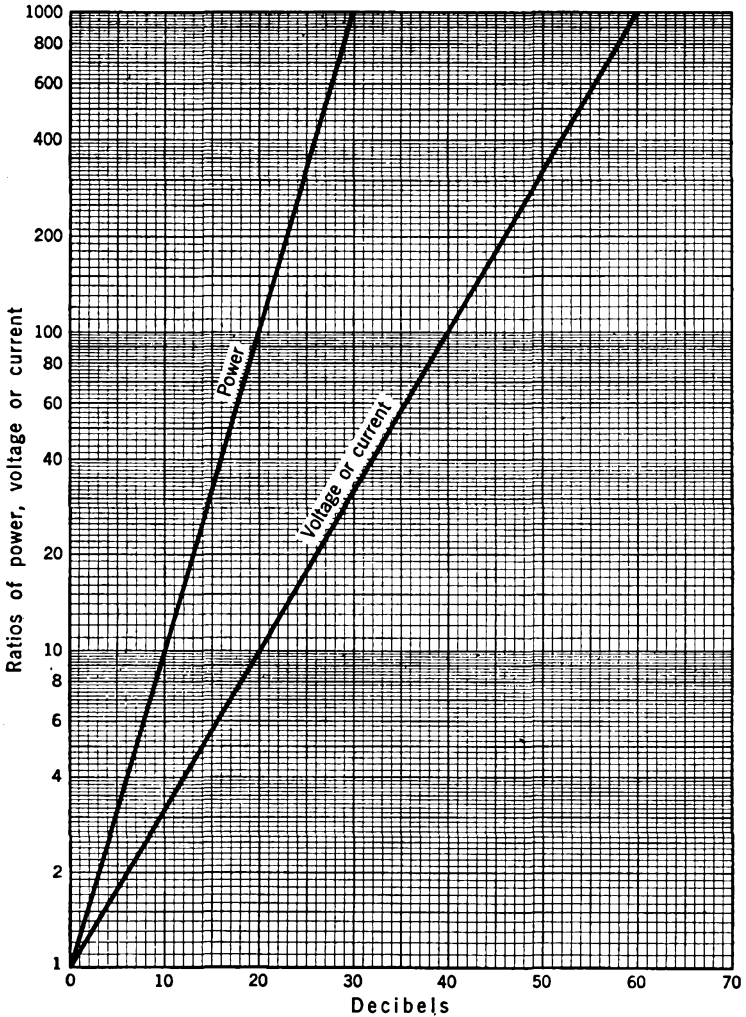


FIG. 2 F. A decibel chart

many factors. It is obvious that, if the wire is wound into a compact unit and is placed in a closed space, the heat losses will be less than if the wire is extended and out in the open air.

2.6 The Decibel. The increase or decrease in power in an amplifier or, in fact, in any device, can be expressed as the ratio of the power out to the power in. There is, however, a different and more useful manner

of showing the gain or loss in the device. This method employs a unit called the *decibel* (abbreviated db.), which is one-tenth of a "bel" (in honor of Alexander Graham Bell who invented the telephone).¹

If a certain sound is slowly increased in intensity the change will not be noticed until the power used in making the sound has been increased by 1 decibel. This loudness change is the same over wide limits regardless of the original loudness of the sound. Thus the decibel gives a measure of the response of the human ear to sounds which have a barely perceptible difference in intensity.

A gain in power is indicated by a plus sign, and a loss of power is indicated by a negative sign. Figure 2 F shows the relationship between the power ratio and the decibel units. It also shows the db. gain or loss when voltage or current ratios are known for circuits whose input and output resistances (impedances, to be more general) are *equal*. Negative and positive decibels can be added numerically. A db. of zero stands for the reference power level, i.e., a power ratio of 1. Reference levels of 1, 6 and 12.5 milliwatts are used in broadcasting and telephone practice. In acoustics, a level of sound intensity of about 24×10^{-16} watts/cm.² under standard atmospheric pressure at 20° C. is used. On this basis the db. of painful sounds is about 130–140; of ordinary conversation, 65–75; of whispering, 25–30 and of the heart beat, 10–15.

¹ If P_1 represents the power output in watts, and P_2 represents the power input in watts, the number of decibels is given by $\text{db.} = 10 \log P_1/P_2$.

CHAPTER 3

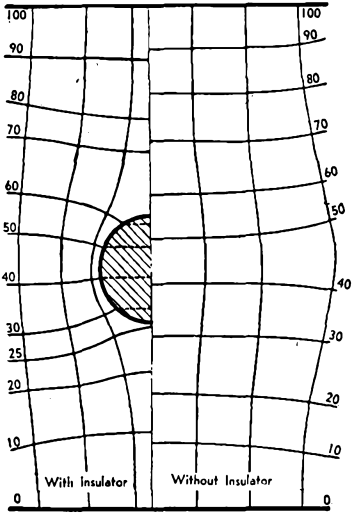
CAPACITANCE AND INDUCTANCE

3.1. Introduction. Suppose we rub a glass rod with a piece of silk. The glass rod will become positively charged and the silk negatively charged. We have not created electricity. Nor can it be destroyed. It can only be transferred from one body to another. A neutral body contains equal amounts of positive and negative electricity, and when electrons are added to it, it is negatively charged; when they are removed, it is positively charged.

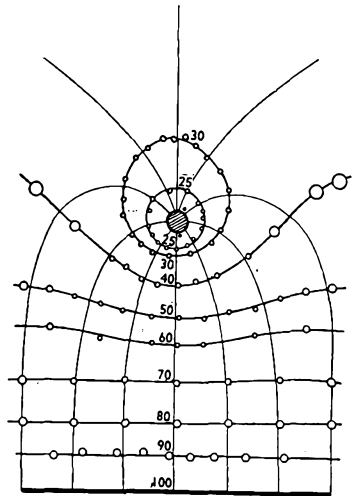
All around the positively charged glass rod there are electrical forces, strong near the glass and weaker farther away. The strength of the electrical forces can be represented by lines; the more *lines of force*, the stronger the field. If we connect the terminals of a battery with wires to two metal plates, an electrical field or region of electrical force is created between the plates. This field is stronger (more lines of force) when the plates are close together or when a higher voltage battery is used.

The directions of the lines of force are very important, for they represent the paths along which free electrical charges tend to move. We can control the motion of the electrons in radio and cathode-ray tubes by sending them through properly designed electrical fields. Figure 3 A shows some electrical fields around metal balls and plates connected to batteries of various potentials, together with the apparatus used to measure the fields (an electrolytic trough). Also in this figure, there are some lines everywhere at right angles to the lines of force. These correspond to the contour lines of a map and are called *equipotential lines*, for the voltage or potential is everywhere equal along a given line. We shall return to the discussion and use of lines of force and equipotential lines in a later chapter.

3.2 Capacitance and Condensers. When a positively charged body is brought near the end of an uncharged metal rod, the near end of the rod becomes negatively charged and the far end becomes positive. The rod is said to be *charged by induction*. The electrical charges at the ends



ELECTRIC FIELD OF PARALLEL PLATES



ELECTRIC FIELD of a POINT and a PLANE

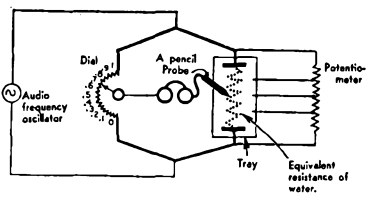
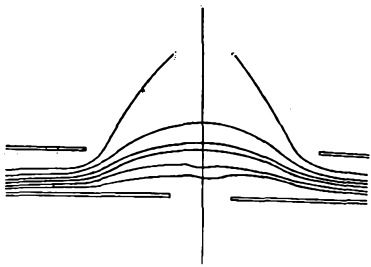
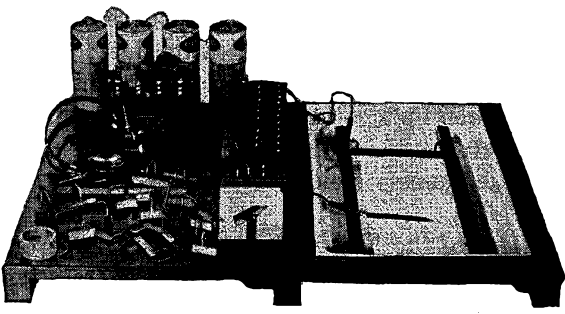


FIG. 3 A. The electrical fields and equipotential lines around several charged bodies together with the apparatus used to measure them. The circuit is taken from the author's book "Electricity Laboratory," distributed by the University of Chicago Bookstore

of the rod are called "induced charges." They are numerically equal to each other. When the original charged body is removed, the rod becomes neutral again.

Figure 3 B shows a source of electricity at E (the battery), connected by two metal wires to two metal plates, A and B . The two plates together with the insulating air between them, are called a *condenser*. Let Q be the amount of electricity on plate A , which is also equal numerically to the opposite charge on plate B . It is found that Q will be larger, and in direct proportion, if the battery voltage E is larger. This fact can be expressed by the equation $Q = CE$, where C is a constant, called the *capacitance* of the condenser. Imagine a tank filled with water to a depth of 1 foot. This amount of water is the "capacity" of the tank, in the sense used above

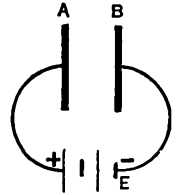


FIG. 3 B. A simple condenser

(quantity stored under unit potential). Of course the condenser will hold more electricity than the unit amount, C ; in fact, it will hold a total of E times the unit amount, just as the water tank will hold water clear up to its top. The "top" point of the condenser is the breakdown point of the insulator. If the voltage E is too great, the condenser will be ruptured and an electrical spark will occur between the plates.

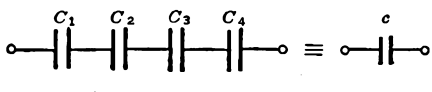
The capacitance C depends on the area of the plates, their separation, and upon the kind of insulator between them. The capacitance will be greater if glass or mica is used as the insulator instead of air. The amount by which the capacitance exceeds the air (or, more accurately, the vacuum) value, is called the *dielectric constant* of the insulator. Some dielectric constants and breakdown voltages are given in Table 3 A.

TABLE 3A. PROPERTIES OF INSULATORS

<i>Insulator</i>	<i>Dielectric Constant</i>	<i>Breakdown. Kilovolts per millimeter</i>
Air	1.00	
Bakelite	5 to 7	10 to 28
Glass	4 to 10	20 to 300
Isolantite	6.1	12
Mica	4 to 7	50 to 225
Mineral Oil	2.2	12 to 16
Fused Quartz	4	8
Hard Rubber	2.8	17

The unit of capacitance is called the *farad*. A condenser is said to have a capacitance of one farad if one coulomb is stored in it under a potential difference of one volt. This can be done by allowing a current of one ampere to flow into the condenser for one second. It is a very large unit. The following, more convenient, units are used in electronics: (1) the microfarad, abbreviated μfd , which is one one-millionth (10^{-6}) of a farad, and (2) the micro-microfarad (10^{-12}), abbreviated $\mu\mu\text{f}$.

The capacitance of a series combination of condensers can be computed by the formula in Fig. 3 C.

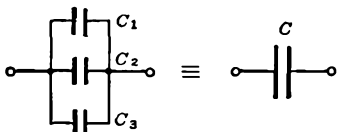


The diagram shows four capacitors labeled C1, C2, C3, and C4 connected in series between two terminals. This is shown to be equivalent to a single capacitor labeled C.

$$C = \frac{1}{\frac{1}{C_1} + \frac{1}{C_2} + \frac{1}{C_3} + \dots}$$

FIG. 3 C. The capacitance of series condensers

The capacitance of a parallel combination of condensers is calculated from the formula given in Fig. 3 D.



The diagram shows three capacitors labeled C1, C2, and C3 connected in parallel between two terminals. This is shown to be equivalent to a single capacitor labeled C.

$$C = C_1 + C_2 + C_3 + \dots$$

FIG. 3 D. The capacitance of parallel condensers

The capacitance of a plane parallel plate condenser is given by,

$$C = \frac{kA}{4\pi d \ 900,000}, \mu\text{fd},$$

where k is the dielectric constant, A is the area of *one* of the plates in square centimeters, and d is the distance between the plates in centimeters.

3.3 Magnetic Fields of Currents. It has been established that a magnetic field is produced whenever an electrical charge moves. If the charge is at rest, only the electrostatic field exists. Thus a magnetic field exists around the electrons moving inside an atom, around a beam of electrons moving through a vacuum tube, and around the free electrons of a metal as they drift down the wire under an impressed potential.

Figure 3 E shows how, with small compasses, Oersted found that the magnetic field around a wire carrying a current exists as complete, concentric circles, in planes perpendicular to the wire.

When a current is sent through a coil of wire properly suspended in a magnetic field, as in Fig. 3 F, the combination of the two fields causes the coil to rotate, and by an amount proportional to the current. If a mirror is mounted on the loop, the rotation can be measured by the deflection of a spot of light. Such a current measuring instrument is called a galvanometer and proves to be quite sensitive to small currents, measuring down to one one-billionth of an ampere. If the loop of wire is pivoted in the magnetic field, has a spiral of wire to restrain its motion, and a pointer is fastened to it, a more rugged current meter is obtained. Then, with suitable resistance shunts around the coil, the instrument is called a *d.c. ammeter* and is calibrated to read amperes directly. Often in radio circuits, the shunt is so chosen that the meter reads directly in milliamperes (= *ma.* = one one-thousandth of an ampere = 10^{-3} amp.) or in microamperes (= $\mu\text{a.}$ = one one-millionth of an ampere = 10^{-6} amp.)

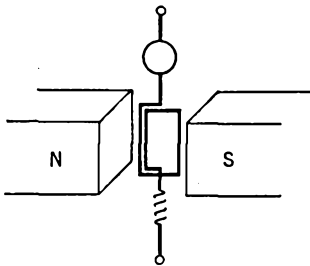


FIG. 3 F. Principle of a galvanometer, ammeter, or voltmeter

If a high resistance is connected in series with the loop, the meter may be connected *across* a circuit and used to read the voltage drop in that circuit. It is then called a *voltmeter*. If the coil is mounted so as to rotate freely, and a "commutator" is added, we have a motor.

The magnetic field around a wire, coiled into the form of a solenoid, as shown in Fig. 3 G, is the same as that around a bar magnet, with a north pole at one end and a south pole at the other. This is called an electromagnet. Its strength can be varied by changing

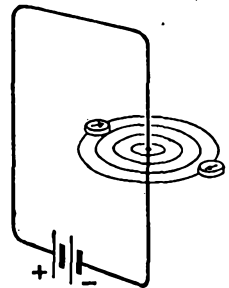


FIG. 3 E. The magnetic field around a wire carrying a current

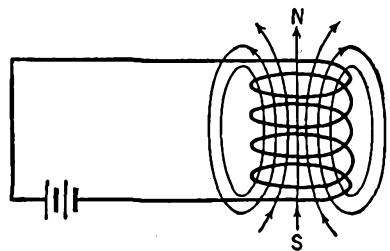


FIG. 3 G. Magnetic field of a solenoid

the amount of the current flowing through it. If an iron core is placed inside the solenoid, the magnetic field becomes much greater.

3.4 Induction. Over one hundred years ago, Michael Faraday performed a simple, most interesting experiment. He made up a coil of a few turns of wire and connected its ends to an instrument which would detect an electric current. A small bar magnet was placed near the coil along its axis. When all was connected as in Fig. 3 H, Fara-

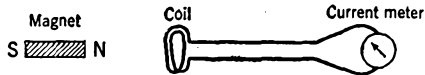


FIG. 3 H. The principle of induction

day plunged the magnet into the coil and found that the pointer of the current meter gave a sizeable kick. When the magnet was pulled out, the meter deflected in the opposite direction; when the magnet was held still, there was no flow of current; when the magnet was moved slowly, the current was small, and when it was inserted or pulled out of the coil quickly, the current "induced" in the coil circuit was large. Faraday then tried holding the magnet still and moving the coil. The results were the same; so he concluded that whenever a conductor, such as a copper wire, is moved through a magnetic field, or whenever a magnetic field moves across a conductor, an induced electromotive force is set up which can drive a current through a completed electrical circuit, and in an amount which is greater the shorter the time of motion. He also showed that the induction is greater when a stronger magnetic field is used. The stronger the field and the faster the lines of force of the magnetic field cut the conductor, the greater the e.m.f. and current. That is Faraday's law of induction. Very small voltages and electrical currents are set up in the metal parts of an airplane as it moves through the earth's magnetic field.

3.5 Inductance. When a battery is connected to a coil of wire, the current rises gradually instead of instantaneously to its final value. This is because of the need to establish the magnetic field of the coil. At first, as the field starts to form, the magnetic lines of force move out, cut the wires of the coil and generate a "back" e.m.f. which opposes that of the battery. This is called *self-induction*. When the battery is disconnected, the lines of force collapse, cutting the coils and generating an e.m.f. which is in the same direction as that of the battery, i.e., in such a direction as to keep the current flowing. In both cases,

the back e.m.f. opposes the change which causes it. This is analogous to inertia or mass in mechanics, as, for example, in the case of a fly-wheel. When a force is first applied to the wheel, its inertia prevents its attainment of full speed of rotation. Again, when the force is removed, it requires some time for the wheel to stop rotating.

The *inductance* of a coil is measured in *henries*. It depends on the number of turns, the cross-sectional area, and the material (air or iron) inside the coil. A straight wire also has a small amount of inductance. The formulas for series and parallel combinations of inductances are the same as for resistances, provided the magnetic fields of the various coils do not interact with each other.

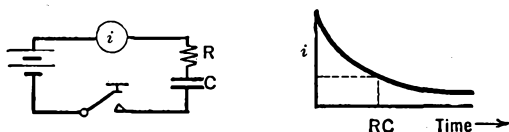


FIG. 3 I. Charging a condenser C through a resistor R . The Time Constant is RC

3.6 The Time Constant. In the circuit of Fig. 3 I, the current i will be large when the switch is first closed. It then decreases "exponentially" with time. Similarly, when a charged condenser is first connected to a resistance (no battery in the circuit), it empties rapidly at first, then more and more slowly. In either charge or discharge of the condenser, the product RC , of R in ohms and C in farads, is known as the *time constant* of the circuit. For the case of discharge, the voltage will drop to $1/2.718$ or approximately 37 per cent of its original value in RC seconds. The accompanying Condenser Discharge Chart (Fig. 3 J) may be used to determine the quantity of electricity left in a condenser C after a certain time of discharge through a resistor R , or the amount which will flow into the condenser through the resistor during a fixed time of charging. A straight edge is used to connect the desired quantities, as indicated. Conversely, the chart may be used

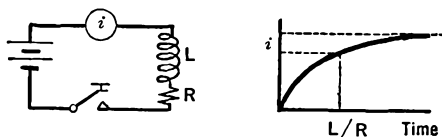


FIG. 3 K. The Time Constant of an inductive-resistive circuit is L/R

Condenser Discharge Chart

A nomographic chart for computing the charge or discharge of a condenser through a series resistor, in terms of time and the RC product

By J. B. Hoag
University of Chicago

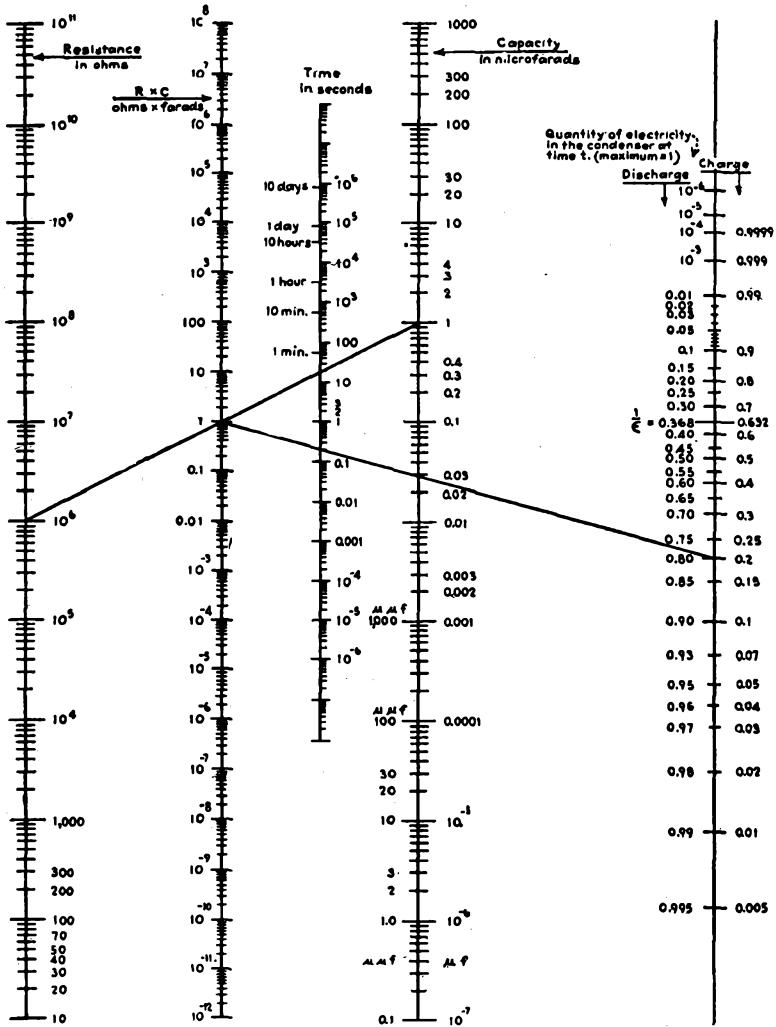


FIG. 3 J. From *Electronics*, Sept. 1937. *Instructions for use:* Connect resistance and capacitance values to obtain RC product. Connect RC product and time values to obtain quantity of electricity (charge) in condenser at the end of given time value. Example: One microfarad and one megohm gives RC product of unity. At the end of 0.2 second, the condenser is 20 per cent charged or 80 per cent discharged

to determine the time, the resistance, or the capacitance when the other quantities are known.

In the LR circuit of Fig. 3 K, it requires L/R seconds (L in henries, R in ohms) for the current to rise to $(1 - 1/2.718)$ or approximately 63 per cent of its final steady value after the switch has been closed. The ratio of L/R is called the time constant of this circuit.

CHAPTER 4

ALTERNATING CURRENTS

4.1 A Simple A.C. Generator. When a conductor moves through a magnetic field, an e.m.f. is produced between its ends. This can drive a current through the wire, provided a complete circuit exists. In Fig. 4 A, a loop of wire is rotated in a magnetic field. The ends of the loop

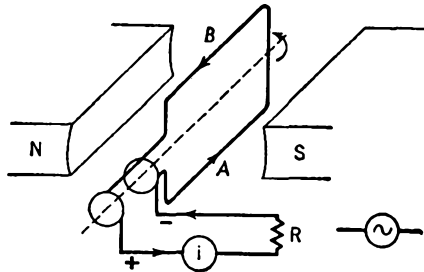


FIG. 4 A. An a.c. generator

are fastened to circular metal rings with brushes so that, as the coil rotates, the generated current can flow by way of the brushes to a load resistance R and a meter i . When the coil is in the vertical plane, its wires will be moving parallel to the magnetic lines of force and there will be zero e.m.f. and no current, as indicated at O , Fig. 4 B. When

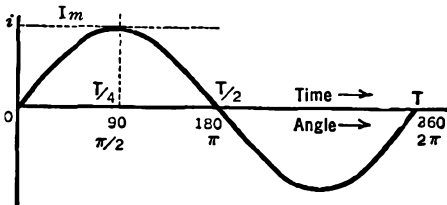


FIG. 4 B. A sine curve

the coil is passing through the horizontal plane its wires are moving directly across the magnetic field, the e.m.f. will be a maximum, and so will the current in the resistance R . This is shown at I_m , Fig. 4 B. It

occurs at a time ($T/4$), which is one-quarter of the total time T taken by the loop for a complete rotation. When wire A , Fig. 4 A, moves up, and B moves down, continuing their rotation in a counter-clockwise direction, the e.m.f. and current decrease until they are zero. This occurs when the loop is again in a vertical plane with A at the top and B at the bottom. The coil has now rotated one-half of one revolution or 180° , or, in radian measure, through an angle of π radians ($\pi = 3.1416$, 1 radian = 57.3 degrees).

As the coil continues its rotation, B now moves up and to the right, while A goes down and to the left; A and B of Fig. 4 A are now interchanged; the e.m.f. and the current are reversed in direction. This is shown in Fig. 4 B, from $T/2$ to T . This is called the "negative half-cycle" of the current. Each time the coil rotates once, a complete cycle is generated; the current, starting from zero, rises to a maximum in one direction, drops to zero, reverses its direction, rises to a maximum, then drops to zero, ready to repeat the cycle again. This is the kind of current we have in our ordinary lighting circuits.

The customary symbol for an alternating current generator is shown near R in Fig. 4 A.

4.2 Frequency. The faster the loop of Fig. 4 A rotates, the shorter the "period" T and the greater the number of cycles of e.m.f. and current that will be produced each second. If the loop rotates sixty times each second, sixty complete cycles of current will be generated each second. The *frequency*, f , is the number of complete cycles per second. The loop will require $1/60$ of a second to rotate once. The time for one rotation or cycle is called the *period*. It is easy to see that $f = 1/T$, i.e., the frequency is the reciprocal of the period.

For power lines, the frequencies in common use are 25, 50, and 60 cycles per second, the latter being by far the most widespread. Incidentally, the direct current from a battery or d.c. generator has a frequency of zero.

There are other methods of producing alternating currents than that of the rotating machine described above. In particular, vacuum tubes have been used in oscillator circuits to good advantage. With these, it is possible to produce much higher frequencies, into the billions of cycles per second.

Frequencies from 15 to 15,000 are known as audio frequencies because they can operate telephone receivers and loud speakers to produce sound waves which are audible to the ear.

Frequencies in the range from 15,000 to 100,000 cycles per second (= 15 to 100 kc. or kilocycles) are called *intermediate* or low radio frequencies. From 100 to 1,500 kc. they are called *medium r.f.* (radio frequency). From 1.5 to 6 megacycles (mega = million) they are called *medium-high* frequencies. From 6 to 30 Mc. (megacycles) they are h.f. (*high* frequencies); from 30 to 300 Mc. they are *ultra-high* frequencies (u.h.f.). Above this they are referred to as *centimeter-waves*, *quasi-optical waves*, or *microwaves*.

4.3 Effective, Peak, and Average Values. The *effective value* of an alternating current is that number of amperes which will produce heat at the same average rate as that number of amperes of steady direct current flowing through a given resistance. It is the square root of the mean of the instantaneous current values squared, and is also known as the *root-mean-square* or r.m.s. value. A.C. ammeters and voltmeters are calibrated to read effective values. For sine curves, the effective value I is approximately 70 per cent of the peak or maximum value, as shown in Fig. 4 C. More accurately,

$$I = \frac{I_m}{\sqrt{2}} = \frac{I_m}{1.414} = 0.707I_m;$$

and similarly for voltages.

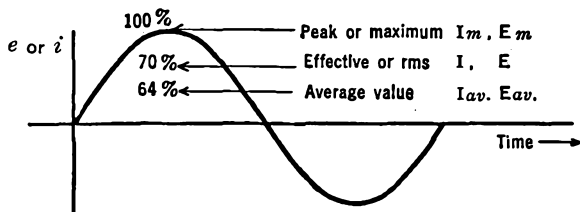


FIG. 4 C. Effective, peak, and average values of sinusoidal currents and voltages

For rectified alternating currents, an *average value* is used. This is simply the average of all the instantaneous values. For a sine wave, it is given by

$$I_{av} = 0.636 I_{max} = 0.9I.$$

4.4 Complex Wave Forms. In electronic circuits, the currents and voltages are often of complicated wave form rather than simple sine curves. However, these can be thought of merely as the sum of a

number of simple sine curves. Some of the combinations encountered in practice are shown in Fig. 4 D.

The lowest frequency f is called the fundamental or first harmonic. The wave of twice this frequency is the second harmonic. The $3f$ wave is the third harmonic. Extremely complex waves may contain as many as 400 harmonics each of appreciable strength compared with the

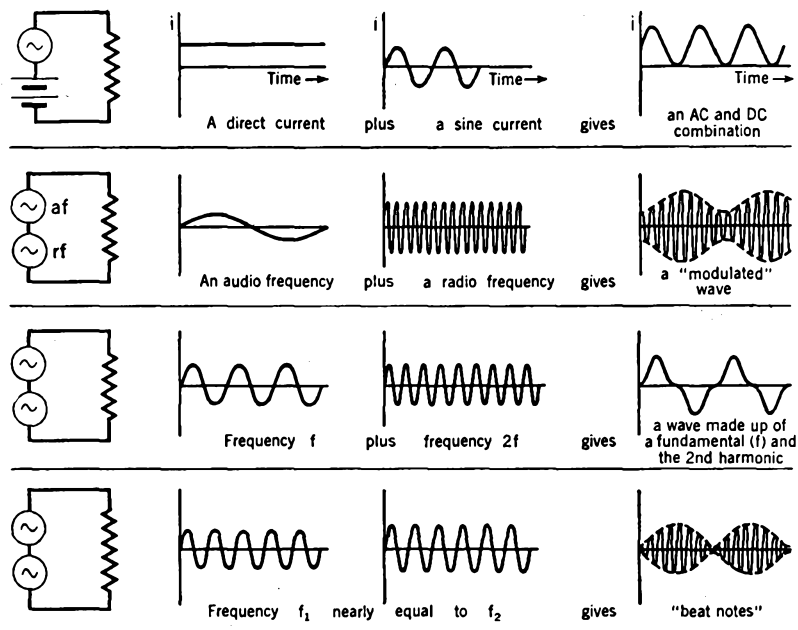


FIG. 4 D. Complex waves and their composition

fundamental. The existence of various harmonics of different strengths makes the difference between the "qualities" of the musical notes sounded by different musical instruments.

It is possible by mathematical analysis (the study of Fourier Series), and also by means of machines called harmonic analyzers, to resolve into its harmonics any periodically repeating wave, no matter how irregular and complex it may be.

4.5 Phase. If an a.c. generator is connected to a pure resistance, the voltage and current through the resistance will be "in phase" with each other. This means that they both reach their positive maximum

values at the same instant. Similarly they have their zero value and their negative maximum value at the same instant. See *a* in Fig. 4 E.

If an a.c. generator is connected to a pure inductance,¹ the electrical "inertia" of the inductance causes the current to lag behind the impressed e.m.f. by 90° , or one-quarter of a period. This is shown in *b* of Fig. 4 E.

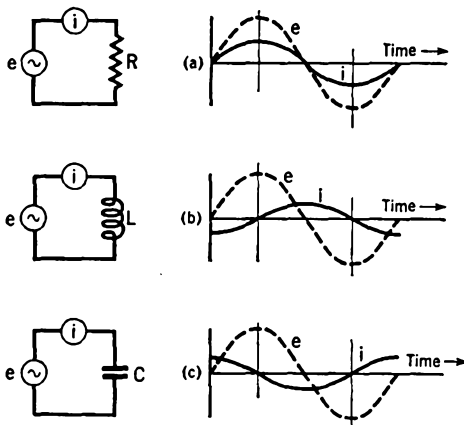


FIG. 4 E. The current i is "in-phase" with the impressed voltage e in a resistance; it lags 90° in an inductance and it leads 90° in a capacitance

In case a condenser is connected to an a.c. generator, the voltage across the condenser terminals is zero when there is no charge in it. Hence, then, even a small e.m.f. can send electricity at a great rate into the condenser. The current decreases as the voltage of the condenser builds up and opposes that of the generator. Hence the current in a capacitive circuit leads the impressed voltage by 90° or one-quarter of a cycle, as shown in *c* of Fig. 4 E.

In a series circuit of inductance and capacitance, the current will lag behind the impressed e.m.f. somewhere between 0° and 90° if the inductive effect is greater, and will lead somewhere between 0° and 90° if the capacitive effect is predominant.

¹ A coil is not a "pure" inductance since there is always some resistance in its wires. In addition, there is capacitance between the turns of the coil. A coil is to be treated as a resistance and an inductance in series with each other, shunted by the "distributed" capacitance.

CHAPTER 5

A.C. CIRCUITS

5.1 Reactance and Impedance. The opposition which a resistor offers to the flow of either direct or alternating current is called *resistance*.

The opposition which a pure inductance (an inductor without resistance or capacitance) offers to the flow of an alternating current is called its *inductive reactance* and is represented by X_L . It will be greater, the greater the inductance L (henries) and the higher the frequency f (cycles per second), and in direct proportion in both cases. Thus

$$X_L = 2\pi fL \quad (\text{ohms}).$$

The opposition to the flow of alternating current which is set up by a pure condenser (capacitor without resistance or inductance) is called *capacitive reactance* and is represented by X_C . The greater the capacitance C (farads) and/or the greater the frequency f (cycles per second), the less X_C will be. Thus

$$X_C = \frac{1}{2\pi fC} \quad (\text{ohms}).$$

The opposing effect of a capacitance and an inductance connected together one after the other (in series) is called the total *reactance*, X , of the circuit. It is given by:

$$X = X_L - X_C \quad (\text{ohms}).$$

The inductive reactance is taken as positive.

The total opposition to alternating current flow, set up by a pure resistance, inductance, and capacitance in series with each other, is called the *impedance* of the circuit and is given by

$$Z = \sqrt{R^2 + X^2} \quad (\text{ohms}).$$

It is to be noted that R and X are not added algebraically but as though they were at right angles to each other.

Ohm's law for an a.c. circuit is:

$$E = IZ,$$

as contrasted with $E = IR$ for a d.c. circuit.

The currents I (r.m.s. values) which flow under the conditions discussed above are shown graphically in Fig. 5 A, where the frequency

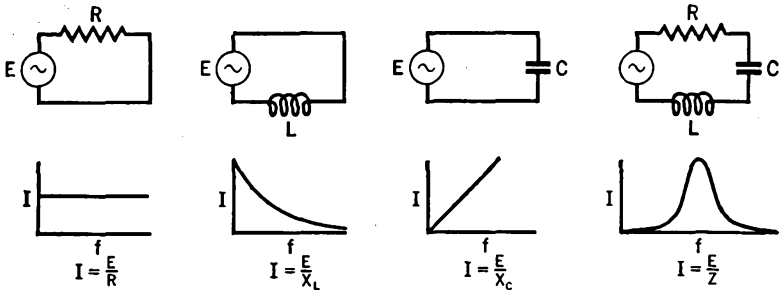


Fig. 5 A. Current from an a.c. generator of variable frequency

of the oscillator is raised from zero (d.c.) to higher and higher values. Comparative reactances are given in Table 5 A and should be examined carefully by the student.

TABLE 5A. NUMERICAL EXAMPLES OF REACTANCE

	Frequency. Cycles per Second	Reactance. Ohms
$L = 0.1 \text{ h.}$	60	$X_L = 38$
	60,000	38,000
$L = 1 \text{ h.}$	60	$X_L = 380$
	60,000	380,000
$L = 100 \text{ h.}$	60	$X_L = 38,000$
	60,000	38,000,000
$C = 0.01 \text{ } \mu\text{fd.}$	60	$X_C = 300,000$
	60,000	300
$C = 0.1 \text{ } \mu\text{fd.}$	60	30,000
	60,000	30
$C = 1 \text{ } \mu\text{fd.}$	60	3,000
	60,000	3
$C = 10 \text{ } \mu\text{fd.}$	60	300
	60,000	0.3

5.2 The Partial Separation of the Component Parts of a Complex Current. Complex currents are often encountered in electronic circuits. It is often desirable to separate the components one from the other. In Fig. 5 B we assume that a combination wave of d.c., 60 cycles, and 60 kc. is applied to the terminals at the left of the circuit. The coil L_1 , called a *radio-frequency choke* (r.f.c.), has sufficient reactance to stop most of the 60-kc. current, but permits most of the 60-cycle current and the d.c. to pass on to the right. However, the condenser C_1 , called an

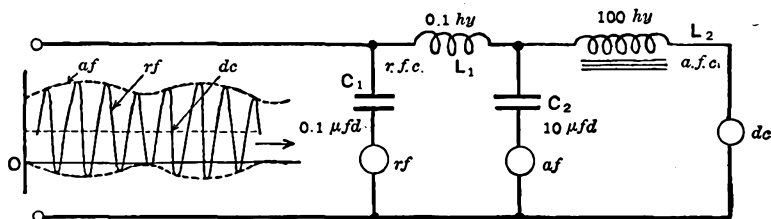


FIG. 5 B. To illustrate the separation or "filtering" of d.c., a.f. and r.f. currents from a complex current

r.f. bypass, has low reactance to the r.f. of 60 kc. so that this current passes through it and is indicated on the r.f. meter. The reactance of C_1 is sufficiently high for the 60-cycle current and is infinite for the d.c., so that these current components do not pass through C_1 . Thus we have separated the 60 kc. from the other two components. The larger condenser C_2 serves similarly to shunt the 60-cycle a.f. currents through it, while the large audio frequency choke coil (a.f.c.) prevents them from passing on to the third arm of the circuit. The d.c. can pass through L_2 , with only a small loss in the coil's resistance.

Later we shall study, under the title of "Filters," more elaborate circuits which are of value in separating currents whose frequencies are not so greatly different as in the elementary case just discussed.

5.3 Power Factor. The power (watts) lost as heat in an a.c. circuit occurs in the resistance alone and is equal to I^2R . The power consumed in d.c. circuits is given by EI (volts \times amperes). This product, in a.c. circuits, may be several times the actual power lost. The *power factor* of an a.c. circuit is defined by

$$\text{Power Factor} = \frac{\text{Watts Lost as Heat}}{\text{Effective Volts} \times \text{Effective Amperes}}$$

5.4 Actual Coils, Condensers, and Resistors in A.C. Circuits. Actual coils of wire have resistance as well as inductance. In addition, they have a small amount of "distributed" capacity between turns. Hence a coil must be thought of as a series resistance and inductance, shunted by a small capacitance. At very high frequencies, the reactance of the condenser may be small enough so that practically all of the current passes through this bypass condenser. The coil then acts, electrically, as though it were a condenser.

The leads and plates of actual condensers have sufficient inductance so that, at very high frequencies, their inductive reactance must be included in the circuit calculations.

In a radio frequency circuit, the magnetic field set up inside a wire forces the current to travel only on the surface of the wire. This "skin effect" increases as the frequency is increased. Due to the reduced cross-section of wire through which the current flows, the resistance of the wire is considerably higher than the d.c. value. Conductors with large surfaces are needed at very high frequencies and, since no current flows in the inner part of the conductor, thin tubing serves just as well as solid wire of the same diameter.

The h.f. resistance of a coil may be many times its d.c. resistance, and also many times the h.f. resistance of the same wire when straightened out. This is because the currents are confined by the magnetic fields to only a small part of the total surface of the wires.

It should be noted that resistors do not offer *pure* resistance and that any and all types of units have capacity to any near-by solid object.

5.5 A.C. Ammeters. An alternating current can be measured by means of a hot-wire ammeter provided the frequency is not so high that the small capacities in the meter bypass the current around the hot wire.

A better r.f. current-measuring meter of the direct reading type is the so-called *thermocouple-galvanometer* or thermocouple-ammeter (or milli-ammeter). In this instrument (Fig. 5 C), a very fine resistance wire is heated by the r.f. current flowing through it. A pair of wires of dissimilar metals, called a thermocouple, is attached to it and generates a small d.c. voltage which, in turn, operates a d.c. meter of ordinary design.

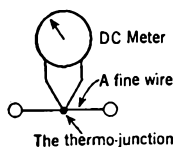


FIG. 5 C. Principle of the thermocouple-ammeter used to measure radio-frequency currents

5.6 Transformers. A transformer consists of two coils of wire near each other. An alternating current in one of the coils, the "primary" coil, sets up an alternating magnetic field which cuts the other "secondary" coil, producing an e.m.f. between its terminals. When the secondary is connected to a load resistance, an alternating current will flow.

The coils may have air cores, or they may be wound upon a laminated iron core, as in Fig. 5 D.

In the case of iron core transformers, the secondary voltage is very nearly equal to the primary voltage multiplied by the ratio of the number of secondary to the number

of primary turns. In a *step-up* transformer, there are more turns on the secondary than on the primary; and the output voltage is correspondingly greater. The reverse is true of a *step-down* transformer.

The power (watts) delivered to the load is about 95 per cent of that taken from the supply line. Since watts = volts \times amperes, the secondary-to-primary current is in the inverse ratio to the secondary-to-primary voltage. If the secondary voltage is twice that of the primary, the secondary current will be one-half (or less) that of the primary.

The impedance of the load in the secondary ($Z_s = E_s/I_s$), divided by the impedance presented by the primary to the supply line ($Z_p = E_p/I_p$), is nearly equal to the square of the ratio of turns of the secondary (N_s) and primary (N_p). Thus, the impedance ratio is given by

$$\frac{Z_s}{Z_p} = \left(\frac{N_s}{N_p}\right)^2$$

We see, then, that a transformer can be used to transform voltages, currents, and impedances.

There is a proposition general throughout electrical circuits, that maximum power is transferred from a generator to a load when their impedances are equal to each other. If the load's impedance is not equal to that of the source, a transformer can be connected between them to bring about the desired impedance match.

5.7 Reflected Impedance. Consider the case of a transformer with a

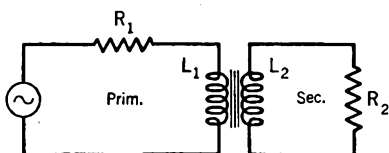


FIG. 5 D. A simple transformer circuit

simple resistance load as in Fig. 5 D. Here R_1 is the total primary resistance including that of coil L_1 , and R_2 is the total secondary resistance, not only of the load but also of coil L_2 . As the alternating current generator sends current back and forth through coil L_1 , its magnetic field rises and falls, cutting coil L_2 , generating an alternating e.m.f. between its terminals, and driving an alternating current through the secondary circuit L_2R_2 . But this current, in turn, produces a magnetic field around the coil L_2 which, in cutting coil L_1 generates a voltage between the primary terminals and causes a current to flow in the primary circuit. This "reflected" current then reacts upon the secondary and the process continues back and forth, with ever-diminishing intensity. The final result is that the current flowing in the primary is altered in such a manner as though the primary resistance had been increased and its inductance decreased, i.e., the total primary circuit's reactance, or, in general, its "impedance" is altered. The amount of the reflected resistance or inductance is greater when the primary and secondary coils are closer together and when they are so oriented with respect to each other that more of the lines of force from one of them can cut the other. The increase of resistance and the decrease of inductance is greater at higher frequencies of the alternating current. It is also affected by the resistance and inductance of the secondary circuit.

CHAPTER 6

RESONANT CIRCUITS

6.1 Series Resonance. When two bodies, or two currents, or two voltages, oscillate at the same frequency they are said to be in resonance.

A series *LCR* circuit can be built which resonates to a generator of given frequency. Then the current which flows through the circuit will have its greatest effective value. This is accomplished by choosing the inductive and capacitive reactances equal to each other. From the equations for the reactances, it is easily proven that the resonant frequency is given by

$$f_r = \frac{1}{2\pi\sqrt{LC}} \times 10^6$$

where f_r is in cycles per second, $2\pi = 6.28$, $10^6 = 1$ million, L is the inductance in microhenries (μh), and C is the capacitance in micro-microfarads ($\mu\mu f$). This is one of the most important equations in radio. Note that the resistance of the circuit does not appear in the equation. At resonance, the only opposition to the flow of the current is that due to the resistance, i.e., $I_r = E/R$ and not $I = E/Z$.

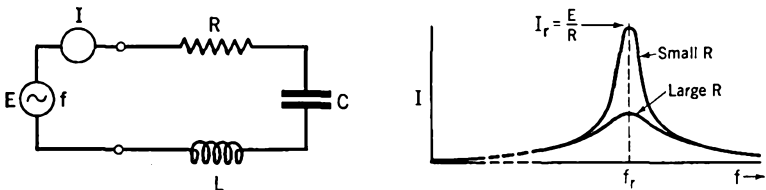


FIG. 6 A. A series circuit and its resonance curve

The current in the "tuned" or resonant series circuit is indicated at the peak of the "resonance" curve of Fig. 6 A. Note that if the total resistance of the circuit is large, the curve is broader and flatter, and vice versa.

6.2 Parallel Resonant Circuits. Fig. 6 B shows a parallel circuit and its impedance curves. The curves are of the same shape as the current curves of a series circuit. Note that the impedance across the terminals of a parallel circuit is a maximum at resonance,¹ whereas it is a mini-

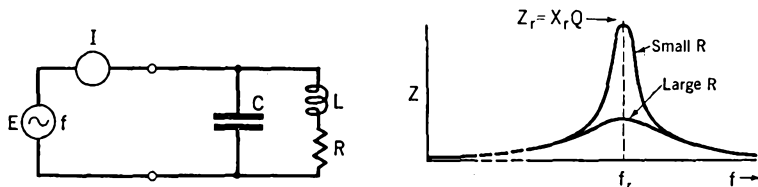


FIG. 6 B. A parallel circuit and its impedance curve

imum for the series circuit. The current in the *LCR* circuit itself is often very large at resonance and can cause considerable heating.

The impedance of a parallel circuit at resonance is given by

$$Z_r = \frac{(2\pi f_r L)^2}{R} = (2\pi f_r L)Q = X_r Q = \frac{L}{RC}$$

if all the resistance is in the coil (which is very nearly true in practice). The meaning of *Q* is given in Section 6.4. The resonant frequency f_r is given by the same equation as for a series circuit provided *R* is small in comparison with *X*. This is often true in radio frequency circuits.

6.3 Selectivity. The sharpness of the resonance curves is greater when the resistances are smaller. Sharpness of tuning is also called "selectivity." It shows the ability of the circuit to discriminate between voltages of different frequencies.

6.4 Q of a Circuit. As current surges back and forth in a resonant circuit, the electrical energy is alternately shifted back and forth between the magnetic field of the coil and the electric field of the condenser, losing a certain proportion of the total into the resistance at each alternation. In order to maintain oscillations, the generator must supply a small amount of energy each cycle. This is analogous to the small push we give to a swing; only a little push is needed at the end of each swing to keep it going. Electrically, the interest lies in the comparison between the total energy in the circuit to that which is dissipated (and must be re-supplied by the generator). This ratio is called the "Q" (quality) of the circuit. In practice, nearly all of a circuit's resistance is in the coil. It may then be shown that

¹ There are really three different ways of defining resonance in the case of a parallel circuit, but, if the resistance is low, the resonant frequency in all three cases is practically identical.

$$Q = \frac{2\pi fL}{R} = \frac{X_L}{R}$$

Practical radio frequency coils have Q 's from 50 to 200 and occasionally 500. Audio frequency coils range from 1 to 10 and occasionally are as low as 1/2. The higher the Q , the better.

The rate at which current dies down in a resonant circuit, after the source has been disconnected, is called the damping of the circuit, whose measure is called "the decrement" δ . $Q = \pi/\delta$. A high Q circuit is lightly damped, has a small decrement, a sharp resonance peak, and a high selectivity.

6.5 The L to C Ratio. In order that a circuit shall resonate to a given frequency f_r , the product LC must have a definite value given by $LC = 1/(2\pi f_r)^2$. This does not tell us, however, whether the product shall be made up of a large L and a small C or vice versa. Within limits, an increase in the number of turns of wire in a coil increases its reactance faster than its resistance. Hence, for circuits alone, or for those connected to high load resistances, such as a vacuum tube, the coils should be made with a relatively large inductance, i.e., the L/C ratio should be large.

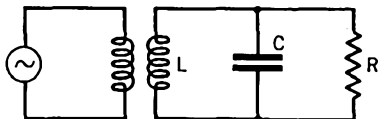


FIG. 6 C. If R is small, the LC circuit will be heavily loaded and will have a low Q . Making the ratio L/C small helps to keep Q large

When the load on a resonant circuit (R in Fig. 6 C) is small, say only a few thousand ohms, as in transmitters and induction heaters, a majority of the energy loss takes place in the load. The coil's resistance plays only a negligible role. In this case, it can be shown that L should be comparatively small and C large if Q is to be satisfactorily high.

6.6 Resonant Voltages. At resonance, the voltage across the inductance is numerically equal to that across the condenser, although they are always of opposite polarity. This voltage, at resonance, is equal to Q times the voltage in series with the circuit. The condenser must be built with an insulator which will not be punctured by this voltage.

6.7 Crystal Resonators. A properly cut and ground piece of quartz, located between two metal plates and placed in series with a high frequency generator, has a natural vibrational period dependent largely upon its thickness. It is equivalent to a series resonant circuit of very high Q .

CHAPTER 7

COUPLED CIRCUITS

7.1 Introduction. It is sometimes desirable to transfer electrical energy from one circuit to a neighboring circuit. This can be accomplished, as in Fig. 7 A, by means of a transformer, wherein the source of energy is in the primary circuit and the load is in the secondary circuit. There are other coupling methods which employ a link circuit

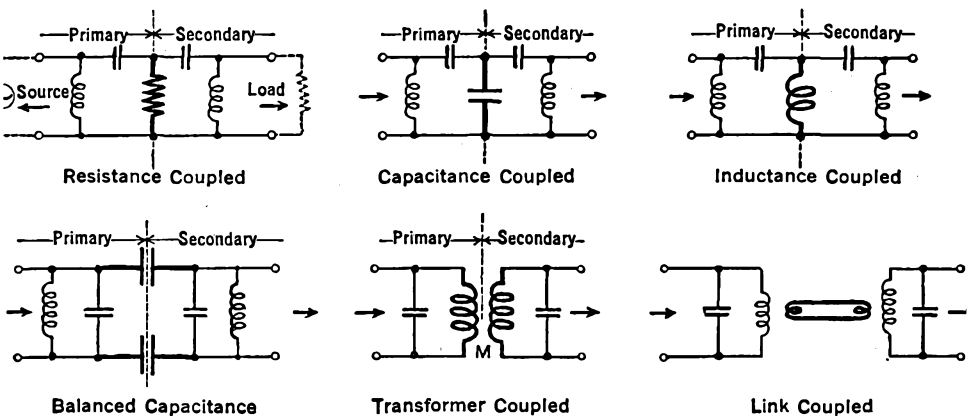


FIG. 7 A. Typical coupling methods

between the primary and the secondary. In still other types of coupling, the primary and the secondary circuits are actually connected together, using a coil or a condenser or a resistance, as the element common to both primary and secondary circuits.

The *transformer*, as shown in Fig. 7 A, differs in its action from the iron core transformer discussed in the chapter on a.c. circuits, in that only a few of the lines of force of the primary cut the wires of the secondary coil. The simple voltage step-up and impedance ratios applicable to the iron core case no longer hold true. The extent to which the lines of force of the primary cut the secondary is measur-

able, and is called the *mutual inductance*. Its symbol is M and its unit is the *henry*. When the secondary coil is placed close to the primary and on the same axis, the *coupling* will be great and M will be large. If the secondary coil is rotated, or is moved farther away from the primary, the voltages set up in it will be smaller, the coupling will be less, and M will represent a smaller number.

The coefficient of coupling is defined by the equation,

$$k = M / \sqrt{L_1 L_2},$$

where the L 's are the self-inductances of the primary and secondary circuits. If all of the lines of force from the primary were to cut the secondary, k would be equal to unity; the coefficient would be 100 per cent. This is the "tightest" possible coupling.

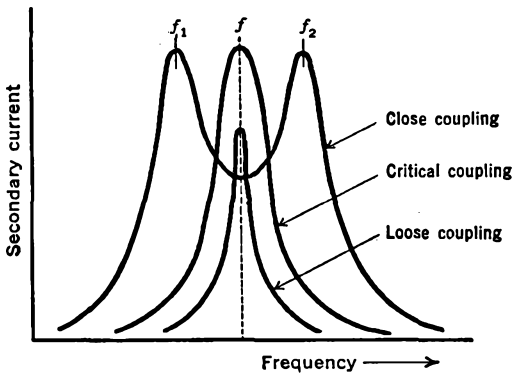


FIG. 7 B. Transformer coupling. The primary and secondary circuits were independently tuned to the same frequency (f)

When the circuits are tuned to the same frequency and are so related that but little energy is transferred from the primary to the secondary, they are said to be *loose coupled*. As the coupling is increased, the secondary increasingly "loads" the primary; and also, the primary increasingly loads the secondary. This loading action broadens the resonance curves of both circuits. At *critical coupling*, maximum energy is transferred and the resonance curve has quite a broad peak, as in Fig. 7 B. If the circuits are still closer coupled, the energy transferred from one circuit to the other decreases, and the resonance curve will have two peaks, one on either side of the single

frequency to which the circuits were originally tuned. The closer the coupling, the greater the frequency separation of these peaks.

If the two circuits are not exactly tuned to the same frequency, their effect upon each other is not only to increase the effective resistance (the Q of the circuit decreases) but also to reduce the self-inductance. Hence the peak of the resonance curve shifts to a different frequency.

7.2 The Effect of "Neighboring Bodies." The secondary circuit need not necessarily consist of a coil, condenser, and resistance, as in the cases we have just discussed, but can consist of any metallic, and even a dielectric body, in the neighborhood of the circuit containing the alternating current. A piece of metal placed inside a coil will have small *eddy currents* induced in it. These currents, in turn, react upon the primary circuit to increase its resistance, i.e., lower its Q , and *decrease* its inductance and hence increase its resonant frequency. Because of the increased resistance, the generator must supply an additional amount of power (current squared, times resistance). Thus, if we use the symbol R_1^1 for the *effective resistance* of a circuit (its actual resistance plus that which is "reflected" from the load), we may write

$$\underbrace{I_1^2 R_1^1}_{\text{Total Heat}} = \underbrace{I_1^2 R_1}_{\text{Prim. Heat}} + \underbrace{I_2^2 R_2}_{\text{Sec. Heat}},$$

where the term on the left side represents the total power which the source must supply. The first term on the right-hand side of the equation represents the heat developed in the primary circuit, and the second term represents the heat developed in the secondary, or load — be it a circuit or a metallic body or an insulator. Now, this state of affairs may be good or it may be bad. For example, it is "good" when the circuit is used as an *induction heater*, which consists of a radio frequency generator with a tuned circuit, the coil of which consists of a few turns of heavy copper wire. The coil is placed around a body which is to be heated; such, for example, as the metal electrodes sealed inside a vacuum tube during its process of manufacture, or of a human body in which it is desired to develop an "artificial fever." The eddy currents set up in the conductive parts of the body inside the coil cause the body to heat up and, in some cases, to an extent such as to melt it completely.

If an insulator is placed inside the coil, the high frequency electro-

static fields cause the electrical charges in its atoms and molecules to oscillate back and forth about their normal positions. This requires energy which can only come from the primary circuit. This causes the dielectric to heat up, and is spoken of as *dielectric loss*. That energy should be absorbed from a circuit by a neighboring dielectric is, in general, undesirable. The resistance of the primary circuit is effectively increased by these losses.

We may generalize the concept of resistance by defining it in the following manner:

$$\text{Generalized Resistance} = \frac{\text{Watts Lost}}{\text{Current Squared}}$$

where the "watts lost" include the heat losses in the circuit itself and in neighboring bodies (as ohmic, eddy current, or dielectric heating); in general, lost in any form whatsoever from the source of power.

7.3 Shielding. A metal shield can be used to prevent coupling between two circuits. Capacitive or electrostatic coupling can be prevented by shielding either the primary or secondary, or both, circuits with an enclosing metal container. The shield should be grounded and be made of material of low resistance. Also, metal shields can be used at radio frequencies to prevent magnetic coupling. Here, the eddy currents in the shield have magnetic fields which oppose the original field and more or less completely keep it out of the inside of the shield. The shielding effect is greater at the higher frequencies, is greater for more conductive materials, and also depends upon the thickness of the shielding material. At low frequencies, the eddy currents are so feeble that this method is not satisfactory. The best that can be done in this case is to surround the circuit with a complete shield of soft iron. This will partially divert the magnetic fields.

A shield changes the resonant frequency and the Q of the circuit being shielded. In shielding a coil, the spacing between the sides of the coil and the shield should be equal to at least half the diameter of the coil, and the distance of the shield from the end of the coil should be not less than the diameter of the coil. Copper and aluminum are satisfactory metals for shields.

7.4 Introduction to Filters. Various combinations of coils and condensers are used:

1. To separate currents of different frequencies from each other.
2. As a coupling unit between two circuits whose impedances are not equal to each other.

3. To shift the phase between voltage and current.
4. To alter the magnitude of voltage or current.

Figure 7 C shows some of the filters with which we are already familiar, together with their curves of output current at different input frequencies, their basic equations, and their names. See also Figs. 5 A and 5 B. More complicated combinations will serve better in separating neighboring frequencies and in more completely suppressing others. In other words, there are filters which have a *sharper cutoff*.

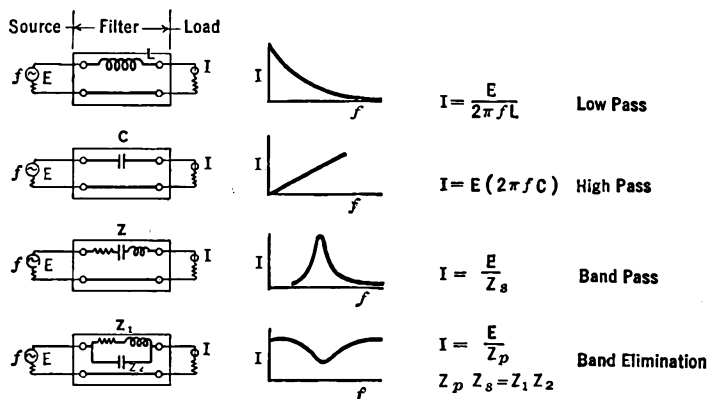


FIG. 7 C. Crude filters. Low-pass types use series inductance (top figure). High-pass use series capacitance. Band-pass use series LC circuits. Band-elimination use parallel LC circuits (bottom figure)

Of the host of possible LC combinations, a few simplified forms have been developed under the following assumptions and simplifications:

1. The resistances of all parts of the filter circuits are to be kept as low as possible. We shall assume that the resistances are zero. Such filters are called "ideal" or *non-dissipative*.
2. There shall be no batteries or other sources of electromotive force, nor vacuum tubes with their attendant amplification, in the filter. Such filters are said to be *passive*.
3. The inductances of all coils which contain iron cores shall be assumed to be the same for any of the currents which flow through them. Filters constructed with such inductances are said to be *linear*.
4. There shall be no magnetic coupling of the lines of force from any of the coils to any other coils in the circuits.

5. The output or load circuit shall consist of pure resistance (no coils or condensers), whose value shall be the same as that of the generator or input circuit.

It is possible to describe the characteristic of filters in terms of the output current as in Fig. 7 C, or in terms of the *ratio* of output to input currents, or the ratio of the output voltage across the load to the input voltage, or the ratio of the power output to the power input, or, as is more common and as we shall now do, in terms of the *attenuation* of the filter. The attenuation is expressed in decibels (Sec. 2.6) and is proportional to the logarithm of the ratio of the output to the input currents or voltages or powers. It is a measure of the losses which take place in the filter at the different frequencies.

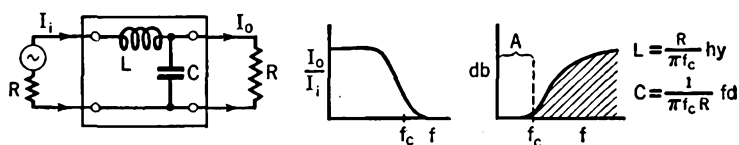


FIG. 7 D. An L-section, low-pass filter. The lower frequencies in the range "A" pass through, while those of higher value are more or less attenuated or lost in the filter

7.5 Low-Pass Filters. The circuit of Fig. 7 D is called an L-type, low-pass filter. It contains a series inductance and a shunt capacitance. From the attenuation (db.) curve in this figure, it can be seen that the choking action of the coil, aided by the bypass action of the condenser, has materially sharpened the curve over that of a single series inductance (Fig. 7 C), especially in the neighborhood of the *cutoff frequency*, f_c . In the equations given in Fig. 7 D, L is in henries, C is in

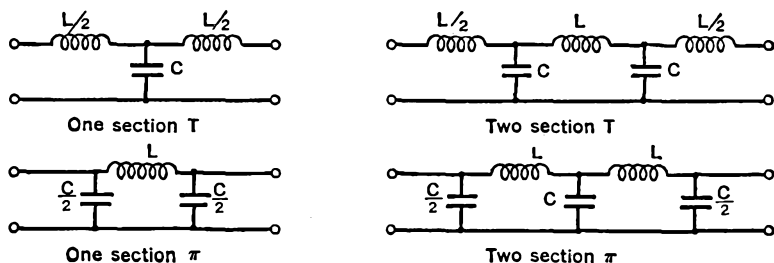


FIG. 7 E. — T- and π -type, low-pass filters

farads, R is in ohms, and f_c is in cycles per second. Note that the generator and the load both have the same resistance.

Referring to Fig. 7 E, we see that several "T"-sections or " π "-sections can be connected in series with each other to form two, three, or more section filters. The cutoff becomes increasingly sharp the more sections used. Then, of two frequencies near f_c , the lower one will get through and the higher one will not. The same design equations are used as for the L-section low-pass filter. Note that, in Fig. 7 E, only one-half the inductance or one-half the capacitance is used in certain places while the full value is used at others.

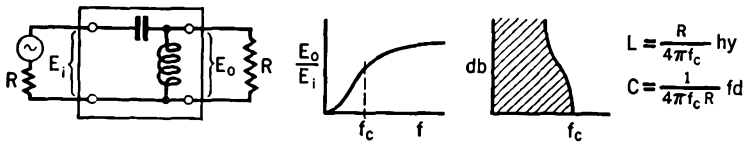


FIG. 7 F. An L-section, high-pass filter. L is in henries, C is in farads, R is in ohms and is the same at the input and output. The cutoff frequency, f_c , is in cycles per second

7.6 High-Pass Filters. Whereas the low-pass filters of the preceding section permitted the passage, more or less, of all frequencies below the cutoff value, and attenuated or suppressed, more or less, all frequencies above this value, high-pass filters do just the reverse. A single L-section high-pass filter is shown in Fig. 7 F and is seen to con-

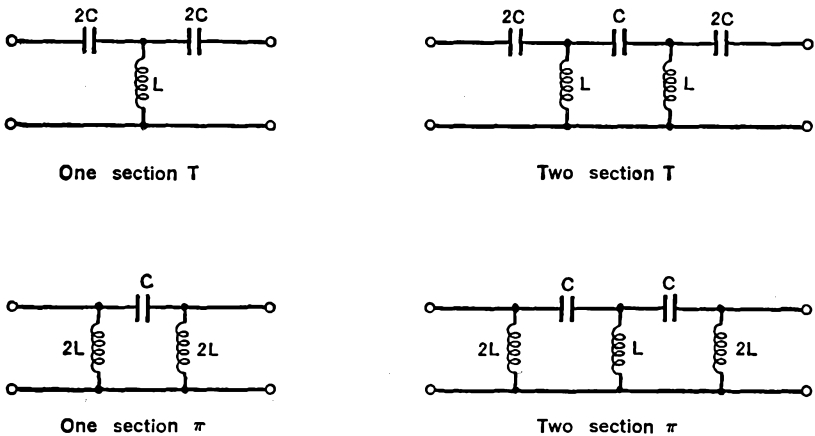


FIG. 7 G. — T- and π -type, high-pass filters

sist of a series condenser, whose reactance is large for low frequencies and small for higher frequencies, and a shunt inductance, which readily bypasses low frequencies but forces the higher frequencies to continue on out to the load R .

Figure 7 G shows T- and π -type, one- and two-section high-pass filters which offer greater discrimination to frequencies near the cutoff. The design equations are the same as for the L-section.

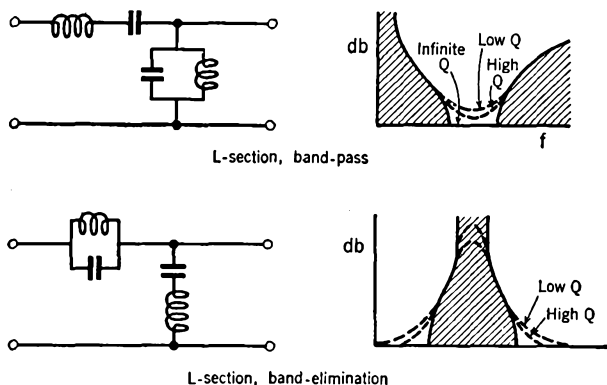


FIG. 7 H. Simple band-pass and band-elimination filters

7.7 Band-Pass and Band-Elimination Filters. It is possible to transmit a certain range of frequencies through a *band-pass filter*, and more or less completely suppress all lower and all higher frequencies. A simple filter of this type, together with its attenuation curve, is given in Fig. 7 H.

It is also possible to construct filters which will, more or less, transmit all frequencies except those which lie within a certain range. A simple form of *band-elimination* or *band-suppression filter* is also given in Fig. 7 H, together with its attenuation curve.

With multi-section filters of these types, the separation of adjacent frequencies can be made much sharper than with the simple L-section. On the other hand, in practice, the coils are not pure inductances but have some resistance. Now Q is our measure of the inductiveness versus resistance of a coil, i.e., $Q = 2\pi fL/R$. In Fig. 7 H, the dotted lines show in what manner the attenuation is affected when low- and high- Q coils are used. Similar unsharpening effects occur in practice with all filters.

It is well known that a quartz slab cut from its crystal in proper fashion and mounted between two metal plates acts like a circuit of very high Q . Hence, in circuits where the frequency of the currents is comparable with the natural vibrational frequency of the quartz, it is possible to obtain very sharp cutoff filters of all types.¹

¹ Details are given by W. P. Mason and R. A. Sykes, in *The Bell System Technical Journal*, Volume XIX, page 221, April 1940.

CHAPTER 8

RADIATION

8.1 Introduction. When a steady current flows through a conductor, a stationary magnetic field is produced in the surrounding space. The strength of the field is great near the wire and weaker farther away.

If the field is moved, an e.m.f. will be induced in a nearby conductor in an amount proportional to the rate at which the field cuts the conductor. The e.m.f. induced in a more distant conductor will be less because the magnetic field is weaker. Between the two conductors a difference of potential is created and hence an electric field is established.

It is not necessary that conductors be specified. The electric field will be established between any two points in space, whether they are separated from each other by a vacuum, an air column, an insulator, or a conductor.

An electric field E accompanies a *moving* magnetic field, just as a magnetic field H accompanies a *moving* electric field. The fields, if in motion, are always associated together. It can be shown that they are at right angles to each other, that both are at right angles to their motion, and that they contain equal amounts of energy. They are spoken of jointly as an *electromagnetic field*.

In 1864, Clerk Maxwell said that light, passing from a source to an observer, consisted of electric and magnetic fields in motion. He predicted that there should be other electromagnetic waves of comparatively low frequency. These were found in the laboratory work of Heinrich Hertz in 1887, and are now called radio waves.

8.2 Radiation. When an alternating current starts to flow through a conductor, its electromagnetic field builds up, with the lines of force in a certain direction, until the current has reached its maximum. Then, as the current decreases, the field continues to collapse back into the wire until it is zero at the end of the first half-cycle. Then the field builds up again, but with the lines of force pointed in the opposite direction.

However, not all of the energy returns to the conductor each time the field collapses. Just why this is so is not known. The percentage of energy which dissociates itself from the original field is very small when the frequency of the alternating current is low. It increases more and more as the alternations of current take place in shorter and shorter intervals of time. One of the important functions of a radio transmitter is to generate currents of sufficiently high frequency so that significant amounts of energy are dissociated from the original fields. The portion of the field which returns to the conductor is called the *induction field* and that portion which is freed is called the *radiation field*.

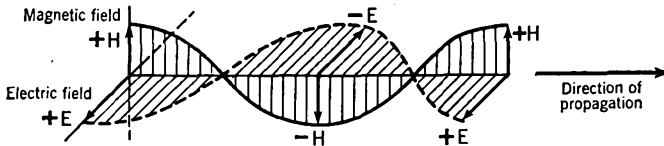


FIG. 8 A. The electric and magnetic fields of a radio wave are at right angles to each other and also at right angles to the direction in which energy is propagated

The radiation field travels away from the conductor with the speed of light. This is symbolized by c and is equal to 3×10^{10} cms. per second, $= 3 \times 10^8$ meters per second, $= 3 \times 10^5 = 300,000$ kilometers per second, or is equal to 186,000 miles per second. Fig. 8 A shows the relationships between the electric and magnetic fields and the direction in which energy is propagated.

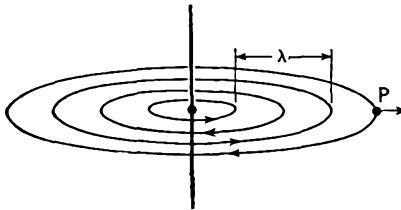


FIG. 8 B. A radiating magnetic field

8.3 Frequency and Wave-Length. Fig. 8 B shows a magnetic field radiating from a simple conductor in which the current is alternating at a frequency f . An observer at P would find that f complete oscillations or reversals of the magnetic field went past him each second. Hence f is also the frequency of the radiated wave. It is expressed in

slow rate by the voice, or by dots and dashes. The wave which goes out is then called a "modulated carrier wave."

In order that a broadcast signal may be intelligible, the field intensity at the receiver must be greater than the "noise level"; otherwise no amount of amplification will make it useful. The background "noise" is due to other radio waves, atmospheric and man-made static, internal circuit and tube noises of the receiver. Field intensities of $100 \mu v./m.$ are considered usable for broadcast reception.

8.5 Standing Waves. An electric light bulb is designed to radiate as much light as possible, with a minimum loss of energy in other forms.

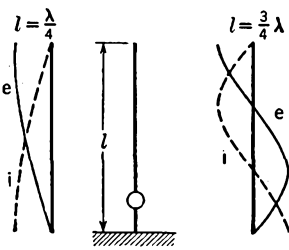


FIG. 8 C. A Marconi type antenna

A flatiron is built to give out heat and not light. An *antenna* is used to radiate as much energy as possible in the form of electromagnetic waves of radio frequency. If the fields from one part of a resonant circuit overlap those from another part they may well cancel each other. It is necessary to spread the circuit out in space if the radiation is to be appreciable. Such an "open circuit" is called an antenna.

The radiation of energy is greatest from those parts of an a.c. circuit where the current is greatest. The current can be increased at certain parts of a circuit by making its dimensions comparable to the operating wave-length. When this is done, *standing waves* of current and of voltage are established in the circuit. This is analogous to the case of sound waves moving back and forth in a pipe where, by suitable choice of the length of the pipe and the length of the sound waves, it is possible to build up large volumes of sound from a feeble source. We shall now see how standing waves can be produced electrically.

8.6 Simple Antennas. In the center of Fig. 8 C, the vertical wire is the antenna, the circle is the h.f. generator, and the shaded area is the earth. When the generator is first connected, an electrical impulse travels up the wire to its end. Here the magnetic field collapses because the current impulse stops at the end of its conductor. The collapse of the magnetic field sets up an electrical field which adds to the existing electric field and increases the voltage at the end of the wire. This starts an impulse back down the wire. As the electric field starts back, it begins to produce a magnetic field, and continues to do so until the

cycles per second (c.p.s.), kilocycles per second (kc.) or in megacycles per second (Mc.).

The distance in space occupied by each oscillation is called the wave-length. It is indicated by λ (lambda) in Fig. 8 B and is usually measured in meters.

The relationship between the free space velocity c , the frequency f and the wave-length is: $f\lambda = c$. If λ is in meters and f is in megacycles per second, we have,

$$\lambda = \frac{300}{f}$$

A low-frequency radio wave of frequency 15 kc. has a wave-length of 20,000 meters; a broadcast frequency of 1,000 kc. corresponds to a 300-meter wave-length; while an ultra-high frequency of 60 Mc. corresponds to a 5-meter wave-length.

8.4 Field Intensity. The strength or *electric field intensity* of a radio wave is measured in terms of the e.m.f. (in microvolts, $\mu v.$) which it produces between two points 1 meter apart. For example, if 20 microvolts are generated between the ends of a conductor 1 meter long when the radio wave cuts across it, the field intensity is said to be 20 microvolts per meter (abbreviated $\mu v./m.$). If the conductor were 5 meters long, the induced potential would be 100 microvolts.

When the fluctuating magnetic field of a radio wave moves across a wire, it sets up a fluctuating e.m.f. or voltage between the ends of the wire and this in turn drives a current through any electrical circuit connected to the ends of the wire. The amount of this current is exceedingly small unless the circuit is "tuned" to the same frequency of fluctuation as that of the radio wave. When you tune your radio receiver you are adjusting its frequency to that of the radio waves from the desired transmitting station. But even with a tuned circuit, the currents are usually small because the energy is sent out in all directions from the transmitter, and the receiving wire or antenna catches only a small part of it. Therefore, part of the receiving set is built to amplify the signal until it is strong enough to operate a loudspeaker or a meter. A message or signal can be impressed at the transmitter on the radio "carrier" wave just described. In the "amplitude-modulated" system, the carrier wave is varied in strength at a comparatively

energy is once more divided equally between them. If a second impulse from the generator starts up the wire just when the first impulse has returned and is ready to start its second trip, the two impulses will aid each other and a condition of resonance will exist between the antenna and the generator. It is also possible that the time for the impulse to travel to the open end and back again should be more than that just described; such that the second trip starts just when the generator starts its third rather than its second pulse.

At the left, in Fig. 8 C, is shown the idealized case of current i and voltage e along the antenna when it is oscillating at its *fundamental frequency* or "first harmonic." On the right in this figure, the voltage and current curves are shown for the second mode of vibration. The fundamental wave-length of the antenna is approximately $\lambda = 4l$.

In Fig. 8 D, the h.f. oscillator is located in the center of a straight wire, with the result that the fundamental wave-length is approximately two times its physical length. The Marconi type is more suitable for the longer wave-lengths because it need be only one-half as long as the Hertz type for a given frequency. For higher frequencies (shorter wave-lengths) the Hertz type becomes sufficiently short to be constructed. In addition, it can be mounted far above the earth or other absorbing bodies, whereas the Marconi type uses a ground connection.

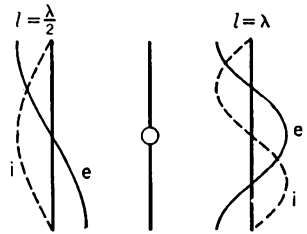


FIG. 8 D. A Hertz type antenna



FIG. 8 E. Radiation patterns from vertical Marconi antennas

8.7 Directed Radiation. A transmitting antenna should be able not only to radiate energy, but also to direct that energy into the areas where it is to be received. Figure 8 E shows typical field patterns from a Marconi antenna. Arrows drawn from the origin to the curves will have lengths proportionate to the field intensity emitted in their directions. The half-wave antenna gives *low-angle* radiation while the full-wave antenna gives *high-angle* radiation.

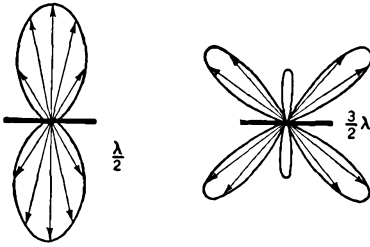


FIG. 8 F. Top view of radiations from horizontal Hertz antennas

Figure 8 F shows the field intensities established in different directions around an isolated Hertz antenna of different lengths, while Fig. 8 G shows the effect of the ground on a half-wave antenna of this type.

Many combinations of the simple antennas just described have been used to increase the directive effect. An example of a *directive*

array is shown in Fig. 8 H. The half-wave radiators are properly spaced and are so connected that the current flows through the different wires in proper order to give the uni-directional characteristic shown.

For the very high frequencies (u.h.f. and microwaves), parabolas may be used to focus the waves along a *beam*, like light rays from an automobile headlamp.

8.8 Transmission Lines. In general, the transmitter apparatus cannot be mounted at the same position as the Hertz antenna. The energy is fed from the h.f. oscillator to the antenna by means of a *transmission line*. This consists of wires so arranged that they radiate as little energy as possible. There are two types, called *tuned* or resonant, and *untuned* or non-resonant lines. Examples are shown in Fig. 8 I.

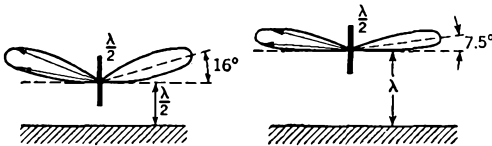


FIG. 8 G. High- and low-angle radiations from vertical half-wave Hertz antennas one-half and one wave-length above the ground

A tuned line may conveniently be thought of as the mid-portion of the antenna folded upon itself in such a manner that the currents in adjacent wires are in opposite phase but are of equal magnitude. Then the radiation from one wire nearly cancels that from the other.

In the case of the untuned line, we shall consider two closely-spaced parallel wires, or, equally as well, a wire down the axis of a hollow metal tube. For a moment, the *parallel wires* or the *concentric line* shall be assumed to be infinitely long. When an alternator is first con-

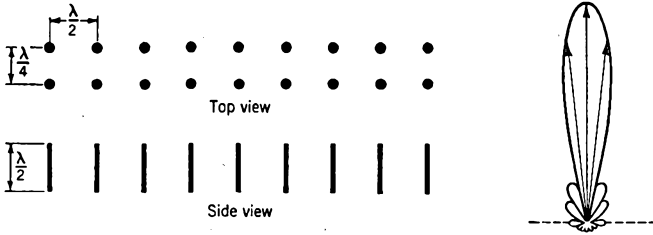


FIG. 8 H. A half-wave broadside array with strong uni-directional radiation

nected at one end, a wave travels outward at a velocity somewhat less than that of light. An ammeter in series with the line or a voltmeter across the line at various points would show a gradual decrease from the input value. The current decreases because some of the current is bypassed at each point through the distributed capacity existing between the wires and because a very small amount passes between them by ordinary conduction through the air or other insulator which separates the conductors. The voltage decreases because of the resistance and inductance drops along the conductors. However, the ratio of the voltage to the current at every point is the same as at all other points. This constant is called the *characteristic impedance* of the line. At radio frequencies, it is practically a pure resistance and hence is independent of the frequency.

A line of finite length, connected at its output end to a resistance load numerically equal to the characteristic impedance, acts just like a line of infinite length. The wave travels down the line and is all absorbed in the load; none is reflected to set up standing waves; the line is *non-resonant*.

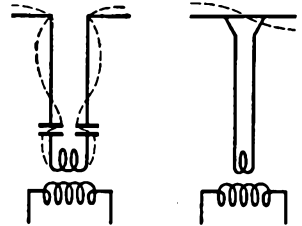


FIG. 8 I. Examples of tuned (left) and untuned transmission lines

CHAPTER 9

PROPAGATION OF RADIO WAVES

9.1 The Ground Wave. Energy is radiated outwards from an antenna in all directions. That part which passes along the surface of the earth is called the *ground wave*. For frequencies above 1,500 kc., its intensity is practically the same day and night, winter and summer. But it is different for different frequencies and for different surface conditions. The curves of Figs. 9 A and 9 B illustrate these effects.¹ It will be

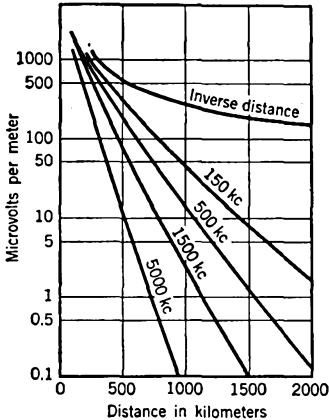


FIG. 9 A. Strength of the ground wave over sea water when the radiated power was 1 kw.

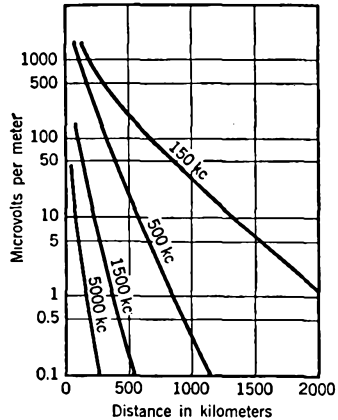


FIG. 9 B. Strength of the ground wave over land from a 1 kw. transmitter

noticed that a wave of given frequency travels farther over sea water, whose conductivity is comparatively great, than over the ground. Obviously, less energy is absorbed from the wave in a body of greater conductivity. As the frequency is increased, the small currents induced in the body by the wave become larger, the heat losses are greater and the wave does not travel as far. At about 2 Mc., the reliable range of

¹ Selected data from the report of the Committee on Radio Wave Propagation, Proceedings of the Institute of Radio Engineers, Oct., 1938.

transmission from a $\frac{1}{2}$ -kw. transmitter is about 200 miles over land and 500 miles over sea water. Above 4 Mc., the ground wave can only be used for short distances.

The ground wave is vertically *polarized*, i.e., its electric field is perpendicular to the earth. This is so because the conductivity of the earth tends to short circuit any electrostatic component parallel to its surface. The curvature of the ground wave around the bulge of the earth is due to *diffraction*, a bending which occurs when a wave grazes an object. The curvature is also partly due to *refraction* or bending of the wave caused by a slightly higher velocity of propagation in the upper than in the lower parts of the atmosphere, a process like that which causes light waves to bend as they pass through a glass prism or lens.

9.2 The Ionosphere. That part of the energy radiated from an antenna which travels in an upwards direction is called the *sky wave*. The fact that field intensities, which are very much larger than can be expected from the ground wave alone, are observed at great distances from a transmitter suggests that the sky wave has been turned back to the earth again. Two scientists, Kennelly and Heaviside, independently and almost simultaneously, proposed that a spherical conducting shell surrounded the earth some miles above it and reflected the sky waves back just as light is reflected from the inner surface of an inverted metal bowl.²

The Kennelly-Heaviside reflecting layer is now called the *ionosphere* and is known to consist of several layers or regions, one outside the other, in which the rarefied air has been broken up into electrons and *ions*, or positively charged gas molecules. The electric field of the sky wave oscillates the small electrons easily back and forth and they, in their turn, set up the electromagnetic field which returns to earth. The ionization or electrification of the air is due in large part to the sun's rays. Thus the location and number of electrons suffers great changes day and night, winter and summer. Hence the sky wave which returns to the earth is also subject to seasonal and diurnal variations. It is subject to changes over the 11-year sunspot cycle. In addition, the ionization of the region is greatly altered whenever unusual changes occur in the earth's magnetic field. Then the layers usually break up and expand, and radio transmission is poor. Sudden

² The mathematical treatment is essentially the same in the two cases; uses the same concepts and similar equations.

disturbances on the sun are accompanied by *fadeouts*, when the sky wave disappears almost instantly. Also, for unknown reasons, "patches" of intensive ionization sometimes occur in small regions and give rise to unexpectedly long distance transmission.

It is not clear just why there should be layers instead of a continuous distribution of ions and electrons. The lowest layer, called the *E region*, is about 70 miles above the earth's surface, has its greatest density of ionization around local noon. At night, without the sun's rays, it is but weakly ionized. At this height, the ions and electrons are

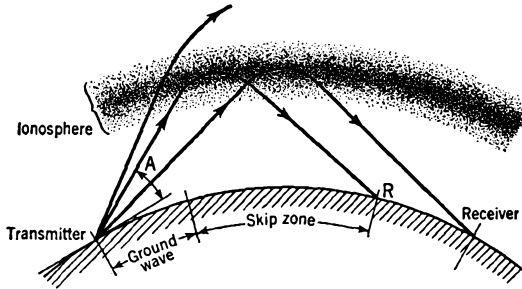


FIG. 9 C. Bending of sky waves

sufficiently close together to re-combine quickly to form neutral particles.

Above the *E region* lies the *F region*, about 175 miles above the earth at night. Here the atmospheric pressure is so low that ions and electrons re-combine slowly. The number of ions reaches a minimum just before sunrise. The layer splits into two layers during the daytime, the lowest of which is called F_1 and the higher F_2 . Their ionization is greatest at about local noon.

If a transmitter is used which sends out a sudden, sharp pulse of energy, and the receiver is located nearby, two (or more) pulses will be received. The first pulse to come in is the direct or ground wave, the second is the pulse which traveled up to the ionosphere and back again. By recording the pulses and measuring the extra amount of time needed for the sky pulse, it is possible to calculate the *virtual height* of the ionosphere. This is the height calculated on the assumption that the wave traveled throughout its entire path at the unabated velocity of light. This is not true in the ionosphere, so that virtual heights are always greater than the actual heights to which the wave rises.

9.3 Propagation of Sky Waves. Figure 9 C shows the paths of three sky waves through the ionosphere.

Low-frequency waves will be returned from the ionosphere even if sent straight up. As the frequency is increased, a *critical frequency* is reached for which the wave does not return to the earth. This is a useful measure of transmitting conditions. If waves are sent upward

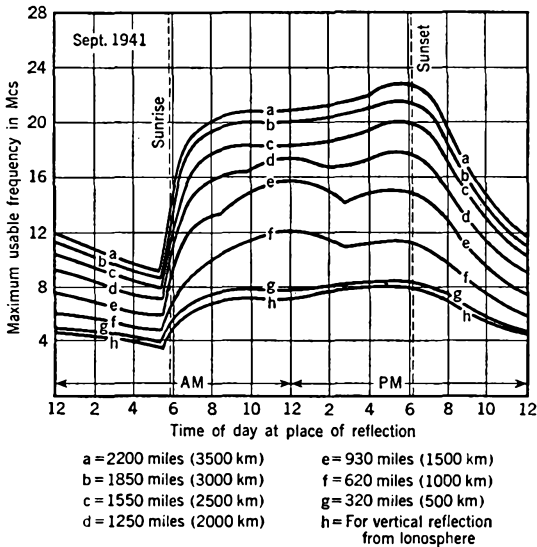


FIG. 9 D. Maximum usable frequencies for reliable radio transmission, for Sept. 1941, at Washington, D.C.

at an angle appreciably less than 90° from the ground, they may be refracted or bent back to the earth even though of higher frequency than the critical value. The *maximum usable frequency*, for waves transmitted at small angles above the ground, is about three times the critical frequency. Figure 9 D shows the values as measured by The National Bureau of Standards during September 1941. It can be seen that for transmission to a given distance, lower frequencies must be used at night than during daylight hours.

After returning to the earth, the sky wave can be reflected by the ground, to travel a second time to the ionosphere and back at a more remote point. This is called a *multi-hop*. In fact, radio waves have been received which have traveled the entire distance around the earth.

If two rays from the transmitter have traveled along slightly dif-

ferent paths to the receiver, they may be out of phase (crest for trough) and cancel each other, or they may be in phase with each other and give a strong signal. Since the paths through the ionosphere are subject to changes, the received signal may be strong at times and weak at others. This is called *fading*.

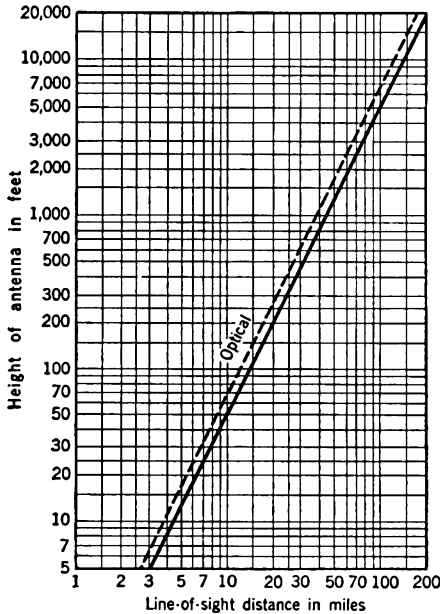


FIG. 9 E. Line of sight distance for u.h.f. transmission from antennas of various heights

9.4 U.H.F. Propagation. For frequencies above approximately 30 Mc., the energy is transmitted in a *direct ray* through the atmosphere. For greatest field strength there must be no obstruction in the path of the waves. The ground proves to be a fairly good reflector for these ultra-high frequencies, so that the received signal is a composite of the direct and a *reflected ray*. The effect of the latter is to weaken the signal because the two waves are, in general, slightly out of phase.

The waves can travel somewhat beyond the bulge of the earth because of a small amount of refraction in the atmosphere. The solid line in the graph of Fig. 9 E gives the line-of-sight distances for antennas of different heights, after allowing for atmospheric refraction ($d = 1.41\sqrt{h}$). Distances are read off the chart (solid line) using

first the height of the transmitting antenna, then that of the receiving antenna. The total distance will be the sum of the separate values.

The range of transmission of u.h.f. waves sometimes exceeds that of the direct ray just discussed because of an increased refraction in the troposphere or lower atmosphere caused by a "temperature inversion." This means that a layer of warm air exists above cooler air near the ground, a condition which is fairly common in the summertime. U.H.F. transmissions over distances of 3,000 miles have sometimes been observed, while sporadic ranges of several hundred miles are common.

CHAPTER 10

HIGH VACUUM DIODES

10.1 Introduction. Electrons evaporate from a hot filament in a vacuum tube just the way water molecules evaporate from a liquid into the air.

Figure 10 A shows a filament F and a metal plate P sealed in a glass bulb which has been highly evacuated so that there is essentially no gas in the tube. At the bottom left, there is a battery which is used

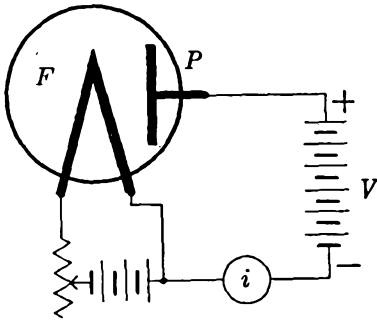


FIG. 10 A. A high vacuum two-electrode tube or diode. (From E. & N. P.)

to heat up the filament. The temperature of the filament can be changed by changing the amount of current flowing from the battery through the filament. This is accomplished by means of the rheostat in the lower left corner where the arrow serves to indicate the sliding contact or knob which increases or decreases the total amount of resistance wire in this so-called A-battery circuit. The plate is charged positively with respect to the filament by means of the battery whose voltage is

marked V . When electrons, which are negatively charged, are emitted from the filament, they are attracted to the positively-charged plate and move through the empty space between these two electrodes in the vacuum. The circuit containing the battery V , the current-measuring instrument i , the filament, and the plate is called the B-battery circuit. Inasmuch as the filament serves as the source of electrons, it is obvious that the current can flow through this two-electrode tube, or diode, in but one direction. In the conventional sense the electricity leaves the positive terminal of the battery, flows along the wire to the plate P , then to the filament, then through the wires to the meter i , to the negative terminal of the battery. In the true electron sense, the current flows in the reverse direction.

10.2 The Evaporation Theory. As explained earlier, there are free electrons moving between the fixed atoms which make up the metal of the filament. Some of these are moving rapidly and some slowly.

At the surface of the filament some of the electrons escape into the vacuum where they travel along curved paths and come back to the filament, like a ball thrown upward from the surface of the earth. If the wire is heated, some of the electrons acquire sufficient speed so that they can escape completely from it. This is called *thermionic emission*. In fact, the escape of electrons from a metal obeys the same mathematical laws as does the escape of molecules from water when it evaporates.

The facility with which electrons escape from different filaments, all at the same temperature, depends on the metal of this filament and upon certain sensitizing coatings placed upon it.

10.3 The Change of Thermionic Current With Temperature of the Filament. Suppose we heat the filament of the tube in Fig. 10 A hotter and hotter, measuring its temperature with an optical pyrometer, the while we observe the plate current i . We will find that the thermionic current increases very rapidly as the filament grows hotter and hotter, as indicated by the line OA in Fig. 10 B, provided only that the voltage of the battery is sufficiently large to draw over to the plate all of the electrons as they are emitted from the filament. O. W. Richardson, using the mathematics of evaporating liquids, was the first to

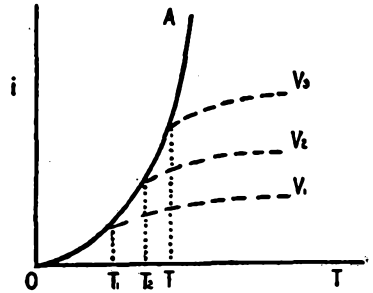


FIG. 10 B. Plate current at different filament temperatures. (From E. & N. P.)

derive a mathematical equation connecting these currents and the temperatures of the filament. The fact that his theoretical equation agrees with the measured values lends great weight to the picture of *free* electrons existing inside of conductors.

10.4 Different Kinds of Filaments. The larger tubes, such as those that are used in powerful broadcasting stations and in X-ray outfits, have a filament made of tungsten wire. Although this is not the most efficient emitter of electrons it has a sufficient ruggedness to warrant its use in these large tubes. For the smaller tubes, on the other hand, the filaments can be coated with special materials which permit them to

emit electrons more copiously at a given temperature. These special coatings are of such a nature that the electrons can escape from the underlying metal with greater ease than in their absence. This could be compared to the spreading of some kind of film over the surface of water which would permit the water underneath to evaporate more rapidly at a given temperature. The scientific measure of the goodness of the filament, insofar as its electron emitting power is concerned, is called the *work function*, defined as the number of volts to remove one electrostatic unit of electricity from the metal. The smaller the value of the work function, the more copious the emission of electrons, other

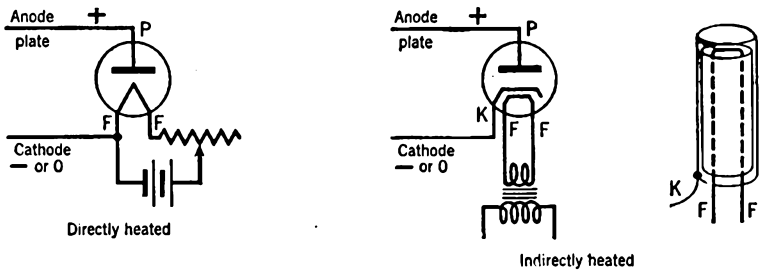


FIG. 10 C. Types of cathodes

conditions being the same. Conversely, the same number of electrons can be obtained from a filament whose surface has been properly treated when it is operated at a lower temperature than from an untreated surface at a higher temperature. Hence, "thoriated" and "coated" filaments are often spoken of as *dull emitters*. Dull-emitter filaments have low values of the work function, of the order of 1 or 2 volts, in contrast with the pure metals whose work function is of the order of 3 to 6 volts.

As another comparison between the various types of filaments let us examine the following numbers: a pure tungsten filament heated to $2,000^{\circ}$ K. will deliver 1 milliamperes of electron current for 23 units (watts) of input heating energy (per sq. cm. of surface); a thoriated filament will give 350 milliamperes for 13 watts per sq. cm. at $1,500^{\circ}$ K.; an oxide-coated filament will give about 150 milliamperes for 6 watts input at $1,200^{\circ}$ K. These are 0.04, 27, and 25 milliamperes per sq. cm. per watt, respectively, but are only approximate figures, and other factors, such as life and durability against vibration, are to be considered in practical cases.

10.5 Types of Cathodes. The cathode may be directly or indirectly heated, as shown in Fig. 10 C. In the latter type, a coated metal sleeve

or thimble K surrounds an insulated heating wire. The sleeve is coated with the alkali earth metals (oxide-coated) so as to be an efficient emitter of electrons at a comparatively low temperature. K is sometimes called an equipotential cathode.

If a.c. is used to heat the simple, direct-type filament, electric and magnetic forces are set up which, in a receiver, cause a hum in the output. The hum may be greatly reduced by the use of a center-tap connection, as shown in Fig. 10 D. The small condensers are used to bypass alternating currents around the transformer secondary.

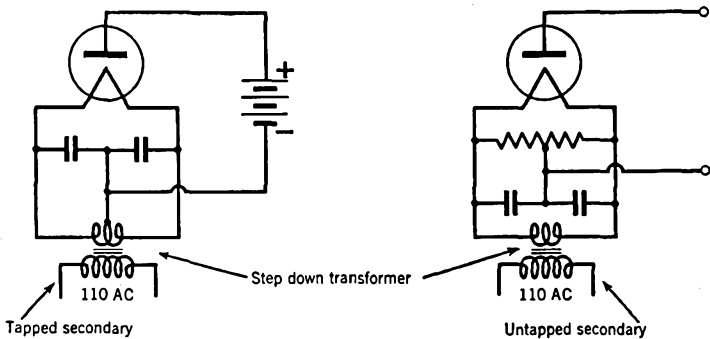


FIG. 10 D. Methods of reducing hum when directly heated filaments are used

10.6 Saturation Currents. Suppose we have a pan of water out in the open where the wind can blow away the water molecules as fast as they evaporate. Then, by way of contrast, suppose we have a pan of water with a box over it, so that the water molecules that have evaporated cannot escape, but remain hovering above the water surface, sometimes returning to become part of the liquid again. In the first case, the liquid will evaporate much more rapidly than in the latter. Similarly, in the case of the electrons evaporating from the filament in Fig. 10 A; if the plate P is very positive with respect to the filament (by use of a large battery V), then all of the electrons emitted by the filament will be drawn over to the plate. But if the battery voltage is small, electrons will collect in the space between the filament and the plate, like the cloud of water vapor above the liquid inside the box. Then the electrical current registered on the meter i will not be as large as that discussed by Richardson (Sec. 10.3). This state of affairs is shown by the dashed lines in Fig. 10 B. The higher the plate voltage, the more nearly will the currents approximate the full saturation value of curve OA .

10.7 Space Charges. Ordinarily, radio tubes are operated with the plate voltage adjusted to a value which is insufficient to draw over all of the electrons which are emitted by the filament. Thus, in usual operation, there is a cloud of electrons or so-called *space charge* surrounding the filament, and *limiting*

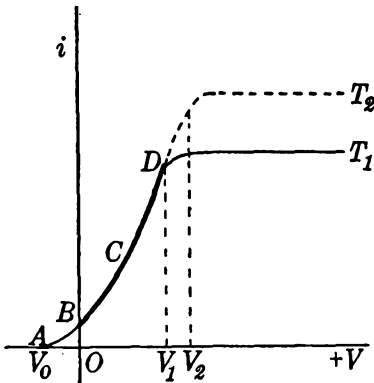


FIG. 10 E. The plate voltage V changes the plate current i . Fixed filament temperatures, T_2 and T_1 . (From E. & N. P.)

the plate current to a value appreciably less than the saturation value.

The electrons which make up the space charge are not at rest in the region just outside of the filament, but are actually in rapid motion. Electrons in transit from the filament to the plate repel other electrons which are behind them and drive some of the newly emitted electrons back into the filament. Thus the space charge is continually pouring some of its electrons onward to the plate, the while they are being supplanted by new electrons just

fresh from the filament. Despite this state of dynamic equilibrium, the net result is the same as though there existed a fixed cloud of electrons in the space between the filament and the plate.

The number of electrons in a unit volume, i.e., the density of space charge, is greatest near the filament and decreases progressively as the plate is approached.

When the filament is quite hot and the plate voltage is quite small, the space charge will keep the plate current down to a very small value. But, if the filament is cooler and the plate voltage is high, the plate current will be nearly equal to that of the saturation of total emission value.

10.8 Plate Control of the Space Charge. The effects due to the space charge can be shown in another fashion. Let the temperature of the filament of the tube in Fig. 10 A be held constant and let the voltage on the plate be increased. As shown in Fig. 10 E, the space-charge-limited current increases along the line AD and eventually equals the saturation value shown by the horizontal line, upper right of the figure. With a hotter filament the dotted curve ADT_2 will be obtained. The rela-

tionship between the applied voltage V and the resulting current i is expressed by the following equation: $i = BV^{3/2}$, where B is a constant. This is variously known as the three-halves-power law, the Child law, and also as the Langmuir law. In actual tubes, the exponent in this equation varies between two-halves and five-halves. This is because of the drop of voltage between one end of the filament and the other, and because of the initial velocities with which the electrons leave the filament.

10.9 Field Emission. Suppose the voltage on the plate of a two-electrode vacuum tube or diode be increased to a very, very large value. Then it will be found that the current passing through the tube will be much greater than the saturation or total emission value discussed in previous sections of this chapter. The electric field between the plate and filament, due to the very-high-voltage battery, causes an increase in the number of electrons escaping from the filament at a given temperature. This so-called field emission is negligible at the usual voltages used on ordinary vacuum tubes. Intense electrical fields, however, are able to assist the electrons inside the metal of the filament to escape into the vacuum outside. Thus, due to the combined pull of the electric field and their own thermal movements, more electrons escape than would do so by thermal emission alone.

With field emission, it is the strength of the electric field rather than the voltage of the battery which counts. In other words, if the filament and the plate are close together, a given voltage of comparatively modest amount can set up an electric "field gradient" of value equal to that produced by a much larger voltage applied to a more widely separated filament and plate. Yet the field emission in the two cases will be the same.

10.10 Secondary Emission. Consider next what happens when streams of high-speed electrons strike a metal plate. If the energy is sufficient, new electrons are actually knocked out of the metal plate. These are called secondary electrons and the process is called secondary emission. In fact, the number of secondary electrons ejected by the oncoming electrons is frequently greater than the number of incident electrons. This does not mean that we get something for nothing, for the energies of the secondary electrons total to an amount less than the energy of the incident electrons.

As the speed of the primary or incident electrons is increased from zero to a few hundred volts, the number of secondaries per primary in-

creases from a low value, near zero, to a maximum. With further increase beyond this value of a few hundred volts energy of the primaries, the number of secondaries slowly decreases, as indicated in Fig. 10 F.

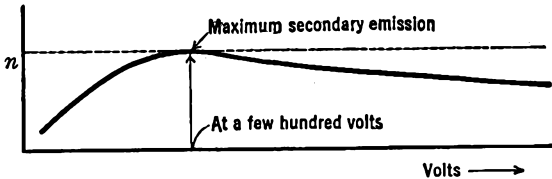


FIG. 10 F. The number n of secondary electrons per primary electron at increasing voltages

Actually the curve just mentioned is not smooth but has very small humps and dips in it.

The maximum number of secondaries per primary depends on the metal used and its surface treatment. For a pure metal, from which all surface gases have been carefully removed, the value ranges from one to one-and-a-half. For untreated metals, it ranges from three to four. It may be as great as eight or ten if certain alkali-metal films have been deposited on the metal plate. In other words, it is greater for surfaces having a low work function. Thus, to secure a copious emission of secondary electrons, specially treated surfaces are needed.

Secondary electrons leave the surface at random in all directions, at velocities corresponding to only a few volts, even when 1,000-volt primary electrons are used.

Insulators, such as glass, will also give off secondary electrons. In these cases, and with high-velocity primary electrons, as used with large transmitting, rectifying, and X-ray tubes, the number of secondaries per primary may be somewhat greater than unity. In these cases, with the negatively charged electrons leaving the surface in larger numbers than the number of incident charges, the insulator will acquire a positive instead of a negative charge. At another point in the same high-voltage tube, the number of secondaries per primary may be less than unity and a negative surface charge accumulates. With the continued increase in opposite charges between the two points, sufficient electrical strains may be set up so as to break down the insulator and destroy the tube.

Later, we shall see how the phenomenon of secondary emission has been put to good use.

CHAPTER 11

SOME DIODE RECTIFIERS

11.1 Rectification. To “rectify” an alternating current means to limit its flow through a circuit to one direction only, preventing its flow in the opposite direction. A diode can be used for this purpose because the flow across the vacuum tube can only take place in one direction; the electrons which move across the vacuum and make up the current through the tube have their source in the hot filament.

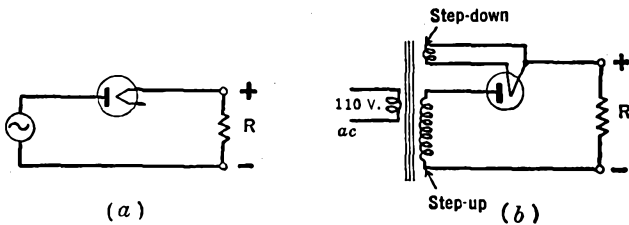


FIG. 11 A. Half-wave rectifiers

11.2 Half-Wave Rectifiers. The operation of a half-wave rectifier can be understood from Figs. 11 A and 11 B. The diode is connected in series with the alternating source and the load R . The source may be directly connected to the circuit or its voltage may be stepped up by means of a transformer as in 11 A (b). Whenever the plate is positive with respect to the filament, current flows through the tube and through the load R , in amount determined by the characteristic curve of the tube, shown in Fig. 11 B(a). When the plate is negative, no current flows. Thus, current flows through R each positive half-cycle of the impressed voltage.

The + and - terminals in Fig. 11 A are used in the conventional sense for current flow (through R from + to -), which is reversed from the direction of the electron flow.

The current through the load is called a *direct-pulsating* current. This type of current is the equivalent of a combination of a direct current and an irregularly shaped alternating current or ripple.

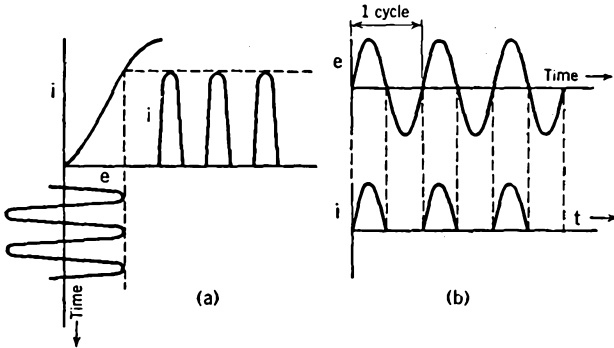


FIG. 11 B. Currents and voltages in the circuits of Fig. 11 A

The *peak-inverse-voltage* across the tube in Fig. 11 A(b) is 1.41 times the r.m.s secondary voltage of the transformer (sine wave assumed).

The *per cent ripple* of a rectifier is defined as 100 times the ratio of the output ripple r.m.s. voltage to the output d.c. voltage. For code transmitters, the ripple may be 5 per cent but for speech transmitters and for receivers it must be less than 0.25 per cent.

The *ripple frequency* in half-wave rectifiers is the same as that of the supply line, i.e., 60 cycles per second for a 60-cycle line.

11.3 Full-Wave Center-Tap Rectifiers. Several circuit diagrams of a full-wave center-tap rectifier are shown in Fig. 11 C, together with the wave form of the direct-pulsating current which flows through the load *R*. When the upper end of the transformer secondary in (a) is +, the upper tube conducts, and on the next half-cycle, when the lower end is +, the lower tube conducts. It will be noted that during each half-cycle, the current flows through *R* in the same direction. Thus both halves of the supply voltage are used. Since only one-half of the

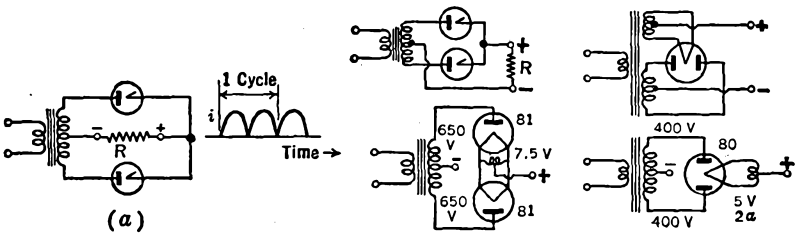


FIG. 11 C. Full-wave center-tap rectifiers

transformer secondary is used at one time, the total secondary voltage must be twice that required with a half-wave rectifier.

The inverse-peak-voltage on the non-conducting tube, which it must be built to withstand, is equal to 1.41 times the total r.m.s. secondary voltage (minus the voltage drop in the conducting tube, which is usually small).

The ripple frequency is twice that of the supply line; 120 for a 60-cycle line.

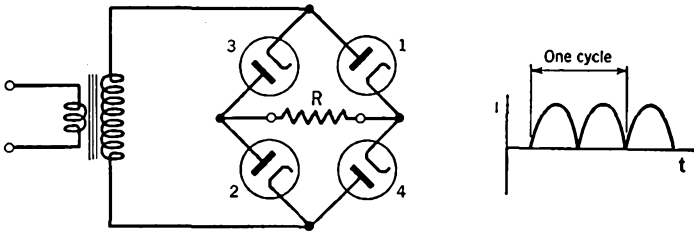


FIG. 11 D. Full-wave bridge rectifier

11.4 The Full-Wave Bridge Rectifier. In Fig. 11 D, when the upper end of the transformer's secondary is positive, the current flows through tube 1, through the load R and then through tube 2, in the conventional sense. During the opposite half-cycle, the flow is through tube 4, through R , and then through tube 3. Note that it is in the same direction through R in both half-cycles. All of the transformer's voltage is used each half-cycle, but four tubes are used instead of the two in the full-wave center-tap rectifier. The inverse-peak-voltage is equal to the

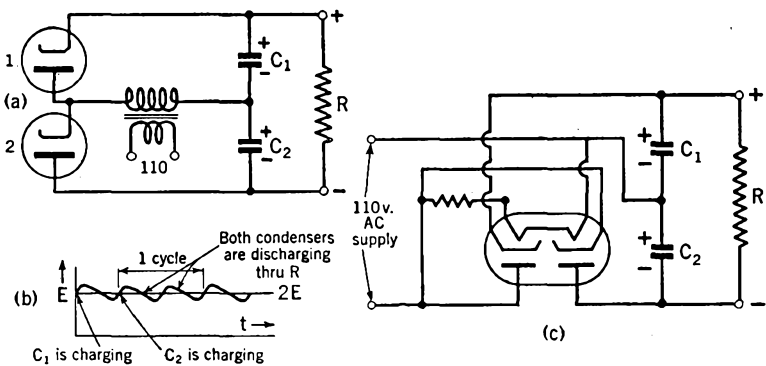


FIG. 11 E. Voltage doublers

maximum transformer voltage. The ripple frequency is 120 for a 60-cycle supply.

11.5 Voltage-Doublers. Figure 11 E shows the principle of the voltage-doubler. Referring to (a), when the transformer secondary voltage is + at the left, the upper tube 1 conducts electricity into the condenser C_1 . During the next half-cycle, the lower tube 2 fills condenser C_2 and

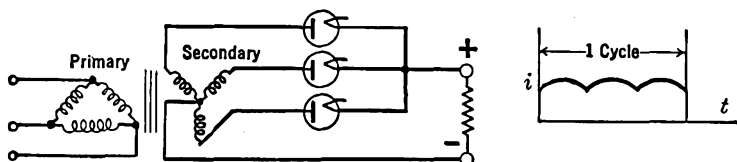


FIG. 11 F. A three-phase rectifier

C_1 is discharging through the load R . If R is not too small, both condensers become charged to nearly the peak supply voltage E . Since they are connected in series, with the polarity indicated, their total voltage, which is applied to the load, is $2E$. Hence the name "voltage-doubler." The output voltage is indicated in (b) and is seen to be comparatively constant, the ripple amounting to approximately 5 per cent of $2E$. When additional filtering circuits are added, the ripple will be only a small fraction of 1 per cent. The ripple frequency is twice the line frequency.

Figure 11 E(c) shows a doubler circuit which is often used without a transformer. The tube is called a *double-diode rectifier*.

The full-wave doubler circuit has been generalized to give $4E$, $6E$, etc., and is then used to produce very high voltages for atom-smashing experiments.

11.6 Three-Phase Rectifier. Figure 11 F shows the circuit and waveform of a three-phase rectifier. The "three-phase" refers to the supply line, which is the equivalent of three generators, each producing a sine wave 120° out of phase with the other. Thus the output voltage has a frequency three times that of the supply and is comparatively free from ripple.

11.7 Filters for Rectifier Circuits. Wherever a supply of current or voltage of constant strength is needed (wherever a battery has been used), one may use an alternating source, a rectifier, and a filter. It is the last-named element of the complete circuit which we now consider. Filters, as used here, consist of combinations of coils, condensers, and resistors suitable to smooth out the ripples in direct-pulsating cur-

rents so as to yield as nearly pure d.c. as possible. By storing energy in the magnetic fields of the coils and in the electric fields of the condensers while the voltage and current are increasing, and by returning it to the load while the voltage and current are decreasing, the "valleys" in the direct-pulsating voltages and currents are filled in. The smaller the "dips" in the direct-pulsating current, i.e., the smaller the per cent ripple, the easier it is to filter. The higher the ripple frequency, i.e., the more humps per cycle of the supply frequency, the easier it is to filter.

In Chapter 5 we have seen that a coil in series with a mixed direct-plus-alternating current will, because of the choking action of the coil, reduce the alternating component while it passes the direct component. It was also shown in Chapter 5 that a condenser across the line will more or less bypass the alternating component, without loss of the direct component. Further details of filters will be found in Chapter 7.

Some of the common types of filters used in rectifier circuits are shown in Fig. 11 G, wherein use is made of the choking action of series

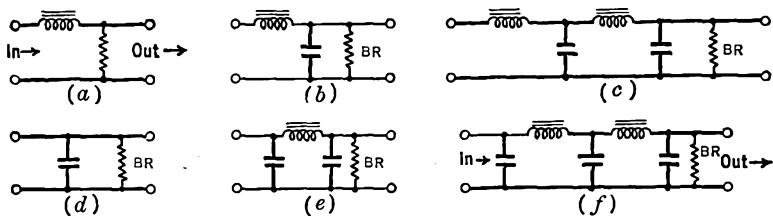


FIG. 11 G. Types of filters used in rectifier circuits

coils and the shunting action of parallel condensers to suppress and to bypass the ripple component of a rectifier while permitting the d.c. component to continue to the output. Filters *a*, *b*, and *c* are of the *choke-input* type and *d*, *e*, and *f* are of the *condenser-input* type. Circuits *b* and *e* are called *one-section* filters and are used when a comparatively large final amount of ripple can be tolerated. The *two-section* filters *c* and *f* are used when better filtering is necessary.

11.8 Component Parts of Rectifier Filters. Figure 11 H shows the complete circuit of a typical rectifier. The chokes or coils are wound on iron cores which have a small air gap. The air gap helps to maintain the inductance of the coil at a high value (10 to 30 henries) even when comparatively large currents pass through the coil. Since the

inductance does vary somewhat with current, the specification of the inductance can only be given with accuracy for a given current.

For voltages up to approximately 800, the compact, high-capacity electrolytic-type of condenser is used. For still higher voltages, the

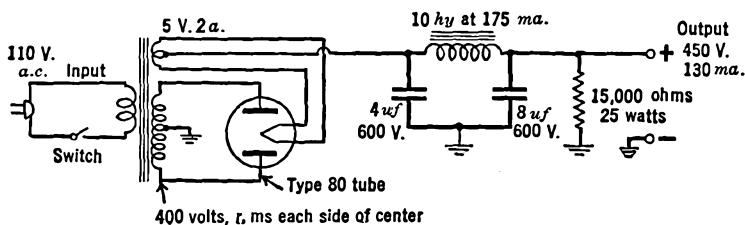


FIG. 11 H. A typical rectifier circuit

insulator or dielectric of the condenser is usually made of thin, oil-impregnated paper. Care must be taken to choose a condenser whose continuous-operation or *working voltage* is high enough so that it will not be punctured. The capacitance of each condenser is usually 4 or $8 \mu\text{fd.}$, although 16 and even $100 \mu\text{fd.}$ are occasionally used.

The high resistance BR in the circuits of Fig. 11 G is called a "bleeder-resistance" and is used to discharge the condensers after the power is removed. It should not pass more than 10 per cent of the output current. For small rectifier units ("B-battery eliminators"), a typical bleeder resistor would have 15,000 ohms resistance and 25 watts power-dissipating ability.

11.9 Voltage Regulation. The voltage output of a rectifier circuit decreases as larger currents are taken out because of the losses which occur in the various resistances in the circuit. This is indicated in Fig. 11 I for a condenser-input filter and for a choke-input filter. The per cent "voltage regulation" is defined as $100 (E_1 - E_2)/E_2$. It is to be noted that, whereas a circuit with a condenser-input filter will deliver a higher voltage, its voltage regulation is poor in comparison with the choke-input filter circuit. The regulation of the circuit of Fig. 11 E(c) is poor even with the addition of a choke and another condenser, and even when the condensers C_1 and C_2 are as large as $16 \mu\text{fd.}$ each.

11.10 Vibrator Units. A common source of power for portable electronic circuits is the 6-volt automobile-type storage battery. This low voltage may be stepped-up to a suitably high value by means of a vibrator and transformer unit, as shown in Fig. 11 J, after which it is

rectified either by means of a diode, as in (a), or mechanically, as in (b), and then filtered in the usual manner.

In (a), when the battery is first connected, the vibrating reed is drawn down by the magnet coil. A pulse of current passes through the lower half of the primary of transformer T and, at the same time, the

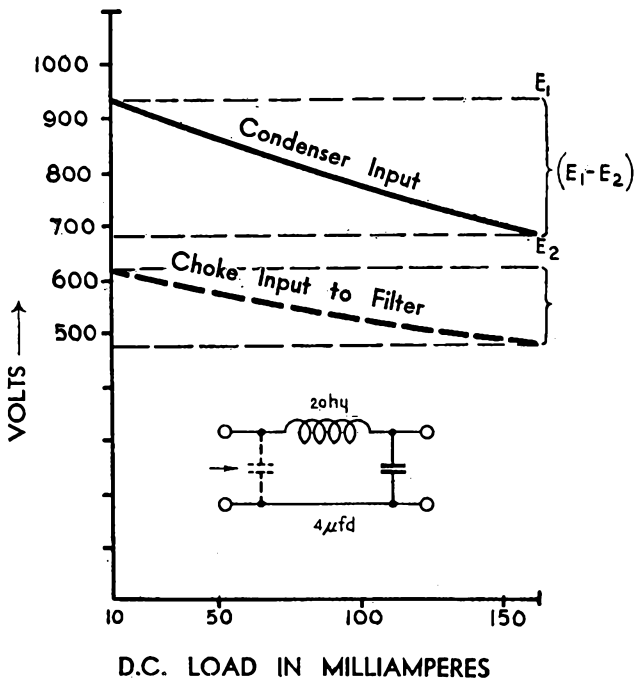


FIG. 11 I. Voltage from a rectifier for various loads

magnet coil is shorted and hence de-energized. The reed then moves upward to close the upper circuit. But then the magnet is again energized and draws the reed down, etc. Condenser C_2 (0.005 to 0.03 μfd . 1,500 to 2,000 volt d.c. rating) absorbs the surges of current in the secondary of T , and hence serves both to protect the rectifier tube and to smooth the current. In order to prevent r.f. interference or "hash" when the circuit is used in a receiver, the entire unit must be carefully shielded in a metal can and hash filters are used. One of these consists of: r.f.c. (50 turns, No. 12 wire, half-inch in diameter) and condenser

C_1 (0.5 to 1 $\mu\text{fd.}$, 50 volts rating). The other hash filter consists of r.f.c. (2.5 millihenry choke) and condenser C_3 (0.01 to 0.1 $\mu\text{fd.}$).

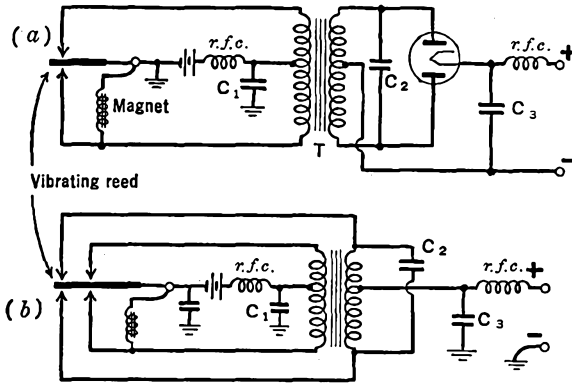


FIG. 11 J. Power supply units for mobile or portable use

The circuit of Fig. 11 J(a) is of the so-called *non-synchronous* type while that of (b) is of the so-called *synchronous* type. In the latter, the double-diode rectifier is replaced by an extra pair of contacts on the vibrator.

CHAPTER 12

HIGH-VACUUM TRIODES

12.1 Grid Control of the Space Charge. A triode or three-electrode tube contains a mesh or grid of wires in addition to the filament and plate of a diode. As usually operated, the grid, located between the filament and the plate in the middle of the space charge, is negatively charged with respect to the filament and hence adds its effect to that of the space charge in limiting the number of electrons which flow to

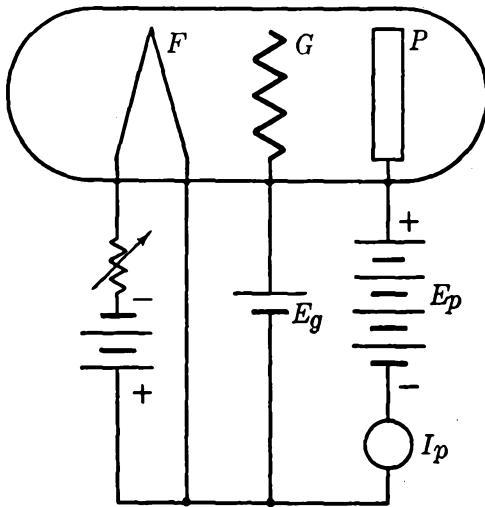


FIG. 12 A. Circuit used to plot the characteristic curves of a triode.
(From E. & N. P.)

the plate. Fig. 12 A shows the circuit used to obtain the family of *characteristic curves* shown in Fig. 12 B. When the grid is made very negative, it strongly repels electrons, prevents them from getting over to the plate, and hence keeps the plate current I_p down to a very small value. If, however, the grid is less negative, more current flows in the plate circuit as shown by the rise in the curves in Fig. 12 B. In this

figure, the different curves correspond to the different voltages on the plate; the upper curves when the plate voltage is large, the lower curves for the cases when it is small.

The characteristic curves of a tube prove very useful both in understanding the principles involved in the applications of the tubes and in the design of electronic circuits. Such curves may be obtained easily for a given tube in the laboratory or they may be obtained from data sheets supplied by the manufacturer of the tube. Note that the curves

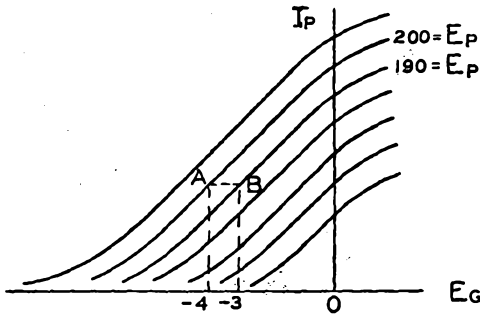


FIG. 12 B. Characteristic curves of a triode. Plate current I_p vs. grid voltage E_g . (From E. & N. P.)

are essentially straight over their central portion, and that they have a longer straight region when the plate voltage is high. Note also that they bend at their lower left or *cutoff* end and at their upper right or *saturation* end.

12.2 The Grid or "C" Bias. In many applications of three-electrode tubes it is necessary to maintain the grid at a fixed negative potential with respect to the cathode. This is accomplished by means of *grid-bias* devices, as shown in Fig. 12 C. A simple, direct method using a C-battery is shown at (a), while the *cathode-resistor* method is shown at (b). In the latter case, the plate current flows through the cathode-resistor R_c (5 to 5,000 ohms) from top to bottom (in the conventional sense of current flow), and sets up a potential drop which makes the grid negative with respect to the cathode. The value of R_c can be computed with the aid of Ohm's law when the desired grid-bias voltage is known and the total current through R_c is obtained from the characteristic curves (Fig. 12 B) of the triode. C_c is known as the *cathode bypass condenser* and is used to shunt alternating or h.f. currents around R_c , thus reducing "negative feedback."

In Fig. 12 C(c), the *grid leak* R_g (10,000 ohms to 10 megohms) is used when the input signal is sufficiently great to drive the grid positive during a portion of its cycle, as in oscillator circuits. When the grid is positive with respect to the cathode, electrons are drawn to it. Flowing through R_g they set up a potential whose negative is at the top

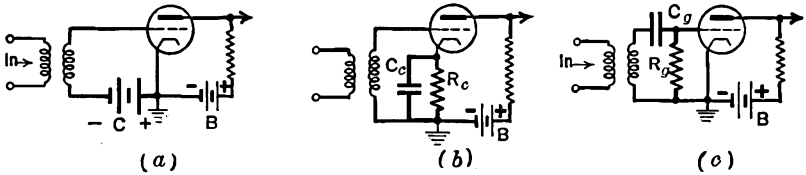


FIG. 12 C. Grid biasing methods: (a) fixed; (b) cathode; (c) leak

of R_g . The grid condenser C_g prevents the grid current from flowing through the transformer shown at the left of the circuit. In order that the grid bias shall be nearly constant, it is necessary that the time constant $R_g C_g$ (see Sec. 3.6) be large in comparison with the period of the signal voltage. The value of R_g can be computed with the aid of Ohm's law if the desired grid bias and the d.c. grid current are known.

12.3 Dynamic Curves. "Static" characteristic curves, such as those shown in Fig. 12 B, are obtained when there is no resistance or impedance in series with the plate battery. Dynamic curves take account of the effect of a plate load and hence show the behavior of the tubes in actual operation.

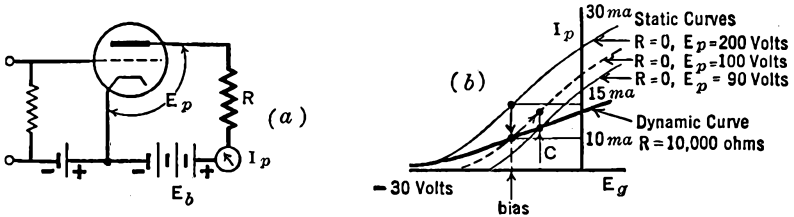


FIG. 12 D. A triode with a resistance load; and its dynamic curve

Consider the case of a pure resistance load, as in Fig. 12 D. The voltage E_p across the tube itself is less than that of the plate battery E_b by an amount equal to the $I_p R$ drop in the load resistance R . For example, if $R = 10,000$ ohms, $I_p = 10$ ma. (milliamperes) and $E_b = 200$ volts, then the voltage lost in R will be $0.01 \times 10,000 = 100$ volts and only one-half the battery voltage is applied to the tube, i.e., $E_p =$

200 — 100 = 100 volts. With a fixed bias voltage on the grid, the plate current I_p is less when the plate voltage is less. Thus, in Fig. 12 D (b), the static or no-load current would be 15 ma. when the full 200 volts was on the plate. With R in the plate circuit, it would be 10 ma., corresponding to 100 volts on the plate.

Any change of the grid voltage will alter the plate current. Suppose an input signal should make the grid less negative. In the absence of R , the plate current would increase along the upper static curve. When R is present, however, the plate current would increase along the dotted static curve [Fig. 12 D (b)], provided the voltage on the plate remained fixed at 100 volts. But this is not true. When the plate current increases, the $I_p R$ drop increases to a value greater than 100 volts, say to 110 volts, leaving only 90 volts on the plate. With this lower plate voltage, the plate current cannot be as large. Eventually, the current attains a value such as that indicated at C in the figure. From a succession of such points for various voltages on the grid, the dynamic curve is obtained. Note that it is straighter and has less slope than the static curve.

12.4 Voltage Amplification Constant ($mu = \mu$). Because the grid is located in the middle of the space charge, its potential proves to be very effective in controlling the number of electrons which reach the plate; much more so in fact than the potential of the plate. The ratio of effectiveness of changes of the grid potential and of the plate potential in changing the plate current is called the voltage amplification constant of the tube.

As indicated by the line AB of Fig. 12 B, a change of 10 volts on the plate may be counteracted by a change of opposite polarity of only 1 volt on the grid (-3 to -4). The ratio of 10 to 1 is the voltage amplification constant in this particular case.

In order to be more accurate, let us now write down the equation for this important vacuum tube constant, namely,

$$\mu = \frac{E_p - E'_p}{E'_g - E_g} = \frac{e_p}{e_g}, \quad (\text{for constant } I_p).$$

Thus the accurate definition of mu is: the ratio of the change of plate voltage ($E_p - E'_p$) to the change in grid voltage ($E'_g - E_g$) for zero change in the plate current ($I'_p - I_p = 0$).

The amplification constant may be obtained from the character-

istic curves or it may be measured directly by means of an instrument called a tube tester, whose details can be found in any of the more advanced treatises on radio.

The value of this constant is different for different tubes according to their structural details, and ranges from 1 to 100 for the various commercial triodes, having a usual value of about 10.

12.5 The Lumped Voltage. From the equation for mu , it can be seen that a voltage e_g applied to the grid can be replaced by an equivalent change of $e_p = \mu e_g$ volts in the plate battery. Hence the combined effect of changes of both the grid and the plate voltages upon the electron stream can be summarized as a single or lumped-voltage e_i , whose equation is as follows:

$$e_i = e_g + \frac{e_p}{\mu}$$

12.6 The Cutoff. If the spaces between the grid wires are uniform and if the filament, grid, and plate are lined up with great symmetry, it will be found that the lower left ends of the curves in Fig. 12 B plunge sharply into the horizontal axis. These tubes are said to have a *sharp cutoff*.

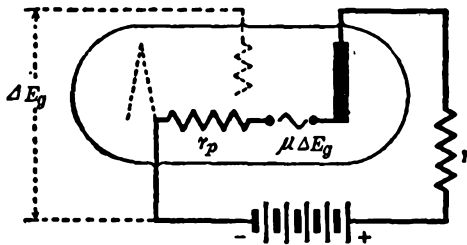


FIG. 12 E. The plate resistance r_p of a triode. The symbol e_g is used in the text in place of ΔE_g in this figure. (From E. & N. P.)

In other tubes, called *variable mu* or super-control or remote cut-off tubes, the spacing between grid wires is made greater in the middle regions of the grid and less at the top and bottom. The result is that the lower left end of the characteristic curve approaches the horizontal axis much more slowly and only reaches it when the grid potential has a comparatively large negative value.

12.7 The Plate Resistance (r_p). The opposition to the flow of electrons between the filament and the plate set up by the space charge and by the

negatively charged grid is the equivalent of a resistance r_p , known as the plate resistance of the tube. A law, similar to that of Ohm, can be written for the case of a three-electrode tube. There is, however, a sharp difference between Ohm's law and the new law, in that the new one uses *changes* in current and *changes* in voltage rather than the currents and voltages themselves. Thus, the change of plate current i_p is given by the change of plate voltage (μe_g) divided by the total resistance of the circuit ($r + r_p$). As shown in Fig. 12 E this leads to the equation

$$i_p = \frac{\mu e_g}{r + r_p},$$

where r is the external or load resistance and r_p is the internal resistance (or plate "impedance") of the tube, defined for zero load by the equation

$$r_p = \frac{e_p}{i_p}.$$

We can better understand the meaning of the plate resistance of a tube by referring to Fig. 12 F which shows the plate current dependence on the plate voltage. Since this curve is not a straight line, r_p varies as the voltage of the plate changes. With a fixed voltage on the plate, r_p is a constant. Note that the d.c. resistance of the tube is given by E_p/I_p whereas $r_p = e_p/i_p$.

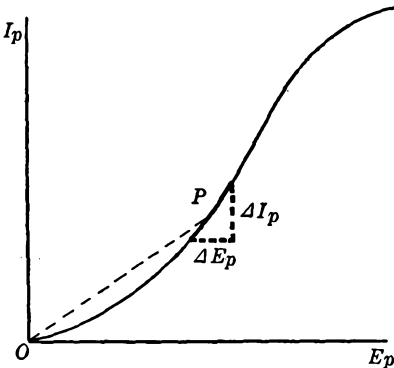


Fig. 12 F. The "plate resistance" of a triode is given by $\Delta E_p/\Delta I_p$ ($= e_p/i_p$ in the text) rather than as the inverse slope of the dotted line. The latter is called the d.c. plate resistance. (From E. & N. P.)

The values of the plate impedance r_p for normal operating voltages of different commercial triodes range from 800 to 150,000 ohms. They can be obtained from the curves of the tube, by means of tube testers, and from data published by the manufacturer of the tube.

12.8 The Mutual Conductance g_m . Very often we are interested in the change of the plate current for different changes in the grid voltage. This is expressed by

means of a quantity called mutual conductance, g_m , or, as it is sometimes called, the transconductance s_m . It is defined as the *change* of plate current for a *change* of 1 volt on the grid. Thus

$$g_m = \frac{i_p}{e_g} = \frac{\mu}{r_p}.$$

Since the plate resistance changes with the voltages on the tube, so also does the mutual conductance. For different triodes on the market, the mutual conductance ranges from 200 to 5,000 micro-mhos (units of conductance). A value of 5,000 micro-mhos means that the plate current will change by 5 milliamperes when the voltage change of the grid is 1 volt.

CHAPTER 13

SOME SIMPLE AMPLIFIERS

13.1 Introduction. A small input voltage, applied between the grid and filament of a triode, proves to be very effective in controlling the flow of current from a local battery in the plate circuit. Grid voltage changes are μ (μ) times as effective in changing the plate current as plate voltage changes, as explained in the preceding chapter. A triode, by itself, has a voltage gain of μ . But, in practical operation, it is necessary to use certain input and output circuits in conjunction with the tube. The overall voltage amplification of the tube and its circuits is sometimes less and sometimes more than that of the tube alone. The stage-gain of the resistance-capacitance (R - C) coupled amplifier of Fig. 13 A is always less than μ , whereas that of the trans-

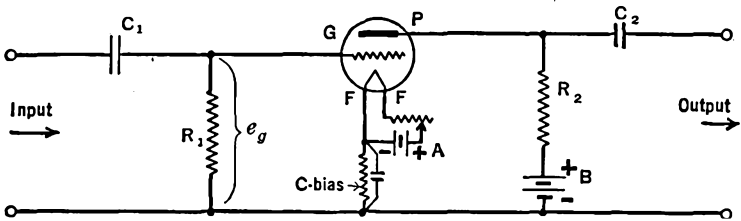


Fig. 13 A. A simple resistance-capacitance-coupled single-stage triode amplifier

former-coupled amplifier of Fig. 13 B may be greater or may be less than μ according to the step-up or step-down ratios of the transformers.

13.2 Class "A" Operation. Let the A, B, and C voltages of the amplifiers shown in Figs. 13 A and 13 B be so adjusted at the start that the tubes are operating at point P in the middle of the straight portion of the dynamic characteristic curve of Fig. 13 C. The filament is operating at its proper temperature, the C-bias is, say, -10 volts, and the plate potential is, say, 200 volts positive above the filament. These so-called d.c. operating conditions are given by the manufacturer of the tube.

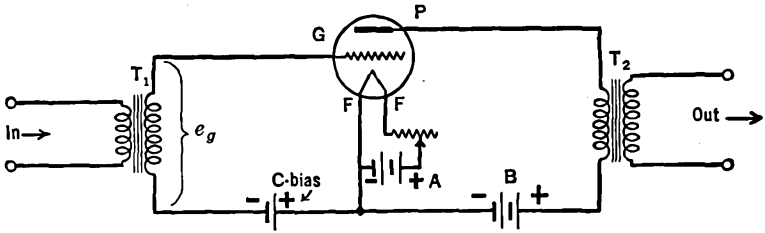


FIG. 13 B. A simple transformer-coupled single-stage triode amplifier

Next, suppose an alternating signal voltage is applied to the input terminals. It will develop a voltage drop across the grid resistor R_1 of Fig. 13 A, or across the secondary of the transformer T_1 of Fig. 13 B. These voltages are obviously in series with the C-bias voltage and cause the grid voltage to alternate back and forth about the fixed C-bias value, as indicated by the $(e_g - t)$ curve in Fig. 13 C. Whenever the grid becomes less negative, the plate current increases and vice versa, as shown by the $(i_p - t)$ curve of this figure.

Provided the signal voltages are not so great as to exceed the straight portion of the characteristic curve, the shape of the fluctuations in the plate current will exactly reproduce the voltage changes of the input circuit. This faithful reproduction of the wave form of the incoming signal is the outstanding characteristic of Class A amplifiers. In addition, these amplifiers are characterized by (1) low efficiency and

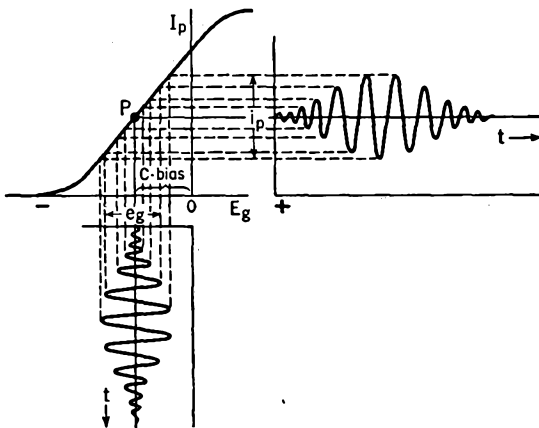


FIG. 13 C. Principle of Class A operation. The output wave-form duplicates the input wave-form

consequent high cost of adequate tubes, (2) a steady d.c. plate drain, which simplifies the plate supply problems.

More will be said concerning Class A amplifiers in Chapter 23. In addition Class AB₁, AB₂, B and C amplifiers are taken up at that point.

13.3 Voltage Amplification per Stage. In Fig. 13 A, let the input voltage change the grid voltage by an amount e_g . This will change the plate current by the same amount as would μe_g volts change in the plate voltage. The voltage μe_g is shared between the load resistance R_2 and

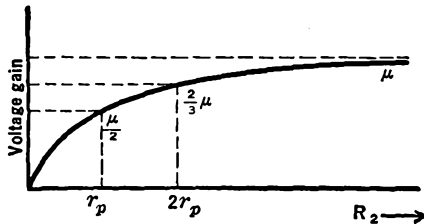


FIG. 13 D. Voltage amplification of a resistance-capacitance-coupled single-stage amplifier

the tube's internal resistance r_p . If these resistances happened to be equal to each other, the output voltage would amount to $\mu e_g/2$. In general, the output voltage is given by $\mu e_g R_2 / (r_p + R_2)$. Hence the ratio of the output to the input voltages, which is the overall gain, will be μ times $[R_2 / (r_p + R_2)]$. The term in brackets is always less than unity; hence the overall gain is always less than μ . Fig. 13 D shows the overall gain for different gain load resistances.

In the transformer-coupled circuit of Fig. 13 B, the voltage gain is nearly equal to the gain of the tube multiplied by the step-up (or step-down) ratio of the transformers.

13.4 Effective Input Capacitance. Although the capacitance between the grid and filament of a triode is small, it is paralleled by the grid-to-plate capacitance and by the plate-to-filament capacitance and by the load, as shown in Fig. 13 E. The combination can be replaced by an *effective* input capacitance whose value is often many times that ex-

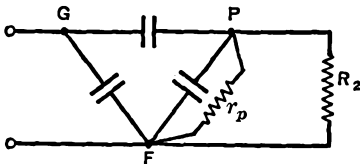


FIG. 13 E. The equivalent circuit of the triode of Fig. 13 A

pected from the grid-to-filament capacitance alone. When very high frequencies are applied to the grid of the tube, the effective capacitance can shunt an appreciable percentage of them to ground and hence lower the voltage amplification very much.

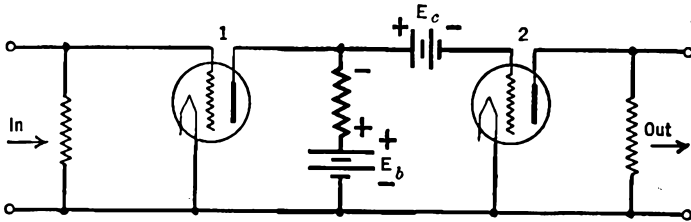


Fig. 13 F. A simple two-stage resistance-coupled or *d.c.* amplifier

13.5 Multistage or Cascade Amplifiers. Whenever it is necessary to increase the amplification by an amount greater than can be accomplished with a single-stage amplifier, several stages are connected one after another. The various methods commonly used to couple one tube to the next will now be discussed briefly. For the time being we shall omit as many of the voltage supplies as possible in order to focus attention upon the coupling units. Later we shall study the more complicated complete circuits.

The amplifier of Fig. 13 F is called a *resistance-coupled* or *d.c.* amplifier because its coupling consists of a single resistance, R , and because the circuit can amplify not only alternating but also direct voltages applied to the input terminals. Were it not for the potential E_c , the voltage on the grid of tube 2 would be the same as that on the plate of tube 1. This amounts to the high positive value given by the battery E_p minus the IR drop in the coupling resistor R . If the grid of tube 2 were allowed to operate at a high positive potential, the plate current of this tube would be extremely large, a heavy grid current would flow and the tube would probably burn out. E_c must be greater

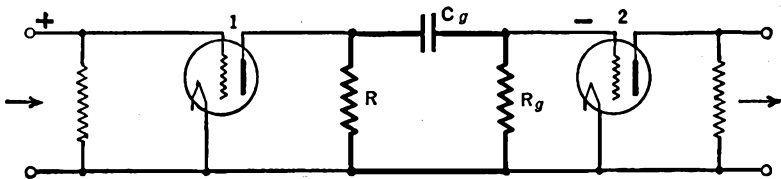


Fig. 13 G. Resistance-capacitance coupling

than $(E_b - IR)$ by such an amount as to bias tube 2 to the middle of the straight portion of its characteristic curve.

In the circuit of Fig. 13 G, which is called a *resistance-capacitance (R-C) coupled amplifier*, the d.c. plate potential of the first tube is kept off the grid of the second tube by means of the coupling condenser C_g . The use of C_g alone, however, would insulate or "float" the grid of the

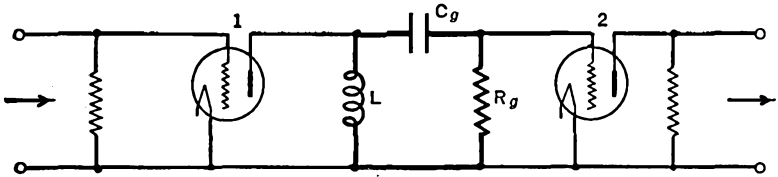


FIG. 13 H. Impedance coupling

second tube. Electrons which reach this grid accumulate, except for a slight leakage over the outer surface of the tube, and build up a negative C-bias of erratic unstable amount. To avoid this, the high resistance grid leak R_g is added.

It will be recalled that the d.c. voltage across the plate of a tube is less than that of the B-voltage supply by an amount equal to the d.c. voltage drop in the plate resistor. An economy can be effected by using a low-resistance, high-inductance coil in place of the resistor, as in the *impedance-resistance-coupled* amplifier of Fig. 13 H. The d.c. loss in the resistance of the coil will be small, yet a fluctuation in the plate current will set up a comparatively high voltage across the coil; and this will be impressed through C_g and R_g , upon the grid of the second tube. But the amount of this voltage will be different for different frequencies of the voltage sent into the amplifier, and frequency distortion will occur. This may be an advantage or a disadvantage, according to the use to which the amplifier is to be put.

The advantage of stepping up the voltage with an inter-tube transformer, as in Figs. 13 I and 13 J, has made the *transformer-coupled* amplifier one of the most commonly used. Here again, however, the

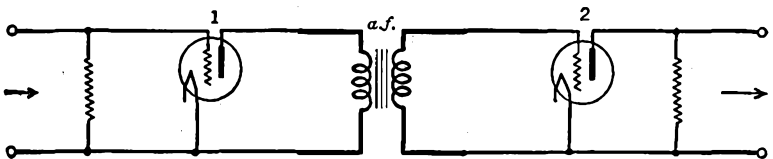


FIG. 13 I. Transformer coupling for audio frequencies

reactive elements of the transformer cause the step-up voltage to have different values for different input frequencies. In Fig. 13 I, the iron core of the audio-frequency transformer is indicated by the parallel vertical lines between its primary and secondary. In Fig. 13 J, the

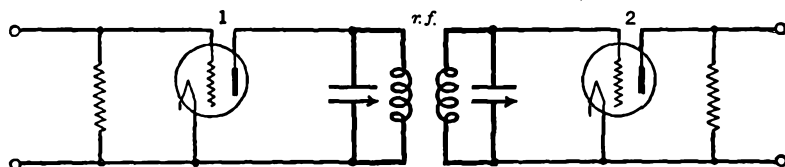


FIG. 13 J. Tuned transformer coupling for radio frequencies

primary and secondaries are tuned by means of condensers so as to amplify a given frequency (together with those in the immediate neighborhood) to a high value, to the exclusion of all others. This type of coupling is used in *radio-frequency* amplifiers.

In addition, more elaborate combinations of coils, condensers, and transformers are sometimes used in the coupling circuit.

13.6 Filtering for the Voltage Supplies. When separate A, B, and C batteries are used for each of the tubes in a multistage amplifier, the fluctuating and the direct currents both flow in the same circuits. It is difficult to design the same circuit for efficient handling of two different kinds of current. For one thing, the a.c. would have to flow far away from the tubes into the batteries and back again, much energy would be lost in the internal resistances of the batteries, the stray electric and magnetic fields of these currents would induce voltages in other parts of the circuit, and the capacities of the batteries to the ground would tend to shunt away some of the alternating currents.

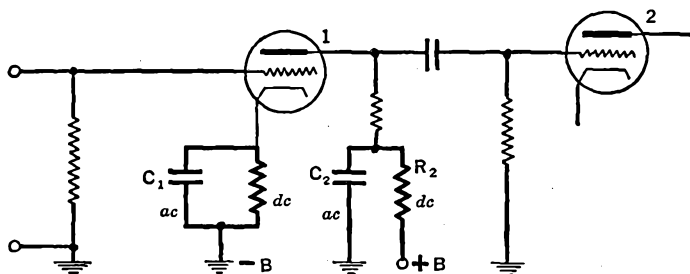


FIG. 13 K. Bypass condensers C_1 and C_2 and decoupling resistor R_2 are used to separate or "filter" the a.c. from the d.c.

Figure 13 K shows how partially to overcome these difficulties by the use of suitably located bypass condensers: C_1 across the C-bias resistor, and C_2 across the plate battery.

It would be uneconomical to use separate B-batteries or plate-voltage supply systems for each tube in a multistage amplifier; nor is it necessary except in certain special cases. Figure 13 L shows a filtered

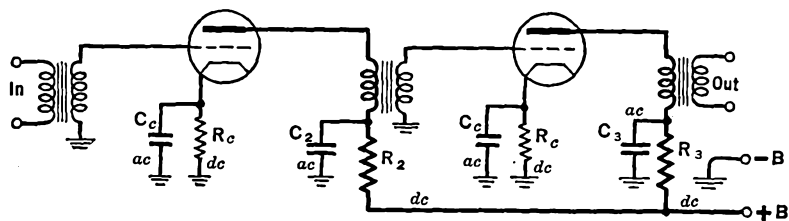


FIG. 13 L. The same B-voltage supply unit may be used in common for several tubes, provided the circuits are carefully filtered

circuit wherein the same B-voltage is used with two transformer-coupled stages.

It will be noticed in Figs. 13 K and 13 L, that additional high resistances R_2 and R_3 (called "de-coupling resistors") are used in series with the supply line. These assist the bypass condensers to keep the a.c. out of the d.c. supply circuits and also to drop the B-voltage to the correct value for each tube.

13.7 Phase Reversal. Suppose that, for a moment, the input signal should make the grid of tube 1 in Fig. 13 G less negative than its static value. Then the plate current would increase and the potential drop across R would increase. The steady-state value was such as to make the top of R negative. Hence an increase in current makes this end still more negative. This change of voltage, feeding through the condenser C_g to the grid of tube 2, will be negative at the upper terminal (with respect to the filament), the reverse of the positive voltage fed onto the grid of tube 1. In other words, there is a 180° phase reversal in each stage of an R - C coupled amplifier.

13.8 Power Amplification. Voltage amplifiers are designed to give the greatest possible alternating output voltage for a given input voltage. Power amplifiers are designed to deliver power (watts) to the load, voltage amplification being incidental.

If the amplifier is to be used to increase power rather than voltage, as is the case with the last tube in a radio receiver, a tube of different

structure is used, and the design of the output circuit is different than in voltage amplifiers. The tubes are selected, not with high μ but with large mutual conductance g_m . The tube and the load impedance are chosen equal to each other for maximum power output. For minimum distortion, the load impedance is often made equal to approximately twice the internal impedance of the tube. Three types of audio-output coupling circuits are shown in Fig. 13 M.

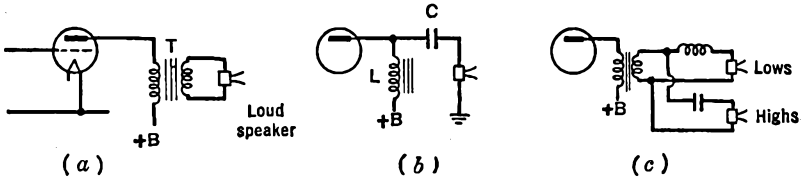


FIG. 13 M. Types of output circuits: (a) transformer coupled; (b) LC coupled (L and C must both have large values); (c) frequency division, the low and high notes operating separate speakers

The *power amplification* is defined as the ratio of the output power to the a.c. power in the grid circuit. For tubes in which no power is consumed in the grid circuit the term *power sensitivity* is used. This is defined as the ratio of the output power to the a.c. grid voltage. There is a third term, *plate efficiency*, which is defined as the ratio of the output power to the d.c. power input to the plate. The latter is given by the product of the plate current and the plate voltage. In general, amplifiers free from distortion have low plate efficiencies and vice versa.

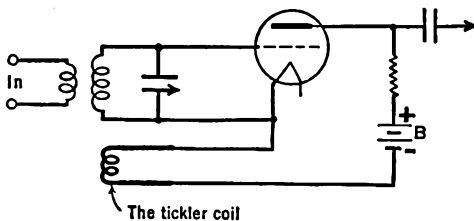


FIG. 13 N. A simple feedback amplifier

13.9 Regenerative and Degenerative Feedback. In Fig. 13 N, a *tickler coil* has been added to a simple amplifier circuit. Some of the amplified energy in the plate circuit is fed back to the grid circuit and is re-amplified. Suppose, for example, that the input signal should for a moment

make the grid positive. The increased plate current, flowing through the tickler coil, causes its magnetic field to spread out. As this magnetic field cuts across the grid coil it induces voltage which will have either the same polarity as the incoming signal, or the reverse. If the feedback voltage aids the original signal, the feedback is said to be positive, the circuit is said to be *regenerative*, and the amplification will be increased. Of course the re-amplified energy is also fed back and the process builds up to a limit set only by the closeness of coupling of the tickler coil to the grid coil and by the losses in the circuits. Positive feedback amplifiers, while having high gain, have a tendency to

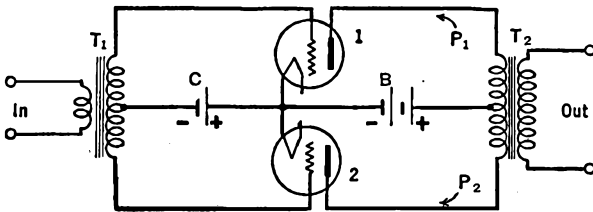


FIG. 13 O. A push-pull amplifier

amplify more at one frequency than at another and hence are used where sharpness of resonance is desirable.

If the tickler coil is reversed from that just described, the voltage fed back to the grid will oppose the original signal voltage and the amplification is decreased. This negative feedback is called *degeneration*. Negative feedback reduces distortion, widens the frequency response, and stabilizes the amplifier against small fluctuations, but it does lower the voltage gain.

13.10 Push-Pull Amplifiers. A circuit diagram of a push-pull amplifier is shown in Fig. 13 O. This type of circuit is able to deliver larger outputs with less distortion than single-tube amplifiers.

Assume that a sine wave signal is applied to the input terminals. During the first half-cycle, the top of the secondary of transformer T_1 becomes positive and the bottom becomes negative. Then the grid of tube 1 becomes positive and the grid of tube 2 becomes negative. The plate current of tube 1 increases and that of tube 2 decreases. But the current increase in P_1 is up and that in P_2 is down. If an *increase* in plate current through P_1 makes the output positive at the top, then a decrease in current through P_2 will also make the output positive at the top. Thus, the outputs of tubes 1 and 2 add together.

It is easy to see that each tube need handle only one-half the secondary voltage of T_1 . In other words, greater voltages may be applied to this circuit than to a single-tube circuit before serious overloading of the tubes and distortion begins.

There is some curvature, even in the "straight" part of a tube's curve, which causes distortion, i.e., harmonics. It can be shown that the push-pull circuit cancels all even-numbered distortion harmonics. Only the odd harmonics come out, i.e., the fundamental, the third, the fifth, etc.

If the upper and lower circuits and tubes of a push-pull amplifier are matched with each other, any change in the A-, B-, or C-battery voltages will cause equal but reversed changes in the plate currents in the upper and lower halves of the output transformer, and hence will not appear in the output. In other words, the circuit is notably stable against changing battery voltages.

CHAPTER 14

SOME SIMPLE OSCILLATORS

14.1 Introduction. A three-electrode vacuum tube may be used to produce electrical oscillations of frequency from a fraction of a cycle each second to many million. The ability to generate oscillations resides in the amplifying property of these tubes, i.e., the energy developed in the plate circuit is greater than that applied to the grid circuit. The additional energy comes from the plate power supply. If part of the amplified energy is "fed back" from the plate to the grid by resistive, magnetic, capacitive or electron coupling devices, and has the proper phase or polarity with respect to that of the grid, there will be continued amplification sufficient to overcome the losses in the circuits and produce sustained oscillations.

14.2 A Tickler Circuit Oscillator. In the chapter on amplifiers we have seen that the amplified current in the plate circuit of a three-electrode

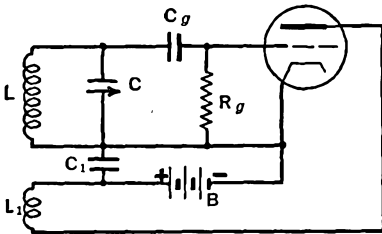


FIG. 14 A. A tickler-circuit oscillator

tube can be fed back to the grid circuit by means of a tickler coil, with resultant increase in the amplification of the signal. If the tickler coil is moved closer and closer to the grid coil, the amplification increases until, at a critical value of "coupling" between the two coils, the tube will produce oscillations within itself, without the aid of an input signal. In order that a tube shall be *self-oscillating*, two main conditions must be satisfied. First, it is necessary that the power transferred from the plate circuit to the grid circuit shall be equal to or greater than the circuit losses. Second, it is necessary that the feedback be positive or *regenerative*.

Figure 14 A shows a simple tickler circuit. When the B-battery is first connected, small random variations — no matter how minute — are rapidly amplified to such a point as to start the tube in oscillation.

External excitation is unnecessary. It will be noted that the B-battery is in series with the feedback coil, L_1 , (the tickler). This is called a *series-fed* oscillator. Condenser C_1 is used to provide a low impedance path for the alternating current around the B-battery. In this and, in fact, in practically all oscillators, the grid becomes positive during part of the cycle, with the result that a flow of electrons occurs through the resistance R_g . Condenser C_g forces this current through R_g , preventing it from short circuiting through coil L . The grid current flow through R_g results in a negative bias voltage on the grid. Practically all oscillators use grid-leak bias.

The frequency of the oscillations will be nearly equal to the resonant frequency of the LC or tank circuit, as given by the equation

$$f = \frac{1}{2\pi\sqrt{LC}}$$

In general, the oscillation frequency will be governed by that circuit in which the losses are least, i.e., by the LC circuit which has the highest Q .

14.3 A Hartley Oscillator. As in the circuit just discussed, so also in the Hartley circuit (Fig. 14 B), the amplified energy of the plate cir-

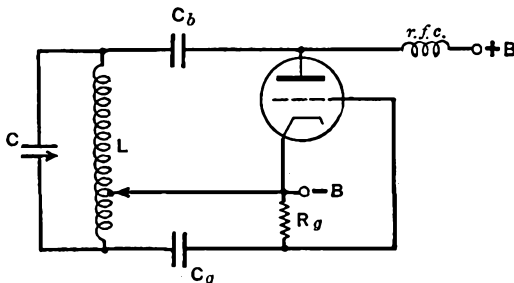


FIG. 14 B. A Hartley oscillator

cuit is fed back to the grid circuit by means of fluctuating magnetic fields. They are both of the so-called magnetic feedback type.

The Hartley circuit uses only one coil, part of which is in the plate circuit and part in the grid circuit. The amount of magnetic coupling between the two parts of the coil is adjusted by moving the tap. This tap is indicated by the arrowhead in Fig. 14 B. The circuit shown is of the so-called parallel-feed type. In other words, the plate circuit is divided into two parallel branches, one of which carries the direct current and the other the alternating current. A choke coil (r.f.c.) keeps

the alternating current out of the d.c. path, and a blocking condenser C_b keeps the d.c. out of the a.c. circuit. The grid condenser C_g and the grid-leak resistor R_g serve the same purpose as in the tickler circuit.

14.4 A Colpitts Oscillator. The feedback of energy from the plate circuit to the grid circuit can be obtained by means of electrostatic coupling as well as by magnetic coupling. Electrostatic coupling is accomplished through a condenser. Such circuits, as, for example, the parallel-fed Colpitts circuit of Fig. 14 C, are said to have *capacity feed-*

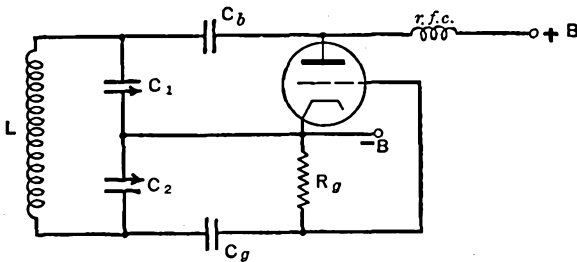


FIG. 14 C. A Colpitts oscillator

back. In this circuit, the tank voltage is divided into two parts by means of condensers C_1 and C_2 .

In order to understand the operation of the circuit, imagine that at a given instant the grid becomes less negative than its static value, causing an increase in the plate current. This raises the potential across condenser C_1 , i.e., stores more energy in this condenser. This increase of energy is transferred via the coil L to the condenser C_2 , making its grid side more negative, the opposite of that across C_1 . The increase of negative potential on C_2 feeding through C_g makes the grid more negative, which is the reverse phase of that which we assumed at the start. When this feedback voltage is sufficiently large, the plate current decreases, less energy is stored in C_1 , and the feedback is again reversed through the coupling of the tank circuit. This process continues. The energy for the oscillations in both the tank circuit (and for the grid bias) comes from the B-voltage source.

14.5 The Tuned-Plate Tuned-Grid Oscillator. Feedback can be accomplished inside the tube through the grid-to-plate capacity. In Fig. 14 D, voltage fluctuations due to oscillations in the L_2C_2 tuned-plate circuit induce voltages directly onto the grid through the tube. These voltages are of the proper polarity to permit oscillations to be main-

tained. Thus, if the plate becomes slightly more positive, the voltage induced on the grid — that is, on the opposite plate of this small condenser — will be negative. This will cause a decrease in the plate current. But this lowers the voltage across the tuned-plate circuit, making the plate potential somewhat less than its static value, the reverse

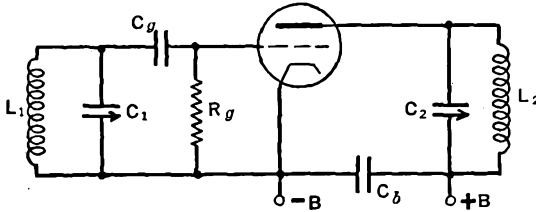


FIG. 14 D. A tuned-plate tuned-grid oscillator

of the original condition. The tuned-grid and tuned-plate circuits, by virtue of their parallel resonant properties, strengthen the otherwise feeble voltage fluctuations of the grid and plate. The two circuits must be tuned to approximately the same frequency in order that oscillation shall occur. However, by slight adjustments in the tuning of either circuit, the amount of feedback, and hence the strength of the oscillations, can be adjusted. In operation, there should be no magnetic coupling between the grid and the plate circuits except that through the tube. The frequency of oscillation of this circuit is determined by the LC combination which has the higher Q .

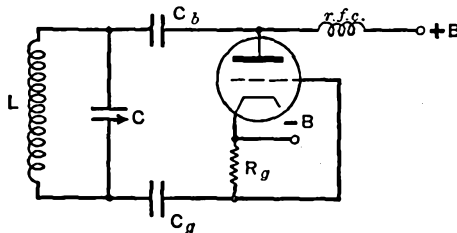


FIG. 14 E. An ultraudion oscillator

14.6 The Ultraudion Oscillator. This circuit, shown in Fig. 14 E, is nearly the same as the Colpitts circuit. The voltage division is accomplished through the plate-to-filament and grid-to-filament capacities of the tube.

14.7 A Simple Crystal Oscillator. A properly cut quartz crystal is the equivalent of a high- Q tuned circuit. In the oscillator circuit of Fig. 14 F, such a crystal replaces the tuned-grid circuit of a tuned-plate tuned-grid circuit. The crystal is mounted between the plates of a small condenser, one of which is connected to the grid and the other to

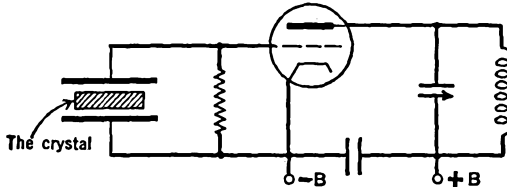


FIG. 14 F. A quartz crystal oscillator circuit

the cathode of the tube. When the grid voltage changes, the electrostatic field across the crystal changes. Due to an inherent property of the crystal, known as the *piezo-electric effect*, small charges of electricity then appear on the surface of the crystal, accompanied by real but very small changes in the dimensions of the crystal. The small potentials so created act back upon the grid of the tube. When the frequency of oscillations of the circuit correspond to the natural mechanical frequency of the crystal, the voltages will be sufficiently augmented to sustain oscillation. As a matter of fact, the frequency of the tuned-plate circuit can differ a little from that of a crystal, yet the circuit will oscillate precisely at that of the crystal itself because of its inherent high Q (9,000 to 16,000). Inasmuch as the crystal frequency is largely determined by its thickness, this offers an unusually satisfactory method of stabilizing the frequency.

14.8 The Multivibrator Oscillator. This unusual circuit, shown in Fig. 14 G, contains no inductances; only resistances and capacitances. It

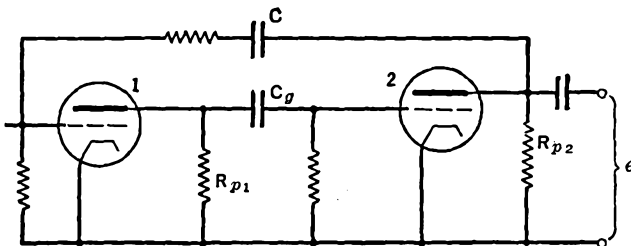


FIG. 14 G. Basic circuit of the multivibrator. Battery voltages omitted for simplicity in explaining its operation

really consists of a resistance-capacitance-coupled amplifier with regenerative feedback. In order to understand how this circuit oscillates, let us imagine that the plate of tube 1 momentarily becomes more positive than its static value. This positive potential, acting through C_g , sends electrons on to the grid of tube 2, making the grid more negative and hence decreasing the plate current. Then the voltage drop in the plate resistor R_{p2} is reduced. Since this was originally negative at its top, due to the direct current through it, the upper end now becomes less negative, or more positive, than it was under static conditions. This positive impulse, passing through the condenser C , makes the grid of

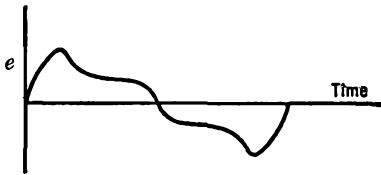


FIG. 14 H. One of the many possible, irregular output wave-forms from a multi-vibrator

tube 1 more positive than normal. This causes an increased current flow through R_{p1} . But this makes the top of this resistor more negative than it was. Thus the original excess of positive on plate 1 is reversed. In other words, the second tube serves to reverse the phase of the first tube. The same might be said of the action of tube 1 on tube 2. The frequency of oscillations depends upon the time constants of the R - C combinations.

Inasmuch as this type of oscillator is very unstable, its frequency can be controlled by the introduction into the circuit of a small signal of constant frequency. This is called *locking*.

As shown in Fig. 14 H, the wave form of the currents generated by a multivibrator circuit is very irregular. This means that the circuit produces many harmonics of considerable strength, along with the fundamental frequency of oscillation. It is not at all uncommon to lock-in this circuit at its tenth harmonic.

14.9 Magnetostriction Oscillators. Figure 14 I shows the circuit of a magnetostriction oscillator. Here the coupling between the plate circuit and the grid circuit is accomplished through a special metal rod made of magnetic material. When its magnetization at the plate end is changed, by virtue of a change in the plate current, a physical con-

striction in the dimensions of the rod occurs, causing it to move inside the grid coil by an exceedingly small amount. The moving magnetism induces voltages in the grid coil which apply themselves to the grid of the tube. These in turn cause a reverse change in the plate current.

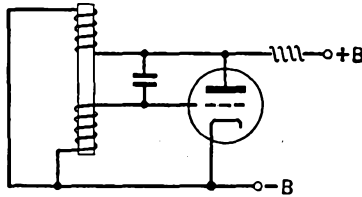


FIG. 14 I. Elementary form of a magnetostriction oscillator

The frequency of the vibrations depends upon the natural resonant frequency of the rod, and is inversely proportional to its length. It is possible with these oscillators to produce very intense oscillations at frequencies of the order of 10,000 to 100,000 cycles per second. Since the rod is also vibrating at these frequencies, it sets up vibrations in the air. These are called *super-sonics* — meaning that they are above the audible limit to which the human ear can respond.

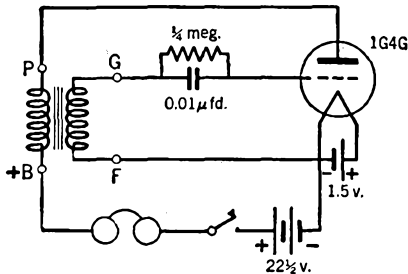


FIG. 14 J. A simple audio frequency oscillator

14.10 A Simple Audio Oscillator. Figure 14 J shows a simple oscillator which may be used for code practice. In order to have sufficient inductance to produce an audio frequency, an iron core transformer such as used in audio transformer-coupled amplifiers is hooked up as shown.

14.11 Push-Pull Oscillators. A push-pull oscillator circuit is shown in Fig. 14 K. When a random voltage fluctuation makes the grid of tube 1 positive, it makes the grid of tube 2 negative. These cause changes in

the plate current. Resonated by the inductance and capacitance (the tank) in the plate circuit, they cause voltage changes on the plate which, fed through the plate to grid capacitance (or by magnetic coupling between the two tank circuits), reverse the polarity of the grids.

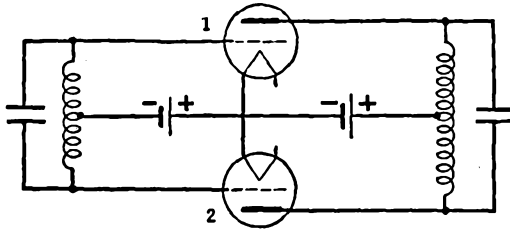


FIG. 14 K. A push-pull oscillator

This continues, the tank circuits strengthening the voltage changes of the grids and plates, so that strong oscillations are developed. In addition to the fact that the two tubes are operating to give greater power, the symmetry of the circuit makes it particularly suitable for use at ultra-high frequencies.

CHAPTER 15

SOME HIGH-VACUUM MULTI-ELECTRODE TUBES

15.1 Tetrodes. There are tubes which contain four electrodes: a filament, a plate, and two grids located between the filament and the plate. As usually operated, the grid nearest the filament serves in the same manner as the single grid of a triode. It is called the *control grid*. The additional grid is generally constructed so as to surround the plate as completely as possible. This type of tetrode is known as a *screen-grid* tube, inasmuch as the new grid structure shields the control grid from changes on the plate without influencing the fixed or static voltages on the plate. A tetrode with its associated circuits is shown in Fig. 15 A.

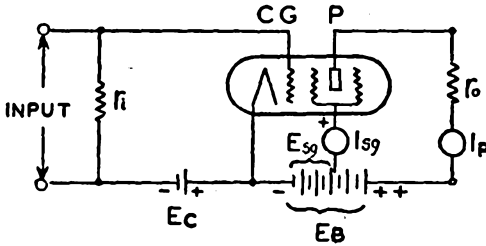


Fig. 15 A. A screen-grid tube. (From E. & N. P.)

In this circuit, the current I_p flows (in the conventional sense) through r_o to P , to the filaments, and back to the battery E_b . As it passes through the resistance r_o , a voltage drop is set up, equal numerically to $I_p \times r_o$. Thus the voltage on the plate of the tube is less than that of the battery E_b by an amount equal to the potential drop in the load resistance r_o . Now, when a signal is applied at the input terminals, a change occurs in the plate current, and likewise a change occurs in the potential drop across the load, of an amount $i_p \times r_o$. In other words, the voltage between the filament and the plate changes by the same amount, $i_p \times r_o$. This change of plate voltage would induce a new voltage on the control grid were it not for the shielding action of the screen

grid. In the absence of the screen, voltages induced upon the control grid can be sufficiently great to start and maintain oscillations throughout the tube circuits. These are undesirable if the tube is to be used in a receiver. In short, the screen grid is intended to prevent oscillations in the circuits.

Tubes of the screen-grid type have high voltage-amplification constants; as great as 800. This is an advantage. But they are also characterized by high plate resistance, of the order of 1,000,000 ohms, which is, generally speaking, a disadvantage.

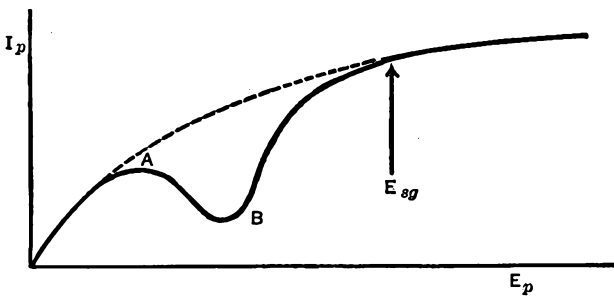


FIG. 15 B. Plate current I_p vs. plate voltage E_p of a screen-grid tube

Figure 15 B shows the plate current at different plate voltages. The arrow points to the fixed voltage of the screen grid. In order to understand the peculiar dip in this curve let us first start with zero voltage on the plate and gradually increase its value. At first, the plate current increases as with a triode. However, the electrons which reach the plate eject *secondary electrons* from it. As the original or primary electrons are sped up more and more by the increase of the plate voltage, starting at zero volts, the number of secondary electrons ejected from the plate gradually increases. See Sec. 10.10. Since the screen grid is more positive than the plate, these secondary electrons flow to the screen grid. The net current in the plate circuit is thus a composite of the original electrons coming to the plate minus the secondary electrons leaving the plate. According to the relative numbers of the primary and secondary electrons, the plate current will increase or decrease as the plate voltage is increased. Throughout the region AB of Fig. 15 B, this ratio of secondaries to primaries is on the increase. When the plate voltage approaches that of the screen grid, the secondary electrons have increasing difficulty in escaping from the plate.

When the plate voltage is greater than the screen-grid voltage, they fail to do so altogether. Then the secondary electrons, although copiously emitted, execute small curved paths and plunge back again into the plate from which they arose, and the net current flowing to the plate is that of the primary electrons alone. When all electrons emitted from the filament are drawn to the plate, further increase in its potential does not increase the current and we have the horizontal section at the upper right of the curve.

There is a different kind of tetrode known as a *space-charge-grid* tube which will be discussed in a later chapter.

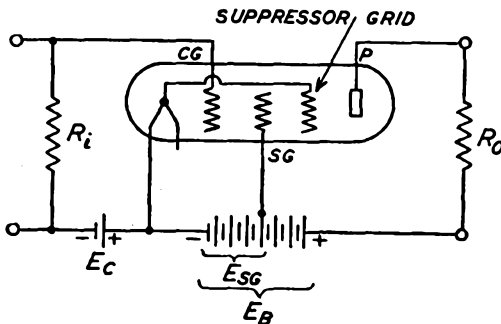


Fig. 15 C. A pentode. (From E. & N. P.)

15.2 Pentodes. A pentode contains five electrodes: a filament, a plate, and three grids, as shown in Fig. 15 C. This is constructed like the screen-grid tube, with the addition of a so-called *suppressor grid* located in the path of the electrons between the screen grid and the plate. The suppressor grid is fastened to the cathode and serves to repel or suppress secondary electrons, driving them back into the plate from which they were ejected by the primary electrons. As a result, the "negative resistance" region *AB* of Fig. 15 B is largely eliminated, the current rising more smoothly from zero up to its saturation value as the plate voltage is increased. The tube may then be used for greater power outputs for a given input grid voltage.

The plate resistance of various commercial pentodes in normal operation is fairly high, ranging from 22,000 to 2,000,000 ohms. The mutual conductance is high, ranging from 400 to 6,000 micro-mhos, and the amplification constant is also large, ranging from 70 to 1,500.

In some of the commercial pentodes the third grid is brought out

of the tube socket instead of being connected inside of the tube to the filament or cathode. Many circuit combinations are then possible.

15.3 Beam-Power Tubes. This class of tubes is useful for the same purposes as the pentodes described in the preceding section. Actually they contain only four electrodes: a filament, a plate, and two grids, and hence should be properly classified as tetrodes. But, by proper design of the internal structures, as shown in Fig. 15 D, the electrons

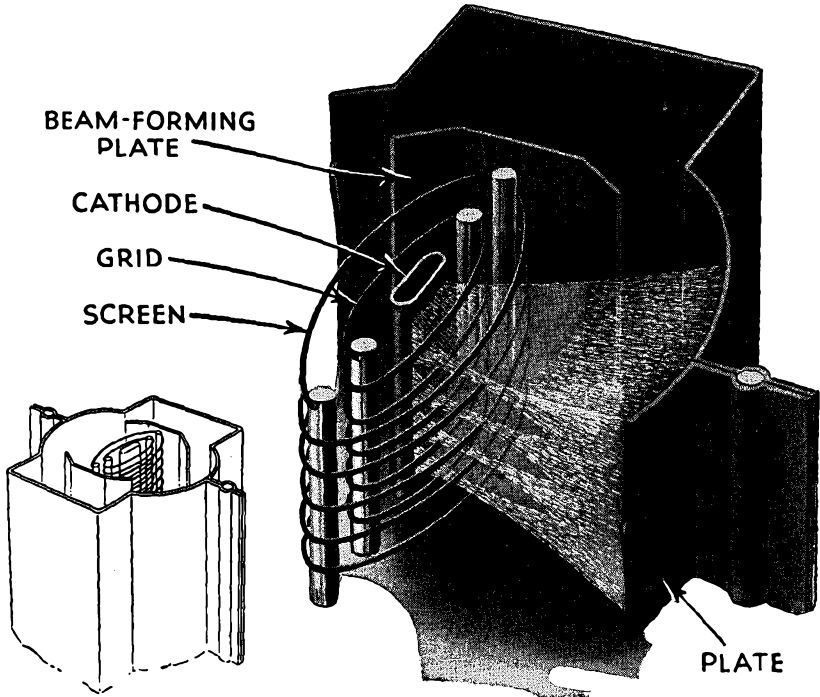


FIG. 15 D. A beam-power tube. (Courtesy R.C.A. Review)

build up a potential which takes the place of the suppressor grid of the pentodes. The electrons en route to the plate are concentrated by beam action in the region between the screen grid and the plate, and serve to repel secondary electrons back into the plate, removing the undesirable kink (*AB*, Fig. 15 B) from the characteristic curve.

In the construction of the tubes, the screen-grid wires are placed in the "electrical shadow" of the control-grid wires. Beam-forming plates, connected to the cathode, are used to direct the electrons in two directions, as shown in Fig. 15 D. The screen and plate are widely

separated so that there will be a large space charge in this region. The potential minimum which is thus created and serves to force secondary electrons back into the plate is shown in Fig. 15 E.

15.4 Combination Tubes. It has been found advantageous to mount two or more tubes within the same glass or metal envelope. Sometimes the separate tubes which are so contained in a single envelope are of the same type as, for example, the double-diode tubes. In this case, the two diodes use a common filament, have separate plates, and are

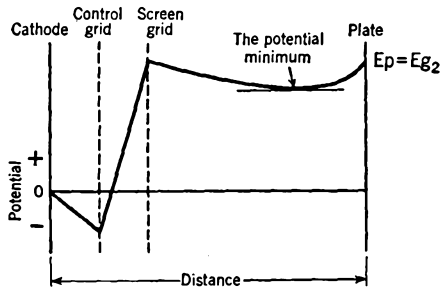


Fig. 15 E. Potential distribution in a beam-power tube

assembled together in a common bulb. Then there are triode-tetrode tubes and, indeed, many other useful combinations. These various tubes operate, part for part, as though the diodes, triodes, and pentodes had been constructed in separate vacuum chambers. Figure 15 F shows some of the possible combinations for tubes used in receivers.

In the code numbering of tubes, the first number stands for the approximate voltage to be applied to the filament, *G* stands for a glass rather than a metal envelope, and *T* at the end stands either for a certain kind of base, known as a miniature "octal" (octa means "eight"), or for a tubular rather than a pear-shaped glass envelope. Tubes with a *T* only are smaller than those not so marked (*T* for "tiny"). The central number stands for the useful number of lead wires brought out of the tube. The letter *S* means that the tube is single-ended, all connections coming through the base. For example: the triple grid *6SK7GT* amplifier tube uses 6.3 volts to heat its cathode; has 7 useful leads (1 and 2, filament leads; 3, cathode; 4, grid; 5, grid; 6, grid; 7, plate); has a tubular and small glass envelope, uses a small wafer octal 8-pin socket and is single-ended.

15.5 Some Electron-Multiplier Tubes. The fact that the number of secondary electrons knocked out of a metal plate can exceed the num-

ber of incident or primary electrons (Sec. 10.10) forms the basis of *multiplier tubes*. In Fig. 15 G, electrons from the cathode *K* are controlled by grid *CG* and accelerated by the second grid *AG*. They are directed by electrostatic fields onto the positively charged metal plate 1, where they give rise to secondary electrons. In the figure two secondary

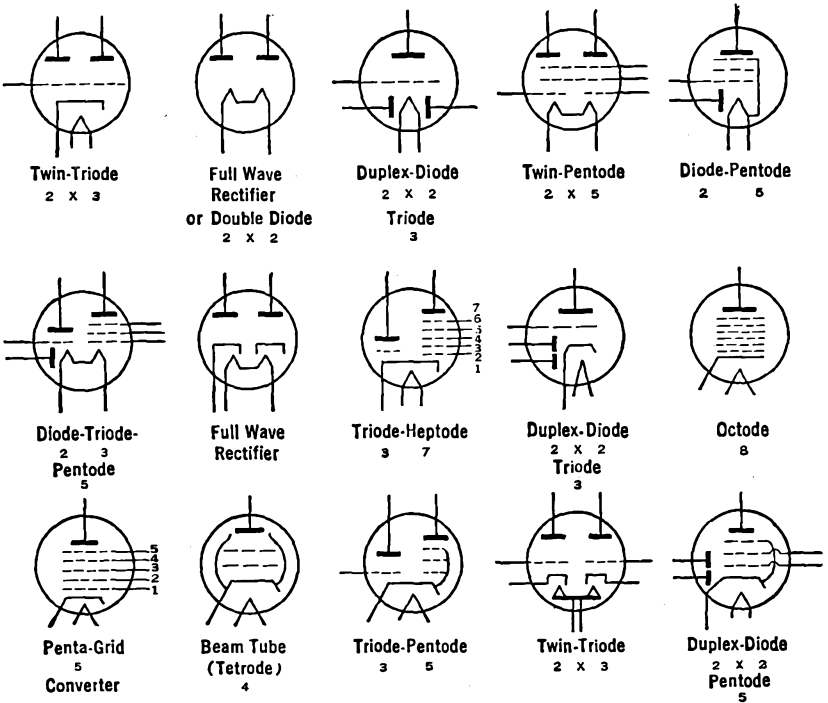


Fig. 15 F. The names and symbols of some multi-electrode and combination tubes

electrons are ejected for each primary electron. The secondaries are attracted to the still more positive plate 2, from which four secondaries are ejected. The latter pass to the plate *P* and to the output. In this case, the current (number of electrons per second) is multiplied four-fold.

A small voltage on the first grid of Fig. 15 G is effective in controlling the number of electrons which pass through it to the next electrode. The effectiveness is tremendously augmented by the fact that the electrons which do pass through the control grid are multi-

plied many fold. In other words, a very small voltage on the control grid will cause a very large change in the output plate current. The

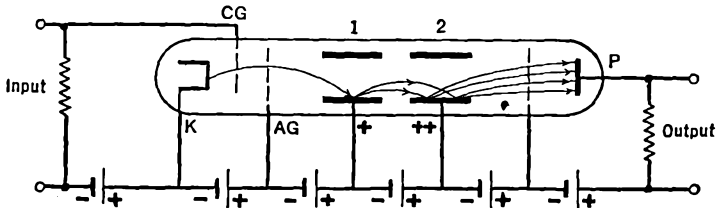


FIG. 15 G. Principle of a multiplier tube

mutual conductance ($g_m =$ change of plate current per volt change on the grid) of these tubes can be varied greatly by changing the voltage applied to each multiplying stage because this changes the number of secondaries per primary.

A more practical form of a multiplier circuit is shown in Fig. 15 H,

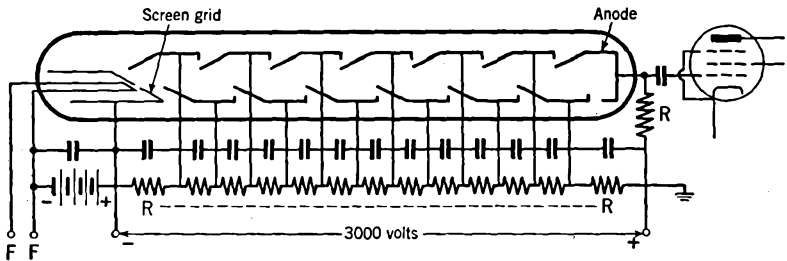


FIG. 15 H. A more practical form of multiplier tube

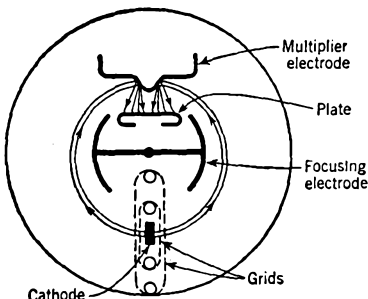


FIG. 15 I. An orbital beam multiplier tube

where a single high-voltage supply source (3,000 volts) is used. The proper voltages on each multiplier stage are obtained from the potential drop in the series of resistors RR .

The absence of coupling stages between one tube and the next makes possible the amplification of a succession of pulses which are very close together, or of very high frequency (microwaves). At the very high fre-

quencies, the time for the electrons to travel from one electrode to another becomes an important fraction of the period of the oscillations. This results in a loss in amplification. The maximum theoretical frequency with present-day tubes is about 2×10^9 cycles per second.

In the orbital-beam multiplier tube of Fig. 15 I, the electrons are deflected in a circular path by a positively charged focusing electrode. The tube should prove useful for frequencies of the order of 500 Mc. (wave-length = 60 cms.).

Further discussion of multiplier tubes will be found in the chapter on photoelectric cells.

CHAPTER 16

THE PRINCIPLE OF AMPLITUDE MODULATION

16.1 The Carrier Wave. When an alternating current flows back and forth in a wire, magnetic and electric fields are constantly forming around the wire, collapsing, reforming in the opposite direction, collapsing, etc. Some of the energy in the fields does not return to the wires but travels outward as a "radio" wave. Although small at low, audio frequencies, the loss of energy from the circuit into the radiated waves increases as the frequency is increased. The form of the radiated wave, which is also the form of the currents or of the voltages in the wire, is shown in Fig. 16 A. It will be noted (dotted lines) that the

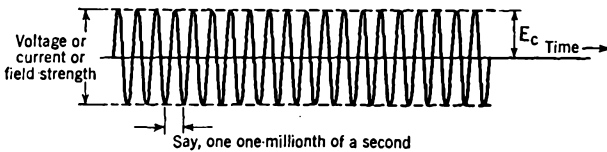


FIG. 16 A. A carrier wave

strength or amplitude of this curve does not change. It is called a *carrier wave* because it serves to *carry* a signal from the transmitter to the receiver.

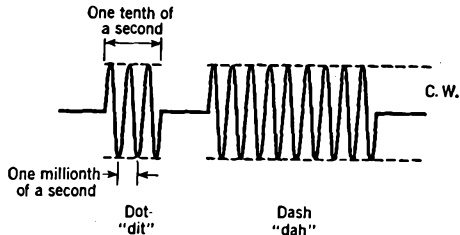


FIG. 16 B. The letter "A" of the International Morse Code

16.2 Modulated Carrier Waves. It is necessary to change or *modulate* the carrier wave in some way if we are to transmit a message. Three methods are used today for this purpose. First, the carrier wave may be stopped and started, so as to break it up into telegraphic dots and

dashes, as in Fig. 16 B. Second, the strength of the continuous wave or current may be increased or decreased by sending it through a microphone, or by more elaborate and practical methods which will be described presently. In this so-called *amplitude-modulation* method, the peaks of the carrier wave rise and fall, as in Fig. 16 C, at the compar-

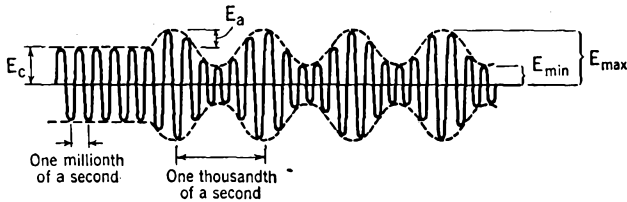


FIG. 16 C. An amplitude-modulated carrier wave

tively low frequency of the sound or audio waves, and to an extent proportionate to the intensity of the sound wave. Third, the amplitude of the carrier wave may be kept constant, but its frequency varied, at a rate dependent upon the frequency of the sounds in the microphone, and by an amount proportional to the loudness of the sounds. This is called *frequency modulation* and is represented in Fig. 16 D.

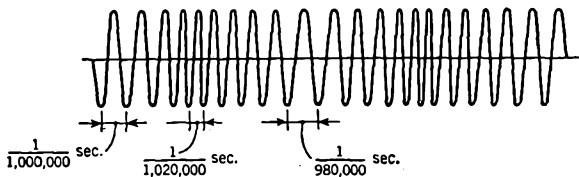


FIG. 16 D. A frequency-modulated wave

In this chapter we shall concern ourselves only with a brief explanation of the principles of amplitude modulation.

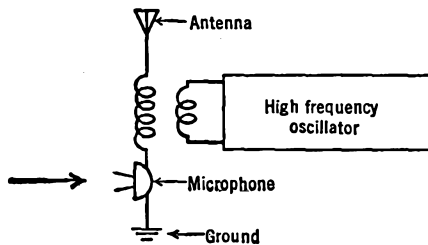


FIG. 16 E. A crude method of amplitude modulation

16.3 A Crude Method of Amplitude Modulation. In Fig. 16 E, a microphone is connected directly in series with the antenna circuit. Sound waves which vibrate the diaphragm of the microphone change its resistance periodically at the frequency of the sound waves, and in proportion to the intensity of the sound waves. Since the microphone is in series with the high-frequency current, its amplitude, and that of the radiated wave, is caused to fluctuate. However, the radio frequency currents tend to "pack" the carbon granules in the microphone so that it ceases to function. There are numerous other difficulties which make this method impracticable.

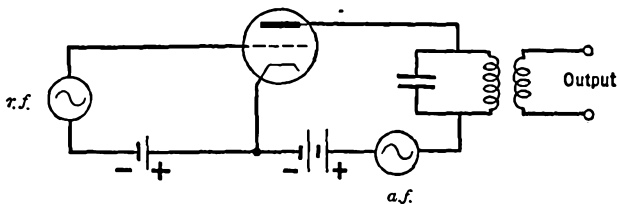


FIG. 16 F. Elementary circuit for plate modulation

16.4 Plate Modulation. Today, the most widely used method for amplitude modulation is known as *plate modulation*. In this system, radio-frequency or "driver" voltages are applied to the grid of an amplifier (called the "modulated" tube). The audio-frequency or "modulation" voltages are inserted into its plate circuit in series with the B-power supply, as in Fig. 16 F. In order that the a.f. in the plate circuit shall be sufficiently strong, it is necessary to strengthen the microphone voltages with a speech amplifier. The last stage in this amplifier is called the *modulator*. The secondary of the audio transformer in the plate circuit of the modulator is in series with the B supply of the modulated tube, as in Fig. 16 G. The radio-frequency-choke coil, r.f.c., keeps the high frequency from shunting through the grid-bias battery, and the bypass condenser *C* keeps it out of the B-battery and speech amplifier. In Fig. 16 H, we see that when, during a positive half-cycle of the audio frequency, the plate voltage is increased above that of the B supply, the plate current likewise increases. Similarly, when the a.f. is in opposition to the steady B voltage, the output decreases. In order that the rise and fall of the amplitude of the output r.f. shall be a faithful copy of the a.f., the driver's voltage must be large, and the C-bias, the B voltage, and the circuit constants must be properly chosen. In

order that the changes in the amplitude of the carrier wave shall be large, the output voltage of the modulator must be nearly equal to that of the B supply.

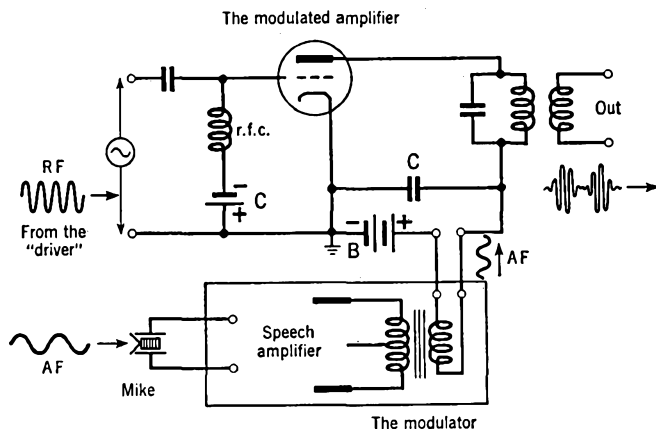


FIG. 16 G. Further details of plate modulation. More elaborate and practical circuits will be given later

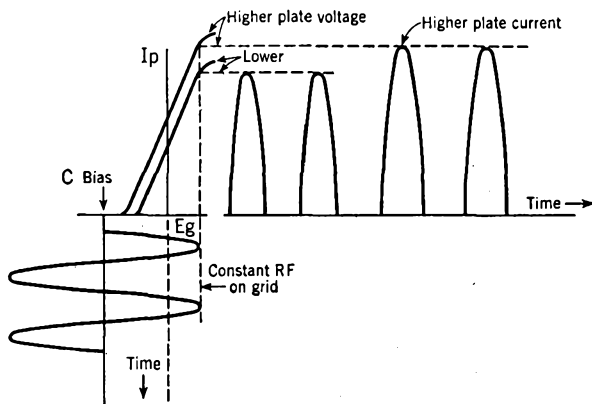


FIG. 16 H. The principle of plate modulation. The a.f. voltage increases and decreases the total voltage on the plate around the "B battery" value

16.5 Grid-Bias Modulation. In this method, audio- and radio-frequency voltages are introduced simultaneously into the grid circuit of an amplifier, while the B supply remains fixed. The circuit is indicated

in Fig. 16 I, with further details in Fig. 16 J. At the bottom of Fig. 16 K, we see that the combined low- and high-frequency voltages apply to the grid a wave whose form is that of the r.f. swinging back and forth on an axis which, instead of being straight, shifts back and forth at audio frequency. The resultant plate current is shown at the right in Fig. 16 K. These pulses of current stimulate proportionately strong oscillations in the tank circuit LC (Fig. 16 J) which is tuned to the radio frequency.

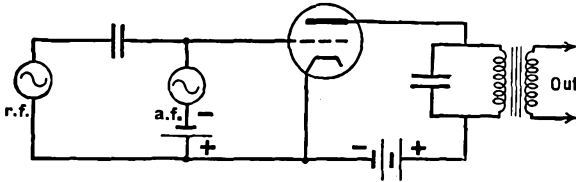


FIG. 16 I. Elementary circuit for grid-bias modulation

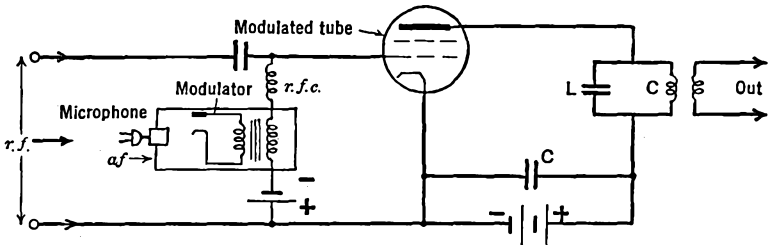


FIG. 16 J. Further details of grid-bias modulation

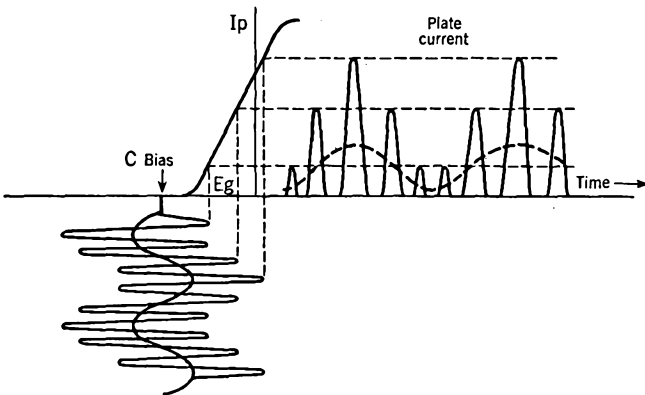


FIG. 16 K. The principle of grid-bias modulation

The output transformer eliminates the d.c. plate current, delivering a modulated carrier voltage to the next amplifier or to the antenna from which the radio wave is radiated. In a way, one might say that the action of the tank circuit and its output coil (Fig. 16 J) is to "straighten the axis" of the plate current (dotted axis in Fig. 16 K).

The efficiency of operation of the grid-bias-modulation method is quite low as compared with that of the plate-modulation scheme. On the other hand, the power output of the modulator tube of the grid-bias method need only be one or two watts to operate a modulated tube of considerable power.

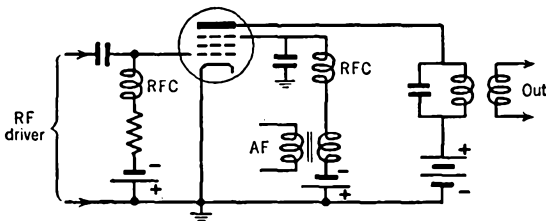


FIG. 16 L. Elementary circuit for suppressor-grid modulator

16.6 Suppressor-Grid Modulation. The audio-frequency voltages can also be introduced into the amplifier tube by applying them in series with the suppressor grid of a pentode, as in Fig. 16 L. The principle of operation is the same as for grid-bias modulation, but the circuit is easier to adjust in practice.

16.7 Cathode Modulation. This is a combination of the plate and grid-bias modulation methods, the a.f. voltages being introduced partly into the grid and partly into the plate circuits of the modulated tube by means of a tapped secondary on the output a.f. transformer of the modulator.

16.8 Modulation Percentage. In the absence of modulation, the carrier wave has a constant amplitude, E_c , of Fig. 16 C. Modulation increases and decreases the voltage above and below the constant value by a maximum amount designated in the figure as E_a . The ratio E_a/E_c is called the modulation coefficient (m). When expressed in percentage, by multiplying by 100, it is called the percentage of modulation, M . We may write,

$$m = \frac{M}{100} = \frac{E_a}{E_c} = \frac{E_{max} - E_c}{E_c} = \frac{1}{2} \frac{E_{max} - E_{min}}{E_{max} - E_a}$$

Figure 16 M shows cases of under-modulation, correct or 100 per cent modulation, and over-modulation. It is to be noted that the peak r.f. voltage for 100 per cent modulation is exactly twice that of the unmodulated voltage. In order to produce 100 per cent modulation, the a.f. voltage's peak value must be equal to that of the r.f. The strength

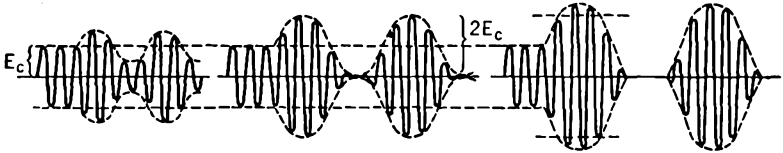


FIG. 16 M. Under-, complete-, and over-modulation

of the carrier wave will determine how far the radio wave can be transmitted, whereas the modulation percentage will determine the audible output at the receiver. Modulation should never exceed 100 per cent or the a.f. will be distorted and contain harmonics not present in the original sounds which entered the microphone.

16.9 Side Bands. A wave of the same shape as that shown in Fig. 16 C can be produced by combining three radio-frequency waves in a "non-linear device" or rectifying tube. Conversely, an amplitude-modulated carrier wave can be thought of as though it consisted of three radio-

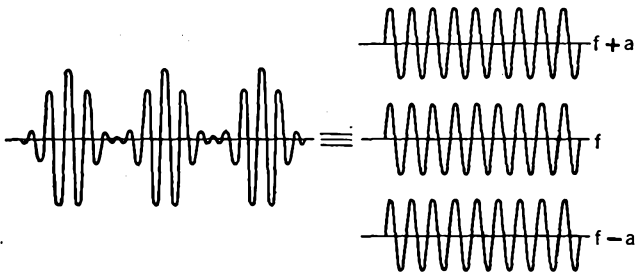


FIG. 16 N. Side bands

frequency waves, as in Fig. 16 N.¹ One of the waves has a fixed amplitude and the same frequency as that of the unmodulated carrier. The other two waves have amplitudes equal to each other. This value changes in proportion to the strength of the audio signal. Their fre-

¹ This viewpoint may not appear simple to the beginner, but it actually proves to be so in the practical analysis of transmitters.

quencies differ from that of the carrier by the frequency of the audio wave. The frequency of one of the waves is greater, the other is less, than that of the carrier. Since the audio frequency changes with the pitch of the sound waves which enter the microphone, the frequencies of these two waves increase or decrease, from that of the carrier (for zero a.f.) to values which are greater or less by the highest a.f. Thus, these frequencies change over *an upper and a lower side band* on the sides of the carrier. Therefore, in order to transmit an intelligible signal, a *channel or band of frequencies* is needed equal to twice the highest pitch of the sound. A band 5 kc. on each side of the carrier, or 10 kc. total width, is used in broadcasting. All of the electrical circuits which handle the modulated-carrier wave in the transmitter and the receiver should have equal amplification of all frequencies over this 10-kc. band, with zero amplification at all other frequencies. In practice this can only be approximated.

CHAPTER 17

THE PRINCIPLE OF DETECTION

17.1 Introduction. When a modulated carrier wave has been received, it is necessary to use a "detector" to separate its audio component from its radio frequency component, if one is to hear the message sent into the microphone at the transmitter. In other words, the modulated wave must be de-modulated. This may be accomplished by sending the wave through a non-linear device, i.e., through one whose current is not directly (linearly) proportional to the impressed voltage. For example, one may use certain crystals such as galena or iron pyrites which are much better conductors of current in one direction than in the other (roughly 10 to 1 better). In Fig. 17 A, the electromagnetic

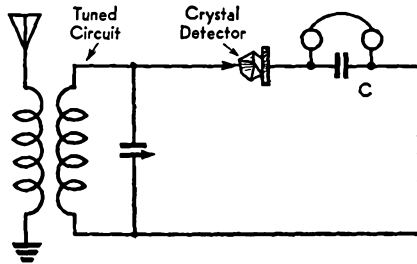


FIG. 17 A. A simple crystal receiver

waves, cutting the antenna wires, induce an e.m.f. whose amount is strengthened by the tuned circuit. The e.m.f. across the condenser sends a current i through the crystal in greater amount in one direction than in the other, as indicated in Fig. 17 B. The semi-direct pulsating current stores energy in condenser C . This, in turn, feeds through the phones in an amount indicated by the dotted line in Fig. 17 B, whose wave form is like the audio-modulation component of the input wave, i.e., like the original audio sound waves at the transmitter.

17.2 Diode Detector Circuits. A two-electrode tube or diode can be used as a detector with much more satisfactory results than the crystal just described. In the circuit of Fig. 17 C, the r.f. current is rectified

by the diode D and flows through the load resistance R . Since (in the conventional sense) current can only flow from the plate to the filament of the tube, the voltage drop across R is $+$ at the top and

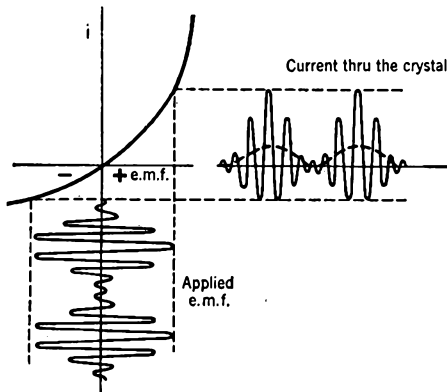


FIG. 17 B. Principle of a crystal detector

— at the bottom, as shown. This voltage varies in strength and frequency in the same way as the modulations of the modulated carrier wave or r.f. input. A typical value of R is 250,000 ohms. Condenser C must have a reactance for the given r.f. which is small compared with the resistance of R . If C is too large some of the a.f. will be lost. A typical value is $250 \mu\text{f}$.

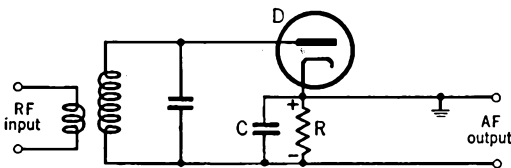


FIG. 17 C. A simple diode detector circuit

In Fig. 17 D, full-wave rectification is used, the principle of operation being the same as described in Sec. 11.3. The audio-frequency voltages are taken out of the circuit through the condenser C_1 ($= 0.1 \mu\text{f}$.) and the voltage divider or "volume control" R_1 (from 0.5 to 1 megohm).

17.3 Plate Detectors. Figure 17 E shows a triode tube used as a detector. It is heavily biased onto the lower knee of its characteristic curve,

near the cutoff, in order that it may operate as a rectifier. This is accomplished by the voltage drop set up by the plate current in R_1 (10,000 to 20,000 ohms). C_1 (0.5 μ fd. or larger) bypasses both r.f. and a.f. around R_1 . The incoming modulated carrier wave fluctuates the grid about the bias point and causes the plate current to flow in the manner

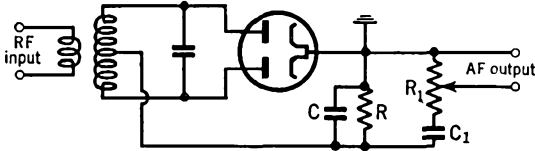


FIG. 17 D. A full-wave diode detector

shown in Fig. 17 F. The r.f. component of this current is bypassed through condenser C_2 (0.001 to 0.002 μ fd.). The average a.f. variation, indicated by the dotted line of Fig. 17 F, which duplicates the modulations of the input wave, sets up a corresponding a.f. voltage across the load resistor R_2 (50,000 to 100,000 ohms). This is transmitted to the output device through the coupling condenser C_3 (0.1 μ fd.). Because small voltages on the grid can cause comparatively large voltage fluctu-

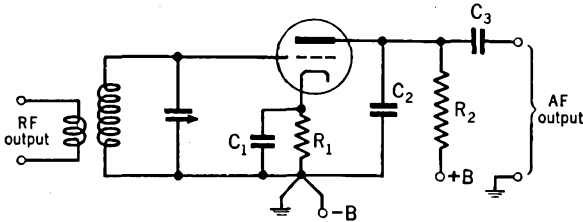


FIG. 17 E. A simple plate detector

ations across the load resistor, this circuit not only detects but also amplifies the incoming signal.

In the pentode plate detector of Fig. 17 G, the principle is the same as that for the triode. The bypass condenser C_4 of the screen must have a low reactance at both a.f. and r.f.; 0.5 μ fd. or more is used. The resistors R_3 (50,000 ohms) and R_4 (20,000 ohms) are used as a voltage divider across the B supply to apply the proper potential (30 volts or so) to the screen. C_2 should be about 250 to 500 μ f.; R_2 about 100,000 to 250,000 ohms; the other constants as for the triode.

17.4 Grid-Leak Detectors. The triode and pentode detectors of Fig. 17 H are equivalent to a combination of a diode rectifier and an a.f.

amplifier. The grid acts like the plate of a diode rectifier. The d.c. rectified current flowing through R_1 sets up a voltage which serves as the C-bias, while the a.f. currents through this grid-leak set up an a.f. voltage between its ends which is applied to the grid-filament cir-

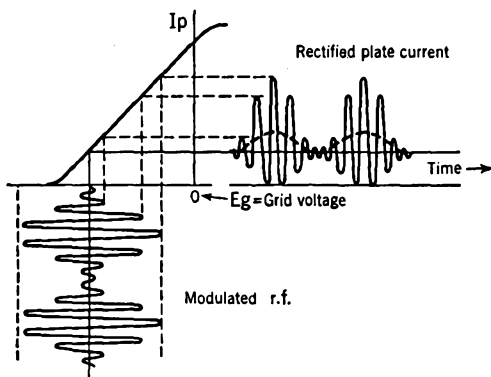


FIG. 17 F. Principle of plate detection

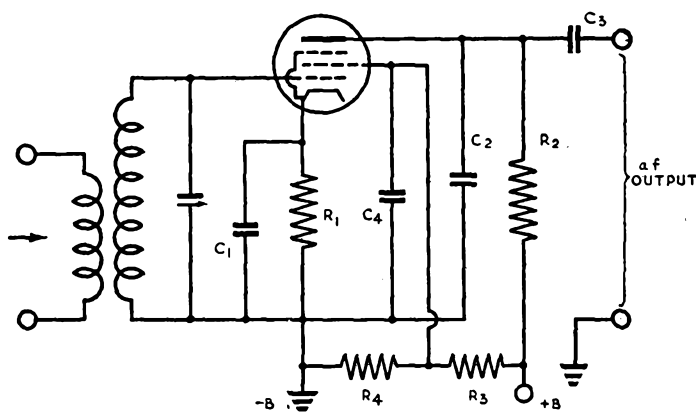


FIG. 17 G. A pentode plate detector

cuit (through coil L_1). These a.f. voltages operate the tube like an ordinary amplifier. With triodes, R_1 ranges from 1 to 2 megohms, while with pentodes it may be as large as 5 megohms. C_1 in both cases ranges from 100 to 250 μ fd. In Fig. 17 H, resistance-capacitance coupling can be used at the output, as in Figs. 17 E and 17 G, but transformer and impedance units are shown in order to illustrate the various

types of outputs possible in these four circuits. L in Fig. 17 H should be very large, say a 500-henry choke. Circuit constants are the same as in Figs. 17 E and 17 G, except R_1 and C_1 , which are given above.

17.5 Regenerative Detectors. Figure 17 I shows a grid-leak detector, like that described in the preceding section, to which has been added a tickler coil L_3 for regenerative feedback. The feedback increases the amplification very much. With L_2 and L_3 wound end to end and in the same direction, connect the plate lead to the outer end of L_3 , and the

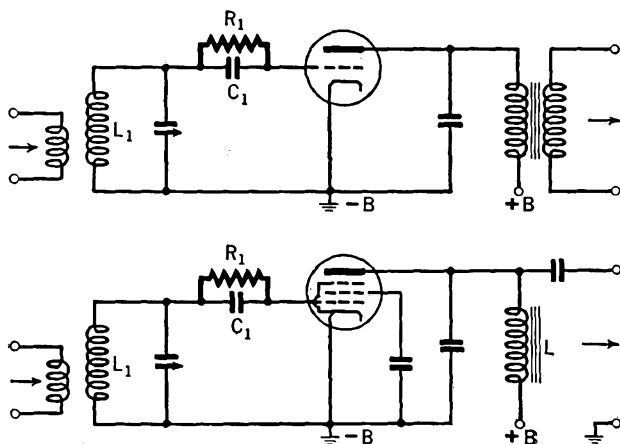


FIG. 17 H. Grid-leak detector circuits

grid lead to the outer end of L_2 , in order that the feedback will be regenerative. The variable bypass condenser C_3 (maximum of 100 μf . or more) is used to control the amount of regeneration. When it has a large value, its reactance is comparatively small and the regeneration is greater. When C_3 exceeds a critical value, the circuit breaks into oscillation. These oscillations are useful for the reception of code but must not be present for the reception of a speech-modulated carrier wave. The circuit is most sensitive just before it goes into oscillation. For code, C_3 should be set so that the circuit just begins to oscillate.

17.6 A Super-Regeneration Detector. An alternating voltage from an external oscillator, whose frequency lies just above the audible range (say 20 to 100 kc.), can be applied to the grid of a regenerative detector which has been adjusted just to the point of oscillation. This serves to shift the operating C-bias back and forth, with the result

that the circuit goes in and out of oscillation at the super-audible frequency. The additional regeneration which can then be obtained makes the circuit extremely sensitive. This circuit has been found to be a very useful circuit for the ultra-high frequencies, but its tendency to radiate strongly and to tune broadly has on occasion created serious interference with other receivers. It is desirable that a tuned r.f. amplifier stage precede such detectors.

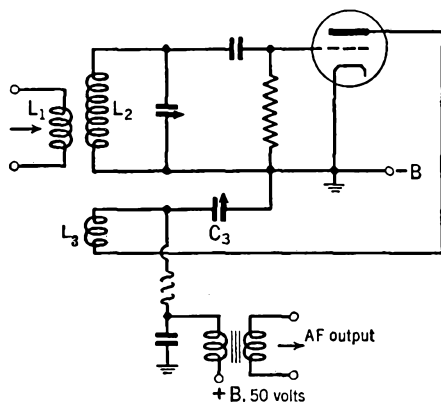


FIG. 17 I. A simple regenerative detector. (L_3 has from 10 to 25 per cent the number of turns of L_2)

17.7 A Comparison. In judging the performance of a detector, we are concerned with the following factors: (1) the *sensitivity* or ratio of a.f. output to r.f. input; (2) the *linearity* or accuracy of reproduction of the wave form of the modulation on the incoming signal; (3) the loading effect of the detector on the tuned circuit in the input. Heavy loading lowers the Q of this circuit, broadens its resonance curve, and makes it less selective; (4) the *input ability* of the detector to handle large amplitude input signals without overloading. A comparison of the various types of detectors just discussed is given in the accompanying table.

Detector Type	Sensitivity	Linearity	Selectivity	Input Ability
Diode	Low	Good	Poor	High
Plate	Medium	Good	Excellent	Medium
Grid Leak	High	Poor	Poor	Limited
Regenerative	Higher	Poor	Excellent	Poor
Super-Regenerative	Still higher	Good	Poor	Medium

CHAPTER 18

GAS-FILLED TUBES

18.1 Introduction. Up to this point we have assumed that the tubes were so highly evacuated that the passage of electrons through them was unimpeded by collisions with any gas molecules. We shall now study the phenomena which occur when a gas is inserted in a previously highly-evacuated tube.

18.2 The Glow-Tube. If a trace of gas, say argon, is admitted to a tube containing two cold metal plates, and a battery is connected as

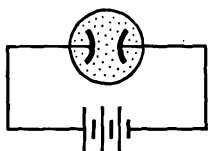


FIG. 18 A. A glow-tube circuit

in Fig. 18 A, a current can be made to pass through the tube and a glow of light will appear on the electrodes. Starting at zero and increasing the battery voltage, it will be found that a certain minimum voltage, called the *striking potential* V_s , must be applied across the tube before the discharge will start. The value of V_s is different for different tubes and

gases. Figure 18 B shows the effect of changing the pressure of the gas in the tube.

The time for the discharge to start, after a voltage equal to or greater than V_s has been applied, is usually very small, a few micro-seconds, especially if the applied voltage is well above V_s . If, however, the electrodes are contaminated or if surface charges exist, the time lag may amount to several minutes. The time for the discharge to cease after the voltage has been removed varies from a few micro-seconds to a few milliseconds.

When the tube is glowing, the applied voltage may be reduced below the striking potential, to the *extinction voltage* V_x , before the discharge will cease.

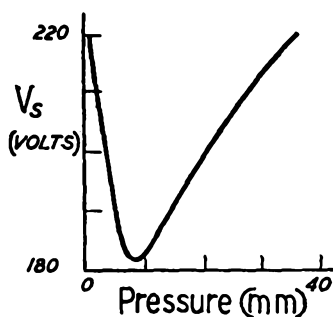


FIG. 18 B. Striking potential, V_s , for helium at different pressures. (From E. & N. P.)

This is illustrated in Fig. 18 C, where the electric current through the tube has been plotted vertically and the applied voltage horizontally.

A glow-tube may be used around a high-frequency oscillator to determine whether the circuit is oscillating or not, and to locate the regions of greatest r.f. voltage. The higher the voltage, the brighter the glow in the tube.

A glow-tube may also be used to produce "relaxation" oscillations. In a relaxation circuit, a battery sends current through a resistor R into a condenser C , charging it rapidly at first, then more and more slowly. This requires a length of time which depends upon RC (see The Time Constant). The greater RC , the longer the time required. A glow-lamp, connected across the condenser, is in a non-conductive state until the voltage across the condenser rises to its striking potential. Then the glow discharge suddenly starts, and the condenser suddenly discharges until the voltage has dropped to the extinction potential of the glow-tube. The process then repeats itself. The frequency of the pulsations can be varied over wide limits by changing R and C .

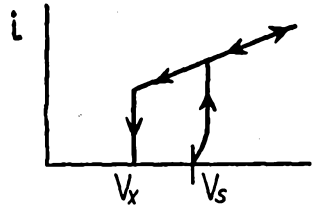


FIG. 18 C. Striking and extinction voltages of a glow-tube. (From E. & N. P.)

18.3 The Strobotron. It is possible to control the rate of charge of a condenser and its discharge through a glow-lamp so as to produce comparatively large amounts of light in short pulses of predetermined duration and spacing. A special tube for this purpose is known as a strobotron. As shown in Fig. 18 D, it contains a cold cathode of cesium

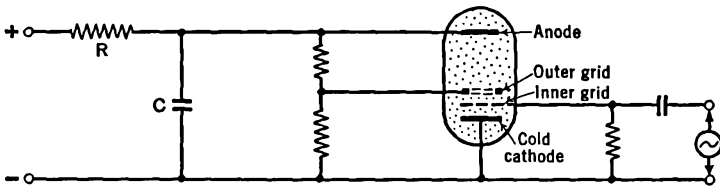


FIG. 18 D. A simple stroboscope circuit using a strobotron tube

compound (to assist in starting the arc) and an anode, an inner grid of wires and an outer grid made of a graphite ring. The tube is usually filled with neon gas at about 1.5 cms. of mercury pressure.

In the circuit of Fig. 18 D, the large condenser C (say $4 \mu\text{fd.}$) is

filled through the comparatively low resistance R (a few hundred or thousand ohms). It will then suddenly discharge through the strobotron to produce a brilliant but very brief flash of light provided the voltages on the grids are such as to permit the arc to strike in the tube. A pulse oscillator, whose frequency can be altered, is connected to the inner grid and serves to control the rate at which the flashes occur. In one commercial form of the apparatus, called a Strobotac, the flashing rate can be varied throughout the range from 600 to 14,400 per minute. Although each flash lasts only a few (about 10) micro-

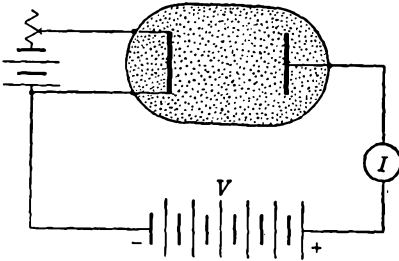


FIG. 18 E. A gas-filled diode.
(From E. & N. P.)

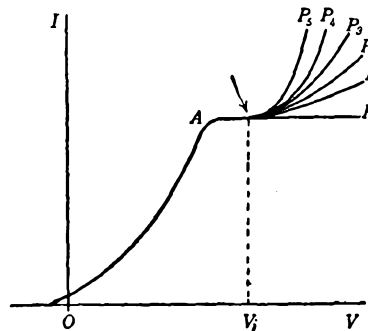


FIG. 18 F. The effect of gases in a diode. (From E. & N. P.)

seconds, the currents through the strobotron are so large (several hundred amperes) that sufficient light is emitted to be useful to illuminate objects in bright daylight.

The pulses of light are used to study vibrating and rotating machinery by the well-known stroboscopic principle and for high speed motion-picture work. With single-flash circuits, the tubes are used for short-stop photography of objects moving at high speed.

18.4 Ionizing Potentials. Figure 18 E shows a hot-cathode diode filled with a gas such as helium at a pressure of 1 or 2 mms. The current-voltage curve of this tube is shown at OAP_1 in Fig. 18 F. The rise of this curve above that for a highly evacuated diode, OAP_0 , is due to the creation of charged particles when the electrons from the filament collide with neutral gas atoms. If the pressure in the tube is greater, the amount of this additional current will be greater, as indicated by the curves P_2, P_5 . It will be observed, however, that these curves all rise above AP_0 at the same plate voltage. This means that when the

electrons are sped up sufficiently, to the voltage V_1 they are just able to knock an electron out of an atom. The potential V_1 is called the *minimum ionizing potential*. It gives a measure of the energy needed to remove the most loosely bound electron in the atom. It is therefore numerically equal to the energy which this electron possessed while in a normal undisturbed atom.

Ionizing potentials range between 3.88 and 24.5 volts. The following values are of interest in commercial tubes: mercury vapor, 10.39; argon, 15.7; nitrogen, 16.3; neon, 21.5; helium, 24.5.

The number of atoms ionized per electron collision increases rapidly from a zero value, just below the ionizing potential, to a maximum value at 135 electron volts for mercury vapor, 140 for argon, 175 for nitrogen, 340 for neon, and 210 for helium. For electrons of still greater energy this ionization probability decreases slowly.

18.5 The Disintegration Voltage. Atoms from which electrons have been ejected are called positive ions. If these ions have been created in the region between the filament and the plate of a gas-filled tube, then the positive potential of the plate repels them toward the cathode. If the energy which they acquire by the time they strike the cathode is sufficiently small they will not damage the cathode. If, however, their energy exceeds 20 to 25 volts, for inert gases and mercury vapor, then the positive ion bombardment will disintegrate the sensitized coatings on the filament and render it a poor emitter of electrons.

The working range of voltages across a gas-filled tube is given as the difference between the disintegration voltage and the ionizing potential. If the voltage across the tube is less than the ionizing potential, the gas will not be ionized, and if the voltage exceeds the disintegration voltage, the cathode will soon be ruined. It is possible, within limits, to control the voltage drop across a tube by choosing its dimensions properly so that it is below the disintegration value.

18.6 Gas-filled Triodes. These are known by the commercial trade names of "thyatron," meaning "door," and "grid-glow" tubes. Their action is quite different from that of high-vacuum triodes, because the grid serves to start an arc discharge between the cathode and the plate, and then loses its ability to affect the magnitude of the plate current. In order to stop the plate current it is necessary to reduce its voltage to zero.¹ Inasmuch as the grid acts only like a trigger

¹ An unusually high negative grid voltage, several hundred- or thousandfold the normal value, will also stop the plate current.

to start the plate current, the tubes are comparable in application to lock-in-relays, wherein a small amount of power is used to turn on comparatively large currents from a local source.

The magnitude of the plate current depends on the voltage of the plate supply and the series load resistance and can have values up to the full emission current of the cathode. In practice, of course, the upper limit to this current is set by the dissipating ability of the tube. Plate currents range from a few milliamperes in the smaller tubes up to hundreds and even thousands of amperes in the larger tubes. The efficiency of these tubes is very high.

It is possible, in the following way, to understand how the grid can start the plate current and then cease to function. Suppose that the grid is quite negative at the start. When the plate voltage is first connected, electrons from the hot cathode create positive ions and electrons by bombardment of the atoms near the grid. The electrons are repelled at great speed from the grid, which is negative, whereas the positive ions are drawn toward it much more slowly, because they are comparatively heavy. The electrons will have moved away from the region around the grid while the positive ions are slowly moving toward their destination. Thus a *positive ion sheath* is formed around the grid wires. With a highly negative grid these sheaths will be sufficiently large to overlap each other and prevent the current flow to the plate. If, now, the grid is made less and less negative, the sheaths become thinner and thinner until, at a critical value of the grid voltage called the *striking potential*, E_c , they no longer close the largest hole in the grid structure. The electric field on the plate is no longer able to attract electrons from the region between the cathode and the grid. A current then flows through the plate circuit. Once the current has started, the sheaths all become very small and, although subject to small changes in size when the grid voltage is changed, they cannot be made sufficiently large to stop the plate current. It requires a reduction of the plate voltage to zero before the current is shut off.

The striking potential of the tube depends on the plate potential, E_p , as shown in Fig. 18 G. Any one of the curves in this figure shows the value of the grid potential for a given plate potential which will just start the flow of current through the tube. The curve shows simultaneous values of plate and striking potentials, in contradistinction to the usual graphs which show how one quantity y depends upon another quantity x . In Fig. 18 G, curve A is typical of the so-called

negatively-controlled tube; *B* is for the *positively-controlled* type of tube. In the latter case, the striking voltage is affected by the formation of negative charges on the inner surfaces of the glass walls of the tube.

The smaller tubes, which handle smaller currents and are operated at lower voltages, contain a rare gas such as argon whose pressure is unaffected by temperature. The larger, more powerful tubes which

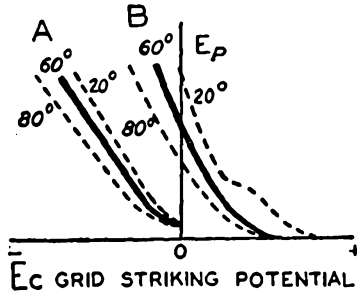


FIG. 18 G. The striking curves of gas-filled triodes. (From E. & N. P.)

operate at potentials above a few hundred volts contain mercury whose vapor pressure varies from 0.001 to 0.1 mm., the higher pressures for the higher temperatures. As shown in Fig. 18 G, by the dotted lines, these pressure changes alter the striking potential.

The striking curves of different tubes are not always as straight as those of Fig. 18 G. When, however, they are straight, their slope serves as a useful constant of the tube. Thus the *grid-control ratio* ρ is defined as the ratio of the plate voltage E_p to the striking potential E_c . The larger this number the more readily will a small change of grid voltage trip the tube and start the plate current flowing.

A word of precaution is necessary for the practical operation of this class of tube. The filament must be heated up to its normal operating temperature before the plate voltage is applied and, second, the plate voltage must be removed from the tube before the filament is allowed to cool down. Otherwise the high voltage drop across the tube will exceed the disintegration voltage and the emitting surface will be destroyed. On the other hand, when the filament is hot and a discharge is started, the voltage drop across the tube comes almost instantly to the safe, fixed value of 10 to 20 volts, depending on the pressure in the tube and its structure.

18.7 Gas-filled Tetrodes. A variety of striking-curves can be obtained with a given tube by adding a second grid. An example of the changes which can result from change of voltage on this shield-grid type of tube is shown in Fig. 18 H.

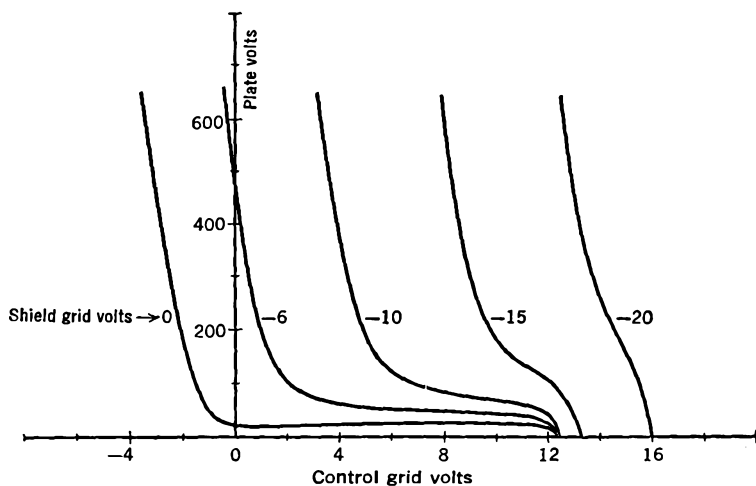


FIG. 18 H. Striking curves of a hot-cathode gas-filled tetrode (type 2050)

CHAPTER 19

OPERATION OF GAS-FILLED TUBES

19.1 A Counting Circuit. In Fig. 19 A, the relay in the plate circuit is turned on whenever the grid voltage becomes more positive than the striking potential of the thyratron. When the relay is energized, its contact is broken, the plate voltage is removed from the tube, and the plate current ceases to flow. The moving part or armature of the relay may be used to operate an ordinary mechanical counting device. In the circuit shown, this is accomplished by means of a ratchet wheel, but other mechanisms can be used. There is an upper limit to the rate at which the parts of the relay, ratchet, and mechanical counting device can move. Consequently there is an upper limit to the rate at which a succession of impulses can be applied to the grid of the tube and still be recorded in correct number.

19.2 A Self-Stopping Circuit. In order to stop the plate current of a thyratron, a relay may be used as described in the preceding section or a combination of resistors and capacitors may be used, as in Fig. 19 B.

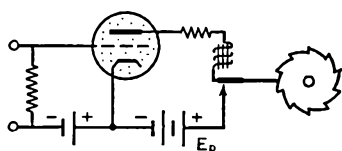


FIG. 19 A. A simple counting circuit.

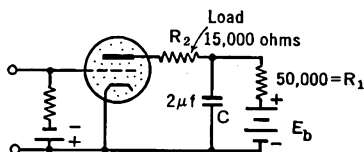


FIG. 19 B. A self-stopping circuit

In order to understand the operation of this circuit, imagine that at the start there is no plate current and that the grid is more negative than the critical or striking potential. The condenser C , of considerable capacitance, has been charged by the battery, E_b , through the resistance R_1 (of fairly high value, say 50,000 ohms). Because there is no potential drop across the load resistance R_2 (of comparatively small value, say 10,000 ohms), the full voltage of the condenser is across the tube. Assume, now, that for a very short time interval, a positive

potential is applied to the grid, causing it to exceed the striking-value. Then the plate current is turned on. This results in the sudden discharge of C through R_2 , and considerable potential drop occurs across R_2 . This reduces the plate voltage to zero and shuts off the plate current. Between successive pulses on the grid, the condenser is refilled from the plate battery.

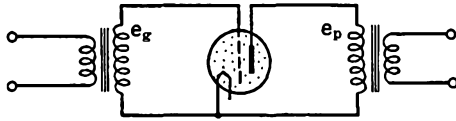


FIG. 19 C. Applying alternating potentials to the grid and plate of a gas-filled tube

19.3 A.C. Plate Voltage and D.C. Grid Voltage. We shall next examine some of the interesting possibilities of applying alternating voltages to both the grid and plate circuits of gas-filled tubes, as in Fig 19 C. Figure 19 D shows what will happen when the plate voltage alternates and a steady grid voltage is progressively raised from a negative value, well below the striking-potential, to a value above that potential. At first, as at the top of the figure, there is no current flow in the plate

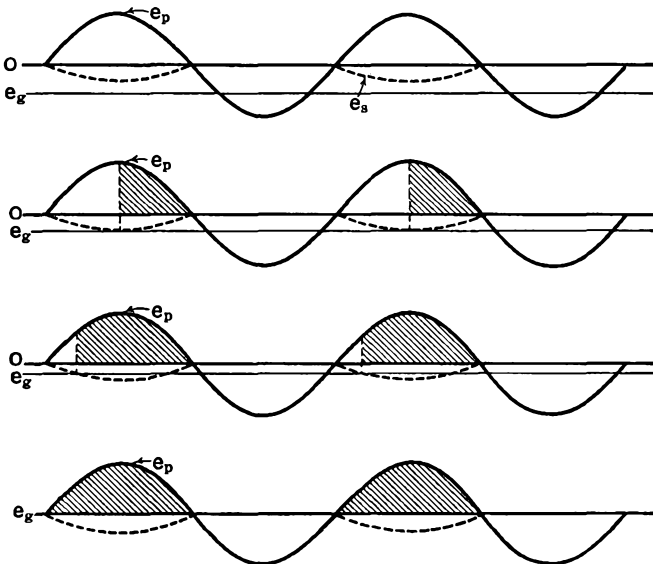


FIG. 19 D. A thyratron operated with a.c. on the plate and d.c. on the grid. The plate voltage is e_p , the grid voltage is e_g , the striking potential is dotted

circuit at any time. When, however, the grid voltage is equal to the maximum striking-voltage (bottom of the dotted curve), for the peak value of the plate voltage, then the plate current is turned on and continues to flow for the remainder of the positive half-cycle. In other words, the plate current flows during one-quarter of each cycle, as indicated by the shaded areas. The strength of this plate current is proportional to the plate voltage.

If the d.c. voltage on the grid is made still less negative, then the plate voltage will be turned on at an earlier time in the positive half-

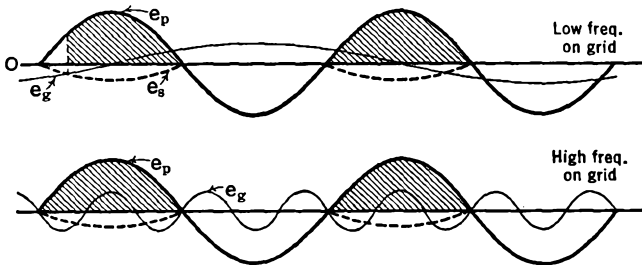


FIG. 19 E. Frequency control of the plate current of a thyratron

cycle and will continue to flow, in an amount proportional to the plate voltage, until that voltage has become zero. For zero grid voltage the plate current flows during the entire positive half-cycle, i.e., for one-half the total time. Thus, by a slight change in the grid voltage, it is possible to vary the plate current from zero up to a value equal to the average of a half-wave rectified current.

19.4 Frequency Control of the Average Plate Current. An interesting case arises when both the plate and grid voltages of a thyratron are alternating. As indicated in Fig. 19 E, the plate current is not turned on until the grid voltage becomes less negative than the striking-potential indicated by the dotted lines. For a low frequency on the grid, this results in current flow every positive half-cycle of the plate for a certain period of time, i.e., when the grid is passing through its positive half-cycle; followed by an interval of time, during most of the negative half-cycle of the grid voltage, when there is no plate current. When the frequency of the grid voltage is increased, the time intervals of current flow become longer, until, at a sufficiently high frequency, the current will flow during every positive half-cycle of the plate voltage.

19.5 Phase Control. We next consider an operating condition much used in practice with gas-filled triodes. We propose, first, to apply a small alternating voltage to the grid and a large alternating voltage to the plate by means of two transformers as in Fig. 19 C. Now, by

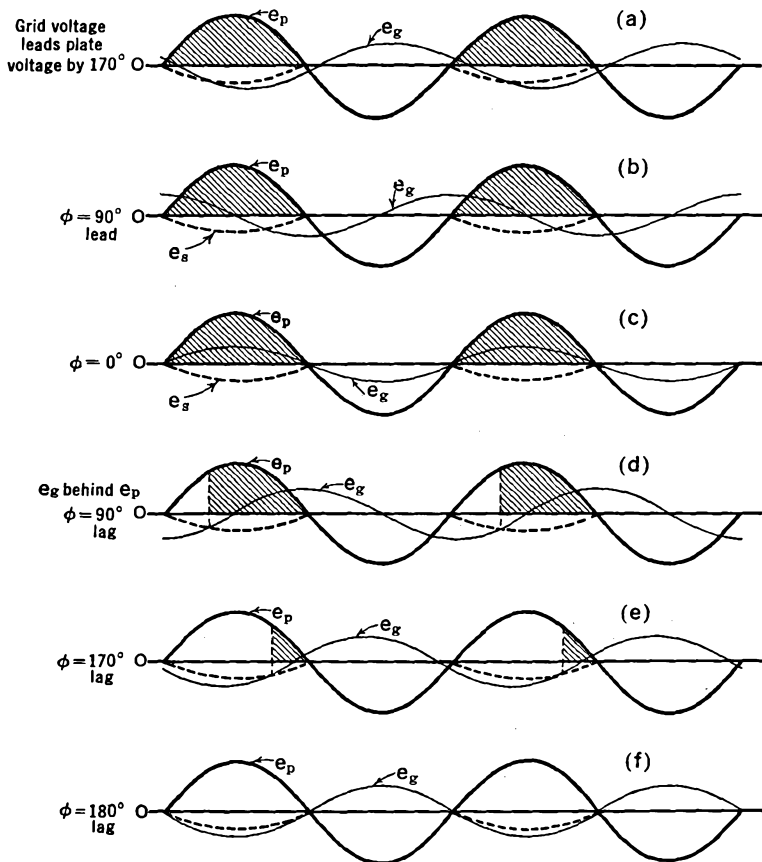


FIG. 19 F. Phase control of the plate current of a thyatron

some hook or crook, we propose to vary the relative phase of these two voltages, that is, the relative time at which they reach their peak values. As shown in Fig. 19 F(a), if the grid voltage reaches its peak value ahead of that of the plate voltage at a time corresponding to 170 electrical degrees, then the plate current will flow for the duration of

the positive half-cycles, as indicated by the shaded areas. If the grid voltage reaches its peak value one-quarter of a period or 90 electrical degrees behind the peak value of the plate voltage, the plate current will flow for only that portion of the positive half-cycles indicated by the shaded areas in Fig. 19 F(d). As we adjust the phase of the grid voltage to lag more and more behind the plate voltage, the plate current flows for shorter and shorter intervals of time until, for a half-cycle or 180° lag, there will be no plate current at all.

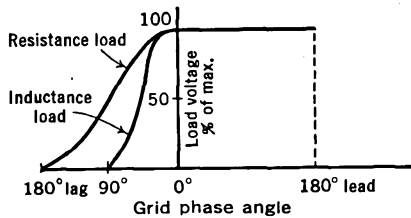


FIG. 19 G. Effect of resistive and inductive loads in the plate circuit of a phase controlled thyatron

Figure 19 G shows the average value of the plate current or load voltage for various phases of the grid voltage (with respect to the phase of the plate voltage), in the case where the load in the plate circuit is resistive, and where it is inductive.

19.6 Phase Shifters. In Section 4.5 we learned that the current through a resistance reaches its peak at the same instant that the voltage across it reaches its maximum value, i.e., the current and voltage are “in phase” with each other. We also learned that the current through a condenser leads the impressed voltage by a quarter-period or 90°, while that through an inductance lags behind the applied voltage by 90°.

In Fig. 19 H, the current from the generator divides along the two paths r and RC . In path r , the voltage and current are in phase. In path RC , the current leads the generator voltage by something between 0° and 90°. Thus the voltage at point 4 reaches its peak value ahead of that at point 2. If R is large, this “phase difference” between 4 and 2 will be small, whereas if C is large it will be appreciable.

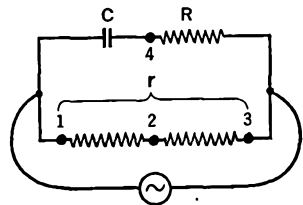


FIG. 19 H. An RC phase shifter

A phase shifter using an inductance and a resistance is shown in

Fig. 19 I. By changing L and/or R , the phase difference between the current and voltage through the load can be changed.

Figure 19 J shows a bridge-type phase shifter where adjustments of the resistances and condensers permit of changing the output phase

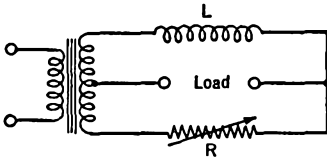


FIG. 19 I. An L-R phase shifter

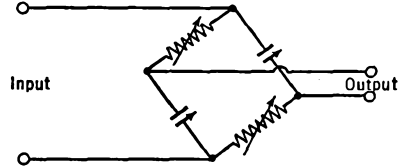


FIG. 19 J. A bridge-type phase shifter

from 0° to 180° with respect to the input. Reversing the leads of either the input or the output gives phase changes from 180° to 360° .

Figure 19 K shows practical circuits for the phase control of gas-filled tubes.

19.7 Thyatron Rectifiers. As we have seen in a previous section of this chapter, the plate current through a thyatron flows only during the positive half-cycles of the plate voltage. Hence a thyatron may be used as a rectifier. Furthermore, it is possible to change the output

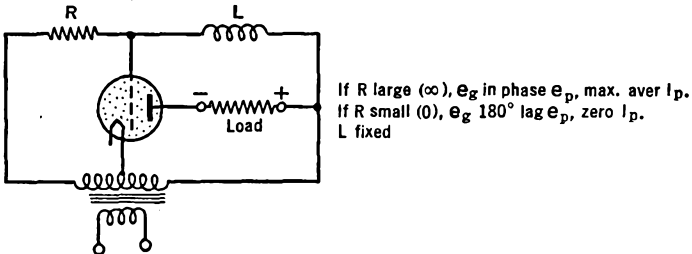
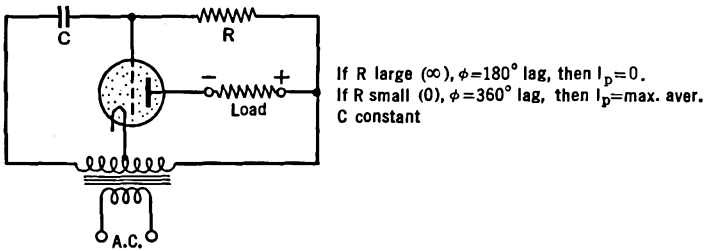


Fig. 19 K. Circuits for the phase control of thyatrons

current of such a rectifier by the phase-control method just described. A circuit of this type is shown in Fig. 19 L. Two-electrode gas-filled tubes may be used as rectifiers in the circuits of Chapter 11 whenever larger current outputs are desired than can be passed by vacuum tubes. In using hot-cathode gas-filled tubes, it must be remembered that the

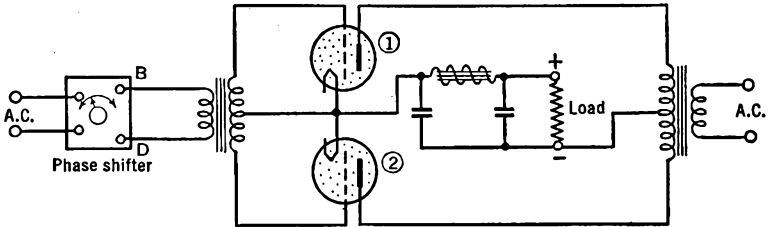


FIG. 19 L. Phase controlled thyatron rectifier circuit

cathode is to be hot before the high voltage is applied and is to be kept hot until the plate voltage has been removed. Otherwise, the operating life of the tube will be reduced by disintegration of the filament under positive ion bombardment. It must also be recalled that with vacuum tubes the internal resistance is sufficiently great to keep the current to a safe value, whereas, with gas-filled tubes, the current flow is determined by the applied voltage and the *external* resistance.

19.8 Inverters. A rectifier circuit is used to convert alternating into direct current. An inverter circuit does just the inverse; it turns a direct current into an alternating current.

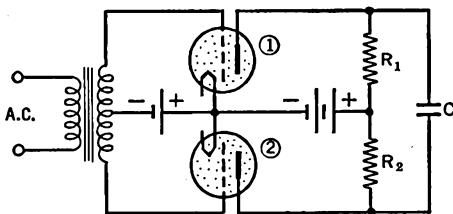


FIG. 19 M. The principle of operation of an inverter

The principle of an inverter using gas-filled triodes is shown in Fig. 19 M. Please examine this figure for a moment. You will notice that the plates and grids of both the gas-filled triodes have the same d.c. voltages due to the common plate and grid batteries. The plate battery is the source of d.c. which is to be converted into an alternating

current. Now, when a small a.c. voltage is applied to the transformer at the left of the circuit, the grid of tube 1 becomes less negative, sufficiently so as to start a current in its plate circuit and through the resistance R_1 . This flow of current makes the top of R_1 negative and the bottom positive, which charges condenser C , with negative on the top. The current in R_1 continues to flow until the second half-cycle of the a.c. voltage makes the grid of tube 2 less negative. When the striking potential of tube 2 is reached, its plate current is turned on and continues to flow during the remainder of the half-cycle. The voltage drop in R_2 charges condenser C in the reverse direction, that is, with

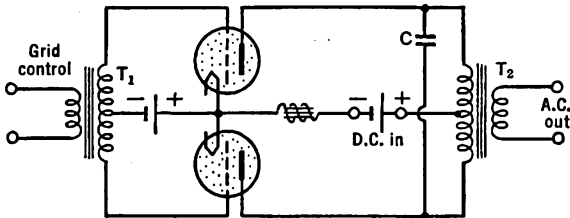


FIG. 19 N. The inverter changes d.c. to a.c.

negative on its bottom plate. This charging current has to pass through R_1 . In so doing, it sets up a potential drop across R_1 of sufficient magnitude and of such polarity as to make the voltage on the plate of the upper tube zero, with the result that this tube shuts off. Thus the upper tube conducts during the positive half-cycles and the lower tube conducts during the negative half-cycles, each reversal of the a.c. serving to switch the current from tube 1 to tube 2 and back again.

We thus see that the current surges in and out of condenser C of Fig. 19 M. A more practical form of the inverter is shown in Fig. 19 N. In this circuit, the resistors R_1 and R_2 of Fig. 19 M have been replaced by the two legs of the primary of the transformer T_2 . When the upper and lower tubes are alternately turned on and off by the grid control, the rise and fall of the magnetic fields in the primary of the output transformer induce alternating voltages in the secondary. By resonating the transformer to the grid control frequency (by means of condenser C), a comparatively pure sinusoidal output voltage is obtained.

In Fig. 19 O, the fluctuating voltages on the grids of the tubes are obtained by feedback through the condensers C_1 from the plates of these tubes. In addition, the a.c. output from the inverter is passed

through a full-wave rectifier tube and then smoothed out with a filter circuit (not shown). Thus d.c. is converted into a.c., stepped up or down in voltage by a transformer and, by means of a rectifier, reconverted into a direct current. The circuit might be called a "d.c. transformer."

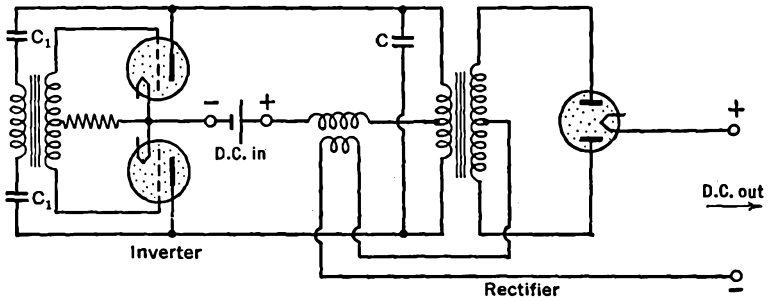


FIG. 19 O. A "d.c. transformer" circuit

CHAPTER 20

PHOTOELECTRIC CELLS

20.1 Introduction. When ultra-violet light falls on the surface of certain metals, electrons are given off. This is called the photoelectric emission effect and was first noticed, although not understood, by Heinrich Hertz in 1887, during the famous experiments in which he discovered radio waves.

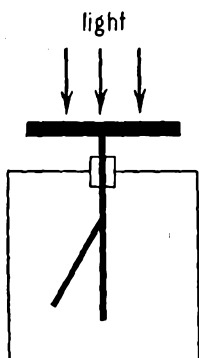


FIG. 20 A. An early study of the photo-emission of electrons. (From E. & N. P.)

Look at Fig. 20 A. Light falls upon the horizontal zinc plate indicated by the heavy black bar near the top of the figure. Below this plate, in the box, is the gold leaf of an ordinary electroscopes. When the light falls on the plate, and when the leaves of the electroscopes are charged positively, there is no loss of electricity, but when the plate is negative, the leaves collapse. This shows that the photoelectrons are negatively charged. In other words, they are held by the attraction of a positive plate and are repelled from a negatively charged plate.

Figure 20 B shows a photoelectric tube in which the cathode is the surface upon which light is incident and from which electrons are emitted. The anode consists of a single straight wire and is charged with respect to the cathode by means of the battery V . The glass bulb surrounding these electrodes is evacuated, or at best contains only a small amount of gas. In the figure, G is a current-measuring instrument of a sensitive type known as a galvanometer. The deflection of the instrument is greater when more electrons leave the cathode, and vice versa.

20.2 The Intensity of Light. The practical unit of luminous flux of light is called the lumen. The International Candle emits a total of 4π lumens in all directions. The luminous flux of light, L , in lumens, which passes through a given area A , in square feet, normal to the path

of the light rays at a distance D (in feet) from a source of candlepower C , is given by the following equation:

$$L = CA/D^2.$$

The "illumination" I received on a given surface must not be confused with the intensity of the light which was given out at the source. Inasmuch as the light which reaches a surface decreases inversely as the square of the distance D from the source, the illumination I in foot-candles is given by the equation: $I = C/D^2$.

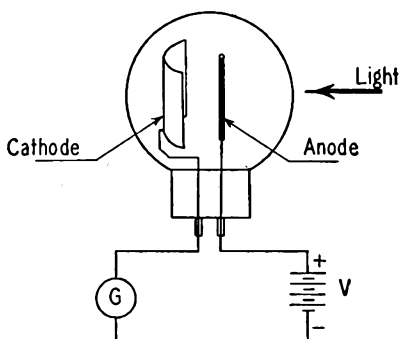


FIG. 20 B. A simple photoelectric tube and circuit. (From E. & N. P.)

The illumination of a surface placed at right angles to the light rays and 1 foot from a source whose intensity is 1 candlepower is called 1 foot-candle. Ordinary lighting amounts to somewhere between 2 and 15 foot-candles. For office work it should be between 5 and 30, and for detailed work, between 15 and one hundred foot-candles. A 60-watt, 110 volt frosted lamp will give about 30 foot-candles at a distance of 14.5 inches from the center of the bulb. A light intensity of 0.2 lumens will pass through an opening 1 square inch in area in a surface which is illuminated by 30 foot-candles.

20.3 The Photoelectric Current. The electric current, as measured by the meter G of Fig. 20 B, is directly proportional to the number of photoelectrons emitted from the cathode each second. This number depends, for a given cathode material, upon the intensity and the color of the incident light. Let I stand for the intensity of a beam of light of but one color (monochromatic) which falls upon the cathode. It is found that the number of photoelectrons is directly proportional to I .

If the intensity of the light is doubled, the photo-current i is likewise doubled, etc. This is expressed mathematically by the equation:

$$i = S \times I, (\lambda \text{ constant}),$$

where S is a constant. Figure 20 C tells the same story in a graphical way. This simple relationship between the photoelectric current and the incident light is accurate over an extremely wide range of intensities,

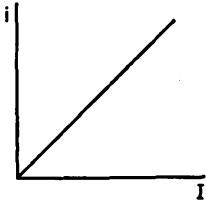


FIG. 20 C. The photoemission i is directly proportional to the intensity of the light, I

from 0.000,07 to 10,000 foot-candles; that is, from light intensities less than the eye can detect up to direct sunlight. It is accurate for thick and for thin coatings of various materials on the cathode or sensitive surface. It is also exact when the incident light is made up of a combination of many colors, provided only that the relative distribution of energies in the various colors remains unchanged as the intensity is changed. Departures from this simple law, which occur in practical photoelectric cells, are due to the accumulation of layers of negative electricity on the walls of the

enclosing glass bulb. In the modern photoelectric tubes the effect of these changes is greatly reduced by proper design and position of the electrodes.

20.4 Photoelectric Currents and the Battery Voltage. Figure 20 D shows two curves which are identical at the left but differ at the right. The one marked V is for the case when the photoelectric cell is very highly evacuated. The other, marked G , is for the case when there is a trace of gas in the bulb. The photoelectric current is plotted vertically and the voltage of the battery is plotted horizontally. In both of these curves it is assumed that the intensity of light and its color are constant. When the cathode or sensitive surface is only slightly negative, and the anode slightly positive, the currents are small. As the battery voltage is increased, the currents quickly rise to a saturation value indicated by the long horizontal portion of the V curve. In other words, in a highly evacuated photoelectric cell, if the battery voltage is greater than a certain small value — shall we say 10 volts — all of the electrons which the light releases from the cathode will be drawn over to the anode. Then any change in the battery voltage cannot change the amount of the electrical current because all emitted electrons are in use. The additional current, shown in the curve G ,

is obtained from the gas in the tube. Electrons coming from the cathode, when sufficiently speeded up by the battery voltage, are able to eject electrons from the neutral gas atoms. The newly created electrons add their number to the original photoelectrons. In addition, the "ionized" atom, which is positively charged, moves toward the cathode. The net result of all of this is that the total current is increased. Furthermore, it is to be seen from the curve *G* that it increases very rapidly as the voltage on the cell speeds up the photoelectrons and in-

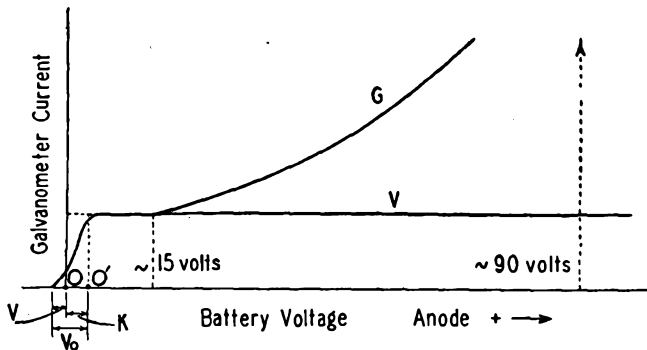


FIG. 20 D. The photoelectric currents for different voltages applied to a vacuum (*V*) and a gas-filled tube (*G*). (From E. & N. P.)

creases the effectiveness with which they can ionize neutral gas atoms. The battery voltage which can be safely applied to a gas-filled cell, indicated roughly by the dotted arrow, lies between 75 and 125 volts. It is usually about 90 volts. Higher voltages may be applied when the intensity of the light is small, and vice versa. If greater voltages are used, the positively charged atoms will bombard the cathode too vigorously and destroy its ability to emit photoelectrons copiously.

20.5 The Time Factor. It has been shown by direct measurements that there is practically no delay between the time light falls on the cathode and the time of emission of electrons. Furthermore, when the light is turned off, the photoelectrons cease to come out of the cathode almost instantaneously. If there is any time delay for a phototube, it is less than one one-hundred-millionth of a second.

Suppose the light which falls on the cathode were turned on and off successively at an increasing rate; then, in the case of a gas-filled photoelectric tube, it would be found that the photoelectric current

gradually decreased, by as much as 20 per cent when the frequency is raised to 10,000 cycles per second. This is due to the gas and not to any time delay of emission of the photoelectrons from the cathode.

20.6 The Scientific Measure of the "Color" of Light. Light is known to consist of tiny waves. The distance from crest to crest or trough to trough of these waves is called the *wave-length*. The wave-length of light ranges from 0.000,04 to 0.000,08 cm., according to the color of

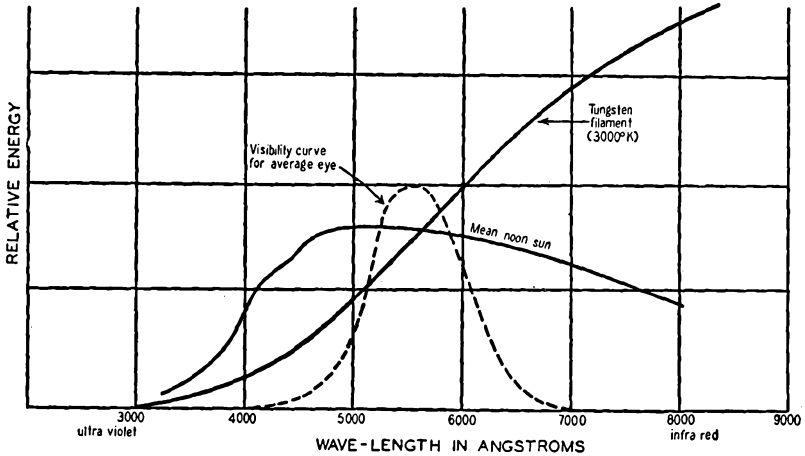


FIG. 20 E. Relative energies of light radiated at different wave-lengths as compared with the response of the human eye to these colors. (From E. & N. P.)

the light. The red rays are the longest. Next in order of decreasing wave-lengths come the orange, yellow, green, blue, and violet rays. We shall use the symbol λ for the wave-length. It can be measured with very great accuracy by means of instruments called spectrometers.

20.7 Photoelectric Current for Light of Different Wave-Lengths.

There is no simple relationship between the color or wave-length of the incident light and the photoelectric current. Furthermore, different sources of light give off different wave-lengths in different proportions, as shown in Fig. 20 E. The light from the sun is of more nearly constant intensity throughout the visible spectral region than is the light from a tungsten filament lamp, where the redder rays are much stronger than the blue rays at the other end of the spectrum.

Let us suppose, however, that there existed a source of light which gave out rays of equal intensity at each wave-length throughout the visible spectrum, from the extreme reds through the extreme violets.

Let us separate this composite light, color by color, and let each in turn fall upon the cathode of a photoelectric cell. The photoelectric current per unit intensity of light is called the *yield*. Let us now examine the curves of Fig. 20 F. Only the general shape of the curves has significance; not their absolute values. One can readily see that at certain favored wave-lengths the photoelectric current (per unit of

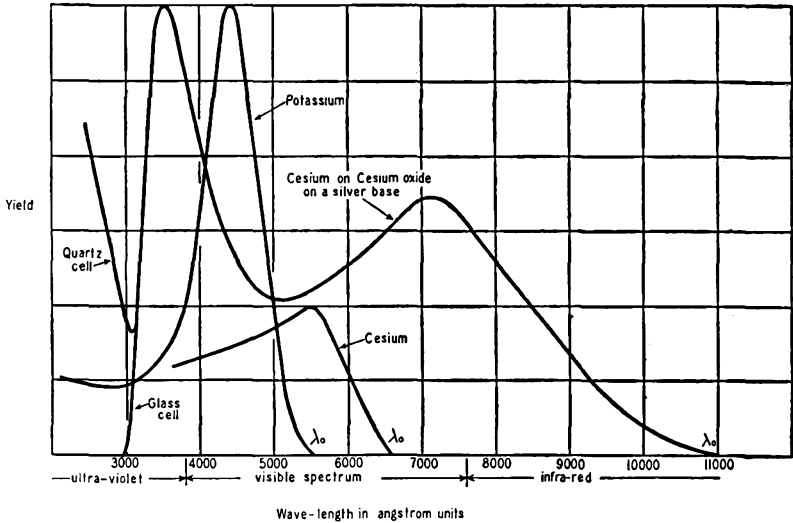


FIG. 20 F. Spectral distribution curves of some photo-emissive surfaces. (From (E. & N. P.)

light intensity) is very much larger than at other wave-lengths. This is called *spectral selectivity*. It is to be noticed that the photoelectric currents are larger for a cathode surface coated with one material than with another. For light rays of about 0.000,043 cm. (a deep purple color) the potassium surface emits electrons copiously. For a surface of cesium on cesium oxide on a silver base there are two favored colors, one a very red color at about 0.000,07 cm., and the other in the extreme ultra-violet region beyond the range of the eye, at about .000,035 cm. Although retaining their general shape and peaks, the curves for a given cathode surface will be found to differ somewhat according to the method of manufacture of the cell. All of this means that certain types of phototubes are preferable for use in one part of the spectrum and others are preferable for other colors.

An important point to be noted in connection with the curves of Fig. 20 F is that they plunge into the horizontal axis at a definite point. This long wave-length is called the *photoelectric threshold*. Light of greater wave-length than this threshold, falling upon the cell, will fail to eject electrons from the cathode, while shorter wave-lengths will do so.

The actual photoelectric currents emitted from a given photoelectric surface by light from a *given* source can be determined: (1) by multiplying the corresponding ordinates of the two curves in Figs. 20 E and 20 F, and (2) measuring the total area under the resulting curve.

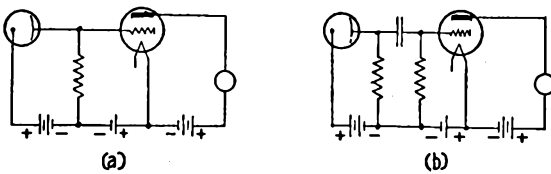


FIG. 20 G. Simple phototube amplifying circuits. (From E. & N. P.)

In order to specify the current from a photoelectric cell, it is necessary to state both the intensity and color of the incident light.

The yield from an exceedingly sensitive photoelectric cell is about 600 micro-amperes per lumen. This corresponds to 5.8×10^{-13} ampere for the smallest amount of light visible to the human eye (9.6×10^{-13} lumen when the pupil diameter is 6 millimeters). Ordinarily, photoelectric cells at best deliver from 20 to 100 micro-amperes per lumen. In sound-on-film, the light flux varies from about 0.01 to 0.04 lumen. Then the current output is a few micro-amperes. The current through a small light bulb is roughly 1,000,000 micro-amperes. In other words, photoelectric currents are quite small and require either delicate indicating instruments or vacuum tube amplifiers.

20.8 Some Phototube Circuits. Two simple phototube amplifier circuits are shown in Fig. 20 G. The one on the left can be used when the incident light is of constant intensity or changes at a slow rate. The circuit on the right is useful when the light intensity changes more rapidly. Figure 20 H shows a circuit in which a common battery *B* is used for both the phototube and the amplifier tube. A useful a.c.-operated phototube circuit is shown in Fig. 20 I. A gas-filled tetrode (2051) is used to supply sufficient power to operate a relay directly. The lamp serves the double purpose of providing a beam of light for

operation of the phototube and to lower the supply voltage to a value suitable for the filament of the 2051 tube.

20.9 Photoconductivity. The resistance offered by a suitably prepared thin layer of selenium to the passage of an electric current from a battery changes according to the amount of light falling upon this material. The resistance differs greatly according to the method of manufacture. In some cases it decreases from 10 to 20 million ohms to around 1 million ohms when exposed to light. Selenium cells are sluggish in their response to changes of light intensity. After the light is first turned on

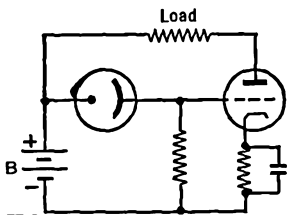


FIG. 20 H. The B battery serves both the photoelectric and the amplifier tube

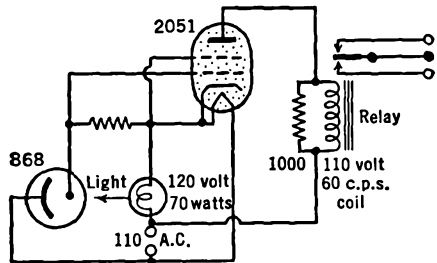


FIG. 20 I. A practical phototube circuit

the resistance decreases sharply. After this it continues to decrease slowly for several minutes or even hours, depending upon the previous history of the cell. When the light is turned off the normal dark resistance is not reached until after an appreciable time interval.

20.10 The Photo-Voltaic Effect. In contrast with photo-emissive tubes and photoconductive cells, which require a battery for their operation, photo-voltaic cells in themselves act like a battery when they are exposed to light. In one of the common commercial forms, the Weston Photronic cell, a thin film of properly annealed selenium is formed on a thick base of iron. When light passes through the thin layer of selenium and reaches the transition region between the two metals, it causes electrons to move from the iron to the selenium. In the conventional sense, the iron serves as the positive and the selenium serves as the negative terminal of a battery. Figure 20 J shows the output of this type of cell for different colors of light, all of the same intensity. Photronic cells can send as much as one-quarter of one milliampere through a low resistance load, even when the illumination is quite moderate, and hence can be used to operate fairly rugged meters and relays

directly, without the use of vacuum tube amplifiers. Photoemissive cells have a high internal resistance but give only small current changes and require extremely delicate meters or vacuum tube amplifiers. On the other hand, photovoltaic cells have comparatively low internal resistance (500 to 6,000 ohms), and deliver quite large currents into low resistance loads. Photoconductive cells are usually intermediate between the other two cells.

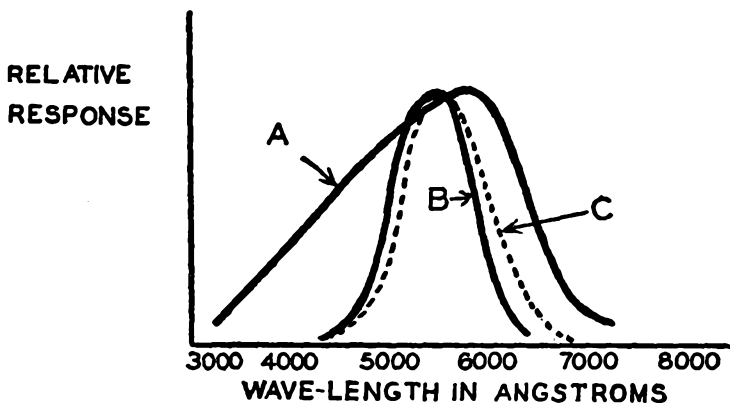


Fig. 20 J. Spectral distribution curves of photonic cells A, compared with the response (B and C) of the human eye to different colors. (From E. & N. P.)

If the external resistance or load of a photovoltaic cell is sufficiently low, say less than 100 ohms, the output currents are found to be directly proportional to the intensity of the incident light. But when the external resistance is greater than a few hundred ohms, and especially when the light is very bright, the output current falls short of the value it might be expected to have. This is due to a leakage of current in the cell itself. If the light is alternately turned on and off at increasing frequencies, the current is increasingly lost in the cell itself, due to its so-called internal capacity. The output becomes negligible at a few thousand cycles per second. Hence this type of cell cannot be used in "talkies."

20.11 Photo-Multiplier Tubes. The phenomenon of secondary emission was discussed in Sec. 10.10 and the nature of "voltage" multiplier tubes was presented in Sec. 15.5. Figures 20 K, L, and M show the arrangement of the electrodes in tubes which take advantage of the multiplication of electrons by secondary emission. Referring to Fig. 20 L,

all of the metal plates except the collector have been sensitized so as to be good emitters of electrons. The number of photoelectrons from *A* is proportional to the intensity of the incident light. These are attracted to the next more positive electrode *B*. The metal plates are shaped so as to bring as many as possible to *B*. They strike with sufficient energy to cause the emission of more secondary than incident elec-

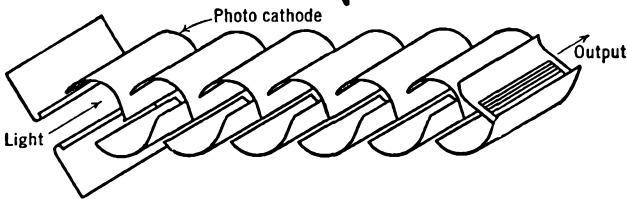


FIG. 20 K. The shape of the electrodes in a photo-multiplier tube

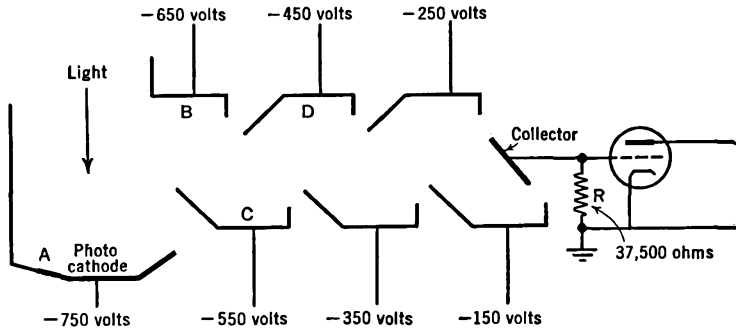


FIG. 20 L. A 6-stage electrostatic photo-multiplier tube

trons (say in the ratio of N to 1). The secondaries from *B* are electrostatically focused onto *C* where, again, N secondaries are created by each incident electron. The total number which then moves toward *D* will be $N \times N$. The process continues, building up more and more electrons until the collector is reached. In an n -stage multiplier tube, there will appear N^n electrons at the collector for each electron released by the light at the cathode. Thus, if $N = 4$ and $n = 6$, the current will be increased 4^6 fold or 4096 times. In the tube of Fig. 20 L, the gain is 70 db. more than for a normal gas-filled photocell.

For the tube of Fig. 20 L, voltages on any one electrode may be incorrectly adjusted by about 5 per cent without seriously changing the sensitivity of the tube. A peak voltage swing of 75 volts may be obtained without distortion.

As an example of the sensitivity of a multiplier, the output may be 40 milliamperes per lumen with 100 volts per stage. At a light level varying from zero to 0.05 lumen, the collector current would then change from zero to 2 milliamperes.

The chief advantage of photo-multiplier tubes lies in their ability to detect and measure *very weak light intensities*. With an ordinary

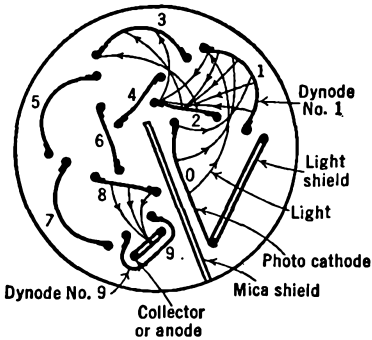


FIG. 20 M. The R.C.A. 931 multiplier phototube

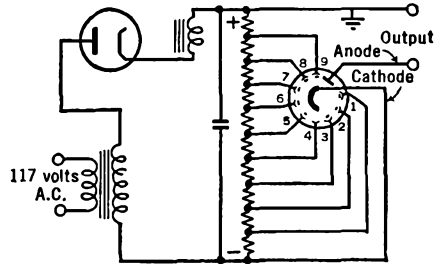


FIG. 20 N. Voltage supply for the tube of Fig. 20 M

phototube, the erratic "dark current" or no-light current is often so great as to mask any current set up by a small amount of light sent onto the cathode.

Figure 20 M shows the structure of a 9-stage electrostatically-focused multiplier phototube. When adjusted so that 5 secondaries appear for each incident electron, the current amplification would be, theoretically, 5^9 or approximately 2 million. The dark current is equivalent to that produced by about 10^{-6} lumen; in other words, is exceedingly small. Approximately 1250 volts are used, 400 of which are applied between dynode No. 9 and the collector. With 100 volts per stage, the sensitivity is 0.6 amp./lumen and the amplification proves to be 60,000. With 125 volts per stage, the gain is approximately one-quarter million. The tube is unusually responsive in the *blue* part of the spectrum. A typical voltage supply system for the tube is shown in Fig. 20 N.

CHAPTER 21

CATHODE-RAY TUBES

21.1 Introduction. There is an analogy between the action of light rays in optical systems such as lenses and prisms, and the action of electron streams in electric and magnetic fields.

Suppose a ray of light were to pass through a glass prism as in Fig. 21 A (a). It would be found that the blue rays of light are bent

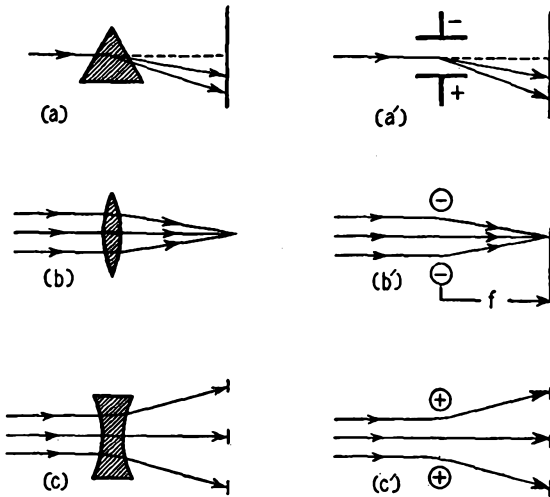


FIG. 21 A. A comparison of light rays passing through glass systems (on the left) with cathode rays in electrostatic fields (on the right). (From E. & N. P.)

more than the red rays of light. Now consider the analogous case of a narrow pencil of electrons passing between two metal plates, one charged plus and the other minus, as at (a') of this figure. Since the faster electrons remain in the electrostatic field of the condenser for a shorter period of time, they are bent away from their straight line path less than are the slower electrons. The light rays are *dispersed* by a glass prism into their component colors, and the electron rays are dispersed into their different electron speeds. We conclude that there

is a reasonable comparison between the extent to which different colors of light are bent and the extent to which different velocity electrons are bent. Now, there is a quantity in optics, called the *index of refraction*, which serves as a measure of the extent to which light rays are bent. We may, analogously, use the velocity of the electrons as a measure of the extent to which they will be bent. It can be said at this point, without further details, that it is possible, starting from this analogy, to carry over en masse the mathematics of optics to serve as the mathematics for the calculation of the action of both electric and magnetic fields upon rays of electrons in vacuum tubes.

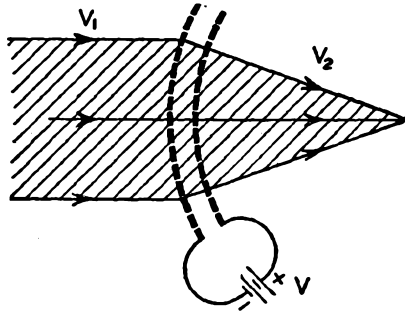


FIG. 21 B. A double-gauze electron lens. (From E. & N. P.)

Figure 21 A (b) shows the focusing action of a glass lens upon light rays, while (b') shows the analogous focusing action of two negatively charged balls upon a parallel beam of electrons. It is to be remembered that electrons are negatively charged and are repelled by the negative charges of the balls. It is necessary that this repulsion increase by the proper amount off the axis if electrons at different distances from the axis are all to come to the same focal point.

Figure 21 A (c) shows how a bi-concave lens diverges the rays of a beam of parallel light. Analogously, the two positively charged metal balls of (c') of this figure diverge the electrons in such a way that they spread out. They all appear to have come from a common source on the left of the charged balls.

21.2 Electron Lenses. In Fig. 21 B, the heavy dashed lines represent two metal gauzes, curved as shown and electrically charged by the battery V , with positive on the right-hand gauze and negative on the left-hand gauze. An electric field is, therefore, established between the gauzes. Its direction is from the positive to the negative. This is the direction of the force action upon positive charges. A stream of

electrons, whose velocity is represented by the symbol v_1 , comes from the left and enters the electric field. Remember that electrons are negatively charged. When they enter the region between the two gauzes, the electric field tries to bend them immediately along its lines of force. Their forward momentum, however, opposes this deflection. As a re-

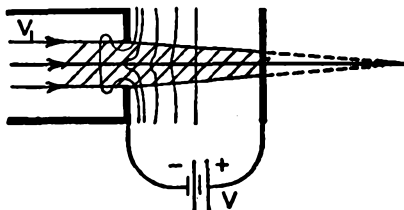


FIG. 21C. A single-aperture electron lens. (From E. & N. P.)

sult, they travel along a curved path which more and more approaches that of the electrostatic lines of force. After passing through both gauzes, they continue along their new paths at the higher velocity v_2 . The shaded area in the figure indicates the total region occupied by the electrons. The fact that the various electrons in this region come to a common focal point is only possible if the gauzes have been so curved that the resultant of the electrostatic deflecting force and the forward momentum of the electrons is directly proportional to the distance of the electrons from the axis.

The first electron lens to be treated mathematically is shown in Fig. 21 C. This is called a diaphragm-hole or *single-aperture* lens. A parallel beam of electrons in the metal can (indicated by the heavy lines at the left of the figure) are deflected by the distorted electrostatic field in the hole at the end of the can, in such a manner as to be converged toward the metal plate (represented by the heavy vertical line at the right of the figure). By proper adjustment of the voltage of the battery V and the speed of the electrons, they can be brought to a sharp focal point on the metal plate.

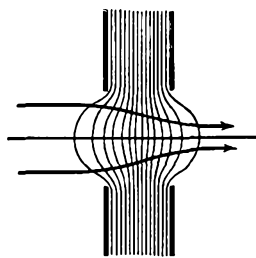


FIG. 21 D. A two-aperture lens

Combinations of two or more diaphragm lenses, as in Fig. 21 D, have been used to produce magnified, inverted, real images of the surface of filaments, thus permitting detailed studies of the emission of electrons from various minute portions of cathodes or hot filaments.

An electron lens can be formed by means of two metal cylinders charged to different potentials. These are known as *double-cylinder lenses*. When a parallel bundle of electrons, traveling at a constant velocity, as in Fig. 21 E, enters the electrostatic field between the ends

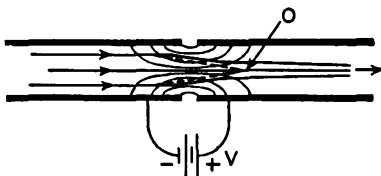


FIG. 21 E. A double-cylinder lens. (From E. & N. P.)

of the cylinders, it is converged toward a point, *O* in the figure, because the electrons must assume a compromise motion between their forward paths and the direction of the electrostatic lines of force. After passing the gap between the two cylinders, the electrons find themselves in an electrostatic field which causes them to diverge. But, at this point, the electrons are traveling faster, having been accelerated across the gap by the voltage *V*. Their momentum being greater and the electric field being the same, their divergence will not be as great as their convergence. Hence they continue down the cylinder, converging toward a more distant point.

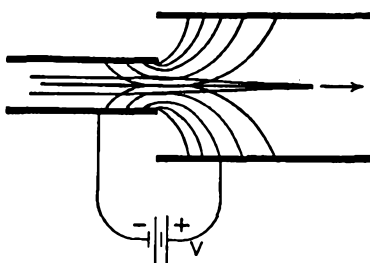


FIG. 21 F. A short-focus double-cylinder lens. (From E. & N. P.)

In Fig. 21 F, the second cylinder is larger than the first cylinder, with the result that the electrostatic lines spread out more in the second cylinder. This means that the electrostatic field in this region is weaker and its divergent action on the electrons is less. Hence the electrons come to a focus sooner than in the case where the two cylinders are of the same diameter.

21.3 Electron Guns. In many radio tubes there is a centralized filament surrounded by the various grids and plates. The electrons spread out from the filament radially in all directions. We might say that they are "broadcast."

There is an entirely different class of tubes, namely, cathode-ray tubes, television tubes, positive-ray and atom-smashing machines, which require that the charged particles should not spread in all directions from their source but should be confined to a parallel beam, or, at most, should diverge but slightly along their entire route to the end plate.

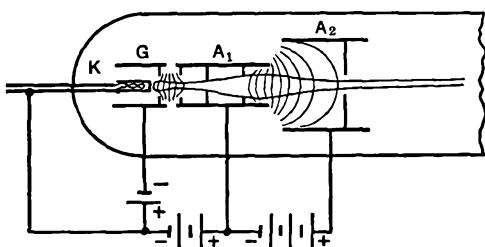


FIG. 21 G. The electron gun of a cathode-ray tube. (From E. & N. P.)

Figure 21 G shows an electron gun used in a cathode-ray oscilloscope. The *cathode*, *K*, is of the indirectly heated type wherein a hot wire is mounted inside a small metal thimble about the size of the lead in a lead pencil. The front end of this thimble is concave and is coated with chemicals which render this portion of the structure a good emitter of electrons. This cathode is surrounded by a metal cylinder, *G*, having a metal diaphragm with a small hole directly in front of the cathode surface. This "grid" is charged negatively with respect to the cathode. As a result, the electrons, which are themselves negative, are prevented from diverging from the cathode and are bent inward along the axis of the tube, even to the point of crossing over and again starting to diverge on the other side of the axis. According to the potential of the grid, larger or smaller numbers of electrons are brought along the axis of the tube, or are permitted to diverge and be lost inside the gun structures. In other words, the grid serves as the chief control of the number of electrons which leave the gun. The number of electrons in the cathode ray or electron beam is easily changed by turning the knob of a rheostat which varies the voltage of the grid.

In front of the grid of Fig. 21 G, there is a cylinder *A*₁ containing

several metal diaphragms with holes in them. This is called the *first anode*. It is charged positively with respect to the cathode, to a potential of several hundred volts. Beyond the first anode there is a shorter but larger diameter anode A_2 , charged to a much higher potential, in some cases amounting to several thousand volts. The electric field set up between the two anodes serves, as in Fig. 21 F, to bring the electrons into a near-parallel beam. The electrostatic field between the two anodes can be shown to be the equivalent of a thick, unsymmetrical converging lens. Its focal length can be readily changed, within limits,

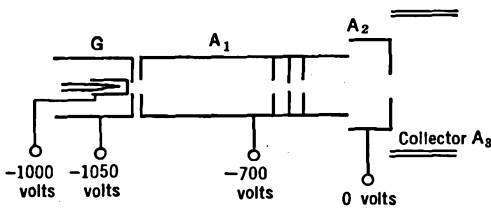


Fig. 21 H. A modern electron gun

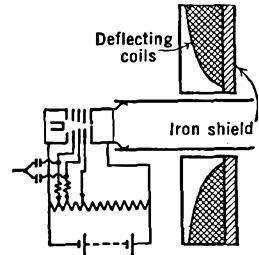


Fig. 21 I. A gun for the production of intense electron beams

by varying the voltage applied between the two anodes. In this respect, electron lenses are greatly superior to optical lenses. With a twist of the wrist to turn a rheostat, it is possible to change the focal length of the lens. Glass lenses cannot be so changed, but the crystalline lens of the human eye can be made of shorter focal length by the muscles which control it.

The gun structure of Fig. 21 H is used with television pickup tubes. The gun of Fig. 21 I produces very intense electron beams (2 ma. at 10,000 volts concentrated into a spot only 0.3 mm. in diameter). It uses both electrostatic and magnetic focusing.

21.4 A Cathode-Ray Tube. The cathode-ray tube in Fig. 21 J consists of a highly evacuated glass tube containing an electron gun at one end and a fluorescent screen at the other end. The *fluorescent screen* consists of certain chemicals deposited on the inside walls of the end of the tube. The chemicals or "phosphors" are sometimes willemite, calcium tungstate, or phosphorescent zinc sulfide, rendered active by traces of other substances. When these chemicals are struck by fast moving electrons, they emit visible light, the color of which is green, white, yellow, or blue, depending upon the screen material. After the electron

impact, the emission of light persists for a more or less short-time interval, usually a small fraction of a second and again depending upon the nature of the screen material. Screens are classified as of long, medium, and short persistence. They are also classified according to the color of the light, the green proving useful for visual observation since the eye is most sensitive to this color, the blue being more satisfactory for photographic purposes, and the white for television applications.

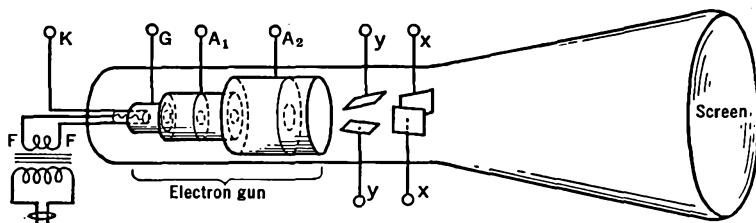


FIG. 21 J. A cathode-ray tube

While passing through the tube from the gun to the screen, the electrons pass between the plates of small condensers, called the *deflection plates*. When one of the plates is made positive and the other negative (by means of an external battery or an applied signal), the electrons are attracted toward the positive plate and are repelled from the negative plate. As seen on the fluorescent screen, the spot of light is moved to a new position away from the central point. When an alternating potential is applied to the deflection plates, the electrons are alternately deflected back and forth to produce a line of light on the screen.

Often there are two sets of deflection plates in a cathode-ray tube as indicated at *xx* and *yy* in Fig. 21 J. The two pairs of plates are mounted at right angles to each other and hence can move the electrons back and forth on the screen in the *X* and *Y* directions, permitting the production of curves as on an ordinary sheet of graph paper.

The amount of deflection caused by the deflection plates depends upon the speed of the electrons, the voltage applied to the deflecting plates, and their separation. The *deflection sensitivity* is usually defined as the number of millimeters movement on the screen produced by one volt on the deflection plates. For small tubes, this amounts to about 0.1 mm./volt. It is greater when the anode voltages are smaller, and vice versa.

In certain cathode-ray tubes, the electron beam suffers its deflections *before* its final acceleration to a high velocity. This offers the advantage that only a small deflecting voltage is required in order to move the electrons large distances across the screen. It is easy to deflect slow electrons by large amounts because they stay for a longer time in the electrostatic field of the deflecting plates.

It is also possible to deflect the electron beam by means of magnetic fields. This is accomplished by passing a current through small

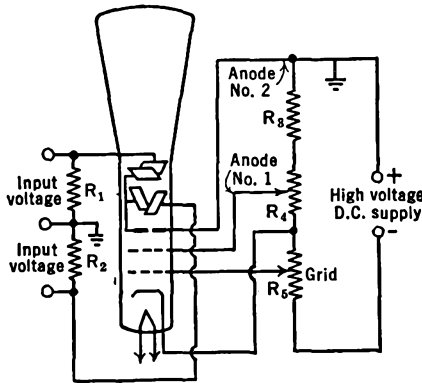


FIG. 21 K. A typical cathode-ray tube circuit. Three-inch 906 tube. R_1 and $R_2 = 1$ to 10 megohms. $R_3 = 0.5$ megohms. $R_4 = 200,000$ ohms. $R_5 = 20,000$ ohms. High voltage = 1300 volts d.c.

coils mounted close to the glass envelope on the outside of the tube, in the same relative positions as the electrostatic deflection plates.

A typical cathode-ray tube circuit is shown in Fig. 21 K, together with suitable constants for the RCA 906 tube. Changing the position of the sliding contact on the potentiometer R_5 changes the number of electrons passing out of the gun and hence the *intensity* or *brightness* of the spot of light on the screen. Changing the sliding contact on R_4 changes the *focus* or sharpness of the spot on the screen. To some extent, a change of either of these controls affects the other. The sharpest focus is obtained when the beam current is low. The input signals, which are to be observed and studied with this machine, are applied across the resistors R_1, R_2 , and hence across the deflecting plates. These resistors, which are of one or more megohms, are used to drain off any accumulation of charge on the deflection plates. Often, adjustable d.c. voltages are also applied to the deflection plates so that the spot can be

brought to the center of the screen when stray electric and magnetic fields are present. Inasmuch as only a small amount of current and power is required for the high-voltage d.c. supply, a half-wave rectifier may be used with a single 0.5 to 2 μ fd. condenser across its output. It will be noted that one side of each deflector, and anode 2, is at ground potential. Anode 1, the cathode, and the grid are all at negative potentials below ground.

21.5 Picture Tubes. Cathode-ray tubes are used in television receivers. A typical *kinescope* is shown in Fig. 21 L. The neck of the tube is kept narrow over the region *D* in order that magnetic deflecting coils

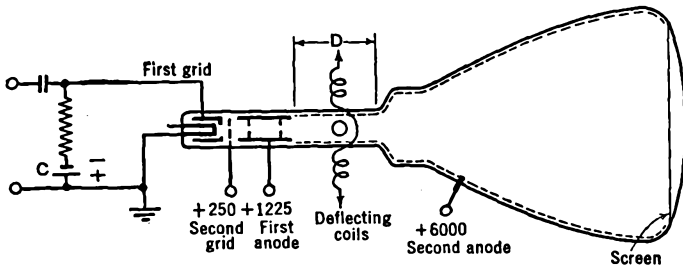


FIG. 21 L. A kinescope (No. 1804)

can be mounted close to the beam. The glass envelope is then enlarged rapidly so that the electrons can be deflected over a large screen without striking the walls of the tube. The second anode consists of a conducting surface (sometimes "aquadag," a colloidal graphite deposit) extending over much of the inner surface of the tube, as indicated by the dotted lines in Fig. 21 L. This offers a field-free space and helps return the electrons from the screen. With high voltages on the second anode, the electrons strike the screen with considerable energy and produce a bright image. If the spot is not cut off by the C-battery, it must be kept in rapid motion or it will destroy the screen material. In some of the tubes, the electrons must pass through a *very* thin metallic coating deposited over the screen material. This coating assists them to return to the cathode. If a negative charge accumulates on the screen, it will serve to deflect away oncoming electrons, and distorted patterns result.

Normally the tube is operated with a C-voltage as in Fig. 21 L, or with a cathode resistor, so that the first grid cuts off all electrons and the light does not appear on the screen. A positive signal applied to the first grid decreases its negativity and allows electrons to proceed down the tube. The brightness of the light on the screen depends on

the beam current (number of electrons per second which strike it). A plot of the beam current versus the control (first) grid voltage looks very much like the characteristic curve of a triode. The grid must not go positive or excessive currents will flow and the tube will be damaged.

21.6 The Iconoscope. In television there is need for a device which will convert impulses of light into equivalent fluctuating electrical currents, just as the microphone is used to generate electrical currents which are proportional to the sound waves which reach it for the cases of broadcasting and public address systems. One type of television pickup tube

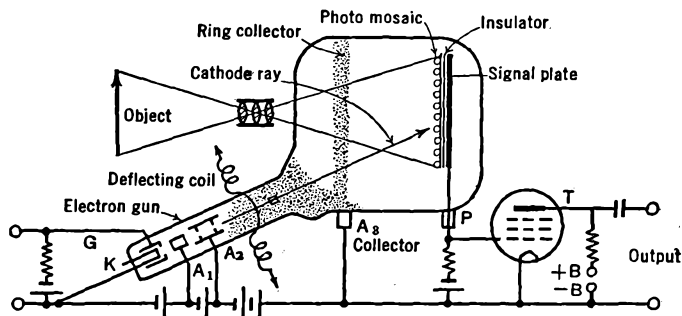


FIG. 21 M. An iconoscope and its circuits

is called the *iconoscope*. Icon means "image" and scope means "to see" (tele-scope, a long distance "see-er"; micro-scope, a small object "see-er"). Figure 21 M shows a modern iconoscope and its associated circuits.

The *photo-mosaic* consists of a large number of tiny photo-sensitive globules in a single layer, supported on a thin insulating surface (mica) and insulated one from the other. One method of forming the mosaic is, first, to dust silver oxide particles over a mica sheet, then to properly heat the unit so that the oxide is reduced. The silver draws up into tiny droplets, separate from each other. These droplets are sensitized to light during a later stage in the manufacture of the tube, much as an ordinary photoelectric cell is prepared. A metallic coating is deposited on the back of the insulating sheet to form the completed unit.

When an image of a distant object is formed on the mosaic by ordinary glass lenses, as in Fig. 21 M, photoelectrons are ejected from each globule and pass to the positive conducting surface A_3 . The number of photoelectrons emitted by a droplet depends upon the brightness of the light which strikes it and the time during which the emission is

allowed to continue. As each globule continues to lose electrons (negative charges), it acquires a proportionate positive charge.

From the side arm of the iconoscope, an electron gun sends a sharply focused beam of electrons onto the mosaic. By means of deflecting coils, the cathode ray is deflected back and forth across the mosaic in a succession of horizontal lines from top to bottom, *scanning* the entire surface in $1/30$ of a second. As the beam passes over a positively charged droplet, it suddenly replaces the electrons which were lost by photo-emission. The sudden reduction of positive charge on the drop-

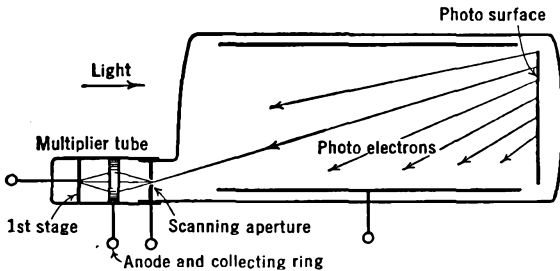


FIG. 21 N. An image dissector with an electron multiplier. Used as a television pick-up tube

let induces a positive charge on the signal plate (see Fig. 21 M) and hence on the grid of an amplifying tube *T*. The amount of this positive impulse is proportional to the amount of light which caused photoelectrons to be emitted from the globule during the time between two successive scanings by the cathode-ray beam. The summing-up of the light over this time interval results in more sensitive response to feeble light intensities.

As the cathode ray progresses from one part of the mosaic to another, a succession of impulses is delivered to the amplifying tube, proportionate to the amounts of light emitted by the corresponding parts of the object. Thus a complete picture or *frame* is scanned every $1/30$ second. This means that the picture is scanned 30 times every second. The impulses applied to *T* (Fig. 21 M) are amplified and used to modulate a transmitter, as in the case of the currents from a microphone.

21.7 The Image Dissector. A different form of pickup tube for television is known as an *image dissector* and is shown in Fig. 21 N. An image of a distant object is projected on a photo-surface. Electrons emitted from different small areas of this surface are brought in suc-

cession to an opening in a multiplier tube by means of deflecting coils (not shown in the figure). In the multiplier, they strike a first-stage sensitive surface where they cause the emission of, say, two or three secondary electrons per incident primary. These pass either to the collecting ring (see Fig. 21 N) or to the back side of the "scanning aperture" to produce an additional number of electrons by the secondary process.

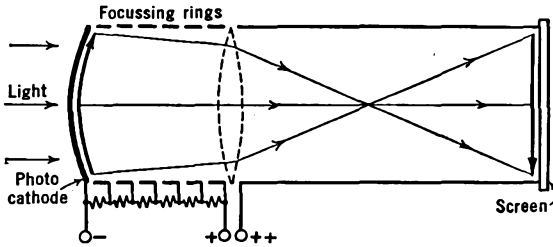


FIG. 21 O. An electron telescope

21.8 An Electron Telescope. With glass lenses, an image of a distant object is projected onto a photosensitized surface, as at the left of Fig. 21 O. A set of positively charged metal rings focuses the electrons emitted from each point of the photocathode onto a fluorescent screen to give a visible image. Invisible ultra-violet or invisible near-infrared rays may be used instead of visible light rays.

21.9 Magnetic Focusing. In Fig. 21 P, electrons from the hot filament are accelerated and collimated so as to focus at the center of the screen *S*. An alternating potential is applied across the deflection plates and sweeps the electron beam back and forth. A line instead of a spot is

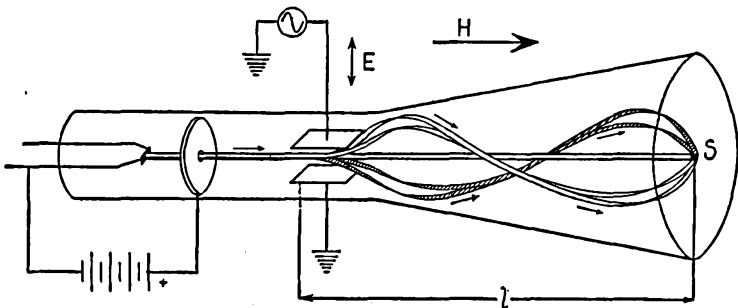


FIG. 21 P. Magnetic focusing. A long solenoid (not shown) around the tube sets up the magnetic field *H*. (From E. & N. P.)

then observed on the fluorescent screen. Finally, a magnetic field, H , is applied, with its lines of force parallel to the axis of the tube and extending along the entire path of the electrons. This field does not change the forward motion of the electrons but it does act upon the transverse motion produced by the deflection plates. The electrons will be deflected in circular paths in planes at right angles to the axis of the tube at the same time that they move down the tube. The combination of their circular and forward motions is such that the electrons travel in *helical* paths down the tube, as shown in the figure.

If it were possible to see the electrons from the screen end while they moved down the tube, it would be found that the circular paths of the various electrons are all tangent to the axis of the tube. This is indicated in Fig. 21 Q, where the black dot represents the intersection of the axis with the screen. Fast electrons travel in larger circles, and vice versa, but the *time* of rotation is the *same* for all. (This is also the basic law of cyclotrons.)

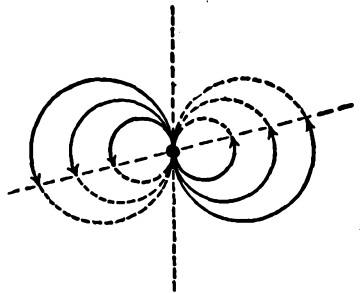


FIG. 21 Q. Projection of electron paths on the screen. (From E. & N. P.)

Let the electrons all have the same velocity. Then let the magnetic field be slowly increased in strength until the time required for the electrons to make one complete revolution is equal to the time for them to travel from the deflecting plates to the screen. Then all electrons will be focused at the central spot. If the magnetic field is still further increased, the electrons will make more than one complete revolution while traveling down the tube. If they make two complete revolutions during this time, they will again be brought into the sharp focus on the screen.¹

Let the electrons all have the same velocity. Then let the magnetic field be slowly increased in strength until the time required for the electrons to make one complete revolution is equal to the time for them to travel from the deflecting plates to the screen. Then all electrons will be focused at the central spot. If the magnetic field is still further increased, the electrons will make more than one complete revolution while traveling down the tube. If they make two complete revolutions during this time, they will again be brought into the sharp focus on the screen.¹

By analogy, we may liken the magnetic field to a converging lens whose focal length is proportional to the velocity of the electrons and inversely proportional to the strength of the magnetic field. Thus, a strong magnetic field, twisting the electrons in the manner just described, is the equivalent of a lens.

It is not necessary that the magnetic lens extend along the entire

¹ It is possible to measure the ratio of charge to mass of electrons with this apparatus. See Chapter 2, *Electron and Nuclear Physics*, by J. Barton Hoag.

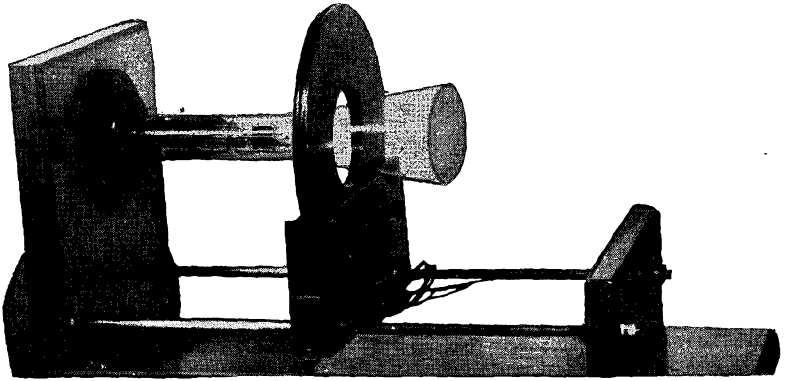


FIG. 21 R. A thin magnetic lens

path of the electron beam in order that it shall serve as a converging lens. In fact, the magnetic field may be confined to an exceedingly short distance along the axis of the tube and still serve to focus the electrons sharply on the screen. In Fig. 21 R, the thin disc-shaped magnetic field produces a magnetic field which extends along the axis of the cathode-ray tube only a few centimeters. With smaller diameter magnetic lenses, the field can be confined to only a few millimeters.

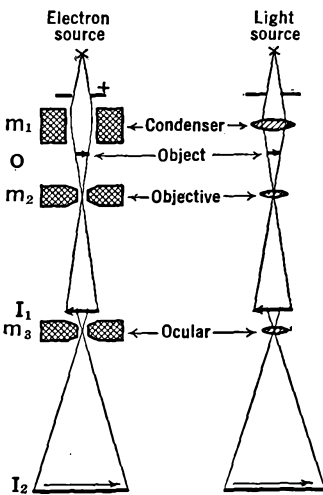


FIG. 21 S. The electron microscope compared with the optical microscope

Such "thin lenses" are used in *electron* microscopes. The principle of the electron microscope can be seen from Fig. 21 S. Here a stream of high velocity electrons are rendered parallel by a magnet m_1 . They pass through a very thin slice of some object which is to be magnified. Some of the electrons are stopped by the object and others get through, just as some of the X-rays passing through the human body are stopped by the bones while others get through the flesh. Electrons which pass through various parts of the object o are focused by the magnetic lens m_2 to form an image of the object at I_1 . This image is a shadowgraph, since it is produced by transmission through the object rather than by reflection from it.

Furthermore, with m_2 close to the object and I_1 far away, the image is greatly magnified, as much so as can be accomplished with an ordinary optical microscope. Electrons which pass I_1 are again focused by the third magnet m_3 to the new and again greatly magnified image I_2 . A fluorescent screen or photographic plate is placed at I_2 . Magnifications as great as 100,000-fold can be produced by this double magnification system. But of still greater importance is the fact that the small parts of the object, when thus magnified, can be distinguished one from the other. Stated technically, the resolving power is much greater in the electron microscope than in the optical microscope. In fact, objects as small as 0.000,000,5 cm. have been observed and studied with this instrument. This is an extension of approximately 100 times that of optical instruments.

CHAPTER 22

THE OPERATION OF OSCILLOSCOPES

22.1 Introduction. An oscilloscope is an instrument which contains a cathode-ray tube with its power supplies, with amplifiers for the deflection plates and with special circuits which permit the electron beam to be deflected over the screen surface in prearranged patterns. There are a great many uses to which the oscilloscope can be put, among which we may mention: studies of the wave form of various voltages and currents; instantaneous plotting of curves such as those of tubes or of the hysteresis phenomena in magnetism; the measurement of phase and

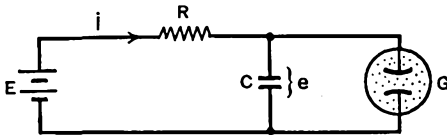


FIG. 22 A. A simple sweep circuit

time delays; the measurement of frequency; checking of the alignment of radio amplifiers; measurement of the percentage modulation of transmitting tubes; as the picture forming element of a television receiving set, etc. Most of the applications fall into the following simple classifications:

1. The study of change of voltage or current with *time*.
2. Comparison of two voltages or currents with respect to their relative *amplitudes*.
3. Comparison of the relative *phase* of one current with another, of one voltage with another, or of a current with a voltage.

As examples of the first class of problems we may cite: measurements of the time of delay of pulses returning from reflecting bodies such as the ionosphere, studies of fading, of field strength, and the waveform of atmospheric waves. As examples of the other two classes of measurements we may cite: direction finding on individual atmospheric waves, or on signals of short duration, and studies of the polarization of waves or pulses.

In this chapter we shall concern ourselves with the oscilloscope itself. Applications of this instrument will be found at various places in the book, associated with the particular equipment under observation, test, or measurement.

22.2 A Simple Sweep-Circuit. In order to deflect the spot of light across the screen at a uniform rate, special "sweep-circuits" have been developed. A crude but simple circuit is shown in Fig. 22 A. Here, a battery whose voltage is E sends a current through the resistor R into the condenser C . The rate at which the current flows into the condenser depends upon the value of R and C . As shown in Fig. 22 B, it occurs rapidly when the battery is first connected, then more and more slowly as the condenser becomes charged.

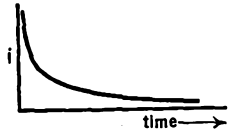


FIG. 22 B. Current flow into the condenser of Fig. 22 A

Across the condenser in Fig. 22 A is a glow-tube, which will start to conduct electricity only when the voltage applied to its terminals has risen to a definite value, called the striking potential (E_s). When the voltage across the condenser terminals has reached this critical value, the glow-tube becomes conductive and the electricity in the condenser suddenly empties out through the low resistance glow-tube's path. The glow-tube becomes non-conductive or "shuts off" at a low voltage called the extinction potential E_x . When the condenser has suddenly discharged its electricity, and the glow-tube has become non-conductive, electricity again comes from the battery slowly through the resistance R , to refill the condenser and repeat the cycle of events. The voltage across the condenser rises and falls in the manner shown in Fig. 22 C.

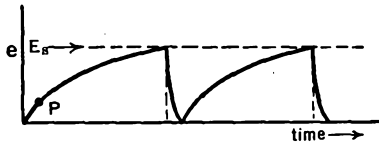


FIG. 22 C. Voltage across the condenser of Fig. 22 A

The frequency of the *relaxation oscillator*, described in the preceding paragraph, depends upon the size of R and C , and upon the comparative voltage at which the glow-tube strikes, and the battery voltage. Suppose we keep everything the same except the resistance R . As R is decreased, the time required to fill the condenser becomes less and less and the frequency of oscillations is increased, as shown in Fig.

22 D. Similarly if C is the only variable, and its value is made smaller and smaller, the time needed to raise the voltage across its terminals to the striking-potential of the glow-tube becomes less and less and the frequency of oscillations again is increased. In other words, the time constant RC (Sec. 3.6) determines the frequency of the oscillations.

We now suppose that all parts of the circuit remain constant except the glow-tube. Imagine that we have at hand a series of glow-tubes

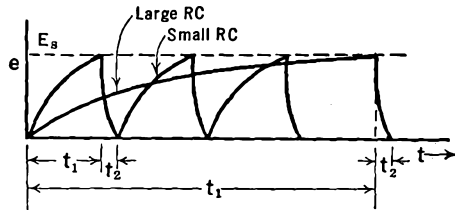


FIG. 22 D. The effect of changing R and C in Fig. 22 A

so constructed and with internal gas pressures such that they strike at different potentials. If we use the tube with highest striking-potential, then it will take a longer time before the voltage across the condenser has risen sufficiently to strike the tube, whereas if we use a tube with a low striking-potential, the condenser's voltage will be sufficient to

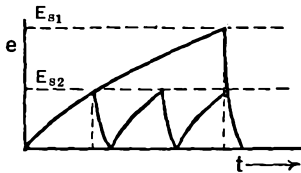


FIG. 22 E. The effect of changing the striking potential (E_s) of the glow-tube in Fig. 22 A

strike the tube after a comparatively short time interval. These conditions are shown in Fig. 22 E.

The voltage across the condenser (which we intend to apply as a sweep-voltage for a cathode-ray oscilloscope) is dependent on the frequency of the oscillations, as can be readily seen in the preceding figure.

22.3 An Approximately Linear Sweep-Circuit. For use with an oscilloscope, we desire a curve of the saw-toothed shape shown in Fig. 22 F, rather than that developed by the simple relaxation oscillator just described. Voltages of the type shown in Fig. 22 F, when applied to the horizontal deflecting plates of the cathode-ray tube, will produce a *linear sweep*¹ of the electron beam across the screen. This means that

¹ When a certain quantity Y is plotted against another quantity X to yield a *straight line* on the graph, Y is said to vary *linearly* with X . This means that if X is changed by a certain amount, resulting in a certain change in Y , then twice the

as the voltage slowly rises at constant rate, the beam is deflected at *constant velocity* from the left side of the screen to the right. In other words, the time it takes in traveling a unit distance in the X direction at one point will be exactly equal to the time required to travel an equal distance at some point farther along the axis. Having traveled to the extreme right end of its path, the electron beam is suddenly flipped back to its starting position on the left of the screen just at the moment the voltage across the deflecting plate is suddenly reduced to zero by the sudden discharge of the condenser. In general, the *fly-back time* must be made as short as possible in comparison with the sweep-time, i.e., in Fig. 22 F, t_2 must be only a small fraction to t_1 .

The voltages developed by the simple relaxation oscillator described above, and shown in Figs. 22 C, D, and E, would not give a uniform or linear sweep. The electron beam would be deflected rapidly at first, then at a slower and slower rate toward the other side of the screen, as the condenser approached its full charge. This non-linear feature is undesirable because it distorts the form of a wave applied to the Y deflecting plates. Hence we proceed to a description of certain modifications of the sweep-circuit which will cause it to develop a linear sweep.

If the voltage of battery E in Fig. 22 A is made very great in comparison with the striking voltage of the glow-tube, then the discharge of the condenser will occur very early along the curved path of Fig. 22 C, such as at point P . Since only a short portion of the curve is used, the voltage rise across the condenser takes place at *almost* a constant rate. There are, however, better methods of insuring the linearity of the sweep, which have the added advantage of ease of change in the time and amplitude of sweep.

22.4 A Linear Sweep-Circuit. In the first place, resistor R of Fig. 22 A is to be replaced by a pentode tube, as shown at P in Fig. 22 G. The pentode is operated with a sufficiently high plate voltage that its plate current is constant despite variations of the plate voltage. In other words, the tube is to be operated well along the curve; on the straight horizontal section of the curve in Fig. 15 B. A current-limiting tube

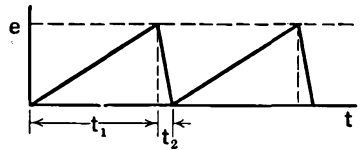


FIG. 22 F. A saw-tooth wave-form which will give a linear sweep

change in X will cause double the change in Y . In other words, Y is directly proportional to X . The graph of Y vs. X is a *straight line*; hence the term "linear."

such as this might be thought of as a variable resistor whose nature was such that, despite different voltages applied to its terminals, it would only pass a fixed and constant value of current. In addition, the use of a pentode makes it possible to vary the amount of this constant current by changing the voltage on the grid of the tube. When

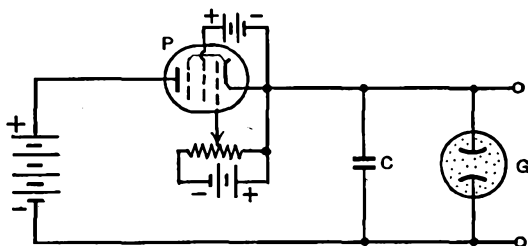


FIG. 22 G. The pentode P replaces resistor R of Fig. 22 A and passes a constant current, regardless of the voltage between its plate and cathode

the tube is highly biased, this constant current will be small, whereas when the grid is less negative the current will be of larger value, but still independent of the voltage applied across the tube from its plate to its filament. When the current flows into the condenser rapidly, it reaches the striking-potential and discharges more frequently than when the current flows in at a slower rate. Thus the control rheostat of the pentode serves to change the frequency of the oscillations without altering their amplitude.

A thyatron may be used in place of the simple glow-tube of the elementary sweep-circuit. As shown in Fig. 22 H, the cathode is connected to the negative side of the condenser and the plate is connected to the positive side. A negative voltage is applied to the grid of the

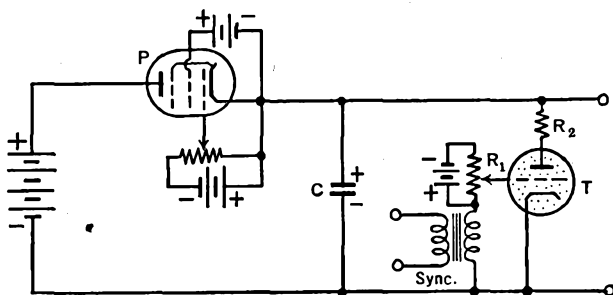


FIG. 22 H. The thyatron T replaces the glow-tube G of Fig. 22 G

thyatron and is adjusted by means of the rheostat R_1 to such a value that the arc between cathode and plate does not occur until the process of charging the condenser has raised its voltage to the desired striking-potential. When, however, the plate potential has risen to this critical value, the condenser is suddenly discharged through the tube, the voltage on the plate suddenly decreases and, aided by the potential drop across the small resistor R_2 , becomes zero or even negative. This, of course, shuts off the current and the condenser starts to refill. A simple change of rheostat R_1 changes the fixed C-bias of the thyatron and hence the voltage at which the tube starts to conduct. If the grid voltage is small, the charging of the condenser takes only a small time to raise its potential to the point where the thyatron becomes conductive. In this case, the maximum voltage across the condenser will be small, but the frequency of sweeping will be high (or the time for one sweep will be small). On the other hand, if the grid of the thyatron is made more negative, the voltage on the plate must rise to a higher value before the tube will "strike" and discharge the condenser. This means that the amplitude and the time of sweep will both be comparatively large.

The ratio of the time to charge and discharge the condenser in the circuit just described can be made as great as 1,000 to 1. Thus the fly-back time will occupy only an insignificant portion of each cycle. This time is primarily determined by that required for the ions in the thyatron to recombine to form neutral particles, i.e., it depends on the de-ionization time of the tube. Stated in a different manner, the maximum frequency of this saw-toothed oscillator cannot exceed that set by the de-ionizing time of the tube. In practice, it is found that the upper limit of satisfactory operation is of the order of 50,000 cycles per second.

22.5 A Second Type of Linear Sweep-Circuit. An entirely different type of sweep-circuit is shown in Fig. 22 I. Any one of a variety of oscillators could be used as well as the one shown. Oscillations of very high frequency, say 2 Mc., are produced by the usual processes. As the oscillations start, condenser C is charged (with negative on the grid side) by grid current flowing through resistor R . This C-bias con-

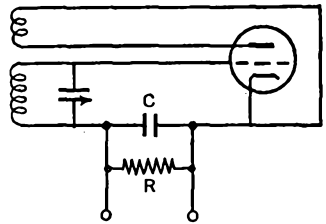


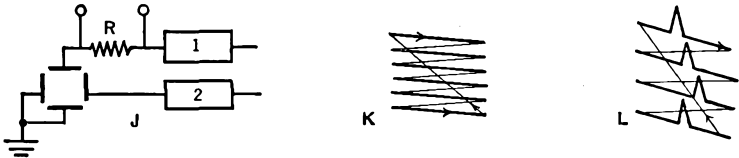
FIG. 22 I. A sweep circuit operating on the principle of blocking-action

tinually increases because R is chosen of very high value. It is so high that it prohibits C from discharging during one, or even many, of the high-frequency oscillations. Finally, the C-bias becomes so great that the plate current, and hence the oscillations, are completely shut off. This is known as *blocking action*. When the oscillations have ceased, the grid is no longer driven positive, there is no longer any current to charge condenser C , and it slowly discharges through R . When the voltage of the grid has risen to a sufficiently small negative value, a "spurt" of high-frequency oscillations takes place, the tube is again blocked, and the slow discharge of the condenser through the resistance is repeated. In practice, resistor R is replaced by a current-limiting tube of the type described in connection with Fig. 22 G. This causes the discharge of the condenser, C , Fig. 22 I, to occur at a constant rate. Hence the voltage drop across the condenser, applied to the deflecting plates of a cathode-ray tube, causes a linear sweep. The frequency of this sweep-circuit depends largely on the time for C to discharge through R . By changing the grid control of the constant-current tube, it becomes easy to change the sweep-frequency. With this circuit, higher frequencies can be attained than with those containing gas-filled tubes, because the de-ionizing factor is no longer present. With an oscillator operating at 5 Mc., essentially linear sweeps have been attained up to one-half million cycles per second. Special precautions are needed with this circuit to keep the oscillator's high frequency, and its harmonics, out of adjacent r.f. receiving apparatus.

22.6 The Use of Two Saw-Toothed Sweeps. In Fig. 22 J, saw-toothed voltages are applied simultaneously to the two sets of deflecting plates of the cathode-ray tube by means of the separate linear sweep-circuits 1 and 2. When the frequency of 2 is greater than that of 1, and is an exact multiple, say six times, the pattern of Fig. 22 K will result. Starting in the upper left corner, the beam is deflected horizontally by 2, flies back, and repeats, the while it is slowly drawn downward on the screen by 1. Just before the end of the sixth horizontal sweep, the fly-back of 1 brings the spot back to the upper left corner at just the right moment to repeat the movements along the original paths. Then a stationary pattern of horizontal lines is seen on the screen. The entire process is called *scanning*.

While the scanning process just described is going on, let the control grid voltage of the cathode-ray tube be altered by a video or television signal. Changes of grid voltage cause changes in the number of

electrons emitted from the electron gun, and hence in the brightness of the moving spot on the screen. The intensity of light can then be made directly proportional to the brightness of the spot scanned by the transmitter. If timed to start at the same instant and to sweep both horizontally and vertically in synchronism with the scanning at the transmitter, an image will be properly reassembled and in proper intensities over all the screen. It is customary in the United States to



FIGS. 22 J, K, and L. Double linear-sweeping

use 431 or 525 lines, where 6 are indicated in Fig. 22 K, in order to show the details of the picture. This complete set of lines (525) is called 1 frame and requires $1/30$ of a second. In other words, 30 frames or complete pictures, each of 525 lines, are produced on the screen each second. Because of the persistence of vision of the human eye (approximately $1/10$ of a second), the successive frames blend from one into the next and the semblance of continuous motion is established.

Another use of the double-sweep circuit is in the study of atmospherics, or static, produced either by nature or man-made machines. In other words, we propose to examine the makeup of a single "crackle" heard in a radio receiver. Frequently these consist of a rapid succession of short time impulses. If a cathode-ray tube is connected to the output of a receiver, and uses only a single horizontal sweep, it would have to be a very large tube indeed in order that the total time axis would be spread out long enough to show all of the individual impulses which occur during the single crackle. On a small tube, one might use a high-speed sweep, but then the individual pulses would be lapped back on each other and cause confusion. On the other hand, with a double sweep of the type discussed above, it is possible to realize the equivalent of a very long-time axis on a small tube. While sweeps 1 and 2 of Fig. 22 J are producing the pattern shown in Fig. 22 K, the series of pulses are applied across the resistor R (Fig. 22 J), yielding the pattern shown in Fig. 22 L. Starting at the upper left-hand corner of the screen, the beam is swept to the right-hand side, folded

back to the left side and displaced downwards, swept to the right, and so on, as though a very long line were folded back repeatedly to condense the great length into a small area. With this *folded pattern*, a total time of sweeping, from upper left-hand to lower right-hand corner, equal to or greater than the total time of one crackle is attained on a small tube. Details of each of the separate pulses in the crackle can then be seen because they are suitably extended.

22.7 Synchronization. Let us suppose that a linear sweep-circuit has been applied to the horizontal deflecting plates of a cathode-ray tube in such a manner that the total sweep requires approximately $1/60$ of a second. Suppose, also, that a 60-cycle alternating voltage is applied to the vertical deflecting plates. Then, as the beam is moved horizontally, it is simultaneously deflected vertically in proportion to the amplitude of the alternating voltage, and traces a typical sinusoidal wave-form on the screen. If the horizontal sweep-time (plus the negligible fly-back time) is exactly $1/60$ of a second, then the spot of light will retrace its path along the sinusoidal curve every cycle and a *stationary pattern* will be produced. This is a condition of great advantage for both visual and photographic study of the individual parts of the cycle. Also, in the case of the double sweep-circuit, the necessity for exact synchronization of the horizontal and vertical sweeps has been pointed out. Without special devices it is difficult to adjust the sweep time to an exact multiple of the signal frequency. Then the pattern appears to move across the screen, either from left to right, or vice versa. In order to stabilize a moving wave-form, a synchronizing device is added to the sweep-circuit. As shown in Fig. 22 H, this is accomplished by the injection of a small fraction of the signal's voltage into the grid circuit of the thyratron tube, in series with the fixed C-bias. Then, as the tube is near its point of striking, a small voltage from the "sync" circuit is added and trips the tube just at the peak of the signal voltage. The magnitude of this "lock-in" voltage need be only a small fraction of the fixed C-bias. Much more elaborate circuits have been devised for synchronization of the horizontal and vertical sweeps used in television. They are necessary for the proper starting time of each frame in synchronism with the starting time of the same frame at the transmitter.

22.8 Multiple and Sub-Multiple Linear Sweep Frequencies. Next, let us suppose that a linear sweep is applied to the horizontal deflecting plates and that the total time for one trip across the screen is greater

than that required for one cycle of the a.c. on the vertical plates. If it is exactly twice the $1/60$ of a second of the a.c. applied to the vertical plates, two complete wave-forms will be seen in a stationary pattern on the screen. If, however, the spot moves across the screen in $1/120$ of a second, the pattern will appear as in Fig. 22 M. If the sweep-frequency is still further increased so that the time represented

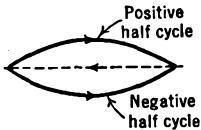


FIG. 22 M. The sweep time is one-half the period of the a.c. under study

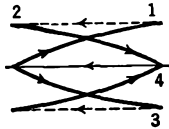


FIG. 22 N. The sweep time is one-quarter of the period of the a.c.

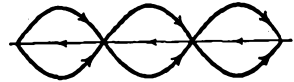


FIG. 22 O. The ratio of the sweep to a.c. frequency is 3 to 2

from the left to the right of the screen is only one-quarter of the a.c. period, then the pattern will appear as in Fig. 22 N. In case the sweep and alternating potentials have a frequency ratio of 3 to 2, the pattern will appear as in Fig. 22 O.

From this discussion it should be obvious that, by observation of the stationary patterns on the screen, it is possible to calibrate the sweep-frequency against a standard alternating frequency such as the 60-cycle line. Actually, this calibration proves to be satisfactory only when the ratio of the two frequencies is not too great. After the calibration of the sweep-frequency, the process may be reversed to determine an unknown frequency applied to the vertical deflecting plates. However, it is difficult to build sweep-circuits in which the frequency is always the same for a given adjustment of the circuit constants. In the case of the circuit of Fig. 22 H, the striking-potential of the thyratron varies slightly with the temperature of the tube.

22.9 Lissajou Patterns. Let a sinusoidal alternating voltage be applied to the *horizontal* deflecting plates alone. A single horizontal line will be seen on the screen. The beam, starting at the left of the screen, moves slowly at first, then rapidly across the center, and slows down to stop at the right of the screen, after which it reverses its direction, again traveling slowly at the ends and rapidly in the center. But to the eye, only a single straight line appears. If, next, an alternating potential is applied to the vertical deflecting plates alone, then a similar

vertical line will appear on the screen. We now consider the patterns which will appear on the screen when alternating voltages are applied simultaneously to both the X and the Y deflecting plates.

First of all, let us assume that the alternating voltages have precisely the same frequency and are in the same phase; in other words, they both pass through their zero values at the same moment and they

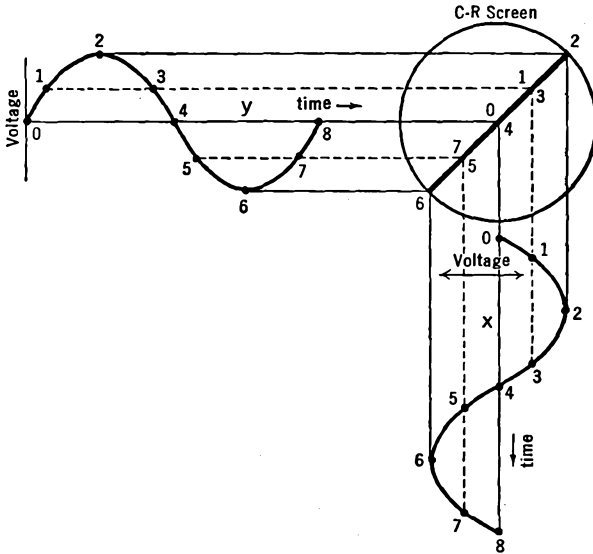


FIG. 22 P. Two sine waves of the same frequency and phase applied to the x and y plates, move the spot along a straight line

both reach their crests at the same moment. In Fig. 22 P, the horizontal wave is shown at X and the vertical wave is shown at Y . Starting at zero voltage in both cases, the spot is at the center of the screen. A moment later, marked 1 in this figure, the spot has been moved upward by voltage Y and to the right by X . After one-quarter of a cycle, it is at the upper right corner of the screen, marked 2. Then, as the voltages decrease, the spot of light retraces this path along the straight line to the central point. During the negative half-cycles the spot of light on the screen moves from o to 6 and back to o again. Thus the addition of two voltages in the same phase and of the same frequency results in a straight line on the screen. The line makes an angle of 45° with the X and Y axes when the voltages are of equal value. If the

two voltages are not of equal amplitude, the straight line will be produced, but it will occur at an angle differing from 45° .

Let us next consider the case when the two voltages have exactly the same frequency and amplitude but start a quarter of a period out of phase with respect to each other. The application of these two voltages to the X and Y plates results in a movement of the spot of light on the screen in a circular pattern as shown in Fig. 22 Q. If the two voltages are not of equal amplitude, an ellipse will be formed on the screen.

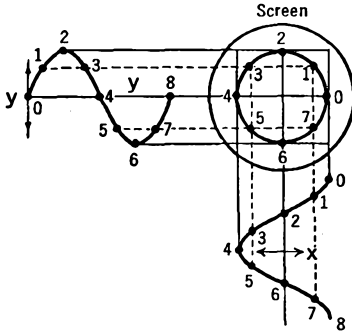


FIG. 22 Q. A circle is obtained when the two waves have the same amplitude and frequency but are in phase quadrature (90°)

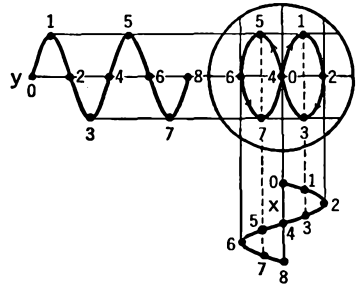


FIG. 22 R. The voltages on the deflection plates are equal in amplitude and phase but the frequency applied to y is twice that on x

Next, let us consider the case when the voltages on the X and Y plates are of equal amounts, start in phase with each other, but differ in frequency in the ratio of 2 to 1. Figure 22 R shows how the figure 8 pattern observed on the screen is compounded from these two "simple harmonic" motions.

It is an interesting problem to work out the shapes of the pattern on the screen when alternating potentials of different amplitude ratios, frequency ratios, and phase differences are applied to the deflecting plates. Figure 22 S illustrates a few of the possibilities. Conversely, when a particular pattern is noted on the screen, Fig. 22 S permits one to tell the frequency, amplitude, and phase relationship of an unknown voltage with respect to a standard. The various figures shown are known as *Lissajou patterns*.

A phase-splitting circuit, used for obtaining elliptical or circular patterns, is shown in Fig. 22 T (see also Sec. 19.6). One set of plates is connected across resistance R . The other deflecting plates are con-

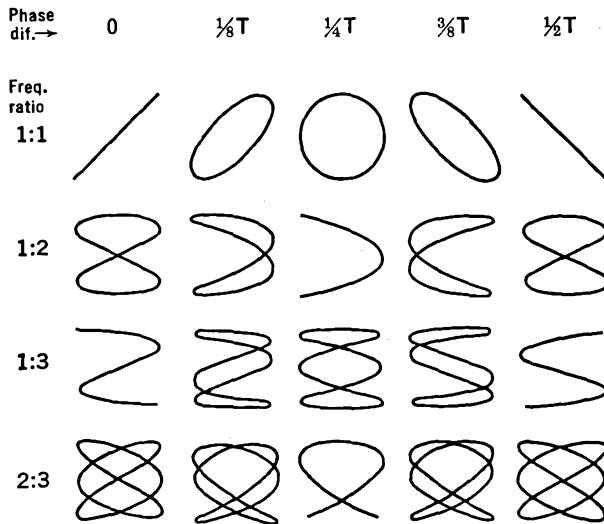


FIG. 22 S. Some Lissajou patterns

nected across condenser C . The voltage across R will always be in phase with the input voltage, whereas the voltage across C will always be 90° ahead of the applied voltage. If R is adjusted so that its resistance is numerically equal to the reactance of C , a circular pattern will appear on the screen. If the resistance and reactance of R and C are not equal to each other, an elliptical pattern will be obtained. Furthermore, an alternating current of unknown frequency may be applied in series with r , as shown in Fig. 22 T. Then patterns such as those of Fig. 22 U will appear on the screen. By counting the number of peaks in these patterns, one has a direct measure of the ratio of the unknown frequency to that of the standard input frequency. This is particularly valuable when the frequencies differ from each other by comparatively large amounts. Unless these frequencies are exact multiples of each other, the pattern will appear to rotate. The speed of rotation is a measure of the lack of exact integral-frequency ratio.

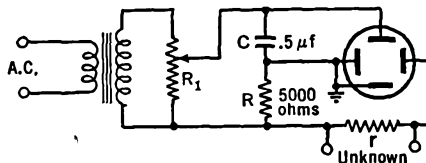


FIG. 22 T. A phase-splitting circuit used to produce circular and elliptical patterns

Having established a circular pattern on the screen by means of the circuit of Fig. 22 T, it now becomes possible to produce a spiral pattern. In order to do so, the sliding contact on resistance R_1 is moved rapidly from one end of the rheostat to the other. This changes the radius of the circle in proportion to the amount of voltage tapped off of R_1 . Elaborate electronic circuits can be devised which are equivalent to this variable applied voltage.

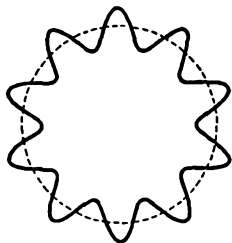


FIG. 22 V. A small *a.c.* voltage is applied in series with the main, lower-frequency *A.C.* voltage of Fig. 22 T

If an unknown but comparatively small voltage is connected in series with the

a.c. input voltage of Fig. 22 T, the deflecting voltages on the *X* and *Y* plates will be proportionally increased and decreased, with the result that the circular pattern becomes crenellated into a pattern such as that shown in Fig. 22 V. Also, short time pulses such as those from the static discharges in storms or those from man-made machines can be similarly injected, to cause momentary

deviations from the circular pattern. In this way, a comparatively long time axis, the circumference of the circle, can be obtained on a small sized screen.

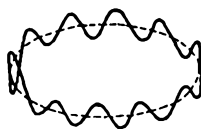


FIG. 22 U. An unknown voltage is applied across *r* of Fig. 22 T

CHAPTER 23

CLASS A, B, AND C AMPLIFIERS

23.1 Introduction. In Chapter 13 some of the principles of amplifiers were discussed and a few simple circuits were given, with special attention to the Class A type. Before continuing with this and other types of amplifiers it is desirable to turn for a moment to the general subject of linearity in circuit elements and devices.

23.2 Linear and Non-Linear Circuit Elements. Imagine, if you will, a sealed box containing electrical circuits of some sort or other, and

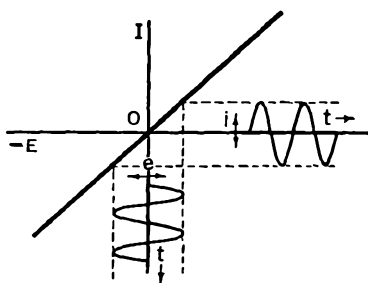


FIG. 23 A. Symmetrical ohmic element

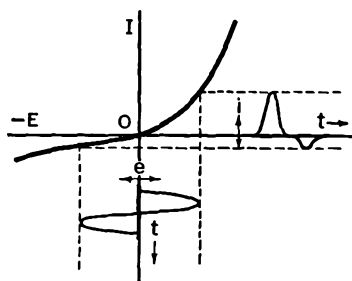


FIG. 23 B. Non-ohmic unsymmetrical element

having four binding posts, two for the "input" and two for the "output." Let the output current I be observed for a succession of voltages E applied to the input terminals, and let a plot be made of these two quantities, with I vertically and E horizontally. If the $I-E$ curve which is obtained is a straight line, the electrical devices in the box are to be called *linear elements*; if a curved line results, the box contains *non-linear elements*.

If the "circuit elements" in the box consist merely of a series resistance, the symmetrical straight line of Fig. 23 A will be obtained. Let a fluctuating voltage ($e-t$) be applied to the input terminals. Then the fluctuating output current ($i-t$), as shown in this figure, will have the same shape as that of the input voltage.

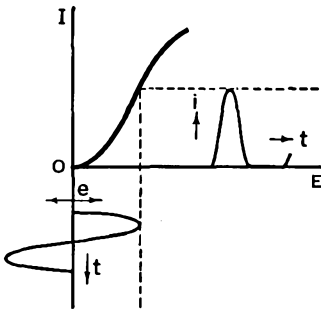


FIG. 23 C. Half-wave non-ohmic element

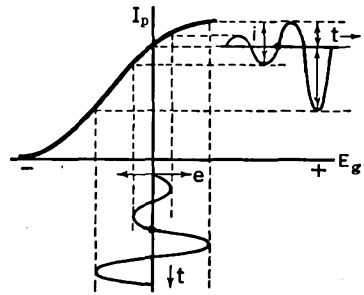


FIG. 23 D. Rectifier action on the upper knee of a triode

If the circuit elements consist of crystals, such as galena or iron pyrites, or if they consist of copper-oxide rectifiers, the unsymmetrical, non-linear (= non-ohmic) curve of Fig. 23 B will be obtained. A pure sinusoidal voltage at the input will not yield an output current of the same (sinusoidal) wave-form. Instead, the current will be partially rectified, as shown in the figure, and will be distorted or "full of harmonics."

If the box contains a diode, the detector or rectifier property shown in Fig. 23 C will result. These conditions were discussed in some detail in earlier chapters. The rectifying action of a triode operating on the upper knee of its characteristic curve is shown in Fig. 23 D.

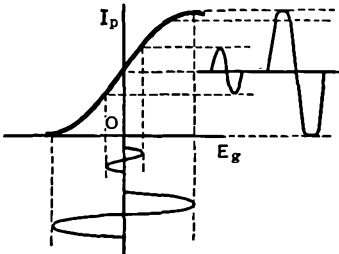


FIG. 23 E. Distortion in Class A amplifiers. Also, the principle of limiters

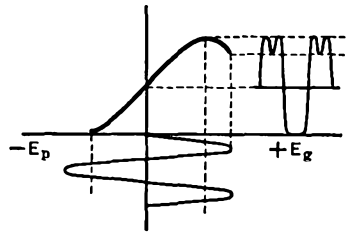


FIG. 23 F. Grid current distortion

Figure 23 E shows the output currents versus input grid voltages of triodes operated from a point in the middle of the straight portion of the characteristic curve. Notice that when too great an input voltage is used, the upper and lower knees of the characteristic curve are in use and the tops and bottoms of the output current are "squared off."

This principle is undesirable in some applications, such as amplifiers, where it is called *distortion*, but it is useful in other applications, such as current-limiting devices and square-wave generators.

When the grid of a triode is made quite *positive*, it diverts considerable numbers of electrons to itself. Then the plate current falls off, as indicated by the drop in the upper end of the curve in Fig. 23 F. An extremely large grid voltage fluctuation gives rise to the peculiar dip in the top of the square wave.

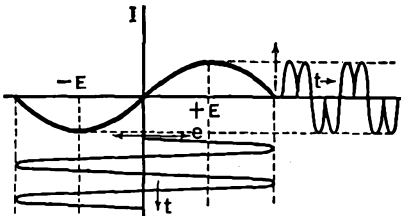


FIG. 23 G. A "characteristic" curve which yields an unusual double-pulse output

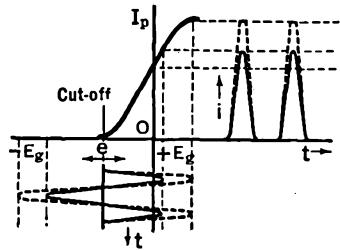


FIG. 23 H. Class B amplification

Figure 23 G shows the output current versus input voltage for an electrical device called a "thyrite bridge circuit." Note that the output has a double hump, or frequency, for each half-cycle of the applied voltage. Figure 23 H shows the characteristic curve of an ordinary triode whose C-bias is so negative that the operating point is located at the cutoff point, i.e., for *Class B amplification*. The output current in this case is rectified. *Class C amplifiers* are operated with the C-bias well to the left of the cutoff point.

23.3 Distortion in Class A Amplifiers. As pointed out in Chapter 13, the output wave-form of Class A amplifiers is the same as the input wave-form. In order that this be true, they must be operated strictly as linear devices, over a straight-line characteristic curve. It should be obvious from the preceding section that distortion will occur in Class A amplifiers if the input signal voltage is so great that the upper and/or lower knee of the characteristic curve comes into use. Referring to Fig. 12 B, it can be seen that a longer straight curve is to be had when the plate voltages on a given tube are greater. For this reason, the successive stages in a Class A amplifier sometimes use higher and higher plate voltages and correspondingly greater and greater grid volt-

ages. It was shown in Sec. 12.3 that the dynamic curves of a tube are straighter over a greater range of grid voltages (and also have smaller slopes) than the static curves, especially when the plate circuit resistance is large. This means that voltage amplification is sacrificed in order to prevent distortion. Thus larger plate circuit resistances are used to reduce distortion in Class A amplifiers.

When the C-bias on a triode is so adjusted that the operating point occurs near the bottom or the top of the curve, the output waves will be distorted, because part or all of the half-cycles of plate currents are

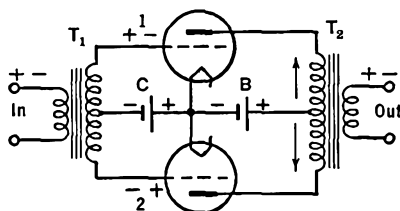


FIG. 23 I. A Class B amplifier delivers a larger output for a given amount of distortion than a Class A or push-pull amplifier. The tapped windings are in the same direction in both transformers

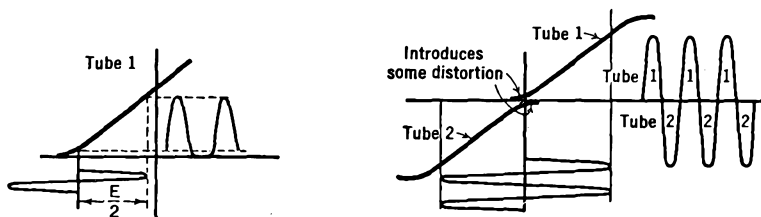
squared off. It will be recalled that an irregular wave-form is the equivalent of a mixture of a direct current and a fundamental sine curve plus its various higher harmonics. When a particular device distorts a sine wave, the output wave will contain the fundamental frequency plus the higher harmonics. The more irregular the wave, or the sharper the bends in it, as at a square top, the stronger will be the harmonics in comparison with the fundamental.

When properly operated, Class A amplifiers are characterized by low power output for a given size of tube, by small distortion compared with Class B or C amplifiers, by high power amplification and by low plate efficiency (20 to 35 per cent).

23.4 A.F. Class B Amplifiers. The circuit diagram of an audio frequency, *double-ended* Class B amplifier (Fig. 23 I) is the same as that of a push-pull amplifier. The C-battery voltage is adjusted so that the tubes operate at, or slightly above, cutoff. Sharp cutoff tubes are used. Figure 23 J shows the action taking place in tube number 1. This curve is redrawn in Fig. 23 K, together with a similar but inverted curve for tube 2.

The principle of operation is as follows: when the grid of tube 1

goes positive, the grid of tube 2 goes negative and the current in the plate circuit of 2 remains at its previous value (zero). But the plate current of the upper tube increases, giving an output voltage which is, say, positive at the top. On the second half-cycle, the grid of the upper tube goes negative; but, since its plate current is already zero, there is no change in the upper circuit. The lower grid, however, becoming positive, gives an increase in its plate current and this, in turn, induces a voltage in the secondary of the output transformer. The polarity of this voltage is the reverse of that when the upper tube was the conductor, i.e., a negative voltage is induced at the top of the output. Thus



FIGS. 23 J and K. Principle of operation of Class B amplifiers

tube 1 handles all of the positive half-cycles, tube 2 handles all of the negative half-cycles, and the output transformer combines them to form a sinusoidal wave, as at the right of Fig. 23 K.

It is clear from the discussion above that a double-ended Class B amplifier can handle nearly twice the input voltage of a push-pull amplifier, for a given amount of distortion. It is also obvious that this is approximately four times greater than the permissible input voltage for a one-tube amplifier having the same amount of distortion. There is, of course, a certain amount of distortion in the Class B amplifiers due to the slight curvature of the characteristic curve near the cutoff. Also, Class B amplifiers eliminate the even harmonics, as in the case of push-pull amplifiers.

As an added advantage, Class B amplifiers prove to be more efficient in operation than Class A. This is because the d.c. plate currents are practically zero in both tubes before the signal arrives. The energy of the plate battery is consumed only during the time of amplifying a signal. Inasmuch as power is proportional to the square of current, the power output of Class B amplifiers is proportional to the square of the exciting grid voltage.

As compared with Class A or Class C amplifiers, Class B ampli-

fiers have intermediate power outputs, plate efficiencies (of the order of 50 per cent), and power amplification.

23.5 Class AB Amplifiers. When the C-bias voltage is of such a value that the tubes of the circuit in Fig. 23 I are operating at a point in between the cutoff and the center of the straight section, small signal voltages will be amplified as in a Class A circuit and large signal voltages will be amplified approximately by the Class B method. This so-called Class AB amplifier (Fig. 23 L) offers low distortion for small signal intensities and high efficiency at high signal levels. Class AB₁ amplifiers draw no grid current and Class AB₂ amplifiers draw grid currents at the higher input signal levels.

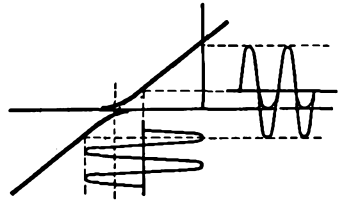


FIG. 23 L. The principle of operation of Class AB amplifiers

23.6 R.F. Class B Amplifiers. In the radio frequency amplifier stages of a transmitter, large amounts of power must be handled by the tubes and circuits. The question of the efficiency of the units becomes of considerable importance. The fact that Class B (and Class C) amplifiers are characterized by greater efficiency than Class A makes their use desirable. A double-ended Class B circuit may be used with two tubes as in Fig. 23 I (but with air-core transformers and with the addition of tuning condensers in the grid and plate circuits). However, it is also possible to use a one-tube or *single-ended* Class B unit for radio fre-

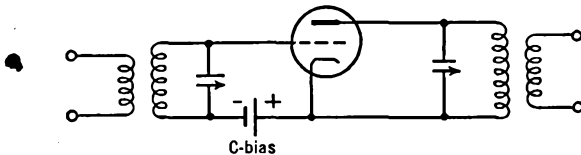


FIG. 23 M. If the C-bias voltage is small, this elementary r.f. amplifier is operating as a Class A unit. If it is larger; Class B; If very large: Class C

quency amplification, as in Fig. 23 M, without suffering the large distortion which might be expected from the rectifier action indicated in Fig. 23 J. This is possible because of the resonant property of the tuned plate circuit, which responds to only one of the many harmonics of the complex plate current wave-form. A tank or tuned plate circuit of fairly high Q (10) is required for effective exclusion of all but one frequency (or narrow band of frequencies). The selectivity or sharp-

ness of the resonance curve (or Q) must not be too great for m.c.w. (modulated carrier wave) amplifiers, or the higher-pitched audio notes will be excluded as well as the undesirable harmonics.

23.7 Class C Amplifiers. The principle of operation of Class C amplifiers is indicated in Fig. 23 N, where the grid bias is set at approximately twice the cutoff value. The plate current flows only during a *portion* of the positive half-cycle of the input signal voltage. The input

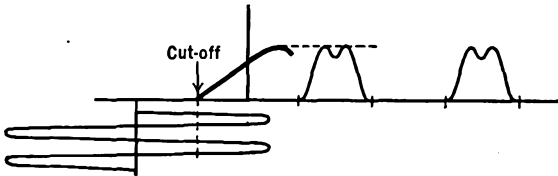


FIG. 23 N. The principle of Class C amplifiers. Plate current flows only during part of one-half cycle

signal voltage must be sufficiently great to drive the grid positive up to saturation. Then the plate efficiency will be high (70 to 75 per cent), the power output will be large, although the power amplification is low. In this type of amplifier, the plate current is proportional to the plate voltage and hence the output power is proportional to the square of the plate voltage. Class C amplifiers are very efficient because the plate current flows only during part of one half-cycle, but their distortion is very bad if they are used without tuned circuits in the amplification of audio signals. The amplifier is generally used in the amplification of a narrow band of frequencies, say the modulated carrier frequency of a transmitting station, in which case the anti-resonant plate load passes only the fundamental frequency and suppresses the harmonics which arise because of the tube distortion. Class C amplifiers require power in their grid circuit, the more so as the grid goes more positive. This represents a minor loss of energy. Because of their high efficiency, Class C amplifiers are used where a very large power output is the primary consideration, as in the last stages of a transmitter.

CHAPTER 24

DIRECT CURRENT AMPLIFIERS

24.1 Direct Current Amplifiers. There are numerous cases in which small electrical currents and voltages must be amplified before they can operate relays, rugged meters, mechanical counters, or other devices. In some cases, the currents and voltages are of a pulse, an audio, or a radio frequency nature and can be amplified by circuits containing condensers and coils; but there are others where the currents flow in but one direction. For these cases a direct current amplifier must be used. A

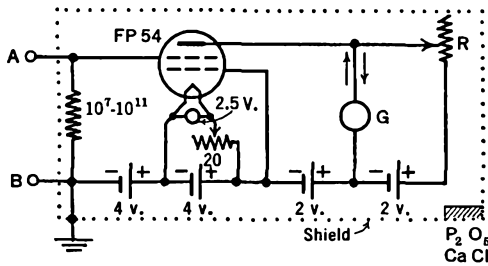


FIG. 24 A. A simple d.c. amplifier

simple d.c. amplifier would consist of a single tube with a resistance input and with the "load" (device to be operated) in the plate circuit. However, the d.c. plate current is so large in such a case that it often overshadows the small change caused by a small input voltage. In order to "balance-out" the d.c. plate current, various circuits have been devised. One of these is shown in Fig. 24 A. A special tube is shown which has an unusually small leakage of current between its input grid and cathode. This permits the use of a very high input resistor, from 10^7 to 10^{11} ohms. Then, when a very small voltage is applied, the drop across this resistance is sufficiently large as to cause a considerable change in the plate current over and above its d.c. value. The galvanometer G in the plate circuit is a current-measuring instrument which will respond to currents as small as one one-billionth of an ampere; it would be badly damaged by the d.c. plate current alone. Hence, in the

absence of an input voltage, the plate current is "balanced-out" by means of the battery in the lower right-hand corner of the figure. This battery sends a current through the adjusting resistance R and the galvanometer, in the opposite direction to the plate current of the tube. In other words, when R has been properly adjusted, there will be no current flow through G . Now, when a signal makes the grid of the tube positive, the plate current will increase by a certain amount. This *increase* causes a flow through the galvanometer and hence a deflection of its moving part; which may be observed and measured. The cir-

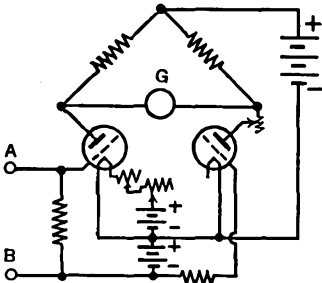


FIG. 24 B. A balanced d.c. amplifier

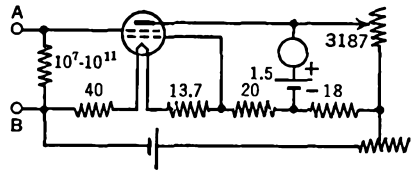


FIG. 24 C. A simple, stabilized d.c. amplifier

cuit can be calibrated so that the deflections of the galvanometer give a direct measure of the strength of the input voltage. If the value of the grid resistance is known, the deflection is a measure of the small current sent into the amplifier. Currents as small as 10^{-17} ampere have been measured with improved forms of this amplifier.

24.2 Stabilized D.C. Amplifiers. One of the greatest difficulties in connection with the amplifier of Fig. 24 A is that caused by small changes in the batteries, or by the heating of the elements inside the tube. Figures 24 B and 24 C show two attempts to stabilize the circuit against these disturbing variations. In Fig. 24 B, the triodes are selected to have as nearly identical characteristic curves as possible. The circuit is balanced so that there is no current through G . A change in voltage in the A, B, or C batteries will (theoretically) cause no flow of current through G . It is only when a voltage is applied between A and B that a deflection is observed. If A is made positive, and B negative, the plate current of one tube is increased, that of the other decreased, the voltage drops across the two plate resistors are no longer the same, and the balance of the "bridge" is destroyed.

In the circuit of Fig. 24 C, an increase in the " B " battery voltage does three things. It increases the B and the C voltages and also heats the filament hotter. If the various resistors are properly chosen, these three changes cancel each other and the d.c. balance remains constant.

In Fig. 24 D is shown a much more satisfactory stabilizing system,

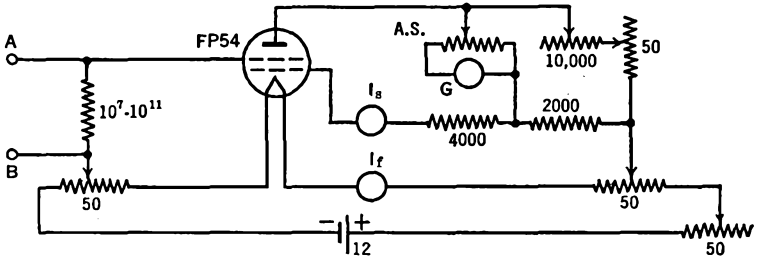


FIG. 24 D. An improved form of a balanced d.c. amplifier

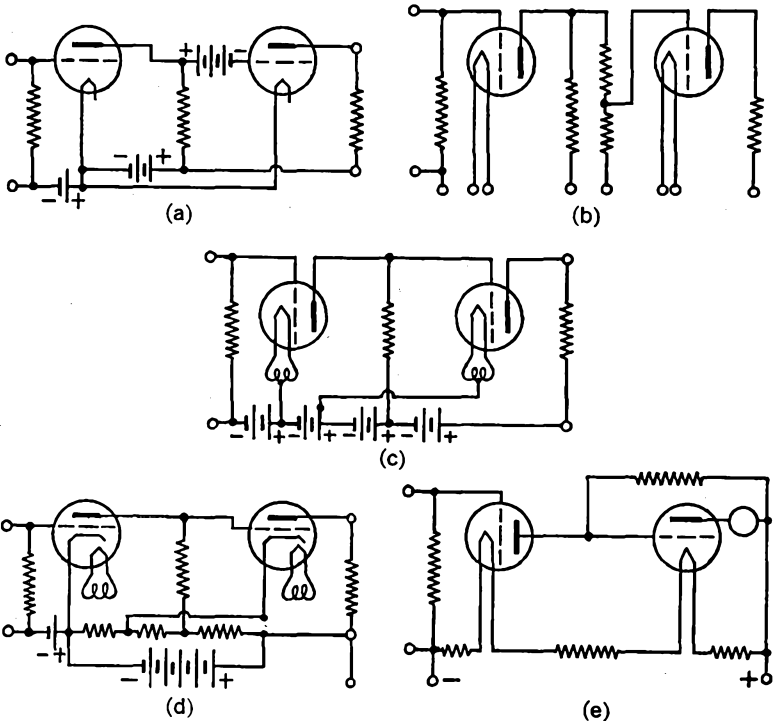


FIG. 24 E. Simple forms of multistage d.c. amplifiers

wherein the extra grid of the tube serves to compensate for changes in the plate, filament, and grid voltages when the battery voltage changes.

24.3 Multistage D.C. Amplifiers. It is also possible to amplify d.c. voltages with *multistage amplifiers*, as in Fig. 24 E. In the Loftin-White circuit of Fig. 24 E(d), a common battery is used for the plate and grid voltages. The filaments of the two tubes are at different voltages and require care in insulation from the ground. In all multistage d.c. amplifiers, the voltage available for the power supply must be comparatively great.

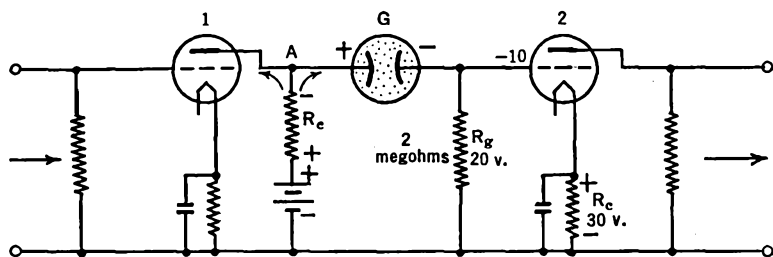


FIG. 24 F. A d.c. amplifier with a glow-tube in the inter-tube coupling unit

In Fig. 24 F, the glow-tube G takes the place of the grid condenser of an R - C coupled amplifier and acts as a constant-voltage device even for currents as small as 10 micro-amperes (10^{-5} amp.) When R_g is 2 megohms (2×10^6 ohms), the drop produced by 10^{-5} amp. will be 20 volts. If R_c is chosen to give 30 volts, the net on the grid of tube 2 will be -10 volts. If the voltage at A changes, due to an input signal, the drop across G remains the same, but its current does change. Then the drop across R_g changes and is applied directly to grid 2. In other words, the circuit acts like an R - C coupled amplifier (see next chapter) with a leaky grid condenser which has the important characteristic that its voltage drop is always the same.

CHAPTER 25

AUDIO-FREQUENCY AMPLIFIERS

25.1 Introduction to Resistance-Capacitance Coupled Amplifiers.

The principle of operation of the resistance-capacitance coupled amplifier was discussed in Sec. 13.5. These amplifiers are characterized:

1. by being relatively inexpensive,
2. by good fidelity over comparatively wide frequency ranges,
3. by freedom from picking up undesired currents from the a.c. heater leads (since there are no coils to pick them up).
4. They are especially suited to pentode and high- μ triodes.

25.2. A Typical R-C Coupled Circuit. A typical circuit is shown in Fig. 25 A, together with the names of the various parts.

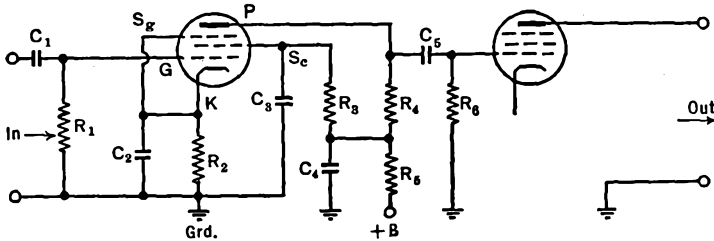


FIG. 25 A. A typical resistance capacitance coupled amplifier

- | | |
|------------------------------------|--|
| R_1 = Grid resistor | C_1 = Input (coupling, blocking) condenser |
| R_2 = Cathode resistor | C_2 = C-bias (cathode) bypass condenser |
| R_3 = Screen resistor | C_3 = Screen bypass condenser |
| R_4 = Plate resistor | C_4 = Plate bypass condenser |
| R_5 = Plate decoupling resistor | C_5 = Output coupling condenser |
| R_6 = Second stage grid resistor | |

Let us first trace the various circuits. The d.c. grid circuit is G, R_1, R_2, K . The a.c. grid circuit is G, R_1, C_2, K . The d.c. screen circuit is $S_c, R_3, R_5, B\text{-Bat.}, \text{Grd.}, R_2, K$. The a.c. screen circuit is S_c, C_3, C_2, K . The d.c. plate circuit is $P, R_4, R_5, B\text{-Bat.}, \text{Grd.}, R_2, K$. The a.c. plate circuit is $P, R_4, C_4, \text{Grd.}, C_2, K$.

25.3. R and C Values. Let us next consider the numerical values of the various resistors and condensers, together with the reasons for these values.

In order that the voltage gain be large, the plate resistor should have as high a value as possible. (See Sec. 13.2.) The higher its value, however, the greater the loss of B voltage across it and the lower the voltage between the plate and cathode of the tube. A value of 50,000 ohms is typical for triodes, whose internal plate resistance is comparatively low, whereas values up to 0.5 megohm are used with pentodes.

The screen resistor is chosen of such a value that, subtracting the voltage drop in it due to the screen-grid current, the correct voltage is left for the screen grid. Values from 0.25 to 2 megohms are used. A screen bypass condenser of 0.1 μ fd. will suffice in most cases.

The value of the cathode or C-bias resistor is determined by the voltage needed for the grid of the tube. It must be remembered that the screen, as well as the plate currents, flow through this resistor. Values range from 500 to 10,000 ohms.

It should be obvious by now, that to design an amplifier, one first chooses the type of circuit, with characteristics most suited to the job at hand; then the tube, with its proper operating voltages supplied by the manufacturer; and finally the values of the resistors and condensers, both to fit the tube and to yield the desired characteristics. Typical values of R_2 , R_3 , and R_4 follow:

<i>Tube</i>	R_2 <i>ohms</i>	R_3 <i>megohms</i>	R_4 <i>megohms</i>
6C5	6000	..	0.1
6J5	3000	..	0.1
6F5, 6SF5	3000	..	0.25
6J7	1200	1.2	0.25
6SJ7	900	1.0	0.25

The decoupling circuit C_4R_5 of Fig. 25 A is intended to keep the a.c. out of the power supply by bypassing the a.c. through C_4 and offering as high a resistance in R_5 as practicable for the B voltage available. (Remember that the loss of voltage in R_5 is due to plate plus screen currents.) The reactance, $1/2\pi fC_4$, is to be as small as possible for the frequencies being amplified. For low frequencies, C_4 must be large, and vice versa. The C_4R_5 circuit is often the cause of low frequency oscillations in multistage R - C amplifiers. When this occurs, the circuit is said to be "motor boating."

The C-bias bypass condenser (C_2) must have as low a reactance as possible in comparison to the resistor R_2 for the frequencies to be amplified. Since the reactance, $1/2\pi fC_2$, is greater at the lower frequencies, some of the currents at these frequencies will be lost in this part of the circuit. For values of R_2 around 10,000 ohms, C_2 can be from 1 to 10 $\mu\text{fd.}$, while with R_2 around 500 ohms, a value of 10 $\mu\text{fd.}$ should be used for audio-frequency amplifiers. Electrolytic condensers, which are compact and inexpensive, serve nicely for C_2 .

A typical frequency response curve of an R - C coupled amplifier is given in Fig. 25 B, where it will be noted that the amplification is poor for the lower and for the higher frequencies.

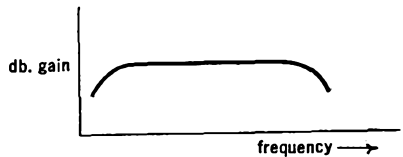


FIG. 25 B. Typical frequency response of an R - C coupled amplifier

The reason for the lowered amplification at the higher frequencies is, chiefly, in the shunting effect of the tube's internal capacitances. (See Sec. 13.4.) Although these capacitances (effective value C_i) may be small, still their reactance, $1/2\pi fC_i$, becomes sufficiently high when f has increased that the input signal fails to give voltages on the grid commensurate with those at lower frequencies.

Part of the reason for the drop at the lower end of Fig. 25 B is due to the ineffectiveness of C_2 (Fig. 25 A) in bypassing the signal around R_2 , as mentioned before; but the major reason lies in the output coupling condenser C_5 . This will be easily understood if we redraw the

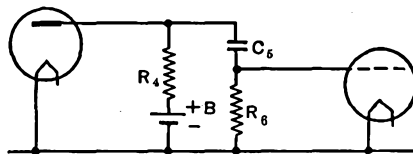


FIG. 25 C. Reasons for poor gain at low frequencies

coupling circuit in the form of Fig. 25 C. Here we see that the a.c. voltage developed across the plate resistor R_4 is divided between C_5 and R_6 . Only that across R_6 is applied to the grid of the next tube. Hence, at the lower frequencies, where the reactance ($1/2\pi fC_5$) is large, the per cent of the total voltage across R_4 which occurs across R_6 is less than at the higher frequencies. Usually, a coupling condenser (C_5) of 0.1 $\mu\text{fd.}$ is used in audio-frequency amplifiers. It must be ca-

pable of withstanding the full plate voltage and must have excellent insulation so that there shall be no leakage through it. A leaky condenser at this point in the circuit will allow a small current to flow through the high-resistance grid resistor (R_6) and establish a positive potential on the grid of the following tube. This could be counterbalanced by increasing the C-bias; but leakage currents are often quite erratic and a well-insulated condenser should be used.

The grid resistor R_6 should be as large as possible without "blocking" the next tube. Blocking means that the time constant R_6C_5 (Sec. 3.6) is so great that electrons on the grid do not have time to leak off of C_5 through R_6 . Then the grid goes negative to such a value that the plate current is shut off or "blocked." R_6 ranges from 50,000 ohms for power tubes such as the 2A3 or 6F6, up to 1 megohm for other tubes.

25.4 A Pulse Amplifier. The time constant of the grid circuit becomes of considerable interest when the input signal consists of a succession of pulses. In particular, the question arises as to the rapidity with which the pulses may follow each other and still be recognized as separate pulses. The limit, in seconds, is called the *resolving time* of the amplifier. Suppose, at the start, that each pulse were of very short duration. Then the grid condenser would be charged up quickly when a pulse was applied, and would discharge between impulses. In RC seconds it would be nearly discharged. The second pulse would then repeat the process and be recognized as a separate pulse. But, if the discharge time (which is arbitrarily taken as RC seconds) were too long, the grid condenser would still retain an appreciable percentage of the charge of the first pulse at the time the second pulse arrived. After a few pulses, the continued charging of the condenser (with too little time for discharge) would prevent the pulses from being distinguished one from the other. Hence in pulse counters, it is customary to use small grid condensers. For example, at the input of the first stage $C = 10 \mu\mu\text{f.}$; at the second stage $C = 100 \mu\mu\text{f.}$

25.5 Shielding. In order to call attention to the necessity of shielding each stage *and* each decoupling unit from the rest of the circuit, the complete circuit of a *linear amplifier* is shown in Fig. 25 D. A linear amplifier is one in which the output voltage is directly proportional to the input voltage. In the figure, the dotted lines represent metal shields. In this circuit, the first tube must be non-microphonic, of fairly high input resistance, and of low input capacity. Noises which might origi-

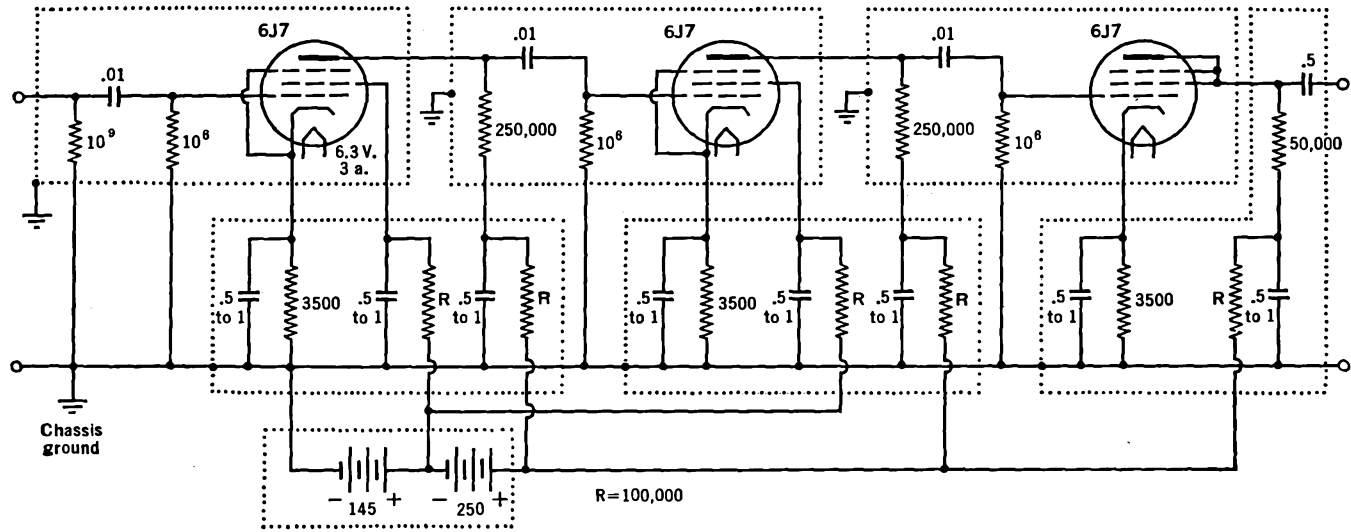


Fig. 25 D. A linear amplifier, filtered and shielded

from 10 to 800 henries in audio amplifiers. The inductance of an iron core coil decreases as the d.c. current through its windings is increased above a certain small value. This is due to a decrease in the magnetic property (called the permeability) of the iron with increase in magnetizing force of the larger currents. In order to keep L large and independent of the d.c. plate current, the plate circuit is sometimes split into two parallel branches, one for the d.c., the other (containing the

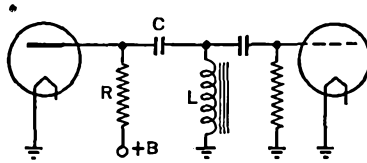


FIG. 25 F. Coupling unit for an impedance-coupled a.f. amplifier using parallel plate feed

coil) for the a.c., as in Fig. 25 F. The blocking condenser C can be chosen so that its reactance is numerically equal to that of the coil L for a given frequency. Parallel resonance (Sec. 6.2) then occurs in the circuit RCL . The voltages which develop across L at the resonant frequency are comparatively large. If $L = 125$ h. and $C = 0.05 \mu\text{fd.}$, then $f_r = 60$ cycles. Then the gain of the amplifier at the low frequency end will be greatly augmented. In fact, the frequency whereat

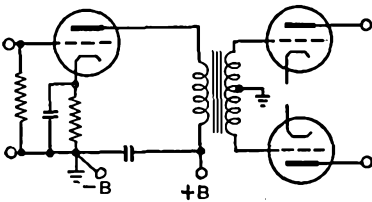


FIG. 25 G. A transformer-coupled amplifier driving a push-pull amplifier

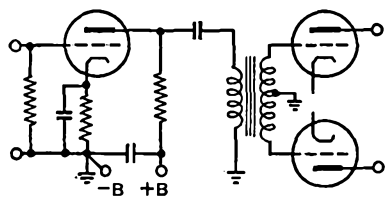


FIG. 25 H. Transformer-coupled a.f. amplifier with parallel plate feed

the resonant character of the RCL circuit is developed can be chosen at will, thus increasing the gain at low, at intermediate, or at high frequencies. If R is kept to a low value, the resonant peak will be sharp, and vice versa. Thus the frequency-response curve of this type of amplifier can be made to have a wide variety of shapes. In conclusion, we may say that impedance-coupled amplifiers give somewhat greater gain per stage than do $R-C$ coupled amplifiers, they do not re-

quire as high a voltage for the B supply, and they do not (in general) have as constant an amplification at different frequencies.

25.8 Transformer-Coupled Amplifiers. For audio-frequency amplification, a transformer is used as the coupling unit between two tubes only when power is to be transferred or when coupling is to be made to a push-pull stage. Usually, triodes, such as 6C5, 6J5, and similar tubes, with a μ of 20 or less, are used. Figure 25 G shows a series-feed circuit whose gain per stage, in the absence of grid currents, is equal to the μ of the tube multiplied by the step-up ratio (usually 2 to 1) of the transformer. The parallel-feed circuit of Fig. 25 H will have better

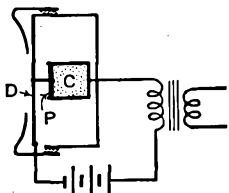


FIG. 25 I. A single-button carbon microphone

low frequency response than that of Fig. 25 G for the same reason advanced in connection with the impedance-coupled amplifier. The gain per stage with the parallel feed is nearly equal to that of the equivalent resistance-coupled amplifier, multiplied by the secondary-to-primary turns-ratio of the transformer.

25.9 Microphones. The construction of a *single-button carbon microphone* is shown in Fig. 25 I.

Some specially prepared carbon granules *C* are contained in a small fixed insulating cup, closed at one end by a flexible membrane or "piston" *P* which is fastened to a metal diaphragm *D*. Sound waves, impinging upon the diaphragm, cause it to vibrate at their frequency and with movements proportional to their intensity. As the piston moves back and forth in the cup, the electrical resistance which the carbon granules offer to the current from the battery is varied in proportionate amounts. The fluctuating currents in the primary of the transformer induce corresponding voltage changes in its secondary. A *double-button* carbon microphone operates with two buttons on the same diaphragm, in a push-pull circuit. Speech input circuits for single- and double-button microphones are shown in

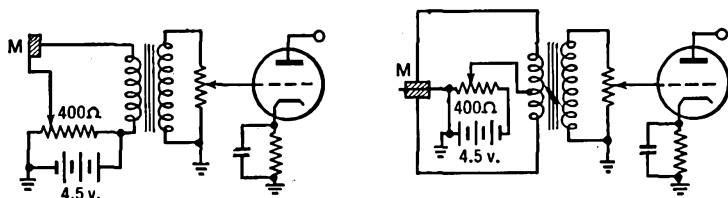


FIG. 25 J. Speech input circuits for carbon-button microphones

Fig. 25 J. The current through these microphones is usually 50 to 100 ma. The output voltage of a single-button microphone amounts to from 0.1 to 0.3 volt across the 50- to 100-ohm primary of the transformer. A peak voltage of 3 to 10 volts will be developed across a 100,000-ohm load on the transformer secondary. With double-button

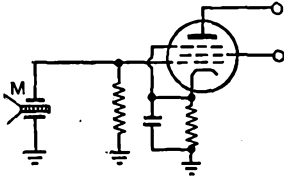


FIG. 25 K. Speech input circuit when a crystal "mik" is used

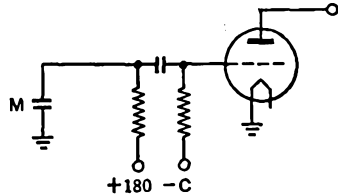


FIG. 25 L. Amplifier circuit for a condenser "mik"

microphones, 0.02 to 0.07 volt is developed across the 200-ohm primary and 0.4 to 0.5 volt is produced across a 100,000-ohm secondary load. Operating currents are usually from 5 to 50 ma. per button. The double-button type is less noisy than the single-button type.

Crystal microphones contain a pair of Rochelle salt crystals, properly cemented together, and with terminals of metal plated directly on their surfaces. The crystal is fastened directly to a diaphragm in the more sensitive types. When sound waves vibrate the crystal, changing its physical dimensions, small alternating potentials are produced

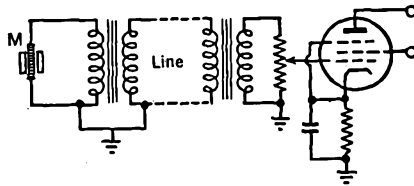


FIG. 25 M. Amplifier circuit for a velocity or ribbon type "mik"

between the electrodes (piezo-electric effect). These are applied to the amplifying tube directly, without the aid of a microphone battery, as shown in Fig. 25 K. The output voltage usually ranges from 0.01 to 0.03 volt. High values (1 to 5 megohms) of the grid resistor of the pentode should be used.

A *condenser microphone* consists of a rigid metal plate in front of which, at a distance of about 0.001 in., is mounted a thin metal dia-

phragm, everywhere parallel to the plate. A d.c. voltage (180) is applied to this condenser, as in Fig. 25 L. When sound waves vibrate the thin membrane, the capacity changes and causes a fluctuating charge and discharge current to flow through the coupling resistor. The

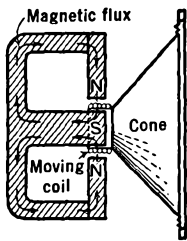


FIG. 25 N. A dynamic microphone (or speaker)

voltage across this resistor is then amplified by a tube. This tube must be mounted close to the microphone in order to avoid losses in the capacitance of a connecting cable. The better condenser microphones are from 1/100 to 1/50 as sensitive as the double-button type.

Velocity or ribbon microphones have a thin, corrugated metal ribbon suspended between the poles of a magnet. When sound waves vibrate the ribbon back and forth in the magnetic field, cutting its lines of force and generating an e.m.f. in the ribbon, voltages of the order of magnitude of 0.03 to 0.05 volt are generated. An input circuit for this type of microphone is shown in Fig. 25 M.

The *dynamic microphone* uses a coil of wire, mechanically coupled to the diaphragm, and free to vibrate in a strong magnetic field. The use of several turns of wire in the coil permits this type to deliver a larger output voltage than the ribbon type. For crude work, a small, permanent-magnet dynamic loudspeaker may be used as a microphone. The construction of such a loudspeaker is shown in Fig. 25 N.

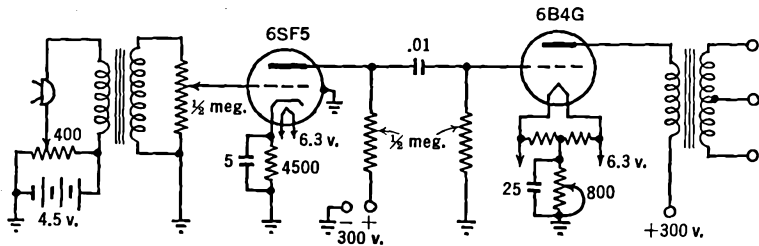


FIG. 25 O. A speech amplifier suitable for carbon-button microphones

25.10 Speech Amplifiers. The purpose of a speech amplifier is to increase the strength of microphone voltages to a sufficient value to operate a terminal amplifier which has a power output of the desired magnitude. The overall voltage amplification is equal to the product of the amplifications of the individual stages. A typical three-stage amplifier would have a first-stage voltage gain of 100, a second of 20 and a third

of 15, or a total of 30,000, corresponding to 89.5 decibels. (See Sec. 2.6.) With carbon microphones, two triode stages and a power output stage are usually sufficient. Such a circuit is shown in Fig. 25 O. With crystal microphones, the gain must be greater; the first tube is usually a pentode, as in Fig. 25 P. For reasonable fidelity of speech, the gain should not vary by more than one decibel over the range from 100 to 4,000 cycles per second. For music, the presence of the higher harmonics requires that the response be flat to much higher frequencies, say 8,000 or 12,000 cycles per second.

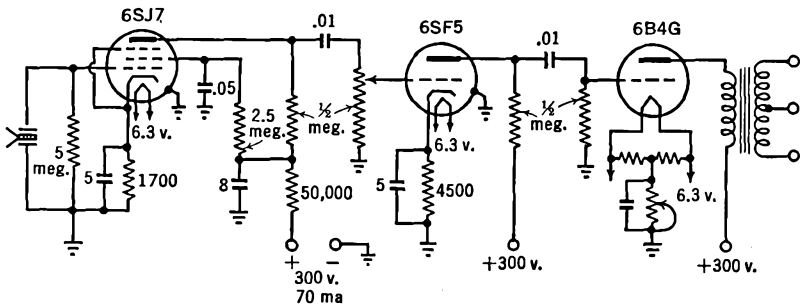


FIG. 25 P. A speech amplifier suitable for crystal microphones

CHAPTER 26

FEEDBACK AMPLIFIERS

26.1 The Principle. Suppose a small voltage is fed back from the output of an amplifier to its input as in Fig. 26 A. If this voltage is in the same phase (crest for crest, trough for trough) as the input or signal voltage, the feedback is said to be positive or *regenerative* and the circuit will likely go into oscillation. If the voltage is in reverse phase (crest for trough of the wave-form), the feedback is negative or *degenerative*.

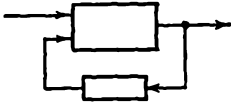


FIG. 26 A. The principle of feedback amplifiers

Let the amount of the feedback voltage be a fraction (F) of the output voltage E . Then the actual input will be FE plus the original signal e . The output voltage is equal to the actual input voltage multiplied by the voltage amplification A . Thus $E = A(e + FE)$. Solving this equation for the effective amplification or gain of a feedback amplifier, we find

$$G = \frac{E}{e} = \frac{A}{1 - FA} = -\frac{1}{F} \left(\frac{1}{1 - \frac{1}{FA}} \right)$$

When F is positive, the circuit is regenerative, and vice versa. When the "feedback factor" FA is very large, the gain becomes $(-1/F)$, and the effective amplification is independent of the gain A of the amplifier alone. This means that, with degenerative feedback, the amplifier will have *great stability*, retaining its overall voltage gain at a constant value for long periods of time despite appreciable changes in battery voltages, temperature, and mechanical vibration.

Degenerative feedback also *reduces* wave-form or *harmonic distortion* arising in the amplifier. This is because the distortion is fed back and is itself degenerated. Noises which arise in the amplifier, particularly in the later stages, are similarly reduced in magnitude.

A third advantage lies in the fact that *wide ranges of frequency* can be amplified, with nearly equal response over the entire band of frequencies.

On the other hand, the total voltage gain is less than with the amplifier alone, unless additional stages are added or a "balanced feedback" is used in the manner to be described later.

26.2 A Single-Stage Degenerative Amplifier. In Fig 26 B, the negative feedback voltage is transmitted through the condenser C_1 and

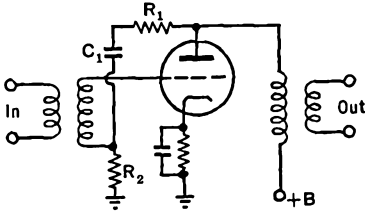


FIG. 26 B. A simple degenerative amplifier

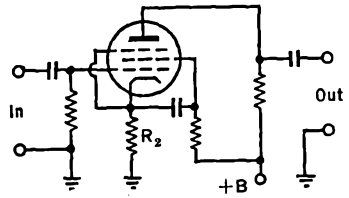


FIG. 26 C. Another simple degenerative amplifier

resistor R_1 and appears across resistor R_2 . Suppose, for instance, that an input signal makes the grid of the tube less negative for a moment. The resultant increase of plate current produces a negative potential at the top of the primary of the output transformer. This is transmitted through R_1, C_1 to R_2 . The top of R_2 becomes negative for a moment, and, through the secondary of the input transformer, makes the grid negative, the reverse of the positive impulse of the input signal.

In Fig. 26 C, the cathode resistor R_2 is used simultaneously to provide the C-bias and for the feedback purpose. When a positive im-

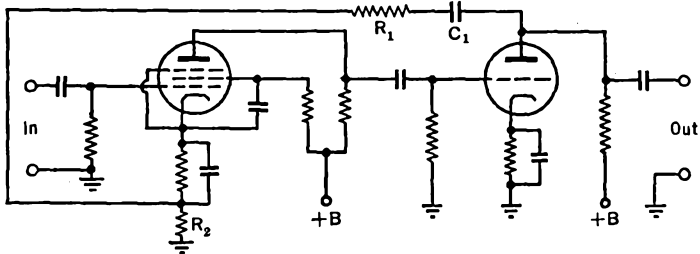


FIG. 26 D. A typical two-stage degenerative amplifier

pulse occurs on the grid, the plate current increases; and also the ir drop in R_2 increases because it is in the plate circuit. An increase of voltage across R_2 makes the grid more negative, the reverse of that of the signal voltage.

26.3 A Two-Stage Degenerative Amplifier. Figure 26 D shows a typical two-stage degenerative amplifier. When a positive impulse is ap-

plied to the grid of the first tube, the grid of the second tube goes more negative, due to the usual phase reversal of a single-stage amplifier (see Sec. 13.7). When, as a result, the plate current of the second tube de-

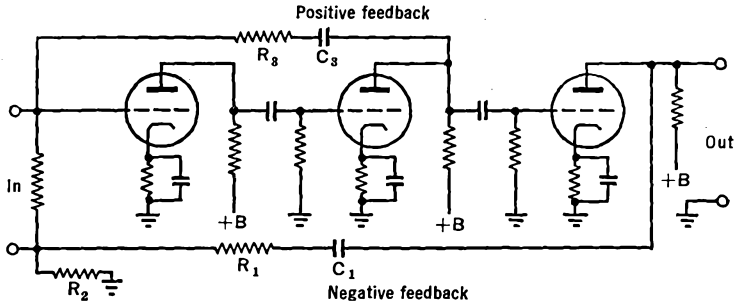


FIG. 26 E. A three-stage feedback amplifier

creases, the top of the output resistor becomes more positive. This is transmitted through C_1R_1 to the top of R_2 , hence making its grounded end more negative. This is applied via the grounds through the input grid resistor to the grid of the first tube, and in opposite phase to that of the impressed signal.

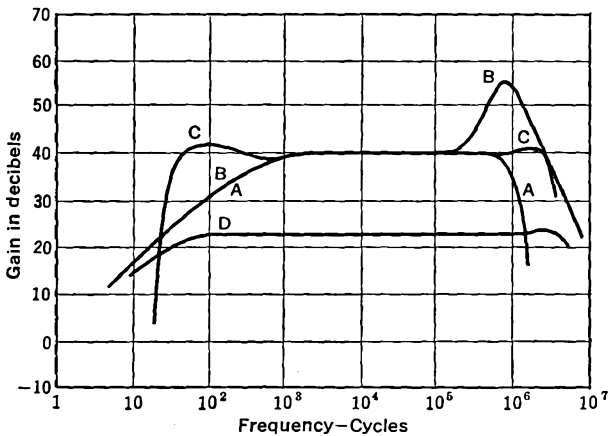


FIG. 26 F. The frequency response curve of a balanced feedback amplifier. Curve A, amplifier alone, no inductances in plate leads. Curve B, amplifier alone, but with inductances. Curve C, balanced feedback amplifier. Curve D, amplifier with negative feedback only. Note the extremely wide range of frequencies which are amplified. See Proceedings of the Institute of Radio Engineers, Vol. 26, page 1378, Nov. 1935

With two stages, the feedback factor FA can be made larger than with one stage, making possible to a fuller extent the potential advantages of this type of amplifier.

A three-stage unit is shown in Fig. 26 E. This operates, in the absence of R_3C_3 , as a degenerative amplifier.

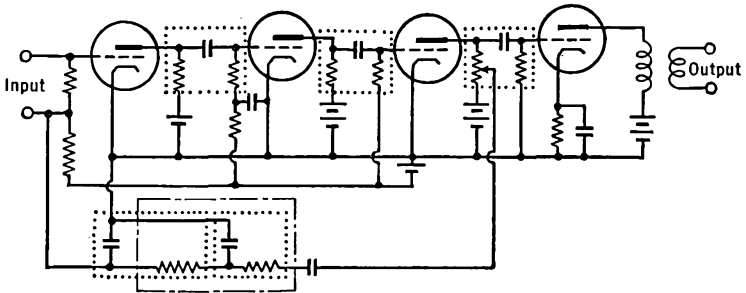


FIG. 26 G. An R - C coupled feedback amplifier

26.4 Balanced Feedback Amplifiers. In the circuit of Fig. 26 E, both positive and negative feedbacks are used simultaneously. The positive feedback is designed so as to be proportional to the input signal and independent of the frequency over that band which is to be amplified linearly. Hence the first two stages are designed to give equal response to all frequencies over the desired range. Since the positive feedback need not be large, the gain in these stages can be small. It is compara-

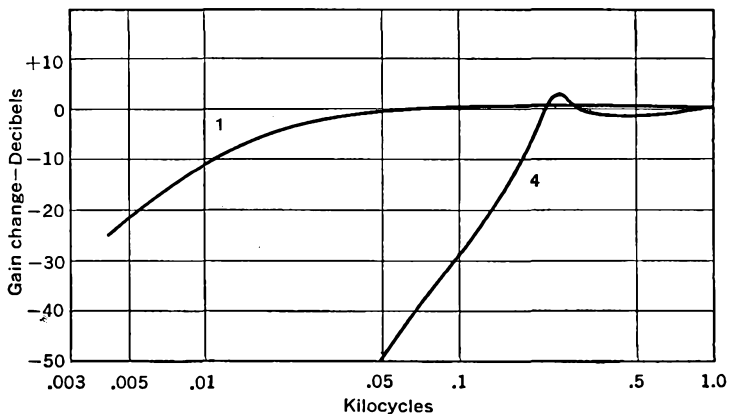


FIG. 26 H. Response curves of the amplifier of Fig. 26 G

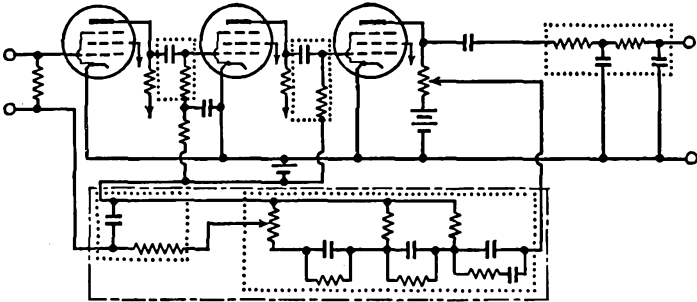


FIG. 26 I. A low-pass amplifier. (Proc. I. R. E., Vol. 26, page 219, 1938)

tively easy to make a low-gain amplifier flat over a wide frequency range. The response curve of this amplifier is shown in Fig. 26 F.

26.5 High- and Low-Pass Amplifiers. It is possible to amplify voltages of different frequencies by the same amount over a wide band. It is also possible to use "filters" (Chapter 7) to suppress all frequencies above (or below) a sharp "cutoff" frequency. It is now proposed to point the way to the design of amplifiers with negative feedback which will accomplish, in a simple and economical manner, the combined functions of these two units.

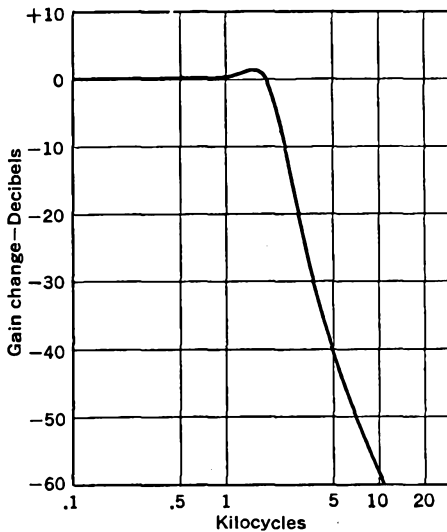


FIG. 26 J. Response curve of the amplifier of Fig. 26 I

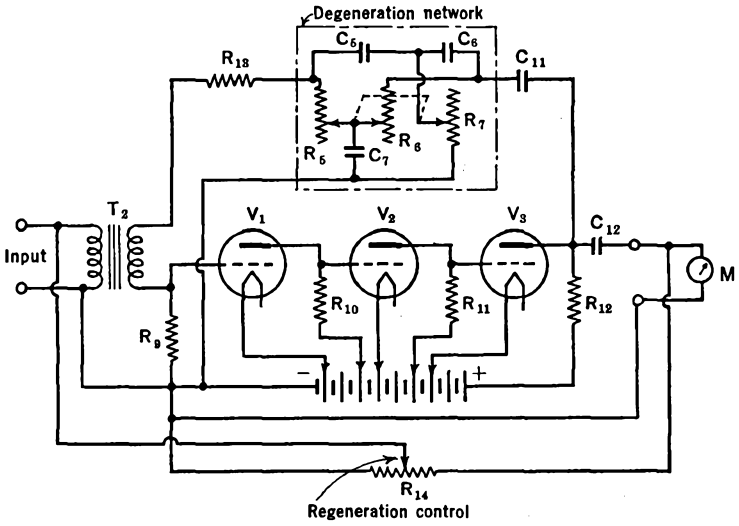


FIG. 26 K. A band-pass amplifier

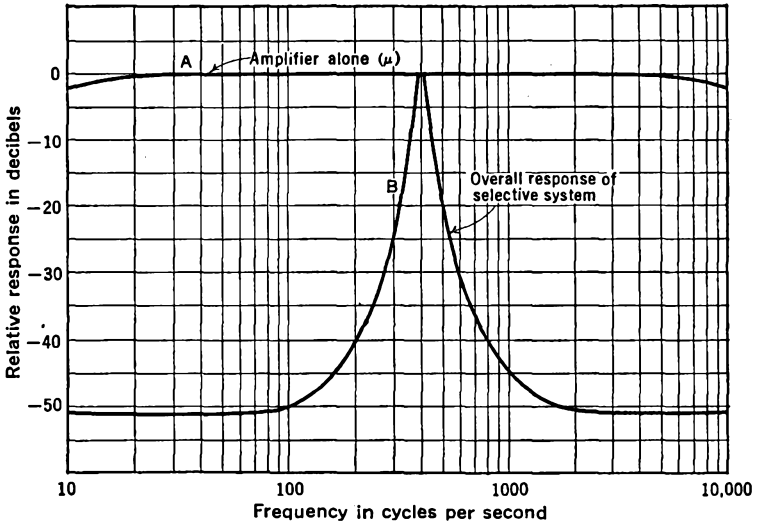


FIG. 26 L. Response curve of the circuit of Fig. 26 K

Figure 26 G shows an R - C coupled amplifier whose negative feedback unit contains several condensers and resistors, so arranged and of such value as to give the overall frequency response curve of Fig. 26 H, curve 4. Curve 1 is for the amplifier alone.¹

Figure 26 I shows a degenerative amplifier which sharply suppresses all frequencies above a certain value, yet passes the lower frequencies with fidelity. Its response curve is given in Fig. 26 J.

26.6 A Selective Circuit. Figure 26 K shows a circuit with a degenerative network whose frequency response has a selective peak, as in Fig. 26 L. By changing the values of R_5 , R_6 , and R_7 (with a single knob), the peak of curve B in Fig. 26 L can be shifted to the various frequencies throughout the range of the amplifier, without changing the relative sharpness of the curve.²

The selective amplifier of Fig. 26 K, without the *regenerative* feature at the bottom, can be used as a *frequency analyzer*. Suppose, for example, that the input signal consisted of the voltages from a microphone and that it was desired to know the relative strengths of the fundamental and various harmonics of a sound wave impinging on the microphone. The meter M (a cathode-ray oscilloscope will do) is read as R_{567} is changed. It will be large when the amplifier passes the fundamental frequency, and proportionally large as each of the harmonics is passed over. Obviously R_{567} must be calibrated in frequency; and allowance must be made for the frequency response of the microphone by calibrating the apparatus with a succession of frequencies all of the same amplitude.

When the regenerative feedback of Fig. 26 K is added, the circuit can be made to *oscillate* at a frequency determined chiefly by its selectivity curve. An unusually pure sine wave is generated by this simple circuit.

¹ See Proceedings of the Institute of Radio Engineers, Vol. 26, page 216 (1938).

² Proc. I. R. E. 26, 233 (1938).

CHAPTER 27

R.F. AND I.F. AMPLIFIERS

27.1 Introduction. Radio-frequency amplifiers are often designed to amplify only one frequency, together with those frequencies in the immediate neighborhood. Thus they serve the dual purpose of an amplifier and of a band-pass filter, strengthening the input voltage and simultaneously selecting a restricted band of frequencies. They use condensers and coils in their grid and plate circuits, tuned to the desired frequency. By changing the inductance or capacitance of these resonant circuits, one may select first one and then another frequency from a complex input voltage, and amplify and use it alone, to the exclusion (more or less) of all the others. In this way a receiver is made to pick out only one of several stations that are "on the air" at the same time. An amplifier which will amplify only an extremely narrow range of frequencies is said to be *highly selective*, while one which amplifies a broader band of frequencies is said to be *broadly tuned*. R.F. amplifiers are used in both transmitters and receivers.

27.2 A Typical R.F. Class A Amplifier for a Receiver. Figure 27 A shows the type of r.f. amplifier commonly used in receiver circuits. The input and output circuits L_1C_1 and L_4C_5 are tuned to the same frequency.

The circuit would oscillate if a triode were used, because of the large feedback through the internal capacities of the tube itself; hence a pentode is used, with its internal screening action. In addition, it is necessary to prevent external feedback from the plate circuit to the grid by means of grounded metal shields, indicated by the dotted lines in Fig. 27 A, and by keeping the plate and grid lead wires as far apart as possible. The shield decreases the inductance and increases the resistance, i.e., changes the tuning, and decreases the Q of the coil, depending upon the shield material and its distance from the coil. Tuning of the circuits must therefore be done while the shield is in place. Also, to prevent oscillation, connect C_3 and C_4 to the ground or cathode with separate wires, each of which is as short as possible.

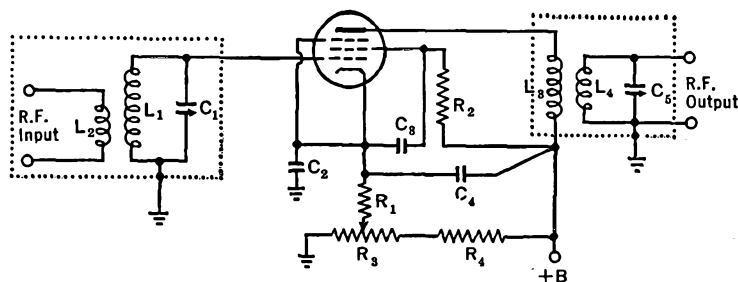


FIG. 27 A. A typical tuned radio-frequency amplifier

$L_2 C_1$ = the tuned-grid circuit	L_2 = input primary coil
R_1 = cathode resistor	L_4 = input secondary coil
C_2 = cathode bypass condenser	$C_1 C_5$ = tuning condensers
C_3 = screen bypass condenser	C_4 = plate bypass condenser
R_2 = screen dropping resistor	L_4 = output secondary coil
L_3 = primary of output transformer	R_4 = bleeder resistor
$L_4 C_5$ = second-stage tuned-grid circuit	R_3 = gain control resistor
— = metal shields	

Bypass condensers C_2 , C_3 , and C_4 should have low reactance at the frequencies to be amplified; $0.01 \mu\text{fd.}$ for ordinary communication purposes. The cathode resistor R_1 should establish the minimum bias voltage recommended for the particular tube used. In applying Ohm's law to calculate R_1 , do not forget that both the screen and plate currents flow through R_1 . Ohm's law is also used to calculate R_2 , such that the voltage drop in it due to the screen current, subtracted from the B voltage, leaves the correct screen voltage. The tuned circuits should have a fairly high L/C ratio. L_3 is usually coupled as closely to L_4 as possible and contains 70 to 80 per cent of the number of turns on L_4 .

With variable- μ tubes, the gain control is accomplished by changing the C-bias voltage. There are three currents passing through the control resistor R_3 , i.e., the bleeder current through R_4 , the screen, and the plate current. The total drop across R_3 should be about 50 volts. Maximum gain occurs when the sliding contact on R_3 is at the grounded end. In multistage amplifiers, the lower ends of the various cathode resistors are sometimes connected together and then to the sliding contact on R_3 . The left end of R_3 must then have a current-carrying capacity sufficient for all the tube currents plus that of the bleeder R_4 .

27.3 I.F. Class A Amplifiers. There is a type of radio-frequency amplifier which is designed to amplify *only one* frequency region. This means that, once its circuits have been properly adjusted, they need not

be changed again. As used in certain broadcast receivers, this frequency region is centered at 455,000 cycles per second (455 kc.), a value which is the intermediate between audio and broadcast frequencies; hence the name *intermediate-frequency* amplifiers. There are two main types of i.f. amplifiers, one for phone reception, where the fixed band of frequencies has a definite width, over which the amplification is as nearly uniform as possible, and the other for the reception of dots and dashes where the band width is made as narrow as possible. These cases are illustrated in Fig. 27 B.

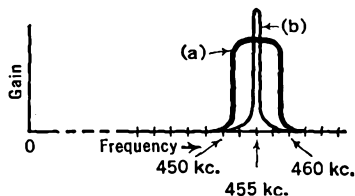


FIG. 27 B. I. F. band widths

I.F. amplifiers usually contain one or two stages. Figure 27 C shows the circuit of a one-stage i.f. amplifier of the type which covers a band of frequencies.

It is to be noted that the circuit differs from that of a tuneable r.f. amplifier only in that there are additional condensers CC across the primaries of the transformers, and that a decoupling resistor R has been added to prevent stray feedback. The tuning units in the shields (dotted lines) use air-core or powdered-iron-core universal-wound coils, the latter offering greater selectivity and gain. The adjustment of these tuned circuits is made by varying the inductance of the iron-core coils or by changing the capacitances across their primaries and secondaries. High stability is important in order to keep all resonant circuits tuned to the same frequency. Any frequency "drift" will reduce the selectivity and gain. More complicated LC circuits are sometimes used to sharpen the sides of the frequency response curve (Fig. 27 B(a)) and to make its top flatter.

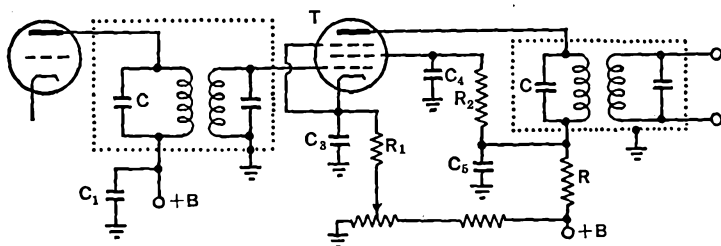


FIG. 27 C. A one-stage i.f. amplifier. T = variable- μ pentode. Typical values; $C_1, C_3, C_4, C_5 = 0.1 \mu\text{fd}$ at 455 kc. ($= 0.01 \mu\text{fd}$ at 1600 kc. or higher); $R_1 = 300$ ohms; $R_2 = 0.1$ megohm; $R = 2000$ ohms

In other i.f. amplifiers, it is desirable to sharpen the tuning as much as possible, as in Fig. 27 B (b), in order to amplify only one, rather than a band of frequencies. *Crystal filters* offer the best method of obtaining this high selectivity. It is to be remembered that a quartz crystal acts like a series circuit of very high Q . A crystal of proper thickness to resonate at the desired i.f. is inserted in the coupling circuits between two tubes, as in Fig. 27 D. It will be noticed that the coupling circuit

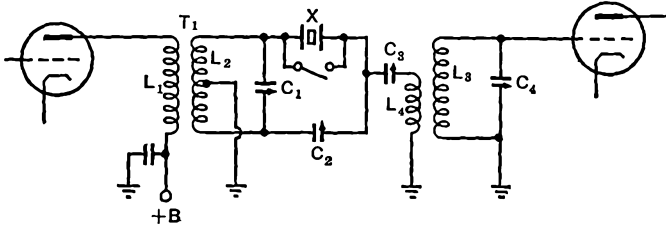


Fig. 27 D. A crystal-filter circuit. T_1 = center-tapped i.f. input transformer with high- L , primary closely coupled to secondary. C_1 and C_3 = 100 μmf . C_2 = 10 to 15 μmf .

forms a bridge, with the upper and lower halves of L_2 on one side of ground and with the crystal, X , and condenser, C_2 , balancing each other. Adjustment is made so that C_2 is equal to the capacitance of the holder of the crystal. This balance prevents undesired frequencies from reaching the output circuit. Condenser C_1 is used to control the selectivity of the circuits, i.e., the sharpness of the response curve, (b) in Fig. 27 B. The selectivity is a minimum when the circuit L_2C_1 is tuned to the crystal frequency, and increases as C_1 is changed from this condition.

27.4 Neutralization. Amplifier circuits tend to oscillate because of the feedback through the inter-electrode capacitances of the tube itself, because of the electrostatic and electromagnetic feedback external to the tube, and because of improper connections whereby currents of the input and output circuits flow through a common wire or through a portion of the shields from one grounded point to another. This is particularly true of radio frequency amplifiers which have tuned-grid and tuned-plate circuits. The feedback through the tube itself is largely alleviated by using tetrodes and pentodes, with condensers (C_2 of Fig. 27 E) shunting r.f. currents directly to ground from the screen and suppressor grids. Even so, certain of these tubes (6L6, 6V6, 6F6, and the like), designed for audio frequency use, do not have sufficient screening for use as r.f. amplifiers unless additional precautions are

taken. Many of the tubes designed for handling large amounts of power, as in the amplifier stages of transmitters, are merely triodes. For these, it is imperative that “neutralization” circuits be used to prevent oscillation.

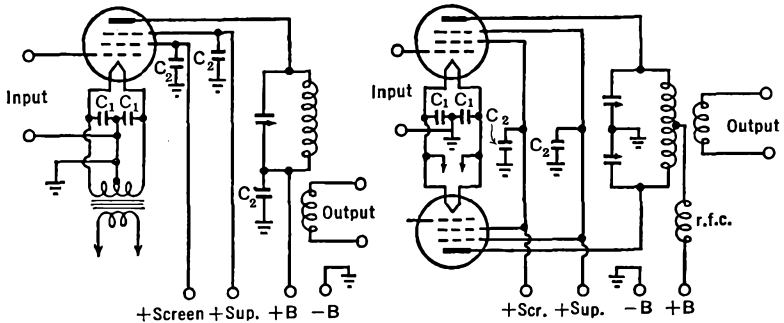


FIG. 27 E. R.F. amplifier circuits. $C_1 = 0.01 \mu\text{fd}$. $C_2 = 0.001 \mu\text{fd}$. or more

Neutralization consists of feeding some of the r.f. voltages from the output or from the input of the amplifier to the other side in such a manner as to cancel the r.f. voltage developed through the grid-to-plate capacitance of the tube itself. There are three main methods, called plate, grid, and inductive neutralization.

In the *plate-neutralized* circuit of Fig. 27 F, the r.f. voltages in the tank circuit LC induce voltages in the closely coupled extension of L . These voltages are of opposite polarity to those on the grid (which originally caused them). They are fed back to the grid through the neutralizing condenser C_n , to balance that which reaches the grid through the grid-plate capacitance of the tube. Neutralization is satisfactory only over a small range of frequencies.

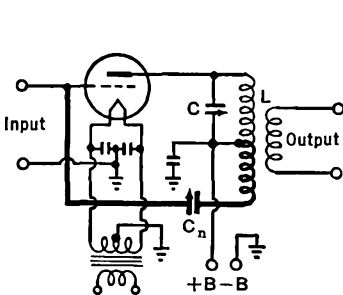


FIG. 27 F. A plate-neutralized r.f. amplifier circuit

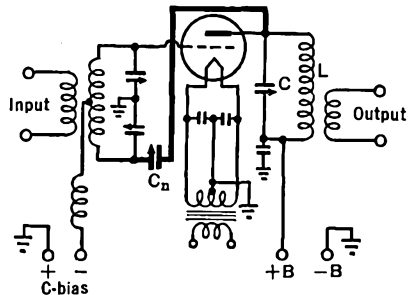


FIG. 27 G. A grid-neutralized r.f. amplifier circuit

In the *grid-neutralized* circuit of Fig. 27 G, the rise and fall of the plate potential is transferred by the neutralizing condenser C_n through the grid coil, to counteract the voltage changes transferred by direct capacitive coupling inside the tube from plate to grid. In general, grid neutralization is less satisfactory than plate neutralization.

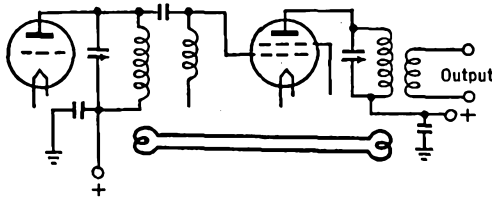


Fig. 27 H. Inductive neutralization of a r.f. amplifier

Figure 27 H shows an *inductive-neutralization* circuit, whereby "link coupling" is used between the grid and plate circuits. This type of neutralization is also complete at only one frequency.

Two condensers ($C_n C_n$) are needed to neutralize a push-pull circuit, as in Fig. 27 I. The capacitances of the two condensers are nearly

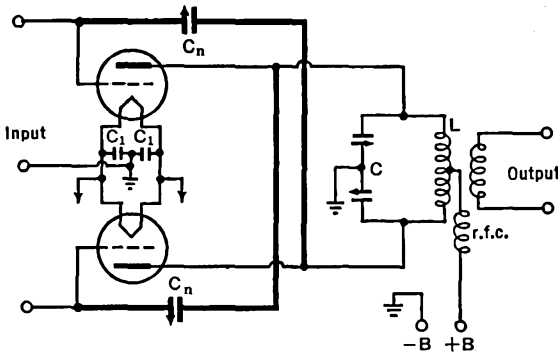


Fig. 27 I. Neutralization of a push-pull amplifier

equal to each other and to the tube's grid-plate value. When the tubes are electrically identical and the circuits are laid out symmetrically, neutralization can be complete and also be independent of frequency. At the very high frequencies, push-pull circuits are the only type which can be satisfactorily neutralized.

In order to neutralize an amplifier, the filament is heated and r.f. is applied to the input terminals. The plate voltage is to be zero. A d.c.

milliammeter is connected in series with the C-bias circuit. The plate tank circuit is tuned back and forth through resonance and C_n is adjusted until the d.c. grid current no longer changes, or, at most, shows a small gradual rise and fall, with a maximum at resonance. The circuit is then neutralized.

27.5 R.F. Linear Amplifiers. These are the same as R.F. Class B amplifiers and were discussed in Sec. 23.6. In general they are not as stable as the amplifiers discussed in the next section.

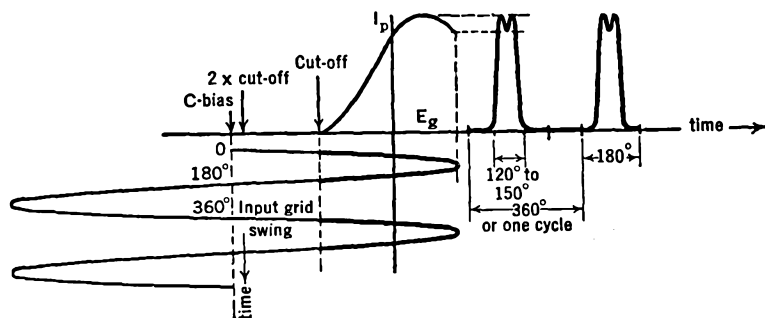


FIG. 27 J. Operation of Class C amplifiers

27.6 Operation of R.F. Class C Power Amplifiers. Radio-frequency amplifiers are sometimes called upon to handle many watts of power. They must then be designed particularly with an eye to efficiency. Class C amplification is commonly used. Inasmuch as the plate current flows only during a portion of the positive half-cycle of input voltage to the grid, and is zero during the remainder of the cycle (see Sec. 23.7), the steady d.c. plate load loss of Class A is avoided. On the other hand, the grid is driven positive in Class C operation and the resultant grid current causes power losses in the grid circuits. The net result, theoretically and experimentally, is that Class C amplification is more efficient than B or A. You get a larger fraction of watts-out per watts-in with Class C than in the other cases.

Improper adjustment, however, can result in very low efficiency. It has been found that optimum conditions exist when the plate current flows from 33 to 47 per cent of the time of one cycle. This means that, of the total of 360° corresponding to one cycle, the grid voltage reaches and remains above the cutoff point for 120° to 150°, as shown in Fig. 27 J. For 120°, the r.f. grid voltage reaches 50 per cent of its peak value at cutoff, and for 150°, it reaches 25 per cent at cutoff. The correct

C-bias is therefore equal to the cutoff plus 25 to 50 per cent of the peak r.f. grid voltage.

Because power is consumed in the grid circuit (and to allow for contingencies), the "driver" or input source should be designed to give an amount of power equal to two or three times the expected grid-circuit losses. This is particularly true at the ultra-high frequencies where the losses occur not only in the wires themselves but also in the dielectric of the glass envelope of the tube.

The plate circuit of an r.f. Class C amplifier contains a resonant circuit, as at LC in Fig. 27 G. When tuned to the frequency of the input signal, this circuit acts like a pure resistance whose value, including the "reflected impedance" (Secs. 6.2 and 7.2) of the output load, is usually of the order of a few thousand ohms. The more power delivered by the amplifier to the output circuit (say the antenna of a transmitter), the lower this resistance, and vice versa. For good efficiency this resistance should be relatively high. Its best value is such that the maximum r.f. grid voltage is equal to the minimum instantaneous plate voltage.

The direct pulsating plate current shown on the right of Fig. 27 J causes the tank circuit currents to oscillate back and forth, transferring energy alternately from the condenser to the coil and back again in the usual fashion. The periodic (and properly timed or resonated) pulses of plate current make up for the circuit and load losses so as to keep the circuit in oscillation. The fluctuating magnetic field of coil L cuts the turns of wire in the output coil (see Fig. 27 G)

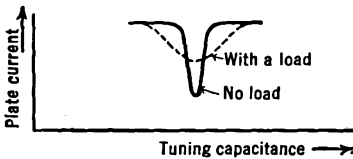


FIG. 27 K. The plate current dips as the plate circuit of a r.f. amplifier is tuned through resonance

to set up an e.m.f. and to drive a current in the output circuit. It is desired that the wave-form of this output should be a replica of that applied to the grid of the amplifier, and hence be free of distortion or harmonic content. This is not possible; yet the harmonic content will be reasonably low when the Q ($= 2\pi fL/R$) of the tank circuit is high. Transmitting coils, which largely determine the Q of the tank circuit, usually have a Q ranging from one hundred to several hundred, with no load, but drop to much lower values when power is drawn from the amplifier, due to the reflected impedance. This change with load can be shown in terms of the sharpness of resonance as in Fig. 27 K. The Q of the tank circuit should be 12 or higher.

CHAPTER 28

THE MODULATION OF R.F. AMPLIFIERS

28.1 Introduction. The Principle of Amplitude Modulation was discussed in Chapter 16 and should now be reviewed. The following chapter contains a description of the commonly used circuits and some of their details.

In the plate-, and the plate-and-screen modulation systems, the audio power, which is found later in the sidebands, is entirely supplied by the modulators. On the other hand, in the grid-modulation system, the audio unit, in considerable part, acts by varying the efficiency of the modulated r.f. amplifier unit.

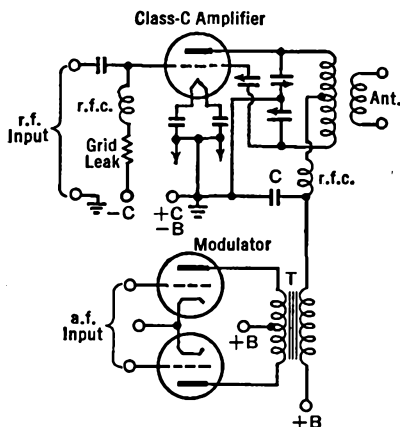


FIG. 28 A. Plate modulation of a r.f. Class C amplifier

28.2 Plate Modulation. Figure 28 A shows the circuit of a Class C amplifier with plate modulation from a Class B modulator. The elementary form of this circuit was given previously in Figs. 16 F and 16 G.

In the design of "plate-modulated" r.f. amplifiers we are concerned with the following problems: (1) that the modulation shall be as

nearly 100 per cent as possible, (2) that the output audio wave-form shall be as nearly a replica of the a.f. sound input to the microphone as possible, (3) that the power output for a given set of tubes in the circuit shall be as great as possible.

In order to attain these objectives we must concern ourselves: (1) that the amplifier tube (which is to be modulated) is properly biased; (2) that the strength of the radio frequency from the driver ahead of this tube is sufficiently great; (3) that the audio frequency voltages from the modulator tube are sufficient but not too great for the most suitable B voltage; (4) that the loading on the amplifier tank circuit is of the proper amount; (5) that the radio frequency circuits are all properly tuned; (6) that the filtering chokes and bypassing condensers are suitably chosen and placed, that all radio frequencies stay where they belong, and all audio frequencies, and all direct currents remain in their proper channels.

Some of the details of the circuit in Fig. 28 A are given in the following paragraphs.

The tube manufacturer usually supplies data on the proper grid bias and grid current for the Class C modulated tube. A well-filtered C-battery supply, having good regulation, should be used to bias the grid to cutoff; and this should be supplemented by the voltage drop in the grid leak so as to make the total grid voltage between two and three times the cutoff value.

If triodes are used, as in Fig. 28 A, the neutralization of the amplifier must be very nearly perfect. See Sec. 27.4.

The voltage of the r.f. driver ahead of the modulated tube should be sufficient to drive the grid of this tube somewhat positive during its peak positive half-cycle, and its power should be two or three times greater than that which is normally consumed in the grid circuit.

The plate bypass condenser, *C* of Fig. 28 A, must have a high reactance for audio frequencies in order to provide tube safety and good modulation. Values less than 0.002 μ fd. are satisfactory.

The output peak voltage of the modulator must be such that the a.f. voltage on the plate of the amplifier tube is equal to the d.c. plate voltage if 100 per cent modulation is to be obtained. Then the r.f. output will fluctuate between twice the unmodulated r.f. voltage and zero. If the audio signal is a pure sine wave, the modulator must furnish an amount of power equal to 50 per cent of the d.c. plate power put into the amplifier stage. Thus, if the amplifier is rated at 1,000 watts input, it

is necessary that the audio amplifier put out 500 watts. For complex speech waves the average power of the modulator need be only one-half of the former figure, but its instantaneous power output must still be the same as for the pure sine wave. In order to adjust the circuits for the above stated conditions (which yield 100 per cent modulation), the load on the amplifier is varied until the product of the d.c. plate voltage and the d.c. plate current is of the desired value. Keep the tank circuit tuned to resonance while changing the load. When the amplifier is properly adjusted, the d.c. plate currents will be the same with or without modulation.

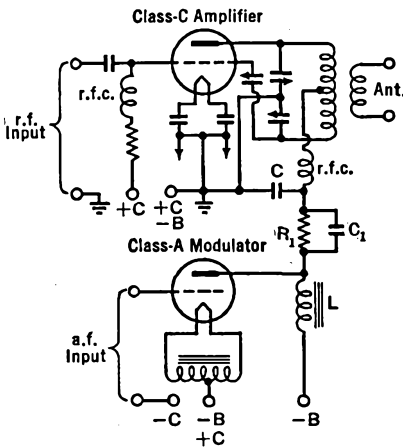


FIG. 28 B. Choke-coupled plate-modulation of a r.f. amplifier

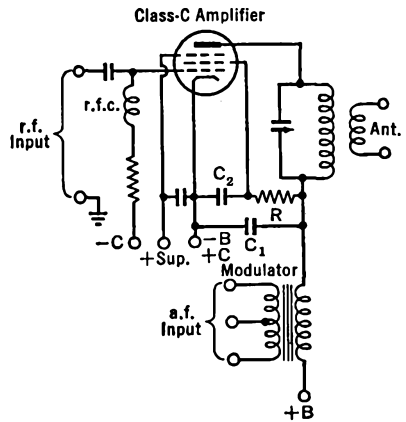


FIG. 28 C. Plate and screen modulation of a pentode amplifier

28.3 Choke-Coupled Plate Modulation. In place of the modulator portion shown at the bottom of Fig. 28 A, it is possible to use the choke-coupled system shown in Fig. 28 B. Here the choke L must have a high impedance at audio frequencies. In order that there shall be 100 per cent modulation, i.e., in order that the peak a.f. voltage developed across the choke L shall be equal to the d.c. voltage on the amplifier tube, it is necessary that the voltage on the amplifier plate be reduced from that on the modulator tube by means of the resistor R_1 . Condenser C_1 is used to bypass audio frequencies around R_1 . Condenser C , on the other hand, must not pass appreciable a.f. and should be 0.002 μ fd. or less. This type of modulation is rarely used except for very low-power sets of the portable type.

28.4 Modulation of a Pentode Amplifier. Pentode and beam-tetrode tubes can be used in a Class C plate-modulated amplifier if the audio frequency modulation voltage is applied in series with both the plate and screen grids, as in Fig. 28 C. Here, the value of the resistor R is chosen in the usual way so as to establish the screen grid at its normal d.c. voltage. In computing the power input to the amplifiers, use the sum of the d.c. screen and plate currents. The plate and screen-grid bypass condensers C_1 and C_2 ($0.002 \mu\text{fd.}$ or less) must both have high reactance for audio frequencies to provide both tube safety and good modulation.

28.5 Grid-Bias Modulation. Figure 28 D shows a Class C amplifier modulated by the grid-bias method. In this circuit it is necessary

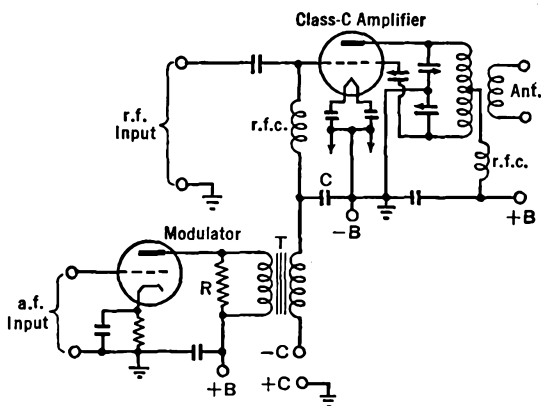


FIG. 28 D. Grid-bias modulation of a r.f. Class C amplifier. The by-pass condenser C should not be greater than approximately $0.002 \mu\text{fd.}$

that the plate supply of the modulator should have good voltage regulation, and that the grid-bias source for the amplifier should have low resistance. A battery might well be used, or a rectifier with regulated output. A grid-leak bias should not be used. The C-bias should be two or three times the cutoff value.

28.6 Suppressor-Grid Modulation. Figure 28 E shows the complete circuit of a system which operates along the same lines as that of the grid-bias modulator, but is somewhat simpler to adjust for proper operation because the modulating, the r.f., and the plate circuits are all three separate and more or less independent of each other.

CHAPTER 29

FURTHER DISCUSSION OF OSCILLATORS

29.1 Electron-Coupled Oscillators.* One of the outstanding problems in the design of vacuum-tube oscillators is that of keeping the frequency constant despite mechanical vibrations, temperature changes, voltage variations in the supply lines, and changes in the amount of power taken out of the circuit by the load. The effects of variable loading are greatly reduced by the use of *electron coupling*. Let us imagine that in the Hartley circuit of Fig. 14 B the actual metal

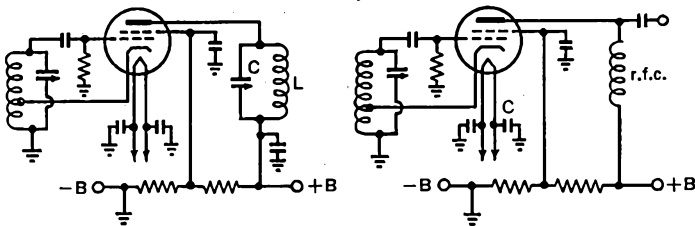


Fig. 29 A. Electron-coupled oscillator circuits

plate is replaced by a grid of wires. The stream of electrons reaching this electrode increases and decreases in number at the frequency of the oscillating circuit in the usual manner. But, with a grid of wires rather than a solid metal plate, a part of this stream of fluctuating electrons passes through the "plate" and can be used in a later portion of the tube. It is as though we had a "virtual" cathode, emitting electrons, whose number varied from maximum to minimum periodically at a high rate. Of course it is impossible to heat and cool an actual cathode at high frequencies. Yet the combination of the Hartley circuit with a grid which acts as the "plate" serves the same purpose. In the circuit on the left of Fig. 29 A, the fluctuating electron current, which has passed through the grids, reaches the solid plate and passes on to the tuned circuit LC . When the periodic fluctuations of the electron

* Commander J. B. Dow, U. S. N., Proceedings of the Institute of Radio Engineers, Vol. 19, page 2095 (1931).

stream correspond to the natural frequency of the tuned circuit, they serve to supplant the losses in this resonant or tank circuit and keep it in oscillation. An important feature of this arrangement is that the upper grid is operated at ground r.f. potential, and hence acts as a shield between the output or load circuit coupled to LC and the oscillating circuit itself. In this way, variations in the load current are prevented from reacting upon the oscillator circuit and changing its frequency. We see in this circuit that the oscillator operates very much in the usual manner, but that the load circuit is "electron coupled" rather than direct, capacity, or magnetically coupled to it.

At the right of Fig. 29 A, an untuned output circuit is shown. In this case, the output voltage and power are lower, lacking the "build up" which a tuned circuit gives, but the plate circuit has better isolation from the oscillator, and hence the frequency stability is greater.

Ordinary tetrodes and pentodes can be used in these oscillators. With a pentode, the suppressor grid should be grounded and not connected to the cathode, in order to give additional internal shielding of the load circuit from the oscillator circuit.

Granting that the electron-coupled feature just described largely solves the problem of stabilizing frequency against load variations, we still have left the other possible influencing factors for consideration. First in importance among these is the Q of the tank circuit of the oscillator. This must be as high as possible. It can best be obtained by making the L/C ratio of the circuit as low as possible. The resistance of the circuit is to be made low by winding the coil with large wire and by using condensers in which the dielectric losses in the insulation are low. The effective Q of the circuit is increased by using a high value of grid-leak resistance and by using the least possible feedback which will maintain stable oscillations. Frequency stability will be greatest when the ratio of the plate to the screen voltage is about three to one. The plate supply should be free from ripple and may well be voltage-stabilized.

In order to maintain frequency stability, constant strength, and freedom from harmonics, oscillators of the type just described should not be built to deliver large amounts of power. They should be followed by power-amplifying equipment.

Mechanical vibration, which causes frequency instability, can be avoided by care in the constructional details as, for example, the use of short leads, heavy chassis and panel materials.

It will be noticed that in Fig. 29 A, the cathode is above ground potential for r.f. The chance for 60-cycle hum from the filament heating supply is reduced by means of the bypass condensers indicated.

29.2 Negative Resistance or Dynatron Oscillators. Any electrical device which has a "negative resistance" can be used as an oscillator.

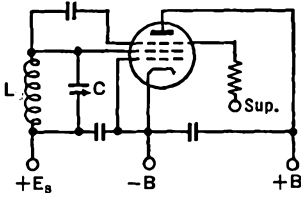


FIG. 29 B. A negative-resistance or "transitron" oscillator

An electric arc and a screen-grid tube have this characteristic. "Negative resistance" means that, as the voltage across the device *increases*, the current through it *decreases*, and vice versa. This is true over the region *AB* of Fig. 15 B, which shows the characteristic curve of a screen-grid tube. Throughout this region, the screen grid is more positive than the plate, and hence attracts not only electrons from the filament but also secondary electrons emitted from the plate. A tuned circuit may be connected in the grid circuit, as in Fig. 29 B. The grid electrons, accumulating on condenser *C*, lower the positiveness of the screen grid so that it captures fewer electrons. The condenser *C* discharges through *L* after which it refills, and the process starts over again. The rate at which the cycle occurs is determined by the resonant frequency of *LC*. The tuned circuit can also be in the plate circuit, but it is necessary in only one of the two positions. It might be said that, since the secondary electrons are alternately shifted back and forth from the grid to the plate, that this type of oscillator is *secondary-electron-coupled*.

29.3 Crystals for Oscillators. Figure

29 C shows a quartz crystal and Fig. 29 D shows the manner in which three types of cuts are made in it to yield suitable slabs for use in the frequency control of vacuum-tube oscillators. The cuts which are commonly used are designated as *X*, *Y*, *AT*, *V*, and *LD*. The first two mentioned can be made to oscillate easily and vigorously but their natural frequency of vibration changes *slightly* with temperature, whereas the latter three types have very low "temperature coefficients." The temperature coefficient

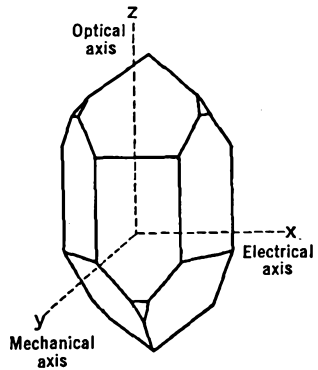


FIG. 29 C. A quartz crystal

is defined as the change of frequency of vibration, in cycles frequency change per megacycle, for each degree centigrade temperature change. If the frequency increases with temperature, the coefficient is said to be positive, and vice versa. Table 29 A lists the range of temperature coefficients for different crystals.

The frequency at which the crystals vibrate depends mainly upon the thickness of the cut, being inversely proportional to the thickness. Thus we may write, $f = k/t$, where f is the frequency in megacycles and t is the thickness of the crystal in thousandths of an inch. Values of the constant k are given in Table 29 A.

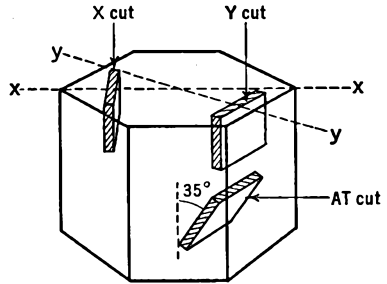


FIG. 29 D. Some crystal cuts

TABLE 29A, QUARTZ CRYSTALS

<i>Cut</i>	<i>k</i>	<i>Temperature Coefficients</i>
X	112.6	-15 to -25
Y	77.0	-20 to +100
AT	66.2	Near zero
V	Near zero

The crystal is placed between two metal plates. In one case the upper plate is pressed lightly against the upper surface of the crystal by means of a spring. In another case, a small air-gap is left between the metal plate and the crystal. In both cases, the metal plates must be quite flat. The pressure type of mounting offers greater rigidity, and hence may be used for portable or mobile installations. The air-gap mounting, however, can be used to advantage to change the frequency of oscillation over a limited range (about 5 kc. for a 3.5 Mc. crystal) by changing the length of the air-gap. This does not mean that the crystal itself has a different frequency of vibration, but that the crystal, together with the small series capacitance of the air-gap, has a slightly different frequency of vibration.

If the crystal vibrates with too great an amplitude, it will crack. The safe amount of radio frequency current which can pass through the crystal ranges from 50 to 200 milliamperes, depending upon the type

of cut. Small flashlight bulbs can be used in series with the crystal, their brightness indicating the r.f. current. And, by proper choice of the bulb, it can be used as a fuse, burning out before the crystal is damaged.

Quartz crystals have two, and sometimes three, widely separated possible frequencies of vibration. By utilizing the different modes of vibration, different crystals can be manufactured to oscillate at different frequencies throughout the range from 16 kc. to 30 Mc. For example, at the lower frequencies, say from 16 kc. to 250 kc., the crystals are cut as "bars," whose frequency of oscillations is largely determined by the length rather than the breadth or thickness. The bars are usually mounted upon knife edges located at the nodal points of vibration. For the very high frequencies, the crystals would be exceedingly thin and fragile unless special cuts were used or the circuits were made to oscillate at harmonic frequencies of the crystal.

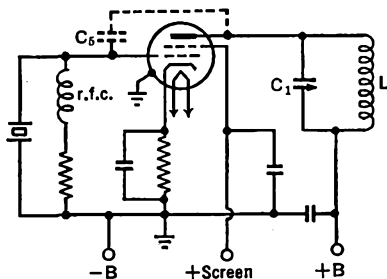


FIG. 29 E. A beam-tetrode crystal oscillator circuit

29.4 Crystal Oscillators. It is advantageous to use pentode or beam-tetrode tubes in crystal oscillator circuits (Fig. 29 E) because they have a high power sensitivity. This means that the power output will be large for a comparatively small grid voltage. The small grid voltage is necessary in order not to damage the crystal. With pentode tubes having a plate voltage of about 300 volts, 4 or 5 watts output will be obtained. Beam-tetrodes, such as the 6L6, will deliver about 15 watts when maximum plate voltage is used. The screen voltage is usually made from one-third to one-half that of the plate. Because the r.f. is grounded through a bypass condenser, the screen plays no part in the operation of the oscillator other than to set the operating characteristics of the tube. A feedback condenser C_5 (Fig. 29 E), of lowest

possible value for stable oscillation, will probably be required to give sufficient feedback for oscillation at the lower frequencies.

In order to adjust a crystal oscillator, a d.c. milliammeter is connected in series with the plate supply. The tuning condenser C_1 (Fig. 29 E) is then varied until the plate current dips as in Fig. 29 F. Maximum power is developed at the point A, but it is best to operate somewhere between B and C, where the oscillator is more stable and the crystal current is smaller. The dotted curve of Fig. 29 F is for the case when the oscillator is delivering power. The dip will be less pronounced the greater the load. The crystal current, and hence its heating, the cause of breakdown, will be less when the oscillator is loaded, than when it is unloaded.

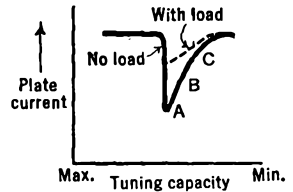


FIG. 29 F. Adjustment of a crystal oscillator

Figure 29 G shows another type of quartz-crystal oscillator which does not require tuning control. It is the equivalent of the ultraudion circuit, with the tuned circuit replaced by the crystal; or of a Colpitts oscillator with the crystal displacing the tank coil inductance. Condensers C_1 and C_2 are in series with the crystal, from the plate to the cathode. Hence these condensers determine the feedback. As tuned tanks are not used in this simple circuit, a wide range of frequencies, one for each crystal used, can be obtained without serious change in the circuit values. The circuit is limited to low power outputs, and must be carefully adjusted to avoid damaging the crystal.

29.5. The Tri-tet Oscillator. Figure 29 H shows the circuit of an oscillator in which the same tube is used both as a triode and as a tetrode. It is a combination of the triode crystal oscillator (Sec. 14.7) and

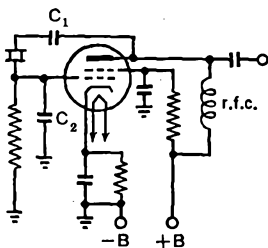


FIG. 29 G. The Pierce crystal oscillator

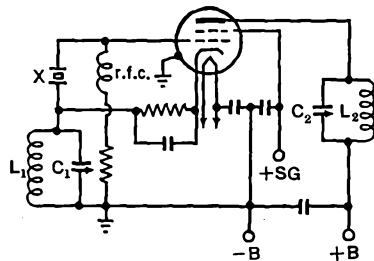


FIG. 29 H. A tri-tet oscillator circuit

the electron-coupled oscillator (Sec. 29.1). The output circuit L_2C_2 is electron coupled to the oscillator and electrostatically shielded therefrom by the suppressor and screen grids. One of the outstanding features of this oscillator is that the tank circuit L_2C_2 can be tuned to either the fundamental crystal frequency or one of its multiples. The cathode tank circuit L_1C_1 is tuned to a frequency somewhat higher than that of the crystal.

The tuning procedure for this oscillator is very much like that of the previously described crystal oscillators. The plate current dip however is symmetrical. After initial adjustment, the cathode con-

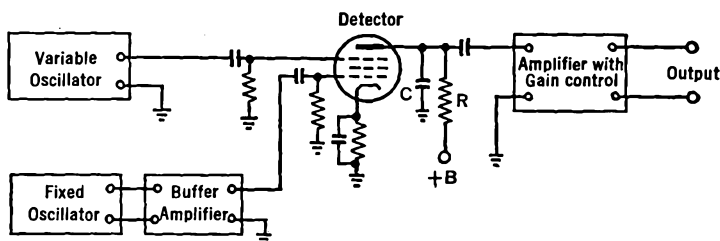


FIG. 29 I. A beat-frequency oscillator

denser C_1 is to be readjusted to obtain maximum power output. Its value should be as small as possible in order to prevent overheating the crystal.

29.6 Beat-Frequency Oscillators. In Fig. 29 I, the voltage output from two oscillators is fed into a common detector. The result is a "beat-note" whose frequency is equal to the difference in frequency between those of the two oscillators. This can be understood from Fig. 29 J. By simple addition, point by point, of the voltages of the two oscillators, the detector's input voltage can be plotted, as in the third curve from the top. It will rise and fall at the difference-frequency previously mentioned. Because the detector passes only the positive half-cycles, and because condenser C (Fig. 29 I) bypasses the higher frequency pulses, the voltage fluctuations across R follow only the average, rectified curve (dotted line Fig. 29 J) of the input voltage (as indicated in the fourth curve down from the top of Fig. 29 J). The fluctuating voltages across R are passed through a condenser to the amplifier and on to the output circuits.

Suppose the frequency of the fixed oscillator of Fig. 29 I were

established at 200,000 cycles per second, while that of the variable oscillator was changed (by varying its tank condenser) from 200,000 to 210,000 cycles per second. Then the beat-frequency heard in a loud-speaker connected to the output terminals would change from zero to 10,000. Thus, with a single dial control on the condenser of the variable oscillator, the entire audio band can be covered.

When the two oscillators have nearly the same frequency, they tend to "pull-in," the stronger one forcing the weaker one to assume its frequency. This tendency can be overcome by use of a buffer-amplifier (which is just like any other amplifier covering the proper frequency range) and by injecting the two oscillator voltages into the detector on two separate grids, with a screen grid between, as indicated in Fig. 29 I.

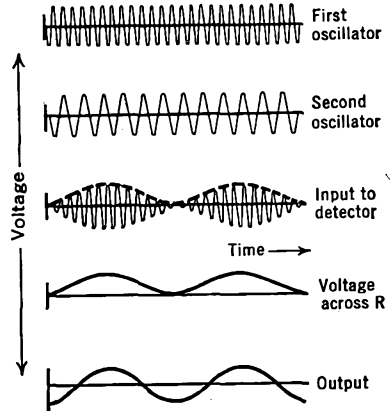


Fig. 29 J. Principle of beats

The production of beats is referred to as a *heterodyne* process. *Hetero* means to mix and *dyne* is a unit of force; hence — a mixture of the outputs of the two oscillators.

Suppose the fixed frequency was 1,000,000, and the other frequency was 1,000,401 cycles per second. The beat-note would have a frequency of 401 cycles per second. Let this be beat a second time against a 400-cycle oscillator. The *second beat-note* would be 1 cycle per second. Now change the variable oscillator by only one part in a million, to 1,000,402. The second-beat would change from 1 to 2 cycles per second, a very noticeable difference. It does not require a very large change in the capacitance of an oscillator to shift its frequency by this small amount. If the plates are moved closer together by one one-millionth of an inch, the change can be detected. Any other shift in the variable oscillator, in its capacitance, resistance, inductance, or voltages can be observed with equal delicacy.

29.7 Phase and Voltage Considerations. There are three necessary conditions for oscillation: (1) an amplifying device such as a vacuum tube; (2) sufficient yet not too much feedback action; (3) proper polarity of the feedback.

In order to understand the phase or polarity relationships, let us imagine that the grid of an oscillating tube becomes more positive than its normal d.c. operating value. This will cause an increase in the plate current. This causes a potential drop across the plate load (for example, the tickler coil of the circuit shown in Fig. 14 A). The end of the load connected to the plate of the tube will become less positive. When the grid potential goes toward positive, the plate potential decreases, and vice versa. This may be stated in different words: namely, the grid and plate fluctuating voltages are 180° out of phase with re-

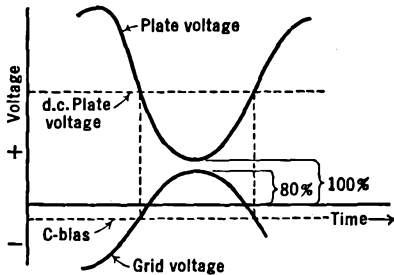


FIG. 29 K. Voltages on the plate and grid of an oscillating vacuum tube

spect to each other. This is illustrated in Fig. 29 K. It is to be recalled that the plate current is a maximum at the same instant that the plate voltage is a minimum. It is at this time that energy from the plate battery is given up to the oscillating circuit. It is also to be noted that the grid of the oscillator becomes positive, and that a certain amount of grid current flows. For optimum operating conditions, the peak value of the grid voltage should amount to approximately 80 per cent of the minimum value of the plate voltage.

29.8 Harmonic Distortion versus Feedback Voltage. If a C-bias voltage is used instead of a grid condenser and resistor, it is necessary to adjust its value to a proper operating point on the characteristic curve of the tube in order to avoid distortion of the wave-form of the oscillations. For example, if the grid bias is adjusted to too high a value, and if the voltages fed back from the plate to the grid are strong, the lower halves of the plate current will be cut off. This unsymmetrical wave-form is equivalent to an alternating current of a certain frequency, plus harmonics of that frequency, plus a d.c. component of cur-

rent. Under these conditions, a d.c. milliammeter in the plate circuit will show an increase when the oscillations start. On the other hand, if the grid is not sufficiently negative, and if the feedback voltages are large, the tops of the plate current curves will be squared off at saturation. This is also due to the fact that the positive grid extracts electrons from the plate current. Then, a d.c. meter in the plate circuit will decrease when oscillations start. Again, if the grid bias is properly established, near the center of the characteristic curve, but the feedback voltages are very strong, the tops and bottoms of the plate current will be squared off; the oscillations will not be of pure sine-wave form, but will contain harmonics. The maximum amplitude of currents in the plate circuit is obviously equal to one-half the saturation or emission current.

The discussion of large-amplitude oscillation given in the preceding paragraph must not be applied to transmitters where the tuned couplings strengthen the fundamental and reject harmonics born of distortion. This is also the case in frequency meters, where the harmonics are useful rather than detrimental.

29.9 Power Output and Plate Efficiency. The power output is defined as the useful a.c. power consumed by the load connected to the oscillator. The plate efficiency is defined, as in the case of amplifiers, as the ratio of the output power to the d.c. plate input power. For oscillators, the efficiency is usually about 50 per cent; a low value because the oscillator has an appreciable grid current.

29.10 Frequency Stability. A low L/C ratio and a light load tend toward greater stability of the frequency of an oscillator. Also, it is desirable to use a comparatively high value grid leak and a relatively high plate voltage.

Temperature changes, because they take place slowly, cause the frequency to *drift*. Mechanical vibrations will cause the frequency to change at corresponding rates.

29.11 Constant-Current Systems. Our commercial power supply system is built in such a fashion that the voltage remains constant regardless of the current load upon it. The lights in a house may dim a little if we draw too much power, but this is due to the voltage drop along the feed wires. The voltage of the generators at the powerhouse is constant at about 115 volts.

There are certain applications which require the current to remain constant despite changes in the resistance of the load. The voltage

may go up or down, but the current must be constant. This is the case with the power supply of high-powered oscillators, and with certain applications of arc lamps.

Figure 29 L shows circuits whereby a constant-voltage system may be transformed into a constant-current system. The reactances of the inductance L and of the capacitance C are made equal to each other at

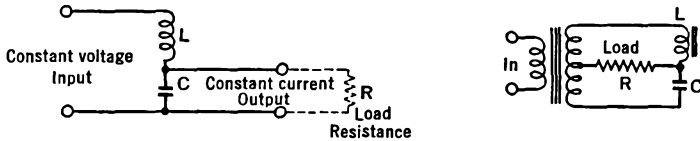


FIG. 29 L. Circuits for changing from a constant-voltage supply system to one of constant output current under varying loads

the supply frequency, i.e., $2\pi fL = 1/2\pi fC$. When the output resistance R is small, the voltage across it decreases, but the current through it remains constant, and vice versa. A short-circuited load is not dangerous but an open circuit will develop high voltage, and perhaps puncture C . The constancy of the current is vitiated somewhat by the fact that the coil has resistance as well as inductance and by the fact that its inductance changes slightly when different currents pass through it.

CHAPTER 30

SOME SPECIAL CIRCUITS

30.1 Square Waves Produced by Clipper Action. Suppose a comparatively large sinusoidal voltage is applied to the grid of an amplifier tube. When the grid goes negative beyond the cutoff point, plate current ceases to flow and the bottoms of the sine curve are clipped or squared off. When the grid goes positive to the saturation region beyond the upper knee of the characteristic curve, the plate current is limited and the tops of the sine curve are clipped off.

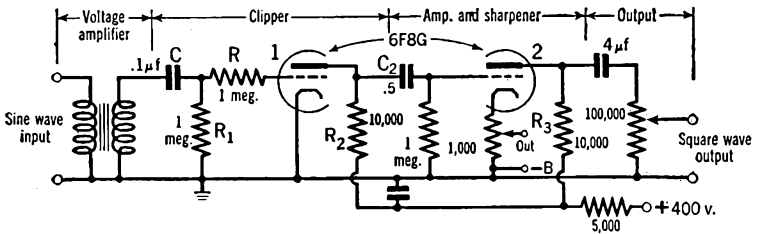


FIG. 30 A. A circuit for changing 60-cycle sine waves into 60-cycle square waves by clipper action. (Martin, *Electronics*, July 1941)

When sharp cutoff tubes are used, the bottoms of the sine waves are squared off with reasonable sharpness. On the other hand, the tops of the waves are not sharply squared off because of the grid current which flows when the grid goes positive and extracts electrons from the plate circuit, as well as develops a C-bias across the input resistors.

Figure 30 A shows a circuit which gives both square tops and bottoms. A comparatively large sinusoidal potential of 166 peak volts from the 60-cycle line is applied to the grid of the first half of the twin-diode tube 6F8G. During the positive half-cycle, the grid would become very positive were it not for the resistor R . When the grid becomes slightly positive, grid current flows through R (and through the usual grid resistor R_1). Then a negative voltage is developed on the

grid which acts as a variable C-bias as in Fig. 30 B to limit the positive voltage on the grid. The resultant plate current then has a slightly rounded top as shown in the figure.

During the negative half-cycles, electrons on the grid condenser, C of Fig. 30 A, flow to ground through resistor R_1 and develop a C-bias of essentially constant amount, as indicated at C in Fig. 30 B. The constancy is due to the fact that the discharge time of C through R_1 (0.1 sec.) is large compared with the period of the input voltage.

When the grid of tube 1, Fig. 30 A, goes positive, its plate current rises, the upper end of R_2 becomes more negative, and this voltage

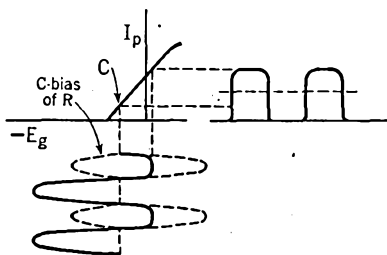


FIG. 30 B. Action of the first tube in Fig. 30 A

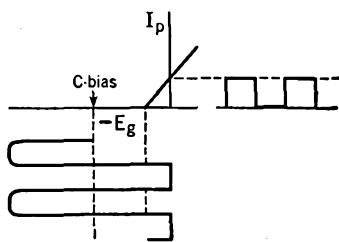


FIG. 30 C. Action of the second tube in Fig. 30 A.

change feeds through C_2 to the grid of tube 2. In other words, there is a phase reversal of 180° between the plate current of 1 and the grid voltage of 2.

The time it takes to discharge C_2 through the grid leak of the second tube is chosen quite long so that a comparatively fixed and large C-bias is established on 2, as indicated in Fig. 30 C. Its value is controlled by the strength of the input voltage and is such that the positive peaks just drive the grid of 2 slightly positive.

Note, in Fig. 30 C, that only the square bottoms of the plate current of the first tube are used to give plate current in tube 2. Hence both the tops and bottoms of the current through R_3 are sharply square. Note, also, that the time constant of the output circuit is very large, so as to retain this squareness.

30.2 Square Waves Produced by Blocking Action. In Fig. 30 D, the 110-volt, 60-cycle current is rectified by the 6H6 tube and develops a direct pulsating voltage across R_1 . The 6SJ7 tube operates with zero bias. The strong negative pulses from R_1 drive its plate current to zero, i.e., block the tube. The resultant voltage changes across R_2 are

of reasonably square wave-form. With a large time constant RC in the output circuit, this wave-form appears across the output terminals. R can be 100,000 ohms and C can be 4 $\mu\text{fd.}$, as in Fig. 30 A. Obviously both of the square-wave generators just described can be operated at other than 60 cycles by suitable changes in the various circuit constants.

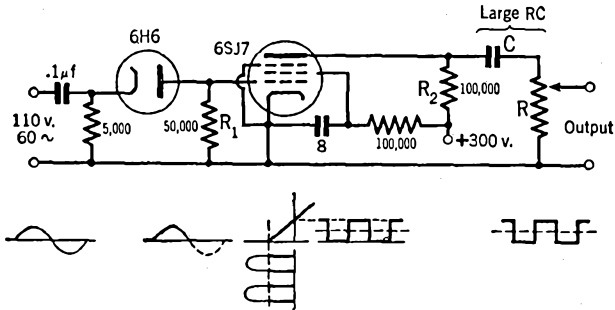


FIG. 30 D. A circuit for changing 60-cycle sine waves into 60-cycle square waves by blocking action. Sharp pulses will be obtained if the time constant RC is made very small

30.3 Square Waves Produced with a Multivibrator. The multivibrator circuit, as is well known, develops an irregular wave-form which is rich in harmonics. See Sec. 14.8. With proper C-bias on the tubes, the output can be made to approximate a square wave-form. A circuit for this purpose is shown at the left in Fig. 30 I, and is discussed in Sec. 30.8.

30.4 Testing Amplifiers with Square Waves. The human ear distinguishes one sound from another by the pitch and intensity not only of the fundamental, but also of the various overtones, i.e., by the shape of the composite wave-form. Although a plot of the db. gain over the audio-frequency range serves as some indication of the faithfulness of an a.f. amplifier, it does not tell the whole story. The phase shift, as will be recalled, of an R - C coupled amplifier is approximately 180° per stage. But it is not exactly 180° , nor exactly the same for all frequencies. Since some frequencies are shifted differently from others, the wave-form is not retained, even though the amplitude response is flat over the entire range. Square waves, which are rich in harmonics, offer a simple and rapid means of testing both the amplitude response and the phase shift in a single test. If a square wave is sent into the amplifier and a square wave comes out (as seen on a cathode-ray tube,

for example), the wave-form has been preserved and the amplifier is a good one. It is to be noted, in choosing a suitable fundamental frequency for the test, that square waves contain only the odd harmonics, $f, 3f, 5f$, etc., and not the even harmonics, $2f, 4f$, etc.

30.5 Pulse Generators. The blocking circuit of Fig. 30 D may be used to generate a succession of sharp pulses if the time constant RC of the output circuit is made small ($R = 10,000$ ohms, $C = 0.001 \mu\text{fd.}$).

The voltage changes across R_2 of this circuit are shown at (a) in Fig. 30 E. When the plate current of the 6SJ7 tube suddenly drops to zero, the upper end of R_2 rises in potential where it remains while the tube is blocked. The sudden positive pulse on the left plate of C draws electrons to its right-hand plate at time 1 (Fig. 30 E). During the time the tube is blocked, these electrons leak off of C through R , at a rate depending upon the product RC (the time constant). The smaller the RC product, the faster C discharges through R , and vice versa. This flow of current through R gives a potential drop across R of the same shape as that of the discharging current. This is indicated at (b) in Fig. 30 E for the case when RC is small; at (c) when RC is of medium value and at (d) when it is large.

If desired, an additional rectifier can be used after the circuit of Fig. 30 D to eliminate the negative or the positive pulses. Also, if short square-topped pulses are desired, the sharp-pointed pulses may be amplified and applied to a "limiter" tube so that their peaks are squared off.

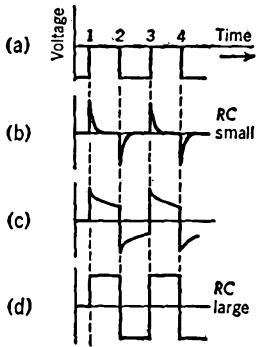


FIG. 30 E. Output waveforms from the circuit of Fig. 30 D as RC is changed

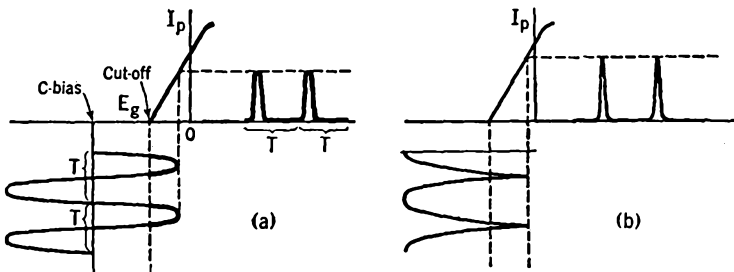


FIG. 30 F. The biasing method of producing sharp pulses

Instead of producing pulses by applying square waves to an RC circuit, as just described, a second method may be used where a sinusoidal e.m.f. is applied to the grid of a tube biased way beyond cutoff, so that only the tips of the applied wave cause plate current to flow. This is illustrated at (a) in Fig. 30 F. With this biasing method, pulses of from 100- to 500-microseconds duration can be produced, spaced at small or large time intervals T one from the other. A circuit for this purpose is shown in Fig. 30 G, where the tube at the left is biased well beyond cutoff. It will be noted that the resistor R is connected at P

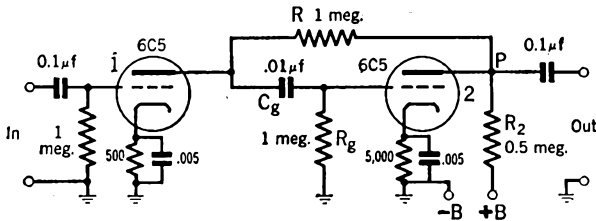


FIG. 30 G. Biased-tube method of producing pulses

instead of at $+B$, as in the usual amplifier circuit. Then, when a pulse of current flows through R and R_2 , the added voltage drop across R_2 assists in sharpening the pulse.

In another circuit, the pulses may be sharpened to only a few microseconds width by applying the output of a full-wave rectified sine wave (through a phase-inverting tube) to a highly biased amplifier tube, as indicated at (b) in Fig. 30 F.

30.6 Some Applications of Pulses. A saw-toothed wave-form may be produced by sending pulses into the input of the circuit of Fig. 30 H. Tube 1 is normally biased to cutoff. The positive pulses e_1 charge C quickly through R_1 . After the brief charging, C empties slowly through R . For a reasonably linear sweep, the time constant RC must be great in comparison with the time between pulses. The output current i can be used in the magnetic deflecting coils of a cathode-ray tube for television purposes. The flyback time is t_1 and the scanning time is t in the figure.

In the pulse method of Breit and Tuve, for measuring the height of the ionosphere, short pulses are radiated from a transmitter. A nearby receiver picks up the direct pulse almost immediately, and then the echo pulse returning from the ionosphere at a later time. The

time delay between the two pulses is measured with a string or cathode-ray oscillograph and is a direct measure of the "virtual" height of the ionosphere above the earth. Similarly, pulses from an airplane, reflected from the ground, can be used to measure its altitude. Indeed, the distance out to any object capable of reflecting the pulses can conceivably be measured in this fashion.

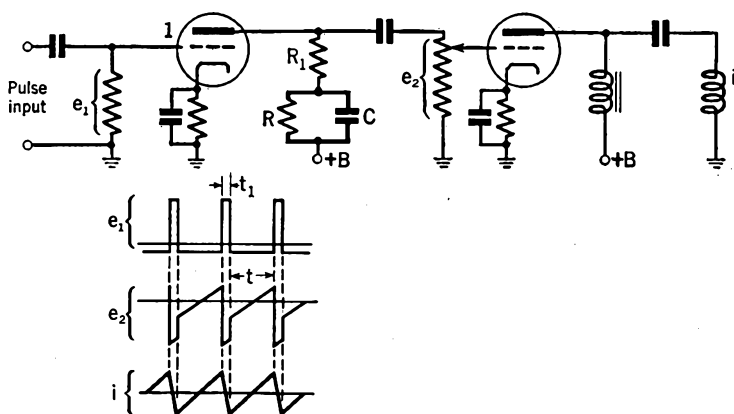


FIG. 30 H. Pulses are converted into saw-toothed waves with this circuit

A direct measurement of the velocity of radio waves over short paths has been made¹ by sending out pulses from a fixed station. These were received at a portable station and re-radiated back to the first station. The time delay represented that taken by the radio wave in traveling twice the distance to the mobile station plus the delay time in the electrical circuits. The latter was eliminated by taking observations with the portable unit at two different known distances. The velocity of radio waves was found to be 2.985×10^{10} cms. per sec., which is in essential agreement with that of light.

30.7 Counting Pulses. There are many occasions which demand the counting of a succession of events which occur rapidly one after the other, such as the number of packages passing a given point each second along a conveyer belt, or the number of atmospheric static pulses picked up in a receiver each second, or the number of smashed fragments of an atomic disintegration, or the number of alternations in a cyclic current (frequency counting), etc.

¹ Proceedings of the Institute of Radio Engineers, March 1942.

A simple thyratron counting circuit was described in Sec. 19.1.

The impulses which are to be counted may come from a microphone, a photocell, a manually or motor operated switching device, an iconoscope, a Geiger-Mueller tube (detecting elementary atomic particles), the power supply line, an audio oscillator, etc. The pulses may be of constant amplitude and equally spaced; they may be of constant amplitude and irregular spacing; of variable strength but constant spacing; or they may be entirely random in nature.

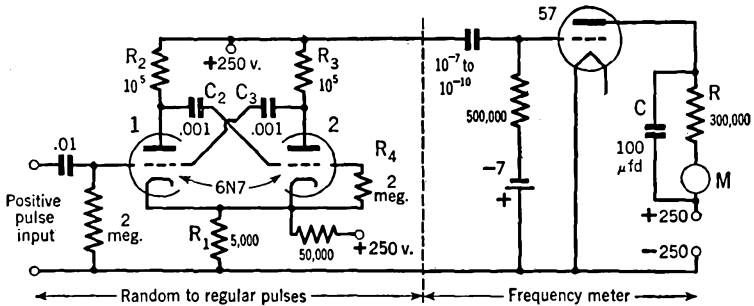


FIG. 30 I. A circuit to convert random pulses into uniform pulses. Also, a frequency meter. (See *Rev. Sci. Inst.*, Dec. 1936)

30.8 A Circuit to Convert Random Pulses into Uniform Pulses. The left half of the circuit of Fig. 30 I will convert random pulses of from 30 to 3,000 counts per minute into pulses of uniform length and amplitude. It is basically a multivibrator, but possesses one marked difference from the usual form of this circuit; namely, that the grid of tube 1 (part of a 6N7 tube) is biased negatively beyond cutoff, whereas the grid of tube 2 is at the more usual zero bias voltage. This is accomplished by passing current from the B supply through R_1 via the 50,000-ohm resistor. Thus, at the start, 1 is off and 2 is on. A positive pulse on the grid of 1 trips this tube, current flows through R_2 , reducing the voltage on the plate of 1. This sends a negative pulse through C_2 onto the grid of the tube 2. The plate current through 2 is thereby reduced and its plate voltage increased. This positive pulse passes through C_3 to the grid of 1, augmenting the original input pulse. The interaction continues until the plate voltage on 1 is very small. The circuit remains in this condition until the charge on C_2 leaks to the cathode through R_4 . When the grid of 2 reaches a certain critical voltage, the entire process reverses itself to restore the original conditions (1 off and 2 on).

Thus an input pulse of any size or duration (within limits) initiates a series of events wherein 2 is turned off and then back on again sharply after a definite time interval determined by the circuit constants and not by the input pulse. The resultant potential variations across R , and across the output terminals shown in Fig. 30 I, are of square wave-form.

30.9 A Frequency Meter. The circuit on the right of Fig. 30 I can be used to indicate the average number of impulses received at its input each minute provided the impulses are of a uniform and not of a random nature. The pulses of current sent through R are smoothed out by condenser C so that the reading of the meter M is an average value. Note that the time constant RC is very large (30 sec.).

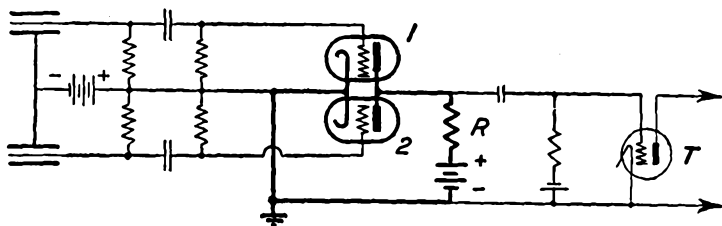


FIG. 30 J. A coincidence counter circuit. (From E. & N. P.)

30.10 Coincidence Counters. The principle of a coincidence-counter circuit may be understood from Fig. 30 J. At the left there are two G - M counter tubes, but any other sources of pulses can be used. It is seen that, by means of resistance-capacitance coupled amplifiers, the impulses are applied to the grids of two tubes (labeled 1 and 2). Of major importance, note that the output plate circuits of these two tubes are connected in parallel. Voltage changes across R are coupled to a thyratron tube in whose output plate circuit some kind of mechanical counting device has been installed. At the start, the grid of the thyratron T is highly biased so that its plate current is zero.

When impulses are applied to just one of the two joint circuits, say the upper one, the plate current in tube 1 is momentarily interrupted. The voltage drop in R is such that its upper end becomes less negative by a certain amount. However, with tube T adjusted well below its starting voltage, the small impulse across R proves insufficient to start its plate current.

On the other hand, if impulses occur *simultaneously* in the two input circuits, due perhaps to the passage of a single particle through the

two *G-M* tubes or perhaps to the incidence of light simultaneously upon two photoelectric cells located at these points, then the plate currents of both tubes are reduced at the same time and the voltage drop across *R* becomes sufficiently great to start a current in the plate circuit of *T*, operate a recording mechanism and give a coincidence count.

Due to the necessary time for the various condensers in these circuits to discharge through their various resistors, the exact simultaneity with which the events occur at the input cannot be established closer than about 1/10,000 of a second.

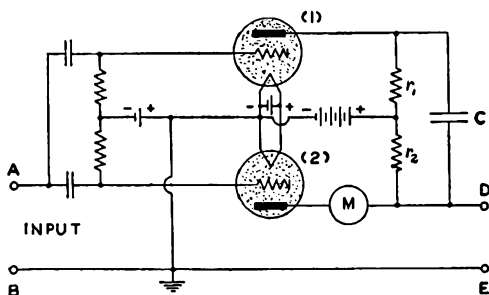


FIG. 30 K. A scale-of-two counter. (From E. & N. P.)

30.11 Scaling Circuits. It is sometimes desired to count a succession of impulses occurring more rapidly than can be followed by even the most delicately constructed mechanical counter. Then one may use a modification of the inverter circuit so that the mechanical counter is operated by every other input impulse. Such circuits are consequently called *scale-of-two* circuits. Furthermore, by cascading a number of scale-of-two circuits, scale-of-four, -eight, -sixteen, and -thirty-two counters have been built. In the last case the mechanical counter's reading is to be multiplied by thirty-two to give the actual input number of impulses.

Referring now to Fig. 30 K, at the start the gas-filled triode, 1, is conducting while 2 is shut off. The plate current of 1, flowing through r_1 , has produced an ir drop which charged *C* positively on the bottom plate and negatively on the top plate. An impulse at the input, which makes *A* positive, does not alter the plate current of 1, but does make the grid of 2 less negative, so that, if 2 were nearly ready to strike before the pulse came in, it will be turned on by the impulse. When 2 is turned on, the mechanical counter *M* is operated and an ir drop is pro-

duced across r_2 , with positive at the top and negative at the bottom, which is the reverse of that across r_1 . For a moment then, the drop across r_2 drives a current through r_1 into C , producing a total voltage across r_1 which is so great that, subtracted from the battery voltage, the plate voltage across 1 falls to zero or even to a negative value. Thus, by this indirect action, the process of starting tube 2 and reversing the polarity of condenser C , automatically shuts off tube 1.

A second impulse, positive on A , starts tube 1 and, in so doing, shuts off tube 2, resetting meter M . Thus the meter counts every other impulse.

When several scale-of-two circuits are connected in cascade and the counting rate becomes very high, the necessary de-ionization time

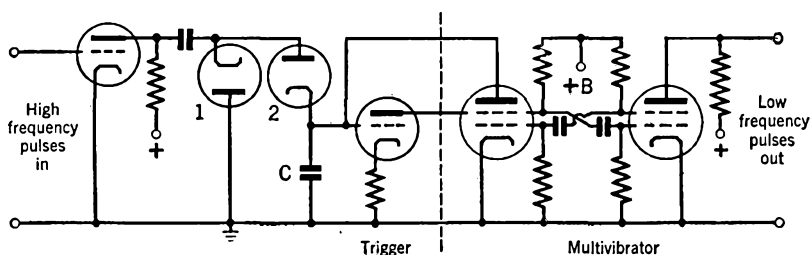


FIG. 30 L. A frequency divider. (See *R.C.A. Rev.*, p. 57, July 1940)

of the first stage gas-filled tubes limits the frequency response of the unit. In addition, gas-filled tubes are notably subject to temperature variations. Hence it has been considered desirable to devise a scale-of-two circuit, using vacuum rather than gas-filled tubes. A circuit of this type² is described in the next section.

30.12 A Frequency Divider. In the circuit of Fig. 30 L, a rapid succession of square pulses is sent in at the left and a slow succession of square pulses is given out at the right. The output pulse rate is a definite sub-multiple of the input rate. The operation of the circuit is as follows: Negative halves of the input pulses are shunted to ground by the diode 1. Positive pulses pass through diode 2 into condenser C . The trigger tube is biased well below cutoff. When a sufficient number of positive pulses have entered C to raise the potential of the trigger tube to cutoff, its plate current starts to flow. This causes the multivibrator to produce one pulse. The number of pulses which had to be

² See also *Review of Scientific Instruments*, 8, 414 (1937).

sent into C to cause this one pulse is the frequency-division-number. Note that the second grids of the multivibrator serve as the usual plates and that the actual plates are used, one for the output circuit, the other to pass electrons back to C to neutralize its charge and restore the initial conditions.

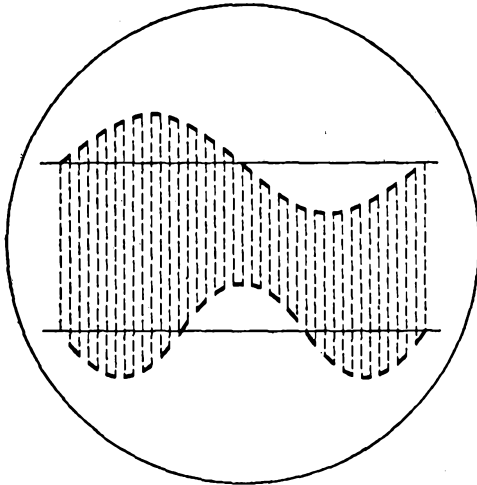


FIG. 30 M. Double tracing on a single-beam cathode-ray tube

30.13 Electronic Switches. It is possible to use electron tube circuits instead of hand-operated switches or motor-driven devices to connect alternately first one and then another input signal to a common circuit. As an example, we may consider the simultaneous observation of two different wave-forms on a single cathode-ray screen. Now there are special cathode-ray tubes with two and even three separate beams (and deflecting plates) in a single glass envelope operating onto a single fluorescent screen. With a switch, however, a single-beam tube may be used to compare two wave-forms by alternately switching the vertical deflecting plates from one input to the other in rapid succession. This is called *double-tracing*. If the switching is accomplished slowly, each wave-form appears as a dotted line, as in Fig. 30 M, whereas, if the switching occurs with sufficient rapidity, the traces appear to be essentially solid lines.

The circuit diagram of a particular electronic switch is shown in Fig. 30 N. A sinusoidal wave applied at S is amplified and then

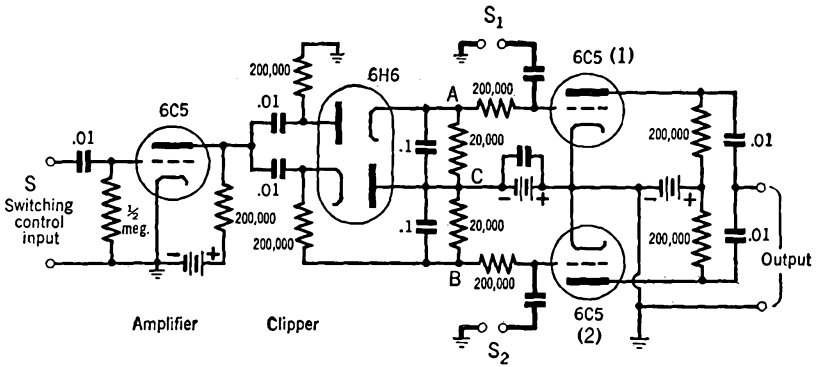


FIG. 30 N. An electronic switch

clipped by the twin diode 6H6. Thus positive half-cycle square-waves appear across *AC* and negative half-cycle square-waves across *BC*. The 6C5 tubes on the right are biased at or beyond cutoff. When the input from 6H6 makes 1 conductive, a signal at *S*₁ will pass on to the output terminals. When the input from 6H6 makes 2 conductive, a second signal at *S*₂ will go to the output but, since 1 is non-conducting at this time, the signal at *S*₁ does not go out. Thus, signals at *S*₁ and *S*₂ are passed on, alternately, and at a rate of succession determined by the frequency of the switching control *S*.

In other electronic switches,³ multi-grid tubes are used instead of the 6C5 tubes at the right of Fig. 30 N, so that the input signals from *S*₁ and *S*₂ can be injected on separate grids from those which un-bias the tubes. Also, a multivibrator circuit is sometimes used instead of the clipper-tube to generate the square-waves for un-biasing the switching tubes.

30.14 An Interval Timer. Time intervals ranging from 0.001 to 0.2 second have been measured with the circuit of Fig. 30 O with an

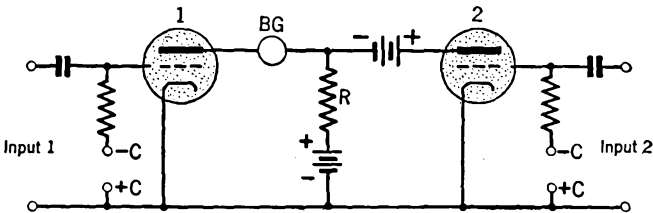


FIG. 30 O. An interval timer

³ See Review of Scientific Instruments, April 1941.

accuracy of 1 per cent. At the start, the gas-filled tubes 1 and 2 are biased by their *C* batteries below the striking voltage so that no plate current flows in either tube. A positive impulse on the grid of 1 starts its plate current. Shortly thereafter, a second impulse on the grid of 2 starts its plate current. The total current from both tubes, flowing through *R*, sets up a sufficiently large *IR* drop to lower the plate potential of 1 below zero and stops its current flow. The deflection of the ballistic galvanometer *BG* is proportional to the total quantity of electricity *Q* which surges through it during the time interval (*t*) between the two pulses ($Q = It$). The circuit locks out and cannot be excited by a second set of events until the plate current of 2 is turned off with a switch. The input pulses may come from photocell, microphone, counter-tube, or other pick-up device, so that a wide variety of timing applications are possible.

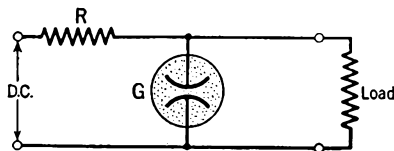


FIG. 30 P. A glow-tube regulator

30.15 Voltage Stabilizers. There are many cases in receivers and transmitters where it is necessary that the voltage of the power supply unit remain constant even though large changes occur in its output load or in its input voltage. For small voltages and currents, glow-tubes may be used, as in Fig. 30 P. The nature of the discharge through the gas in the tube *G* is such that, when an attempt is made to raise the voltage across its electrodes, more current passes through but the voltage drop retains its original value. This constancy is only true over a limited range of voltages for any one tube, so that various tubes must be used for stabilizing various voltages. For example, the VR 150-30 tube regulates voltages in the neighborhood of 150 volts. The number 30 refers to the maximum current in milliamperes which can be passed through the tube without shortening its life. If the series resistor *R* in Fig. 30 P is as small as 3000 ohms, the voltage control of the VR 150-30 will be limited, whereas, if *R* is 20,000 ohms or more, the control range around 150 volts will be much greater. The control feature is lost if the current through the tube falls below 5 ma. Two or more glow-tubes may be connected in series to handle larger

voltages. Taps may be taken off between the glow-tubes to obtain various desired voltages.

Figure 30 Q shows a circuit which will stabilize at 300 volts to within 1 volt for line or load changes of 25 per cent. The regulator tube acts like a series resistor. Its resistance is changed by the grid-

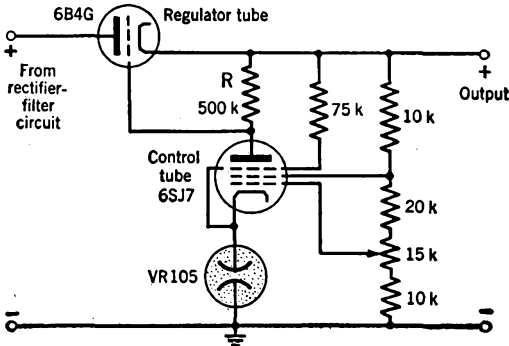


FIG. 30 Q. A voltage stabilizing circuit. ($k = 1000$ ohms)

bias change developed across R by the plate current of the control tube. In turn, the change of resistance of the regulator tube changes the voltage across the control tube and hence its plate current. Thus, if the voltage at the top of R should increase, the bias voltage and the internal resistance of the regulator tube will be increased and the voltage at the top of R will return to its proper value. The remainder of the circuit serves to apply the proper voltages to the grids of the 6SJ7 tube to assist in the stabilizing action. The constant voltage drop across the VR 105 glow-tube maintains the cathode of the control tube at a fixed voltage above ground.

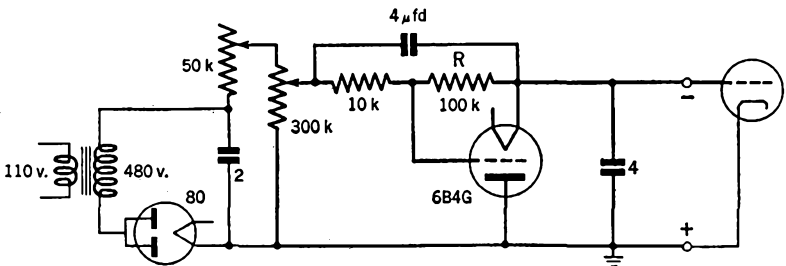


FIG. 30 R. A voltage-stabilized C-bias supply circuit. ($k = 1000$ ohms)

The grid current of a tube flows, in the conventional sense, from the grid to the cathode. Hence, the current flow from a C-bias pack is in the reverse direction to that from a B power supply. In the circuit of Fig. 30 R, the grid current through resistor R makes the grid of the regulator tube 6B4G go positive, which lowers its internal resistance. Thus the regulator tube acts as a variable bleeder resistance across the output of the rectifier circuit and automatically maintains a constant output voltage. In the circuit shown, changes of the 300,000-ohm resistor (rough adjustment), and the 50,000-ohm resistor (fine adjustment), give voltages from 100 to 600. The maximum grid currents permissible for these voltages are 100 ma. and 25 ma., respectively.

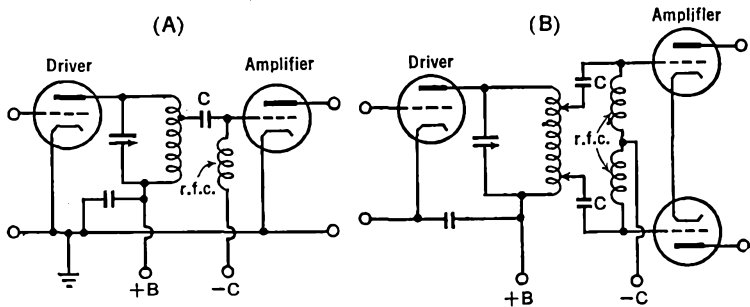
CHAPTER 31

TRANSMITTERS

31.1 Introduction. In preceding chapters, the component parts of transmitters have been presented in some detail. Here, the method of linking oscillators, amplifiers, modulators, antennas, and microphones into a single unit, called a transmitter, becomes the main problem; together with observation of any new phenomena which result from the mutual influence of these parts upon each other. In a broad way, we realize that the transmitter must contain an oscillator in order to generate currents whose frequency is sufficiently elevated that appreciable electromagnetic radiation can take place from a suitably designed antenna, and that some means must be devised to add human intelligence to the emitted energy. Our transmitter (of the amplitude modulated type) must be so designed and adjusted that its frequency will remain constant; also the carrier wave, when unmodulated, must not change in amplitude. In other words, we desire stable output. If we attempt to devise a single oscillator of great power, we find a unit which is beautifully flexible, but not particularly stable. Hence it has become recognized that a more satisfactory plan is to use a very low-power oscillator, with inherent self-stability, followed by either straight amplifiers and/or frequency multiplying stages. Between the oscillator and the frequency multiplier, it is found necessary to introduce a *buffer amplifier* to prevent interaction of the load upon the oscillator.

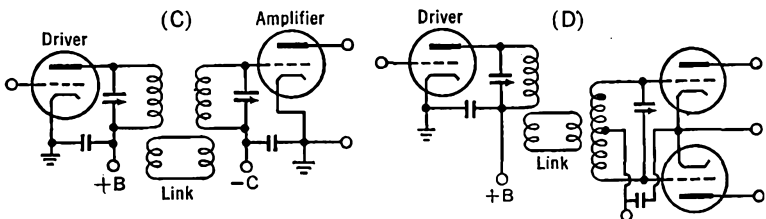
In planning a transmitter, one of the first steps is to choose the frequency at which the oscillator is to be operated. The circuit, the tube or tubes, and the numerical values of the component parts can then be determined. The second step in planning the transmitter is the choice of the output power of the entire unit. This, of course, fixes the requirements of the final amplifier stage. For this stage, a suitable circuit is chosen, and a suitable tube capable of handling the desired power. From the tube manufacturer's data one can determine the required grid driving-power. This sets the requirements for the preceding stage. The design is then followed, stage by stage, back to the

low-power "master" oscillator. If the intelligible message is to be transmitted by means of code signals, it is necessary to decide at what point, and how, to break the carrier wave up into the dots and dashes. This is generally accomplished at a low-power stage in the transmitter. On the other hand, if the communication is to be carried on by means of a phone, one must plan the point at which the modulator tube ties into the radio frequency assembly. If the speech amplifier has but small output, then *low-level modulation* must be used. It is often common practice, however, to modulate the r.f. at or near the final amplifier stage (*high-level modulation*); in which case the speech amplifier must of-itself have considerable output power.



FIGS. 31 A and 31 B. Direct, capacity-coupling between a driver and an amplifier

31.2 Interstage Coupling Methods. There are two commonly used methods of coupling between stages in a transmitter. These are of the capacitive and link methods mentioned in Sec. 7.1. Typical circuits are shown in Figs. 31 A, B, C, D, and E. In the first two, the condenser *C* serves as a coupling device and also as a blocking condenser to keep the d.c. plate voltage of the driver off the grid of the amplifier stage. The amount of voltage exciting the amplifier can be controlled by moving the tap on the driver's tank coil. In Fig. 31 B, the two taps



FIGS. 31 C and 31 D. Link coupling between a driver and an amplifier

should be equidistant from the center of the coil. Capacitive coupling is not particularly satisfactory at the higher frequencies. In this case, link coupling is used. The latter reduces the effects of the amplifier tube capacitances on the L/C ratio of the tank circuit of the driver. With link coupling, the various stages can be constructed as separate

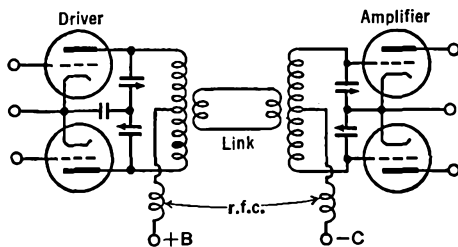


FIG. 31 E. Complete symmetry in coupling

units and then assembled on a common rack. The link coupling coils consist of a turn or two of wire mounted close to that point of the tank circuit where the r.f. potential is least. In the single-ended driver, feeding the push-pull amplifier of Fig. 31 D, one link coil is mounted at the bottom of the driver's tank circuit, and the other is at the center of the amplifier's grid tank. In the double-ended driver of Fig. 31 E,

complete symmetry can be attained. The wires between the coils of the link are closely spaced and parallel to each other. A method of changing the coupling between the link and the tank coils is necessary. This can be accomplished by spreading the turns of wire, rotating them, or moving them farther away from the tank coil.

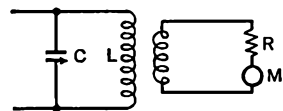


FIG. 31 F. A simple "dummy antenna" circuit used to measure the power output and to adjust the transmitter. LC is the tank circuit of the last stage of the transmitter

31.3 Measurement of Power Output. In order to measure the power output of the

transmitter, a "dummy antenna" is used instead of a regular antenna. The dummy is supposed to have the same electrical characteristics as those of the real antenna, except that it does not radiate energy. There are certain "standard" dummy antennas, whose design can be found in more advanced books. However, a simple dummy suitable for comparison purposes can be built of a *non*-inductive resistor R , in series with an r.f. ammeter M and a few turns of wire. This circuit is coupled to the tank circuit as in Fig. 31 F. The coupling is adjusted until the amplifier

draws its rated plate current when tuned to resonance. Then the power output P , in watts, is given by $P = I^2R$, where I is the current in amperes as read on the r.f. ammeter, and R is the resistance in ohms of the non-inductive resistor. Special resistors for this purpose, with resistances ranging from 73 to 600 ohms, and for power ratings up to 100 watts, can be purchased on the market. Higher power requirements can be met by the use of series-parallel combinations of these units. For crude work, incandescent lamp bulbs may be used in place of the resistor and meter.

31.4 Harmonics. The power stages of the r.f. amplifier of a transmitter are usually operated Class C. In this method, the plate current consists of a succession of pulses equivalent to d.c. plus a large number of strong harmonics. All but the fundamental or first harmonic are suppressed by tuning the plate circuit and hence do not pass to the next stage. In order that this be essentially true in practice, the plate tank circuit of each amplifier stage should have a Q of 12 or more when the circuit is loaded, i.e., when the next stage is connected and is in operation.

The harmonic feed from the final tank circuit to the antenna can be kept to a small value by use of capacitive coupling. With magnetic coupling, an electrostatic shield may be used, as in Fig. 31 G. The shield is constructed as follows: Insulated wire is wound in a single layer on a suitable form and is scraped bare along a single straight line parallel to the axis. A stiff straight wire is then soldered along this line, making contact with every turn. The wires are then cut along one side of the soldered line and the coil is flattened out. Insulating "dope" is used to keep the wires in position. The net result is a comb-shaped *Faraday shield*. The wire which was soldered on, and forms the back of the comb, is connected to the ground.

31.5 Parasitic Oscillations. Spurious oscillations, whose frequency is neither that of the fundamental nor harmonics thereof, often occur when a transmitter is first built. They are called parasitic oscillations. They extract energy from the desired operating frequency, throwing it away in non-useful form, and also interfering with transmission on other channels. Hence they are undesirable and must be removed. They are due to the excitation of various circuits at the natural reso-

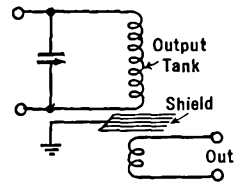


FIG. 31 G. The use of a Faraday shield to reduce the harmonics from a transmitter

nant frequencies of these units. The elimination of parasitics consists of introducing properly located resistances, chokes, or bypassing condensers, so as to prevent the offending element from oscillating at its own frequency. The location and elimination of parasitics is an art in itself, much of which can only be acquired from actual experience. One can detect the existence of parasitic oscillations by running a receiver through wide frequency ranges on the sides of the carrier frequency. These oscillations are often of considerable strength, whereas harmonics are usually quite weak in comparison with the fundamental frequency. Furthermore, parasitics generally have poor stability. Often, when a transmitter cannot be tuned or adjusted properly by the customary procedures, the trouble will be found to be due to the existence of parasitic oscillations.

31.6 Frequency Multipliers. In a frequency multiplier, the plate's tank circuit is tuned to a harmonic multiple of the frequency applied to the grid. The appearance of the circuit diagram of such a multiplier is the same as that of an ordinary amplifier and hence need not be repeated here. See Fig. 13 J. Since the grid and plate circuits are tuned to different frequencies, it is not necessary to neutralize the amplifier, even when a triode is used. Frequently, multipliers operate on the second harmonic, and as such are called *frequency doublers*. Push-pull amplifiers can only be used for multiplication of the odd harmonics because the even-numbered harmonics are almost completely cancelled out in the tank circuit. With doublers, the C-bias, the r.f. input voltage, and the grid driving power must be considerably greater than the usual values for normal Class C amplifiers. The efficiency of these circuits ranges from 40 to 50 per cent. The tank circuit should have a high L/C ratio.

31.7 A Complete Phone Transmitter. Figure 31 H shows the wiring diagram of a 400-watt plate-modulated phone transmitter. The radio frequency units are across the top portion of the figure. The crystal-controlled oscillator in the upper left-hand corner is capacitively-coupled to the HK54 or 35T amplifier, which is link-coupled to the Class C modulated output amplifier stage containing the 100TH or HK254 tubes.

In the central portion of the figure, the output of a crystal microphone is amplified by the 6J7 and 6C5G tube circuits to operate a push-pull 2A3 circuit which drives the modulator (203Z tubes).

The various voltage supplies are shown in the bottom portion of

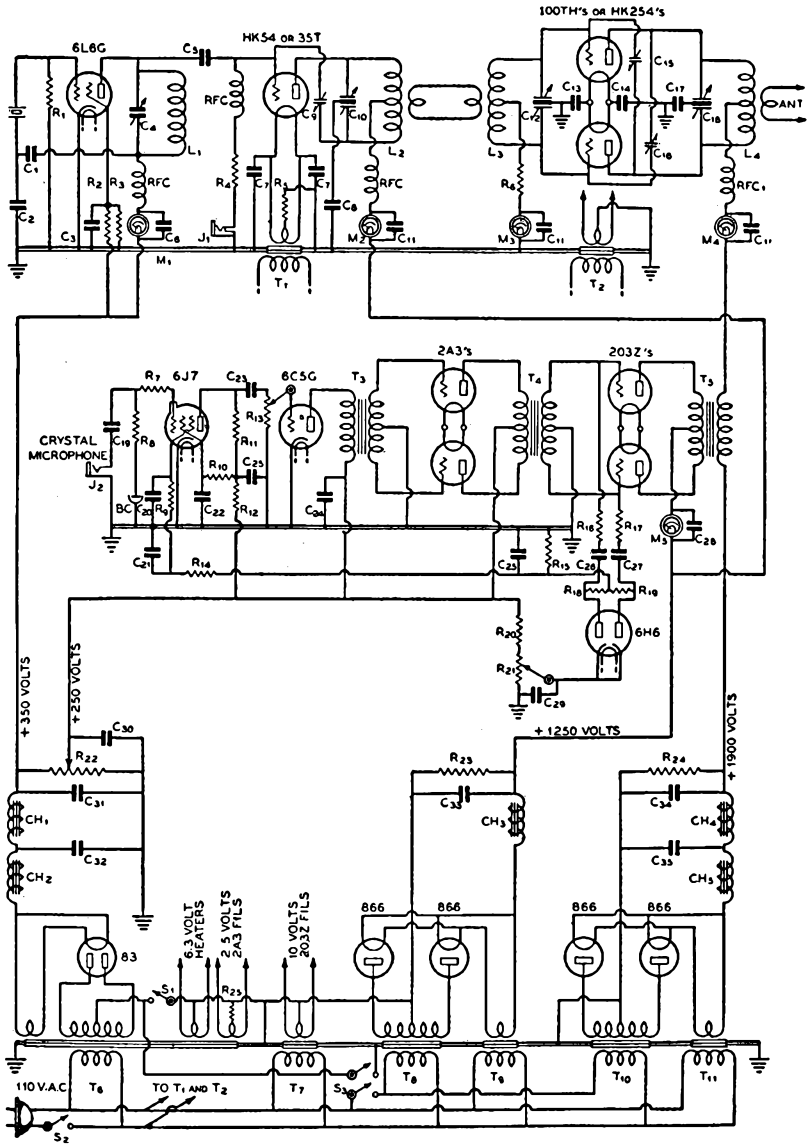


FIG. 31 H. The circuits of a complete transmitter. The r.f. units are at the top, a.f. in the middle and power supplies at the bottom. (Courtesy The "Radio" Handbook, Eighth Edition, Santa Barbara, Calif.)

the figure. Circuit constants and assembly details of this transmitter will be found on pages 369 to 374 of *The Radio Handbook* (eighth edition).

31.8 Checking Phone Transmitters. There are two methods of measuring modulation percentage by means of an oscilloscope. These are known as the *wave-envelope* and the *trapezoid* methods.

For the first of these methods, a small amount of the transmitter's output is picked up with a few turns of wire and fed by a parallel or twisted wire or concentric line to the vertical deflecting plates of the

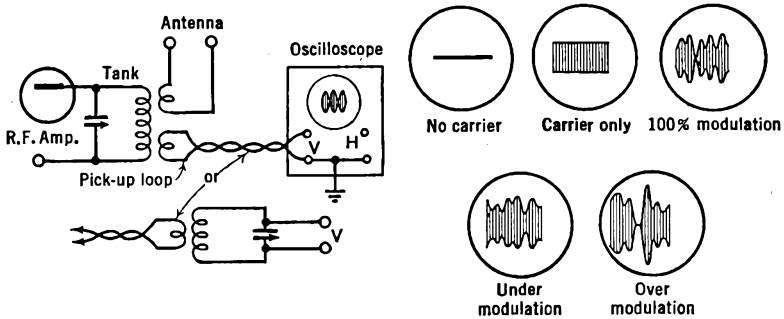


FIG. 31 I. Oscilloscope circuit and wave-envelope patterns for checking the modulation of a transmitter

oscilloscope, as in Fig. 31 I. A horizontal sweep is used at audio frequencies. R.F. harmonics can be eliminated from the vertical deflections by using a tuned circuit at the input terminals of the oscilloscope. The various patterns which will appear on the screen of the oscilloscope are shown in Fig. 31 I. A gap appears in the pattern when the transmitter is over-modulated, as shown at the bottom right of the figure. If a constant intensity tone source is operating in front of the microphone, and the sweep-frequency of the oscillator is properly adjusted, then a stationary pattern will be obtained which looks like that in Fig. 16 C. As explained in Sec. 16.8, one can apply an equation and compute the percentage modulation. It is to be made as nearly equal to 100 per cent as possible. Adjustments for bringing this about have been described in Sec. 28.2.

The second method of checking the modulation, the so-called trapezoidal method, differs from the one just described in that, instead of the linear horizontal sweep, the beam is deflected horizontally by the audio

frequency from the speech amplifier. A suitable circuit for this purpose is shown in Fig. 31 J. The sum of resistors R_1 and R_2 should be sufficiently great that only a small fraction of 1 milliampere flows through them. Roughly, their resistance should amount to one-quarter of a megohm for each 150 volts of modulator output. The blocking condenser C should be $0.1 \mu\text{fd.}$ or more. The patterns which appear on the screen are shown in the figure and should now be examined with care.

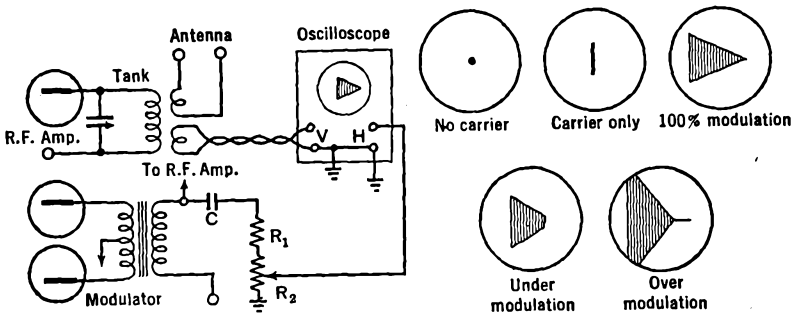


Fig. 31 J. Oscilloscope circuit and trapezoidal patterns for checking the modulation of a transmitter

Of the two methods, the latter is easier to interpret. Sometimes the sloping sides of the trapezoid are not perfectly straight. This may be due to imperfect neutralization of the amplifiers. (See Sec. 27.4) Or it may be caused by incorrect C-bias, or weak excitation of the modulated amplifier, or both. If the amplifier is perfectly linear, which is the correct operating condition, the sides of the trapezoids will be perfectly straight. Sometimes the patterns on the oscilloscope differ radically from those shown in the figure. In this case one should seek for stray r.f. induced into the horizontal deflecting circuits of the oscilloscope, or for some trouble in the oscilloscope circuits themselves.

If the power supplies applied to the transmitter have not been sufficiently filtered or if they have not been shielded from the r.f. circuits, an audio frequency *hum* will be superimposed upon the r.f. This modulation can be detected by listening with a receiver. If hum has been detected, proceed in the following manner: shut off the modulator; if hum persists, check the filtering of the power supplies of the different r.f. stages. Next, add the modulator, but not the speech amplifier. If the hum has still not been eliminated, the trouble lies in the speech

amplifier or in the microphone. An oscilloscope, instead of a receiver, may be used in these tests for hum.

Unless properly shielded from each other, r.f. voltages will be induced into the speech amplifier from the r.f. circuits, with the result that an audio frequency oscillation or "howl" will be set up. This will modulate the carrier frequency. The microphone, its cord, and the speech amplifier must be shielded and grounded to prevent this r.f. pickup.

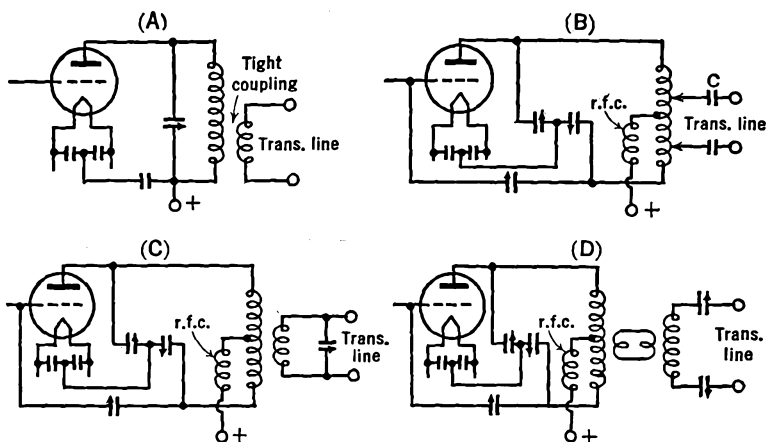


FIG. 31 K. Coupling the transmitter to a transmission line

31.9 Output-Coupling Devices. As will be explained later, antennas are very frequently adjusted to resonate with the carrier frequency. When so doing, like lumped circuits, they act as pure resistances. These pure resistances are connected across a transmission line (which is used to feed power to it from the transmitter). By properly designing the transmission line (see Chapter 35), essentially all of the power leaving the transmitter, passing through the transmission line and arriving at the antenna, will be absorbed by the antenna and radiated out into space. Our immediate problem, therefore, is properly to couple the transmission line to the output stage of the transmitter. There are a wide variety of methods for doing this. In the first place, we may place a few turns of wire near the grounded end of the tank circuit and connect their ends to the transmission lines as in Fig. 31 K. A little care in the adjustment of the spacing between these turns and the coil in the tank circuit will suitably load the plate circuit of the tube so that

its current will have the correct value, as specified by the manufacturer of the tube. It is also possible to connect to the transmitting line through series condensers. In addition, it is possible to use a coupling

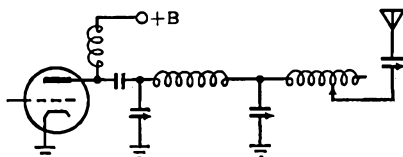


FIG. 31 L. A pi network for coupling the transmitter to the antenna. A commonly used circuit in commercial practice

unit consisting of a coil and a condenser. A third method, that of link coupling between the tank and the transmission line, is sometimes used and has great flexibility. Figures 31 L and M show two coupling methods commonly used in commercial practice.

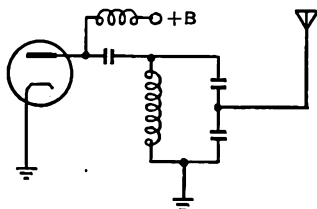


FIG. 31 M. A capacitively-coupled antenna circuit

CHAPTER 32

RECEIVERS

32.1 Introduction. In the preceding chapters, the component parts of receivers have been presented in some detail. In this chapter we propose to study the most suitable combinations of radio, intermediate, and audio-frequency amplifiers, and also oscillators, for the amplification and detection of the weak voltages picked up by the receiving antenna. The simple crystal detector circuits described in the chapter on Principles of Detection are hardly suited for modern reception.

When a radio wave cuts across the wires of the receiving antenna, the voltages generated will only drive an exceedingly small current through the receiver's input end. It is necessary to resonate or augment these by means of inductance-capacitance tuned circuits. In addition, the use of a "pre-selector" circuit at the beginning of a receiver makes it possible to tune in only one of the many carrier waves which may be on the air at the same time.

The next step is to amplify the voltages developed across the capacity in this tuned circuit, and to extract or unscramble the useful intelligence which was superimposed upon the carrier wave at the transmitter. Figure 32 A shows one of the simplest receiver circuits which has proven satisfactory after much experimentation with different kinds of circuits. This is seen to be a regenerative circuit of the type pre-

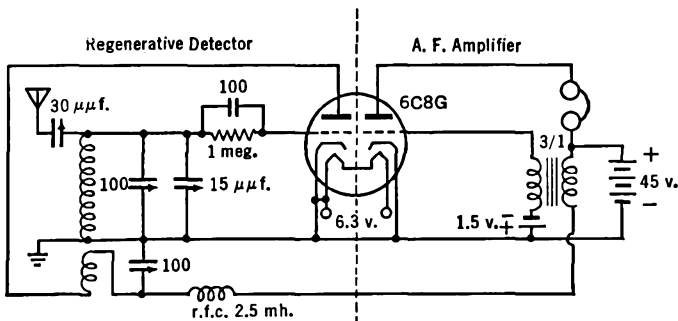


FIG. 32 A. A simple receiver circuit

viously described in Secs. 13.9 and 17.5, together with a one-stage audio amplifier. For the very high frequencies, the simplest usable circuit has been found to be the super-regenerative type discussed in detail in Sec. 17.6.

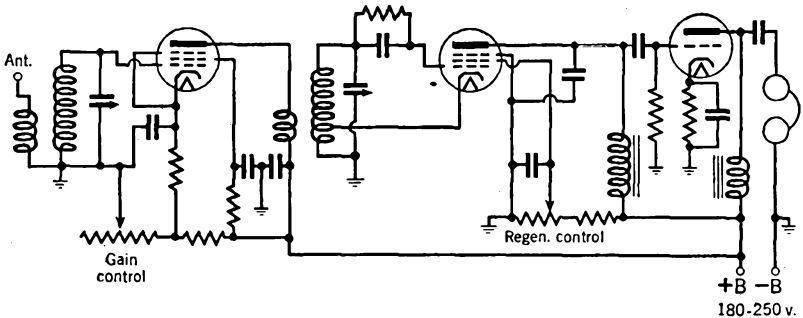


FIG. 32 B. A simple receiver consisting of a one-stage r.f. amplifier, a detector, and a one-stage a.f. amplifier

In order to increase the amplification and the ability of the receiver to select but one of several carrier waves, cascade amplifying systems have been built. A simple receiver will consist of a three-stage unit, as in Fig. 32 B. The first stage is the radio frequency amplifier, with its resonant circuits; the second stage is a simple detector circuit, serving to rectify the signals so that its output consists only of the audio or modulated signal, and the last stage is an audio-frequency amplifier of the "power" type. The function of the latter is to deliver enough power to operate a loudspeaker.

If a continuous wave (dots and dashes = c.w.) is received with the circuit of Fig. 32 B, it will be found that sound will not come out of the loudspeaker. The reason for this will be clear from a study of Fig. 32 C. If, however, a local oscillator is used in connection with the detector, as suggested in Fig. 32 D, and its frequency is adjusted to a value differing from that of the incoming

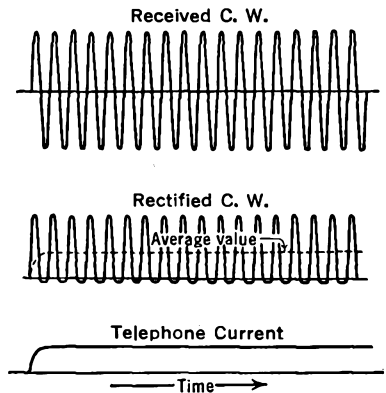


FIG. 32 C. An unmodulated carrier wave will not operate the receiver of Fig. 32 B

signal by some convenient audio frequency (say, 500 to 1,200 cycles), then a beat-note will be produced, as was described in Sec. 29.6. This audio-frequency beat-note is amplified and delivered to the loudspeaker. Therefore, when continuous waves, such as dots and dashes of a code message, have appeared at the input of the receiver, beat-notes will be produced throughout the comparatively long time intervals of each dot

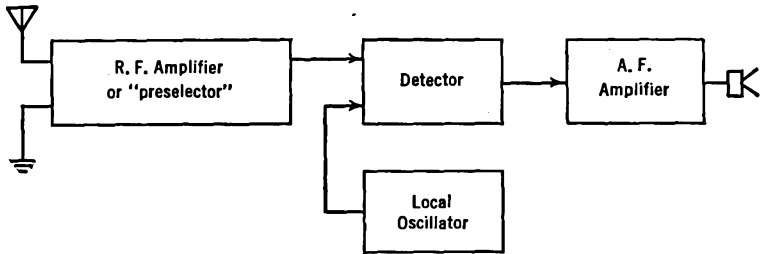


FIG. 32 D. For the reception of c.w.

and each dash, thus rendering the signal audible. The local oscillator must not be used, of course, when voice modulated waves are received, for then the beat-note will be superimposed upon the speech, and will cause a jumble of sound. It is possible to have the local oscillator in operation if its frequency is adjusted to be exactly that of the carrier, for then the beat-frequency will equal zero. In this case, the signal strength will be augmented. Due, however, to the difficulty of maintaining both frequencies continuously at the same value, this method is not commonly used.

Before we approach our study of the more common modern type of receiver (the superheterodyne), we must specify certain desirable properties of a receiver more accurately than we have yet done.

32.2 Sensitivity and Circuit Noise. The sensitivity of a receiver is defined as the minimum input signal voltage which will deliver a standard output signal voltage. A receiver will be more sensitive if it has a large radio-frequency amplification. The limit of sensitiveness is set by the various noises which are picked up in the antenna, be they man-made or natural atmospheric, and by the noises developed in the receiver itself, particularly in the first-stage r.f. amplifier. Hence, particularly for long-distance reception, where the incoming signal comes in very weak, studies of the signal-to-noise ratio become of importance. Man cannot do much about the external natural noises, but he can reduce the internal noises of the receiver considerably. However, even with a

very carefully constructed receiver, where all joints have been properly soldered and where all parts have been designed to have high stability, a definite amount of noise will be heard. This will sound like a hiss. It is due to the thermal motions of the electrons in the input circuit of the first tube (see Sec. 2.2), and to the short-time sporadic changes which occur in the space charge of the first tube (a phenomenon called "tube noise"). In addition, any mechanical vibration of the circuit parts, or of the internal electrode structures, especially in the first tube, will change the normal current flow in these circuits. Upon amplification through the rest of the receiver, these appear in large volume in the loudspeaker. These are called "microphonics," and are eliminated by properly supporting and shielding the first stage from mechanical vibrations.

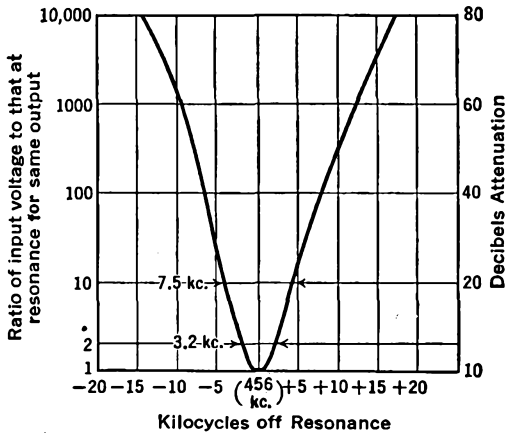


FIG. 32 E. A selectivity curve of a modern receiver

It is found that these noises are distributed more or less uniformly over the entire frequency spectrum. Hence the signal-to-noise ratio will be improved if the receiver is adjusted to respond to only an exceedingly small band of frequencies.

32.3 Selectivity. The selectivity of a receiver is defined as the ability of the receiver to differentiate between a desired signal and other signals or other disturbances occurring at a different frequency. The overall selectivity of a receiver depends upon the sharpness of the resonance curves of the individual tuned circuits and upon the number of such circuits cascaded one after the other in the receiver. The selectivity curve of Fig. 32 E is much like an inverted resonance curve. It is ob-

tained by measuring the r.f. input voltage to the receiver needed for the delivery of a standard output voltage at various frequencies in the neighborhood of the carrier frequency. The selectivity curve may be exceedingly sharp (i.e., the band-width can be very small) for c.w. reception, whereas it should be broader for phone reception, where the audio signals use a channel of approximately 5 kc. on each side of the carrier frequency. For the reception of frequency modulated signals (Chap. 33) the band-widths must be even greater, say 30 or 40 kc.

Let us suppose that the receiver has been adjusted for the reception of signal number 1, but that a second transmitter is operating at the same time on a nearby carrier frequency. The response of the receiver for these two signals will be in proportion to the arrows 1 and 2 shown in Fig. 32 F. From this consideration, the more selective a receiver,

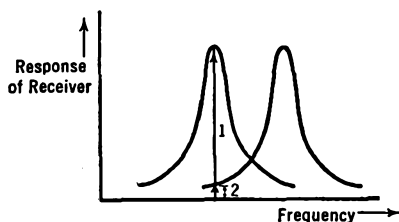


Fig. 32 F. The reception of a desired (1) and an undesired (2) signal

the greater will be its ability to receive the desired signal in goodly strength and to exclude the undesired signal.

32.4 Fidelity. The fidelity of a receiver is its ability to reproduce in its output the wave-form of the modulations which were superimposed upon the carrier wave at the transmitter. A receiver which did not amplify the high-pitched notes to the same degree as the low-pitched notes would sound "boomy," whereas, if the reverse were true and the low-pitched notes were incorrectly suppressed, the high pitches would make the reception sound "tinny." For phone reception, then, the selectivity curve should ideally be such that equal intensity signals over the entire audio range would give the standard signal output. This ideal, however, need not be fulfilled in practice, because, especially with speech, most of the energy in a sound wave is carried in the lower frequency range. For example, the average peak of energy of a man's voice in speaking is around 130 cycles per second, while that for a woman's voice is around 300 cycles per second. Therefore, the rounded curve of Fig. 32 E is permissible in practice. With c.w. reception, these

considerations do not apply and the resonance curve can well have great sharpness.

32.5 Stability. The stability of a receiver is its ability to deliver the same output over a considerable period of time, when a standard signal of constant strength and frequency is applied to its input end. Temperature and voltage changes and mechanical structural features determine the stability of a receiver.

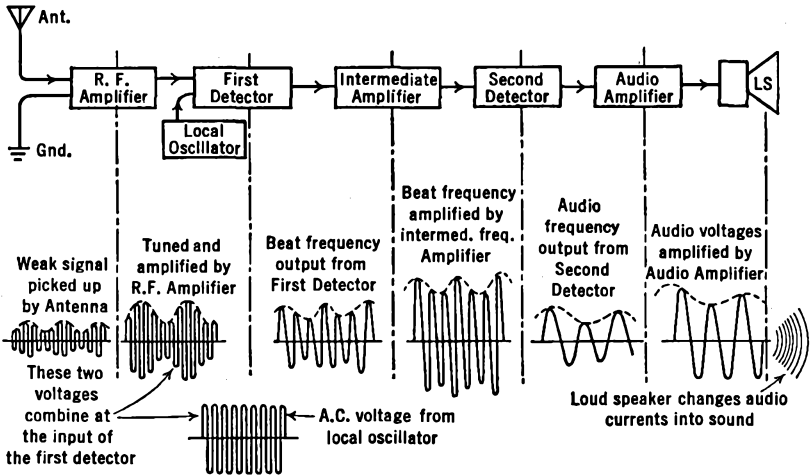


FIG. 32 G. Superheterodyne reception of phone signals

32.6 The Superheterodyne Receiver. The essential idea of the superheterodyne receiver is to change the radio frequency of the signal to a lower, fixed value, where the amplifying circuits can be designed to have great stability and gain, and proper selectivity and fidelity. These circuits constitute the *intermediate frequency (i.f.) amplifier* discussed in Chapter 27. They operate at a frequency above (super) audibility, say at 455,000 cycles per second. The change of frequency just before the i.f. amplifier is accomplished by a beat or heterodyne circuit, called a *frequency-converter*. This contains a *local-oscillator* and the *first-detector or mixer*. The sequence of circuits in a "superhet" is shown in Fig. 32 G. The r.f. amplifier ahead of the converter is sometimes called the *preselector*. Figure 32 H shows the action of the circuit when receiving a c.w. signal.

As an example, assume that the incoming signal frequency is 1,500 kc., and that the local oscillator is adjusted to 1,955 kc. Then the inter-

mediate frequency will be 455 kc., which is the difference or beat-frequency between 1,955 and 1,500. If a signal at 1,600 kc. is to be received, the r.f. stages are tuned to this new value and the local-oscillator is adjusted to 2,055 kc. The i.f. will be the same as before, i.e., 455 kc. The i.f. amplifier can, therefore, be built to operate on this one frequency (including the band of frequencies in the immediate neighborhood). Once the i.f. stages have been properly "aligned," they can be sealed in a shielding metal can and left untouched from then on.

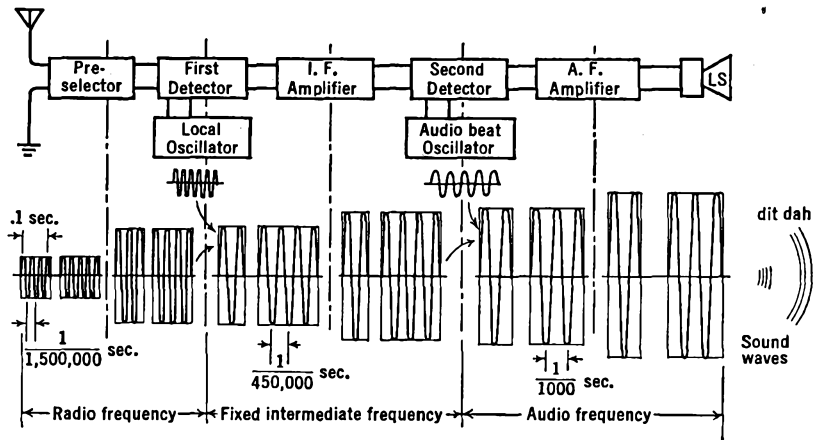


FIG. 32 H. Superheterodyne reception of c.w. signals

Suppose that two transmitting stations simultaneously delivered equal-strength r.f. signals to the converter stage, and that the carrier frequency of one is 1,500 kc., that of the other 2,410 kc. Then, with the local oscillator set at 1,955 kc., a beat-note of 455 kc. ($1,955 - 1,500$) would be produced by one station and a beat-note of 455 kc. ($2,410 - 1,955$) would be produced by the other. With an i.f. amplifier set at 455 kc., both stations would "come in" in equal strength at the same time and a jumble of sounds would come out of the loudspeaker. If it is intended that only one signal be received at a time, say the lower, at 1,500 kc., then the other at 2,410 kc. (or *image frequency*) must be eliminated. This is accomplished by means of the preselector. The preselector furnishes selectivity and eliminates undesired signals whose frequencies differ *appreciably* from that at resonance; the i.f. amplifier rejects frequencies which differ but *slightly* from that at resonance.

The image frequency always differs from the desired signal fre-

quency by an amount equal to twice the intermediate frequency. If equal strength signals (desired and image frequency) are applied to the converter, the ratio of the output voltages is called the *signal-to-image-ratio*, or *image-ratio*. Within limits, the higher the i.f., the higher the image-ratio. Practically all good preselector circuits give high image-ratios.

Spurious reception can be had from beats with harmonic frequencies of both the received signal and the local oscillator. Proper preselector circuits and good shielding, especially in the converter stage, to prevent stray pick-up, will eliminate these undesired effects.

For very high frequencies, the incoming frequency is sometimes reduced with a converter to a lower r.f. (1.5, 5, or 10 Mc.) and this, after amplification, is again lowered to the usual 455 kc. The receiver is then called a *double superheterodyne* or *double-detection receiver*.

32.7 Frequency-Converters. The frequency-converter may use two tubes, one as the oscillator, the other as the first-detector or mixer. A typical mixer circuit is shown in Fig. 32 I, where both the signal and the local-oscillator voltage are applied to the *same* control grid of the pentode. The tube acts as a plate-detector. (See Sec. 17.3.) Instead

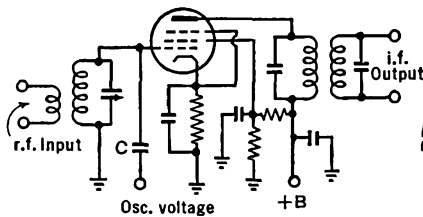


FIG. 32 I. A frequency-mixer circuit

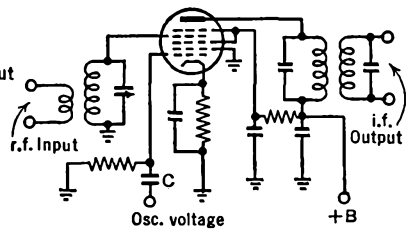


FIG. 32 J. A frequency-mixer circuit using a pentagrid tube

of the capacitive coupling C to the oscillator, inductive coupling may be used. The oscillator should deliver as high a voltage as possible, up to the point where the sum of this voltage and that of the signal are equal to the C -bias on the control grid. Actually this voltage is quite small. The oscillator need not deliver power.

In Fig. 32 J, the signal's voltage and that of the local oscillator are applied to *separate* grids of a pentagrid-converter tube (penta means "five"). A small amount of power must be supplied by the oscillator. This is an excellent circuit.

Although more stable operation is obtained with a separate oscillator and mixer tube, it is possible to combine these functions into a single tube. A typical circuit is shown in Fig. 32 K, where the cathode and first two grids are used in the oscillator circuit. The first grid acts like the usual control grid of the oscillator, while the second grid acts like the usual plate. The oscillator circuit shown is of the tuned-grid or tickler type discussed in Sec. 14.2. The electrons which pass through the second grid, en route to the plate, increase and decrease in number at the frequency of the local oscillator. They are still further controlled

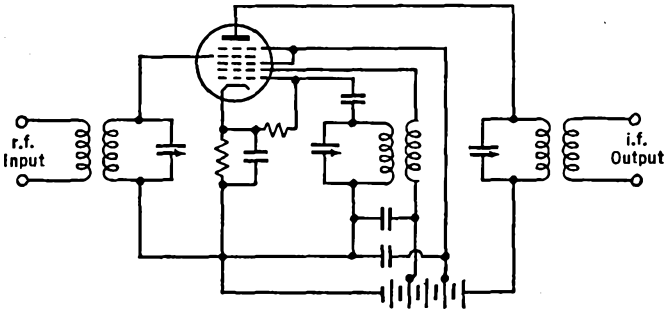


FIG. 32 K. A typical pentagrid converter

by the signal voltage on the fourth grid. The latter is carefully shielded from the oscillator by the third grid and from plate voltage fluctuations by the fifth grid.

Voltages of signal and oscillator frequency are bypassed to ground in the plate circuit because they are not wanted in the i.f. stages; only the beat-frequency is to be passed on. Hence the plate tank circuit of the mixer tube is tuned to the intermediate frequency.

When the i.f. output voltage is large for a given r.f. input voltage, the *conversion efficiency* is said to be high. This is desirable.

Sometimes, tuning the grid circuit results in changes in the frequency of the oscillator. This is bad. It is called *pulling*. It is lessened with careful shielding and with smaller difference between signal and oscillator frequencies.

32.8 Alignment Methods. In order to operate several stages of tuned r.f. amplifiers with a single control, the tuning condensers are mechanically coupled together. Often these "*ganged*" condensers are all mounted on a common shaft. It is necessary that, as the control knob is turned, the various stages shall all "*track*" or tune to the same radio

frequency at every position on the knob's scale. When this is true, the circuits are said to be "*tracking*" each other. In order that this shall be possible, the coils must be as nearly identical as possible and the capacity of the individual condensers in the gang must all increase at the same rate as the knob is rotated. Even so, the circuits may not track because of differences at the zero setting of the condensers, where the small capacities are not all the same. These differences are adjusted by connecting *trimmer condensers* of comparatively small capacity c in parallel with the main tuning condenser C , as in Fig. 32 L. A test oscillator, adjusted to the highest frequency to be received, is coupled to the last stage of the r.f. amplifier. The tuning condenser C is set at its minimum value and the trimmer c is adjusted until maximum output is obtained from the receiver, i.e., until maximum hiss is heard, or, better, until an "output meter" reads maximum. The next to the last r.f. stage is added and its trimmer adjusted in the same manner. This is repeated stage by stage to the input end of the receiver. Next, the control knob of the ganged condensers CCC is turned to the other end of its scale, the test oscillator is adjusted to the lowest r.f. to be received and, stage by stage, the trimmers are adjusted for maximum output. If, during this test, a particular trimming needs to be changed from the previous h.f. setting, the tuning coil should be altered. When larger trimmer capacitance is found necessary for the low-frequency than for the high-frequency end, increase the inductance until the original value of c is restored, and vice versa. When the tracking has been attained at the end frequencies, it is usually sufficiently accurate throughout the entire tuning range for all practical purposes.

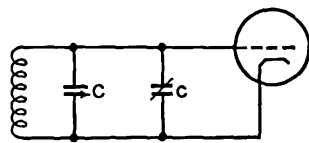


FIG. 32 L. Tracking with a trimmer

In the case of a superhet, it is also necessary that the frequency of the local oscillator be changed simultaneously and by such an amount that the beat or intermediate frequency shall always be of a fixed amount regardless of the signal frequency. Figure 32 M shows a typical converter circuit with its *padding condensers* C_5 . In this combination, C_5 consists of a small fixed condenser paralleled by a still smaller variable condenser. The trimmer condenser C_4 is first adjusted at the high-frequency end of the tuning range so as to deliver the correct i.f. (maximum output). The low-frequency end is then adjusted by means of C_5 to give the same i.f. (maximum output).

When a receiver has to cover a wide range of frequencies, the tuning coils are changed either by means of a switch or by a plug-in arrangement. For ease of tuning with a given coil, it is desirable that one rotation of the condenser should cover a definite band of frequencies. In order to spread these frequencies out over the entire dial of the condenser, small trimmer and/or padding condensers are used.

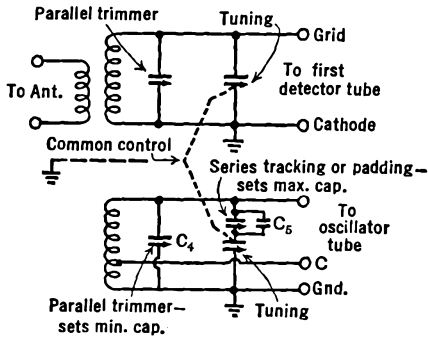


FIG. 32 M. Tracking a converter

For the *i.f. alignment*:

1. A test oscillator is set at the *i.f.* and is connected, with one terminal to the grid of the last *i.f.* stage, the other to the chassis. The trimmers of the output *i.f.* and input second detector unit are adjusted for maximum audio output. The automatic-volume-control featured on some receivers should be disconnected during the *i.f.* alignment described here. If the receiver has an automatic tuning unit, this may be used instead of the output meter, in which case the a.v.c. is left on.
2. The test oscillator is similarly connected across the grid circuit of the next to last *i.f.* stage and the grid trimmers between the last and the next to last *i.f.* tubes are adjusted for maximum output. As one progresses towards the converter, the test oscillator's output should be decreased to prevent overloading the tubes and causing distortion.
3. When aligning the first *i.f.* coupling unit, the test oscillator is connected across the mixer grid; in which case it is often necessary to disconnect the mixer's grid-tuning circuit in order to be able to apply sufficient voltage to the tube.
4. If the *i.f.* amplifier has a crystal filter (Sec. 27.3), set the test oscillator as closely as possible to its frequency, switch out the

crystal and align as above. Switch in the crystal and vary the test oscillator's frequency to maximum output. Then repeat the complete alignment again.

The usual alignment sequence is: (1) i.f., (2) local oscillator, (3) mixer, (4) r.f. But differing sequences are used by different operators.

32.9 A Bird's-Eye View — Looking Backwards and Forwards. It is interesting at this point to glance back for a moment to several subjects, scattered in this book, but related in basic thought (*the feedback principle*). For example: with a single tube we used feedback to increase the gain in regenerative and super-regenerative circuits and also to produce self-sustained oscillations; with several tubes we have used feedback of the *degenerative* type to produce stability in amplifiers and, combined with regeneration, to create planned amounts of equality or inequality of gain over a range of frequencies.

Then, too, we have studied *filters*, made of *LCR* combinations, which can separate one class of currents from another: d.c. from a.c.; a.f. from r.f.; or even pass or eliminate a narrow band of frequencies. In our studies of Detectors we have seen how to "pull-out" a.f. from a mixture of a.f. and r.f. (modulated carrier). With Frequency Converters, we have supplanted one carrier frequency with another. With Modulators we have *injected* one frequency (a.f.) upon another (r.f.). And we have combined these basic processes into our final transmitters and receivers.

We now look ahead to the possibility of applying the *feedback principle* to the combinations of r.f., i.f., and a.f. units which make up our receivers (and transmitters). We are confronted with the interesting possibilities of feeding back i.f. onto the r.f. stages; or a.f. to the previous i.f. or r.f. circuits; or even of rectified average values of a.f. and i.f. to the earlier stages.

Nor is this the end: we must consider the inverse possibilities of feeding from the front end of a receiver toward its output end; of diverting some of the modulated carrier to a special circuit which removes all but a certain component, and of re-injecting this component beyond the diversion point. To cover this general class of circuits we shall use the term *feedahead principle*.¹

There are many useful feedback and feedahead circuits. We proceed to a detailed discussion of only one, automatic volume control, and shall then but briefly outline some of the others.

¹ The term "feedahead" has been coined by the author.

32.10 Automatic Volume Control (a.v.c.). Due to fading (Sec. 9.3), the carrier frequency often varies in amplitude. This causes undesirable changes in the volume of sound radiated from the loudspeaker. The fading sometimes occurs too rapidly to be compensated for manually by a gain-control system. Within limits, an a.v.c. circuit automatically keeps the output at constant volume.

In Fig. 32 N, the diode-detector rectifies the r.f. (or the i.f.) currents and develops a d.c. voltage across resistor R_1 , with negative at its

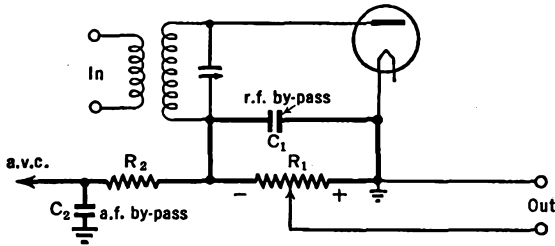


FIG. 32 N. Principle of automatic volume control (a.v.c.)

ungrounded end, and of an amount proportionate to the audio signal plus the fading modulation on the carrier. The audio component is bypassed through C_2 (the r.f. goes through C_1 and is kept out of C_2 by resistor R_2), leaving the undesired fading voltage to continue to the left as indicated by the arrow marked a.v.c. If the carrier strength increases, the voltage across R_1 increases proportionately, and that part

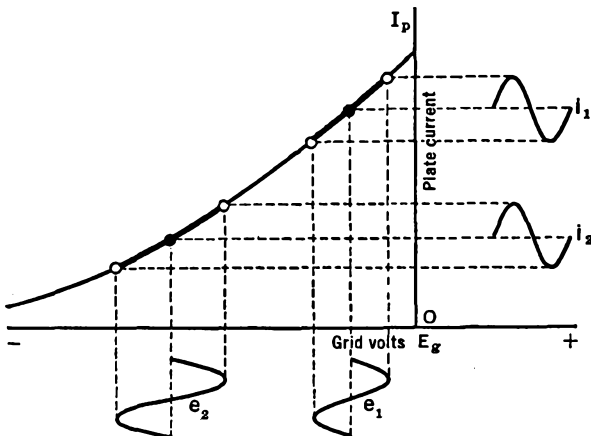


FIG. 32 O. Effect of a.v.c. voltage on the r.f. (or i.f.) pentode

due to the undesired changes (fading) is fed back as a negative value onto the grids of the r.f. and i.f. amplifiers, to undo the increase. This can be understood from Fig. 32 O which shows the dynamic curve of a remote-cutoff pentode used in an r.f. or i.f. stage. With a weak carrier e_1 , the plate current has a certain value i_1 . A stronger carrier e_2 swings the grid more, but also increases the C-bias, so that the plate current i_2 remains of about the same strength. The changes in this figure are exaggerated. In practice it is found necessary to apply the a.v.c. voltage to several stages simultaneously in order that the accumulated effect will be satisfactory.

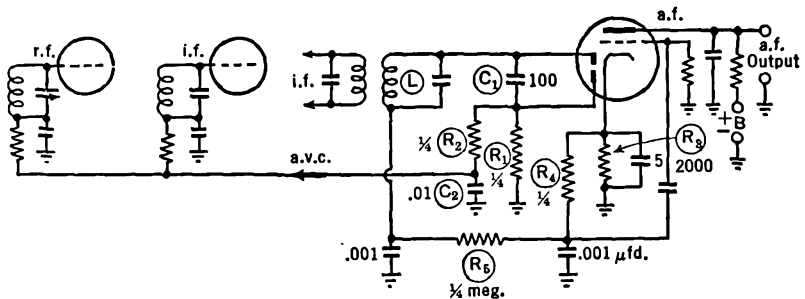


FIG. 32 P. A modern second-detector circuit with delayed a.v.c.

The a.v.c. system just described operates on weak as well as on strong carrier waves, and hence makes the circuit less sensitive than desired. In the *delayed a.v.c.* circuit of Fig. 32 P, the a.v.c. action does not occur unless the signal strength is above a predetermined minimum value. In this figure; one of the diodes serves as a rectifier, one for a.v.c., while the grid and the regular plate are used as the first audio stage; the a.v.c. resistor is R_1 , the r.f. bypass is C_1 , the r.f. blocking resistor is R_2 and the a.f. bypass is C_2 . The bias voltage developed across R_3 is applied to the a.v.c. diode plate through R_4 , R_5 , and L , so that no rectified current flows until the input voltage has become equal to or greater than this bias voltage.

32.11 Some Special Features of Receivers. *Noise-limiters* are used to suppress strong impulses of short duration, such as those from sparking contacts and atmospheric static. In one circuit, Fig. 32 Q, a part of the i.f. is diverted along a path paralleling the regular i.f. amplifier. It reaches a detector tube which has been heavily biased; so much so that the i.f. signal in this path stops at this point. If, however, a sud-

den sharp pulse raises the detector tube above cutoff, the pulse passes through and is fed back in reverse phase to block the pulse which tries to carry through the regular i.f. amplifier.

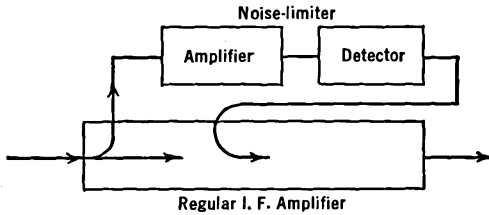


Fig. 32 Q. Block diagram of a noise-limiter

Sometimes, suitable combinations of resistors and condensers, called *scratch-filters*, are used in the audio output stage to eliminate the high-pitched audio-frequency band of "scratchy" noise from a phonograph pick-up.

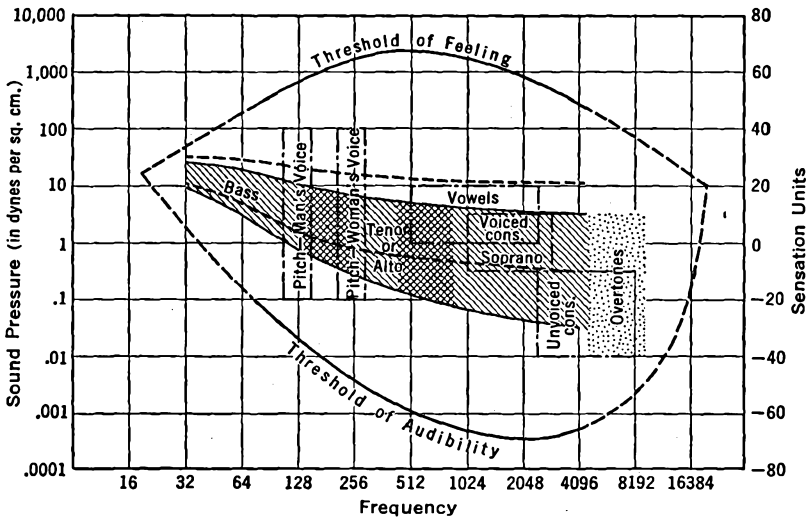


Fig. 32 R. Threshold curves of hearing and feeling

The human ear has a peculiar response to just barely audible sounds of different pitches. It is found that more energy must be used at low or at high frequencies than at intermediate values if the *threshold* of hearing is to be reached. See Fig. 32 R. A series condenser and inductance are shunted across part of the gain control of a receiver, and

adjusted for resonance at approximately 1,000 cycles per second, where the ear has a low threshold. Then the audio frequencies in this intermediate region are bypassed more than those at the higher and lower ends. This is called *compensated volume control*.

A variable resistance and a fixed condenser tied across the primary of the output or speaker transformer can be used to emphasize the low- or the high-pitched sounds. This is called a *tone control system*.

A d.c. meter in the plate circuit of an r.f. or an i.f. circuit, or a miniature cathode-ray tube, called a "magic eye," can be used to show when the circuits are in resonance with the received signal. These are called *tuning indicators*.

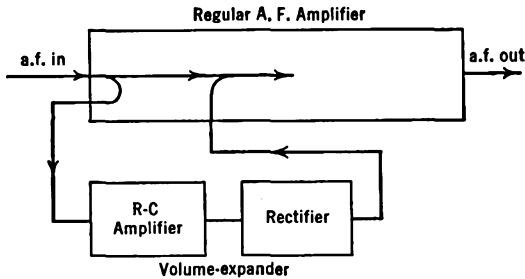


FIG. 32 S. Block diagram of a volume expander

A receiver can have *automatic tuning* such that by pushing a button, a mechanical system, sometimes a motor, moves the tuning condensers to their proper positions for the reception of a desired station.

It is desirable to increase the loudness of the loud sounds and to soften the weak ones, especially in phonograph amplifiers. *Automatic-volume expanders* have been developed for this purpose. Their operation can be understood from Fig. 32 S. Part of the a.f. at the input end of a regular audio amplifier is diverted to the volume expander where it is amplified and rectified. The output voltage is greater if the a.f. is of greater strength, and vice versa. This is fed back to the regular amplifier (via one of the grids of a multi-grid tube) in such phase as to aid the regular signals. In this way loud signals are aided a great deal, while soft sounds are only increased by a comparatively small amount.

In order to keep the intermediate frequency of a superhet centered on its band, *automatic-frequency control* (a.f.c.) is used. This is very useful to compensate for frequency changes in the local oscil-

lator, and especially with circuits which have automatic tuning. Details of its operation can only be understood after studying the chapter on Frequency Modulation, but the principle can be learned from Fig. 32 T. If the i.f. shifts off the center of its band, the "discriminator" (a rectifier) turns the frequency change into a proportionate voltage

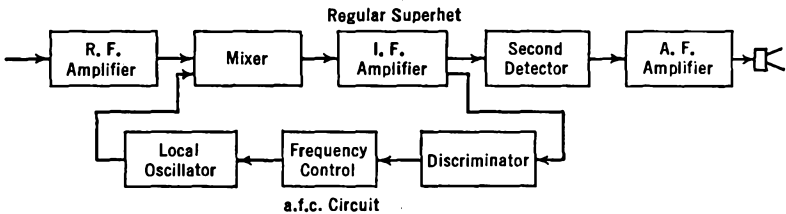


FIG. 32 T. Block diagram for automatic-frequency control

change. This voltage is fed to a tube in the "frequency control" which, together with a condenser and resistor across the tank circuit of the local oscillator, changes the reactance (but not the resistance) of the tank and hence the frequency of the local oscillator. When properly adjusted, any shift in the i.f. is applied through the a.f.c. circuit so as to bring the local oscillator frequency to just the correct value to re-establish the i.f. on the center of its channel.

CHAPTER 33

FREQUENCY MODULATION

33.1 Introduction. First re-read Sec. 16.2.

The amplitude of the carrier wave remains constant in the frequency-modulation scheme. The frequency is varied from the mean or "carrier" value by an amount called the *deviation frequency*. If the deviation frequency is directly proportional to the amplitude of the audio signal, the transmitter is operating properly or *linearly*.

33.2 A Reactance Modulator. A reactance modulator changes the frequency of the tank circuit of the oscillator by changing its reactance. This is accomplished by a combination of a resistor, a condenser, and a vacuum tube (the modulator) connected across the tank circuit of the

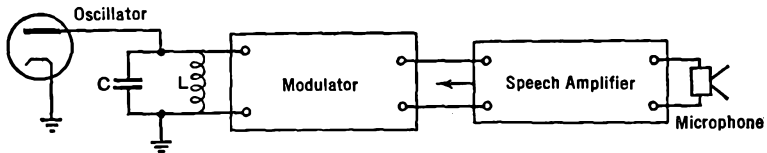


FIG. 33 A. Principle of a reactance modulator

oscillator as in Fig. 33 A, and so adjusted as to act as a variable inductance or capacitance. The net result is to change the resonant frequency of the LC circuit by amounts proportional to the instantaneous a.f. voltages applied to the grid of the modulator tube, without changing the resistance of the LC circuit or the amplitude of the oscillations.

A modulator circuit is shown in Fig. 33 B. The voltages supplied to both the modulator and oscillator must be carefully stabilized to prevent undesired frequency changes. The speech amplifier (Fig. 33 A) does not have to deliver any power and need supply only a small output voltage, say 10 or 15 volts. A pentode and triode, $R-C$ coupled, will be sufficient even with a sensitive microphone and a high-powered oscillator. The frequency change of LC per volt change on the a.f. grid of

the modulator tube will be greater when C_1 , Fig. 33 B, is made smaller. The blocking condenser C_2 has a comparatively high value, and hence offers but small reactance to r.f. currents.

In Fig. 33 B, the radio-frequency voltages which are developed across the tank in the oscillator circuit also appear across the RC_1 circuit and across the parallel 6L7 modulator tube. Now look up the phase-shifting circuit of Fig. 19 H. The resistance r has been replaced by the internal resistance of the modulator tube of Fig. 33 B. The voltage drop across C_1 is 90° out of phase with the tank voltage. It is

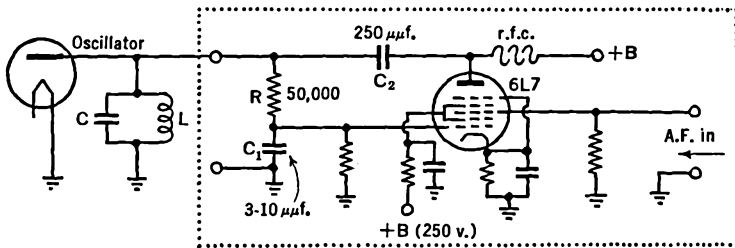


FIG. 33 B. A reactance modulator

applied to the control grid of the 6L7 whose r.f. plate current responds in the same phase. Thus this current is made to lag 90° behind the tank voltage. The r.f. plate current flows through the tank circuit and, combined with the current therein, is equivalent to a new current whose phase differs from the normal value just as though an additional reactance (not resistance) had been connected in with L and C . This, of course, changes the frequency of the LC circuit and hence of the transmitter. When a.f. is fed into the modulator tube, it causes proportionate changes in the r.f. plate current and hence in the equivalent reactance of the LC circuit.

33.3 Deviation. The ratio of the maximum deviation frequency to the maximum audio frequency is called the *deviation ratio*. Values from 1 to 5 are used in practice. With a value of 5, if the maximum voice frequency is 4,000 cycles, then the deviation frequency will have a maximum value of $5 \times 4,000 = 20,000$ cycles per second on either side of the carrier. A 40-kc. channel must then be allotted, and all r.f. and i.f. amplifiers must have frequency response curves wide enough to give nearly equal gain throughout this width of band, as contrasted with the usual 10-kc. band for amplitude modulation.

It is not necessary to change the frequency of the oscillator by the total amount of the frequency deviation, say 30 kc., because frequency multipliers may be used. Suppose, for example, that the oscillator's frequency is changed by the a.f. input by 5 kc., and that its output is multiplied fourfold. Then the frequency deviation will be increased fourfold to a frequency of 20 kc.

An advantage of the frequency-modulation method over the amplitude-modulation scheme is the reduction of noise at the receiver. The ratio of strength of the signal to that of the noise is greater with the f.m. scheme than with the a.m. scheme under certain conditions. With a fairly large deviation ratio, say 5 to 1, the signal-to-noise ratio of f.m. is better than with the a.m. method out to a considerable distance from the transmitter, after which the two become comparable. With weak signals, a deviation ratio of 1 to 1 is preferred.

33.4 Checking the Transmitter. In order to check the linearity of the f.m. transmitter, a highly selective receiver which has an internal oscillator is tuned to the carrier frequency. If frequency multiplication is used in the transmitter, the receiver can be tuned to any one of the frequencies of the successive stages. An audio tone source of constant frequency is then placed in front of the microphone and increased in intensity until the carrier frequency is found to change. This will be noted by a change in the loudness of the output of the receiver. In using the transmitter, the sound intensity should always be kept below this level.

In order to check the frequency deviation, repeat as above, leaving the audio level just below the point where non-linearity begins, but this time slowly change the audio frequency from zero to higher and higher pitches until there is no sound output from the receiver. The audio frequency at this point, multiplied by 2.4, is the frequency deviation. If measurements are made in front of the output stage of the transmitter, be sure to multiply by the frequency multiplication, in order to get the total frequency deviation.

An unchanged antenna current, with or without audio input, indicates that the transmitter is free from amplitude modulation.

33.5 Differences Between F.M. and A.M. Receivers. Superheterodyne receivers are used in the reception of frequency-modulated signals, as in Fig. 33 C. Although much like those used with amplitude modulation, they differ in several important points.

1. Since f.m. is used at the ultra-high frequencies (28 Mc. or higher)

where there is sufficient room for their wide bands, the intermediate frequency is usually chosen between 4 Mc. and 5 Mc.

2. The r.f. and i.f. tuned circuits must respond equally over the comparatively wide band which is used (20 kc. to 40 kc.).

3. The i.f. stages must apply a large voltage to the "limiter," even with weak input signals.

4. A limiter is used, over and above the usual circuits of a superhet.

5. A special detector, called a "discriminator," is used. The a.f. stages are the same as for amplitude-modulation receivers.

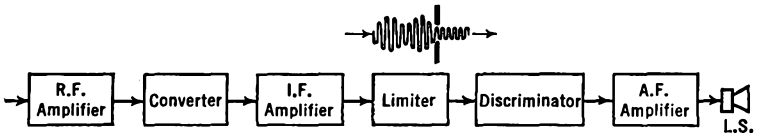


FIG. 33 C. Block diagram of an f.m. receiver

33.6 The Limiter. In order to eliminate any possible variation in the amplitude of an f.m. signal before it is detected, a circuit called a "limiter" is used. The strength of the input voltages to this stage are so great that they saturate the tube, and the tops and bottoms of the waves are clipped off. A circuit of this type was described in Chapter 30 for the generation of a square wave. In the present case, however, the plate circuit contains a tank circuit which resonates sharply to the carrier wave and its accompanying band of frequencies. Thus the harmonics, produced by cutting off the tops of the waves, are not emphasized (by resonance) and do not pass on to the next stage in the receiver. Fig. 33 D shows a typical limiter circuit.

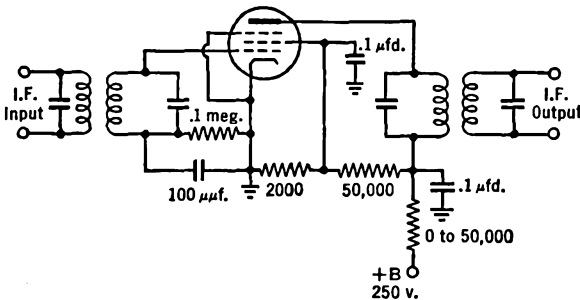


FIG. 33 D. An f.m. limiter circuit

33.7 The Discriminator. A typical detector or discriminator circuit is shown in Fig. 33 E. The secondary of the input transformer is center-tapped and is adjusted to resonance by condenser C_4 to the same frequency as the primary, i.e., the center of the i.f. band. The voltages on the plates of the diodes are those induced in the secondary of the input transformer, together with those developed across condenser C_2 and fed back through the radio-frequency-choke, r.f.c. When the input signal is at its center (unmodulated) frequency, equal and opposite

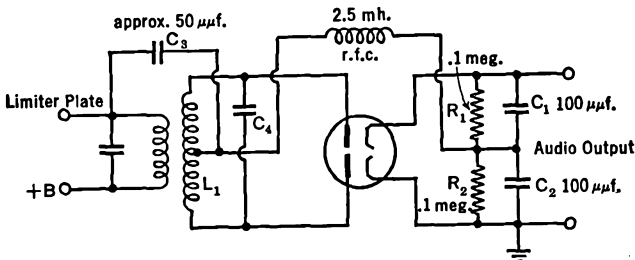


FIG. 33 E. A typical discriminator circuit

voltages are set up across R_1 and R_2 and there is no output. This is the case when there is no modulation at the transmitter. When, however, the signal's frequency changes, one of the diode's voltages lags behind the other. Thus, at a given moment in a cycle, the voltage on one of the diode plates is greater than that on the other. The output voltage is then the difference between the voltages across R_1 and R_2 . The faithfulness with which the output voltage changes in strength with change of input frequency is called the "linearity" of the detector. It is greater if the Q 's of the input transformer's primary and secondary are small and if they are closely coupled.

33.8 Aligning the Receiver. The alignment up to the limiter is the same as for an a.m. superhet. A sensitive d.c. milliammeter is connected in series with R_1 of Fig. 33 D, at the grounded end, and a test oscillator injects a series of frequencies (into the input end of the i.f. stages) which cover the full band-width (usually 30 kc.). If nearly symmetrical readings of the meter are not obtained on both sides of the center frequency, the i.f. trimmer condensers must be readjusted. At the edges of the band, the output should not be down by more than about 25 per cent.

To check the limiter, disconnect C_3 of Fig. 33 E, also the upper ends

of R_1 and C_1 , and insert a sensitive rectifier milliammeter in series with R_2 at the grounded end. The meter should show no change as the frequency of the test oscillator is changed over the band. Now restore all broken connections.

With the meter in series with R_2 as before, and with the test oscillator at center-frequency, adjust the trimmer condensers of the discriminator until the meter reads zero. Then note the meter readings when the test oscillator is set on the two frequencies (one above, the other below the center-frequency) which correspond to the desired frequency deviation. (The meter terminals will have to be reversed.) If the meter readings are not the same, adjust the primary trimmer, then readjust the secondary trimmer for zero reading as above and repeat.

CHAPTER 34

DIRECTION FINDERS

34.1 Loop Antennas. Consider a loop of wire placed in the path of a vertically polarized¹ radio wave. If its plane is set at right angles to the wave, *equal* voltages are induced in the two vertical arms, none in the horizontal wires. But the two voltages are in *opposite* directions, so that current cannot flow into an attached receiver, even if it is tuned to the transmitter; and there will be no output of sound, or any reading on an output electrical meter.

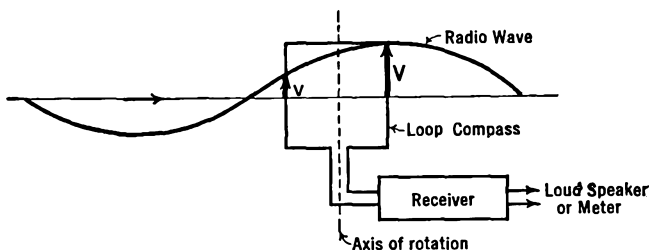


Fig. 34 A. Directional principle of a loop antenna

On the other hand, if the plane of the loop is rotated about a central vertical axis until it is the same as that of the oncoming radio wave, the opposing voltages will not be equal in amount at a given instant and a current will flow through the tuned receiver circuits. This is illustrated in Fig. 34 A. As the wave passes over the loop, the voltages induced in one of the vertical wires alternate at the same fre-

¹ In a vertically polarized wave the *electric* field is straight up and down, perpendicular to the earth's surface. There is no electric field in the horizontal plane nor is there any in the direction of a propagation of the wave. The ground-wave (Sec. 9.1) is vertically polarized. This is because all horizontal electric fields are short circuited by the earth, which has quite good electrical conductivity. It has good conductivity because of its water-dissolved and undissolved mineral contents. On the other hand, when a sky-wave approaches the receiver, coming down from a reflection in the ionosphere or from an airplane in flight, its electric field is at an angle with the earth's surface; or, if you will, the sky-wave's electric field has a vertical *and* a horizontal component.

quency as that of the radio wave, and in an amount proportional to its field intensity. But the voltage in one vertical wire reaches its peak value at a different moment than that in the other vertical arm of the loop. Hence we may say that the two voltages are out-of-phase with each other. When the plane of the loop is at right angles to the wave, the voltages are 180° out-of-phase (crest over trough), whereas with the plane of the loop the same as that of the oncoming wave, they are somewhat less than 180° out-of-phase.

If the distance between the vertical arms were one-quarter wavelength, the crest of the waves would exist at one arm when zero existed at the other. Then the voltage in the first arm would be a maximum, that at the other would be zero; we would say that the two voltages were 90° out-of-phase or in "phase-quadrature." If the loop were one-half wave between vertical arms, the induced voltages would be of

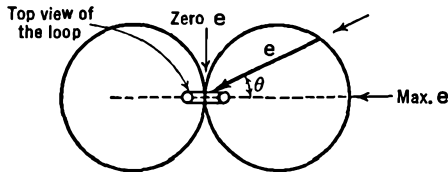


FIG. 34 B. Ideal response curve of a loop antenna

equal strength and in the same direction, i.e., the phase difference would be zero. Except at the very high radio frequencies (= short wavelengths), the construction of a loop of dimensions comparable to the wave-length becomes an expensive problem. We shall, therefore, confine our present discussions to loops which are small in comparison with the wave-length.

The voltages induced in the loop are very small; a good deal of amplification is needed in the receiver. By using a large number of turns of wire instead of a single loop, this voltage can be proportionately increased. There is a limit to the number of turns which can be used, set by the necessity of tuning the loop to resonance with the highest frequency to be received.

Another way of describing the directional receiving ability of a loop antenna is in terms of its *response curve*. As indicated in the *idealized* case of Fig. 34 B, maximum reception, and hence maximum output of the receiver, occur when the wave is in the plane of the loop, and zero reception occurs when it is at right angles to this plane. If

the wave comes in from some intermediate direction, say θ , the net voltage e from the two arms will be intermediate in value and of an amount represented by the length of the arrow marked e in this figure.

34.2 The Radio Compass or Goniometer. In order to determine the line of direction of a given transmitter, the loop is slowly rotated about a vertical axis. When the output of sound, or the reading of an output meter is a maximum, the plane of the loop is in line with the transmitter. When the output is a minimum, the plane of the loop is at right angles to the line of propagation. In practice it is found possible to judge the minimum more accurately than the maximum. The reason for this will be clear from a study of Figs. 34 C and D. A horizontal pointer is fixed to the vertical shaft of the loop and moves over a circular disc marked off in degrees. The loop is rotated until the radio signal can no longer be heard, or is as faint as it can be made. At that position, the plane of the loop is at right angles to the line joining the receiver and the transmitter. The use of the minimum has the disadvantage that it may be obscured by background noises from other stations, static, etc.

This simple compass, however, shows only the path of the radio wave. It does not tell whether the transmitter lies ahead of, or behind, the receiver.

Cross bearings may be taken on two transmitters. The receiver is tuned to one station, its loop is rotated to a minimum, and the angle

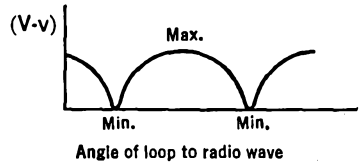


FIG. 34 C. Intensity of output as the loop is rotated

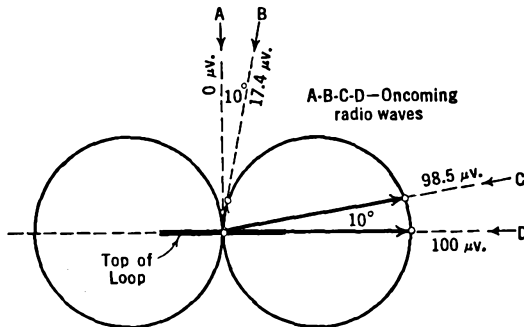


FIG. 34 D. Sharper direction finding can be obtained using the minimum rather than the maximum output of a loop

noted. This procedure is repeated for the second transmitter. The two directions are then laid out on a map. Their intersection is at the location of the receiver. See Fig. 34 E.

A different method, often used by commercial airlines in the United States, when a plane is flying along a known path, say along a radio beam, is to fix the loop with its plane the same as the heading of the airplane and to tune the receiver to a station located somewhere off the known path. See Fig. 34 F. Then, just as the airplane passes di-

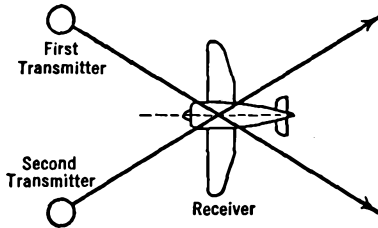


FIG. 34 E. The method of cross-bearings

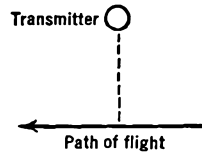


FIG. 34 F. Position fixing

rectly opposite the transmitter, the signal drops to a minimum. From his maps, the pilot may then say that he is on such-and-such a path and is so-and-so many miles due south, say, from the particular town where the transmitter is placed.

34.3 Sense Determination from a Fixed Position. It is possible to determine from a single fixed position the *sense* of the signal, i.e., whether the transmitter is ahead of or behind the receiver along the line of propagation of the radio wave. This can be accomplished by using a vertical antenna in conjunction with the loop. As in Fig. 34 G, a short

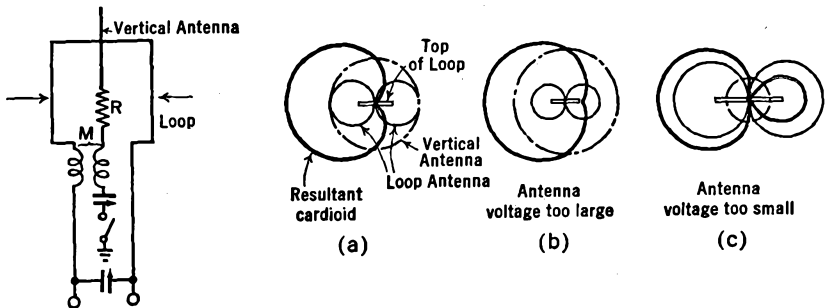


FIG. 34 G. A sense-determining radio-compass

FIG. 34 H. Principle of sense determination

vertical wire is placed along the axis of the loop. The voltages induced in the directional loop and in the non-directional vertical antenna are combined in the mutual inductance M to give response curves of the types shown in Fig. 34 H. If the vertical antenna voltage is equal to that of the loop, the two will add on the left, Fig. 34 H(a), and cancel on the right, to yield the cardioidal (heart-shaped) response curve shown. If the antenna voltage is too great, the curve of Fig. 34 H(b) will be obtained, while if too small there will be appreciable intensity of reception from the right. The coupling at M is adjusted until Fig. 34 H(a) is most nearly obtained. Then, for a radio wave approaching from the left, the signal will be strong, while if it is arriving from the right, the signal will be weak or zero. It is only necessary that the signal be noticeably stronger in the sense (direction) of the transmitter than in the reverse direction for this method to succeed, so that precise adjustment of M is not required. The procedure, then, is to determine the line of reception by the minimum method, with the loop alone, then switch on the vertical antenna and set for a maximum to get the sense. The procedure may obviously be reversed; the sense may be found first and then an accurate line obtained by the minimum method.

34.4 Errors Due to Background Voltages. Often, extraneous or background voltages are induced in a simple loop antenna. These enter in equal strength from all directions. They, therefore, act in the same manner as the pickup voltages from a vertical antenna, as discussed in the preceding section. If the spurious voltages are in-phase with those of the loop, a response curve like that of Fig. 34 I (at the left) will be obtained. It should be obvious that the two minimal or zero intensities of reception are not diametrically opposite each other. In the figure, they are 15° off the vertical, on each side of the loop; but note that they are on the left of the vertical in both cases. In case the

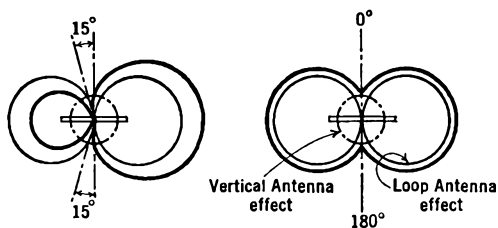


FIG. 34 I. Effect of background voltages when in-phase (left) with the loop voltages, and at 90° (quadrature, on the right)

spurious and loop voltages are in quadrature (90°) (right figure of Fig. 34 I), the minima will be opposite each other but will not be sharp. Then, the correct line of propagation will be obtained, but the accuracy will be greatly reduced because the minima are not sharp.

The in-phase errors are corrected by balancing the loop with, say, condensers, and by using an electrostatic shield, as in Fig. 34 J. The

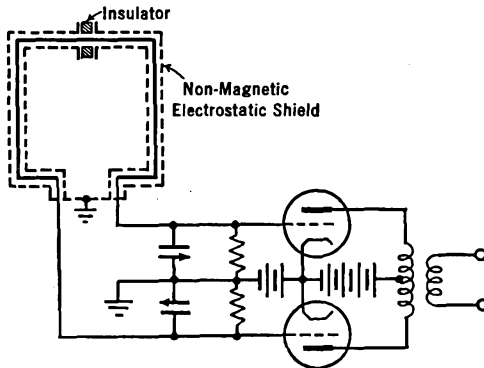


FIG. 34 J. A balanced and shielded loop

out-of-phase voltages are frequently caused by the re-radiation of the energy of the oncoming wave from nearby conductors, which produce small currents, which re-radiate as feeble waves of the same frequency as that being received directly from the transmitter. With the loop installed in a given setting on an airplane or on a ship, compensating loops of wire are added to the main loops, nearby rigging is broken up with insulators, and, if necessary, a vertical antenna is added such that its voltages counteract the spurious ones. Finally, for 1° accuracy, the dial of the compass is calibrated by direct visual observation of the position of a nearby transmitter, located, for example, on a ship which circles the receiver.

34.5 The Shore Effect. If the radio waves pass along the shore of a body of water, their slightly higher velocity over the water than that which they possess over the land causes them to be bent shorewards. The error which this introduces into radio direction finders is shown in Fig. 34 K. The same trouble is encountered among the valleys and peaks of mountainous country. The use of transmitters operating on the higher frequencies, say 125 Mc. (= 2.4 meters wave-length), helps. These short waves are not as much subject to bending or refraction as the longer waves.

34.6 The Night Effect. At sunset, at night, and at sunrise, it has been observed that signals from a fixed transmitter *appear* to come from one which is slowly moving back and forth in a line at right angles to the transmitter-to-receiver direction. This has been found to be due

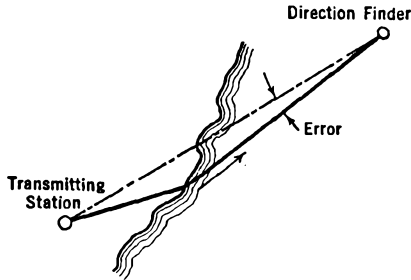


FIG. 34 K. An explanation of the "shore" effect

to the presence of the sky-wave, which is particularly strong at night, for frequencies below 500 kc. It also appears when bearings are taken on an airplane in flight. The student should now read the footnote at the beginning of this chapter. The horizontal component of the electric field will induce voltages in the horizontal arms of the loop, while the vertical component will produce voltages in the vertical arms. The combination of these voltages, added according to their relative strengths and phases, determines the output signal. Obviously, if the ratio of the vertical to the horizontal electric field components changes, the output will change. The ratio will change as an airplane transmitter flies overhead, or as the sky-wave returns from reflection from different places in the ionosphere.

The Adcock antenna, Fig. 34 L, uses two loops so placed and so phased with respect to each other that the voltages in the horizontal arms cancel each other, while those in the vertical arms do not.

34.7 Homing Devices. A homing device is mounted on a moving body and continuously points the way home to a fixed transmitter. In this apparatus, a loop and a vertical antenna are used to produce a cardioidal response curve like the one at the left in Fig. 34 H. A switch is incorporated in the circuits which automatically reverses the polarity of the loop at an audio-frequency rate. The response curve then shifts back

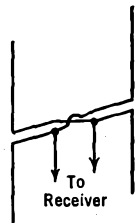


FIG. 34 L. A simple form of the Adcock antenna

and forth between the two patterns, solid and dotted, of Fig. 34 M. The loop voltages, which are thus reversing in direction at an audio frequency, are amplified, rectified, and passed into a meter whose zero is at the center of its scale. If the two voltages e_1 and e_2 are equal in amount, as is the case when moving directly toward the oncoming radio wave, the meter reads zero. If, however, the ship or airplane is moving to the right of the true course, the two voltages e_1 and e_2 (see right side of Fig. 34 M) are not equal, and the pointer on the meter moves to the right. If off-course to the left, the pointer moves to the left of zero.

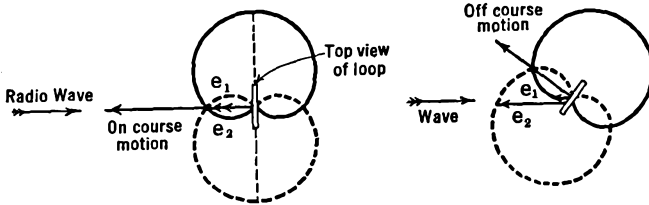


FIG. 34 M. Principle of a homing device

In a slightly different form, a double loop gives two currents which, at an audio rate, are alternately connected to flow through two magnets, one to pull a pointer to the right, the other to pull it to the left.

The extent of the left or right movements of the pointer is not a satisfactory measure of *how far* from the left or right the body is moving from the on-course path. An *automatic homing device* has been devised to overcome the difficulty. The pointer is fitted with contacts which turn on a battery to run a motor in one direction or the other. The motor is fastened to the shaft of the double loop and automatically rotates it into a position pointing to the transmitter whenever it gets out of line. The pilot does not need to turn the loop manually; he merely notes the angle of the loop as registered on its dial. If he changes his heading, the loop rotates so as to point toward the transmitter, and the dial reading measures the amount by which he is off-course.

Two complete automatic direction finders, tuned to two separate transmitters, are used in one device to control two electron beams in a vacuum tube. Two lines of light appear on the fluorescent screen at the end of the tube, giving the bearing of the stations. A map of the flight area is projected at the same time on the screen so that the pilot sees his location as the intersection of the two lines on the map. The

apparatus is controlled in position with a gyro compass so that north, for example, is always at the top of the screen, regardless of the direction of flight.

34.8 The Principle of the "A and N" Radio Beacon. Instead of using a loop as a receiving antenna, one may use it as the transmitting radiator. A transmitting loop does not send out the same strength signal in all directions. The radio wave is stronger in the plane of the loop and falls off to zero at right angles, yielding a radiation pattern of the same shape as the receiving response curve.

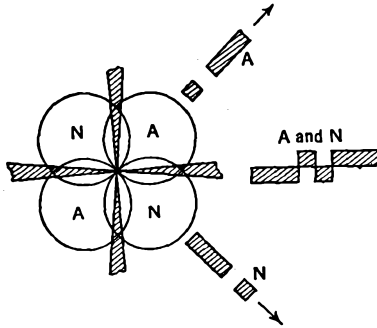


FIG. 34 N. Principle of the A and N beacon

A second loop, placed at right angles to the first one, will give a similar field-strength pattern, but rotated by a quarter of a turn. In use, energy from a common transmitter is connected first to one loop, then the other, back again to the first, and so on. While connected to the "A" loop, Fig. 34 N, it transmits a dot (of one second duration) and a dash (three seconds), the International Morse code for the letter *A*; and while on the other loop, a dash and a dot, the letter *N*. A plane, flying in the *A-A* direction, will pick up a series of *A*'s; while one flying in the *N-N* direction will pick up the *N* signal. Along the *A-N* line of flight, however, the *A*'s and the *N*'s will both be heard in equal strength and, because they are properly interlaced, will give a continuous buzzing sound. The pilot follows a path which gives him a steady note in his earphones. He knows when he is off the beacon for then he will hear an *A* on one side or an *N* on the other. The farther off the beam, the more prominently does the letter sound above the steady background note.

At present, the beacon transmitters are located approximately

every 125 miles apart along the main air lanes. Each transmitter has its own frequency, in the range from 200 to 400 kc., corresponding to a wave-length range of from 750 to 1,500 meters.

In order to overcome the troublesome night error, it has been found greatly helpful to eliminate those parts of the loop which radiate energy in an upwards direction. This has been accomplished by the use of four towers arranged in pairs like those in Fig. 34 O, each supporting a

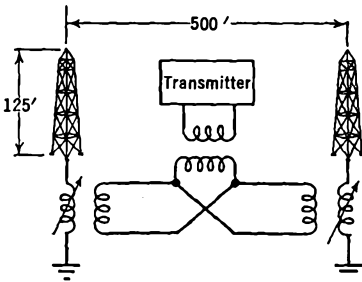


FIG. 34 O. One-half of an A and N transmitting antenna system

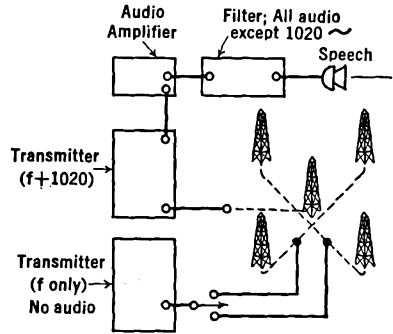


FIG. 34 P. Simultaneous message and beacon transmission

vertical antenna wire, with each pair replacing a single loop. The power from the transmitter is carried to the towers in buried coaxial transmission cables, a system which prevents the radiation of energy vertically. Opposite towers of a given pair are so "phased" that the horizontal field strength pattern is like that from a loop.

By changing the phase of the currents in the various towers, it is possible to so orient the field patterns as to give equi-strength or on-course signals in any of the preferred directions from the antennas.

34.9 Simultaneous Weather and Beacon Transmission. The government radio beacons, established for the guidance of aircraft, are also used in peacetime for the very important purpose of broadcasting weather reports. Formerly it was necessary to interrupt the beacon signals in order to transmit the weather reports. When the pilot was working an orientation problem, this interruption made it necessary for him to circle until the broadcast was complete. This waste of flying time, and of gasoline, made for unsafe conditions. In order to transmit both beacon and weather signals simultaneously, a fifth tower has been added to the previously described antenna array, as shown

in Fig. 34 P. The carrier frequency sent out from this new tower differs in frequency from that of the beacon by only 1,020 cycles per second. Combining with that from the beacon, it gives a 1,020-cycle "beat-note" in the receiver. This is a moderately high-pitched note. The central tower's carrier wave is modulated by the weather report, covering all audible frequencies except for a very narrow band in the neighborhood of 1,020. The removal of this note by means of a band elimination filter does not affect the intelligibility of the speech. The output of the aircraft receiver is passed through two separate filters, as in Fig. 34 Q, one of which allows only the 1,020-cycle note to pass and is used for the beacon signals. When desired, the pilot may turn a switch and listen to the weather reports coming through the other filter, the one which passes all audio notes except 1,020 cycles.

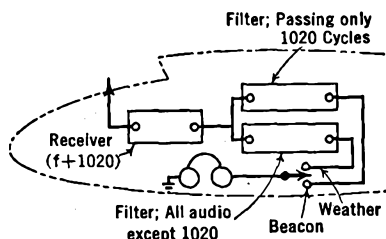


FIG. 34 Q. Reception of message or beacon

34.10 The Reduction of Static. The static electricity in the air, which in concentrated amounts causes lightning strokes, has been a source of noise in receivers, masking the desired signals, especially while a plane is flying near or through certain types of clouds. This has been greatly reduced by enclosing the receiving loop in a metal shield. The hollow, metal, doughnut-shaped shield completely surrounds the loop, except for a narrow transverse gap, and cuts off practically all electrostatic (but not magnetic) fields.

With high-speed airliners passing through regions in which rain or snow is falling, the shielding of the loop has been found to be insufficient. The removal of some of the "precipitation" static has been accomplished by trailing behind the plane a very fine wire in series with a high-value resistor. The theory behind this device is that the wire acts as a lightning rod to prevent the accumulation of high voltages on the plane. The resistor prevents the electrical discharges from the fine wire from becoming oscillatory in such a way as to produce radio waves of static.

34.11 Markers. Above the beacon transmitters (of the type which suppress the sky-wave) there is a "cone of silence." This may be used by the pilot to inform him that he is passing over the station. It is not

infallible, because the silence might also be due to a breakdown of the receiver or of the transmitter.

Radio *markers* are sometimes used. They consist of narrow pencils of radio waves transmitted vertically at 75 megacycles (wave-length of 4 meters). These are about 1 mile wide at 1 mile up. Near an airport there is an outer marker, about 5 miles out, and near the edge of the field there is an inner marker.

34.12 Instrument Landing. At certain airports, a radio wave is transmitted on 93 megacycles (wave-length of 3.23 meters) to provide a *glider path* for "blind" or *instrument landing*. The pattern of field strength sent out for this purpose is indicated in Fig. 34 R. A pro-

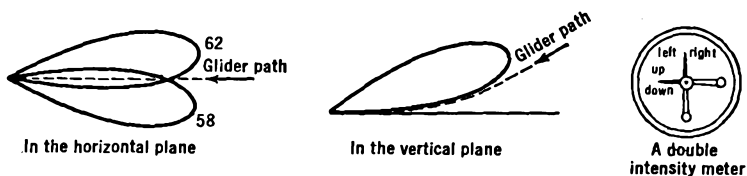


FIG. 34 R. Glider path and indicator for instrument landing

cedure for establishing the proper field pattern is described under Wave Guides, Sec. 38.6. The glider path is indicated by the dotted lines of Fig. 34 R. If the plane is too far to one side of the correct path, a white-line pointer on the "intensity" meter in front of the pilot moves to one side, the movement resulting from the radio wave modulated by either a 62- or a 58-cycle note. Also, if the plane is too high or too low, a second pointer built into the same instrument will be moved up or down. The pilot need only keep the intersection of the two white pointers over the center dot. He will then glide onto the airport at the proper angle and in the path of the runway. Readings up and down are correct to within 50 feet. It must be a day of very poor visibility indeed if this is not close enough to see the land and bring the plane safely to earth.

34.13 A Cathode-Ray Direction Finder. In one system of direction finding which has been applied to the reception of atmospheric pulses (static) and other equally important work of similar nature, two loops or directive antennas are mounted on the same shaft, at right angles to each other. Assume that one of these has its plane in the north-south line, the other in the east-west line, and that they are connected through suitable amplifiers to the deflecting plates of a cathode-ray

oscillograph, as in Fig. 34 S. Voltages in the *N-S* loop move the spot vertically while those induced in the *E-W* loop give a horizontal deflection. If the signal arrives from the east, a horizontal line appears on the screen, of a length proportionate to the strength of the signal. If the signal is from the north, a vertical line is formed. If the signal arrives from the northeast, the spot is deflected simultaneously in both

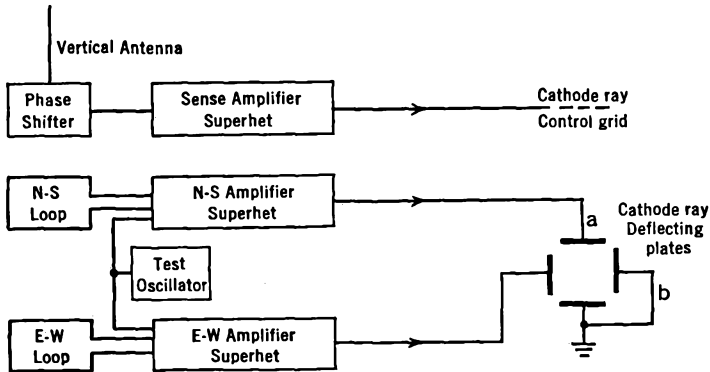


FIG. 34 S. A cathode-ray direction finder

directions and therefore travels along a line at 45° to the *E-W* or *N-S* line. If the signal arrives from some other direction, say more nearly north, the voltages in the *N-S* loop will be greater than those in the *E-W* loop, the spot will be deflected by a larger amount in the vertical than in the horizontal direction, and will mark out a line on the screen which literally points out the line of transmission and has a length proportionate to the strength of signal.

In order to determine the direction or sense of the transmission along this line, a non-directive single-wire antenna is mounted along the vertical axis of the loops. Voltages from this are amplified and applied to the control grid of the cathode-ray tube so as to change the brightness of the light on the screen. The signal from the vertical antenna is properly phased with the signals from the loops. Suppose, then, that the signal comes in from the east, not from the west. The *E-W* loop moves the spot into a horizontal line while the single-wire antenna brightens it from the origin to the right and back again, but dims or cuts it off entirely to the left of the origin.

Certain necessary adjustments must be made for proper operation of this system. It is assumed that the *X*-plates give horizontal lines

and the Y -plates give vertical lines. To test this point, a and b of Fig. 34S are joined together and to a single alternating source. Then the line on the screen will be formed at its true "45°" position (even if the tube be rotated about its axis). A scale marked off in degrees is then set with its 45° mark coinciding with the line. There are electrical methods of setting the line at any desired angle: by keeping the phases on a and b the same, but changing their relative strengths. Furthermore, the gain of the N - S and E - W amplifiers must be the same. To be sure of this, a common test oscillator is used to inject *equal* voltages into the two loops, at which time the line on the screen must appear at 45°, or the gain of one of the amplifiers must be altered until it is at 45°. If the pattern is an ellipse instead of a circle, the N - S and E - W units do not have the same time delay or phase relationship. (In fact, the ellipses have been used as a means of studying phase shifts.) Phase correction can be made by changing the capacitance of a condenser connected across one pair of the deflecting plates. The test oscillator should be applied to the input of the superhets, while the loops are shorted; then, with the loops in operation, in order to check for unsymmetrical conditions in them. It will be found that "closing the ellipse" is a sharper and better final check on the complete identity of the two systems than the angle setting. One-half a degree phase difference will noticeably open a straight line into an ellipse. *Complete* screening of the test oscillator is essential.

To adjust the phase and magnitude of the control-grid voltage from the vertical or "sense" antenna, the test oscillator is applied to it, and to first one of the loops, then the other. The sense system is altered in gain and phase until the line (E - W or N - S) is undistorted and extends only from the origin (center of the screen) in one direction. For the final checkup, all three systems are put into operation and a test oscillator (not wired to any portion of the outfit) is moved around the loops, while directions are observed on the screen. In this, and in practical operation, the loops will need to be set by hand, with their planes roughly at 45° to the oncoming signal. This is to prevent the strong signal from the loop whose plane is more nearly that of the direction of transmission, from becoming so great as to overload the amplifier. Such distortion will give false direction readings.

CHAPTER 35

LONG-LINES

35.1 Introduction. In this chapter we shall consider systems of conductors whose lengths are great in comparison with the wave-lengths of the radio waves with which they are associated.

Much of the study of "radio" is concerned with the opposite case, where the length of the conducting systems is very short in comparison

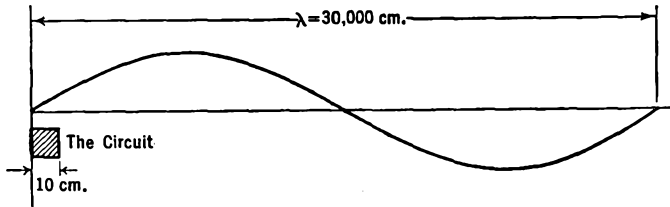


FIG. 35 A. A system of conductors is called a "circuit" when the wires in it are very short compared with the wave-length of the radio waves

with the wave-length of the associated wave. In Fig. 35 A, the shaded square represents any one of the conventional amplifiers, oscillators, transmitters, or receivers which have been studied in the preceding chapters. If one of the wires in it is 10 cms. long, while the radio wave-length is 30,000 cms., corresponding to a frequency of 1,000,000 cycles per second, then their ratio is 1 to 3,000. The term *circuit* is usually used when this ratio is much less than unity, whereas the words *long-line* are used when the ratio is considerably greater than unity. Later we shall consider the case when the circuits and the waves are of comparable lengths; called *short-lines* or *linear circuits*.

Long-lines have two uses: (1) to transmit power with as little loss as possible from one point to another, as from a transmitter to an antenna or from an oscillator to an atom-smashing cyclotron or from a telephone in one city to another in a distant city; (2) to serve as antennas to radiate as much electromagnetic energy as possible. We shall be concerned here more with *transmission lines* than with *antennas*.

35.2. Types of Transmission Lines. One of the main problems in the design of a transmission line is that there shall be as little loss of energy as possible, either by radiation, or by heating in resistances or in neighboring conductors or dielectrics. There are several types of transmission lines whose losses are small: (1) the *open-wire* line consisting of two parallel wires; (2) the *twisted-pair* line of two insulated wires twisted together; (3) the *concentric cable* or coaxial line, where a central wire is mounted along the axis of a metal tube, (a) with insulating spacers every so often, (b) with continuous rubber insulation along the line (usually used with a flexible outer metal mesh); and (4) a *single-wire* feeder, where radiation is kept low by keeping the current in it small, the ground serving as the return wire.



FIG. 35 B. A transposed open-wire transmission line

In order that the losses shall be small, transmission lines have their go and return wires very close to each other in comparison with the wave-length. Then the magnetic and electric fields of one wire cancel or nearly cancel those of the other and radiation does not occur in appreciable amount.

For the open-wire line a spacing of 2 to 6 inches is used, the smaller values at the higher frequencies.¹ In order that the line shall be electrically symmetrical with respect to its surroundings, a *transposition* system is sometimes used. This is illustrated in Fig. 35 B. The method proves more useful on longer than on shorter lines, i.e., when the line has a length greater than one or two wave-lengths.

35.3 Non-Resonant Transmission Lines. At the top of Fig. 35 C there are two parallel wires extending from the generator at the input end at the left to infinity at the right. The separation between the wires is only a fraction of one wave-length. At a given moment, when the top of the generator is positive and the bottom is negative, the electric and magnetic fields at the left end of the wires will appear as in Fig. 35 D, the dotted lines representing the magnetic field. As time goes on, these fields progress down the wires. Since they are set up by the moving

¹ The open-wire line cannot be spaced so closely if considerable power is to be transmitted. One must either use larger spacing, with larger wire to keep down the impedance, or use an enclosed line under (gas, usually nitrogen) pressure to avoid flashing and brushing.

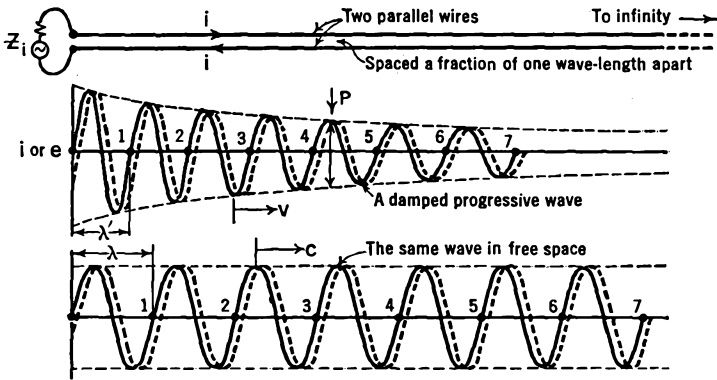


FIG. 35 C. A "long-line" is long in comparison with the wave-length associated with it

charges (currents) in the wires, they are constrained to follow the wires, be they straight or curved. Thus a long-line may be thought of as, and in truth is, a *wave-guide*.

As the electromagnetic field travels down the wires, the currents which give rise to it also move down the wires, with the current in one wire always flowing in the opposite direction to that in the other wire. This follows from the simple fact that the wires are hooked onto the opposite terminals of the generator. Because the magnetic field of one current is always reversed from that set up by the other current, a negligible amount of radiation takes place. This is but another way of saying that the wires, by preventing outward radiation, serve as wave-guides.

The outward progression of energy from the generator or input terminal of the line may be represented as a sinusoidal wave, as in the central part of Fig. 35 C. The solid wave represents conditions at a given moment, a flashlight picture or instantaneous view, while the dotted wave shows its position a short time later. If we could observe the impulse as it moved down the line past a fixed point, say *P* in the figure, we would find that the current had a maximum value in one direction, decreased to zero, reversed its direction and increased to a maximum, then dropped to zero, repeating a complete cycle once

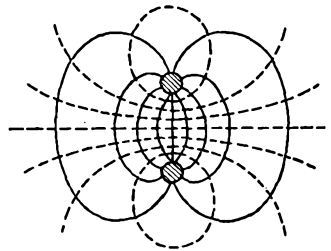


FIG. 35 D. Electric and magnetic fields around two parallel wires

for each period of the generator. The current in the other wire would do the same, but would always be directed oppositely to the first one.

As the wave progresses along the line, some energy is lost in the form of radiation, some in heating the wires, some in leaking through the air or other insulation between the wires. This loss of energy takes place "exponentially" or "logarithmically" along the line, and is represented in Fig. 35 C by the gradual decrease in the amplitude of the wave from left to right. Thus, on a long-line we have a *damped, progressive wave*.

The velocity with which the wave progresses down the line is less than that in free space; that is, it is less than 3×10^{10} cms. per sec. The numerical value of the velocity can be computed from the geometry of the line and the nature of the conductors and dielectrics between the conductors. The equation for the velocity is $v = 1/\sqrt{LC}$, where L and C are the distributed inductance and capacitance of a one-centimeter length of the double line. Formulas have been derived for L and C in terms of the size of the wires, their magnetic properties, their spacing, and the kind of insulation between them. Inasmuch as the frequency of the generator is a fixed quantity, whereas the velocity along the wires is less than that in free space, the wave-length λ' along the wires is less than that in free space. Since the frequency of the oscillator is constant, whether it sends its energy into the transmission line or out into free space, we may write

$$f = \frac{v}{\lambda'} = \frac{c}{\lambda} \quad \text{or,} \quad \lambda' = \lambda \frac{v}{c}$$

For a long-line of the parallel wire type which we are considering here, made of copper wires spaced from 2 to 6 inches apart, λ' is approximately 0.975λ or, in other words, the wave travels down the wire at about 97.5 per cent the velocity of light.

Although the amplitudes decrease as the wave goes out along the line, the ratio of the voltage across the line to the current at any one point in the line is the same as that at another point. This ratio is called the *characteristic impedance*, Z_c , of the line. Just as the velocity of propagation is determined by the geometry of the line and the medium between the conductors, so also we find that Z_c can be computed in terms of the "line constants." The equation is $Z_c = \sqrt{L/C}$. Values of this important quantity are shown in Fig. 35 E. In this figure it will

be noticed that it is possible to design a line by choosing the sizes of the conductors and their spacing so as to obtain a desired characteristic impedance anywhere from a comparatively small value up to several hundred ohms.

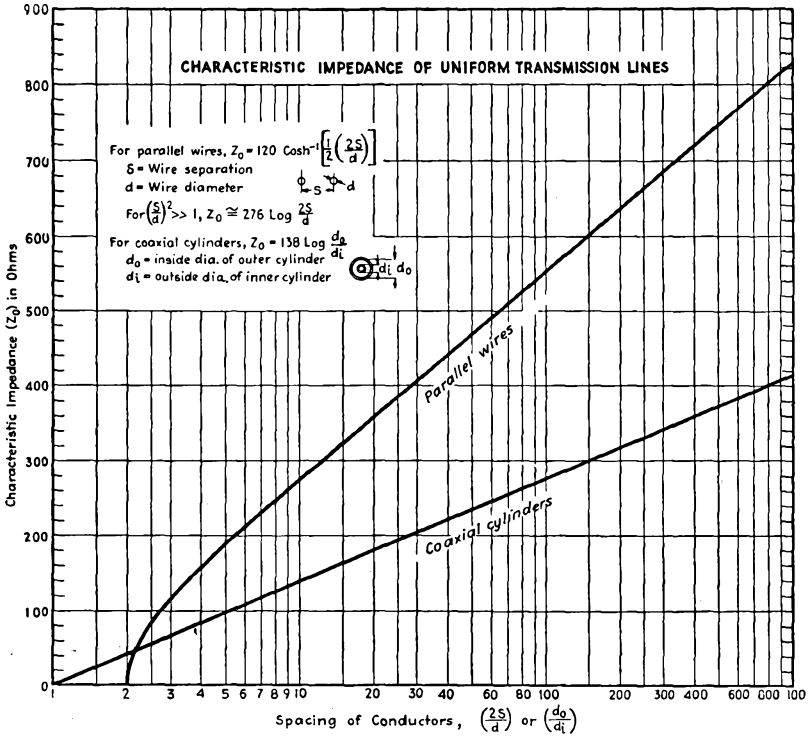


FIG. 35 E. Characteristic impedances of parallel wires and concentric cables with air insulation. The impedance of a single wire transmission line is about 500 ohms, that for a lamp cord is about 130 ohms. (Courtesy of "Electronics," page 48, Jan. 1942)

In practice, transmission lines are not infinitely long. However, if a resistance numerically equal to the characteristic line impedance is connected across the output end of a transmission line of finite length, the line will act at its input end exactly like one of infinite length. A wave which has traveled the length of the line will be completely absorbed in the terminating impedance. No reflection will occur at the output end. The line is said to be *non-resonant*.

The length of a line can be expressed in feet, meters, or other units. Because of the vital importance of the relative length of the line and the length of the radio wave, it is often given in terms of the *number of wave-lengths* which, laid end to end, would reach from the input to the output terminals. A little care is needed here, because the wave-length of the waves along the line (λ') is somewhat shorter than that of the waves radiated outwards into free space (λ) as shown in Fig. 35 C. If l stands for the actual length of the line in feet, and f for the

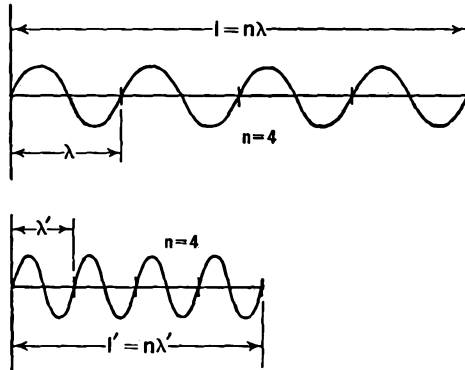


FIG. 35 F. The actual or physical length of the line is l , whereas l' is its "electrical length"

frequency of the generator in megacycles, then the number n of free-space waves (each of length λ) which could be used end to end to measure l is given by $n = lf/984$. In other words, the *physical length* of the line is $l = 984/f$. A line 984 feet long would be 10 wave-lengths long if used with an oscillator whose frequency was 10^7 cycles per sec. ($\lambda = 30$ m.) and it would be 100 wave-lengths long for a frequency of 10^8 ($\lambda = 3$ m.).

Because the wave-length along the line is not that in free space, but somewhat less, the "electrical" length is sometimes used. Referring to Fig. 35 F, we see in the lower part an imaginary line of such length that the same number ($n = 4$) of shortened (λ') waves will fit along it as the number of free-space waves (λ) fit along the actual line l . The *electrical length* of a line, in feet, is given by

$$l' = \frac{984n}{f} \left(\frac{v}{c} \right) = l \left(\frac{v}{c} \right),$$

where f is the frequency of the generator in megacycles, v is the velocity of the waves along the wires, and c is the velocity in free space.

The *energy lost* along a line can be expressed in decibels per unit length (mile, meter, or free-space wave-length). The values given here will be in db. per wave-length. For a transmission line we wish to lose as little energy as possible, whereas with an antenna the radiation "loss" must be as great as we can make it. The following losses are for transmission lines: non-resonant parallel wires, about 0.14; rubber insulated twisted-pair or coaxial, about 1.00; dry lamp-cord, 1.4; dry air-insulated coaxial, very small. Losses are directly proportional to the length of the line. Thus a dry lamp-cord 3 wave-lengths long will have a loss of $3 \times 1.4 = 4.2$ db.

35.4 Resonant Transmission Lines. Non-resonant lines are either so very long that the energy has all been lost along the line before reaching the end, or they are terminated by an impedance equal to that of the line so that the energy is all absorbed in the load at the output end and none is reflected. If, however, these conditions are not fulfilled, the waves will be reflected, at least in part, from the output end and travel back toward the generator. If the impedance of the generator is the same as that of the line, the energy will be absorbed at this point. But, if neither input nor output ends are matched to the line, the waves travel back and forth repeatedly to set up a complicated system of waves. This is analogous to moving a piston inside an organ pipe or fog horn. If the length of the line, the pipe, or the horn, is adjusted correctly so that a wave from the source starts out just when the returning wave has reached it and is ready to travel down the system again, the two waves will add to each other, crest for crest, trough for trough. This reinforcement or resonance builds up a much greater final amplitude than that of one wave alone. Under these conditions, the line is said to be *resonant* to the generator and the waves along it are called *standing-waves*. In this way the sounding board of a piano reinforces the weak sound waves of the vibrating strings to make them easily heard throughout the room.

When exact resonance has been produced along a line, it will be found that the current at certain points is zero, and remains at zero at all times. These are called *current nodes*. At other points, one-quarter of a wave-length (λ' , not λ) away (halfway between the nodes), the current will be a maximum. These are called *current loops* or *antinodes*. The voltage across the line also varies from zero to a maximum

and back again as one progresses down the line. The voltage loops occur at the same points as the current nodes, and the voltage nodes are at the same place as the current loops.

When exact resonance has not been established, and it never is in practice, the value of the current (or voltage) at a node is not exactly equal to zero. The *standing-wave ratio* is the ratio of the current (or voltage) at a loop to the value at a node. It is determined by the terminal and by the characteristic impedances. It is equal to the characteristic impedance of the line divided by the terminating impedance or resistance, or the inverse, according to which gives a number greater

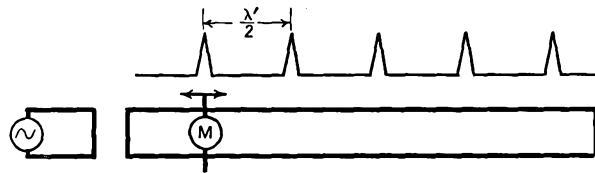


FIG. 35 G. Lecher wires are used to measure wave-length (λ)

than 1. A 500-ohm line terminated in a resistance of 50 ohms, or a 50-ohm line terminated in a 500-ohm resistance, both have a standing-wave ratio of 10. If the terminal impedance matches the characteristic line impedance, the standing-wave ratio is unity, all energy passing down the wire is absorbed at the terminus, and there is no reflection at this point. A line in which the standing-wave ratio is about equal to 1 is said to be non-resonant. If this ratio is fairly large, the line is said to be resonant. The losses of an air-insulated parallel-wire transmission line increase slowly from 0.14 db. per wave-length as the standing-wave ratio increases from 1 to about 15, after which they increase rapidly.

A transmission line may be used to measure the length of the waves. In Fig. 35 G, an r.f. meter M , or a glow-lamp, is shorted across the line and moved along until a maximum reading or glow is observed. The location of this point can be made quite accurately because the peaks are very sharp. M is then moved along the line to a second peak. The distance between the two positions is equal to one-half wave-length. Lines so used are sometimes referred to as *Lecher wires*.

35.5 Long-Wire Antennas. In transmission lines, the two conductors are kept close to each other in order that their fields will cancel and radiation will be kept to a minimum. With antennas, the conductors

are separated from each other in order that as much radiation as possible can be secured. Figure 35 H shows the current distribution along an antenna in which the wires have been opened up to the fullest extent.

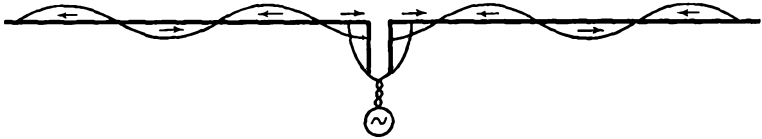


FIG. 35 H. Current distribution along a center-fed $7/2$ -wave antenna

A quarter-wave resonant feeder is used to connect the antenna to the transmission line. With proper connections, these antennas may be fed from the end or from any of the points one-quarter wave-length apart down the wire. Sometimes the conductors are not opened up fully 180° from each other. The V and the rhombic or diamond antennas of Fig. 35 I are of this type. The V antenna directs the transmitted energy

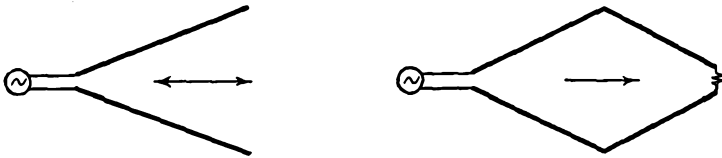


FIG. 35 I. "V" and Rhombic types of antenna

more or less sharply in both directions along the line bisecting the angle between the wires, while the rhombic antenna is uni-directional as indicated by the arrow. Further discussion of the directive properties of antennas will be given later.

CHAPTER 36

SHORT-LINES

36.1 Introduction. In the 1880's, Hertz carried out the first radio experiments, with damped waves only a few millimeters long. For many years thereafter, the trend was to use longer and longer waves, up to 20,000 meters or more. During the past twoscore years, the reverse trend has been followed, back again to the "microwaves," but with the important difference that undamped waves are used and that the tubes and circuits have been so thoroughly studied that accurately controllable and predictable operation can be obtained.

In this chapter we shall be concerned with the systems of conductors whose physical lengths are comparable to the wave-lengths of the radio waves. It is difficult to call these systems "circuits" or "lines" in the conventional sense, so the term "*short-line*" will be used. As in the case of long-lines discussed in the preceding chapter, short-lines may be designed either to prevent or to favor radiation. In the latter case they are called *short-antennas*, while in the former they are called *linear-circuits* (sometimes "feeders"). In practice, both types are operated in the *resonant* rather than the non-resonant condition.

36.2 Linear-Circuits. A linear-circuit can be made of two short parallel wires or of a section of coaxial line, whose length is approximately one-quarter, one-half, etc., the wave-length of the radio waves with which it is resonant. The physical appearance is so simple that one can easily miss the necessary fundamental principles involved in its design. What we need is a system of conductors which:

1. will have the least possible radiation of energy,
2. will resonate accurately with the generator so as to build up the voltages and currents to as large values as possible,
3. will have low ohmic, eddy-current, and dielectric losses.

In order to satisfy the first requirement, it is necessary that adjacent conductors shall carry currents which at every point and at every instant are out-of-phase with each other; one current flows to

the left, while the other flows to the right. Suppose we had two hollow pipes, side by side, and that you blow a puff of air into one of them while I suck on the other pipe. The puff will move down the pipe and so will the vacuum in the other tube. The air continually flows toward the vacuum, trying to fill it, and, in so moving, creates a new vacuum farther down the tube. The currents of air in the two pipes are flowing in opposite directions. The positive terminal of the h.f. oscillator at the left of Fig. 36 A draws ("sucks") electrons to it, while the negative terminal drives them away. Thus the currents which start out

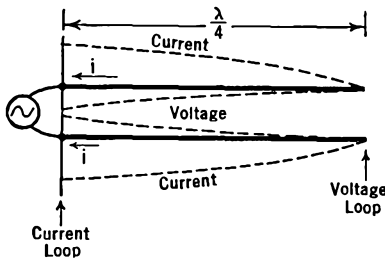


FIG. 36 A. Current and voltage distribution along a quarter-wave folded resonant-line circuit

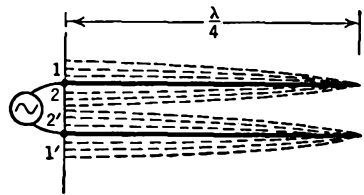


FIG. 36 B. Current changes along a quarter-wave line during one cycle of the generator

from the end of the linear-circuit are 180° out-of-phase, and continue so to the end of the conductors. With suitable choice of the length of the line and its terminations, standing waves will be produced as discussed previously in Sec. 35.4. Then, not only will the currents which are reflected back and forth keep this out-of-phase relationship at all points and instants, but also, by adding together in their to-and-fro motions, will build up to very large values in the loops. In Fig. 36 A, note that the voltage at the right-hand end of the wires is much greater than that of the generator at the left end. Note that the currents are greatest where the voltages are least, and vice versa. Also note that the currents and voltages at all points along one of the wires are out-of-phase with the corresponding values along the other wire. As time goes on, the current in each wire at the input end passes from the maximum value shown in Fig. 36 A to zero, to a reversed maximum, and back again during each cycle of the oscillator. As shown in Fig. 36 B: at the start, the currents are 1 and $1'$ in the two wires; at the half-cycle they are 2 and $2'$ and are still out-of-phase with each other. Finally, therefore, the currents in a quarter-wave resonant line are out-of-phase

with each other not only at every point along the line but also at every instant. Under these conditions, the magnetic and electric fields surrounding the two conductors are always in opposing directions and the radiation from the system is kept to a minimum.

The desirable condition of standing-waves can be produced with short-lines which are any multiple of one-quarter wave-length long.

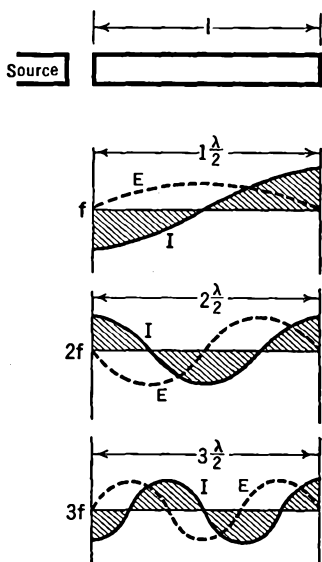


FIG. 36 C. A short-line closed at both ends and resonating to its fundamental and overtones

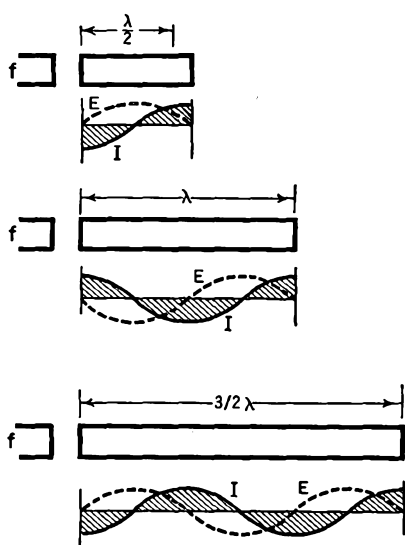


FIG. 36 D. Tuning a short-line to an oscillator of fixed frequency

One may start with a line of fixed length and vary the frequency of the oscillator to find these "modes of vibration," or one may use a generator of fixed frequency and change the length of the line. Figures 36 C and 36 D illustrate these two possibilities. In Fig. 36 C, the frequency of the source is supposed to be steadily increased; or the wave-length is decreased. When the length of the wave (λ) is twice that of the line (l), the fundamental or first-harmonic mode of vibration is attained. With the ends of the line shorted, as shown, the voltage at these points is always zero, as indicated by the dotted (E) line. As the wave-length is further shortened, a second harmonic standing-wave will be produced when the line and the wave are of the same length. Then, too, the voltages at the ends will be zero, whereas the currents will

have maximum value. Figure 36 D shows a "trombone" line, whose length can be progressively increased, while the frequency (f) of the source remains fixed. The first three harmonic or resonant conditions are shown in the figure.

The physical length of a short-line is never exactly equal to one-quarter (or a multiple of $\lambda/4$) because of end-effects and because the waves do not travel along the wires as fast as they do in free space. The effect of the velocity retardation has been discussed in the chapter on Long-Lines. For a quarter-wave line, $n = \lambda'/4$, so that, if the electrical length is l' and the physical length is l , we have $l' = (246/f)(v/c) = l(v/c)$, where f is the frequency in megacycles and the ratio (v/c) has the following approximate values: for parallel wires, 0.975; air-insulated concentric lines, 0.85; rubber-insulated concentric and twisted pair, 0.60. The end-effects can be understood by referring to Fig. 36 E. A voltage induced at point P must travel along the end-

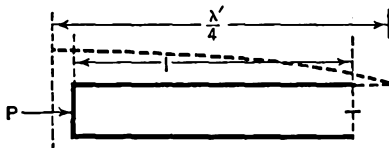


FIG. 36 E. End effect on short-lines

shorting-bar before reaching the line itself. There is, then, a correction equal to one-half the separation of the wires. Even this is not an exact statement, for the bends in the wire distort the field from what it would have been along a straight wire. We can only say that at a short-circuited end, the correction is *approximately* equal to one-half the line spacing. Similarly, a correction is needed at the open end. If a condenser is fastened across the open end, the correction can become comparatively large. When the wires are farther apart, the closed-end corrections become larger, but the velocity of propagation along the wires becomes more nearly that of light; hence the equation and numerical values given above serve well for practical purposes for lines of the type shown in Fig. 36 E.

In order to keep the radiation to as small a value as possible, the parallel wires should not be farther apart, center to center, than 10 per cent of the wave-length. Also, they must not be placed too close together in comparison with their diameter, for the following reason:

The h.f. currents are confined to the skin of the conductors; their penetration is only one one-thousandth of a millimeter at the ultra-high frequencies ($\lambda = 10$ m. or less). See Fig. 36 F. The fields of these currents

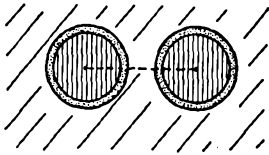


FIG. 36 F. End view of parallel wires which are too close together

extend throughout the space, not only around the outside of the wires, but also *inside* the conducting layer. Outside, there may be only small conduction or dielectric losses in the insulation (air), but inside, the fluctuating magnetic fields set up eddy currents which absorb energy from the line and dissipate it in the form of heat. One obvious solution to this difficulty is to use hollow tubes. In practice, at

the ultra-high frequencies, large copper tubes are used. They offer large surface area (low ohmic losses), small internal losses, and desirable rigidity for stabilization of the line (both mechanical and electrical).

In order to reduce the radiation of energy from parallel wires, they can be enclosed in a metal shield, as in Fig. 36 G. Then the electric

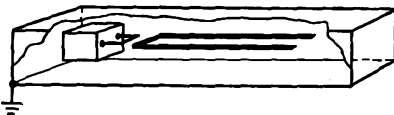


FIG. 36 G. Metal box to shield a line

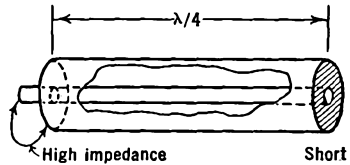


FIG. 36 H. A concentric resonant-line

field of the line does not affect neighboring circuits; nor do external fluctuating electric fields affect it. But the eddy currents set up in the shield cause losses from the line; the more so the closer the shield is to the line. The problem of shielding has been solved much more elegantly by the use of concentric-lines, as in Fig. 36 H. The central metal rod is one wire and the hollow metal tube is the other "wire." Between the two, a standing-wave of electric and magnetic fields is set up. Energy in this field which tries to radiate away is absorbed in the outer cylinder; the eddy currents produce fields back into the inside of the line. In other words, radiation losses are greatly reduced. Of course, the eddy currents suffer ohmic losses, but only on the large inner surface of the outer cylinder. The total loss in concentric cable is appreciably less than in a corresponding length of open, parallel

wire line. Another way of saying the same thing is that the Q of a concentric line is very high, as much as 15,000 or more.

Suppose we have a line which is one half-wave long, or any integral multiple of a half-wave in length. Then the impedance, as measured at the input end, will be equal to the impedance connected to its output end. With a condenser at the output, whose reactance is given by $1/2\pi fC$, the system will act capacitatively on the load, and with a value equal to $1/2\pi fC$ ohms. With an inductance at the output, the system will have an inductive reactance of an amount given by $2\pi fL$. With a pure resistance load (R), the input impedance will equal R ohms.

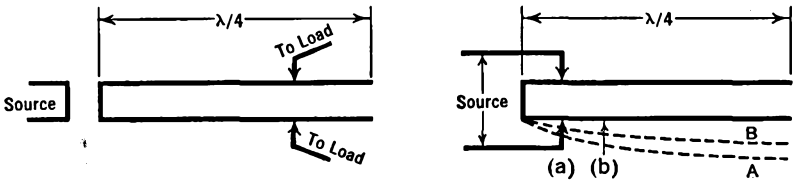


FIG. 36 I. A quarter-wave line as a "linear" transformer

With a resonant LCR load, the input impedance will be a pure resistance equal to R , because the capacitive and inductive reactances cancel each other. In other words, a half-wave line acts like a *one-to-one transformer*.

With a line which is one-quarter of a wave long, or any odd multiple of a quarter-wave, the input impedance Z_i is given by $Z_i = Z_c^2/Z_l$, where Z_c is the characteristic impedance of the line and Z_l is the output impedance. The line acts, therefore, as an *impedance-transformer* for coupling a source of one impedance to a load of a different impedance. By introducing the source or the load at various suitable points along the line, as in Fig. 36 I, adjustments can be made so as to match the impedance of the source or the load. In these cases, the impedances, looking into the line in either direction from the selected point, are equal to each other. In Fig. 36 I, the left circuit is sometimes used to feed an antenna (the load). The right circuit has been used to produce high output end-voltages in a cyclotron (the "dees" are at the output end). In this case, tapping the fixed voltage of the source onto the line at (b) gives a voltage distribution (B). Moving the tap closer to the shorted end, the same voltage source results in the distribution shown at (A) and hence gives much higher voltages at the open end.

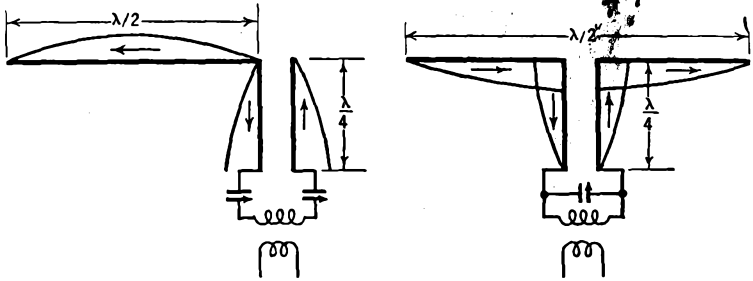


FIG. 36 J. Half-wave antennas

36.3 Short-Wire Antennas. The half-wave Hertz type of antenna is used extensively today. Figure 36 J shows the current distribution on end-fed and center-fed half-wave antennas, together with the resonant quarter-wave feeders and the coupling condensers and inductances.

The actual length l of the wires in a half-wave antenna is somewhat less than one-half the wave-length of the radio wave in free space.

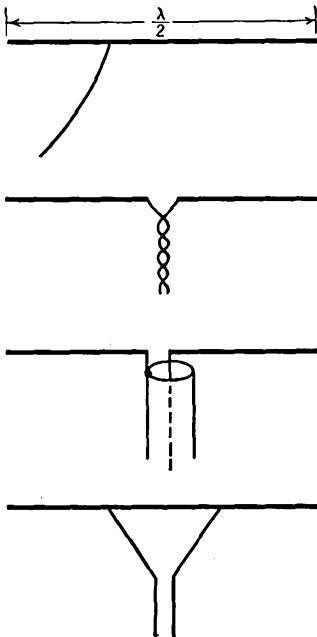


FIG. 36 K. Non-resonant line feeders

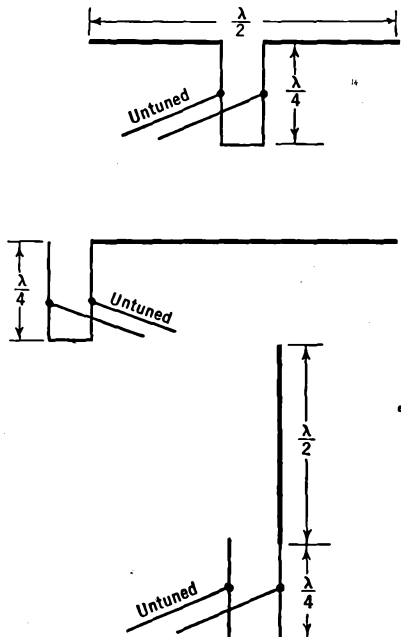


FIG. 36 L. Matching impedances with linear-transformers

It is given in feet by $l = K/f$, where f is the frequency of the radio waves in megacycles and K is a constant ranging from 468 to 462, the larger value for frequencies below 30 Mc., the smaller values for frequencies around 60 Mc.

The feeders may be one-quarter of a wave-length long, or any whole number multiple of a quarter-wave. Series tuning is used when the bottom of the feeder has high current and low voltage (low impedance), as on the left side of Fig. 36 J. Parallel tuning is used when the current is a minimum (voltage is a maximum) at the bottom of the feeder, as in the right-hand side of this figure. The end-fed antenna is also called a "Zepp" or voltage-fed-antenna. The center-fed system is sometimes referred to as a current-fed system.

Non-resonant lines may also be used to feed from the transmitter to the half-wave antenna. From top to bottom, in Fig. 36 K, they are called: single feed, twisted pair, concentric, and delta matched feeders. The adjustment of the antenna's impedance (to be taken up shortly) to that of the line can be accomplished by means of a linear-transformer, as in Fig. 36 L. The point at which the untuned line is attached to the quarter-wave feeder is adjusted until all energy fed from the line is absorbed into the antenna. The output impedance of the non-resonant line is then equal to its characteristic impedance (see Long-Lines). The lower system in Fig. 36 L is called a "J" antenna.

An antenna must radiate as much energy as possible in the form of an electromagnetic wave. In the case of a resistor, we have spoken of its ability to dissipate energy in the form of heat by using the term "resistance" (= watt-lost divided by current-squared). It is common practice to use a fictitious "resistance," called *radiation-resistance*, to measure the amount of radio power sent out from an antenna. All other factors being the same, the greater the *radiation-resistance*, the better the antenna. The value for a half-wave antenna in free space, measured at the *center* of the wire where the current is greatest, is 73.2 ohms. The value changes as the antenna is moved closer to the ground, because energy reflected from

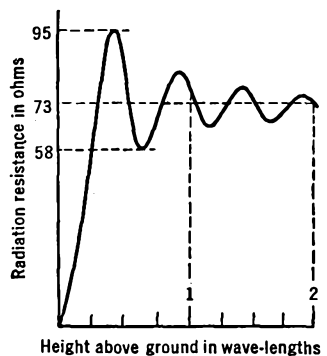


FIG. 36 M. Radiation-resistance of a half-wave horizontal antenna at various distances above the ground

the ground sets up voltages in the antenna. See Fig. 36 M. The value, measured at the *end* of a half-wave antenna in free-space is approximately 2,400 ohms. Other losses from an antenna, such as those due to ohmic resistance, corona discharge, and insulator losses are small, say 5 per cent of the power put into the antenna.

The half-wave antenna may be mounted vertically or horizontally. With the wire straight up and down, it radiates (and receives) equally well from all directions. When horizontal, however, it sends out more energy (and also receives better) from the direction at right angles to

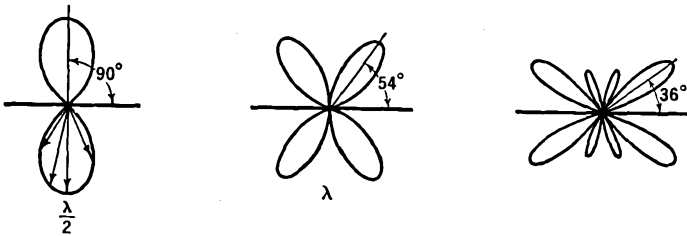


FIG. 36 N. Top view of the field patterns of straight wire, horizontal, isolated antennas of various lengths

the wire. The field patterns "laid down" by isolated antennas, one-half, one, and two wave-lengths long, are shown in Fig. 36 N. A line from the center of the antenna to the curved "lobes" is proportional to the strength of the signal radiated in that direction. It will be noticed that the half-wave antenna gives bi-directional, "broadside" radiation. When a longer antenna is used, the radiation is broken up into a whole lot of weaker radiations, scattered at various directions. In other words, if you want to direct the radiation (more or less sharply), use a quarter-wave antenna, but if you wish to broadcast the energy, use a longer one.

By combining half-wave antennas, at correct spacings and with their currents properly phased, strong radiation can be obtained either broadside to the array or in its line ("end-fire" systems). Figure 36 O shows the field patterns when eight vertical dipoles are used. In the end-fire system at the left, the currents in adjacent dipoles are 180° out-of-phase with each other and the pattern is fairly broad. At the right of Fig. 36 O, the currents in all dipoles flow in the same direction at the same time (in-phase) and a sharp broadside radiation takes place on both sides of the antenna. Figure 36 P shows the top view (the dots)

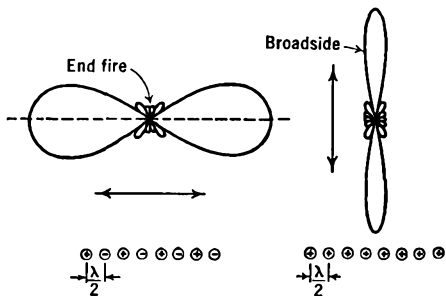


FIG. 36 O. Bi-directional patterns of vertical dipoles with half-wave spacings

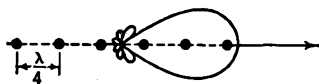


FIG. 36 P. Unidirectional pattern of vertical dipoles with quarter-wave spacings

of a row of vertical dipoles spaced one-quarter wave from each other and with currents in quadrature (90°) (max. in one, when min. current in next wire). In this case, a broad beam is obtained, but it is in only one direction, say east, and not along a line, say east-west. In Fig. 36 Q, the sharpness of the broadside antenna of Fig. 36 O and the uni-

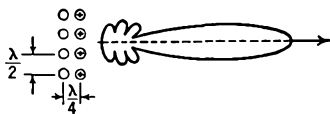


FIG. 36 Q. Sharp, unidirectional pattern, using parasitic wave reflectors behind a broadside antenna

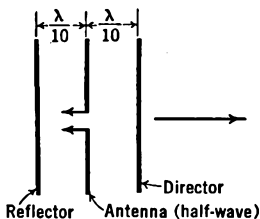


FIG. 36 R. Use of parasitic reflectors and directors with a half-wave antenna

directional feature of Fig. 36 P have been combined by using tuned wire reflectors one-quarter of a wave behind a broadside antenna. The more dipole and reflector wires used, the sharper the beam and the smaller the side lobes. Figure 36 R shows a half-wave antenna with two parasitic elements. This system is directive towards the right, in increasing amount as more and more directors are added (with the same spacing).

36.4 Coaxial Line Filters. It is possible to build filter circuits (see Chapter 7) out of resonant coaxial lines, of such a nature as to provide comparatively sharp cutoff; to pass certain frequencies and suppress

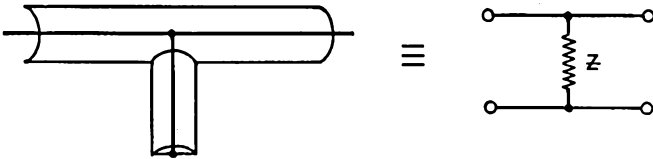


FIG. 36 S. A coaxial filter equivalent to a shunt impedance, Z

others. Figure 36 S shows the construction of a coaxial element which is the equivalent of a shunting impedance, and Fig. 36 T shows a possible structure for a series impedance. The dimensions are such that the branches operate essentially as quarter-wave resonant lines. Combinations of these elements have been used as high-pass filters in the frequency range from 40 to 100 Mc. Obviously, the physical dimensions will be less as the frequency is raised.

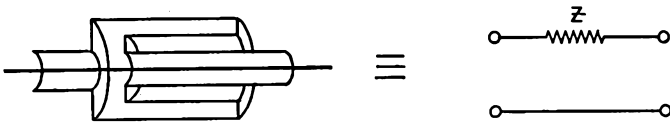


FIG. 36 T. A coaxial filter equivalent to a series impedance, Z

CHAPTER 37

U.H.F. TRANSMITTERS AND RECEIVERS

37.1 Introduction. Now we are to consider the transmitters and receivers for use at frequencies higher than 30 megacycles, corresponding to wave-lengths shorter than 10 meters. The division at 30 Mc. is entirely arbitrary and must *not* be considered as a sharp boundary line.

The circuits used at the lower "communications" frequencies and at the ultra-high frequencies are very much the same, but the constructional features change progressively as the frequency becomes higher and higher. For example, the physical size of a grid condenser in a receiver is of minor importance at low frequency, despite the small capacitance which exists between it and its surroundings (the grounded chassis or shields). As the frequency increases, the reactance ($1/2\pi fC$) of this shunting capacitance becomes smaller and smaller. Very high frequency currents will be shunted to the ground in appreciable amount. Then, the voltage on the grid of the tube will be small and the grid-tuning circuit will be heavily loaded, have a low Q , and poor selectivity. In other words, the set will not operate properly unless the condenser is made physically small and is kept well away from the ground.

At the higher frequencies, the size and relative location of every part of a transmitter or receiver becomes of great importance.

Furthermore, as the frequency becomes higher, the capacitances and inductances needed to tune the circuits become smaller and smaller. A single, short, straight wire instead of a coil and condenser will be sufficient if the frequency is very high because it has the necessary distributed inductance and capacitance. There is capacitance between every point on the wire and all of the objects which surround it.

It is to be remembered that, as the frequency increases, the currents travel more and more on the skin of the conductors. The resistance can only be kept down by using conductors with large surface areas. Large copper tubes, isolated from other parts of the circuit as much as possible, are used both to maintain high Q and to give freedom from mechanical vibration. Quarter-wave concentric lines prove to be particularly desirable as tuning circuits at the very high frequencies.

To build a transmitter for the very high frequencies (say 300 Mc.) one needs to be as much a mechanic as an electrician; and the physical appearance of units, with their large metal tubes and concentric lines, is very different from that of the units used for communication frequencies where lumped inductors, capacitors, and resistors are connected to each other by small wires.

In the ultra-high frequency region, the physical dimensions of the circuits become comparable with the wave-lengths to be handled. Standing-waves are common, with the result that the currents and voltages are not of the same magnitude at one point in a wire as they are at another (see the chapter on Short-Lines).

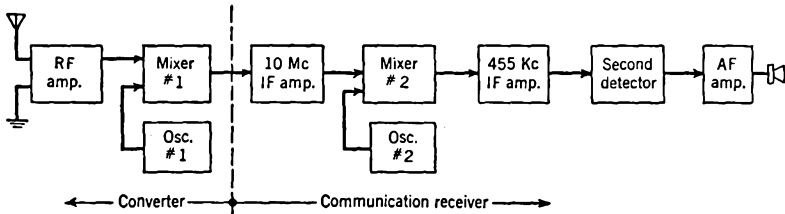


FIG. 37 A. Block diagram of a 5-meter, double-superheterodyne receiver

As the frequency is increased to the order of one hundred million cycles per second, the time for the electrons to travel from the filament to the plate in a vacuum tube becomes an appreciable part of one cycle. A voltage on the control grid may change the number of electrons flowing to the plate, but this change will not affect the plate current until some time later. Thus the transit time of the electrons can be thought of as the equivalent of an inductive lag in an ordinary circuit. If the time delay exceeds one-quarter of a cycle, it will act capacitatively. The tube capacitances and the transit time effects can be reduced by building tubes with smaller electrodes and by bringing out their leads so that grid and plate wires are distant from the cathode and from each other. The "acorn" and "doorknob" tubes (954, 955, 316A, 368A) are of this class.

37.2 U.H.F. Receivers. Superheterodyne receivers are used extensively for frequencies up to 60 Mc. ($\lambda = 5$ m.) and occasionally for frequencies up to 100 Mc. (3 m.). The customary procedure at 60 Mc. is to use two intermediate frequencies, as in Fig. 37 A. A *converter* is employed to amplify the incoming signal and replace its carrier frequency with an "intermediate" value of say 10 Mc. (30 m.). This i.f.

is then fed into a regular short-wave receiver tuned to the 10 Mc. Of course, a special i.f. amplifier tuned at 10 Mc. (or other suitable fixed value) may be used instead of the usual r.f. stages of a regular receiver. Since the f.m. and a.m. receivers differ only in the last i.f. and in the detector stage, the addition of a converter to the regular set is all that is required. The circuit of an excellent 56-mc. converter with an r.f. amplifier is shown in Fig. 37 B.

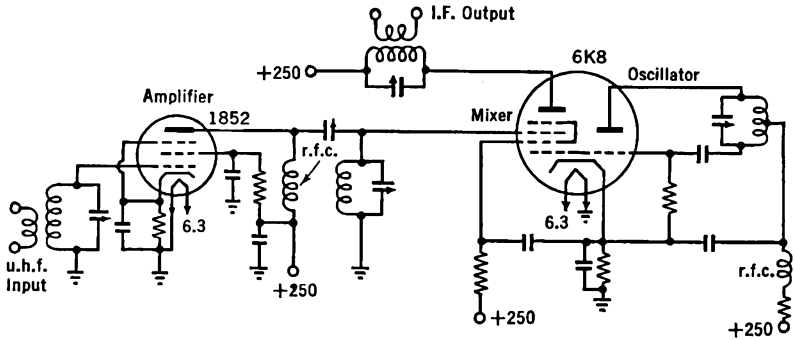


FIG. 37 B. Circuit of an u.h.f. amplifier and converter

Super-regenerative circuits are often used for the reception of frequencies from 100 Mc. to 300 Mc. (3 m. to 1 m.). A circuit using a self-quenched detector and two a.f. stages is shown in Fig. 37 C.

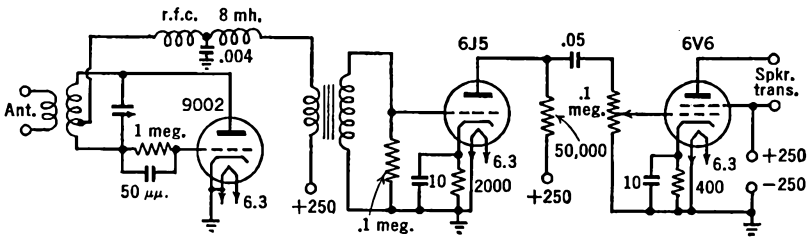


FIG. 37 C. Circuit of an u.h.f. super-regenerative receiver

At still higher frequencies, the circuits must be of the linear type and the tubes must be of special design. Figure 37 D shows a quarter-wave concentric line used as the grid-tuning circuit of a simple "acorn" tube detector.*

* Circuit constants and constructional details for receivers and transmitters like those of Figs. 37 B, C, D and E will be found in The Radio Amateur's Handbook and in The "Radio" Handbook.

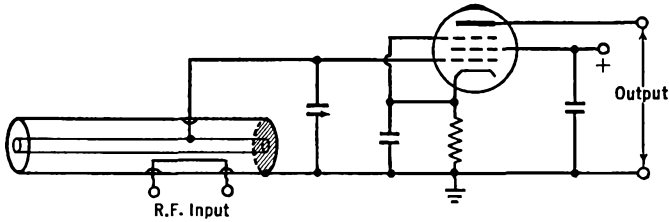


FIG. 37 D. An ultra-high frequency receiver using a quarter-wave concentric line in the tuning circuit

37.3 An U.H.F. Transmitter. The circuit diagram of the u.h.f. transmitter of Fig. 37 E looks the same as though the unit had been built for operation at much lower frequencies. There is a crystal oscillator (lower half of the 7N7 tube) whose plate tank LC is tuned to twice the fundamental frequency of the crystal. The r.f. voltages across LC are fed through C_1 to the grid of the first amplifier (upper half of the 7N7 tube). The h.f. is then coupled through a tuned transformer to the 7C5

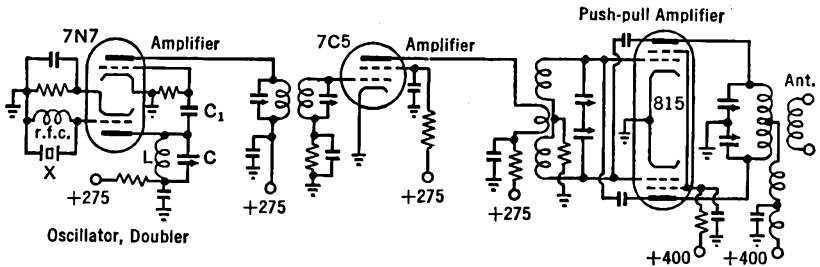


FIG. 37 E. Circuit diagram of an u.h.f. transmitter

beam-power second-doubler amplifier and from there to the neutralized push-pull amplifier using an 815 double-beam-power tube. At the ultra-high frequencies, the tuning condensers are small both electrically, (10 to 100 $\mu\mu\text{f.}$) and physically, but the coils, while small electrically, are comparatively large in physical dimensions, the more so the higher the frequency. Around 100 Mc., for example, the 815 tank coil may consist of a foot and a half of quarter-inch copper tubing bent into a circle six inches in diameter, with a quarter of an inch spacing between turns. This gives the completed transmitter an entirely different appearance from one operated at lower frequencies. At the higher frequencies, the tank circuit of the 815 tube may well be replaced with a parallel-line linear-circuit in order to attain lower losses and higher output.

37.4 The Use of Linear-Circuits in U.H.F. Oscillators. The use of a quarter-wave parallel-wire line as a tuning unit has been discussed in the chapter on Short-Lines, where it was pointed out that these "circuits" have comparatively high Q even at the higher frequencies. Their great length ($\lambda/4$) prevents their widespread use at lower frequencies. But when the wave-length is only 1 meter or thereabouts, the line has reasonable physical dimensions. And it is just in these regions that the requirement of high Q becomes difficult to attain with ordinary circuits.

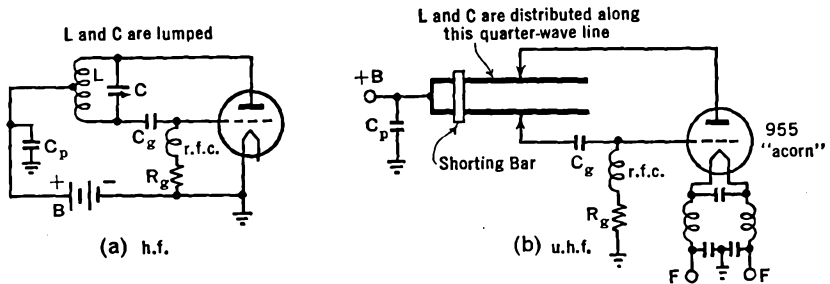


FIG. 37 F. Comparison of low and high frequency ultraudion oscillator circuits

Our purpose now is to learn how to connect a quarter-wave line to a vacuum tube to form an efficient oscillator for the production of ultra-high frequencies. The student should now turn back to Fig. 14 E and study the parallel-fed ultraudion oscillator circuit for a few minutes. Series feed is also possible, as in (a) of Fig. 37 F. The lumped L and C of this circuit is replaced by the quarter-wave line of (b) for u.h.f. Compare (a) and (b) part by part. In general, the LC circuits used in the various types of oscillators of Chapter 14 can be replaced by quarter-wave lines.

In the u.h.f. oscillator of Fig. 37 F, large copper or brass tubes may be used for the line. The lead wires to the tube are made as short as possible. The shorting bar can be shifted along the line (within limits) to change the frequency. The plate and grid leads are tapped onto the line as close to the shorted end as possible in order that, for a given voltage from the tube, the open-end voltage may be as high as possible. The effect is shown in Fig. 37 G. High voltage at the open end means strong electrostatic fields, and this means large electrostatic energy. This is similar to the action of a large flywheel in stabilizing the rotation of a machine. It results in frequency stability in the electrical

case. On the other hand, if the tap is too close to the shorted end, the energy from the tube may not be sufficient. Thus, if a loop of wire is placed near the line to pick up energy for delivery to an antenna, the power output may be so great that the feedback voltages of the tube

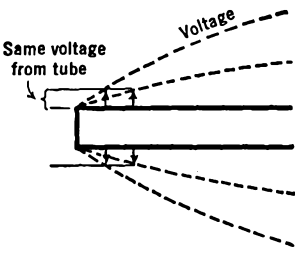


FIG. 37 G. The effect of tapping onto a quarter-wave line close to the shorted end

cannot keep the large storage " tank " filled. Then oscillations cease; the circuit is overloaded. In practice, the taps are shifted toward the shorting bar, with full load on, until oscillations cease. The tap is moved back a little, or the power supply on the tube is increased until oscillations again take place. It might be added that the impedance of the line is the same when looking in either direction from the taps.

A small capacitance may be connected across the open end of the line in Fig. 37 F. It is then necessary to shorten the physical length of the line in order that its electrical length shall remain one quarter-wave. The losses in the condenser lower the Q of this tuning circuit appreciably. In one application, the capacitance at the open end consists of the " dees " of a cyclotron. R.F. potentials of

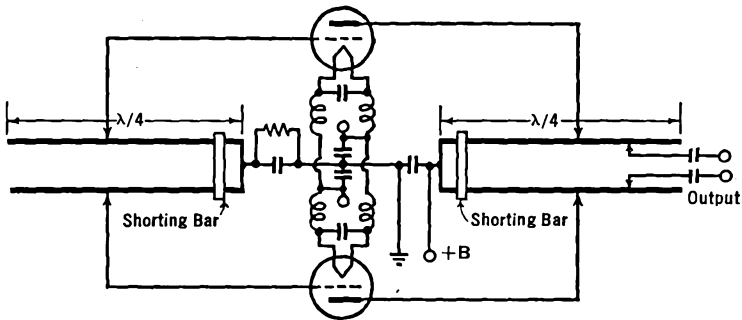


FIG. 37 H. A tuned-grid, tuned-plate, push-pull u.h.f. oscillator

the order of several hundred thousand volts have been built up between the condenser plates (between the dees) by this method.

It will be noticed in Fig. 37 F, that the filament leads of the u.h.f. circuit contain coils and condensers. The effective or electrical length of this circuit is one-half wave-length. Then the FF terminals will be at the same potential as that at the shorted end of the line. In

practice, this condition is found by changing the coils until maximum power output and stability are realized. In general, at the ultra-high frequencies, it is necessary to tune not only the plate and grid circuits but also the filament circuit. Usually, only two of the three circuits are tuned with high- Q resonant lines.

Figure 37 H shows a push-pull circuit in which the grid and plate circuits are tuned with quarter-wave lines, while Fig. 37 I shows a

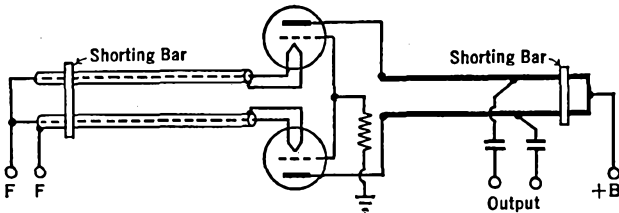


FIG. 37 I. A tuned-filament, tuned-plate, push-pull u.h.f. oscillator

similar circuit with the filament and plate circuits tuned in this manner. These circuits have the advantage of symmetrical structure and increased power (two tubes). Furthermore, in Fig. 37 H, the grid line is not loaded by the output and hence has a high- Q . A Q of 500 or more is necessary in the grid circuit for good frequency stability, whereas a Q of 12 or more is sufficient in the plate circuit. Hence, push-pull circuits like that of Fig. 37 J sometimes use a line in the grid

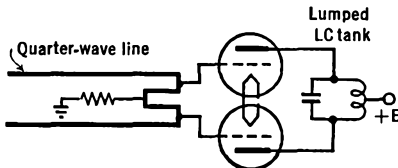


FIG. 37 J. A line-tuned-grid-tank, lumped-tuned-plate-tank, push-pull u.h.f. oscillator

circuit and a lumped LC tank plate circuit. It will be noticed in this figure that the grid lead wires are made short by folding the quarter-wave line. Further details of this type of oscillator may be seen in Fig. 37 K.

There are two alternative ways of saying the same thing:

1. A circuit loses very little energy in the ohmic, hysteresis, eddy current, dielectric, or radiation forms;
2. A circuit has high- Q .

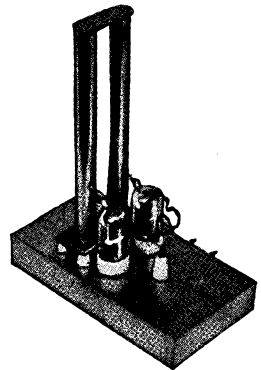
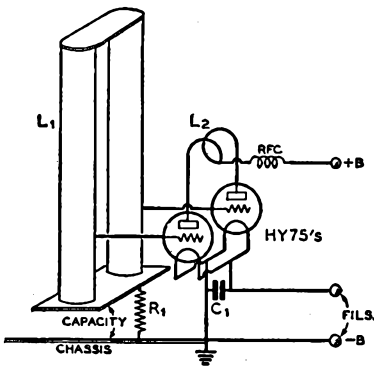


FIG. 37 K. A push-pull 224 Mc. oscillator and its semi-schematic diagram. (From The "Radio" Handbook, 8th edition)

The Q of a concentric line is generally higher than that of a parallel-wire line because all energy remains in the concentric line whereas some energy is lost by radiation from the "open" parallel-wire line. Above 300 Mc., the losses of the latter become appreciable and Q drops rapidly with increasing frequency. The use of concentric lines becomes essential.

Figure 37 L shows a tuned-plate, tuned-grid oscillator which uses a concentric line to tune the grid circuit. Compare with Fig. 14 D, for lower frequencies. The circuit of Fig. 37 L may be tuned by means of condenser C or by the use of a sliding piston at the shorted end of

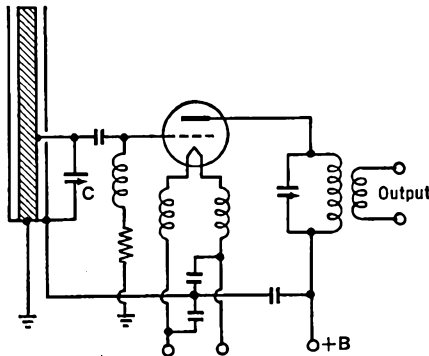


FIG. 37 L. A concentric line as the resonant element of the grid circuit of a t.g.t.p. oscillator

the line. If a metal piston is used, great care must be taken that spring contacts insure good contact with both the outer cylinder and the central rod.

Figures 37 M and 37 N show the photograph and circuit of a com-

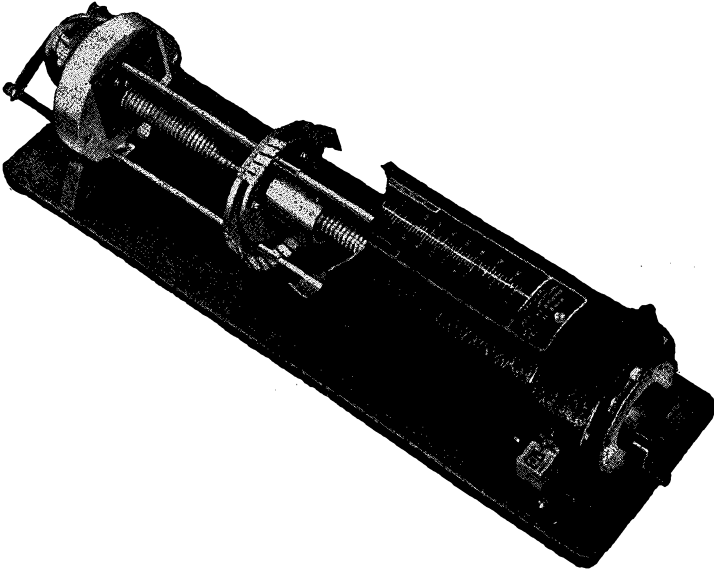


FIG. 37 M. Cut-away view of the G-R u.h.f. oscillator. (Courtesy of the General Radio Co.)

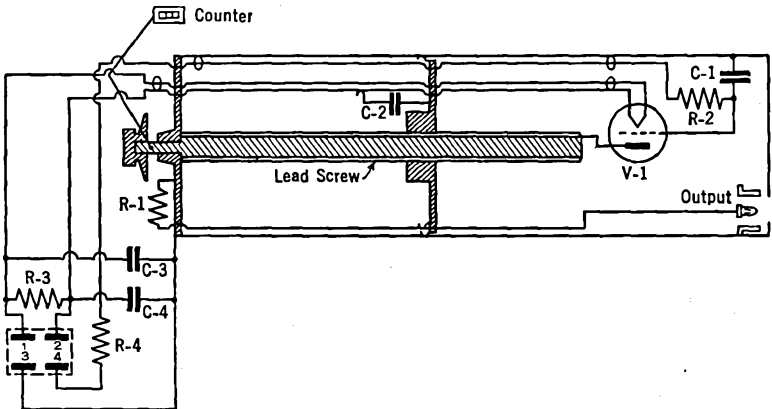


FIG. 37 N. Schematic circuit diagram for the u.h.f. oscillator of Fig. 37 M

mercial u.h.f. oscillator for the frequency range from 150 to 600 Mc. ($\lambda = 200$ to 50 cm.). The frequency is changed by a variable piston, and is marked on a scale along the top of the concentric line. A type 316A tube is used; 1 to 4 watts are developed, the smaller output at the higher frequency.

Figure 37 O shows an u.h.f. oscillator circuit for use up to 1,700 Mc. (wave-length about 17 cm.), while Fig. 37 P shows a "door-knob" tube suitable for this circuit.

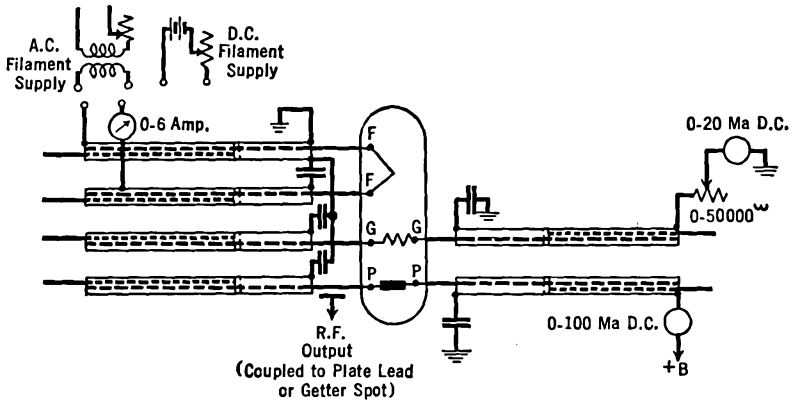


FIG. 37 O. Concentric lines are used to tune the filament, grid, and plate circuits of a 368A "door-knob" tube

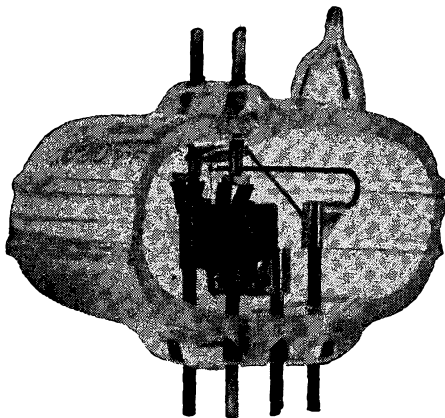
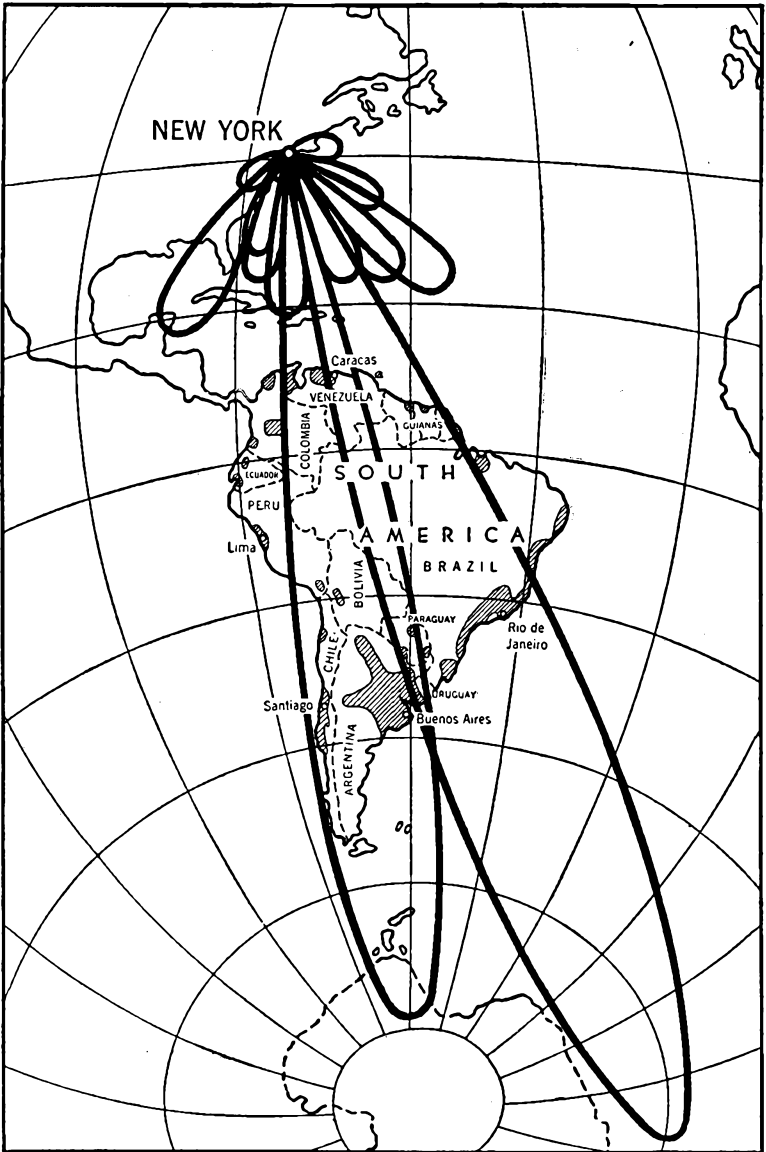


FIG. 37 P. Type 368A tube



Field patterns from stations WCBX and WCRC
 (See *Proc. I.R.E.* 30, 118, Mar. 1942)

CHAPTER 38

MICROWAVES

38.1 Introduction. Radio waves whose length is less than approximately 1 meter are variously designated as *microwaves*, quasi-optical waves, centimeter or decimeter waves, and hyper-frequency waves. In the preceding chapter, a few oscillators were described which can produce these waves. In this chapter, additional methods of generating microwaves will be described, together with a brief treatment of their peculiarities.

38.2 Positive-Grid Oscillators. A type of oscillator was discovered in 1920 by Barkhausen and Kurz, which is variously known by the name of *B-K*, retarding field, or positive-grid oscillator. It differs from the usual oscillator in that the grid, instead of being negative, is positive; while the plate, instead of being positive, is at the potential of the filament or somewhat negative thereto. A majority of the electrons from the filament are accelerated toward the grid by its positive potential. They pass through its meshes into the retarding field between the grid and the plate and stop just before reaching the plate. Reversing their direction, they are accelerated back toward the grid. As before, a majority pass through the meshes and enter the retarding field between the filament and grid. Again they stop, just in front of the filament, and, replenished by a few new electrons from the filament, return toward the grid. Thus the cloud of electrons oscillates back and forth between the filament and the plate, picking up a few new electrons from the filament and losing a few to the grid each cycle.

An explanation of the processes whereby the oscillating electrons extract energy from the batteries and deliver it to associated high frequency circuits is not at all easy to give. The exact mathematical treatment is very complicated and does not assist greatly in the practical operation of the oscillators. Suffice it to say that, due to the pendulations of the electrons back and forth about the grid, high frequency oscillations are produced in a tuned circuit connected

across the grid and the plate. A circuit of this type is shown in Fig. 38 A.

The period of the oscillations which are generated is equal to the time taken by the electrons for one complete excursion inside the tube. Because the electrons travel very fast, this time is exceedingly small;

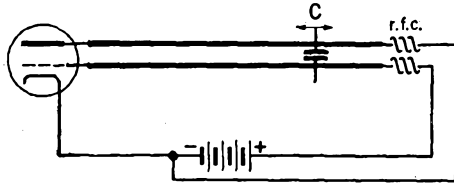


FIG. 38 A. A Barkhausen-Kurz oscillator circuit

hence the frequency of the radio waves is very high. The resonant circuits should, therefore, be of the linear-circuit type, as shown in Fig. 38 A. The intensity of the oscillations can be increased by using a double-ended tube, as in Fig. 38 B, where there are two wires from the plate and two from the grid. These are taken out on opposite sides of the glass envelope.

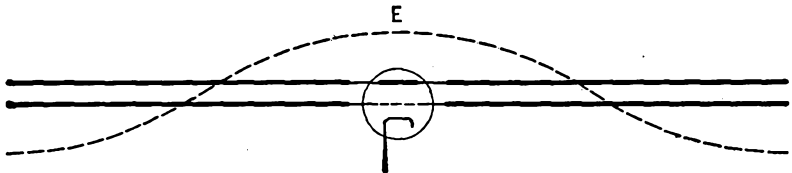


FIG. 38 B. Double tuning of a B-K oscillator

Peculiar non-harmonic oscillations are sometimes generated in B-K tubes. They have been found to be due to parasitic oscillations whose frequencies correspond to the natural electrical periods of the electrode structures inside the tubes, such as the filament lead wires and so on. These are, generally, of comparatively long wave-lengths.

The wave-lengths radiated from these oscillators are very short, ranging from a few meters down to approximately 10 cms. If the grid is equidistant from the filament and plate, and if the plate is at the same potential as the filament, then the following simple equation can be used to predict the wave-length λ (cms.) of the oscillations:

$$\lambda = 1000 \frac{D}{\sqrt{E_a}},$$

where D is the inside diameter of the cylindrical plate, in cms., and E_0 is the potential of the grid, in volts.

Referring now to Fig. 38 A, let us measure the wave-length produced as the condenser across the two parallel wires is moved outward

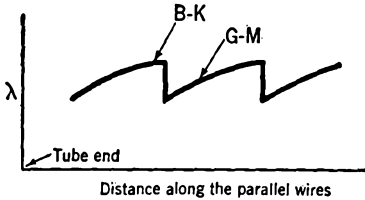


FIG. 38 C. Effect of moving condenser C of Fig. 38 A along the parallel wires

from the tube. The curve in Fig. 38 C shows that for a short distance, marked $B-K$, the wave-length generated is independent of the external tuning circuit. Suddenly, however, the wave-length drops to a smaller value, after which it rises along a line, marked $G-M$, to its former value. In the $G-M$ condition, the external circuit obviously influences the oscillations inside the tube so that they take place differently than they did by the pure $B-K$ method. This operating condition was first discovered in 1922 by Gill and Morell (hence the initials $G-M$). It is found in practice that the $G-M$ oscillations are not only shorter than the $B-K$ type but also are very much more intense. Their wave-length, however, is subject to changes in the external system, whereas the $B-K$ oscillations are determined exclusively by the voltages upon the given tube.

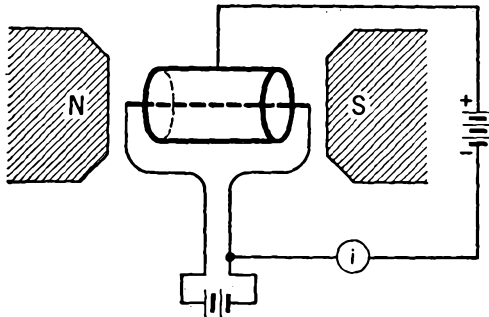


FIG. 38 D. A magnetron

38.3 The Magnetron. Figure 38 D shows a magnetron tube. This consists of a cylindrical plate and axial filament in a highly evacuated tube, located between the poles of a strong magnet. The filament, the plate, and the magnetic lines of force are all in the same direction. In the absence of the magnetic field, electrons from the filament travel

outward to the plate, radially like the spokes of a wheel. With a small magnetic field, the electron paths are curved. At a critical field strength, the electrons just miss the plate. At this point the plate current i suddenly drops to zero. This cutoff is indicated at H_c in Fig. 38 E.

38.4 The Magnetron Oscillator. Let us suppose that the magnetic field has been adjusted to the cutoff value described in the preceding

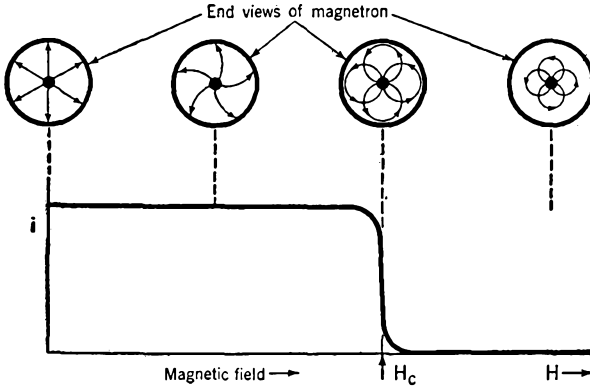


FIG. 38 E. Plate current i of a magnetron as the magnetic field strength H is changed section. It will be found that very high frequency radio waves are then generated. Their frequency is determined by the time it takes an electron to move around a heart-shaped path, from the filament outward toward the plate and back again toward the filament. This time-of-running can be made very short by applying high voltages to the tube. Of course, when two to three thousand volts are used to accelerate the electrons, strong magnetic fields are required to curve the electrons sufficiently that they just miss the anode. By using high voltages, strong magnetic fields and very small-diameter anodes, however, the world's shortest undamped radio waves have been generated. These are just a little under one-half centimeter in length.

The wave-length which will be generated can be predicted from the following equation:

$$\lambda H_c = 13,000,$$

where λ is the wave-length in centimeters and H_c is the field strength in oersteds. This is only an approximate equation, the constants ranging from 10,000 to 16,000, according to the temperature of the filament.

Figure 38 F shows a *split-anode* magnetron. The shaded area represents a tuned circuit. This can be sufficiently small for the short waves generated that it can be built right inside the vacuum tube. With the split-anode type of magnetron, the tuned circuit interacts upon the electrons in such a way that they move along a spiral trajectory, as indicated at the right of the figure. Magnetrons with three,

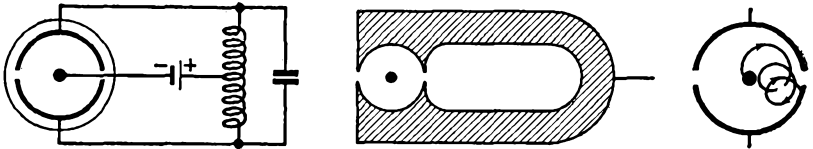


FIG. 38 F. The split-anode magnetron

four, five, and six slits have been constructed. The three-slit magnetrons have been used to produce three-phase high frequency currents.

The electrons which return toward the filament often bombard it with sufficient energy to raise its temperature appreciably and cause the emission of a larger number of new electrons. Thus, just at the beginning of the cutoff, the plate current can be made to rise in the manner shown at (b) in Fig. 38 G. The intensity of the oscillations becomes increasingly great from (a) toward

(b) but so does the danger of burning out the filament. Hence in practice, the tubes are generally operated at a point just to the right of (a). The intensity of the oscillations can be increased very much, either by *tilting* the axis of the tube to about 5° from the direction of the magnetic lines of force, or by the addition of *end-plates*. An end-plate magnetron is shown in Fig. 38 H, where it will be observed that one of the end-plates is positive and the other negative. The electric field between the end-plates causes the electrons to move axially while they are executing their customary circular motions. This is the same net result as produced by tilting a simple tube in the magnetic field. Apparently, for maximum radio frequency output, the electrons must not be allowed to accumulate around the filament after their excursions to the plate and back. A more advanced magnetron has been built in which the end-plates were divided up into a number

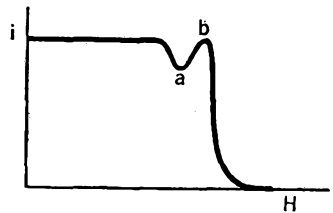


FIG. 38 G. The effect (at a b) of electron bombardment of the filament

of segments. Then, as the electrons rotated in their orbits while approaching the end-plates, they induced charges on the segments. The resultant u.h.f. potentials are built up to considerable magnitude by attaching linear circuits to the segments.

The place of the magnetron in the present-day picture of microwaves can be simply summarized as follows: the tube will produce the shortest known wave-lengths, but, because of the necessary high voltages and strong magnetic fields, it is a comparatively heavy and cumbersome unit.

38.5 Cathode-Ray Oscillators.—

The Klystron. Let a parallel beam of electrons, moving with constant velocity, pass through two wire gauzes connected to a high frequency oscillator, as in Fig. 38 I. The high frequency electrostatic field

between the grids is parallel to the electron stream and will accelerate the electrons at one moment, retard them at another. We assume that the change of velocity of the electrons produced in this manner is an appreciable, but not too large, fraction of their original velocity. The electrons which leave the grids at the higher velocity will catch up with electrons ahead of them, while those at lower velocity will be bunched

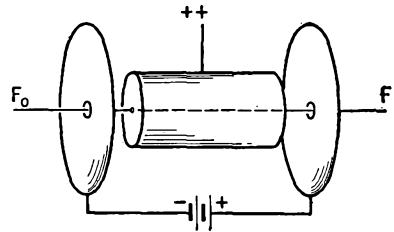


FIG. 38 H. An end-plate magnetron

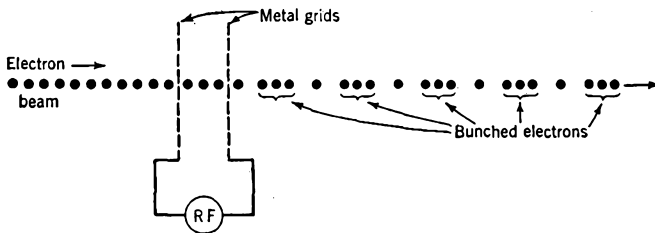


FIG. 38 I. Velocity modulation of a cathode ray

with those behind. Thus the emerging electrons will be grouped together in bunches along the direction of motion. This is referred to as *velocity modulation*.

If a velocity-modulated beam of electrons passes through two gauzes, as at 2 in Fig. 38 J, the higher and lower speed electrons will induce different amounts of potential between the gauzes. These al-

ternating potentials may be strengthened by an LC circuit tuned to the frequency of the bunched electrons, i.e., to the frequency of the r.f. generator at 1 in this figure.

Next, it is desired that the h.f. voltages of 2 in Fig. 38 J shall be fed back to 1 in such a phase and strength that they will serve to replace the r.f. generator. Then, if energy conditions are satisfactory,¹ a *self-generating* device will be available. Inasmuch as the electron transit time down the tube is very small, it is obvious that the scheme is useful at the ultra-high frequencies.

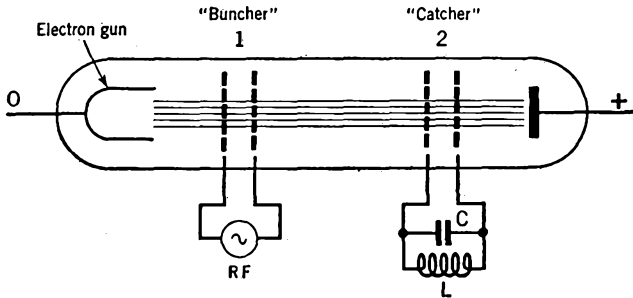


FIG. 38 J. The principle of the klystron

We recall that, at ultra-high frequencies, the "circuits" should be of the concentric-line type in order that the losses shall not be too great, i.e., that Q shall be high. As the frequency is raised higher and higher, the distance between the inner and outer conductor of the concentric line becomes more and more nearly comparable with the wave-length involved. It is necessary to consider not only the length but also the transverse dimensions, because standing waves can exist in the air between the inner and outer conductors as well as longitudinally. In fact, the inner conductor can be removed, leaving only a hollow tube, and still have suitable resonance conditions. Not only hollow tubes, but many other shapes, such as spheres, ellipsoids, etc., have been used. They are called *cavity resonators*. The electromagnetic field patterns inside these systems are often complicated (they are in three dimensions). Their study follows the same lines of reasoning used in the study of the acoustics of rooms, where the sound waves reverberate back and forth from the walls, floor, and ceiling. If the physical dimen-

¹ The theory by which more energy is given up by an electron to the tuned circuit than is given to it by the "buncher" is not easy to explain in non-mathematical form.

sions are properly chosen for the wave-lengths involved, three-dimensional standing-wave patterns are set up which greatly strengthen the sound intensity; and similarly strengthen the electric and magnetic fields in the electrical case. Cavity resonators may be likened to three-dimensional resonant short-lines, while the wave-guides (see later section) are like long-lines.

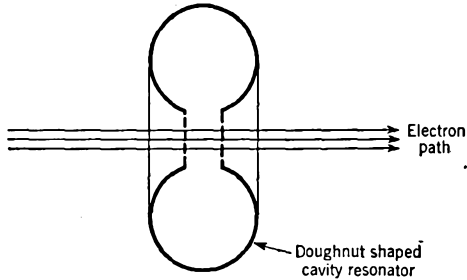


FIG. 38 K. A cavity resonator

Cavity resonators have been used as the tuning "circuits" of the buncher and catcher systems, in the manner shown in Fig. 38 K. A complete oscillator of this type, called a *klystron*, is shown in Figs. 38 L and 38 M.

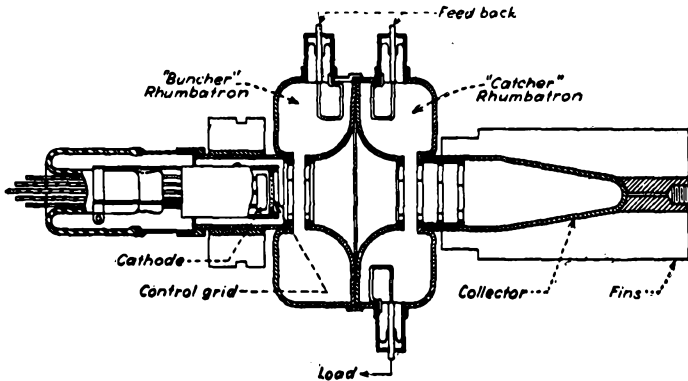


FIG. 38 L. Cross-sectional view of a klystron. (Courtesy of *Electronics*)

The method of feeding energy from the catcher to the buncher, and also of removing energy to a load, such as an antenna, is shown in Fig. 38 L. The distance between the grids of the buncher is made less than the distance traveled by an electron in a half-cycle, i.e., less

than $v\lambda/2c$ centimeters apart, where v = electron velocity, c = velocity of light, λ = wave-length generated. The grids of the catcher may be spaced $v\lambda/4c$ cms. apart. The Q of the cavity resonators is approximately 1,000. Considerable power has been generated at microwavelengths as short as 10 cms. The klystron can also be used as an amplifier and as a detector.

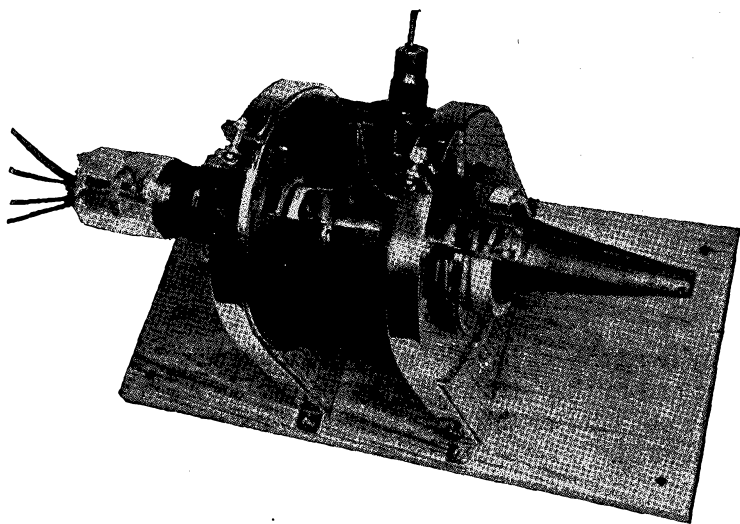


FIG. 38 M. Photograph of a klystron (cutaway). (Courtesy of *Electronics*)

38.6 Wave-Guides. An electromagnetic wave, traveling outward from a transmitter on the earth's surface, is *guided* by a double layer of conducting materials, i.e., the ground and the ionosphere, to curve and pass beyond the bulge of the earth. Let us imagine that we shall build a small scale model of this double conducting layer, out of sheets of tin, galvanized iron, brass, or copper. We must use a tiny dipole antenna and a very short wave-length. For simplicity, we shall not curve the metal plates into spherical form but shall leave them flat. It might profit us to keep the waves from spreading sideways, by using a second set of plates at right angles to the first. This would give us a long rectangular metal box which would confine the waves and, by reflecting them back and forth, as in Fig. 38 N, force them to travel down the length of the box. The waves would be guided; this is a *wave-guide*. A cylindrical or an elliptical metal pipe may also be used.

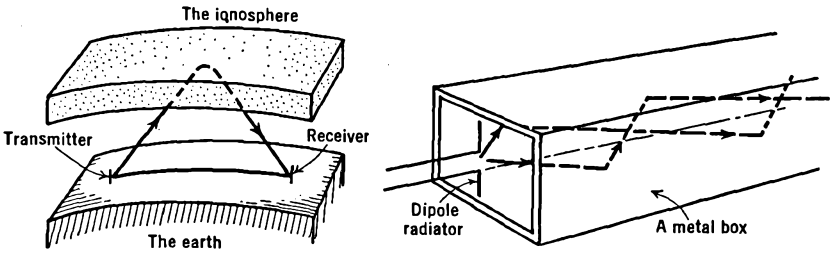


FIG. 38 N. Two shapes of conducting surfaces which will guide electromagnetic waves

It is necessary to understand that the same guide can operate with several types or *modes of vibration* of the three-dimensional electric and magnetic field patterns. Fig. 38 O shows various methods of feeding energy into a rectangular wave-guide, together with the resultant field patterns of the E_{11} and the H_{01} waves inside the guide. The elec-

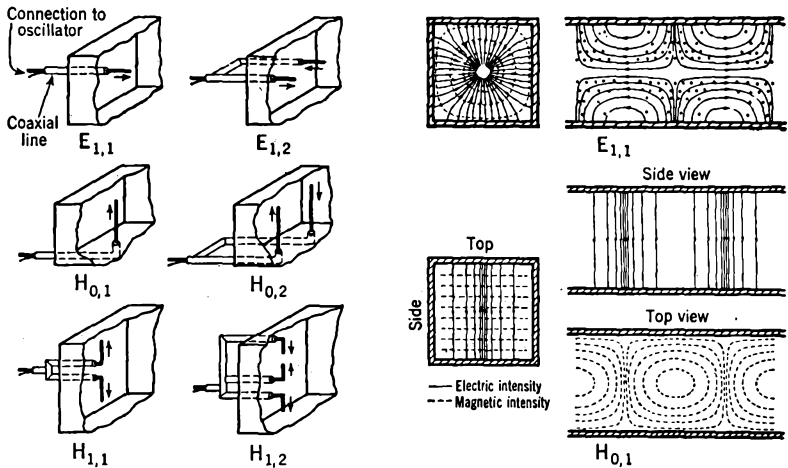
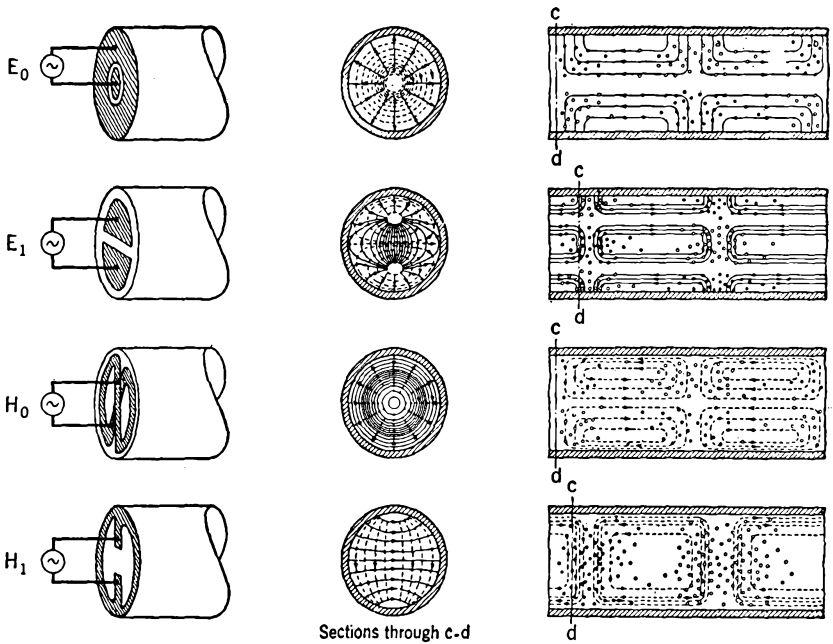


FIG. 38 O. Methods of launching electromagnetic waves into a rectangular wave-guide, together with the E_{11} and H_{01} field patterns. (See references to Barrow at end of chapter)

tric fields are shown by solid lines, the magnetic fields by dotted lines or by small dots and circles. These are the patterns at a given instant; actually, the waves are in rapid motion down the guide at velocities somewhat less than that of light. In Fig. 38 P, the structures for launching waves down a cylindrical wave-guide are shown, together with the corresponding field patterns, in the respective cases.



Sections through c-d

FIG. 38 P. Various feeding methods and the resultant field patterns for a cylindrical wave-guide. Electric lines of force, solid; magnetic lines, black dots when toward observer, small circles when away. (See references to Southworth at end of chapter)

The same electrode structures shown in Figs. 38 O and 38 P can be used for the reception of their corresponding waves, the oscillator being replaced by a crystal or diode detector. Figure 38 Q shows a detector mounted in a resonant cavity of a cylindrical guide for the reception of H_1 waves. In order that the reception shall be strong, the electrode used must not only be of the same type as that used at the

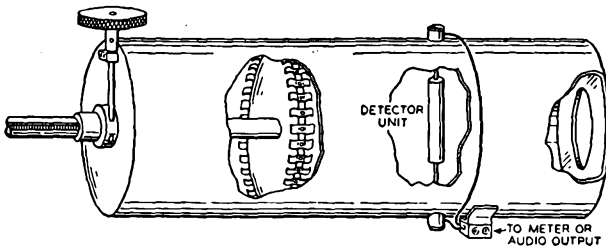


FIG. 38 Q. A receiver for the H_1 type of waves in a cylindrical guide. (Southworth; Bell System Tech. Jr. April, 1936)

transmitter, but it must also be oriented in the same direction. Different types of waves may thus be transmitted down the same tube and sorted from each other at the receiving end.

It is only possible to transfer energy down a wave-guide when the wave-length is sufficiently short. As shorter and shorter wave-lengths are applied to the end of a guide, a critical value or cutoff wave-length is found. All waves shorter than this will pass down the tube, all longer waves will not; the system acts like a high-pass filter. Table 38 A gives the equations for the cutoff frequencies. It will be observed

TABLE 38A — CUTOFF WAVE-LENGTHS

<i>Cylindrical Wave-guides</i>		<i>Rectangular Wave-guides</i>		
	$\lambda =$	$\lambda =$	When $a = b$	
E_0^*	$1.31 d\sqrt{\mu\epsilon}$	E_{11}	$\frac{2ab}{\sqrt{a^2 + b^2}}$	1.41 a
E_1	$0.82 d\sqrt{\mu\epsilon}$	E_{12}	$\frac{2ab}{\sqrt{4a^2 + b^2}}$	0.9 a
H_0	$0.82 d\sqrt{\mu\epsilon}$	H_{01}^*	$2b$	2.0 a
H_1	$1.71 d\sqrt{\mu\epsilon}$	H_{11}	$\frac{2ab}{\sqrt{a^2 + b^2}}$	1.41 a

$a, b =$ inside height and width of rectangle
 $\mu = \epsilon = 1$

$d =$ diameter of pipe

$\mu\epsilon =$ permeability and dielectric constant of material inside the guide. For air $\mu = \epsilon = 1$.

$\lambda =$ wave-length in free space. Inside the guide, the waves are shorter, due to their lower velocity.

* Frequently used modes of vibration.

that the wave-length must be approximately equal to or less than the opening of the pipe before energy will pass down the guide.

When sufficiently short waves are used that the guide is reasonably small and not too costly, wave-guides prove to be unusually satisfactory as paths for electromagnetic energy because their losses can be made smaller (by proper operation) than with other forms of conducting systems. The loss of energy in a wave-guide depends on the mode of vibration and on the frequency. A typical *attenuation* curve

is shown in Fig. 38 R. Also, the loss depends on the metal used in the construction of the guide. In the case of an E_0 wave, the minimum attenuation in decibels per mile, is as follows: copper, 1.9; aluminum, 2.5; lead, 6.5; iron, 45. The value of 1.9 just cited may be compared with that of 8.3 for a two-and-one-half inch diameter copper coaxial line, and of 25 for a No. 6-gauge open line.

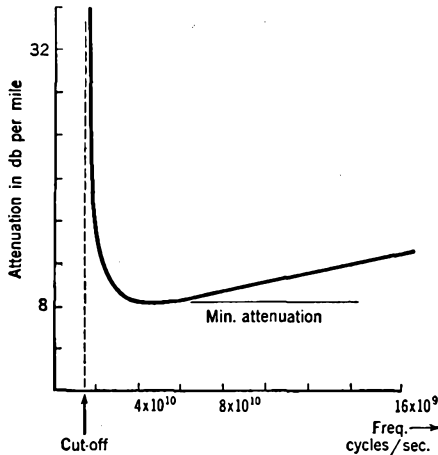


FIG. 38 R. Loss in a square wave-guide, H_{01} waves

The same guide may be used for the simultaneous and independent transmission of several waves. At the receiving end, short waves can be separated from longer ones by using a constriction in the wave-guide, or a diaphragm with a hole in it. Only waves shorter than that permitted by the cutoff values of Table 38 A will pass beyond the constriction or hole. Also, filtering action may be accomplished so as to pass one mode of vibration and restrict another. For example, if a series of radial wires are mounted in a plane at right angles to the axis of a cylindrical tube, the E_0 waves will be reflected whereas the H_0 waves will pass through and continue on down the tube. If a series of parallel wires are mounted transversely across the tube, H_1 waves will pass through at one position of the wires but will be cut off when the wires have been rotated 90 degrees. An examination of Fig. 38 P will show that this filtering action occurs when the electric vector of the electromagnetic wave is parallel to the conducting wires of the filter.

If the end of a wave-guide is left open, radiation will take place into the space beyond the mouth of the guide. The end of the guide

may be flared in a simple manner, as in Fig. 38 S, or in more complicated fashions, such as the exponential horn, in order to obtain either broadcast or highly directional radiation of microwave energy.

38.7 Properties of Microwaves. In many ways, microwaves act like light rays. They can be focused with lenses made of wax or paraffin.

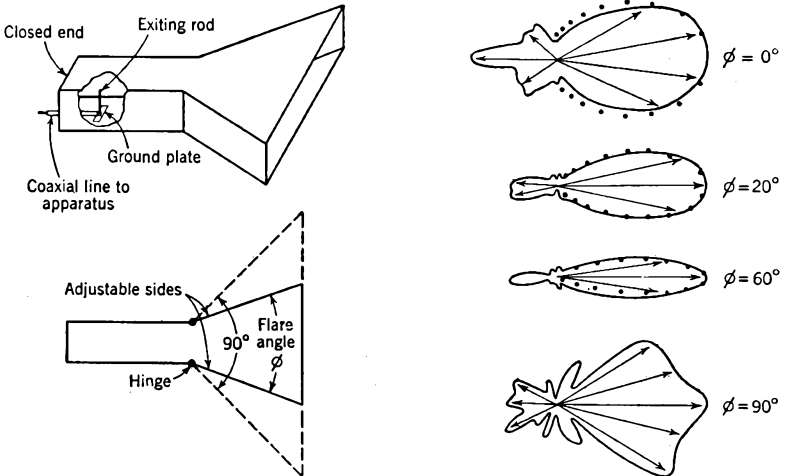


FIG. 38 S. An electromagnetic horn and its field patterns for various flare angles ϕ . (See reference to Barrow at end of chapter)

They can be refracted with prisms of these materials. They can be reflected from large, plane sheets of metal, as light is reflected from plane mirrors. Metal parabolas may be used to produce parallel beams. (The maximum diameter of the parabola should be greater than two or three times the wave-length if reasonably parallel beams are to be obtained.) The waves can be diffracted by slits in metal surfaces. Interferometers can be constructed for their use. In many ways, the name *quasi-optical* is justified. On the other hand, microwaves will pass through dry wood, whereas light waves will not. The dielectric constant of pure water for 1-meter waves is around 80; it is around 1.3 for 1-centimeter radio waves and for light waves. Apparently the electrical constituents of water molecules cannot vibrate faster than about 1 billion times each second. Likewise, the elementary magnets or "domains" of a piece of iron cease to follow an applied magnetic field if the oscillation rate is of this same order of magnitude.

READING LIST FOR CHAPTER 38

WAVE-GUIDES

- LORD RAYLEIGH, *Phil. Mag.*, **43**, 125 (1897).
SOUTHWORTH, *Bell Sys. Tech. Jr.*, **XV**, 284 April (1936).
BARROW, *Proc. I. R. E.*, **24**, 1298 Oct. (1936).
SOUTHWORTH, *Proc. I. R. E.*, **25**, 807 July (1937).
SOUTHWORTH, Jr. *App. Phys.*, **8**, 660 Oct. (1937).
BARROW and GREENE, *Proc. I. R. E.*, **26**, 1498 Dec. (1938).
CHU and BARROW, *Proc. I. R. E.*, **26**, 1520 Dec. (1938).
BARROW and LEWIS, *Proc. I. R. E.*, **27**, 41 Jan. (1939).

MAGNETRONS

- See KILGORE, Jr. *App. Phys.*, **8**, 666 Oct. (1937).

POSITIVE-GRID OSCILLATORS

- HOLLMAN, *Proc. I. R. E.*, **17**, 229 (1929).

CATHODE-RAY OSCILLATORS

- VARIAN, Jr. *App. Phys.*, **10**, 140 (1939).
HANSEN, Jr. *App. Phys.*, **9**, 654 (1938).
HAHN and METCALF, *Proc. I. R. E.*, **27**, 106 (1939).
HEIL, *Zeits f. Physik*, **95**, 752 (1935).
HOAG and FOSTER, *Phys. Rev.*, **51**, 60 (1937).

PROBLEMS AND QUESTIONS

1.1 — A 1000-volt battery is connected between the filament and plate of the vacuum tube shown in Fig. 1 B. Compute the velocity and energy with which the electrons strike the screen. Compare your computed velocity with that given in the graph of Fig. 1 C.

1.2 — A moving electron has an energy of 500 e.v. What is its velocity in cms. per sec. and in miles per hour?

1.3 — Ten coulombs equal one "e.m.u." of electricity. From the numbers given in Sec. 1.2, compute the ratio of e.m.u. to electrostatic units. Compare with the velocity of light and with the velocity of radio waves. This comparison led Maxwell to the prediction of radio waves in 1864.

2.1 — A No. 14 copper conductor is 200 feet long, a second No. 14 copper conductor is 600 feet long.

2.1a — How will the resistance of the second compare with the first?

2.1b — If the first has a resistance of 0.516 ohm, what is the resistance of the 600-foot length?

2.1c — In general, how does the length of a conductor affect its resistance?

2.2 — The theory of metallic conduction tells us that the resistance of a conductor decreases as the cross-section or area of the conductor increases. (The mathematician calls this an inverse relationship.) No. 10 copper wire has a cross-section of 10,400 circular mils (abbrev. CM.), while No. 16 has a cross-section of 2,600 CM. (Both values are approximately correct.)

2.2a — How should the resistance of 500 feet of No. 16 copper wire compare with that of 500 feet of No. 10 copper wire?

2.2b — If the resistance of 1,000 feet of No. 10 copper wire is 1 ohm, what is the resistance of 500 feet of No. 16 copper wire?

2.3 — Copper wire is the kind most frequently employed in radio apparatus. Discuss several reasons why this metal is used.

2.4 — A resistor of 4 ohms is used in the filament circuit of a vacuum tube to limit the current to 0.3 ampere.

2.4a — What is the voltage drop across the resistor?

2.4b — What is the power in watts dissipated in the resistor?

2.4c — If the battery voltage is 6.2 volts, what is the voltage applied to the tube?

2.5 — Two 10,000-ohm, 1-watt resistors are connected in parallel.

2.5a — What is the effective resistance of the combination?

2.5b — What is the wattage dissipation of the two in parallel?

2.6 — Two 5,000-ohm, 2-watt resistors are connected in series.

2.6a — What is the effective resistance of the combination?

2.6b — How many watts can the combination dissipate?

- 2.7 — A 6,000-ohm, 10-watt resistor is connected in series with a 4,000-ohm, 10-watt resistor.
- 2.7a — What is the resistance of the combination?
- 2.7b — If 40 milliamperes flow through the combination, determine the voltage drop across each and the power dissipated in watts by each resistor.
- 2.8 — The two resistors of 2.7 are connected in parallel and 40 ma. flow into the combination.
- 2.8a — What is the resistance of the combination?
- 2.8b — What is the voltage drop across the parallel circuit?
- 2.8c — What current flows in each branch?
- 2.8d — How does the sum of the branch currents compare with the current flowing into the combination?
- 2.8e — What is the dissipation in watts of each resistor and of the combination?
- 2.9 — A 5,000-ohm, 10-watt variable resistor is used in a certain experiment to regulate current.
- 2.9a — What is the maximum safe current when using all the resistance?
- 2.9b — What is the maximum safe current when using 2,500 ohms of the rheostat? (Hint: Half the resistance means half the wattage rating. Why?)
- 2.10 — What is the voltage drop across the rheostat under the conditions stated in 2.9?
- 2.11 — Show the most *economical* connection for the filaments of three type-807 tubes (6.3 volts at 0.9 amp.) and 1 type-6C6 (6.3 volts at 0.3 amp.) if they are to be operated off 32 volts d.c. Determine the proper values of all resistors employed.
- 2.12 — The battery supply-leads to a transmitter have a total resistance of 0.0125 ohm and carry a current of 65 amperes. (a) Calculate the voltage drop in the leads. (b) Calculate the power loss in the leads.
- 2.13 — Four resistors are placed in parallel. The first has a resistance of 36 ohms, the second a resistance of 30 ohms, the third a resistance of 16 ohms, and the resistance of the fourth is unknown. The current through the entire circuit is 7 amperes, through the 16-ohm resistor it is 2.5 amperes. Determine the value of the unknown resistance and the currents through the branches.
- 2.14 — The combined resistance of two resistors in parallel is 750 ohms. One has a value of 1,200 ohms. What is the other resistance?
- 2.15 — A broadcast station increases its power from 50 kw. to 500 kw. Determine the power increase in decibels.
- 2.16 — An amateur has a transmitter which produces an antenna current of 1.3 amperes. He rebuilds his transmitter and then obtains an antenna current of 3.1 amperes. Determine the gain in decibels. The antenna remains the same.
- 2.17 — An audio transformer has a 3-to-1 turns ratio. If 0.4 volt is applied to the primary, determine the db. gain of the transformer.
- 2.18 — The output of a receiver is 2 watts into a 600-ohm load. A second receiver with the same input delivers 5.3 watts into a 2,000-ohm load. What is the output level of the first receiver with respect to the second? What is the output of each receiver with respect to 6 mw.?
- 2.19 — An amplifier has a rating of 12 watts output and a gain of 60 db.

Calculate: (a) output level, (b) input level in db., (c) input power in watts, (d) If the input and output impedances are 250 ohms, determine the voltage gain in db., (e) the power gain in db.

2.20— A carbon microphone has an output of 10 millivolts and a condenser microphone has an output voltage of 0.5 millivolt, both measured across equal impedances. Determine the level of the condenser microphone with respect to the carbon microphone.

2.21— A thermocouple-galvanometer has a scale of 100 equal divisions. Its resistance is 4.5 ohms and full scale deflection current is 125 ma. Determine the current when the meter deflection is 35 divisions.

3.1— What is the practical unit of capacitance?

3.2— When is the microfarad used in radio work? What is the symbol?

3.3— When is the micromicrofarad used? What is the symbol?

3.4— Why are air dielectric condensers physically so much larger than equivalent capacitance mica or paper dielectric types?

3.5— Show various symbols which would appear on a schematic diagram for a variable condenser and a fixed condenser for the following types: variable air, variable air split-stator, compression-type variable mica condenser, fixed mica or paper condenser, fixed electrolytic condenser.

3.6— What is the practical unit of inductance?

3.7— When are the millihenry and the microhenry used?

3.8— What is the symbol for a fixed air-core inductance, an air-core tapped inductance, an iron-core inductance?

3.9— What types of windings for inductances are employed principally for radio work?

3.10— What is meant by the term "Time Constant"?

3.11— What is the time constant for an R - C circuit of 0.05 μ fd. capacitance and 0.5-megohm resistance?

3.12— What is the effect on the TC of increasing either R or C ?

3.13— When testing iron-core filter inductances with an ohmmeter (a milliammeter, resistor, and low-voltage dry battery in series), it is frequently observed that the needle on the meter changes quite slowly. Comment on this.

3.14a— Two coils, well shielded from each other, are connected in series. One has an inductance of 250 μ h., the other an inductance of 120 μ h. What is the inductance of the combination?

3.14b— The coils of problem 3.14a are connected in parallel. What is the effective inductance of the combination?

3.15— A condenser of 600 μ μ f. is connected in parallel with one of 400 μ μ f.

3.15a— What is the capacitance of the two together?

3.15b— If these condensers are charged across a source of 100 volts, what is the charge in coulombs in each?

3.16— The two condensers of problem 3.15 are connected in series across the same 100-volt source. (The leakage is negligible.)

3.16a— What is the capacitance of the series combination?

3.16b— What is the charge in each condenser?

3.16c— What is the potential across each condenser?

3.17 — Show by means of a sketch how you would connect four 0.002- μ fd. condensers to obtain a resultant capacitance of 0.002 μ fd. This arrangement is sometimes used in transmitters. State several reasons why it is a useful device.

4.1 — A 4-pole alternator rotates at a uniform speed of 600 r.p.m. Determine the output frequency in cycles per second.

4.2 — An a.c. motor operating on 60 cycles per second rotates at the rate of 3,600 r.p.m. Determine the number of poles.

4.3 — What is the least number of poles that an a.c. synchronous motor can have to operate on 60 cycles?

4.4 — What is the effective value of a sinusoidal a.c. voltage which can produce the same degree of lamp brilliance as a 120-volt d.c. source produces? What is the maximum value of this a.c. voltage? What is the average value of the a.c. voltage averaged over the complete cycle? Why?

4.5 — Make a sketch showing an a.c. voltage in phase with an a.c. current.

4.6 — Make a sketch showing an a.c. voltage leading an a.c. current by 30° .

4.7 — Make a sketch showing an a.c. current leading an a.c. voltage by 60° .

4.8 — A radio-frequency ammeter, measuring sinusoidal current, reads 11.5 amperes. What is the peak value of this r.f. current?

4.9 — A peak-reading voltmeter reads 156 volts. Determine the effective value of this voltage, which is known to be sinusoidal.

4.10 — Make a sketch of a wave which has a peak value of 100 volts but whose effective value cannot be 70.7 volts.

4.11 — Make a sketch of an a.c. current whose value, averaged over a cycle, cannot be zero.

4.12 — Make a sketch of an a.c. wave whose peak and effective values are identical.

4.13 — Make a sketch of a series of unidirectional pulses, each a half sine-wave in shape, and indicate as nearly to scale as you can the average value.

5.1 — A 5- μ fd. condenser is used as an a.f. "bypass" condenser. What is its reactance at 100 cycles and at 4,000 cycles?

5.2 — What is the reactance of a 0.01- μ fd. condenser at 456 kilocycles? At 3 Mc.?

5.3 — Determine the reactance of a 3-henry choke coil at 120 cycles and a 120- μ h. coil at 3 megacycles.

5.4 — Coils for use at radio frequencies are often "doped" or dipped in wax to impregnate them. What effect will this have on the coil Q ($= X_L/R$) and the distributed capacitance?

5.5 — A coil has a reactance of 40 ohms and a resistance of 30 ohms. Determine the impedance of this coil.

5.6 — A condenser of 10- μ fd. capacitance is connected in series with a 100-ohm resistor across a 50-volt, 1,000-cycle source. Find the circuit impedance, the circuit current, the voltage drop across the condenser, and the voltage drop across the resistor.

5.7 — A vacuum tube has both d.c. and a.c. in its output. Show by a sketch how a coil and a condenser could be used to separate the a.c. from the d.c.

5.8 — A coil has an inductive reactance of 100 ohms and a resistance of 10

ohms. Determine the impedance of the coil. How does this value of impedance compare with the coil reactance?

5.9 — Under what conditions may the resistance of a coil or a condenser be neglected in comparison with its reactance value? (Hint: the answer to problem 5.8 will help.)

5.10 — What factors influence the voltage ratio of an iron-core transformer? What is the relation between the primary current and the secondary current in a voltage step-up transformer? Express the voltage and current ratios as a statement that the two ratios are equal.

5.11 — Since the magnitude of impedance can always be expressed by $|Z| = E/I$, state why a transformer may be regarded as an impedance-changing device.

5.12 — A transformer is wound with 20,000 primary turns and 200 secondary turns. What is the impedance transformation ratio of this transformer?

5.13 — A certain vacuum tube requires a load impedance of 7,000 ohms and is to operate a 10-ohm permanent-magnet type loudspeaker. What is the proper turns ratio for the "matching transformer"?

5.14 — The voltage across a 2.5-ohm voice coil with a 400 cycle-sinusoidal voltage is 1.5 volts r.m.s. (a) How much power is supplied to the voice coil? (b) What is the peak value of the a.c. voltage?

5.15 — Why is an ordinary low-frequency a.c. ammeter or a.c. voltmeter useless at radio frequencies? What type of meter is used at radio frequencies? What is the principle upon which it operates? Make a neat sketch of the scale of a 0-3 ampere radio-frequency ammeter showing the positions of the 0-, 1-, 2-, and 3-ampere positions.

6.1 — A series circuit has a 253- μ h. inductance and 100- μ mf. condenser. The radio frequency resistance of the coil is 8.2 ohms. One volt is applied to the circuit.

6.1a — What is the resonant frequency of the circuit?

6.1b — What is the circuit Q ?

6.1c — What is the voltage appearing across the condenser at resonance?

6.1d — What is the voltage across the coil at resonance?

6.2a — If the coil and condenser of problem 6.1 are connected in parallel, what is the resonant impedance of the combination?

6.2b — 1,000 volts at the resonant frequency is applied to the parallel circuit. What is the current through the coil and what is the current through the condenser?

6.3 — A parallel circuit, resonant at 1,000 cycles, is required. A 0.2- μ fd. condenser is available. What value of inductance will be required for this circuit?

6.4 — The output circuit for a transmitter has an inductance of 4.2 μ h. in one branch and a capacitance of 120 μ mf. in the other branch. When the circuit is properly loaded, the resistance in the inductive branch is at 10 ohms.

6.4a — At what frequency is the circuit resonant?

6.4b — What is the impedance of the parallel circuit when loaded?

6.4c — When the load is removed from the circuit, the resistance in the inductive branch becomes 0.8 ohm. What is the impedance of the circuit unloaded?

6.5 — A coil has an inductance of $180 \mu\text{h}$. and a resistance of 10.2 ohms at 1,200 kc. Determine the coil Q at this frequency.

6.6 — A coil has an inductance of 2.5 henries and a resistance of 2,000 ohms at 400 cycles. Determine the Q of this coil.

6.7 — Determine the resonant frequency of a coil of $200 \mu\text{h}$. in series with a $0.0002\text{-}\mu\text{fd}$. condenser.

6.8 — What value of coil is required to resonate with a $25\text{-}\mu\text{mf}$. condenser at a frequency of 15 Mc.?

6.9 — The minimum capacitance in a tuned-circuit, tuned by a variable condenser to cover a band of frequencies beginning at 1,700 kc., is $40 \mu\text{mf}$. The maximum capacitance is $400 \mu\text{mf}$.

6.9a — Determine the inductance of the coil required.

6.9b — Determine the frequency range covered by the coil and condenser.

6.10 — A "wave trap" may be either a series or a parallel resonant circuit. When such a series trap is connected across the input of a receiver, and tuned to an interfering signal, the interference is considerably reduced. A 10- to $250\text{-}\mu\text{mf}$. variable condenser is available. Determine how much inductance would be required to trap out an interfering signal on 1,420 kc. and discuss the action of the wave trap. Comment on the reasons for your choice of L and C values.

6.11 — A certain antenna circuit looks like a 20-ohm resistance and a 200-ohm capacitive reactance at a frequency 3,105 kc. Determine the inductance required to resonate the antenna circuit. If this circuit has induced in it from the transmitter a voltage of 50 volts, what will the antenna ammeter read at 3,105 kc.? How much power will be delivered to the antenna?

6.12 — Why are quartz crystal resonators used in receiving apparatus? By means of two curves, compare the selectivity of an ordinary tuned circuit with that obtained when the crystal filter is introduced.

6.13 — What factors affect the sharpness of resonance of a tuned circuit? What determines the value of the current at resonance in a series resonant circuit? Why is a high ratio of L to C desirable in a tuned circuit? What factor or factors control the practical limit of the L/C ratio?

6.14 — Under what conditions does a series circuit present minimum impedance which is entire resistance? At what frequencies will it present inductive reactance and at what frequencies will it present capacitive reactance? At what frequencies is the current almost solely determined by the reactance?

6.15 — Under what conditions does a parallel circuit present maximum impedance entirely resistive? At what frequencies will it present inductive reactance? At what frequencies will it present capacitive reactance?

6.16 — Any inductance coil has distributed capacitance. Can you show that any coil will have an apparent inductance greater than its true inductance at certain frequencies, that it may appear as a pure resistance at certain discreet frequencies, and as a capacitance at other frequencies?

7.1 — When a coil used at radio frequencies is placed inside a shield: What is the effect on the coil's inductance? What is the effect on the coil's resistance? What is the effect on the distributed capacitance?

7.2— At a.f., the use of non-magnetic materials for coil shielding is practically useless, while at radio frequencies the use of non-magnetic materials such as copper or aluminum is required. Explain why this is so.

7.3— An r.f. shield with seams of high resistance running lengthwise of the shield is very detrimental, while the same type of seam running around the shield has little effect on the shielding. Account for this behavior.

7.4— Indicate by a diagram how you would connect coils and condensers to make a π -type low-pass filter, a high-pass "T"-type filter.

7.5— What class of filter would you employ to separate a zero frequency (d.c.) component from a number of a.c. components?

7.6— What class of filter would you use to separate an r.f. component at 3,500 kc. from an a.f. component at 5,000 cycles?

7.7— Show by a diagram how a low-pass π -type filter, with cutoff frequency of 3,000 cycles, could be combined with a high-pass π -type, with cutoff of 2,000 cycles, to pass a band of frequencies approximately 1,000 cycles wide. Explain why the effect is "band pass."

7.8— Show by the use of a diagram how a low-pass T-type filter and a high-pass T-type could be connected to eliminate a band of frequencies from 1,500 cycles to 2,000 cycles but pass all other frequencies from 100 to 5,000 cycles. Indicate the approximate cutoff frequency of each type and explain the operation.

7.9— When is more than one filter section required?

7.10— If one filter section provides an attenuation of 60-to-1 of an undesired voltage, how much attenuation will two similar filter sections provide?

7.11— A low-pass filter working from 5,000 ohms into 5,000 ohms is to cut off at 4,000 cycles and be of the π -type. Determine the values of L and C required.

7.12— Determine the constants for a T-type high-pass filter to cut off at 5,000 cycles working from 100,000 ohms into 100,000 ohms.

8.1a— What is the distance in feet from "crest-to-crest" of a wave-length of 4,000 meters, 500 meters, 200 meters, 40 meters 7.5 meters and 20 centimeters?

8.1b— Determine the frequency in kilocycles for each of the above wave-lengths.

8.2— What is the wave-length in meters of a 2,000-kc. wave? Of a 7-Mc. wave, of a 120,000-kc. wave, of a 5,000-Mc. wave?

8.3a— A certain antenna acts in such a way that each meter of its length is equally effective in having a voltage induced in it by a passing wave. If it has induced in it a voltage of 72 μ v. and has a length of 8 meters, what is the field strength?

8.3b— If this antenna is connected to a receiver, what voltage will appear at the receiver input posts if the field strength of a broadcast station at that locality is 0.4 millivolt per meter?

8.4— What is the effect on the operation of an antenna when its electrical wave-length is the same as that of a passing wave?

8.5— Suppose that a transmission line is 4 wave-lengths long and that energy is sent down the line. The end of the line is open circuited. Comment on

the distribution of voltage and current on the line for this open circuit condition.

9.1 — What part of the radiated wave energy is a low-frequency radio telegraph or a broadcast station particularly interested in? Why?

9.2 — Explain why the ionosphere is useful for radio communication.

9.3 — What approximate frequency band is useful for long-distance, low-power, daytime communication? Night-time? Do the seasons affect the useful frequencies? Illustrate.

9.4 — How can fading in the broadcast band, at distances approximately 70 miles from the transmitter, be explained?

9.5 — How does fading probably occur on the high-frequency bands where only the sky-wave is received?

9.6 — State several striking differences between transmission on 7,000 kc. and 60,000 kc.

10.1a — Under what conditions will the anode current be independent of anode voltage in a high-vacuum tube?

10.1b — Under what conditions will the anode current be dependent on the anode voltage?

10.2 — What is meant by "space charge"? In the presence of space charge, where is the most negative space in the tube?

10.3 — What type of cathode is most commonly used in receiving tubes and some low-powered transmitting tube types? What type is most frequently used in most glass envelope transmitting types and what type is used in high-power types? Discuss the probable reason for this.

10.4 — Which type of filament can be damaged by overload? What can be done in some cases to repair this condition? What is this process called?

10.5 — Distinguish between direct and indirect heating of the cathode. What class of tubes mostly employ indirect heating of cathode. Where would you expect to find practically all types directly heated? What advantages are possessed by indirect cathode heating?

10.6 — What is meant by "cathode leakage"? In what tube types would it be found?

10.7 — Suggest a possible condition whereby a meter inserted in the anode circuit might indicate a direction of electron flow *opposite* to that ordinarily expected. Account for this behavior.

10.8 — Why must thoriated tungsten filaments be operated at specified voltage whereas the filament voltage on the other types is not so critical?

11.1 — A half-wave, single-phase rectifier tube is used with a condenser-input type of filter. The r.m.s. value of the voltage is 117 volts. Why is the peak inverse voltage applied to the tube considerably greater than the peak value of the peak a.c. voltage from the supply source? What is the greatest value that the peak inverse voltage could attain?

11.2 — A full-wave, center-tap single-phase rectifier uses a transformer and an 80-type tube. The rectifier operates into a π -type condenser-input filter. The r.m.s. secondary voltage per half is 300 volts. Represent the load by a 5,000-ohm resistor.

11.2a — Make a diagram showing the apparatus properly connected.

11.2b — Trace the current flow for each alternation and show that the current in the load is unidirectional.

11.2c — Make a diagram to show why the current through each half of the rectifier is peaked and explain why it flows for less than half the time per alternation.

11.2d — Explain in your own words the purpose of each filter element (i.e., choke and condensers).

11.2e — State why the output voltage will increase as the load current decreases and why the output voltage decreases as the load increases.

11.2f — What factors will influence the regulation of the output voltage?

11.3 — Why is a three-phase rectifier system preferable to a single-phase full-wave rectifier system in higher power units?

11.4a — What are the two principal types of vibrators?

11.4b — Why is the polarity of the supply voltage very important for one type but unimportant for the other?

11.4c — Make a schematic circuit diagram for each type and explain the operation.

11.4d — State the important points in the care and maintenance of a vibrator power supply.

11.5 — D.C. core saturation of the transformer secondary is a limitation in the operation of a half-wave rectifier. How is this limitation removed in the full-wave connection?

12.1 — In general, how would you determine the cutoff bias for a triode tube?

12.2a — From the characteristic curves for a typical triode tube, determine the amplification factor graphically.

12.2b — Also determine the a.c. plate resistance.

12.2c — From these two, determine the transconductance.

12.3 — What feature of the I_p - E_p characteristic curves indicates whether the tube has relatively high or low plate resistance?

12.4 — What is meant by the "linear portion" of the characteristic?

12.5 — Under what conditions may the so-called "static" characteristic curves for a tube be considered as the "dynamic" characteristics?

12.6 — Which of the tube constants μ , r_p , g_m , gives the maximum voltage amplification most readily? Why?

13.1 — State the characteristics of "Class A" operation.

13.2 — What are the important factors affecting the input capacitance of a triode tube?

13.3 — One stage in a two-stage resistance-coupled amplifier has a measured gain of 60, and a second has a gain of 12. What is the total voltage gain of the amplifier?

13.4a — A d.c. meter inserted in the plate circuit of a Class A amplifier, with proper bias and excitation, will show negligible change in reading. Explain.

13.4b — If the bias is excessive, the meter will show an increased reading with normal excitation. Explain.

13.4c — Similarly, with too low bias, the meter will show a decrease with normal excitation. Explain.

13.5—Make a diagram, with time as horizontal axis, to show the instantaneous relations in the grid and plate voltage. Use a sinusoidal a.c. component of excitation and show (not necessarily to scale) the average bias voltage, the excitation voltage, the average plate voltage, the instantaneous plate voltage, the average and instantaneous plate current. From this diagram, show that the a.c. voltage in the plate circuit is 180° out of phase with the a.c. grid voltage.

13.6—Explain in your own words why the omission of a cathode bypass condenser will decrease the gain of a stage.

13.7—What is the essential difference between Class A power amplifier tubes and Class A voltage amplifier tubes?

14.1—State in your own words how you distinguish a Hartley type oscillator circuit from a Colpitts type.

14.2—What is the principal function of an oscillator?

14.3—What is the effect on oscillator operation of an excessively high value of grid-leak resistor?

14.4—A pendulum clock has a pendulum, a main spring, and escapement movement. An oscillator circuit comprises a tube, an L - C circuit and a "B" battery. Pair up the analogous parts.

14.5—Make a schematic diagram of a tuned-plate Hartley-type oscillator employing a 6J5GT tube and a series feed of the power supply. (This circuit is often found in superheterodyne receivers.)

14.6—How is the feedback voltage controlled in the Hartley, Colpitts, and tuned-grid tuned-plate types of oscillators?

14.7a—How can a two-stage resistance-coupled amplifier be converted into a multivibrator?

14.7b—What are some uses of the multivibrator? How can the frequency of a multivibrator be controlled?

14.7c—Why do the values of R and C in the grid circuits of a multivibrator influence the output frequency?

14.8a—Under what conditions do you think the use of a push-pull oscillator desirable?

14.8b—When is a single-ended oscillator more advantageous than a push-pull oscillator? Justify your statements.

15.1—What are the characteristics of a tetrode tube which make it superior to a triode as an r.f. amplifier? Explain.

15.2—Why is the pentode superior to both the triode and tetrode as an r.f. amplifier? Explain.

15.3—Show by means of the characteristic curves for a triode and a pentode why the a.c. plate resistance of the pentode is much greater than the triode.

15.4—Discuss the difference between a variable- μ pentode and a sharp cut-off pentode and state where each type would be most advantageously employed.

15.5—What advantages does the beam tube possess over other tube types? Where are beam tubes principally employed?

15.6—List several combination tubes and state the uses to which each type may be put.

15.7 — What is the effect of gas in a high-vacuum type of tube? How can the presence of gas in such a tube be detected and what is the principal remedy for dealing with a gassy tube?

16.1 — A carrier wave on 3,000 kc. is amplitude modulated with a 1,000-cycle tone.

16.1a — State the frequencies appearing in the output.

16.1b — What are these additional frequencies called?

16.1c — What determines the width of the transmission band required for a radio telephone transmitter using amplitude modulation?

16.2 — A carrier with peak voltage of 50 volts is amplitude modulated. The peak r.f. voltage at the modulation crest is 90 volts, at the trough is 10 volts.

16.2a — Make a diagram to scale showing the modulated wave.

16.2b — Determine the percentage modulation produced.

16.2c — What would be the crest voltage for 100 per cent modulation?

16.2d — What would be the trough voltage for 100 per cent modulation?

16.3 — Why must the r.f. driver stage for a grid-modulated Class C amplifier have good regulation?

16.4 — Why cannot suppressor-grid modulation be employed with a triode tube?

16.5 — Suppressor-grid modulation is similar to control-grid modulation of a triode. Explain.

16.6 — Cathode modulation is said to embody simultaneous grid and plate modulation. Explain why this is true.

17.1 — In the diode detector, there are at least three components appearing across the diode load resistance when an amplitude-modulated signal is demodulated. Consider a carrier on 2,500 kc. with tone modulation at 1,000 c.p.s.

17.1a — What are these three components?

17.1b — If the carrier has a value of 20 volts peak and the modulation is 50 per cent, what is the peak value of the 1,000-cycle tone appearing across the diode load resistance? Show by a diagram why this is so.

17.2 — Explain why the grid-leak detector is more sensitive than the plate detector.

17.3 — By a diagram show how the plate detector rectifies the signal applied to it.

17.4 — Why does the tuned circuit supplying the plate detector have better selectivity than the same circuit applied to a diode detector?

17.5 — What is the principle upon which the regenerative detector operates?

17.6 — Make a schematic diagram of a regenerative detector using a pentode tube. Control the regeneration by controlling the screen voltage.

18.1 — Draw the circuit of a relaxation oscillator using a glow-tube, and a graph of the voltage across the condenser *vs.* time.

18.2 — A small wheel, with one spoke painted white, is rotated by a motor. When illuminated by a Strobotac whose flashing rate is 3,600 per min., two stationary white spokes are seen, diametrically opposite each other. Explain. What is the r.p.m. of the motor?

18.3 — Mercury vapor is used in the larger thyratrons. What advantage and what disadvantage does it have in comparison with the argon used in the very small tubes?

18.4 — What precautions must be followed in the operation of gas-filled tubes and in the design of their circuits to prevent damaging them?

19.1 — Draw diagrams such as those of Figs. 19 E and F to illustrate a few of the possibilities of applying a.c. on the grid, the shield-grid, and the plate of a gas-filled tetrode.

19.2 — Draw the circuit of a full-wave rectifier using gas-filled two-electrode tubes and state the precautions which must be taken in its operation.

19.3 — Why does a tuned output transformer in an inverter circuit yield comparatively pure sinusoidal output voltages?

20.1 — Describe several applications of photocells, stating the type of cell which would preferably be used in each case.

20.2 — Draw a circuit for photocell control of an a.c. operated thyatron. Hint: see Phase Shifters.

20.3a — Ten foot-candles are received on a surface 2 ft. from a source. What is the candlepower? What will be the illumination at twice this distance?

20.3b — What will be the light flux in lumens passing through an area of 1 sq. in. at a distance of 4 ft. from the source in problem 20.3a?

20.3c — What is the total flux in lumens from the source in problem 20.3a?

20.3d — The source of light in 20.3a is used to illuminate a photocell of area 1 sq. cm. and sensitivity of 40 microamperes per lumen. If the cell is at a distance of 1 ft., what is the output current from the cell?

20.4 — Under what conditions does a photo-multiplier tube prove to be especially advantageous?

21.1 — State at least two precautions which must be followed in order to prevent damaging a cathode-ray tube.

21.2 — If the electric deflection sensitivity of a cathode-ray tube is 0.1 mm. per volt, how long a line will appear on the screen when the 110-volt a.c. supply is connected across the deflection plates?

21.3 — State two methods of changing the brightness of the light on the screen of a cathode-ray tube.

22.1a — How could the CRO be used as a voltmeter? Would it read peak or r.m.s. volts?

22.1b — How could it be used as an ammeter? Show by means of a diagram how you could observe the shape of the charging current to a storage battery from a half-wave Tungar rectifier.

22.2 — What is the main reason for the use of a linear sweep-circuit? What is the principal limitation of the linear sweep-circuit in most modern oscilloscopes?

22.3a — How can Lissajou figures be employed to check the frequency of an audio-frequency oscillator? Make a diagram to show the connections of the apparatus employed.

22.3b — Could the same scheme be used to check the frequency of a crystal oscillator against a standard frequency? Explain.

22.4 — A square wave of 100 c.p.s. is applied to VERT. plates while a linear saw tooth of 200 c.p.s. is applied to the HOR. plates. Show by a diagram the pattern resulting.

22.5 — Develop graphically the pattern resulting when two equal but 90° out-of-phase voltages are applied to the VERT. and HOR. deflection plates of the CRO.

23.1 — Distinguish between a linear circuit element and a non-linear circuit element. Give an example of each.

23.2a — How can amplitude distortion be produced in a Class A amplifier? How is it minimized?

23.2b — How can frequency distortion be produced in a Class A amplifier?

23.3 — What is the approximate upper limit of distortion permissible in triodes? Pentodes?

23.4a — What is meant by Class AB operation?

23.4b — Distinguish between Class AB₁ and Class AB₂ amplifiers.

23.5 — Class C amplifiers operate with the highest power output and plate efficiency of all types. Explain how this is accomplished.

23.6 — The plate current in a Class C amplifier is rich in harmonics. Explain how these harmonics are greatly reduced by the use of a tuned "tank circuit."

24.1 — Make a schematic diagram of a Class A voltage amplifier using a cathode bias and a resistance-capacitance coupling to the following stage. Indicate approximately suitable values for the circuit elements. Use a pentode tube.

24.2 — In the resistance-capacitance coupled amplifier, the grid blocking condenser must have a very high leakage resistance. Tell why this is so.

24.3 — In most applications of tubes as amplifiers, the Tube Manual makes the statement, "The grid leak must not exceed 1 megohm," or some similar value. Can you suggest why the grid-leak resistance must not exceed a certain value?

24.4 — The value of the actual plate voltage available at the plate of a resistance-capacitance-coupled pentode amplifier must be maintained at a fairly high value, thus limiting the maximum plate loading resistor. Explain why this is true.

24.5 — Why are plate and grid filters essential in high-gain amplifiers? Make a diagram to show an amplifier with grid and plate filtering.

24.6 — Resistance-capacitance-coupled amplifiers are commonly called "resistance-coupled" amplifiers. Differentiate between these and true resistance-coupled amplifiers, both in their circuits and in their applications.

25.1 — What is the equivalent electrical circuit of a transformer-coupled amplifier?

25.2 — What is the controlling factor in frequency distortion of a transformer-coupled amplifier?

25.3 — Compare the single-button carbon, dynamic, and crystal microphones as to (1) relative output, (2) output impedance, (3) frequency range, (4) cost, (5) maintenance, (6) ruggedness.

25.4—What is meant by the term “pre-amplifier”? When is the pre-amplifier used?

25.5—Make a diagram of a typical two-stage speech amplifier which could be used with either a SB carbon or a dynamic microphone. Include a gain control which is practical.

25.6—What is meant by “packing” in a carbon microphone? How would such a condition occur, how would you test for it, and how can such a condition be remedied?

26.1—Compute the effective gain of a degenerative (and of a regenerative) feedback amplifier whose voltage amplification is 50, when the feedback voltage is 1 per cent of the output voltage.

26.2—Discuss the tendency of feedback amplifiers to go into oscillation.

26.3—Compare the circuit of a regenerative feedback amplifier with that of a multivibrator.

26.4—State the advantages of a feedback amplifier which has both regeneration and degeneration.

27.1—How does a radio-frequency amplifier differ from an audio-frequency amplifier?

27.2—Why are radio-frequency amplifiers as used in receivers usually operated Class “A”?

27.3—What is meant by “sharpness of resonance”?

27.4—What is a band-pass radio-frequency amplifier?

27.5—How does the amplification and selectivity of a radio-frequency amplifier vary with frequency? Why?

27.6—What is the effect of regeneration in a radio-frequency amplifier?

27.7—What class of radio-frequency amplifier is generally used for transmitting purposes?

27.8—What is the average efficiency of radio-frequency power amplifiers?

27.9—Why is it necessary to neutralize a triode radio-frequency amplifier both in receivers and transmitters?

27.10—What are the two principal types of neutralizing circuits employed in practice? Make a diagram of a typical amplifier for both types.

27.11—State, in the proper order, the steps necessary to neutralize a triode amplifier.

27.12—How would a sensitive thermocouple milliammeter be used in the neutralizing process? Could a CRO be used as an indicator of neutralization? If so, show how it should be connected to the amplifier being neutralized?

27.13—A Class C, r.f. amplifier supplies 140 watts to an antenna with a plate efficiency of 70 per cent. If the d.c. plate voltage is 1,250 volts, what is the d.c. plate current?

27.14—Distinguish between plate efficiency and power amplification ratio. What class of amplifier has the highest efficiency? What class has the highest power amplification ratio?

28.1—In a plate-modulated Class C, r.f. amplifier what is the source of the energy for modulation?

28.2a—The plate input to a Class C amplifier unmodulated is 200 watts. How much audio power is required for complete modulation?

- 28.2b**— If the plate efficiency of the amplifier in problem 28.2a is 75 per cent, how much power will be supplied to the antenna if the coupling circuit is 95 per cent efficient?
- 28.2c**— How much power is present in the radiated sideband energy when the modulation in 28.2b is 100 per cent?
- 28.3**— Itemize the required conditions to be fulfilled for a Class C amplifier to be capable of practically distortionless modulation characteristics.
- 28.4**— Why do the readings of the plate current and grid current meters in a Class C plate-modulated amplifier remain substantially constant regardless of the presence or absence of modulation?
- 28.5**— Show by means of a block diagram how to use a CRO in checking the modulation characteristics of a telephone transmitter.
- 28.6**— State the cause and remedy of three defects that can produce “downward modulation” in a radio telephone transmitter.
- 28.7a**— Using the Heissing “common choke” method of plate modulation, with the same d.c. voltages on the modulator and modulated amplifier plates, why is it impossible to obtain 100 per cent modulation without severe distortion?
- 28.7b**— How is the condition of 100 per cent modulation obtained in practice when the above scheme is used?
- 28.8**— A Class C, r.f. amplifier is to be plate modulated 100 per cent using the common choke method from a Class A modulator, type 845. For a plate supply voltage of 1,250 on the 845, the RCA Trans. Tube Manual states that the undistorted power output is 24. watts when working into a load of 16,000 ohms. Find:
- 28.8a**— The proper value of plate voltage for the r.f. amplifier.
- 28.8b**— The proper plate current for the r.f. amplifier.
- 28.8c**— The value of the dropping resistor between the modulator and the modulated amplifier.
- 28.8d**— What size and voltage rating bypass condenser would you recommend for bypassing the resistor of problem 28.8c?
- 28.8e**— What current rating and inductance would you recommend for the modulation choke?
- 28.9**— When using a tetrode or pentode modulated amplifier why is it advantageous to modulate the plate and screen simultaneously?
- 28.10**— How is grid modulation of a Class C amplifier accomplished?
- 28.11**— What factors determine the degree and linearity of modulation in a Class C amplifier?
- 28.12**— What methods of coupling the modulator to the modulated amplifier are commonly used? What are their relative advantages and disadvantages?
- 28.13**— A Class C modulated amplifier operates with E_p equal to 2,000 volts, antenna current unmodulated being 6.4 amperes. If the plate voltage is reduced to 1,250 volts, what is the unmodulated antenna current for the new plate voltage condition?
- 28.14**— With a d.c. grid current of 15 ma. average value, what grid-leak resistor will be needed to furnish an operating bias of 75 volts?
- 28.15**— A Class B audio amplifier has an output transformer with taps at 5,000 and 10,000 ohms. It is to be used to modulate a Class C amplifier. The

28.15a — What Class C amplifier input will this amplifier modulate completely?
28.15b — Under what Class C amplifier operating condition would you use the 5,000-ohm tap and when the 10,000-ohm tap?

28.16 — Discuss the necessary relationships which must exist between the modulator and the modulated amplifier in a Class C plate modulation system for optimum operation of both.

28.17 — Compare plate modulation, grid bias, and suppressor-grid modulation methods with respect to their practical advantages and disadvantages.

29.1 — Make a workable schematic diagram of an electron-coupled oscillator using the Hartley circuit. Indicate the parts of the circuit which determine the frequency and the parts associated with the "work" circuit.

29.2 — In the practical version of the electron-coupled circuit, approximately where should the cathode tap be placed from the ground end?

29.3a — Why is the use of a voltage divider advisable in supplying voltage for the screen grid of the electron-coupled oscillator tube rather than the use of a series resistance?

29.3b — What advantages does the electron-coupled oscillator possess over other types of self-controlled oscillators?

29.4a — What characteristic of the quartz crystal makes it excellent to control the frequency of oscillators?

29.4b — Why are the low temperature-frequency-coefficient quartz crystals superior to other types in crystal-controlled oscillators?

29.5 — An X-cut crystal has a temperature-frequency coefficient of -18 cycles per megacycle per degree C. and is operating in an oscillating circuit at 1,410 kc. at a temperature of 50° C. What is the frequency if the temperature changes to 85° C.?

29.6 — An AT-cut crystal has a thickness of 1.27 mm. Determine its approximate operating frequency.

29.7 — What defect of the standard quartz crystal circuit does the Tri-tet circuit overcome? Explain why this is so.

29.8a — Name five important uses of oscillators.

29.8b — Comment on the need in certain cases for a high order of frequency stability in an oscillator, whereas in certain other cases the power output may be paramount.

29.9a — What phase relation must be observed between the grid and plate voltages? How is this obtained in a "tickler" feedback oscillator?

29.9b — What is the usual order of plate efficiency in an oscillator?

29.9c — A 203A tube requires 7 watts to supply the grid losses and this tube delivers 120 watts to its tank circuit. The plate voltage is 1,000 volts and the plate current is 170 ma. The tank circuit absorbs 10 watts in inherent losses. How much power will be supplied to the load? What is the plate efficiency?

29.10 — A power-type Hartley oscillator is to be used in a transmitter for the master oscillator stage and is to cover a frequency range from 250 kc. to 550 kc. What considerations should be made with respect to obtaining reasonable efficiency and frequency stability?

30.1 — What alterations should be made in the circuit of Fig. 30 A to change it from a square-wave to a pulse generator?

30.2 — Explain in detail how a multivibrator oscillates.

30.3 — Plan the circuits of a "fathometer," wherein a succession of short sound pulses sent to the bottom from a ship are reflected back and picked up with a microphone. Compute the time delay between the direct and reflected pulses when the depth is 100 fathoms.

30.4 — Compute the virtual height of the ionosphere when the echo delay time of the pulse method is 0.001 sec.

30.5 — What type of circuit needs to be added in front of the circuit of Fig. 30 I to use it as a frequency meter for alternating current?

30.6 — Draw the circuit of a triple coincidence counter using photocells at the input. Explain how it might be used to determine the direction of a distant light source.

30.7 — In how many steps will the condenser of Fig. 30 L be charged for each discharge if the input pulse rate is 20,000 and the output rate is 4,000?

30.8 — Draw the circuit suggested at the end of Sec. 30.13.

30.9 — Draw a time-delay circuit operating on the principle that it takes time for a condenser to fill up through a resistor.

31.1a — Why do modern transmitters employ an oscillator and one or more stages of power amplification rather than having the oscillator work directly into the antenna?

31.1b — What factors govern the number of stages a transmitter will require?

31.2 — What factors govern the choice of a buffer amplifier to be used as a driver stage?

31.3 — What is the essential difference between r.f. amplifiers in transmitters and r.f. amplifiers in receivers? Why should this difference exist?

31.4 — An r.f. amplifier is supplied in the plate with 200 ma. at 475 volts. If the plate efficiency is 65 per cent, what power will be supplied to the tank circuit?

31.5a — What condition must be fulfilled in the plate circuit if the amplifier tube is to operate with maximum efficiency for a given set of bias, excitation and supply voltage values?

31.5b — How is this condition realized in practice?

31.6a — What does the term "parasitic oscillations" mean?

31.6b — What operating characteristics of an amplifier leads one to suspect the presence of parasitics?

31.6c — At what frequencies do parasitic oscillations occur? What is responsible for their presence? Why may they appear to be entirely absent in low-power stages yet pronounced in higher-power stages?

31.7a — Why is it unnecessary to neutralize a frequency multiplier stage?

31.7b — Why is it necessary to operate a frequency multiplier at a high bias voltage?

31.7c — What tube types make better frequency multipliers than others? What tube types should follow a multiplying stage?

31.8 — A crystal oscillator operates on 2,200 kc. It is desired to have the output of the transmitter on 13.2 Mc. Explain how this could be done.

31.9a — Explain what is meant by "high-level" modulation.

31.9b — A transmitter has a crystal-controlled oscillator, two buffer stages

and a power-amplifier output stage. The second power-amplifier stage is plate modulated. What class of telephone transmitter is this? What class of amplifier operation must the P.A. stage be?

31.10 — State the steps necessary to place a high-level telephone transmitter "on the air."

31.11 — Explain the procedure to adjust properly a Class B, r.f. amplifier for proper operation as an amplifier of a modulated wave.

31.12a — Why cannot a Class C amplifier be used to amplify an amplitude-modulated wave?

31.12b — Why is Class B the type of operation for amplification of a modulated wave?

32.1a — What determines the usable sensitivity of a receiver?

32.1b — What noise voltages are generated in a receiver?

32.1c — Why is the first stage in a receiver the important stage from the standpoint of inherent noise?

32.2 — What simple test could you make to determine whether the noise is being generated in the first tuned circuit or the tube?

32.3 — Why is a receiver with at least one stage of radio-frequency amplification less noisy (even though more sensitive) than a receiver in which the first tuned circuit feeds the mixer tube directly?

32.4a — Discuss the selectivity requirements for a receiver to be used for telegraphy, communication telephony (150–3,000 cycles), normal broadcasting (100–10,000 cycles), and high fidelity broadcasting (30–15,000 cycles).

32.4b — What part (or parts) of the receiver is (or are) mainly responsible for the selectivity?

32.4c — Is the use of a narrow band-pass filter in the audio section of the receiver ever employed? What is the advantage of such a scheme?

32.5 — Discuss a method to measure the over-all fidelity of a receiver. State what equipment is required and how you would conduct the test.

32.6 — A superheterodyne receiver is tuned to 2,738 kc. The intermediate frequency is 475 kc. To what frequency is the demodulator circuit tuned?

32.7 — A superheterodyne receiver has an i.f. of 465 kc. and is tuned to 1,712 kc. What is the frequency of the high-frequency oscillator circuit?

32.8 — A superheterodyne receiver is tuned to 1,450 kc. It has an i.f. of 456 kc., and is experiencing "image" interference. Determine two possible "image" frequencies to cause this interference.

32.9a — State cause and effect of space-charge coupling in a converter tube.

32.9b — At what frequencies in the range of an all-wave receiver is this trouble most likely to be serious?

32.10 — State the principal reasons for the development of the pentagrid converter tube.

32.11 — What is the principal reason for the use of a separate oscillator tube when used with a pentagrid mixer tube? What defect will the use of a separate oscillator not eliminate?

32.12 — What are the principal problems to be considered in the design of an oscillator to be used in the frequency conversion system of a superhet receiver?

32.13 — If the gain of an r.f. stage is 5, mixer gain is 15, and an i.f. amplifier per stage is 100, and two i.f. stages are used, what is the over-all gain?

32.14 — What are three conditions which must be fulfilled if two tuned circuits are to track?

32.15 — The high-frequency oscillator of a superheterodyne receiver is almost universally operated at a higher frequency than the received signal. Why is the procedure justified economically?

32.16a — A broadcast receiver with one tuned circuit between the antenna and the mixer grid receives a local broadcast station (assigned frequency 1,500 kc.) at both 1,500 kc. and 570 kc. The receiver's i.f. is 465 kc. Explain why this occurs.

32.16b — How could this defect in the receiver operation be remedied?

32.17a — What apparatus is required to align a receiver?

32.17b — A receiver is to be aligned. The aligning frequencies are 2,850 kc. and 1,750 kc. The receiver i.f. is 456 kc. and has one r.f. stage, a mixer stage, and a separate h.f. oscillator stage. Make a schematic diagram of the circuits to be aligned, indicating the aligning condensers.

32.17c — Outline, step-by-step, the alignment process.

32.18 — In many multi-band superheterodyne receivers, there is no provision for oscillator alignment at the low frequency end of the higher frequency bands. Account for the reason why these are not required.

32.19a — What are the important requirements of an a.v.c. system?

32.19b — What is meant by "straight a.v.c."? "delayed a.v.c."? "amplified a.v.c."?

32.20a — What is the principal defect of an a.v.c. system which has too small a Time Constant?

32.20b — What is the principal defect of an a.v.c. system which has too great a Time Constant?

32.21 — Why do not a.v.c. systems, of the type ordinarily used, work satisfactorily for the reception of telegraph signals?

32.22 — State two important results in the use of r.f. amplification ahead of a detector stage in a t.r.f. receiver.

33.1 — What are some advantages of f.m. over a.m.? Why is narrow-band f.m. (± 15 kc.) better than wide-band (± 75 kc.) for communication circuits?

33.2a — How might a condenser microphone be used with a low-power oscillator to produce a frequency modulated signal?

33.2b — What are the methods employed commercially to produce frequency modulation?

33.3 — What is meant by a reactance tube modulator?

33.4 — A reactance tube modulator produces a total swing of 2 kc. about a mean frequency of 4,800 kc. How may this frequency-modulated oscillator be used to produce a signal on 38.4 Mc. and what will be the total deviation?

33.5 — If the highest modulation frequency is 4,000 cycles, what is the deviation ratio of the above transmitter?

33.6 — Why is it not possible to employ a CRO to check an f.m. transmitter? What class of amplifier operation would be used in all stages of the f.m. trans-

mitter? Why can an amplifier tube be more completely utilized in an f.m. transmitter than in an a.m. transmitter?

33.7a — What variation will be observed in the d.c. plate and grid current meters on an f.m. transmitter? Explain.

33.7b — What variation will be observed on the antenna current ammeter? Explain.

33.8 — Compare the modulator power needed for an f.m. transmitter as contrasted with the modulator power needed for a.m. transmitters.

33.9 — Outline a method for measuring the deviation linearity of an f.m. transmitter. State the equipment required and show by means of a block diagram how it would be connected.

33.10a — To receive frequency-modulated signals, the tuned circuits of the receiver must be much wider than for the reception of amplitude-modulated signals. How is this accomplished in the f.m. superheterodyne and what circuits are considered?

33.10b — What other differences exist in the superheterodyne receiver for the reception of f.m. as contrasted with a.m. receivers?

33.11a — What is the purpose of the limiter tube in an f.m. receiver? Why is a cascaded two-stage limiter superior to a single limiter stage?

33.11b — How is limiter operation accomplished in the tube operation?

33.12 — Explain why no special a.v.c. circuit is required in the f.m. receiver.

33.13 — A receiver designed for reception of wide-band f.m. (± 75 kc. swing) can be used for the reception of narrow-band f.m. (± 15 kc.), but a narrow-band receiver will not receive wide-band signals without excessive distortion. Comment on the results to be expected with either type receiver when receiving signals for which it is not designed.

33.14 — The input signal which will saturate the limiter (or second limiter) will determine the ultimate receiver sensitivity. Why is this so?

33.15 — State the method you would use and the equipment required to adjust a frequency modulated receiver for proper operation.

34.1 — A ship fixes its position by cross-bearings on two known transmitting stations. As a check, another bearing is taken on a third transmitter. The three lines do not intersect at the same point. What would you do?

34.2 — Would you ground or open all other antenna circuits when taking a bearing with a direction finder? Why?

34.3 — A direction finder has just been installed aboard a ship. State the procedure for its calibration.

34.4 — Why are marker beacons installed at frequent intervals in mountainous country?

34.5 — Why does the accuracy of the *A* and *N* beacon increase as you approach the transmitter?

34.6 — What advantage does the vertical antenna radiator system possess over the crossed-loop antenna system?

35.1 — A power amplifier tube is designed to work into a load of 4,000 ohms. The antenna resistance at the point of coupling is 24 ohms. The P.A. output circuit is a parallel resonant circuit inductively coupled to the output which

consists of a coil and condenser in series with the antenna circuit connected conventionally. Explain clearly how the 24 ohms at the antenna are transformed into a 4,000-ohm load for the tube.

35.2a — What is the difference between a resonant and a non-resonant transmission-line system?

35.2b — Why does any transmission line which is terminated in its characteristic impedance look like a line infinitely long to the source of energy?

35.2c — What is the effect on transmission-line operation if a transmission line is not terminated in its proper impedance? How could a line be checked to determine if the line termination is correct?

35.3 — What is the difference in the operation of a line which is an odd number of quarter wave-lengths long as compared with one which is an even number of quarter wave-lengths?

35.4 — An ungrounded antenna is operated on its eighth harmonic at a frequency of 21.2 Mc. Determine the antenna length required.

35.5 — Make a diagram of the voltage and current distribution on a grounded antenna which is being operated on its third harmonic. Also make a diagram for the voltage and current distribution on an ungrounded antenna operated on its third harmonic. If both antennas are operating on the same frequency, how do their physical lengths compare?

35.6 — If a concentric line is to have a characteristic impedance of 75 ohms and the inner conductor is $1/4$ inch in diameter, what is the proper value for the inner diameter of the outer conductor?

35.7 — State several uses of transmission lines for both resonant and non-resonant applications.

36.1a — A $\lambda/4$ wave antenna has a natural wave-length of 120 meters. What is the natural frequency of this antenna?

36.1b — If the antenna of problem 36.1a is operated on a frequency of 2,200 kc., what kind of reactance will the antenna present at the coupling point?

36.1c — Similarly, if the antenna is operated at 2,800 kc. what reactance will appear at the base?

36.1d — What kind of loading is required to make the antenna of problem 36.1a resonant at 2,200 kc.? At 2,800 kc.?

36.2 — A resistance of 2,500 ohms is to be matched to a 100-ohm resistance by means of a quarter-wave transmission line at a frequency of 8,210 kc. Determine the proper value of the line's characteristic impedance and the line length. If the line is to be constructed from No. 10 wire, what is the proper value for the line spacing?

37.1 — A u.h.f. transmitter is to supply a half-wave antenna at a frequency of 240 Mc. The transmitter will be crystal controlled. Determine the approximate length of the antenna, taking into account the decreased velocity of the waves at this frequency.

37.2 — Show by block diagram the circuit you might use for the transmitter of problem 37.1 if the highest frequency at which the crystal will oscillate is not greater than 10,000 kc., even at harmonic operation of the crystal.

37.3a—Outline briefly the limitations of regenerative oscillators and amplifiers at the ultra-high frequencies.

37.3b—Discuss briefly the present approaches to the solution of these limitations.

37.4—State four distinct uses of transmission lines at ultra-high frequencies.

38.1—A positive-grid oscillator tube has a cylindrical anode whose diameter is 1 cm. and whose potential is the same as that of the filament. What grid voltage will be needed to generate 50-cm. waves? What would be the wave-length if the anode diameter were 2 mm.?

38.2—What is to keep the grid of a *B-K* tube from overheating under electron bombardment?

38.3—The magnetic field intensity applied to an oscillating magnetron is 2,000 oersteds. What wave-length is being generated?

38.4—An electron has been accelerated by a 200-volt battery. How far will it travel during one period of a 50-cm. wave?

38.5—State in your own words why a cavity resonator is used to tune micro-waves.

38.6—Compute the cross-sectional dimensions of cylindrical and rectangular wave-guides which will just admit 50-cm. waves of the E_o and H_{o1} modes of vibration, respectively.

38.7—Why is a wave-guide built of galvanized iron superior to one built of plain iron sheeting?

INDEX

- A and N radio beacon 285
- A. C. 22
 - ammeters 30
 - circuits 27
 - operation of thyratrons 128
 - resistance 30
- Acorn tubes 312
- Accuracy
 - of direction finding 282
- Adcock antenna 283
- a.f.c. 29, 269
- Aircraft
 - aids to navigation 277-288, 335
- Alignment of
 - a.m. receiver 262
 - f.m. receiver 275
 - i.f. amplifier 264
- Alternating currents 22
 - effective, peak, average values 24
 - generator 22
 - phase 25
- Altimeter 234
- Ammeter 17
 - a.c. 30
 - thermocouple 30
- Ampere 8
- Amplification
 - constant 76
 - of Class A 179
 - of Class B 180
 - of Class C 182
 - per stage 82, 198
 - power 86
- Amplifiers
 - a.f. Class B 179
 - alignment of 264
 - audio 84
 - audio-frequency 187-197
 - balanced feedback 200
 - band-pass 203
 - buffer 224, 244
 - Class A 80
 - Class AB 181
 - Class A, B, and C 176-182
 - Class C 182, 213-217
 - degenerative 87, 198
 - direct current 83, 183-186
 - distortion in Class A 178
 - feedback 198-204
 - filters for 85
 - for receivers 205-208
 - for transmitters 208-212
 - frequency doublers 248
 - frequency multipliers 248
 - high- and low-pass 200, 201
 - impedance-coupled 194
 - intermediate frequency 206
 - in superheterodyne receivers 259
 - linear 191
 - modulation of 213-217
 - modulator, adjustment of 215
 - neutralized 208-211
 - neutralization procedure 210
 - phase reversal 86
 - power output 87
 - pulse 190
 - pure sine wave 204
 - push-pull, principle of 88
 - r.f. and i.f. 205-212
 - r.f. Class B 181
 - radio-frequency, simple 85
 - regenerative 87, 198
 - selective 202
 - simple 80-89
 - simple feedback 87
 - speech 196
 - square wave 191
 - stable 198
 - testing with square waves 231
 - transformer-coupled 194
 - video 192, 200
 - wide-band 192, 200
- Amplitude, large
 - in oscillators 227
- Amplitude modulation
 - cathode 111, 217
 - choke-coupled 215
 - comparison with f.m. 273
 - crude method 107

- grid-bias 109, 216
- plate 108, 213
- principle of 106-113
- requirements 213
- suppressor-grid 111, 216
- see receivers
- see transmitters
- Analogy between light and electron rays 147
- Analyzer, frequency 204
- Anti-nodes 297
- Atmospherics
 - see static
- Antennas
 - Adcock 283
 - broadside 309
 - coupling to transmitters 252
 - direction-finding 277-282
 - directive antennas 308
 - directors 309
 - dummy 246
 - end fire 309
 - feeders 306
 - field patterns
 - directive 308
 - loop 278-281, 285
 - half-wave 306
 - Hertz 49, 306
 - impedance matching 307
 - J-type 306
 - length of 307
 - long-wire 298
 - loop 277
 - Marconi 48
 - parasitic 309
 - radiation resistance 307
 - rhombic 299
 - short-wire 306-309
 - simple 48
 - tuning of 307
 - V-type 299
 - vertical 280
 - Zepp 307
- Array
 - directive 50
 - broadside 51
- Attenuation
 - of filters 40-43
 - of lines 294, 297, 304, 311, 398
 - in wave-guides 333
- Audibility, threshold curve 268
- Audio
 - amplifiers, simple 84
 - frequencies 23
 - oscillator 92
 - transformers 31
- Audio-frequency
 - amplifiers, simple 84
 - see amplifiers
 - choke 29
 - range of 23
- Audio-frequency amplifiers 187-192
 - balanced feedback 200
 - blocking 190
 - blocking action 230
 - clipper action 229
 - complete unit 229
 - degenerative 198-204
 - design of 188
 - feedback 198-204
 - for microphones 194
 - for pulses 190
 - for speech 196
 - frequency response 189
 - high- and low-pass 200
 - impedance-coupled 192
 - limiter action 229
 - linear 191
 - parallel plate feed 193
 - R-C* coupled 187-192
 - R* and *C* values 188
 - resolving time 190
 - selective 203
 - shielding 190
 - speech input 194
 - testing with square waves 231
 - transformer-coupled 194
 - video 192
 - wide-band 192
 - see modulators
- Automatic
 - direction finders 284
 - frequency control 269
 - switching 239
 - tuning 269
 - volume control 266
 - volume expanders 269
- a.v.c. 266
- Average value 24
- B** battery
 - common 86
 - eliminators, see power supplies
- Back e.m.f. 18

- Background noises
 - in loops 281
- Balanced
 - d.c. amplifier 184
 - feedback amplifier 200
 - loop antennas 282
 - see Class B amplifiers
 - see pushpull amplifiers
- Band-spread in receivers 264
- Band width 113
 - in f.m. 272
 - in receivers 258
- Barkhausen-Kurg oscillators 322
- Barrow 331, 336
- Beacons 285
- Beam multiplier tubes 104
- Beam power tubes 101
- Beams, radio 285
- Bearings, cross 279
- Beat-frequency oscillator 224
- Beats 225
 - for c.w. reception 256
- Bias for grid 75
- Bird's-eye view 265
- Bleeder resistor 71
- Blocking action
 - square wave production 230
 - sweep-circuit 167
- Breakdown
 - of condensers 15
- Breit 233
- Bridge rectifier 67
- Bridge, Wheatstone 10
- Broadside antennas 308
- Buffer amplifier 224, 244
- Buncher 328
- Bypass
 - condenser 29
 - cathode 74
- C Bias 74**
 - voltage stabilization 243
 - c.p.s. 47
 - C.W. receivers 255
- Capacitance 15
 - coupling 36
 - distributed 26 see lines
 - in parallel 16
 - in series 16
 - input of tubes 82
 - of simple condenser 16
 - phase lead 26
- Capacitors 30
- Capacitive reactance 27
- Carbon microphones 194
- Carrier wave 106
- Cascade amplifiers 83
- Catcher 327
- Cathode
 - bypass condenser 74
 - resistor 74
- Cathode modulation 111
 - details 217
- Cathode-ray direction finder 284, 288
- Cathode-ray oscilloscopes
 - see oscilloscopes
- Cathode-ray tubes 147-161
 - control of brightness 154
 - control of focus 154
 - deflection sensitivity 153
 - double sweeping 168
 - electron guns 151
 - electron microscope 160
 - electron telescope 158
 - iconoscope 156
 - image dissector 157
 - kinescope 155
 - klystron 327
 - magnetic focusing 158
 - operation of 162-175
 - patterns on screen 171-175, 250
 - photograph of 160
 - picture of 153
 - picture tubes 155
 - scanning 168
 - screen classification 153
 - screen materials 152
 - sweep-circuits for 162-168
 - synchronization 170
 - uses of 162
 - velocity modulated 327
 - voltage supply circuit 154
 - see oscilloscopes
- Cathodes, types of 60
 - virtual 218
- Cavity resonators 328, 332
- Centimeter waves 322
- Channel width 113
- Characteristic
 - chart 295
 - equation 294
 - impedance, of a line 51
- Characteristic curves
 - of diodes 62

- of triodes 74
- thyatron 125, 126
- Characteristics of filters 40-43
- Charge of electron 1
- Charging
 - of a condenser 19
- Chart
 - condenser discharge 20
 - decibel 11
 - line impedance 295
- Child 63
- Choke
 - audio-frequency 29
 - radio-frequency 29
- Choke coupling
 - audio amplifiers, simple 84
 - for modulation 215
- Circuit elements
 - linear 176
 - non-linear 176
 - ohmic and non-ohmic 176
- Circuits
 - coupled 36
 - loaded 35
 - parallel 34
 - resonant 33
 - tuned 33
- Circuits, a.c. 27
- output 87
- Class A amplifiers 80
 - audio 84
 - characteristics of 179
 - degenerative 87
 - direct current 83
 - distortion 178
 - filters for 85
 - intermediate frequency 206
 - multistage 83
 - phase reversal 86
 - plate efficiency 179
 - power amplification 179
 - power output 87, 179
 - push-pull principle of 88
 - radio-frequency, simple 85
 - regenerative 87
 - simple 80-89
 - simple feedback 87
- Class AB amplifiers 181
- Class B amplifiers
 - advantage of 180
 - audio-frequency 179
 - characteristics of 180
 - comparison with A and C 180
 - double-ended 179
 - input ability 180
 - plate efficiency 181
 - power amplification 180
 - power output 180
 - principle of 177, 180
 - radio-frequency 181
 - reduction of harmonics 181
 - single-ended 181
- Class C amplifiers
 - adjustment for 100 per cent modulation 215
 - characteristics of 182
 - operation of 211
 - plate efficiency 152
 - power output 182
 - principle of 182
- Clipper action 229
- Close coupling 37
- Coaxial cable
 - see concentric lines
 - see transmission lines
- Code reception 255
- Coated filaments 60
- Coils
 - distributed capacitance of 26
- Coincidence counters 236
- Color of light 140
- Colpitts oscillator 92
- Comparison detectors 119
- Compass, radio 279
- Complex current
 - separation of components 29
- Complex wave-forms 24
- Concentric lines 50, 292, 304
 - advantages 304
 - feeders 306
 - filters 309
 - impedance chart 295
 - impedance matching 305
 - length of 296, 303
 - modes of vibration 302
 - quarter-waves 304
 - standing waves 302
 - tuning circuits 318
 - see transmission lines
- Condenser
 - actual 30
 - breakdown of 15, 35
 - bypass 29
 - charging of 19

- chart 20
- discharging of 19
- equation of 16
- ganged 262
- in parallel 16
- in series 16
- padding 263
- resonant voltage 35
- simple 15
- trimmer 263
- Condenser microphones 195
- Conductance
 - of triodes 78
- Conduction, metallic 6
- Constant
 - constant current 227
 - constant-current system 227
 - dielectric 15
 - time 19
 - see voltage stabilizers
- Constants of
 - pentodes 100
 - tetodes 99
 - triodes 76-79
- Control of gas-filled tubes 128-132
- Control ratio of grid 125
- Conversion efficiency 262
- Converters, in superheterodyne receivers 261, 313
 - adjustment 263
 - in u.h.f. receivers 312
- Coulomb 8
- Counters
 - coincidence 236
 - of pulse 190, 234
 - scaling 237
 - see frequency meters
 - see scaling circuits
- Counting circuit, simple 127
- Coupled
 - circuits 36
- Coupling
 - coefficient of 37
 - critical 37
 - electron 218
 - for output stage 87
 - in transmitters 245
 - interstage 83-85, 190
 - methods 36, 218
 - transmitter output 252
- Critical
 - coupling 37
- frequency of ionosphere 55
- wave-length of wave-guides 333
- Cross bearing 279
- Crystal microphones 195
- Crystals
 - amplifier 197
 - cuts 220
 - filters 208
 - frequency range 222
 - microphones 195
 - mounting 221
 - oscillator, simple 95
 - oscillators 222
 - Q of 94
 - resonators 35
 - Rochelle salt 195
 - safeguarding 221
 - temperature coefficients 221
 - thickness coefficients 221
- Current
 - complex 29
 - constant system 227
 - diode 59
 - direction of flow 9, 58
 - distribution along lines 293, 301
 - Eddy 38
 - limiting tube 166
 - magnetic field of 17
 - photoelectric 137-142
 - saturation 61
- Currents, alternating 22
- Cutoff
 - frequency of filters 41
 - of triodes 74, 77
 - of wave-guides 333
- Cyclotron, basic law 159
 - high voltage for 305, 316
- Cylindrical wave-guides 332
- db. 12
 - gain in amplifiers 189, 201-204, 207
 - line loss 294, 297, 298, 304, 311
- Decibel 11
 - see db.
- Decimeter waves 322
- Decoupling resistors 85, 188
- Decrement 35
- Deflection sensitivity 153
- Degeneration in amplifiers
 - simple 88
- Degenerative amplifier 198-204
- Delayed a.v.c. 267

- Design of *R-C* coupled amplifiers 188
- Detection, principle of 114-119
- Detectors
- comparison of 119
 - crystal 114
 - diode 114
 - double 312
 - for f.m. 275
 - full-wave diode 116
 - grid-leak 116
 - input ability 119
 - linearity of 119
 - plate 115
 - regenerative 118
 - sensitivity of 119
 - super-regenerative 118, 313
 - types of 119
- Deviation
- checking 273
 - frequency 271
 - ratio 272
- Dielectric constant 15
- loss 39
- Diffraction of radio waves 53
- Diode 58
- detector 114
 - rectifiers 65
- Dipoles
- see short-wire antennas
- Direct current amplifiers 183-186
- balanced 184
 - multistage 185, 186
 - simple 183
 - stabilized 184
- Direction finders 277-290
- A and N beacon 286
 - automatic 284
 - background noises 281
 - beacon 285
 - cathode-ray 284, 288
 - cross bearings 279
 - errors 281
 - goniometer 279
 - homing device 284
 - instrument landing 288
 - loop antennas 277
 - markers 287
 - message and beacon 286
 - night effect 283
 - of pulses 288
 - position fixing 280
 - principle of 277
 - radio compass 279
 - sense determination 280
 - shielded 282
 - shore effect 282
 - static reduction 287
- Directive antennas 50, 309
- Directive horns 335
- Directors, parasitic 309
- Discharging
- of a condenser 19
- Discriminators 275
- Disintegration voltage 123
- Dissector, image 157
- Distance, of transmission
- ground wave 53
 - ultra-high frequency 56
- Distortion
- due to grid current 178
 - in Class A amplifiers 178
 - in Class B 178
 - in Class C 182
 - in oscillators 226
 - reduction of
 - by feedback 198
 - in Class C amplifier 212
- Dividers
- frequency 238
 - voltage 10
- Doorknob tubes 312, 320
- Double-button microphones 194
- Double-pulse 178
- Doublers, voltage 68
- frequency 248
- Double-superheterodyne 312
- Double-tracing 239
- Dow, J. B. 218
- Drift, in i.f. amplifiers 207
- Dull emitters 60
- Dummy antenna 246
- Dynamic curves 75
- Dynamic microphones 196
- Dynatron oscillators 220
- Eddy currents 38
- e.m.f. 8
 - e.s.u. 8
- Effective
- input capacitance of tubes 82
 - value of 24
- Effective resistance 38

- Efficiency
 conversion 262
 modulation 111
 of Class A amplifiers 179
 of Class B amplifiers 181
 of Class C amplifiers 182, 211
 of filaments 60
 of frequency multipliers 248
 of oscillators 227
 plate 87
- Electric
 field intensity 47
- Electrical fields 14
 polarization of radio waves 277, 283
- Electrical units 8
- Electromagnetic
 field 45, 46
 horn radiators 335
 waves in guides 331
- Electromotive force 8
- Electron 1
 charge of 1
 free 7, 59
 mass of 2
 secondary, in tetrodes 99
 velocity of 4
 volt 5
- Electron-coupled oscillators 218-224
- Electron coupling 218
- Electron guns 151
- Electron lenses 148-150
- Electron microscope 160
- Electron-multiplier tubes 102-105
 in image dissector 157
 photoelectric 144-146
- Electron oscillators 322-330
- Electron rays, analogy with light rays 147
- Electron telescope 158
- Electronic switch 239
- Electrostatic focusing 149-152
- Electrostatic induction 13
- Electrostatic lenses 149-152
- Eliminators
 see power supplies
- Emission
 field 63
 secondary laws 63
 in multiplier tubes 102
 in photo-multiplier tubes 144-146
- End-effect of lines 303
- End-fire antennas 308
- End-plate magnetrons 326
- Equations
 a.c. values 24
 audio transformer 31
 B-K oscillator 323
 capacitance 16
 capacitive reactance 27
 coupling coefficient 37
 effective peak average 24
 feedback amplifier 198
 for long-lines 294-296
 for short-lines 303, 305
 frequency 47
 gain of amplifiers 82
 general resistance 29
 heating 9
 high-pass filters 42
 impedance 28
 inductive reactance 27
 klystron 330
 LC 35
 low-pass filters 41
 lumped voltage 77
 magnetron oscillator 325
 modulation percentage 111
 mu of tubes 76
 mutual conductance 79
 parallel impedance 34
 plate current 78
 plate resistance 78
 positive grid oscillators 323
 power 9
 power factor 29
 Q 35
 quartz crystal 221
 resistances 10
 resonant frequency 33
 secondary heating 38
 series impedance 27
 simple filters 40
 transmitter power output 247
 wave-guides 333
 wave-length 47
- Equipotential
 cathodes 61
 lines 13
- E-region 54
- Errors, in direction finders 281
- Evaporation theory 59

- Expanders, automatic-volume 269
Extinction voltage 120
- F-region** 54
Fadeouts 54
Fading 56
Farad 16
Faraday 18
Faraday shield 247
Feedahead system 265
Feedback
 degenerative 87, 198
 distortion due to 226
 effective capacity of 82
 inter-electrode 208
 regenerative 87, 198
 simple amplifier 87, 198
 see amplifiers
Feedback amplifiers 198-204
 balanced 200
 band-pass 203
 degenerative 198
 equation 198
 high- and low-pass 201
 principle of 87, 198
 pure sine wave 204
 regenerative 87, 198
 selective 202
Feeders
 for antennas 292, 299, 306
 for wave-guides 331
Fidelity
 receiver 258
Field emission 63
Field intensity 47
Fields
 electric 14
 from wave-guides 335
 in wave-guides 331
 magnetic 17
 of antennas
 directive 308
 loop 278-281, 285
 of parallel wires 293
 polarization 277, 283
Filaments 59
 electron bombardment of 326
Filtering
 of complex currents 29
 of voltage supplies 85, 241
Filters
 amplifiers 201-204
 band-pass 43
 concentric line 309
 crude 40
 crystal 44
 band-elimination 43
 for amplifiers 85, 188
 for rectifiers 68
 for voltage supplies 85, 241
 high-pass 42
 idealized 40
 low-pass 41
 scratch 268
 simple 29
 use of 39
 wave-guide 333, 334
Flux, luminous 136
Flyback time 165
Focusing
 electrostatic 149-152
 magnetic 158-161
Folded patterns 170
Foot-candle 137
Frame, in television 157
Frequency 23, 46
 audio 23
 critical, for ionosphere 55
 cutoff of filters 41-42
 deviation 271-273
 image 260
 intermediate 23, 259
 maximum usable 55
 microwave 322
 multiplication 248, 273
 of human voice 258, 268
 radio 23
 ranges of 23
 resonant, equation 33
 ripple 66
 sweep 170
 u.h.f. 311
 versus wave-length 47
Frequency analyzer 204
Frequency control
 automatic 269
Frequency control of gas-filled tubes
 129
Frequency converters 261
Frequency divider 238
Frequency division number 239
Frequency doublers 248
Frequency drift 207, 227
Frequency meter 236

- Frequency mixers 261
 Frequency modulation 271-276
 alignment 275
 checking transmitter 273
 comparison with a.m. 273
 deviation frequency 271
 deviation ratio 272
 discriminator 275
 limiter 274
 principle of 107
 reactance modulator 271
 Frequency multipliers 248
 Frequency response
 broad-band 200
 i.f. amplifier 207
 of feedback amplifiers 200-204
 of photocells 139, 144
 of receivers 257
 R-C coupled amplifiers 189
 Frequency stability
 of oscillators 227
 Full-wave detectors 115
 Full-wave rectifiers 66

Gain of amplifiers
 equation 82
 frequency response 189, 198, 201-204,
 207
 overall 196
 simple amplifier 82
 Galvanometer 17
 thermocouple 30
 Gas-filled tubes 120-126
 glow-tube 120
 grid control ratio 125
 grid-glow tubes 123
 negatively controlled 125
 positively controlled 125
 striking potentials 124
 strobotron 121
 tetrodes 126
 thyratrons 123
 Gas-filled tubes, operation of 127-
 135
 a.c. on plate 128
 counting circuit 127
 frequency control 129
 inverters 133
 phase control 130
 rectifiers 132
 self-stopping circuit 127
 Geiger-Mueller tube 235

 Generator, a.c. 22
 see amplifiers
 Gill-Morell oscillations 324
 Glider path 288, 335
 Glow-tube 120
 for Lecher wires 298
 in d.c. amplifiers 186
 in voltage stabilizers 241
 G-M oscillator 324
 G-M tube 235
 Goniometer 279
 Grid bias 74
 details 216
 modulation, principle of 109
 Grid control of space charge 73
 Grid-control ratio 125
 Grid current distortion 178
 Grid current in oscillators 226
 Grid-glow tubes 123
 de-ionization time 120
 in sweep-circuit 163
 operation of 127-135
 Grid leak 75
 Grid-neutralized amplifier 210
 Ground wave 52
 polarization of 277, 283
 Guns, electron 151

 Half-wave rectifiers 65
 Harmonic distortion
 see distortion
 Harmonics, 25
 Class C amplifiers 182, 212, 247
 in wave-guides 331
 on antennas 299, 306
 on short lines 302
 square waves 232
 transmitter 247
 Hartley oscillator, simple 91
 Heating
 effect of current 9
 Heaviside 53
 Height, of ionosphere 54
 Henry 19, 37
 Hertz 45, 49, 136, 300
 Heterodyne 225
 see superheterodyne
 High frequency
 ranges of 24
 thermocouple-ammeter 30
 Homing devices 283
 Horns, electromagnetic 335

- Hum, reduction of 61
 - in transmitters 251
 - in tubes 65
- Hyper-frequency waves 322
- Iconoscope 156
- I.F. see intermediate frequency
- Illumination
 - definition 137
 - proper amount of 137
- Image dissector 157
- Image frequency 260
- Image ratio 261
- Impedance 27
 - characteristic of a line 51, 294
 - coupled amplifiers 84, 192
 - coupling 36
 - for max. power transfer 31
 - for modulators 215
 - input of lines 305
 - matching 295, 303-306
 - output of long-lines 295
 - output of short-lines 305, 316
 - parallel circuit 34
 - reflected 31
- Impedance-coupled amplifiers 192
- Inductance 18
 - in parallel 19
 - in series 19
 - mutual 37
 - phase lag 26
 - powdered iron-core 207
 - self- 18
 - unit of 19, 37
- Induction
 - electrostatic 13
 - heater 38
 - magnetic 18
- Induction field 46
- Inductive neutralized amplifiers 210
- Input ability of detectors 119
- Input capacitance of tubes 82
- Input impedance of lines 305
- Instrument landing 288
- Insulators
 - properties of 15
- Intensity
 - electric field 47
 - of light 136, 138
 - meter, double 288
- Intermediate frequencies 24
 - Intermediate frequency amplifiers 206
 - alignment 264
 - drift 207
 - gain 207
 - in superheterodyne receivers 259
 - selective 208
 - typical circuit 207
 - with crystal filters 208
 - International candle 136
 - Interstage coupling
 - in amplifiers 83-85, 190
 - in transmitters 245
 - Interval timer 240
 - Inverters 133-135
 - Ion 7
 - Ion sheath, positive 124
 - Ionization 7
 - Ionizing potentials 122
 - Ionosphere 53
 - measurement of height 233
 - vs. wave-guides 330
- J-antenna 306
 - k.c. 47
 - Kennelly 53
 - K-H layer 53
 - Kinescope 155
 - Klystron 327
- L to C ratio 35
 - for frequency stability 227
 - in frequency multiplier 248
 - in oscillators 219
 - of long-lines 294
- Landing, instrument 288
- Langmuir 63
- Law
 - of magnetic induction 18
 - Ohm's 9
- Laws for resistances 10
- Lecher wires 298
- Lenses, electron 148-150
 - electrostatic 148-150
 - magnetic 152, 158-161
- Length, electrical vs. physical
 - antennas 306
 - long-lines 296
 - short-lines 303
- Light
 - intensity of 136

- radiation from sources 140
- units of 136
- velocity of 46
- wave-length of 140
- Limiters
 - alignment 275
 - f.m. receivers 274
 - principle of 177
 - square wave production 229
- Line-of-sight distance 56
- Linear amplifier 191
- Linear circuit elements 176
- Linear circuits 300-305
 - as filters 309
 - as transformers 305
 - as tuning elements 314-320, 323
 - concentric 304
 - current and voltage distribution 301
 - end-effects 303
 - feeding 305
 - impedance 305
 - input impedance 305
 - in u.h.f. 314-320
 - length of 303
 - loading 305
 - losses 304
 - modes of vibration 302
 - principles of 300
 - shielding 304
 - standing waves on 302
 - trombone 303
- Linear sweep-circuit 165-168
- Linear transformers 305, 306
- Linearity
 - of detectors 119
 - of f.m. transmitters 273
- Lines
 - as filters 309
 - concentric 50
 - equipotential 13
 - long-, 291-299
 - losses on 294, 297, 298, 304
 - non-resonant 50
 - of force 13
 - parallel wires 50
 - resonant 50
 - see antennas
 - see transmission lines
 - short-, 300-310
 - transmission, simple 50
 - untuned 50
- Link coupling 36
- Lissajou patterns 171-175
 - summary of 174
- Load
 - on simple circuit 35
- Loftin-White circuit 186
- Long-lines 291-299
 - see antennas
 - see transmission lines
- Long-wire antennas 298
- Loop antennas 277
- Loops of current and voltage 297, 301
- Loose coupling 37
- Loss, dielectric 39
- Losses
 - along lines 294, 297, 298, 304, 311
 - in *R-C* coupled amplifiers 189
 - in wave-guides 333
 - see gain
 - vs. *Q* 317
- Lumen 136
- Luminous flux 136
- Lumped voltage 77
- Magnetic**
 - focusing 158
 - lenses 158-161
 - radiating field 46
- Magnetic field of currents 17
- Magnetostriction oscillators 95
- Magnetron 324
- Magnetron oscillators 325
- Mc. 47
- m.c.w. 106, 182
- Marconi 48
- Markers 227
- Mass
 - of electron 2
- Matter
 - structure of 6
- Maximum usable frequency 55
- Maxwell 45
- Metallic conduction 6
- Meters
 - d.c. 17
 - double intensity 288
- Microampere 17
- Microfarad 16
- Micro-microfarad 16
- Microphones 194-196
- Microphonics 257

- Microscope, electron 160
 Microwaves 322-336
 frequency
 range of 24, 322
 references 336
 Milliampere 17
 Mixers in superhet receiver 261
 in u.h.f. receivers 312
 Modes of vibration
 in wave-guides 331
 on antennas 299, 306
 on lines 302
 Modulated carrier wave 106
 Modulation
 adjustment for 100 per cent 215
 amplitude, details 213-217
 principle 106-113
 cathode 217
 frequency
 principle of 107
 details 271-276
 grid-bias 216
 low- and high-level 245
 measurements of 250
 of pentode amplifiers 216
 of r.f. amplifiers 213-217
 percentage 111
 plate-and-screen 215
 requirements for 100 per cent
 214
 suppressor-grid 216
 under- and over-, 250
 velocity 327
 Modulator 108
 output voltage 214
 reactance 271
 requirements of 214
 see modulation
 see speech amplifiers
 Multi-electrode tubes
 high-vacuum 98-105
 Multi-hop 55
 Multipliers, frequency 248
 Multiplier tubes 102-105
 in image dissector 157
 photoelectric 144-146
 Multistage amplifiers 83
 d.c. amplifiers 186
 Multivibrator
 details 235, 238
 simple 94
 Mutual
 conductance 78
 inductance 37
 Navigation aids 277-288, 335
 Negative feedback
 see degenerative amplifiers
 Negative resistance 100
 Negative resistance oscillators 220
 Neighboring bodies
 effect of 38
 Neon tubes
 see glow-tubes
 Neutralization 208-211
 grid
 induction 210
 of push-pull amplifier 210
 plate, 209
 procedure 210
 Night effect 283
 Nodes and loops 297
 Noise
 in f.m. transmission 273
 in loops 281
 in receivers 256
 limiters 267
 thermal, in amplifiers 8
 Noise limiters 267
 Non-harmonic oscillations 247, 323
 Non-linear circuit elements 176
 Non-ohmic circuit elements 176
 Non-resonant lines 50, 292-297
 Oersted 17
 Ohm 9
 Ohm's law 9
 for a.c. circuits 28
 Ohmic circuit elements 176
 Open-wire lines
 see parallel-wire lines
 Orbital-beam multiplier tubes 104
 Oscillation
 frequency of 33, 91
 large amplitude 227
 parasitic 247, 324
 square wave 229
 Oscillators
 adjustment of 223
 audio-frequency 96
 Barkhausen-Kurz 322
 beat-frequency 224
 cathode-ray 327

- cavity resonators 328
- Colpitts, simple 92
- constant-current supply 227
- converter 261, 313
- crystal circuits 222
- crystal, simple 94
- crystals for 220
- distortion in 226
- dynatron 220
- electron-coupled 218
- frequency drift 227
- frequency modulation of 271
- frequency stability 227
- General Radio 319
- Gill-Morell 324
- grid current 225
- harmonic distortion 226
- Hartley, simple 91
- heterodyne 225
- klystron 327
- large amplitude 227
- linear circuits for 315
- local 256-263
- magnetostriction, simple 95
- magnetron 324-327
- mixer 261
- multivibrator, details 235, 238
- multivibrator, simple 94
- negative resistance 220
- phase and voltage 225
- Pierce 223
- plate efficiency of 227
- positive-grid 322
- power output 227
- pulse 232
- pure sine wave 204
- push-pull simple 97
 - ultra-high frequency 314, 316-318
- relaxation 121, 163
- retarding field 322
- saw-toothed 234
- simple 90-97
- square wave 229
- sweep 163-168, 234
- tickler circuit 90
- transitron 220
- tri-tet 223
- tuned-filament, tuned-plate 317
- tuned-plate tuned-grid simple 92
- ultra-high frequency 315-321
- ultraudion, simple 93
 - ultra-high frequency 315
 - velocity-modulated 327
- Oscillograph
 - see oscilloscope
- Oscilloscopes
 - cathode-ray tubes for 152
 - checking phone transmitters 250
 - circular pattern 173
 - crenellated pattern 175
 - direction finders 284, 288
 - double sweep 169
 - double tracing 239
 - elliptical pattern 174
 - folded pattern 169
 - hum tests 252
 - linear sweep-circuit 165-168
 - Lissajou pattern 171-174
 - modulation measurement 250
 - multiple frequencies 170
 - operation of 162-175
 - patterns 171-175, 250
 - scanning 169
 - spiral pattern 175
 - sub-multiple frequencies 170
 - sweep-circuit 163-168
 - synchronization 170
 - trapezoidal method 250
 - uses of 162
 - wave-envelope method 250
- Output
 - amplifier circuits 87
 - impedance of lines
 - long-, 295
 - short-, 305
 - see power output
 - transmitter circuits 252
- Oxide-coated filaments
- Padding condenser 263
- Parallel
 - capacitances 16
 - resistances 10
 - resonant 34
- Parallel-wire lines
 - characteristic impedance
 - chart 295
 - equation 294, 305
 - feeding 305
 - fields around 293
 - impedance matching 305
 - Lecher wires 298
 - length 296, 303

- linear circuits 300
- long-lines 291-298
- losses 297, 298, 304
- non-resonant 292-297, 300-305
- progressive wave 293
- resonant 297
- shielding 304
- short-lines 300-305, 315-317
- spacing 292, 304
- standing waves 297, 301
- termination 295, 303
- transformers 305
- transposed 292
- tuning elements 315, 323
- tuning circuits 315-317, 323
- velocity along 294
- wave-length on 294
- Parasitic
 - directors and reflectors 309
 - oscillations 247, 323
- Patterns
 - from wave-guides 335
 - in wave-guides 331
 - on cathode-ray tubes 169, 171-175
 - radiation 278-288, 308
- Peak-inverse voltage 66.
- Peak value 24
- Pentode amplifiers
 - Class C 213-217
 - modulation of 216
- Pentodes 100
- Percentage Modulation 111
- Period 23
- Phase 25
 - in oscillators 225
 - measurement 162, 290
 - quadrature 278, 309
 - reversal per stage 86
- Phase control of thyatrons 130, 133
- Phase shifters 131
- Phase-splitting circuit 174
- Phone transmitter, 248
 - checking 250
- Photoconductivity 143
- Photoelectric cells 136-146
 - color response
 - emissive 137
 - frequency response 139, 144
 - internal resistance 144
 - max. safe voltage 139
 - multiplier type 144-146
 - photoconductive 143
 - photo-voltaic 143
 - photronic 143
 - practicable circuits 143
 - selenium 143
 - simple 137
 - simple circuits 142
 - spectral selectivity 141
 - threshold 142
 - time of response 139
 - vacuum vs. gas-filled 139
 - yield 142
- Photoelectric current 137-142, 146
 - time factor 139
 - total 142
 - vs. battery voltage 138
 - vs. color of light 140
 - vs. light intensity 138
 - vs. wave-length 140
 - yield 141, 142
- Photoelectric effect 136
- Photomosaic 156
- Photo-multiplier tubes 144-146
 - in image dissector 157
 - multiplier tubes 102-105
- Photo-tubes
 - see photoelectric cells
- Photo-voltaic effect 143
- Photronic cells 143
- Picture tubes 155
- Pierce crystal oscillator 223
- Plate control, of space charge 62
- Plate current
 - vs. filament temperature 59
 - vs. plate voltage 62
- Plate detectors 115
- Plate efficiency 87, 227
- Plate modulation
 - details of 213
 - principle of 108
- Plate-neutralized amplifiers 209
- Plate resistance of tubes 77
- Polarization of radio wave 53, 177, 283
- Position fixing 280
- Positive feedback 87, 200
- Positive-grid oscillators 322
- Positive ion sheath 124
- Potential 8
 - disintegration 123
 - dividers 10
 - drop 9
 - extinction 120

- ionizing 122
- starting 120
- striking 120
- Power 9
 - factor 29
 - max. transferred 31
 - modulator requirement 214
- Power amplification 86
- Power amplifier
 - audio 87
 - r.f. Class C 211
- Power output
 - Class A amplifiers 87, 179
 - Class B amplifiers 180
 - Class C amplifiers 182
 - measurement of 246
 - of oscillators 227
 - transmitter 247, 252
- Power pack 65-72
- Power sensitivity 87
- Power supplies
 - current-regulated 227
 - filters for 69
 - rectifiers for 65-69
 - regulation 71
 - three-phase 68
 - typical circuit 69
 - vibrators 72
 - voltage doublers 67
 - voltage-regulated 241
- Power tubes
 - beam 101
- Preselector 254, 256, 260
- Problems 337
- Propagation
 - of radio waves 52
 - ultra-high frequency 56
- Pulling
 - in beat-frequency oscillators 262
 - in converters 262
- Pulse amplifier 190
- Pulses
 - applications of 233
 - counting of 234
 - direction of arrival 236, 288
 - generators 232
 - random 235
- Push-pull amplifiers
 - frequency multipliers 298
 - neutralization of 210
 - simple 88
- Push-pull oscillators 96, 316
- Q 34, 317
 - of amplifier tank 212, 247
 - of concentric line 305
 - of quartz crystals 94
 - values of 35
- Quartz crystals
 - see crystals
- Quasi-optical waves 322, 335
- Questions 337
- Radiation
 - directed 49
 - explanation of 45
 - field 46
 - from wave-guides 835
 - high-angle 49
 - low-angle 49
 - patterns
 - antenna 278-288, 308
 - wave-guide 331, 335
 - polarized 277, 283
 - reduction with lines 304, 317
 - resistance 307
 - uni-directional 51
- Radio aids to navigation 277-288, 335
- Radio beacons 285
- Radio beams
 - A and N 285
 - from horns 335
 - landing 288
 - see antennas
- Radio compass 279
- Radio frequency
 - adjustment for 100 per cent modulation 215
 - ammeter 30
 - amplifiers, details 205-212
 - amplifiers, simple 85
 - choke 29
 - ranges of 24
- Radio frequency amplifiers
 - Class A for receivers 205
 - Class C 211
 - details 205-212
 - linear 191, 211
 - modulation of 213-217
 - neutralization 208
 - power 211
 - simple 85
- Radio markers 287
- Radio wave 46

- polarization 277, 283
- velocity of 46
- Random pulses 235
- Range of transmission
 - ground wave 52
 - ultra-high frequency 57
- Ratio
 - L* to *C* 35
 - standing wave 298
 - transformer 31
- R-C* coupled amplifiers
 - see resistance-capacitance-coupled amplifiers
- Reactance 27
 - capacitive 27
 - coupling 36
 - examples of 28
 - inductive 27
 - modulator 271
- Reading list, microwaves 336
- Receivers
 - alignment methods 262
 - amplitude modulations 254-270
 - automatic frequency control 269
 - automatic tuning 269
 - automatic volume control 266
 - band-spread 264
 - comparison with f.m. 273
 - compensated volume control 269
 - conversion efficiency 262
 - crystal, simple 114
 - fidelity 258
 - for c.w. 255
 - for code 255
 - for wave-guides 332
 - frequency-converters 261
 - frequency modulation 273-276
 - alignment procedure 275
 - comparison with a.m. 273
 - discriminator 275
 - for u.h.f. 313
 - limiters 274
 - ganged condensers 262
 - i.f. amplifiers for 206
 - microwave 332-336
 - noise in 256
 - noise-limiters 267
 - pattern condensers 263
 - r.f. amplifiers for 205
 - scratch filters 268
 - selectivity 257
 - sensitivity 256
 - simple circuit 254
 - special features 267
 - stability 259
 - superheterodyne 259-265
 - tone control 269
 - tracking 263
 - trimmer condensers 263
 - tuning indicators
 - ultra-high frequency 312
 - concentric line tuning 314
 - converter circuit 313
 - design principles 311
 - double superheterodyne 312
 - super-regenerative 312
 - tube for 312
 - volume expanders 269
- Rectangular wave-guides 331
- Rectification 65
- Rectifiers
 - component parts 69
 - diode 65-72
 - filters for 68
 - regulation 71
 - thyatron 132
 - typical circuit 70
 - vibrator 71
 - voltage stabilization 241
- Reduction of static 287
- r.f.c. 29
- References, microwaves 336
- Reflected
 - impedance 31
- Reflectors
 - for microwaves 335
 - parasitic 309
- Refraction of radio waves 53
- Regeneration in amplifiers
 - simple 87
- Regenerative detectors 118
- Regenerative receiver 254
- Regulator
 - of current 227
 - of voltage 241
 - see glow-tubes
- Relaxation oscillator 121, 163
- Remote cutoff tubes 77
- Resistance
 - coupled amplifiers 83
 - h.f. of a coil 30
 - laws 10

- negative 100
- of tubes 77
- photocells 144
- Resistance-capacitance-coupled amplifiers
 - balanced feedback 200
 - blocking action 230
 - characteristics 187
 - clipper action 229
 - decoupling 188
 - degenerative 199
 - design of 188
 - feedback 198-204
 - filtering 188
 - for pulses 190
 - frequency response 189
 - high- and low-pass 201
 - limiter action 229
 - linear 191
 - R and C values 188
 - resolving time 190
 - selective 203
 - shielding 190
 - simple 80
 - speech input 195-197
 - testing with square waves 231
 - typical circuit 187
 - video 192
 - wide-band 192
 - with microphones 195-197
- Resistance-coupled amplifiers
 - see also resistance-capacitance-coupled amplifiers
 - see also direct current amplifiers
- Resistors
 - coils in radio circuits 30
 - decoupling 85
- Resolving time of amplifiers 190, 237
- Resonance
 - along lines 297, 302
 - effective 38
 - generalized definition 39
 - in cavities 328
 - series 33
 - sharpness of 34
 - with various couplings 37
- Resonant
 - circuits 34
 - circuits with load 35
 - frequency 34
 - lines 50, 297, 300-305
 - voltages 35
- Resonators
 - cavity 328, 332
 - crystal 35
 - short-lines 302
- Response curves, of loops 278
- Retarding-field oscillators 322
- Rhombic-type antenna 299
- Ribbon microphone 196
- Richardson 59
- Ripple
 - elimination of 241
 - frequency 66
 - per cent 66
- r.m.s. 24
- Root-mean-square value 24
- Saturation currents
 - for diodes 61
 - for triodes 74
- Saw-tooth wave-form 165
 - double sweep 168
 - from pulses 234
- Scale-of-two circuit 237
- Scaling circuits 237
- Scanning 157, 168
- Scratch filters 268
- Screen-grid tube 98
- Secondary emission 63
 - in multiplier tubes 102
 - in photo-multiplier tubes 144-146
 - laws of 63
- Secondary electrons
 - in tetrodes 99
- Selective amplifier 203
- Selectivity 34
 - and detectors 119
 - of receivers 257
- Selenium cells 143
- Self-induction 18
- Self-stopping circuits 127
- Sense determination 280
- Sensitivity
 - deflection 153
 - of detectors 119
 - of receivers 256
 - power 87
- Separation
 - components of complex current 29
- Series
 - capacitances 16

- resistances 10
- resonance 33
- Sharpener
 - of pulses 232
 - of square waves 229
- Sharpness of resonance 34
 - in receivers 257
- Sheath, positive ion 124
- Shielding 39
 - Faraday 247
 - in amplifiers 190
 - in converters 262
 - in transmitters 252
 - of loop antennas 282
 - of parallel wires 304
- Shore effect 282
- Shore-lines 300-310
 - see antennas
 - see transmission lines
- Side-bands 112
- Signal-to-image ratio 261
- Signal-to-noise ratio 256
 - in f.m. transmission 273
- Sine curve 22
- Sine waves
 - addition of
 - at right angles 172
 - in series 25
 - simple 22
- Single-button carbon microphone 194
- Single-wire feed 292, 306
 - impedance of 295
- Skin effect 30, 304, 311
- Sky wave 53, 55
 - polarization of 277, 283
- Small current amplifier 183
- Solenoid
 - magnetic field 17
- Southworth 332, 336
- Space charge 62
 - grid control of 73
 - plate control of 62
- Space-charge-grid tube 100
- Speaker, dynamic 196
- Spectral distribution 140
- Spectral distribution curves
 - photoelectric 141
- Spectral selectivity
 - of photo-cells 141
- Spectrometer 140
- Spectrum
 - visible 140
- Speech amplifiers 196
- Split-anode magnetron 326
- Spurious oscillations 247
- Square waves
 - amplifier testing 231
 - applications of 231, 240
 - production of 229
- Stability
 - of amplifiers 184, 248
 - of oscillators 227
 - of receivers 259
- Stabilized
 - current system 227
 - d.c. amplifiers 184
 - voltage 241
- Stabilizer
 - current 227
 - voltage 241
- Standing waves 48, 297-306
 - ratio 298
- Starting voltage
 - of a glow-tube 121
 - of thyratrons 125
- Static
 - direction finding 288
 - method of study 169, 175
 - reduction, of aircraft 287
- Static curves 74
- Strength
 - of radio waves 47, 52
- Striking curve
 - of a gas-filled tetrode 126
 - of a glow-tube 121
 - of a thyatron 125
- Striking voltage
 - of a glow-tube 121
 - of thyratrons 125
- Stroboscope 121
- Strobotac 122
- Strobotron 121
- Sunlight, intensity of 138
- Super-control tubes 77
- Superheterodyne receiver 259-265
 - alignment 262
 - conversion efficiency 262
 - double detection 261, 312
 - for c.w. reception 260
 - for phone reception 259
 - for u.h.f. 313
 - frequency converters 261
 - image frequency 260

- image ratio 261
- principles of 259
- Super-regenerative detector 118, 313
- Supersonics, 96
- Supply
 - B-voltage, common 86
- Suppressor grid 100
- Suppressor-grid modulation 111
 - details 216
- Sweep-circuits
 - amplitude change 164
 - double 168
 - frequency change 164
 - linear 165-168
 - multiple 170
 - simple 163
- Switch, electronic 239
- Synchronization 170
- Telephone transmitter 248
 - checking 250
- Television tubes
 - see cathode-ray tubes
 - scanning 169
 - telescope, electron 158
 - thyrite ridge 178
- Temperature dependence
 - of thermionic currents 59
- Tetrodes 98
- Theory
 - evaporation of electrons 59
 - of matter 6
 - of metallic conduction 7
- Thermal noise, in amplifiers 8
- Thermionic emission 59
- Thermocouple-ammeter 30
- Thoriated filaments 60
- Three-halves power law 63
- Three-phase rectifier 68
- Threshold
 - of feeling 268
 - of hearing 268
 - photoelectric 142
- Thyratron 123
 - de-ionization time 167
 - grid control ratio 125
 - in sweep circuits 166
 - shield-grid type 126
 - striking curves 125
 - tube 123
- Thyratrons, operation of 127-135
 - a.c. on plate 128
 - counting circuit 127
 - frequency control 129
 - inverters 133
 - phase control 130
 - rectifiers 132
 - self-stopping circuit 127
- Tickler 87
- Tickler circuit oscillator 90
- Tilt magnetrons 326
- Time constant 19
 - blocking action 167, 230
 - chart for 20
 - in pulse generators 232
 - in *R-C* amplifiers 188
 - in square wave oscillators 230
- Time factor
 - in photoelectric cells, 139-143
- Timer, of intervals 240
- Tone control 269
- Tracking 263
- Transconductance 79
- Transformer
 - coupled amplifiers 84
 - impedance, line 305
 - see amplifiers
- Transformers 31
 - audio 31
 - coupled modulators 213-217
 - coupling 36
 - d.c. 135
 - impedance ratio 31
 - interstage 81, 84
 - voltage ratio 31
- Transition oscillator 220
- Transmission
 - distances 52, 56
 - range of 52, 55, 56
 - ultra-high frequency 56
- Transmission lines 291-298
 - characteristic impedance 294, 305
 - concentric 304
 - coupling to transmitter 252
 - damped progressive waves 293
 - distributed capacitance 294, 311
 - electrical length 296
 - feeders 306
 - fields around 293
 - impedance matching 305, 306
 - Lecher wires 298
 - length 296, 303
 - loading 305
 - losses 294, 297, 298, 304

- nodes and loops 297
- non-resonant 292, 295
- resonant 297
- shielded 304
- short-lines 300-305
- simple principles 50
- spacing 292, 303
- standing wave ratio 298
- standing waves on 297, 301
- termination 295, 303
- transposed 292
- types 292
- velocity of propagation on 294
- wave-length along 294, 298
- waves on 293
- Transmitters, a.m. 244-253
 - buffer amplifier 314-321
 - checking modulation 250
 - circuits 249
 - complete unit 248
 - coupling methods 245-252
 - design steps 244
 - doublers, frequency 248
 - frequency multipliers 248
 - harmonic production
 - see distortion
 - harmonic suppression 247
 - hum eliminaton 251
 - interstage coupling 245
 - low- and high-level modulation 245
 - modulation measurement 250
 - output coupling devices 247, 252
 - parasitic oscillations 247
 - phone 248
 - power output measurement 246
 - telephone 248
 - typical circuit 249
 - ultra-high frequency 314-321
- Transmitters, f.m. 271
 - checking 273
 - deviation 272
 - reactance modulator 271
- Transmitters, u.h.f. 314-321
 - design principles 311
 - with linear circuits 315
 - see microwaves
- Transposed lines 292
- Trapezoid
 - modulation measurement 250
- Trimmer condenser 263
- Triodes 73
 - characteristic curves 74
- Tri-tet oscillator 223
- Trombone line 303
- Tubes
 - acorn 312
 - B-K 322
 - beam power 101
 - cathode-ray 147-161
 - cathode-ray oscillator 327
 - code numbering 102
 - combination 102
 - diodes 58
 - doorknob 312, 320
 - effective capacity of 82
 - electron microscopes 160
 - electron telescopes 158
 - FP 54, 183
 - gas-filled 120-216
 - Geiger-Mueller 235
 - glow- 120
 - grid-glow 123
 - iconoscopes 156
 - image dissector 157
 - inter-electrode 208
 - kinescopes 155
 - klystron 327
 - magnetron 324
 - microphonics 257
 - multi-electrode 98-105
 - multiplier 102-105
 - in image dissector 157
 - photoelectric 144-146
 - neon, see glow-tubes
 - noise in 257
 - orbital-beam multiplier
 - pentodes 100
 - photo-multiplier 144-146
 - picture 155
 - positive-grid 322
 - reactance modulator 271
 - retarding field 322
 - screen-grid 98
 - space-charge-grid 100
 - strobotron 121
 - tetrodes 98
 - gas-filled 123
 - thyatron 123
 - triodes 73-79
 - gas-filled 123
 - two-electrode 58
 - velocity-modulated 327
 - voltage regulator 241
- Tuned circuit 33

- Tuned lines 50, 297, 300
- Tuned-plate, tuned-grid oscillator 92, 316
- Tuning
 - alignment methods 262
 - automatic 269
 - band-spread 264
 - indicators 269
- Tuvc 233
- Twisted-pair 292
 - impedance 295
 - losses 297
- Two-electrode tube 58
- U.H.F. 311**
 - receivers 311-314
 - transmitters 314-320, 322-330
- Ultra-high frequencies 24
 - range of 24, 311
- Ultraudion oscillator 93
- Units, electrical 8
- Untuned lines 50
- V-type antennas 299**
- Vacuum
 - diodes 58
 - triodes 73
- Variable- μ tubes 77
- Velocity
 - along transmission lines 294
 - of electrons 4
 - of light 46
 - modulation 327
- Velocity microphone 196
- Vibrators 72
- Video amplifier 192-200
- Virtual cathode 218
- Virtual height 54
- Visibility curve
 - of eye 140
- Voice, frequency of 258, 268
- Volt 8
- Voltage
 - amplification constant 76
 - B-supply 65-72
 - disintegration 123
 - distribution along lines 293-301
 - doublers 68
 - extinction 120
 - filter regulation 71
 - gain per stage 82, 198
 - ionizing 122
 - lumped 77
 - modulator requirement 214
 - peak-inverse 66
 - stabilizers 291
 - striking 120
- Voltage dividers
 - breakdown of dielectrics 15
- Voltage stabilizer 241
- Voltmeter 17
- Volume control
 - compensated 269
 - receiver 255
- Volume expanders
 - automatic 269
- Watts 9**
- Wave envelope
 - modulation measurement 250
- Wave-forms, complex 24
 - pulse 232
 - saw-tooth 165, 234
 - square 229
- Wave-guides 330-334
 - long-lines 293
- Wave-length 46
 - along transmission lines 294
 - measurement, Lecher wires 298
 - of $B-K$ oscillations 323
 - of light 140
 - of magnation oscillators 325
 - of microwaves 322
 - of u.h.f.
 - vs. frequency 47
- Waves
 - electromagnetic 46
 - polarized 277, 283
 - standing 48
- Weather transmission 286
- Wide-band amplifier 192, 200
- Work function 60
- Yield**
 - photoelectric 141, 142

