

Radio  
up  
to  
the  
Minute



ARTHUR R.  
NILSON



ໂປລາດ ທ່າປເກຣີ  
ອໂປລາ ກູນສ່ວນໂປ

R A D I O  
UP TO THE MINUTE

BY

ARTHUR R. NILSON

MEMBER INSTITUTE OF RADIO ENGINEERS;  
FELLOW RADIO CLUB OF AMERICA



NEW YORK  
EDWARD J. CLODE. Inc.

COPYRIGHT, 1929, BY  
EDWARD J. CLODE, INC.

---

*All rights reserved*

*Printed in the United States of America*

## CONTENTS

CHAPTER	PAGE
I. EARLY DAYS OF RADIO . . . . .	1
II. ELEMENTARY ELECTRICITY . . . . .	11
III. MAGNETISM AND ELECTRO-MAGNETISM . . . . .	45
IV. EXPLANATION OF RADIO . . . . .	58
V. THE AERIAL EXPLAINED . . . . .	81
VI. FUNDAMENTALS OF RADIO RECEPTION AND RECEIVING APPARATUS . . . . .	109
VII. VACUUM TUBES IN RADIO . . . . .	144
VIII. RECEIVING APPARATUS . . . . .	190
IX. HEADPHONES AND LOUDSPEAKERS . . . . .	228
X. BATTERY CHARGERS AND ELIMINATORS . . . . .	241
XI. RADIO TRANSMITTING STATIONS . . . . .	266
XII. TELEVISION . . . . .	291
XIII. POWER AMPLIFICATION . . . . .	312

## PREFACE

THIS revised and enlarged edition of RADIO UP TO THE MINUTE incorporates a complete theoretical and practical explanation of radio in non-technical language. Stress has been laid on broadcasting and amateur equipments rather than on commercial apparatus.

It has been the aim of the author to set forth in common language the Principles Underlying the Operation of Radio and to show how each piece of apparatus functions in the radio circuit.

It is hoped that the experimenter will find the volume useful as a handbook. Radio Clubs will find material for radio talks and discussions. As far as possible, information given ordinarily in radio periodicals has been omitted.

It is intended that this volume shall be true to its name and bring to its readers up-to-the-minute information on Radio as it finds its way day by day into the millions of American homes.

A. R. N.

New York City

# RADIO UP TO THE MINUTE

## CHAPTER I

### EARLY DAYS OF RADIO

It is appropriate that any explanation of radio to the uninitiated should include, however brief, something of the origin of the art.

The complete history would require several volumes and would include the efforts of experimenters who have contributed to the final result, but who did not in their day even dream of what they had individually assisted in constructing.

The radio art owes its origin to Professor Heinrich Hertz, a German scientist, who in the eighties conducted a series of experiments which led to the construction of the first apparatus for propagating and detecting ether waves, which he described in 1888 in his book "Electric Waves." Professor Hertz's work, however, was not fully proclaimed until Guglielmo (William) Marconi, then a very youthful Italian student, conceived its

commercial advantages and utilizing Hertz's experiments and his own ideas originated the first practical radio stations.

Hertz, the pioneer, had understood and applied the principle of resonance. Marconi took the Hertz oscillator and resonator and adapted them for a transmitter and a receiver, respectively, by making both circuits open instead of closed, and grounding the antenna. Tuning between the transmitting and receiving antennæ in this pioneer work was accomplished by increasing or decreasing the capacity of the plates on top of his aerials.

In his experiments Hertz had used for a detector a microscopic spark gap. Marconi in his work utilized a Branley-Lodge coherer as a detector.

Using the Morse telegraph code, Marconi commenced by signaling a few hundred yards, but with the aid of the Italian and British governments he increased the range of his apparatus until he had demonstrated that radio was a practical commercial possibility with unlimited scope.

It is interesting at this stage to note that Signor Marconi, more fortunate than some famous inventors, surrounded himself with associates who had the foresight and imagination to picture the future possibilities of the new science. It was this



that has enabled Marconi to-day, in the prime of his life, to reap the material benefits of his pioneer work.

No historical reference to modern radio would be complete without appreciating the experiments of Sir Oliver Lodge, the famous English scientist who, as early as 1888, experimented along the lines originated by Hertz and contributed valuable aid towards making the art the success of to-day. Later Professor Lodge was to become associated with the Marconi interests, as also was another eminent Englishman, Professor J. A. Fleming, who has contributed to the radio art several valuable text books. In fact, it might be stated that he was first to write any substantial work on the subject. Later he was to revolutionize radio with his original work on vacuum tubes, which we will deal with in its place or chronological order.

Following Marconi's entrance into the field and the filing of his first patent in 1895, radio telegraphy was taken from the academic to the commercial stage and from that date various improvements by innumerable experimenters have followed with endless repetition.

It may be stated, at this stage, without fear of contradiction, that radio telegraphy and telephony

has been productive of more patents and more patent litigation than any other science, art or industry invented by man. Patents issued to date in the United States and foreign countries already number tens of thousands. Litigation upon the subject has littered the courts. Reference to all who have contributed to the art can, therefore, not be made within the scope of this volume, and any neglect to give credit, where credit is due, is not premeditated. We will endeavor to give the reader only the principal events which seem to occur, as it were, as stepping stones in radio engineering.

Following Marconi's commercialization of radio, as we may term it, came rapid developments on both sides of the Atlantic.

Nicolas Tesla, in 1897, introduced the tuned transmitter and receiver, or what was to become known as the two circuit transmitter and receiver, which was eventually to lead to much litigation in the courts. In 1898 Marconi patented his first double circuit receiver, retaining, however, his original plain aerial transmitter. Della Riccia, in the same year, adopted a closed and open oscillatory transmitter, while Braun and Stone, in 1899, both devised inductively coupled apparatus.

Ducretet and Pupin, in 1899-1900, it would seem,

were the first engineers to resort to what is known as conductively coupled circuits, which were used most successfully commercially for a number of years prior to the introduction of radio laws and regulations. After the promulgation of these laws, conductively coupled circuits became impractical as the wave emitted did not comply with the requirements of the new regulations.

In 1900 Signor Marconi and Professor Braun shared the Nobel prize for their efforts in the radio field. This was the first public recognition of the new science and an acknowledgement of its importance in the scheme of human events.

**High Spark Frequency.**—Wireless telegraphy had now reached a stage when its study attracted the brightest minds of the scientifically thinking world.

All the earlier equipments had employed as a primary source of energy induction coils, with various means of breaking the direct current. Owing to mechanical difficulties these "make and break" devices were necessarily slow in action, with the resultant low spark frequency. The manipulation of these early equipments required considerable skill on the part of the pioneer operators to maintain a "spark," indeed, the old time radio telegrapher, in despatching a batch of busi-

ness, necessarily would conduct a series of experiments during his efforts.

These induction coil sets gradually gave way to "power" sets, in other words, alternating current supplied by motor generators, supplied the power source. The usual commercial frequency of sixty cycles was first employed. While the practical operation of radio apparatus was immeasurably improved, the low spark frequency objection still remained.

Fessenden appears to be the first radio engineer to suggest a remedy to low spark frequencies and apparatus known by his name appeared which gave forth a high musical note and did much to overcome "static" or "atmospherics," which has been and continues to be the bugbear or hoodoo of radio.

A German system known as "Telefunken" also utilized a high frequency alternator to produce the high musical note.

These high spark frequency equipments utilized either rotating gaps to convert sixty cycle alternations or "quenched" gaps.

The spark system, however, is rapidly becoming extinct. In its place has come the vacuum tube. The advantages of the vacuum tube system over the old spark system are manifold. Trans-

mission over greater distances with less power ranks, perhaps, first. Interference is cut to a minimum and the signals of the vacuum tube system are more easily heard through static. The days of the spark are numbered.

While the development of radio was progressing rapidly, during the decade of 1900-1910, the "spark" was practically the only system used in commercial wireless telegraphy. Great progress, however, had been made in what is to-day known as the "continuous wave" or the "arc" systems. As the former term indicates, this system employed a continuous or "undamped" wave as its principle.

Poulsen was the originator of the "arc" method, while Alexandersen produced a high frequency alternator, which, while having a comparatively low rate of R. P. M., delivered an exceedingly high frequency. Both systems are used extensively to-day by operating companies.

An evolution of the vacuum tube, dealt with later, also produced another form of continuous wave radio transmission, which can be said to have put radio telephony where it is to-day.

Undoubtedly, owing to its greater efficiency, continuous wave radiotelegraphy will eventually displace the spark systems, although, especially on shipboard, both systems are often used in one

station. This, however, is merely as a convenience and a necessity under existing conditions, as a complete change from one system to the other would be too radical from a commercial or practical point of view. It is one that will come very gradually.

It will now be necessary to go back to the comparative early days of radio to bring the reader to the development in the science, which possibly, has resulted in the astonishing, and we might say, miraculous results that are obtained to-day.

***Vacuum Tube Discovered.***—Professor J. A. Fleming, after associating himself with Marconi, developed what is known as the “Fleming Valve.” This invention was to be the most important development in the radio field.

The Fleming valve was inspired from the effects of the Edison incandescent electric lamp, and takes us into a study of the “electron theory.” Thomas Edison, the inventor of the lamp, had experimented in its pioneer days and discovered that by placing a plate within a bulb separate and untouching the filament, a flow of electrons was observed from the filament to the plate.

Fleming, casting about for an improved detector, studied this effect and discovered that this flow of electrons was always in the same direction

and of a negative nature, flowing from the heated filament to the cold plate. This flow could be controlled by inserting a rheostat in the filament circuit and increasing or decreasing the filament current. These valves when properly constructed made excellent detectors for "spark" radio signals.

After Fleming's valve came the discovery by Dr. Lee DeForest, of the "three element" vacuum tube, which he called an "audion." DeForest inserted what he termed a "grid" between the filament and plate. This was possibly the most important discovery yet made in the new science of radio, and during the years of the World War, was to revolutionize the art. With the coming of the audion, methods of amplifying or increasing the intensity of radio signals were devised.

## STANDARD GRAPHICAL SYMBOLS

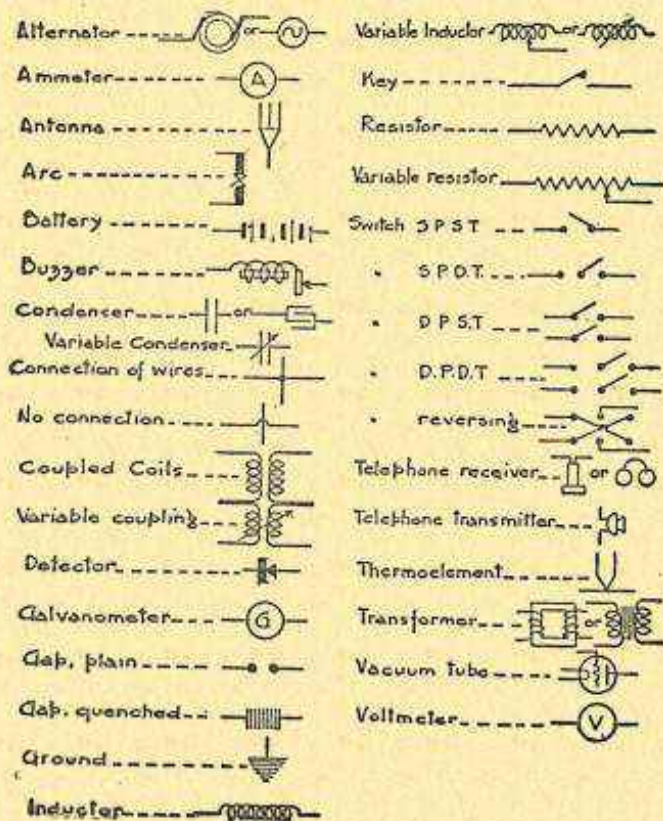



## CHAPTER II

### ELEMENTARY ELECTRICITY

THERE is a wonderful phenomena, the exact nature of which we know nothing definite, yet we are able to govern, actually measure and otherwise control its action. This peculiar phenomena is called "electricity." In its action we often compare it with water, as it has analogous characteristics, which are frequently used for comparative purposes in teaching the elementary principles of radio or electricity.

It should, however, be carefully borne in mind whenever electricity and water are likened to each other that expressions of "flow" and "current" and other similar terms are merely analogous. They are methods that originated in the early days of electricity, when electricity was considered some form of invisible fluid which actually flowed. These terms and expressions are utilized to-day in explanatory prefaces only as they are useful in forming mental photographs of the theoretical action of electricity in motion.

Electrical phenomena may be placed in two

general classes, one of which is termed "static" electricity, when the electrical charges are at rest, and the other is "dynamic" or "current" electricity, when the charges are in motion along a conductor.

When an insulator, such as sealing wax, is rubbed with fur, or a glass tube with silk, it ac-

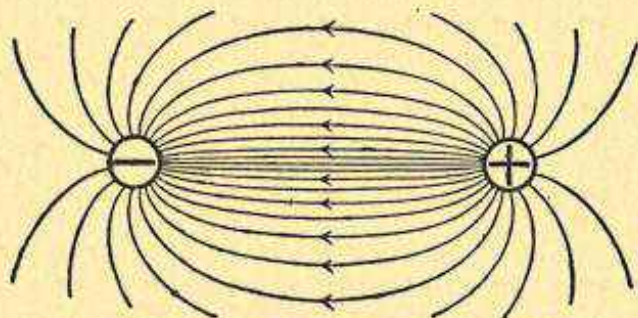

FIG. 1. Unlike bodies attract each other.

quires the property of attracting light bodies near it, and is said to be "charged." This action shows that forces exist in adjacent space, and there is said to be an "electrostatic," or, to use another term, a "static field of force," about the charged body. When two charged bodies are brought near together they may either be attracted or repelled, depending on the nature of the two charges. If the rubbed glass is brought near particles touched and

charged by the rubbed sealing wax, they will be attracted to it, and similarly, if the rubbed wax is brought near particles charged by the glass, they will be attracted (Fig. 1); but two bodies both of which have been charged by either the glass or the wax, will repel each other. Hence, like charges

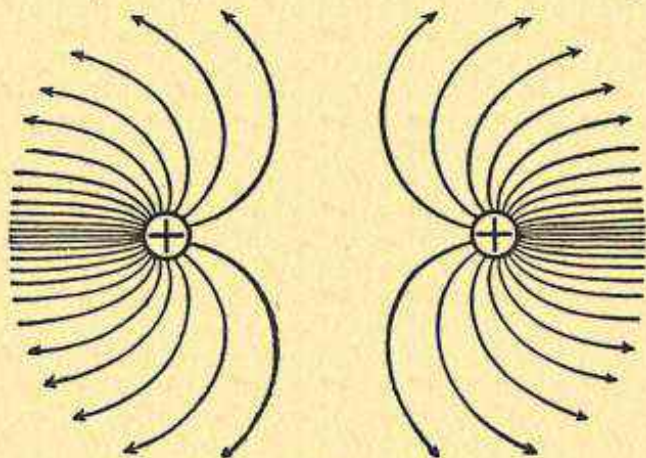

FIG. 2. Like bodies repel each other.

repel each other and unlike charges attract each other (Fig. 2). The names "positive" and "negative" have been given respectively to these charges.

It is common knowledge that a battery or dynamo supplies what is known as a current of electricity. To obtain the current there must be a complete closed or conducting path from the bat-

tery or dynamo through the apparatus it is desired to be actuated by the current, and back again to the battery or dynamo. For example, when connecting up an electric bell, a wire is carried from one binding post or terminal of the battery, to one of the bell, and a second wire is brought from the other binding post of the bell back to the remaining terminal of the battery. Any break in the wire immediately causes the current to stop and the bell would cease ringing. This example furnishes an illustration of the easy control of an electric circuit, since it is only necessary to break the circuit at one point to stop the flow of current, or to connect across the gap a piece of metal to start the current going again.

Similar considerations apply when we are using the common house lighting facilities. Wires are brought direct or indirectly, but always in a circuit, from the electric light plant or station to the lamp, a small gap in the socket is provided. When the current is on and the circuit complete this gap is bridged by a metal connection, this is usually controlled by a snap spring. When the light is no longer required, you snap the switch and the metal connection is opened, the gap is formed in the circuit and the current ceases (Fig. 3).

Sometimes the lamps suddenly go out, and it is explained that a fuse has been blown. A short piece of easily fused metal through which current has been passed has suddenly melted. This has caused a gap in the circuit and the current ceases to

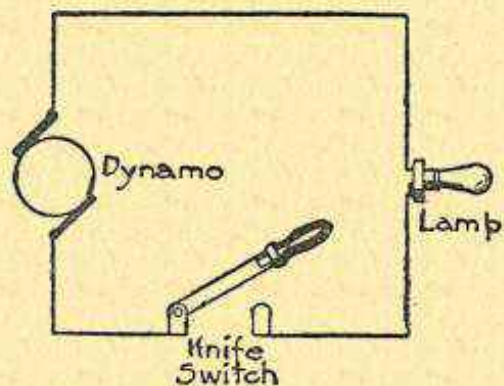

FIG. 3. Simple electrical circuit.

flow and your lights are extinguished. Electricity must therefore flow in every part of the circuit served, so that it is leaving one side of the battery or dynamo and returning to it at the other side. The current flowing in a circuit is no stronger at one point of the circuit than at another. This is proved by connecting a measuring instrument called an "ammeter" into the circuit. Place the ammeter at different points and it will register the same at whatever point the test is made. A useful

illustration of the electric current is a closed pipe completely filled with water, provided with a pump or some other device for causing a circulation of the water. The amount of water which leaves a given point in each second is just the same as the amount which arrives in the same length of time.

In the electric circuit we have no material fluid, but we suppose that there exists a substance, which we call electricity. This electricity behaves in the above described circuit in very much the same manner as an incompressible fluid in a pipe line. We are very sure that electricity is not like any material substance that we know, we will, therefore, have to imagine current to be a stream of electricity flowing around the circuit.

One way of measuring the rapidity with which water is flowing, is to let it pass through a meter which registers the total number of gallons which pass through. By dividing the quantity by the time it has taken to pass, we may obtain the rapidity of the flow. There are instruments by which it is possible to measure the total quantity of electricity which passes in the circuit during a certain time. If we divide this quantity by the time, we obtain the amount of electricity which has passed in one second. This is a measure of the current strength.

In practice, however, the strength of the current is measured by instruments known as ammeters, which show at any moment how strong the current is. It also enables us to tell at a glance what changes may take place in the current flow from moment to moment. We may, also, by means of an ampere-hour meter, ascertain the amount of energy that has passed over the circuit. These two recording instruments, the ammeter and the ampere-hour meter, therefore, would correspond to the speedometer on an automobile which points out, on one dial, the number of miles the car is speeding at the moment, and on another dial the number of miles the car has traveled.

***Electromotive Force.***—Water will not flow in a pipe line unless there is some force pushing it along, as, for example, a pump, and it cannot be kept flowing without continuing the pressure. Electricity, also, will not flow in a circuit unless there is pressure brought to bear. In the case of an electrical circuit a battery or dynamo provides this source of pressure, which is called “electromotive force,” or, in other words, a force which puts electricity in motion. In common practice this is always abbreviated to e.m.f. The larger the number of cells in the battery, the greater will be the electric pressure and the larger the current

which may flow in the circuit. The size of the battery or the dynamo would correspond to the size of a tank or reservoir of water, and the amount of current which may be allowed to flow in the electric circuit would represent a pipe in which the water from the tank flowed. The amount of water in the tank would be expressed in "gallons." In the case of electricity the amount of pressure would be expressed in "volts" and the amount of current would be shown in "amperes". Volts multiplied by amperes give watts.

**Resistance and Conductance.**—There is always some resistance or impediment to a flow or current of electricity, just as there is always resistance of some kind which hinders a flow of water. In the case of water, some partially closed valve or faucet would check the flow, also there is always a roughness in the pipe line which causes friction. Similarly in an electric circuit there are certain hindrances which are termed by the name "resistance." The greater the resistance the smaller the amount of current which will pass through the circuit (Fig. 4).

Resistance is determined by the kinds of materials of which the circuit is made up, just as the passage of a stream of water is determined by the character of the path over which it passes, or the



pipe through which it flows. Just as the amount of water in a pipe line may be limited by the size of a pipe, so may the amount of electricity in a

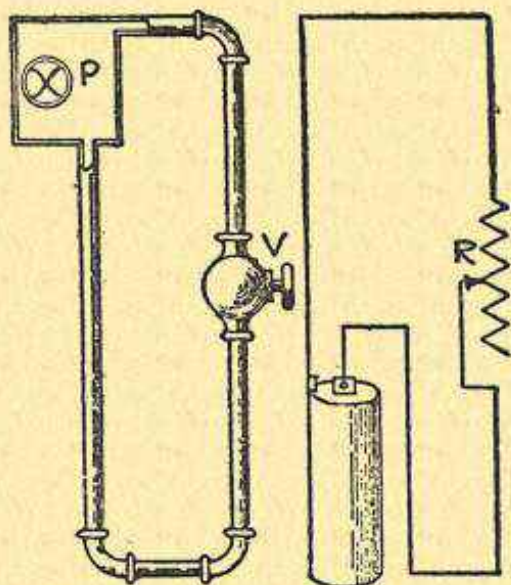

FIG. 4. Illustration of resistance by partially closed valve. P, pump. V, valve. R, resistance in electrical circuit.

certain circuit be limited by the size and material of the wire conducting it.

In governing the flow of water we use valves or faucets to check the flow of water. In handling electricity we use "resistance coils" to govern the

flow of current in any given circuit. There is a well defined law which is used in this relation, which is called Ohm's law, being named after its discoverer, Professor Ohm, and in speaking of a given amount of resistance in any given circuit, we always describe the circuit as having so many ohms resistance, an "ohm" being the unit of resistance.

Certain metals or materials offer more or less resistance to a flow of electricity than others. These are well known and divided into well defined groups. A material through which a current will pass readily and with least resistance is called a "conductor," or described as good conducting material, while those possessing qualities which will oppose great resistance and almost prevent any current of electricity to pass are called "insulators" or good insulating material. We also allude to the latter as non-conductors. Among conductors it is well known what amount of resistance a piece of wire of a given metal will offer. It is from this knowledge that we utilize copper for the purpose of conducting electricity without great resistance, and why we generally use "German silver" to manufacture certain resistance coils when we wish to offer resistance in the passage of a current.

It is also known that materials such as glass, porcelain and rubber possess excellent insulating qualities and are therefore used very largely as insulators. However, there is no material that will permit the passage of no electricity whatever, and for that reason we have what is called "leakage current" and "line losses."

While it is a question of material in determining the factor of resistance in a conducting circuit, it is also the size of the conductor which must be considered. In the case of a given piece of wire of a uniform cross section, its resistance is always found to be proportional directly to its length and inversely to its cross sectional area.

Electrical resistance in all substances is found to depend upon temperature and is found to alter more or less with any change of temperature. All metals and mostly all alloys used in electrical engineering increase their resistance with a rising temperature, while carbons and liquid conductors like electrolyte used in batteries, show a decrease in resistance as the temperature rises.

**Electrical Control.**—Having discussed the question of resistance, we should now pass to the subject of current control. In radio the need is constantly arising for controlling electrical pressure and current to certain required values. This

is generally accomplished by varying the resistance in the circuit by means of resistors. Resistors are made in a variety of ways and known by several names, depending upon their current carrying capacity and their range. Some are called "resistance boxes," others, "rheostats," and are generally manufactured in a form which permits of easy variation and are compact for convenience. However, banks of incandescent lamps are very often used as resistance units and are, indeed, most satisfactory in experimental work where fine adjustment is needed. The change in resistance in such a rheostat is made by switching individual lamps on or off as desired.

**Conductors.**—Conductors of electricity used in leading a current from one point to another are, as pointed out earlier, usually made of metals or metallic alloys. If the conductor is transmitting energy to a distant point, some of that energy will be wasted in heat. These losses should be kept as small as possible and therefore great care is taken in choosing the material and the size of the wire. For economic reasons it is desirable that the cross section be not too great, and a desirable material must be selected that will accomplish two purposes, economy and efficiency. After much experiment, copper is found to be such a material.

Where light weight is important and increased dimensions not undesirable, aluminum is sometimes used. Steel or iron are seldom used in radio work as a conductor. For conductors in antennæ, where strength and atmospheric conditions must be considered, phosphor-bronze and silicon-bronze are almost exclusively used. Copper, however, is the best metal conductor, where all considerations must be averaged.

Now, on the other hand, where resistors or resistance coils are essential, the opposite of good conductivity is desired and a material of great resistivity is demanded. A metal is required high and constant in resistivity, yet not bulky. Iron is neither high enough in resistivity nor constant in action. German silver or manganese are generally acceptable as resistors and found to cause less variations in temperature, in fact, their temperature coefficient in the circuit is practically negligible.

**Insulators — Non-Conductors.** — We have dwelt upon the subject of good conductivity and must next show the importance of good insulation in the scheme of radio.

In order that the electric energy may be confined to the definite and limited path that we desire in radio, it is most essential that the insulation

we use be of the best material. Insulators are also known as dielectrics, and the latter expression will often be used later when we deal with the subject of condensers.

We are all familiar with the fact that electric wires are covered with materials composed of layers of cotton, silk, rubber and compounds of various kinds, known to be non-conducting, and that they are generally supported on or strung along glass, hard rubber, porcelain or compound knobs. An excellent insulator is a special glass known as "Pyrex."

Most insulators except glass show a decrease in their power of resistance with changes of temperature and atmospheric conditions. Humidity and fog lower their insulating standards, and in the event that such substances as slate, marble, bakelite, hard fiber and similar materials are used as panel boards, unless they are carefully protected from atmospheric conditions will "sweat" and cause a surface leakage.

**Sources of Electricity.**—In preceding pages we have alluded to electro-motive force, or emf., and having discussed how electrical energy can be conducted along definite lines or paths, we will go into the question of its source.

There are several methods in which electrical

energy may be derived from other sources of power. Each one of these power or energy transformations sets up a condition which causes current or emf. to flow, in short, produces electromotive force.

The two most common and practical methods will be discussed in the following pages. These are "static" or "frictional" electricity and "batteries" or electricity produced by "chemical action."

In earlier paragraphs we described how a piece of sealing wax when rubbed with a piece of fur, acquired new properties and could be said to be "electrified." A force would be required to separate the wax and fur and therefore work is done if they are to be moved apart. After rubbing the wax and fur both bodies would now have the power of attracting light substances, such as pieces of tissue paper or light particles of wheat chaff. The wax is said to have a negative charge, and the fur a positive charge of electricity.

These charges exist in equal amounts and taken together neutralize each other. A body that is uncharged is said to be neutral. When these charges are at rest on conducting bodies they are called electrostatic charges.

Electrostatic charges, as a rule are very small.

There are, in radio practice, two methods of deriving the primary source of power. These are from batteries and from "induced" electromotive force. We shall deal with each in its turn.

**Batteries.**—In general practice, there are two types of batteries used in radio work, one called a "primary" and the other a "secondary" or "storage battery."

With a primary cell new energy can be obtained by putting in new chemicals or parts, in the secondary cell, energy is renewed by sending a current of electricity derived from a mechanical or some other source, through the chemicals already in the cell, and by charging and recharging can be used over and over again. We shall first describe the primary battery.

**Wet or Gravity Cell.**—If two metal plates, one of pure zinc and one of pure copper, not in contact with each other, are immersed in dilute sulphuric acid, no chemical action will take place. However, when the plates are connected by a wire or some other conductor outside of the liquid, a current will flow in the conductor, as a chemical action takes place in the cell. The sulphuric acid acting on the zinc plate forms zinc sulphate, and the hydrogen liberated from the acid appears at the copper plate. The direction of this flow of



current is always from the copper plate, through the conductor or metallic circuit to the zinc plate and back through the diluted acid to the copper plate. The copper plate is termed the "positive" pole and the zinc plate the "negative" pole, and the direction of flow is arbitrarily said to be from positive to negative. For purposes of simplicity

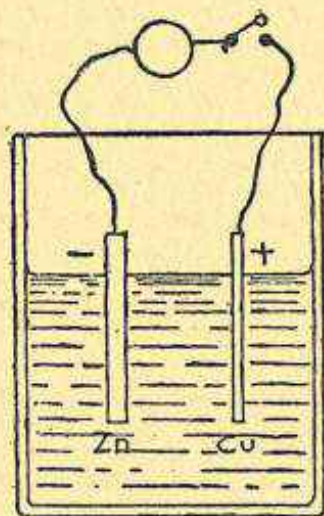

FIG. 5. Simple wet or gravity cell.

in marking terminals or preparing diagrams, the plus (+) sign is always given to the positive and the negative sign (-) to the negative plates (Fig. 5).

The current given by the simple cell described does not remain constant, as it begins to weaken after the connection between the plates is made, or, in other words, the circuit closed. This diminishing current is caused by the hydrogen, liberated from the acid, accumulating in small bubbles on the copper plate. This accumulation of hydrogen bubbles diminishes the area of contact of the liquid on the faces of the copper plate, thus increasing the resistance of the cell. This action is called "polarization." To overcome this, what is known as a "depolarizer" is utilized, in the form of a chemical substance added to the acid, or electrolyte, as the sulphuric solution is also called. The action of the depolarizer is confined to the positive plate and is kept from contact with the negative plate.

There are two principal types of primary cells, the "wet" and "dry" cells. The wet or "gravity" cell, above described, is used largely by telegraph and telephone companies, due to economy and also as it is mainly free from polarization. If a large output is desired, the internal resistance must be low, that is, with a minimum of polarization. In these cells the depolarizer is generally placed in the bottom of the cell and is kept free from the electrolyte by gravity, hence the name. The cop-

per electrode is placed in this solution which consists of copper sulphate. The zinc negative plate is kept separate in the sulphuric electrolyte above.

The voltage given by the average cell is between one and two volts per cell. The voltage of a cell depends upon the substances used for plates or electrodes, and is also effected by the electrolytic solution. Therefore, many varieties of electrolytes are used when the electrodes are copper and zinc, but all give approximately one volt per cell.

When a certain electromotive force is required and no regular source of supply available, it is useful to know that an emergency source of voltage may be obtained by taking two different kinds of metal and placing them in any kind of acid, or even in water. It must be remembered, however, that the solution attacking the plates most violently will produce the best results, bearing in mind the above remarks regarding polarization.

**Dry Cells.**—The dry or sal ammoniac cell is used largely in radio, not for its superior qualities as compared with the gravity cell, but because of its convenient, compact form. The solution of sal ammoniac used in it is contained in an absorbent material and the cell is thoroughly sealed against spilling or leakage. The outer shell is made of zinc, forming one electrode. The positive elec-

trode is a carbon rod in the center, this is surrounded by a mixture of carbon and manganese dioxide. The latter mixture is saturated with a sal ammoniac solution and takes up most of the interior of the container. This sal ammoniac electrolyte is partly in a depolarizing mixture and partly in a porous separator placed between the zinc and depolarizing mixture.

These dry cells are not as free from polarizing effects as the previously described wet or gravity cells. They are made in several sizes. For heavy or ignition purposes they will deliver a current of thirty amperes when short-circuited, provided they are new or little used. They lose their energy-producing powers very quickly when used constantly, but in intermittent service have a fairly useful term of life, sometimes six months.

Dry batteries for telephones and bells are generally made smaller, delivering about twenty amperes upon short-circuiting, but lasting longer than ignition cells, sometimes they are useful for over a year.

Miniature dry cells for vacuum tube work and for flashlights, are made in varying sizes, but lose their effectiveness quickly, of course, depending upon the period the vacuum tube or flashlight is used.

The emf. developed in an unused dry cell is from 1.5 to 1.65 volts. In purchasing new cells the reader should know that any new dry cell having less e.m.f. than 1.4 volts indicates a defect or deterioration through long "shelf life."

The amount of energy delivered from the dry cell increases with increasing temperatures, but the higher the temperature, the faster does the cell deteriorate when not in use. It is, therefore, best to keep them in a temperature below 25 degrees centigrade.

Owing to various causes, due to compactness in manufacturing and its comparatively rapid polarization, dry cells are not useful for delivering a steady current for a long time in service and should only be used in radio when an intermittent current or a very small current is required, such as plate battery service or buzzer ringing. When heavier duty is required, it is much more preferable and economical to utilize "storage" or secondary batteries, described below.

***Storage or Secondary Batteries.***—The difference between the gravity primary cell, previously referred to, and the secondary or storage cell, is in the method of renewing the active material. While the primary cell is renewed by supplying new electrolyte and replacing the worn out

zinc electrode with a new one, dry cells cannot be renewed. In the storage battery, however, the necessary chemical conditions of the plates is restored by the action of a current of electricity from some outer source, usually from a dynamo.

While the cell is supplying emf., it is said to be "discharging" and when receiving a renewal of energy it is said to be "charging." The direction of the current when charging is always opposite to the current when discharging.

Storage batteries in general have low internal resistances when in good order and will therefore deliver relatively large currents, this is a great advantage. Care must, however, be taken to prevent accidental short-circuiting, as this would cause an excessive current and rapid deterioration, or even ruination, of the battery.

Voltage changes during the period of discharge are small and thus fairly-constant current can be maintained.

There are two types of storage batteries in general use, the "lead" cell and the "Edison" or "alkaline" cell.

**The Lead Plate Cell.**—In the cell type of battery, the plates are made of lead, in the form of a grid. Each plate contains many tiny cells, like honeycomb, and often called by the name "grid."

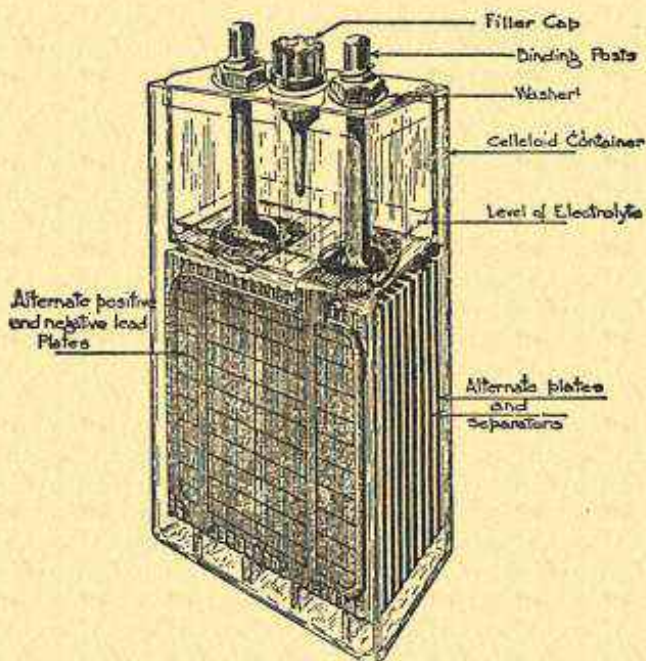

FIG. 6. Lead cell storage battery.

Into these noneycombed cells is heavily pressed, or forced, a mixture of red lead, litharge and sulphuric acid. When two plates thus prepared are immersed in an electrolyte consisting of a twenty per cent sulphuric acid solution, and an electric current passes between them, hydrogen will accumulate on the plate from which the current leaves the cell, thus in one plate the active

material is reduced to a spongy lead, and in the other the same material is being changed to lead peroxide, as it takes up oxygen. The cell now contains a lead peroxide plate, called positive (+) and a spongy lead plate, called negative (—) (Fig. 6).

After the charge is cut off, assuming it is fully charged, if the cell is connected in a circuit, current will flow in an opposite direction to that by which it was charged. The cell upon completion of the full charge, should show a voltage, on open circuit, of approximately 2.2 volts, this, however, will quickly drop to about 2 volts. As the battery is discharged the voltage will gradually fall. The discharge should never be carried below 1.75 volts.

The container of a lead cell must be of a material sulphuric acid will not attack and is usually of either glass or hard rubber. The former for large stationary batteries and the latter for the portable types.

The negative plates appear gray and the positive reddish in color.

There are innumerable types and each manufacturer carefully enumerates on the name plate the specific rate, in amperes, of charge and discharge. This is necessary as he is the only one who knows the size, weight and number of plates



in the cell, upon which the discharge and charging rate is based, and the life and general efficiency of the battery is greatly decreased if this normal rate is not adhered to.

There is a chemical action between the lead and the electrolyte, which forms lead sulphate during the course of a discharge. This uses up the acid and the density of the electrolyte grows less, this results in the formation of lead sulphate, whitish gray in appearance (when dry) which is dissolved in the solution.

For testing the density of battery electrolytes, an instrument called a "hydrometer" is the best instrument to use, as the density of the solution is the best indication of its condition. In other words, the density of electrolyte rises and falls with the charging and discharging of the cell, and a test of the density or specific gravity of the solution readily indicates its condition.

Great care is required in the handling of storage batteries to prevent "sulphating."

If a cell is repeatedly charged and discharged at its normal rate, as indicated by the manufacturer's name plate, the amount of lead sulphate formed will be small and not harmful. However, if the battery is misused, for instance, charged and discharged at an excessive rate, or perhaps

allowed to be idle when in a rundown condition, there will form an excessive deposit of lead sulphate. As the crystals of sulphate increase they crowd out the active materials, stresses are formed and the plates disintegrate or buckle. This renders the cell into such a condition that it is almost impossible to repair, and certainly the battery will never be normal again.

Storage batteries of all types, both lead and alkaline, are graded when manufactured and rated according to the ampere-hour capacity. This capacity is generally expressed by the maker on the same name plate as the rate of charge or discharge. The larger the plate the greater may be the current used from it. For example, a forty ampere hour battery should yield one ampere for forty hours, or, to put it in another way, ten amperes for four hours. If, however, five amperes is the rate mentioned on the normal discharge and charge rate of the cell, it should only be discharged at that rate and also recharged at that rate, which would give the normal usefulness as five amperes for eight hours.

Batteries are seldom used as they were intended and it is thus that so many experimenters have considerable trouble and do not enjoy the full life of the cell.

**Edison Cells.**—This is a type of storage battery developed by the famous Thomas Edison, as the name indicates, and also known as the “Nickel-Iron and Alkaline Cell” (Fig. 7).

In construction, the positive plate consists of

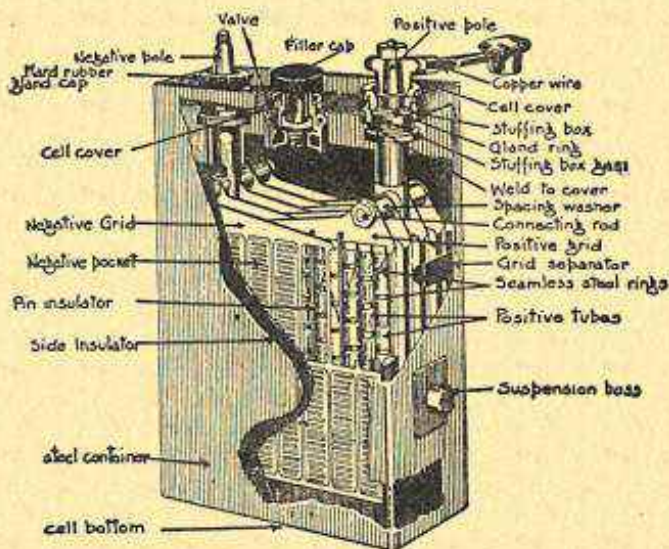

FIG. 7. Edison cell storage battery.

alternate layers of nickel hydrate and pure nickel flake, packed in perforated nickel-plated steel tubes. Several are arranged in a steel frame. The negative plate is of iron oxide packed similarly. These plates are immersed in a twenty

per cent solution of caustic potash and water, and the whole is contained in a tightly sealed sheet steel container. This electrolytic solution carries oxygen between the plates, but does not form chemical compounds with the active materials, remaining approximately constant in density during charge and discharge.

The voltage of an Edison cell while charging may rise to 1.8 volts. When discharging this will drop suddenly to about 1.4 volts and as the discharge continues will drop more gradually to 1.1 volts, near the end of the discharge. Discharge should not be allowed to go below 0.9 volt; when that rate is reached the cell should be recharged.

If it is found after much use that the density of the alkaline electrolyte has fallen as low as, about, 1.16, measured by the usual means of ascertaining specific gravity of liquids, the solution must be renewed. This should be done by pouring off the old and refilling with entirely new electrolyte.

The height of the electrolyte above the plates should always be kept at about half an inch. This applies to both lead and Edison cells. As there is always more or less evaporation of the solutions, this may be accomplished by adding distilled or chemically pure water to bring the height half an inch above the plates.

**Comparisons of Storage Batteries.—**

The construction of previously mentioned types of secondary batteries is so radically different, that a brief comparison of the two is not out of place.

The lead cell will suffer serious injury if not well cared for and if not charged and discharged according to the use for which it is rated. Further, it will deteriorate rapidly if allowed to remain idle without care.

An Edison battery, on the other hand, by nature of its sturdier construction and the materials utilized, may be said to be as near "fool-proof" as anything thus far placed upon the market. It will retain its charge over a long period of idleness. It may remain idle for an indefinite time, either charged or discharged, without injury. It may be completely short-circuited and totally discharged without harm, whereas this would ruin a lead cell. An Edison cell can be charged or discharged at rates differing from its normal rate, while it has been previously shown that the lead cell must be handled at near its normal rate.

**Charging Storage Batteries.—**While the general method of charging both lead and Edison cells is similar, there are features which are

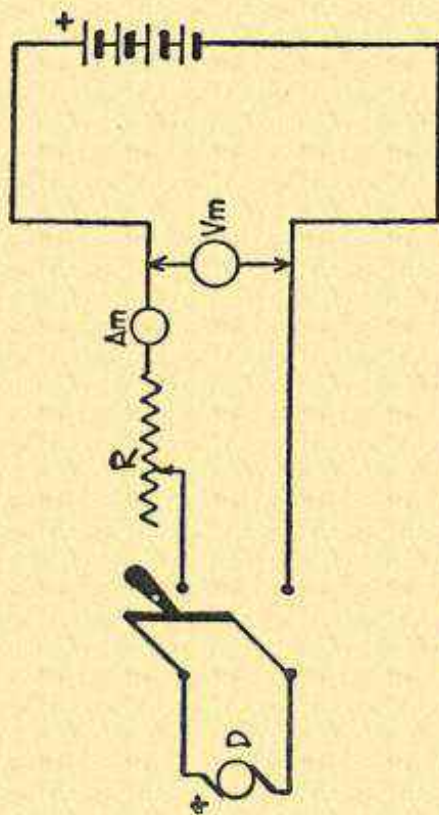

Fig. 8. Storage battery charging circuit.

not alike that would require some differentiation in the description of these charging methods.

**Lead Cells.**—Previously we have mentioned that there are certain charge and discharge rates prescribed for certain types and sizes of lead cell batteries.

While a battery is receiving a current from some outside source it is said to be “charging.”

In Figure No. 8 is given a diagram of a circuit, which is typical for charging batteries. The dynamo, or supply of direct current, is marked D, and is connected through the ammeter and rheostat, marked R, to the battery, so that the positive pole of the supply source or dynamo, is connected to the positive pole of the battery; this will send the charging current against the electromotive force of the battery. To thus connect the positive pole of the dynamo to the positive pole of the battery, is most important, as a reversal of this would cause the storage battery to discharge instead of charge and cause great injury to the cells.

Before charging, an inspection of the electrolyte should be made and if found less than one-half inch above the top, chemically pure or distilled water should be added until that amount of

electrolyte shows over the top of the plate. Do not spill the water over the top of the cover of the cell, or a short circuit will result through the water from the positive to the negative poles and a leakage occur, resulting in a total discharge of the cell, if the leakage is allowed to continue.

If suitable measuring instruments, such as a voltmeter and ammeter, are not used, it may not always be known which is the positive and negative line in the source of supply. A very simple experiment may determine this question. Take a glass of water that contains a little salt or acid, place both supply leads in the liquid, being careful to keep them apart, say, by half or one inch. Bubbles will be observed to come from the negative terminal.

For lead cells, in charging, it is necessary to allow two and one-half volts for each cell. If a smaller voltage than that which is to be reached by the cell, you would discharge instead of charge the cell. If the source of supply voltage is not sufficient to charge all your cells in series, they may be divided into groups and these groups may be placed parallel to each other. If this arrangement is necessary, care must be exercised that the negative lead from one bank of cells in series, to the negative pole of the other bank, and from



positive to positive terminals of each bank, then the leads from the two banks thus joined will be lead as described previously. From the positive pole to the positive terminal of the dynamo and negative to negative.

Hydrogen is given off from charging batteries, and great care must be taken to keep naked lights from the vicinity of the cells, or an explosion will result. Some very painful accidents have happened to numerous unwary people who have, for instance, lighted a match to peer into a charging battery, in order to ascertain its condition. This precaution applies to both lead and Edison cells.

**Edison Battery Charging.**—The same circuit utilized for charging lead cells may be employed for charging Edison cells.

The charging source should have a voltage equal to 1.85 times the number of cells in series.

Before starting to charge, open the covers of the compartment, if the battery is in one. See that the solution is at the proper level.

Do not allow the temperature of the solution to exceed 115 degrees Fahrenheit. Excessive temperature on charge will shorten the life of the battery.

As in lead cell charging, be sure to connect the positive side of the line to the positive pole of the

#### 44      RADIO UP TO THE MINUTE

battery, and the negative line to the negative pole.

The specific gravity of the solution will not change during the charge or discharge except in cases of extreme low or high temperature and therefore hydrometer readings are of no value in determining the state of charge or discharge of the battery.

The proper length of charge is determined by the extent of the previous discharge. If the battery is totally discharged, recharge it at the normal rate for the proper number of hours. If the battery was only one-half discharged, recharge at the normal rate for one-half the time, etc.

If the extent of the previous discharge is unknown, charge at the normal rate until the voltmeter reading has remained constant for thirty minutes at about 1.80 volts per cell, with normal current flowing.

If necessary, and full capacity is not required, a battery may be taken off charge at any time.

## CHAPTER III

### MAGNETISM AND ELECTRO-MAGNETISM

THERE is a form of iron found in the earth known as black oxide of iron, also called magnetite or magnetic iron ore. This particular iron ore has remarkable properties. For instance, if a piece of magnetite is dipped into iron or steel filings, the filings will adhere to it and is known as a "natural magnet." If a small piece of this substance is suspended by a very slender thread, such as silk, it will point in northerly and southerly direction.

If a small rod of iron is brought near a piece of magnetite, or is rubbed on it in a certain way, it will show the same properties as the piece of magnetite. If the rod be made of hard steel this effect will persist after the magnetite has been removed from its vicinity, and is known as a "permanent magnet."

We are almost all acquainted with the horse-shoe shaped magnet, and probably have played with them when children.

Magnets are also made by winding a coil of wire around a rod of soft iron and passing an electric current through the coil (Fig. 9). As long as the electricity passes through the coil the

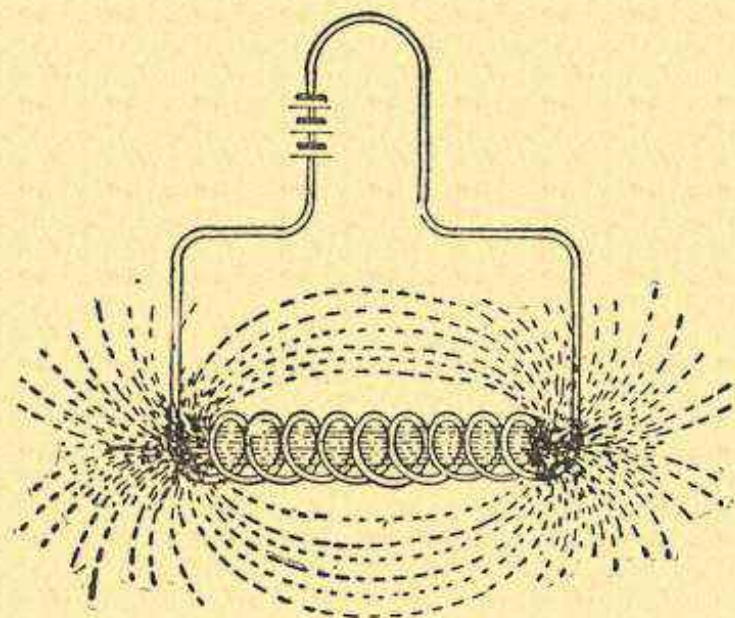

FIG. 9. Magnetic field of a solenoid.

iron is magnetized and is called an "electromagnet." These are the familiar examples we find in electric bells, buzzers and telegraph sounders, and if you screw the ear cap off a tele-

phone receiver you will find an excellent simple electro-magnet. If the bar around which the coil is wound is made of certain hard steel, that bar would be permanently magnetized.

A small steel rod mounted pivocally will turn in almost a north and south direction and is the familiar compass needle used by mariners to determine the direction they are proceeding. The

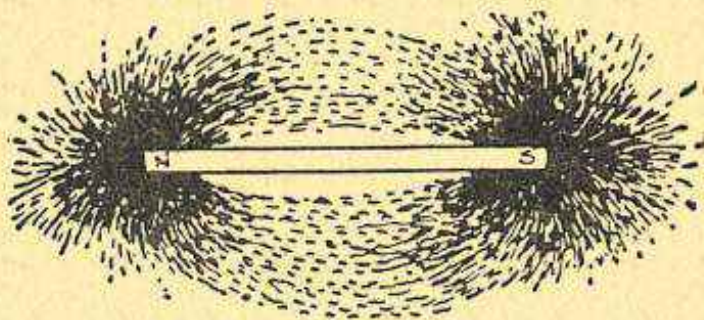

FIG. 10. Magnetic field of bar magnet as shown by iron filings.

end pointing north is called the "North Pole" and that pointing south, the "South Pole."

Two magnetic poles are said to be alike when they both attract or both repel the same pole. If one pole attracts the other they are unlike, if a pole repels another, they are alike, therefore, as previously explained in the discussion of negative and positive connections of a battery, like mag-

netic poles repel each other and unlike poles attract each other. It is then very easy to determine which is the north or south pole of a magnet by placing a small compass near the magnet and observing which way the needle points.

Place a sheet of paper over a magnet and sprinkle iron filings upon it and you will find they will arrange themselves in two groups, one group over the north and the other over the south pole (Fig. 10). This indicates that there are forces in the space around the magnet that act on its poles. These forces are called "magnetic lines of force" and appear to center in the two poles of the magnet.

The space around the magnet in which these lines of forces may be detected is called the "magnetic field," and the direction of the magnetic field is the direction in which the compass needle will point, if a compass is used as above described. This needle will always point north.

Experiments with a compass, as shown above, determine that there is a magnetic field about a wire in which a current of electricity is flowing, and that this field is in the form of concentric circles about the wire. These circles lie in planes at right angles to the axis of the wire. If the wire is grasped by the right hand with the thumb

pointing in the direction of the current, the fingers will show the direction of the magnetic field (Fig. 11). This field extends to an indefinite distance from the wire, but as it becomes more distant the effect becomes correspondingly feeble and there is

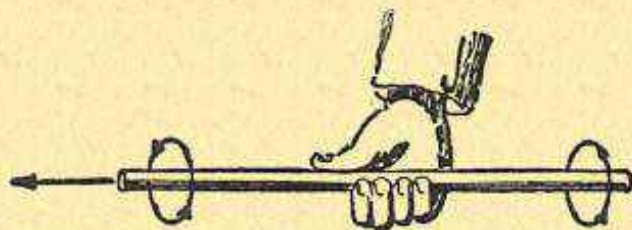

FIG. 11. Right hand rule for determining direction of current and magnetic lines of forces.

greater difficulty in detecting its presence. If the current is cut off, the magnetic field likewise disappears. When a current is flowing in a wire, we must imagine the magnetic field as started and sweeping outward from the conductor, with the axis of the wire as its center.

If the wire in which a current is flowing is bent into many circles or turns and these turns wound close together the intensity of the magnetic field is increased in direct proportion to the number of turns in the wire.

If the space within the coil is filled with iron,

the magnetic lines or "flux" is greatly increased. This is due to a peculiar property of iron which is called magnetic "permeability." This is to say that when the space is filled with iron instead of air alone that the magnetism is stronger.

It should be remembered that this magnetic induction in a coil depends upon the number of ampere turns in the coil and the permeability of the iron.

If the current in the windings is reversed the direction of the magnetic field is also reversed.

If two different magnetic fields are brought together in the same space, with their directions parallel, a force is always developed. If the lines of magnetic flux are in the same direction, the two fields mutually repel one another, and if the flux lines are in opposite directions the two fields will be drawn together. When a current flows in a wire which is at right angles to a magnetic field, a force will act on the wire.

When the wire which carries the current is at right angles to the direction of the magnetic field, the pushing force on the wire is equal to the product of the current, the intensity of the magnetic field, and the length of wire which lies in the magnetic field.

If the wire makes some other angle with the



direction of the magnetic field, the direction of the force is still the same as for the right angle position, but the value of the force is smaller. In the single instance that the direction of the current coincides with the direction of the magnetic field, the force is zero.

This push on a single wire is in most cases small, but by arranging many wires in a very intense magnetic field, very large forces may be obtained. The powerful turning effect of an electric motor depends upon these principles.

There is always a magnetic field about an electric current. The lines of magnetic flux are closed curves and the electric circuit is also closed. The lines of magnetic flux are then thought of as always interlinked with the wire turns of the circuit. The number of flux lines through a coil will depend upon the current, and any change in the current will change the number of linkings. If there are two turns of wire the circuit will link twice with the same magnetic flux, and so, for any number of turns the number of linkings increases with the number of turns.

***Induced Electromotive Force.*—**

Whenever there is any change in the number of linkings between the magnetic flux lines and the wire turns, there is always an emf. induced

in the circuit. If the circuit is closed a current will follow. This is called an induced current. As an example we can observe the effects produced by two solenoids fixed in the position

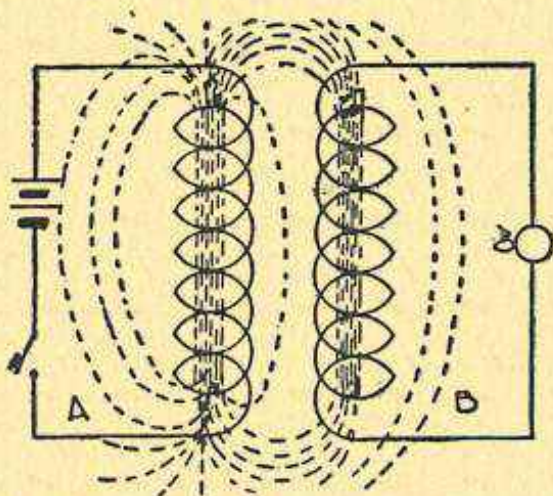

FIG. 12. Illustrating an induced current. Current started in A induces current in B.

shown in Fig. 12. If a current is started in one of them, A, there will be a current induced in the other, which will continue to flow as long as the current in A is increasing. If the current in A becomes steady, there is no current induced in B. If the current in A falls off, the induced current in B is reversed in direction. In all cases it must

be remembered that the magnetic field about the induced current tends to oppose the change that is causing the induced current. The magnitude of the induced emf. depends upon the time rate of change of the number of linkings.

**Inductance.**—The value of inductance depends upon the shape and size and upon the permeability of the medium about the circuit. The inductance does not depend upon the current which is flowing, except when iron is present. By coiling up a piece of wire in many turns and introducing it into the circuit, the inductance of the circuit may be greatly increased. In that case the inductance is said to be concentrated. It must not be overlooked that the entire circuit has inductance. This may be distributed more or less uniformly throughout the circuit.

If a piece of wire is connected to one terminal of a dry cell, and tapped on the other terminal, a very slight spark may be seen in a darkened room. If a coil of many turns of wire is included in series, with this cell, the same process of tapping will show brilliant sparks, particularly if the coil has an iron core. The explanation of this lies in the fact that the cell voltage of 1.5 is too feeble to cause much of a spark. However when the large inductance is included in the current, there

is a large number of linkings between wire turns and flux lines. If these flux lines collapse suddenly, as they do when the circuit is broken, there will be a large change in the number of linkings taking place in a very small interval of time. This principle is made use of in ignition apparatus and spark or induction coils.

In mechanics it is well known that a piece of matter cannot set itself in motion and that energy must be supplied from outside. So in the electric circuit, a current cannot set itself in motion, and energy must be supplied by some form of generator or source of electromotive force.

As an illustration of inductance we may use the following example. When a nail is forced into a piece of wood, the mere weight of the hammer as it rests on the head will produce but little effect. However, by raising the hammer and letting it acquire considerable speed, the kinetic energy stored is large and when the motion of dropping the hammer is stopped, this energy is expounded in forcing the nail into the wood. In the electric circuit a cell with its small emf. can only cause a feeble spark. By including a piece of wire of many turns in the circuit, however, a small current will enable a large amount of energy to be stored in the magnetic field, if the inductance is

large. Then when the circuit is broken and the field collapses, this large amount of energy is released suddenly, and a hot spark of considerable length is the result.

**Alternating Current.** — An alternating current is one in which electricity flows around the circuit, first in one direction and then in the oppo-

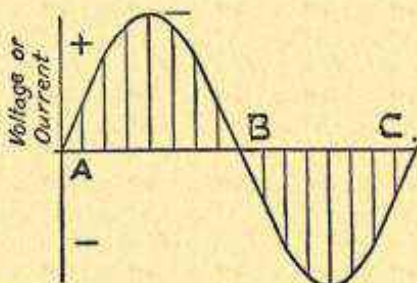

FIG. 13. Showing a cycle of alternating current.

site direction, the maximum value of the current in one direction being equal to the maximum value in the other. All changes of current occur over and over again at perfectly regular intervals. A graphical representation of this is shown in Fig. 13, the potential commences at A, which represents zero potential, rising to its maximum voltage of, say, 110 volts, then falling to zero at B, the current then reverses itself and flows in the opposite polarity, again rising to 110 volts and drop-

ping to zero at C. From A to B represents an "alternation" and from A to C, a "cycle," thus each cycle consists of two alternations.

The frequency of alternating current is determined by the number of cycles per second. In ordinary commercial use, for lighting and power, 25 to 60 cycles per second is the usual frequency, mostly 60 cycle. In Europe they often use 50 cycle alternators. However, in radio practice higher frequencies are desirable and in modern spark transmitters 500 cycles is considered the standard. This gives the emitted signals a high musical tone, as the spark frequency from such an alternating current would be 1,000 per second, or one spark discharge for every alternation of the current. This matter of spark frequency is only mentioned in passing and will be fully discussed later under the caption of radio transmission.

**Alternators.**—Alternating current is produced by electrical machinery. Electrical machines are used for conversion of power from mechanical to electrical form, or *vice versa*. If driven by some sort of prime mover like a steam engine, gas engine or water wheel, they convert mechanical power into electrical power and are called "generators." If supplied with current

and used to drive machinery, vehicles, or other devices, thus converting electrical power into mechanical power, they are called "motors."

While there are various types of motors and various types of generators, the difference is more in the use than in the appearance or construction. Electric machines may be built for either direct or alternating current. If a generator of alternating current, called an alternator, is driven by a motor, this machine is known as a motor generator.

## CHAPTER IV

### EXPLANATION OF RADIO

RADIO signals are produced by propagating waves in that peculiar medium known as the ether. These waves are originated by setting up high frequency oscillations radiating from an "antenna" or, as it is also known, an "aerial."

The antenna oscillations cause waves in the surrounding ether to be radiated into space in all directions at the tremendous speed of 186,000 miles per second, which is the same speed at which light travels.

These ether waves, coming in contact with an antenna at a receiving station, set up in the receiving antenna oscillations which, by means of suitable apparatus (hereafter described in this volume), are rectified by means of a detector so as to be audible to the human ear, generally by the use of telephones.

By this means the signals of the Morse code or telephonic speech can be carried on.

The force or amplitude of ether waves depends on the energy developed in the antenna circuit.



The greater the amplitude of ether waves, the farther do they travel and the farther can they be perceived before their force is spent. But the amplitude of the waves in no way affects their rate of travel, nor their frequency.

The speed at which these waves follow each other is termed "wave frequency." Wave frequency depends upon the characteristics of the sending circuit, and is controlled by varying the capacity, inductance and resistance. In other words, by varying the size of the condenser unit or the inductance coil. Details of various types of apparatus, such as condensers, etc., are discussed elsewhere and will be alluded to in these preliminary pages only as aids to a general understanding of radio.

A given circuit will produce oscillations at only a certain fixed rate depending on the factors of inductance, etc., just as a pendulum can swing at only a fixed rate, depending upon its length and weight. In ordinary commercial practice the wave frequency varies from as much as 2,000,000 per second to as little as 100,000 per second.

**Wave Length.**—We now come to what is known as "wave length," or in other words the distance from the peak of one wave to the peak of

the succeeding wave. As an analogy we can picture the distance from the top of a water wave to the top or peak of the succeeding wave, although ether waves may be of different form to water waves.

Dividing the velocity of the waves, 186,000 miles per second, by the number of waves per second, gives us the wave length. We may put this in another form and say that the product of the wave length by the frequency is always 186,000. It will, therefore, be seen that it is of importance that a student should bear in mind the speed with which ether waves travel.

In discussing wave lengths, it should be carefully noted that it is only by means of variations of wave lengths that it is possible to operate a number of radio stations within the same area or region. Any desired wave length can be obtained by varying the circuit which determines wave frequency.

Wave lengths used in commercial practice vary from a few meters to thousands of meters.

Wave length plays such an important part in radio that a perfect understanding of the subject is essential. For illustrative purposes, we may compare several radio stations working in the same locality, on similar wave lengths, to several

persons speaking in the same room at the same time. A listener at a receiving station, or another person listening in the same room to the speakers, would be "jammed," or "interfered with," to use radio terms of expression.

Supposing you could devise something that would eliminate all but one of the stations and all but one of the speakers, you would eliminate interference. In radio, interference is overcome by what is known as "tuning." Stations in the same vicinity, by laws, regulations and mutual agreement, employ different wave lengths. By a receiving instrument known as a "tuner" or "receiver" it is possible to listen to only one station, or if desired, an arrangement of circuits can be made for "broad tuning" and "sharp tuning." As the names imply, broad tuning enables the person receiving to listen to several stations, working on various wave lengths (within a certain scope), but with resultant interference, while the latter permits only the reception of signals from one station.

In commercial practice this arrangement for listening in on broad tuning is very desirable, as an operator is enabled to catch any "call," and by arrangement of switches and dials rapidly throw over to the tuning devices providing for

sharp or selective tuning. Details of such receivers will be found under that heading within these covers.

**Wave Frequency.**—Early in 1923 the Department of Commerce under Secretary Hoover called on a group of radio experts to formulate temporary rules for the regulation of radio broadcasting with the object of reducing interference between stations. This group held what was known as the Second National Radio Conference. One of the important recommendations was that the wavelength at which a station was to operate on be referred to as being composed of so many kilocycles and that kilocycles be the standard term to be used instead of meters. The reason for this as well as its advantages are easily understood.

The waves sent out by a radio transmitter are in fact an alternating current of a very high frequency, the frequency varying inversely with the wavelength. In other words, the longer the wavelength the slower the oscillations, just as if it took longer for the oscillations to make a round trip in a long wavelength than in a shorter wavelength. An oscillation is a complete reversal of an alternating current. The current value at the start of the oscillation is zero and gradually builds

up to its maximum value in one direction, which for the sake of explanation may be called positive, it then dies down to zero in value and starts off in the opposite direction which may be called negative. A complete reversal such as this is called an oscillation consisting of one cycle. The longer the wavelength the slower will be these oscillations. There is a definite relationship between the number of oscillations taking place per second and the wavelength which is shown by the following formulæ:

$$\text{kilocycles} = \frac{300,000}{\text{meters}} \qquad \text{wavelength} = \frac{300,000}{\text{kilocycles}}$$

Velocity of waves in kilometers per second =  
wavelength  $\times$  kilocycles.

Using the above method of calculation the following table has been prepared which shows directly the conversion of meters to kilocycles.

meters	kilocycles	meters	kilocycles
100	3000	550	545
150	2000	600	500
200	1500	650	461
250	1200	700	428
300	1000	750	400
350	860	800	375
400	750	850	353
450	666	900	333
500	600	1000	300

It is seen from the above table that there is a difference of 1000 kilocycles in the fifty meters between 100 and 150 meters, while there is only a difference of 33 kilocycles in the 100 meters between 900 and 1000 meters. The difference in kilocycles gradually becomes less as the wavelength increases.

On the above basis, therefore, it is quite evident that it is not logical to expect the same number of stations to work without interfering with one another in the fifty meters between 600 and 650 meters, a difference of only 39 kilocycles, as between 300 and 350 meters, a difference of 140 kilocycles. Yet under the old scheme of allocating by wavelength this was the result.

In 1927 a law regulating radio was passed by Congress which is generally known as the Radio Act of 1927. This law governs all radio transmission in the United States and its possessions. Another act was passed creating a commission to administrate the law. This commission is known as the Federal Radio Commission and its members are appointed by the President.

In November, 1927, an International Radio Convention was held in Washington which further drew up regulations governing radio transmissions in most of the countries of the world. This

convention assigned wavelengths to the various services, such as the amateurs, broadcasting, commercial ship and shore, transoceanic, transcontinental and aviation stations.

The result of the vast growth of radio transmissions simultaneously occupying the air is the design of better receiving apparatus.

**Wave Trains or Groups.**—A “wave train” is a group of ether waves, sent out at one condenser discharge and contains numbers of individual waves, depending on the circuit conditions previously alluded to.

Wherever these waves strike a receiving antenna in their travel from the transmitting station, they will set up in the receiving antenna oscillations identical to those from the transmitting station. These oscillations, as we have shown, are very frequent, usually so rapid (say over a million per second) that they are beyond the range of the audibility of the human ear, which can only detect sounds of a frequency not greater than 4000 or 5000 per second.

We must, therefore, utilize some device to detect ether waves. In common practice this is called a “detector” and using a pair of telephones in conjunction therewith we are enabled, as it were,

to take the energy from the antenna, which, passing through the detector produces a click in the telephones. The characteristics of the many detectors together with their associated receiving circuits is fully dealt with in succeeding chapters.

**Resonance.**—From the foregoing, it will be seen that high frequency oscillations, radiated as ether waves from a transmitting antenna, will set up characteristic oscillations in a receiving antenna, within their path or range.

In practice, however, best results are obtained only when the sending and receiving antennæ are “in tune,” or as it is commercially termed, “in resonance.”

To properly understand this phenomenon, it would be well to take examples well known to everybody with even a slight knowledge of music, or through acoustics.

Take the example of two bells of similar tone, strike one and the other bell will respond without being struck. Also, the instance of two tuning forks of the same characteristics, strike one until it gives forth a musical note, it will, on the principle of resonance, sound a similar note in the second fork without the latter being struck. However, neither the fork nor the bell will actuate



another fork or bell unless they are similar in every characteristic.

A similar condition exists in radio and is a condition that must predominate in the thoughts of the experimenter who would be successful in his efforts.

In order to have radio signals very high frequency currents in the order of a million or more oscillations per second must be produced in both the transmitting and receiving sets. To produce this effect the sending and receiving apparatus must constitute electric circuits within themselves. They must have inductance and capacity and are called oscillating circuits. Every electric circuit whether it be oscillating or otherwise, has an electrical length. In other words, it takes a high frequency current a certain time to pass through it and return. This electrical length is called the "period" of the circuit. The natural period of a circuit, therefore, determines its wavelength and also the number of oscillations that can take place in it in one second of time. As an example, a circuit with a certain value of inductance and capacity may allow 1000 kilocycles to oscillate in it per second. This is the number of oscillations which can pass through it traveling at the rate of 186,000 miles per second. It

is easily seen that inasmuch as all electric oscillations travel at this rate of speed the number of oscillations depends entirely upon the length of the circuit electrically. The wavelength in this case is 300 meters according to the formula below:

$$\text{Wavelength} = \frac{300,000,000 \text{ meters}}{\text{natural period of circuit (frequency)}}$$

Three hundred million meters equals 186,000 miles and is the speed of the waves.

A transmitting circuit having a natural period like the above example would send out waves of 300 meter wavelength and the receiving circuit would have to be placed in resonance to this period of oscillation in order that the signals might be received. If the sending station above were sending out signals on 300 meters or had a period of 1,000 kilocycles (1,000,000 cycles) it has a certain relative electrical length. Now remember the example referred to where two bells of similar tone were struck. Both bells had the same period of oscillation. Likewise, the receiving station to respond to the transmitting station above must have the same electrical length or natural period. When this condition exists the circuits are said to be in resonance.

The energy sent out by the radio transmitter and received by the receiver manifests itself in the form of oscillations which may be likened to waves of unseen energy. It is believed that these waves would appear like the air vibrations seen over a hot radiator if they were visible. Radio waves, however, are electric in nature and travel at the rate of 1860,000 miles per second.

**Radio Oscillations.**—If a stone is thrown in a pool of still water, waves or ripples are set up on the surface of the pool radiating out in all directions from the point where the stone entered the water. The waves were most violent at the instant when and at the point where, the stone struck the water. As the waves were propagated out in circular form they became weaker in direct proportion to the distance from the point where the stone struck. Likewise, they became weaker in direct proportion to the lapse of time. In other words, they were very strong at the first second, but considerably weaker after the tenth second. To use a scientific term it might be said that the waves were “damped out” shortly after they were started. They could not go on indefinitely because there was no continuous source of disturbing power to “generate” them. Radio waves, too, are “generated” and unless the

source of power that makes the waves is continuous, without the slightest interruption, they are also damped waves. If, on the other hand, the source of generating power is continuous the waves are undamped, sustained or continuous, the three adjectives used to designate such waves or oscillations.

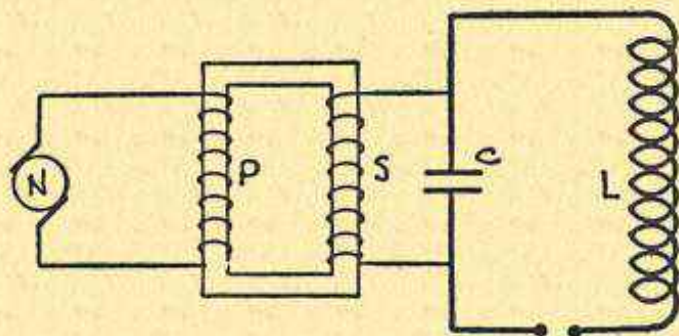

FIG. 14. Simple spark discharge circuit.

**Damped Waves.**—The circuit in Fig. 14 will produce damped waves, the alternator, N, generates a low voltage current, for example 100 volts. This current flows through the primary of the high potential transformer, P. This sets up a field of force in the primary which induces an electromotive force in the secondary, S. The secondary has many more turns than the primary, therefore the transformer is called a step-

up transformer. It will step up the voltage in the same proportion as the winding of secondary is to that of the primary. For example, if the primary has 500 turns and the secondary 5000 turns of wire the ratio of transformation will be as 500 to 5000 or 1 to 10. If the voltage in the primary is 100, as in the above example, then the voltage in the secondary will be 1000; ten times increased or stepped-up.

A condenser, C, is connected across the secondary, S, and is charged by the high voltage current. A condenser may be likened to a tank in that it will hold just so much of an electric charge and no more; when it is full it spills over or discharges, so to speak. The condenser will continue to store electricity which is pumped into it by the secondary as long as there is no conducting path through which it may discharge. It is to be noticed that a coil of wire called an inductance, L, is connected around the condenser, but that the circuit is broken at the point indicated by the two terminating dots. This break is called the spark gap and the distance between the points of this gap determines the break down voltage of the condenser. Let us assume, for example, that the gap is set a fraction of an inch apart; there is a small air space between its points. If it takes

1000 volts to leap this gap the condenser will store up 1000 volts of static electricity and then the potential energy in the condenser which is continually seeking to flow through the inductance circuit will be strong enough to leap the gap and a spark is seen and the condenser has discharged. At the start of the discharge the energy in the discharge is relatively very strong and produces correspondingly strong electromagnetic waves in the same way that the stone caused strong water waves in the pool at the time it struck. Like the pool waves these electric waves, having no continuous source of power, the energy in the condenser being dissipated until it again is charged or pumped up, so to speak, by the secondary, gradually get weaker and weaker until after a few oscillations have taken place they cease or die out. It is said then that they have been damped or smothered and they are called damped waves. A damped wave train may be said to be a train of oscillations in which there is a decrease in the amplitude of each succeeding oscillation, commencing at maximum and decreasing to minimum for each train. The number of oscillations which take place in a given circuit depends on the voltage in the secondary of the step-up transformer,

the capacity of the condenser, the value of the inductance, and the length of the spark gap. Damped waves may be received on either a crystal or vacuum tube detector.

**Undamped Waves.**—If the source of electric power in the Fig. 14, marked N, were a high voltage generator, 500 volts for example, and the condenser connected across the generator, the transformer being left out, and an arc (copper and carbon electrodes) substituted for the spark gap the circuit will generate undamped oscillations. This is due to the fact that the generator, N, keeps the arc burning continuously and the arc in turn discharges continuously through the oscillating circuit. A curve of these oscillations would appear as in Fig. 13, each alternation having the same amplitude, or in other words being undamped. Undamped waves are more efficient than damped waves and are, therefore, used for long distance transmission in such as the transoceanic stations located throughout the world. Undamped waves modulated to conform to sound waves are used in radio broadcasting. Pure undamped waves cannot be received on a crystal detector but require a device called a tikker or some form of beat receiver which is

known as the heterodyne or regenerative receiver and which will be described in a later chapter.

An undamped wave may, therefore, be defined as a train of oscillations of constant amplitude; each oscillation being identical with the one preceding it.

**Radio in Operation.**—Radio or wireless as it was previously called, means to communicate between two distant points without the use of intervening wires. Such a system must do several things and these are listed below:

First, Create radio waves.

Second, Radiate these waves.

Third, Detect the waves.

Fourth, Amplify the waves.

Fifth, Reproduce or make audible the waves.

All radio systems perform the above functions, some do more, such as in the broadcasting transmitter the waves are modulated and sometimes amplified before being radiated.

Radio waves are created or generated in several ways. Damped waves are generated by the discharge of a condenser as described in a previous paragraph. Undamped waves are generated by an arc generator as previously described, by a high frequency alternator connected directly to



the aerial and ground or by vacuum tube oscillators. Damped waves are produced by what are called "spark sets" and are used mostly on shipboard or at low power coast stations. They are the source of a great amount of interference due to the broadness of the damped waves which makes it impossible to tune it out. In other words, a damped wave can be heard over a wide range on the receiving set compared to the undamped wave.

Radio waves are radiated by means of the aerial and ground system. An aerial for radiating or transmitting purposes must be much larger than a receiving aerial relatively speaking.

The coherer was the first practical type of detector used in a radio system. It was soon found to be impractical for distance work and was replaced by the crystal detector. Next in order came the two electrode vacuum valve and the most recent inventions for this purpose the three and four element vacuum tube. Two element tubes are now used as rectifiers.

It was not until the invention of the vacuum tube that radio signals could be amplified. It is now possible to amplify the original signal to many hundreds of times its original power. In the amplification circuit small transformers known as amplifying transformers are used in

conjunction with the vacuum tubes. There are two methods of amplification employed. One is known as the audio frequency and the other as the radio frequency method of amplification.

Radio signals are reproduced usually by means of headphones or loudspeakers. There are other means of automatic recording used in commercial work but they are beyond the scope of our discussion. Headphones and loudspeakers are made in many types and vary greatly in efficiency.

***Fading of Signals.***—If you have ever listened to a distant station transmitting it is quite probable that you have noticed that the signals in some cases seem to be strong and weak in an irregular manner. This is called fading and may be due to the fact that as the radio waves leave the transmitting station they take the form of “sky waves” and “ground” waves” which sometimes oppose and sometimes augment each other. A study of Fig. 15 will illustrate the theory of signal fading as accepted by radio engineers.

This fading is not noticeable from all stations, it depends upon the distance the sending station is from the receiving station. A certain station may fade in one section and not fade at all in another

The theory of fading is based on an explanation

given by Sir Oliver Heaviside and it is not a proven theory, but simply a logical explanation. Twenty or fifty miles up, the atmosphere surrounding the earth is very rare and is an electrical conductor. Inasmuch as all electrical conductors are also good electrical reflectors we have a mirror, so to speak, which reflects the radio waves in the same way that a common mirror reflects light waves. It is called by scientists the "mirror layer" and theoretically reflects the radio waves as shown in Fig. 15. This mirror layer, however, is not effective during the day; it is, in fact, almost neutralized and instead of being a smooth-surfaced reflector, its surface is very irregular. This is due to sunlight which converts this layer into a sort of fog which readily absorbs the radio waves. We have, therefore, the condition of a reflector by night and an absorber during the day. This no doubt accounts for the fact that radio signals travel at least twice as far by night as by day for a given power.

The Fig. 15 shows that the waves received by the receiving station come through the ground as well as from the sky. It is, furthermore, understood that the sky waves travel twice the distance the ground waves do before they are completely absorbed. It is easily understood, therefore, why

night is superior to day transmission. During the day, there are no sky waves due to the absorption effect of the "Heaviside layer" and all of the energy comes through ground waves to all but stations close to the transmitting station. It is also true that ground waves encounter many obstructions not met with by sky waves which accounts for their being of shorter duration.

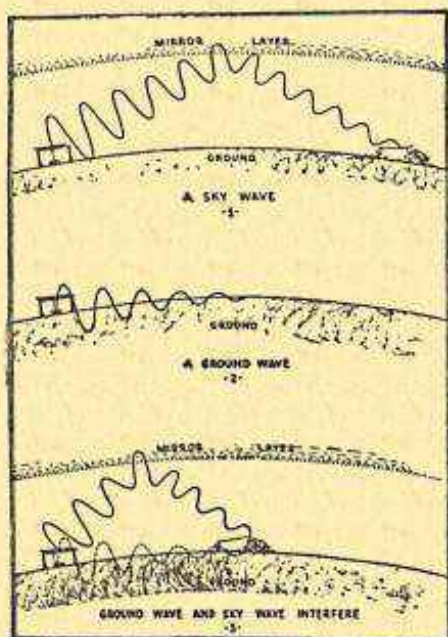

FIG. 15. Why radio signals fade is shown graphically by the curves above.

A study of the Fig. 15 will make clear how the fading effect takes place. Notice the sky waves, how much farther they travel than the ground waves. Also notice the polarity of the ground and sky waves. When they are both positive at the same instant the resultant signal is strong whereas when they differ in polarity the resultant signal is weak. It is a case of positive and negative bucking each other with the resultant or tertiary effect of a weak received signal.

***Ether and Ether Waves.***—There are two kinds of ether, the most common perhaps is that produced by the action of sulphuric acid on alcohol and used in medical practice as an anesthetic. It is a chemical compound. Then, there is another kind of ether properly known to physicists and scientists as “luminiferous ether” because it has the property of conducting light waves. It is this sort of ether which is of interest to the radio scientist. It is that something which conducts electromagnetic waves through space. It is the substance referred to throughout this book and in any explanation of radio.

Ether is said to be present everywhere, even in solid rock. It has no weight, but is said to have elasticity and density. In other words, it has the properties of restitution and inertia. It is not

known whether the light waves or the longer radio waves plow through the ether, that is, displace it, or whether the ether passes through them like wind through a tree. The fundamental theory is that ether is not affected by the passage of matter through it unless the matter is electrically charged.

The subject of the ether is a difficult one to the average reader. Faraday, in his early experiments, assumed that there was ether. The theory of the ether has been discussed from different angles by eminent scientists throughout the history of electricity and astronomy. Einstein proposed a new theory in his papers on relativity and the American astronomer T. J. See has deduced a new theory of the ether.

It is sufficient, however, for the average reader to think of ether as the conducting medium for radio waves. Bear in mind it exists in all matter.

## CHAPTER V

### THE AERIAL EXPLAINED

THE antenna is used in radio communication for two purposes: (1) to radiate electric waves, and (2) to absorb or detect the electric waves which come to it. An antenna consists essentially of one or more wires, suspended at some elevation above the earth. When electric waves reach an antenna, they set up an alternating emf. between the wires and the ground. As a result of this electromotive force (emf.), an alternating current will flow in the antenna wires. The energy of the current is absorbed from the passing wave, just as some of the energy of a water wave, is used up in causing vibrations in a slender reed which stands in its way.

A receiving antenna needs to be large, in order to gather in enough energy from the passing waves to effect the receiving apparatus. Likewise a transmitting antenna should be as large as practicable in order to send waves to a greater distance. However, several conditions govern the

size of the transmitting aerial, just, for instance, as the size of the heat radiators in an apartment are governed by the amount of heat available to be radiated. The same antenna may be used for both receiving and transmitting, in such cases a change-over or antenna switch is provided in the set to change from reception to transmission, and *vice versa*. An antenna used for receiving only, may, however, be made simpler than one which is also required for sending purposes, as it is obvious, with the absence of the high potential emitted by a transmitter, that the insulation need not be so heavy.

In practice, stranded wire is used for an antenna. High frequency currents with a high potential travel over the surface of a wire, therefore, a stranded wire offers a large surface. It has another advantage, in the event of a strain being placed upon the antenna, one or more of the strands may part, but the remainder will keep the antenna in commission.

As discussed in the chapter dealing with conductors, copper is the best conductor, but for several reasons, it has been discovered that pure copper is not as practicable as some alloys, therefore, in almost universal radio practice, silicon-bronze or phosphor-bronze are used. The standard



gauges are usually 7-22 or 7-19. In other words seven strands of number 22 or number 19 wire.

All joints in an antenna must be soldered, or a suitable patent joint used, such as that called a "MacIntyre" splice. If joints are soldered, care must be taken that too much heat is not employed, otherwise the wiring at the joint becomes tempered and very brittle and is liable to break when any strain or jar is met with.

The insulation of an antenna is of the utmost importance, especially in damp foggy climates. For damped apparatus using moderate power, an insulator known as "Electrose" is very suitable and is manufactured in a very large variety which meets all demands. For undamped or continuous wave radio, and for high potentials, porcelain is possibly the best insulator; these are also made in a great variety and can be readily obtained for any purpose. Not only should the actual antenna receive great care in its insulation, but the guy wires of masts or towers should also be insulated with strain insulators. If they are lengthy several strain insulators should be employed, inserted in series with the guy at suitable intervals.

*Types of Antennae.*—Early in the history of radio, Marconi demonstrated that radiation

from an antenna was directional in its effect, according to the shape of the aerial employed. It was this discovery which led in later years to the wonderful success of the direction finder or radio compass.

It is well known, that a single vertical wire is, for its size the best radiator, but it has to be made so extremely long in order to obtain sufficient capacity that it is not a practical antenna for long wave or long distance work. Antenna of different numbers of horizontal or inclined wires are therefore used, and are very practicable and radiate very well. It must be remembered that an antenna is merely a large condenser and may have various shapes consistent with this condition, although some forms will radiate much better than others.

Antennae that radiate more energy in one direction than in the opposite, are termed "directional," while an antenna radiating equally in all directions, is called "uni-directional."

The following types of antennae are the most common in practical use, and are easier to erect under conditions that confront the average experimenter. They are shown in Fig. 16.

What may be considered as the standard form of antenna for ship stations, and also for low

powered land stations, is known as the T or inverted L type of aerial. This is an antenna of horizontal wires, usually two or four in number, separated at equal distance on what is termed a spreader, and supported between two masts or towers.

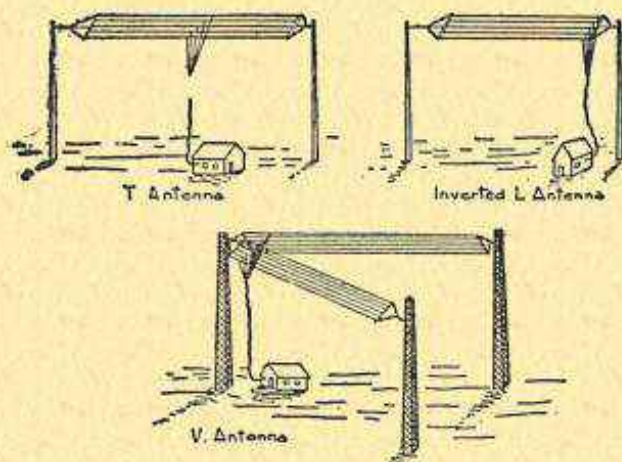

FIG. 16. Typical antennæ construction.

Whether the down leading-in wires are taken from the center or at the end of the horizontal portion determines whether the antenna is of the T or inverted L type.

Another very practicable type for certain work is the V antenna, consisting of two sets of hori-

zontal wires supported by three masts or towers, so that the horizontal portions form an angle or V.

The directional effect of an inverted L or V type is greater than a T. There is a greater amount of energy sent in the direction in which the angle of the L points than in the opposite. With the T type the effect is more undirectional, although more energy is sent in the parallel direction of the horizontal wires, than at right angles. The resultant wave would be oval in shape.

A more recent development in this field is what is known as the loop antenna. This consists of a coil frame constructed by fastening four wooden struts together in the form of a triangle, the apex of which fits into a wide slot in a center fastening, usually in the form of a casting. Four of these are provided and converge into the center casting, where they are held by bolts. This provides a square frame over which many coils of wire are wound. The two ends of the wire are brought in as leads. This loop is mounted on a shaft enabling the loop to be rotated in all directions, and the antenna thus cuts any lines of force desired. This is the type used for radio compasses.

*Function of the Aerial.*—Fundamentally the radio circuit is made up of inductance and capacity. A circuit of this kind may be made to function in the radiation or reception of radio signals. In some cases both the capacity and inductance is lumped in the form of a condenser and an inductance coil. In other cases, the capacity is formed by an elevated wire called the aerial which forms one plate of the condenser, and the ground which forms the other plate of the condenser. It is this latter method which is in most common use.

The loop aerial or antenna is an example of concentrated inductance and capacity, as a condenser is used in conjunction with the loop.

It may be said that in the case of the ordinary radio aerial system that energy is received because the aerial is exposed to the radio waves. The energy is received through the capacity of the aerial and ground and then transferred to the inductance coil. This is not true, however, in the case of the loop aerial. In this type of radio circuit both the inductance and capacity are concentrated and the energy is received due to the exposure of the loop to the radio waves.

In all cases the amount of energy radiated or

received depends upon the physical dimensions of the circuit.

When the aerial or loop is used for transmitting, it is used for radiating purposes. Radiation is the moving disturbance of the ether, the energy associated with which does not return to the radiator. In other words, it differs from induction in that the energy thus radiated is lost to the circuit forever. It has gone out into space like heat from a stove and it is this energy which affects the receiving aerial which acts as a receptor.

Generally speaking, the elevated aerial wire is most convenient as a radiator and receptor. It is true, however, that a loop aerial, if its dimensions approach those of the elevated aerial, will function equally as well as an aerial as a radiator and a receptor. The coil or loop aerial works best on short wavelengths. As a matter of fact, the amount of received current in a loop varies in inverse proportion to the cube of the wavelength. The loop aerial also has directional characteristics which make it valuable as a direction finder and interference eliminator.

**Height of the Aerial.**—It is assumed that most of the readers of this volume will be interested more in the aerial as used with a receiv-

ing set than as used with a transmitter, consequently a detailed discussion of the receiving set aerial will be undertaken.

To most people the aerial is the most conspicuous part of a radio set and it is indeed an important part of the radio equipment. For ordinary purposes a receiving aerial may consist of a single strand of copper wire 100 to 125 feet in length erected between two supports usually fifteen or more feet above the ground. It is important to erect the aerial as high as possible when using a crystal detector but with the adoption of the vacuum tube detector and amplifier a great height for the aerial is unnecessary.

When using a crystal detector set, a general rule is to erect the aerial as high as possible. If the aerial in such a case is so high up that the length of wire from aerial binding post on the receiving set to the farthest end of the aerial is more than 150 feet it is necessary to put a variable condenser in series with the aerial lead to the set in order to be able to cut down the natural wavelength of the aerial circuit and permit tuning-down to wavelengths in the vicinity of two hundred meters and lower.

When a vacuum tube receiver is employed it is advantageous to use a low aerial for two reasons:

first, so called static or atmospheric interference is cut down considerably; second selectivity of tuning is increased to a considerable degree. Both of these advantages are to be had without a loss of signal strength to any marked degree. This is shown by the curves in Fig. 17. Curve A

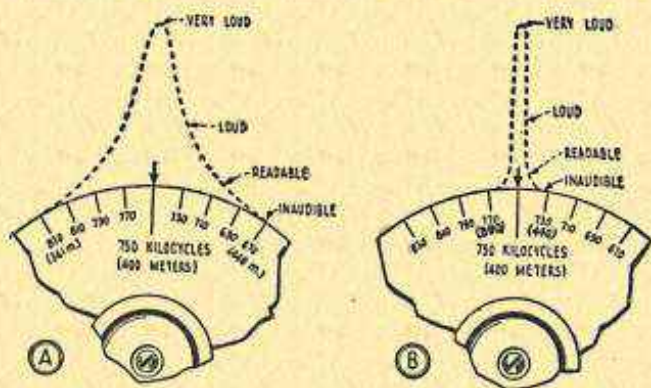

FIG. 17. Curve A shows the "broadness of tuning" resulting from the aerial being erected too high. Curve B shows the "sharpness of tuning" possible with the same aerial erected in a lower position.

shows the effect using an aerial 35 feet, and curve B the same aerial 15 feet above the ground. The same receiving set was used in both cases. The signal strength with the 35 foot aerial is only slightly greater than when using the 15 foot high aerial. On the other hand, notice that the signal



in case A is heard between the tuning range 830 to 670 on the receiver tuning dial while in case B the signal is heard only between the range 770 to 730 on the dial. In the first case, the dial may be moved 160 kilocycles. In the second case, the signal is heard only over a range of 40 kilocycles on the dial. The first case shows poor while the second shows very good selectivity.

The importance of aerial height is readily seen from the explanation already given and must be considered in planning the aerial.

**Aerial Erection.**—Aerials are divided into several classes but only those types generally used by the radiophone listener will be described here.

The most common type of receiving aerial is the one wire type, strung between two convenient points. The next in order is the inverted L type of aerial consisting usually of four wires, as shown in Fig. 16. It is called the inverted L because of the fact that the lead-in wires are taken from one end and the system of wires as a whole resembles an inverted L. The T type of aerial is the same in construction as the inverted L except that the lead-in wires are taken from the center instead of from one end.

The two most important points in connection with the erection of the aerial is that it be properly

insulated and that it be not surrounded by obstructions, such as buildings, trees and other aerials. An insulator should be placed at every point where the aerial wire touches a support. There are no exceptions to this rule.

The aerial should be erected as far as possible in a clear space free from trees and tall buildings, especially steel buildings. A good aerial for broadcast receiving may be made by stringing a copper wire about 100 feet long between two points as explained before and in such a position that the lead-in wire shall not be over 25 feet in length. (See Fig. 18.) A good inverted L or

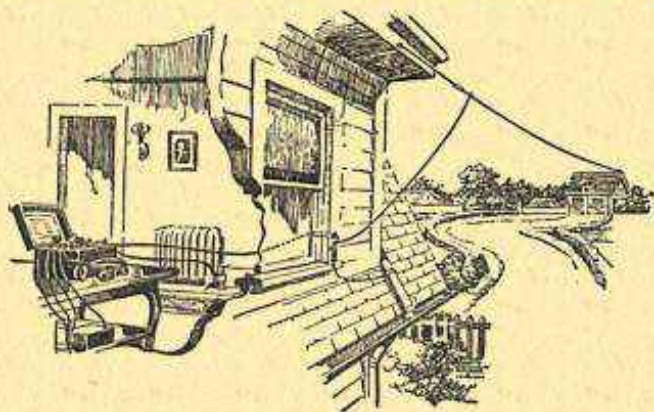

FIG. 18. An aerial should be erected in a space free from surroundings. The above aerial is an ideal one for broadcast receiving.

a T type aerial may consist of four wires fastened three feet apart to a spreader. It may be from 25 to 60 feet high and 100 feet long. The lead-in wires may taper to a point where the lead-in enters the building.

Wire for aerial construction is preferably of copper although a copper coated steel wire is now on the market which serves the purpose well.

Aluminum wire also serves the purpose but becomes extremely brittle after exposure to the elements and, therefore, is not used to a great extent. The aerial wire must offer little resistance to the flow of the high frequency radio currents and it is for this reason that copper rather than steel alone is used for aerial wire.

Care must be taken not to erect the aerial parallel to another nearby aerial or power line as induction from these is likely to be heard in the receiver. When induction causes much interference in the form of a constant buzzing in the receiver the remedy in many cases is to change the position of the aerial. This is especially true if the aerial is located near to and parallel with an aerial to which a regenerative receiver is connected. The radiation of feeble impulses from this receiver may cause interference in your set.

In installations that are intended to be perma-

nent the question of making the aerial strong enough to withstand stormy weather must be considered. Commercial companies use an aerial wire made up of seven small strands of phosphor bronze wire twisted together. By this means a very great tensile strength is secured.

The table below gives the tensile strength of various kinds of wire.

Soft drawn copper	34,000 lbs. per square inch.
Hard drawn copper	50,000 lbs. per square inch.
Hard drawn aluminum	30,000 lbs. per square inch.
Phosphor bronze	90,000 lbs. per square inch.
Galvanized iron	50,000 lbs. per square inch.

It is difficult for the novice to solder aluminum wire but no such difficulty is found with copper wire. If aluminum is used it is important that it be of a good grade otherwise it will soon corrode, become brittle and break down.

All connections of a good aerial are soldered. This reduces any possibility of resistance between joints.

If the aerial is supported by a mast supported by guy wires these guy wires should be broken at least in one place by an insulator. This is to prevent the guy wires from absorbing too much energy which rightfully should go into the aerial.

Glazed insulators are the best and the glazing should be of good quality and able to withstand bad weather.

The length of the aerial is important and for broadcast listening it should not be over 100 feet except in cases where the station to be received transmits on a wavelength about four hundred meters when the aerial may be 150 feet long. If after erection the aerial is found to be too long the remedy is to insert in series with the aerial a variable condenser. In this way the effective length of the aerial can be reduced as much as fifty per cent.

The aerial in a way similar to everything else may get old and dirty, the connections become poor and the insulation bad. To safeguard against poor receiving results because of this inspect the aerial at least every six months and if it doesn't look good it may pay to erect a new one. A new aerial with clean insulation always improves the range of a receiving set. If after using your set for some time it seems to lose its old time efficiency try a new aerial. Many times this is the main trouble with a set.

Great care should be taken in the method employed to insulate the lead-in wire where it comes through the building. It should be brought

through a porcelain tube or a small hole drilled in the window pane.

In some respects the transmitting aerial differs from the receiving aerial but principally in insulation and methods of bringing in the lead-in wires. In a great many respects similar rules apply to both.

**Indoor Aerial.**—In the city it is sometimes inconvenient to erect an outdoor aerial and in such a case an indoor aerial as shown in Fig. 19

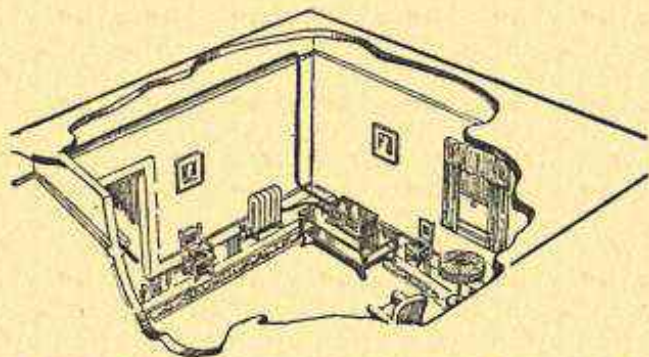

FIG. 19. How an indoor aerial might be installed.

may be employed. Any kind of copper wire may be used, the smaller the wire the less noticeable it will be. It may be tacked along the upper edge of the picture moulding and in this way made very inconspicuous. There should be at least 75

feet of wire used and as much as 125 feet if possible.

An indoor aerial will give good results for local signals provided the building in which it is erected is not all steel. In nearly every case, however, an outdoor aerial will give better results than an indoor aerial. The indoor type may be easily erected and is worth trying out. If it does not work, plans should be made for an outdoor aerial.

**Lightning Arrester.**—The lightning arrester is a protective device which is connected between the aerial and the ground to provide a path to the ground for high voltage charges gathered on the aerial which otherwise might discharge at the point of weakest insulation and shortest path to the ground causing a spark which may result in fire. A common type of arrester now being sold looks like a large electric cartridge fuse. Inside are two terminals spaced a fraction of an inch apart. A vacuum is pumped into the shell of the container and the gap between the two terminals offers little resistance to a high voltage electric charge. As a matter of fact, after the spark has jumped across the gap, the device is a good conductor of electricity and serves as an automatic switch which connects the aerial to the

ground. Lightning arresters are made in two types, namely, indoor type and outdoor type. There is also a universal type which may be used either outdoors or indoors. The type made for indoor use cannot, however, be used outdoors. In most sections of the country the indoor type is not approved of by the Underwriter's Regulations.

In selecting the lightning arrester, ease of installation is an important factor. It is also of consequence that the device comply with the Underwriter's Regulations. In other words, it must be of an approved type. This is usually stated on the label and should be looked for.

When properly erected an aerial is a protection rather than a menace. In a lightning storm it acts, as a matter of fact, like a system of lightning rods. It is not so long ago that this sort of protection was considered essential, at least in suburban sections. In case of a direct stroke, a protective device such as an arrester or even a grounding switch is of little value as the power contained in a stroke of lightning is too great to be controlled without the use of apparatus far beyond the cost of radio set owners. Lightning arresters will, however, drain the aerial of all



electric static charge over 500 volts and conduct it safely to the ground.

It is interesting to know that in a period of fifteen years there is only one case in the City of New York in which an aerial was struck by lightning. Another remarkable case is one where the aerial was erected above some telephone wires. The lightning struck the telephone wires, but left the aerial undamaged.

**Lead-In.**—Bringing the lead-in from outdoors to the set is often a problem to the set owner. There is sold a specially designed lead-in connector which is a piece of copper strip fitted with connectors on both ends and heavily insulated which fits on the window sill and makes the drilling of a hole unnecessary. This type of lead-in is not approved by the Underwriters and is used at the owner's risk. A lead-in to comply with the regulations may come through an insulating tube inserted in a hole which has been drilled in the window sill. This tube should be preferably of porcelain and the wire passing through it must sit loosely and not be tight or binding in any way. This is indicated in the Figure 18.

**Spreaders.**—A spreader is used when more than one wire goes to make up the aerial. It is

not common to employ this type of aerial unless the station is to transmit. Spreaders may be made of iron pipe, bamboo, or strong wood. The length of the spreader depends upon the number of wires and the length of the aerial. A safe rule is to spread the wire at least one-fiftieth of the length of the aerial apart. As an example, suppose the aerial is 150 feet long, then the wires should be spread about three feet apart. In no case, however, should the wires come closer than 18 inches apart. The more spreader the greater the capacity of the aerial as a whole.

**Guy Wires.**—When guy wires are used to support a mast or to prevent spreaders from swaying they should be broken up into short electrical lengths of not more than 25 feet by means of strain insulators. This prevents the guys from absorbing too much of the radio waves surrounding the aerial. For small equipments it is best to use a strong tarred rope instead of wire for guying purposes. Rope, being a non-conductor, absorbs no energy from the aerial. But even when a rope is employed it is well to use strain insulators as carbon will gather on the surface of the rope and in wet weather may provide a leakage path to the ground.

**Loops.**—A loop or coil aerial is shown in Figure 20 and consists of a number of turns of wire mounted on a frame. Where it is difficult to erect an outdoor aerial or where a portable

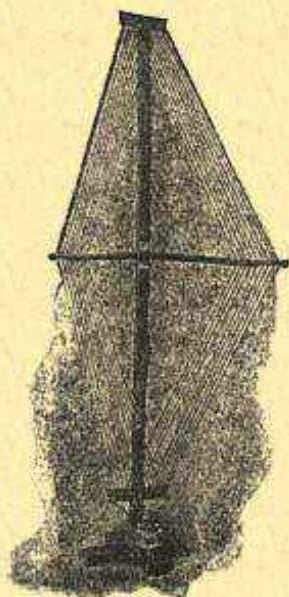

FIG. 20. Loop.

aerial is desirable the loop serves the purpose. It is, however, necessary that several stages of amplification be provided. The loop works best on such a set as the super-heterodyne.

The loop aerial has marked directional characteristics. By this is meant that the intensity of the received signal will depend upon the position of the loop and for this reason the loop is valuable in reducing interference. The loop may be used as a direction finder and the radio compass depends for its ability to indicate the direction from which received signals are coming on the directional characteristics of the loop.

The fundamental wavelength of a loop depends upon the size and number of turns of wire mounted on the frame. The table below gives the characteristics of several sizes of loop aerials as given in the Signal Corps Manual, "Principles Underlying Radio Communication."

Length of a side of the square in feet	No. of turns	Spacing of wire in inches	Fundamental wavelength in meters
8	3	$\frac{1}{2}$	160
6	4	$\frac{1}{4}$	170
4	6	$\frac{1}{4}$	174
3	8	$\frac{1}{8}$	183

Using the above data as a basis it is a simple matter to build a loop suitable for broadcast receiving. The two ends of the loop are connected, with a variable condenser in one lead, to the aerial and ground posts of the receiving

set. A variable condenser can also be connected in parallel to the loop to increase its fundamental wavelength.

The loop operates in a way quite different from the aerial, depending upon having a current induced in it by passing electromagnetic waves rather than being charged like a condenser by these waves, as is the case with the elevated aerial wire.

One of the fundamental principles of the generation of electromotive force is what *when a conductor is cut by lines of force, a current is generated in it*. This current flows in a certain direction depending upon the direction in which the lines of force are cutting the conductor. If the direction of cutting is reversed the direction of current flow is reversed.

This is the principle of the simple alternator, a machine for generating alternating current. The conductor in the case of the simple alternator is the rotating armature and the lines of force are supplied by the field magnets. In principle the loop may be compared to the armature and the lines of force to the radio waves. In the alternator the armature moved and the field (lines of force) was stationary but in the case of the loop the lines of force, the radio waves (the field) move, and the armature is stationary.

It makes no difference which of these two prime requisites move, the condition being that the conductor shall cut the lines of force, the field, like the prow of a boat cuts the water.

In this last analogy, imagine the boat as the conductor and the water as the field of force. If the body of water is perfectly still and the boat is propelled we have a case of the boat (conductor) cutting the water (field). If, on the other hand, the boat is anchored in a rapid stream where a strong current of water is flowing, we have the case of the water (field) being cut by the boat (conductor).

In both cases the effect at the prow of the boat is the same and if we were to gaze at the prow and not take into view surrounding objects such as land there would be no different optical effect between the case of the boat moving in a still body of water or the water moving past a still boat.

The principle, when a conductor is cut by lines of force a current is generated in the conductor, is one of the most important things to remember in considering anything that has to do with electricity.

The loop has directional characteristics and is used in radio compass work. It is possible by employing a loop and a special receiving circuit

to tell quite exactly the direction from which signals are coming. This is due to the fact that the amount of current induced in the loop by the passing radio waves depends upon the position of the loop in relation to the direction in which the radio waves are travelling. If the plane of the loop is turned at right angles to the source of the signals, the signal response is minimum. While, on the other hand, if the plane of the coil lies in the direction from which the signals are coming the current received by the loop will be maximum. This is due to the fact that in the first instance the voltage in both sides of the loop being in phase, tend to cancel each other and in the second case the voltage in the side of the loop nearest the transmitting station is out of phase with the voltage in the opposite side and, therefore, there is no bucking effect and a current flows in the loop.

When using a loop with a radio receiver it is necessary to use a variable condenser to tune the circuit to resonance. A loop to give best results should have just as many turns as the wavelength requirements will permit. The turns should be spaced well apart in order to get maximum inductance. The longer each side of the loop, the greater will be the induced voltage in each side

and, therefore, the greater will be the signal strength received by the loop. It must not, of course, have a greater inductance value than that required for tuning.

**Ground Connection.**—The efficiency of the set as a whole is greatly dependent upon the efficiency of the ground connection. Sometimes it is possible to increase the volume of a received signal fifty percent by improving the ground connection.

There are various ways of making a ground connection and the method employed will depend upon the location of the receiving apparatus. In general it is best to have the ground lead as short as possible. Avoid long bended wires leading from the receiver to the ground connection. If in the city the best ground connection is made by connecting directly to the water pipe. A special ground clamp which can be purchased in any electrical or radio supply store should be used. The water pipe should be carefully cleaned with sandpaper making sure that all rust and other verdigris is removed so that the clamp can make a good connection. The wire leading to the receiver should be soldered to the ground clamp to insure good contact. Unless no water pipe is available



the gas or radiator piping system should not be used.

In the country where no water pipe is available a good ground connection may be made by burying about 100 square feet of chicken fence wire about ten feet in the earth and the lead wire soldered to it. In making this sort of a ground moist ground should be chosen. Dry or rocky soil will not serve the purpose. It is sometimes the practice to fill in the hole which has been dug for the ground with charcoal to aid in keeping that particular piece of ground moist and to improve the connection between the fence wire and the earth. If fence wire is not available any kind of sheet metal will serve the purpose.

**Counterpoise.**—In sections where it is not possible to make a ground as described above a counterpoise may be used instead. A counterpoise takes the place of a ground and consists of a network of wires laid on but insulated from the ground similarly to the aerial. The wires of the counterpoise may stretch out radially from the center where the receiver is located. In area the counterpoise should cover about fifty percent more ground than the aerial system

Theoretically the counterpoise is one plate of the huge condenser of which the aerial is the other

plate. This huge condenser constitutes the distributed capacitance of the open oscillating system. In many cases on record the transmitting range of a station has been increased to a very large extent by using a counterpoise instead of the usual ground connection to the earth.

On aeroplanes the counterpoise must be used because of the impossibility of making connection to the earth as in land installations. In these equipments the counterpoise may consist of a special network of wire or the stress guy wires; engine and other metal equipment are electrically connected together and formed into a counterpoise system.

The counterpoise is used to a great extent on portable equipments such as supplied to the Signal Corps of the Army. It is used where the ground itself is rocky in nature and where the earth is especially dry and sandy.

## CHAPTER VI

### FUNDAMENTALS OF RADIO RECEPTION AND RECEIVING APPARATUS

**Introductory.**—A radio receiver may look complicated and difficult to understand to any one who does not know its real purposes and construction. In this chapter, therefore, we will analyze the separate parts and characteristics which go to make it up.

There are many classes of radio receivers, each of which is designed for a definite purpose and each of which is different in construction. Roughly, receivers may be classed as follows: transoceanic and transcontinental long-wave receivers; short-wave receivers for the same service; commercial ship-to-shore intermediate-wave receivers; aircraft receivers; broadcasting receivers; amateur receivers. The reader of this book is probably most concerned and interested in the two latter classes of receivers, namely, broadcasting and amateur. We will, therefore, confine our discussion to these classes, as the fundamen-

tal principles underlying the operation of all of the classes are similar.

***The Function of the Detector.***—In modern radio receivers the detector acts as a valve, controlling the current flowing through the headphones or loudspeaker in exact synchronism with the radio waves sent out from the transmitting station.

For example, if the word "hello" is spoken into the microphone of the broadcasting station, a corresponding radio wave "hello" is sent out from the aerial of the station. This wave travels out in all directions just as the ripples do in a pond when a stone is thrown into it.

As the "hello" wave passes the receiving aerial it induces oscillations identical to itself in the receiving set and operates the detector. The detector in turn releases a current to the headphones or loudspeaker identical in modulation to the received "hello" wave. If we listen, therefore, and everything is in working order, we hear the word "hello" at the receiving set.

Similarly, if the sending station is a radio telegraph station and not a radio telephone station, the outgoing radio waves leave the transmitting aerial in the form of dots and dashes as controlled by a telegraph key manipulated by an op-

erator. These waves, in the form of dots and dashes, cut through the receiving aerial and cause the detector to pass or valve a similar current from the B-battery through the headphones or loudspeaker.

**Radio Headphones.**—The distinctive features of telephone receivers for radio work are lightness of the moving parts and the employment of a great many turns of wire around the magnet poles. The lightness of the moving parts enables them to follow and respond to rapid pulsations of current. The large number of turns of wire causes a relatively large magnetic field to be produced by a feeble current. The combined effect is to give a very sensitive receiving device. Inasmuch as the size of the wire used is always about the same (No. 40 copper), the amount of wire and, therefore, the number of turns are usually specified indirectly by stating the number of ohms of resistance in the coils. Telephone receivers of fair sensitiveness for radio work have about 1000 ohms in each receiver (measured with direct current), while the better ones usually have 1500 to 2000 ohms per receiver.

The most common type, called the magnetic diaphragm type, has a U-shaped, permanent magnet with soft iron poles, and a thin soft iron

diaphragm very close to the poles, so that it vibrates when the attraction is rapidly varied, producing sounds to correspond with the frequency of the pulsations of current.

**Watch-Case Type Receiver.**—The type of small receiver used in connection with radio is called the watch-case type to contrast it with the long receiver used on an ordinary telephone line. It is possible to make the radio receiver both light as well as small due to the extremely feeble currents handled in the circuit. The watch-case type of receiver permits the wearing of it on the head continuously with comfort. They are usually fitted to a leather or light steel head-band and the cases themselves are made of aluminum or hard rubber.

Two permanent magnets are formed by the ends of a horseshoe magnet, which is bent into a circular form, and fits snugly into the receiver case. On these magnets are wound several thousand turns of very fine insulated copper wire. Silk or enamel covered wire is most commonly used. The magnet coils are wound in opposite directions, which makes one pole of the magnet North and the other South in polarity. The receivers are connected to the radio set by a bi-

furcated silk or cotton covered conducting cord, flexible and five or six feet long.

Sound is produced in the telephone receiver by virtue of vibration of the diaphragm, which is set over the magnets, and is effected by the current flowing in them. The diaphragm is bent in slightly when sitting in its normal position due to the pulling force of the magnets.

Great care must be taken in the manufacture and handling of the diaphragm not to bend it in any way. It is a very difficult matter to make a diaphragm perfectly flat and, therefore, every effort should be made by the persons using the receivers not to bend it out of shape. The efficient operation of the receiver depends in great part on the diaphragm being perfectly flat. It is true, of course, that a diaphragm may become bent as usage goes on, but this cannot be helped and is usually so slight that it does no harm. If the diaphragm sits loosely over the magnets, or if it hits the pole faces of the magnets, a rattling sound will be heard when the receivers are being used. The remedy is to raise it slightly from the pole faces by inserting a paper washer under the diaphragm seat.

It is important that the diaphragm have equal clamping all round if the receiver is to work well.

The character of the magnetic circuit of the receivers depends upon the distance between the pole faces and the diaphragm. This distance should be as small as it is possible to make it without having the diaphragm touch the magnets. Usually it varies between  $1/100$  and  $1/1000$  of an inch. The inside of the receiver case should not be affected by temperature, as a contraction or an expansion caused in this way would affect the air gap, referred to above, and disturb the efficient working of the receiver.

***Sensitivity of Telephone Receivers.***—

Telephone receivers are rated in ohms. Those most commonly used for radio work being the 2000 or 3000 ohms type. It is logical to think that the rating of an instrument having to do with the reproduction of sound, such as the telephone receiver, would be an indication of its sensitiveness expressed in units directly related to this property. Such is not the case, however, since the rating of telephone receivers is according to the resistance of their magnet windings to direct current expressed in ohms.

The sensitivity of a telephone receiver depends upon the magneto-motive force exerted on the diaphragm by its magnets. Magneto-motive force in turn depends upon the number of turns



of wire wound on the magnets and the current flowing through these turns. The actual value of these two things is summed up by referring to the number of ampere-turns of wire with which the magnets are wound. Since wire has resistance, it became the practice in the early days of telephone receiver manufacture to designate the

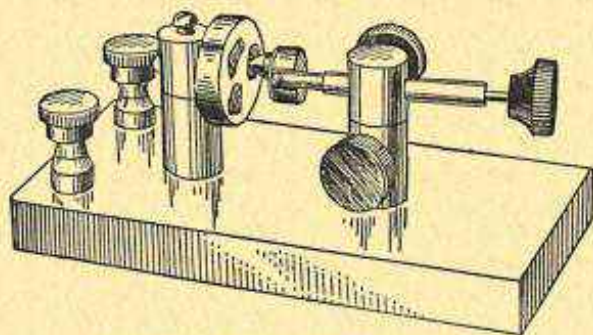

FIG. 21. Typical crystal detector.

number of ampere-turns by the resistance they offered, rather than by the more proper way of giving the amount of magneto-motive force they produced. The more ampere-turns on a magnet winding the more magneto-motive force produced. It is for this reason that extremely small wire is used on the magnet windings. The size used is usually No. 40 B. & S. American gauge.

If resistance alone were desired, telephone receivers would be wound with German silver or other high resistance wire. This is not desirable, of course, and is not done.

**Telephone Receiver Troubles.**—The magnets are usually made of the best grade of tungsten or silicon steel and are permanent magnets. If the receivers are dropped very many times they lose their sensitiveness due to the fact that any permanent magnet tends to lose its magnetism if severely jarred. Telephone receivers should, therefore, be handled with care.

If the diaphragm of the receiver becomes bent in any way, the sensitiveness of the instrument is reduced. Never, therefore, take a receiver apart unless absolutely necessary and never poke a pencil or other prong into the cap opening so that it touches the diaphragm.

An open magnet coil will make a receiver inoperative, and in case of trouble the windings of the magnets should be inspected for a break, especially at the point where the terminals are soldered to the connecting terminals.

The magnets will also tend to lose their magnetism if the diaphragm is left off the magnet faces, and this obviously should not be done.

Telephone receivers used for radio work may

be tested by wetting the tips of the receiver cord on the tongue and bringing them together with a snappy motion. If they are sensitive a slight click will be heard, due to the feeble current generated by the friction of one tip on the other.

**Mica Diaphragm Type.**—Another very efficient type of telephone receiver used in radio work is called the mica diaphragm or Baldwin receiver. This type differs radically from the ordinary receiver previously described, in that it has a mica diaphragm which is not acted upon directly by the magnets, but is independently balanced and actuated by an armature set between magnetic poles. There is no strain on the diaphragm unless a current is passing through the magnets or, in other words, unless a signal is being received.

The principal advantages of this type of receiver are as follows: responsiveness to extremely feeble signals due to the small current necessary to actuate the armature; a small magnetizing force will cause a relatively large deflection of the diaphragm with a correspondingly intensified signal strength, due to the mechanical construction of the armature and diaphragm on a lever arrangement.

When this receiver is used with a vacuum tube

detector or any other detector requiring a battery current in its operation, there is a slight pull on the diaphragm even when no signal is being received.

**Inductance.**—Inductance may be defined as the property of a circuit by virtue of which energy is stored up in electro-magnetic form. Physically speaking, inductance takes the form of a coil of wire in a radio circuit. Wherever an electric current flows, a field of force is set up surrounding the conductor carrying the current. The conductor, if formed into turns of wire in a coil form, is termed an inductance coil or simply inductance, for short. When a conductor is coiled, the fields of force about each turn interlink and strengthen each other. Therefore, if inductance is desired the conductor is coiled to get the concentrated effect of the field surrounding the conductor as a whole.

The following pieces of apparatus are used for their inductance effect in a radio circuit: variometer, variocoupler, loading coil, grid coils (for transmitters), receiving transformer or loose coupler, honeycomb coils, duolateral coils, multi-step inductors (load coils), and tuning coils.

**Capacity.**—Capacity may be defined as the property of a circuit by virtue of which energy

is stored up in electrostatic form. Because the term capacity most commonly used to designate this property in a circuit is rather misleading, it has been suggested that the word capacitance be used when referring to radio and electrical circuit properties. This is in order to differentiate between the term *capacity* when used to designate the physical holding capacity of a container such as a box or barrel.

Capacitance, in concentrated form in an electrical or radio circuit, is obtained by the use of a condenser. A condenser may be charged with electrostatic energy and discharged at any desired time after it has been so charged. It will retain a charge until a path has been provided for the charges accumulated on its plates to flow together or neutralize, so to speak. A condenser consists of two conducting surfaces separated electrically by an insulator known as the dielectric. The value of capacitance in a condenser depends upon the area of the conducting surfaces and the kind and thickness of the dielectric used. Capacitance is found in the radio circuit in the form of receiving and transmitting condensers. They are made up as fixed, variable and adjustable condensers. A variable receiving condenser is shown in Fig. 22 and a small fixed condenser is

shown in Fig. 23. This type of fixed condenser is used mostly to shunt the telephone receivers and causes the signals to come in stronger and clearer. Its capacity is approximately .0165 microfarads. It is called a by-pass condenser when used with any detector which employs a battery in its operation. The main difference between receiving and transmitting condensers is

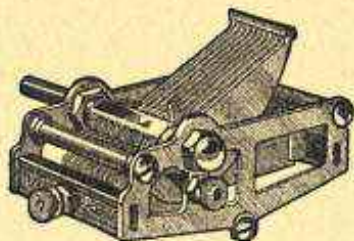

FIG. 22. Variable receiving condenser.

in the dielectric used. In transmitting circuits where the potential of the current flowing in the condenser circuit is high a dielectric such as mica or glass is used. On the other hand, where the potential value of the current is low, as in receiving circuits, the dielectric not being subjected to a strain may be air or a much thinner form of mica, or even paraffin paper.

**The Oscillating Circuit.**—Every radio oscillating circuit is made up of inductance and

capacitance. In other words, it has an inductance coil and a condenser. Either or both of these pieces of apparatus may be variable. The natural period or wavelength of a circuit depends entirely upon the value of the inductance and capacitance in the circuit. Changing either or both of these values changes the wavelength of the circuit. As was explained in the discussion on resonance the receiving circuit must be tuned to the transmitting circuit, or, in other words, the combined

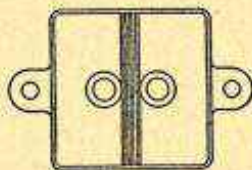

FIG. 23. Fixed condenser.

value of inductance and capacitance in both circuits must be the same. Adjusting the inductance and capacitance in this manner and for this purpose is called tuning.

The unit of inductance is the Henry and is the value of inductance through which a current changing at the rate of one ampere per second will produce a pressure of one volt. The Henry is too large for practical use and one-thousandth part of it, the milli-henry, is the practical working

unit. For very small values the micro-henry is used, which is equal to one one-millionth of a Henry. Inductance is also measured in centimeters, one milli-henry being equal to one million centimeters.

The unit of capacity is the Farad and is the value of a condenser's capacity when it takes one coulomb of electricity to raise it from zero potential to one volt. The Farad is too large for practical use and one millionth part of it, the microfarad, is the practical working unit.

**Receiving Condensers.**—The function of the condenser is to supply capacitance to the radio circuit where needed. A common form of variable condenser has already been shown in Fig. 22 and a fixed condenser in Fig. 23. The term variable condenser refers to a condenser the capacitance value of which may be readily adjusted by the operator. A fixed condenser is one the value of which is predetermined and fixed.

Practically, if a condenser is connected in series with a coil it decreases the wavelength range to which the circuit may be tuned. If we are speaking in terms of frequency rather than wavelength, we would say that by so connecting a condenser, the frequency range is moved up to a band of



higher frequencies. This is similar to moving up to a higher key in music.

For example, let us suppose that with a certain receiving set using an aerial 100 feet long, the wavelength range is from 200 to 700, which is over a band of 500 meters. Speaking in terms of frequency, the tuning range of this set is from 428 to 1200 kilocycles, a band of 772 kilocycles.

Let us assume that a variable condenser is connected in series with the aerial. This means that the lead-in wire from the aerial to the set is interrupted and the movable plates of the condenser connected to the end leading to the aerial and the stationary plates connected to the end leading to the set, or vice versa. The condenser is now in series with the aerial.

It will now be found that instead of responding to a wavelength range of from 200 to 700 meters, the range may be from 150 to 650 meters. This is equivalent to shortening the aerial by a certain number of feet. In terms of frequency, the set will now respond to frequencies from 461 to 2000 kilocycles instead of from 428 to 1200 kilocycles as before.

As explained above, the condenser was connected in series with the aerial and the inductance coil of the receiving set. This is about the only

place where a condenser is used as a *series condenser* in a receiving set.

If a condenser is placed in parallel to or across an inductance coil, the frequency of oscillation of the circuit is decreased or the wavelength increased. For example, if a given circuit responds to a minimum frequency of 461 kilocycles or a maximum wavelength of 650 meters, this situation may be changed by connecting a variable condenser in parallel to the inductance coil used in the circuit so that the frequency of oscillation will be decreased or the wavelength increased.

As a practical illustration, suppose your set would not respond to, let us say, WGY, Schenectady, broadcasting on a frequency of 790 kilocycles, which is a wavelength of 380 meters. Suppose further, that the set would respond to WFI, Philadelphia, frequency 740 kilocycles, wavelength 405 meters. Assuming that WGY is received well in your neighborhood, it is possible that your aerial is too long. Two things might be done, either shorten the aerial, or connect a variable condenser in series with it as explained before. It should then be possible for you to hear WGY.

If your set responded to WOR, frequency 710 kilocycles, wavelength 422 meters, but not to

WNYC, 570 kilocycles, 526 meters, the condenser might be placed in parallel across the inductance, or the aerial might be lengthened.

Condensers are also used to *balance* the feedback effect due to the capacity between the plate and the grid in the vacuum tube. The neutro-



FIG. 24. Gang condenser.

(Courtesy Ansco Products Co., Inc.)

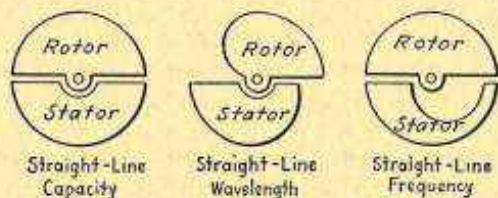

FIG. 24A. Straight-line condenser plates.

dyne circuit utilizes such condensers and they are sometimes called neutrodons when used in this circuit. Their position in the circuit will be seen later in the discussion of this circuit.

When it is necessary and desirable to allow radio frequency currents to pass in a circuit and not to allow low frequencies to pass, a condenser

known as a *by-pass condenser*, or simply as a by-pass, is used.

Its various uses and positions in the circuits will become apparent later.

In a circuit in which it is necessary to use more than one variable condenser the *multiple*, or two,

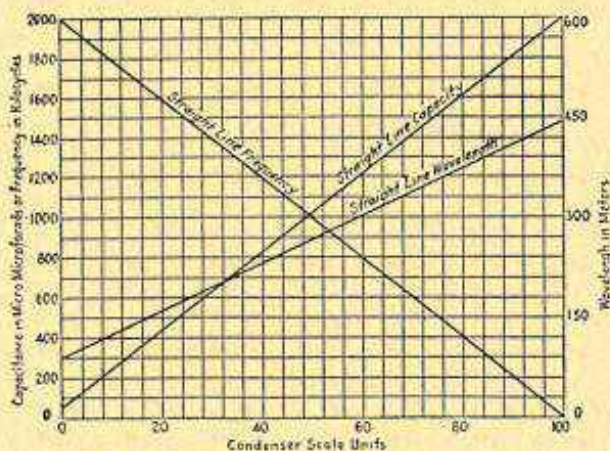

FIG. 25. Straight-line condenser curves.

or three gang condenser, is used. A condenser of this type is shown in Fig. 24.

To vary the capacity of a variable condenser, it is necessary to rotate the movable plates so that they move in and out of mesh with the stationary plates. A pointer or dial is attached to the movable plates, which indicates in a relative

way either directly or indirectly the capacity of the condenser as the plates are rotated. The capacity variation depends entirely on the shape of the plates and a variable condenser may be constructed so that its characteristic curve will be a straight line, as shown in Fig. 25. This may be true whether the curve shows the variations of capacity, wavelength or frequency, as shown in Fig. 25.

There is no particular advantage to having a straight-line capacity or a straight-line wavelength condenser under any ordinary conditions, but there is an advantage in having a straight-line frequency condenser. With a straight-line frequency condenser, it is possible to more easily tune in stations on various frequency assignments. The stations will be found also to be more evenly distributed over the entire condenser scale. The table below shows approximately the results obtained with the three types of condensers. The figures given are hypothetical.

	<i>Divisions on scale</i>	<i>Kilocycles covered</i>	<i>Stations covered</i>
Straight-line capacity	0 and 10	500	50
between . . . . .	55 " 100	100	10
Straight-line wavelength	0 and 10	200	20
between . . . . .	75 " 100	100	10
Straight-line frequency	0 and 10	100	10
between . . . . .	90 " 100	100	10

A small fixed condenser is sometimes used to stop the flow of direct low potential current into a part of a circuit. When it is so used, the condenser is called a stopping or blocking condenser.

***Function and Construction of Coils.—***

While, theoretically, the radio oscillating circuit

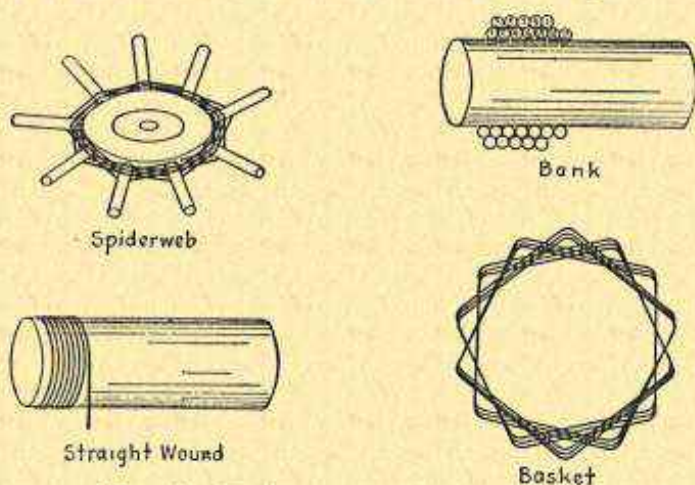

FIG. 26. Various types of coil windings.

is made up of inductance and capacitance, practically these properties of the circuit take the form of coils and condensers. As a matter of fact, radio sets, both transmitting and receiving, consist, in the main, of coils and condensers. Coils supply the inductance, and condensers the capacitance.

Coils for radio receivers are made up in various forms as shown in Fig. 26.

The simplest and perhaps the most widely used is the single-layer, straight-wound coil. This type is simple to manufacture, efficient, and durable. By leaving a slight air-space between the turns of this type of coil, that is, by space winding it, the general efficiency of the coil for radio purposes is increased, due to the reduction of the capacitance effect between turns.

The spiderweb coil, as its name implies, looks like a spiderweb. In its most efficient form it is wound in what is called the diamond weave. This type of coil is compact and electrically efficient. It is extensively used by manufacturers of the less expensive types of broadcast receivers.

The basket wound type of coil is another attempt to cut down the losses due to distributed capacity. Due to the characteristics of this coil, which make it necessary to use on it more wire for a given amount of inductance value than is necessary on a straight-wound, single-layer cylindrical coil, its use is not wide. From a radio efficiency standpoint, this coil is considered fairly good.

The bank-wound coil is used where space is restricted and where it is not feasible to wind

enough inductance as a single-layer coil. Its electrical efficiency is low and this type is, therefore, avoided wherever possible.

A *loading coil* is a coil used in series with the aerial to increase the wave band over which a given set may be tuned. It is mostly used on commercial ship-and-shore installations and not in connection with broadcasting or amateur receivers.

The *tickler coil* is a part of the regenerative receiver circuit and is used to feed back energy from the plate to the grid circuit. It probably got its name from the fact that it "tickles," so to speak, the circuit into oscillation. In some types of receivers the tickler coil's position is variable, but in other types, such as in amateur short-wave equipment, it is stationary.

**Low-loss Coils.**—The name low-loss has come to be a big selling point with many radio set manufacturers. This name was, perhaps, first coined by the American Radio Relay League laboratories at Hartford, Connecticut, and grew out of the attempt to build inductance coils and condensers for low wavelength use where it was of prime importance to eliminate high frequency current losses.

While all radio designers strive to make losses



low in the radio circuit, it was not until low waves came into general use that this feature of design was greatly stressed.

*Low-loss coils and condensers* are built with a minimum number of insulating supports. The electrical circuits are as far as possible physically self-supporting. An example is found in the well-known basket-weave coil, where supports for the wire turns are completely eliminated. A high grade of insulating material and careful circuit design will tend to cut down current leakage and make a set low-loss. Radio signals are so extremely weak when received by the receiving set that low-loss design is a big advantage to the otherwise well-built set.

**Crystal Detectors.**—A very simple and convenient form of detector is obtained by the contact of two dissimilar solid substances properly chosen. The number of substances which have been found suitable for use in such detectors is large. This type of detector is easily portable, but requires frequent adjustment and is less sensitive than the vacuum tube.

Among the combinations of solid substances which have been used as contact detectors may be mentioned silicon with steel, carbon with steel and tellurium with aluminum. The most impor-

tant contact detectors, however, are crystals, natural or artificial, in contact with a metallic point. Examples of such minerals are galena, iron pyrites, molybdenite, bornite, chalcopyrite, carborundum, silicon, zincite, and ceruscite. The first three are respectively lead sulphide, iron sulphide, and molybdenum sulphide. Bornite and chalcopyrite are combinations of the sulphides of copper and iron. Carborundum is silicon carbide, formed in the electric furnace. The fused metallic silicon commonly used is also an electric furnace product. Zincite is a natural red oxide of zinc.

Probably the three most widely used crystals are galena, silicon and iron pyrites. Sensitive specimens of iron pyrites are more difficult to find than sensitive galena, but they usually retain their sensitiveness for a longer time than galena.

These sensitive pyrites detectors are often sold under the trade name of "Ferron." The detector sold under the name of *Perikon* consists of a bornite point in contact with a mass of zincite.

Fig. 21 shows a typical crystal detector. This particular sample being of silicon with an antimony contact point. Another excellent crystal is ceruscite and is sold under that name.

In order to act as a detector for radio signals

a crystal contact should either allow more current to flow when a given voltage is applied in one direction than when it is applied in the opposite direction, or its conductivity should vary as different voltages in the same direction are applied. Practically all detectors formed by contact of two dissimilar substances possess both of these properties, at least to a slight extent.

To make use of the latter property, a battery is required in series with the crystal, as explained below. Some crystals, such as galena, silicon, ceruscite and iron pyrites, give about as good results as simple rectifiers as when the battery is used, and as a matter of fact, in common practice no battery is employed with them, thus making the apparatus more simplified and effecting economy.

In order to make use of the second property, a local or "booster" battery is inserted in series with the crystal. Generally a small battery of 2 to 4 volts, controlled by a potentiometer, is employed.

The positions of the various coils in the receiving circuit will be discussed further on in connection with the explanations of receivers.

#### ***Open and Closed Oscillating Circuits.***

—Every radio receiver has two distinct oscillat-

ing circuits, namely, the open and the closed oscillating circuits. Both of these circuits must be tuned to the incoming wave in order that it may be received and heard by the listener. The open oscillating circuit is the circuit to which the aerial and ground are connected. The closed oscillating circuit has connected with it the detector or radio frequency amplifying tubes. Both of these circuits also include inductance coils and condensers, as will be seen later on in the description of receiving circuits.

**Coupled Circuits.**—Circuits are said to be *coupled* when they are placed or connected so that there is a transfer of electrical energy between them. There are various types of coupled circuits, such as direct or magnetically coupled circuits, electromagnetic or inductively coupled circuits, electrostatic or capacity coupled circuits.

**Receiving Circuits.**—Having discussed the principal units composing a receiver, we shall now turn our attention to the various types of tuners and their circuits.

The fundamental principle of the reception of signals is that of resonance, which has been discussed fully in the portion of this work devoted to transmitters. If the receiving circuits are tuned to oscillate at the same natural frequency

as the incoming waves, these waves, though extremely feeble, will after a few impulses build up comparatively big oscillations in the circuits. In reality, then, for the reception of signals, all that is needed is an antenna circuit tuned to the same wavelength as that of the transmitting station, and an instrument capable of registering the current which flows in the antenna connecting wire.



FIG. 27. Simplest form of receiving apparatus.

In Fig 27 is shown the simplest connection for the reception of signals with a telephone receiver. It is suitable only for damp waves, and also will receive only waves from a transmitting station that correspond to its own, or nearly its own natural period. At D is shown the crystal rectifier, commonly called a "detector," although, really, it detects nothing and merely alters the waves, so that the telephones may receive them.

It must be remembered that the waves received are of radio frequency, which are inaudible to the human ear. The upper limit of audio frequency for the human hearing is about 15,000 sound waves per second, so that even if the telephone receiver diaphragm could, without the detector (rectifier), follow the radio frequency, the ear would not hear the signals; the detector rectifies the radio high frequency current, that is, allows but one alternation to pass through it, and lopping off, so to speak, the other alternation of the opposite direction, thus reducing the alternating to direct current and permitting audible signals to be heard in the telephones. Tuning to resonance is made possible if a tuning coil is introduced into the circuit, in series with the antenna, such as L in Fig. 28, to vary the inductance of the circuit and hence the wavelengths.

It is well to observe how simple is the apparatus actually needed for reception, contrary to what the uninitiated person supposes. Three pieces of apparatus, telephone receiver, crystal detector (rectifier), and tuning coil will effectively receive certain radio signals. The main disadvantage of the circuit shown above is not being able to tune out stations that one does not wish to hear. Also the amplitude of the oscilla-

tions is much diminished by the high resistance of the detector and telephones. The principal resistance is that of the crystal detector.

To avoid the difficulties attendant upon the presence of the detector in the antenna circuit, it is customary to place the detector in a separate circuit coupled to the antenna; or, in other words,



FIG. 28. Simplest form of tuned receiving apparatus.  
Single circuit receiver.

the detecting instruments are placed in shunt to the tuning coil. For instance, Fig. 29 is an improvement and requires no more apparatus than that previously described, except that the tuning coil has two adjustable connections instead of one. Oscillations now take place freely between antenna and ground. Two telephone receivers are shown, connected in series, one for each ear.

A further improvement, as regards selectivity,

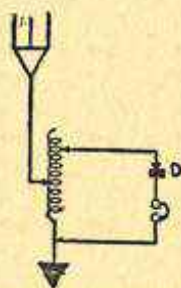

FIG. 29. Simple direct coupled receiving set without variable condenser. Two circuit receiver.

that is, elimination of undesirable signals, is shown in Fig. 30, where a variable condenser has been added,  $C_2$ . This is called the direct coupled connection. The antenna circuit is called the primary or open circuit and consists of the inductance and capacitance of that circuit. The secondary in  $L_2$  and  $C_2$ , known as the closed cir-

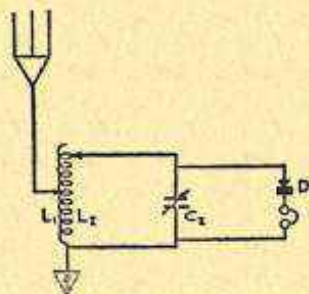

FIG. 30. Direct coupled receiving set with variable condenser. Two circuit receiver.



cuit. In the same manner in which the transmitting antenna circuit is a good radiator of power, so is the receiving antenna a good absorber. It is tuned to resonance with the incoming wave by adjustment of the inductance  $L_1$ . The power is given over magnetically to the secondary, which

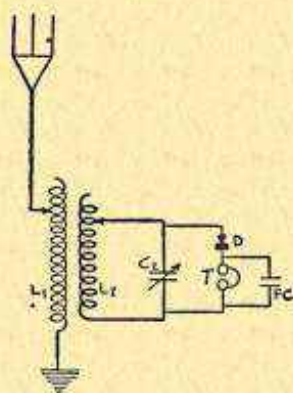

FIG. 31. Inductively coupled receiving circuit. Two-circuit receiver.

is tuned to resonance by adjustments to  $L_2$  and  $C_2$ . Comparatively large oscillations result in the secondary, producing voltages across the condensers which are detected by the crystal and telephone, and which are not in either oscillating circuit, but shunted across the condenser of the secondary. The oscillations are not damped thereby and sharp tuning is obtained.

***Inductively Coupled Tuners.***—Hitherto we have dealt with the simplest circuits possible for receiving damped or spark radio signals, circuits employing the least amount of apparatus and fewest adjustments.

In Fig. 31 is shown an inductively coupled receiving set, which may be said to be the standard set of modern practice, and the one upon which all later changes are based. A fixed condenser (F.C.) of about 0.0005 microfarads is shunted around the telephone and this increases the strength of the signals. Its action is explained as follows: Suppose the principal current flows downward through the detector (D) and telephone (T). While the current flows, the fixed condenser (F.C.) is charged with top plate positive. When the reversal of the radio oscillations comes, the current through detector and telephones ceases. Then the condenser discharges through the telephones and tends to maintain the current until the next oscillation flows through the instruments. In this way, the gaps between the successive pulsations of rectified current are filled in, and the cumulative effect of a wave group is strengthened. In practice the telephone cord, containing as it does two conductors separated by rubber, cotton and silk dielectric, forms

a condenser which in many cases is sufficient so that an added fixed condenser gives no improvement.

The connection in this set is similar in its action to the direct coupled arrangement above described. In either case, on account of the coupling between primary and secondary coils, there are reactions of each coil upon the other, with consequent double oscillations when the coils are near together. It is found, however, that if the resistance of the circuits is low, by varying the coupling, extremely sharp tuning is possible. The antenna is tuned to incoming waves, by changes of the inductance  $L_1$ . If very sharp tuning is desired, a variable condenser is shunted around  $L_1$ , and fine adjustments are made therewith. The secondary is tuned to the primary, the operations of tuning being done alternately until the telephone gives the best response. In the secondary the coarser tuning is done by changes of the inductance  $L_2$ , and the finer tuning with the variable condenser  $C_2$ .

For receiving a longer wave in the primary circuit than is possible by using all of the inductance  $L_2$ , a series inductance  $L_3$  called a loading coil is added. This is shown in Fig. 32. Also, a variable condenser may be connected as shown at

## 142 RADIO UP TO THE MINUTE

$C_3$  to increase the wavelength and afford fine tuning. The secondary may also be provided with an extra inductance in series with  $L_2$  if needed. For receiving short waves on a large antenna, series condenser  $C_4$  is inserted in the

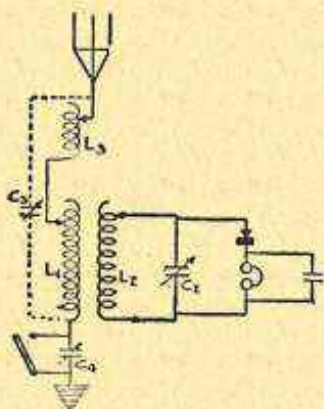

FIG. 32. Receiving circuit for both long and short waves, showing loading inductance and short-wave condenser. Variable condenser as in dotted lines to increase wavelength range of receiver.

ground wire. It is short circuited when not in use.

The receiving circuits explained thus far have utilized a crystal detector. Circuits employing the vacuum tube detector have been purposely left out of our discussion of radio reception be-

cause it is desirable that the theoretical functioning of the vacuum tube be explained before its operation in actual reception circuits be considered. The next chapter, therefore, will cover this subject in detail.

## CHAPTER VII

### VACUUM TUBES IN RADIO

THE introduction of vacuum tubes, also known as audions, radiotrons, vacuum tubes, vacuum valves and under numerous other technical and trade names, resulted in remarkably great advances in radio communication. Such tubes may be used for many purposes: to generate, to modulate radio oscillations, to detect or rectify, as well as to amplify radio signals, and they are now used in all types of modern equipment. The further development of the tube is rapidly progressing and new applications of its use develop so rapidly that one engaged in radio work must be an assiduous reader to keep in touch with these new developments. Therefore, it is of the utmost importance that the principles underlying the use of vacuum tubes and their operations under the widely different conditions met in actual radio practice be given careful study.

If two wires are connected to a battery, one to each terminal, the other ends may be brought

very close together in air, yet so long as they do not touch, no current flows between them. The two ends may be enclosed in a bulb like an ordinary incandescent lamp, and the air pumped out, leaving a vacuum, and still as long as the ends are separated, no current flows. A common experience will illustrate this. When the filament of an electric lamp breaks, the current stops and the light goes out. But if one of the two wire ends mentioned above is heated to a bright red, or hotter, it is an interesting fact that a current can be made to flow across the apparently empty space between them.

Call the two ends of wire the "electrodes" of the tube. The current between the hot and cold electrode is made possible by the electrons given off by the hot electrode and is a large enough current to be measured by a sensitive instrument and to have highly important uses in radio communication, as will be shown in the succeeding pages.

***The Two-Electrode Vacuum Tube.***—

The question will perhaps arise as to how a single electrode can be heated when it is inside of a glass bulb. That is simply done by shaping it into a loop and both ends brought through the base of the bulb, in exactly the same manner that

the filament of an incandescent lamp is used. These ends are connected to a battery of a few cells, generally giving a voltage of about six volts. The current from this battery heats the loop in a similar manner as the filament of the above-mentioned electric lamp. Thus the hot filament becomes one of the electrodes. For the other electrode a little plate of metal is used. A bulb containing a hot and a cold electrode as thus described forms a "two-electrode vacuum tube" and was originally designed by Professor J. A. Fleming.

The action of these tubes depends upon the fact that when a metal is heated in a vacuum it gives off electrons into surrounding space. A study of these electrons is important, the reason for this is that all matter contains them. Matter of all kinds is made up of atoms, which are extremely small portions of matter (a drop of water contains billions of them). These atoms in turn contain electrons, which consist of negative electricity. The electrons are all alike and are much smaller than the atoms. Besides containing electrons, each atom also contains a certain amount of positive electricity. Normally the positive and negative electricity are just about equal. However, some of the electrons are not held so



firmly to the atom but what they can escape if the atom is violently knocked or jarred. Therefore, when an electron, negatively charged, leaves an atom, there is then less negative electricity than positive in the atom; in this condition the atom is said to be positively charged. The atoms in matter are constantly in motion, and when they strike against one another, electrons are jarred from an atom. This electron then moves about freely between the atoms. Heat has an effect upon this process. The higher the temperature, the faster the atoms move and the more electrons given off. It is this action of electrons that is made use of in the vacuum tube.

As the electrons have a negative charge, the charge remaining on the metal is positive; therefore, few of the electrons go very far, but are attracted back to the metal, so that there is a kind of balance established between the outgoing and the returning electrons. Now, suppose a battery is connected between the two electrodes, that is, between the hot filament and the plate. This battery is so connected as to make the plate positive with respect to the filament. The electrons, being of negative electricity, would be attracted by the plate and retained, returning no more to the filament. Thus the battery causes a continuous

flow of negative electrons from the filament to the plate. In other words, a current of negative electricity is flowing in space between the two electrodes of the tube.

The current ceases when the filament is cold, because no electrons are then escaping from the metal. No current will flow if the battery is wrongly connected, since, when the plate is negative with respect to the filament, the negative charge of the plate will repel the electrons back into the filament.

The distinction between direction of current and direction of electron flow must be carefully noted. It happens that for a great many years the direction from the positive toward the negative terminal has been arbitrarily called the direction of the current. It is now found that these little electrons travel from the negative toward the positive electrode. The direction of current and the direction of the motion of the electrons are therefore opposite.

***Ionization.***—The foregoing explanation of the action of the flow of current between filament and plate, commonly called the “plate current,” in a vacuum tube applies to the case where the vacuum of the bulb is very complete. If there is more than the merest trace of gas remaining in

the tube, the operation is more complicated, and a larger current will usually flow with the same applied voltage. This is accounted for in the following manner:

In a rarefied gas, some of the electrons are constituent parts of atoms and some are free. These free electrons move about with great velocity, and if one of them strikes an atom it may dislodge another electron from the atom. Under the action of the electro-motive force (e.m.f.) between plate and filament, the newly freed electron will acquire velocity in one direction, which will be similar to that of the colliding electron and the positively charged remainder of the atom will move in the opposite direction. Thus both parts of the disrupted atom become carriers of electricity and contribute to the flow of current through the gas. This action of a colliding electron upon an atom is called "ionization by collision," and on account of it relatively large plate currents are obtained in vacuum tubes having a poor vacuum. The earlier tubes were of this sort, but modern tubes, as a rule, are made with a better vacua than formerly, so that ionization by collision is responsible for but a small part of the current flow.

In the earlier use of vacuum tubes it would

seem an advantage to have ionization by collision, because a larger plate current can be obtained, but there are two difficulties which have proved so great that tubes are now usually made to have only a pure electron flow. One of these difficulties is a rapid deterioration of the filament when a large plate current flows. The positively charged parts of the atoms are driven violently against the negatively charged filament and since they are much more massive than electrons, this bombardment, so to speak, actually seems to wear away the surface of the filament.

The tube described above was the first used in radio practice and after its inventor is called the "Fleming valve." The Fleming valve was originally used as a detector, but has been replaced by the three-element tube discussed below because the latter has proved so much more sensitive, and as previously described, can be utilized for a variety of purposes.

However, before proceeding to the modern vacuum tube, it is well to consider that types of two-electrode tubes are most useful in another field of electrical work. One type, known as the "kenotron," developed by the General Electric Company, has a higher vacuum than the Fleming valve and is made in larger dimensions. It is

used as a rectifier of currents of high voltage, but low frequency. It changes alternating current into a pulsating current all in one direction. Small currents, well below one ampere, are rectified by these tubes, and power up to several kilowatts can be handled even if the applied voltage exceeds 25,000.

Another type, known as a "Tungar rectifier," is utilized for charging storage batteries from a 110-volt alternating current circuit. This type contains rarefied argon gas and relatively large currents are produced mainly through ionization by collision, in the manner before described.

#### ***The Three-Electrode Vacuum Tube.***

—A great improvement upon a two-electrode tube for radio purposes, consists in the addition of a third electrode, or element, inside the tube in the form of a metallic gauze, or, as it is known, a "grid." This grid consists of an electrode of fine wires between the filament and the plate of the vacuum tube. This makes it possible to increase or decrease the current between plate and filament through wide limits. In order to understand how this result is obtained it will be necessary to first consider what happens in a two-electrode tube having a good vacuum, when

either the voltage of the "B" battery or the temperature of the filament is varied.

Suppose that the filament temperature is kept constant, then a definite number of electrons will be sent out per second. The number of electrons that travel across the tube and reach the plate per second determines the magnitude of the current through the plate circuit. The number of electrons that reach the plate increases as the voltage of the "B" battery increases. If this voltage is continuously increased, a value will be reached at which all the electrons sent out from the filament will arrive at the plate; therefore, we arrive at what is termed the "saturation" current, as no further increase of the electron flow can be obtained by increasing the voltage.

Suppose now that the voltage of the "B" battery is kept at a constant value, and the filament temperature gradually raised by increasing the current from the heating battery, known also as the "A" battery. The number of electrons sent out will continue to increase as the temperature rises. The electric field intensity, due to the presence of negative electrons in the space between the filament and plate, may at last equal and neutralize that due to the positive potential of the plate so that there is no force acting on the

electrons near the filament. This effect of the electrons in the space is called the "space charge effect." It must not be supposed that the space charge effect is caused by the same electrons all the time. Electrons near the plate are constantly entering it, but new electrons emitted by the filament are entering the space, so that the total number between filament and plate remains constant at a given temperature. After the temperature of the filament has reached the point where the effect of the electrons present in the space between filament and plate neutralizes the effect of the plate voltage, any further increase of the filament temperature is unable to cause an increase in the current. The tendency of the filament to emit more electrons per second because of the increased temperature is offset by the increase in space charge effect, which would result if electrons were emitted more rapidly; or, to put it more exactly, for any extra electrons emitted, an equal number of those in the space are repelled back into the filament.

Thus, whether the "A" battery is kept at a constant value and the "B" battery varied, or vice versa, in either case we find that the electron flow or plate current can only rise to a certain value.

In the three-electrode tube, by inserting a grid between the filament and the plate, as stated before, in the form of several small wires, the grid is placed in the path of the stream of electrons which constitute the plate current. When this grid is charged positively, the space charge will be neutralized, as it is of a negative character and thus a greater plate current will result. Also, if the grid be charged negatively, the space charge will be increased, and a greater number of electrons driven back to the filament, with a lessening of the plate current. Thus it will be seen that the value of the plate current can be controlled by means of the third element or grid in the vacuum tube. This control is accomplished in a variety of ways, depending upon the use for which a given set is designed; also, upon the characteristics of the particular vacuum tube used. Various tubes have a variance of characteristics.

Circuits that may be utilized in the employment of the vacuum tube, showing various methods of vacuum tube control, are to be found in the following pages.

***The Four-Electrode Screen-Grid Tube.***—This tube, the UX 222, has an outward appearance similar to the ordinary three-elec-



trode tube except that it has a metal cap at the top of the tube. This cap is the connection to the control grid which is equivalent to the grid of the three-electrode tube. The fourth electrode is an additional grid element which serves to almost eliminate the effective capacity between the plate and grid of the tube without the necessity of external neutralizing schemes.

The Fig. 33 shows the constructional position of the electrodes in both the three and four-electrode tubes and methods of connecting the tube in the circuit.

This tube is the greatest development in radio receiving equipment since the advent of broadcasting. Its possibilities for improving the reception of radio signals are multifold.

As an example of what this tube does; using the ordinary three-electrode tube as a radio frequency amplifier, we might under good conditions get a voltage amplification of about eight, while with this newer tube we might under the same conditions get an amplification of 25. This means that if we use two stages of radio frequency amplification, using the old tube we would get an amplification of 64. The new tube, using two stages of amplification, gives us 625 times the original incoming voltage strength. This is almost

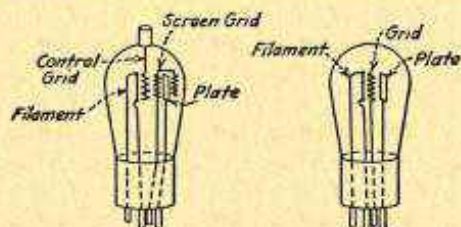

FIG. 33. Showing constructional position of elements in four and three electrode vacuum tubes.

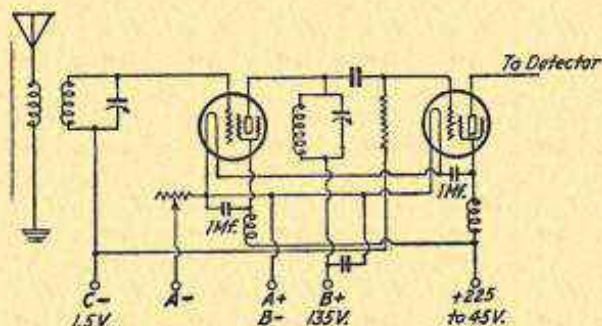

FIG. 33A. Screen-grid tube circuit.  
(Radio frequency amplifier.)

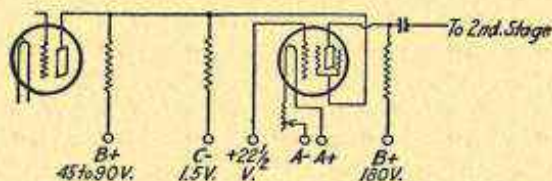

FIG. 33B. Space-charge-grid tube circuit.  
(Audio frequency amplifier.)

ten times as much! Truly, a remarkable achievement.

This should mean a great improvement in the reception of distant stations and better quality of reception for local stations.

This tube will be more commonly used in Amer-

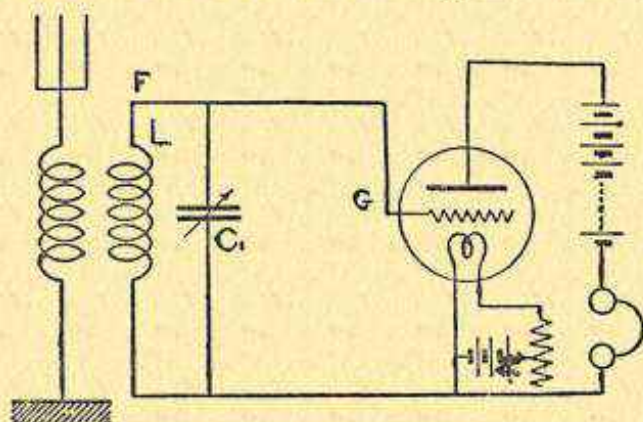

FIG. 34. Connections for using vacuum tube as a simple detector.

ica as a radio frequency amplifier screen-grid tube than as a space-charge audio frequency tube as the four-electrode tube is used in Europe.

This tube may also be used as a detector, but such usage is not apt to become common. As this tube is very sensitive to external influences, an external metal shield which fits over the tube like

a cover is provided sometimes to reduce noises.

The name "shielded grid tube" is used synonymously with the names "screen-grid" and "four-element tube."

***The Five-Electrode Vacuum Tube.***—A new five-electrode tube called the "Pentode" has made its appearance in England. This tube is designed along the lines of the screen-grid tube but is made to handle larger powers. It is expected that this tube will be even more efficient than the four-electrode tube. This tube will probably enable us to get satisfactory results with fewer tubes than are at present necessary.

***The A. C. Vacuum Tubes.***—By A. C. Vacuum Tubes are meant tubes that operate directly from the A. C. house lighting circuit, making direct current rectifiers, batteries and eliminators unnecessary. There are two types of A. C. tubes, namely, the raw A. C. tube (UX 226) and the heater type tube (UY 227). The raw A. C. tube has the same construction that the ordinary battery type tube has, with a four-prong base, two for the filament connections, one for the plate and one for the grid. The heater type tube, on the other hand, does not depend on a filament for its operation in the radio circuit. It has instead a "cathode" which is brought to a

high temperature by a "heater" element. When the cathode gets hot it throws off electrons in the same way that the filament of the common tube does. The raw A. C. tube (UX 226 type) is used in the audio frequency circuit, while the heater type tube makes a good detector and radio frequency amplifier. This latter tube has five prongs in its base, two for the heater, one each for the plate, grid and cathode.

***The Vacuum Tube as a Simple Detector.***—We shall first take a simple detector circuit and an explanation of its action. In order to understand how a vacuum tube acts when used as a detector, consider the circuit shown in Fig. 34. Suppose the receiving antenna picks up a signal. Oscillations in the tuned circuit LC are set up, because L is inductively coupled to the antenna circuit. The radio frequency alternating voltage between the terminals of L is impressed between the filament and grid, and brings about changes in the plate circuit. On the average the plate current is increased while the signal is passing. The frequency of the wave trains should be within the range of audible sound, preferably between 300 and 2000, because the telephone inductance smooths out each train of high frequency oscillations into a single pulse and the

pulse frequency must, therefore, be within the audible range in order that signals may be heard.

In some cases it may be necessary to use a "C" battery between points F and G in Fig. 34 in order to bring the plate current to a correct value. This, however, does not change the action; the variations of the plate current are brought about by the alternating e.m.f. between the terminals of coil L just the same as when the "C" battery is absent.

If the grid battery voltage is adjusted so that the plate current has a value near the upper bend of the plate current-grid voltage curve instead of the lower bend, the action will be essentially the same, but the effect of the arrival of a wave train will be to decrease momentarily the plate current instead of to increase it. As before, there will be fluctuations of the plate current keeping time with the arrival of train waves; and a sound in the telephone of a pitch corresponding to the number of wave trains per second.

Care must be taken in the use of receiving tubes that the "B" voltage is never high enough to cause the plate current to become so large that it is unaffected by variations of the grid voltage. Furthermore, the tube gets hot and its safety is endangered by too much plate current.

If the circuit shown in Fig. 35 is used, having a condenser in series with the grid, the action of the tube as a detector is different. When the grid voltage is the same as that of the filament and there are no oscillations, the grid current is

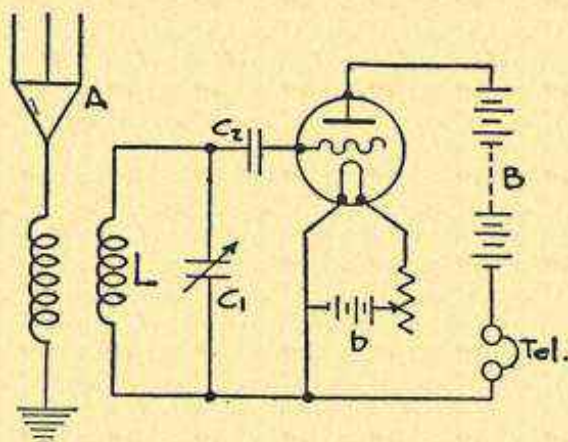

FIG. 35. Vacuum tube as detector of undamped waves.  
Condenser in grid circuit.

zero; that is, no electrons are passing from the filament to the grid. Now suppose that a series of wave trains, as shown in (1) of Fig. 36, falls upon the antenna of Fig. 35. If the circuit LC is tuned to the same wavelength as the antenna circuit, oscillations will be set up in it, and similar voltage oscillations will be communicated to the

grid by means of the stopping condenser  $C_2$ . (A suitable capacity value for this condenser would be 0.0001 mfd.). Each time the grid becomes positive, electrons will flow to it, but during the negative half of each oscillation no appreciable grid current will flow. This is shown in curve (2) of Fig. 36. Thus during each wave train the grid will continue gaining negative charge and its average potential will fall as shown in (3) of the same figure. This negative charge on the grid opposes the flow of electrons from filament to plate, causing, on the whole, a decrease in the plate current. At the end of each wave train this charge leaks off through either the condenser or the walls of the tube (or both) and the plate current rises again to its normal value as shown in (4) of the same figure. This should happen before the next wave train comes along, but sometimes the leak is not fast enough for the discharge to take place. In this case a better result is secured if a resistance of a megohm or so is shunted across the condenser. Such a resistance is called a grid leak.

The telephone diaphragm cannot vibrate at radio frequency, but the high inductance of its coils smooths out the plate current variations into some such form as shown in (5) in Fig. 36.



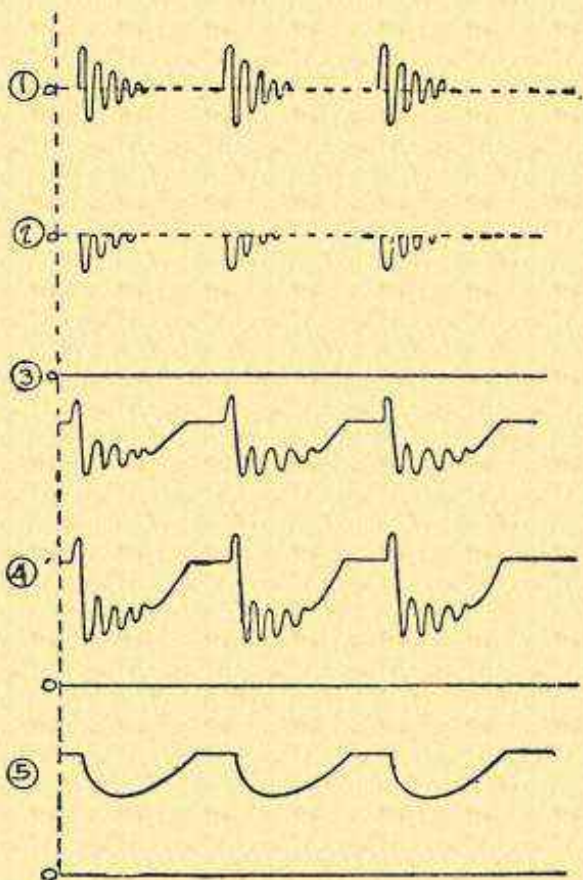

FIG. 36. Reception with grid condenser in circuit. (1) Incoming oscillations, (2) grid current, (3) grid potential, (4) plate current, (5) current in phones.

Thus, as in the case of the circuit in Fig. 35, the note heard in the telephone corresponds in pitch with the frequency of the wave trains. To receive undamped waves which are not divided up into groups of audible frequency, vacuum tubes

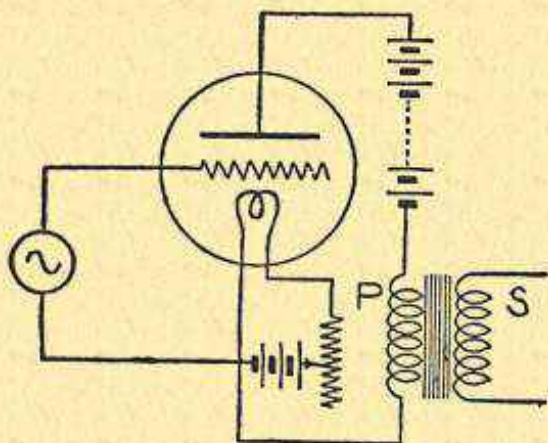

FIG. 37. Vacuum tube as an amplifier.

may be used in special ways called the heterodyne and audodyne methods, which are explained later in this chapter.

**The Vacuum Tube as an Audio Amplifier.**—If, as in Fig. 37, a source of alternating e.m.f. were interposed between the filament and grid of a vacuum tube, the potential of the

grid with respect to the filament would alternate in accordance with the alternations of the generator. These variations of the grid potential produce changes in the plate current corresponding to the plate characteristic. If the mean potential of the grid and the amplitude of its alter-

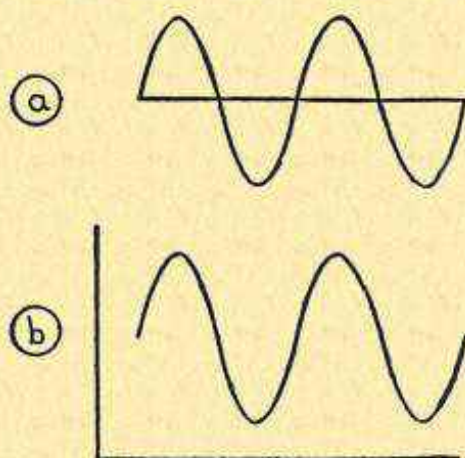

FIG. 38. Variations of plate current with grid voltage. nations are such that the plate current is always in that portion of its characteristic where it is a straight line, then the alternations of the grid potential will be exactly duplicated in the variations of the plate current and the latter will be in phase with the former, at least in a high vacuum tube. Thus, if (a) of Fig. 38 represents the al-

ternating potential of the grid, then (b) would represent the fluctuations of the plate current. For a given amplitude in (a) the amplitude of the alternating component in (b) will depend upon the steepness of the plate characteristic, increasing with increasing slope. The alternator in the grid lead supplies only the very small grid filament current, thus the power drawn from it is extremely small. The power represented by the alternating component of the plate current is, however, considerable; thus there is very large power amplification. This larger source of power might be utilized by inserting the primary, P, of a transformer in the plate circuit, as in Fig. 37, in which case the alternating component above would be present in the secondary, S. This illustrates the principle of a vacuum tube as a relay. The voltage in S might again be inserted in the grid lead of a second vacuum tube and with proper design a further amplification obtained in the second tube. This may be carried through further stages and illustrates the principle of multiple amplification.

**Regenerative Amplification.**—It has been shown by Mr. E. H. Armstrong, that amplification similar to that obtained with several stages may be secured with a single tube. In-

stead of feeding the voltage of the secondary coil S into the grid circuit of a second tube, it is fed back into the grid circuit of the same tube so as to increase the voltage operating upon the grid. This results in an increased amplitude of the

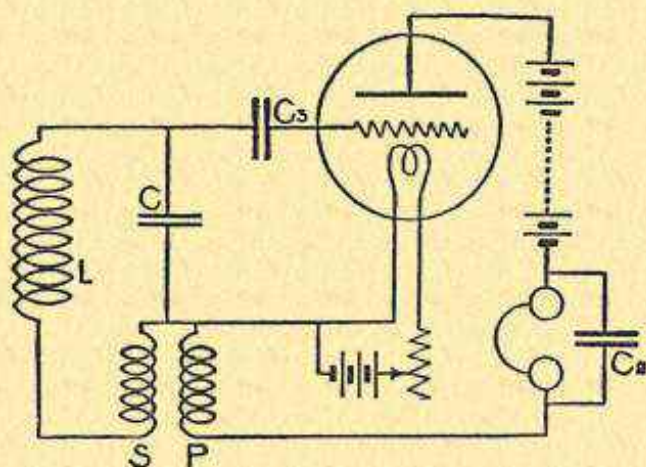

FIG. 39. Use of vacuum tube as a regenerative amplifier (feed-back circuit).

plate current alternations, which likewise being fed back into the grid circuit increases the voltage operating upon the grid, etc.

One form of the so-called feed-back circuit for rectifying and amplifying damped oscillations is shown in Fig. 39. The operation of the circuit,

used as a receiving device, is the same as that described above for the case of a condenser in the grid leak. The condenser  $C_2$  is merely to provide a path of low impedance across the phones for high frequency oscillations. The coils P and S constitute the feed-back by means of which the oscillations in the tuned circuit are reënforced. The mutual inductance between S and P must be of the proper sign, so that the e.m.f. feed-back aids the oscillations instead of opposing them.

***Heterodyne and Autodyne Reception.***—If two tuning forks, mounted on resonance boxes, one vibrating 256 and the other 260 times per second are sounding together, a listener a short distance away will hear a sound alternately swelling out and dying away four times per second. These tone variations are called "beats." Similarly if two sources of undamped electrical oscillations act simultaneously upon the same circuit, one of a frequency of 500,000 and the other of 501,000, the amplitude of the combined oscillation will successively rise to a maximum and fall to a minimum 1,000 times per second. If rectified by a vacuum tube (or a crystal) their variations will produce an audible note of frequency 1,000 per second in a suitable telephone

receiver. If one of the two oscillations is the received signal in the antenna and the other is generated by a circuit in the receiving station, we have "heterodyne" or "beat reception." In the receiving telephone a musical note is heard, the pitch of which is readily varied by slight variation of tuning of the local generating circuit.

If a regenerative circuit similar to that of Fig. 39 is used (L being coupled to the antenna), the same tube may be used as a detector and as a generator of local oscillations. This is called the "autodyne" reception. The procedure is to tune the antenna circuit to the incoming signals and adjust the local oscillating circuit so that it is slightly out of tune with these incoming signals. Thus beats of audible frequency are produced.

By these methods of reception very faint signals can be received. Also interference from other stations is reduced to a minimum, because a slight difference in frequency of the interfering signal would give a note of an entirely different pitch, or even an inaudible note. For instance, if the local oscillation had a frequency of 500,000 the received oscillation 501,000 and the interfering oscillation 502,000 the interfering note would have a frequency of 2,000, or be a whole octave higher in pitch than the received note. If the

interfering source had a frequency of 530,000, its beat tone would be so high as to be entirely inaudible.

***Oscillating and Non-Oscillating Circuits.***—The oscillating vacuum tube circuit is one in which the plate circuit is coupled to the grid circuit as in Fig. 39. In this method of connection three important actions take place: first, the grid controls the plate current; second, the plate reacts upon the grid circuit due to the fact that it is coupled to it; third the grid again affects the plate circuit in a more pronounced way, due to the added impetus of action two. These actions are called regeneration, and result in the original impulse, referred to as action one, being amplified many times its original value.

The non-oscillating vacuum tube is shown in Figs. 34 and 37. In both cases there is no coupling of the plate and grid circuits, and the tube acts merely as a valve, which automatically releases a large plate current every time an impulse is impressed on the grid. The grid in this case shuts on and off the plate current. In Fig. 35, therefore, no plate current flows until a signal is received by the aerial circuit and impressed on the grid.



**Filament Current Supply.**—The filament current (called "A" supply) is employed to heat the filament. The voltage of the supply depends upon the type of vacuum tube or tubes employed. It is important that the polarity of the supply be in such direction that it will not oppose the plate supply to which a connection is

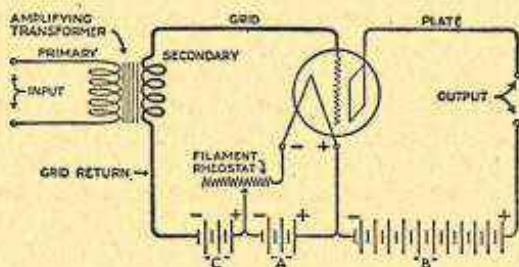

FIG. 40. Method of connecting A, B, and C batteries in circuit.

made from one side of the filament as shown in the diagrams. (See Fig. 40.)

The current flowing into the filament is controlled by a rheostat, or some sort of special variable resistance device.

The brilliancy of the filament which is in direct proportion to its heating is controlled by the rheostat or other control device referred to above. This in turn affects the stream of elec-

trons leaving the filament for the plate when the tube is in operation.

**Plate Supply.**—The plate supply (called “B” supply) is connected in the plate circuit with the positive terminal always connected to the plate of the vacuum tube. (See Fig. 40.) Compared with the filament supply, the plate supply gives a high voltage. This is required due to the operating characteristics of the vacuum tube. The plate supply voltage varies from  $22\frac{1}{2}$  to 425 volts depending upon the particular tube and use of the tube in the circuit. A detector tube usually requires  $22\frac{1}{2}$  volts, while a power amplifier may require as much as 425 volts.

In a battery set, because of the extremely small current consumed by the plate circuit, the “B” battery will last for a relatively long time, its actual life depending entirely upon the number of hours the set is in operation.

**“C” Bias.**—The “C” or “grid bias” is connected in the grid circuit, and acts to keep the grid at a negative potential in respect to the filament. (See Fig. 40.) When the tube is used as an amplifier it acts as a valve to release the high-powered plate battery current. Small changes in the grid potential with respect to the filament potential cause a large change in the plate current.

If distortion is to be prevented, it is important to have the plate follow exactly the variations of the grid potential, otherwise the signals received will be blurred. Distortion usually occurs when the grid is positive with respect to the filament. Therefore, it is desirable to make the grid permanently negative. For instance, suppose that the maximum grid signal strength is eight volts, then if a "C" bias potential of four volts is applied to the grid negatively, the grid potential cannot become positive, and distortion, because of this characteristic, will not take place.

The method of connecting the "A," "B," and "C" supplies in the circuit are shown in Fig. 40. Particular notice should be taken of the polarity connections. If any of these sources of current are connected in the wrong direction, the operation of the vacuum tube will be seriously interfered with.

The value of the "C" voltage depends upon the plate voltage used. The proper values are usually supplied by the tube maker with the tube when purchased.

***Developments in Vacuum Tubes.***—In the early days of radio broadcasting, multi-tube sets were undesirable due to the heavy current used by the vacuum tubes then in use. For ex-

ample, a common type of tube used at that time was the UV-201, which consumed one ampere of filament current. If six of these tubes were used in a receiver, the current drain would be six amperes. This is what 24 of our present UV-201-A tubes would consume, drawing  $\frac{1}{4}$  of an ampere each! In other words, six UV-201-A tubes draw only  $1\frac{1}{2}$  amperes from the A supply. Two of the old style tubes would draw more current than six of our new ones.

***The Thoriated Filament.***—A remarkable advance in tube economy came with the development of the thoriated filament. All of our modern receiving tubes employ this new filament.

The old type of filament was made of pure tungsten and had many disadvantages: short operating life, weak electrical robustness, noise in operation and non-uniformity of electronic emission. All of these disadvantages have been eliminated by the thoriated filament. The old pure tungsten filament was burned at a fair brilliancy, while the thoriated filament is lighted with a very faint glow, sometimes hard to see during the daytime.

The important features of the thoriated filament are: during the life of the filament the electronic emission is several times that of the old

type filament and only a fraction of the current necessary to light the old filament is necessary for the thoriated type. The table below shows how the UV-201, which has the old type filament, compares with the UV-201-A, which has the thoriated filament:

	<i>Filament Voltage</i>	<i>Filament Current</i>	<i>Plate Current</i>
UV-201 . . . . .	5	1 amp.	7.5 milamps
UV-201-A . . . . .	5	$\frac{1}{4}$ amp.	45 milamps

It is seen that the electronic emission is six times as great when the thoriated filament is used, and the current consumption is only one quarter as great.

Due to the low operating temperature of the thoriated filament internal tube noises are practically eliminated

The thoriated filament has a very long life due to its low operating temperature. As a matter of fact, the life of this filament is terminated by the loss of electronic emission rather than by the burning out of the filament.

The X-L or thoriated filament is a tungsten filament in which a small percentage of thorium is mixed early in the process of manufacture. When the filament is heated in a vacuum there is a change from the chemical compound to pure

thorium. By certain heating processes, the thorium atoms are brought to the filament surface one layer deep. This layer has a high radio activity and accounts for the great increase in electronic emission from this type of filament as compared with the old type.

**Noises in Tubes.**—Certain noises heard in the radio receiver are due to the tubes themselves and are not static, as a great many people believe. Internal tube noises may be due to loose elements inside the tube which cause a variation in the internal resistance of the tube producing a microphonic noise. This kind of noise may also be caused by vibration of the cabinet or table on which the set is placed.

Soft rattles and hisses may be caused by erratic electron emission from the filament. In a soft tube (one in which the degree of vacuum is not high and in which gas is present), a certain point will be reached where hissing starts. This point and above it is a poor operating point and operation should be carried on below this adjustment.

**Types of Vacuum Tubes.**—The *WD-11* and the *C-11* has a prong base and an adapter is required to make it fit in the standard base. The *WD-12* and the *C-12* is the same tube with a standard base. This type operates on a filament

voltage of 1.1 and dry cells are used. For filament current regulation a 6-ohm rheostat is necessary. The plate voltage may be  $22\frac{1}{2}$  volts when used as a detector and from 45 to 90 volts when used as an amplifier. The "C" battery may be 1.5 to 4.5 volts. The grid condenser may be .00025 microfarads shunted by a grid leak of 2 to 3 megohms. The plate current is from 1.1 to 2.6 milliamperes.

The outstanding advantage of this tube is that it may be operated on one dry cell. It was the first of the dry cell tubes and is very popular with thousands of broadcast listeners. It works best as a detector or audio frequency amplifier, but not so good as a radio frequency amplifier. It is classed as a hard tube.

*The UV-199 and the C-299* is designed for use as a detector and amplifier and operates on dry cells. The filament voltage is three volts and the current consumption is 0.06 amperes. A 30-ohm rheostat should be used as the filament current regulator. The plate voltage when the tube is used as a detector varies from  $22\frac{1}{2}$  to 45 volts. The best voltage may be found by trial. When the tube is used as an amplifier the plate voltage may be from 45 to 90 volts, best found by trial. The "C" battery may vary from  $\frac{1}{2}$  to 4.5 volts,

best found by trial. A grid condenser of .00025 microfarads shunted by a grid leak of from 2 to 6 megohms has been found to give satisfactory operation. The plate current varies from 1 to 2.5 milliamperes.

This tube, due to its small size, acts only as a fair detector and audio frequency amplifier, but for radio frequency amplification it is very efficient. It is classed as a hard tube, which means that the vacuum is very high and little gas has been left in the tube. It is especially popular for portable sets, and sets having several stages of radio frequency amplification. Size of tube, 3½ inches high and 1 inch in diameter.

*The Radiotron UX-120* is a dry battery power amplifier tube operating on 3 volts and is designed especially for use in the last stage of an audio frequency amplifier. It will give a large volume of undistorted signals to the loudspeaker.

The plate potential may be 90 to 135 volts; a lower plate voltage will reduce the volume in the loudspeaker. When this tube is used in the last stage of audio frequency amplification, large size "B" batteries will give most economical operation.

All high plate potential audio frequency amplifiers need a "C" battery. In this case, the grid return lead should go to the negative terminals



of a  $16\frac{1}{2}$  to  $22\frac{1}{2}$  volt "C" battery. The positive terminal of this battery is connected to the negative filament lead between the rheostat and the tube.

A special base (small "UX" base) is used with this tube. An adapter provides for its use in the regular UV-199 socket.

The Radiotron UX-120 is a power amplifier tube to be used usually as the last audio stage of sets employing UV-199 tubes.

*The UV-201-A and the C-301-A* may be used as a detector or an amplifier, and was designed to replace the UV-200 and C-300. It draws only one quarter the filament current of these latter tubes, and is, therefore, more economical to operate. The filament voltage is 5 volts, and the current consumption is  $\frac{1}{4}$  ampere. While this tube may be operated on dry cells, if the set is not used more than one or two hours daily, the storage battery as a source of filament current is desirable. It works best as an audio frequency amplifier, and only fairly well as a detector and radio frequency amplifier. In some cases, however, it has worked very well in these last two functions and is considered by some users to be good.

For filament current control a 16 to 30-ohm rheostat is necessary. When used as a detector

the plate voltage may be 45 volts, but when used as an amplifier from 45 to 135 volts should be provided. The "C" battery may be from  $\frac{1}{2}$  to 9 volts. The grid condenser and grid leak may be the same as for the UV-199 or C-299. It is a hard tube and gives good volume when used as an audio frequency amplifier. Although the filament requires only five volts, a six-volt "A" battery is usually used. Size of tube:  $4 \frac{3}{16}$  inches high and  $1\frac{3}{4}$  inches in diameter.

*The UX-200-A* is a special detector tube superior in sensitivity to the UX-200. Unlike the UX-200, the UX-200-A does not require critical filament or plate voltage adjustment. Because of its peculiar characteristics, a cushioned socket is desirable with this tube to reduce tube noises.

This tube is especially good for long distance reception when its increased sensitivity is equal approximately to an extra stage of radio frequency amplification.

Due to its extreme sensitivity, this tube permits the use of a shorter and lower antenna without loss of volume.

When first lighted, this tube may give off a whistling or hissing sound, which disappears after the tube has been lighted for a short time.

The filament of this tube requires 5 volts and

this tube may, therefore, be operated on a 6-volt supply. The tube draws  $\frac{1}{4}$  ampere. The plate requires 45 volts and the "C" bias should be 1 volt.

The term "high mu" means that the tube has a high amplification factor, that is, it will give more amplification (louder volume) with a given plate voltage than a tube having a "low mu" or low amplification factor.

The *UX-112-A* tube is designed to be used on storage battery sets as the last audio stage amplifying tube. Due to its heavier current carrying capacity, a greater volume with less distortion than when using the *UV-201-A* type of tube is to be had.

As an audio frequency amplifier, the *UX-112-A* tube occupies a position half way between the *UX-120*, which is a dry cell tube, and the power amplifier tube *UX-210*.

Care should be taken not to operate this tube above a dull red heat, as excessive filament current shortens the life of the tube.

The filament supply, current drain, and filament voltage is similar to the *UX-200-A* described before. When used as a detector, the plate voltage should be 45; when used as an amplifier this voltage may be increased to from 90 to 180. The "C" voltage likewise may be from 4.5 to 13.5.

**Power Amplifier Tube.**—When very loud reception is desired, as in large assembly halls, stores, and other places of a similar character, a power amplifier tube may be employed. One such tube is known as the UX-171 Power Amplifier Tube and is especially designed to handle great volume without distortion. In spite of its remark-

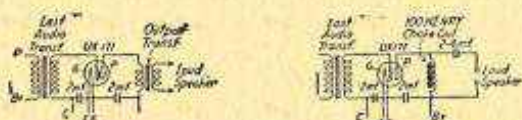

FIG. 40A. Loudspeaker coupling devices in circuit.

able amplification power it consumes only a half ampere of filament current. This tube may be operated on a plate voltage of 90, 135, or 180. When more than 90 volts are used, some form of loudspeaker coupling device must be employed, such as an output transformer or a choke coil and by-pass condenser to prevent the full plate voltage from passing through the loudspeaker and burning it out. This is diagrammatically shown in Fig. 40 A.

The "C" voltage required for this tube varies from 16.5 to 40.5, depending upon the plate supply voltage used.

The UX-210 Radiotron handles a relatively

heavy power. It is designed primarily for use as a power amplifier with loudspeaker where great volume without distortion is required. It may also be used in any ordinary amplifier circuit where long life is necessary, or where the plate voltage is high.

As the plate voltage of this tube may be as high as 425 volts, great care must be taken to avoid shock when handling exposed circuits. However, if the high voltage circuit wires are not exposed there is no more danger in handling this than any other Radiotron. All current should be turned off at the source before any adjustments are made in the circuit. The user is cautioned not to use excessive filament or plate voltage with this tube. The plate temperature should never exceed a dull red heat.

A large standard (UX) base is used with this tube.

Because this tube has a rated output as an oscillator of 7.5 watts, it should prove popular in amateur transmitting sets. With plate voltage under 160, the filament may be operated direct from a 6-volt storage battery without a rheostat. The "C" voltage varies from 12 to 35 volts, depending upon the plate voltage used and as given

in the table of characteristics, it varies with the plate voltages.

*The UX-222* is the four-electrode vacuum tube also known as the screen-grid or shielded-grid tube. This tube may be used as a radio or audio frequency amplifier. When used for audio amplification, resistance coupling is used. This tube is similar in appearance to the common three-electrode tube except that it is fitted with a metal cap. It is to this cap that the regular or operating grid of the tube is connected. The tube is fitted with a large standard UX base which has four prongs, two for the filament, one for the plate and one for the extra or screen-grid.

The filament supply should be  $4\frac{1}{2}$  volts and may be supplied from either dry cells, storage battery or eliminator. The actual filament voltage drawn is 3.3 and the current is .132 amperes.

When used as a radio frequency amplifier, the plate voltage should be 135, the "C" voltage of the inner or control grid should be  $1\frac{1}{2}$ , and the outer or screen-grid should be 45 volts. The plate current will then be approximately  $1\frac{1}{2}$  milliamperes.

When used as an audio frequency amplifier, the plate voltage should be 180 volts applied through a plate coupling resistance of 25,000

ohms. The "C" voltage in this case may be  $22\frac{1}{2}$  on the control grid and  $1\frac{1}{2}$  volts on the outer or screen-grid.

*The UX-226* is a raw A. C. tube which operates on  $1\frac{1}{2}$  volts taken directly from the house lighting circuit through a step-down transformer. The filament current is 1.05 amperes. This tube is not suitable as a detector because of the hum, and is best used as an audio frequency amplifier. When so used, its plate voltage may be from 90 to 180 and the "C" voltage from 6 to  $16\frac{1}{2}$  volts. The filament circuit must be designed with either a center tapped transformer or with a potentiometer arrangement for the grid return for prevention of hum from the supply current.

*The UY-227* is a heater type tube made to operate directly on the A. C. line. It may be used as a radio frequency amplifier or detector. The filament voltage is 2.5 and the current drain is 1.75 amperes. When used as a detector, its plate voltage should be 45, but when used as a radio frequency amplifier its plate must be supplied with from 90 to 180 volts with a "C" voltage of from 6 to 13.5 volts.

*The UX-250* is a power amplifier tube designed to give a very loud signal volume. It is suited especially for large assembly halls, auditoriums,

theaters, and other places of a similar character. This tube should be used in the last audio stage of the amplifier and it works best if preceded by two stages of double impedance amplification employing UX-112 tubes.

The filament, which is of the coated ribbon type, operates at 7.5 volts and draws 1.25 amperes. It should be operated at a dull red heat. This tube is a "low mu" tube, its amplification factor being only 3.8.

A low resistance output choke with a condenser or a transformer must be provided to handle the heavy plate current delivered by this tube to protect the loudspeaker windings. The connections for this device are shown in Fig. 40a in which diagram the UX-171 tube is used, but the UX-250 may be used the same way.

The plate voltage of this tube varies from 250 to 450 with a "C" bias of from 45 to 84 volts.

*The UX-852* is an improved type of vacuum tube designed for use in transmitting circuits on short waves. It has a normal power output of 75 watts and is especially adapted for amateur transmitting stations. It is sold by the Radio Corporation of America.

The plate leads enter on the side of the tube, the grid leads from the top, and the filament con-



nections are made through the standard UX base suitable for either the push type or the Navy type socket. This special construction of the plate and grid leads has been employed to reduce the inter-element capacity; resulting in a tube which has a very low internal capacity. The operating characteristics make the tube very efficient in low or short wave work.

The normal plate voltage for this tube is 2,000 volts, but this may be increased to 3,000 volts, provided the plate dissipation does not exceed 100 watts. A large dissipation of energy is affected by radiating fins on the plate.

The filament voltage of this tube is 10 volts and the filament current is 3.25 amperes. The plate current is 75 milliamperes.

*The UX-240* detector and "high mu" amplifier tube is designed for use as a detector or in resistance or impedance coupled audio amplification circuits. Its filament voltage and current are similar to the UX-200-A described above. The plate supply should be 90 volts when it is used as a detector and from 90 to 180 volts when it is used as an amplifier. The negative "C" voltage may be from 1.5 to 4.5 volts.

*The Radiotrons UX-216-B and UX-213* are half and full-wave rectifiers, respectively. They are

used to supply D. C. power from an A. C. source. Two model UX-216-B tubes connected in parallel will function as a full-wave rectifier.

On the model UX-216-B only three of the prong contacts are used, one being left disconnected. This tube has only two elements, a filament and a plate. The model UX-213 has a filament and two separate plates and, therefore, uses all four of the prong terminals in the base. The operating characteristics of these tubes are given in the table.

The characteristics of various types of auxiliary tubes are given on the next page.

Tube	Use	Filament Supply Volts	Filament Terminal Volts	Filament Current Amperes	Max. A.C. Voltage Plate to Filament	Max. D.C. Load Current (milli-amperes)
UX-213	Full-wave rectifier	A.C.	5.0	2.0	220 per anode	65
UX-280	Full-wave rectifier	A.C.	5.0	2.0	300 per anode	125
UX-216-B	Half-wave rectifier	A.C.	7.5	1.25	550	65
UX-281	Half-wave rectifier	A.C.	7.5	1.25	700	85
UX-874	Voltage regulator	Rated voltage 90 Volts D.C.		Starting volts 125 Volts D.C.	Maximum D.C. current 50 milliamperes	
UX-876	Ballast tube	Current 1.7 amps.		Voltage range 40 to 60 volts	Standard Mogul Type Screw Base	
UV-880	Similar in every respect to the UX-876, except that its filament current is 2.05 amperes.					

## CHAPTER VIII

### RECEIVING APPARATUS

IN previous chapters we have studied the fundamentals of the receiving circuits and the operation and theory of vacuum tubes. We are ready now, therefore, to consider some of the receiving sets met with in common usage. All receiving sets, whether they be factory made or home made, are simply certain well-known circuits made up for practical use. To understand the receiving set, therefore, it is necessary to know the various circuits employed, their names, construction and general operating characteristics.

Most radio broadcast receivers in use to-day consist of parts as schematically illustrated in Fig. 41. Some of these parts have already been explained; for example, the first section, the tuning unit consisting of an inductance coil and condenser. The operation of such a tuning unit used with a crystal detector was explained in Chapter VI. Its operation when used in conjunction with a vacuum tube detector and amplifiers does not

change. Its purpose always is to tune the receiving set to the frequency or wavelength of the transmitting station.

The operation of the vacuum tube as a detector in conjunction with a tuning unit was described in Chapter VII. Likewise, the fundamental ideas underlying the operation of the vacuum tube as an audio frequency amplifier were discussed in the same chapter.

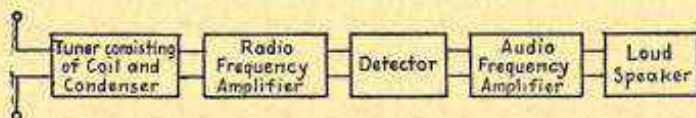

FIG. 41. Sections comprising a broadcast receiver.

**Radio Frequency Amplifiers.**—The vacuum tube may also be used as a radio frequency amplifier, and when it is so used it amplifies the radio frequency oscillations received by the aerial and passes on a stronger current to the detector.

As was explained before, the detector is like a valve which controls the audio frequency currents in the loudspeaker. If the detector is just slightly energized by the incoming wave, it is like opening the valve very slightly, only a small audio current is released by the detector. The volume of the received signal or sound depends entirely

upon the amount of audio frequency current released by the detector. If the wave is weak when it reaches the detector, the volume in the loudspeaker will be weak. On the other hand, if the energy reaching the detector is strong, the volume in the loudspeaker will be strong, provided, of course, that there are enough stages of audio frequency amplification. It is the purpose of the radio frequency amplifier to amplify the radio waves before they reach the detector and thus cause the detector to be operated by a relatively strong current, and causing it, therefore, to pass along a heavier current to the audio frequency amplifiers and loudspeaker.

The radio frequency amplifier tubes, coils and condensers are always connected in the circuit ahead of the detector, so that the incoming waves must pass through them first. The radio frequency transformers are unlike the audio frequency transformer in that the former are usually air-core transformers and not iron-core transformers like the latter.

**Audio Frequency Amplifiers.**—The function of the audio frequency amplifier is to amplify the audio frequency currents flowing in the plate circuit of the detector to the volume desired by the listener. The volume of amplifica-

tion now available is almost unlimited, sound being so amplified that it can be heard for miles.

In this chapter, however, we are interested only in the audio amplification systems commonly used on radio broadcast receivers.

An audio amplifier consists of one, two, or more vacuum tubes so connected in the circuit that the signal to be amplified is impressed upon the grid of the first tube, causing variations of the larger current in its plate circuit. This plate current of the first tube is then impressed on the grid of the second tube which causes a like effect on its plate current. The signal may then be made audible through the telephone receivers or loud-speaker. An amplifier repeats the signal from tube to tube, making it stronger each time until the last tube is reached when the signal is made audible. There may be many stages of amplification; audio frequency amplification, however, is usually limited to four stages, because after that amount of amplification the signal becomes distorted.

In order to pass on the energy from the first stage of amplification to the second, to the third and so on, the plate circuit of the first stage is coupled to the grid circuit of the second stage and the second to the third until the last tube is

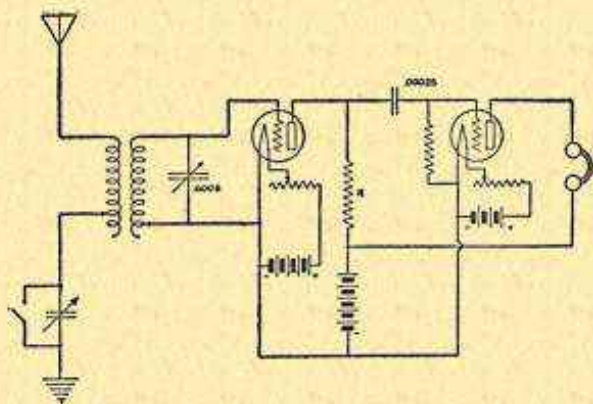

FIG. 42. Resistance coupled radio frequency amplifier circuit.

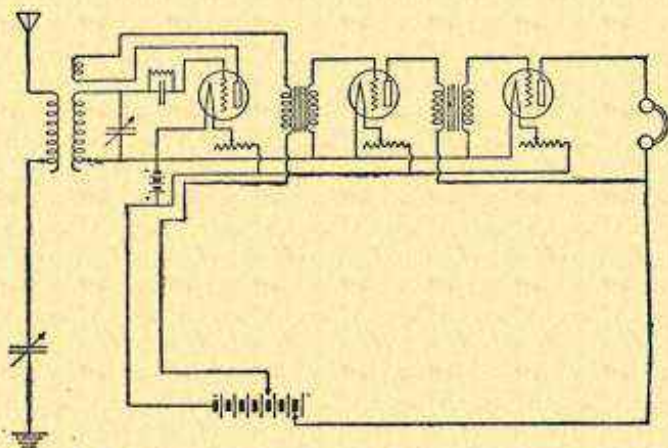

FIG. 43. Transformer method of amplifier coupling.



reached. The coupling between the stages is the heart of the amplifier system. There are various methods of coupling the successive stages and these may be classified as follows: resistance coupling, choke-coil coupling, and transformer coupling. These methods are shown by Figs. 42 and 43.

Resistance coupling is especially recommended when amplification without distortion is necessary. In Fig. 42 the coupling of the first tube plate circuit to the second tube takes place through the resistance  $R$ , which may be approximately from 10,000 to 100,000 ohms. A resistance-coupled amplifier, while it gives practically constant amplification over a wide range of frequencies, does not give as much amplitude of signals or volume as the transformer coupled amplifier, and, therefore, an extra step of amplification, one additional stage, is usually provided. This means that a three-tube amplifier resistance coupled will not give much louder signals than a two stage amplifier, but the quality of the received signal will vary very little with frequency. It is now possible to purchase resistance units built especially for amplifiers.

For very long wavelengths, in the order of several thousand meters, the inductance method of

coupling is preferable to the resistance coupling due to the fact that equal results can be obtained with a lower plate battery voltage. The circuit is the same as the resistance-coupled circuit, the only difference being that instead of a resistance  $R$ , an inductance or choke-coil is substituted. For short wavelengths of the higher frequencies, however, the choke-coil method is less desirable than the resistance or transformer methods of coupling. A choke-coil built for coupling purposes may have a value of from 50 to 75 Henrys inductance.

The transformer method of coupling the successive stages of both radio and audio frequency transformers is the most practical way of repeating the energy from tube to tube for wavelengths used by broadcasting stations. The transformers in addition to coupling the successive stages serve to step up the voltage, and thus increase the amplification results. Fig 43 shows how transformers are connected in the circuit. The transformer primary is connected in the plate circuit of the first tube, and the secondary is connected to the grid and filament of the next stage, and so on until the last tube is reached. It is a good rule to make all connections as short as possible.

Just what methods of amplification to use on a

given set must be determined by the builder. If the set is to receive from great distances, it is preferable to first increase the strength of the received signals by one or more stages of radio frequency, after which the amplified signal may be detected and again amplified by audio frequency.

The radio frequency amplifier does not amplify atmospheric disturbances, static, as much as the audio frequency amplifier, but has the disadvantage of being very difficult to construct and adjust.

On the other hand, the audio frequency amplifier amplifies equally well both the static and the radio signal being received.

**Operation of Amplifiers.**—Assuming that the amplifier has been properly constructed, the operation of the amplifier depends upon proper "A," "B," and "C" voltage, and voltage adjustment, and on the proper tuning-in of the received signal. One of the greatest difficulties with amplifiers is commonly referred to as squealing. This whistling noise is in fact the oscillation of the vacuum tubes in the amplifier circuit, or in the circuit from which current is sent into the amplifier. Because an amplifier does not squeal is no sign that it is properly designed; as a mat-

ter of fact, it may be that the over-all amplification of such an amplifier is lower than it should be.

Certain precautions may be taken in the design of the amplifier which will eliminate squealing to some extent, but in some cases the amplifier will squeal in spite of such precautions. To prevent or cut down squealing see that the output and input circuits are not coupled in any way. All wires and connections must be kept as far apart and as short and straight as possible. The transformers may be mounted at right angles to one another. Each radio frequency stage may be shielded. This shield may be connected to the ground. This prevents any induction effects between tubes. (See Shielding.)

In some cases noises in an amplifier are due to the tubes themselves, and the only way to test for this sort of trouble is to try different tubes. Low "B" voltage will cause noises in the amplifier. If batteries are used they should be carefully checked up with a voltmeter from time to time.

Mechanical movements of the apparatus or looseness of construction may cause noises in the amplifier. All parts should be securely fastened. Great care should be taken in the way the tubes

are supported, as they are the most common cause of noises due to vibration. It is easily understood that if the tube vibrates, and the elements in the tube are in any way insecure, the distance between the grid and the filament and the plate will vary and change the resistance of the tube, thereby causing noises.

**Shielding.**—In order to prevent a feed-back of energy between the various stages of radio frequency amplification in some well-designed modern broadcast receivers, it is the practice to surround each amplification unit with a metal covering of thin copper, brass or aluminum. All shielding is connected together and grounded. By so shielding each radio frequency amplification unit, much squealing and loss of signal strength are avoided.

**Kinds of Circuits.**—By far the most important receiving circuit in use to-day is the tuned radio frequency circuit. The neutrodyne circuit is but an adaptation of the radio frequency circuit, as will become apparent later on. Another circuit that gives excellent results is a combination of the radio frequency circuit with the regenerative circuit. One of the most efficient circuits is the superheterodyne. Circuits such as the reflex and duplex and those bearing many

other especially coined names have more or less passed out of the picture. Most of the sets found to-day utilize either the radio frequency or regenerative circuits or a combination of both in their construction. Emphasis in this book will, therefore, only be laid on these circuits.

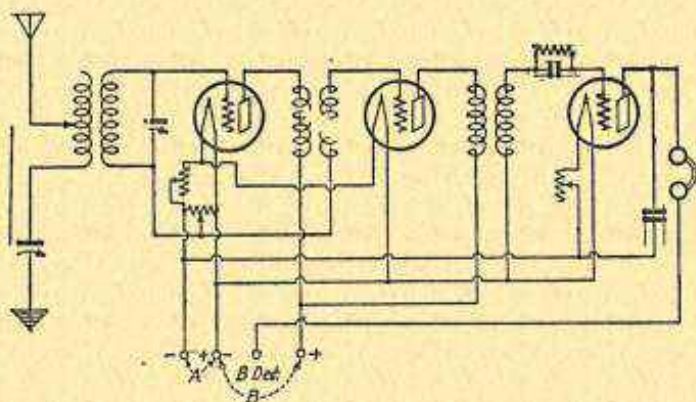

FIG. 44. Radio frequency circuit with grid potentiometer for regeneration control.

**Radio Frequency Circuit.**—In this circuit, the radio frequency amplifying tubes amplify the incoming waves and pass them on in an increased amplitude to the detector tube. This is seen by referring to Fig. 44, which is a typical tuned radio frequency amplification circuit.

The difference between the tuned and the

untuned radio frequency circuit is that the frequency values or wavelengths of the radio frequency (R.F.) transformers in the former are variable over a limited waveband, while in the latter, the untuned, this value is fixed. It is possible, therefore, to get better results with the tuned radio frequency circuit than with the untuned circuit. This is especially true when a various number of stations may be received. In Fig. 44 the sources of "A" and "B" current are omitted, as the radio circuit is the same

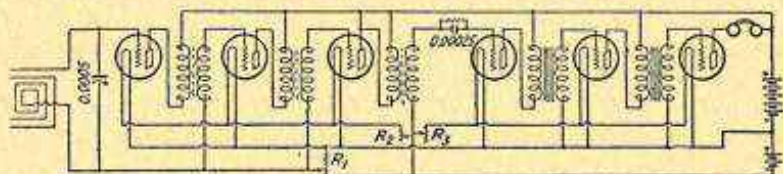

FIG. 45. Radio frequency receiver with loop.

whether the set be operated by batteries or direct from the lighting circuit through power reduction devices. The untuned radio frequency circuit is similar to the tuned radio frequency circuit except that the variable condenser (V.C.) across the secondaries of the radio frequency transformers are omitted.

**Loop R. F. Receiver.**—If desired, the radio frequency circuit can be made to operate on

a loop. The system of connection is then shown in Fig. 45. More stages of radio frequency amplification are necessary when using a loop instead of an aerial. For example, if a certain broadcasting station can be received with sufficient volume when using two stages of radio frequency amplification and an outdoor aerial, then from three to four stages would be necessary to get a similar volume using a loop. Generally speaking, volume is decreased about one-third when using a loop rather than an outdoor aerial.

The advantage of the loop set is that it has

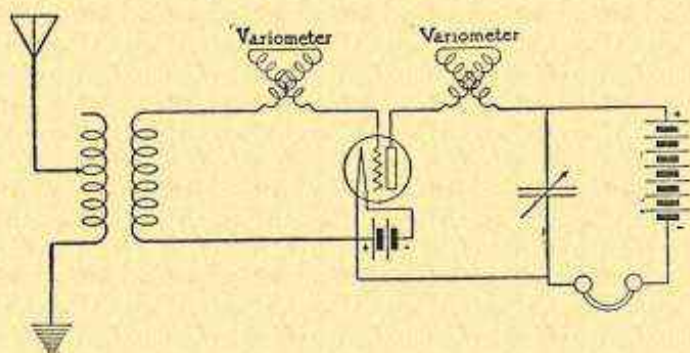

FIG. 46. Regenerative circuit with tuned plate and grid circuits.

directional characteristics governed by the position of the loop with respect to the transmitting



station. Strongest signals will be received when the plane of the loop lies in the direction from which the signals are coming. This type of circuit is, therefore, very selective, as the loop is also an aid to tuning the set. The loop set may also be made up in portable form and easily operated anywhere.

**Simple Regenerative Circuit.**—In the regenerative circuit shown in Fig. 46, the plate circuit is tuned to the grid circuit by a variometer connected as shown. The action is as follows: Oscillations in the grid circuit produce corresponding oscillations in the plate circuit which is tuned to it. This plate current in turn affects the grid circuit, both circuits being in tune with one another, and causes an increased impression of energy on the grid circuit; in other words, it regenerates the original grid current. This produces a larger current in the grid circuit and still greater variations in the plate circuit, the result being a reënforcement of the currents in the circuit as a whole. Much louder signals in the headphones are heard because of this regenerative action. The principle to remember is that the circuit regenerates because the grid and plate circuits can be tuned alike. The tuning may be accomplished by connecting in the grid and plate

circuits variable inductances in the form of variometers as shown in the diagram.

The disadvantage of this type of circuit is that it may act as a radiator of feeble waves; in other words, it may oscillate and become a low power transmitter. When this takes place interference

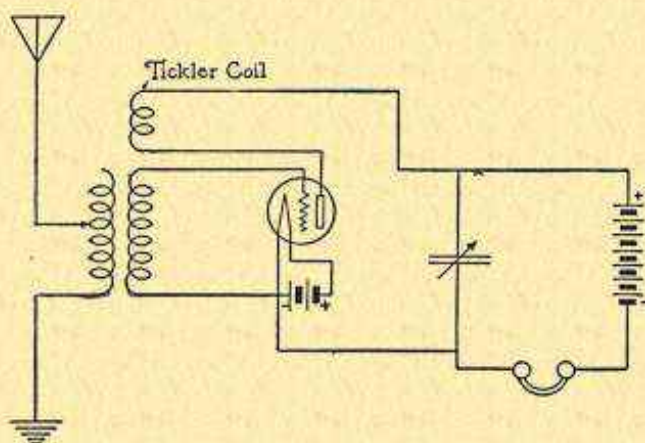

FIG. 47. Regenerative circuit with tickler coil.

in the form of squealing is caused in nearby receivers. In congested districts where many sets of this type are in operation, it is sometimes impossible to enjoy a complete broadcast program due to this re-radiation and the resultant squeals. It is estimated that in some instances a regenera-

tive receiver so adjusted as to make it oscillate may transmit feeble oscillations for several miles and any receiving set within its radius will be interfered with.

The regenerative receiver operates on the feedback principle; that is, the energy in the plate circuit is fed back to the grid and re-amplified, so to speak. The coupling of the plate to the grid circuit is usually accomplished by a tickler coil arrangement as shown in Fig. 47.

When the tickler coil is set at minimum coupling, little regeneration takes place, but as the coupling is made closer, the regeneration increases and a point will be reached where hissing can be heard in the telephones. As the hissing increases distortion of signals takes place, and as the coils are brought closer together, a point will be reached where a "blub-blub" sound will be heard in the telephones. The hissing and "blub-blub" points are the adjustments where the circuit starts oscillating and if this adjustment is allowed to stand, a great deal of howling and squealing will be caused in nearby receivers, as explained above. As soon as the hissing noise is heard, the tickler should be turned back so that instead of increasing in intensity, the hissing sound is decreased. The point of adjustment just

below the hissing sound is the best point of operation on a regenerative set.

If when the coupling of the tickler coil is decreased the set does not regenerate, the connections of the tickler coil should be reversed. This is necessary because the flow of current through the tickler coil should be in the same direction as through the secondary coil of the receiving transformer to which it is coupled.

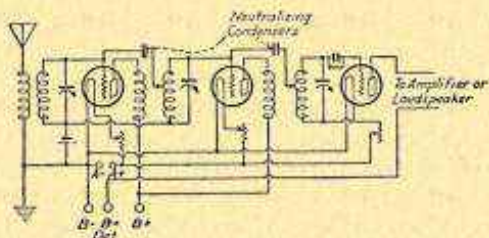

FIG. 48. Neutrodyne circuit.

When the tuned plate and grid circuit shown in Fig. 47 is used, the same hissing and "blub-blub" points will be found and the same operating rules apply regardless of the method used to obtain regeneration.

Because of its simplicity of operation and its great sensitivity, the regenerative receiver has found extensive use.

**Neutrodyne Circuit.**—This circuit, Fig.

48, was developed by Professor Hazeltine, an American radio engineer, and is now commonly used in broadcast receivers. At first glance the circuit appears to be a simple radio frequency circuit, but it will be noticed that a small neutralizing condenser called a "neutrodon" is connected from the grid of each radio frequency tube to the secondary of the succeeding radio frequency transformer. This is the only essential difference between the neutrodyne circuit and the simple radio frequency circuit.

Technically the *Neutrodyne* circuit neutralizes the inherent coupling capacities of both the vacuum tubes and their associated circuits. This eliminates distorting regeneration, local radiation and other radio receiver circuit disadvantages.

The neutrodyne radio receiver requires several special pieces of apparatus. The tuned radio frequency transformers or *Neutroformers*, and the special very low capacity variable condensers or *Neutrodons* are the most important units in the circuit.

***The Super-Heterodyne Receiver and the Principle Underlying Its Operation.***—Anything not clearly understood in principle seems complicated and of questionable value to the ordinary radio listener. If we adopt for

our use something which we do not understand, we do so either because it is recommended by some authority in whom we have faith or we take a chance, so to speak, on it being able to fulfill requirements.

Because no less a firm than the General Electric Company has concentrated its resources on the development of the Super-Heterodyne circuit into a practical receiver for household use, it can be taken for granted that the receiver will meet the most exacting requirements.

The Super-Heterodyne circuit is a result of the war. It was first constructed in the form of a practical receiver by the well-known radio engineer, Armstrong, then a Major in the American Expeditionary Forces in France. The receivers constructed were very few in number and far from being as compact as the models now found on the market. The results obtained, however, were of such extraordinary character that Armstrong continued his research work upon returning to the United States and after three years' labor presented his ideas to the radio commercial organizations for further refinement.

**Heterodyne.**—The word heterodyne is a combination of two words: hetero meaning “another” or “unequal” and dyne meaning power.

So we have the combination "another-power" or "unequal power." Now, the circuit used in this type of receiver is based on a principle which produces "another" or an "unequal" power in the circuit. And the way it is done is very simple when it is understood.

A good practical analogy may be had by using the following illustration: Assume you are riding in a train and the train is passing two ordinary picket fences about a mile in length. Both fences are on the side of the train from which you are looking out the window; one fence is built running along, say fifty feet from the track, and the other is built one hundred feet from the track, both running parallel to the rails. As we look through the pickets of the nearest fence at the pickets of the fence farthest away, we see not the pickets of the first nor the second fence as single rows of pickets but a periodic blur occurring at regular intervals about half a second apart. If we stop to reason this out, it is obvious that we do not see the nearest pickets because we are not looking at them but through them and we do not see the pickets of the second fence in a normal way as a single fence because the pickets of the first fence obstruct our view at regular intervals. What we do see is the third

optical effect described above, a periodic blur or third set of reflections, which is the result of the reflection of the first or nearest fence and the second or farthest fence upon the eye.

If the pickets in the nearest fence are spaced six inches apart and the second fence is similarly made the spacings between pickets of the farther fence will seem closer together because they are farther away from the eye. In other words, if the speed of the train is such that fifty pickets of the nearest fence pass the eye every second, a lesser number will be seen of the farthest fence, say perhaps thirty. We can then say that the pickets in the first fence pass the eye at a frequency of fifty and the second at a frequency of thirty. In this case the periodic blurs will be seen at a heterodyne frequency, which is the difference between the frequency of the two fences taken separately, or twenty. The heterodyne frequency of these two optical effects is, therefore, twenty.

The same effect may be seen by placing two ordinary window screens one in front of the other about a foot apart and moving one screen from right to left and vice versa in its own plane. The blur seen is caused by the heterodyne



principle and is the result of two slightly different optical effects on the eye.

**Heterodyne Receiver.**—The definition of a heterodyne receiver as given by the Standardization Committee of the Institute of Radio Engineers is as follows: "A radio receiver for

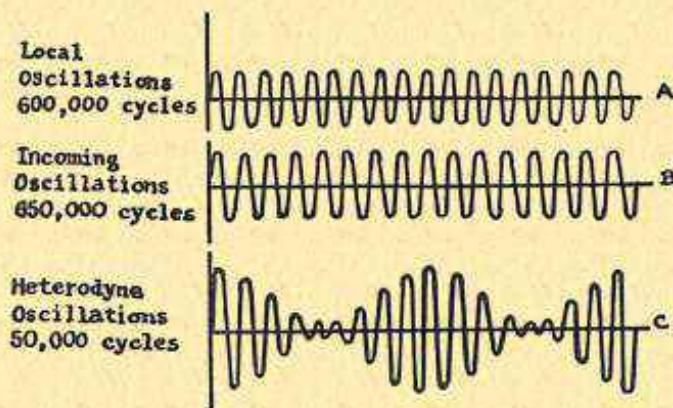

FIG. 49. Oscillations.

continuous waves employing the principle of reaction between locally generated oscillations and incoming oscillations." Note that it is the "reaction" or resultant effect of two sets of oscillations. In the same way the periodic blur seen by looking at the two fences is analogous to this definition. We might use the definition as applying to the fences if it is worded like this:

“The blur was caused by the reaction between nearest fence (locally generated oscillations) and the farthest fence (incoming oscillations).”

In the heterodyne circuit there is provided a set of oscillations which are generated by an oscillator. In modern sets this oscillator is a vacuum tube, although in early models the electric arc was used. This is shown as curve A in Fig. 49. Let us assume that these oscillations occur 600,000 times per second; in other words, this is their frequency.

The signals coming in from the station being received are called the incoming oscillations. These are represented as curve B in Fig. 49. Let us assume these are of a frequency of 650,000 cycles. The difference then between the oscillations in curve A which are locally generated and the oscillations in curve B which are incoming from the received station is 50,000 cycles. The heterodyne result is, therefore, a set of oscillations of a frequency of 50,000, curve C.

**Super-Heterodyne Receiver.**—High frequency oscillations of the order of several hundred thousand cannot be satisfactorily amplified by vacuum tubes and for this reason it is desirable to lower the frequency before amplifying it. This is readily done by the heterodyne method.

The vacuum tube heterodyne receiver incorporates other principles which make it extremely sensitive and therefore, in order to differentiate from the old type heterodyne receiver invented long before the war by Fessenden, an American radio engineer, the word *super* was prefixed and the modern set called the *Super-Heterodyne*

The ordinary, older super-heterodyne receiver, as built experimentally by a few advanced radio enthusiasts in the past, used from eight to ten tubes, was difficult to operate, and did not have many of the other characteristics of a satisfactory set for use in the broadcast reception field.

All super-heterodyne receivers are members of the well-known heterodyne receiver group, and these have long been used to receive so-called continuous wave radio telegraph and radio telephone signals. It is a complicated class of receivers which require expert radio knowledge in their construction, but they may be used by any one when properly built.

The term "super-heterodyne" means that this set does not depend alone on radio frequency amplification, nor yet on audio frequency amplification alone, nor on regeneration, nor even on a combination of these powerful methods of increasing the signal strength. More was re-

quired in the way of stable and selected amplification than these two previously used methods of amplification could alone yield. It became necessary to have a third and new frequency at which to amplify, namely: an "intermediate frequency," which is considerably higher than the audio frequency and much lower than the radio frequency. The combined use of these three frequencies gives an over-all amplification of an amazing magnitude which makes the set so sensitive that it reaches further on a small loop than other type sets do on a large antenna.

The super-heterodyne is so sensitive that it can hear across the continent on its own self-contained loop under good conditions, needs no antenna or ground and installing in the home means placing it where you think it looks best and leaving it there.

The adjustment of the set is simple since there is no variable antenna to take account of, but only a permanent and constant self-contained loop. It is possible to mark on dials provided for this purpose the setting corresponding to the stations desired, no matter where the set is located. After this is done, getting a station means merely setting the pointers to the desired station and listening. If desired, the music can be made

louder or softer by an additional control which influences in no way the tuning adjustments of the set.

The loop circuit of the receiver is a tuned circuit at radio frequency. It is adjusted by the listener. At three different points in the receiver are circuits sharply tuned to the intermediate frequency but not adjusted by the listener. They are set once and for all by the maker of the set and to make full use of them all that the listener needs to do is to tune the oscillating detector so that it will produce the proper intermediate frequency from the incoming waves. This means, in plain language, that he simply turns a second knob until the signals are loudest. The listener, therefore, has only two tuning-adjustments, and these are stable and definite. So that the intermediate frequency employed by this receiver enables the receiver to have no less than four sharply tuned selecting circuits in it, one after the other, and yet only two of which are ever adjusted. And the nature of these selective circuits is such that the selectivity must be carefully controlled and limited in order to avoid making the set unusable because of excessive selectivity.

The super-heterodyne receiver admits a band of frequency or wavelengths just wide enough to

enable radio telephone music to be perfectly reproduced and no more. With the existing type of broadcasting transmitters more selectivity would simply ruin the musical quality and not improve station selection in the least. This means an increased enjoyment to the broadcast listener for it is possible to listen without interference to concerts from distant stations while nearby stations on neighboring wavelengths are broadcasting on high power.

**Super-Heterodyne Circuit.**—This type of receiver is perhaps the most sensitive yet devised. It is, however, rather complicated in construction and operation and requires considerable study before it is completely understood or before it can be worked at its highest efficiency. Generally, the super-heterodyne receiver employs eight vacuum tubes as follows: independent oscillator, first detector, three-tube frequency changer, second detector, two-tube audio frequency amplifier, making eight tubes necessary. The last stage of audio frequency amplification may be left out and in such a case only seven tubes are necessary. Fig. 50 shows the connections employed with this circuit.

This circuit was originally invented by E. H. Armstrong of New York and given to the public



early in 1921. Since that time it has been improved and is now the most sensitive receiving circuit available. It gives excellent results on either a loop or an outdoor aerial. It is used chiefly for receiving short-wave signals. Fundamentally it transforms the extremely high frequency current received by the aerial into a current of a lower frequency which can be more easily amplified.

The action of the super-heterodyne is based on what is known as the "beat" phenomenon. This phenomenon is the result of the difference of two high frequency alternating currents; one being received from the transmitting station and one being generated in the heterodyne receiver. Suppose, for example, that the incoming oscillations are of 3,000,000 cycles per second (100 meters) and there is generated by a separate oscillating vacuum tube included in the super-heterodyne receiver cabinet oscillations of a frequency of 2,950,000 cycles or 3,050,000 cycles per second, the difference then between the incoming oscillations and those generated locally is 50,000 cycles and this is the "beat" current. The beat current is the resultant of two differing oscillation frequencies and its frequency is the difference be-



tween the two frequencies of the currents from which the beats result.

The first detector tube picks up the beat current and passes it on to the radio frequency amplifier which consists of the next three tubes. The radio frequency amplifier amplifies the beat current in a very great ratio, and, therefore, the oscillations after having first passed through the first detector tube and then through the radio frequency amplifier are still of a radio frequency and similar to the original oscillations coming into the aerial circuit. At this point the second detector functions and passes on a rectified audio frequency current to the two-tube amplifier to which the headphones or loudspeaker are connected.

The super-heterodyne is rather hard to adjust at first, but after practice becomes very simple. It is very selective and permits the tuning out of unwanted stations without much difficulty.

**Radio Frequency with Regeneration.**—One of the most efficient receiving circuits now available is a combination of the simple radio frequency circuit with regeneration.

A schematic wiring diagram of this set is shown in Fig. 51 and consists of one stage of radio frequency amplification which is balanced

by a simple neutralizing device, next comes a regenerative detector tube, followed by one stage of impedance-coupled amplification, one stage of resistance-coupled amplification and a final stage of resistance-coupled amplification with an impedance leak and an output filter. This last-mentioned device consists of a low-frequency choke coil and a small fixed condenser (about 4 mfd.) which are connected as shown in the diagram and prevent the high plate voltage of the last stage of amplification from passing through the loudspeaker at its full value but does allow a reduced equivalent to flow through the windings of the loudspeaker, thus saving them from possible damage.

This receiver is remarkable for its simplicity of control, quality of reproduction, sharpness of tuning, and sensitiveness. It can also be made to operate directly from the electric light circuits. The inventors of this circuit advise the use of a vertical antenna 50 to 75 feet in length, although the receiver works well in certain localities on a much shorter antenna, such as a 10 or 20-foot indoor antenna.

**Band-Pass Filter.**—The band-pass filter is a special circuit made up of especially designed and balanced coils and condensers which vastly

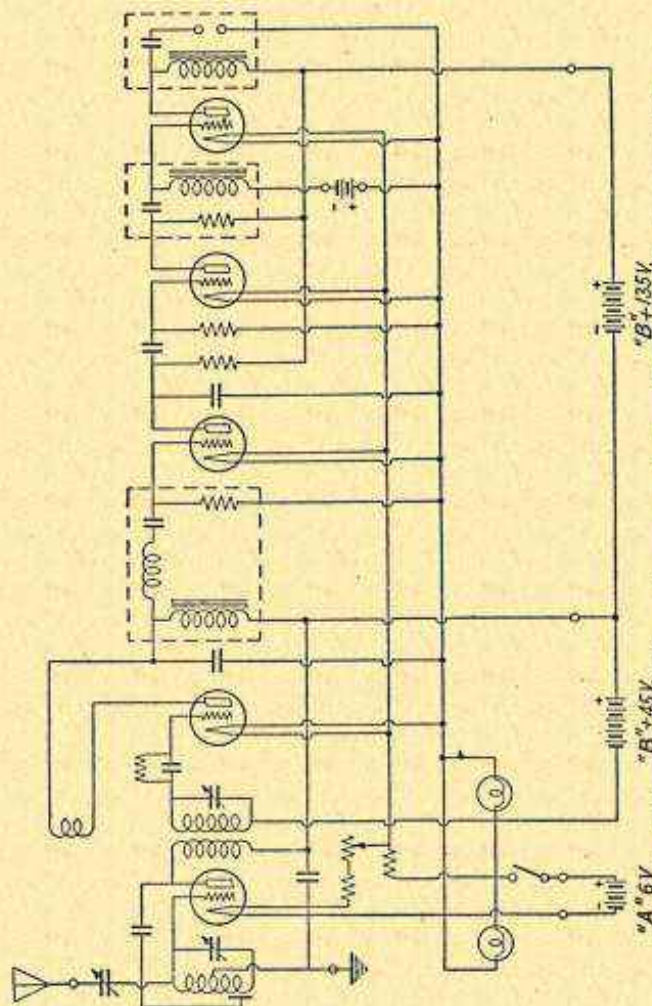

Fig. 51. Schematic wiring diagram of the Browning-Drake receiver.  
(Radio frequency circuit with regeneration.)

improve the tonal quality and selectivity of the broadcast receiver incorporating it. This development is credited to Dr. F. K. Vreeland, an American radio research engineer.

In order to get high quality reproduction it is

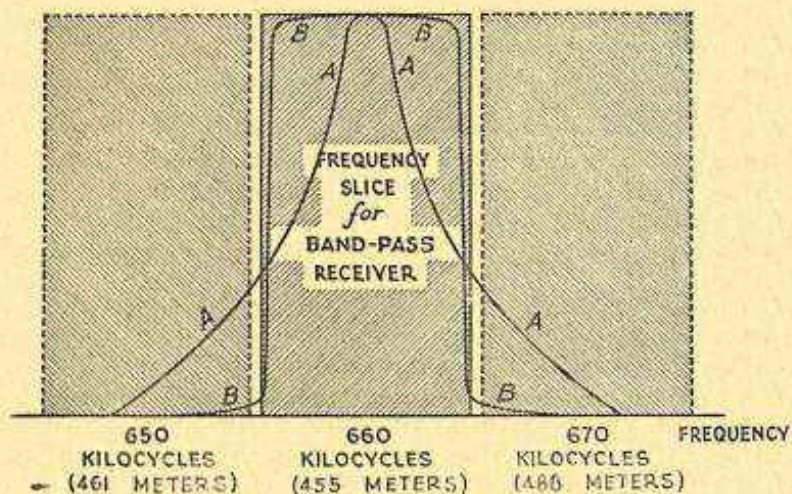

FIG. 52. Curves showing effect of band-pass filter.

necessary that the receiver respond over a band ten kilocycles wide. In other words, to properly receive a broadcasting station sending on 660 kilocycles, it is necessary that the receiver respond to the band beginning at 655 kilocycles and extending to 665 kilocycles. This is shown

graphically in Fig. 52. The shaded portions represent the broadcasting channels. Until 1928 the best designed non-interference receiving circuits available, outside of the laboratories, eliminated a good part of the overtones, so necessary to good quality reception. The overtone frequencies were

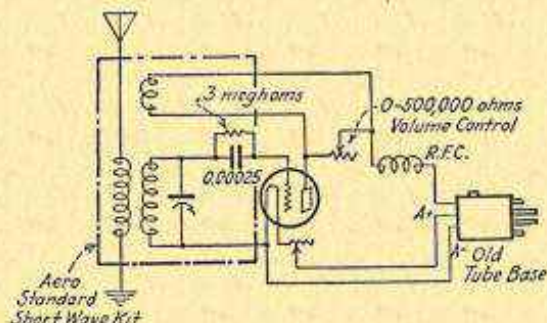

FIG. 53A. Short wave adapter to the standard broadcast receiver.

cut out by the sharpness of the tuning of the receiving circuit. The curve A shows how much of the desired frequency slice was lost and also how this type of circuit allowed some interference from adjoining channels. The band-pass filter circuit, on the other hand, covers the entire desired band and sharply cuts out adjoining frequency channels.

There are two technical ideas by which a band-

pass filter circuit can be evolved. One is to slightly stagger the three tuning condensers of a tuned radio frequency circuit and thereby cause it to tune slightly above and slightly below the exact resonance point of the incoming wave. The other idea is to compose the band-pass filter of two closely coupled circuits, one being tuned slightly above and the other slightly below the resonance point of the desired frequency to be received. Either of these ideas if incorporated in a receiving circuit should be capable of tuning in a slice of frequency as shown in Fig. 52. Receiving sets incorporating the band-pass filter idea have already made their appearance on the market. See Fig. 79 for circuit diagram.

***Short Wave Broadcast Converter.***—

There are many types of short wave receivers which are designed for broadcast reception on short wavelengths, but one of the simplest methods would be to make use of the standard broadcast receiver. The receiver could at the same time be used for the standard broadcast range and when it is desired to listen in on the short wave broadcasting band it would merely be necessary to take out the detector tube and insert an old tube base connected as in Fig. 53A. This is

the ideal method for a quick change from the high to the low wavelengths.

The operation of this receiver is as follows: Regeneration is controlled by a 0 to 500,000-ohm resistor, connected across the tickler. A .00025-mf. variable condenser is used, with a set of three Aero coils, to tune from 15 to 200 meters. A vernier dial is necessary, as the tuning is sharp.

The choke coil is important and must not be omitted. When by-passed with a .002-mf. condenser it will permit the plate lead to be long enough to reach the receiving set. If a choke coil cannot be easily secured, one can be made by winding 100 turns of No. 26 D.C.C. wire at random on a wooden spool,  $\frac{1}{2}$  inch in diameter and with a  $\frac{1}{4}$  inch iron core.

To operate the short-wave converter, select the plug-in-coil covering the waveband in which you want to receive and plug it into the coil jacks, connect the plug to the receiving set as previously described, and transfer the aerial and ground leads. You may listen either with headphones on the intermediate jack, if your present set is so arranged, or use the loudspeaker as ordinarily connected. Turn the resistor until the receiver oscillates. Tune in a station and clear

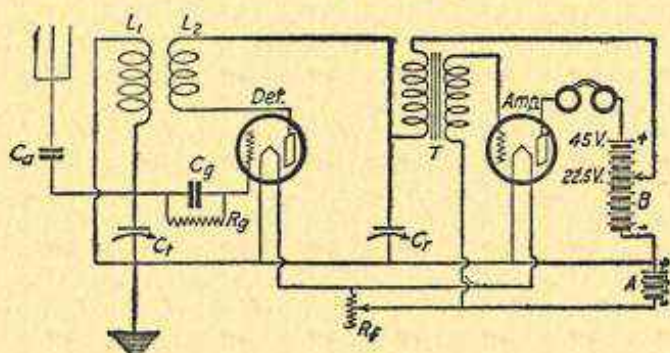

FIG. 53B. A short wave receiver.

$C_a$  = Antenna coupling condenser. Two  $\frac{3}{4}$ " metal discs, adjustable in binding posts.

$C_t$  = Tuning condenser. Three rotary plates, any low-loss condenser.

$C_r$  = Regeneration control condenser. 0.00025; any good make.

$C_g$  = Grid condenser. 0.00025 MFD fixed mica.

$L_1$  = Grid coil, diameter 3 in. No. 16 D. C. C. copper wire, Lorenze type.  $17\frac{1}{2}$  turns for 80 meter band,  $7\frac{1}{2}$  turns for 40 meter band,  $2\frac{1}{2}$  turns for 20 meter band.

$L_2$  = Ticker coil, diameter 3 in. No. 16 D. C. C. copper wire, Lorenze type.  $9\frac{1}{2}$  turns for 80 band,  $4\frac{1}{2}$  turns for 40 meter band,  $3\frac{1}{2}$  turns for 20 meter band.

$R_f$  = Filament rheostat. 30 ohms for 199 tubes, 6 ohms for 201A tubes.

$T$  = Audio transformer. Any good make.

$R_g$  = Grid leak. Fixed, 9 megohms. (Different tubes may require from 5 to 9 megs.)

Coils for each wave band fixed in position relative to one another by 3 glass rods and few drops of collodin.

up the signal by a further adjustment of the resistor or rheostat as required.

**Short Wave Receiver.**—A short wave receiver designed especially for amateur use is shown in Fig. 53B. This is the kind of a receiver



used by thousands of code transmitting amateurs throughout the United States. An explanation of the make-up of this receiver appears under the diagram. This particular model was designed by the Burgess Battery Company and is described in detail in their Engineering Circular No. 7.

## CHAPTER IX

### HEADPHONES AND LOUDSPEAKERS

RADIO headphones and loudspeakers are identical as far as their theoretical operations are concerned, and if the elementary theory of the headphone is thoroughly understood the necessary knowledge for the conventional loudspeaker will be understood.

The headphones used with radio receivers consist of a permanent magnet, around each pole of which is wound a bobbin of wire. The greater the number of turns in each of these bobbins, the more sensitive the headphones will be. In modern headphone sets, the number of turns reaches many thousands, and the wire used is very fine; as a result the resistance of the headphone is very high (2,000 to 3,000 ohms per pair).

The resistance of the headphones may be taken as an indication of the number of turns on the bobbins, and consequently of the relative sensitivity of the headphones. It should be borne in mind that although the resistance may be such

an indicator, it need not be so under all conditions. For example: if a headphone were wound with a high resistance wire such as German silver or Manganin wire, the high resistance would certainly be obtained, but the comparative number of turns would be very small. Of course, such telephones with a small number of ampere turns (as they are technically called) are absolutely worthless.

The coils on the bobbins carry all the current that flows through the headphone set. In order that the effect of this current may be proportional to the current, the permanent magnet mentioned above is inserted. The iron diaphragm is placed over the poles of this magnet, and held in position by means of the cover and action of the poles. Should a current pass through the coils of the bobbins, the pull of the poles on the diaphragm will be varied. This variation causes the vibration of the diaphragm and the production of sound results.

The operation of the type of headphone just described is satisfactory in most cases. However, where an extraordinary degree of sensitivity is desired this type fails, because of the rigidity of the metal diaphragm. This obstacle has been overcome by the insertion of a mica dia-

phragm instead of a metal one. This principle is now being used extensively in some of the very sensitive headphones and loudspeakers, such as the Baldwin telephone, Western Electric loudspeaker, Radiola, Stromberg Carlson, etc. The latter three utilizing a thin parchment cone-shaped vibrating disc; corrugated or plain, instead of mica.

The theoretical action of this type of receiver or loudspeaker is as follows (see Fig. 54).

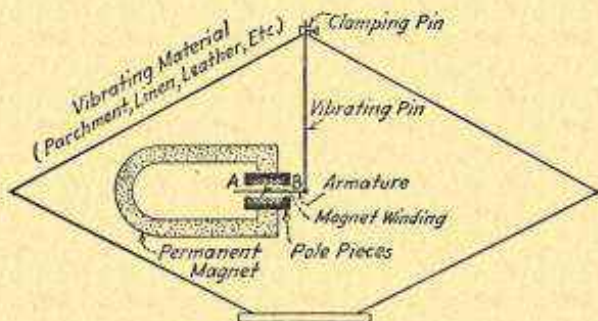

FIG. 54. Cone speaker.

It is evident that when no signal is being received the armature is balanced in its neutral position because the number of magnetic lines of force traversing through the holes at A and B is the same and being equal in value no pull is ex-

erted on the mica diaphragm. If a signal pulsation of current passes through the receiver winding, however, it produces a flux, which, combining with the permanent flux, results in an uneven distribution of the flux, causing a force to be exerted on the armature and thus on the diaphragm and again resulting in sound reproduction simultaneous with the transmitting station.

This should illustrate clearly the theoretical action of the telephone. However, perhaps the most important thing to consider in voice reception, regardless of the volume, is the clarity with which the voice is reproduced. Of what use is it to have a famous artist sing into a transmitter at the broadcasting station if the telephone receiver distorts the result and adds its own inharmonic and unmusical sounds to those of the singer? We, therefore, see that with the advent of radio broadcasting we face the serious problem of faithful sound reproduction. Upon what does faithful reproduction depend and how can it be ascertained?

The answer: Elimination of mechanical distortion due to the diaphragm, armature, connecting rod and the proper design of the magnetic structure. These things are the most important

toward the development of a perfect loudspeaker.

Thus it will be readily seen that the absence of a metallic diaphragm will bring us closer to the acme of perfection. Of course a properly designed metallic diaphragm with absence of its own mechanical frequency from audibility will produce excellent results.

**Loudspeakers.**—Fundamentally the loudspeaker performs the same function as the simple headphone, i.e., it converts electrical vibrations into sound vibrations. The loudspeaker, however, must be so designed that a faithful reproduction of all frequencies in the audible range will be faithfully reproduced. This is a very important factor in modern broadcast reception and, therefore, has given rise to a tremendous development for faithful reproduction. Various types of loudspeakers have been manufactured in recent years but the ultimate necessity for fine quality reproduction has eliminated many of the older designs such as the metal horn types. These older types lacked the ability to reproduce faithfully the lower band of frequencies between 20 and 100 cycles of sound vibration and, therefore, gave the effect of "tinny" reproduction. This discrepancy has given rise to two types of speakers which are extremely efficient in the reproduction

of low and high frequencies, thus making it possible to produce more natural-like reproduction.

These speakers are classified under two headings, i.e., cones and exponential horns. The cone speakers are also under two classifications, i.e., magnetic and dynamic types.

**Magnetic Cone Speaker.**—The magnetic type of cone speaker is illustrated in Fig. 55. Here the vibrating armature between the mag-

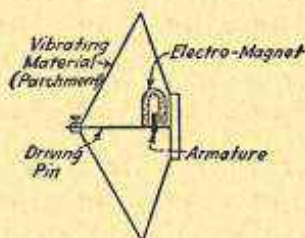

FIG. 55. Cone speaker.

nets is connected to a very thin driving pin which is made to extend into the apex of the cone. When a signal passes through the coils located between the magnetic pole pieces, a fluctuating magnetic field is produced which causes the armature to vibrate, and, since the driving rod is connected to the armature, the vibrations will be carried to the apex of the cone, consequently setting it into vibration.

The vibrating parchment will then transform these magnetic variations into sound vibrations at whatever signal frequency is being passed through the windings.

If a low frequency, such as would be produced from a kettledrum, is now passed through the winding the parchment will vibrate very readily because the material itself has a low frequency period.

The frequency range of this type of speaker is also dependent upon the character of the vibrating material and its physical dimensions. For example, if a cone speaker is made up of a very thin fiber paper and the area of the cone is extremely small it will still be possible to produce low frequencies, but they will not be as accentuated as with a larger vibrating area. Hence, the larger the vibrating area the deeper will be the bass note reproduction. Sometimes this is undesirable with this type of speaker because if the base notes are too heavily amplified the sounds will have a barrel-like or "drummy" effect not altogether pleasing to listen to. However, this effect is sometimes more desirable than the screechy horn type of speakers. Of course the ideal condition would be an even distribution of frequencies over the entire audible range.



This can be partially obtained with the magnetic cone type of speaker which does not exceed a three-foot area. The main disadvantage of the magnetic cone type of speaker is not its lack of faithful reproduction but rather its inability to handle heavy volume without "rattling."

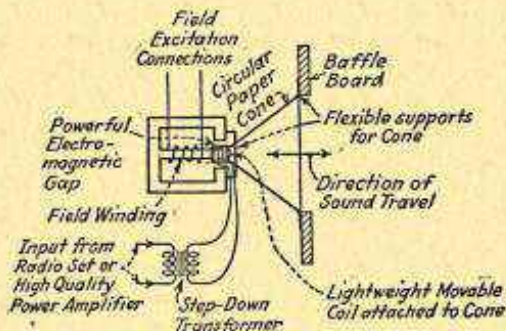

FIG. 56. Dynamic speaker.

**Dynamic Loud Speaker.**—Perhaps the greatest contribution to the loudspeaker field has been the dynamic cone speaker. This type of speaker is capable of handling extreme volume without rattling, and in addition can be made to amplify the entire range of audible frequencies from 20 to 6000 cycles. This, of course, depends upon their construction.

Fig. 56 illustrates a cross-section of a very

efficient dynamic speaker. From the figure it will be noted that the dynamic speaker consists of the following parts, i.e., magnet with field winding, small coil of wire attached to paper cone, flexible supports to paper cone, step-down transformer and baffle board. The operation is as follows:

When the field winding is excited by passing a direct current through it a powerful magnetic field is produced at the gaps between the moving coil and the magnet pole pieces. In order to maintain this magnetic field very powerful and to minimize current consumption by the field winding the gap must be very close. Now, as soon as a signal is passed into the step-down transformer from the audio amplifier, the signal voltage is dropped, due to the transformer, in order to prevent excessive currents from flowing into the movable coil, which, due to its low resistance, would otherwise burn out. The signal variation, however, is still great enough to produce a varying magnetic field about the moving coil. The field about the moving coil now being in the vicinity of the powerful magnetic field across the air gap will cause the both fields to buck or interlink with one another, depending upon the direction of the current flow through the moving coil.

If now the field about the moving coil is constantly varying due to the signal variation, the coil will be pushed in and out of the air gap at a rate of vibration depending upon the signal variation passing through it. Hence, if the coil is connected to the paper cone the vibrations will emanate in the form of sound. Here the most important feature for the faithful reproduction of sound presents itself in this form of speaker.

In all speakers operating upon the free edge cone principle such as the dynamic types there are two distinct sound waves emitted, one in front of the cone and the other in the back. Thus, if the speaker is operated in this manner, the sound waves will interfere with one another, causing a neutralization of the fields and consequently a serious reduction in volume and quality. In order to prevent the waves from interfering with one another, the speaker must be mounted in a baffle plate or board as illustrated in Fig. 57.

It can be seen from this illustration that the greater the area of the baffle the lower will be the possibility of the sound returning to the rear. The interesting feature about this baffle is that the greater its area the lower will be the frequency range of the speaker and since the lower frequencies are the hardest to reproduce without

having a "drummy" effect, it would seem that a dynamic speaker with a suitable baffle will give almost ideal results in excellent tone quality. The proper size for a baffle which is to go down as low as 30 cycles can be readily computed if we know a standard for a certain frequency. It so happens that if the distance from the outside

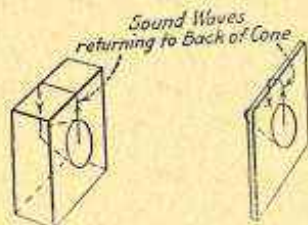

FIG. 57. Box and flat type baffles.

center to the rear of the speaker is 32 inches then the best low frequency which can be reproduced is 100 cycles. Hence, if the distance is doubled it will reproduce down to 50 cycles and so up to 96 inches or 35 cycles. This would of course be impractical for the average home if a flat baffle were used.

If, however, the box baffle is used the distance can be made up in length, width and height and the frequency could still be made to go as low as 35 cycles without impracticability. If the box

baffle is used it is important to keep the rear of the box open, otherwise a condition of muffling will result, consequently seriously impairing the quality of reception.

It is, of course, obvious that there is no advantage gained with a large baffle if the audio amplifier does not cover the entire range of frequencies, especially below 100 cycles.

**Exponential Horn.**—Acoustical engineers are agreed that the exponential horn is the most uniform of all sound radiators. By this is meant the ability of the speaker to radiate all the frequencies at the same rate of energy. In other words, it does not favor the very low notes, nor the very high, nor the medium, nor any other notes.

The well-constructed exponential horn is as close to uniform as can be attained in practice and hence it is capable of quality as near perfection as possible, provided, of course, that perfect quality is delivered to it by the amplifier.

The exponential horn is without a doubt the most perfect radiator but impractical for home purposes due to its required size. The word exponential was derived from the rate at which the cross-sectional area increases as the distance from the end increases. It has been found that

an exponential horn which is to deliver frequencies as low as 30 cycles must be about 15 feet in length and this is certainly an impracticability for home use. Hence in order to have an ideal exponential horn the length must be about 20 feet and the diameter at the open end about 48 inches and that at the small end about 4 inches.

**Condenser Type Speaker.**—There is no doubt that this type of speaker will be used in the near future. It possesses vast possibilities for improvement over the well-known magnetic and dynamic types. It minimizes the reaction between input and output and due to its great sensitiveness will eliminate undue resonances.

The great possibilities in this type of speaker lie in the fact that the electro-static field can be equally extended over a large surface, which will tend to eliminate the possibility of self-oscillation. This simply means that with this type of speaker self-oscillation of the vibrating elements will be kept out of the musical range and, therefore, practically no distortion will take place.

## CHAPTER X

### BATTERY CHARGERS AND ELIMINATORS

**Battery Chargers.**—A discharged storage battery of the lead type is in a condition where the acid of the electrolyte has gone into and combined with the active materials of the plates. The plates have soaked the acid up, so to speak, and the specific gravity of the electrolyte (consisting of acid and water) is lower than before this action took place.

In order to again charge the battery it is necessary to draw this acid out of the plates and back into the electrolyte. During this process the specific gravity of the electrolyte is continually rising until it is about 1.250 when the battery is fully charged.

It is seen from the above that the change from charge to discharge is purely a chemical one in the electrolyte and plates. This is likewise true for the Edison type of battery, although no acid is used and the chemical action affects the elements (which are nickel and iron) in a different

way. The basic principle of charging a battery is that a chemical action must take place in a direction the reverse of that which took place during discharge. This chemical action is, in the case of discharge, the cause of an electric current in the battery and in the case of charge the electric current is the result of the chemical action. During discharge the current flows from the negative to the positive plate inside the battery, while during charge the flow is from positive to negative. In both cases the current flows through the electrolyte, which is thereby decomposed if the current is too strong, as is many times the case during charge. The battery is then said to be gassing.

If during charge all of the acid is not driven out of the plates and into the electrolyte the remaining acid will clog up the pores in the active material of the plates and the battery is said to be sulphated. Badly sulphated batteries require an extra heavy charging current to dislodge the hardened acid which is clogging the pores of the active material. As the sulphation is removed less current is necessary and, therefore, the charging current is tapered; in other words, it is gradually reduced from maximum rate at the



commencement of the charge to minimum rate at the finish of the charge.

Because the action in a battery during charge or discharge is either from negative to positive (discharging) or vice versa, the resultant current is a direct current flowing in one direction only during discharge, and reversing during charge. A direct current, therefore, is necessary to charge a storage battery.

An alternating current cannot be used because it changes its direction of flow periodically. The usual alternating current used for lighting purposes is of a frequency of 60 cycles. It is made up of alternate positive and negative alternations; two alternations make a complete cycle. If this current is to be used to charge a storage battery, one polarity of alternations must be removed or prevented from flowing. This is called rectification and if the negative polarity is the one removed the resultant rectified current would be a series of positive alternations. In the case of a 60-cycle current there would be 30 positive pulsations in a second of time. While the current is not steady in value it is all in the same direction and, therefore, suitable for charging purposes.

A battery charger is a device for rectifying al-

ternating current so that it will flow in one direction only through the battery which is on charge. This does not hold true for direct current chargers.

**Direct Current Charging.**—For example, if direct current (DC) is available in the lighting system then the battery may easily be charged without the use of a charger by simply

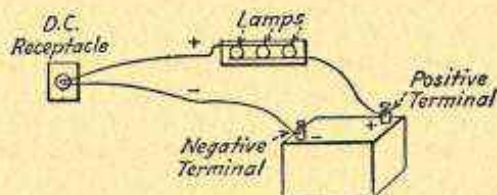

FIG. 58. Using lamps to charge battery.

connecting the battery to the 110-volt lighting system as illustrated in Fig. 58. A number of lamps are placed on a board and connected in parallel. The lamps are then connected in series with one of the direct current wires (either one) and then to the battery terminals. Great care must be taken that the positive terminal of the battery is connected to the positive wire of the line, otherwise the battery may be completely ruined. It is a very simple matter to determine which one of the two wires is positive by placing

the two wires into a glass dish filled with water and a tablespoon full of salt. The wires should not be too close but about three or four inches apart. Then upon inserting the wires into the solution it will be noted that bubbles will form at the tips of both wires and the one which has the greatest amount is the negative terminal.

The two wires may then be connected to the battery through the lamps with the positive wire going to the positive terminal of the battery. The number of lamps may be from one to five, depending upon the charging rate specified on the battery plate. This is usually about four amperes and can be readily obtained by using ~~four~~ ordinary 75-watt lamps. The battery should be left on charge until it has gassed for about two hours.

***Alternating Current Chargers or Rectifiers.***—The modern types of rectifiers are as follows:

- (a) Bulb rectifier
- (b) Electrolytic rectifier
- (c) Dry rectifier

The heart of the bulb type charger is a tube, containing two elements. In construction, these tubes are similar to the ordinary three-electrode

receiving tubes except that they have no grid and are larger in size. The plate is called the cold electrode and the filament the hot electrode. The tubes have a very high vacuum. In the bulb there is an inert gas, at a low pressure, which is ionized by the electrons emitted by the filament. This ionized gas acts as the principal current carrier.

The filament is known as the cathode and consists of a small tungsten wire in the form of a closely wound spiral. The anode or plate is a piece of graphite relatively large in cross section.

The bulb acts as a rectifier because on the negative alternation of the cycle the filament electronic emission is pulled directly towards the anode. These electrons collide with the gas molecules, ionizing them and making them conductive in the direction of anode to cathode. On the positive alternation of the cycle, the filament is positive and its electrons instead of being attracted towards the plate are repelled back to the filament, so that no current passes between the elements during this half of the cycle. This bulb is conductive, therefore, on only one half of the cycle, which accounts for its rectifying properties.

The bulb after being exhausted to the highest possible vacuum is filled with argon. To keep

the gasses within the bulb pure a purifying agent in the form of a wire ring on the anode is introduced which reacts chemically with any impurities. In so doing the purifier is volatilized and somewhat discolors the interior of the bulb.

There are two types of bulb rectifiers; namely, the half-wave and full-wave types. The full-

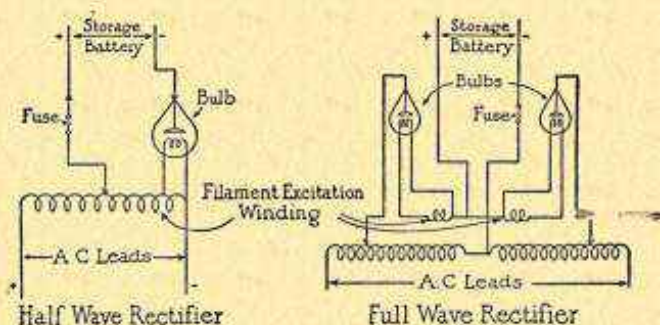

Fig. 59. Two types of battery chargers—bulb type.

wave type employs two tubes and the half-wave type employs one. The full-wave type is more expensive to purchase and operate and is, therefore, not commonly used by radio listeners. All the popular types of bulb type chargers now on the market are of the half-wave type and for this reason this is the only type discussed fully in this book. Both types are shown in Fig. 59.

In the bulb type rectifier a relatively high voltage is required to make the bulb "pick-up" or start operating and for this reason an arrangement is provided which lowers the voltage automatically after the bulb picks-up. It takes but a few seconds for the bulb to get into operation or start rectification. This inherent reactance, as it is called, also tends to keep the voltage constant during the entire charging period of the battery. Bulb type chargers now on the market are made in two sizes, the 2-ampere and the 5-ampere types. Which one is best suited to a given need is determined best after the needs are known. In general if the storage battery employed is of the 40-ampere hour size or smaller the 2-ampere charger will serve the purpose. If, on the other hand, the battery is larger than this in size, the 5-ampere size should be used. The smaller size will charge the larger sizes of battery, but the time required is relatively much longer than when the larger size charger is employed.

Another point which has a bearing on the choice of the size of charger to be used is the extent to which the receiving set is operated. If a set having four or more tubes is used for several hours each night it is advisable to have a 5-ampere charger even though the storage bat-

tery employed is of the 40-ampere hour or smaller type.

The auto-transformer in both types of chargers must be very carefully designed in order that the bulb or bulbs pick up properly. In the 5-ampere outfit the auto-transformer has two secondary windings. One of these windings consists of a relatively few turns of heavy wire which is connected in series with the filament. This winding serves to excite the filament and enables it to pick up in a few seconds. The other winding consists of a greater number of turns and these function to supply current for charging the battery. Three taps are usually brought out near one end of the primary winding (the heavy wire turns) which serves to adjust the charger for various line voltages.

When the line current is shut off the circuit to the battery is automatically opened due to the fact that the bulb is in series with the battery. The bulb is connected in the negative terminal of the battery and when the filament goes out, electronic emission being thus stopped, current cannot flow between the two elements of the bulb. The battery, therefore, cannot discharge back through the charger.

The 5-ampere type will charge 3 cells at 5 am-

peres or 6 cells at 3 amperes. The 2 ampere type will charge 3 cells at 2 amperes or 6 cells at about 1.5 amperes.

**Electrolytic Rectifier.**—This rectifier consists of two electrodes immersed in a solution called electrolyte. The electrodes may be carbon and lead, tantalum and lead or aluminum and lead. Other combinations will also function as rectifiers. The principle accepted as the rectification theory of the electrolytic type of rectifier is that a gas film forms on one electrode (called the valve metal) when the current is flowing towards this electrode and permits the flow of electrons in one direction only. It does not permit the passage of electrons from the electrolyte to the valve metal but does permit a flow from the valve metal into the electrolyte.

Among those metals which show this valve action are aluminum, tantalum, magnesium, zinc, cadmium, and tungsten. Aluminum and tantalum are the only two which are used commercially. The valve action in the others is not pronounced enough to permit dependable operation.

The rectifying action in an electrolytic type charger consisting of aluminum and lead plates in a dilute solution of sulphuric acid would be as follows. As a result of exposure to the air



the aluminum plate has deposited on its surface a very thin coating of aluminum oxide. The acid of the electrolyte leaks through the pores of this oxide coating and attacks the metal of the plate. This forms more oxide which results in a thicker coating which is also porous. When the current is turned on the acid in the solution is ionized and oxygen molecules are liberated which are negatively charged. These oxygen molecules are drawn towards the positive aluminum plate, where they are neutralized and form oxygen gas. This gas forms an effective resistance to the passage of current towards the positive electrode during one half cycle and permits a passage during the other half. The action of the valve plate towards the flow of current is, therefore, valve-like with the resultant rectification. The alternating current is changed to a series of direct current pulsations, the number of pulsations depending upon the frequency of the charging A. C. line. If the frequency is 60-cycle, which is ordinarily the case, the number of pulsations will be 30 per second.

Unless the electrolyte is pure sulphuric acid and water considerable leakage is likely to occur, destroying the valve action. Among the impurities which will have this effect are chlorine,

bromine or iodine. Carbonate or borate solutions are preferable to the sulphuric acid solution and the efficiency of the rectifier is higher when these are used.

Although the aluminum type of electrolytic charger has been used to a great extent the tantalum is better for quick charging at higher rates.

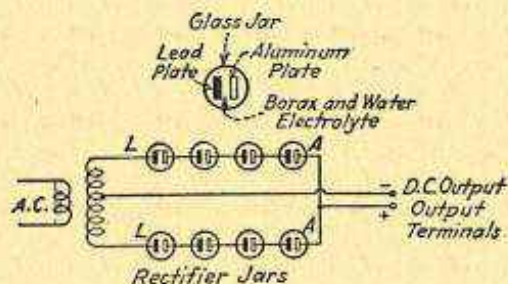

FIG. 60. Electrolytic rectifier.

The tantalum type is constant in operation over a wide range of temperature and is independent of changes in frequency and line voltage.

The electrolytic type of chargers causes no disturbances in the line since there are no circuits to be opened or closed mechanically, nor are there any magnetic fields built up to collapse and cause surging. The efficiency of electrolytic rectifiers is approximately the same as for other types.

The method of connection for the electrolytic

type of rectifier is shown in Fig. 60. The electrolyte may consist of a dilute solution of sulphuric acid or ordinary washing borax (three heaping teaspoonsful of borax to two pints of water) and water.

**Dry Rectifier** (copper-oxide type). This type of rectifier is one of the most extensively

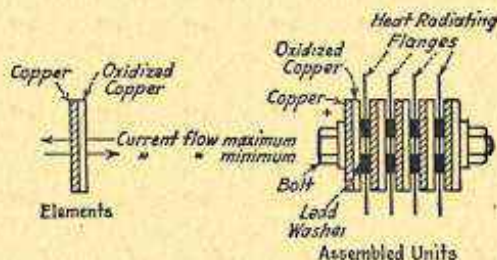

FIG. 61. Dry rectifier.

used in modern broadcast receivers, especially for rectifying the alternating currents from power transformers for "B" supply and also for exciting the field windings in dynamic speakers.

The obvious advantage of this type of rectifier can be readily seen, i.e., no tubes to break and no electrolyte to spill.

Fig. 61 illustrates a dry rectifier of this type.

The rectifying properties of this type of rectifier have been found to be due to the ability of an

electrical current to flow better from the oxide to the copper than from the copper to the oxide. In other words, the resistance offered to a current flow when these two metals are contacted is less from oxide to copper and greater from copper to oxide. This resistance ratio has been found to be about  $3\frac{1}{2}$  to 1.

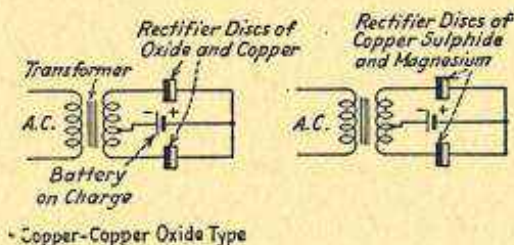

FIG. 62. Dry rectifier connections.

This rectifier may be used in either a full-wave or half-wave arrangement as illustrated in Fig. 62 (left). This depends upon the quality of the rectified output desired and also the amount of rectified current that is to pass through it. For example, if a large amount of current is to be rectified through a small number of units there will be a considerable amount of power lost and, therefore, in order to dispose of any unnecessary loss a larger number of units provided with heat

radiating flanges must be used to force air ventilation.

**Dry Rectifier** (Magnesium-Cupric sulphide type). This is another type of metal rectifier operating on the same principles as the copper-oxide type, but using different metals. It is also being extensively used in modern broadcast receivers for the rectification of alternating currents for filament and plate current supply to vacuum tubes.

The operation of this type of rectifier is based upon certain physical facts that when a high electro-positive and electro-negative body is brought into proper contact and a current passed so that an electrochemical reaction takes place at their surface junction a film is formed which allows the current to pass in one direction only. The forming of this film usually takes place during the first cycle, after which a rectified current will pass from the cupric sulphide disc to the magnesium disc. These discs are stacked and then held together by pressure which insures uniform contact throughout the junction points. Fig. 62 (right) illustrates how a series of these discs may be connected to give full wave rectification.

**“B” Eliminators.**—Many types of “B” eliminators have been developed in recent years, but all are based upon the same fundamental principles. It will be remembered that the function of the “B” battery is to supply the plate current for the vacuum tubes. Similarly, the “B” eliminator is used to supply the plates of vacuum tubes from an alternating or direct current lighting system of usually 110 volts. In D. C. districts the voltage for the plates of the tubes can only be supplied up to 110 volts because the voltage cannot be “stepped up.” If, therefore, voltages in excess of 110 volts are desired, then batteries must be added in series with the line to increase the voltage to the required value. If the voltages to be used are below 110 volts then resistances are inserted in series with the plate supply lead of each tube to bring it down to the proper value. See Fig. 77 for details of a high quality D. C. eliminator and audio frequency amplifier. In A. C. districts, however, the voltage may be “stepped up” many times from 110 volts by using a transformer.

**Transformers.**—The transformer is a device for stepping up or down alternating current voltages. The construction of a typical transformer used in “B” eliminators is as follows: A

rectangular or square shaped magnetic core of a high permeable character such as silicon steel, resembling a picture frame, is used. The outside area of the core is approximately 6 inches square and the inside "window" opening is about 4 inches square. The width of the core in a high grade type of transformer is about 2 inches, the thickness being made up of thin sheets of silicon steel stacked up until the proper thickness is obtained. If the core is made up of a solid block of steel considerable heat losses would result due to the generation of small currents in the core when subjected to magnetic reversals. This breaking up of the core into sheets is called "laminating." Before assembling the sheets of steel, each plate is carefully treated to prevent rusting, with a coat of enamel and shellac. After the sheets have been assembled, wires are wrapped around the core to form the windings. These are known as the primary and secondary windings. The primary winding is connected to the A. C. supply line and the secondary to the various vacuum tube plate circuits through proper values of resistances. The voltages in the secondary windings now depend upon the ratio of turns in the secondary as compared to the primary. For example, if it is desired to step up the A. C. voltage

from 100 to 500 volts, such as is done in the modern eliminator for power tube supply, then the secondary winding must have five times as many turns as the primary, or in other words, the ratio of turns must be five to one. If, on the other hand, voltages below 100 volts are desired, such as is necessary for lighting tubes, then an additional winding having less turns than the primary is wrapped around the same core. This is called the step-down winding and must also have the proper ratio of turns to obtain the desired low voltage.

The theoretical operation of the transformer when connected to the A. C. line is as follows: The alternating current flowing through the primary winding rises and falls and changes its polarity periodically at a definite rate or frequency (usually 60 cycles or 120 reversals).

This produces a rising and falling magnetic field about the primary winding which in turn causes the steel core, upon which it is wrapped, to be magnetized, first in one direction and then the other. These magnetic lines of force rising and falling about the magnetic core are now of great density due to the ability of iron and steel to increase the number of magnetic lines of force. Hence, the secondary windings which are



wrapped on the core are cut by this moving magnetic field and have induced across them an alternating electromotive force (voltage) depending upon the number of turns. This high voltage may then be supplied to the plates of the various vacuum tubes but only after it has been rectified and smoothed out by a suitable arrangement of tubes and filtering devices.

**“B” Eliminator Rectifiers.**—The rectifiers used in “B” eliminators are the same as the three types previously described, i.e., bulb, electrolytic (chemical) and dry rectifiers. It will be remembered that in the tube type rectifiers previously mentioned a filament and a plate are the rectifying elements. In many of the modern eliminators, however, another type of tube rectifier is used having no filament. This tube is commonly known as the “S” tube rectifier or Raytheon tube. With this type of tube, rectification is produced by using two positive electrodes projecting slightly into a cup containing helium gas. The gas is maintained at a low pressure (high vacuum) to prevent a current from flowing through the gaseous medium. The construction is of such a character that the positive terminal surface exposed to the helium cup is very small and hence currents can flow much more readily

in one direction than another. This simply means that when the tube is connected to an alternating current supply the current will flow in one direction only, due to its uni-lateral conductivity, and, therefore, if the current which is supplied to the receiving vacuum tube plates is always in the same direction, the tubes will function just the same as with "B" batteries. There is, however,

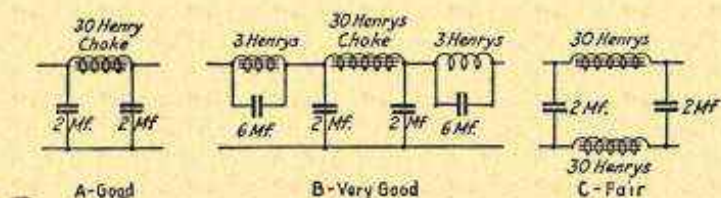

FIG. 63. Filters.

one disadvantage over the "B" battery supply system and that is the current does not flow as steadily. This condition can, however, be remedied by connecting a filtering device between the rectifier tube and the receiver tubes.

**Filters.**—The object of a filter system is to smooth out the rectified variations to a steady flow of current similar to that produced by a battery. Fig. 63 illustrates various efficient filtering systems.

The theory of a filter action is based entirely

upon three factors. First, an inductance permits a low frequency or small current variation to pass through it more readily than a higher frequency or higher current variation; second, a condenser does just the opposite, i.e., it permits a high frequency current to pass through it more easily than a low frequency current, and, third, any cir-

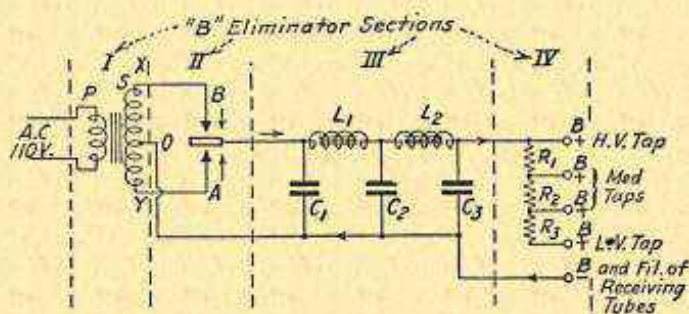

FIG. 64. Typical "B" eliminator circuit.

cuit consisting of condensers and inductance has a tuned effect which in the particular case of filters, where the condensers form a parallel circuit, exists a certain selective effect; that is, the tuned circuit will pass certain desired frequencies and block undesired frequencies.

The particular type of filter used in "B" eliminators allows the current of low frequency to pass through, but only after a certain amount of

opposition. This opposition is offered by the "choking" effect of the inductance when a varying current is passing through it. The condensers shunted before and after the choke coil serve as a sort of "reservoir" which takes up or absorbs these variations and, therefore, the only current that can pass beyond the chokes and condensers can be an unvarying current such as is obtained from batteries. This results in a pure direct current capable of supplying a steady potential to the plates of the various vacuum tubes. It is, of course, very important to have the filter properly designed to adequately effect this "smoothing out" process and, therefore, a high value of inductance and capacity is absolutely essential. Fig. 64 illustrates a typical "B" eliminator circuit showing the transformer, a tube rectifier of the Raytheon type, filter, and resistances for controlling the output voltages to the various tube plate circuits.

Section I is the alternating current transformer which steps up the voltage from 110 volts A. C. to 200 volts A. C. The latter voltage is the most common delivered by standard eliminators unless high power tubes such as the 210 or 250 are used in the amplifier circuits.

Then the voltage is stepped up to 600 or 1,200, depending upon the system of power amplifica-

tion used. This type of eliminator system is shown in the power amplifier section of this book.

Section II is the rectifier system. Here the alternating voltage across the secondary winding S is constantly changing at the points X and Y. That is to say, during one instant X is positive, and Y is negative, and then the next instant Y is positive, and X is negative. The point O, however, being in the exact center of the winding, is always at zero voltage and hence it is used as the negative terminal of the "B" eliminator. Now as X is positive a current will flow in the direction of the arrow pointing downward and thence to the right through the choke coils  $L_1$ ,  $L_2$  to the various taps and through the receiving tube plates and through these tubes to their filaments and then back to the center point O of the transformer. This completes the circuit.

The next instant the point Y will be positive and the current will flow upward in the direction of the arrow and then to the right in the same manner as before. Thus it will be seen that a current is flowing at all times in one direction only through the choke coils and the receiving tubes, due to the action of the rectifier tube allowing current to flow only in one direction. If only two electrodes were used in the rectifier, i.e., the

plate and either one of the top or bottom electrodes alone, then a current would only flow when that side of the transformer which is positive is connected to the electrode. For example, if electrode A is omitted a current will flow upward only when the side Y and electrode B becomes positive and no current would flow as soon as Y becomes negative. This is known as half-wave rectification and if the two electrodes A and B are used it is known as full-wave rectification. Similarly, if a filament type of rectifier tube is used with only one plate, half-wave rectification will be produced and if two plates are used full-wave rectification will be produced. It is also possible to use two rectifier tubes, each having a plate and a filament, to produce full-wave rectification by simply connecting the filaments in parallel and the plate of one tube to X and the plate of the other tube to Y. The filaments would then have to be lighted by a separate transformer for filament lighting or a transformer having both high voltage and filament windings in one. This is described in the Amertran A, B and C eliminator system under the chapter on power amplifiers.

Section III. Here the alternating current is

smoothed out as it passes through the filter system.

Section IV. The resistances  $R_1$  drops the voltage below the maximum to the desired point. This is determined by the value of the resistance. Similarly, resistances  $R_2$  and  $R_3$  cut the voltage down still further until the desired amount is obtained. It will be remembered that various tubes in the receiving circuits require different voltages, depending upon their design. For example, a detector tube is usually operated at approximately 40 volts maximum, the radio frequency tubes between 90 and 135 volts and the amplifiers between 90 and 180. Hence the various resistances will give the proper voltage drop to the various tubes.

All types of "B" eliminators operate upon the principle just described, but a more detailed explanation will be given under the chapter on power amplifiers. Both alternating current and direct current systems of high quality amplification are completely analyzed there.

## CHAPTER XI

### RADIO TRANSMITTING STATIONS

**Broadcasting.**—Within the last few years broadcasting has become one of the necessities of public life. Radio programs of all natures are being broadcast daily over networks of stations covering the entire country. The engineers have developed telephony almost to a point of perfection, especially in the transmission of speech and music. The quality of the emitted wave from many of the high-powered stations is perfect. Atmospherical conditions which have previously marred good quality reception have been overcome by the use of super-power transmitting stations. Almost perfect reproduction can now be obtained at the receiving end with the proper type and arrangement of receiving equipment. Perhaps the only outstanding factor which has not been overcome is the atmospherical interference known as "static." This is usually manifested in the form of heavy cracking or crackling in the loudspeaker or telephones especially dur-



ing thunder and electrical storms or very warm weather. However, since the high power stations have been erected this interference has been considerably reduced by sending out waves of a higher power level than that of the static.

It may thus be stated that if reception from one of the high-powered broadcasting stations is distorted in the loudspeaker when no atmospheric disturbance is present, it is a sure indication that the distortion is due to either a poorly designed receiver, amplifier or loudspeaker. In other words, the question of poor transmission from high-powered stations is no longer considered since the advent of specially designed studios and equipment for the faithful reproduction of speech and music.

A broadcasting station consists of three principal parts: power plant, control equipment and studio. In some cases all of these three parts are contained in one room, while in the others they are separated by several floors in the same building. In certain cases the studio apparatus may be separated by miles, as is the case when church services are broadcast directly from a church or a speech broadcast directly from a meeting held at some remote point.

The power plant is the mainspring of the

broadcasting station and includes all the apparatus necessary to generate, modulate, and radiate the radio frequency power which leaves the aerial at the rate of 186,000 miles per second and reaches thousands and thousands of broadcast listeners.

It is necessary to provide several thousand volts for the plate current of the vacuum tubes used in the transmitter and this is usually done by transforming an alternating current from a low to a high voltage and then rectifying it through a number of rectifier tubes. This is really the "power" behind the radiophone transmitter.

This high voltage power operates the vacuum tube oscillators which generate the high frequency radio currents sent out through the aerial wires. There may be one or more of these oscillator tubes working together. When the oscillator is generating the high frequency undamped alternating current as it is called there is set up in the air an unexplained electric strain called oscillations.

This strain is in the form of electric waves which could we but see them would perhaps look much like the heat waves visible over a hot radiator. The number of waves per second, however,

is constant and they occur with such a rapidity that they are inaudible to the human ear unless modulated.

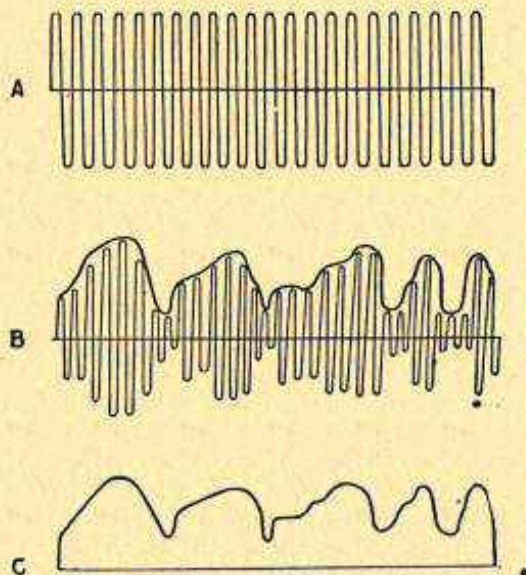

FIG. 65. Changes in wave form in a radio transmitter.

By modulating the wave sent out by the oscillator is meant to make the amplitude of this wave correspond to the amplitude of the sound waves to be transmitted. A current corresponding to the modulated wave is then set up in the circuit of any receiving apparatus tuned to the trans-

mitter. A better idea of these various wave transformations may be had by looking at Fig. 65. The top curve (a) shows the high frequency "carrier wave" generated by the oscillator tubes, the middle curve (b) shows this same wave modulated to correspond to the sound waves which are impinged on the microphone, and the bottom curve (c) shows the resultant effect on the radio receiving apparatus.

It is easy to realize that any speech or other matter transmitted from a broadcasting station must be carefully censored and the operator of the station must be ever on the alert to disconnect the studio from the transmitter if anything undesirable is about to be sent out. The manager of a broadcast station owes a distinct responsibility to his radio audience in this respect. To effect this control the operator is provided with a control cabinet which regulates the quality of the broadcasting and enables the operator to disconnect the studio from the transmitter at will. Then it is also necessary that the operator listen in constantly and be ready to shut down in case a distress signal from a ship is received. It is an unforgivable sin for any radio station to interfere with the reception or transmission of distress signals.

## RADIO TRANSMITTING STATIONS 271

The studio of the broadcasting station may be separated by a considerable distance from the room in which the transmitter itself is located. In some cases the studio is on the ground floor of a building and the power and control rooms are located on the roof directly under the aerial wires.

In most cases at least two studios are provided, one for large assemblies and a smaller one for individual speakers. The studio must be very carefully planned, for on it depends the success of a broadcasting station. No matter how well the transmitter operates if the acoustical properties of the studio are bad the broadcasting will sound bad in the radio receivers.

The placing of the singer, speaker or musical instruments in the studio is very important. Experience tells the studio director just how this should be done. The control operator can usually tell whether or not the modulation is good.

The operation of a broadcasting station calls for great care on the part of the entire personnel from the operator down to the studio manager and announcer. The equipment is thoroughly tested at regular intervals and always before the starting of a program. During the time that a program is being sent out the operator must con-

tinuously check up to see that the power and modulation sent out are satisfactory. In the studio the announcer and program director must see that the singers, speaker and other performers are properly arranged before the microphone pick-up device.

When everything is ready in the studio the control operator is notified through a signal light system, he flashes back and the program starts. If the operator notices anything wrong he can talk to the studio by telephone.

***Broadcast Transmitter Operation.***—

The theoretical operation of a broadcast transmitter will be clearly understood by referring to Figs. 66 and 67 during the course of reading. This illustration shows how the wave is impressed upon the microphone, amplified, carried, radiated and then received, amplified, detected and amplified again.

The operation is as follows: The sound vibrations produced by the man speaking is a result of the air particles being set into motion between the microphone opening and his lips. These vibrations cause a very thin diaphragm to vibrate in the microphone. The microphone is constructed in a manner so that when the diaphragm vibrates a small chamber containing loosely

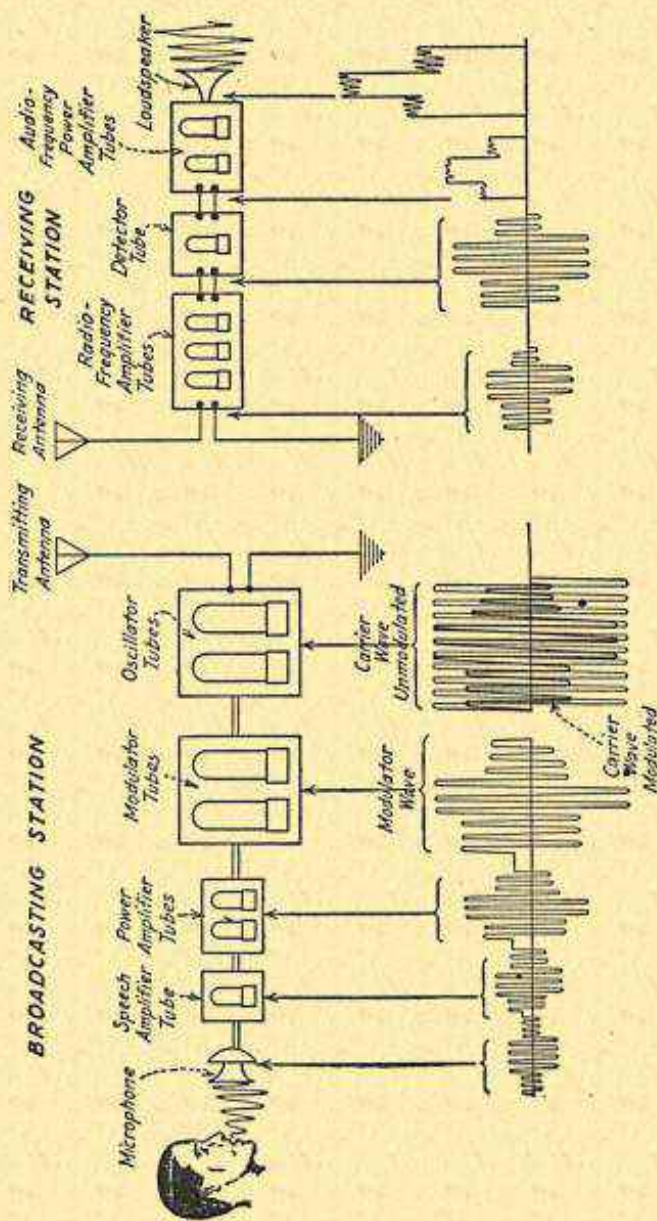

Fig. 66. Schematic diagram, transmitting station.

Fig. 67. Schematic diagram, receiving apparatus.

packed granules of carbon are set into motion. These granules form a conductive path for a small current flowing through them causing the effect of a resistance. Consequently the amount of current flowing through these granules is unvarying and steady. However, as soon as the diaphragm commences to vibrate due to the sound vibrations impinged upon it the small granules also commence to vibrate, which in turn varies the resistance.

Now, if the resistance changes, the current flowing through the carbon granules will likewise change, and since these changes are a result of a voice sound vibrations the current will vary at the same rate as that in which the voice vibrations are impinged upon the diaphragm.

Now, these electrical variations are extremely feeble and, therefore, must be suitably amplified before they can be transmitted. This is accomplished by passing the feeble signal variations to a vacuum tube known as a speech amplifier; from there the variations are impressed upon the grids of two more tubes called power amplifiers. In other words, the microphone signal variations must be stepped up considerably in order to feed the proper signal voltage to the grids of the modulator tubes, otherwise they would not oper-



ate satisfactorily. Now let us assume that the two oscillating tubes are adjusted to maintain a continuous oscillation at a certain wavelength, say 492 meters. These oscillations when put into the antenna system are of a high frequency (610,000 cycles per second) and of a continuous character. This is called the carrier wave in broadcast transmission. Now if these oscillator tubes are connected to the two modulator tubes in the proper manner, i.e., the plates of the modulator tubes to the grids of the oscillator tubes, the current variations in the plate circuits of the modulator tubes will be impressed upon the grids of the oscillator tubes. These variations upon the grids of the oscillator tubes when they are oscillating have the effect of what is known as modulating the high frequency or carrier wave. In other words, the process of modulation is the molding of the high frequency carrier wave to the outline of the voice signal variation so that the voice wave goes through space with the carrier wave. This can be likened to the following analogy, i.e., a man can be likened to the message carrying property or voice wave, while the high frequency carrier wave can be likened to an airplane carrying the man. This simply means that the airplane not being able to talk could not

convey a voice to a distant point unless it carried a speaking device, which in this case is the man. Similarly, the voice wave alone in a broadcast transmitter could not carry very far through space without the aid of a wave having high speed carrying abilities such as the high frequency carrier wave generated by the oscillator tubes. Hence, the modulator tubes when connected to the oscillating tubes will alter the shape of the carrier wave as illustrated in the figure.

At the receiving station the carrier wave of high frequency is amplified through a number of high frequency or radio frequency tubes and then passed to a tube which rectifies the high frequency signals, or in other words, separates the high frequency variation from the voice variation. The voice signal variation is then amplified through two or more audio frequency transformers and power tubes until the desired signal is heard from the loudspeaker.

**Types of Microphones.**—There are various types of microphones used in broadcasting studios for picking up the sound vibrations. Some of these are the carbon, magnetic and condenser types. The most commonly used microphones are the high quality carbon and condenser types.

The carbon microphone for very low power sets

may be the customary telephone carbon grain transmitter of the size used on telephones but built to stand slightly higher currents. The carbon microphone for high power transmitters is much larger in size and more sensitive to the sound waves within the broadcasting studio. Such a transmitter is affectionately known as "Mike" (microphone).

The carbon type transmitter consists of two conducting surfaces between which are placed carbon granules. Either one or both of these surfaces may be diaphragms. If only one is a diaphragm the transmitter is of the single button type, while if both conducting surfaces are diaphragms it is a two button type. The carbon type gives very good results and is used to a great extent in broadcasting work.

The magnetic transmitter consists of a coil so arranged that it is affected directly by the vibrations of the sound waves. It is surrounded by a strong magnetic field, and as the sound waves cause it to vibrate there is induced in it potentials corresponding to the frequency of the sound waves; these are amplified by a special first stage amplifier, and control directly the amplitude of the oscillating waves. This makes the modulator tube unnecessary.

This type of transmitter is very satisfactory when large orchestral ensembles are being broadcast, as individual control of the volume from any selected instrument may be effected.

Another type of transmitter pick-up device is the condenser transmitter. It is used to some extent in broadcast studio work and consists of a variable capacity mounted directly on or very near to the first stage amplifier of the modulator system. One or two additional stages of amplification are introduced to step-up the energy of the sound waves when this type of transmitter is used. There is an electromotive force of 500 volts impressed on the plates of the condenser when the transmitter is in operation. This type of transmitter is not used when remote control is desired, as it must be placed on or near the transmitting apparatus itself.

**Modulating Systems.**—There are various methods of obtaining modulation; one of the simplest is to insert an ordinary telephone transmitter directly in the aerial circuit. The resistance of the aerial to the radiation of the carrier wave was effected in such a way as to make the carrier wave conform to the shape of the sound wave. It was only possible to connect in a transmitter in the aerial circuit on very low power sets

and from an engineering standpoint the power lost did not make it a desirable method to use for modulation. It is not used except by amateurs for low power work. Using this method any regenerative receiver could be used as a radio telephone with a very limited range. This range might be three miles.

Another method of modulation is called the absorption method. It consists of placing a few turns of wire around the oscillation transformer of the transmitting outfit and connecting a carbon grain transmitter in a circuit with these turns of wire. The resistance of this absorption circuit is changed as the transmitter is spoken into, and it in turn "absorbs" energy from the carrier wave and molds it to conform to the sound waves.

Another method of modulation is called the magnetic modulating system. It consists of a special transformer with an iron core, the primary winding being in series with a low voltage electromotive force and a carbon transmitter, and the secondary (low resistance) is placed in the ground lead of the aerial circuit. When the microphone is spoken into it sets up a fluctuating field in the primary corresponding to the frequency of the sound waves. This field is induced into the secondary, which is in series with the

ground lead, and causes an identical modulation of the carrier wave. This method is very similar to the first method described except that there is very little energy lost by direct resistance in the aerial circuit. Magnetic amplifiers have the further advantage in that they can be made to handle any power, regardless of the size of the transmitter.

Grid modulation is now commonly used among amateurs. This is an efficient method of modulation and consists of a transformer of special design, the primary of which is connected in series with a low voltage electromotive force and carbon transmitter and the secondary connected between the grid and the filament of the oscillator tube. The transformer has an iron core.

The theory of operation is as follows: A high alternating current corresponding to the original sound waves is induced in the secondary of the modulation transformer referred to above; this changes the grid current, which in turn changes the plate current, which is being radiated out into space through the aerial.

This method is very efficient, for a small change in the grid current will produce a large change of plate current. All of the methods of modulation thus far described are for low power sets. The

## RADIO TRANSMITTING STATIONS 281

more powerful transmitters such as are used for broadcasting use a system similar to the Heising, or constant current system, now to be described.

For simple sets using one oscillator tube, one modulator is used. Fig. 68 shows one of the finest methods of modulation. It is to be noted that for simplicity's sake only one oscillator and

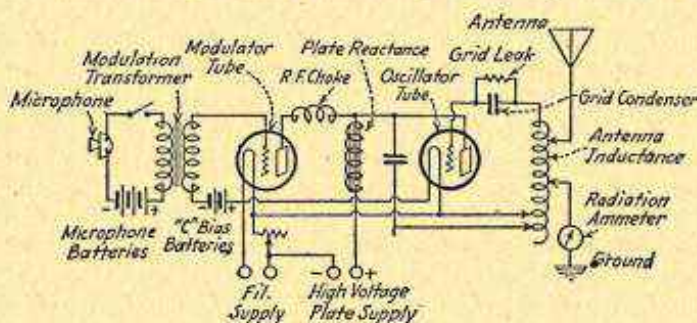

FIG. 68. Heising system of modulation.

its modulator are shown in the diagram. •The same general scheme is followed out when more tubes are used, both as oscillators and modulators. In this circuit the secondary of the modulation transformer controls the grid current. In addition a "C" battery is used which controls the modulator grid potential and, therefore, the plate current. This prevents overheating and controls the quality of the modulation. The plate

reactor (R. F. Choke) shown in the plate lead consists of several hundred turns of wire on an iron core. In cases where a filter bank is used this plate reactor is omitted. The radio frequency choke-coil which connects the plates of the oscillator and modulator tube together consists of about a hundred turns of wire on a 3-inch tube. This coil prevents radio frequency currents from entering the modulator tube and becoming dissipated in that circuit.

Modulation is accomplished by this circuit as follows: If the plate current of the modulator increases, due to the action of the plate reactor, the plate current of the oscillator decreases. The reverse is also true. Consequently, the oscillator plate current swings between the limits of the modulator plate current. If the plate of the modulator heats too much, more "C" battery must be added. The negative side of the "C" battery is always connected to the grid.

**Short Waves.**—Since 1924 rapid strides have been made in the transmission and reception of short waves in all the branches of the radio science, i.e., Broadcasting, Television and Telegraphy. Never before in any industry have so many revolutionary steps been made as in radio since the advent of short-wave transmission.



Practically unheard of and furthermore conceived as an impractical possibility when broadcasting first started, short-wave communication is the most talked-of radio development in use to-day. It has made possible such things as international broadcasting from the United States to all parts of the world. This is now being done every day by various stations in the United States such as WGY, WABC, KDKA, etc., in addition to their regular broadcasting wavelengths between 200 and 560 meters. These transmissions take place simultaneously over both wavelengths by using two transmitters.

Perhaps the greatest amount of credit for this advance is due to the amateur operators who in their early periods of experimentation illustrated how signals could be transmitted with a small vacuum tube such as is used in modern radio receivers to all parts of the world. Many amateurs in the United States communicated with other amateurs in Australia, Africa, Europe and South America with marvelous success, using but one receiving tube connected in a properly designed circuit. So many interesting phenomena have presented themselves in this method of communication that the Navy Department, Radio Corporation, and many commercial companies entered the

field to determine its true value. In the course of extensive research by these organizations the following outstanding facts have been determined which will no doubt make it the most important communication system of the future.

First, extreme distances can be covered with extremely small power. Second, due to the very high frequencies many more stations can transmit without interference in a very narrow band of wavelengths. Third, static or other atmospheric disturbances are considerably minimized, and, fourth, by the use of a certain band of wavelengths it was found that daylight transmission over thousands of miles could be obtained with very small power as compared to the very high power necessary for daylight transmission on the high wavelengths.

Of course, many obstacles and queer phenomena also presented themselves, one of which is the "skipping" of waves over certain areas in the vicinity of the transmitter. For example, a station transmitting signals from Connecticut would sometimes be inaudible in New York City but would come in with great volume in Florida or California, etc. This phenomena is assumed to be due to the property of the waves on account of their extremely high frequencies to move up-

## RADIO TRANSMITTING STATIONS 285

ward towards the sky and there reflect back to earth at certain points. This condition was somewhat relieved by the commercial companies by using higher powers but still much below the amount necessary for high-wave transmission during the daytime. Thus it was found that for night transmission higher waves were more efficient and for daytime transmission lower waves were more efficient. A list of the wavelengths found to be most efficient at different periods of the day and night are approximately as follows:

- 10 - 20 meters Daybreak to noon
- 20 - 30 meters " to middle afternoon
- 40 - 50 meters Afternoon to early evenings
- 60 - 80 meters Evenings and early mornings

After the 80-meter wave is passed transmission is always better during dark periods. In addition, however, it might be stated that the higher waves above 1,000 meters do not fade or skip as do the very low waves and for this reason the majority of trans-oceanic telegraphy and telephony is carried on at the high wavelengths. Once the fading and skipping phenomena have been thoroughly solved there is no doubt that transmission on short wavelengths will be much superior.

**Simple Short - Wave Transmitter.—**

Fig. 69 illustrates a simple short-wave telegraph transmitter similar to the one used by many amateurs who successfully communicate with foreign amateurs by dots and dashes.

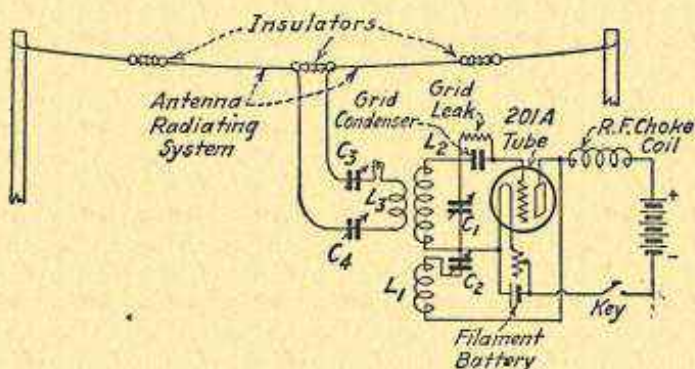

FIG. 69. Simple short-wave transmitter.

The reader will remember that when a filament is lighted and a "B" battery is connected between the plate and filament a current will flow from the "B" battery positive terminal to the plate, then through the tube space to the filament, back to the negative side of the battery, thus completing the circuit. Now in the above circuit the same thing happens as soon as the key is pressed.

Bearing in mind that a steady current is flow-

ing between the plate and the filament, note that the coil  $L_1$  and condenser  $C_2$  is really connected directly across the plate and the filament. Now if a condenser has the ability to store up energy in an electrical form it will be seen that a certain amount of current must have passed through the inductance coil  $L_1$  before passing into the condenser. Hence, whenever a current flows through a coil, if only for an instant (as in the case where condenser is connected across a non-varying direct current), a magnetic field will be set up about the coil. This action causes the magnetic field to induce an electromotive force or pressure across the coil  $L_2$ , which in turn causes a pressure to be applied to the grid condenser. The grid condenser being connected to the grid will then apply a pressure to it. Now this pressure might be of either a positive or a negative charge of electricity depending upon the direction of the current passing through coil  $L_1$  at the first instant. Assume for example that the grid receives a positive charge and see what happens.

It will be recalled that whenever the grid receives a positive charge the current which is flowing between the plate and the filament will be increased and if the grid receives a negative charge this current will be decreased. Hence if

the coil  $L_1$  induces an electromotive force into coil  $L_2$  by the cutting action of the magnetic field, and the grid is made positive, then the positive charge on the grid will increase the current flow between the plate and the grid. Thus, if at the first instant when the key was closed a current flowing between the plate and the grid caused a momentary current to flow through  $L_1$  and  $C_2$ , then as soon as the grid and its positive charge has increased the current between the plate and the filament, there will obviously be a current flow again through  $L_1$  and  $C_2$  which in turn would further increase the positive charge on the grid.

It would seem that the positive charge on the grid would become greater and greater indefinitely. This it does, but not indefinitely because the tube design and resistance in the circuit will only allow it to go up to a certain point, called saturation. Now as soon as this point is reached the charge on the grid disappears, and the grid automatically returns to normal (no charge). However, as soon as the grid drops to normal then the charge on the grid reverses to a negative charge, which in turn starts to decrease the plate current. Finally it also reaches a saturation point and returns to zero, but as soon as it starts to reach zero the grid is automatically made posi-

tive again and the entire procedure is repeated. It can be seen from this explanation that the current through the coil  $L_1$  and condenser  $C_2$  has a constantly rising and falling current through it which in turn effects the circuit  $L_2$  and  $C_1$  in the same manner. This rising and falling field in the circuit  $L_2$  and  $C_1$  will now be at a definite frequency or wavelength which depends upon the number of turns on the inductance  $L_2$  and the condenser  $C_1$ . Thus the circuit from the plate through  $L_1$  and  $C_2$  functioned as a sort of exciting circuit, i.e., to set the circuit  $L_2$   $C_1$  into motion (oscillation). Now if the inductance  $L_2$  has only about 10 turns of wire about 3 inches in diameter (fairly heavy) and the condenser a small variable capacity, then the circuit will oscillate at a very high frequency, that is, the smaller the number of turns on an inductance and the smaller the capacity shunted across it, the greater will be the frequency of the oscillations and consequently the lower will be the wavelength.

This entire action just described is known as "generating oscillations" and no matter how large or small the tube or tubes used, this principle is the same. Of course there are many different circuits for producing oscillations but the

one explained is one of the most commonly used by amateurs.

Now let us assume the circuit  $L_2 C_1$  to be oscillating at a very high frequency, say 7,500,000 cycles in a second, or 40 meters. These oscillations will produce a magnetic field around the coil  $L_2$  rising and falling at the above frequency. Now to transfer these oscillations into the radiating system, the coil  $L_3$  must be located in a magnetic relation to the coil  $L_2$  so that the high frequency magnetic field will induce a current flow into the radiating circuit. This necessitates adjusting the radiating circuit to the exciting circuit to exact resonance. This is accomplished by varying the resonating condensers  $C_3$  and  $C_4$  until the lamp burns brightly. The high frequency currents will then flow into both halves of the radiating wires and will produce electromagnetic waves which are radiated at a frequency of 7,500,000 cycles.

This frequency was used for illustration purposes because it is near one of the most commonly used amateur wavelengths.

Broadcasting stations sending out waves on the short wavelengths use similar oscillating systems, but the continuous wave or "carrier" is modulated, as was previously described in the broadcasting chapter.



## CHAPTER XII

### TELEVISION

IN this modern era of scientific accomplishments one of the outstanding contributions to the radio art is the development of television. Although impractical for commercial application at this stage, a tremendous amount of research has been carried on to make it an eventual reality. Just as radio broadcasting years ago was in a crude stage of development so is television today, but if we consider the strides that have been made in the former during the past few years there is every reason to believe that the latter will approach similar proportions in years to come.

**Basic Principle.**—In broadcast reception it will be remembered that it was necessary to convert the high frequency electrical variations into audible sound variations by a system of rectification (detection) and then amplifying these sounds through an audio system of amplification for loud speaker operation.

In television the outstanding requirement is to convert light fluctuations into current fluctuations and then to amplify these fluctuations through a suitable amplifier having a fine amplifying characteristic. The entire success of this conversion is due to a small cell known as the photo-electric cell which when subjected to light variations will produce a current flow in a properly connected

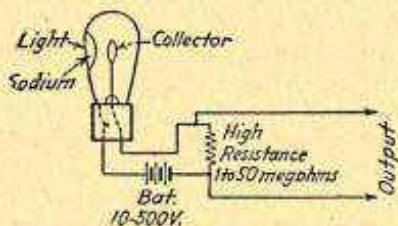

FIG. 70. Photo-electric cell.

circuit which will vary with the intensity of the light reflected upon it.

**The Photo-Electric Cell.**—The practical photo-electric cells consists essentially of an evacuated bulb containing two electrodes as shown in Fig. 70. The light sensitive material of sodium or potassium is deposited on the inner walls of the bulb and the collector electrode is in the center. A rare gas is used to create a current flow when the voltage is applied between the collector

and the sodium. If, therefore, a beam of light is directed upon the sodium surface the gas will become affected and cause a change in the current flow between the collector and the sodium. This result may then be amplified through the medium of vacuum tubes and recorded. The cell may, therefore, be termed an electrical eye which converts light fluctuations into current fluctuations.

For example, if a perforated disc operated by a motor is placed in the path of the light so that it will act as a shutter then the beam of light on the photo-electric cell will be controlled by the speed and the number of perforations of the disc and, consequently, if the light is interrupted at the rate of 1,000 times a second a feeble voltage variation will be obtained at the output terminals of Fig. 70. If now this output is connected to the grid and filament of a vacuum tube audio amplifier, an audible signal will be heard in the loudspeaker. It can therefore be seen that the function of the disc is to vary the intensity of the light reflected upon the photo-electric cell.

**Scanning.**—This is known as the process of dissecting the picture or subject to be transmitted. This is accomplished by a successive transmission of an electrical impression of the intensity of each spot on the picture or subject

until the entire surface has been explored or "scanned."

In other words, the more thoroughly a picture is scanned, the greater will be the detail but the longer the time required to transmit it. The light beam reflected from the picture to the cell is then interrupted by the disc so that the picture pulsations are converted into a low frequency current, fluctuating with the intensity of the picture. This signal is then combined with the transmitting station's carrier wave and broadcast just as the voice signal variations are superimposed on the carrier wave in modern broadcasting.

**Pioneer Television.**—One of the earliest demonstrations in practical television was given at the Royal Institute in Great Britain in 1926. The apparatus used was very crude but serves very well to illustrate the principle of television for the layman. Fig. 71 illustrates the arrangement used at this experiment.

The object to be transmitted is illuminated by a light tight partition with a system of lights similar to a photographic studio. These lights are trained on the object and by an arrangement of lenses in the partition the reflection from the object is collected by the lenses in a manner similar to a camera. The collecting lenses then throw

the light on the photo-electric cell, resulting in a current flow in the cell. This current will not fluctuate because the constant reflection of light merely produces a steady current flow in the cell and consequently no image can be produced. Therefore, in order to produce current fluctuations in the cell the light covering the cell must be interrupted into dark and light moments,

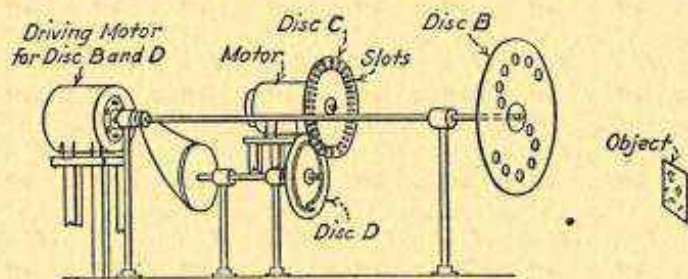

FIG. 71. Scanning disc apparatus.

thereby changing the resistance of the cell in exact accordance with the intensity of light falling upon it. These light impulses are then transferred into electrical impulses and amplified by vacuum tubes. These impulses are then fed to the vacuum tube broadcast transmitter and radiated by the carrier wave. Here the television impulses modulate the carrier wave instead of the ordinary speech impulses as in the modern broadcast transmitter.

The arrangement used in this pioneer system for interrupting the beam of light collected by the lenses is accomplished by interposing a combination of discs between the object and the photo-electric cell as in Fig. 71.

The first disc, lettered B, is made up of a series of lenses, which as the disc revolves, causes a succession of images of the object to be passed to the next disc, C. This disc contains a great number of slots and revolves at a high speed. After the light passes disc C the light flashes must pass through the spirally arranged slots of disc D. This action causes a subdivision of the image to a tiny square of the image, or in other words, each flash corresponds to a tiny square of the image. It is the arrangement of the lenses on disc B that selects a narrow strip of the image as projected through the collecting lenses which are located between the object and the disc. The narrow portion of the image is then swept across the openings in disc C by the rotation of disc B by virtue of the lens arrangement, i.e., each succeeding lens is set a little nearer to the center of the disc, so that, as it revolves successive parts of the image are covered until the entire image has been swept across the openings in disc C. Hence the rotary action of both discs C and D

have the effect of chopping up the long image strips into very small squares similar to a sheet of finely graduated graph paper. Each square represents a small portion of the image and the light intensity in each square depends upon the amount of light reflected from the object under observation.

This model has been considerably improved by some of the more recent developments to be described in the following paragraphs.

**Improved Methods.**—In the earlier methods of picture transmission the object to be transmitted was scanned with a single photo-electric cell which necessitated a more thorough examination of the picture to be transmitted in a similar manner to a person having one eye closed. This analogy would seem to indicate that one photo-electric cell would be even more thoroughly handicapped because it had to view the object about twenty times at least every second to create the illusion of a continuous vision at the recording end. Thus if two or more photo-electric cells are used it is possible to reduce the speed of the scanning device so that each cell will linger longer on a given point, or if the speed is kept constant it will be possible to reduce the illumination of the object many times. It was insuffi-

cient illumination of the object which presented the greatest obstacle in the earlier developments of television due to the fact that in order to properly reproduce definite points on the subject a light in excess of sunlight had to be used which is obviously impractical from a physical standpoint. The use of a number of photo-electric cells

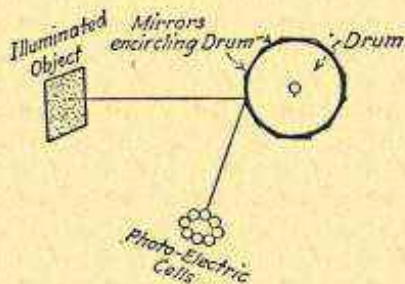

FIG. 72. Reflecting scheme.

relieved this condition and greatly aided in the development of television.

Fig. 72 illustrates a system using a group of photo-electric cells.

If the object is illuminated and a revolving disc is equipped with mirrors set at different angles and seven photo-electric cells placed as shown, the group of cells will receive light fluctuations by the reflecting mirrors and revolving disc which will produce a current fluctuation between the collector



and sodium of the cells, resulting in a current variation which will then be superimposed upon the carrier wave of the transmitter and radiated.

Another development which is perhaps the greatest contribution to the television art is the Gray system, invented by Dr. Frank Gray of the Bell laboratories. This system of scanning has made it possible to send pictures over telephone lines of almost perfect reproduction and will no doubt play an important rôle in the future of television.

It will be remembered that in the previous system the object to be transmitted was floodlighted with great brilliancy as the photo-electric cells were looking it over systematically. Here the great drawback lies in the objectionable illumination of the subject and the limitations of the photo-electric cells in handling heavy currents. This is due to the fact that if a heavy current is flowing through the cell as a result of the bright light, distortion will ruin the picture reproduction. Therefore, in order to obtain the proper results small photo-cells had to be used to prevent distortion and thus the floodlights had to be exceptionally bright to give the proper detail to the picture. Thus, with the previous system satisfactory results could only be obtained by using

extremely bright illumination and a number of photo-cells, which if carried on would reach obvious limitations.

In this new system of scanning the photo-electric cells are kept in a fixed position and the light is played on the object, similar to an eyeball in a fixed object. The difference can be seen in that in the former method the eyeball rolled, so to speak, and the illumination remained constant.

It must be remembered that if both the object and the photo-cell are in darkness no current will flow between the collector and the sodium, but if a light is played on both the object and the cell simultaneously a current will flow. However, under this condition the current flow will be steady and, since there is no variation of the current flow, the transmission will not be affected. The only noticeable effect will be a gray monotone in the cells due to the object contrast which is similar to a camera out of focus.

It is important to note that the cells respond to a diffused reflection of light such as produced by a fine ray of concentrated light from an arc lamp. The arc light is rich in ultra-violet wavelengths and has a pronounced effect upon the action of the cell. This concentrated ray of light is now played on the object in a similar manner

to a person reading a newspaper with the aid of a narrow beam of light, point to point and line to line. The difference being merely in the rapidity with which the object is covered. In television, using this system, the whole object must be covered at a greater speed from point to point and line to line in about  $1/18$  of a second and repeated 18 times a second until the transmission is completed.

In this system the light is made to flit about so that the observer can only see that particular portion of the object on which the concentrated beam is shining and the light is never at more than one point at a time. In addition, the light must cover the object so rapidly that the effect in the observer's eye, caused by the reflection of the light as it is moving from point to point, does not die out before the light is again reflected from that point. In television the light must be moved as rapidly as possible so as to give a more detailed result and a minimum flicker. This rate of repetition is about 24 times in a second as contrasted with motion pictures, where the rate of change to give illusion of continuous motion is 16 per second.

It can thus be seen that with this system two outstanding improvements are obtained, i.e., the

intensity of the scanning beam can be greatly increased because of its concentrated effect, and, second, it permits the use of larger and more sensitive photo-electric cells without danger of picture distortion due to excessive cell currents. The use of the larger cells also permits a greater speed of scanning because they will pick up more of the

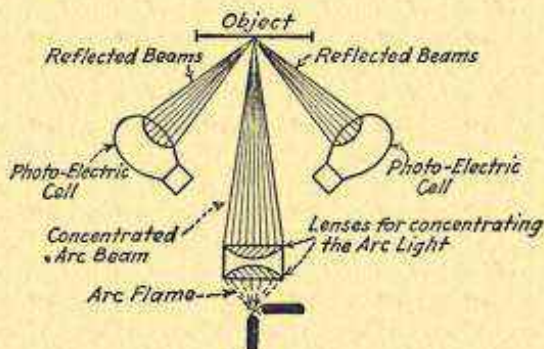

Fig. 73. Method of lighting object to be transmitted.

light beam that is reflected and consequently will produce a more accurately defined picture because of the lower photo-electric current that will be amplified by the vacuum tube amplifiers.

Fig. 73 illustrates the scanning arrangement of the Gray system.

**The Photo-Radio System.**—Developed by the Radio Corporation as early as 1922 and

perfected for commercial use in 1924 easily makes this one of the outstanding systems in the commercial field to-day. Fig. 74 illustrates a schematic layout of the apparatus used. The function of each part is as follows:

The light rays emanating from the light cham-

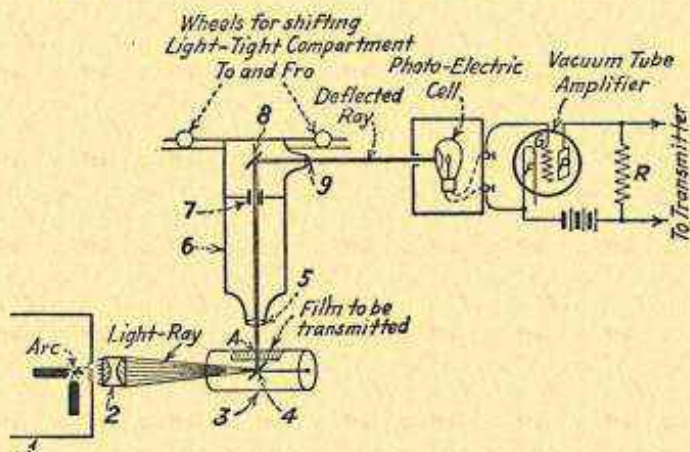

FIG. 74. Photo-radio apparatus.

ber (1) are condensed through the condensing lenses (2). These lenses prevent the light rays from spreading out in order that the rays may pass through the glass cylinder (3) and on to the deflecting mirror (4). At this point the light rays are deflected ninety degrees onto the focusing lens (5) of the light-tight compartment (6).

This lens then focuses the rays through the small opening (7) so that the light rays strike the mirror (8) which bends the rays and passes them out onto the photo-electric cell.

**Operation.**—A negative or positive film is attached to the glass cylinder and the light is turned on. The rays from the source of light are now directed on a very small spot of high brilliancy at point A. Hence the light passes through the glass cylinder and the film by virtue of the reflecting mirror (4).

The light-tight compartment is now set in motion by a motor causing it to move to and fro in a horizontal direction. This action shifts the spot of light back and forth across the film due to the fact that both the reflecting mirror (4) and the focusing lens (5) have the same relative position. Hence as the light-tight compartment is shifted from the extreme left to the extreme right of the glass cylinder the spot of concentrated light also moves horizontally across the surface of the film on the cylinder. However, as soon as the light spot reaches the extreme right, the cylinder turns a fractional part of an inch and the light beam which is now moving from the extreme right to the extreme left will scan the new portion of the film. Thus as the light is shifted from left to

right and vice versa, the cylinder turns at each change until the entire film is "scanned." It can thus readily be seen that if no film is attached to the glass cylinder the light reflected through the compartment by means of the reflecting mirror upon the deflecting mirror and thence to the photo-electric cell would not vary and therefore no current fluctuation would be manifested in the cell. If, on the other hand, a film is placed on the glass cylinder then the light passing upward through the light-tight compartment would have a varying density due to the different shades of transparency on the film. For example, if the film is heavily shaded in one portion and light in another portion then the rays of light would be decreased in intensity during the period that the darker portion is being scanned and consequently if the film has various shades then the light fluctuations will vary accordingly.

It is this fluctuation of light when deflected by the mirror (8) upon the photo-electric cell which produces current fluctuations in exact proportion to the variation of light density.

These fluctuations being of very feeble amplitude must be amplified in order to produce the proper amount of modulation upon the transmitting tubes. This is accomplished by connecting

the photo-electric cell to the grid and filament of a vacuum tube as in Fig. 74. Here the feeble voltage fluctuations between G and F will produce corresponding fluctuations across the resistance R but of greater amplitude due to the amplifying action of the tube and the resistance. These may be further amplified by adding more tubes and resistances until the proper voltage is obtained, which can modulate the carrier wave produced by the transmitting tubes and thus radiate the picture fluctuations being transmitted.

**Television Receiver.**—The television receiver is practically the same as any standard broadcast receiver, and may use one or more stages of radio frequency amplification as desired.

The audio frequency system, however, is a very important item and must be constructed very carefully and efficiently. The perfection of a good picture depends upon how good a signal is transmitted in the first place and upon how efficiently it is reproduced at the receiving end. This is important because the frequencies emitted in picture transmission range from 18 to 20,000 cycles and therefore the amplifier must have an even amplifying characteristic over the entire band of frequencies. Such amplifying systems as



resistance, impedance and transformer coupling may be used with very good results. The transformer method is probably the most costly because transformers designed for broadcast reception may not have a straight line amplifying characteristic over the 18 to 20,000 cycles. This range may be obtained, however, by choosing the proper values of coupling condensers and resistances. If, therefore, the amplifier is properly designed and connected to a standard tuned radio frequency receiver and detector the picture signals will be properly amplified. Now, then, the object is to reproduce the picture just as the loudspeaker in the broadcast receiver reproduces the speech and music. The loudspeaker in a television receiver is a scanning device and a small tube known as a neon or Kino-Lamp. Before continuing with the operation of the receiver the neon tube will be explained.

**The Neon Tube.**—This tube is most commonly known as a "glow lamp" and consists of an evacuated glass bulb with two square metallic plates. Into this bulb a neon gas is inserted which when subjected to a potential by connecting batteries across the plates produces a soft orange colored "glow" on one of the plates, depending upon which plate is connected to the positive and

which to the negative side of the power supply. This glow takes place uniformly over the surface of either plate. The plates are placed very close together so as to prevent a glow from taking place between the plates. This is done due to the fact that when the plates are separated the electrons which are emitted from one of the plates will collide with the gas atoms and will result in an ionization between the plates which will produce a path of low resistance between the two plates. This condition does not take place when the plates are close together because the electrons emitted have not been able to gain speed enough to collide with and break up the gas atoms, therefore, maintaining a path of low conductivity or high resistance. This condition is desirable because it will produce a greater amount of lumina<sup>tion</sup> of the plate and consequently a more satisfactory operation for the reproduction of television signals.

***Receiver Scanning Device.***—This disc arranges the light signal fluctuation from the glow lamp to the proper image arrangement. This is accomplished by placing the neon tube near the perforated scanning disc in such a manner that the light fluctuations will pass through the small holes in the disc. Hence, when the disc

is placed into operation by connecting it to a motor, the light variations will pass through the perforations in the proper proportions, which is dependent upon the number of holes in the disc and the speed of rotation.

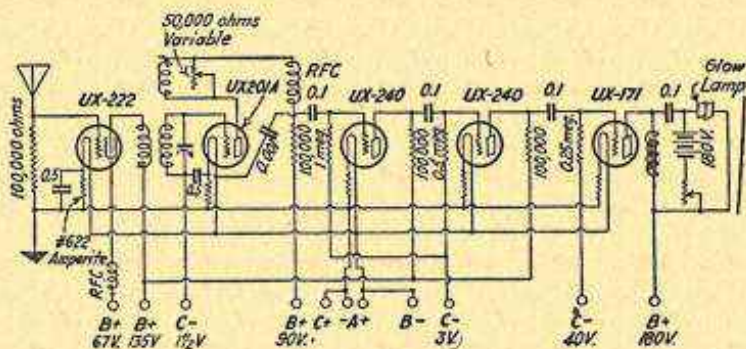

FIG. 75. Television receiver (scanning disc not shown).

### ***Complete Operation of the Receiver.***—

Fig. 75 illustrates an efficient television receiver complete from the antenna system to the scanning disc. This diagram should be referred to freely for a clear understanding of its operation.

Adjust the tuning condensers to the proper dial setting of the station transmitting the pictures. Insert a pair of telephones or loudspeaker in place of the glow lamp and disconnect the batteries which connect to the two plates. If the sta-

## 310 RADIO UP TO THE MINUTE

tion is transmitting signals a distinct whistle will be heard in the telephones or loudspeaker. Adjust the receiver for maximum volume in the usual manner. Reconnect the glow lamp and batteries. Start the motor which rotates the scanning disc. Place the scanning disc parallel with the plates of the glow lamp. Change the speed of the motor up and down until the criss-cross lines that are shooting up and down and back and forth on the surface of the disc, in front of the neon tube, disappear and then the image of the object that has been transmitted will appear. If the images wander in and out it simply means that the speed of the motor is not properly synchronized with the light fluctuations and, therefore, the motor speed controlling resistance must be carefully adjusted until the image is clearly presented. It will be noticed that before the signal is fed to the neon tube the square of orange colored light observed through the disc will be streaked with fine dark lines. Then as soon as the receiver is adjusted to the wavelength of the transmitting station the current in the glow lamp will fluctuate because it has been modulated by the variations of the incoming signal. If, when the picture is clearly reproduced it is found that the image is rightside up but reversed,

then reverse the disc, and also the direction of rotation of the motor. If, on the other hand, the image is negative instead of positive as in a photograph film it will be necessary to reverse the A. C. connections to the glow tube.

## CHAPTER XIII

### POWER AMPLIFICATION

ONE of the outstanding necessities for the production of fine quality amplification is the design of the amplifier system. It has been stated how the signal is rectified by the detector tube and then amplified by a system of audio frequency amplification. There are many of these systems in use, such as the resistance coupling, impedance coupling and transformer coupling methods. All of these systems can produce perfect quality if they are carefully designed to amplify all the frequencies of the voice and musical range from approximately 30 to 8,000 cycles. The difficulty encountered is mainly the inability of the ordinary tubes to handle the signal without being overloaded after it has passed through one or more of the amplifier stages. This results in serious distortion no matter how perfect the loudspeaker may be. This condition, therefore, necessitates not only the proper resistance, impedance or transformer design for the amplification of all

the frequencies in the audible range but the efficient handling of the increased stepped-up voltages without distortion. In other words, if the amplifier has a good frequency range and very little volume is desired, such as for ordinary telephone operation, then the ordinary tubes will be able to take care of the signals without overloading.

In broadcast reception, however, it is absolutely necessary to have both volume and quality if perfect reception is to be had. This can only be obtained by a suitable system of amplification which uses large tubes capable of handling greater power without distortion.

It is the generally accepted belief that a power tube is used to generate a maximum voltage in the plate circuit, where the loudspeaker is connected, to give greater volume. This, however, is not the case. The power tube is used for supplying the maximum of power, *not* voltage, to the output device to which it is coupled. There is a great difference between voltage amplification and power amplification and if the former were all that were necessary then the ordinary tubes with more stages of amplification would certainly give enough volume. Hence, since it is desired to have both volume and quality, a number of

highly efficient audio frequency power amplifier systems will be discussed.

**Push-Pull Amplification.**—This system is one of the most extensively used to-day for the production of high volume and quality amplification. Fig. 76 illustrates the method of connecting a push-pull transformer to power tubes.

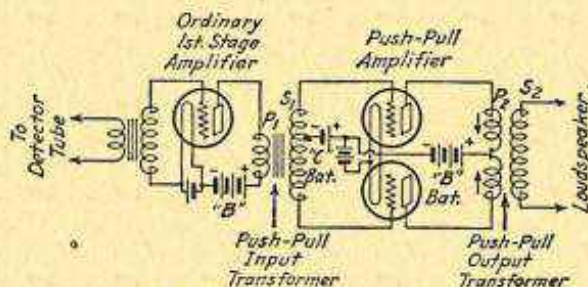

FIG. 76. Push-pull amplifier.

The high efficiency and distortionless reproduction produced by this amplifier is due to various electrical reactions which may briefly be defined as follows:

The push-pull amplifier consists essentially of two identical power tubes which are operated at the same grid and plate voltages, respectively, and excited by the electromotive force applied across the secondary winding S<sub>1</sub>, due to the alternating signal fed from the detector and the first



audio amplifier. These alternating voltages across  $S_1$ , apply to the grids of both tube charges of different polarity, that is, when the top end of the winding is at one certain polarity, then the bottom end of the winding will be at an opposite polarity. Then when the secondary changes its polarity due to the audio alternating current reversals then the grid charges again change, and so on until the signal ceases. In other words, the grids are excited in what is known as phase opposition. This effect, more completely analyzed, means that the fundamental frequency part of the output electromotive force of one tube will be in phase opposition by 180 degrees with that of the other tube. This simply means that the grids of the power tubes never receive the charges at the same instant. Thus there is really a double frequency going through one complete cycle for every half cycle of the fundamental frequency. If the grids receive charges due to both the two fundamental frequencies and the double-frequencies, the plate current in the two halves of the windings of  $P_2$  will vary accordingly. For example, the two fundamental frequency currents flowing in the plate circuits will be in opposition to each other because they are 180 degrees out of phase, which

will result in their being neutralized. This is illustrated in the figure by the two arrows pointing towards each other showing that the currents flowing through the two coils produce magnetic fields in opposition to one another, hence resulting in neutralization. On the other hand the double frequency current parts, being in phase with each other, tend to build up or, in other words, add to one another. This constitutes the adding of the electromotive forces and operates as a sort of frequency doubling device. If, on the other hand, the two output windings which are connected in series are so wound that they buck each other, then the double frequencies would be neutralized and the fundamental frequencies, being of opposite polarities, would add to each other and constitute the electromotive output into the speaker.

This is the desirable effect because, by eliminating the double-frequency currents (technically known as the second harmonic frequency currents) the output electromotive force to the speaker will represent an undistorted amplified reproduction of the input electromotive force.

The middle point on the winding S, is to supply the proper negative grid bias simultaneously

to both tube grids so that the proper negative voltage may be constantly supplied. The middle tap of the winding  $P_2$  is to supply to both plates the proper direct current voltage. These values depend upon the type of tube used and are usually given by the manufacturer on the tube carton; these values must be strictly adhered to if proper results are to be expected.

It is, of course, quite obvious that perfect reproduction cannot be obtained if the signal output from the detector is distorted to begin with. A good amplifier faithfully amplifies whatever it gets. Hence, if poor quality is fed into the first transformer poor quality will be reproduced by the loudspeaker.

There are many causes for feeding distorted signals to the amplifier. The most important of which are as follows:

1. Defective tubes in the radio frequency or detector stages.
2. Plate potentials too high or too low.
3. Negative "C" bias too high or too low (not critical).
4. Receiver tuned too sharply.
5. Circuits not properly by-passed with condenser.

(Note the complete circuit diagram Fig. 79.)

## 318 RADIO UP TO THE MINUTE

6. Tubes oscillating due to coupling between coils or wires. (Remedied by shielding.)
7. Grid wires and plate wires running parallel and close.
8. Circuits improperly adjusted for resonance.
9. If "B" eliminators with poor filters are used.

If the distortion is in the amplifier system it usually can be traced to some of the following troubles:

1. Improper grid bias on one or more tubes.
2. Improper plate potential on one or more tubes.
3. Poor grade of transformers.
4. Transformer input and output leads, not bypassed.  
(See diagram Fig. 79.)
5. Grid and plate leads too close to each other.
6. Audio transformers too close to each other.
7. If "B" eliminators with poor filtering devices are used.
8. Tubes oscillating (Remedy: insert a 50,000 ohm resistance in each grid bias lead. Keep grid and plate wires apart. Use lower plate voltages.)
9. Defective tubes.
10. Poor grade of loudspeaker. (Dynamic recommended.)

All distortion in the audio amplifier can be eliminated if one of the high quality amplifiers described in this chapter are used.

***Most Sensitive Receiver and Finest Quality Amplifier.***—The receiver and power amplifier illustrated in Fig. 77 is without question one of the finest that can be made.

The receiver uses the band-pass system of tuning previously described. In addition it is equipped with the extremely sensitive shielded grid tubes thus making distant reception appear local.

The amplifier utilizes the very efficient system of push-pull amplification with the most powerful receiving tubes made in recent years. This complete receiver and amplifier make possible tremendous volume with perfect quality when used with one or more dynamic speakers and is highly recommended where extreme volume is desired such as in theaters, dance halls, etc.

The complete list of parts required for this great receiver and amplifier is as follows:

*Receiver Parts:*

- 1—Hammarlund coil set No. H Q 29 ( $A_1, A_2, A_3$ )
- 5—Hammarlund midline condensers ( $C_1$  to  $C_5$ )
- 1—Sangamo fixed condenser .00025 mfd. ( $C_6$ )
- 1—Sangamo fixed condenser .001 mfd. ( $C_7$ )
- 4—Parvult by-pass condensers ( $C_8$  to  $C_{11}$ )
- 3—Hammarlund chokes No. 85 ( $L_1, L_2, L_3$ )
- 1—Carter "Hi-Pot" potentiometer ( $R_1$ )



- 1—Durham Metallized resistor 2 megohms ( $R_2$ )
- 4—Filament resistors, 10 ohms ( $R_6, R_7, R_8, R_9$ )  
each ( $R_{10}, R_{11}$ )
- 2—Hammarlund knob-control drum dials No. SDW
- 9—Benjamin 4 prong sockets
- 1—Benjamin 5 prong sockets for UY 227
- 1—Hi-Q 29 Master foundation unit.

This includes all hardware, shields, chassis, shafts, binding post strips, clips, panel, etc.

- 1—6-volt storage battery

*High Quality Amplifier Parts:*

- 2—type 250 amplifier tubes
- 2—type 281 rectifier tubes
- 1—audio choke (secondary of old audio transformer ( $L_1$ ))
- 1—audio choke ( $L_2$ ) also old secondary
- 1—1,000 ohm wire wound resistance with one sliding contact ( $R_2$ )
- 1—1,000 ohm wire wound resistance to pass 110 milliamperes
- 1—1,000 ohm wire wound resistance with three sliding contacts
- 1—Amertran DeLuxe Audio Transformer
- 1—Amertran Input Transformer Type 151
- 1—Amertran Interstate Transformer Type No. 710
- 1—Amerchoke Type No. 641
- 1—Amerchoke Type No. 557
- 1—Amerchoke Type No. 709
- 1—Amerchoke Type No. 854
- 1—Amertran Voltage Divider, Type No. R400

- 1—Amertran Power Transformer, Type PF No. 250
- 1—Amertran Heater Transformer, Type H No. 67
- 1—UY 227 Heater Type Tube
- 2—UX 226 Tubes



