

CONSTRUCTION OF NEW TYPE TRANSATLANTIC RECEIVING SETS

COMPLETE INFORMATION, WITH SPECIAL DRAWINGS,
HOOK-UPS AND PHOTOGRAPHS, ON HOW TO BUILD AND
USE THE NEW TYPES OF TRANS-OCEANIC RECEIVING SETS

INFORMATION IS ALSO GIVEN ON THE USE AND EX-
TERNAL CONNECTIONS OF THE LOUD SPEAKER AND
ITS APPLICATION IN RECEIVING HIGH SPEED SIGNALS
FROM DISTANT STATIONS

SCHEDULE OF THE TRANS-OCEANIC STATIONS AND THE
RECENT RECOMMENDATIONS OF THE NATIONAL BOARD
OF FIRE UNDERWRITERS IS INCLUDED

By

M. B. SLEEPER

*Author of "Radio Hook-Ups," "Design Data," "Radio Experimenters' Handbook,"
"Construction of Radio Phone and Telegraph Receivers for Beginners," etc.*

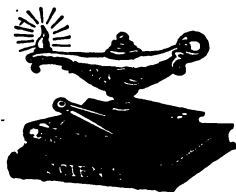

NEW YORK

THE NORMAN W. HENLEY PUBLISHING COMPANY
2 WEST 45TH STREET

1922
L. C.

THE
HARVARD
VOLUME

COPYRIGHTED, 1922

BY

THE NORMAN W. HENLEY PUBLISHING Co.

PRINTED IN U. S. A.

Composition, Electrotyping and Press Work
By Publishers Printing Company, New York

PREFACE

At this time a good deal of interest is being shown in the reception of the music, speeches, etc., from the local and distant broadcasting stations. It is not as difficult as ordinarily believed to be able to receive the transoceanic telegraph stations almost anywhere in the United States. It gives one a decided thrill to be able to listen to messages being transmitted from London, Nauen, Rocky Point, L. I.; Bolinas, California; Honolulu or even Japan, in a single evening at the same time the ordinary Broadcasting Stations are transmitting their afternoon or evening schedules. This—all of this is possible and the most of the long distance stations transmit at a slow rate of speed—a decided advantage to the beginner.

It is the purpose of this little book to show just how some of the receiving sets, capable of doing just that which has been described, can be built.

The use of the loud-speaking telephone receiver (to eliminate the necessity of wearing head receivers) is also described. The loud-speaker may be used in connection with a talking machine to record telegraph signals. All this is intensely interesting. A schedule of the transoceanic stations and the latest recommendations of the National Board of Fire Underwriters is given for the information of the novice and experimenter.

M. B. SLEEPER.

July, 1922.

537.811

3

S 200

481130

230676

CONTENTS

	PAGE
PREFACE.....	3
CHAPTER I—Trans-Oceanic Reception on Long Waves....	11
CHAPTER II—Single Circuit Receiver.....	16
CHAPTER III—Loosely Coupled Oscillating Receiver.....	27
CHAPTER IV—High Efficiency Long Wave Receiver.....	37
CHAPTER V—Loud Speakers, Relays and Phonograph Recorders.....	46
CHAPTER VI—Home-Made Wavemeters.....	56
CHAPTER VII—The Increasing Complexity of Radio Equip- ment Makes Necessary Clear Marking of the Parts and Connections.....	80
CHAPTER VIII—Recent Recommendations of a Com- mittee of the National Board of Underwriters with Rules and Regulations for Fire Protection.....	86
CHAPTER IX—Notes and Schedules on Some of the High Power Trans-Oceanic and Point to Point Radio Tele- graph Stations of the World.....	94

INTERNATIONAL RADIOTELEGRAPHIC CONVENTION



LIST OF ABBREVIATIONS TO BE USED IN RADIO COMMUNICATION



ABBREVIATION	QUESTION.	ANSWER OR NOTICE.
FRB	Do you wish to communicate by means of the International Signal Code?	I wish to communicate by means of the International Signal Code.
QRA	What ship or coast station is that?	This is
QRB	What is your distance?	My distance is
QRC	What is your true bearing?	My true bearing is degrees.
QRD	Where are you bound for?	I am bound for
QRF	Where are you bound from?	I am bound from
QRG	What line do you belong to?	I belong to the Line.
QRH	What is your wave length in meters?	My wave length is meters.
QRJ	How many words have you to send?	I have words to send.
QRK	How do you receive me?	I am receiving well.
QRL	Are you receiving badly? Shall I send 20 ₄ * * * * * for adjustment?	I am receiving badly. Please send 20 ₄ * * * * * for adjustment.
QRM	Are you being interfered with?	I am being interfered with.
QRN	Are the atmospheres strong?	Atmospheres are very strong.
QRO	Shall I increase power?	Increase power.
QRP	Shall I decrease power?	Decrease power.
QRQ	Shall I send faster?	Send faster.
QRS	Shall I send slower?	Send slower.
QRT	Shall I stop sending?	Stop sending.
QRU	Have you anything for me?	I have nothing for you.
QRV	Are you ready?	I am ready. All right now.
QRW	Are you busy?	I am busy (or: I am busy with). Please do not interfere.
QRX	Shall I stand by?	Stand by. I will call you when required.
QRY	When will be my turn?	Your turn will be No.
QRZ	Are my signals weak?	Your signals are weak.
QSA	Are my signals strong?	Your signals are strong.
QSB	Is my tone bad?	The tone is bad.
QSC	Is my spark bad?	The spark is bad.
QSD	Is my spacing bad?	Your spacing is bad.
QSE	What is your time?	My time is
QSF	Is transmission to be in alternate order or in series?	Transmission will be in alternate order.
QSG	Transmission will be in series of 5 messages.
QSH	Transmission will be in series of 10 messages.
QSI	What rate shall I collect for?	Collect.
QSK	Is the last radiogram canceled?	The last radiogram is canceled.
QSL	Did you get my receipt?	Please acknowledge.
QSM	What is your true course?	My true course is degrees.
QSN	Are you in communication with land?	I am not in communication with land.
QSO	Are you in communication with any ship or station (or: with)?	I am in communication with (through).
QSP	Shall I inform that you are calling him?	Inform. that I am calling h/m.
QSQ	Is calling me?	You are being called by
QSR	Will you forward the radiogram?	I will forward the radiogram.
QST	Have you received the general call?	General call to all stations.
QSU	Please call me when you have finished (or: at o'clock)?	Will call when I have finished.
*QSY	Is public correspondence being handled?	Public correspondence is being handled. Please do not interfere.
QSW	Shall I increase my spark frequency?	Increase your spark frequency.
QSX	Shall I decrease my spark frequency?	Decrease your spark frequency.
QSY	Shall I send on a wave length of meters?	Let us change to the wave length of meters.
QSZ	Send each word twice. I have difficulty in receiving you.
QTA	Repeat the last radiogram.

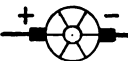

*Public correspondence is any radio work, official or private, handled on commercial wave lengths. When an abbreviation is followed by a mark of interrogation, it refers to the question indicated for that abbreviation.

- LIST OF SYMBOLS -

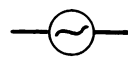
Battery 



Direct Current Dynamo ...  or 

Alternating Current Generator }  or 

Fixed Capacitance (Condenser)  or 

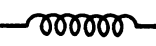
Variable Capacitance (Var. Condenser) 

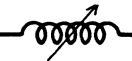
Fixed Inductance (Air Core Coil) 

Variable Inductance (Air Core Coil)  or 

Variometer (Variable Inductance) 

Fixed Coupling of Coils (Fixed Inductive Coupling) 

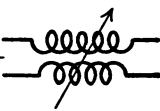
Variable Coupling of Coils 

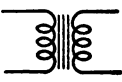
Transformer 

Iron Core Inductance (or Reactance Coil) 

~ LIST OF SYMBOLS ~

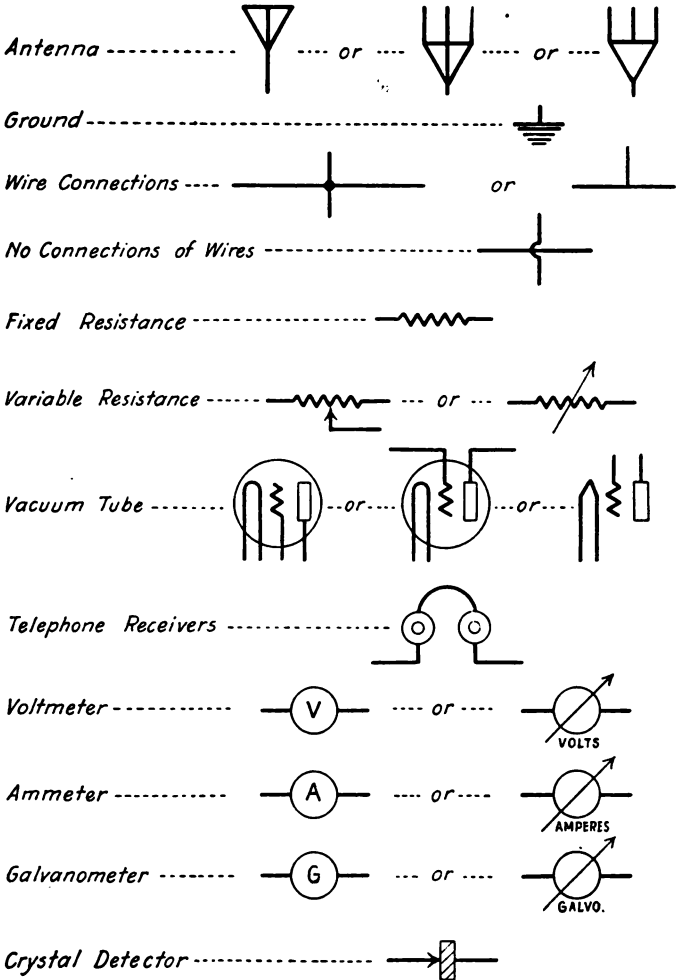

INTERNATIONAL MORSE CODE AND CONVENTIONAL SIGNALS

TO BE USED FOR ALL GENERAL PUBLIC SERVICE RADIO COMMUNICATION

1. A dash is equal to three dots. 8. The space between two letters is equal to three dots.
 2. The space between parts of the same letter is equal to one dot. 4. The space between two words is equal to five dots.

<p>A •••••</p> <p>B ••••••••</p> <p>C ••••••••••</p> <p>D ••••••••</p> <p>E ••••••</p> <p>F ••••••••••</p> <p>G ••••••••••</p> <p>H ••••••••••</p> <p>I •••••••</p> <p>J ••••••••••••</p> <p>K ••••••••••</p> <p>L ••••••••••</p> <p>M ••••••••••</p> <p>N ••••••••••</p> <p>O ••••••••••••</p> <p>P ••••••••••••••</p> <p>Q ••••••••••••••</p> <p>R ••••••••••••</p> <p>S •••••••••••••</p> <p>T •••••••••••••</p> <p>U ••••••••••••••</p> <p>V ••••••••••••••</p> <p>W ••••••••••••••</p> <p>X ••••••••••••••</p> <p>Y ••••••••••••••</p> <p>Z ••••••••••••••</p> <hr/> <p>Ä (German) ••••••••••••</p> <p>Á or Ā (Spanish-Scandinavian) ••••••••••••</p> <p>CH (German-Spanish) ••••••••••••</p> <p>É (French) ••••••••••••••</p> <p>Ñ (Spanish) ••••••••••••••</p> <p>Ö (German) ••••••••••••••</p> <p>Û (German) ••••••••••••••</p> <hr/> <p>1 ••••••••••••••</p> <p>2 ••••••••••••••</p> <p>3 ••••••••••••••</p> <p>4 ••••••••••••••</p> <p>5 ••••••••••••••</p> <p>6 ••••••••••••••</p> <p>7 ••••••••••••••</p> <p>8 ••••••••••••••</p> <p>9 ••••••••••••••</p> <p>0 ••••••••••••••</p>	<p>Period •••••</p> <p>Semicolon ••••••••••</p> <p>Comma ••••••••••••</p> <p>Colon ••••••••••••</p> <p>Interrogation ••••••••••</p> <p>Exclamation point ••••••••••••</p> <p>Apostrophe ••••••••••••••</p> <p>Hyphen ••••••••••••</p> <p>Bar indicating fraction ••••••••••</p> <p>Parenthesis ••••••••••••••</p> <p>Inverted commas ••••••••••••</p> <p>Underline ••••••••••••••</p> <p>Double dash ••••••••••••</p> <p>Distress Call ••••••••••••••••</p> <p>Attention call to precede every transmission .. ••••••••••</p> <p>General inquiry call ••••••••••••••••</p> <p>From (de) ••••••••</p> <p>Invitation to transmit (go ahead) ••••••••</p> <p>Warning—high power ••••••••••••••••</p> <p>Question (please repeat after)—inter- rupting long messages ••••••••••••</p> <p>Wait ••••••••••••</p> <p>Break (Bk.) (double dash) ••••••••••</p> <p>Understand ••••••••••••</p> <p>Error ••••••••••••••••</p> <p>Received (O. K.) ••••••••••</p> <p>Position report (to precede all position mes- sages) ••••••••••••••</p> <p>End of each message (cross) ••••••••••</p> <p>Transmission finished (end of work) (conclu- sion of correspondence) ••••••••••••</p>
---	--

Construction of New Type Transatlantic Receiving Sets

CHAPTER I

TRANS-OCEANIC RECEPTION ON LONG WAVES

Setting up and operating a long distance receiving station, with notes on the antenna, working conditions, and schedule of transmitter.

In the early days of transatlantic sending and receiving an outfit for copying the high power, long wave stations was a maze of enormous loading coils, huge loose couplers, assorted condensers, with a thicket of controls on long sticks to prevent body capacity effects upon the set. The process of tuning was elaborate and uncertain for frequently it was not possible to get the set in adjustment during the time available for experimenting.

A revolutionary series of developments occurred during the period from 1917 to 1919 under pressure of necessity, for orders and instructions running into hundreds of thousands of words were transmitted and received across the Atlantic. An operator who has not followed the changes in long wave receiving equipment does not recognize the simple equipment now in use. A turn on a knob or two and the experimenter is in the far parts of North or South America, in England, Russia, Germany, Italy, or the Orient, the radio waves his magic carpet. A few homemade instruments, the mere arrangement of wires, plates, and batteries, takes the mind to foreign countries which the eye may never see. Five thousand miles away a key is pressed. In one-thirty-fifth of a

second, across countries and kingdoms, arid waste and stormy water, the radio wave brings a reproduction of the movement made by that control. The local transmission of speech is interesting, but that seems commonplace when signals from points clear 'round the world come singing with their measured, musical notes.

Most of the high power stations send at slow speed, a special advantage to the inexperienced operator. In fact, a speed of ten or fifteen words a minute is frequently employed. Usually automatic sending devices are used, making the signals clean cut and steady. In Chapter V means for receiving the high speed transmission are described. Deciphering what seems to be a steady hum into intelligible signals has a special interest of its own. The appendix gives information relative to the calls, the wavelength and the schedules of a number of high power stations.

Strange as it may seem, it is easier to copy stations across the Atlantic or Pacific than to receive the familiar short wave transmitters a few hundred miles away. A single wire antenna and a few instruments, covered by an investment far less than is required for a short wave regenerative outfit, are needed to do the work described.

Regardless of the receiving set, the antenna and ground are fairly standard. With the types to be described any set detailed in the subsequent chapters can be used. For the benefit of the novice full data on antennas and ground connections suitable for different locations will be given.

There is no need to make the antenna high or of more than one wire when a stretch of 300 ft. is available. If you live in the city, go on the roof and select a stretch 250

or 300 ft. to another house top. Masts are not needed to elevate the wire. Chimneys or other natural supports are sufficient. In the country the antenna can be run from the house to a tree. No. 12 or 14 B. & S. gauge copper wire should be used for the conductor, or stranded wire of equal cross section is good if available.

Strong insulators should be employed preferably of all material suitable for withstanding high frequency currents. Many insulators which withstand voltages running into the hundred thousands break down quickly with a few thousand volts of high frequency current. While high voltages are not applied to the receiving antenna it is advisable to use the very best insulators to prevent even the slightest leakage. It must be born in mind that an accumulation of small losses may result in very poor signals giving less signal strength, perhaps, than a set with some outstanding fault. If the antenna is to be of permanent construction, insulators for a single wire 200 to 300 ft. long should be able to stand up to 500 lbs. strain. G. A. high frequency insulators or Hopewell insulators are recommended for this apparatus. High winds, and during the winter, when the best long distance work is done, collection of sleet puts a very heavy load on the wires, running up to several times the normal tension on the insulators.

In the country a long range antenna can be set up with very little difficulty for the houses can be employed at one end and trees, wind mills or barns used for the other. With a length of 250 to 300 ft. a height of more than 30 ft. is not required. In fact static interference is increased with greater antenna height.

The lead-in from a single wire antenna can be taken from either end or the middle without appreciably affecting the results or the directional tendency. A solid soldered joint is needed where the lead-in is brought off for resistance. This point will greatly decrease the efficiency of the antenna. This lead should be of the same wire as is employed for the antenna and brought down as directly as possible to the point where it enters the operating room. Here it should be connected to a length of high tensioned cable and put through a porcelain tube. Another wire attached to the cable inside the room should run directly to the receiving equipment.

The antenna should be protected against lightning by either a single pole double throw switch which must be thrown in the grounded position at all times except when the set is in use (Fig. 1) or a lightning arrester. The connections of the lightning arrester are shown in Fig. 2. The Board of Fire Underwriters have revised their require-

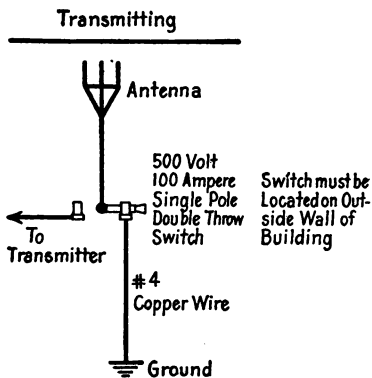

Fig. 1—Protection of Antenna Systems from Lightning

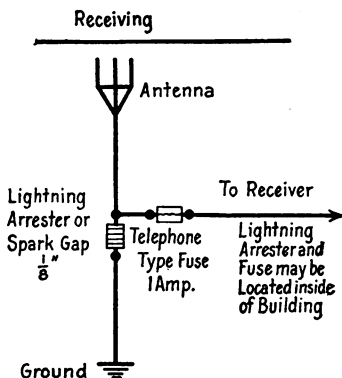

Fig. 2—Protection of Antenna Systems from Lightning

ments to permit the use of protective apparatus (carbon block lightning arresters), usually used on telephone lines on receiving antennas. See appendix.

The ground connection is naturally just as important as the antenna. Usually a water pipe, a steam heating system pipe or an iron frame of a steel frame building is used for ground connection. While these are very

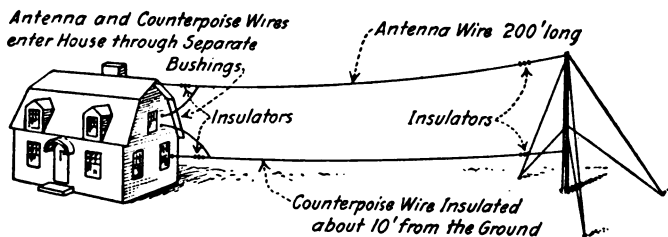

Fig. 3—Antenna and Counterpoise Systems for Receiving Set

satisfactory, for the man who has the space available, much sharper tuning and better signals can be obtained by using a counterpoise ground insulated from the ground and run directly under the antenna about 10 feet from the ground. An antenna system of this type is illustrated in Fig. 3.

CHAPTER II

SINGLE CIRCUIT RECEIVER

The simplest type of receiving set for tuning from 12,000 to 20,000 meters.
Tuning is done by only arc variable condensers.

Today many of those who have become interested in radio through the radio broadcasting stations, simple receivers, etc., are becoming radio enthusiasts and want

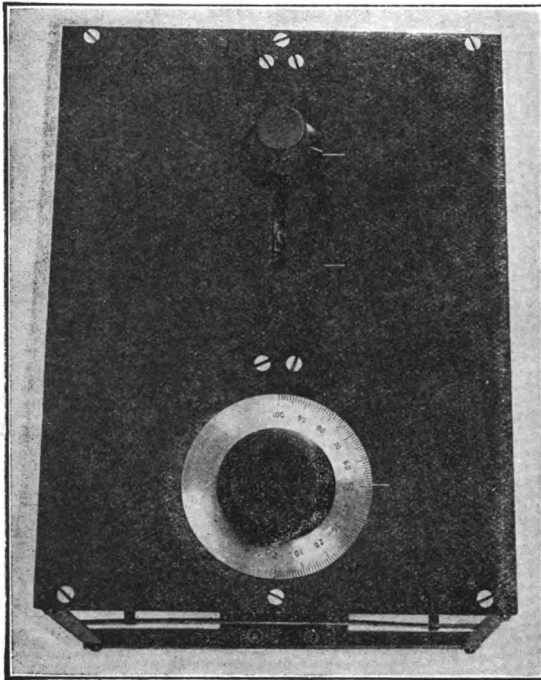

Fig. 4—Two Controls only are used to tune from 12,000 to 26,000 meters, covering the range of Trans-Oceanic Stations

to be able to hear the long distance stations. These stations because of the slow speed with which most of the messages are sent afford an excellent opportunity for the new man to learn the continental Morse code.

In the old days the long wave radio station looked very weird with the barrel inductances of mammoth size and the many adjustments which had to be made by means of long sticks attached to the condenser handles. This apparatus required quite some skill to operate and for that reason the long wave reception was only taken up by the "Dyed in the Wool Radio Bug." Today, with the simpler equipment which can be built, thanks to the large amount of development work crowded into the short years our country was engaged in war, not only the experimenter, but the novice too can enjoy the thrill of hearing the musical Telegraph signals of Nauen, Germany, Pearl Harbor, Hawaii, Italy and many other high power stations located in all parts of our globe. Another advantage of long wave reception is this:—The long waves travel equally as well in the day time as at night, and there are so many stations operating that it is difficult not to find a time when at least one station is operating. The table in appendix I gives an idea of the operating schedules of a number of stations, some of which can be heard anywhere in the United States.

Figs. 4, 5 and 6 show the extreme simplicity of the 12,000-20,000-meter single circuit receiver about to be described. The single circuit, while not as selective as the double circuit, gives excellent results and is recommended because of its simplicity, cheapness of construction and ease of operation.

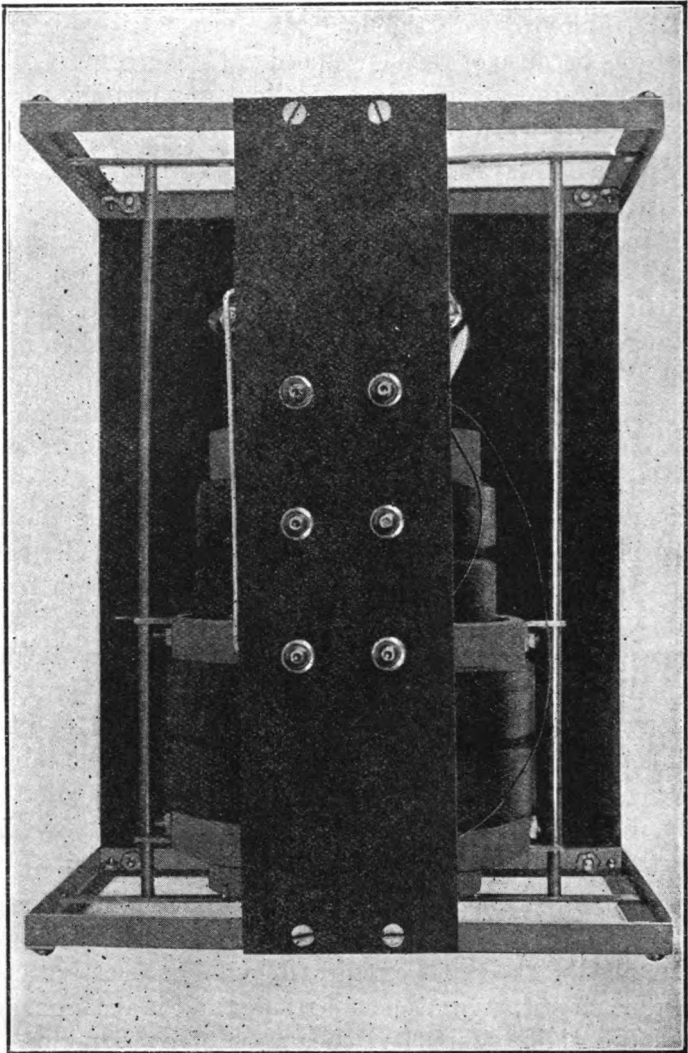

Fig. 5—Rear view of the Long Wave Receiver, as fine a set as you have ever operated. Suitable for General Receptions or Experimenting

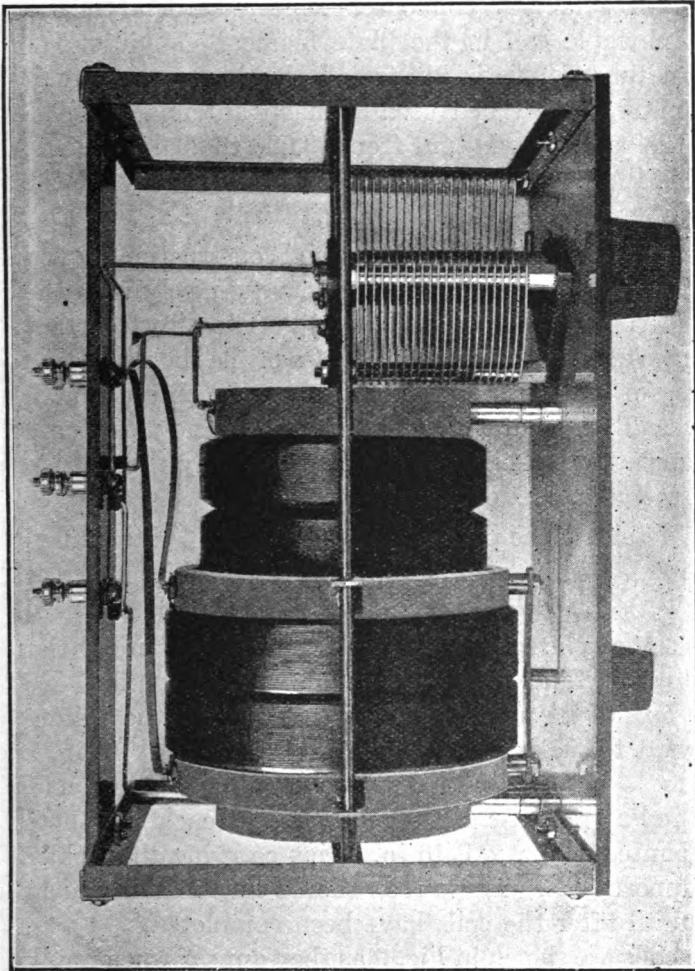

Fig. 6—Bottom View of the Long Wave Receiver

It consists of a stationary coil of fixed inductance and .0008 mfd. variable air condenser connected around the coil and a movable coil in the plate filament circuit of the vacuum tube. This is illustrated clearly by the circuit diagram Fig. 7. When used with an antenna of .0003 mfd., the receiver will tune from 12,000 to 20,000 meters, which is the range of wavelengths used by many of the high power long distance stations.

The layer wound coils of the special construction proved to be very satisfactory and work in very nicely with the other mechanical features of the set. The direct current resistance of these coils is less because of the shorter length of wire, for a given inductance than can be obtained with a universally wound coil. The high frequency losses are kept down too by reason of the fact that only the outside layer receives a coat of varnish.

The details of the panel are given in Fig. 8. Its dimensions are as follows: $7\frac{1}{2}$ in. x 10 in. x $\frac{3}{16}$ in. and it is drawn to $\frac{1}{2}$ in. scale.

The slot can be easily made by drilling a number of holes close together and finishing the job with a flat file. No dimensions of the angles are given, as it is felt the builder may want to make his set slightly different. A 10 in. x $2\frac{1}{2}$ in. x $\frac{1}{8}$ in. panel with six binding posts mounted on it, is secured at the rear of the receiver. At each end there are mounted $\frac{3}{8}$ in. x $\frac{1}{16}$ in. strips carrying the tickler coil support rods. These rods should not be soldered in place until after the coils have been completed.

The coils are shown in Fig. 9 as they appear when ready to mount. The $3\frac{1}{2}$ in. G.-A. lite tube six inches long is used for the antenna coil. The winding starts $\frac{5}{8}$ in. from

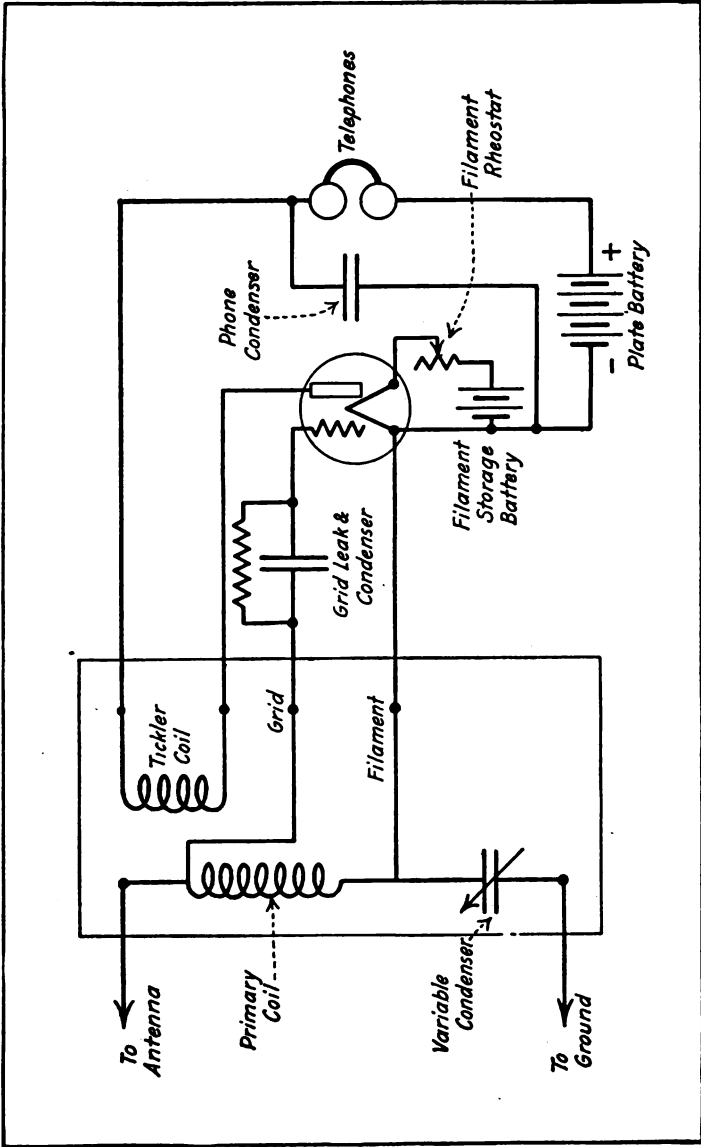

Fig. 7—Circuit Diagram of Receiver showing its Connection to an Audion Detector

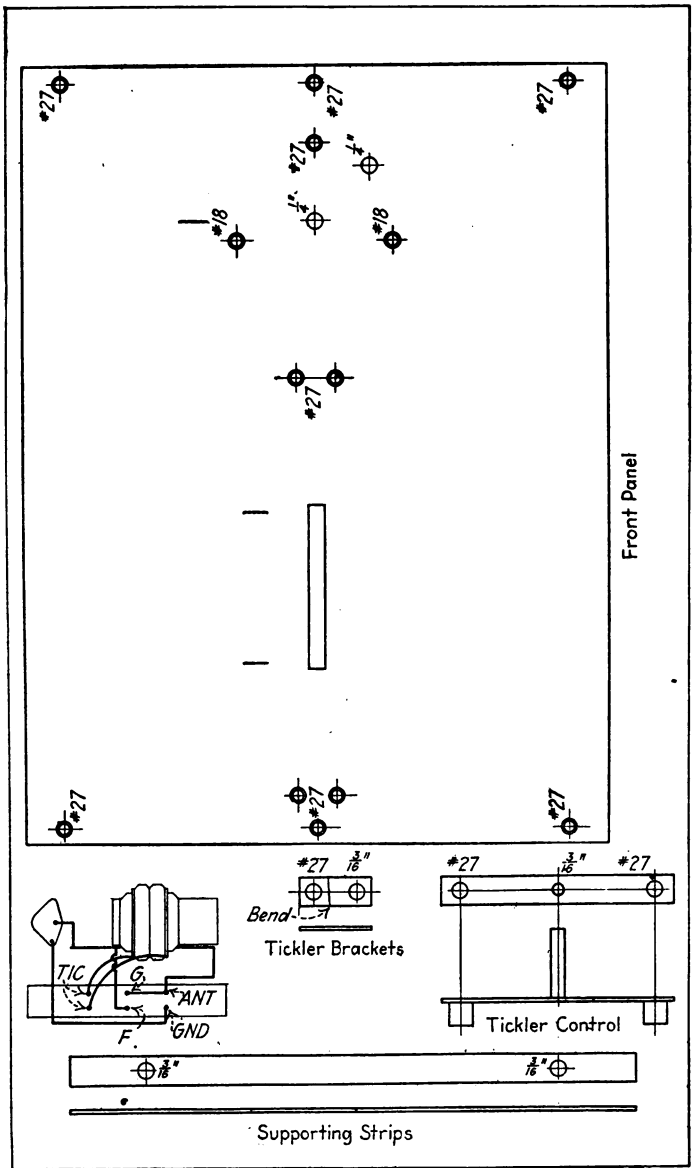

Fig. 8—Details of 12,000-20,000 Meter Receiver

one end and the first 44 turns of No. 24 B & S single silk magnet wire are wound on. Then the wire is brought up between the 43rd and 44th turns and 43 turns are wound back over the first layer. This is continued until 11 layers have been wound on, giving 44, 43, 42, 41, 40, 39, 38, 37, 36, 35 and 34 turns per layer, or a total of 492 turns per section.

Three such sections are wound on and the inductance of the combination is 124 milli henrys. The end of the winding is terminated at a screw and lug $\frac{1}{2}$ in. from the end of the tube.

The tickler is wound on a G.-A. lite tube 3 in. long and $4\frac{1}{2}$ in. in diameter, the winding being started $\frac{1}{2}$ in. in and made up of two sections of 7 layers having 44, 43, 42, 41, 40, 39 and 38 turns per layer respectively. A better coil is made if the winding is given a coat of Valspar varnish and baked in a warm oven.

Next come the angle pieces which slide on the $\frac{3}{16}$ in. rods and the $\frac{3}{16}$ in. rod by which the coil is moved. Both of these details are shown in Fig. 8. In order to give clearance all screws used are of the flat head type with their heads inside the tube.

It is necessary to mount the antenna coil quite a distance back of the panel. Therefore in addition to the coil mounting pillars held to the tube by $\frac{1}{2}$ in. 6-32 F. H. screws two G.-A. Std. threaded posts are put over 1 in. 6-32 F. H. screws from the front of the panel and the screws threaded into the coil mounting pillars.

With the parts ready, the supporting frames should be put on the panel and the coils mounted, without cutting off the $\frac{3}{16}$ in. rods to length. Next the condenser is

mounted on the panel with its binding posts already fastened to it and the set is ready for wiring.

The tickler leads in order to provide for the flexible connections should be of thin phosphor bronze strips. Fig. 9 is a diagram illustrating this.

It is a simple matter to wire up the receiver, for it is only necessary to attach the antenna and ground, run the wires from G and F posts to corresponding terminals on the detector and to insert the tickler in the plate circuit. Reverse the tickler connections if the circuit does not oscillate. When an amplifier is used add a .001 phone condenser across the transformer. If this is not done the operation of the set will be impaired. Most of the foreign stations can be copied with only a detector tube and with two steps of amplification extremely loud signals should result.

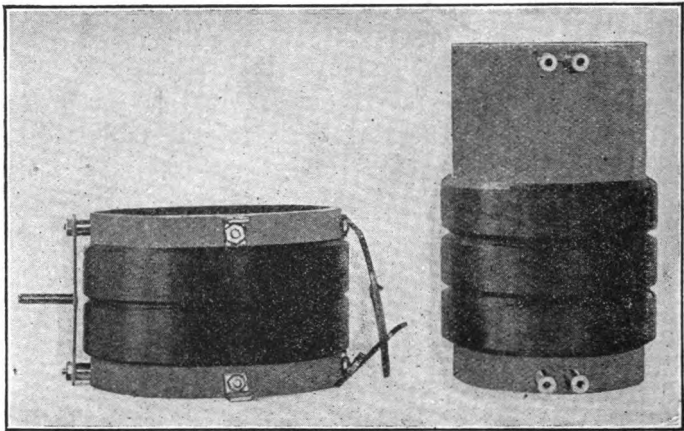

Fig. 9—Details of the Completed Coils, ready to mount on the Panels, the Tickler at the left and the Antenna Coil at the right

The indoor loop is for the most part easy to build and operates quite satisfactorily on long waves. For good results the loop should consist of about 40 turns $\frac{1}{4}$ in. apart of No. 20 D.C.C. wire wound on a wooden frame 8 to 10 feet square. The terminals of this loop antenna should be connected to the antenna and ground posts of the receiver. If possible, the loop should be so mounted that it can be swung in azimuth. This can be accomplished in a number of cases by supporting the loop from the ceiling of the room by a piece of rope or wire. This is very satisfactory.

Such an antenna, while not as satisfactory as an open wire antenna of two or three hundred feet in length, is nevertheless quite satisfactory and is useful in the elimination of interference and static.

The detector unit which may be used with this receiver consists of a vacuum tube socket, a filament rheostat, a grid condenser, a phone condenser and a number of binding posts. Fig. 7 shows the connections of this unit and its connection to the receiver unit.

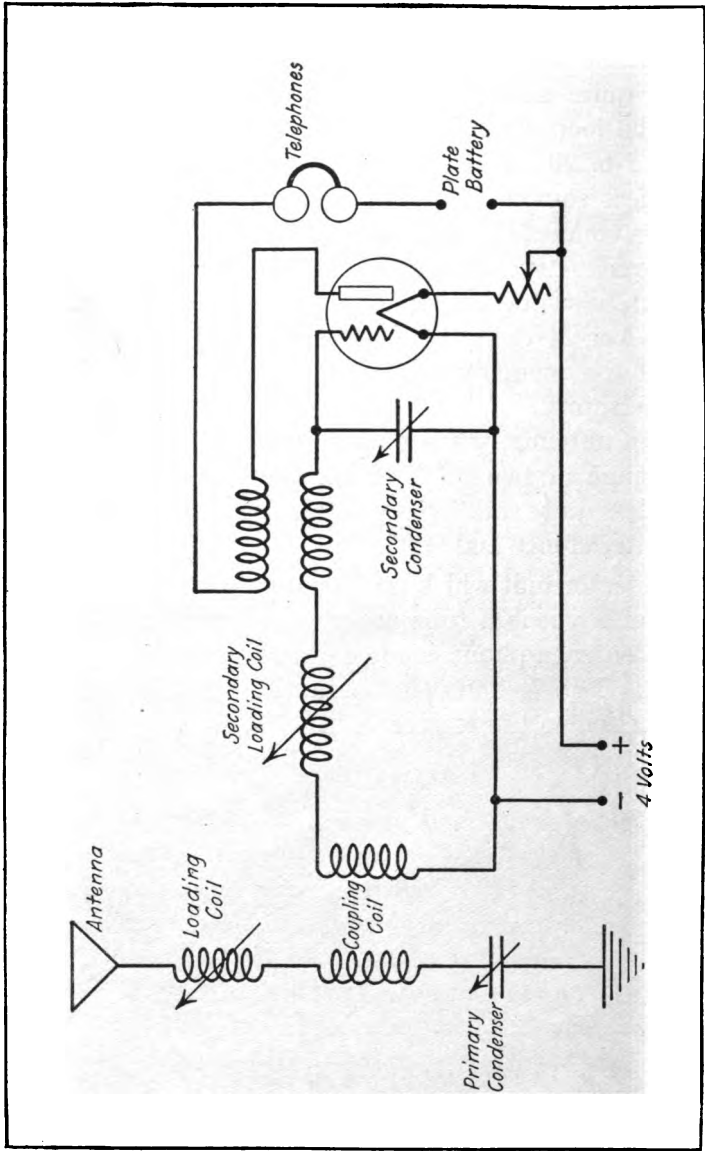

Fig. 10—Simple Schematic Diagram of the Loosely Coupled Oscillating Receiver

CHAPTER III

LOOSELY COUPLED OSCILLATING RECEIVER

A concentrated inductance type receiver in the primary, secondary, and tickler coils for covering any wavelength range.

The loosely coupled receiver is far superior to the single circuit one just described but, naturally, is more difficult to build or operate. The antenna circuit consists of the primary loading coils, the coupling coil, the variable air condenser, the ground and the antenna. This circuit is tuned by means of the switch which connects in more or less of the antenna loading inductances and the variable air condensers to the wavelength to be received. The closed or secondary circuit, as it is usually called, comprises the coupling coil, the secondary loading coils and the secondary condenser. The tickler coil which is necessary to feed back into the secondary circuit the amplified signals is a necessary part of the receiver, and is used to make it oscillate and regenerate.

This type of receiver is so well illustrated by the Grebe CR-7 that it will be described as illustrative of this type of circuit.

Electrical circuits and mechanical design have been carried out on the CR-7 set in a way which will meet the unqualified approval of the most exacting experimenter. The design of the primary and secondary inductances, described farther on, is an unusually clever piece of work, representing an amount of thought seldom shown by other apparatus.

Fig. 11 illustrates the bakelite panel, 12 x 21 $\frac{1}{4}$ in., with the various controls. An oak cabinet carries the panel on

which all the instruments are mounted. A hinged cover permits the examination of the set.

Across the top, from left to right, are the primary-secondary coupling, primary inductance switch, opening for the insertion of the audion bulb, secondary inductance switch, and tickler coupling, while at the bottom are the primary condenser, antenna compensating inductance switch, rheostat, bridging condenser, secondary condenser, and telephone jack.

In the rear view, Fig. 12, the primary condenser and inductance are at the right hand end of the panel. The tube at the center carries the audion socket. Dust is, in this way, kept out of the set.

Three small bridging condensers are located at the left of the socket tube, any one of which can be cut in by the three-point switch.

Fig. 13 shows, in the primary circuit, four concentrated inductances and a divided tubular coil wound with two banks of high frequency cable. The appearance of the assembled coils can be seen in Fig. 12.

The concentrated coils, instead of having the same inside diameters, have the same outside diameters, so that they fit snugly inside a tube on the end of which are the divided coils. The purpose of dividing the coils is to allow for the shaft of the secondary coupling coil.

The end section of the banked coil is tapped at three points, and is used to compensate for variations in the capacities of different antennas. By setting this switch at the proper point, determined experimentally, corresponding adjustments of the primary and secondary condensers

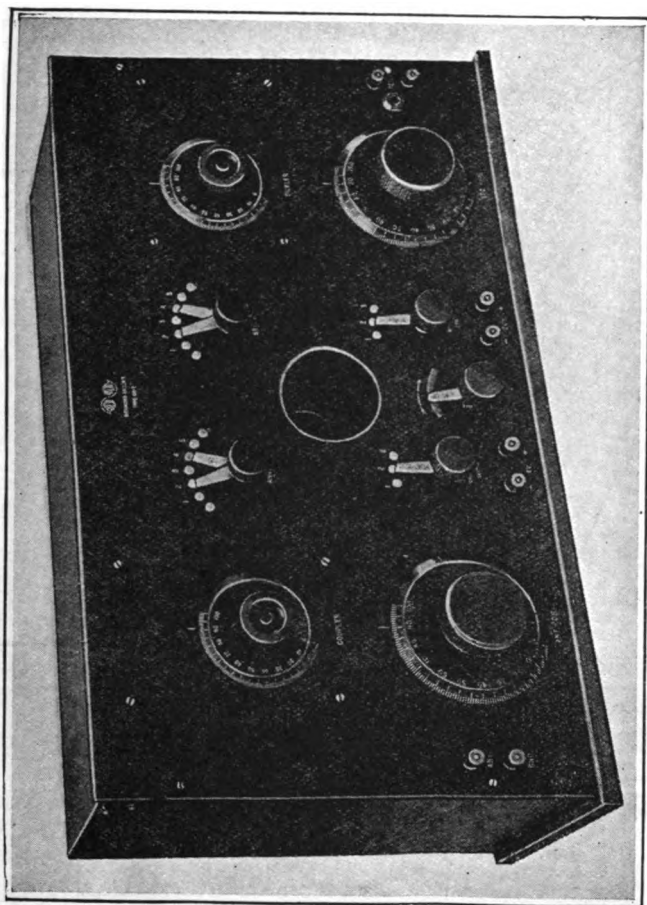

Fig. 11—The Arrangement of the Controls makes possible very rapid Adjustment

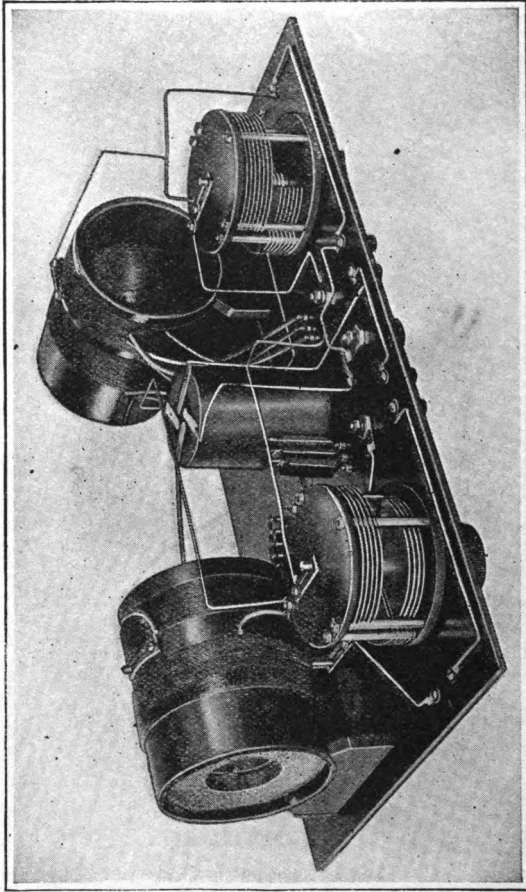

Fig. 12—The Wiring of this set is a Prominent Feature

and inductances give very nearly the same wavelengths in both circuits.

Two contacts are employed on the inductance switch to short circuit the two sections ahead of the last one in use, a method of cutting down dead-end losses which is quite effective.

A 26-plate balanced condenser, having a maximum capacity of .0008 mfd., is connected in series with the ground. The method of establishing connection to the rotating plates is interesting. A short strip of brass, drilled and slotted at one end, clamps the end of the shaft tightly enough to give a low resistance contact.

Fig. 12 shows clearly the coil assembly, similar to that of the primary. It is mounted at right angles to the other, to prevent any coupling effect. Here the tickler coil is mounted at the end of the tube. One part of the tickler is wound on the tube, and the other on the variometer ball. The coupling from the straight part of the tickler is not great enough, however, to cause any noticeable feed-back effect when the adjustable section is at 0.

In Fig. 13 this coil is marked COUP. It can be seen at the end of the primary coils. The ends of the coil are soldered to the shaft, which is made in two pieces. Slotted brass strips are fastened to the tube and one to the panel, clamp on the shafts and make connections. These can be seen more readily on the tickler coil.

An 18-plate balanced condenser is provided for tuning the secondary circuit. At maximum, the capacity is .0004 mfd. Tuning is made sharper when a small condenser is employed in the secondary circuit.

Fig. 14 shows the wavelength of the secondary circuit at

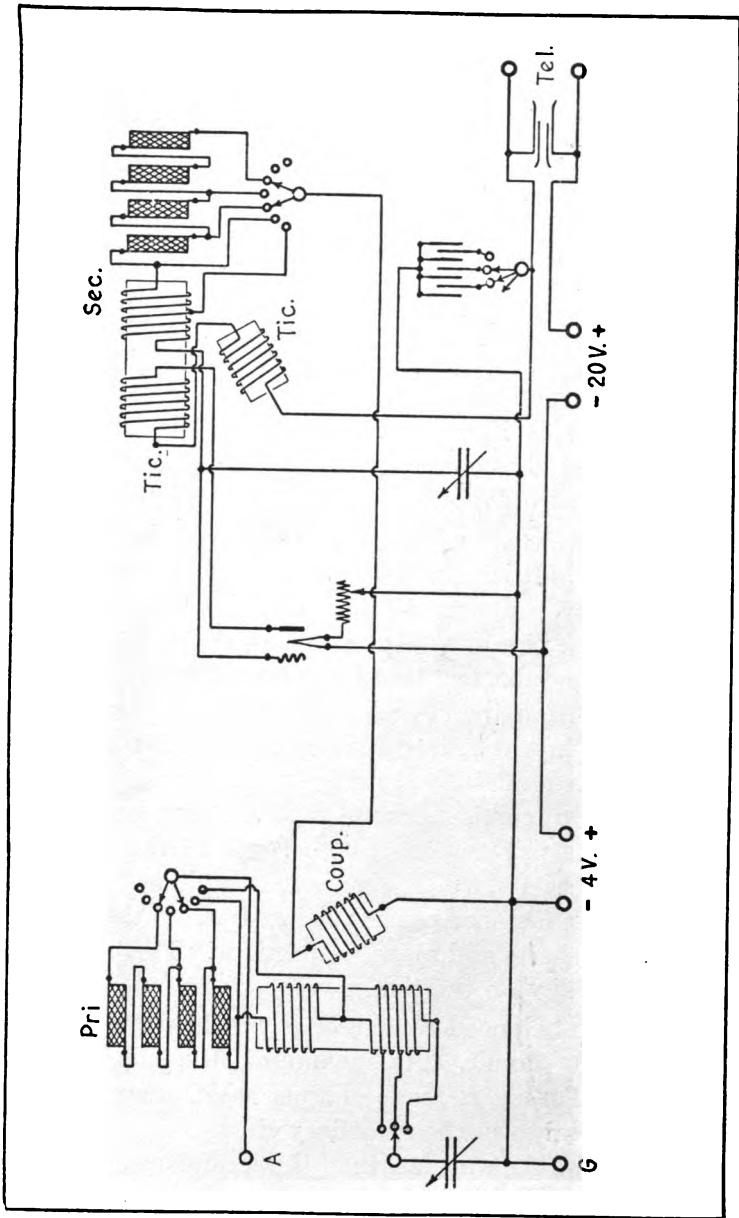

Fig. 13—Circuit for the Grebe CR-7 Receiver

various settings. These curves are approximately correct for the primary circuit when the compensating coil is adjusted according to the antenna capacity.

Energy from the plate circuit is fed back to the grid by means of a tickler coil. This method gives the best control, particularly on a long wave set.

At 0 coupling, spark stations come in the usual manner. As the coupling is increased, regenerative and finally oscillating effects occur. The table below shows the dial settings.

<i>Dial Setting</i>	<i>Reception</i>
0	Damped waves (not amplified).
0-40	Damped waves (amplified by regeneration).
40-100	Undamped waves (set oscillating locally).

No grid leak or condenser is used with this set, as provision is made for a constant negative grid potential. Particularly on undamped waves, this is an advantage, as reception is better without a grid condenser.

Fig. 13 shows the connections of the by-pass condenser which shunts the telephones and batteries. The adjustment of this condenser has quite an appreciable effect on long wave signals.

A 4-volt battery is required for the audion filament, and a 20- or 22.5-volt battery for the plate.

The CR-7 is extremely simple to operate and, as the elements are all connected with heavy bus wire, the circuits are easy to follow.

To tune to a given wavelength, consult the wavelength curve and set the secondary condenser and switch to the positions corresponding to the desired wavelength. Next

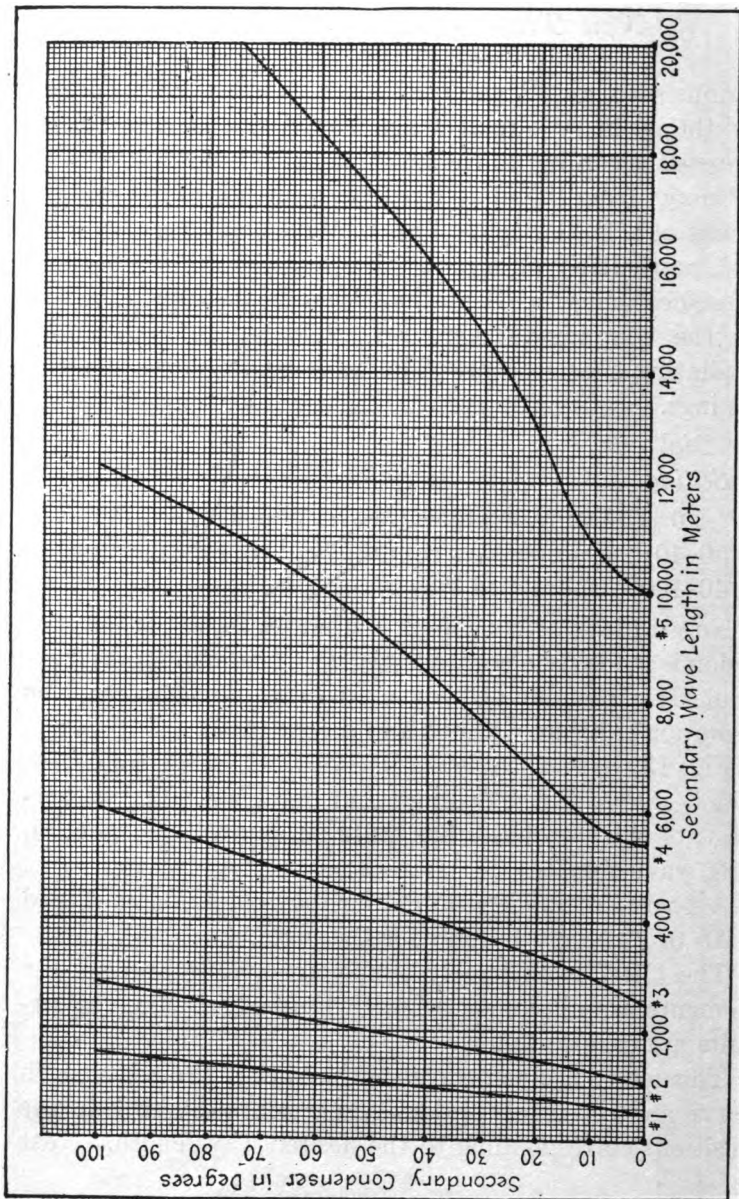

Fig. 14—Wavelength Calibration for the Secondary Circuit. The numbers refer to the points on the Secondary Inductance Switch

adjust the primary circuit to the same settings, making final adjustment for maximum signal strength when the signals are received.

For regeneration or amplification of spark signals, the tickler dial is turned towards the 100 mark until the signals have increased to the maximum, just below the point where a mushy and distorted note is obtained; for continuous wave reception, the tickler is increased to the oscillating point, and the proper beat obtained by adjustment of either the primary or secondary condensers.

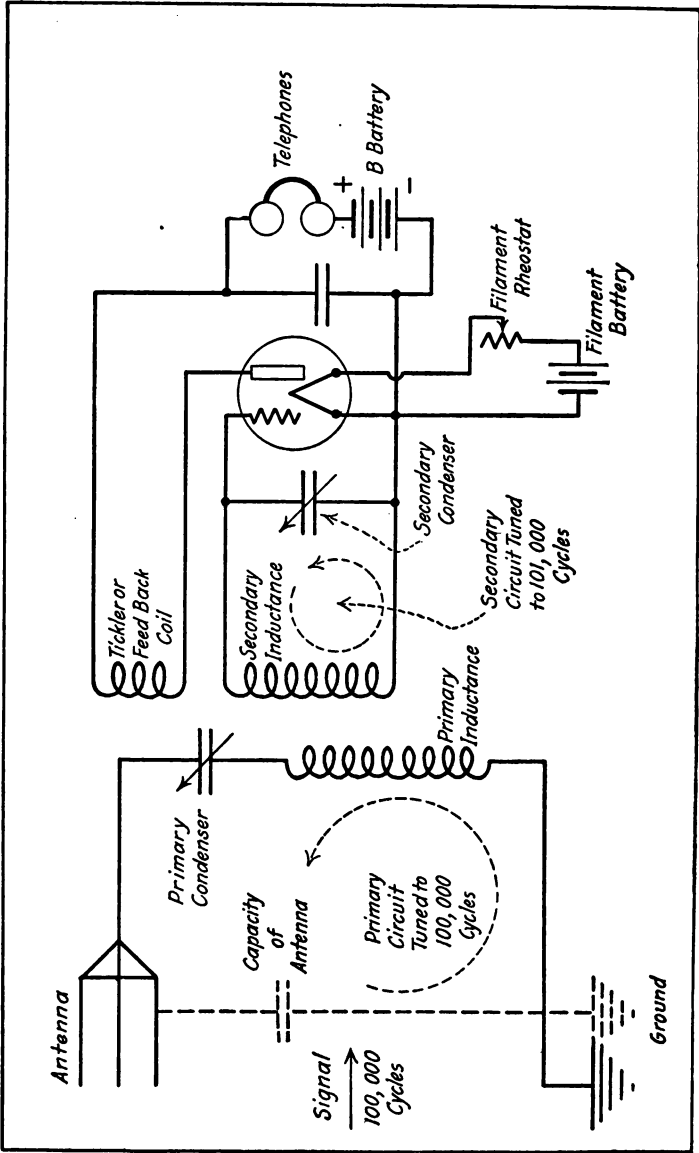

Fig. 15.—Schematic Diagram of the Feed Back Receiver

CHAPTER IV

HIGH EFFICIENCY LONG WAVE RECEIVER

This set uses an ordinary receiving set in the separate vacuum tube oscillator, giving much greater efficiency than is obtained in the other circuits.

In order to show why the separate oscillator circuit is best for long wave reception, let us follow closely the following few paragraphs.

The reception of undamped wave signals is accomplished by imposing a slightly different frequency voltage on the detector with the signal voltage.

The local voltage of slightly different frequency is generated by the detector tube and its frequency is determined by the value of the tuning of the secondary circuit, Fig. 15. If, for example, oscillations of 100,000 cycles are being received, and local oscillations of 101,000 cycles are impressed, a beat note of 1,000 cycles will be produced in the telephones. This method, while good for short waves, causes a loss, by detuning, at long wavelengths.

In practice, the primary circuit is closely tuned to the transmitter. The secondary is detuned, to give an audible frequency. So it is that the secondary circuit is not adjusted to the frequency of the received signals.

At short waves, a slight detuning in wavelength makes a large difference in frequency, so that this effect is not pronounced. Long waves, however, have a low frequency. Thus a small difference in frequency requires a considerable change in wavelength.

Consider Fig. 16. This shows the signal strength when a receiver is tuned above and below the wavelength of the transmitter. A maximum amount of energy flows in the

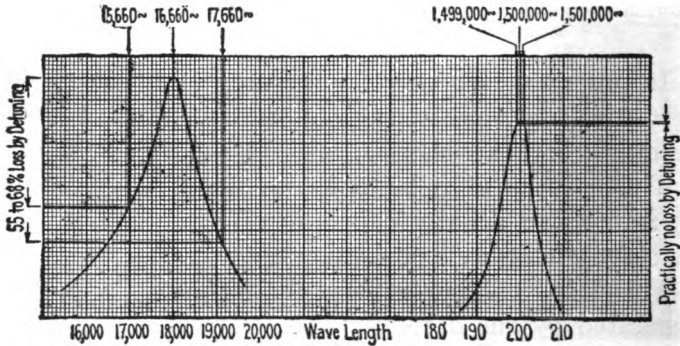

Fig. 16—Showing the Loss at Long Waves from the use of a Locally Oscillating Receiver

secondary when it is adjusted to 18,000 meters, but, at 17,000 the wavelength for a 1,000-cycle beat note, only 55 per cent. of the available energy is being used. This is obviously a considerable loss, of special importance when the signals are weak.

That this percentage of loss decreases with decreasing wavelength is shown by Fig. 16. Here the curve shows the energy in the secondary when it is tuned above and below the wavelength of a 200-meter transmitter. The detuning to produce 1,000-cycle beats is less than 1 meter, and practically no signal strength is lost.

On wavelengths about 5,000 meters, heterodyne reception should be accomplished by means other than the use of a detuned, oscillating circuit. The simplest method is to set up a separate oscillator, coupled to a straight receiving set.

This is illustrated quite satisfactorily by the diagram of Fig. 17. Here the antenna circuit and the secondary circuit is tuned to the desired signal frequency and the oscillator, which is coupled to the secondary circuit, is

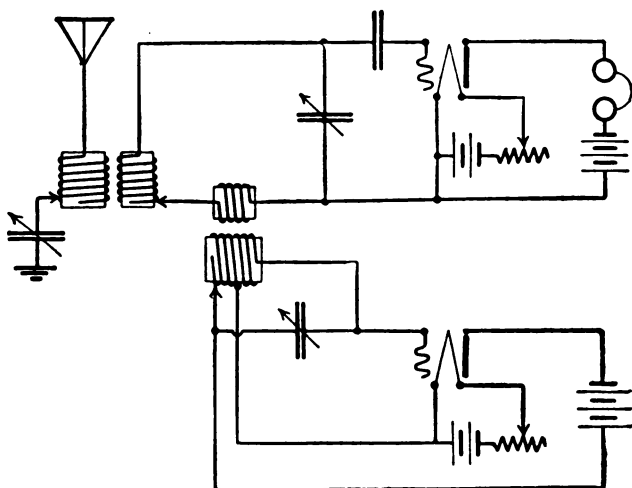

Fig. 17—The Separative Oscillator provides the most efficient means for receiving Undamped Waves

adjusted until the difference between the signal frequency and the oscillator frequency produces the desired note in the telephone receiver.

Now that we have seen the reason for the increased efficiency of the separate oscillator receiver, one which is efficient and which makes use of the concentrated inductance coils will be described.

The old type of receiver for transatlantic work made use of bulky inductance coils and did not lend itself to either portability or a pleasing design. At the present

time there are on the market various types of concentrated inductances which have small distributed capacity and are very satisfactory for the construction of long wave receivers. Such a coil is illustrated in Fig. 18. These coils are made in convenient sizes and are very useful for loading coils, primary and secondary coils and oscillator coils. The following few paragraphs will be devoted to a description of a radio receiver having a wavelength range of 3,000 to 25,000 meters and making use of a separate oscillator.

The circuit diagram Fig. 19 shows the circuit arrangements of the receiver.

An arrangement for holding the DeForest honeycomb coils and providing means for varying the coupling between the oscillator and the secondary circuit and the secondary circuit and the antenna circuit is clearly shown in Fig. 20.

A similar arrangement, but arranged for holding three of the Duo-lateral coils, is shown in Figs. 21 and 22.

TABLE I

CALIBRATION TABLE FOR HONEYCOMB COIL

<i>Inductance value in milli henrys</i>	<i>Wavelength range for condenser of .0001 to .001 mfd.</i>
4.5	1,300- 4,000 meters
6.5	1,550- 4,850 "
11.0	2,000- 6,300 "
20.0	2,700- 8,500 "
40.00	4,000-11,400 "
65.00	4,800-15,300 "
100.00	6,000-19,000 "
125.00	6,700-21,200 "
175.00	7,900-25,000 "

If both the primary and secondary condensers of



Fig. 18—Honeycomb Coils represent one of the most important recent advances in Experimental Work

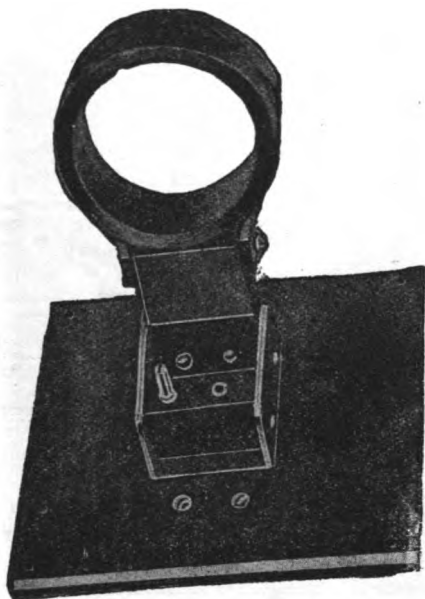

Fig. 20—Two Coils Can be mounted in this Device to form a Loose Coupler

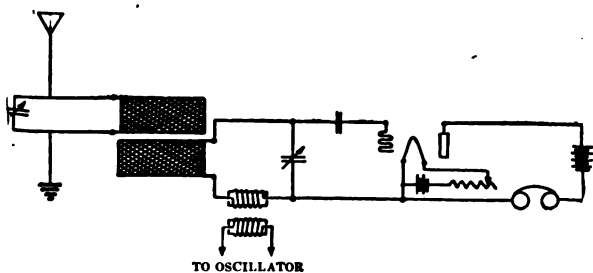
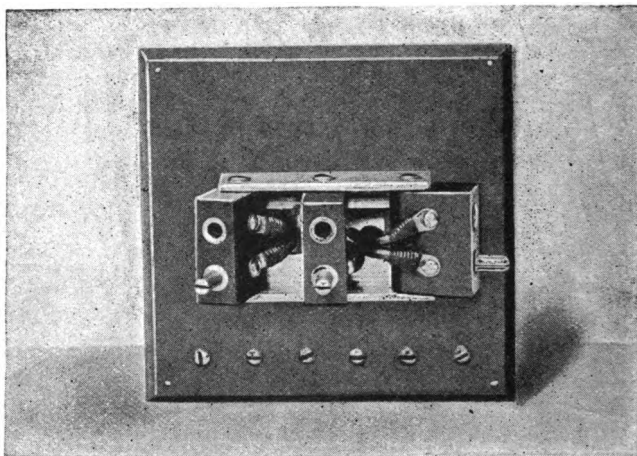
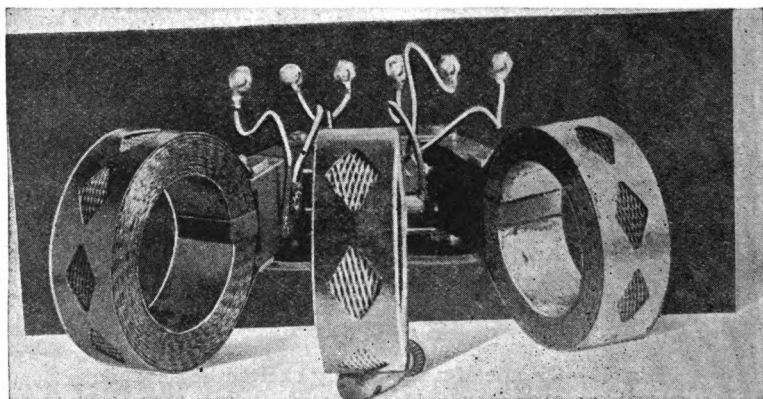

Fig. 19—Circuit of a separately excited heterodyne receiver



**Fig. 21—Honeycomb coil mounting
with the coils removed**



**Fig. 22—A Loose Coupler for Damped or Undamped Waves
using Honeycomb coils**

Fig. 19 have a capacity range of .0001 to .001 mfd., the number and sizes of coils to cover the wavelength range can be picked out from Table I.

Since the primary condenser will have in parallel with it the capacity of the antenna, the primary coils will be smaller than the secondary coils and more of them will be required.

The oscillator coil which is in parallel with the oscillator condenser, will be the same size as the secondary coil, provided the condensers are the same. The tickler coil should preferably be smaller than the oscillator coil. The circuit of the oscillator is shown in Fig. 23.

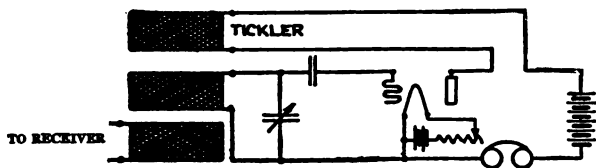

Fig. 23—Oscillator to be used with separately excited receiver Fig. 19

Although most of the high power transatlantic stations can be heard in most any part of the United States with a single tube, it is nevertheless more satisfactory to use an amplifier and hear the signal much louder. There are a number of different types of amplifiers for the amplification of the signal before it is detected—i. e., radio frequency—and after it is detected—i. e., audio frequency.

Of these types only the most satisfactory one, namely the transformer coupled audio frequency amplifier, will be described.

Fig. 24 illustrates the connections of a one-stage transformer coupled amplifier connected to a simple detector. Additional stages can be connected in place of the tele-

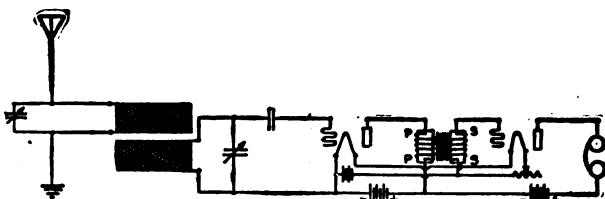

Fig. 24—Circuit of a Receiver with a Simple One-Step Amplifier

phone receivers of Fig. 24. If the amplifiers are properly designed (use the proper tubes and transformers) only two stages of audio frequency amplification can be used because of the fact that noises such as those which occur in the batteries, static, etc., are so loud that a weak signal cannot

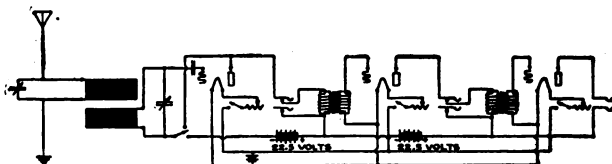

Fig. 25—Circuit of a Receiver with a Two-Step Amplifier

be read through them. Fig. 25 shows the connections of a detector and two-stage amplifier.

The amplifying transformer, although a simple transformer, is more or less difficult to build, but there are so many such transformers on the market that most experimenters will purchase them.

Fig. 26 illustrates a typical amplifying transformer built to operate between the VT- or UV-200 and UV-201 type tubes now available for experimental use.

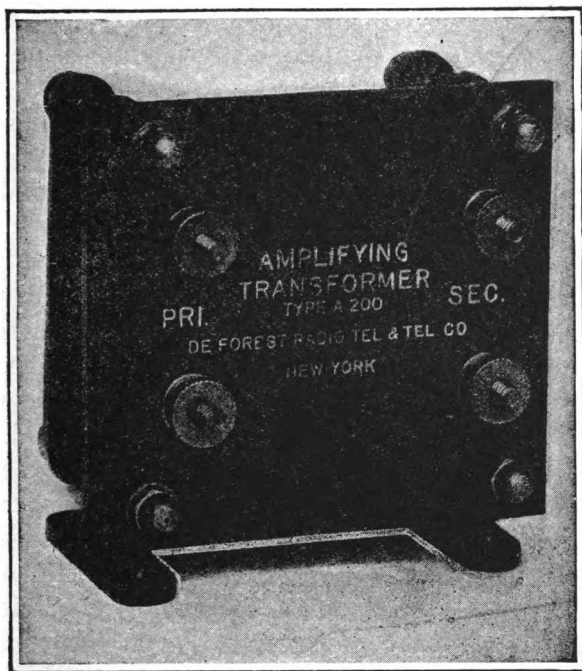

Fig. 26—Amplifying Transformer of a commercial type

CHAPTER V

LOUD SPEAKERS, RELAYS, AND PHONOGRAPH RECORDERS

An amplifier for operating loud speakers, the construction of relays working on the radio signals, and recording signals on a phonograph.

For the reception of the long distance stations on telephone receivers it is not necessary to use amplifiers in a great many cases. Of course, by their use if static is not too severe, an amplifier will enable one to hear more stations and those which could be heard before, louder.

An amplifier for telegraph signals is a very easy instrument to construct. The circuit diagram shown in Fig. 27 is a typical amplifier circuit of the transformer coupled type. The transformer will not be described as there are so many on the market that it will not pay the experimenter to build one. Most of these transformers are designed to give very satisfactory results when used with the General Electric UV-201 tube and the Western Electric VT-1 tube. The filament rheostats provide an adjustment for the filament current. At this point it may be well to say that the tube should be operated at the lowest filament current at which it will operate satisfactorily. This will materially increase the life of the tube, which means a reduction in the cost of operation of a vacuum tube set.

The next step in the evolution of the transatlantic receiving set is the addition of a loud speaking receiver. By its use it is not necessary to wear the cumbersome head receivers. In order to be able to use a loud speaker, as they are sometimes called, the received signal must be of sufficient strength to produce the required amount of current in the telephone receiver.

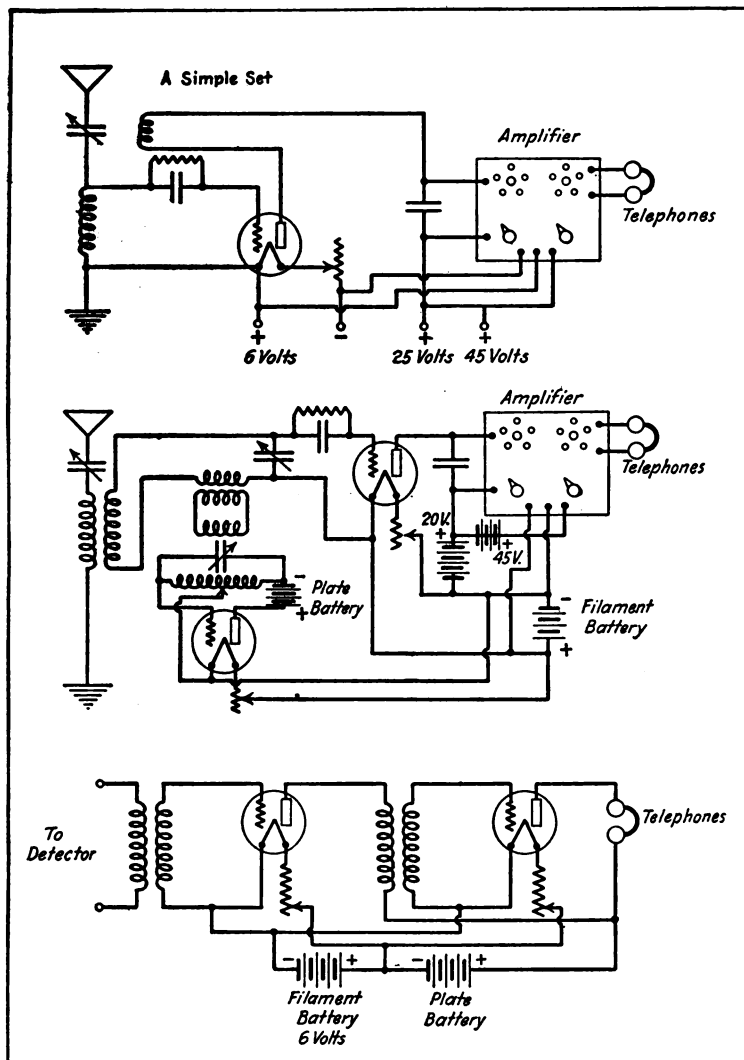

Fig. 27—Circuit Diagrams showing how the Amplifier can be used with radio receivers and its circuit diagram

In most receivers it will require the addition of an amplifier to produce sufficiently strong current to operate a



**Fig. 28—Western Electric Loud Speaking Receiver,
with curved Horn**

loud speaker satisfactorily. This may be a one- or two-stage amplifier, depending on the type of receiver used and the strength of the received signals.

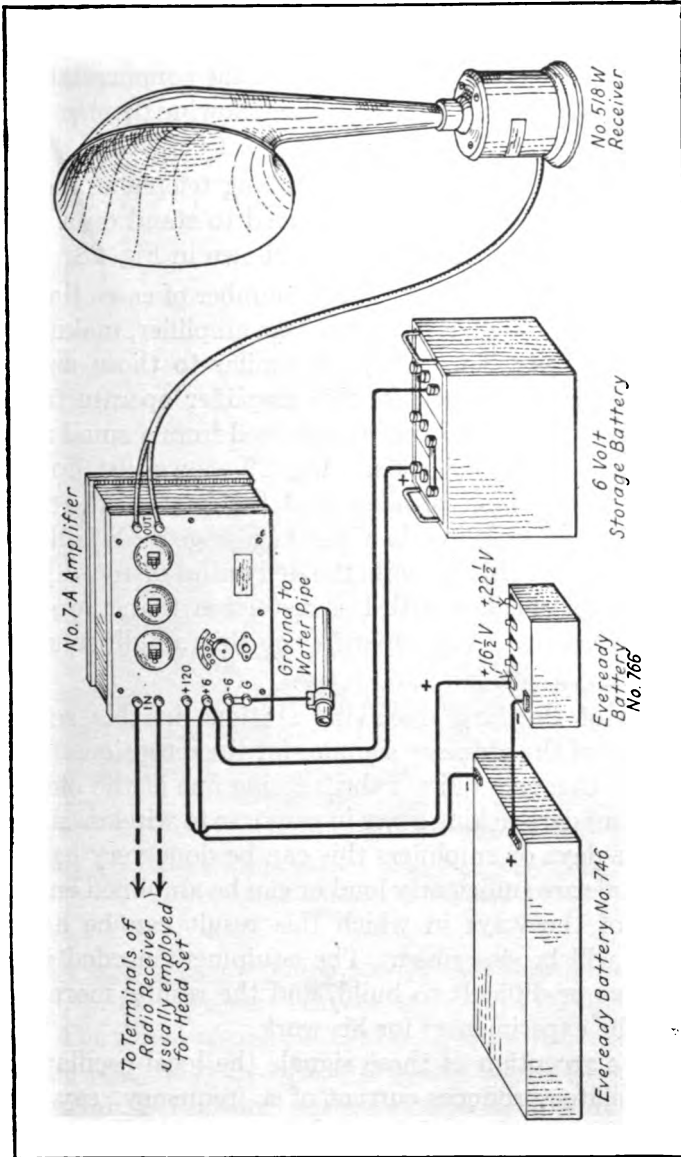

Fig. 29—Diagram of the External Connections of the Amplifier and Loud Speaker

As an illustration of what some of the commercial companies are doing in this respect the following description of the Western Electric 10-A amplifier set is given.

This set consists of a loud speaking telephone receiver mounted in a case which is arranged to stand on a table. The horn fits into this receiver as shown in Fig. 28.

In order to take care of a large number of cases the loud speaker is provided with a two-stage amplifier, making use of three tubes. The tubes are similar to those used on telephone repeaters and in this amplifier operate from a 120-volt source. This can be obtained from a small motor generator or from dry cells. Fig. 29 shows just how the amplifier, the loud speaker and the batteries are connected. This amplifier is of the two stage push pull type. This type of circuit permits the delivering of more power to the loud speaker with less distortion than the simple type of circuit. A photograph of this amplifier unit is shown in Fig. 30.

Some of the large receiving stations in this country make use of the ordinary sounder for the reception of radio signals. One gets quite a thrill seeing one of the old telegraph sounders ticking away in response to wireless signals. In these days of amplifiers this can be done very easily if the signals are sufficiently loud or can be amplified enough.

One of the ways in which this result can be accomplished will be described. The equipment needed is not expensive or difficult to build, and the results more than repay the experimenter for his work.

In the reception of these signals the local oscillator or self-oscillator produces current of a frequency, say 1,000 cycles different from the signal frequency. The current

which produces the sound in the telephones connected to the detector is, in the case mentioned, 1,000 cycles per second. In order to operate a relay this 1,000-cycle

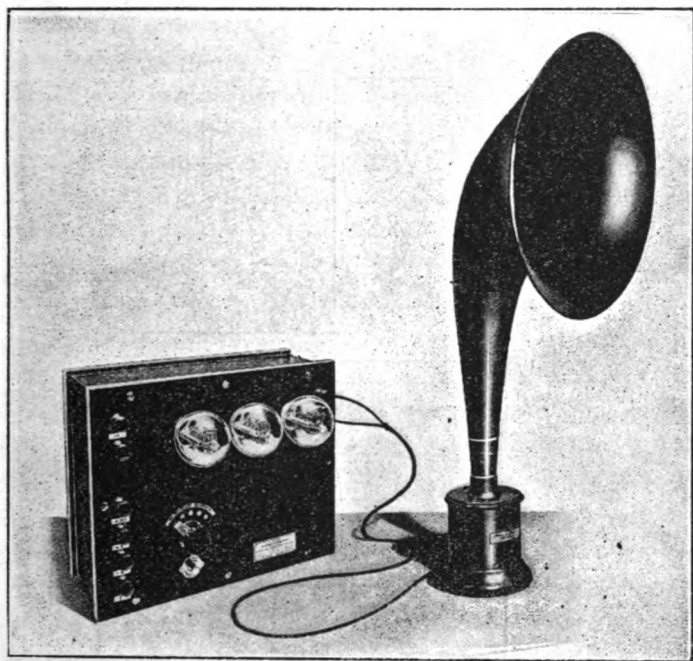

Fig. 30—Western Electric two-stage Vacuum Tube Amplifier, equipped with three Vacuum Tubes

circuit is greatly amplified and passed through a rectifier which produces direct current at or and 1,000 cycles. Fig. 31. The direct current is used to operate the relay.

The relay may be of the ordinary telegraph type with the magnets rewound with copper wire No. 32 or 34 to

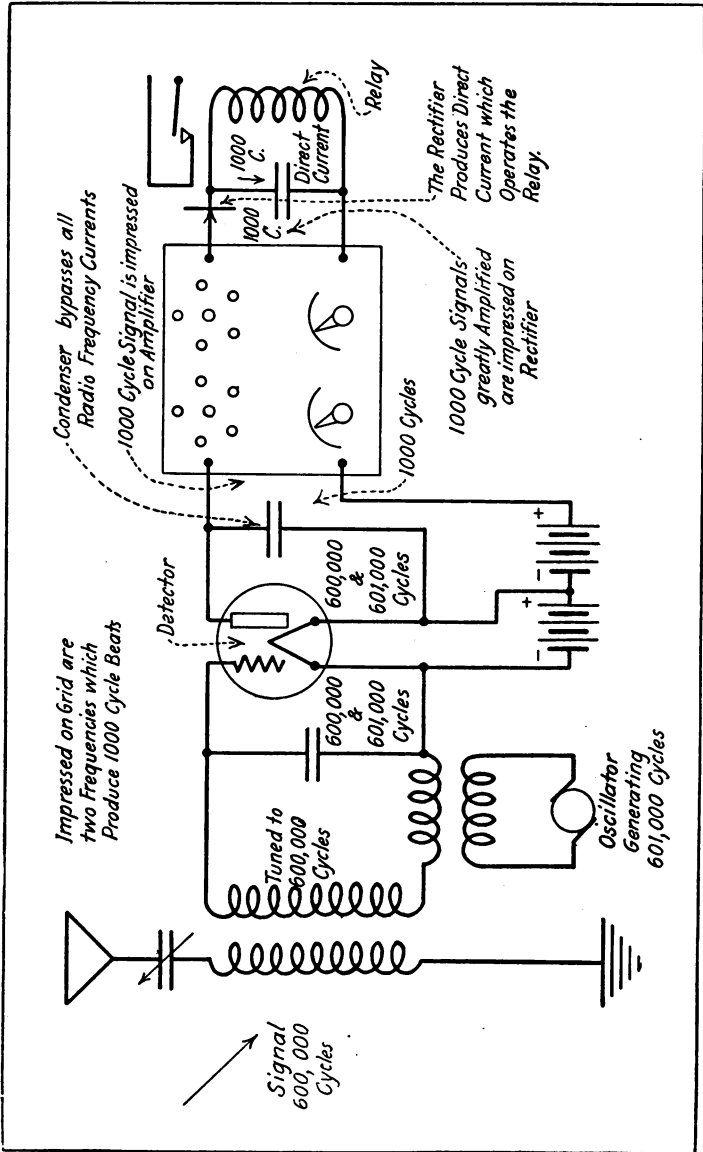

Fig. 31—Diagram Showing a Trans-Oceanic Receiver designed to Operate a Relay and Sounder

three or four thousand ohms. The magnets should be very close to, but not touching, the armature of the relay.

Fig. 32 gives details of the rectifier unit and the relay connections as well as that of the sounder.

The battery to be applied to the grid of the tube is very important and because of the wide variation in tubes, had best be adjusted by trial. Insert a pair of telephone receivers in the plate circuit and add grid battery until no click is heard when the receivers are connected or disconnected from circuit.

Today there are a few radio telegraph stations in operation which are equipped with automatic transmitting and recording apparatus. These stations transmit their messages at a much higher speed than it is possible to accomplish by hand sending. In order to receive the messages transmitted at this speed the automatic recorder is resorted to by the commercial companies. The automatic recorder is similar to an oscillograph and is almost as difficult to build and operate. Therefore it is almost beyond the use of the experimenter.

The reception of these high speed signals can be accomplished quite simply, however, by making use of a loud speaking telephone receiver and an Ediphone Dictaphone or other recording phonograph. Fig. 33 shows a possible arrangement in which the mouthpiece of the dictating machine is placed over the mouth of the loud speaker which has had the horn removed.

Signals recorded on the record when it is revolved at high speed can be read very easily when the record is played at a very much slower speed. For example, suppose the cylinder is cut at 80 revolutions per minute

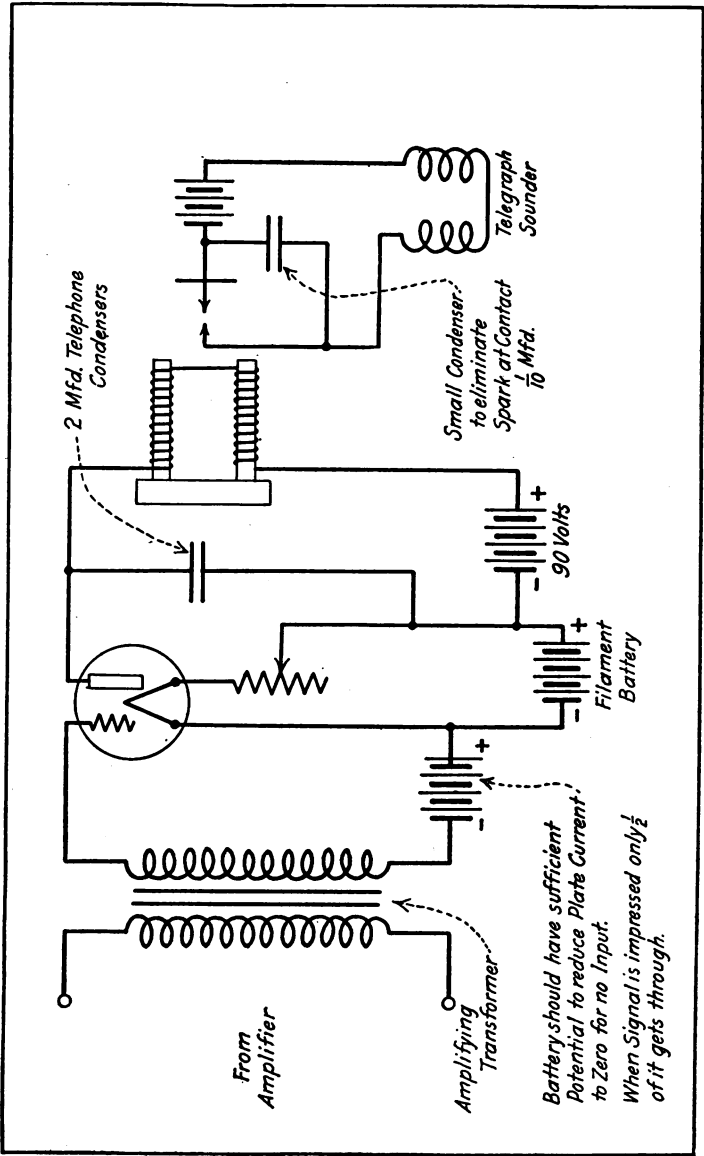

Fig. 32—Details of Rectifier Unit and Relay and Sounder

and the telegraph signals, which are being transmitted at a speed of sixty words per minute, are recorded on the cylinder. When the record is played at 40 revolutions per minute the telegraph signals can be read by a good operator as the speed is only thirty words per minute.

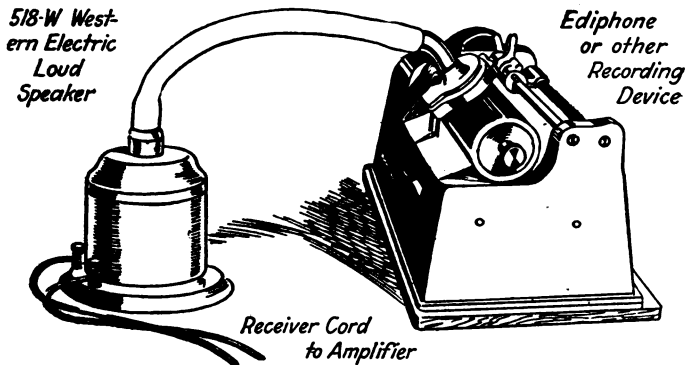

Fig. 33—Arrangement of Loud Speaker and Ediphone for the Recording of Signals

This is a very satisfactory way to receive high speed transmission of telegraph signals. It is very instructive, too, for the beginner because the ordinary transmissions at, say thirty words per minute, can be reduced by this means to say ten words per minute. The record can then be played almost any number of times until the message is copied correctly.

CHAPTER VI

HOME-MADE WAVEMETERS

Data on making wavemeters for testing and measuring the wavelength of radio circuits.

Not a few amateurs are under the impression that a wavemeter is more or less of a luxury—a desirable adjunct to the equipment of a modern amateur radio station but not necessarily an essential factor. That this idea is a fallacy is admitted by most amateurs after they have installed and used the important instrument that makes it possible accurately to determine not only the wavelength of their own stations but those of their friends as well.

Given the design and curve or table of wavelengths of a simple meter, the amateur may readily construct the instrument in his home shop without great expenditure of time or money. The wavemeter, in fact, consists merely of a standard variable condenser and an inductance comprising a few turns of insulated wire wound upon a form of wood or perhaps cardboard tubing. While there are refinements in the more expensive instruments that make for convenience and greater accuracy, still the principle is exactly the same.

The first requisite is a variable condenser which may be of the standard amateur type having a maximum capacity of .0005 mfd. There are a number of suitable condensers on the market, and the one chosen for the model herein described was selected merely because it happened to be in stock. This explanation is given in order to dispel any impression that its use in our model is an indication of partiality or indorsement. The instrument is, in our

estimation, no better or worse than many others available to the amateur.

The condenser shown in the illustration is known as a Murdock No. 368 with sixteen stationary and fifteen rotary plates of standard amateur size. The capacity is .0005 mfd., and upon this capacity and scale the curve reproduced has been made. If a condenser having a

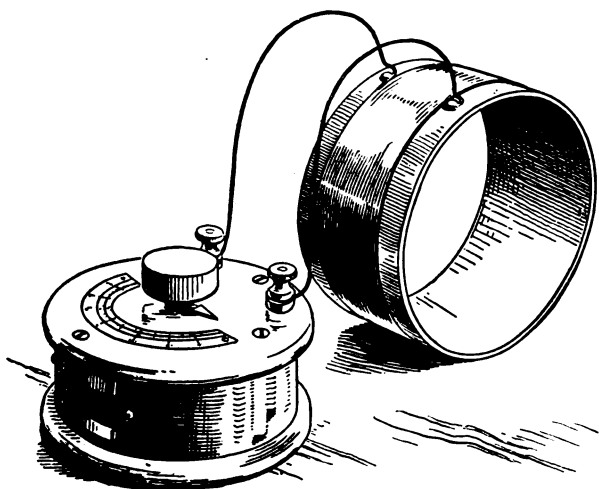

Fig. 34—The Winding is Connected to the Terminals of the Condenser

different capacity or size and shape of plates is used, the wavemeter must be calibrated by comparison with a standard instrument.

The inductance coil is the only part of the instrument that requires specific description from the builder's standpoint. It is composed of 34 turns of No. 20 D.S.C. magnet wire wound in a single smooth layer upon a cylinder of

cardboard tubing $4\frac{1}{8}$ in. in outside diameter and $2\frac{1}{4}$ in. long. The ends of the winding are left exactly 7 in. too long when the coil is finished. A brass screw placed as shown in the photograph holds each end of the winding in

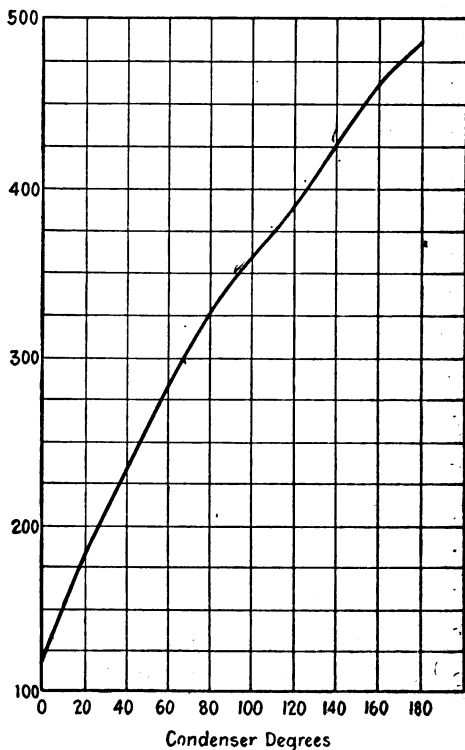

Fig. 35—The Wavemeter Curve

place while the 7-in. leads are left free to go to the terminals of the condenser. It is quite essential that the length of leads, diameter of cylinder, size of wire, etc., be adhered to

in the event that the builder has no means for recalibrating the instrument when it is finished. Outside of this precaution, no particular care or skill will be required.

In the table which follows, the wavelengths with the fixed inductance and variable condenser described are given:

Condenser Degrees	Wavelength in Meters
0.....	118
20.....	185
40.....	237
60.....	285
80.....	328
100.....	345
120.....	395
140.....	435
160.....	470
180.....	485

In the following paragraphs comprehensive directions for the calibration and use of the wavemeter are given.

The wavemeter may be used to tune up an old type spark transmitter for the measurement of the wavelength of the received signal or many other useful purposes.

To measure the wavelength of the closed circuit of a spark set, disconnect aerial and ground from the secondary of the oscillation transformer and make coupling very loose so that no inductive effect takes place between primary and secondary windings. The upper part of Fig. 36 shows the connections of a standard spark transmitting set with secondary of oscillation transformer not shown, but disconnected from the closed oscillatory circuit as explained above.

The wavemeter is shown at the lower part of Fig. 36, showing a small tungsten filament flashlight bulb con-

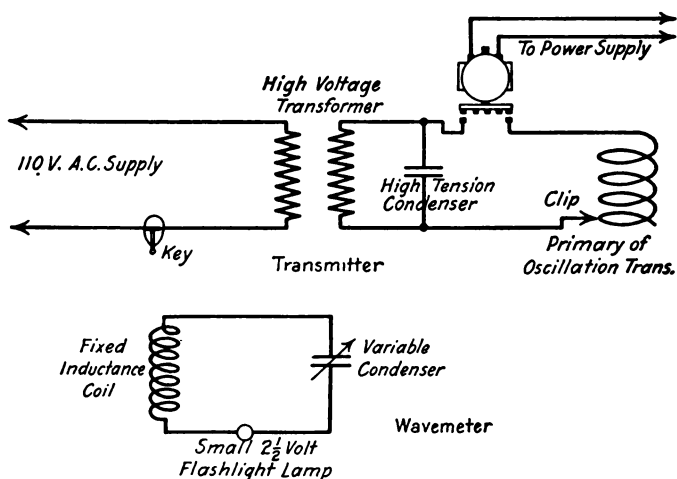

Fig. 36—Diagram of Connections for Tuning the Closed Oscillating circuit of Transmitter

nected in series with the condenser and inductance. This lamp will light to incandescence when the resonance point between the transmitter closed circuit in operation and the wavemeter circuit is reached. Care should be taken that the wavemeter inductance coil is not placed too near the oscillation transformer, otherwise the induced currents will burn out the lamp.

For tuning the transmitter to a definite wavelength, set the clip at some point on the oscillation transformer primary. Place the wavemeter inductance about 3 feet from the oscillation transformer and, with the key closed, adjust the variable condenser until the lamp lights brilliantly. If the lamp does not light, place the inductance nearer until the desired results are obtained. By taking

note of the variable condenser reading, which is graduated in degrees from 0 to 180, and referring to the curve, the wavelength at that particular point is known.

If the wavelength is too high, decrease the number of turns in the oscillation transformer, and if too low increase the number of turns until the definite wavelength is found. If this wavelength is found to be with less than three turns of the primary, it is better to leave the clip at three turns and decrease the capacity of the high tension condenser until the desired wave is found. It has been found that not less than three turns are needed to transfer the energy efficiently from the primary to the secondary circuit.

To tune the open oscillating circuit to the wavelength of closed circuit, excite this circuit with a small induction coil or transformer as shown in Fig. 37. Make sure that the spark length used is very small, otherwise the wave emitted will be too broad to read correctly on the wavemeter. The wavelength will be found by noting the point on the condenser scale, when the lamp lights to incandescence, as

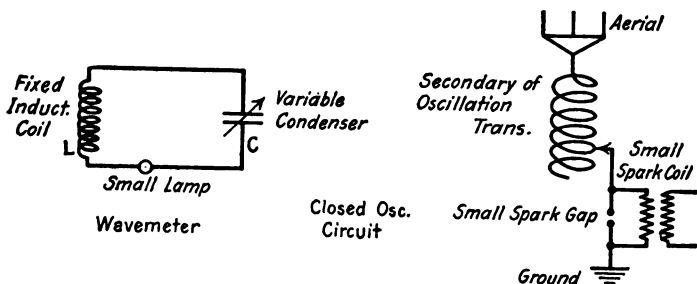

Fig. 37—Tuning the Open Oscillating Circuit of a Transmitter

was the case in finding the wavelength of the closed circuit.

If the wavelength is too long, due to the natural period of the aerial itself, insert a high tension condenser in series with the aerial. If the aerial is not too long and the proper condenser is used, the wavelength will be found without any difficulty.

Now that you have both the open and closed circuit tuned to one wavelength, you will find that two wavelengths will be found on the wavemeter when the distance between the primary and secondary windings is too small. This is due to a reaction which takes place in both oscillating circuits. By varying the coupling or distance you will find that *one* wave will be the result at a certain coupling. This is the point of sharpest tuning and highest efficiency.

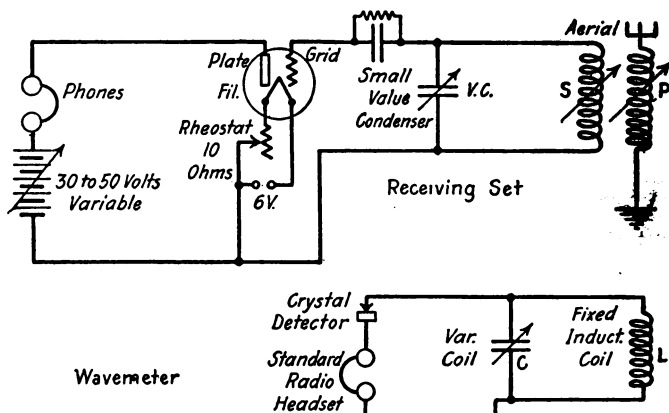

Fig. 38—To Determine the Wavelength of an Incoming Signal

For determining the wavelength of an incoming signal, tune the receiver until the signal is at its highest point, then place the wavemeter inductance coil about 3 in. from the receiving transformer primary as shown in Fig. 38.

You will note that an ordinary crystal detector and telephones are used in place of the small flashlight lamp, because the incoming energy is too small to light the lamp. By varying the condenser capacity the incoming signal will be heard at some definite condenser reading and by referring to the curve the wavelength of the incoming signal will be found.

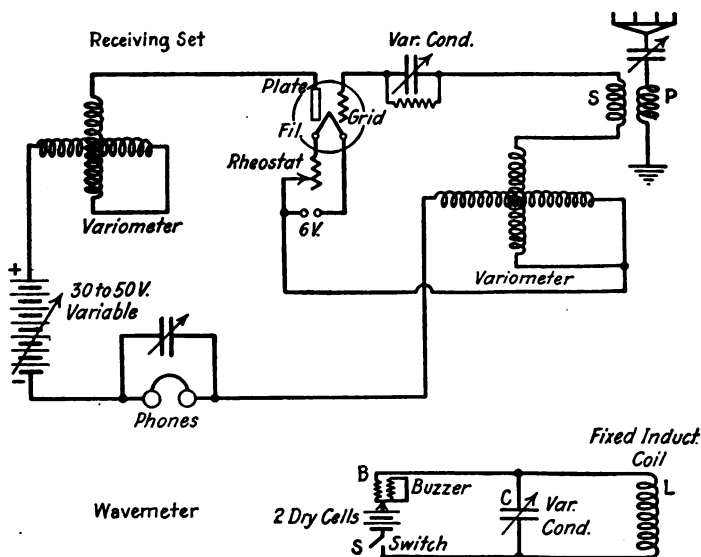

Fig. 39—To find the Wavelength of a Receiving Set or any Oscillating Circuit

64 *New Transatlantic Receiving Sets*

If the wavelength of the signal is shorter or longer than the range of the wavemeter no result will be obtained.

For finding a certain wavelength in a receiving set, excite the wavemeter with a high note buzzer as shown in Fig. 39,

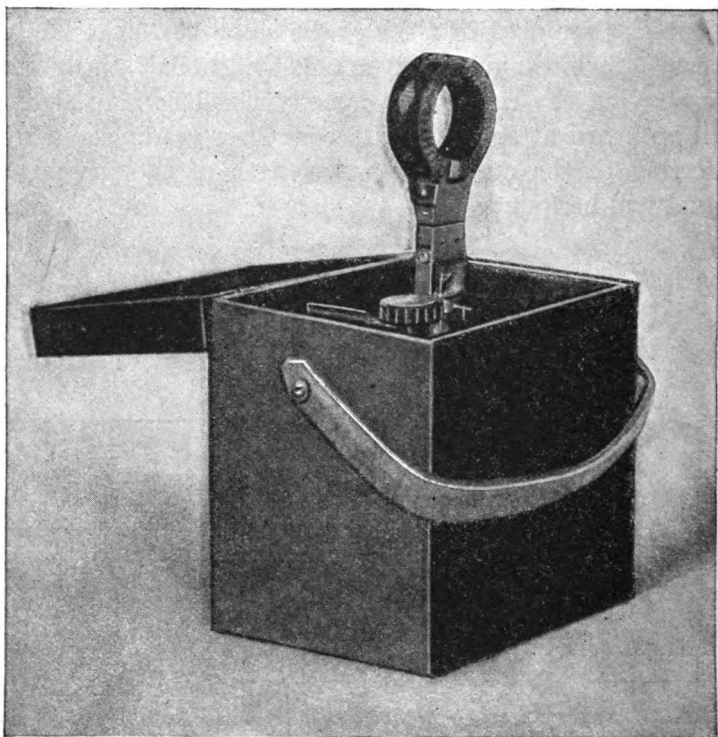

Fig. 40—The Completed Meter ready for use Mounted in the Carrying Case. (Side view.)

and adjust the variable condenser so that the wavemeter sends out a certain wavelength, acting as a small transmitting set. By manipulating the receiving set in the

ordinary manner as if receiving from a definite station, the buzzer signal will be heard at a certain setting and this shows that the resonance point has been reached. The same method can be used for finding the wavelength of any oscillatory circuit consisting of one or more inductances or capacities.

The first part of this chapter tells us how to use the wavemeter, the few paragraphs which follow tell rather fully how a wavemeter can be built which will be portable, which uses the honeycomb coils and which is a very useful piece of apparatus for the amateur station.

This instrument is rather expensive for the average experimenter to buy complete, but one of the type to be described goes a long way toward putting the wavemeter within reach of radio men.

One of the greatest difficulties with a wavemeter is that it must be calibrated. Since standard coils are used in this instrument, and a calibration curve for the condenser is given, wavelengths can be determined approximately by calculation. The condenser is type CV-1000, built by the de Forest Company. While individual condensers of this sort may vary slightly, the calibration curve given here is accurate enough for practical purposes. The error is smaller at long wavelengths than at short ones.

Figs. 40, 41, 42 and 43 show the constructional details of the instrument. Because a carrying case was already available, a standard 5 x 10 in. panel was cut to a length of 7 in. If the full length had been retained, however, there would have been room enough to mount a small hot-wire ammeter of the Clapp-Eastham or General Radio type.

The construction of the condenser lends itself readily to

66 *New Transatlantic Receiving Sets*

mounting under the panel. A brass disc $4\frac{1}{2}$ in. in diameter is cut out and drilled so that it can be placed between the top of the condenser and the panel. A $\frac{1}{2}$ in.

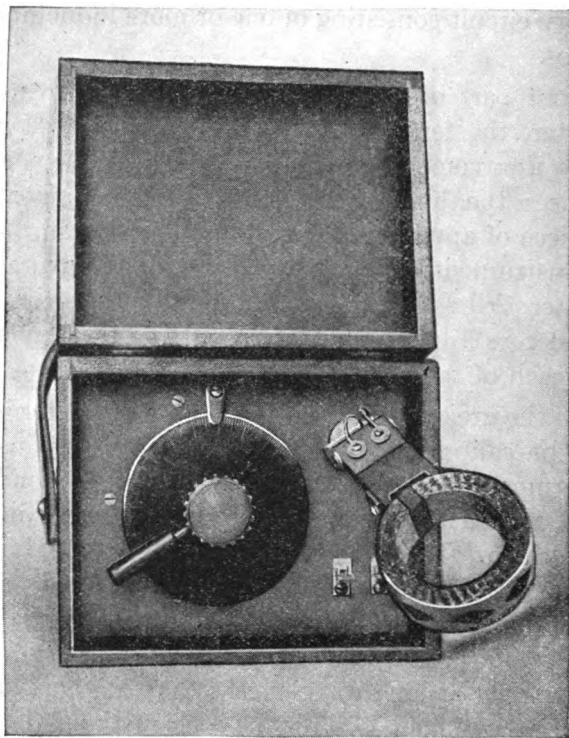

Fig. 41—The Completed Meter ready for use Mounted in the Carrying Case. (Top view.)

hole is allowed around the shaft. In assembling, a washer is placed on each mounting screw to separate the shield from the panel, to increase the leakage path to the shaft.

The indicating dial is made from a 4 in. bakelite disc, engraved or scratched with 100 divisions. This dial is clamped to the under side of the knob by a 2-56 brass screw. Opposite the single set-screw already in the handle, a hole is made with an 8-32 thread to take the brass rod of the auxiliary adjustment. The outer end of the rod is slotted, so that it can be put firmly into the handle as a second set-screw.

In place of a pointer, a piece of thin celluloid is used, supported by a long washer and machine screw. A scratch on the under side of the celluloid gives an accurate indication against the scale.

Next comes the coil mounting. Flexibility requires that the coil shall turn in all planes. An examination of the illustrations will show that the coil plug is pivoted on a U-shaped piece, set on a hollow shaft. This shaft has three diameters, the top part $\frac{3}{32}$ in. long and $\frac{5}{16}$ in. in diameter, the center section $\frac{1}{8}$ in. long by 1 in. in diameter, and the bottom part $\frac{3}{8}$ in. long and $\frac{5}{16}$ in. in diameter. Through the center is a $\frac{3}{16}$ in. hole.

The top portion of the shaft is pined over around a $\frac{5}{16}$ in. hole in the coil supporting yoke. Then the other end is put through a hole in the panel. The large section of the shaft, bearing upon the panel, causes the mounting to turn smoothly. Under the panel is a clamping piece 1 in. in diameter, with a $\frac{3}{8}$ in. shoulder carrying two set-screws. This is put over the part of the shaft which extends from under the panel. By this method the mounting is held firmly in place.

Parts for the plug can be taken from a standard mounting. When the plug shaft has been put into the holes in

the yoke, the ends are headed over to keep it tightly in place. Thus a sufficient tension can be maintained on the plug to prevent the weight of the coil from moving it.

Connections to the condenser are made by flexible cord put through the center hole in the mounting shaft. Fig. 42 shows an arm and stopping pins arranged so that the coil can turn only 90°. This is a sufficient movement, and prevents twisting of the lead wires. Two brass strips, Fig. 43, provide connections to the fixed and moving plates.

As the wiring diagrams show, two binding posts, or in this case Fahnestock clips, are required for the connections of auxiliary apparatus. Wiring of the posts is illustrated in Fig. 43.

The calibration curve, Fig. 44, shows the capacity of this condenser at the different settings. If the standard honeycomb coils are used, the wavelengths can be determined approximately from catalogues of dealers in honeycomb coils. For accurate calibration, however, comparison with a known wavemeter is required. Radio Inspectors are usually willing to help in this work.

With the capacity of this condenser, wavelength ranges with sufficient overlaps can be obtained from the following coils:

Milli henrys	λ Min.	λ Max.
0.04	100	400
0.15	250	750
0.60	450	1,550
2.3	900	3,000
11.0	2,000	6,600
40.0	4,000	12,500
175.0	8,000	24,500

Thus, if required, a range of 100 to 24,500 meters can be covered.

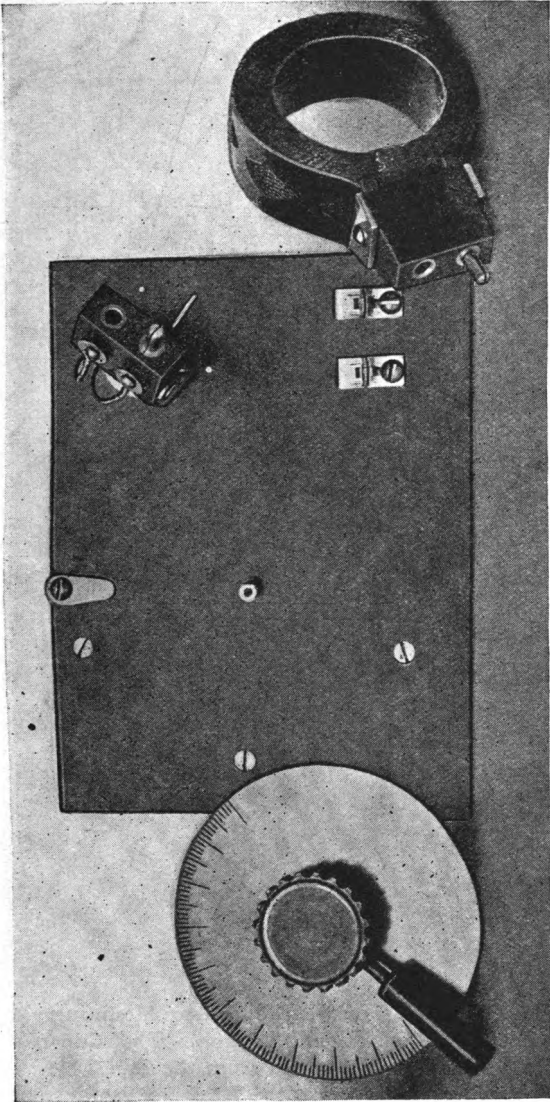

Fig. 42—Showing the Mounting for the Honeycomb Coil and the Indicating Dial with its Auxiliary Handle

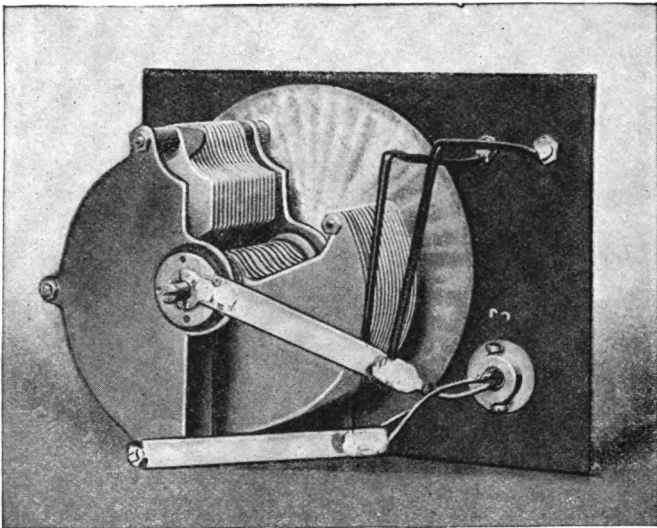
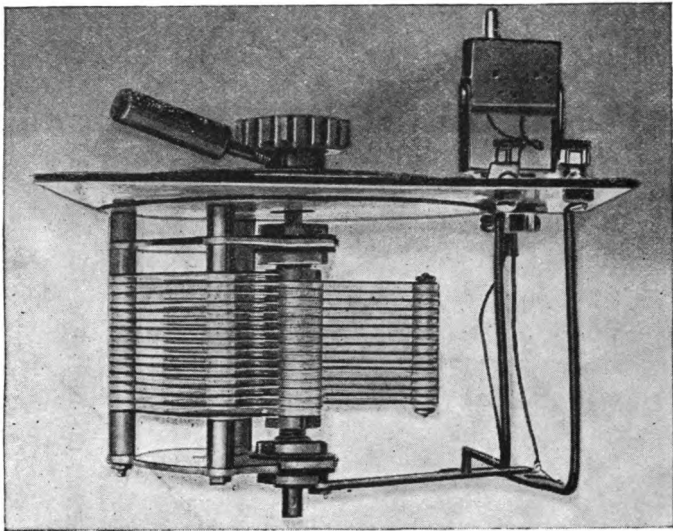

Fig. 43—Details of the Condenser Mounting and Connections with the Coil. The Condenser Shield is Separated from the Panel by Washers to Increase the Leakage Path

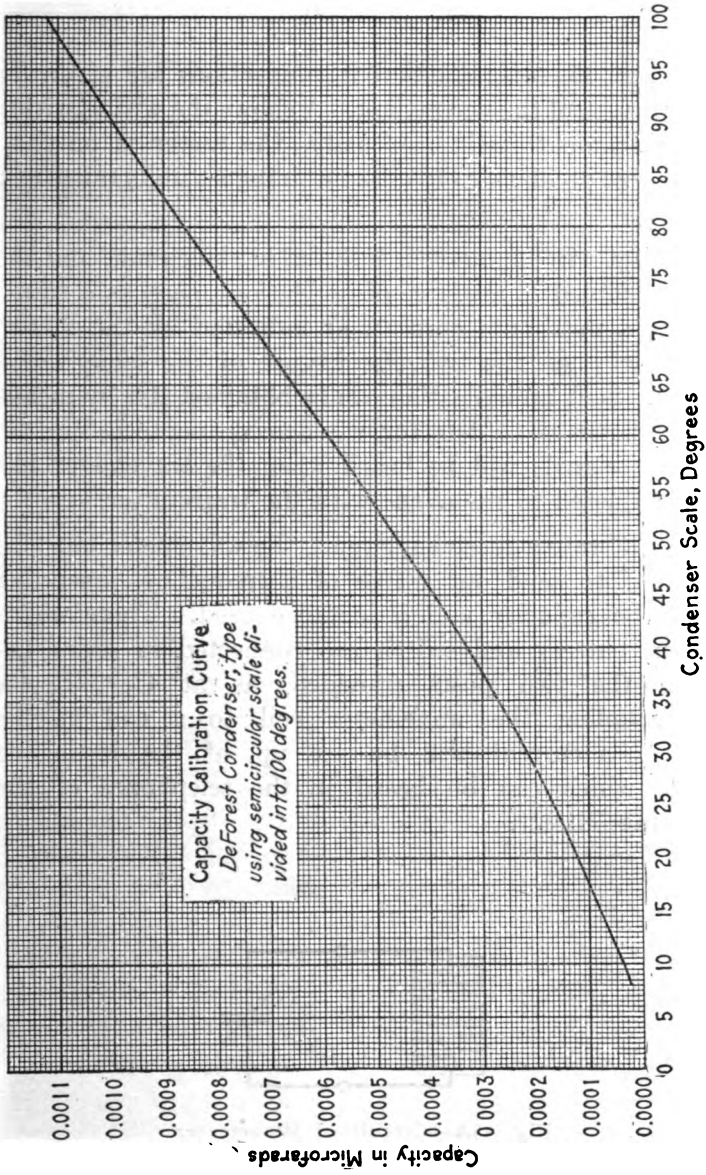

Fig. 44—Calibration Curve of the Condenser used in this Wavemeter

In Fig. 45, several different connections are given for various uses of the wavemeter. A shows the wiring within the instrument itself. Actually, the meter is only an adjustable oscillating circuit containing an inductance and capacity.

If a hot wire ammeter is inserted in the circuit, and the coil is coupled to a source of oscillations, such as a transmitter, a maximum current, as indicated by the meter, will flow when the two circuits are of the same wavelength. Such an indication can be obtained also by means of telephones and a detector, wired according to B, Fig. 45. Loudest signals will be heard when the wavemeter has been adjusted to resonance with the transmitter.

To calibrate a receiving circuit, the wavemeter must be arranged to send out waves of a frequency depending upon the capacity and inductance used. Therefore, a buzzer, battery and switch are connected in series between the two posts provided, as at C, Fig. 45. By coupling the wavemeter coil to a coil in the receiver, a current will be set up, at the resonance point, which can be heard in the telephones of the receiving circuit.

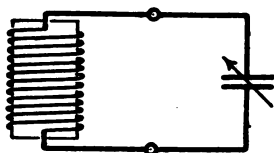

Fig. 45A—Circuit of Wavemeter

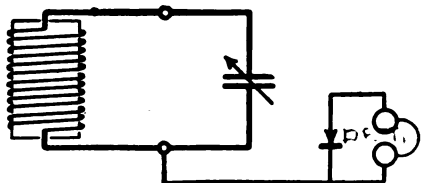

Fig. 45B—Method of Receiving Signals for Transmitter Calibration

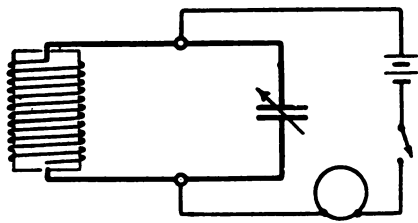

Fig. 45C—Sending Signals of known Wavelength

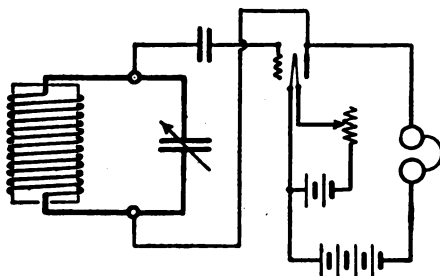

Fig. 45D—An Oscillating Circuit for Undamped Wave Work

This instrument, connected as at Fig. 45D, will generate undamped oscillation of any frequency. For undamped wave reception, the wavemeter can be coupled to the secondary of the loose coupler, and beats set up with the incoming signals. The wavelength of the signals is indicated at the point of silence, on each side of which signals can be heard.

The heterodyne wavemeter is a later application of the audion oscillator to the measurement of wavelength.

Since this type of wavemeter is very convenient and useful, a description of it is given in this chapter.

Have you ever worked and worked to get a resonance point in making measurements with a wavemeter, giving up in the end or taking a chance that the readings you made were somewhere near correct? You won't have to do that with an oscillating wavemeter. The circuit is simple, and contains only the elements of an oscillating circuit, an inductance connected at one end to the grid of a tube, a center tap to the filament, and the other end running to the negative side of a plate battery, the positive battery lead to the telephones, and the phones to the tube plate. A variable condenser is connected across the ends of the coil. This is a laboratory oscillator which, when calibrated, becomes a wavemeter.

There are many uses to which the instrument can be put described in detail at the end of this article.

Fig. 46 shows the completed meter connected and ready for use on wavelengths from 180 to 600 meters. A G-A-STD-A-15 variable condenser, .0002 mfd. capacity, is mounted on a 5 by 5 by 3/16 in. panel fitted on a box 2½ in. deep inside and 5 in. square outside. Three special clamping posts are needed for connections, made to hold the coil connection lugs in the center and wires to the audion at the top. They are located 5/8 in. from the edge, the left hand post being 1 5/16 in. from the side of the panel, the next ½ in. to the right and the third 1 15/16 in. from the second.

The coil is 1 7/16 in. long, of 65 turns of No. 24 S.S.C. wire on G-A-Lite tube 3½ in. in diameter and 2¾ in. long. Winding is started 1 in. from the left hand end, and a tap

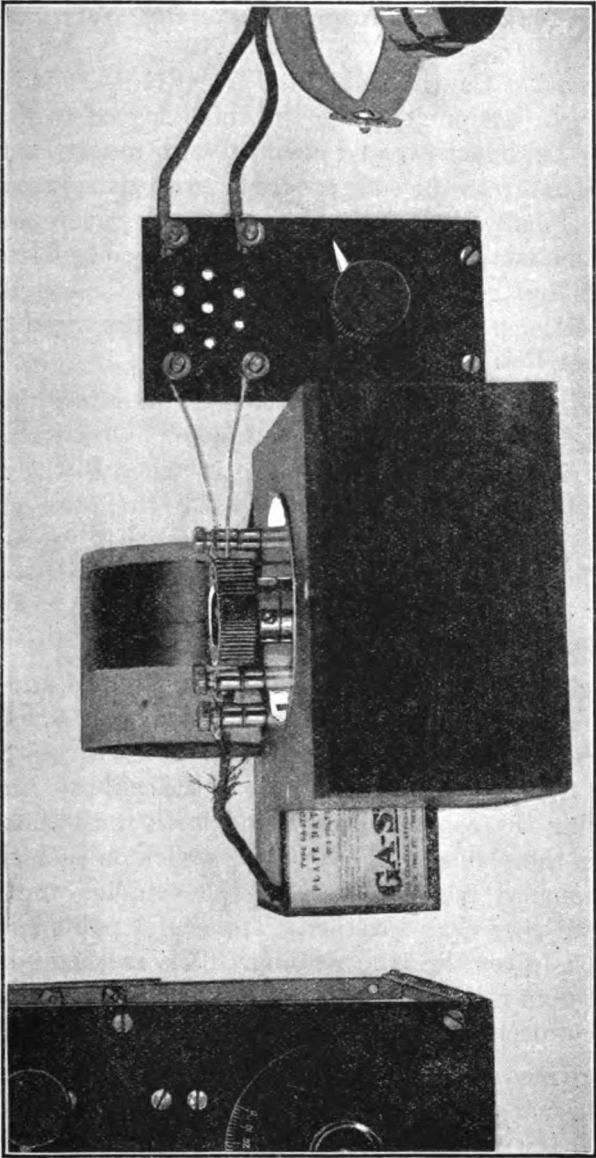

Fig. 46—The Complete Wavemeter set up, Coupled to a Receiving Set

is taken off at the thirtieth turn. Next, 1 in. round head 8-32 screws are put through the tube, spaced to line up with the binding posts and clamped with nuts. End and center leads from the coils are soldered to their respective screws. Finally large size soldering lugs are put in position on the binding posts and the screws on the coil soldered to them. Thus the screws provide support for the coil as well as connections. The outside binding posts are wired to the condenser terminals.

Connections to the audion have been described already. When a Laboratory Type Control is employed, as in Fig. 46, the right hand wavemeter post is joined to the upper left hand control post, the center post to the lower control post, negative plate battery lead to the left wavemeter post, and the positive lead to the regular positive plate battery connector at the rear of the control. The right control panel posts take the telephones.

To calibrate this meter, connect it as directed and light the tube filament. If a UV-200 is used, put 22.5 volts on the plate, or for more power a UV-201 with 45 volts. Couple the coil to the inductance of the calibrated meter, and swing the condenser back and forth until clicks are heard in the phones. There will be a click on each side of the resonance point. Decrease the coupling until the clicks are very close together. The center point between the clicks gives the true reading. This method, though it may seem rather uncertain from the description, works out very nicely in practice.

Before measuring the wavelength of a circuit disconnect any other circuit coupled to it or set the coupling at zero. Whether the circuit is for transmitting or receiving it is not

necessary to excite it. Merely couple the wavemeter to it and listen for the clicks which indicate resonance.

If the wavemeter is set up near a telephone or undamped wave transmitter, beat notes will be heard on both sides of the resonance point.

There are many interesting uses for this instrument. It may be coupled to a non-oscillating audion or crystal circuit and used for heterodyning undamped wave signals. For experiments on impedance coupled radio frequency amplifiers the meter itself can be used as the impedance circuit. Again, it may be connected in the plate circuit of a non-oscillating detector, and it will cause the circuit to oscillate and regenerate.

The only way to compare tubes, amplifying transformers, receiving sets, and other devices is to connect one and then the other, keeping the conditions the same. A handy switch for this purpose is shown in Fig. 47 at the left.

It is a Federal anti-capacity switch mounted on an L.P.F. panel 5 by 5 by 3/16 in. The panel is supported on a wooden base. Fahnestock clips for the center contacts are mounted across the top of the panel, and the clips on the sides for the side contacts. It might have been better to have the handle thrown to the side instead of up and down. For simplicity, small wire was used for connections, insulated with Empire tubing.

The top and side clips should be given corresponding numbers to facilitate the wiring of instruments to be compared. Whatever devices are to be compared should be connected to the side clips, while the top clips go to the auxiliary apparatus.

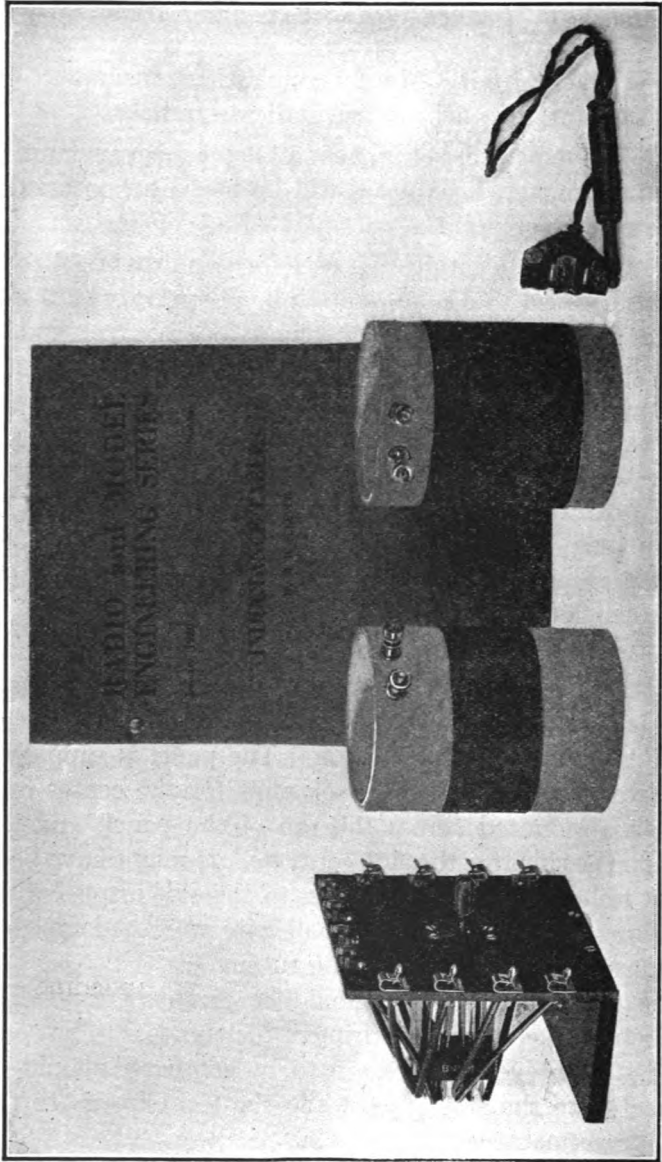

Fig. 47—Testing Switch, Inductance Standards, Phone Bob and Inductance Tables, all Useful Things for the Radio Man

All kinds of experiments call for inductance standards. Every laboratory should have an assortment, running from .1 to 10.0 milli henrys. While these are expensive in the forms in which they are usually manufactured, the coils in Fig. 47 can be wound up quickly, and to an accuracy of well within 5 per cent.

So many times we have needed two pairs of phones on a set provided with only one jack that we now use a phone bob. It is just a little piece of L.P.F. cut from a $2\frac{1}{2}$ by 5 by $\frac{1}{8}$ in. panel, carrying four Fahnestock clips, with a cord running to the phone plug. A phone bob, as we call it, is shown at the left of Fig. 47. Its convenience has more than compensated for the time it took to make it.

CHAPTER VII

THE INCREASING COMPLEXITY OF RADIO EQUIPMENT MAKES NECESSARY CLEAR MARKING OF THE PARTS AND CONNECTIONS. AN INTELLIGIBLE SYSTEM IS GIVEN IN THIS CHAPTER

There is a certain amount of misunderstanding due to the various terms which different manufacturers and individuals apply to the same instrument, but still more confusing are the abbreviations engraved on apparatus. Such a simple thing as the primary tuning inductance switch is marked in the following ways by six manufacturers:

PRIMARY INDUCTANCE,
PRI SWITCH,
PRIMARY,
P S,
PRI,
P

An examination of several sets showed the following markings for the plate terminal of a vacuum tube:

ANODE,
PLATE,
WING,
W,
P

In fact, there are from three to six different names or abbreviations given to almost all the parts which are marked by name-plates or engraving.

A system of standardized nomenclature must assure its intelligibility so that the uninformed will not be

puzzled by it, yet it must call for as few letters as possible to make it applicable to instruments whose cost does not warrant expensive engraving. The abbreviations cannot be chosen arbitrarily then, but they must be either letters which, in familiar formulas, are used to represent certain factors, or else they must suggest phonetically the words for which they stand. That is, L is the natural mark for inductance, as is R for resistance. Other markings which we all know are G, P, F, and AC, for grid, plate, filament, and alternating current.

On the other hand, REO, MIC, OM, and GND, if pronounced, suggest immediately rheostat, microphone, ohm, and ground. Experimenters who, by the home-made method, engrave their panels, will find that this system minimizes their work.

An alphabetical list is given of the abbreviations and of the words for which they stand. The list covers practically everything used for receiving sets and vacuum-tube transmitters, as well as individual instruments.

STANDARDIZED RADIO NOMENCLATURE

A amperes	BFD bilateral direction finder
A, B, C, D secondary inductance large steps, or loading coil	BRG bridging
a, b, c, d secondary inductance, or small steps	C condenser
AC alternating current	CM centimeter
AF audio frequency	CPG coupling
AM amplifier	CR crystal
ANT antenna	CY cycles
AP aperiodic	D damped
	DC direct current
BZ buzzer	DET detector
BAT battery	DMY dummy

E potential	OSC oscillator, oscillations
F filament	OUT out, outside output
FD farad	P plate
FX fixed	PAR parallel
G grid	POT potentiometer
GEN generator	PRI primary
GND ground	R resistance
H henry	RCT rectifier
HDN heterodyne	REC receive
I current	REO rheostat
IN in, inside	REMCN remote control
INC increase	REST receiving set
IPT input	RF radio frequency
JK jack	SBY standby
JPR jumper	SEC secondary
K per cent. coupling	SH shunt
KY key	SM smoothing
L inductance	SND send
LDG loading	SS small steps
LK leak	STD standard
LP loop	STG stopping
LS large steps	STP step, stage
LSCPR loose coupler	SW switch
M meters	TEL telephone receivers
MFD microfarad	TGR telegraphy
MH milli henry	TIC tickler
MIC microphone	TLP telephony
MOD modulator	TR transformer
OFF off	TRST transmitting set
OM ohms	TRT transmit
ON on	TUN tune
OPT output	U undamped
	UDF unilateral direction finder
	VT vacuum tube
	V volts
	VAR variable
	VMR variometer

W watts
 WV waves
 X reactance
 Z impedance

λ wavelength
 1, 2, 3, 4 primary inductance, or
 small steps
 I, II, III primary loading induc-
 tance, or large steps

INDEX TO STANDARDIZED RADIO NOMENCLATURE

alternating current.....	AC	grid.....	G
amperes.....	A	ground.....	GND
amplifier.....	AM	henry.....	H
antenna.....	ANT	heterodync.....	HDN
aperiodic.....	AP	impedance.....	Z
audio frequency.....	AF	in.....	IN
battery.....	BAT	increase.....	INC
bilateral direction finder.....	BDF	inductance.....	L
bridging.....	BRG	inductance, primary, or	
buzzer.....	BZ	small steps.....	1, 2, 3, 4
centimeter.....	CM	inductance, primary load-	
condenser.....	C	ing, or large steps.....	I, II, III
control, remote.....	REMCN	inductance, secondary, or	
coupling.....	CPG	small steps.....	a, b, c, d
coupling, per cent.....	K	inductance, secondary load-	
crystal.....	CR	ing, or large steps.....	A, B, C, D
current.....	I	input.....	IPT
current, alternating.....	AC	inside.....	IN
current, direct.....	DC	jumper.....	JPR
cycles.....	CY	key.....	KY
damped.....	D	large steps.....	LS
detector.....	DET	leak.....	LK
direction finder, bilateral.....	BDF	loading.....	LDG
direction finder, unilateral....	UDF	loop.....	LP
dummy.....	DMY	meters.....	M
farad.....	FD	microfarad.....	MFD
filament.....	F	microphone.....	MIC
fixed.....	FX	milli henry.....	MH
frequency, audio.....	AF	modulator.....	MOD
frequency, radio.....	RF		

off.....	OFF	secondary loading inductance, or large steps.....	A, B, C, D
ohm.....	OM	send.....	SND
on.....	ON	set, receiving.....	REST
oscillations.....	OSC	set, transmitting.....	TRST
oscillator.....	OSC	shunt.....	SH
out.....	OUT	small steps.....	SS
output.....	OPT	smoothing.....	SM
outside.....	OUT	stage.....	STP
parallel.....	PAR	standard.....	STD
plate.....	P	standby.....	SBY
potential.....	E	step.....	STP
potentiometer.....	POT	stopping.....	STG
primary inductance, or small steps.....	1, 2, 3, 4	switch.....	SW
primary loading inductance, or large steps.....	I, II, III	telegraphy.....	TGR
radio frequency.....	RF	telephone receivers.....	TEL
reactance.....	X	telephony.....	TLP
receive.....	REC	tickler.....	TIC
receivers, telephone.....	TEL	transformer.....	TR
receiving set.....	REST	transmit.....	TRT
rectifier.....	RCT	transmitting set.....	TRST
remote control.....	REMCON	tune.....	TUN
resistance.....	R	undamped.....	U
rheostat.....	REO	variable.....	VAR
secondary.....	SEC	variometer.....	VMR
secondary inductance or small steps.....	a, b, c, d	volts.....	V
		watts.....	W
		wavelength.....	T
		wavemeter.....	WM
		waves.....	WV

Oftentimes several abbreviations are used together. For example, if separate plate batteries are used for an amplifier, the connections might be marked

AF AM P BAT

22.5 V,

meaning "audio frequency plate battery 22.5 volts."

Thirteen letters are used in the abbreviation, and thirty-nine in the full spelling. Again,

PRI L SS

indicates "primary inductance, small steps," requiring less than one-fourth the number of letters.

It is also of interest to note that some manufacturers are using the Bureau of Standards Classification for type numbers. The type number for a loading coil might be

BI-6,

where the B indicates the modification and the I-6 classifies the instrument as an inductor. Similarly a vacuum-tube transmitter might be

DC-4,

D being the modification and C-4 the classification for electron-tube generators.

CHAPTER VIII

RECENT RECOMMENDATIONS OF A COMMITTEE OF THE NATIONAL BOARD OF UNDERWRITERS

NATIONAL FIRE PROTECTION ASSOCIATION

AVAILABLE FOR RELEASE, APRIL 29, 1922

Electrical Committee
DANA PIERCE, Chairman

REPORT OF STANDING COMMITTEE ON SIGNAL SYSTEMS,
WIRELESS AND LIGHTNING

COMMITTEE

WILLIAM S. BOYD, CHAIRMAN

175 West Jackson Boulevard, Chicago, Ill.

J. M. CURTIN

F. A. RAYMOND

C. W. MITCHELL

RALPH SWEETLAND

To Electrical Inspectors:

The following report of the Technical Sub-Committee on Radio Equipment (National Electrical Code, Rule 86) has been approved by the Standing Committee on Signal Systems, Wireless and Lightning, and in co-operation with Mr. Dana Pierce, Chairman of the Electrical Committee, is promulgated in order to produce field experience to substantiate the wisdom of the proposed rules before final submission to the Electrical Committee for incorporation into the 1923 edition of the National Electrical Code. Neither the Standing Committee nor the Electrical Committee has authority to suspend or replace the present Rule 86 of the National Electrical Code, but this report is issued by the authority granted to the Chairman of the Standing Committee and the Chairman of the Electrical Committee for the information of inspection departments having jurisdiction over the application of the Code.

Suggestions for improvements in these proposed rules should be sent to Mr. William S. Boyd, Chairman, 175 W. Jackson Boulevard, Chicago, not later than September 1, 1922.

(Signed) DANA PIERCE, Chairman,
Electrical Committee, N. F. P. A.

(Signed) WILLIAM S. BOYD, Chairman,
*Standing Committee on Signal Systems,
Wireless and Lightning.*

Rules and Regulations for Fire Protection

CORRECTED FINAL REPORT

The following requirements are submitted as proposed revisions of Rule 86, National Electrical Code:

RULE 86, RADIO EQUIPMENT

NOTE: These rules do not apply to Radio Equipment installed on ship-board.

In setting up radio equipment all wiring pertaining thereto must conform to the general requirements of this code for the class of work installed and the following additional specifications:

FOR RECEIVING STATIONS ONLY

ANTENNA

a. Antennas outside of buildings shall not cross over or under electric light or power wires of any circuit of more than six hundred (600) volts or railway trolley or feeder wires nor shall it be so located that a failure of either antenna or of the above-mentioned electric light or power wires can result in a contact between the antenna and such electric light or power wires.

Antennas shall be constructed and installed in a strong and durable manner and shall be so located as to prevent accidental contact with light and power wires by sagging or swinging.

Splices and joints in the antenna span, unless made with approved clamps or splicing devices, shall be soldered.

Antennas installed inside of buildings are not covered by the above specifications.

LEAD-IN WIRES

b. Lead-in wires shall be of copper, approved copper-clad steel or other approved metal which will not corrode excessively

Rules and Regulations for Fire Protection

and in no case shall they be smaller than No. 14 B. & S. gauge except that approved copper-clad steel not less than No. 17 B. & S. gauge may be used.

Lead-in wires on the outside of buildings shall not come nearer than four (4) inches to electric light and power wires unless separated therefrom by a continuous and firmly fixed non-conductor that will maintain permanent separation. The non-conductor shall be in addition to any insulation on the wire.

Lead-in wires shall enter building through a non-combustible, non-absorptive insulating bushing.

PROTECTIVE DEVICE

c. Each lead-in wire shall be provided with an approved protective device properly connected and located (inside or outside the building) as near as practicable to the point where the wire enters the building. The protector shall not be placed in the immediate vicinity of easily ignitable stuff, or where exposed to inflammable gases or dust or flyings of combustible materials.

The protective device shall be an approved lightning arrester which will operate at a potential of five hundred (500) volts or less.

The use of an antenna grounding switch is desirable, but does not obviate the necessity for the approved protective device required in this section. The antenna grounding switch if installed shall, in its closed position, form a shunt around the protective device.

PROTECTIVE GROUND WIRE

d. The ground wire may be bare or insulated and shall be of copper or approved copper-clad steel. If of copper the ground wire shall be not smaller than No. 14 B. & S. gauge, and if of approved copper-clad steel it shall not be smaller than No. 17 B. & S. gauge. The ground wire shall be run in as straight a line as possible to a good permanent ground. Prefer-

Rules and Regulations for Fire Protection

ence shall be given to water piping. Gas piping shall not be used for grounding protective devices. Other permissible grounds are grounded steel frames of buildings or other grounded metallic work in the building and artificial grounds such as driven pipes, plates, cones, etc.

The ground wire shall be protected against mechanical injury. An approved ground clamp shall be used wherever the ground wire is connected to pipes or piping.

WIRES INSIDE BUILDINGS

e. Wires inside buildings shall be securely fastened in a workmanlike manner and shall not come nearer than two (2) inches to any electric light or power wire unless separated therefrom by some continuous and firmly fixed non-conductor making a permanent separation. This non-conductor shall be in addition to any regular insulation on the wire. Porcelain tubing or approved flexible tubing may be used for encasing wires to comply with this rule.

RECEIVING EQUIPMENT GROUND WIRE

f. The ground conductor may be bare or insulated and shall be of copper, approved copper-clad steel or other approved metal which will not corrode excessively under existing conditions, and in no case shall the ground wire be less than No. 14 B. & S. gauge except that approved copper-clad steel not less than No. 17 B. & S. gauge may be used.

The ground wire may be run inside or outside of building. When receiving equipment ground wire is run in full compliance with rules for Protective Ground Wire, in Section *d*, it may be used as the ground conductor for the protective device.

FOR TRANSMITTING STATIONS

ANTENNA

g. Antennas outside of buildings shall not cross over or under electric light or power wires of any circuit of more than

Rules and Regulations for Fire Protection

six hundred (600) volts or railway trolley, or feeder wires nor shall it be so located that a failure of either the antenna or of the above-mentioned electric light or power wires can result in a contact between the antenna and such electric light or power wires.

Antennas shall be constructed and installed in a strong and durable manner and shall be so located as to prevent accidental contact with light and power wires by sagging or swinging.

Splices and joints in the antenna span shall, unless made with approved clamps or splicing devices, be soldered.

LEAD-IN WIRES

h. Lead-in wires shall be of copper, approved copper-clad steel or other metal which will not corrode excessively and in no case shall they be smaller than No. 14 B. & S. gauge.

Antenna and counterpoise conductors and wires leading therefrom to ground switch, where attached to buildings, must be firmly mounted five (5) inches clear of the surface of the building, on non-absorptive insulating supports such as treated wood pins or brackets equipped with insulators having not less than five (5) inch creepage and air gap distance to inflammable or conducting material. Where desired approved suspension type insulators may be used.

i. In passing the antenna or counterpoise lead-in into the building a tube or bushing of non-absorptive insulating material shall be used and shall be installed so as to have a creepage and air-gap distance of at least five (5) inches to any extraneous body. If porcelain or other fragile material is used it shall be installed so as to be protected from mechanical injury. A drilled window pane may be used in place of bushing provided five (5) inch creepage and air-gap distance is maintained.

Rules and Regulations for Fire Protection

PROTECTIVE GROUNDING SWITCH

j. A double-throw knife switch having a break distance of four (4) inches and a blade not less than one-eighth ($\frac{1}{8}$) inch by one-half ($\frac{1}{2}$) inch shall be used to join the antenna and counterpoise lead-ins to the ground conductor. The switch may be located inside or outside the building. The base of the switch shall be of non-absorptive insulating material. Slate base switches are not recommended. This switch must be so mounted that its current-carrying parts will be at least five (5) inches clear of the building wall or other conductors and located preferably in the most direct line between the lead-in conductors and the point where ground connection is made. The conductor from grounding switch to ground connection must be securely supported.

PROTECTIVE GROUND WIRE

k. Antenna and counterpoise conductors must be effectively and permanently grounded at all times when station is not in actual operation (unattended) by a conductor at least as large as the lead-in, and in no case shall it be smaller than No. 14 B. & S. gauge copper or approved copper-clad steel. This ground wire need not be insulated or mounted on insulating supports. The ground wire shall be run in as straight a line as possible to a good permanent ground. Preference shall be given to water piping. Gas piping shall not be used for the ground connection. Other permissible grounds are the grounded steel frames of buildings and other grounded metal work in buildings and artificial grounding devices such as driven pipes, plates, cones, etc. The ground wire shall be protected against mechanical injury. An approved ground clamp shall be used wherever the ground wire is connected to pipes or piping.

OPERATING GROUND WIRE

l. The radio operating ground conductor shall be of copper strip not less than three-eighths ($\frac{3}{8}$) inch wire by one-sixty-

Rules and Regulations for Fire Protection

fourth (1-64) inch thick, or of copper or approved copper-clad steel having a periphery or girth (around the outside) of at least three-quarters ($\frac{3}{4}$) inch (for example, a No. 2 B. & S. gauge wire) and shall be firmly secured in place throughout its length. The radio operating ground conductor shall be protected and supported similar to the lead-in conductors.

OPERATING GROUND

m. The operating ground conductor shall be connected to a good permanent ground. Preference shall be given to water piping. Gas piping shall not be used for ground connections. Other permissible grounds are grounded steel frames of buildings or other grounded metal work in the building and artificial grounding devices such as driven pipes, plates, cones, etc.

POWER FROM STREET MAINS

n. When the current supply is obtained directly from street mains, the circuit shall be installed in approved metal conduit, armored cable or metal raceways.

If lead covered wire is used, it shall be protected throughout its length in approved metal conduit or metal raceways.

PROTECTION FROM SURGES, ETC.

o. In order to protect the supply system from high-potential surges and kick-backs there must be installed in the supply line as near as possible to each radio-transformer, rotary spark-gap, motor in generator sets and other auxiliary apparatus one of the following:

1. Two condensers (each of not less than one-half ($\frac{1}{2}$) microfarad capacity and capable of withstanding six hundred (600) volt test, in series across the line and mid-point between condensers grounded; across (in parallel with) each of these condensers shall be connected a shunting fixed spark-gap capable of not more than one-thirty-second (1-32) inch separation.

Rules and Regulations for Fire Protection

2. Two vacuum tube type protectors in series across the line with the mid-point grounded.

3. Non-inductively wound resistors connected across the line with mid-point grounded.

4. Electrolytic lightning arresters such as the aluminum cell type.

In no case shall the ground wire of surge and kick-back protective devices be run in parallel with the operating ground wire when within a distance of thirty (30) feet.

The ground wire of the surge and kick-back protective devices shall not be connected to the operating ground or ground wire.

SUITABLE DEVICES

p. Transformers, voltage reducers, keys and other devices employed shall be of types suitable for radio operation.

CHAPTER IX

NOTES AND SCHEDULES ON SOME OF THE HIGH POWER TRANS-OCEANIC AND POINT TO POINT RADIO TELE- GRAPH STATIONS OF THE WORLD

THE WAY TO CHANGE GREENWICH TIME INTO LOCAL TIME FOR ANY PLACE IN THE UNITED STATES

The following table has been compiled of the schedules of a good many of the high power Radio telegraph stations of the world. For convenience the times are given for the longitude of Greenwich.

When it is remembered that the earth is divided into 360° and that it takes 24 hours for the sun to pass through the 360° , one hour of time must be equivalent to 15° of longitude. Therefore to convert Greenwich time to that of San Francisco for instance, the following is the procedure. The longitude of San Francisco is 122° and the official time is the 120° Meridian time. This is $\frac{120}{15}$ hours ahead of Greenwich. For example, 10 A. M. Greenwich time corresponds to 10-8 or 2 A. M. San Francisco time.

Similarly 9 A. M. Greenwich corresponds to $9 - \frac{75}{15}$ or 4 A. M. New York time since the standard New York time is that of the 75th Meridian.

LIST OF RADIO TELEGRAPH STATIONS AND THEIR OPERATING SCHEDULES

Greenwich Mean Time	Station	Call Sign	Wave-length	System	Remarks
12:00 Midnight	Cadiz	EAC	2,500	Spark	Press in Spanish (daily, except Sunday night).
12:00	Leafield (Oxford)	GBL	8,750	C.W.	Press in English.
12:00	Paris	FL	8,000	C.W.	Working with FF (Sofia) and WAR (Warsaw).
12:00	Darien	NBA	10,500	C.W.	Calls NPL (San Diego).
12:00	Lyons	YN	15,100	C.W.	
12:00	New Brunswick	WII	13,400	C.W.	
12:15 A.M.	San Diego	NPL	9,800	C.W.	Traffic with NBA (Darien).
12:30	Azores	WBP	4,000	C.W.	
1:00	Lyons	YN	15,000	C.W.	Working to WII (New Brunswick) intermittently.
to					
3:00	Paris	FL	8,000	C.W.	Working with HFB (Belgrade) and SEW (Nicolaieff).
1:00					
1:00	Nauen	POZ	12,600	C.W.	Traffic with WSO (Marion).
1:00	Tours	YG	5,300	C.W.	Traffic with CNM (Morocco).
1:00	Poldhu	MPD	2,800	Spark	Press in English.
1:00	Devizes	GKU	2,100	C.W.	Marine traffic.
to					
1:30	Toulon-Mourillon	EUT	2,800	C.W.	Mediterranean meteorological report.
1:30	Azores	BWP	4,000	C.W.	

Greenwich Mean Time	Station	Call Sign	Wave-length	System	Remarks
2:00 A.M.	Lyons	YN	15,000	C.W.	Working with WII (New Brunswick).
2:00	Paris	FL	8,000	C.W.	Working with FF (Sofia).
2:00	Air Ministry	GFA	1,400	C.W.	Meteorological message.
2:30	Azores	BWP	4,000	C.W.	
2:30	Nantes	UA	9,000	C.W.	Calls FRI (General call or French war vessels).
2:30	Aberdeen	BYD	3,300	C.W.	Meteorological report.
2:45	Paris	FL	2,000	Spark	Meteorological report.
2:55	Annapolis	NSS	17,000	C.W.	Time signals followed by weather reports.
3:00	Paris	FL	6,500	C.W.	Working to HB (Budapest) and PSO (Posen).
3:00	Lyons	YN	15,000	C.W.	
3:00	Ain-el-Turk (Algiers)	FUO	3,300	C.W.	Algerian meteorological report.
3:00	Cayey	NZR	10,500	C.W.	Traffic with NBA (Darlen).
3:00	Darlen	NBA	10,100	C.W.	Traffic with NZR (Cayey) followed by traffic with NSS (Annapolis).
3:15	Paris	FL	6,500	C.W.	Working to VSL (Vasluin).
3:15	Sidi-Abdallah	FUA	5,150	C.W.	North African meteorological report.
3:30	Azores	BWP	4,000	C.W.	
3:30	Paris	FL	6,500	C.W.	Working to OHD (Vienna).
4:00	New Brunswick	WII	13,400	C.W.	Working to YN and LY.
4:00	Annapolis	NSS	16,500	C.W.	
4:00	Nauen	POZ	9,400	C.W.	Experimental traffic with Athens.
4:00	Bucharest	BUC	7,500	C.W.	Roumanian meteorological report.
4:00	Paris	FL	3,200	C.W.	Working to FUD (Dunkirk), etc.

4:30	Paris	FL	8,000	C. W.	Press in French, and traffic with MSK (Moscow).
4:30	Azores	BWP	4,000	C. W.	Calls NSS (Annapolis).
5:00	Nauen	POZ	12,600	C. W.	Working with BUC (Bucharest).
5:00	Rome	IDO	11,000	C. W.	Working with WII (New Brunswick).
5:00	Lyons	YN	15,000	C. W.	
5:00	Devizes	GKU	2,100	C. W.	Marine traffic.
5:30	Pola	QZ	3,200	Spark	Navigation warnings.
5:30	Marseilles	YJ	1,900	C. W.	Meteorological report.
5:30	Azores	BWP	4,000	C. W.	
5:50	Königswusterhausen	LP	5,250	C. W.	Meteorological report (aviation).
to					
6:30	Nauen	POZ	9,400	C. W.	Traffic with MSP (Moscow).
6:00	Bucharest	BNS	3,000	Spark	Meteorological report.
6:00	Air Ministry	GFA	1,400	C. W.	Retransmission of 2:00 report.
6:00	Moscow	MSK	5,000	Spark	Press.
6:00	Rome	IDO	11,000	C. W.	Press.
6:05	Paris	FL	8,000	C. W.	Working with WAR .
6:30	Azores	BWP	4,000	C. W.	
6:30	Paris (Le Bourget)	ZM	1,400	C. W.	Retransmission of British and French night meteorological reports.
6:35	Königswusterhausen	LP	5,250	C. W.	Meteorological report (aviation) and forecast for Central Europe.
6:35	Tours	YG	1,900	C. W.	W.S.W. and Central France meteorological report.

Greenwich Mean Time	Station	Call Sign	Wave-length	System	Remarks
6:40 A.M.	Metz	YG	1,450	C.W.	E. France and Rhine meteorological report.
6:45	Königswusterhausen	LP	5,250	C.W.	European meteorological report.
6:45	Paris (Le Bourget,	ZM	1,400	C.W.	Aviation forecast.
6:45	Soesterberg	STB	1,680	C.W.	Meteorological report (aviation) for Holland.
7:00	Bordeaux	LY	23,450	C.W.	Working with HZH (Brazzaville.)
7:00	Paris	FL	3,200	C.W.	Working with FUE (Brest) and UA (Nantes).
7:00	Nicolaiev	SEW	4,000	Spark	C.Q.'s and Press.
7:00	Annapolis	NSS	16,500	C.W.	
7:00	Prague	PRG	4,600	C.W.	Traffic with FF (Sofia).
7:00	Königswusterhausen	LP	2,500	C.W.	Telephony.
7:15	Brussels	HS	1,400	C.W.	Belgian meteorological report.
7:15	Nauen	POZ	12,600	C.W.	Traffic with WSO (Marion).
7:15	Paris	FL	6,500	C.W.	Working to HFB (Belgrade).
7:25	Brussels	HS	1,680	C.W.	Meteorological report (aviation).
7:30	Frankfort-on-Maine	FR	1,875	C.W.	
7:30	Borkum	KBM	1,250	Spark	
7:30	Toulon-Mourillon	FUT	2,800	C.W.	Mediterranean meteorological report.
7:30	Marseilles	YJ	1,900	C.W.	Meteorological report.
7:30	Azores	BWP	4,000	C.W.	
7:30	Nantes	UA	9,000	C.W.	Calls FRI (general call to French war vessels).
7:30	Paris (Le Bourget)	ZM	1,680	C.W.	Meteorological report (aviation).

7:35	Air Ministry	GFA	1,680	C.W.	Meteorological report (aviation).
7:35	Tours	YG	1,900	C.W.	W.S.W. and Central France meteorological report.
7:35	Lyngby	OXE	3,650	C.W.	Danish meteorological synoptic report.
7:40	Reval	ELN	2,000	Spark	Esthonian synoptic meteorological report.
7:40	Metz	YC	1,450	C.W.	Meteorological report for E. France and Rhine.
7:45	Belgrade	YSB	7,000	C.W.	Meteorological report.
7:45	Berlin	DL	2,000	C.W.	
7:45	Soesterberg	STB	1,680	C.W.	Meteorological report (aviation).
7:45	Swinemünde	KAW	1,000	Spark	
7:50	Bucharest	BUC	7,500	C.W.	Roumanian meteorological report.
7:55	Warsaw	WAR	2,000	Spark	Polish meteorological report.
8:00	Lyons	YN	15,500	C.W.	Time signals in siderial time.
8:00	Rome	IDO	11,000	C.W.	Press in French.
8:00	New Brunswick	WII	13,400	C.W.	Working to YN and LY .
8:00	Gibraltar	BWW	4,800	C.W.	Meteorological report.
8:00	Aranjuez	EAA	6,700	C.W.	Traffic with POZ (Nauen).
8:00	Nauen	POZ	9,400	C.W.	Replies to EAA (Aranjuez).
8:00	Vienna	OHD	5,600	C.W.	Traffic with MSK (Moscow).
8:00	Air Ministry	GFA	1,400	C.W.	British meteorological report.
8:15	Paris	FL	2,600	Spark	French, Belgian, Swiss and Netherlands meteorological reports.
8:15	Athens	SXG	4,300	Spark	Working to Bucharest (BUC) Times irregular.
8:24	Stonehaven	GSW	4,000	Spark	Traffic to TFA .
8:25	Brussels	HS	1,680	C.W.	Meteorological report (aviation).
8:30	Helsingfors	OJA	2,000	Spark	Finnish meteorological report.

Greenwich Mean Time	Station	Call Sign	Wave-length	System	Remarks
8:30 A.M.	Paris (Le Bourget)	ZM	1,680	C.W.	Meteorological report (aviation).
8:30	Constantinople	OSM	8,000	C.W.	
8:30	Azores	BWP	4,000	C.W.	
8:30	Aberdeen	BYD	3,300	C.W.	British meteorological report.
8:30	Lyons	YN	15,100	C.W.	Press service to Central Africa.
8:30	Prague	PRG	4,600	C.W.	Traffic with WAR (Warsaw).
8:35	Belgrade	YSB	4,590	C.W.	Jugo-Slavian meteorological report.
8:35	Air Ministry	GFA	1,680	C.W.	Meteorological report (aviation).
8:40	Reval	ELN	1,900	C.W.	
8:40	Karlsborg	SAJ	4,000	C.W.	Swedish meteorological report.
8:45	Air Ministry	GFA	1,680	C.W.	Calibration waves.
8:45	Medicuna	CNM	5,000	C.W.	Moroccan meteorological report.
8:50	Lyons	YN	15,500	C.W.	Times for 8:00 time signals.
8:50	Air Ministry	GFA	1,400	C.W.	Retransmission of OXE and LCH reports.
8:50	Christiania	LCH	8,000	C.W.	Norwegian meteorological report.
8:55	Soesterberg	STB	1,900	C.W.	Dutch upper air report.
8:57	Lyons	YN	15,500	C.W.	French time signals (old system).
9:00	Ain-el-Turk	FUA	3,300	C.W.	Algerian and Moroccan meteorological re- port.
9:00	Bordeaux	LY	23,450	C.W.	Working to WHI (New Brunswick).
9:00	Malta (Rincella Bay)	BYZ	4,200	C.W.	Meteorological report.
9:00	Devizes	GKU	2,100	C.W.	Marine traffic.
to					
9:30	Nauen	POZ	4,700	C.W.	German meteorological report (I.C.W.).
9:00					

9:00	Air Ministry	GFA	1,400	C.W.	C.W.
9:00	Bucharest	BUC	7,400	C.W.	Press in French.
9:04	Lyons	YN	15,100	C.W.	Service with FRU.
9:05	Air Ministry	GFA	900	C.W.	
9:05	Paris	FL	6,500	C.W.	Press in German for OHD (Vienna).
9:10	Air Ministry	GFA	1,300	C.W.	Calibration waves.
9:10	Strasbourg	C3	4,400	C.W.	Traffic with PRG (Prague).
9:15	Air Ministry	GFA	1,400	C.W.	Meteorological report for Great Britain.
9:15	Nauen	POZ	9,400	C.W.	Traffic with MSP (Moscow).
9:15	Porquerolles (Toulon)	FUQ	1,350	Spark	Meteorological report.
9:20	Amsterdam	STB	1,680	C.W.	
9:20	Sidi Abdallah	FUA	5,150	C.W.	North African meteorological report.
9:20	Budapest	HB	3,000	Spark	Hungarian meteorological report.
9:20	Lisbon	CTV	1,100	Spark	C.Q. calls.
9:20	Prague	PRG	4,500	C.W.	Czecho-Slovakian meteorological report.
9:25	Brussels	HS	1,680	C.W.	Meteorological report.
9:25	Paris	FL	2,600	Spark	International time signals.
9:30	Azores	BWP	4,000	C.W.	
9:30	Poldhu	MPD	2,800	Spark	Repetition of Admiralty meteorological report for W. and S.W. of British Isles.
9:30	Königswusterhausen	LP	5,250	C.W.	European meteorological report.
9:30	Helsingfors	OJA	6,200	C.W.	Press in English.
9:30	Rome	IDO	11,000	C.W.	Italian meteorological report.
9:30	Rome (Centocelle)	ICD	2,250	Spark	Italian meteorological report.
9:30	Paris (Le Bourget)	ZM	1,680	C.W.	Meteorological report.
9:35	Air Ministry	GFA	1,680	C.W.	Meteorological report.
9:35	Sofia	FF	3,500	Spark	Bulgarian meteorological report.

Greenwich Mean Time	Station	Call Sign	Wave-length	System	Remarks
9:40 to 9:50	Königswusterhausen	LP	5,250	C.W.	Meteorological report (aviation and forecast for Central Europe).
9:45	Rome	IDO	11,000	C.W.	Stock Exchange news.
9:45	Soesterberg	STB	1,680	C.W.	Meteorological report (aviation).
10:00	Vienna	OHD	5,600	C.W.	Austrian meteorological report.
10:00	Madrid	EGC	2,000	Spark	Spanish meteorological bulletin.
10:00	Paris	FL	2,600	Spark	Time signals in siderial time.
10:00	Toulon-Mourillon	FUT	2,800	C.W.	Mediterranean meteorological report.
10:00	Marseilles	YJ	1,900	C.W.	Meteorological report.
10:00	Rome (Centocelle)	ICD	3,200	C.W.	Telephony.
10:03	Paris	FL	3,200	C.W.	Working with PRG (Prague).
10:05	Tours	YG	1,900	C.W.	Meteorological report for S. and S.W. and Central France.
10:07	Paris	LO	6,500	C.W.	Calibration waves on 1st, 10th and 20th of month.
10:10	Warsaw	WAR	2,100	Spark	Press message.
10:15	Norddeich	KAV	600	Spark	General meteorological information (in German).
10:15	Metz	YC	1,450	C.W.	E. France and Rhine meteorological report.
10:20	Paris	LO	8,000	C.W.	Calibration waves on 1st, 10th and 20th of month.
10:25	Brussels	HS	1,680	C.W.	Meteorological report (aviation).
10:30	Paris (Le Bourget)	ZM	1,680	C.W.	Meteorological report (aviation).

10:30	Azores	BWP	4,000	C.W.	General information relative to W. and
10:30	Swinemünde	KAW	600	Spark	Central Baltic (in German).
10:30	Königswusterhausen	LP	2,500	C.W.	Telephony.
10:35	Paris	FL	2,600	Spark	Times for 10:00 time signals.
10:35	Air Ministry	GFA	1,400	C.W.	Meteorological report (aviation).
10:35	Paris	LO	1,680	C.W.	Calibration waves on 1st, 10th and 20th of month.
10:40	Christiania	LCH	5,400	C.W.	Press to PTG (Petrograd).
10:44	Paris	FL	2,600	Spark	Time signals (old system).
10:45	Swinemünde	KAW	1,000	Spark	
10:45	Soesterberg	STB	1,680	C.W.	Meteorological report (aviation).
10:50	Belgrade	YSB	4,590	C.W.	Jugo-Slavian meteorological report.
11:00	Eilvese	OUI	9,600	C.W.	Transatlantic Press (in German).
11:00	Borkum	KBM	1,250	Spark	
11:00	Nauen	POZ	9,400	C.W.	Traffic with EAA (Aranjuez).
11:00	Paris	FL	6,500	C.W.	Service with HB (Budapest).
11:00	Lyngby	OXE	5,600	C.W.	Press in English.
11:00	Prague	PRG	4,100	C.W.	Calls NSS (Annapolis).
11:15	Scheveningen Haven	PCH	1,800	Spark	Dutch meteorological report for North Sea.
11:25	Brussels	HS	1,680	C.W.	Meteorological report (aviation).
11:30	Azores	BWP	4,000	C.W.	
11:30	Paris	FL	2,600	Spark	European synoptic meteorological report.
11:30	Paris (Le Bourget)	ZM	1,680	C.W.	Meteorological report (aviation).
11:35	Air Ministry	GFA	1,680	C.W.	Meteorological report (aviation).
11:45	Ain-el-Turk	FUO	3,300	C.W.	Algerian meteorological report and fore- cast.

Greenwich Mean Time	Station	Call Sign	Wave-length	System	Remarks
11:45 A.M.	Soesterberg	STB	1,680	C.W.	Aviation.
11:55	Paris (Le Bourget)	ZM	1,400	C.W.	Meteorological forecast (aviation).
11:55	Nauen	POZ	3,900	Spark	Time signals and "Debeg" Code.
12:00 Noon	Brussels	HS	1,500	C.W.	General forecast.
12:00	Sidi-Abdallah	FUA	1,350	Spark	Algerian and Tunisian meteorological report and forecast.
12:00	Coltano	ICI	4,200 or 5,900	Spark C.W.	Traffic with EAB (Barcelona).
12:00	Tours	YG	5,500	C.W.	Press in German for OHD (Vienna).
12:00	Nauen	POZ	12,600	C.W.	Traffic with WSO (Marion).
12:00	Paris	YA	1,950	C.W.	
12:00	Prague	PRG	4,100	C.W.	Press in French.
12:00	New Brunswick	WII	13,400	C.W.	Working to YN and LY.
12:05 P.M.	Paris	FL	3,200	Spark	Press in French.
12:10	Vossegat	BE	1,000	Spark	Netherlands meteorological forecast.
12:20	Nauen	POZ	9,400 } 4,700 }	C.W.	Press in German on 9400 repeated on I. C.W. on 4700.
12:30	Paris (Le Bourget)	ZM	1,680	C.W.	Meteorological report.
12:30	Lyons	YN	15,100	C.W.	Press in English for NSS (Annapolis).
12:30	Azores	BWP	4,000	C.W.	
12:35	Air Ministry	GFA	1,680	C.W.	Meteorological report.
1:00	Vienna	OHD	5,600	C.W.	Traffic with HFC (Sarsjevo).
1:00 to 1:30	Devizes	GKU	2,100	C.W.	Marine traffic.

1:00	Moscow	MSP	6,700	C.W.	Working with FSO and HB.
1:10	Amsterdam		1,800	C.W.	Telephony (Stock Exchange).
1:15	Elivese	OUI	14,400	C.W.	Press.
1:15	Brussels	HS	1,400	C.W.	Belgian meteorological report.
1:20	Prague	PRG	4,600	C.W.	Press in Czech.
1:25	Borkum	KBM	1,250	Spark	
1:25	Brussels	HS	1,680	C.W.	Meteorological report.
1:30	Paris (Le Bourget)	ZM	1,680	C.W.	Meteorological report.
1:30	Marseilles	YJ	1,900	C.W.	Meteorological report.
1:30	Toulon-Mourillon	FUT	2,800	C.W.	Mediterranean meteorological report.
1:30	Paris	FL	6,500	C.W.	Traffic with PSO (Posen).
1:30	Bordeaux	LY	23,450	C.W.	Press in English for WGG (Tuckerton)
1:30	Azores	BWP	4,000	C.W.	
1:35	Tours	YG	1,900	C.W.	W., S.W. and Central France meteorological report.
1:35	Lyngby	OXE	3,650	C.W.	Danish meteorological report.
1:35	Air Ministry	GFA	1,680	C.W.	Meteorological report.
1:40	Metz	YC	1,450	C.W.	Meteorological report for E. France and Rhine.
1:45	Belgrade	YSB	7,000	C.W.	Meteorological report.
1:45	Soesterberg	STB	1,680	C.W.	Meteorological report (aviation).
1:50	Bucharest	BUC	7,500	C.W.	Roumanian meteorological report.
1:50	Frankfort-on-Maine	FR	1,875	C.W.	
2:00	Gibraltar	BWW	2,700	Spark	Meteorological report.
2:00	Bucharest	BNS	4,000	Spark	Meteorological report.
2:00	Air Ministry	GFA	1,400	C.W.	British meteorological report.
2:00	North Foreland	GNF	600	Spark	Navigation warnings.
2:00	Prague	PRG	4,600	C.W.	Traffic with IQZ (Pola).

Greenwich Mean Time	Station	Call Sign	Wave-length	System	Remarks
2:10 P.M.	Swinemünde	KAW	1,000	Spark	French, Belgian and Swiss meteorological report.
2:15	Paris	FL	2,600	C.W.	
2:25	Berlin	DL	2,000	C.W.	Moroccan meteorological report. Meteorological report. Calls FRI (general call for French war vessels).
2:30	Medicuna	CNMM	5,000	C.W.	
2:30	Paris (Le Bourget)	ZM	1,680	C.W.	
2:30	Nantes	UA	9,000	C.W.	
2:30	Aberdeen	BYD	3,300	C.W.	Meteorological report.
2:30	Azores	BWP	4,000	C.W.	
2:35	Air Ministry	GFA	1,680	C.W.	Meteorological report. Working with HFB (Belgrade).
2:35	Paris	FL	6,500	C.W.	
2:40	Karlsborg	SAJ	4,000	C.W.	Swedish meteorological report. Algerian and Moroccan meteorological report.
2:45	Ain-el-Turk	FUO	3,300	C.W.	
2:50	Helsingfors	OJA	2,000	Spark	Finnish meteorological report.
2:50	Christiana	LCH	8,000	C.W.	
3:00	Nauen	POZ	9,400	C.W.	Norwegian meteorological report. Calls BUC (Bucharest).
3:00	Paris	YA	1,950	C.W.	
3:00	Nantes	UA	9,000	C.W.	Working with OSM (Constantinople).
3:00 to 5:00	The Hague	PCGG	1,050	C.W.	
3:05	Soesterberg	STB	1,900	C.W.	Dutch upper air report.

3:15	Paris	FL	8,000	C.W.	Traffic with BUC (Bucharest).
3:20	Sidi Abdallah	FUA	5,150	C.W.	North African meteorological report.
3:25	Brussels	HS	1,680	C.W.	Meteorological report (aviation).
3:30	Arlington	NAA	5,950	C.W.	Meteorological report (marine and aviation) prefixed by "U.S.W.B."
3:30	Madrid	EGC	2,000	Spark	Spanish meteorological report.
3:30	Paris (Le Bourget)	ZM	1,680	C.W.	Meteorological report.
3:30	Azores	BWP	4,000	C.W.	
3:30	Warsaw	WAR	2,000	Spark	Polish meteorological report.
3:35	Air Ministry	GFA	1,680	C.W.	Meteorological report.
3:40	Vienna	OHD	5,600	C.W.	Austrian meteorological report.
3:45	Prague	PRG	4,500	C.W.	Czecho-Slovakian synoptic meteorological report.
3:45	Belgrade	YSB	4,590	C.W.	Jugo-Slavian meteorological report.
3:50	Königswusterhausen	LP	5,250	C.W.	European meteorological report.
4:00	New Brunswick	WII	13,400	C.W.	Working to YN and LY.
4:00	Tours	YG	5,500	C.W.	Press for Bucharest.
4:00	Moscow	MSK	5,100	Spark	Traffic with LCH (Christiania).
4:05	Königswusterhausen	LP	5,250	C.W.	Meteorological forecast for Central Europe.
4:30	Paris (Le Bourget)	ZM	1,680	C.W.	Meteorological report.
4:30	Azores	BWP	4,000	C.W.	
4:35	Air Ministry	GFA	1,680	C.W.	Meteorological report.
4:45	Swinemünde	KAW	1,000	Spark	
4:55	Annapolis	NSS	17,000	C.W.	Time signals, followed by weather report.
5:00	Devizs	GKU	2,100	C.W.	Marine traffic.
to					
5:30					

Greenwich Mean Time	Station	Call Sign	Wave-length	System	Remarks
5:00 P.M.	Constantinople	OSM	8,000	C.W.	
5:00	Sofia	FF	2,800	Spark	
5:00	Cadiz	EAC	2,500	Spark	Press in Spanish.
5:05	Paris	FL	3,200	C.W.	Calls FUT (Toulon) and FUA (Bizerte).
5:30	Azores	BWP	4,000	C.W.	
5:30	Tours	YG	5,500	C.W.	Press for Bucharest.
5:40	Bandoeng (Java)	PKX	8,800	C.W.	Traffic with PCG (Sambeek).
6:00	Paris	FL	6,500	C.W.	Working to FF .
6:00	Nauen	POZ	12,600	C.W.	Calls NSS (Annapolis).
6:00	Paris	FL	5,000	C.W.	Calibration waves (3-minute dash 1st and 15th of each month).
6:00	Moscow	MSK	5,000	Spark	Press.
6:00	Bucharest	BUC	7,000	C.W.	Calls OHD (Vicenna).
6:10	Paris	FL	7,000	C.W.	Calibration waves (3-minute dash 1st and 15th of each month).
6:15	Brussels	HS	1,400	C.W.	Belgian meteorological report.
6:20	Lyons	YN	10,000	C.W.	Calibration waves (3-minute dash 1st and 15th of each month).
6:25	Swinemünde	KAW	1,000	Spark	
6:30	Tours	YG	1,900	C.W.	W., S.W., and Central France meteorological report.
6:30	Marseilles	YJ	1,900	C.W.	Meteorological report.
6:30	Lyons	YN	15,000	C.W.	Calibration waves (3-minute dash 1st and 15th of each month).
6:30	Toulon-Mourillon	FUT	2,800	C.W.	Mediterranean meteorological report.

6:30	Nauen	POZ	12,600	C.W.	Traffic with WSO (Marion).
6:30	Nauen	POZ	9,400	C.W.	Traffic with MSP (Moscow).
6:30	Azores	BWP	4,000	C.W.	
6:30	Lyngby	OXE	3,650	C.W.	Danish meteorological report.
6:40	Frankfort-on-Maine	FR	1,875	C.W.	
6:40	Metz	YC	1,450	C.W.	Meteorological report for E. France and Rhine.
6:45	Borkum	KBM	1,250	Spark	
6:45					
to					
7:00	Lyons	YN	15,000	C.W.	(Exact values of calibration waves sent out on 1st and 15th of each month.)
6:50	Berlin	DL	2,000	C.W.	
7:00	Paris	FL	8,000	C.W.	Traffic with BUC (Bucharest).
7:00	Eilvесе	OUI	9,600	C.W.	Working with EAM.
7:00	Rome	IDO	11,000	C.W.	C.Q's., then works with IHM, ICW, IRB, etc.
7:00	Eilvесе	OUI	9,600	C.W.	Press.
7:00	Bucharest	BNS	3,000	Spark	Meteorological report.
7:00	Gibraltar	BWW	4,800	C.W.	Meteorological report.
7:00	Air Ministry	GFA	1,400	C.W.	British meteorological report.
7:20	Christiania	LCH	8,000	C.W.	Norwegian synoptic meteorological report.
7:30	Prague	PRG	4,600	C.W.	Press in Czech.
7:30	Azores	BWP	4,000	C.W.	
7:30	Paris	FL	2,600	Spark	French and Belgian meteorological report.
7:30	Aberdeen	BYD	3,300	C.W.	Meteorological report.
7:40	Nauen	POZ	4,700	C.W.	German meteorological Report (C.W.).
7:40	Karlsborg	SAJ	4,000	C.W.	Swedish meteorological report.

Greenwich Mean Time	Station	Call Sign	Wave-length	System	Remarks
7:40 P.M.	Vossegat	BE	1,000	Spark	Meteorological forecast for Holland.
7:45	Medicuna	CNM	5,000	C.W.	Moroccan meteorological report.
7:45	Warsaw	WAR	2,100	Spark	Press.
7:50	Bordeaux	LY	23,450	C.W.	Times for 8:00 time signals of previous day.
8:00	Algiers (Ain-el-Turk)	FUO	3,300	C.W.	Moroccan and Algerian synoptic meteorological report.
8:00	Paris	FL	6,500	C.W.	Working with HB (Budapest).
8:00	Leafield (Oxford)	GBL	8,750	C.W.	Press in English.
8:00	Karlsborg	SAJ	2,500	Spark	Swedish press.
8:00	Rome	IDO	11,000	C.W.	Communications with LP.
8:00	Coltano	ICI	4,100	Spark	Working with MSK.
8:00	Bordeaux	LY	23,450	C.W.	Scientific time signals in sidereal time.
8:00	New Brunswick	WII	13,400	C.W.	Working to YN and LY.
8:00	Madrid	EGC	1,600	Spark	Inland working.
8:00	Air Ministry	GFA	1,400	C.W.	General forecast for Great Britain.
8:00	North Foreland	GNF	600	Spark	Navigation warnings.
8:05	Königswusterhausen	LP	5,250	C.W.	European meteorological report.
8:10	Paris	FL	8,000	C.W.	French press.
8:20	Sidi Abdallah	FUA	5,150	C.W.	North African meteorological report.
8:20	Königswusterhausen	LP	5,250	C.W.	Meteorological forecast for Central Europe.
8:20	Warsaw	WAR	2,000	Spark	Polish meteorological report.
8:30	Bordeaux	LY	23,450	C.W.	Press in French.
8:30	Pola	IQZ	3,200	Spark	Navigation warnings.
8:30	Azores	BWP	4,000	C.W.	

8:30	Nauen	POZ	9,400 } 4,700 }	C. W.	German press on 9400, repeated on chopped C.W., 4700.
8:30	Lyons	YN	15,100	C.W.	Press.
8:30	Paris	FL	6,500	C.W.	Working with VSL (Vasluin).
8:30	Prague	PRG	4,500	C.W.	Czecho-Slovakian meteorological report.
8:30	Madrid	EGC	2,000	Spark	Spanish meteorological report.
8:35	Rome	IDO	11,000	C.W.	Italian meteorological report.
8:45	Rome	ICD	2,250	C.W.	Italian meteorological report.
9:00	Devizis to	GKU	2,100	C.W.	Marine traffic.
9:30					
9:00	Malta	BYZ	4,200	C.W.	Meteorological report.
9:00	Paris	YA	1,950	C.W.	
9:00	Reval	ELN	2,000	Spark	Esthonian meteorological report.
9:20	Nicolaiev	SEW	4,000	Spark	
9:30	Norddeich	KAV	600	Spark	
9:30	New Brunswick	WII	13,400	C.W.	Traffic with LY (Bordeaux).
9:30	Budapest	HB	3,100	Spark	Press in French for FL.
9:30	Norddeich	KAV	600	Spark	Meteorological report.
9:30	Azores	BWP	4,000	C.W.	
9:30	Poldhu	MPD	2,800	Spark	Admiralty meteorological report for W. and S.W. Coasts and warnings.
9:45	Swinemünde	KAW	600	Spark	General information (in German).
9:55	Moscow	MSK	5,000	Spark	Time signal commencing with V's.
10:00	Annapolis	NSS	16,900	C.W.	Long navigation warning.
10:00	Paris	FL	2,600	Spark	Time signals in sidereal time.
10:00	Moscow	MSK	5,000	Spark	Time signals and Russian meteorological report.

Greenwich Mean Time	Station	Call Sign	Wave-length	System	Remarks
10:10 P.M.	Moscow	MSK	5,000	Spark	Russian report.
10:15	Nauen	POZ	6,300	C.W.	Traffic with WSO (Marion).
10:30	Azores	BWP	4,000	C.W.	
10:30	Lyons	YN	15,100	C.W.	Press in French.
10:35	Paris	FL	2,600	Spark	Times for 10:00 time signals.
10:45	Paris	FL	2,600	Spark	French time signals (old system).
11:00	Iours	YG	5,500	C.W.	Press for Bucharest.
11:00	Darien	NBA	10,100	C.W.	Traffic with NSS (Annapolis).
11:00	Rome	IDO	11,000	C.W.	C.Q. calls and working with IHM, ICW, IRB, etc.
11:01 to 11:30	Nauen	POZ	12,600 and 6,300	C.W.	Duplex Traffic with WSO (Marion).
11:15	Scheveningen Haven	PCH	1,800	C.W.	Dutch synoptic meteorological message for North Sea.
11:30	Azores	BWP	4,000	C.W.	
11:30	Nauen	POZ	12,600	C.W.	Transocean Press.
11:55	Nauen	POZ	3,900	Spark	Time signals and "Debeg" code.
11:55	Pearl Harbour (Hawaii)	NPM	11,200	C.W.	Time Signals.

STATIONS HAVING NEARLY CONTINUOUS SCHEDULES

Long Island	WQK	16,465	C.W.	Traffic with Europe, etc.
Stavanger	LCM	12,000	C.W.	Transatlantic Traffic.
Tuckerton	WGG	16,100	C.W.	Transatlantic Traffic.
Marion	WSO	11,500	C.W.	Transatlantic Traffic
New Brunswick	WII	13,400	C.W.	Transatlantic Traffic.
Glace Bay	GB	7,850	C.W.	Transatlantic Traffic.
Nauen	POZ	12,600	C.W.	Transatlantic Traffic.
Eilvese	OUI	14,400	C.W.	Transatlantic Traffic.
Stonehaven	GSW	4,600	C.W.	High Speed Commercial Traffic with LP (Berlin): LP replics on 5,250 meters.
Devizes	GKU	2,100	C.W.	Marine Traffic.
Clifden	MFT	5,600	C.W.	Transatlantic Traffic.
Carnarvon	MUU	14,000	C.W.	Transatlantic Traffic.

CATALOGUE

of LATEST and BEST

Radio Books

Our Standard and Up-to-date Radio Books are described in the following pages. They are Practical Books for the Practical man. Each written by an authority and in a manner that makes them easily understood.

Radio Hook-Ups by M. B. Sleeper,	\$.75
Radio Design Data by M. B. Sleeper,	.75
Construction of New Type Trans-Atlantic Receiving Set by M. B. Sleeper,	.75
Construction of Radiophone and Telegraph Receivers for Beginners by M. B. Sleeper,	- - - .75
How to Make Commercial Type Radio Apparatus by M. B. Sleeper,	- - .75
Wireless Telegraphy and Telephony Simply Explained by A. P. Morgan,	1.50
Experimental Wireless Stations by P. E. Edelman,	- - - 3.00
A B C of Vacuum Tubes Used in Radio Reception by E. H. Lewis,	- - 1.00

Any of these books will be sent prepaid to any part of the world on receipt of price. Remit by Draft, Postal Order, Express Order or Registered Letter.

Published and For Sale by
The Norman W. Henley Publishing Co.

2 West 45th Street, New York, U. S. A.