

*Lawrence W. Davis*

# PHOTOFACT TELEVISION COURSE

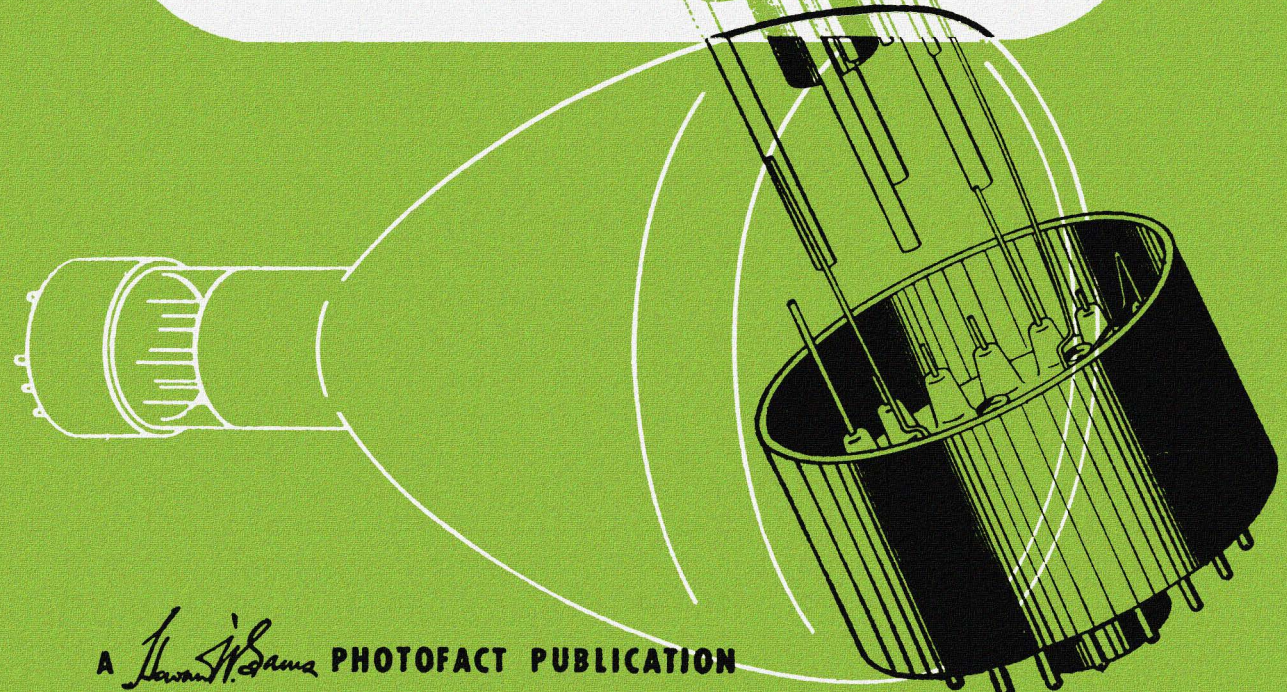

A *Lawrence W. Davis* PHOTOFACT PUBLICATION



*Howard W. Sams*

# PHOTOFACT TELEVISION COURSE

Based on a series of lectures by  
**ALBERT C. W. SAUNDERS, M. A. O.**

Member Institute of Radio Engineers: Founder and Director Saunders  
Radio and Electronic School; Founder Radio Technicians Guild

**Editor in Chief, B. V. K. FRENCH**

Senior Member Institute of Radio Engineers,  
Member The Radio Club of America, Inc.

Editorial Staff . . . . . W. W. Hensler, W. D. Renner, J. R. Ronk  
Illustrative Material . . . . . Barnard Studios

(TV-1)

FIRST EDITION—FIRST PRINTING—JANUARY 1949

Reproduction or use, of editorial or pictorial content, in any manner, without express  
permission, is prohibited. No responsibility is assumed with respect to application  
or patent liability of the included material.

Entire Contents Copyrighted 1949 by Howard W. Sams & Co., Inc.  
Indianapolis 7, Indiana

Printed in the United States of America

COMPILED AND PUBLISHED BY  
HOWARD W. SAMS & CO., INC., INDIANAPOLIS 7, INDIANA

A *Howard W. Sams* PHOTOFACT PUBLICATION



# ACKNOWLEDGEMENT

The editorial staff wishes to acknowledge its indebtedness to the many engineers, service managers, technicians, receiver and component parts manufacturers, on whom we have drawn for technical information or illustrative material. This assistance has been invaluable in assuring that the text is factual and current. We wish to express our sincere appreciation to the following:

R. S. Burnap, Radio Corporation of America	American Phenolic Corp. Andrew Corp.
E. F. Carter, Sylvania Electric Products, Inc.	A-1 Radio Tower Co. Belmont Radio Corp.
Nelson P. Case, The Hallicrafters Co.	L. S. Brach Mfg. Corp. Cole-Warner Corp.
Madison Cawein, Farnsworth Television & Radio Corp.	Allen B. DuMont Laboratories, Inc. Dielectric Products Co.
George C. Connor, Sylvania Electric Products, Inc.	Emerson Radio & Phonograph Co. Farnsworth Television & Radio Corp.
Lewis M. Clement, Crosley Div., AVCO Mfg. Corp.	General Electric Co. General Instrument & Appliance Corp.
Donald G. Fink, "Electronics", McGraw-Hill Publishing Co., Inc.	The Hallicrafters Co. King Electronics
George W. Fyler, Motorola, Inc.	P. R. Mallory & Co., Inc. Meissner Mfg. Div., Maguire Industries
Charles E. Honeywell, The Hallicrafters Co.	The Motorola Co. The National Broadcasting Co.
Prof. John D. Kraus, Ohio State University	North American Phillips Co., Inc. The Philco Corp.
Jerry Minter, Measurements Corp.	Radio Corporation of America R. C. A. Service Co., Inc.
Donald A. Nelson, Nelson Technical Enterprises	R. M. A. Data Bureau The Rauland Corp.
F. B. Ostman, Farnsworth Television & Radio Corp.	Sears, Roebuck & Co. The Senn Corp.
W. L. Parkinson, General Electric Company	F. W. Sickles Co. Sylvania Electric Products Co., Inc.
Richard Purington, The Amphenol Corp.	Sarkes Tarzian Technical Appliance Corp.
John A. Rankin, Belmont Radio Corp.	Telrex Co. Tricraft Products Co.
Robert W. Sanders, Farnsworth Television & Radio Corp.	Ward Products Corp. Wind Turbine Co.
Stuart W. Seeley, Radio Corporation of America	Workshop Associates
Paul Ware, Allen B. Dumont Laboratories, Inc.	
Anthony Wright, The Magnavox Co.	



# TABLE OF CONTENTS

## SECTION I

### CATHODE-RAY - BEAM FORMATION AND CONTROL

- Chapter 1 The Beam Source (Electron Gun) - Its Electrostatic Control
- Chapter 2 Magnetic Control of the Electron Beam
- Chapter 3 The Camera Tube
- Chapter 4 Television Power Supplies

## SECTION II

### CATHODE-RAY - BEAM DEFLECTION SYSTEMS

- Chapter 5 Resistance-Capacitance (RC) Circuit Characteristics
- Chapter 6 Sawtooth Generators
- Chapter 7 The Sawtooth Scanning Raster
- Chapter 8 Deflection Systems - Commercial Applications

## SECTION III

### CATHODE-RAY - BEAM MODULATION AND SYNCHRONIZATION

- Chapter 9 Sync Pulse Separation and Use
- Chapter 10 Television Receiver Controls - Application and Adjustment
- Chapter 11 The Composite Television Signal
- Chapter 12 The Television Receiving Antenna
- Chapter 13 Television Input Tuning Systems
- Chapter 14 Television Intermediate Frequency Amplifier Systems
- Chapter 15 The Video Amplifier
- Chapter 16 DC Restoration
- Chapter 17 Contrast Control and A. G. C. (Automatic Gain Control)
- Chapter 18 Intercarrier Sound Systems



# PREFACE

The Howard W. Sams' PHOTOFAC T Television Course appeared originally in serial form available only to Photofact Service subscribers. Throughout the period of serialized publication, we were besieged by a consistent and pressing demand for the presentation of the Course material in a single, complete unit. Our analysis of this demand revealed that requests came from all sections of the electronic industry - - from the fields of engineering, manufacturing, distribution, broadcast, installation and service.

The requirements of the servicing profession prompted our original undertaking of the Course project. That the Course has created so widespread and favorable an interest in fields not directly connected with service activities, is naturally gratifying to us. It is in answer to this interest and demand that the publication of the Course in the form of this present volume has become essential and inevitable.

We have expended every effort and the best of our knowledge and skill to provide in the text of the Photofact Television Course, the most accurate, timely and complete information available on the subject. Our objective is plain; to familiarize those with experience and training in radio fundamentals with the basic principles of practical Television theory and operation.

The method of treatment followed here differs from the conventional approach in Television instruction. We make the Cathode-Ray tube our starting point for the following reasons:

1. Television circuits (other than those directly energizing or controlling the cathode-ray beam) are simply a further application of techniques already familiar to the service

technician. These circuits are not radically different. They are more complex than those associated with conventional and well understood broadcast, short wave, and FM receivers.

2. In the case of AM and FM receivers, the technician has in the past used the sound of the receiver for guidance when making his initial service analysis. Similarly, in the case of Television receivers, the technician will employ the picture for his first diagnosis.

3. By employing the cathode-ray tube as a diagnostic agent, the service technician can and will reduce the total number of service operations required, particularly on service calls away from the shop. In a surprising number of instances, the story told on the face of the cathode-ray tube will indicate the source of trouble.

It follows clearly from these practical facts that a thorough understanding of cathode-ray tube operation is absolutely essential for grasping the subject and for success in service operations. Therefore, we have placed primary emphasis on the picture tube and have approached the whole subject from this vital starting point.

To those who have a sound groundwork in basic radio training and practice, the Television Course will prove an excellent guide to a clear understanding of the TV art. This art is destined for phenomenal growth and expanding development. Our work will parallel that growth and development. We are in continuous operation both in the laboratory and in clinical practice, keeping abreast of developments. You can be assured that from these activities will come a steady flow of authoritative data to meet the full need of the industry for such material.

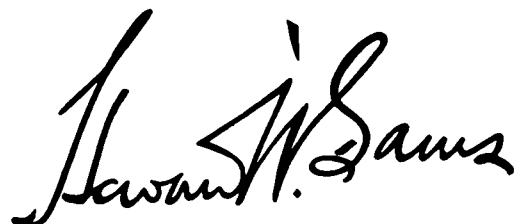



# SECTION I CATHODE RAY TUBES — BEAM FORMATION AND CONTROL

## CHAPTER 1. THE BEAM SOURCE (ELECTRON GUN) - ITS ELECTROSTATIC CONTROL

### TELEVISION

Television is a specialized branch of the radio industry and requires study of the various types of circuits utilized for the production of high voltages and special wave-shapes, together with a thorough knowledge of the cathode-ray tube.

Modern television receivers are designed around the cathode-ray tube ... the reason for this being that every circuit contributes ultimately to the operation and control of a cathode-ray, commonly known as an electron beam.

### THE CATHODE-RAY TUBE

The cathode-ray tube is essentially a vacuum tube with special design features to produce a narrow beam of electrons accelerated by a large positive potential, and caused to move at a high velocity toward a chemically prepared screen which fluoresces when bombarded by high speed electrons. The beam can be deflected and modulated so easily that it has many properties which are desired in the art of television.

Television requires the use of two distinctly different functional types of cathode-ray tubes; namely, the Camera tube which is located in the television studio, and the

Picture tube for the reproduction of the transmitted picture at the receiving end.

The Camera tube converts light energy into electrical energy which represents the video signal. This signal from the camera is amplified and used to modulate a carrier wave; then, after transmission and reception, the Picture tube reconverts the video signal back into light energy for viewing. Transmitted simultaneously with the video signal are blanking and synchronizing pulses which hold the horizontal and vertical scanning circuits in synchronism with the transmitter, to produce 30 frames per second, each frame being made up of 525 horizontal lines, according to present-day standards.

For ease of comprehension in the study of television reception, the receiver is broken down into three major circuit sections which have independent functions. They are as follows:

1. Cathode-ray beam formation and control.
2. Cathode-ray beam deflection systems.
3. Cathode-ray beam modulation and synchronization.

Figure 1 shows this division in block diagram form.

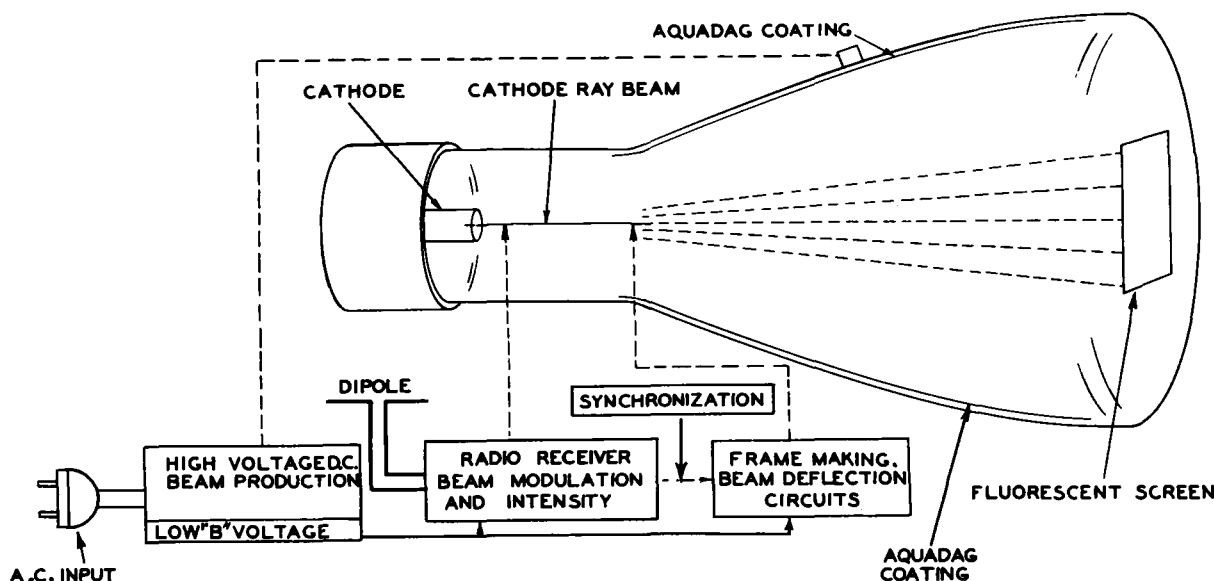

Fig. 1. Radio Plus Video Creates Television.



## CATHODE-RAY TUBES -- BEAM FORMATION AND CONTROL

These three master subjects serve as a guide of what to study, and how to study, and are in the correct sequence to afford the reader a clear understanding of what takes place in a television receiver.

**BEAM FORMATION AND CONTROL:** Involves the study of high potentials, testing techniques, the cathode-ray tube and electron optics.

**BEAM DEFLECTION SYSTEMS:** Involves the study of blocking oscillators, free-running multivibrators and wave-shaping circuits.

**BEAM MODULATION and SYNCHRONIZATION:** Involves the study of high frequency broadband receivers, video detectors, video amplifiers, and D.C. restorers. The reader is advised to thoroughly grasp one subject at a time to prevent confusion and disappointment. The study will not be difficult if this simple rule is followed.

### BEAM FORMATION AND CONTROL

Figure 2 shows a simple cathode-ray tube used in early experiments to develop a narrow beam of electrons. Emitted from a hot filament, the electrons proceed forward under the attraction of a positively charged plate. Accelerated by this positive charge, the beam reaches a velocity of many thousand miles per second, depending upon the force of this attraction. The equal negative charges carried by each electron tend to set up a repelling action that causes the emitted beam to widen or scatter. However, the small hole in the center of the anode narrows the beam and permits some of the fast-moving electrons to proceed to the end of the tube without appreciable loss of velocity.

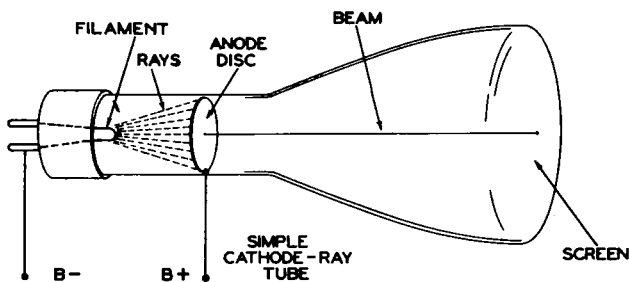

Fig. 2. Formation of a Narrow Beam of Electrons. (Early Experimental Form)

The electrons that make up this narrow beam are traveling too fast for any effective scattering action to take place, thus causing a small illuminated spot to be produced on the fluorescent screen. In the process of

narrowing the beam, the electrons that scatter are collected by the positively charged anode, causing a current to flow through the "B" supply circuit. This type of cathode-ray tube is very elementary, but serves adequately to facilitate a discussion on the production and formation of a narrow beam of electrons which will strike a fluorescent screen developing a spot of light. The color of the spot depends upon the type of chemical used on the screen. For further information regarding the chemicals in common use for this purpose, reference should be made to the table which will appear later in the text.

Cathode-ray tubes used in television are fundamentally comprised of the following: (1) An electron beam source; (2) A fluorescent screen for visible indication; (3) A provision for varying the intensity, which controls the brilliancy of the spot; (4) A provision for focusing the beam on the screen, which controls the size of the spot, and (5) A provision for deflecting the beam, which controls the position of the spot on the screen.

In modern cathode-ray tubes, the electron source is an indirectly heated cathode or electron emitter, which is a small cylinder of nickel about one-eighth of an inch in diameter and about one-half inch long. This nickel sleeve is coated on one end with oxide, which permits a copious number of electrons to be emitted in the direction of the fluorescent screen. The heater is a tungsten wire filament, wound to form a non-inductive spiral, which tends to cancel any magnetic field that might affect the electron beam. The filament coil is insulated and inserted into the cathode sleeve, and for good heat conduction to the cathode tube the insulating material contacts the nickel sleeve. An illustration of this important element is given in Figure 3.

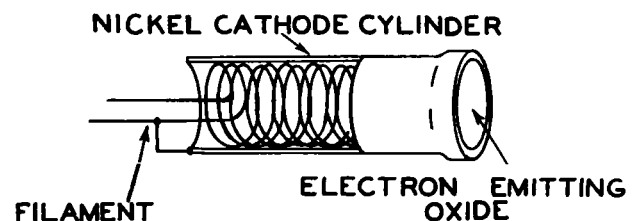

Fig. 3. Heater and Cathode Assembly

**GRID CONTROL ELEMENT:** The elementary cathode-ray tube illustrated in Figure 2 has no controlling element which can limit the

number of electrons emitted from the cathode. In television, some means must be provided for controlling the brilliancy of the picture. This calls for an additional element, designated as the control grid, to be inserted between the cathode and the positively charged anode. In modern tubes, this element is a metal cylinder completely enclosing the cathode element, as illustrated in Figure 4A. The strategic position of the control grid element constitutes a means of controlling the quantity of electrons admitted into the beam. This, in turn, limits the number of electrons impinging on the screen; hence the brilliancy of the pattern, because the more negative the control grid is biased with respect to the cathode, the fewer electrons in the beam, and the less the intensity of light produced on the screen. The direction of the electron emission is governed by an aperture in the disc at the end of the grid cylinder.

The lines of force of the electrostatic field developed by the difference of potential between the two elements, that is, cathode and control grid, and their effect on the beam, are illustrated in Figure 4B.

If the voltage on the control grid is made more negative with respect to the cathode, fewer electrons will be admitted to the beam. If the control grid is sufficiently negative, it will completely shut off or blank out the beam.

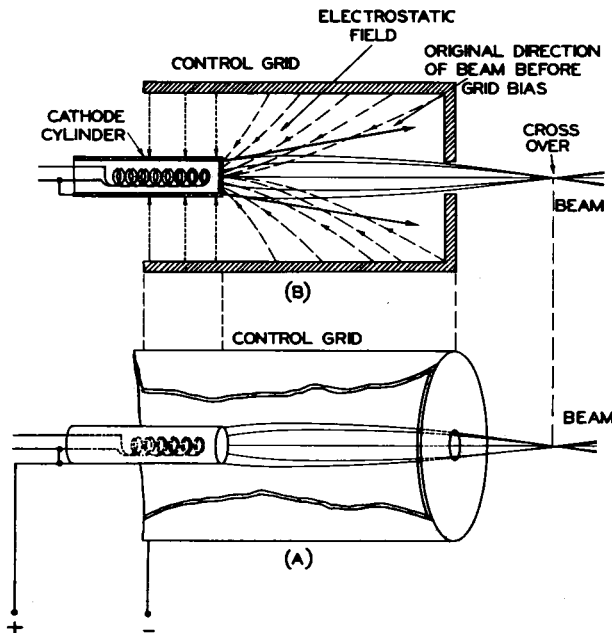

Fig. 4. Action of Cathode and Control Grid Assembly.

In earlier cathode-ray gun construction, the negative field of the control grid also lessened the effect of the positively charged focus anode located immediately beyond the control grid and further contributed to the reduction of the beam. Many present production cathode-ray tubes employ a different physical placement of the anodes to reduce this inter-action of control grid (brilliance) and focus adjustments. A complete discussion of anode function and structure is given later in this text.

Also, the action of the negative field associated with the control grid causes the beam to have a cross-over point after it passes through the control grid aperture; refer to illustration 4B.

This cross-over action is similar to a lens and concentrates the beam of electrons to a fine point. Hence, the phrase "electron optics." A close resemblance is given in Figure 5.

Summing up the foregoing, the control grid has three functions:

1. Controls brilliancy at the cathode-ray screen from zero to maximum.
2. Lens action to concentrate the beam by effecting a cross-over.
3. Provides a means for inserting the video output from a television receiver.

A potentiometer is included for varying the control grid bias and provides manual control to enable the viewer to adjust the brilliancy of the picture to a comfortable level. In oscillography this control is referred to as the intensity control.

**FOCUS CONTROL ELEMENTS:** So far, we have been able to control the brilliancy of the spot, but yet another control is necessary; that is, the spot must be brought into sharp focus. The focusing of an electron beam in a cathode-ray is similar to the focusing of light, as illustrated in Figure 6. As understood from previous discussion, the control grid did focus the beam to a point slightly beyond its (control grid) aperture, but the beam begins to widen again after the cross-over point; therefore, additional focusing is needed. In the earlier types of electrostatically controlled television picture tubes, this was accomplished by having two cylindrical anodes, as illustrated in Figure 5.



CATHODE-RAY TUBES -- BEAM FORMATION AND CONTROL

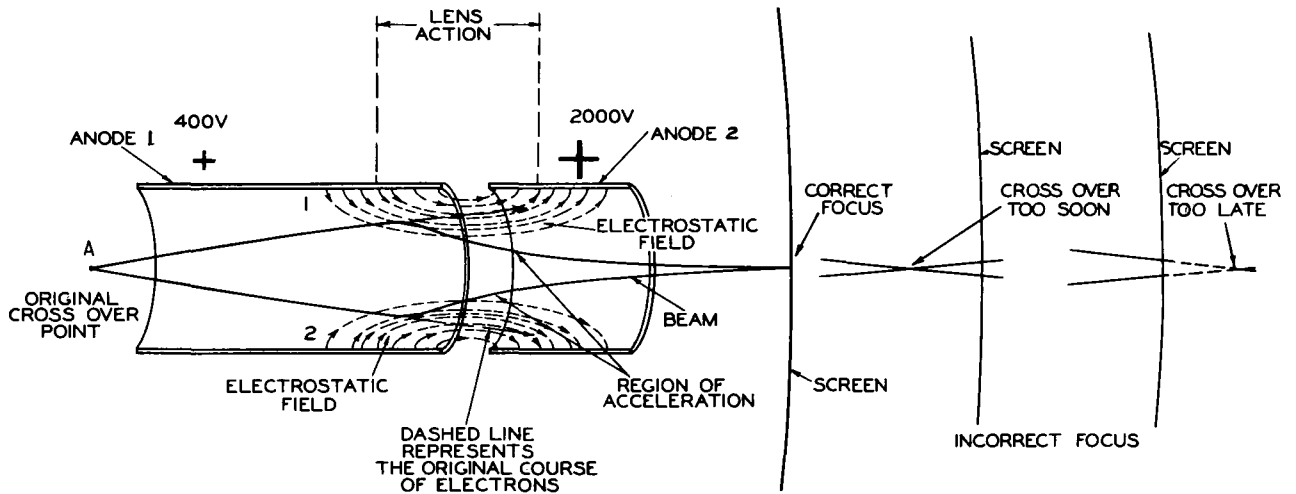

Fig. 5. Effect of an Electrostatic Field on an Electron Beam

The two anodes are operated at different potentials and the lines of force developed between the two elements establish the lens action in the following manner. The moving electrons will be subjected to forces as they enter the electrostatic field set up by Anode 1 and Anode 2. To understand clearly what takes place, let us refer to Figure 5. Here, the electron beam is seen entering the electrostatic field developed by a difference of potential existing between the two anodes. Coming from point "A," the original cross-over, the beam enters a new field. As the electrons cross the first static lines (1) and (2), Figure 5, the tendency is to change their course because the forces acting on them are

repelling to negative charges due to the potential gradient existing between anodes 1 and 2. Although both anodes are positive with respect to the cathode, anode 1, operating at a much lower potential, is negative with respect to anode 2, creating an electrostatic field which tends to repel the electrons entering that field.

The electrons, traveling at a high speed, are gradually bent into a beam, the greatest repelling force occurring at a point somewhere between the two anodes. When the electrons of the beam converge near the axis of the tube (center), where the lines of force are running almost parallel to the axis, an

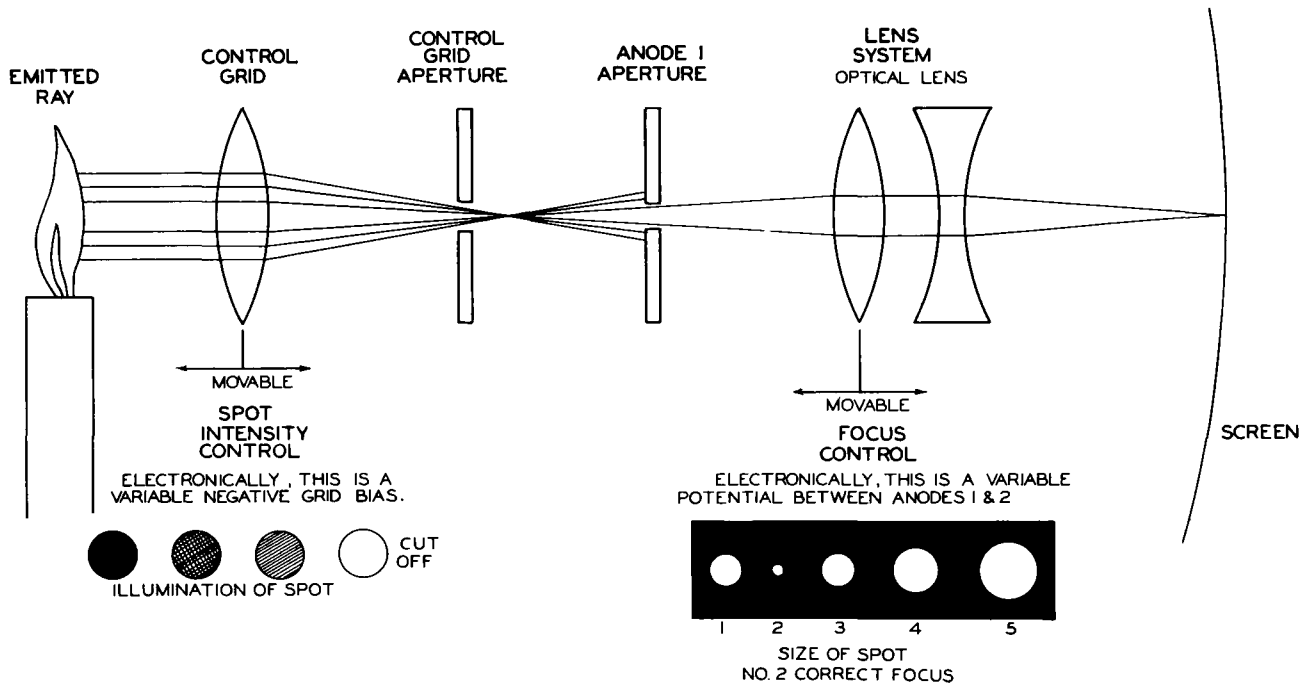

Fig. 6. Similarity of Light Ray and Cathode Ray

acceleration takes place and the electrons in the beam gain velocity. At the end of anode 2, the field is relatively weak and the electrons keep their direct course, aided by the velocity gained while traveling through anode 2. In this construction, the two anode cylinders are similar to the grid cylinder, with the exception of anode 1, which is generally longer and has two aperture discs spaced to provide better focus action.

After the beam has passed through anode 2, a second cross-over point takes place. This second cross-over point should be adjusted so that it takes place when the beam arrives at the surface of the screen.

The focus of an electrostatic type cathode-ray tube, construction of which is shown in Figure 5, is generally adjusted by varying the voltage applied to anode 1. This controls the amount of force the electrostatic field exerts on the electron beam, and by rotating the focus control and observing the screen, it is very easy to bring the beam into sharp focus.

Before proceeding into a discussion of variations in anode structure from the type just discussed and illustrated in Figure 5, it might be wise to clarify the terminology existing at present with regard to these elements.

Since the first cathode-ray tubes employed in television corresponded to the two cylindrical anode type illustrated in Figure 5, the terms "first anode," and "second anode" were quite logically used for reference purposes. However, with the advent of new constructions wherein more than two anodes, or physically split anodes, are used, we begin to have difficulty in titling them by their relative position in the tube, and it is, therefore, advisable to label them by their use or purpose. Consequently, anode 1, which controlled the focus action of Figure 5, can be called the "focus anode," and anode 2, the higher potential element, can be referred to as an "accelerating anode."

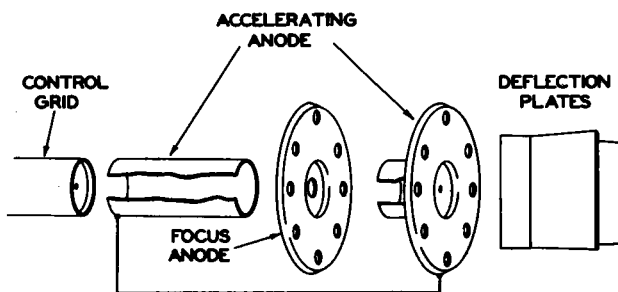

Fig. 7. Typical Anode Assembly

Figure 7 shows a more recent form of cathode-ray anode assembly in a typical 7-inch electrostatic tube. As noted in the illustration, the cylindrical anode adjacent to the control grid is an accelerating anode instead of a focus anode as employed in Figure 5. The circular disc with the rather large aperture, following the accelerating anode, is actually the focus anode. The shorter cylindrical anode combined with the second circular disc is electrically connected to the first cylindrical anode and is considered part of the accelerating anode structure. The reasons for this construction are as follows:

1. Removal of the focusing anode from its position near the control grid lessens any inter-action between intensity and focus control adjustments.

2. By proper placement of the focusing anode, it is possible to make its aperture larger and thereby reduce the amount of beam current drawn by this anode, lessening its effect on the beam intensity.

3. Item 2 is made possible because of the separation of portions of the accelerating anode, enabling the insertion of the focusing anode.

4. In any cathode-ray tubes which employ appreciable focusing anode current, the focusing control circuits must use sufficient bleed current to insure reliable operation. With the construction outlined in Figure 7, it is possible to considerably reduce or eliminate the requirement for bleed currents.

It should be borne in mind that construction of the tubes may vary according to the manufacturers' preferences of electrical design and physical support of the various elements.

Summing up, the focus and accelerating anodes have two functions:

1. Focusing the beam for sharp detail of the image on the screen. The focusing is manually controlled.
2. Acceleration of the beam.

**GENERAL SUMMATION TO THIS POINT:** The cathode-ray tube requires a high potential between the cathode and the accelerating anode. The voltage of the focus anode is usually around one-fifth that of the accelerating anode, and is normally variable to provide a means of focusing. The bias supply to the control grid also is made variable to provide a means of controlling the brilliance.



## CATHODE-RAY TUBES -- BEAM FORMATION AND CONTROL

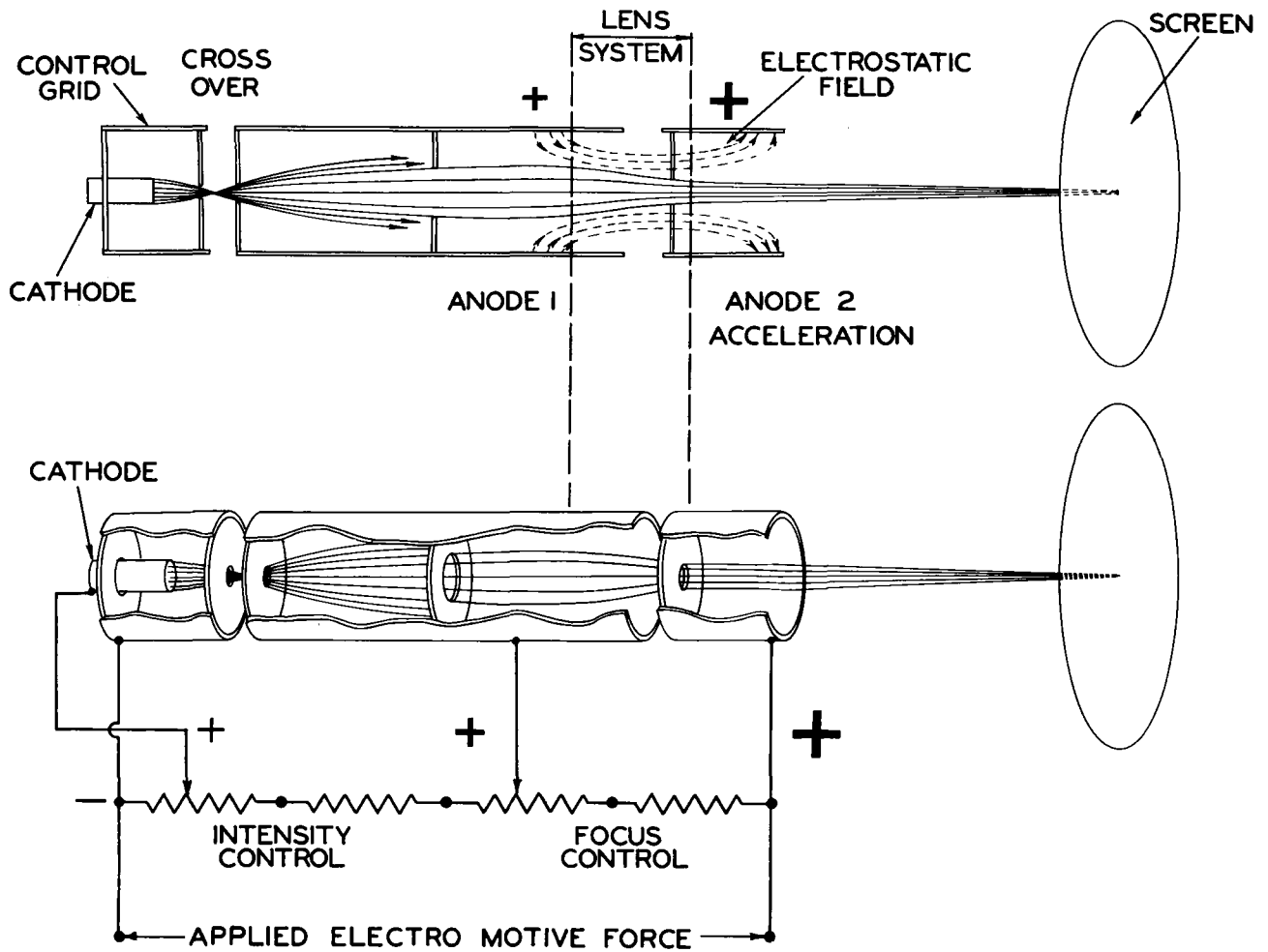

Fig. 8. Electron Gun Assembly

The assembly so far discussed constitutes the electron gun, so called because it shoots bullets (negative particles) to a screen or target. Figure 8 shows a typical electron gun assembly.

Since the electrons in the beam are negatively charged, their movement will be governed by the basic law of attraction and repulsion; that is, "like charges repel one another, unlike charges attract one another." Therefore, a positively charged plate will attract, while a negatively charged plate will repel.

### BEAM DEFLECTION

**ELECTROSTATIC:** Now that we have produced and accelerated the beam and are able to manually control its intensity and focus, a means must be provided to give it universal motion of deflection; that is, a horizontal and vertical movement within the area of the fluorescent screen. To obtain this effect, two sets of deflecting plates, with horizontal and vertical orientation (see Figure 9), are mounted in the neck of the tube and so arranged that the electron beam passes between the plates of each pair, after it has sped through the anode structure toward the screen. The complete assembly of a cathode ray tube with deflection electrostatically controlled is illustrated in Figure 10.

An electrostatic field exists between two adjacent plates of opposite polarity. Referring again to Figure 9, when an electron is shot into an electrostatic field whose lines of force cross its path, the electron has a tendency to drift off of its normal course toward the positively charged plate. The reason the electron actually crosses the lines of force is due to its own momentum, since the action of the static lines is to pull the electron in their direction. The high speed at which the electron beam passes through the static field delays slightly its deflection, thus preventing it from hitting the positive plate. Therefore, the amount the beam is deflected off of its normal course is dependent on the velocity of the beam and the strength of the deflecting field. The horizontal and vertical deflection

## CATHODE-RAY TUBES -- BEAM FORMATION AND CONTROL

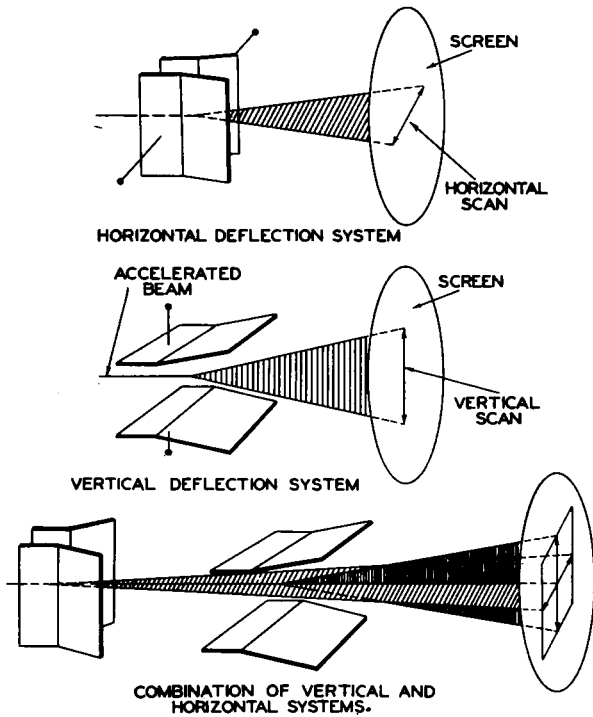

Fig. 9. Electrostatic Beam Deflection Systems

could be increased by increasing the distance between the point of deflection and the screen; this, of course, would increase the physical length of the cathode-ray tube. It will be noted in some specifications that the sensi-

tivity of the horizontal deflection plates is greater than that of the vertical, since the horizontal plates are further from the screen. However, when a cathode-ray tube is designed, the velocity of the beam and the position of the electrodes is fixed; therefore, to increase the deflection, the deflecting voltage must be increased.

The distance the beam or spot is moved across the screen by an applied voltage of one volt across the deflection plates, is called the deflection sensitivity.

Another way of increasing the deflection sensitivity is to increase the length of the deflection plates so that the static field is active on the beam for a longer period of time. In this case it will be necessary to bend the ends of the plates to form a flare; see Figure 9.

### EFFECT OF A FAST MOVING LIGHT SPOT ON THE FLUORESCENT SCREEN

The capability of the human eye to retain an image is about 1/16 of a second after it disappears. This is indicated by the practice followed in the projection of motion pictures where a series of still pictures is projected on the screen, in such rapid succession that the eye cannot detect them as separate pictures. In a cathode-ray tube the beam is swept so fast that the moving spot appears as a straight line. If the beam is swept over the same line

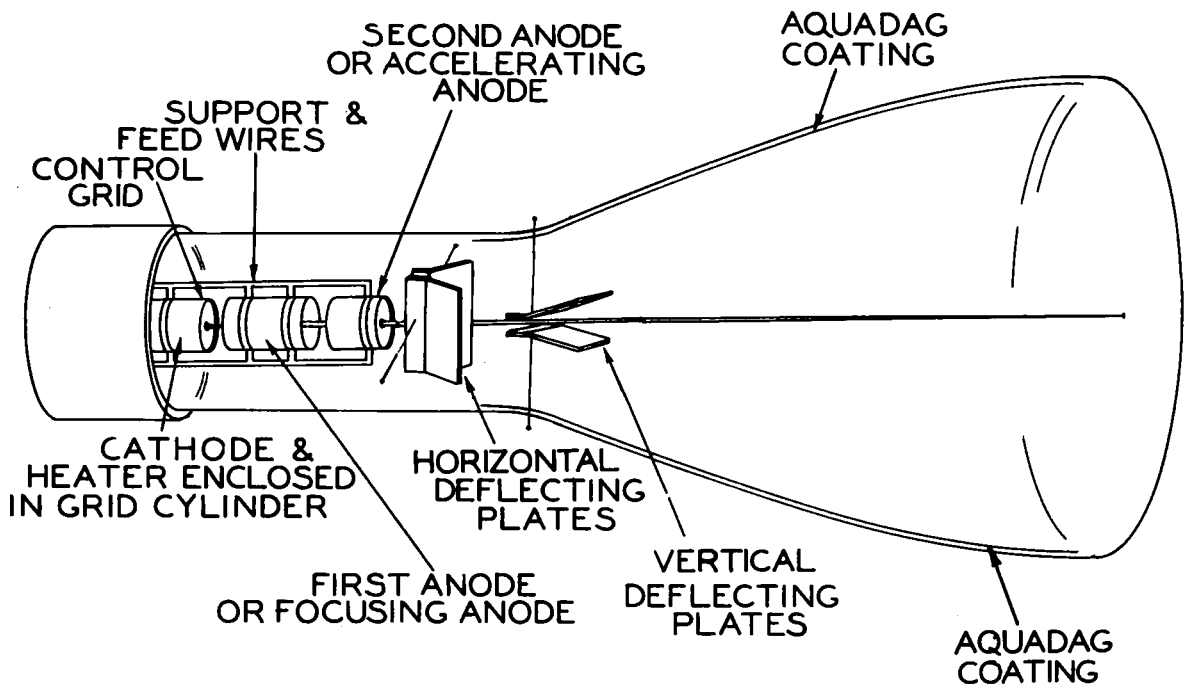

Fig. 10. Electrostatic Focus and Deflection



## CATHODE-RAY TUBES -- BEAM FORMATION AND CONTROL

or path at least 16 times a second, the spot appears to the viewer as a continuous line of light, without flicker. Therefore, if the combined action of the horizontal and vertical deflection voltages sweeps the beam horizontally and vertically at the same time, a frame of light will appear on the screen. See Figure 9. The summation is as follows:

A small spot of light appears at the point where the electron beam strikes the screen. If the beam is deflected left to right and top to bottom very rapidly, the whole screen is illuminated. In television, this pattern of light is called a raster.

In early cathode-ray tube practice, deflection voltage was obtained from single-ended amplifiers. One plate of each set of deflection plates was tied together and, in turn, connected to the accelerating anode. When a deflection voltage was applied to the deflection plates a difference of potential existed between the accelerating anode and deflection plates causing a defocusing action and change in velocity of the beam. This effect is called astigmatism.

In present construction of cathode-ray tubes, separate terminals are provided for each deflection plate, making possible the use of push-pull deflection amplifiers. The average potential remains constant between the plates of either pair of plates, since the potential of one plate is increased by an amount equal to the decrease in potential of the other plate. This minimizes any defocus action or change in velocity of the beam. Some tubes also have a ring or element placed between the horizontal and vertical deflection plates and connected to the accelerating anode. Its purpose is to prevent the defocusing action which would be the result of any disturbing field set up between the pairs of deflecting plates.

Summation at this point is as follows:

1. We have finally produced a frame of light, the intensity of which can be controlled.
2. Knowing that the frame is built up of small spots of light, it is now possible to insert into the control grid circuit of the

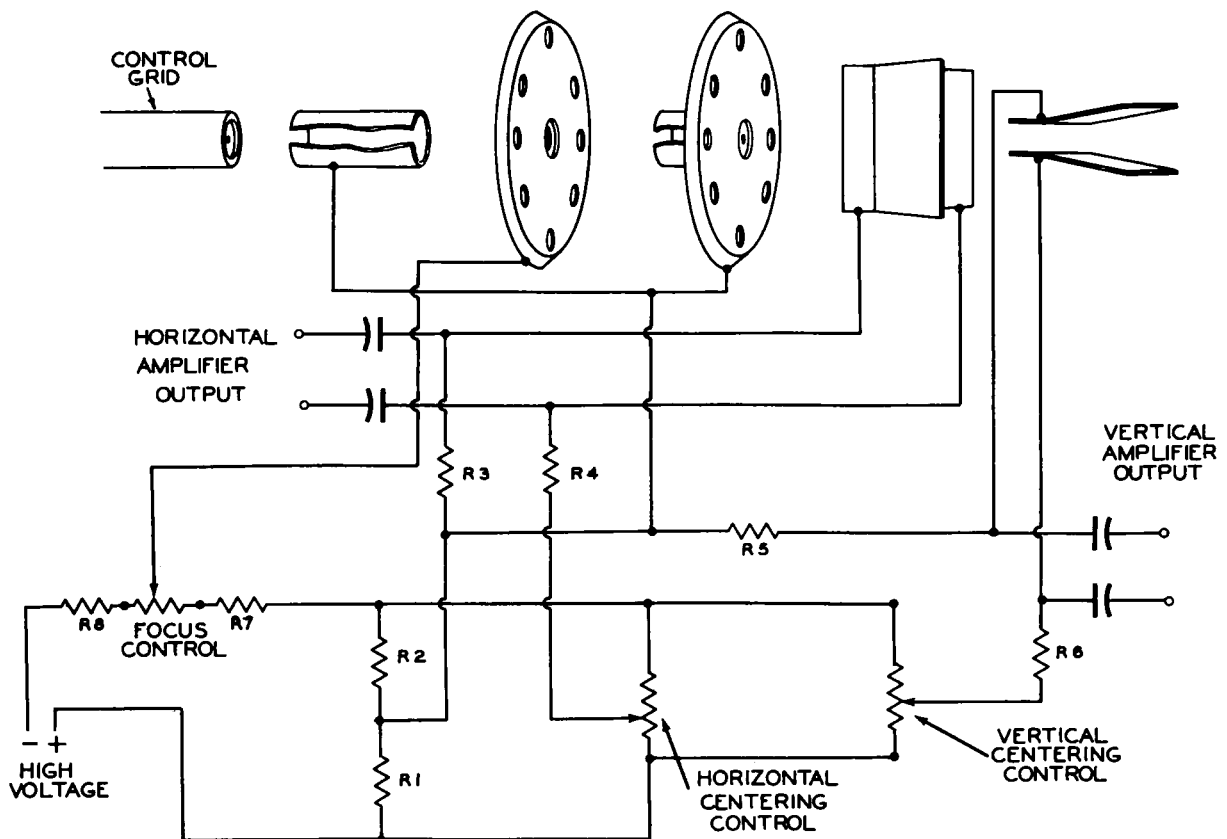

Fig. 11. Typical Centering Control Circuit

## CATHODE-RAY TUBES -- BEAM FORMATION AND CONTROL

cathode-ray tube, a video signal that will modulate the beam, causing each spot to vary in brilliancy. An analogy of this action may be obtained by looking at a picture in a newspaper under a magnifying glass. It can be seen plainly that each small dot varying from black to white, through various shades of grey, produces the necessary elements to form a picture.

**CENTERING CONTROLS:** There is an additional control function required to insure proper operation of the cathode-ray tube as used in television applications.

For correct operation, the cathode-ray electron beam, in the absence of deflection potentials, should strike in the center of the fluorescent screen. Effects such as stray electric and/or magnetic fields, distortion of forces within the cathode-ray tube itself, and aging or replacement of the tube or its associated supply components may cause the beam to move off center. To correct any "off center" condition that may exist, two centering controls are generally made available on the back apron of the receiver chassis to enable the serviceman to adjust the picture frame for proper horizontal and vertical positioning.

Figure 11 illustrates a typical centering control system. A high positive potential is applied across the divider network consisting of  $R_1$ ,  $R_2$ ,  $R_7$ , the focus control, and  $R_8$ . From the junction of  $R_1$  and  $R_2$ , potentials are applied to the accelerating anode, through  $R_3$  to one horizontal plate, and through  $R_5$  to one vertical plate. As shown in the illustration, each of the centering controls parallels the combination of  $R_1$  and  $R_2$ . The variable arm of the horizontal centering control supplies the remaining horizontal deflection plate through  $R_4$ , and, similarly, the variable arm of the vertical centering control supplies the remaining vertical deflection plate through  $R_6$ .

When the variable arms of the centering controls are at their mid-point, no DC potential exists between the individual plates of each pair of plates.

Consider for a moment the horizontal plates. A simplified diagram of their supply circuit is shown in Figure 12.

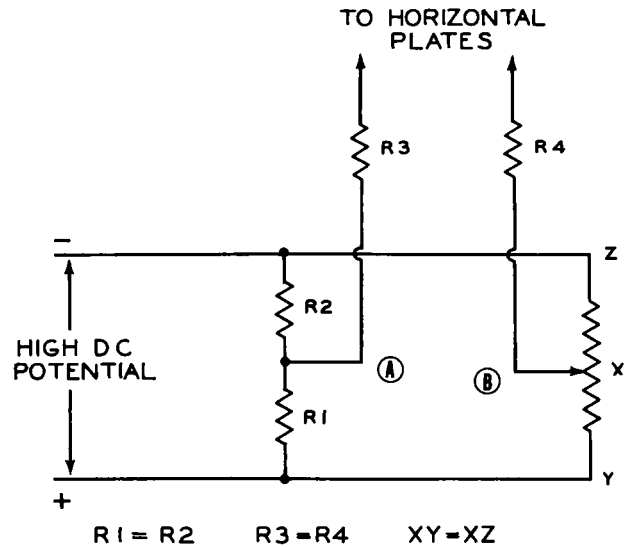
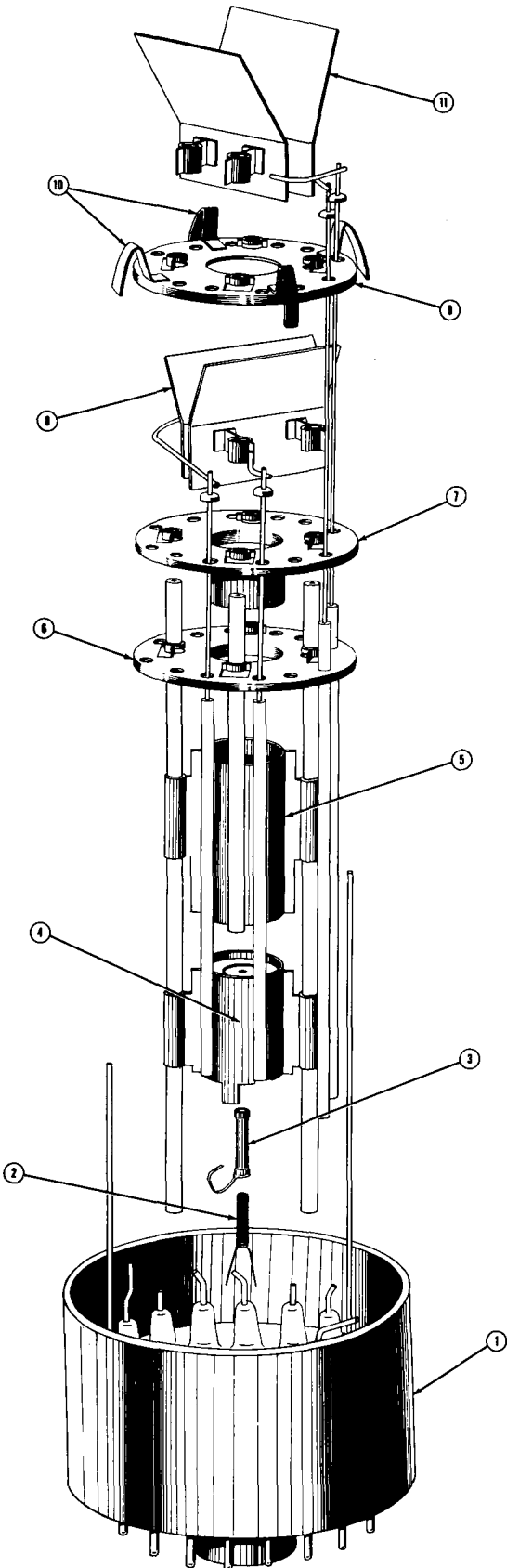

Fig. 12. Simplified Beam Centering Circuit

Since  $R_1$  is equal to  $R_2$ , and  $XY$  is equal to  $XZ$  when the centering control is at mid-point, we have, in effect, a bridge circuit and no potential will exist between the arms of this bridge represented by points A and B in Figure 12. It will be seen that one horizontal plate is supplied by each bridge arm through the series resistors  $R_3$  and  $R_4$ , which are equal in value. Thus, it is possible to maintain a condition of no DC potential between these plates. Should an "off-center" electron beam be encountered, due to any one or a combination of the effects mentioned previously, the beam may be centered by moving the control arm to provide a counteracting DC potential.

By applying the above analysis to the vertical centering supply circuit, it will be seen that an identical method of control is used.

CATHODE-RAY TUBES -- BEAM FORMATION AND CONTROL



Typical 7-inch Cathode-Ray  
Tube Structure Using  
Electrostatic Deflection

1. Medium Shell Diheptal Base. (Designation 14-G)
2. Heater Element
3. Cathode Sleeve
4. Control Grid
5. Accelerating Anode
6. Focus Anode
7. Accelerating Anode
8. Horizontal Deflection Plates
9. Barrier Anode
10. Support and Aquadag Contact Springs
11. Vertical Deflection Plates

Sample Tube Structure Courtesy  
Sylvania Electric Products, Inc.



# SECTION I CATHODE RAY TUBES — BEAM FORMATION AND CONTROL

## CHAPTER 2. MAGNETIC CONTROL OF THE ELECTRON BEAM

### ELECTROMAGNETIC CONTROL

Up to this point, our discussion of beam formation and control has been related primarily to cathode-ray tubes using electrostatic control methods.

A second type of cathode-ray electron beam control is obtained through electromagnetic focusing and deflection by varying the relative force, position, or area of fields adjacent to the beam.

To more easily understand the overall operation of this tube, let us first review the effect of magnetic fields upon an electron beam.

**EFFECT OF MAGNETIC FIELDS UPON AN ELECTRON BEAM:** The stream of electrons from the beam source may be considered as equivalent to a stream of electrons in a solid conductor carrying direct current. The effect of an external magnetic field upon either stream will be the same since any flow of electrons produces its own magnetic field. The direction of the electron flow and the direction of the magnetic lines it produces are at right angles. (See Figure 13)

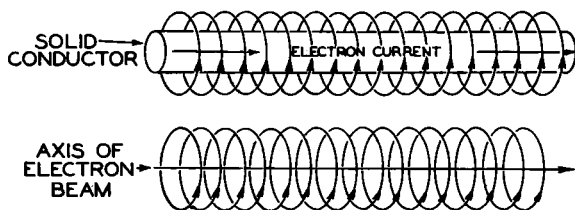

Fig. 13. Similarity of Solid Conductor and Electron Beam

Should this current-carrying conductor be placed in an existing magnetic field with the conductor parallel to the lines of force of this field, no force will be exerted on the electron

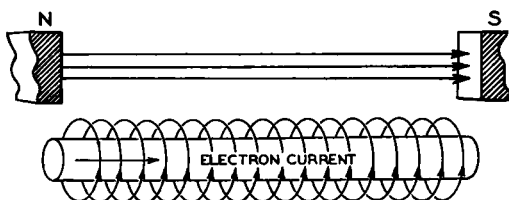

Fig. 14. Conductor Parallel to Magnetic Field

stream. The magnetic lines from the two sources are at right angles, neither aiding nor opposing one another; therefore, no interaction will result. (See Figure 14)

However, should the conductor be laid at right angles to the existing field, a torque or distortion of the magnetic lines will tend to move the conductor from the field, since the lines of the two fields are opposing on one side of the current-carrying conductor or stream of electrons, and aiding on the other side. (See Figure 15)

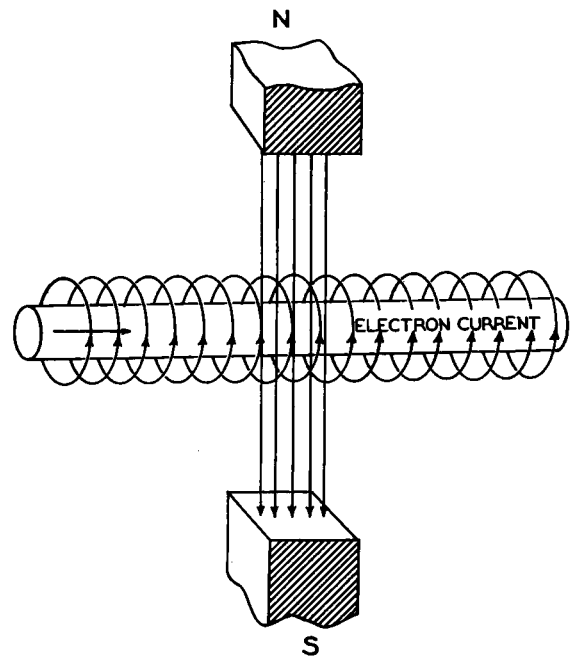

Fig. 15. Conductor at Right Angles to Magnetic Field

It should also be noted that while Figure 15, for the purposes of illustration, shows the electron stream or conductor at a full right angle with respect to the external magnetic field, that an electron stream entering the magnetic field at any angular variation from the parallel condition of Figure 14 will be affected by the external magnetic field to an extent proportionate to the amount of such angular variations.

To apply the foregoing in terms of electromagnetic control of the cathode-ray tube, consider first the construction of this tube (shown in Figure 16) as compared to the electrostatically controlled type. The electron gun assembly is quite similar to that of the electro-

## CATHODE-RAY TUBES -- BEAM FORMATION AND CONTROL

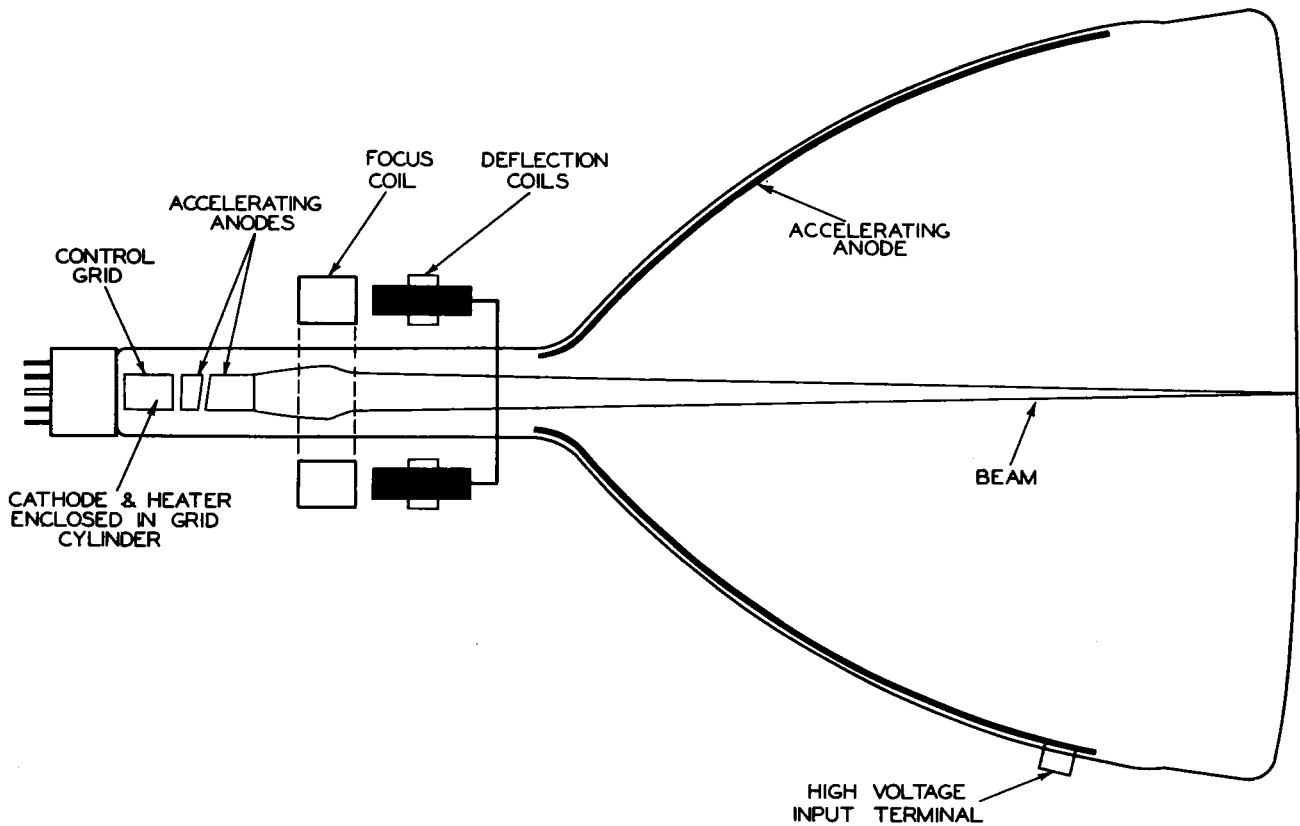

Fig. 16. Magnetically Controlled Cathode-Ray Tube

static unit. Heater and cathode elements are enclosed in the grid cylinder, as before, and the function of the grid in controlling the number of electrons admitted to the beam is identical. The anode structure differs in that there is no provision for internal focusing.

An accelerating anode is placed immediately following the control grid cylinder with its connection terminating in the tube base. Another cylindrical accelerating anode is often used connected through contact springs to the aquadag coating on the inner surface of the flared section of the tube. This aquadag coating terminates in a button contact placed on the outside of the flared section.

**MAGNETIC FOCUSING:** It will be noted from Figure 16 that the focus coil is placed along the neck of the tube, and since the magnetic field of the coil controls the size of the electron beam and causes the formation of a narrow spot of light on the tube face, no internal focusing elements are required.

The construction and application of a typical focus coil is shown in Figure 17.

A coil of wire is wound with soft iron annular pole pieces placed in such position as to concentrate the magnetic field about the neck of the tube, thus surrounding the beam of electrons inside the tube with parallel lines of magnetic force. An annular gap is placed so as to aid the concentration of these magnetic lines. By concentrating these lines of force, two results are obtained: First, the direct current through the coil is less for a given field strength than would be necessary with other magnetic structures, and second, stray fields are lessened and, therefore, are less likely to affect the action of the other control elements.

Provision is made in television to move the focus coil along the neck of the tube. After it is in its approximately correct position, fine control of focus is obtained by varying the direct current through the coil. This is normally accomplished by using a potentiometer, usually called the focus control.

Referring again to Figure 14, we see that any electrons traveling along a path parallel to the lines of an external magnetic field will not be affected by that field and will con-

# CATHODE-RAY TUBES -- BEAM FORMATION AND CONTROL

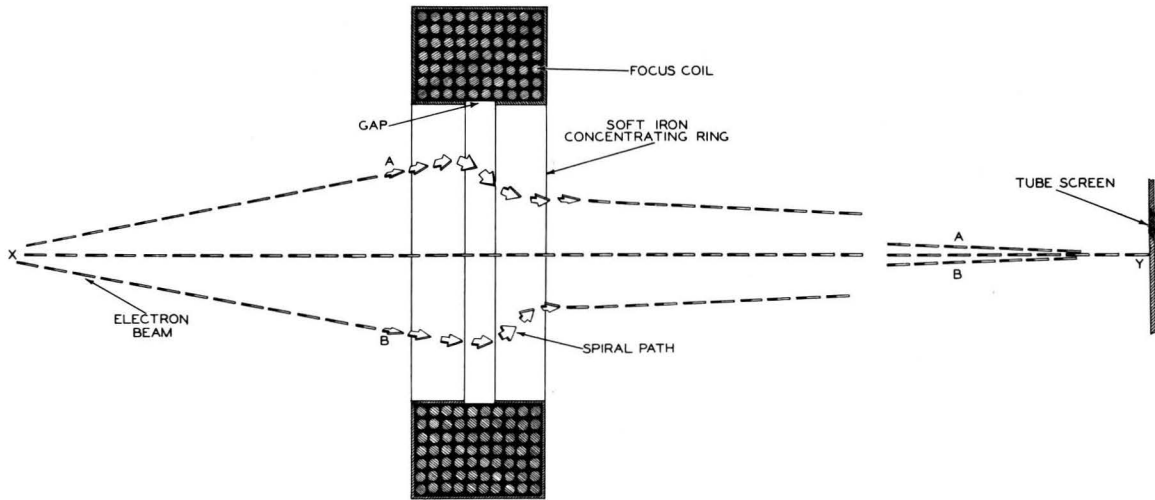

Fig. 17. Action of Focus Coil

tinue to travel in a straight line. Axis XY of Figure 17 shows this path.

Referring to Figure 15, we see that a stream of electrons entering an external magnetic field at right angles will be deflected or forced out of the field. Any time this stream of electrons enters the field at an angle away from the parallel condition, some deflection or sidewise movement of the beam will take place. Lines A and B of Figure 17 represent the paths of electrons which are not parallel to axis XY, and, therefore, since this beam is entering the magnetic field of the focus coil at an angle, a push or sidewise motion of the stream will result. Since the electrons are all traveling at a high velocity, each electron having its own magnetic field, the resulting action of the beam within the focus field will be to take a path

similar to the thread of a wood screw. By achieving the proper balance of beam velocity, magnetic field produced by the focus coil, and potential applied to the accelerating anode, the electron beam will leave the focus field in a converging stream having a focal point at the fluorescent screen.

**MAGNETIC DEFLECTION:** The effect of a magnetic field on fast-moving electrons will be to deflect the beam in a direction which is at right angles to the direction of the field and direction of the electronic motion; therefore, electromagnetic deflection of the beam may be secured by two sets of coils arranged horizontally and vertically over the neck of the tube near the bulge of the bulb, and located close to the focus coil. (See Figure 16)

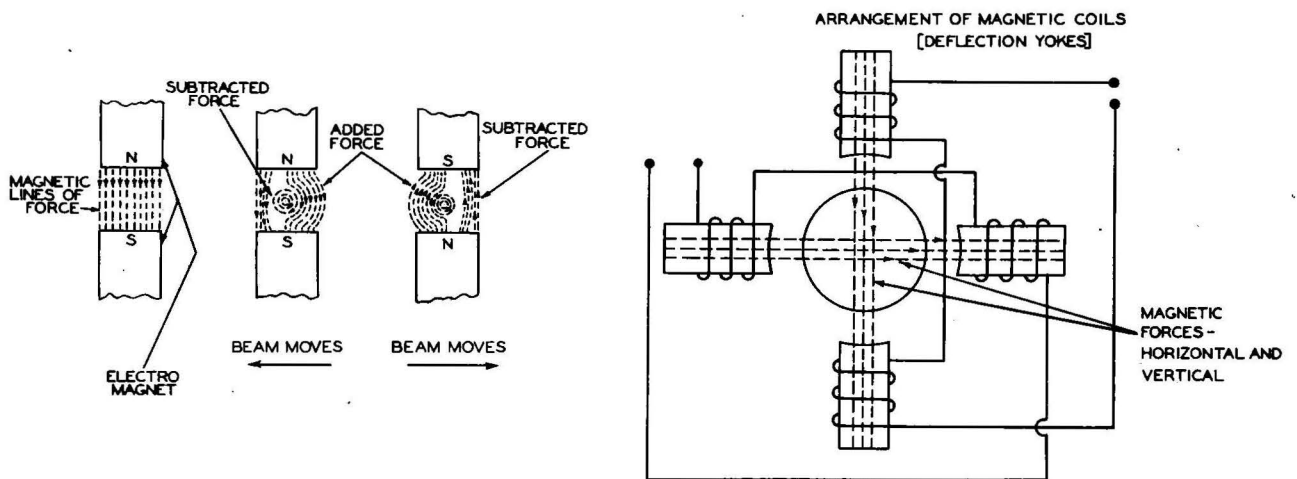

Fig. 18. Action of Deflection Coils

CATHODE-RAY TUBES -- BEAM FORMATION AND CONTROL

The two sets of coils, called deflection yokes, are comprised of four windings, two for horizontal deflection and two for vertical deflection. The two horizontal coils are mounted opposite each other and connected in series for correct polarity, so that the magnetic field passes through the neck of the tube at right angles to the path of the beam and will be oriented on a vertical plane to secure horizontal deflection. The vertical deflection coils are arranged and connected in the same manner, but oriented on a horizontal plane to secure vertical deflection. (See illustration in Figure 18)

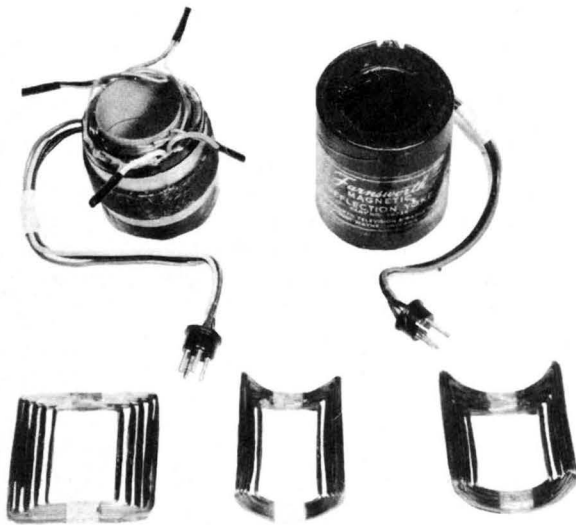

Fig. 19. Deflection coil Assembly (Sample Courtesy of Senn Corporation)

Thus the spot produced by the beam may be moved to any part of the screen by passing the correct amount of current through each set of coils. It is necessary to provide good magnetic shielding between the focus and deflection coils to prevent interaction.

Figure 19 shows coil construction, assembly, and appearance of a complete magnetic deflection yoke.

If a sawtooth of current is passed through the horizontal yokes, it will cause the spot to move from left to right across the screen and fly back; and similarly, if a sawtooth of current is passed through the vertical yoke, the beam will be made to move from top to bottom and fly back. The combined action of the horizontal and vertical fields will produce a frame of light, or raster, similar to that in electrostatic deflection.

A complete discussion of the development of these sawtooth waveforms will be given in a later section of the course covering horizontal and vertical oscillators.

**REMOVAL OF IONS FROM ELECTRON BEAM:** The emitted electrons from the cathode are mixed with charged atomic particles called "ions". These ions are present in the tube because first, no matter how well the elements making up the internal tube structure are cleansed, some slight amount of foreign material will be present, and second, as the cathode is heated, small particles of it will tend to "break loose". Each ion particle is approximately 2000 times heavier than the electron, and if permitted to strike the screen, a brown spot will gradually appear since the ions will actually remove the phosphor as they strike. The net result is a spot on the screen where no picture material can be produced, causing a poor viewing condition.

Electrostatically deflected tubes are not affected by the presence of ions since the electron beam and the ions are deflected simultaneously by an electrostatic field. However, magnetic fields do not materially affect an ion, and tubes using magnetic deflection systems must have some provision for preventing the ions from reaching the phosphor coating on the face of the tubes; otherwise, the spot will result.

Two methods are currently used for beam purification when the electromagnetic tube is used. The first method takes advantage of the fact that ions are not affected by magnetism.

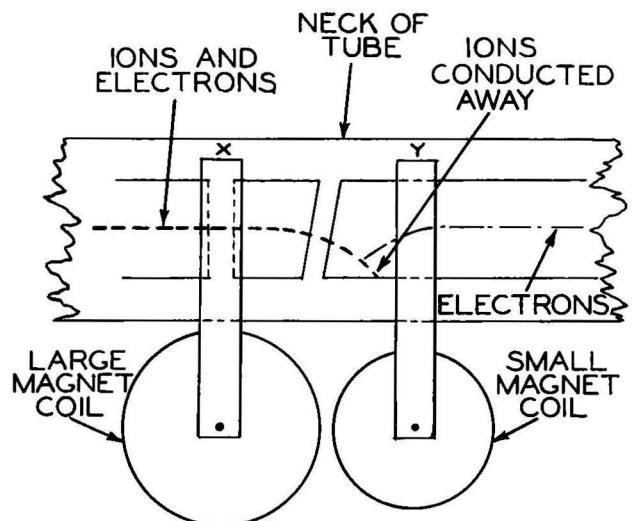

Fig. 20. Action of Ion Trap



The entire beam, containing both ions and electrons, is deflected electrostatically within the gun assembly, and an electromagnet is used to straighten the electron beam allowing the ions to continue on their bent path until they hit an accelerating anode, removing them from the beam. (See Figure 20, which represents a typical "ion trap" assembly.)

The field from the ion trap magnets causes the electron beam to be deflected or bent at points X and Y. The ion trap assembly is adjustable to provide a means of bending the beam at these two points. For correct adjustment, the raster is used as an indicator. The entire assembly is adjusted for maximum brilliancy and good horizontal line focus. Thus a stream of electrons only is allowed to emit from the gun structure. These electrons then pass through the neck of the tube, are focused, deflected, and accelerated toward the tube face. "Bent gun" assemblies are also used in addition to the one illustrated in Figure 20. In either type, the theory of operation is the same.

A second widely used method of beam purification involves the use of an extremely thin film of aluminum placed on the "beam side" of the phosphor viewing screen. The thickness of aluminum is chosen so as to allow the electrons to pass through and strike the phosphor. Since the ions have greater mass, they will not penetrate the aluminum but will be stopped and, therefore, not strike the phosphor. The use of the "aluminized" screen is also felt to give other advantages, namely, that of providing better contrast and brilliance on the picture screen. Of course the use of

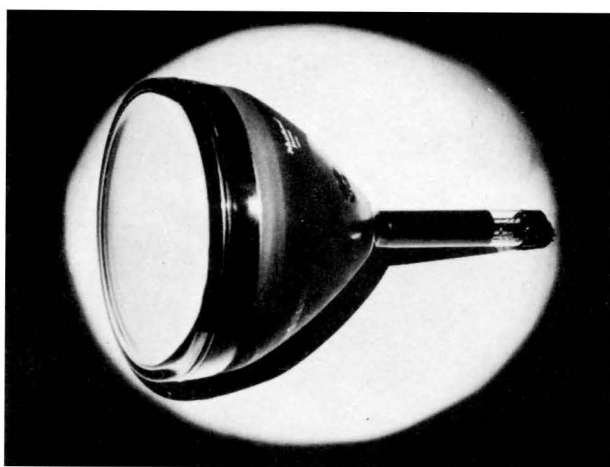

Fig. 21. Type 10FP4 Aluminized Screen Construction (Photo from Sample Courtesy Rauland Corp.)

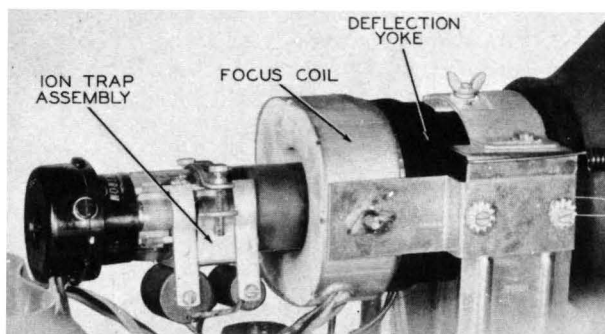

Fig. 22. Electromagnetic Tube Assembly in Receiver

this tube eliminates the need for external coils in the beam purification since the beam does not have to be "bent" within the gun assembly.

Figure 21 shows a tube employing the aluminized screen construction.

Figure 22 illustrates a type 10BP4 magnetically focused and deflected tube with ion trap, focus coil and deflection yoke in position as used in a typical receiver.

Some television receivers employ cathode-ray tubes having electrostatic focus and electromagnetic deflection. Such a tube employing this combination is the RCA type 5TP4 projection unit shown in Figure 23.

The general types of picture tubes and their requirements for deflection have been covered. Before discussing the method of translating received signals into visual patterns on the face of the picture tube, let us examine the method of converting the televised scene into video signal at the transmitting studio.

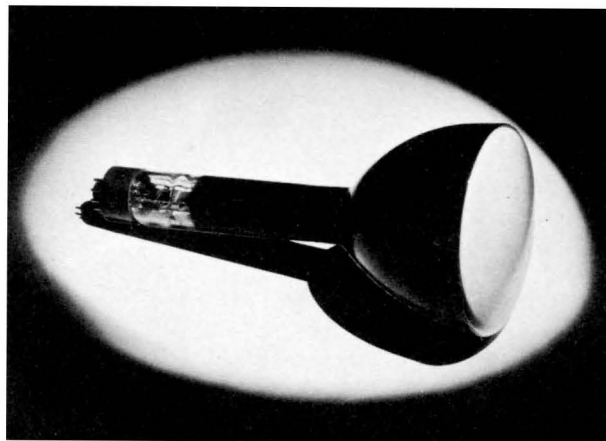
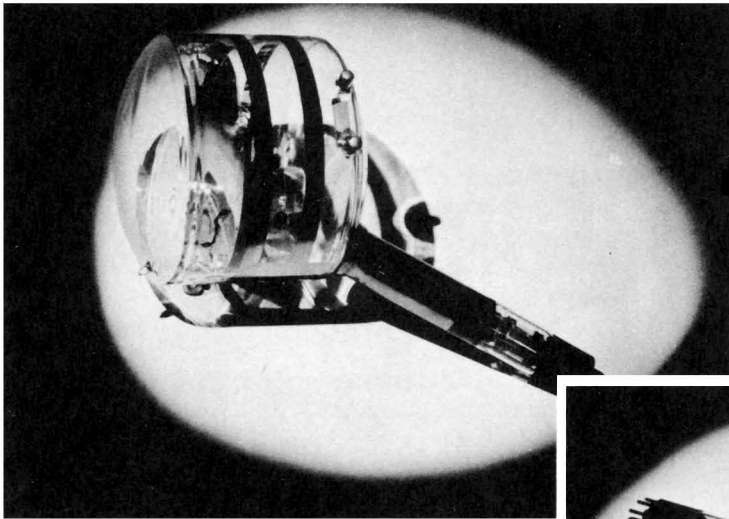
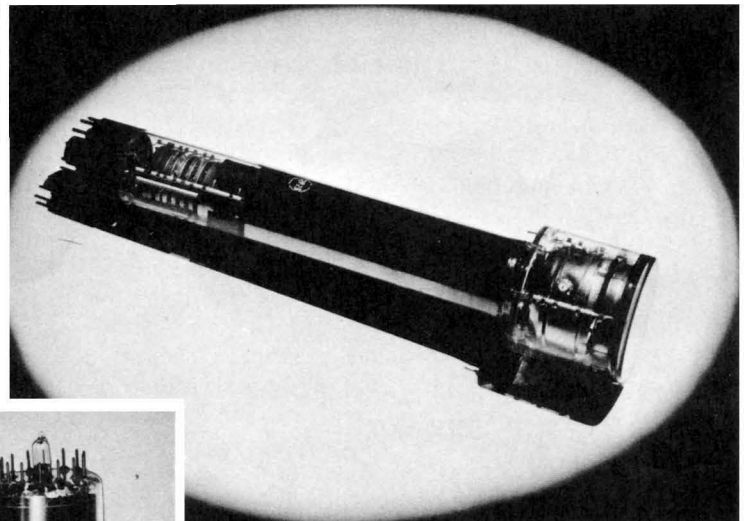

Fig. 23. Type 5TP4 Projection Tube (Sample Courtesy RCA)

CATHODE-RAY TUBES -- BEAM FORMATION AND CONTROL



Left: **ICONOSCOPE**  
(Photo from sample courtesy RCA)



Right: **IMAGE ORTHICON**  
(Photo from sample courtesy RCA)

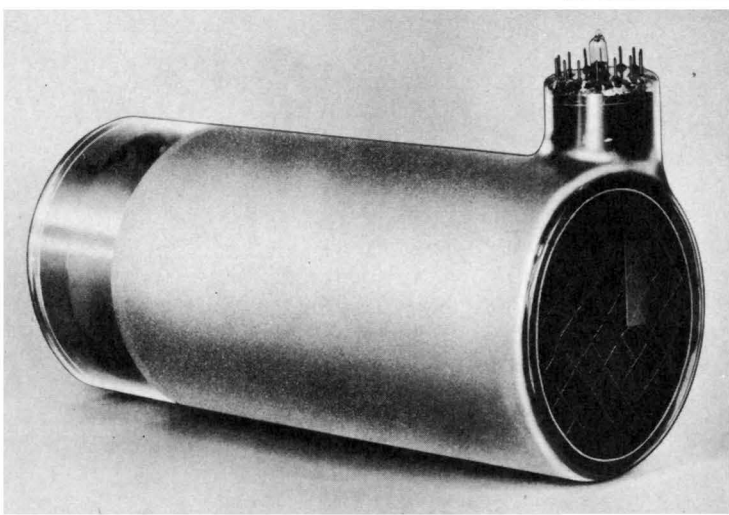

Left: **IMAGE DISSECTOR**  
(Photo courtesy Farnsworth Television & Radio Corp.)

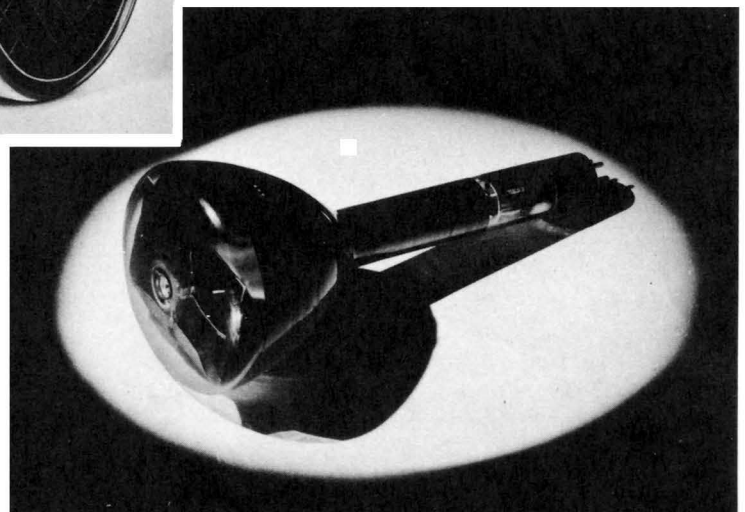

Right: **MONOSCOPE**  
(Photo from sample courtesy RCA)

# SECTION I CATHODE RAY TUBES — BEAM FORMATION AND CONTROL

## CHAPTER 3. THE CAMERA TUBE

There are at present four types of camera tubes: Iconoscope, Image Orthicon, Image Dissector, and Monoscope. A photograph of each type is given on page 18.

A brief discussion of the internal construction and operation of the camera tubes will assist the reader in connecting the scanning technique and transmitted picture to that of the picture tube for reproduction of the transmitted image.

### ICONOSCOPE

The Iconoscope is simply a cathode-ray tube, specially designed for translating the scene to be transmitted into electrical impulses. It consists of an electron gun similar to that of the receiving tube, but instead of a fluorescent screen, a large rectangular plate of thin mica is used for a scanning area.

On the front side of this mica sheet are deposited many microscopic particles of caesium silver compound - a photo sensitive material. Each particle or globule is insulated from the other, which gives the mica sheet a mosaic appearance. The back of the mica sheet is covered with a conductive film which is connected to an output lead. The whole arrangement appears as myriads of small condensers or cells, with a common lead through which to discharge their stored energy.

In order to understand the action of the scanning beam, let us assume that no scene is being projected on the mica sheet or mosaic. As the beam strikes the small particles of caesium silver, secondary emission takes place. The number of secondary electrons emitted is several times greater than the primary electrons in the beam which strike the particle. Since more electrons, which are of negative potential, are emitted than the number striking the particle, the potential of the particle will change in a positive direction. It will rise to an "equilibrium potential" of approximately positive three volts. The secondary electrons which have been emitted either go to the collector or to other parts of the mosaic. Since each of the particles is insulated from all others, this "charge" cannot leak off. However, after the beam continues on its sweep, the particle which has been positively charged will attract secondary electrons which have

been emitted from other particles in the mosaic. It will then change potential in a negative direction. Due to the abundance of free electrons on the face of the mosaic the particle will actually charge to approximately minus 1-1/2 volts. This action parallels very closely the method of obtaining bias in audio amplifiers known as "contact bias", with which we are familiar. The proximity of the grid to the cathode places it in a cloud of electrons which causes current flow in the grid circuit. In the case of the particle in the mosaic, however, there can be no current flow so the particle takes on a negative charge and maintains it until the beam again strikes it. It can now be seen that each particle changes from negative 1-1/2 volts to a positive three volts each time the beam strikes it.

The output from the Iconoscope is obtained from a resistive load which is connected between the conductive film on the back of the mosaic and ground. A certain capacitance exists between each of the particles and the conductive film. At the instant the beam strikes the particle, the charge on this capacitance cannot change, so the entire voltage will appear across the resistive load. A number of electrons equal to the amount lost by the particle will flow from ground to the conductive film to maintain the charge on the existing capacity. This current flow results in a four and one-half volt potential across the load. Since in the above case no scene has been projected on the mosaic, the potential on each of the particles will change an equal amount. This results in no change in the amount of current flow in the load as the beam scans the mosaic. Since there is no a-c component there is no output from the Iconoscope.

We have discussed the action of the tube with no image projected on the mosaic. In order to understand the action of the tube when illuminated areas are present on the mosaic, let us assume that half of it is illuminated. The caesium silver particles, as stated above, are photo sensitive and will emit electrons when struck with light. When the beam of electrons has passed over a particle which is being struck with light, the particle will attract free electrons. Since some electrons are being emitted due to the photo sensitive properties of the compound, the particle will not take on a

charge of negative one and one-half volts. Instead it will assume some charge in a positive direction from the negative one and one-half volts. The amount, of course, depends upon the amount of light present. For illustration purposes let us assume that the intensity of light present on the illuminated half of the mosaic is such that allows the illuminated particles to charge to a negative one volt. The particles in the non-illuminated area will charge to a negative one and one-half volts, as was the case of the non-illuminated mosaic. As the beam of electrons from the electron gun strike the non-illuminated particles a change of four and one-half volts takes place resulting in a four and one-half volt potential across the load. When the beam strikes the illuminated particles, however, the particle in charging to the "equilibrium potential" of plus three volts, will change only four volts since the original charge was only negative one volt. This results in a potential of four volts across the load giving an a-c component in the output.

When an image is projected on the mosaic each particle will charge to a certain potential depending on the amount of light present. As the scanning beam scans the mosaic horizontally from left to right, and vertically from top to bottom, each particle will be returned to the "equilibrium potential" which causes current pulses to flow in the load resistor. This train of pulses, varying with the charge on the particles, constitutes the video signal.

The output from the Iconoscope is of negative polarity since there is less current flow when an illuminated particle is scanned than when a non-illuminated particle is scanned. Figure 24 shows the major elements of the Iconoscope.

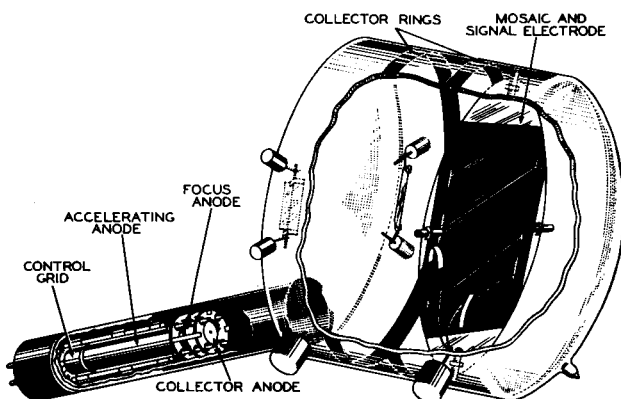

Fig. 24. RCA Type 1850A Iconoscope (Drawing from Sample Courtesy RCA)

### IMAGE ORTHICON

This tube is a more recent development than the Iconoscope and will function over a wide range of light values. It is ideal for outdoor pickups and other installations where the light available is not under the control of the pickup crew. For a better understanding of the operation of the Image Orthicon, refer to Figure 25 while studying the following paragraphs.

Light from the scene being televised is focused on the photo-cathode which is semi-transparent. This photo-cathode emits electrons proportional to the amount of light striking the area. These electrons are accelerated toward the target by grid No. 6 and are focused by the magnetic field produced by an external coil. The target consists of a special thin glass disc with a fine mesh screen on the photo-cathode side. Focusing is also accomplished by varying the potential of the photo-cathode.

When the electrons strike the target, secondary emission from the glass takes place. These secondary electrons are collected by the wire mesh, which is maintained at a constant potential of approximately one volt. This limits the potential of the glass disc and accounts for its stability in varying intensities of light. As electrons are emitted from the photo-cathode side of the glass disc, positive charges are built up on the other side of the disc which vary with the amount of electrons which were emitted. Thus it can be seen that a pattern of positive charges are set up which correspond to the intensities of light of the scene which is being televised. This constitutes the image section of the Image Orthicon and the action described is completely independent of the electron beam and the scanning circuits of the tube.

The back side of the target is scanned with a low velocity beam from the electron gun. The beam is focused by the magnetic field generated by an external coil and by the electrostatic field of Grid No. 4. The potential applied to Grid No. 5 adjusts the decelerating field between Grid No. 4 and the target. As the low velocity beam strikes the target it is turned back and focused on dynode No. 1, which is the first element of an electron multiplier. As the beam is turned back from the target, however, some electrons are taken from the beam to neutralize the charge on the glass. The greater the charge on the glass, the more electrons are taken from the beam. Thus, when the beam



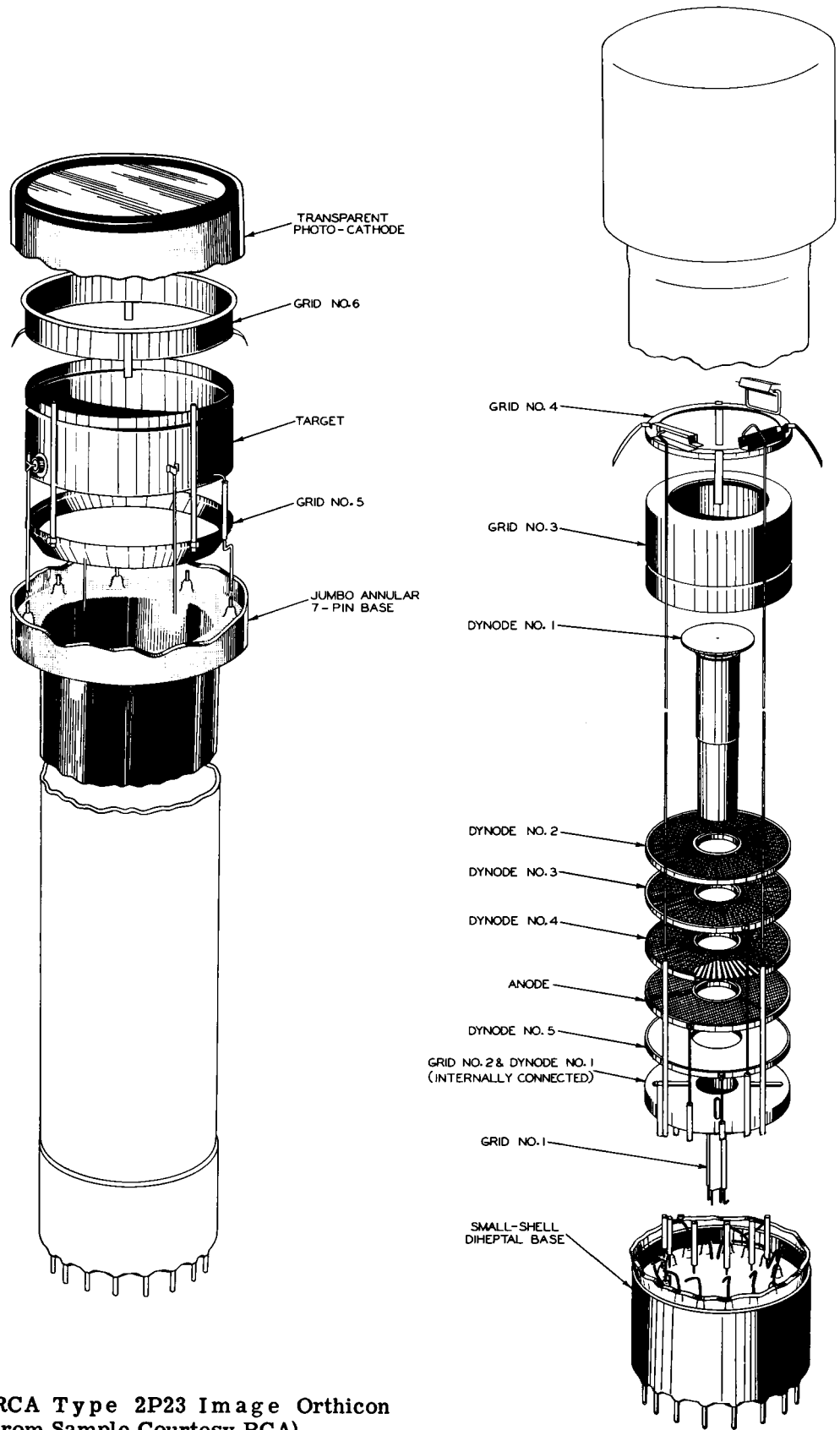

Fig. 25. RCA Type 2P23 Image Orthicon  
(Drawings from Sample Courtesy RCA)

scans a more positively charged area, which corresponds to a brighter area in light intensity, fewer electrons are returned to dynode No. 1. This action leaves the scanned side of the target negatively charged while the opposite side is positively charged. Due to the extreme thinness of the glass disc target, however, these charges will neutralize themselves by conduction through the glass. This neutralization takes place in less than the time of one frame.

As the amplitude modulated stream of electrons strike dynode No. 1, secondary electrons are emitted. The number emitted is proportional to the number striking it. Several secondary electrons are emitted for each primary electron striking the element. These free electrons are then accelerated toward dynode No. 2 where, upon striking the element, more secondary emission takes place. This same process continues on through dynode No. 3, dynode No. 4, dynode No. 5 and the electrons are finally collected by the anode or plate. Thus it can be seen that the electrons returned to dynode No. 1 are amplified or multiplied many times before the signal reaches the anode. The amount of multiplication per element is equal to the difference of secondary electrons emitted and the electrons striking the element. The approximate gain of the multiplier section of this tube is 500. The load resistor of the Image Orthicon is connected from the anode to the power supply. More current flow in the multiplier, which corresponds to a dark area in the televised scene, causes more current flow in the load giving a negative output. A brighter area causes less current flow giving a positive output. Thus it can be seen that the output of the Image Orthicon is of positive polarity.

Figure 25 is an exploded view of the internal construction of the Image Orthicon.

### IMAGE DISSECTOR

Both camera tubes previously discussed are known as the "storage" type since their operation depends upon the neutralization of positive charges by the scanning beam. The Image Dissector, on the other hand, employs instantaneous scanning.

The tube consists of an evacuated glass cylinder which is closed at both ends. The elements within the tube are the photo-sensitive cathode, an anode, a shielded target having a

small aperture and an electron multiplier. The cathode, upon which a caesium-silver oxide film has been formed, is placed at one end of the cylinder. The anode, whose purpose is to accelerate the electrons emitted from the photo-cathode, is a conductive coating on the inner surface of the cylinder. The target is placed near the other end of the cylinder, which is a plane glass end. The target is at the end of an electron multiplier which is used for amplification. In front of the target is a small aperture which will allow only a small portion of the electron image to fall on the target.

The entire cylinder is placed within a focusing coil which produces an axial magnetic field throughout the entire length of the cylinder. The horizontal and vertical deflection coils are also placed around the cylinder, and act also as a supporting framework.

In operation the scene to be televised is focused on the photo-cathode. Electrons are emitted from this cathode according to the amount of light striking that particular area. It can be said that an "electron image" is emitted from the cathode which corresponds to the optical image projected on the cathode. This "electron image" is then accelerated toward the target by the anode which has a positive potential of several hundred volts. The image is maintained in focus by the axial magnetic field of the focusing coil.

The "electron image" is deflected horizontally and vertically by the magnetic field set up by the sawtooth current flow in the deflection coils. As the "electron image" is deflected past the aperture, only a small portion of the image can strike the target. The image, however, is swept past the aperture in a series of 525 interlaced lines thirty times per second. Instead of a beam scanning the

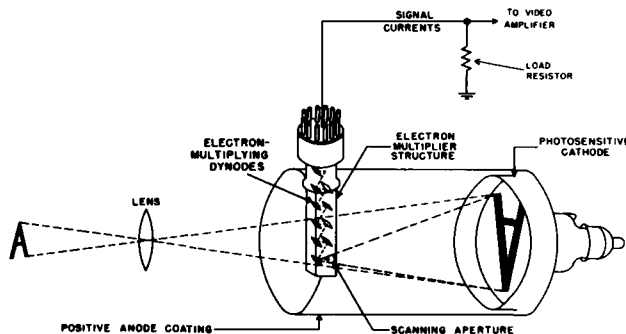

Fig. 26. Image Dissector Operation (Courtesy Farnsworth Television and Radio Corp.)

image, the entire image is scanned past the aperture which "dissects" the image. Thus the name, Image Dissector.

As the image is moved in front of the aperture a varying amount of electrons strike the target. The amount is dependent on the amount of light present in that particular area of the televised scene. As these electrons strike the target, secondary electrons are emitted which are drawn to the next element of the electron multiplier. Each element in the multiplier is maintained at a potential approximately 100 volts positive with respect to the preceding element. The electron multiplying action is similar to that which took place in the Image Orthicon. However, in the Image Dissector eleven stages are used to multiply the photo-cathode emitted electrons.

The amount of resolution obtainable from the Image Dissector is dependent on the size of the aperture in front of the target and to the ratio of the "electron image" to the optical image. As the aperture is made smaller the resolution increases, as is the case when the "electron image" is made larger. An aperture .012"x.012" gives a good signal-to-noise ratio for 525-line resolution. This size aperture is used in present day construction of Image Dissectors.

Figure 26 illustrates the operation of the Image Dissector.

## MONOSCOPE

Another cathode-ray tube used in transmission of the television signals is the Monoscope, shown in Figure 27.

It is used for testing and adjusting studio equipment and when its signal is transmitted by the station, it is useful for the proper adjustment of the receiving equipment. The primary difference of this tube from the other camera tubes discussed previously is the inclusion of a test pattern which is placed in the front of the tube envelope. This test pattern is then reproduced as the video signal.

The difference in amount of secondary emission of electrons between two materials is used to produce the output. Usually a sheet of aluminum, which has high emission, is marked with high carbon content ink. Carbon has fairly low emission and as the electron beam scans the entire pattern, secondary electrons are emitted from both materials in proportion to their emission ratios. Any pattern with any line shape may be drawn on the aluminum sheet.

The Monoscope is a stable video signal source and, therefore, provides both the television engineer and the service technician with a useful tool.

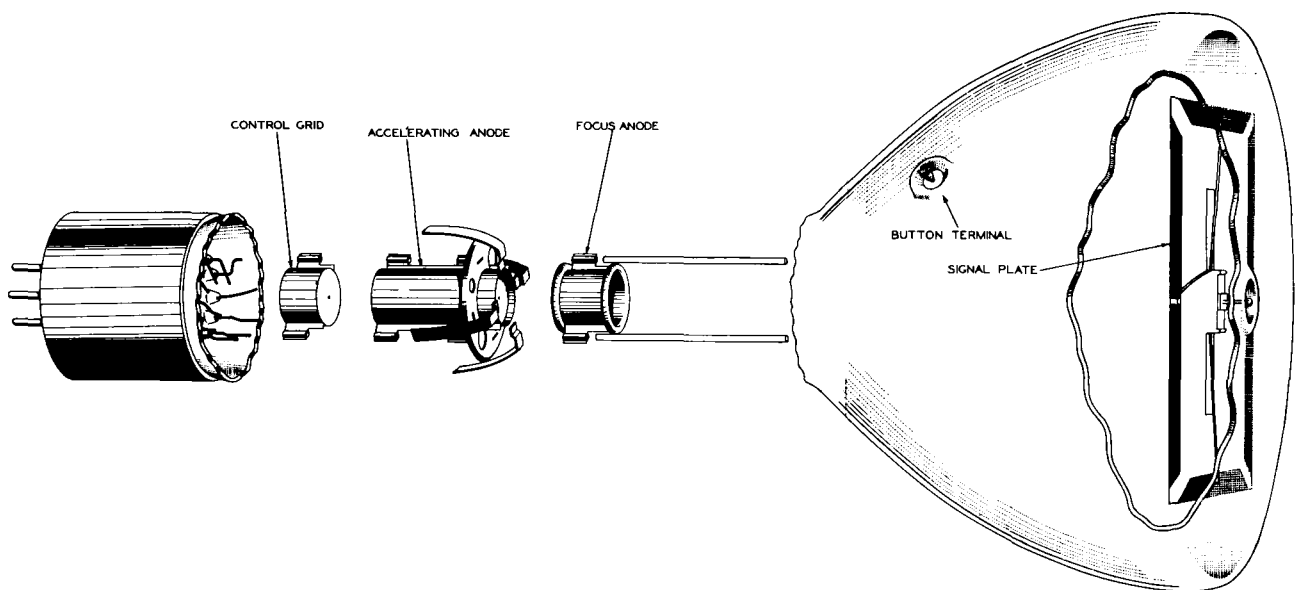

Fig. 27. RCA Type 2F21 Monoscope (Drawing from Sample Courtesy RCA)

CATHODE-RAY TUBES -- BEAM FORMATION AND CONTROL

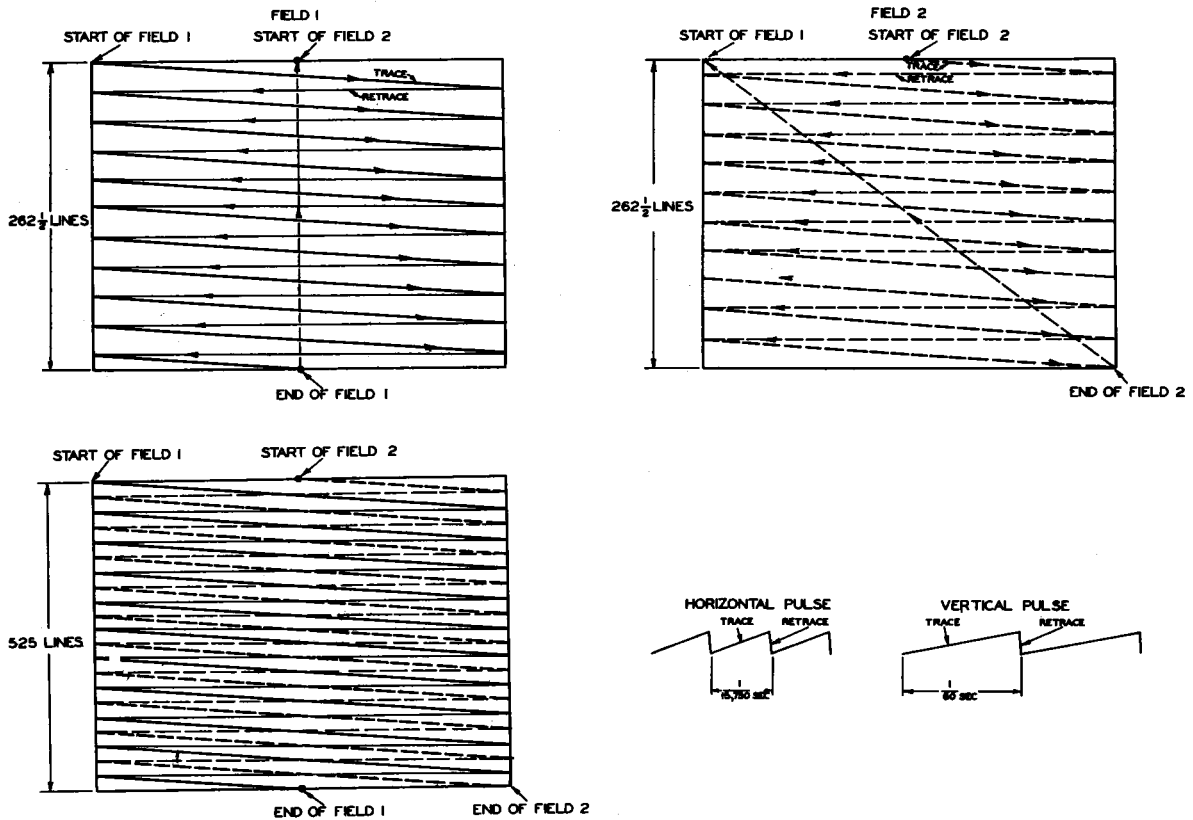

Fig. 28. Interlaced Scanning

SCANNING

All of the picture generating tubes discussed have associated external focus and deflection elements which cause the electron beam to scan the active picture surface at the front of the tube.

The video signal carries the picture information to be transmitted over the air. Since the timing of the scanning process is very important, the video signal must contain other information in the form of electrical impulses. These impulses are termed blanking pulses, which blank out the return trace of the cathode-ray beam in the camera tube during fly-back time, and synchronizing pulses, which are utilized by the receiver to synchronize the horizontal and vertical sawtooth generators.

The path travelled by the beam across the screen of the picture tube should be identical to the path travelled by the beam in the camera tube so that the picture may be reconstructed in the correct sequence at the receiver.

For picture resolution, the present standards for television broadcasts are 30 frames per second, each frame being constructed of 525 horizontal lines, using interlaced scanning. (If alternate lines be transmitted in such a way that two series of lines are necessary to produce a complete frame, the system is called interlacing.)

Therefore, to produce one frame of 525 lines interlaced, 262-1/2 horizontal lines are scanned on the first down sweep of vertical deflection, and the beam returns to the top and scans 262-1/2 alternate lines. The horizontal and vertical scanning traces are the result of passing current having a sawtooth form through the respective deflection coils. The rapid return of the electron beam, or retrace, for the start of the succeeding scanning function, is a result of the rapidly decreasing current in this sawtooth form. In order to produce interlaced scanning with 525 lines and 30 complete frames per second, the vertical sweep frequency must be 60 cycles per second, and the horizontal sweep frequency must be 15,750 cycles per second. Figure 28 further explains the complete scanning operation.

# SECTION I CATHODE RAY TUBES – BEAM FORMATION AND CONTROL

## CHAPTER 4. TELEVISION POWER SUPPLIES

The peculiarities of power requirements in the several parts of representative television systems make necessary the use of power supplies more complicated than those normally found in other radio and electronic devices. In general, it is necessary to provide for at least two separate and basically different load conditions.

1. A low-voltage, high-current system to power oscillator, amplifier, and similar stages where applied potential does not exceed approximately 450 volts. In addition, some receivers power modulation and deflection systems from this source.

2. A high-voltage, low-current system to supply the accelerating anode potential, and, in some applications, DC deflection potentials, for the cathode-ray or picture tube.

**LOW-VOLTAGE, HIGH-CURRENT POWER SUPPLY:** What might be termed the signal reception portion of the receiver, which includes sound and video amplifier or control tubes, presents a power requirement not greatly different in voltage range from that of other radio devices, and, therefore, this portion of the television receiver power supply system is very similar to those used in large radio sets.

In general, the voltage requirement is no more than the conventional 450-volt value. The current required, however, is frequently much greater than that necessary for radio operation:

and, in addition, there is also a necessity for rather good supply regulation. This need is occasioned by the operation of "sawtooth" oscillators for deflecting the electron beam of the cathode-ray tubes from this source. These oscillators tend to produce currents in the power supply system, which, if not properly filtered, would appear as serious modulation hum in the beam control and sound circuits.

It is not unusual to encounter power supply currents for the low-voltage application of as much as 300 milliamperes. Television receivers produced to date may employ from one to three rectifiers for this low-voltage, high-current supply, the number, of course, dependent upon the current requirement and the designer's preference as to voltage and current distribution. Thermionic and selenium rectifiers have been used up to this time in circuits which largely duplicate those for equivalent radio set power supplies, including full-wave transformer types and transformerless half-wave doubler designs.

Figure 29 provides schematic diagrams of representative low-voltage, high-current supply systems.

**HIGH-VOLTAGE, LOW-CURRENT POWER SUPPLIES:** The high-voltage supply differs considerably from the supply just discussed in that the current requirement is very small, usually in the neighborhood of 300 micro-

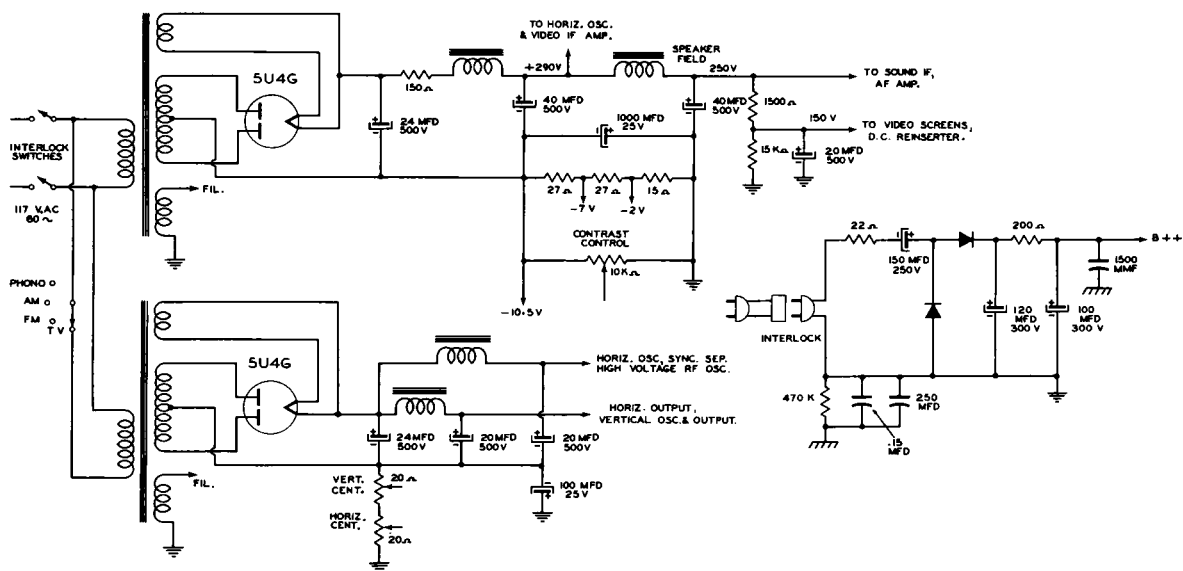

Fig. 29. Left - Low Voltage Transformer Type Supply. Right - Half-Wave Doubler Low Voltage Supply



## CATHODE-RAY TUBES -- BEAM FORMATION AND CONTROL

amperes, while the voltages employed may range to extremely high values, especially in television receivers using projection-type cathode-ray tubes. Receivers currently in production may use accelerating potentials from 3,000 to 30,000 volts.

**SAFETY PRECAUTIONS:** Since these high-voltage power supplies represent extremely dangerous shock hazards, perhaps it might be well to consider normal precautions to be followed in working with them.

First, locate your bench well away from metal objects, or wiring, which might provide an accidental contact to ground or a voltage source. Don't use metal bench tops. If you have a concrete floor, it is essential that it be covered with a substantial rubber mat, or other good insulating material, in an area sufficient to preclude any possibility of stepping off the mat during normal service operations. The mat isn't a bad idea even if you don't have a concrete floor.

Second, don't attempt high-voltage measurements unless they are actually necessary. It is the general opinion, on the basis of experience to date, that resistance measurements are adequate to identify power supply troubles in at least 90% of all failures.

In the event that it is necessary to measure high potentials, do so in the approved manner. With power switch off and plug disconnected, hook up the test lead to the ground or low potential side of the circuit. If a clip lead is to be used for connection to the high potential side of the circuit, make this connection with power off, using one hand only, so that if a residual charge remains there will be no possible circuit through the body. It is usually advisable to make sure that the high-voltage supply is completely discharged before making any connection to the television receiver.

If a probe-type instrument is to be used with the power supply operating, always use one hand only for placement of the probe to the test point. Keep the other hand in the pocket so that there is no possibility of contact with the result of establishing a circuit through the heart.

In other service operations, such as alignment, etc., it is advisable to disable the high-voltage circuit.

Try to detect the fault by individual component diagnosis. There are nine mental

operations to one manual operation in the testing of any electronic circuit. Think - then act! You owe it to yourself and your family to take all necessary precautions.

**TYPES OF HIGH VOLTAGE SUPPLIES:** At the time of going to press, there are four basically different types of high-voltage power supplies being used in commercial television receivers:

A. The conventional, or "brute force," 60-cycle half-wave power supply system.

B. The r-f power supply system which uses an r-f oscillator as a high frequency voltage source, steps up this voltage through a suitable RF transformer, and then rectifies it for application to the accelerating anodes.

C. The "horizontal flyback" or "kick-back" type high-voltage supply employing the pulse voltage generated by the collapsing field in the primary of the horizontal deflection transformer. This pulse voltage is stepped up, rectified, and supplied to the accelerating anodes.

D. The pulse-type power supply using a blocking oscillator whose pulses then trigger the plate current of a power tube. This sudden change of plate current is fed to a transformer, thence to a rectifier or a series of rectifier-doublers or triplers to produce the high voltage.

**"BRUTE FORCE" POWER SUPPLY:** Almost all pre-war and some post-war television receivers use the half-wave "brute force" power supply. In theory and operation, it is not essentially different from power supplies commonly used in ordinary radio receivers with the exception that the power transformer must be adequately insulated for high voltages. The half-wave circuit is employed for the obvious reason that through its use the high voltage transformer may be held to the lowest possible number of turns and smallest physical size. The fact that the filter must be effective for a 60-cycle hum or ripple, instead of the 120-cycle ripple of the full-wave supply, is not particularly bothersome since the current requirement is relatively small.

A schematic diagram of a representative "brute force" power supply appears in Figure 30. Note that this system employs one transformer to supply all voltages for receiver operation. Winding "A" supplies the heater current for the type 2X2 rectifier. Any tube used in this application must be capable of



capacitance in the circuit, which would result if a hand were inadvertently placed near it, will reduce the output of the oscillator and lessen the danger of a high-voltage shock. Nevertheless, all aforementioned precautions should be taken when making any voltage measurements and care should be taken not to get too close to the cap of the rectifier tube as a severe r-f burn may result.

The 8016 or 1B3GT tube, which is used as the rectifier, requires only one quarter watt of power for heating the filament and since this is only a small percentage of the power generated by the r-f oscillator, the filament voltage is taken from an additional secondary winding of one or two turns on the oscillator coil. Obtaining the filament voltage in this manner eliminates the need for a large iron-core transformer with high-voltage insulation.

Care should be taken that the position of this winding is not changed because any change in coupling would result in an increase or decrease in filament voltage. Since the voltage applied to the filament is r-f and there is no practical method of measuring its heating efficiency, a reasonably accurate check may be made by a visual comparison of the brilliance of the heater on a similar tube with its filament connected across a 1.6 volt dry-cell battery. The filament of the 8016 tube is quite easily paralyzed by a momentary overload and it is suggested that another tube be tried if trouble is suspected in the rectifier circuit.

Due to the frequency of the r-f voltage and the low-current drain (approximately 200 to 400 microamperes) on the power supply, a very small value of capacitance is required for filtering the output voltage. Likewise a large value of resistance up to 500K ohms may be used as a filter, further lessening the chance of a lethal shock.

This power supply has good regulation and there is no need for additional voltage regulation circuits. Even with a varying current from 0-200 microamperes, occurring as the electron beam in the tube is modulated, there is less than 5% fluctuation in voltage, which is a permissible range.

A schematic of an RF High-Voltage power supply is shown in Figure 32. A type 12A6 tube, connected as a triode, is used as the oscillator, feedback being obtained from a tickler winding in the grid circuit. The voltage is stepped up in the secondary winding and fed to the plate of the rectifier tube, rectified and

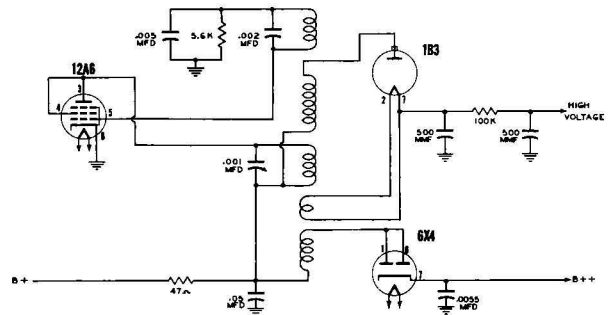

Fig. 32. RF Oscillator-Rectifier High Voltage Supply System

filtered. This particular receiver has an additional secondary winding which is connected to the plate of the 6X4 rectifier tube, providing additional "B" plus voltage for use in the vertical and horizontal sweep generators.

Although most receivers employ a tickler winding for obtaining a feedback to sustain oscillations, another method in use eliminates the need of a separate winding on the transformer. Feedback is obtained through capacitive coupling to the plate of the rectifier by placing a spring around the rectifier tube at the exact position giving correct feedback. The position of this spring is critical and instructions for positioning it should be followed closely.

RF power supplies should be shielded to prevent radiation into the receiver. Such radiation causes "birdies" in the sound channel and r-f bars to appear on the screen. This shield also gives protection against shock.

Figure 33 shows a typical complete RF high-voltage power supply system.

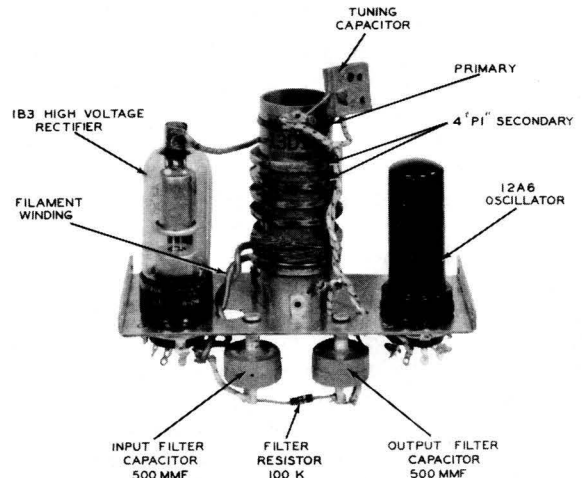

Fig. 33. Typical RF High Voltage Supply (Shield Cover Removed)

**HORIZONTAL FLYBACK HIGH VOLTAGE SUPPLY SYSTEMS:** This method of obtaining high voltage makes use of the high-voltage pulse created in the plate circuit of the horizontal amplifier during retrace time. In using this system, relatively few additional components are required beyond those that would normally be necessary, since all magnetically deflected receivers make use of a matching transformer between the horizontal output and the horizontal deflection coil.

Another reason for employing this system is that it guards against modulation of the video signal by stray energy from the high-voltage supply, since the screen is blanked out during the retrace time.

The addition of two windings to the horizontal matching transformer makes possible the use of this system. When the quick collapse of plate current through the horizontal deflection amplifier takes place, due to the sawtooth of voltage on its grid, the primary winding, which is part of the plate circuit of the horizontal deflection amplifier, will have produced across it a relatively high pulse voltage because of self induction.

By adding an auto-transformer winding to the primary of this deflection transformer, the pulse voltage may be stepped up to any desired value. This high voltage is then fed to the plate of a hot cathode type rectifier, rectified and filtered, and becomes the high accelerating potential for the picture tube.

The second additional winding on this transformer consists of one or two turns, which provide the filament power for the rectifier tube. This is possible since the current requirements of the particular tube developed for this purpose is low.

Figure 34 shows a representative Horizontal Flyback System.

The transformer itself is of unique design employing pressed powdered iron in the form of a shell about the windings. It is possible to use powdered iron for this transformer since the horizontal scanning frequency is 15,750 cycles per second. The time of one cycle is, therefore, approximately 63 microseconds. Of this, 53 microseconds are used up in the forward scan and the remaining 10 are employed for flyback and starting the next horizontal line.

The transformer resembles a design which one would expect for the handling of power at low radio frequencies. The windings are of the universal type and are well impregnated. The parts of a typical horizontal flyback transformer are shown in Figure 35. Since the frequency is high and the current drain low, the filtering required on this high-voltage supply is very small. Actually, the output filter capacity is often realized by using the capacity between the outer and inner layers of aquadag coating on the picture tube.

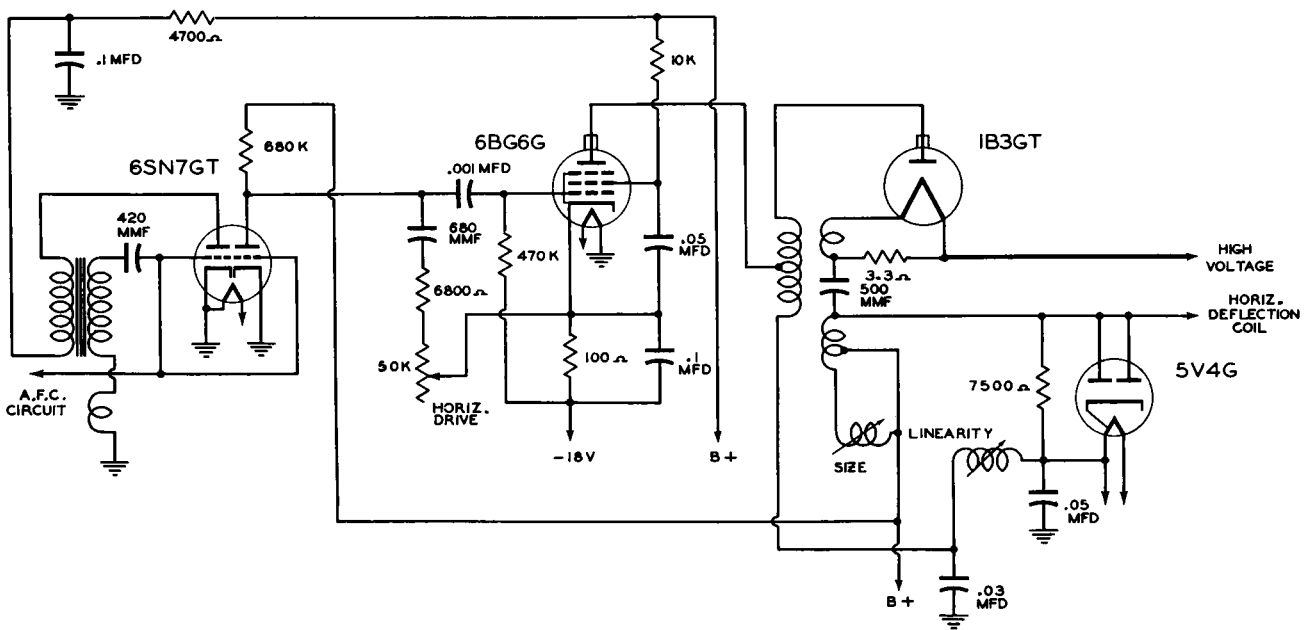

Fig. 34. Horizontal Flyback High Voltage System

CATHODE-RAY TUBES -- BEAM FORMATION AND CONTROL

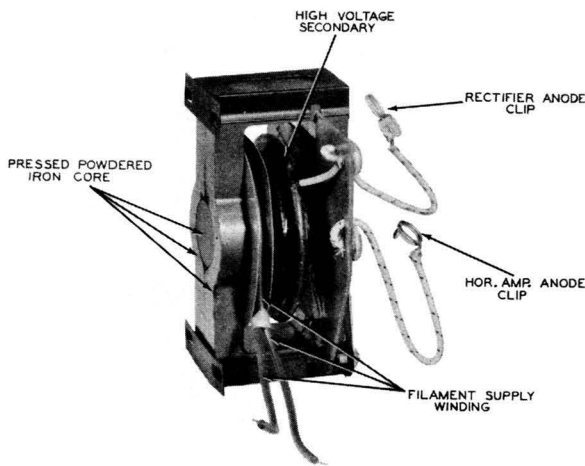

Fig. 35. Typical Horizontal Flyback Transformer (Photo from Sample Courtesy RCA)

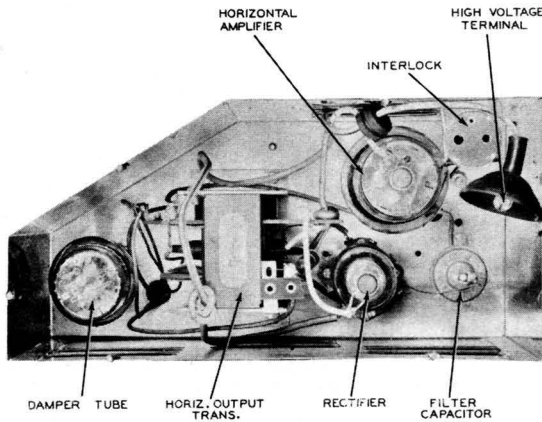

Fig. 36. Typical Horizontal Flyback High-Voltage Assembly. (Photo from Sample Courtesy Emerson Radio and Phono. Corp.)

Figure 36 is a photograph of a complete Horizontal Flyback High-Voltage System.

**PULSE TYPE HIGH-VOLTAGE POWER SUPPLY:** A second method has been developed for generating the high voltage during the horizontal retrace time. This system uses essentially the same type of transformer and rectifier as discussed under "Horizontal Flyback High-Voltage systems," except the transformer has no secondary deflection coil winding. It derives its pulse voltage from a blocking oscillator, which is triggered by the horizontal flyback decay. These oscillations are then amplified and fed to the primary of an auto-transformer whose output is connected to the plate of the rectifier. Voltage regulation is usually obtained by controlling the amplitude of the pulse fed to the rectifier. A typical schematic of this type system is shown in Figure 37.

In this application, a portion of the high DC voltage output is fed to the grid of half of the 6SN7, which has a type VR105 in its cathode circuit. The plate current of the 6SN7 is drawn through the 15K ohms screen-dropping resistor of the type 807 amplifier stage. A change in plate current will change the screen voltage of the 807, thus regulating the amplitude of the pulse supplied to the auto-transformer.

**HORIZONTAL FLYBACK SYSTEM FOR PROJECTION TELEVISION USING VOLTAGE TRIPLERS:** In the systems previously described, a single rectifier tube was employed to obtain voltages ranging up to 10,000 volts. Projection tubes require potentials of between 25,000 and 30,000 volts, and such voltages

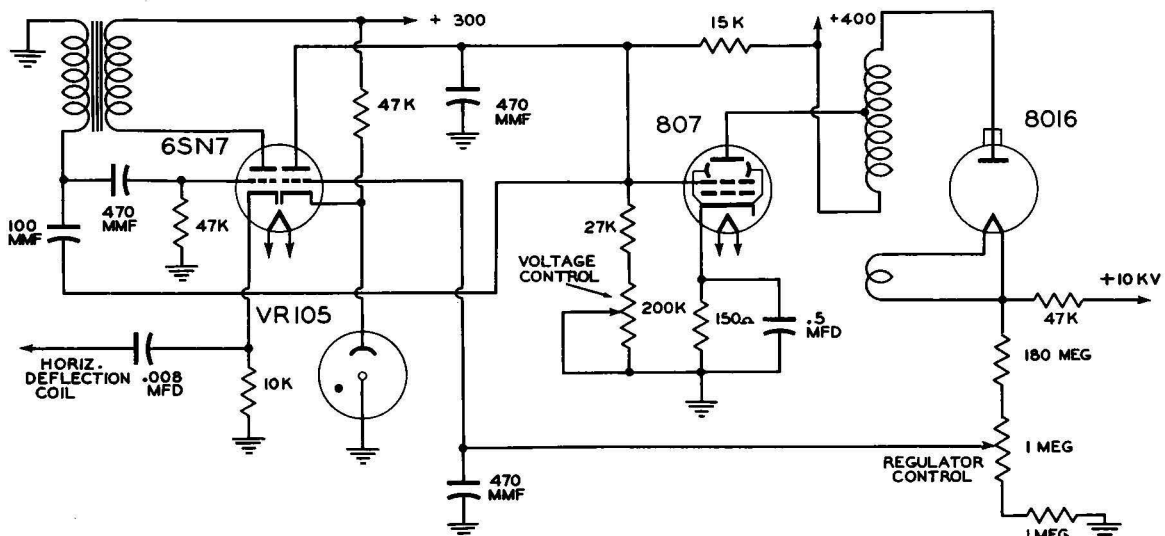

Fig. 37. Pulse Type High-Voltage Power Supply



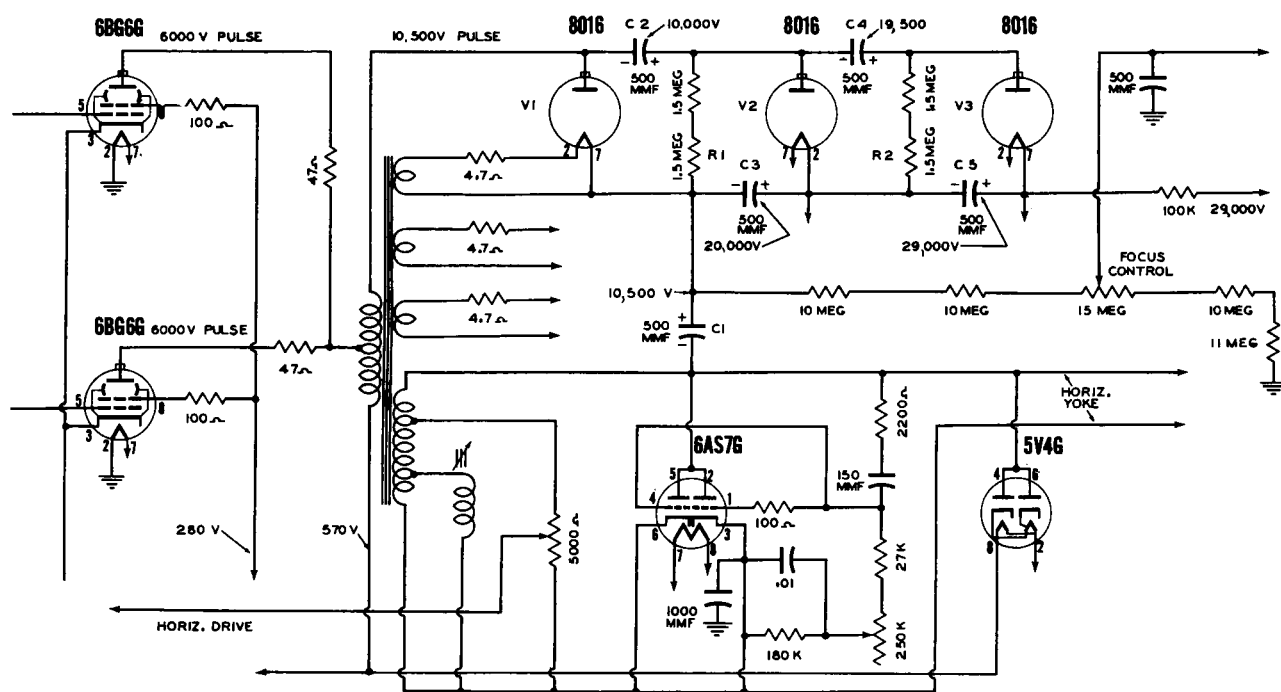

Fig. 38. Horizontal Flyback High-Voltage Tripler

cannot be obtained readily by single rectifiers due to limitations of the tubes themselves. To overcome this difficulty the power supply systems for projection tubes employ a principle of voltage multiplication in which a number of capacitors are individually charged to the peak voltage of the system through respective rectifier tubes associated with the capacitor.

Figure 38 shows a power supply of this type.

The transformer is similar in design to the one already described and illustrated in Figure 35, but differs in that it has three filament windings for three individual type 8016 high-voltage rectifier tubes.

Another difference in this system is the use of two horizontal output tubes, type 6BG6G, connected in parallel to provide the additional energy required.

The diagram shows a "ladder" arrangement of rectifier tubes, condensers and resistors to accomplish this voltage multiplication. This circuit is somewhat different from the familiar "common line" type of voltage doubler or tripler, in that the individual capacitors need a voltage rating no greater than the peak supply voltage, whereas, in the familiar multiplier circuits, the voltage ratings increase in each stage.

The voltages shown on the diagram are measured from ground. The operation of the circuit is as follows:

A pulse produced across the primary of the transformer is applied to tube V1, and the rectified current of this tube charges capacitor C1 to approximately peak value of the pulse. In the interval between pulses, capacitor C1 discharges into capacitor C2 through resistor R1. Since rectifier tube V2 is conductive in the proper direction, capacitor C3 is charged by capacitor C2. Capacitor C3 can then charge capacitor C4 through resistor R2. The final step of the multiplication consists of the charge of capacitor C5 through rectifier tube V3 from the charge existing in C4.

This series of events will require a number of cycles of operation of the horizontal oscillator for each of the capacitors to assume their final charges. When a steady state condition is reached, the charge across each of the capacitors in this group will be approximately the peak voltage of the supply system. Capacitors C1, C3 and C5 in series provide the output voltage used for the accelerating voltage of the projection tube.

Another pulse-type high-voltage supply, which was developed in Holland and recently introduced in this country, is shown in Figures 39 and 40.

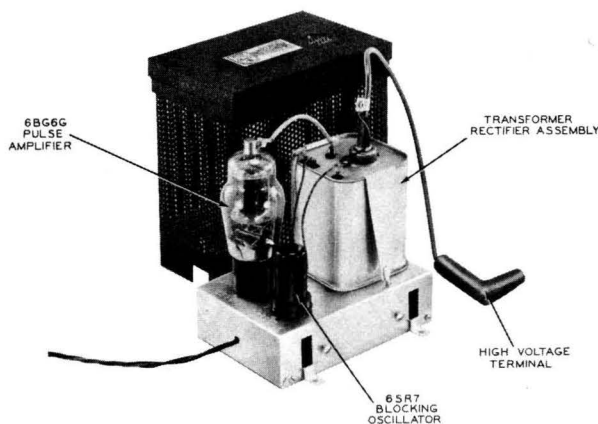

Fig. 39. Pulse Type High-Voltage System. (Hallicrafters-Norelco) Photo Courtesy North American Phillips Company, Inc.

It is an entirely self-contained unit measuring 8-1/2x7x4-1/2 inches, which can be mounted adjacent to the projection tube and supplied with heater and plate voltages from the television chassis by a three-lead cable.

While a total of five vacuum tubes is used in this system, only two of the tubes can be seen upon removal of the perforated cover. The other three tubes are specially designed, miniature-size rectifiers and are hidden from view in the sealed, oil-filled, transformer assembly. The circuit components comprising the assembly are shown enclosed by dotted lines in the schematic diagram Figure 41. The

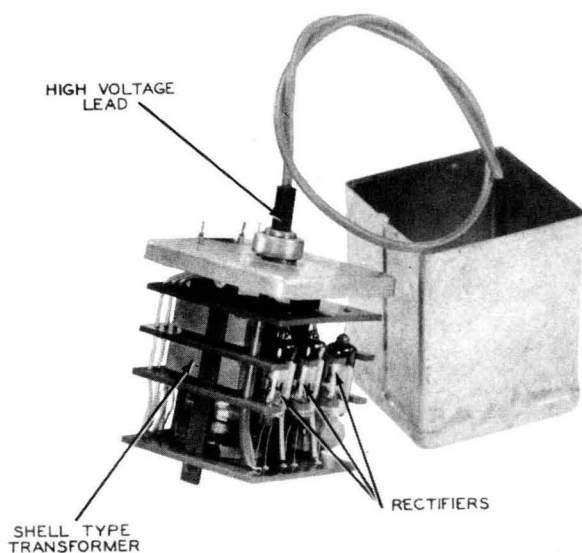

Fig. 40. Transformer-Rectifier Assembly with cover removed. (Hallicrafters-Norelco) Photo Courtesy of The Hallicrafters Company

photograph in Figure 40 shows this unit with the can removed.

The circuit shown in Figure 41 comprises a blocking-type oscillator employing the triode section of a 6SR7 to produce a "sawtooth" voltage whose frequency is approximately 1000 cycles per second. This waveform, represented by  $V_g$  in Figure 42, is coupled to the grid of the 6BG6G power amplifier, which is biased beyond cutoff by a combination of cathode self bias and an additional voltage from an automatic regulating circuit to be described later. Plate current,  $I_p$  in Figure 42, in the 6BG6G tube flows only for a short portion of the positive peak of the sawtooth wave applied to the grid. This positive excitation is made sufficiently great to cause plate current pulses almost equal to the maximum emission of the tube. These pulses of plate current flow through part of the primary of an iron-core transformer. The current in the transformer is represented by  $i_L$  in Figure 42. Note that the current waveform across the transformer at the time of conduction of the 6BG6G contains no oscillatory component. However, when the tube is cut off, the field generated by the plate current in the transformer collapses. Since the tube is now cut off, there is no heavy damping, due to plate current flow, and the coil will start oscillating at its natural resonant frequency. This resonant frequency is governed by the inductance in the transformer and the distributed capacity in the transformer and associated circuits. The resonant frequency of this particular supply is approximately 30KC. These 30KC oscillations, shown in the  $i_L$  waveform of Figure 42, will continue oscillating until plate current is drawn through the winding. This heavy current flow completely damps out the oscillations and another cycle is started. Note that at the time the oscillatory circuit is free running, the oscillations are damped. This is due to the loading of the rectifier filament windings and the losses in the transformer.

The voltage is stepped up by auto-transformer action and applied to the rectifiers. The waveform of this voltage is shown in  $V_o$  of Figure 42. Since the high voltage is additive to the  $B+$  supply, represented by  $V_b$ ,  $V_{max}$  is equal to the peak voltage plus  $V_b$ .

The first positive oscillation peaks, which are approximately 8,500 volts, charge the capacitor  $C_1$ , through  $V_1$ , to peak voltage. When the oscillation peaks are negative, the voltage across  $C_1$  (negative on the lower plate) is

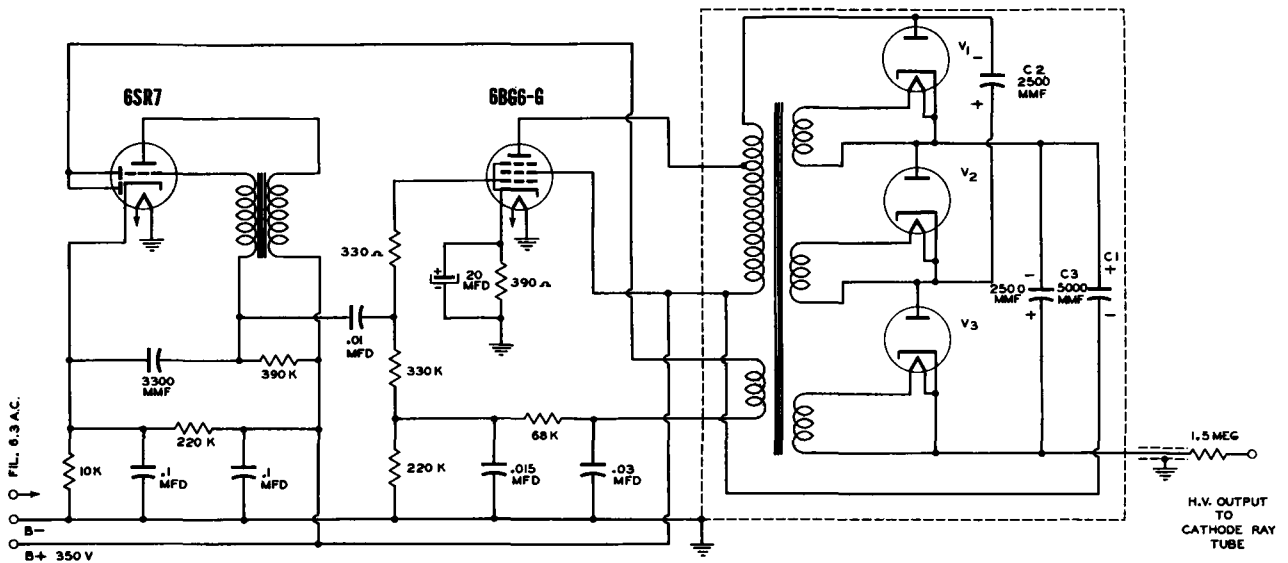

Fig. 41. Schematic Diagram of Hallicrafters-Norelco High Voltage Power Supply

additive to the peak voltage of the source, and C2 is charged to two times the peak voltage through V2. On the next positive peaks, the conductive path will be through C1, the source, C2 and V3. Since the voltage across C1 is equal to the source and of opposite polarity, C3 will charge to a peak voltage equal to that of C2. It can now be seen that voltage across C1, which is peak voltage, and the voltage across C3, which is two times peak voltage, are of the correct polarity to be additive and result in an output equal to three times peak voltage.

The additional feedback winding, mentioned previously, provides an ingenious method of improving the voltage regulation of the system. Normally, a power supply system is improved in regulation by reducing its internal resistance and providing more storage of energy by increasing the capacity of the filter capacitors. Both of these expedients tend to increase size, weight, and cost, and in a high-voltage system has the additional disadvantage of making the device more dangerous from the standpoint of electrical shock.

The voltage from this fourth winding is fed back to the diode plates of the 6SR7 blocking oscillator tube. The rectified current from these diodes passes through a filter network and is added to the bias of the 6BG6G amplifier tube. Thus, when the voltage of the system tends to drop due to greater output load, the bias of the amplifier tube is made less negative and the duration of the pulse is increased. This tends to increase the output.

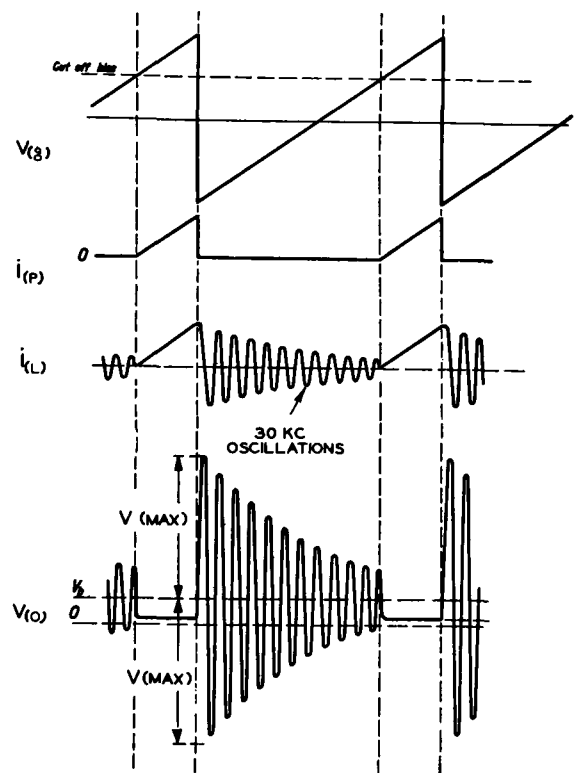

Fig. 42. Voltage and Current Waveforms - Pulse Type Power Supply

With constant input supply voltages to this power pack, the output voltage is 25,500 volts plus or minus 2,000 volts at no load, and drops less than 600 volts at a load of 60 microamperes and less than 1,200 volts at a load of 125 microamperes.

## SECTION II CATHODE RAY — BEAM DEFLECTION SYSTEMS

### CHAPTER 5. RESISTANCE-CAPACITANCE (RC) CIRCUIT CHARACTERISTICS

#### RC CIRCUITS

The elements in a cathode-ray or picture tube provide an emitter or source of electrons, a means of forming an electron beam and accelerating its speed, and a phosphor surfaced screen which will fluoresce or glow when bombarded by the stream of electrons. They also provide for the movement of the beam horizontally and vertically to form a frame of light, or raster, on the face of the picture tube.

The voltage or current waveforms which are required for deflecting the electron beam are obtained from sweep generators which are followed by special wave-shaping circuits. The sweep generators are triggered by the synchronizing pulses which are clipped from the transmitted signal. This makes possible the synchronization of the sweep circuits in the receiver with those of the transmitter. The formation of certain waveshapes is required in order to obtain a linear sweep. This waveshape may be a sawtooth, as is required for electrostatic deflection, or a more complex voltage waveform used to obtain a sawtooth current flow in magnetic deflection coils. Some circuits are designed to pass a waveform with a minimum of distortion, while others are designed to effect great distortion when generating, amplifying, or passing a waveform. The behavior of these distortion circuits can best be understood by studying a charging or discharging capacitor in series with a resistor.

It is elemental in radio theory that when electrons flow through a resistor, a voltage or IR drop is developed across that resistor.

The value of voltage developed by a current flowing through a resistance is found by applying Ohm's law:

$$E = I \times R$$

where E is in volts, I in amperes, and R in ohms.

A further study of fundamentals reveals that a capacitor is capable of storing or holding a charge of electrons. When charged, one plate contains more free electrons than the opposite plate; when the capacitor is completely discharged, both plates contain the same number of free electrons. The difference in number of electrons is a measure of the charge that exists across the capacitor. When the accum-

ulation of electrons on one plate exceeds the accumulation on the other plate, a potential difference exists across the terminals of the capacitor, and this potential will continue to increase until it equals, for practical purposes, the applied or charging voltage. The value of voltage developed by a charging capacitor is computed by applying the following equation:

$$E = \frac{Q}{C}$$

where Q is in coulombs, C in farads, and E in volts. One coulomb is the quantity of electrical charge transferred if one ampere flows for one second.

**R-C CIRCUIT CHARGING:** A capacitance and a resistance employed in a voltage divider circuit, as shown in Figure 43, develop a pressure or potential across their respective terminals. This circuit is commonly known as an R-C circuit, to which both Kirchoff's and Ohm's laws apply. Referring to the graphs and diagram in Figure 43, the voltage divider AB of the circuit diagram is shown in various time positions on the graph after closing the switch. As time progresses, the voltage  $E_c$  on the capacitor gradually increases, while the voltage developed across the resistor  $E_r$  gradually decreases.

When the switch is closed, electrons are displaced from the upper plate of the capacitor, thus developing a positive charge causing electrons to be attracted to the lower plate through

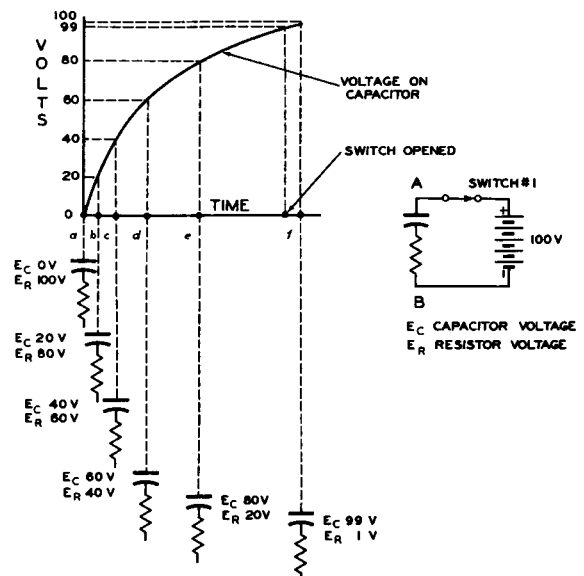

Fig. 43. Resistor-Capacitor Charging Curve

the resistor. This flow of electrons is the current that charges the capacitor. At the instant the current begins to flow, no charge is present on the capacitor, as seen at point "a" on the graph; therefore, the applied voltage E across the divider must all appear as a voltage drop across the resistor. The initial charge current, therefore, must be equal to  $\frac{E}{R}$ .

In recalling Kirchoff's law, it states that the sum of the voltages in a closed circuit is equal to zero. Likewise, the sum of the voltage drops in a closed circuit must equal the applied voltage. Therefore, if 100 volts is applied to an R-C circuit, this entire voltage appears across the resistor at the time the switch closes. The graph shows that at the instant the switch is closed, the entire applied voltage appears across R, while the voltage across C is zero.

However, the current flowing in the circuit soon charges the capacitor a small amount, and a voltage will appear across this capacitor. See position "b" of the voltage divider plotted on the graph. Note:  $E_c$  is now 20 volts and  $E_r$  is 80 volts, the sum of the two being equal to the applied voltage. As time elapses,  $E_c$  becomes greater and  $E_r$  smaller, as will be noted at the time points "b", "c", "d", "e", and "f". Actually, the capacitor voltage becomes a re-active voltage, or back pressure (opposite in polarity and opposed to the applied potential). This causes the charging current to decrease and the IR drop across the resistance to fall, resulting in the capacitor charging at a slower rate.

This charging action continues until the capacitor is almost fully charged. At this time, the voltage across R must be near zero, and the charging current is practically zero. Theoretically, a capacitor never fully charges, and some minute voltage will always appear across the resistor. However, if the switch is closed long enough, an almost steady state condition is reached and the capacitor is considered fully charged for all practical purposes.

Charging a capacitor electrically can be likened to inflating a flat tire where a current of air first rushes into the inner tube and gradually tapers off as the tire becomes inflated. The current of air flowing into the tire from the compressor sometimes rings a bell. At first the bell rings in rapid succession, but gradually slows up as the tire builds up a back pressure.

**R-C CIRCUIT DISCHARGE:** Suppose that, just before point "f" on the charging curve, the

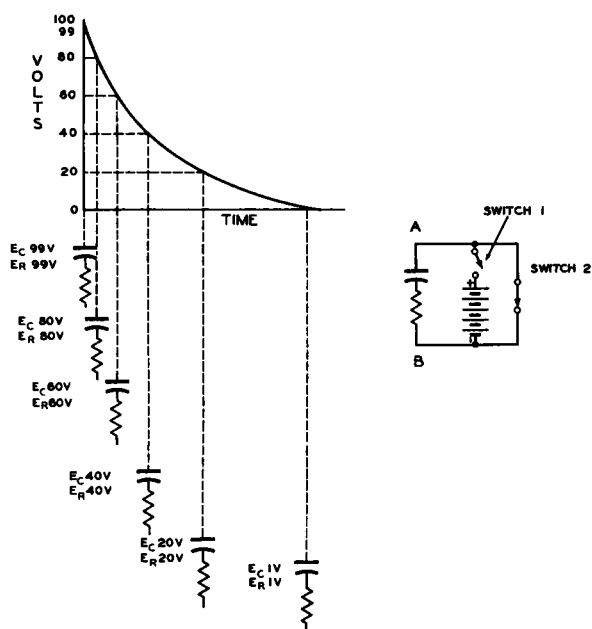

Fig. 44. Resistor-Capacitor Discharging Curve

charging switch is thrown open and the discharging switch closed, as shown in Figure 44.

Note that the capacitor voltage reached a value of 99 volts. This value would have been slightly higher if the charging circuit had been left closed for a longer period of time. In Figure 44, the battery switch is open and a short circuit path is switched across the divider. The 99 volts of potential energy stored by the capacitor now becomes an applied voltage of the discharge circuit and will cause a current to flow around the circuit. The discharge current will be opposite in direction to the charging current, developing an IR drop across the resistor. The voltage drop across the resistor, due to the discharge current, will be opposite in polarity to that developed by the charging current. The discharge curve will vary exponentially in exactly the same manner as the charge curve, but will be diminishing in value.

During discharge, the capacitor voltage is shown dropping from its initial value, and, representing the applied voltage of the discharge circuit, will be equal to the voltage drop across the resistor (Kirchoff's Law). Seeing that the capacitor voltage now represents the applied voltage of the discharge circuit,  $E_c$  and  $E_r$  will slowly approach zero together. (The plotted charging curve is not linear throughout. However, the initial charge portion of the curve, Figure 43, is practically straight up to 40 volts, and it is this portion of the curve that we will be more concerned with in television

# CATHODE-RAY - - BEAM DEFLECTION SYSTEMS

sweep circuits because of this linearity. This is the most important point of the discussion and should be borne in mind for future reference.) Also note that the capacitor voltage does not reverse in polarity during the charge and discharge cycle. This is not true in the case of the resistor voltage because the current actually reverses its direction between the charge and discharge period.

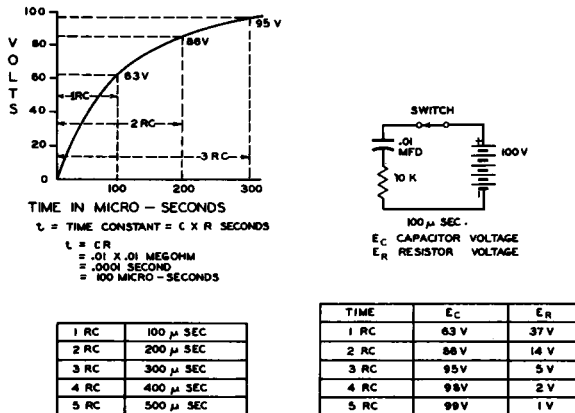

Fig. 45. R-C Time Constants

**TIME CONSTANTS OF AN R-C CIRCUIT:** The diagram in Figure 45 shows an R-C circuit connected across an applied voltage. The time required to charge the capacitor to 63.2% of the applied voltage is known as the time constant of the circuit. The value of this time constant in seconds is equal to the product of the circuit resistance in ohms and the capacity in farads, and may be found by using any of the following relations:

1. R (in ohms) x C (in farads) = t (in seconds)
2. R (in megohms) x C (in microfarads) = t (in seconds)
3. R (in ohms) x C (in microfarads) = t (in microseconds)
4. R (in megohms) x C (in micro-microfarads) = t (in microseconds)

**EXAMPLE:** A 0.1 microfarad capacitor in series with a 100K ohm resistor will take .01 of a second or 10,000 microseconds to reach 63.2% of the applied voltage.

Referring to Figure 45, a .01 mfd. capacitor is in series with a 10K ohm (.01 megohm) resistor.

Now, we find from the above table that multiplying microfarads by megohms will give an R-C time constant of .0001 seconds or 100 microseconds for this circuit.

Therefore, we interpret from the time constant that when 100 microseconds has elapsed since switching on, 63.2% of the applied voltage is across the capacitor and 36.8% across the resistor.

The applied voltage being 100 volts, the capacitor charge will be approximately 63 volts and the IR drop across the resistance, due to the charging current, will be approximately 37 volts.

In twice the R-C time, or 200 microseconds, 63.2% of the remaining 37 volts is added to the original 63.2% charge, making approximately 86 volts across the capacitor and 14 volts drop across the resistor.

200 microseconds = 2RC = 63 volts + (63.2% x 37) = 86.4 volts. This value may be found by following the  $E_C$  curve in Figure 45.

Theoretically, the capacitor never reaches a fully charged condition; but at the completion of 5 R-C seconds, approximately 99% displacement of voltage across the circuit has occurred and for all practical purposes, this is sufficient to be considered as full charge. Refer to chart in Figure 45.

**DISCHARGE:** The time required to discharge a capacitor is the same as that required in charging. Therefore, the time constant (R-C) is proportional to the time required to charge or discharge a capacitor.

In 1 R-C time of the discharge period, 36.8% of the original charge will remain in the capacitor. The charge and discharge curves are shown in Figure 46. Note the similarity; exponentially they are the same.

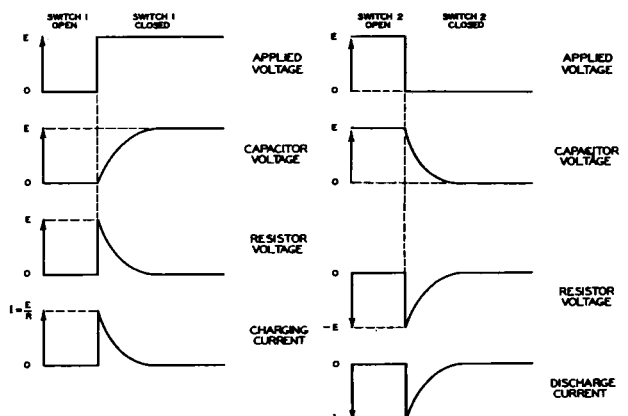

Fig. 46. R-C Charge and Discharge Curves



**FORMATION OF SQUARE AND SAWTOOTH WAVES:** If a source of DC voltage connected to a resistive load is switched on and off in equal alternate periods, the applied electrical pressure across the resistor will take the form of a symmetrical square-wave of voltage - see Figure 47.

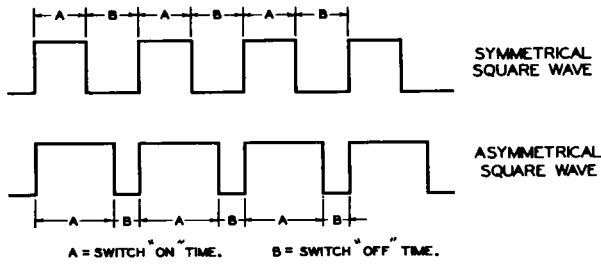

Fig. 47. Square Waveforms

On the other hand, if the circuit is switched on and off in unequal alternate periods, the applied voltage to the load would appear as an asymmetrical square-wave - see Figure 47. Therefore, by mechanically operating an on-and-off switch, we are able to generate two types of voltage wave forms. They are:

1. Symmetrical square-wave of voltage.
2. Asymmetrical square-wave of voltage.

Now, if a fairly large capacitor is connected in series with the resistor, and a DC source of supply is switched on and off in equal time periods to produce an applied square-wave of voltage, the resistive and capacitive components of the circuit will produce the following wave-shapes.

1. The capacitor voltage, known as the "integrator" voltage, will appear as a back-to-back sawtooth - see Figure 48.

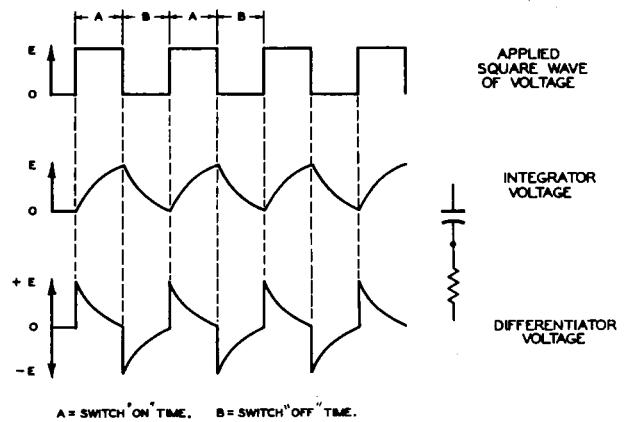

Fig. 48. Application of Square Wave of Voltage to R-C Circuits

2. The voltage drop across the resistor, known as the "differentiator" voltage, will appear as a partially distorted square-wave - see Figure 48.

**NOTE:** The polarity of the integrator voltage is unchanged during the charge and discharge period, while the differential voltage is driven in two directions: i. e., positive and negative.

By increasing or decreasing the value of the capacitor in the RC network, the integrator and differentiator voltage waveforms are changed, as shown in Figure 49.

Note that the output waveforms for the 100 microsecond circuit are similar to the ones shown in Figure 48. When the capacitor is increased in value to give a time constant of 1000 microseconds, only a slight voltage is obtained across the capacitor, while the voltage across the resistor is distorted very little from the applied waveform. On the other hand, when the value of the capacitor is reduced to

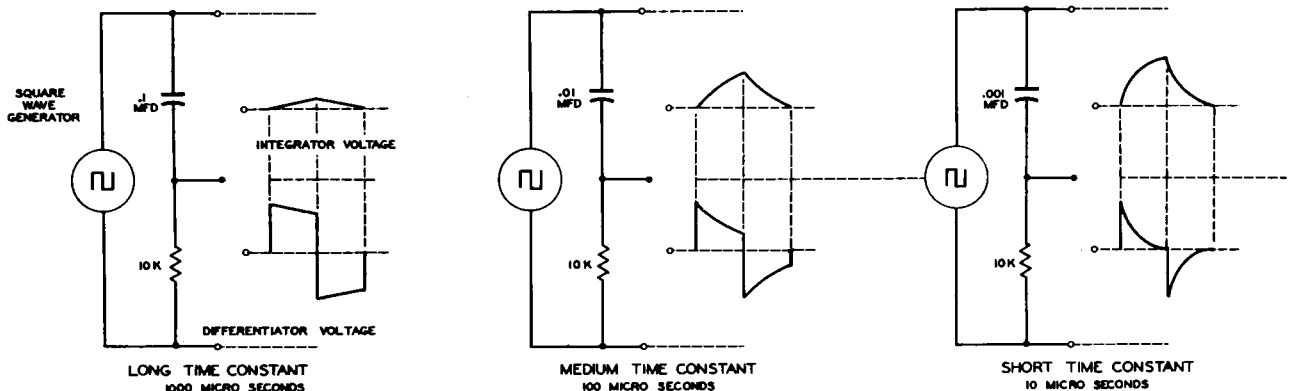

Fig. 49. Examples of Time Constants and their R-C Waveforms

give a time constant of 10 microseconds, the voltage waveform across the capacitor is similar to the applied voltage, while the waveform across the resistor is differentiated a great amount, giving very sharp positive and negative peaks. Keeping in mind that the waveforms applied to each of the circuits in Figure 49 are identical as to frequency and amplitude, it can be seen that a square wave can be differentiated or integrated a variable amount to give the desired wave-shape by properly selecting the values in the RC circuit.

At this point we are interested in the integrator voltage; so, advancing still further in the study of wave-shapes and circuit analysis, let us refer to Figure 50.

Here we have a circuit arrangement where a capacitor is permitted to charge through a 10K ohm resistor, and by throwing a switch the capacitor is discharged through a 1K ohm resistor. If the charge time is longer than the discharge time, for instance, let us say 10 times longer, the charge and the discharge voltage of the capacitor will take the form of a sawtooth of voltage. See Figure 51.

The slow charge and the rapid discharge effects can be clearly seen. To obtain linear

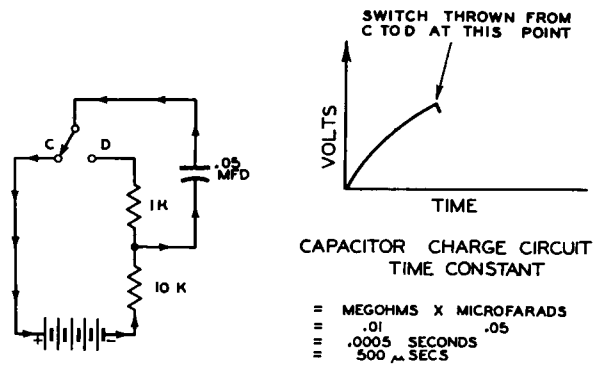

Fig. 50.

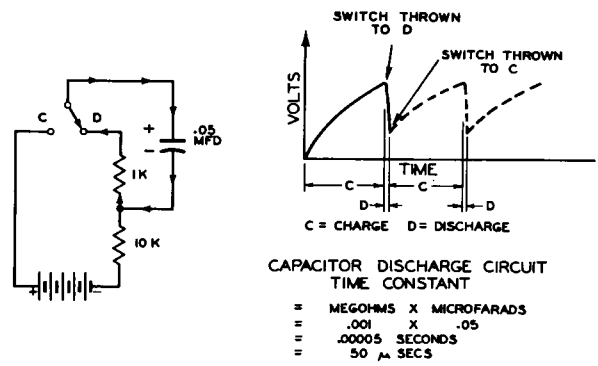

Fig. 51.

horizontal and vertical scanning for building a frame or raster, it is necessary to generate and apply linear sawtooth waves to the deflection systems of the cathode-ray tube.

## SECTION II CATHODE RAY — BEAM DEFLECTION SYSTEMS

### CHAPTER 6. SAWTOOTH GENERATORS

Generally, production of a sawtooth wave involves the charge and discharge of a capacitor through resistors which differ greatly in size between the charge and discharge circuits. An introduction to this concept has been covered under the heading of R-C Circuits (pages 34 to 38). It has been shown that, to produce a sawtooth waveform, we need a simple circuit consisting of a source of voltage, a single pole-double throw switch, resistors and a capacitor. The capacitor is charged through a high value of series resistance. The voltage across the capacitor at any instant of time has been shown in Figure 43. It will be noted that the initial portion of this voltage-time curve is essentially a straight line. If we can short-circuit the capacitor before extreme curvature of the charge-time has occurred, and immediately initiate another charging cycle, we have produced a sawtooth wave. This sequence of events could be accomplished by the use of a mechanically operated switch. (See Figure 51.) Since this entire operation must occur in a few

millionths of a second, it is obvious that the use of such a mechanically operated switch is impractical. For this reason we will resort to some of the properties of electron tubes to accomplish the switching sequence.

While modern television receivers employ vacuum tube oscillators and vacuum tube wave shaping circuits to accomplish the production of the ideal sawtooth scanning motion previously described, it will be instructive to examine the earlier forms of circuits employed. These methods are no longer used in television sets, but they are undoubtedly familiar since their application is still common in the cathode-ray oscilloscope.

**NEON TUBE RELAXATION OSCILLATORS:** The familiar neon gas-filled tube, employed in sign lighting, is one of the simplest automatic switches for the purpose of short-circuiting the capacitor at the proper instant to produce a sawtooth voltage wave. A gas-filled tube hav-

ing a pair of electrodes and connected to a source of electrical potential exhibits interesting properties as the voltage across the electrodes is gradually increased. No electrical current will flow through such a tube until the voltage reaches a value known as the "ionization potential". The tube, until this voltage has been reached, has acted as an open circuit or as an extremely high resistance. However, when the ionization potential has been reached, the pressure, or voltage, tears electrons from the atoms of the gas and leaves such stripped atoms with a positive potential. Under this set of conditions the free negative electrons are rapidly collected by the positive electrode, the positively charged atoms are correspondingly attracted to the negative electrode and current passes through the tube. The resistance of the tube suddenly changes and it can be considered as a voltage operated switch. Figure 52 shows the method of using such a gas-discharge valve as a switch across a capacitor.

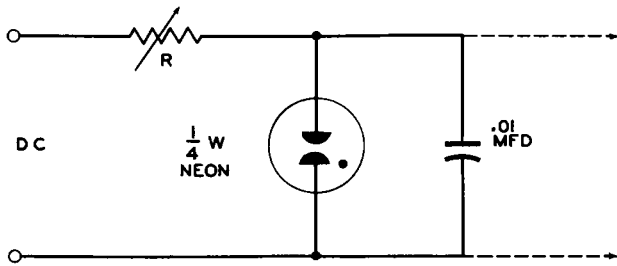

FREQUENCY OF SAWTOOTH WAVES MAY BE VARYED BY VARYING RESISTOR "R".

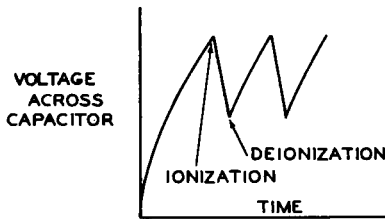

Fig. 52. Neon Tube Relaxation Oscillator

It will be seen that when the charge in the capacitor has produced a voltage across the tube equal to its ionization potential, the tube will suddenly conduct and start to discharge the capacitor. An interesting property of the tube, is the fact that once conduction of current has started it will continue even though the voltage has dropped below the original ignition point. Current will continue to flow until a lower level of voltage, known as the de-ionization potential, is reached. At this point the atoms of the gas regain their free electrons

and the tube returns to its non-conducting condition.

The charging cycle from the voltage source through the series resistor is resumed and the cycle continues until ionization again occurs. This sequence of events is shown diagrammatically in Figure 52. Such an automatically operated switching circuit is known as a relaxation oscillator because during the periods between its trip-over action the circuit is under normal (or relaxed) charging condition.

**THYRATRON RELAXATION OSCILLATORS:**

The negative grid-controlled thyatron is an improved form of gas-discharge tube. Such a tube is essentially the same in action as the simple neon lamp previously described, with the following exceptions:

1. A source of electrons in the form of an electrically heated cathode, supplies the electrical current for the discharge portion of the cycle.
2. The trip-over, or triggering action, is under the control of an additional element similar to the grid of the familiar radio vacuum tube. This element is normally held at a negative potential and prevents current conduction between the cathode and plate, or anode, by its repelling action on the electrons emitted by the cathode.
3. The gas normally employed is not neon but preferably mercury or argon.

A relaxation oscillator can be built with this tube and its action is more easily controlled than that of a simple neon gas tube. Figure

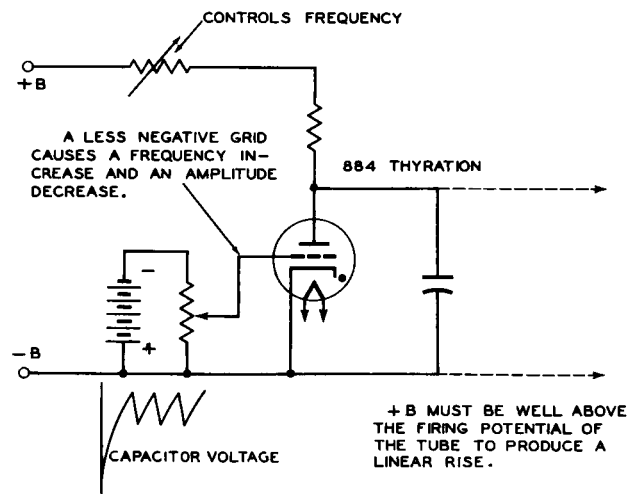

Fig. 53. Thyatron Relaxation Oscillator

53 shows the basic circuit of a thyratron sawtooth generator. In order to assure that the rise of the charging potential is linear, only a small portion of the plate or "B" voltage is allowed to charge the capacitor. The grid is held at a sufficiently negative potential to insure that there is no plate current. In the diagram this grid potential is provided by a bias battery. Trip-over of the circuit can be produced by a positive pulse of voltage applied to the grid. Once initiated, plate current will flow until the plate voltage has dropped to a point which corresponds to the de-ionization potential as described in connection with the neon oscillator.

A circuit of this type is frequently employed in cathode-ray oscilloscopes and has also been used in pre-war television sets both in this country and abroad. Post-war receivers no longer employ gas tube relaxation oscillators due mainly to the fact that such oscillators are not sufficiently reliable in operation with fluctuating power line voltage, temperature and time.

**VACUUM TUBE SAWTOOTH GENERATORS.** We have seen that the requirements of a device to produce a sawtooth voltage waveform are basically those of applying a voltage to a capacitor through a series resistance and after the capacitor has reached a pre-determined charge, removing the voltage by a virtual short-circuit. This order of events can readily be accomplished by high vacuum type tubes rather than gas tubes.

In general, modern television sets have employed three distinct types of circuit arrangements, or combinations of these circuits, to produce sawtooth waveforms.

1. The multivibrator. This circuit arrangement admits of many variations, the most popular of which is the cathode-coupled version.

2. The blocking oscillator. This type of circuit permits the formation of a short-time interval pulse of energy which can be used to produce the sawtooth wave across a capacitor directly associated with the oscillator tube, or can employ the pulse to trigger a "discharge" tube which acts as a switch across the capacitor.

3. The sine-wave oscillator. An oscillator of the correct frequency supplies the

timing voltage for the discharge tube and has sine-wave output modified to the form of short-time pulses by intermediate or wave-shaping circuits. These pulses are then used to operate a discharge tube to produce sawtooth waves.

**THE MULTIVIBRATOR CIRCUIT.** One of the most popular of television scanning generator circuits is the multivibrator. This is another form of relaxation oscillator which employs vacuum tubes, resistors and capacitors in a feedback arrangement.

The multivibrator derives its usefulness from the fact that tubes can be made to act as automatic switches to control the charge and discharge of capacitors. This produces a sustained output of rectangular wave form, the frequency of which can easily be controlled by the horizontal or vertical synchronizing pulses.

Several versions of the multivibrator circuit are found in modern television sets but since they are derived from a basic or conventional type we will first examine the operation of the fundamental circuit.

The Conventional Multivibrator. The basic free-running multivibrator might be considered as a two stage resistance-capacitance coupled amplifier with overall feedback applied by means of a capacitor connected from the output of the second stage to the input of the first.

Figure 54A shows a familiar two stage audio amplifier. The addition of one circuit element (C1 shown in dotted lines) converts this amplifier into a free running multivibrator type oscillator. Figure 54B shows a symmetrical rearrangement of the same circuit as it is usually presented in text books and receiver schematic diagrams.

Since, in a single stage resistance coupled amplifier, the phase of the plate voltage is inverted (180°) with respect to that of the input or grid voltage, it follows that the output voltage of the second stage (T2) of the two stage amplifier will have again been inverted and will be in phase with the input (T1) voltage. Capacitor C1 of Figure 54 will therefore impress upon the first grid, a voltage of the proper polarity to increase or augment the original input voltage and oscillation can take place.

To follow through the manner in which oscillation starts and is maintained in this cir-

(A) AS A TWO STAGE AMPLIFIER WITH CAPACITIVE OVERALL FEEDBACK.

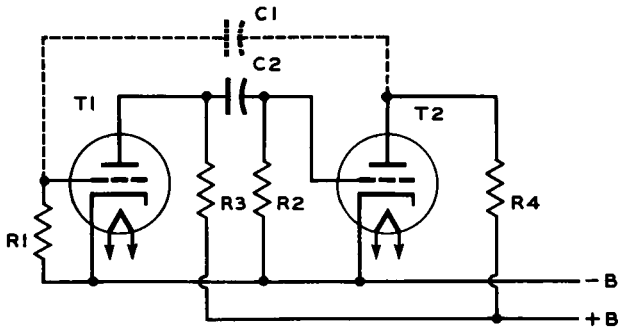

(B) SAME CIRCUIT AS USUALLY DRAWN.

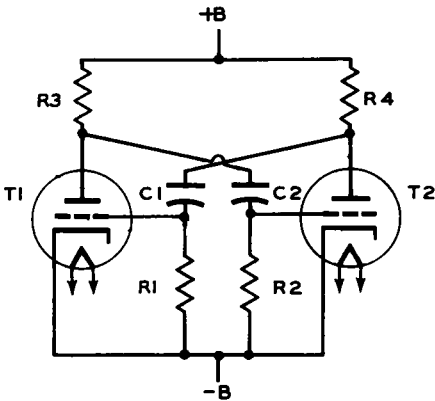

Fig. 54. The Conventional Multivibrator

cuit, let us assume that the cathodes are heated and that B+ voltage is suddenly applied. Both grid circuits are returned to their respective cathodes through grid resistors and at the instant of applying B+ voltage the grids will be substantially at cathode potential or zero bias. Grid current as well as plate current will start to flow in each tube.

It will be instructive at this point to list in numerical order with reference to Figures 54 through 57, the sequence of events which produces the sustained rectangular shaped output wave of the multivibrator.

1. Since the resistance of the internal cathode to grid path, under this initial condition of zero bias and high grid current, is much lower than the resistance of the grid resistors R1 and R2, the two capacitors C1 and C2 will begin charging from the B+ supply through resistors R4 and R3 respectively. This charging path is shown by the arrows of Figures 55A and 55C.

2. Now, if the characteristics of both tubes and the value of the circuit elements were exactly matched, the charging rate of both capacitors would be identical and plate current rise of both tubes would occur simultaneously. Under these conditions, a state of equilibrium would be reached and the circuit would not produce oscillation. Such a set of conditions is not met in practice and a balance is not established.

3. In the practical case, one of the tubes will start to conduct plate current sooner than the other. This could be due to a number of causes such as, lower plate resistance, hotter cathode or slightly lower plate load resistor. Let us assume that the plate current of T1 has started to rise a fraction of a second ahead of that of T2.

4. This rise of plate current will be accompanied by a drop in plate to cathode resistance and a corresponding drop in plate to cathode voltage. Figure 56A shows this set of operating conditions. The low plate resistance of T1 forms a discharge path for C2 as shown in Figure 55D.

5. The discharge current of C2, flowing through the high value of grid resistor R2, develops a high negative grid bias on the grid of T2. This drives the tube beyond plate current cut-off as shown in Figure 56B. The bias de-

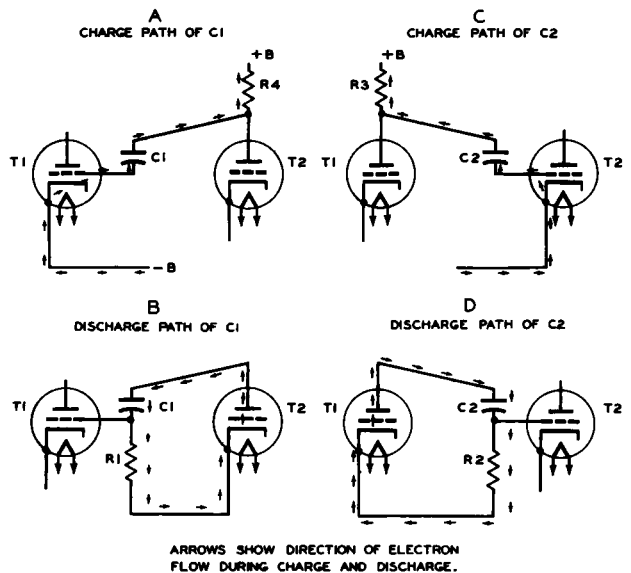

Fig. 55. Capacitor Charge and Discharge Paths in a Multivibrator

CATHODE-RAY - - BEAM DEFLECTION SYSTEMS

A. TUBE CONDUCTING PLATE  
CURRENT MAXIMUM.

B. TUBE NON-CONDUCTING PLATE  
CURRENT CUT-OFF.

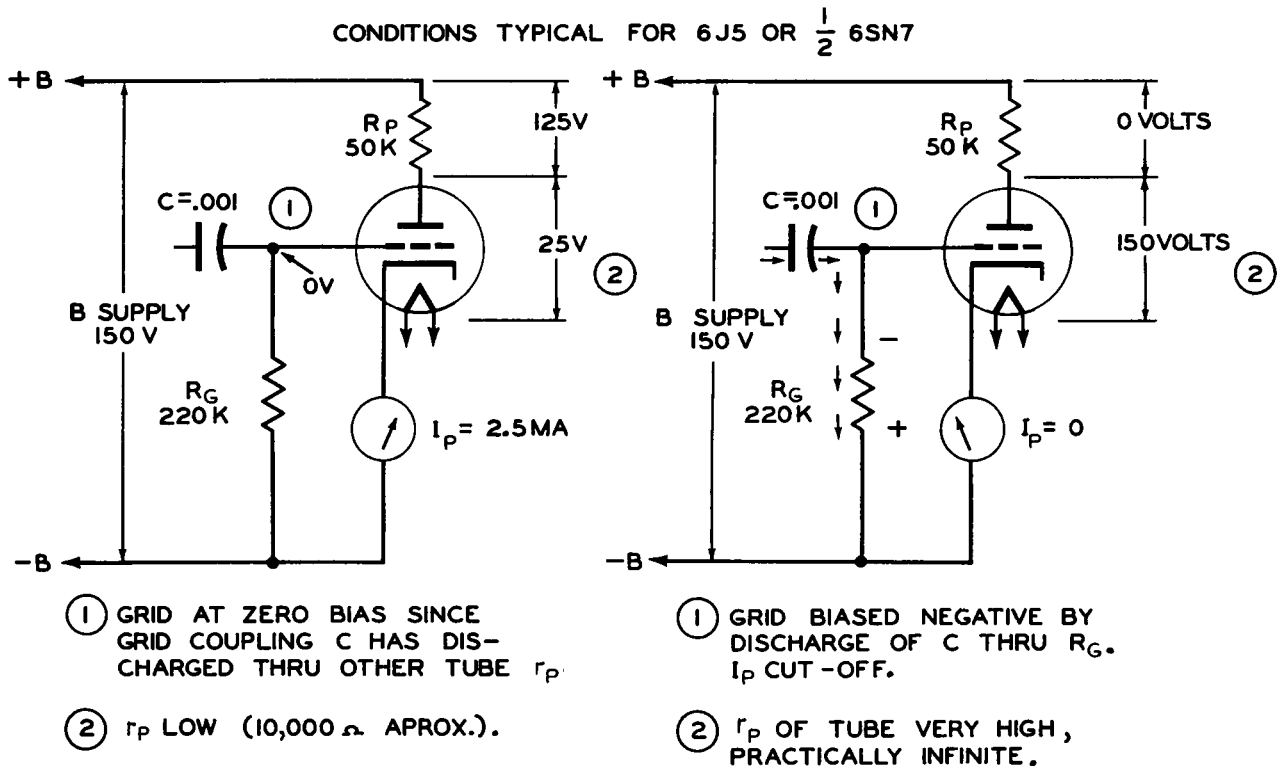

Fig. 56. Tube Operating Conditions in Multivibrator Oscillators

veloped by this discharge action may be as high as 30 to 50 volts in the example shown.

6. Since the plate current of T2 has been cut off, its plate to cathode voltage becomes that of the B supply (see Figure 56B), and will remain at that value until the grid voltage has arrived at such a point on the discharge-time curve that the grid is no longer cut off.

Note: Since the above set of conditions has brought the cycle of operation to one of the two stable or "relaxed" operating points of the circuit it would be helpful to summarize the changes of circuit voltages which have occurred over the period covered by steps 1 - 6.

T1 -- Plate to cathode voltage at its minimum value and steady. Tube conducting.

T2 -- Plate to cathode voltage at its maximum value and steady. Tube not conducting.

T1 -- Control grid voltage zero and steady.

T2 -- Control grid voltage highly negative but falling exponentially with time as C2 discharges through R2.

7. The time required for C2 to discharge will depend on the time constant of the discharge circuit which comprises C2, R2 and the plate resistance of tube T1. See Figure 55D. The negative voltage across R2, which constitutes the grid bias of T2, finally decreases to a value which will allow T2 to conduct heavily. Figure 57 shows the wave forms of the grid and plate voltages of both tubes as a function of time. The part of these waves between (a) and (b) in this figure cover the steps which have been outlined up to this point.

8. As T2 starts to conduct, conditions in this tube become identical to those described in step 4 for T1, except that the tubes and capacitors have exchanged functions, and the discharge path of capacitor C1 is now as shown in Figure 55B.

9. The discharge current of C1 flowing through R1 now biases T1 beyond cut-off as described in step 5.



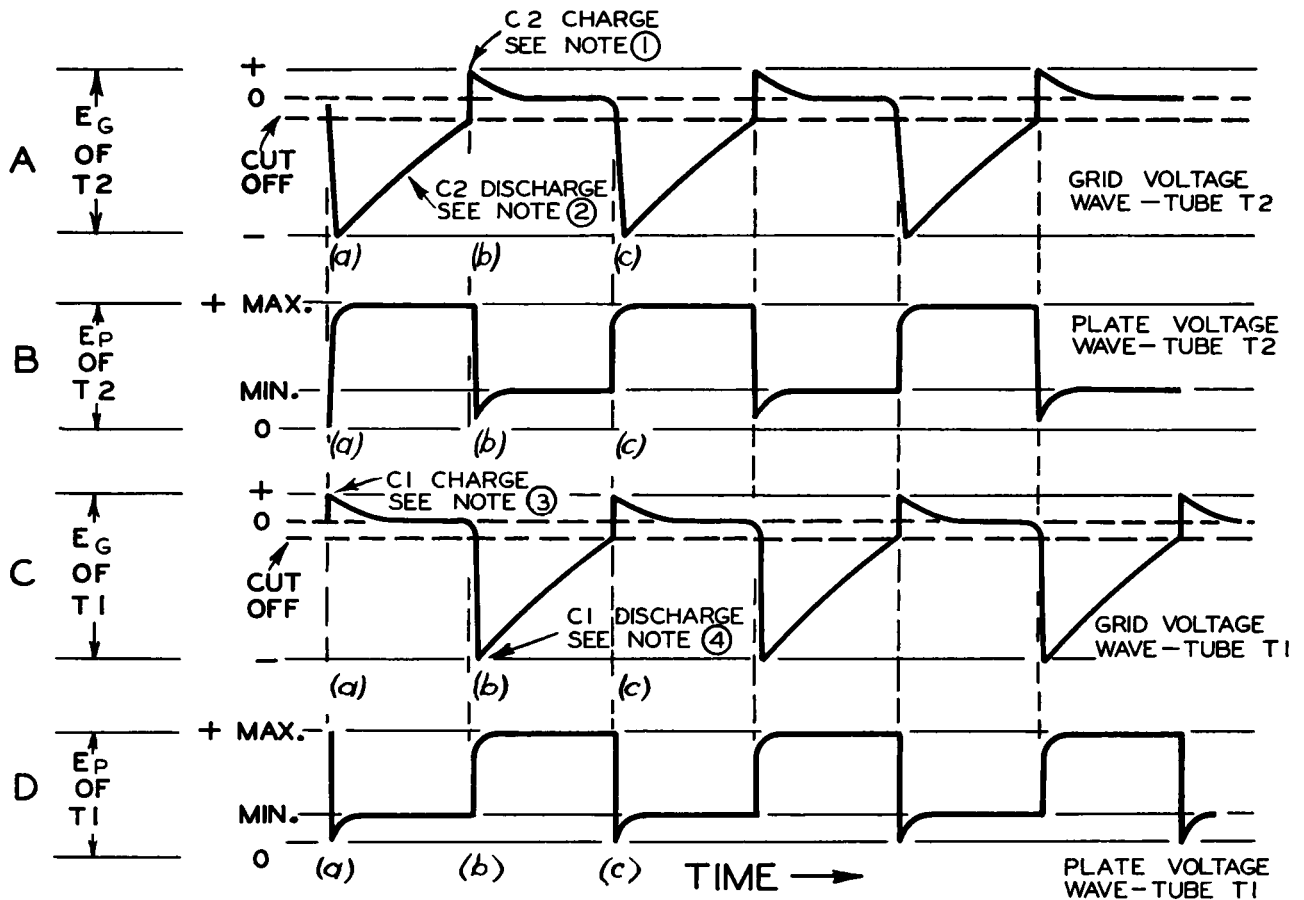

- NOTES —  
 CIRCUIT SHOWN FIGURES 54 & 55.  
 ①—C2 CHARGE PATH — SEE FIGURE 55C ③—C1 CHARGE PATH — SEE FIGURE 55A  
 ②—C2 DISCHARGE " " " 55D ④—C1 DISCHARGE " " " 55B

Fig. 57. Typical Waveforms of a Symmetrical Multivibrator Showing Square Wave Switch Action

10. Since the plate current of T1 has been cut off, the plate to cathode voltage assumes the value of the B+ supply in similar fashion to T2 in step 6.

11. The rise in plate voltage of T1 is impressed on capacitor C2 starting a charging cycle as shown in Figure 55A.

12. Since the internal grid to cathode path of T2 is conductive due to the zero grid bias condition, the charging resistance is very small and C2 is charged very rapidly. This is shown at time (b) of Figure 57.

A new cycle has been started and we have arrived at a similar set of conditions to those described at the end of step 6.

We can now summarize the conditions of circuit voltage and compare them with those found at the end of step 6.

- T1 -- Plate to cathode voltage at its maximum value and steady. Tube not conducting.
- T2 -- Plate to cathode voltage at its minimum value and steady. Tube conducting.
- T1 -- Control grid voltage highly negative but falling exponentially with time as C1 discharges through R1.
- T2 -- Control grid voltage zero and steady.

## CATHODE-RAY - - BEAM DEFLECTION SYSTEMS

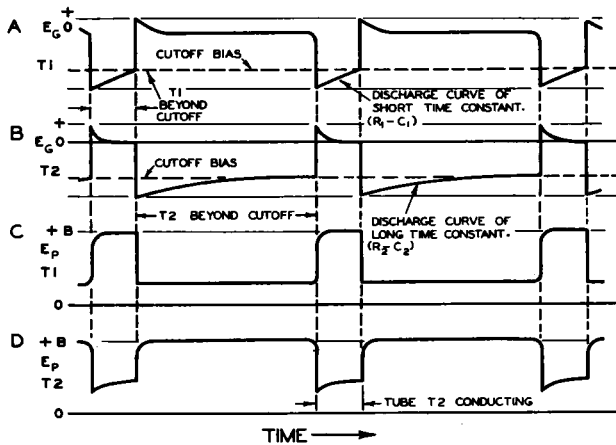

Fig. 58. Waveforms of an Asymmetrical or Unbalanced Multivibrator

It will be noted that the new set of conditions which represent the other stable or relaxed operating point is the same as before except that the tubes and grid circuits have changed places with one another. This cycle of events is shown in the waveform diagrams of Figure 57 between times (b) and (c). This generation of a square wave will continue at a frequency that is determined by the charge and discharge time constants of the coupling networks  $R_1 - C_1$  and  $R_2 - C_2$ .

In this symmetrical circuit it has been assumed, but not previously stated, that the corresponding grid resistors, plate resistors and coupling capacitors are equal. When this is the case, the time constants are equal and the output wave shape from the plates is essentially identical. The frequency of this multivibrator can be changed by altering either the resistors  $R_1$  and  $R_2$  or the capacitors  $C_1$  and  $C_2$ . A decrease in value of the time constant will increase the frequency. If the  $R$  values or the  $C$  values are changed equally the output wave will remain symmetrical.

The Asymmetrical or Unbalanced Multivibrator. In order to use the multivibrator to produce the type of sawtooth wave required for television scanning, it is necessary that succeeding square waves be unequal in length or spacing, and for this reason the time constant of the  $R-C$  circuit of one tube is deliberately made much greater than the time constant of the other. A multivibrator of this type is called asymmetrical. Figure 58 shows the waveforms obtained when the circuit constants of the symmetrical multivibrator just described, are changed in such a manner that the product

$(R_1 \times C_1)$  in the grid circuit of  $T_1$ , is much smaller than the product  $(R_2 \times C_2)$  of  $T_2$ .

Waveform D of Figure 58 shows a short time pulse of plate current occurring in tube  $T_2$  once each cycle, and it is this pulse which we will employ to produce the scanning sawtooth in proper time relationship to the scanning of the camera tube at the transmitter.

Use of the Multivibrator to Produce Sawtooth Scanning. Figure 59 shows a circuit similar to those which we have discussed under the headings of symmetrical multivibrators and also as an asymmetrical multivibrator. By the addition of two new circuit elements we can convert this arrangement into a method of generating sawtooth voltage waves for the control of the electron beam by either the horizontal or the vertical deflection plates of an electrostatic television picture tube. These new circuit elements are  $C_3$  and  $C_4$  (Figure 59).  $C_3$  is used as a coupling capacitor to connect the multivibrator circuit to a source of synchronizing pulses which are part of the transmitted television signal. The function of the synchronizing pulses and their action in the control of the frequency of the multivibrator will be covered in a later chapter.

At this time, the additional circuit element which concerns us, is the capacitor  $C_4$  connected between the plate and the cathode of  $T_2$ . For horizontal line scanning frequency of 15,750 cycles per second, the circuit is so arranged that the time constant  $(R_1 \times C_1)$  is approximately  $1/9$ th of the time constant  $(R_2 \times C_2)$ . Under these conditions the plate current of  $T_2$  will consist of short pulses as shown in Figure 58. These pulses represent a condition of low resistance, and it is obvious

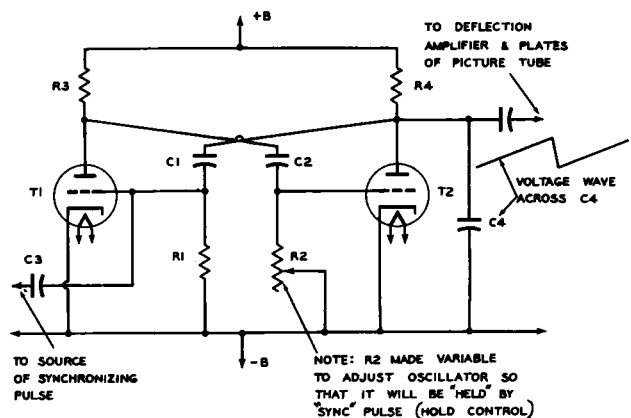

Fig. 59. Sawtooth Scanning Wave from Asymmetrical Multivibrator

that during the time shown as the "conducting period", tube T2 will act as a virtual short circuit across capacitor C4. In this manner the multivibrator is acting as a periodic switch and has fulfilled the requirements for the production of a sawtooth wave as covered in pages 37 and 38.

This type of controlled multivibrator has been used for both horizontal and vertical deflection scanning, in many of the lower priced electrostatically deflected television sets.

The voltage of the sawtooth wave across capacitor C4 (Figure 59) is of insufficient magnitude to produce the required deflection. Amplifiers are therefore needed, and usually take the form of push-pull circuits incorporating a phase inverter. Another significant difference between the circuit Figure 59 and Figure 54 is the fact that R2 has been made variable. This variable resistor is one of the major controls of a television receiver. From the previous discussion of multivibrator theory it is obvious that variation of R2 will alter the length of the portion of the operating cycle shown controlled by (R2-C2) in Figure 58. This represents the portion of the sawtooth wave which is active in scanning the face of the cathode ray picture tube during video modulation. Since this variable adjustment permits the multivibrator to be "locked-in" with the synchronizing pulse and "held" in step by that pulse, it has been known in engineering circles as a "hold" control. This nomenclature has been carried over into the trade and many modern television sets label this control knob as "horizontal hold" or as "vertical hold" depending upon the particular function concerned.

**CATHODE-COUPLED MULTIVIBRATOR:** An interesting variation of the multivibrator which is becoming practically a standard for inexpensive electrostatically deflected type television receivers is the cathode-coupled multivibrator or "Potter" circuit. This circuit is shown in Figure 60. A significant difference between this circuit and the conventional multivibrator is the fact that feedback is accomplished in two ways. The coupling capacitor C2 serves, as before, to transfer charges from the plate of T1 to the grid of T2. In addition, this circuit employs a cathode bias resistor which is common to T1 and T2. This common cathode resistor is responsible for the unique action and the name of the circuit. The second tube (T2) functions as a switch or discharge tube for capacitor C4 which produces the sawtooth waveform. From the theory of

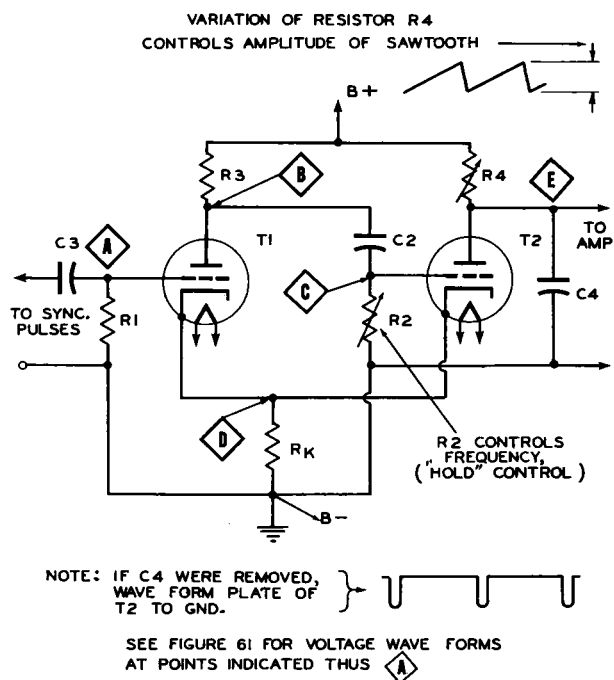

Fig. 60. Cathode-Coupled Multivibrator as Sawtooth Wave Generator

the conventional and asymmetrical multivibrators as previously discussed, the action of this cathode-coupled version can be readily understood. As before, we will assume that the cathodes of the tubes are heated and that B+ potential is suddenly applied. Let us again follow through in numerical order the sequence which allows this circuit to generate asymmetrical pulses.

1. Capacitor C2 will charge through the path consisting of R3 and the grid to ground or B- circuits of T2. This action will occur very rapidly since the grid of T2 is initially at zero potential.

2. Plate current will start to flow in both T1 and T2 causing a bias voltage for both of these tubes to be developed across the cathode resistor, Rk.

3. This bias voltage will immediately start to decrease the plate current of both tubes which were initially in a conductive condition since the control grids were at substantially zero potential.

4. The flow of plate current through T1 causes a lower plate to cathode voltage drop and a correspondingly lower plate resistance of this tube.

## CATHODE-RAY - - BEAM DEFLECTION SYSTEMS

5. The low resistance path of T1 initiates the discharge of coupling capacitor C2 through R2. As in the conventional multivibrator previously discussed, this current flow through R2 produced a high negative bias on the control grid of T2 which immediately sweeps the tube to beyond its plate current cut-off point. It will be noted that this circuit differs from the conventional multivibrator in that there is no coupling capacitor between the plate of T2 and the grid of T1. For this reason, T2 is immediately thrown into a condition of plate current cut-off.

6. As in our discussion of the conventional multivibrator, it will be constructive at this time to summarize the voltage conditions which have occurred up to this point:

T1 - Plate to cathode voltage at its minimum value. Tube conducting.

T2 - Plate to cathode voltage rising along a portion of the charging curve which is substantially linear. This rise of plate voltage is charging capacitor C4 and initiating the first part of what will eventually become a sawtooth wave of voltage.

T1 - Control grid voltage negative and steady. The tube is self-biased by its own plate current flowing through the common cathode resistor Rk.

T2 - Control grid potential highly negative and exponentially diminishing in value.

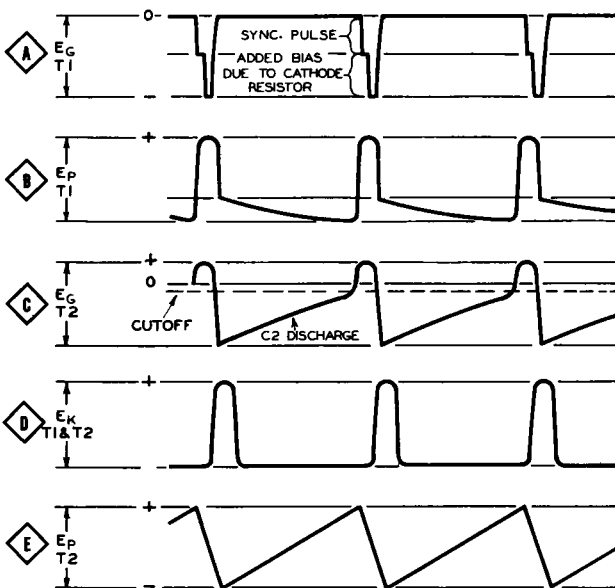

Fig. 61. Voltage Waveforms in Cathode-Coupled Multivibrator

7. T2 has been cut off during this period and no plate current has been flowing. C2 has been discharging through the path R2, Rk and the cathode to plate circuit of T1. It is interesting to note, that as the plate current of T2 was cut off by the high negative bias produced across R2 by the discharge of C2, the plate to cathode voltage did not immediately assume the value of the B+ supply since the plate voltage of this tube was maintained by the charge existing in C4, which started simultaneously with the closure of the B+ circuit. For this reason, the plate voltage wave of T2 instead of being rectangular form will be of sawtooth shape due to the charge flowing into C4 (if C4 is removed from the circuit then the plate to cathode voltage of T2 would rise immediately to the B+ value since the grid of this tube is cut off by the high negative voltage resulting from the discharge of C2).

8. As in the other types of multivibrators already discussed, when the bias of T2 falls to a value equal to the cut-off grid potential, T2 will start to conduct.

9. When conduction occurs in T2, C4 will be discharged rapidly through the plate to cathode circuit of this tube and its plate to cathode voltage will drop to its minimum value. See Figure 61. The sequence of events to this point has resulted in the production of a sawtooth wave of voltage across capacitor C4. Thus far, the action of the circuit has resembled that of the conventional and asymmetrical multivibrators previously discussed.

10. A significantly different action now takes place. The sudden pulse of plate current which occurs when T2 conducts, flows through cathode resistor Rk, and since this resistor is common to the cathode circuits of both T1 and T2, the voltage produced by this plate current pulse immediately drives the grid of T1 negative with respect to its own cathode.

11. This negative bias causes a sudden increase in the plate to cathode resistance and the plate to cathode drop of T1. The effect of the sudden increase of T1 plate voltage is to cause C2 to charge, thus instantaneously impressing a positive voltage on the grid of T2, momentarily increasing the value of the plate current pulse of T2 which started the cycle.

12. The cumulative increase of plate current flowing through common cathode resistor Rk finally produces sufficient negative bias on the grid of T1 to completely cut off the plate

current, and the plate to cathode voltage rises to its maximum value.

13. Capacitor C2 has become charged and the plate current of T2 "relaxes".

14. This decrease in current flow in Rk reduces the bias of T1. As T1 conducts, C2 is discharged through R2, Rk and the plate circuit of T1. This current flow in R2 drives the grid of T2 to cut-off and the cycle is repeated.

The fact that a sudden and cumulative action was produced in this circuit by the coupling of tubes T1 and T2 through a common cathode bias resistor, accounts for its designation as a cathode-coupled multivibrator. The reasons for the preference for this type in television design over the asymmetrical multivibrator previously discussed, are as follows:

1. It can be triggered and controlled by a negative pulse of voltage which often leads to simplification of control circuits.
2. Its sudden and cumulative pulsing action in tube T2 permits a higher ratio of linear sweep time to return time.
3. Simple variable resistors R2 and R4 of tube T2 (see Figure 60) permit control of both the frequency of scanning and its amplitude.

The wave shapes of the voltages at various points in this circuit, as a function of time, are shown in Figure 61. These wave shapes are identified by letters enclosed in 'diamonds' in Figure 60. In all cases voltages are measured to B- or ground.

**THE BLOCKING OSCILLATOR.** Another type of vacuum tube circuit for the production of controlled sawtooth voltage waves is known as the "blocking oscillator". The blocking oscillator is becoming increasingly popular in modern television sets as a means of producing either vertical or horizontal scanning. This popularity is due to the fact that its reliability of operation and ease of adjustment are dependent upon circuit elements such as transformers, resistors and capacitors rather than being dependent upon the characteristic of a vacuum tube which is employed in the circuit. Vacuum tubes are manufactured to rather wide commercial tolerance values and are subject to change of characteristics with age.

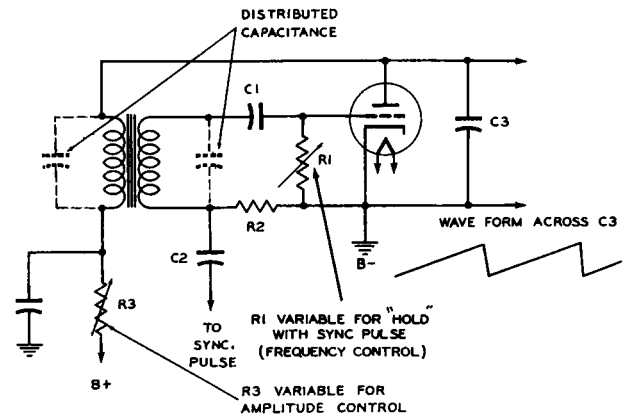

Fig. 62. Blocking Oscillator as a Sawtooth Generator

Figure 62 shows the blocking oscillator in its simplest form. It appears upon casual inspection to be a Hartley oscillator employing an iron core transformer. In essence it is such an oscillator, but instead of providing sustained sine wave oscillations it produces short time pulses of energy with correspondingly long intervals of relaxed action. For this reason, it is classified as another form of relaxation oscillator. Two significant differences distinguish this circuit from the common Hartley oscillator, namely:

a. The time constant of the grid resistor R1 and the grid capacitor C1 is such that long periods of blocked plate current occur between short periods of plate current conduction. During these short conductive periods oscillation takes place.

b. The natural period of oscillation of the transformer, with its associated distributed and lumped circuit capacitances, is such that the desired pulse time approximates one-half cycle of the frequency at which the circuit would oscillate if it were of the continuous sinusoidal type.

As in the case of the other types of sawtooth oscillators it will be instructive to follow through, in sequence, the various actions which take place in this circuit.

1. We will again assume that the cathode of the tube is heated and that the plate circuit is suddenly closed to provide B+ potential. Since the grid is initially at cathode or zero potential, plate current will start to flow through the primary of the transformer. This sudden rush of current will set up a magnetic field in the core of the transformer, inducing a

## CATHODE-RAY - - BEAM DEFLECTION SYSTEMS

secondary voltage across the grid winding. The direction of these windings is such that the primary current will cause a positive potential to appear at the grid with respect to cathode or ground.

2. The positive voltage thus applied to the coupling capacitor C1 causes the grid to become more positive than the cathode. The grid then attracts electrons from the emitted cathode current, starting grid current through resistor R1.

3. Simultaneously, the increasingly positive grid potential causes the plate to draw still more current and the action is cumulative until plate current saturation is reached. As the plate current reaches a steady maximum value no further change of current occurs through the primary winding of the transformer.

4. Induction of voltage into the secondary depends upon the change of magnetic flux and therefore at this time the secondary voltage of the transformer ceases to rise.

5. As the grid tends to become less positive (C1 discharging through R1), the plate current through the primary begins to decay and the magnetic field linking the secondary coil starts to collapse. Note: The time taken for this sudden rise and decay of grid voltage is governed by the natural resonant frequency of the transformer with its associated circuit capacitances.

6. The collapsing field in the transformer due to the dropping plate current induces a secondary voltage which is in the opposite direction to the original plate current pulse. This causes C1 to discharge through resistor R1 which drives the grid more and more negative, hastening the decay of plate current and finally causing it to reach a cut-off point. While this action of reversal of grid voltage and cut-off of plate current has taken considerable time to describe, in reality it is practically instantaneous.

7. From this point, action in the tube follows that described in the multivibrator and the grid potential follows an exponential curve of R-C discharge until the point of plate conduction is again reached.

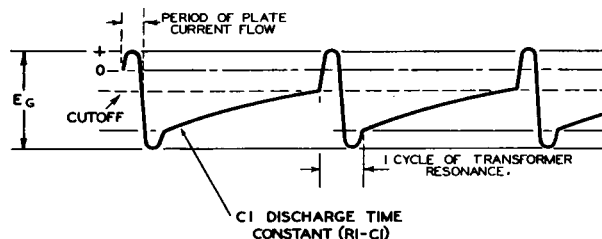

A. GRID VOLTAGE WAVEFORM.

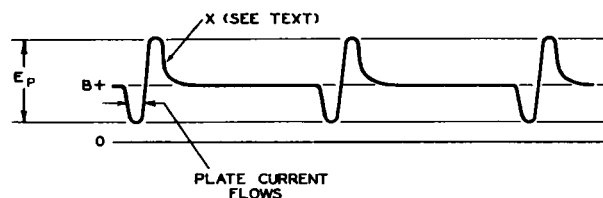

B. PLATE VOLTAGE WAVEFORM WHICH WOULD OCCUR IF C3 (FIGURE 62) IS DISCONNECTED.

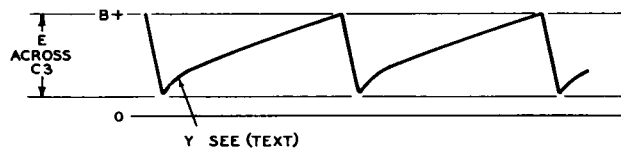

C. SAWTOOTH VOLTAGE WAVE ACROSS C3.

Fig. 63. Voltage Waveforms in Blocking Oscillator

8. The time taken for this discharge of C1 is dependent upon the time constant  $(R1+R2) \times C1$ .

9. As the tube starts to conduct again, oscillation starts and the cycle is repeated. It will be seen from the curve of Figure 63 that the plate voltage of the tube is nearly steady and at its maximum value between the occurrence of these oscillatory pulses. It is evident that we have fulfilled the conditions of sawtooth charge and discharge of capacitor C3 in Figure 62 and have therefore produced a sawtooth scanning wave. As in previous circuits, the Grid resistor R1 can be made variable as a frequency control ("hold" control) and a plate circuit resistor made variable as a width or height control.



Continuing the study of the blocking oscillator, it is important to note that in the circuit of Figure 62, the sawtooth generating capacitor C3, which is connected from plate to cathode of the tube, modified the shape of the plate voltage wave. We have seen that a similar type of action occurred in the cathode-coupled multivibrator circuit of Figure 60. If, in this case, capacitor C3 had not been present the voltage wave occurring between plate and cathode of the tube would have the shape of Figure 63B. The excursion of the wave above the B+ axis at point x is caused by the stored energy in the primary of the transformer. This action is analogous to that of the constant current Heising modulation choke of a transmitter. We have already discussed a similar phenomenon in connection with the "flyback" system of developing high voltage on pages 29 and 30.

When the capacitor C3 is connected the voltage wave from plate to cathode assumes the shape shown in Figure 63C. This is the desired sawtooth deflection wave except for the distorted section shown at y. This sudden rise of the curve at this point is due to the additional contribution of charging voltage which occurred when the magnetic flux of the transformer collapsed as explained above. The plate voltage was prevented from following the curve of Figure 63B by the terminal voltage contribution of capacitor C3. In the practical use of this circuit in television receivers the distorted section of the wave at y is of no consequence since it is "blanked out" as will be explained later.

Discharge or Trigger Tube. In many modern television sets, pulse generators are not used as the direct control of the sawtooth charge and discharge of the capacitor, but rather are used to trigger an additional tube known as a "discharge tube". This tube in turn short-

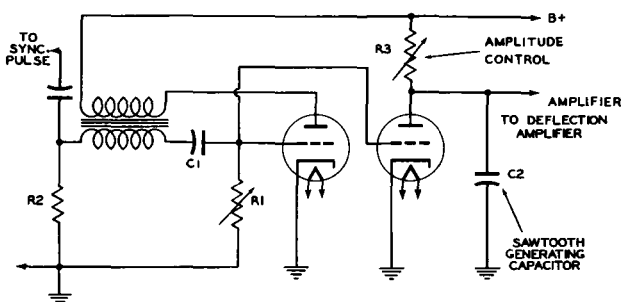

Fig. 64. Blocking Oscillator and Discharge Tube as a Sawtooth Generator

circuits or discharges the capacitor. Figure 64 shows a blocking oscillator, of the form previously described, whose grid is connected directly to a second tube the only function of which is to conduct plate current, and in consequence discharge capacitor C2 at the proper instant to produce the sawtooth wave. The introduction of this extra tube provides independence of functions as compared with the simpler form of Figure 62 which might suffer from some interaction of controls. The discharge tube can be used with any type of relaxation oscillator in which the plate current occurs over short intervals of the operating cycle.

SINE WAVE GENERATORS. It is possible to employ the familiar sine wave oscillator to produce pulses which, in turn, will trigger a discharge tube associated with a sawtooth wave-forming capacitor. Only a short portion of the sine wave is used and it is passed through what are known as "clipping" stages to "bite" off a small section of the wave. In this manner the output of the clipper is in the nature of a pulse. The utility of this type of circuit will be discussed later when we consider the control of scanning by the synchronizing pulses.

These oscillators are biased to run in a similar fashion to class C transmitter technique in which plate current is cut off for part of the cycle. Part of the necessary clipping of the sine wave to produce a pulse is already accomplished in the oscillator. Their action will be covered in greater detail when we discuss actual television deflection circuits.

#### SUMMATION OF THE THEORY OF MULTIVIBRATOR AND BLOCKING OSCILLATOR ACTION:

1. Multivibrator circuits constitute a means of employing vacuum tubes as electronic switches to control the charge and discharge cycles of a capacitor for the production of sawtooth waves.

2. This switching action by the tubes is practically instantaneous and is limited in timing by the circuit elements, rather than by the tube itself. It is interesting to note that the velocity of the electrons in a tube, which is suddenly driven to saturation after a condition of plate current cut-off, can approach one-tenth of the velocity of light or approximately 19,000 miles per second.

## CATHODE-RAY - - BEAM DEFLECTION SYSTEMS

3. When an electron tube acts as a voltage operated switch, it is suddenly changed from a condition of "no plate current" to one in which plate current is limited only by the ability of the cathode to supply electrons (plate current saturation). These two states are illustrated in Figure 56. Since this action is used in other sections of a television receiver, it is valuable to become thoroughly familiar with the steps involved.

4. Multivibrator circuits may be either symmetrical or asymmetrical. In the first case, the result is the production of square voltage waves. These resemble a "Roman Key" pattern. The symmetrical multivibrator is useful at the television transmitter in the production of the complex television signal. It has no present use in the receiver and for that reason we are interested only in the asymmetrical type.

5. The asymmetrical multivibrator produces voltage output waves in which a short pulse of rectangular shape is followed by a long space or "gap". This short pulse of voltage can be used to switch a vacuum tube from a condition of plate current cut-off to a condition of plate current saturation.

6. If a capacitor of the correct value has been connected across the plate of this tube, the long periods between pulses will have been occupied by the gradual or exponential charging cycle, and the voltage across the capacitor will rise in a substantially linear fashion.

7. When the short rectangular pulse of voltage is suddenly applied to the grid of the tube, and the tube becomes conductive, it will short circuit the capacitor and start a new sawtooth wave.

8. An important reason for the use of this means of generating sawtooth waves, is the fact that dual triode tubes such as the 6SN7 can be employed in lieu of the two tubes shown in the illustrations.

Dual tubes in one envelope present a difficult control problem in the plant of any tube manufacturer. For this reason, erratic scanning action in a television set can often be remedied by tube interchange. Fortunately, there are many other circuits, such as clippers, sync separators, etc., where the same tube type is used, and where its characteristics are not critical. The cure for unstable multivibra-

tor action is often found in the simple interchange of tubes.

9. Checking the values of resistors and capacitors, determining that there are no open or short circuits, and substituting tubes, constitutes the normal service procedure in multivibrator scanning generators.

10. The blocking oscillator requires only one vacuum tube, as contrasted with the multivibrator which depends upon a phase rotation of  $360^\circ$  through two tubes. The phase of feedback in the blocking oscillator is provided by the relationship of transformer windings.

11. The characteristics of the transformer determine the length of the conduction time or "closed switch" part of the cycle. This time is approximately one half cycle of the transformer resonant frequency as tuned by its associated capacitances.

12. The "relaxed" time between "switch on" or conduction periods is determined by the time constant of the grid circuit capacitor and its discharge resistors. The grid resistor can be made variable to control the frequency of oscillation, and allow synchronization with the transmitted signal.

13. In the blocking oscillator, plate to grid feedback through the transformer sets up a grid current which charges the grid capacitor, causing the grid to be driven positive momentarily. This, in turn, causes the plate current to rise to its saturation value. The plate current then begins to decay, and reversal of direction of the induced grid voltage causes the grid capacitor to discharge through the grid resistor. The grid is then driven very negative, cutting off plate current. The cycle repeats itself as soon as the voltage across the resistor reaches a value which will allow the grid to again initiate plate current.

14. Discharge or "trigger" tubes are frequently used with pulse generators, such as the blocking oscillator, to provide separate control of scanning wave size and shape. Another function of discharge tubes is to provide a means of producing special wave shapes for particular scanning requirements. This subject will be covered in detail later in the text.

## SECTION II CATHODE RAY — BEAM DEFLECTION SYSTEMS

### CHAPTER 7. THE SAWTOOTH SCANNING RASTER

It will be instructive, at this time, to examine in somewhat greater detail the requirements of the sawtooth scanning waves which produce the raster. We have mentioned at several times in the text that the horizontal and vertical sawtooth motion of the electron beam of the picture tube must keep in step accurately with a similar set of sawtooth scanning movements occurring at practically the same instant in the camera tube at the transmitter.

To accomplish this synchronization, pulses of a distinctively different nature for the control of horizontal and vertical scanning respectively, are transmitted as an integral part of the television signal. These pulses occur between each horizontal frame. During the scanning of the frame itself the operation of the receiver is "on it's own". However, during the short interval which occurs between successive horizontal frames, the action of the deflection circuits of the receiver are the absolute "slave" of the transmitter, providing the set is well designed, operating properly, and being used in an area of adequate field strength.

While the method of separating or sorting these pulses from the complex signal are properly a matter to be taken up later in this course, at this point we should examine the re-

lationship in timing which these pulses bear to the control of the sawtooth scanning action of the receiver. Figure 65 shows the sequence of events which occur during the scanning of one horizontal line and the return of the electron beam to start the scanning of the next line.

It should be understood that the sawtooth motion is that of the electron beam of the cathode ray picture tube and not necessarily the form of voltage applied to the deflecting plates of an electrostatic tube or the wave of current which must occur through the deflecting coils of a magnetically controlled tube. We will find somewhat later that it will be necessary to introduce deliberate distortion of these voltages and currents to accomplish the linear sweep and rapid flyback of the beam of electrons which is tracing the picture.

As a radio service technician, you have been familiar with alternating currents whose frequencies are in the order of millions of cycles or alternations per second. Up to this time it has not been necessary to consider these frequencies in terms of actual motion. The sequence of events which happen in the picture tube of a television receiver involve the motion of an electron stream at speeds which have not as yet been accomplished mechanically even in rocket propulsion.

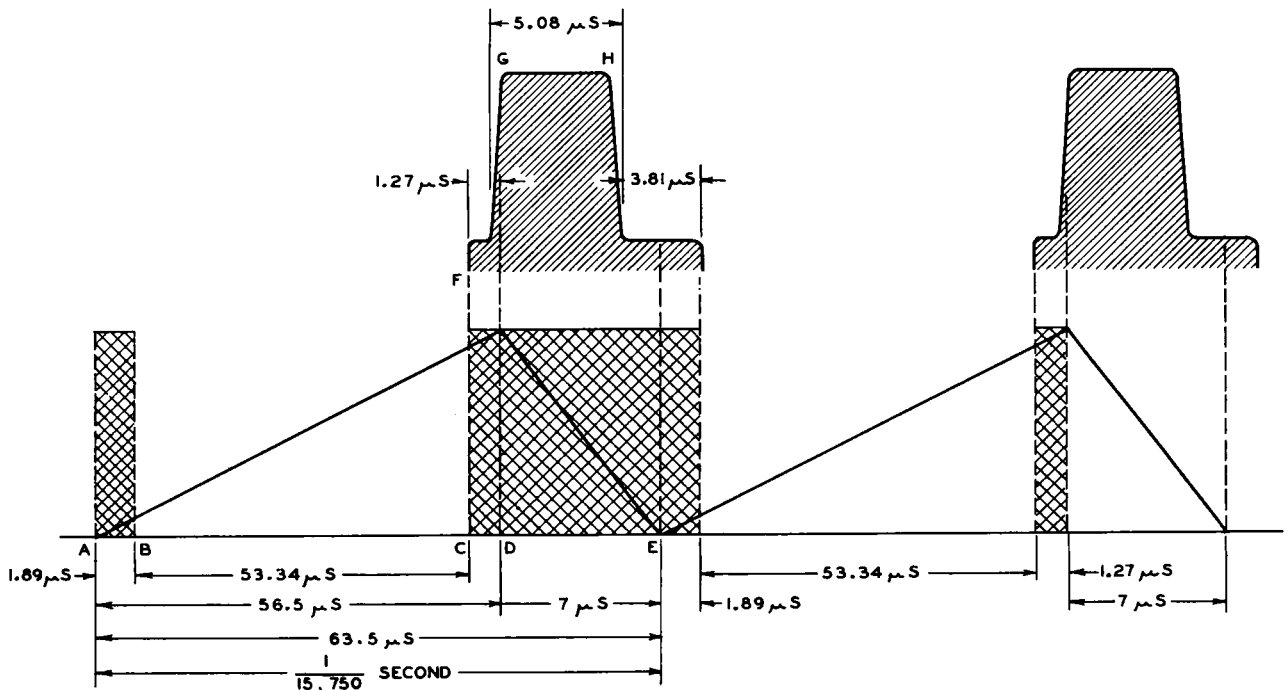

Fig. 65. Horizontal Scanning Wave

## CATHODE-RAY - - BEAM DEFLECTION SYSTEMS

Figure 65 shows the ideal sawtooth for the control of the horizontal scanning motion of a television set. At point 'A' the electron beam starts to cross the face of the picture tube, which we will assume is ten inches in diameter, and has an active picture length in the horizontal direction of eight inches. The beam has blanked out over the distance 'A' to 'B' and the picture itself starts at the point 'B'. Between the points 'B' and 'C' as the uniform motion progresses, the video modulation is active in producing the picture.

As we have previously stated, the picture frame consists of 525 horizontal lines which are reproduced each 1/30th of a second. (30 frames per second times 525 lines per frame equals 15,750 horizontal lines per second.) This means that the time which can be allowed for the trace of a line and its return to start another line is 1/15,750th of a second.

At this point we should introduce the idea of talking about these extremely short time intervals in multiples of one millionth of a second. This unit of time is known as the "micro" second. Such a term should be familiar to you as a practical radio service technician as it is the length of time required for the completion of one cycle of carrier wave at the middle of the broadcast band or 1000 KC. The entire horizontal action including the tracing of the picture line and the return to start a new line occurs in 63.5 microseconds.

In order to comprehend what this means in terms of motion of the electron beam over the active part of the picture we can divide the eight inches of picture length by the time of scanning (53.34 microseconds) and obtain a velocity of 2.37 miles per second. The retrace time which is shown in the figure between the point 'D' and 'E' is 7 microseconds and since this retrace is over the same eight inches of horizontal motion it is obvious that the speed of the spot (blanked out to produce no light) must be much more rapid. Actually this retrace in the ideal case amounts to a beam velocity of 21.64 miles per second.

As was previously stated, the sequence of events must occur in absolute synchronism with a similar sequence occurring at the same instant in the camera tube at the transmitter. In order to accomplish this, pulses are sent out from the transmitter between each horizontal trace. The shape of these pulses is shown above the sawtooth wave, in Figure 65. At

the instant shown as 'F' enough voltage appears at the grid of the picture tube to "blank out" all light. The region from 'F' to 'G' is known in television slang as the "front porch". The region is slightly more than one millionth of a second in duration. At point 'G' the carrier wave of the transmitter instantly increases by approximately 25% of its average value. This sharp rise in carrier is utilized to "trigger" scanning generators in the receiver which are used to produce the required sawtooth motion of the electron beam of the picture tube. The exact means of utilizing the pulse to accomplish this triggering will be described later in this course. The horizontal beam does not trace a line parallel with the top of the picture but has a downward slope which is 1/60th of the vertical height of the picture. Refer to Figure 28, Page 24.) This motion in the vertical direction is under the control of a vertical scanning sawtooth which serves to move the picture to the bottom of the image and then rapidly return it to the top. The motion of the electron beam from the top to the bottom of the picture occupies 1/60th of a second. It is easy to see that this vertical scanning motion is very much slower than the horizontal line tracing action and requires 16,666 microseconds for its repetition. Pulses are sent out between successive fields to lock in, or control as a "slave", the vertical scanning oscillator of the receiver.

A cycle of the vertical deflection sawtooth wave is shown in Figure 66, together with an enlarged section of that part of the wave which occurs during blanking and retrace.

It will be seen that the portion of the television signal which controls vertical retrace and synchronization is much more complicated than the single horizontal pulses which occur between successive horizontal lines. In appearance the vertical synchronizing signal resembles a comb with uneven teeth. If its only function were to trigger the vertical oscillator and to blank out the picture tube screen during retrace, it could be made in the form of a single long rectangular pulse, whose time duration is that of from 20 to 22 horizontal lines (1250 - 1450 microseconds).

However, it has to perform two other functions, namely: those of continuing to keep the horizontal scanning oscillator in step during the vertical retrace period and also to assure that alternate fields have proper interlace of the horizontal lines.

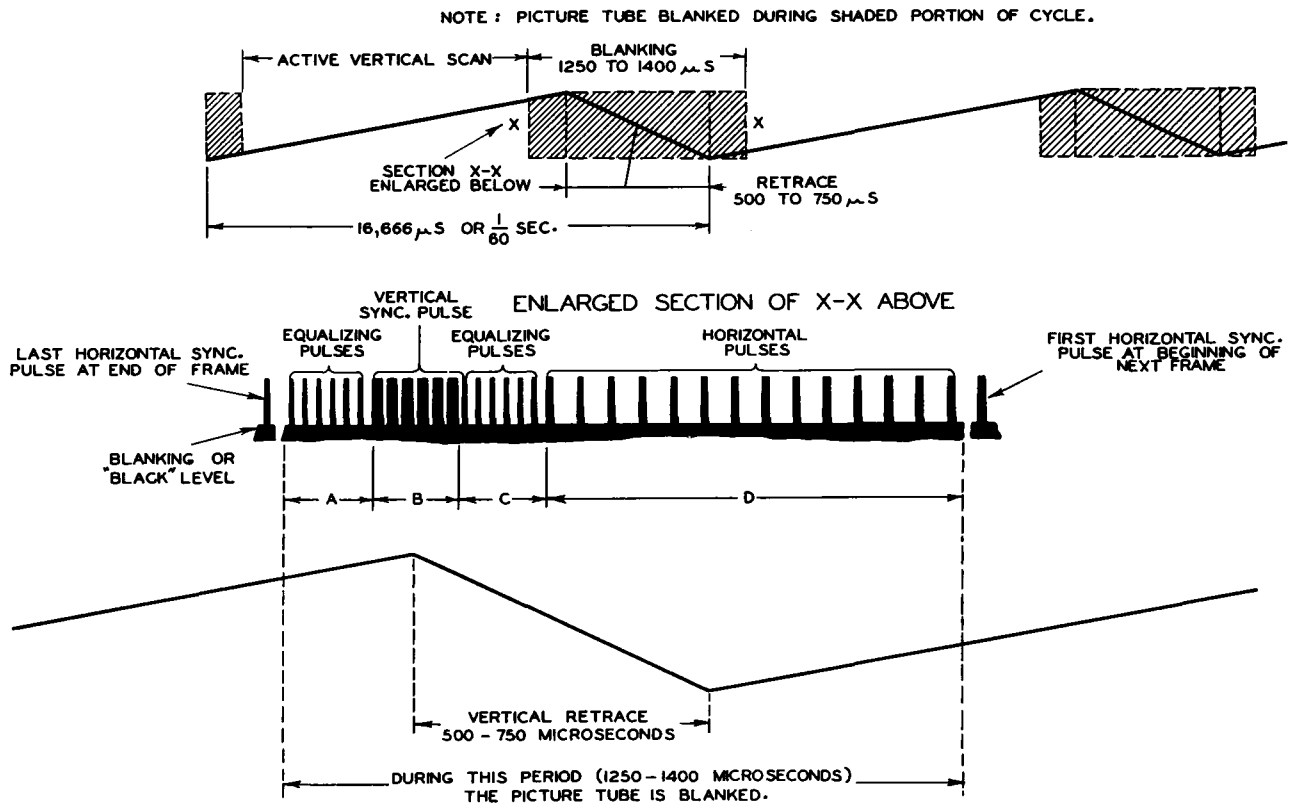

Fig. 66. Vertical Scanning Wave

The first function of keeping horizontal synchronization correct is accomplished by the serrations (notches) 'B' and pulses 'A', 'C' and 'D' shown in Figure 66. The second function of controlling interlace is taken care of by the use of the equalizing pulses 'A' and 'C' shown in Figure 66, preceding and following the vertical sync pulse itself.

The exact composition of the complex wave which constitutes the television signal does not need to concern us at this time, because it involves an understanding of those portions of a television receiver which, as stated on page 3, are included under "Cathode-ray beam modulation and synchronization".

**CONTROL OF SCANNING GENERATORS BY SYNC PULSES:** We have seen that it is necessary for the scanning systems of the receiver to keep in accurate step with the scanning raster of the camera tube at the transmitter, and have described the type of synchronization pulses which are made part of the television signal to satisfy this requirement.

For the reproduced picture to be of satisfactory character, the picture elements of adjacent horizontal traces must line up with considerable accuracy, and the lines of alternate fields must interlace or space accurately between one another.

To avoid a displacement of more than one picture element in successive horizontal lines, the frequency stability of the horizontal oscillator must be .2 percent or better. Figure 67A serves to illustrate horizontal displacement.

To avoid "pairing" of the lines of successive fields (the lines lying on top of those of the preceding field instead of being properly interlaced), the stability of the vertical oscillator must be better than .05 percent. Figure 67B illustrates this displacement.

In each of the impulse generating circuits (cathode-coupled multivibrator and blocking oscillator), which have been described as suitable for television scanning, coupling means have been indicated in the grid circuits for the introduction of synchronizing pulse controls. See Figures 60, 62 and 64.

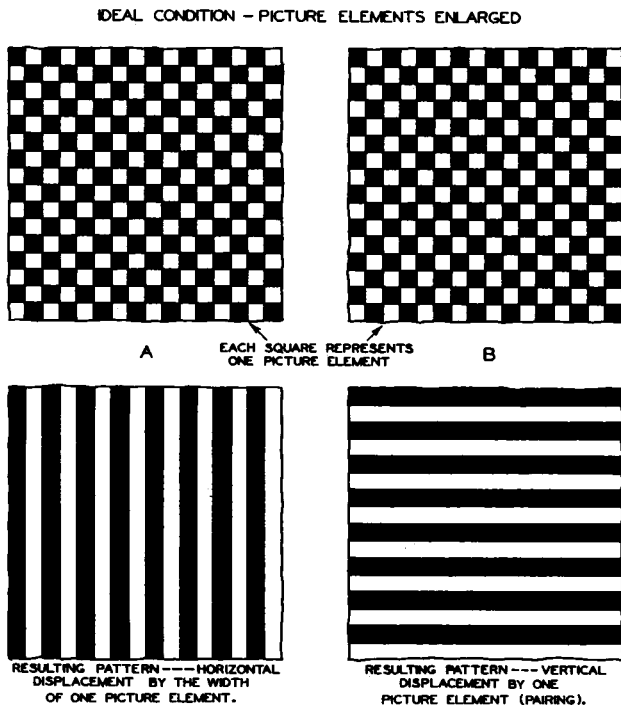

Fig. 67. Picture Element Displacement which might Result from Scanning Oscillator Instability

The horizontal and vertical pulses are "clipped" from the signal, amplified, and passed through circuits which "classify" them so that each will control only its own scanning oscillator. The methods of accomplishing these operations will be described later. The end result is a short, sharp "pip" for the horizontal control and a long triangularly shaped pulse for the vertical control.

In considering the manner in which the pulse controls oscillator frequency, three factors are of importance:

1. The free running frequency of the sweep generator. - - This is the frequency which would be generated at any particular setting of the "hold" control, if the sync pulses are not present. It can be slower than the pulse repetition rate, faster, or in exact step. It will be shown later that for proper stable operation of the receiver, the slow condition is required.

2. The firing point of the sweep generator. - - This is the grid bias voltage of the controlled tube which initiates conduction in the discharge tube, thus starting capacitor dis-

charge and retrace of the scanning wave. It is this point in the cycle at which the oscillator is most sensitive to control by the sync pulse.

3. The synchronizing frequency. - - This is the rate at which the pulses are applied to the control input terminal of the oscillator, and is determined by the signal. See Figures 65 and 66.

Since the control action of the blocking oscillator can be more readily illustrated diagrammatically, we will consider its operation first.

**PULSE CONTROL OF THE BLOCKING OSCILLATOR.** As has been shown on pages 47 and 48, the "firing" point of a blocking oscillator is the instant that the grid potential passes the cut-off point. When the oscillator is "free running" this point is determined by the time constant of the grid capacitance and resistance. If at any time during the discharge of the grid capacitor through the resistor, positive voltage were to be added to the grid potential from an external source, to the extent that the grid potential passed the cut-off point, the tube would start to conduct and the sawtooth forming capacitor would discharge. This would start retrace and a new sawtooth scanning cycle would begin.

Figure 68 illustrates this action in detail. At A is shown an enlarged portion of the blocking oscillator grid voltage wave, whose operation has been described on pages 47 and 48 and illustrated in Figure 63. The series of synchronizing pulses below "A" shows a series of pulses marked "O" whose leading edges are in exact "step" with the wave. In this case, the free running frequency of the oscillator is not affected by the pulses. They merely add to the grid voltage at the same instant that it was being driven positive by the plate current pulse. If, on the other hand, the sync pulses were occurring at the points indicated as "1", the addition of the pulse voltage, to the voltage due to the discharge of C1 through R1 (see Figure 62), is still short of the cut-off bias point, and will not "fire" the tube. However, if the pulses were occurring at times 2 or 3, the critical bias would be exceeded, the tube would immediately become conductive, and retrace would start at that point. The oscillator has been "forced" into step with the repetition rate of the sync pulses.



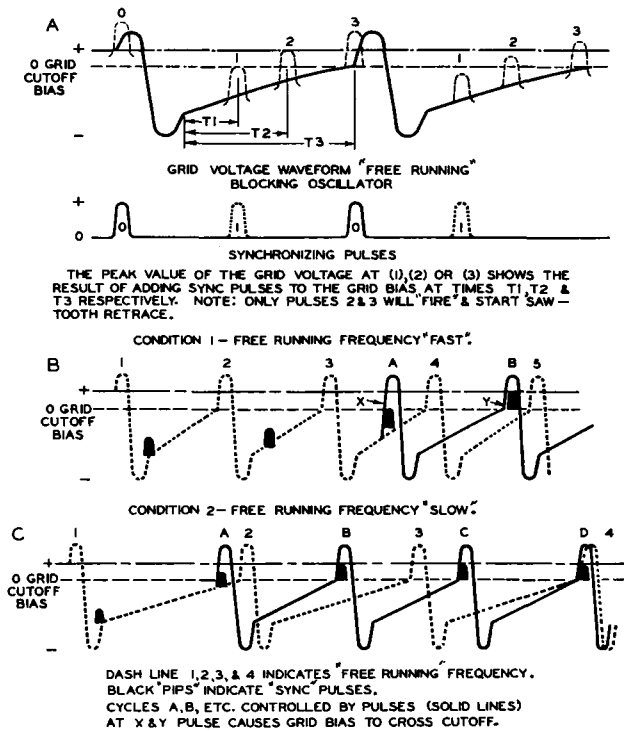

Fig. 68. Pulse Control of the Blocking Oscillator

At this time it is interesting to examine the differences in this forced drive action under the conditions; (1) oscillator running faster than sync pulse rate, (2) oscillator running slower than sync pulse rate.

Figure 68B shows the condition of an oscillator which is running faster than the sync pulse rate. A number of cycles occur before the contribution of the pulse to the grid voltage wave is able to "fire" the tube. This action occurs at point x. It would appear that after this "lock in" has taken place, and repetition of action ensues as at y, control would be satisfactory. Such is not the case, for two reasons, namely:

1. The synchronizing pulses are occurring during the active scanning interval, and the picture is divided in two during the "blanking" interval. This phenomenon is similar to the frequent occurrence in old time movies when the projector "got out of frame" and the picture was divided in the middle with the hero's feet at the top of the screen and his

head at the bottom. This situation will be taken up in greater detail later when we discuss "controls" and the effect of their maladjustment.

2. In the fast running condition, the oscillator is very susceptible to "triggering" by static and automobile ignition interference. The effect on the picture is to "tear out" horizontal lines.

Figure 68C shows the condition which occurs when the free running frequency of the oscillator is lower than the sync pulse repetition rate. It is evident that "lock in" occurs much faster and a more stable operation ensues. This is a desirable mode of operation because the sync pulses always occur at the end of scanning action and the possibility of "parting" the picture, as described, cannot occur.

For control of the blocking oscillator just described, the sync pulses are in the positive direction. When we reach the study of pulse clipping and amplification, we will find that a sync pulse can be made either positive or negative with respect to ground (or the chassis), depending upon the number of tubes through which it passes. Some economy in the number of tubes may occur if the pulse is negative when it reaches the pulse generator grid. Such a condition is ideal for the cathode-coupled multivibrator.

**PULSE CONTROL OF THE CATHODE-COUPLED MULTIVIBRATOR.** Figure 61 and the text of pages 45, 46 and 47 indicate that "tripping", or discharge action of the cathode-coupled multivibrator, is initiated by a negative voltage pulse on the grid of the first tube. Once this action starts, it immediately receives a contribution in the form of additional negative voltage from the cathode bias resistor, which is common to both tubes. While the control actions and principles just described for the blocking oscillator hold true, it is not feasible to show them in diagram form. As a matter of fact, the small step in the grid voltage curve of Figure 61A (indicating the sync pulse contribution to the grid voltage), is really a matter of "poetic license" so to speak, since the action is so rapid and cumulative that it is not possible to tell where pulse control stops and the circuit takes over.

### SUMMATION OF PULSE CONTROL OF SCANNING GENERATORS

1. A positive synchronizing pulse is used to control the frequency of a blocking oscillator.

2. A negative pulse is used to control the frequency of a cathode-coupled multivibrator.

3. The free running frequency of the scanning oscillator should always be made just slightly less than the synchronizing pulse repetition rate. This is accomplished by adjustment of the "hold" or frequency control of the oscillator.

4. As the grid voltage of a pulse generator approaches the "trigger" point, the oscillator becomes increasingly sensitive to control by additional grid voltage. At this point the scanning can be "tripped" by interference. Special circuit combinations have been devised which are controlled by the "pattern" of the pulses, rather than by the individual pulses themselves. Such a system is relatively insensitive to interference, which seldom has a regular pattern, and its operation will be described when specific circuits are covered later in the course.

### REQUIREMENTS FOR SCANNING WITH ELECTROSTATIC PICTURE TUBES

It was pointed out in discussing the sawtooth scanning raster, that we were considering the motion of the spot or "pencil" of electrons at the picture tube fluorescent screen surface.

In an electrostatic tube, we can produce the desired raster by applying sawtooth voltage waves of the shape and time requirements shown in Figures 65 and 66 respectively to the horizontal and vertical deflecting plates.

The use of electrostatically deflected picture tubes, until recently, has been confined to the 7-inch diameter size or smaller, usually employed in table models selling in the lower price bracket. As this is being written, a 10-inch diameter, electrostatically deflected tube is being made available to the design engineer, and will undoubtedly be introduced in console type receivers.

The popular 7-inch type 7JP4 requires deflection voltages of the order of 200 volts per inch of picture tube screen to move the beam. The picture size on this tube is 4x5-1/2 inches. This means that horizontal deflecting plates will require a "peak to peak" voltage of the sawtooth wave of 5.5 times 200, or 1100 volts.

The sawtooth generators described usually are not designed to give voltages of this order directly. For this reason, amplifiers are used between the scanning generator circuit and the picture tube deflecting plates. As has been shown on pages 10 and 11, the deflection and centering circuits of the tube are of a balanced or push-pull type. Therefore the deflection amplifier feeding them is made of the push-pull type, usually by means of a phase inverter. Typical electrostatic deflection systems will be covered in detail later.

### REQUIREMENTS FOR SCANNING WITH ELECTROMAGNETIC PICTURE TUBES

We have seen that electrostatically deflected tubes require only an amplified sawtooth wave of voltage to produce the desired pattern or raster. Magnetically deflected tubes, however, impose a new set of requirements due to the nature of the deflecting coils.

Pages 15 and 16 explained in detail the theory and mechanical arrangement of the horizontal and vertical deflecting coils. It was stated at that point, that a sawtooth wave of current through the coils could be made to produce the desired raster.

To re-state this in another manner: - The amount of deflection of an electron beam, in electromagnetically deflected cathode-ray tubes, is dependent upon the strength of the magnetic field produced by the external deflecting coils. The magnetic field produced is proportional to the amount of current passing through the coils and these fields cross the path of the electron beam within the neck of the tube.

We must supply a linear sawtooth of current through the coil so that the electron beam will trace the proper raster under the combined influence of the horizontal and vertical deflecting coils. Such a deflection will not be

produced by a linear sawtooth of voltage across the terminals of either coil.

To understand why this is the case let us assume for a moment that the deflecting coil is a pure inductance (no resistive component). Reviewing our theory of "Inductance" and its circuit function we find:

1. Surrounding an inductance carrying current, there exists a magnetic field whose intensity at any point is proportional to strength of the current.

2. If the current is altered in value, the magnetic field is also altered, increasing or decreasing with corresponding changes of the current.

3. This magnetic field constitutes a storage of energy and requires for its production a definite expenditure of energy, dependent on the amount of magnetic flux and the ampere-turns of the circuit.

4. The expenditure of new energy is required only when we are attempting to change the amount of flux associated with the inductor, by changing the current through it. This energy appears as a voltage of "self-induction" which opposes the voltage impressed on the circuit to start the current flow.

5. When current is increasing, due to an increase of the externally applied voltage, this opposing voltage of "self induction" tends to retard the flow of current, and make it "lag" behind the increase of applied voltage.

With this brief "refresher" in magnetic theory, we are ready to determine the shape of voltage wave which will be required across a pure inductance to produce a sawtooth wave of current through it. The effect of the resistance of the coil, and the consequent wave shape modification to account for it, will then be discussed.

In Figure 69, we see the resultant shape of current wave which would flow through a pure inductance if a symmetrical square wave of voltage were to be applied across its terminals. This type of wave, as we have seen, can

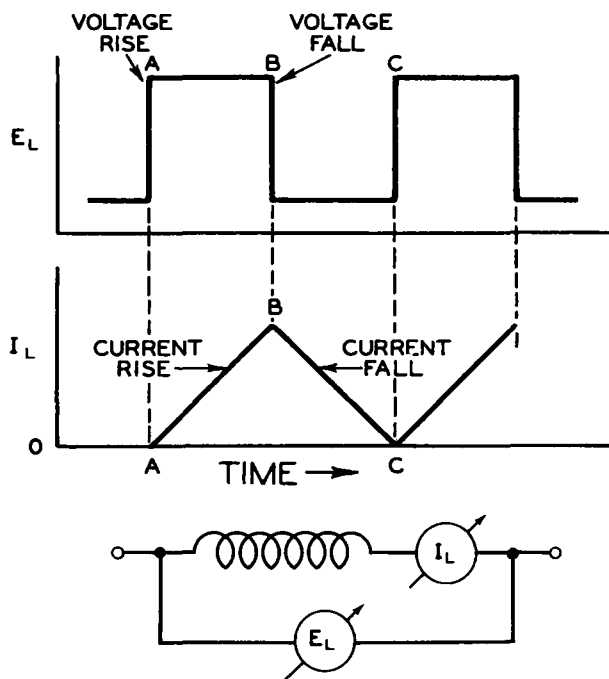

Fig. 69. Linear Rise and Fall of Current through a Pure Inductance under the Application of a square Voltage Wave

be developed by a conventional or symmetrical multivibrator. At point A the voltage has suddenly been applied to the coil in much the same fashion as though a switch had been closed to connect the coil to a DC source of potential, such as a battery.

It will be noted that the current through the coil did not rise immediately to maximum. The voltage of self induction of the coil opposed the sudden change, and the current therefore increased in a linear fashion over the portion of the cycle when the applied voltage was steady. At point B, the impressed voltage was suddenly removed (switch opened). At this point the current did not fall immediately to zero, since it was maintained by the energy "stored" in the magnetic field. The voltage of self induction of the coil served as the driving potential to produce the linear fall of current from point B to point C.

We have now produced a "triangular" wave of current through the coil. If we can lengthen the "rise" portion of the curve with respect to the "decay" portion, we have attained our objective of producing the desired sawtooth scanning current wave. This can be

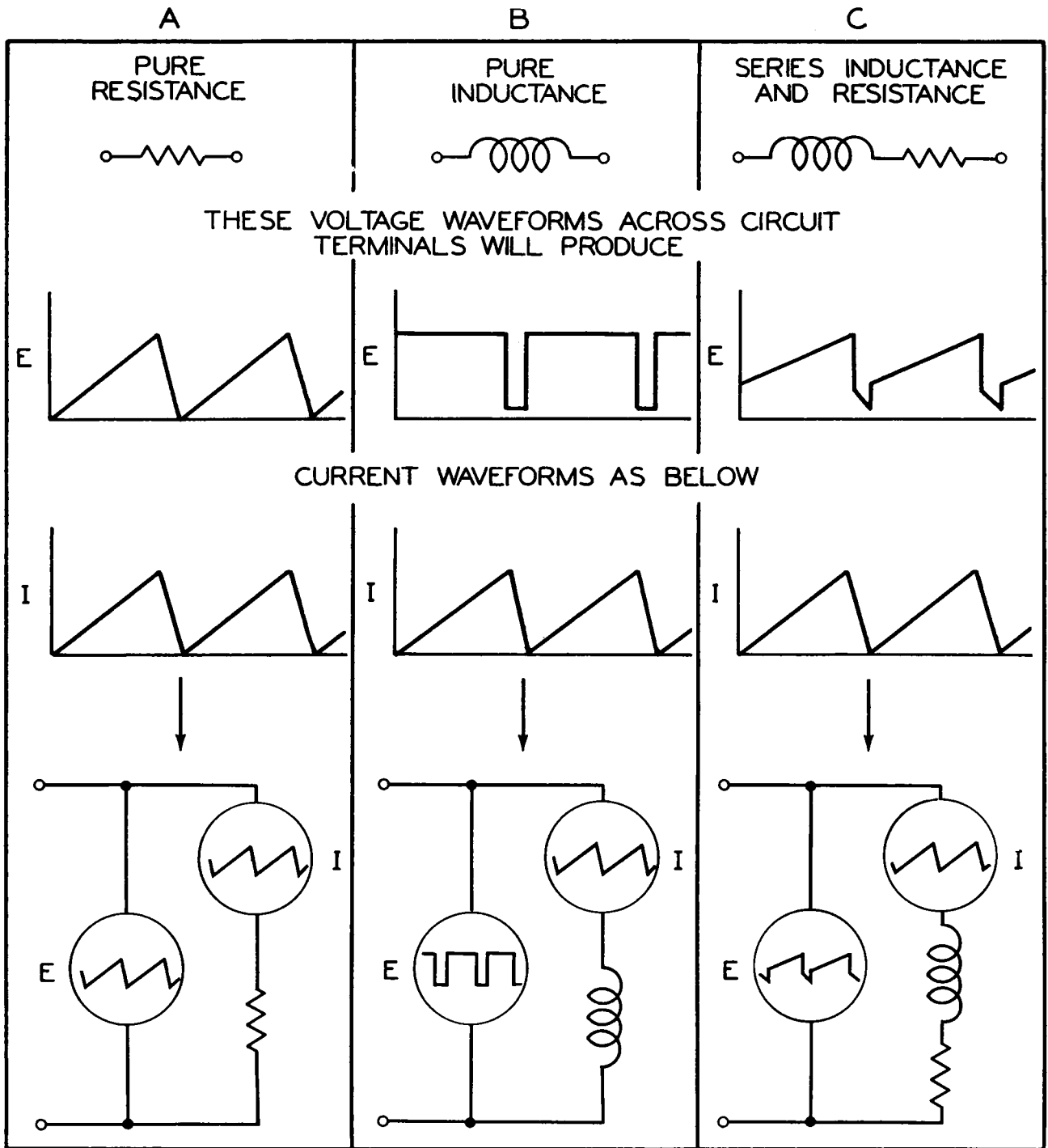

Fig. 70. Voltage and Current Waveforms - - Inductance and Resistance Circuits

accomplished by making the impressed voltage wave asymmetrical as shown in Figure 70B.

resistance of the windings, as regards the required voltage waveform to produce a sawtooth of current.

Since it is not possible to build a practical deflection coil as a pure inductance, it is now necessary for us to consider the effect of the

Figure 70 illustrates three types of circuits, and shows the voltage wave form which it is necessary to impress, in order to produce

a sawtooth wave of current through each circuit.

Figure 70A shows the case of a pure resistance. Here the current is in phase with the voltage, and a sawtooth wave of voltage impressed across the resistor will cause a sawtooth wave of current through it. Energy loss occurs only in the form of heat, and the voltage required to produce a certain current is equal to the IR drop as determined by Ohm's law.

Figure 70C shows the circuit represented by a practical deflection coil. The voltage waveform will be seen as a combination of the sawtooth of A and the rectangular wave of B. In reality, this shape is the sum of an instantaneous pulse and a sawtooth. We might think of its function as follows:

1. The sawtooth or linear rise portion of the wave tends to produce a sawtooth wave of current through the resistive part of the circuit.
2. The instantaneous pulse portion of the wave forces a sawtooth wave of current through the inductive part of the circuit.

To produce this combination wave shape, additional circuit elements are added to the sawtooth capacitor charging circuit. When this is done, the circuit is then known as a "peaking" type of wave-shaping circuit. By choice of capacitor and resistor values, it is possible to make either the sawtooth portion of the wave

or the impulse portion predominate. The details of its action will be described later.

It is interesting to note that the deflection requirement, of having one part of the wave predominate over the other, is dictated by fundamental differences between the horizontal and the vertical deflection coils.

In the vertical deflecting coil of a typical television receiver, the resistive component predominates over the inductive component. For this reason, the sawtooth portion of the wave predominates over the impulse portion. As an example, this coil might have a resistance in a practical case of 68 ohms with an inductance of 50 millihenries. When operating at the 60 cycle retrace rate, this presents a predominately resistive circuit.

In the horizontal deflecting coil of the same receiver, the conditions are reversed and the inductive component predominates. The impulse portion is more important and the required wave shape approaches that of Figure 70B. To continue the practical example, we would find a resistance of only 14 ohms with an inductance of 8 millihenries. Since this coil operates at the much higher frequency of 15,750 cycles per second, the circuit is essentially inductive.

Figure 71 represents a comparison, in block diagram form, between the basic elements of electrostatic and electromagnetic scanning circuits.

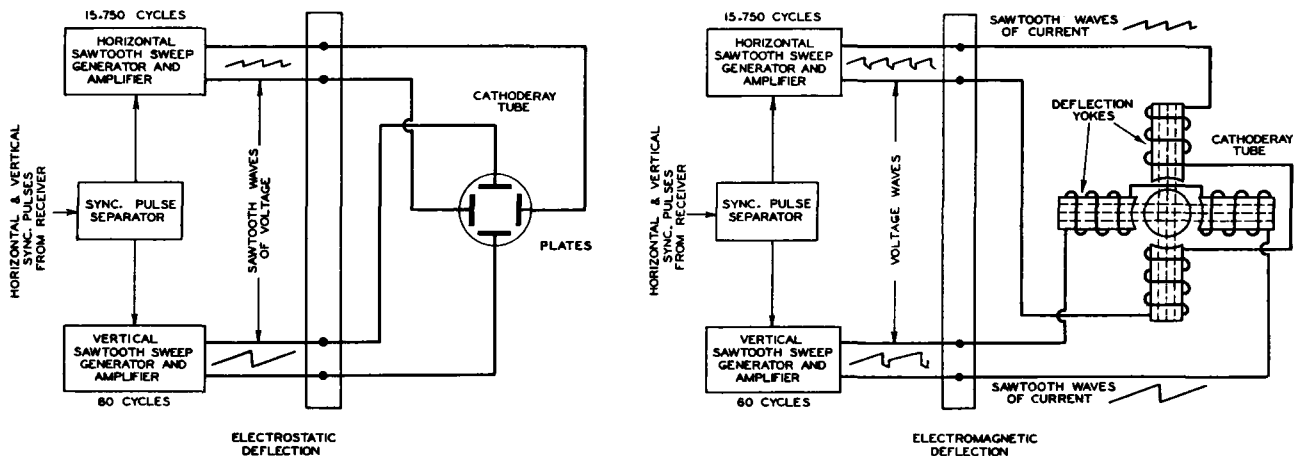

Fig. 71. Electrostatic and Electromagnetic Scanning Systems

**PEAKING CIRCUITS FOR ELECTROMAGNETIC DEFLECTION.** A very simple change in the discharge tube circuit, which has been previously described and shown in Figure 64, makes it possible to generate the combination sawtooth and impulse wave required for electromagnetically deflected scanning.

The modified circuit is shown in Figure 72, and consists of the addition of resistor R2 in series with the discharge capacitor C2. The circuit action will be described in sequence:

1. The sawtooth forming capacitor C2, is charged from the B+ source through resistors R3 and R2. This charging action takes place during the portion of the cycle when the tube is not conducting.

2. The output voltage waveform of the circuit is taken across the series combination of R2 and C2. R2 is known as the "peaking" resistor.

3. During the charging portion of the cycle, the voltage across the capacitor is a sawtooth wave as has previously been explained.

4. When the tube suddenly becomes conductive due to a positive pulse on its grid, the voltage across C2 and R2 is suddenly shunted by the low plate resistance of the tube.

5. The voltage across the capacitor cannot change instantly, since its discharge path through R2 and the plate resistance of the tube is not zero. The difference in voltage must therefore appear suddenly across peaking resistor, R2. After this initial sudden change of voltage, the capacitor discharges exponentially,

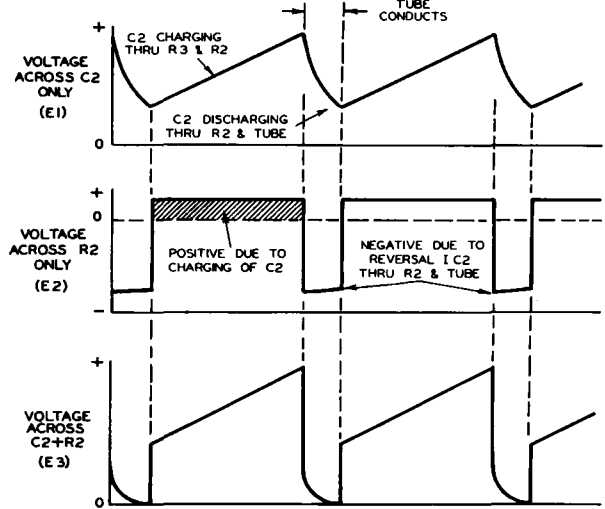
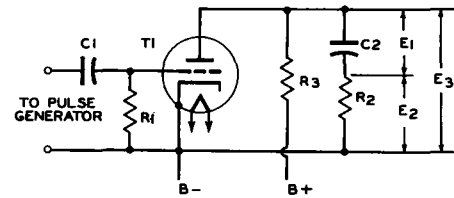

Fig. 72. Representative Peaking Circuit

through R2 and the tube, until the tube again becomes nonconductive.

6. As the tube is cut off, the B+ potential is suddenly applied to the capacitor through R2 and R3 in series. Again, the capacitor voltage cannot rise instantaneously. The voltage across R2 must once more change abruptly after which the capacitor charges through R2 and R3 in its normal sawtooth fashion.

By changing the values of R2 and C2, the ratio of the amplitude of the peaking impulse to that of the sawtooth can be adjusted to match the inductance and resistance requirements of the particular deflecting coil.

## SECTION II CATHODE RAY — BEAM DEFLECTION SYSTEMS

### CHAPTER 8. DEFLECTION SYSTEMS - COMMERCIAL APPLICATIONS

#### A TYPICAL ELECTROMAGNETIC DEFLECTION CENTERING AND FOCUSING CIRCUIT

Pages 10 and 11 of Chapter 1 illustrated and described the circuits for the control of beam centering in both horizontal and vertical directions in the case of the electrostatic type of picture tube. Pages 13 through 17 described the methods of focusing and deflecting the electron beam in an electromagnetically controlled picture tube. The circuits used for the control of focusing and centering of electromagnetic tubes were purposely not shown at that time, since they are inter-related with the action of sweep and deflection circuits and with the peculiar voltage waveform requirements of electromagnetic deflection.

Figure 73 shows the schematic diagram of the picture tube control circuits in a popular type of receiver design. It has been drawn in slightly different form from the presentation of service manuals in order to clarify circuit study. The circuit has been simplified to combine electrolytic capacitors in one unit at each point on the diagram where they occur as a single by-pass value. In the actual receivers, these units are often in separate cans in order to provide radiating area for the high ripple currents encountered.

**FOCUS CONTROL ACTION.** On pages 14 and 15 the action of the focus coil, L1 of Figure 73, was described and illustrated. By controlling the current through the coil, as determined by the setting of the variable resistor R1, the electron beam paths are brought together to form a very small, concentrated spot at the surface of the fluorescent screen. In the circuit illustrated, a high current coil of relatively low resistance (250 ohms) has been used. This coil, together with the ion trap electromagnet coils, is placed in the negative return lead of the power supply system and carries a large portion of the total "B" current. In this example, the average current through the coil is approximately 115 ma. Other receiver designs may use focus coils having more turns of finer wire, hence higher resistance, in other parts of the supply circuit. Although the circuit shows R1 as a single variable resistor, this control is often part of a network of series and parallel resistors to achieve smoother control action.

As will be noted in Figure 22, page 17, the focus coil is mounted in such a manner that

its axis can be rotated relative to the axis of the picture tube. We will see later that this serves two purposes; the positioning of the spot so that it is centered on the fluorescent screen and also, in some receiver designs, a fixed control of the range of action of the "back mounted" centering controls.

**ION TRAP CIRCUIT:** Ion trap action was described and illustrated on pages 16 and 17. In this particular circuit, the ion trap magnet coils (L2) are shunted by resistor (R2). This shunt is used because the ion coil current for proper operation is less than the focus coil current (approximately 105 ma.).

Some of the latest receivers appearing on the market are employing permanent magnets of the "Alnico" type rather than electromagnets, for the ion trap action. The permanent magnet ion trap assembly is independent of the power supply circuits of the receiver and is another example of simplification in television receiver design.

**VERTICAL CENTERING ACTION:** The vertical centering circuit, shown in simplified form in inset A, Figure 73, consists of a series arrangement of the vertical deflection coils (L3), the vertical output transformer secondary (L4), and a source of DC voltage from the potentiometer R5. R5 is provided with a center tap, and it will be seen that, as the contact arm passes this center point, the voltage introduced into the series circuit changes polarity. In this way it is possible to produce a DC polarizing current through the deflection coils in either direction, causing a steady magnetic field bias to exist in the deflection system. The sawtooth scanning current operates about this bias as a center point, and the picture can be moved up or down on the face of the tube by adjustment of R5.

It is interesting to note that the by-pass capacitor (C1), across the centering potentiometer, has an unusually large value (1000 mfd). It serves a dual purpose: (a) to keep any residual hum originating in the filter system of the power supply from entering the vertical scanning system and thereby causing interference with the 60 cycle scanning action; and (b) to keep the combination sawtooth-pulse voltage wave of vertical scanning from interfering with the operation of the video and audio amplifier systems through introduction of ripple into the "B" supply circuits. While this capacitor has been rated in microfarads as a matter of con-



## CATHODE-RAY - - BEAM DEFLECTION SYSTEMS

venience, the design engineer specifies its measurement in terms of impedance over the frequency range which it must by-pass. This fact is mentioned because the actual value in microfarads may vary greatly as measured by a bridge or capacitance tester, and yet have sufficiently low impedance to do an adequate by-passing job.

**HORIZONTAL CENTERING ACTION:** Horizontal centering circuits in pre-war receivers were usually of the same type as that just described for vertical centering (a center-tapped wire-wound control carrying high current in the "B" return). In post-war receivers this has been abandoned in favor of an expedient which allows circuit simplification.

Inset B, Figure 73, shows, in simplified form, that portion of the large diagram which governs horizontal centering. As before, we find a series circuit consisting of the horizontal deflection coils (L4), the secondary of the horizontal output transformer (L6) with its shunt "width" control coil (L7), and the source of centering voltage, potentiometer R6. In this circuit, however, the DC bias current through the horizontal deflection coils cannot be made to reverse in direction as was possible in the case of the vertical centering system.

To obtain the equivalent of control in both directions, use is made of the fact that positioning of the focus coil, in its mounting, can exert a magnetic field bias on the electron beam. In practice, when initial receiver installation is in process, the following steps are taken:

1. The horizontal centering control, potentiometer R6, is first set in the middle of its range.
2. The position of the focus coil is adjusted in its mounting to center the "raster" in the picture area.
3. Adjustment of R6 will now serve to make minor correction of the picture in the horizontal direction (right or left). The focus coil position has provided a magnetic field bias which is equivalent to the introduction of an opposing current to that flowing in the series deflection circuit, due to the initial setting of potentiometer R6.

There appears to be a trend, as evidenced by the latest receivers appearing on the

market, to dispense entirely with the use of potentiometer type centering controls.

In these sets, mechanical adjustment of focus coil position has been improved by the use of four corner adjustment screws. These screws have been provided with spring backing to assure that their adjustment will not change. Access to these screws is provided from the rear of the receiver without the necessity of removing the cabinet back panel. It is possible to make either horizontal or vertical centering corrections by these purely mechanical adjustments.

### HORIZONTAL SWEEP DAMPING CIRCUITS

The horizontal output circuit of Figure 73 will be recognized as the high voltage supply system described on pages 29 and 30, which utilizes the collapse of magnetic energy in the horizontal output transformer and horizontal deflection yoke. No explanation was given at point of the action of the 5V4G "damping" or "reaction scanning" tube. Its function, as well as the action of the horizontal linearity control (inductor L8), and horizontal width control (inductor L7), will now be considered. This tube, together with its associated circuit components, is used to stop or "damp out" oscillations in the system, and help produce the required linear current sawtooth through the deflection coils.

Referring again to Figure 65, which illustrated the timing requirements of the horizontal sawtooth current wave, it will be seen that retrace must be accomplished in the extremely short time of 7 microseconds. Since the deflection coil system is predominately inductive, it is necessary to employ a different method of operation than that of the lower frequency vertical system. To obtain the rapid reversal of current through the horizontal deflection coils, the output transformer and deflection coil circuit is tuned to a frequency of approximately 71 kilocycles by the associated circuit capacitances. This frequency is used because one half cycle of oscillation is equal to the required retrace time of 7 microseconds.

The current through the deflection coils is at its maximum value at either the extreme left or extreme right of the picture frame, the axis or zero point occurring at the center.

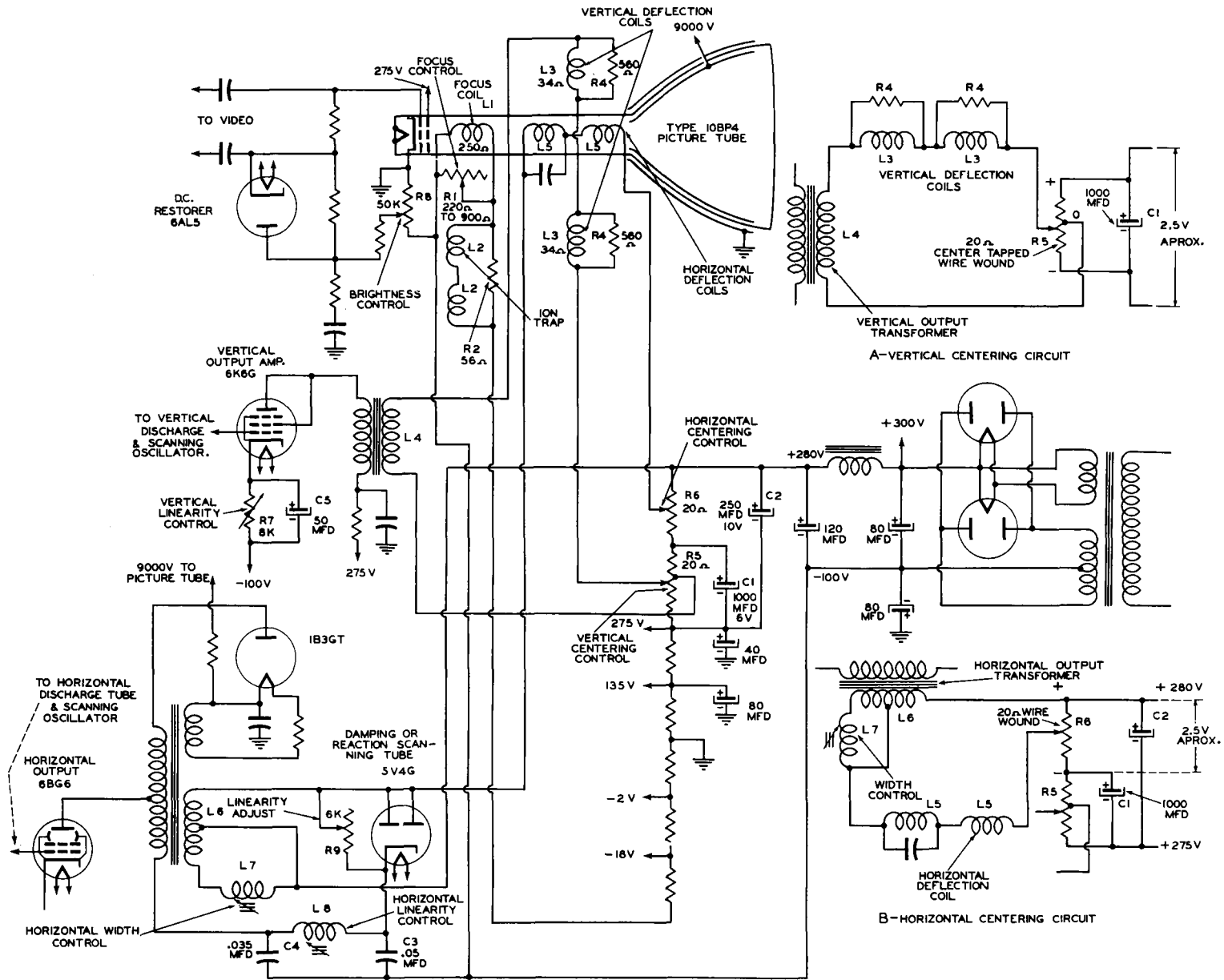

Fig. 73. A Typical Electromagnetic Deflection System

## CATHODE-RAY - - BEAM DEFLECTION SYSTEMS

When the right hand end of the trace is reached, the horizontal output tube is conducting high plate current and a maximum of magnetic energy is stored in the deflection coils. At this instant, a negative pulse arrives at the grid of the horizontal output tube from the plate circuit of the horizontal discharge tube, and the output tube plate current is suddenly cut off. The magnetic field in the transformer and deflection starts to collapse at a rate determined by the resonant frequency of the system (71 kc). This will shock-excite the circuit into a state of damped oscillation, which if allowed to continue would produce a wave form of current as shown in Figure 74.



Fig. 74. Horizontal Deflection Coil Oscillation Which Would Occur If Damping Tube Were Not Used

Continuation of this oscillation would cause serious distortion of the left hand side of the picture. An "absorption" or damping device is used to "kill" the oscillation during the 10 microsecond period in which the picture tube is "blanked". This function is provided, in the circuit of Figure 73, by the 5V4G damping or reaction scanning tube.

Immediately, as the output tube plate current is cut off by the negative scanning pulse, the induced voltage, caused by the collapsing magnetic field, becomes negative in polarity at the plate of the damping tube. The tube will not conduct and there is no load imposed upon the circuit, allowing it to oscillate for one half cycle at its resonant frequency of 71 kc (approximately 7 microseconds). This causes the current through the deflection coils to reverse to a maximum in the other direction and accomplishes the rapid return trace. The circuit would continue to oscillate for many cycles if it were not for the damping tube which comes into action during the second half cycle.

As the current reverses through the deflection coils to start the second half cycle of oscillation, the voltage of self induction also reverses and the polarity becomes positive at the plate of the damping tube. This tube starts conducting and acts as a load across the term-

inals of the deflection coil system, preventing any further tendency toward oscillation. The current through the tube decays at a linear rate determined by the circuit constants. This linear current starts the next active scanning wave for the visible or "unblanked" trace.

If no additional current were supplied to the circuit from the horizontal output tube, the electron beam would come to rest at the center of the picture tube as the current through the damping tube decreased to zero. The latter portion of the current decay curve departs from the desired linear sawtooth form. To overcome this non-linearity, conduction of the horizontal output tube is so timed by the scanning generator and discharge tube, that it starts contributing current to the deflection coils before the original current has completely decayed.

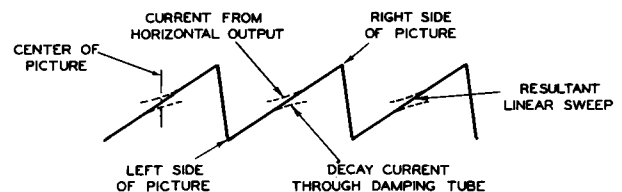

Fig. 75. Current Waveforms In Horizontal Reaction Scanning

This current contribution from the horizontal output tube, which deflects the beam from the center to the right hand side of the screen, is so shaped at its start to correct the non-linearity of the original decay current wave. As shown in Figure 75, the two current waves overlap at the center of scanning action, and the combination produces a coil current which is linear.

To summarize the circuit action to this point, note:

1. The damping tube, sometimes called a reaction scanning tube, allows one half cycle of natural resonant oscillation to occur in the deflection circuit, after which it loads the circuit and prevents further oscillation.
2. The first half cycle of oscillation accomplishes beam retrace in the required 7 microseconds.
3. Decay of current through the damping tube produces the first half of the 53 microsecond active trace.

4. The horizontal output tube starts to contribute power to the system before final decay of the damping tube current, and produces the final half of the active scanning wave.

5. At the end of the active scanning cycle, a negative pulse causes plate current cut-off of the output tube, and starts a new oscillation to repeat the cycle.

**CONTROL FUNCTIONS IDENTIFIED WITH HORIZONTAL SWEEP DAMPING CIRCUITS:** Three adjustable circuit components appear associated with the damping tube of Figure 73. These are the horizontal linearity control (inductor L8), the horizontal width control (inductor L7), and the linearity adjustment (resistor R9).

**HORIZONTAL LINEARITY CONTROL.** The network comprised of L8, C3, and C4, performs two functions in this circuit. It provides a means of operating the horizontal output tube at a higher plate voltage than that of the power supply, and, at the same time, functions as an adjustable means for making small corrections in the shape of the active sweep section of the sawtooth current wave.

Since these two functions are inter-related, an explanation of the voltage addition action will precede the description of the control operation. It will be noted that the plate voltage of the horizontal output tube is supplied by a series circuit consisting of the primary of the output transformer, the inductor L8 and the cathode-to-plate conducting path of the 5V4G damping tube. The damping tube is conducting over the major portion of the sawtooth as shown in Figure 75. Capacitors C3 and C4 are charged during this conduction period and then discharge while the damping tube is not conducting. In this manner, the plate current of the horizontal output tube is maintained over the portion of the cycle when the damping tube is not conducting.

The charge on these capacitors is greater than the "B" supply voltage because the rectified surge or "kickback" of the deflection coils is added to the charge placed upon them by the "B" supply. In a typical receiver, employing this circuit, the output tube plate voltage is approximately 50 volts higher than the "B" voltage.

It will be noted that capacitors C3 and C4 do not seem to be high enough in value to

act as storage capacitors. This fact is a clue to the action of the circuit as a linearity control. During the first half of the trace period, the voltage across C3 rises due to the rectified deflection coil "kickback", and during the second half of the period, the voltage falls due to the current demand of the horizontal output tube which is conducting at that time. In this manner, a ripple voltage of the same frequency as the sawtooth is impressed on the plate supply of the horizontal output tube. By shifting the phase of this ripple with respect to plate current requirements of the output tube, it is possible to modify the shape of the output current wave of the tube. Changing the value of inductor L8, by adjustment of a powdered iron core, controls the phase of the ripple current and permits minor adjustments of horizontal linearity. Other controls which affect horizontal linearity are, the horizontal drive control (to be described later), the linearity adjustment (R9), and the horizontal width control (L7). While the major effect of certain of these controls is for another purpose, they are interdependent and the adjustment of one of them often necessitates re-adjustment of the others.

**LINEARITY ADJUSTING RESISTOR.** Resistor R9 is known as a damping resistor and is provided with a series of taps rather than being made continuously variable. This adjustment is primarily intended as a factory means to compensate for manufacturing variations in the deflection yoke and output transformer. It controls the linearity of the trace on the left hand side of the picture only.

**HORIZONTAL WIDTH CONTROL.** Variable inductor L7 shunts a portion of the secondary of the horizontal output transformer (L6). This controls the output voltage and hence the extent or "width" of the sweep. Since it also has a minor effect on the phase relations in the plate of the output tube, it causes slight changes in the linearity of the right hand side of the picture, as width changes are being made.

**HORIZONTAL DRIVE CONTROL.** The horizontal drive control is a variable resistor which constitutes the "pulse" forming element in the plate circuit of the horizontal discharge tube. An explanation of its action appears on page 60. Figure 34 on page 29 shows its application to the circuit under discussion. The value of this resistor determines the ratio of the negative pulse amplitude to the sawtooth amplitude impressed on the grid of the hori-

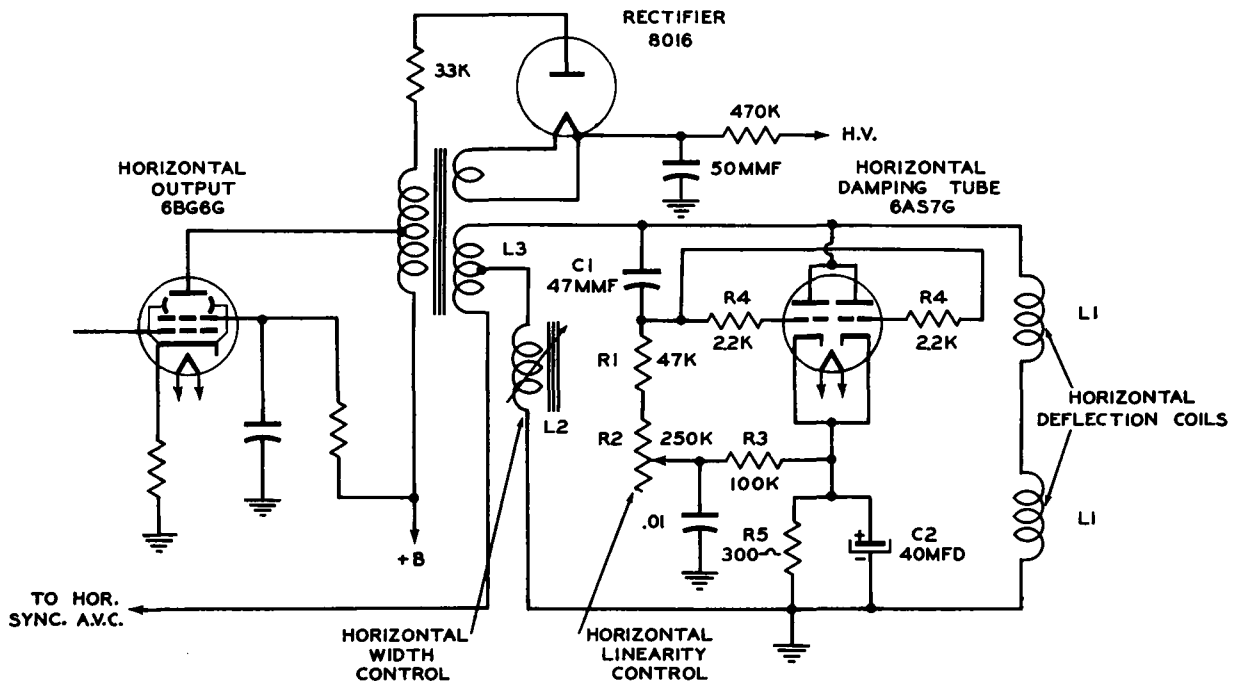

Fig. 76. Use Of Triode As Horizontal Damping Tube

zontal output tube. It can, therefore, control the point on the trace at which the output tube conducts. Increasing its value causes a greater picture width, crowds the right side of the picture and stretches the left side. Adjustment may require a new setting of the horizontal "width" control.

**USE OF THE TRIODE FOR HORIZONTAL DAMPING:** In the circuit just discussed, a power rectifier type of diode (5V4G) was used to damp the oscillation produced in the horizontal deflection coil system, by cut-off of output tube plate current. In some receivers, a triode is used as the damping tube, since the presence of a control grid gives the designer another opportunity to modify circuit action to obtain better sweep linearity.

Figure 76 illustrates a circuit application of the 6AS7G, low- $\mu$ , dual, power triode, as a damping tube. To act effectively as a damping tube, the plate resistance must be very low during the conduction period. The 6AS7G was designed especially for voltage regulator and television work and meets this requirement.

The circuit conditions at the instant of plate current cut-off in the horizontal output

tube are similar to those just described for the 5V4G. The natural resonant frequency of the deflection circuit is approximately 71 kc. The first half cycle of oscillation finds the plate of the tube negative and no plate conduction can occur. During this time (7 microseconds), horizontal retrace takes place.

On the next half cycle, the plate of the tube becomes positive, causing the following series of events:

1. Plate current immediately starts to flow, since no charge exists on C1 and the grid is at cathode or zero bias. The tube damps the oscillation.
2. Discharge of the energy, stored in the vertical deflection coils, through the tube begins to initiate the next active retrace.
3. At the start of conduction, capacitor C1 has been charged through the internal grid to cathode path of the tube. Resistors R4 in the grid circuit limit the grid current to a safe value.
4. The time constant of the discharge path, capacitor C1 and resistors R1 and R2, can be varied from 2 to 15 microseconds by the adjustment of R2.

5. The changing bias on the grid of the tube makes its plate resistance vary as scanning progresses, and allows the shape of the decay part of the curve of Figure 75 to be altered by adjustment of R2.

With this type of horizontal "linearity" control, the action is independent of the horizontal output tube plate circuit. Some interaction with the horizontal "width" control (L2 of Figure 76 occurs, however, and the setting of one may require the readjustment of the other.

The horizontal "width" control (L2) varies the proportion of the horizontal transformer output which reaches the deflection coils, thus controlling the sawtooth current strength and the width of the picture.

**VERTICAL OUTPUT AMPLIFIER AND DEFLECTION CIRCUITS:** The vertical deflection system of Figure 73 is much less involved in its action than the horizontal system shown. A type 6K6G, triode-connected, is used as the output amplifier. Transformer L4 matches the plate impedance of the tube to the resistance of the vertical deflecting coil assembly.

Any tendency for shock-excited oscillations to occur following vertical retrace is nullified by the damping resistors (R4) which are connected across the vertical deflection coils (L3).

The proper shape of the combination sawtooth and pulse wave of voltage is supplied to the vertical output tube grid from a blocking oscillator having a "peaking" C-R circuit in its output.

The only circuit element of this system which we have not covered is the vertical "linearity" control (R7).

**VERTICAL LINEARITY CONTROL.** The grid voltage versus plate current characteristic of the triode-connected 6K6G is not a straight line over its entire range. The cathode bias resistor (R7) is made variable to shift the point of operation of the tube. As the operating point is shifted along its curve, changes in shape of the output scanning wave occur. These variations are sufficient to correct any lack of vertical linearity.

Since the gain of the tube varies as the bias is changed, this linearity adjustment will also affect height, and readjustment of the vertical "height" control may be required after linearity correction.

#### TYPICAL DEFLECTION CIRCUITS AS USED IN COMMERCIAL RECEIVERS

An analysis of the sawtooth forming deflection circuits employed in twenty-two of the most popular current television receivers shows that the basic types of vacuum tube sawtooth generators described on pages 40 through 50 have been used in many differing combinations. The type of deflection system chosen for a particular design depends upon a number of factors. Of these design considerations two are of primary importance in determining the choice, namely:

1. The method of beam deflection (electrostatic or electromagnetic) determines whether a sawtooth of voltage or a sawtooth of current is required. The electrostatic requirement is readily accomplished in the generator circuit and we therefore find less diversity between sets using electrostatically controlled picture tubes.

2. The type of synchronizing system or method of using the "sync" pulses to "lock in" the sweep generator is also a determining factor in the choice of deflection circuit. While the details of separating the pulses from the signal and utilizing them for sweep control will be taken up in detail later, at this time it will be necessary to note that there are two basic types of synchronizing circuits used in television receivers at present. These are known as "triggered" sync and A. F. C. (automatic frequency control) or "flywheel" sync. Triggered sync may use any of the types of sawtooth generators previously discussed while A. F. C. sync usually employs the sine wave generator discussed briefly on page 49.

In the analysis of present day receivers, mentioned above, it was found that two basic deflection systems have been used in sets employing electrostatic beam control; the cathode-coupled multivibrator, and the blocking oscillator.

CATHODE-RAY - - BEAM DEFLECTION SYSTEMS

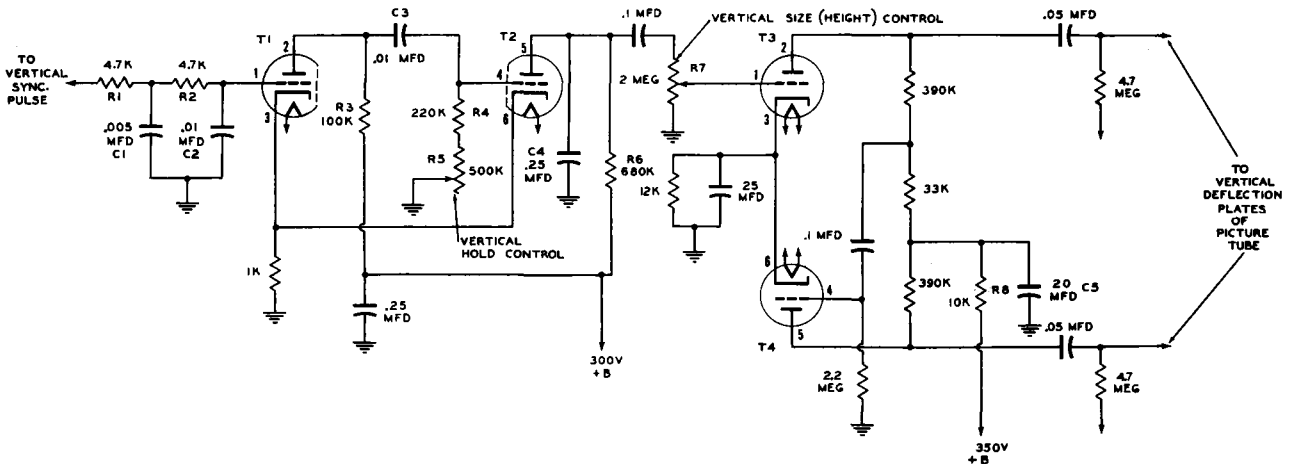

Fig. 77. Typical Vertical Deflection Circuit For An Electrostatic Picture Tube

**TYPICAL COMMERCIAL ELECTROSTATIC DEFLECTION SYSTEMS:** The requirements for electrostatic scanning, discussed on page 56, consist of the production of a sawtooth wave of voltage and its application to the deflection plates by a push-pull output circuit.

Two methods of meeting these requirements have appeared to date. The first, and most widely used, consists of a pulse controlled, cathode-coupled, multivibrator feeding a phase-inverted push-pull amplifier. The second method is an unusual adaptation of the blocking oscillator in which a single tube and its associated circuits fulfill all of the scanning requirements.

**ELECTROSTATIC DEFLECTION CIRCUITS USING THE CATHODE-COUPLED MULTIVIBRATOR.** The majority of electrostatic type television sets on the market, at present, employ the cathode-coupled multivibrator with a phase inverted amplifier for both horizontal and vertical systems. Since a number of differences in circuit constants and arrangement exist between the vertical and the horizontal systems, typical circuits of each will be discussed separately.

A Typical Vertical Deflection Circuit. Figure 77 shows a vertical deflection circuit which is typical of many receivers using the 7GP4 picture tube. Its action is as follows:

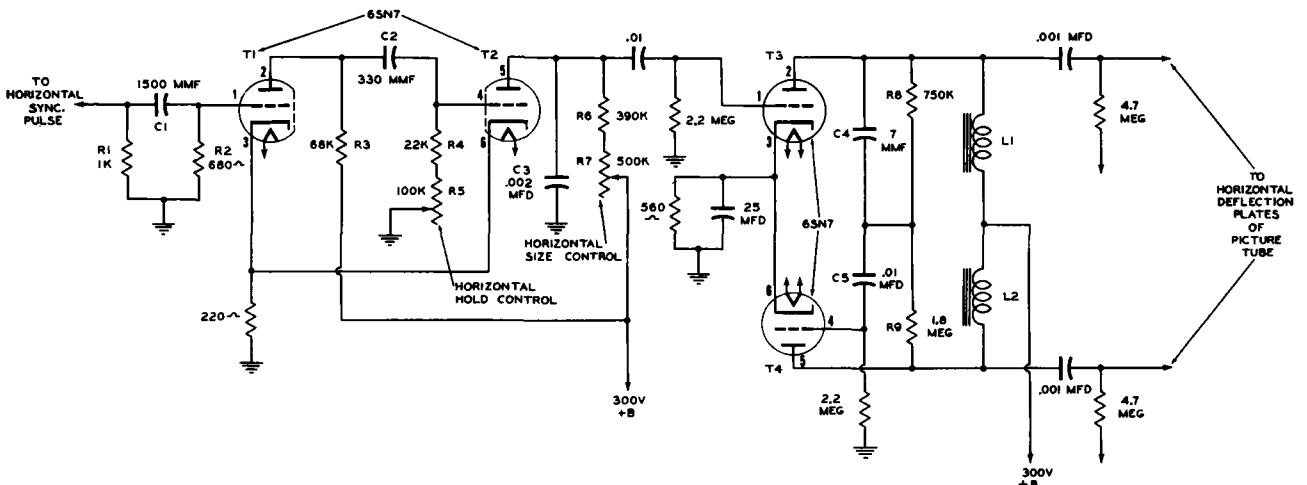

Fig. 78. Typical Horizontal Deflection Circuit For An Electrostatic Picture Tube



1. The vertical synchronizing signal, consisting of a series of pulses spaced as shown in Figure 66 (page 53), of negative polarization with respect to ground, passes through the network comprised of R1, C1, R2 and C2. This is known as an "integrating" circuit and its action is to add up all of the small "serrations" of the vertical signal as a voltage across capacitor C2, until the negative potential on the grid of T1 reaches a value corresponding to plate current cut-off. This "trips" the multivibrator circuit as described on pages 45 through 47.

2. The time constant, determined by the values of capacitor C3 and the sum of resistors R4 plus R5, controls the "free running" frequency of the multivibrator. R5 can readily adjust the frequency to "lock in" with the vertical sync pulse at 60 cycles per second and is called the vertical "hold" control.

3. During the interval between the "triggered" conduction pulses of T2, the sawtooth wave forming capacitor C4 is linearly charged from the "B" source through resistor R6. Firing of T2 by the "sync" pulse discharges C4, causing retrace.

4. Control R7 adjusts the input voltage impressed on the phase inverted, push-pull amplifier consisting of tubes T1 and T2 and since this control varies the output of the system it is known as the vertical "size" or "height" control.

5. The circuit associated with these tubes is of the same type as used in the audio system of many broadcast receivers and requires no further mention except to note:

- a. The coupling capacitors and load resistors are of such values that the circuit gain remains flat to the low frequency of vertical scanning (60 cycles).
- b. The plate decoupling capacitor (C5) has a higher value than would ordinarily be required for an audio system. This is necessary to keep the vertical sawtooth ripple out of the video and audio supply circuits.

This circuit has no "linearity" control. Such a control is not necessary because the sawtooth produced across C4 is sufficiently linear to provide good pictures.

A Typical Horizontal Deflection Circuit. Figure 78 illustrates the horizontal system employed in the same receiver as the vertical system of Figure 77. It is similar to the vertical system with the following exceptions:

1. The horizontal synchronizing signal, which consists of short time pulses (5 microseconds) at the end of each horizontal picture line as shown in Figure 65, are impressed upon the grid of T1 through the network comprising R1, C1 and R2. This is known as a "differentiating" circuit. Here the grid "triggering" voltage is taken across the resistor rather than across the capacitor as is done in the vertical circuit. It should be noted that the circuit sharpens the pulse and delivers a negative "stab" of voltage on the grid to "lock in" the oscillator at the proper time.

2. The time constant of "free running" oscillation, which is determined by the product of the value of C2 times the sum of R4 plus R5, is much shorter (1/262.5 of the vertical time) than the vertical time constant just discussed. This accounts for the lower values of capacitance and resistance as compared with those of Figure 77. Again, as in the vertical circuit, R5 can be adjusted to accomplish lock-in with the repetition rate of the "sync" pulses and is known as the horizontal "hold" control.

3. The size or width of the picture is adjusted by a voltage control in the plate circuit of T2 (R7 in series with "B" plus). This type of size control is sometimes used in both the vertical and horizontal circuits. It controls the charging voltage impressed on the sawtooth wave forming capacitor (C3) and hence the height of the wave.

4. The phase inversion circuit is a bit unusual as compared with familiar audio practice. Since the fundamental frequency of horizontal scanning is 15,750 cycles, the capacitance as well as the resistance balance must be considered. This accounts for capacitor C4.

5. A word or two of explanation is in order with regard to the use of the choke supply to the plates of T3 and T4. Many of the receivers on the market employ resistance coupling in this circuit as shown in the vertical circuit of Figure 77. Chokes can be employed in this case since the high frequency (15,750 cycles) allows an economical design in which the impedance of the chokes is high enough to have negligible shunting action across R8 and

## CATHODE-RAY - - BEAM DEFLECTION SYSTEMS

R9 as far as the horizontal line frequency is concerned. The advantages from the use of chokes are that the plate voltage, and consequently the output, is higher and also that their series impedance acts as an excellent isolation of the system from the audio and video supply.

**ELECTROSTATIC DEFLECTION CIRCUITS USING THE BLOCKING OSCILLATOR.** An interesting combination of circuits, designed around the blocking oscillator, have recently made their appearance in a table model, electrostatically deflected receiver. The vertical and horizontal systems are shown in Figures 79 and 80 respectively.

**VERTICAL DEFLECTION CIRCUIT USING THE BLOCKING OSCILLATOR.** Figure 79 combines a number of the circuit arrangements which we have covered separately in our consideration of sawtooth generators and deflection means. The circuit is conventional with regard to the blocking oscillator tube T1 and its associated circuit elements. The unusual features are found in the phase inverted, push-pull amplifier (T2-T3).

As in the cathode-coupled multivibrator just described, an "integrating" network (R1, C1, R2, C2) "sorts" the vertical sync pulse from the picture signal. In this case, however, the polarity of the pulse is positive with respect to ground. Control of the oscillator frequency by the pulse occurs as described on pages 54 and 55.

The adjustment of the oscillator "free-running" frequency is accomplished by control of the time constant of the C-R network in the grid circuit of the blocking oscillator tube T1. R5 in this circuit constitutes the vertical "hold" control.

Vertical "size" or "height" of the picture is controlled by adjusting the charging voltage impressed on the sawtooth wave-forming capacitor (C6) by means of the vertical "size" control (R7).

The phase inverted, push-pull amplifier (T2-T3) is a 6SL7GT high-mu twin-triode. The voltage division, to supply the grid voltage of T3, is by means of a capacitance voltage divider, consisting of C7 and C8, rather than the usual resistance divider found in the audio systems of broadcast receivers. "Contact" bias of both tubes is derived by grid current through the 10 megohm grid resistors (R8 and R9). The plate supply voltage of approximately 900 volts (from a bleeder across the high voltage supply) feeds the tubes through the 4.7 megohm plate resistors (R10 and R11). The actual voltage at the plate is approximately 450 volts. With this supply, it is possible to derive a plate swing of approximately 700 volts.

As in the case of the cathode-coupled multivibrator circuit, the linearity of the sawtooth voltage wave produced by this circuit is sufficiently good to assure satisfactory pictures. Therefore, no "linearity" control is required.

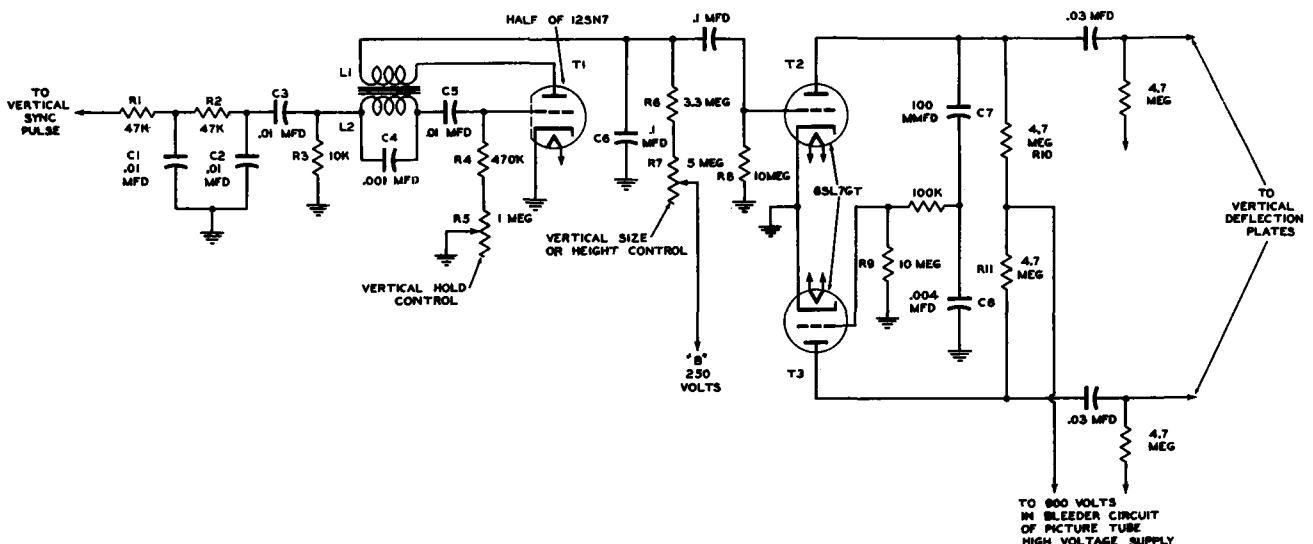
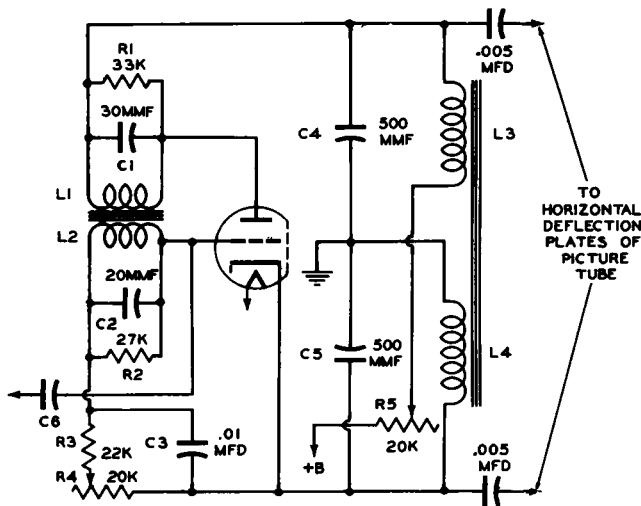

Fig. 79. Blocking Oscillator - Vertical Electrostatic Deflection Circuit

FIG. 80A



**Horizontal Deflection Circuit Using the Blocking Oscillator.** In the horizontal system employing the blocking oscillator, the deflection sawtooth voltages (balanced to ground) are developed in the oscillator itself. No amplifier stage is required. With a DC plate supply of only 250 volts this circuit delivers a balanced linear sweep of 1200 volts, peak to peak, to the deflection plates of the picture tube. This circuit differs from the customary blocking oscillator in that the cathode is not grounded. The plate-to-ground and cathode-to-ground circuits are symmetrically arranged with respect to ground or "B" minus. This accounts for its balanced or push-pull output.

In explanation of the action of the circuit (see Figures 80A, B, C and D) it will be instructive to follow, in sequence, the steps in the production of a sawtooth voltage wave.

FIG. 80B DISCHARGE OR "FIRING" CIRCUIT

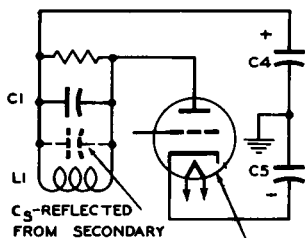

TUBE IS A VIRTUAL "SHORT" COMPLETING TUNED CIRCUIT BY CONNECTING C4 & C5, IN SERIES, ACROSS L1

FIG. 80C SAWTOOTH GENERATING CIRCUIT

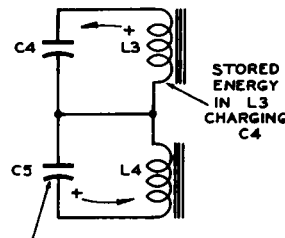

STORED CHARGE IN C5 DISCHARGING THRU L4

FIG. 80D VOLTAGE ACROSS C4

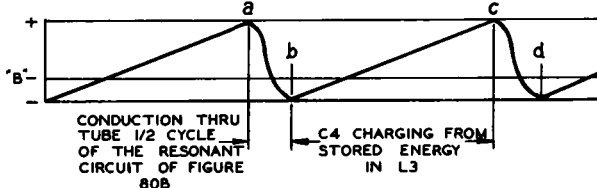

VOLTAGE ACROSS C5

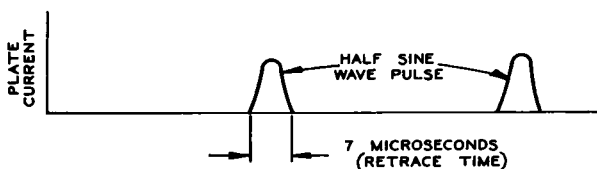
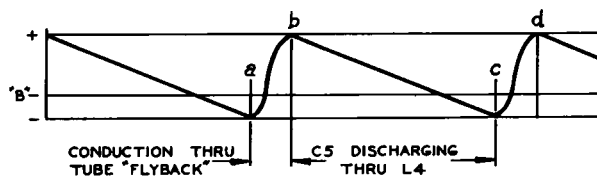

Fig. 80. Blocking Oscillator - Horizontal Electrostatic Deflection Circuit

1. Let us assume that we are at point "a" of Figure 80D, and that a positive sync pulse through C6 (Figure 80A) is starting to "fire" the tube. This causes plate current conduction, and provides a low resistance path for the discharge of capacitors C4 and C5 through the tube and the primary of the feedback transformer. (See Figure 80B.)

2. The plate winding of the transformer is the inductive branch of a tuned circuit. This tuned circuit consists of L1 with a group of tuning capacitances. These are: C1; Cs, the reflected capacitance from the secondary, or grid winding; and the series combination of C4 and C5. This tuned circuit is resonant to approximately 71 kc, corresponding to a frequency in which a half cycle is equal to the horizontal "flyback" time of 7 microseconds. (See Figure 65.)

3. When the tube conducts, as controlled by the positive sync pulse which has arrived at its grid, an oscillation starts in the plate circuit. This continues for the half cycle "a" to "b" of Figure 80D.

4. At the end of this half cycle, the grid has been driven to the point of plate current cut-off. The oscillation is now stopped for two reasons:

- a. The tube, acting as a switch, has removed the main tuning capacitors C4 and C5.

- b. Damping resistors R1 and R2 (Figure 80A) have suppressed any tendency toward further oscillation.

5. The swing of voltage, due to the half cycle of plate current oscillation, has caused a condition wherein the polarity of the charge on capacitors C4 and C5 has been reversed during the retrace period. We now find that at time "b" (Figure 80C), capacitors C4 and C5 are oppositely charged and the "high" side of C4 is negative with respect to ground. The cathode, or low side of C5, is positive with respect to ground.

6. Since the tube is now cut off, capacitors C4 and C5 have no other path, for charge or discharge, than the windings of the output chokes L3 and L4. These choke windings are shown on the same core in Figure 79A, as in the actual receiver. This construction is not essential for the operation of the circuit, and we have shown them as separate chokes in the partial circuit of Figure 80C. The inductance of these choke windings is high, and when such a high impedance choke is connected across a charged capacitor, the current flow is constant and the voltage across the capacitor changes linearly with time.

7. During the time interval from "b" to "c" of Figure 80D, capacitor C4 is being charged linearly by the voltage of self induction of choke L3. Current starts flowing from the "B" source to sustain the charging cycle.

8. During the same time interval, the charge in capacitor C5, due to the resonant swing of voltage during the "firing" cycle, discharges through choke L4 and produces the sawtooth voltage wave shown in Figure 80D. It is seen that the sawtooth waves across C3 and C4 are symmetrical and of opposite polarity. Hence, the requirements for balanced electrostatic deflection have been fulfilled.

Another method of explaining the sweep interval (time "b" to "c", Figure 80D) is to consider the chokes and their parallel sawtooth wave-forming capacitors as individual tuned circuits. These circuits are resonant at approximately 1/10th of the horizontal line frequency, or about 1600 cycles. The portion of a sine wave where the curve passes through zero and reverses voltage is very close to a straight line. At time "b", an oscillation

starts in these tuned circuits, but it is allowed to continue only for about 1/10th of a cycle. The wave produced is still on the essentially linear portion of the sine curve when the next firing interval occurs and starts a new wave.

The free running frequency of blocking action is controlled by the time constant of the grid circuit. Therefore, resistor R4 functions as a "hold" control.

Resistor R5 functions as a "width" or "size" control by adjusting the value of voltage applied to the plate circuit and consequently controls the amplitude of the sawtooth wave.

Coupling capacitor C6 serves to introduce the horizontal sync pulse which "trips" the proper time for synchronization with the transmitted signal.

**TYPICAL COMMERCIAL ELECTROMAGNETIC DEFLECTION SYSTEMS:** When we analyse the circuits of electromagnetically deflected television sets, which have appeared on the market to date, we find much greater diversity of design than in electrostatic systems. The chart of Figure 81 shows the result of such an analysis. The combinations selected by the design engineers for the horizontal and vertical systems respectively have been arranged in the order of the frequency of use in current production models. From this diversity of design, we can infer that the art is in a state of flux, and that as new models appear, many unusual circuit arrangements will be employed. The ultimate aim of the research and design departments is toward simplification and economy.

The combinations shown in the chart are each representative of receivers of several manufacturers. Example No. 1, for instance, has been employed with minor design differences by at least six companies. It will be instructive to examine the typical combinations and determine the operating principles of the various parts of the circuits.

**ELECTROMAGNETIC SYSTEM - - EXAMPLE 1.** The deflection system outlined, Example 1 in the chart of Figure 81, has been used in more models than any other to date. We have shown examples of its application in Figure 34 of page 29 and Figure 73 of page 63. Let us examine the circuit of a different receiver than that used previously.

**Vertical Deflection System.** Figure 82 shows the details of the vertical deflection system of this receiver. It combines a number of the circuit elements which we have previously discussed such as: the vertical pulse-integrating circuit, the blocking oscillator, the discharge tube, and the series C-R circuit which forms the combination sawtooth and pulse wave required for electromagnetic deflection.

The network of resistors and capacitors R1-C1, R2-C2, and R3-C3 comprises the "integrating" circuit which shapes the vertical sync signal and applies it in series with the grid circuit of the blocking oscillator tube (T1). The pulse arrives at the grid at the proper

time to "trigger" the plate current pulse as described and illustrated on pages 54 and 55. This insures that retrace of the vertical scanning from bottom to top of the picture occurs at the correct instant as shown in Figure 66.

The action of the blocking oscillator circuit of tube T1 has been covered in pages 47 through 49. In the present circuit its application is conventional. The "free running" frequency is controlled by the time constant of capacitor C4 and its discharge resistors R4 and R5 in series. R5 is variable and acts as the "hold" control to adjust the oscillator frequency to "lock" with the repetition rate of the vertical sync pulses.

	HORIZONTAL SYSTEM	VERTICAL SYSTEM
1.	A. F. C. Sync Discriminator Reactance Tube Sine Wave Oscillator Pulse Forming Stage Output Amplifier Damping Tube	Blocking Oscillator Output Amplifier
2.	A. F. C. Sync Discriminator D. C. Amplifier Cathode-Coupled Multivibrator Output Amplifier Damping Tube	Assymetrical Multivibrator Output Amplifier
3.	Blocking Oscillator Output Amplifier Damping Tube	Blocking Oscillator Output Amplifier
4.	A. F. C. Sync Discriminator D. C. Amplifier Cathode-Coupled Multivibrator Output Amplifier Damping Tube	Blocking Oscillator Output Amplifier
5.	A. F. C. Sync Discriminator Reactance Tube Sine Wave Oscillator Pulse Forming Stage Current Oscillator Output Stage	Cathode-Coupled Multivibrator Output Amplifier
6.	A. F. C. Control Stage Blocking Oscillator Output Amplifier Damping Tube	Assymetrical Multivibrator Output Amplifier

Fig. 81. Chart of Electromagnetic Deflection Systems as Used in Present-day Receivers

# CATHODE-RAY - - BEAM DEFLECTION SYSTEM

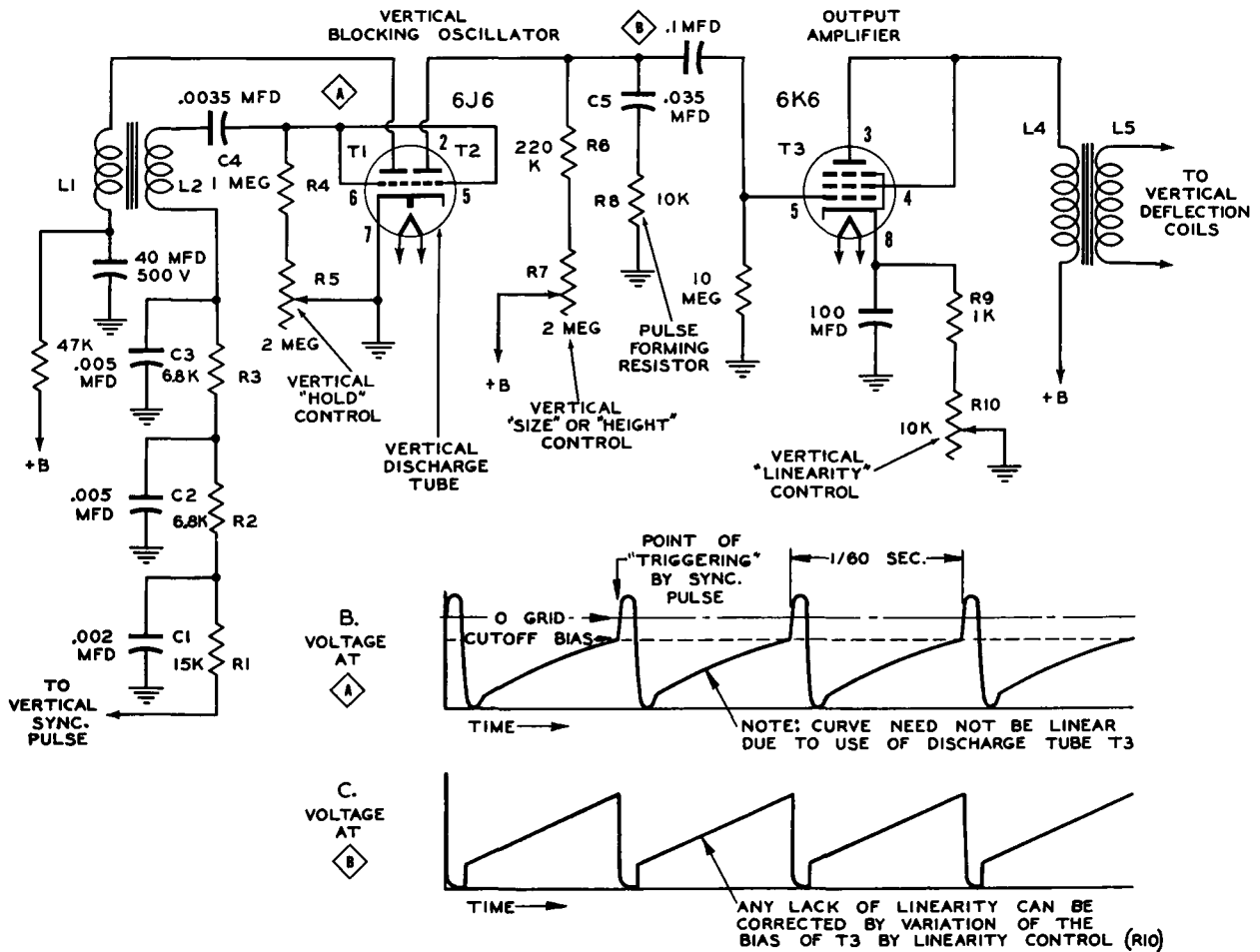

Fig. 82. Electromagnetic Deflection Systems - Example 1. Vertical Circuit

The second section of the dual triode acts as a discharge tube to "short" the network consisting of C5 and R8, which forms a voltage wave consisting of a linear sawtooth followed by a pulse as described on page 60.

The charging voltage, supplied to network C5-R8, is controlled by the series combination R6 and R7 connected to the "B" supply. R7 is made adjustable to act as the "height" or "size" control.

Tube T3 is a triode-connected output amplifier and serves to increase the amplitude of the "sawtooth-pulse" to the proper level for action of the vertical deflection coils. The only feature of special interest in this part of the circuit, is the variable cathode bias resistor (R9 and R10 in series). Adjustment of the operating point on the grid voltage-plate current curve, by the setting of R10, serves to

introduce the proper amount of distortion to correct any departure from linearity of the sawtooth scanning wave. This control is known as the vertical "linearity" control.

In practice, adjustment of R7 (vertical "height") and R10 (vertical "linearity") are somewhat interdependent. In this type of circuit, the vertical "size" or "height" control primarily affects the lower half of the picture, while the vertical "linearity" control has its major effect upon the upper half of the picture.

Figure 82B and 82C show the form of voltage waves appearing between ground and points A and B respectively.

**Horizontal Deflection System.** Figure 83 shows the horizontal deflection system of the receiver which has been selected as typical of Example 1 (Figure 81). It consists of a com-

combination of circuit elements which have been treated separately in our discussion to this point, namely: the sine wave oscillator (controlled by the sync pulse through an A. F. C. system and "reactance" tube), pulse shaping circuits and tubes, followed by a horizontal output tube and a triode damping tube.

The sync pulses are separated from the signal and applied to the grid of a "sync amplifier" T1 through network C1-R1. The plate circuit of this tube supplies the vertical amplified pulses directly from the plate to the "integrating" network of Figure 82. The amplified horizontal pulses are taken from a tap on the voltage divider R3-R4, and applied through C2 to the A. F. C. sync discriminator or "phase detector." This circuit, employing a dual-diode (6AL5), will be recognized as the "Seeley-Foster" discriminator used for FM detection. Its use in this circuit is to compare the repetition rate of the sync pulses with the frequency of the horizontal oscillator, and to produce a DC output voltage for control of the reactance tube (T4). The reactance tube automatically adjusts the frequency of the horizontal oscillator and keeps it in step with horizontal scanning. The action of this circuit will be described in more detail later.

Tube T5 is employed as an electron-coupled oscillator. The screen is at ground potential, for the oscillator frequency (15,750 cycles), due to the bypass capacitor C7. Feedback, to sustain oscillation, is furnished by the "hot" cathode tap on the transformer secondary L2. In this circuit, there are two adjustable frequency controls: the iron core tuning "slugs" of transformer windings L1 and L2, and the grid resistor combination R10 and R11. The transformer adjustments are pre-set, or semi-fixed, to assure that the action of the horizontal "hold" control (R11) will cover the proper frequency range on either side of center of its rotation.

Figure 83B shows the sine wave voltage appearing across the oscillator grid circuit. This voltage is electron-coupled to the plate circuit of tube T5. In this circuit, the first shaping of the wave from its sine form to the required pulse occurs as shown in Figure 83C. This action takes place when the plate swing reaches the region of plate current cut-off during part of the cycle.

The coupling network C8-R12, C9-R13, acts as a "differentiating" circuit and further sharpens the wave-shape as shown in Figure 83D.

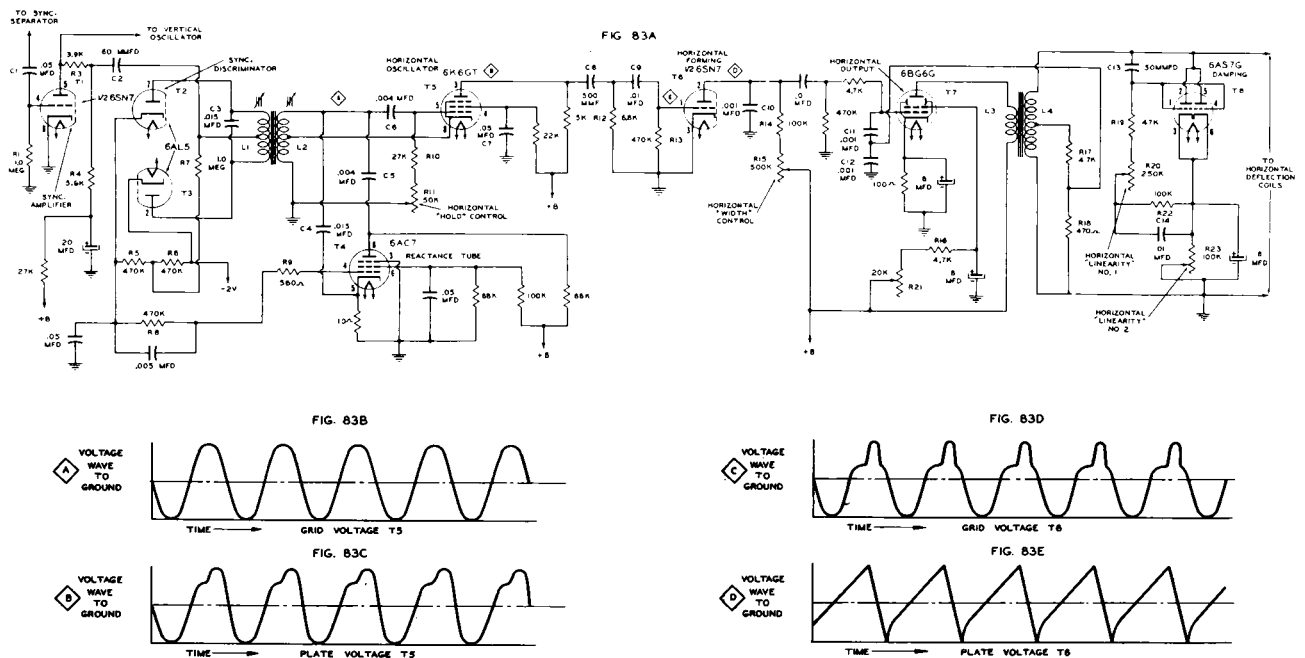

Fig. 83. Electromagnetic Deflection Systems - Example 1. Horizontal Circuit



## CATHODE-RAY - - BEAM DEFLECTION SYSTEMS

The voltage wave, of Figure 83D, is impressed on the grid of the horizontal "forming" tube (T6). This tube acts in much the same manner as the discharge tube described on page 49. The positive voltage peaks on the grid cause plate conduction to discharge a sawtooth capacitor C10 in its plate circuit. This produces the wave form (Figure 83E) which is used to "trip" the horizontal output tube (T7). R14 and R15, in the plate circuit of tube T6, control the charging voltage of C10, and therefore, the variable portion (R15) acts as a horizontal "size" or "width" control.

The horizontal output and horizontal damping circuits are similar to those described in pages 62 through 67. In this case, however, a number of new circuit features and additional controls appear:

1. An "inverse" or "negative" feedback circuit consisting of the resistance divider (R17 and R18), across part of the horizontal output transformer secondary, and the capacitance divider (C11 and C12) in the grid circuit of T7, feeds back a small "corrective" signal to the input of the stage. This aids in correcting departure from linearity of the part of the sawtooth current wave contributed by tube T7.

The expedient of employing a small amount of negative feedback to improve linearity is used in other deflection circuits and the service technician should be able to recognize it. Often this feedback takes the form of coupling from the cathode circuit of the output tube to a capacitance divider in the input of the same tube.

2. The screen voltage of the horizontal output tube (T7) has been made variable by means of resistor R21. This control serves to adjust the amplitude of plate current contribution by tube T7, to the scanning wave. In this case, the control is a "semi-fixed" adjustment and has no descriptive name. It is an auxiliary "width" adjustment for the right hand half of the picture.

3. The damping tube circuit, shown in Figure 83A, is similar to that described on pages 66 and 67, with the addition of a second "linearity" control (R23). In this case, "linearity" control No. 1 (R20) is used as describ-

ed on page 67 and its function is to adjust the center area of the picture. "Linearity" control No. 2 (R23) is used to expand the left hand side of the picture.

As in other deflection circuits discussed, these controls, "width" (R15), "linearity" No. 1 (R20), and "linearity" No. 2 (R23) are interdependent and the adjustment of any one may necessitate readjustment of the others.

**ELECTROMAGNETIC SYSTEM - - EXAMPLE 2.** Example 2 in the chart of Figure 81, employs a grounded cathode asymmetrical multivibrator in the vertical circuit, and a cathode-coupled version in the horizontal system. Figure 84 shows the details of the vertical system, and Figure 85 illustrates the horizontal circuit.

**Vertical Deflection System.** The vertical deflection circuit of Figure 84, employs elements which have been previously covered: the sync amplifier, the asymmetrical multivibrator and the vertical output tube.

A circuit not previously discussed, known as a "sync clipper", is included since its plate circuit components are an essential part of the deflection circuit under consideration. The "sync clipper" operates at very low plate voltage, (approximately 15 volts in this circuit), and derives its bias by grid rectification of the video signal. Plate current conduction occurs on the peaks of the video signal only. These peaks actually are the sync pulses. Thus tube T1 "clips" the sync pulses and passes them on to the sync amplifier tube (T2). (See Figure 84B.)

Although we have labeled T2 as a sync amplifier (its common commercial name), in reality it should be considered as a coupling tube and isolation stage. Since the load of the tube, resistor R10, is in the cathode circuit, the voltage gain of the stage is less than unity. The output is taken from the cathode and the voltage pulse which this tube delivers to the grid of the multivibrator tube (T3) is negative with respect to ground. This is the requirement for "tripping" the sweep action, as described on page 55. The shape of the negative pulses which appear at the grid of T3 is shown in Figure 84C. The coupling network between the "sync clipper" (T1) and the "sync amplifier" (T2) has several unusual features:

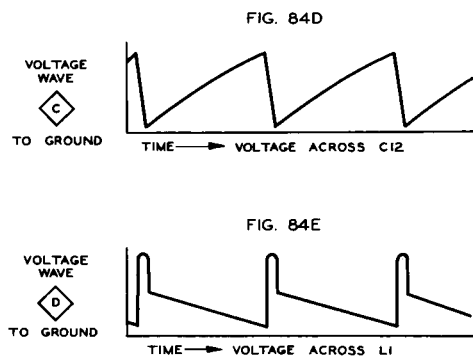
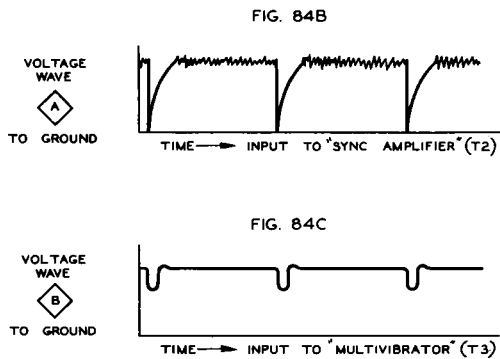
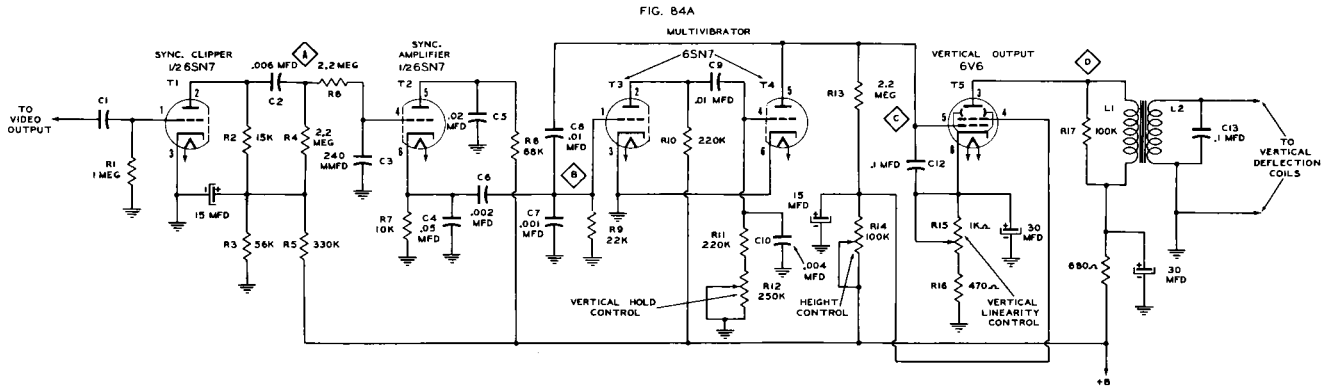

Fig. 84. Electromagnetic Deflection Systems - Example 2. Vertical Circuit

1. Resistor R6 and capacitor C3 constitute an "integrating" circuit to accept the vertical sync signals and reject the horizontal sync signals. To make use of this circuit, an unconventional grid biasing method becomes necessary.

2. It will be noted that the grid circuit of T2 is connected to "B" plus through resistors R6, R4 and R5 and to ground through resistor R3. This group of resistors acts as a voltage divider, across "B" plus. The positive voltage impressed on the grid causes a plate current through the cathode bias resistor (R7). This bias is opposed to the positive bias from the plate circuit and, as a result, the actual grid bias with respect to ground is approximately plus 3 volts. The positive bias assures a condition of plate current conduction until cut-off action is initiated by the negative pulse from the horizontal sync signal.

The asymmetrical multivibrator, consisting of tubes T3 and T4, actually a single triode 6SN7, is the same circuit as covered in

Figure 59. It will be noted that the time constant of tube T4 grid circuit is approximately ten times that of tube T3. The short time constant of T3 corresponds to the retrace period, while the longer time constant of T4 controls the active trace portion of the sawtooth wave.

As in multivibrator circuits previously discussed, the free running frequency is controlled by the time constant of capacitor C9 and the series combination of R11 and R12. R12 is made variable to act as the vertical "hold" control.

An interesting circuit variation is the use of capacitor C12 as a combined sawtooth generator and coupling means to the vertical output tube (T5). The bias voltage of tube T5 is determined by a balance of the cathode voltage drop across R15 and R16, and a positive voltage from the "B" supply through R14 and R13. The net bias voltage of the tube is approximately plus 7 volts. Capacitor C12 is charged from the "B" source through R14 and R13. R14 acts as the vertical "size" or

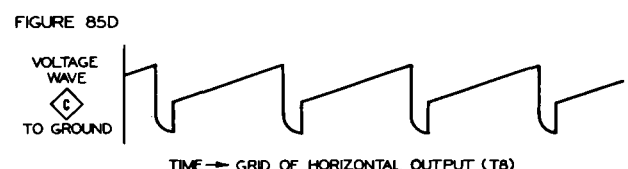
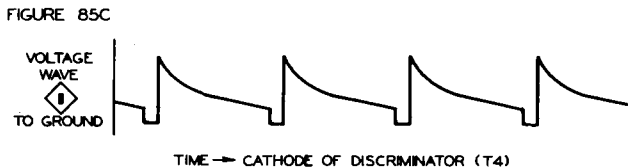
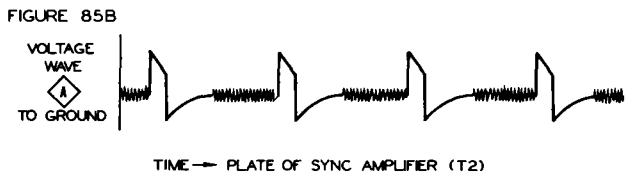
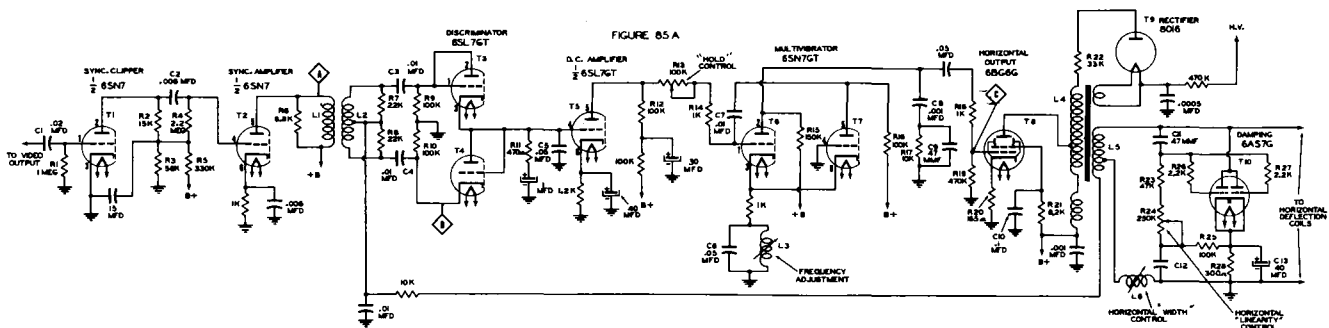

Fig. 85. Electromagnetic Deflection Systems - Example 2. Horizontal Circuit.

“height” control. It will be noted that R14 controls not only the plate voltage of T4 but also the screen voltage of the vertical output tube (T5). Since the amplification of a pentode is partially dependent on the screen voltage, this control exerts a dual influence on the overall gain of the vertical system and hence the height of the picture.

The adjustable cathode bias resistor (R15) serves as a “linearity” control. A slight amount of inverse, or negative, feedback occurs in this stage due to the connection of C12 to the cathode of the tube, rather than to ground. This feedback assists in improving the linearity of the sweep applied to the deflection coils.

Two new circuit elements, capacitor C13 and resistor R17, appear in connection with the output transformer. As in the circuit of Figure

73 and its explanation on pages 62 and 64, the secondary of the vertical output transformer (L2), and the vertical deflection coils, are tuned to resonate at a frequency such that the first half cycle corresponds to the vertical retrace time (500-750 microseconds). (See Figure 66, Page 53.) When the plate current of vertical output tube is suddenly cut off by the negative swing of voltage on its grid, as shown in Figure 64D, the “ringing”, or oscillation, of the output circuit causes a rapid retrace of scanning. Any tendency of this circuit to continue in a state of oscillation is suppressed by the damping resistor (R17).

**Horizontal Deflection System.** The horizontal deflection system of this general class (Example 2, Figure 81) is similar in some respects to that described in Example 1, since it employs “flywheel”, or A. F. C., control of the scanning oscillator by the repetition rate of the sync pulses.

This circuit, Figure 85A, employs the same “sync clipper” tube as was shown in Figure 84A. In this case, however, the grid of the horizontal “sync amplifier” is coupled directly to the plate of tube T1 by means of capacitor C2. This allows the short time (5 microseconds) pulses to be passed directly to the A. F. C. circuit through amplifier T2.

The sawtooth generation is accomplished by a cathode-coupled multivibrator rather than a sine wave oscillator. A “sample” of the scanning wave voltage is taken from the output transformer secondary L5 and injected into the series diode discriminator, or “phase detector”, where it is compared with the repetition rate of the horizontal sync pulses.

The direct current output of discriminator tubes T3 and T4 is applied to the grid of

a DC amplifier. It will be noted that a high- $\mu$  twin triode (6SL7-GT) has been employed as a dual-diode by connecting the grids and plates of the respective sections to each other. The plate resistance of amplifier tube T5 is part of the discharge resistance network which determines the operating frequency of the cathode-coupled multivibrator.

The function of this DC amplifier tube (T5) is similar to that of the reactance tube (T4) of Figure 83A. The resistor discharge network comprised of R12, R13, R14 and the plate resistance of tube T5 controls the time constant of the multivibrator grid circuit tube (T6). One of these resistors, R13, is made variable to adjust the free-running frequency, and therefore, acts as the horizontal "hold" control. The tuned circuit in the cathode return of tubes T6 and T7, consisting of capacitor C6 and inductor L3, is an additional control of the free-running frequency of the multivibrator. This is a service or "semi-fixed" adjustment, and is used to set the range of the "hold" control so that it operates symmetrically about its mid-position.

The operation of the remainder of the circuit, consisting of horizontal output tube (T8) and damping tube (T9) needs no further explanation at this time since it has been described on pages 62 through 67.

Figures 85B, 85C and 85D show the waveforms found at various points in this circuit. The wave of Figure 85B requires explanation since it differs from the series of single horizontal pulses delivered to the grid of T2 by the "sync clipper" (T1). It consists of a positive "pip" followed immediately by a negative "pip". The reason for this action lies in the fact that the plate load of tube T2 consists of the primary of the discriminator transformer (L1). When a square wave pulse of plate current passes through the inductance, magnetic flux is generated during the rapid rise of current at the leading edge of the pulse, and the rapid fall of current at the trailing edge. Since these current changes are in opposite directions, they produce the waveform of Figure 85B.

**ELECTROMAGNETIC SYSTEM - - EXAMPLE 3.** Example 3 in the chart of Figure 81, uses blocking oscillators in both the verti-

cal and horizontal deflection systems. This combination has been employed mainly in table models using the 7DP4 or the 10FP4 picture tubes. Synchronization of both oscillators is caused by "triggering" action of the "clipped" and "shaped" pulses. Figure 86 shows both the vertical and the horizontal deflection circuits of a typical commercial receiver employing this combination.

**Vertical Deflection System.** The circuit employs the following elements: a "sync amplifier", a diode "clipper" or "sync leveler", a "sync separator", an "integrating" circuit, a blocking oscillator, and a vertical output tube.

The video signal, with its vertical and horizontal sync pulses, is impressed on the grid of the "sync amplifier" tube (T1), Figure 86, through a coupling network comprised of C1 and R1. This stage is a normal voltage amplifier, biased so as to amplify the signal without change in waveshape. The polarity of the video signal applied to the grid of T1 is such that the sync pulses are in the positive direction in its plate circuit.

Diode T2 is connected, by coupling capacitor C2, across the plate load resistor (R2) of tube T1. The diode load resistor (R3) also acts as the grid resistor of "sync separator" tube (T3). The resistor is returned to a negative bias supply of -20 volts and this bias performs two functions:

1. It causes tube T3 to act as a "detector", since it places operation beyond plate current cut-off. Under this condition of operation, only the most positive portion of the input signal (the synchronizing pulses) causes plate current flow. Thus the tube T3 can separate or "clip" the sync pulses.

2. This negative voltage also acts as delay bias for the diode "clipper" or "leveler" tube (T2). When the level of the amplified pulses, appearing across plate load resistor (R2), exceeds this delay bias, rectification occurs in diode T2 causing a negative voltage to appear across the diode load resistor (R3). This voltage adds to the normal bias and is in effect an A. V. C. voltage for the control of sync separator tube (T3). This "levels" the line of sync pulses so that each recurring pulse in the output of tube T3 is of an equal amplitude.

# CATHODE-RAY -- BEAM DEFLECTION SYSTEMS

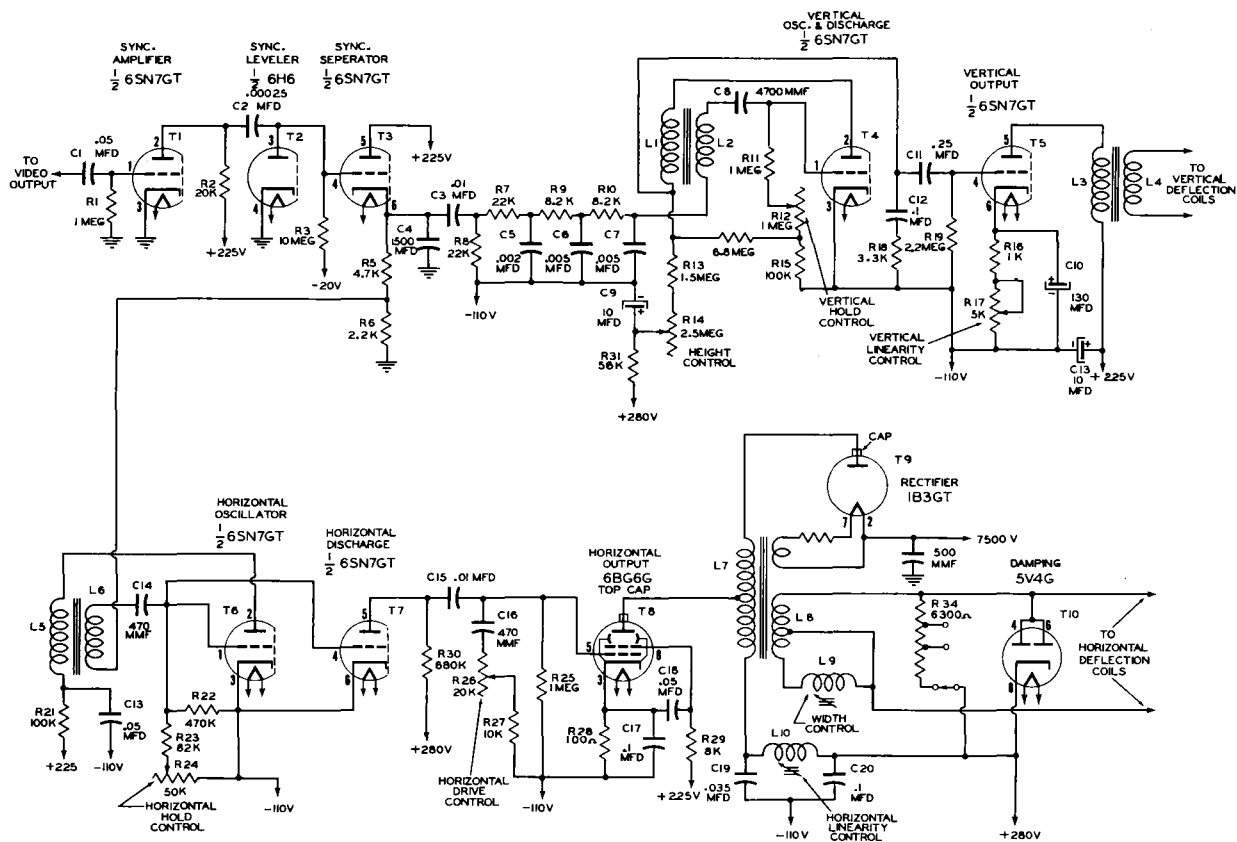

Fig. 86. Typical Electromagnetic Deflection System - Example 3

The series combination of resistors R5 and R6, in the cathode circuit of T3, acts as the output load of the sync separator, and feeds the separated pulses to both the vertical and horizontal systems. The integrating network, for acceptance of the vertical sync signal, is composed of capacitors C3, C4, C5, C6 and C7 together with resistors R7, R8, R9 and R10.

Control of the blocking oscillator tube (T4), by the sync pulses, is accomplished through series injection in the grid circuit as covered on pages 54 and 55. The action of the blocking oscillator is the same as that described and illustrated on pages 47 and 48, with the exception of the addition of peaking resistor (R18) in series with the sawtooth forming capacitor (C12).

Vertical "hold" is controlled by R12 in the grid circuit and vertical "height" by R14 in the plate circuit, as previously covered.

The action of vertical output tube (T5), with its cathode bias control of vertical "linearity", has been covered previously.

**Horizontal Deflection System.** The horizontal deflection system is similar to that described on pages 61 - 64 and illustrated in Figure 73, with the substitution of a pulse "triggered" blocking oscillator for the A. F. C. controlled sine wave generator. The elements of the circuit are: a blocking oscillator, a discharge tube, a horizontal output tube and a damping tube.

Horizontal sync pulses are fed to the grid of the blocking oscillator tube (T6) from the voltage drop across resistor R6 in the cathode circuit of the sync separator tube (T3). The circuit consisting of resistor R6 and the secondary L6, with its distributed capacitance, accept the horizontal pulses and reject the vertical group. Blocking oscillator tube T6 is thus controlled by the sync pulses and proper scanning occurs.

The grid of horizontal discharge tube (T7) is directly connected to the grid of the blocking oscillator tube (T6) and functions as described on page 49. The sawtooth generating and peaking circuit, consisting of C16, R26 and R27, is discharged or triggered by plate conduction of tube T7 as controlled by the oscillator tube (T6). Resistor R26 is made variable as a horizontal "drive" control. The action of this control was discussed on page 65.

The action of the remainder of the circuit (horizontal output, damper, and high voltage rectifier) have been covered previously.

Figure 87 shows a commercial variation of the blocking oscillator which has several unusual features. The feedback action involves the use of both sections of a high-mu twin triode (6SL7GT). The input section (T1) operates with cathode bias due to its plate current flow through R2. This establishes a negative bias as shown in Figure 87B. T1 is coupled to the cathode of a "grounded grid" triode T2. The plate of T1 feeds the cathode of T2 through C3.

The unusual feature of this circuit is the incorporation of a tuned circuit comprised of L3 and C4 in the plate return of T1. The combination of L3 and C4 is tuned to a frequency slightly lower than the horizontal scanning rate of 15,750 cycles per second and is shock excited by the pulse action caused by feedback through transformer windings L1 and L2. The sudden positive pulses shown in Figure 87B have an action similar to the "push" given a pendulum in a "grandfather's clock" by the mechanism. The mechanical pulses are correctly timed to sustain the simple harmonic motion. The action of the electrical pulses results in a condition of sustained oscillation in which the voltage wave across L3 is practically sinusoidal. (See Figure 87F.)

The C-R circuit in the cathode of T2, consisting of C3, R3 and R4, has a variable time constant of from 15 to 30 microseconds (see page 36) and by adjusting R3 it is possible to effect small changes of the free running frequency. Resistor R3, therefore, functions as a "hold" control. It will be noted from the waveform of the cathode to ground voltage (Figure 87D) that the combination of pulse action and capacitor discharge produces a sharply peaked input to T2.

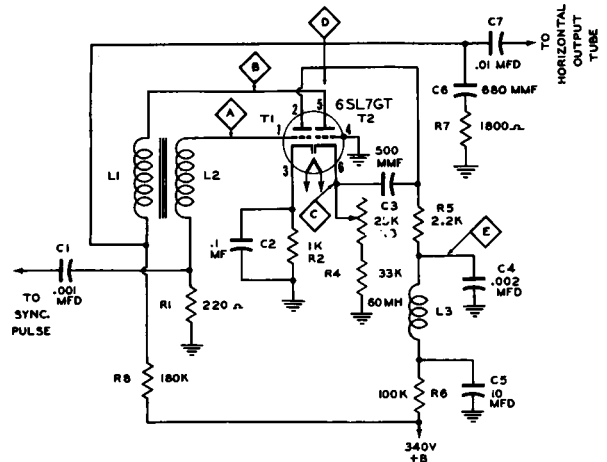

FIG. 87A

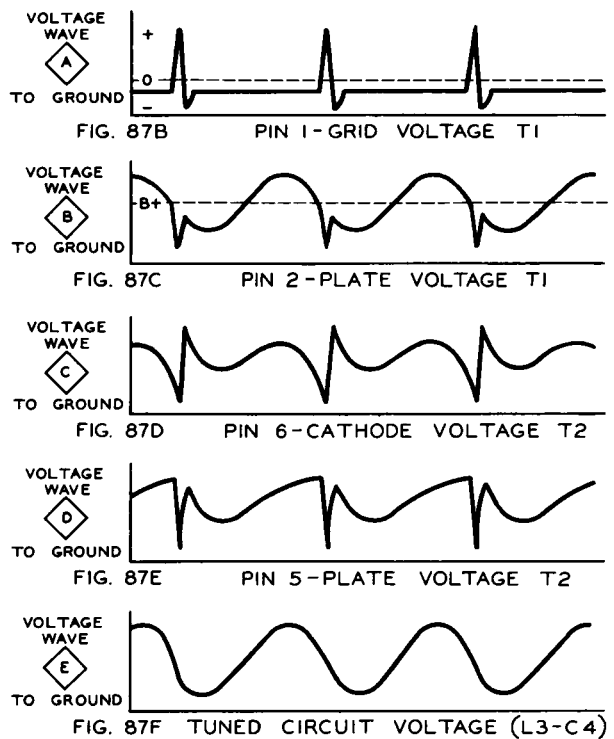

Fig. 87. A Variation of the Blocking Oscillator

The plate current conduction pulses of T2 (see Figure 87E) "trip" the charge on the sawtooth and pulse forming circuit C6-R7. The path of this discharge action includes transformer primary L1, the internal plate to cathode path of the tube T2, and parallel circuits from cathode to ground comprised of R3, R4 and C3, R5, C4.

## CATHODE-RAY - - BEAM DEFLECTION SYSTEMS

This oscillator is very stable in action due to the "flywheel" effect of the tuned circuit (L3-C4). It is not readily tripped by random noise pulses which arrive at times other than the synchronizing pulses.

**ELECTROMAGNETIC SYSTEM - - EX-AMPLE 4.** In the combination example 4, Figure 81, the horizontal circuits are identical to those described under Example 2, and illustrated in Figure 85A. The vertical system, however, exhibits several interesting features and merits description.

**Vertical Deflection System.** The elements of this system include: a sync "clipper", an integrating circuit, a vertical sync amplifier, a blocking oscillator and a vertical output tube. Figure 88 shows the circuit details of this combination.

Tube T1, a sharp cut-off pentode (6SH7), operates at low plate and screen potentials and is self-biased by grid circuit rectification of the video signal impressed through C1 and R1. Under these conditions, only the positive peaks of the input signal cause output plate current. Thus the sync pulses are "clipped" from the video signal.

The sync signals are passed to the vertical sync amplifier tube (T2) through a three stage integrating circuit (R5-C4, R6-C5, R7-C6). The sync pulses, having been inverted in polarity through tube T1, arrive at the grid of tube T2 as a negative voltage swing which drives the tube to cut-off. This results in positive "going" pulses in the plate circuit which are of the proper polarity for the control of the blocking oscillator circuit. It will be noted that tube T2 is given a small initial pos-

itive bias from the "B" plus supply through a one megohm resistor (R8). Since this tube is a high- $\mu$  triode (6SL7GT) these operating conditions result in a large swing of plate voltage under control of the sync pulse. It will be noted that the entire swing of the plate voltage of tube T2 is applied to the secondary (L2) of the blocking oscillator feedback transformer.

The blocking oscillator is conventional in its circuit features. As in the systems previously described, grid circuit resistor (R12) acts as the vertical "hold" control and plate supply resistor (R15) serves as the "size" or "height" control.

The vertical output stage (T4) employs a power pentode (6L6GT) with the feedback method of linearity correction from the cathode circuit. Variable bias resistor (R18) controls vertical "linearity".

**ELECTROMAGNETIC SYSTEM - - EX-AMPLE 5.** In the deflection system listed as Example 5 of chart Figure 81, the only element which we have not previously considered is the "oscillating output stage" or "beam relaxor". Circuits of this general type, in which the generator itself supplies the deflection current, are also called "current oscillators".

Figure 89 shows a version of this type output stage which has been used in a number of models now on the market. In this circuit a beam power pentode (6L6) has its control grid connected to the secondary (L3) of the output transformer, with proper polarization to cause oscillation. The screen grid of this pentode is coupled to the plate of a sync pulse clipper and can inject a voltage pulse at the

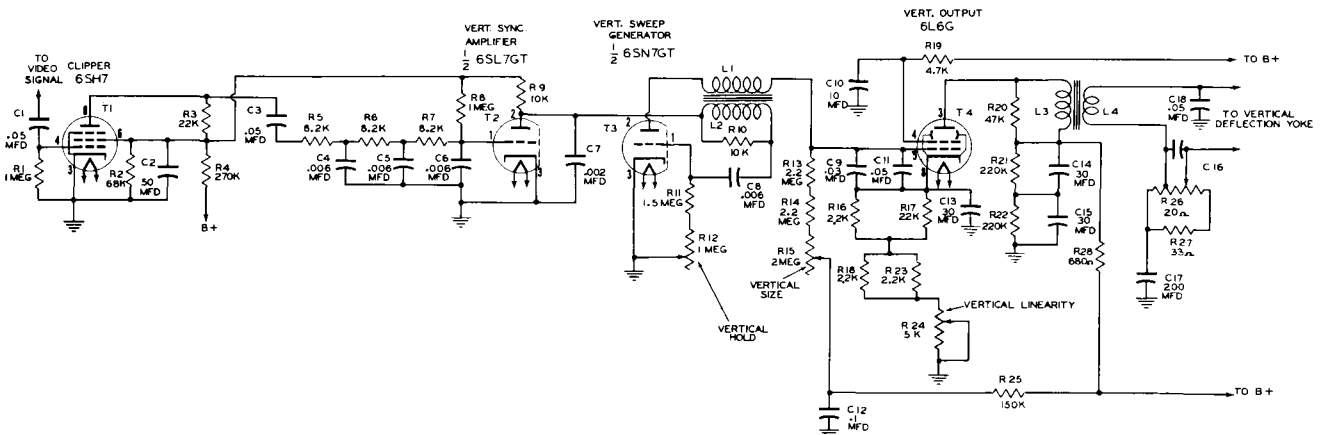

Fig. 88. Electromagnetic Deflection Systems - Example 4. Vertical Circuit



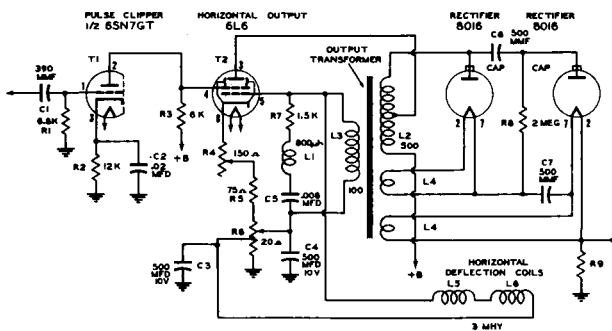

Fig. 89. Oscillating Horizontal Output Stage

correct time to synchronize the frequency of oscillation with the rate of the horizontal sync pulses. Since the action of this circuit differs considerably from any which we have previously considered, a step by step analysis of its operation follows:

1. As a starting point, let us assume that the plate current of the tube has just been cut off, by the negative sync pulse at the screen or by the oscillator action itself. This cut-off occurs at the instant that retrace of scanning starts a new line. The magnetic flux stored in the transformer collapses inducing a high negative voltage on the grid. This collapse of magnetic flux, and its resultant voltage change across the horizontal deflection windings, produces the change in polarity necessary for retrace of the scanning wave.

2. A series circuit consisting of R7 (1.8K ohms), L1 (800 microhenries), and C5 (.008 MFD) is connected across this winding. This network critically damps out any tendency for continued oscillation. Following retrace, the grid potential grows less negative until plate current starts to flow.

3. The rate at which the plate current will flow is determined by:

- a. The plate resistance of the tube, which is controlled by the cathode bias network. Since we are now considering the trace or linear part of the cycle, the influence of the variable portion of the cathode circuit resistance (R4) can act as a horizontal "hold" control.
- b. The inductive load in the plate circuit. This consists of the plate to "B" plus part of winding L2 with the reflected effect of secondary grid winding L3.

4. The time constant of a circuit consisting of inductance and resistance is determined by the ratio of L to R. When an inductance is suddenly disconnected from a source of direct current and allowed to discharge its stored energy through a resistor, a change of current, with time, will occur which is identical in shape to the change of the voltage wave discussed in connection with capacitor sawtooth wave forming circuits.

With an effective plate circuit inductance of 60 millihenries and an AC or dynamic plate resistance of 500 ohms, the L/R ratio corresponds to the required time constant for 15,750 cycle scanning. These conditions are met in the circuit of Figure 89.

5. As the sawtooth current wave builds up in the plate circuit, it induces a similar wave, by transformer action, in winding L3, which supplies the horizontal deflection coils and the grid of the "beam relaxor".

6. As the current wave increases in amplitude, a point is reached at which the grid voltage has become sufficiently negative, with respect to the cathode, to produce plate current cut-off. It will be noted, by examining the plate current versus plate voltage curves of the 6L6 beam pentode, that there is a sharp "knee" in the curve after which the plate current reaches saturation. In this circuit, the action takes place by sweeping rapidly from the region below the "knee" of the curve to the saturation region. The saturation or flat region corresponds to the active sweep. The low current region below the "knee" corresponds to the retrace period.

In a "beam" pentode, a negative pulse of voltage applied to the screen will cause a sharp increase of applied plate voltage. The pulse is supplied in this circuit, by the pulse clipper tube (T1). This initiates the retrace cycle and assures "lock-in" with the video signal.

**ELECTROMAGNETIC SYSTEM - - EXAMPLE 6.** The circuits of the combination outlined as Example 6 (Figure 81) are similar to those of Example 2, with the exception of a different type horizontal oscillator sync control. While, for simplicity, it has been listed as an A. F. C. control, in reality "pulse width control" would be a more accurate description.

Figure 90 shows the essential details of this system, which include a sync clipper, a

## CATHODE-RAY - - BEAM DEFLECTION SYSTEMS

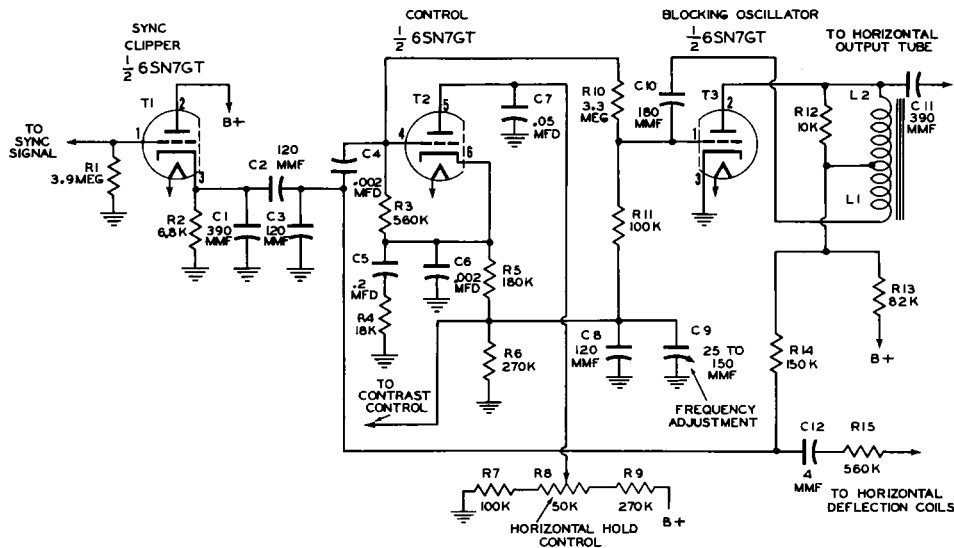

Fig. 90. Automatic Pulse Width Control of Blocking Oscillator

control tube, and a blocking oscillator. The other elements of the system have been fully covered.

The pulse output of the clipper (T1) which appears across the cathode resistor (R2) is positive with respect to ground. This pulse is applied to the grid of control tube (T2) through the differentiating network consisting of C1, C2, and C3. The action of the remainder of the circuit involves simultaneous events which can best be described in sequence:

1. The control tube (T2) fulfills a number of functions, namely;
  - a. Since a portion of its cathode circuit, resistor R6, is common to the grid circuit of the blocking oscillator tube (T3), it is able to affect the frequency of oscillation by influencing the time constant of the circuit comprised of C10, R11 and R6 (paralleled by C8 and C9).
  - b. The voltage drop across R6, due to the plate current of tube T2, can be controlled by potentiometer R8, which adjusts the plate voltage. R8 constitutes the horizontal "hold" control.
  - c. Tube T2 serves as a means of automatic frequency control of scanning by "mixing" the original pulse from tube T1, a signal fed back from the output of the blocking oscillator tube (T3), and a pulse from the horizontal deflection coils through R15 and C12.
2. The pulse voltage derived from the deflection coil is that which occurs at the in-

stant of retrace. It is "sharpened" by network R15 and C12. This pulse is negative with respect to the original sync pulse.

3. A small portion of the sawtooth voltage in the plate circuit of the blocking oscillator tube (T3) is also fed back through resistor R14 to the grid of control tube (T2). This voltage is positive (the same polarity as the original sync pulse) and is combined with the sharp negative pulse from the deflection coil. The result of this combination produces a sawtooth which has a very sharp or vertical return.

4. The combination voltage just described is applied to the control tube grid. It will coincide with the original sync pulse only if the oscillator is in exact step with the video sync pulses.

5. As exact synchronism is reached, the control tube grid pulse, which consists of the original sync pulse added to the fed back pulse, will be narrow and of high amplitude. If the fed back pulse is slightly fast or slow it will not add to the original sync pulse, but instead will have the effect of widening the original pulse.

6. From this combination of variable width and height of the voltage pulse on the grid of tube T2, a very precise timing is achieved.

7. The plate current pulse of tube T2, flowing through cathode resistor R6, adjusts the grid circuit time constant of the blocking oscillator tube T3 and produces the required exact synchronization.

## SECTION III CATHODE RAY — BEAM MODULATION AND SYNCHRONIZATION

### CHAPTER 9. SYNC PULSE SEPARATION AND USE

Up to this point, we have considered those sections of a television receiver concerned with the formation of an electron beam or "pencil" in a cathode-ray picture tube, the control of this beam in intensity, and its deflection in the horizontal and vertical directions.

It has been shown that the path traced by the beam can be made to cover the picture area in a regular sequence, which corresponds to a similar sequential scanning action occurring in the "pick-up or camera" tube at the transmitter. The methods by which synchronized control of the receiver scanning action is accomplished have been described.

In the following sections we will cover those portions of the receiver which concern:

1. The interception and selection of the desired television signal and its amplification.
2. The detection and separation of the video or "sight" portion of the signal from the accompanying sound signal.
3. The use of the video signal to modulate the intensity of the picture tube electron beam.
4. The reconstruction or insertion of the average or "background light level" (dc restoration).
5. The separation, amplification and use of the sync pulses.

#### SYNCHRONIZING PULSE SEPARATION, AMPLIFICATION AND UTILIZATION

Sync pulse separation has been mentioned in connection with the description of deflection systems on pages 73 to 84. At this time we will consider in greater detail the methods of separation, amplification and subsequent use of the sync pulses. Before starting such a study, it will be of value to review as a "refresher", some of the fundamental actions and characteristics of vacuum tubes as amplifiers and rectifiers.

**REVIEW OF THE ACTION OF VACUUM TUBES AS APPLIED TO THE SEPARATION AND USE OF SYNC PULSES:** In analyzing commercial receivers with regard to the method of separating the sync pulses from the "composite" video signal, we find circuits in which this function is accomplished by diodes, triodes and pentodes employed under widely different circuit and operating conditions. These include: diode and inverted diode rectification, triodes and pentodes working at either plate current cut-off or saturation, and "cathode follower" circuits. As an introduction to our study of the individual applications and their use in typical television circuits, the following review of vacuum tube action should be considered together with a study of the characteristic curves and data presented in receiving tube manuals available from the tube manufacturers.

1. The limits of the plate current range of a vacuum tube are determined by cut-off and saturation. Plate current cut-off can be accomplished by a fixed negative grid bias or by negative bias derived from grid circuit rectification of the signal in the case of triodes and pentodes. A series "delay" bias can produce cut-off in the case of diodes. Plate current saturation is produced by operation at low plate voltage in the case of triodes, and at low plate and screen voltages with pentodes.

2. The voltage developed across a cathode resistor, by the plate current flow, provides a negative bias if the grid circuit is returned to the end of the resistor opposite the cathode. A tube biased by its own plate current cannot cut itself off. Self bias from the cathode resistor is often augmented by additional negative bias in series with the grid return or by "bleeding" current through the cathode resistor from the plate supply, to assure operation at or beyond cut-off. (See Figure 91.)

3. A change of the control grid voltage will produce a change of plate current in the same direction or polarity. Stated in another way, the grid voltage and the plate current are in phase with one another.

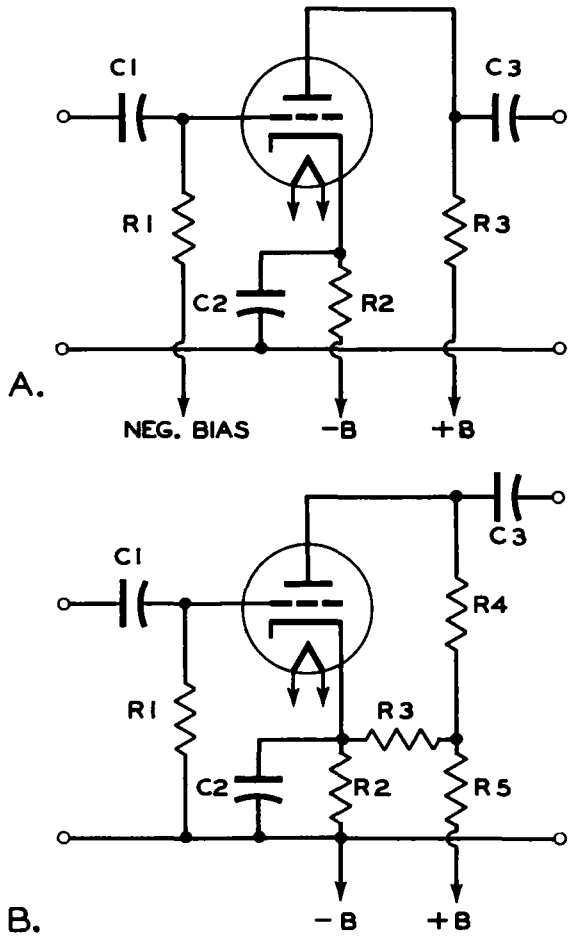

Fig. 91. Cut-off by Combination Bias

4. The plate voltage change caused by a change of grid voltage is in the opposite direction and hence the plate voltage is 180° out of phase with the grid voltage. For this reason, a vacuum tube amplifier is essentially a phase inverter.

5. A drop of plate voltage caused by a positive pulse applied to the grid is known as a "negative going" pulse. As we have seen, such a pulse is required for the control of a cathode-coupled multivibrator.

6. An increase in plate voltage caused by a pulse, which drives the grid more negative than its initial bias condition, is known as a "positive going" pulse. This is the requirement for "tripping" a blocking oscillator.

7. The effect of a plate load resistor is to cause the plate-cathode voltage to decrease with an increase in plate current. Conversely,

with such a load, the plate to cathode voltage will increase with a drop in plate current.

8. The amount of change in plate to cathode voltage caused by a change in plate current can be transmitted or transferred to the grid circuit of a following tube, in the same polarity, by means of a coupling capacitor.

9. When the load resistor of a vacuum tube is in the cathode to "B" minus circuit of the tube and the output is taken from the cathode (see Figure 93) the circuit is known as a "cathode follower". Since this type of circuit is frequently employed in television receivers and has not been widely used in broadcast receivers, its action will be described before considering the general subject of sync separation.

**THE CATHODE FOLLOWER CIRCUIT:** Figure 92 shows a circuit having many interesting characteristics. Its features are: a high input impedance, a low input capacitance, a low output impedance, and an output voltage which "follows" the input voltage and hence is of the same polarity. Although it is a power amplifier, the voltage gain can never reach unity and therefore the loss which it introduces often has to be compensated by additional amplification. These characteristics result from the fact that the unbypassed cathode load resistor (R2) produces inverse or negative feedback to the grid. The action of the circuit is as follows:

1. The plate bypass capacitor (C2) is made sufficiently large that, for the lowest frequency to be encountered, the plate is substantially at ground potential. The cathode resistor (R2) is unbypassed or if a bypass capacitor is used it is made of low value so

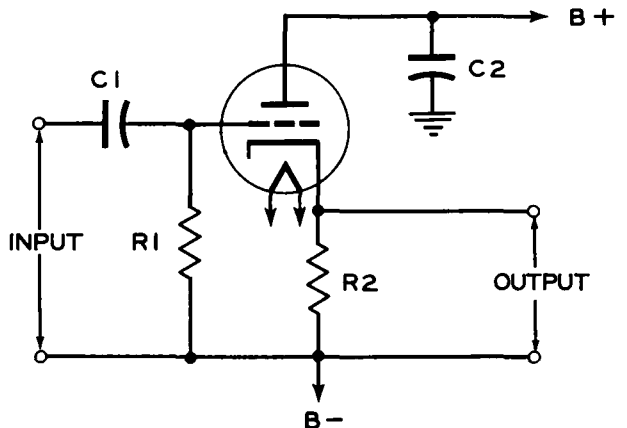

Fig. 92. The Basic Cathode Follower Circuit

## CATHODE-RAY - - BEAM MODULATION AND SYNCHRONIZATION

that its reactance is high at the highest frequency which the stage is required to pass. The grid is biased negative with respect to cathode by the plate current which flows through the cathode resistor (R2). This automatically establishes an operating point near, but not at, plate current cut-off.

2. Under operating conditions just described, let us examine the results of applying a positive pulse or signal to the grid. The plate current rises, and the increased plate current flowing through R2 causes the cathode to become more positive. If a negative pulse is applied to the grid, the consequent drop in plate current will decrease the voltage drop across R2, and cause the cathode to become less positive with respect to ground. Since the voltage change of the cathode in each case is in the same direction as the grid change which causes it, the cathode "follows" the grid and the circuit is consequently known as a cathode follower.

3. The effective control voltage of the tube, or voltage between grid and cathode, is the difference between the input voltage across R1 and the voltage across the cathode resistor (R2). Thus, the variation of cathode voltage caused by the varying input decreases the effectiveness of the input signal and the stage is said to be "degenerative".

4. This "degeneration" or negative feedback produces the effects of low loading on any circuit across which the stage is connected (high input resistance and low input capacitance). It is interesting to note that the effective input capacitance can be lower than the measured value with the tube cold. To understand how this seemingly impossible condition can occur, let us examine the manner in which the tube and circuit can change the voltage conditions as viewed from the input terminals.

5. Let us assume that when, with a particular tube and plate voltage, a voltage change

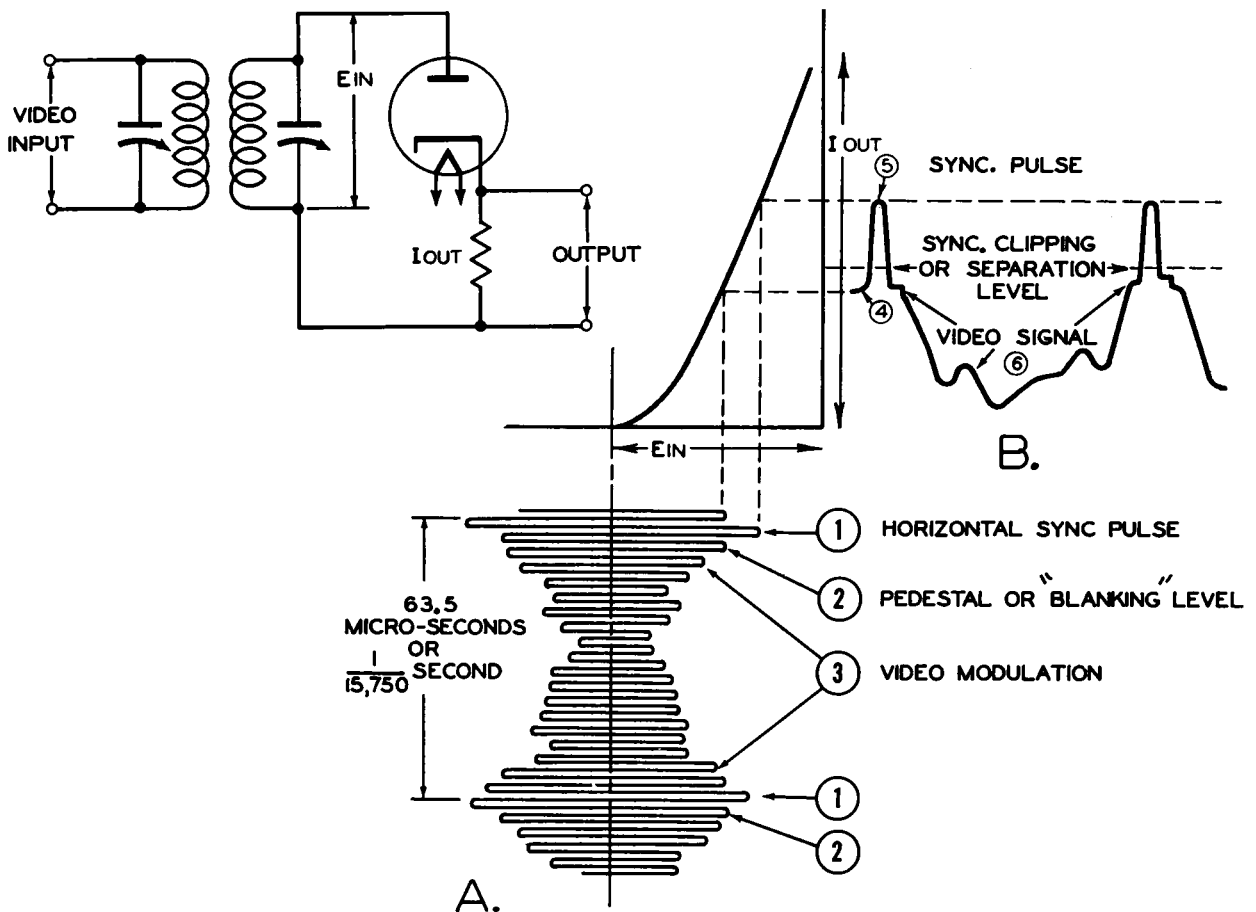

Fig. 93. Demodulation (Detection) of the Video (Picture) Carrier

## CATHODE-RAY - - BEAM MODULATION AND SYNCHRONIZATION

of 1 volt appears across the input terminals and that this impressed voltage causes a resultant change of cathode to ground voltage of .9 volts. The applied input voltage "attempts" to charge the input capacitance of the tube to a potential of 1 volt. Immediately, there appears a voltage of the same polarity from the cathode on the other "plate" of this capacitor and the resultant charge is .1 volt rather than 1 volt. In this way, the input capacitance of the tube is apparently much lower than its actual "static" value. A similar effect occurs with respect to the input resistance of the tube. In the example used, the effective input capacitance would be only one-tenth of the actual capacitance.

6. In a similar fashion, the effective output impedance of the stage is very low. Its value depends upon the amplification factor and the mutual or transconductance of the tube. As an example, a tube such as the 6J5 with a  $\mu$  of 20, a plate resistance of 7700 ohms and a  $G_m$  (transconductance) of 2600 micro-mhos, will have an effective output impedance across a 1000 ohm cathode load resistor of only 268 ohms.

The cathode follower, which was used extensively in radar equipment during the war, finds many applications as a coupling means in television transmitters and receivers.

**SYNCHRONIZING PULSE SEPARATION:** The nature of the horizontal and vertical synchronizing pulses and their time relationship to the sawtooth scanning raster were described and illustrated on pages 51 to 53. It was indicated that these pulses occurred during the time that the electron stream in the picture tube is cut off or "blanked" out. While we will examine all of the details of the complex television signal later in the course, it will be instructive at this time to examine the video IF signal as it reaches the video detector. The manner in which the sync pulses are separated from the signal and used to control the horizontal and vertical scanning systems of the receiver will be discussed. Since the horizontal pulses occurring at the end of each of the 525 lines which constitute the picture, are representative of the pulse separation principle, our discussion at present will be confined to their separation and utilization. A treatment of the vertical pulses will be covered when we consider the methods of segregating the vertical from the horizontal pulses.

The pulses can be clipped from the signal in three places in the circuit:

1. At the input of the video or "sight" detector.
2. From any of the video amplifying stages.
3. At the point of restoration of the average background light of the picture. For this reason, Figure 93 shows the nature of the video signal with its picture and synchronizing "information" as it appears at the output of the last video IF amplifier. The video IF carrier at the input of the video second detector, shown in Figure 93 as a diode, is represented at point "A". It will be seen to consist of horizontal pulses (as detailed in Figure 65) mounted on a "shelf" or "pedestal". These are identified in Figure 93 as (1), the pulse, and (2), the pedestal. Between the edges of the pedestals is found the modulated envelope of the carrier which represents the variations of light and dark of the video signal (3), used to modulate the cathode ray beam.

Figure 93B shows the form of the detected or demodulated wave with the sync pulses in the region from (4) to (5). The "picture information" or video signal is shown in the portion of the wave shown at (6).

It will be noted that the sync pulses are at the "top" of the signal. Since these occur when the picture tube is "black" or blanked, it will be evident that the darker tones of the picture are just below the "pedestal", or point (4), of Figure 93B. While the exact nature of the video signal will be discussed in detail later, it is of importance to note that, after passing through the video amplifier, the signal must reach the grid of the "picture" tube in such a phase that the sync pulses are the most negative part of the wave. This accomplishes blanking during the return trace. We have seen that the polarity of the sync pulse, as it arrives at the grid of the scanning oscillator, must be of the proper sign to assure control. For this reason, the method of sync pulse separation selected in any particular receiver design will depend upon: the number of stages of video amplification, the point in the circuit at which sync separation is accomplished, and the number of sync amplifier or clipping stages employed.

All of the methods of separating the synchronizing pulse from the rest of the video signal, involving the fact that the "pedestal" or blanking level is always maintained in transmission, at a definite point on the carrier wave (75% of maximum carrier) and therefore the sync pulses occupy the top 25% of the wave. The problem of sync clipping thus resolves itself into one of "amplitude separation" or of removing the top 25% of the wave without passing the lower values which contain the video signal. The methods commonly employed will be covered under headings of the types of tubes used.

**DIODE SYNC SEPARATION CIRCUITS.**

Figure 94 shows the commonly used diode sync separation circuits. The first three of these (A, B and C) involve the "clipping" of the pulse by rectification of the video IF carrier. In each case, the diode will be found connected across the video detector circuit. The video detectors have been omitted for simplicity.

In Figure 94A the picture signal is of positive polarity, meaning that the output of the detector becomes more positive as the picture carrier increases. Since the sync pulses are at the "top" of the carrier modulation, the output from the diode separator is in the form of positive pulses. One stage, or any odd number of stages, of video amplification, which will invert the phase, will be required following a detector and separator of this type. This polarity of the video signal is correct for control of the picture tube grid, since a negative voltage is required for beam cut-off. The negative bias shown in the circuit of Figure 94A biases the diode to the "pedestal". Anode current flows for the duration of the sync pulses only.

Figure 94B shows an "inverted" version of the same circuit. In this case, an increase of video carrier causes a more negative output voltage. The pulse output is negative and the video output of the detector diode, connected across the separator, is in the correct direction to actuate the picture tube grid. For this reason, an even number of video stages must be employed, causing the output to be of the same phase as the input. As in the preceding case (Figure 94A), a delay bias is employed. Diode rectification is limited to the level of the sync pulses and the rest of the video signal is rejected. The bias in this case, however, is positive with respect to ground or chassis.

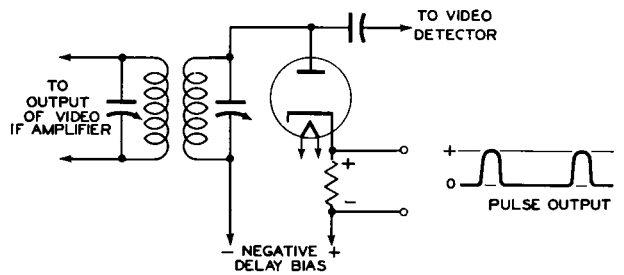

A. POSITIVE PICTURE POLARITY - POSITIVE PULSES.

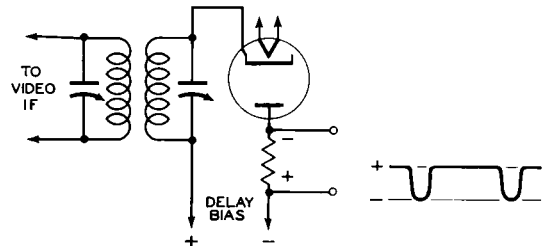

B. NEGATIVE PICTURE POLARITY - NEGATIVE PULSES.

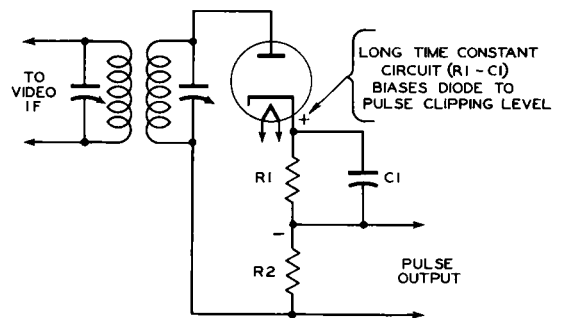

C. CATHODE BIAS WITH SERIES LOAD.

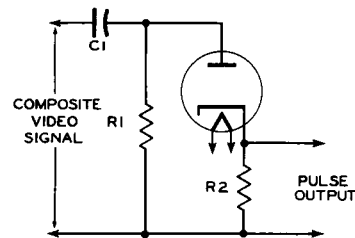

D. RECTIFIED SIGNAL BIAS WITH CATHODE LOAD.

Fig. 94. Diode Sync Separation Circuits

The operation of the circuit (Figure 94C) is similar to that of Figure 94A except that the bias required for delay of the diode action to the correct point is derived from rectification of the signal itself. Two load circuits are employed in series as the cathode return circuit. A bias voltage appears across one of these (R1-C1), and the output sync pulse is developed

across the other (R2). The bias circuit (R1-C1) features the use of a time constant which is long compared with the horizontal and vertical scanning times. The resistor is in the megohm range and the capacitor in the order of .5 mfd. The D-C component resulting from the charge of the rectified sync pulses, in capacitor C1, automatically biases the diode to the "pedestal" or "black" level. This type of circuit can also be used with a rectified video signal as well as with video carrier input as shown.

In the circuit of Figure 94D, the bias for separation of the sync pulse from the rest of the video signal is also derived by rectification of the signal itself. The composite video signal is applied to the input terminals in such a direction that an increase of the signal tends to drive the plate of the diode more positive. This action charges the capacitor C1 and its discharge through resistor R1 during the period between pulses establishes a negative voltage drop with respect to the plate. With proper choice of time constant, the diode can be automatically biased by the video signal to proper point for "clipping" of the sync pulses from the signal.

#### TRIODE SYNC SEPARATION CIRCUITS.

In many receivers, triodes or pentodes are employed rather than the diode circuits just discussed. The choice of tube type depends upon a number of design factors involving type of sync control, polarity requirement, and point in the circuit at which separation is accomplished. In general, the use of these multi-element tubes allows some voltage gain to be realized in the separation process and, in certain of the circuits, the additional feature of "leveling" or "limiting". Three basic types of triode sync separating circuits are shown in Figure 95.

The circuit of Figure 95A makes use of grid rectification of the video signal, to bias the control grid, so that cut-off of the plate current occurs at the desired pedestal level. This action is similar to that just discussed for the diode circuit of Figure 94D. Two additional actions are found in this circuit:

1. The sync pulses are sufficiently high in magnitude to drive the grid into the positive region and the lowered grid resistance limits the input signal by loading.

2. Some amplification of the sync pulse occurs due to the amplifying properties of the triode.

In the arrangement shown in Figure 95B, the operating conditions are quite different from those of the circuit of Figure 95A. The tube is biased from an external source of voltage, through resistors R1 and R2, to such a point that it is just starting to draw grid current at the "black" or pedestal level. The input signal is inverted in polarity from that of the preceding example. In this case, the sync pulse portion of the video input signal is the most negative region. The plate voltage is made very low so that saturation of the plate current occurs at a grid voltage close to its zero value. The portion of the video input signal, more positive than the desired "clipping" level, lies in the saturation region and produces no further rise in plate current. For this reason, "limiting" or "leveling" occurs at this saturation point. The negative excursions of grid voltage, caused by the sync pulse portion of the input signal, cause a drop in plate current as shown in the wave form drawings of Figure 95B. Although the amplitude of the sync input pulses has been limited in the drawing (in order to better illustrate the circuit action), it is evident that if their amplitude is extended to beyond the grid cut-off point, limiting will also occur due to plate current cut-off and the output pulses will be uniform in size.

The series resistor in the grid circuit (R1) limits the amount of grid current which can flow over any one frame. This prevents a long-time blocking condition from developing due to an excessive charge on capacitor C1.

The circuit of Figure 95C employs cathode bias to establish the correct operating point for plate circuit separation of the sync pulses. In this case, the values chosen for resistor R2 and capacitor C2 are determined by the following considerations:

1. The resistor must have such a value that the plate current pulses above the "clipping" level will produce a voltage-drop equal to the required operating point. For high-mu tubes, this resistor will be in the order of 10,000 ohms.

2. The value of the capacitance C2 must be a compromise between several factors. It



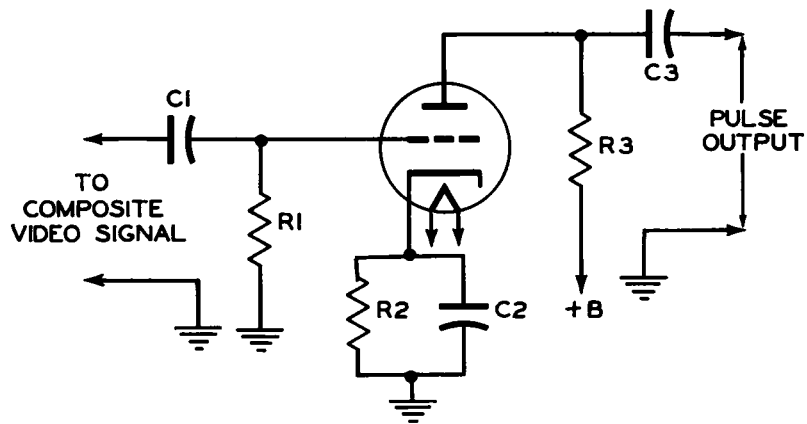
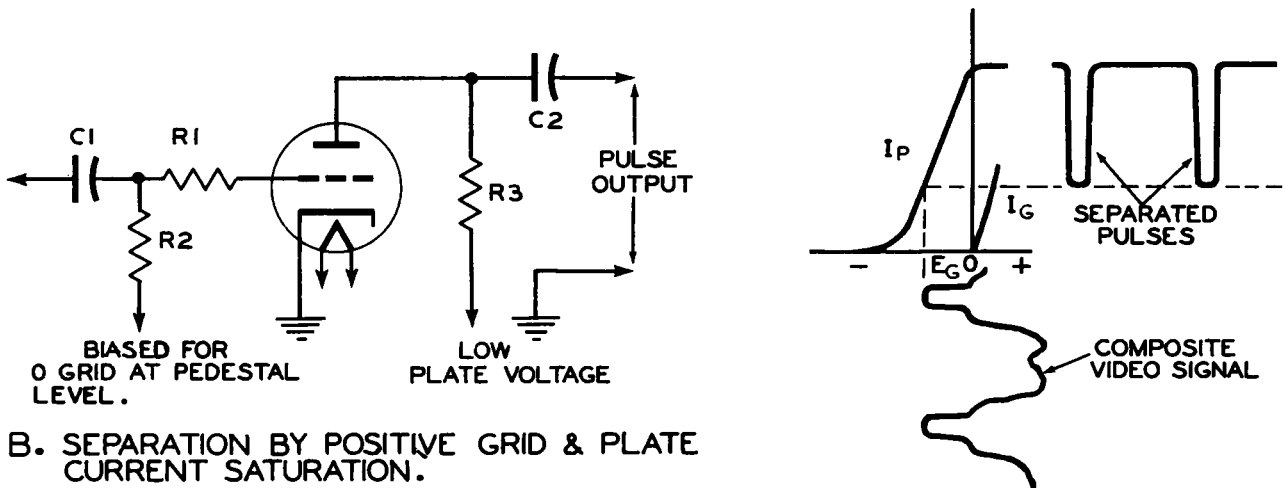
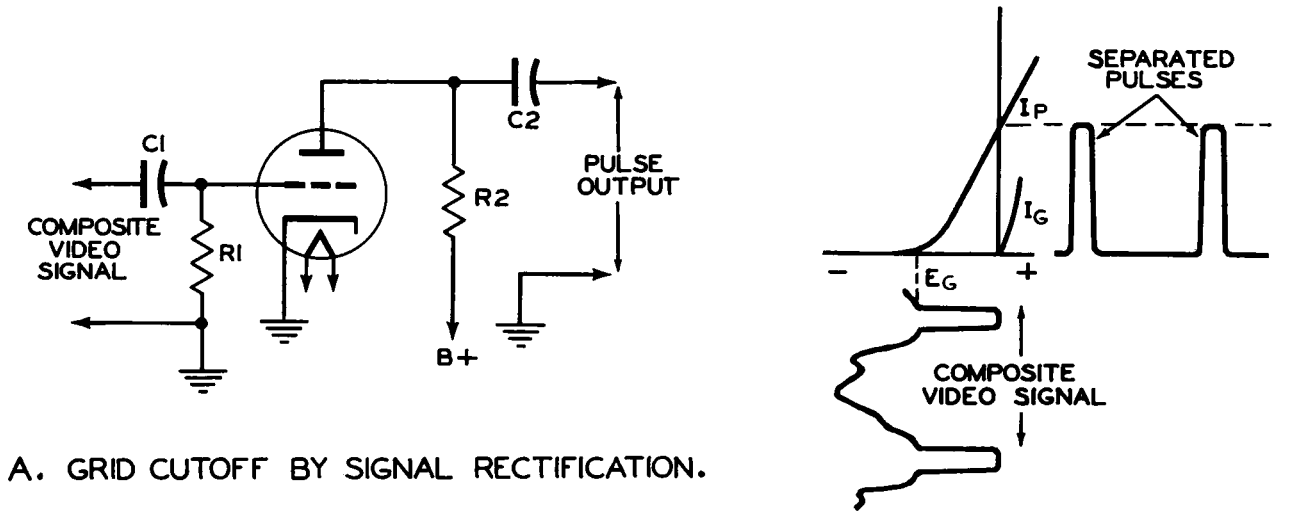

C. CATHODE BIAS CIRCUIT.

Fig. 95. Triode Sync Separation Circuits

## CATHODE-RAY - - BEAM MODULATION AND SYNCHRONIZATION

must be high enough to maintain constant bias voltage throughout at least one vertical blanking period and yet low enough in value that it can change its charge in accordance with changes of the average background lighting of the scene.

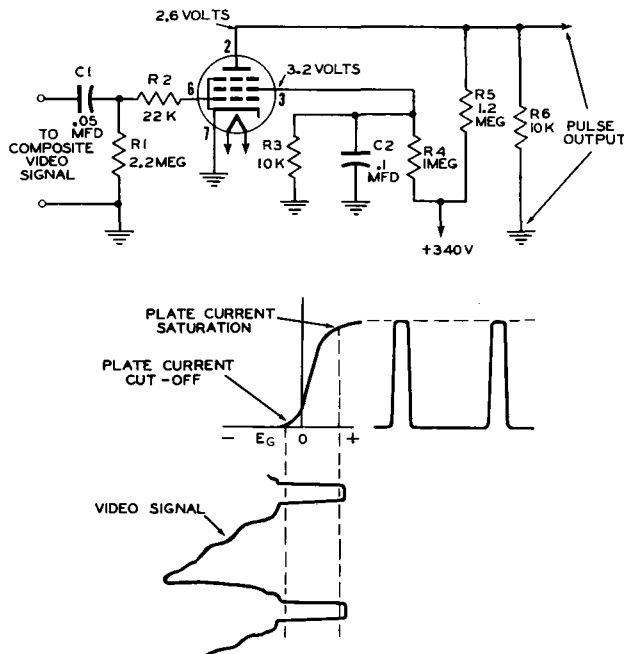

Fig. 96. Pentode Sync Separating Circuit Incorporating "Leveling" or "Limiting"

**PENTODE SYNC SEPARATION.** Figure 96 illustrates the use of a sharp cut-off pentode as a combination sync separator and limiting amplifier. Plate current saturation is assured by operating both the screen and plate at extremely low voltages. This is accomplished by the use of dividing networks. The screen network consists of resistors R3 and R4 and it will be seen that with a "B" supply voltage of 340 volts, the screen is held at the extremely low voltage of 3.2 volts. In like manner, the plate supply network consisting of resistors R5 and R6 maintains the plate at 2.6 volts. Under these conditions, plate current saturation occurs just after the grid voltage has passed into the positive region as shown in the diagram of Figure 96. The grid circuit network, consisting of resistors R2 and R1 with capacitor C1 establishes the operating point of the circuit by grid circuit rectification of the video signal. This assures plate current cut-off at a level just above the "pedestal" or "black" region. It will be seen from the drawings that the synchronizing

pulses are clipped at both ends and leveling or limiting occurs. Since a pentode operating under these conditions exhibits very low voltage gain, it is necessary to operate a circuit of this type either at a high voltage level point in the system or to follow it with sync amplifiers.

The series grid resistor (R2) in this circuit functions in a manner similar to that of the positive grid triode of Figure 95B. In this case, however, it serves an additional function. Sharp noise pulses, such as those due to motor car ignition, whose amplitude might be higher than the sync pulses in the absence of this resistor would drive the grid highly positive and result in a blocking condition. This would cause loss of synchronization, during the period that the tube was blocked, resulting in loss of grid and plate current which can flow during any one sync or noise pulse.

**CATHODE FOLLOWER SYNC SEPARATION CIRCUITS.** Figure 97 shows two circuits which employ the cathode follower principle for the separation of synchronizing pulses from the video signal. In both cases the action is at high voltage level and the input to the cathode follower is taken from the final stage of the video amplifier.

Figure 97A shows a 6V6 output pentode operating as a high transconductance triode with screen and plate connected together. This tube, in turn, feeds a diode acting as a sync clipper in a manner similar to that described in connection with Figure 94B.

Several unusual circuit features are evident:

1. The grid circuit of the cathode follower is returned to plus 300 volts through the network consisting of R1, R2 and R6. If the diode (T2) were to be removed from its socket so that no plate current could flow through R6, the grid of tube T1 would be at a positive potential.

2. The circuit consisting of resistor R6 and capacitor C4 is charged by the rectified sync pulses from tube T2. The values chosen for the components of this circuit produce a long time constant. A steady bias voltage, negative to ground, appears across R6.

## CATHODE-RAY - - BEAM MODULATION AND SYNCHRONIZATION

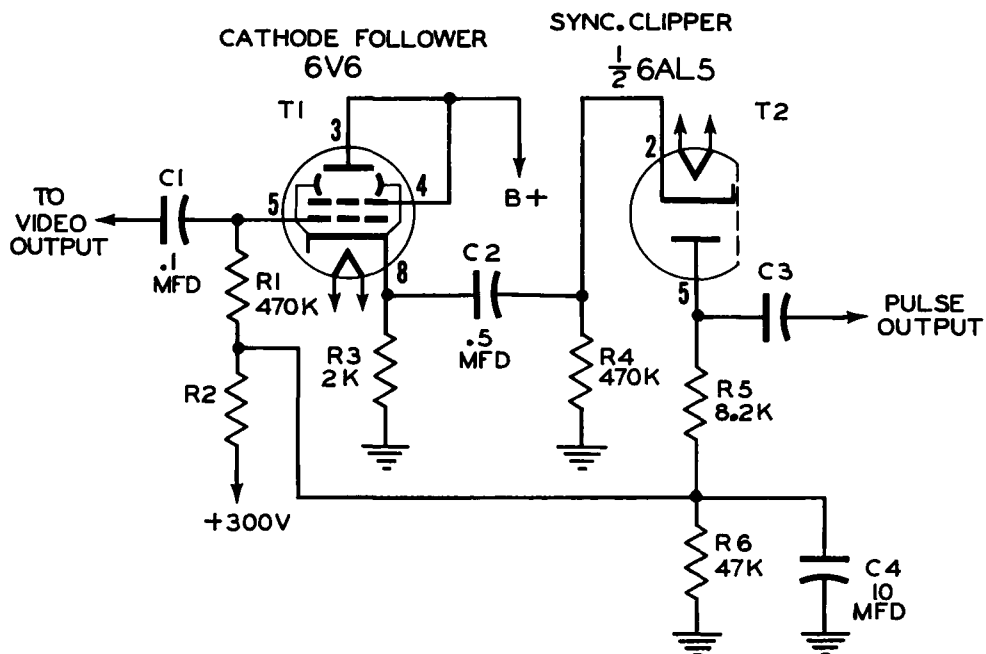

(A) CATHODE FOLLOWER - SYNC CLIPPER CIRCUIT

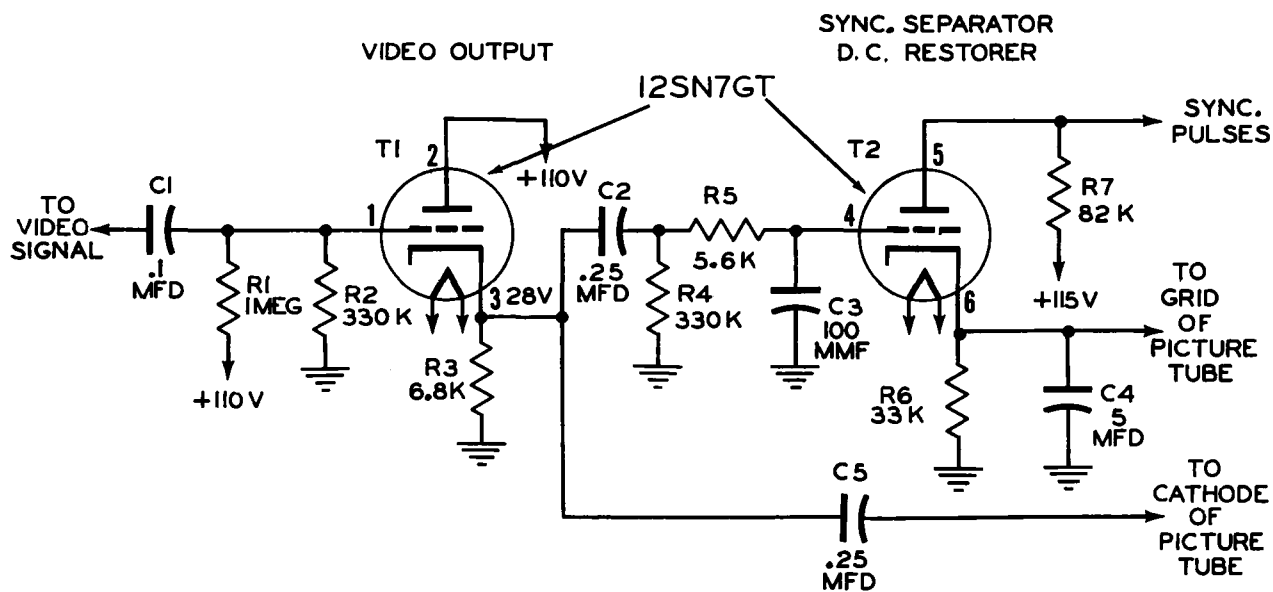

(B) CATHODE FOLLOWER WITH TRIODE SEPARATOR

Fig. 97. Cathode Follower Sync Separation Circuits

3. This bias voltage is introduced into the grid circuit at the tap between resistors R1 and R2 and opposes the positive voltage from the plate circuit.

4. Plate current of the cathode follower itself flowing through resistor R3 produces another source of bias voltage which also tends to oppose the original positive bias.

5. The combination of this group of voltages produces a condition whereby the grid of the cathode follower is slightly negative with respect to its own cathode and operation of the tube is on the linear portion of the characteristic curve. This operation tends to become automatic since that portion of the bias which is contributed by circuit R6-C4 is dependent upon the peak level of the synchronizing pulses.

6. The pulse output for control of scanning is taken across the un-bypassed resistor R5 in the plate of the diode sync clipper tube (T2).

The circuit of Figure 97B is similar in some respects to that just described since operation of the cathode follower tube (T1) occurs on a linear portion of the curve due to the balance of the bias developed across resistor R3 and the voltage from the plate circuit produced by the network R1 and R2. In this case, a net negative voltage of minus 2 volts appears between grid and cathode.

The cathode follower tube (T1) performs the dual functions of video output and sync take-off. The video output for the cathode of the picture tube is taken directly from the cathode load resistor (R3) through capacitor C5.

This same load resistor feeds a triode (sync separator and D-C restorer) tube T2, through the network consisting of C2, R4, R5, and C3. The combination of R5 and C3 constitutes a filter for the removal of the high frequency components of the video signal.

Sync pulses are taken from the plate of triode T2, which operates in a manner similar to that of Figure 95C. Use is made of the direct current bias voltage existing across network R6-C4 to restore the average component of the picture signal which is responsible for the average light of the televised scene. This D-C component of the signal has been lost in passing through the video amplifier stages. A more detailed explanation of D-C restoration will be given later in this course.

**SYNC PULSE AMPLIFICATION. CLIPPING AND SHAPING.** In most television receiver designs, more stages than a one tube circuit are employed for the separation of the sync pulses from the video signal. These additional stages are introduced for the purpose of: inverting the phase of the pulses (when not of the proper polarity for control of the scanning

oscillator), clipping the pulse width (for more reliable control of scanning), amplifying the pulse (if it is not of sufficient strength for control), leveling the pulse (to take care of variations of the video signal and minimize the effect of interfering noise pulses).

There appears to have been little standardization to date in naming these stages, and we find the following descriptive titles in the service literature of the various manufacturers: "sync clipper", "pulse stripper", "sync amplifier", "sync inverter", "sync leveler", "sync limiter", "pulse limiter" and "clapper". These various actions are self-explanatory and have been covered in the preceding text. It should be noted that even though a stage is labeled as a "sync amplifier", it is usually biased in such a manner that either cut-off or saturation contributes some element of "leveling" or "clipping" as well as the desired voltage amplification.

Examples of the application of these stages in typical commercial receiver designs will be found in the circuits covered under "Typical Commercial Deflection Systems" of Chapter 2 and in the samples of "Typical Synchronizing Systems" at the end of this section.

**"SORTING" OF THE INDIVIDUAL HORIZONTAL AND VERTICAL PULSES.** In the foregoing description of the various methods of separating the synchronizing pulses from the composite video signal, only the narrow horizontal pulses were mentioned. The longer vertical pulses are clipped from the signal in the same separation process.

After these sync pulses have been removed from the video signal, by any one of the methods described, it is then necessary to "sort" the vertical from the horizontal and feed each pulse to its respective deflection scanning systems. Since the horizontal and vertical pulses are equal in amplitude or height, the methods of separation which were described for clipping them from the video signal cannot be used to distinguish between them. They do, however, differ in time duration and it is on this basis that the "sorting" is accomplished.

Several times, in the description of deflection systems, mention has been made of "differentiating" networks for the removal of horizontal pulses and "integrating" networks

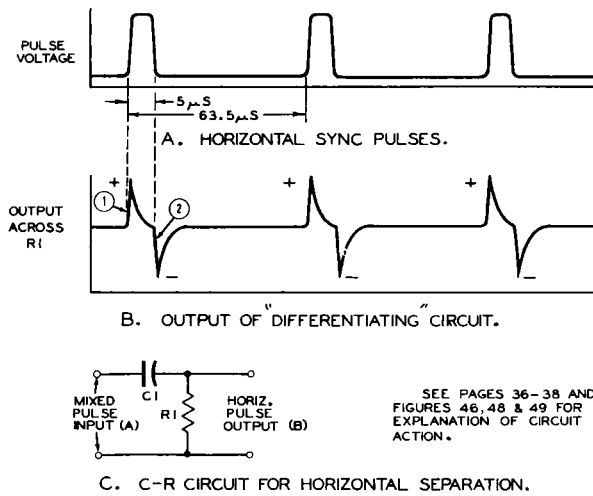

Fig. 98. Horizontal pulse separation or "Differentiation"

for the vertical pulse acceptance. At this time, we will consider the action of such systems in greater detail.

**HORIZONTAL PULSE SEPARATION.**

The horizontal pulses of the transmitted signal are approximately five microseconds in "width" or duration as shown in Figure 65. These pulses are impressed on a circuit of the type shown in Figure 98, which is known as a "differentiating" R-C circuit.

The term "differentiation" is a mathematical expression used in calculus and means simply the "breaking down" of a quantity into a number of small parts. In this case, the pulses of Figure 98A are "made into" smaller parts as shown in Figure 98B by the action of the circuit shown in 98C.

The circuit consists of a capacitance and resistance combination in which the capacitance is in series with the separated pulse input, and the resistor is in "shunt" across the output. The time constant of this circuit is made short compared with the duration of a horizontal sync pulse. The sync pulse is held between 4 and 5 microseconds in time duration and the time constant of the horizontal differentiating circuit is made between 1 and 2 microseconds. As described on pages 37 and 38 and illustrated in Figure 49, for a C-R circuit in which the time constant is short compared with the duration of the applied square wave pulse, the capacitor is completely discharged. A sharp "pip" of voltage occurs across the resistor at both the leading and trailing edges of the applied square wave pulse.

The amplitude of the "pip" is determined by the "steepness" of the edge of the square wave and, for this reason, limits are placed by the Federal Communication Commission on the allowable slope of the leading and trailing edges. These slopes must not occupy more than 5 percent of the horizontal line scanning interval of 63.5 microseconds.

The voltage "pip" due to the leading edge of the horizontal synchronizing square wave, is shown as a positive "pip" at (1) of Figure 98 and the "pip" due to the trailing edge of the horizontal pulse is shown as a negative voltage at (2) of Figure 98. The leading edge pulses are the ones which are employed for control of the horizontal scanning oscillator and the negative pulses are rejected by cut-off or saturation of one or more stages of the sync system.

When the longer duration vertical synchronizing pulses arrive, the action of the differentiating circuit becomes that shown in Figure 99. Here again, a positive "pip" occurs at the leading edge of each vertical pulse and a negative "pip" at the trailing edge. The leading edge pulses continue to control the horizontal oscillator during the time of vertical retrace. In this instance, however, two pulses occur during a horizontal line-scanning interval. Only the first of these is used to control the horizontal oscillator. The second cannot cause lock-in since it happens at a time in the sawtooth wave when the amplitude is insufficient to trip the oscillator.

The horizontal pulses can be separated from the complex video signal by means other than the C-R "differentiating" circuit just described. Figure 100 shows two types of differentiating circuits which employ inductance, and a third type which uses the properties of a resonant circuit.

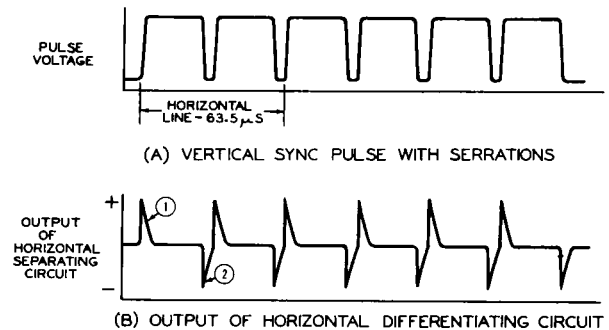
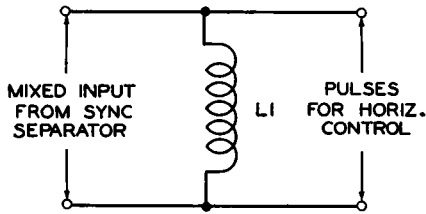
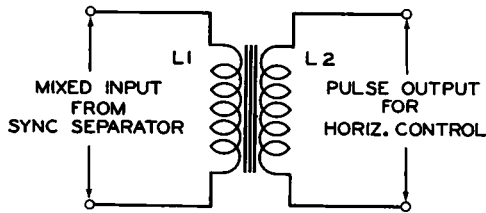

Fig. 99. Action of Vertical Sync Signal on Horizontal Differentiating Circuit



A. DIFFERENTIATION BY SELF INDUCTANCE.



B. DIFFERENTIATION BY MUTUAL INDUCTANCE (TRANS. ACTION).

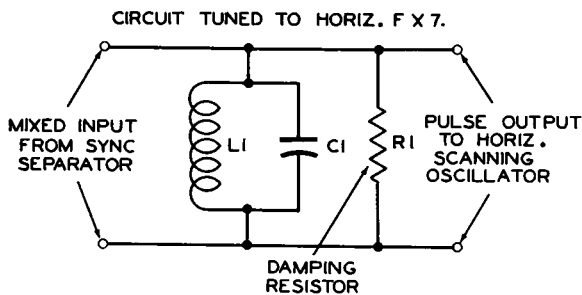

C. HORIZONTAL SEPARATION BY TUNED CIRCUIT ACTION ( $\frac{1}{2}$  CYCLE OF "RINGING" EMPLOYED).

Fig. 100. Other Methods of Horizontal Sync Pulse Separation.

The inductance of Figure 100A is connected in series with the plate circuit of a tube which has been biased to clip the sync pulses from the video signal. The waveform of the sync-pulse plate current consists of steep slopes, which correspond to very rapid changes of current. The voltage which appears across the inductance is proportional to the rate of change of the current through it. Thus, at the leading and trailing edges of each plate current pulse, a high voltage is produced across the inductor of the same form as shown for the C-R type of differentiator (Figure 98B). If the pulses are of proper polarity and sufficient amplitude, they may be applied directly to the scanning generator by a capacitor con-

nected to the plate end of the inductor. In case the polarity is incorrect, phase reversal may be accomplished by an amplifier stage or by transformer action as shown in Figure 100B. When a transformer is used, the secondary L2 has induced voltage pulses of opposite polarity to those occurring across the primary L1. The secondary can be connected directly to the horizontal scanning generator grid circuit.

The circuit shown in Figure 100C operates quite differently from the two just described. The resonant circuit consisting of L1 and C1 is tuned to approximately seven times the horizontal line frequency of 15,750 cycles (110 kilocycles). The separated sync-pulses are impressed across the circuit and "shock excite" it into oscillation at its resonant frequency. The oscillation is quickly damped out by the parallel resistor R1. Only the first half cycle of voltage across the circuit is used for control of the horizontal scanning oscillator. This corresponds to a pulse duration of approximately 5 microseconds. Several advantages can be cited for this method of horizontal sync discrimination:

1. It allows the design of an extremely simple pulse separation and oscillator control system. The circuit can be connected directly in the plate return of the sync separator tube and can be coupled directly to the scanning oscillator because the function of pulse shaping is performed by the resonant action.

2. It is relatively immune to excitation by static or ignition noise because such pulses would have to be of the proper time duration (5 microseconds long) and of the proper repetition rate (15,750 cycles) to produce the "ringing" action. The probability of such coincidence in random noise excitation is slight. A typical example of the use of this circuit in a commercial design will be found at the end of the sync pulse separation section.

**VERTICAL PULSE SEPARATION.** In the description of vertical scanning systems we have mentioned "integrating" networks for segregation of the long time vertical field pulses from the "sharp" horizontal line pulses. At this time we will consider the means of "sorting" these vertical "field scanning" pulses from the composite scanning pulses and their use to control the timing of the vertical oscillator.

The "integrating" action which is employed to "sort" the vertical pulses from

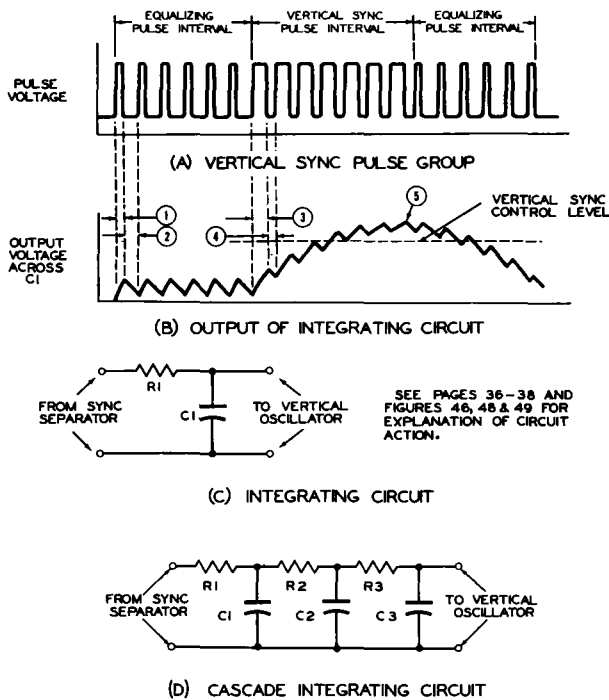

Fig. 101. Vertical Pulse Separation by "Integration"

the complex video signal is exactly opposite in nature to the "differentiation" process used for separation of the horizontal pulses. "Integration" is a mathematical term used in calculus and means the addition of a number of small elements or parts to form a whole. Figure 101 shows the circuit employed to accomplish this action, and it will be seen that it is exactly the reverse of the "differentiation" circuit of Figure 98. In this case, the resistor is in series with the input and the capacitor is connected across the output. The time constant of the combination is much longer than that employed for "sorting" the horizontal pulses. This time constant is made approximately equal to the duration of a horizontal pulse and consequently the charge accumulated by the capacitor, due to a horizontal pulse, is small and will decay rapidly. This action is shown in Figure 101B. During the time shown as (1) the equalizing pulses produce only a small voltage across the capacitor. This voltage decays to zero in the interval between pulses as shown at (2). The much longer vertical synchronizing pulses produce a greater charge in the capacitor during period (3). This charge does not completely decay during the short serration interval (4). Consequently, each of the vertical pulses adds an element of charge to the capacitor and the voltage continues to build up for

the entire duration of the interval of vertical pulses. The dotted line shown on Figure 101B indicates the level at which this voltage becomes of sufficient amplitude to "trigger" the vertical scanning oscillator. In most designs, this point is made to occur after two or three of the vertical pulses have charged the capacitor.

In commercial television receivers, the vertical integrating network is seldom the two-element type shown in Figure 101C, but is usually a cascade network as shown in the example of Figure 101D. The resultant time constant of this network is smaller than that of any of the individual branches (R1-C1, R2-C2 or R3-C3). The value of the over-all time constant can be calculated in the same manner as used for the determination of the effect of resistors in parallel. For the three branch circuit of Figure 101D, using T1 for the time constant  $R1 \times C1$ , T2 for  $R2 \times C2$  and T3 for  $R3 \times C3$ , the effective circuit time constant (T) will be  $\frac{1}{T} = \frac{1}{T1} + \frac{1}{T2} + \frac{1}{T3}$ . Typical values for the individual time constants for a three branch circuit such as that of Figure 101D, as found in modern receivers are from 30 to 60 microseconds. The effective over-all circuit time constants will therefore be between 10 and 20 microseconds.

The reasons for the use of cascaded integrating circuits are:

1. To prevent the erratic control of vertical retrace by random noise or static pulses. For such pulses to assume control of the vertical oscillator they would have to be comparable in duration and spacing to the vertical sync pulses.

2. To smooth out the contour of the rising voltage wave, shown in the interval 3 to 5 of Figure 101B, across the output capacitor. The action is similar to that of the familiar resistance-capacitance power supply filter system, in which the ripple is reduced by successive stages.

As a result of this smoothing action, an individual horizontal pulse cannot assume control at the instant of retrace and cause "pairing" of lines.

The sections of this cascade network are not usually made with equal time constants. This unbalance assists in rendering the system immune from accidental triggering by noise pulses.

CATHODE-RAY - - BEAM MODULATION AND SYNCHRONIZATION

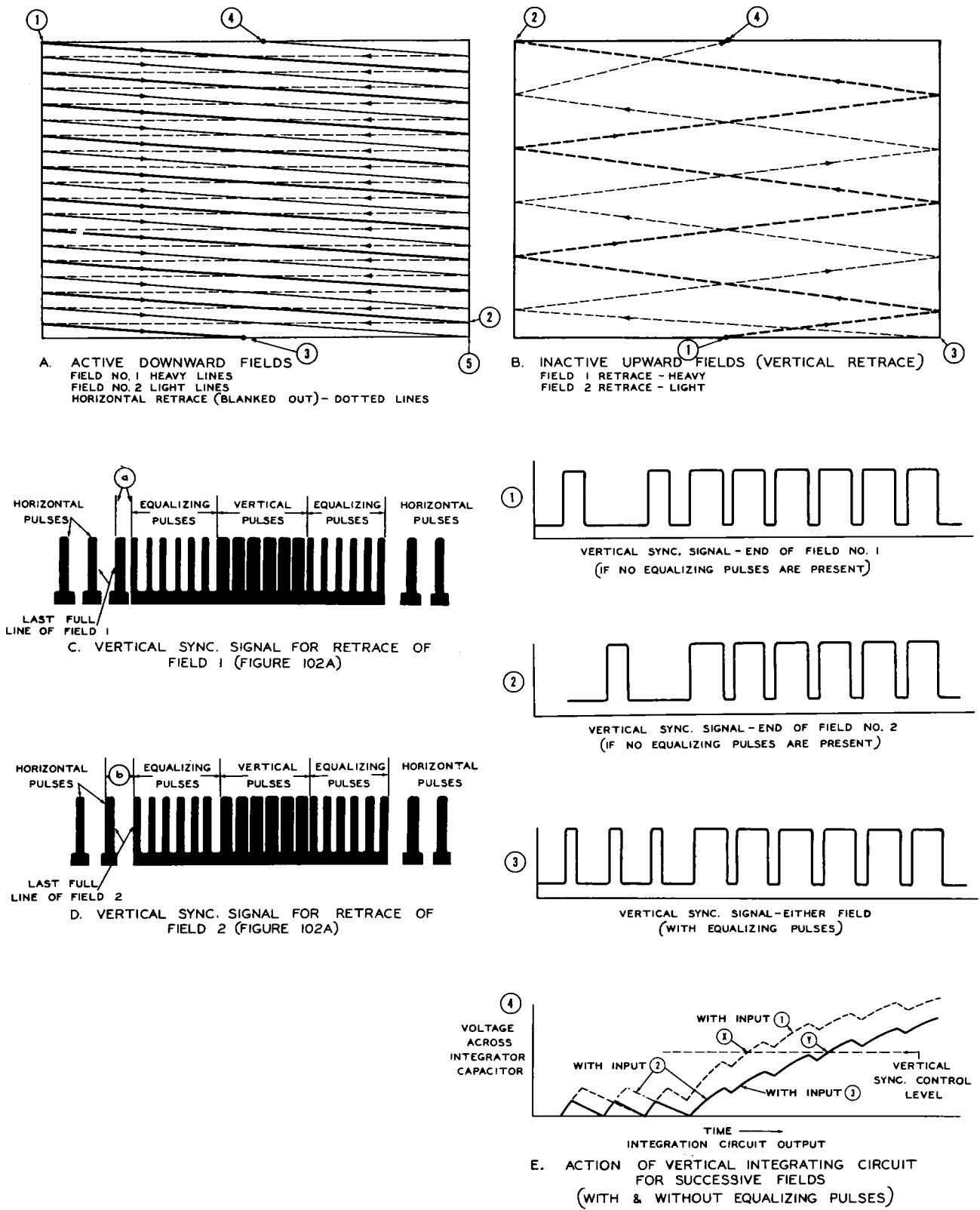

Fig. 102. Use of Equalizing Pulses to Assure Correctly Interlaced Vertical Scanning



The Function of Vertical Equalizing Pulses. On page 24, we discussed briefly the subject of interlaced scanning which is employed to prevent "flicker" of the image. For simplicity, the retrace which occurs from bottom to top of the picture was shown at that time as a straight line or single "jump". Actually, it is necessary to keep the horizontal oscillator running in exact step or synchronism with the transmitter during the vertical retrace period which lasts from 1250 to 1400 microseconds (20 to 22 horizontal lines). Figure 102A shows a simplified version of the active downward scanning of the picture in which nine and one-half lines have been drawn to represent a field. Actually a field consists of two hundred sixty-two and one-half lines less the number of lines lost during the retrace period. The first field which starts at the upper left hand corner (Point 1) and ends at the center bottom of the picture (Point 3) has been shown by heavy lines. The second or interlaced field, starts at the top center (Point 4) and ends at the lower right hand corner (Point 5) and is shown by light lines. During the vertical retrace period, when the picture tube is blanked out, the beam moves upward under the combined action of both the vertical and the horizontal deflection systems. This is represented in simplified form by the diagram of Figure 102B. In this case, five and one-half lines have been used to represent the twenty to twenty-two lines actually required during the vertical retrace period. The same convention has been employed, namely, a heavy dotted line for the retrace of field No. 1 and a light dotted line for the retrace of field No. 2.

The dual functions, of producing vertical retrace at the proper instant and of keeping the horizontal oscillator in synchronism, are controlled by the action of the groups of equalizing and vertical pulses shown in Figures 102C and 102D. It will be seen that the vertical sync signal for the retrace of field No. 1 differs from that of field No. 2 by the spacing between the last horizontal pulse and the first equalizing pulse. In Figure 102C, for field No. 1, this space (a) consists of only one-half of a horizontal line since field No. 1 ends at the middle of the last line as shown at Point 3 of Figure 102A. In the case of Figure 102D, for field No. 2, the space (b) between the last horizontal pulse and the first equalizing pulse consists of an entire horizontal line as shown at Point 5 of Figure 102A. Vertical blanking starts at the leading edge of the equalizing pulses and thus

the successive field blanking time is accurately set up by the signal.

Even though blanking for the retrace period is accurately established, vertical retrace itself may not take place at the proper instant unless the critical charge on the integrating capacitor occurs at exactly the same point for each successive vertical sync signal. The manner in which the equalizing pulses assure this condition is shown in Figure 102E. At (1) is shown the composition of a vertical sync signal which would follow field No. 1 if the equalizing pulses were not present. This signal input to the integrating circuit would charge the capacitor as shown by the dotted line labeled (1) in curve (4). This curve crosses the sync control level at time (X). The set of conditions which would occur for the type of vertical signal, without equalizing pulses, for retrace at the end of field No. 2 is shown at (2) in Figure 102E. In this case, the critical sync control level is reached at point (Y) which is sufficiently later than point (X) so that proper interlace would not occur. When equalizing pulses are employed as shown at (3), the critical "firing" point for the vertical oscillator is seen to coincide with the condition shown at (2). Successive fields preceded by equalizing pulses will therefore produce accurate control of the oscillator and assure proper interlace.

**ACTION OF THE HORIZONTAL DIFFERENTIATING CIRCUIT DURING THE VERTICAL PULSE PERIOD.** The formation of positive and negative "pips" respectively at the leading and trailing edges of the vertical sync pulses was described briefly on page 95. We will now consider, in somewhat greater detail, the action of the horizontal differentiating circuit during the entire vertical pulse

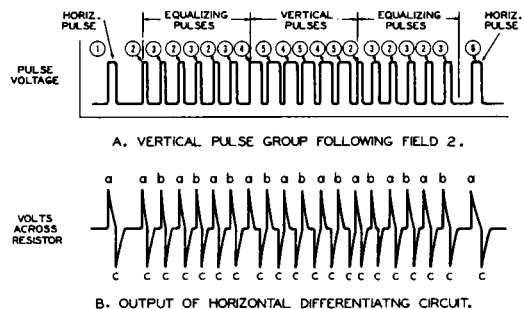

Fig. 103. Action of Horizontal Differentiation Circuits During Vertical Pulse Period

period. Figure 103A shows the configuration of the vertical signal which follows field No. 2.

The horizontal pulse which starts retrace of the bottom line of the picture is shown at (1) in Figure 103A and the positive output "pip" produced by its leading edge is shown at (a) in Figure 103B. The "pip" produced by the trailing edge of this same horizontal pulse, as well as those produced by the trailing edges of all of the other pulses of the period (labeled c), are rejected by the sync system as previously explained.

Each of the equalizing pulses (2, 3) which precede and follow the vertical pulse group also give rise to a pair of positive and negative pips as shown. Only the pips marked (a) are used for oscillator control. Those labeled (b) are rejected since they occur at a time in the scanning cycle at which the horizontal oscillator is not sensitive to pulse control (see Figure 68 and page 55).

Each of the pulses of the vertical group (4, 5) also produces a pair of positive and negative pips. In this case, only the positive pips ("a" of Figure 103B) are utilized.

The horizontal pulse shown as (6) is one of a group occurring during the blanking period. (See page 53.) The pips produced by it are identical to those produced by the horizontal pulse (1) of Figure 103.

It is evident that the vertical pulse group is able, by the action of the individual pulses and by the differences in length of these pulses, to perform the dual functions of assuring vertical retrace at the correct instant and of keeping the horizontal oscillator under control (in step with the scanning in the camera tube at the transmitter).

Vertical Pulse Separation by Use of the First Serration of the Vertical Signal. Another method of "sorting" the vertical sync pulse from the composite video signal, which depends only indirectly on R-C circuit principles, is illustrated in Figure 104. This type of vertical sync separation is not dependent, for accurate retrace and proper interlace, upon the existence of equalizing pulses.

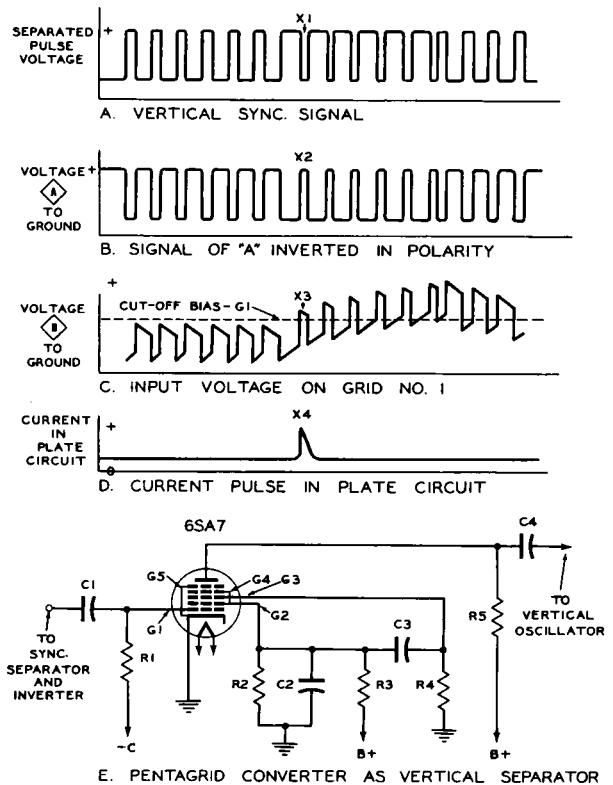

Fig. 104. Vertical Sync Pulse Separation Using First "Serration" of Vertical Signal for Scanning Control

The first "serration" of the vertical pulse group (X1 of Figure 104A) always occurs at the same instant of time, i. e.: one-half of a horizontal line after the beginning of the first vertical pulse. This first "serration" is separated from the "mixture" and used for control of the vertical scanning oscillator. In order to accomplish this result, it must be changed from a "negative going" pulse to a "positive going" pulse. This is done by passing the separated pulse group through an amplifier stage which inverts the phase or polarity (see Figure 104B).

The inverted signal is fed to Grid No. 1 of a pentagrid converter tube (6SA7), see Figure 104E, through a differentiating network (C1-R1). This circuit has a time constant of approximately one-half of the horizontal line scanning time or about 30 microseconds. This grid is biased negatively to such a value that the differentiated pulses, due to the equalizing pulse period, are not of sufficient amplitude to cause any flow of plate current (see Figure 104C).

When the inverted pulse arrives, due to the first serration of the vertical signal, (Point X3 of Figure 104C) it has developed sufficient voltage, across R1, to cause the grid to pass its cut-off bias and start a pulse of plate current.

Screen Grids Nos. 2 and 4 are connected together and are held at a low voltage by the high resistance divider network (R2, R3). Bypass capacitor C2 is of relatively small value and as Grid No. 1 is driven positive by pulse X3 the screen voltage drops rapidly.

The third grid, normally the input when the tube is acting as a converter, is coupled to the screens through capacitor C3. This grid will undergo the same voltage drop as the screens and will cut off the plate current as the screen voltage goes negative. Grid No. 3 is held beyond cut-off until the charge on capacitor C3 has "leaked" off through resistor R4. The time constant of C3-R4 is made sufficiently long to allow the rest of the vertical pulse group to pass before Grid No. 3 can regain control.

As the result of this action, only the first pulse which passes the cut-off bias of Grid No. 1 (Point X3) will cause any plate current. This plate current occurs as a single sharp "pip" pulse is coupled to the vertical scanning oscillator through capacitor C4.

**SYNCHRONIZING SYSTEMS (METHODS OF UTILIZING THE SEPARATED SYNC PULSES):** There are three general types of synchronizing systems in use in modern television receivers. They are classified as follows:

1. "Triggered" sync. This system depends upon the use of individual sync pulses to control the scanning of each horizontal line and the vertical retrace of each field. The elements of this type of system have been covered in the preceding text and the circuit illustrations of pages 74 and 84.

2. "Flywheel" or A. F. C. sync. The A. F. C. system, which was described briefly on pages 75-76 and illustrated in Figure 83, depends upon the average of the synchronizing pulses and their rate of repetition rather than

the individual pulses. A fully detailed description of the circuit operation will be presented in this chapter.

3. "Pulse width" controlled sync. In this method, the sync pulse is compared in timing with the output of the scanning oscillator and produces a narrow, augmented pulse for control of the instant of retrace. Its action has been covered on pages 83-84 and illustrated by Figure 90.

**FLYWHEEL OR A.F.C. SYNC CONTROL.** Figure 105 shows a typical circuit adaptation of the automatic frequency control of horizontal scanning by the sync pulses. More properly, it should be called "automatic phase control" since its action "locks" the phase, as well as the frequency, of the horizontal oscillator.

The operation of the circuit is as follows:

1. A very stable oscillator, tube T4 and its associated circuits, generates a sine wave of 15,750 cycles per second. This oscillator circuit is of the "hot cathode" Hartley type and its frequency determining components are inductance L3 and capacitance C2. The free running frequency is adjusted by the powdered iron core of inductor L3 with the hold control (R7) in mid-position.

2. A tapped coil circuit, L1-L2, is tightly coupled to L3 and tuned slightly "off resonance". The voltage across these coils is applied to a "discriminator" circuit similar to the type used for frequency modulation detection. The voltages, from the horizontal oscillator, which are applied to the plates of the discriminator tubes (T1 and T2) are equal in amplitude and opposite in phase (180° out of phase with each other). See Figure 106, (1) and (2).

3. The "clipped" and amplified sync pulses are applied to the discriminator across resistor R3 and appear "in phase" and of the same amplitude at each diode of the discriminator as shown in Figure 106.

4. Three conditions of the system in which the relation of the oscillator frequency to the sync pulse repetition rate is slow, correct, and fast are shown in Figures 106A,

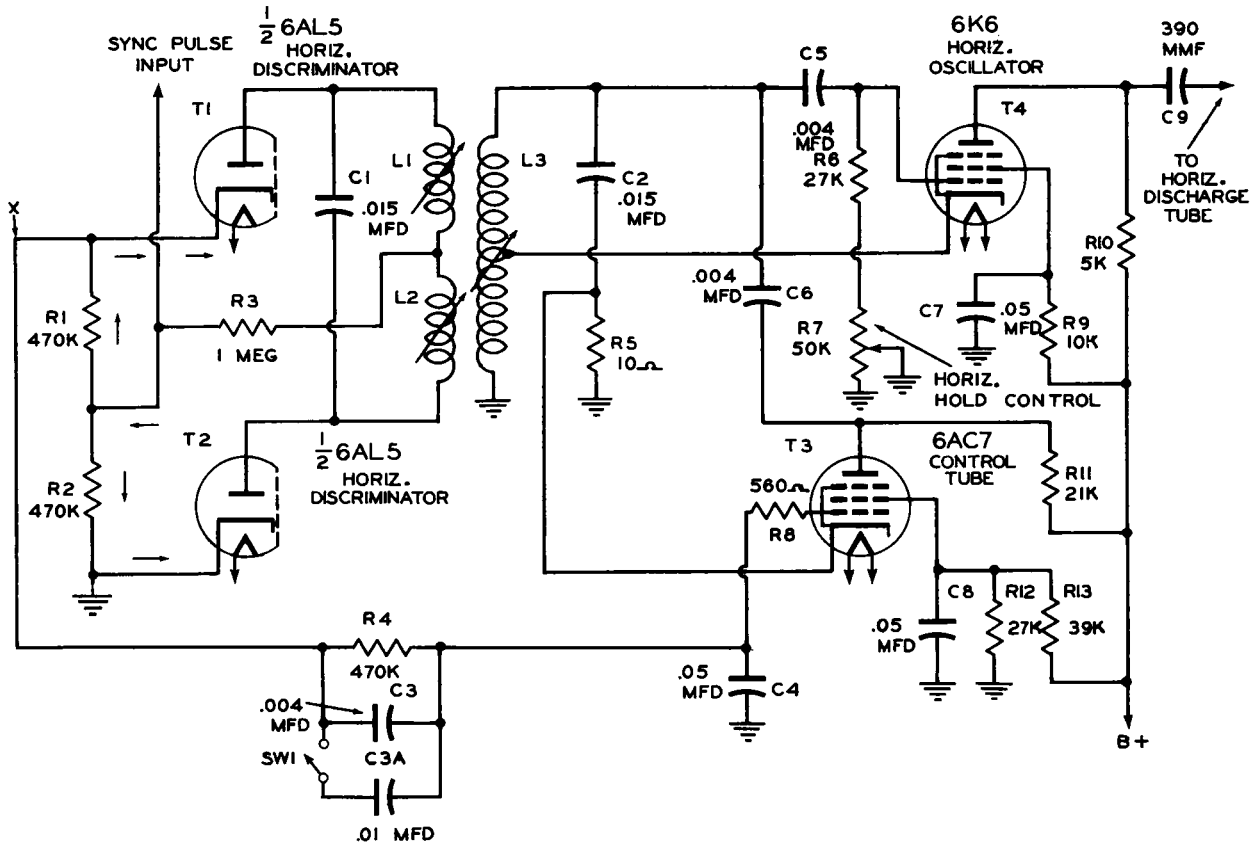

Fig. 105. "Flywheel" or A. F. C. Control of Horizontal Scanning Oscillator

106B, and 106C respectively. It will be noted that the diode load resistors R1 and R2 are so connected that the voltage from ground to point X is the difference between the rectified output of the diode, tubes T1 and T2. Arrows show the direction of electron flow due to the plate current of these tubes.

5. If tube T1 alone is conducting, point X will be positive with respect to ground and if tube T2 is conducting, with no current flow through tube T1, point X will be negative with respect to ground. In the absence of sync pulses, equal and opposite voltages appear across the diodes, tubes T1 and T2, and the total rectified voltage appearing between point X and ground is zero, over the cycle.

6. The condition of stable operation occurs with the sync pulses riding at zero phase, or on the axis of the wave as shown at (B) of Figure 106. In this case, the rectified output of the upper diode, tube T1, would produce a voltage across R1, as shown in Figure

106B (3). The lower diode, tube T2, would produce the voltage wave shown in Figure 106B (4). These voltages oppose each other due to the method of connection of the diodes to the series load resistors, R1 and R2. The net charge on the filter network, C3, R4, and C4; is zero, as shown in Figure 106B (5).

7. If the horizontal scanning oscillator is running faster than the repetition rate of the sync pulses (see Figure 106A), the upper diode output voltage will exceed that of the lower diode as shown at 106A (3). After smoothing through the filter network, a positive voltage will appear at the grid of reactance control tube (T3).

8. In a similar manner, if the oscillator is running slower than the repetition rate of the sync pulses, the set of conditions shown in Figure 106C will apply. In this case, a negative control voltage will appear at the grid of tube T3.

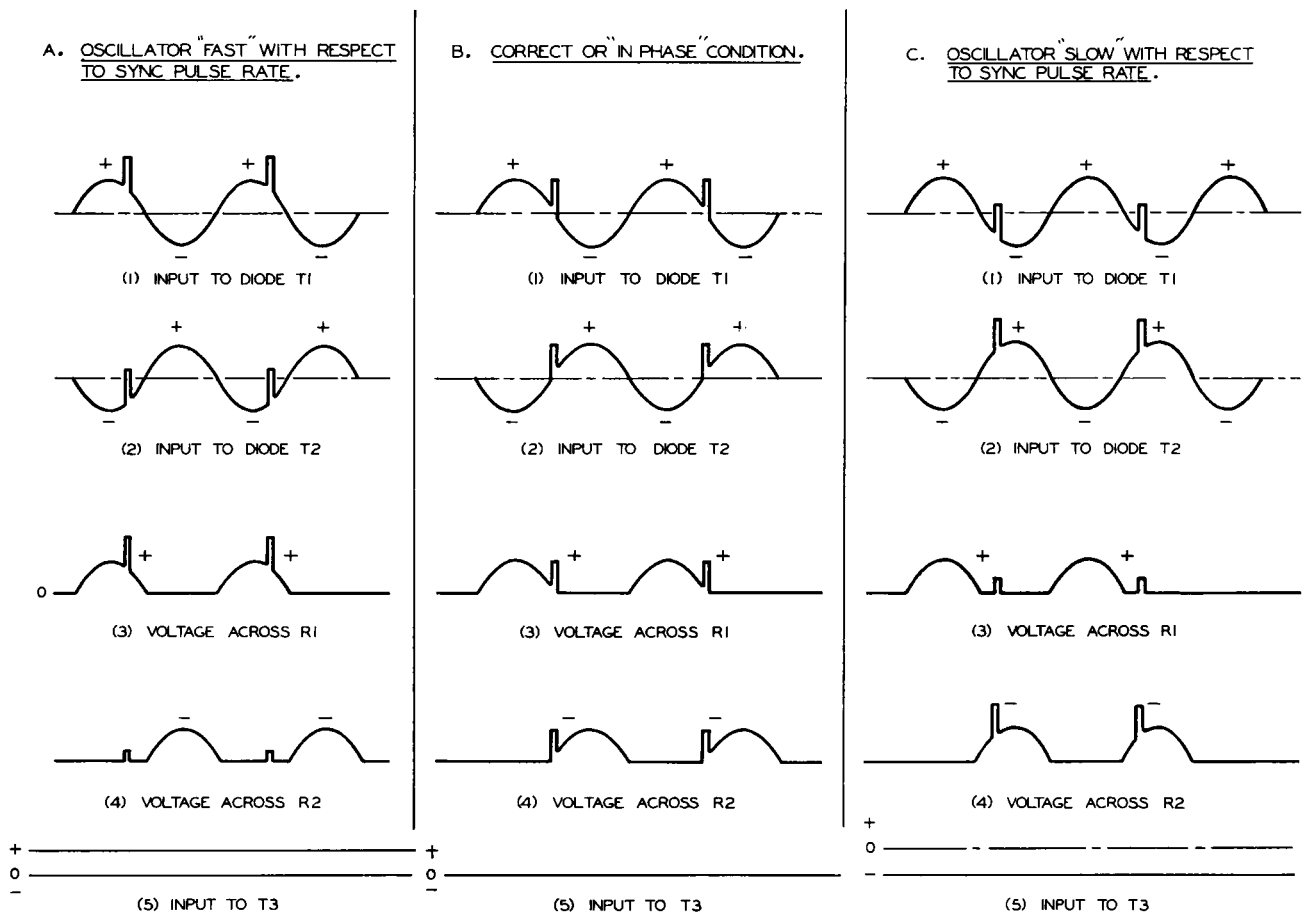

NOTE: VOLTAGE WAVES 2 & 3 ARE WITH RESPECT TO GROUND AND WITH CIRCUIT OPENED AT X.

Fig. 106. Discriminator Action in Horizontal AFC Sync Control Circuit of Figure 105

9. The 6AC7 reactance control tube is connected across the oscillator "tank" inductance L3. The manner in which this tube can control the instantaneous frequency of the oscillator is as follows:

- a. The plate current versus plate voltage curves of a high gain, sharp-cut-off pentode, such as the 6AC7, exhibit a long range of plate voltage over which there is substantially no change of plate current. This region is shown in Figure 107B. The plate current is under the control of the grid voltage as indicated by the individual curves of the plate current-plate voltage family.
- b. Referring to Figure 107A, we find that the plate is connected to the high side of the oscillator tuned circuit

through capacitor C2. The alternating voltage from the oscillator, appearing across the tube, is swinging over the flat portion of the curve and therefore no change of plate current occurs. If, on the other hand, an alternating voltage is applied between grid and cathode the plate current will be changed in amplitude, and this change will be in phase with the alternating grid voltage.

- c. If the alternating voltages applied to the grid and plate are made 90° out of phase, the plate current will then have an alternating component which is 90° out of phase with the plate voltage, i. e. in phase with the grid voltage.
- d. Any circuit in which the current flow-

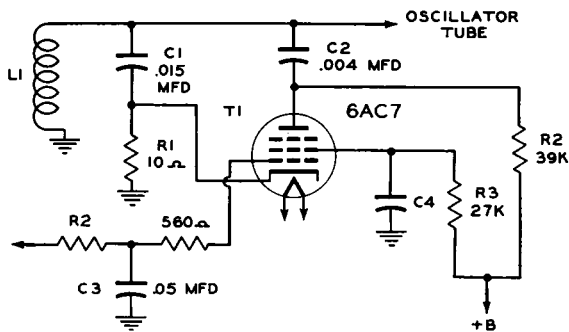

FIG. 107A

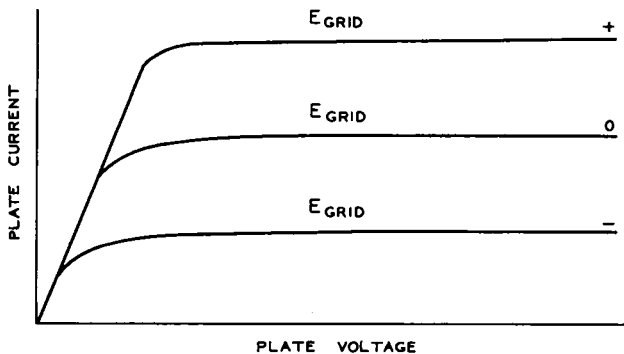

Fig. 107. Reactance Control Operation

ing is not in phase with the applied voltage is reactive. The circuit then appears to be capacitive or inductive. Thus, tube T1 of Figure 107A can be made to appear as a reactance connected across the oscillator inductance L1.

- e. The phase shift of applied alternating grid voltage, with respect to the alternating plate voltage, is provided by the network C1-R1. The voltage across R1 is leading the voltage across the tank circuit by almost 90°. Since the reactance of the coupling capacitor C2 is low, the voltage applied between cathode and grid is approximately 90° out of phase with that applied between plate and ground.
- f. The control grid is returned to ground, or to the end of R1 opposite the cathode, through capacitor C3. The reactance of C3 is very low at the oscillator frequency of 15,750 cycles. The DC return path of the control grid is through the output load resistors of the discriminator stage (R1 and R2

of Figure 105). Since the alternating grid voltage is applied between cathode and the grounded grid, rather than between grid and ground, the plate differs by 180° from the phase it would have if the cathode had been grounded and the grid voltage made variable. In this case, the plate current will lag the plate voltage and the tube will appear as an inductance to the tuned circuit.

- g. The bias voltage on the grid of the reactance tube controls the value of its transconductance (ratio of change in plate current to the change in grid voltage which caused it). The alternating plate current amplitude can thus be changed by varying the bias on the control grid. A low or positive bias will result in an increase in the AC plate current while a more negative bias will reduce the value of AC plate current. Since the AC plate voltage is fixed by the output of the oscillator, a bias change will change the ratio of voltage to current and thus, the apparent value of inductance across the oscillator circuit.

10. If the frequency of the horizontal oscillator should shift with respect to the sync pulse rate, due to variation of supply voltage or other cause, a change of the DC output of the discriminator would occur. This changes the transconductance of the control tube, shifting the instantaneous oscillator frequency to restore the equilibrium condition of Figure 106B.

The network of resistors and capacitors, (R4, C3 or C3A, C4 and R8), which connect the output of the discriminator to the grid of the control tube T3 (Figure 105) requires explanation. The purpose of resistor R4 is to provide a DC return path for the grid of the control tube (T3). Resistor R8 acts as a parasitic suppressor to prevent any possible ultra-high frequency oscillation which might occur in the high mutual conductance type 6AC7 control tube.

Capacitor C3 and capacitor C4 constitute a voltage divider and a filter. The "ripple" on the rectified output of the discriminator diodes is smoothed to furnish a DC voltage to the control tube. Since the reactance of the smaller capacitor C3 (.004 mfd) is on the top side of

the divider, and the larger capacitor C4 (.05 mfd) on the bottom, extremely rapid voltage changes are prevented from affecting the grid voltage of the control tube. Rapid changes can be caused by bursts of noise or by the serrations of the vertical sync signal. These changes are rejected by the action of this voltage divider.

The ratio of the voltage divider consisting of C3 and C4 can be changed by "switching" capacitor C3A (.01 mfd) in parallel with C3. This link connection for the addition of C3A is provided to take care of a condition existing in some television transmitters. If any "phase" modulation of the exact position of the horizontal sync pulse occurs, it is necessary for the A. F. C. control tube to follow this modulation and a "faster" response circuit is required. This is provided by increasing the capacitance of C3 by the addition of C3A. The effect of the phase modulation of the horizontal pulses, if suppressed by the original capacitance ratio, would be to produce a horizontal displacement of part of the picture with respect to the raster.

The use of the higher capacitance, C3A, will result in some sacrifice of "immunity" of the system from horizontal "tearing" by noise. Transmitting technique is constantly improving and the service technician should re-check any installation in which it was originally necessary to employ the higher capacitance to determine whether the advantages of a "fast" circuit with its attendant noise immunity can be tolerated.

The A. F. C. type of sync system has been covered in detail because its use is becoming increasingly popular in television receiver design. The reasons for its popularity are: (1) its relative immunity from triggering by noise, (2) it can take advantage of the entire horizontal pulse time for the discriminator control, and (3) it allows the horizontal trace return time to be slower than could be tolerated with "triggered" sync operation. The reason for its immunity to the effects of static, man-made interference, and receiver input-circuit noise lies in the fact that the frequency distribution of such noise energy is approximately the same both above and below the sine wave oscillator frequency. Thus, the average DC contribution of the two discriminator diodes due to the noise tends to be equal and cancel at point "x" of Figure 105.

**TYPICAL COMMERCIAL SYNC SYSTEMS.** The circuits described and illustrated on pages 73 to 84 covered the sync-controlled scanning system from the point of separation of the pulses to the deflection of the electron beam in the picture tube. Means of separating the sync pulses from the complex video signal have been covered on pages 85 through 98. It has been shown that sync pulse separation can be accomplished at several places in the circuit between the video detector tube and the picture tube.

To illustrate the many points in the television receiver system at which the sync synchronizing pulses may be separated from the signal, a composite circuit is presented in

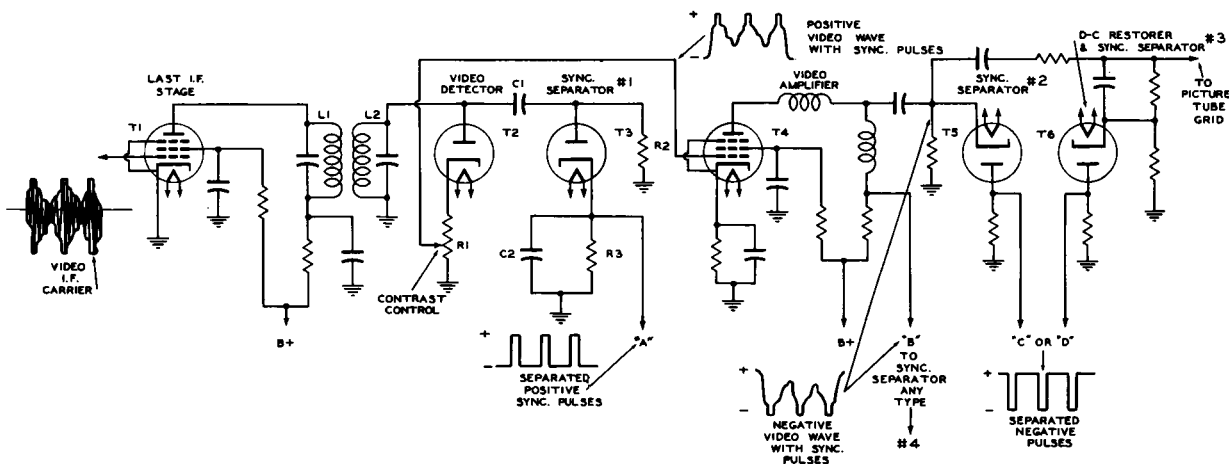

Fig. 108. Composite Circuit Showing Points at which Sync Pulses Might Be Separated

Figure 108. It should be understood that this circuit does not represent an actual or practical television system since extra tubes have been added to present the possible points of sync separation. Four possible positions of sync separation are shown at "A", "B", "C", and "D". The choice of any one of these points by the receiver designer is governed by the required polarity of the pulses and by the amount of signal energy required by the remainder of the sync system.

When a diode such as tube T3 is coupled directly to the output of the video I-F amplifier, illustrated by sync separator No. 1 of Figure 108, the pulses obtained across the cathode resistor R3 are positive with respect to ground. If sync separation is taken at this point, it is usually necessary to employ additional amplification to obtain a pulse of sufficient amplitude to control the horizontal and vertical scanning oscillators. Sync separation at the video I-F output has the advantage of being independent from the setting of the video gain or "contrast control" R1. When separation is done at this point the last I-F transformer secondary, L-2, is usually phased so that the negative half of the video carrier on the last IF amplifier grid is rectified and employed for sync control.

This is done to take advantage of the fact that strong noise impulses will be "clipped", to some extent, since they are more negative than the sync pulses and will drive the last IF amplifier tube beyond plate cut-off, thus causing it to become a "limiter". The action of tube T3 at this point has been covered on pages 88-89 and illustrated in Figure 93.

Sync signal separation at point "B" occurs after rectification of the video carrier and since the rectified video has passed through the amplifier tube T4, the polarity of the signal will be negative as shown by the wave form at point "B" of Figure 108. A signal taken at this point is usually passed through an inverter stage to reverse its polarity and then applied to a sync separator (the triode type covered by Figure 95A or the pentode type of Figure 96).

Separation of the pulse by tubes T5 or T6, as shown at "C" and "D", occur at high level and require very little, if any, additional amplification. When the method represented by tube T5 is used, the tube fulfills only the function of sync separation. The pulse at "C" is negative with respect to ground and can be used for the direct control of cathode-coupled multivibrators after differentiation or integration.

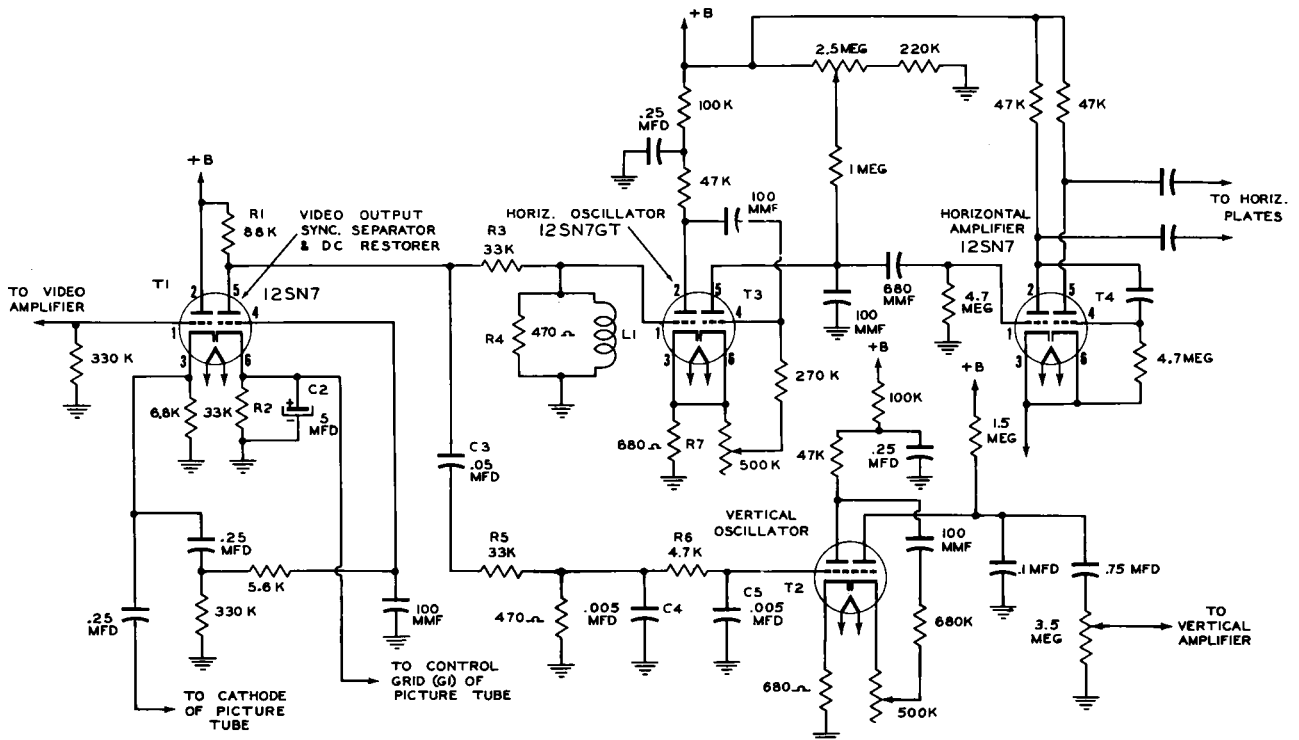

Fig. 109. Horizontal Sync Pulse Differentiation by Means of a Tuned Circuit. (Also See Figure 100C)  
106



When diode tube T6 is employed, it serves the dual function of sync separation and DC restoration. Restoration of the direct current component of the signal is required since the use of capacitance-coupled video amplifiers causes the loss of DC component present in the video signal. The necessity for restoration of the DC component, which is responsible for the average background lighting of the scene, will be covered when we consider the video signal in greater detail.

It should be noted that any particular television receiver circuit will employ only one of the sync separation tubes shown, and that the circuit of Figure 108 would reduce to four tubes rather than the six tubes shown. One exception to this reduction exists when the horizontal pulses are taken off by one separator, such as tube T3, and the vertical pulses at a later tube, such as T5 or T6.

Figure 109 shows an unusual sync separation system in which a single type 12SN7 tube is employed for the functions of video output, DC restoration and sync separation. In this case, the second section of tube T1 acts as a "kangaroo" cathode follower. The plate load of this tube, resistor R1, develops the sync pulses. The long time constant circuit comprised of R2 and C2 develop the direct current bias required for restoration of the background lighting level. Separation of the vertical sync pulses is accomplished by coupling the vertical oscillator tube T2 directly to the plate of tube T1 through the integrating network consisting of C3, R5, C4, R6, and C5.

Horizontal pulse differentiation is accomplished by the use of a tuned circuit comprised of inductor L1 and its associated circuit capacitances. This circuit is resonant at a frequency of approximately 110 kilocycles and is allowed to oscillate for one half-cycle or 5 microseconds. This use of resonance was covered in the text of page 96 and illustrated in Figure 100. Since this first half-cycle pulse controls a cathode-coupled multivibrator, it must be a "negative-going" pulse as discussed under the description of pulse control, pages 54-56. The input section of tube T3 has a net bias determined by its cathode resistor R7 and the divider from the plate circuit of tube T1. This plate circuit network consists of R1, R3 and the parallel resistance of L1 and R4. Resistor R4 "damps" the shock-excited oscillation of the tuned circuit, caused by the horizontal sync pulses. This damping prevents

the continuance of oscillation beyond the first half-cycle, which is required for the control of the horizontal scanning oscillator tube T3.

**SUMMARY OF SYNCHRONIZATION METHODS AND SYSTEMS:** As explained in the introduction to this course, the major difference between television receivers and other types of radio equipment, is the group of circuits which are peculiar to the formation of a cathode-ray produced image, and its control by scanning systems at the transmitter and receiver. The horizontal and vertical scanning systems, the use of pulses as part of the television carrier for control of scanning, and the methods of segregating or separating these pulses have been covered in considerable detail up to this point. Experience with television receivers, which have been in service for the past several years in metropolitan areas, discloses the interesting fact that the majority of service failures have occurred in the scanning and synchronization circuits of these sets. In many cases, the trouble has been readily traced to vacuum tube failures, especially in multivibrator and blocking oscillator circuits. Ageing of components of these oscillator circuits has quite often been responsible for a drift of frequency. This is usually serious enough to cause failure of the receiver scanning to "lock-in" with the transmitted signal. The service technician is urged to study these portions of the television system thoroughly, since the proper installation of new receivers and the maintenance of those in service, will, in the majority of cases, require adjustment or repair of scanning and synchronization circuits.

**BRIGHTNESS CONTROL:** Our previous study of the television receiver system has concerned itself with the motion of the electron beam in the picture tube to accomplish scanning of the picture area. It was shown in Chapter 1, pages 4 through 7, that the intensity of illumination of the cathode-ray screen surface could be controlled by a grid cylinder in the picture tube "gun" structure. We have indicated at several points in the text that the variation of video or picture signal on this control grid is responsible for the instantaneous changes of spot illumination which make up the elements of the picture. The signal voltage on this control element is negative in nature so that a swing in the negative direction produces a darker spot. Finally, at some critical negative

# CATHODE-RAY - - BEAM MODULATION AND SYNCHRONIZATION

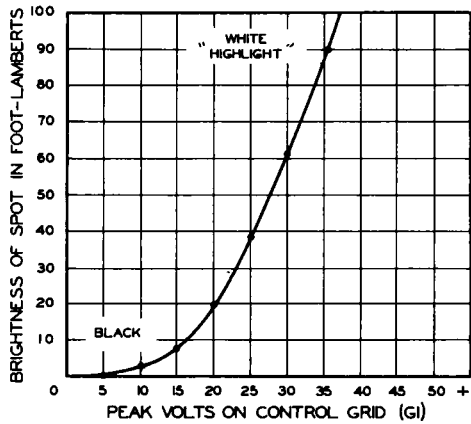

(A) BRIGHTNESS-VERSUS VOLTAGE - GRID 1

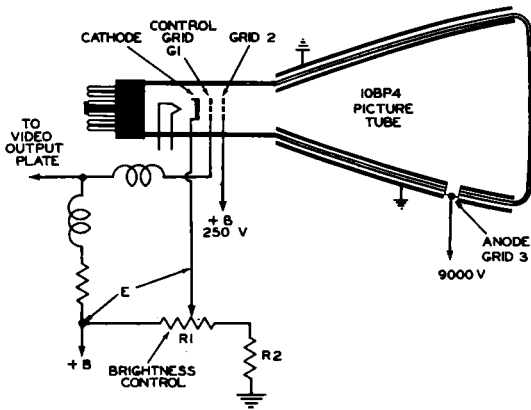

B. "BRIGHTNESS CONTROL WITH GRID AT HIGH SIDE OF CIRCUIT.

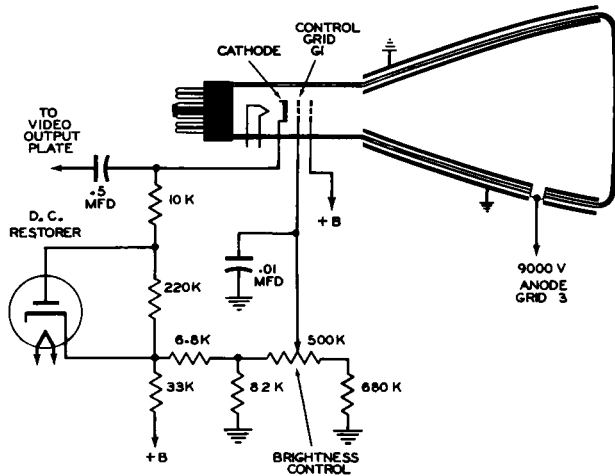

C. BRIGHTNESS CONTROL IN CIRCUIT WITH CATHODE AT HIGH SIDE OF VIDEO OUTPUT.

voltage, the spot of light is entirely extinguished.

Figure 110 shows the relation of the control grid voltage to the brightness of the picture spot for a typical ten inch picture tube (Type 10BP4). In this particular tube, with normal voltages on other elements, the spot is extinguished (picture tube black) for all grid voltages below a value of positive five volts. A swing to a positive 35 volts on the control grid, with respect to the cathode, produces the brightest spot or "highlight" of the picture.

One of the essential controls of the television receiver is an adjustment of the bias on the grid to assure that the blanking level or pedestal of the signal occurs at the "black" point which, in the case of this particular tube, would be 5 volts. Figure 110B shows a bias system in which the voltage, E, established by the adjustment of potentiometer R1 biases control grid G1 with respect to cathode and determines the correct picture brightness. In this case, the polarity of the video signal is such that the plate of the video output tube is connected to the control grid. It is possible to operate the picture tube with the control grid connected to the low side of the video output stage and the cathode coupled to the high or plate side, as shown in Figure 110C.

In either case, the "brightness" control is a voltage adjustment of the bias between the control grid and cathode, which establishes the correct blanking or black level.

As the "brightness" control is adjusted, with no picture signal present, a point will be reached at which the vertical retrace lines, caused by the motion of the spot from bottom to top of the picture, will become visible. The control should be adjusted in a counter clockwise direction until these lines just disappear. The "brightness" control, as well as the "contrast" control, are normally made "front panel" or customer operated, to allow adjustment of picture quality to accommodate the existing conditions of room illumination.

Fig. 110. Control Characteristic of 10BP4 Picture Tube

# SECTION III CATHODE RAY — BEAM MODULATION AND SYNCHRONIZATION

## CHAPTER 10. TELEVISION RECEIVER CONTROLS - APPLICATION AND ADJUSTMENT

### TRANSMITTER TEST PATTERNS FOR RECEIVER ADJUSTMENT

For a period of from fifteen to thirty minutes preceding each television broadcast, the station transmits a test pattern or chart which usually carries the station's call letters or a distinguishing insignia. This same test pattern is frequently broadcast for longer periods of time when no regular television program is scheduled. The purpose of the test pattern is to provide the television service technician with a useful "tool" to assure proper adjustment of the various receiver controls which effect a correct presentation of the television picture. Another purpose of the test pattern is to give the user an opportunity to adjust the front panel controls for the best picture before the regular program starts. Such controls as horizontal and vertical hold, horizontal and vertical centering, linearity in both directions, and sharp focus can all be precisely adjusted by the use of the test pattern. In this section we will present a review of the use of those controls which have been discussed up to this point and show their effect upon the appearance of a transmitted pattern.

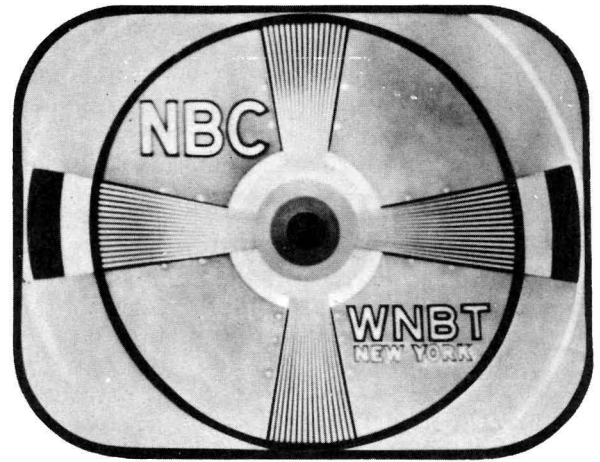

Fig. 111. Normal Transmitted Test Pattern

Figure 111 shows the appearance of a typical transmitted test pattern as received on a correctly-adjusted modern television re-

ceiver. The various characteristics of the pattern are similar in application to those of a more complex test chart which has been developed as a standard by the television transmitter committee of the Radio Manufacturers Association engineering department. This R. M. A. standard resolution chart is used in testing the performance of both television transmitters and receivers and a study of its features will serve to explain the use of less complicated television broadcast station test patterns such as Figure 111.

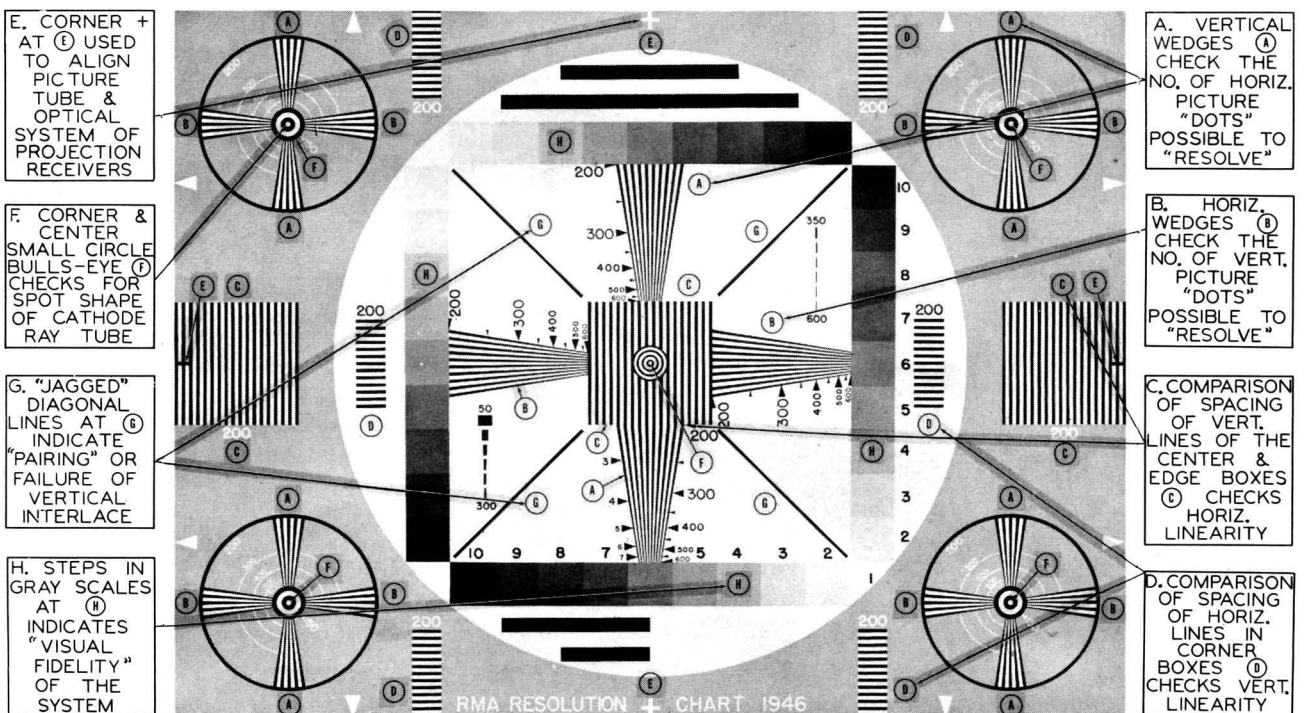

Fig. 112. R. M. A. Standard Transmitter Test Chart. (Courtesy R. M. A. Data Bureau)

CATHODE-RAY - - BEAM MODULATION AND SYNCHRONIZATION

Figure 112 is a reproduction of the R. M. A. television resolution chart, with the addition of explanatory letter symbols for some of its salient features. The chart will be seen to consist of a series of geometric forms and a number of tones ranging from black through a series of gray steps to white. The gray scales are of value in determining whether all elements of the television system are preserving the correct ratios of light intensities (as video modulation) to accurately reproduce the televised scene at the receiver picture tube.

The "fan shaped" wedges in both horizontal and vertical directions are composed of lines whose width gradually decreases as the lines approach the center. By observing the point at which the lines are no longer distinguished from one another, an estimate of the "resolving power" of the television system including the receiver under test, can be determined. The standard test chart shows by numbers placed beside the horizontal and vertical wedges, the corresponding numbers of lines which are being reproduced when the individual lines of the fan are just distinguish-

able from one another. It should be noted that the vertical fans of the test picture are used to determine the performance of the horizontal system of the receiver and conversely the horizontal fans of the test pattern are used to determine vertical receiver performance.

Tests for vertical and horizontal linearity, as well as other requirements, such as interlace, are also provided by this chart and are described in the captions accompanying the chart. Their application in the simplified type of pattern represented by the station transmission of Figure 111 will be discussed in greater detail, as we consider the effect on the reproduced pattern caused by maladjustment of controls or malfunctioning of the various circuits.

CONTROLS - THEIR USES AND ADJUSTMENT

In our study of the operation of the circuits employed for the production of the scanning raster, the control of this scanning by signal pulses and the modulation and focusing

Order of Use	Name of Control	Function of the Control	% of Sets Use
1	Station Selector, Channel Selector, T. V. Tuning . . . . .	To select the desired T. V. Station.	100
2	Volume, Volume Control, Sound Volume . . . . .	To adjust the sound volume.	100
3	Brightness, Brilliance, Background . . . . .	To adjust average light intensity.	95
4	Contrast, Picture, Picture Control . . . . .	To adjust video signal amplitude.	100
5	Fine Tuning, Sharp Tuning, Vernier . . . . .	To tune accurately to sound channel.	85
6	Focus, Focusing Control . . . . .	To adjust C. R. tube spot definition.	55
7	Horizontal Hold, Horizontal Speed, Framing . . . . .	To adjust free running period of the horizontal oscillator.	40
8	Tone, Tone Control . . . . .	To vary audio frequency response.	35
9	Vertical Hold, Vertical Speed . . . . .	To adjust free running period of the vertical oscillator.	30
10	High-Low Bandswitch . . . . .	To select input system for high or low channel group.	5

Fig. 113. "Operating" or "Front Panel" Controls

Order of Use	Name of Control	Function of the Control	% of Sets Use
1	Width, Horizontal Size, Horizontal Amplitude, Picture Width Control . . . . .	To adjust the picture size in the horizontal direction.	100
2	Height, Vertical Size, Vertical Amplitude, Picture Height Control . . . . .	To adjust the picture size in the vertical direction.	100
3	Vertical Linearity No. 1 . . . . .	To adjust the scanning wave shape in the vertical plane.	80
4	Horizontal Linearity No. 1 . . . . .	To adjust the scanning wave shape in the horizontal plane.	75
5	Vertical Hold, Vertical Speed . . . . .	To adjust free running period of the vertical oscillator.	70
6	Horizontal Centering, Horizontal Position Control . . . . .	To adjust the picture position in the horizontal direction.	70
7	Vertical Centering, Vertical Position Control . . . . .	To adjust the picture position in the vertical direction.	70
8	Horizontal Hold, Horizontal Speed, Framing . . . . .	To adjust free running period of the horizontal oscillator.	60
9	Focus, Focusing Control . . . . .	To adjust C. R. tube spot definition.	45
10	Horizontal Oscillator Frequency Adjustment, Horizontal Lock . . . . .	To adjust frequency of sine-wave oscillator (A. F.C. control).	45
11	Horizontal Drive, Horizontal Peaking . . . . .	To adjust amplitude of peak portion of horiz. scanning wave	30
12	Horizontal and Vertical Centering by Adjustment of Focus Coil Position . . . . .	To center scanning raster in both planes.	30
13	Focus Coil Adjustment . . . . .	To adjust spot size by focus coil position.	30
14	Horizontal Linearity No. 2 . . . . .	Same as item 4 (secondary adjustment).	25
15	Horizontal Oscillator Phase Adjustment . . . . .	To adjust phase of horiz. oscillator to pulse rate (A.F.C. disc.)	20
16	Picture Cut-Off or C. R. T. Bias Adjustment . . . . .	To adjust "black" level of picture tube (grid 2 voltage).	10
17	Horizontal Linearity No. 3 . . . . .	Same as items 4 and 14 (tertiary adjustment).	5
18	Vertical Linearity No. 2 . . . . .	Same as item 3 (secondary adjustment).	5
19	Ion Trap Adjustment, Beam Bender . . . . .	To adjust current through the ion trap magnet coils.	5
20	Service Control, Screen Voltage Horizontal Output Tube . . . . .	To adjust output of horizontal amplifier (aux. width control).	5
21	Coarse Focus . . . . .	To set range of main focus control.	5
22	Phase Detector Balance . . . . .	To adjust balance of A. C. F. discriminator.	5
23	Excitation, Anode Voltage Control of Projection Tube . . . . .	To adjust operating point projection picture tube.	5
24	Brightness, Brilliance, Background . . . . .	To adjust average light intensity.	5

Fig. 114. "Non-Operating" or Pre-Set Controls (Not on Front Panel)

of the cathode-ray beam, we have covered the action of a number of variable adjustments known as controls. Controls can be generally classified in two distinct groups:

1. "Operating" or Front Panel Controls. These controls which are located on the front panel of the receiver are operated by the user. They normally include the sound level volume control with an associated switch to turn the receiver on and off, a station selector to allow the set to be tuned to the desired television broadcasting station and a group of controls to adjust the appearance of the picture. The picture control group permits the user to adjust the brilliance, contrast, clarity and stability of the image.

2. "Non-Operating" or Pre-Set Service Controls. The circuit controls which require adjustment only during original installation or at infrequent intervals are located in such a position that they are not readily accessible to the user. Most television manufacturers, realizing that the proper adjustment of these "service type" controls determines the satisfactory operation of the receiver, insist that these controls be accessible only to well qualified, authorized television service technicians. The number and complexity of these pre-set or semi-fixed adjustments differ greatly between the designs of individual manufacturers.

The Radio Manufacturers Association through its engineering standards group are attempting to standardize the names of controls and their functions. Due, however, to the accelerated pace of receiver production in its initial stage and the enthusiasm of sales and advertising departments, controls have been called by a variety of names.

An analysis of the receivers of leading manufacturers, including electrostatic deflection, electromagnetic deflection and projection types, reveals the fact that as yet, no design pattern has evolved to determine which controls should be placed on the front panel or relegated to a position within the receiver.

**PLACEMENT OF ADJUSTABLE CONTROLS:** A representative group of television receivers which from our analysis covers all of the design variations, has been studied to determine the placement of controls. The results of this study are presented in the form of two charts shown as Figures 113 and 114.

In these charts, the control function is first described by the name which has been

suggested for radio industry standardization and the other names following it are those which are still in use in the service literature of many companies.

In the chart of Figure 113, the operating or front panel controls are classified in order of frequency of use in modern receiver design. It will be seen that all television sets employ at least three of the front panel controls in common with one another. These are: station selector, volume, and contrast. In addition to these three basic operating controls, others are employed in the frequency shown in the chart. The number of front panel controls varies from a minimum of three to a maximum of eight. Five percent of the receivers had three front panel controls, ten percent had five, forty percent used six, another forty percent employed seven and the remaining five percent had eight controls.

Figure 115 shows typical examples of the layout of receivers employing from five to eight front panel controls. The functions of the various controls are "called-out" on the pictures. It will be noted that concentric control knobs are employed in certain designs for reasons of styling and simplicity of operation.

The functions of the station selector, volume, and contrast controls are properly a part of the study of RF and Video amplifiers and will be covered later in the course. The other controls listed in the chart of Figure 113 will be discussed in common with the "non-operating" or pre-set controls analyses in chart shown as Figure 114.

The controls to be adjusted by the service technician and listed in Figure 114 are much more varied in number and diversity than the front panel group. In the receivers analyzed, the range of usage of these types varied from a minimum of five in a table model to a maximum of fifteen in a large projection receiver.

The pre-set controls are mounted on any surface or plane of the chassis as determined by the particular mechanical design. In general, the controls which will most likely require occasional readjustment are located in such a position that they will be accessible without removing the chassis from the cabinet. In some designs certain of these controls are made available by knob or screw driver slot through the back panel and do not require back panel removal. Figure 116 shows a variety of designs indicating the location of many of the controls listed in the chart of Figure 114.

CATHODE-RAY - - BEAM MODULATION AND SYNCHRONIZATION

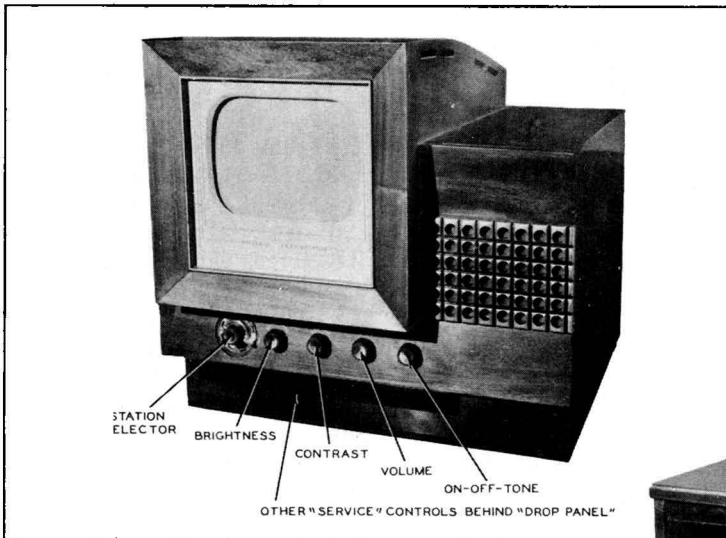

Receiver example employing five front panel controls. (Photo from a sample receiver courtesy the Philco Corporation.)

Receiver example employing six front panel controls. (Photo from a sample receiver courtesy Sears Roebuck & Co.)

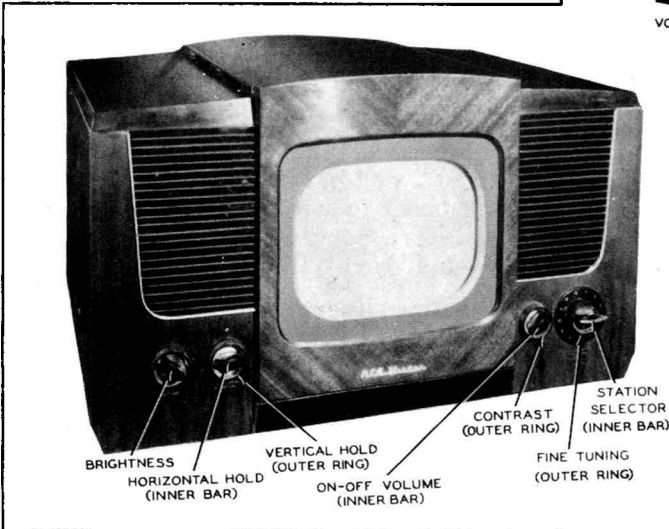
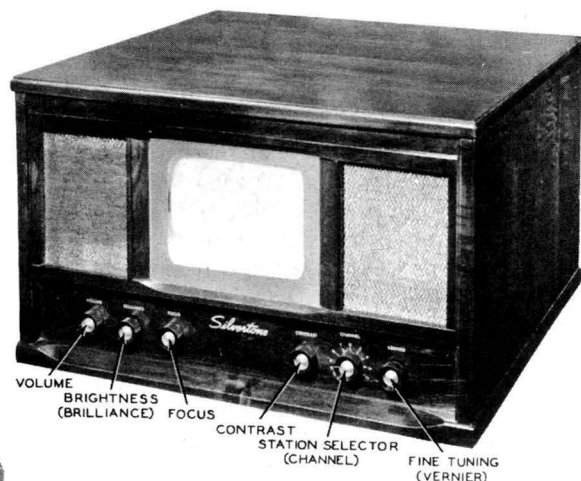

Receiver example employing seven front panel controls. (Photo from a sample receiver courtesy R. C. A.)

Receiver example employing eight front panel controls. (Photo from a sample receiver courtesy General Electric Company.)

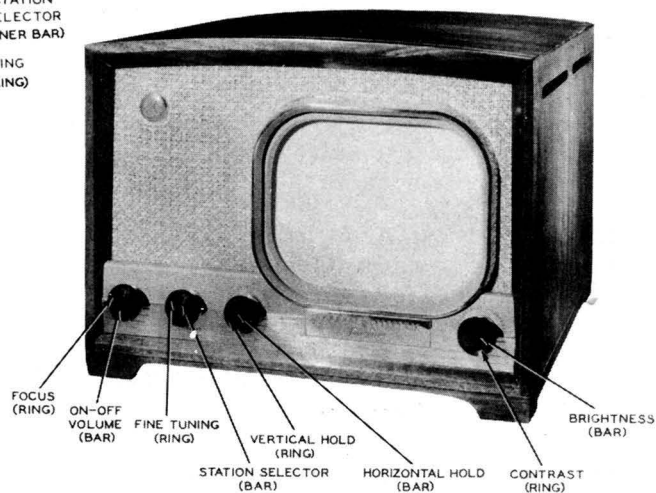
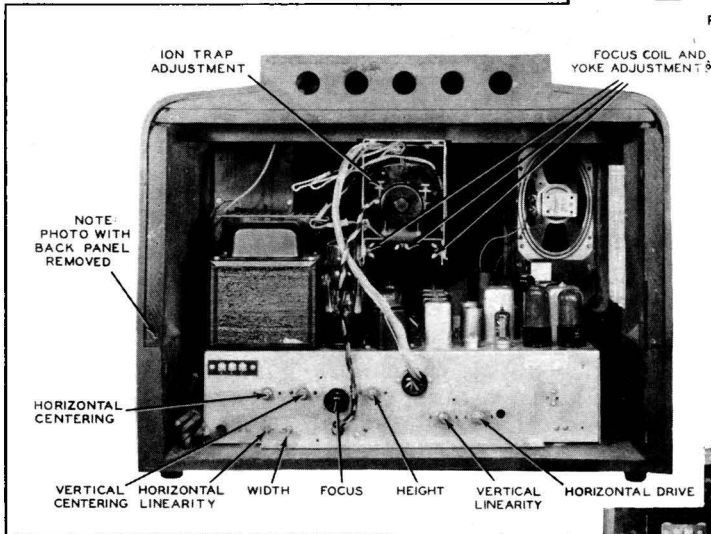
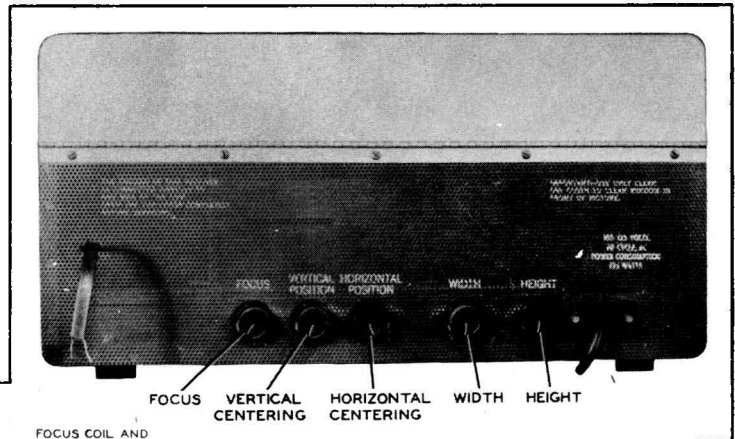

Fig. 115. Typical Examples of Operating or Front Panel Controls



An example of service controls available without removal of the back panel. (Photo from sample receiver courtesy the Hallicrafters Co.)



An example of service controls available at back of chassis. Back panel removable for servicing picture tube. (Photo from sample receiver courtesy Emerson Radio and Phonograph Corp.)

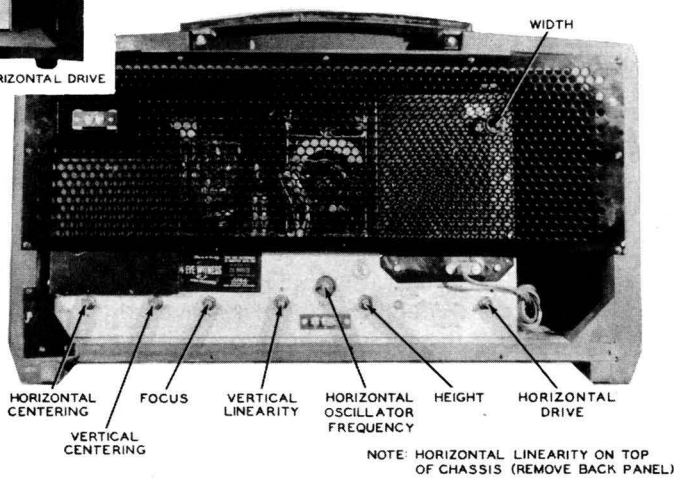

An example of service controls at the back of the chassis with top chassis and tube controls available by removing protective screen. (Photo from sample receiver courtesy R. C. A. Mfg. Co.)

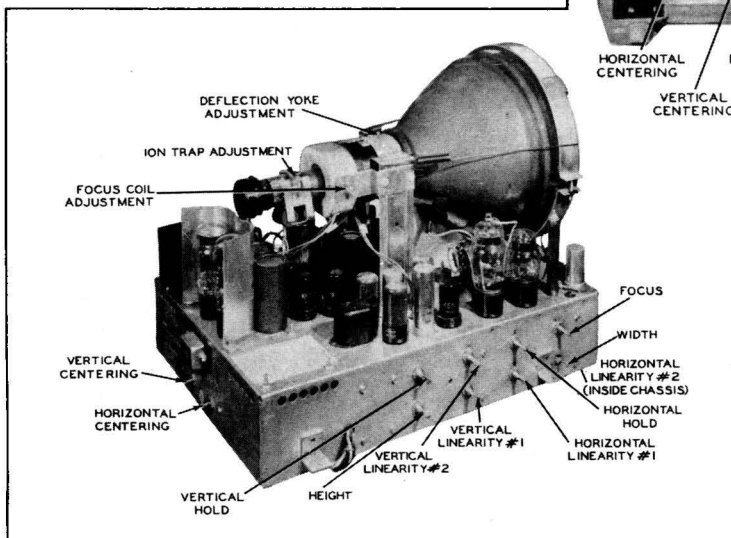

An example of service controls available on top, back and side of chassis. (Photo from sample courtesy the Motorola Co.)

Fig. 116. Typical Examples of Non-Operating or Pre-Set Controls

## CATHODE-RAY - - BEAM MODULATION AND SYNCHRONIZATION

The controls of a television receiver may be classified into four main groups:

1. Those which adjust the operating conditions of the cathode-ray picture tube.

- a. Adjustment of ion trap position and current to return the beam to screen.
- b. Adjustment of the deflection yoke to position scanning raster correctly.
- c. Focus to obtain sharp definition.
- d. Adjustment of C-R tube operating voltages to establish proper "black level" and highlight brightness.
- e. Control of scene brightness.

2. Those which establish the correct "lock in" or hold of the horizontal and vertical scanning oscillators.

- a. Horizontal hold which sets the free running frequency of the horizontal scanning oscillator.
- b. Vertical hold which sets the free running frequency of the vertical scanning oscillator.
- c. Horizontal sine wave oscillator frequency adjustment, in A.F.C. systems.
- d. Horizontal discriminator phase control to establish discriminator balance.

3. Those which adjust the dimensions and position of the picture.

- a. Width control adjusts horizontal size.
- b. Height control adjusts vertical size.
- c. Horizontal centering which moves the entire picture in the horizontal plane.
- d. Vertical centering which moves the entire picture in the vertical plane.

4. Those which determine the shape of the scanning voltage waves to produce an undistorted picture.

- a. Horizontal linearity controls the shape of the horizontal scanning wave.
- b. Horizontal drive determines the ratio of pulse to linear sawtooth for the voltage wave in magnetic deflection.
- c. Vertical linearity controls the shape of the voltage wave from the vertical scanning oscillator.

The effect of misadjustment of these controls will be shown in the order outlined.



Fig. 117. Focus Coil and Ion Trap Misaligned

**FOCUS COIL AND ION TRAP ADJUSTMENT:** Figure 117 shows the received test pattern when the focus coil (see pages 14-15 and Figure 17) and the ion trap (pages 16-17 and Figures 20-21) are not in correct position on the neck of the picture tube. The ion trap rear magnet poles should be positioned so that they are approximately over the little "flags" which are attached to the ion trap cylinder.

The picture tube must be mounted in such a position that these ion trap flags are in a horizontal plane when looking down upon the tube. When this has been done, and the tube secured in position, the ion trap can be moved slightly back and forth along the tube neck and at the same time rotated slightly around the tube, until the brightest raster is obtained on the screen. The trap adjustment screws should then be tightened sufficiently to hold the trap in position but still allow further adjustment.

The focus control setting (see page 61 and Figure 73), the focus coil position, and the ion trap magnet position are interdependent, and in the original installation procedure an adjustment of one may require readjustment of the others. The shadowed corner, as well as the poor vertical positioning shown in Figure 117, indicates that the electron beam is striking the neck of the tube. To correct this condition the focus coil should be adjusted in its mounting until the picture is properly centered.

If no raster can be obtained on the picture tube screen it is an indication of improper mounting of the ion trap magnet assembly. An inverted mounting from top to bottom or from front to back can cause such a condition.



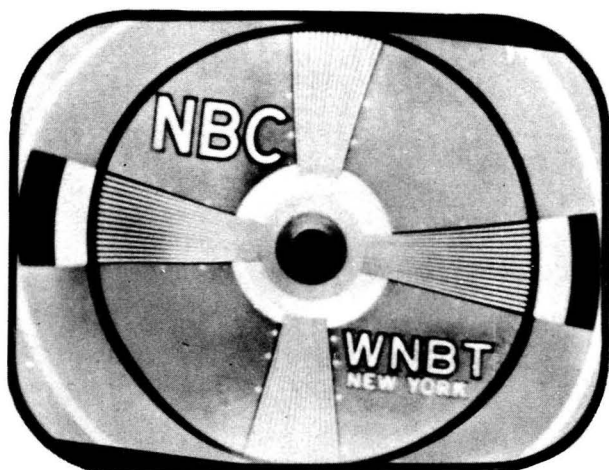

Fig. 118. Deflection Yoke not Properly Adjusted. (Rotated)

**DEFLECTION YOKE ADJUSTMENT:** Figure 118 shows the effect on the test pattern of improper mounting of the deflection yoke assembly. The action of the deflection coils in moving the electron beam was covered on pages 15-16 and illustrated in Figures 18, 19 and 22.

If the lines of the raster are not horizontal and squared with the edge of the picture mask, it is an indication that the deflection yoke, made up of both the horizontal and the vertical deflection coils, is not correctly positioned. To correct this condition the adjustment screws which hold the yoke should be loosened, and the coil assembly rotated about the axis of the tube until the raster is properly lined up with respect to the edges of the picture mask. The yoke adjustment screws or wing nuts should then be securely tightened.

The position of the deflection yoke along the picture tube neck will affect the deflection sensitivity (amount of scanning voltage for a given deflection).

**FOCUS CONTROL AND FOCUSING ADJUSTMENTS:** Figure 119 illustrates the appearance of the received test pattern when the electron beam is "out of focus". The image is not sharply defined as in the normal picture of Figure 111.

The theory of focusing the electron beam in electrostatically controlled picture tubes has been covered on pages 5 through 8 and the circuit elements were illustrated in Figures 8 and 11. The variable control takes the form of a carbon type of voltage divider.

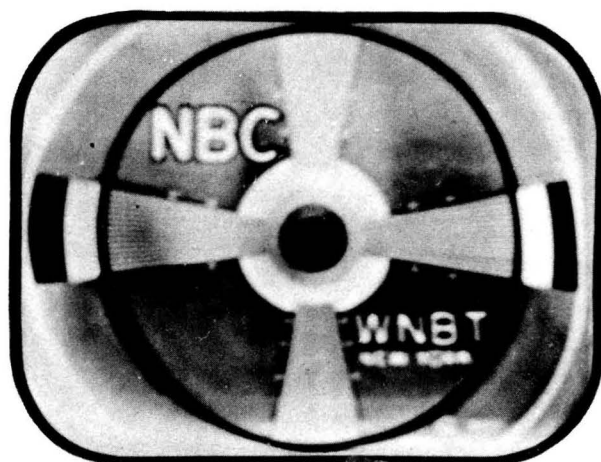

Fig. 119. Focus Control Misadjusted

Electromagnetically focused picture tubes require two separate service adjustments. The first is the mechanical positioning of the focus coil as covered under "Focus Coil and Ion Trap Adjustments", and the second is the variation of the current through the focus coil by means of a variable resistor. The action of the focus coil has been covered on pages 14, 15 and 61. (Figures 17, 22 and 73.)

The best focus adjustment is made by sliding the focus coil back and forth along the neck of the picture tube while adjusting the focus control and watching the test pattern for the sharpest picture. In some designs two variable controls (coarse and vernier) are used.

**BRIGHTNESS CONTROL:** As indicated in the chart of Figure 113, the brightness control is usually made one of the front panel group and is a "user" operated control. It is employed in conjunction with the contrast control to obtain the best possible picture quality. It is possible to cut off the beam with this control, in which case no picture is seen and the tube remains dark. Conversely, too high a setting of the contrast control will result in a light, "washed out" picture as shown in Figure 120. In this case the shadows and lower key half tones have disappeared and the vertical retrace lines have become visible.

The circuit function of the brightness control is to establish the operating control grid bias of the picture tube. Two methods of accomplishing this bias control have been described on pages 107 and 108. Figures 110B and 110C show the circuit arrangements employed.

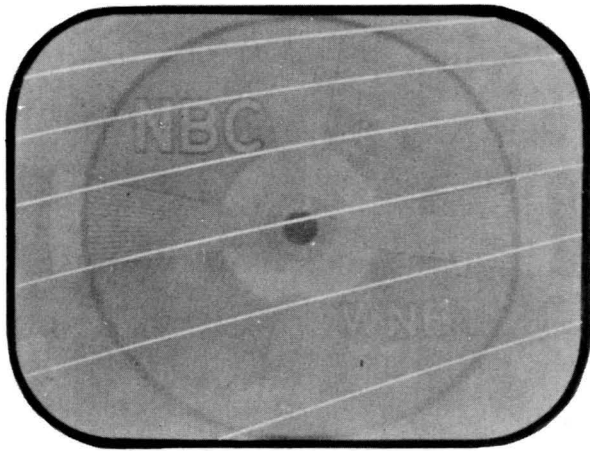

Fig. 120. Brightness Control Misadjusted. (Brightness too High)

**HOLD ADJUSTMENTS:** Hold adjustments, both horizontal and vertical, enable the television technician, or user, to adjust the free running frequency of the two receiver scanning systems so that a stable condition of synchronism or lock-in with the transmitted sync pulses is obtained.

In "flywheel" or A. F. C. sync systems, the hold control is of the same type, but it is placed in the grid circuit of a sine wave oscillator. Its function is to control the phase of the oscillator with respect to the sync pulses. (See pages 101 through 105.)

In the case of "triggered" sync systems (see page 101) these controls are variable resistors in the scanning oscillator circuit. (See pages 45 through 56 and the circuit diagrams of pages 73 through 84.)

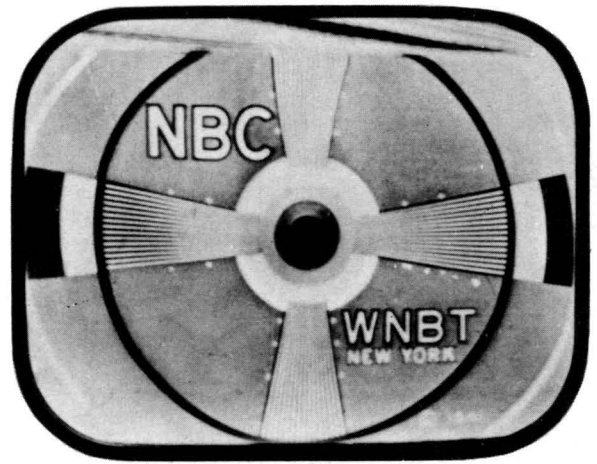

Fig. 122. Horizontal Hold Control Misadjusted

**HORIZONTAL HOLD ADJUSTMENT.** Figures 121 and 122 illustrate the effect on the receiver test pattern of two degrees of misadjustment of the horizontal hold control. The actual appearance of the image cannot be reproduced in a printed illustration since the image is in continual motion until a stable lock-in has occurred. When the hold control is adjusted to such a position that the oscillator is nearly in sync with the signal pulses, the image will first appear as a series of diagonal bars similar to those of Figure 124, which is an illustration of horizontal oscillator frequency misadjustment. As synchronism is approached more closely, the image will appear as in Figure 121 and then start to lock-in as in Figure 122.

**VERTICAL HOLD ADJUSTMENT.** Figure 123 shows the effect of misadjustment of the vertical hold control. The effects on the

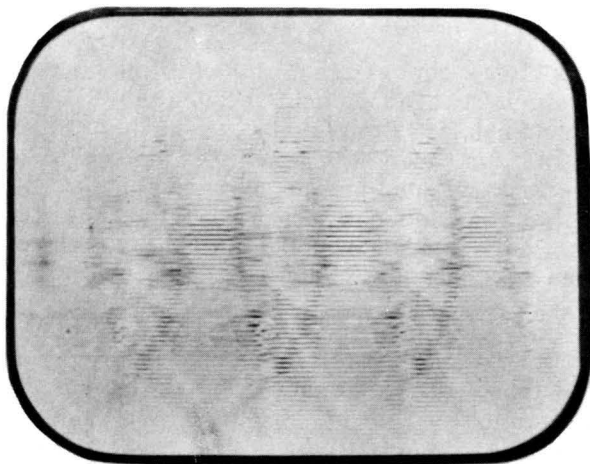

Fig. 121. Horizontal Hold Control Misadjusted  
116

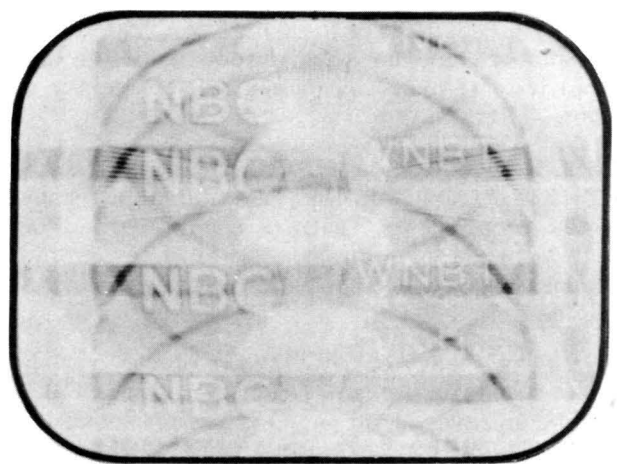

Fig. 123. Vertical Hold Control Misadjusted

picture are similar to those discussed for "Horizontal Hold" except that, in this case, the motion of the image, before lock-in occurs, is from the bottom to the top of the picture rather than from left to right.

Careful adjustment of vertical hold is essential to avoid "pairing" of horizontal lines of alternate fields which would reduce the vertical definition of the picture.

**HORIZONTAL OSCILLATOR FREQUENCY ADJUSTMENT (A. F. C. SYSTEMS).** In the flywheel or A. F. C. system of horizontal sync control, described on pages 101 through 108, the major control of the free running frequency of sine wave oscillation is seen to be the tuning of the circuit by adjusting an iron core in the inductance (see Figure 105). With reference to this figure, it will be noted that the horizontal hold (R7) and the discriminator phase control (adjustment of primary L1-L2) also exert an effect on the oscillator frequency. For this reason, the adjustment of the horizontal oscillator frequency must be re-checked if it is found necessary to change the discriminator phase control. The hold control should be set at the middle of its range while making these adjustments.

The service manuals of the television receiver manufacturers contain explicit instructions concerning the order in which these adjustments are to be made in the particular A. F. C. circuit design.

The final setting of this control should be such that, with the hold control at either end of its range, the scanning system will lock-in to

signal sync. To test for this condition, tune to a signal while the control is in its mid-position. The hold control is then turned to its extreme position in either direction. Next the signal is removed by detuning the receiver. Upon retuning the system should pull into sync. The same check should then be made at the other end of the control range. If the receiver will not pull into sync at both ends of the hold range, the horizontal oscillator frequency should be readjusted until this is accomplished.

**HORIZONTAL DISCRIMINATOR PHASE ADJUSTMENT.** As described on pages 101-108, the discriminator stage compares the sync pulse rate with the horizontal oscillator rate or frequency and delivers a DC voltage for the control of the oscillator. If the voltage at the plates of the two diodes, impressed by the oscillator, is equally divided, the DC output will not be zero at the correct time for retrace at the end of the horizontal line. This off-balance condition will result in the received test pattern shown in Figure 125.

In this case, the picture is locked-in and steady but retrace has occurred at the wrong time in the scanning cycle. The black band at the right side of the picture is the blanking period during which horizontal retrace should have occurred.

The adjustment of this control, for retrace at the proper instant, also affects the setting of the horizontal oscillator frequency adjustment as previously described. The service technician should follow the service manual of the receiver manufacturer for the proper sequence of adjustment of these controls.

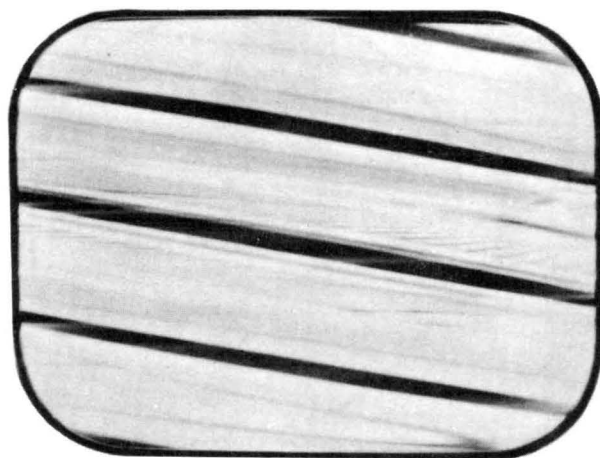

Fig. 124. Horizontal Oscillator Frequency Misadjusted. (A. F. C. System)

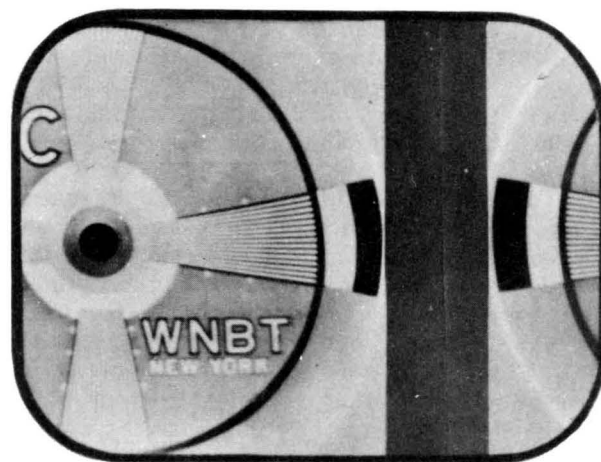

Fig. 125. Horizontal Discriminator Phase Misadjusted

**PICTURE SIZE AND CENTERING CONTROLS.** The group of controls which are used to fit the picture to the mask or frame are, in most instances, mounted on the back or side and are not "user" operated. Included in this group are: width, height, horizontal centering, and vertical centering.

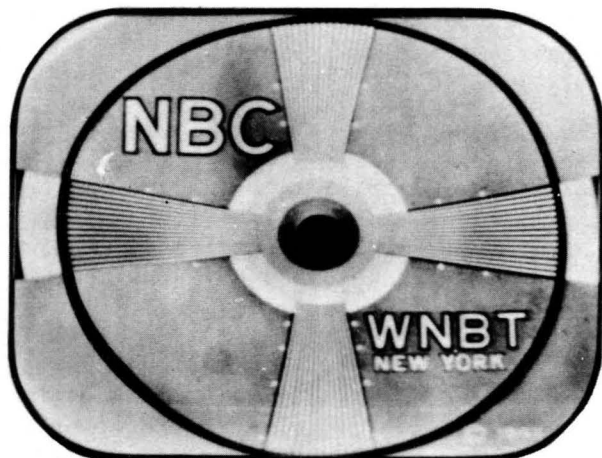

Fig. 126. Width Control Misadjusted

**WIDTH CONTROL.** The width control adjusts the voltage applied to the horizontal deflection plates or the deflection coil. The effect on the received test pattern, when this control is not properly adjusted, is shown in Figure 126.

Width control can be accomplished by regulating the output of the horizontal oscillator, as described on pages 44 through 48, or by controlling the output of either the discharge tube or horizontal amplifier. (See the Figures on pages 74 through 84.)

In many instances the width control is not a single adjustment, since the effect of changing other controls, such as horizontal linearity and horizontal drive, may require a readjustment of the width control.

**HEIGHT CONTROL.** The height control serves a similar function to that of the width control but in the vertical direction. In this case, the vertical oscillator or vertical amplifier is controlled in output.

Figure 127 shows the effect of an incorrect adjustment of the height control on the received test pattern. In this case, as well as that of the width control (Figure 126), the picture is shown as "too high", or "too wide", but symmetrical with respect to the center of

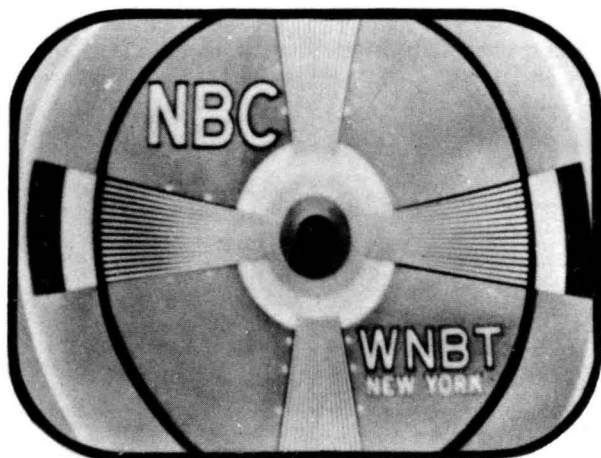

Fig. 127. Height Control Misadjusted

the picture. Often the picture is found to be both incorrect in size and "off center". It will be necessary to adjust the size controls (width and height) simultaneously with the horizontal and vertical centering controls.

The methods and circuits employed to accomplish height control are similar to those described for width. The same page and Figure references apply.

**HORIZONTAL CENTERING.** Misadjustment of the horizontal centering control will cause an effect on the received test pattern similar to that shown in Figure 128.

As shown in the chart of Figure 114, two distinctly different methods of centering the picture are employed. The mechanical mounting of the focus coil may be provided with screw adjustments to accomplish both horizontal and vertical centering. Electrical circuit

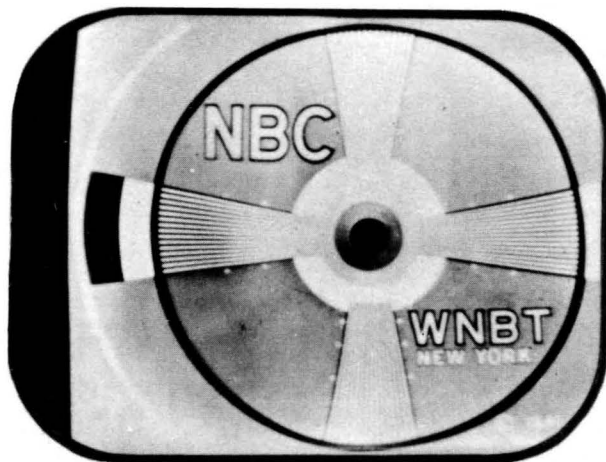

Fig. 128. Horizontal Centering Control Misadjusted



means for accomplishing centering have been described on page 11 for the electrostatic type, and on pages 61-62 for the electromagnetic type.

When centering is accomplished by positioning the focus coil, it may be found necessary to make readjustments of the ion trap position simultaneously with the movement of the focus coil, as explained on page 114.

**VERTICAL CENTERING.** Figure 129 shows the effect of misadjustment of the vertical centering control. As in the case of the horizontal centering control, just discussed, vertical centering is accomplished either by mechanical means (adjustment of the focus coil position) or by electrical means (voltage bias of the plates in an electrostatic picture tube or current bias in the case of an electromagnetic tube). The same text references mentioned under horizontal centering apply also to the methods employed for vertical centering.



Fig. 129. Vertical Centering Control Mis-adjusted

**CONTROLS WHICH AFFECT SCANNING WAVE SHAPE:** In the discussion of the sawtooth scanning raster (pages 51 through 60) it was pointed out that the electron beam must trace at a linear rate in both the horizontal and vertical planes to avoid distortion of the picture. The shape of voltage wave (electrostatic) or current wave (electromagnetic) required to produce the linear beam motion has been covered on pages 56 through 60. In the discussion of beam deflection systems (pages 61 through 84) the various circuits and the controls employed to achieve linearity of scanning are discussed in detail.

The output voltage wave of scanning oscillators of the cathode-coupled multivibrator or blocking oscillator type can be made sufficiently linear to satisfactorily operate the electrostatically deflected type of picture tube and, for this reason, linearity controls are not required on sets using such tubes. In the case of magnetically deflected picture tubes, the scanning current wave consists of the combination of a linear sawtooth and a pulse. In the generation of such a wave, it is necessary to incorporate variable controls to achieve the proper time and amplitude relationship of the various sections of the wave shape. These include linearity controls, which may include as many as three for the horizontal scanning, and drive controls which adjust the amplitude of the pulse portion.

**HORIZONTAL LINEARITY CONTROLS.** Figure 130 shows the effect of the misadjustment of horizontal linearity. It will be noted that the circle of the test pattern has been rendered elliptical or "egg shaped." The picture has been cramped in the middle.

Correction of distortion of various parts of the picture, in the horizontal direction, are accomplished by controls affecting the circuit elements which contribute these portions of the scanning current wave. In the case illustrated by Figure 130, correction could be made by horizontal linearity control (L8 of Figure 73) or a similar adjustment for correcting the center of the picture without affecting the sides. Additional linearity controls, such as resistor R9 of Figure 73, may be employed to correct the right hand side of the picture.

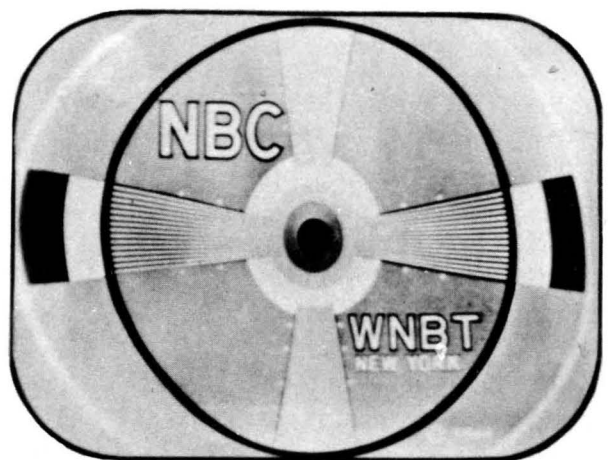

Fig. 130. Horizontal Linearity Control Mis-adjusted

Since the number and circuit function of linearity controls differ between receiver designs, the television service technician is advised to study the service manual issued by receiver manufacturer for the particular linearity adjustment and the interaction of the control adjustment with other linearity and width controls are invariably covered in the service literature.

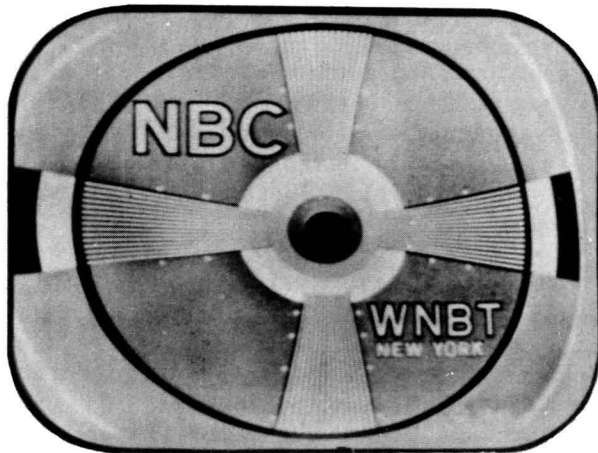

Fig. 131. Horizontal Drive Control Misadjusted

**HORIZONTAL DRIVE CONTROLS.** The horizontal drive control adjusts the ratio of the pulse to the linear portion of the horizontal sawtooth scanning current wave (pages 65-66). This controls the point on the scanning trace at which the horizontal output tube conducts. The effect of its misadjustment is shown by Figure 131. In effect it is seen to be an auxiliary linearity and width control, since a clockwise rotation will increase the picture width, crowd the right hand side of the picture and stretch the left.

Feedback is often employed in the output stage to provide a negative pulse from the horizontal output transformer to the grid of the output tube. In this case, the drive control is a voltage divider across a winding on the output transformer. The voltage pulse is fed back in series with the output tube grid return.

**VERTICAL LINEARITY CONTROL.** Figure 132 shows the effect on the transmitted test pattern of the misadjustment of the verti-

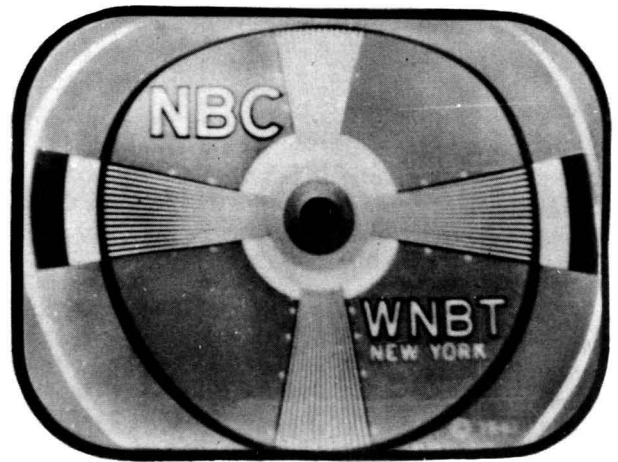

Fig. 132. Vertical Linearity Control Misadjusted

cal linearity control. The type of linearity control most often employed in the vertical circuit is an adjustment of the operating point of the vertical amplifier. This usually takes the form of an adjustable cathode bias resistor, such as R7 of Figure 73. Curvature of the plate current versus grid voltage characteristic is employed to produce a "counter-distortion" which corrects any curvature of the voltage wave applied to the grid of this output tube.

In receivers which employ more than one linearity control, the secondary or additional control to that described, is made a variable resistor in the peaking circuit which constitutes the plate load of the vertical discharge tube. This control acts in a manner similar to the horizontal drive control previously discussed.

In the adjustment of linearity controls of either the horizontal or the vertical type, it should be noted that the result of adjustment is interdependent with the effect of the size (width or height) controls. This interlocking action may necessitate readjustment of one of these controls if it is necessary to adjust the other.

Photographs of transmitted test patterns showing the effect of receiver misadjustments courtesy of the National Broadcasting Company and the R. C. A. Service Company, Inc.

# SECTION III CATHODE RAY — BEAM MODULATION AND SYNCHRONIZATION

## CHAPTER 11. THE COMPOSITE TELEVISION SIGNAL

**BLOCK DIAGRAMS:** Television receivers usually employ many more circuits and tubes than other types of entertainment and communication sets. For this reason, functional or "block" diagrams are frequently employed in service literature as an aid in analyzing the more complicated circuit schematic diagram.

Any particular receiver can be represented by a block diagram in which the various tubes and their functions are represented by individual blocks. The attempt has been made in Figures 134 and 135 to present generalized block diagrams of those elements of both electrostatic and electromagnetic systems which have been covered to date. It will be realized that the choice of one particular television system for presentation must involve only one means of accomplishing the desired circuit operations and that different diagrams may be drawn for other circuit combinations.

The block diagram indicates the sequence of circuit performance by means of "flow" arrows between the various boxes which represent distinct circuit elements.

The television service technician is urged to study these diagrams as well as those available in the service literature since they constitute an excellent method of studying the entire television system.

### COMPOSITE TELEVISION SIGNAL (A RADIO CARRIER MODULATED BY VIDEO AND AUDIO)

In our study of the television system up to this point, we have considered the actions of the circuits associated with the picture tube, enabling it to produce a replica of the image focused on the camera tube at the transmitter. At several points in the text, the statement has been made that as the electron beam is being swept across the screen of the picture tube to produce a horizontal line, it is simultaneously being modulated in intensity in accordance with the video signal. We will now examine the nature of the radio carrier wave with its video (sight) and audio (sound) modulation.

The principles underlying the interception of the waves by special antennae, R-F amplification, detection, subsequent I-F amplification, and conversion to a modulating video

signal, will be covered in the order of signal progression through the receiver.

We have now analyzed those elements of a television receiver which are pulse-controlled or under "slave" action. We can now logically cover those parts of the receiver which accept the transmitted television signal and use it to produce audio and video output voltages.

The television signal is much more complex than broadcast and short wave signals which carry only speech or telegraphic information. In order to understand the reasons for the necessary complexity of the television signal, a short review of the composition of the familiar broadcast band amplitude-modulated carrier will precede the description of the television carrier.

During the amplitude modulation of the carrier wave by speech or music, frequencies higher and lower than the carrier are produced, known as "side-bands". These occur as a result of the beat or heterodyne between the carrier frequency and the modulating frequency. In the broadcast band for example, the highest modulating frequency for speech or music transmission is approximately 5,000 cycles per second. Thus, if a broadcast station is operating at 1,000kc (one million cycles) the 5,000 cycle top modulation will produce side-bands which extend from 1,000,000 cycles minus 5,000 cycles to 1,000,000 cycles plus 5,000 cycles (995kc to 1005kc). A graphic representation of such a double side-band modulated broadcast carrier is shown in Figure 133.

The modulating frequencies encountered in the video signal of television extend from less than 30 cycles per second to over 4,000,000 cycles per second. It will be interesting to examine the reasons for this tremendous frequency range in the output of the transmitter camera tube.

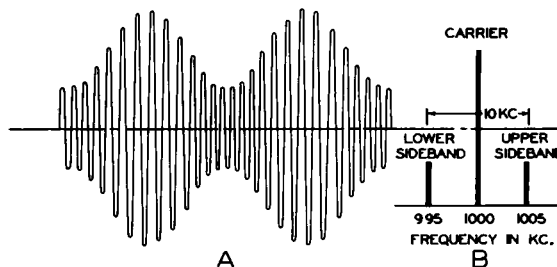

Fig. 133. Double Side-Band Modulated Carrier Wave. 50 Percent Modulation - 5,000 Cycle Tone

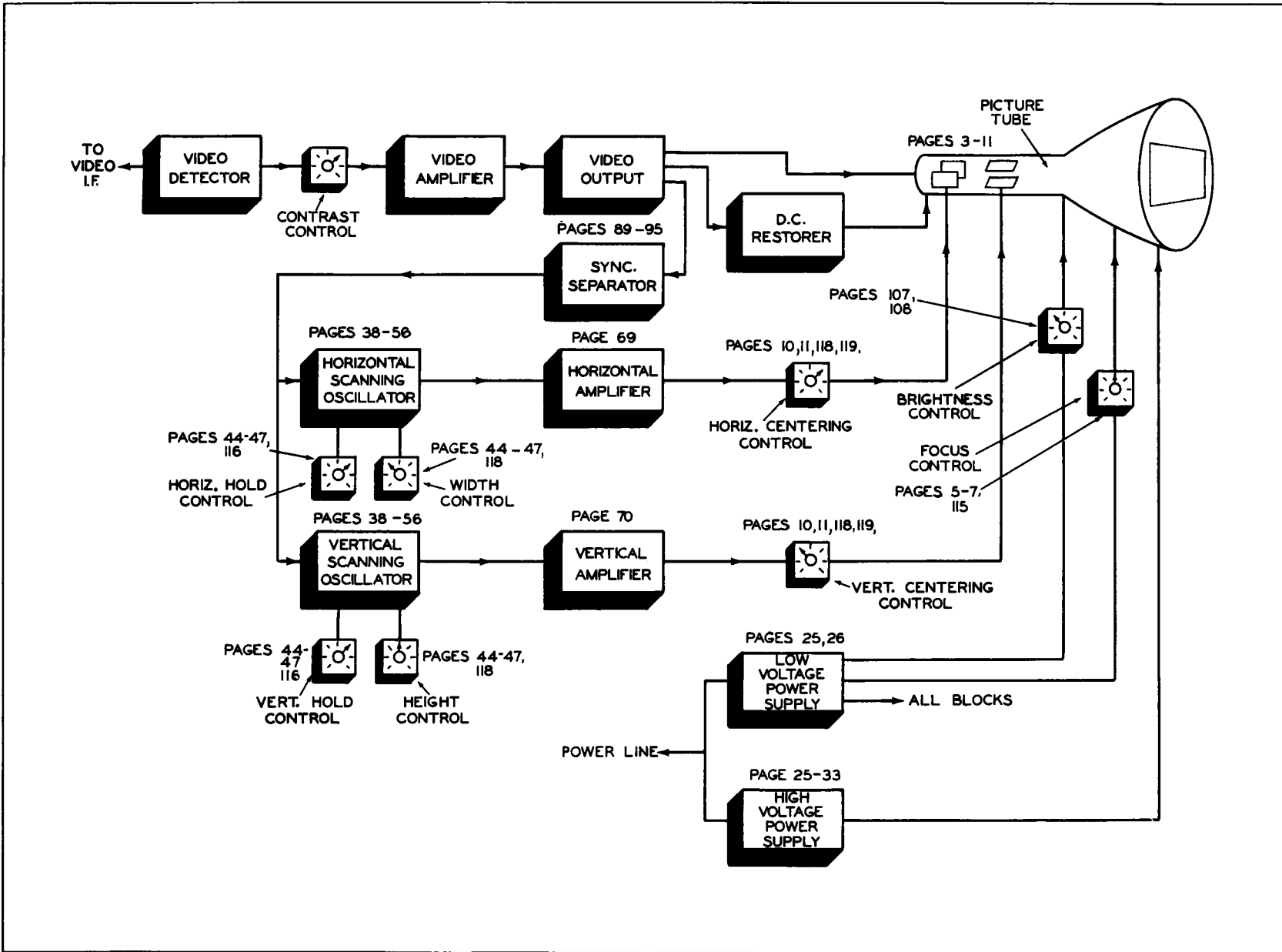

Fig. 134. Functional Block Diagram - Electrostatic Type. Supply, Deflection, Synchronization and Control Circuits



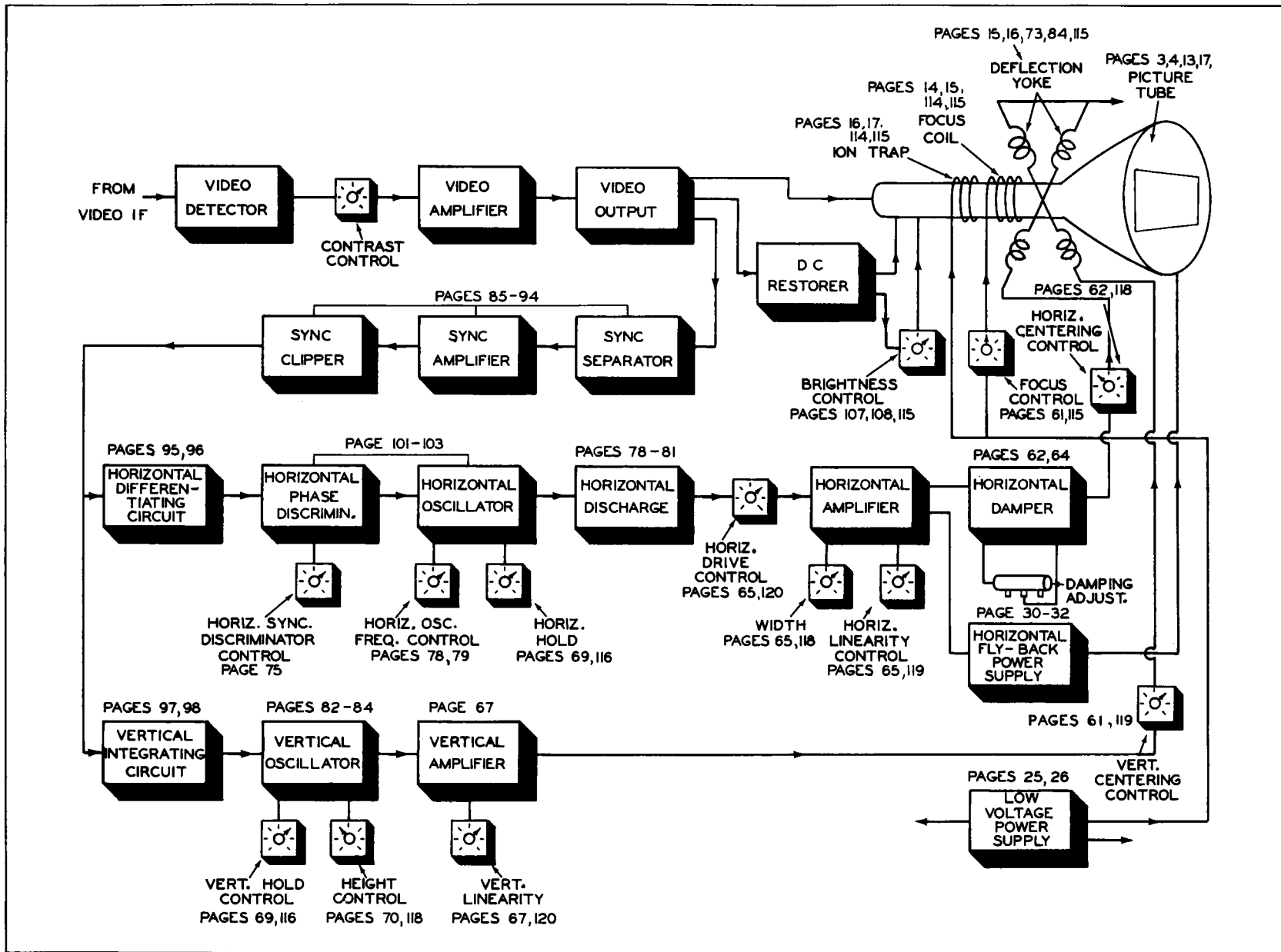

Fig. 135. Functional Block Diagram - Electromagnetic Type. Supply, Scanning, Deflection, Sync, and Control Circuits

## CATHODE-RAY - - BEAM MODULATION AND SYNCHRONIZATION

As the signal spot in the camera tube sweeps across the mosaic of the iconoscope, the photo cathode of the image dissector, or the target of the image orthicon, approximately 480 lines are scanned in 1/30th of a second. (Although there are 525 lines per frame only 480 lines contain video modulation due to those lost during vertical retrace.)

If the assumption is made that the picture element is square, and that the definition or resolution is the same in both the horizontal and vertical directions, it is possible to calculate the maximum frequency which will be produced.

The ratio of the length of the picture to its height has been set in the R. M. A. and the F. C. C. standards as 4/3. Assuming there are 480 lines in the vertical direction, the number of horizontal dots for equal resolution would be  $480 \times 4/3$ , or 640. Multiplying the number of vertical lines (480) by the number of horizontal dots (640) we obtain a possible maximum of 307,200 picture elements for a single frame. Thirty frames per second (two 60 $\sim$ fields) multiplied by this figure of 307,200, produces an upper frequency of 9,216,000 picture elements

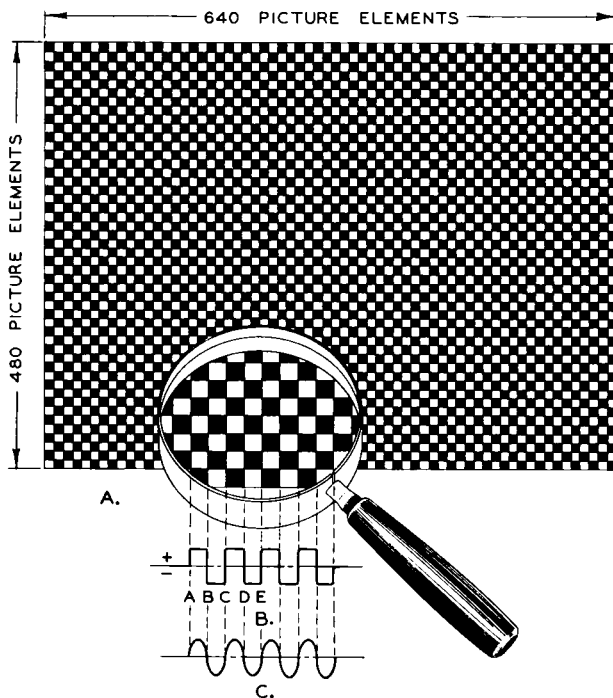

Fig. 136. Video Modulation Produced by Scanning a Checker Board in which the Picture Elements Are the Limit of System Resolution. (Diagram one-tenth scale)

per second. Fortunately, this figure does not represent the top frequency as will be seen from a consideration of the video signal which would be produced by scanning a checker board, consisting of alternate white and black squares and having 480 squares in the vertical direction and 640 in the horizontal. (See Figure 136.)

In the system of television transmission now adopted as standard in the United States, an increase in carrier strength caused by an increase in video modulating voltage produces a darker spot on the cathode ray picture tube. The brightest spot in the picture corresponds to the lowest modulating voltage. Thus when the scanning beam in the camera tube reaches the edge of a black square at A of Figure 136, the video modulating voltage of the transmitter assumes its maximum positive value and remains at this value as the scanning action crosses the black portion of the image. At point B the scanning reaches a white area and the modulating voltage changes to its maximum negative value. The video voltage then remains negative until point C is reached, at which point the cycle repeats itself. Since two picture elements have been scanned in this operation to produce one cycle of video voltage, the top modulating frequency required will be one half of the number of picture elements or in this example 4,608,000 cycles (4.6 megacycles) for 9,216,000 picture elements. Since we have used as an example the maximum resolution of the system, in which a picture element has been made the same size as the scanning spot, the video output would be a sine wave as shown at 136C rather than a square wave at 136B.

If double side-band modulation, of the type employed in standard radio broadcasting, were to be used in television (see Figure 133), side-bands extending 4.5 megacycles on both sides of the carrier would require a bandwidth for the video signal of 9.0 megacycles. In the early days of television research, when the pictures were of much lower definition (90 lines instead of 525), double side-band modulation was employed. In addition to the bandwidth required for the video carrier, the accompanying sound carrier and a "guard" space must be provided. The Federal Communication Commission has assigned a channel space of only 6 megacycles for each television channel and it is therefore impossible to use the double side-band type of modulation and still retain the definition which is possible in a 525 line picture. Other types of modulation, which require less channel space to accommo-

date the wide band of modulation frequencies encountered in television are; single side-band modulation, and vestigial side-band modulation. (One side-band plus a "vestige" of the other.)

In the process of detecting or demodulating an amplitude modulated carrier, one side-band is always eliminated, and the information in the other is amplified and utilized for the production of the picture. The single side-band method requires only half of the space in the radio spectrum for a given maximum modulating frequency as compared with the double side-band method. Single side-band modulation is produced by passing a double side-band modulated carrier through a radio frequency filter network which suppresses the undesired side-band. Although the single side-band method allows the greatest utilization of channel space, it is considered impractical for transmission of television signals, and has been replaced by the vestigial side-band method because:

1. The type of filter which must be employed for the complete suppression of one side-band introduces serious distortion of the low frequency components of the video signal which results in a "blurred" picture.

2. Even though means of correcting the phase shift may be developed, the single side-band method requires extremely accurate tuning of the receiver and a high degree of freedom from oscillator frequency drift. Otherwise, a loss of the low frequency portion of the video modulation results.

**VESTIGIAL SIDE-BAND VIDEO MODULATION:** The system of modulation employing all of one side-band and a "vestige" of the other has been adopted as standard in the United States to overcome the difficulties encountered with single side-band modulation. The fact that a "part" or "vestige" of one side-band is transmitted gives rise to the name of the method, i. e., vestigial side-band modulation.

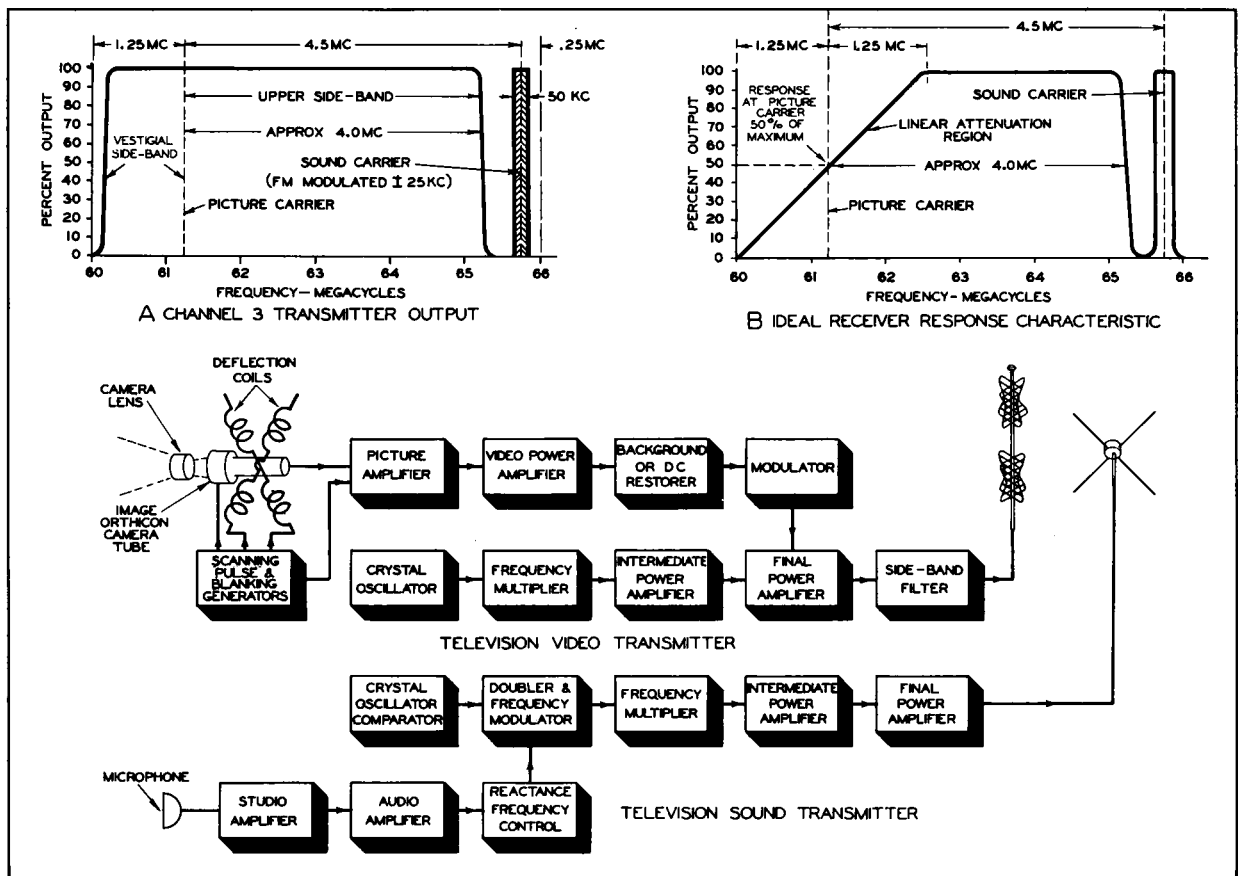

Fig. 137. Output Characteristic of a Television Transmitter, the Required Receiver Response Characteristic, and the Block Diagram of the Essential Elements of the Transmitter

Figure 137A shows a typical television channel employing vestigial side-band modulation. Channel No. 3 has been chosen for this example. A block diagram of the essential parts of the transmitter to produce this type of carrier and modulation, is shown in Figure 137C.

It will be seen that, in this channel which extends from 60 to 66mc, the picture carrier frequency is placed 1.25mc above the lower limit of the channel or at 61.25mc. Video modulation of this carrier produces an upper side-band with frequencies extending to approximately 4mc. The accompanying sound of the program has a carrier frequency 4.5mc above the video carrier, or - in this case - at a frequency of 65.75mc. A guard channel, or space, of .5mc separates the video modulation from the sound channel. The sound produces a frequency modulation of its carrier with a maximum deviation of 25kc (a total carrier swing of 50kc). Between the sound carrier and the upper end of the channel (66mc) is another guard band, or space, of .25mc.

It will be noted that the lower side-band frequencies are extended to approximately 1 mc below the video carrier frequency. For video modulation frequencies extending to 1 mc the transmitting system is essentially double side-band in character. The presence of the lower side-band would result in an over-emphasis of low frequencies if the response characteristic of the receiver were flat throughout the entire band. To compensate for this possible over-emphasis, the receiver characteristic is such that the carrier suffers a loss or attenuation of 50 percent as shown in Figure 137B. The response of the receiver is made to "drop off" at a linear rate from a frequency 1.25mc above the video carrier frequency to the lower limit of the band. When the receiver is correctly tuned to the channel, this attenuation of the lower side-band produces a flat output from approximately 25 cycles to 4.5mc.

When the Federal Communications Commission first announced channel allocations, 13 channels were assigned for television broadcasting. These channels were divided into a low and a high band group. Each channel occupies a band of 6mc. The first six channels (1 through 6, inclusive) originally covered a band of 44 to 88mc (72mc to 76mc being reserved for other services). The second group of seven channels (7 to 13 inclusive) covered a band of 174 to 216mc. The lowest frequency

channel (No. 1, 44 to 50mc) has been eliminated from the assigned group, and at this time there is some indication that channel No. 13 (210 to 216mc) may also be denied for television broadcasting.

Field experience now being correlated indicates that the original frequency assignments for various cities may cause interference fringes in those sections of the country, where the signal level from a distant city on the same channel is comparable to that of the desired signal. The entire situation is being studied by the F. C. C., and the J. A. T. C. (Joint Advisory Technical Committee). New assignments, reassignments of issued licenses, and the possible opening of new television bands, will await the result of the F. C. C. investigation and hearings. Receivers now in use can be tuned to the channels indicated in the following table.

Channel Number	Channel Freq. Mc	Picture Carrier Freq. Mc	Sound Carrier Freq. Mc
2	54-60	55.25	59.75
3	60-66	61.25	65.75
4	66-72	67.25	71.75
5	76-82	77.25	81.75
6	82-88	83.25	87.75
7	174-180	175.25	179.75
8	180-186	181.25	185.75
9	186-192	187.25	191.75
10	192-198	193.25	197.75
11	198-204	199.25	203.75
12	204-210	205.25	209.75
13	210-216	211.25	215.75

Fig. 138. Channel Allocations for Commercial Television

Figure 139 illustrates the consecutive arrangement of channel spacing, and it will be noted that a guard space of .25mc exists between the sound carrier of the adjacent television channel and the low end of the desired channel. Similarly a space of .25mc is provided between the sound carrier of the desired channel and the low end of the video modulation of the next higher channel. Television receivers must be designed so as to provide a high degree of attenuation or rejection of these undesired transmissions occurring in adjacent channels.

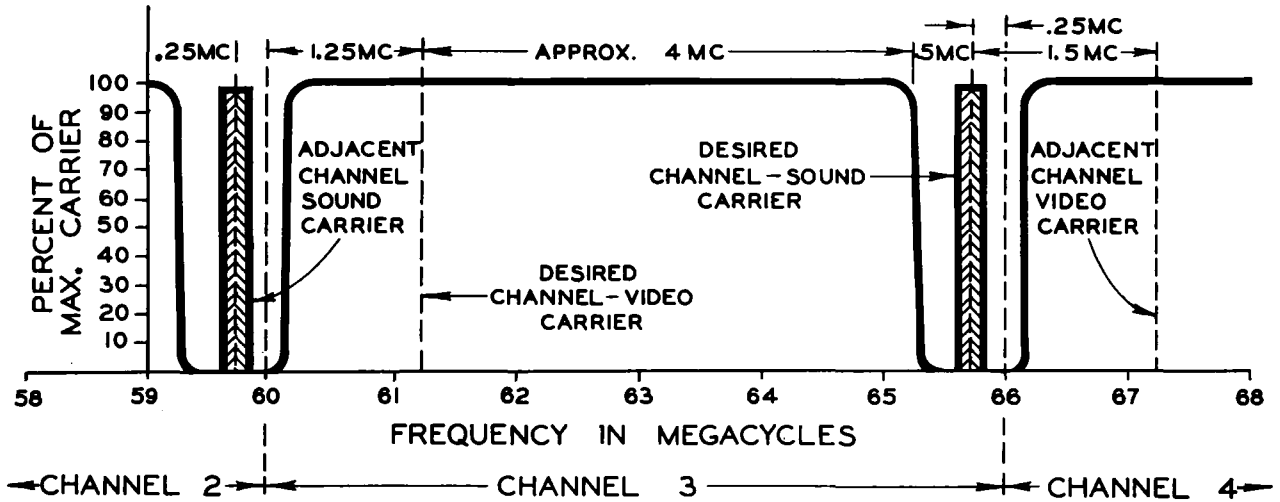

Fig. 139. Arrangement of Consecutive Channel Spacing for Television Channels 2, 3 and 4

**THE VIDEO MODULATION:** Figure 140 shows the nature of the video signal which would be produced if a card, carrying a series of tones ranging from pure white through a number of gray values to black, were to be placed in front of the television camera. Figure 140A represents one horizontal line scanned across the series of tones. The line is preceded and followed by pedestals upon which are "mounted" the horizontal synchronizing pulses. At the left of this figure will be found a scale which indicates the percentage modulation of the carrier corresponding to the various light values. The region from 75 percent to 100 percent is reserved for scanning impulses and therefore the 75 percent point itself is the blackest part of the picture. The region beyond this black point is known as "blacker than black" in television slang. It is also known in engineering circles as the "infra-black" region.

At the other end of the modulation scale at a value of from 10 percent to 15 percent of maximum amplitude, is found the brightest highlight or "white region". The F. C. C. regulations specify that this white level shall not exceed 15 percent of maximum carrier amplitude. One basic method of receiver design, known as inter-carrier sound, requires for its performance a white level of at least 10 percent of maximum carrier, and, for this reason, television broadcast stations must now hold the white level of transmission within quite narrow limits.

The intermediate gray tones occupy positions between the two extremes just discussed, as shown in Figure 140A and C. Figure 140A shows a series of tones in which the white portion of the picture is at the left and the black portion at the extreme right, while in Figure 140C is shown a succession of white through black to white again, and in this case the black level or pedestal is reached at the center of the active scan.

The television video carrier envelopes which would be produced by the video-modulating waves of Figures 140A and C are shown in Figures 140B and D.

An actual television subject will be represented by continuously varying tone values along each of the 470 to 480 active scanning lines. Figure 141A illustrates a typical television image. In this case, however, the line structure has been produced by approximately 75 lines rather than the 480 lines of an actual transmission. One of these horizontal lines, which crosses all of the tone values of the subject, has been analyzed for change of video signal due to the major differences in reflected light intensity from the subject. The variation of camera signal, due to scanning the line X-X, results in a video modulating voltage as shown in Figure 141B. The sudden changes caused by crossing such regions as the eyeball-iris-pupil "catch light" of the eye, represent rapid excursions of the video voltage. For faithful reproduction of such sudden changes, the sys-

# CATHODE-RAY - - BEAM MODULATION AND SYNCHRONIZATION

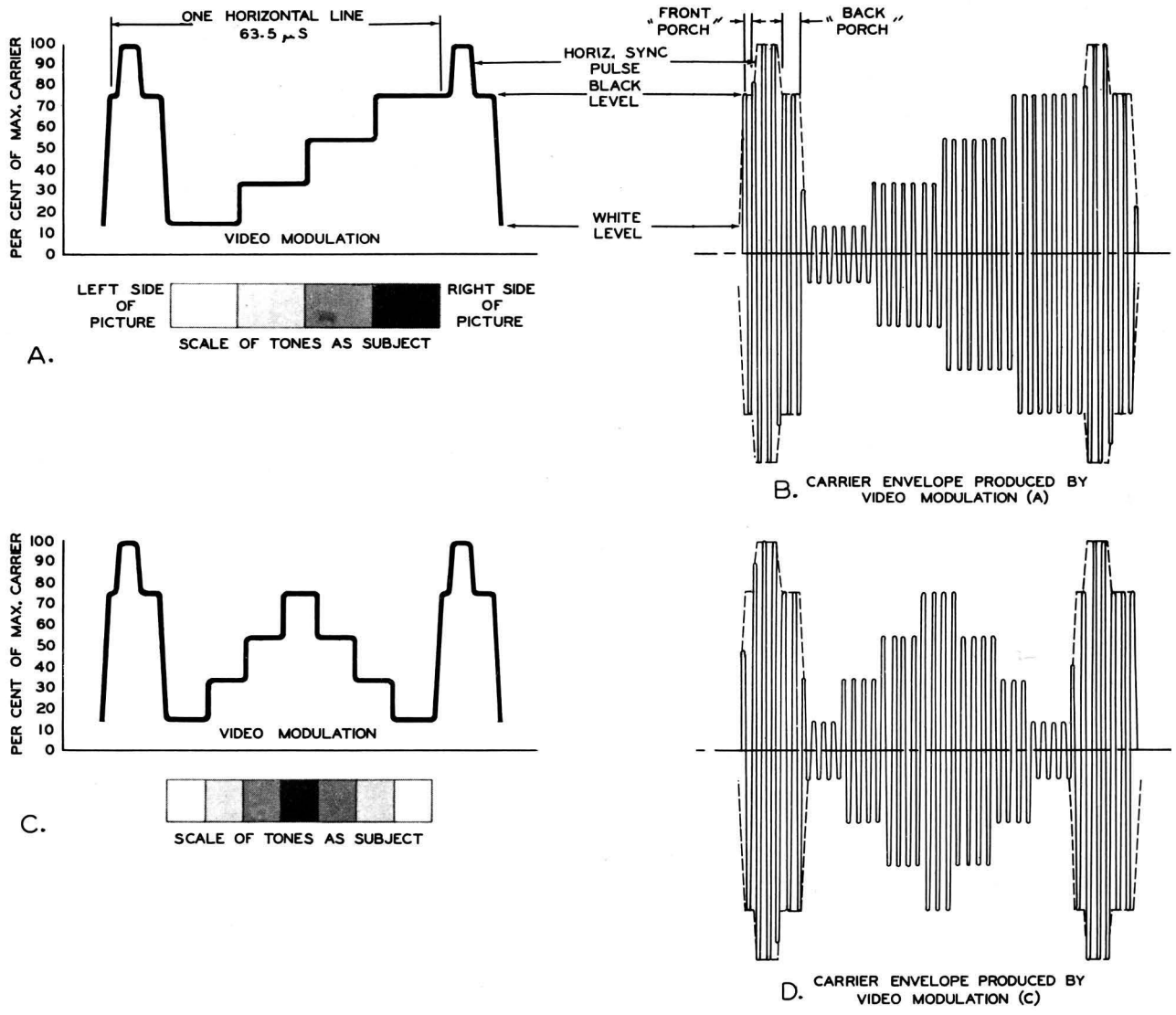

Fig. 140. Video Signal and Carrier Envelope Produced by Scanning a Range of Tones

tem must have extremely wide band response characteristics. Gradual variations, such as are represented by the slight variations of half-tone values in the flesh tones of the face, and gradual transitions of the shadow in the background can be accommodated by middle frequencies of the video band.

A number of times in our discussion of video modulation, we have indicated that an increase of carrier strength produces a darker picture until finally the spot on the picture tube is extinguished and produces a black dot. This is known as negative modulation and was chosen by the National Television Standards Committee (a radio industry group, which acted as

an advisory committee to the F. C. C.) after trial of positive and negative systems both in the laboratory and in experimental field demonstrations. The reasons for the choice of negative transmission as the United States standard are:

1. Static and noises, both in the receiver and man-made sources, such as automobiles, oil burner ignition, electric razors, etc., should produce black spots on the picture in negative transmission, but would produce bright flashes of light if the video modulation were positive. The former condition is the least annoying.

2. In the negative system, both horizontal and vertical synchronizing pulses are at

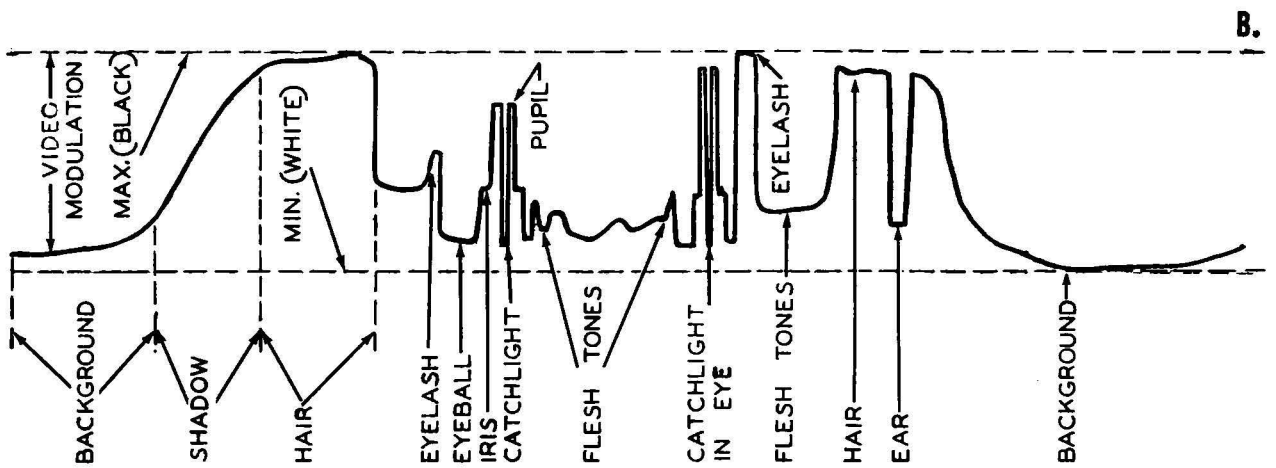

Fig. 141. Variation of Video Voltage Produced by Scanning Line X-X. (Typical Television Subject)

maximum carrier amplitude, assuring receiver synchronization with the transmitter even under conditions of low signal strength at the limits of the service area.

Television transmission on a commercial scale has been in progress in Great Britain for a number of years. The British system is based on positive transmission. A comparison of both systems under similar conditions is being conducted in Australia, and the results will undoubtedly be published in the technical publications. Unlike radio broadcasting, which can be received by many types of systems from a simple crystal detector to a complicated super-heterodyne, television is absolutely controlled by the choice of type of transmission, and for this reason the final decision of the F. C. C. on television standards was delayed for many years pending industry accord.

In the foregoing discussion of the nature of the video modulation caused by scanning the image in the camera tube, we have considered the polarity of the video voltage wave as becoming increasingly more negative as the scene being scanned grows darker. In each case the polarity illustrated (see Figures 140 and 141), is that required for the modulation of the carrier wave. The polarity of the video modulation envelope has been adopted in this discussion as a reference basis rather than the polarity of the camera tube, since the various camera types (see pages 19 through 23) do not all supply the same output polarity with decrease in intensity of the image.

The television service technician should at this time refer to the discussion of camera tube action covered in pages 19 through 23, since some text books and magazine articles may use, as illustrative material, the output wave of the camera tube rather than the video modulation envelope.

**THE DIRECT CURRENT COMPONENT OF THE VIDEO SIGNAL:** Video modulation differs basically from the audio modulation employed in sound broadcasting. It is in the form of a varying direct current rather than the familiar alternating current form of speech and music modulation.

The direct current component or "bias" corresponds to the average illumination of the scene being televised. This is equivalent to an average of the camera output for all of the lines comprising a frame-scanning interval. The

camera tube itself produces an alternating voltage output which is proportional, at any instant, to the brightness of the particular picture element being scanned at that time. Since the output element of the picture tube (such as the mosaic of the iconoscope) is capacitance-coupled to the input grid of the camera amplifier, it is not possible for any direct current components of the picture tube output to be passed on to the succeeding stages. The remaining video amplifying stages of the transmitter are likewise capacitance-coupled and therefore not able to amplify the direct current component.

Direct current components in the video signal are due to those portions of the scene being televised which have no change in brilliance over a portion of a horizontal line. A uniform gray background, for instance, will produce a uniform, single value charge on that part of the mosaic, representing its image. As the scanning beam of the camera tube crosses this section, no change of output voltage will occur and consequently no alternating voltage will be passed on to the camera amplifier input.

If the average lighting of the scene or background were not taken into account, by the addition of the correct DC bias to the video modulator, the contrast or ratio of brightness of the various parts of the picture with respect to each other would be correct but the background illumination or shading would be incorrect.

Several instances of typical television subjects will serve to illustrate the effect on the received image, if the average or DC component were not transmitted:

1. A dancer dressed in a white costume with a black curtain as a background is chosen as the television subject. Let us assume that the television system, from camera tube to the receiving picture tube, has been adjusted so that the dancer's costume is rendered on the picture tube as a satisfactory highlight, and that the black curtain appears as "black". Let us now consider what will happen if several more dancers, similarly garbed in white, come on the scene. If the DC component representing the new average light value of the scene is present both in the transmitted carrier and restored at the picture tube, the scene will be reproduced correctly. If on the other hand the new DC bias were not provided at the transmitter, the highlights of the dancers would be rendered as gray and any gray areas in the background would disappear into the black area beyond cut-off.



2. As an opposite extreme to the example just cited, consider a hockey arena as the televised subject. The system has been set up for proper rendition of the ice as the highlight value. If the opposing teams now skate into the field of view, the large area of dark figures will now degrade the highlight tones of the ice and will, themselves, not be rendered as dark as the actual scene contrasts would require.

To understand the reasons for the effects described in the examples just discussed, we have chosen two types of subject material which, in the absence of the DC component, would produce the same video signal, and would cause confusion in the reproduced image.

Figure 142A shows the video signal from the camera amplifier which is caused by scanning a gray line on a black background. Since no DC component is present, the alternating current is averaged about the line X-X. Figure 142B shows the camera amplifier output when a white line across a gray background is scanned. The contrast between the line and the background is the same in each case and the AC video modulation produced would be the same. When the video signals in each of these cases are referred to the black level as shown in Figure 142C, the light values are then placed at their proper points on the scale, and no confusion exists. The direct current component caused by taking into account the average value of the background now differentiates the gray line on the black background and the white line on the gray background.

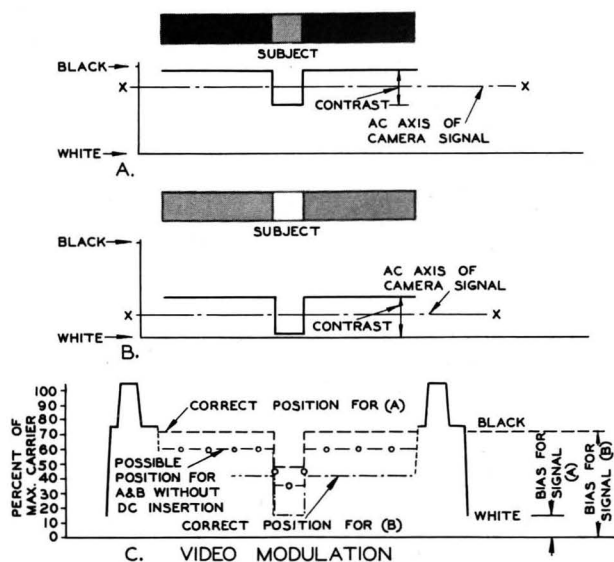

Fig. 142. Examples of Necessity for DC Component of Video Signal.

The proper value of DC bias can be produced at the transmitter in several ways:

1. It may be added directly to the modulation circuit by a manually operated control which is monitored by an observer who compares the image on a television screen, with the actual scene being televised and continually adjusts the background or average lighting.

2. An auxiliary camera operated in conjunction with the pickup camera utilizes a photoelectric cell to "integrate" the light of the scene and automatically provide a DC bias for establishing the background level.

3. Certain camera tubes, such as the Farnsworth image dissector, which are non-storage devices, employing a direct coupled output, can produce a direct current component, which is representative of the brightness of the scene. This type of tube is ideally suited to the television transmission of programs directly from motion picture films.

4. Orthicon types of camera tubes, as well as "flying-spot" scanners, can also be made to accomplish DC insertion automatically.

In all of these methods of inserting the DC component or bias level, the end result is the establishment of a fixed DC value for the "black" level of each frame.

In television transmitter practice, the DC component is often added to the video signal in the camera amplifiers, but is subsequently lost by passing the signal through higher level capacitance-coupled video amplifiers. The DC component is then re-inserted by rectifying the peak value of the video signal and adding the rectified DC voltage to the signal.

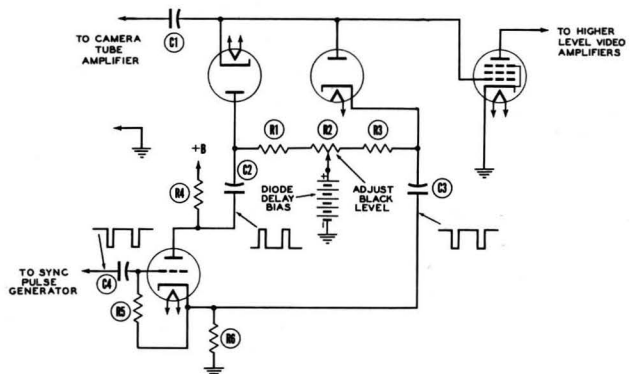

Fig. 143. Typical Double Diode "Clamp" Circuit, for Re-inserting DC at Transmitter

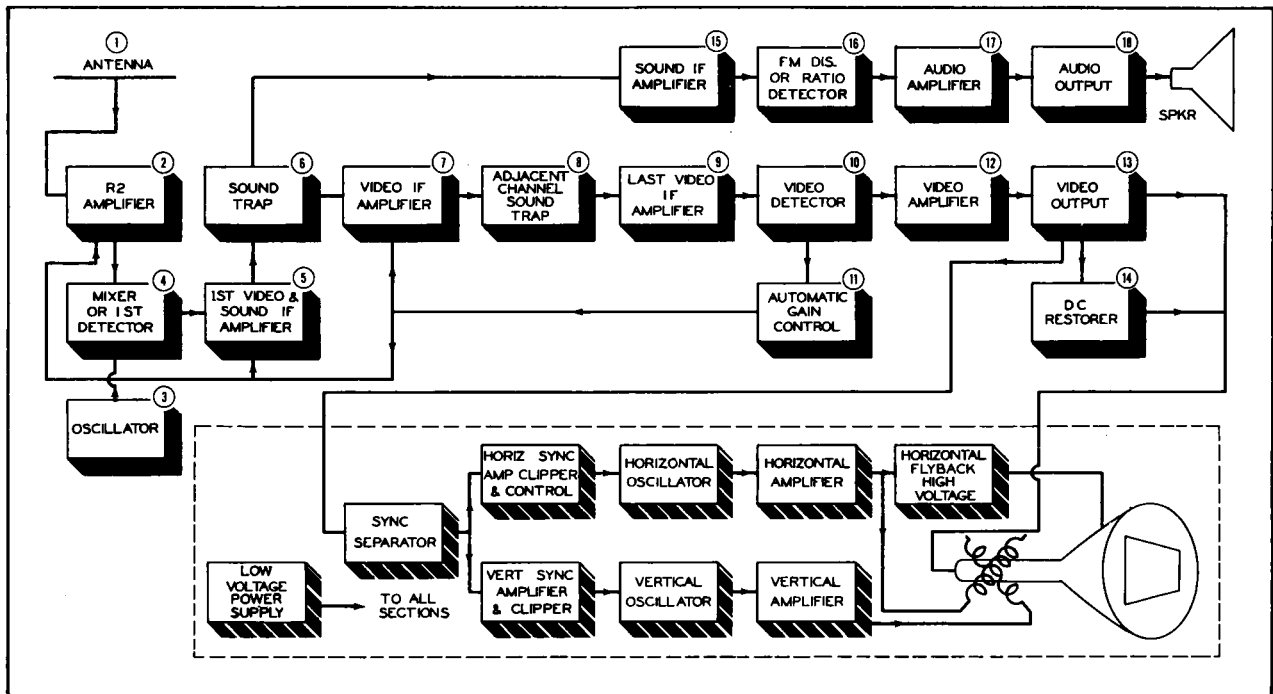

Fig. 144. Block Diagram of Complete Television Receiver. (Electromagnetic Deflection Type)  
 Note: Portion of Receiver Enclosed in Dotted Lines Covered by Preceding Text. (See Fig. 134)

Figure 143 shows a typical transmitter DC re-insertion circuit. The circuit employs a double diode tube in a bridge network and is known as a "double diode clamp" circuit since it "clamps" the video signal at the black level. The sync pulses of the video signal establish the level at which this circuit operates. The DC furnished by the circuit for re-insertion is thus referred to a level previously established by the DC component inserted in the camera amplifier.

Figure 144 shows, in block diagram form, all the essential elements of the television receiver from the antenna to the picture tube for "sight" and to the loud speaker for "sound". Those portions of the circuit which are shown enclosed by the dotted line are the "slave circuits". These circuits include the power supply portions as well as those which control scanning and synchronization. Our study of the television receiver has also covered an explanation of the means for controlling the functions of these circuits.

We will now begin the study of the radio frequency amplifiers, intermediate frequency amplifiers (both video and audio) and the detectors which convert the television carrier wave into audio and video intelligence.

The block diagram of Figure 144 illustrates one particular type of television receiver. Another basic type, in which the sound is not separated from the signal until the combined signal reaches the video output stage (known as the "inter-carrier" sound system), will be covered when we consider video I-F amplification.

Consideration of the balance of the television receiver will be in the numerical order indicated in Figure 144, as follows:

1. The Television Antenna.
2. Radio Frequency Amplifier.
3. The Oscillator.
4. The Mixer or First Detector.
5. First Video and Sound I-F Amplifier.
6. Sound Trap.
7. Video I-F Amplifier.
8. Adjacent Channel Sound Trap.
9. Final Video I-F Amplifier.
10. Video Detector.
11. Automatic Gain Control.
12. Video Amplifier.
13. Video Output.
14. DC Restorer.
15. Sound I-F Amplifier.
16. FM Discriminator or Ratio Detector.
17. Audio Amplifier.
18. Audio Output.

# SECTION III CATHODE RAY — BEAM MODULATION AND SYNCHRONIZATION

## CHAPTER 12. THE TELEVISION RECEIVING ANTENNA

The satisfactory performance of a television receiver is more dependent on the efficiency and placement of the antenna and lead-in, than on any other single factor encountered in the installation and maintenance of the set.

Receiving antennas for television are far more critical in performance, and play a more important role in the production of satisfactory television reception, than do the antennas employed for ordinary sound or FM reception. Sets for AM or FM sound reception are sufficiently sensitive, and the broadcast signal strength is sufficiently great, to render the use of outside antennas unnecessary in most instances. The design trend, of the last few years, has been to incorporate the antenna within the receiver cabinet. A loop is normally employed for the broadcast band and a simple half "dipole" or "doublet" for the FM band. Reception with such a simple installation is usually satisfactory except when the receiver is located in a steel building.

It is seldom possible to operate a television receiver without an outside antenna. An exception to this statement would be the case of a receiver operating in a position close to the transmitter, and where reception of only the single station is required.

Many unique factors exist in television wave propagation which are not encountered, to as great a degree, in other forms of broadcasting. A discussion of these factors will assist the television service technician in understanding the nature of the major problems which will be experienced, and in arriving at the best compromise solution under each particular condition.

The elements of the antenna problem which must be considered are:

1. The nature of radiation and propagation of radio waves in the television bands.
2. Horizontal versus vertical polarization of television waves.
3. The wideband nature of the television channel, and its relation to the susceptibility of the system to noise.

4. "Ghost" images due to multiple signal paths caused by the reflection of the signal from buildings, mountains, hills or other obstructions.

5. "Ghost" images due to "mismatch" between the impedance of the transmission line (lead-in) and the antenna or receiver input circuit. (Reflections in the line.)

6. The necessity for special types of antennas to achieve a desired directional reception pattern.

7. "Wideband" antennas to allow reception of stations widely separated in the television frequency spectrum.

8. Problems peculiar to "fringe" reception. (Reception of stations beyond the limits of the "primary service" area.)

**PHENOMENA OF RADIATION AND PROPAGATION OF WAVES IN THE TELEVISION SPECTRUM:** In our study of the nature of the television channel, with its vestigial amplitude modulated video, and frequency modulated audio components, we have seen that a channel width of 6 megacycles is required for high definition television. (See pages 125-127.) The modulation process requires that the carrier frequency be made at least ten times the top modulating frequency. For this reason, the carrier frequencies of the television transmitters have been assigned in the portion of the radio spectrum above fifty megacycles. The standard classification of the part of the spectrum between 30 and 300 megacycles is V. H. F. (Very high frequencies). The propagation characteristics of V. H. F. waves are considerably different from those of the lower frequencies employed for sound broadcasting. A review of the manner in which radio waves travel from the transmitter to the receiver, as the frequency of the carrier is increased, will be helpful in understanding some of the transmission phenomena which occur in the television bands.

After a radio wave has traveled several wavelengths from the transmitting antenna, it will be found to consist of two components: an electrostatic field and a magnetic field. These two fields consist of "lines of force" at right angles to each other. The energy in the radio wave is divided equally between these two

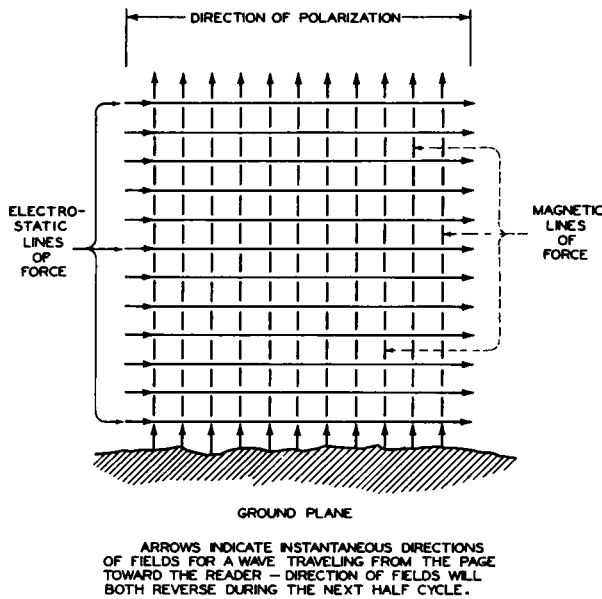

Fig. 145. Graphical Representation of an Horizontally Polarized Electromagnetic Wave Front

traveling, alternating fields. Figure 145 shows a graphical representation of part of the wave front of an electromagnetic wave in space. Since the wave is traveling in all directions from a point source (the transmitting antenna), the lines of Figure 145 represent a small portion of a spherical surface.

**POLARIZATION OF THE TRANSMITTED WAVE.** The direction of the lines of force of the electrostatic component of the wave define the direction of polarization. In the graph of Figure 145, these are the solid horizontal lines and such a wave is said to be "horizontally" polarized with respect to the earth's surface. If the direction of the electrostatic lines are perpendicular to the earth's surface, the wave is said to be "vertically polarized".

In the V. H. F. portion of the spectrum, utilized for television, the plane of polarization of the transmitted wave is the same as the position of the transmitting antenna with respect to the earth's surface; that is, a vertical antenna produces vertically polarized waves and a horizontal antenna produces horizontally polarized waves. The television broadcasters of the United States have adopted horizontal polarization and this type is becoming standard for television transmission.

The reasons advanced for the choice of horizontal polarization are:

1. Many types of "man made" interference as well as interference from other radio communication transmitters is vertically polarized and the horizontal polarization of the receiver antenna helps to reduce interference from these sources.
2. Horizontally polarized waves suffer less loss or "attenuation" when reflected from the earth or in passing through the atmosphere.

**TYPES OF WAVE PATHS BETWEEN THE TRANSMITTER AND RECEIVER.** Radio waves of different carrier frequencies follow different paths between the transmitter and the receiver. The waves, themselves, are basically the same and would act alike in free space (beyond the atmosphere of the earth). The effect of the earth's surface, the nature of the earth's atmosphere and the presence of objects, comparable in size to the length of the wave, modify the transmission path as the frequency of the wave is changed.

The paths which radio waves follow can be classified generally in two main groups: ground waves and sky waves.

The ground wave group, which is of main interest to us in our consideration of television transmission, can be further subdivided into: a "direct" wave, a "surface" wave, and a "space" wave.

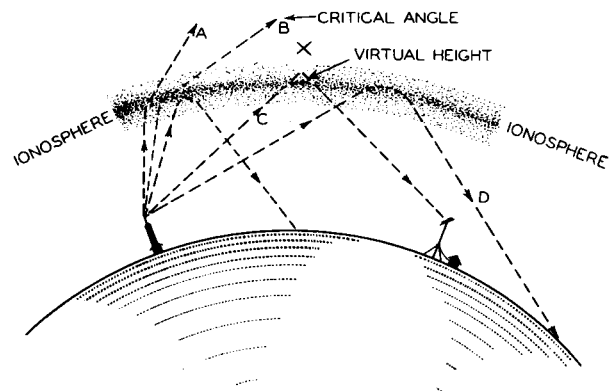
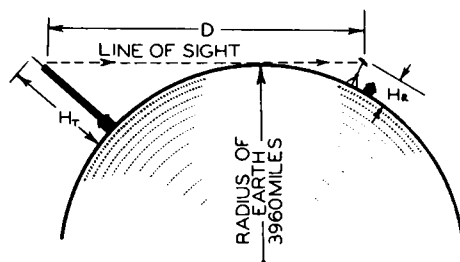

Fig. 146. The Bending of Radio Waves Back to the Earth from the Ionosphere. (Occurs at Frequencies below 40 Mcs)

The sky wave, which accounts for long distance reception on the lower frequencies such as the broadcast and short wave bands, is "bent" back to the earth by ionized "layers" or "strata" in the earth's upper atmosphere. Figure 146 shows this type of transmission. The ionized "layer", which consists of atoms and molecules of the air (principally nitrogen and oxygen), acts like a mirror at the "virtual" height "X". (See Figure 146.) In reality the wave front is steadily bent as it passes into regions of gradually increasing free electron density and emerges toward the earth as though it had been reflected. The amount of bending which a wave will encounter is a function of the wavelength. For each wavelength there exists a critical angle (see B of Figure 146) at which the wave will pass through the "layer" and not return to the earth. Frequencies of more than 30 to 40 megacycles are not returned by the ionosphere, except under unusual sporadic conditions and therefore this type of wave-path cannot be depended upon for television transmission.



$$A. \text{LINE-OF-SIGHT } D \text{ (MILES)} = 1.23 \left[ \sqrt{H_T \text{ (FT.)}} + \sqrt{H_R \text{ (FT.)}} \right]$$

**GROUND WAVE OR LINE-OF-SIGHT TRANSMISSION ON TELEVISION FREQUENCIES.** The action of frequencies in the range above approximately 40 megacycles is often termed "quasi-optical" since the waves act in a manner similar to light rays. (Quasi means "as if" and optical means "light" in Latin.) Radio transmitters operating in this frequency range, such as television stations, employ as high an antenna structure as practicability and economics will permit. The radio carrier waves leaving the antenna act in a manner similar to the rays of light which might be produced if a powerful electric light were to be mounted on the top of the antenna mast. The curvature of the earth would cut off these light waves at the horizon. The horizon distance can be extended by erecting a tower for the observer of the light.

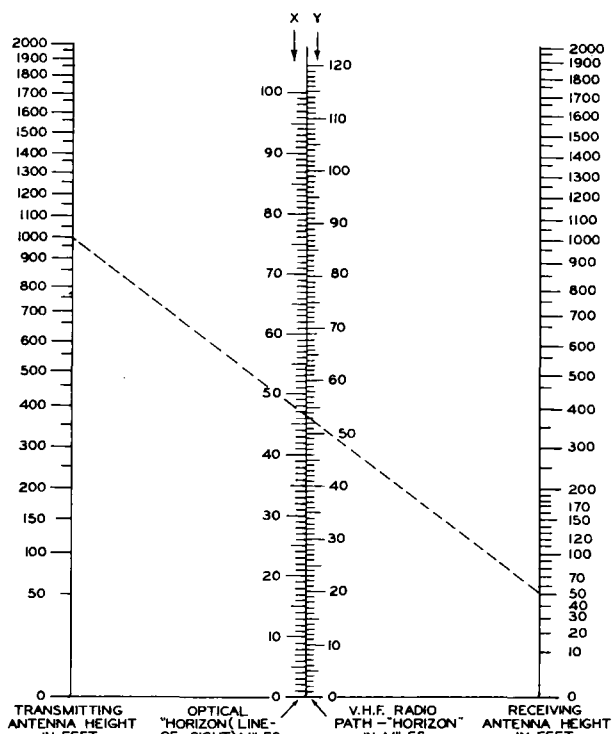

B. THEORETICAL MAXIMUM LINE-OF-SIGHT PATH CHART  
(V.H.F. RADIO PATH = OPTICAL HORIZON DISTANCE X 1.56)  
EXAMPLE: TRANSMITTING ANTENNA - 1000 FT. HIGH - RECEIVING ANTENNA - 53.5 MILES - OPTICAL HORIZON - 46.5 MILES - V.H.F. PATH - 83.5 MILES.

Fig. 147. V. H. F. Path Length as a Function of Height of Transmitting and Receiving Antennas

Waves emitted by transmitters in the television bands exhibit this "line-of-sight" action as shown in Figure 147A. In the case of the radio waves, however, the cut-off at the horizon is not sharply defined. In traveling through the air, the wave is bent or "refracted" slightly toward the earth and the V. H. F. radio horizon is considered to extend some 15% beyond the "line-of-sight" or optical horizon. Beyond this radio horizon the strength of the signal decreases very rapidly.

Figure 147B shows, by means of a "nomograph" chart, the effect of the height of the transmitting and receiving antennas, on the optical horizon (shown at X) and the radio path horizon (shown at Y). This chart is calculated for a smooth, spherical earth. If the transmitting and receiving antennas are at different relative heights above sea level, this difference should be taken into account in calculating the radio path horizon. The presence of large intervening objects such as buildings or hills

CATHODE-RAY - - BEAM MODULATION AND SYNCHRONIZATION

can reduce seriously the signal level and thus the range of satisfactory reception. Figure 147B indicates the advisability of locating the receiving antenna as high as possible.

**WAVELENGTHS OF THE TELEVISION CHANNELS.** In the range of frequencies assigned to television transmission (54 to 88 megacycles and 174 to 216 megacycles) the length of the electromagnetic wave in space is small when compared with the size of obstructions such as buildings. This accounts for some of the peculiar transmission phenomena encountered, which will be described when we examine the effect of reflections. Another consequence of the short wavelength, on the "credit side of the ledger", is the fact that highly efficient antenna, which are "resonant" to the wavelength and possess directional characteristics, can readily be constructed.

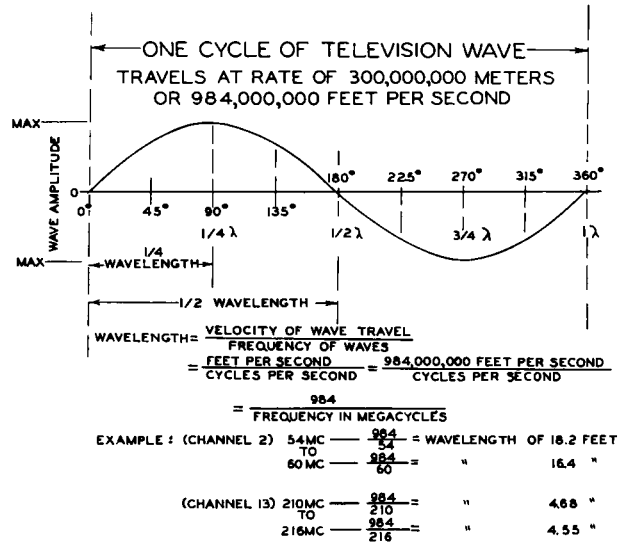

Fig. 148. Relation of Carrier Frequency to Wavelength of Television Channels

For these reasons it will be instructive, at this time, to review some of the fundamental relationships between the frequency of an electromagnetic wave and its wavelength. It will also be valuable for the television service technician to become familiar with the actual wavelengths in feet of the television carrier frequencies of stations in his locality, since the size of the antenna structure required is directly related to the wavelength.

All electromagnetic waves (cosmic waves, x-rays, ultra-violet waves, light, infra-red and radio waves) travel through space with the same velocity or speed. This velocity has been quite precisely measured as 299,796,000 meters per second. For our purposes, this figure can be "rounded off" to 300,000,000 meters, or 186,000 miles per second.

The distance in space which an electromagnetic wave travels in one cycle (360° of its sine wave oscillation) is called one wavelength. Figure 148 shows the relationship of wavelength, velocity and frequency. It will be seen that, when the velocity is expressed in feet per second and the carrier frequency in cycles, both numerator and denominator of the fraction can be divided by one million and the simple expression, 984 divided by the frequency in megacycles, results. The wavelengths encountered in the television bands lie between four and twenty feet.

A handy "rule-of-thumb" which is apparent from Figure 148 is that the television wave travels approximately 1000 feet in one microsecond (actually 984 feet). This information is of value in determining the effect of reflections of the wave from objects.

**TELEVISION CHANNEL BAND-WIDTH IN RELATION TO THE ANTENNA PROBLEM.** We have seen that television requires an extremely wide band to accommodate the video modulation and sound. (See pages 121-130). One of the "axioms" or principles of electrical communication, when employing amplitude modulation, is that the noise susceptibility of a system is proportional to its band-width. This situation is aggravated by the fact that automobile ignition systems produce interference which, due to the length of the spark plug wiring, is tuned in the television bands.

Fortunately the radiated interfering field drops rapidly with distance from the car. If the antenna system is relatively high, not sensitive to vertically polarized waves and has a balanced lead-in system, the effects of this, and other types of man made interference, can be reduced. This consideration is an added reason for the installation of an efficient antenna.

"GHOSTS" DUE TO MULTIPLE PATH TRANSMISSION. Before considering the television antenna itself in detail, it will be

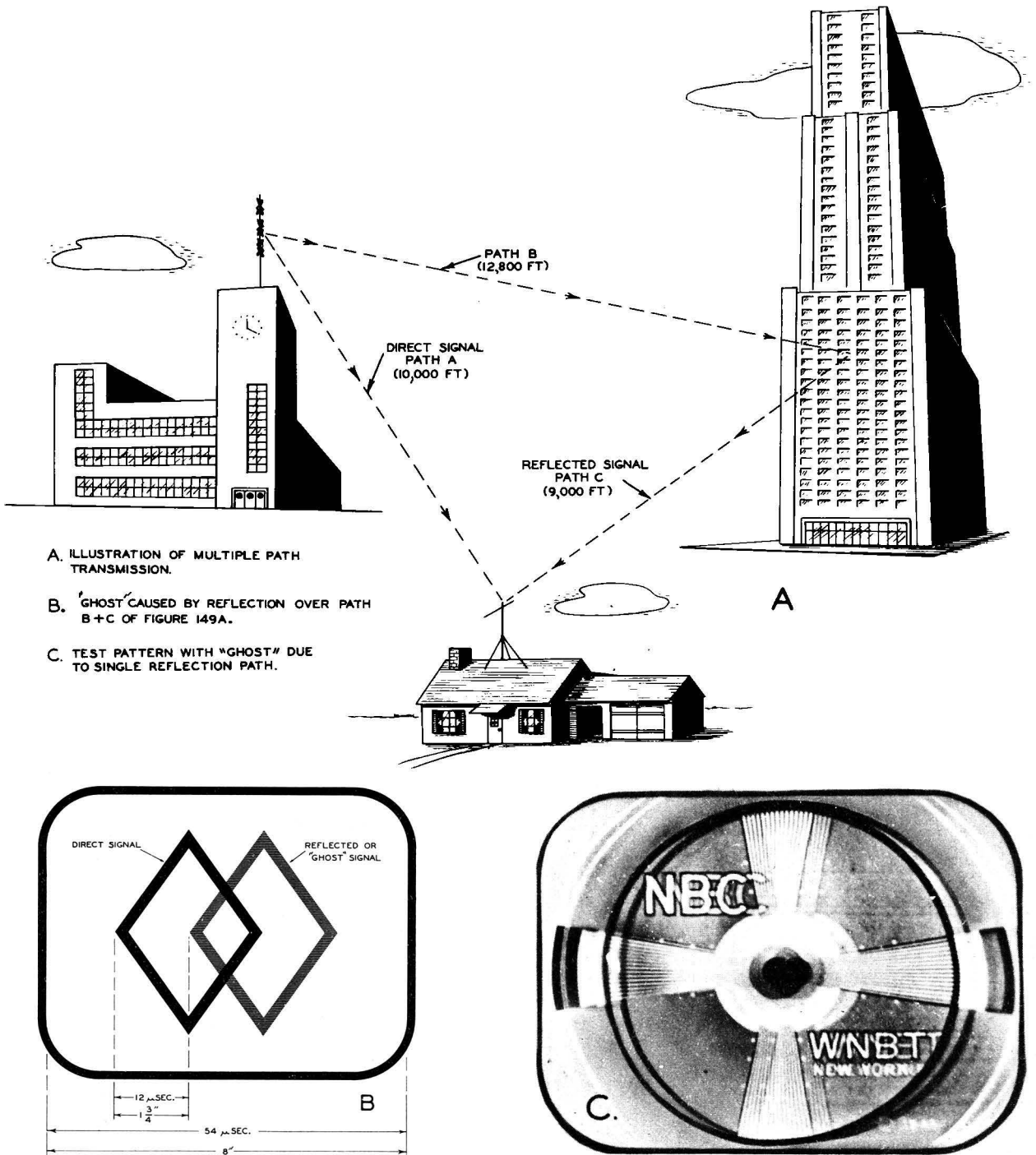

Fig. 149. Production of a Ghost Image by Multiple Path Transmission

instructive to examine some of the distortions of the picture which are caused by vagaries of the transmission path and to determine their causes. The expedients employed in antenna design to overcome or alleviate these defects will then be discussed.

Figure 149A shows a set of conditions which might occur in the residential section of a city. The direct signal arrives at the receiver over path A (assumed to be 10,000 feet from the transmitter). At a distance of 12,800 feet from the transmitter, an office building



acts as a "mirror" and reflects the signal to the receiver over path C (9,000 feet). The combined path B plus C is 21,800 feet. This reflected wave path is 11,800 feet longer than the direct path. We find from the wavelength-frequency relations of Figure 148 that the wave travels at the rate of 984 feet per microsecond. In this instance the reflected wave will arrive  $11,800/984$  or 12 microseconds later than the direct wave.

Figure 149 shows the effect of the delayed or "ghost" signal on the picture. The horizontal scanning time relations discussed on page 51 will serve to explain the image displacement. Approximately 54 microseconds elapse during active scan of one line. On a ten inch tube, the horizontal dimension of the picture is about eight inches. The signal arriving over paths B plus C requires twelve microseconds more than the direct path, and during this time scanning will have advanced one and three quarters inches. Thus, a second image, due to the reflected wave, will appear displaced from the main image as shown. In general this "ghost" image will suffer some loss of signal strength due to imperfect reflection and absorption of energy and will therefore be less intense than the image caused by the direct signal.

Figure 149C shows the appearance of a "ghost" of the type just discussed, as photographed from a television receiver with the station test pattern as a subject. In the example just discussed and in Figures 149B and 149C the ghost is caused by a single reflection. In many cases a series of overlapping ghost images will appear due to multiple reflections from a number of buildings or other obstructions. When such multiple ghost images arrive over paths only slightly longer than the direct signal path, the effect on the picture is to "widen" lines and obscure the fine detail. Since this "smears" the picture, it has become known in television slang as a "smear" ghost.

The types of ghost images just discussed are all positive in nature. By this is meant the fact that a black line in the picture will be represented by a black line in the ghost and conversely, white picture elements will be followed by a white ghost. A negative ghost (see Figure 150) can be caused by reflected signals which arrive at the TV antenna in such phase as to cause partial or complete cancellation of portions of the video modulation envelope. These can be caused by re-radiation

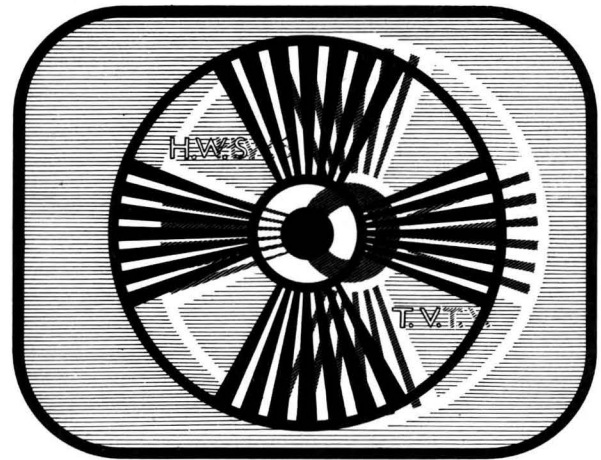

Fig. 150. Negative Ghost Caused by Partial Cancellation of the Carrier.

of the carrier from metal objects which are of a size comparable to the wavelength of the video carrier frequency affected. A similar effect can be caused by defects in the video amplifier. (See Figure 230.)

Elimination of ghost images, or their reduction to such a point that they are no longer objectionable, is accomplished by making use of the directional properties of certain types of antennas. The theory and application of such antennas will be covered later in this section.

In certain urban locations the receiving location is shielded by buildings from a direct line-of-sight signal from the transmitter. In this case, one of the reflection paths will often produce a stronger signal than the "shadow" of the direct path. The antenna, in this case, is "beamed" to accept or favor the strongest reflected signal. The dominant reflection is then considered to be a "substitute" primary signal, and the direct path produces a ghost which must be suppressed.

**GHOSTS DUE TO REFLECTIONS IN THE LEAD-IN OR TRANSMISSION LINE.** The resonant type of antennas employed for television require a special type of lead-in. This lead-in or transmission line consists of either a "parallel wire" line, a "twisted pair" line, a shielded "twisted pair" line or a "coaxial" (concentric) cable.

The reasons for these special types of lead-ins are twofold: to transfer the maximum



amount of energy from the low impedance type antenna to the first tube input in the receiver, and to restrict signal pick-up to the antenna only.

Maximum energy transfer of the intercepted signal from the antenna to the input amplifier of the television receiver requires that the "characteristic impedance" of the line be matched to the impedance of the antenna and the impedance of the receiver input circuit. The various types of lead-in constructions and their application will be covered in greater detail later. At present we will consider the effect of line mismatch in the production of ghost images.

When the impedance of the transmission line is considerably different from that of the antenna or the receiver input, energy will be reflected from the receiver, back to the antenna, and back to the receiver again. This will produce a ghost image when the reflection reaches the receiver. Unless the mismatch is of considerable degree, only one secondary or ghost image will be produced.

In the case of ghost images caused by line mismatch only a small displacement of the image occurs due to the relatively short length of the lead-in in the transmission line. If the length of the lead-in is less than 70 feet, the ghost will be so close to the main image that the eye cannot distinguish it as a separate image. The horizontal resolution is impaired in this case and the image appears to be improperly focused.

It is possible to distinguish between a ghost image due to line reflection and one due to reflection by some object. If an assistant rotates the antenna while the service technician watches the image, it will be found that a ghost due to line mismatch will not change. If, on the other hand, the ghost is due to a reflected path it will change in intensity with respect to the main image, due to the directional characteristic of the antenna.

**THE HALF WAVE DIPOLE AS A TELEVISION RECEIVING ANTENNA:** Having reviewed the nature of wave propagation and some of the basic phenomena of transmission of television signals, we are prepared to examine the types of antennas which have been developed to cope with the problems encountered.

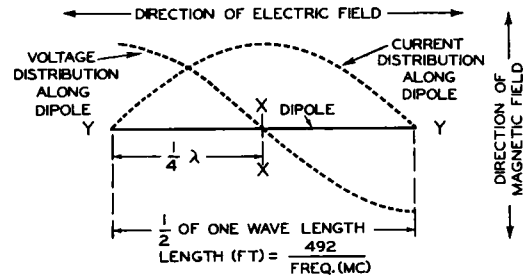

A. A THEORETICAL DIPOLE (A VERY THIN WIRE ISOLATED IN SPACE) LENGTH EQUALS HALF OF CARRIER WAVE LENGTH.

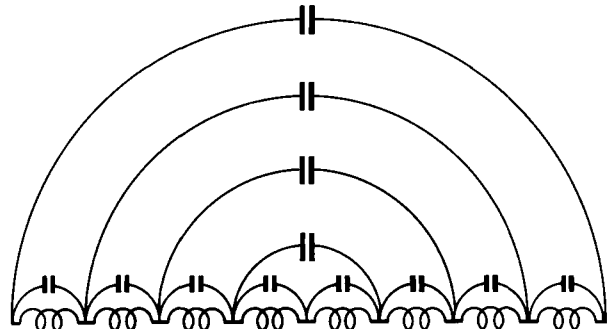

B. ELECTRICAL CIRCUIT EQUIVALENT OF THE DIPOLE.

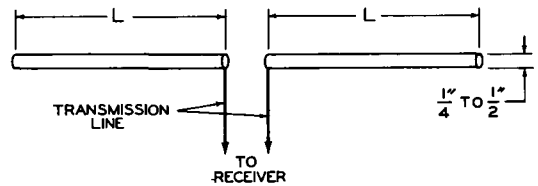

C. A PRACTICAL RECEIVING DIPOLE. (5% SHORTER THAN  $\lambda$ )

$$2L = \frac{1}{2} \text{ WAVELENGTH} \times .95$$

$$L (\text{FT}) = \frac{234}{\text{FREQ. (MC)}}$$

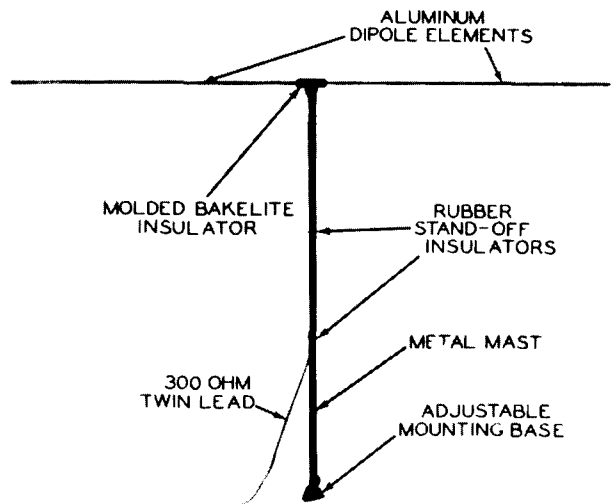

D. COMMERCIAL FORM OF DIPOLE ANTENNA

Fig. 151. The Half-Wave Dipole Antenna. (Photo Courtesy Ward Products Corporation)

Since the advent of commercial television in the United States, there has been no single phase of television development which has seen more concentrated activity than the search for types of antennas to meet the requirements. Among the desirable characteristics are: more uniform response or higher pickup and sharper directional pattern. As this course is being written, new antenna designs are appearing daily and the present study will cover basic types and some of the variations which have found widespread use up to this time. The television service technician will undoubtedly find many technical articles on further antenna developments appearing in the radio press from now on.

Practically all types of antennas used for television reception are variations of the basic half-wave dipole or "Hertzian doublet". An understanding of the action of this "resonant" type will help in the study of more complicated "arrays". The basic nature of the half-wave doublet is indicated by the fact that it is used by the industry as a standard against which the efficiency of other types is compared.

Figure 151A shows the concept of a half-wave dipole in space. If such an antenna is made of very small wire, and could be far removed from the influence of the earth, its resonant electrical length would be equal to its physical length. This length in turn would be one half of the wavelength of the electromagnetic wave in space.

Although Figure 145 shows the electric and magnetic fields as fixed uniform lines, it is to be understood that both of these fields are varying in intensity at a sine wave rate. Thus, a varying magnetic field will induce an alternating flow of electrons in the dipole wire and a wave of current will pass down the dipole to its end. At the end, reflection will occur and a "standing" wave will build up along the wire having the voltage and current distributions shown in Figure 151A. Since the length of the theoretical dipole of Figure 151A is exactly equal to one wave in space, the build-up of voltage along the wire and the current through it will reach a resonant condition similar to that found in a parallel tuned circuit. Actually, the dipole may be considered as such a tuned circuit, but in this case the inductance is "distributed" along the length of the wire and the capacitance consists of many elements across the individual small inductances. This

tuned circuit equivalent is shown in Figure 151B.

The foregoing discussion has been concerned with an hypothetical or theoretical dipole which could never exist in actuality since it requires that the dipole wire be infinitely small in diameter compared with its length, and that the dipole is positioned at a distance so far from surrounding objects, including the earth itself, that no influence of such objects exists. In practice, the dipole must be erected within a few wavelengths of ground and must be physically large enough in diameter to be self-supporting. Both of these requirements cause the velocity of wave travel in the practical dipole to be less than the speed of electromagnetic waves in free space.

While the actual length of the dipole, for resonance, will vary slightly depending upon the proximity of other objects, it has been found that a good average figure for the reduction in length, due to the proximity effect, is 5%. Or, in other words, the half wave length value obtained from the formulas of Figure 148 should be multiplied by .95 to find the length of the required dipole for any given frequency. A practical dipole formula is found in Figure 151C, and a commercial dipole antenna for installation on a roof is illustrated by the Figure 151D.

The dipole produces the greatest current when it is parallel to the electric field of the wave front. In other words, a line drawn from the receiving location to the transmitter should be at right angles or perpendicular to the length dimension of the dipole. As the dipole is rotated with respect to the distant transmitter, its response varies in the manner shown in Figure 152A. A curve of this type is known as a "polar" response diagram. The relative response at different angles away from the "normal" or maximum response position, is determined by taking the ratio of the length of the radius at any point to the maximum radius, or line A-A.

The response curve of Figure 152A represents a cross section taken in the plane of the antenna. The response to waves arriving from the sky or reflected from the ground at any angle is determined by the solid figure obtained by rotating curve 152A around the axis X-Y as shown in Figure 152B. This solid figure is seen to be "doughnut shaped".

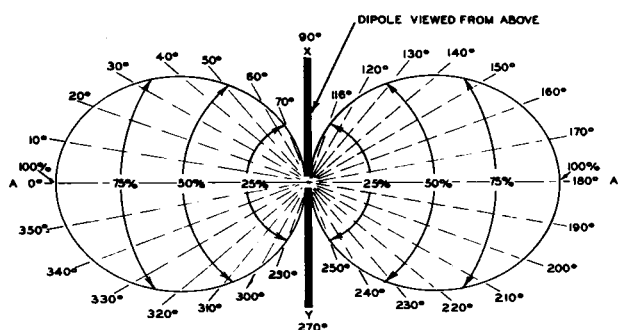

A. RECEPTION PATTERN OF A HALF WAVE DIPOLE SHOWING RELATIVE RESPONSE VERSUS DIRECTION

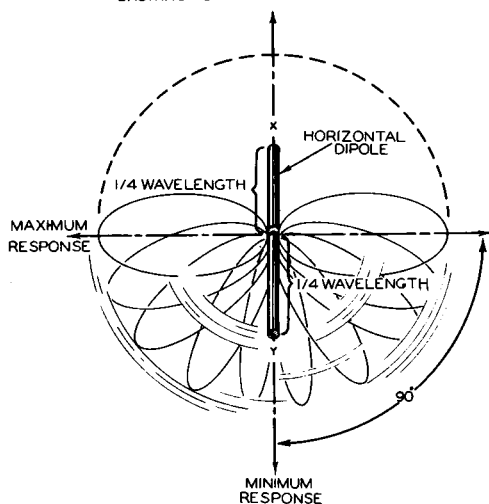

B. "SOLID" PATTERN IN SPACE - HALF-WAVE DIPOLE

Fig. 152. The Reception Pattern in Space of a Half-Wave Dipole

It is also seen from the reception pattern (Figure 152A) that the simple dipole is "bi-directional", and will receive equally well from the front or rear, but shows practically no response at right angles or in line with the length of the dipole. This directional characteristic is of value when it is desired to discriminate against spurious reflection objects which would produce ghosts in the television picture. The simple dipole is a satisfactory television receiving antenna in locations in which the signal strength is high, only one station (or stations close to each other in frequency assignment) is to be received, and in which the multiple reflection or ghost problem is not severe.

If greater directional selectivity or more signal pick-up is required, the pattern of the simple dipole, and its response, can both be improved by the use of additional elements known as "reflectors and directors". The use of these elements, in more complicated an-

tenna structures or "arrays", will be covered in detail later.

The impedance of the simple half-wave dipole at its center is approximately 72 ohms and, for maximum energy transfer, the lead-in or transmission line should have a characteristic impedance of this value. Such value of impedance is rather low and is best suited to the coaxial type transmission line. It is found that the mismatch of the antenna to the transmission line can vary as much as two to one without serious loss in the signal and without the production of disturbing ghosts, providing the line is appropriately matched to the receiver input. This means that transmission lines having impedances between 36 ohms and 144 ohms can be used with the half-wave dipole.

The simple half-wave dipole is most efficient when its length is correct for a particular carrier frequency. If several stations in adjacent television channels are to be received with a simple antenna, its length should be made correct for the geometric mean of the lowest and highest channel frequencies required. For example, if a station on channel three (video carrier frequency 61.25mc), and a station on channel six (video carrier frequency 83.25mc) are to be received with approximately equal antenna response, the dipole should be made the correct length for the geometric mean of these frequencies, i. e.:  $\sqrt{61.25mc \times 83.25mc} = 71.4mc$ . Each dipole section would thus be 234 divided by 71.4, or 3.28 feet long (3 feet - 3-3/8 inches).

**THE FOLDED DIPOLE.** If two half-wave dipoles are placed closely parallel to each other with their ends connected, the received currents will be "in phase". The effect of the reaction of one dipole upon the other is to increase the impedance at the center of either dipole from 72 ohms to approximately 300 ohms. Figure 153A shows such a folded dipole with the formula for calculating the required dimensions. The folded dipole possesses several advantages over the simple single half-wave dipole:

1. Its higher impedance provides an ideal match for the popular polyethylene insulated parallel, or twin-lead, flat strip, transmission line. The most popular type of this lead-in has a characteristic impedance of 300 ohms, and the majority of television receivers

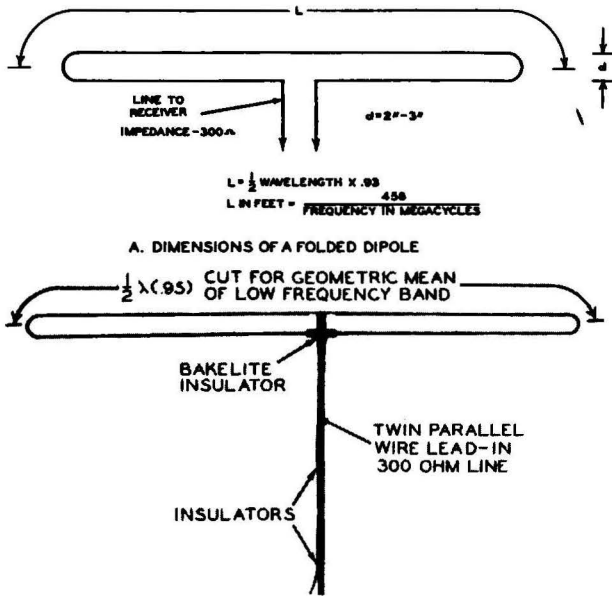

Fig. 153. The Folded Dipole. Photo Courtesy Ward Products Corporation

are designed to match a 300 ohm transmission line.

2. The folded dipole is receptive to a wider frequency band than the simple half-wave dipole, but possesses the same directional pattern.

3. Because of its design, it has a more rigid structure and will withstand greater wind pressure. Figure 153B shows a commercial form of such a folded dipole.

ANTENNA STRUCTURES EMPLOYING THE DIPOLE WITH REFLECTORS AND/OR DIRECTORS - "YAGI ARRAYS": If a second half-wave dipole is placed parallel to and closer than a half-wave length from the receiving dipole, the magnetic and electrostatic fields of this element will modify the directional pattern of the receiving dipole and also increase its effectiveness or gain, compared with the performance of the dipole alone. When such a "parasitic" element is placed behind the receiving dipole, i. e., on the side away from the transmitter, it is known as a "reflector" element. If, on the other hand, it is placed on the side of the dipole toward the transmitter, it is known as a "director". When employed as a reflector the element is made approximately 5% longer than the receiving antenna, and when employed as a director it is made about 4% shorter than the dipole.

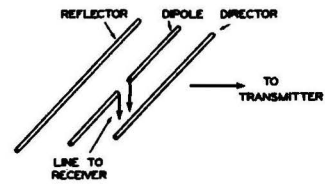

A. DIPOLE WITH DIRECTOR AND REFLECTOR

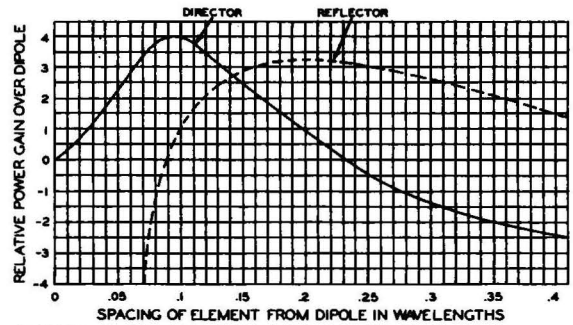

B. EFFECT OF DIRECTOR AND REFLECTOR SPACING ON GAIN OF PARASITIC ARRAY.

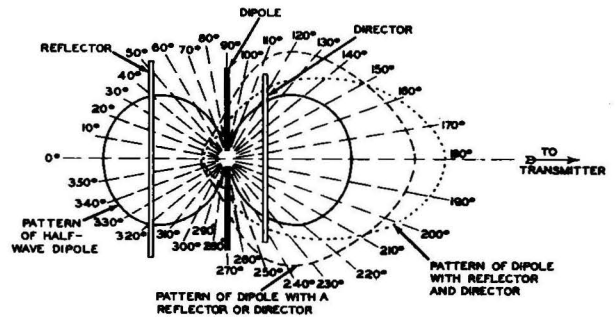

C. TYPICAL RECEPTION PATTERNS OF A DIPOLE WITH DIRECTOR AND REFLECTOR ELEMENTS SINGLY OR IN COMBINATION.

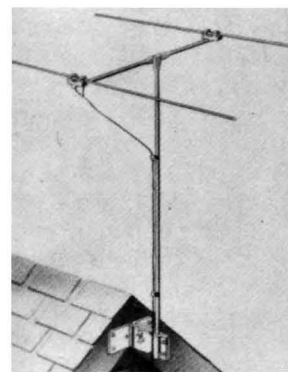

D. DIPOLE WITH REFLECTOR

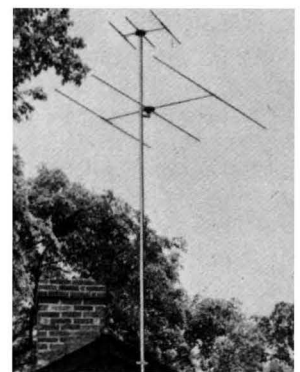

E. DIPOLE ARRAYS WITH DIRECTORS AND REFLECTORS SEPARATE FOR EACH BAND

Fig. 154. The Dipole Antenna with "Parasitic" Elements (Directors and Reflectors) (D) Courtesy L. S. Brach Manufacturing Corporation. (E) Courtesy Workshop Associates

This is equivalent to saying that the reflector is tuned to a frequency somewhat lower than the operating frequency and that the director is tuned to a slightly higher frequency. Figure 154A shows the arrangement of the dipole with a director and a reflector. The effect of the spacing of these elements on the power gain of the dipole antenna is shown in Figure 154B.

Figure 154C compares the directional pattern and gain of the dipole alone, with a dipole using either a reflector or a director and also with a dipole using both a reflector and a director. It will be seen that the gain in the desired direction (toward the transmitter) is increased by these additional elements, and the directional pattern is made sharper so that stations at other points of the compass are not received with the same strength. For this reason, arrays of this type are beneficial in increasing the pick-up from the desired station and, at the same time, suppressing reflection paths which would produce ghosts.

These multiple element arrays are sometimes called "Yagi", since a Japanese by that name first proposed their use as directional antennas.

Arrays with directors and reflectors, while constituting an improvement over the dipole from the standpoint of pattern and gain, will not accept as wide a frequency band as the simple dipole or folded dipole. It is often necessary to erect a number of these antennas tuned to various stations in the band. Figure 154D illustrates a dipole with reflector, while Figure 154E shows two sets of arrays on a single pole. The lower array is used for the low band of television frequencies, i. e., channels two through six; and the upper array of smaller size is used for channels seven through thirteen.

If increased gain and directivity are required, additional director elements can be added and arrays with as many as five elements are often employed for the reception of a single station, when the receiving location is at the edge or fringe of the service area. Several such arrays will be illustrated when we discuss fringe reception. When five elements are used (a reflector and three directors added to the dipole) the antenna will accept only a single channel, and may not adequately cover the entire six megacycle band required for the channel.

EQUATIONS FOR DIPOLE ANTENNA ARRAY DIMENSIONS	
Length of Dipole Element in Feet =	$\frac{468}{\text{Frequency (Megacycles)}}$
Length of Reflector Element in Feet =	$\frac{492}{\text{Frequency (Megacycles)}}$
Spacing of Reflector Element in Feet = (.15 wavelength)	$\frac{148}{\text{Frequency (Megacycles)}}$
Length of Director Element in Feet =	$\frac{450}{\text{Frequency (Megacycles)}}$
Spacing of Director Element in Feet = (.1 wavelength)	$\frac{984}{\text{Frequency (Megacycles)}}$

DIMENSIONS FOR DIPOLE ELEMENTS						
Channel Number	Channel Freq. Mc.	Dipole Length	Reflector Length	Spacing of Reflector	Director Length	Spacing of Director
2	54-60	8ft. 5-3/8in.	8ft. 10-7/8in.	2ft. 8-1/8in.	8ft. 1-3/4in.	1ft. 5-3/8in.
3	60-66	7ft. 7-3/4in.	8ft. 3/8in.	2ft. 3-3/4in.	7ft. 4-1/4in.	1ft. 7-1/4in.
4	66-72	6ft. 11-1/2in.	7ft. 3-7/8in.	2ft. 2-5/8in.	6ft. 8-3/8in.	1ft. 5-1/2in.
5	72-78	6ft. 3/4in.	6ft. 4-1/2in.	1ft. 11in.	5ft. 10in.	1ft. 1-1/2in.
6	82-88	5ft. 7-1/2in.	5ft. 10-5/8in.	1ft. 9-1/4in.	5ft. 4-7/8in.	1ft. 2-1/8in.
7	174-180	2ft. 8in.	2ft. 9-5/8in.	10-1/8in.	4ft. 6-3/4in.	6-3/4in.
8	180-186	2ft. 8in.	2ft. 8-1/2in.	9-3/4in.	2ft. 5-3/4in.	6-1/2in.
9	186-192	2ft. 9-3/4in.	2ft. 7-1/2in.	9-1/2in.	2ft. 4-3/4in.	6-1/4in.
10	192-198	2ft. 5in.	2ft. 6-1/2in.	9-1/4in.	2ft. 4in.	6-1/8in.
11	198-204	2ft. 4-1/8in.	2ft. 5-5/8in.	8-7/8in.	2ft. 3-1/8in.	5-7/8in.
12	204-210	2ft. 2-3/4in.	2ft. 4-3/4in.	8-5/8in.	2ft. 2-1/4in.	5-3/4in.
13	210-216	2ft. 2-5/8in.	2ft. 4in.	8-3/8in.	2ft. 1-1/2in.	5-5/8in.

Fig. 155. Equations for the Dimensions of Practical Dipole Arrays

Figure 155 shows in tabular form the formulas for the length of dipole elements and the optimum spacing of these elements for each channel.

The following table shows the effect on the power gain of the array, as compared with the half-wave dipole used alone, and the ratio of forward reception to that of the reverse side of the antenna. These figures depend upon the care with which the system is adjusted. This is especially true with respect to the front-to-back ratio, in which the highest values are obtained only at the frequency to which the system is tuned.

Number of Elements	Power Gain (Compared to Dipole)	Front-to-Back Reception Ratio
2	2.5	10/1 to 30/1
3	3.6	30/1 to 300/1
4	5.0	100/1 to 1000/1

**THE BROADBAND PROBLEM.** The half-wave dipole and arrays employing half-wave elements are most efficient at the frequency for which they have been cut. Satisfactory performance is obtained with such antennas when only one station serves the area, or when relatively high signal strength exists for several stations in the same television band. When reception of stations in both the low band (54mc to 88mc) and the high band (174mc to 216mc) is required, antenna structures of wider frequency response are necessary.

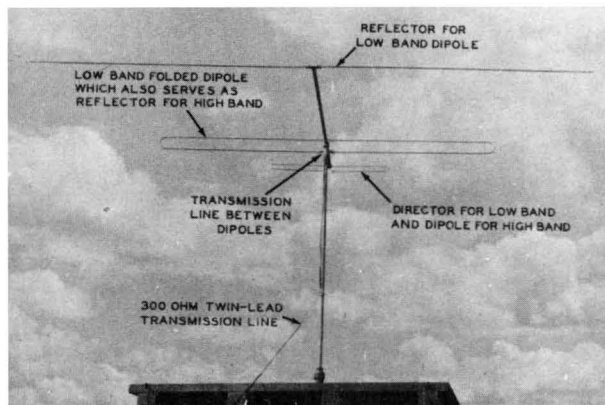

Fig. 156. Antenna Array of Folded Dipoles for Reception on Both Bands. Photo Courtesy American Phenolic Corporation

The folded dipole exhibits the broadest frequency response of any of the types of television antennas discussed to this point. Figure 156 shows a combination of folded dipoles which provide reception in both bands as well as directional discrimination.

In the low frequency band, this antenna acts as a three-element array in which the larger folded dipole is the receiving antenna, backed by a reflector, and the smaller folded dipole is properly positioned to act as a director. In the high frequency band, the small folded dipole functions as the antenna and the large dipole behind it acts as a reflector. The two dipoles are connected to each other at their center (high current) points, by the proper length of twin-lead transmission line, so that a transition of operation occurs between the two bands. An additional feature of this array, as determined by the size of the elements and their spacing, is a low efficiency in the gap between the two television bands. This gap contains the FM broadcast stations (88mc to 108mc), which constitute a possible source of television interference.

In the following text, means for increasing the bandwidth, other than by use of the folded dipole, are described and illustrated.

A Large Diameter Dipole. A dipole whose diameter is increased with respect to its length has a wider frequency response than the thin rod type. If the dipole is made in the form of a large cylinder, i. e., three to six inches in diameter, its "Q" will be decreased and its response to a band of frequencies

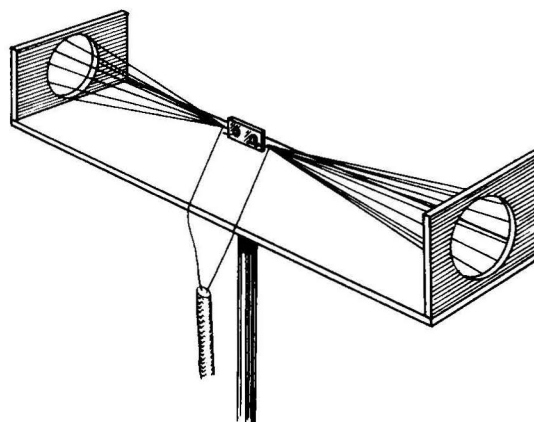

Fig. 157. The "Cage" Antenna, Variation of the Dipole for Wide Band Reception

broadened. Such a cylinder would be awkward to install and would possess a large surface which would be easily damaged by wind. An equivalent of the cylinder can be obtained by constructing a cage of wires with their ends connected to rings.

A Dipole in the Form of a Cone. The cage construction can further be modified to the form of two cones whose apexes meet at the lead-in or feed point. Figure 157 shows such an antenna.

A Modified "Cage" or "Cone". Several dipoles arranged in the form of a fan, and with varying element lengths, will provide a pattern similar to the simple half-wave dipole, but will have broad frequency response characteristics. Figure 158 shows a commercial form of such an antenna, known as the "Di-Fan".

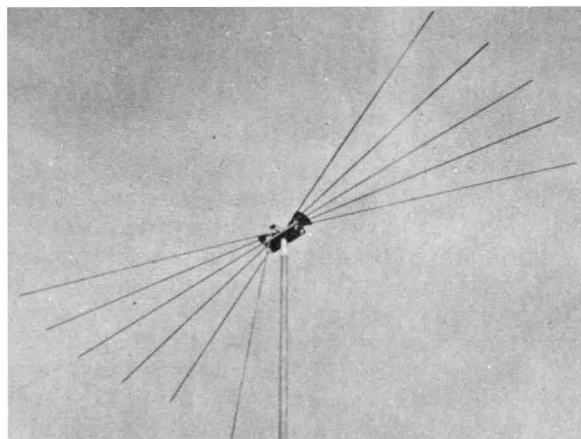

Fig. 158. Broadband Response by a "Fan" of Dipoles. Photo Courtesy Andrew Corporation

A Non-Parallel Dipole. The "V" type antenna, in its simplest form, consists of a dipole whose elements are not in a straight line, but are positioned at an angle of less than 180 degrees (in other words, "V" shaped). The effect of moving the dipole elements from a straight line is to broaden the band and still retain the directional pattern. Figure 159A shows the "V" antenna in its simplest form. Figure 159B shows a modification of the "V" antenna known as the "Double-V" which, due to the parallel operation of the dipoles, shows an increased impedance and matches 300 ohm transmission line.

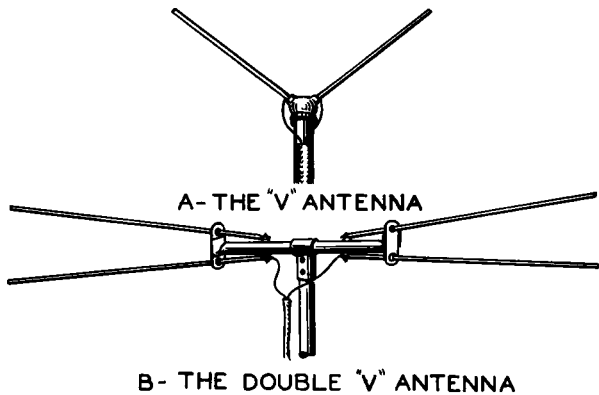

Fig. 159. The "V" and "Double-V" Variations of the Dipole Antenna. (B) Courtesy Technical Appliance Corp.

Special Dual Element Combinations. Dipole combinations, in which the high frequency element is a physical extension of the low frequency element, can be made to exhibit wide frequency response. Many variations of this type of construction are appearing on the market, a number of which are illustrated in Figures 160A, B and C. Such antenna structures can also be used with reflector elements, as shown in Figure 160C. Their characteristics include wide band response, desirable directional patterns, and attenuation of the FM region. Certain of these antennas use balancing transformers, consisting of short lengths of coaxial cable, which aid in matching the transmission line.

"STACKED" ARRAYS. Any type of antenna can be used in a "stacked" arrangement in which a second identical antenna is erected directly above the first and in the same vertical plane. The antennas are positioned at

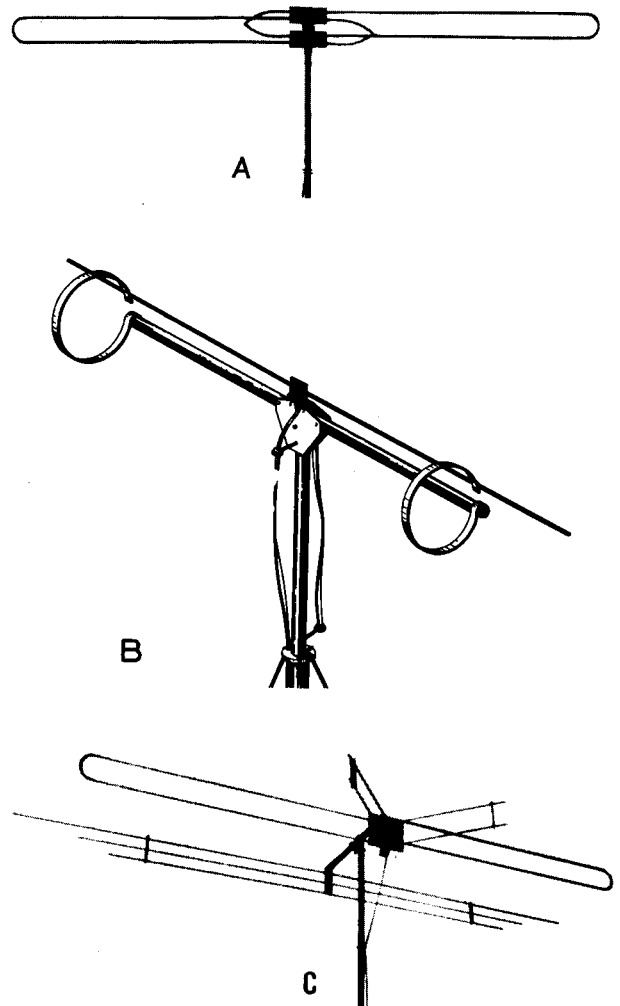

Fig. 160. Dual-Element, Wide Band, Television Antennas. (A) Courtesy Dielectric Products Co. (B) Courtesy Tricraft Products Co. (C) Courtesy L. S. Brach Manufacturing Corp.

a critical spacing (usually one half wavelength), which provides in-phase operation to a common transmission line. The advantages of vertical stacking are twofold.

1. Additional gain is obtained due to the contribution of the added antenna.

2. Some vertical directivity is contributed by the mutual interaction of the antennas which discriminates against a reflected wave from the ground and confines the reception to the direct or sky wave. Figure 161 illustrates several versions of vertically stacked arrays.

ROTATABLE ANTENNAS. From the discussion of multiple path reception difficul-

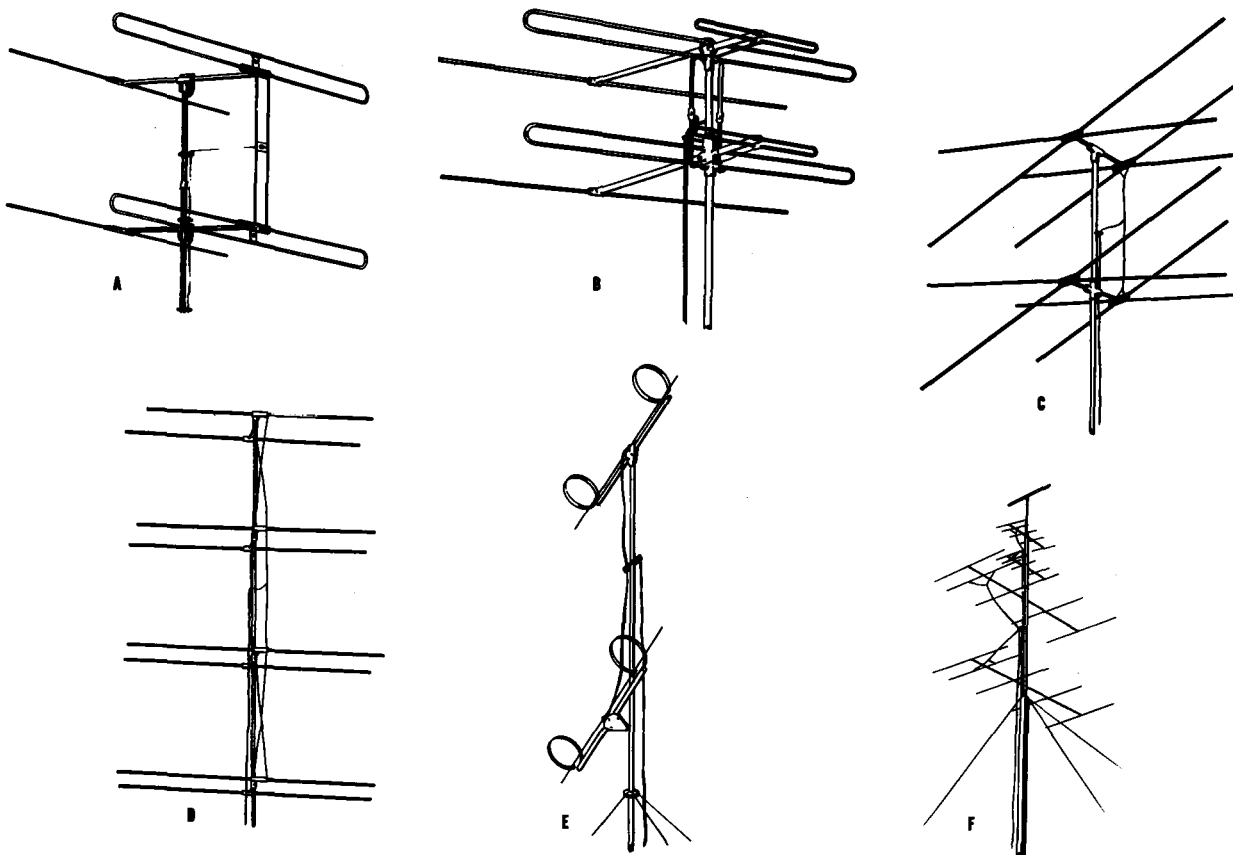

Fig. 161. "Stacked" Arrays for Higher Gain and Improved Directional Pattern. (A) Courtesy Ward Products Corp. (B) Courtesy American Phenolic Corp. (C) Courtesy Telrex Co. (D) Courtesy Cole-Worner Corp. (E) Courtesy Tricraft Products Co. (F) Courtesy Esse Radio Co.

ties, it is evident that a highly desirable feature for a television antenna would be the ability to rotate it to different positions as conditions might require. Figure 162 shows a remotely controlled, motor driven antenna which accomplishes this result. It consists of two half-wave dipoles positioned at right angles to one another. The longer dipole is cut for the average frequency of the low frequency band, while the shorter dipole is tuned to the average frequency of the high band. A motor, housed within the antenna structure, allows rotation of the structure for optimum reception. Motion is accomplished by a control box located at the receiver. Slip-ring construction allows the antenna to be continuously rotated. On alternate 180 degree positions, the mechanism at the base of the antenna automatically switches from one band of TV frequencies to the other.

Other types of rotators are available which provide remote indication of the antenna

position. With these devices the user may "log" the best position of the antenna for any given station, and subsequently return the antenna to the proper position.

THE CORNER REFLECTOR ANTENNA. Figure 163 shows an antenna structure which

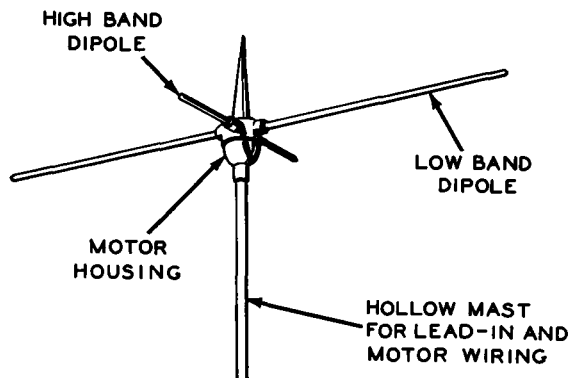

Fig. 162. Motor Driven Remote Control Antenna. Courtesy Kings Electronics.



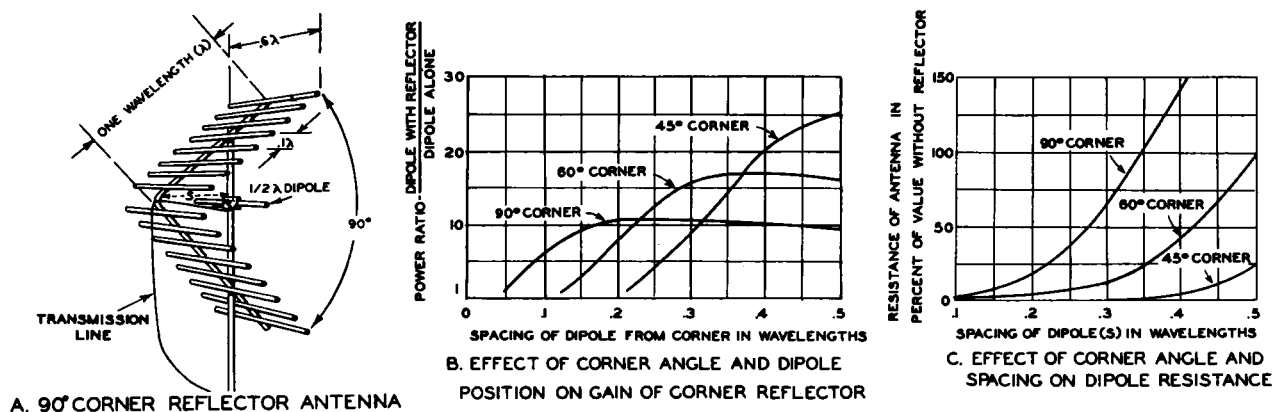

Fig. 163. The Corner Reflector Antenna

is of interest because it has a very high "front-to-back" ratio and greatly increases the pick-up of the dipole.

Its size, weight, and cost are justified in locations of low signal strength, high noise level and excessive interference.

This type of antenna was originally introduced for use in the frequency range known as U. H. F. (Ultra high frequencies), extending from 300 mc to 3000 mc. In this range, the corner reflector is usually made as a solid sheet of metal, since the dimensions of the dipole and the reflector are conveniently small.

When applied to the V. H. F. television region, a solid metal reflector would be exceedingly massive and easily damaged by high winds. It has been found that the solid sheet can be replaced by a "grid" of rods made longer than the dipole element, and spaced closer than .1 wavelength, as shown in Figure 163A.

Figure 163B shows the gain or ratio of power received with the reflector, to power received with the dipole alone - for various spacings of the dipole from the corner, and for corner angles of 90 degrees, 60 degrees, and 45 degrees. Figure 163C illustrates the influence of the corner reflector on the impedance of the antenna. This has been expressed in percentage change of dipole impedance since the corner reflector can be used with any type of dipole.

**TYPES OF TRANSMISSION LINES:** In our discussion of ghosts produced by reflections in lead-in or transmission line, we have indicated

that maximum power transfer and freedom from reflections occur when the transmission line has a characteristic impedance which exactly matches both the antenna resistance and the input resistance of the radio receiver. It is important that the power developed in the antenna structure be transferred to the grid of the first radio frequency amplifier tube with as little loss as possible in order to over-ride noise and produce high-contrast, steady pictures. To accomplish this, four types of lead-ins or transmission lines have been used extensively. These are:

- The Twisted Pair Line.
- The Two-Wire Parallel Line.
- The Coaxial or Concentric Cable.
- The Shielded Two-Wire Parallel Line.

Each of these types exhibits its own particular characteristics of impedance range possibilities and loss or attenuation per foot.

**THE TWISTED PAIR LINE.** This type of transmission line is similar to twisted lamp cord but is made of higher grade insulation and weather proof covering. It is the most economical type of lead-in, but possesses several disadvantages. Its impedance is normally in the range of 100 to 300 ohms, depending upon the size of wire used and the thickness of the insulation. The losses are fairly high and the line is subject to deterioration by weather and dirt. Its use has been supplanted, in most instances, by more efficient types of lines.

**THE TWO-WIRE PARALLEL LINE.** The most popular type of television lead-in consists of two-stranded wires molded parallel to each other, at a uniform spacing, in a flat strip of insulating material. This low-loss material,

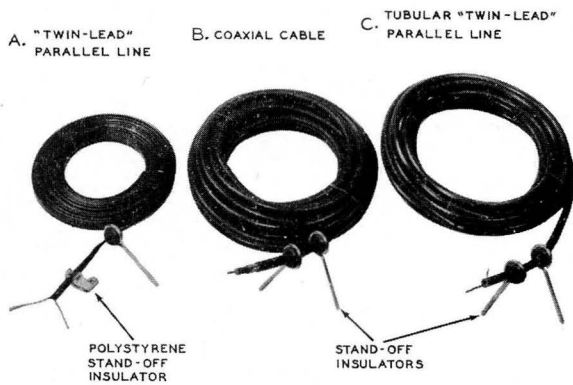

Fig. 164. Typical Television Transmission Lines. Courtesy American Phenolic Corp.

a plastic known as polyethylene, has excellent radio frequency properties including high resistivity, low water absorption and low dielectric constant. It is commercially available in impedances of 75, 150 and 300 ohms, which provide a match for any of the types of antennas discussed. Parallel wire lead-in is available in both clear and brown colored plastic. Each type is equally efficient. The color has been added, in the case of the brown cable, to mask a slight color change which appears with aging of the transparent cable. Figure 164A shows this type of parallel lead-in cable together with two different types of stand-off insulators. Both types of insulators are used to support the cable away from buildings, and to keep it from twisting. The only disadvantage in the use of parallel lead cable is the fact that it is not shielded and therefore can pick up man-made noises from electric equipment and automobile ignition.

A recently introduced variation of this type of parallel line consists of two wires which are molded diametrically opposite one another in the side walls of a hollow plastic tube. The advantages of this construction are: (1) the leakage path has been increased, (2) the dielectric between the wires is substantially in air and, (3) the spacing between the wires (the diameter of the tube) can be smaller for a given characteristic impedance than the width of comparable ribbon type. Its construction decreases the loss per foot and improves the performance, especially in wet weather. Figure 164C shows such a tubular two-wire line together with the stand-off insulators designed to support it.

**COAXIAL OR CONCENTRIC CABLE.** Coaxial cable, as used for television lead-ins,

consists of a flexible conductor molded in the center or axis of a solid polyethylene cylinder. This cylinder is surrounded by a copper braided outer conductor and the entire cable is covered by a weather-proof vinylite sheath. The outer conductor is grounded at the receiver and acts as a shield for the inner conductor. Coaxial cable has the properties of very low loss per foot and freedom from noise pick-up. It is made in characteristic impedances of from 50 to 150 ohms. The impedance is determined by the ratio of the diameter of the outer conductor to the diameter of the inner conductor and, for this reason, impedances higher than 150 ohms would require either a large outer diameter or an extremely small and weak inner conductor. Figure 164B shows a sample of coaxial cable with the various layers cut back to show the construction. The coaxial cable is an unbalanced type of line, and if the receiver is designed for a balanced input with a grounded center tap, it may be necessary to remove the ground connection before connecting the cable.

**SHIELDED TWO-WIRE PARALLEL LINE.** This type of construction is similar to the coaxial cable except that two conductors, equally spaced from the center, are molded in the solid dielectric. Such a line is balanced since the outer conductor is merely a shield and can be connected to ground, while the two inner conductors can be connected to the balanced input of the receiver and to the dipole. The losses per foot are higher than coaxial cable of the same impedance and the impedances, commercially available, are from 40 to 100 ohms. It is especially valuable for short transmission lines in unusually noisy locations.

**TELEVISION RECEPTION IN FRINGE AREAS:** The service area of the television transmitter is normally considered to be a contour in which the signal strength is 200 microvolts per meter, or higher. This contour depends upon a number of factors which include the power of the transmitter, the height of the transmitting antenna, the topography of the land, the effect of shielding by buildings and other structures, and the height of the receiving antenna.

Television reception at points beyond the radio horizon (see Figure 147) is not reliable, and for this reason many of the television manufacturers have restricted the sale of television receivers to areas in which reliable performance can be anticipated. How-

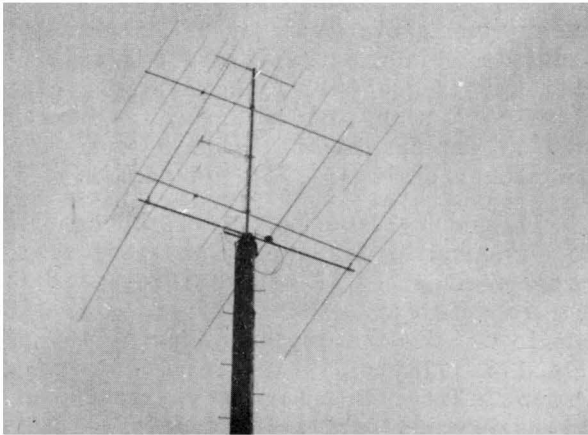

Fig. 165. Multi-Element "Yagi" Antennas. Courtesy Mr. Elmer Tafflinger.

ever, the competitive nature of the radio business, as well as the intense public interest in television, is resulting in the sale of receivers in localities beyond the defined service area of transmitters. The Federal Communications Commission has granted higher power licenses to "rural stations" for service areas larger than metropolitan coverage. Long distance reception is being attempted with these stations. The radio service technician should realize that operation in these fringe areas cannot be guaranteed and is subject to the vagaries of transmission due to weather conditions and other effects, not completely understood. Extensive experimentation is being conducted in fringe areas and the following suggestions are offered for the experimentally minded technician:

1. Highly efficient antenna structures, such as four and five element arrays (see Figure 165), will assist in increasing the signal pick-up. Such arrays are used primarily for a single channel reception.

2. As shown in the nomograph of Figure 147, the radio horizon is increased by additional height at the receiving location. Towers for this purpose are commercially available.

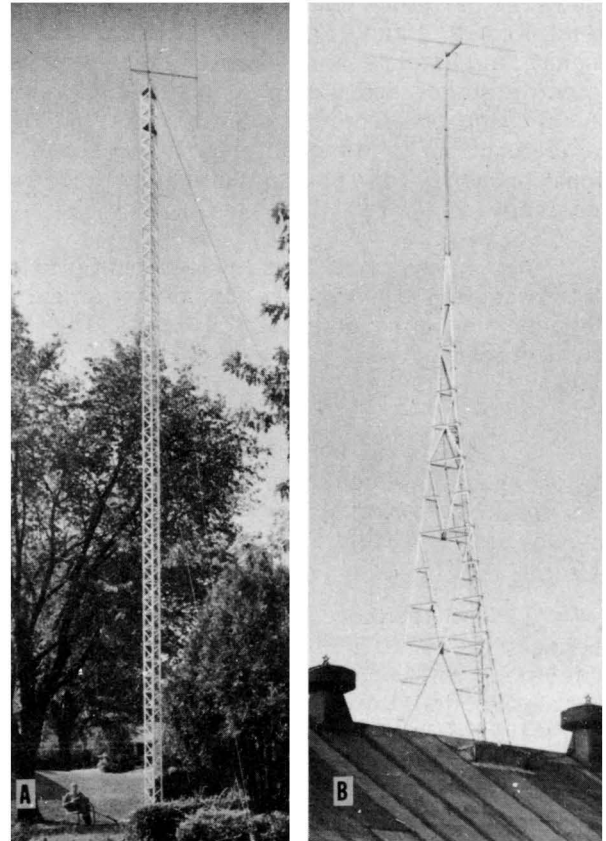

Fig. 166. Special High Tower Assemblies for Fringe Area Reception. (A) Courtesy A-1 Radio Tower Co. (B) Courtesy Wind Turbine Co.

Representative types are shown in Figure 166.

3. Television boosters can provide additional RF gain.

Care should be exercised to insure a sufficiently wide band for reception of the channel. The addition of the selectivity of a "booster" to that of the multi-element array may harm the quality of the received picture. The band width may be restricted to such an extent that the sound channel suffers from attenuation or that picture quality is impaired.

# SECTION III CATHODE RAY — BEAM MODULATION AND SYNCHRONIZATION

## CHAPTER 13. TELEVISION INPUT TUNING SYSTEMS

The RF section of the television receiver, shown in the block diagram of Figure 144 as items Nos. 2, 3 and 4, consists of a radio frequency amplifier stage, a converter or first detector stage, and a local oscillator. This combination of circuit elements performs the same function as its counterpart in a conventional broadcast or short wave superheterodyne receiver.

A number of factors, not encountered in the reception of ordinary broadcast signals, require a more complicated design than is found in standard broadcast sets. Among these are:

1. The broad-band nature of the television channel, which requires the acceptance and amplification of a band of frequencies six megacycles in extent. (See Figures 137 and 139.)

2. The frequency allocation of television channels (54mc to 88mc and 174mc to 216mc), which necessitates special types of coupling circuits to maintain uniform gain at the extremes of the bands.

3. Balanced types of input circuits matched in impedance to the characteristic of available parallel lead or coaxial transmission lines.

4. Rejection of undesired or "spurious" responses, due to radio transmissions outside of the desired television band.

- a. The adjacent channel sound carrier.
- b. Cross modulation due to other television channels.
- c. Direct transmission, through the RF system, of signals at the intermediate frequency.
- d. Images due to other television channels and to FM stations.
- e. Overloading of the input tube due to strong broadcast stations.

5. Radiation of local oscillator energy by the antenna. Such radiation must be suppressed to prevent interference with neighboring television receivers.

Television RF input systems can be classified in several different ways, according to the mechanical means of channel selection,

or the type of electrical circuit employed. From the standpoint of mechanical arrangements, tuning systems may be grouped as, (a) continuous tuning systems (see Figures 167 and 169), and (b) step tuning systems: rotary switch selection, push button switch selection, and mechanical detent, or turret construction. (See Figures 171, 173, 176, 178 and 180.)

From the standpoint of listing according to electrical circuit, input systems may be broadly classified as balanced to ground (see Figures 172 and 181), or unbalanced (with single ended circuits), (see Figures 168, 170, 174, 175, 177, and 179). Another method of grouping, from the standpoint of circuit design, is possible:

1. Lumped equivalent of quarter-wave transmission line. (Figure 172.)

2. Circuits with a variable inductance as the tuning or "trimming" element. (Figures 168, 170, 172, 174, 175, and 177.)

3. Circuits with variable capacitance as the tuning or "trimming" element. (Figures 179 and 181.)

All of the tuning systems illustrated in this section use the post war button base miniature construction. This has not been done primarily for the conservation of space, but rather is due to the fact that these small tubes are much more efficient in the V. H. F. region than their larger metal or "octal" counterparts. Another observation which can be made with respect to the choice of tubes, is the frequent use of three-element types, or triodes, especially in the RF stage. This choice of triodes is of interest since it serves to emphasize phenomena peculiar to operation in the V. H. F. region, coupled with the necessity for broad band (six megacycles wide) response.

At the lower frequencies, and with the modulation envelope extending not more than 10kc either side of the carrier frequency, highly selective circuits of high "Q" are universally employed. The necessity for wide-band response, in the television band, requires the use of low "Q" circuits, or circuits deliberately reduced in efficiency by means of parallel resistors, in order to "broaden" the response. These circuits are, by virtue of their loading, of low impedance (between 1000 and 10,000 ohms).

A pentode is useful as an RF amplifier, in the lower frequency bands, by virtue of the fact that its plate resistance is extremely high and thus high-"Q", high-impedance plate load

circuits can be used. In the television band the necessity for wide band response precludes the use of high impedance circuits and, for this reason, a pentode stage will not develop much more voltage gain than a triode. The triode, on the other hand, exhibits several advantages namely:

1. Appreciably lower tube noise level. This is of extreme importance in the RF stage, where the noise energy, due to electrons in the tube and those circulating in the antenna circuit, may be comparable to the energy of the television signal itself.
2. The inter-electrode capacitances of triodes are lower than comparable pentodes.
3. Triodes are adaptable to grounded grid circuits and provide better stability than pentodes at V. H. F.

We have indicated that a number of methods of classification of input systems are possible. From the standpoint of interest to the radio service technician we have chosen to present our study on the basis of a grouping by the means of tuning or adjustment employed, i. e.: inductively tuned systems, and capacitively tuned systems.

**INDUCTIVELY TUNED INPUT SYSTEMS:** Two general types of continuously variable inductively tuned systems have appeared: The continuously sliding contactor type (Mallory-Ware "Inductuner"), and the sliding powdered iron core type (exemplified by the Belmont multiple core tuner). (See Figures 167, 168, 169 and 170.) Semi-fixed adjustable cores with a rotary switch for channel selection, are used in a number of arrangements. (Figures 171, 173 and 175.)

**CONTINUOUSLY VARIABLE INDUCTIVELY TUNED INPUT SYSTEMS.** Television channel tuning by variable inductance has been accomplished by two distinct methods, namely: inductance variation by sliding electrical contactor and by sliding iron cores.

Tuning by Continuously Variable Contactor Type Inductor. Figures 167A and B illustrate a tuner which is unique in that the inductance of the circuit is made continuously variable. Such a method of tuning is particularly adapted to the V. H. F. range because it makes possible a high ratio of inductance to capacitance and consequently higher circuit

"Inductuner" - Reg. Trade Mark P. R. Mallory & Co., Inc.  
 "Inputuner" - Reg. Trade Mark Allen B. Dumont Lab. Inc.

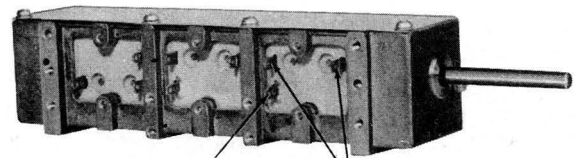

A. BOTTOM VIEW OF "INDUCTUNER"

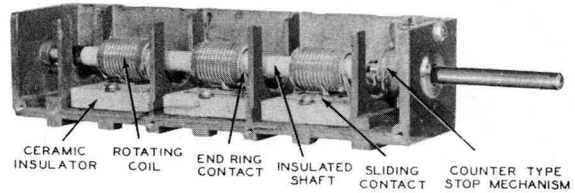

B. TOP VIEW OF "INDUCTUNER" (SHIELD REMOVED)

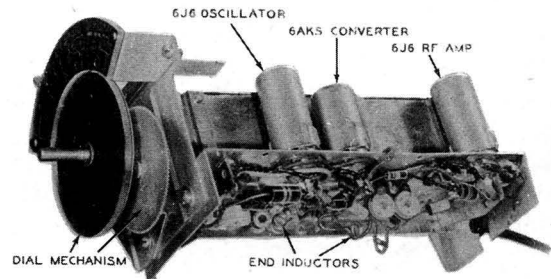

C. INPUTUNER WITH ASSOCIATED CIRCUIT ELEMENTS

Fig. 167. (A) and (B) A Continuously Variable Inductance Tuner for Television Reception. Photo from Sample Courtesy P. R. Mallory & Co., Inc. (C) Input Tuning System ("Inputuner") employing the "Inductuner". Photo from Sample Courtesy Allen B. Du Mont Laboratory, Inc.

impedance at the high frequency end of the range. In this tuner, a sliding contactor made of high silver content alloy, possessing spring properties, rides in "trolley fashion" on an inductor made of "fine" silver wire. End rings on the inductor permit circuit connection to both ends of the inductance. The sliding contactor "shorts" the unused portion of the inductance. The "Inductuner" is a three-gang inductor equivalent to a three-gang condenser, and in the input system shown in Figures 167C and 168, the three units are used as a coupled band pass selector stage and a local oscillator. Coupling elements C5, C7 and the shunt circuit L6-C6, are so proportioned that the acceptance band remains constant at six megacycles width over the entire tuning range of the system. The tuning range extends continuously from 44 to 216 megacycles and includes not only the television channels but also FM stations, two amateur bands, aviation channels, V. H. F. radio telephone and commercial services. A

CATHODE-RAY - - BEAM MODULATION AND SYNCHRONIZATION

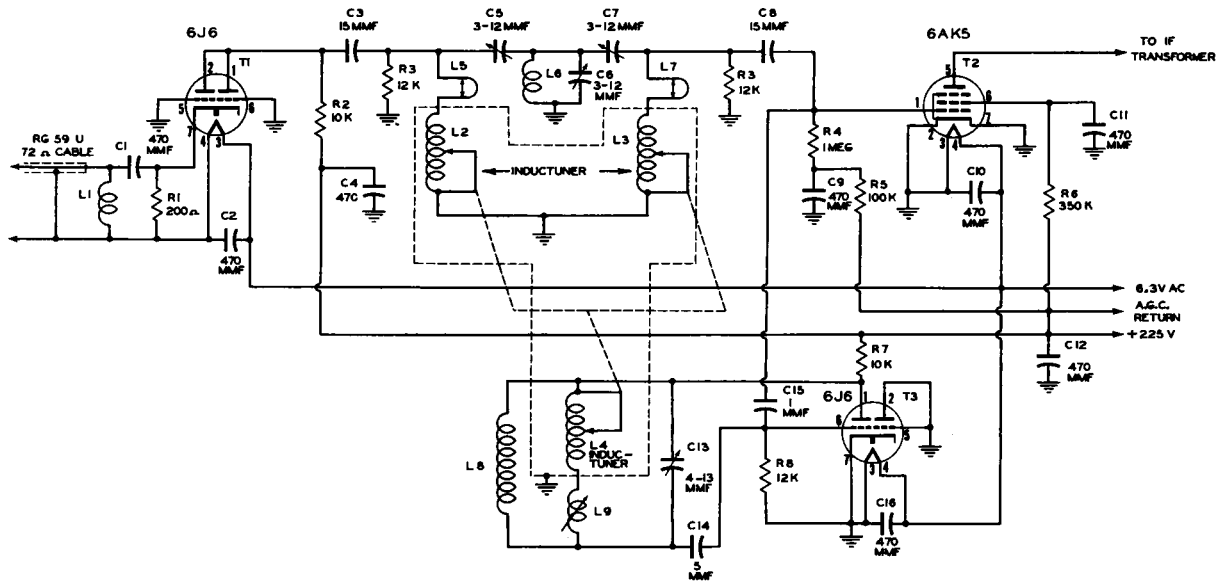

Fig. 168. Schematic of Inductively Tuned Input System Illustrated in Figure 167.

unique dial arrangement shown in Figure 167C makes it possible to use the television receiver for the reception of the high band FM as well as the assigned television channels.

Adjustable end inductors L5, L7 and L9 of Figure 168 perform the same function circuit-wise as the high frequency trimmers of the variable gang condenser. The oscillator circuit shunt inductor (L8) is equivalent to the series "padder" of the conventional superheterodyne oscillator circuit. Since inductors L5 and L7, by structure, possess a higher "Q" than the "Inductuner" itself, performance of the system is improved as the high frequency end is approached. A continuously variable, capacitively tuned system, on the other hand, would suffer in "Q" at the high frequency end of the tuning range.

The circuit of Figure 168 introduces to the television service technician a method of vacuum tube operation, which was introduced during the second World War, known as "grounded grid". Tube T1 is connected so that the signal voltage is introduced between cathode and grid, with the grid connected to ground. Such a connection is of advantage for two reasons: the grid acts as a shield between the input and the output of the tube, to suppress feed-back, or a tendency toward oscillation; injection of the input voltage in the cathode circuit allows a broad band "match" to low impedance parallel lead or coaxial transmission lines. Inductor L1 performs a dual

function. It acts as a low pass filter to short-circuit voltages which might be caused by nearby broadcast stations in the 550kc to 1600kc band, and it is broadly resonant to the television band since it is tuned by the cathode-to-ground capacitance of the tube and the associated circuit wiring. This tuning prevents the cathode-to-ground capacitance from decreasing the input impedance of the circuit.

The television service technician will recognize other features of the schematic diagram of Figure 168 as similar to the input systems of lower frequency entertainment receivers. The injection of local oscillator voltage by capacitance coupling between the oscillator and the control grid of the converter tube is a conventional method in the V. H. F. television region.

Continuously Variable Tuning by Powdered Iron Cores. Figure 169 shows a tuning system in which a special type of high frequency powdered iron core is used to change the value of the tuned circuit inductances. This permits selection of television channels on both the low and high frequency bands. In this case, a separate set of inductors and sliding cores are used for each band and electrical switching accomplishes transfer from one band to the other. Figure 170 shows the electrical circuit employed for this input system. Since tuning is continuous, both in this circuit and that of Figure 167, it is not necessary to provide separate fine tuning control. The tuning adjust-



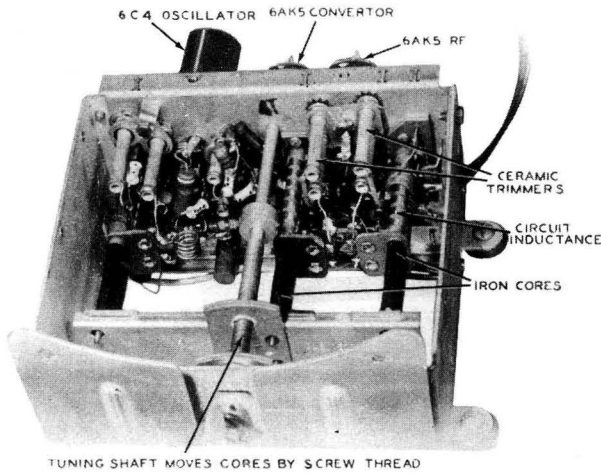

Fig. 169. A Variable Inductance Tuner Employing Movable Powdered Iron Cores. Photo from Television Receiver Courtesy Belmont Radio Corp.

ment is set for optimum performance of the sound channel and this automatically assures a proper setting for the video or picture carrier.

The antenna primary coils, L1 and L3, are balanced to ground, with a center tap connected to the chassis-ground. This permits

the use of balanced, parallel-lead transmission line with single ended tube circuits. Both the RF and converter employ the miniature type 6AK5 in pentode connection. Broad band response is obtained by loading the tuned circuits with parallel resistors of low value. In the high frequency band the use of parallel resistors is not required, due to higher circuit losses.

Artificial Line Type of Input Tuner. Figure 171 shows a type of input system which has been employed in many receiver designs. The 6J6 twin triode is used and push-pull operation is employed in each stage. The artificial equivalent of a quarter-wave transmission line, made up of a series of inductors with their associated distributed capacitances, is employed in the RF, converter, and oscillator circuits to perform the functions usually associated with "lumped" tuned circuits. These lines are balanced with respect to the chassis or ground. Tuning of the various television channels is accomplished by switching a "short circuit" progressively along the "line".

An understanding of the operation of this type of "front end" is essential to the television service technician both because of its

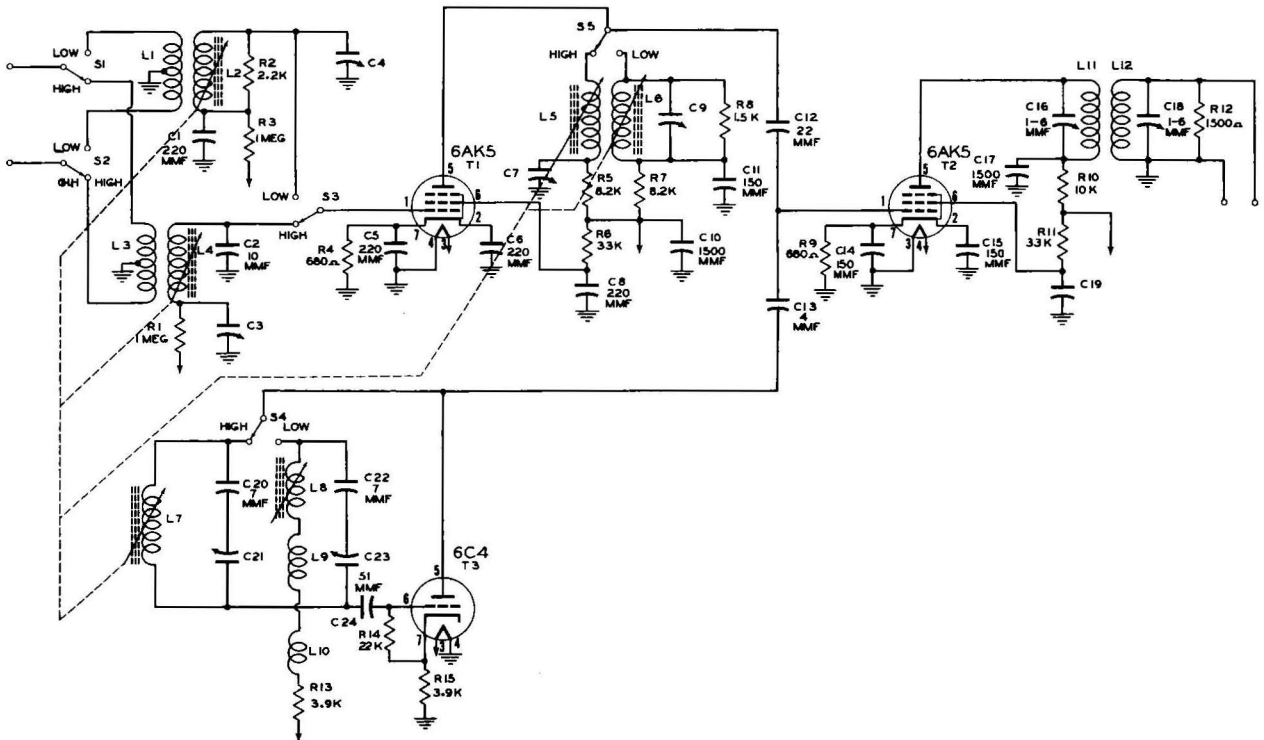

Fig. 170. Schematic of the Iron Core Tuning System Illustrated in Figure 169.

# CATHODE-RAY - - BEAM MODULATION AND SYNCHRONIZATION

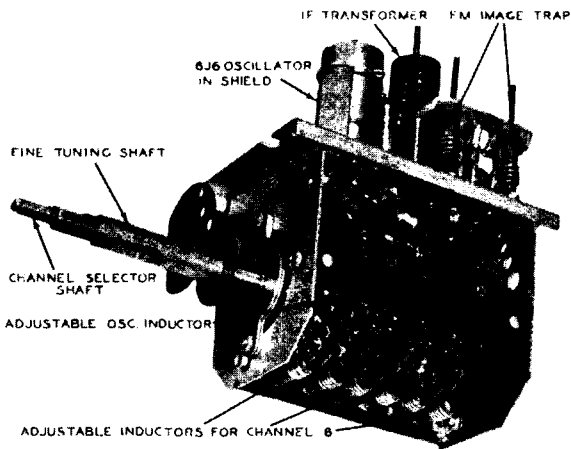

Fig. 171. Input Tuning System Employing "Lumped Equivalent" of Quarter-Wave Transmission Lines. Photo from Sample Courtesy R. C. A.

unusual nature and its frequent use in television receiver design.

The input circuit of tube T1 (see Figure 172), fulfills three distinct functions:

1. Chokes L27 and L28 (center tapped to ground) provide a low frequency bypass for signal frequencies lower than the television band. This prevents cross-modulation effects

in the input tube T1. Important sources of such low frequency interference may be:

- a. 60 cycle pickup from power lines near the television antenna.
- b. Local stations, in the broadcast band.
- c. Local high frequency stations such as police, commercial transmitters, etc.

2. Balanced, series-tuned circuits, L29-C9, and L30-C16, can be adjusted to reject "images" due to local FM stations in the 88mc to 108mc band. Such images would fall on several of the television channels (depending on the IF frequency). Adjustment of inductors L29 and L30 permit reduction of such an image to such a point that it will not affect the picture. Another use for these trap circuits is the elimination of the interference between two television stations in certain areas. In this case the image of a station in the low band group, i. e.: channels 2 through 6, may fall on a station in the high band group, channels 7 through 10. The trap circuits may be adjusted to minimize such interference.

3. Resistors R3 and R4 perform the dual functions of matching the 300 ohm transmission

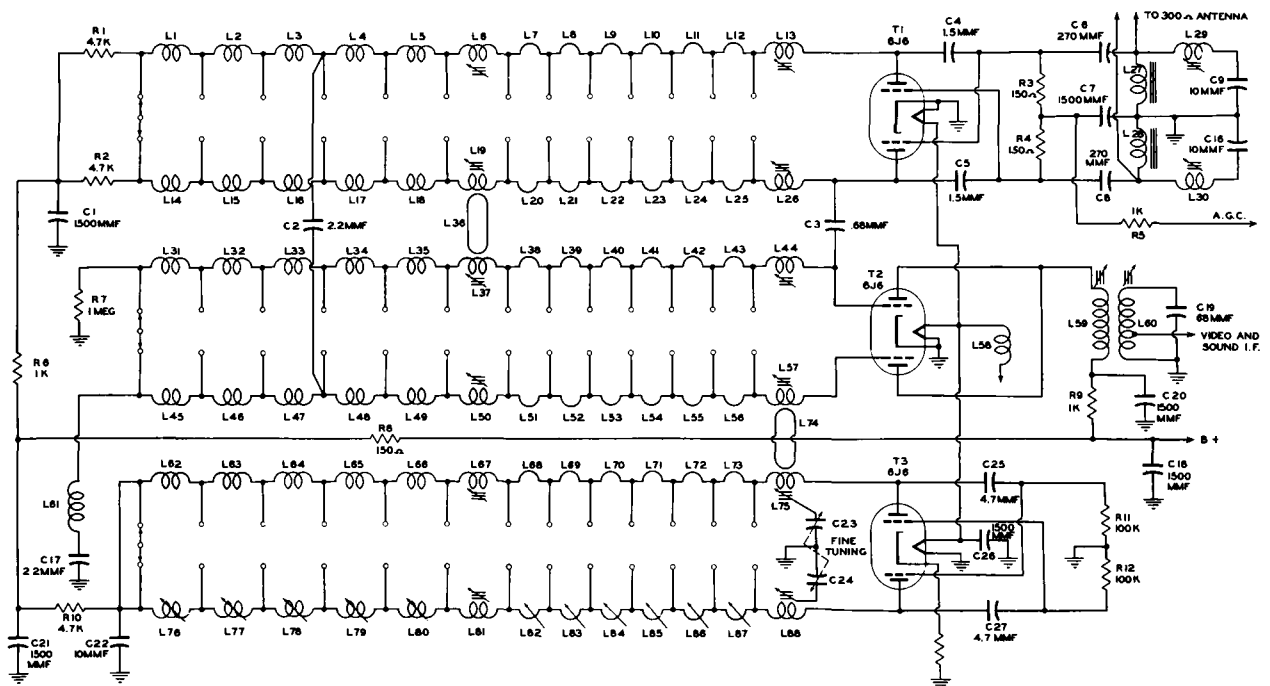

Fig. 172. Schematic Diagram of Tuning System Illustrated in Figure 171.



line to the tube input, and providing a grid return path for automatic gain control, which will be described later.

The RF amplifier tube T1 (6J6) is push-pull connected and "cross neutralized" by means of capacitors C4 and C5. This neutralization increases the stability of the stage by preventing regeneration or oscillation and also reduces the transmission of oscillator energy back through amplifier tube T1 to the antenna.

The plate load of T1 consists of the equivalent of a quarter-wave transmission line, and is made up of inductors L1 through L26. Rotary switch section SW1 "shorts out" sections of the line to tune it to any one of the twelve television channels.

Capacitors C2, C3 and inductive link L36 act as coupling elements between the "line" in the RF plate circuit, and the corresponding "line" comprised of inductors L31 through L57 in the converter grid circuit. The value of these elements is such as to keep the channel width constant over both television bands.

The series-tuned circuit, consisting of L61-C17, is series-resonant at the IF frequency and prevents the direct transmission of interfering signals (short wave broadcast) through the IF amplifier.

The oscillator circuit consists of a transmission line similar to those just described, but with the additional feature that each channel inductance is separately adjustable (see inductors L67, L75 and L76 through L88). The oscillator tube (a push-pull connected 6J6) derives its plate-to-grid feedback, for sustained oscillation, from a crossed pair of capacitors (C25 and C27), whose values are greater than the grid-to-plate capacitance of the 6J6.

Injection of oscillator voltage into the converter grid circuit is accomplished by magnetic coupling between the tuned transmission lines, augmented by the coupling link (L74).

Another input tuning system which employs the quarter-wave resonant line principle is illustrated in Figure 173 and the schematic wiring diagram is shown in Figure 174. In this case, only two lines are employed. Inductors L2 through L25 are used as coupling means between the RF tube, T1, and the converter tube, T2. Inductors L26 through L49 constitute the resonant line for oscillator tuning.

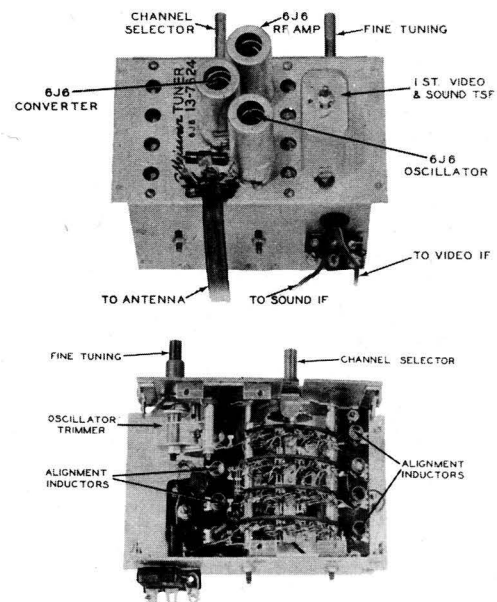

Fig. 173. Another Example of a Quarter-Wave Line Type Input Tuning System. Photo from sample Courtesy Meissner Manufacturing Division, Maguire Industries, Inc.

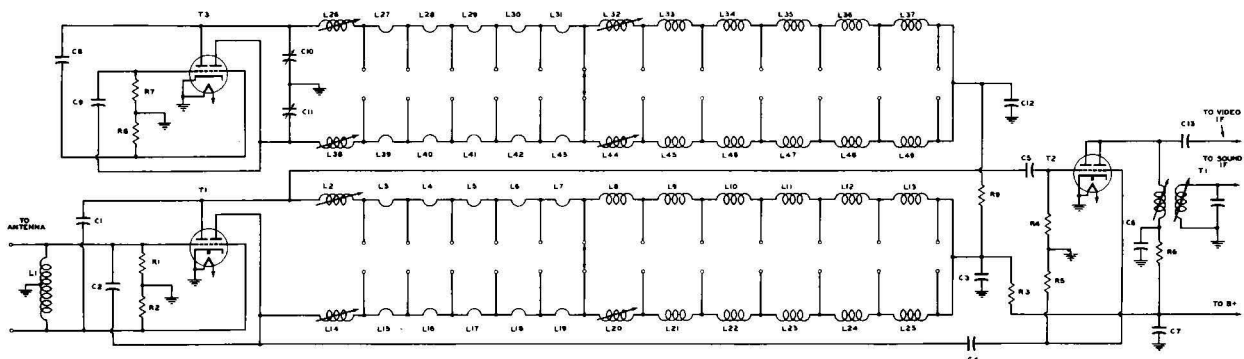

Fig. 174. Schematic Diagram of Tuning System Shown in Figure 173.

# CATHODE-RAY - - BEAM MODULATION AND SYNCHRONIZATION

The antenna input system is balanced to ground. Inductor L1 serves as a low frequency shunt trap and, in conjunction with the circuit capacitance, is broadly resonant to the television bands.

Adjustment of the resonant-lines is accomplished by variation of the inductors associated with channels 6 and 13. Fine tuning is provided by the dual section vernier capacitor C10 and C11.

Input Systems with Switch-Selected Variable Inductors. Figures 175 and 176 show an input system in which a rotary switch is employed to select the proper inductances for tuning to the desired television channel. Several features not previously discussed are evident in this circuit. The input circuit and method of connection of tube T1 constitutes a means of coupling between a balanced-to-

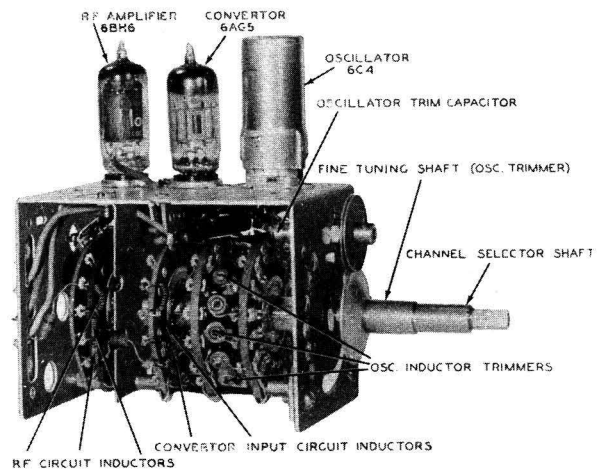

Fig. 175. Input Tuning System Employing Rotary-Switch Selected Inductors. Photo from Sample Courtesy Sarkes Tarzian.

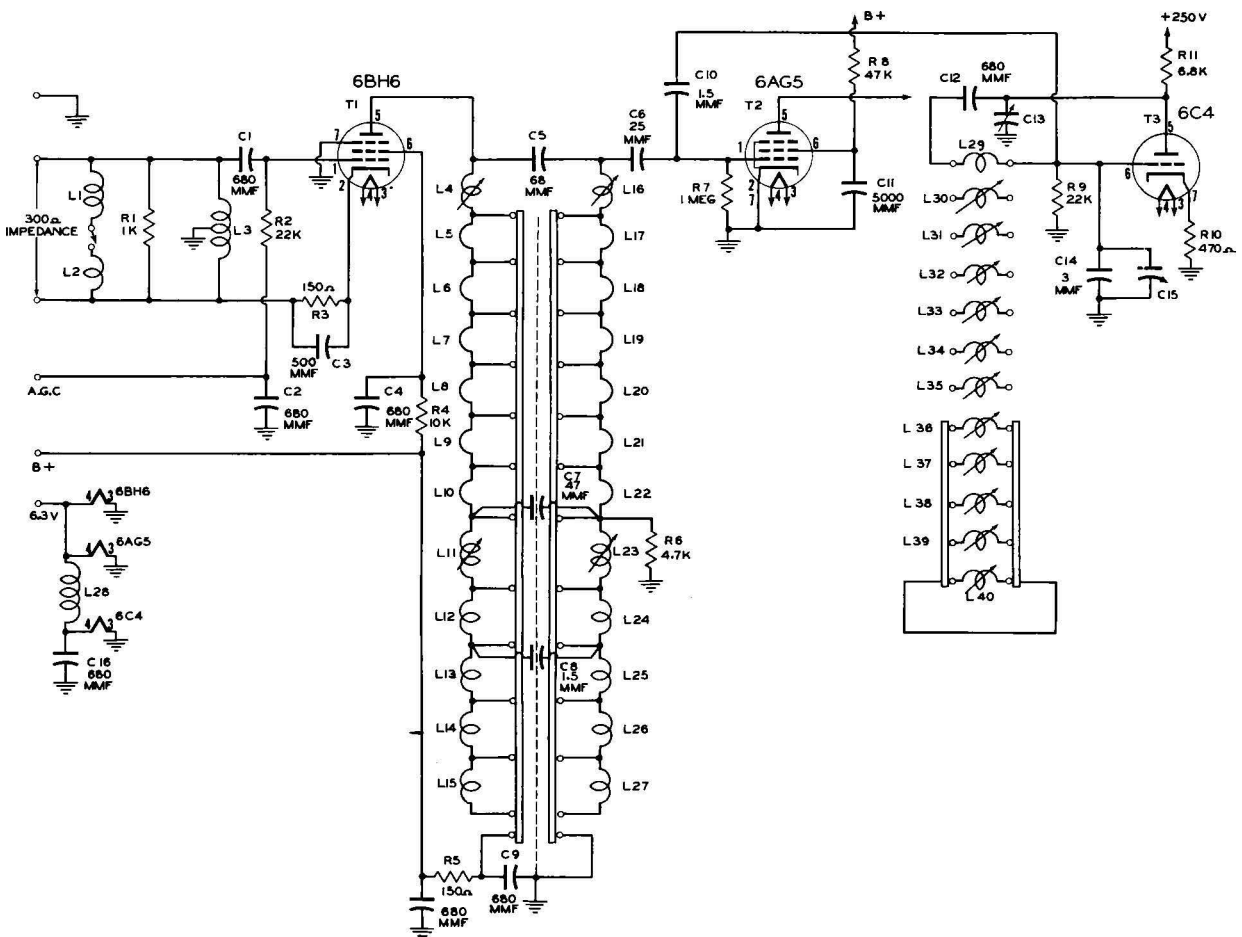

Fig. 176. Schematic Diagram of Input Tuning System Illustrated in Figure 175.

ground transmission line, and a single ended tube circuit. In this case both the grid and the cathode act as input elements and are connected to opposite ends of the center-tapped inductor L3. On the high frequency band (channels 7 through 13) inductors L1 and L2, in series, are connected across L3 to resonate broadly at the higher frequencies.

The inter-stage coupling system consists of two tuned circuits with coupling adjusted to obtain proper band width for all channels. The plate and grid circuit inductances (L4 through L15 and L16 through L27) are selected by the rotary switch. The tuning capacitances of these circuits are made up of the inherent capacitance of the tubes and the capacity of the wiring to ground. Both the circuit shunt loading (R6) and the coupling (C5, C7, C8, and C9) are switch-controlled to help provide uniform (6mc) band width for all channels.

The oscillator circuit switching involves the selection of individually adjusted inductors (L30 through L40). Oscillator tuning capacitor (C13) is made variable for fine tuning.

Another circuit employing switch-select-inductors is shown in Figure 177. In this case the first tube is a triode-connected 6AU6

used as a grounded-grid amplifier. Since the input circuit is heavily loaded to provide matching for the 300 ohm transmission line, its resonance curve is very broad. Only 5 coils (L2 through L6) are required to cover both high and low TV bands.

Interstage coupling is provided by means of a series of wide band transformers (L7 through L33), which are individually switch-selected for television channel. The windings are self resonant, being tuned by their own distributed capacitance, together with the tube capacitances. On the first two channels, image rejection trap circuits (L7-C5) and (L10-C6) are pre-tuned to reject FM station images which might occur on these channels.

The oscillator system (a variation of the Colpitts circuit) selects individually adjusted coils (L34 through L46) for each channel. Oscillator trimmer capacitance C12 is used for fine tuning.

Turret Tuners. Figures 178 and 179 show a tuning system in which the input, converter and oscillator tuned circuits are mounted on a rotating turret. Only the circuit elements associated with a single selected television channel are connected in the circuit

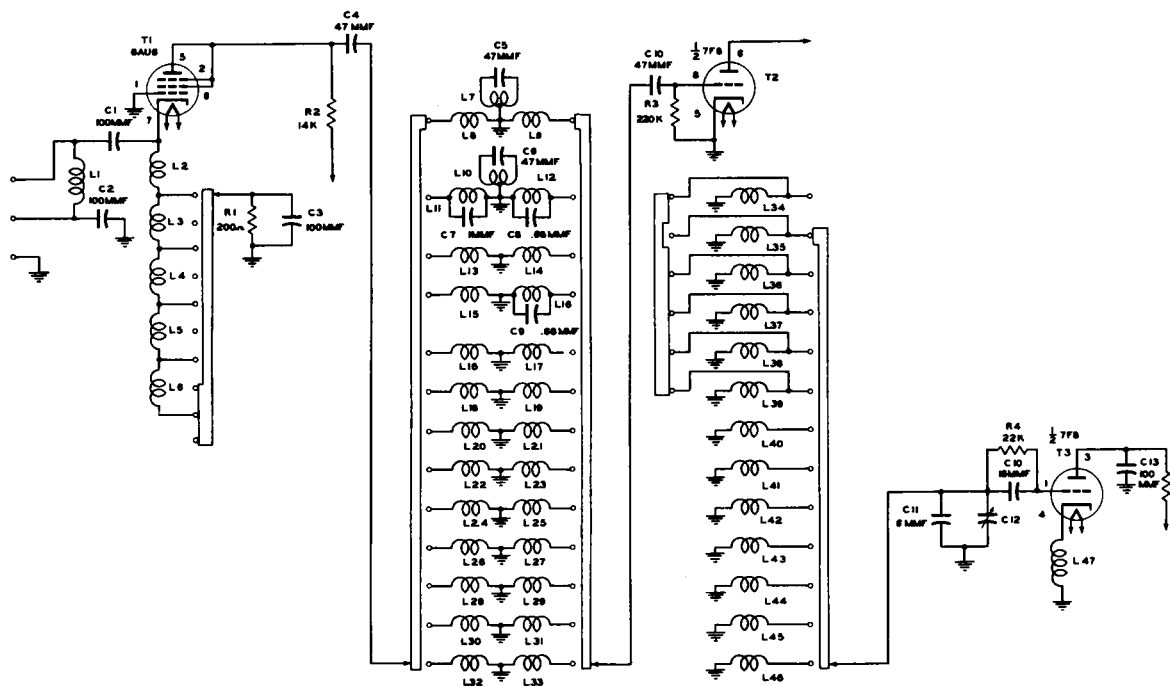

Fig. 177. Schematic of Input Tuning System Employing Switch Selected Inductors. (Broad Tuned, Cathode-Input System.) Courtesy General Electric Co.

CATHODE-RAY - - BEAM MODULATION AND SYNCHRONIZATION

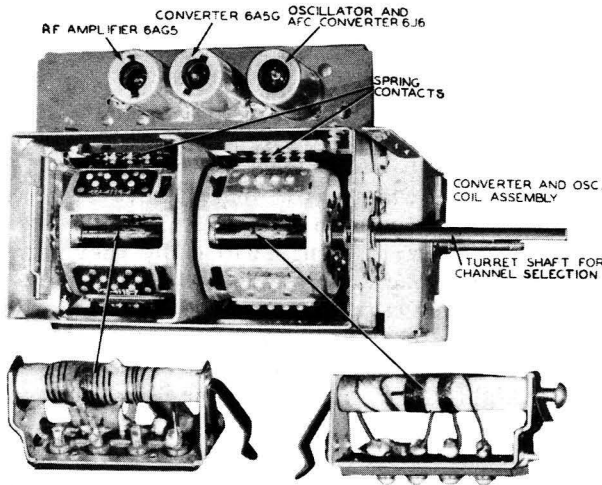

Fig. 178. A Turret Type of Input Tuning System. Photo from Sample Receiver Courtesy Philco Corp.

at any one time. The turret is octagonal in shape and provides tuning for eight channels. The pair of coil assemblies (see Figure 178) for any channel are easily removed, and another pair for a different channel "snapped" in place. Since no more than seven channels are assigned to any given locality, this arrangement should accommodate the allocations of any specific area.

A set of spring backed contacts, associated with the various tube circuits, provide a means of connection to the terminals of the tuned circuits. As the turret is rotated by means of the channel selector knob, studs which terminate each set of coils are positively indexed into contacting position by a wiping action which assures low circuit resistance.

Separate input terminals are provided for the low and high frequency television bands, thus, individual antennas may be employed for high and low band reception. Since the coil design can be altered to accommodate the requirements of each channel, uniform band width is assured. (Figure 179 illustrates

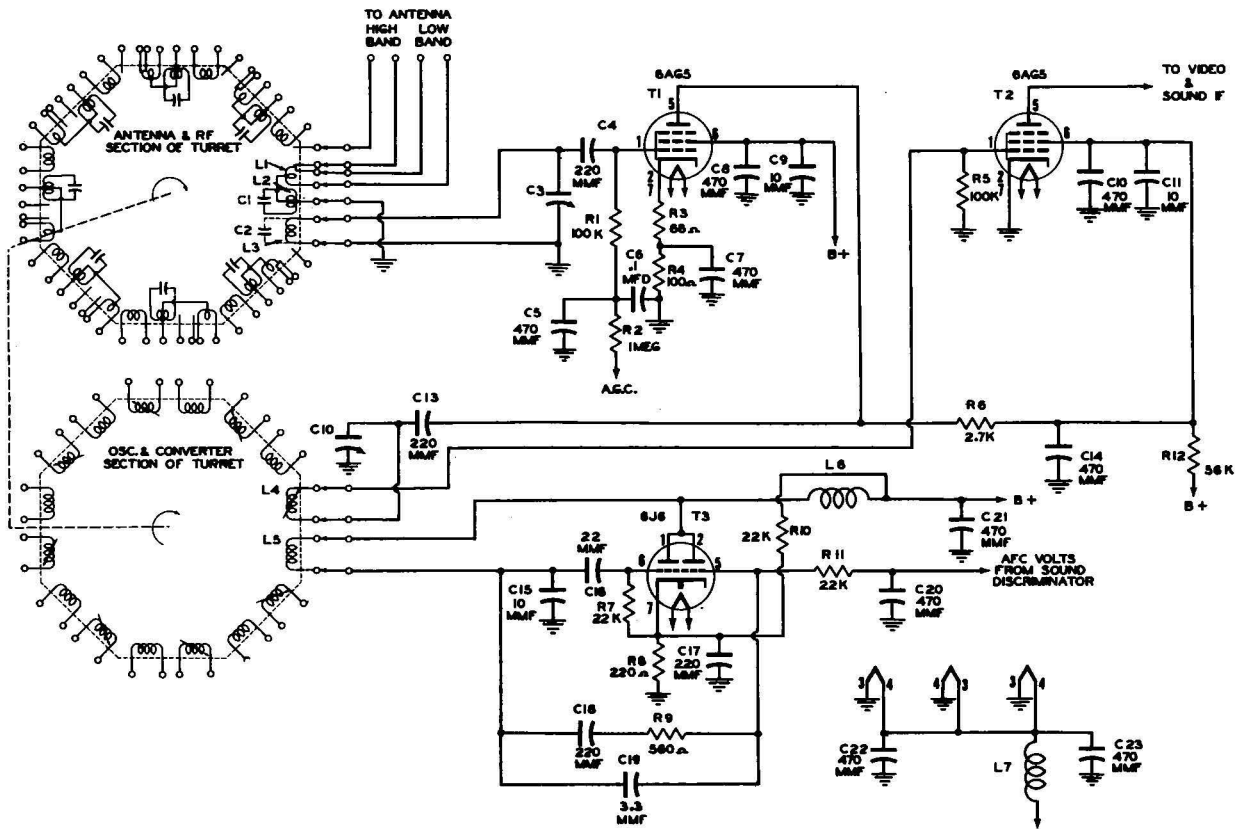

Fig. 179. Schematic of Input Tuning System Illustrated in Figure 178.

variations in wiring of the antenna and RF assemblies for individual channels.)

An unusual feature of this circuit is the omission of the fine tuning control, made possible by automatic frequency control of the local oscillator. The first, or right half, of tube T3 (see Figure 179) functions as an ultra audion (or modified Colpitts) oscillator, while the second, or left half, acts as an automatic frequency control tube to automatically adjust the oscillator to correct frequency. The action of the circuit associated with the second section of T3 is similar to that of the reactance control tube described under AFC horizontal sync control, pages 101 through 105. In this case, the DC control voltage is provided by the FM discriminator, or detector, at the end of the sound channel. The deviation of the oscillator frequency from the center of the correct sound IF frequency will result in the production of a positive or negative voltage on the grid (terminal 5 of tube T3). The plate-to-cathode capacitance of tube T3 (terminals 2 to 7), which is in shunt with the oscillator tuned circuit, can be made to vary in effective value by the change of the DC potential on the grid of the reactance tube, as determined by DC output of the sound channel discriminator.

An RF voltage is fed from the tuned circuit of the oscillator to the grid of the reactance tube through a series network consisting of capacitor C18 and resistor R9. Capacitor C19, which parallels this series network, is

employed to neutralize the grid-to-plate capacitance of the reactance tube. Due to the choice of values of capacitor C18 and resistor R9, a phase shift of the oscillator voltage occurs, and causes the reactance tube to draw a plate current that is out of phase with the voltage appearing across the oscillator coil L5. The current drawn by the reactance tube is leading the voltage, and therefore the tube acts as a capacitor whose value at any time is determined by the magnitude of the plate current. In this manner, the grid bias of the reactance tube, which determines the plate current, can vary the effective capacitance of the tube, and thus the frequency of the local oscillator. Since the grid bias at any instant is determined by the frequency of the audio IF carrier, any drift of the oscillator which would produce a change of the IF carrier is automatically compensated. This system, when properly adjusted, reduces the tuning operation to that of merely turning the channel selecting turret to the proper channel.

**CAPACITIVELY TUNED INPUT SYSTEMS:** Television channel selection by variable capacitance tuning has not appeared as frequently in television designs as have the inductively tuned types previously discussed.

In this type of tuning, it is possible to employ a switch-selected group of circuits which are adjusted by individual trimmers, or to employ a variable capacitor with fixed coils

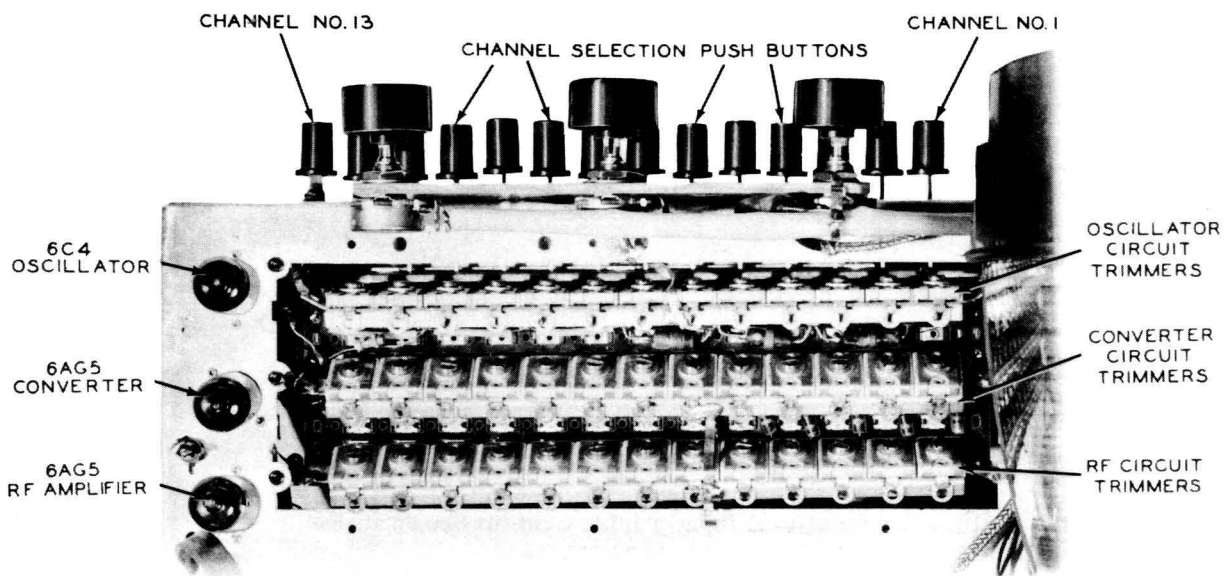

Fig. 180. An Input Tuning System Employing Push Button Selected Trimmer Tuned Circuits. Photo from Sample Courtesy The Hallicrafters Co.

# CATHODE-RAY - - BEAM MODULATION AND SYNCHRONIZATION

Both methods have appeared commercially in television sets now on the market.

**INPUT SYSTEMS WITH SWITCH-SELECTED "TRIMMER" TUNED CIRCUITS.** Figures 180 and 181 show a capacitance-tuned input system in which individually adjusted trimming capacitors are connected into the circuit by a push button switch. A separate bank of 13 trimmers (one for each channel) is used for RF amplifier converter and oscillator tuning.

The input circuit, which matches 300 ohm parallel-lead transmission line, is similar to that described in connection with Figure 176. The RF amplifier tube (T1) has an input circuit balanced to ground, with half of the voltage injected from grid-to-ground and the other half from cathode-to-ground.

The coupling network between the plate of the RF tube and the grid of the converter consists of two tuned circuits with "high side" capacitance coupling. The value of the coupling is varied individually for each of the low frequency channels (capacitors C24, C25, C26, C27, C28, and C29). When a channel of the high frequency group (channel 7 through 13) is selected, sufficient coupling is provided by inherent capacitance between the parts of the circuit (switch, wiring and trimmer banks). In this manner the bandwidth is kept sufficiently broad for all channels.

It will be noted from the schematic diagram of Figure 181, that the tuned circuits employ the trimmer capacitor in series with the tuning coil and the capacitance of the tube. This allows the use of a reasonably large trimming capacitance and still makes it possible to maintain a high L to C ratio.

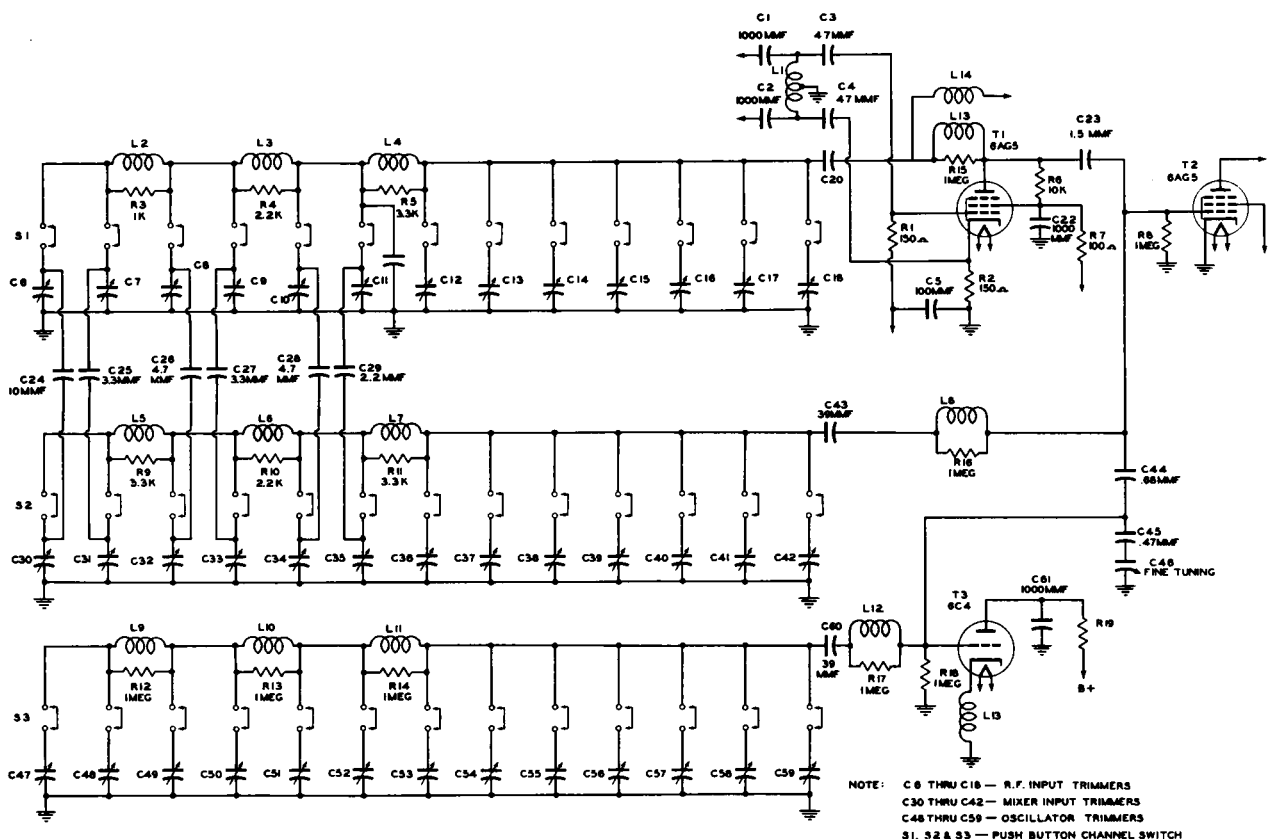

Fig. 181. Schematic of Input Tuning System Shown in Figure 180.

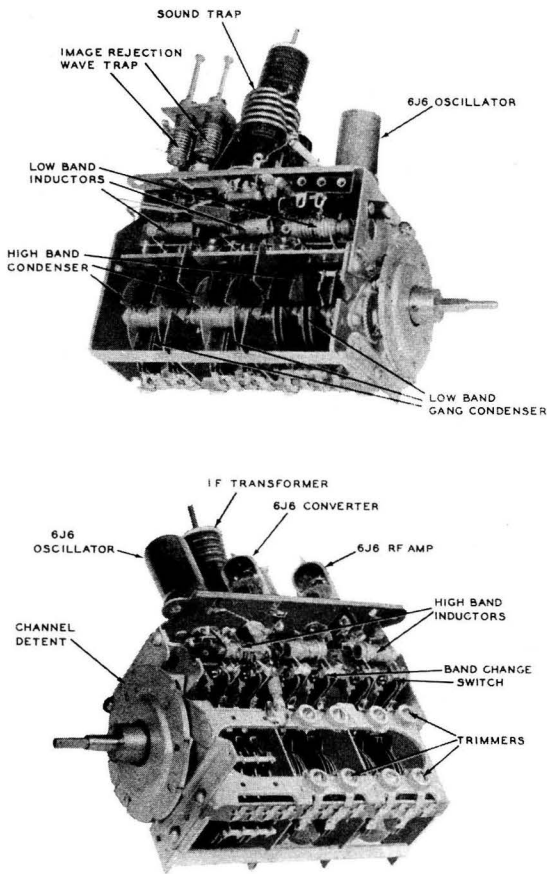

Fig. 182. An Input Tuning System Employing a Variable Gang Condenser with Mechanical Detent for Channel Selection. Photo from Sample Courtesy General Instrument & Appliance Corp.

INPUT SYSTEM EMPLOYING VARIABLE CONDENSER TUNING WITH MECHANICAL DETENT FOR CHANNEL SELECTION. Figure 182A and B illustrates the use of a special design of variable gang condenser for television tuning. The schematic diagram of the circuit employing this tuner is shown in Figure 183. The gang condenser itself is of special construction and employs separate sections for the tuning of the low and high frequency bands. The oscillator section (at the front of the unit) uses very thick soft copper plates to preclude the possibility of "microphonics". An ingenious mechanical arrangement provides a positive detent at each of the positions corresponding to a television channel. On the back side of the detent cam, there is a recessed groove in which a follower stud tracks continuously through 360 degrees of rotation. However, between channels 6 and 7 there is a step in the groove which actuates a lever arrangement controlled by the follower stud. This lever arrangement is attached to the shaft of a gang change-over switch, whose single pole, double throw sections are shown as S1, S2, S3, S4, S5, and S6 of Figure 183.

Referring to Figure 183, it will be noted that a separate set of coils, gang condenser sections, and trimmers, are employed for low band tuning as contrasted with high band tuning. The mechanical arrangement just described, automatically switches from one group of components to the other group, as the channel selector knob is turned from the lower to the higher television bands.

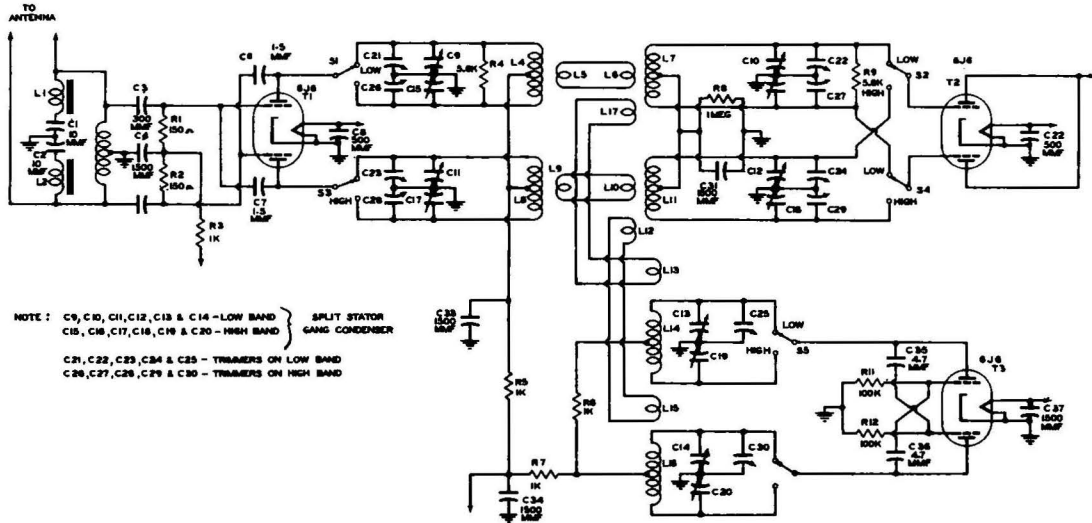

Fig. 183. Schematic Diagram of Input Tuning System Shown in Figure 182.



## CATHODE-RAY - - BEAM MODULATION AND SYNCHRONIZATION

The following circuit features should be noted:

1. All tubes are dual triode type 6J6, and are operated in push-pull connection.

2. The R-F stage is cross-neutralized for stability and reduction of oscillator radiation. The input system is similar to that employed in the quarter-wave line type of tuner illustrated in Figures 171 and 172. This system provides matching for a balanced parallel wire, 300 ohm, transmission line, and

also provides a trap for reduction of F-M interference or an image due to another television channel signal. The use of separate coils and condensers for the two television spectrum locations has made possible optimum circuit design from the standpoint of L/C ratio and proper loading of circuits to provide the desired bandwidth.

The push-pull operation of the converter tube (T2) allows rejection of spurious responses due to cancellation of even-order harmonics.

### SECTION III CATHODE RAY - BEAM MODULATION AND SYNCHRONIZATION

#### CHAPTER 14. TELEVISION INTERMEDIATE FREQUENCY AMPLIFIER SYSTEMS

In our discussion of the composite television signal, carrying amplitude-modulated video information and frequency-modulated sound (pages 121 - 132), it has been shown that a six megacycle wide channel (Figure 137A) is required. Since the television receiver is essentially a high frequency superheterodyne, the major part of the signal amplification and the required selectivity are obtained in the intermediate frequency amplifier system. The television intermediate frequency amplifier system differs in one major respect from the familiar broadcast or short-wave type. The signal which arrives at the grid of the converter consists of two carriers separated by 4.5 megacycles. These two are the video or picture carrier and the audio or sound carrier.

Some method must be provided for separating the information contained in the modulation of these carriers and converting the first to a video voltage at the picture tube grid, and the second to an audio voltage at the grid of the output tube feeding the loud speaker. This separation is accomplished in conventional television receivers by providing two intermediate frequency amplifier systems, the first for the video I-F amplification and the second for the audio I-F amplification. (See block diagram of Figure 184.) Since an accurate separation of the two carrier frequencies is provided at the transmitter by "crystal" control, the local oscillator of the receiver, by beating with the composite television signal, automatically produces two intermediate

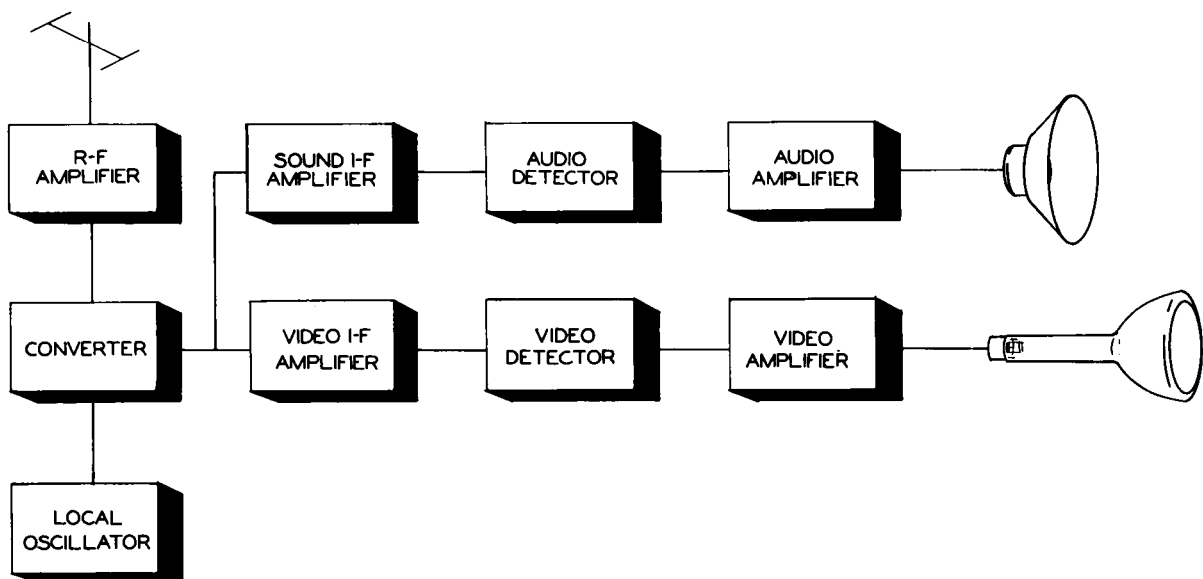

Fig. 184. Block Diagram of a Conventional Dual I-F Channel Television Receiver.



frequencies in the plate circuit of the converter (first detector).

The fact that the video carrier and audio carrier are always separated by a fixed difference of 4.5 megacycles, makes possible a very ingenious method of separating the video and audio signals. This system, which is known as "inter-carrier sound", "inter-channel sound", or "carrier difference reception", was proposed during the war as a means of simplifying military television equipment. It offers several advantages in the simplification of the television receiver. A block diagram of the "inter-carrier sound" system is shown in Figure 185. In the inter-carrier sound system, the I-F amplifier is made sufficiently broad in response to accept both the video and the audio I-F carriers. At the output of the second detector a new beat note of 4.5 appears between the two signals. This beat is in effect a new intermediate frequency and is frequency-modulated in accordance with the audio signal. It is also amplitude-modulated to some extent by the video or picture signal. Since the video amplifier is sufficiently wide band in response, this frequency-modulated 4.5 megacycle signal appears in amplified form at the picture tube grid. It is prevented from modulating the picture tube by the use of a trap circuit. The 4.5 megacycle signal, at the output of the video amplifier, is passed to an F-M detector and audio amplifier. The inter-carrier sound system will be considered in greater detail at the conclusion of our study of video amplifier systems.

Requirements of the I-F amplifier system are similar for either of the two basic systems just described, and are more complex

than those encountered in broadcast receiver design.

In a broadcast type superheterodyne receiver, the I-F amplifier need pass a band of frequency extending only 10 kilocycles either side of the center frequency. In F-M receivers the bandwidth need be not more than + or - 200 kilocycles. In a television receiver the intermediate frequency amplifier must pass a band approximately 5 megacycles in width. Coupled with this band pass requirement is the necessity for rejection of interfering signals from the adjacent television channels (see Figure 139).

The factors which influence the choice of I-F frequency are:

1. Bandwidth requirement.
2. Selectivity.
3. Harmonics of the I-F frequency which might occur in a television band.
4. Direct I-F interference. (Signals of I-F frequency passing through the R-F amplifier.)
5. Image rejection due to F-M or television stations on the image frequency.
6. Cross modulation, due to television and F-M stations.
7. Oscillator radiation which will interfere with the operation of other television receivers or F-M receivers in the vicinity.

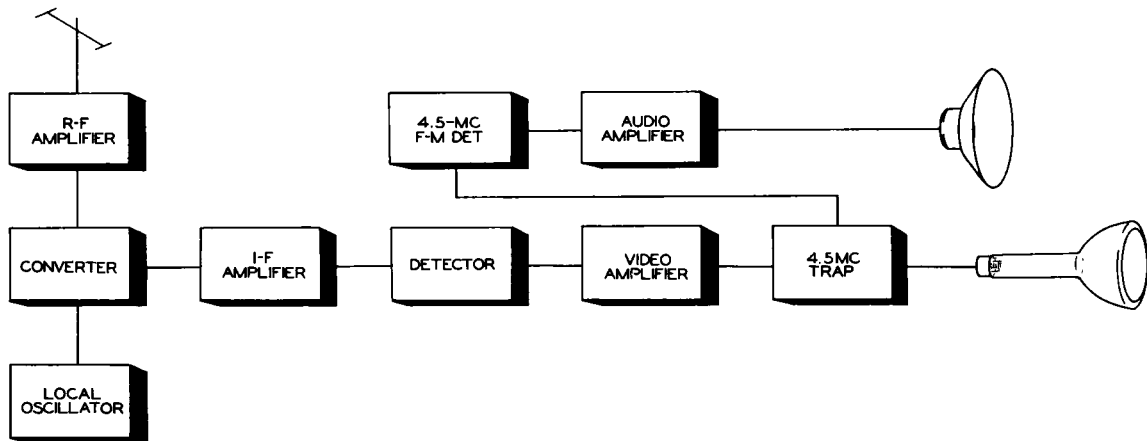

Fig. 185. Block Diagram of an Inter-Carrier Sound Television Receiver.

The choice of any particular intermediate frequency must be a compromise between the various factors just listed, but it appears that the higher intermediate frequencies are a better choice in all respects except direct I-F interference and stage gain.

**VIDEO I-F SYSTEMS:** The requirements of the video I-F system are fourfold.

1. The bandwidth must be sufficient to accept a total band approximately five megacycles wide.
2. Frequencies beyond the edges of the pass band must be rejected or attenuated to such an extent that they do not interfere with the picture. These frequencies are:
  - a. The associated or co-channel sound must be rejected, or reduced to such an extent that "sound bars" do not appear in the picture.
  - b. The sound carrier of the adjacent, lower-frequency channel (see Figure 139) must be rejected for the same reason.
  - c. The video carrier, with its modulation, in the next higher adjacent channel must be rejected to prevent an interfering pattern on the picture.
3. The shape of the response characteristic of the video I-F amplifier must be such

that the lower frequencies corresponding to the double side-band part of the transmission (Figures 137A and B, page 126) are properly attenuated to prevent over-emphasis.

**REQUIRED RESPONSE CHARACTERISTICS OF THE OVERALL VIDEO SYSTEM.** An analysis of the transmitter output shown in Figure 137A reveals the fact that the amplitude is constant from the video or picture carrier frequency to a carrier frequency approximately .75 megacycles lower and to a frequency of approximately 4 megacycles higher than the center of the video carrier. If such a carrier is impressed on a linear detector, the double side-band nature of the region below the picture carrier will result in an increased output for modulating frequencies extending from zero to 1.25 megacycles. Beyond this point the output will be reduced, since only one side-band is employed for frequencies higher than 1.25 megacycles. Figure 186 shows the output of such an ideal detector with an impressed signal from the transmitter modulated by a sweep signal which would produce the envelope of Figure 137A.

It will be seen that the output over the region of zero to .75 megacycles is twice that of the region from 1.25 megacycles to 4 megacycles, and that the output drops in an essentially linear fashion from .75 megacycles to 1.25 megacycles.

In order to compensate for this increased low frequency output, due to the lower side-

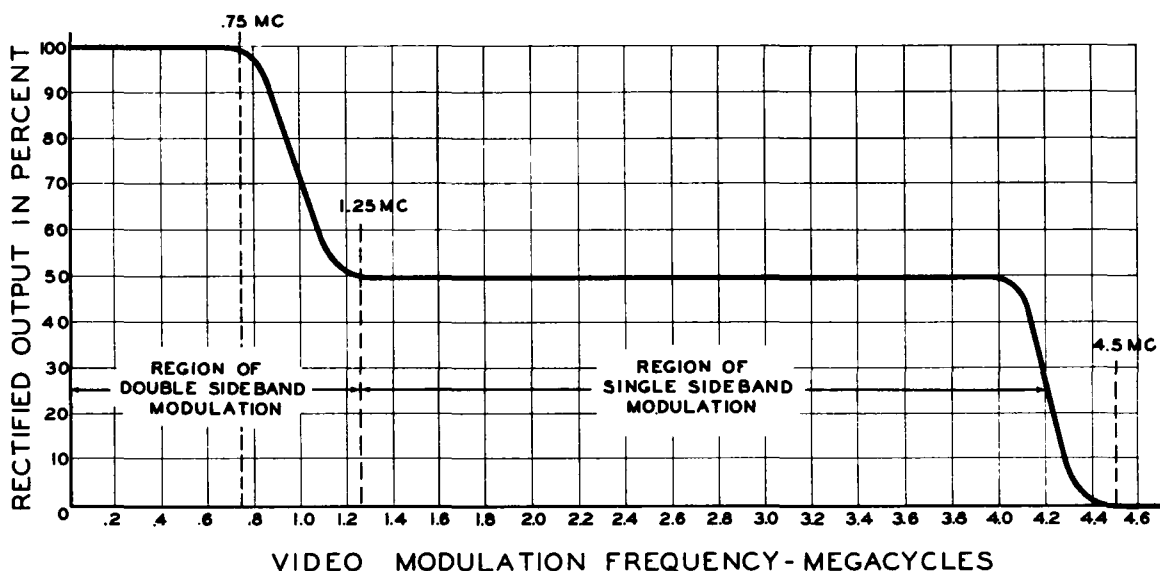

Fig. 186. Output of an Ideal (Linear) Detector when Rectifying the Vestigial Side-Band Modulated Television Video Carrier.

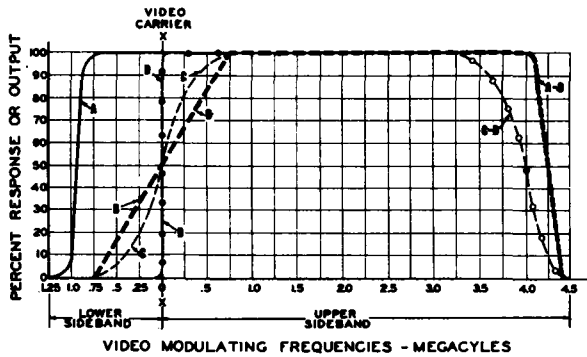

Fig. 187. Overall Receiver Characteristic Required to Compensate for Vestigial Side-Band Type of Modulation.

band, the overall response curve of the receiver should follow the linear slope of the curve shown as B in Figure 187. This curve passes the 50% response band at the frequency of the video carrier. In actual television receivers we find that the I-F curve is usually of the shape shown as C in Figure 187.

As long as the area under the curve to left of the line X-X is equal to the area above the curve to the right of the line X-X, these increments of the video detector output will add to produce the desired curve, D-D. Since the television receiver is normally tuned by means of the sound channel, it is of advantage to have as close an approach to the curve B-B as possible, so the effect of mistuning the video channel will not cause distortion of the low frequency portions of the video modulation, (low frequency "smearing"). The ideal response characteristic for the high frequency end of the band is a sharp cut-off at 4 mega-

cycles, shown as curves A and B of Figure 187. While some receivers do approach this type of curve, most designs provide a more sloping cut-off such as shown by C and D of Figure 187.

While the reduction of high frequencies will result in the loss of some fine detail, when observing a stationary test pattern, this loss is not noticeable if motion occurs in the scene being televised and, in the interest of economy, it has been found possible to reduce the pass band to 3 megacycles without noticeable degradation of the picture.

Up to this point our discussion of the position in the television channel of the video and sound carriers, as well as the adjacent channel frequency, has been concerned with their position in the spectrum as transmitted R-F signals. Since the local, or beating, oscillator of the television receiver is positioned at a frequency higher than the signal, all of these frequencies will be inverted in position when they appear as intermediate frequencies in the detector output. Figure 188 shows, in chart form, the various channel frequencies, video and audio carriers, local oscillator frequencies and I-F frequencies, of a typical television receiver.

Figure 189 shows the overall video I-F response curve for the receiver employing the frequency compensations of Figure 188. On this curve are shown not only the significant I-F frequencies of the desired channel, but also the position of adjacent channel frequencies which might interfere with the operation of the receiver. The curve is seen to be depressed at these points. This reduction in response is accomplished by means of "trap" circuits.

Channel Number	Channel Freq. Mc	Video Modulated Carrier Freq. Mc	Audio Modulated Carrier Freq. Mc	Receiver Local Oscillator Freq. Mc	Video IF	Audio IF
					Freq. Mc	Freq. Mc
2	54-60	55.25	59.75	81	25.75	21.25
3	60-66	61.25	65.75	87	25.75	21.25
4	66-72	67.25	71.75	93	25.75	21.25
5	76-82	77.25	81.75	103	25.75	21.25
6	82-88	83.25	87.75	109	25.75	21.25
7	174-180	175.25	179.75	201	25.75	21.25
8	180-186	181.25	185.75	207	25.75	21.25
9	186-192	187.25	191.75	213	25.75	21.25
10	192-198	193.25	197.75	219	25.75	21.25
11	198-204	199.25	203.75	225	25.75	21.25
12	204-210	205.25	209.75	231	25.75	21.25
13	210-216	211.25	215.75	237	25.75	21.25

Fig. 188. Chart of Typical Frequencies for the Local Oscillator and I-F Amplifiers of a Television Receiver.

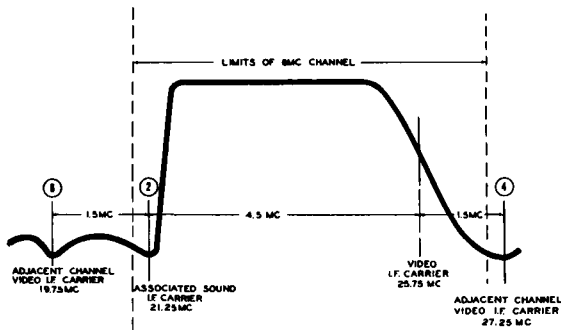

Fig. 189. Overall Video I-F Response Curve Showing Location of I-F Trap Frequencies.

This operation will be covered in the discussion of typical video I-F amplifier designs.

With regard to the choice of an intermediate frequency for television, it should be noted that a number of limitations are set by standards of the television system and frequency assignments. The I-F frequency chosen must lie between the highest video frequency component on the one side and the lowest television frequency channel assignment on the other. This means that television I-F frequencies cannot be lower than approximately 8 megacycles nor higher than 50 megacycles. Figure 190 lists the video and audio I-F frequencies which have been employed in commercial television receivers in the post-war period. The present design trend indicates that the higher frequencies may be chosen as the eventual standard for television receivers. Industry standardization committees are considering possible advantages of frequencies as high as 45.7 megacycles for video I-F, which would necessitate the use of 41.2 megacycles for the audio I-F.

Video IF Frequency Mc	Audio IF Frequency Mc
15.2	10.7
22.9	27.4
25.75	21.25
26.1	21.6
26.2	21.7
26.4	21.9
26.25	21.75
26.6	22.1
26.75	22.25
37.3	32.8

Fig. 190. Television Intermediate Amplifier Frequencies in Commercial Use.

**METHODS OF OBTAINING WIDE BAND RESPONSE REQUIRED FOR VIDEO I-F.** There are many types of coupling networks which can be used between the amplifier tubes of the video I-F amplifier to accomplish the wide band response required. Three major methods are currently used in receiver design. These are:

1. Over-coupled transformers with shunt resistance loading.
2. Staggered-tuned circuits.
3. Pairs of single-tuned circuits with overall negative feedback.

Of these systems, the second (or staggered-tuned circuit) is the most popular. The performance of the various types will be described and illustrated by typical examples later in this section. The circuits employed to reject undesired responses will be described separately from the coupled means used to assure a wide pass band.

Video I-F Amplifiers with Over-Coupled Tuned Transformers. If an interstage transformer with primary and secondary tuned to the same frequency has the coupling between the circuits progressively increased, a "double-humped" resonance curve will result after a point known as "critical coupling" has been passed. These double humps can be "smoothed" to a flat-top response curve by loading the primary and secondary circuits with the correct values of resistance. This of course results in lower Q and consequently lower gain than would be obtained with a narrower pass band. Figure 191 shows an intermediate frequency amplifier system using over-coupled transformers. The placement of parts of this system are shown in Figure 192.

The amplifier of Figure 192 makes use of three band-pass coupled stages employing type 6AU6 miniature tubes. Transformers L3-L4, L7-L8, L10-L11, and L12-L13 are over-coupled, and are then loaded with resistance in the secondary circuits to produce the flat-top band-pass characteristic. Although no primary shunt resistance is shown except in the case of coil L3, the plate-to-cathode resistance of the tubes provides the required primary loading. Broad tuning of the primary circuits is accomplished by the output capacitance of the stage and the associated wiring. No tuning adjustment is provided in the primary circuits with the exception of the last transformer (L12 - L13).

## CATHODE-RAY - - BEAM MODULATION AND SYNCHRONIZATION

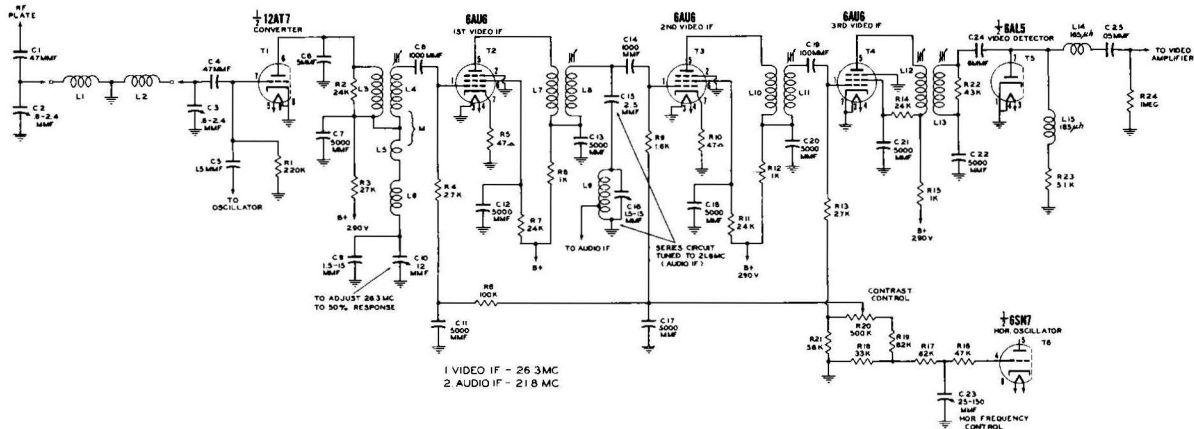

Fig. 191. Video I-F Amplifier Employing Over-Coupled Transformers.

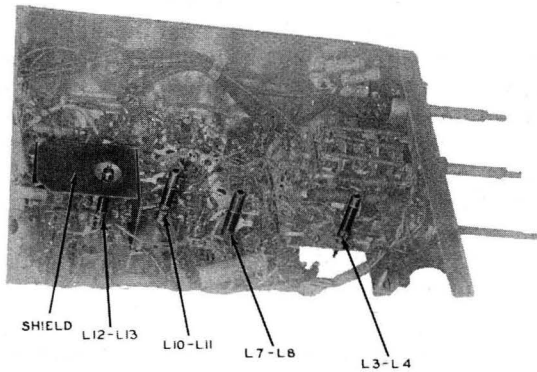

Fig. 192. I-F Amplifier Inductances of Figure 191. Photo from Sample Receiver Courtesy General Electric Company

Winding L5 of the input circuit of the amplifier tube T2 connects to a series-tuned trap, consisting of L5, L6 and capacitors C9 and C10 in parallel. This network is used to adjust the slope of the curve at the high frequency end of the I-F band. This is the section of the curve which is essentially double side-band (due to vestigial side-band modulation). (See pages 125 and 126.) While viewing the response curve on an oscilloscope, the television service technician can adjust capacitor C10 to place the 50% response point at the position of the video I-F carrier (26.3 megacycles in this particular receiver).

The series-tuned trap circuit, consisting of coupling capacitor C15 with tuned circuit elements L9 and C16, is adjusted to reduce or attenuate the sound carrier of the channel being tuned (21.8 megacycles). A tap on inductor L9

provides the audio intermediate frequency voltage for amplification by a second I-F amplifier system. At the frequency of series resonance of this circuit (21.8 megacycles), it effectively shunts the grid circuit by a low impedance, which puts a "notch" in the response curve of the amplifier.

Video I-F Amplifiers with Staggered-Tuned Circuits. Another solution to the problem of designing a video intermediate frequency amplifier to meet the requirements discussed, is that of coupling the tubes by single-tuned circuits which are tuned to different frequencies within the desired pass band.

If a number of single-tuned circuits (between amplifier tubes) are all tuned to the same frequency, the bandwidth decreases as stages are added, and the overall response grows more "peaked" or selective. However, if the tuning of the individual circuits are "staggered" about the center frequency, and the Q values of the circuits are adjusted by proper shunt resistor loading, the desired bandwidth can be obtained and a very satisfactory overall curve shape will result.

Curves B and C of Figure 193 illustrate the effects of the frequency of tune on the bandwidth of a pair of identical circuits (Figure 193A) as discussed above, first to the same frequency and then to frequencies separated from the center frequency by half of the bandwidth of the individual circuits. The bandwidth of a circuit is defined as the frequency "spread" between the points on the resonance curve at which the response is .7 of that at resonance.

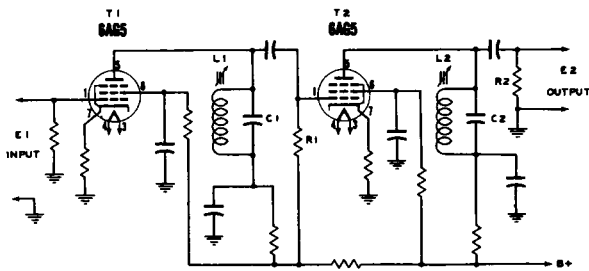

A. SINGLE TUNED COUPLING CIRCUITS BETWEEN VIDEO AMPLIFIER STAGES

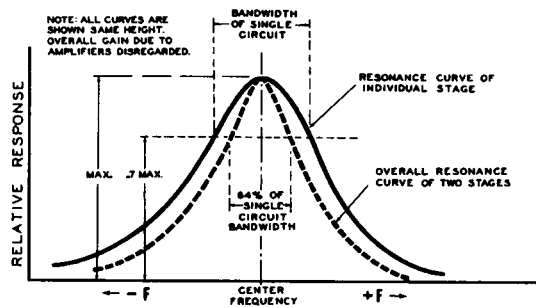

B EFFECT OF CASCADING CIRCUITS ON SAME FREQUENCY

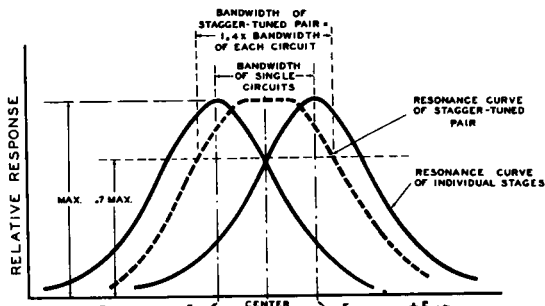

C EFFECT OF STAGGER TUNING CIRCUITS

Fig. 193. (A) An I-F Amplifier Stage Employing Single Circuit Impedance Coupling. (B) Effect of Tuning the Circuits of Amplifier A to the same Frequency. (C) Effect of "Stagger-Tuning" the Frequencies of Amplifier A.

When both circuits are tuned to the same frequency as shown in Figure 193B, the overall bandwidth of the amplifier (Figure 193A) will be 64 percent of the bandwidth of the individual circuit. If, on the other hand, the tuning of the individual circuits is "staggered" above and below the center frequency as in Figure 193C, the overall bandwidth becomes 40% greater than that of the individual circuits.

While we have used the case of two circuits to explain the effects of stagger-tuning,

the practical television video amplifier involves the staggering of more circuits to achieve the 4 to 6 megacycle bandwidth required. In the case of the two circuits just illustrated, the individual bandwidths and circuit Q values have been made identical for the sake of simplicity. In the actual circuits employed in television receivers, the circuit Q values are varied to produce resonance curve shapes and stage gains which will in turn cascade to produce the overall curve shape of Figure 189.

Figures 194, 195, 196 and 197 illustrate the details of a stagger-tuned video I-F amplifier system which is typical of many receiver designs in use.

Figure 194 shows the individual resonance curves of the various coupling circuits. Four stages of video I-F amplification are required to obtain sufficient I-F gain, and the necessary wide band characteristic. The effective Q of each circuit is determined by either the shunt plate resistance or a grid circuit resistor, so that the response curves produce the desired overall response shown by the dotted line of Figure 194. It will be noted that circuits 7 and 3 are high Q, circuits 5 and 6 of lower Q, and that circuit 9 of lowest Q is used to "fill" in the center of the curve.

In a stagger-tuned system variations of the individual amplifier tube gains do not affect the shape of the response curve and thus the amplifier is not unduly sensitive to tube interchange.

Figure 196 shows the various coupling units employed in this circuit identified by symbol numbers as to circuit position in the schematic of Figure 194. The converter plate unit (L1 - L2) and the coupling unit between the second and third stages (L8 - L9) are shown as used and also in disassembled form.

One of the advantages of the stagger-tuned amplifier is the fact that stability or freedom from a tendency to regenerate or oscillate is provided by the fact that grid and plate circuits of each amplifier tube are tuned to different frequencies. This makes it possible to construct the amplifier with a minimum of shielding. Figure 197 shows the corner of the chassis employing the circuit of Figure 194. It will be seen that the only shield employed is that surrounding circuit number 8. This circuit (sound trap for the accompanying sound I-F) is tuned to the same frequency as circuit 2

# CATHODE-RAY - - BEAM MODULATION AND SYNCHRONIZATION

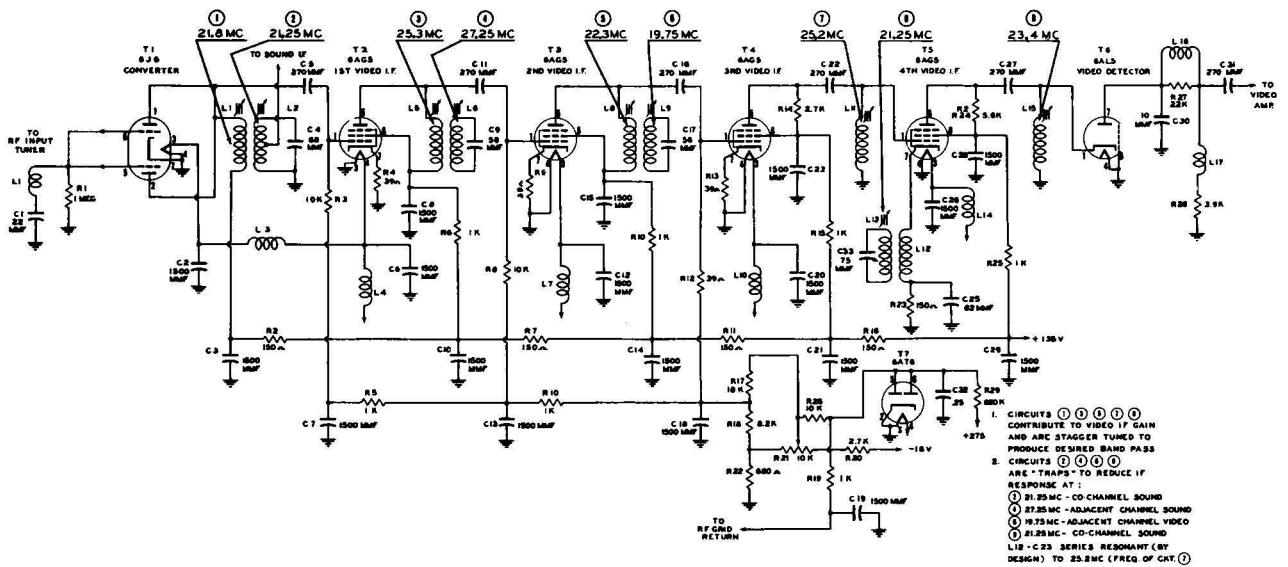

Fig. 194. An Example of a "Stagger-Tuned" Video I-F System.

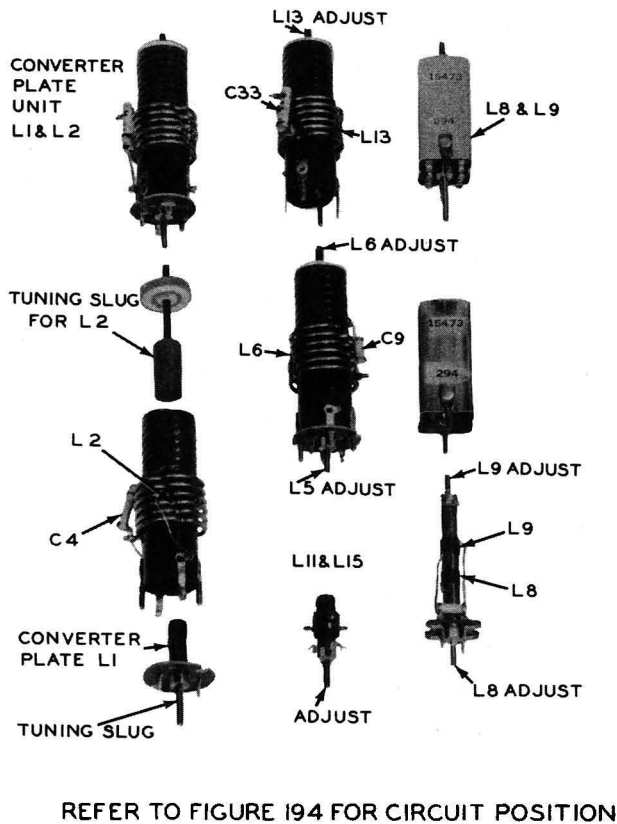

Fig. 196. Video Coupling Coils Used in the Video I-F Amplifier of Figure 195. Photo from Samples Courtesy F. W. Sickles Co.

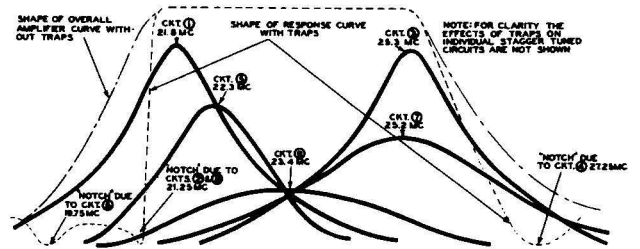

Fig. 195. The Effect of Cascading the "Stagger-Tuned" Circuits of Figure 194.

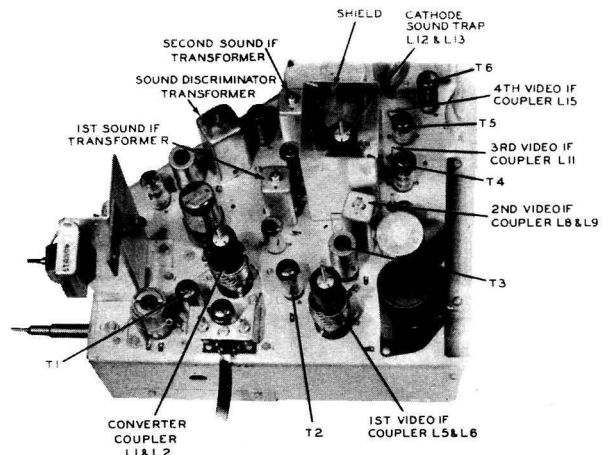

Fig. 197. Video and Audio I-F System of Figures 194, 195, and 196. Photo from Sample Receiver Courtesy R. C. A.

CATHODE-RAY - - BEAM MODULATION AND SYNCHRONIZATION

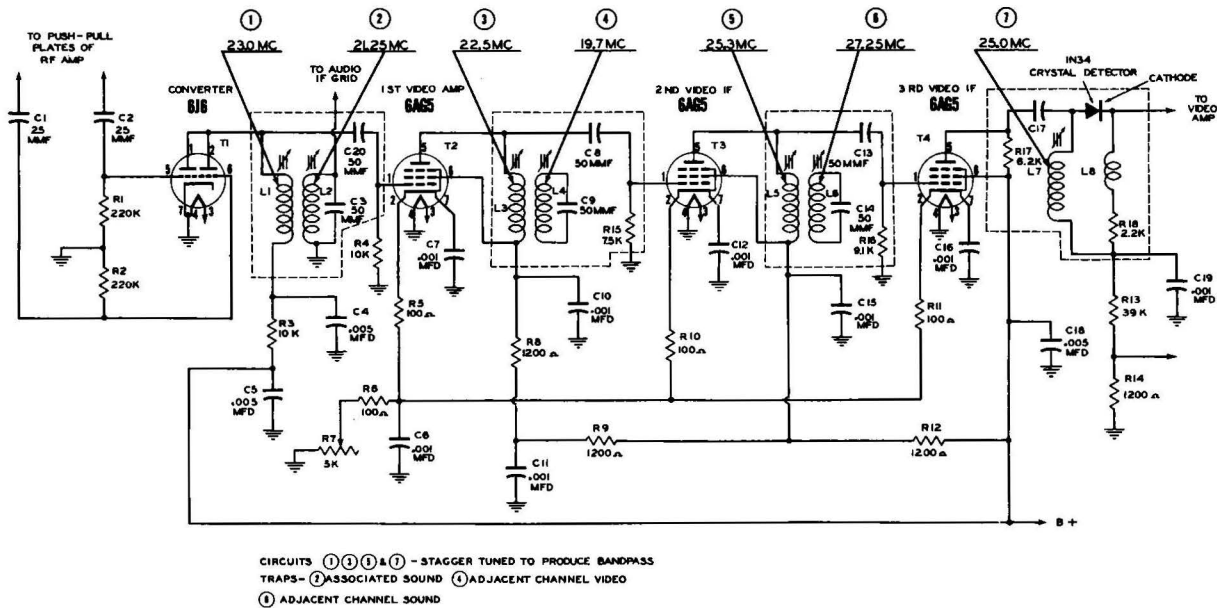

Fig. 198. Another Example of a "Stagger-Tuned" Video I-F Amplifier.

(L2 - C4). Overall oscillation by magnetic coupling would occur if it were not shielded.

Another important feature of stagger-tuning is the fact that alignment can be accomplished by a signal generator set to each of the individual circuit frequencies, while using a VTVM at the video detector for output indication. A sweep generator and oscilloscope are required for observation of the overall curve only.

The "trap" circuits, employed to reduce the response of the amplifier at the frequencies corresponding to the adjacent higher channel video carrier, the accompanying sound carrier, and the next lower adjacent channel sound carrier, have been indicated in Figure 194 and will be explained in detail later in this section.

Another example of a stagger-tuned video amplifier is shown in Figures 198, 199 and 200. In this case the entire video I-F amplifier, video detector, video amplifier and video output tube have been constructed as a strip sub-assembly. This unit is available for the assembly of television receivers by experimenters and students. Figure 198 shows the schematic wiring diagram of the unit which is illustrated photographically in Figures 198A and 198B. In this case the same principle of stagger-tuning is employed with the exception of the fact that different frequencies have been chosen to produce the required wide band

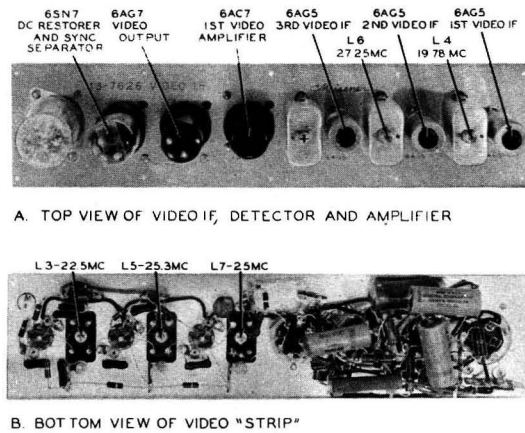

Fig. 199. (A) Top View of Amplifier Shown in Figure 198. (B) Bottom View of Amplifier (Figure 198.) Photo from Sample Courtesy Meissner Mfg. Div., Maguire Industries, Inc.

curve. Absorption type traps are used to reduce the co-channel and adjacent channel interference. The coupling units are placed in individually shielded containers which make possible a very compact design. Figure 199B shows the bottom view of this assembly.

A unique feature of the design is the use of a germanium crystal as the video detector. It is housed within the shield compartment of the final coupling unit, L7. The details of construction of an interstage assembly (L5, L16, C13, C14, R16) and the output-detector



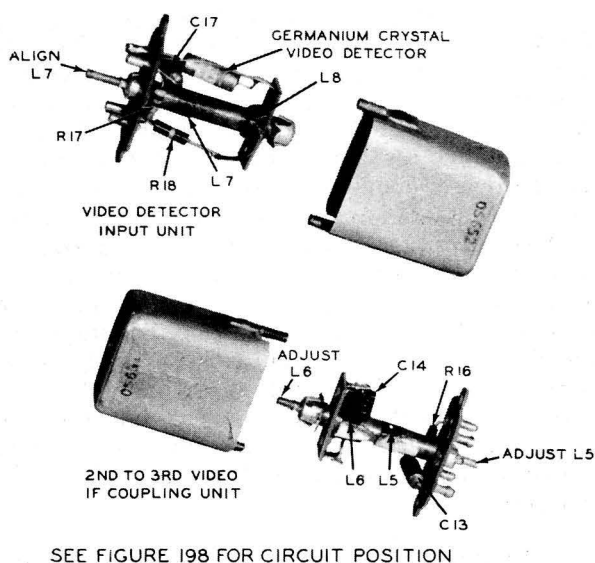

Fig. 200. Coupling Units Used in Amplifier (Figure 199). Photo from Sample Courtesy Meissner Mfg. Div., Maguire Industries, Inc.

stage R17, C17, L7, L8 and R18 are shown in Figure 200. The balance of the video system shown on the strip will be described when we consider in detail, the subject of the video amplification.

**Wide Band Video I-F Amplification Employing Negative Feedback.** Another method for obtaining wide band response with simplified alignment procedure is the use of negative feedback or degeneration around an amplifier stage comprised of input and output tuned circuits. Amplifiers of this type were employed in the intermediate frequency section of

radar equipment during the war and are currently under consideration for television use. A four stage amplifier is shown in Figure 201. The coupling between tubes consists of a variable conductor (L1, L3, or L5) with the associated interelectrode tube and circuit capacitances. Resistors R3 and R15 connected from plate to grid of tubes T2 and T4 respectively, apply feedback voltage which results in broadening the bandwidth of the amplifier. An amplifier of this type can be aligned by disconnecting one end of each of the feedback resistors, and then tuning all of the circuits to the center frequency, taking into account the slight change of capacity caused by removal of the resistor (approximately .3mmf).

Since a change in the gain of the degenerated stage would result in a change of the bandwidth of the stage, it is possible to apply gain control to tubes R1 and T3 only. These tubes are not involved in the degeneration.

For simplicity, trap circuits for the reduction of undesired responses have not been included in this diagram.

**REJECTION OF UNDESIRED ADJACENT CHANNEL AND CO-CHANNEL CARRIERS.** In our consideration of the required response curve shape of the video I-F amplifier (see Figure 189) we have seen the necessity of reducing the response at the position which would be occupied by the sound carrier of the same channel being received, the video carrier of the next higher adjacent channel, and the sound carrier of the next lower adjacent channel. The production of low response points or

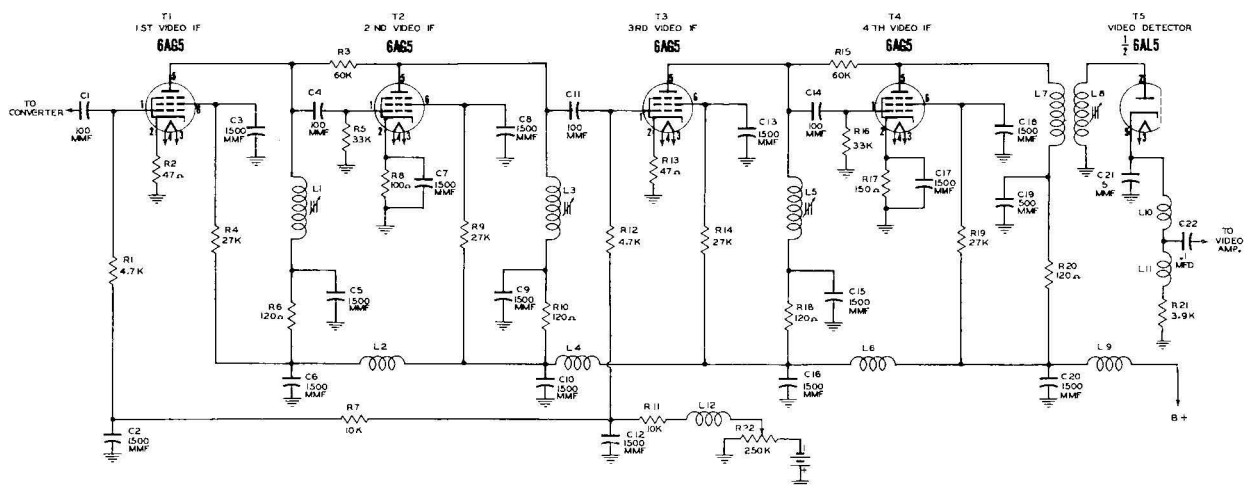

Fig. 201. A Video I-F Amplifier Employing Negative Feedback for Band Widening.

“notches” at the I-F frequencies corresponding to these carriers can be accomplished in the video amplifier by one or a combination of the following circuits:

1. Series-tuned circuit traps.
2. Parallel-tuned circuit “absorption” traps.
3. Cathode circuit or degenerative traps.
4. Bridged T networks as coupling elements and rejection circuits.

The trap circuits, items 1 and 2 (series and parallel tuned), are similar in function of operation to interference elimination traps which have been used in the radio service profession for the elimination of image interference or interference by strong local stations. The degenerative trap principle is often used in audio circuits for compensation, while the fourth or bridged T type of trap is similar in action to a null bridge, such as is employed for measurement purposes.

Series-Tuned Traps. The series-tuned trap is of the acceptance type and acts as a virtual short circuit across the system at its frequency of resonance. The impedance at this frequency is very low and is equal to the AC resistance of the circuit components. In the amplifier shown in Figure 191, the circuit comprising L5 and L6 in series, tuned by capacitors C9 and C10 in parallel, is used to adjust the slope of the high frequency end of the band pass curve. It permits the control of the point at which the video carrier falls (50% of maximum response for compensation of vestigial side-band effect). When this adjustment is made the curve falls off at a sufficient rate to reject the next lower channel sound carrier also. In this case the adjacent sound carrier falls at 27.8 megacycles. This series-tuned circuit is coupled to the secondary circuit (L4) by means of the coupling coil (L5).

In the grid circuit of the second video stage of this same amplifier (Figure 191) will be found another series-tuned trap. In this case, C15 and the parallel combination of L9 and C16, are tuned for maximum attenuation at 21.8 megacycles which is the associated or co-channel sound I-F carrier. It is necessary to reject this carrier from the video amplifier to prevent the production of “sound bands” on the picture. The trap serves the dual purpose of rejecting the sound channel and at the same time providing a resonant pick-off of the sound or audio I-F voltage for amplification through an audio I-F amplifier.

Shunt-Tuned or Absorption Type Traps. The absorption type trap is the most frequently used type of rejection circuit for undesired responses. Three traps of this type are shown in the schematic diagram of Figure 194 (circuits 2, 4 and 6). They consist of a parallel-tuned circuit coupled to the plate load of the video I-F stage. At the frequency of resonance of the circuit, a high circulating current is developed in the trap. The trap reacts through its inductive coupling in such a manner as to reduce the load impedance of the stage and greatly decrease the amplification at the point of tune. The effects of trap circuits 2, 4 and 6, of Figure 191, on the response curve of the amplifier are shown in the correspondingly numbered points on the overall amplifier curve of Figure 189.

Cathode Circuit or Degenerative Traps. Another method employed to reduce the amplifier gain at a particular point, is to use selective degeneration. This is done by placing a parallel resonant circuit in the cathode-to-ground circuit of one of the amplifier stages. This may be done either directly in the cathode circuit, or by coupling to it. At the resonant frequency of the trap, a high impedance appears in the circuit and the trap acts like a large un-bypassed resistor, causing degeneration and reducing the amplification of the stage to a very low value. The rejection figure of such a degenerative trap never can be greater than the gain of the stage, which in the case illustrated is approximately eight to one.

To prevent degeneration at the frequency of tune, or 25.2 megacycles, the primary coil L12 has been made broadly series-resonant at this frequency by means of tuning capacitor C25. This makes the cathode impedance low at 21.25 megacycles and prevents a loss in gain.

Figure 202 shows the use of a network of circuit elements known as the “bridged T”. These circuits, for rejection of the undesired associated sound and adjacent sound I-F carriers, use a T shaped branch consisting of two capacitors and a resistor (C13, C14 - R12) and (C18, C19 - R19) “bridged” by an inductor (L5 and L13 respectively). The I-F amplifier shown in the photograph of Figure 203, uses the schematic of Figure 202.

The action of this arrangement is equivalent to a bridge circuit, but has the advantage that the input and output circuits can have a common terminal at ground potential.

# CATHODE-RAY - - BEAM MODULATION AND SYNCHRONIZATION

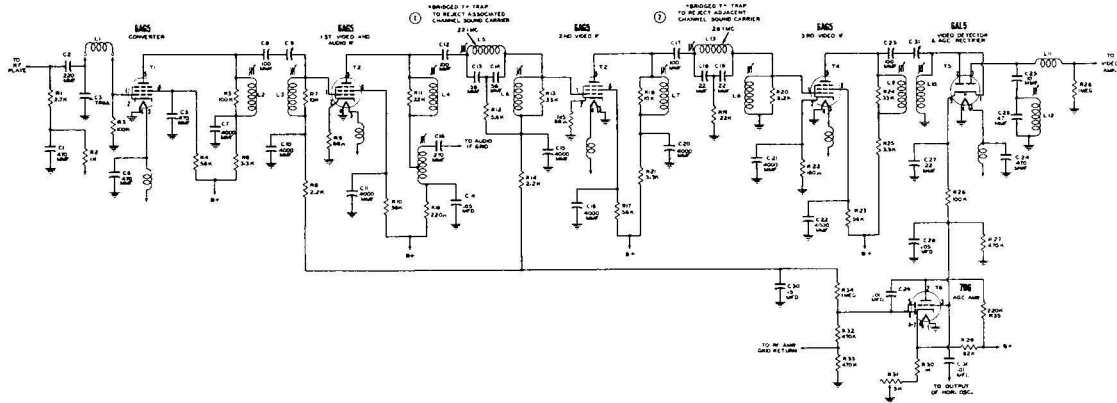

Fig. 202. A Video I-F System Using "Bridged T" Networks as Interference Traps.

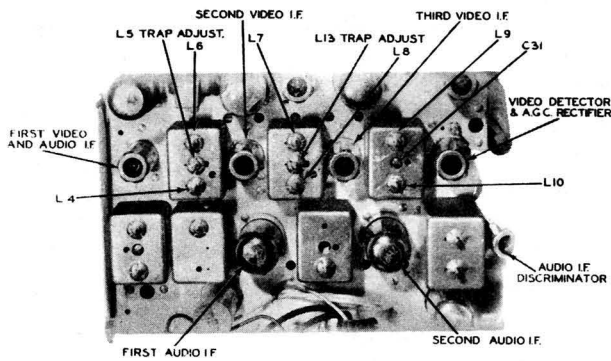
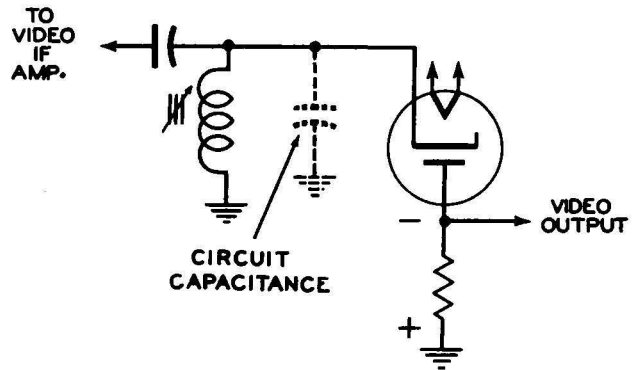

Fig. 203. Video I-F System Shown in Schematic (Figure 201). Photo from Sample Receiver Courtesy Philco Corporation.

The conditions of balance (for a null or low output) occur when the reactance of the variable inductance is made equal to the reactance of capacitors in series, and when the resistor in the center leg of the T is approximately one fourth of the parallel resistance of the tuned circuit. Another explanation of the circuit is that of an anti-resonant trap in the line with a secondary balance for the resistance losses of the circuit. Much sharper null "notches" and greater degree of rejection can be obtained by the use of the bridged T connection than with the trap circuit alone.

Over the video I-F band (22.6mc to 28mc in the example of Figure 202) trap circuit 1, which is tuned to a frequency lower than the band, acts as a capacitance coupling unit between the two stagger-tuned circuits, and circuit 2, tuned above the band, acts as an inductive coupling element.



A. VIDEO OUTPUT INCREASES NEGATIVELY WITH RESPECT TO GND. AS CARRIER INCREASES.

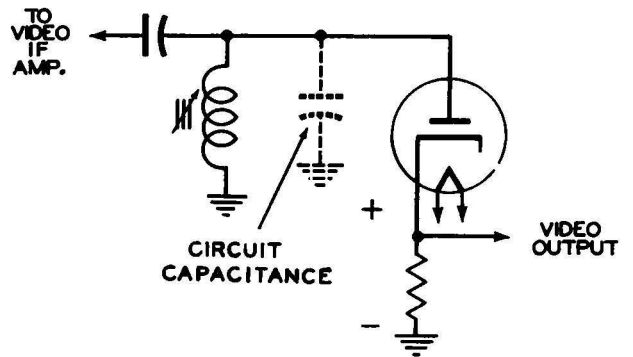

B. VIDEO OUTPUT INCREASES POSITIVELY WITH RESPECT TO GND. AS CARRIER INCREASES.

Fig. 204. Diode Video Detector Output Polarity.

Another variation of the bridged T circuit (not illustrated) employs a center-tapped coil for the resistance branch and a single trimmer for the capacitance branch.

**VIDEO DETECTORS.** The video detector which follows the video I-F amplifier just discussed, is essentially the same type of demodulator as is used for the second detector of an A-M broadcast or short wave radio receiver. The only significant circuit differences between a video second detector and the familiar A-M second detector resides in the fact that the polarity of its output must be taken into consideration and compensation must be employed to prevent loss of the higher video frequencies.

Since the system of television broadcasting, in use in this country, is based on negative video modulation, the detector output must be of such polarity that an increase of carrier strength causes the video voltage at the picture tube control grid to become more negative and thus decrease the brilliance of the picture element.

If there are an even number of video amplifying stages between the detector and the picture tube grid, the output of the detector must be "negative going". In other words, an increase in I-F carrier strength, applied to the detector, results in a more negative video signal with respect to ground. Figure 204A shows a detector which supplies a negative picture polarity followed by two video stages.

If an odd number of stages are employed (in most instances this will be a single stage), a detector must be connected as shown in Figure 204B. This circuit, with the plate of the diode connected to the high side of the video

coupling circuit, produces a video output across the load resistor which increases in positive polarity as the video carrier strength is increased.

A typical video detection and amplifying system which employs negative polarity video signal from the diode is shown in Figure 205. In this case the load resistor (R2) has a value of 3900 ohms, and has associated with it a group of circuit elements, C3, L3, L4, and R1, whose purpose is to assist in producing a flat video response characteristic over a range of from 30 cycles to more than 4 megacycles.

A significant difference between the operation of the diode as an A-M detector and as a video detector lies in the value of the load resistor. In the familiar broadcast application, a typical diode load varies from .5 to 2 megohms, and maintains this high load resistance over the range of frequencies required for sound reproduction. In most instances this involves frequencies no higher than 5000 cycles. In the video detection case, however, the capacitance of the diode and the capacitance to ground of its associated circuit prevent the use of a high diode load resistance, since it is necessary to provide flat response to at least 4 megacycles. At these high frequencies, the reactance of the circuit and tube capacitance would become lower than the load resistance, and thus by-pass the high frequencies. For this reason, the load resistance is made of the low value and the compensating elements just discussed produce a resonant rise of circuit impedance at the high end of the video band.

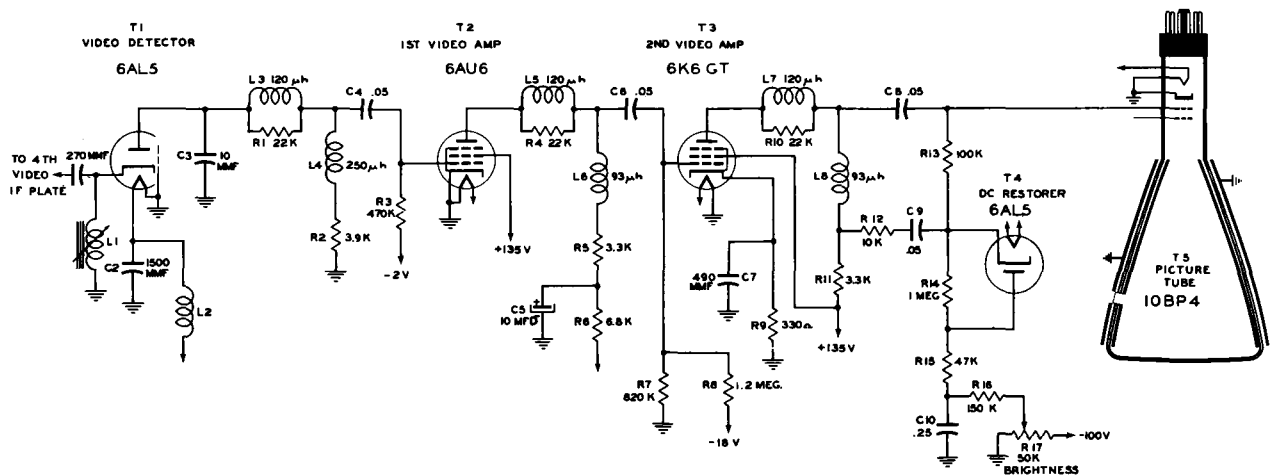

Fig. 205. Video Detector of Negative Polarity Feeding Picture Tube Grid through Two Video Stages.

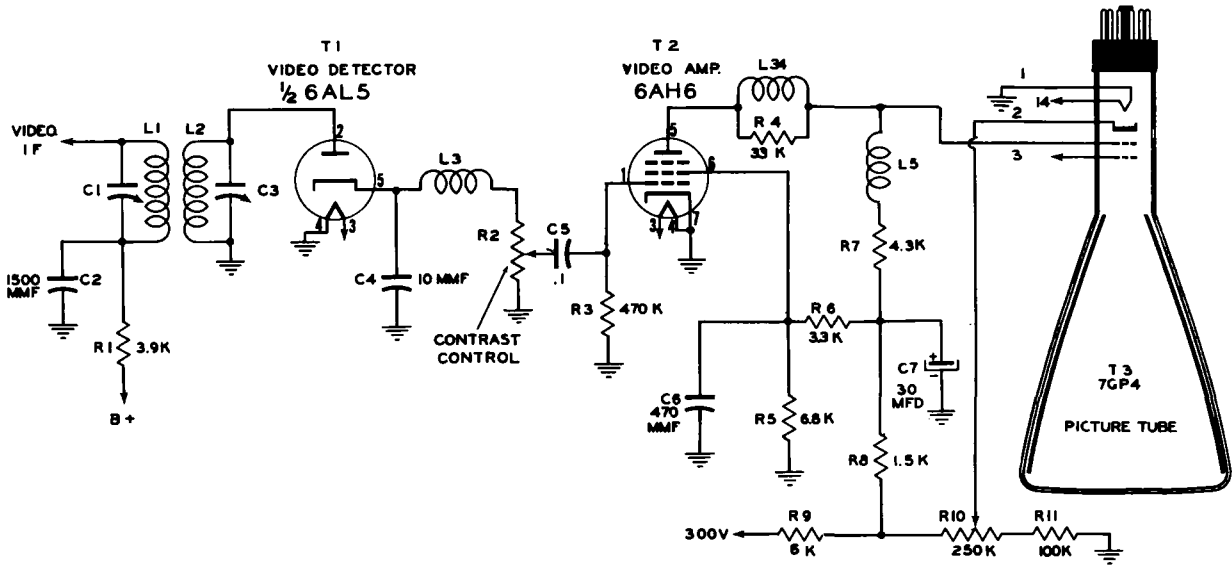

Fig. 206. Video Detector of Positive Polarity Feeding Picture Tube Grid through a Single Video Stage.

L3 is called a series-peaking choke, and L4 a shunt-peaking choke. These compensating elements are employed in each video stage (L5 - L6, L7 - L8, of Figure 205). A more complete discussion of their function will be presented when the subject of video amplification is considered.

Figure 206 shows a video detection and amplification system which employs the diode

with its plate connected to the high side of the I-F input circuit in order to produce a "positive-going" video signal. In this case a single video amplifier stage is used, inverting the polarity, thus producing a more negative voltage at the picture tube control grid as the carrier strength increases. A combination of L3 and C4, together with the circuit capacitances, resonates at the high end of the video band and maintains a flat response from the

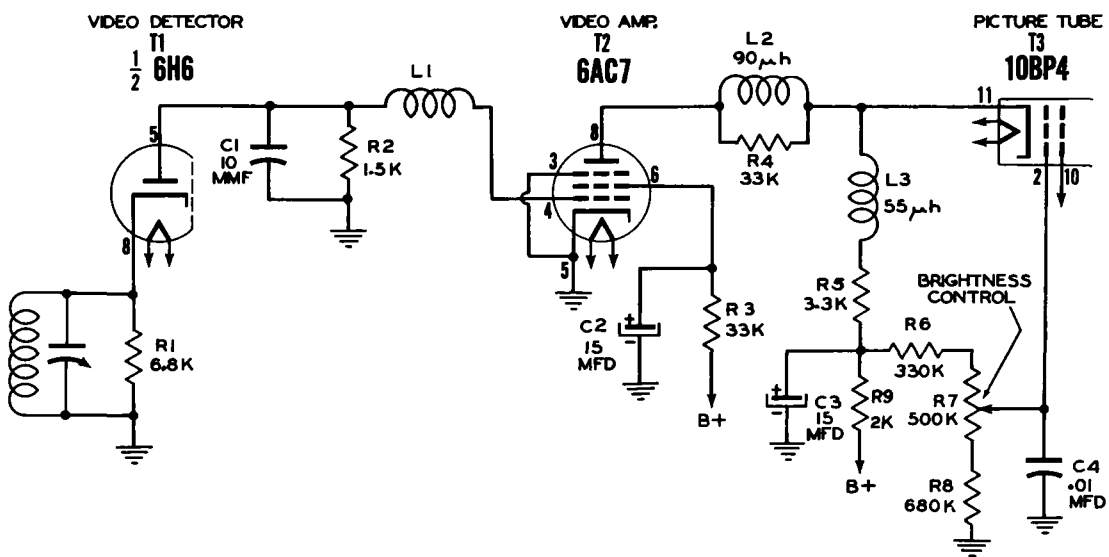

Fig. 207. A Positive Output Detector Feeding the Cathode of the Picture Tube through a DC Amplifier.

detector. Choke L3 also serves to reduce the 4.5 megacycle beat which occurs due to the associated sound I-F carrier beating with the video carrier. The presence of this 4.5 megacycle video interference would reduce the fine detail of the picture.

In the foregoing discussion, as illustrated by the circuits of Figures 205 and 206, the video output tube is coupled to the control grid of the picture tube. In certain television designs, for reasons of circuit simplification, the input to the picture tube is inverted and the plate of the video output tube is coupled to the cathode rather than to the control grid. When this is done, in order to turn over the signal at the picture tube input, it is necessary to reverse the rule previously stated and employ a positive rather than a negative-going signal for an even number of video stages. Figure 207 shows an example of such a circuit which employs the negative output detector (T1) with a single stage amplifier (T2) feeding the cathode of the picture tube (T3). A novel feature of this circuit, to be discussed in greater detail later, is the fact that the output of the detector is "direct-coupled" through the entire video amplifier to the picture tube. No coupling or blocking capacitors are employed and

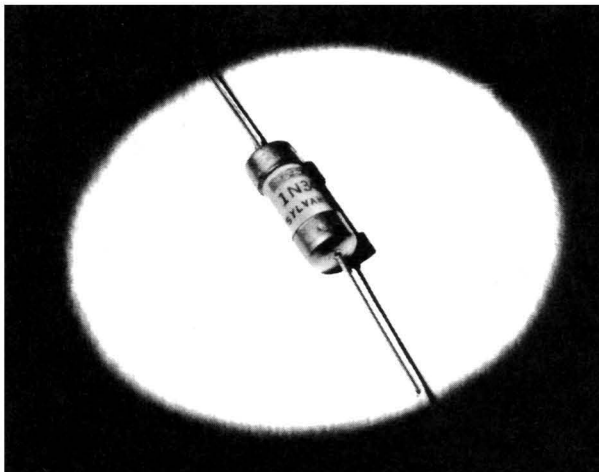

Fig. 208. Germanium Crystal Diode Type 1N34. Photo from Sample Courtesy Sylvania Electric Products, Inc. (For service the 1N34 can be used to replace the 1N36. The 1N34 has a higher voltage rating.)

the diode (T1) therefore can fulfill the dual roles of detection and DC re-insertion.

**THE GERMANIUM CRYSTAL DIODE AS A VIDEO DETECTOR.** The small, cartridge-type, fixed crystal rectifiers (see Figure 208) which were developed during World War II for radar converters are finding applications in television design as a substitute for a thermionic diode. The germanium type (1N34) is being employed not only as a video detector but also as a DC restorer or DC re-insertion diode.

Figure 209 shows two typical applications of crystal detectors as video demodulators. Figure 209A shows a load circuit, consisting of resistor R5 and high frequency compensation network C4, L2, L3 and R4, connected in series with the diode. Figure 209B shows a shunt connection of similar elements.

Several features of the germanium crystal diode recommend its use as compared with the vacuum tube type. These are: lower capacitance, smaller size, lower dynamic resistance, reduction of power consumption (no heater required) and ease of mounting (no socket required). The lower capacitance and materially lower dynamic resistance result in improved performance as a video detector by providing higher rectification efficiency for a given bandwidth. Its improved linearity at low signal levels helps preserve highlight detail in the picture.

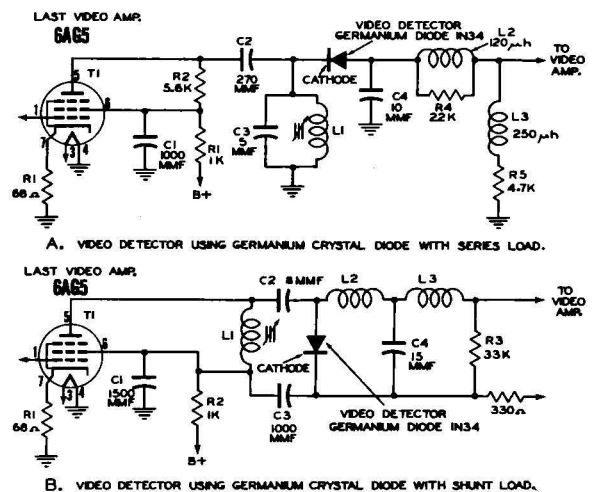

Fig. 209. The Germanium Crystal as a Video Detector.

**AUDIO IF SYSTEMS:** The audio IF system of the television receiver is similar in design to the IF system of the conventional FM receiver. Two major differences from the standard FM set will be noted:

1. The intermediate frequency which has become standard for FM broadcast receivers is 10.7mc. No standard is yet apparent for television audio IF frequency. This value is automatically established by the choice of video IF frequency (a difference of 4-1/2mc exists between the video IF frequency and the audio IF frequency). (See pages 125, 126, 165 and 166.)

2. The deviation of the television sound carrier for maximum modulation has been established as 25kc (a total sweep of 50kc), whereas the maximum deviation for standard FM broadcasting has been set at 75kc (a maximum sweep of 150kc). The fact that a lower deviation is employed for television sound would indicate the possibility of using a narrower pass band for the audio IF channel and a shorter linear region for the second detector or discriminator. The pass band of the IF amplifier is kept at several hundred kc and the linear region of detection extended to the same figure. This audio IF pass band is required to render the receiver operation immune from frequency drift. An extremely small percentage drift of frequency of the local oscillator would be sufficient to move the audio IF frequency out of the pass band if it were made only wide enough to accommodate the 50kc sweep. This small drift would not disturb the quality of the picture due to the vestigial side band nature of the video signal. (See pages 125 and 126.)

In the intercarrier sound receiver system, to be described in detail later, a drift of the sound IF frequencies (4.5mc) is not possible. The difference between the video and audio carriers is established by crystal control at the transmitter. A wide pass band is employed, however, since any drift of tune of the IF amplifier cannot be corrected by receiver tuning, and some tolerance must be provided for such a condition.

**METHOD OF AUDIO IF "TAKE-OFF".**

In the conventional dual IF channel television receiver (Figure 184) two separate intermediate frequencies exist in the output of the converter. We have considered the nature of the composite IF signal in pages 164 through 176,

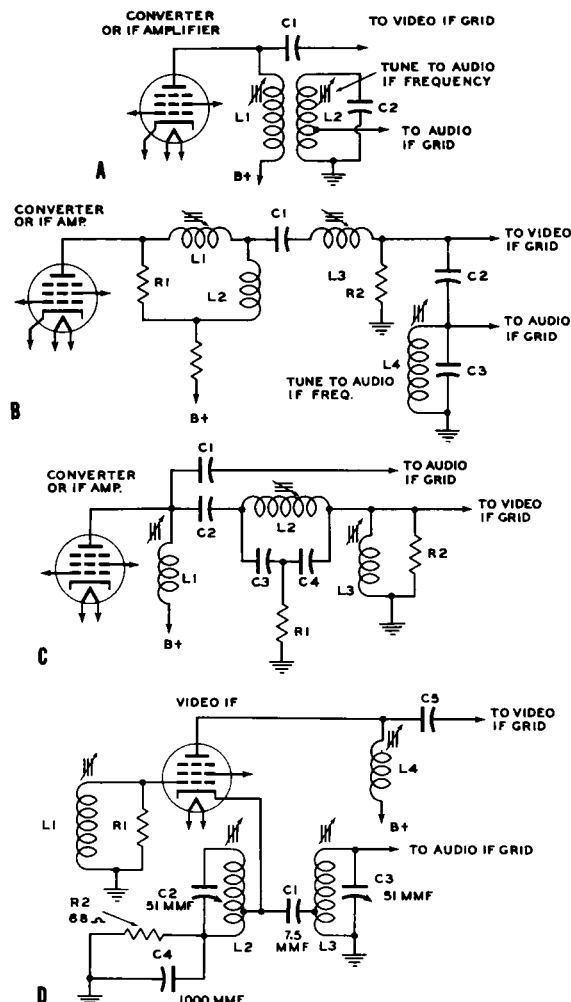

Fig. 210. Methods of Separating the Audio IF from the Composite IF Signal.

and have indicated in various schematic diagrams (Figures 191, 194, 198 and 202), the points at which the audio IF is taken from the composite signal and passed on to the audio IF system.

Figure 210 shows in simplified form, the various circuits employed for separation or "take-off" of the audio IF signal. In each instance the take-off circuit serves the dual purpose of providing a resonant system for the development of audio IF voltage, and a trap circuit to prevent this audio IF voltage from progressing further through the video IF amplifier to produce interference in the picture. The point in the video IF amplifier system at which the audio IF is separated, is determined by considerations of bandwidth and total gain



# CATHODE-RAY - - BEAM MODULATION AND SYNCHRONIZATION

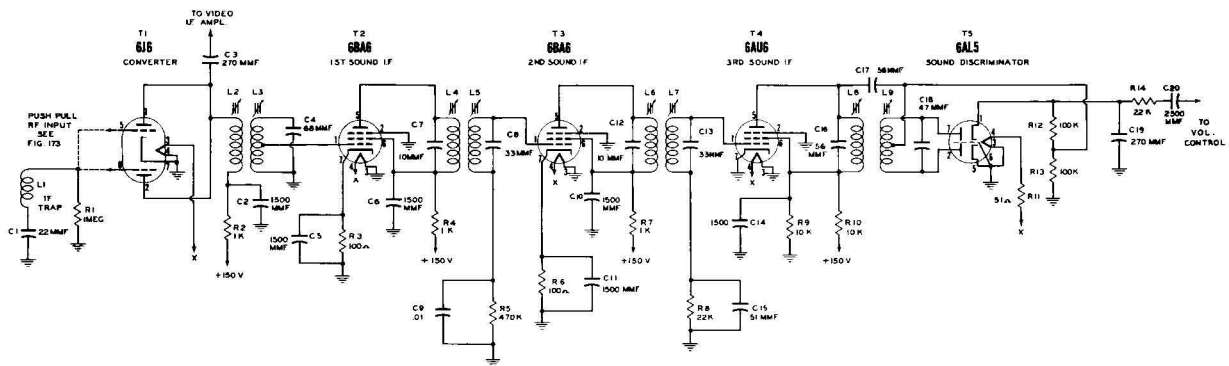

Fig. 211. A Typical Audio IF System. Illustrated in Figure 197.

required to produce an adequate signal at the sound detector or discriminator.

In many receivers, audio IF separation is accomplished in the converter plate circuit as shown in Figures 194 and 198. In other receivers, one or more video amplifier stages are interposed between the converter and the sound take-off point. Such amplifier stages must have a sufficiently wide pass band to accept both the video IF signal and the audio IF signal. A total bandwidth of approximately 5mc is required for these stages. Examples of audio IF take-off following several stages of combined video and audio IF amplification will be found in Figures 191 and 202.

Figure 210A shows a combination audio IF absorption trap and sound take-off. The audio IF grid is "tapped down" on the circuit in order to preserve high circuit Q for rejection, since the grid loading would normally reduce the Q, and thus the effectiveness of the circuit as a trap. The construction of the transformer L1 - L2, of Figure 210A is shown in Figure 194.

In Figure 210B, the combined trap and take-off circuit L4 - C3 is capacitance-coupled to the video amplifier interstage circuit by means of capacitor C2, and thus acts as a shunt acceptance circuit.

Figure 210C shows the use of the bridged T network as explained on pages 172 and 173. In this case, the entire video and audio IF signal appears across L1, and is passed through C1 to the audio IF amplifier. Selection of the audio IF portion is accomplished by the tuned circuits which follow. The audio IF signal is prevented from reaching the balance of the video IF amplifier by the action of the trap circuit consisting of L2, C3, C4 and R1.

Figure 210D shows the degenerative cathode trap circuit, discussed on page 172, as a sound take-off. In this case, the video IF amplifier tube serves as a cathode follower type of stage, as far as the audio IF signal is concerned. The stage acts as a cathode loaded amplifier at the frequency of the audio IF, due to the tuned circuit (L2 - C2) in the cathode return. Because of this tuned cathode load, the audio IF is degenerated as far as the plate

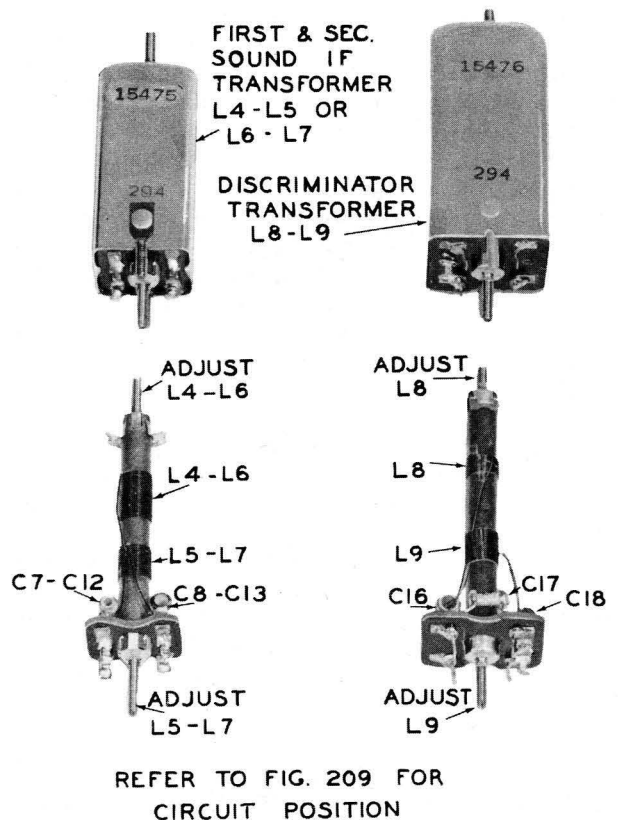

Fig. 212. IF Transformers Used in the Circuit of Figure 211. Photo from Samples Courtesy F. W. Sickles Co.



## CATHODE-RAY - - BEAM MODULATION AND SYNCHRONIZATION

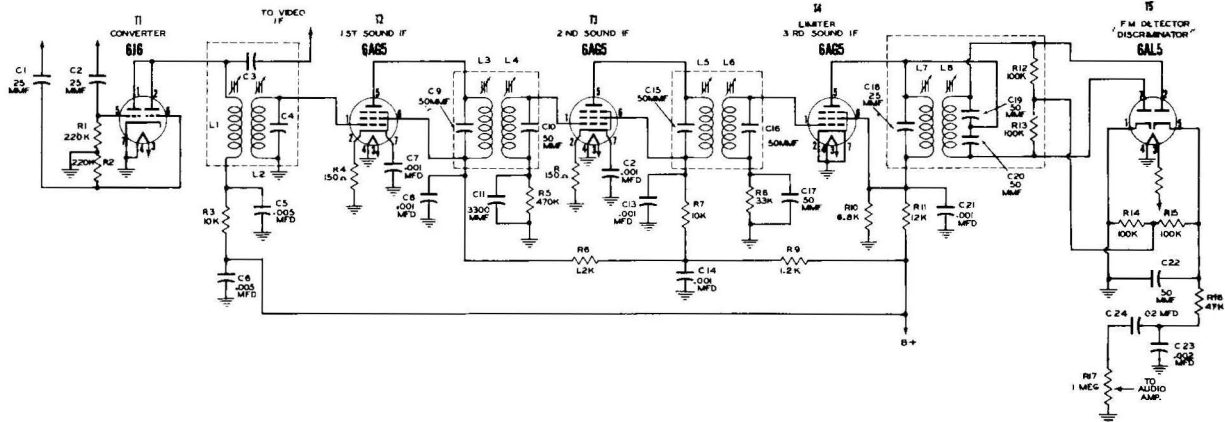

Fig. 213. Another Example of a Television Audio IF Channel.

circuit is concerned, and very little voltage appears for amplification by the succeeding video IF amplifying stages.

**TYPICAL AUDIO IF SYSTEMS.** Figure 211 shows, in schematic form, the audio IF system which is the companion of the video IF circuit of Figure 194. The transformers employed are shown in Figure 212. Interstage transformers, L4 - L5, and L6 - L7, are over-coupled, with a center frequency of 21.25mc. The third stage (tube T4) acts as a limiter. Circuit R8 - C15 in the grid return, provides a bias by grid rectification of the signal to clip one side of the IF envelope by plate current cut-off. The plate and screen run at low voltage (48 volts) as established by the divider comprised of resistors R9 and R10. This provides clipping of the operation beyond the "knee" of the plate voltage - plate current characteristic (the saturation region). The discriminator is seen to be of the familiar Foster-Seeley type.

Another typical audio IF system is shown in the circuit of Figure 213 and the photographs of Figures 214A and B. Again we find the use of over-coupled transformers, a limiting stage and an FM discriminator. The discriminator network is somewhat unconventional and will be described in greater detail under "Variations of the Foster-Seeley circuit". In this amplifier, limiting is accomplished in both the second and third stages by circuits of widely differing time constants. The circuit of Figure 213 and the amplifier strip of 214 are companions to those of Figures 198 and 199 respectively.

Due to the fact that audio IF systems employed in television are identical in type to

those employed in standard FM receivers, no detailed theory of their operation will be given here. Many excellent explanations are to be found in current books and magazine articles available to the service technician.

Television sound differs from the standard FM transmission in deviation. Wideband (75kc) deviation is superior in noise reduction to television (25kc) deviation. Both are capable of the same fidelity and volume range.

**THE FOSTER-SEELEY FM DISCRIMINATOR AND ITS VARIATIONS IN TELEVISION SOUND SYSTEMS.** At least three basically different types of FM demodulation circuits are employed in FM broadcast receivers, namely: the Foster-Seeley discriminator, the ratio detector and the locked oscillator. Of these only the first two types have been employed to date in television receivers.

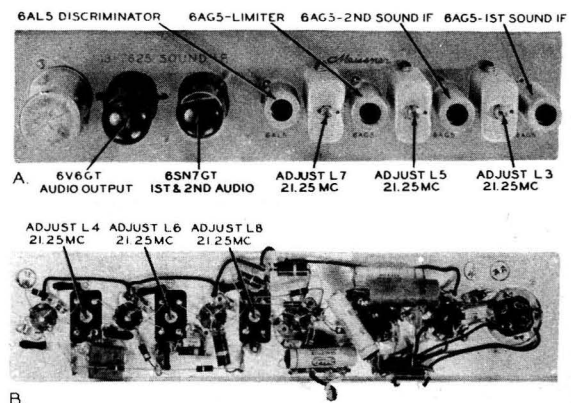

Fig. 214. The Television Audio IF Channel of Figure 213. (A) Top View. (B) Bottom View. Photo from Sample Courtesy Meissner Mfg. Div., Maguire Industries, Inc.

CATHODE-RAY - - BEAM MODULATION AND SYNCHRONIZATION

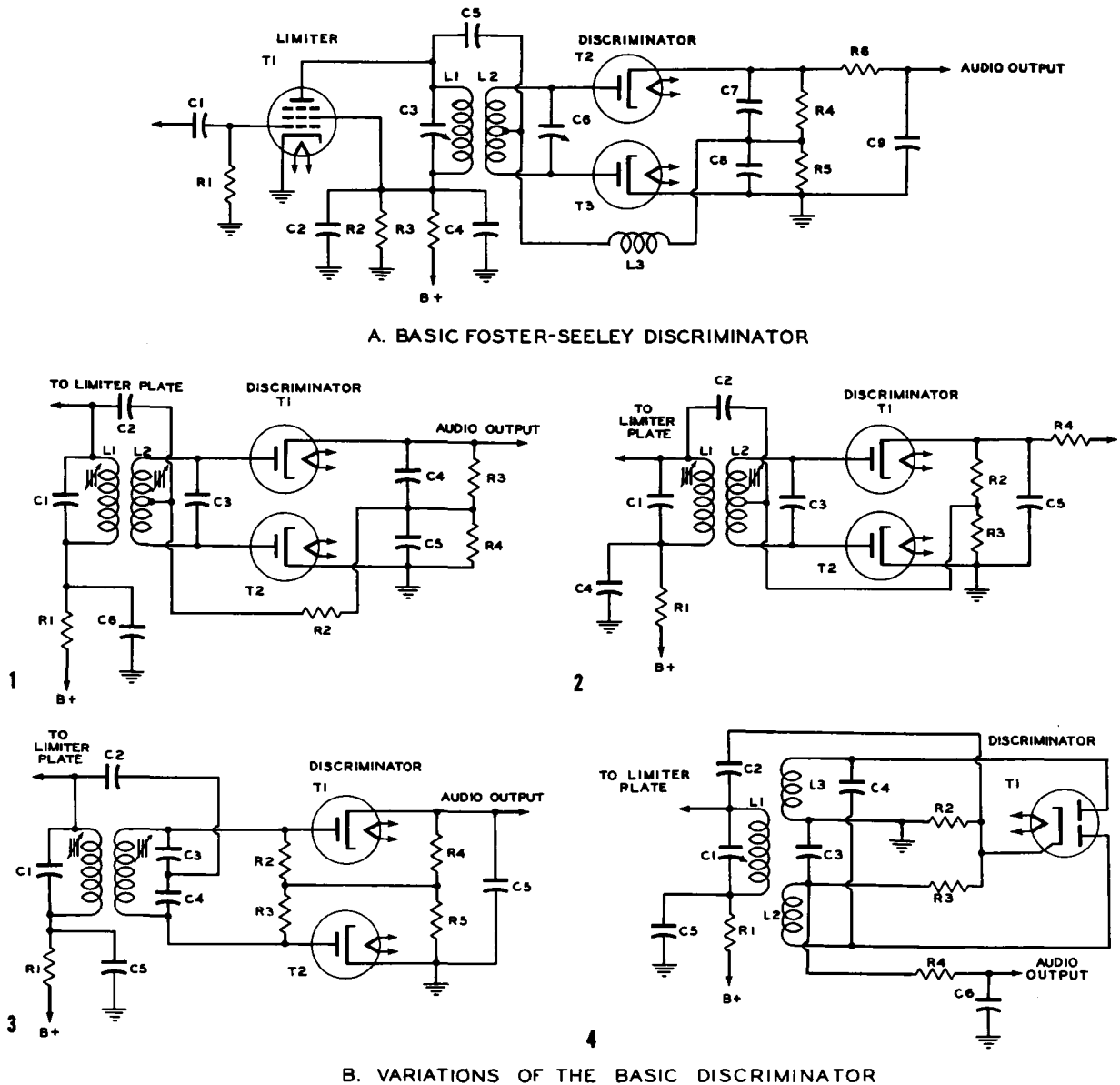

Fig. 215. The Basic "Foster-Seeley" Discriminator and the Variations Employed in TV Receivers.

The Foster-Seeley discriminator shown in Figure 215A is familiar to the television service engineer, not only as an FM detector but also as a method of obtaining a control voltage for A. F. C. systems (see flywheel or A. F. C. horizontal scanning control, pages 101 - 105 and control of the local oscillator of the RF system, see pages 157 - 159).

The discriminator of Figure 215A provides an audio output which, at any instant, is equal to the difference between the rectified

output of diode T2 (across R4) and that of diode T3 (across R5). The IF input is applied to the diodes by the circuit consisting of the tuned IF transformer L1 - L2, C3 - C6 and in-phase network C5 - L3 with bypass capacitors C7 and C8. The action of this system is to combine the output of the transformer, which is supplied to the diode plates 180° out-of-phase with a 90° or quadrature component. As the frequency shifts either side of the IF center frequency, the instantaneous voltage on one diode will increase as that on the other decreases. This

results in the production of both DC and audio voltages across the series combination of load resistors R4 and R5.

This type of FM detector will discriminate against amplitude change only at its center tune or zero modulation frequency. For this reason it is usually preceded by a limiting stage as described on page 179.

To improve the signal to noise ratio, it is standard practice to "pre-emphasize" the high frequency portion of the audio signal in the modulation of the television transmitter. This "pre-emphasis" is corrected in the receiver by a "de-emphasis" circuit consisting of a series resistor and shunt capacitor (R6 and C9 of Figure 215A). The time constant of this combination is fixed at 75 micro-seconds to conform to the FCC standard.

Several variations of the basic discriminator, in current use, are illustrated in Figure 215B.

In Figure 215B-1, the resistor R2 replaces the reactor L3 of Figure 215A. Figure 215B-2 eliminates both the choke and the resistor of the preceding circuit by introducing the quadrature component at the junction of the audio load resistors R2 and R3, the resistors being bypassed by a single capacitor C5.

Figure 215B-3 shows another method of introducing the quadrature voltage. In this case, the tuning capacitance for the transformer secondary consists of two equal capacitors, C3 and C4. The voltage fed from the plate of the limiter is thus coupled to the diode plates "in-phase" and of equal amplitude. To complete the DC return paths of the diodes, resistors R2 and R3 have been added to the circuit.

Figure 215B-4 illustrates a method of using a duo-diode tube with a common cathode in a discriminator circuit. To accomplish this, the secondary of the input transformer has been constructed in two halves with the diode loads in series in the individual plate-to-cathode paths.

**RATIO DETECTORS.** The ratio detector is a popular type of FM demodulator in television receivers. Several features distinguish it from other types of FM detectors. These are: an inherent rejection of amplitude modulation, and the ability to provide an automatic volume control voltage proportional to the peak value of the audio IF carrier.

Figure 216A shows the basic ratio detector circuit. The input network is identical to that of the basic Foster-Seeley discriminator of Figure 215A. The resemblance stops at this point because the diodes are arranged in series or additive fashion rather than in opposition to one another as in the discriminator. Another difference which is significant is the use of an electrolytic capacitor C10 across the diodes and load resistors.

The electrolytic capacitor is charged, through the diodes, by rectification of the applied IF carrier. The time constant of C10 and the series combination of R4 and R5 is approximately a quarter of a second. The bias voltage from this circuit "clamps" the diode conduction level at a value determined by the applied carrier. An instantaneous change, such as might be caused by a burst of noise, cannot change this bias due to the long time constant of the circuit. For the same reason, the total audio voltage across the series capacitors C8 and C9 is held constant. Any change in output of either diode, caused by a shift of frequency will thus cause the ratio of voltages across the capacitors to change, but will not change their sum. Thus the detector output is proportional to the ratio of IF voltages on the diodes, and not to the difference between these voltages.

Due to its insensitivity to amplitude modulation, the ratio detector does not require a preceding limiter and the last audio IF stage can be run at full voltage and gain.

Figure 216B shows several variations of the basic type of ratio detector.

In Figure 216B-1, the major difference is the use of a close coupled winding L2 to supply the quadrature voltage.

Figures 216A, 216B-1, 3 and 4, are of the balanced type, i. e., the circuit is balanced with respect to ground. Figure 216B-2 is known as the unbalanced type. In this case, one end of the electrolytic capacitor is grounded, as well as its shunt resistor R1. The IF path, which supplies diode T1, is completed by the bypass capacitor C4. The capacitor C6 is made variable to take care of stray circuit capacitance balance.

Figures 216B-3 and B-4, both illustrate expedients employed to assure a condition of equal diode inputs at the zero modulation or IF carrier frequency. In Figure 216B-3, separ-

CATHODE-RAY - - BEAM MODULATION AND SYNCHRONIZATION

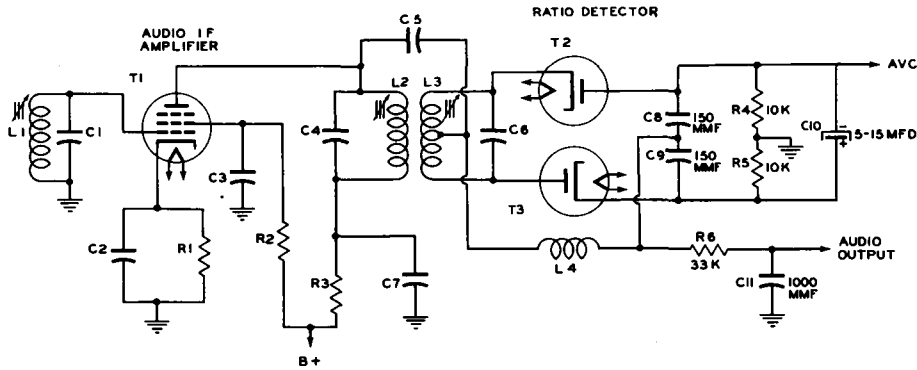

A. BASIC RATIO DETECTOR CIRCUIT

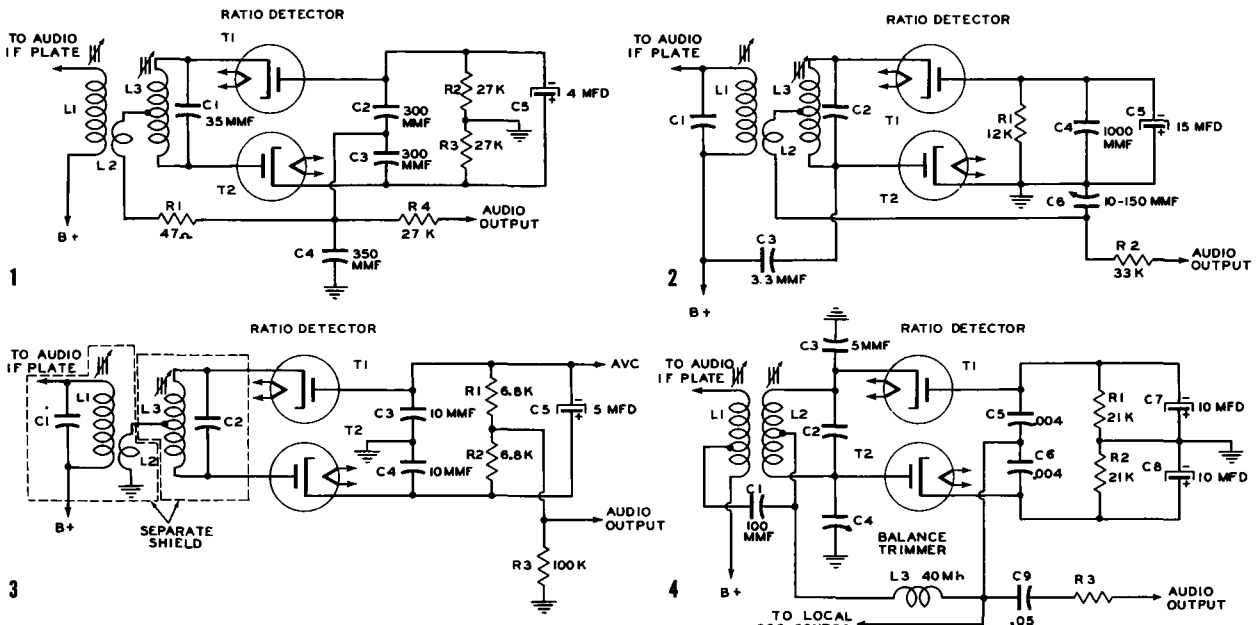

B. VARIATIONS OF THE BASIC RATIO DETECTOR CIRCUIT

Fig. 216. The Ratio Detector for FM Demodulation and its Variations Employed in Television.

ate shielding of portions of the input circuit has been provided to reduce unbalanced coupling. Figure 216B-4 illustrates the ratio detector circuit used to provide an A. F. C. voltage for automatic control of the RF local oscillator, shown in Figure 179. An accurate balance for the carrier tune point is assured by the use of trimming capacitor C4. A small capacitor C3 (5 mmf.) has been added, between the top of the circuit and ground, to assure that the balance point will be within the range of the trimmer C4.

While the ratio detector can provide an A. V. C. voltage for IF amplifier control, this

is normally not utilized. A. G. C. from the video system usually provides this function.

The television sound signal is employed as a means of fine tuning the receiver for both sound and picture, since a drift of tune which would distort or lose the sound, would cause very little change of picture contrast or detail. It is important however, that the audio IF system and the alignment of the detector be centered at the correct intermediate frequency which differs by exactly 4.5 megacycles from the video IF carrier frequency. When the receiver is so tuned, the extra bandwidth allows additional latitude for oscillator drift.

# SECTION III CATHODE RAY — BEAM MODULATION AND SYNCHRONIZATION

## CHAPTER 15. THE VIDEO AMPLIFIER

The output of the video detector (see pages 174-178) seldom exceeds a few volts and since the picture tube requires a grid swing of approximately 40 volts (see Figure 110), for its range of black to white, it is necessary to amplify the signal through one or more stages of video amplification.

In our study of the nature of the video modulating signal (see pages 121-132), we have seen that the range of frequencies encountered extends from 30 cycles to over four million cycles per second. The design of an amplifier to provide uniform gain over this extended band, involves the use of compensating circuits and pentode amplifying tubes of high transconductance. The basic circuit, to which correction networks are applied, is the familiar resistance and capacitance-coupled audio amplifier.

Figure 217A shows a typical pentode amplifier with its coupling elements, and with the inter-electrode capacitance of the tubes indicated in dotted lines. When employed in a conventional broadcast receiver, the solid line curve of Figure 217B would represent a gain versus frequency characteristic which would be entirely adequate for sound reproduction.

The dotted line of Figure 217B shows the required gain characteristic of an amplifier for the video band of frequencies.

For purposes of analysis, the effect of the circuit elements on the frequency characteristic can be represented as shown in Figure 218. The equivalent circuit of the amplifier at

all frequencies is shown by the network of Figure 218A. This network has been re-drawn at B, C, and D to represent the equivalent circuits at low, medium and high frequencies. These ranges correspond respectively to the regions 1, 2, and 3, of Figure 217B.

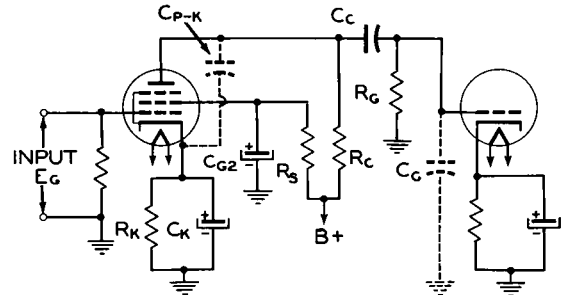

A. TYPICAL RESISTANCE COUPLED AUDIO AMPLIFIER STAGE

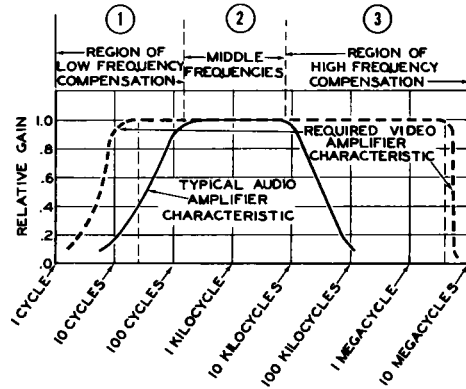

B. REQUIRED VIDEO BANDWIDTH COMPARED WITH TYPICAL AUDIO BANDWIDTH

Fig. 217. Response Requirements of Video Versus Audio Amplifiers.

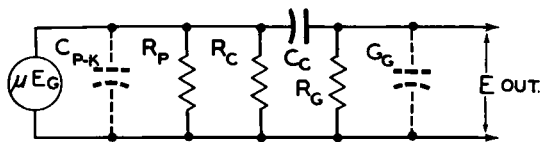

A. EQUIVALENT CIRCUIT OF FIG. 217A

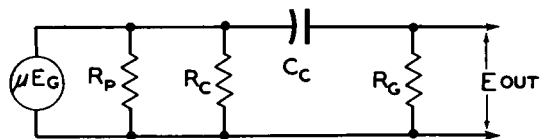

B. SIMPLIFIED CIRCUIT FOR LOW FREQUENCIES (REGION 1 OF FIG. 217B)

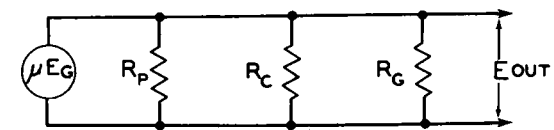

C. SIMPLIFIED CIRCUIT FOR MIDDLE FREQUENCIES (REGION 2 OF FIG. 217B)

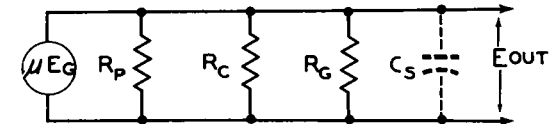

D. SIMPLIFIED CIRCUIT FOR HIGH FREQUENCIES (REGION 3 OF FIG. 217B)

$R_c$  = Plate Coupling Resistor       $C_c$  = Coupling Cap.       $C_{p-k}$  = Plate to Cathode Cap.  
 $R_p$  = Plate Resistance               $C_g$  = Grid to Cathode Cap.       $C_s$  = Total Shunt Cap. =  $C_{p-k} + C_g$   
 $R_g$  = Grid Resistor

Fig. 218. Equivalent Circuits of Resistance-Coupled Stage at Low, Middle and High Frequencies.

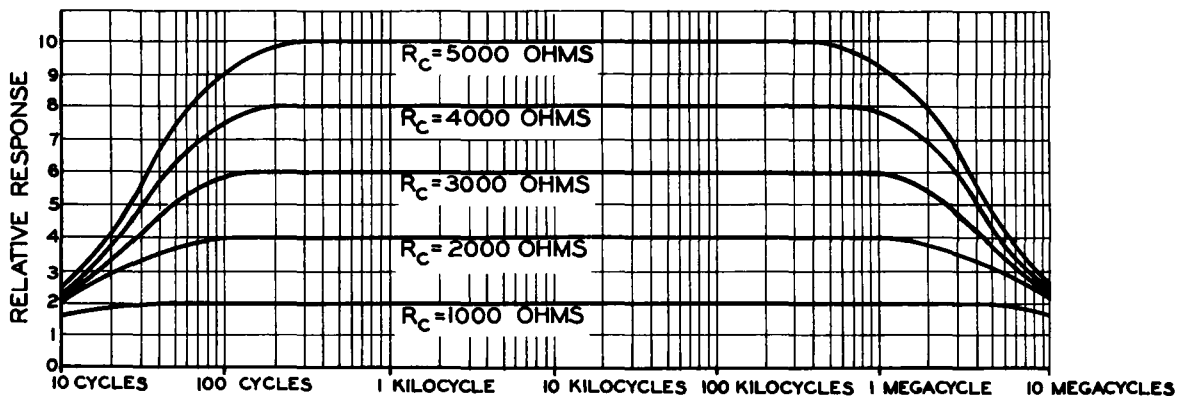

Fig. 219. Effect of Plate Coupling Resistor on Gain and Bandwidth.

Three separate expedients are employed to extend the range of a resistance and capacitance-coupled amplifier for video use. These are:

1. The use of low values of plate load or coupling resistance  $R_c$  in conjunction with high trans-conductance tubes.
2. Low frequency compensation for the effects of the coupling network  $C_c - R_g$ .
3. High frequency compensation for the effects of total circuit capacitance  $C_s$ .

**EFFECT OF THE PLATE LOAD RESISTOR ON BANDWIDTH AND GAIN:** Figure 219 shows the effect of changing the value of the plate load resistor  $R_c$  (see Figures 217 and 218) in a resistance-coupled amplifier stage employing a high trans-conductance pentode, such as the 6AC7, or 6AU6. It will be noted that the band of video frequencies over which the output is sensibly flat is extended greatly as the value of the coupling resistance is decreased. The choice of load resistor is determined as a compromise between bandwidth and gain. The voltage gain of a video stage is seldom more than 20, whereas in the resistance-coupled audio stages, gains of as high as 150 are possible. Load resistors of the order of two to four thousand ohms are common in video amplifiers. After determining the value of load resistance, the stage is then compensated to raise the gain at frequencies below approximately one hundred cycles, and above several hundred kilocycles.

**LOW FREQUENCY COMPENSATION:** At the low frequency end of the video range (region 1

of Figure 217B) the equivalent circuit of the amplifier is that of Figure 218B. The circuit consisting of the coupling capacitor  $C_c$  in series with the grid resistor  $R_g$  acts as a voltage divider. As the frequency is decreased, the reactance of the capacitor  $C_c$  increases. Since the voltage across the grid resistor  $R_g$  constitutes the output voltage of the amplifier, it is seen that the output will drop as the capacitor reactance increases.

To compensate for this drop in voltage a "bass boost" type of circuit, R4-C4 of Figure 220A, is connected in series with the plate load or coupling resistor R3. The effect of this circuit is to increase the plate load as the frequency decreases. The size of capacitor C4, usually an electrolytic, is such that at all frequencies above approximately 100 cycles its reactance is low compared with resistor R4, and it virtually short-circuits the resistor, leaving the load resistor R3 effective for the middle and high frequency range.

As the frequency decreases, the reactance of C4 increases, thus causing the total plate load to increase. The stage gain follows this increase in plate load as shown in Figure 219.

Figure 220C shows the effect on the low frequency gain of changing the product of R4 times C4 (the time constant of the correction network). In the circuit of Figure 220A the time constant of R4 times C4 is one second.

The low frequency components of the video signal are generated by scanning large objects, or areas of uniform tone. The effect of poor low frequency response is to render the scene with improper contrast of those large

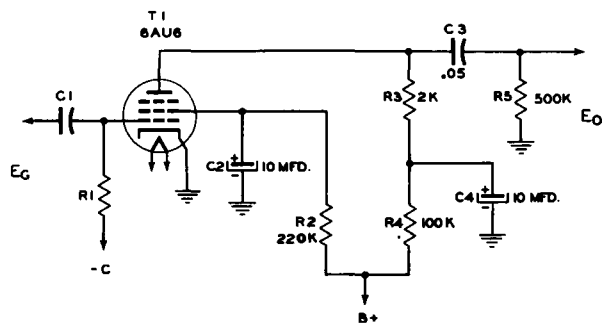

A. LOW FREQUENCY COMPENSATION FOR EFFECT OF COUPLING NETWORK C3 - R5

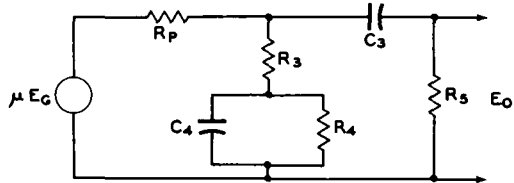

B. EQUIVALENT LOW FREQUENCY CIRCUIT

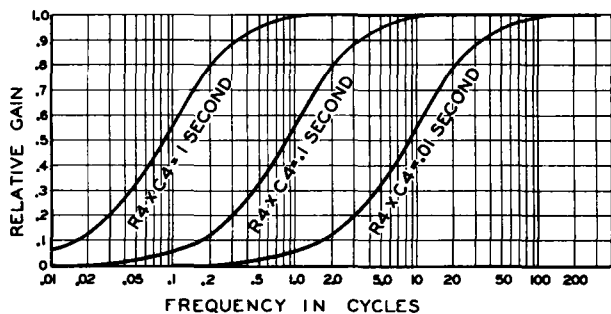

C. EFFECT OF CORRECTION NETWORK R4 - C4 ON GAIN

Fig. 220. Low Frequency Compensation for Loss of Gain Due to Coupling Circuits.

areas with respect to the smaller objects, or fine detail of the picture.

Other sources of attenuation or loss of low frequency gain, in the resistance-coupled amplifier of Figure 217A, are the screen and cathode circuits. The effect of the screen circuit is minimized by the use of a large electrolytic bypass capacitor.

When negative grid bias voltage for the video amplifying stage is obtained from a resistor in the cathode circuit, the resistor can introduce degeneration and cut the stage gain, unless it is bypassed by a sufficiently large capacitance. This capacitance increases in reactance as the frequency is decreased and can thus cause a loss of low frequency gain with respect to the middle and high frequency

range. Compensation for low frequency loss due to this source can be accomplished in the same manner as just described for the coupling network. To avoid this loss, many receivers operate with the cathode grounded and the bias voltage developed by grid current through a high value of grid leak.

**HIGH FREQUENCY COMPENSATION:** The high frequency region of video amplification (region 3 of Figure 217B), is responsible for the fine detail of the reproduced picture. If the gain of the video amplifier is deficient at high frequencies, fine lines or small picture elements will be missing from the picture, or blurred together. Lack of high frequency gain can be detected by examining the center or narrow portion of the vertical "wedges" of the test pattern transmitted by the television station. (See page 109.)

Loss of high frequency gain in a resistance-coupled amplifier is caused by the shunting effect of the capacitance of the various circuit elements to ground. These include the plate-to-cathode capacitance of the amplifying tube, the capacitance of the various resistors and the coupling capacitor, to the chassis, and the input or grid-to-cathode capacitance of the next tube. In the equivalent circuit of Figure 218D, the shunt capacitance, which is the sum of these elements, has been shown in dotted lines as  $C_s$ .

We have seen (Figure 219) that the high frequency response can be extended by decreasing the value of the plate load resistor. This is accomplished at the expense of stage gain.

The gain of the stage at high frequencies is proportional to the impedance of the parallel combination of the plate coupling resistor  $R_c$ , the grid resistor  $R_g$ , and the total shunt capacitance  $C_s$ . At the frequency for which the capacitive reactance of  $C_s$  ( $1/2 fC_s$ ) is equal to the value of the resistors in parallel, the gain is 70.7% of its flat, middle frequency value. This frequency is usually chosen as the point at which the gain is equalized, to the uniform level, by corrective networks. These networks employ inductances (known as peaking coils) which increase in reactance with increasing frequency, and thus compensate for the loss of impedance due to the shunt capacitance.

A great variety of high frequency compensating circuits have been proposed, but commercial receivers have employed only two basic circuits. These are known as shunt and series compensation. A combination of shunt and series compensation is frequently employed.

**HIGH FREQUENCY COMPENSATION BY "SHUNT PEAKING"**. Figure 221 shows the basic "shunt peaking" type of high frequency compensation. Although the peaking coil ( $L$ ) is in series with the plate load resistor  $R_c$ , it operates to raise the impedance of the shunt circuit comprised of  $R_c$  and  $C_t$  which in turn is in parallel or shunt with the plate resistance and the following grid resistor. (See Figure 221B.)

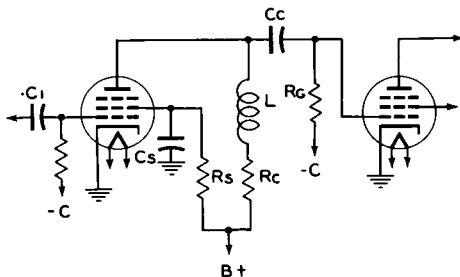

A. "SHUNT PEAKING" HIGH FREQUENCY COMPENSATION

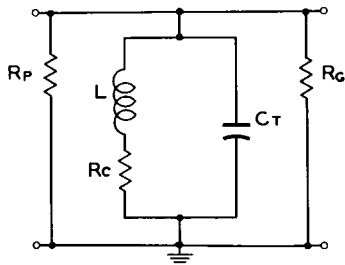

B. HIGH FREQUENCY EQUIVALENT OF CIRCUIT A

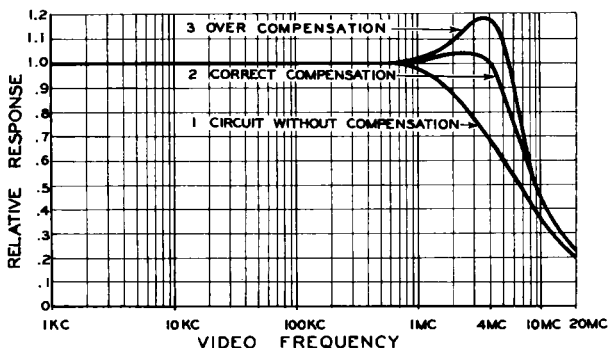

C. EFFECT OF SHUNT PEAKING CHOKE

Fig. 221. High Frequency Compensation by Shunt Peaking.

Curve 1 of Figure 221C shows the frequency characteristic of the circuit of Figure 221A before correction is applied. It will be noted that the point of 70% response occurs at 3.5 megacycles. At this point  $X_c$  of  $C_s$  equals the effective shunt resistance of  $R_c$  and  $R_g$  in parallel. The value of  $L$  is chosen so that at this frequency, the parallel impedance of the circuit comprised of  $R_c$ ,  $R_g$ ,  $C_s$  and  $L$  is increased to yield the same gain as is obtained in the middle frequency range. This condition is shown as curve 2 of Figure 221C.

The network of Figure 221B will be recognized as a parallel tuned circuit with series and shunt resistors. Under the condition for correct compensation (curve 2 of Figure 221C), the resonant frequency of the circuit is 1.41 times the frequency discussed in the previous paragraph. If the value of inductance is increased to reduce the resonant frequency, a condition of over-compensation will be obtained. (See curve 3 of Figure 221C.) The effect of such over-compensation is to render fine detail in improper contrast with respect to the rest of the picture, i. e., too dark. The peaking coils of a television receiver are designed to operate with the particular type of tube and circuit capacitances, and in the event it is necessary to replace them, an exact duplicate must be used.

**HIGH FREQUENCY COMPENSATION BY "SERIES PEAKING"**. Figure 222 shows another method of raising the response curve at the high frequency end by the use of a series peaking coil. In this case, the coil is in series with the circuit, producing an equivalent net-

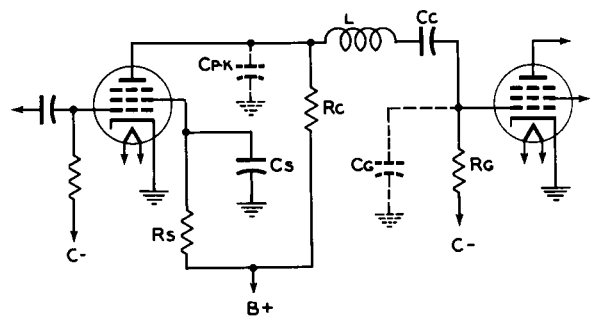

A. "SERIES PEAKING" HIGH FREQUENCY COMPENSATION

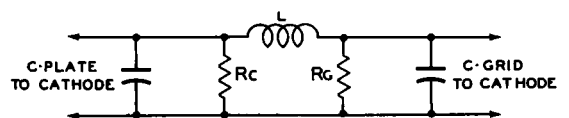

B. EQUIVALENT CIRCUIT AT HIGH FREQUENCIES

Fig. 222. High Frequency Compensation by Series Peaking.



work as shown in Figure 222B. This will be recognized as a filter network of the Pi type. The inductance serves to isolate the plate-to-cathode capacitance of the amplifier tube, from the input capacitance of the following tube. It is of advantage since it allows a higher coupling resistor with consequent higher stage gain. In practice, the gain of the stage with series peaking can be made 50% greater than that of one with shunt peaking alone, for the same bandwidth. In the series peaking case, the resonant frequency of the circuit  $L - C_g$  is made higher than the upper limit of the desired video range, and tends to counteract the loss due to capacitance  $C_{p-k}$  across the coupling resistor  $R_c$ .

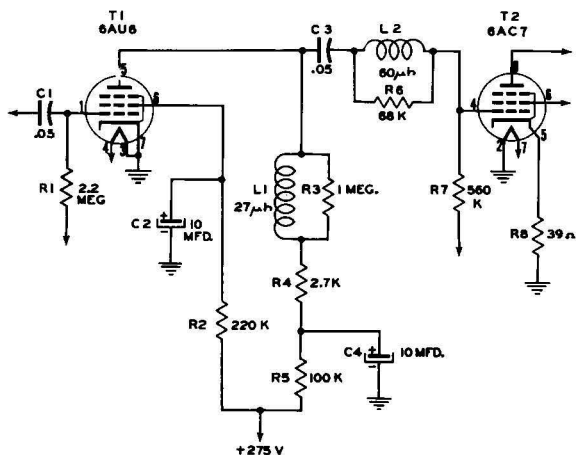

Fig. 223. Video Stage with Both High and Low Frequency Compensation.

**COMBINATION SHUNT AND SERIES PEAKING.** From the foregoing discussion it is evident that the operation of shunt peaking and series peaking are independent, and can complement one another. The majority of modern television receivers employ a combination of both methods. A typical example is shown in Figure 223, in which inductor L1 operates as a shunt peaking inductor and L2 as a series peaking inductor. It will be noted that both of these coils have a resistor connected across them. The purpose of the shunting resistor is to reduce the Q of the circuit to smooth out the gain versus frequency curve, and also to damp the circuit and thus prevent it from being shock-excited into transient oscillation by sharp video impulses or noise peaks. Such oscillation will produce smearing and a negative image following fine detail portions of the picture as shown in the photographic example of Figure 230.

The circuit of Figure 223 also includes the low frequency compensation network  $R5 - C4$  for compensation of the loss in the coupling network  $C3 - R7$ . The screen is adequately by-passed by electrolytic condenser C2, and therefore does not reduce the low frequency gain. The series coil is often placed in the circuit between the plate and the coupling resistor, rather than between the coupling capacitor and the following grid. Examples of circuits of this type are Figures 205, 206 and 207.

In the discussion of video detectors, pages 174 through 176, mention has been made of series and shunt peaking for correction of high frequency losses occurring in the detector output circuit. These are seen to be of the same type as just discussed. The series inductor of the detector circuit (see Figures 206 and 207) serves the additional purpose of attenuating the 4.5 megacycle beat, between the sound and video carriers, which, if not suppressed, would cause sound bias to appear on the picture.

**Typical Video Peaking Coils.** Figures 224 and 225 show typical video peaking coils. Figure 224 is an interesting example of a combination of the functions of the resistor and inductor in a single unit. The plate-coupling resistor ( $R_c$  of Figures 221 and 222) is of the wire wound type, and is connected between the center and right hand lugs. This resistor is wound with a wire of such diameter and so spaced as to automatically provide the correct inductance for the shunt peaking



Fig. 224. Video Coupler - Combining Coupling Resistor, Shunt and Series Peaking Coils in a Single Unit. Photo from Sample Courtesy P. R. Mallory & Co., Inc.

element. The series peaking coil is seen at the left and is of the universal type. This provides the coupling and compensation elements of a video stage in a single unit.

Figure 225 shows two video peaking coils. The coil of Figure 225A is wound on an insulated carbon resistor of the correct value to provide the required damping, while the coil of Figure 225B is wound on a bakelite form.

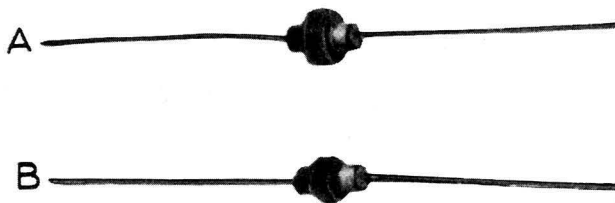

Fig. 225. Video Peaking Coils. Photo from Samples Courtesy F. W. Sickles Co.

**PHASE SHIFT IN THE VIDEO AMPLIFIER:** In our discussion of the video amplifier up to this point we have considered only the requirements of gain versus frequency. Another and equally important consideration is the possible phase shift or time-delay of the signal as it passes through the amplifier.

In the amplification of audio voltages in a broadcast receiver, phonograph amplifier or sound system, phase shift or delay of one end of the audio frequency spectrum with respect to the other is seldom of consequence. The ear is not sensitive to phase shift, and for this reason, the radio technician is not required to give it any consideration. In the case of the television video amplifier, however, phase shift and time delay are of great importance and, if not corrected, can cause badly distorted and smeared pictures.

In the reproduction of sound, wave forms are, in the great majority of cases, sinusoidal; and an understanding of the action of sine waves of voltage in passing through an amplifier is sufficient to cover the theory of operation of audio amplifiers. In television work, the video signal in many cases is of square or rectangular waveform. This can readily be understood by considering the output obtained from the camera tube as it scans across a black bar in front of a white background. During the scanning process, the video signal is near its zero amplitude while crossing the background, and suddenly rises to maximum

amplitude and remains there as the bar is crossed, dropping back to zero amplitude again as the background is reached. The length of the bar determines the half wave of a low frequency, which can be considered to be the fundamental frequency for that particular element of the picture. The square wave is composed of this fundamental frequency and a great number of harmonics of different amplitudes, which, when added up, will produce the rapid rise and rapid fall at the ends of the bar. Thus, to reproduce a black bar, no matter what its length, will require the ability to amplify all of the harmonic frequencies which, as we have seen, can extend to four megacycles.

We have seen, in our study of the action of amplifier stages, that the wave, applied to the grid, is shifted  $180^\circ$  in phase when it appears across the plate load resistor.

As far as the tube itself is concerned, a wave of any frequency in the video range is shifted  $180^\circ$  in phase in the process of voltage amplification through a single tube. The network of resistors and capacitors, which constitute the coupling elements between the tubes, cause a shift of phase which is different both in amount (number of degrees) and direction for different frequencies in the video range.

For the middle range (region 2 of Figure 217B) the coupling network is sensibly resistive (see Figure 218C), and a constant phase shift of  $180^\circ$  occurs due to the tube action.

**LOW FREQUENCY PHASE SHIFT.** At low frequencies (region 1 of Figure 217B), the coupling network,  $C_c - R_g$ , whose effect on low frequency gain was discussed on pages 184 and 185, and illustrated in Figure 217, produces a leading phase shift which increases as the frequency decreases. This phase shift is proportional to the ratio of the reactance of the coupling capacitor, to the resistance of the grid resistor, and would cause the effects shown in the table of Figure 226, if no correction were applied. It is seen that a very small phase shift, measured in degrees, can cause a large time difference at the very low frequencies. The effect on the reproduced picture is to produce "smearing" of the edges of large areas and an uneven tonal reproduction of these areas. An excessive phase shift at the very low frequencies (30 to 70 cycles) will also cause a gradual shading of the picture from top to bottom, since the effect of a single picture element can exist for more than one horizontal line.

Since the phase shift is a leading effect, it can be corrected by a shunt circuit consisting of a parallel combination of capacitance and resistance of the same type of network as is required to compensate the low frequency loss of gain (R4 - C4 of Figure 220, see pages 184 and 185). Thus both phase shift and gain can be corrected by the same network of added circuit elements.

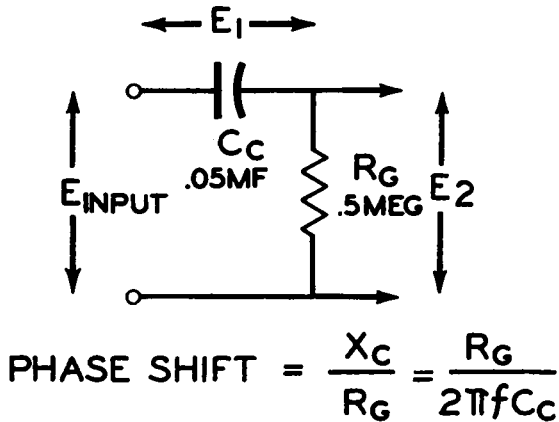

F	Phase Shift of E2 in Degrees	Time Delay $\mu S$	Horizontal Displacement of Image (10 in. Tube)
500	.7	4	.576 in.
200	1.8	25	3.7 in.
100	3.6	100	1 line + 8.6 in.
70	5.2	206	3 lines + 6.5 in.
50	7.2	400	7 lines + 3.3 in.
30	12	1110	20 lines + 3 in.

Fig. 226. Chart Showing Low Frequency Phase Shift Due to Coupling Elements.

**HIGH FREQUENCY PHASE SHIFT.** At high frequencies (region 3 of Figure 217B) we find that the capacitance  $C_T$  across the coupling network can cause a lagging phase shift of the high frequencies with respect to the middle frequency portion of the video signal. Figure 227 shows the parts of the equivalent amplifier circuit (see Figure 217 and 218) responsible for high frequency phase shift. The chart shows that while the phase shift increases in degrees as the frequency increases, the time delay drops and the image displacement becomes a smaller amount. Again as in the case of low frequency phase shift, the same corrective networks which are employed to compensate for loss in gain are used to produce a phase shift in the opposite direction to that of

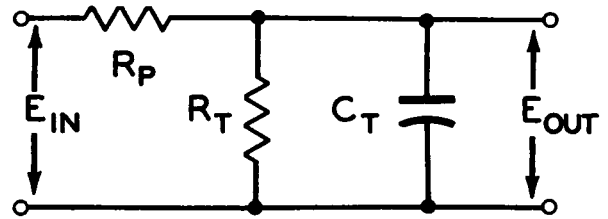

$$R_T = 4000 \Omega$$

$$C_T = 50 \text{ MMF}$$

$$\text{PHASE SHIFT} = -2\pi f C_T R_T$$

Freq.	Phase Shift in Degrees	Time Delay $\mu S$	Horizontal Displacement of Image (10 in. Tube)
10 kc	.72	2.0	.286 in.
100 kc	7.2	2.0	.286 in.
1 mc	64.4	1.8	.266 in.
2 mc	103.8	1.4	.207 in.
3 mc	124	1.266	.187 in.
4 mc	136.6	.95	.141 in.

Fig. 227. Chart Showing High Frequency Phase Shift Due to Shunt Tube and Circuit Capacitances.

the network. The shunt and series peaking coils and their combinations are used to produce an overall circuit phase shift which is proportional to frequency.

**THE IDEAL - PHASE SHIFT PROPORTIONAL TO FREQUENCY OR UNIFORM TIME DELAY.** At the speed of horizontal scanning (15,750 cycles per second), the spot moves across a picture 8 inches in width, at approximately 111,000 inches per second. This means that a time delay of one micro-second, of any part of the video signal, will produce a difference in position of almost an eighth of an inch. If all frequencies in the video signal suffered this time delay, the picture would be satisfactory, but displaced an eighth of an inch to the right. It could be moved back by adjustment of the horizontal centering control. A uniform time delay means a different phase shift at each frequency (a phase shift proportional to the frequency).

The relation between time delay and frequency is expressed by the equation:

$$\text{Time Delay} = \frac{\text{Phase Shift in Degrees}}{360^\circ \text{ Times Frequency in Cycles}}$$

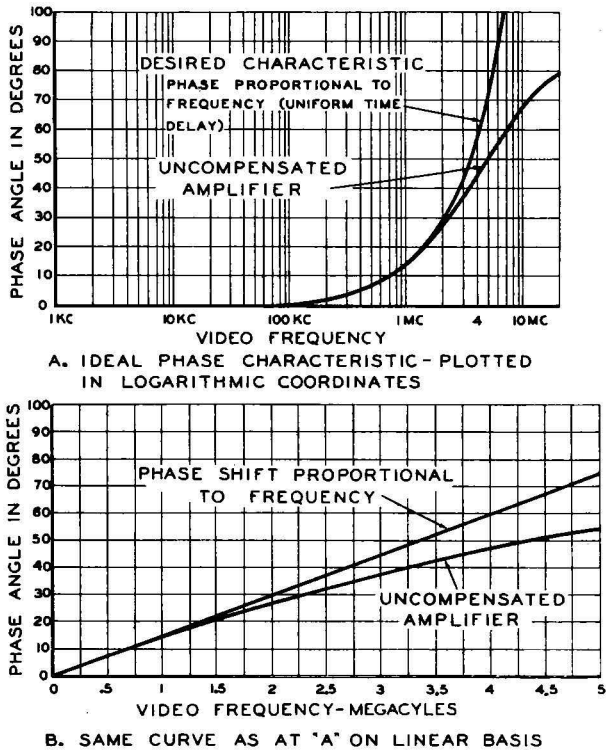

Fig. 228. Phase Shift Requirements of a Video Amplifier for Perfect Reproduction.

Figure 228 shows the desired relationship of phase shift proportional to frequency, or uniform time delay, as applied to the video amplifier of a television receiver. It will be seen that at the high frequencies, the phase shift of the uncompensated amplifier drops below the desired proportional curve which will produce a picture without "blurred" or shifted elements.

**"SMEARING" OF THE TELEVISION IMAGE BY AMPLITUDE OR PHASE DISTORTION:** Figure 229 illustrates the effects on the square wave of video modulation representing a black bar, when various deficiencies exist in the video amplifier.

Figure 229B shows the result after the square waveform has passed through an amplifier having insufficient high frequency gain. The leading edge of the amplified wave has a gradual slope rather than an abrupt rise. This will cause shading from gray to black in the reproduction. At the trailing edge, the exponential decay of the wave will cause a gray to white smear.

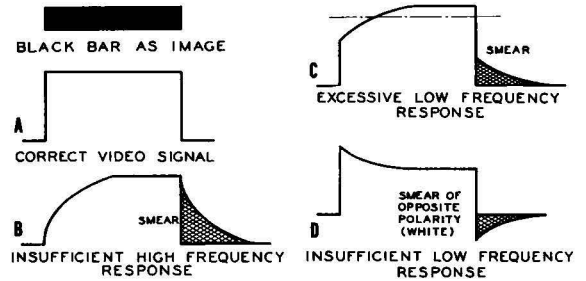

Fig. 229. Square Wave Video Signals Showing the Effect of Amplifier Deficiencies.

Figure 229C shows the effect of over-compensation or excessive low frequency response. This effect is seen to be of the same nature as that caused by insufficient high frequency response, although not as pronounced.

Figure 229D illustrates the case of insufficient low frequency response accompanied by attendant phase shift. In this case, the front edge of the bar is rendered black shading to gray, while the smear which follows the bar is white shading to gray. This type of a smear is known in television slang as a "trailer".

Figure 230 shows the effect of insufficient damping of the peaking circuits used for high frequency compensation. The oscillation due to shock excitation of these circuits by the short duration square wave picture elements, can be seen as alternate white and gray ghosts adjacent to the black circular rings of the test pattern.

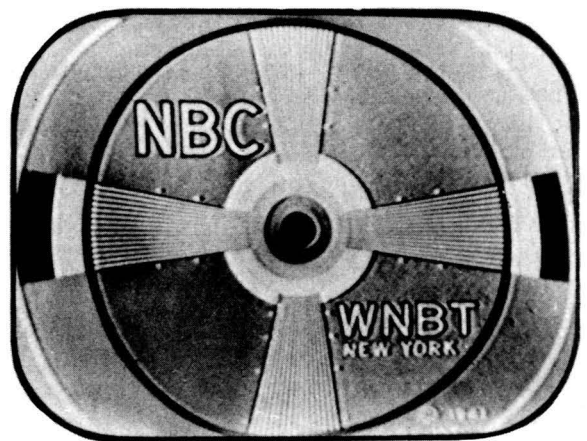

Fig. 230. A Station Test Pattern Showing the Effect Due to either Transient Oscillation or a Reversed Polarity Smear. (See Figure 229C.) Photo Courtesy National Broadcasting Company and the R. C. A. Service Company, Inc.

# SECTION III CATHODE RAY — BEAM MODULATION AND SYNCHRONIZATION

## CHAPTER 16. DC RESTORATION

In our study of the nature of video modulation (Pages 121 - 132), we have seen that the video signal is essentially unidirectional in nature, with its AC component superimposed on a varying direct current component. This DC component represents the average shading or background of the picture, and is lost whenever the video signal passes through a coupling capacitor. The text and illustrations of Pages 130 through 132 explain the manner in which the DC component is restored or re-inserted at the television transmitter. At this time we will consider the manner in which DC restoration is accomplished in the receiver.

Figure 231 illustrates the necessity for restoration of the DC component. We have again selected, as an example, a black bar against a white background (Figure 231A). The video modulating signal of the transmitter for two successive horizontal lines is shown in Figure 231B.

When the video signal of Figure 231A is passed through a capacitance-coupled video amplifier, the DC component is lost and the signal appears as an alternating voltage (Figure 231C) around an average value (the average of the white and black areas or about 25% of maximum signal in this example).

If a signal of this type is applied to the picture tube grid, as in Figure 231D, all of the picture components on the negative side of the average signal, including the sync pulses, will extend into the cut-off region. The white background will be rendered as a dark gray.

If the DC component is restored, the operating point on the picture tube characteristic is established at its proper gray value. This places the black level (75% of maximum signal) just at the cut-off grid bias as shown in Figure 231E.

The problem of proper DC restoration is thus resolved to a method of maintaining the blanking, or black level, of the video signal, at the voltage which corresponds to the light cut-off bias value of the picture tube grid.

The blanking level which acts as the reference point for the DC component, and the DC component itself, are present in the video signal as it appears across the detector load resistor. This level is a fixed value to which the picture carrier returns at the end of each horizontal line. If the entire video system,

from the detector load to the picture tube grid, is direct coupled (without the use of coupling capacitors) the DC component is established automatically. While such a direct coupled circuit is capable of good performance, it is not always convenient in application.

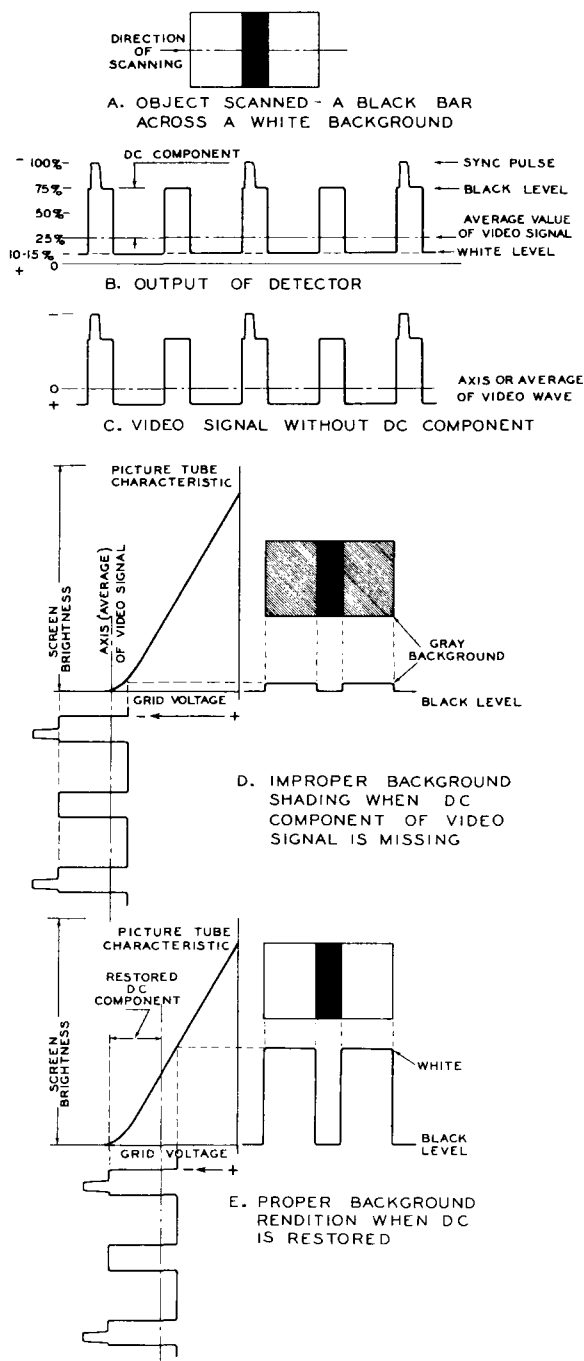

Fig. 231. The Effect of the DC Component of the Video Signal on Image Reproduction.

**THE DIODE DC RESTORER:** The method of DC re-insertion, most frequently employed, is the use of a diode directly coupled to the picture tube control element or grid. Figure 232A shows the essential circuit elements of the diode restorer. A typical video output system incorporating diode restoration is shown in Figure 233.

The operation of the diode restoration circuit is shown in the waveform diagrams of Figure 232B and C. Figure 232B shows three horizontal lines of a video signal which has passed through a capacitance-coupled video amplifier, and consequently has lost its DC component. In this case, the DC to be restored is the value from the AC axis to the tip of the sync pulse, or 25 volts. Let us follow through several cycles of operation of the restorer:

1. During the interval from "a" to "b" the polarity of the video signal is such that the cathode of the diode is positive with respect to its anode. The tube will not conduct. (Region "f" to "g" of Figure 232C.)

2. When the voltage reverses, during the interval from "b" to "c" of Figure 232B, 25 volts will appear across the diode in the correct direction for conduction, quickly charging capacitor C1. The change of voltage across

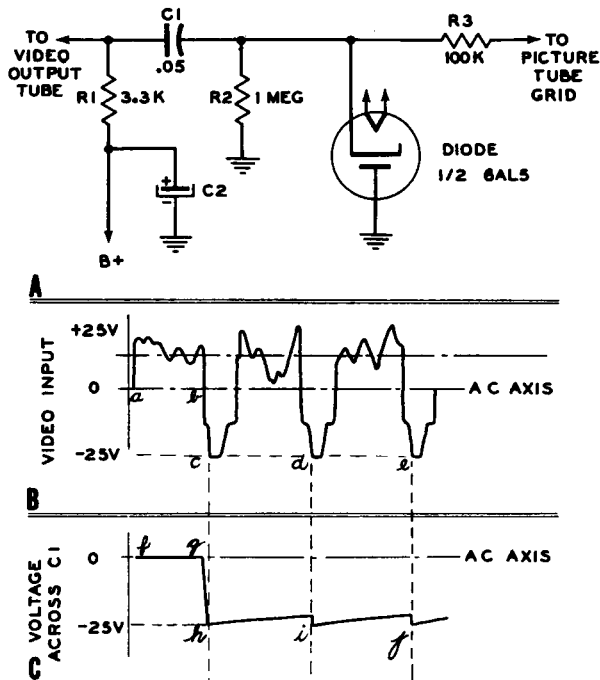

Fig. 232. DC Restoration by Diode Rectification of the Video Signal.

the capacitor during this interval is shown in Figure 232C from "g" to "h".

3. Since the time constant of the diode coupling network (C1 - R1) is .05 seconds, the charge on capacitor C1 has decreased very little during the horizontal line interval from "c" to "d". (Note: The voltage drop across the capacitor has been exaggerated at "i" and "j", for illustration.)

4. Conduction occurs again due to the sync pulse tip "d" which charges the capacitor to the peak value of the signal.

Figure 233 shows the complete circuit including the video output tube, the picture tube input circuit, and the fixed bias adjustment circuit (brightness control).

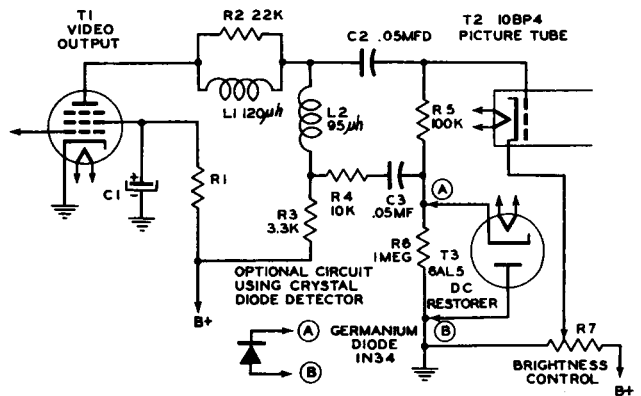

Fig. 233. A typical Video Output System with Diode Restoration.

It will be seen that the load resistor of the diode restorer (R6) is in series with the grid-to-cathode circuit of the picture tube, and thus any bias set up by the diode acts in series with a fixed bias determined by the setting of the brightness control (R7). The AC component of the video signal is superimposed on this combination bias through coupling capacitor C2, in such polarity that the blanking signals and sync pulses drive the tube to cut-off (black region).

The DC component is applied in positive polarity to the grid and acts to reduce the fixed negative bias (from R7), to a degree determined by the average level of the alternating video signal (background illumination).

The diode restorer can be classified as a peak rectifier of long time constant (affected

by changes in video level which occur at a rate lower than approximately 50 cycles).

The vacuum tube diode may be replaced by the 1N34 germanium diode as shown in the alternate circuit of Figure 233. Since the crystal diode has a lower dynamic resistance than the vacuum tube type, it produces a more secure clamping action at the sync tip level, and also tends to produce an even alignment of sync tips, thus improving the scanning control action.

**DC RESTORATION BY GRID RECTIFICATION:** The video output tube can perform the dual functions of providing the voltage swing for picture tube operation, and the restoration of the DC component. In this case, the grid and cathode act as a diode, as in the familiar grid leak detector. A circuit embodying this method is shown in Figure 234. Its operation is as follows:

1. The excursions of the video signal in the positive direction, caused by the sync pulses, produce a current flow into capacitor C1 via the grid-to-cathode path.
2. A charge of a value equal to the sync pulse tips accumulates on the capacitor.
3. During the active picture interval, the grid circuit is non-conductive and the capacitor starts to discharge through resistor R9.
4. The voltage thus established across R9 acts as a DC component which may be considered as adding to the AC signal. The amplified signal, with its added DC, is impressed on the picture tube input.

**RESTORATION BY RECTIFICATION IN THE PICTURE TUBE INPUT CIRCUIT:** Figure 235 shows a method of using the picture tube grid-to-cathode as a diode for restoration of the DC component. This method has been called "AC stabilized brightness control". A self-bias

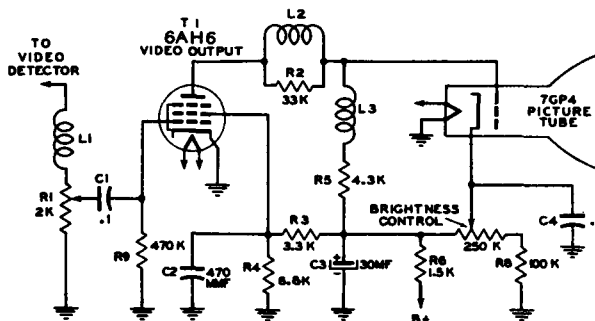

Fig. 234. DC Restoration by Grid Circuit Rectification in the Video Output Stage.

(in the absence of signal) is established across resistors R4 and R5 or a total picture tube beam current. This bias tends to correct automatically for changes in brilliance, due to power line or high voltage variations. The video signal is coupled to the cathode through capacitor C2, and the DC bias, whose peak value is established by the synchronizing pulse tip, is set up across resistor R4 in the same manner as that described in the preceding text covering diode restoration.

**DC RESTORATION EMPLOYING A TRIODE:** Figure 236 shows a circuit in which a triode is employed for the dual purpose of DC restoration and sync separation. This circuit will be recognized as similar to that of Figure 95C, page 91. The cathode bias developed across

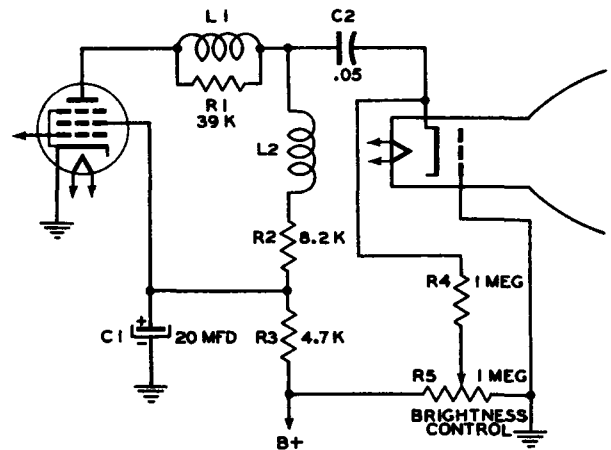

Fig. 235. DC Restoration by Self Bias in Picture Tube Grid Circuit.

circuit R2 - C3, due to plate rectification, is determined by the peak value of the synchronizing pulses, and this bias constitutes the DC component. A more detailed description of the

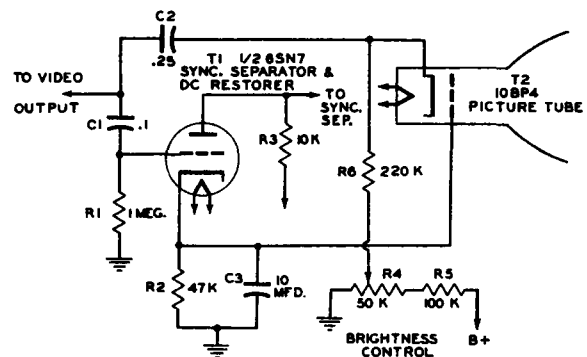

Fig. 236. Use of a Triode for DC Restoration and Sync Separation.







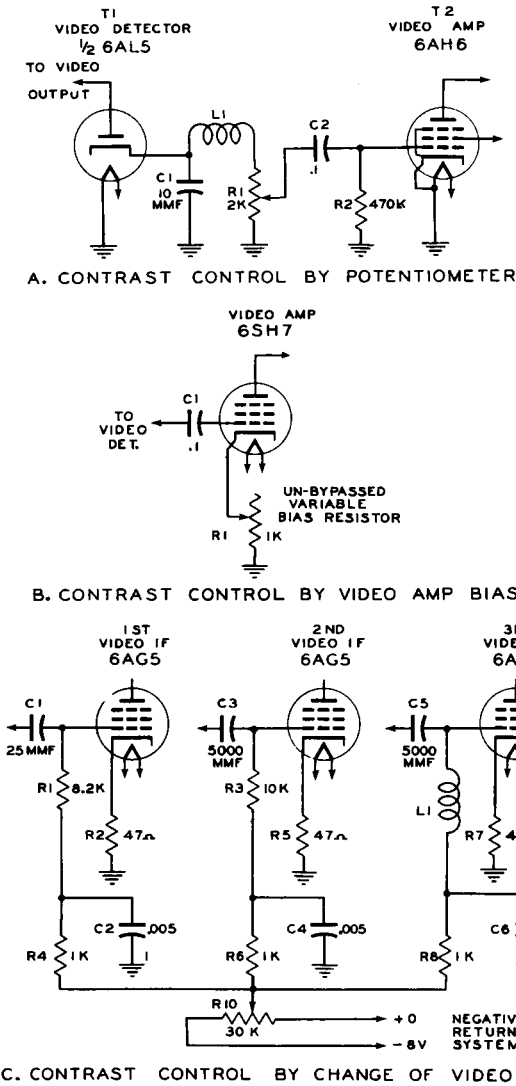

Fig. 238. Contrast Control by Change of Video Gain.

eral methods of deriving a negative voltage for this control purpose are employed: 1. The power supply system has an intermediate point in a voltage divider connected to ground rather than the center tap of the supply transformer tube. 2. A selenium rectifier is used to derive approximately 8 volts DC from the 6.3 volt AC filament supply. (The peak of the 6.3 volt AC wave is 8.9 volts.) 3. The negative bias developed in the grid of the horizontal scanning oscillator is filtered and used as a source of contrast control voltage.

**CONTRAST CONTROL BY DIVIDED BIAS ON RF AND IF STAGES.** An important consideration in the design of gain control by variation of bias in the RF and IF amplifiers

is to avoid grid overload of any of the stages under control, by the signal. Since sharp cut-off tubes such as the 6AG5 and 6AU6 are frequently employed in the video IF amplifier in combination with tubes of a more extended cut-off, such as the 6J6 in the RF amplifier, a bias system which supplies more control voltage to the 6J6 is required.

Figure 239 shows a system in which the bias on the 6J6 RF tube varies from -1.1 volts to -8 volts, while the bias on the 6AG5 video IF tubes is controlled from -1.1 to 15 volts.

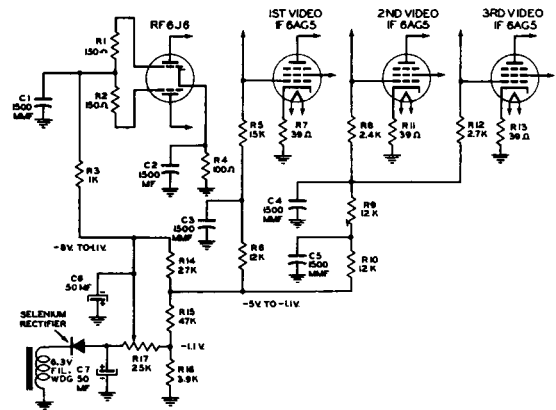

Fig. 239. Contrast Control by Divided Bias - Full Control on RF Stage - Partial Control on IF Stages.

**THE DIODE "GATE" AND ITS FUNCTION IN A CONTRAST CONTROL SYSTEM.** Figure 240 shows a refinement of the divided bias system of Figure 239. In this case a novel arrangement of employing a diode is used in conjunction with the control circuit. The pri-

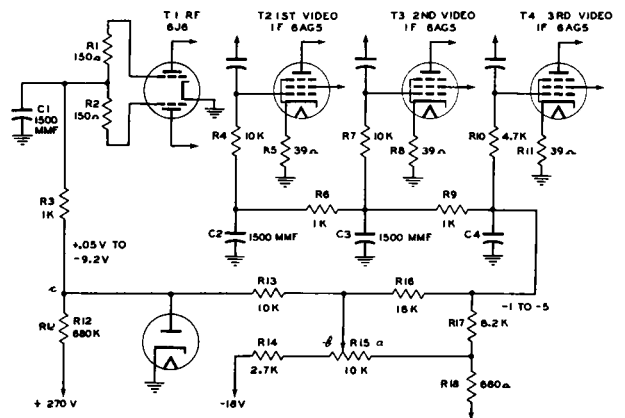

Fig. 240. Use of a Diode Gate to Provide Improved Contrast Control Action.

mary function of the diode is to allow the RF stage to run at full gain over a considerable range of the contrast control. This assists in maintaining a high signal-to-noise ratio. The gain of the RF stage is reduced only when it becomes necessary in order to prevent overload of the first IF stage. The operation of the circuit is as follows:

When the contrast control (R15) is at maximum gain position, "a", the bias on the video IF amplifier is approximately -1 volt. The RF bias, taken from the tap "c" on the divider network connected to +B would be several volts positive if it were not for the heavy conduction of the diode. (The diode resistance when conducting is only a few hundred ohms.) This holds the RF bias at approximately zero. As the contrast control is moved away from its maximum position the RF and IF biases fall as shown in Figure 241. The IF bias immediately goes negative to produce the major portion of the gain control. Diode conduction decreases and at approximately 75% of maximum rotation the slope of the RF bias changes more rapidly. As the contrast control is reduced still further, the diode conduction stops and the RF bias voltage proceeds at an even more rapid rate and passes that of the IF bias. Although triodes are normally not considered to be remote cut-off tubes, sufficient

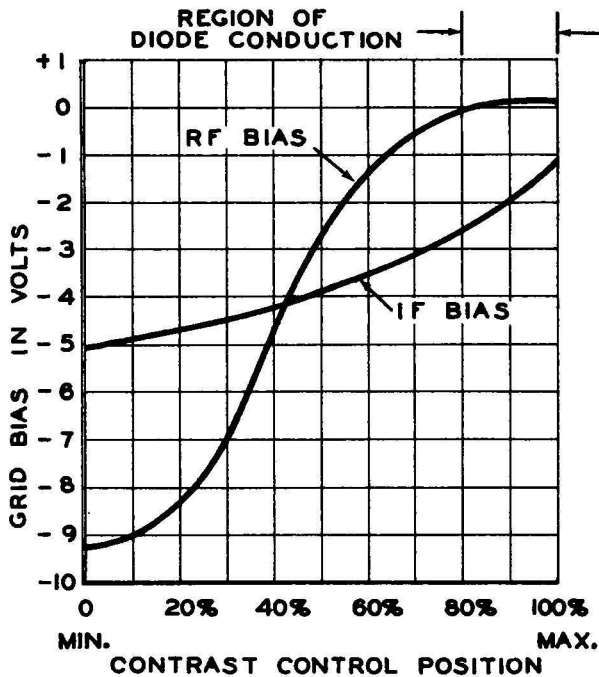

Fig. 241. Bias Characteristics of the Circuit Shown in Figure 240.

curvature of the grid bias versus transconductance curve exists in the case of the 6J6 to permit approximately 10/1 gain reduction over the range shown in Figure 241. This prevents overload at any point in the control range.



Fig. 242. Station Test Pattern Showing the Effect of Misadjustment of the Contrast Control. Photo Courtesy National Broadcasting Company and the R. C. A. Service Company, Inc.

**A. G. C. (AUTOMATIC GAIN CONTROL):** The television service technician is familiar with automatic volume control in standard broadcast and short wave receivers. Its purpose is to compensate automatically for fading, and also to hold the gain of the receiver constant as it is successively tuned to stations of varying carrier strength. Actually the A. V. C. system of a broadcast receiver is an A. G. C. system, because the function of volume control is normally accomplished by variation of the audio gain. In a television receiver, the A. G. C. system functions to hold the overall gain or contrast constant, as the receiver is tuned to various channels representing stations of various carrier strengths. It is not normally called upon to compensate for fading because, in the majority of cases, the receiver is being operated in a region of fairly constant field strength, (the primary service area). In fringe reception, however, the additional function of compensation for fading is present.

Another function of A. G. C. is to hold the video voltage constant and thus line up the tips of the sync pulses. This is of importance in receivers of the triggered sync type which do not have the advantage of automatic frequency control sync system.

Figure 243 shows a circuit in which an A. G. C. diode (T4) is connected in parallel with the video detector by means of the coupling capacitor (C5). The diode rectifies the video IF envelope and the capacitor C5 is charged to a value determined by the tips of the sync pulses. The combination of resistor R8 and capacitor C5 represents a long time constant (approximately .2 second). This tends to average short time variations of the carrier. Coupling network R7 - C4, filters the detector output and provides a DC control voltage for the grids of the RF and IF amplifier. In the example shown, sync separation is accomplished by dividing the diode load and taking the sync pulses from the cathode.

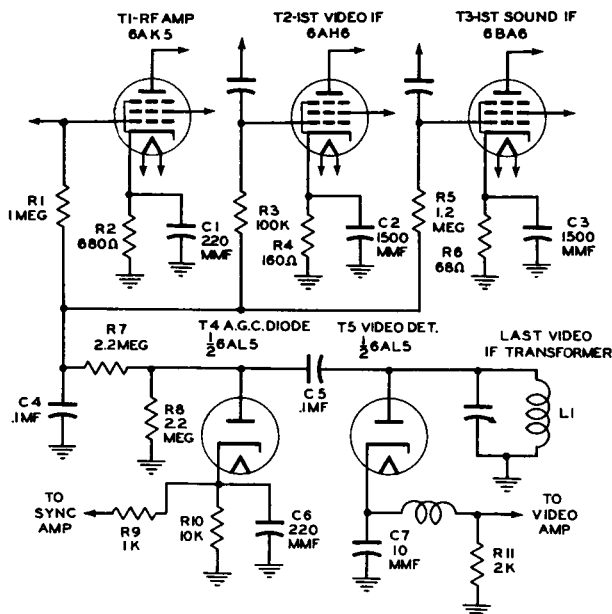

Fig. 243. Basic Automatic Gain Control Circuit.

A significant difference between the operation of the A. V. C. of a sound receiver, and the A. G. C. of a television set, is the fact that A. V. C. establishes a bias voltage which is proportional to average carrier strength, while A. G. C. assures that the controlling bias is proportional to maximum carrier strength (i. e., the top of the video carrier envelope is held constant, in transmission, at the sync pulse maximum value).

In sound transmission, the carrier envelope constantly changes in accordance with the modulation depth.

**AMPLIFIED A. G. C.:** A. G. C. systems can employ triode amplification of the rectified carrier voltage in a manner similar to amplified A. V. C. Figure 244 shows such a system. In this case T1 acts as the A. G. C. diode. The cathode-to-ground circuit is a double section network in which R1 acts as a decoupler and C2 as an RF bypass. The long time constant circuit consisting of R2 (4.7 meg.) and C3 (.05 mfd.) develops a DC voltage since the capacitor C3 is charged up to the peak value of the sync pulses, and discharges very slowly through R2 during the picture intervals.

Voltage which is fed to the grid of the triode amplifier tube T2 is in the positive direction, but the net operating bias on the grid is maintained in the negative region by the cathode bias. The operating bias is developed in the bleeder circuit from +B, consisting of R4, R5 and the variable resistor R6. R6 is employed to set the point of A. G. C. operation (delay-bias). In addition to the controlling voltage from the A. G. C. rectifier (T1), a pulsating voltage is supplied to the grid of T2 by injecting some of the output of the horizontal sweep generator through coupling capacitor C4.

The amplified plate current appearing across resistor R7 in the plate of T2 is thus seen to consist of pulses and amplified horizontal sweep voltage controlled in strength by a DC bias proportional to maximum carrier value. This amplified pulsating voltage is impressed on the diodes of T2 through coupling capacitor C5 and is thus rectified to provide the gain control of voltage across the output network consisting of R8 and R9. Divided control is again employed to produce a different rate of change of the RF bias with respect to the video IF bias.

**NOISE CLIPPING IN A. G. C. CIRCUITS:**  
A refinement of amplified A. G. C., which

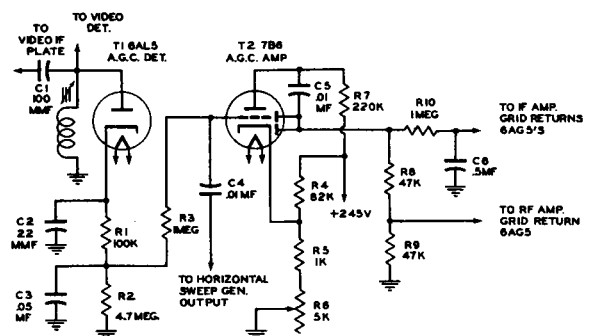

Fig. 244. An Amplified A. G. C. Circuit.

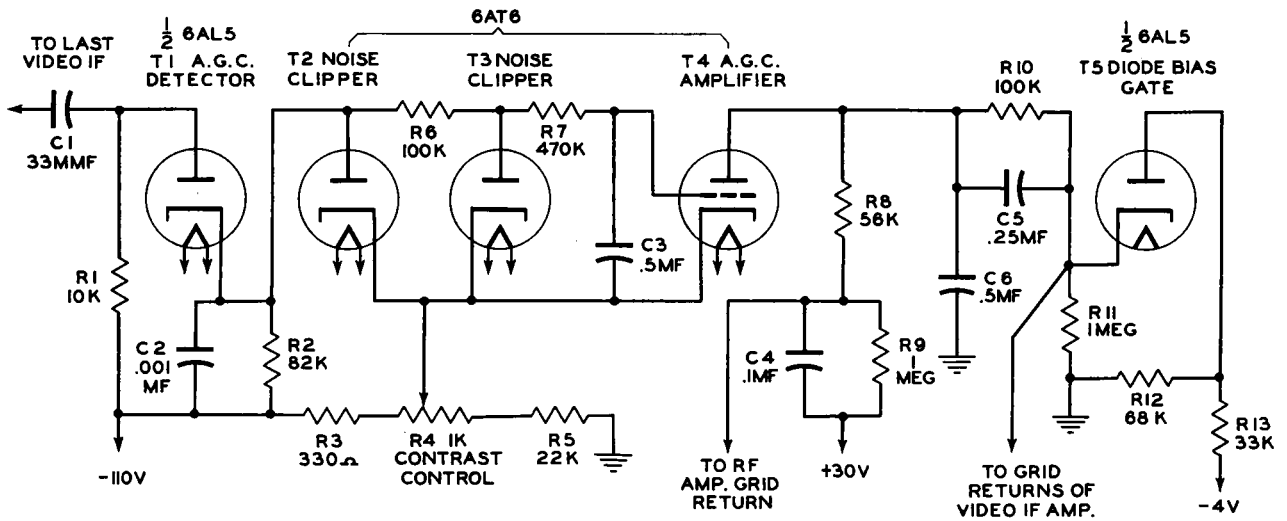

Fig. 245. An A. G. C. Circuit Employing Clipping, Amplification and Gate Action.

improves the circuit performance, is the use of diode clippers between the A. G. C. rectifier and the A. G. C. amplifier tubes. Figure 245 shows a circuit which incorporates clipping, amplification, and diode gating (or delay action). The performance of this system is shown in the graph of Figure 246. The use of an elaborate system of this type is justified in deluxe projection models.

In this instance, the time constant of the load circuit of the A. G. C. diode (T1), has been made much shorter than that of the systems previously described ( $R2 \times C2 = 82$  microseconds). The diode thus acts as a peak reading voltmeter at the horizontal scanning frequency (15,750 cps).

The fast time constant will allow the system to follow the peak of noise pulses as well as the sync pulse tips. To prevent this from affecting the A. G. C. action, a two stage noise clipping system is employed. It consists of diodes T2 and T3, coupled by resistor R6. In addition to the clipping action, further protection against noise is provided by feeding the A. G. C. amplifier triode T4, through the integrating circuit consisting of R7 and C3. This circuit removes the effect of random noise.

The delay bias on the clipping diodes T2 and T3, provided by the drop across R3 and the contrast control potentiometer (R4), determines the level at which clipping action occurs.

This same variable bias is applied as an operating bias for the A. G. C. amplifier tube

T4, through series resistors R2, R6, and R7, which constitute the grid return of T4. The bias thus establishes the gain of the A. G. C. amplifier, and control R4 can thus act to establish both the gain of the system, and the level at which noise clipping occurs.

Amplifier tube T4 operates with its cathode 110 volts negative with respect to ground, and its plate at, or slightly below, ground potential. Thus, as its grid goes positive with A. G. C. control voltage, the plate goes negative with respect to ground, and the drop across R8 and R9 can act as a control bias for the RF and IF amplifiers. Diode gate tube (T5) performs the same function as described on pages 195 and 196 and illustrated in Figure 241.

The overall performance of the system is shown in Figure 246.

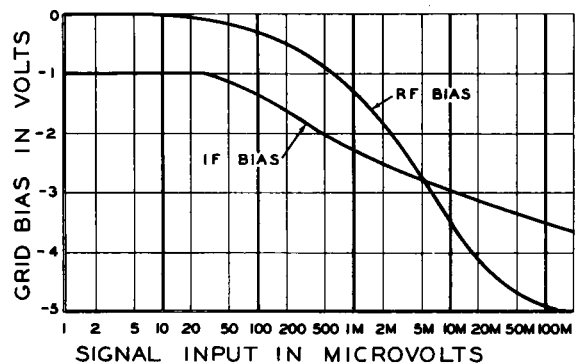

Fig. 246. A.G.C. Bias Versus Signal Input for Circuit of Figure 245.

## SECTION III CATHODE RAY — BEAM MODULATION AND SYNCHRONIZATION

### CHAPTER 18. INTERCARRIER SOUND SYSTEMS

The introduction of the intercarrier sound (Parker System) of television reception, which was described briefly on page 163 and illustrated by the block diagram of Figure 185, has resulted in a reduction of the number of tubes required and has furthered the design of table model TV sets.

In this system, the video and audio IF carriers are amplified together in the intermediate frequency amplifier. The gain versus frequency characteristic of the IF system differs from that of the dual IF system as shown in Figure 247. In this case, sound IF traps are not used and the end of the band is allowed to slope gradually as shown at B of Figure 247.

At the output of the second detector, a beat between the video IF and audio IF carriers (4.5mc) appears. This beat, which is frequency-modulated by the sound signal and amplitude-modulated (to some extent) by the video signal, constitutes a new intermediate frequency. The video amplifier which follows the second detector can be considered as an IF amplifier for this beat.

The intercarrier beat is separated from the combination signal at the picture tube grid and is passed through a frequency-modulation detector which is not sensitive to the amplitude (video) modulation of the beat. The sound modulation is thus sorted from the picture and subsequently amplified for operation of the loud speaker.

Since the intercarrier sound system represents an economical method of producing a less complicated receiver, the television service technician should become familiar with the principles of operation and the re-

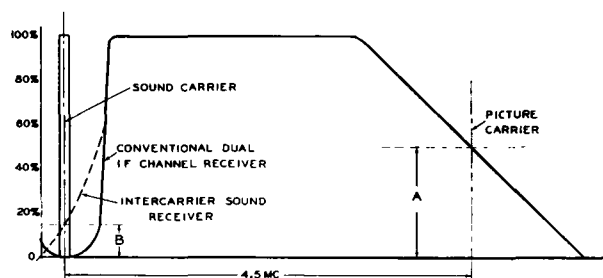

Fig. 247. IF Response Characteristics of Conventional Dual Channel and Intercarrier Sound Systems.

quirements which it places on the characteristics of the composite television signal.

**TRANSMITTER PERFORMANCE CHARACTERISTICS REQUIRED FOR SUCCESSFUL INTERCHANNEL SOUND OPERATION:** Since the intercarrier sound system is made possible by the fact that separate modulation methods are employed for the video and audio carriers, it follows that the performance of the system is dependent upon the exact composition of the transmitted television signal. Characteristics of the signal which are of importance are: 1. The frequency stability of the video and audio carriers. 2. The accuracy of the difference-frequency between the video and audio carriers. 3. The depth of modulation of the video carrier allowed for maximum white signal. 4. The amount of phase or frequency modulation present in the video carrier.

Since the difference beat is produced between the video and audio carriers, any drift of frequency of either of them will cause an off-tune condition in the FM detection circuit at the receiver. This will result in either poor quality or loss of the sound portion of the transmission. Nothing can be done by the user to correct this since the alignment of the FM system is a factory or service technician operation. In the conventional dual channel system this condition can be corrected by adjustment of fine tuning. With crystal control at the transmitter, this requirement should present no difficulty.

The minimum modulation of the video carrier represents the white level (see page 127). If the modulation of the sound carrier should be allowed to go to zero (100% video modulation) the 4.5mc beat upon which the operation of the system depends, would disappear. No sound output could occur during such periods of over-modulation. This would cause disagreeable sound interference in the form of a 60 cycle buzz (field repetition rate) or a 15,750 cycle whistle (horizontal scanning rate). The drop-out of audio IF would occur at field and line scanning rates and would appear as a modulation of the audio IF signal.

Any phase or frequency modulation of the picture carrier would result in a corresponding modulation of the 4.5mc beat. The result would be the same type of 60 cycle or 15,750 cycle interference just described. Misadjustment of transmitter tuning or neutralization can cause such phase modulation.

CATHODE-RAY - - BEAM MODULATION AND SYNCHRONIZATION

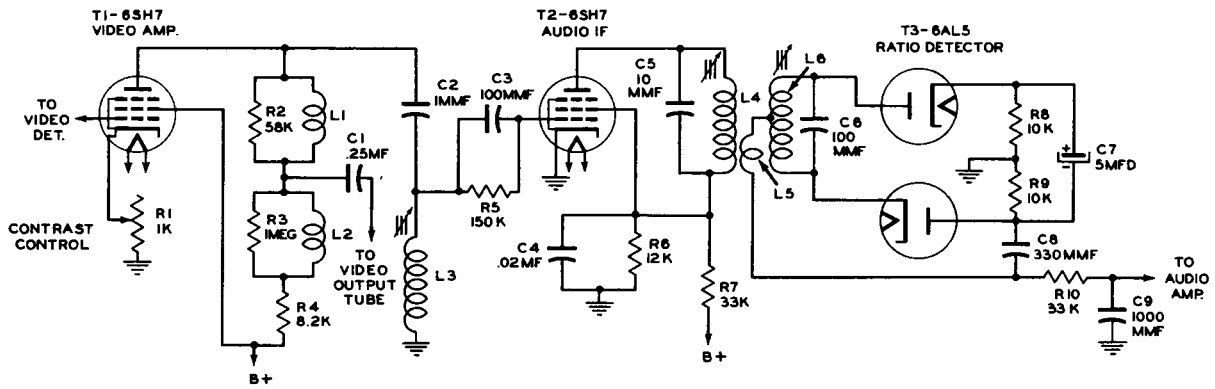

Fig. 248. Typical Intercarrier Sound Circuits.

**TYPICAL INTERCARRIER SOUND SYSTEMS:** Figure 248 shows a typical intercarrier sound system, while Figures 249 and 250 illustrate variations of the method of take-off of the 4.5mc audio modulated beat. In Figure 248, the circuit consisting of C2 and L3 acts as a series-tuned trap to remove the 4.5mc beat from the picture tube input, and at the same time, develop a resonant voltage across the inductor to feed the modulated IF to the amplifier tube (T2) and the ratio detector (T3). The operating voltages of T3, as well as the grid circuit constants, are such that the stage acts as a limiter for the suppression of amplitude modulation.

Figure 249 shows an absorption trap L3 - C4, coupled to the video output plate through capacitor C3 (2.2 mMf.). The operation of the circuit is similar to that of Figure 248.

The circuit of Figure 250 shows a variation in which the trap circuit is in the screen return. The screen acts as a triode plate for amplification of the IF beat, and the 4.5mc tuned circuit suppresses this frequency in the video output or plate circuit.

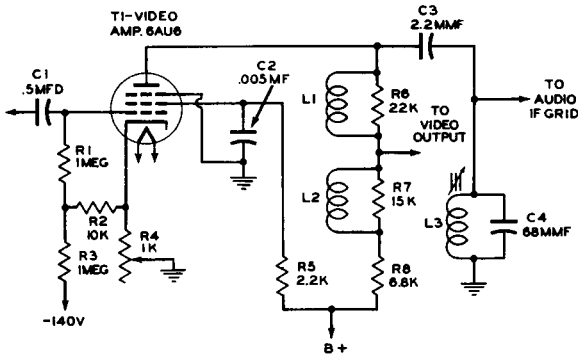

Fig. 249. Audio IF Take-off Employing a Shunt-Tuned Trap.

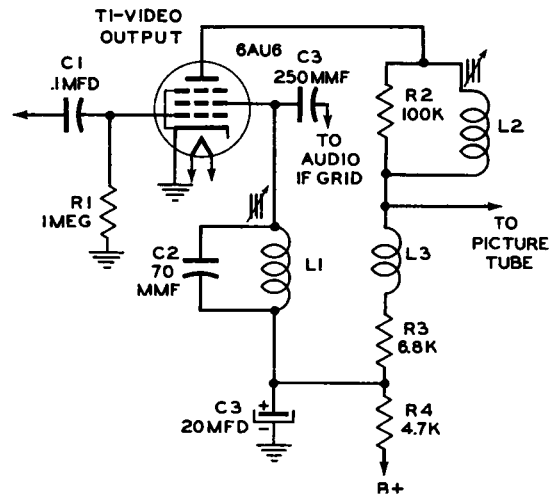

Fig. 250. Audio IF Take-off from the Screen Circuit of the Video Output Tube.

The constant daily analysis of Television equipment in the laboratories of the Howard W. Sams & Co., provides the continuing research and study necessary for the production of Photofact Folders covering such equipment. By-products, of almost equal importance, include the publication of practical educational information such as the Photofact Television Course.

To keep current on the latest developments in the TV art, and to become familiar with specific design and operational data, it is suggested that reference be made to the Photofact Folders issued for this equipment.

## SUBJECT INDEX

### A

Absorption traps, 172  
AC component of video signal, 127, 128, 130, 131  
Active lines, 51, 52, 53, 127, 128, 129  
Added phase shift, 188, 189, 190  
Adjacent channel, 126  
Adjacent channel rejection, 171, 172, 173  
A. F. C. sync discriminator, 75, 76, 78, 79, 101 to 105  
Aluminized screen, 17  
Amplification, audio IF, 177, 178, 179  
    IF, 162 to 183  
    RF, 149 to 162  
    video, 183 to 190  
    video IF, 164 to 169  
Amplifier, A. G. C., 197  
    clipper, 94, 95  
    horizontal output, 29, 30, 31, 73, 75, 78, 80, 83, 84  
    vertical output, 73, 74, 76, 77, 78, 79, 80, 82  
    sync, 94  
    video, 183 to 190  
Amplitude characteristic, receiver, 125, 126  
    transmitter, 125, 126, 127  
    video detector, 164, 165  
Amplitude-frequency response, high frequency video, 184 to 188  
    low frequency video, 183 to 185  
Amplitude modulation, 121  
Amplitude separation of sync pulses, 85 to 101  
Anode, accelerating, 6, 7, 8  
Antenna, cage, 144  
    corner reflector, 146, 147  
    dipole, 139 to 145  
    dipole dimensions, 143  
    dipole director, 142, 143  
    dipole reflector, 142, 143  
    dipole reception pattern, 140, 141  
    fan type, 144  
    folded dipole, 141, 142  
    front-to-back ratio, 143  
    power gain, 143  
    receiving, 133 to 149  
    rotatable, 145, 146  
    stacked array, 145, 146  
    V type, 145  
    Yagi array, 143, 143  
Aquadag, 9  
Arrays, antenna, 145 to 149  
Aspect ratio, 124  
Assymetrical square waves, 37  
Automatic gain control, 196, 197, 198  
Automatic pulse-width control, 83, 84, 101

### B

Background, 130, 131, 191  
Band pass circuits, audio IF, 177, 178, 179  
    RF, 149 to 162

    video, 183 to 190  
    video IF, 164 to 174  
Bandwidth, 136, 143, 164, 165, 166, 177, 183  
Beam centering, electromagnetic, 61, 62  
    electrostatic, 10, 11  
Beam control, electron, 4 to 7, 107, 108  
Beam deflection, electrostatic, 8, 9, 10, 68-72  
    electromagnetic, 15, 16, 73 to 84  
Beam focus, electromagnetic, 14, 15, 61, 115  
    electrostatic, 5, 6, 7, 115  
Beam formation, electron, 4, 5  
Beam relaxor, 82, 83  
Blacker-than-black region, 127  
Blanking oscillator, 47 to 50, 70, 80, 81, 82, 84  
Bridged-T circuits, 172, 173, 178  
Brightness control, 107, 108, 115, 193, 194  
Brute force power supplies, 26, 27

### C

Camera tube, 19 to 23  
    iconoscope, 18, 19, 20  
    image dissector, 18, 19, 22  
    image orthicon, 18, 19, 20  
    monoscope, 18, 19, 23  
Capacitance tuned input systems, 156 to 162  
Capacitor charging, 34, 35, 38  
Capacitor discharging, 35, 36, 38  
Carrier frequencies employed in television, 126  
Carrier relation, video and audio carriers, 125, 126  
Carrier signal, modulated by video, 127 to 131  
Carrier transmission of video signals, 121 to 132  
Cathode, bias, effect on low frequency video response, 185  
    follower, 86, 87, 88, 92, 93, 94, 193  
    input-grounded grid amplifier, 151, 152  
    traps, 172, 173, 178  
Cathode-ray tube, 3 to 25  
Centering, electromagnetic, 61, 62, 118, 119  
    electrostatic, 10, 11, 118, 119  
Channel, adjacent, 126, 127  
    width, 126  
Channels, television, 126  
Chart, television image test, 109, 110  
Checkerboard image, 124  
Circuit, effect of plate load resistor on bandwidth, 184  
    resistance coupled, equivalent at video frequencies, 183  
    charging, RC, 34, 35  
Clipping, 85 to 97  
    circuits, 85 to 97  
Coaxial cable, 148  
Co-channel rejection, 171, 172, 173  
Compensated amplifier, high frequency response, 185 to 188  
    low frequency response, 184, 185  
    series peaking, 186, 187  
    shunt peaking, 186

## SUBJECT INDEX

Compensation, effect of improper, 186  
Composite sync signal, 97, 98  
Composite video signal, 121 to 132  
Contrast control, 194 to 199  
Contrast of picture, 194  
Control grid, picture tube, 4, 5  
Controls, summary and function, 110 to 114  
Converters in input systems, 151 to 163  
Crossover region, electron beam, 5  
Crystal detector, germanium video, 176  
Crystal restorer, germanium diode, 192, 193

### D

Dc, amplifier, 78, 79, 194  
    component of video signal, 130 to 133, 191 to 195  
    coupled video amplifier, 194  
    restoration in reception, 191 to 195  
    restoration in transmission, 130 to 133  
    restorer, 131, 191 to 195  
Damping, 62, 66, 75, 76, 79  
Definitions of television terms, 201 to 207  
Deflection, electromagnetic, 15, 16, 59, 60, 73 to 84  
    electrostatic, 8, 9, 10, 59, 68 to 72  
Deflection yoke, adjustment, 115  
Degenerative traps, 172, 173, 178  
Delay, uniform time, 189, 190  
Demodulation, audio IF, 179 to 183  
    video IF, 174, 175, 176  
Detail, horizontal line, 124  
Detection, audio IF, 179 to 183  
    RF, first, 149 to 163  
    video IF, 173 to 177  
Differentiating circuit, 94, 95, 96  
Differentiator voltage, 37, 76, 94, 95, 99  
Diode clamp, 131, 192, 193  
Diode detection, video IF, 174 to 177  
Diode, germanium crystal, 176, 192, 193  
    sync separation, 89, 90  
Dipole antennas, 139 to 145  
Discharge tube, 49, 74  
Distance of reception over flat earth, 135, 136  
Drive, horizontal, 65, 120  
Dynode, 20, 22

### E

Electromagnetic deflection, 61 to 67, 73 to 84  
Electron beam, deflection of, 34 to 85  
    electrostatic focusing of, 5, 6, 7  
    focusing of, 5 to 8, 14, 15  
    formation of, 2 to 35  
    magnetic focusing of, 14, 15  
Electron gun, 8  
    lens, 6  
    multiplier, 2 to 24  
    scanning, 24, 51 to 61  
Electrostatic deflection, 8, 9  
Equalizing pulses, 98, 99

### F

Field, 24, 52, 53  
    of half wave dipole, 139, 140, 141  
    of Yagi arrays, 142  
    repetition rate, 24, 52  
    scanning, 24, 52, 53  
Filter, capacitance-resistance, 30 to 34  
    circuits, high voltage, 25 to 34  
    vestigial sideband, 125, 126  
Fine tuning control, 110, 149 to 163  
First anode, 5 to 13  
Fluorescent screen, 3, 4, 9, 10  
    metal backed, 21  
Flyback, horizontal, high voltage systems, 29, 30, 31  
FM, discriminator, 179, 180, 181  
    limiter stage, 129  
    ratio detector, 181, 182  
    television sound channel, 126, 127, 162, 163, 177, 199, 200  
Focus, control, 115  
    electromagnetic, 14, 15, 61, 114, 115  
    electrostatic, 5, 6, 7  
Focus coil, adjustment, 114  
Frame, 24, 52, 53  
    frequency, 24, 52, 53  
    number of lines, 24, 52, 53, 124  
Free running, frequency of multivibrator, 53, 54, 55  
Frequency, allocations, 126

### G

Generator, sawtooth scanning, 38 to 51, 73 to 85  
Germanium crystal diode, 176, 192  
Ghost, images, 133, 136 to 139, 190  
    negative, 138  
    smear, 190, 191  
Glossary of television terms, 206 to 210  
Grid circuit, DC restoration, 193  
Grid leak, bias limiting, 179  
Grounded grid, RF amplifier, 151

### H

Height control, 70, 73 to 85, 118  
High frequency, phase shift, 189  
    video compensation, 186, 187, 188  
    video response, 183 to 189  
High voltage power supply, types, 25 to 34  
    brute force type, 26, 27  
    horizontal flyback type, 29, 30, 31  
    pulse type, 31, 32, 33  
    RF type, 27, 28  
    tripler rectifier circuits, 30 to 34  
Hold adjustments, 116



Hold control, horizontal, 69, 76, 79, 116  
 vertical, 69, 70, 74, 77, 80, 116  
 Horizon, effect of, 135, 136  
 Horizon distance, relation to height of transmitting and receiving antennas, 135  
 Horizontal, centering control, 11, 62, 110, 111, 118  
     centering, electromagnetic, 62, 110, 111, 118  
     centering, electrostatic, 10, 11, 110, 111, 118  
     discriminator phase adjustment, 117  
     drive control, 65, 81  
     hold control, 44, 45, 47, 61 to 85, 110, 111, 116  
     linearity control, 65, 67, 119  
     oscillator frequency adjustment, 117  
     sweep damping, 62 to 65  
     width control, 65, 67, 118  
 Horizontal flyback, high voltage supplies, 29, 30, 31

I

IF, amplification, 162 to 183  
     audio, 177, 178, 179  
     systems, 162 to 183  
     video, 164 to 169  
 Iconoscope, 18, 19, 20  
 Ideal sawtooth waveform, 51 to 54  
 Image dissector, 18, 19, 22  
     orthicon, 18 to 23  
 Inductive tuners, 151, 152, 153  
 Infra-black region, 127  
 Input systems, 149 to 163  
 Integrating circuit, 97, 98  
 Integrator voltage, 37, 70, 77, 82, 97, 98  
 Inter-carrier sound, 163, 199, 200  
 Interference, 134, 136, 137, 138  
 Interlace, 24, 97 to 100  
 Intermediate frequencies, video and audio  
 165, 166  
 Ion trap, 16, 17, 61, 114

L

Linear displacement of image, 137, 138, 188, 189, 190  
 Linearity, horizontal, 65, 76, 119, 120  
     vertical, 67, 75, 78, 82, 120  
 Line-of-sight, distance, 135, 136  
 Lines, active horizontal, 51, 52, 124  
     antenna transmission, 147, 148  
     number per field, 24, 52, 53  
     number per frame, 24, 52, 53  
 Local RF oscillators, 149 to 163  
 Low-frequency, phase shift, 188, 189  
     video amplifier compensation, 185  
     video amplifier response, 183, 184  
 Low signal-to-noise ratio, 150, 151

M

Magnetic deflection, 15, 16, 59, 60, 73 to 84  
 Magnetic focus, 14, 15, 61, 114, 115  
 Magnetic field, effect on electron beam, 13, 14  
 Maximum video frequency, 124  
 Metal-backed, picture tube screen, 17  
 Modulation, audio, 126  
     by video and audio, 121  
     video, 125 to 132  
 Monoscope, 18, 19, 23  
 Mosaic, 19, 20  
 Multivibrators, cathode-coupled, 45, 46, 68, 78  
     conventional, 40 to 44  
     unbalanced or asymmetrical, 44, 45, 76

N

Names of controls, 110, 111  
 Negative feedback, 171  
 Negative ghost, 138  
 Negative transmission, 127, 130, 174  
 Negative video detector output, 173, 174  
 Noise, 128

O

Odd line interlace, 24, 97 to 100  
 Ohm's law, 34  
 Oscillator, horizontal scanning, 61 to 85  
     local RF, 149 to 163  
     pulse control of, 54, 55, 56  
     sawtooth scanning, 38 to 51  
     vertical scanning, 61 to 85  
 Output, of television transmitter, 125  
 Output amplifier, horizontal, 61 to 85  
     vertical, 61 to 85  
 Over-coupled IF systems, 166, 167

P

Pairing of interlaced fields, 98  
 Path, carrier wave, direct and reflected, 136, 137, 138  
 Peaking, circuits, 60, 174, 175, 176  
     coil, 186, 187, 188  
     resistor, 80  
 Pedestal, 87, 127 to 133, 191  
 Pentode sync separation, 92  
 Phase, delay, 188, 189, 190  
     inversion, 69, 70  
 Phase shift, compensation for, 188, 189, 190  
     high frequency, 189  
     low frequency, 188, 189  
 Photocathode, 20  
 Photoelectric surface, 19 to 24  
 Picture element, 124  
 Picture polarity, 174, 175, 176  
 Picture signal, 127 to 133  
 Picture tube, 3 to 19  
 Power supplies, high voltage, 25 to 33  
     low voltage, 25

## SUBJECT INDEX

Pre-emphasis of audio modulation, 181  
Propagation of television waves, 133 to 136  
Pulse shaping, 94 to 101  
Pulse stripper, 85 to 101  
Pulse type power supplies, 30, 32, 33

### Q

Q of tuned circuits, 150, 151  
Quarter wave line input tuning circuits, 153 to 157  
Quasi-optical, 135

### R

RC circuits, 34 to 39  
RC differentiating circuits, 94, 95, 96  
RC integrating circuits, 97 to 101  
RF oscillators, input system, 149 to 163  
    power supply, 27, 28  
RF power supplies, 27, 28  
RF tuning systems, 149 to 163  
R. M. A. standard television signal, 124 to 128  
Radiation from local oscillator, 150  
Raster, 24, 51 to 55, 124  
Reactance tube, 75, 104  
Receiving antennas, 133 to 150  
Rectifiers, high voltage, 26 to 29  
Reflected and direct carrier waves, 136, 137, 138  
Reinsertion of DC component, 130 to 133, 191 to 195  
Relaxation oscillators, 38, 39, 40  
Resolution of image, 124  
Retrace, horizontal, 51, 52  
    vertical, 52, 53, 98

### S

Safety precautions, 26  
Sawtooth, formation, 37 to 51  
    generation, 38 to 51  
    scanning raster, 24, 51 to 55, 124  
Scanning, 24, 51 to 55, 124  
    electromagnetic, requirements for, 56 to 61  
    electrostatic, requirements for, 56  
    generator control, 53 to 57  
    wave, horizontal, 51, 52, 53  
    wave, vertical, 52 53  
Second anode of picture tube, 6 to 10  
Secondary emission, 19, 20, 22  
Separation, amplitude, of sync pulses, 85 to 108  
Series and shunt peaking, combination of, 187  
Series peaking, 186, 187  
    coil, 186, 187, 188  
Serrated vertical pulses, 97 to 101  
    integration of, 97 to 101  
Shunt and series peaking, combination of, 187  
Shunt peaking, 186  
Signal, horizon effect on, 135, 136  
    R. M. A. standard, 121 to 133

Sine wave generators, 49, 75  
Size control, horizontal, 65, 67, 69, 76, 118  
    vertical, 69, 70, 75, 78, 82, 118  
Sound, carrier, 126, 127  
    IF, 177 to 183  
Square wave, 37, 38  
    generator, 40 to 46  
Stagger-tuned IF systems, 167 to 171  
Switch-type tuners, 153 to 161  
Symmetrical square waves, 37  
Sync pulse, amplifier, 75, 77, 78, 79, 82, 94  
    clipper, 76 to 80, 82, 84, 94  
    inverter, 76 to 80, 82, 84, 94  
    leveler, 76 to 80, 82, 84, 94  
    separation of, 85 to 108  
    separator, 79, 80  
    shaping, 56 to 61, 119  
    sorting of, 94 to 98  
    triggering by, 54, 55, 56, 67 to 85  
    use of, 53 to 57, 69, 74, 77, 79, 80, 84, 101

### T

Television, antennas, 133 to 139  
    camera tubes, 19 to 23  
    channels, 126  
    R. M. A. signal, 124 to 128  
    vestigial sideband, 125 to 128  
Television receiver, typical block diagrams, 122, 123, 132, 162, 163  
Test patterns, 109, 110  
Time constants, 34 to 39  
Time delay, 189, 190  
Transients, effect of, 190, 191  
Transmission lines, 147, 148, 149  
Transmitter, output characteristic, 125, 126  
Trap circuits, 171, 172, 173  
Triggered sync, 101  
Triode sync separation, 90, 91, 92  
Triplers, high voltage, 31, 32, 33  
Tuned line input systems, 153 to 157  
Turret tuners, 157, 158  
Typical commercial sync circuits, 105, 106, 107  
Typical deflection circuits, 67 to 85

### U

Uncompensated video amplifier, 190

### V

Vacuum tube theory, review, 85 to 89  
Variable capacitor tuners, 161, 162  
Velocity of scanning spot, 51, 52  
Vertical blanking, 53, 97, 98  
Vertical centering, electromagnetic, 61, 119  
    electrostatic, 10, 11, 119  
Vertical equalizing pulses, 97, 98, 99  
Vertical hold control, 69, 73 to 85, 116, 117

## SUBJECT INDEX

Vertical linearity control, 67, 120  
Vertical output amplifier, 67, 68, 70, 75, 77, 80, 82  
Vertical resolution, 124  
Vertical retrace, 52, 53, 98  
Vertical serrated synchronizing signals, 97 to 101  
Vertical size control, 69, 73 to 85, 118  
Vertical synchronizing pulse separation, 97 to 101  
Vertical synchronizing signals, 53, 97 to 101  
Vestigial sideband modulation, 164, 165  
Video amplification, 183 to 191  
Video amplifier, 183 to 191  
    high frequency compensation, 185 to 189  
    high frequency phase shift correction, 189  
    high frequency response, 183 to 188  
    low frequency compensation, 184, 185  
    low frequency phase shift correction, 188, 189  
    low frequency response, 183 to 185  
    phase shift characteristic, 189 to 191

Video detection, 87, 173 to 177  
Video IF systems, 164 to 174  
Video response characteristics, 164, 165, 166, 183, 184  
Video signal, 121 to 132  
    DC component of, 130, 131, 132  
    R. M. A. standard, 124  
Volume control, 110 to 115  
Voltage doubler, 25

### W

Wavelengths of television channels, 136  
Waves, sawtooth scanning, 51 to 61  
    television carrier, polarization of, 133, 134  
    V. H. F., propagation characteristics of, 133 to 137  
Width, horizontal, 65, 67, 69, 76, 118

### Y

Yagi antenna arrays, 142, 143

## GLOSSARY OF TELEVISION TERMS

### A

**ABSORPTION TRAP** - A parallel-tuned circuit coupled either magnetically or capacitively, to absorb and attenuate interfering signals.

**ACCOMPANYING AUDIO (SOUND) CHANNEL.** The RF carrier frequency which supplies the sound to accompany the picture. Also known as Co-channel Sound Frequency.

**ACTIVE LINES** - The lines which produce the picture as distinguished from the lines occurring during blanking (horizontal and vertical retrace lines).

**ADJACENT AUDIO (SOUND) CHANNEL** - The RF carrier frequency which carries the sound modulation associated with the next lower frequency television channel.

**ALUMINIZED SCREEN PICTURE TUBE** - A cathode-ray picture tube in which a thin layer of aluminum has been deposited on the back of the fluorescent surface to improve the brilliance of the image and prevent ion spot formation.

**AMPLITUDE MODULATION (AM)** - A method of modulating an RF carrier in which the instantaneous amplitude of the carrier is proportional to the instantaneous value of the modulating voltage.

**AMPLITUDE SEPARATION** - The method of sorting part of a voltage wave (particularly the sync pulses of the video signal) from the rest of the wave by differences in amplitude. This is usually accomplished by employing a biased clipper.

**AQUADAG** - A colloidal solution of graphite in water, used to produce a conductive coating on the surface of the glass envelope of cathode-ray picture tubes. This is done internally to collect secondary electrons emitted by the fluorescent screen and externally (in some types) to utilize the tube as a final capacitor of the high voltage filter circuit.

**ARRAY** - A combination or arrangement of antenna elements to produce a desired directional pattern or increase in signal pickup as compared with a half wave dipole.

**ASPECT RATIO** - The numerical ratio of the picture width to its height. The television and motion picture standard is 4/3.

**ASYMMETRIC SIDE-BAND TRANSMISSION** - (See Vestigial Side-Band Transmission.)

**AUDIO CHANNEL** - (See Accompanying Audio Channel.)

**AUTOMATIC GAIN CONTROL (A. G. C.)** - A method of automatically regulating the overall amplification (gain) of a television receiver to produce constant output (contrast of the picture) for varying input signals.

**AUTOMATIC CONTRAST CONTROL** - (See Automatic Gain Control.)

**AUTOMATIC PHASE CONTROL** - A method of automatically holding the frequency and phase of the horizontal scanning oscillator in step with the repetition rate and phase of the horizontal sync pulses.

### B

**BACKGROUND** - In television this refers to the average illumination of the scene and is represented by the DC component of the video signal. (See DC Video Component.)

**"BACK PORCH"** - The portion of the synchronizing signal (at blanking or black level) which follows the horizontal sync pulse and precedes the start of the next horizontal active line. (3.81 microseconds in duration for the standard R. M. A. signal.)

**BANDWIDTH** - The difference in frequency between the highest and lowest frequencies involved. A television channel has a bandwidth of 6 megacycles.

**BEAM** - In television this refers to a stream of electrons moving in a parallel path.

**BEAM CURRENT** - The electrical current comprised of a beam of electrons.

**BEAM RELAXOR** - A type of sawtooth scanning oscillator circuit which generates the current wave required for magnetic deflection in a single beam-power pentode without employing subsequent amplification.

**"BI-DIRECTIONAL"** - Refers to the shape of the reception pattern of an antenna which responds equally well to stations located 180° apart with respect to the receiver.

**"BLACKER-THAN-BLACK"** - Also "Infra-Black". That portion of the video modulating voltage of the transmitter of greater amplitude than the black level (from 75% to 100% of maximum signal). This region is occupied by the synchronizing pulses.

**BLACK LEVEL** - The amplitude of the video modulating wave at which the beam of the picture tube is extinguished (becomes

black), to blank retrace of the beam. This level is established at 75% of the maximum of the signal.

**BLANKING PULSES** - The portion of the video modulating signal during which the beam of the picture tube is extinguished (at or above 75% of maximum signal.) (See Black Level.)

**BLOCKING OSCILLATOR** - A type of relaxation oscillator circuit, for the generation of sawtooth waves, employing an iron core feedback transformer and a long time constant grid capacitor-resistor network.

**BLOOMING** - The phenomenon of defocusing of regions of the picture due to excessive brilliance. The spot size is enlarged to halation (spreading of light at the fluorescent screen).

**"BOOSTER"** - A separate radio frequency amplifier connected between the antenna and the television receiver to amplify weak signals.

**BRIGHTNESS CONTROL** - The adjustment means of a television receiver whereby the operating point of the picture tube is set to prevent the appearance of the beam retrace.

### C

**CAMERA TUBE** - The device employed at the television transmitter to change the light variations of the scene into a video modulation. Examples: Iconoscope, Image Orthicon, Image Dissector and Monoscope.

**CATHODE FOLLOWER** - A vacuum tube circuit in which the input signal is applied between control grid and ground, while the output is taken between cathode and ground. The plate is bypassed to ground. A cathode follower exhibits high input impedance and low output impedance.

**CATHODE INPUT** - (See Grounded Grid Amplifier.)

**CENTERING CONTROL** - Adjustment means for controlling the position of the raster on the picture tube screen. (See Horizontal Centering Control, and Vertical Centering Control.)

**CHANNEL** - The band of frequencies assigned for the transmission of the television signal.

**CHARACTERISTIC IMPEDANCE** - The ratio of the voltage to the current at every point on an RF transmission line. This holds only when the line is properly terminated and no standing waves are present.

**CLAMPING CIRCUIT** - See also DC Restoration. A circuit which maintains one extreme of a voltage wave at a predetermined DC level.

**CLIPPING CIRCUIT** - A vacuum tube circuit arranged to operate under conditions which remove one or both extremities of an impressed voltage wave. This produces a flat topped output. Employed in sync pulse shaping.

**COAXIAL CABLE (COAX)** - A high frequency transmission cable consisting of a central inner conductor and a cylindrical shaped surrounding conductor, the conductors being separated by an insulator. Often employed as a television antenna lead-in.

**COMPOSITE SIGNAL** - A television signal whose waveform is composed of video modulation, blanking pedestal and synchronizing pulses. In the R. M. A. standard the blanking pedestal occurs at 75% of maximum signal and the sync pulses occupy the remaining 25%.

**CONTRAST** - The range of light to dark values of the image, proportional to the voltage swing at the picture tube input.

**CONTRAST CONTROL** - The adjustment means of a television receiver whereby the input voltage swing to the picture tube input is set to produce the most acceptable image contrast.

**CRITICAL VIEWING DISTANCE** - The ratio of the distance of the observer to the height of the picture, at which the line structure just disappears (about 5 to 1, with present standards).

### D

**DC REINSERTION** - The combining of the DC component of the video signal (lost in capacitance-coupled amplifiers) with the AC component to re-establish the average light value of the reproduced picture.

**DC VIDEO COMPONENT** - The part of the video signal caused by the average steady background illumination of the scene being televised.

**DAMPING TUBE** - A vacuum tube (diode or triode) used to momentarily short circuit the stored energy in a deflecting coil system and prevent transient oscillation.

**DEFINITION** - The sharpness of fine detail in the reproduced picture.

## GLOSSARY OF TELEVISION TERMS

**DEFLECTION** - The process whereby the electron beam of a picture tube is deviated from its axial path (either electrostatically or electromagnetically) to produce the scanning raster.

**DEFLECTION YOKE** - An assembly consisting of the horizontal and vertical deflection coils of a magnetically deflected TV set.

**DETAIL** - The least perceptible elements or areas of an image which can be recognized as different from one another.

**DIATHERMY** - An interfering signal caused by certain types of medical apparatus. Contains strong 60 cycle modulation and produces a "herring-bone" pattern on the picture.

**DIFFERENTIATING CIRCUIT** - A combination of circuit elements which produce an output pulse proportional to the rate of change of the input signal.

**DIPOLE** - An antenna whose length is approximately one half of the electromagnetic wavelength to which it is resonant. It is usually divided in the middle for connection to the transmission line.

**DIRECTOR** - A dipole placed in front of a dipole antenna element (toward the transmitter). Its function is to increase the pick-up and obtain a directional pattern.

**DISCHARGE TUBE** - A vacuum tube (usually a triode, normally biased to be non-conductive which is arranged to discharge a condenser when triggered by a positive voltage pulse.

**DISCRIMINATOR** - An FM detector circuit using a pair of diodes. The audio output is proportional to the frequency deviation.

**DISSECTOR** - A camera tube in which an electron image is moved across the aperture of an electron multiplier.

### E

**ECHO** - A delayed signal due to reflection. This may refer either to the television carrier (ghost signals) or to effects in the video amplifier.

**ELECTRON FOCUS** - The reduction in size of the electron beam in a picture tube by variation of the electrostatic field.

**ELECTROMAGNETIC DEFLECTION COIL** - A circular coil placed around the neck of a picture tube to cause deflection of the electron beam.

**ELECTRON** - The elementary electrical charge of negative sign or polarity (1.6x10<sup>-19</sup> coulombs).

**ELECTRON GUN** - An arrangement of cylindrical electrodes and baffles with apertures which produce a small beam of electrons.

**ELECTRON MULTIPLIER** - An electron tube in which a number of electrodes are arranged in cascade. Each electrode delivers to the next a greater number of electrons than it receives. The increase is due to secondary emission.

**ELECTRON SCANNING** - The deflection of an electron beam to form a regular pattern or raster.

**ELECTROSTATIC FIELD** - A strain in space which exerts a force on an electrical charge (electron) within its region of influence.

**ELECTROSTATIC SCANNING** - The deflection of an electron beam, to form a raster, by means of an electrostatic field.

**EQUALIZING PULSES** - A series of pulses (usually six in number), occurring at twice line frequency, which precede and follow the serrated vertical synchronizing pulse. The purpose of these pulses is to cause vertical retrace to occur at the correct instant for proper interlace.

### F

**FIELD** - One complete scanning operation from top to bottom of the picture including retrace to the top again. In the R. M. A. standard this requires 1/60th of a second and occurs twice per frame.

**FIELD FREQUENCY** - The number of fields transmitted per second (60 in the standard R. M. A. system).

**FIELD FREQUENCY SYNCHRONIZING IMPULSE** - (See Vertical Blanking Impulse.)

**FIELD PERIOD** - The time required to transmit one field (reciprocal of the field frequency) or 1/60th of a second.

**FLUORESCENT SCREEN** - The coating on the inside surface of the picture tube (a phosphor which emits light under the impact of the electron beam).

**FLYBACK** - The return of the electron beam after tracing a horizontal line. (See retrace.)

**FLYWHEEL SYNC** - A method of horizontal synchronization in which the control of scanning is determined by the average tim-

ing of the sync pulses rather than by each individual pulse as in triggered sync.

**FOCUSING CONTROL** - The adjustment means of a television receiver whereby the electron beam is brought to the smallest possible spot size on the fluorescent screen.

**FOLDED DIPOLE** - A dipole antenna which consists of two half wave dipoles arranged parallel to one another and with their extremities connected together. One of the dipoles is open at its center point for connection to the transmission line.

**FRAME** - The complete single picture contained in an image. In the standard double interlace system, a frame consists of two fields and has a repetition rate of 30 per second.

**FRAME FREQUENCY** - The number of times per second the picture is completely scanned - the standard is 30 per second.

**"FRONT PORCH"** - The portion of the synchronizing signal (at blanking or black level) which precedes the horizontal sync pulse and occurs at the end of each active horizontal line (1.27 microseconds in duration for the standard R. M. A. signal).

**FRONT-TO-BACK RATIO** - The ratio of the sensitivity of an antenna for signals arriving from the front (desired direction) to the sensitivity for signals arriving from the back, 180 degrees from the front.

### G

**GAMMA** - The ratio of the contrast of any two elements of the picture to the original contrast of these same elements in the scene being televised.

**GHOST IMAGE** - A second or echo image superimposed on the reproduced picture due to a reflected and delayed carrier wave.

**GRID LIMITING** - The use of grid current bias derived from the signal through a large series grid resistor to cause plate current cut-off and consequent leveling of the output wave for all input signals above a critical value.

**GROUNDING GRID AMPLIFIER** - A vacuum tube circuit in which the input signal is applied between a grounded grid and the cathode. The grid thus acts as a shield between the input circuit (cathode-to-ground) and the output circuit (connected between plate and ground).

### H

**HALATION** - A halo immediately surrounding a point of high brilliance on the fluorescent screen. This may be due to light scattering in the phosphor or multiple reflections between front and back surfaces of the glass.

**HALF WAVE DIPOLE OR "DOUBLET"** - (See Dipole.)

**HEIGHT CONTROL** - The adjustment means of a television receiver which controls the vertical scanning amplitude and hence the height of the picture.

**HOLD CONTROL** - The adjustment means of a television receiver which permits control of the frequency of a scanning oscillator (horizontal or vertical) to produce coincidence with the synchronizing rate of the transmitted signal.

**HORIZONTAL BLANKING** - The process of cutting off the electron beam during retrace between successive active horizontal lines.

**HORIZONTAL BLANKING IMPULSE** - The rectangular shaped pedestal of the composite television signal which occurs between active horizontal lines. This causes the beam current of the picture tube to be cut off during retrace.

**HORIZONTAL CENTERING CONTROL** - The adjustment means of a television receiver whereby the image may be moved in the horizontal direction.

**HORIZONTAL DISCHARGE TUBE** - A vacuum tube in the horizontal deflection circuit which is used to discharge a capacitor to form the sawtooth scanning wave. (See Discharge Tube.)

**HORIZONTAL DRIVE CONTROL** - The adjustment means of an electromagnetically deflected television receiver which adjusts the ratio of pulse to linear portion of the scanning current wave.

**HORIZONTAL FLYBACK** - (See Horizontal Retrace.)

**HORIZONTAL HOLD CONTROL** - (See Hold Control.)

**HORIZONTAL REPETITION RATE** - The number of horizontal lines per second (15,750 cycles in the R. M. A. standard system).

**HORIZONTAL RESOLUTION** - The number of picture elements, in the horizontal direction, which can be distinguished from each other.

**HORIZONTAL RETRACE** - (See Retrace.)

**HORIZONTAL SCANNING FREQUENCY** - (See Horizontal Repetition Rate.)

## GLOSSARY OF TELEVISION TERMS

**HORIZONTAL SYNC DISCRIMINATOR** - A circuit employed in the flywheel method of synchronization to compare the phase of the horizontal sync pulses with that of the horizontal scanning oscillator. The output of the discriminator controls the frequency and phase of the oscillator by means of a reactance tube.

**HORIZONTAL SYNC IMPULSE** - The rectangular shaped pulses which occur, above pedestal level, between each active horizontal line. These pulses are employed to hold horizontal scanning of the receiver in coincidence with that of the transmitter.

**HUM-BAR** - A dark band extending across the picture caused by excessive 60 cycle hum (or harmonics thereof) in the signal applied to the input of the picture tube.

### I

**ICONOSCOPE** - A television camera tube in which an optical image on a mosaic of photo-sensitive elements causes charges proportional at each point to the image intensity. An electron scanning beam releases these charges in the form of a video signal.

**IMAGE DISSECTOR** - (See Dissector.)

**IMAGE INTERFERENCE** - A spurious response in a television receiver due to signals of a frequency removed from the desired signal by twice the intermediate frequency of the TV set. Usually due to a local FM carrier, or another television carrier.

**IMAGE ORTHICON** - A camera tube combining the orthicon principle with that of the electron multiplier. It possesses a very high value of light sensitivity.

**"IMPLODE"** - The term applied to the bursting of a television picture tube. Due to the high degree of vacuum the glass fragments move inward with terrific force.

**"INFRA-BLACK"** - (See "Blacker-than-Black".)

**INTEGRATING CIRCUIT** - A combination of circuit elements which produce an output potential which is proportional to the stored-up value of a number of pulses of input signal.

**INTERCARRIER SOUND** - A method of utilizing the 4.5mc beat between video and sound carriers as an IF frequency for the sound signal of the television receiver.

**INTERLACE** - A method of scanning an image in several successive fields, each of which contains only part of the horizontal line structure, the fields being arranged to fit together so that successive fields supply the lines missed by the preceding fields. In the standard R. M. A. system double interlace is employed. Half the lines (262.5) are scanned in one field and the other half in the next field. The lines of the second field are arranged to fall exactly between the lines of the first. This system overcomes flicker of the picture.

**INTERLACED SCANNING** - A method of scanning the television image to reduce flicker. (See Scanning.)

**ION** - A charged atom. In the picture tube such ions interfere with the operation by producing a dark spot at the center of the fluorescent screen unless deflected away from the screen by an ion trap.

**ION SPOT** - A dark spot on the fluorescent screen of a picture tube caused by bombardment by ions.

**ION TRAP** - An arrangement of picture tube electrodes in combination with an externally applied magnetic field which allows electrons to pass but obstructs the passage of ions.

### K

**KEystone** - A trapezoid shape. A television picture with one side shorter than the other is said to have keystone distortion. May be encountered due to faulty adjustment of the optical system of projection television receivers.

**KEystone DISTORTION** - (See Keystone.)

### L

**LIMITER** - An amplifier stage preceding an FM detector so operated that all input signals above a predetermined minimum drive the stage to cut-off and plate current saturation thus limiting the output signal to a fixed value. Used to remove amplitude modulation.

**LINE FREQUENCY** - (See Horizontal Repetition Rate.)

**LINE FREQUENCY BLANKING IMPULSE** - (See Horizontal Blanking Impulse.)

**LINE SCANNING FREQUENCY** - (See Horizontal Repetition Rate.)

**LINEARITY** - The distribution of picture elements over the

image field as determined by the shape of the horizontal and vertical scanning waves. In a linear picture the elements are uniformly and correctly distributed. Any departure from linearity of scanning motion will result in distortion of the picture.

**LINEARITY CONTROL** - The adjustment means of a television receiver employed to correct distortion of the sawtooth voltage or current waves used for deflection. Linearity controls are employed for both horizontal and vertical correction.

**LINE DOUBLING** - Another term applied to Horizontal Equalizing Pulses.

### M

**MAGNETIC DEFLECTION** - The method of moving the electron beam by means of a magnetic field produced by a coil external to the picture tube. A linear sawtooth motion is produced when the current through the coil has a sawtooth form.

**MARKER PIP** - A frequency index mark employed in cathode-ray oscilloscope alignment of TV sets and used in conjunction with a sweep driven signal generator. The marker pip is produced by coupling a fixed frequency oscillator to the output of the signal generator.

**MAGNETIC FIELD** - The space near a magnet or electromagnet in which a force is exerted upon a moving electron.

**MONITOR** - A cathode-ray picture tube, and its associated circuits, usually connected directly to the video system of the transmitter and used to view the picture being transmitted.

**MONOSCOPE** - A cathode-ray tube used to produce a video signal for testing purposes. A fixed internal test pattern is employed.

**MOSAIC** - The photo-sensitive surface of an iconoscope or orthicon camera tube. It consists of an insulating surface covered with a multitude of photo-sensitive "islands". A collector plate behind the insulator collects the charges on the mosaic when scanned by an electron beam.

**MULTI-PATH RECEPTION** - The reception of a direct wave from the television transmitter accompanied by one or more reflected and delayed waves. (See Ghost Image.)

**MULTIPLIER** - (See Electron Multiplier.)

**MULTIVIBRATOR** - A relaxation oscillator used for the production of sawtooth scanning waves in a television receiver, employing two tubes with the output of each coupled to the input of the other through C-R networks which determine the period of oscillation.

### N

**N. T. S. C.** - The abbreviation for National Television System Committee. Disbanded since adoption of R. M. A. standards. Now superseded by J. T. A. C. (Joint Technical Advisory Committee).

**NEGATIVE TRANSMISSION** - This refers to the polarity of modulation of the R. M. A. standard television signal. The sync pulses and signals corresponding to black, drive the carrier to maximum modulation, while signals of highest brilliance (white) drive the carrier toward zero modulation.

**NOISE** - In terms of television, noise (a term carried over from sound broadcasting) produced by atmospheric, tube fluctuation effects and man-made interference, causes a salt and pepper, or "snow" pattern on the picture.

**NON-LINEARITY** - The crowding of picture elements in the horizontal direction or crowding of lines at top or bottom due to departure of the scanning action from a linear form. (See Linearity.)

### O

**ODD-LINE INTERLACE** - Refers to the double interlace system in which there are an odd number of lines per frame and in which, therefore, each field contains a half line.

**ORTHICON** - A camera tube of similar design to the iconoscope but employing a translucent mosaic with a ring collector and using a lower velocity scanning beam. An improved form of iconoscope.

### P

**PAIRING** - A failure of proper interlace in which the lines of alternate fields do not fall exactly between those of the preceding field. When failure is most pronounced the lines of alternate

## GLOSSARY OF TELEVISION TERMS

fields fall on one another and result in separated lines with half of the possible vertical resolution.

**PEAKING COIL** - An inductance employed in a video amplifier to resonate with the circuit capacitance beyond the upper limit of the band and thus compensate for high frequency loss of gain and also to correct the amplifier phase shift.

**PEDESTAL** - The level of the video signal at which blanking of the beam of the picture tube occurs. (See Blanking Pulses and Black Level.)

**PERSISTENCE OF VISION** - A characteristic of the eye and brain whereby the sensation of an image remains after the light causing it has vanished. This effect lasts for approximately an eighth of a second and makes television as well as motion pictures possible.

**PHASE** - A point in the cycle of an alternating current or voltage as compared to the time of zero value (expressed in degrees out of 360, which represents the total cycle).

**PHASE-DISTORTION** - A condition of different phase delays for different video frequencies. This causes distortion of the peak values of the video signal and results in defective contrast and resolution.

**PHOTO-ELECTRIC** - The phenomenon whereby electrons are emitted from certain substances by absorption of light. Employed in camera tube operation. The substance is said to be photo-emissive.

**PICKUP TUBE** - Used synonymously with camera tube.

**PICTURE ELEMENT** - The smallest picture area which can be defined in the process of scanning, transmitting and reproducing the video signal.

**PICTURE TUBE** - A special version of the cathode-ray tube used in television reception for the translation of the video signal to a picture.

**"PIX"** - Television slang abbreviation for picture.

**POLARIZATION** - The direction of the electric field of a radiated wave. The magnetic field is perpendicular to the electric. Television transmission is usually horizontally polarized.

**PRE-EMPHASIS** - The practice of amplifying the high frequency end of the audio spectrum to a greater extent than the low frequencies. Employed in FM transmission of the television sound channel.

**PULSE** - Shortened expression for impulse.

**PULSE WIDTH** - The time duration of the narrow or peaked portion of an impulse wave.

### Q

**"Q"** - The figure of merit of a capacitor, an inductor or a tuned circuit. It is numerically equal to the ratio of the reactance to the resistance.

**"QUASI-OPTICAL"** - Having properties similar to light waves. Thus the propagation of waves in the television spectrum is said to be "Quasi-optical", i. e., cut off by the horizon.

**"QUASI-SINGLE SIDEBAND"** - Same as Vestigial Sideband.

### R

**RC CIRCUIT** - A time determining network of resistors and capacitors in which the time constant is defined as the product of the resistance times the capacitance.

**R. M. A.** - The Radio Manufacturers Association. The technical committees of this association have been instrumental in establishing the television standards now accepted by the Federal Communication Commission.

**RASTER** - The scanned area on the fluorescent screen of the picture tube. The illuminated rectangle composed of all of the horizontal scanning lines. (Visible when the brilliance control is turned up with no signal.)

**RATIO DETECTOR** - An FM detector which inherently discriminates against amplitude modulation. It uses a pair of diodes connected in such a manner that the audio output is proportional to the ratio of the FM voltages applied to the two diodes.

**REACTANCE TUBE CIRCUIT** - A vacuum tube circuit in which a high transconductance tube is so connected that it appears as a reactance (inductive or capacitive) to a circuit across which it is connected. The value of the reactance can be controlled by changing the DC grid bias. Used for A. F. C.

**REFLECTIONS** - In television this refers to the reflected carrier wave from structures and also to the "Ghost Image" on the picture caused by the reflected carrier.

**REFLECTOR** - A half wave dipole placed behind a dipole re-

ceiving antenna, to intensify the received signal and improve the shape of the directional antenna pattern.

**REGISTRY** - The superposition of one image on another, as in the formation of an interlaced scanning raster.

**REINSERTER** - Same as DC Restorer. (See DC Reinsertion.)

**RELAXATION OSCILLATOR** - An oscillator which generates periodic waves (usually of a sawtooth form for scanning purposes) in which a sudden excursion of plate current from cut-off to saturation is followed by a relatively long period of quiescence or relaxation.

**RESOLUTION** - This refers to the smallest element of the picture which can be distinguished. It is usually expressed as the number of alternate black and white lines which can be seen in a television test chart. The resolution in the horizontal and vertical directions are expressed separately.

**RESOLUTION PATTERN** - (See Television Test Chart.)

**RETRACE** - The return of the electron beam after horizontal or vertical scan to start a new line or field.

**RETRACE TIME** - The time which elapses during retrace. In the R. M. A. signal this is approximately 7 microseconds for the horizontal retrace and 500 to 750 microseconds for the vertical retrace.

**RHOMBIC ANTENNA** - A diamond shaped arrangement of conductors, each of the same length (rhombus). Joined at 3 corners with a transmission line connected at the open corner. The length of the conductors to be more than a wavelength. Used for fringe or low signal reception.

### S

**SAWTOOTH** - The descriptive term used for the waveform employed in television scanning.

**SCANNING** - The process of successively analyzing the light values of the picture elements which constitute the entire scene being televised according to a predetermined method.

**SCANNING GENERATOR** - A vacuum tube circuit used to produce the sawtooth wave of voltage or current required for transmitter camera tube or receiver picture tube operation.

**SCANNING LINE** - A single active horizontal line of the picture.

**SCANNING SPOT** - The cross section of the electron beam at the fluorescent screen of the picture tube.

**SCHMIDT SYSTEM** - An optical system employed to produce large size projection images. A large hemispherical mirror is employed to project the image formed on a small picture tube onto a translucent screen. Optical distortion is compensated by interposing an aspherical corrector lens in the projection path.

**SCREEN PERSISTENCE** - The property of the fluorescent screen of a picture tube to continue the radiation of light for a short time after the electron beam causing the light spot has passed.

**SECONDARY ELECTRON** - An electron which is knocked out of a metal surface under the bombardment of another electron, called the primary electron.

**SECONDARY EMISSION** - The phenomenon of the production of secondary electrons. (See Secondary Electron.)

**SEQUENTIAL INTERLACE** - A system of interlace in which the lines of one field fall directly alongside the lines of the preceding field. (See Odd Line Interlace.)

**SESQUI-SIDEBAND TRANSMISSION** - The transmission of a carrier modulated by a full sideband and half of the other. (See Vestigial Sideband Transmission.)

**SERIES PEAKING** - The use of an inductance in series with the plate of a video amplifier tube to compensate for loss of high frequency gain and to correct high frequency phase shift.

**SERRATED PULSES** - "Notches" in the long vertical sync pulse which provide a means of keeping the horizontal oscillator in synchronism during the vertical retrace period.

**SHADOWS** - Used synonymously with "Ghost".

**SHUNT PEAKING** - The use of an inductance in a parallel circuit branch of a video amplifier to compensate for the high frequency loss due to the shunt circuit capacitance. It is also used to correct the high frequency phase shift.

**SINGLE ENDED** - This refers to input circuits of television receivers in which one side of the transmission line is connected to the chassis or ground.

**SINGLE SIDEBAND** - A method of radio transmission in which the carrier and only one sideband are radiated.

**"SMEAR" GHOST** - A spurious image caused by a number of multiple reflections or by phase shift in the video amplifier.

**"SNOW"** - Television slang for the effect of random noise on the reproduced picture. (See Noise.)

## GLOSSARY OF TELEVISION TERMS

**SPURIOUS SIGNAL** - Refers either to the effect of reflections of the carrier wave or undesirable shading signals occurring in the camera tube at the transmitter.

**STACKED ARRAYS** - This term is applied to antenna systems in which two or more antenna arrangements are positioned above one another at a critical spacing and connected together with lengths of transmission line. Stacking increases the pickup and improves the directional pattern.

**STAGGERED CIRCUITS** - Interstage coupling circuits of a video IF amplifier are said to be staggered when they are tuned to different frequencies. Staggered tuning is adopted to obtain broadband response.

**SURGE IMPEDANCE** - Same as Characteristic Impedance.

**SWEEP** - Same as scan. Refers to motion of an electron beam at right angles to its direction.

**SWEEP VOLTAGE** - The voltage applied to the deflection plates of an electrostatically deflected picture tube.

**SYNC** - An abbreviation for synchronization.

**SYNC CLIPPER** - A vacuum tube circuit which is biased so as to remove the sync signals from the composite video signal.

**SYNC INVERTER** - A vacuum tube circuit which produces a phase shift of the sync pulses of 180° to provide the necessary polarity for control of the scanning oscillator.

**SYNC LEVELER** - (See Sync Limiter.)

**SYNC LIMITER** - A vacuum tube circuit which produces uniform height sync pulses.

**SYNC SEPARATOR** - (See Sync Clipper.)

**SYNCHROGUIDE** - A type of control circuit for horizontal scanning in which sync signal, oscillator voltage pulse and scanning voltage are compared and kept in synchronism.

**SYNCHRONIZING PULSES** - The portions of the transmitted signal which control horizontal and vertical scanning of the receiver. (See Horizontal and Vertical Sync Pulses.)

### T

**TEARING** - A fault of the synchronizing system in which groups of lines are displaced causing the appearance of a "torn" picture.

**TELEGENIC** - The suitability of a subject or model for televising.

**TELEWISE** - The act of converting a scene or image field into a television signal.

**TELEVISION TEST CHART** - A chart placed before the camera of the transmitter, having geometric patterns which enable the service technician or set user to determine the horizontal and vertical resolution of the receiver.

**TEST PATTERN** - (See Television Test Chart.)

**TIME CONSTANT** - The time required for the voltage or current of an electric circuit to rise to 63% of its final value or to fall to 37% of its initial value.

**TIME DELAY** - The time which elapses between the start of a modulation wave or impulse at the transmitter and the start of its reproduction on the picture tube screen.

**TRANSIENT RESPONSE** - The manner in which an electrical circuit responds to sudden changes in applied potential.

**TRANSMISSION LINE** - A two-conductor circuit, having uniformly distributed electrical constants, used for transmitting radio frequency signals.

**TRIGGERING** - Starting of action in a circuit, which then continues to function for a predetermined time under its own control.

**U. H. F. (ULTRA HIGH FREQUENCY) WAVES** - The band of frequencies from 300 to 3000 megacycles. Proposed for extension of the present black and white television and for experimental transmission of color television.

### V

**V. H. F. (VERY HIGH FREQUENCY) WAVES** - The portion of the spectrum employed, at present, for television transmission. The limits are 30 to 300 megacycles.

**VERTICAL BLANKING** - The blanking signals which occur at the end of each vertical field and cause the picture tube to become dark during vertical retrace.

**VERTICAL BLANKING IMPULSE** - (See Vertical Blanking.)

**VERTICAL CENTERING CONTROL** - The adjustment means of a television receiver whereby the picture can be moved in a vertical direction on the picture tube.

**VERTICAL HOLD CONTROL** - (See Hold Control.)

**VERTICAL OSCILLATOR** - The sawtooth scanning generator which furnishes the required voltage or current wave for vertical scanning.

**VERTICAL RESOLUTION** - The line-structure of the television picture. The number of lines or picture elements which can be resolved in the vertical direction.

**VERTICAL RETRACE** - The return path of the electron beam (blanked out) across the raster from bottom to top at the end of each field.

**VERTICAL SCANNING** - The movement of the beam on the picture tube in the vertical direction.

**VERTICAL SCANNING GENERATOR** - (See Vertical Oscillator.)

**VERTICAL SYNC PULSES** - A series of six pulses (longer in time duration than the horizontal pulses) which occur between each field and are used to synchronize the vertical scanning oscillator.

**VESTIGIAL SIDEBAND TRANSMISSION** - The system of video modulation employed under R. M. A. standards. The carrier is modulated by a complete upper sideband and a vestige (1.25mc) of the lower sideband.

**VIDEO (LATIN FOR "I SEE")** - Refers to the frequencies employed for modulation of the carrier by the output of the camera tube.

### W

**WEDGE** - The convergent, fan shaped pattern of equidistant black and white triangularly shaped lines used on a television test pattern.

**WIDTH** - In television this term may refer to the horizontal dimension of the picture or to the time duration of a pulse (pulse width).

**WIDTH CONTROL** - The adjustment means of a television receiver whereby the horizontal dimension of the picture is adjusted to fill the picture tube.

### Y

**"YAGI" ARRAY** - An arrangement of dipole antenna elements employed for television reception in which one element acts as the antenna and the others as parasitic elements (directors and/or a reflector) to improve gain and directional reception pattern.



## BIBLIOGRAPHY

### BOOKS

- Antenna Manual, Woodrow Smith, Editors and Engineers, Ltd., Santa Barbara, Calif.
- Cathode-Ray Tube in Television, I. G. Maloff and D. W. Epstein, McGraw-Hill Book Co., New York
- Electron Optics in Television, I. G. Maloff and D. W. Epstein, McGraw-Hill Book Co., New York
- Electronic Television, George H. Eckhardt, Wilcox & Follett Co., Chicago, Ill.
- Farnsworth Television Handbook, Farnsworth Television & Radio Corp., Fort Wayne, Ind.
- 4000 Years of Television, Richard W. Hubbell, G. P. Putnam Sons, New York
- Frequency Modulation, Vol. I, R. C. A. Review, Princeton, N. J.
- Future of Television, Orin E. Dunlap, Jr., Harper Bros., New York
- Get Ready to Sell Television, Caldwell-Clements, Inc., New York
- Here Is Television, T. H. Hutchinson, Hastings House, New York
- Introduction to Television, C. T. Hylander and Robert Harding, Macmillan Co., New York
- Modern Practical Radio & Television, C. A. Quarrington, Caxton Pub. Co., London, Eng.
- Modern Radio, Kingdon S. Tylor, Harcourt, Brace & Co., New York
- New Television, R. F. Yates, Didier, Toronto, Canada
- Practical Radio - Including Television, Mayer and Wostrel, McGraw-Hill Book Co., New York
- Practical Television, R. C. A. Service Division, Camden, N. J.
- Principles of Radar, Members of Staff, Radar School, Massachusetts Institute of Technology, McGraw-Hill Book Co., New York
- Principles of Television Engineering, Donald G. Fink, McGraw-Hill Book Co., New York
- Radio at Ultra-High Frequencies, Vol. II, A Collection of R. C. A. Papers, R. C. A. Review, Princeton, N. J.
- Radio Broadcasting & Television Bibliography, O. Rose, Ed., H. W. Wilson Co., New York
- Radio Engineers' Handbook, Frederick Emmons Terman, Sc. D., McGraw-Hill Book Co., New York
- Televasting and Color, K. S. Tyler, Harcourt, Brace & Co., New York
- Television, W. C. Eddy, Prentice-Hall, Inc., New York
- Television, M. G. Scroggie, Blackie & Son, London, Eng.
- Television, V. K. Zworykin and G. A. Morton, John Wiley & Sons, New York
- Television, Vols I, II, III and IV, R. C. A. Review, Radio Corp., of America, Princeton, N. J.
- Television and F-M Receiver Servicing, Milton S. Kiver, D. Van Nostrand Co., Inc., New York
- Television Antennas - Design Construction, Installation and Trouble Shooting, Donald A. Nelson, Howard W. Sams & Co., Inc., Indianapolis, Ind.
- Television as a Profession, J. T. Southwell, McGraw-Hill Book Co., New York
- Television Broadcasting: Production, Economics, Technique, Lenox R. Lohr, McGraw-Hill Book Co., New York
- Television Encyclopedia, Stanley Kemper, Fairchild Pub. Co., New York
- Television Explained, W. E. Miller, Trader, London, Eng.
- Television for Beginners, J. R. Cameron, Cleaver-Hume, London, Eng.
- Television for Radiomen, E. M. Noll, Old York Road Pub. Co., Jenkintown, Pa.
- Television - How It Works, John F. Rider Publisher, Inc., New York
- Television Primer on Production and Direction, Louis A. Sposa, McGraw-Hill Book Co., New York
- Television Production Problems, J. F. Royal, McGraw-Hill Book Co., New York
- Television Programming, Richard Hubbell, Murray Hill Books, Inc., New York
- Television Receiving Equipment, W. T. Cocking, Iliffe, London, Eng.
- Television Show Business, Judy Dupuy, General Electric Co., Schenectady, N. Y.
- Television Simplified, Milton S. Kiver, D. Van Nostrand Co., Inc., New York
- Television Simply Explained, Pub. by Chapman, London, Eng.
- Television Standards & Practice, Donald G. Fink, McGraw-Hill Book Co., New York
- Television Techniques, Bettinger, Harper Bros., New York
- Television - The Eyes of Tomorrow, Captain Wm. C. Eddy, Prentice-Hall, Inc., New York
- Television: The Revolution, Robert W. Lee, Essential Books, New York
- Television Today, R. C. Norris, Rockliff, London, Eng.
- Television, Today and Tomorrow, Lee De Forrest, Dial Press, Inc., New York
- The A. R. R. L. Antenna Book, The American Radio Relay League, Inc., West Hartford, Conn.
- The Mysteries of Television, A. F. Van Dyck, The House of Little Books, New York
- The Servicing of Television Receivers, Philco Service Div., Philco Corp., Philadelphia, Pa.

## BIBLIOGRAPHY

The Story of Electronic Television, Farnsworth Television & Radio Corp., Fort Wayne, Ind.  
Understanding Television, O. E. Dunlap, Greenberg, New York  
We Present Television, John Porterfield and Kay Reynolds, W. W. Norton & Co., New York

### PAMPHLETS

**FARNSWORTH TELEVISION & RADIO CORP.,**  
Fort Wayne, Ind.:

Television - Let's Understand It (Series)  
Damping Circuits  
FM Detection  
Pre-emphasis in FM & Television  
Smearing in Television Production  
Television Antennas  
Television History & Books to Read  
Television Terminology & Definitions

**GENERAL ELECTRIC COMPANY,**  
Syracuse, N. Y.:

Television - Principles and Practice, Chapters 1, 2, 3 and 4, K. Fowler and H. Lippert, Technical Service Section

**INSTITUTE OF RADIO ENGINEERS,**  
New York, N. Y.:

Standards on Television - Definition of Terms  
Standards on Television - Methods of Testing  
Television Receivers

**P. R. MALLORY & CO.,**  
Indianapolis, Ind.:

Inductuner - A variable inductance unit designed for continuous tuning of the entire Television-FM Band

**PHILCO CORP.,**  
Philadelphia, Pa.:

Television Trouble Shooting - 8 Lessons in 4 Pamphlets

**RADIO CORPORATION OF AMERICA:**

An Analysis of Modern Antennas for FM & Television, M. Kaufman, R. C. A. Radio Service News, June - July, 1947, (Harrison, N. J.)  
Explanation of the Ratio Detector as an Aid in FM Servicing, R. C. A. Radio Service News, Part 1, March - April, 1947, Part II, June - July, 1947, (Harrison, N. J.)

How the Image Orthicon Works, R. C. A. Radio Service News, Sep. - Oct., 1948 (Harrison, N. J.)

New Practical Method of Curing T. V. I. (Reducing Harmonic Power Output of Amateur Transmitters) John L. Reinartz, R. C. A. Ham Tips, Nov. - Dec., 1948 (Harrison, N. J.)

Television Antennas and Transmission Lines, John R. Meagher, R. C. A. Radio Service News, Part 1, Nov. - Dec., 1948 (Harrison, N. J.)

Television Service, John R. Meagher, R. C. A. Radio Service News, Part 1, May - June, 1948, Part II, July - August, 1948, Part III, September - November, 1948, (Harrison, N. J.)

Television Trouble Shooting and Alignment, John R. Meagher, R. C. A. Service Company, Inc., Camden, N. J.

The Use of Wave Traps as a Remedy for Interference in Video Reception, Staff Article, R. C. A. Radio Service News, August - September, 1947

**SYLVANIA ELECTRIC PRODUCTS,**  
Emporium, Pa.

Electromagnetic Cathode Ray Tubes, Sylvania News, August, 1948

Fundamentals of Television, Sylvania News, September, 1948

Intercarrier Method of Sound Reception, Sylvania News, January, 1949

Making Sylvania Television Picture Tubes, Stratovision Broadcast, Sylvania News - Technical Section, Vol. 15 - No. 7

Television DC Reinsertion with Germanium Diodes, Sylvania Electric Engineering News Letter #5

Television Fundamentals, Sylvania News, Technical Section, Vol. 15 - No. 8

Television Mixer, Oscillator and AFC, Sylvania News, Technical Section, Volume 15 - No. 10

Television Needs Better Tubes, Sylvania News, Technical Section, Volume 15 - No. 10

Television R. F. Amplifier, Sylvania News, Technical Section, Volume 15 - No. 9

Television Video Detection with Germanium Diodes, Sylvania Electric Engineering News Letter #4

Television Video IF Amplifier, Sylvania News, Technical Section, Volume 15 - No. 11

The Crystal Diode Dynamic Limiter for Frequency Modulation Receivers, Sylvania Electric Engineering News Letter #2

The Germanium Diode FM Ratio Detector, Sylvania Electric Engineering News Letter #3

### MAGAZINE ARTICLES

**ANTENNAS:**

All-Channel TV, Gardiner Greene, FM & Television, June, 1948

Antenna Design for Television and FM Reception, F. A. Kolstes, Proceedings of the I. R. E., October, 1948

- Antennas FM and Television, Milton Kaufman, Radio Maintenance, Part 1, March, 1947, Part 2, April, 1947
- Antennas for Apartments, Donald G. Fink, Electronics, May, 1947
- Antennas for Television, Part 1, Edward M. Noll and Matt Mandl, Radio-Electronics, January, 1949
- Broadband Television Array, E. G. Hills, Tele-Tech, December, 1948
- Cathode-Follower TV-Antenna System, E. G. Hills, Communications, January, 1948
- Indoor Television Antenna, John H. Newitt, Electronics, August, 1948
- Master TV Antennas vs. Indoor Antennas for Multi-set Applications, Ira Kamen, Radio Service Dealer, January, 1948
- Stacked Array - Table of Spacing of Elements, Edward M. Noll, Radio News, October, 1948
- TV Antenna Installation, Ira Kamen, Service, July, 1948
- TV Antenna Installation Tools, Ira Kamen, Service, May, 1948
- TV Antenna-Receiver Installation Methods, Edward M. Noll, Service, March, 1948
- TV Installations in Fringe Areas, Ira Kamen, Service, December, 1948
- Television and FM Antennas, H. Winfield Secor, Radio-Craft, January, 1948
- Television Antenna and RF Distribution Systems for Apartment Houses, Heinz E. Kallman, Proceedings of the I. R. E., September, 1948
- Television Antenna Installations, Giving Multiple Receiver Outlets, J. H. Ehret, Tele-Tech, June, 1947
- Television Receiving Antennas, G. P. Krease, Electronics, November, 1948
- The Corner Reflector Antenna, John D. Kraus, Proceedings of the I. R. E., November, 1940
- Triplex Antenna for Television & FM, L. J. Wolf, Electronics, July, 1947
- Transmission Lines and Antennas for FM and Television, M. Kaufman, Radio Maintenance, March, April, 1947
- Wide-Range Dual-Band TV Antenna Design, Lester L. Libby, Communications, June, 1948

**CAMERA TUBES:**

- The Iconoscope, Video Storage by Secondary Emission from Simple Mosaics, Robert A. McConnell, Proceedings of the I. R. E., November, 1947
- The Image Orthicon - A Sensitive Television Pickup Tube, Albert Rose, Paul K. Weimer and Harold B. Law, Proceedings of the I. R. E., July, 1946

**DC RESTORATION:**

- DC Restorer Circuit Operation, Emmanuel Last, Electronics, September, 1945
- Television DC Component, K. R. Wendt, R. C. A. Review, March, 1948

**COLOR TELEVISION:**

- An Experimental Simultaneous Color-Television System, Part 1 - Introduction, R. D. Kell, Part 2 - Pickup Equipment, G. C. Sziklai, R. C. Ballard and A. C. Schroeder, Part 3 - RF & Reproducing Equipment, K. R. Wendt, G. L. Fredenhall and A. C. Schroeder, Proceedings of the I. R. E., September, 1947
- Color Television, Dr. P. C. Goldmark, Proceedings of the Radio Club of America, May, 1946

**DEFLECTION AND SYNCHRONIZATION:**

- Automatic Frequency and Phase Control of Synchronization in Television Receivers, K. R. Wendt and G. L. Fredendall, Proceedings of the I. R. E., January, 1943
- Automatic Frequency-Phase Control in TV Receivers, A. Wright, Tele-Tech, February, 1947
- Checking Video and Synch Waveforms Using a CRO, Radio Service Dealer, Part I - December, 1948
- Clipping and Clamping Circuits, N. W. Mather, Electronics, July, 1947
- Controlled and Uncontrolled Multivibrators, Eugene R. Shenk, Proceedings of the Radio Club of America, February, 1946
- Current Oscillator for Television Sweep, G. C. Sziklai, Electronics, September, 1946
- Magnetic Deflection Circuits for Cathode-Ray Tubes, O. H. Schade, R. C. A. Review, September, 1947
- Magnetic Deflection of Kinescopes, Kurt Schlesinger, Proceedings of the I. R. E., August, 1947
- Multivibrator Circuits, M. V. Kiebert and A. F. Inglis, Proceedings of the I. R. E., August, 1945
- TV Sync and Inter-sync Systems, Edward M. Noll, Service, Part 1 - September, 1948, Part 2 - October, 1948, Part 3 - November, 1948, Part 4 - December, 1948
- Television Deflection Circuits, A. W. Friend, R. C. A. Review, March, 1947
- Television Receivers, Flywheel Sync, Morton Scheraga, Radio Maintenance, July, 1947
- The Horizontal Sweep, Morton Scheraga, Radio Maintenance, April, 1947
- The Vertical Sweep, Morton Scheraga, Radio Maintenance, March, 1947

## BIBLIOGRAPHY

Sweep Circuit (Cathode Coupled Multivibrator), J. L. Potter, Proceedings of the I. R. E., June, 1938

### DETECTORS:

TV Video Detectors, Edward M. Noll, Service, November, 1947  
The Ratio Detector, S. W. Seeley & S. Avins, R. C. A. Review, June, 1947  
Video Detectors, S. L. Marshall, Radio Service Dealer, May, 1948

### GENERAL:

ABC's of Home Television Servicing, Morton C. Shore, Radio News, August, 1948  
Cathode-Coupled Wide-Band Amplifiers, G. C. Sziklai and A. C. Schroeder, Proceedings of the I. R. E., October, 1945  
FM & TV Boosters, W. H. Buchsbaum, Radio Service Dealer, August, 1948  
How to Clear up the Picture, Max Alth, Radio Maintenance, December, 1948  
Individualized Television Installations, B. Taber, Radio News, September, 1948  
Modern Television Receivers, Milton S. Kiver, Radio News, 1 - April, 1948, 2 - May, 1948, 3 - June, 1948, 4 - July, 1948, 5 - August, 1948, 6 - September, 1948, 7 - October, 1948, 8 - November, 1948, 9 - December, 1948, 10 - January, 1949  
Progress in Television, Dr. Vladimir K. Zworykin, Radio-Craft, January, 1948  
Resolution Test Chart, R. M. A. Staff, Electronics, December, 1947  
TV Receiver Installation Pointers, W. H. Buchsbaum, Service, November, 1948  
Television Handbook, Madison Cawein, FM & Television, December, 1946, January, 1947, February, 1947, March, 1947, April, 1947, June, 1947, August, 1947, September, 1947, April, 1948, May, 1948, August, 1948  
Television Installation, W. W. Waye, Radio News, 1 - September, 1947, 2 - October, 1947, 3 - November, 1947, 4 - December, 1947, 5 - January, 1948, 6 - February, 1948  
Television Production Line Testing, M. S. Kiver, Radio News, Part 1 - December, 1948, Part 2 - January, 1949  
Television Receivers, A. Wright, R. C. A. Review, March, 1947  
Television Remote Viewers, Vin Zeluff, Electronics, December, 1948

### IF AMPLIFIERS:

Automatic Gain Controls for Television Receivers, K. R. Wendt and A. C. Schroeder, R. C. A. Review, September, 1948

Simplified Wide Band Amplifiers, F. L. Burroughs, Radio News, October, 1948  
Stagger Tuned Video IF Systems, Staff Article, Radio News, October, 1948  
TV IF Systems, Edward M. Noll, Service, October, 1947  
TV Wide-Band Amplifiers, Edward M. Noll, Service, September, 1947  
Television Receiver Intermediate Frequencies, P. F. G. Holst, Electronics, August, 1948  
Video IF Circuits and Applications, S. L. Marshall, Radio Service Dealer, April, 1948

### INPUT SYSTEMS:

Inductive Tuning at Ultra-high Frequencies, B. V. K. French, Electronics, April, 1941  
Inductive Tuning System for FM-Television Receivers, Paul Ware, Proceedings of the Radio Club of America, May, 1946  
Local Oscillator Radiation, E. W. Herold, R. C. A. Review, March, 1946  
RF Input Circuits for TV Receivers, Frank R. Norton, Tele-Tech, October, 1948  
Radio-Frequency Performance of some Receiving Tubes in Television Circuits, R. M. Cohen, R. C. A. Review, March, 1948  
Simplified TV Receiver Channel Switching Mechanism, J. A. Hansen, Tele-Tech, December, 1948  
TV Variable Inductance Tuning, John B. Ledbetter, Service, December, 1948  
Television Front Ends, A. D. Sobel, Electronics, September, 1947  
Television RF Amplifiers, Edward M. Noll, Service, April, 1947  
The Television Receiver, RF Tuning Systems, Morton Scheraga, Radio Maintenance, October, 1947  
Variable Inductance Tuning for TV Receivers, Myron F. Melvin, Communications, April, 1947

### INTERFERENCE:

Cause and Cure of Spurious TV Receiver Oscillations, R. T. Cavanaugh, Tele-Tech, May, 1948  
Curing Interference in TV Receivers, M. Seybold, Q. S. T., August, 1947  
Interference Traps for Television, Stanley N. Finley, Radio News, March, 1948  
TV Interference - Causes and Remedies, Ira Kamen, Service, October, 1948  
Trap Circuits for Television Receivers, Staff Article, Radio News, September, 1948

### PICTURE TUBES:

TV Picture Tubes, Samuel L. Marshall, Radio Service Dealer, Part 1, October, 1948

Television Receivers - Cathode Ray Tube, Morton Scheraga, Radio Maintenance, May, 1947

The Negative-Ion Blemish in a Cathode-Ray Tube and its Elimination, R. M. Bowie, Proceedings of the I. R. E., December, 1948

#### POWER SUPPLY:

High Frequency Power Supplies, Morton Scheraga, Radio Maintenance, August, 1947

New Television Power Supplies Use Selenium Rectifiers, George Eannarino, Radio News, September, 1948

Pulsed Rectifiers for Television Receivers, I. G. Maloff, Electronics, August, 1947

R. F. Operated High Voltage Supplies for Cathode-Ray Tubes, O. H. Schade, Proceedings of the I. R. E., April, 1943

Selenium Rectifiers for Television Receivers, George Eannarino, Electronics, February, 1948

TV and Picture Tube Voltage and Signal Systems, Edward M. Noll, Service, Part 1 - June, 1948, Part 2 - July, 1948, Part 3 - August, 1948

Television High Voltage RF Supplies, R. S. Mautner and O. H. Schade, R. C. A. Review, March, 1947

Television Power Supplies, M. Kaufman, Service, July, 1947

Television Receivers - Power Supply, Morton Scheraga, Radio Maintenance, June, 1947

#### PROJECTION RECEIVERS:

Home Projection Television, Part 1 - Cathode Ray Tube & Optical System, H. Rinia, J. de Gier and P. M. van Alphen; Part 2 - Pulse-type High Voltage Supply, G. J. Siezen and F. Kerkhof; Part 3 - Deflection Circuits, J. Haantjes and F. Kerkhof; Proceedings of the I. R. E., March, 1948

Projection Television, Allen Lytel, Radio Service Dealer, Part 1 - October, 1948, Part 2 - December, 1948

Projection Television, Dr. I. G. Maloff, Proceedings of Radio Club of America, May, 1946

Projection Type Television Receivers, E. L. Clark, Radio News, September, 1947

Protelgram - A New Projection Television System, Staff Article, Radio News, April, 1948

Reflective Optical System for Projection Television, V. K. Zworykin, R. C. A. Review, September, 1947

Television Projection System, H. G. Boyle and E. B. Doll, Electronics, April, 1948

#### SERVICE:

Faster TV Trouble-Shooting, Walter H. Buchsbaum, FM and Television, January, 1948

New R. C. A. Test Equipment, Speeds Video Servicing, Art Liebscher, Radio News, July, 1948

TV Receiver Visual Alignment Techniques, Lester L. Libby, Service, Part 1 - October, 1948, Part 2 - November, 1948

Tele-pad & Tel-adjust, Alden Capen, Radio Maintenance, October, 1948

Television Test Equipment, Morton Scheraga, Radio Maintenance, November, 1947

Television Trouble Chart, Staff of National Radio Institute, Radio-Craft, January, 1948

The Television Test Pattern, M. S. Kay, Radio News, January, 1949

#### SOUND:

Carrier-Difference Reception of Television Sound, R. B. Dome, Electronics, January, 1947

F. M. Detectors, M. S. Kay, Radio News, August, 1948

Television Intercarrier Sound Design Factors, S. W. Seeley, Electronics, July, 1948

The Sound Channel, Morton Scheraga, Radio Maintenance, February, 1947

#### VIDEO:

Low-Frequency Compensation of Video Frequency Amplifiers, M. J. Larsen, Proceedings of the I. R. E., October, 1945

TV Receiver Video Amplifiers, Edward M. Noll, Service, January, 1948

TV Video Amplifiers and A. G. C. System, Service, February, 1948

Video Amplifiers, Samuel L. Marshall, Radio Service Dealer, July, 1948

Video Amplifiers - DC Component, S. J. Marshall, Radio Service Dealer, August, 1948

What's New in Video Sections? Morton Scheraga, Radio Maintenance, January, 1948