

1001

WAYS

to use your...

VOM and VTVM

by

ROBERT G. MIDDLETON

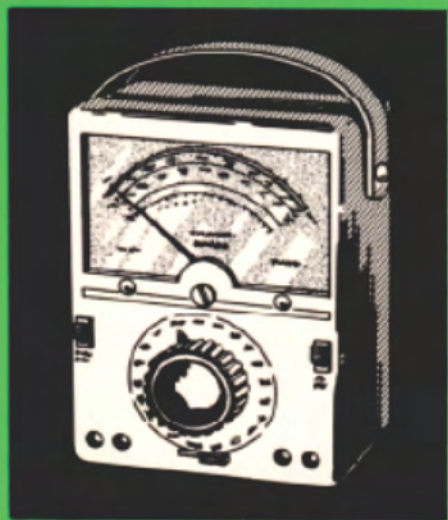

A Howard W. Sams PHOTOFACT PUBLICATION • TEM-3

\$2.00

Cat. No. TEM-3

101 ways to use your VOM and VTVM

by ROBERT G. MIDDLETON



HOWARD W. SAMS & CO., INC.

THE BOBBS-MERRILL COMPANY, INC.

Indianapolis • New York

FIRST EDITION

FIRST PRINTING — APRIL, 1959
SECOND PRINTING — OCTOBER, 1959
THIRD PRINTING — JUNE, 1960
FOURTH PRINTING — JULY, 1961
FIFTH PRINTING — MAY, 1962
SIXTH PRINTING — NOVEMBER, 1963

**101 ways to use your
VOM and VTVM**

Copyright © 1959 by Howard W. Sams & Co., Inc., Indianapolis 6, Indiana. Printed in the United States of America.

Reproduction or use, without express permission, of editorial or pictorial content, in any manner, is prohibited. No patent liability is assumed with respect to the use of the information contained herein.

Library of Congress Catalog Card Number: 59-11827

PREFACE

The VOM and VTVM are unquestionably the most popular and the most useful service instruments. Their ability to show circuit-action data is exceeded only by the oscilloscope. There is also an inherent functional appeal in their outward simplicity.

Technicians with a bump of curiosity will find that the applications picture is two-sided. It is usually thought that VOM and VTVM uses are limited. The other side of the story is an extensive field of tests far beyond simple measurement of DC voltage and resistance values.

This book describes the other side of the picture. The "yarn" unravels into 101 straight lines with no loose ends. Each line is the shortest distance between a service problem and its solution.

This handbook has the same general format as its companion volumes, *101 Ways to Use Your Sweep Generator* and *101 Ways to Use Your Oscilloscope*. You will find just about every practical use for a VOM and VTVM categorized and referenced for quick location.

Bob Middleton

TABLE OF CONTENTS

	Page
INTRODUCTION	9
EQUIPMENT CHECKS	
U1 To Check the Accuracy of Ohmmeter Indications (VOM or VTVM)	11
U2 To Check the Distribution Error of an Ohmmeter Scale (VOM or VTVM)	13
U3 To Check DC Voltage Indication Accuracy against DC Current Indication Accuracy (VOM)	14
U4 To Check the Positive Deflection against the Negative Deflection in a Zero-Center VTVM	16
U5 To Check the AC Voltage Indication against the DC Voltage Indication in a VOM	16
U6 To Check for a Faulty Resistor in a Full-Wave Bridge (VOM)	18
U7 To Check the Ohms-Per-Volt Rating of a VOM on Its Various DC Voltage Ranges	20
U8 To Check the Frequency Response of a VOM on Its AC Voltage Ranges	21
U9 To Check for Hum Voltage at the Ohmmeter Terminals of a VTVM	22
U10 To Check a Signal Generator for Uniformity of Output	24
DC VOLTAGE TESTS	
U11 To Check an Electrolytic Capacitor for Leakage	25
U12 To Measure Capacitance Values with a DC Voltmeter (VTVM)	26
U13 To Measure Capacitance Values with a DC Voltmeter (VOM)	26
U14 To Check a Coupling Capacitor for Leakage (VTVM)	27
U15 To Measure Signal-Developed Bias with a VOM	28
U16 To Check for Linearity of Amplifier Operation	29
U17 To Check a Push-Pull Amplifier for Balance (VOM)	30
U18 To Measure the Internal Resistance of a Circuit (Potentiometer Method)	31
U19 To Measure the Internal Resistance of a Circuit (Range-Switching Method)	31
U20 To Check the Operation of an Oscillator	32
U21 To Measure the Oscillator-Injection Voltage at the Mixer-Tube Grid	33
U22 To Check a Radio or Television Receiver for IF Oscillation	34
U23 To Check the IF Sensitivity of a TV Receiver	34
U24 To Check the DC Voltage Output from a Video Detector	35
U25 To Check the Noise Level in the RF and IF System of a TV Receiver	35
U26 To Adjust a Color-AFC Balance Control.....	36
U27 To Measure AGC Voltage with a VOM	36
U28 To Measure AGC Voltage Accurately with a VOM (Bias-Box Method)	38

TABLE OF CONTENTS

DC VOLTAGE TESTS—continued		Page
U29	To Accurately Measure AGC Voltage with a VOM (Potentiometer Method)	39
U30	To Accurately Measure AGC Voltage with a VOM (Range-Switching Method)	40
U31	To Check for Circuit Loading in AGC Voltage Measurements with a VTVM	40
U32	To Measure the Cathode Current of a Horizontal-Output Tube with a DC Voltmeter (VOM or VTVM)	41
U33	To Measure Screen Dissipation of a Horizontal-Output Tube..	42
U34	To Measure DC Voltage When High-Voltage AC Pulses Are Present (VTVM)	43
U35	To Measure the Plate Dissipation of a Horizontal-Output Tube (VTVM)	44
U36	To Measure DC Voltage in the Presence of High-Voltage AC Pulses (VOM)	45
 OHMMETER TESTS		
U37	To Measure Resistance Values Up to 200 Megohms with a VOM	47
U38	To Measure Resistance Values Down to Small Fractions of an Ohm	48
U39	To Check a Semiconductor Diode	50
U40	To Check the Condition of a Global Resistor	51
U41	To Check a Paper Capacitor for Leakage (VTVM)	51
U42	To Test a Paper Capacitor for Leakage with a High-Ohms Probe (VTVM)	52
U43	To Check an Electrolytic Capacitor for Leakage	53
U44	To Make a Hot Check for Interelectrode Leakage in a Picture Tube	53
 SIGNAL-TRACING TESTS		
U45	To Check for Open Screen and Cathode Capacitors.....	55
U46	To Make Signal-Tracing Tests with No Current Drain from the Circuit under Test	59
U47	To Measure Peak-to-Peak Voltage Values without Current Drain from the circuit under Test (VOM)	60
U48	To Measure the Voltage in a Modulated Waveform (VTVM)..	61
U49	To Determine the Demodulating Capability of a Demodulator Probe (VTVM)	63
U50	To Multiply the Sensitivity of a Signal-Tracer Probe	63
U51	To Check the Local-Oscillator Stage	64
U52	To Signal-Trace from the Output of the RF Tuner through the IF Amplifier (VOM)	65
U53	To Check the Operation of the Signal Circuits from the Mixer Tube to the Picture Detector	66
U54	To Check the Video-Signal Output from the Picture Detector (VOM or VTVM)	67
U55	To Check the Video-Signal Drive to a Picture Tube (VOM or VTVM)	67

TABLE OF CONTENTS

SIGNAL-TRACING TESTS—continued

U56	To Check the Sound Signal at the FM Detector	68
U57	To Signal-Trace the Sync Section of a TV Receiver	69
U58	To Measure the Peak-to-Peak Voltage of the Vertical-Sync Pulse (VTVM)	69
U59	To Measure the Peak-to-Peak Voltage of the Horizontal-Sync Pulse (VTVM)	70
U60	To Check the Drive Voltage to the Vertical-Output Tube (VOM or VTVM)	70
U61	To Check the Sync and Comparison Waveforms at the Horizontal-Phase Detector	71
U62	To Check the Drive Voltage to the Horizontal-Output Tube...	72
U63	To Check for Presence of Horizontal-Output Voltage.....	72

AC VOLTAGE TESTS

U64	To Measure Audio-Amplifier Gain in Decibels.....	75
U65	To Measure AC Voltage or Decibels When DC Voltage Is Present	79
U66	To Determine Whether the Output from an Audio Oscillator Contains Harmonics	80
U67	To Measure Capacitance Values from .001 to 1 Mfd (VOM)...	81
U68	To Measure the Capacitance of an Electrolytic Capacitor.....	82
U69	To Measure the Power Factor of an Electrolytic Capacitor....	83
U70	To Measure the Impedance of an Inductor	85
U71	To Measure Inductive Reactance and Inductance	86
U72	To Measure the Power Factor of a Coil	86
U73	To Measure the Turns Ratio of a Transformer (Audio Output, Power, or Flyback Transformer)	87
U74	To Measure the Power Consumption of a Radio or TV Receiver (VOM or VTVM)	88
U75	To Measure the AC Impedance of a Circuit	89
U76	To Measure the Power Factor of a Radio or TV Receiver Power Supply	90
U77	To Check the Ripple Voltage in a Power Supply	91
U78	To Check the Voltage across the Vertical-Deflection Coils	91

DC CURRENT TESTS

U79	To Measure the Grid Current of a Tube (VOM)	93
U80	To Measure the Screen Dissipation of an Output Tube	94
U81	To Check the Uniformity of Raster Brightness (VOM)	94
U82	To Make Tests at Very Low Light Levels	95
U83	To Measure the Cathode Current of a Horizontal-Output Tube.	96
U84	To Check the Adjustment of a Horizontal-Linearity Coil	96
U85	To Measure the Current Drain on a Power Supply	96

ALIGNMENT APPLICATIONS

U86	To Align an AM IF Transformer	99
U87	To Measure the Stage Gain of an AM IF Amplifier	100

TABLE OF CONTENTS

ALIGNMENT APPLICATIONS—continued		Page
U88	To Align an Overcoupled IF Transformer by Alternate Loading	100
U89	To Align an FM Discriminator Secondary	101
U90	To Align an FM Discriminator Primary	102
U91	To Peak-Align an FM IF Transformer	103
U92	To Plot the Response Curve of an FM Receiver	104
U93	To Peak-Align a TV IF Amplifier	105
U94	To Adjust a Trap in a TV IF Amplifier	106
U95	To Check the Frequency Response of the IF Amplifiers of a TV Set	107
U96	To Check a TV IF Amplifier for Regeneration	108
U97	To Check an IF System for Mixer Regeneration	108
U98	To Signal-Trace an IF Amplifier for a Regenerative Feedback Loop	109
U99	To Peak-Align a Bandpass Amplifier	110
U100	To Measure the Gain of a Bandpass Amplifier	110
U101	To Check Chroma Channel Gains	111
INDEX	113

INTRODUCTION

The VOM and VTVM are the basic test instruments in any shop. These instruments have very wide fields of use. Many of their important applications are not commonly recognized.

Experienced technicians use VOM's and VTVM's to adjust horizontal-drive and -linearity controls, to measure plate and screen dissipation, to check amplifier linearity, to measure the internal resistance of a circuit, to check receiver noise levels, to analyze regeneration and oscillation in IF amplifiers, to check receiver sensitivity, to measure DC millivolts, to check picture-tube rasters, to measure capacitance values, to measure extremely high and low resistance values, to make signal-tracing tests, to check for open screen and cathode capacitors, to measure audio gain or loss in decibels, to measure power consumption, to measure AC impedance, to measure power factors, to measure inductance and inductive reactance, and to make many other useful tests not generally recognized.

Beginners will be interested to learn that a VOM can be completely checked out and that tests can be made for indication accuracy on resistance, DC voltage, DC current, and AC voltage ranges with no other equipment than a battery and a few precision resistors. We show how to check function against function without using standard voltage or current sources.

The usability of VOM's and VTVM's is greatly extended by suitable probes. You will find in these pages explicit instructions concerning the use and constructional details of such probes.

It is true that some of the more common applications of VOM's and VTVM's, such as alignment procedures, can often be performed to better advantage with specialized equipment. However, not every shop can afford expensive sweep generators and oscilloscopes. Hence, the latter portion of this book discusses alignment methods using signal generators with a VOM or VTVM. Technicians interested in advanced alignment procedures are referred to the companion volume, *101 Ways to Use Your Sweep Generator*.

For troubleshooting TV receiver circuits, a VOM or VTVM can be made to do much of the work usually assigned to the scope. Peak-to-peak voltages can be measured. Horizontal components of waveform can be checked independently from vertical components, and vice versa. High-frequency signals can be traced through the IF amplifier, sync, and sound systems. However, technicians who desire to make more elaborate waveform tests are referred to the companion book, *101 Ways to Use Your Oscilloscope*.

You will observe that this is neither a theory book nor a textbook. Instead, it is a practical handbook for the professional technician. Each application is categorized and cross-referenced for quick location. The necessary practical information, showing how to connect instruments and equipment for the specific application, is given for each test. Typical test results are included to guide the user to correct conclusions.

EQUIPMENT CHECKS

U1

To Check the Accuracy of Ohmmeter Indications (VOM or VTVM)

Equipment: Precision resistors ($\pm 1\%$ rated accuracy). Values should be chosen to provide approximately center-scale indication on each ohmmeter range.

Connections Required: First short-circuit the ohmmeter leads for ohmmeter adjustment. Then connect meter leads across resistor for test.

Procedure: Adjust VOM or VTVM for "0" indication. If checking a VTVM, adjust for " ∞ " indication also.

Evaluation of Results: Check ohmmeter scale indication against rated value of resistor. Repeat the check on each resistance range.

The ohmmeter scale of a VOM or VTVM is nonlinear. The high-resistance end of the scale is cramped. This can be seen in the following illustration, which shows the ohmmeter scale, along with the other scales of a typical VOM.

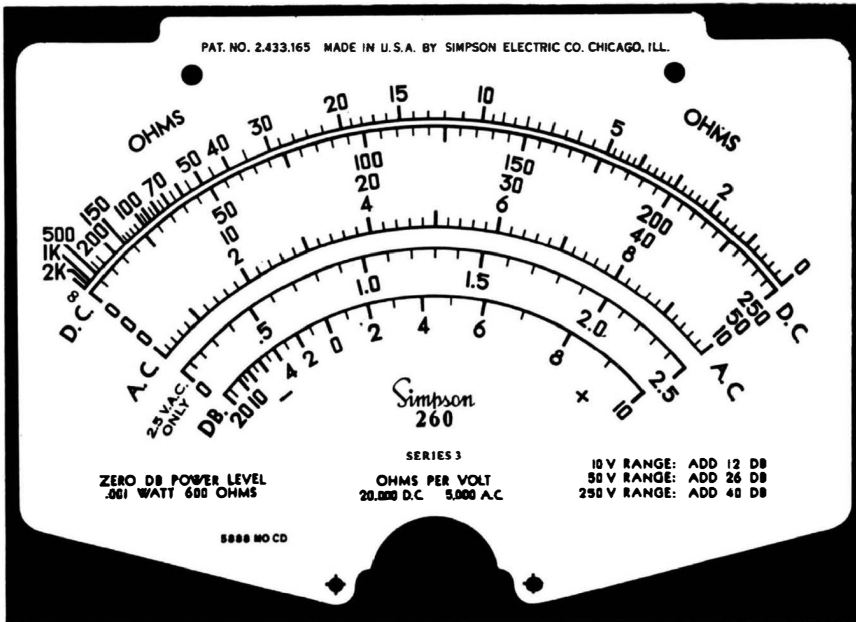

Dial scale of a typical VOM. (Courtesy of Simpson Electric Co.)

NOTE 1

Ohmmeter Accuracy Is Checked in Terms of DC Voltage Accuracy

An ohmmeter scale is cramped at the high-resistance end; hence, the absolute error usually increases as the pointer indicates higher values. The rated accuracy of an ohmmeter is commonly stated in *degrees of arc*. This figure refers basically to the accuracy of the DC voltmeter. For example, the DC voltage accuracy might be rated at $\pm 2\%$ of full scale. On a 10-volt scale, this rating indicates an accuracy of ± 0.2

volt. In turn, a certain number of degrees of arc corresponds to this interval of 0.4 volt, as shown in the following illustration. This arc defines the accuracy of the ohmmeter scale.

Generally, the ohmmeter is assumed to be as accurate as the DC voltmeter. However, a weak ohmmeter battery can greatly lessen the accuracy of the ohmmeter. (See Note 4.)

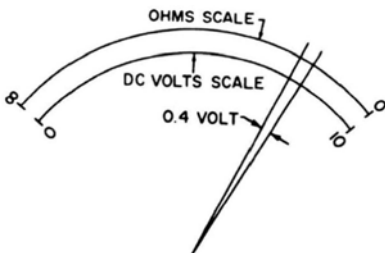

An accuracy of $\pm 2\%$ corresponds to an interval of 0.4 volt on a 10-volt scale.

NOTE 2**Body Resistance Impairs Accuracy of Resistance Measurements**

When making resistance measurements, keep your fingers off the test clips or prods. Your hand-to-hand resistance has a definite value which

will make the reading in error. Body resistance varies widely; a value of 100,000 ohms is typical.

U2**To Check the Distribution Error of an Ohmmeter Scale (VOM or VTVM)**

Equipment: Precision resistors ($\pm 1\%$ accuracy) to provide ohmmeter indications at 25%, 50%, and 75% of full scale.

Connections Required: First short-circuit the ohmmeter leads for ohmmeter adjustment. Then connect meter leads across resistor for test.

Procedure: Adjust VOM or VTVM for "0" indication. If checking a VTVM, adjust for " ∞ " indication also.

Evaluation of Results: The arc of error usually varies from one part of the scale to another. However, the error should not exceed the rated accuracy of the instrument at any point on the scale.

Distribution errors are inherent in the meter movement because of nonuniform flux distribution. Hence, a DC volts scale, for example, may not be quite linear. Meter manufacturers use different scale plates with differing amounts of nonlinearity to obtain a *practical correction of distribution error* in final production. Hence, you cannot necessarily use a scale plate from one movement on another movement even though the model and type of equipment may be the same.

NOTE 3**Ohmmeter Batteries Should Have Nonmagnetic Shells**

When replacing ohmmeter batteries, do not use steel-jacketed cells. The shells are magnetic and will affect

the indication accuracy in some instruments.

NOTE 4

Ohmmeter Accuracy Depends Upon Battery Condition

Good accuracy cannot be obtained from an ohmmeter unless its batteries are new. For example, when a battery slumps off enough that you wouldn't even notice it on the "zero

set" adjustment, a resistance of $12\frac{1}{2}$ ohms could read $11\frac{1}{4}$ ohms, a resistance of 100 ohms could read 80 ohms, and a resistance of 105,000 ohms could read 80,000 ohms.

U3

To Check DC-Voltage Indication Accuracy Against DC-Current Indication Accuracy (VOM)

Equipment: Dry cell or battery and precision resistors ($\pm 1\%$ rated accuracy).

Connections Required: First connect test leads to dry-cell terminals to measure the indicated voltage as shown at A in the following illustration. Next connect dry cell and resistor in series (as shown at B) and measure the indicated current flow.

Procedure: Carefully note the indicated voltage and current values.

Evaluation of Results: From the instrument instruction manual, determine the input resistance of the VOM on its various current ranges. (Or use the method explained in Note 5.) Add this input resistance to the value of the precision resistor used in the test. Then apply Ohm's law to determine whether the voltage and current indications are consistent.

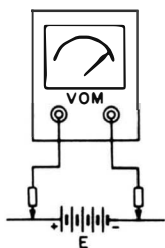

(A) Measuring battery voltage.

Test setup.

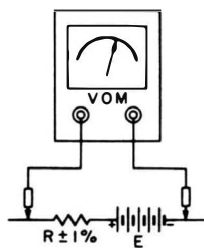

(B) Current measurement with resistor and battery in series.

NOTE 5

Measuring the Input Resistance of a VOM on Its Various Current Ranges

Sometimes the input resistance of a VOM on various current ranges is not given in the instrument instruction manual. In such a case, the input resistance can be measured by using a cell or battery and a pair of precision resistors. Connect one resistor as shown in the following illustration and measure the current, then connect a second resistor and measure the current. Values of the resistors should be chosen to give readings on the *same* current range.

The first reading should be about $\frac{1}{3}$ full scale. The second reading should be $\frac{2}{3}$ or $\frac{3}{4}$ full scale. The input resistance of the VOM on the given current range is then:

$$R_M = \frac{I_2 R_2 - I_1 R_1}{I_1 - I_2}$$

where,

R_M is the input resistance of the VOM,

I_1 is the current measured with R_1 in circuit,

I_2 is the current measured with R_2 in circuit.

Test setup.

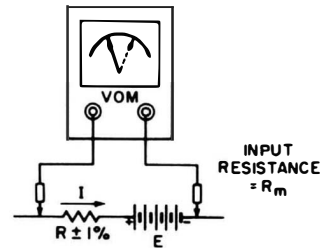

NOTE 6

Electrochemical Action Gives Spurious Voltage Indication

Beginners are sometimes puzzled by a voltage indication which occurs on a VOM or VTVM when a dead circuit is completed by being touched with a finger. This spurious indica-

tion is caused by electrochemical action between a sweaty finger and dissimilar metals. A 20,000 ohms-per-volt meter will read $\frac{1}{4}$ volt in a typical situation of this type.

NOTE 7

Small Current Measurements

Note that a VOM usually has clips or prods which are not copper-plated. Consequently, when they are connected to a copper wire, dissimilar metals are in contact. If one of these junctions is cold and the other is hot, a small current indication is

obtained on the lowest-current range of the instrument (such as $50 \mu\text{a}$, although the test leads are short-circuited by the copper wire.) This is thermoelectric action, which sometimes puzzles the beginner.

To Check the Positive Deflection Against the Negative Deflection in a Zero-Center VTVM

Equipment: VTVM with zero-center scale indication and dry cell or battery.

Connections Required: First connect VTVM leads to voltage source in one polarity as shown at A in the following illustration. Then connect leads in opposite polarity as shown at B.

Procedure: Observe voltage indication obtained in each test.

Evaluation of Results: The same voltage indication (within rated error) should be observed in the two tests.

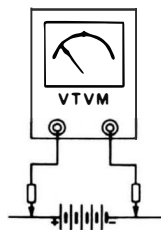

(A) First test.

Test setup.

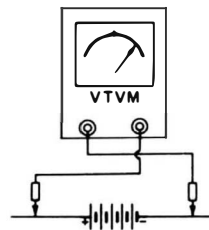

(B) Test with leads reversed.

To Check the AC Voltage Indication Against the DC Voltage Indication in a VOM

Equipment: Dry cell or battery.

Connections Required: Connect instrument leads to battery terminals.

Procedure: Switch VOM from DC to AC voltage indication. Observe the voltage readings. (Read DC voltage scale when instrument is switched to DC voltage function. Read AC voltage scale when instrument is switched to AC voltage function.)

Evaluation of Results: Consult instruction book or inspect instrument to determine whether a half-wave rectifier or a full-wave bridge is used on the AC function. If a half-wave

rectifier is used, the battery voltage when measured on the AC function should read 2.22 times higher than the reading observed on the DC voltage function. The reading is higher because a half-wave rectifier supplies an output that has an average value equal to 0.318 of peak. The meter movement responds to this *average* value. The AC scales of the VOM are calibrated in *rms* values or 0.707 of peak. A DC voltage having the *average* value will produce an *rms* scale reading that is 2.22 times higher. On the other hand, if a full-wave bridge or full-wave semibrige rectifier is used in the instrument, the battery voltage measured should be 1.11 times higher than the reading on the DC function, since a full-wave rectifier supplies an output that has an average value equal to 0.637 of peak. Therefore, the AC scale in an instrument having a full-wave rectifier is calibrated for an *rms* value equal to 1.11 times the *average* value to which the meter responded. (The foregoing relationships apply only to a sine wave.)

Note that it should make no difference which polarity of battery voltage is applied on the AC function when the VOM uses a full-wave bridge (See U6). On the other hand, if the VOM uses a half-wave rectifier, you must polarize the battery connections suitably to get a reading on the AC function. Wrong polarity in this case results in zero or small reverse reading on the AC function.

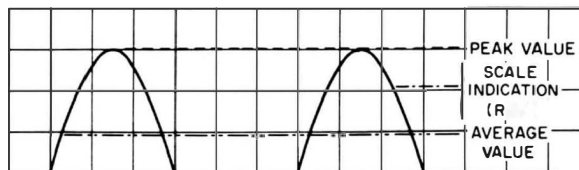

Output of half-wave rectifier.

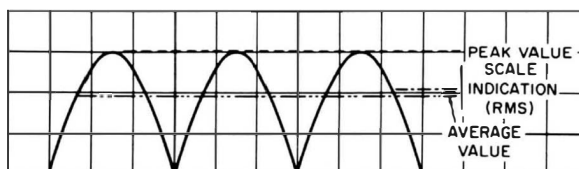

Output of full-wave rectifier.

To Check for a Faulty Rectifier in a Full-Wave Bridge (VOM)

Equipment: Dry cell or battery.

Connections Required: Connect instrument leads to battery terminals.

Procedure: Operate VOM on its AC voltage function. Note scale indication. Then reverse instrument leads to battery and note scale indication again.

Evaluation of Results: The two scale indications should be very nearly equal. Unequal scale readings indicate that the full-wave bridge rectifier is faulty.

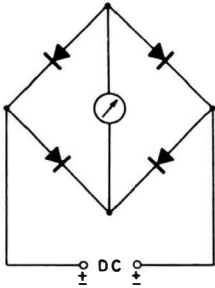

The basic full-wave bridge rectifier circuit.

NOTE 8

AC Voltage Values Are Read on Special Scales, Not on the DC Scales

Note that the AC voltage scales are cramped at the low-voltage end. The scales with the least full-scale value are most cramped because instrument rectifiers are nonlinear. When the multiplier resistance is small (on the low-voltage ranges), the rectifier nonlinearity shows up most prominently; therefore, the lowest voltage is cramped most. On the other hand, when the multiplier resistance is

large (on the high-voltage ranges), the rectifier nonlinearity shows up to a lesser extent. This is a *swamping* effect. Nevertheless, VOM's commonly measure all AC voltage values on scales separate from the DC scales. There is an appreciable cramping at the low end of the AC scale, even when high voltages are being measured.

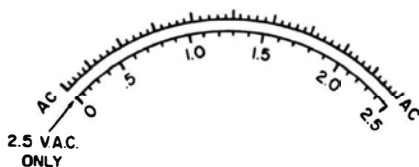

AC voltage scales, showing cramping at low end.

NOTE 9**VOM and VTVM Respond to Stray AC Field Voltages**

When working with VOM's and VTVM's on AC current ranges, you will often observe that a voltage indication is obtained when you touch a test prod. This indication is due to stray AC fields picked up by body capacitance to power wiring and

equipment in the room. This stray-field voltage is rectified and indicated on the meter scale. The internal resistance of a stray-field source is high, and hence, a VTVM gives a higher stray-field indication than a VOM.

NOTE 10**Instrument Rectifiers Lessen Accuracy of AC Indication**

The accuracy of a VOM is less on AC functions than on DC functions because of aging tolerances on the instrument rectifier. Thus, a VOM rated for 3% of full-scale accuracy on DC voltage and current ranges will customarily be rated for 5% of full-scale accuracy on AC ranges.

Consider, for example, a 100-volt range: On the DC function, this rating means the accuracy will be within ± 3 volts at any point on the 100-volt DC scale. On the other hand, the AC rating means the accuracy will be within ± 5 volts at any point on the 100-volt AC scale.

NOTE 11**Common Causes of Inaccurate Scale Indication**

Inaccurate indication in a VOM or VTVM can be traced to various causes.

1. Overloads can damage multiplier resistors and change their resistance values. On AC ranges, VOM contact rectifiers can be damaged by overload.

2. Overloads can also damage the meter movement.

3. Excessive jarring and vibration can weaken the permanent magnets in the movement.

4. Placing a degaussing coil over or near a meter can weaken the permanent magnets in the movement.

5. Static electricity on the meter faceplate, commonly caused by wiping with a cloth, can cause the pointer to deflect incorrectly or to stick to the faceplate.

6. Some VOM's use printed-circuit wiring. Overloads due to accidental application of DC voltage or AC voltage on the ohmmeter function can burn out sections of the printed circuit.

7. AC voltage applied to a VOM on its DC ranges does not move the pointer. However, excessive AC voltage can burn out the multiplier resistors or the meter movement without producing any deflection.

To Check the Ohms-Per-Volt Rating of a VOM on Its Various DC Voltage Ranges

Equipment: Precision resistors with values equal to the ohms-per-volt rating of the VOM times the full-scale values of the various DC voltage ranges. For example, to check a rated 20,000 ohms-per-volt VOM with 2.5-, 10-, 50-, 250-, 1,000-, and 5,000-volt DC ranges requires precision resistors of 50,000 ohms, 200,000 ohms, 1 meg, 5 meg, 20 meg, and 100 meg. Any convenient DC voltage sources can be used.

Connections Required: First connect VOM leads directly to voltage source and measure the voltage value. Then connect the appropriate precision resistor in series with the instrument and the voltage source.

Procedure: Observe scale readings in the foregoing tests. Repeat for each DC voltage range.

Evaluation of Results: Scale indication drops to one-half (within limits of rated error) if the ohms-per-volt rating of the VOM times the full-scale value of the range is equal to the value of the precision resistor.

The same method can be used to check the ohms-per-volt rating of a VOM on its various AC voltage ranges. An AC voltage source is used, and the VOM is operated on its AC voltage functions.

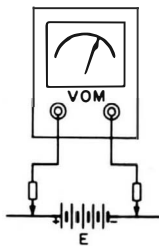

Test setup for measuring voltage.

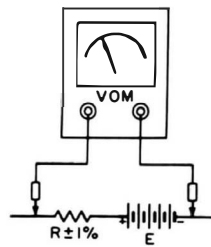

Test setup with resistor in circuit.

To Check the Frequency Response of a VOM on Its AC Voltage Ranges

Equipment: Audio oscillator.

Connections Required: Connect VOM test leads to audio-oscillator output.

Procedure: Vary frequency of oscillator. Switch meter to adjacent ranges. Note voltage readings on adjacent ranges without changing the oscillator output.

Evaluation of Results: At some upper frequency, AC readings will become inaccurate. This occurs when the same reading is not obtained on adjacent ranges. The range-switching test is used to eliminate the possibility of nonuniform output from the oscillator at different frequencies. A VOM has a typical frequency response, as shown in the following. The rise or fall in response at high frequencies is caused by resonances. On some ranges, the stray capacitance in the meter bypasses part of the current. On other ranges, the stray capacitance resonates at high frequencies with the inductance of the movement. This resonance causes a false rise of voltage indication. At low frequencies, the pointer vibrates on the scale. This vibration is due to incomplete mechanical filtering of the rectified half cycles by inertia of the meter movement. VOM's vary greatly in frequency response. Those with half-wave, copper-oxide rectifiers are flat through the audio range only, or even less in some cases.

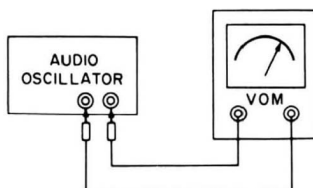

Test setup.

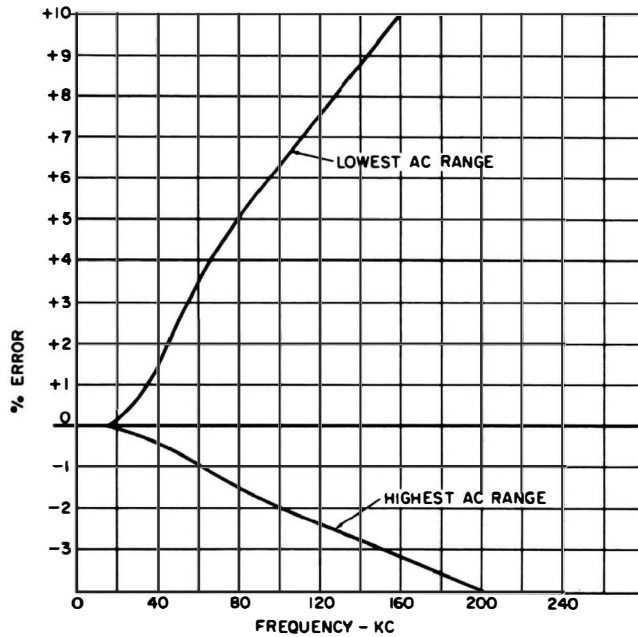

Typical AC voltage indication errors for VOM at high frequencies—full-wave bridge rectifier.

U9

To Check for Hum Voltage at the Ohmmeter Terminals of a VTVM

Equipment: VTVM with AC voltage ranges. (A second VTVM is used to check the ohmmeter section of the first VTVM.)

Connections Required: Connect the leads of the second VTVM to the ohmmeter terminals of the first VTVM.

Procedure: Set the first VTVM to its Ohms function. Set the second VTVM to its AC voltage function and to the lowest AC voltage range. Turn the range switch of the first VTVM through all its positions, from $R \times 1$ to $R \times 1$ meg. Observe scale of second VTVM for AC voltage indication.

Evaluation of Results: No AC voltage should be observed on any resistance range of the VTVM under test. AC voltage would be undesirable at the ohmmeter terminals because measurements of semiconductor diode resistance will then be in error.

Note that a VOM is *not* suitable for measuring the AC hum voltage from the ohmmeter terminals of a VTVM because the ohms-per-volt rating of the VOM is too low on its AC function to obtain a practical test.

NOTE 12

VTVM Ground Return Should Not Be Used as "Hot" Test Lead

It is often important, when DC or AC voltages are being measured with a VTVM, to apply the test leads properly to the circuit under test. The VTVM ground lead cannot be used as a "hot" lead without the danger of serious error in voltage indication because the lead is connected to an extensive ground system in the VTVM. On the other hand, the VOM test leads can be reversed without an error in voltage reading. Also, many VTVM's will in-

dicating wrong DC voltage values if the ground lead is applied at a point above ground in the receiver circuits. For example, the cathode of a tube is sometimes operated substantially above ground, and a measurement from some circuit point to the cathode may be in error. Always measure with the VTVM ground lead connected to the chassis ground or B—. You can make pairs of measurements and subtract values, if necessary.

NOTE 13

Tolerances of Multiplier Resistors Connected in Series and in Parallel

Resistors in VOM and VTVM multipliers are usually rated at $\pm 1\%$ tolerance. Therefore, a nominal 1000-ohm resistor could have an absolute value from 990 ohms to 1010 ohms. If two resistors with a tolerance of $\pm 1\%$ each are connected in series, their tolerance is still $\pm 1\%$. For example, if two resistors with a nominal value of 1000 ohms are connected in series, the combination series arrangement is 2000 ohms. If each resistor has a tolerance of $\pm 1\%$, the range of absolute resist-

ance is from 1980 ohms to 2020 ohms, or a variation of $\pm 1\%$ on the 2000-ohm nominal value. Again, consider the two 1000-ohm resistors connected in parallel. The nominal resistance of the combination is 500 ohms. If each resistor has a tolerance of $\pm 1\%$, the tolerance of the parallel combination can range from 495 ohms to 505 ohms absolute. This is also a variation of $\pm 1\%$ on the nominal value of the parallel configuration.

NOTE 14

Multiplier and Movement Tolerances Are Additive

When a multiplier resistor is connected in series with a meter movement, the tolerances of the resistor and movement are additive. For example, a $\pm 1\%$ resistor connected to a $\pm 2\%$ meter movement gives a total tolerance of $\pm 3\%$. Consider a meter movement that reads 2% low at full scale. If the multiplier resistor is 1% over its nominal value,

the scale still reads lower by a total amount of 3%. Of course, if the multiplier resistor is 1% below its nominal value, the scale error is then reduced to 1%. Note that the same considerations apply for meter shunts; the total tolerance is the sum of the shunt tolerance plus the movement tolerance.

U10

To Check a Signal Generator for Uniformity of Output

Equipment: Rectifier probe, transistor, 47-ohm resistor, 3K resistor, and 6-volt battery.

Connections Required: Construct a probe as shown in the following illustration and connect this probe to signal-generator output cable. Connect probe output cable to VOM as shown.

Procedure: Tune signal generator through the frequency range of interest. Note indication on DC current range of VOM (use 1-milliamper range).

Evaluation of Results: Some signal generators have uniform output over a wide range of frequencies. Others show considerable variation within a small frequency range. This variation must be taken into account when wide-band amplifiers are being checked.

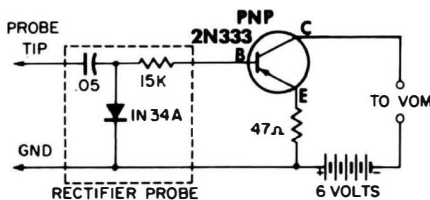

Construction of a sensitive rectifier probe for checking signal-generator output.

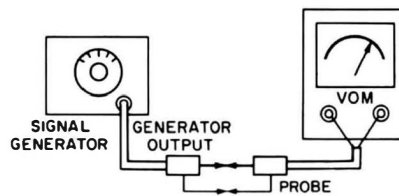

Test setup.

DC VOLTAGE TESTS

U11

To Check an Electrolytic or Paper Capacitor for Leakage

Equipment: Power supply or battery.

Connections Required: First connect voltage source across capacitor terminals (observe polarity for electrolytic capacitors). Then disconnect voltage source and connect instrument test leads across capacitor.

Procedure: Apply working voltage or near working voltage to capacitor for the most conclusive test. For a very thorough test, wait about ten seconds after disconnecting the voltage source before connecting voltmeter to capacitor. Note initial reading of voltmeter when leads are connected.

Evaluation of Results: A good capacitor, after holding a charge for ten seconds, will initially measure practically the same voltage as the source. A poor capacitor will give a low or zero initial reading. Note that small capacitors cannot be tested satisfactorily: the initial reading cannot be obtained because the input resistance of the voltmeter rapidly discharges the capacitor.

To Measure Capacitance Values with a DC Voltmeter (VTVM)

Equipment: Battery, resistor, and a watch with a second hand.

Connections Required: Connect battery, resistor, and the capacitor under test, as illustrated.

Procedure: Close the circuit and note the time required for the capacitor to charge to 63.2% of the final voltage.

Evaluation of Results: Suppose we use a 100-volt battery in the test. At the end of X number of seconds, the capacitor has charged to 63.2%. We then divide the number of seconds (X) by the value of the resistor to obtain the value of the capacitor. For example, if a 100-volt battery and a 1-megohm resistor require 40 seconds to charge a capacitor to 63.2%, the capacitor has a value of 40 microfarads. Or, if a 100-volt battery and a 100K resistor require 4 seconds to charge a capacitor to 63.2%, the capacitor has a value of 40 microfarads.

This test is accurate only for capacitors having high insulation resistance. If the resistor has a value of 1 megohm, and the VTVM has an input resistance of 10 megohms, the final charge on the capacitor when 100 volts is applied is 90.91 volts.

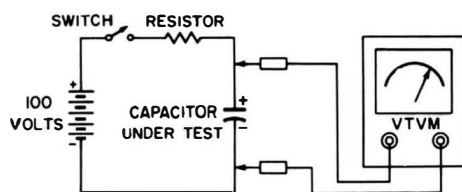

Test setup.

To Measure Capacitance Values with a DC Voltmeter (VOM)

Equipment: Battery and a watch with a second hand.

Connections Required: First connect battery to capacitor, then connect capacitor to VOM as shown (or use SPDT switch).

Procedure: Observe the time required for the reading to fall to 36.8% of its initial value.

Evaluation of Results: If the reading takes X seconds to fall to 36.8% of the battery voltage, we find the capacitance value by dividing X by R_{in} , the input resistance of the VOM. For example, suppose we have a 100-volt battery. If the VOM is set to the 100-volt range, R_{in} is 2 megohms. If the reading takes 80 seconds to fall to 36.8 volts, the capacitor has a value of 40 microfarads. Or, if we have a 10-volt battery and operate the VOM on the 10-volt range, the input resistance is 200,000 ohms. If the reading takes 8 seconds to fall to 3.68 volts, the capacitance value is 40 microfarads. This test is accurate only for capacitors having high insulation resistance.

Test setup.

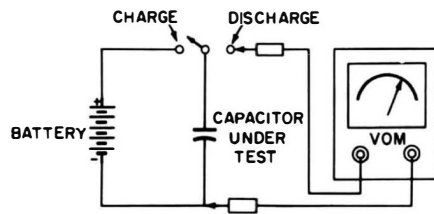

To Check a Coupling Capacitor for Leakage (VTVM)

Equipment: None.

Connections Required: (Transformer-type receiver.) Pull the tube driven by the coupling capacitor to eliminate grid contact potential. Ground AGC line, if the grid resistor is not grounded. Connect VTVM test leads across the grid resistor.

Procedure: Set VTVM to lowest DC voltage range. Observe scale for any pointer deflection.

Evaluation of Results: Any DC voltage reading indicates that the coupling capacitor is leaking and should be replaced. This is a moderately sensitive test because B-plus voltage is applied to the capacitor. To make a highly sensitive test, disconnect the capacitor from the following circuit and measure from the open end of the capacitor to ground.

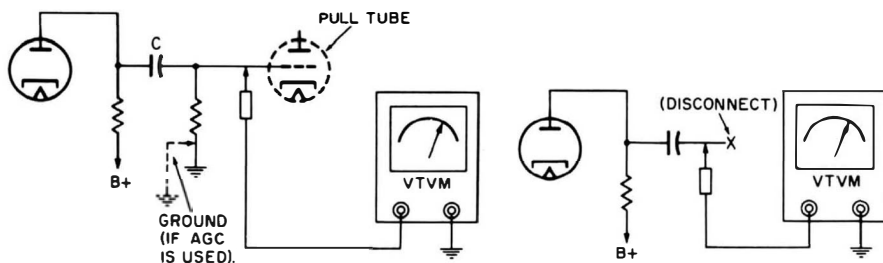

Test setup for in-circuit test.

Test setup for more sensitive test.

U15

To Measure Signal-Developed Bias with a VOM

Equipment: Precision resistor having the same value as the VOM input resistance on the DC range used.. (If operating on the 2.5-volt range of a 20,000 ohms-per-volt VOM, use a 50,000-ohm resistor.)

Connections Required: Use the precision resistor as a probe at the end of the VOM lead which is applied to the tube grid.

Procedure: Observe indication on VOM scale.

Evaluation of Results: The VOM indicates one-half the DC voltage at the “probe.” Hence, multiply the scale indication by 2. For example, if you are checking at the grid of the oscillator in an RF tuner and the VOM indicates -1.25 volts, the actual voltage at the grid is -2.5 volts.

The purpose of the “probe” resistor is to minimize shunt capacitance at the grid of the tube.

NOTE 15

DC Probe of VTVM Contains Isolating Resistor

When a VTVM is used to measure signal-developed bias, a supplementary resistor is unnecessary. The DC

cable for a VTVM contains a resistor (often 1 megohm) to provide low input capacitance.

NOTE 16

Polarity-Reversing Probe Can Be Used Instead of Reversing Test Leads

When making DC voltage tests in TV receiver circuits with a VOM, we often must reverse the test leads to measure positive and negative values. Many VOM's have no polarity-reversing switch. For finger-tip control of polarity indication, you can use a polarity-reversing probe, as shown in the following illustration. This is a simple switch-type arrangement for conveniently reversing the test leads of a VOM.

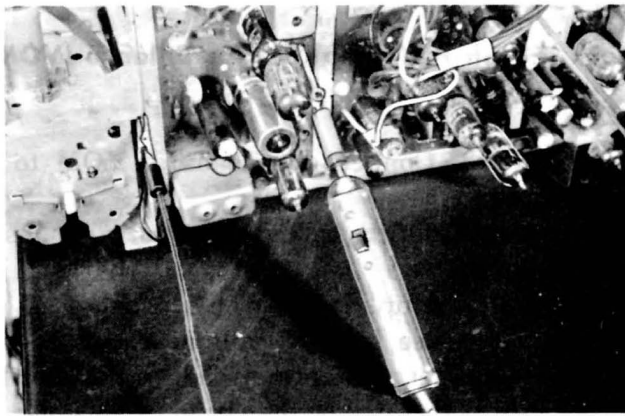

A polarity-reversing probe for a VOM. (Courtesy of Futuramic Co.)

U16

To Check for Linearity of Amplifier Operation

Equipment: Signal generator or audio oscillator. (Use signal generator for RF and IF tests, audio oscillator for AF tests.)

Connections Required: Apply output from generator to amplifier or to stage under test. Connect VOM or VTVM between plate of tube and chassis ground.

Procedure: Advance output from generator while watching DC voltage indication on meter.

Evaluation of Results: If the reading changes, the amplifier is operating nonlinearly and is generating harmonics.

NOTE 17

Test Adapters Permit Voltage Measurements from Tube Side of Chassis

A test adapter is most convenient for measuring voltages from the tube side of the chassis when the tube is operating. The only limitation is in the high-frequency circuits, where the added stray capacitance of the adapter can detune the circuit.

U17

To Check a Push-Pull Amplifier for Balance (VOM)

Equipment: None.

Connections Required: Connect test leads of VOM to plates of push-pull tubes.

Procedure: Adjust amplifier balance control(s). Observe DC voltage readings.

Evaluation of Results: Amplifier is properly balanced when the VOM reads zero (use low DC voltage range as balance is approached). This test cannot be made satisfactorily with a VTVM because both sides of the circuit are "hot": a VTVM requires that one side of the circuit be grounded or nearly at ground potential.

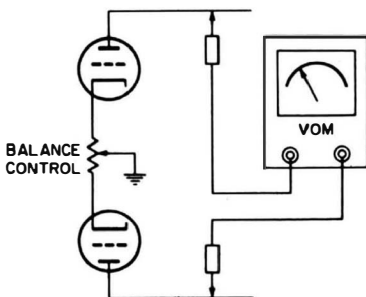

Test setup.

To Measure the Internal Resistance of a Circuit (Potentiometer Method)

Equipment: Potentiometer.

Connections Required: Connect potentiometer in series with VOM test lead. Apply arrangement to circuit under test, as shown in the following.

Procedure: With potentiometer set to zero resistance, read voltage value on the DC scale of the VOM. Then increase the potentiometer resistance until the voltage reading is reduced to one-half. Disconnect potentiometer and measure its resistance.

Evaluation of Results: The internal resistance of the circuit is equal to the resistance of the potentiometer minus the input resistance of the VOM. For example, if you are operating on the 30-volt range of a 20,000 ohms-per-volt VOM, its input resistance will be 600,000 ohms. If you measure a given voltage at the plate of an amplifier and find that a potentiometer resistance of 800,000 ohms is required to reduce the reading to one-half, the internal resistance of the plate circuit will be 200,000 ohms.

Test setup.

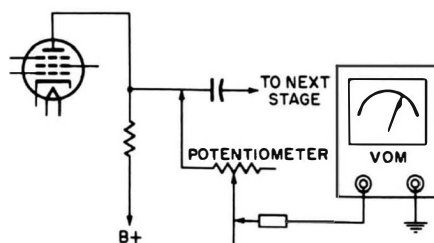

To Measure the Internal Resistance of a Circuit (Range-Switching Method)

Equipment: None.

Connections Required: Connect VOM test leads to circuit under test.

Procedure: Make DC voltage readings on two ranges.

Evaluation of Results: Calculate the internal resistance by:

$$R_{in} = \frac{R_1 R_2 (E_2 - E_1)}{E_1 R_2 - E_2 R_1}$$

where,

R_{in} is the internal resistance of circuit,

R_1 is the input resistance of VOM on the first range setting,

E_1 is the scale reading on the first range setting,

R_2 is the input resistance of VOM on the second range setting.

E_2 is the scale reading on the second range setting.

U20

To Check the Operation of an Oscillator

Equipment: None if VTVM is used. Isolating resistor if VOM is used.

Connections Required: Apply leads from meter to grid of oscillator tube and to chassis ground. Then apply leads from plate of tube to chassis.

Procedure: Measure DC voltage at grid and observe change as oscillator tank is tuned. Do the same at the plate.

Evaluation of Results: The DC voltage at the grid of an oscillator is a signal-developed bias which indicates the peak voltage of the AC signal at the grid. Zero (or nearly zero) grid voltage indicates that the oscillator is inoperative. Correct grid-voltage values are usually specified in receiver service literature. The DC voltage at the plate of an oscillator rises when the tube is oscillating (because of the negative grid-bias developed). Receiver service literature usually indicates normal operating voltage at the plate.

NOTE 18

VTVM Pointer Shift Caused by Internal Contact Potential

Contact potential is present in the tubes of a VTVM. This contact potential causes the zero setting of the pointer to shift from one DC voltage range to the next. Generally,

the greatest shift is found when the VTVM is switched to its lowest DC voltage range. The pointer should be zero-adjusted with the test leads short-circuited. Otherwise, there will

be a contact-potential error in the measurement when the test leads are connected across a circuit under test. For a completely accurate zero setting, the pointer should be zero-adjusted, and the test leads should be connected across a resistor having

the same value as the internal resistance of the circuit to be tested. However, this step becomes of practical importance only when small voltages are to be measured in very high resistance circuits.

U21

To Measure the Oscillator-Injection Voltage at the Mixer-Tube Grid

Equipment: None.

Connections Required: Apply voltmeter leads between "looker point" of RF tuner and chassis ground.

Procedure: Tune receiver to vacant channel. Short-circuit its antenna-input terminals. Switch RF tuner through the various channels. Observe DC voltage indication on meter.

Evaluation of Results: Proper tuner operation depends upon correct oscillator-injection voltage. The meter indicates the injection voltage indirectly as a signal-developed bias. Compare scale reading with service data or with another RF tuner of the same type known to be in good operating condition.

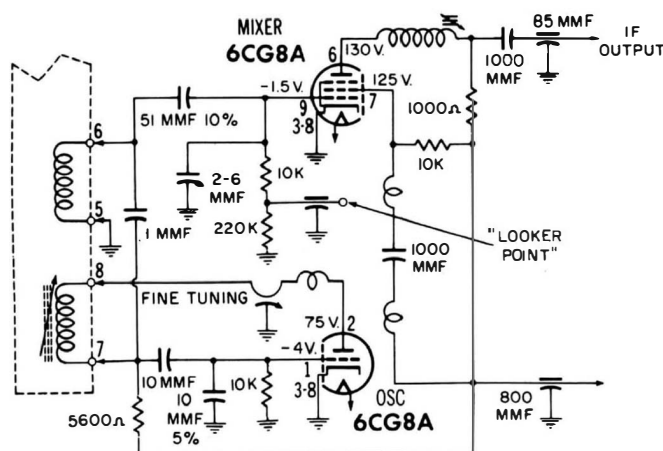

A typical oscillator-mixer circuit.

To Check a Radio or Television Receiver for IF Oscillation

Equipment: None.

Connections Required: Apply leads from VOM or VTVM across the video-detector load resistor.

Procedure: Tune in a station signal and observe DC voltage indication.

Evaluation of Results: A high DC voltage reading, such as 5, 10, or 15 volts, indicates IF oscillation. In most instances, application of override AGC bias will stop the oscillation. Incorrect peak-alignment of IF coils is a common cause of IF oscillation.

To Check the IF Sensitivity of a TV Receiver

Equipment: Calibrated IF signal generator; or uncalibrated generator and a good field-strength meter to check generator output. (Use a balun, as explained in the companion volume, *101 Ways to Use Your Sweep Generator*.)

Connections Required: Short the RF secondary coils of the RF tuner to ground. Connect a DC voltmeter across the video-detector load resistor. Apply the generator output through a 470-mmf capacitor to the grid of the mixer tube.

Procedure: Determine how many microvolts of signal must be applied from the generator to obtain a 1-volt rise above noise level at the picture-detector output.

Evaluation of Results: In a typical receiver, 300 microvolts or less are required. Consult receiver service notes or make comparative test on a receiver of the same type known to be in good operating condition.

To Check the DC Voltage Output from a Video Detector

Equipment: None. (Pattern generator optional.)

Connections Required: Apply leads from VOM or VTVM across the video-detector load resistor.

Procedure: Tune in a station signal and observe DC voltage indication.

Evaluation of Results: The DC voltage indication fluctuates unless a pattern generator is used. The meter indicates the DC component or background voltage in the video signal. Average values are often specified in receiver service notes. Zero (or near zero) DC voltage indicates a faulty RF amplifier, IF amplifier, or video detector.

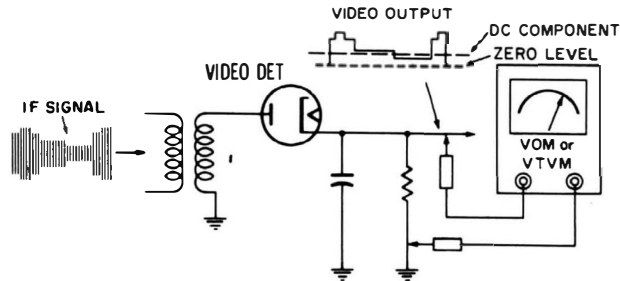

Video-detector circuit.

To Check the Noise Level in the RF and IF System of a TV Receiver

Equipment: None.

Connections Required: Connect leads from VOM or VTVM across video-detector load resistor.

Procedure: Short antenna-input terminals of receiver. Tune to vacant channel. Observe DC voltage indication.

Evaluation of Results: Consult receiver service literature for the permissible voltage reading in the test, or compare with value found in a similar receiver known to be in good operating condition. Higher than permissible readings indicate noisy tubes or noisy resistors in the signal circuits. This handicaps reception of weak signals.

To Adjust a Color-AFC Balance Control

Equipment: None.

Connections Required: Connect VTVM between arm of balance control and chassis ground.

Procedure: Tune in a color broadcast or drive the receiver from a color-bar generator. Operate VTVM on its lowest DC voltage range. Adjust the balance-control potentiometer.

Evaluation of Results: Potentiometer is correctly adjusted when VTVM indicates a slow positive and negative drift near the zero-volts point.

To Measure AGC Voltage with a VOM

Equipment: None.

Connections Required: Connect VOM between the AGC line and chassis ground (or B-).

Procedure: Operate VOM on DC voltage function. Turn the range switch through the positions on which a useful reading can be obtained. Operate the receiver as specified in the service data to obtain a test under standard conditions.

Evaluation of Results: In general, different voltage indications are obtained on each range because the VOM loads the AGC circuit. The input resistance of the VOM increases when a higher range is used. The most accurate measurement will be obtained on the highest usable range. (See the following chart.)

**Typical AGC Voltage Indications with a 20,000
Ohms-Per-Volt VOM**

(True AGC voltage is -7.8 volts)

Range (Volts)	Indication (Volts)	Actual Error (%)
2.5	-1.7	78
10	-4.1	47
50	-6.6	15

Note that the foregoing also gives us a quick test for circuit loading. If *different* voltage values are measured on *adjacent* ranges of a VOM, we know that circuit loading is present.

NOTE 19

Microampere Range of VOM Is a Millivoltmeter

A VOM can measure low voltages (below 250 millivolts in low-impedance circuits) if a microamp current range is used as a DC voltage range. For example, a typical VOM has a 50-microamp range with a 250-millivolt drop at full scale. Hence, the "50" scale can be read in terms of microamps, or the "250" scale can

be read in terms of millivolts. You will note that, although this 250-mv range is a 20,000 ohms-per-volt range, the input resistance of the VOM is only 5000 ohms ($.250 \times 20,000 = 5,000$). Hence, DC voltage measurements on this range will be in error unless the circuit has a low internal resistance.

NOTE 20

Instrument Loading Causes a Different Error at Various AGC Circuit Points

The indicated value of AGC voltage depends upon the point of test in the AGC circuit and upon the VOM range used. For example, in the following diagram we will meas-

ure a higher value of voltage at X than at Y. The internal resistance of the circuit is much lower at X, and the VOM has correspondingly less loading effect at this point.

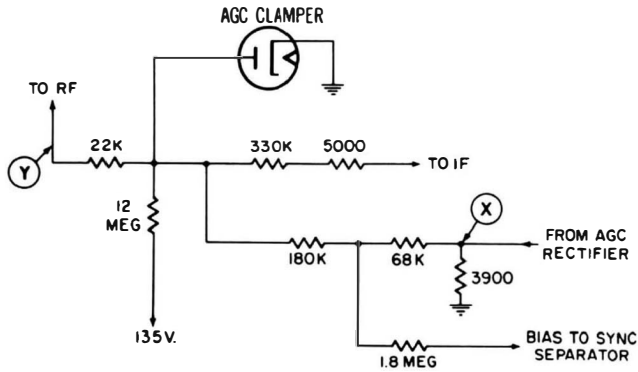

A typical AGC circuit.

NOTE 21

Floating Grid of Operating Tube Shows Contact Potential

When the AGC line is disconnected from an operating tube, negative

voltage can still be measured at the open grid. This voltage is contact

potential and disappears if the tube is cold. Using a 20,000 ohms-per-volt VOM, you will measure a typical value of -1 volt contact potential on the 10-volt range. On the 2.5-volt range, you will measure a

lesser value, such as $-\frac{1}{4}$ volt, because of the internal resistance of the contact-potential source. On a VTVM, contact potential will measure about -1 volt.

U28

To Measure AGC Voltage Accurately with a VOM (Bias Box Method)

Equipment: DC bias box and fixed resistor. (Value of resistor is not critical, but should be approximately the same resistance as the internal resistance of the AGC circuit.)

Connections Required: Connect VOM, bias box, and resistor as shown at A in the following diagram.

Procedure: Set the VOM to its lowest DC voltage range. Adjust bias box for zero indication on VOM scale. (You can make and break the VOM connection to the circuit to make sure you have a true zero; the pointer does not move at true zero.) Next, without changing bias-box setting, connect the VOM leads across the bias-box terminals, as shown at B in the following illustration.

Evaluation of Results: The reading obtained with the VOM connected across the bias-box terminals is the actual AGC voltage present at the point of test in the AGC circuit. (Switch VOM to suitable voltage range.)

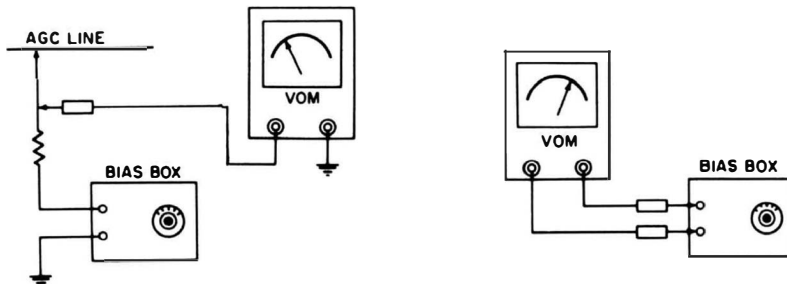

(A) Bias box connected to AGC line.

(B) Measuring voltage at bias-box terminals.

Test setup.

To Accurately Measure AGC Voltage with a VOM (Potentiometer Method)

Equipment: Potentiometer.

Connections Required: Connect potentiometer in series with VOM test lead, as shown in the following. Apply arrangement between AGC line and chassis ground.

Procedure: Observe reading on DC volts scale of VOM, with potentiometer set for zero resistance. Then increase the potentiometer resistance to reduce the reading to one-half and measure resistance of the potentiometer.

Evaluation of Results: The AGC voltage can be calculated from the readings obtained in the foregoing tests by using the formula:

$$E = \frac{E_M R_1}{R_M}$$

where,

E is the true AGC voltage,

E_M is the initial reading in volts,

R_M is the input resistance of the VOM,

R_1 is the potentiometer resistance necessary to reduce the voltage reading in half.

For example, assume that we read 2 volts on the 10-volt range of a 20,000 ohms-per-volt VOM and that a potentiometer resistance of 500,000 ohms is needed to reduce the voltmeter reading to 1 volt. The true AGC voltage can then be calculated as follows:

$$\begin{aligned} E &= \frac{E_M R_1}{R_M} \\ &= \frac{2 \times 500,000}{200,000} \\ &= \frac{1,000,000}{200,000} \\ &= 5 \text{ volts.} \end{aligned}$$

Test setup.

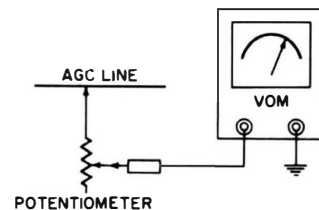

To Accurately Measure AGC Voltage with a VOM (Range-Switching Method)

Equipment: None.

Connections Required: Connect VOM test leads to AGC line.

Procedure: Observe meter readings on two DC voltage ranges.

Evaluation of Results: Calculate the actual AGC voltage from:

$$E = \frac{E_1 E_2 (R_2 - R_1)}{E_1 R_2 - E_2 R_1}$$

where,

E is the true AGC voltage,

E_1 is the meter reading on the first range setting,

R_1 is the VOM input resistance for the first range setting,

E_2 is the meter reading on the second range setting,

R_2 is the VOM input resistance on the second range setting.

To Check for Circuit Loading in AGC Voltage Measurements with a VTVM

Equipment: Precision resistor having a value equal to the VTVM input resistance.

Connections Required: First connect VTVM leads to AGC circuit under test. Then insert resistor in series with VTVM lead.

Procedure: Observe voltage indications obtained in each test.

Evaluation of Results: The second voltage indication should be one-half the first indication. If the second indication is more than one-half, circuit loading is present.

To Measure the Cathode Current of a Horizontal-Output Tube with a DC Voltmeter (VOM or VTVM)

Equipment: None.

Connections Required: Connect voltmeter test leads across cathode resistor.

Procedure: Observe reading on DC scale of instrument. Determine value of cathode resistor. Current is calculated by Ohm's law. Adjust drive and linearity controls as follows.

Evaluation of Results: Adjust the horizontal-drive control for minimum current; maintain full sweep width without drive lines. Adjust the horizontal-linearity coil for a current dip or for minimum current without distortion. The meter indicates average cathode current. (Tube manuals give maximum ratings for both peak and average currents.) The 6BQ6 is rated for a maximum of 110 ma cathode current; 6CD6, 200 ma; 6DQ6, 140 ma.

If the horizontal-output circuit has no cathode resistor, the method described in U83 must be used.

NOTE 22

Current Drawn by Any Tube Electrode Can Be Measured

The current drawn by any tube electrode can be measured in the same manner as is explained in U32. However, if there is no series resistor in the circuit, the DC current must be measured by opening the circuit, as described in U83.

NOTE 23

DC Voltage Indication Obtained in Corona Field

When working in the vicinity of the flyback system, you will sometimes observe that a DC voltage deflection occurs on the meter if the test prod is brought near the horizontal-output tube or other parts of the high-voltage circuit. This is a corona indication. DC voltage is indicated because of invisible spark rectification between the test prod and the corona field.

NOTE 24

AC Pulses Have an Average Value of Zero, Although Peak Voltages Differ

Beginners sometimes suppose that a pulse voltage can be measured on a DC voltmeter. This is not possible because the average value of an AC pulse voltage is zero. As illustrated

in the following, the positive area of the AC pulse voltage is equal to the negative area of the AC pulse voltage. Therefore, a DC meter will indicate zero.

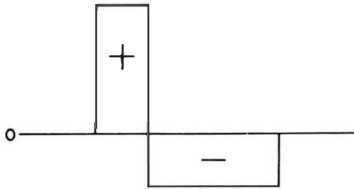

An AC pulse voltage.

U33

To Measure the Screen Dissipation of a Horizontal-Output Tube

Equipment: None.

Connections Required: Connect voltmeter test leads across screen resistor; then connect leads from screen terminal to cathode.

Procedure: Observe readings on DC scale of voltmeter.

Evaluation of Results: Note the color-coded value of the screen resistor (or measure value of screen resistor by using an ohmmeter with the set turned off). The screen dissipation is calculated by the formula:

$$P_s = \frac{E_s \times E_{sR}}{R}$$

where,

P_s is the screen dissipation in watts,

E_s is the screen voltage,

E_{sR} is the voltage drop across the screen resistor,

R is the value of the screen resistor in ohms.

Check the value found for screen dissipation against ratings for the tube as specified in the tube manual.

The screen dissipation of any tube can be found in this manner if a screen resistor is used. If no screen resistor is used, proceed as explained in U80.

NOTE 25

Measurement of DC Voltage in Presence of High-Voltage AC Pulses

The dissipation of any tube electrode, such as plate, grid, etc., can be determined by the method given in U33. If you wish to measure plate dissipation, for example, and there is no plate-load resistor, use the

method in U80. (Also see Note 63.) If you are measuring the plate dissipation of a horizontal-output tube, measure the plate voltage, as explained in U34.

U34

To Measure DC Voltage when High-Voltage AC Pulses Are Present (VTVM)

Equipment: High-voltage DC probe with 100-to-1 attenuation factor.

Connections Required: Apply probe between point of measurement and chassis ground (such as plate of damper tube to chassis). Feed probe output to input terminals of VTVM.

Procedure: Switch VTVM to one of its low DC-voltage ranges, such as 3 or 5 volts. Observe scale indication.

Evaluation of Results: Multiply scale indication by 100. This is the value of DC voltage at the point under test.

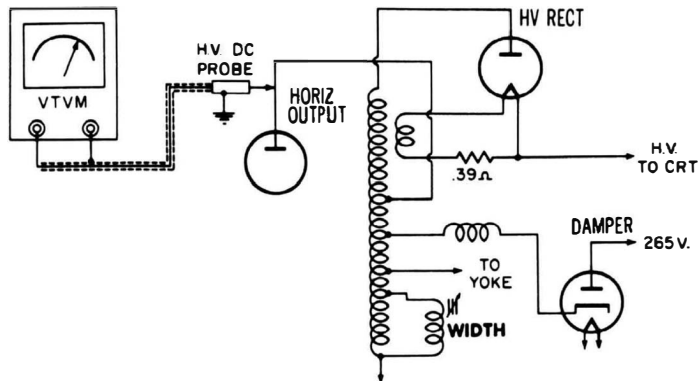

A typical flyback circuit.

NOTE 26

How High-Voltage DC Probe Protects Meter Against AC Pulses

When a high-voltage DC probe with a shielded output cable is used to check DC voltage in the presence of high-voltage AC pulses, the RC network (formed by the resistor and the capacitance between the resistor and the shield of the probe and between the lead-in wire and the shield of the cable) operates as a low-pass filter. The AC voltage is prevented from reaching the VTVM and possibly damaging its input circuit. Because the DC voltage is so much smaller than the AC voltage, a 100-to-1 probe is required to ob-

tain the desired attenuation of AC voltage. A VTVM must be employed in this type of test because the probe multiplies *each* range of a VTVM by 100. On the other hand, a VOM cannot be employed because a probe is designed for the top voltage range of the instrument only. If the probe is used on the lower range of a VOM, the indication will not be useful and the attenuation factor (unless calculated) will be unknown. Hence, such tests are made with a VTVM only.

U35

To Measure the Plate Dissipation of a Horizontal-Output Tube (VTVM)

Equipment: 100-to-1 high-voltage DC probe.

Connections Required: Connect VTVM to probe output cable.

Measure plate voltage, as explained in U34. Then measure the plate current by using the conventional DC input cable for the VTVM. Measure plate current by reading the voltage drop across the plate decoupling resistor and by applying Ohm's law.

Procedure: Multiply the plate voltage by the plate current (in amperes) to get the plate dissipation (in watts).

Evaluation of Results: Check the measured plate dissipation against the maximum rating published in tube manuals.

To Measure DC Voltage in the Presence of High-Voltage AC Pulses (VOM)

Equipment: High-voltage DC probe (see Note 27).

Connections Required: Connect probe and shielded output cable into instrument jacks in place of the usual test leads. Apply probe to plate of horizontal output (cathode of damper tube or horizontal-deflection coils), and connect braid of shielded cable to chassis ground.

Procedure: Observe reading obtained on the DC volts scale of the VOM.

Evaluation of Results: Multiply scale reading by two to obtain the DC voltage value.

NOTE 27

High-Voltage DC Probe

Construction of a typical high-voltage DC probe is shown in the following illustration. Ten 500K, ½-watt resistors are connected in series. When this probe is used with a 20,000 ohms-per-volt VOM having a 250-volt DC range, the indication is one-half the value obtained with the usual test leads. The series resistance of 5 megohms, working

into the shunt capacitance of the shielded input cable, operates as a low-pass filter. This filter permits the VOM to measure the DC voltage at the point under test, but suppresses passage of high AC-voltage pulses into the instrument. (A single 5-megohm resistor must not be used because it will arc over and break down.)

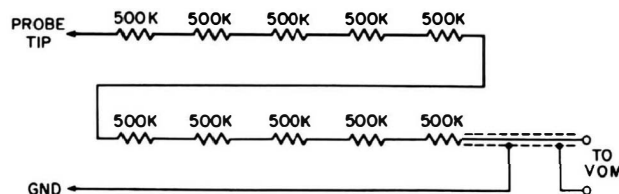

A high-voltage DC probe for use with a VOM.

OHMMETER TESTS

U37

To Measure Resistance Values Up to 200 Megohms With a VOM

Equipment: High-ohms probe for VOM.

Connections Required: Plug probe into VOM input terminals.

Connect probe across capacitor or other component under test.

Procedure: Operate VOM on its highest resistance range. Observe scale reading. Multiply reading by 10.

Evaluation of Results: Since resistance values beyond 200 megohms cannot be read on usual VOM's with a high-ohms probe, high-resistance measurements must be restricted to components having values within this range. Also note that a VOM high-ohms probe permits more accurate measurements of resistance values in the range from 1 to 20 megohms (compared with the use of ordinary test leads), because readings are obtained on the more expanded portion of the ohmmeter scale. The circuit given below is for a VOM having 120,000 ohms input resistance on the $R \times 10,000$ ohms range and an internal battery of 7.5 volts. The 67.5 volts for the probe is obtained by using three 22½-volt hearing-aid batteries.

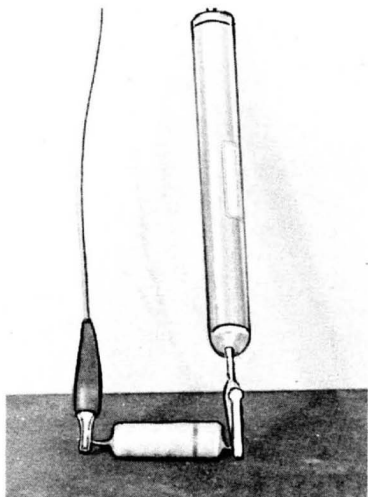

Checking the insulation of a paper capacitor with a high-ohms probe.

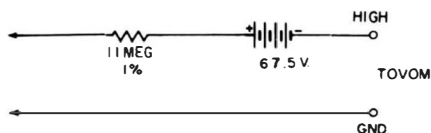

Circuit for a VOM high-ohms probe.

U38

To Measure Resistance Values Down to Small Fractions of an Ohm

Equipment: Low-ohms probe. (See Note 28.)

Connections Required: Plug low-ohms probe into VOM. Connect probe leads across component or circuit under test.

Procedure: Use the external zero-set adjustment, as for a usual ohmmeter function. VOM is operated, however, on its micro-ampere range. (Internal battery of VOM is not used with low-ohms probe because heavy current is required for low-resistance measurements with a series ohmmeter.)

Evaluation of Results: Ohmmeter scale reading is multiplied by 0.1.

NOTE 28

Construction of a Low-Ohms Probe

The configuration for a low-ohms range with an input resistance of 2,500 ohms (full-scale voltage drop of 250 millivolts) and 12 ohms cen-

ter-scale indication is given below. Note that the circuit, including the 1.15-ohm Manganin-wire resistor and test leads, must have very low resistance. Use bus leads from Manganin-wire resistor, heavy ultraflex armature wire for the test leads,

and heavy copper clips to terminate the test leads. Manganin wire is used for the resistance to maintain a constant value of 1.15 ohms whether hot or cold. Battery can be any 1.5-volt type with very low internal resistance and high current capability.

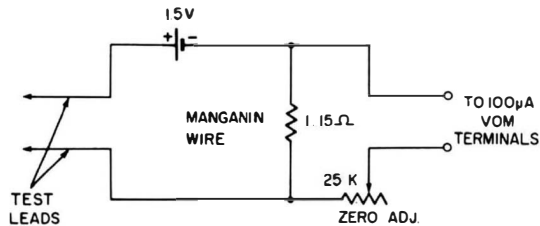

Circuit for a VOM low-ohms probe.

NOTE 29

Low-Ohms Probe Runs Down Short Circuits

A low-ohms probe or box is useful for running down short circuits. As the short-circuit point is approached, the resistance reading decreases. A

low-ohms probe is also handy for checking switch-contact resistance, cold-soldered joints, and resistance values of small coils.

NOTE 30

Probe Values Must Be Suitable to Make Scale Track

When calculating configurations for high-ohms or low-ohms probes, keep in mind that we wish to make the VOM or VTVM ohms scale "track" when the probe is used. Thus, we cannot use just any values of voltage and resistance in the probe network. A convenient starting point is to ob-

serve the center-scale indication of the ohms scale. Next observe the battery voltage and the reference resistor used on the $R \times 1$ range. In calculating probe configurations, maintain proportional values to obtain scale tracking.

To Check a Semiconductor Diode

Equipment: None.

Connections Required: Connect ohmmeter leads to diode terminals. Then reverse the test leads.

Procedure: Set ohmmeter to range which gives readable scale indications. Observe readings obtained in the two tests. To obtain the front-to-back ratio, divide the smaller reading into the large reading.

Evaluation of Results: The most useful evaluation is obtained by comparing the measured front-to-back ratio with that obtained from a known good diode of the same type, with same ohmmeter set to the same range.

NOTE 31

Readings Will Differ on Various Ranges

Semiconductor diodes, like transistors, are nonlinear resistance devices. Consequently, the actual resistance values indicated by an ohmmeter depend greatly upon the battery voltage and internal resistance of the

ohmmeter. These values are not the same for different instruments and are different for the same instrument when it is switched to another range. The following readings are typical for a 1N34 germanium diode:

Ohmmeter Set to R × 1 Range

Forward resistance	140 ohms
Back resistance	Unreadable

Ohmmeter Set to R × 100 Range

Forward resistance	400 ohms
Back resistance	200,000 ohms

Ohmmeter Set to R × 10,000 Range

Forward resistance	2,000 ohms
Back resistance	200,000 ohms

To Check the Condition of a Global Resistor

Equipment: None.

Connections Required: Make sure the receiver is off and the resistor is cold. Connect ohmmeter test leads across the Global resistor. Then disconnect the ohmmeter. Turn receiver on for two or three minutes. Finally, turn receiver off, and reconnect ohmmeter leads across Global resistor.

Procedure: Observe resistance readings obtained in each of the two tests.

Evaluation of Results: Compare readings with values specified in receiver service data. The cold resistance is normally about 15 to 150 times the hot resistance. Thermal resistors tend to change characteristics with age.

To Check a Paper Capacitor for Leakage (VTVM)

Equipment: None.

Connections Required: Connect ohmmeter test leads across capacitor terminals.

Procedure: Set ohmmeter to its highest range (usually $R \times 1$ Meg).

Evaluation of Results: A paper capacitor should test over 1,000 megohms insulation resistance. In general, if any resistance reading other than infinity is obtained in this test, the capacitor should be discarded. Since this test is made with only the ohmmeter voltage across the capacitor, it is inconclusive.

To Test a Paper Capacitor for Leakage With a High-Ohms Probe (VTVM)

Equipment: High-ohms probe.

Connections Required: Disconnect capacitor from circuit. Connect probe across capacitor terminals.

Procedure: Set ohmmeter to its highest range. Observe scale indication. Multiply reading by 10.

Evaluation of Results: A good coupling capacitor should check well over 1,000 megohms insulation resistance. A VTVM high-ohms probe permits measurement of resistance values up to 10,000 or 20,000 megohms. This test is not completely conclusive because the high-ohms probe usually applies only a small voltage—approximately 15 volts—to the capacitor under test.

NOTE 32

High-Ohms Probe

The circuit of a high-ohms probe for a VTVM having 10 megohms input resistance and a 1.5-volt ohmmeter battery is given in the following illustration. The 15-volt battery is a hearing-aid type and the 1.5-volt bucking battery is a penlight cell. This probe multiplies the $R \times 1$ Meg range of the VTVM by 10.

Sometimes the resistance readings obtained with a high-ohms probe are unstable. This unstable condition is due to the line-operated power supply in the VTVM and can be corrected by grounding the case to a water pipe as shown in the illustration.

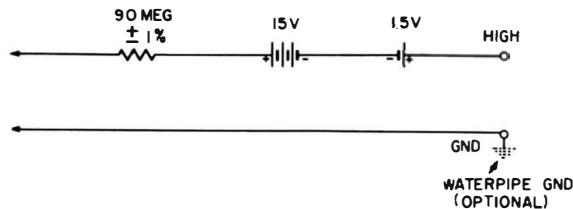

Circuit for a VTVM high-ohms probe.

To Check an Electrolytic Capacitor for Leakage

Equipment: None.

Connections Required: Connect ohmmeter leads to terminals of electrolytic capacitor (observe polarity).

Procedure: Observe indication on Ohms scale. Note that large capacitors can be charged more quickly by switching the ohmmeter progressively from the lowest range to the highest range.

Evaluation of Results: The test will indicate electrolytic capacitors which are definitely "bad." However, because limited voltage is applied, this test is not conclusive, except for low-voltage electrolytic capacitors in transistorized equipment. In the latter, you must be careful not to exceed the voltage rating of the capacitor. Note also that a VOM high-ohms probe commonly applies up to 75 volts across the capacitor under test; a VTVM high-ohms probe commonly applies up to 15 volts.

To Make a Hot Check for Interelectrode Leakage In a Picture Tube

Equipment: Test leads.

Connections Required: Disconnect the high-voltage cable from the picture tube. Short the high-voltage terminal of the tube to chassis, to discharge tube. Connect ohmmeter between terminals of tube to be tested. Socket must be removed from tube, and temporary heater connections made with test leads.

Procedure: Operate ohmmeter on its highest resistance range. Check for leakage resistance from cathode to control grid, second grid, focusing anode (if present), and second anode. Repeat test from control grid to second grid, focusing anode (if present), and second anode. Make a final check from the focusing anode to the second anode.

Evaluation of Results: Any reading other than infinite resistance is cause for rejecting, or at least suspecting the usability of, the picture tube.

A hot check is more reliable than a cold resistance test. Observe that the positive ohmmeter lead must be connected to the cathode of the picture tube when making hot resistance tests. Otherwise, the ohmmeter battery will cause a small beam current to flow and falsely indicate the presence of leakage resistance.

NOTE 33

Burning Out Shorts or Leaks in Picture Tubes

If the ohmmeter shows the presence of leakage resistance in the test of U44, it is sometimes possible to burn out the leakage path. Use a filter capacitor as a voltage source. Charge up the filter capacitor from a plate-supply lead in the chassis. Then, touch the capacitor leads to the tube pins which have leakage resistance between them. If the ohmmeter

shows that the leakage resistance is not completely burned out on the first application of surge voltage, the procedure can be repeated. Note that the plate-supply voltage or the second-anode voltage should not be used to clear leaks or shorts. Damage to the picture tube can result from use of excessive current or voltage in this procedure.

SIGNAL-TRACING TESTS

U45

To Check for Open Screen and Cathode Capacitors

Equipment: Signal-tracing probe.

Connections Required: Connect probe to VOM or VTVM. Apply probe across capacitor under test.

Procedure: Operate meter on DC voltage function and observe reading.

Evaluation of Results: When a screen or cathode capacitor opens, the AC voltage across the capacitor rises greatly. This fact is used to localize open capacitors. For example, when the screen capacitor in a typical horizontal-output circuit opens, the meter reading increases about 10 times. If a full-wave probe is used with a VTVM, the peak-to-peak voltage can be checked against the value in the receiver service literature.

CAUTION: In some receivers, the AC screen voltage is large enough to damage a semiconductor diode; therefore, a voltage divider should be used, as explained in Notes 34 and 35.

NOTE 34

Capacitance Divider for Signal-Tracing Probe

When testing in circuits with AC voltages greater than the rating of the semiconductor in the signal-tracing probe, use a simple 10-to-1 capacitance divider (see the accompanying diagram). The capacitance divider is merely a 50- to 150-mmf fixed capacitor. The exact value which will provide 10-to-1 attenuation depends upon the VOM range. For example, the value becomes

progressively greater for 10-to-1 attenuation on the 50-volt, 10-volt, and 2.5-volt ranges of a 20,000 ohms-per-volt meter. On the other hand, a given capacitor provides 10-to-1 attenuation on all ranges of a VTVM. Note that a simple capacitance divider is useful in the horizontal circuits only. Another type of divider must be used in the vertical circuits. (See Note 35.)

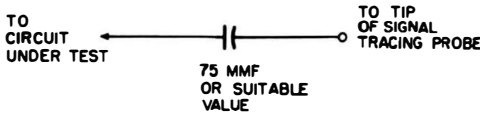

Capacitance divider for signal-tracing probe.

NOTE 35

Compensated Voltage Divider for Signal-Tracing Probe

To obtain 10-to-1 attenuation at both low and high frequencies, use an R-C divider with a signal-tracing probe, as shown in the following illustration. The values for R and C can be chosen for proper attenuation on any range of a VTVM. On the

other hand, different values are required for various ranges of a VOM. Select R to provide 10-to-1 attenuation at 60 cycles. Select C to provide 10-to-1 attenuation at 15,750 cycles.

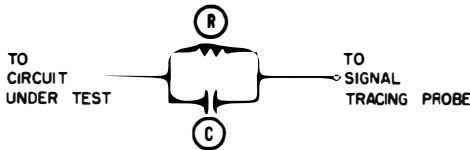

Wide-band voltage divider for signal-tracing probe.

NOTE 36

Half-Wave Signal-Tracing Probe

The following configuration is for a half-wave signal-tracing probe and can be used with either a VOM or VTVM. The probe is not intended

for highly accurate voltage measurements, only for general signal-level checks.

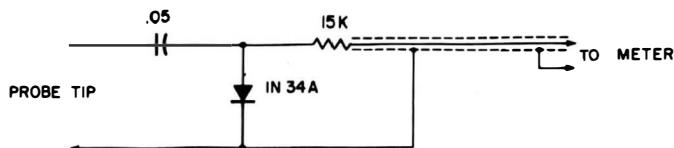

Half-wave signal-tracing probe for VOM or VTVM.

NOTE 37

Low-Frequency Response of a Rectifier Probe

Better low-frequency response can be obtained if a larger charging capacitor is used in a rectifier probe. On the other hand, large values of charging capacitance cause a damaging surge of transient current through the semiconductor diode when the probe is applied to a plate-voltage source. Hence, a 0.05-mfd charging capacitor is a compromise between low-frequency re-

sponse and transient protection for the diode. A rectifier probe has better low-frequency response when used with a VTVM because the current demand from the charging capacitor is less. Likewise, a rectifier probe has better low-frequency response when used with a 100,000 ohms-per-volt VOM than with a 20,000 ohms-per-volt VOM.

NOTE 38

Probe Provides Peak-Voltage Indication on VTVM

The peak voltage of an AC waveform can be measured with a rectifier probe and a VTVM (as shown in the following schematic). The probe replaces the usual DC input cable, which normally has a 1-megohm isolating resistor in the probe housing. Hence, a 1-meg calibrating resistor

must be used in the rectifier probe. This type of rectifier probe will not work with a VOM because the calibrating resistor is much too large. The probe indicates positive-peak or negative-peak level, depending upon polarity of the 1N34A.

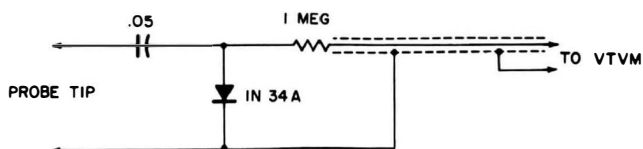

Half-wave signal-tracing probe for VTVM.

NOTE 39

Peak Voltages of Complex Waveforms

The positive-peak voltage of complex waveforms usually is different from the negative-peak voltage, as shown in the following illustration. In a complex waveform, there is always a zero-volt level which divides the waveform into positive and negative

portions. The areas on either side of the zero-volt level are always equal. Whether you measure the positive-peak voltage or the negative-peak voltage depends upon the polarity of the semiconductor diode in the rectifier probe.

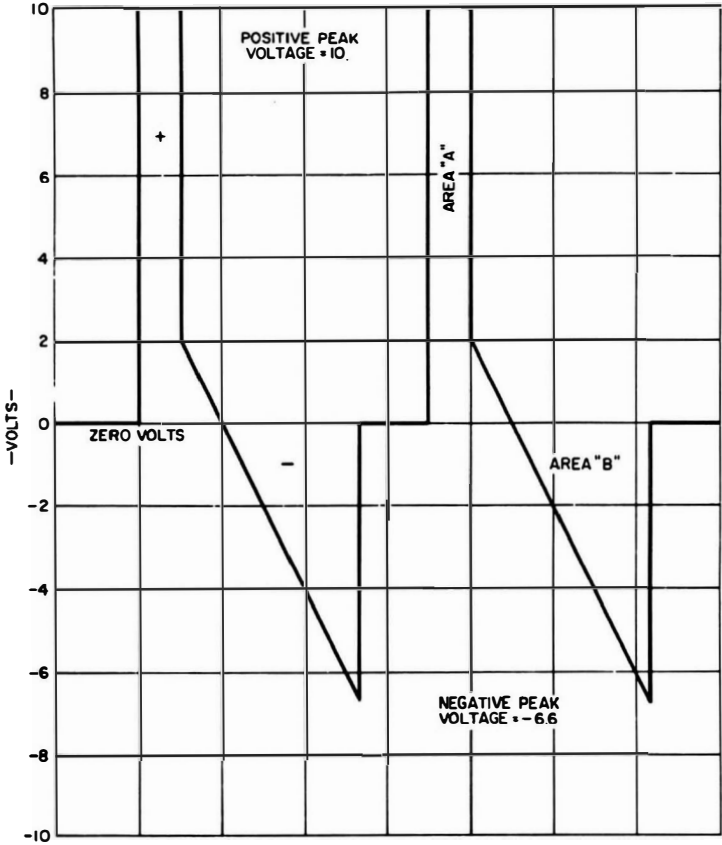

A complex waveform.

NOTE 40

Probe Provides Peak-to-Peak Voltage Indication with a VTVM

You can use a peak-to-peak rectifier probe and a VTVM to measure peak-

to-peak voltages of complex waveforms. The probe replaces the usual

DC input cable to the VTVM. This cable usually contains a 1-meg calibrating (or isolating) resistor. Hence, a 1-meg calibrating resistor is used in the rectifier probe. Note that any

probe using semiconductor diodes has a limited voltage range; therefore, input signals should not exceed about 75 volts peak-to-peak because the diodes may be damaged.

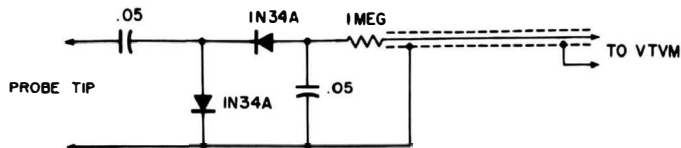

A peak-to-peak signal-tracing probe for a VTVM.

To Make Signal-Tracing Tests With No Current Drain from the Circuit Under Test

Equipment: DC bias box, signal-tracing probe, and fixed resistor.

Connections Required: Connect probe to resistor, bias box, and VOM, as shown. Apply probe to test point in receiver circuits.

Procedure: Set VOM to its lowest possible DC range. Adjust bias box from zero indication on voltage scale. Switch VOM to lowest DC voltage scale and readjust bias box for zero indication. (Meter connection can be made and broken for a very accurate balance indication.) Finally, apply VOM across bias-box terminals and read voltage indication.

Evaluation of Results: The voltage from the bias box cancels the voltage from the probe, so that the meter draws no current from the circuit under test. The value of voltage measured across the bias-box terminals is the peak voltage of the signal. Whether positive-peak or negative-peak voltage is measured depends upon the polarity of the semiconductor diode in the probe.

The value of the isolating resistor is not critical, but should have a value on the order of the isolating resistor in the probe. Note that the arrow on a semiconductor diode points in the direction opposite to electron flow. The diode in the probe can be reversed if the bias-box polarity is also reversed. This method also improves the low-frequency response from a VOM probe because the probe does not supply current to the meter.

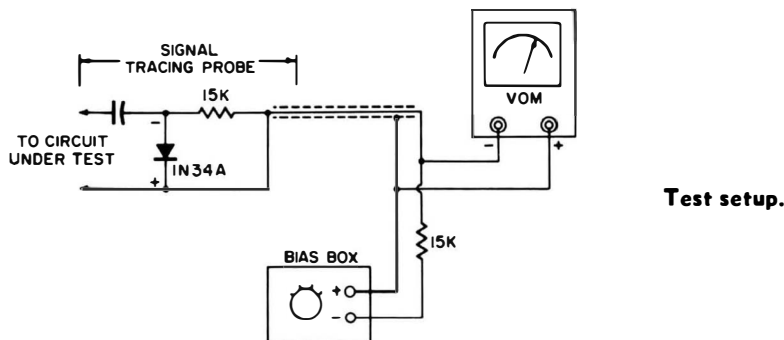

NOTE 41

Capacitive Loading of Probe

The test method in U46 eliminates current drain from the circuit under test and thus gives more accurate peak-voltage measurements. On the other hand, note that the input capacitance of the probe is still pres-

ent and can detune an IF stage, for example. For this reason, the probe and meter can give off-value indications in high-frequency tuned circuits.

U47

To Measure Peak-to-Peak Voltage Values Without Current Drain from the Circuit Under Test (VOM)

Equipment: VTVM-type signal-tracing probe, bias box, and resistor.

Connections Required: Connect equipment as shown. Apply probe to circuit under test.

Procedure: Adjust bias box for zero indication on DC voltage scale (lowest range) of VOM. Make and break VOM connection to obtain highly accurate zero indication. Finally, measure voltage at bias-box terminals.

Evaluation of Results: The voltage measured at the bias-box terminals is equal to the peak-to-peak voltage of the waveform. (See Note 41 for the exception.)

The low-frequency response of a VOM peak-to-peak probe is improved with this method because no current is taken from the probe by the meter.

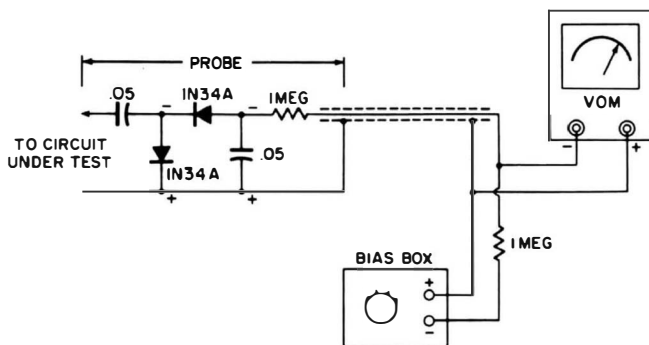

Test setup.

NOTE 42

Built-in AC Rectifier of VTVM Increases Capacitive Loading Error

Some VTVM's do not use an external probe for measurement of peak-to-peak voltage values; instead, they have a built-in full-wave rectifier designed for high-frequency response. The advantage of the built-in arrangement is that the rectifier is placed after the range multiplier, so

that higher values of AC voltage can be conveniently measured. On the other hand, a disadvantage of the built-in arrangement is that the input capacitance is much higher. This higher capacitance increases the loading error when high-frequency circuits are being tested.

To Measure the Voltage in a Modulated Waveform (VTVM)

Equipment: Demodulator probe (see the accompanying illustration).

Connections Required: Connect probe to modulated waveform voltage source. Feed probe output to VTVM input connector.

Procedure: First, operate VTVM on its DC voltage function. This gives the peak voltage of the carrier frequency. Then

operate the VTVM on its AC voltage function. This gives the voltage of the modulating waveform (usually a 400-cycle modulating frequency in standard test work).

Evaluation of Results: The demodulator probe provides both AC and DC output. The rectifier and filter network in the probe converts the high carrier frequency into a DC voltage. This DC voltage is equal to the peak carrier voltage. On the other hand, the rectifier and filter network of the probe passes the 400-cycle AC modulating voltage without rectifying or filtering it. Hence, it can be measured separately on the AC function of the VTVM. If the VTVM provides rms indication of sine waveforms, this measurement will be in rms values. On the other hand, if the VTVM provides peak-to-peak indication of AC voltages, this measurement will be in peak-to-peak values.

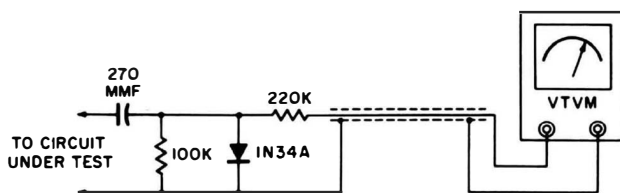

Test setup.

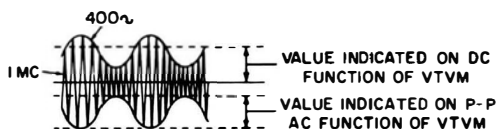

Modulated waveform.

NOTE 43

Measurement of Modulating Voltage Value

If a peak-to-peak demodulator probe is used in U48, the DC scale of the meter will indicate the peak-to-peak voltage of the carrier. The modulat-

ing voltage will be measured in rms or peak-to-peak values, depending upon the type of VTVM.

To Determine the Demodulating Capability of a Demodulator Probe (VTVM)

Equipment: Signal generator and audio oscillator.

Connections Required: Connect audio-oscillator output cable to External Modulation terminals of signal generator. Connect demodulator probe to signal-generator output cable. Connect VTVM to probe output cable.

Procedure: Operate signal generator on maximum output at about 1 mc. Vary frequency of audio oscillator through a suitable range. Operate VTVM on AC voltage function. Note change in scale indication as the audio oscillator is tuned to higher frequencies.

Evaluation of Results: The demodulating capability of the probe is the audio frequency at which the meter reading starts to drop.

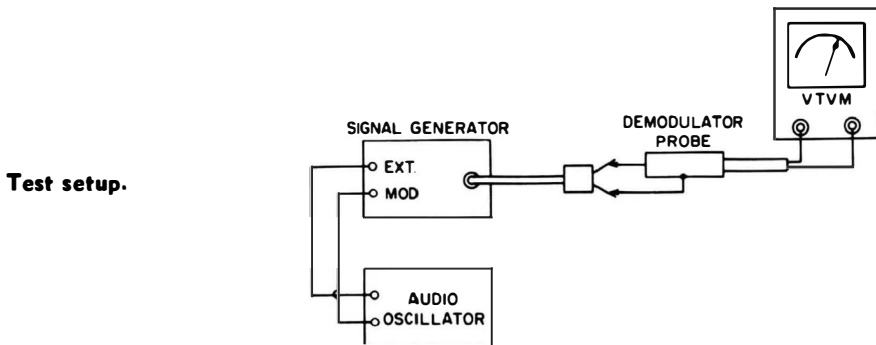

To Multiply the Sensitivity of a Signal-Tracer Probe

Equipment: Transistor, 3K resistor, 47-ohm resistor, and 6-volt battery.

Connections Required: Connect components as shown in the following diagram. (Battery voltage and probe cable terminals must be reversed if an NPN transistor is used.) Apply probe output to input of transistor circuit. Connect VOM to output of transistor circuit.

Procedure: Operate the VOM on its low-current range, such as 100 microamps. Apply signal-tracing probe to circuit under test.

Evaluation of Results: The transistor increases the sensitivity of the meter ten times or more. Hence, it is possible to check much lower-level circuits (such as the output of an RF tuner).

There is sometimes a small leakage current when no signal is applied to the signal-tracing probe. This is a characteristic of the transistor. By selecting transistors, you can minimize the leakage current. This leakage current causes the pointer to rest slightly above zero when there is no signal input.

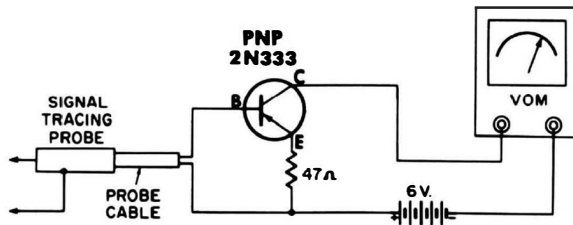

Transistor probe amplifier.

NOTE 44

Transistor Extends Low-Frequency Response of Probe

When a transistor is used as shown in U50, the low-frequency response of a VOM signal-tracing probe is also extended greatly because there is much less current drain from the probe.

To Check the Local-Oscillator Stage

Equipment: Signal-tracing probe.

Connections Required: Plug output cable from probe into meter jacks. Apply probe between floating tube shield over oscillator tube and chassis ground.

Procedure: Operate VOM or VTVM on DC voltage range. Observe scale indication while turning channel-selector switch through its range.

Evaluation of Results: A zero indication indicates a dead oscillator. You will normally observe a reading from 0.5 to 2 volts, depending upon whether you use a VOM or VTVM and a half-wave or full-wave probe.

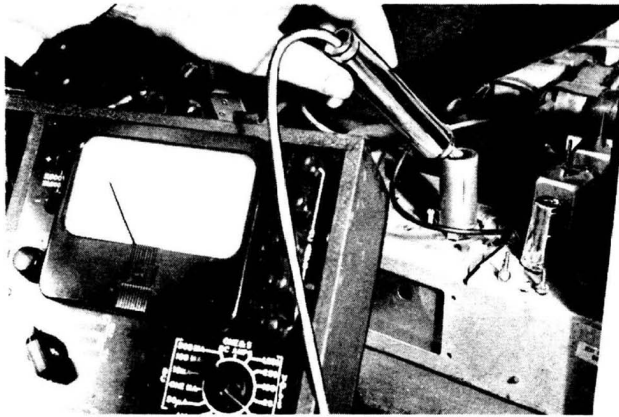

Checking local-oscillator operation.

To Signal-Trace from the Output of the RF Tuner Through the IF Amplifier (VOM)

Equipment: Transistor probe accessory (see U50) and signal-tracing probe.

Connections Required: Connect components as shown in U50. Apply probe output to input of transistor circuit. Connect VOM to output of transistor circuit.

Procedure: Tune in TV station signal or use RF signal from pattern generator. Apply probe at RF tuner output and at following IF grid and plate terminals.

Evaluation of Results: A peak-to-peak probe and a transistor provide at least 20 times the sensitivity of a conventional probe and permit signal-tracing tests with a VOM at the RF-tuner output.

To Check the Operation of the Signal Circuits From the Mixer Tube to the Picture Detector

Equipment: Signal-tracing probe.

Connections Required: Plug output cable from probe into instrument jacks. Apply probe at input or output of picture detector.

Procedure: Operate instrument on DC voltage range. Lift the mixer tube shield, and grasp it while noting the scale indication.

Evaluation of Results: Stray fields are coupled to the plate of the mixer tube by body capacitance applied to the floating tube shield over the mixer tube. Zero indication shows that the signal is not getting through from the mixer to the picture detector. The indication level depends upon the strength of stray fields in the shop.

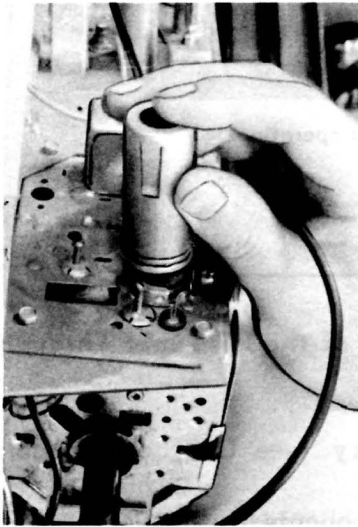

Coupling stray fields to mixer tube by body capacitance.

NOTE 45

Generator Must Be Used If Stray Fields Are Weak

In some shops, stray fields at IF frequencies are too weak for a practical test by the method explained in U53. In such case, the output from

an IF signal generator must be applied to the floating tube shield over the mixer tube.

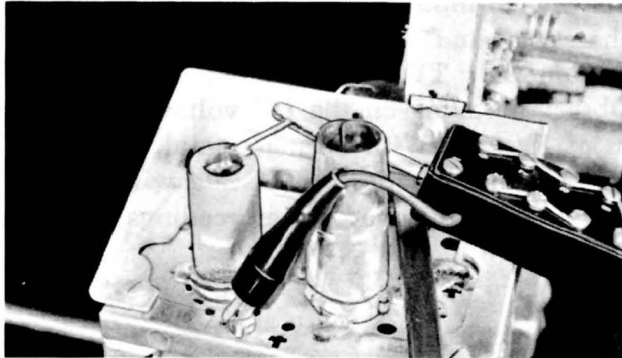

Applying output of signal generator to floating tube shield.

U54

To Check the Video Signal Output from the Picture Detector (VOM or VTVM)

Equipment: Signal-tracing probe.

Connections Required: Plug probe into meter. Apply probe between picture-detector output and chassis ground.

Procedure: Tune in TV station (or use pattern generator). Observe voltage reading on the DC volts function of the instrument.

Evaluation of Results: From 0.5 to 2 volts will be observed in normal operation, depending upon whether a VOM or VTVM is used with a half-wave or a full-wave probe.

U55

To Check the Video-Signal Drive to a Picture Tube (VOM or VTVM)

Equipment: Signal-tracing probe.

Connections Required: Plug probe output lead into instrument input jacks. Remove picture-tube socket and apply probe

between signal-input electrode pin in picture-tube socket and chassis ground.

Procedure: Tune in a TV station, or use a pattern-generator signal. Observe reading on the DC voltage scale.

Evaluation of Results: With normal signal drive to the picture tube, the reading on the VOM scale will be approximately 20 to 30 volts. Somewhat higher readings are obtained with a VTVM.

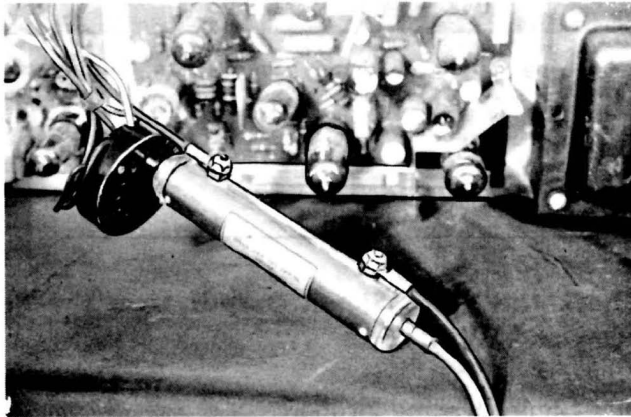

Checking drive to picture tube.

U56

To Check the Sound Signal at the FM Detector

Equipment: Signal-tracing probe.

Connections Required: Connect probe output cable to meter.

Apply probe in turn at cathode and plate terminals of FM detector tube.

Procedure: Operate instrument on DC voltage range. Observe scale indication with a TV station signal present.

Evaluation of Results: If a full-wave probe is used with a VTVM, voltages can be compared with data in receiver service literature. Otherwise, lower voltage readings will be obtained. These readings can be compared with those obtained from a receiver of the same type in good operating condition.

To Signal-Trace the Sync Section of a TV Receiver

Equipment: Signal-tracing probe.

Connections Required: Connect probe cable to instrument. Apply probe between circuit terminal under test and chassis ground.

Procedure: Operate VOM or VTVM on its DC voltage function. Tune in a TV station (or use a pattern generator). Note the reading on the DC scale.

Evaluation of Results: If a full-wave probe is used with a VTVM, peak-to-peak voltage values can be compared with data in the receiver service literature. (A VTVM probe loads high-impedance circuits slightly more than a 10-to-1 low-capacitance probe for scope). If a half-wave probe is used with a VOM, lesser voltage values will be indicated, and circuit loading will be substantial.

To Measure the Peak-to-Peak Voltage of the Vertical Sync Pulse (VTVM)

Equipment: Full-wave signal-tracing probe and LC circuit resonant at 15,750 cycles. (See the following illustration.)

Connections Required: Connect probe to parallel-resonant circuit. Plug probe output cable into VTVM. Apply lead from LC circuit to point under test. Return probe to chassis ground.

Procedure: Operate VTVM on its DC voltage function. Note peak-to-peak voltage value indicated on DC scale.

Evaluation of Results: The resonant circuit largely rejects the horizontal sync pulses, but passes the vertical sync pulses. Hence, the voltage of the vertical sync pulses in a composite sync signal can be checked individually.

Test setup.

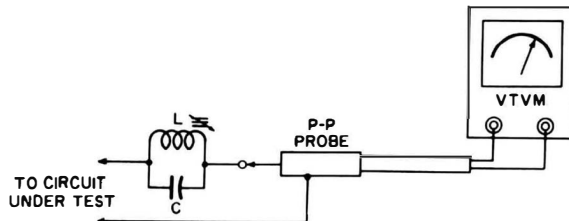

To Measure the Peak-to-Peak Voltage of the Horizontal Sync Pulse (VTVM)

Equipment: Full-wave signal-tracing probe and LC circuit resonant at 15,750 cycles. (See the following illustration.)

Connections Required: Connect probe to series-resonant circuit. Plug probe output cable into VTVM. Apply lead from LC circuit to point under test. Return probe to chassis ground.

Procedure: Operate VTVM on its DC voltage function. Note peak-to-peak voltage indicated on DC scale.

Evaluation of Results: The resonant circuit largely rejects the vertical sync pulses, but passes the horizontal sync pulses. Hence, the voltage of the horizontal sync pulses in a composite sync signal can be checked individually.

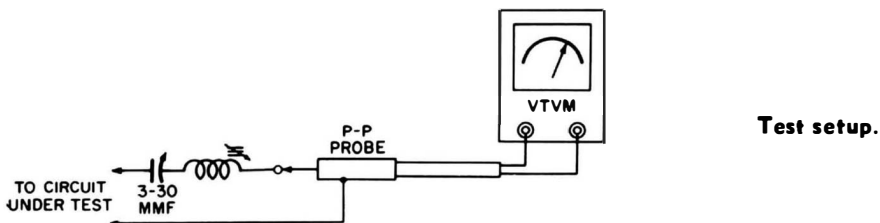

NOTE 46

Vertical Oscillator Disabled to Make Integrator Test

When signal-tracing through the vertical integrator, you must disable the vertical-oscillator tube. Otherwise, the energy from the oscillator

will be coupled back through a stage or two of the integrator and will give a false indication of signal level.

To Check the Drive Voltage to the Vertical-Output Tube (VOM or VTVM)

Equipment: Signal-tracing probe.

Connections Required: Connect probe to instrument and apply probe between grid of vertical-output tube and chassis ground.

Procedure: Operate the meter on its DC voltage function and observe scale indication.

Evaluation of Results: If a peak-to-peak (full-wave) probe is used with a VTVM, the indicated voltage can be compared with the specified p-p voltage in the receiver service literature. If a 20,000 ohms-per-volt meter is used, the reading will be lower. In a typical receiver, a VOM indicates a normal drive voltage of approximately 4 volts.

U61

To Check the Sync and Comparison Waveforms at the Horizontal-Phase Detector

Equipment: Signal-tracing probe.

Connections Required: Connect probe output cable to VOM or VTVM. Apply probe in turn to the signal terminals of phase-detector circuit.

Procedure: Observe indication on meter DC scale with and without a sync signal (from a TV broadcast station or a pattern generator). Next, observe the scale reading with and without the horizontal-oscillator tube disabled.

Evaluation of Results: With no sync signal, the scale reading indicates the level of the comparison waveform from the horizontal-sweep circuit. With a sync signal, the scale reading indicates the level of the combined comparison waveform and sync waveform. A reading can be made with a sync signal and with the horizontal oscillator disabled, so that the level of the sync signal alone can be determined. If a full-wave probe is used with a VTVM, peak-to-peak voltage values can be compared with those in receiver service literature.

CAUTION: Loss of drive to the horizontal-output tube can overheat or damage it in receivers that depend entirely upon signal-developed bias to obtain a suitable operating point for the tube. Therefore, the output tube and the horizontal-oscillator tube must both be pulled in these receivers.

To Check the Drive Voltage to the Horizontal-Output Tube

Equipment: Signal-tracing probe.

Connections Required: Connect probe to meter. Pull the horizontal-output tube (transformer-type receivers only). Apply probe between grid terminal of socket and chassis ground.

Procedure: Operate instrument on DC voltage function and observe reading.

Evaluation of Results: A typical reading of 20 volts is normally obtained when a half-wave probe and a 20,000 ohms-per-volt VOM are used. A full-wave probe and a VTVM permit the peak-to-peak voltage of a drive waveform to be checked against value specified in receiver service literature.

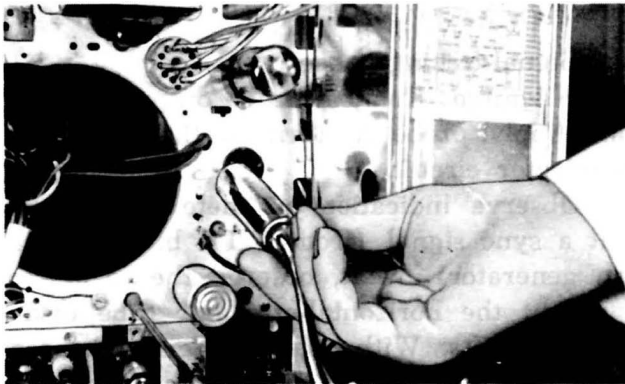

Checking drive to horizontal-output tube.

To Check for Presence of Horizontal-Output Voltage

Equipment: Signal-tracing probe.

Connections Required: Plug probe output cable into instrument jacks. Hold probe tip halfway up side of glass envelope on horizontal-output tube. Clip probe return lead to chassis ground.

Procedure: Operate meter on DC voltage range. Observe scale indication.

Evaluation of Results: A normally-operating horizontal-output stage will indicate approximately 2 volts on a 20,000 ohms-per-volt VOM when a half-wave probe is used. Higher indications are obtained with a VTVM and with a full-wave probe. Zero indication shows that there is no output voltage.

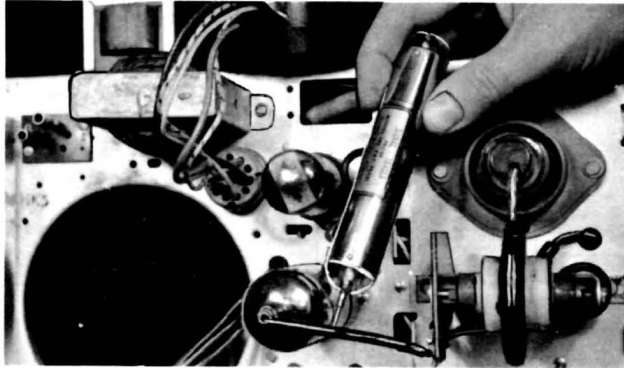

Checking for presence of horizontal-output voltage.

AC VOLTAGE TESTS

U64

To Measure Audio-Amplifier Gain in Decibels

Equipment: Audio oscillator.

Connections Required: Apply output from audio oscillator to input of audio amplifier. Connect VOM or VTVM, first across input load impedance and then across output load impedance. (If DC voltage also is present, see U65.)

Procedure: Apply signal below overload level to amplifier. Note readings on decibel scale at both the input and the output of the amplifier.

Evaluation of Results: Correct the scale readings for the values of the load impedances, unless the meter is connected to a value of load impedance for which the decibel scale is calibrated. (See Note 49.) Then, subtract the input reading from the output reading to obtain the gain in decibels.

NOTE 47

Decibels Proportional to Ear Response

It is helpful to measure audio gains and losses in decibels because the db unit is proportional to ear response, whereas voltage units are not. Decibel units are based on power levels and are additive and subtractive. Thus, if we take a loss of 20 db in a volume control and if we have a gain of 30 db in a following amplifier, the system gain will be 10 db. Note that a gain of 6 db is judged as "about twice as loud"

as the original level. Likewise, a loss of 6 db is judged about "half as loud" as the original level. The db scales on a voltmeter read correct db values only when measurements are made across a value of load impedance for which the db scales have been calibrated (see Note 49). An example of a db check across 600-ohm loads with instruments calibrated to read db across 600 ohms is given in the following illustration. With the audio oscillator supplying a signal level of 2 db to the 600-ohm volume control and the audio amplifier supplying a signal level of 12 db to the 600-ohm load, the gain of the amplifier is 10 db.

Many VOM's and VTVM's have only one db scale, which is usually calibrated for operation on the lowest AC voltage range. Accordingly, when the meter is operated on a higher AC voltage range, you must add a suitable number of db to the scale reading. The number of db to be added will be noted on the meter scale plate or in the instrument instruction manual.

NOTE: Although two meters are shown in this and the following illustrations, it should be understood that only one meter is necessary and the test leads are merely connected to the different points. Two meters are included to show the readings obtained at each point.

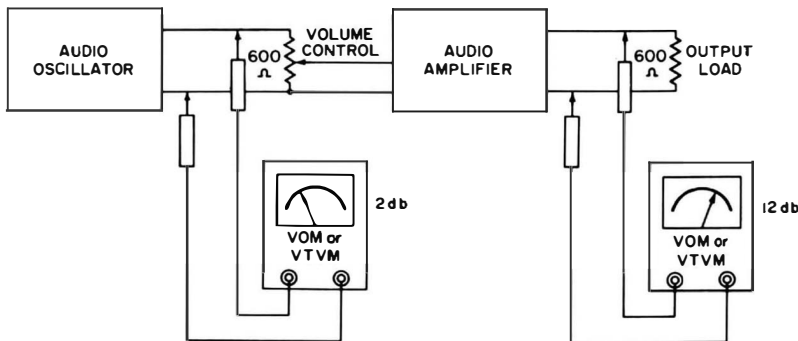

Test setup.

NOTE 48

A Poor Waveform Can Cause Inaccurate Db Measurements

A good waveform is essential for accurate decibel measurements. For example, if an audio oscillator supplies a good waveform to an amplifier which in turn introduces harmonic distortion, the measurement

of db gain will be incorrect. The same considerations of waveform error discussed for AC voltage measurements also apply to decibel measurements.

NOTE 49

Measuring Db Across Various Load Impedance Values

When measuring db levels across impedances other than those for which the db scale of the meter has been calibrated, you must recognize two important situations: (1) If the impedances are *different* from the *reference* value of the meter, but are *equal* in value, we can observe the scale readings and find the db gain or loss by taking the difference between the two readings. The reference impedance of the meter for db readings might be 600 ohms. If the input and output impedances of an amplifier are both 75 ohms, we can still use the meter designed for 600-ohms impedance. This is shown at A in the following illustration. Neither the 3-db nor the 13-db figure is correct by itself, but the difference of 10 db is correct because the readings were obtained across equal impedances. Therefore, in this example, the

gain of the amplifier is 10 db. (2) On the other hand, if the impedances differ from the reference value of the meter and the two impedances are *unequal* as shown at B, the difference figure is *not correct*. Here, the first measurement is made across 100,000 ohms and the second measurement is made across 12 ohms. A gain is present in the amplifier, although the readings indicate a loss of 12 db. This is one of the principal mistakes beginners make when measuring db values with a voltmeter. You must use logarithms to convert the figures obtained with unequal impedances to useful gain figures. This type of calculation will not be given here, but interested readers may refer to such textbooks as *Cook's Mathematics for Electricians and Radiomen*.

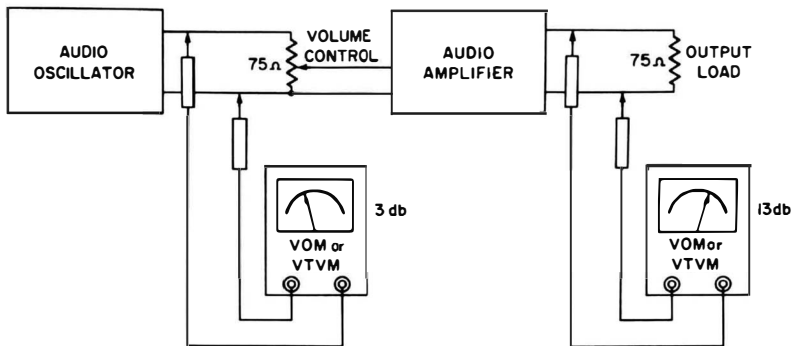

(A) Equal impedances.

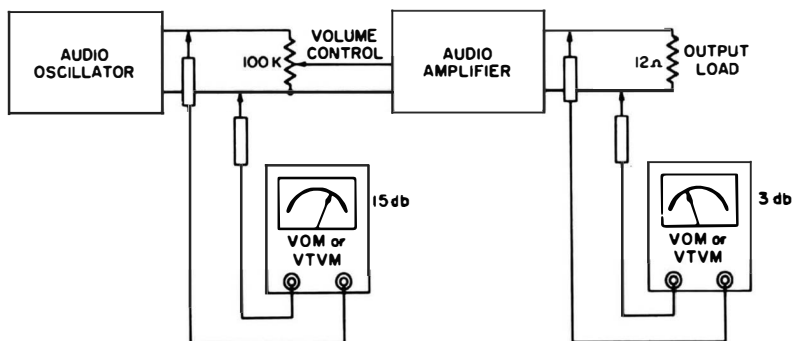

(B) Unequal impedances.

Test setup.

NOTE 50

Relative and Absolute Db Levels

Distinction must be made between *relative* db levels versus *absolute* db levels. A db scale has a certain arbitrary level chosen as zero db. This zero-db level might be 1 milliwatt in 600 ohms or 6 milliwatts in 500 ohms—it makes no difference. All db values below the reference level are taken as minus, and all db levels above the reference level are taken as plus. Often, red and black figures are used on the db scale to call attention to the change in sign. We must use the proper sign when comparing db levels at different ends of the scale. If we read db values across an impedance with a value equal to

the reference value for the meter, we can use a suitable table to convert a db reading into a power value. This is an *absolute* db reading and corresponds to a definite power value. On the other hand, if we read db values across 1,000-ohm loads, for example, with a meter calibrated for a 500-ohm load, the absolute readings on the db scale will *not* be correct; but if we take a *pair* of readings across 1,000-ohm loads, we can take the *difference* between these readings, and it will be the actual number of db *between* the two levels. This is an example of *relative* db readings.

NOTE 51

DB Measurements Across Reactive Loads

Sometimes we measure db across impedances which are reactive as well as resistive. In other words, the load may contain capacitance or inductance, in addition to resistance. If so, the db reading and its corresponding power do not indicate *real*

power alone, but a combination of real power and reactive power. We are usually interested in real power only. Hence, db measurements are most meaningful when made across resistive loads. Let us take an extreme example of this point. Sup-

pose we have an audio amplifier terminated in a 500-ohm load consisting of a fixed capacitor. If we check across the capacitor with a meter calibrated to read db in 500 ohms, we find a db indication which corresponds in turn to a power of—let us say—2 watts. Now, this is *reactive power* (VARS), which does no useful work. There is no real power output from the amplifier—it does

no useful work except for delivering 2 watts of power to the capacitor, which in turn returns 2 watts to the amplifier tube. Most situations usually represent substantially resistive loads with a certain amount of reactance, which we customarily neglect. We assume, for practical purposes, that an output transformer and speaker are purely resistive circuit components.

To Measure AC Voltage or Decibels When DC Voltage Is Present

Equipment: None (a large blocking capacitor may be required).

Connections Required: Connect test leads across point under test. (If the blocking capacitor is used, connect it in series with one test lead of the VOM.)

Procedure: Operate VOM on Output function. Note voltage indication on AC scale. If frequency is low, insert the series blocking capacitor and operate the meter on its AC voltage function.

Evaluation of Results: A VOM contains an internal blocking capacitor to prevent DC current from flowing into the instrument. This capacitor passes only the AC voltage which is present. The internal blocking capacitor may have a value from 0.1 to 1 mfd, depending upon the type of VOM. At low frequencies, the blocking capacitor has an appreciable reactance and reduces the apparent value of the AC voltage. Therefore, a larger blocking capacitor is necessary; and the meter must be operated on its AC voltage function if an accurate reading is to be obtained.

To Determine Whether the Output from an Audio Oscillator Contains Harmonics

Equipment: Capacitor, resistor, and audio oscillator.

Connections Required: Connect capacitor and resistor in series across the audio-oscillator output, as shown. (Choose values for R and C that will give approximately the same voltage values at E_2 and E_3 .) Apply AC voltmeter across audio-oscillator output, then across capacitor, and finally across resistor.

Procedure: Note voltage readings in each of the three measurements.

Evaluation of Results: Let each volt represent a certain length, and plot as shown in the illustration. E_2 and E_3 are drawn at right angles. The length of E_1 will equal the diagonal of a rectangle if no harmonics are present in the source voltage.

If a VTVM is used, less circuit loading occurs. However, both sides of the audio oscillator output must be above ground or the ground lead of the VTVM will load the circuit in the measurement of E_3 .

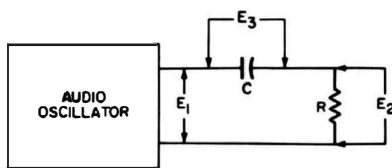

Test setup.

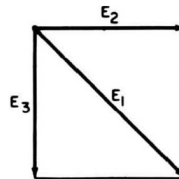

Plot of voltages.

NOTE 52

Basis of Distortion Test

The principle of the test explained in U66 is that a capacitor has lower reactance for higher frequencies and causes a different phase shift at different frequencies. For example, if we apply a square wave instead of a

sine wave to the RC series circuit, E_2 will become a small pip voltage and E_3 will become a distorted sawtooth. Thus E_1 , E_2 , and E_3 will not form a rectangle.

To Measure Capacitance Values from .001 to 1 Mfd (VOM)

Equipment: 2,960-ohm resistor and 231-ohm resistor.

Connections Required: Connect resistor and the capacitor under test in series as shown. (Note: For capacitance values from .001 to .01 mfd, no resistor is used.) Connect instrument across resistor (or from capacitor to opposite side of line). Energize capacitor and resistor from a 115-volt, 60-cycle power outlet.

Procedure: Note reading on AC scale and determine the capacitance value by referring to the following tabulation. The following tabulation is for AC voltmeters having a sensitivity of 1,000 ohms-per-volt and operated on the 10-volt range only. For VOM's with other AC voltage sensitivities or for operation on other ranges, make a new tabulation. Use close-tolerance capacitors while making the new tabulation.

Test setup.

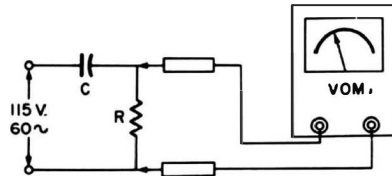

CAUTION: Use a range higher than 115 volts to make the initial test. This will protect the meter if the capacitor under test should be shorted.

Readings Obtained for Different Values of Capacitors

Capacitor Value (Mfd)	Approximate Reading (AC Volts)	Capacitor Value (Mfd)	Approximate Reading (AC Volts)	Capacitor Value (Mfd)	Approximate Reading (AC Volts)
.001	0.6	.01	1	.1	1
.002	1.1	.02	2	.2	2
.003	1.5	.03	3	.3	3
.004	1.9	.04	4	.4	4
.005	2.5	.05	5	.5	5
.006	3.0	.06	6	.6	6
.007	3.6	.07	7	.7	7
.008	4.0	.08	8	.8	8
.009	4.4	.09	9	.9	9
.01	4.8	.1	10	1.0	10
R = ∞		R = 2,960 Ω		R = 231 Ω	

To Measure the Capacitance of an Electrolytic Capacitor

Equipment: Battery, audio oscillator, and 1-ohm precision resistor.

Connections Required: Connect components as shown. (The 45-volt battery supplies the polarizing voltage.) Connect the AC voltmeter in turn across the audio-oscillator output, across the resistor, and across the capacitor.

Procedure: Set the audio oscillator to 1,000 cps and note the AC voltage readings obtained. (If DC voltage is found across R, use Output function of the meter to measure AC voltage values.)

Evaluation of Results: Let each volt represent a certain length and plot a rectangle, as shown. If the audio oscillator is operated at 1,000 cps, the capacitance value is found from the formula:

$$C = \frac{E_1}{6280E_C}$$

An AC VTVM will provide somewhat better accuracy should DC be present across resistor R. The reason is that, on the Output function many VOM's use a .1-mfd blocking capacitor which feeds into a 5,000 ohms-per-volt network. A VTVM, on the other hand, requires little signal current.

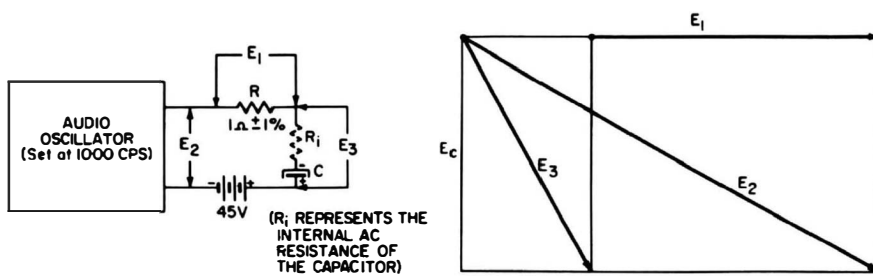

Test setup.

Plot of voltages.

To Measure the Power Factor of an Electrolytic Capacitor

Equipment: Resistor, battery, and audio oscillator.

Connections Required: Connect components as shown. (The 45-volt battery supplies the polarizing voltage.) Connect AC voltmeter in turn across the audio-oscillator output, across the resistor, and across the electrolytic capacitor.

Procedure: Note the AC voltage readings in the three tests. (If a DC voltage drop is present across R, operate instrument on Output function.)

Evaluation of Results: Combine the three voltages (represented as line lengths) into a rectangle, as shown. This gives us a length for X. Divide X by E_3 to obtain the power factor of the electrolytic capacitor.

A more accurate test is obtained with an AC VTVM than with a VOM. The VTVM has less current drain and thus loads the test circuit less.

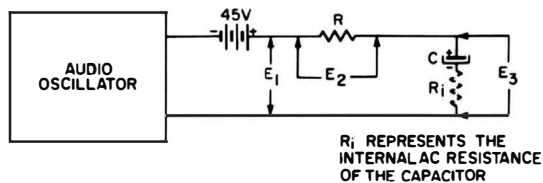

Test setup.

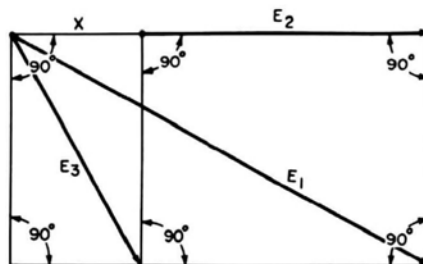

Plot of voltages.

NOTE 53

"Perfect" Capacitor Has Zero Power Factor

An ideal capacitor has zero power factor. A capacitor with more than zero power factor can be represented as a capacitance in series with a resistance. This is the basis of the test explained in U69. An ideal capacitor returns all of its charge to the driving circuit. A poor capacitor consumes power internally, and this consumed power is not returned to

the circuit. A leaky capacitor is equivalent to a capacitance in parallel with a resistance. This also causes a power factor other than zero. In this test, leakage is treated as an equivalent series resistance. However, we can measure leakage separately by making a DC voltage check across R. Ohm's law then tells us the value of leakage resistance.

NOTE 54

Turnover in AC Voltage Measurements

Turnover sometimes is encountered in AC voltage measurements. It is present when a supposedly sine waveform has even harmonics and shows up as a change in AC voltage reading when the test leads are reversed. You can make a *turnover test* for harmonics with any type of half-wave rectifier. The half-wave

rectifier can be inside a VOM or it can be external, in a signal-tracing probe for example. On the other hand, note carefully that you *cannot* check turnover with a full-wave probe or full-wave bridge rectifier—the even harmonic error cancels, and instead we measure a voltage based on both half cycles of the waveform.

NOTE 55

How to Improve an Audio-Oscillator Waveform

Sometimes an audio oscillator does not provide a good waveform because harmonics are present. These harmonics cause inaccurate AC voltage readings. A poor waveform from an audio oscillator can be greatly improved if a suitable RC low-pass filter is used, as shown in the follow-

ing illustration. The values of R and C depend upon the test frequency—lower frequencies require larger values. A good working rule is to make R and C as large as possible, consistent with the needed output voltage level for the given application.

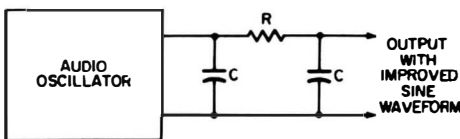

An R-C low-pass filter for removing harmonics.

To Measure the Impedance of an Inductor

Equipment: Precision 10-ohm resistor and audio oscillator.

Connections Required: Connect resistor and inductor in series with output from audio oscillator. Connect AC voltmeter across the inductor, then across the resistor.

Procedure: Adjust audio oscillator to desired test frequency, such as 60 cycles, 400 cycles, or 10,000 cycles. Observe readings across the inductor and resistor at the test frequency.

Evaluation of Results: The 10-ohm resistor drops 1 volt for each 100 ma of current. Consequently, the current equals $.1 \times E_2$. The voltage divided by the current gives the impedance of the inductor. Therefore, the impedance of the inductor can be calculated by the formula:

$$Z = \frac{E_1}{0.1E_2}$$

Test setup.

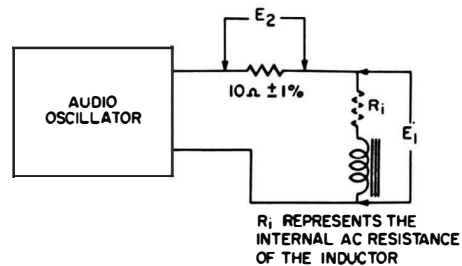

NOTE 56

Ohmmeter Measures the DC Resistance of an Inductor — Not the AC Resistance

It is sometimes supposed that the AC resistance of an inductor can be measured with a DC ohmmeter. Often, the AC resistance is considerably higher than the DC resistance because of core loss and eddy cur-

rents in copper. These losses generally increase as the frequency increases. Accordingly, the AC resistance of an inductor cannot be measured accurately except with suitable AC tests.

To Measure Inductive Reactance and Inductance

Equipment: Precision 1-ohm resistor and audio oscillator.

Connections Required: Connect resistor and coil in series across audio-oscillator output. Connect AC voltmeter in turn across audio-oscillator output, across resistor, and across coil.

Procedure: Observe the AC voltage readings in the three tests. Operate the audio oscillator at a frequency of f cps.

Evaluation of Results: Represent the voltages as line lengths. Combine into a rectangle, as shown in the accompanying diagram. The length for E_1 , is the voltage across the inductive reactance. We can calculate the inductive reactance in ohms by dividing E_1 , by E_2 . We calculate the inductance in henries by dividing E_1 , by $6.28f E_2$.

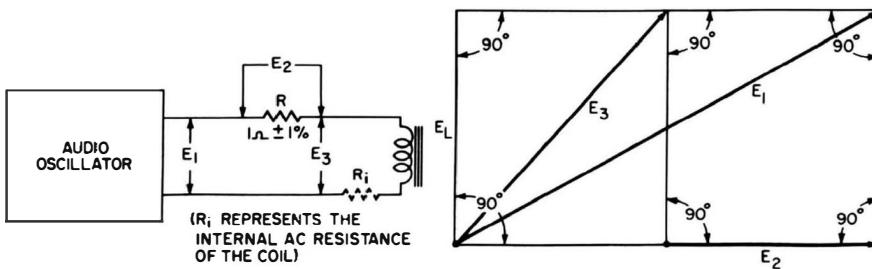

Test setup.

Plot of voltages.

To Measure the Power Factor of a Coil

Equipment: Precision 1-ohm resistor and audio oscillator.

Connections Required: Connect resistor and coil in series across audio-oscillator output. Connect AC voltmeter in turn across audio-oscillator output, across resistor, and across coil.

Procedure: Observe the AC voltage readings in the three tests. Operate the audio oscillator at a frequency of f cps.

Evaluation of Results: Let each volt represent a certain distance and plot E_1 , E_2 , and E_3 into a rectangle as shown in the following illustration. Measure the length of X and divide X by E_3 to find the power factor of the coil. In an "ideal" coil,

X equals 0; hence, the power factor is equal to zero. On the other hand, if the coil has a very low inductance and a very high resistance, X becomes almost the same as E_3 , and the power factor approaches 1.

Plot of voltages.

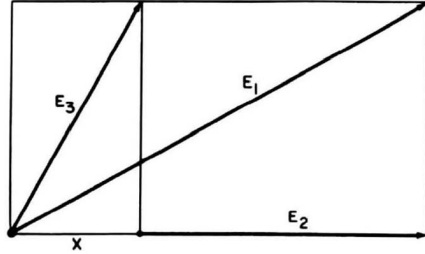

To Measure the Turns Ratio of a Transformer (Audio-Output, Power, or Flyback Transformers)

Equipment: Audio oscillator.

Connections Required: Connect audio-oscillator output to the transformer primary. Apply AC voltmeter across primary terminals of transformer, then across secondary terminals.

Procedure: Set audio oscillator to an audio frequency, such as 1,000 cycles, for an audio-output transformer test; to approximately 60 cycles for a power transformer test; and to approximately 5,000 cycles for a flyback transformer test. Observe voltmeter readings obtained at terminals of primary and secondary windings.

Evaluation of Results: The turns ratio of any two windings is equal to the voltage ratio measured across the windings.

To Measure the Power Consumption of a Radio or TV Receiver (VOM or VTVM)

Equipment: 1-ohm power resistor.

Connections Required: Connect resistor in series with the line, as shown in the following illustrations. Connect the meter across the resistor.

Procedure: Operate the meter on its AC voltage function. Turn the receiver on and observe the scale reading.

Evaluation of Results: If the resistor is actually 1 ohm, a current of 1 ampere will cause a scale indication of 1 volt. Thus, we measure the amperes drawn by the receiver. Multiply this amperage by the line voltage to obtain the volt-amperes drawn by the receiver.

The number of volt-amperes drawn is generally greater than the number of watts used by the receiver. The reason is that the input impedance to the power supply is not purely resistive, but has a certain amount of reactance. However, the volt-ampere value is customarily regarded as the watts drawn by the receiver.

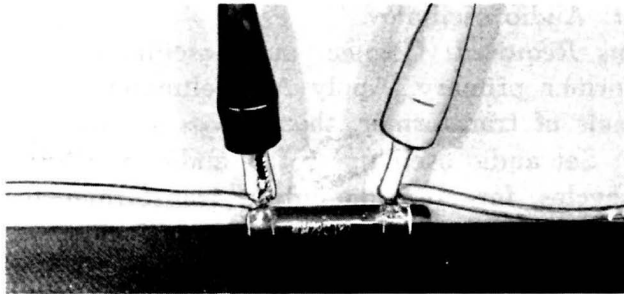

A standard power resistor connected in series with the line to the receiver.

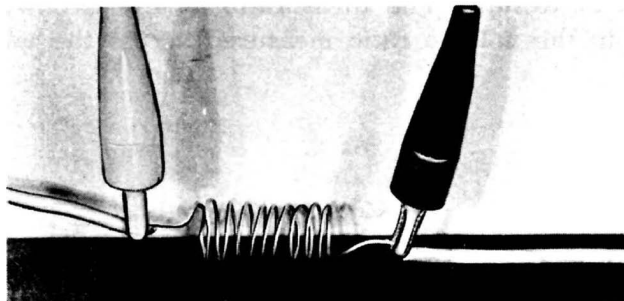

A Manganin wire spiral used as a power resistor in the line.

NOTE 57

Good Waveform Required for Accurate Power Measurements

The test described in U74 will be incorrect if the power line does not supply a good sine waveform. Normally, the power waveform is reasonably good. Sometimes, however, it is poor. To make a waveform check, see U66. You can use the same

method to check the power-line waveform. Power-line harmonics, if present, are usually odd, particularly third (iron) harmonics. In some heavily industrialized areas, even harmonics also are found in the power-line waveform.

U75

To Measure the AC Impedance of a Circuit

Equipment: 1-ohm power resistor.

Connections Required: Connect resistor in series with the line, as shown in the following illustration.

Procedure: Measure voltage drop across resistor and calculate the current flow. Then measure voltage applied to circuit (see illustration).

Evaluation of Results: The voltage value divided into the current value gives the input impedance of the circuit. This impedance value is for the test frequency only. At other frequencies, other impedance values will be found.

Test setup.

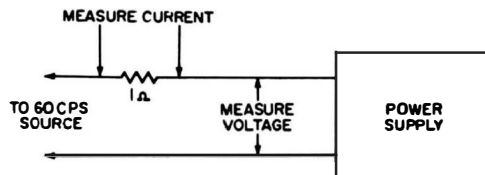

To Measure the Power Factor of a Radio or TV Receiver Power Supply

Equipment: Power resistor.

Connections Required: Connect power resistor in series with line to receiver. Connect AC voltmeter in turn across the power resistor, across the line, and across the receiver input.

Procedure: Note AC voltage values obtained in the above three connections. Let each volt represent a certain distance. Then fit E_1 , E_2 , and E_3 into a rectangle, as shown.

Evaluation of Results: Measure the length of X , and divide the length of X by the length of E_3 . This is the power factor of the circuit.

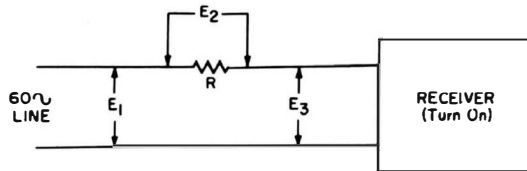

Test setup.

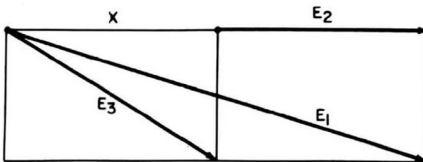

Plot of voltages.

NOTE 58

Resistive Circuit Has Unity Power Factor

When the power factor is equal to 1 (when $X = E_3$), the circuit has a purely resistive input. On the other hand, when the power factor is equal

to zero (when $X = 0$), the circuit has a purely reactive input. Most circuits have both a resistive and a reactive input.

NOTE 59

Power-Factor Measurement Inaccurate If Waveform Is Poor

Keep in mind that the test described in U76 cannot be made accurately unless the line voltage has a good sine waveform. Harmonics in the supply voltage can cause startling errors. When the waveform is poor,

it is quite possible to read more AC voltage across the resistor than across the line itself. This is a typical example of waveform error which is both surprising and baffling to the beginner.

To Check the Ripple Voltage in a Power Supply

Equipment: None.

Connections Required: Connect meter test leads from power-supply output to chassis ground.

Procedure: If a VOM is used, operate on Output function. If a VTVM is used, operate on AC voltage function.

Evaluation of Results: If a peak-to-peak VTVM is used, the value of ripple voltage indicated can be compared against the minimum ripple voltage specified in receiver service literature. On the other hand, a VOM is subject to waveform error, and a comparative test must be made on a receiver of the same type in good operating condition.

To Check the Voltage Across the Vertical-Deflection Coils

Equipment: None.

Connections Required: Connect test leads from VOM to terminals of vertical-deflection coils.

Procedure: Operate VOM on Output function. Otherwise, the VOM may be damaged by the DC voltage at the vertical-deflection coils.

Evaluation of Results: A reading of several volts normally is obtained. The normal reading depends upon the type of yoke, size of picture tube, and voltage range. A comparison test can be made against a receiver of the same type in good operating condition.

NOTE 60

Typical VOM Indications of Vertical-Output Voltage

Typical "Output" voltage indications of vertical-deflection voltage with a 20,000 ohms-per-volt VOM (1,000 ohms-per-volt sensitivity on Output function) are as follows:

- On 10-volt range
of VOM4.5 volts
- On 50-volt range
of VOM7.0 volts

Higher voltage indications are obtained with a 100,000 ohms-per-volt

VOM (5,000 ohms-per-volt sensitivity on Output function):

- On 8-volt range
of VOM7.5 volts
- On 40-volt range
of VOM8.0 volts

Note that some 20,000 ohms-per-volt VOM's have a 5,000 ohms-per-volt Output sensitivity.

DC CURRENT TESTS

U79

To Measure the Grid Current of a Tube (VOM)

Equipment: None.

Connections Required: Open the grid-return circuit. Complete the circuit with the VOM test leads.

Procedure: Tube can be checked under no-signal condition or with applied signal. Make initial measurement on high-current range to avoid possible damage to the VOM. Switch progressively to lowest current range if necessary.

Evaluation of Results: Tubes that are properly biased and not gassy will have very low values of grid current. Sometimes a tube develops grid emission, which causes appreciable grid-current flow.

NOTE 61

Removable Pin-Type Test Adapter

To measure current from the tube side of the chassis, use the type of test adapter that has a removable pin between the clips of each terminal. Remove the pin and connect the meter test leads between the clips.

To Measure the Screen Dissipation of an Output Tube

Equipment: None.

Connections Required: Open the screen lead and complete the circuit through the VOM. Then close the screen lead and connect the meter test leads from screen to cathode.

Procedure: Observe the current and voltage readings obtained.

Evaluation of Results: Multiply the screen current by the screen voltage to obtain the screen dissipation. Since the current is in amperes and the voltage is in volts, the screen dissipation will be in watts. Check value of screen dissipation against value specified in tube manual.

NOTE 62

Use Caution in Connecting VOM for Current Measurements

Beginners must be cautious when measuring current values and *never* connect across a voltage source. If appreciable voltage is applied to a milliammeter or microammeter, it will be instantly burned out. A cur-

rent meter must always be connected in series with the circuit under test. Make the initial measurement with the VOM set to its highest current range. Then reduce the range setting as required.

NOTE 63

Bypass Capacitor Protects Current Meter from AC Pulses

The dissipation of any tube electrode (plate, grid, etc.) can be measured by this method. If you are measuring DC current in a lead which also carries strong AC current pulses, the

VOM should be protected by shunting a 0.25-mfd capacitor across the test leads. The capacitor bypasses the AC pulse voltage, but permits the DC current to pass through the meter.

To Check the Uniformity of Raster Brightness (VOM)

Equipment: Photovoltaic cell.

Connections Required: Connect VOM test leads to terminals of light cell.

Procedure: Operate VOM on its lowest current range (such as 50 microamperes). Tune receiver to vacant channel. Advance brightness control for medium level of raster. Slide the light cell over the entire face of the picture tube and note the meter readings.

Evaluation of Results: If the picture tube is in good condition and if there are no spurious AC voltages at the picture-tube electrodes, the meter reading will be practically constant at any point on the raster.

Checking raster brightness.

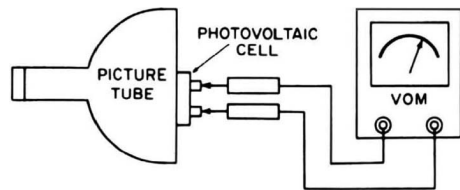

To Make Tests at Very Low Light Levels

Equipment: Transistor, 47-ohm resistor, 3K resistor, and 6-volt battery.

Connections Required: Connect as shown in the following illustration.

Procedure: Operate VOM on its lowest current range.

Evaluation of Results: The transistor increases the sensitivity of indication approximately ten times.

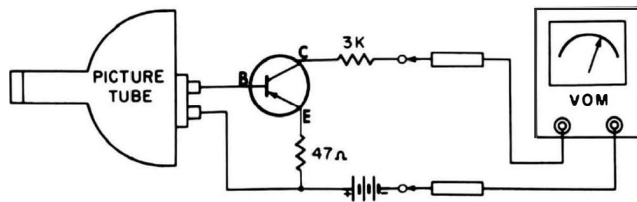

Checking raster brightness at low-brightness levels.

To Measure the Cathode Current of a Horizontal-Output Tube (VOM)

Equipment: None.

Connections Required: Open the cathode lead to the output tube. Connect the meter to the ends of the lead to complete the cathode circuit.

Procedure: Operate the VOM on its DC current function.

Evaluation of Results: Adjust the horizontal-drive control for minimum current, maintaining full sweep width without drive lines. Adjust the horizontal-linearity coil for a current dip or for minimum current without sweep distortion.

U84**To Check the Adjustment of a Horizontal-Linearity Coil (For Flyback Circuits as Noted in Receiver Service Data)**

Equipment: None.

Connections Required: Remove flyback fuse. Connect VOM test leads across fuse clips.

Procedure: Use suitable current range (500 ma for color receivers). Note DC current reading. Adjust linearity coil (also adjust width coil in some receivers).

Evaluation of Results: Correct adjustment is indicated by a minimum current reading.

U85**To Measure the Current Drain on a Power Supply**

Equipment: None.

Connections Required: Disconnect power-supply output lead from filter. Connect test leads to complete the circuit.

Procedure: Operate VOM on DC current function. Note reading on scale.

Evaluation of Results: Some receivers have two or three power-supply outputs. Each output is tested separately and the scale readings added to obtain the total current demand. Note that the demand depends upon the settings of the receiver controls. Also, the demand in some receivers fluctuates widely during warm-up.

ALIGNMENT APPLICATIONS

U86

To Align an AM IF Transformer

Equipment: Signal generator and 0.1-mfd capacitor.

Connections Required: Connect output from signal generator to grid of IF tube preceding the transformer to be aligned. If a transformerless set is under test, connect a 0.1-mfd capacitor in series with the generator ground lead to the receiver chassis. Connect VOM or VTVM across the speaker voice coil.

Procedure: If a VOM is used, operate on the Output function. If a VTVM is used, operate on the AC voltage function. Set the generator for modulated-RF output. Tune generator to IF frequency specified in receiver service literature (usually 455 kc). Observe other procedures specified in the service literature, such as setting the receiver tuning capacitor fully open. Adjust tuning slugs (or trimmers) in the IF transformer. Use as low output as possible from the generator to avoid overload.

Evaluation of Results: Adjust the IF tuning slugs (or trimmers) for maximum indication on the meter.

NOTE 64

Eliminating Hum Modulation of Generator Signal

In transformerless radios, hum modulation of the generator signal may be troublesome unless a small blocking capacitor is used. For example,

use a 0.001-mfd capacitor in U86, instead of a 0.1-mfd capacitor if necessary.

To Measure the Stage Gain of an AM IF Amplifier

Equipment: Signal generator and 0.1-mfd fixed capacitor.

Connections Required: Connect output from signal generator to grid of IF stage being checked. If a transformerless set is under test, connect a 0.1-mfd capacitor in series with the generator ground lead to the receiver chassis. Connect VOM or VTVM across the speaker voice coil.

Procedure: Observe meter reading. Then apply generator output to preceding or succeeding IF grid. Do not change the output from the generator. Again observe the meter reading.

Evaluation of Results: The stage gain is equal to the ratio of the two meter readings. Note that the measurement will be incorrect if an IF stage is overloaded; therefore, keep the signal-generator output at the lowest point which will give a readable signal.

To Align an Overcoupled IF Transformer by Alternate Loading

Equipment: Signal generator, blocking capacitor, and 300-ohm resistor.

Connections Required: Same as for usual AM alignment. Make the first test by connecting the 300-ohm resistor across the primary of the IF transformer. Make the second test by disconnecting the resistor from the primary and connecting it across the secondary of the IF transformer.

Procedure: Tune generator to the center of the passband (such as 455 kc). Use modulated RF output. Adjust secondary trimmer when the resistor is connected across the IF transformer primary. Adjust primary trimmer when the resistor is connected across the secondary. Finally, remove resistor from transformer.

Evaluation of Results: Alternate loading permits correct adjustment of overcoupled transformers by a simple peaking procedure. An overcoupled transformer (used for hi-fi reception) normally has a double hump. Shunting the resistor

across the primary lowers its Q and changes the double-humped response to a single peak. Thus, the secondary can be peak-aligned to the center frequency. Likewise, shunting the resistor across the secondary permits the primary to be peak-aligned to center frequency. Finally, when the resistor is disconnected, the transformer has its correct double-humped wide-band response.

NOTE 65

Alternate Loading Method Applies to Overcoupled Transformers Only

When an IF stage is normally stagger-aligned or is normally over-coupled *and* stagger-aligned, the alternate loading method cannot be used. Instead, sweep-alignment pro-

cedures are advised. For details of sweep alignment, see the companion volume, *101 Ways to Use Your Sweep Generator*.

To Align an FM Discriminator Secondary

Equipment: Blocking capacitor (about 0.05 mfd) and signal generator.

Connections Required: Connect blocking capacitor in series with generator ground lead. Apply generator signal between grid of limiter tube and chassis ground. Connect VOM or VTVM between audio-output lead of discriminator and chassis ground.

Procedure: Tune signal generator to IF center frequency (usually 10.7 mc). Operate VOM or VTVM on DC volts function. Use unmodulated RF output from generator. Adjust secondary slug on discriminator transformer. Observe any precautions specified in receiver service literature.

Evaluation of Results: Align secondary for zero-voltage indication. A positive and a negative meter reading are obtained on either side of the correct alignment point.

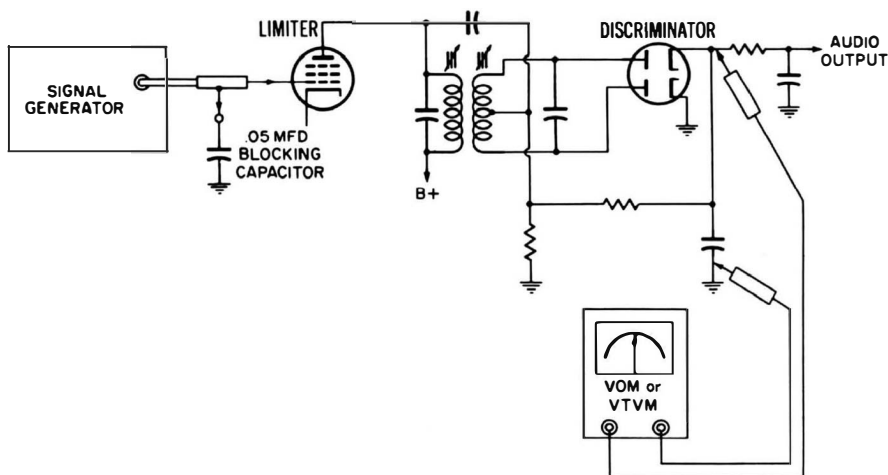

Test setup.

U90

To Align an FM Discriminator Primary

Equipment: Signal generator and blocking capacitor (about 0.05 mfd).

Connections Required: Connect blocking capacitor in series with generator ground lead. Apply generator signal between grid of limiter tube and chassis ground. Connect DC probe of VTVM to center tap of discriminator secondary winding.

Procedure: Observe any precautions specified in receiver service literature, such as receiver control settings. Tune signal generator to specified IF frequency (usually 10.7 mc). Use unmodulated RF output from generator. Adjust slug or trimmer in discriminator transformer primary. Operate VTVM on DC volts function.

Evaluation of Results: Adjust trimmer for maximum reading on meter.

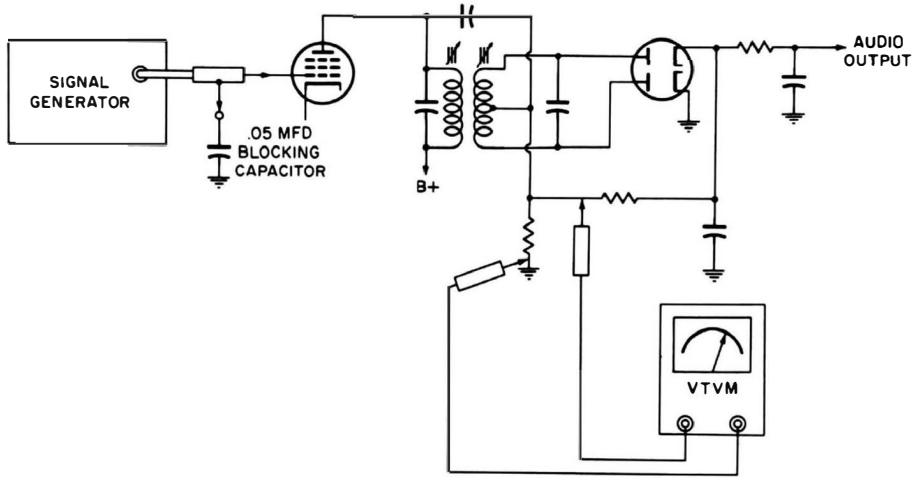

Test setup.

To Peak-Align an FM IF Transformer

Equipment: Signal generator and blocking capacitor (about 0.05 mfd).

Connections Required: Connect blocking capacitor in series with the generator ground lead. Apply generator output between grid of IF tube preceding transformer and chassis ground. Connect DC probe of VTVM at limiter grid. Return VTVM to chassis ground.

Procedure: Observe any incidental notes specified in receiver service data. Tune signal generator to IF center frequency (usually 10.7 mc). Operate VTVM on DC volts function. Operate generator on unmodulated RF output. Adjust slugs or trimmers for primary and secondary of transformer.

Evaluation of Results: Alignment is correct when the meter shows maximum indication on DC volts scale.

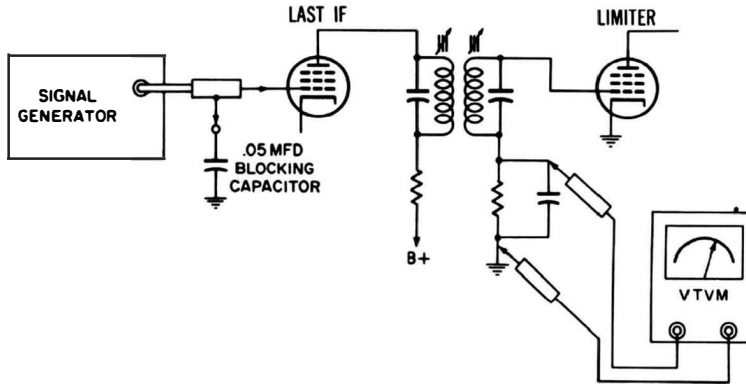

Test setup.

U92

To Plot the Response Curve of an FM Receiver

Equipment: Signal generator and graph paper.

Connections Required: Connect terminated output cable from signal generator to antenna-input terminals of receiver. Connect DC probe of VTVM at limiter grid. Return VTVM to chassis ground.

Procedure: Tune FM receiver to desired channel. Mark off a suitable range of frequencies on the graph paper. At right angles, mark off an appropriate range of voltage readings. Tune generator through the receiver passband and note the voltage readings at a sufficient number of frequencies to obtain the shape of the response curve.

Evaluation of Results: Compare plotted response curve with specified curve in receiver service literature.

Unless the signal-generator output cable is correctly terminated, the generator output can vary enough over the passband to cause an erroneous curve plot. Standing waves in the generator cable will cause this output variation.

To Peak-Align a TV IF Amplifier

Equipment: Signal generator and AGC override bias box. (If a VOM is used, a 50,000-ohm resistor should be inserted in series with the "hot" lead to the meter.)

Connections Required: Apply output from signal generator to a floating tube shield over the mixer tube (a floating tube shield is a shield lifted clear of the chassis). Connect output from bias box to IF AGC line. Connect VOM through 50K isolating resistor across video-detector load resistor. If a VTVM is used, no isolating resistor is required.

Procedure: Use about -3 volts of AGC override bias. Disable local oscillator by cutting off the grid or plate pin from the tube base. Set signal generator to peaking frequency, as specified in receiver service literature. Operate meter on DC voltage function. Turn slug in IF coil until meter indicates maximum value. Repeat the procedure for each IF stage.

Evaluation of Results: When the meter reading is maximum, the stage is peaked to the generator frequency, regardless of the tuning of the other IF stages.

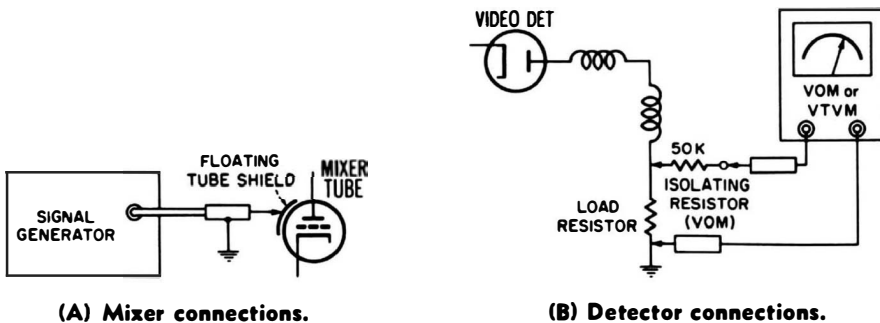

Test setup.

NOTE 66

Peak Alignment Provides a Rough Adjustment Only

Peak alignment, although often adequate, is always somewhat incomplete because of component tolerances in the IF amplifier. For this reason, better receiver operation is obtained if the peak alignment is followed with compromise adjust-

ments of individual stages. These adjustments must be done with a sweep generator and oscilloscope. For details, see the companion volume, *101 Ways to Use Your Sweep Generator*.

U94

To Adjust a Trap in a TV IF Amplifier

Equipment: Signal generator and AGC override bias box. (If a VOM is used, a 50,000-ohm resistor should be inserted in series with the "hot" lead to the meter.)

Connections Required: Apply output from signal generator to a floating tube shield over the mixer tube (a floating tube shield is a shield lifted clear of the chassis). Connect output from bias box to IF AGC line. Connect VOM through 50K isolating resistor across video-detector load resistor. If a VTVM is used, no isolating resistor is required.

Procedure: Set generator as accurately as possible to the trap frequency specified in receiver service literature. Turn slug in trap and observe meter reading.

Evaluation of Results: Trap is properly adjusted when meter reading is minimum. In most cases you will find a null, with a little response on the other side of minimum. To clarify a null, increase generator output or reduce value of AGC override bias.

To Check the Frequency Response of the IF Amplifiers of a TV Set

Equipment: Signal generator and AGC override bias box. (If a VOM is used, a 50,000-ohm resistor should be inserted in series with the "hot" lead to the meter.)

Connections Required: Apply output from signal generator to a floating tube shield over the mixer tube (a floating tube shield is a shield lifted clear of the chassis). Connect output from bias box to IF AGC line. Connect VOM through 50K isolating resistor across video-detector load resistor. If a VTVM is used, no isolating resistor is required.

Procedure: Tune signal generator through the IF passband, and plot the voltage readings on graph paper.

Evaluation of Results: Compare the plotted curve with specified curve in receiver service literature. Note that the signal generator should have reasonably uniform output (see U10).

NOTE 67

Sweep Alignment and Square-Wave Tests Are Required for Optimum Performance

Optimum response from a TV receiver is obtained if a sweep-alignment test is followed with a transient test. This test is made with a square-wave generator and an oscilloscope. For details, see the companion volume, *101 Ways to Use Your Oscilloscope*. Ideal frequency-response curves do not always give the best possible picture reproduction. This is due to component tolerances, which cause the phase response of the complete signal system

to depart from the ideal. For good picture reproduction, phase response is more important than frequency response. There is only one practical way you can adjust a receiver for best phase response: make over-all square-wave tests from the antenna-input terminals of the receiver to the video-amplifier output. Faulty phase response causes displacement of picture elements, plus associated distortions.

To Check a TV IF Amplifier for Regeneration

Equipment: Signal generator and AGC override bias box. (If a VOM is used, a 50,000-ohm resistor should be inserted in series with the "hot" lead to the meter.)

Connections Required: Apply output from signal generator to a floating tube shield over the mixer tube (a floating tube shield is a shield lifted clear of the chassis). Connect output from bias box to IF AGC line. Connect VOM through 50K isolating resistor across video-detector load resistor. If a VTVM is used, no isolating resistor is required.

Procedure: Tune signal generator for midband response of IF amplifier. Then reduce the generator output to a very low value. Finally, reduce the bias-box voltage and watch how the meter response rises.

Evaluation of Results: The meter response should rise smoothly, without any abrupt jumps up or down. Jumps in the meter reading indicate regeneration. If the reading suddenly jumps to a very high value, such as 10 or 15 volts, the IF stage has broken into oscillation.

To Check an IF System for Mixer Regeneration

Equipment: Signal generator and AGC override bias box. (If a VOM is used, a 50,000-ohm resistor should be inserted in series with the "hot" lead to the meter.)

Connections Required: Apply output from signal generator to a floating tube shield over the mixer tube (a floating tube shield is a shield lifted clear of the chassis). Connect output from bias box to IF AGC line. Connect VOM through 50K isolating resistor across video-detector load resistor. If a VTVM is used, no isolating resistor is required.

Procedure: Set signal generator for a response of 1 volt DC at the midband frequency of the IF amplifier. Then rotate the receiver channel-selector switch through the low and high channels while observing the meter reading.

Evaluation of Results: When there is no regeneration, the meter

reading will not change during this switching test. On the other hand, if the meter reading varies greatly, the mixer is objectionably regenerative.

U98

To Signal-Trace an IF Amplifier for a Regenerative Feedback Loop

Equipment: Signal generator, 0.01-mfd bypass capacitor, 50K isolating resistor (if VOM is used; otherwise, use DC probe of VTVM without isolating resistor), and injection resistor (value determined by trial).

Connections Required: Connect VOM through isolating resistor across video-detector load resistor (or connect VTVM DC probe across load resistor). Apply signal-generator output to grid of last IF tube through an injection resistor which should be as large as possible, yet permit reasonable deflection on the meter.

Procedure: Tune a signal generator to midband region of IF passband. Observe meter reading. Then shunt the bypass capacitor in turn from each preceding tube grid to chassis. Note any change in meter reading.

Evaluation of Results: Any change in meter reading shows the bypass capacitor is being applied inside a feedback loop. No change in meter reading shows you have moved out of the feedback loop. This test does not show where the regenerative loop ends. However, it does show where the regenerative loop begins.

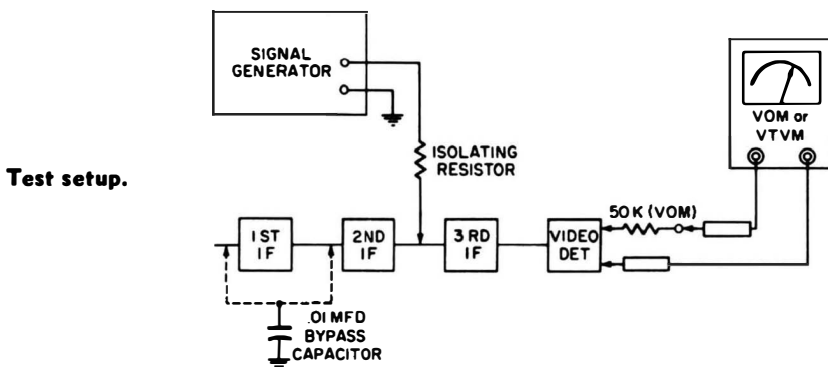

To Peak-Align a Bandpass Amplifier

Equipment: Signal generator and high-frequency rectifier (signal-tracing) probe.

Connections Required: Apply generator signal to grid of bandpass amplifier tube. Connect probe to VOM or VTVM. Apply probe across a low-impedance point in the bandpass-amplifier output circuit.

Procedure: Set signal generator to peaking frequencies specified in receiver service literature. Adjust slug in associated bandpass-amplifier coil for maximum DC indication on meter. Repeat for each tuned circuit in the bandpass-amplifier network.

Evaluation of Results: Peak alignment is often satisfactory, but for best receiver operation, a final sweep-alignment check is recommended. For details, see the companion volume, *101 Ways to Use Your Sweep Generator*.

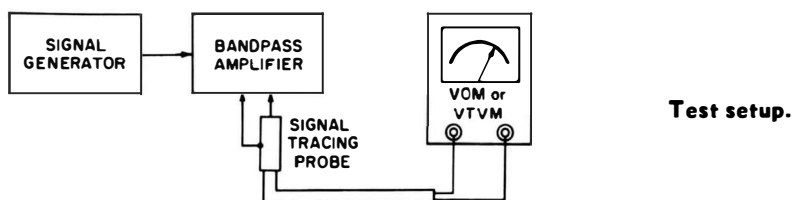

To Measure the Gain of a Bandpass Amplifier

Equipment: Signal generator and high-frequency rectifier (signal-tracing) probe.

Connections Required: Apply generator signal to grid of bandpass amplifier tube. Connect probe to VOM or VTVM. Apply probe across a low-impedance point in the bandpass amplifier output circuit. Then, apply probe across the generator output terminals.

Procedure: With meter connected at output of bandpass amplifier, tune signal generator for maximum meter indication.

Then apply probe at the signal-generator output. Observe drop in meter reading.

Evaluation of Results: The ratio of the two meter readings is the gain of the bandpass amplifier.

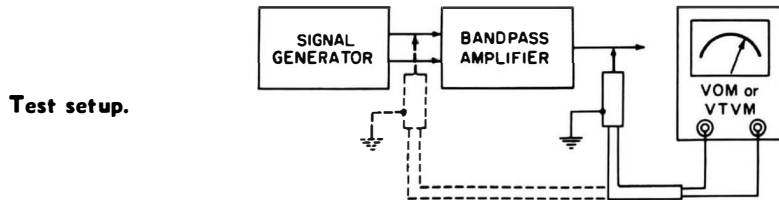

To Check Chroma Channel Gains

Equipment: Signal generator and high-frequency rectifier (signal-tracing) probe.

Connections Required: Connect signal-tracing probe to VOM or VTVM. Apply generator output to grid of bandpass amplifier tube. Connect probe in turn to a low-impedance point in the R-Y circuit, in the B-Y circuit, and in the G-Y circuit (grid terminals of picture tube are suitable).

Procedure: Adjust signal generator to 3.56 mc (this insures loss of color sync, which is required in this test). A rainbow pattern will be observed on the picture-tube screen. Observe meter readings while the probe is applied in turn at the chroma-channel outputs.

Evaluation of Results: Check relative meter readings against specified gains of chroma channels in receiver service data.

INDEX

A

- Accuracy
 - ohmmeter indications, 11, 12
 - resistance measurements, 13
- AC
 - impedance measurement, 89
 - measurements of, 23
 - pulses, 42
 - rectifier, 61
 - voltage, excessive, results of, 19
 - voltage indication vs. DC indication, 16, 17
 - voltage scale, 18
 - cramping of, 18
 - voltage test, 75-92
 - voltage turnover measurements, 84
 - voltage with DC present, measurement of, 79
- Adjustment
 - horizontal-linearity coil,
 - check of, 96
 - color-AFC balance control, 36
- AGC
 - circuit loading, check for, 40
 - voltage, measurement of, 36, 37
 - bias-box method, 38
 - potentiometer method, 39
 - range switching method, 40
- Aging rectifier tolerances,
 - effect of, 19
- Alignment applications, 99-111
- Alternate loading method, 100, 101
- AM IF transformer, alignment of, 99
- Amplifier operation, linearity check, 29
- Audio
 - amplifier gain, measurement of, 75
 - oscillator harmonics, check for, 80
 - oscillator waveform, improvement of, 84

B

- Bandpass amplifier
 - measurement of gain, 110, 111
 - peak alignment, 110
- Basic full-wave bridge rectifier, circuit of, 18
- Batteries
 - condition of, 12-14
 - hearing aid, 47
 - nonmagnetic shells, 13
 - ohmmeter, 12-14
 - steel-jacketed cells, 13
 - types of, 13
- Body
 - capacitance, 66
 - resistance, effect of, 13
- Bridge, full wave, 16-18

- Brightness
 - check of, 94, 95
 - test of at low levels, 95

C

- Capacitance
 - body, 66
 - divider for signal-tracing probe, 56
 - electrolytic, measurement of, 82
 - values, measurement of, 81
 - VOM, 26, 27
 - VTVM, 26
 - loading of probe, 60
- Capacitor
 - electrolytic, power factor, measurement of, 83
 - paper, leakage check, 51
 - zero power factor, 84
- Cathode current of horizontal output tube, measurement of, 41, 96
- Chroma channel gain, check of, 111
- Circuit loading, test for, 36, 37
- Circuit of oscillator-mixer, 33
- Coil power factor, measurement of, 86, 87
- Color-AFC balance control, adjustment of, 36
- Complex waveforms, peak voltages of, 58
- Consumption, power, measurement of, 88
- Corona field, DC voltage indication, 41
- Correction of distribution error, 13
- Coupling capacitor leakage, check for, 27
- Cramped ohmmeter scale, 11, 12
- Cramping of AC voltage scale, 18
- Current drain of power supply, measurement of, 96, 97
- Current tests, DC, 93-97

D

- DC
 - current indication accuracy, check of, 14, 15
 - current test, 93-97
 - probe of VTVM, 28
- DC voltage
 - accuracy, 12
 - indication accuracy, check of, 14, 15
 - indication in corona field, 41
 - measurement in presence of high voltage AC pulses, VTVM, 43
 - measurements of, 23
 - output of video detector, check of, 35
 - scale, 18
 - tests, 25-45

Decibel 75-79
 levels, relative and absolute, 78
 measurement across reactive load, 78, 79
 inaccurate measurement, cause of, 76
 measurement across various load impedance values, 77
 measurement of, 75, 76
 with DC present, 79
 Deflection of zero-center VTVM, check of, 16
 Demodulating probe, 63
 Dial scale, VOM, 12
 Diode, germanium, 50
 Distribution error
 correction of, 13
 of ohmmeter scale, check of, 13
 Drive voltage
 to horizontal-output tube, check of, 72
 to vertical-output tube, check of, 70, 71

E

Electrochemical action, 15
 Electrolytic capacitor leakage, check for, 25, 55
 Equipment checks, 11-24
 Erroneous readings, causes of, 13-15, 19, 21, 22, 33, 37, 70

F

Faulty rectifier in full-wave bridge, check of, 18
 Floating grid, 37, 38
 FM
 discriminator primary, alignment of, 102, 103
 discriminator secondary, alignment of, 101, 102
 IF transformer, peak alignment of, 103, 104
 receiver response curve, plotting of, 104
 frequency response on AC voltage ranges, 21, 22
 Frequency response
 probe, 64
 rectifier probe, 57
 TV IF amplifier, check of, 107
 VOM, 21, 22
 Full wave
 bridge, 16-18
 rectifier output, 17
 semibrIDGE rectifier, 17

G

Gain
 audio amplifier, measurement of, 75
 bandpass amplifier, measurement of, 110, 111

Germanium diode, 50
 Globar resistor, check of, 51
 Grid current, measurement of, 93

H

Half wave
 rectifier, 16, 17
 rectifier output, 17
 signal-tracing probe, 56, 57
 Harmonics, audio oscillator, check for, 80
 Hearing aid batteries, 47
 High-ohms probe, 48
 circuit of, 52
 High-voltage DC probe, construction of, 45
 use of, 44
 Horizontal-linearity coil, adjustment check, 96
 Horizontal-output tube
 cathode current, measurement of, 96
 plate dissipation, measurement of, 44
 screen dissipation, measurement of, 42, 43
 Horizontal-output voltage, check for, 72, 73
 Horizontal-phase detector, waveform check, 71
 Horizontal sync pulse, measurement of, 70
 Hum modulation, elimination of, 99
 Hum voltage at ohmmeter terminals, 22, 23

I

IF
 amplifier, regenerative, check for, 108
 oscillation, check for, 34
 cure for, 34
 sensitivity, check for, 34
 Impedance, inductor, 85
 Inaccurate AC reading, cause of, 21, 22
 Inaccurate scale indication, causes of, 19
 Indication accuracy, check of, 14, 15
 Inductance, measurement of, 86
 Inductive reactance, measurement of, 86
 Inductor, impedance of, 85
 Input resistance, measuring of, 15
 Instrument loading, results of, 37
 Interelectrode leakage, picture tube, 53, 54
 Internal contact potential, result of, 32, 33
 Internal resistance of circuit, measurement of, 31
 range switching method, 31, 32

- J**
- Jarring, excessive, results of, 19
- L**
- Leakage
 coupling capacitor, check for, 27
 current, transistor, 64
 electrolytic or paper capacitor, 25
- Linearity of amplifier operation,
 check for, 29
- Local oscillator, checking of, 64, 65
- Low-ohms probe, 48, 49
 circuit of, 49
 construction of, 48, 49
 for short circuit check, 49
- M**
- Measurement of
 AGC voltage, 36, 37
 capacitance values, VOM, 26, 27
 VTVM, 26
 DC voltage in presence of high-
 voltage AC pulses, 45
 input resistance, 15
 signal-developed bias, 28
- Microampere range of VOM, explan-
 ation of, 37
- Mixer regeneration in IF, check for,
 108, 109
- Modulated waveform voltage, meas-
 urement of, 61, 62
- Multiplier resistor tolerances, 23, 24
- N**
- No current drain test, 59, 60
- Noise level, check of, 35
- Nonmagnetic shells, ohmmeter bat-
 tery, 13
- Nonuniform flux distribution, effect
 of, 13
- O**
- Ohmmeter
 batteries with nonmagnetic shells,
 13
 DC voltage accuracy, 12
 indication accuracy, check of, 11,
 12
 scale
 cramped, 11, 12
 distribution error, 13
 plates, nonlinearity of, 13
 test, 47-54
- Ohms-per-volt rating, checking of,
 20
- Oscillator-injection voltage, meas-
 urement of, 33
- Oscillator operation, check of, 32
- Output
 full-wave rectifier, 17
 half-wave rectifier, 17
- Output voltage, horizontal, check for,
 72, 73
- Overcoupled IF transformer, align-
 ment of, 100, 101
- Overloads, results of, 19
- P**
- Paper capacitor, leakage check, 51
 high-ohms probe, 52
- Peak alignment
 bandpass amplifier, 110
 TV IF amplifier, 105, 106
- Peak voltage, measurement of, 57
- Peak-to-peak
 measurement without current
 drain, 60, 61
 probe, 59
 voltage measurement, 58, 59
 horizontal sync pulse, 70
 vertical sync pulse, 69
- Picture tube leakage, check for, 53,
 54
- Picture tube shorts, burning out
 method, 54
- Plate dissipation, measurement of, 44
- Polarity-reversing probe, 29
- Power consumption, measurement of,
 88
- Power factor of
 coil, measurement of, 86, 87
 electrolytic capacitor, measurement
 of, 83
 power supply, measurement of, 90
- Power measurements, good waveform
 required, 89
- Power supply
 measurement of current drain, 96,
 97
 power factor, measurement of, 90
 ripple voltage, check of, 91
- Probe
 capacitive loading of, 60
 demodulating capability of, 63
 frequency response, 64
 high ohms, 48
 low ohms, 48
 peak-to-peak, 59
 reversing polarity, 29
- Pulses, AC, 42
- Push-pull amplifier, balance check,
 30
- R**
- Rectifier
 AC, 61
 half wave, 16, 17
- Rectifier probe, response of, 57
- Reduced accuracy of AC indication,
 causes of, 19
- Regeneration, check for, 108
 IF amplifier, 108
 mixer, 108, 109

INDEX

- Resistance values, measurement of, 47, 48
Resistors, thermal, 51
Response curve, plotting of, 104
Response to stray AC field voltage, 19
Resonance, effect of, 21, 22
Ripple voltage, check of, 91
- S**
- Scale tracking, 49
Semiconductor diode, check of, 50
Screen and cathode capacitors, open check, 55
Screen dissipation, measurement of, 42, 43
 output tube, 94
Sensitive rectifier probe, construction of, 24
Sensitivity of signal-tracer probe, 63, 64
Signal check
 at FM detector, 68
 from mixer tube to picture detector, 66
 video signal drive to picture tube, 67, 68
 video output from picture detector, 67
Signal developed bias, measurement of, 28
Signal generator output, uniformity check, 24
Signal trace
 IF amplifier for regeneration, 108
 output of RF tuner through IF amplifier, 65
 sync section, 69
Signal tracing probe
 sensitivity of, 63, 64
 compensated voltage divider for, 56
 half wave, 56, 57
Signal tracing tests, 55-73
Spurious voltage indication, cause of, 15
Stage gain, measurement of, 100
Stray AC field voltages, response to, 19
Stray fields, 66
Swamping effect, 18
- T**
- Test
 adapter, 30, 93
 ohmmeter, 47-54
 signal tracing, 55-73
- Thermal resistors, 51
Thermoelectric error, cause of, 15
Tolerances, multiplier resistor, 23, 24
Tracking, scale, 49
Transformer turns ratio, measurement of, 87
Transistor leakage current, 64
Trap, adjustment of, 106
Tube current, measurement of, 41
Turnover in AC voltage measurements, 84
TV IF amplifier
 frequency response check, 107
 peak alignment of, 105, 106
 regeneration, check for, 108
TV IF trap, adjustment of, 106
- U**
- Uniformity
 raster brightness, check of, 94, 95
 signal generator output, check of, 24
- V**
- Vertical-deflection coils, voltage check of, 91
Vertical-output tube drive voltage, check of, 70, 71
Vertical sync pulse, measurement of, 69
Vibration, excessive, result of, 19
Video detector, circuit of, 35
Voltage test, AC, 75-92
VOM
 frequency response, 21, 22
 input resistance, measuring of, 15
 peak-to-peak probe, response of, 61
 uses of (general), 9, 10
VTVM pointer shift, cause of, 32, 33
VTVM uses of (general), 9, 10
- W**
- Waveform, audio oscillator, improvement of, 84
Weak ohmmeter battery, results of, 12, 14
- Z**
- Zero power factor, 84

101 ways to use your VOM and VTVM



ABOUT THE AUTHOR

BOB MIDDLETON was born in Watsonville, Calif., in 1908. He spent his early years on a farm in the Bay region. Becoming interested in wireless in 1919, he operated a "boot-leg" spark transmitter until he was old enough to become a licensed operator. In 1921, he held the state record for long-distance reception on a cats-

whisker detector. Bob operated his own radio service business for a number of years and later entered design engineering. In 1948, he moved into field engineering and technical lecturing. He has become well known also for his writing on service problems and instrumentation. Bob is a senior member in the I. R. E., and his biography appears in "Who's Who in the Midwest." He has written two previous companion volumes—*101 Ways to Use Your Sweep Generator* and *101 Ways to Use Your Oscilloscope*.



HOWARD W. SAMS & CO., INC.

THE BOBBS-MERRILL COMPANY, INC.

Indianapolis • New York